

Practical Electronics

FEBRUARY 1966

PRICE 2'6

HOW TO MAKE

- * ELECTRONIC VIBRATO UNIT
- * COMPACT POWER UNIT

NEW SERIES

RADIO CONTROL of MODELS

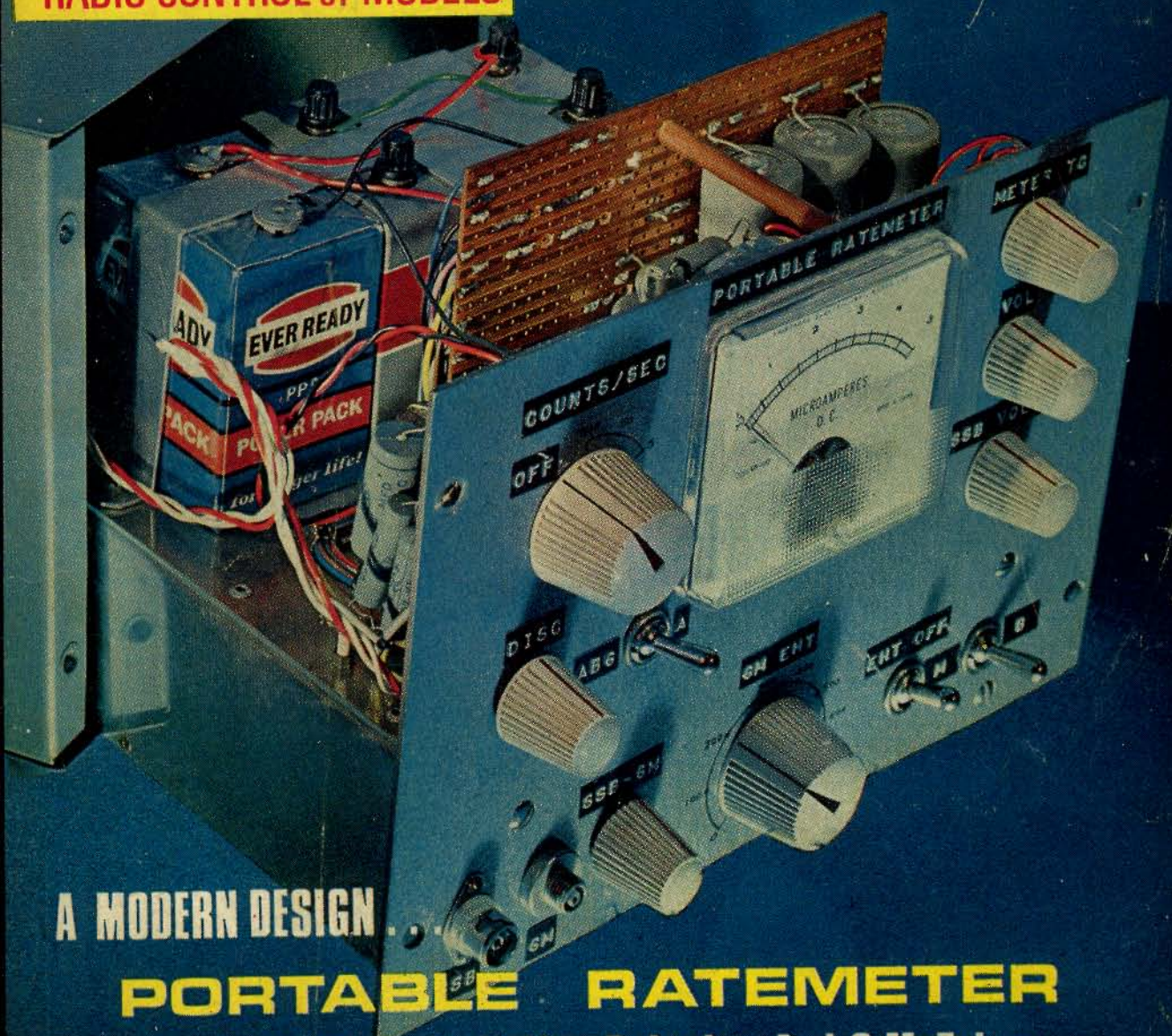

A MODERN DESIGN

PORTABLE RATEMETER

For Solid State Radiation Detector And G.M. Tubes

ADCOLA
PRODUCTS LIMITED
(Reg. Trade Mark)

**SOLDERING
EQUIPMENT**

"A" SERIES

STANDARD APPROVED IN ALL LEADING COUNTRIES

BIT SIZES FROM $\frac{3}{32}$ " TO $\frac{1}{4}$ " TO CHOICE

ILLUSTRATED IS L64 $\frac{3}{16}$ " BIT INSTRUMENT

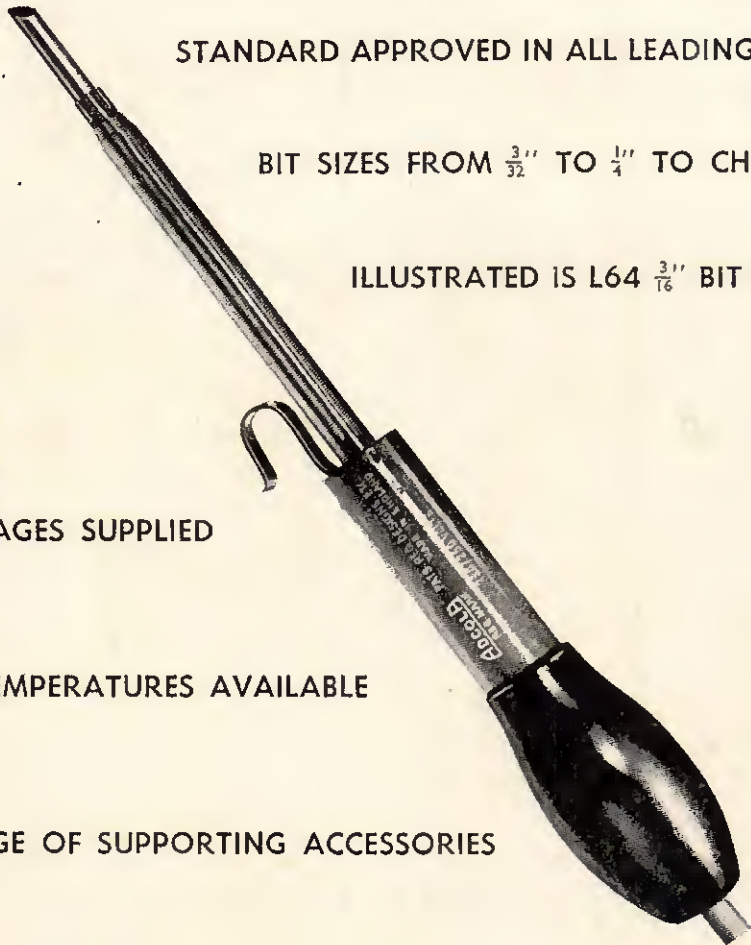

ALL VOLTAGES SUPPLIED

SPECIAL TEMPERATURES AVAILABLE

FULL RANGE OF SUPPORTING ACCESSORIES

FOR SALES & SERVICE APPLY DIRECT TO:

**ADCOLA PRODUCTS LTD.
ADCOLA HOUSE
GAUDEN ROAD
LONDON, S.W.4**

**TELEPHONE:
MACAULAY 4272 & 3101**

**TELEGRAMS:
SOLJOINT, LONDON S.W.4**



LAFAYETTE HA-43 COMMUNICATION RECEIVER
7 valves plus Rectifier, 4 Bands, 500 kc/s-31 Mc/s. "S" Meter—BFO—ANT—Bandspread Tuning. 200/250v. A.C. Brand New 24 Gns. Carr. Paid.

STAR SR.40 COMMUNICATION RECEIVER
4 Bands, 550 kc/s-30 Mc/s. "S" Meter—BFO—ANT—Bandspread Tuning—Built-in speaker 200/250v. A.C. Brand New. 18½ Gns. Carr. 10/-.

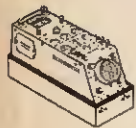
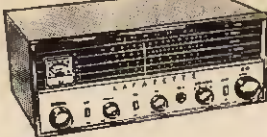

OS/BB/U OSCILLOSCOPES
High quality Portable American Oscilloscope. 3" c.r.t. T/B 3 c/s-50 kc/s X Amp: 0-500 kc/s Y Amp: 0-2 Mc/s. Power requirements 105-125v. A.C. Supplied in brand new condition, fully tested. 225. Carr. 10/-. Suitable 230/115v. Transformer 16/6.

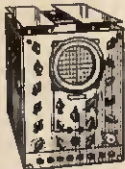

ERSKINE TYPE 13 DOUBLE BEAM OSCILLOSCOPE
Time base 2 c/s-750 kc/s. Calibrators at 100 kc/s and 1 Mc/s. Separate Y1 and Y2 amplifiers up to 5.5 Mc/s. Operation 110/230 volt A.C. Supplied in perfect working order. 227/10/-. Carriage 20/-.



CLEAR PLASTIC PANEL METERS

First grade quality, Moving Coil panel meters, available ex-stock. S.A.E. for illustrated leaflet. Discounts for quantity. Available as follows: Type MR. 35P, 1 1/4" x 3 1/2" square fronts.

5mA.....	22/6	1 A D.C.....	22/6	300V D.C.....	22/6
10mA.....	22/6	2 A D.C.....	22/6	500V D.C.....	22/6
20mA.....	22/6	5 A D.C.....	22/6	750V D.C.....	22/6
50mA.....	22/6	3V D.C.....	22/6	15V A.C.....	22/6
100mA.....	22/6	10V D.C.....	22/6	60V A.C.....	22/6
150mA.....	22/6	20V D.C.....	22/6	150V A.C.....	22/6
200mA.....	22/6	50V D.C.....	22/6	300V A.C.....	22/6
300mA.....	22/6	100V D.C.....	22/6	500V A.C.....	22/6
500mA.....	22/6	150V D.C.....	22/6	"S" Meter MA 29/6	
1000mA.....	22/6				

POET EXTRA Larger sizes available—send for lists.
ILLUMINATED "S" METERS. 1 1/2" square front. Cal. in 8 units. 6V. lamp. 29/6. P. & P. 1/-. Ditto 3 1/2" x 3 1/2" square 39/6. P. & P. 1/-.
2mA..... 22/6



TRANSISTORISED TWO-WAY TELEPHONE INTERCOM.

Operative over amazingly long distances. Separate call and press to talk buttons. 2-wire connection. 1000's of applications. Beautifully finished in ebony. Supplied complete with batteries and wall brackets. 7 gns. pair. P. & P. 5/-.

MAGNAVOX 363 TAPE DECKS

New 3-speed tape deck, supersedes old Colarno studio deck. 2-track £10.10.0, 4-track £13.10.0. Carr. Paid.

GARRARD RECORD PLAYERS

Brand new and guaranteed

SRP-10 Player.....	24 17 8
AUTOSLIM Changer.....	25 5 0
1099 Changer.....	25 19 0
2090 Changer.....	27 10 0
3000 Changer—Stereo.....	28 8 0
SR25 Player—Stereo.....	212 10 0
DECCADEC, with Derram.....	2 17 0
A70 (less cart.).....	222 1 0
LAB80—Mono.....	227 0 0
491 Transcription.....	230 0 0

All plus P. & P. 6/-.

MINE DETECTOR No. 4A

Will detect all types of metals. Fully portable. Complete with instructions. 39/6. Carr. 10/-. Battery 9/6 extra.

CALLERS WELCOME!

Open 9 a.m. to 6 p.m. every day Monday to Saturday. Trade supplied.

MODEL ZQM TRANSISTOR CHECKER

It has the full capacity for checking on A, B and Ico. Equally adaptable for checking diodes, etc. R.P.C. & A: 0-7-0-9967. B: 5-200. Ico: 0-50 microamps, 0-5 mA. Resistance for diode 200 Ω-1 MEG. Supplied complete with instructions, battery and leads. 26/19/6. P. & P. 2/6.



SILICON RECTIFIERS

200 v. P.I.V. 200mA.....	2/6
400 v. P.I.V. 3 amp.....	7/6
1,600 v. P.I.V. 650 mA.....	7/6
800 v. P.I.V. 500mA.....	5/6
400 v. P.I.V. 500mA.....	3/6
70 v. P.I.V. 1 amp.....	3/6
150 v. P.I.V. 150mA.....	1/-

Discounts for quantities. Post extra.

AMERICAN TAPE

First grade quality American tapes. Brand new and guaranteed. Discounts for quantities.

3in., 225ft. L.P. acetate.....	4/-
3in., 600ft. T.P. mylar.....	10/-
6in., 600ft. std. plastic.....	8/6
6in., 900ft. L.P. acetate.....	10/-
6in., 1,200ft. D.P. mylar.....	15/-
6in., 1,800ft. T.P. mylar.....	35/-
5 1/2in., 1,200ft. L.P. acetate.....	12/6
6 1/2in., 1,800ft. D.P. mylar.....	22/6
6 1/2in., 2,400ft. T.P. mylar.....	45/-
7in., 1,200ft. std. mylar.....	12/6
7in., 1,800ft. L.P. acetate.....	15/-
7in., 1,800ft. D.P. mylar.....	20/-
7in., 2,400ft. T.P. mylar.....	25/-
7in., 3,600ft. T.P. mylar.....	58/6

Postage 2/- Over 23 post paid.

NEW MODEL! LAFAYETTE HA-230 AMATEUR COMMUNICATIONS RECEIVER

Supersedes model HE-30. 8 valves + rectifier. Continuous coverage on 4 bands. 500 kc/s-30 Mc/s. Incorporates 1 RF & 2 IF stages, Q Multiplier, B.F.O., AXL, "S" Meter, Electrical bandspread, Aerial trimmer etc. Supplied brand new and guaranteed. 22 gns. S.A.E. for full details. Also available in semi Kit Form. 25 gns.



NEW MODEL! LAFAYETTE HA-55 AIR-CRAFT RECEIVER

104-136 Mc/s. High selectivity and sensitivity. Incorporates 3 RF stages including 6CW4 Nuvistor, 8 tubes for 11 tube performance, solid state power supply, adjustable squelch control, slide rule dial, built in 4in. speaker and front panel phone jack. 220/240V. A.C. Supplied brand new and guaranteed. 19 gns. Carr. 10/-.

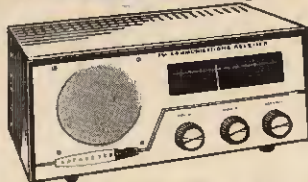

TE22 SINE SQUARE WAVE AUDIO GENERATORS

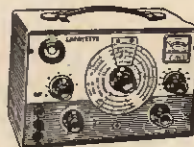

Size: 20 cps to 200 kc/s on 4 bands. Square: 20 cps to 20 kc/s. Output impedance 5,000 ohms. 200/240v. A.C. operation. Supplied Brand New and Guaranteed with instruction manual and leads. £15. Carr. 7/6.

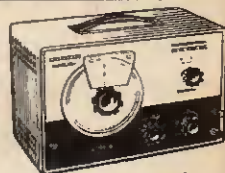

LAFAYETTE TE-46 RESISTANCE CAPACITANCE ANALYZER

2 PF-2,000 MFD. 2 ohms-20 Megohms. Also checks impedance, turns ratio, insulation 200/250v. A.C. Brand New £15. Carr. 7/6.

LAFAYETTE NUVISTOR GRID DIP METER

Compact true one hand operation. Frequency range 1.7-180 Mc/s. 230v. AC operation. Supplied complete with all coils and instructions. £12.10.0. Carr. 5/-.



2-WAY RADIOS

Superb quality. Complete with all accessories and fully guaranteed.

3 Transistor £7.18.6 pr.
4 Transistor 11 gns. pr.
9 Transistor £22.10.0 pr.
10 Transistor 23 gns. pr.

Post extra. (S.A.E. for full details).
These cannot be operated in U.K. without licence.



VOLTAGE STABILIZER TRANSFORMERS

Input 80-120v. and 150-240v. Constant output 110v. or 240v. 250 watts. Brand New Guaranteed. £10.10.0. Carr. 7/6.



VARIABLE VOLTAGE TRANSFORMERS

Brand New Guaranteed—Fully Shrouded. Input 230v. 50/80 cjs. Output 0-250 Volts.
1 Amp..... £4.10.0
2.5 Amp..... £5.17.6
5 Amp..... £9.0.0
8 Amp..... £13.10.0
10 Amp..... £17.0.0
12 Amp..... £19.10.0
20 Amp..... £32.10.0
2.5 Amp Portable—Metal Case with Meter-Fuses, etc. 29/17/6.



MODEL PV-58 VALVE VOLTMETER

11 meg. input. 7 D.C. volt ranges. 1.5-1,500 v. 1,500 v. 7 A.C. volt ranges 1.5-1,500 v. 4,000 Peak to Peak. Resistance 2 ohm to 1,000 megohm. Decibels -10db to +66db. Supplied brand new with instructions, leads and probe. £12/10/- P. & P. 3/6.



TS-76 20,000 O.P.V. PUSH BUTTON MULTI-TESTER

Simple operation, D.C. volts up to 1,000 v. A.C. volts up to 1,000 v. Resistance up to 10 megohm. Current up to 250 mA. Decibels -20 to +36 db. £5.5.0. P. & P. 2/-.



MODEL TE-12
20,000 O.P.V. 0/0.6/0/30/120/600/1,200/3,000/6,000 v. D.C. 0/6/30/120/600/1,200v. A.C. 0/600µA 0/160/600 MA. 0/6K/600K/6 Meg. 0/6 Meg. Ω. P.P. 2 MFD. £5/18/6. P. & P. 2/0.



MODEL 500 30,000 o.p.v. 0/5.1/2.5/10/25/100/250/500/1,000v. D.C. 0/1.25/10/25/100/250/500/1,000v. A.C. 0/50µA/5/50/500mA. 12 amp. D.C. 0/60K/6 Meg./60. Meg. Ω. £8/17/6 Post Paid.

TE-51 NEW 20,000Ω/VOLT MULTIMETER
0/0/60/120/1,200v. A.C. 0/0.3/30/60/300/600/3,000v. D.C. 0/60µA/12/800 MA. D.C. 0/60K/6 Meg. Ω 85/- P. & P. 2/6.



G.W. SMITH & CO (RADIO) LIMITED
Phone: GERRARD 8204/9155
Cables: SMITHEX LESQUARE
3-34 LISLE STREET, LONDON, W.C.2

YOU ARE ALWAYS AHEAD WITH A SINCLAIR DESIGN

The world's smallest radio

SINCLAIR MICRO-6

No transistor set has ever yet compared in its class with the Micro-6 for size, power performance and design. Everything except the lightweight earpiece is contained within the smart minute white, gold and black case which weighs under one ounce in working order. Quality of reproduction is outstandingly good so you are certain to derive enormous pleasure from this fantastic set. Order your Micro-6 now. See why it cannot be too highly recommended to build and to use. You can easily have it working in an evening!

SIZE: $1\frac{4}{8}'' \times 1\frac{3}{10}'' \times \frac{1}{2}''$
WEIGHT: Under 1 oz.
FANTASTIC RANGE AND POWER

... and an amazing letter

I have had one of your Micro-6 receivers here in Sydney for about a year and I must say that its performance is very good. The sensitivity is high and the selectivity is quite adequate (it has to separate no less than 8 local stations) and all of them legal too. It is quite a miniature masterpiece!

Congratulations on the release of your F.M. set. You certainly are the leaders in miniature electronics. I shall look forward to the release of the Sinclair shirt-pocket colour T.V. receiver with micro-alloy CRT. Thanking you in anticipation and with best wishes for the future.

(signed) P. K. Voucluse, N.S.Wales

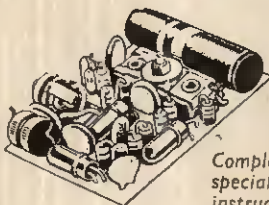

Complete kit of parts inc. special earpiece and instructions

MALLORY MERCURY CELL TYPE ZM.312

(2 required)
Pack of six

59/6

each 1/11
10/6

**NEW
SINCLAIR
DESIGNS**

see next page

THE WORLD'S MOST ADVANCED AMPLIFIER

SIZE: $8\frac{1}{4}'' \times 3\frac{1}{4}'' \times 1''$

OUTPUT:

20 WATTS RMS

- 20 WATTS R.M.S. OUTPUT INTO 7.5 ohms
- 20-20,000 c/s ± 1 dB
- Constant square wave amplitude
- 95% conversion efficiency at output
- Input sensitivity—1mV into 5K ohms
- Power requirements—36V.d.c. at 700 mA

The only amplifier in the world to use Pulse Width Modulation, which, with circuitry developed specially by Sinclair gives power and quality years ahead of anything in its class. You can feed any signal source into the X-20—including modern high quality pick-up, radio tuner, guitar. The X-20 manual shows circuits by which pick-ups, etc. can be matched to the integrated pre-amplifier of the X-20 both in mono and stereo. When you have built this 12-transistor amplifier you use it in the same way as any other top quality hi-fi unit except that it is smaller, costs less and behaves perfectly.

Complete kit of parts including transistors and X-20 manual in sealed carton

£7.19.6

Built and tested with X-20 manual in sealed carton

£9.19.6

X-20 Power Pack sufficient to drive two X-20's £4.19.6

THE X-20 MANUAL details tone and volume control systems for X-20, Mono and Stereo. FREE WITH EVERY X-20. Available separately—2/- post free.

FULL SERVICE FACILITIES AVAILABLE TO ALL SINCLAIR CUSTOMERS



**SINCLAIR
X-20**

SINCLAIR RADIONICS LTD.
COMBERTON, CAMBRIDGE Telephone: COMBERTON 682

A BRILLIANT NEW TUNER



THE WORLD'S FIRST POCKET-SIZE F.M. TUNER-RECEIVER

SINCLAIR

MICRO
FM

- SIZE 2 1/8" x 1 5/8" x 3/4"
- 7 TRANSISTORS
- 2 DIODES
- NO ALIGNING
- PULSE-COUNTING DISCRIMINATOR
- HI FI STANDARDS

*A joy for anyone
to build!*

Use it as —

AN F.M. TUNER
FOR YOUR TAPE
RECORDER.

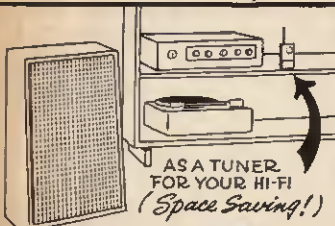
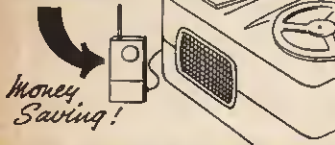

AS A SELF-
CONTAINED
POCKET F.M.
RECEIVER.

*(The only
one in the
World!)*



In styling, the Sinclair Micro FM is the most elegant, most professional looking design in miniaturised equipment ever made available to constructors. It is also the most original FM design in years. This high quality FM tuner has one output for feeding to hi-fi amplifier or tape recorder; a second output enables it to be used independently as a self-contained pocket FM receiver for personal listening. Barely half the size of a packet of twenty cigarettes, this fully fledged 7 transistor design incorporates many unique and original design features to achieve fantastically good standards of performance. Thanks to Sinclair designers, you can at last build an FM receiver without alignment problems, so that your Micro FM is ready to use the moment you finish building it. With pulse counting detection for better audio quality, excellent sensitivity and A.F.C. for easy tuning, the set's own telescopic aerial will suffice for good reception almost everywhere. **THE MICRO FM COSTS POUNDS LESS AND MEANS THAT ANYONE CAN ENJOY THE ADVANTAGES OF FM AT ITS BEST TO-DAY.**

Seven transistor, two diode FM superhet for use as a tuner and as a self-contained pocket receiver. The R.F. amplifier is followed by a self oscillating mixer. Low I.F. dispenses with the need for alignment. A three stage I.F. amplifier produces a square wave of constant voltage which is fed into the pulse counting discriminator. This is converted into uniform pulses, the average output from which is directly proportional to the signal frequency, reproducing the original modulation exactly. After equalisation, the signal is fed to the audio output socket and to the receiver's own audio amplifying stage for using the Micro FM as an independent self-contained receiver. A.F.C. "locks" on each station automatically. THE SINCLAIR MICRO FM is self-contained within a neat black plastic case faced by an elegantly designed front panel of brushed and polished aluminium with spun aluminium tuning dial to match.

- TUNES FROM 88-108 Mc/s.
- ONE OUTPUT FOR HI-FI AND TAPE, ONE FOR PERSONAL LISTENING
- STANDARD 9-VOLT BATTERY HOUSED IN CASE
- AUDIO RESPONSE 10-20,000 c/s ± 1dB
- SIGNAL TO NOISE RATIO 30dB at 30mV

Complete kit including telescopic aerial, case, dial, earpiece and instructions

£5.19.6

FULL SERVICE FACILITIES AVAILABLE TO ALL SINCLAIR CUSTOMERS

sinclair

SINCLAIR RADIONICS LTD., COMBERTON, CAMBRIDGE

Telephone: COMBERTON 6

A BRILLIANT NEW AMPLIFIER

USE IT FOR YOUR HI-FI, FOR YOUR CAR RADIO

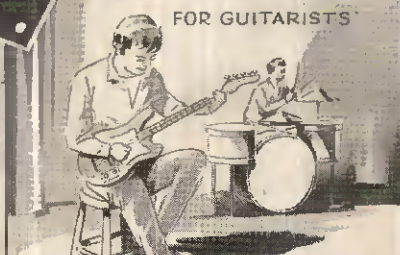
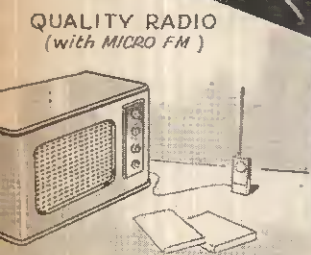
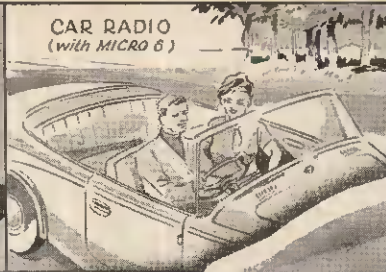
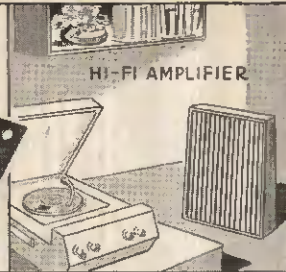
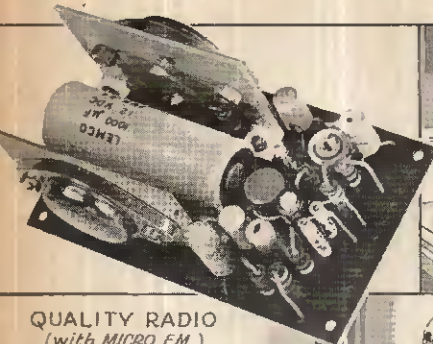

QUALITY RADIO
(with MICRO FM)

FOR GUITARISTS

CAR RADIO
(with MICRO 6)

P.A.

WITH YOUR SINCLAIR F.M., FOR MUSIC AND P.A.

SINCLAIR Z.12 COMBINED 12 WATT HI-FI AMPLIFIER AND PRE-AMP

Greater Power and Versatility

3" x 1 1/4" x 1 1/3"

WEIGHS 3 oz.

12 WATTS R.M.S.
(24 WATTS PEAK)

USE IT WITH THE
MICRO-6 OR
MICRO F.M.

Here is the hi-fi amplifier you have always dreamed of—very small, very powerful and of the highest possible quality. Sinclair's latest design, the Sinclair Z.12 meets all these requirements AND MORE to give you the most versatile, dependable amplifier system ever. In conformity with original Sinclair design, the Z.12 incorporates its own special pre-amplifier to which you add whichever of the tone and volume control circuits shown in the Z.12 manual suits you best. The Z.12 achieves even greater versatility, since it operates efficiently from any power supply between 6 and 20 volts, D.C. This makes it as attractive for use in car radios, guitars, P.A. systems, etc. as for the very best hi-fi it is designed for. In fact, the Z.12 is the ideal amplifier wherever the need is for great power and quality from the smallest possible unit. The Sinclair Z.12 comes to you ready built, tested and guaranteed. The Z.12 manual included makes simple work of installing and using the unit.

Technical Details: 8 transistor hi-fi amplifier with pre-amp and ultra-linear class B output. Special H.F. transistors are used in original circuitry to achieve laboratory standards of performance. Superb quality is assured by generous negative feedback. **FREQUENCY RESPONSE**—15-50,000 c/s ± 1 dB! **OUTPUT**—12 watts RMS continuous sine wave (24 watts peak), 15 watts RMS music power (30 watts peak). **OUTPUT IMPEDANCE**—suitable for 3, 7.5 and 15 ohm speakers. Two 3-ohm speakers can be used in parallel if required. **INPUT**—2mV into 2K ohms. **POWER SUPPLY**—6 to 20V d.c. from power unit available or batteries. **SIGNAL TO NOISE RATIO**—better than 60dB. **QUIESCENT CURRENT CONSUMPTION**—only 15mA. **IDEAL FOR BATTERY OPERATION.**

Z.12 Amplifier and pre-amp ready built, tested and guaranteed

Sinclair Power Pack for above £2.14.0

89/6

GUARANTEE ORDER FORM

To: SINCLAIR RADIONICS LTD.
COMBERTON CAMBRIDGE

Please send me

.....
.....
.....

for which I enclose Cash/Cheque/Money

Order value £.....s.....d.

NAME.....

ADDRESS.....

Should you not be completely satisfied with your purchase when you receive it from us, your money will be refunded in full and at once without question. It is important to quote Pr.E26 should you prefer to write your order instead of cutting out this coupon.

sinclair

SINCLAIR RADIONICS LTD.
COMBERTON, CAMBRIDGE
Telephone: COMBERTON 682

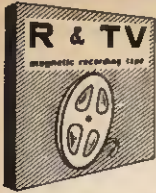

FIRST QUALITY PVC TAPE

5 $\frac{1}{2}$ " Std. 850 ft. 9/- 5" L.P. 850 ft. 10/6
 7" Std. 1200 ft. 11/6 3" T.P. 600 ft. 10/6
 3" L.P. 240 ft. 4/- 5" T.P. 1800 ft. 25/6
 5 $\frac{1}{2}$ " L.P. 1200 ft. 11/6 5 $\frac{1}{2}$ " T.P. 2400 ft. 32/6
 7" L.P. 1800 ft. 18/6 7" T.P. 3600 ft. 42/6

P. & P. on each 1/6, 4 or more post free.

Complete with Variable Thermostat 90° to 180°F. 20 amp. A.C. and GEC double pole 20 amp. mains switch. 11", 14", 27", 30" and 36". State length required. £2.0.0 plus 5/- P. & P.

3 kW IMMERSION HEATER



"PREMIER" KETTLE ELEMENT

1000 w. 5/- 3/- P. & P. Retaining nut and flange 2/6, switch plug to suit 2/6.

GEC FLAT HEATER ELEMENT 500 w.



Can be used for wash boilers, washing machines, etc. Five or six elements can be used in parallel to give 2500/3000 watts. Sizes 5 $\frac{1}{2}$ " x 1 $\frac{1}{2}$ ", copper enclosed. 2/6 each, P. & P. 1/- 4 or more Post Paid.

3 to 4 WATT AMPLIFIER KIT

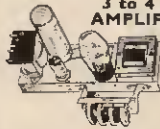

comprising chassis 8 $\frac{1}{2}$ " x 2 $\frac{1}{2}$ " x 1". Double wound mains

transformer, output transformer, volume and tone controls, resistors, condensers, etc. 6V6, ECC81 and metal rectifier. Circuit 1/6 free with kit. 29/6 plus 4/6 P. & P.

40w. FLUORESCENT LIGHT KIT



incorporating GEC Choke size 8 $\frac{1}{2}$ " x 1 $\frac{1}{2}$ " x 1 $\frac{1}{2}$ ", 2 bi-pin holders, starter and starter holder, 11/6. P. & P. 4/6.

Similar to above: 80w. Fluorescent Light Kit incorporating GEC choke size 11 $\frac{1}{2}$ " x 1 $\frac{1}{2}$ " x 1 $\frac{1}{2}$ ", 2 bi-pin holders, starter and starter holder, 17/6. P. & P. 5/6.

8-watt 5-valve PUSH-PULL AMPLIFIER & METAL RECTIFIER

Size: 9 x 6 x 1 $\frac{1}{2}$ " A.C. Mains 200-250v. 5 valves. For use with Std. or L.P. records, musical instruments, all makes of pick-ups and mikes. Output 8 watts at 5 per cent total distortion. Separate bass and treble lift controls. Two inputs, with controls, for gram. and mike. Output Transformer tapped for 3 and 15 ohms speech coils. Built and tested. £3.19.6. P. & P. 8/-.

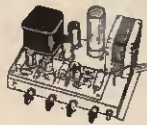

ELEGANT SEVEN Mk. II

Combined Portable and Car Radio
The Radio with the "Star" Features



- ★ 7-transistor superhet. Output 350 mW.
- ★ Wooden cabinet, fitted handle with silver-coloured fittings, size 12 $\frac{1}{2}$ " in. x 8 $\frac{1}{2}$ " in. x 3 $\frac{1}{2}$ " in.
- ★ Horizontal tuning scale, size 11 $\frac{1}{2}$ " in. x 2 $\frac{1}{2}$ " in. in silver with black lettering.
- ★ All stations clearly marked.
- ★ Ferrite-rod internal aerial.
- ★ Operated from PP9 battery.
- ★ I.F. neutralisation on each stage 480 kc/s.
- ★ D.C. coupled output stage with separate A.C. negative feed back.
- ★ All components, ferrite rod and tuning assembly mounted on printed board.
- ★ Fully comprehensive instructions and point-to-point wiring diagram.
- ★ Printed circuit board, back-printed with all component values.
- ★ Fully tunable over medium and long waveband.
- ★ Car aerial socket. ★ Full after-sales service.

4 in. SPEAKER. Parts list and circuit diagram 2/6. FREE with parts.
Shop Hours 9 a.m. — 6 p.m. Early Closing Wednesday

All enquiries stamped addressed envelope

RADIO & T.V. COMPONENTS (ACTON) LTD.
21D, HIGH STREET, ACTON, LONDON, W.3

ONLY
£4.4.0

Plus 6/6 Post & Packing

POWER SUPPLY KIT to purchasers of Elegant Seven parts, incorporating mains transformer, etc. A.C. mains 200-250v. Output 9v. 50mA, 7/6 extra.

EXCEL

11/11

ELECTRONICS

Through this ICS 3-way Training Method:

1

MASTER THE THEORETICAL SIDE

From basic principles to advanced applications, you'll learn the theory of electronic engineering, quickly and easily through ICS. That's because each course is set out in easy-to-understand terms.

2

MASTER THE PRACTICAL SIDE

ICS show you how to develop your practical abilities in electronic engineering—alongside your theoretical studies. It's the only sure way to success. All training manuals are packed with easy-to-follow illustrations.

3

MASTER THE MATHEMATICAL SIDE

To many this aspect is a bitter problem. Even more so because no electronic engineer is complete without a sound working knowledge of maths. But new ICS teaching makes mathematics easier to learn.

Wide range of courses available include:

Radio/T.V. Engineering and Servicing, Colour Television, Electronics, Electronics Maintenance, Instrumentation and Servomechanisms, Telemetry, Computers, etc.
NEW! Programmed Course on Electronic Fundamentals

EXPERT COACHING FOR:

INSTITUTION OF ELECTRONIC AND RADIO ENGINEERS
CITY AND GUILDS TELECOMMUNICATION TECHNICIANS
CITY AND GUILDS SUPPLEMENTARY STUDIES
R.T.E.B. RADIO/T.V. SERVICING CERTIFICATE
RADIO AMATEURS' EXAMINATION
P.M.G. CERTIFICATES IN RADIOTELEGRAPHY

And there are practical "learn as you build" radio courses as well.

Member of the Association of British Correspondence Colleges.

FOR **FREE** HANDBOOK POST THIS COUPON TODAY

I.C.S., Dept. 151, INTERTEXT HOUSE,
PARKGATE ROAD, LONDON, S.W.11

NAME

ADDRESS

OCCUPATION.....AGE..... 2.66

INTERNATIONAL CORRESPONDENCE SCHOOLS

R.S.C.

(MANCHESTER) LTD.

MAIL ORDERS TO:
DEPT. P
102 HENCONNER LANE
LEEDS 13

Terms: **C.W.O.** or **C.O.D.** No **C.O.D.** under £1. Postage 2/9 extra under £2. 4/6 extra under £5. Trade Supplied. S.A.E. with all enquiries please. Personal shoppers welcome at any of the branches below.

All branches open all day Saturday.

- BRADFORD:** 10 North Parade, (Half-day Wednesday) Tel: 25349
- BRISTOL:** 14 Lower Castle Street, (Half-day Wednesday) Tel: 22904
- BIRMINGHAM:** 30/31 Gt. Western Arcade, opp. Snow Hill Station, CENTRAL 1279 No half-day
- DERBY:** 26 Osmenton Rd. The Spot, (Half-day Wed.) Tel: 41361
- DARLINGTON:** 13 Post House, Wynd, (Half-day Wed.) Tel: 68043
- EDINBURGH:** 133 Leith Street, (Half-day Wednesday)
- GLASGOW:** 326 Argyle St. (No Half-day) Tel: CITY 4158
- HULL:** 51 Savile Street, (Half-day Thursday) Tel: 20505
- LEICESTER:** 32 High Street, (Half-day Thursday) Tel: 56420
- LEEDS:** 57 County (Mecca) Arcade (No Half-day) Tel: 26252
- LIVERPOOL:** 73 Dale St. (No Half-day) Tel: CENTRAL 3573
- LONDON:** 238 Edgware Road, W.2, (Half-day Thursday) Tel: PADDDINGTON 1629
- MANCHESTER:** 60A-60B Oldham St. Tel: CENTRAL 2778. (No Half-day) New large store
- MIDDLESBROUGH:** 106 Newport Rd. (Half-day Wednesday) Tel: 47096
- SHEFFIELD:** 13 Exchange Street, Castle Market Bldgs. (Half-day Thursday) Tel: 20716

Staff required at various branches. Experience unnecessary

COLLARO 4 SPEED RECORD PLAYING UNITS with Crystal pick-up, fitted turn-over cartridge. Limited quantity. **69/9** Carr. 5/- each only
INTERNATIONAL RECTIFIERS SEMI-CONDUCTORS. Catalogue 10d. All items available.

R.S.C. MAINS TRANSFORMERS (FULLY GUARANTEED)

Interleaved and Impregnated. Primaries	MIDGET MAINS. Primaries 200-250v.
200-230-250v. 50 c/s. Screened.	50 c/s. 250v. 60mA. 6.3v. 2a
TOP SHROUDED DROP THROUGH	250-0-250v. 60mA. 6.3v. 2a
250-0-250v. 70mA. 6.3v. 2a, 0-5-6.3v. 2a	Both above size 2 1/2 x 2 1/2 in.
250-0-350v. 80mA. 6.3v. 2a, 0-5-6.3v. 2a	FILAMENT TRANSFORMERS
250-0-250v. 100mA. 6.3v. 2a, 0-5-6.3v. 1a	200-250v. 50 c/s Primaries 6.3v. 1.5a, 5/9; 6.3v. 2a, 7/6; 12v. 1a, 7/10; 6.3v. 3a, 8/11; 6.3v. 5a, 17/6; 12v. 1.5a, twice 17/6
250-0-250v. 100mA. 6.3v. 3.5a. C.T.	OUTPUT TRANSFORMERS
250-0-250v. 100mA. 6.3v. 4a, 0-5-6.3v. 3a	Push-Pull 8 watts, EL84 or 6V6 to 3 1/2 or matched to 15 0/9
300-0-300v. 130mA. 6.3v. 4a, 0-5-6.3v. 3a	Push-Pull 10-12 watts to match 6V6 or EL84 to 3-5-9 to 15 0/9
300-0-300v. 130mA. 6.3v. 4a, 0-5-6.3v. 3a	Following types for 3 and 15 0 speakers:
350-0-350v. 150mA. 6.3v. 4a, 0-5-6.3v. 3a	Push-Pull 10-12 watts. 6V6 or EL84 18/9
350-0-350v. 150mA. 6.3v. 4a, 0-5-6.3v. 3a	Push-Pull 15-18 watts. 6L6, KT66 22/9
425-0-425v. 200mA. 6.3v. 4a, C.T. 5v. 3a	Push-Pull Mullard 510 Ultra Linear 29/9
425-0-425v. 200mA. (6.3v. 4a Twice). 5v. 3a	Push-Pull 20 watts, sectionally wound 6L6, KT66, EL34, etc. 49/9
450-0-450v. 250mA. 6.3v. 4a, C.T. 5v. 3a	CHARGER TRANSFORMERS. All with 200-230-250v. 50 c/s. Primaries; 0-9-15v. 1a, 12/9; 0-9-15v. 2a, 14/9; 0-9-15v. 3a, 16/9; 0-9-15v. 5a, 19/9; 0-9-15v. 6a 23/9; 0-9-15v. 8a, 28/9

R.S.C. A10 30 WATT ULTRA LINEAR HIGH FIDELITY AMPLIFIER

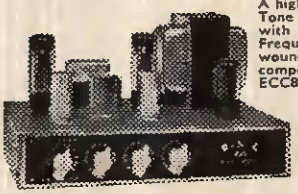

A highly sensitive Push-Pull high output unit with self-contained Pre-Amp-Tone Control Stages. Certified performance figures compare equally with most expensive amplifiers available. Hum level 70 dB down. Frequency response ±3dB 30-20,000 c/s. A specially designed sectionally wound ultra linear output transformer is used with 807 output valves. All components are chosen for reliability. Six valves are used EF86, EF86, ECC83, 807, 807, GZ34. Separate Bass and Treble Controls are provided. Minimum input required for full output is only 12 millivolts so that ANY KIND OF MICROPHONE OR PICK-UP IS SUITABLE. The unit is designed for CLUBS, SCHOOLS, THEATRES, DANCE HALLS OR OUTDOOR FUNCTIONS, etc. For use with Electronic ORGAN, BASS, LEAD OR RHYTHM GUITAR, STRING BASS, etc. For standard or long-playing records. OUTPUT SOCKET PROVIDES L.T. and H.T. for RADIO FEEDER UNIT. An extra input with associated vol. control is provided so that two separate inputs such as Gram and "Mike" can be mixed, 200-250v. 50 c/s. A.C. Mains output for 3 and 15 ohm speakers. Complete kit of parts with fully punched chassis and point-to-point wiring diagrams and instructions. Supplied factory built with EL34 output valves and 12 months' guarantee, for 14 Gns. If required perforated cover with carrying handles can be supplied for 19/9. Send S.A.E. for leaflet, also speaker. Terms: DEPOSIT 11 Gns. 45/- and 9 monthly payments of 32/4 (Total 16 Gns.) Carr. 10/-

HIGH FIDELITY 12-14 WATT AMPLIFIER TYPE A11

PUSH-PULL ULTRA LINEAR OUTPUT "BUILT-IN" TONE CONTROL PRE-AMP STAGES
Two input sockets with associated controls allow mixing of "mike" and gram, as in A10. High sensitivity. Includes 5 valves, ECC83, ECC83, EL84, EL84, EZB1. High Quality sectionally wound output transformer specially designed for Ultra Linear operation and reliable small condensers of current manufacture. **INDIVIDUAL CONTROLS FOR BASS AND TREBLE "Life" and "Cut".** Frequency response ±3 dB 30-20,000 c/s. Six negative feedback loops. Hum level 60 dB down, ONLY 23 millivolts input required for FULL OUTPUT. Suitable for use with all makes and types of pick-ups and microphones. Comparable with the very best designed STANDARD OR LONG PLAYING RECORDS. For MUSICAL INSTRUMENTS such as STRING BASS, LEAD OR RHYTHM GUITARS, etc. OUTPUT SOCKET with plug provides 300v., 20mA, and 6.3v. 1.5a for supply of a RADIO FEEDER UNIT. Size approx. 12 x 9 x 7in. For A.C. mains 200-250v. 50 c/s. Output for 3 and 15 ohms speaker. Kit is complete to last nut. Chassis is fully punched. Full instructions and point-to-point wiring diagrams supplied. (Or factory built 51/6 extra). If required perforated metal covers with 2 carrying handles can be supplied for 18/9. Terms ON ASSEMBLED UNITS: DEPOSIT 33/3 and 9 monthly payments of 24/1 (Total £12,10,0). Send S.A.E. for illustrated leaflet detailing Cabinets, Speakers, Mikes, etc.

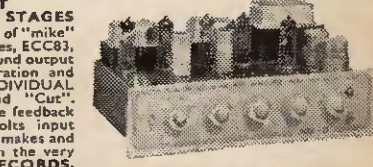

AUDIOTRINE HI-FI TAPE RECORDER KIT

REALISM AT INCREDIBLY LOW COST. CAN BE ASSEMBLED IN AN HOUR.
Incorporating the latest Tape Transcriber. The Audiotrine High Quality Tape Amplifier with negative feedback equalisation for each of 3 speeds. High Flux P.M. Speaker, empty Tape Spool, a Reel of Best Quality Tape and a Handsome Portable Carrying Cabinet taste fully covered in two contrasting shades of Resine and Vynair. Size 14 1/2 x 15 x 8 1/2 in. high and circuit. Total cost if purchased individually approximately £40. Performance equal to units in the £60-£90 class. S.A.E. for leaflets. TERMS: 25 1/2 Gns. Carr. 10/- 12 monthly payments of 42/- (Total 28 Gns.)

25 1/2 GNS.

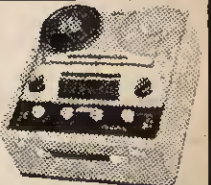

TRANSISTOR SALE Mullard OC71 2/11, OC45 3/11, OC44 3/11, OC72 2/11, OC81 2/11, OC71 8/9, Ediswan XA101 3/9, XA112 3/9, XC101A 3/9, AF117 8/9. Postage 6d. for up to 3 transistors.

PRINTED CIRCUIT KIT. Etch your own circuits. Includes 72 sq. ins. laminate, fluids, brush and instructions. Only 16/9

SELENIUM RECTIFIERS F.W. (BRIDGED) TYPES
6/12v. 1a 3/11 6/12v. 3a 9/9 6/12v. 6a 15/3
6/12v. 2a 6/11 6/12v. 4a 12/3 6/12v. 10a 26/9

COMPLETE POWER PACK KIT
Consisting of Mains, Trans., Metal Rectifier, Double electrolytic, smoothing choke chassis and circuit. For 200/250v. A.C. mains. Output 250v., 60mA. 6.3v. 2a. 19/11

FANE 12X120 10 WATT. HEAVY DUTY LOUDSPEAKER. 12in. 15 ohm. With exceptionally robust 2 in. diameter voice coil assembly. 5 GNS. Post 5/6

WALKIE-TALKIE SETS. Range up to 1 mile. Perfect for short range outside or inside communication. Complete with Internal Speakers and "Mikes", Telescopic aerial, batteries and manual. 9 1/2 PAIR 9 1/2 GNS.

W.S. "STENTORIAN" HIGH FIDELITY P.M. SPEAKERS. HF1012. 10 watts rating. Where a really good quality speaker at a low price required, we highly recommend this unit with an amazing performance. £4,19,9. Please state whether 3 ohm or 15 ohm required.

NOBRIX SIGNAL GENERATOR Model 27. Covers 150 Kcs. to 350 Mc/s. in 8 ranges. Accuracy ±2%, or better. R.F. Modulated or unmodulated average 50 M.V. Separate A.F. output at 400 c/s. 3 volts peak. Direct calib. £9.10.0

R.S.C. Battery to Mains Conversion Units
Type BM1. An all-day battery eliminator. Size 5 1/2 x 4 1/2 x 2 in. approx. Completely replaces batteries supply 1.4v. and 90v. where A.C. mains 200-250v. 50 c/s. is unavailable. Suitable for all battery portable receivers requiring 1.4v. and 90v. Complete kit with diagram 39/9 or ready for use 46/9

AUDIOTRINE HI-FI SPEAKER SYSTEMS
Consisting of matched 12in. 12,000 line, 15 ohm high quality speaker; crossover unit (consisting of choke, condenser, etc.) and Tweeter. The smooth response and extended frequency range of this class ensure surprisingly realistic reproduction. Standard 10 watt, rating. £4,19,9. Carr. 5/- Or Senior 20 watt. £6,19,6. Carr. 7/6

R.S.C. BABY ALARM or INTER-COMM KIT. Complete set of parts with diagrams, etc. Housed in two polished walnut finished cabinets of pleasing design. High sensitivity. For 200-250v. A.C. mains. Fully isolated. Controllable at both ends. An intercomm. of this class would normally cost £20-£30. Only 89/6, carr. 5/-. Ready for use, 6 Gns.

R.S.C. COLUMN SPEAKERS

Covered in two-tone Resine/Vynair. Ideal for vocalists and Public Address. Normally supplied for 15 ohm matching but can be supplied for 100v. line for 35/- extra. 20 watts. Fitted five 8in. high flux speakers. Overall size approx. 42 x 10 x 5in. 12 1/2 Gns. Carr. 10/- Or deposit 9 monthly payments of 27/9 (Total £14,9,9)
Type C412. 40 watts. Fitted four 12in. 12,000 line 10 watt speakers. Overall size 56 x 14 x 9in. approx. Carr. 15/- 19 1/2 Gns.
Or deposit 9 monthly payments of 43/2 (Total 211 Gns.)

12 in. 10 WATT HIGH QUALITY LOUDSPEAKER

In walnut veneered cabinets. Gauss 12,000 lines. Speech coil 3 ohms or 15 ohms. Only Carr. 5/6 £4.19.6
Terms: Deposit 11/3 and 9 monthly payments of 11/3 (Total £5,12,6). 12in. 20 WATT HI-FI LOUDSPEAKERS IN CABINETS. Size 18 x 18 x 10in. Finish as above. Terms: Deposit 17/9 and 9 monthly payments of 17/9 (Total £8,17,6). Carr. 8/6

SNIPERSCOPE

Famous wartime "sea's eye" used for acting in the dark. This is an infra-red image converter cell with a silver caesium screen which lights up (like a cathode ray tube) when the electrons released by the infra-red strike it. It follows that as light from an ordinary lamp is rich in infra-red, these cells will work burglar alarms, counting circuits, smoke detectors and the hundred and one other devices as will the simpler type of photo cell. Here then is a golden opportunity for some interesting experiments, price 5/6 each, Post 2/6. Data will be supplied with cells if requested.



SPEAKER BARGAIN

19th. High fidelity loudspeaker. Highflux magnet type with either 3 ohm or 15 ohm speech coil. Will handle up to 10 watts. Brand new by famous maker. Price 2/6 + 3/8 post and insurance.



SPOT OR FOG LAMP

Made by Lucas, flat or pencil beam, 30 watts. Suitable for car, boat, caravan, etc. Complete with 6 or 12v bulb, flex, cables and fixing bolt. Remarkable bargain. Price 12/6 + p. & p. 3/6



THERMOSTATS

Type "A" 15 amp for controlling room heaters, greenhouse, airing cupboard. Has spindle for pointer knob, quickly adjustable from 30°-80°F. 9/6 plus 1/6 post. Suitable box for wall mounting, 8/-, P. & P. 1/-.

Type "B" 15 amp. This is a 17in. long rod type made by the famous Sunvic Co. Spindle adjusts this from 00-550°F. Internal screw alters the setting so this could be adjustable over 30° to 1,000°F. Suitable for controlling furnace, oven, kiln, immersion heater or to make firestat or fire alarm. 2/6 plus 2/6 post and insurance.

Type "C" is a small porcelain thermostat as fitted to electric blankets, etc. 1/4 amp. setting adjustable by screw through side. 3/6, P. & P. 6d.

Type "D" We call this the Ice-stat as it cuts in and out at around freezing point, 2/3 amps. Has many uses, one of which would be to keep the loft pipes from freezing if a length of our blanket wire (16 yds. 10/-) is wound round the pipes, 7/6, P. & P. 1/1.

Type "E" This is a standard refrigerator thermostat. Spindle adjustments cover normal refrigerator temperature, 7/6 plus 1/6 post.

9-Way push-button switch

Each way having two single pole change over and one shunting switch, good length push rods 80/- per doz. 8/6 each, post 2/3 per doz.

Waterproof Heater Wire

16 yds. length 70 watts, self regulating temperature control. 10/-, post free.

Three Unusual Items

OZONE OUTPUT—for removing smells and generally improving any oppressive atmosphere. Kit consists of Philips Ozone Lamp and mains unit, only needs box. 19/6 plus 3/6 postage and insurance.

BLACK LIGHT UNIT. 40 watt intensely, comprises lamp, lamp holder and 40 watt choke. Only 19/6 plus 6/6 carr. & ins.

TIMER KIT. Special offer of all components included in special box to make mains operated interval timer for photography, etc. 12/6 plus post 2/6.

Simmerstat Heater Regulator

Suitable to control elements, heater, soldering irons and boiling rings up to 2,500 watt. Complete adjustable, normal price 55/- each, special snip price 12/6 plus 2/- postage and insurance.

Where postage is not definitely stated add 2/- to all orders under 23. Also add 2/6 if you would like our new 100 page list of bargains.

INFRA-RED HEATERS

Make up one of these latest type heaters. Ideal for bathroom, etc. They are simple to make from our easy-to-follow instructions—uses silica enclosed elements designed for the correct infra-red wavelength (3 microns). Price for 750 watts element, all parts, metal casing as illustrated, 23/6 plus 3/8 post and insurance. Post switch 3/- extra.



SNIP FOR RECORD LOVERS

Acos GP73 Turnover Cartridge

for Stereo—LP—and 78 records fitted with two styl—diamond for Stereo and L.P.—Sapphire for 78. This is mounted and is a standard replacement for the most famous record players using Garrard—B.S.R. Collaro, etc. The regular price of this Cartridge is 55/-, we offer these new and perfect for 15/- (less than the price of one Stylus) plus 2/- post and insurance.



GANGED POTS

Standard Type and size with good length of spindle—made by Morganite. List price is 10/- each but if you act quickly you can have them at 15/- doz. (or 1/6 each if less than doz.). Following values in stock all "fin"—5K + 5K—10K + 10K—100K + 100K—500K + 500K—1 Meg + 1 Meg, all new and unused. Post 2/6 on first doz. then 1/- per doz. 6 doz. or more post free.



OUR BARGAIN OF THE YEAR



A complete kit of parts to build this 8-transistor 8 wave superhet receiver at only 39/6 plus 3/6 post and ins.

"CORONET" Mk. IV

It fully covers the medium-wave band and that part of the long-wave band to bring in B.B.C. Light. The circuit includes a highly efficient slab aerial, 2 1/2 in. P.M. speaker. Overall size approximately 4 1/2 x 2 1/2 x 1 1/2 in. Supplied complete with carrying case and instructions.

750 mW TRANSISTOR AMPLIFIER

4 transistors including two in push-pull-input for crystal or magnetic microphone or pick-up—feedback loops—sensitivity 5mV. Price 19/6. Post and insurance 2/6.



THIS MONTH'S SNIP

Transistor set case with carrying handle size 10" x 8" x 3"

Made from best plywood and covered two-tone fabric—very smart—suitable for receiver—amplifier extension Speaker, etc.—Originally listed at 39/6—but offered this month at only 15/- plus 5/- post and insurance; also given free with it is a printed circuit board to suit it and building instructions for fine two-wave radios—Don't miss this grand offer.



THE "MINY" TAPE RECORDER



of the many tape recorders to offer at 12/6 or less we have at last found one we can recommend. This instrument uses two motors, is completely portable and is beautifully styled and looks like a good tape recorder.

Among its many good features is a switch on the microphone to stop and start the tapes. A very useful feature for you when recording, and for your typist for note-taking, stock-taking, etc. Other points are twin track recording—40 mins. with normal tapes, standard batteries.

Although originally sold at 16/10/0, we are able this month to offer for only 12/10/6 plus 5/- Post and Insurance. Brand new and complete with microphone, batteries, tape and spools, nothing else to buy.

Don't miss this AMAZING Offer

MAINS POWER PACK

MAINS POWER PACK designed to operate transistor sets and amplifiers. Adjustable output 6 v.-9 to 12 volts for up to 500 mA. (class B working). Takes the place of any of the following batteries: 4F1, 4F2, 4F3, 4F4, 4F5, 4F6, 4F7, 4F8 and others. Kit comprises: mains transformer—rectifier, smoothing and load resistor, 5,000 and 500 mfd. condensers, sauer diode and instructions. Retail snip at only 14/6 plus 3/- post.



SEED & PLANT RAISING

Soil heating wire and transformer. Suitable for standard size garden frame. 12/6 plus 2/6 post & insurance.

TWO-WAY RADIOS

Give communication over 1/2 in. FULLY transistorized—crystal controlled, built-in telescopic aerial—press button operation—PP3 batteries—pair instruments, complete and ready to use 57/9/6, plus 6/- post and insurance. G.P.O. Lic. Req.



FOUR-STATION INTERCOM



Will save time and improve efficiency. Ideal in home—office—shop—surgery, etc. Complete outfit comprises Master unit and three substations each of which can call the master and have full two-way working. No wiring problems as sube fitted with 50ft. twin flex and they plug into sockets. Also included is packet of staples—and battery. Nothing else to buy—57/15/6 plus 4/6 post and insurance.

13 AMP SOCKETS



Change all those old-fashioned ones to these modern fused types or install a new ring main. White sockets for surface mounting or for letting into wall or skirting

—best make (G.E.C.). 5/6 with switch or 3/6 less switch. Six or more post free, otherwise add 2/-.

HEAT AND LIGHT UNIT

Gives 300 watts of heat with approx. 150 watts of light and simply fits in place of lamp. 29/6 Plus 3/6 carriage and insurance.



BATTERY ELIMINATOR



With this you can operate your pocket radio from the mains. You can also recharge PP3 batteries five or six times. Only 18/6 plus 3/- post and insurance. Will save its cost in no time.

FINE TUNERS



50 pF with long spindle as illustrated. 1/6 or 12/- dozen.

TURRET TUNERS



By the famous Cylon or Brayhead firm, complete with coils, but less coil cover, valves and knobs—all 28mc/ie—wonderful bargain at 6/6 each plus 2/6 post.

FIVE CORE CABLE

Ideal for switching circuits, intercoms, P.A. rms, etc., each core flex copper with rubber insulation, cores covered overall in tough rubber or P.V.C. 6d. per yd. or 50 yds. length 15/- plus 5/- post.

Months and Crosses Machine—an opportunity to make this very amusing item described in Practical Electronics. Kit of 19 switches only 40/- post paid.

News for Panel Game Switch, etc., not the midjet type but possibly more suitable. 13 for 10/6 post paid.

Midjet wired enamel type (1/8 Ex-equip.) or 1/9 new.

ELECTRONICS (CROYDON) LIMITED

266 LONDON ROAD • WEST CROYDON • SURREY
Post orders to: Dept. PE, 4 SPRINGFIELD RD., EASTBOURNE, SUSSEX

Circuits·Diagrams·Data

HERE'S ALL YOU NEED
FOR SERVICING OVER

1,450 Models

(1962—1965)

There is no other publication like Newnes RADIO & TV SERVICING . . . the greatest time-saver and money-maker you can own! 3 volumes packed with circuits, data and hints for repairing over 1,450 models (1962-65).

TV, radio, tape recorders . . . all the famous makes are here. Plus big section of latest Radio and TV developments. Examine it, USE it for a week FREE. Don't miss this opportunity simply post coupon today.



All these makes

Aca, Aerodyne, Ajax, Alba, Argosy, Baird, Berac, Bush, Corsor, Dansette, Decca, Defiant, Deric, Dynatron, E.A.R., Ekco, Elizabethan, Elpico, E.M.I., Emerson, Eumig, Ever Ready, Ferguson, Ferranti, Fidelity, G.B.C., G.E.C., Grundig, H.M.V., Hitachi, Invicta, K-B, Magnavox, Marconiphone, Masteradio, McMichael, Motorola, Murphy, National, Newmatic, Pam, Perdio, Peto Scott, Philco, Philips, Playmate, Portadone, Portogram, Pye, Radiomobile, Recording Devices, Redifusion, Regentone, Retra, Revelation, R.G.D., Roberts' Radio, Sharp, Sinclair, Sobell, Sonolor, Sony, Sound, Standard, Stella, Stereosound, Stuzzi, Teletron, Thorn, Trans Arena, U.K.W., Ultra, Volmar, Waltham-Standard, Zenith

3 VOLUMES
1,848 PAGES
Over 2,000 Circuits
and Diagrams

Easy no-interest terms
if kept after free trial

Examine it—use it
FREE FOR A WEEK

- TELEVISION ● RADIO
- RADIOGRAMS
- TAPE RECORDERS
- RECORD REPRODUCERS

ONE REPAIR JOB CAN REPAY ITS COST

Compiled by a team of research engineers this big 3-volume library gives you, instantly, the vital data and circuits you need. Cuts out guesswork and delays, steps up your earning-power.

Nearly 60,000 Sets of previous editions sold! Are you missing extra income? Find out why this big servicing aid is in such demand—send for your Free Trial Set today. You'll be delighted. It costs you nothing to see, and there's no obligation to buy.

To: George Newnes Ltd.
15-17 Long Acre,
London, W.C.2

PLEASE send RADIO & TV SERVICING (3 volumes) without obligation to buy. If you accept this application I will post 10/- deposit 8 days after receipt of books, then 20/- monthly for 8 months, paying 28 10s. in all—or return the books. Cash in 8 days 28 10s.

43/1757

Free Trial applies G.B. For Ireland send cash price (refundable if title returned in 8 days).

If under 21 your father must fill up coupon.

Full Name (BLOCK LETTERS) (Mr., Mrs., Miss)

Address

Occupation

Signature

Tick V where applicable

The address on left is—

My Property

Rented unfurnished

Parents' Home

Furnished Accom.

Temporary Address

BECKASTAT



A complete comfort level control system in a compact tough plastic block that you install simply by plugging into any 3-pin power point. Just insert the heater plug in the socket provided on the Beckastat, set the thermostat knob control and room temperature is automatically controlled with the greatest operating economy. Cuts electricity consumption by half. For 200/250v A.C. Suitable for all electrical heaters — maximum efficiency obtainable with appliances up to 2 kW. Can be supplied with 15A round pin or 13A ring main power point fittings. State type required.

MINIATURE NIFE CELLS

High grade leak proof nickel iron accumulators, each enclosed in a vitreous enamelled welded iron case, size overall 2 1/2 in. x 1 in. x 3 1/2 in. high. Cells are rated 1.2 v at 2.5 AH and are almost indestructible; they will withstand tremendous overloads without damage and may be left in a discharged condition for long periods without deterioration. Can be used singly or in multiple units for lamps, models, controls, bells, burglar alarms, flash equipment, radios, etc. Each cell is unfiled and unused and supplied with dry electrolyte and filling and charging instructions 15/- Corr. 5/-

Make a wonderful range
of inexpensive devices

with DRY REED SWITCHES

Can be actuated by permanent or electromagnets to provide excellent basis for a wide range of inexpensive devices such as burglar alarms, limit switches, door bell switches, etc. Tremendous reliability factors and a working life of about 100 times that of microswitches and the uses to which they can be put is limited only by imagination. Each switch supplied complete with specification, instructions and ideas information. SUITABLE MAGNETS 1/- extra.

REED SWITCH COILS 4/- post free

Specially manufactured to provide electro-magnetic operation of Dry Reed Switch described above. Coil is simply pushed on to glass tube and centrally located over switch contacts. Works from any 4-12 v. D.C. supply. Size overall 1/2 in. diam. x 3/4 in. long.

CHANGEOVER REED SWITCH. 12/6 Post Free

Similar in construction to types listed above except that the reed is spring-loaded against one contact until actuated by a field from a permanent or electromagnet to transfer connection to a second contact. Glass size: 1.375 in. long x 0.201 in. dia. Breakdown voltage 350 volts DC minimum. Contact rating for long life 250 mA at 250 volts AC. Amperes turns to Just Operate 70-120. Release 30-70.

PROOPS
BROTHERS LIMITED



Cadmium Sulphide photocells are photo-conductive devices, i.e. they act as light sensitive resistors which become more conductive when exposed to light. They combine robust construction with great reliability, and can be readily fitted as light triggering devices into a wide range of simple control circuits. Typical uses include automatic light controls for home and car, flashing barricade or breakdown lights, exposure meters, brightness controls. They are not polarity conscious and can be used with AC or DC supplies. Spectral response covers entire visible light range.

TYPE 1—Plastic encapsulated 1 1/4 in. diam. x 1/4 in. thick. Time response 2 megohms. Resistance 100 Lux-700 to 3,000 ohms. Max. volts 200. Max. current 10/- Post 250 mW.

TYPE 2—Plastic encapsulated 1/2 in. diam. x 1/4 in. thick. Time response 1 megohm. Resistance 100 Lux-500 to 2,000 ohms. Max. volts 150. Max. current 7 mW. 8/6 Post 150. Max. current 7 mW. 8/6 Free

TYPE 3—Glass sealed with M.E.S. base. Glass envelope 1/4 in. diam., 1/2 in. overall length 1 in. Time response 90 megohms. Resistance 100 Lux-0.05 to 0.15 megohms. Max. volts 150. 6/6 Post Max. current 75 mW.

TYPE 4—Hermetically sealed, glass window faced. 1/4 in. diam. x 1/4 in. thick. Time response 1 megohm. Resistance 100 Lux-15,000 to 50,000 ohms. Max. volts 100. Max. current 5/- Post 20 mW.

SELENIUM PHOTOCELLS

Selenium cells are photogenerative, i.e. light energy is converted by the cell into electricity which can be measured directly by a microammeter or used, in conjunction with an amplifier, as the triggering current for alarm and safety devices and photo-electric counting mechanisms. Selenium cells are particularly suitable for use in luminous fluxmeters, exposure meters, photo-electric colorimeters, fire alarms, etc. Type available size 1 1/4 in. x 1 1/4 in. Spectral response represents a curve resembling that of a man's visual sensitivity. Output is approximately 200 μA 3/6 Post at 3,000 Lux.

DEKATRON TYPE GS10E

by Ericsson, supplied brand-new, complete with performance and connection data. Max. operating speed: 10 kc/s. Anode voltage: 440/475 v. Current: 0.8 mA. Cathode voltage: 35 v. max. Pulse Amplitude: 120 v. min. Size overall 1.3 in. dia. x 2.64 in. Fitted with standard 15/- Post duodecal base.

52 TOTTENHAM COURT ROAD, LONDON W1
PHONE: LANGHAM 0141. HOURS: 9am-6pm
THURS: 9am-1pm. OPEN ALL DAY ON SATURDAY

Why

NOT BUILD ONE OF OUR PORTABLE TRANSISTOR RADIOS...

All components may be purchased separately if desired. Parts price lists and easy build plans available separately at prices stated. Overseas post 10/-.

BACKED BY OUR SUPER AFTER SALES SERVICE

NEW ROAMER SEVEN Mk IV

Amazing performance and specification
FULLY TUNABLE ON ALL WAVEBANDS

★ Now with PHILCO MICRO-ALLOY R.F. TRANSISTORS

Covers Medium and Long Waves, Trawler Band and three Short Waves to approx. 15 metres. Push-pull output for room filling volume from rich toned heavy duty 7" x 4" speaker. Air spaced ganged tuning condenser. Ferrite rod aerial for M & L Waves and telescopic aerial for S Waves. Real leather-look case with gilt trim and shoulder and hand straps. Size 9" x 7" x 4" approx. The perfect portable and the ideal car radio. (Uses PP7 batteries available anywhere.)

★ EXTRA BAND FOR EASIER TUNING OF PIRATE STATIONS, etc. Total cost of parts now only **£5.19.6** P. & P. 5/6

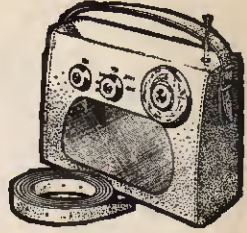

Parts Price List and easy build plans 3/- (Free with kit)

7 WAVEBAND PORTABLE OR CAR RADIO

● 9 stages—7 transistors and 2 diodes

NEW ROAMER SIX

NOW WITH PHILCO MICRO-ALLOY R.F. TRANSISTORS

● 6 WAVEBAND!!
● 8 stages—6 transistors and 2 diodes

Listen to stations half a world away with this 6 waveband portable. Tunable on Medium and Long Waves, Trawler Band and two Short Waves.

Sensitive Ferrite rod aerial and telescopic aerial for short waves. Top grade transistors. 3-inch speaker, handsome case with gilt fittings. Size 7½" x 5½" x 1½". (Carrying Strap 1/6 extra.)

★ EXTRA BAND FOR EASIER TUNING OF LUX, ETC. Total cost of all parts now only **£3.19.6** P. & P. 3/6 Parts Price List and easy build plans 2/- (Free with kit)

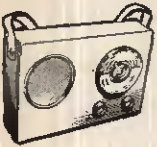

NEW TRANSONA FIVE

"Home, Light, A.F.N. Lux. all at good volume"
G.P., Durham

● 7 stages—5 transistors and 2 diodes

Fully tunable over Medium and Long Waves and Trawler Band. Incorporates Ferrite rod aerial, tuning condenser, volume control, new type fine tone super dynamic 2½ in. speaker, etc. Attractive case. Size 6½" x 4½" x 1½ in. with red speaker grille. (Uses 1289 battery available anywhere.)

Total cost of all parts now only **42/6** P. & P. 3/6 Parts Price List and easy build plans 2/- (Free with kit)

TRANSONA SIX

● 8 stages—6 transistors and 2 diodes

This is a top performance receiver covering full Medium and Long Waves and Trawler Band. High-grade approx. 3in. speaker makes listening a pleasure. Push-pull output Ferrite rod aerial. Many stations listed in one evening including Luxembourg loud and clear. Attractive case in grey with red grille. Size 6½" x 4½" x 1½ in. (Uses PP4 battery available anywhere.) Carrying Strap 1/6 extra.

Total cost of all parts now only **59/6** P. & P. 3/6 Parts Price List and easy build plans 1/6 (Free with kit)



POCKET FIVE

● 7 stages—5 transistors and 2 diodes

Covers Medium and Long Waves and Trawler Band, a feature usually found in only the most expensive radios. On test Home, Light, Luxembourg and many Continental stations were received loud and clear. Designed round supersensitive Ferrite Rod Aerial and fine tone 2½ in. moving coil speaker, built into attractive black case with red speaker grille. Size 5½" x 1½" x 3½ in. (Uses 1289 battery available anywhere.)

Total cost of all parts now only **42/6** P. & P. 3/6 Parts Price List and easy build plans 2/- (Free with kit)

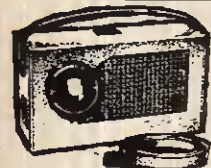
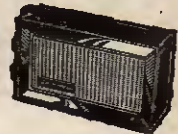

MELODY SIX

● 8 stages—6 transistors and 2 diodes

Our latest completely portable transistor radio covering Medium and Long Waves. Incorporates pre-tagged circuit board, 3in. heavy duty speaker, top grade transistors, volume control, tuning condenser, wave change slide switch, sensitive 6in. Ferrite rod aerial. Push-pull output. Wonderful

reception of B.B.C. Home and Light, 208 and many Continental stations. Handsome leather-look pocket size case, only 6½" x 3½" x 1½ in. approx. with gilt speaker grille and supplied with hand and shoulder straps.

Total cost of all parts now only **£3.9.6** P. & P. 3/6 Parts Price List and easy build plans 2/- (Free with kit)

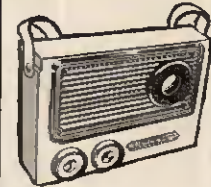

SUPER SEVEN

● 9 stages—7 transistors and 2 diodes

Covers Medium and Long Waves and Trawler Band. The ideal radio for home, car, or can be fitted with carrying strap for outdoor use. Completely portable—has built-in Ferrite rod aerial for wonderful reception. Special circuit incorporating 2 RF Stages, push-pull output, 3in. speaker (will drive

large speaker). Size 7½" x 5½" x 1½ in. (Uses 9v battery, available anywhere.)

Total cost of all parts now only **£3.19.6** P. & P. 3/6 Parts Price List and easy build plans 2/- (Free with kit)

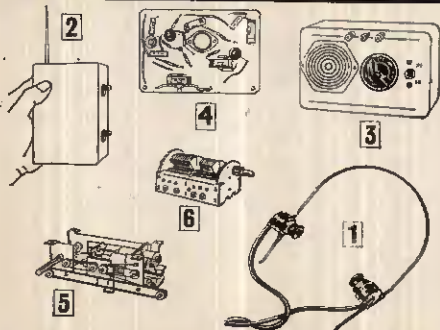

1. HEADPHONES. Sonotone H.S.30 High Fidelity Headphones. Made by famous American manufacturers. Approx. 160 ohms impedance for direct matching into most transistor circuits. BRAND NEW in original sealed cartons. 15/- P. & P. 1/6. Matching Transformers for higher impedance 2/6 extra.
2. THE SIG-GEN. A versatile Signal Injector. Something no constructor should be without. This ingenious device generates an audible signal through the Audio and R.F. ranges. With variable output. Telescopic Probe. Pocket size slim-line case measures 4½" x 3½" x 1½ in. Complete set of parts with full instructions. 19/6. P. & P. 1/6.
3. QUICK CHECK TRANSISTOR TESTER. Checks gain of R.F. and Audio Transistors. Also checks for noise level and diode. All parts ready to be assembled in attractive grey case with red grille, complete with Dial, Knobs, and 2½" Speaker. Simple assembly instructions free with set of parts. 89/6. P. & P. 3/6.
4. 1200mw TRANSISTOR AUDIO AMPLIFIER. Designed to give high quality at low cost. This superb Amplifier uses 4 Transistors including a special power type operating from a 12 volt battery. Variable input impedance. Matches directly into 25 ohms—35 ohms Loudspeaker. Special gain control circuit can also reduce noise to a minimum. All parts including Transistors, Printed Circuit Board, etc. 82/6. P. & P. 2/6. Easy build plans free with set of parts. 6" x 4" 35 ohm speaker. 12/6. P. & P. 1/6.
5. CYLOND PERMEABILITY TUNERS. By famous manufacturer. Full M.W. coverage. Fitted coupling coil, oscillator coil, ferrite slugs and slow motion tuning with cursor, etc. GIVE AWAY PRICE 10/- P. & P. 1/6. Switched type 2/6 extra.
6. TUNING CONDENSERS. Air spaced fine quality German manufacture with slow motion drive. 0.0005. With oscillator section. BRAND NEW! Only 8/6. P. & P. 1/6.

Callers side entrance
Barratts Shoe Shop.

RADIO EXCHANGE Ltd

Open 9—5 p.m.
Saturdays 9—12.30 p.m.

61a HIGH STREET, BEDFORD. Phone: 52367

TUNE TO



Armstrong

A 223 AM-FM Tuner, shown above, or a 224 FM Tuner will enable you to take full advantage of the wonderful source of quality sound FM broadcasts offer. Matching any high fidelity amplifier (including our models 221 and 222) they are self powered and only need the simple addition of an Armstrong Multiplex Decoder for stereo broadcast reception. Tuning is by meter with complete freedom from drift, and the units may be built into your own cabinet or housed in our handsome case of teak and vinyl hide (as shown). For full details and technical specifications of all models, plus lists of over 300 stockists, post coupon or write mentioning 2PE66.

model 223 AM-FM TUNER £28-15-0
 model 224 FM TUNER £22-10-0
 optional case for either model £3-10-0

ARMSTRONG AUDIO LTD - WARLTERS ROAD - N.7
 Telephone: NORTH 3213

Name

Address

2PE66

D & B TELEVISION (WIMBLEDON) LTD.

131 KINGSTON ROAD, SOUTH WIMBLEDON, LONDON, S.W.19

Telephone: CHerrywood 3955

ALL BRAND NEW VALVES GUARANTEED 3 MONTHS

Postage and Packing on Valves 6d. each

AZ31	10/6	EL34	9/9	PL500	14/-	U301	13/9
DAF91	7/10	EL36	9/9	PY33	9/6	U801	19/-
DAF96	7/10	EL41	8/-	PY80	6/-	UJ9	8/6
DF91	6/8	EL84	6/4	PY81	7/-	6F1	9/6
DF92	6/8	EM80	7/8	PY82	3/6	6F13	12/8
DF96	7/10	EM81	7/8	PY83	9/6	6F14	15/-
DK91	7/10	EM84	8/8	PY88	7/-	6F15	12/6
DK92	7/10	EM85	10/-	PY800	7/-	6F23	10/6
DK96	7/10	EY51	7/-	PY801	7/-	6F24	10/9
DL92	6/8	EY86	7/-	UABC80	7/-	6F25	10/9
DL94	6/8	EZ40	5/6	UBC41	7/-	6F28	9/8
DL96	6/8	EZ41	5/6	UBC81	7/-	6L1	15/6
DY86	7/-	EZ80	5/6	UBF80	7/-	6L18	12/6
DY87	7/-	EZ81	5/6	UBF89	7/-	6/30L2	9/8
EABC80	7/6	EZ90	5/-	UCC84	8/10	10C2	12/-
EA42	8/6	GZ32	11/-	UCC85	7/4	10F1	8/6
EBC33	11/2	GZ34	11/-	UCF80	9/4	10F9	8/-
EB91	4/8	HBC90	6/4	UCH42	9/6	10F18	8/-
EBC41	7/2	PABC80	7/6	UCH81	7/3	10P13	12/6
EBC81	6/6	PC86	8/10	UCL82	8/8	10P14	11/-
EBF80	7/-	PC88	8/10	UCL83	10/8	20L1	12/6
EBF89	7/-	PC97	7/6	UF41	9/-	20P1	15/-
ECC81	7/4	PCC84	7/4	UF42	9/-	20P2	12/-
ECC82	7/4	PCC85	7/4	UF80	7/6	20P3	12/-
ECC83	7/4	PCC88	12/6	UF85	7/6	20P4	13/-
ECC84	7/8	PCC89	10/6	UF89	7/-	20P5	13/-
ECC85	7/4	PCC189	10/6	UL41	7/6	30C15	9/6
ECF80	9/6	PCF80	8/4	UL46	10/6	30C17	11/6
ECH35	13/-	PCF82	9/4	UL87	8/8	30C18	10/-
ECH42	8/6	PCF86	10/6	UY41	5/6	30F5	10/-
ECH81	7/-	PCF801	10/-	UY85	5/6	30FL1	10/3
ECL80	7/4	PCF802	10/-	SY3	3/5	30L15	13/8
ECL82	8/8	PCF86	10/-	SZ4	3/4	30L17	11/6
ECL83	10/6	PCL82	8/4	6Y6	7/7	30P12	9/6
ECL86	8/8	PCL83	9/8	6X5	7/5	30P4	12/-
EF80	7/-	PCL84	8/8	R19	14/8	30P19	12/-
EF85	7/-	PCL185	8/8	U25	10/3	30P11	12/6
EF86	9/4	PCL96	8/8	U26	10/6	30PLIX3	12/6
EF89	7/-	PL36	10/-	U191	9/9	30PLIX4	11/8
EF91	11/-	PL81	8/4	U193	7/-	30FL14	10/6
EP92	9/-	PL82	6/4	U251	11/8	30FL12	10/6
EF183	9/8	PL83	8/4	U281	13/9	30FL18	10/6
EL33	10/6	PL84	7/-	U282	13/9		

We are open 9 a.m. to 6 p.m. Monday, Tuesday, Thursday and Saturday
 9 a.m. to 7 p.m. Friday. Closed all day Wednesday

SERVICE SHEETS. TELEVISION!! ALL MAKES and
 MODELS. 4/- each. P. & P. 4d.



For quick, easy faultless soldering

Ersin Multicore 5-core solder is easy to use and economical. It contains 5 cores of non-corrosive flux, cleaning instantly heavily oxidised surfaces. No extra flux is required. Ersin Multicore Savbit Alloy considerably reduces the wear of copper soldering iron bits.

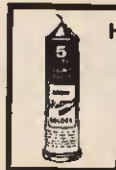

HANDY SOLDER DISPENSER

12 ft. of 18 s.w.g. SAVBIT alloy in a continuous coil, used direct from free-standing dispenser. 2/6 each



LOW TEMPERATURE SOLDER

Size 9 pack contains 24 ft. of 60/40 high tin quality 22 s.w.g. 2/6 each
 Size 10 pack 212 ft. 15/- each.



SAVBIT SIZE 1 CARTON

Contains approx. 30 ft. of 18 s.w.g. SAVBIT alloy. Also available in 14 and 16 s.w.g. 5/- each

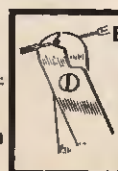

BIB WIRE STRIPPER AND CUTTER

Strips insulation, cuts wire cleanly. Adjusts to any size. 4/- each

Available from all Electrical and Hardware shops.
 If unobtainable write to:

MULTICORE SOLDERS LTD.

Multicore Works, Hemel Hempstead, Herts. Hemel Hempstead 3636 M.4/B

IF YOU ARE LOOKING for the UNUSUAL

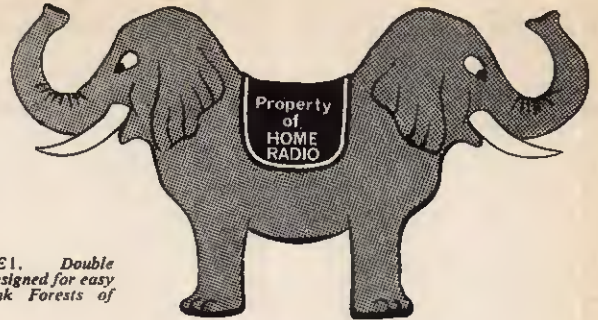

Catalogue No. DHE1. Double Headed Elephant. Designed for easy reversing in the Teak Forests of Mandipore.

... you may find it in our Catalogue. The number of times we hear a customer say "I have been searching everywhere for one of these" leads us to believe that many items which to us are quite standard, may be unusual to many of our customers. May we pin-point a few ...

THERMISTORS

Also stocked :	R53	£1.1.0
	A15	12/6
	A25	12/6
	A54	12/6
	A55	12/6
	R24	£1.1.0

HIGH VOLTAGE RECTIFIERS

Also stocked :	K3/40	9/-
	K3/15	6/-
	K3/50	12/4
	K3/100	£1.0.3
	K3/160	£1.5.6

S.T.C. F.M. CRYSTALS

£3.15.0

GANGED STEREO POTS

Also stocked :	10K Log plus 10K A/Log	10/-
	10K plus 10K Log D.P. switch	12/3
	Log or Linear 10K, 25K, 50K, 100K, 250K, 500K, 1M, 2M	10/-
	Log/A Log, 500K, 1M, 2M	10/-
	Log with D.P. switch 500K, 1M	12/3

P.S. We hasten to add that the last two-headed elephant has been sold* but we still have left some excellent catalogues consisting of 210 pages, plus a 21-page supplement, 5800 items (over 900 illustrated). Don't hesitate, send off the coupon and 9/- P.O. or cheque today. Every catalogue contains 5 coupons, each worth a 1/- if used as directed.

* To a politician who wasn't sure which way to go.

RESISTORS

1% 1/2 watt 2/-
Most values between 22 Ohms and 10 Meg.

VALVES

TT21 £2.8.6
We stock a very comprehensive range of valves, but the following may be considered unusual :-

EN91	18/-	VR105/30	18/6	85A1	£2.11.6
ORP90	£1.6.0	VR150/30	18/6	85A2	15/-
150B2	15/4	6146	£2.0.0	2803U	18/6
150C4	15/9	QVO6/20	£2.8.0	OA2	15/-
5763	£1.0.0			OB2	16/-

TRANSISTORS AND DIODES

AF186	£1.7.6	GET103	7/-	OC76	7/-
AC107	14/6	GET106	17/-	OC77	12/-
BYZ13	11/6	GET111	12/-	OC83	6/-
ASY28	8/6	GET115	9/6	OC84	8/-
GEX66	15/-	(also matched pairs of GET115)		SVC1	18/-
OA5	6/-	GET116	17/-	OAZ222	£1.0.6
OA10	8/-			OAZ223	17/6
OA85	3/-			OAZ224	14/-

Well there they are, but if on the other hand you require all the usual items, Resistors, Condensers, Coils, Transformers, etc., they are all in the Catalogue too, clearly indexed and priced.

Please write your Name and Address in block capitals

Name

Address

Home Radio Ltd., Dept. PE, 187 London Road, Mitcham, Surrey

DRAWING THE LINE

THE demarcation between electrics and electronics has never been altogether clear and obvious. Sometimes the distinction is based on quite tenuous grounds. For example, the presence of a solitary rectifier might be considered a valid reason for applying the description "electronic" to a circuit composed otherwise entirely of conventional electrical devices. Whereas this classification might be in order according to the word of the generally accepted definition of electronics, it is arguable whether it is in accord with the spirit of this definition.

Anyhow most of us have an instinctive feeling for what is legitimate electronics, and such border line cases have not caused any undue concern—except maybe to the pedant. Every circuit or piece of apparatus has usually fitted nicely into the electronic or the electric pigeon hole without any bother at all.

But now things are changing, and with that rapidity we are becoming accustomed to in electronic affairs. The encroachment on electric territory by electronics has developed from a surreptitious movement into unconcealed full scale invasion. The vital force behind this offensive is the thyristor, alias the silicon controlled rectifier, known colloquially as s.c.r. This semiconductor device was invented only a few years ago, but already it has caused a minor revolution in electrical power technology. The thyristor is the solid state counterpart of the gas filled triode or thyratron and it is far more versatile and easier to use than this older device. In this vigorous campaign, valuable support has been provided by the new kind of semiconductor rectifiers, which are closely related to the thyristor.

With the aid of these semiconductor electronic devices (and make no mistake, we do claim these as being 100 per cent genuine members of the electronic clan) the smooth and precise control of high voltage and high current circuits has become almost effortless—both in terms of manual exertion by the operator and electrical power consumed in the controlling circuit. Thyristors are also being widely used in static convertors for changing a.c. to d.c., and in inverters where the reverse process takes place.

Lower down the power scale we find the thyristor equally useful and versatile. And here we are getting quite literarily nearer home, with a host of interesting possibilities concerning mains operated appliances: lighting, heating, and power tool control—for instance. (Watch these pages!)

With this fusion of electrics and electronics the rather arbitrary and artificial distinction between these two related fields will be harder to maintain in the future. Perhaps British Standards will be called upon one day to redefine these terms for the general convenience of all. So far as this magazine is concerned, our readers may rest assured we will know where to draw the line. It will anyhow be fairly flexible, and we will always be prepared to give or take a diode or two!

THIS MONTH

CONSTRUCTIONAL PROJECTS

ELECTRONIC VIBRATO UNIT	93
BURGLAR ALARM	96
PORTABLE RATEMETER	112
COMPACT POWER UNIT	126
A.F. AND R.F. SIGNAL TRACER	133

SPECIAL SERIES

NEON NOVELTIES—6	103
BUILDING BLOCKS—11	108
BEGINNERS START HERE—16	122

GENERAL FEATURES

RADIO CONTROL OF MODELS	88
MORE ABOUT DISCS	101

NEWS AND COMMENT

EDITORIAL	87
THE 73 PAGE	104
BOOK REVIEWS	107
TRADE LITERATURE	119
ELECTRONORAMA	120
NEW PRODUCTS	124
NEWS BRIEFS	130
DETACHED PARTICLES	141
READOUT	142

*Our March issue will be published on
Thursday, February 17*

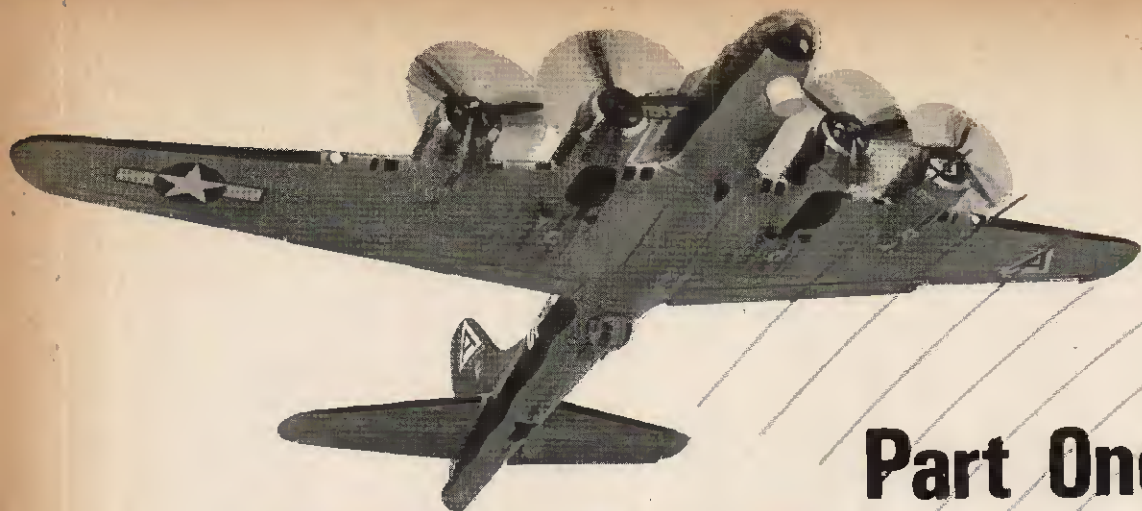

Part One Radio Control

BASICALLY this series aims to provide as comprehensive a description as possible of model radio control systems, their scope and the type of circuits and equipment employed. Emphasis will be placed on descriptions of proven circuits rather than original designs since the demands involved are highly specialised.

Certain requirements peculiar to radio control operation, as such, are only properly met by practical development and proving under typical working conditions. By far the greater majority of successful radio control operation, in fact, is done with commercial equipment, which has reached its high degree of reliability through continual practical development.

The majority of circuits to be published can readily be used by the individual constructor, should he so desire. However, demands for home construction are usually best met by commercial kits which are normally based on a printed circuit panel and thus conform to "professional" standards as regards layout, as well as offering proven designs.

Kits are readily available of both single-channel and conventional multi-channel transmitters and receivers,

and undoubtedly represent the best starting point for those who do not wish to purchase ready-made commercial equipment. There is also a substantial saving in cost by building from kits, compared with the price of ready-made equipment. The kit price is very little more than a complete set of components and materials for building completely from scratch from a circuit design.

Certain elements, such as pulsers, decoders, servo-amplifiers, and so on, do lend themselves more readily to individual designs since these are ancillary to the basic requirement of a proven transmitter-receiver combination, and here the home constructor can feel on easier ground. This can also apply where the application can be regarded as "derated" compared with model control requirements, e.g. for simple remote control switching systems.

The description "model radio control" refers specifically to units produced for authorised operation for command signalling only (i.e. not speech), and now widely used for the remote control of model aircraft, boats and other working models. Identical, or similar, units are also employed industrially and com-

GLOSSARY OF TERMS...

ACTUATOR

An electro-mechanical device providing a mechanical output force for control movement or operation

A.F.

Audio frequency (nominally within the range 20 to 16,000 c/s)

AMPLIFICATION

Increase in voltage of current of a signal

ANTENNA

American terminology for aerial (commonly quoted in association with American equipment)

"BANG-BANG" CONTROL

Control movement which is either full "on" (on receipt of signal) or neutral (with no signal)

CARRIER WAVE

Transmitter r.f. (radio frequency) signal which may be turned on and off for signalling purposes; also basic transmitter signal on which audio frequency tones may be superimposed for "tone" operation

CASCADE

System or method of electrically connecting a number of actuators (usually escapements) in series to increase the number of sequential controls available

CHANNEL

A single source of control intelligence or signal

COMPOUND ACTUATOR

A sequential actuator with additional

facilities for switching or operating an additional actuator or actuators

CRYSTAL

Circuit component used to control the frequency of an oscillator

CRYSTAL CONTROLLED

Transmitter circuit stabilised at a "spot" carrier frequency by a crystal

DETECTOR

That part or element of a receiver circuit which detects or "picks up" the signal

DROP-OUT

The current at which the armature of a relay or escapement "drops out" or moves on to the back contact under spring tension

mercially, although the basic essence of model control units is simplicity and compactness, with a light duty requirement only in terms of mechanical output.

For mass appeal, too, price is a major factor, resulting in the development of transmitter-receiver combinations retailing at £15-£20, or something like one half this figure in prefabricated kit form for home assembly. At the other end of the scale, however, model radio control units embrace quite sophisticated miniaturised electronics in the form of superhet receivers capable of decoding multi-channel transmitter signals in the form of quadruple-proportional electro-mechanical (servo) outputs. Price for the complete equipment in this category can range as high as £400-£500.

ably greater technical problems involved), the expanding use of 27-255Mc/s by other services in America, notably for street traffic lights, seriously restricted the usefulness of the band from a practical hobby point of view.

Accordingly the F.C.C. allocated a further five spot frequencies for "Citizens Service" in 1958: 26-995, 27-045, 27-095, 27-145, and 27-195Mc/s. More recently, the subject of additional "spots" has received further review to take advantage of and expand the possibilities of simultaneous superhet operation. Currently the (American) Academy of Aeronautics and the F.C.C. are also negotiating for five additional v.h.f. frequencies: 72-08Mc/s, 72-24Mc/s, 72-40Mc/s, 72-96Mc/s and 75-64Mc/s.

of Models

By R.H.WARRING

FREQUENCY ALLOCATION

Model radio control, as such, started in the United States in the mid-1930s, utilising home-built equipment capable of providing a reasonably reliable single-channel signalling system with a carrier frequency of the order of 50Mc/s.

The majority of such designs—and successful designs were relatively few in number—were produced by radio "hams" who were also model aircraft enthusiasts. Despite a considerable growth and development in the immediate post war years, it was not until early 1950 that the (American) F.C.C. approved "Citizens Service" frequencies, which eliminated written and code tests on these frequencies and put radio control within the reach of thousands of model enthusiasts rather than radio enthusiasts. The permitted frequencies, known as "Citizens" bands, were 465 and 27-255Mc/s, with a maximum of 5 watts input to the final stage of the transmitter.

Apart from the inevitable "crowding" resulting from the use of a single spot frequency (the u.h.f. band being largely neglected because of the consider-

able greater technical problems involved), the expanding use of 27-255Mc/s by other services in America, notably for street traffic lights, seriously restricted the usefulness of the band from a practical hobby point of view.

A licence for operating any such transmitter is obligatory, but is obtainable simply on application to the Radio Branch, Radio and Accommodations Dept., G.P.O. Headquarters, London, E.C.1. The cost of the licence is £1, covering a period of five years.

Whilst designers and manufacturers were at one period actively concerned with development of equipment for the 465Mc/s band, this has now largely fallen into disuse (and was never at any time particularly popular due to the high cost; the severe limitation imposed by the directional nature of such u.h.f. signals). The so-called 27Mc/s band has, therefore, become the accepted world "standard" for model radio control, leading manufacturing countries in addition to the U.S.A. and Great Britain being Germany and

END VOLTAGE

Minimum practical (useable) voltage of a battery on discharge, also used to describe minimum useful voltage, although this can be a different value.

ESCAPEMENT

Electro-mechanical device or actuator embodying an escapement movement, triggered by movement of an armature.

FIELD STRENGTH

Actual or measured strength of a transmitter signal at a specified distance (range).

FIELD STRENGTH METER

Circuit with meter capable of tuning to a transmitter signal and measuring the strength of signal received.

FILTER

Electronic equipment for passing a required tone frequency and blocking all other tones.

GALLOPING GHOST

Spacing type of simple simultaneous control (see also "Simple Simul").

GAP

Distance between armature and inner ("make") contact on a relay; distance between armature and coil core on an escapement; distance between a reed and its fixed contact.

GROUND RANGE

Range of a transmitter between two ground positions (strictly speaking the range achieved ground-to-ground with a particular transmitter-receiver combination).

HARD VALVE

Conventional vacuum tube triodic valve.

HARNES

Complete wiring system for a transmitter circuit or, more usually, a complete receiver installation.



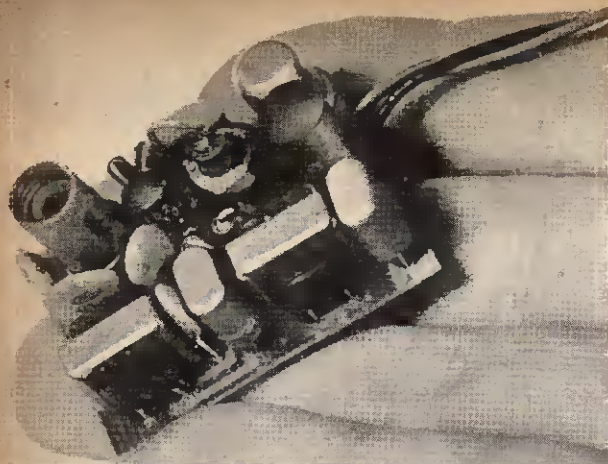

Miniature single-channel receiver

Japan. Some equipment is still designed to operate on the 50–54Mc/s band in the U.S.A., and on the 40–41Mc/s band in Germany; the circuitry involved is basically the same but can be adapted to 27Mc/s operation, if necessary, by change of component values.

CRYSTAL CONTROL

About the only marked difference between the productions of the various countries is that the United States, with its insistence on "spot" frequencies, has invariably employed crystal-controlled transmitters. The crystal control of transmitters is also obligatory in Germany, but not in this country.

Consequently, the majority of earlier British equipment featured non-crystal controlled transmitters and such types are still produced today, where the saving in the cost of the crystal can represent a favourable selling (or building) price. In the main, however, the advantages offered by freedom of drift with a crystal controlled transmitter are universally recognised, and such a simple method of transmitter carrier frequency control becomes strictly necessary for the operation of a superheterodyne receiver.

From a diversity of early original designs, modern circuits fall into a more or less standard and well established pattern. Apart from seeking greater

reliability (i.e. largely better circuit stability and efficiency), the most marked trends have been towards miniaturisation and increasing the functions obtainable from a single carrier frequency.

Miniaturisation has been greatly influenced by the development and availability of suitable transistors, both for valve functions and switching duties (e.g. to replace relays). This is even more desirable with multiple-function signalling when the receiver circuit must be extended to decode pulsed or modulated signals.

HOW MANY CHANNELS?

A basic distinction is drawn between a *single-channel* and a *multi-channel* system. In the case of simple single-channel radio control a single signal only is transmitted, the receiver decoding this in the form of an on-off switching function. The transmitter signal may be simply the *carrier* signal (27Mc/s) which is switched on and off; or a lower frequency *tone* signal (usually of the order of 600–1,000c/s) which is applied to modulate the carrier. In the latter case the carrier may remain switched on all the time and the tone keyed for signalling, or carrier and tone keyed simultaneously (e.g. to conserve the transmitter batteries). The two methods are known respectively as "carrier (or c.w.)" and "tone".

With a *multi-channel* system the usual method is to provide for modulating the carrier by a number of different audio frequency tones which can be keyed separately. The receiver circuit is then so designed to decode each tone modulated signal separately, or distinctively. Provision may also be made to transmit and decode two or more tone-modulated signals simultaneously, in which case the multi-channel transmitter-receiver combination is said to be capable of *simultaneous* operation.

ACTUATOR CONTROL

As far as the output side of the receiver is concerned, regardless of the number of channels involved, each channel performs an on-off switching function, which is used as a "command" for an actuator circuit. An actuator is, basically, an electro-mechanical device, which translates on-off signalling into mechanical

GLOSSARY OF TERMS CONTINUED

HORN

Fixed lever arm attached to control surfaces, connecting to a pushrod for movement.

IDLING CURRENT

Current drawn by a receiver under "idling" or quiescent conditions (i.e. with no transmitter signal present).

KEYING LEAD

Separate switch (usually microswitch) and lead plugging into a transmitter (usually ground-standing type).

KEY or KEYING SWITCH

The switch or switches on the transmitter controlling on-off switching of the signal.

KICK-UP

Mechanical linkage on a compound

actuator providing an additional mechanical movement.

27 MEGACYCLES PER SECOND

The nominal frequency for model radio control operations in Great Britain (27 million cycles per second).

MICROSWITCH

Precision on-off switch with light action and extreme sensitivity.

MODULATION

Superimposition of an audio frequency (i.e. a tone) on an r.f. signal (e.g. a carrier wave).

MODULATOR

Circuit for providing modulation in model radio control work normally an audio oscillator.

M.O.P.A.

Master oscillator power amplifier

circuit (transmitters).

MULTI-CHANNEL or "MULTI"

Transmitter or receiver or transmitter-receiver combination capable of working via separate tone signals.

NOISE

Extraaneous random or spurious signals present in a receiver circuit.

NO-LOAD VOLTAGE

Open-circuit battery voltage (i.e. measured directly with a high resistance voltmeter).

"p"

Positions on an actuator - e.g. 3p, 2PS/N etc.

PACK

A set of batteries made up to the required voltage or voltages.

output. In its simplest form it could consist merely of a d.c. electric motor. An "on" signal completing the motor circuit would then cause it to drive in a certain direction for as long as the signal was held on; the motor would stop when the signal was released (producing an "off" function). If controlled by two separate servo circuits with opposite battery polarity, each switched by its own signal channel, operation of one signal would cause the motor to drive in one direction; and operation of the other signal would drive the motor in the other direction.

Whilst this may have certain applications, the practical actuator normally operates on a limited movement basis—i.e. on receipt of signal "on" it drives or moves to a limiting position and stops. On release of the signal, the actuator then drives or moves back to its original position or "self-centres". The resulting control movement is thus either full on (on receipt of signal), or neutral, i.e. centred (on release of signal).

This type of control movement is known as "bang-bang" and is characteristic of the greater majority of all model control systems as regards main or critical controls. It is the only simple way of knowing where a control surface is, i.e. it must be either full on or neutral. If the self-centring action of the actuator was removed, the control could be "inched" to intermediate positions according to the amount of time the signal was held on, but the actual position could only be determined indirectly by observing the response.

This is an entirely unsatisfactory action for practical control of a fast moving object, such as a model aeroplane in flight, although it may be quite satisfactory for secondary or "trim" controls. It is, in fact, used in such cases where it is not critically important that the actual position of the control should be known.

Proportional movement can only be obtained accurately by using the actuator on a closed loop system with feedback, coupled with a proportional control signal from the transmitter. This can be accomplished, for example, by pulsing the control signal and varying the mark-space ratio for proportional signalling. The necessary modifications can be applied to standard circuitry, but only at the expense of considerable complication. Attempts to simplify the overall system (for example, by a simplified form of

"proportional" actuator operating on an open loop) are not as satisfactory as conventional "bang-bang" controls as a control method, and are generally much less reliable.

Typical radio control transmitter unit

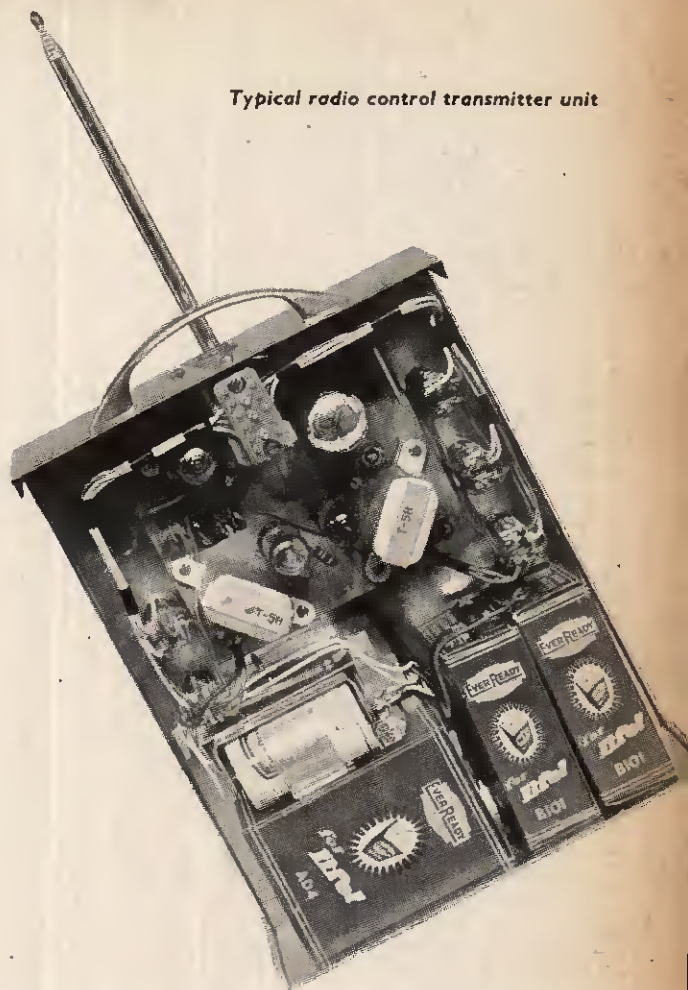

PROPORTIONAL CONTROL

Graded control movement where the displacement of a control is directly proportional to the displacement of the keying switch.

PROGRESSIVE CONTROL

Non self-centring control movement where the control position may be "inched" in either direction and stops in its last position on cessation of signal.

PULSE

Basically any quick signal, but normally applied to a transmitter signal interrupted with a specific or variable mark-space ratio.

PULSER

A device for connecting to a transmitter to provide a pulsed signal.

PULSE RATE

Rate of pulsing an interrupted signal (pulses per second).

PULSE WIDTH

Duration of signal-on pulses, or "mark".

QUICK-BLIP

Very quick signal on transmitter key or button used to close momentarily a pair of contacts on a suitable actuator for operation of a "compound" service.

RANGE

Nominally the distance over which a transmitter will continue to provide satisfactory response from a receiver.

REED BANK

A special form of relay with a number of individual reeds as armatures, each resonant at specific tone frequencies.

REED RECEIVER

Multi-channel receiver incorporating a reed bank.

RELAY

Electro-mechanical switch comprising

coil, spring-loaded armature and sets of contacts (usually two contacts only for model work, the armature forming the third contact).

RELAYLESS

Receiver with amplified output operating on actuator direct.

R.F.

Radio frequency.

SELF-NEUTRALISING

An actuator which automatically reverts to its neutral or central control position on release of signal.

SEQUENCE

Operation of individual control movements one after the other or in sequence rather than by individual selection.

SEQUENCE SWITCHER

Device used with single-channel control systems providing individual circuit outlets for sequential switching.

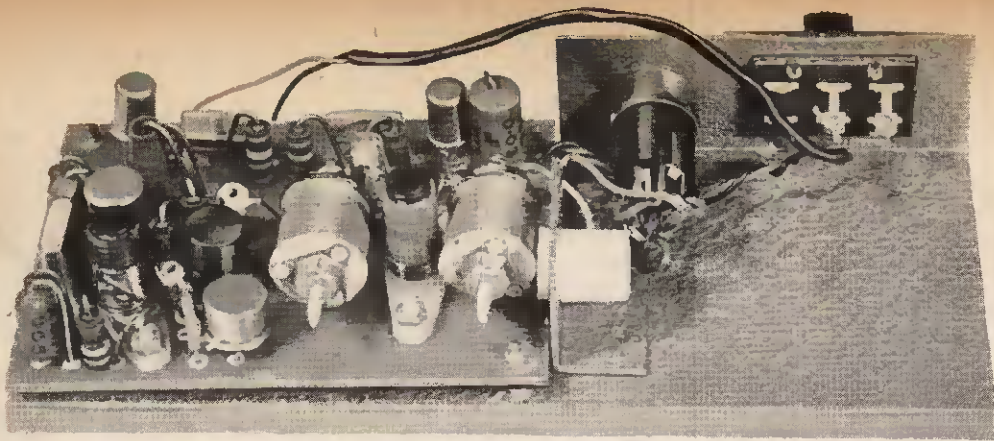

Basic transmitter unit removed from its case

WHICH SYSTEM?

The design and application of the circuit elements and the various systems involved will be discussed in detail under separate headings in subsequent articles. It is important to appreciate that radio control for models is not a single entity but embraces a range of different types of equipment. Equally, its performance as a functional unit is tied both to its "command" scope (i.e. single- or multi-channel) and the mechanical performance of the actuator(s) under command.

The majority of commercial radio control productions, in this country at least, are of the simple single-channel type, principally because this is the least expensive form of radio control and thus enjoys the largest demand. The scope offered by simple single-channel radio control is, however, strictly limited, since if the actuator is designed to produce more than one control movement it can only repeat a particular movement in sequence. This sets a definite limit to the maximum number of separate sequential movements which can be operated on a practical control basis, depending on the speed of the object being controlled.

Multi-channel signalling, on the other hand, offers direct selection and signalling of the same number of control movements as there are signalling channels available. The number of individual channels available is limited only by practical considerations of

circuit element design—12 channels being a practical maximum where a reed-relay is used as the decoding element in the receiver, virtually no limit in the case of tone filter decoding, except for the increasing bulk and cost of the receiver.

Ten or twelve channel "multi" is quite adequate coverage for all likely model applications as this will give complete control of a model aircraft, with "bang-bang" control movements for rudder, elevators, and ailerons, and progressive (non-self-centring) controls for engine throttle and elevator trim. The more complex, and considerably more expensive, quadruple-proportional control systems are an advance on this but do not give more control—only smoother control.

Modern circuits achieve a very high degree of reliability, equivalent virtually to that of the domestic radio. Many such sets, in fact, are fully wired and cater for external leads for batteries and servos, and are retuned, so that they can be installed and operated by modellers with no previous radio experience.

The design and development of model radio control units is highly specialised, requiring more than just a knowledge of electronics. Problems arise which are peculiar to the demands of radio control systems as such, and not just to sound receiver and transmitter design. Such factors are only worked out by practical operating experience.

GLOSSARY OF TERMS CONTINUED

SHORTING PLUG

Two-pin plug with outlets connected (i.e. short circuited) to provide a bridge across a two-point socket

SIGNAL

Any real control (transmitter) signal

"SIMPLE-SIMUL"

Simplified form of "proportional" control response from a pulsed transmitter signal

SIMULTANEOUS

Operation of two controls at the same time via two simultaneously keyed transmitter signals

SINGLE-CHANNEL

Transmitter or receiver, or transmitter-receiver combination operating on a single signal system

SUPERHET

Type of receiver working on the superheterodyne principle matched to its corresponding transmitter by a crystal frequency separated by the i.f. frequency

SUPER-REGEN

Super-regenerative type of receiver, and the most commonly used type for simple systems

TONE

Audio frequency superimposed on carrier wave, each tone representing a separate signal

TONE FILTER

filter element for decoding tone signals at the receiver end

TONE RECEIVER

Receiver which responds to a tone modulated signal (single-channel); or a number of separate tone modulated signals (multi-channel)

TONE TRANSMITTER

Transmitter employing an a.f. tone signal superimposed on a carrier for transmitting signal intelligence (single-channel); or a number of separate superimposed tone signals (multi-channel)

TRIM

Basically the adjustment of a model aeroplane for satisfactory flight performance, but also referred to a progressive control movement (e.g. elevator trim)



ELECTRONIC VIBRATO UNIT

by G. WAREHAM

SOME PEOPLE find the vibrato or tremolo stop (so frequently used in cinema organs) sufficiently pleasing to want to add it to their sound systems. This article shows how it can be done simply and easily by using modern silicon transistors. No bulky coils or transformers are needed and the power supply can be obtained from the main amplifier. Apart from the power supply, only two connections are needed to insert the vibrato unit into the sound system.

A vibrato circuit is just a device for modulating the amplitude of the audio signals. It is often achieved by inserting into the a.f. amplifier an extra stage of amplification, but in this case a stage whose gain is varied periodically is used to produce the desired effect. Unfortunately, it is hazardous to add an extra stage to a multi-stage amplifier. Doing so carries a risk of unexpected low frequency instability in the form of "motor-boating". The constructor then finds he has two vibrato effects, one of which can be controlled at will and another which cannot be controlled.

The device to be described here adds no extra stage. Instead, it is placed across the path of the audio signals, and modulates them by periodically short-circuiting them. It is called a shunt modulator.

BASIC PRINCIPLE

The principle of operation is shown in Fig. 1a. If switch S is closed, the audio signal is all dissipated in R1, and nothing appears at the output. Periodically opening and closing of the switch at a suitable low frequency (say 10c/s) would produce a vibrato effect. Musicians tend to use the term "vibrato" for deep modulation at low frequencies, and "tremolo" for the fluttering effect produced by shallower modulation at a higher frequency. The unit described here produces both effects.

Of course, the circuit in Fig. 1a is impractical on its own. Real vibrato units use, instead of a mechanical switch, a non-linear impedance controlled by a low-frequency oscillation. Ordinary semiconductor diodes are suitable, and can be connected as shown in Fig. 1b. Here R1 is in practice the source impedance of the a.f. signals, and R2 is the input impedance of the next stage of the main a.f. amplifier.

We have as yet no means of "fading in" the vibrato effect, and Fig. 1c shows how a potentiometer VR1 can be added to make this possible. (It should be a "log. law" component as used for a volume control.)

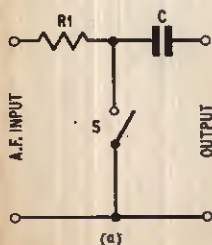

Fig. 1a. Principle of the shunt modulator

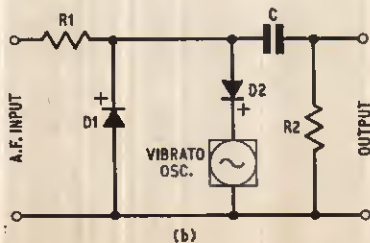

Fig. 1b. Practical modulator using diodes instead of a mechanical switch

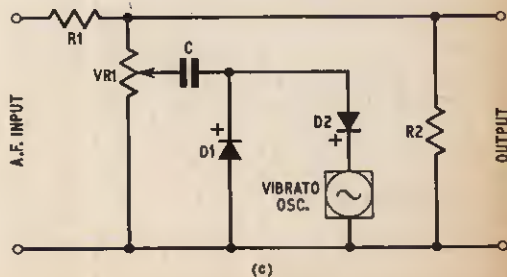

Fig. 1c. Modulator with a fader control

INSERTION LOSS

Connecting a shunt modulator inevitably attenuates the a.f. signals, and if one is not careful the amount of attenuation can be excessive. It is necessary to select certain component values to suit the particular equipment to which the vibrato unit is to be added. This is quite straightforward. The equivalent circuit of the modulator is given in Fig. 2. Here r_d is the effective resistance of the two diodes in parallel, and the other resistances are the same as before.

Ideally, r_d varies between zero and infinity, to produce the required modulation. In practice, it varies between a few hundred ohms and a few hundred-thousand ohms, the exact figures depending on the type of diode used.

The circuit behaves as a potential divider or inverted-L attenuator even when r_d is infinitive, and thus produces the "insertion loss" of the device. Thus if the value of R_3 is small compared with that of R_1 the loss is large, and vice versa. The insertion loss could be eliminated by making R_1 zero, but this would prevent total modulation; R_1 is usually there already, and outside the control of the constructor.

A little thought shows that, for small loss, the value of R_1 should not be larger than that of R_2 and R_3 in parallel. A good rule is to make R_1 equal to R_2 and R_3 in parallel. (The insertion loss is then 6dB.) A typical case is shown in Fig. 3, where the vibrato modulator is connected across the grid circuit of one of the amplifier stages. Here the source resistance is virtually equal to the anode load R_L of the preceding stage, and the load R_2 is virtually the same as the grid leak resistor (R_g) of the next stage. In this case, VR_1 can have a value somewhere between that of R_1 and R_2 . The precise value is not critical, but it should not be too large compared with R_1 , or the vibrato fade-in control will be too "fierce", that is, the vibrato will come in suddenly when VR_1 is turned up almost to maximum. In valve amplifiers a typical value for VR_1 would be about 250 kilohms; in transistor amplifiers it would be about 5 kilohms.

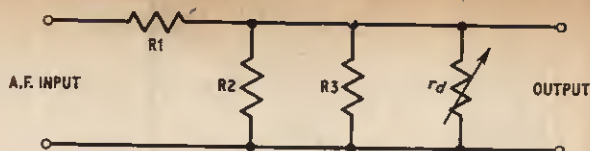

Fig. 2. Equivalent circuit of the shunt modulator

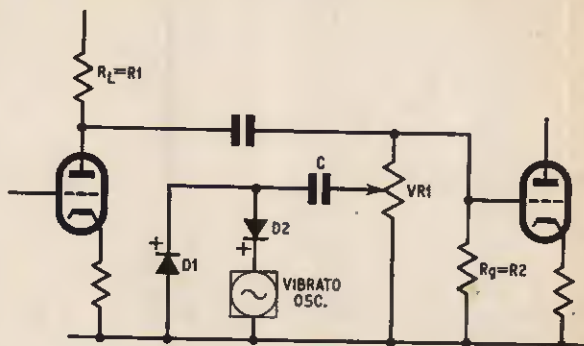
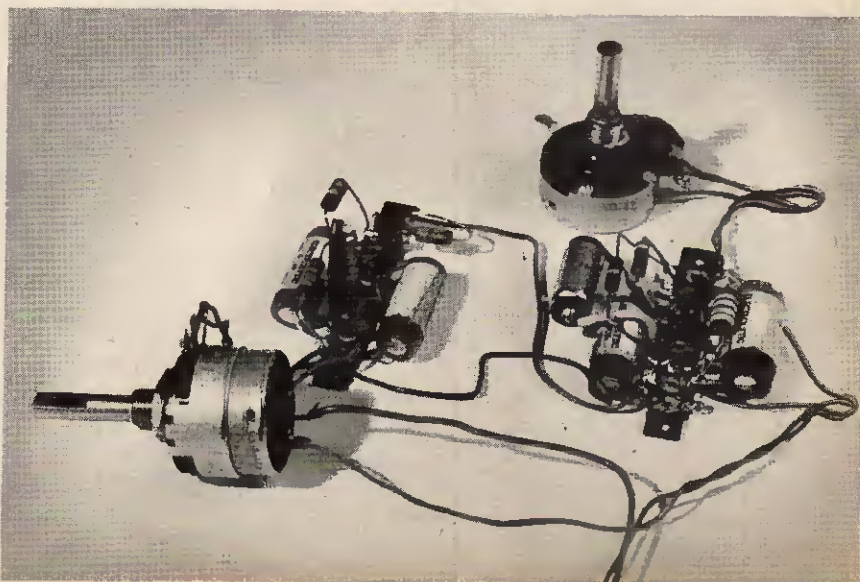

Fig. 3. One method of connecting the modulator between two stages of an existing valve amplifier

BREAKTHROUGH

One more component must be selected by the user. This is the capacitor C shown in Fig. 1c and Fig. 3. If it is too small, modulation depth is reduced. If it is too large, unwanted ticking noises will be produced on the loudspeaker. These are simply the audible effects of the vibrato oscillator output, some of which appears at the junction of the two diodes and then gets into the amplifier via C . To reduce this effect, the value of C is chosen so that its impedance is no smaller than R_1 at the lowest frequency of interest. If it is equal to R_1 , then $C = 1/(2\pi f R_1)$. In valve amplifiers C is usually in the range $0.01\mu\text{F}$ to $0.1\mu\text{F}$; in transistor amplifiers it would be between about $0.1\mu\text{F}$ to $1\mu\text{F}$.

Photograph of the assembled tag strips ready for mounting in the amplifier cabinet or chassis



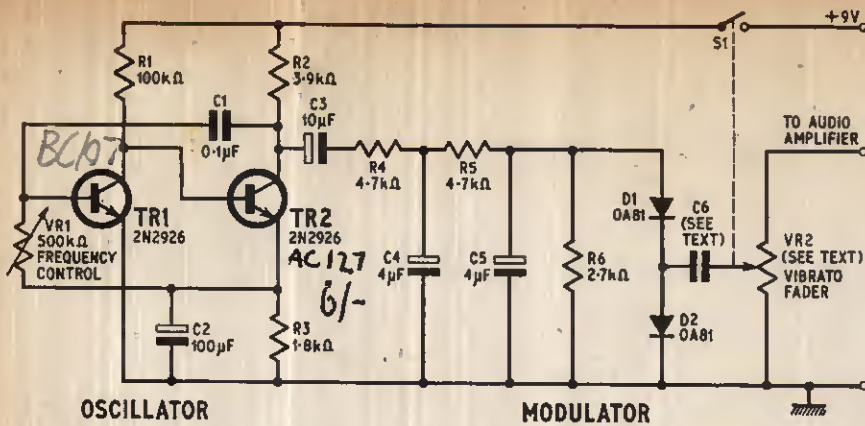

Fig. 4. Complete circuit of the vibrato unit for construction. The values of C6 and VR2 depend on the impedance of the amplifier to which it is connected (see text). VR1 is ganged to S1 so that the unit can be switched on and off

Choice of C is invariably a compromise, but by good luck it is made easier by a peculiarity of human hearing. Vibrato effects can be produced without modulating the entire a.f. band down to the lowest frequency. Modulating the harmonics is enough to create the effect. Thus C can be smaller than at first seems necessary, and breakthrough of the fundamental frequency is correspondingly reduced.

Vibrato harmonics are attenuated less by C, and they must be reduced by making sure that the vibrato waveform applied to the diodes contains no high harmonics. Perfectionists may say that the vibrato oscillator should generate a pure sine wave. This is difficult to achieve, especially if the vibrato frequency is variable, and even a pure sine wave gets distorted by the diodes, and harmonics are thereby created. The ideal design would ensure that the vibrato wave form which appears at the junction of the diodes was a sine-squared pulse.

In practice, there is always some breakthrough, but good results can be obtained without too much difficulty, partly by selecting C and partly by ensuring that the audio input signals to the vibrato modulator are between approximately 100mV to 1 volt.

This is typical of the level of signals at the input to a modern power amplifier. Thus a possible position for the vibrato unit is between the pre-amplifier and the power amplifier. If the pre-amplifier has a low impedance output, e.g. a cathode follower, it will probably be necessary to use an actual physical resistor for R1—a few thousand ohms. The modulator may also be connected across the audio path at some intermediate stage, say between first and second stages of a pre-amplifier (see Fig. 3). The vibrato circuit should not be connected so that it comes inside a negative feedback loop, or the negative feedback will act against the modulation.

COMPLETE CIRCUIT

Now let us look at the complete circuit (Fig. 4). Two npn silicon planar transistors type 2N2926 are used in a relaxation oscillator type of circuit. The frequency (5–30c/s approx.) is controlled by C1 and VR1. An inverse-log. potentiometer is best, but if this is not available use an ordinary log.-law volume control, connected so that the resistance increases when the knob is turned clockwise. The frequency then decreases with clockwise movement.

Before being applied to the diodes, the oscillator output is filtered by R4, C4, R5, and C5, removing some of the harmonic content.

COMPONENTS . . .

Resistors

R1 100kΩ	R4 4.7kΩ
R2 3.9kΩ	R5 4.7kΩ
R3 1.8kΩ	R6 2.7kΩ

All resistors 10% ¼ watt carbon.

Potentiometers

VR1 500kΩ inverse log. or log. carbon
VR2 250kΩ or 5kΩ log. carbon (see text) with S1 ganged switch (Radiospares)

Capacitors

C1 0.1μF	paper	150V
C2 100μF	elect.	12V
C3 10μF	elect.	12V
C4 4μF	elect.	12V
C5 4μF	elect.	12V
C6 (see text)	paper	150V

Transistors

TR1 2N2926	} (Obtainable from Amatronix Ltd., 396 Selsdon Road, Croydon, Surrey)
TR2 2N2926	

Diodes

D1 OA81	} (Mullard)
D2 OA81	

H.T. Dropper for 9V supply

Either

Resistors

R7 To be calculated (see Fig. 6a)
R8 2.7kΩ
Both 10% 1 watt carbon

Capacitor

C7 1,000μF elect. 12V

Or

Resistor

R7 (see Fig. 6b) 10% 1W carbon

Diode

D3 OAZ212 (9 volts) (Mullard)

Miscellaneous

Two 8 way tag strips; P.V.C. wire; Screened wire
--

continued on page 119

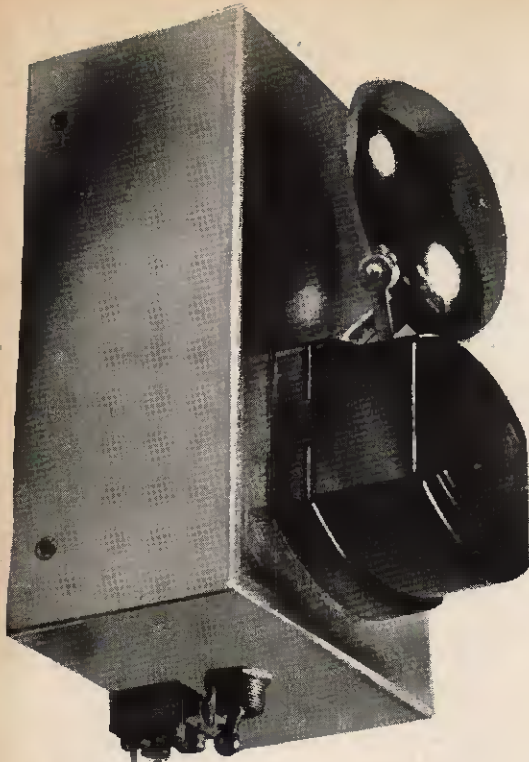

Burglar ALARM

by B.H.BAILY



MANY OF us have, at some time or other, spent considerable time and money on our doors, ensuring that they are quite secure against the threat of the nocturnal prowler. But how many stop to think how easy it is for the would-be thief to slip the catch on a ground floor window.

For less than the price of a good lock, it is possible to ensure the safety of the whole house. The burglar alarm described here can be made up from equipment to be found in most experimenters' spares boxes. Even if all parts had to be purchased, the total cost need not exceed 35s.

OPERATION

The device operates on a simple but most effective principle employing a continuous "loop" of fine enamelled wire, such as found in a.f. chokes and transformers. Since the loop carries only a few microamps of current, its resistance is not likely to affect the operation. If the loop is broken at any point, the cessation of the small flow of current immediately results in the ringing of an alarm bell, which will not be stopped by the subsequent closing of the broken loop. Hence, even if the thin inconspicuous wires are traced and cut, the alarm will still be operated. A switch, conveniently mounted on the main alarm unit, enables the unit to be made inoperative whilst doors and windows are in use during daylight hours.

ALARM POSITIONS

All windows and doors are fitted with simple contacts made from thin brass shim. Stationary contacts are arranged in pairs, secured close together by means of small brads on the closing side of the casement. A moving contact, having bowed ends, is fixed to the door or window such that it bridges the two stationary contacts. A self-cleaning action takes place when the moving contact on the window passes over the fixed contact.

Using the twin wire technique, installation is simplicity itself, since the twin loop is simply run from one pair of contacts to the next, in strict rotation. No short circuit must be allowed across the twisted pair, except by the contact pair at the window end of a run. Any number of individual or collective runs can be joined into the main loop circuit by splicing them into one leg of the existing run.

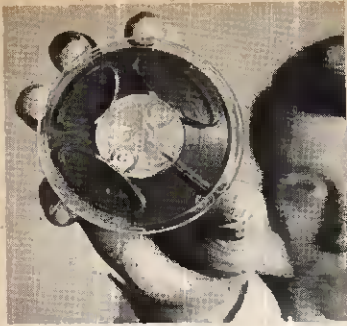

Amazing Kodak Quadruple Play Tape brings mains recorder playing times to battery portables!

Tiny 3 1/2" reel gives up to 5 1/2 hours playing time

Now—revolutionize your battery tape recorder, add *hours* of extra playing time and enjoyment with Kodak Quadruple Play Tape, the modern miracle in sound recording. Just one tiny 3 1/2" reel holds 800ft. of tape—enough for up to 5 1/2 hours playing time.* (That's over 100 'pops' with time to spare!). And a 4" reel, holding 1,200 ft. can give you up to 7 3/4 hours playing time. There's a 3" reel, too. Sound recording pleasure has never been extended like this before!

THE SECRET

The secret of these phenomenally long playing times lies in the unique thinness of the tape base. The thinner the base the greater the length that can be wound on to a given reel—and the longer the playing time. Kodak Quadruple Play Tape, has a base so fantastically thin it's even thinner than the *oxide coating* on Standard Play Tape!

STRENGTH WITH LENGTH

Microscopically thin as it is, Kodak Quadruple Play Tape is no weakling. The Polyester base has been specially pre-stretched and treated to overcome distortion during use. In fact, it will stand up to every stress likely to be met with under all normal conditions, *no matter what the make of your battery tape recorder*. And if you exercise a little extra care you can even use Kodak Quadruple Play Tape on mains recorders, too.

TOTAL UNIFORMITY

Advanced techniques of emulsion coating, developed in Kodak's world-famous research laboratories, have been applied to Quadruple Play Tape with the result that its oxide coating is uniform to within *millionths* of an inch. *The combination of smoothness, sensitivity and signal-to-noise ratio that stems from this extreme coating precision cannot be equalled by any other tapes in the world.*

PLANNED FOR LOW SPEEDS

Another unique extra! Kodak Quadruple Play Tape is actually *planned* for low-speed operation and has a boosted high-frequency response at low tape speeds. This means that at the speeds you'll most likely be using with a portable you'll suffer far less of the usual drop in quality. Your battery portable will surprise even you!

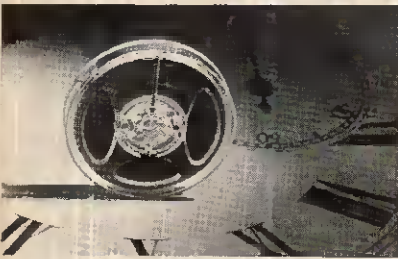

You don't miss a minute of pleasure with the tape that plays on . . . and on . . . and on!

What the magazine 'Tape Recorder' said about Kodak Quadruple Play Tape. August 1965.

"My tests show that the sensitivity at optimum bias is higher than normal, that the high-note response is much improved over normal tapes and that the drop-out count and amplitude fluctuation are the lowest of any tape yet tested".

"Test tones and sustained musical notes showed a smoothness seldom heard at this tape speed (3 3/4 i.p.s.)".

Review by Alec Tutchings.

MINIMUM PRINT-THROUGH

Normally, thin tapes are highly susceptible to print-through. But Kodak Quadruple Play Tape has a remarkable resistance to this unwelcome 'echo' effect. In fact, print-through is up by only an inaudible 1.5dB on Standard Play Tape. This feature alone would be enough to set this tape apart!

ACCLAIMED BY THE EXPERTS

Britain's Sound Recording press and many independent experts have been unanimous in praising this and other Kodak Tapes. The BBC and ITV use millions of feet of Kodak tape—and so do professional recording studios the world over. Without a doubt Kodak Tapes have set totally new standards in performance and quality—standards of which you can now take advantage. Fill in the coupon below for full details—then see your Kodak dealer and give your recorder the tape it *really* deserves!

*4-track 1 7/8 i.p.s.

Kodak Tapes—Standard, Long, Double, Triple and Quadruple Play—are available from Kodak Photo Dealers everywhere.



To Kodak Ltd., Dept. 70, Kodak House, Kingsway, London WC2

Please send me full details of all Kodak Tapes

NAME _____

ADDRESS _____

P.E.

KODAK SOUND RECORDING TAPES...the best tapes in the world

The
SUPER 6
LONG & MEDIUM WAVE
TRANSISTOR RADIO

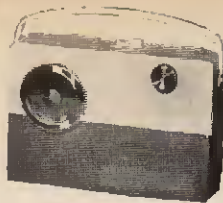

A quality radio available in parts or ready built. The sparkling performance and superb finish of the completed receiver give you value equivalent to a £12. 12. 0 commercial model.

- ★ All new parts. ★ 6 transistors and diode. ★ 350mW output.
- ★ Superhet circuit. Ferrite rod aerial. ★ Weymouth Radio printed circuit board. ★ Component positions and references printed on back of board. ★ Nicely styled wooden cabinet. 11 x 7½ x 3½ in.
- ★ Vinyl covered in various colours. ★ 6 x 4in. speaker giving good bass and treble response. ★ Full instruction booklet 2/-. Free with kit.
- ★ I.F. frequency 470 kc/s. ★ Lining up service if required.
- ★ All parts supplied separately. Write for list. S.A.E. please. ★ 9v. battery required. VT9 or P.P.9. (3/9 with kit).

COMPLETE SET OF PARTS ONLY £4.0.0.

PLUS 5/- POST

OR FULLY BUILT £6.17.6 Tax & Carr. Paid

BRAND NEW AM/FM (V.H.F.) RADIO GRAM CHASSIS AT £13.13.0 (Carriage Paid)

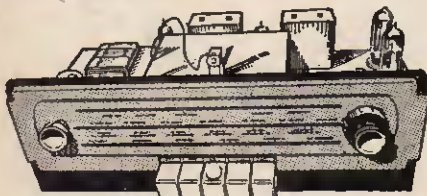

Chassis size 15 x 6½ x 3½ in. high. New manufacture. Dial 14½ x 4in. in 2 colours, predominantly cream. 200-250v. A.C. only. Pick-up. Ext. Speaker. Ac., E., and Dipole Sockets. Five pushbuttons—OFF, L.W., M.W., F.M., and Gram. Aligned and tested. With O.P. Transformer. Tone control. 1000-1900 Mc.: 200-530 Mc.: 88-98 Mc/s. Valves EZ80 rect.; ECH81, EF89, EABC80, EL84, ECC85, 5-ohm speaker required. 10 x 6in. ELLIPTICAL SPEAKER 25/- to purchasers of this chassis. **TERMS: £3.10.0 down and 5 monthly payments of £2.4.0, total £14.10.0.** Room Dipole for V.H.F., 12/6. Feeder 6d. per yard. **ALTERNATIVE DESIGN.** Similar to above chassis. With addition of short wave 6-17 Mc/s. Price £15.15.0 (curr. paid). **TERMS: £3.10.0 down and 5 monthly payments of £2.4.0. Total H.P. price £16.14.0.** Circuit diagram 2/6.

BATTERY ELIMINATORS

For 4 low consumption valves (8G range) 90v. 15mA and 1.4v. 125mA, 42/6. (4/- post), 200-250v. A.C. Also for 250 mA, 1.4v. and 90v. 15 mA at same price.

Two units 3½" x 3½" x 1½" high.

For Transistor Radios requiring 9v. Fully smoothed (5000 + 1000mfd) 5" x 3½" x 1½" overall. Tapped input for 200/10; 220/30; 240/50v. Output 9v. at 100mA. Good regulation. Price 25/-. (3/- P. & P.)



SELF-POWERED V.H.F. TUNER CHASSIS. Covering 88-95 Mc/s. Dims. 8 x 6 x 6in. high. Valves ECC85, EABC80 and 2-EP80's with metal rectifier. Mains transformer. Fully wired and tested **ONLY £6.17.6** (curr. paid). Room dipole 12/6. Feeder 6d. per yard.



VHF Pre-Amplifier (3½" x 3½" x 1½"). AP.114 Transistor. 85-105 mc/s. Gain at least 3:1. Price 82/6. (3/- P. & P.)

PUSH-PULL O.P. AMPLIFIER
£5.5.0 (6/- Carr.)

Brand new 200-240 A.C. mains. Bass, treble and vol. controls, with valves EZ80, ECC83 and 2-EL84 giving full 8 w. Chassis 12 x 3½ x 3½ in. With o.p. trans for 2-8 ohm speaker. Front panel (normally screwed to chassis) may be removed and used as "flying panel". Supplied with cream/black control panel whole length of front chassis.



GLADSTONE RADIO

66 ELMS ROAD, ALDERSHOT, Hants.

(2 mins. from Station and Buses.) Aldershot 22240

CLOSED WEDNESDAY AFTERNOON

CATALOGUE 6d.

Regret overseas orders cannot be executed

AT LAST—A TRANSISTORISED AMPLIFIER WHICH FULFILLS ALL NEEDS

• THE TYPE MA. 30 •

- ★ Capability of continuous 30-watt sine wave output.
- ★ Input sensitivity can be varied between 5 millivolts and 200 millivolts.
- ★ Will drive electrostatic loudspeaker at full output.
- ★ Unconditionally stable.
- ★ Distortion at 1 kc. 30-watt output less than 0.5%.
- ★ Signal-to-noise ratio in excess of 80 db. below full output at 100 millivolt sensitivity.
- ★ Modular concept.

Overall size: 7in. long x 4in. wide x 4in. high.

RETAIL PRICE: £14.0.0

— N.B. Power Pack extra —

Trade enquiries invited.



LIMITED

338 Aldridge Road, Streetly, Sutton Coldfield

Telephone: STReetly 3771

CRESCENT RADIO LTD.

40 MAYES ROAD
WOOD GREEN, N.22

LONDON'S ELECTRONIC COMPONENT CENTRE

BEST QUALITY • KEEN PRICES

VALVES • TRANSISTORS • MIKES • AERIALS
DIODES • CONDENSERS • AMPS • PLUGS
SPEAKERS • RESISTORS • CABLES • SOCKETS
CHASSIS • TRANSFORMERS • TAPES • BOOKS
RECTIFIERS • VALVE HOLDERS • COILS • METERS

Everything you want in a friendly atmosphere

START YOUR RADIO CONTROL CAREER WITH FLIGHT LINK PROPORTIONAL

SMOOTH PRECISE CONTROL SYSTEMS

From £89

Comprehensive Handbook - 2/6

D.I.Y. Dept. Circuits - - 5/-

Servos - - - £6

Technical advice gratis

FLIGHT LINK CONTROL LTD.

26 INWOOD AVENUE, HOUNSLOW

HOU 2777



COMPONENTS . . .

Resistors

R1 15k Ω R2 220 Ω
Both 10%, $\frac{1}{2}$ watt carbon

Transistor

TR1 NKT217 (Newmarket)

Diode

D1 OA81 (Mullard)

Relay

RLA 150 Ω (G.P.O. type 600) with set of change-over contacts (available from G. W. Smith & Co. (Radio) Ltd.)

Switch

S1 Single-pole on/off toggle switch

Bell

3-8 volt bell

Miscellaneous

Two flat pack $4\frac{1}{2}$ volt batteries
Chassis 6in \times 4in \times 2 $\frac{1}{2}$ in (aluminium)
Eyelet board or laminated wiring board for mounting TR1, D1 and R1
Enamelled copper wire (about 30 s.w.g.)
Two-way clip terminal block
Spring clip (see photograph)
P.V.C. covered wire, 4 B.A. and 6 B.A. nuts and bolts.

CIRCUIT

With the alarm loop circuit completed the quiescent current drain via R1 is about 300 microamps. Slightly higher quiescent currents may occur if the unit is mounted near a radiator, but this current will never normally build up sufficiently to operate the relay.

Battery economy can be achieved by experimenting with the value of R1, as the current gains of a batch of transistors of the same type can be diverse in value. This can be achieved by replacing R1 by a 50 kilohm potentiometer. The base-emitter circuit is left open and the potentiometer reduced from 50 kilohms until the relay operates. Remove the potentiometer and measure its resistance. Reduce this value by ten per cent as this compensates for battery deterioration, then insert a preferred value resistor approximating to this calculated resistance but not exceeding it. The relay used was a 150 ohm G.P.O. 600 type with two sets of changeover contacts. The unused contacts were removed to improve its sensitivity, the packing spacers being replaced and the securing screws carefully adjusted so as not to damage the bobbin. Other switching transistors may be tried as there is nothing

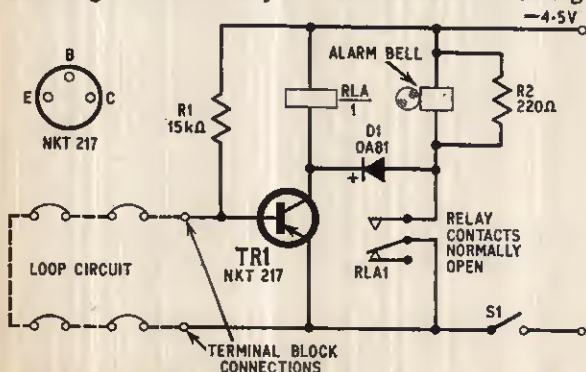

Fig. 1. Circuit diagram of the burglar alarm. The transistor connections are shown looking at the underside

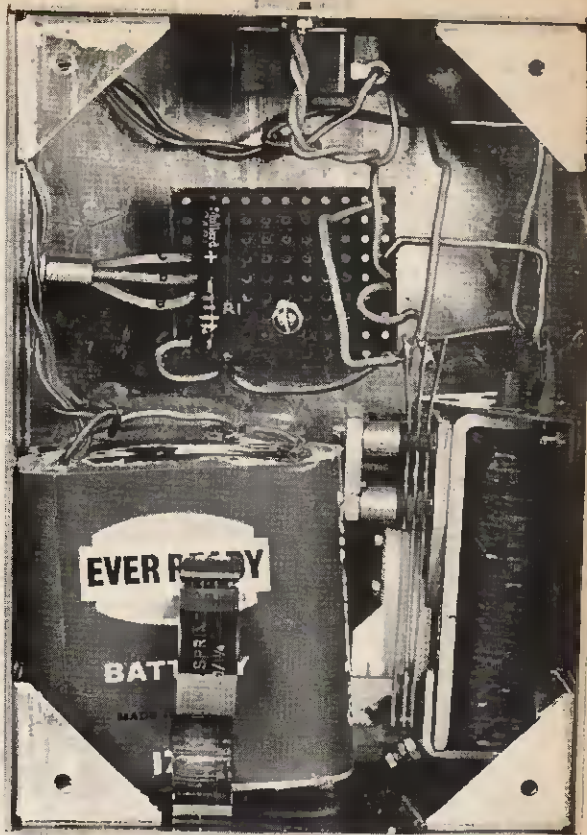

Fig. 2. Layout of components under the chassis. R2 is mounted inside the bell housing.

critical in their choice, however the selection of R1 will have to be ascertained for each transistor type as previously described.

Diode D1 prevents the collector current from taking the low resistance bell path and so not actuating the relay. It also acts as a hold-in path for the relay when the contacts close. It can be seen that the bell maintains its clamour even though the loop circuit may be completed.

Testing of the system is just a matter of listening for the bell when the alarm is switched on, and then checking windows and doors to ensure that the contacts are closed. Resistor R2 damps the transient "ringing" spikes that appear across the bell in its action. These induced back e.m.f.s. could easily damage the transistor if they were not suppressed.

CONSTRUCTION

The unit was assembled on a chassis 6in \times 4in \times 2 $\frac{1}{2}$ in. This makes a compact and attractive mounting for the bell. A piece of copper clad wiring board or a tagstrip serves to mount TR1, D1, and R1. The board is fitted to the chassis with a spacer so that it stands clear from the chassis. The board and spacer are fixed with a 6 B.A. nut and bolt. The relay position is not critical provided sufficient space is left for the two $4\frac{1}{2}$ volt batteries which are held by a cut down spring clip. The batteries are wired in parallel, i.e. with positive terminals common and negatives common. The loop circuit from the windows is connected to the unit via the two-way plastics covered terminal block. ★

NEXT MONTH!

SPECIAL PRINTED CIRCUIT NUMBER

HOW TO MAKE PRINTED CIRCUIT BOARDS

A fully illustrated step-by-step guide, showing you how to make these invaluable all-purpose boards cheaply and easily

PLUS THESE CIRCUITS :

- SIMPLE PRE-AMPLIFIER AND TREBLE BOOSTER
- DRIVE AMPLIFIER
- RADIO TUNER
- GUITAR PRACTICE ADAPTOR

**Practical
Electronics** **MARCH**
issue out
FEB. 17th
2'6

**BIG EXTRA DEMAND!
ORDER YOUR COPY NOW!**

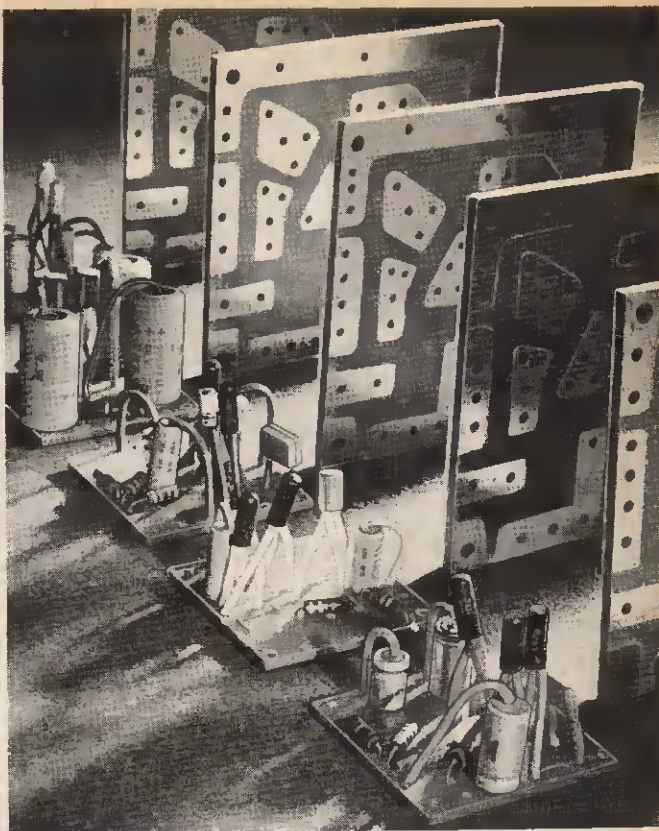

- Combine these simple projects with each other — or with further circuits to appear later — to produce a versatile range of equipment.

INEXPENSIVE PRINTED BOARD HOLDER

Guidance on making this practical "third hand" for the electronics workshop.

Also: RADIO CONTROL OF MODELS

Practical circuits and advice on transmitter equipment.

— FILL IN AND HAND TO YOUR NEWSAGENT —

Please send/reserve PRACTICAL ELECTRONICS (2/6) each month, beginning with the March issue, on sale Feb. 17th.

To
(Name of Newsagent)

NAME

ADDRESS

MORE

about

DISCS

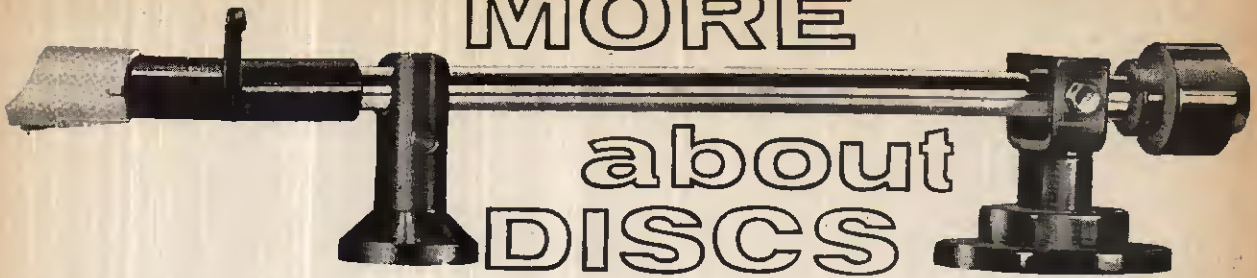

AN EARLIER article (October, 1965 issue of *PRACTICAL ELECTRONICS*), intended as an introduction for the layman interested in experimenting with audio through the medium of disc reproduction, described the main features of mono and stereo discs and provided some guidance on the often misunderstood question of stylus size. The comments offered on that occasion inevitably lead us on to the pick-up—its characteristics and the form it takes.

CHOOSING A CARTRIDGE

The following notes summarise the most important points that the experimenter—and particularly the beginner—will wish to bear in mind when choosing a pick-up. They are of course technical points, but first there is a matter which comes under the heading of common-sense. Plan sensibly: do not get into the situation where too much is spent on electronics and too little is left for the pick-up.

In disc reproduction, disappointment is all too often attributable to inadequacies at the pick-up end of the chain. Therefore enough money must be allocated to this component. Of course, sensible planning also means consistency: one does not use a £30 pick-up with a 5-watt breadboard amplifier. But do start the right way; if disc reproduction is to be given pride of place, then the pick-up must head the list of components to be purchased. Much depends on this.

CERAMIC OR MAGNETIC

The next matter to be emphasised is quite a fundamental one, for it affects cost and much else besides. Pick-ups can be divided into two main groups—ceramic and magnetic—and the experimenter must choose according to the cash he has available and the standard of quality he wishes to achieve.

In general, ceramic types cost up to about 6 guineas (in cartridge form), and there are a few models at around £3, including a diamond stylus, for stereo. Crystal cartridges, on the other hand, are quite rare nowadays and are largely superseded by the ceramics.

From the point of view of cost and quality, magnetic pick-ups start approximately where the ceramics leave off. Prices for cartridges range up to about £30, but the most popular price range for stereo models is £10-20. Are magnetics “better” than ceramics, as the prices suggest? Yes, they are; compare the best magnetic with the best ceramic and the conclusion will be that the former gives livelier and cleaner yet more delicate sound.

To develop this theme, the magnetic type offers better transient response and is capable of performing with less distortion. Its construction is generally such

that it offers a tinier mass (the armature and stylus assembly) to be moved and accelerated by the modulated groove. This in fact is one of its most important attributes, making for better fidelity of reproduction. But there is a penalty to be paid for such refinement: the magnetic pick-up gives a small output, typically 5mV average from each stereo channel.

We shall have to say a little more about the significance of output voltages. But first we shall return to the ceramic pick-up. Recent examples represent remarkably good value for money, and the experimenter with a limited amount to spend will certainly be attracted to one or other of them. In fact, ceramics are well suited to medium and low-cost stereo outfits—those costing up to about £100, this estimate being based on retail prices of ready-made equipment. The enthusiast intent on assembling a non-compromise system, well clear of the £100 mark, will almost certainly include a magnetic.

Pick-up playing weight is another relevant point. The best magnetic types track at lower pressures than their ceramic counterparts, and with some examples the figure may be around 1 gramme. This makes for reduced record wear and also means less distortion provided the arm is equal to the task. However, beware of making rules about this. One regularly encounters “difficult” discs which confound theory and complicate practice by refusing to reproduce unless the anticipated pressure is increased. (The answer is: don't buy them; but that is another story.)

The word “cartridge” has been used freely so far, and probably every reader will know that it refers to the actual mechanism of the pick-up. The arm in which it is mounted must of course be of suitable quality, and the beginner will find it convenient to get the cartridge and arm from the same manufacturer. (The advanced enthusiast needs no reminding of alternative approaches; the enthusiast needs no reminding of alternative approaches.)

We should note that in a few cases the two parts are designed as one integral unit. However, the experimenter will want the interchangeability and versatility of separate components, and therefore the other possibilities are excluded from this article.

OUTPUT AND RESPONSE

Now we must return to pick-up characteristics. A data sheet presented with last November's *PRACTICAL ELECTRONICS* listed the main operating principles of cartridges, but it is necessary to summarise here some outstanding points about output and response.

As already mentioned, the magnetic pick-up is a low output device. The ceramic gives a higher output,

typically around 70mV average from each channel. In specifications the output is often quoted in relation to recorded velocity, so that a magnetic model might be said to deliver 1mV per cm/sec at some particular frequency. In that case it would be fair to say that the average output was 5mV.

Obviously this question of output affects the choice of amplifier. In the case of the magnetic pick-up just quoted, the amplifier must have a sensitivity of at least 5mV. If a ceramic is to be used, the amplifier can be correspondingly less sensitive. In practice, amplifiers are designed with one or the other of the main types in mind, and sometimes there are facilities for both types. An owner of a low-sensitivity amplifier, wishing to change to a magnetic pick-up, will probably be able to make or buy a transistorised pre-amplifier which will boost the pick-up voltage.

A related matter is that of equalising the output of the cartridge. It consists essentially of raising the level of the bass and reducing that of the treble—accurately and in a controlled way. The means of doing this depends on the type of cartridge and its response to the signal on the record.

A ceramic cartridge has built-in equalisation for the recording characteristic as long as the amplifier input presents a load of about 2 megohms. The result, seen as a response curve, is far from precise but is generally thought to be acceptable having regard to the low price of the cartridge. Moreover this useful property of the ceramic does mean that circuit complications are minimised. Connected to its high-impedance load the cartridge gives a signal voltage which does not have too big a departure from a level response in the bass and treble. Not surprisingly, the more costly ceramics do this job most successfully.

Things are quite different with the magnetic pick-up. Its response follows the recording characteristic, exhibiting a drop in the bass and a rise in the treble. An expensive pick-up adheres closely to this characteristic, with departures from it as small as 1 dB. This means that the amplifier input circuits must not only provide high sensitivity, but also a very accurate response equalisation.

In fact the circuits must have a response which is the opposite of the recording curve—a mirror image, as it were. The signal, after passing through these circuits, emerges with a practically level response and is passed on for further amplification. The amateur need not worry about the actual circuit details unless he is designing his own amplifier from scratch (if he is doing so, he will hardly need the above explanation).

Of course, in nearly all cases the procedure will be to take a proven circuit and use it as it stands. Thus, if a magnetic cartridge is to be used, the main requirement is to check that the circuit has been designed for the job. It must give adequate sensitivity and the correct response characteristic.

In practice it is the R.I.A.A. characteristic, which is the same as that defined in the British Standard dealing with recording matters. Stereo and mono discs can be regarded the same way as far as response is concerned (provided that the mono discs are not very old ones).

STYLUS LIFE

At the present stage of development of disc reproduction, it is essential to use a diamond stylus. There is little to be said for a sapphire as its life is so short. A diamond lasts at least twenty times as long if treated with care. Even the most moderately priced cartridge has a diamond as standard fitting, though of course this must be checked before purchase.

It is difficult to do more than generalise about stylus life. As a rough guide, a diamond may give 1,500 hours of use, but carelessness over record cleanliness and pick-up adjustment might halve this figure. The figure just quoted is for a lightweight magnetic pick-up, but styli give different lengths of service according to type of pick-up and conditions of use.

Most users realise that dust influences record wear and stylus life. Take precautions to exclude it as far as is practicable. Anti-static and other cleaning preparations which leave a thin deposit in the record groove cannot be recommended without qualification. Indeed, they should not be used at all if the pick-up is of very advanced type tracking at around 1 gramme.

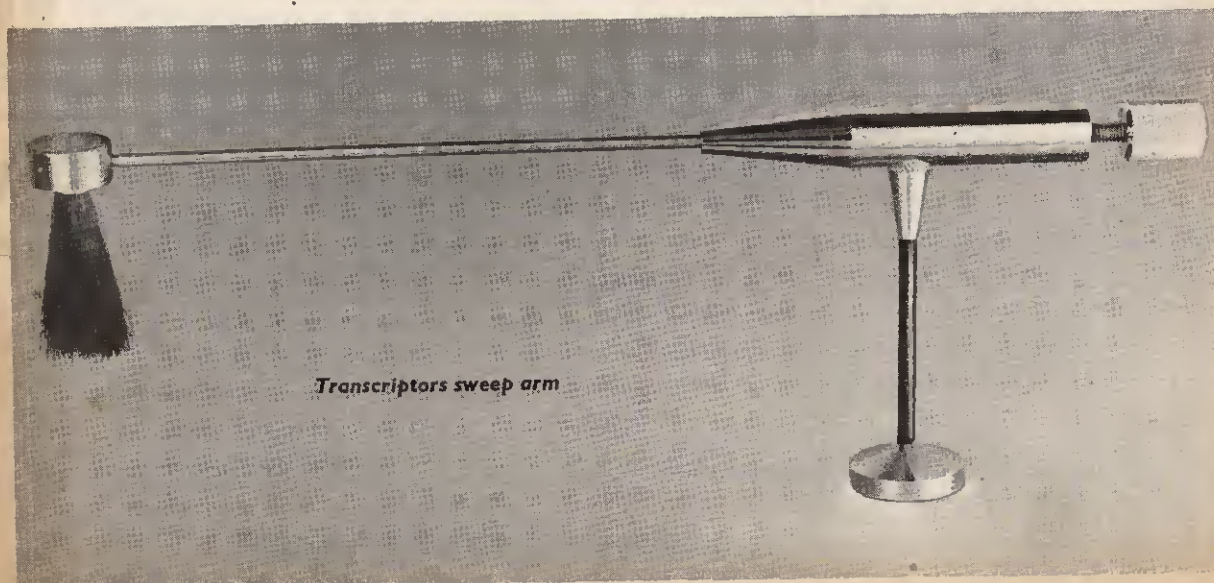

Transcriptors sweep arm



Pickering 380A cartridge

Sparing use of well known and proven preparations is not a bad thing when playing weights are higher. There are, incidentally, cleaning devices which sweep the groove without leaving a film. Microscopic

inspection of the stylus for damage and wear is especially important. It is a good plan to find a suitably equipped dealer and to have the stylus inspected at intervals of not more than 500 hours of use. Keep a check on use: you can say that three l.p. record sides equals one hour of use.

A final word. It is most unwise to flick the stylus to check whether the amplifier is working! Damage can all too easily result. Some users touch the stylus with the intention of cleaning it, but a miniature cleaning brush is safer and more effective. Devices are available for fixing near the turntable and pick-up head.



NEON NOVELTIES



THIS is the sixth of a series of short articles illustrating some of the many uses of neon lamps. The neons employed are all miniature wire-ended types as shown above.

Two examples which are ideally suited to these applications are those supplied by Radiospares (striking voltage 65 volts), and the Hivac type 3L general purpose neons. The latter type requires a striking voltage of 80 volts and maintaining voltage of 60 volts.

Some neon indicators have a resistor wired in series with one of the neon wires to make them suitable for mains voltages. These would normally be unsuitable for the circuits described unless the resistor is removed or short-circuited.

SIX

NEON WARBLER

by R. Bebbington GRAD.I.E.R.E.

THIS SIMPLE but unusual circuit has a variety of uses and can be assembled in a few minutes. As an audible alarm indicator or call device its distinctive tone makes it easily recognisable and, by using different values of resistors as indicated, several push-button positions may be easily identified. The larger the series resistor, the slower the warble. When a push-button is operated the neons will flash alternately and the circuit will oscillate by virtue of the small capacitor across one of the neons. Thus the circuit combines a warning warbler with a warning winker.

A small transistor amplifier is adequate for most audio applications as the output from the 1,000pF coupling capacitor (C3) is quite large. If this device is used in conjunction with a valve audio amplifier its supply may be derived from the h.t. line with a suitable series dropping resistor.

For those readers interested in amateur dramatics the sound of the warbler makes it ideal for science fiction sound effects. The flashing neons also provide an effective display particularly in a darkened room. The pitch of the note may be varied by replacing the

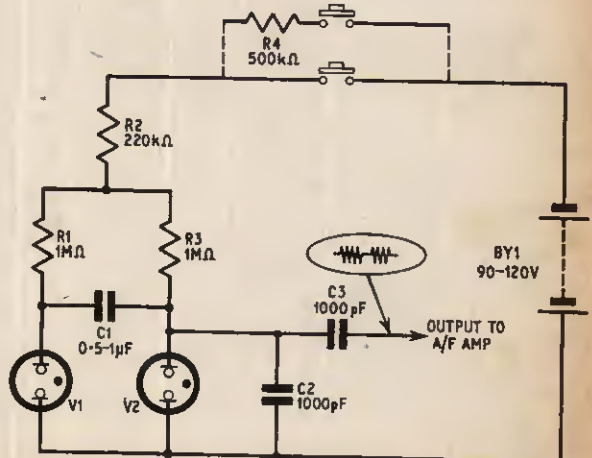

1,000pF capacitor (C2) across the neon by a different value capacitor. A smaller value will produce a higher frequency note; a larger value lowers the frequency.

the 73 page

by Jack Hum
G5UM

that enables those weak and distant stations, not only to be winkled out, but to be held at a readable level clear of the disconcerting fading so characteristic of the short waves.

Six Bands

The six high frequency bands allocated by international agreement to the Amateur Service are shown in the accompanying diagram. When it is remembered that they provide a mere 3,100kc/s of space to accommodate a total world amateur population of some hundreds of thousands (and increasing every year), two inescapable conclusions emerge: that there is little enough room for all who wish to transmit, and that fortunately not all of them come on at once!

Many years ago it was "Forty" that provided most interest to the listener to amateur transmissions. As the band where equipment and aerial needs were modest in both

and the listener who is anxious to improve his knowledge of morse is in his element.

Harmonically related to "One Sixty" is the 80 metre band. Here again much excellent telegraphy may be heard in the lower frequency area with telephony in the upper section in accordance with the tidy band planning system self-imposed by the amateur movement.

On each of the three remaining bands starting at 14, 21 and 28 Mc/s—their extents are shown in the diagram—it is once again a case of "c.w. at the low end, phone in the rest". These are the bands where, subject to many laws of nature, world wide communication is possible. No wonder they exert a constant fascination upon the great majority of transmitting men throughout the world and remain a source of never-ending interest to the short-wave listener: he never knows what may turn up.

How—and where—to Listen

"How best to achieve a satisfactory return from the operation of a newly acquired communication set". This we said last time was the question which "The 73 Page" should discuss as a matter of first priority in 1966.

Why? Because every year the thousands of young people who discover radio for the first time—and especially amateur communication radio—have little idea, and less guidance, about how they should approach this exciting new world with a view to participating actively in it.

Many come to it through accidentally overhearing an amateur transmission while they are tuning the short wave bands on their domestic radio sets. Some indeed are intrigued by the sudden breaking in of a mystery voice on top of the favourite television or broadcast programme (received on a maladjusted set, be it added!). It turns out to belong to "that chap down the road with the big aerial".

To many more the interest is triggered off by the casual purchase of a magazine such as PRACTICAL ELECTRONICS in which attention is paid to the world of amateur communication—and it is this purchase which can mean that you are hooked for life!

Whatever the initial trigger pulse, there is no question at all that before long the urge to explore the short wave spectrum needs to be satisfied by the acquisition of a receiver capable of doing the job properly—which most broadcast sets with short waves are not. A fully equipped communication receiver becomes a "must"—and by "fully equipped", we mean engineered to give high sensitivity, associated with a particularly effective a.g.c. characteristic

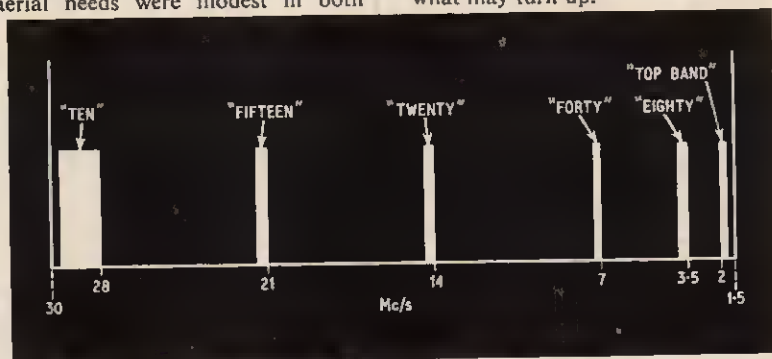

The high frequency spectrum showing the positions within it of the six amateur h.f. band allocations and their respective widths, as follows:

"Top Band"	1.8 to 2.0 Mc/s	"Twenty"	14.0 to 14.350 Mc/s
"Eighty"	3.5 to 3.8 Mc/s	"Fifteen"	21.0 to 21.450 Mc/s
"Forty"	7.0 to 7.1 Mc/s	"Ten"	28.0 to 29.7 Mc/s

Total available space 3,100kc/s; much of it shared by other Services.

size and cost, and where European friendships could be made with the greatest of ease—and at great signal strength—7 Mc/s had no peer.

Sadly, this is no longer true. At successive international conferences more of "Forty's" space has been given over to broadcasters and less to amateurs, and in the mere 100kc/s that remain intruders devastate the kilocyclic scene.

Top Band Topics

Today it is not "Forty" but "Top band" that attracts newcomers to "the 73 movement", and for many good reasons. Power input is restricted to 10 watts, aeriols in the average urban locale must of necessity be small (the half wavelength required for efficient radiation demands an exorbitant 264 feet of space), and daylight attenuation is high; all these factors make "One Sixty", or "Top Band", ideal for cosy local contacts. At night the range extends to 1,000 miles, a large amount of c.w. activity emerges,

Systematic exploration of each of these bands by day as well as by night discloses their special characteristics, especially if supported by a well documented log. This way the listener achieves a satisfactory return from the use of his communication receiver—which is where we came in.

A final thought; the entire h.f. amateur allocation discussed above would fit easily into just one of the u.h.f. allocations. To this area we must address ourselves next time.

the 73 page

by



Cyril Ornadel



Antony Hopkins

It's people like this



Steve Race

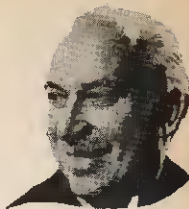

Sir Arthur Bliss

who choose records like these

Johann Strauss
117 Danube; Emperor; Vienna Woods etc. Vienna SO Ruvel.

George Shearing
WITH DAKOTA STATION
63 Steam-boat! Cuban Carnival; Yester. days; 9 more!

NAT KING COLE
59 Walking; Because You're Mine
more Nat greats.

RAY CHARLES
The Golden Years
131 Kiss Me Baby & lots more by the Blues Kings.

EVERYONE WHO HAD A HIT
126 12 top hits of '64. Great album — great year!

SINATRA
19 Melody of Love; White Christmas; 10 more tops.

TOAST TO THE DUKE
58 Honeysuckle Rose; 7 more terrific Duke specials.

TV Themes
Steve Race
102 Z-Cars! Kildare; Maltreat; lots more — swinging!

OKLAHOMA
28 Surrey; Beautiful Mornin'—star cast, all the hits.

GLENN MILLER
77 In The Mood; Bugle Call; Choo-Choo—9 originals!

The Fabulous PEGGY LEE
108 Stormy Weather; Sweet Charlotte; Hold Me; plus 9.

BURL IVES
162 Vintage ballads inc. Irish Rover; Early One Morn.

South Pacific
25 Ian Wallace; Joyce Blair. The plate score!

The Seekers
127 Ox Driving; Blowing in the Wind; 10 more hits.

for people like you!

Now WRC invites you to TAKE ANY FOUR for only £1

World Record Club releases *hundreds* of exclusive recordings like these to its members, both as 12" LPs and as pre-recorded tapes. They are *superb* recordings, chosen for collectors like you who really *know* music by advisers who are great musicians themselves. Although they cost far less than you would expect, this is only because the huge 'bulk buying power' of WRC's 200,000 members makes enormous savings possible. *The quality reaches unsurpassed standards of international hi-fi recording.* Each is custom-made for the Club by the famous EMI organisation, and is sold to members *only* on a hear-before-you-buy basis. So every WRC release is *unconditionally guaranteed* to be absolutely perfect. See for yourself how WRC brings you the cream of classical, jazz, folk and modern music—and in such an easy and economical way. **CHOOSE ANY FOUR** of the collector's gems featured here. Without parting with a penny, listen to them in your own home for 7 days. Then if you're as delighted with them as we say you will be send us just £1 and *keep all four!* But please act quickly! This is a special offer to introduce you to WRC, and it's only open for a limited period!

Selections available in Stereo, Mono and 3½ ips Tapes

Indicates mono disc only



Don't miss your chance—Post this now!

To: World Record Club Ltd (164) · P.O. Box 11 · Richmond · Surrey

I would like to have the four recordings I have listed here on

7 DAYS TRIAL—SEND NO MONEY

If I decide to keep them, I will send you just £1 (plus 3/6 postage) and will then automatically become a full member of WRC. All I promise is that as a member I will choose five more LPs or tapes from the whole year's programme of over 100 which will be offered to me at the members' privilege price of only 27/6 each (29/6 for tapes) plus postage. These I will be able to order in advance, and none will be sent that I have not asked for. If for any reason I don't like my four trial records, I will simply return them and owe you nothing.

IMPORTANT! THIS IS YOUR ADDRESS LABEL— PLEASE PRINT CLEARLY

TO: NAME _____
164

ADDRESS _____

For office use only.

MY CHOSEN FOUR ARE:

Enter record numbers only in boxes



Tick for stereo LPs



Tick for mono tapes

This offer applies to G.B. and N. Ireland only

TYGAX FEET (Contem. pat.), 12 x 19in. 2/-; 12 x 18in. 3/-; 12 x 24in. 4/-, etc.
EXPANDED ANODISED METAL—Attractive gilt finish 1/4in. x 1/4in. diamond mesh 4/8 sq. ft. Multiples of 6in. cut. Max. size 4ft. x 3ft., 47/8 plus carr.
BONDACOUT Speaker Cabinet Acoustic Wadding (1in. thick approx.) 18in. wide, any length cut, 6/- yd.

Volume Controls—5K-2 Meg. ohms, 3in. spindle, Morganite Midget Type 1 1/2in. diam. Guar. 1 year. LOG or LIN ratios less Sw. 3/- DP. Sw. 4/8. Twin Stereo less Sw. 7/6. 100 K. to 2 M/ohms with DP. Sw. 9/6.

WAVECHARGE SWITCHES. 1 p. 12-way, 2 p. 2-way, 3 p. 6-way, 3 p. 4-way, 4 p. 2-way, 4 p. 3-way, long spindle, 8/6 ea.

ENAMELLED COPPER WIRE—1lb. reels 14g-20g, 3/-; 22g-28g, 2/6; 30g-34g, 4/8; 36g-38g, 4/8; 39g-40g, 5/-, etc.
TINNED COPPER WIRE. 1lb-22g, 4/- 1/2 lb. 2/6
RESIN MULTICORE SOLDER, 60/40 4d. per yard. Carbons 6d, 1/-, 2/6, etc.

New Boxed	VALVES	Reduced Bargain Prices
IT4	3/6	EF86 8/6
1K5	185 8/-	EL33 12/6
384	3V4 7/-	EL34 12/6
6CC81	7/-	EL54 7/-
6CC82	7/-	EL51 9/-
6CC83	7/-	EY88 9/-
ECL80	9/-	EZ81 7/-
ECL82	10/-	GZ82 9/6
ECL88	10/6	PC284 2/-
EF80	7/6	PCF80 8/-
		PCL83 10/8
		PCL84 10/-
		PCL85 11/8
		PL36 10/8
		PL81 9/6
		PL83 8/6
		PY33 10/8
		PY82 7/6
		U25 10/8
		UL84 9/-

CO-AX 80 ohm CABLE
 High grade low loss Cellular Air Spaced Polythene—1/4in. diam. Standard Cond.
 Now only 6d. per yard
BARGAIN PRICES—SPECIAL LENGTHS
 20 yds. 8/- carr. 2/-; 40 yds. 17/6 carr. 3/-; 60 yds. 25/- carr. 3/6; Coax. Plugs 1/-; Sockets 1/-; Couplers 1/8.

26 1/2 gns TAPE RECORDER

for
ONLY £19.10.0 carr. 12/6

Bargain of the Year Offer—Cancelled Export Contract

Famous manufacturer's brand new unused and factory tested 2-speed, 3 1/2 and 7 1/2 i.p.s., twin track tape recorders. 3 Watt output. Tape position Rev-counter, fast forward and rewind, takes 7" reels, mike and gram input. Straight through amplifier facilities. Output sockets for ext. speaker, monitor or external amplifier. Superimpose switching, magic eye recording level and mains neon indicators. Volume and tone controls. 7" x 4" speaker. Attractively styled cabinet, with detachable lid, mike and reel storage facilities. AC 200/250 volts operation. Complete with crystal mike, tape, spare reel and screen lead, etc.



TRANSISTOR COMPONENTS

Midget I.F.s—465 Kc/s 1/4 in. diam. first, second or third..... 5/6
 Osc. Coil M. & L.W. 1/2 in. diam..... 5/-
 Midget Driver Trans. 5/1..... 6/-
 Midget Output Trans. Push-Pull—3 ohms..... 6/-
 Elect. Condensers—Midget Type 1 mfd./50 mfd. ea. 1/8, 100 mfd. 2/-, 12V. Condensers 150 V. working: .01 mfd., .02 mfd., .03 mfd., .04 mfd., .05 mfd., .1 mfd., 1/-; .25 mfd., 1/3; .5 mfd., 1/8, etc.
 Midget Tuning Condensers. J.B. "OD" 208 pF and 176pF, 8/8; ditto with trimmers, 9/8. J.B. 220pF and 105pF conc. slow motion 10/8. 350pF angle 7/8.

Condensers—Silver Mica. All values 2pF to 1,000pF, 6d. each. Dittos German 8d. Tub. 450V T.C.C. etc. 0.001 mfd. to 0.01 and 0.1/800V, 8d. 0.02-0.1/800V, 1/-, 0.25 Hunt. 1/8. 0.5 T.C.C. 1/8, etc., etc. Close Tol. 2/Micas—19% 5pF-600pF, 8d. 600-5,000pF, 1/1. 1/-; 2pF-100pF, 8d. 100pF-500pF, 11d. 570pF-5,000pF, 1/4. Beaters—Full Range, 10 ohms-10 meg. ohms 2/-; 1 and 1W, 3d., 1W, 5d. (Midget type modern rating) 1W, 8d., 2W, 9d. Hi-Stab. 5% 1W, 1W, 8d. (100 ohms-1 meg.). Other values 9d. 1 1/2 W, 1/8, etc., etc.

L.P. RECORDING TAPE BARGAIN

By leading British manufacturers—**PROFESSIONAL GRADE—DOUBLE-SIDED**

(each side coated) 5 1/2" reels only
Special Price Offer 1,450 feet 20/- post free (2 reels)
 Ideal for the experimenter who wants to record both sides, and a good L.P. Tape for the enthusiast who wishes to record single side only.

SPECIAL OFFER 3" Message tape 150', 3/8; 3" L.P. 225', 4/8; 3" D.P. 300', 6/8. P. & P. per reel 6d.

TAPE REELS Mfrs. surplus 7", 2/8; 5", 2/-; 6", 2/-; 3", 1/8; Plastics spool containers, 5", 1/8; 6", 2/-; 7", 2/8.

Speakers P.M.—3 ohms 2 1/2" R.M.I. 15/8. Goodmans 3 1/2" 16/8. 5" Kola 16/8. 6" Elco 16/8. 7" x 4" Goodmans 15/8. 8" Kola 19/8. 10" K. x A. 25/- 9" x 6" Goodmans 22/8. E.M.I. Ceramic Magnet 37/8. Tweeter 22/8. Jack Plugs, Standard 2 1/2" Igranite Type, 2/8. Screened ditto, 3/3. Miniature var. 1 1/2", 2/8. Sub-min. 1/8.



RADIO COMPONENT SPECIALISTS
 79 Brighton Rd., Thornton Heath, Surrey.
 THO 2188. Terms C.W.O. or C.O.D. Post and Packing up to 1/8. 1/-; 1 1/8. 1/8; 3/8. 2/-; 5/8. 3/8; 8/8. 4/8.

TRIMMERS, Ceramic (Compression Type)—30pF 50pF, 70pF, 8d. 100 pF, 100pF, 1/3; 250pF, 1/8; 600pF, 1/8
PHILIPS. Bee Hive Types (conc. air spaced)—2-8pF, 1/-; 3-30pF, 1/-
KNORR—Modern Continental types. Brown or Ivory with Gold centre; 1" dia., 9d. each; 1 1/2", 1/8 each. Conc. knobs ivory with gold centre 1 1/2" dia. 2/8. Matching dials 2/6 ea. **LARGE SELECTION AVAILABLE.**

METAL RECTIFIERS. S.T.C. Types—RM1, 4/8; RM2, 6/8; RM3, 7/6; RM4, 16/-; RM5, 21/-; RM4B, 17/6; Mullard BY100, 8/6.

TUB-ELECTROLYTIC-CAN
 25/25 v. 50/12v. 1/8; 8+8/450v. 4/8; 50/50v. 100/125v. 2/-; 82+32/275v. 4/8; 8/450v. 4/8; 4/350v. 2/8; 50/50/350v. 6/8; 16+16/450v. 5/8; 80/250/275v. 12/8; 32+32/450v. 6/8. 100+200/275v. 12/8.

The most accurate pocket size CALCULATOR in the world

Send a postcard today for free booklet, or if you prefer, send 67/6 for this invaluable spiral slide rule on approval, with money back guarantee if not satisfied.

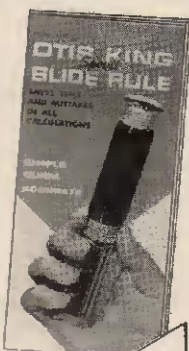

CARBIC LTD.
 (Dept. PE2),
 54 Dundonald Road
 London, S.W.19

TRANSISTOR POCKET BOOK

by R. G. Hibberd, B.Sc., M.I.E.E., Sen.M.I.E.E.E.
 Manager of the Research & Development Department of Texas Instruments Ltd.
 25/- Postage 1/-

- TAPE RECORDER SERVICING MANUAL**, by H. W. Hellyer, 63/-, Postage 2/-.
- TROUBLESHOOTING WITH THE OSCILLOSCOPE**, by R. G. Middleton, 20/-, Postage 1/-.
- ELECTRIC ORGAN HANDBOOK**, by H. E. Anderson, 35/-, Postage 1/3.
- UNDERSTANDING DIGITAL COMPUTERS**, by R. M. Benrey, 16/-, Postage 1/-.
- ABC'S OF TAPE RECORDING**, by N. H. Crowhurst, 16/-, Postage 1/-.
- BEGINNERS' GUIDE TO ELECTRIC WIRING**, by J. H. M. Sykes, 15/-, Postage 9d.
- TECHNICAL TOPICS FOR THE RADIO AMATEUR**, compiled by RSGB, 10/-, Postage 1/-.
- TELECOMMUNICATION PRINCIPLES (IN M.K.S. UNITS)**, by R. N. Renton, 50/-, Postage 2/6.
- SERVICING TRANSISTOR RECEIVERS**, by F. R. Patric, 7/6, Postage 6d.
- COMPLETE CATALOGUE 1/-.**

THE MODERN BOOK CO.
 BRITAIN'S LARGEST STOCKISTS
 British and American Technical Books
 19-21 PRAD STREET
 LONDON, W.2
 Phone: PADdington 4185
 Open 6 days 9-6 p.m.

Teleradio ELECTRONICS

THE RADIO CONTROL PEOPLE
 LARGE STOCKS OF SPECIAL MINIATURE COMPONENTS, TRANSISTORS AND ACTUATING MECHANISMS

Many designs to choose from, including:
 Single Channel Transmitter Kit 100 sc. £7.17.0. 10 Channel Transmitter Kit 88, £16.10.0. 3 Channel Proportional Kit 250, £19.10.0. Superhet Receivers 63 and 1500 approx. £7.0.0. Super Regen Receivers for £3.10.0. Complete Transmitter/Receivers from £14.

ALSO PLANS AND MATERIALS FOR CONSTRUCTING RADIO CONTROLLED BOATS AND AIRCRAFT

COMPLETE RADIO CONTROL BOAT £26.10.0
 COMPLETE RADIO CONTROL CAR £18.10.0

SEND LARGE STAMPED ADDRESSED ENVELOPE FOR LEAFLETS TO:
 325/327 FORE ST., EDMONTON, N.9
 (ILLUSTRATED LISTS 1/6d)

Book reviews

UNDERSTANDING ELECTRONIC CIRCUITS

By **Farl J. Waters.**

Published by **W. Foulsham & Co. Ltd.**

160 pages, 8½in. × 5½in. Price 24s.

I HAVE no doubt that many newcomers to electronics have been confused in their search for a primer in this exploding technology by the vast weight of books aimed at them specifically. In this cornucopia of basic electronic texts, it is difficult to find one book that is lucid and succinct in its presentation of commonly used electronic circuits.

In this book, however, these facets are evident. Beginning with an explanation of the circuit essentials such as resistors, capacitors, reactance, impedance, transistor and valve fundamentals, it moves on to the theory and functioning of amplifiers, oscillators, modulators, frequency mixers, converters, limiters, detectors, discriminators, power supplies, pulse generators, a.v.c. and a.f.c. control circuits.

Every component that appears in a circuit has a functional explanation so that a step by step analysis of the whole is obtained, making the grasping of the most complex circuit an easy task.

An additional bonus to would-be students is the list of review questions that appears at the end of each chapter, each of which is fully answered at the end of the book.

G.G.

THE ELECTRON IN ELECTRONICS

By **M. G. Scroggie, B.Sc., M.I.E.E.**

Published by **Iliffe Books Ltd.**

276 pages, 8½in × 5½ in. Price 45s

A SERIOUS study of electronics is impossible without some knowledge of modern physics. Whereas classical ideas of an easily visualised model of the atom with its planetary electronics may still suffice for an elementary understanding of ordinary electrical currents, they are totally inadequate to explain (for example) how heat and light cause electrons to be emitted from surfaces, how conduction takes place in semiconductor materials, and other electronic phenomena.

A new mental approach is needed when considering the modern ideas of sub-atomic particles. Unless one is a physicist, or versed in higher mathematics, much must be taken on trust in this bewildering world of the quantum theory, wave mechanics and the uncertainty principle.

Mr. Scroggie has undertaken no slight task in interpreting these abstruse ideas for the electronically-minded reader. His book is intended to provide an introduction to the subject; the treatment is largely descriptive and the mathematics involved do not go beyond G.C.E. "A" level. The author's relaxed and entertaining style of writing will no doubt provide encouragement for the inevitably oft perplexed reader to persevere with the task of assimilating these strange and sometimes contradictory notions that form part of modern physics.

J.V.

RADIO AMATEURS' EXAMINATION MANUAL (Fourth Edition)

By **B. W. F. Mainprise, B.Sc. G5MP**

Published by **Radio Society of Great Britain**

60 pages, 9½in × 7½in. Price 5s

"All applicants for an amateur transmitting licence must first pass the Radio Amateurs' Examination—no exemptions are allowed by the General Post Office. . . ."

It is well to quote the opening words of the Foreword to this manual, for there is much general misunderstanding concerning the requirements to be met before one can legally operate transmitting equipment.

Prospective amateurs will appreciate this book. The subject matter is arranged to correspond closely with the various items of the RAE syllabus. Most of the text is in question-and-answer form. Specimen questions taken from previous years' examination papers are included. The final chapter contains model answers to all the questions set for the 1962 examination. Among the appendices are the Conditions of the Amateur (Sound) Licence A, including changes made in July 1964; and the RAE syllabus.

FUNDAMENTALS OF MODERN SEMI-CONDUCTORS

By **Barron Kemp and R. H. McDonald**

Published by **W. Foulsham & Co. Ltd.**

160 pages, 8½in. × 5½in. Price 24s.

THIS book could well be described as a compendium of semiconductor technology. The presentation is entirely qualitative with no recourse to mathematics. It is liberally illustrated with circuit applications, characteristics and physical diagrams indicating individual semiconductor action, which does much to complement what is, in essence, a reference book of semiconductor families.

Commencing with an introductory chapter on solid state physics, it goes on to demonstrate transistor action with typical characteristics. The treatment given to various industrial techniques of junction formations is comprehensive and this lends itself to a fuller understanding of the working principles of multilayer semiconductors in later chapters.

A chapter on diodes and rectifiers deals with the well known Zeners and s.c.r.'s as well as those types with more specialised application to computers, such as binistors.

The transistor family of mesa, planar, epitaxial, field effect, photo types and many others are described adequately but at times rather dryly in terms of chemical synthesis. This is one of my criticisms of an otherwise excellent book. There is a great deal on manufacturing techniques that might have been given to a fuller description of the principles and applications of some of the lesser known devices.

My other criticism is the lack of a glossary which would be in character with a book of reference, for words such as "gigacycles" and "eutetic temperature".

G.G.

ELECTRONIC BUILDING BLOCKS

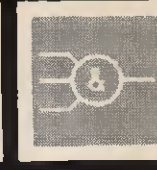
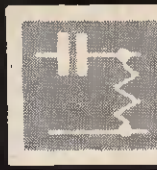
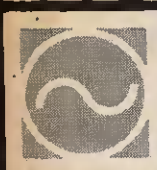

PART 11

by R. A. DARLEY

LAST MONTH we discussed the monostable and bistable members of the multivibrator family, including the binary version of the bistable. This month we shall deal with the applications of this particular circuit.

BINARY SYSTEM

When using numbers for counting, adding, and multiplying, it is common practice to employ the decimal system based on the number 10, i.e. we use ten numerals, 0, 1, 2, 3, 4, 5, 6, 7, 8, and 9 as basic units, and we indicate the magnitude of any complete number by showing the numerals against a power of 10.

To give a specific example, the number 9278 is our shorthand way of saying $9000 + 200 + 70 + 8$. All numbers are based on the power of 10; for example, $100 = 10 \times 10 = 10^2$. Similarly $1000 = 10^3$ and $1 = 10^0$. A number derived from powers of 10 is shown in Table 11.1. This number 9278 is equal to $(9 \times 10^3) + (2 \times 10^2) + (7 \times 10^1) + (8 \times 10^0)$.

TABLE 11.1. DECIMAL NOTATION

Powers	10^3	10^2	10^1	10^0
Decimal factor	1000	100	10	1
Decimal number		9	2	7	8

Unfortunately, transistors and other electronic devices do not have a convenient way of counting in powers of 10. All that the transistor can offer as the basis of a system of numbers is its alternatives of being either on or off, i.e. a choice of two states. Thus, the basic system that is used in electronics is based on the "power-of-two" or binary system. Table 11.2 gives the equivalent powers-of-two for decimal numbers, and the appropriate binary digits in the last line representing the decimal number 87, expressed in its binary form as 1010111. Note that the "power" table starts with "1" (expressed as 2^0 in the power-of-two series).

TABLE 11.2. BINARY NOTATION

Powers	2^6	2^5	2^4	2^3	2^2	2^1	2^0
Binary factor	64	32	16	8	4	2	1
Binary number		1	0	1	0	1	1	1

In the coded section, a choice of only two numbers, either 0 or 1, are available. Using this table, other numbers may be expressed in binary form as shown by

the following examples:

$$\begin{array}{l} 109 = 1101101 \\ 23 = 10111 \end{array} \qquad \begin{array}{l} 117 = 1110101 \\ 11 = 1011 \end{array}$$

The highest number that can be derived from the above table is 127, i.e. twice the highest number (128) minus 1.

BINARY COUNTER CIRCUITS

The circuit that is generally associated with binary counters and dividers is the binary bistable multivibrator, shown in "block" form in Fig. 11.1a. Here, the elements that are of interest are the two output terminals, taken from the transistor collectors, and the single input terminal. The circuit may be any one of the binary types described in detail last month.

Assume initially that the transistor TR1 is off and TR2 is on; if *pnp* transistors are used, TR1 output terminal will be at near full negative potential and TR2 output terminal at near zero volts. Thus, if the negative potential is used to indicate a number, TR1 output terminal is indicating that "0" input pulses have been fed to the circuit.

When a positive input trigger pulse is fed to the circuit, the transistors will change state and TR2 output terminal will go negative, indicating that "1" input pulse has been fed to the circuit.

To indicate numbers greater than "1", binary units can be connected in cascade; Fig. 11.1b shows the connection of four such cascade units. The individual blocks are of the type just discussed.

The output at TR2 collector (b) of each block is used to supply the input trigger pulse for the following block: two input pulses are needed to give a single output trigger pulse from each block. Thus, one block divides by 2, two blocks divide by 4, three blocks divide by 8, and so on.

The table included in Fig. 11.1b shows the state of the circuit with succeeding input pulses. On each block, "1" indicates an "off" transistor (near full negative potential output at collector) and "0" indicates the on transistor (output at near earth potential). TR1 output terminals are indicated by (a) and TR2 outputs by (b).

The four block circuits shown give one output pulse for 16 input pulses, i.e. the circuit divides by 16. Note that, on the sixteenth pulse, the circuit reverts to the state as at "0" input pulses; the cycle of events then repeats itself again, and so on *ad infinitum*.

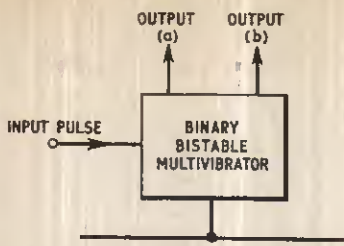
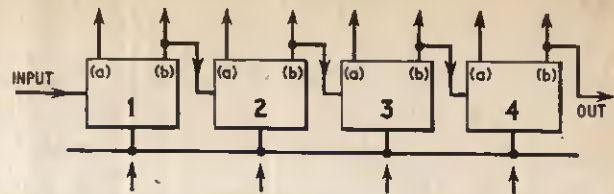

Fig. 11.1a (above). Block diagram of the binary bistable multivibrator



PULSE	0	1	0	1	0	1	0	1	0
1	0	1	1	0	1	0	1	0	0
2	1	0	0	1	1	0	1	0	0
3	0	1	0	1	1	0	1	0	0
4	1	0	1	0	0	1	1	0	0
5	0	1	1	0	0	1	1	0	0
6	1	0	0	1	0	1	1	0	0
7	0	1	0	1	0	1	1	0	0
8	1	0	1	0	1	0	0	1	0
9	0	1	1	0	1	0	0	1	0
10	1	0	0	1	1	0	0	1	0
11	0	1	0	1	1	0	0	1	0
12	1	0	1	0	0	1	0	1	0
13	0	1	1	0	0	1	0	1	0
14	1	0	0	1	0	1	0	1	0
15	0	1	0	1	0	1	0	1	0
16	1	0	1	0	1	0	1	0	0

Fig. 11.1b (right). Four binary bistable circuits connected in cascade form. The associated table shows the state of the circuit with succeeding input pulses

BINARY "DECIMAL" DIVIDER CIRCUIT

Whilst the binary system is the only one that the electronic circuit can basically work with, man finds it far more useful to use a "scale-of-ten" or decimal system; to be of any real use, therefore, the machine must be made to show results in a decimal form. As far as divider circuits are concerned, this means that the circuits must be made to divide by 10, as opposed to 8 or 16.

The circuit of Fig. 11.1b can be quite easily modified to give decimal operation, and Fig. 11.2 shows the block diagram in modified form.

Here, two feedback loops are included in the circuit, one taking the output from block 1(b) forward to the base of block 4(a), and the other taking the output of 4(b) back to the base of 2(a). A diode is included in the line from 1(b) to 4(a) connected in such a way that only positive going trigger pulses are passed, their purpose being to switch 4(a) off if it is turned on. During most of the working cycle of the circuit, 4(a) is switched off, so positive trigger pulses from 1(a) have no effect on this transistor.

Included in Fig. 11.2 is a table showing the state of the circuit with succeeding input pulses. Comparing this table with that of Fig. 11.1b, it can be seen that, up to and including the ninth pulse, the two circuits operate in an identical manner. In Fig. 11.2 it is the operation of the circuit on the tenth pulse that is of greatest interest. Note that, if the feedback loops were not included, block 2 would again switch on the arrival of this pulse; by including the feedback loops, however, the operation of the circuit is changed at this stage.

Before the arrival of the tenth pulse, block 4 had been switched, so that 4(a) is now on and is vulnerable to positive trigger pulses from 1(b) which will switch

if off again; when the tenth pulse arrives, block 1 switches and sends the positive going trigger signal to 4(a), switching 4(a) off and 4(b) on; an output trigger pulse is thus made available at 4(b) output. The trigger signal from 1(b) output is coupled to 2(a) and tends to switch that transistor on; the output of 4(b) is coupled back to 2(a) base, however, and as

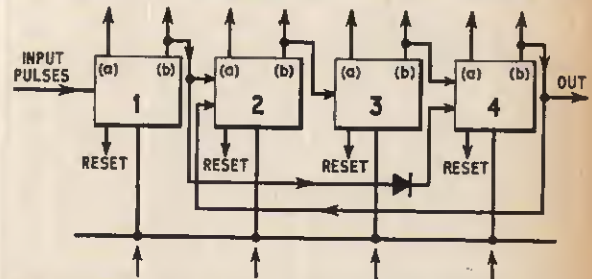

PULSE	0	1	0	1	0	1	0	1	0
1	0	1	1	0	1	0	1	0	0
2	1	0	0	1	1	0	1	0	0
3	0	1	0	1	1	0	1	0	0
4	1	0	1	0	0	1	1	0	0
5	0	1	1	0	0	1	1	0	0
6	1	0	0	1	0	1	1	0	0
7	0	1	0	1	0	1	1	0	0
8	1	0	1	0	1	0	0	1	0
9	0	1	1	0	1	0	0	1	0
10	1	0	1	0	1	0	1	0	0

Fig. 11.2. Feedback loops convert the circuit in Fig. 11.1b to a "divide-by-ten" or "decimal" divider

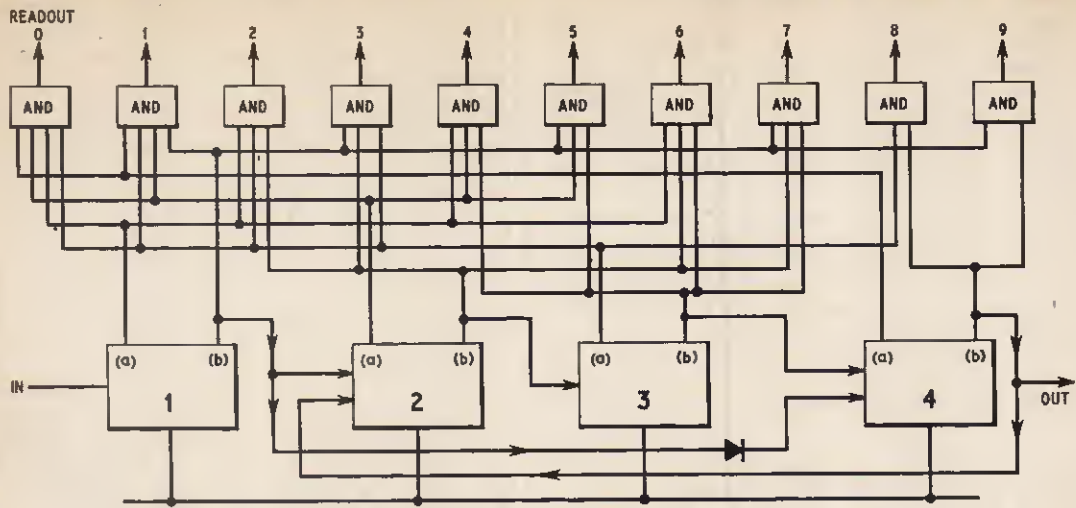

Fig. 11.3b. Combination of the four binary bistable circuits and the AND gate decoder

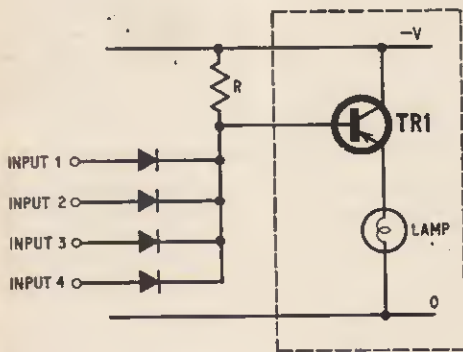

Fig. 11.3a. AND gate with readout facility

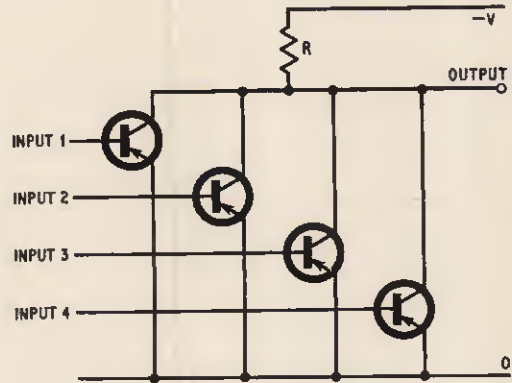

Fig. 11.4a. Basic circuit of a transistor NOR gate

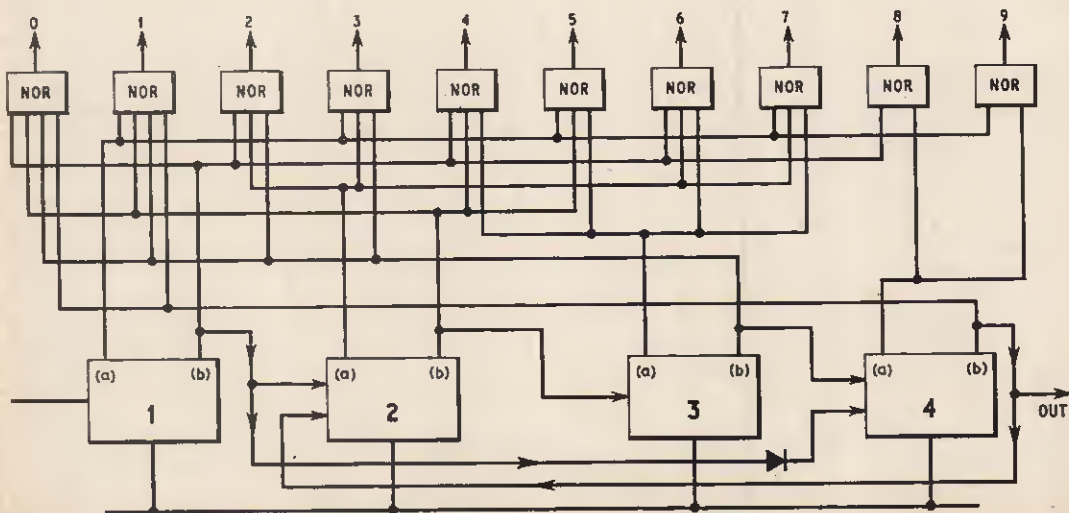

Fig. 11.4b. Complete decimal unit and NOR gate decoder

block 4 switches it sends back a signal to 2(a) base which countermands that arriving from 1(b). Thus, 2(a) remains off.

On the arrival of the tenth pulse, the circuit reverts to the condition it was at with no pulses; this condition, referred to as "reset", can be obtained artificially by applying a positive trigger pulse to TR1 transistors in all blocks simultaneously. This can be achieved by taking the "reset" terminals via a reset switch to a positive potential.

It may be noted that, although the "decimal" system described above is the most widely used type, it is not the only one in use; the feedback paths can be arranged in a number of ways; one manufacturer, for example, prefers to use a system in which the output of 4(a) is fed back to both 2(a) and 3(a) simultaneously. These alternative systems, as is so often the case with electronic circuits that have a wide number of variations, offer little or no advantage over one another.

COUNTING AND DECODING

So far we have considered the binary "decimal" unit purely as a divider, giving a single output pulse for every 10 input pulses; as often as not, however, the circuit is required to "count" the number of pulses fed into it and give a visual indication of that count in the decimal system.

Referring back to the table in Fig. 11.2, it can be seen that each individual input pulse begets its own set of transistor states, unique to itself. A count of three pulses is indicated by 1(b), 2(b), 3(a) and 4(a) outputs all being at near full negative volts; this condition of the circuit is unique to the third pulse. This information is held in coded form in the circuit according to the number of pulses that have been counted. If suitable "decoding" circuits are used, this information can be translated into decimal form.

In principal, such "decoding" circuits are simple, but can be fairly complex in practice. Referring to the above example and to the tables, any given number within the range 0-9 inclusive can be represented by no more than four "bits" of information; for example, when negative potentials are available at 1(b), 2(b), 3(a) and 4(a) simultaneously, the number "3" is indicated.

GATE CIRCUITS

All that is needed, then, to indicate that number, is an electronic "gate" with four input terminals and a single output terminal, the circuit being so arranged that an output is available only when all four inputs are connected. The four input terminals must be connected to the relevant points on the counter unit, and the output terminal taken to a visual read-out device, such as a lamp. Such an electronic gate is known as an AND gate, for the simple reason that input 1 and 2 and 3 etc. must be connected before the output becomes available. Fig. 11.3a shows an example of the AND gate; to be more precise, a negative logic AND gate. The explanation of the gate circuit is a slight over simplification.

The four diodes and the resistor comprise the gate. For simplicity, assume that input signals will be either fully negative or at zero potential, and that the impedance of the resistor is high compared with that of the diodes. The output of the gate is taken from the junction of diodes and resistor.

If any one of the inputs to the gate is at zero potential, current will flow through that diode to the negative rail via the resistor; since the impedance of the diode is low, the output of the gate will be at near zero potential, due to the fact that the diode and resistor act as a potential divider.

Connecting two or more inputs of zero potential will cause little significant change to the output potential of the gate; conversely, connecting one or more of the inputs to a negative signal will make no difference to the gate output, since the zero potential input signal holds the output at near zero potential, and thus reverse biases those diodes that have the negative potential applied to their inputs. It is only when all inputs have negative potentials applied (no inputs at zero) that the output of the gate can rise to a significant negative value.

In Fig. 11.3a this negative output potential is shown as being used to drive a read-out unit (shown within the dotted square), which in this case is simply an emitter follower with a lamp as its emitter load; in practice, it is more likely that the transistor would be Darlington connected with another, to give a reasonably high input impedance.

Fig. 11.3b shows the block diagram of a complete decimal counting unit, and an AND gate decoding system and readout facilities. The basic binary "decimal" unit is the same as that shown in Fig. 11.2 and the table in Fig. 11.2 can be applied to both diagrams. A large collection of diode gates, as shown, is sometimes referred to as a "matrix".

ALTERNATIVE DECODING UNIT

In the case that we have just considered, the system relies on the negative potentials from the off transistors in the binary "decimal" unit to operate the decoding unit. An alternative system relies on the zero potential of the on transistors to give gate operation and decoding.

In this case the gates also have, say, four inputs and one output, but the negative output only becomes available when no negative inputs (or zero volts to all inputs) are applied. Such a gate is called a NOR gate, since the negative output is available when neither 1 nor 2 nor 3 etc. negative inputs are applied.

Fig. 11.4a shows the gate in basic form, but using transistors as active elements. Here, all transistors share a common collector load.

If a negative signal is applied to one of the inputs, its transistor will be biased hard on and the common collector, which also serves as the output of the gate, will fall to near zero potential.

If another negative input signal is applied to another input, all that will happen is that the current flowing in the common collector resistor will be shared between two transistors and the output of the gate will change by no significant amount. It is only when no negative inputs are applied, i.e. all inputs are at zero potential, that all currents are cut off and a significant negative output potential becomes available at the output of the gate. A number of variations of this gate exist, in some no transistors are used at all.

Fig. 10.4b shows, in "block" form, the connections used when employing the NOR gate decoding system with the binary "decimal" counting unit.

Next month: Counter/timer units, electronic gates, and triggering circuits

THE instrument to be described embodies a number of circuits used collectively for the purpose of operating a range of Geiger-Müller (G.M.) counters and silicon surface barrier (s.s.b.) detectors.

The ratemeter in its complete form could represent to the science teacher an ideal means of demonstrating the relative characteristics of the two types of detector with various kinds of radiation. To the amateur it might be a useful and interesting instrument for radioactivity investigation at home or in the field where its self-contained power supplies and low weight allow complete freedom of movement.

GENERAL ARRANGEMENT

The electronics of the ratemeter are divided into five sub-units: G.M. Amplifier; S.S.B. Amplifier; Expander Stage; Ratemeter; and E.H.T. Generator and Power Supplies.

The physical arrangement of the instrument closely follows the same general pattern.

The majority of components comprising each sub-unit are mounted on a separate printed wiring board; four of these boards are installed in the underside portion of the main chassis and the fifth, the power supply board, is mounted on the top decks. The two transformers, and certain other components, as well as the dry batteries, are mounted directly onto the chassis. All operating controls and the meter are on the front panel. The loudspeaker unit is fitted inside the metal case.

Fig. 1 provides the key to the whole assembly. All sub-units are shown in block diagrammatic form with key references to inter-unit wiring and also references to appropriate circuit diagrams. All those components not included on the separate boards, but mounted on the chassis, front panel, and case, are shown in detail with all appropriate wiring.

Although the instrument is described in its complete form, capable of operating both types of detector, there is no reason of course, why only one type of detector should not be catered for with obvious economies where limited resources or interest so

dictate. An example of this might, for instance, be where only alpha particles were to be detected. In this case only the S.S.B. detector amplifier, the ratemeter and two 9 volt batteries would be required to use S.S.B. detectors such as the 20th Century types SSNO3K and SSNO5K.

CHASSIS CIRCUIT

With reference to the inter-unit diagram Fig. 1, it can be seen that the instrument permits a solid state radiation detector and a G.M. counter to be connected simultaneously, the switch S1 ("s.s.b./G.M.") selecting the required device. An e.h.t. supply is internally generated and is available for direct application to the G.M. circuit or, suitably reduced, to the s.s.b. detector circuit. The amount of reduction needed will depend upon the maximum permissible voltage for the particular detector used.

With S1 in the "G.M." position the e.h.t. voltage is variable from zero to maximum by the front panel control VR1 ("G.M. E.H.T.").

In the "s.s.b." position S1 makes operative an internal preset e.h.t. control VR2 which sets the voltage across a variable attenuator chain R1, R2 and VR3 before being applied to the s.s.b. detector. VR3 is a front panel control ("s.s.b. VOLTS").

S2 ("ABG/A") is associated with the s.s.b. detector amplifiers. The purpose of this switch is to select the output either of the s.s.b. amplifier, whose output for alpha pulses is large in relation to others, or that of the expander stage whose added gain enables beta and gamma radiations to be detected in addition to alpha. In this way discrimination against beta and gamma pulses can be obtained by virtue of their small size. In the "ABG" (alpha + beta + gamma) position of S2 the noise discriminator control VR5 ("DISC") is operative. S4 ("M/B") selects internal battery or mains power and S5 ("E.H.T. OFF") enables the e.h.t. generator to be shut off completely.

The count rate, in three switched ranges (0-5, 0-50, and 0-500 counts per second) selected by S3 ("COUNTS/SEC and OFF") is displayed on a moving coil meter M1.

by D.V. SMITH

COMPLETELY PORTABLE

MAINS OR BATTERY OPERATION

ALL SOLID STATE CIRCUITRY

SEMI-MODULAR CONSTRUCTION

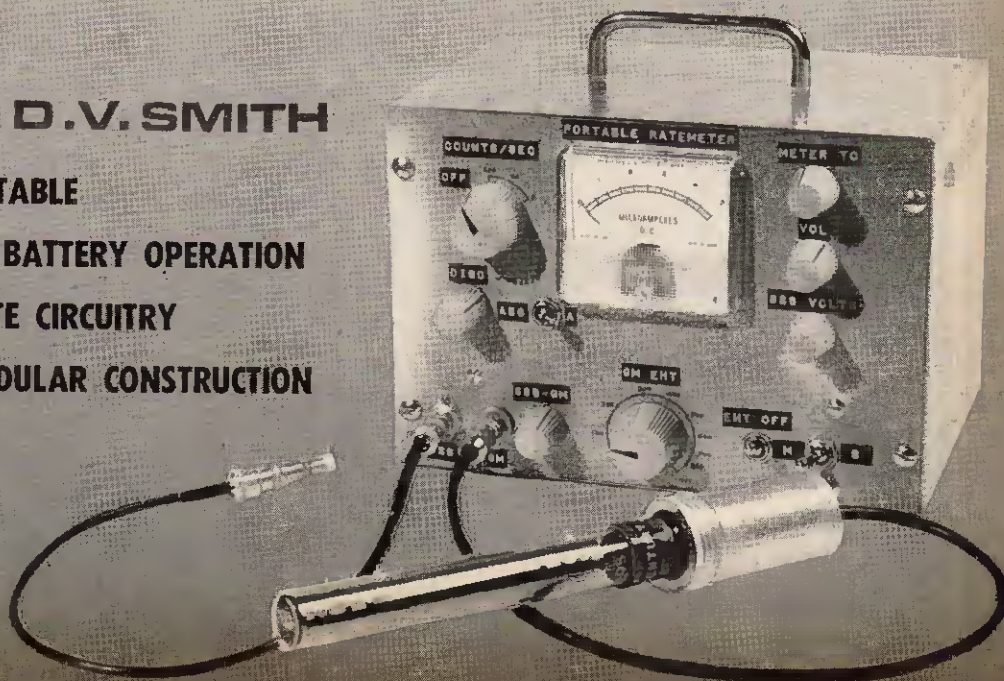

The "OFF" position of this control disconnects all power supplies. Audible indication of counts is provided via a loudspeaker LSI, the volume of which is controllable by VR4 ("VOL"). Control is given also of the meter time constant by VR6 ("METER T.C.").

The individual circuits of the sub-units will now be described.

G.M. AMPLIFIER

The simplest of these circuits is the G.M. amplifier (Fig. 2) in which TR1 and TR2 are connected as a cascaded emitter follower amplifier.

No voltage amplification is required with the large pulses usually obtained from a G.M. counter, but since the source impedance is rather high, some impedance transformation is necessary to drive the ratemeter circuit without undue attenuation. The cascaded emitter-follower circuit adequately fulfills this requirement.

The diodes D1 and D2 protect TR1 from the danger of large voltage transients.

The output is taken from point H4 to the ratemeter, via S1.

S.S.B. DETECTOR ELECTRONICS

NOTE: A full description of the electronic circuitry required for solid state detectors appeared in an introductory article entitled *A Solid State Radiation Detector*—see PRACTICAL ELECTRONICS June 1965. Reference to this previous article is recommended if amplification of the concise circuit descriptions which appear below is required.

The s.s.b. circuitry is arranged in two sections, the first, the S.S.B. Amplifier, is for alpha particle detection. In this application large signals are experienced not requiring high gain, and consequently a high signal to noise ratio is achieved. The Expander Stage is intended as an add-on unit to extend the capability of the combination for the detection of beta and gamma radiation.

S.S.B. AMPLIFIER

The circuit of the S.S.B. Amplifier is shown in Fig. 3. The outer shell of the s.s.b. detector is taken to the common earth line and the collector connected via the 1 megohm load resistor R10 to a positive bias supply. The voltage pulse appearing across the load is applied to the base of TR3 which is operating as a low noise emitter follower. TR4 and TR5 are conventional voltage amplifiers with a total gain of about 500. The output from TR5 collector is fed via a differentiating network, C13, R21, and R22; to TR6 which operates as a phase splitter output stage. The purpose of this differentiation is to enhance the signal to noise ratio by limiting the bandwidth of the amplifier.

A positive output (with link between A-B) is obtained via C15 at point F2.

If it is not intended to add the expander stage for beta and gamma detection, an economy may be made where an instrument sensitive to negative pulses is used. The output in this case may be taken via the output capacitor C15 direct from the collector of TR5 and so obviating the need for TR6. The loss of the differentiating network making no difference in this type of operation.

EXPANDER STAGE

The circuit of the expander stage is shown in Fig. 4. It consists of an input emitter follower, a variable current discriminator/amplifier and an emitter follower output stage with a similar protecting network as in the S.S.B. Amplifier.

The positive going output from point F6 on Fig. 3 is applied to the input of the expander stage. The input emitter follower TR7 is necessary to drive the low impedance current discriminator TR8 without upsetting the output of TR6 in the first section.

The operation of TR8 as a current discriminator is very simple. The standing base current set by VR5 and the 15 kilohm base resistor R31 is used as the negative discriminator bias which the positive going signal current from TR7 must overcome for the pulse

PORTABLE RATEMETER

SPECIFICATION...

APPLICATION

For use with wide range of G.M. and solid state radiation detectors
100mV

G.M. SENSITIVITY

S.S.B. INPUT SENSITIVITY

Single Stage Only

Alpha particles down to 200keV

With Expander Stage

Beta and gama radiation down to 50keV

THREE COUNT RANGES

0-5; 0-50; 0-500 counts per sec

RESOLVING TIMES

10msec, 1msec, and 100µsec respectively for the above ranges

METER

Variable time constant; set zero and calibration control

E.H.T. SUPPLY

0-800V, continuously variable

COMPONENTS . . .

Resistors

R1	22M Ω 1W	R28	120k Ω
R2	22M Ω 1W	R29	1.2k Ω
R3	22M Ω 2W	R30	100k Ω
R4	2.2M Ω	R31	15k Ω
R5	4.7M Ω	R32	10k Ω
R6	4.7M Ω	R33	120k Ω
R7	4.7M Ω	R34	120k Ω
R8	4.7k Ω	R35	3.3k Ω
R9	4.7k Ω	R36	1M Ω
R10	1M Ω	R37	10k Ω
R11	2.2M Ω	R38	3.3k Ω
R12	2.2M Ω	R39	100k Ω
R13	68k Ω	R40	68k Ω
R14	150k Ω	R41	3.3k Ω
R15	4.7k Ω	R42	330 Ω
R16	47 Ω	R43	68k Ω
R17	100 Ω	R44	4.7k Ω
R18	150k Ω	R45	2.2k Ω
R19	4.7k Ω	R46	100 Ω
R20	47 Ω	R47	18k Ω
R21	68k Ω	R48	470 Ω
R22	33k Ω	R49	10 Ω
R23	3.3k Ω	R50	10 Ω
R24	3.3k Ω	R51	430 Ω
R25	1M Ω	R52	68 Ω
R26	100 Ω	R53	12k Ω
R27	120k Ω	R54	12k Ω

All $\pm 10\%$, $\frac{1}{2}$ W carbon unless otherwise stated.

Potentiometers

VR1	10k Ω linear	VR5	10k Ω log
VR2	10k Ω linear, preset	VR6	500 Ω linear
VR3	2M Ω linear	VR7	2k Ω linear, preset
VR4	10k Ω linear	VR8	5k Ω skeleton preset

Capacitors

C1	2,500pF paper 500V (T.P.C.)
C2	0.025 μ F paper 500V (T.P.C.)
C3	0.25 μ F paper 500V (T.P.C.)
C4	100 μ F elect. 6V (Sub mins)
C5	5,000 μ F elect. 6V (Sub mins)
C6	500 μ F elect. 25V (Tubes)
C7	1 μ F paper 250V (T.P.C.)
C8	470pF ceramic (1,000V)
C9	5,000pF ceramic (500V)
C10	0.5 μ F elect. 15V (Sub mins)
C11	8 μ F elect. 15V (Sub mins)
C12	0.5 μ F elect. 15V (Sub mins)
C13	1,000pF ceramic 500V
C14	50 μ F elect. 15V (Sub mins)
C15	0.1 μ F plastic 250V (Polyesters)
C16	0.1 μ F plastic 250V (Polyesters)
C17	0.1 μ F plastic 250V (Polyesters)
C18	0.1 μ F plastic 250V (Polyesters)
C19	0.1 μ F plastic 250V (Polyesters)
C20	0.1 μ F plastic 250V (Polyesters)
C21	250 μ F elect. 25V (Tubes)
C22	0.1 μ F plastic 250V (Polyesters)
C23	22pF ceramic
C24	47pF ceramic
C25	1 μ F elect. 15V (Sub mins)
C26	2,000 μ F elect. 25V (Tubes)
C27	0.05 μ F elect. 500V (T.P.C.)
C28	1 μ F elect. 250V (T.P.C.)
C29	0.05 μ F elect. 500V (T.P.C.)
C30	0.1 μ F elect. 1,000V (T.P.C.)
C31	0.1 μ F elect. 1,000V (T.P.C.)
C32	2,000 μ F elect. 25V (Tubes)
C33	2,000 μ F elect. 25V (Tubes)

Note: Information in brackets is the form of coding used by Radiospares Ltd.

Switches

S1	Midget wafer 4-pole, 2-way
S2	Toggle, s.p.d.t.
S3	Wafer, 4-pole, 4-way
S4	Toggle, d.p.d.t.
S5	Toggle, s.p.d.t.

Transformers

T1	Mains transformer, 200-250V tapped primary. Secondary 16.3V 0.3A centre tapped
T2	Mains transformer, 200-250V tapped primary. Secondary 6.3V 1A centre tapped

Transistors

TRI-TR13	OC44 Mullard (13 off)
TR14-TR17	OC81 Mullard (4 off)

Diodes

D1	Silicon	OA202	Mullard
D2	Silicon	OA202	Mullard
D3	Zenker	6.8V OAZ244	Mullard
D4	Silicon	125V r.m.s. 500mA	Radiospares REC50
D5	Zenker	6.8V OAZ244	Mullard
D6	Silicon	800 p.i.v. 500mA	International Rectifier SD98 or 98S
D7	Silicon	800 p.i.v. 500mA	International Rectifier SD98 or 98S
D8	Silicon	125V r.m.s. 500mA	Radiospares REC50

Plugs and Sockets

PL1	Coaxial free plug	} P.E.T. type 101
SK1	Coaxial fixed socket	
PL2	Coaxial free plug	} Belling Lee
SK2	Coaxial fixed socket	
PL3	Mains input fixed 3-pin plug	} Radiospares
SK3	Mains input free 3-pin socket	

Miscellaneous

BY1	9V battery	2X Exide H30	4.5V
BY2	9V battery	Ever Ready	PP9
FS1	Fuse cartridge,	1A	
LS1	Loudspeaker	3in, 35 Ω speech coil	
MI	Moving coil meter,	100 μ A f.s.d., 2 $\frac{1}{2}$ in, panel mounting	

Sundry Items

Chassis: 18 s.w.g. aluminium 6 $\frac{1}{2}$ in \times 8 $\frac{1}{2}$ in \times 3in. Battery clamps: 18 s.w.g. aluminium. Component board cradle and retaining strip: $\frac{1}{4}$ in thick s.r.p.b. Case: 10in \times 7in \times 7in (Tele-Radio). Carrying handle. Seven knobs. Four stand-off insulators. One fuse holder. Screened lead (single miniature microphone cable). Veroboard.

Radiation Detectors

G.M. tube	Type G10H	} 20th Century Electronics
SSB detector	Type SSNO3K or SSN05K	

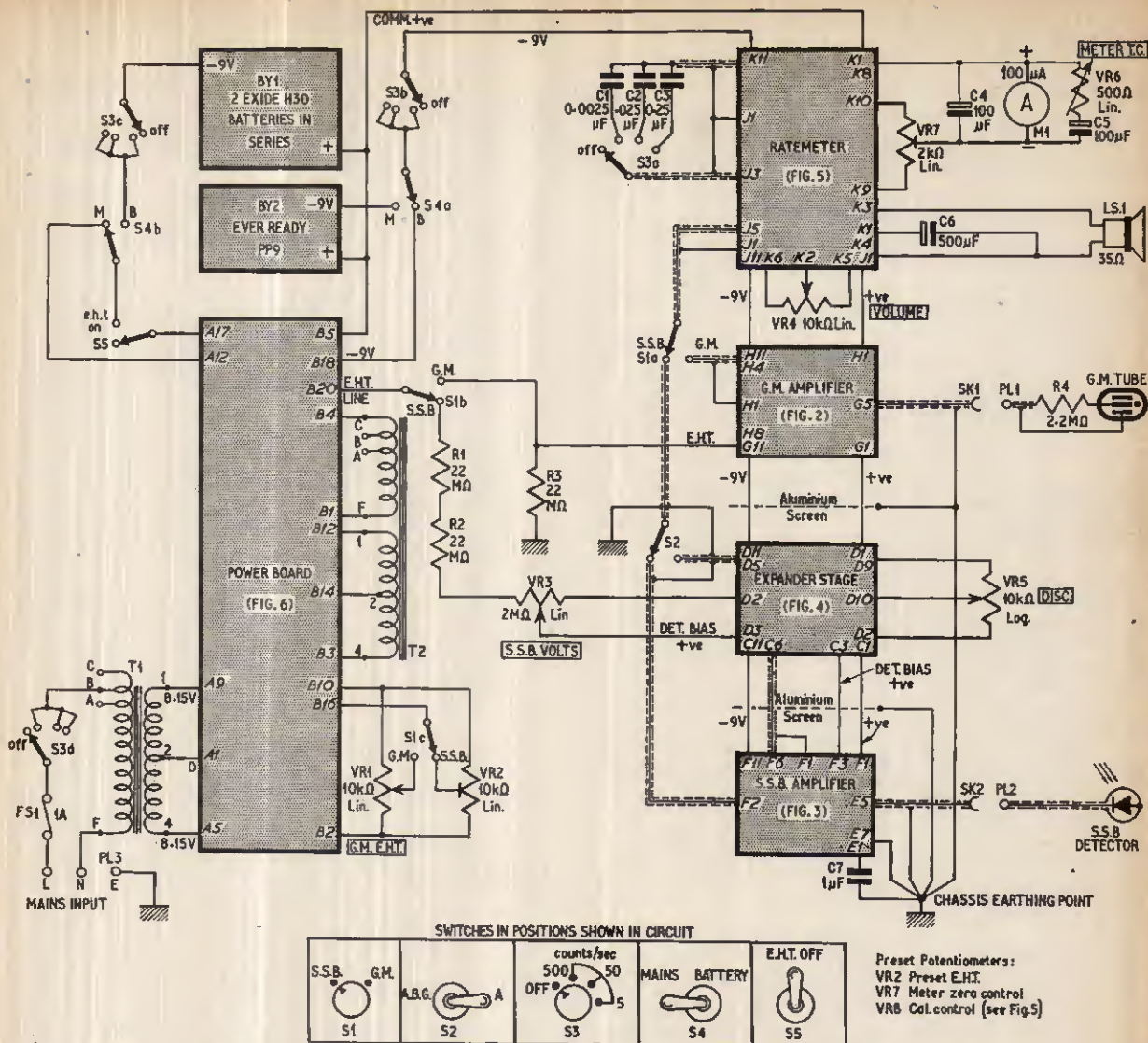
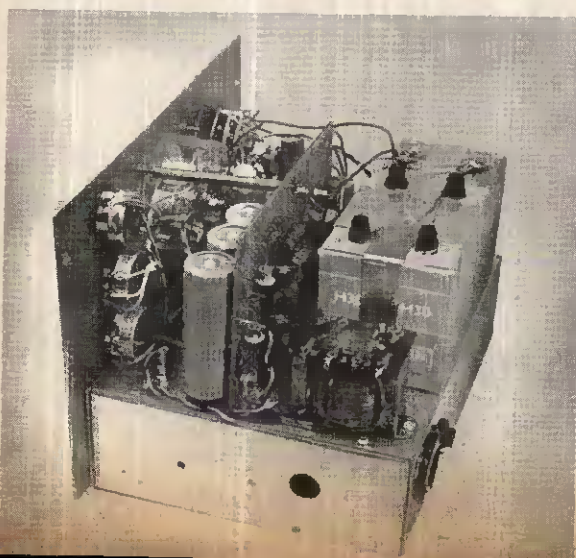

Fig. 1. Portable Ratemeter Inter-unit wiring diagram. The ratemeter is divided into five sub-units and the physical arrangement follows closely the same general pattern as this key diagram



to be detected. Once this has happened TR8 operates as an amplifier, and the resulting negative pulse is fed to the output (point D5) via emitter follower TR9.

Due to the action of the discriminator the output pulses are no longer proportional to the radiation energy lost into the detector.

RATEMETER

Simply expressed, the ratemeter circuit (Fig. 5) applies a constant charge to a meter for every input pulse regardless of its size or duration. The meter then reads the average current which is proportional to the count rate.

If the pulses applied to the meter were of the same short duration as those from the radiation detector then the average current on low pulse rates would be rather too low to be of great use. A more satisfactory arrangement has therefore been adopted in which the length of the pulse is artificially "stretched" by a monostable multivibrator.

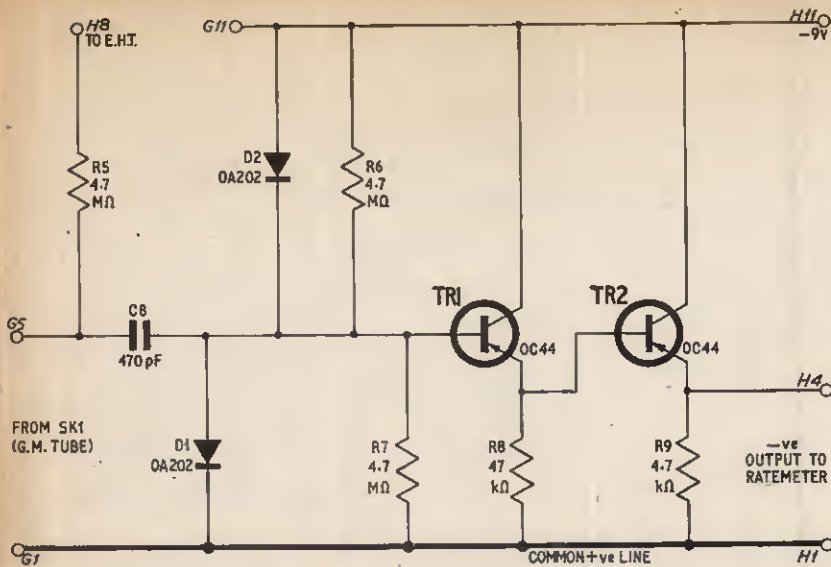

Fig. 2. Circuit diagram of the Geiger-Muller tube amplifier. The diodes D1 and D2 protect TR1 from the danger of large voltage transients

The effect of this is to magnify the charge per pulse applied to the meter while still retaining the necessary linear relationship of average current to count rate. The amount of stretching is related to the count rate range and is a satisfactory compromise between meter deflection and count losses. In other words if the stretching were too long the likelihood of pulses occurring during the insensitive period would be too high and an unacceptable counting error would result although the meter deflection would be good.

The resolving (stretching) time "T" is defined such that if one or more pulses arrive within a time "T" of a former pulse, only the former is recorded. The circuit is therefore "paralysed" for a time "T" after each registered pulse.

The true count rate of random pulses can be obtained from the expression:

$$N_t = \frac{N_o}{(1 - N_o T)}$$

where N_t is the true count rate
 N_o is the observed count rate
 T is the resolving time

For example, if our system has a resolving time of 1 millisecond and a count rate of 25c/s, is observed, the true rate will be:

$$N_t = \frac{25}{(1 - 25 \cdot 10^{-3})} = 25.7c/s,$$

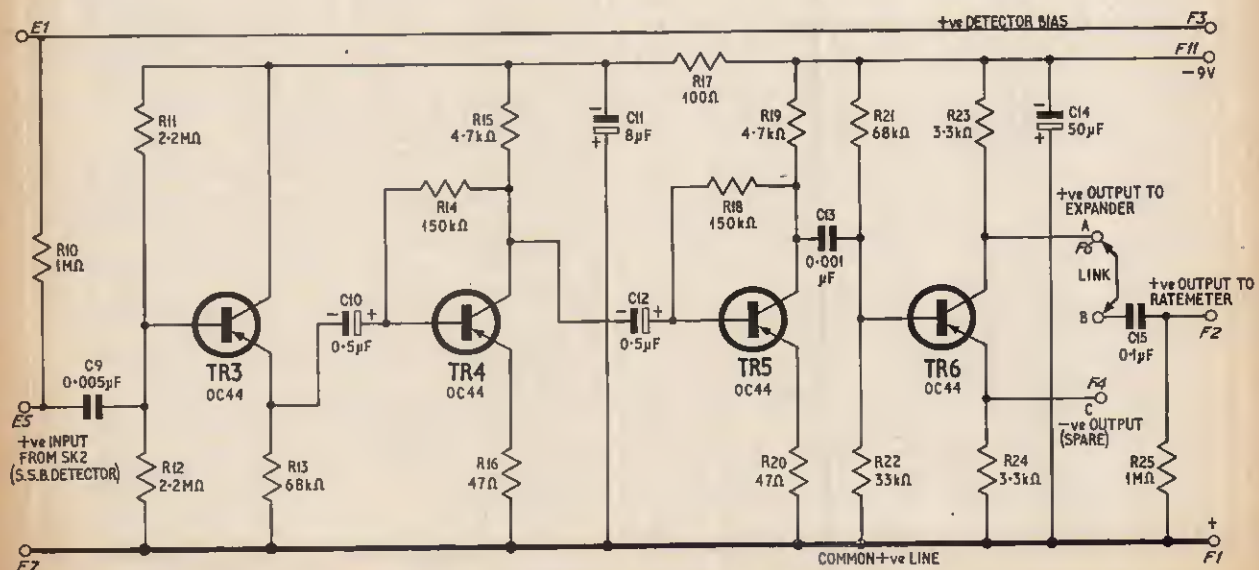

Fig. 3. Circuit diagram of the s.s.b. amplifier. The outer shell of the s.s.b. detector is taken to the common earth line via PL2, SK2, see Fig. 1

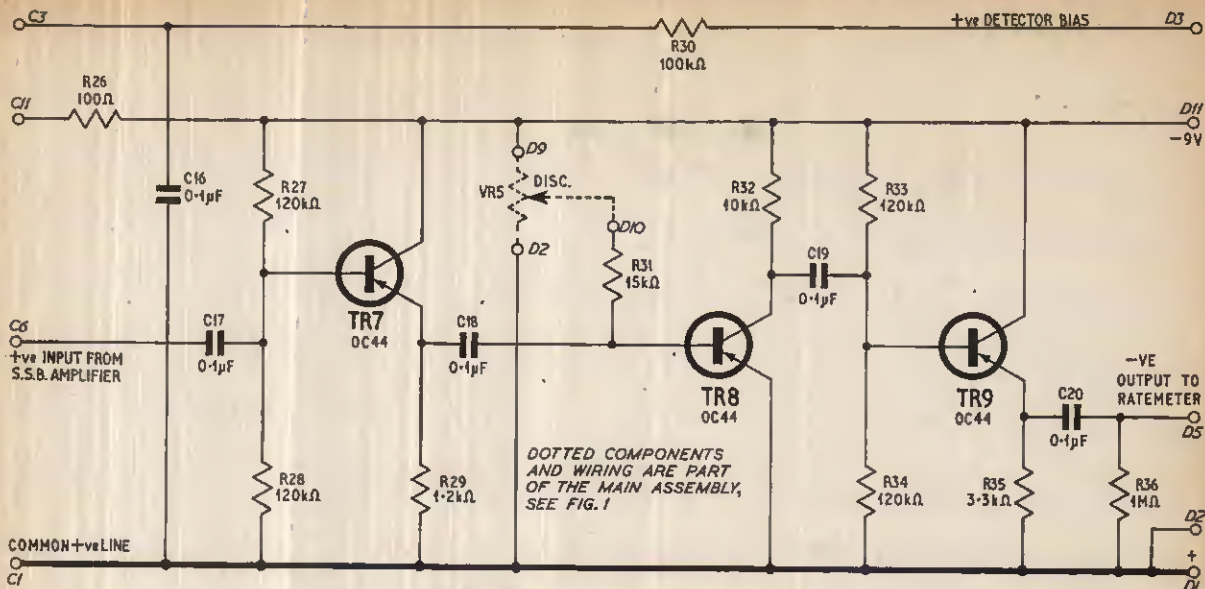

Fig. 4. Circuit diagram of the expander stage

which is near enough for most purposes. The approximate resolving times of the ratemeter on its three ranges are 10ms on 5c/s, 1ms on 50c/s, and 100μs on 500c/s. If the G.M. counter has a longer "dead" time than the resolving time of the system then this will be the governing factor. The s.s.b. detector is much faster than the G.M. tube and so will not complicate the issue in this way, although very little difference will be made in any case.

The action of the circuit (Fig. 5) is briefly as follows: A negative going input pulse greater than about 100 millivolts in amplitude will start to turn TR10 on. The positive going pulse appearing at TR10 is transferred via one of the three timing capacitors C1, C2, C3, to TR12 base. This transistor, normally held

on by the current through R40, begins to turn off. The negative pulse produced at TR12 collector is fed via R39 and C23 to TR11 base and begins to turn TR11 on. The current through TR11 is in phase with the current through TR10 through R38 and therefore the action is regenerative, causing a rapid transition to the astable condition.

At the end of the duration of the input pulse TR10 cannot initiate a reversal of the action in turning off as TR11 has "clamped" TR10 collector.

The charge on the timing capacitor leaks away through R40 until TR12 begins to turn on and the circuit rapidly reverts to its original state. The duration of the astable condition depends on the value of the timing capacitor and R40.

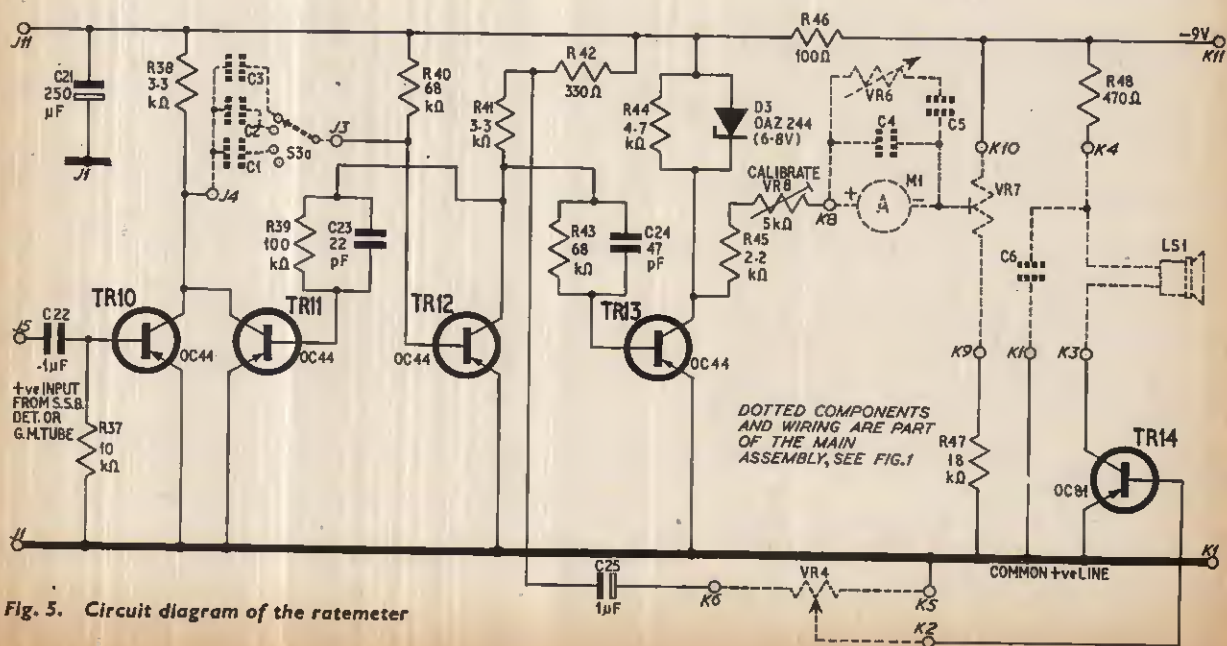

Fig. 5. Circuit diagram of the ratemeter

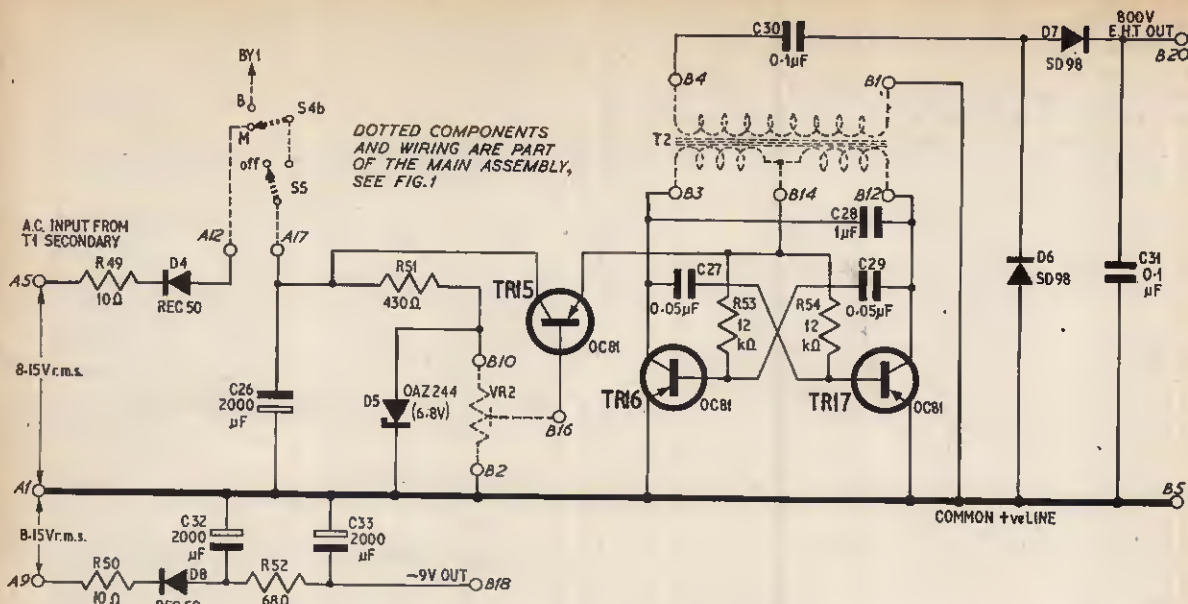

Fig. 6. The e.h.t. generator and power supply circuits. The components above the common positive line are the e.h.t. generator and those below this line form the h.t. supply circuit

The rectangular negative-going pulse appearing at TR12 collector during the astable period is fed to TR13 base via C24 and R43 turning TR13 hard on. Current then flows through the meter circuit for the duration of the pulse, causing a deflection of the pointer of M1.

METER CONTROLS

The meter time constant potentiometer VR6 ("METER T.C.") and its associated capacitors C4 and C5 are a simple arrangement provided so that the meter is slow to change its deflection on low or fluctuating count rates if desired.

VR7 is a meter zero control for backing off current in the meter caused by leakage in TR13. In the instrument described it is a preset control mounted inside the case but it is felt that many constructors might prefer it to be a front panel control and there is no reason why this should not be so if space can be found for it. The need for this control can be eliminated at extra cost by replacing TR13 by a silicon transistor type OC202.

The purpose of the Zener diode D3 is to stabilise the meter reading against variations caused by changes in the supply voltage.

The values used for the timing capacitors are nominally, $0.25\mu\text{F}$ for 5c/s, $0.025\mu\text{F}$ for 50c/s, and $0.0025\mu\text{F}$ for 500c/s. These ranges should suffice for most purposes but can obviously be altered to suit individual requirements.

With a fixed value of R40, the values of the timing capacitors must be fairly accurate multiples of each other for good range agreement. Adjustment can be made by "padding" where necessary with suitable value capacitors in parallel.

The calibrating control VR8 enables the instrument to be initially set up. Ideally this should be done with a pulse generator but a source of low voltage 50c/s pulses can be used for the 50c/s range and to check the corresponding point on the 500c/s range.

The split collector load of TR12 is a source of low impedance pulses for driving the audio stage TR14. The combination of R48 and C6 is to prevent excessive pulses appearing on the supply line. It will also have the effect of causing the volume of sound to decrease somewhat as pulse rate increases, particularly on the higher count ranges. This, the author believes, is a desirable feature as audible indications of counts are more useful at low rates and tend to become a nuisance at high rates.

E.H.T. GENERATOR AND POWER SUPPLIES

The circuit of Fig. 6 can be divided into two distinct sections: all that above the common positive line is the e.h.t. generator; below this line is the h.t. supply circuit. Each section is supplied from separate halves of the mains transformer secondary.

Dealing first with the e.h.t. generator: the transistors TR16 and TR17 are operated as a free running multivibrator, the load of which is the tuned 6.3 volt winding of T2. This transformer is the readily available *Radiospares* Standard Filament (6.3V) type which has a centre tapped 6.3 volt winding and is ideal for this purpose. It is drawn in dotted, since it is physically located on the main chassis (see Fig. 1). The operating frequency of the multivibrator is about 1kc/s, determined by C28, together with R53, R54, C27 and C29.

The winding on T2 which normally is the mains primary is now the secondary from which the e.h.t. voltage is obtained. This output is fed to the voltage doubling circuit C30, C31, D6, and D7, and appears as smooth d.c. at the e.h.t. output point B20. The output voltage is controlled by VR1 or VR2 which, via the transistor TR15, regulates the drive to the multivibrator. The e.h.t. voltage has a near linear relationship to the angular rotation of VR1 and use is made of this by calibrating the "G.M. E.H.T." knob in volts. Zener diode D5 stabilises the output against input supply variations.

R1, R2 and VR3 form the potential divider for attenuation and fine control of the bias applied to the s.s.b. detector. The above values should be chosen in conjunction with the setting of VR2 to suit the maximum rating of the detector. The total resistance of the chain should not be less than 20 megohm. However, this arrangement is shown only as a demonstration of possible systems where specially selected detectors are used operating at up to 300 volts and normal battery operation becomes unwieldy.

For the most popularly used detectors a maximum of 25 volts is the limit and it would obviously be more economical to obtain this voltage from a battery.

Drive voltage for the e.h.t. generator is obtained from one half of the centre tapped secondary of the mains transformer T1. The a.c. output of approximately 8.15 volts r.m.s. is rectified by D4 and applied to TR15 and so to the multivibrator.

The other half of T1 secondary provides the h.t. for the other four sub-units. After rectification by D8 and filtering by C32, R52, and C33, a d.c. output of -9V is obtained at point B18.

The primary of T1 is connected to the a.c. mains supply via S3d and FS1, see Fig. 1.

BATTERIES

Two separate 9 volt batteries are incorporated in the ratemeter. These enable the instrument to function normally in the absence of a.c. mains supplies. BY1 is composed of two 4.5V batteries connected in series and is used to drive the e.h.t. generator. This supply is fed in at point A17. BY2 is a single 9V layer type battery and it supplies h.t. to the various sub-units.

The mains input circuit and all power supply switching arrangements are clearly shown in the inter-unit wiring diagram, Fig. 1.

The construction of the ratemeter will commence next month.

Trade literature

readers requiring further information about any of the items mentioned in this column should forward request direct to the company concerned. It is requested that all enquiries be made by post only.

SIGNAL LAMPS AND LAMP HOLDERS

Thorn Special Products Ltd., Great Cambridge Road, Enfield, Middlesex

A NEW coloured catalogue of their range of screw and press-fit mains signal lamps and holders, 50-200 pulse/min blinker lamps and neon indicators.

HENRY'S COMPONENTS CATALOGUE price 2s
Henry's Radio Ltd., 303 Edgware Road, London, W.2

THIS firm specialise in transistor and associated components and will be pleased to quote for any transistorised circuit published in P.E. Their catalogue containing more than 3,500 mostly standard parts is recommended to readers.

HOME RADIO COMPONENT CATALOGUE

price 7s 6d, plus 1s postage
Home Radio (Mitcham) Ltd., 187 London Road, Mitcham, Surrey

ANOTHER must for readers of P.E. containing over 5,000 references in easy to follow layout.

All prices are now contained in a separate supplement which, due to price changes, will be reprinted from time to time to keep the catalogue up to date.

ELECTRONIC VIBRATO UNIT

continued from page 95

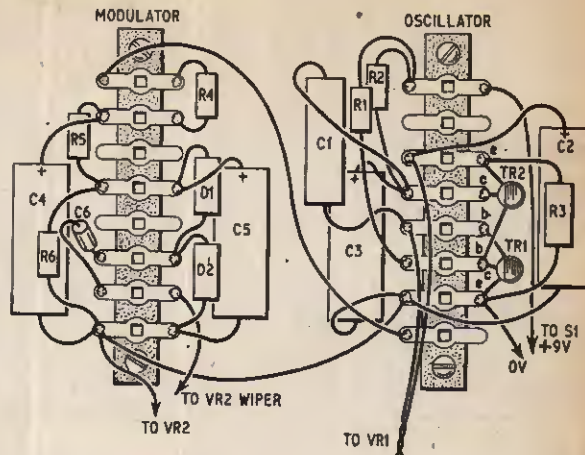

Fig. 5. Wiring of the modulator and oscillator

TWO TAG STRIPS

The complete vibrato unit can be made up in any one of a variety of methods. The prototype, shown in the photograph, was made on two separate tag strips.

Fig. 5 shows the layout and wiring of the components on the tag strips. Little description is necessary since the illustrations give all the required details.

When the final unit has been completed and the wiring has been checked, the terminals across VR2 can be connected to the guitar amplifier across the grid resistor as shown in Fig. 3. Since this part of the amplifier circuit has a high impedance, the connecting wire from the vibrato unit should be as short as possible and screened, with the screen connected to chassis.

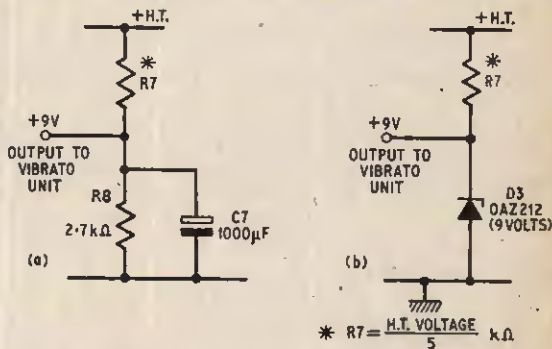

Fig. 6a. Method of obtaining a 9 volt supply for the vibrato unit using a resistive potential divider

Fig. 6b. Another method of obtaining 9 volts. R8 and C7 are replaced by a 9 volt Zener diode

POWER SUPPLIES

Most amplifier h.t. supplies will provide an extra 5mA without trouble, and this is ample. Two ways of connecting the power supplies are shown in Fig. 6. Of these, the method (b), shown in Fig. 6b, using a Zener diode, is the best and occupies less space. Alternatively, a 6.3 volt l.t. supply may be rectified and smoothed, or the unit may be battery operated.

This unit should not be used on a.c./d.c. equipment.★

ELECTRONORAMA

HIGHLIGHTS FROM THE CONTEMPORARY SCENE

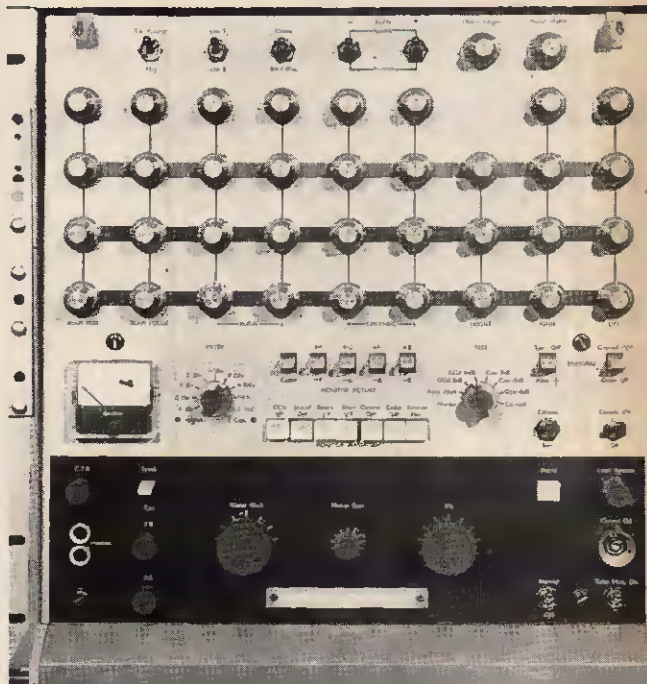
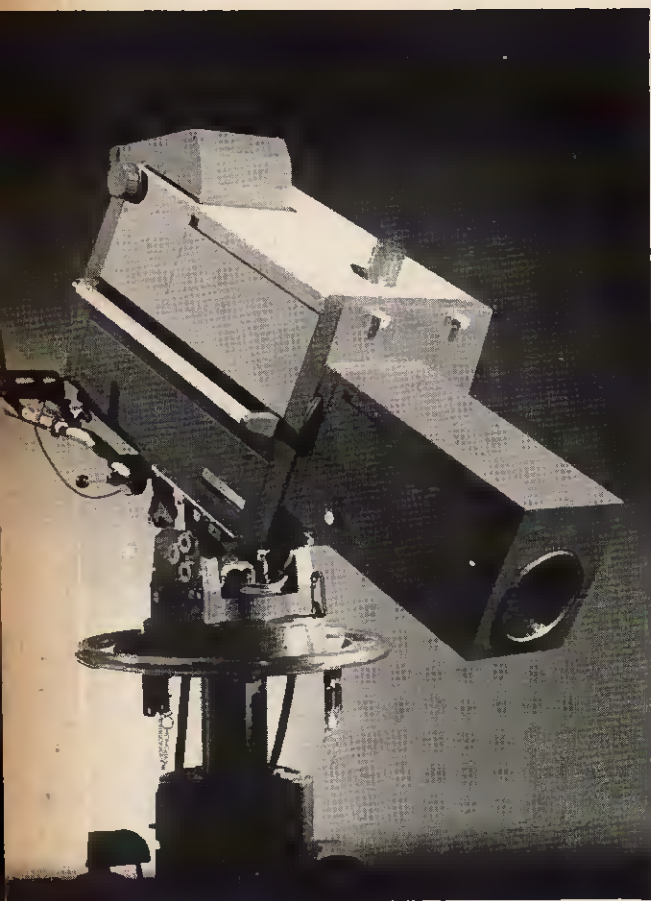

New Colour Television Camera

A new colour television camera using four plumbicon pick-up tubes has been developed by The Marconi Company. It is claimed that this new camera will avoid the difficulties previously encountered with previous versions using three colour tubes. Colour pictures are not so dependent on accurate registration and compatible monochrome pictures should be considerably better.

Transistor circuitry is used with over sixty "thin films". A high quality luminance signal is produced by a single tube and the other three are used to contribute colour information to the signal.

This Mark VII camera is virtually unaffected by external magnetic fields.

The three pictures on this page show the camera itself (above left), the camera control unit (above), and a "thin film" circuit of the video amplifier (left). The resistors can be seen as transparent grey tracks, while the gold pad connections appear black. The ni-chrome resistors are deposited on a thin layer of glass and are virtually unaffected by changes in temperature.

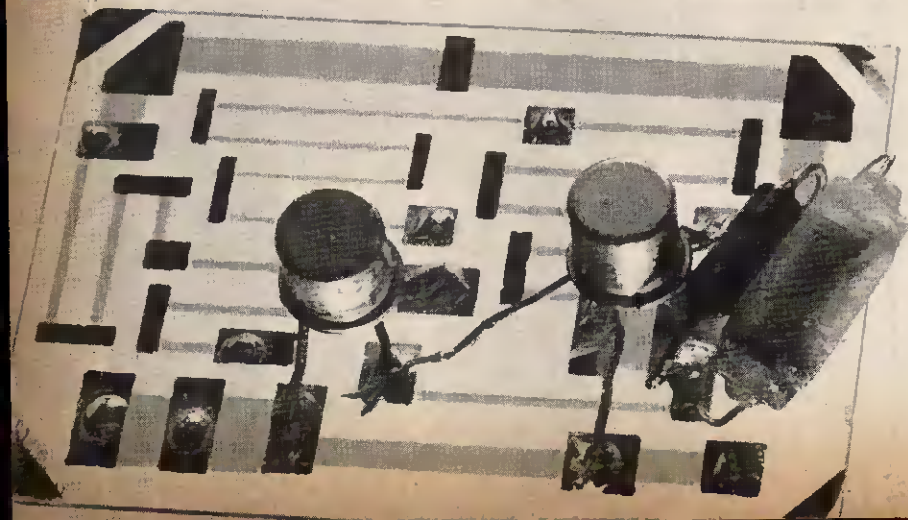

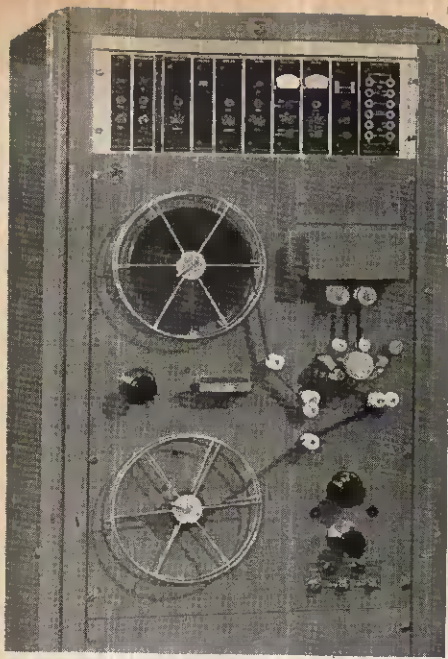

Magnetic Film Recorder

A NEW British magnetic film recorder and reproducer has been developed by RCA Great Britain Ltd., using solid state circuits built in plug-in modular form. Single or multi-track heads can be used on films up to 35mm wide using adjustable rollers. The plug-in modules are housed in a "nest" shown above.

The equipment has been designed so that schools as well as industry can record their own sound tracks on 16mm or 17½ and 35mm film. The heads can be positioned to provide centre or edge track recording or a combination of both.

New Scanning Electron Microscope

THE picture below shows an enlarged view (X49) of a relay contact that has become pitted. This photograph was taken with the help of a new electron microscope (shown right). The microscope is the brain child of the Cambridge Instrument Company and Professor Oatley at Cambridge University.

By scanning the specimen with an electron beam it can give much clearer and more detailed pictures which are displayed on a cathode ray tube.

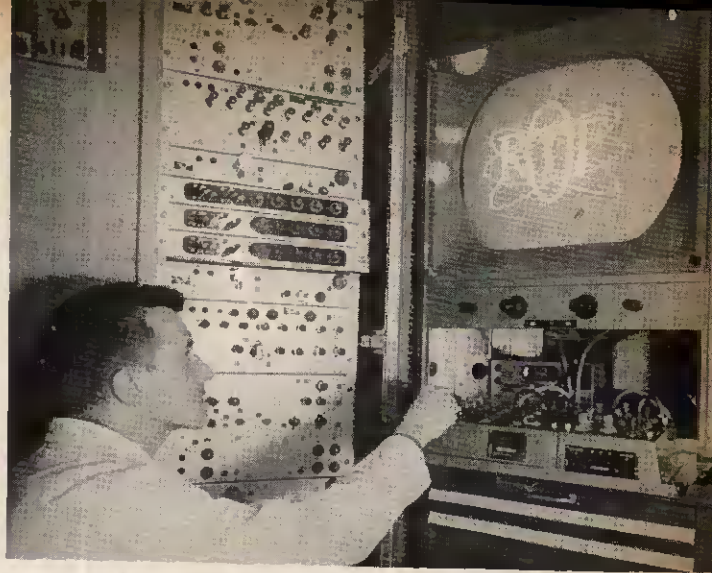
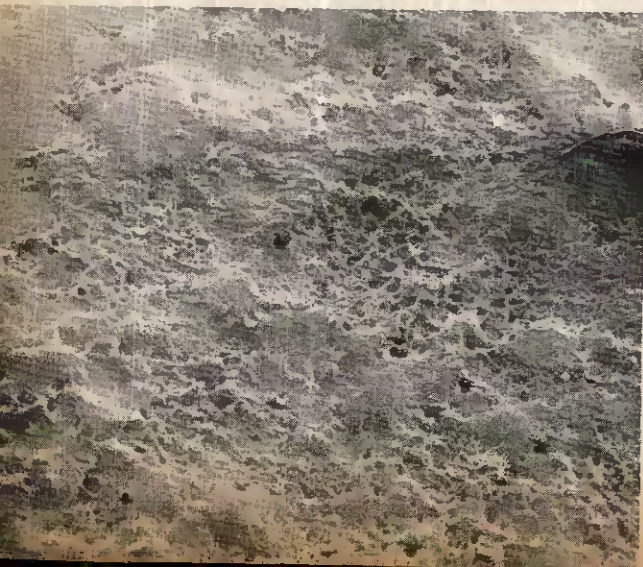

British Colour TV Equipment in France

THE Office de Radiodiffusion Television Française in Paris is fitted with telecine equipment and image analysis which have been supplied by British colour television companies in the Rank Organisation. In the picture above an O.R.T.F. technician is shown adjusting the preset control of a Bush colour monitor, on which the O.R.T.F. programme symbol is displayed. Telecine and scanner equipment were supplied by Rank Cintel.

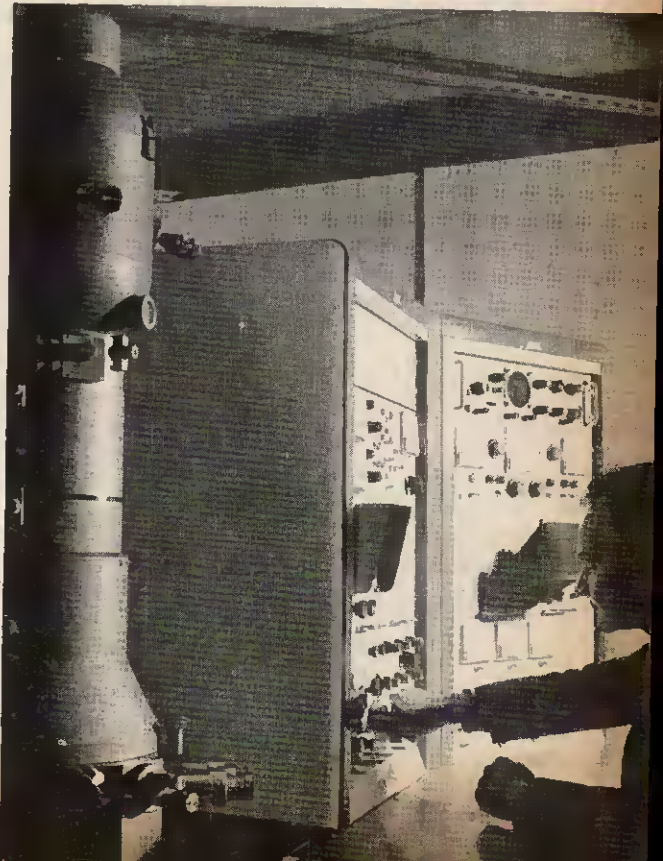

BEGINNERS start here...

16

An Instructional Series for the Newcomer to Electronics

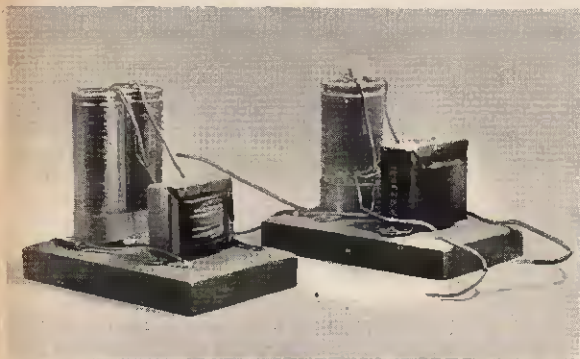

As an example of our new knowledge, consider the smoothing network found in most power packs. It generally consists of two capacitors and an inductance arranged as in Fig. 16.1.

The alternating current from the mains supply is converted into "pulsating d.c." by the action of a rectifier (not shown here). This current, really a.c. mixed with d.c., is too rough to use in electronic equipment. It is therefore passed through a smoothing or filter circuit.

Referring to Fig. 16.1, the first capacitor C1 offers an easy path for the a.c. variations, but the inductor L1 opposes them. To d.c., however, L1 offers very low resistance, while capacitors C1 and C2 offer an infinite barrier. The small amount of a.c. that manages to pass through L1 is provided with an easy return path via C2.

COMPONENTS . . .

HIGH VOLTAGE FILTER

- | | | |
|----|------------------------------|---|
| C1 | 16 μ F electrolytic 500V | Dual unit, both capacitors in same can |
| C2 | 16 μ F electrolytic 500V | |
| L1 | 10 henry choke, 65mA | Standard h.t. smoothing choke, approximate size 1 $\frac{1}{2}$ in \times 2 $\frac{1}{2}$ in \times 1 $\frac{1}{2}$ in. Osmabret or similar |

LOW VOLTAGE FILTER

- | | |
|----|--------------------------------------|
| C1 | 5,000 μ F electrolytic 15 to 25V |
| C2 | 5,000 μ F electrolytic 15 to 25V |
| L1 | .0-1 henry choke 2A |
- Not generally available, but easily made up as described in the text. Material required: old loudspeaker transformer; small reel of 24 s.w.g. enamelled copper wire

Miscellaneous Items for Both Units

Wooden baseboard, approximately 5in \times 3in \times $\frac{1}{2}$ in. Brass wood screws. Black and red plastic covered wire. Perforated zinc for the cover.

The first capacitor C1 charges up on the positive going "peaks", but returns some of this charge to the supply line when the a.c. component is moving negative-wise. This capacitor is often referred to as a *reservoir* capacitor, and it contributes largely to the smoothing or filtering action of this circuit.

In this manner smooth, steady d.c., like that from a battery, is obtained to work the "load" which is some electronic device connected across points c and d.

Transformation of the pulsating d.c. into "pure" d.c. is indicated graphically in Fig. 16.2.

We will now proceed to the construction of two filter units—both based on the circuit given in Fig. 16.1. This work will enable you to gain a little more soldering experience, and afford the opportunity to handle further types of components in a practical sense. The filters themselves will be very useful in later work. In fact they will be essential for producing smooth d.c. from the a.c. mains, via suitable transformers and rectifiers, which will be put to work operating the future practical projects we have lined up for this series.

HIGH VOLTAGE FILTER

This unit will smooth rectified a.c. (that is, pulsating d.c.) of about 250 volts pressure, supplying currents up to about 60mA. (Don't forget m stands for "milli", meaning a thousandth, and A is the abbreviation for "ampere", which is a measure of current flow.) This filter can therefore be used to supply valve equipment drawing not more than the above mentioned amount of current.

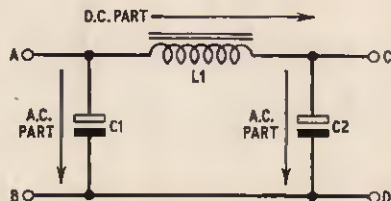

Fig. 16.1. A typical LC filter, used to smooth pulsating d.c. It is often called a "pi" (Greek letter pi) filter, from its shape

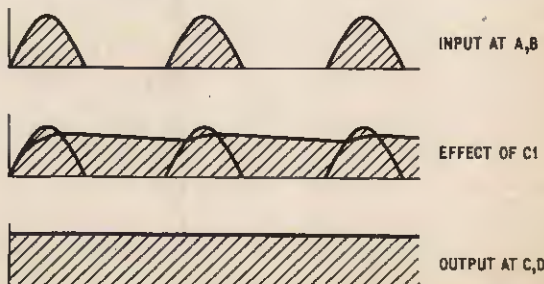

Fig. 16.2. These waveforms illustrate the smoothing action of the filter

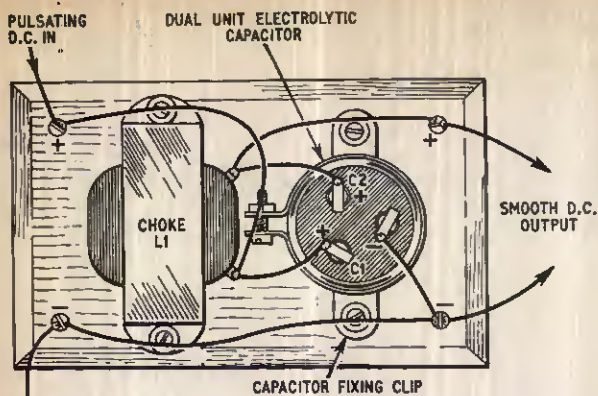

Fig. 16.3. A top view of the high voltage filter unit. The low voltage filter is identical except that C1 and C2 will be two separate components

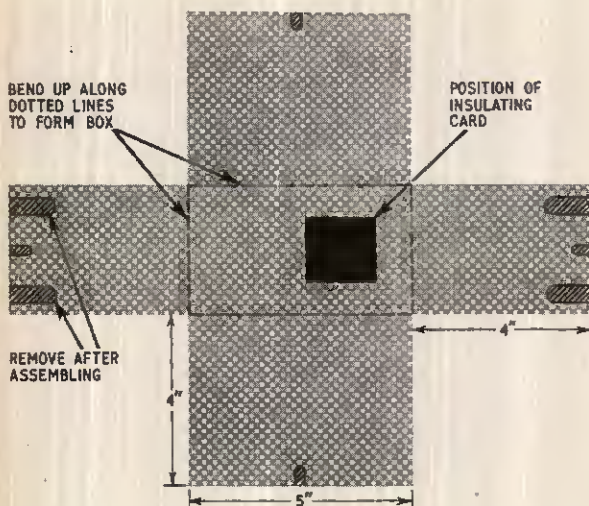

Fig. 16.4. Preparation of the perforated zinc sheet to make a cover. The sides can be bent up, and card corners stuck on. This is strong and easier to carry out than soldering the perforated zinc

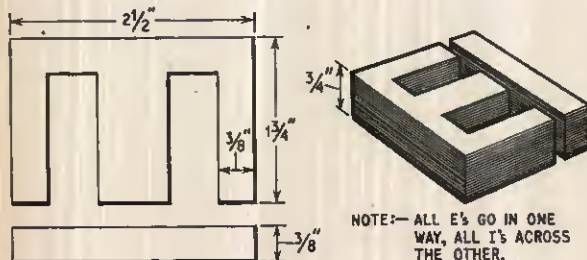

Fig. 16.5. Size of standard laminations suitable for the O-1H 2-amp choke for second filter. The stack of laminations should be about $\frac{3}{4}$ in for best results. A thin piece of paper should be inserted between the E and I stack. This just keeps the laminations apart, thus introducing a small air gap in the magnetic path

Construction is carried out on one of our standard wooden baseboards, and a perforated zinc cover is added to shield the high voltage points from the possibility of being touched. The diagrams and photographs show just where everything goes. It is useful to remember that this unit added to the output of an existing power pack will give a vast improvement in the smoothing, probably eliminating any residual hum still present in the original circuit.

IMPORTANT POINTS

Remember to connect up the electrolytic capacitors correct way round and to connect the supply positive to positive and negative to negative. Note carefully any information printed on the electrolytic capacitors. Make sure that the voltage ratings indicated on the capacitors agree with the details given in the components list.

Sometimes the aluminium can is connected internally to the negative side of the capacitors; when this is so, a separate negative solder tag may not be provided and external connection is then made by attaching a lead under one of the screws on the metal fixing clip. This brings us to another important point: always ensure that you obtain the appropriate fixing clips when you purchase electrolytic capacitors.

Small wooden panels, nearly the size used in our designs, are on sale in Woolworth's Stores. These are meant to take electrical fittings, (plugs points etc.) mounted on walls. As they say—just the job!

LOW VOLTAGE FILTER

The second filter unit supplies around 12 volts at one to two amps, and is suitable for supplying circuits employing transistors. There is no need to cover up with a shield this time, unless you would like to make one for matching the other unit, but be careful not to mistake which unit is which, or trouble will arise indeed! (Perhaps different coloured paint would overcome this hazard.)

SMOOTHING CHOKE

The components list mentions everything except the smoothing choke (L1) for the low voltage, high current unit. This particular component cannot be readily obtained in the shops, but can be made from an old loudspeaker transformer or choke similar in size to the one used in the high voltage filter. Such components can be salvaged from an old radio or television set, or a dealer will supply them. Secondhand components are quite suitable for this purpose.

Strip the transformer or choke right down, keep the laminations and bobbin, but dispose of the fine wire that formerly filled it. Now wind on about 400 turns of 24 s.w.g. enamelled copper wire. When you have covered the coil you have produced with a protecting layer of tape, replace the laminations. Notice that all the "E" laminations go in one way, and all the "I" strips go on the other end, with a piece of paper between. See Fig. 16.5. The lamination shroud now goes on, and the component is ready to be screwed down.

It is unlikely that you will be able to obtain a dual unit capacitor for the values required in this second filter unit. Two separate capacitors (as detailed in the components list) can be mounted side by side on the board. Note the remarks concerning electrolytic capacitors in general given in the section dealing with the high voltage filter.

Next time we shall discuss changing a.c. into d.c. and d.c. into a.c.

NEW PRODUCTS

Miniature 12 watt Amplifier

Sinclair Radionics Ltd., Comberton, Cambridge.

Our photograph shows a really small amplifier, measuring $3\text{in} \times 1\frac{1}{2}\text{in} \times 1\frac{1}{2}\text{in}$. Called the Sinclair Z-12 it has a claimed maximum power output of 15 watts music power (12 watt r.m.s.) with a signal-to-noise ratio of less than 60dB. There are eight transistors in the amplifier, which operates from any d.c. power supply between 6 and 20 volts. The frequency response is 15 to 50,000 c/s $\pm 1\text{dB}$ and the quiescent current consumption is 15mA. Input sensitivity is 2mV into 2 kilohms.

The user can add his own tone and volume control circuit to suit his own requirements. Some suggested tone control circuits are given in the manual which is supplied with the amplifier.

The price of the Z-12 amplifier supplied built, tested and guaranteed is £4 9s 6d.

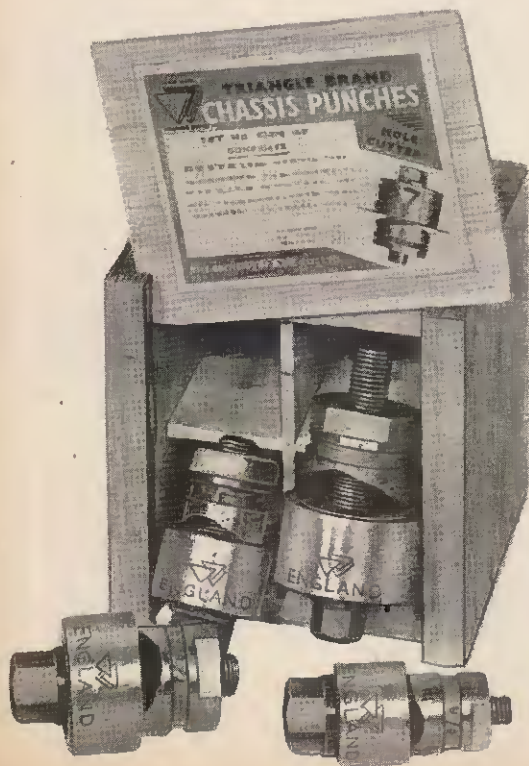
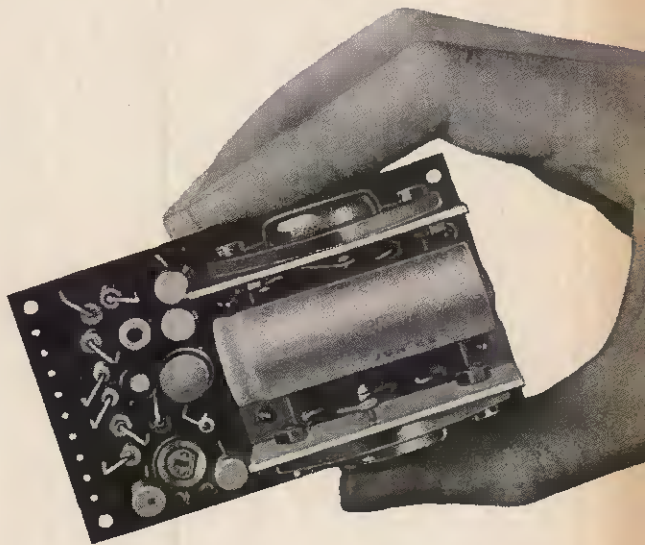

Chassis Punches

The British Tap & Die Co. Ltd., Triangle Works, Montagu Road, Edmonton, London, N.9.

The chassis punches depicted here are made from ground hardened steel and designed to cut accurate, clean holes in flat or curved sheet metal up to 16 s.w.g. mild steel, aluminium, brass or copper.

Although chassis punches are rather expensive items the amount of time saved and the clean burr-free finish obtained is well worth the outlay.

These punches are available individually or in four sets of four punches in the following ranges: $\frac{1}{8}\text{in}$; $\frac{3}{16}\text{in}$; $\frac{1}{4}\text{in}$; 1in , $\frac{3}{8}\text{in}$; $\frac{1}{2}\text{in}$; $\frac{7}{8}\text{in}$; 1in , $1\frac{1}{8}\text{in}$; $1\frac{1}{4}\text{in}$; $1\frac{1}{2}\text{in}$; 2in , $1\frac{1}{8}\text{in}$; $1\frac{1}{4}\text{in}$; $1\frac{3}{8}\text{in}$; $1\frac{1}{2}\text{in}$.

The price of the sets range from £3 13s 0d to £5 12s 0d; all sets are packed in polished wooden cases.

Instrument Cleaner

Multicore Solders Ltd., Multicore Works, Maylands Avenue, Hemel Hempstead, Herts.

We are always being warned by manufacturers to be extremely careful when cleaning certain types of instruments, meters, tape heads, etc. Now Multicore Solders have just announced their new Bib instrument cleaner which is ideal for cleaning tape heads (without risk of damage to the tape) as well as instrument panels, radio and television cabinets, telephones, and other items made from plastics, chrome and glass.

The new cleaner is contained in a plastics "squeeze" bottle (4fl ozs) and is anti-static, non-flammable, non-toxic, antiseptic and will not scratch or smear. During testing we found that when used on television screens to prevent static it is desirable to use a chamois leather. The use of other types of materials tended to leave "detached particles" on the screen which were very difficult to remove.

The retail price of the 4fl ozs size is 4s 6d.



Low Voltage Fluorescent Light Fitting

Osmabet Ltd., 46, Kenilworth Road, Edgware, Middlesex.

A new product with many applications, (for example, in caravans, cars, boats, workshops, and as emergency lighting) is the "Newlite" low voltage fluorescent light fitting. This unit is claimed to be equal to any mains operated fitting and uses standard mains 2ft 20 watt tubes.

The main feature of the unit is a transistor operated inverter for use with a 12 volt battery which is rated at 2 amp to step up the voltage.

The unit weighs 2½lb less tube, is 25in long and fixed by means of two screws. The retail price of the Newlite is £6 10s 0d less tube.

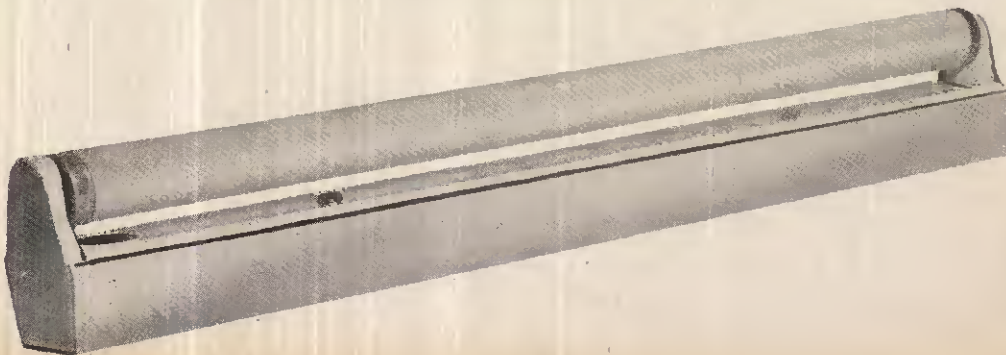

COMPACT POWER UNIT

A USEFUL adjunct to a workshop bench is a d.c. power source that has a general purpose appeal to the majority of valve circuit applications. The beginner, attempting the construction of mains-operated equipment for the first time, should find little difficulty in making this unit. It will provide a valuable exercise in wiring commonly used components.



INTRODUCTION

The unit was originally designed to provide power for a small amateur radio station, comprising a home built receiver and transmitter for top band. The usual heater supply of 6.3 volts at a few amps was required, together with an h.t. supply of 250 volts at 60 to 70mA. The receiver and transmitter were not intended to draw h.t. at the same time!

Also, and most important, there was very little room available on an already crowded table top, and so the unit had to be physically small.

Thus this unit was evolved, using a chassis 7in x 5in x 2½in. It was constructed as far as possible with components that were to hand.

by K. Adkins

A double pole switch S1 is incorporated in the mains input, thus ensuring complete isolation from the mains when S1 is off. The unit is equipped with fuses to protect it from overload conditions.

An EZ81 was used as the double diode rectifier. This valve has a 6.3 volt heater which is supplied by the 6.3 volt 1 amp transformer winding with one side taken to chassis. A pilot lamp LP1 is fitted and connected across the same winding.

After rectification, the supply is smoothed by the π -filter made up of C1, L1, and C2. On no load the reservoir capacitor C1 is charged to about 350 volts. On full load of 65mA the output is reduced to 250 volts.

CIRCUIT

It can be seen from Fig. 1 that the circuit employs full wave rectification, with the usual capacitor and choke smoothing and filtering arrangement.

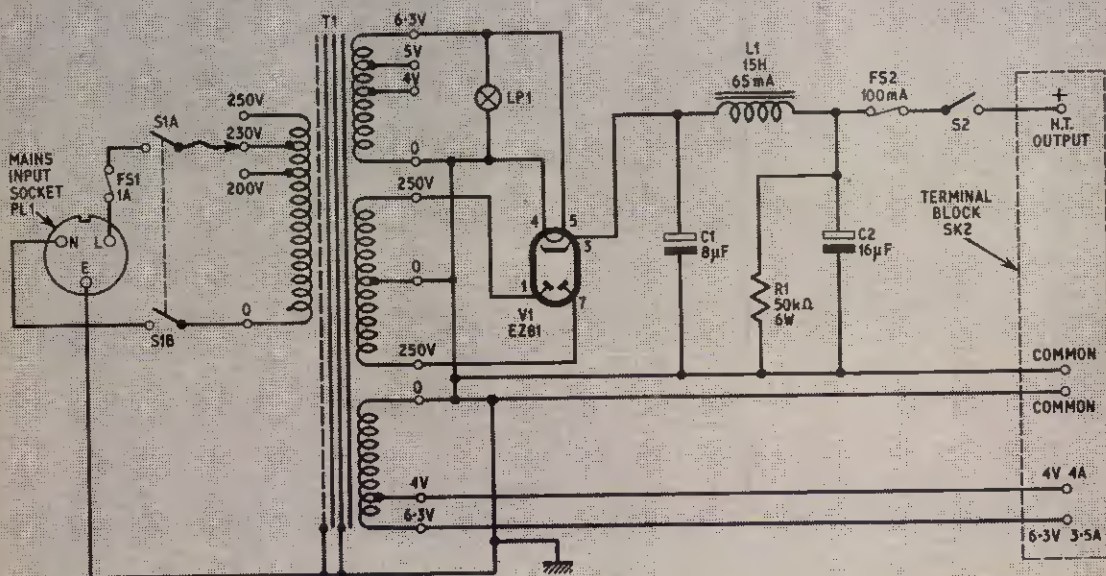

Fig. 1. Circuit diagram of the complete power unit

SPECIFICATION...

A.C. INPUT	200 to 250 volts, 50c/s mains
D.C. OUTPUT	250 volts, 65mA
A.C. OUTPUT	6.3 volts, 3.5 amp or 4 volts, 4 amp

It is a characteristic of this type of power unit, where the regulation is poor, that the output voltage will vary between the limits given, dependent on the load current drawn.

The ripple fundamental frequency of 100 c/s is reduced by the factor $L_1 C_2 \omega^2 - 1$. This was measured and found to have an r.m.s. value of less than 0.5 volts which can be neglected for many practical applications.

A single "canned" electrolytic, $3 + 16\mu\text{F}$ at 500V working was used for capacitors C1 and C2, the latter being shunted by a "bleeder" resistor R1, the function

COMPONENTS...

Resistor

R1 50k Ω 10% 6W wirewound

Capacitors

C1 8 μF elect. 500V
C2 16 μF elect. 500V } in the same can

Choke

L1 15H 65mA

Transformer

T1 Primary 200-230-250 volts
Secondary 1: 250-0-250V, 80mA;
2: 4V 4A or 6.3V 3.5A;
3: 4V, 5V 2A, or 6.3V 1A
(Douglas mains transformer type MT 1 AT)

Valve

V1 EZ81 (Mullard)

Switches

S1 Double-pole, on-off, toggle switch
S2 Single-pole, on-off, toggle switch

Fuses

FS1 1A (cartridge type with panel mounting fuseholder)
FS2 100mA (cartridge type with panel mounting fuseholder)

Plugs and Sockets

PL1, SK1 Chassis mounting mains connectors 3-pin (Bulgin type P73 or similar)
SK2 Terminal block, at least 5-way (see photographs)

Lamp

LPI 6.5V, 0.15A with red indicator mounting

Miscellaneous

Chassis 7in \times 5in \times 2 $\frac{1}{2}$ in (H. L. Smith & Co. Ltd., 287 Edgware Road, London W2); B9A valveholder; Five-way tag strip, centre tag chassis mounting; Grommets for $\frac{3}{8}$ in dia. mounting hole; P.V.C. covered wire; Nuts and bolts 4B.A. and 6B.A., $\frac{1}{2}$ in long; Expanded metal 16in \times 14in for protective cover.

of which is to discharge C1 and C2. This is a rather important feature since it prevents the possibility of shocks should the h.t. line be touched immediately after switching off the unit. An h.t. switch, S2, is incorporated after the "bleeder" resistance so that the h.t. may be switched off independently of the 6.3V heater supply.

There is one other heater winding made available on the unit giving either 4 volts 4 amp, or 6.3 volts 3.5 amp. It will be seen from the circuit diagram that one side of each 6.3V heater winding is connected to chassis. In the wiring of the output side of the transformer, all tags marked "0", including the tag marked screen should be taken to a common point on the chassis.

All the output voltages at the terminal block are quoted as being relative to "0" or "chassis". If the valve heaters of an external piece of equipment connected to the unit are connected to chassis on one side, it is important that both earth lines are made common, otherwise the heater winding will be short-circuited.

The 1 amp fuse gives transformer protection, but prudence should be exercised in all cases. It is worth mentioning at this point that the common line should be connected to earth at the power unit end only, otherwise hum may arise from earth loops.

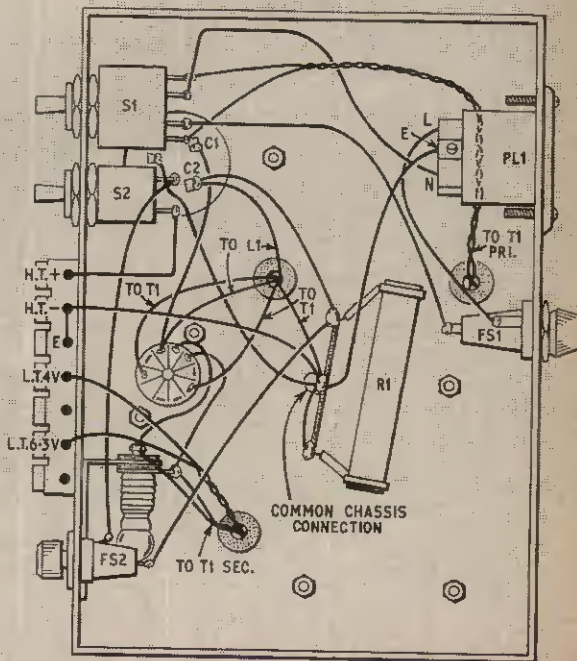

Fig. 2. Underside view of the chassis

CONSTRUCTION

The chassis of 16 s.w.g. aluminium sheet, was bought. It is a commonly available size and no difficulty should be found in acquiring one (see components list).

The mains supply is connected via socket SK1 to the mains fuse and mains windings of T1. Make sure that the correct mains tapings are used to suit the mains supply voltage. The chassis drilling details in Fig. 3 conform to the components specified and these should be followed if the small physical size of the whole unit is to be maintained.

Leads are taken from the transformer and choke to the underside of the chassis, through rubber grommets fitted to the chassis, to the valveholder tags and capacitors. R1 is mounted on the tag strip, the mounting tag of this strip is the common connection for all leads going to chassis.

All leads carrying a.c. should be twisted, to reduce the risk of hum pick-up. The wire used for the 6.3V and 4V supplies should not be too thin if several amperes are to be carried (18 s.w.g. will suit all heater wiring here). The outputs are taken by way of five holes drilled through the front of the chassis. The ends are then bared and held securely by the lower screws of the terminal block. It is important that the holes drilled should be free from burrs to obviate any chance of short-circuits due to puncturing the insulation. The use of grommets will also obviate these risks. The output leads should be insulated as far as possible into the terminal block.

When the wiring has been completed it should be thoroughly checked; then the power unit may be tested. No difficulty should be experienced in getting the unit to work as the circuit is quite simple.

In practice, the unit has served its purpose very well, producing virtually no hum and running quite cool with a continuous drain of 70mA from the h.t. terminals. ★

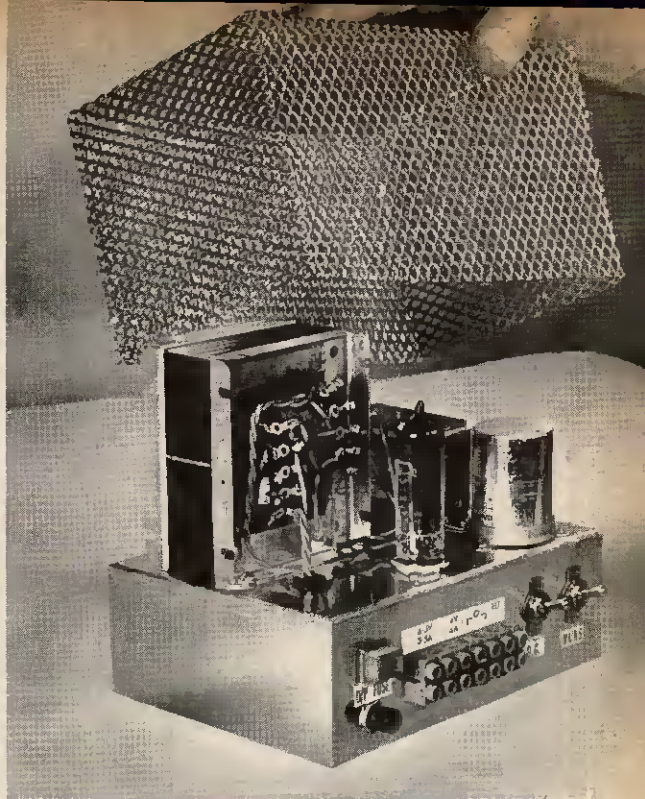

Complete power unit showing the cover made from expanded metal. This cover can be attached to the chassis with self-tapping screws

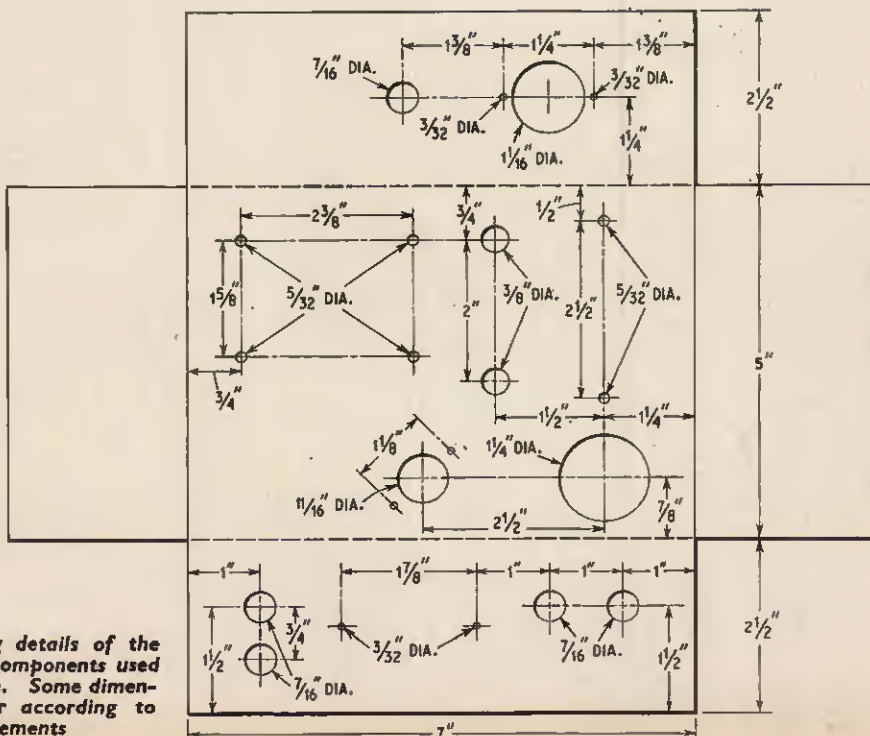

Fig. 3. Drilling details of the chassis for the components used in the prototype. Some dimensions may differ according to individual requirements



Electronics Enthusiasts take note

Two valuable new Pitman books for the Electronics enthusiast

FREE!

If you want to know more about the three other books by Alan Douglas, or the whole range of PITMAN books on electronics write to :

Dept. PE, Sir Isaac Pitman & Sons Ltd., 39 Parker Street, London, W.C.2.



Making music the hard way!

Transistor Electronic Organs for the Amateur

By Alan Douglas and S. Astley

There are undoubtedly easier ways of making music than by first constructing an electronic organ—but to the enthusiast there can be no other way. This is the fourth book by Alan Douglas, who is probably the country's leading writer on this type of equipment. It presents not only a detailed design for a full scale organ, but a complete explanation of everything to do with transistorised organs. It is written in a simple style especially for the amateur constructor, and profusely illustrated with clear diagrams.

eighteen shillings net

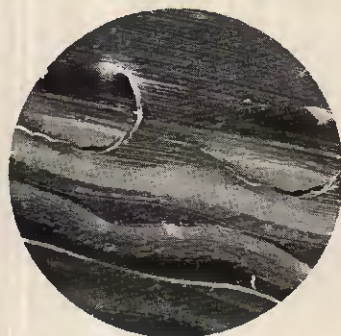

*Dispelling
an old
theory*

Pick-ups The Key to Hi-Fi

By J. Walton

For many years it has been the assumption that the loudspeaker is the weakest link in the record reproducing chain. This book challenges that theory. The author, after many years of research into the subject, concludes that it is the pick-up that causes most distortion. It is no exaggeration to say that, by following his advice, the owner of an ordinary gramophone or record player or the hi-fi enthusiast will not only achieve a superior standard of record reproduction, but will ensure that his records will last much longer.

"... can be highly recommended as a first-class introduction to the subject of high quality record reproduction."—*Hi-Fi News*.
ten shillings net

NEWS BRIEFS

Audio Fair 1966

THE AUDIO FESTIVAL AND FAIR will be held as usual in the Hotel Russell in London from 14 to 17 April.

Visitors will see a few changes in the layout of the Festival exhibits this year when they will be invited to climb yet another flight of stairs; an extra floor is being used with the aim of encouraging exhibitors to hire a second demonstration room in place of a booth. The purpose of this idea is to reduce the number of booths on the ground floor and provide extra gangway space which, in the past, has been hopelessly congested.

Fog Warning

A NEW photoelectric device to detect and give warning of fog on motorways and other major roads has been developed by the Lancashire Dynamo Electronic Products. An infra-red beam is projected by a light source transmitter to a remotely mounted photocell receiver. If the beam is partially or completely cut off by fog, the warning system is brought into operation.

The device has been undergoing tests by Staffordshire County police and local authority officials.

Degree Course in Computing Science

THE FIRST full-time degree course in Computing Science has already begun at the Stafford College of Technology. Students are being trained in all aspects of programming and data processing (generally known as "software") but not in electronics technology, which is covered in other courses.

The principle aims of the course are: to help to fill the increasing need for skilled computer programmers throughout the country; to offer to suitable candidates with the G.C.E. in subjects other than science subjects (for example, Geography, Economics, Languages) an opening where these subjects could be suitably applied during the course and later in industry.

The course is open to students who have two G.C.E. "A" levels and three other G.C.E. "O" levels, similar in fact to the requirements for almost any other degree course. It is based on a four year curriculum (honours degree) of combined college work and industry experience arranged in the now familiar and popular "sandwich" system.

Applicants who do not possess these qualifications, but who have other suitable qualities, aptitude, and a keen sense of vocation, will be considered on individual merits, but competition is keen and due regard will be exercised to the *potential* of candidates.

The approval of the Ministry of Education and Science and the Council for National Academic Awards has been given, bringing the course in line with other types of university degree course. It has been devised with the full co-operation of the English Electric Leo Marconi Company who have provided computing equipment and lecturers.

Our photograph shows the English Electric "Deuce" computer being introduced to students in the College by the computer supervisor.

Full details of the course can be obtained from The Principal, Staffordshire College of Technology, Beaconside, Stafford.

Teaching Aids

DEVELOPMENT of "language laboratories" for schools has progressed very well. A new prototype, made by Tolnai of Sweden, uses 2in wide tapes. The master tape has 36 tracks with a capacity for up to 84 hours of instructional material (enough for one year's syllabus); a slave loop tape can store some of this material as required for short repetition sessions.

This equipment was exhibited by RCA Great Britain Limited recently with another prototype programmed teaching aid which uses 16mm film strip. This uses a simple "telephone dial" type of answer selection system in which, if the answer is correctly selected, steps the film on to the next frame or, if incorrectly selected, steps it to additional information.

Two models of video tape recording equipment were also demonstrated, using the revolving head, frequency modulated, no-bias recording principles already well established.

PAL Colour for U.K.

THE Postmaster-General, the Rt. Hon. Anthony Wedgwood Benn, M.P., announced in the House of Commons on 2 December, 1965, that the Television Advisory Committee appointed by the Government had recommended the adoption of the German PAL colour television system for United Kingdom. This was immediately followed by an urgent request by Mr. Bryan, M.P., for the granting of a second channel for I.T.A. to operate on the 625 line system, so that it can come into line with the B.B.C. and broadcast colour pictures on 625 lines.

Royal Charter

A ROYAL CHARTER has been granted to the Engineering Institutions' Joint Council, which is now called the Council of Engineering Institutions. The E.I.J.C. was formed three years ago by councils of thirteen engineering institutions, including the I.E.R.E. and the I.E.E., to promote greater mutual exchange of ideas and co-operation in allied subjects.

The Duke of Edinburgh has agreed to accept the office of Founder-President for a period of five years. Existing corporate members of any of the constituent institutions are entitled to describe themselves as Chartered Engineers (C.Eng.).



USERS ACCLAIM *Kedoco* PRODUCTS

KEDOCO CLASSIC SS20/7 20 WATTS

£9-19-6

READY BUILT

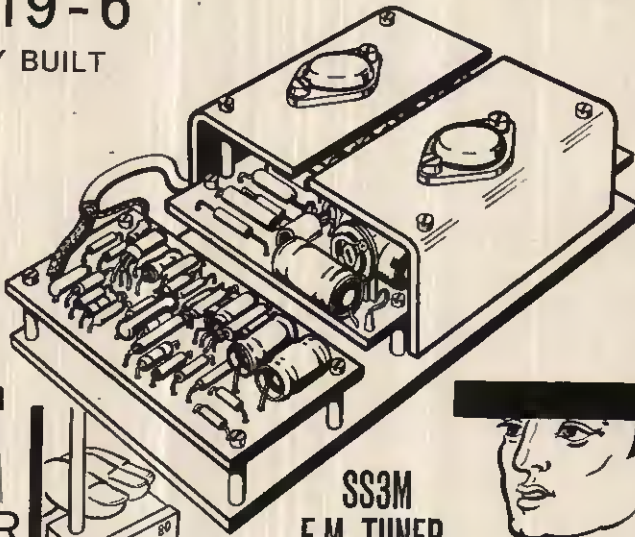

Believe it or not we have actually produced an all transistor integrated HIFI amplifier complete with pre-amp and tone controls giving 20 watts power output and ready to operate for only £9 19s. 6d. The KEDOCO CLASSIC SS20/7 is the result of several years of research and investigation into the various approaches to solid state amplification. The end product, Kedoco engineers claim, with complete confidence, is the finest power amplifier available today and stands above all others for quality in a class of its own. The CLASSIC requires a 30 volt power supply but consumes only 20mA*. It will operate into most speakers but the best results are obtained with 3 ohms. We are confident you find this amplifier excels others costing many times its price.

SPECIFICATION—

20 watts output max. Distortion less than 0.1%. Frequency response flat from 16c/s to 20kc/s. Noise 80dB down on max. output.

* quiescent

POWER SUPPLY

30 volt
3 amps
Ready built
and ideal for
your Kedoco Classic and
will power 2 of them

69/6

Quantity discounts on application for all semi-conductors

ZENER DIODE

Silicon planar diffused units featuring very sharp knee. Type No. specifies voltage. KZ5.1 Types KZ7.5, KZ5.6 KZ8.2, KZ6.2 KZ9.1, KZ6.8

10% tolerance. Slope resistance nominally 10 ohm at 5mA. Dissipation 250mW Temperature coefficient 0.01% per degree C.

3/11

EACH

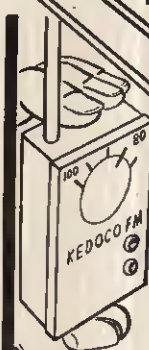

SS3M F.M. TUNER

80—100 mc/s

The smallest 7 transistor FM Tuner. Tunable through the whole broadcast V.H.F. band housed in case measuring only 84mm. by 42mm. by 20mm. unbeatable value at

119/-

Kit with full Instructions

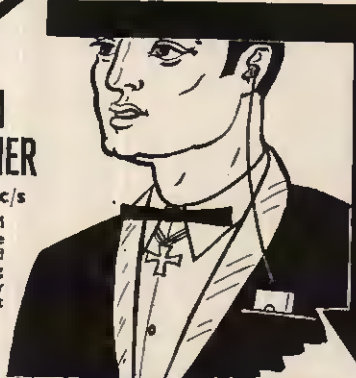

MINICLASSIC SS3/9

3 watts output. 6 silicon planar epitaxial transistors. 2 diodes and one zener. All mounted on precision printed circuit board.

HIFI at its cheapest — 16 c/s to 30 kc/s flat response. Many other uses. Requires 18 volt power supply. Will operate directly from crystal pick-up. Used with tape Pre-amp it makes a complete Tape Amplifier. Also tone controlled HIFI Pre-amp available at 39/-.

69/-

READY BUILT

PLANAR EPITAXIAL SILICON TRANSISTOR

Double diffused npn. Suitable from audio to RF power applications. I_{co} less than 100nA. V_{bebo} greater than 30 volts. Power output at 28mc/s typically 300mW. Emitter/base breakdown voltage greater than 5 volts. Typical f_t 300mc/s. hfe KPS 24 min hfe 20 KPS 25 min 50

KPS 24 7/11
KPS 25 9/11

UNIQUE FRONT PANEL SYSTEM

In a choice of three hardwood finishes, mahogany, oak, or walnut, with superb high gloss polish and beautifully engraved. This unique idea offers you the facility of putting your whole system speedily into your own cabinet.

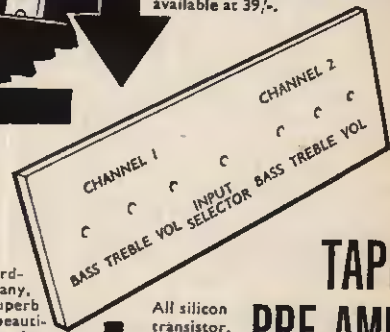

MONO 9/6
STEREO 19/6
12" x 6" 24" x 6"

All silicon transistor. Zero hum.

TAPE PRE-AMP

High gain fully compensated to give flat response output. Suitable for medium impedance heads such as Collaro, Truvox, B.S.R., equalised for 3 1/2 inches/second. Simple mod. allows equalisation at any speed.

29/6

COMPLETE

NEW BOOK

3/11

Theory and applications of planar epitaxial transistors. Explains significance of these new transistors and gives many interesting circuits.

ORDER FORM: To KEDOCO ELECTRONICS, BEVERSTONE WORKS, TETBURY, GLOS.

PLEASE SUPPLY _____ ADDRESS _____

Enclose Cheque/P.O. for _____ Postage 2/6 extra for all orders under £1

All KEDOCO products are fully guaranteed and should you not be completely satisfied with your purchase we will gladly refund your money.

A.F. and R.F. SIGNAL TRACER

by C. P. May

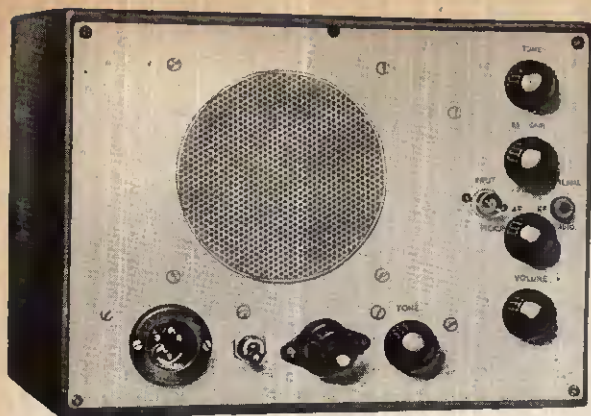

DUE TO changing techniques in construction and new components, there is very likely to be a substantial surplus of old, but still serviceable, components in constructors' work rooms. It is with this in mind that the following article is aimed at making good use of these parts; alternatively, if purchases have to be made, the cost could be very low.

This unit will perform well as a signal tracer for both a.f. and r.f. signals, as an amplifier suitable for use with a microphone or pick-up, or as a radio receiver. An extremely versatile test set such as this can be made up quickly and cheaply. Component values are, to a certain degree, flexible.

VARI-MU

Referring to Fig. 1, it can be seen that the first two stages constitute an r.f. amplifier. The anode loads (R2 and R7) of both of these valves are resistors, so that the gain is independent of frequency up to about 1 Mc/s. Hence the unit does not have to be tuned to the same frequency as the signal being traced.

Above about 1 Mc/s the shunt capacitance from anode to earth of each valve reduces the gain. The response can be improved at the expense of gain by reducing the value of R2 and R7 or by removing C4 and C6. Alternatively, C4 and C6 can be reduced to about 1,000pF so that their decoupling effect only applies at high frequencies—but this latter technique requires a wide-band oscillator and an oscilloscope.

The first stage is a variable- μ pentode and the gain is controlled by a potentiometer in the cathode circuit. This is better than using a "straight" r.f. pentode and a potentiometer in the grid circuit, for in this position it damps the input and is liable to pick-up phenomena. The second stage is a high- μ pentode. Since the stage gain is approximately equal to $R_L g_m$, where R_L is the load resistor, a high g_m enables a low value of R_L to be used. This in turn reduces the effect of stray shunt capacitances since the gain falls by 3dB when $R_L = 1/\omega C_s$.

The detector (V3) is a 6H6 with both halves strapped in parallel. This could, with advantage, be replaced by a semiconductor diode such as an OA78. This is

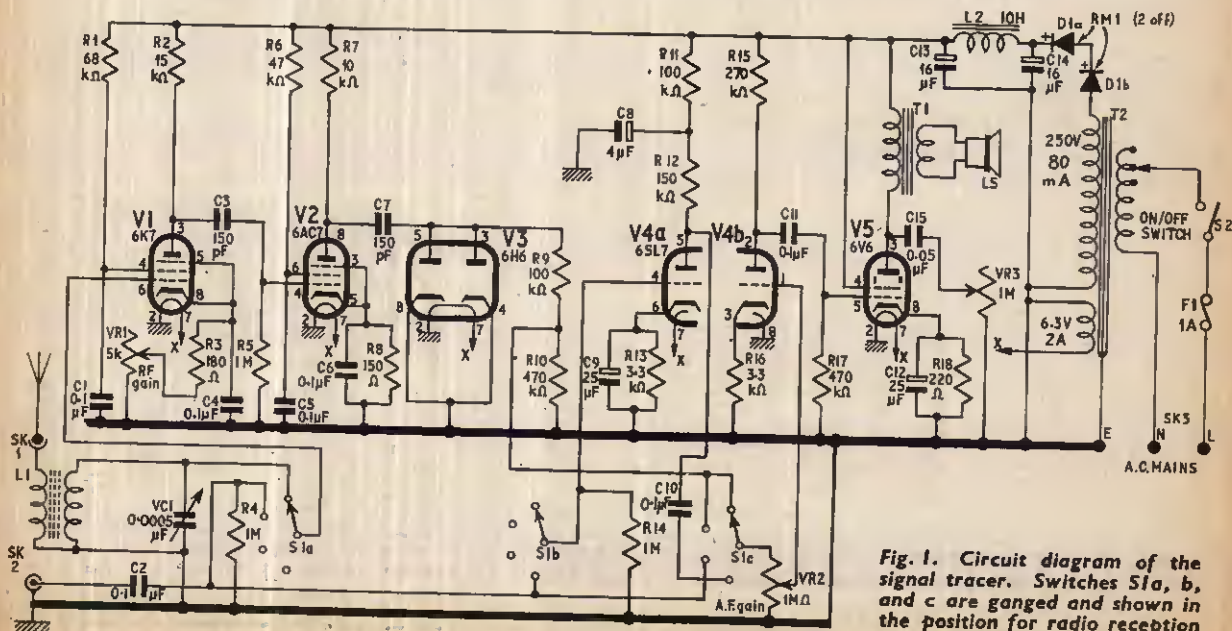

Fig. 1. Circuit diagram of the signal tracer. Switches S1a, b, and c are ganged and shown in the position for radio reception

followed by two triode audio amplifiers (V4a and V4b) in cascade. When used to trace r.f. signals, or as a radio, only one stage (V4b) is needed. The other stage (V4a) is provided to give sufficient gain for use with microphones or pick-ups, or for tracing very low level audio signals. The anode of V4a is decoupled by C8. If hum is excessive in the "radio" position, the anode load of V4b (R15) could be divided into two components, 100 kilohms and 150 kilohms, with an $8\mu\text{F}$ decoupling capacitor between their junction and chassis, as in the case of V4a anode load.

The output stage (V5) is a conventional power beam tetrode. A certain degree of tone control is possible by C15 and VR3. These components by-pass high frequencies to earth. The degree of attenuation is controlled by VR3. The value of C15 can be varied to suit individual loudspeakers and personal preferences. The unit does not really merit the inclusion of more elaborate tone controls, since it is not intended as a high fidelity instrument.

A simple power supply is included. This uses a metal rectifier, giving half-wave rectification, a reservoir capacitor (C14) and a smoothing circuit L2 and C13. Provided a separate heater supply is available on the transformer, a valve rectifier such as an EZ80 or a 6X4 could be used. In this case, it is best to include a protecting resistor of about 100 ohms and 2 watts rating in series with each anode of the rectifier.

FOUR FUNCTIONS

The various functions of the instrument are selected by the 3-pole 4-way rotary switch S1. In the first position (as shown in Fig. 1), the signal from the aerial, connected to SK1, is fed to the grid of V1 via the tuned circuit comprising L1 and VC1. This single tuned circuit provides adequate selectivity if only local stations are required. Some improvement can be achieved by ensuring that the "chassis" is earthed through the mains plug.

A probe can be connected to the coaxial socket SK2, so that the signal in a radio receiver or amplifier can be traced. With the switch in the second position this

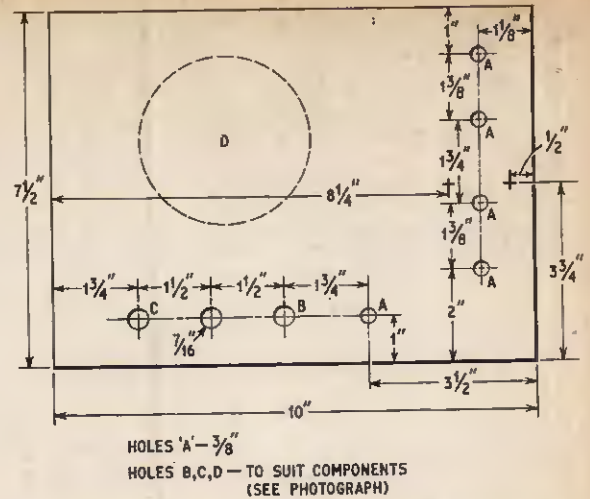

Fig. 2. Suggested layout and drilling details of the front panel

signal is fed via the d.c. blocking capacitor C2 through S1a to the grid of V1.

The other two switch positions provide high level and low level a.f. inputs to V4b and V4a respectively. Both are high impedance inputs.

CONTROL PANEL

The front panel is made from 14 s.w.g. aluminium but other strong material will suit just as well. The spacing of the controls on this panel is not critical but it will be found that the diagram in Fig. 2 shows a logical scheme whereby leads are kept to a minimum. All fixing holes for the controls are $\frac{3}{16}$ in diameter except possibly the mains switch, which may need a $\frac{1}{8}$ in hole. The mains socket hole is $1\frac{1}{16}$ in diameter and the indicator lamp hole will depend on the actual item if fitted.

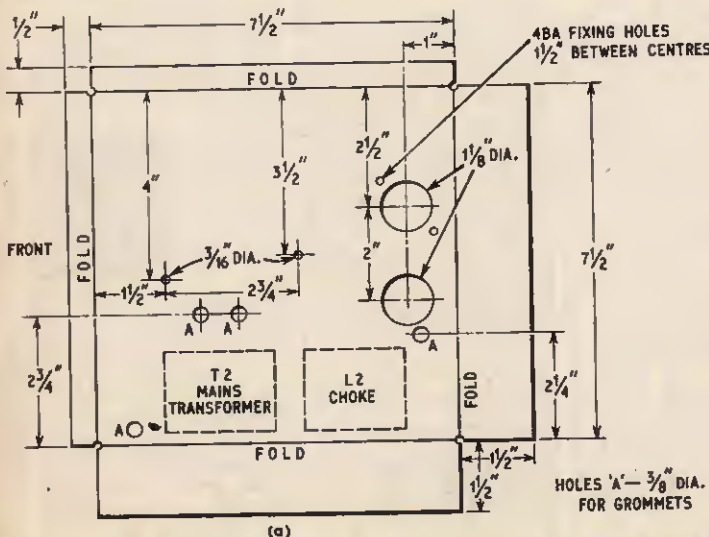

Fig. 3a. Drilling details of the power unit chassis with suggested positions of T2 and L2. The output transformer T1 will have to be fitted in position after final assembly according to the space available

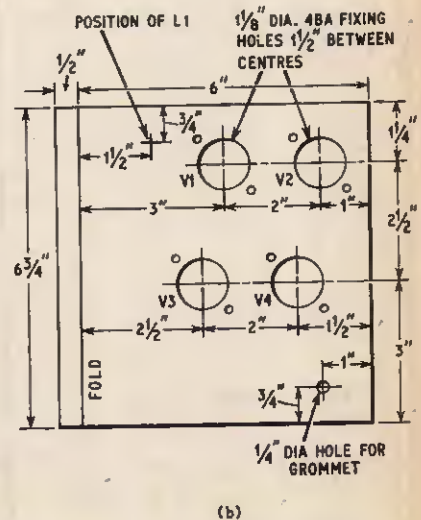

Fig. 3b. Drilling details of the side panel, with a fold for fixing to the front panel

LASKY'S RADIO

For the Finest Value and Service to the HOME CONSTRUCTOR AND THE ELECTRONICS ENTHUSIAST

We consider our construction parcels to be the finest value on the home constructor market. If on receipt you feel not competent to build the set, you may return it as received within 7 days, when the sum paid will be refunded less postage.

TRANSISTOR PORTABLES

THE SKYROVER RANGE

7 transistor and 2 diode superhet portables—covering full med. plus 6 SW Bands.

The SKYROVER Mk III.

(Illustrated). Now supplied with redesigned plastic cabinet in black, grey and chrome with edgewise controls.

Controls: Waveband Selector, Volume Control with on/off switch, Tuning Control. In plastic cabinet, size 10 x 6 1/2 x 3 1/2 in. with metal trim and carrying handle.

Can now be built for **£8.19.6** Post 5/- extra
H.P. Terms: 27/- deposit and 11 monthly payments of 15/9. Total H.P.P. £10.0s.3d.

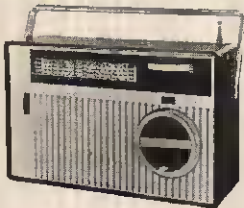

The SKYROVER De Luxe

Tone Circuit is incorporated, with separate Tone Control in addition to Volume Control. Tuning Control and Waveband Selector. In a wood cabinet, size 11 1/2 x 6 1/2 x 3 1/2 in. covered with a washable material, with plastic trim and carrying handle. Also car aerial socket fitted.

Can now be built for **£10.19.6** Post 5/- extra
H.P. Terms: 33/- deposit and 11 monthly payments of 19/2. Total H.P.P. £12.3s.10d.
Data for each receiver: 2/6 extra. Refunded if you purchase the parcel. Four U2 batteries 3/4 extra. All components available separately.

★ LONG WAVEBAND COVERAGE IS NOW AVAILABLE FOR THE SKYROVER

A simple additional circuit provides coverage of the 1100/1960M. band (including 1500 M. Light programme). This is in addition to all existing Medium and Short wavebands. All necessary components with construction data.

Only **10/-** extra Post Free. This conversion is suitable for both receivers that have already been constructed.

REALISTIC SEVEN

Fully tunable long and medium bands. Uses 7 Mullard Transistors; plus Diode OA70.

STAR features:

● 7 Transistor Superhet. ● 350 Milliwatt output 4in. High Bass speaker. ● All components mounted on a single printed circuit board, size 3 1/2 in. x 3 1/2 in. in one complete assembly. ● Plastic cabinet, with carrying handle, size 7 in. x 10 in. x 3 1/2 in. in blue/grey. ● Easy to read dial. ● External socket for car aerial. ● I.F. frequency 470 Kc/s. ● Ferrite rod internal aerial. ● Operates from P.B. or similar battery. ● Full comprehensive data supplied with each Receiver. ● All coils and I.F.s, etc., fully wound ready for immediate assembly. An outstanding Receiver.



Can be built for **£5.19.6**
P. & P. 4/6

REALISTIC SEVEN De Luxe

With the same electrical specification as standard model—PLUS A SUPERIOR WOOD CABINET IN CONTEMPORARY STYLE—covered in attractive washable material, with super-chrome trim and carrying handle. Also a full vision circular dial, externally mounted to further enhance the pleasant styling. **ONLY £1 EXTRA**
Both models: Battery 3/6 extra. (All components available separately.) Data and instructions separately 2/6, refunded if you purchase parcel.

SINCLAIR SUPER MINIATURES

We stock the complete range of Sinclair Super-miniatures.

THE MICRO-6 miniature radio only 1 1/2 x 2 1/2 x 1 1/2 in.	£2 19 6
THE 8LIMLINE 2-transistor pocket radio	£2 8 6
THE X-20 20 watt P.W.M. amplifier	£7 19 6
Available ready built, tested and guaranteed	£9 19 6
THE X-10 10 watt amplifier and pre-amp.	£5 19 6
Available ready built, tested and guaranteed	£6 19 6

VEROBOARD — NOW IN STOCK

Veroboard is a high grade laminated board with copper strips bonded to it and pierced with a regular matrix of holes. Ideal for producing single items.

As featured in "Practical Electronics" April '65 issue.

Boards	
49/1503 2 1/2 x 5 in.	3/8
49/1504 2 1/2 x 3 1/2 in.	3/-
45/1507 3 1/2 x 5 in.	5/2
46/1508 3 1/2 x 3 1/2 in.	3/8
44/1505 3 1/2 x 17 in.	12/6
Accessories	
Terminal pins — pkt. of 50	3/-
Spot face cutter tool	2/6
Pin inserting tool	3/6
Post 6d. per item extra.	
Orders of 10/- and over post free.	

TRANSISTORS

ALL BRAND NEW AND GUARANTEED
GET 81, GET 85, GET 86 2/6; 673A, 574P 3/6; OC46, OC71, OC81D 4/6; OC 44, OC 70, OC 76, OC 81 5/6; (match pair 10/6); AP 117, OC 75, OC 200 8/6; OC 49, OC 43, OC 73, OC 82D 7/6; OC 201, OC 204 15/-; OC 203, OC 206 18/6; OC 28 24/6.

TRANSFILTERS

By BRUSH CRYSTAL CO. Available from stock.
TO-01B 465 kc/s. ± 2 kc/s.
TO-01D 470 kc/s. ± 2 kc/s.
TO-02B 465 kc/s. ± 1 kc/s.
TO-02D 470 kc/s. ± 1 kc/s.
7/6 EACH
Post 6d.

CONSTRUCTORS BARGAINS

SPECIAL ANNOUNCEMENT

Our Head Office and Mail Order Departments have now been transferred to our new building: **3-15 CAVELL STREET, TOWER HAMLETS, LONDON, E.1**

Telephones: **STEney Green 4821/2**
All Mail Orders, correspondences, H.P. enquiries/accounts etc. should now be sent to the above address.

These premises have been especially designed for us to facilitate the handling of Mail Orders and continue our aim of rapid dispatch coupled with good service, with which our name has been synonymous over the past 55 years.

The "Sixteen" Multirange METER KIT

This outstanding meter was featured by *Practical Wireless* in the Jan. '64 issue. Lasky's are able to offer the complete kit of parts as specified by the designer.

RANGE SPECIFICATION: D.C. volts: 0-2.5-25-50-250-500 at 20,000 Ω/V; A.C. volts: 0-25-50-250-500 at 1,000 Ω/V; D.C. current: 0-50 μA, 0-2.5-50-250 mA. Resistance: 0-2,000 Ω, 0-200 kΩ, 0-20 MΩ. Basic movement: 40 μA I.s.d. moving coil. With universal shunt full scale deflection current is 50 μA. Black plastic case—3 1/2 x 2 1/2 x 1 1/2 in. Controls: 12 position range switch; separate slide switch for A.C. volts—D.C. ohms; ohms zero adjustment pot, meter, meter zero. Power requirements: One 1.5v. and one 1.5v. batts. Complete with all parts and full construction details. H.P. Terms available.



Data and circuit available separately, 2/6; refunded if all parts bought. Pair of batteries 2/- extra.

LASKY'S PRICE **£5.19.6** P. & P. 5/-

FROM PRE-AMP TO 20 WATT HI-FI STEREO ASSEMBLY WITH MARTIN AUDIOKITS

Using specially developed circuits, the very latest transistors and printed circuits—these kits are all fully checked and tested before leaving the factory. Although the kits are basically designed for use together the pre-amplifier and mixer stages may be used to great advantage with existing valve or transistor equipment.

KIT 1. 8-stage Matching Input Selector Unit	LASKY'S PRICE 47/6
KIT 2. Pre-amplifier with volume control	LASKY'S PRICE 37/6
KIT 3. 3-Channel Mixer with plug-in adaptors for individually matching each circuit. Adaptors 5/6 each	LASKY'S PRICE 79/6
KIT 4. Pre-amplifier with tone/volume control stages	LASKY'S PRICE 62/6
KIT 5. 10 and 3 watt Main Amplifier	LASKY'S PRICE 55/12/6
KIT 6. Power supply converter unit	LASKY'S PRICE 52/6
KIT 7. 15 ohm version of Kit 5	LASKY'S PRICE 48/12/6
KIT 8. Power supply for Kit 7	LASKY'S PRICE 42/15/6

SPECIAL INTEREST ITEMS!

Give a Lasky's Gift Voucher

The ideal gift for all special occasions. Any value in multiples of 10/6 (min.) upwards.

Special Inaugural Offer—Vouchers worth more than you pay! e.g. 1 Guinea Voucher for £1—10/6 Voucher for 10/- etc.

You save money and give pleasure with a Lasky's Gift Voucher.

TEST METER ADAPTOR

Type P.E. 280—this is a fully transistorised device which enables any 50 microamp D.C. Multimeter to be used in place of a valve volt meter. On the 1V. range an impedance of 1 megohm is offered which increases on the 1000 V. range to 100 megohms. 7 ranges: 1 to 1000 volts. Designed for immediate connection to Avo 8 and similar size meters but quite suitable for use with any other 50 microamp meter. Size 0 x 0 x 5 in. New and boxed. List Price 7/6.

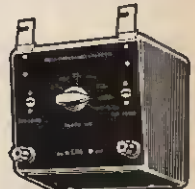

LASKY'S PRICE **39/6**

Post 2/6. Set of batteries 7/5 extra.

GORLUR UT 340 FM/VHF TUNING HEART

Permeability tuned—covering 87 to 108 Mc/s. For use with one EC68 valve. In metal case, size 3 x 2 1/2 x 1 1/2 in. Circuit supplied.

LASKY'S PRICE **19/11** Post 2/-

EC68 valve 9/- extra

U.H.F. TUNERS

Only a few available. Complete with PC68 and PC88 valves. We regret no circuit or data is available. Knobs included.

LASKY'S PRICE

69/6 Post 2/6.



207 EDGWARE ROAD, LONDON W.2 Tel: PAD 3271
33 TOTTENHAM CT. RD., LONDON, W.1 Tel: MUS 2605

Both open all day Saturday. Early closing Thursday.

Please address all Mail Orders and Correspondence to 3-15 Cavell St., Tower Hamlets, London, E.1. Tel.: STE 4821/2

42 TOTTENHAM CT. RD., LONDON, W.1 Tel: LAN 2573
152/3 FLEET STREET, LONDON, E.C.4 Tel: FLE 2833

Both open all day Thursday. Early closing Saturday.

LASKY'S FOR SPEEDY MAIL ORDER SERVICE

HERE'S VERSATILITY FOR YOU...

The **Brenell**

MONO/STEREO HI-FI TAPE LINK

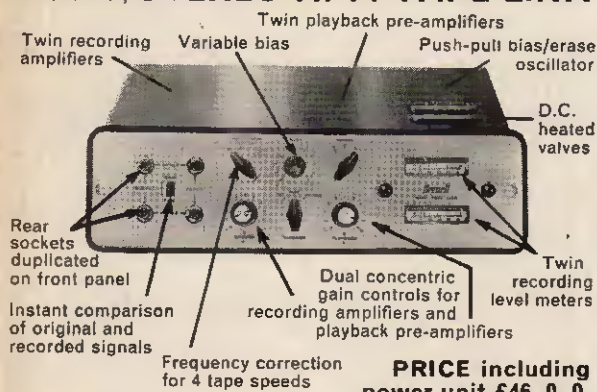

Designed for use with 2/2 or 2/4-track heads

Built to the same high standards as our tape recorders and decks this HI-FI TAPE LINK has been developed for use with your high fidelity equipment. It is capable of giving superb results when matched to one of our Mark 5 Series 3 decks fitted with the appropriate heads. Write for full details of this amplifier and deck and complete range of tape recorders.

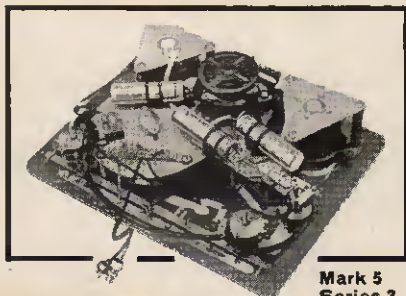

Mark 5
Series 3
Deck

Brenell

BRENELL ENGINEERING CO. LTD.,
231/5 Liverpool Road, London, N.1.
Telephone: NORTH 8271 (5 lines) GD378

The finest in the World

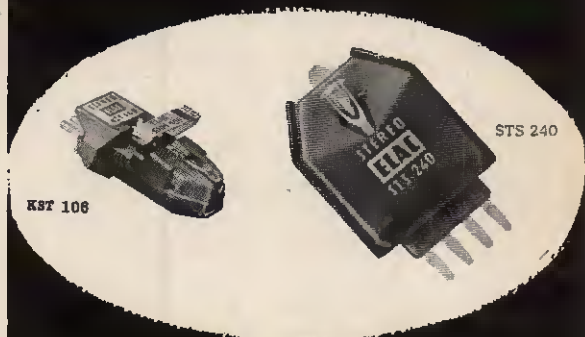

ELAC Cartridges

KIEL-GERMANY

THE ELAC CARTRIDGES MENTIONED IN THE "AUDIO TRENDS" FEATURE WHICH APPEARED IN THE JULY 1965 ISSUE OF PRACTICAL ELECTRONICS, ARE PART OF THE COMPLETE RANGE OF ELAC TRANSCRIPTION QUALITY EQUIPMENT AVAILABLE FROM: THE BRITISH AGENTS

MITCHELL ENTERPRISES LTD.

61 WEST STREET · DORKING · SURREY Telephone 4229



D.I.Y. with GOODMANS HIGH FIDELITY MANUAL

A new, larger and more colourful edition—revised and completely up-to-date. It contains articles of particular interest to the D.I.Y. enthusiast—including special beginners page, advice on stereo, stage-built systems and full cabinet drawings. Whether building or improving your own audio set-up or choosing a complete speaker system, you'll find it useful and interesting as well as informative. Ask your Goodmans dealer or send coupon for your FREE copy.

Please send me a free copy of the Goodmans High Fidelity Manual

Name

Address

P.E.2/66

GOODMANS GOODMANS INDUSTRIES LIMITED
Axiom Works, Wembley, Middlesex
Telephone: WEMbley 1200
A Member of the Rentasel Group

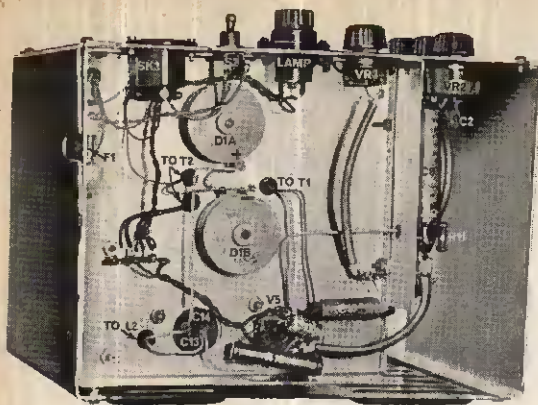

Fig. 4. View of the underside of the main chassis

COMPONENTS . . .

Resistors

R2	68k Ω	R10	470k Ω
R1	15k Ω	R11	100k Ω
R3	180 Ω	R12	150k Ω
R4	1M Ω	R13	3.3k Ω
R5	1M Ω	R14	1M Ω
R6	47k Ω	R15	270k Ω
R7	10k Ω	R16	3.3k Ω
R8	150 Ω	R17	470k Ω
R9	100k Ω	R18	220 Ω 2W

All resistors 10% $\frac{1}{2}$ watt carbon except R18

Potentiometers

VR1	5k Ω	log. or linear, carbon
VR2	1M Ω	log. carbon
VR3	1M Ω	log. carbon

Capacitors

C1	0.1 μ F	paper	350V
C2	0.1 μ F	paper	350V
C3	150pF	mica	350V
C4	0.1 μ F	paper	150V
C5	0.1 μ F	paper	350V
C6	0.1 μ F	paper	150V
C7	150pF	mica	350V
C8	4 μ F	elect.	350V
C9	25 μ F	elect.	25V
C10	0.1 μ F	paper	350V
C11	0.1 μ F	paper	350V
C12	25 μ F	elect.	25V
C13	16 μ F	elect.	350V
C14	16 μ F	elect.	350V
C15	0.05 μ F	paper	350V
VC1	500pF	variable, mica or air dielectric	

} combined in one can

Plugs and sockets

PL1 & SK1	Single-pin wander plug and socket.
PL2 & SK2	Coaxial plug and socket
PL3 & SK3	Mains connector 3-pin 5A (Bulgin type P73 or similar)

(PL1 is connected to the aerial lead and PL2 is connected to an external probe)

Construction and drilling details for the main chassis and the side plate are shown in Figs. 3a and 3b. This side plate is attached to the side of the chassis by 4 B.A. nuts and bolts; if required the plate can be bent along one side to secure it to the front panel, giving a firm mounting for this panel.

Full dimensional details for drilling have not been provided in the interests of the constructor, who may prefer to use different components or possibly devise an improved layout.

CHASSIS

It is probably best to obtain a ready made chassis of approximately similar dimensions as shown. Constructors who have facilities for bending sheet metal to the shape of the chassis, will find it easier if they mark out the positions of the bends with a scribe, then lay out the main components to be mounted on the chassis.

The positions of the fixing holes can then be marked and drilled before bending. Additional holes (for example, for grommets where leads will pass through

Transformers

T1	Output transformer: pri. 8,500 Ω , sec. 3 Ω
T2	Mains transformer: pri. 200-250V; sec. 250V 80mA, 6.3V 2A

Inductors

L1	Medium wave coil (Denco miniature dual purpose type "blue" range 2)
	Or (if to hand) Wearite type PHF3
L2	L.F. choke 10H 80 mA

Valves

V1	6K7	} (These can be replaced by miniature types with similar characteristics)	} EF85 EF80 EB91 ECC81 6BW6
V2	6AC7		
V3	6H6		
V4	6SL7		
V5	6V6		

Diode

D1a & b Metal rectifier type RMI (2 off in series) or Silicon rectifier type BY114

Switches

S1	3-pole 4-way wafer switch
S2	Single-pole, on-off, toggle switch

Fuse

F1	Chassis mounting fuseholder and 1A fuse
----	---

Loudspeaker

LS	5 in. circular, 3 ohms
----	------------------------

Miscellaneous

Chassis $7\frac{1}{2}$ in \times $7\frac{1}{2}$ in \times $1\frac{1}{2}$ in or sheet aluminium 16 s.w.g. $9\frac{1}{2}$ in \times $9\frac{1}{2}$ in;
 Side plate made from sheet aluminium 16 s.w.g. $6\frac{3}{4}$ in \times $6\frac{3}{4}$ in;
 Front panel made from sheet aluminium 14 s.w.g. 10 in \times $7\frac{1}{2}$ in;
 Case made from 16 s.w.g. aluminium or plywood;
 Tag strips; p.v.c. covered wire, coaxial cable;
 4 B.A. and 6 B.A. nuts and bolts;
 Grommets to fit $\frac{1}{4}$ in and $\frac{3}{8}$ in diameter holes;
 Five knobs; five international octal valveholders

Fig. 5. The completed unit ready for fitting in a cabinet. V3 and T1 are hidden from view in the inside corner. The tuning coil L1 used on the prototype and shown here is the type PHF3

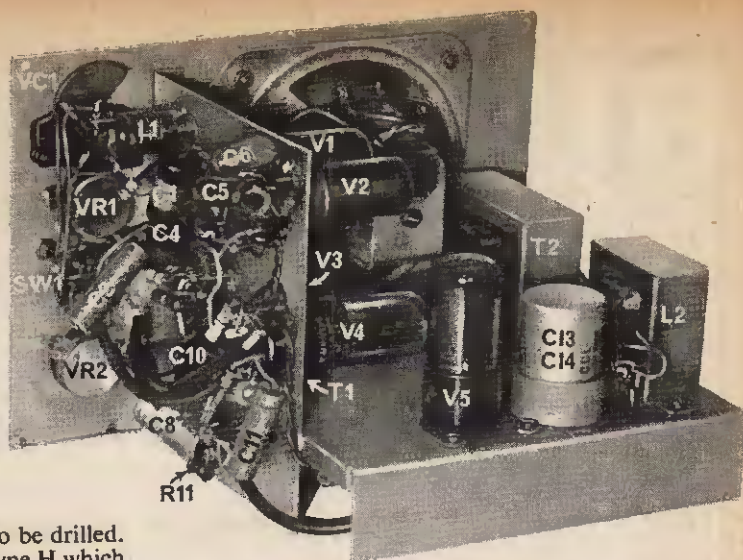

the chassis) will be required and should also be drilled. A common and useful size grommet is the type H which requires a $\frac{3}{8}$ in diameter hole drilled in the chassis. These and $\frac{1}{4}$ in types are suggested for this unit.

After completing the drilling and bending operations, the components can be mounted and wired up. Start with the heater leads, which should be twisted and run from the 6.3V winding of the mains transformer to each valveholder in parallel. One side of the heater winding is connected to chassis as close to the transformer as possible. The majority of components (resistors and capacitors) are connected direct to the valveholder tags and tag strips.

The layout is not critical but the important points to bear in mind are to use short grid and anode leads and keep them apart. Screened cable should be used for all grid leads, with the screen connected to chassis at the end furthest from the grid connections.

A guide to component positions is indicated on the two photographs in Figs. 4 and 5. It will be appreciated by many readers that full wiring details in this case cannot be provided due to the massing of components near the valveholders. The pin connections for each valve are shown in the circuit diagram (Fig. 1); the

pins are numbered in a clockwise direction starting from the spigot key, when looking at the underneath.

Since resistors are so cheap, there is no point in departing from the values given. However, most of the capacitors can be altered, provided a little common-sense is used. The mains transformer is not critical, but if the output voltage is significantly greater than 250V, C13 and C14 must be of higher voltage rating, and an additional stage of RC decoupling applied to reduce the smoothed h.t. voltage to less than 300 volts.

PERFORMANCE

No test equipment, with perhaps the exception of a voltmeter is required. There should be no trouble from instability provided due care is taken in the layout and screening. When used as a radio, good reception of medium wave programmes is possible with a few feet of wire as an aerial. The gain of the a.f. stages may be increased by decoupling R16 with a $25\mu\text{F}$ 25V electrolytic capacitor. Conversely, a lower gain is obtained if C12 is omitted. ★

PRACTICAL

WIRELESS FEBRUARY FREE!

- BLUEPRINT TO BUILD A PROGRESSIVE SHORT WAVE RECEIVER
 - EXPERIMENTER'S QUIZ MACHINE
- ON SALE
20 JANUARY**

TELEVISION FEBRUARY

- MEET THE SETMAKERS
 - OSCILLOSCOPE FROM A TV CHASSIS
 - EFFECT OF FAULTY CAPACITORS
- ON SALE
NOW**

Contributed Articles

The Editor will be pleased to consider for publication articles of a theoretical or practical nature. Constructive articles are particularly welcome, and the projects described should be of proven design, feasible for amateur constructors and use currently available components.

Intending contributors are requested to observe the style in our published articles with regard to component references on circuit diagrams and the arrangement of the components list.

The text should be written on one side of the paper only with double spacing between lines. If the manuscript is handwritten, ruled paper should be used, and care taken to ensure clarity, especially where figures and signs are concerned.

Diagrams should be drawn on separate sheets and not incorporated in the text. Photographic prints should be of a high quality suitable for reproduction; but wherever possible, negatives should be forwarded.

The Editor cannot hold himself responsible for manuscripts, but every effort will be made to return them if a stamped and addressed envelope is enclosed.

BUILD OVER 40 CIRCUIT/EXPERIMENTS

and master electronics the LERNAKIT way

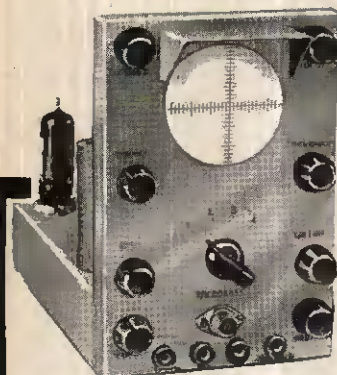

- No maths — No unnecessary theory
- NO PREVIOUS KNOWLEDGE NEEDED
- BUILD A PROFESSIONAL
CATHODE RAY OSCILLOSCOPE

Learn how to

- READ AND DRAW CIRCUIT DIAGRAMS
- RECOGNISE, HANDLE AND UNDERSTAND
every type of modern ELECTRONIC COMPONENT

OVER 40 EXPERIMENTS — including:-

- | | |
|--------------------------------|--------------------------|
| ● Valve Experiments | ● Square Wave Generator |
| ● Transistor Experiments | ● Morse Code Oscillator |
| ● Electro-magnetic Experiments | ● Simple Transmitter |
| ● Basic Amplifier | ● Electronic Switch |
| ● Basic Oscillator | ● Photo-electric Circuit |
| ● Basic Rectifier | ● Basic Computer Circuit |
| ● Signal Tracer | ● Basic Radio Receiver |
| ● Simple Counter | ● A.C. Experiments |
| ● Time Delay Circuits | ● D.C. Experiments |

This complete practical course will teach you all the basic principles of electronics by carrying out experiments and building operational apparatus. You will learn how to recognise and handle all types of modern components, their symbols and how to read a complete circuit or schematic diagram. The course then shows how all the basic electronic circuits are constructed and used and **HOW THEY ACTUALLY WORK BY USING THE OSCILLOSCOPE PROVIDED**. An application is given in all the main fields of electronics, i.e. Radio; control circuits; computers and automation; photoelectrics; counters, etc., together with rules and procedure for fault finding and servicing of all types of electronic equipment. For a new and exciting approach which gives a real understanding of electronics in an entirely practical way—this course has no equal anywhere to-day.

POST NOW FOR FREE COLOUR BROCHURE

To: **BRITISH NATIONAL RADIO SCHOOL, READING, BERKSHIRE**

Please send free Brochure, describing your LERNAKIT Oscilloscope Course without obligation, to:

NAME

ADDRESS

BLOCK CAPITALS PLEASE

OR WRITE IF YOU PREFER NOT TO CUT COUPON

(No representatives employed)

P.E.2.66

British National Radio School

IMPROVED STANDARDS of Accuracy and Reliability!

Modern styling in light grey with legible black engraving.

Constructed to withstand adverse climatic conditions.

Ever ready case including leads, prods and clips.

Improved internal assemblies.

Re-styled scale plate for easy rapid reading. 2 basic scales each 2.5 inches in length.

New standards of accuracy using an individually calibrated scale plate: d.c. ranges 2.25% of full scale deflection, a.c. ranges 2.75% of full scale deflection.

Available accessories include a 2,500V d.c. multiplier and 5, 10 and 25A shunts for d.c. current measurement.

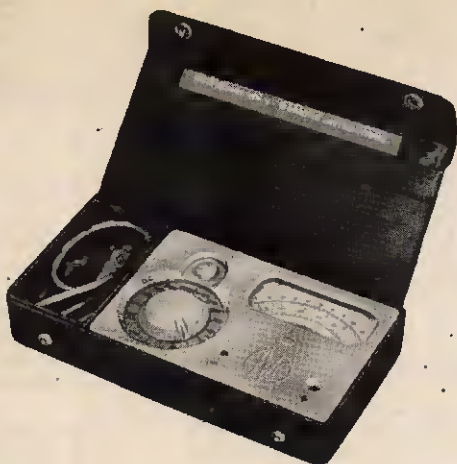

The Mk. 4 MULTIMINOR is the latest version of this famous Avo instrument and supersedes all previous models. It is styled on modern lines, with new high standards of accuracy, improved internal assemblies, and incorporating panci-matic properties.

The instrument is supplied in an attractive black carrying case, which also houses a pair of leads with interchangeable prods and clips, and an instruction booklet. It is packed in an attractive display carton. Robust real leather cases are available, if required, in two sizes, one to take the instrument with leads, clips and prods, and the other to house these and also a high voltage multiplier and a d.c. shunt.

D.C. Current: 100 μ A f.s.d. — 1A f.s.d. in 5 ranges.
A.C. Voltage: 10V f.s.d. — 1,000 f.s.d. in 5 ranges.
D.C. Voltage: 2.5V f.s.d. — 1,000 f.s.d. in 6 ranges.
D.C. Millivolt range: 0 — 100mV f.s.d.

RESISTANCE: 0-2M Ω in 2 ranges, using 1.5V cell.
SENSITIVITY: 10,000 Ω /V on d.c. Voltage ranges.
1,000 Ω /V on a.c. Voltage ranges.

★ For full details of this great pocket size instrument, write for descriptive leaflet.



MULTIMINOR Mk 4

AVO LTD

AVOCET HOUSE, 92-96 VAUXHALL BRIDGE ROAD, LONDON, S.W.1

Telephone: VICTORIA 3404

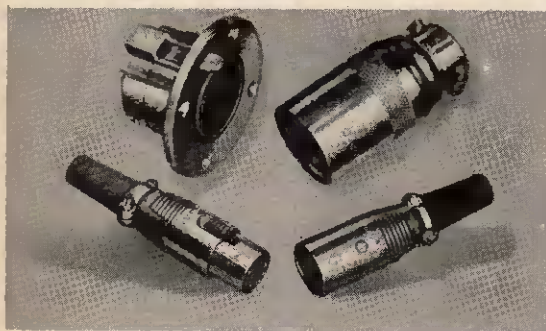

XLR/EP AUDIO CONNECTORS

Widely used Standard Audio/Video series with latch coupling. Up to 18 contacts in 15 shell styles.

Cannon Electric
(Great Britain) Ltd.,
Lister Road,
Basingstoke, Hants.
Tel: Basingstoke 3171



Registered Trademark

CANNON



CONCHORD
equipment cabinet £24

RECORD HOUSING

Turntables, tape recorders, loudspeakers, amplifiers, tuners, records and tapes, there is a Record Housing cabinet to suit your choice. Write for illustrated catalogue of complete range, plus list of stockists. Tel. Bowes Park 7487
Record Housing, Dept 2PE, Brook Road, London, N22

detached particles

JOHN VALENCE

MIND MORE THAN MATTER

To those without at least some elementary theoretical knowledge, a piece of electronic apparatus is just a meaningless collection of parts and wiring. The secrets of its operation cannot be deduced by patient observation. The components remain inanimate and betray to the onlooker nothing that is indicative of their purpose or present state of operation. Even that one visible manifestation of life—the emissive surface of the thermionic cathode—is becoming increasingly rare.

I suspect that so far as the uninitiated are concerned, the mystery will only deepen as time goes by. Not because of greater complexity of circuits, but because of the shrinking of the physical components. Conventional, or perhaps I should use the vogue expression *discrete*, components can at any rate usually be recognised and related to the symbolic representation on the circuit diagram. It is an entirely different story in the case of microminiature components and integrated circuits. Due to their small size they are naturally less revealing to the naked eye. Potted, canned, or encapsulated—they don an anonymity that completely baffles the casual onlooker.

It seems quite certain that electronics will become more and more a study of the abstract. There will be an even greater dependence on theoretical knowledge in the future. Without such knowledge the tiny sliver of silicon will be as meaningless and as insignificant as a bread crumb. But to the minds of those "who know", the marvellous secrets of such microcosms of modern electronics will be exposed.

MINI EXCHANGE

Where will it all end? A fascinating thought on the possibilities arising from further micro-miniaturisation was given by Professor Cherry during his recent lectures on World Communication delivered to the Royal Society of Arts.

The Professor suggested that it would one day be possible to build a complete telephone exchange in a sealed container and install this down in a manhole. I think this is a wonderful succinct illustration of the effect advancing technology may well have on our way of life.

Just consider such a small container replacing a large building that at present houses racks of equipment with heating, lighting and other services (such as are necessary even in an automatic exchange) all laid on. And consider all those valuable building sites the G.P.O. will be able to relinquish in 1984 or thereabouts. Sold or rented to builders of office blocks or perhaps multistorey car parks, the income would solve all the financial problems of the G.P.O. for quite a little time to come I reckon.

ART IN INDUSTRY

It is the fashionable thing for industry to act as patron to the arts. The famous firm of Mullards are as generous in their sponsorship of modern artists as they are in the educational field. Anyone who has seen this Company's educational films will agree that the artist and cartoonist are well employed in putting over a difficult and most abstract subject in a lively and yet factual manner.



Sometimes art is used purely for its own sake. The Mullard Electronics Centre in London has three specially commissioned works by leading contemporary artists. A 50ft mural in aluminium by Niczewski occupies the central position. Called "Creation Sequence" this mural depicts in both abstract and directly representational forms the sequence of events from the development of an idea to its realisation as something tangible and of value to mankind.

"Theme on Electronics" by Barbara Hepworth has stood in the Centre for a number of years and has no doubt been seen by many readers. Commissioned in 1957, this brass sculpture is (as these things go) inevitably dated, and perhaps that is why I find it attractive and easy on the eye.

How different are my reactions when I gaze upon the Centre's latest acquisition: Bobrowski's "Nucleus".

I confess to being a Philistine in matters concerning modern art. They say the main purpose of this kind of work is to provoke thought. Well it certainly does that. This weird contraption suggests to me the unfortunate offspring of some crustacean animal which had been frightened by a radar scanner! To my mind, this heavy metallic machinery is a most inappropriate symbol of the mysterious, nebulous heart of the atom.

After gazing on this sinister masterpiece of modern sculpture it was refreshing to turn and look at another form of art displayed near by. The subjects were the everyday work of the electronic tube factory. Could the graceful, elegant shapes of the cathode ray tubes and valves and their delicate internal structures be bettered by an artist?

It is here, I suggest, in these and other examples of electronic hardware that we have the true symbolism of electronics. Many of the functional parts of electronic engineering are not without a beauty of their own. Do we really have to look outside the industry and import kinky symbolic art to provide a supposed artistic interpretation of this virile industry?

Readout —

A SELECTION FROM OUR POSTBAG

Crookes radiometer

Sir—I am trying to obtain a Crookes Radiometer and wonder if any of your readers know where these may be obtained.

The Crookes Radiometer is an evacuated glass bulb with a "paddle wheel" mounted on an almost frictionless bearing inside the bulb. One face of each paddle blade is painted white, the other side is black, and when a light is shone on the paddle it rotates slowly.

I would be very grateful for information from readers as to where I might obtain one.

M. J. Bunce,
Gillingham,
Kent.

Your description is correct except that a little gas (air) is left inside the bulb. The black faces of the paddle blades absorb heat energy from rays falling on them and so become slightly warmer than the white faces. Molecules of air striking the black faces absorb some of this energy and are accelerated. The sum of the impulses of the rebounding accelerated molecules creates a pressure over the black area greater than that over the white area on the opposite face of the paddle. Thus the wheel rotates.—R.W.S.

Microwave cooking

Sir—Would it be at all possible that in the near future you might produce in your magazine a design etc., for a microwave heater or cooker?

I know that so far, no periodical has touched this subject yet is one which I am sure would attract much interest. The expense I know is high, but not out of the reach of the average man's pocket when compared with other hobbies etc., and if a reliable cooker could be made to function, electricity bills would soon repay expenditure in units saved.

P. Stonelake,
Torquay.

We are afraid your suggestion is not feasible for amateur construction, yet! For one thing the special u.h.f. radio valve is extremely expensive and hardly likely to be available on the open market.

Tachometer circuit

Sir—I have had every copy since the first number and find something of interest in most numbers.

The tachometer circuit shown is very simple and rugged, I make no claim as the originator of it as it comes from a Mullard publication. The recommended Zener is OAZ224 for 12V systems and OAZ222 for 6V systems. These are not available in New Zealand so I have used a OAZ204 which seems O.K.

The 1 henry choke is rather bulky but can be constructed on a Mullard transformer core, type FX2240, with 500 turns of 36 s.w.g. copper wire on a 25mm former type number DT2179.

I would like to ask if anyone has made up the "Voice Display Unit" by Mr. J. Hermiston in the June '65 issue.

The main trouble here is that much of the equipment advertised in European magazines is unobtainable in New Zealand hence most things have to be as simple as possible.

I am interested in this particular subject and would welcome any information from your readers.

John C. W. Hardy,
Tauranga,
New Zealand.

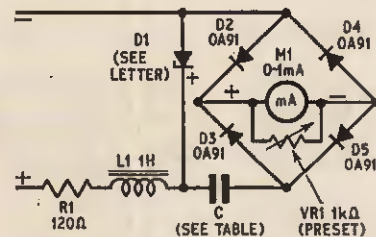

CAPACITOR 'C' VALUE TABLE

THE RATING OF CAPACITOR 'C' IS APPROX 125 VV	RANGE IN R.P.M.	4 CYL	6 CYL	8 CYL
	0-5000		68μF	47μF
0-7000		47μF	33μF	22μF
0-9000		33μF	22μF	—

Switching problem

Sir—I have an electrical problem. I would like to know if it is possible to make one master switch operate a group of light switches, 20 in number, so that each light is switched in numerical order and remains on. The master switch could be cam or perhaps photo-electric cell operated.

O. Havard,
Stroud,
Glos.

The solution to your problem calls for relays instead of ordinary switches. Each light being controlled by the contacts of a relay (a relay for each light) and the master switch energising all the relays but not simultaneously. The idea is to arrange timing circuits in relation to the relay windings so that the relays energise, thereby switching on their appropriate lights, in the required order.—G.J.K.

Any other ideas?

Unstable neons

Sir—With reference to *Neon Novelties No. 4, "Music Generator"*. I would like to warn intending constructors that, from my own experience, simple neons are very unstable as oscillators. I doubt if they are suitable even for a monophonic instrument and I am certain that they are useless for polyphonic purposes using the simple circuit shown.

Their striking and extinguishing voltages drift continually and the position of the discharge on the electrodes can change from time to time.

I have constructed a fully polyphonic two manual and pedal electronic organ using simple neons. In my case they are synchronised from a 12-valve master oscillator and in effect operate as frequency dividers each neon feeding its own buffer amplifier. Even today, after six years domestic use, drift is still taking place and during most playing sessions it is necessary to adjust the charging resistor associated with some note or other. I also noted that the simple neon is very unstable and hard to synchronise in darkness.

Probably neons with stabilising characteristics such as the NT2 would be very satisfactory but lack of funds prevented me from trying this out.

The tone produced from an unfiltered saw-tooth waveform is horrible!!!

Peter J. Horn,
Wallasey,
Cheshire.



Home Construction made easy by Building Heathkit models

A wide range of well designed quality kit sets to choose from
A KIT FOR EVERY INTEREST... HOME, SERVICE WORKSHOP, LABORATORY

Ease of assembly is guaranteed

Even for those without previous experience—by the comprehensive, yet simple step-by-step construction manuals supplied with every Heathkit model.

Save ££'s building the models

Heathkit units cost considerably less than comparable pre-assembled equipment. You cannot buy the parts any other way as cheaply.

Guaranteed performance

Every Heathkit product—assembled in accordance with our comprehensive construction manuals is guaranteed to meet published performance specifications, or your money will be cheerfully refunded.

Convenient credit terms

By taking advantage of our credit terms—you can enjoy your model right away—and pay for it in easy monthly instalments. Deferred terms available over £10 in U.K.

AUDIO

Cabinets, Turntable units, Mono and Stereo Amplifiers, Pick-ups, Speakers, Speaker Systems, Mono and Stereo Control Units, Tape Pre-amplifiers, Tape Decks, Transistor Mixer.

RADIO

AM/FM and FM Tuners, Transistor Radios, SW and Communication Receivers.

TEST INSTRUMENTS

A wide range of Audio Test, Home Workshop, Service and Laboratory Instruments.

AMATEUR GEAR

A wide range of equipment.

MISCELLANEOUS

Hobby kits for the youngster, Tool kits, Intercoms, Electronic Organs, PA/Guitar Amplifiers, etc.



OSCOPES

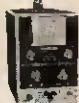

POWER SUPPLIES



TRANSISTOR TESTER



SIGNAL GENERATORS

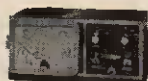

VALVE VOLTMETERS



TV ALIGN GENERATORS

Instruments for Test, Service, Home Workshop

3 in. LOW-PRICED OSCILLOSCOPE. Model OS-2. Ideal for servicemen. Compact: 5" x 7" x 12". Wt. 9 1/2 lbs. "Y" bandwidth, 2 c/s—3 Mc/s. T/B 20 c/s—200 kc/s in 4 ranges. Kit £22.18.0. Assembled £30.8.0.

MULTIMETER. Model MM-1U. Ranges 0-1.5 v to 1,500 v A.C. and D.C. 150 µA to 15A D.C.; 0.2 to 20 MΩ. 4 1/2 in. 50µA meter. Kit £12.18.0. Assembled £18.11.6.

REGULATED POWER SUPPLY. Model 1P-20U. Transistorised, compact unit. Current range: from 50 mA to 1.5 A f.s.d. Voltage ranges: from 5 to 50 volts f.s.d. Kit £35.8.0. Assembled £47.8.0.

TRANSISTOR TESTER. Model 1M-30U. Unmatched in quality, performance and price. Provides complete d.c. analysis of PNP, NPN transistors and diodes. Internal battery for tests up to 9 v. Kit £24.18.0. Assembled £35.10.0.

R.F. SIGNAL GENERATOR. Model RF-1U. Freq. coverage from 100 kc/s-100 Mc/s on six bands on fundamentals and up to 200 Mc/s on calibrated harmonics. Kit £13.8.0. Assembled £19.18.0.

6 in. DE LUXE VALVE VOLTMETER. Model 1M-13U. Measures ac and dc volts 0-1.5 to 1,500 V in 7 ranges. Res. to 1,000 MΩ in 7 ranges. Modern styling, with gimbal mount. Kit £18.18.0. Assembled £26.18.0.

TV ALIGNMENT GENERATOR. Model HFV-1. 3.6 to 220 Mc/s on fundamentals. Unique electronic sweep oscillator. Built-in fixed and variable marker generators (5 Mc/s crystal). Kit £37.18.0. Assembled £47.10.0.

DECADE RESISTANCE. Model DR-1U. Range 1-99,999Ω in 10 steps. Kit £10.8.0. Assembled £14.8.0.

DECADE CAPACITOR. Model DC-1U. Range 100µµF to 0.111 µF in 100 µµF steps. Kit £7.5.0. Assembled £10.8.0.

INTERNATIONAL MAIL ORDER SCHEME covering the American Heathkit range of 250 models. Illustrated American catalogue and full details can be obtained from us for 1/- post paid.

Kits for Hi-Fi, Audio, Radios, Miscellaneous construction kits

"MALVERN" HI-FI EQUIPMENT CABINET. Will house all your Hi-fi equipment. Left "in the white." Size 39" x 32" x 21" in. Kit £18.1.0 (inc. P.T.). A wide range of other cabinets.

HI-FI FM TUNER. Range 88-108 Mc/s. Available in two units, sold separately. TUNER (FMT-4U) 10.7 Mc/s IF £21.5.0 (inc. P.T.). IF AMPLIFIER (FMA-4U) power supply and valves £13.13.0. Total Kit £16.8.0.

JUNIOR ELECTRONIC WORKSHOP. Model EVV-1. 20 exciting experiments can be made. Special solderless connections. Kit £7.13.6 (inc. P.T.).

TRANSISTOR MIXER. TM-1. A must for the tape enthusiast. 4 inputs, 9 v. battery operation. Kit £11.16.0. Assembled £16.17.6.

"OXFORD" LUXURY TRANSISTOR PORTABLE. Model UXR-2. Beautiful solid leather case. LW and MW Coverage. Kit £14.18.0 (inc. P.T.).

GENERAL COVERAGE RECEIVER. Model RG-1. Freq. coverage 600 kc/s-1.5 Mc/s. 1.7-32 Mc/s in 6 switched bands. Many features incl. 1/2 lattice crystal filter. Kit £39.16.0. Assembled £53.0.0.

6W QUALITY STEREO AMPLIFIER. Model S-33H. An inexpensive stereo/mono amplifier. Ideal for use with the Decca Deram lightweight pickup. Modern attractive styling. Kit £15.17.6. Assembled £21.7.6.

STARMAKER-33 TRANSISTOR PA/Guitar AMPLIFIER. Full 20 watts (33 watts IHFM) output. Four inputs on two channels. Two heavy duty speakers. Compact size. Tremolo. Elegant cabinet. Kit £24.19.0. Assembled £59.10.0, legs or castors extra.

TRANSISTOR GENERAL COVERAGE RECEIVER. Model GC-1U. Frequency coverage 580 kc/s-30 Mc/s in 5 bands. Kit £37.17.6. Assembled £45.17.6.

TRANSISTOR INTERCOM. Master Unit. Kit £10.19.6. Assembled £16.19.6. Remote. Kit £47.6. Assembled £5.16.0. Will operate up to 5 remotes.

"COTSWOLD" HI-FI SPEAKER SYSTEMS. Std. model. Size: 26 x 23 x 14 in. Kit £25.12.0. MFS "Cotswold" for the smaller room. Size: 36 x 16 1/2 x 14 in. Kit £25.12.0.

SSU-1 SPEAKER SYSTEM. A practical solution to the problem of a low-price speaker system. Two speakers. (Bookcase) £11.7.6. Kit (inc. P.T.) (With legs) £12.12.0. Kit (inc. P.T.)

See the complete Heathkit range in the FREE catalogue



HI-FI CABINETS



FM & AM/FM RADIO TUNERS



TRANSISTOR PORTABLES



SW RECEIVERS TRANSMITTERS



QUALITY STEREO AND MONO AMPLIFIERS

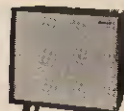

SPEAKER SYSTEMS

MANY OTHER MODELS
For the home, Hi-Fi enthusiast, Home workshop, Service and Test bench, Laboratory.

FULL RANGE OF MODELS IN FREE CATALOGUE

SIMPLY SEND COUPON TO:

To **DAYSTROM LTD., DEPT. PM-2, GLOUCESTER, ENGLAND**

Please send me **FREE BRITISH CATALOGUE (Yes/No)**

Full details of model(s).....

American Catalogue.....

(Yes/No).....

NAME (BLOCK CAPITALS).....

ADDRESS.....

PM-2

Practical Electronics Classified Advertisements

The pre-paid rate for classified advertisements is 1/- per word (minimum order 12/-), box number 1/6 extra. Semi-displayed setting £3.5.0 per single column inch. All cheques, postal orders, etc., to be made payable to PRACTICAL ELECTRONICS and crossed "Lloyds Bank Ltd." Treasury notes should always be sent *registered post*. Advertisements, together with remittance, should be sent to the Advertisement Manager, PRACTICAL ELECTRONICS, George Newnes Ltd., Tower House, Southampton Street, London, WC2, for insertion in the next available issue.

SERVICE SHEETS

SERVICE SHEETS for all makes of Radio and TV 1925-1965. Prices from 1/- with free fault-finding guide. S.A.E. inquiries. Catalogue of 6,000 models, 1/8. Valves, modern and obsolete. Radio/TV Books. S.A.E. lists, HAMILTON RADIO, Western Road, St. Leonards, Sussex.

TRADE SERVICE SHEETS. Radio, TV, etc. Mixed dozen @ 4/-, 100—22/6d. p.p. TELRAY, Maudland Bank, Preston.

STATE MODEL NO. Radio 2/-. TV 2/6. S.A.E. DARWIN, 19 George Street, St. Helens, Lancs.

SERVICE SHEETS

4/- each, plus postage.

We have the largest supply of Service Sheets for all makes and types of Radios, Televisions, Tape Recorders, etc. in the country. Speedy Service.

To obtain the Service Sheet you require, please complete the attached coupon:

From:

Name:

Address:

.....

.....

.....

To: **S.P. DISTRIBUTORS**

44 Old Bond St., London, W.1

Please supply Service Sheets for the following:

Make:

Model No.: Radio/TV

Make:

Model No.: Radio/TV

Make:

Model No.:

New 1965 List now available.

I also require list of Service Sheets at 1/6.

(please delete items not applicable)

I enclose remittance of

MAIL ORDERS ONLY Feb. PE

TAPE RECORDERS, TAPES, ETC.

TAPE TO DISC. New High-level Cutters 45 r.p.m. 21/- S.E.A. Leaflet. DEROY, 52 West Bank Lane, Lancaster.

MUSICAL INSTRUMENTS

FRANK HESSY LTD.

Liverpool's Leading Musical Instrument Dealer

QUICK SERVICE BY MAIL ORDER

STRINGS? REEDS? PICK-UPS?

TUTOR BOOKS? MICROPHONES?

MAKING OR BUYING, WE CAN

SUPPLY ANY INSTRUMENT OR

ACCESSORY

WE PAY ALL POSTAGE

Send for **PRICE LIST**

27/29/62 STANLEY STREET

LIVERPOOL 1

Suppliers to all Leading Bands and Groups

RECEIVERS AND COMPONENTS

BARGAIN PARCELS 25 TRANSISTORS 10/- 2G371/81 AF 2G414/7 RF/VHF 2N1303/7. Switching all PNP untested but tested. Also 100 diodes for 12/-. 100 High Stability Resistors for 17/6d. Many testimonials. Send 6d. stamp for details and stock list of other items. Examples: OC7P Phototransistors 9/6d. 2N1132 27/6d. 100 pty 3amp silicon diodes 1/9d. OC71 equivalents 9d. and much more.

LST COMPONENTS

23 NEW ROAD, BRENTWOOD, ESSEX

PI-PAN PRINTED CIRCUIT BOARD makes any circuit by soldering connections only. S.a.e. to M.E.D.S., 20 Knolls View, Tottenhamhoe, Bedfordshire, for leaflet.

6 TRANSISTOR PRINTED CIRCUIT RADIO

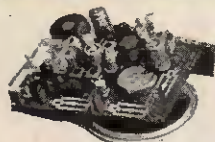

COMPONENTS for the Above as follows:— 6 transistor printed circuit 1/9. 2 1/2 in. speaker 6/6. Ferrite block 1/-. Edge volume control D.P.S.K. 1/6. I.F. and Osc. coils (set of 4) 6/8 set. Slide switch D.P.D.T. 1/-. Ganged condenser 5/-. P.P. output transformer 7/6. Driver transformer 7/6. Circuit 1/6. All the above made special 37/6 post free. sly and ready for assembly. Add 1/6 P. & P. when order less than 10/-.

CLEVELEYS ELECTRICAL ENGINEERING CO.
HOLMEFIELD AVENUE
CLEVELEYS, NR. BLACKPOOL

RECEIVERS AND COMPONENTS

(continued)

SILICON RECTIFIERS. 50 Piv. 1-5A, 2/6d. 100 Piv. 8A, 4/6d. 400 Piv. 0-75A, 2/6d. Zener Diodes, 12v 5 per cent 1w, 3/6d. 62v 8w, 4/-. Transistors in makers' sealed packs, 1F or AF, 9d. each, 6d post on orders under 10/-. J. COOPER, Outwell, Wisbech, Cambs.

LOOK!

AUTOCHANGE UNITS

GARRARD 3000 STEREO 9 GNS.
AT6 MONO 9 GNS. STEREO 10/- EX.
Reg. P.P. 7/-

THE RADIO SHOP
THE HAYMARKET, BRISTOL 1
Radio and TV components stocked

HALF-WATT CARBON RESISTORS 10% Tol. 18 ohms to 10 meg, preferred values, 6 of each of 45 values (270 resistors) carded £2 10s. Manufacturer's Surplus. DELTA ELECTRONICS, 25a Bishopgate, York.

SPECIAL OFFER

1 Watt S.T.C. 300 MC/S N.P.N. Silicon Planer. 100% Transistors. Limited Stocks. £1 for 6.

3/- each. OC44, OC45, OC70, OC71, OC81, OC81D, OC200, Get 16, Get 20.

4/- each. AF114, AF115, AF116, AF117, OC170, OC171.

5/- each. OC139, OC140, Get 7, Get 8, Get 9, XC141, BY100, OA211.

SUN SOLAR CELL KITS

24 Page Booklet on Experiments inc. 4 Solar Cells 11/- Set.

G.P.O. DIAL TELEPHONES
20/- each. 35/- pair.

Send 6d. for full lists: inc. S.C.R. Zeners.

Cursons

78 Broad Street
Canterbury
Kent

RECEIVERS AND COMPONENTS

(continued)

TRANSISTORS AND COMPONENTS

OC71, OC44, OC45, OC72, OC81, OC81D—
5/- each. OC83 6/4 each. AF115, AF116, AF117,
OC171—3/6d each.

BY100 Mullard Branded 250V 550 M/A—5/- each.
Westinghouse 1,000V P.V. 1 Amp.—6/6d each.
BYZ13 Silicon Rectifier 200V P.V. 6 Amps.—
5/4d each.

BYZ15 200V P.V. at 40 Amps.—£2. 17. 0.
ORP12—7/9 each. BYZ15 200V P.V. at 40
Amps.—£2. 17. 0.

AC126—8/- each. ASY28—8/6d each. AF186
cut of FREQ 800 Mc/s—27/6.

STC Silicon Rectifiers, P.V. 200 3 Amps.—3/6
each.

M.A.T. TRANSISTORS

MAT 100 7/9.
MAT 101 8/6.
MAT 120 7/9.
MAT 121 8/6.
ADT 140 15/-.

Acos Record Player Cartridge Replacements for
Callaro, Garrard, B.S.R., etc.—12/6d each.

3 Transistor Walkie Talkies £7. 10. 0. pr. Xtal
Controlled.

TEXAS TRANSISTORS

2N1302—ASY28 6/6 each.
GM290—AF139 19/6.
2G302—GET872 7/6.
2G301—GET873 6/6.

Other types available on request.

NEWMARKET TRANSISTORS

NKT 128	13/-	NKT 228	8/-
NKT 214	6/6	NKT 263	8/-
NKT 213	8/-	NKT 264	8/-
NKT 713	12/6	NKT 265	6/6
NKT 224	6/6	NKT 271	8/-
NKT 279A	3/-	NKT 272	8/-
NKT 212	8/-	NKT 273	8/-
NKT 224	6/6	NKT 274	8/-
NKT 225	6/6	NKT 275	6/6

S.A.E. all enquiries.

All Above Post Paid

Mail Order Only:

J. ROBINSON

(Radio & T.V.)

4 Highcliff Road, Blackley, Manchester 9

“EXPERIMENTAL”

PRINTED CIRCUIT KIT

Contents

- (1) 2 Copper Laminate Boards 4 1/2" x 2 1/2".
- (2) Resist. (3) Etchant. (4) Resist Solvent.
- (5) Cleanser/Degreaser.
- (6) 16-page illustrated booklet.

“PRINTED CIRCUITS FOR AMATEURS”

containing full etching instructions.
Also free with every kit (7): Essential Design
Data and Constructional Details of

- 24 SUGGESTED PROJECTS which you can
build on a P.C. chassis made from this kit
using your own components. Circuit
Diagrams. P.C. Chassis Plans. Assembly
Drawings. Photographs. Many recently
developed very efficient designs you
probably haven't heard of yet, including...
4 Crystal Sets. Carrier Power Conversion
Receiver. Matchbox Photocell Radio.
Solar Battery L/S Radio. Pocket L/S Double
Reflex. Triple Reflex with self-adjusting
regeneration. Bacteria-powered Radio.
3 micro-miniature radios just released. Post-
age-Stamp Radio 1-62" x .95" x .25". Wrist-
Watch Radio 1-15" x .80" x .55". Ring
Radio .70" x .70" x .55". 2 Intercoms. 4
Amplifiers. Photoelectric Alarms. Light-
controlled Robot. Human Body Radiation
Detector. “Perpetual Motion” Machine.
Transistor Tester and many more...
(8) Attractive case 4 1/2" x 2 1/2" to suit chassis.
- (9) Miniature Radio Dial MW/LW.
- (10) Miniature Radio Dial SW/MW/LW

Price 7/6 Post. and Packing 1/-

Extra copper laminate available.

“YORK ELECTRICS”

181a, York Road, London, S.W.11

Send S.A.E. for full details

RECEIVERS AND COMPONENTS

(continued)

A.1 POST FREE BARGAINS. 25k or 50k 3watt
w/wound pots with S.P. switch new and boxed
5/- ea. Guaranteed reclaimed valves. S.A.E.
for list. **A.1 RADIO COMPONENTS**, 14 The
Borough, Canterbury, Kent.

SHOEBURYNESSE ELECTRONICS

We offer the greatest ever parcel of all new
components.
Over 350 mixed new electronic components.
Each parcel will include:
Capacitors, Resistors, Diodes, Transistors,
Silicon Rectifiers, Potentiometers, IFT's, Valve
Bases, Tuning Condensators, Transformers,
Printed Circuits, Coils, etc.

The Price: 10/- plus 3/6 P.P.

90 BUNTERS AVENUE, SHOEBURYNESSE, ESSEX

COMPLEMENTARY Silicon Planar for the first
time at low prices! 18V, 200mW, 100mA.
PNP 200Mc/s, $\beta = 100$ to 180 @ 5/-, $\beta = 150$
to 300 @ 5/8, $\beta = 250$ to 500 @ 7/-, PNP
100Mc/s, $\beta = 60$ to 180 @ 5/-, $\beta = 150$ to
300 @ 7/-, Quality discounts. "By return"
service. **ELECTROVALVE**, 6 Mansfield
Place, Ascot, Berks.

PRINTED CIRCUITS

Prototype Service Available to Home
Constructors at a Very Reasonable Charge.

Individual Boards to Your Own Design for
Under 20/- Olympic T.V. 50/- per set of 8
boards, all drilled ready for use.

P.E. tape recorder boards. S.A.E. for details to

EDEN ELECTRONICS

140 EYHURST AVENUE, ELM PARK, HORNHURGH, ESSEX

R. & R. RADIO & TV SERVICE

Dept. P.E.

44 Market Street, BACUP. Tel. 465

Salvage Valves

6F13	4/5	PCF80	4/-
6F15	5/-	PCL83	5/-
6L18	4/6	PL81	3/-
6K25	10/-	PL82	4/-
6U4GT	5/-	PL83	3/-
68W6	5/-	PY81	4/6
6/30L2	5/-	PZ30	5/-
EB91	1/-	U801	7/6
6F1	2/6	U301	6/-
EBF80	5/-	U329	5/-
EF80	1/6	10F1	1/-
EF91	2/6	10LD11	5/-
EF85	5/-	10P13	3/6
ECC82	4/-	10P14	5/-
EY86	4/-	PY800	3/-
ECL80	4/-	20F2	5/6
20P3	5/-	20D1	2/-
20P4	7/6	20P1	6/6
30F5	5/-	20P5	6/6
30PL1	5/-	30FL1	6/6
EF37A	7/6	30P12	5/-
PL36	7/6	30P4	7/6
PY33	7/6	PY32	6/-
PCC84	4/-	PY82	5/-

Postage on valves 6d.—3 or more post free.

1 Pole 8-way switch, complete with 8 resistors 2
@ 1K, 2 @ 15K, one each of 22K, 15K, 18K,
6.8K. 3/6 incl. post.

Fireball Tuners as removed 14/9. Selected
Tuners 18/9. Speakers ex T.V. 6 x 4 inch 3/6.
8 inch rnd 6/-. Resistors New: 1/2 watt 3 1/2,
1 watt 5d., 2 watt 9d. all 10%.

Postage on Tuners and Speakers 2/6.

S.A.E. with all enquiries. All goods subject to
satisfaction or money refunded.

MISCELLANEOUS

CONVERT ANY TV SET into an Oscilloscope.
Diagrams and Instructions, 12/6. **REDMOND**,
42 Dean Close, Portlisle, Sussex.

TRANSFORMERS Rewound. Output or
mains. Specials made to order. Reasonable
prices. S.A.E. enquiries. **RATCLIFFE**, 27
Station Road, Holmfirth, Yorks.

ELECTRONIC KITS, RADIOS, ETC. Assembled.
Moderate Charges. **D. KEITH**, 1G West
George Street, Coatbridge, Lanarkshire, Scot-
land.

GOVERNMENT SURPLUS Electrical and Radio
Equipment. Our new catalogue No. 16 now
ready, 2/6 Post Free, cost refunded on purchase
of goods over £2. **ARTHUR SALLIS RADIO
CONTROL LTD.**, 93 North Road, Brighton.

1/2" EMBOSSED TAPE. 2d. per inch. Min. 1/-
Send S.A.E. for estimate, sample or order.
R. HENDERSON, 51, Philforth Avenue,
Fraserburgh, Aberdeenshire.

WANTED

G.E.C. RELAY
(ORANGE CASE)

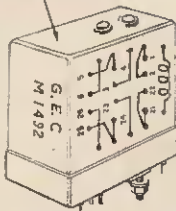

WANTED

**THIS TYPE AND
SIMILAR
RELAYS, ANY
CONDITION.**

**SEND S.A.E. FOR
DETAILS TO:**

**112 GROBY ROAD
GLENFIELD
LEICESTER**

FOR SALE

ARMATURE REWINDS. Hoover Junior Ex-
change Service. Models 375/119/1224, 32/6
inc. post. Fields 15/-. Send for lists. **JERVIS &
TONGE LTD.**, Ringwood Road, Brimington,
Chesterfield, Derbys. Tel. Chest. 75267.

GRACKLE PAINT. Black or Grey, 1/2 pint tins
4/-, post 6d. from the component specialists,
SERVIO RADIO, 156-8 Merton Road,
Wimbledon, London, S.W.19.

VENNER TIME SWITCHES. Reconditioned,
14 day clock, once on once off every 24 hrs.
jewelled movement, fully guaranteed. 1 amp
25/-, 5 amp 32/6d., 15 amp 38/6d. Post etc.
2/6d. Cast Aluminium Cases 7/6d. A. R.
BATCHELOR, P.E. Dept. 4 Park Road,
Bromley, Kent.

HAMMERITE

HAMMER PATTERN
BRUSH PAINT FOR
PANELS AND BOXES

★ THE PATTERN IS IN THE TIN ★
ALL YOU DO IS BRUSH IT ON!

2 1/2 oz. tins 3/6 1/2 gallon 35/-*

1 pint 7/6 1 gallon 58/-*

1 pint 15/- (* sent by road)

Carriage: Orders up to 5/-, 9d.; up to 10/-, 1/9;

over 10/-, 2/9. Colours: Blue, Silver or Metallic
Black. Return of post service, Monday to Friday.

From your component shop or direct from the
manufacturer:

FINNIGAN SPECIALITY PAINTS (PE)

Mickley Square, Stocksfield, Northumberland
Tel. Stocksfield 2280

CONTINUED OVERLEAF

FOR SALE

(continued)

A.C. STANDARD. Mains Motors Fractional H.P. 3/4in dia x 4in long with 1/4in spindle. Many uses. Brand new, 25/- each. P. & P. 2/6d. Small Battery Motors 1 1/4in dia x 2 1/2in long—4 1/2 to 9 volts. Heavy construction; only 7/6d. each. P. & P. 1/-. **WALTONS WIRELESS STORES**, 15 Church Street, Wolverhampton.

FIVE-TON FACTORY CLEARANCE: Radio, TV Electrical Components in mixed parcels. Example: 22lb. mixed parcel 21, p.p. 7/6. Speakers, grilles, valves, bases, i.f.s. covers, condensers, etc. Hundred other items. S.A.E. list and postal orders to **P. NEWTON**, 16 Shalcross Crescent, Hatfield, Herts.

"P.E." Fire Alarm System. Neon Novelties. Doorphone. Audio Oscillator and Valve Voltmeter. Water Level Alarm. New Look Tape Recorder. General Purpose Scaler. Echo Unit. Noughts and Crosses Machine. Transistor and Diode Tester. Simple Analogue Computer. Stereo Record Player. Integrated Transistor Amplifier. Two Band Radio Tuner. Intercom Unit. V.H.F. Broadcast Receiver. R/C Bridge. Inexpensive Oscilloscope. Mullard Miniature Electrolytics and Hi-stab Resistors. S.A.E. for itemised price lists. **AJAX ELECTRONICS**, 18A Rumbold Road, Fulham, London, S.W.6.

TRANSISTORS UNMARKED UNTESTED. 40 for 10/-. P. & P. 1/-. 4 packets post free. Relays, thousands of types, special catalogue free. General Catalogue of Mechanical & Electrical Gear, Tools, etc., 5,000 items, free. **K. R. WHISTON** (Dept. PET), New Mills, Stockport.

FOR SALE

(continued)

STOCK OF MODERN RADIO COMPONENTS for sale. Suitable for person considering opening shop/mail order business. **BOX NO. 2.**

BOOKS AND PUBLICATIONS

VISATECHNICA. The up-to-date TECHNICAL language course French—German—English on records or tape. Three-language illustrated book covering 280 technical subjects. Send 4d. stamp for descriptive leaflet to **VISAPHONE CO. LTD.**, 17 Middleton Rd., London, N.W.11.

SURPLUS HANDBOOKS

19 set Instruction Handbook ...	3/6 P.P. 6d
1155 Instruction Handbook ...	3/6 P.P. 6d
H.R.O. Instruction Handbook ...	3/6 P.P. 6d
38 set Instruction Handbook ...	3/6 P.P. 6d
46 set Walkie-talkie circuit & notes	3/6 P.P. 6d
88 set Walkie-talkie Instruction Handbook ...	4/6 P.P. 6d
Frequency Meter BC221 Instruction Handbook ...	3/6 P.P. 6d
Wavemeter Class D Handbook Mk. I, II, III ...	3/6 P.P. 6d
18 set Circuit Details & Notes ...	3/6 P.P. 6d
A.R.88D Instruction Handbook ...	15/- P.P. 1/6d
R.107 Instruction Handbook ...	4/6 P.P. 6d
CR.100/B.28 Receiver Handbook	8/6 P.P. 9d
R1116/A Circuit Diagram & Details	1/9 P.P. 6d
R1224/A Circuit Diagram & Details	1/6 P.P. 6d
R1353 Circuit Diagram & Details...	1/6 P.P. 6d
RF Unit 24 Circuit Diagram & Details ...	1/6 P.P. 6d
RF Unit 25 Circuit Diagram & Details ...	1/6 P.P. 6d
RF Unit 26 Circuit Diagram & Details ...	1/6 P.P. 6d
Amplifier A134 Circuit Diagram & Details ...	1/9 P.P. 6d
Resistor Colour Code Indicators. Indicates the value of a resistor at a glance	1/6 P.P. 6d

All mail orders to:
Instructional Handbook Supplies
Dept. P.E. Talbot House, 28 Talbot Gardens
Roundhay, Leeds, 8

EDUCATIONAL

B.Sc.(ENG.), A.M.I.Mech.E., A.M.I.E.R.E. City & Guilds, etc., on "Satisfaction or Refund of Fee" terms. Wide range of expert Home Study Courses in Electronics, Computers, Radio, T.V., etc. 156-page Guide—FREE. Please state subject of interest. **BRITISH INSTITUTE OF ENGINEERING TECHNOLOGY**, 124k College House, Wright's Lane, London, W.8.

Full-time courses in **RADAR** and **RADIO-TELEGRAPHY** for prospective marine Radio Officers. Govt. approved exam. centre.

Also courses in basic **ELECTRONICS, RADIO, TELEVISION** and **COMPUTERS**.

Apply—Director, British School of Telegraphy, 20 Pennywern Road, Earls Court, London, S.W.5

STUDY RADIO, TELEVISION AND ELECTRONICS with the world's largest home study organisation. **I.E.R.E., City & Guilds, R.T.E.B.**, etc. Also Practical Courses with equipment. All books supplied. Write for FREE Prospectus stating subject to **I.C.S.** (Dept. 577), Intertext House, Parkgate Road, London, S.W.11.

HOME STUDY COURSES in Practical Electronics. Free Brochure without obligation from: **BRITISH NATIONAL RADIO SCHOOL**, Reading, Berks.

A.M.I.Mech.E., A.M.I.E.R.E. City & Guilds, G.C.E., etc. Become a Technician or Technologist for high pay and security. Thousands of passes. For details of Exams. and Courses in all branches of Engineering, Building, Electronics, etc., write for 156-page handbook—FREE. **B.I.E.T.** (Dept. 125k), London, W.8.

SITUATIONS VACANT

TECHNICAL TRAINING by ICS IN RADIO, TELEVISION AND ELECTRONIC ENGINEERING

First-class opportunities in Radio and Electronics await the **ICS** trained man. Let **ICS** train YOU for a well-paid post in this expanding field.

ICS courses offer the keen, ambitious man the opportunity to acquire, quickly and easily, the specialized-training so essential to success. Diploma courses in Radio/TV Engineering and Servicing, Electronics, Computers, etc. Expert coaching for:

- INSTITUTION OF ELECTRONIC AND RADIO ENGINEERS
- C. & G. TELECOMMUNICATION TECHNICIANS' CERTS.
- C. & G. SUPPLEMENTARY STUDIES
- R.T.E.B. RADIO AND TV SERVICING CERTIFICATE.
- RADIO AMATEURS' EXAMINATION.
- P.M.G. CERTIFICATES IN RADIOTELEGRAPHY.

Examination Students Coached until Successful.

NEW SELF-BUILD RADIO COURSES.

Build your own 5-valve receiver, transistor portable, signal generator and multi-test meter—all under expert tuition.

POST THIS COUPON TODAY and find out how **ICS** can help YOU in your career. Full details of **ICS** courses in Radio, Television and Electronics will be sent to you by return mail.

MEMBER OF THE ASSOCIATION OF BRITISH CORRESPONDENCE COLLEGES.

INTERNATIONAL CORRESPONDENCE SCHOOLS
A WHOLE WORLD OF KNOWLEDGE AWAITS YOU!

International Correspondence Schools
(Dept. 152), Intertext House, Parkgate Road,
London, S.W.11.

NAME

ADDRESS
Block Capitals Please

..... 2.66

RADIO TECHNICIANS

A number of suitably qualified candidates will be required for training, leading to permanent and pensionable employment. (Normally at Cheltenham but with opportunities for service abroad or appointment to other U.K. establishments including London).

Applicants must be 19 or over and be familiar with the use of Test Gear and have had Radio/Electronic workshop experience. They must offer at least "O" level GCE passes in English Language, Maths and/or Physics, or hold the City and Guilds Telecommunications Technician Intermediate Certificate or equivalent technical qualifications.

Pay according to age, e.g. at 19 £747, at 25 £962 (highest age pay on entry) rising by four annual increments to £1,104.

Prospects of promotion to grades in salary range £1,032—£1,691.

Annual Leave allowance of 3 weeks 3 days, rising to 4 weeks 2 days.

Normal Civil Service sick leave regulations apply.

Apply
Recruitment Officer (RT/54)
Government Communications Headquarters
Oakley
Priors Road
CHELTENHAM, Glos.

SITUATIONS VACANT (continued)

A FULL TIME TECHNICAL EXPERIENCED SALESMAN required for Retail sales. Write giving full details of age, previous experience, and salary required to: The Manager, HENRY'S RADIO LTD., 303 Edgware Road, London, W.2.

**UNIVERSITY OF LONDON
GOLDSMITHS' COLLEGE**
New Cross, London, S.E.14

Required immediately for Educational Television Research Unit an electronics engineer (young man or woman) to supervise and help operate two mobile "Mini-Studios". Good salary offered for the right combination of adaptability, initiative, ingenuity and practical electronics experience. Post would suit ambitious service engineer, or newly qualified graduate wanting to widen experience, and attracted by pioneer work in a small team. Applications (THREE copies) to Registrar from whom further particulars may be obtained on request.

INSTRUMENT WIREMEN & TESTERS

LONDEX LIMITED, a member of the Elliott-Automation Group, manufacture an extensive range of electrical automatic control equipment and systems. Men are urgently required to fill the following vacancies.

EXPERIENCED INSTRUMENT WIREMEN

Men having recent practical experience of instrument work are needed in this expanding department.

EXPERIENCED TEST ENGINEER - Senior

An experienced Test Engineer is required in the final inspection Department. Applicants should possess a minimum of O.N.C. or equivalent, and have current practical experience of testing and adjusting automatic electrical control equipment.

JUNIOR TEST ENGINEER

We also require a junior tester. The person appointed will be encouraged to study for technical qualifications and a day release scheme is in operation. The work is interesting and demands a methodical and enquiring mind. Reliability, accuracy and integrity are more important than speed. There are ample opportunities for promotion: many of our senior executives entered the Company through the Test Department. Applications for all vacancies should be made to:

Mr. C. F. Bailey
Works Manager
LONDEX LIMITED
15 Howard Road, London, S.E.20
Telephone: SYDenham 6258

 A member of the Elliott-Automation Group

CASH BUYING DISCOUNT!

HI-FI AMPLIFIERS, TUNERS, SPEAKERS, TURNTABLE UNITS, Etc.
Any make supplied with a **DISCOUNT**
S.A.E. with enquiries please to:
HIGH FIDELITY CENTRE
61 West Street · DORKING · Surrey

BATTERY ELIMINATORS

The ideal way of running your TRANSISTOR RADIO, RECORD PLAYER, TAPE RECORDER, AMPLIFIER, etc. Types available: 9v; 6v; 4.5v (single output) 39/6 each. P. & P. 2/9. 9v + 9v; 6v + 6v; or 4.5v + 4.5v (two separate outputs) 42/6 each. P. & P. 2/9. Please state output required. All the above units are completely isolated from mains by double wound transformer ensuring 100% safety.

R.C.S. PRODUCTS (RADIO) LTD.
(Dept. P.E.), 11 Oliver Road, London, E17

EX-RENTAL TELEVISIONS

14 in.
£7.10.0
17 in.
£11.10.0



12 months
3 Star
Guarantee

★ Tube ★ Valves ★ Components
COLOURED FREE LIST
Channels for all areas
Demonstrations daily from Large Selection
Personal collection or insured Carriage 14in.
20/-; 17in. 30/-

AERIALS. BBC/ITA combined Loft and room aerials—25/-. BBC2/UHF and colour aerials—29/6.
SEND FOR FREE LIST

VALVES £1 per 100. Assorted TV and Radio. Surplus ex-rental dismantled receivers. Post 4/6. Send for list.

CONDENSERS 10/- per 100. New Assorted Electrolytics and p.p.s. P. & P. 2/6.

RESISTORS 5/- per 100. New. Mostly High Stabs. Assorted. P. & P. 2/-. Overseas 3/6.

SPEAKERS 7/9, 4in. 5in., 7 x 4in., 8 x 5in. Ex-mtd. Salvage. P. & P. 2/6. Overseas 4/-.

DUKE & CO. (LONDON) LTD.
621/3 Romford Road · Manor Park · E.12
Liverpool Street — Manor Park — 10 mins.
Phone: H/Ford 6091/2/3 Stamp for Free List



Cockrobin

has available a small but growing range of light electrical equipment, including panel-mounting switches, lamps, meters, "Masterbox" sectional switchboards, reed switches, magnets and accessories, wire and sundries. For full details, send a 3d. stamp to the address below-information will be sent by return of post.

COCKROBIN CONTROLS

36 Villiers Avenue, Surbiton, Surrey

RESISTANCE SUBSTITUTION BOX.

15 ohms to 10 Meg in 24 steps, 28/- post 1/-.

CAPACITY SUBSTITUTION BOX.

100 pF to .22 µF in 9 steps, 19/6 post 1/-.

MULTIMETERS, EP10K, 10K Ω/V, 67/6 post 2/-; EP30K, 30K Ω/V, 105/- post 2/9;

EP50K, 50K Ω/V, 145/- post 2/9; Leather cases, EP30K, 22/6; EP50K 30/- post 1/3.

NOUGHS AND CROSSES MACHINE.

Uses switches and lamps only, cannot be beaten. Circuit, wiring diagrams, instructions 3/6.

Precision Wirewound Resistors 1 Watt

1Ω to 5K 1%, 3/-; to 20K 4/3; 1% add 3d.

Your value wound to order.

High Stability Resistors 1% 1 W 2/- each.

Full range 10Ω to 10MΩ.

PLANET INSTRUMENT CO.

25(E) DOMINION AVENUE
LEEDS 7

"PRACTICAL ELECTRONICS"

CONSTRUCTIONAL DESIGNS

All specified 1st grade Components, complete Metalwork, full range of Materials, engraved Panel Plates, Ancillary Equipment and Assembled Units. Comprehensive lists available for each "P.E." Constructional Article.

Please send 6d. in stamps for each design

MALVYN ENGINEERING WORKS

Engineers to the Radio and Electronic Industries

7 CURRIE STREET, HERTFORD, HERTS

TELEPHONE: HERTFORD 2264

A SUCCESSFUL CAREER IN ELECTRONICS, RADIO AND T.V. CAN NOW BE YOURS AT VERY LITTLE COST!

NEW No. 500. RADIO AND TELEVISION COURSE, 75/-. Here at last is your opportunity to own a most complete course at a very modest cost! This expanded course which now includes television as well as radio repair training could get you started on a whole new career!

The Radio Section of the course was **ORIGINALLY DEVELOPED BY THE RADIO TECHNICAL INSTITUTE**, while the Television Servicing Course has formed the basis of instruction provided by one of the world's largest television and electronics firms!

Compare lesson by lesson with some courses costing ten times as much! You save because you receive all the lessons at one time and are not required to purchase equipment you may not need.

The lessons are crystal clear, practical, easy to master and use. Early lessons make fundamentals clear even to the beginner, while other lessons will give you the practical know-how of an expert!

The new 500 Radio and Television Course consists of 352 large quarto size pages of instruction, hundreds of illustrations. We positively guarantee that you will be delighted or your money refunded!

NEW No. 800. RADIO-TELEVISION-ELECTRONICS COURSE, 85/-. This is really a big value in home training. Similar in details to the above course excepting that you get an extra 56 pages of instruction making a total of 408 quarto size pages. Hundreds of illustrations. Includes all the usual subjects plus Radio Transmitter Circuits, Electronic Test Equipment, Thyatron Tubes, Inter-Communicators, Board Level Meters, Servicing Printed Circuits and many more similar items. This course could be your first step into the fascinating world of electronics!

No. 400 ELECTRONICS COURSE, 45/-. A complete home-study course of 36 lessons. Consists of 216 large quarto size pages of instruction. Comes complete with instructor's notes and test questions. This is a modern course that teaches without resorting to comic strip methods. . . Thousands of readers of this magazine have taken this course and enjoyed every minute of it. . . Why not you? Clip the coupon for your free trial offer now!

UNCONDITIONALLY GUARANTEED TO GIVE COMPLETE SATISFACTION! Any course not satisfactory may be returned within 10 days post-paid for full refund or credit of the purchase price.

IF YOU SEND CASH WITH ORDER WE WILL INCLUDE A FREE BOOK worth 4/6 to 5/- if bought separately. By sending cash you reduce book-keeping and other costs which we pass back to you. But you must include cash at the time of order to get this special offer!

★ ★ FREE TRIAL OFFER ★ ★

PAY ONLY 5/- per week if you wish.

To Sim-Tech Technical Books, Dept. H3, Gater's Mill, West End, Southampton, Hants.

Please send the courses I have circled.

No. 500 No. 600 No. 400

If not delighted I may return any book post-paid without further obligation on my part, otherwise I will pay cash price or 5/- weekly (10/- fortnightly) commencing not later than 10 days after delivery. I am over 21 years of age. (If under 21 parents should place order.)

I enclose cash to the sum of £
I understand you will refund this money if I am not 100% satisfied and I return the book within 10 days.

Please send me the free book(s) I have ticked.

- Oscilloscope Book.
- Electronic Gadgets Book.
- Transistor Book.
- Radio Instruments Book.

Name

Address

**INTERNATIONALLY FAMOUS
NATIONAL RECEIVER**

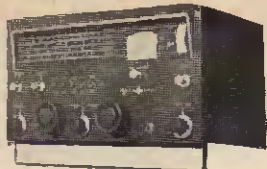

NC190—10 valves, 540 kc/s to 30 Mc/s, S-meter, noise limiters, product detector, bandspread, double conversion. £97.4.2.

EAGLE VALVE VOLTMETER K-142 Large 6" x 4" 200 microamp meter. 11 megohm, 2pF input, 0.1.5/5/15/50/150/500/1500v. AC also 0-4000v. peak-to-peak in 7 ranges.

Decibels:—20 to +5/16/25/36/45/56/65 db. 0.1.5/5/15/50/150/500/1500v. DC. Resistance: 0.2 ohm to 100 megohm. 240 volts, 50/60 c/s. 7½ x 6½ x 4½". 4½ lbs. Complete with DC probe, test leads & instruction manual. 16 gns. post free. S.A.E. for leaflet.

HAYATO PRINTED CIRCUIT ETCHING KIT PK-1

Complete with polisher, paint, etching liquid, paint eraser, flux, 6" x 4" copper laminate, knife, spatula, etc. etc. Satisfaction guaranteed. *Fantastic value at 19/6.* P.P. 2/-. S.A.E. for illustrated leaflet.

WESTINGHOUSE SILICON RECTIFIER S10AR2

1000 v. P.I.V. 750 mA. 9/6. each P.P. 6d. 2 for 17/6. P.P. 9d.

BRIAN J. AYRES & CO.

Dept. DW, 21 Victoria Road
Surbiton, Surrey
Telephone: Elmbridge 2833

4-STATION INTERCOM

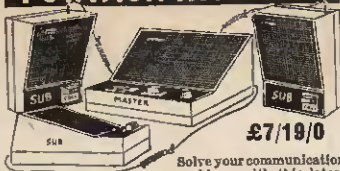

£7/19/0

Solve your communication problems with this latest 4-Station Transistor Intercom system (1 Master and 3 Subs), in de-luxe plastic cabinets for desk or wall mounting. Call/talk/listen from Master to Subs and Subs to Master. Operates on one 9V battery. On/off switch. Volume control. Ideally suitable to modernize Office, Factory, Workshop, Warehouse, Hospital, Shop, etc. to keep instant inter-departmental contacts. Complete with 3 connecting wires, each 66 ft. & other accessories. Nothing else to buy. Post Free

INTERCOM/BABY ALARM



Usually ~~£6/6~~
Our Price ONLY
57/6

Modernize your Office, Shop, Warehouse, Workshop, Surgery, Nursery, and home with this latest two-way Transistor Intercom, consisting of two units, Master and Sub, in strong plastic cabinets with chromium stands. Elegantly designed to use as two-way instant communication system—Call/talk/listen—between two persons anywhere indoors or outdoors. Both units operate on one 9V battery. Complete with 60 ft. wire. Battery 2/6. P. & P. 2/6.

BATTERY ELIMINATOR AND CHARGER 27/6

Use your Transistor Radio or Intercom from domestic A.C. mains and charge dry battery PP3 9V to boost battery's life many times. Unbeatable value. Save your pounds on batteries. P. & P. 1/6. Complete with Plug, Lead and Snap cord.

Full price refunded if not satisfied in seven days.

WEST LONDON DIRECT SUPPLIES (PE/1)
6 Chigwell Place, West Baling, London, W.13

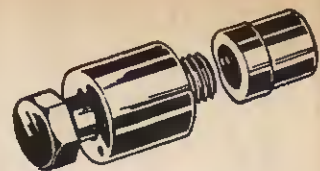

*The PUNCH
you need!*

HOLE PUNCHES

Instant Type	Price	Quantity
1/4" diameter	...	6/10 ea.
Screw-up Type	...	
3/8" diameter Toggle switch	...	8/6 "
1/2" " "	...	8/6 "
5/8" " "	...	9/- "
3/4" " "	...	7/6 "
7/8" " "	...	10/2 "
1" " "	...	10/8 "
1 1/8" " "	...	11/8 "
1 1/4" diameter Int. Octal	...	13/4 "
1 1/2" " "	...	16/2 "
1 3/4" " "	...	18/10 "
1 7/8" " "	...	21/8 "
2" " "	...	24/4 "
2 1/4" " "	...	33/2 "

Complete Set £9.3.6.
No extra charge for postage and packing in the U.K.

Now supplied by:

TOMPKINS & LONGMAN LTD.

237 GIPSY ROAD

WEST NORWOOD, S.E.27

Tel.: Gipsy Hill 5000

BBC2 (625 LINE) TV AERIALS



MAST MOUNTING ARRAYS, 9 element 45/-; wide spaced high gain, 11 element 55/-; 14 element 62/6. **WALL MOUNTING WITH CRANKED ARM**, 9 element 60/-; wide spaced high gain, 11 element 67/6; 14 element 75/-.

CHIMNEY ARRAYS COMPLETE, 9 element 72/-; wide spaced high gain, 11 element 80/-; 14 element 87/6. **LOFT ARRAYS**, 7 element 32/6; wide spaced high gain, 11 element. **WITH TILTING ARM** 62/6; 14 element 70/-.

ALL HIGH GAIN UNITS HAVE SPECIAL MULTI-ROD REFLECTOR. LOW LOSS CO-AXIAL CABLE 1/6 yd. UHF transistor pre-amps from 75/-.

BBC + ITV + F.M. AERIALS



B.B.C. (BAND 1), Telescopic loft 21/-. External S/D 30/-.

I.T.V. (BAND 3), 3 Element loft array 25/-. 5 element 35/-. Wall mounting, 3 element 35/-. 5 element 45/-.

COMBINED B.B.C./I.T.V. Loft 1+3, 41/3; 1+5, 48/9. Wall mounting 1+3, 56/3; 1+5, 63/9. Chimney 1+3, 63/9; 1+5, 71/3.

VHF transistor pre-amps from 75/-.

F.M. (BAND 2), Loft S/D 12/6. "H" 30/-, 3 element 52/6. External units available. Co-ax. cable 8d. yd. Co-ax. plugs 1/3. Outlet boxes 4/6. Diplexer Crossover Boxes 12/6. C.W.O. or C.O.D. P. & P. 4/6. Send 6d. stamps for illustrated lists.

K.V.A. ELECTRONICS (Dept. P.E.)
27 Central Parade, New Addington, Surrey
LOD 2266

Just Published

**TRANSISTOR
POCKET BOOK**

R. G. Hibberd, B.Sc.,
M.I.E.E., Sen.M.I.E.E.E.

A comprehensive guide to the characteristics and use of the various types of transistor now available. The manufacture of the various types of transistor, up to and including the latest epitaxial planar, field of effect and metal-oxide silicon transistors, is described in detail in order to make clear the different characteristics of each. Includes notes on the use and handling of transistors, and chapters on solid state circuit techniques and recent developments.

7½" x 5". About 280 pages,
about 200 line diagrams and
photographs. 25s.

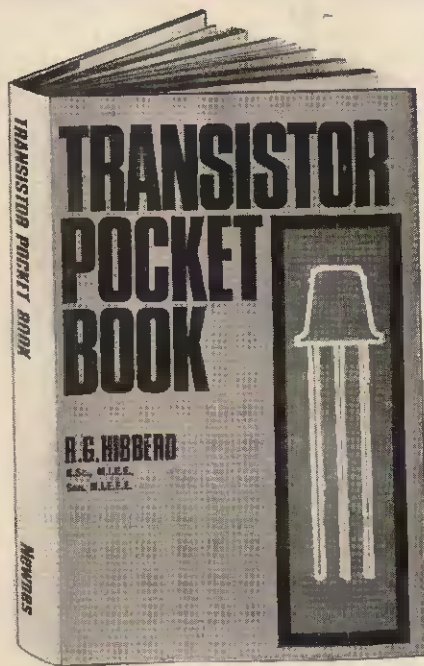

From your Bookseller, or in case of difficulty, 27s.
from **G. NEWNES LTD., SOUTHAMPTON STREET, W.G.2**

VERO board

gives
constructors
the
simplest...
most
efficient...

WIRING BASE

for any electronic assembly work — whether experimental or quantity production. Patented Veroboard is an advance on tag board wiring techniques and printed circuits, and because of its absolute stability under all conditions it is in fact now extensively used by manufacturers all over the world instead of printed circuits.

Veroboard is obtainable in many sizes of which 4 are available through the retail trade. For the name and address of your nearest Retailer please write to:—

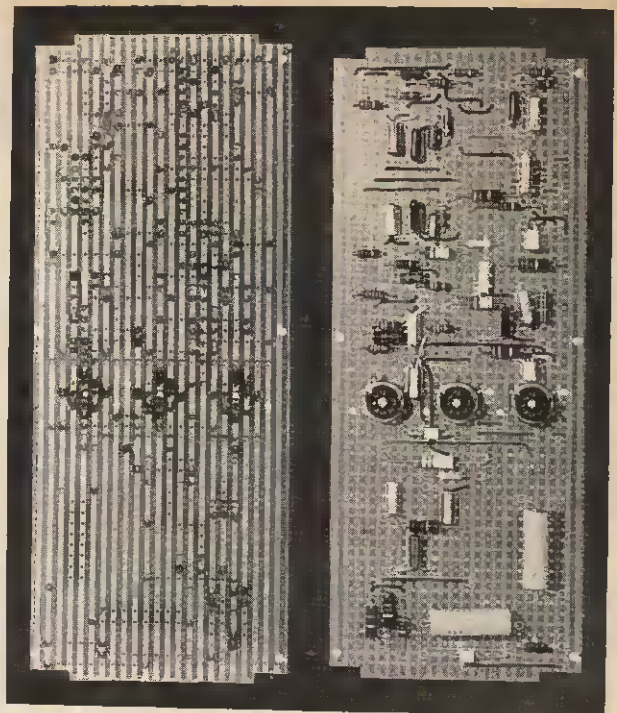

VERO ELECTRONICS LTD. (DEPT P12)
SOUTH MILL ROAD, REGENTS PARK, SOUTHAMPTON
TEL. 71061
ENQUIRIES FROM RETAILERS AND MANUFACTURERS WELCOMED
TELEX 47593

SENSATIONAL HALF PRICE OFFER!

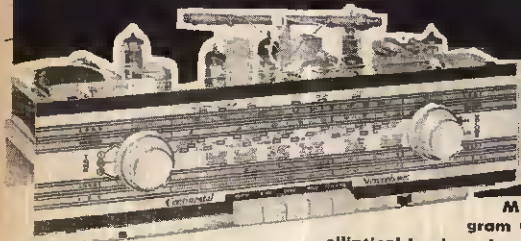

THE FAMOUS
'Continental'
RADIOGRAM
AT
HALF PRICE!

Magnificent Stereophonic Radiogram Chassis complete with two 10" elliptical loudspeakers, plus a Mono/Stereo 4-speed automatic record changer.

Only £29-19-6

- Easily fitted
- No soldering or Technical knowledge necessary
- Fits almost any cabinet with minimum trouble
- Modernises your old radiogram
- Built-in ferrite rod aerial
- Piano key switching

- Luxembourg and Caroline received at full strength
- Listen to U.S.A., Russia, Africa, Canada and even Australia
- Unique Lewis Radio 365 day guarantee, even on all the valves
- All British make

SPECIAL terms available of £4.10.0 deposit followed by 18 monthly payments of £1.13.0 (total H.P. £34.4.0) + postage & packing 15/- extra.

INDIVIDUAL CABINETS SUPPLIED ON REQUEST

Send your cheque or P.O. today for £5.5.0 while stocks last to Dept. PE26

LEWIS radio

LEWIS RADIO, 100, CHASE SIDE, SOUTHGATE
LONDON, N.14. Telephone: PAL 3733/9668

CHEAPER BY THE DOZEN

RED SPOT TRANSISTORS 9/- Doz.
Audio Similar to OC71
or 1/- each + 4d. postage
6d. Extra

WHITE SPOT TRANSISTORS 10/6 Doz.
Similar to OC45
or 1/3 each × 4d. postage
6d.

GERMANIUM RECTIFIERS 24/- Doz.
GJ7M 24V 1/2 Amp
or 2/6 each + 6d postage
Postage 1/-

MINIATURE GERMANIUM DIODES
6/- Doz. Postage 6d.

TANK AERIALS

6 Section. Total Length 10' 10"
Perfect for Vertical Aerial or Fishing Rod.

10/6 each 1/6 P. & P.

VEROBOARD Now in Stock

2 1/2" × 5" 3/8 2 1/2" × 3 3/4" 3/-
3 3/4" × 5" 5/2 3 3/4" × 3 3/4" 3/8
Postage 6d. each extra.

MAT TRANSISTORS

MAT 100 7/9 MAT 101 8/6
MAT 120 7/9 MAT 121 8/6
Postage 4d.

PETHERICK'S RADIO SUPPLIES

Dept. C

22 HIGH STREET, BIDEFORD, N. DEVON
Tel.: Bideford 3217

VARIABLE VOLTAGE TRANSFORMERS

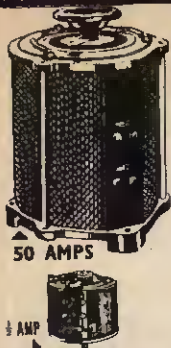

INPUT 230/240v. A.C. 50/60— OUTPUT VARIABLE 0-260v. BRAND NEW Carriage Paid. Buy direct from the importer, keenest prices in the country. All Types (and Spares) from 1/2 to 50 amp. from stock.

OPEN TYPE (Panel Mounting)
 1/2 amp, £3. 3. 0. 1 amp, £4. 17. 6.
 2 1/2 amps, £5. 12. 6.

SHROUDED TYPE
 1/2 amp, £4. 10. 0. 2.5 amps, £5. 17. 0. 4 amps, £8. 7. 6.
 5 amps, £9. 0. 0. 8 amps, £13. 10. 0. 10 amps, £17. 0. 0.
 12 amps, £19. 10. 0. 15 amps, £22. 0. 0. 20 amps, £32. 10. 0.
 37.5 amps, £65. 0. 0. 50 amps, £85. 0. 0.

PORTABLE TYPE
 2.5 amps, Portable £9. 17. 6.

ULTRA VIOLET BULBS
 Easy to use source of U.V. for dozens of practical and experimental uses.
 12 volt 36 watt A.C./D.C. SBC 6/6. P. & P. 1/-.
 12 volt 60 watt A.C./D.C. SBC 8/6. P. & P. 1/-.

Transformer to suit the above. Input 200-240 v. A.C., 12 volt 36 watts, 16/6; P. & P. 2/6. Input 200-240 v. A.C. 12 volt 60 watt, 22/6. P. & P. 3/6.

Set of 4 Colours FLUORESCENT PAINT. Red, yellow, green and cerise. In 1/2 oz. tins. Ideal for use with the above Ultra Violet Bulbs. 9/6, plus 1/6 P. & P.

NICKEL CADMIUM BATTERY. Sintered Cadmium Type. 1.2 v. 7AH. Size: height 3 1/2", width 2 1/2" x 1 1/2". Weight: Approx. 13 ozs. Ex-R.A.F. Tested. 12/6. P. & P. 2/6.

100 WATT POWER RHEOSTATS (NEW) AVAILABLE IN THE FOLLOWING 9 VALUES

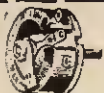

10 ohm, 3 a.; 25 ohm, 2 a.; 50 ohm, 1.4 a.; 100 ohm, 1 a.; 250 ohm, .7 a.; 500 ohm, .45 a.; 1,000 ohm, 280 mA; 1,500 ohm, 230 mA; 2,500 ohm, .2 a. Diameter 3 1/2 in. Shaft length 3 in., dia. 1/8 in. All at 27/6 each. P. & P. 1/6.

230 v. A.C. RELAY

Type 1.2 c/o. 2 amp. contacts, 9/6. Type 2.2 x 15 amp. break, 2 x 2 amp. make, 1 x 2 amp. break. 11/6. Both types, ex new equip. P. & P. 1/6 each.

"GABY" MULTI-RANGE TEST METER



Model B40. D.C. volt, 0.5 v., 2.5 v., at 10,000 ohm per volt. Ideal for transistor circuit testing. A.C. and D.C. volt, 10 v., 50 v., 250 v., 500 v., 1,000 v., at 4,000 ohm per volt. Resistance, 2K ohm, 20 K ohm, 2 megohm, 20 megohm. Fully guaranteed, complete range of spares available from stock. Price includes Test Leads, Battery, Instruction book, Packing and Post (U.K.). £6/2/6. 3 additional models available from 5/- to £14/14/-. Leaflet gladly sent on request.

14,000 OHM SEALED RELAY

High Speed single c/o. Platinum contacts. Super-sensitive, ideal for Transistor circuitry. Will operate on 1 milliamp; 25/- . P. & P. 1/-.

230 VOLT A.C. GEARED MOTORS

5 r.p.m. 1.7lb inch £2/9/6. P. & P. 2/6
 13 r.p.m. 1.45lb. inch £2/12/6. P. & P. 2/6

ELECTRIC CHECK METER (Sangamo Weston) 200/240 volt, A.C., 40 amp. As new 35/- plus 3/6 P. & P.

LATEST HIGH SPEED MAGNETIC COUNTERS

4 figure 10 impulses per second. Type 100D, 4.1 ohm coil, 3-6 v. D.C. operation. Type 100A, 500 ohm coil, 18-24 v. D.C. operation. Type 100B, 2,300 ohm coil, 36-48 v. D.C. operation. Any type, 15/- each, plus 1/6 P. & P.

L.T. TRANSFORMERS

Type No.	Sec. Taps	Price Carr.
1	30, 32, 34, 36 v. at 5 amps.	£2/19/6 6/-
2	30, 40, 50 v. at 5 amps.	£4/15/0 6/-
3	10, 17, 18 v. at 10 amps.	£3/2/6 4/6
4	6, 12 v. at 20 amps.	£3/12/6 6/6
5	17, 18, 20 v. at 20 amps.	£5/2/6 6/6
6	6, 12, 20 v. at 20 amps.	£4/13/0 7/6
7	24 v. at 10 amps.	£3/9/6 5/6
8	28, 29, 30, 31 v. at 21 amps.	£6/13/0 10/-

VENNER 14 DAY CLOCKWORK TIME SWITCHES 5 amp. 230 v. contacts. 24 hr. phase, 1/2 hr. divisions allows setting for 1 make, 1 break every 24 hrs. Complete with key and mounting block. Used but guaranteed. 35/6. P. & P. 2/6.

230V. A.C. MOTOR AND REDUCTION GEAR BOX



Reversible 1/2 h.p., 1,450 r.p.m. 8" dia. 1" long shaft. Mounted in anti-vibration cradle. Supplied complete with precision 20-1 reduction gear box and pulleys. Made to highest standard for computer work. Ex equip. First class condition. Price £35.0. P. & P. 7/6.

BUILD AN EFFICIENT STROBE UNIT FOR ONLY 37/6. We supply a simple circuit diagram and all electrical parts including the NSP2 Strobe tube which will enable you to easily and quickly construct a unit for infinite variety of speeds, from 1 flash in several seconds to several thousands per minute. 37/6 plus 3/- P. & P. **NSP2 TUBE** brand new. I.O. base. Price 15/-. P. & P. 1/6.

UNIVERSAL DEMONSTRATION TRANSFORMER

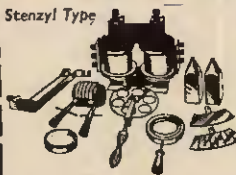

A complete composite apparatus, comprising a Transformer and electro-magnet with removable coils and pole pieces. Coil tapped for 230 v, 220 v, 110 v, 115 v; 6, 12, 36, 110 v. A.C. These coils are also used for D.C. experiments.

Complete with all accessories as shown. £17 + 10/- carriage. Leaflet on request.

12 VOLT D.C. RELAY
 Single c/o, 600 ohm coil, New. 2 for 10/- plus 1/6 P. & P.

12-18 VOLT D.C. RELAY
 168 ohm coil, 3 x 5 amp. N.I. c/o contacts. New. 16/6 plus 1/- P. & P.

LIGHT SENSITIVE SWITCH. Kit of parts, including ORP12 Cadmium Sulphide Photo-cell, Relay, Transistor and Circuit, etc., price 25/- plus 2/6 P. & P. ORP 12 including circuit, 10/6 each, plus 1/- P. & P.

A.C. MAINS MODEL
 Incorporates Mains Transformer, Rectifier and special relay with 3, 5 amp mains c/o contacts. Price inc. circuit 47/6 plus 2/6 p. & p.

WORLD RADIO

AND

T.V. HANDBOOK 1966

Lists every B/C Station in the world, frequencies, times of operation, etc. by Johansen. 29/3

TRANSISTOR ELECTRONIC ORGANS FOR THE AMATEUR, by Douglas. 19/-
BUILDING AND USING SOUND MIXERS, by Steele. 31/3
TRANSISTOR RECEIVERS AND AMPLIFIERS, by Rayer. 31/3
101 WAYS TO USE YOUR SIGNAL GENERATOR, by Middleton. 19/-
SERVICING WITH DIP METERS, by Lenk. 25/-
RADIO AMATEURS' V.H.F. MANUAL, New Edition, by A.R.R.L. 20/-
TECHNICAL TOPICS FOR THE RADIO AMATEUR, New Edition, by R.S.G.B. 11/-
ABCs OF COMPUTERS, by Lytel. 17/-
MULLARD REFERENCE MANUAL OF TRANSISTOR CIRCUIT, 13/6
SERVICING ELECTRONIC ORGANS by Pittman. 31/3

All prices include U.K. postage
 Where possible 24-hour service guaranteed

UNIVERSAL BOOK CO.

12 LITTLE NEWPORT ST., LONDON, W.C.2
 (Leicester Square Tube Station)

SUB-MINIATURE

Set of 3 T.F.'s and oscillator coil, 465-470 Kc/s. Size approximately 1/2 x 1/2 x 3/16 in. Limited quantity available at only 8/- per set. P. & P. 1/6.
 Also: Eagle I.P. and osc. coil kit with tuning capacitor and dial, and bar aerial. All complete, miniature and boxed. Supplied with s/h.t. oct. at only 24/6 complete. P. & P. 2/6.

SILICON RECTIFIER

Type BY100, 6/- (230v. 500ma) P. & P. 1/6-

TRANSFORMERS

AUTO	60W	only 24/-	P. & P. 2/6
	150W	only 35/-	P. & P. 3/6

FILAMENT 230-6-3v.
 TRANSISTOR Complete range of driver and output transformers available.

EARPHONES

New and Boxed
 2,000 ohms — 14/3 P. & P. 2/6
 4,000 ohms — 17/3 P. & P. 2/6
 Also full range of earpieces from 4/11 to 12/5. P. & P. 1/-

VOLUME CONTROLS

Standard, linear and log trucks. All values. Less switch, only... 2/10 P. & P. 1/6
 With d.p. sw. only... 3/0 P. & P. 1/6
 Full range of TEST METERS always in stock— drop in and see for yourself. A fine example is our popular 20Kohms/v. multimeter at only 44/0.6.

We are also stockists of the following items and we will be pleased to furnish you with detailed information and literature on request:
LANDER range of D.T.Y. Burglar Alarm Kits
Phillips Electronic Kits
Sinclair Products
Vero-board

REMEMBER

BOTHWELL ELECTRIC SUPPLIES (Glasgow) LTD.
 54 EGLINGTON STREET
 GLASGOW, G5
 Member of the Lander Group
 have all you need for your industrial and domestic electrical applications. See for yourself or telephone 80Uth 2904 for further information.
TRADE ENQUIRIES WELCOME

SERVICE TRADING CO

All Mail Orders—Also callers:
 47/49 HIGH STREET, KINGSTON ON THAMES
 Telephone: KINGston 9450

Personal callers only
 9 LITTLE NEWPORT STREET
 LONDON, W.C.2 Tel: GERnard 0576

STEREO AMPLIFIER

Incorporating 2 ECL82s and 1 EZ80, heavy duty, double wound mains transformer. Output 4 watts per channel. Full tone and volume controls. Absolutely complete.

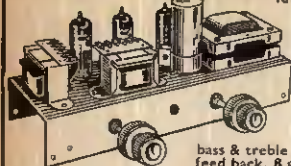

ONLY £4.19.6

P. & P. 6/6

Super De-luxe version with ECL86 valves, sep. bass & treble controls, full feedback. 8 gns. P. & P. 6/6

HSL 'FOUR' AMPLIFIER KIT.

A.C. Mains 200/250v., 4 watt, using ECC83, EL84, E280 valves. ★ Heavy duty double-wound mains transformer with electrostatic screen. ★ Separate Bass, Treble and Volume controls, giving fully variable boost and cut with minimum insertion loss. ★ Heavy negative feedback loop over 2 stages ensures high output at excellent quality with very low distortion factor. ★ Suitable for use with guitar, microphone or record player. ★ Provision for remote mounting of controls or direct on chassis. ★ Chassis size only 7 1/2 in. wide x 4 in. deep. Overall height 4 1/2 in. ★ All components and valves are brand new. ★ Very clear and concise instructions enable even the inexperienced amateur to construct with 100% success. ★ Supplied complete with valves, output transformer (3 ohms only), screened lead, wire, nuts, bolts, solder, etc. (No extras to buy.) PRICE 79/6. P. & P. 6/-.

Comprehensive circuit diagram, practical layout and parts list 2/6 (free with kit). This kit although similar in appearance to HA34 it employs entirely different and advanced circuitry.

MAINS TRANSFORMERS

Semi shrouded drop type. Pri. 200, 220, 240v. Sec. 250v. 1/2 wave at 70mA and 6.3v. at 2 amp. r.a.c. Stack size 3" x 2 1/2" x 1 1/2". PRICE 11/- P. & P. 3/-.

BRAND NEW 3 OHM LOUDSPEAKERS
5 in., 12/6; 6 in., 15/-; 8 in., 21/-; 10 in., 25/-; 12 in., 27/6; (12 in. 15 ohm, 30/-), 10 in. x 6 in., 26/-.
E.M.I. 13 1/2 x 8 in. with high flux ceramic magnet, 42/-, (15 ohm, 45/-). P. & P. 4" & 5" 2/-, 6" & 8" 2/6, 10" & 12" 3/6 per speaker.

ACOS CRYSTAL MIKES. High imp. For desk or hand use. High sensitivity, 18/6. P. & P. 1/6.

TSL CRYSTAL STICK MIKE. Listed at 45/-. Our price, 38/6. P. & P. 1/6.

BRAND NEW 12" 15w. H/D Speakers, 3 or 15 ohm. Current production by well-known British maker. Offered below list price at 87/6. P. & P. 5/-. (25w. guitar model £53.0). (35w. guitar model £88.0).

MATCHED PAIR OF 21 WATT TRANSISTOR DRIVER AND OUTPUT TRANSFORMERS. Stack size 1 1/2 x 1 1/2 x 1 in. Output trans. tapped for 3 ohm and 15 ohm output. 10/- pair plus 2/- P. & P. 3.

BRAND NEW PLESLEY 12 v. 4 pin non-syn-c. Vibrators. Type 12.1.4SD. ONLY 8/6. P. & P. 1/6

4-WAY NON-TANGLE TELEPHONE CABLE
Latest spring-back coil type, extends 12 in. to 5ft. Complete with rubber bushes, 4/6 each. P. & P. 1/6.

VYNAIR AND REXINE SPEAKER AND CABINET FABRICS app. 54 in. wide. Usually 35/- yd., our price 13/6 per yd. length (min. 1yd.) P. & P. 2/6. S.A.E. for samples.

QUALITY RECORD PLAYER AMPLIFIER

A top-quality record player amplifier. This amplifier (which is used in a 29 gn. record player) employs heavy duty double wound mains transformer, ECC83, EL84, E280 valves. Separate Bass, Treble and Volume controls. Complete with output transformer matched for 3 ohm speaker. Size 7 in. w. x 2 1/2 in. d. x 5 1/2 in. h. Ready built and tested. PRICE 89/6. P. & P. 4/9.

ALSO AVAILABLE mounted on board with output transformer and 6in. speaker ready to fit into cabinet below. PRICE 89/6. P. & P. 5/9.

QUALITY PORTABLE R/P CABINET

Unicou motor board. Will take above amplifier and B.S.R. or GARRARD Autochange or Single Record Player Unit. Size 18 x 14 x 8 1/2 in. PRICE £39/6. Carr. 7/6.

4-SPEED PLAYER UNIT BARGAINS

All brand new in maker's original packing.
SINGLE PLAYERS
B.S.R. TU/12 £39/6. Carr. 5/6.
GARRARD SP25 De Luxe... £12/10/6. Carr. 5/6.
B.S.R. GU7 with unit mounted pickup arm. £4/18/8. Carr. 5/6.

AUTO CHANGERS

B.S.R. UA15 £6/19/6. B.S.R. UA6 £6 19 6
Latest B.S.R. UA25 Super slim £6 2 6
Latest GARRARD AT5 £8 8 0
GARRARD AT6 £9 10 0
GARRARD Auto-Slim £5.10.0, Carr. 6/6 on each.
All the above units are complete with c/o mono head and sapphire stylus or can be supplied with compatible stereo head for 12/6 extra.

BRAND NEW CARTRIDGE BARGAINS!

ACOS 71-5. Single sided Crystal Cartridge for Stereo and L.P. records. Complete with diamond stylus and unusual mounting bracket. List price £26.4. Our price 18/6. P. & P. 1/-.

PORTABLE TAPE RECORDER CASE

Beautifully made and expensively finished in dark grey heavy grade rexine. Satin Chrome metal grille front and chrome fittings. Speaker aperture 9" x 4". Overall size 15 1/2 w. x 15" d. x 7 1/2 h. Will take any standard tape deck or single record player. Limited number only. Worth at least £5. OUR PRICE 49/6. P. & P. 5/-. Brand new and unused.

TAPE DECKS

B.S.R. MONARDECK (Single speed) 3 1/2 in. per sec., simple control, uses 5 1/2 in. spools, £6/15/- plus 7/6 carr. and ins. (Tapes extra.)

10/14 WATT HI-FI AMPLIFIER KIT

A stylishly finished monaural amplifier with an output of 4 watts from 2 EL84s in push-pull. Super reproduction of both music and speech, with negligible hum. Separate inputs for mike and gram allow recordings and announcements to follow each other. Fully shrouded section wound output transformer to match 3-15Ω speaker and 2 independent volume controls, and separate bass and treble controls are provided giving good life and cut. Valve line-up 2 EL84s, ECC83, EF86, and E280 rectifier. Simple instruction book 1/6 (free with parts.) All parts sold separately. ONLY £6/19/6. P. & P. 8/6. Also available ready built and tested complete with std. input sockets, £8/15/-. P. & P. 8/6.

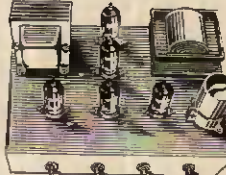

3-VALVE AUDIO AMPLIFIER MODEL HA34



Designed for Hi-Fi reproduction of records, A.C. Mains operation. Ready built on plated heavy gauge metal chassis, size 7 1/2 in. w. x 4 in. d. x 4 1/2 in. h. Incorporates ECC83, EL84, E280 valves. Heavy duty, double wound mains transformer and output transformer matched for 3 ohm speaker, separate Bass, Treble and volume controls. Negative feedback line. Output 4 1/2 watts. Front panel can be detached and leads extended for remote mounting of controls.

The HA34 has been specially designed for us and our quantity order enables us to offer them complete with knobs, valves, etc., wired and tested for only **£4.5.0** P. & P. 6/-.

HIGH GAIN 4 TRANSISTOR PRINTED CIRCUIT AMPLIFIER KIT Type TAI

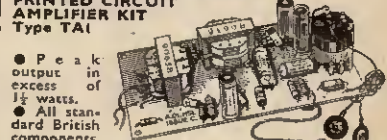

● Peak output in excess of 1 1/2 watts. ● All standard British components. ● Built on printed circuit panel, size 6 x 3 in. ● Generous size Driver and Output Transformers. ● Output transformer capped for 3 ohm and 15 ohm speaker. ● Transistors (GET 114 or 51 Mullard OC81D and matched pair of OC81 e/p). ● 9 volt operation. ● Everything supplied, wire, battery clips, solder, etc. ● Comprehensive easy to follow instructions and circuit diagram (free with kit). All parts sold separately. SPECIAL PRICE 45/-. P. & P. 3/-. Also ready built and tested, 52/6. P. & P. 3/-. A pair of TAIs are ideal for stereo.

HARVERSON'S F.M. TUNER Mk. I

● F.M. tuning head by famous maker. ● Guaranteed non-drift. ● Permeability tuning. ● Frequency coverage 88-100 Mc/s. ● Balanced diode output. ● Two I.F. stages and discriminator. ● Attractive maroon and gold dial (7 x 3 in. glass). ● Self powered, using a good quality mains transformer and valve rectifier. ● Valves used ECC85, two EF86s, and E280 (rectifier) ● Fully drilled chassis. ● Size of completed tuner 8 x 6 x 5 1/2 in. ● All parts sold separately. Set of parts if purchased at one time £5/19/6, plus 8/6 P.P. and ins. Circuit diagram and instructions 1/6 post free. Mark II Version as above but complete with magic eye, front panel and brackets, £6/12/6. P. & P. 8/6. Mark III Version as Mark I but with output stage (ECL82) and tone control, £7/7/-. P. & P. 8/6.

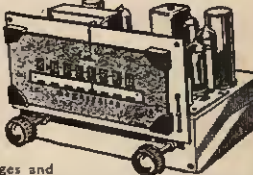

SPECIAL PURCHASE!

from LEADING HI-FI MANUFACTURER
7-10 watt OUTPUT TRANSFORMERS
to match pair of ECL 86's in push-pull to 3 ohm output. ONLY 11/-. P. & P. 2/6.
7-10 watt ULTRA LINEAR OUTPUT TRANSFORMERS to match pair of ECL 82's in push-pull to 3 ohm output. ONLY 15/-. P. & P. 2/6.
SPECIAL MAINS TRANSFORMERS to match either of the above. Tapped primary. Secondary 250v. 80mA. half wave and 6.3v. 2 amps. ONLY 12/6. P. & P. 3/6.

HARVERSON SURPLUS CO. LTD.

170 HIGH ST., MERTON, S.W. 19. CHERRYWOOD 3985

Open all day Saturday Early closing Wed., 1 p.m.
A few minutes from South Wimbledon Tube Station. (Please write clearly)
OVERSEAS P. & P. CHARGED EXTRA. S.A.E. with all enquiries.

ANNOUNCING COMPONENTS AT PRICES YOU CAN AFFORD

BELOW ARE JUST A FEW OF OUR MANY BARGAINS THAT CAN BE SEEN ALONG WITH HUNDREDS OF OTHERS AT OUR RETAIL SHOP

- RED SPOT 9d.
- WHITE SPOT 9d.
- AF117 2/6
- OC44 2/6
- OC71 2/6
- OC81D 2/6
- OC26 10/-
- OC76 2/6
- OC45 2/6
- OC72 2/6
- OC81 2/6
- AD140 10/-

BARGAIN OF THE MONTH
Set of Six Transistors
OC44 OC45 OC45
OC81D OC81 OC81
12/6 P. & P. 6d.
Sets with
OC71, OC72, OC72 AF output
are available

- 1-W RESISTORS 10Ω-22M 2d.
- CERAMICS 4d.
- SILVER MICA 6d.
- HI-STABS 1% 1/- OABI 1/-
- MAGNETIC EARPIECES 3/-
- CRYSTAL EARPIECES 4/4
- MIN TRANSISTOR ELECTROLYTICS 1/2

30w 240v PORTABLE SOLDERING IRONS 9/3
EAGLE POCKET CRYSTAL SETS WITH EARPIECE 14/11
We welcome enquiries for all types of components. Lists, S.A.E. Terms, cash with order, P/P. add 9d. for orders under £2
WENTWORTH RADIO, 1a, Wentworth Court, Alston Rd., Barnet. Tel.: BAR 3087

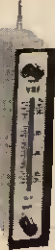

TELECOM MK. II
Pocket size, V.H.F.
118-136 Mc/s

AIRCRAFT-BAND TRANSISTOR RECEIVER

complete with telescopic aerial, loudspeaker and battery
£26.0.0
carr. paid in U.K.

BRITEC LIMITED
17 Charing Cross Road
London, WC2 WHITEHALL 3070

TRANSISTOR ELECTROLYTICS

COMPARE THESE PRICES!

32uf ... 1.5Volt	3-2uf ... 6Volt	3uf ... 12Volt	16uf ... 15Volt
25uf ... 3Volt	4uf ... 6Volt	4uf ... 12Volt	32uf ... 15Volt
2uf ... 3Volt	8uf ... 6Volt	10uf ... 12Volt	50uf ... 15Volt
3uf ... 3Volt	10uf ... 6Volt	20uf ... 12Volt	64uf ... 15Volt
8uf ... 3Volt	25uf ... 6Volt	25uf ... 12Volt	2.5uf ... 25Volt
10uf ... 3Volt	30uf ... 6Volt	30uf ... 12Volt	16uf ... 25Volt
12uf ... 3Volt	50uf ... 6Volt	1uf ... 15Volt	32uf ... 25Volt
20uf ... 3Volt	100uf ... 6Volt	2uf ... 15Volt	2uf ... 30Volt
30uf ... 3Volt	2uf ... 9Volt	4uf ... 15Volt	16uf ... 30Volt
40uf ... 3Volt	10uf ... 9Volt	5uf ... 15Volt	25uf ... 30Volt
25uf ... 6Volt	20uf ... 9Volt	6uf ... 15Volt	1uf ... 40Volt
2uf ... 6Volt	2uf ... 12Volt	8uf ... 15Volt	5uf ... 70Volt

All the above at 1/2 each

320uf ... 2.5Volt	250uf ... 15Volt	150uf ... 25Volt	All at 1/6
200uf ... 3Volt	500uf ... 15Volt	100uf ... 30Volt	
250uf ... 6Volt	100uf ... 18Volt	200uf ... 30Volt	All at 2/-
400uf ... 6Volt	64uf ... 25Volt	50uf ... 150Volt	
1,000uf ... 6Volt	500uf ... 25Volt		
1,000uf ... 12Volt	500uf ... 50Volt		
4,000uf ... 12Volt	1,000uf ... 50Volt		
750uf ... 15Volt			
1,000uf ... 15Volt			

200/100uf ... 275Volt or 200/200uf ... 275Volt ... 6/6 each

CONDENSERS

Silver Mica 3-3pf to 6,800pf. Including High Voltage Disc Ceramics. (Normally 3/- each) ... 10/- 100 Paper Condensers .0001uf, .001uf, .002uf, .005uf and .04uf ... all at 7/6 per 100. £3 per 1,000 .1uf, .25uf, .5uf ... 10/- per 100

RESISTORS

1/10th 1/6th 1/4Watt ... Assorted Values 10/- per 100

Mixed wattages 1/2Watt to 3Watt. Close Tolerance. Assorted Values. Polythene wrapped on cards of 10. Give-away price 50/- per 1,000 plus 5/- post and packing.

TRANSISTORS Special offer. Unmarked. State R.F. or A.F. 6/- doz. £1 10z

(At a price you can afford)

OC71 equivalent, 1/- each, 25 for £1, 100 for £3. NKT124 or NKT 125, Switching transistors, 2/- each, 6 for 10/- Large Car Radio type Output Transistors OC25, OC35, NKT405, 10/- each. Packet containing: 3 2G417, 2 2G371, 1 2G381, 1 2G339, 1 diode (for making superhet with complementary symmetry transformerless output stage), £1 complete. Diodes, 1/- each. Zener Diodes, ZE12, ZB4-3, 5/- each. BY100 Mains Rectifiers for TV Sets, 7/6 each.

SIGNAL INJECTOR

R.F./I.F./A.F. Transistors, components and circuit to make, only 10/- complete.

LOUDSPEAKERS

Brand-new 4in. Excellent reproduction, 10/- each

Midget Earpieces complete with plug and lead	5/- each
Magnetic Lapel Microphone with plug and lead	10/- each
Transistor Holders	1/- each
Miniature Soldering Irons complete with Bit	30/- each
Set of 5 assorted Bits to suit any job	20/- set
Crystal Set kits	15/- each
POCKET-SIZE MULTIMETERS, AC/DC/OHMS	£3
Transistor Intercomm. Units	55/- pair
5ft. FLUORESCENT FITTINGS. With choke and starter	39/6*
4ft. ditto With choke and starter	32/6*

* Carriage 10/- per fitting

ACOS PICK-UP HEADS. Complete with needles

This is the price you would expect to pay for the Needles only!

Monaural	14/-
Stereo	21/-
Diamond Stereo	28/9

Will fit most record changers. Can be very profitable!

RELAYS, Miniature, 1 1/2" x 1" x 3/4"

700 ohm or 2,500 ohm coil. Transparent dust cover. Two pairs of change-over contacts. PLUG-IN TYPE. Base included in price ... 25/- each

For orders less than 10/- please add 6d. towards postage.

G. F. MILWARD

17 PEEL CLOSE, DRAYTON BASSETT
Nr. TAMWORTH, STAFFS

Telephone: TAMWORTH 2321

POST ONLY

SILICON PLANAR EPITAXIAL 200 MC/S

5/- 5/- 5/- 5/-

At last! Truly general-purpose silicon transistors at germanium prices. These tiny epoxy-encapsulated NPN devices are suitable for practically every low-power application — low-noise audio, r.f. amplifiers and mixers up to the edge of the v.h.f. band, d.c. amplifiers, low-power output stages ...

- ★ Selected 2N2926
- ★ Current gain (h_{fe}) 55-300 at 2 mA
- ★ Collector dissipation 200 mW
- ★ Cut-off frequency (f_T) 200 Mc/s
- ★ A.f. noise figure 2.8 dB at 10 kc/s
- ★ First grade. Data supplied

Price includes U.K. postage. Cash with order. Mail order only.
AMATRONIX LTD., 396 SELSDON RD., CROYDON, SURREY

YUKAN SELF-SPRAY

Get this Air Drying Grey
HAMMER FINISH
Now —

IT'S SUPERB . . . THE PUSHBUTTON WAY!

YUKAN Aerosol spraykit contains 16 ozs. fine quality durable easy instant spray. No stove baking required. Available in Grey Hammer at 14/11 at our counter or 15/11, Carr. paid, per pushbutton self-spray can. SPECIAL OFFER: I can plus optional transferable snap-on trigger handle (value 5/-) for 18/11.



Choice of 13 self-spray plain colours and primer (Motor car quality) also available

Please enclose cheque or P.O. for total amount to:

YUKAN

Dept. PE/11, 307a EDGWARE ROAD, LONDON, W.2

Closed Thurs. afternoons

Open all day Saturday

MARTIN Audiokits

FOR HI-FI
AND F.M.

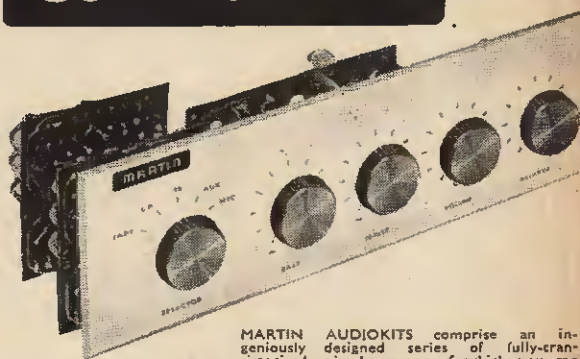

20 WATT INTEGRATED STEREO

ADD-ON UNIT SYSTEM

F.M. TUNER

THE EASY WAY TO BUILD AND SAVE

Leaflet on request.

From good stockists everywhere.

Martin Electronics Ltd
154-155 High St., Brentford,
Middlesex. ISLeworth 1161/2

MARTIN AUDIOKITS comprise an ingeniously designed series of fully-transistorised units by means of which you can build up a hi-fi assembly starting with a simple mono amplifier system and adding to it to make a fully integrated 20-watt stereo installation, for well under £30. This can be used with low output as well as crystal pick-ups, radio, tape-heads, microphones, etc. Building is pleasantly easy. Quality is outstanding. Now units for making an FM Tuner are available for adding to Audiokit assemblies or using separately.

MARTIN ELECTRONICS LTD,
154-155 HIGH ST., BRENTFORD, MIDD
Martin Leaflet on Audiokits
FM Tuner , please.

NAME
ADDRESS
Pre.2

VALUABLE NEW HANDBOOK FREE TO AMBITIOUS ENGINEERS

Have you had your copy of "Engineering Opportunities"?

The new edition of "ENGINEERING OPPORTUNITIES" is now available—without charge—to all who are anxious for a worthwhile post in Engineering. Frank, informative and completely up to date, the new "ENGINEERING OPPORTUNITIES" should be in the hands of every person engaged in any branch of the Engineering industry, irrespective of age, experience or training.

On 'SATISFACTION OR REFUND OF FEE' terms

This remarkable book gives details of examinations and courses in every branch of Engineering, Building, etc., outlines the openings available and describes our Special Appointments Department.

WHICH OF THESE IS YOUR PET SUBJECT?

MECH. ENGINEERING
Gen. Mech. Eng.—Maintenance Eng.— Diesel Eng.— Press Tool Design — Sheet Metal Work — Welding — Eng. Pattern Making — Inspection - Draughtsmanship — Metallurgy — Production Eng.

ELEC. ENGINEERING
General Electrical Eng. — Installations — Draughtsmanship — Illuminating Eng. — Refrigeration — Elem. Elec. Science — Elec. Supply — Mining Elec. Eng.

RADIO ENGINEERING
General Radio — Radio & TV Servicing — TV Eng. — Telecommunications — Electronics—Sound Recording—Automation—Practical Radio —Radio Amateurs' Exam.

AUTO ENGINEERING
General Auto Eng. — Auto. Maintenance — Repair — Auto. Diesel Maintenance — Auto. Electrical Equipment—Garage Management.

CIVIL ENGINEERING
General Civil Eng. — Municipal Eng. — Structural Eng. Sanitary Eng. — Road Eng. Hydraulics—Mining—Water Supply—Petrol Tech.

BUILDING
General Building — Heating & Ventilation — Plumbing — Architecture — Carpentry — Painting — Decorating — Specifications & Quantities — Surveying — Architectural Draughtsmanship.

WE HAVE A WIDE RANGE OF COURSES IN OTHER SUBJECTS INCLUDING CHEMICAL ENG., AERO ENG., MANAGEMENT, INSTRUMENT TECHNOLOGY, WORKS STUDY, MATHEMATICS, ETC.

Which qualification would increase your earning power?
A.M.I.Mech.E., A.M.S.E., A.M.I.C.E., A.M.I.E.R.E., B.Sc., A.M.I.P.E., A.M.I.M.I., A.R.I.B.A., A.I.O.B., A.M.I.Chem.E., A.R.I.C.S., M.R.S.H., A.M.I.E.D., A.M.I.Mun.E., CITY & GUILDS, GEN. CERT. OF EDUCATION, ETC.

BRITISH INSTITUTE OF ENGINEERING TECHNOLOGY

316A COLLEGE HOUSE, 29-31 WRIGHT'S LANE, W.8

THIS BOOK TELLS YOU

- ★ HOW to get a better paid, more interesting job.
- ★ HOW to qualify for rapid promotion.
- ★ HOW to put some letters after your name and become a key man . . . quickly and easily.
- ★ HOW to benefit from our free Advisory and Appointments Depts.
- ★ HOW you can take advantage of the chances you are now missing.
- ★ HOW, irrespective of your age, education or experience, YOU can succeed in any branch of Engineering.

156 PAGES OF EXPERT CAREER - GUIDANCE

PRACTICAL EQUIPMENT

Basic Practical and Theoretical Courses for beginners in Radio, T.V., Electronics, Etc., A.M.I.E.R.E. City & Guilds Radio Amateurs' Exam. R.T.E.B. Certificate P.M.G. Certificate Practical Radio Radio & Television Servicing Practical Electronics Electronics Engineering Automation

INCLUDING TOOLS

The specialist Electronics Division of B.I.E.T. NOW offers you a real laboratory training at home with practical equipment. Ask for details.

B.I.E.T.

You are bound to benefit from reading "ENGINEERING OPPORTUNITIES", and if you are earning less than £30 a week you should send for your copy now—FREE and without obligation.



POST NOW!

TO B.I.E.T., 316A COLLEGE HOUSE,
29-31 WRIGHT'S LANE, W.8.

3d. stamp if posted in an unsealed envelope.

Please send me a FREE copy of "ENGINEERING OPPORTUNITIES." I am interested in (state subject, exam., or career).

NAME

ADDRESS

WRITE IF YOU PREFER NOT TO CUT THIS PAGE

THE B.I.E.T. IS THE LEADING INSTITUTE OF ITS KIND IN THE WORLD

1966 — 150 BIG PAGES CATALOGUE

5,000 stocked items. Fully detailed and illustrated. **PRICE 6/-**
FREE vouchers give 2/- in £ (post paid) discount on purchases.

PROVED AND TESTED DESIGNS

FULL AFTER SALES SERVICE AND GUARANTEE

★ **CALL IN FOR DEMONSTRATIONS** ★
 DETAILED LEAFLETS FREE ON REQUEST

FREE New 12 page catalogue 500 transistors, rectifiers, sers, light devices, heat sinks, 1000 crystals, 800 valves etc. Ask for your **FREE** copy NOW

MW/LW POCKET SUPERHET RADIO



TOTAL COST TO BUILD

85/- P.P. 2/-
 (Battery 2/6 Phone 5/-)

★ All parts sold separately.

- ★ 6-Transistor design. Push-pull output.
- ★ 2½ in. Cleartone speaker. Printed circuit.
- ★ Attractive moulded cabinet.
- ★ Slow motion tuning.
- ★ Full med. and long waves.
- ★ Size: 5 × 3 × 1½ in.

● **AMAZING SENSITIVITY & SELECTIVITY** ●

- ★ 6-Transistor push-pull Superhet design.
- ★ Uses factory built panels.
- ★ Permeability geared tuning.
- ★ Full med./long wave tuning with push-button wave change.
- ★ Double tuned IFT's.
- ★ Chromed front panel plate.
- ★ Size: 7 × 4 × 2 in. Fits any car.
- ★ Pre-built units sold separately.

TOTAL COST TO BUILD

£8.19.6 P.P. 3/6

(7 in. × 4 in. speaker with car fixing kit and baffle board 20/- extra).

TWO WAVEBAND ALL TRANSISTOR CAR RADIO TO ASSEMBLE

● **HIGH PERFORMANCE SUPERHET** ●



2- AND 4-TRACK TAPE RECORDERS TO ASSEMBLE

Now with New "363" Tape Decks 6-Valves—Collaro Studio Decks—Portable Cabinets with Speakers.

Complete record and playback.



- ★ 2-track deck 10 gns. P.P. 5/- Amplifier 11 gns. Cabinet with speaker 5 gns.

OR SPECIAL PRICE **£26 8/6** P.P. **TWO TRACK**

- ★ 4-track deck £13. 19.6. P.P. 5/- Amplifier 12 gns. Cabinet with speaker 5 gns.

OR SPECIAL PRICE **£30 8/6** P.P. **FOUR TRACK**

Prebuilt and tested units. Low distortion, low noise

10 Watt & 20 Watt HI-FI AMPLIFIERS

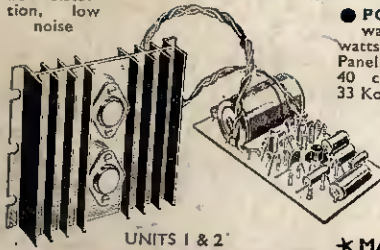

UNITS 1 & 2

● **POWER AMPLIFIERS.** 10 watts R.M.S. music power. 20 watts peak. 6-Transistor design. Panel size 4 × 2½ × 3 in. Response 40 c/s to 20 kc/s. 100mV into 33 Kohm input.

UNIT 1. For 12/15 ohm speakers. PRICE **£5.19.6** P.P. 2/6

UNIT 2. For 3 to 5 ohm speakers. PRICE **£5.10.0** P.P. 2/6

★ **MAINS UNITS.** 59/6. To power one amplifier or 69/6 to power two amplifiers (State 24 or 40 volt)

PREAMPLIFIERS. Mono and stereo versions, 8 inputs, 1½ to 300mV at 1k to 500k. Response 30 c/s to 20 kc/s. Complete range of controls. Mains unit or battery operated. For pickups, tuners, tape, microphones, etc.

UNIT 3. Mono full-function pre-amplifier. Size: 9½ × 2½ × 2 in. PRICE **£5.10.0** P.P. 2/6 (Brown/Gold front panel plate 8/6)

UNIT 4. Simplified version of Unit 3. Price 65/- P.P. 1/6. Panel plate 6/6.

UNIT 5. Stereo preamplifier for use with two units 1 or 2. Size 9 × 3½ × 1½ in.

PRICE **£10.19.6** P.P. 3/6
 (Front panel plate 12/6)



UNIT 5



UNIT 3

THE FINEST QUALITY HI-FI AT UNBEATABLE PRICES

TRANSISTOR TRANSMITTER/RECEIVERS



● ½ mile range PRICE PER PAIR **£7.19.6**

● 5 mile range PRICE PER PAIR **£22.10.0**

4-CHANNEL MICROPHONE MIXER Transistorised, 4 inputs up to 100 Kohm. Full mixing. PRICE **49/6**

Stereo version 72/6

Let us quote for parts for your circuit. Send a list for quick reply. Quality components at realistic prices

● Complete Reconstructor Kit with meter box, 79/6, p.p. 2/- All parts in stock for "PE" transistor Tape Recorder.

SINCLAIR DESIGNS

- ★ New Pocket FM Radio Kit **£5.19.6**

- ★ Micro-6 MW/ radio 59/6

- ★ TR750 "Addon" power amp. 39/6

- ★ Micro injector 27/6

- ★ Micro amp. 28/6

- ★ X10 Amp. kit **£5.19.6**

- ★ BUILT **£6.19.6**

- ★ Z12 89/6

- ★ X20 kit **£7.19.6** BUILT **£9.19.6**



5 WATT AND 1½ WATT PACKAGED AMPLIFIERS

- ★ 6-Transistor push-pull printed circuit designs

- ★ Size only 2½ × 2 × 1½ in.

- ★ 5 watt 18 volt, 1½ watt 12 volt

- ★ For 3 to 5 ohm speakers

- ★ 7mV into 1 Kohm. 30 c/s to 16 kc/s

- ★ P.P. 15w. 65/- 1/6

- ★ P.P. 5w. 79/6 1/6

- ★ BUILT **15w. 65/- 1/6** P.P. **5w. 79/6 1/6**



(New Version)

MONO PREAMPLIFIER

Full range of controls. Inputs for M/c, Pu, tuner etc. Output 6-10mV. Suitable for any sensitive transistor amplifier (as above) 7½ or 12 or 18 volt operated.

Price Built and Tested 79/6 p.p. 2/6

TRANSISTOR PORTABLE TEST EQUIPMENT



All units size 6½ × 4½ × 2½ in.
 ★ RF generator, 150 kc/s to 350 mc/s in 8 ranges. RF, Mod. RF, AF outputs.
 PRICE **£9.10.0**

- ★ Resistance/capacitance bridge. **£8.5.0**.
- ★ Audio generator 10 c/s—100 kc/s. 4 ranges. **£16.15.0**.



VHF/FM TUNER TO ASSEMBLE
 ★ Two pre-built units plus metal work and front panel
 Total Cost **£12.17.6**
 P.P. 2/6

- ★ Size: 9½ × 3½ × 4 in.
- ★ 88 to 108 mc/s tuning
- ★ 100mV to 100Kohm output
- ★ 6-Transistor printed cct. superhet design (All units available separately)

NEW 3-WAVEBAND PUSH-BUTTON PORTABLE SUPERHET TO BUILD

- ★ SHORT WAVES (17-50m)
- ★ MED. WAVES
- ★ LONG WAVES

TOTAL COST TO BUILD **£8.19.6** P.P. 3/6

6 Transistors. 1 watt push-pull output. Special circuit for car aerial. Car and tape sockets. Telescopic and ferrite aerials. Full tuning on all wavebands. Push-button coil pack. Cabinet size 11 × 7½ × 3½ in. Black fabric with chromed handle and fittings. **THE ONLY FULLY TUNABLE MW/LW/SW RADIO AVAILABLE FOR HOME CONSTRUCTION.**

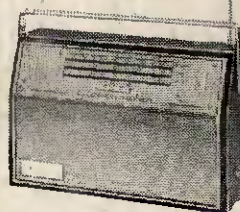

HI-FI All makes available—New demonstration room opening shortly.

VHF/FM TRANSISTOR TUNER TO BUILD

TOTAL COST **£8.19.6**

P.P. 2/6 (complete with frontplate) (Gold sprayed cabinet 20/- extra).

- ★ 5-Transistor 4 diodes
- ★ Printed circuit superhet
- ★ Geared tuning 87 to 105 mc/s FM
- ★ RF stage and double tuned IFT's
- ★ Output up to 1 volt peak up to 100 Kohm
- ★ 9 volt 9mA supply
- ★ Size in cabinet 4 × 3½ × 2½ in.
- ★ All parts sold separately

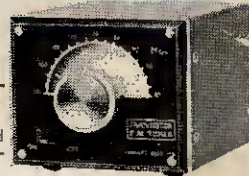

HENRY'S RADIO LTD.

303 EDGWARE RD., LONDON W2
 PADDINGTON 1008/9
 Open Mon. to Sat. 9-6. Thurs. 1 p.m.
 Open all day Saturday