



Data and Asset Information Standard

Ref. no: AI

Ver. 1.1

Date: 12 November 2020

Revision	Description	By	Date
0.1	First draft	J de Villiers	04/03/2016
0.2	Draft for internal review	J de Villiers	02/06/2017
0.3	Update as part of strategic transformation program	J de Villiers	7/05/2018
0.4	Data hierarchy update	J de Villiers	29/06/2018
0.5	Data hierarchy update, asset type updates, asset type definition updates	J de Villiers	16/10/2018
0.6	Update group codes	J de Villiers	19/11/2018
0.7	Working draft. First publication	J de Villiers	30/09/2019
1	Release with updates from feedback	J de Villiers	20/4/2020
1.1	Minor updates links provided to code tables	J de Villiers	12/11/2020

Summary of changes

Version	Section	Description of revision
1	Part A, 3	Included requirements for EIR in delivery of information
	Part B, 2.1, table	Update definition of ejector
	Part B, 4.17	Update maximum torque definition for valves
	Part B, 4.2	Included dropper feature for chamber structures
	Part C, 4.7.6	Update to transmission wastewater pipeline number schematic
	Part C, 5.2.10	Update equipment list
	Part G, 8	Added torque switch
	Part G, 15.	Added lockers and cabinets for site services
1.1	Part A, 4.6	Added reference to EIR that may change the typical delivery milestones depending on the contractual agreement
	Part A, 4.7	Update service status definitions
	Part B, 4	Remove reference to 'tier' in tables to not confuse with hierarchy defined tiers
	Part C, 5	Remove codes lists and provide links for downloading or contact to be provided with the codes lists in Excel format. Also added link to pipe service codes that was previously missing
	Part D	O&M manual template section 7 – added note to provide links to web-based supplier information where its too large to include
	Part F, 1.3.2	Reference added to condition inspection criteria and scoring

Table of contents

PREAMBLE	8
BIBLIOGRAPHY REFERENCES	9
STANDARD TERMS AND DEFINITIONS	10
PART A: DATA POLICY	16
1. INTRODUCTION	17
2. PUBLIC RECORDS ACT	18
3. LEVEL OF DATA CAPTURE BY RISK CLASSIFICATION	18
4. DATA PLAN	20
4.1 DATA MODEL	20
4.2 WATERCARE SYSTEMS.....	21
4.2.1 <i>System connectivity</i>	21
4.3 RECORD FILE FORMATS	22
4.3.1 <i>Drawings</i>	22
4.3.2 <i>Design reports and calculations</i>	22
4.3.3 <i>Site reports and consents</i>	22
4.3.4 <i>Operational documentation</i>	22
4.3.5 <i>GIS data</i>	22
4.3.6 <i>Metadata upload</i>	22
4.4 DATA STEWARDSHIP	22
4.5 STORAGE.....	22
4.5.1 <i>Documents and records system</i>	22
4.5.2 <i>GIS</i>	22
4.5.3 <i>Asset management information system (AMIS)</i>	22
4.5.4 <i>Dynamic data - PI (Plant Information)</i>	23
4.6 DATA SUBMISSION SCHEDULE	23
4.7 DATA MAINTENANCE	25
5. DATA ACCESS AND COPYRIGHT	26
5.1 DATA RECEIVING	26
5.2 DATA INTERNAL ACCESS	26
5.3 DATA EXTERNAL ACCESS	26
6. MANAGEMENT OF DATA QUALITY	26
6.1 BEFORE COLLECTION.....	27
6.2 DURING DATA ENTRY	27
6.3 POST DATA ENTRY	27
PART B: DATA STRUCTURE	28
1. DATA STANDARDS	29
2. DATA HIERARCHY	29
2.1 ASSET CLASSES, TYPES AND DEFINITIONS	32
3. ASSET TYPES AND GROUPING RULES FOR DATA CAPTURE	54
3.1 ASSETS VERSUS COMPONENTS OF ASSETS.....	54
3.2 CATEGORISING ASSETS	54
4. METADATA	60

4.1	ASSET CLASS: BUILDINGS	60
4.2	ASSET CLASS: CHAMBERS AND MANHOLES.....	65
4.3	ASSET CLASS: CIVIL	72
4.4	ASSET CLASS: CONTAINMENT STRUCTURES	79
4.5	ASSET CLASS: CONTROL SYSTEMS.....	86
4.6	ASSET CLASS: ELECTRICAL – ROTATING	97
4.7	ASSET CORE CLASS: ELECTRICAL - STATIC.....	107
4.8	ASSET CLASS: INSTRUMENTS	114
4.9	ASSET CLASS: LAND.....	123
4.10	ASSET CLASS: MECHANICAL – ROTATING	126
4.11	ASSET CLASS: MECHANICAL – STATIC	139
4.12	ASSET CLASS: PIPES AND CONDUITS	149
4.13	ASSET CLASS: RETAINING STRUCTURES.....	156
4.14	ASSET CLASS: ROAD/BRIDGE/RAIL.....	162
4.15	ASSET CLASS: SITE SERVICE COMPONENTS	166
4.16	ASSET CLASS: TOOLS	171
4.17	ASSET CLASS: VALVES	175
4.18	ASSET CLASS: VEHICLES	182
5.	FEATURE SELECTION LISTS FOR METADATA	186
6.	DYNAMIC DATA	194
7.	EXTERNAL DATA SOURCES	194
PART C: DATA PREPARATION AT DESIGN		195
1.	CREATING DRAWINGS.....	196
2.	INFORMATION ON MATERIAL SELECTION	196
3.	DESIGN DATA PARAMETERS.....	196
4.	EQUIPMENT NUMBERING	196
4.1	GENERAL PRINCIPLES	196
4.2	EQUIPMENT NUMBER HIERARCHY.....	197
4.3	EQUIPMENT NUMBER ELEMENTS.....	198
4.3.1	<i>Facility code</i>	<i>199</i>
4.3.2	<i>Process area</i>	<i>199</i>
4.3.3	<i>Asset group</i>	<i>200</i>
4.3.4	<i>Numerical identifier</i>	<i>200</i>
4.4	LOOP AND INSTRUMENT DUPLICATION RULES.....	203
4.5	PROCESS PIPE (LINE) NUMBERING	203
4.6	WATER TREATMENT SPECIFIC REQUIREMENTS.....	204
4.6.1	<i>Water Quality Analysers</i>	<i>204</i>
4.7	LINEAR WATER ASSETS SPECIFIC NUMBERING REQUIREMENTS	204
4.7.1	<i>Pipeline sections.....</i>	<i>205</i>
4.7.2	<i>Line valve chambers.....</i>	<i>207</i>
4.7.3	<i>Water bulk supply points (SP)</i>	<i>208</i>
4.7.4	<i>Flow metering station (FM)</i>	<i>209</i>
4.7.5	<i>Flow control station (FC).....</i>	<i>209</i>
4.7.6	<i>Wet chambers, manholes and wastewater pipelines</i>	<i>209</i>
4.8	ELECTRICAL EQUIPMENT SPECIFIC REQUIREMENTS.....	210
4.8.1	<i>Type 1 Electrical Equipment.....</i>	<i>210</i>
4.8.2	<i>Type 2 Electrical Equipment.....</i>	<i>211</i>
5.	NUMBERING CODES.....	211
5.1	PROCESS AREA CODES	211

5.2	GROUP CODES.....	211
5.3	LINE MATERIAL CODES	211
5.4	SERVICE CODES.....	211
PART D: OPERATIONAL SUPPORT RECORDS.....		212
1.	SUPPORTING OPERATIONAL DOCUMENTS.....	213
2.	OPERATION AND MAINTENANCE (O&M) MANUALS	213
2.1	GENERAL REQUIREMENTS	213
2.2	O&M MANUAL TEMPLATE	214
3.	FUNCTIONAL DESCRIPTIONS (FD).....	216
3.1	GENERAL REQUIREMENTS	216
3.2	FD TEMPLATE	216
3.3	STANDARD OPERATING PROCEDURES (SOP)	226
3.3.1	<i>Wastewater Plant template.....</i>	<i>226</i>
3.3.2	<i>Water Plant template.....</i>	<i>231</i>
PART E: FIELD IDENTIFICATION		233
1.	AS-BUILT SURVEY DATA FOR GEOGRAPHIC INFORMATION SYSTEM (GIS).....	234
2.	FIELD IDENTIFICATION AND LABELLING OF ASSETS	234
2.1	STANDARDS.....	234
2.2	GENERAL.....	234
2.3	ABBREVIATIONS.....	235
2.4	EXAMPLES.....	235
PART F: CONDITION ASSESSMENT DATA – POST CONSTRUCTION.....		237
1.	ASSET INSPECTIONS AND DATA.....	238
1.1	DATA COLLECTION.....	238
1.2	MAINTENANCE INDICATORS – EQUIPMENT IMPORTANCE LEVELS	238
1.3	CONDITION ASSESSMENT.....	239
1.3.1	<i>Overview.....</i>	<i>239</i>
1.3.2	<i>Inspection criteria</i>	<i>240</i>
1.3.3	<i>Assessment strategy.....</i>	<i>241</i>
2.	CCTV FOR PIPE ASSET CONDITION DATA COLLECTION.....	243
2.1	CCTV RECORD TEMPLATE.....	243
PART G: ASSET TYPE ATTRIBUTE AS-BUILT		244
1.	BUILDINGS	245
2.	CHAMBERS AND MANHOLES.....	249
3.	CIVIL.....	255
4.	CONTAINMENT STRUCTURES	260
5.	CONTROL SYSTEMS	267
6.	ELECTRICAL ROTATING	273

7.	ELECTRICAL STATIC.....	278
8.	INSTRUMENTS.....	287
9.	LAND.....	296
10.	MECHANICAL ROTATING.....	297
11.	MECHANICAL STATIC.....	304
12.	PIPE AND CONDUIT.....	317
13.	RETAINING STRUCTURE.....	322
14.	ROAD, RAIL, BRIDGE.....	326
15.	SITE SERVICE COMPONENTS.....	329
16.	TOOLS.....	332
17.	VALVES.....	335
18.	VEHICLES.....	339

Preamble

The purpose of this document is to improve data accuracy and completeness, prevent duplication and provide consistency through an established data structure.

To meet these purposes, this document is an inclusive representation of Watercare's engineering data system. Data evolution and the systems that are developed to manage data, is continually improved and adapted to the needs of data suppliers and data miners. Not all aspects contained in this document are relevant to any individual's use, however by its all-inclusive nature allows future improvements to be made in a structured nature without compromises to Watercare's engineering activities that may otherwise be omitted.

To make the requirements of this standard relevant to the various data partners the document is presented in several parts.

Part A: Data Policy

- Audience: Asset managers, Risk managers, Information system providers, System developers
- The policy covers the data plan, Watercare's current system interactions, data formats as well as the roles and responsibilities of parts of the business to meet the policy.

Part B: Data structure

- Audience: Designers, contractors, asset managers, financial managers, risk managers, information system providers, system developers.
- Sets out the data framework. Covers the fields of master data and metadata field to be captured for various asset types that must be captured as part of any as-built information.

Part C: Data preparation at design

- Audience: Designers, contractors, asset managers, system developers
- Data collection and correct numbering is an important part of the design process. This section describes at high level the information that is expected and details the numbering of equipment for both linear and plant assets.

Part D: Operational support records

- Audience: Designers, contractors, Watercare Operations
- Provides templates and guidelines for creating document records that will be used for operational purposes over the life of and asset or facility.

Part E: Field identification

- Audience: Contractors, Watercare Operations
- Provides the technical details for identifying equipment in the field to be traceable to the applicable electronic information.

Part F: Condition assessment data – post construction

- Audience: Contractors, Watercare Operations, asset managers, system developers
- Condition grading and procedures for identifying post installation data to be used as part of the data analytics when replacement and renewal planning is done.

Bibliography references

1. Water Research Foundation (2012), ISBN 978-1-60573-171-1, Key Asset Data for Drinking Water and Wastewater Utilities
2. BS EN ISO 14224:2006, Petroleum, petrochemical and natural gas industries – Collection and exchange of reliability and maintenance data for equipment
3. Fiatech (2011), An introduction to ISO 15926
4. New Zealand Water and Wastes Association Inc. (2006), New Zealand Pipe Inspection Manual 3rd edition
5. New Zealand Asset Metadata standard (2017), Ver.1. (Vol.1 Water and Vol.1 Wastewater)

Standard terms and definitions

General

Abandoned	See Out of Service
Assets	Water and wastewater infrastructure owned and operated by Watercare, anything of financial value or provides service potential.
As-built drawing	Drawings showing the exact dimension, geometry and locations of assets
Attributes	Data that can be collected about the asset to support affective asset management
Controlling Authority	Person(s) in a position of responsibility that is authorised to decide on changes, provide access and provide direction.
Document	A collective of information in a single unit.
Drawing	Document presenting graphic information.
Function	The main purpose of the asset in its installed state
Infrastructure	Facilities in an operational capacity that is managed by a controlling authority.
Metadata	Data used to describe data / data about data.
Nominal diameter (DN)	Average internal pipe diameter expressed in millimetre (mm) irrespective of the pipe class or wall thickness. Dimension used for pipe where the manufacturing process controls the internal pipe diameter – at different pressure classes the external diameter changes. Note: for PE or PVC the nominal diameter does not reflect the average internal diameter (ref. Nominal bore) but the average external diameter. Nominal diameter is not to be used alone where an additional lining has been used to extend the asset life.
Nominal bore (NB)	Average internal pipe diameter expressed in millimetre (mm). Dimension used for pipe where the manufacturing process controls the external pipe diameter. Applies to PE, PVC or where a lining significantly alters the nominal diameter (i.e. CLS pipe) of the host pipe.
Vested [assets]	Infrastructure designed and constructed in compliance with the standards prescribed by Watercare that has been handed over to Watercare as assets.
Out of service	The asset is not in operation, having some or no financial value and may be retained for future use. (Also see Abandoned)
Type	a category of assets having common attribute fields

Operational areas

Local networks	Reticulated distribution piping that is downstream connected from a transmission water main or upstream for wastewater where the peak dry weather flow is less than 78l/s.
-----------------------	--

Transmission	<p>High volume supply (water) or collection (wastewater) for transmitting liquid in bulk over long distances. For Wastewater see Interceptor.</p> <p>Water is potable (after treatment stage in Water Supply – ref. “Water Supply”) and reticulated between reservoirs. Reservoirs are included.</p>
Water supply	<p>Raw water collection into dams or abstraction from rivers or wells, including conveyance to treatment facilities and the treatment process.</p>
Treatment	<p>Conditioning of the receiving and outgoing liquid. (see “Water supply”)</p> <p>Water treatment plants for the treatment of raw water by mechanical or chemical processes to meet the Drinking Water Standards for New Zealand, or</p> <p>Wastewater treatment that receives wastewater from Wastewater transmission (ref. “Transmission”) to remove contaminants through mechanical, chemical and biological processes.</p>
Bulk	<p>The collective operational areas of Transmission, Water supply and Treatment (other than in networks) i.e. all infrastructure upstream of a bulk supply point for water, or in reference to wastewater where the peak dry weather flow is more than 78l/s.</p>

Processes and components

Booster Chlorination System/plant	<p>A facility to increase chlorine levels in the network or transmission areas</p>
Booster pump	<p>Pump facility inline on a main that boosts the pressure or flow velocity of the water or other media</p>
Borehole	<p>The underground supply (well) with abstraction system such as pump, casings, etc. See Well</p>
Bulk supply point (BSP)	<p>Metered connection off a transmission pipeline to a network.</p>
Chamber	<p>A partially below ground or below ground enclosure where equipment and dry pipework is housed for inspection or maintenance purposes.</p>
Containment structures	<p>an impounded body of material for distribution or process application such as a tank or reservoir for storage, regulation and control. Excluding dams.</p>
Control systems (DCS, SCADA, RTU’s, and PLC’s)	<p>Devices to control equipment and return data on processes and devices of operational infrastructure</p>
Dam	<p>Impoundment (retaining) structure that is used for catchment and storage of raw water (not potable)</p>
Domestic wastewater	<p>Liquid wastes including matters in suspension discharged from premises used solely for domestic purposes, or wastes of the same character, but does not include any soils, liquids, gases or materials which may not be legally discharged to public sewers</p>

Dry well	dry compartment for locating pumps in a pumping station
Drying bed	an area of porous material on which sludge is dewatered by drainage and evaporation
Filtration	Removal of suspended material in water by passing through a filter medium. Filter medium be mechanical, chemical or biological
Fire main	a water pipe in the network system that only supplies water for firefighting.
Gate valves	Valve with a gate that is lowered or raised within the valve body to isolate flow. Refer variants: Sluice valve, Peet valve and Toby valve. Gate valves are not differentiated in the Transmission area.
Gravity pipe [system]	a piping system where flow occurs through gravitation fall of the liquid medium without exerting internal pressure on the pipe walls and for which no pumping is required
Lagoon	Detention or holding pond used for containing sludge that may promote evaporation, sedimentation or biological oxidation
Landfill	Regulated disposal site for waste material by burying
Manhole	A partially below ground or below ground enclosure where equipment is housed. Manholes are wet areas where pipework or channels have open flow. Typical examples are directional changes and for maintenance by man access for wastewater gravity systems, or man access to large diameter pressure pipe when not in service.
Master meter	Metered connection within a network system that operates as a main metering point for slave meters situated on a private network.
Peet valves	Resilient seated gate valve used in the water network area that is installed on a rider main. Clockwise closing.
Point of supply	The point at which an owned asset stops and a private network starts. At this point the responsibility for ownership and maintenance off assets and equipment transfers to the customer.
Potable water	Treated water that complies with the drinking water standards for New Zealand
Pump(ing) station	Structure containing pumps, associated pipes, valves, mechanical and electrical equipment for pumping fluid.
Pressure main	Piping system where fluid exerts internal pressure on the pipe walls by liquid elevation or by means of pumping
Principal main	Also referred to as “mains” to describe a water pipe in the network system of minimum 100mm diameter and fitted with fire hydrants
Raw Water	Untreated water from the water supply source
Reservoir	A water retaining structure where potable water is stored and controlled for distribution.
Rider main	Water pipe supplied off a principal main on the frontage of lots not fronted by a principal main. A rider main does not typically have fire hydrants connected onto it.

Rising main	A pumped pressure main discharging into a receiving structure. See Pressure main
Sludge	By-product of treatment processes that contains most of the solids
Sluice valves	Resilient seated gate valve used in the water network area that is installed on a Principal main. Anti-clockwise closing.
Toby valve	Gunmetal gate valve used in the water network area that is installed on domestic service connections. Clockwise closing.
Tradewaste	As defined by the Auckland Council trade waste bylaw 2013: means any liquid, with or without matter in suspension or solution, that is, or may be discharged, from trade premises to a wastewater system in the course of any business, industrial or trade process or operation, or in the course of any activity or operation of a like nature.
Transmission watermain	A large main designed for the conveyance of bulk water to other transmission mains, reservoirs or bulk supply points. Transmission mains do not supply service connections to customers. Also see Bulk supply point (BSP)
Transmission wastewater main	The wastewater conveyance from a wastewater local network to the treatment plant. The peak dry weather flow is generally greater than 78 litres per second
Tunnel	An underground passage for conveyance of water, vehicles piping or conduit
Wastewater	Domestic wastewater with or without trade-waste
Wastewater local network	The wastewater collection system used to convey wastewater from a drain line to the wastewater main. The peak dry weather flow is generally less than 78 litres per second and pipe sizes are typically less than 300mm nominal diameter.
Watermain	Collective term used for pipe (any) carrying water in the transmission or network operational areas
Well [for water abstraction]	The subsurface source of water, typically accessed through drilling and supplied by an aquifer. See Borehole .
Wet well	Chamber in which water or wastewater is collected and to which a submersible pump is connected
Control valves	Valve designed to control flow, pressure or volume. The control valve may include mechanical and electrical control means necessary to operate the valve. The main valve may be a diaphragm valve, needle valve or float valve. It excludes ordinary automated operation for isolation valves.

Acronyms

AC	Asbestos (fibre) cement [pipe]
AC [electrical reference]	Alternating current

AMIS	Asset management information system
CAD	Computer aided design
CC	Cubic centimetres
CLS	Concrete lined steel [pipe]
DC	Direct current
dd-mm-yyyy	Date in the format of day – month – year
DI	Ductile iron
DN	See nominal diameter
EIR	Exchange of information requirements
FD	Functional description
FH	Fire hydrant
FMECA	Failure modes, effects and criticality analysis
GL	Ground level
GRP/FRP	Glass fibre reinforce pipe
ha	Hectare
kg	Kilogram
kN	Kilo Newton
kPa	Kilo Pascal
kVA	Kilo volt ampere
kW	Kilowatt
L	Litre
LINZ	Land Information New Zealand
l/s	Litre per second
m	Metre
mA	Mille-ampere
m²	Metre square
m³	Metre cubic
mm	Millimetre
NB	See Nominal bore
NZD	New Zealand dollars
O&M	Operations and Maintenance

Pdf	Portable document format (Adobe Acrobat)
PE	Polyethylene
PI	Plant Information [system]
P&ID	Process/piping and instrumentation diagram
PVC	Polyvinyl chloride pipe
RL	Reduced level
rpm	Revolutions per minute
RRJRC	Rubber ring jointed reinforced concrete
SCADA	Supervisory control and data acquisition – A control system used for alarm monitoring, control and data collection
SN	Nominal stiffness
SoP	Standard operating procedure
VC	Vitrified clay

Part A: Data Policy

1. Introduction

Watercare manages the data collected from new and existing assets to provide its services to its customers in a coherent, accurate and responsible manner. This standard is to ensure that data is captured with accuracy and common characteristics. Consistency in data capture allows correct interpretation for:

- Maintenance planning
- Short and long-term infrastructure upgrade and renewal planning
- Health, safety and environmental management
- Sharing of information for decision making
- Interaction of other utilities or stakeholders
- Long and short-term performance benchmarking

A high level lifecycle for data established on standard fundamentals is illustrated below:

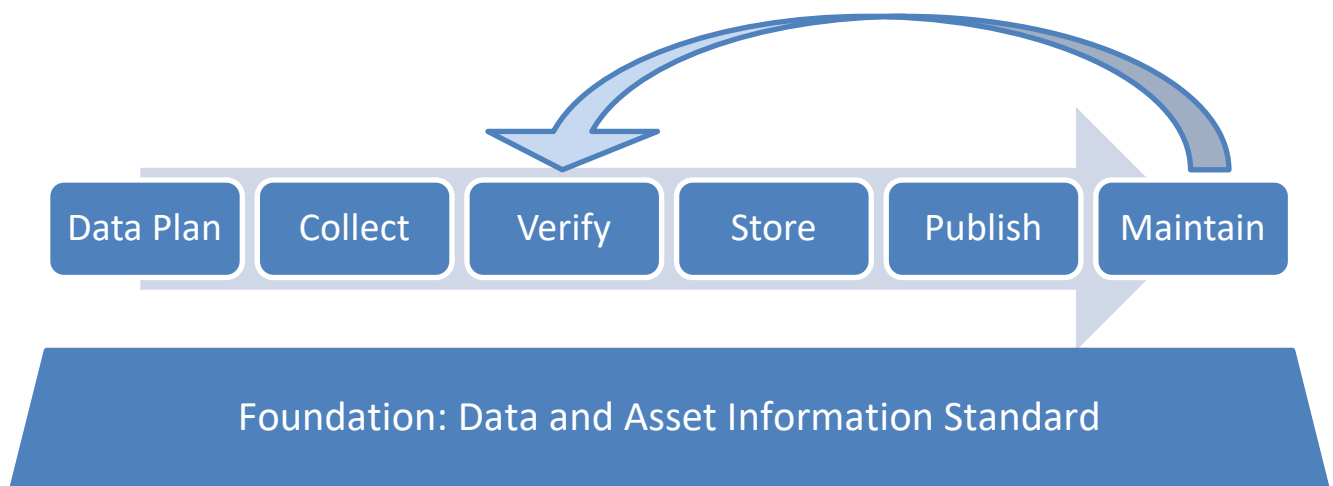

Data plan – The data plan identifies the systems, formats, ownership and processes that Watercare uses to store, manipulate and expose data.

Collect – Data is collected through various mediums, most commonly through the design, procurement and construction phases of projects. Data is also collected through vestment of assets to Watercare by external parties, sharing of information between organisations and discovery during operational activity or planning analysis.

Verify – Before data may be accepted it shall meet the minimum requirements set by this standard. The verification of data is important to ensure that shared data (incoming and outgoing) is accurate. Verification may also involve ongoing analysis through modelling, statistical data analysis and data interpretation by suitably qualified persons.

Store – Data is stored in accordance with the requirements of the New Zealand Public Records Act as supported by the Records Management Standard for the New Zealand Public Sector, May 2014.

Publish – The ability to use data internally and where appropriate share data between organizations and the public. The data format is important to establish common interpretation in fields of operation, planning and asset management.

Maintain – Data maintenance identifies the controls and processes for the disposal of outdated, irrelevant information. It distinguishes incorrect information for verification or update to data with asset characteristic changes.

2. Public Records Act

Watercare must comply with the Public Records Act (2014). The following principals must be achieved:

1. Create and maintain records
2. Classify and organise records
3. Assign records management metadata to records and aggregations
4. Provide access to records
5. Appraise records and dispose of them appropriately
6. Maintain the integrity of records
7. Manage records systematically

All systems and records shall maintain the minimum requirements set by the New Zealand standard.

For more information refer to: <http://records.archives.govt.nz/managing-records2/records-management-standard/>

3. Level of data capture by risk classification

Watercare bases its minimum data requirements to satisfy the data needs across the organisation's operations. Whilst the impact of data may be minor in some areas compared to others, by having minimum data requirements the same we are able to do cross-functional analysis on the following:

- Sound financial management
- Effective asset management
- Health, safety and environmental impact
- Asset reliability
- Customer impact/responsibility

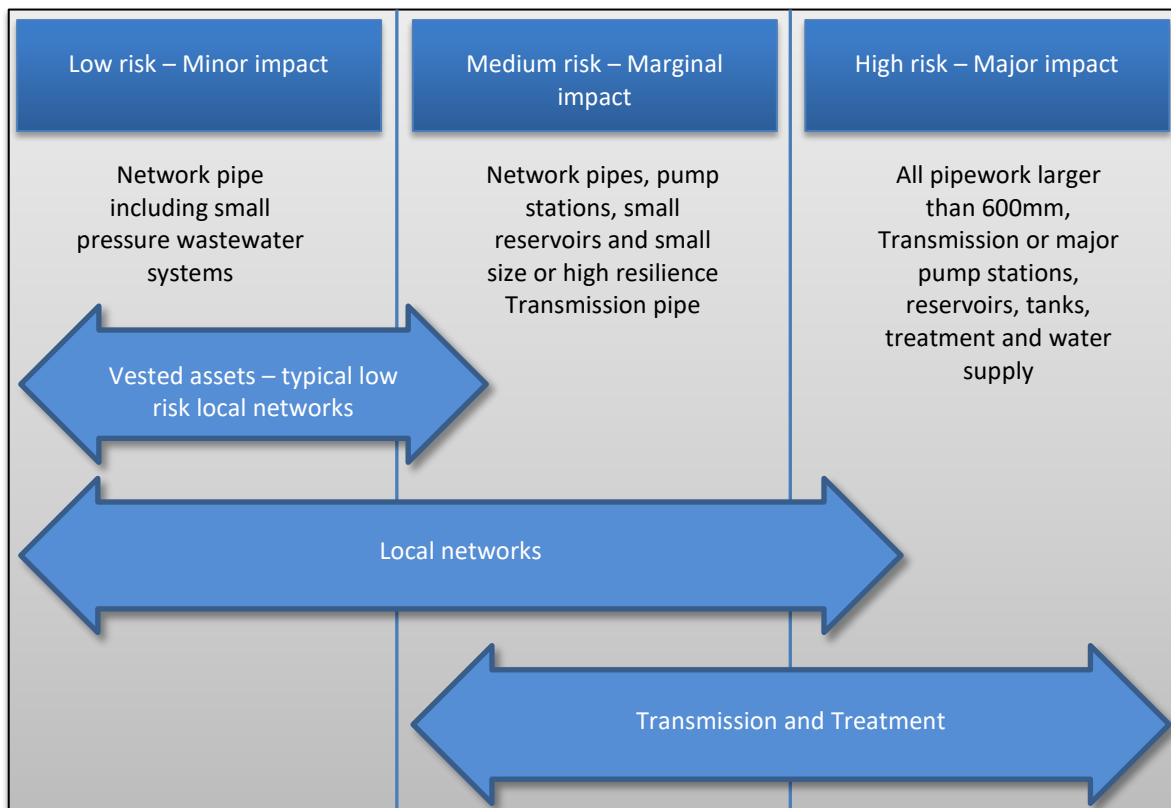

Asset data therefore extends beyond the attribution of the asset to its location and function to fully understand the above impacts.

Assets are assigned a criticality rating on a scale of 1 to 5 based on the impact of failure on loss of service, compliance with regulations and consents and health and safety of people of the asset in its installed environment. The scale and risk of failure can be compounded by the location and function of the asset, or likewise the impact in isolation may be minor, but on a large volume could have a detrimental impact to such as in the case of low risk network assets.

Understanding these data influences allows static data (or base metadata) to be analysed against ongoing condition inspections and dynamic data (runtime data) to effectively plan maintenance, replacements and upgrade to manage operational risks.

Information to Watercare must be delivered as set out in the Exchange Information Requirements (EIR) which must form part of all contracts and other work delivered or vested to Watercare. (Document number: EIR)

The EIR sets the minimum information delivery requirements, is contractually equal to the physical works delivery, and is configurable for larger or more complex information delivery.

4. Data Plan

4.1 Data model

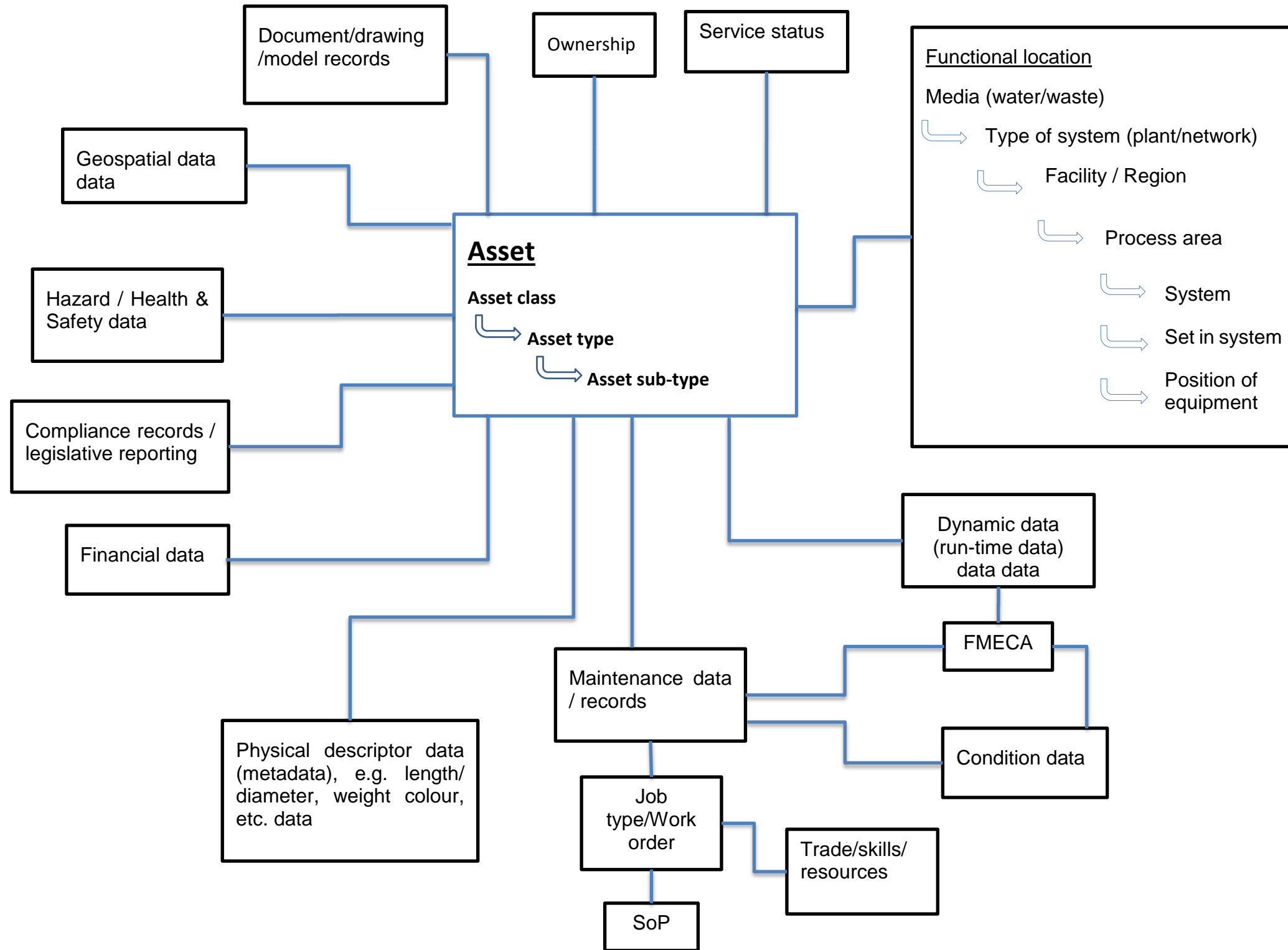

4.2 Watercare systems

Note: Watercare is currently changing its data systems. Some systems will remain and be integrated whilst others will be replaced by the year 2020.

Watercare utilises several systems to store and manage its data:

- Records management (ProjectWise) – All engineering data records that includes:
 - Drawings in AutoCAD and Pdf
 - Design calculations
 - Operational documentation that includes Functional descriptions, Operation and Maintenance manuals, Standard operating procedures, Handover documentation, Vendor manuals, Electrical certificates of compliance
 - Reports e.g. design reports and geotechnical reports
 - Resource consents
 - Photos
 - Maintenance reports
 - Engineering standards
 - Record entry metadata
- GIS – Geospatial information system that spatially and graphically presents the infrastructure. Data is linked to data information in the asset management system.
- AIMS – Asset management information system that contains the financial data and asset engineering metadata through specific data sets.
- PI – SCADA collected data from field operational history is stored in PI (Plant Information system). Data is used to calibrate modelling systems and report on operational performance.

4.2.1 System connectivity

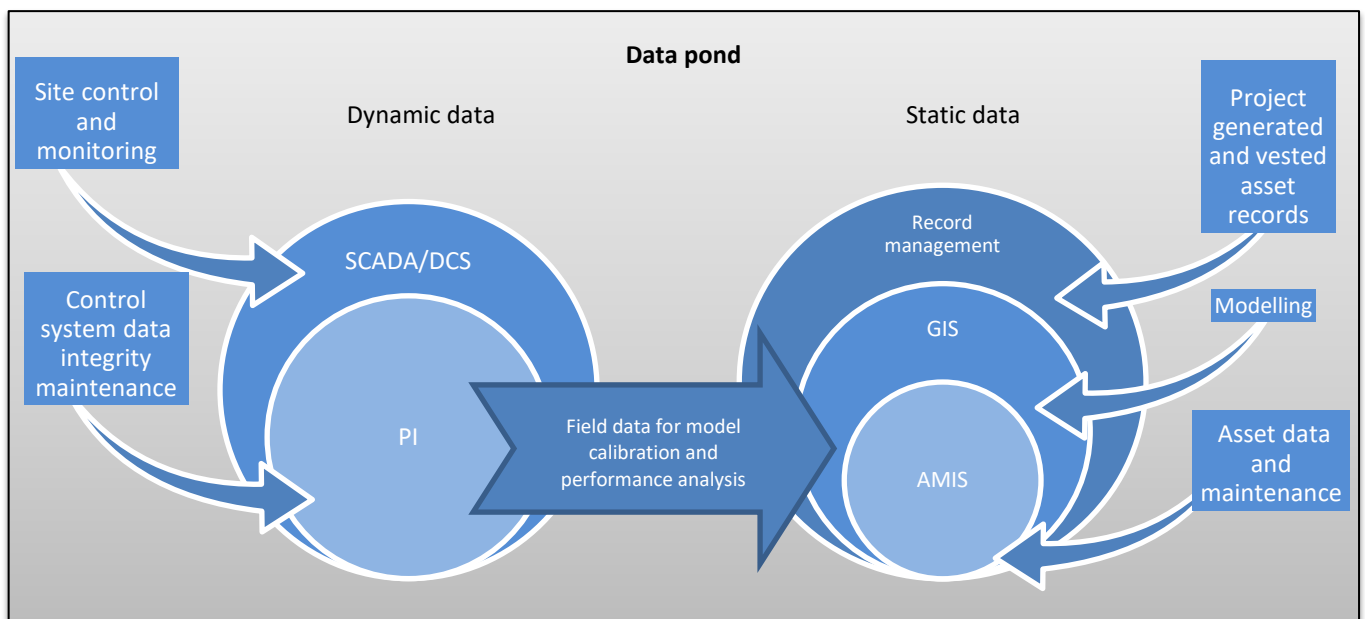

- Records management system integration with GIS through main engineering document records
- GIS and the asset management system integration through equipment numbering
- PI integration through equipment numbering. Data is manually updated as required.

Operational data is fed back to modellers for calibration and updated in GIS once verified.

4.3 Record file formats

4.3.1 Drawings

Drawings shall be created as specified by the Watercare Standard for creating CAD drawings.

4.3.2 Design reports and calculations

Provide in Pdf format.

4.3.3 Site reports and consents

Provide in Pdf format.

4.3.4 Operational documentation

Provide in editable format of Microsoft Word as well as Pdf.

4.3.5 GIS data

- Line work digital data shall be supplied in .dwg file format with each survey point (survey point data) recorded in a Microsoft Excel file. Where work is staged the files and sets shall be supplied accordingly.
- Point codes (Transmission only) are to comply with Watercare standard codes in Section 7.2
- XY coordinates are to be to New Zealand Transverse Mercator (NZTM) Projection
- Levels are to be to LINZ Auckland 1946 Datum
- Any additional codes used must be documented
- For Networks include ESRI shape files (.shp) with attribute information for every feature (see Section 6.1)

4.3.6 Metadata upload

The data for asset attribution shall be captured according to the hierarchy, classification and asset types as set out in Part B. Attribution data shall be complete with no open fields as per Part B, section 4.

4.4 Data stewardship

Data stewardship is internal to Watercare. Data distribution to the field follows data access and copyright rules.

Engineering records – Watercare Asset systems - Asset information

Geospatial – Watercare Asset Systems – GIS

Financial – Watercare Financial Control – Finance

Asset Maintenance – Operations and Infrastructure Delivery – Maintenance

SCADA – Information Systems – Delivery and support

4.5 Storage

4.5.1 Documents and records system

All engineering records are held in the records management system server.

4.5.2 GIS

All Geospatial data is held in GIS server. Metadata is drawn from that asset management information system.

4.5.3 Asset management information system (AMIS)

Asset financials, master data and metadata records are captured through the AMIS. Integration to GIS and the document records systems is through an equipment number, additionally the engineering records are also maintained by facility name (where specific facilities such as the “Mangere Wastewater treatment plant”) and type of facility (such as wastewater networks or water treatment plant).

4.5.4 Dynamic data - PI (Plant Information)

Asset tag numbering is related to the equipment numbering in the asset management system. Integration to GIS and the AMIS is through equipment numbering (Refer to section 6.4). Field operational data is stored on a separate server.

4.6 Data submission schedule

Data records during the development of new assets shall be submitted as and when it becomes available and not necessarily as a set at the end of the asset development. Watercare also requires certain information to be recorded in its systems earlier than others i.e. operational documentation or certification before placing an asset into operation. Specific quality assurance requirements are identified by Watercare’s construction standards. Asset data capture in public areas shall be at intervals not exceeding 3 months. The following framework shall be the minimum but may be different depending on the contractual agreement of the EIR and the flow of information to the specified data environment:

Note: Items marked with * is not required in all circumstances and relates to property and/or structural and/or process infrastructure. Unmarked items are the minimum requirement elsewhere.

Asset development phase	Data / Document	Data milestones
Planning	Business need document	Final report
	Investigations and Option analysis report	Final report
	Modelling outcome report	Final report
	Concept design report	Final report
	Land transfer plan easements*	Final report
	Capital expenditure approval	Final report
	Consent application*	Final application
Preliminary design	Design brief	Final report
	Design contract	Signed final contract
	Preliminary design report	Draft and final report
	Drawings and model (BIM) sets (tender)	Draft versions of drawings in Pdf Model in open source IFC
	Calculations	Draft and final
	Consents*	Approved consents
	Land transfer plan / easements*	Legal documentation
	Process flow diagram*	Draft
	Functional description*	Draft
	SCADA*	Draft SCADA TAG list
	O&M manual	Draft
	Detail design report	Final report

Asset development phase	Data / Document	Data milestones
Detailed design / Engineering approval	Producer statements * and Watercare compliance statements	Final
	Drawings and model (BIM) sets (tender)	“-“ version of drawings in Pdf Model in open source IFC
	Final approved drawing set (for construction set)	Final AutoCAD and Pdf
	Functional description*	Design version at design signed off
	Asset numbers	Draft asset list at design sign-off
	New equipment schedules	Final with attribution available at time of design or early procurement (excludes final location co-ordinates)
	Risk / HAZOP register	Draft
	Construction contract for tender	Final
	Commissioning plan	Draft
	Project execution plan	Final
Construction	Construction contract	Final
	Drawings (changes to final approved set)	All revisions. Redlines with progressive capturing as construction continues. Drawings updated at minimum 3 month interval (NZCoP)
	BIM model sets (tender)*	Model in open source IFC
	Construction and environmental management plans	Final
	Access authority approvals and induction records	Final
	Training plan	Final
	Producer statements* and Watercare compliance statements	Final
	Contract Supervision Producer statements, CM (level as determined by contract, standard or design)	Final
	Construction QA/QC	Final (excl. required as part of commissioning)
Commissioning and Interim handover	Drawings	Preliminary as-built in AutoCAD or Redline mark-up in Pdf (next drawing version)

Asset development phase	Data / Document	Data milestones
	Electrical certificate of compliance*	Final certificate
	Infrastructure test results as required by construction standards / Factory acceptance testing	Final report
	P&ID*	AutoCAD or Redline mark-up in Pdf
	O&M manual	Updated draft (for commissioning)
	Standard operating procedure*	Draft (for commissioning)
	Risk / HAZOP register	Updated draft with residual risk
	Commissioning plan	Final
Handover / vestment to Watercare	Drawings / As-builts / BIM models	Final drawings, survey drawings and point data, Final IFC updated
	Asset schedules	Completed templates for new and demolished assets – metadata fully completed per data sets
	Risk / HAZOP register	Final
	Construction QA/QC	Final (remaining as completed for commissioning)
	O&M manual	Final
	Functional description*	Final
	Standard operating procedure*	Final

4.7 Data Maintenance

Changes to existing data through the data life may be entered where the data is maintained or verified:

- Through asset maintenance recorded into the asset management system i.e. condition rating and maintenance replacements.
- BIM model updates
- Geospatial verification i.e. Modelling data and updated survey of old assets or discovered assets
- Project or vested assets driven information changes i.e. functional requirements, location, size and asset discovery.

Where a change to any of the existing data is entered a workflow requires the data to be verified across the other systems (Records management system, GIS, the Asset information management system) before the entry may be accepted.

Refer to section 6 for management of data quality.

5. Data access and copyright

5.1 Data receiving

All Pdf documents are to be supplied without any copyright or other measure that prohibits use by Watercare. The exception is national and international standards or independent technical literature held under the Library in the records management system.

Documentation supplied in editable format (Excel, Word, AutoCAD, etc.) and shall be without any copyright or any other restraint on use or modifications of the document by Watercare.

5.2 Data internal access

- Access to master data – limited by Watercare’s delegated authority rules
- Metadata – view only authority for all. Delegated authority to update
- Pdf records in general – view and download authority
- Operational documentation (O&M, SoP, FD’s etc.) – View to all with limited editing rights
- Drawings, models and documents in editable format – limited view and editing rights

5.3 Data external access

- Access to master data – no access
- Metadata – authorised view only. Limited exposure through public GIS
- Pdf records in general – authorised view only
- Operational documentation (O&M, SoP, FD’s etc.) – authorised view only. Data currency in the field is the responsibility of the infrastructure operator.
- Drawings and documents in editable format – no access

6. Management of data quality

Data quality relates to the following aspects for individual assets:

- Accuracy
- Completeness
- Relevance
- Consistency across sources
- Appropriate presentation
- Accessibility

Maintaining data quality requires ongoing evaluation of the current data on hand, updates and standardisation of data records. There are three main opportunities where data is reviewed: before new data is collected and inserted into an existing set; during data entry; after entry during operation of the asset.

Masterdata of the asset management system must include a confidence rating / reliability of the data collection:

Data reliability
As-built
Inspected
Assumed/desktop
Legacy
No information

The service status of the asset must also be shown as below:

CODE	Status Description
OPNV	Operational - not vested
OP	Operational - in use. An asset that is in service and capitalised
OUT	Not Operational - not in use
AB	Abandoned - installed but unusable
DISP	Disposed - no longer owned

6.1 Before collection

Before data is collected the source, extent and accuracy of the data must be validated.

When dealing with existing assets, options may include trial excavations, CCTV, locational survey, site investigation/physical verification and data mining from other sources such as historical data and public records. This data is then evaluated against current records.

At this time, it is important to recognise incomplete fields against the current data sets and where practicable to identify the validated data for updating during data entry.

6.2 During data entry

Transfer of data between sources could compromise the data integrity, such as incorrect manual entries or entering data against the wrong asset.

To limit in-accuracies and maintain data consistencies across sources look-up tables and templates shall be established.

6.3 Post data entry

Post data entry is during the stages of operation and maintenance as data fields and condition change over the life of the asset.

Assets may be added onto or changed during maintenance activities. The same procurers for data collection and validation apply during these activities.

Data fields may be expanded, leaving gaps in the existing data. It is not always possible to update these fields where the data does not exist, however where opportunity exist during maintenance or upgrade works the data shall be expanded and verified.

Part B: Data structure

1. Data standards

Assets (by asset class and asset type) are sorted at master data level allowing for dependable data retrieval. By describing the asset by asset class instead of asset type, common data sets are established. Assets are differentiated by location and type in the master data set. The common technical attribute fields are established at asset class level and where uncommon fields are encountered to fully describe the asset, this is provided as data conditional on the asset type (or asset sub-type) within the asset class. This approach reduces the number of tailored data entry sets by using pick lists and conditional fields and reduce the number of open fields, making data entry fields compulsory.

2. Data hierarchy

Asset Location hierarchy (vertical): The asset location rules are used to determine the asset data location (master data). Hierarchy levels are reduced for lesser complex systems such as linear pipe systems. Watercare based its hierarchy on model exemplars set by WERF and the IIMM:

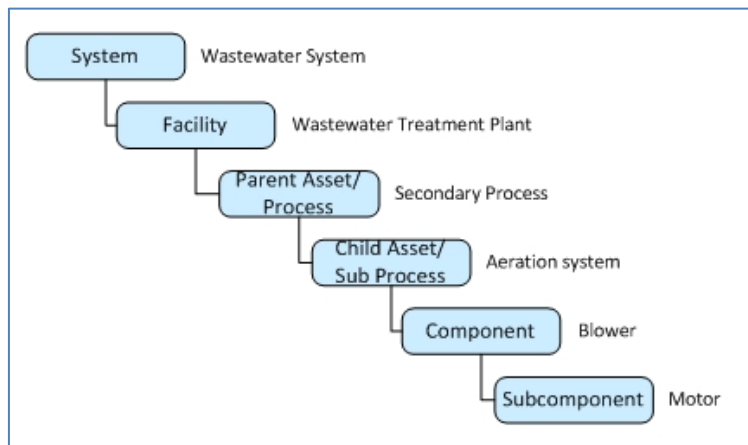

Fig.1 WERF typical asset location hierarchy model – the Watercare model closely aligns with WERF

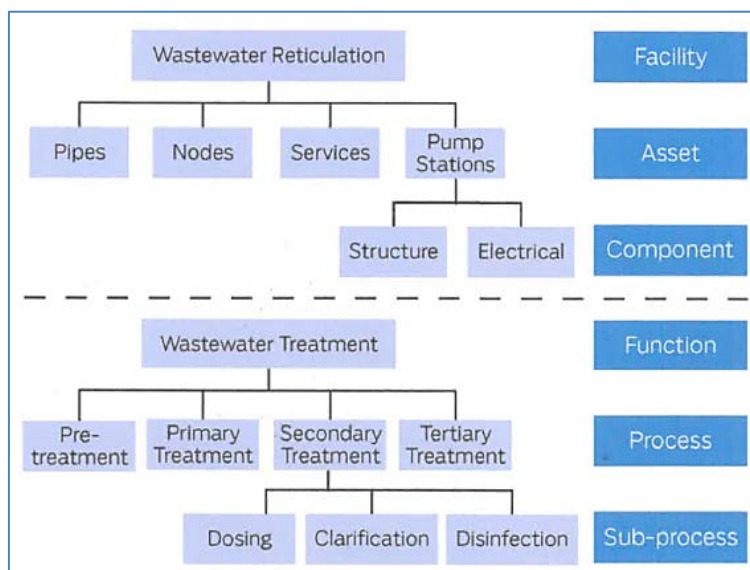
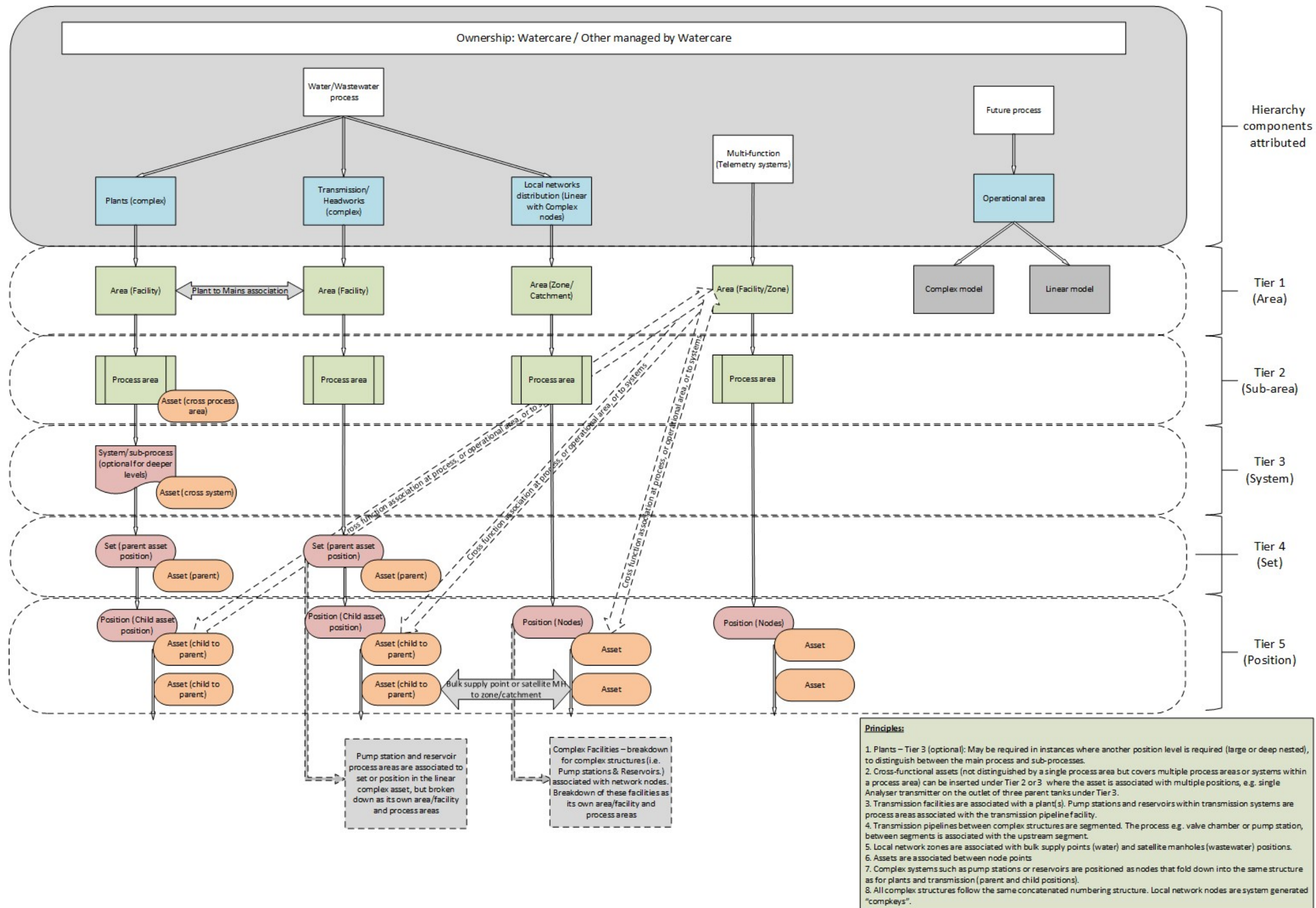
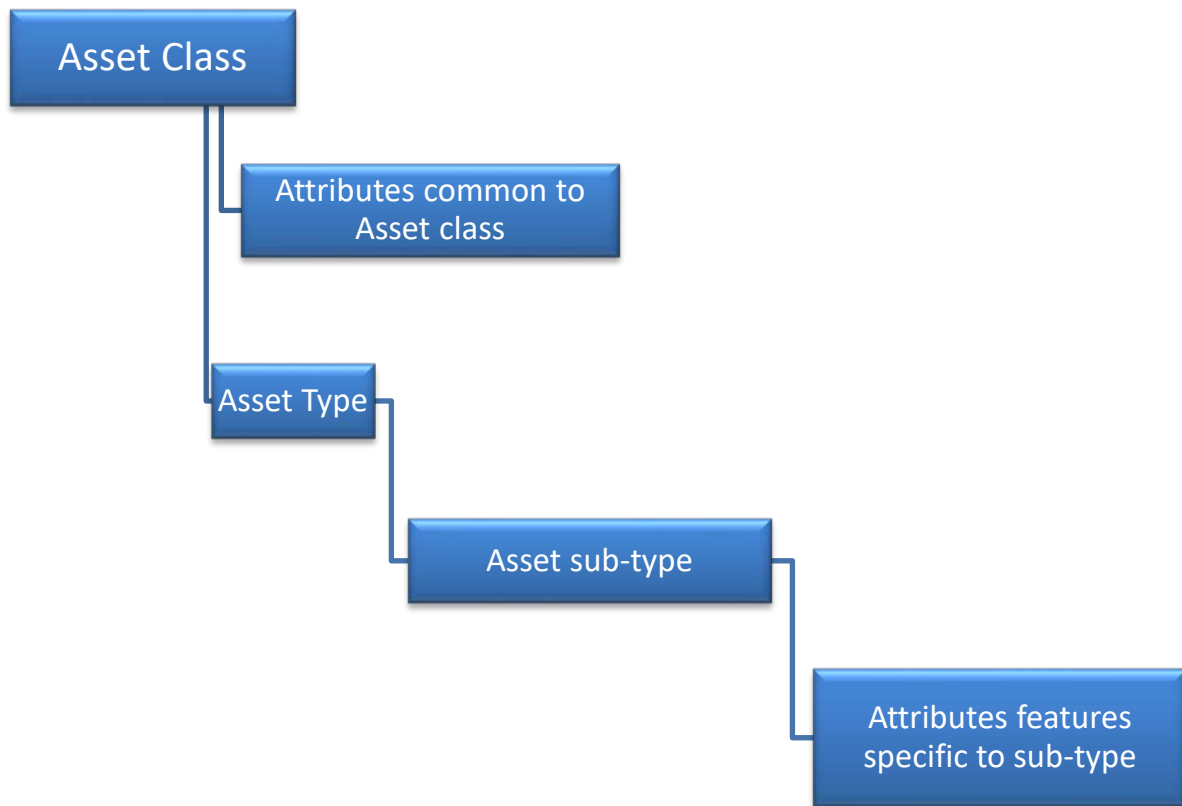

Fig.2 IIMM example hierarchies

Watercare's adaptation of these models are shown below:



Asset data classification (horizontal hierarchy): For data attribute hierarchy refer the below illustration. Attributes are collected at asset class level however some asset types may not be fully described at this level. Additional attributes, conditional to the asset type, is described at asset type level. These attributes are classed as conditional in the asset data sets in section 6.



2.1 Asset classes, types and definitions

The classes are principally split along engineering disciplines for Communications and control, Mechanical, Electrical and Civil, however some of these disciplines are broken down further in order to match main attributes and descriptors. With a more granular structure some analytics can then be achieved based on asset class rather than at asset type level. Examples of this principle is electrical that is split between “rotating” and “static”. Rotating equipment will degrade at a different rate and have additional attributes such as rotational speed and torque, which is not present for static equipment. Another example is the Pipe and Conduit class that are essentially civil assets but are described in a very different manner than the Buildings class due to its shape, form, and functional purpose.

The asset classes with asset types and sub-types are listed in the following table:

Asset class	Asset type	Asset type description	Asset sub-type	Asset sub-type description
BUILDINGS	BUILDING	A structure with floor, roof and walls with above ground walk-in access	REINFORCED	A structure that has steel reinforcing
			NOT REINFORCED	A structure without steel reinforcing
			PORTABLE	A building that can be transported without structural compromise
CHAMBERS AND MANHOLES	CHAMBER	A partially below ground or below ground enclosure where equipment and pipework is housed for inspection or maintenance purposes	DRYWELL	An underground chamber for housing pumps that are connected to an adjacent wet well
			PENSTOCK	A collection chamber where flow is isolated
			WET WELL	An underground chamber collecting incoming flows for discharge through a pump system
			SUMP	A collection bund that is lower than the surrounding floor level to collect fluid run-off for disposal
			STILLING WELL	A chamber designed to still the energy created by an incoming flow before discharging it at laminar flow
			VALVE TOWER	The outlet from a dam water storage structure into the downstream pipework
			MANHOLE	An underground inspection and maintenance chamber to wastewater pipework
			VALVE CHAMBER	An underground chamber providing access for operation and maintenance of valves. Size range from man-accessible down to accessing the top or key component of the valve only.
			INSPECTION POINT	A small chamber or tube extended typically from a gravity pipe up to the ground surface to allow an entry point for lowering lighting, cctv cameras or rodding equipment.
			TUNNEL	An underground passage that may contain instrumentation and pipework
CIVIL	DRAIN	A pit for receiving and draining surface water to below ground		
	FOOTPATH			

Asset class	Asset type	Asset type description	Asset sub-type	Asset sub-type description
	HARD STANDING	A concrete platform designed to withstand loading applied by mobile or temporary plant		
	SPILLWAY	The overflow structure of a Dam retaining structure design to discharge excess water		
	SUPPORT STRUCTURE	A civil structure that is designed to carry the load and provide structural support to other components	ANCHOR BLOCK	A heavy structure resisting thrust forces
			PIER	A pillar structure supporting a bridge
			ROLLER	A type of pipe support
			PAD/PLINTH	A heavy base that supports machinery
PONTOON	A floating support for aerators			
CONTAINMENT STRUCTURE	AQUEDUCT	An artificial open duct to permanently convey water over land		
	BUND	An embankment around liquid holding vessels or containers that will fully contain the volume of fluid held by the container in the event of spoilage or container failure		
	CHANNEL	A conveyance structure that is longer than it is in width between water bodies or holding tanks		
	POND, STORAGE	A small, reasonably shallow, body of water that has been artificially formed		
	STORAGE UNIT	A container that is used for the temporary or long-term storage of things	CONTAINER	A holding container typically used for short term storage
			SKIP	A container that is used for temporarily holding discarded product for removal
			HOPPER	A funnel-shaped container from which material is dispensed
			TIPPING BUCKET	Container that tips its contents once full
	TANK		PRESSURISED	
			NOT PRESSURISED	
	WELL		BOREHOLE (EXPLORATION/MONITORING)	An underground bore used for monitoring of underground water levels or the exploration of ground formations

Asset class	Asset type	Asset type description	Asset sub-type	Asset sub-type description	
			WELL (WATER EXTRACTION)	An underground bore or shaft designed used for extracting ground water	
CONTROL SYSTEMS	ANTENNA	A device used to transmit or receive radio signals	YAGI		
			PHASING		
			BASECOIL		
			WHIP		
			LOWPROFILE		
			DIPOLE		
			COLLINEAR		
	COMPUTER/SERVER/ELECTRONIC STORAGE			MONITOR	A video monitor
				SERVER	A computer that manages access to a centralised network service
				ELECTRONIC STORAGE	
				PRINTER	
				KEYBOARD VIDEO MONITOR	Keyboard and video monitor used at sites to access site controls
				WORKSTATION	Complete computer desktop setup
	CONTROL COMPONENTS			CONTROLLER	
				I/O MODULE	Control signal input and output module
				MULTIPLEXER	Device that selects one of several analogue or digital input signals and forwarding the selected input into a single line
				HUMAN MACHINE INTERFACE	Industrial field interface between human and computer to allow effective operations and control of a system
DATA AND TELECOMMUNICATION COMPONENTS			WIRELESS ACCESS POINT/BRIDGE		
			FIREWALL UNIT	Computer access security hardware system	

Asset class	Asset type	Asset type description	Asset sub-type	Asset sub-type description	
			MEDIA CONVERTOR		
			MICROWAVE UNIT	A unit that transmits communications over microwave	
			MODEM	Device that makes communication form computer to telecommunication possible	
			NETWORK SWITCH	Networking device that is a multi-port network bridge connecting devices together on a computer network using hardware addresses to process and forward data	
			PROTOCOL CONVERTOR	A hardware device used to convert a data protocol from one device to another for automation processes	
			PATCH PANEL	A number of network ports that may be connected in various combinations	
			ROUTER	Device that controls data network trafficking on the system	
			ANTENNA FEEDER CABLE		
			TELEPHONE		
	DCS/SCADA FIELD CABINET			Control cabinet located in the field usually as a sub-cabinet, not located at a central location or control room	
	PROGRAMMABLE LOGIC CONTROLLER/RTU	An industrial digital computer for the control of automation processes			
	RADIO		RADIO UNIT		
	SOFTWARE			OPERATING SYSTEM	Software required to operate the system, load and run other software types
				USER SOFTWARE SYSTEM (APP)	
				CONFIGURATION SOFTWARE	Software specifically written a for a configured operation of a SCADA DCS control element
SYSTEM SOFTWARE				Supporting software such as anti-virus software	
POWER SUPPLY					
Electrical (Rotating)	ALTERNATOR	Electrical motor that converts mechanical energy into electrical energy			
	MOTOR	An electrical motor that drives mechanical equipment			

Asset class	Asset type	Asset type description	Asset sub-type	Asset sub-type description	
	GENERATOR	A device that converts motive power to electrical power for use in an external electrical circuit. For small mobile units this includes the mechanical generating engine, the electrical generator motor and controls. Generators as part of plants where the mechanical drive and control systems are separate is called alternators – see definition for alternator above			
Electrical (Static)	AUTO TRANSFER SWITCH	Switch that shifts electrical load between two sources	MECHANICAL TYPE		
			STATIC TYPE		
	WARNING HORN				
	AUTOMATIC VOLTAGE REGULATOR	A circuit that provides stable direct current (dc) independent of the; load current, temperature and alternating current (ac) line voltage variations			
	BATTERY				
	BATTERY CHARGER				
	CABLE			EXTRA LOW VOLTAGE	Electrical supply voltage in a range that carries low risk of dangerous electrical shock, generally not exceeding 50 Vac or 120 Vdc
				LOW VOLTAGE	Single phase voltage over 50 Vac to 230 Vac
				HIGH VOLTAGE	Single phase voltage over 230 Vac or three-phase
				FIBRE OPTIC	
				OVERHEAD POWER LINE	
	CATHODIC PROTECTION		A metal protection system where the metal being protected act as an electrical cathode	ANODE BED	Underground series of electrodes to provide cathode protection
				CORROSION RATE COUPON	A piece of material used to estimate the rate and type of corrosion
				EARTH COUPLER	A coupler used to connect earthing rods together
				REFERENCE ELECTRODE	An electrode with stable and defines electrode potential
				TRANSFORMER RECTIFIER/RECTIFIER	Electrical device that converts alternating current to direct current
				TEST POINT	

Asset class	Asset type	Asset type description	Asset sub-type	Asset sub-type description	
	CIRCUIT BREAKER		HIGH VOLTAGE		
			LOW VOLTAGE		
	CONTROL PANEL	A machine control panel where control and monitoring instrumentation is displayed that operators can access for example to stop or start a system manually			
	CONTROL STATION (LOCAL)	A machine control interface panel located in the field at a specific machine (see difference to CONTROL PANEL)			
	DISTRIBUTION BOARD	Component of an electrical supply system that divides an electrical power feed into subsidiary circuits whilst providing circuit protection and a point of isolation			
	EARTHING			ELECTRODE	
				EARTH GRID	
	GENERATOR CONNECTION BOX				
	HARMONIC FILTER				
	HEATER			AIR CONVECTION	
				IMMERSION	
				TRACE HEATING	
				FAN HEATER	
	HYPOCHLORITE GENERATOR				
	INVERTER	Device that converts direct current into alternating current			
	ISOLATOR				
	JUNCTION BOX				
	LIGHTING			EMERGENCY LIGHTING	
				GENERAL LIGHTNING AND SMALL POWER	
				LAMP MODULE	

Asset class	Asset type	Asset type description	Asset sub-type	Asset sub-type description
	OZONE GENERATOR	Used for oxidation and disinfection applications		
	POLE		POWER	
			LIGHT	
			CCTV TOWER	
			ANTENNA	
	POWER FACTOR CORRECTION EQUIP			
	POWER SUPPLY UNIT, ELV/LV			
	RECTIFIER	Device that converts alternating current into direct current by allowing current to flow in one direction only		
	RELAY, ELECTRICAL PROTECTION			
	NEUTRAL/EARTH RESISTOR			
	RING MAIN UNIT	A sealed compact switchgear unit with mechanical and electrical interlock. Basically used for in secondary distribution system for uninterrupted power supply	GAS	
			OIL	
	SOLAR CELL			
	STARTER (ELECTRIC MOTOR)	Device that controls the use of power to equipment, usually a motor	DIRECT ON-LINE	
			SOFT STARTER	
			VARIABLE SPEED DRIVE	
	SURGE ARRESTER			
	SWITCHBOARD		HIGH VOLTAGE	
			LOW VOLTAGE	
	SWITCH, HIGH VOLTAGE (HV)		FUSED	
			NO LOAD BREAK	

Asset class	Asset type	Asset type description	Asset sub-type	Asset sub-type description
	SWITCH, LOW VOLTAGE (LV)		FUSED	
			LOAD BREAK	
			NO LOAD BREAK	
	ULTRAVIOLET	Ultraviolet light disinfection method using short-length ultraviolet light to kill or inactivate microorganisms	UV LAMP MODULE	
			UV BALLAST	Device placed in line with the lamp load to limit the electrical current to a certain level.
	UNINTERRUPTIBLE POWER SUPPLY (UPS)			
	TRANSFORMER		CURRENT TRANSFORMER	Type of transformer (CT) used to reduce or multiply an alternating current. These transformers are instrument transformers.
			VOLTAGE TRANSFORMER	Voltage transformers (VT) (sometimes referred to as potential transformers) are used to present negligible load to the supply being measured and have an accurate voltage and phase relationship for instrumentation.
			POWER	Transforms a system of alternating voltage and current into another systems for the purpose of transmitting electrical power.
	MIDGE SCREEN	Electrical device that exterminate bugs		
Instruments	ANALYZER INDICATING TRANSMITTER			
	CONDUCTIVITY INDICATING TRANSMITTER			
	FLOW INDICATING TRANSMITTER			
	PRESSURE INDICATING TRANSMITTER			
	LEVEL INDICATING TRANSMITTER			
	LEVEL INTERFACE INDICATING TRANSMITTER			
	TEMPERATURE INDICATING TRANSMITTER			

Asset class	Asset type	Asset type description	Asset sub-type	Asset sub-type description
	WEIGHT INDICATING TRANSMITTER			
	POWER INDICATING TRANSMITTER			
	EVENT/DATA/STATE RECORDER			
	GEAR PLATE	A panel with a selection of instruments that operate as a complete unit	WET	Typically instruments that have water or another liquid flowing through them are mounted as a unit
			DRY	Typically, electrical instruments are mounted on this unit only
	PRESSURE INDICATOR			
	PIEZOMETER			
	WATER METER	Instrument used for measuring water volume in the transmission and network areas	CONSUMER SUPPLY	
			BULK SUPPLY	
			FIRE SUPPLY	
			BACKFLOW MONITORING	
			STAND PIPE	
			SMART READER DEVICE	
	ANALYSER ELEMENT			
	FLOW ELEMENT/SENSOR	Flow measuring element (meter) used in process/plant applications	MAGNETIC	
			MECHANICAL	
			ULTRASONIC	
			DIFFERENTIAL PRESSURE	
			THERMAL MASS	
	LEVEL ELEMENT/SENSOR	Level measuring element (meter) used in process/plant applications	ULTRASONIC	
GUIDED RADAR				

Asset class	Asset type	Asset type description	Asset sub-type	Asset sub-type description	
			CONDUCTIVE FLOAT SWITCH		
			PADDLE SWITCH		
			MICROWAVE		
			DIFFERENTIAL PRESSURE		
	DEVIATION ELEMENT				
	WEIGHT ELEMENT/LOAD CELL				
	TEMPERATURE ELEMENT/PROBE				
	POSITION INDICATING CONTROLLER				
	FLOW SWITCH				
	LEVEL SWITCH				
	PRESSURE SWITCH				
	TEMPERATURE SWITCH				
	POSITION SWITCH				
	FLOW TRANSMITTER				
	PRESSURE TRANSMITTER				
	TEMPERATURE TRANSMITTER				
	WEATHER STATION			MECHANICAL	
				NON-CONTACT	
	WATER MONITORING			FLOAT AND COUNTER-WEIGHT ENCODER	
				SUBMERSIBLE PRESSURE TRANSDUCER	

Asset class	Asset type	Asset type description	Asset sub-type	Asset sub-type description
			DRY TRANSDUCER	
			RADAR	
			ULTRASONIC	
Land	Land			
Mechanical (Rotating)	ACTUATOR	A machine for moving or controlling a mechanism, such as opening a valve	AIR	
			ELECTRIC	
			SOLENOID	
	AERATOR	Apparatus for introducing air into water or other fluids		
	AIR CONDITIONING UNIT	A complete air treatment system		
	COMPRESSOR	Machine that supplies air or gas at an increased pressure	AIR	
			GAS	
	CONVEYOR	A system that mechanically transfers things	BELT TYPE	
			ROLLER TYPE	
			SCREW TYPE	
	DEWATERING UNIT		CENTRIFUGE	
			PRESS	
			GRAVITY BELT THICKENER	
	DRIVESHAFT (EXTENDED)			
	FANS and BLOWERS	A rotating vane machine that moves air by centrifugal action	AXIAL	Gas flow through the fan in an axial direction parallel to the shaft. The fan is designed to produce pressure difference
CENTRIFUGAL FAN / BLOWER			Typical gas flow is entering at the centre of the fan cage and discharged perpendicular to the shaft by centrifugal force. Often referred to as "squirrel cage fan"	

Asset class	Asset type	Asset type description	Asset sub-type	Asset sub-type description
			POSITIVE DISPLACEMENT BLOWER	Air is trapped between rotating parts and forced out against a system pressure
	GEARBOX	A machine that transfers an input force to apply speed and torque		
	COMBUSTION ENGINE	A mechanical engine that converts fuel into mechanical energy by combusting the fuel to create expanding gas to rotate a drive	COMBUSTION ENGINE	
	TURBINE	A machine to produces rotational potential energy and is fitted with vanes to allow a media to produce the rotational force	WATER TURBINE	A turbine that is turned by water hydraulic advantage
			GAS TURBINE	A combustion turbine that rotates as a compressor with each internal explosion
			WIND TURBINE	A turbine that is turned by wind action
	MIXER		AGITATION / ROTATIONAL	Motor is dry-mounted
			SUBMERSIBLE (ROTATIONAL)	Complete unit is submersible
	PUMP		AXIAL	A centrifugal pump with propeller type vanes that propels water through a pipe
			MIXED/RADIAL FLOW	A centrifugal pump where liquid enters along the axis or centre of the pump accelerating the fluid with vanes and exists the pump volute as it is flung by centrifugal force by the pump vanes
			REGENERATIVE	A turbine pump is where the fluid travels into the pump but enters and moves over the vanes multiple times accelerating the fluid as the vane travels along the pump circumference until it reaches the discharge volute. Used for clean water application only.
			GEAR	A positive displacement pump that displaces liquid by meshing gears
			VANE	A positive displacement pump that rotates vanes making contact with the cavity of the pump. The cavity can be offset, and the vanes tensioned. As fluid is moved along the "chambers" created by the vanes
			PROGRESSIVE CAVITY	A positive displacement pump that transfer fluid through a series of small, fixed shape cavities as the rotor is turned, along the length of the rotor, leading to volumetric flow.
			PERISTALTIC	A positive displacement pump that compresses or pinches a tube along the circular pump casing with a roller, shoe or wiper forcing a volume of fluid in front of the pinched tube section
			DIAPHRAGM	A positive displacement pump (also called a membrane pump) that uses a reciprocating action to move the diaphragm to create suction and discharge
			RECIPROCATING/PISTON	A positive displacement pump that reciprocates a plunger or piston to move media through the cylindrical chamber.

Asset class	Asset type	Asset type description	Asset sub-type	Asset sub-type description
	SAMPLER	A unit that take a sample of a product at predefined intervals.		
	SCRAPER	Used to agitate or move material that settles and the bottom of tanks	RAKE TYPE	
			RUBBER BLADE TYPE	
	SCREEN ROTATING	Rotating mesh screen		
	SKIMMER (SCUM COLLECTOR)	A device that separates material due to different density. Typically, a rotating drum or blade that skims the surface of a liquid to remove the lower density product at the top of the surface		
	VIBRATOR	A mechanical device that produces vibration by means of an unbalanced mass or off-centre oscillation		
	WASHPACTOR UNIT	A wastewater and sludge screening wash unit. Sludge from the screens are conveyed into the unit where water and high turbulence is used to break down material. The turbulence causes water and washed solids into a channel which separates the water and the waste. Waste is compacted by an on-board screw compactor and expelled		
GRIT CLASSIFIER UNIT	A unit that separates grit from wastewater or slurry through settlement with a helical screw			
Mechanical (static)	AFTERCOOLER	Apparatus for cooling the discharge air from compressors to remove condensed moisture		
	HEATING VENTILATION and AIR CONDITIONING SYSTEM/PLANT COMPONENTS (HVAC)	A system that changes the condition of air by temperature, humidity and purity	CHILLER (HVAC)	A machine that removes heat from liquid by a vapour-compression or absorption refrigerant cycle
			DAMPER (HVAC)	A device that controls the volume of air flow and houses the humidity control for a room
			DUCTING (HVAC)	Enclosed air passage
			HUMIDIFIER (HVAC)	A device that adds water to the conditioned air
			LOUVRE (HVAC)	Air dispersion device
	AIR LUBE UNIT	A unit the injects oil into an air-line to provide lubrication to internal working parts of air equipment		
	BAFFLE	A mechanism to regulate flow	CURTAIN TYPE	A floating or hanging curtain to still flow
			PLATE TYPE	A plate designed to spread and disperse a stream of flow

Asset class	Asset type	Asset type description	Asset sub-type	Asset sub-type description
			BAFFLE CHAMBER	A chamber used to still generated energy
	BELLOWS	A fitting that can expand, contract or allow an amount of offset and movement and tolerate vibration without passing the vibration onto the connected device	LATERAL EXPANSION	
			SINGLE PLANE	
			BI-PLANAR	
			HINGED TYPE	
			ANGULAR	
			UNIVERSAL/MULTI-PLANE	
	BOILER, INDUSTRIAL	An enclosed vessel that heats fluid or other liquids		
	RUPTURE DISC	A pressure safety disc that burst a sacrificial diaphragm when pressure is exceeded. Rupture discs are non-closing pressure relief devices		
	CHLORINE, CHLORINATOR	A device that discharges chlorine and a defined rate		
	CONTAINMENT BOOM	A string of inflated or floating material fitted with a short curtain extending slightly below the water surface to prevent floating particle on the surface of a dam or pond to enter the inlet.		
	CYCLONE UNIT	A method to remove particles from air, gas or liquid without using filters through creating a vortex. The effects of rotation and gravity separates mixtures of solids and fluid		
	DAMPENER	A device that laces a restraining or subsiding effect on a mechanical action	HYDRAULIC PISTON	A hydraulic piston that creates resistance to slow moving objects
			SPRING ASSISTED	Spring assisted dampeners absorbs impact
			COUNTER BALANCE WEIGHT	Counter balance dampeners provides an opposing force by added weight in the opposite direction of movement
			VESSEL WITH PRESSURISED BLADDER	Used in pressure systems to sustain pressure by a pre-charged balder. Similarly, when there is a shock in the system the bladder will expand to absorb the hydraulic wave
	DEMINERALISER, WATER	A package system that removes minerals from process water that can be harmful to equipment or influence the process		
	DIFFUSER	A device that diffuses liquid or gas through widening or dispersing through multiple exits	AIR	
			WATER	

Asset class	Asset type	Asset type description	Asset sub-type	Asset sub-type description
	DOSE TIMER	A tube used to measure the dosing rate delivered by a dosing system		
	DOOR			
	DRIER	A device that dries air from moisture that are harmful to the compressed air system	DESICCANT TYPE	Solids that absorb water
			REFRIGERANT TYPE	Supplies dried air by cooling the air
	EDUCTOR	A nozzle that accelerates a high-pressure stream through the nozzle using flow dynamics principles to pump (jet pump)		
	EJECTOR	Ejectors use the venturi principle to create vacuum as a pollution control device installed on air exhaust systems to scrub the air		
	FILTER	A device that separates/removes impurities from a liquid or gas	BARK (BIOFILTER)	A biological filter containing living material that digest and biologically degrade odour pollutants
			CARBON	
			GRAVEL	
			SAND	
			MEMBRANE	
			PAPER	
			RESIN (BEAD TYPE)	
	FLAME ARRESTER	A device that stops fuel combustion by extinguishing the flame		
	FLARE, GAS	A combustion tower or flare stack device to protect the gas system from over-pressurising by burning off excess gas		
	FUEL BURNER	A device that combines fuel and air to a point of ignition		
	HEAT EXCHANGER	Device consisting of a network of looped pipes used to transfer heat between an object and fluid, or between two or more fluids.		
	HOSE REEL			
	HYDRAULIC POWER PACK	The main driving unit for a hydraulic system consisting of a frame, reservoir valves and piping. The motor is separated out as component.		

Asset class	Asset type	Asset type description	Asset sub-type	Asset sub-type description
	INJECTOR	A series of cones containing nozzles using the venture affect converting pressure to velocity for injecting cold water into a boiler, o similar thermodynamic process in gas, air and combustion systems.		
	LIFTING EQUIPMENT	Equipment used to lift and manipulate loads or heavy equipment	OVERHEAD CRANE OR 'A' FRAME	Lifting equipment operating from a single point or pivot fitted with a winch mechanism
			RUNNING BEAM & HOIST	A beam that can be moved along two rails fitted with a winch mechanism
			CEILING HOOK	A single fixed rated lifting point where a winch mechanism can be attached
	POLYMER BATCH UNIT	Batch processing unit controlling the release of polymer. Associated motors and pumps are separated out		
	SCREEN STATIC		SCREEN	A flexible or rigid (typical metal) woven mesh filter expanded across an opening
			STRAINER	Similar to screen with woven mesh contained in a body allowing unwanted material to settle in the strainer body
	SILENCER		ATTENUATOR	A louver shaped system to break up sound in air ducting
			MUFFLER	A noise reduction device fitted over the exhaust of combustion machines
			DIFFUSER	Devise that spread sound waves over and architectural surface to prevent the transfer of reverberant sound waves
			ACOUSTIC ENCLOSURE	A container that wall-in and isolate sound
	SLUDGE CONE	Cone shaped to allow solids to drop out and collect sludge		
	WATER DEMINERALISER	Unit that removes most minerals and salt ions		
	WATER SOFTENER	A contained exchange system removing calcium, magnesium and other metal from hard water to eliminate scale build-up and extend equipment life		
	MECHANICAL FITTINGS		VENTURI	A short tube with tapered mid-section to increase flow velocity to increase and then decrease. Used for measuring flow or creating suction
			ORIFICE PLATE	A plate installed in a pipeline used for measuring flow rate, or reducing pressure, or restricting flow. The orifice size is calculated and calibrated for specific conditions
			NOZZLE	Cylindrical spout at the end of a pipe or tube to jet liquid or gas
BOLTED JOINT			A fixed joint that is mechanically secured with bolts under tension. Designed for a specific tension point for assembling or designed shear point	

Asset class	Asset type	Asset type description	Asset sub-type	Asset sub-type description
			JOINT (FLEXIBLE)	A mechanical joint that is designed to move under load or vibration on a specified axis within a set of parameters
			JOINT (ISOLATED)	A joint designed to separate components from Cathodically protected (CP) pipework, or separate CP systems
			SADDLE JOINT	Mechanical or welded joint over an existing pipe to make a connection
			END CAP	A cap on the end of a pipeline
	MIXER STATIC	In-pipe mixer using a set of fixed blades inside the bore of the pipe to mix two fluids		
WASHDOWN UNIT	Pressurised water washing system installed over or in a tank			
Pipe and conduit	CULVERT	A short tunnel carrying a stream or open drain under a road or railway		
	PIPE	A tube used to convey fluid or gas	PRESSURE RATED	
			NON-PRESSURE RATED	The pipe is not pressurised and there is typically an air gap between the fluid level and the pipe soffit
			PIPE-TUNNEL	A long pipe passage built through a hill or under a river. Pipe tunnels are not pressurised. (when pressurised refer to pressure rated pipe)
CONDUIT	A tube used for carrying another self-contained service, such as electrical cables or a water pipe of smaller diameter			
Retaining structure	ABUTMENT	The structure at the end of bridges whereon the bridge structure rests that holds back fill on the bridge approach		
	DAM	A barrier that holds back water to create a body/lake of water storage	DAM WALL	
	WALL		WING WALL	A retaining structure at the edge of abutments forming an extended wing or more typically over the flared outlet of pipework on a soil bank to retain the soil.
			RETAINING WALL	A supporting structure that holds soil back at different levels
			STOP BANK	A continuous mound of earth built near rivers or overland flooding areas to prevent flood water flowing into certain areas.

Asset class	Asset type	Asset type description	Asset sub-type	Asset sub-type description
			FIREWALL	A fire-resistant barrier typically used at control system chambers and plants to prevent fire spreading from one location to another
	WEIR	A low-level dam shaped to regulate water flow over the retaining structure		
Road/Bridge/Rail	BRIDGE	A structure to span obstacles without closing the way underneath it such as a body of water, valley or road	PEDESTRIAN	A bridge designed to carry people
			PIPE SUPPORT	The support structures under a pipe that bridges an open span
			RAIL	A bridge designed to carry trains
			ROAD	A bridge designed to carry vehicles
	RAILWAY LINE & TRAMLIN			
	ROAD	Hard surface designed to carry vehicles	CONCRETE	
			METAL	A road formed with graded stone
SEALED			A road constructed using a pavement treatment other than concrete or stone, such as chip-seal and bitumen	
Site service components	FENCE	A site access control barrier	FENCE	Wire, wood or similar fence
			BARRIER	A railing or intermittent obstacle preventing access
			BOLLARDS	Pillars positioned such as to prevent vehicle access
	FIRE FIGHTING EQUIPMENT	Equipment that is used in the alarming and suppression of fire	FIRE EXTINGUISHER	
			FIRE HOSE REEL	
			GAS SUPPRESSION	
			SPRINKLER HEAD/SYSTEM	
			FIRE ALARM CALL UNIT	
	GATE, ACCESS	Controlled opening in a fence or wall		

Asset class	Asset type	Asset type description	Asset sub-type	Asset sub-type description
	HATCH COVER	A frame and cover to prevent access to equipment or areas. (may be used for larger hatches which are required to be captured separate to containment structures due to value, or where the hatch is not an integral part of another asset)		
	HANDRAIL	Rails and posts used on a typical elevated position for support and segregation or as a barrier to separate people from an area		
	LADDER	A series of bars or steps in upright or slightly canted position used for lining between two levels		
	OFFICE COMPONENTS		FRIDGE	
			DISHWASHER	
			OVEN	
			MICROWAVE	
			DESK	
			CHAIR	
	PLATFORM	A raised surface that people and things can stand on		
	SAFETY EQUIPMENT	Equipment that is used in the protection from harm and in first aid	FALL PREVENTION GRILLE	A rigid grille or barrier installed underneath lids over openings into tanks or chambers
			FALL PREVENTION NET	A catch net installed underneath lids over openings into tanks or chambers
			EYE WASH	An emergency water station at chemical installation to reduce harm
			EMERGENCY SHOWER	An emergency water station at chemical installation to reduce harm
			BREATHING APPARATUS	A self-contained breathing apparatus used for rescuing purposes or where the air is not suitable for breathing
			PERSONNEL WINCH	A tri-pod with mechanical hauling device used for entry into deep chambers and manholes
			FIRST AID EQUIPMENT	Equipment used in first assistance medical treatment
			FALL PREVENTION HARNESS	A harness worn by workers working at height that is clipped onto a safety point or winch
	SECURITY COMPONENTS	The make-up of a site or building security system	CARD READER	Alarm and/or lock card deactivation reader

Asset class	Asset type	Asset type description	Asset sub-type	Asset sub-type description
			DOOR/WINDOW SWITCHES	Open/close contact switches installed at door and window frames
			CCTV CAMERA	Closed circuit television
	SIGN	A public display that provides information or instruction	SAFETY	A display providing safety instruction
			GENERAL	A display providing general information
			MARKER	A display that identifies or marks a location
	STAIRS	A set of steps leading from one level to different level, typically inside a building		
Tools	TOOLS	Handheld devices or devices that are small enough to be moved by hand that aids in accomplishing a work task such as cutting, shaping, measuring or tightening	MECHANICAL	Manual or machine operated hand-held tools
			ELECTRICAL SUBJECT TO TESTING	Electrically drive hand tools
			INSTRUMENT SUBJECT TO CALIBRATION	Hand-held instrumentation typically used for measurement
Valves	VALVE	A device halting or controlling the passage of a fluid or gas through pipes, ducts and at the inlet or outlet of containment vessels	AUTO FLUSH	Fluid flow is triggered by timer or movement sensor
			AIR RELEASE	Releases air from fluid without letting fluid pass
			ALTITUDE	Operation to fill a tank or vessel to a pre-set high point
			BUTTERFLY	Isolation valve with central rotating circular sealing disc
			BACKFLOW PREVENTER DUAL	Inline plunger type check valve to protect the public water supply from contamination in low risk scenarios
			BACKFLOW PREVENTER DOUBLE	Two back-to-back non-return valves to protect the public water supply from contamination in medium risk scenarios
			BACKFLOW PREVENTER RPZ	Reduced pressure zone valve to protect the public system from contamination in high risk areas
			BALL	Quarter turn valve with hollow pivoting ball

Asset class	Asset type	Asset type description	Asset sub-type	Asset sub-type description
			DIAPHRAGM	Operation is hydraulically controlled by adding or reducing pressure to a membrane that moves the valve seat into position
			FERRULE	Valve with ferrule connection ends Variant include hot-tapping ferrule for service lines
			FLOAT	A ball-cock valve that opens and closes as a connecting float falls or rises with fluid level.
			FOOT	A type of one-way valve used on the suction end of a pump inlet pipe
			GATE	Valve with vertical sliding gate
			GLOBE VALVE	Globe shaped body valve with a rubber seating disc operating in a vertical plane through a hand-operated stem over multiple turns
			HYDRANT	For the specific connection of a hose for firefighting purposes. Hydrants seal with a rubber seating disc operating in a vertical plane through a hand-operated stem over multiple turns
			KNIFE GATE	Type of gate valve that has a sharp bevelled bottom edge to cut through media.
			LIFT GATE	Similar to a penstock valve but the gate is lifted by hand and not a rotating spindle or gearbox
			NEEDLE	A flow control valve with a cone or needle shaped plunger sitting in the flow, controlling the amount of flow through a circular seat.
			NON RETURN / REFLUX / CHECK	A retention or one-way valve that allows flow in only one direction
			PENSTOCK	A low-pressure type of gate valve typically used for open channels or at ponds
			SLIDE GATE	Horizontally installed to isolate dry media. The gate is a rectangular slide operating between two flanges
			SOLENOID (POSITION) VALVE	Electromagnetically operated with typical multiple ports to switch flows between ports.
			PINCH	Valve with an internal rubber sleeve that is pinched to close off flow.
			PILOT	A small valve that controls a limited flow feed to operate hydraulically operate the position of another control valve such as a hydraulic.
			REGULATOR	Control valve that reduces input pressure to a desired output pressure
			SLUICE	A resilient seated gate valve and installed on principal reticulation mains
			STOP LOG	An adjustable barrier in an open channel or pond edge that is height-adjusted to control the upstream level.

Asset class	Asset type	Asset type description	Asset sub-type	Asset sub-type description
			PLUG	A quarter turn valve with a cylindrical or tapered plug that may have a variety of ports. Typically the port is rectangular shaped
			TAP	Outlet valves for human access to the water supply that includes drinking and washing.
			TRAP (CONDENSATE)	Used on steam or air applications to trap and discharge condensate
			FIXED CONE	Also known as a free discharge valve, used to discharge water from high pressure to the atmosphere. The cone shape produces a hollow jet to dissipate energy.
			VACUUM BREAKER	A type of backflow prevention device used to keep non-potable (or contaminated) water from entering the water supply.
Vehicles	VEHICLES	An asset used for the transportation of people or goods	MOTOR VEHICLE	An automotive vehicle that is self-propelled, operated on land but not rail. Sub-type features include distinction between cars, utes, trucks, bike or quad bike.
			BOAT	Small vessel for travelling on water. Excludes drive/propulsion system
			LOCOMOTIVE, ENGINE DRIVE UNIT	Powered railway vehicle for pulling rail cars
			RAIL CARS/COACHES	Rail car drawn behind a locomotive
			OUTBOARD	Propulsion system for small vessels
			TRAILER	Unpowered vehicle pulled by a motor vehicle
			CARAVAN	A vehicle equipped for temporary living
			TRACTOR	A high tractive vehicle used for hauling equipment or trailers used in agricultural or grounds maintenance
			MOWER	Ride-on mower or mower trailer
			FORKLIFT	Powered industrial truck used to lift and move materials over short distances

3. Asset types and grouping rules for data capture

3.1 Assets versus components of assets

An asset is any grouping of parts to have a usable unit to perform a function and components are the interchangeable parts that allows the unit to be complete. In example a vehicle is complete as an asset when it is assembled and able to be used for transporting goods or people. The components, such as the wheels, doors, or air filter aren't assets.

However, it becomes a bit more complex when an asset as a system is separable in maintainable units of large size, distinct maintenance regime and significant replacement cost. A further example to demonstrate this is an air conditioner unit for a house or small office compared the HVAC system for a complete building. The former is small and of relative low cost compared to the latter that consists of large distinct units such as ducting, evaporators, chillers and condensers. Each of these units have a significant component list but should not be regarded as a component of the HVAC system, but instead a maintainable asset.

3.2 Categorising assets

Most assets used in the delivery of water and wastewater services are items that are made up of subcomponents that function in systems or parts of complex equipment. Physical assets that commonly appear in asset registers generally consist of large numbers of component parts that are aggregated or grouped into functional units based on defined criteria.

Watercare assets are categorised by class, type and subtype and described by a range of attributes which facilitate a standardised and systematic approach to capturing asset information. The Asset Hierarchy provides a parent/child tiered structure to allow for convenient and organised management of assets and asset data based on location and function. The lowest child level in the hierarchy represents the uniquely numbered individual asset which is deemed to be a maintainable asset and will retain historical maintenance and financial data for analytical and reporting purposes. This asset data can be rolled up to the desired level in the asset hierarchy to provide aggregated information. Subcomponents of an identified asset become integral and have no unique metadata.

A balanced approach is required when deciding on the level of asset breakdown in an asset register – unwieldy with information overload at one extreme and lacking in appropriate detail at the other. The rules regarding how assets should be broken down to sub-component level are therefore important to ensure that asset management data is fit for the intended purpose.

Table 1. The following guidelines provide a basis for categorising assets for capture as individual assets in the asset register.

Grouping Guideline	Description
1. Appears on the P&ID	All items appearing on the P&ID will be registered as individual assets
2. Maintenance/Replacement Characteristics	All items requiring specific preventative maintenance schedules, or those that could be fully replaced as part of the maintenance program, will be registered as individual assets. (e.g. motors, pumps, turbines)
3. Requires regulatory certification	All items requiring regulatory certification will be registered as individual assets.

Grouping Guideline	Description
4. Serves an important process operation purpose	Any items that are not covered by the other grouping guidelines, but which serve a significant process operation purpose and are referenced in the site SOPs, will be registered as individual assets
5. Has a value >\$500	Any items that are not covered by the other grouping guidelines but have a value >\$500. will be registered as individual assets

Generally, the grouping descriptions shown in Table 1 should be similar to the categorisation required for capitalisation purposes. However, due to the wide range of assets in the asset register and the detailed grouping requirements specified to meet operational requirements, the grouping of assets for capitalisation purposes can be streamlined where the detail is not required. Table 2 summarises grouping rules that should be applied for the capitalisation of selected assets. Note: the list is not exhaustive and final decisions on appropriate asset grouping for capitalisation should be at the discretion of asset managers with a full understanding of the broader issues relating to new asset deployment.

Table 2. The following guidelines provide a basis for aggregating assets for capitalisation when they are added to the asset register.

Item	Rules for Capitalising Assets
Actuators	Actuators shall be capitalised as separate assets.
Antenna System	Includes cable to the antenna, brackets and lightning protection equipment. Exception: Microwave systems. Outdoor units (ODU), IDU (indoor units) and antenna/dish need to be capitalised as individual assets.
Buildings & Large Chambers	Capitalisation of buildings shall be inclusive of all doors, windows and other building items. New doors and/or windows would be either an improvement or a maintenance cost, depending on the reason for replacement. A significant upgrade to a building, e.g. new roof on a building would either be a maintenance project or an improvement. The project manager shall discuss these projects with the Finance Department in these instances. A good way to separate structures is by process area, e.g. Clarifiers, membrane tanks, wastewater tank, chemical building etc. Ladders and platforms are separated out. Lids may be captured with a tank as an attribute, however in some instances for compliance and criticality may be separated out. Also see 'Platforms & Steel Work' and 'Lids/hatch covers'.
Cables – Instrumentation, data & communications	All instrument cable, including communications cables are capitalised with the connecting instrument as appropriate for each site. Communication patch leads (UTP or fibre) should be capitalised with the network switch/router/patch panel asset they are plugged into.

Item	Rules for Capitalising Assets
	Exception: Fibre optic cables need to be capitalised separately either grouped into segments (same cable specification) or into specific logical networks. Fibre optic cables and associated cable ways/tubes to be capitalised together.
Cables – 230v LV Cabling	All 230V cables are capitalised with the process area of the connecting equipment otherwise grouped under the sites' electrical process area as a single asset.
Cables – 415 LV Cabling	All 415V cables are capitalised with the process area of the connecting equipment otherwise grouped under the sites' electrical process area as a single asset.
Cables - HV Cabling (3.3, 11, 22 & 33kV)	3.3kV cables or larger are individually capitalised.
Cathodic Protection (CP)	Identify as separate assets as per the asset type tables. Note that isolated flanges are identified in the mechanical asset class.
Communications	Control System radios are individually capitalised.
Cranes and Lifting Gear	The mechanical components such as the crane or beam and lifting gear are captured separate to electrical motors that may be associated with the lifting gear.
DCS & SCADA	Servers, work stations, LAN/WAN switches, hubs & firewalls are capitalised as individual assets. <ul style="list-style-type: none"> - Monitors/KVM units to be capitalised with their associated computer. - HMI touch panel need to be capitalised separately from its associated Industrial computer
DCS Cabinets	The Controller shall be itemised as an individual asset. Standalone I/O cards (i.e. IO cards not physically integrated with a PLC/Controller) should be capitalised as individual assets. The balance of materials within the DCS cabinet shall be capitalised against the cabinet. See the asset types table for a complete list
Distribution Board / Sub Board (DB) & Junction Box (JB)	Refer Switchboards, otherwise Identify each electrical distribution board separately. Some electrical componentry is separated out, see the asset tables for a complete list.
Earthing	Identify each earth system and associated equipment and capitalise.
Field Cabinet	Each field cabinet should be identified separately. Instrumentation within are separated out.
Lids/hatch covers	Lids or hatches are typically captured as an attribute to the structure, most commonly such as for wastewater manholes. However, hatches may need to be split out as separate assets where they are larger than

Item	Rules for Capitalising Assets
	a typical operator access such as for equipment handling or partitioned where multiple small covers opened creates a large entry. Other instances may be due to regulation.
Instruments	Instruments are capitalised as individual assets. Mounting brackets and wet gear plates inclusive of small instrument-associated pipework and cabling can be capitalised with the asset if appropriate. Otherwise such ancillary components may be capitalised with an associated housing, e.g. monitoring box.
Control/monitoring Boxes	The RTU cabinets around the network will have the controller and any individual instruments itemised as individual assets. Batteries shall be capitalised as a group, not individually. The balance of materials (e.g. wiring, etc.) shall be capitalised with the monitoring box.
Motor Control Centre (MCC)	Refer Switchboards.
Motor Starters	Refer switchboards.
Pipe Bridges	Refer Wastewater and Water Mains.
Pipe work	Pipework $\geq 100\text{mm}$ diameter shall be capitalised individually from valves and fittings – See Watermains.
Non-mains: $<100\text{mm}$ i.e. service connections, process pipework in plants.	On small diameter pipe work ($<100\text{mm}$ diameter), the manual valves and fittings shall be capitalised with the associated pipework, unless there is a specialist (and expensive) fitting. Actuators shall be capitalised individually. Bypass pipe work of a diameter and construction within a line valve, meter or cross-connection assembly should be shown as one asset. Assets are split at diameter and material type changes. T-sections are captured as nodes only – no value is assigned. Process Pipe work - aggregated assets are defined for all pipe work of a given diameter within a process area, a definable location, or between two nodes or processes. For example, “40mm Pipe work, Lime Dosing” would be an asset. However, based on the specific risk assessment that pipework may need to be defined as individual assets where specific valves may need to be separated out.
Platforms & Steelwork	<p>Where there are significant quantities of platforms and steelwork, these shall be capitalised separately to the asset they are associated with but collectively as single asset i.e. All the steelwork and steel staircases within a pump station could be a single asset. Ladders are captured separately. Also see ‘Buildings & Large Chambers’ and ‘Lids/hatch covers’.</p> <p>Note that pipe steel supports or bases are captured as separate assets as civil support structures.</p>

Item	Rules for Capitalising Assets
Power Factor Correction (PFC)	<p>Refer to Switchboards otherwise:</p> <p>Power Factor assets includes capacitors, mountings, enclosure and ancillary equipment for each unit.</p>
Pumps/Motors/Rotating equipment.	<p>Separate assets are required for a pump and motor, unless it is assembled as a single unit i.e. submersible pump. Sump pumps are considered a separate asset.</p>
RTU's, PLC's & DCS Controllers	<p>RTU's, PLC's and DCS controllers are capitalised as individual assets. Individual cards are capitalised as part of the controller.</p>
Security	<p>Includes card scanners, electronic locks, detector units, swipe cards and associated security equipment as a grouped asset by area served.</p>
Software	<p>Capitalise control system software (user configured/engineered code) for large process plants into a single asset (rather than for each separate process area).</p> <p>Clarification:</p> <ul style="list-style-type: none"> - RTU software (and associated SCADA user software for that site) needs to be capitalised against the remote site (e.g. pump station) rather than the SCADA control centre/room (CCREM site). - PLC/RTU/DCS + HMI/SCADA software required to integrate discrete, single pieces of equipment (e.g. one PIT, one FIT, one AIT etc.) should be capitalised against the instrument rather the site software asset.
Switchboards	<p>230V switchboards and distribution boards are capitalised as individual assets, inclusive of all the wiring and components. Switchboards of voltage greater than 230V (i.e. 415V and larger) typically found in pump stations, process areas etc. Identify each switchboard as a primary asset. Identify the major components in the switchboard separately as associated assets. A major component is deemed to be a device with a current capacity of more than 100 Amps. This may include: Isolators; Circuit Breakers; Motor Protection Relays; Soft Starters; Variable Speed Drives and Power Factor Correction Capacitors. If unsure, the project manager shall confirm the degree of capitalisation with the Assets Specialist.</p>
Valves	<p>Separate assets are required for every valve separately identified in the P&ID, As-Built or other drawings. Generally, valves < 100mm are captured with the pipe unless it serves a special function i.e. 50mm valves on rider mains are important valves to be captured. Refer to Pipework.</p>
Tanks	<p>Each tank to be a separate asset. Ladders and platforms are separated out. Lids may be captured with a tank as an attribute, however in some instances for compliance and criticality may be separated out.</p>

Item	Rules for Capitalising Assets
Transformer ≥400V	Each transformer is a separate asset. This does not include 240V transformers that connect to single-phase power outlets.
Ventilation System	Each fan, ducting, silencers, filters, louvres, etc. of a HVAC system should be separated out. Only complete air-conditioning units may be captured as a single asset.
Wastewater	A manhole is an asset and each section of pipe/sewer between manholes is also an asset. Asset is split at diameter and material type changes. Separate assets are required for pipe bridges
Watermains	Separate assets are required for sections of pipe between isolation valves (not hydrants, air valves or scours). Asset is split at diameter and material type changes. T-sections are captured as nodes (position) only – the fitting itself is not, it is considered pipework. Separate assets are required for pipe bridges (between sections/nodes). Bypass valves and associated small bore pipe work shall be capitalised individually.

4. Metadata

This section covers the metadata to be collected for each class. The attributes per asset type and sub-type is shown in Part H which is the as-built of the individual asset types.

Table key	
Requirement	Symbol
Common data for class set	C
Asset type specific features	FT

4.1 Asset Class: Buildings

Asset Class	Buildings	Common /Feature field	Definitions	Attribute usage
			Attribute name	
			A structure with floor, roof and walls with above ground walk-in access	
Sub type	Alpha numeric - selection list	C	A distinguishing feature of a sub-type of asset	To describe a uniqueness or distinguishing feature of an asset sub-type that is important for analytical and functional purposes
Ownership	Text - selection list	C	The entity that that has financial and legislative responsibility of the asset	Future management of assets owned by others
Process	Text - selection list	C	The main media process stream i.e. Water or wastewater	Differentiate media process stream
Operational area	Text - selection list	C	The area where the asset is in operation as managed by the operational business unit	Differentiate operational process areas
Photo/3D model	PDF, Bitmap, Image, file link	C	A live colour photo of the installation or asset within its installed location. Alternative to a photo is a 3D drawing	Visual familiarisation and confirmation

Asset Class	Buildings	Common /Feature field	Definitions	Attribute usage
			A structure with floor, roof and walls with above ground walk-in access	
Attribute name	Attribute unit			
Equipment number	Alpha numeric, Watercare design generated number	C	A unique Watercare generated comprising of the facility, process area code, asset type and its sub-location as a parent asset or child asset within the system that it is installed at.	Unique identification. Reference number used between systems and field identification of assets
Functional area	Alpha numeric	C	The systems and sub-process description of the area where the assets functions and is maintained	To identify the assets' physical location of functionality and where it is maintained in relationship to the plant/process.
Manufacturer/Constructor	Alpha numeric	C	The name of the company/organisation that built/manufactured the Asset.	Quality assurance and traceability. Manufacturer/contractor analysis across assets
Year of Manufacture / construction	yyyy	C	The year that the Asset was built/manufactured.	Quality assurance, vendor liability and traceability of equipment changes from manufacturer
Warranty Start Date	dd-mm-yyyy	C	The effective start date of the warranty period for an Asset.	Quality assurance
Warranty End Date	dd-mm-yyyy	C	The effective end date of the warranty period for the Asset.	Quality assurance
Coordinates (x)	Alpha numeric	C	Geographic coordinates used to define precise positions on the Earth's surface (where an Asset can be located). Coordinates come from the related GIS spatial representation of the Asset held within the GIS database - which currently is the COMPKEY or Equipment ID.	Geospatial awareness and area based analytics
Coordinates (y)	Alpha numeric	C	The x coordinate represents a point on an east-west axis (longitude).	Geospatial awareness and area based analytics

Asset Class	Buildings	Common /Feature field	Definitions	Attribute usage
			A structure with floor, roof and walls with above ground walk-in access	
Attribute name	Attribute unit			
Coordinates (z)	Alpha numeric	C	The y coordinate represents a point on a north-south axis (latitude). The z coordinate indicates height or level above or below sea level (expressed in metres to two decimal places).	Geospatial awareness and area based analytics
Street Name	Text	C	Relationship to Address	Geospatial awareness and area based analytics
Suburb	Text	C	Relationship to Address	Geospatial awareness and area based analytics
District	Text	C	Relationship to Address	Geospatial awareness and area based analytics
Post Code	Numeric, no decimal	C	Relationship to Address	Geospatial awareness and area based analytics
Confined Space Located	Text - selection list	C	Indicates if the Asset is located in a confined space.	H&S to show when an asset or classed as a confined space
Hazardous area rating	Alpha numeric	C	The safety rating/specification of the Asset.	Replacement of like-for like equipment which have been selected at time of design to comply with certain protection criteria for the installed environment, as well as when equipment is rotated or moved to different locations to identify in what areas it may be re-used.
Linked Documents	Alpha numeric	C	Documents, warranties, specifications, plans/drawings ('as-built'), photos and videos relating to a particular Asset.	Traceability
acquisition value	Numeric, two decimals	C	The purchase price of the Asset (in NZ dollars).	Financial, service performance measure and replacement strategy
acquisition date	dd-mm-yyyy	C	The date that the Asset was purchased/acquired (by Watercare).	Required for valuation and warrantee purposes
Project reference	Alpha numeric	FT	The project ID, code or C-number of the project that the Asset was acquired/procured for.	Contractual links and business case documentation to capture decision making history

Asset Class	Buildings	Common /Feature field	Definitions	Attribute usage
			A structure with floor, roof and walls with above ground walk-in access	
Attribute name	Attribute unit			
Start up date	dd-mm-yyyy	C	The date that the asset was first placed into operation	Some assets may be installed but have considerable delays before starting operation. Differential deterioration rates apply
asset designed life	Numeric, no decimal	C	The expected/designed lifetime of an Asset (expressed as a number of years).	Financial, service performance measure and replacement strategy
Service status	Alpha numeric - selection list	C	Asset lifecycle status codes that record the effective dates that an Asset was in a particular state (requires 'service status effective date' attribute as well).	Assets in-service or out of service status is used for analytical purposes on life expectancy as well as Watercare's ongoing liability towards assets that are no longer in used but are still installed.
Condition rating	Numeric, no decimal, selection list	C	Asset lifecycle status codes that record the effective dates that an Asset was in a particular state (requires 'service status effective date' attribute as well).	Analytical input to investment to maintain level of service
Criticality rating	Numeric, no decimal	C	An indicator of the criticality or importance (to the business, production, process, safety) of a particular Asset. Denotes the level of impact/consequence that will result from loss/breakdown of the Asset. If impact to Watercare's business, processes or reputation (of loss or breakdown of an Asset) is high/extensive the criticality rating will also be high.	Analytical input to investment to maintain level of service
Condition assessment date	dd-mm-yyyy	C	The date that the assessment was conducted/determined.	Tracking condition assessment

Asset Class	Buildings	Common /Feature field	Definitions	Attribute usage
			A structure with floor, roof and walls with above ground walk-in access	
Attribute name	Attribute unit			
Assessed remaining life	Numeric, no decimal	C	An assessment of the remaining lifetime of an Asset (expressed as a number of years). The value is calculated based on physical evaluation, time in service and condition rating	Financial, service performance measure and replacement strategy
Material type (majority component)	Text - selection list	C	Describes the (defining) material used to construct the external casing / majority component of the Asset.	Evaluation of deterioration
External coating	Text - selection list	C	Describes the protective corrosion or structural coating used on the exterior of the Asset.	Impacts on service live and maintenance scheduling
Length	metre (m)	C	The end-to-end measurement of an asset (expressed in metres to three decimal places).	Geospatial awareness and cost valuation
Width	millimetre (mm)	C	The extend measurement from side-to-side of an asset (expressed in millimetres).	Geospatial awareness and cost valuation
Height	millimetre (mm)	C	The extend measurement from base-to-top of an asset (expressed in millimetres).	Geospatial awareness and cost valuation
Ground level (GL)	metre (m)	C	The level in relation to the asset (typically buried) in relation to a datum level	Geospatial reference
Area	square metre (m ²)	C	Surface extent	Geospatial awareness and cost valuation
Earthquake Quake design lvl	Alpha numeric - selection list	C	The level of design actions undertaken for design as prescribed by structural design codes	Structural design safety factors for legislative compliance
Design resilience rating	Alpha numeric - selection list	C	The ability of the designed asset to sustain a level of service and absorb or adapt to changing conditions when there is a failure in the system	Drives organisational response / capability to maintain levels of service

4.2 Asset Class: Chambers and manholes

Asset Class	Chambers and Manholes	Common /Feature field	Definitions	Attribute usage
			A partially below ground or below ground enclosure where equipment and pipework is housed for inspection or maintenance purposes	
Attribute name	Attribute unit			
Sub-type	Alpha numeric - selection list	C	Breakdown of some assets types where required to distinguish asset types to a more granular level	
Sub-type feature	Alpha numeric - selection list	C	A distinguishing feature of a sub-type of asset	To describe a uniqueness or distinguishing feature of an asset sub-type that is important for analytical and functional purposes
Ownership	Text - selection list	C	The entity that that has financial and legislative responsibility of the asset	Future management of assets owned by others
Process	Text - selection list	C	The main media process stream i.e. Water or wastewater	Differentiate media process stream
Operational area	Text - selection list	C	The area where the asset is in operation as managed by the operational business unit	Differentiate operational process areas
Photo/3D model	PDF, Bitmap, Image, file link	C	A live colour photo of the installation or asset within its installed location. Alternative to a photo is a 3D drawing	Visual familiarisation and confirmation
Equipment number	Alpha numeric, Watercare design generated number	C	A unique Watercare generated comprising of the facility, process area code, asset type and its sub-location as a parent asset or child asset within the system that it is installed at.	Unique identification. Reference number used between systems and field identification of assets
Functional area	Alpha numeric	C	The systems and sub-process description of the area where the assets functions and is maintained	To identify the assets' physical location of functionality and where it is maintained in relationship to the plant/process.

Asset Class	Chambers and Manholes	Common /Feature field	Definitions	Attribute usage
			A partially below ground or below ground enclosure where equipment and pipework is housed for inspection or maintenance purposes	
Attribute name	Attribute unit			
Manufacturer/Constructor	Alpha numeric	C	The name of the company/organisation that built/manufactured the Asset.	Quality assurance and traceability. Manufacturer/contractor analysis across assets
Model/Class	Alpha numeric	C	The model id/number (assigned by the manufacturer) for this Asset.	Quality assurance and traceability. Model/class analysis across assets
Serial Nbr	Alpha numeric	C	The manufacturer's serial number allocated to this Asset.	Quality assurance and traceability
Year of Manufacture / construction	yyyy	C	The year that the Asset was built/manufactured.	Quality assurance, vendor liability and traceability of equipment changes from manufacturer
Weight	Kilogram (kg)	C	The weight of the Asset (expressed as a number of kilograms).	Design baseline (SiD), equipment handling for replacement and maintenance. Onsite material handling equipment or need to hire material handling equipment
Supplier/Vendor	Alpha numeric	C	The name of the company/organisation that sold/supplied the Asset.	Quality assurance and vendor liability
Warranty Start Date	dd-mm-yyyy	C	The effective start date of the warranty period for an Asset.	Quality assurance
Warranty End Date	dd-mm-yyyy	C	The effective end date of the warranty period for the Asset.	Quality assurance
Coordinates (x)	Alpha numeric	C	Geographic coordinates used to define precise positions on the Earth's surface (where an Asset can be located). Coordinates come from the related GIS spatial representation of the Asset held within the GIS database - which currently is	Geospatial awareness and area based analytics

Asset Class	Chambers and Manholes	Common /Feature field	Definitions	Attribute usage
			A partially below ground or below ground enclosure where equipment and pipework is housed for inspection or maintenance purposes	
Attribute name	Attribute unit			
Coordinates (y)	Alpha numeric	C	the COMPKEY or Equipment ID. The x coordinate represents a point on an east-west axis (longitude). The y coordinate represents a point on a north-south axis (latitude). The z coordinate indicates height or level above or below sea level (expressed in metres to two decimal places).	Geospatial awareness and area based analytics
Coordinates (z)	Alpha numeric	C		Geospatial awareness and area based analytics
Street Name	Text	C	Relationship to Address	Geospatial awareness and area based analytics
Suburb	Text	C	Relationship to Address	Geospatial awareness and area based analytics
District	Text	C	Relationship to Address	Geospatial awareness and area based analytics
Post Code	Numeric, no decimal	C	Relationship to Address	Geospatial awareness and area based analytics
Locality	Text - selection list	C	Records the setting or placement of an Asset within its functional area.	Evaluation of deterioration and impact of the setting on the asset performance
Confined Space Located	Text - selection list	C	Indicates if the Asset is located in a confined space.	H&S to show when an asset or classed as a confined space
Linked Documents	Alpha numeric	C	Documents, warranties, specifications, plans/drawings ('as-builts'), photos and videos relating to a particular Asset.	Traceability
acquisition value	Numeric, two decimals	C	The purchase price of the Asset (in NZ dollars).	Financial, service performance measure and replacement strategy
acquisition date	dd-mm-yyyy	C	The date that the Asset was purchased/acquired (by Watercare).	Required for valuation and warrantee purposes

Asset Class	Chambers and Manholes	Common /Feature field	Definitions	Attribute usage
			A partially below ground or below ground enclosure where equipment and pipework is housed for inspection or maintenance purposes	
Attribute name	Attribute unit			
Project reference	Alpha numeric	FT	The project ID, code or C-number of the project that the Asset was acquired/procured for.	Contractual links and business case documentation to capture decision making history
Start up date	dd-mm-yyyy	C	The date that the asset was first placed into operation	Some assets may be installed but have considerable delays before starting operation. Differential deterioration rates apply
asset designed life	Numeric, no decimal	C	The expected/designed lifetime of an Asset (expressed as a number of years).	Financial, service performance measure and replacement strategy
Service status	Alpha numeric - selection list	C	Asset lifecycle status codes that record the effective dates that an Asset was in a particular state (requires 'service status effective date' attribute as well).	Assets in-service or out of service status is used for analytical purposes on life expectancy as well as Watercare's ongoing liability towards assets that are no longer in used but are still installed.
Condition rating	Numeric, no decimal, selection list	C	Asset lifecycle status codes that record the effective dates that an Asset was in a particular state (requires 'service status effective date' attribute as well).	Analytical input to investment to maintain level of service
Criticality rating	Numeric, no decimal	C	<p>An indicator of the criticality or importance (to the business, production, process, safety ...) of a particular Asset.</p> <p>Denotes the level of impact/consequence that will result from loss/breakdown of the Asset.</p> <p>If impact to Watercare's business, processes or reputation (of loss or breakdown of an Asset) is high/extensive the criticality rating will also be high.</p>	Analytical input to investment to maintain level of service

Asset Class	Chambers and Manholes	Common /Feature field	Definitions	Attribute usage
			A partially below ground or below ground enclosure where equipment and pipework is housed for inspection or maintenance purposes	
Attribute name	Attribute unit			
Condition assessment date	dd-mm-yyyy	C	The date that the assessment was conducted/determined.	Tracking condition assessment
Assessed remaining life	Numeric, no decimal	C	An assessment of the remaining lifetime of an Asset (expressed as a number of years). The value is calculated based on physical evaluation, time in service and condition rating	Financial, service performance measure and replacement strategy
Media Type Wtr/WWtr/chem/gas	Text - selection list	FT	Describes the substance that is contained in, processed by or transported by an Asset.	Evaluation of deterioration and impact of media on the asset performance
Material type (majority component)	Text - selection list	C	Describes the (defining) material used to construct the external casing / majority component of the Asset.	Evaluation of deterioration
Diameter (internal)	millimetre (mm)	FT	A straight line going through the centre of a pipe connecting two points on the external circumference	Hydraulic performance, future connectivity and evaluation of deterioration
Diameter (external)	millimetre (mm)	FT	A straight line going through the centre of a pipe connecting two points on the internal circumference	Future connectivity, repair sizing and evaluation of deterioration
Diameter (Nominal)	millimetre (mm)	FT	The nominal diameter may not match the internal or external (see definitions for internal and external diameter) diameter but is used a size name identification	Naming convention
Load rating (kN)	Kilo Newton (kN)	FT	The proof load or design load rating of the asset is the loading vertical load that can be applied to the asset without causing permanent damage or deflection	Structural safety for working around or with the asset

Asset Class	Chambers and Manholes	Common /Feature field	Definitions	Attribute usage
			A partially below ground or below ground enclosure where equipment and pipework is housed for inspection or maintenance purposes	
Attribute name	Attribute unit			
Internal lining	Text - selection list	FT	Describes the protective corrosion or structural coating used on the interior of the Asset.	Impacts on service live and maintenance scheduling
Length	metre (m)	FT	The end-to-end measurement of an asset (expressed in metres to three decimal places).	Geospatial awareness and cost valuation
Width	millimetre (mm)	FT	The extend measurement from side-to-side of an asset (expressed in millimetres).	Geospatial awareness and cost valuation
Height	millimetre (mm)	FT	The extend measurement from base-to-top of an asset (expressed in millimetres).	Geospatial awareness and cost valuation
depth	millimetre (mm)	FT	The extend measurement from top to the bottom (expressed in millimetres) and is used to expressed buried assets.	Geospatial awareness and cost valuation
Invert level (RL)	metre (m)	FT	The base interior level of a pipe, tunnel or civil structure in relation to the ground level	Geospatial awareness, also required for hydraulic modelling
Ground level (GL)	metre (m)	FT	The level in relation to the asset (typically buried) in relation to a datum level	Geospatial reference
Lid type	Text - selection list	FT	An access hatch into chambers and manholes	Identify access requirements/limitations for operators and equipment
Lid level (RL)	metre (m)	FT	The level in relation to the ground level	Geospatial awareness. Lids may be sitting proud or deeper than the ground level requiring H&S actions to be taken for maintenance or upgrades

Asset Class	Chambers and Manholes	Common /Feature field	Definitions	Attribute usage
			A partially below ground or below ground enclosure where equipment and pipework is housed for inspection or maintenance purposes	
Attribute name	Attribute unit			
Fall protection	Text - selection list	FT	The mechanism used to prevent personnel from falling into open containment structures or structures at height	Field staff can identify safety gear requirements for fall protection where it is/is not installed as part of the asset (Safety in Design)
earthquake Quake design lvl	Alpha numeric - selection list	FT	The level of design actions undertaken for design as prescribed by structural design codes	Structural design safety factors for legislative compliance
Design resilience rating	Alpha numeric - selection list	FT	The ability of the designed asset to sustain a level of service and absorb or adapt to changing conditions when there is a failure in the system	Drives organisational response / capability to maintain levels of service

4.3 Asset Class: Civil

Asset Class	Civil	Common /Feature field	Definitions	Attribute usage
			A structure that provides adequate rigidity to withstand its own weight and can resist external loads. The load elements relate to civil structures e.g. anchor blocks, bridge piers or equipment bases	
Attribute name	Attribute unit			
Sub type	Alpha numeric - selection list	FT	A distinguishing feature of a sub-type of asset	To describe a uniqueness or distinguishing feature of an asset sub-type that is important for analytical and functional purposes
Ownership	Text - selection list	C	The entity that that has financial and legislative responsibility of the asset	Future management of assets owned by others
Process	Text - selection list	C	The main media process stream i.e. Water or wastewater	Differentiate media process stream
Operational area	Text - selection list	C	The area where the asset is in operation as managed by the operational business unit	Differentiate operational process areas
Photo/3D model	PDF, Bitmap, Image, file link	C	A live colour photo of the installation or asset within its installed location. Alternative to a photo is a 3D drawing	Visual familiarisation and confirmation
Equipment number	Alpha numeric, Watercare design generated number	C	A unique Watercare generated comprising of the facility, process area code, asset type and its sub-location as a parent asset or child asset within the system that it is installed at.	Unique identification. Reference number used between systems and field identification of assets
Functional area	Alpha numeric	C	The systems and sub-process description of the area where the assets functions and is maintained	To identify the assets' physical location of functionality and where it is maintained in relationship to the plant/process.
Manufacturer/Constructor	Alpha numeric	C	The name of the company/organisation that built/manufactured the Asset.	Quality assurance and traceability. Manufacturer/contractor analysis across assets

Asset Class	Civil	Common /Feature field	Definitions	Attribute usage
			A structure that provides adequate rigidity to withstand its own weight and can resist external loads. The load elements relate to civil structures e.g. anchor blocks, bridge piers or equipment bases	
Attribute name	Attribute unit			
Model/Class	Alpha numeric	FT	The model id/number (assigned by the manufacturer) for this Asset.	Quality assurance and traceability. Model/class analysis across assets
Serial Nbr	Alpha numeric	FT	The manufacturer's serial number allocated to this Asset.	Quality assurance and traceability
Year of Manufacture / construction	yyyy	C	The year that the Asset was built/manufactured.	Quality assurance, vendor liability and traceability of equipment changes from manufacturer
Weight	Kilogram (kg)	FT	The weight of the Asset (expressed as a number of kilograms).	Design baseline (SiD), equipment handling for replacement and maintenance. Onsite material handling equipment or need to hire material handling equipment
Supplier/Vendor	Alpha numeric	FT	The name of the company/organisation that sold/supplied the Asset.	Quality assurance and vendor liability
Warranty Start Date	dd-mm-yyyy	C	The effective start date of the warranty period for an Asset.	Quality assurance
Warranty End Date	dd-mm-yyyy	C	The effective end date of the warranty period for the Asset.	Quality assurance
Coordinates (x)	Alpha numeric	C	Geographic coordinates used to define precise positions on the Earth's surface (where an Asset can be located). Coordinates come from the related GIS	Geospatial awareness and area based analytics

Asset Class	Civil	Common /Feature field	Definitions	Attribute usage
			A structure that provides adequate rigidity to withstand its own weight and can resist external loads. The load elements relate to civil structures e.g. anchor blocks, bridge piers or equipment bases	
Attribute name	Attribute unit			
Coordinates (y)	Alpha numeric	C	spatial representation of the Asset held within the GIS database - which currently is the COMPKEY or Equipment ID. The x coordinate represents a point on an east-west axis (longitude).	Geospatial awareness and area based analytics
Coordinates (z)	Alpha numeric	C	The y coordinate represents a point on a north-south axis (latitude). The z coordinate indicates height or level above or below sea level (expressed in metres to two decimal places).	Geospatial awareness and area based analytics
Street Name	Text	FT	Relationship to Address	Geospatial awareness and area based analytics
Suburb	Text	FT	Relationship to Address	Geospatial awareness and area based analytics
District	Text	FT	Relationship to Address	Geospatial awareness and area based analytics
Post Code	Numeric, no decimal	FT	Relationship to Address	Geospatial awareness and area based analytics
Locality	Text - selection list	FT	Records the setting or placement of an Asset within its functional area.	Evaluation of deterioration and impact of the setting on the asset performance
Confined Space Located	Text - selection list	FT	Indicates if the Asset is located in a confined space.	H&S to show when an asset or classed as a confined space
Hazardous area rating	Alpha numeric - selection list	FT	The safety rating/specification of the Asset.	Replacement of like-for like equipment which have been selected at time of design to comply with certain protection criteria for the installed environment, as well as when equipment is rotated or moved to different locations to identify in what areas it may be re-used.

Asset Class	Civil	Common /Feature field	Definitions	Attribute usage
			A structure that provides adequate rigidity to withstand its own weight and can resist external loads. The load elements relate to civil structures e.g. anchor blocks, bridge piers or equipment bases	
Attribute name	Attribute unit			
Linked Documents	Alpha numeric	C	Documents, warranties, specifications, plans/drawings ('as-built'), photos and videos relating to a particular Asset.	Traceability
acquisition value	Numeric, two decimals	C	The purchase price of the Asset (in NZ dollars).	Financial, service performance measure and replacement strategy
acquisition date	dd-mm-yyyy	C	The date that the Asset was purchased/acquired (by Watercare).	Required for valuation and warrantee purposes
Project reference	Alpha numeric	FT	The project ID, code or C-number of the project that the Asset was acquired/procured for.	Contractual links and business case documentation to capture decision making history
Start up date	dd-mm-yyyy	C	The date that the asset was first placed into operation	Some assets may be installed but have considerable delays before starting operation. Differential deterioration rates apply
asset designed life	Numeric, no decimal	C	The expected/designed lifetime of an Asset (expressed as a number of years).	Financial, service performance measure and replacement strategy
Service status	Alpha numeric - selection list	C	Asset lifecycle status codes that record the effective dates that an Asset was in a particular state (requires 'service status effective date' attribute as well).	Assets in-service or out of service status is used for analytical purposes on life expectancy as well as Watetrcare's ongoing liability towards assets that are no longer in used but are still installed.
Condition rating	Numeric, no decimal, selection list	C	Asset lifecycle status codes that record the effective dates that an Asset was in a particular state (requires 'service status effective date' attribute as well).	Analytical input to investment to maintain level of service

Asset Class	Civil	Common /Feature field	Definitions	Attribute usage
Attribute name	Attribute unit			
Criticality rating	Numeric, no decimal	C	<p>A structure that provides adequate rigidity to withstand its own weight and can resist external loads. The load elements relate to civil structures e.g. anchor blocks, bridge piers or equipment bases</p> <p>An indicator of the criticality or importance (to the business, production, process, safety) of a particular Asset. Denotes the level of impact/consequence that will result from loss/breakdown of the Asset. If impact to Watercare's business, processes or reputation (of loss or breakdown of an Asset) is high/extensive the criticality rating will also be high.</p>	Analytical input to investment to maintain level of service
Condition assessment date	dd-mm-yyyy	C	The date that the assessment was conducted/determined.	Tracking condition assessment
Assessed remaining life	Numeric, no decimal	C	An assessment of the remaining lifetime of an Asset (expressed as a number of years). The value is calculated based on physical evaluation, time in service and condition rating	Financial, service performance measure and replacement strategy
Material type (majority component)	Text - selection list	C	Describes the (defining) material used to construct the external casing / majority component of the Asset.	Evaluation of deterioration
Diameter (internal)	millimetre (mm)	FT	A straight line going through the centre of a pipe connecting two points on the external circumference	Hydraulic performance, future connectivity and evaluation of deterioration
Diameter (external)	millimetre (mm)	FT	A straight line going through the centre of a pipe connecting two points on the internal circumference	Future connectivity, repair sizing and evaluation of deterioration

Asset Class	Civil	Common /Feature field	Definitions	Attribute usage
			A structure that provides adequate rigidity to withstand its own weight and can resist external loads. The load elements relate to civil structures e.g. anchor blocks, bridge piers or equipment bases	
Attribute name	Attribute unit			
Diameter (Nominal)	millimetre (mm)	FT	The nominal diameter may not match the internal or external (see definitions for internal and external diameter) diameter but is used a size name identification	Naming convention
Load rating (kN)	Kilo Newton (kN)	FT	The proof load or design load rating of the asset is the loading vertical load that can be applied to the asset without causing permanent damage or deflection	Structural safety for working around or with the asset
External coating	Text - selection list	FT	Describes the protective corrosion or structural coating used on the exterior of the Asset.	Impacts on service live and maintenance scheduling
Length	metre (m)	FT	The end-to-end measurement of an asset (expressed in metres to three decimal places).	Geospatial awareness and cost valuation
Width	millimetre (mm)	FT	The extend measurement from side-to-side of an asset (expressed in millimetres).	Geospatial awareness and cost valuation
Height	millimetre (mm)	FT	The extend measurement from base-to-top of an asset (expressed in millimetres).	Geospatial awareness and cost valuation
depth	millimetre (mm)	FT	The extend measurement from top to the bottom (expressed in millimetres) and is used to expressed buried assets.	Geospatial awareness and cost valuation
Invert level (RL)	metre (m)	FT	The base interior level of a pipe, tunnel or civil structure in relation to the ground level	Geospatial awareness, also required for hydraulic modelling
Ground level (GL)	metre (m)	FT	The level in relation to the asset (typically buried) in relation to a datum level	Geospatial reference

Asset Class	Civil	Common /Feature field	Definitions	Attribute usage
			A structure that provides adequate rigidity to withstand its own weight and can resist external loads. The load elements relate to civil structures e.g. anchor blocks, bridge piers or equipment bases	
Attribute name	Attribute unit			
earthquake Quake design lvl	Alpha numeric - selection list	FT	The level of design actions undertaken for design as prescribed by structural design codes	Structural design safety factors for legislative compliance
Design resilience rating	Alpha numeric - selection list	FT	The ability of the designed asset to sustain a level of service and absorb or adapt to changing conditions when there is a failure in the system	Drives organisational response / capability to maintain levels of service

4.4 Asset Class: Containment structures

Asset Class	Containment Structure	Common /Feature field	Definitions	Attribute usage
			A structure or vessel that that manages media for storage or process balancing such as reservoirs, and process tanks	
Attribute name	Attribute unit			
Sub-type	Alpha numeric - selection list	FT	Breakdown of some assets types where required to distinguish asset types to a more granular level	
Sub-type feature	Alpha numeric - selection list	FT	A distinguishing feature of a sub-type of asset	To describe a uniqueness or distinguishing feature of an asset sub-type that is important for analytical and functional purposes
Ownership	Text - selection list	C	The entity that that has financial and legislative responsibility of the asset	Future management of assets owned by others
Process	Text - selection list	C	The main media process stream i.e. Water or wastewater	Differentiate media process stream
Operational area	Text - selection list	C	The area where the asset is in operation as managed by the operational business unit	Differentiate operational process areas
Photo/3D model	PDF, Bitmap, Image, file link	C	A live colour photo of the installation or asset within its installed location. Alternative to a photo is a 3D drawing	Visual familiarisation and confirmation
Equipment number	Alpha numeric, Watercare design generated number	C	A unique Watercare generated comprising of the facility, process area code, asset type and its sub-location as a parent asset or child asset within the system that it is installed at.	Unique identification. Reference number used between systems and field identification of assets
Functional area	Alpha numeric	C	The systems and sub-process description of the area where the assets functions and is maintained	To identify the assets' physical location of functionality and where it is maintained in relationship to the plant/process.
Manufacturer/Constructor	Alpha numeric	C	The name of the company/organisation that built/manufactured the Asset.	Quality assurance and traceability. Manufacturer/contractor analysis across assets

Asset Class	Containment Structure	Common /Feature field	Definitions	Attribute usage
			A structure or vessel that that manages media for storage or process balancing such as reservoirs, and process tanks	
Attribute name	Attribute unit			
Model/Class	Alpha numeric	FT	The model id/number (assigned by the manufacturer) for this Asset.	Quality assurance and traceability. Model/class analysis across assets
Serial Nbr	Alpha numeric	FT	The manufacturer's serial number allocated to this Asset.	Quality assurance and traceability
Year of Manufacture / construction	YYYY	C	The year that the Asset was built/manufactured.	Quality assurance, vendor liability and traceability of equipment changes from manufacturer
Weight	Kilogram (kg)	FT	The weight of the Asset (expressed as a number of kilograms).	Design baseline (SiD), equipment handling for replacement and maintenance. Onsite material handling equipment or need to hire material handling equipment
Supplier/Vendor	Alpha numeric	C	The name of the company/organisation that sold/supplied the Asset.	Quality assurance and vendor liability
Warranty Start Date	dd-mm-yyyy	C	The effective start date of the warranty period for an Asset.	Quality assurance
Warranty End Date	dd-mm-yyyy	C	The effective end date of the warranty period for the Asset.	Quality assurance
Coordinates (x)	Alpha numeric	C	Geographic coordinates used to define precise positions on the Earth's surface (where an Asset can be located). Coordinates come from the related GIS spatial representation of the Asset held within the GIS database - which currently is the COMPKEY or Equipment ID .	Geospatial awareness and area based analytics
Coordinates (y)	Alpha numeric	C	The x coordinate represents a point on an east-west axis (longitude). The y coordinate represents a point on a	Geospatial awareness and area based analytics

Asset Class	Containment Structure	Common /Feature field	Definitions	Attribute usage
			A structure or vessel that that manages media for storage or process balancing such as reservoirs, and process tanks	
Attribute name	Attribute unit			
Coordinates (z)	Alpha numeric	C	north-south axis (latitude). The z coordinate indicates height or level above or below sea level (expressed in metres to two decimal places).	Geospatial awareness and area based analytics
Street Name	Text	FT	Relationship to Address	Geospatial awareness and area based analytics
Suburb	Text	FT	Relationship to Address	Geospatial awareness and area based analytics
District	Text	FT	Relationship to Address	Geospatial awareness and area based analytics
Post Code	Numeric, no decimal	FT	Relationship to Address	Geospatial awareness and area based analytics
Locality	Text - selection list	C	Records the setting or placement of an Asset within its functional area.	Evaluation of deterioration and impact of the setting on the asset performance
Confined Space Located	Text - selection list	C	Indicates if the Asset is located in a confined space.	H&S to show when an asset or classed as a confined space
Linked Documents	Alpha numeric	C	Documents, warranties, specifications, plans/drawings ('as-builts'), photos and videos relating to a particular Asset.	Traceability
acquisition value	Numeric, two decimals	C	The purchase price of the Asset (in NZ dollars).	Financial, service performance measure and replacement strategy
acquisition date	dd-mm-yyyy	C	The date that the Asset was purchased/acquired (by Watercare).	Required for valuation and warrantee purposes
Project reference	Alpha numeric	C	The project ID, code or C-number of the project that the Asset was acquired/procured for.	Contractual links and business case documentation to capture decision making history
Start up date	dd-mm-yyyy	C	The date that the asset was first placed into operation	Some assets may be installed but have considerable delays before starting operation. Differential deterioration rates apply

Asset Class	Containment Structure	Common /Feature field	Definitions	Attribute usage
			A structure or vessel that that manages media for storage or process balancing such as reservoirs, and process tanks	
Attribute name	Attribute unit			
asset designed life	Numeric, no decimal	C	The expected/designed lifetime of an Asset (expressed as a number of years).	Financial, service performance measure and replacement strategy
Service status	Alpha numeric - selection list	C	Asset lifecycle status codes that record the effective dates that an Asset was in a particular state (requires 'service status effective date' attribute as well).	Assets in-service or out of service status is used for analytical purposes on life expectancy as well as Watetrcare's ongoing liability towards assets that are no longer in used but are still installed.
Condition rating	Numeric, no decimal, selection list	C	Asset lifecycle status codes that record the effective dates that an Asset was in a particular state (requires 'service status effective date' attribute as well).	Analytical input to investment to maintain level of service
Criticality rating	Numeric, no decimal	C	An indicator of the criticality or importance (to the business, production, process, safety ...) of a particular Asset. Denotes the level of impact/consequence that will result from loss/breakdown of the Asset. If impact to Watercare's business, processes or reputation (of loss or breakdown of an Asset) is high/extensive the criticality rating will also be high.	Analytical input to investment to maintain level of service
Condition assessment date	dd-mm-yyyy	C	The date that the assessment was conducted/determined.	Tracking condition assessment
Assessed remaining life	Numeric, no decimal	C	An assessment of the remaining lifetime of an Asset (expressed as a number of years). The value is calculated based on physical evaluation, time in service and condition rating	Financial, service performance measure and replacement strategy
Media Type Wtr/WWtr/chem/gas	Text - selection list	C	Describes the substance that is contained in, processed by or transported by an Asset.	Evaluation of deterioration and impact of media on the asset performance

Asset Class	Containment Structure	Common /Feature field	Definitions	Attribute usage
			A structure or vessel that that manages media for storage or process balancing such as reservoirs, and process tanks	
Attribute name	Attribute unit			
Material type (majority component)	Text - selection list	C	Describes the (defining) material used to construct the external casing / majority component of the Asset.	Evaluation of deterioration
Pressure Rating (kPa) static	kilo-Pascal (kPa)	FT	The maximum pressure (expressed in kilopascals) that an Asset is designed to operate at (i.e. a pump) or withstand (i.e. pipes).	Design baseline for future performance measurement. Evaluation of future connection, deterioration and life expectancy
Stiffness rating (SN)	Nominal stiffness (SN), selection list	FT	A measurement of the crush resistance of a pipe or fitting as nominal stiffness (kN/m ²).	Design baseline for future performance measurement. Evaluation of future connection, deterioration and life expectancy
Max Designed flow	Litres per second (l/s)	FT	The maximum flow rate (expressed in litres per second) that the Asset was designed for / is capable of.	Design baseline for future performance measurement
Min Designed flow	Litres per second (l/s)	FT	The minimum flow rate (expressed in litres per second) that the Asset was designed for.	Design baseline for future performance measurement
Diameter (internal)	millimetre (mm)	FT	A straight line going through the centre of a pipe connecting two points on the external circumference	Hydraulic performance, future connectivity and evaluation of deterioration
Diameter (external)	millimetre (mm)	FT	A straight line going through the centre of a pipe connecting two points on the internal circumference	Future connectivity, repair sizing and evaluation of deterioration
Diameter (Nominal)	millimetre (mm)	FT	The nominal diameter may not match the internal or external (see definitions for internal and external diameter) diameter but is used a size name identification	Naming convention

Asset Class	Containment Structure	Common /Feature field	Definitions	Attribute usage
			A structure or vessel that that manages media for storage or process balancing such as reservoirs, and process tanks	
Attribute name	Attribute unit			
Construction method	Text - selection list	FT	The construction industry methodology used to construct the asset (generally associated with civil works)	Different installation methods can alter the asset performance over time e.g. groundwater ingress on cast-insitu vs. precast, or directional drilling forces with un-engineered trench vs open cut installation
External coating	Text - selection list	FT	Describes the protective corrosion or structural coating used on the exterior of the Asset.	Impacts on service live and maintenance scheduling
Internal lining	Text - selection list	FT	Describes the protective corrosion or structural coating used on the interior of the Asset.	Impacts on service live and maintenance scheduling
Jointing method	Text - selection list	FT	The mechanical method by which joints have been assembled	Evaluation of failure mode, servicing of mechanical joints and future connectivity
Length	metre (m)	FT	The end-to-end measurement of an asset (expressed in metres to three decimal places).	Geospatial awareness and cost valuation
Width	millimetre (mm)	FT	The extend measurement from side-to-side of an asset (expressed in millimetres).	Geospatial awareness and cost valuation
Height	millimetre (mm)	FT	The extend measurement from base-to-top of an asset (expressed in millimetres).	Geospatial awareness and cost valuation
depth	millimetre (mm)	FT	The extend measurement from top to the bottom (expressed in millimetres) and is used to expressed buried assets.	Geospatial awareness and cost valuation
Volume/capacity	cubic metre (m ³)	FT	The maximum amount of fluid a container can contain	Supply analytics
Invert level (RL)	metre (m)	FT	The base interior level of a pipe, tunnel or civil structure in relation to the ground level	Geospatial awareness, also required for hydraulic modelling

Asset Class	Containment Structure	Common /Feature field	Definitions	Attribute usage
			A structure or vessel that that manages media for storage or process balancing such as reservoirs, and process tanks	
Attribute name	Attribute unit			
Ground level (GL)	metre (m)	FT	The level in relation to the asset (typically buried) in relation to a datum level	Geospatial reference
Area	square metre (m ²)	FT	Surface extent	Geospatial awareness and cost valuation
Lid type	Text - selection list	FT	An access hatch into chambers and manholes	Identify access requirements/limitations for operators and equipment
Lid level (RL)	metre (m)	FT	The level in relation to the ground level	Geospatial awareness. Lids may be sitting proud or deeper than the ground level requiring H&S actions to be taken for maintenance or upgrades
Fall protection	Text - selection list	FT	The mechanism used to prevent personnel from falling into open containment structures or structures at height	Field staff can identify safety gear requirements for fall protection where it is/is not installed as part of the asset (Safety in Design)
Earthquake Quake design lvl	Alpha numeric - selection list	FT	The level of design actions undertaken for design as prescribed by structural design codes	Structural design safety factors for legislative compliance
Design resilience rating	Alpha numeric - selection list	FT	The ability of the designed asset to sustain a level of service and absorb or adapt to changing conditions when there is a failure in the system	Drives organisational response / capability to maintain levels of service
Discharge capacity	cubic metre per second (m ³ /s)	FT	The average rate at which a vessel, container or pipe can be discharged	Required for system management when emptying services to calculate downtime of the asset
Overflow	Text - selection list	FT	The spilling mechanism of a tank or containment type structure	Overflow mechanisms can be simple or complex maintainable components of the asset and is important to manage due to the connection to environmental management requirements
Overflow level	metre (m)	FT	The level at which a tank or containment type structure will start to overflow	Management of compliance with environmental consent conditions

Asset Class	Containment Structure	Common /Feature field	Definitions	Attribute usage
			A structure or vessel that that manages media for storage or process balancing such as reservoirs, and process tanks	
Attribute name	Attribute unit			
Inhibit level	metre (m)	FT	The level at which an imminent overflow is alarmed in order to prevent the overflow from occurring	Management of compliance with environmental consent conditions

4.5 Asset Class: Control systems

Asset Class	Control systems	Common /Feature field	Definitions	Attribute usage
			Asset systems that integrates software and hardware with network connectivity to manage, command, direct or regulate the behaviour of other devices or systems using control loops that are either automated and/or manually directed.	
Attribute name	Attribute unit			
Sub-type	Alpha numeric - selection list	C	Breakdown of some assets types where required to distinguish asset types to a more granular level	
Sub-type feature	Alpha numeric - selection list	FT	A distinguishing feature of a sub-type of asset	To describe a uniqueness or distinguishing feature of an asset sub-type that is important for analytical and functional purposes
Ownership	Text - selection list	C	The entity that that has financial and legislative responsibility of the asset	Future management of assets owned by others
Process	Text - selection list	C	The main media process stream i.e. Water or wastewater	Differentiate media process stream
Operational area	Text - selection list	C	The area where the asset is in operation as managed by the operational business unit	Differentiate operational process areas

Asset Class	Control systems	Common /Feature field	Definitions	Attribute usage
			Asset systems that integrates software and hardware with network connectivity to manage, command, direct or regulate the behaviour of other devices or systems using control loops that are either automated and/or manually directed.	
Attribute name	Attribute unit			
Photo/3D model	PDF, Bitmap, Image, file link	FT	A live colour photo of the installation or asset within its installed location. Alternative to a photo is a 3D drawing	Visual familiarisation and confirmation
Equipment number	Alpha numeric, Watercare design generated number	FT	A unique Watercare generated comprising of the facility, process area code, asset type and its sub-location as a parent asset or child asset within the system that it is installed at.	Unique identification. Reference number used between systems and field identification of assets
Functional area	Alpha numeric	C	The systems and sub-process description of the area where the assets functions and is maintained	To identify the assets' physical location of functionality and where it is maintained in relationship to the plant/process.
Manufacturer/Constructor	Alpha numeric	C	The name of the company/organisation that built/manufactured the Asset.	Quality assurance and traceability. Manufacturer/contractor analysis across assets
Model/Class	Alpha numeric	C	The model id/number (assigned by the manufacturer) for this Asset.	Quality assurance and traceability. Model/class analysis across assets
Serial Nbr	Alpha numeric	FT	The manufacturer's serial number allocated to this Asset.	Quality assurance and traceability
Year of Manufacture / construction	yyyy	FT	The year that the Asset was built/manufactured.	Quality assurance, vendor liability and traceability of equipment changes from manufacturer
Weight	Kilogram (kg)	FT	The weight of the Asset (expressed as a number of kilograms).	Design baseline (SiD), equipment handling for replacement and maintenance. Onsite material handling equipment or need to hire material handling equipment
Supplier/Vendor	Alpha numeric	C	The name of the company/organisation that sold/supplied the Asset.	Quality assurance and vendor liability

Asset Class	Control systems	Common /Feature field	Definitions	Attribute usage
			Asset systems that integrates software and hardware with network connectivity to manage, command, direct or regulate the behaviour of other devices or systems using control loops that are either automated and/or manually directed.	
Attribute name	Attribute unit			
Warranty Start Date	dd-mm-yyyy	C	The effective start date of the warranty period for an Asset.	Quality assurance
Warranty End Date	dd-mm-yyyy	C	The effective end date of the warranty period for the Asset.	Quality assurance
Coordinates (x)	Alpha numeric	FT	Geographic coordinates used to define precise positions on the Earth's surface (where an Asset can be located). Coordinates come from the related GIS spatial representation of the Asset held within the GIS database - which currently is the COMPKEY or Equipment ID. The x coordinate represents a point on an east-west axis (longitude). The y coordinate represents a point on a north-south axis (latitude). The z coordinate indicates height or level above or below sea level (expressed in metres to two decimal places).	Geospatial awareness and area based analytics
Coordinates (y)	Alpha numeric	FT		Geospatial awareness and area based analytics
Coordinates (z)	Alpha numeric	FT		Geospatial awareness and area based analytics
Street Name	Text	FT	Relationship to Address	Geospatial awareness and area based analytics
Suburb	Text	FT	Relationship to Address	Geospatial awareness and area based analytics
District	Text	FT	Relationship to Address	Geospatial awareness and area based analytics
Post Code	Numeric, no decimal	FT	Relationship to Address	Geospatial awareness and area based analytics
Locality	Text - selection list	FT	Records the setting or placement of an Asset within its functional area.	Evaluation of deterioration and impact of the setting on the asset performance

Asset Class	Control systems	Common /Feature field	Definitions	Attribute usage
			Asset systems that integrates software and hardware with network connectivity to manage, command, direct or regulate the behaviour of other devices or systems using control loops that are either automated and/or manually directed.	
Attribute name	Attribute unit			
Confined Space Located	Text - selection list	FT	Indicates if the Asset is located in a confined space.	H&S to show when an asset or classed as a confined space
Hazardous area rating	Alpha numeric	FT	The safety rating/specification of the Asset.	Replacement of like-for like equipment which have been selected at time of design to comply with certain protection criteria for the installed environment, as well as when equipment is rotated or moved to different locations to identify in what areas it may be re-used.
Linked Documents	Alpha numeric	C	Documents, warranties, specifications, plans/drawings ('as-built'), photos and videos relating to a particular Asset.	Traceability
acquisition value	Numeric, two decimals	C	The purchase price of the Asset (in NZ dollars).	Financial, service performance measure and replacement strategy
acquisition date	dd-mm-yyyy	C	The date that the Asset was purchased/acquired (by Watercare).	Required for valuation and warrantee purposes
Project reference	Alpha numeric	C	The project ID, code or C-number of the project that the Asset was acquired/procured for.	Contractual links and business case documentation to capture decision making history
Start up date	dd-mm-yyyy	C	The date that the asset was first placed into operation	Some assets may be installed but have considerable delays before starting operation. Differential deterioration rates apply
asset designed life	Numeric, no decimal	C	The expected/designed lifetime of an Asset (expressed as a number of years).	Financial, service performance measure and replacement strategy

Asset Class	Control systems	Common /Feature field	Definitions	Attribute usage
			Asset systems that integrates software and hardware with network connectivity to manage, command, direct or regulate the behaviour of other devices or systems using control loops that are either automated and/or manually directed.	
Attribute name	Attribute unit			
Service status	Alpha numeric - selection list	C	Asset lifecycle status codes that record the effective dates that an Asset was in a particular state (requires 'service status effective date' attribute as well).	Assets in-service or out of service status is used for analytical purposes on life expectancy as well as Watetrcare's ongoing liability towards assets that are no longer in used but are still installed.
Condition rating	Numeric, no decimal, selection list	C	Asset lifecycle status codes that record the effective dates that an Asset was in a particular state (requires 'service status effective date' attribute as well).	Analytical input to investment to maintain level of service
Criticality rating	Numeric, no decimal	C	An indicator of the criticality or importance (to the business, production, process, safety) of a particular Asset. Denotes the level of impact/consequence that will result from loss/breakdown of the Asset. If impact to Watercare's business, processes or reputation (of loss or breakdown of an Asset) is high/extensive the criticality rating will also be high.	Analytical input to investment to maintain level of service
Condition assessment date	dd-mm-yyyy	C	The date that the assessment was conducted/determined.	Tracking condition assessment
Assessed remaining life	Numeric, no decimal	C	An assessment of the remaining lifetime of an Asset (expressed as a number of years). The value is calculated based on physical evaluation, time in service and condition rating	Financial, service performance measure and replacement strategy

Asset Class	Control systems	Common /Feature field	Definitions	Attribute usage
			Asset systems that integrates software and hardware with network connectivity to manage, command, direct or regulate the behaviour of other devices or systems using control loops that are either automated and/or manually directed.	
Attribute name	Attribute unit			
IP Rating	Alpha numeric - selection list	FT	Water and dust ingress protection rating for industrial equipment, electrical equipment and instruments	Replacement of like-for like equipment which have been selected at time of design to comply with certain protection criteria for the installed environment, as well as when equipment is rotated or moved to different locations to identify in what areas it may be re-used. Performance indicator for ongoing analysis
Comms protocol	Alpha numeric - selection list	FT	Rules determining the format and transmission of data for automation processes	Replacement of like-for like equipment which have been selected at time of design to comply with certain communication protocols, as well as when equipment is rotated or moved to different locations to identify in what areas it may be re-used. Performance indicator for ongoing analysis
Instrument range	Alpha numeric	FT	The span (range) of an instrument's measurement, output or resolution (responsiveness)	Replacement of like-for like equipment which have been selected at time of design to comply with a certain measurement range, as well as when equipment is rotated or moved to different locations to identify in what areas it may be re-used. Performance indicator for ongoing analysis
Input voltage	Volt (v)	FT	The size of the electromotive force expressed in volt to power electrical equipment	To identify electrical power supply requirements of the asset. Power consumption analysis, replacement and equipment rotation

Asset Class	Control systems	Common /Feature field	Definitions	Attribute usage
			Asset systems that integrates software and hardware with network connectivity to manage, command, direct or regulate the behaviour of other devices or systems using control loops that are either automated and/or manually directed.	
Attribute name	Attribute unit			
Input voltage Type (AC/DC)	Text - selection list	FT	Voltage is carried by the flow of current. The current can either be alternating current or direct current. The current type required to drive the equipment	To identify electrical power supply requirements of the asset. Power consumption analysis, replacement and equipment rotation
Output voltage	Volt (v)	FT	The size of the electromotive force expressed in volt that is output by the electrical equipment	To identify electrical power supply requirements of the asset. Power consumption analysis, replacement and equipment rotation
Output voltage Type (AC/DC)	Text - selection list	FT	Voltage is carried by the flow of current. The current can either be alternating current or direct current. The current type that is delivered by the equipment	To identify electrical power supply requirements of the asset. Power consumption analysis, replacement and equipment rotation
Insulation Class	Alpha numeric - selection list	FT	The maximum allowable operating temperature classification of electrical componentry in accordance with IEC standards	Replacement of like-for like equipment which have been selected at time of design to comply with certain protection criteria for the installed environment, as well as when equipment is rotated or moved to different locations to identify in what areas it may be re-used. Performance indicator for ongoing analysis
Energy (Kw) Rating	Kilowatt (kW)	FT	The rate by which the equipment consumes electrical energy under the potential (voltage) and flow (current) to deliver work	To identify electrical power supply requirements of the asset. Power consumption analysis, replacement and equipment rotation
Length	metre (m)	FT	The end-to-end measurement of an asset (expressed in metres to three decimal places).	Geospatial awareness and cost valuation

Asset Class	Control systems	Common /Feature field	Definitions	Attribute usage
			Asset systems that integrates software and hardware with network connectivity to manage, command, direct or regulate the behaviour of other devices or systems using control loops that are either automated and/or manually directed.	
Attribute name	Attribute unit			
Width	millimetre (mm)	FT	The extend measurement from side-to-side of an asset (expressed in millimetres).	Geospatial awareness and cost valuation
Height	millimetre (mm)	FT	The extend measurement from base-to-top of an asset (expressed in millimetres).	Geospatial awareness and cost valuation
depth	millimetre (mm)	FT	The extend measurement from top to the bottom (expressed in millimetres) and is used to expressed buried assets.	Geospatial awareness and cost valuation
Ground level (GL)	metre (m)	FT	The level in relation to the asset (typically buried) in relation to a datum level	Geospatial reference
Antenna base level above ground (IL)	metre (m)	FT	The level of the antenna in relation to the ground level. When mounted on an antenna pole, it is the level where the antenna is mounted on the pole	To assess signal degradation, benchmarking and replacement
Vegetation condition	numeric - selection list		A visual evaluation of the clear path for radio	To assess signal degradation
Quality of radio path condition	numeric - selection list	FT	A visual evaluation of the clear path for radio	To assess signal degradation
Transmit Azimuth	Numeric, Degrees	FT	The magnetic direction from north to which the ratio antenna is pointing	To assess signal degradation, benchmarking and replacement

Asset Class	Control systems	Common /Feature field	Definitions	Attribute usage
			Asset systems that integrates software and hardware with network connectivity to manage, command, direct or regulate the behaviour of other devices or systems using control loops that are either automated and/or manually directed.	
Attribute name	Attribute unit			
Forward Power Measured (dBm) at the Antenna Port	Numeric, Decibels to one milliwatt (dBm)	FT	Signal forwarding strength. The power ratio in decibels (dB) of the measured power referenced to one milliwatt (mW).	It is used in radio, microwave and fibre-optical communication networks as a convenient measure of absolute power. Replacement of like-for like equipment which have been selected at time of design, as well as when equipment is rotated or moved to different locations to identify in what areas it may be re-used. Performance indicator for ongoing analysis
Reverse Power Measured (dBm) at the Antenna Port	Numeric, Decibels to one milliwatt (dBm)	FT	Signal receiving strength. The power ratio in decibels (dB) of the measured power referenced to one milliwatt (mW).	It is used in radio, microwave and fibre-optical communication networks as a convenient measure of absolute power. Replacement of like-for like equipment which have been selected at time of design, as well as when equipment is rotated or moved to different locations to identify in what areas it may be re-used. Performance indicator for ongoing analysis
Forward Power Measured (dBm) at the back of the Radio	Numeric, Decibels to one milliwatt (dBm)	FT	Signal forwarding strength. The power ratio in decibels (dB) of the measured power referenced to one milliwatt (mW).	It is used in radio, microwave and fibre-optical communication networks as a convenient measure of absolute power. Replacement of like-for like equipment which have been selected at time of design, as well as when equipment is rotated or moved to different locations to identify in what areas it may be re-used. Performance indicator for ongoing analysis

Asset Class	Control systems	Common /Feature field	Definitions	Attribute usage
			Asset systems that integrates software and hardware with network connectivity to manage, command, direct or regulate the behaviour of other devices or systems using control loops that are either automated and/or manually directed.	
Attribute name	Attribute unit			
Reverse Power Measured (dBm) at the back of the Radio	Numeric, Decibels to one milliwatt (dBm)	FT	Signal receiving strength. The power ratio in decibels (dB) of the measured power referenced to one milliwatt (mW).	It is used in radio, microwave and fibre-optical communication networks as a convenient measure of absolute power. Replacement of like-for like equipment which have been selected at time of design, as well as when equipment is rotated or moved to different locations to identify in what areas it may be re-used. Performance indicator for ongoing analysis
Configured Radio Transmit Power Left (Watts)	Numeric, Watt	FT		To assess signal degradation
EIRP Calculated Value dBW (Derived from EIRP calculator)	Numeric, Decibels to one watt (dBW)	FT	Calculated effective isotropic radiated power of an antenna in a specific direction	It is used in radio, microwave and fibre-optical communication networks as a convenient measure of absolute power. Replacement of like-for like equipment which have been selected at time of design, as well as when equipment is rotated or moved to different locations to identify in what areas it may be re-used. Performance indicator for ongoing analysis
Watercare Channel	Alpha numeric	FT	Channel number	Identifies the Watercare channel number. Benchmarking
Communicates via Repeater	Alpha numeric	FT	The repeater site name	To identify connectivity of field radios to a repeater site. Benchmarking
RSM Licence Id	Alpha numeric	FT	Identifies the radio spectrum management ID number	Demonstrate compliance with Radio Spectrum Management Regulations

Asset Class	Control systems	Common /Feature field	Definitions	Attribute usage
			Asset systems that integrates software and hardware with network connectivity to manage, command, direct or regulate the behaviour of other devices or systems using control loops that are either automated and/or manually directed.	
Attribute name	Attribute unit			
RSM Licence Number	Alpha numeric	FT	Identifies the radio spectrum management licence number	Demonstrate compliance with Radio Spectrum Management Regulations
RSM License fee	Numeric, two decimals		Identifies the radio spectrum management annual licence cost	To capture licencing costs of RSM per radio
RSM Channel	Alpha numeric	FT	Identifies the radio spectrum management channel number	Demonstrate compliance with Radio Spectrum Management Regulations
RSM EIRP Power dBW	Numeric, Decibels to one watt (dBW)	FT	Actual effective isotropic radiated power of an antenna in a specific direction	To assess signal degradation
RSM Emission	Alpha numeric	FT	Internationally agreed system for classifying radio frequency signals. Each type of radio emission is classified according to its bandwidth, method of modulation, nature of the modulating signal, and type of information transmitted on the carrier signal	Demonstrate compliance with Radio Spectrum Management Regulations
RSM Transmit Location	Alpha numeric	FT	The location where the radio spectrum is transmitted from	Demonstrate compliance with Radio Spectrum Management Regulations
RSM Receive Location	Alpha numeric	FT	The location where the radio spectrum is received at	Demonstrate compliance with Radio Spectrum Management Regulations
RSM Transmit Location NZGD2000 Latitude	Alpha numeric	FT	Geographical location (y)	Demonstrate compliance with Radio Spectrum Management Regulations
RSM Transmit Location NZGD2000 Longitude	Alpha numeric	FT	Geographical location (x)	Demonstrate compliance with Radio Spectrum Management Regulations

Asset Class	Control systems	Common /Feature field	Definitions	Attribute usage
			Asset systems that integrates software and hardware with network connectivity to manage, command, direct or regulate the behaviour of other devices or systems using control loops that are either automated and/or manually directed.	
Attribute name	Attribute unit			
RSM Reference Frequency MHz	Numeric, mega hertz (MHz)	FT	The frequency of electromagnetic waves	Demonstrate compliance with Radio Spectrum Management Regulations
RSM Bandwidth MHz	Numeric, mega hertz (MHz)	FT	The difference between upper and lower frequencies - the range within a ban of wavelengths	Demonstrate compliance with Radio Spectrum Management Regulations
RSM Licence Holder	Text	FT	Name of RSM licence holder	Identifies on responsibility of radio spectrum licence. Demonstrate compliance with Radio Spectrum Management Regulations

4.6 Asset Class: Electrical – Rotating

Asset Class	Electrical Rotating	Common /Feature field	Definitions	Attribute usage
			Electrical equipment that is the motive or drive to mechanical equipment to perform work or rotated by a mechanical machine to produce electricity.	
Attribute name	Attribute unit			
Ownership	Text - selection list	C	The entity that that has financial and legislative responsibility of the asset	Future management of assets owned by others
Process	Text - selection list	C	The main media process stream i.e. Water or wastewater	Differentiate media process stream
Operational area	Text - selection list	C	The area where the asset is in operation as managed by the operational business unit	Differentiate operational process areas

Asset Class	Electrical Rotating	Common /Feature field	Definitions	Attribute usage
			Electrical equipment that is the motive or drive to mechanical equipment to perform work or rotated by a mechanical machine to produce electricity.	
Attribute name	Attribute unit			
Photo/3D model	PDF, Bitmap, Image, file link	C	A live colour photo of the installation or asset within its installed location. Alternative to a photo is a 3D drawing	Visual familiarisation and confirmation
Equipment number	Alpha numeric, Watercare design generated number	C	A unique Watercare generated comprising of the facility, process area code, asset type and its sub-location as a parent asset or child asset within the system that it is installed at.	Unique identification. Reference number used between systems and field identification of assets
Functional area	Alpha numeric	C	The systems and sub-process description of the area where the assets functions and is maintained	To identify the assets' physical location of functionality and where it is maintained in relationship to the plant/process.
Manufacturer/Constructor	Alpha numeric	C	The name of the company/organisation that built/manufactured the Asset.	Quality assurance and traceability. Manufacturer/contractor analysis across assets
Model/Class	Alpha numeric	C	The model id/number (assigned by the manufacturer) for this Asset.	Quality assurance and traceability. Model/class analysis across assets
Serial Nbr	Alpha numeric	C	The manufacturer's serial number allocated to this Asset.	Quality assurance and traceability

Asset Class	Electrical Rotating	Common /Feature field	Definitions	Attribute usage
			Electrical equipment that is the motive or drive to mechanical equipment to perform work or rotated by a mechanical machine to produce electricity.	
Attribute name	Attribute unit			
Year of Manufacture / construction	YYYY	C	The year that the Asset was built/manufactured.	Quality assurance, vendor liability and traceability of equipment changes from manufacturer
Weight	Kilogram (kg)	C	The weight of the Asset (expressed as a number of kilograms).	Design baseline (SiD), equipment handling for replacement and maintenance. Onsite material handling equipment or need to hire material handling equipment
Supplier/Vendor	Alpha numeric	C	The name of the company/organisation that sold/supplied the Asset.	Quality assurance and vendor liability
Warranty Start Date	dd-mm-yyyy	C	The effective start date of the warranty period for an Asset.	Quality assurance
Warranty End Date	dd-mm-yyyy	C	The effective end date of the warranty period for the Asset.	Quality assurance
Coordinates (x)	Alpha numeric	C	Geographic coordinates used to define precise positions on the Earth's surface (where an Asset can be located). Coordinates come from the related GIS	Geospatial awareness and area based analytics

Asset Class	Electrical Rotating	Common /Feature field	Definitions	Attribute usage
			Electrical equipment that is the motive or drive to mechanical equipment to perform work or rotated by a mechanical machine to produce electricity.	
Attribute name	Attribute unit			
Coordinates (y)	Alpha numeric	C	spatial representation of the Asset held within the GIS database - which currently is the COMPKEY or Equipment ID. The x coordinate represents a point on an east-west axis (longitude).	Geospatial awareness and area based analytics
Coordinates (z)	Alpha numeric	C	The y coordinate represents a point on a north-south axis (latitude). The z coordinate indicates height or level above or below sea level (expressed in metres to two decimal places).	
Street Name	Text	C	Relationship to Address	Geospatial awareness and area based analytics
Suburb	Text	C	Relationship to Address	Geospatial awareness and area based analytics
District	Text	C	Relationship to Address	Geospatial awareness and area based analytics
Post Code	Numeric, no decimal	C	Relationship to Address	Geospatial awareness and area based analytics
Locality	Text - selection list	C	Records the setting or placement of an Asset within its functional area.	Evaluation of deterioration and impact of the setting on the asset performance
Confined Space Located	Text - selection list	C	Indicates if the Asset is located in a confined space.	H&S to show when an asset or classed as a confined space

Asset Class	Electrical Rotating	Common /Feature field	Definitions	Attribute usage
			Electrical equipment that is the motive or drive to mechanical equipment to perform work or rotated by a mechanical machine to produce electricity.	
Attribute name	Attribute unit			
Hazardous area rating	Alpha numeric	C	The safety rating/specification of the Asset.	Replacement of like-for like equipment which have been selected at time of design to comply with certain protection criteria for the installed environment, as well as when equipment is rotated or moved to different locations to identify in what areas it may be re-used.
Linked Documents	Alpha numeric	C	Documents, warranties, specifications, plans/drawings ('as-built'), photos and videos relating to a particular Asset.	Traceability
acquisition value	Numeric, two decimals	C	The purchase price of the Asset (in NZ dollars).	Financial, service performance measure and replacement strategy
acquisition date	dd-mm-yyyy	C	The date that the Asset was purchased/acquired (by Watercare).	Required for valuation and warrantee purposes
Project reference	Alpha numeric	FT	The project ID, code or C-number of the project that the Asset was acquired/procured for.	Contractual links and business case documentation to capture decision making history
Start up date	dd-mm-yyyy	C	The date that the asset was first placed into operation	Some assets may be installed but have considerable delays before starting operation. Differential deterioration rates apply
asset designed life	Numeric, no decimal	C	The expected/designed lifetime of an Asset (expressed as a number of years).	Financial, service performance measure and replacement strategy

Asset Class	Electrical Rotating	Common /Feature field	Definitions	Attribute usage
Attribute name	Attribute unit			
Service status	Alpha numeric - selection list	C	Electrical equipment that is the motive or drive to mechanical equipment to perform work or rotated by a mechanical machine to produce electricity.	Assets in-service or out of service status is used for analytical purposes on life expectancy as well as Watercare's ongoing liability towards assets that are no longer in used but are still installed.
Condition rating	Numeric, no decimal, selection list	C	Asset lifecycle status codes that record the effective dates that an Asset was in a particular state (requires 'service status effective date' attribute as well).	Analytical input to investment to maintain level of service
Criticality rating	Numeric, no decimal	C	An indicator of the criticality or importance (to the business, production, process, safety) of a particular Asset. Denotes the level of impact/consequence that will result from loss/breakdown of the Asset. If impact to Watercare's business, processes or reputation (of loss or breakdown of an Asset) is high/extensive the criticality rating will also be high.	Analytical input to investment to maintain level of service
Condition assessment date	dd-mm-yyyy	C	The date that the assessment was conducted/determined.	Tracking condition assessment
Assessed remaining life	Numeric, no decimal	C	An assessment of the remaining lifetime of an Asset (expressed as a number of years). The value is calculated based on physical evaluation, time in service and condition rating	Financial, service performance measure and replacement strategy

Asset Class	Electrical Rotating	Common /Feature field	Definitions	Attribute usage
			Electrical equipment that is the motive or drive to mechanical equipment to perform work or rotated by a mechanical machine to produce electricity.	
Attribute name	Attribute unit			
IP Rating	Alpha numeric - selection list	C	Water and dust ingress protection rating for industrial equipment, electrical equipment and instruments	Replacement of like-for like equipment which have been selected at time of design to comply with certain protection criteria for the installed environment, as well as when equipment is rotated or moved to different locations to identify in what areas it may be re-used. Performance indicator for ongoing analysis
Installation Mounting (Wet/Dry)	Text - selection list	C	An extension to the Locality field to the installation setting of certain equipment types	Specific identification of equipment and instruments in wet or dry conditions for performance monitoring
Installation Orientation	Text - selection list	FT	An extension to the Locality field to the installation setting of certain equipment types to identify how it has been specially orientated in the installed environments	Relates to bearing type applications on some equipment that places limitations/enabling an asset to operate under certain load conditions imposed by the installation orientation. Required for replacement, performance analysis and equipment rotation.
Design Speed (rpm)	revolutions per minute (rpm)	C	The maximum speed (expressed in revolutions per minute) that the Asset was designed for / is capable of.	Replacement of like-for like equipment which have been selected at time of design to comply with certain protection criteria for the installed environment, as well as when equipment is rotated or moved to different locations to identify in what areas it may be re-used. Performance indicator for ongoing analysis

Asset Class	Electrical Rotating	Common /Feature field	Definitions	Attribute usage
			Electrical equipment that is the motive or drive to mechanical equipment to perform work or rotated by a mechanical machine to produce electricity.	
Attribute name	Attribute unit			
Bearing Type	Text - selection list	FT	Describes the type of bearing used/associated to the Asset. [A bearing is a device to enable rotational or linear movement, while reducing friction and handling stress. Resembling wheels, bearings literally enable devices to roll, which reduces the friction between the surface of the bearing and the surface it's rolling over.]	The type of bearing selection places limitations/enabling an asset to operate under certain load conditions and installation orientation. Required for replacement, performance analysis and equipment rotation.
Input voltage	Volt (v)	FT	The size of the electromotive force expressed in volt to power electrical equipment	To identify electrical power supply requirements of the asset. Power consumption analysis, replacement and equipment rotation
Input voltage Type (AC/DC)	Text - selection list	FT	Voltage is carried by the flow of current. The current can either be alternating current or direct current. The current type required to drive the equipment	To identify electrical power supply requirements of the asset. Power consumption analysis, replacement and equipment rotation
Nbr of Phases	Numeric, no decimal, selection list	FT	The number of electrical supply phases	To distinguish between single phase and three phase equipment. Power consumption analysis, replacement and equipment rotation
Output voltage	Volt (v)	FT	The size of the electromotive force expressed in volt that is output by the electrical equipment	To identify electrical power supply requirements of the asset. Power consumption analysis, replacement and equipment rotation
Output voltage Type (AC/DC)	Text - selection list	FT	Voltage is carried by the flow of current. The current can either be alternating current or direct current. The current type that is delivered by the equipment	To identify electrical power supply requirements of the asset. Power consumption analysis, replacement and equipment rotation

Asset Class	Electrical Rotating	Common /Feature field	Definitions	Attribute usage
			Electrical equipment that is the motive or drive to mechanical equipment to perform work or rotated by a mechanical machine to produce electricity.	
Attribute name	Attribute unit			
Insulation Class	Alpha numeric - selection list	C	The maximum allowable operating temperature classification of electrical componentry in accordance with IEC standards	Replacement of like-for like equipment which have been selected at time of design to comply with certain protection criteria for the installed environment, as well as when equipment is rotated or moved to different locations to identify in what areas it may be re-used. Performance indicator for ongoing analysis
Energy (Kw) Rating	Kilowatt (kW)	C	The rate by which the equipment consumes electrical energy under the potential (voltage) and flow (current) to deliver work	To identify electrical power supply requirements of the asset. Power consumption analysis, replacement and equipment rotation
Frame Size	Alpha numeric	FT	The international standardised dimension of the base frame for the equipment	Certain types of assets are standardised by frame size to allow replacement and rotation without the need to adjust mounting dimensions and connection height e.g. a motor base connecting mounted to the plinth (width and length) and having a standard height to connect the drive shaft.
Output current (A)	Amps (A)	C	The size of the flow of current to deliver voltage	To identify electrical power supply requirements of the asset. Power consumption analysis, replacement and equipment rotation
Cooling System Fitted	Text - selection list	FT	Integral cooling system fitting to some mechanical equipment to cooling bearings or drive trains	To identify integrated systems to equipment that affects performance and maintenance. Equipment performance analysis

Asset Class	Electrical Rotating	Common /Feature field	Definitions	Attribute usage
Attribute name	Attribute unit			
Torque (output rating)	Newton metre (Nm)	FT	Electrical equipment that is the motive or drive to mechanical equipment to perform work or rotated by a mechanical machine to produce electricity. Maximum output force to allow rotation to occur	Replacement of like-for like equipment which have been selected at time of design to comply with certain protection criteria for the installed environment, as well as when equipment is rotated or moved to different locations to identify in what areas it may be re-used. Performance indicator for ongoing analysis
Length	metre (m)	FT	The end-to-end measurement of an asset (expressed in metres to three decimal places). The length of motors is measured along the length of the shaft.	Geospatial awareness and cost valuation
Width	millimetre (mm)	FT	The extend measurement from side-to-side of an asset (expressed in millimetres). The width of motors is measured across the shaft.	Geospatial awareness and cost valuation
Height	millimetre (mm)	FT	The extend measurement from base-to-top of an asset (expressed in millimetres) in its installed orientation.	Geospatial awareness and cost valuation

4.7 Asset Core Class: Electrical - Static

Asset Class	Electrical (static)	Common /Feature field	Definitions	Attribute usage
			Equipment used in the distribution, protection and management of AC and DC electricity supply.	
Attribute name	Attribute unit			
Sub-type	Alpha numeric - selection list	FT	Breakdown of some assets types where required to distinguish asset types to a more granular level	
Sub-type feature	Alpha numeric - selection list	FT	A distinguishing feature of a sub-type of asset	To describe a uniqueness or distinguishing feature of an asset sub-type that is important for analytical and functional purposes
Ownership	Text - selection list	C	The entity that that has financial and legislative responsibility of the asset	Future management of assets owned by others
Process	Text - selection list	C	The main media process stream i.e. Water or wastewater	Differentiate media process stream
Operational area	Text - selection list	C	The area where the asset is in operation as managed by the operational business unit	Differentiate operational process areas
Photo/3D model	PDF, Bitmap, Image, file link	C	A live colour photo of the installation or asset within its installed location. Alternative to a photo is a 3D drawing	Visual familiarisation and confirmation
Equipment number	Alpha numeric, Watercare design generated number	C	A unique Watercare generated comprising of the facility, process area code, asset type and its sub-location as a parent asset or child asset within the system that it is installed at.	Unique identification. Reference number used between systems and field identification of assets
Functional area	Alpha numeric	C	The systems and sub-process description of the area where the assets functions and is maintained	To identify the assets' physical location of functionality and where it is maintained in relationship to the plant/process.
Manufacturer/Constructor	Alpha numeric	C	The name of the company/organisation that built/manufactured the Asset.	Quality assurance and traceability. Manufacturer/contractor analysis across assets

Asset Class	Electrical (static)	Common /Feature field	Definitions	Attribute usage
			Equipment used in the distribution, protection and management of AC and DC electricity supply.	
Attribute name	Attribute unit			
Model/Class	Alpha numeric	C	The model id/number (assigned by the manufacturer) for this Asset.	Quality assurance and traceability. Model/class analysis across assets
Serial Nbr	Alpha numeric	C	The manufacturer's serial number allocated to this Asset.	Quality assurance and traceability
Year of Manufacture / construction	YYYY	C	The year that the Asset was built/manufactured.	Quality assurance, vendor liability and traceability of equipment changes from manufacturer
Weight	Kilogram (kg)	FT	The weight of the Asset (expressed as a number of kilograms).	Design baseline (SiD), equipment handling for replacement and maintenance. Onsite material handling equipment or need to hire material handling equipment
Supplier/Vendor	Alpha numeric	C	The name of the company/organisation that sold/supplied the Asset.	Quality assurance and vendor liability
Warranty Start Date	dd-mm-yyyy	C	The effective start date of the warranty period for an Asset.	Quality assurance
Warranty End Date	dd-mm-yyyy	C	The effective end date of the warranty period for the Asset.	Quality assurance
Coordinates (x)	Alpha numeric	C	Geographic coordinates used to define precise positions on the Earth's surface (where an Asset can be located). Coordinates come from the related GIS spatial representation of the Asset held within the GIS database - which currently is the COMPKEY or Equipment ID. The x coordinate represents a point on an east-west axis (longitude). The y coordinate represents a point on a north-south axis (latitude). The z coordinate indicates height or level	Geospatial awareness and area based analytics
Coordinates (y)	Alpha numeric	C		Geospatial awareness and area based analytics
Coordinates (z)	Alpha numeric	C		Geospatial awareness and area based analytics

Asset Class	Electrical (static)	Common /Feature field	Definitions	Attribute usage
			Equipment used in the distribution, protection and management of AC and DC electricity supply.	
Attribute name	Attribute unit			
			above or below sea level (expressed in metres to two decimal places).	
Street Name	Text	C	Relationship to Address	Geospatial awareness and area based analytics
Suburb	Text	C	Relationship to Address	Geospatial awareness and area based analytics
District	Text	C	Relationship to Address	Geospatial awareness and area based analytics
Post Code	Numeric, no decimal	C	Relationship to Address	Geospatial awareness and area based analytics
Locality	Text - selection list	C	Records the setting or placement of an Asset within its functional area.	Evaluation of deterioration and impact of the setting on the asset performance
Confined Space Located	Text - selection list	C	Indicates if the Asset is located in a confined space.	H&S to show when an asset or classed as a confined space
Hazardous area rating	Alpha numeric	C	The safety rating/specification of the Asset.	Replacement of like-for like equipment which have been selected at time of design to comply with certain protection criteria for the installed environment, as well as when equipment is rotated or moved to different locations to identify in what areas it may be re-used.
Linked Documents	Alpha numeric	FT	Documents, warranties, specifications, plans/drawings ('as-built'), photos and videos relating to a particular Asset.	Traceability
acquisition value	Numeric, two decimals	C	The purchase price of the Asset (in NZ dollars).	Financial, service performance measure and replacement strategy
acquisition date	dd-mm-yyyy	C	The date that the Asset was purchased/acquired (by Watercare).	Required for valuation and warrantee purposes

Asset Class	Electrical (static)	Common /Feature field	Definitions	Attribute usage
			Equipment used in the distribution, protection and management of AC and DC electricity supply.	
Attribute name	Attribute unit			
Project reference	Alpha numeric	FT	The project ID, code or C-number of the project that the Asset was acquired/procured for.	Contractual links and business case documentation to capture decision making history
Start up date	dd-mm-yyyy	C	The date that the asset was first placed into operation	Some assets may be installed but have considerable delays before starting operation. Differential deterioration rates apply
asset designed life	Numeric, no decimal	C	The expected/designed lifetime of an Asset (expressed as a number of years).	Financial, service performance measure and replacement strategy
Service status	Alpha numeric - selection list	C	Asset lifecycle status codes that record the effective dates that an Asset was in a particular state (requires 'service status effective date' attribute as well).	Assets in-service or out of service status is used for analytical purposes on life expectancy as well as Watercare's ongoing liability towards assets that are no longer in used but are still installed.
Condition rating	Numeric, no decimal, selection list	FT	Asset lifecycle status codes that record the effective dates that an Asset was in a particular state (requires 'service status effective date' attribute as well).	Analytical input to investment to maintain level of service
Criticality rating	Numeric, no decimal	C	<p>An indicator of the criticality or importance (to the business, production, process, safety) of a particular Asset.</p> <p>Denotes the level of impact/consequence that will result from loss/breakdown of the Asset.</p> <p>If impact to Watercare's business, processes or reputation (of loss or breakdown of an Asset) is high/extensive the criticality rating will also be high.</p>	Analytical input to investment to maintain level of service
Condition assessment date	dd-mm-yyyy	FT	The date that the assessment was conducted/determined.	Tracking condition assessment

Asset Class	Electrical (static)	Common /Feature field	Definitions	Attribute usage
			Equipment used in the distribution, protection and management of AC and DC electricity supply.	
Attribute name	Attribute unit			
Assessed remaining life	Numeric, no decimal	FT	An assessment of the remaining lifetime of an Asset (expressed as a number of years). The value is calculated based on physical evaluation, time in service and condition rating	Financial, service performance measure and replacement strategy
Calibration authority	Text	FT	The certified/registered 3rd party that completes calibration work	To identify 3rd party quality assurance and liability
Calibration number	Alpha numeric	FT	The reference number of the certification issued with the calibration	To identify 3rd party quality assurance and liability
Calibration expiry date	dd-mm-yyyy	FT	The date by which calibration must be renewed	To identify when calibration needs to be updated
IP Rating	Alpha numeric - selection list	FT	Water and dust ingress protection rating for industrial equipment, electrical equipment and instruments	Replacement of like-for like equipment which have been selected at time of design to comply with certain protection criteria for the installed environment, as well as when equipment is rotated or moved to different locations to identify in what areas it may be re-used. Performance indicator for ongoing analysis
Installation Mounting (Wet/Dry)	Text - selection list	FT	An extension to the Locality field to the installation setting of certain equipment types	Specific identification of equipment and instruments in wet or dry conditions for performance monitoring
Comms protocol	Alpha numeric - selection list	FT	Rules determining the format and transmission of data for automation processes	Replacement of like-for like equipment which have been selected at time of design to comply with certain communication protocols, as well as when equipment is rotated or moved to different locations to identify in what areas it may be re-used. Performance indicator for ongoing analysis

Asset Class	Electrical (static)	Common /Feature field	Definitions	Attribute usage
			Equipment used in the distribution, protection and management of AC and DC electricity supply.	
Attribute name	Attribute unit			
Input voltage	Volt (v)	FT	The size of the electromotive force expressed in volt to power electrical equipment	To identify electrical power supply requirements of the asset. Power consumption analysis, replacement and equipment rotation
Input voltage Type (AC/DC)	Text - selection list	FT	Voltage is carried by the flow of current. The current can either be alternating current or direct current. The current type required to drive the equipment	To identify electrical power supply requirements of the asset. Power consumption analysis, replacement and equipment rotation
Nbr of Phases	Numeric, no decimal, selection list	FT	The number of electrical supply phases	To distinguish between single phase and three phase equipment. Power consumption analysis, replacement and equipment rotation
Output voltage	Volt (v)	FT	The size of the electromotive force expressed in volt that is output by the electrical equipment	To identify electrical power supply requirements of the asset. Power consumption analysis, replacement and equipment rotation
Output voltage Type (AC/DC)	Text - selection list	FT	Voltage is carried by the flow of current. The current can either be alternating current or direct current. The current type that is delivered by the equipment	To identify electrical power supply requirements of the asset. Power consumption analysis, replacement and equipment rotation
Insulation Class	Alpha numeric - selection list	FT	The maximum allowable operating temperature classification of electrical componentry in accordance with IEC standards	Replacement of like-for like equipment which have been selected at time of design to comply with certain protection criteria for the installed environment, as well as when equipment is rotated or moved to different locations to identify in what areas it may be re-used. Performance indicator for ongoing analysis
Energy (Kw) Rating	Kilowatt (kW)	FT	The rate by which the equipment consumes electrical energy under the potential (voltage) and flow (current) to deliver work	To identify electrical power supply requirements of the asset. Power consumption analysis, replacement and equipment rotation

Asset Class	Electrical (static)	Common /Feature field	Definitions	Attribute usage
			Equipment used in the distribution, protection and management of AC and DC electricity supply.	
Attribute name	Attribute unit			
Output current (A)	Amps (A)	FT	The size of the flow of current to deliver voltage	To identify electrical power supply requirements of the asset. Power consumption analysis, replacement and equipment rotation
Cooling System Fitted	Text - selection list	FT	Integral cooling system fitting to some mechanical equipment to cooling bearings or drive trains	To identify integrated systems to equipment that affects performance and maintenance. Equipment performance analysis
External coating	Text - selection list	FT	Describes the protective corrosion or structural coating used on the exterior of the Asset.	Impacts on service life and maintenance scheduling
Length	metre (m)	FT	The end-to-end measurement of an asset (expressed in metres to three decimal places). The length of motors is measured along the length of the shaft.	Geospatial awareness and cost valuation
Width	millimetre (mm)	FT	The extend measurement from side-to-side of an asset (expressed in millimetres). The width of motors is measured across the shaft.	Geospatial awareness and cost valuation
Height	millimetre (mm)	FT	The extend measurement from base-to-top of an asset (expressed in millimetres) in its installed orientation.	Geospatial awareness and cost valuation
depth	millimetre (mm)	FT	The extend measurement from top to the bottom (expressed in millimetres) and is used to expressed buried assets.	Geospatial awareness and cost valuation

4.8 Asset Class: Instruments

Asset Class	Instruments	Common /Feature field	Definitions	Attribute usage
			A device used directly or indirectly to measure and/or control a variable. The term does not apply to parts (e.g., a receiver bellows or a resistor) that are internal components of an instrument.	
Attribute name	Attribute unit			
Sub-type	Alpha numeric - selection list	FT	Breakdown of some assets types where required to distinguish asset types to a more granular level	
Sub-type feature	Alpha numeric - selection list	FT	A distinguishing feature of a sub-type of asset	To describe a uniqueness or distinguishing feature of an asset sub-type that is important for analytical and functional purposes
Ownership	Text - selection list	C	The entity that that has financial and legislative responsibility of the asset	Future management of assets owned by others
Process	Text - selection list	C	The main media process stream i.e. Water or wastewater	Differentiate media process stream
Operational area	Text - selection list	C	The area where the asset is in operation as managed by the operational business unit	Differentiate operational process areas
Photo/3D model	PDF, Bitmap, Image, file link	C	A live colour photo of the installation or asset within its installed location. Alternative to a photo is a 3D drawing	Visual familiarisation and confirmation
Equipment number	Alpha numeric, Watercare design generated number	C	A unique Watercare generated comprising of the facility, process area code, asset type and its sub-location as a parent asset or child asset within the system that it is installed at.	Unique identification. Reference number used between systems and field identification of assets
Functional area	Alpha numeric	C	The systems and sub-process description of the area where the assets functions and is maintained	To identify the assets' physical location of functionality and where it is maintained in relationship to the plant/process.

Asset Class	Instruments	Common /Feature field	Definitions	Attribute usage
			A device used directly or indirectly to measure and/or control a variable. The term does not apply to parts (e.g., a receiver bellows or a resistor) that are internal components of an instrument.	
Attribute name	Attribute unit			
Manufacturer/Constructor	Alpha numeric	C	The name of the company/organisation that built/manufactured the Asset.	Quality assurance and traceability. Manufacturer/contractor analysis across assets
Model/Class	Alpha numeric	C	The model id/number (assigned by the manufacturer) for this Asset.	Quality assurance and traceability. Model/class analysis across assets
Serial Nbr	Alpha numeric	C	The manufacturer's serial number allocated to this Asset.	Quality assurance and traceability
Year of Manufacture / construction	YYYY	C	The year that the Asset was built/manufactured.	Quality assurance, vendor liability and traceability of equipment changes from manufacturer
Weight	Kilogram (kg)	FT	The weight of the Asset (expressed as a number of kilograms).	Design baseline (SiD), equipment handling for replacement and maintenance. Onsite material handling equipment or need to hire material handling equipment
Supplier/Vendor	Alpha numeric	C	The name of the company/organisation that sold/supplied the Asset.	Quality assurance and vendor liability
Warranty Start Date	dd-mm-yyyy	C	The effective start date of the warranty period for an Asset.	Quality assurance
Warranty End Date	dd-mm-yyyy	C	The effective end date of the warranty period for the Asset.	Quality assurance
Coordinates (x)	Alpha numeric	C	Geographic coordinates used to define precise positions on the Earth's surface (where an Asset can be located). Coordinates come from the related GIS spatial representation of the Asset held	Geospatial awareness and area based analytics

Asset Class	Instruments	Common /Feature field	Definitions	Attribute usage
			A device used directly or indirectly to measure and/or control a variable. The term does not apply to parts (e.g., a receiver bellows or a resistor) that are internal components of an instrument.	
Attribute name	Attribute unit			
Coordinates (y)	Alpha numeric	C	within the GIS database - which currently is the COMPKEY or Equipment ID. The x coordinate represents a point on an east-west axis (longitude). The y coordinate represents a point on a north-south axis (latitude). The z coordinate indicates height or level above or below sea level (expressed in metres to two decimal places).	Geospatial awareness and area based analytics
Coordinates (z)	Alpha numeric	C		Geospatial awareness and area based analytics
Street Name	Text	C	Relationship to Address	Geospatial awareness and area based analytics
Suburb	Text	C	Relationship to Address	Geospatial awareness and area based analytics
District	Text	C	Relationship to Address	Geospatial awareness and area based analytics
Post Code	Numeric, no decimal	C	Relationship to Address	Geospatial awareness and area based analytics
Locality	Text - selection list	FT	Records the setting or placement of an Asset within its functional area.	Evaluation of deterioration and impact of the setting on the asset performance
Confined Space Located	Text - selection list	FT	Indicates if the Asset is located in a confined space.	H&S to show when an asset or classed as a confined space
Hazardous area rating	Alpha numeric - selection list	FT	The safety rating/specification of the Asset.	Replacement of like-for like equipment which have been selected at time of design to comply with certain protection criteria for the installed environment, as well as when equipment is rotated or moved to different locations to identify in what areas it may be re-used.

Asset Class	Instruments	Common /Feature field	Definitions	Attribute usage
			A device used directly or indirectly to measure and/or control a variable. The term does not apply to parts (e.g., a receiver bellows or a resistor) that are internal components of an instrument.	
Attribute name	Attribute unit			
Linked Documents	Alpha numeric	FT	Documents, warranties, specifications, plans/drawings ('as-built'), photos and videos relating to a particular Asset.	Traceability
acquisition value	Numeric, two decimals	C	The purchase price of the Asset (in NZ dollars).	Financial, service performance measure and replacement strategy
acquisition date	dd-mm-yyyy	C	The date that the Asset was purchased/acquired (by Watercare).	Required for valuation and warrantee purposes
Project reference	Alpha numeric	FT	The project ID, code or C-number of the project that the Asset was acquired/procured for.	Contractual links and business case documentation to capture decision making history
Start up date	dd-mm-yyyy	C	The date that the asset was first placed into operation	Some assets may be installed but have considerable delays before starting operation. Differential deterioration rates apply
asset designed life	Numeric, no decimal	C	The expected/designed lifetime of an Asset (expressed as a number of years).	Financial, service performance measure and replacement strategy
Service status	Alpha numeric - selection list	C	Asset lifecycle status codes that record the effective dates that an Asset was in a particular state (requires 'service status effective date' attribute as well).	Assets in-service or out of service status is used for analytical purposes on life expectancy as well as Watercare's ongoing liability towards assets that are no longer in used but are still installed.
Condition rating	Numeric, no decimal, selection list	C	Asset lifecycle status codes that record the effective dates that an Asset was in a particular state (requires 'service status effective date' attribute as well).	Analytical input to investment to maintain level of service

Asset Class	Instruments	Common /Feature field	Definitions	Attribute usage
			A device used directly or indirectly to measure and/or control a variable. The term does not apply to parts (e.g., a receiver bellows or a resistor) that are internal components of an instrument.	
Attribute name	Attribute unit			
Criticality rating	Numeric, no decimal	C	<p>An indicator of the criticality or importance (to the business, production, process, safety ...) of a particular Asset.</p> <p>Denotes the level of impact/consequence that will result from loss/breakdown of the Asset.</p> <p>If impact to Watercare's business, processes or reputation (of loss or breakdown of an Asset) is high/extensive the criticality rating will also be high.</p>	Analytical input to investment to maintain level of service
Condition assessment date	dd-mm-yyyy	C	The date that the assessment was conducted/determined.	Tracking condition assessment
Assessed remaining life	Numeric, no decimal	C	<p>An assessment of the remaining lifetime of an Asset (expressed as a number of years). The value is calculated based on physical evaluation, time in service and condition rating</p>	Financial, service performance measure and replacement strategy
Measured output	Alpha numeric - selection list	FT	Identify products being measured	To differentiate the type of equipment to its intended function. Some instruments and equipment may measure or perform a function other than its type definition affecting equipment analysis, maintenance and replacement considerations
Media Type Wtr/WWtr/chem/gas	Text - selection list	FT	Describes the substance that is contained in, processed by or transported by an Asset.	Evaluation of deterioration and impact of media on the asset performance
Material type (majority component)	Text - selection list	FT	Describes the (defining) material used to construct the external casing / majority component of the Asset.	Evaluation of deterioration

Asset Class	Instruments	Common /Feature field	Definitions	Attribute usage
			A device used directly or indirectly to measure and/or control a variable. The term does not apply to parts (e.g., a receiver bellows or a resistor) that are internal components of an instrument.	
Attribute name	Attribute unit			
Calibration authority	Text	FT	The name of the company/organisation that calibrated the Asset. Calibrate = to correlate the readings of an instrument with those of a standard in order to check the instrument's accuracy.	for audit purposes
Calibration number	Alpha numeric	FT	The calibration reference number of the calibration test / work order.	for audit purposes
Calibration expiry date	dd-mm-yyyy	FT	The date that the calibration is valid until.	for audit purposes
IP Rating	Alpha numeric - selection list	FT	Water and dust ingress protection rating for industrial equipment, electrical equipment and instruments	Replacement of like-for like equipment which have been selected at time of design to comply with certain protection criteria for the installed environment, as well as when equipment is rotated or moved to different locations to identify in what areas it may be re-used. Performance indicator for ongoing analysis
Installation Mounting (Wet/Dry)	Text - selection list	FT	An extension to the Locality field to the installation setting of certain equipment types	Specific identification of equipment and instruments in wet or dry conditions for performance monitoring
Comms protocol	Alpha numeric - selection list	FT	Rules determining the format and transmission of data for automation processes	Replacement of like-for like equipment which have been selected at time of design to comply with certain communication protocols, as well as when equipment is rotated or moved to different locations to identify in what areas it may be re-used. Performance indicator for ongoing analysis

Asset Class	Instruments	Common /Feature field	Definitions	Attribute usage
			A device used directly or indirectly to measure and/or control a variable. The term does not apply to parts (e.g., a receiver bellows or a resistor) that are internal components of an instrument.	
Attribute name	Attribute unit			
Instrument range	Alpha numeric	FT	Records the levels or range that an instrument is designed/rated to measure.	Replacement of like-for like equipment which have been selected at time of design to comply with certain protection criteria for the installed environment, as well as when equipment is rotated or moved to different locations to identify in what areas it may be re-used. Performance indicator for ongoing analysis
Operating range	Alpha numeric	FT	The commissioned range setting of the instrument (within the range of the instrument)	To refine output accuracy within the operating window of the instrument. Replacement of like-for-like.
Pressure Rating (kPa) static	kilo-pascal (kPa)	FT	The maximum pressure (expressed in kilopascals) that an Asset is designed to operate at (i.e. a pump) or withstand (i.e. pipes).	Replacement of like-for like equipment which have been selected at time of design to comply with certain protection criteria for the installed environment, as well as when equipment is rotated or moved to different locations to identify in what areas it may be re-used. Performance indicator for ongoing analysis
Max Designed Flow	numeric unit Litres per second (l/s)	FT	The maximum flow rate (expressed in litres per second) that the Asset was designed for / is capable of.	Replacement of like-for like equipment which have been selected at time of design to comply with certain protection criteria for the installed environment, as well as when equipment is rotated or moved to different locations to identify in what areas it may be re-used. Performance indicator for ongoing analysis

Asset Class	Instruments	Common /Feature field	Definitions	Attribute usage
			A device used directly or indirectly to measure and/or control a variable. The term does not apply to parts (e.g., a receiver bellows or a resistor) that are internal components of an instrument.	
Attribute name	Attribute unit			
Min Designed Flow	numeric unit Litres per second (l/s)	FT	The minimum flow rate (expressed in litres per second) that the Asset was designed for.	Replacement of like-for like equipment which have been selected at time of design to comply with certain protection criteria for the installed environment, as well as when equipment is rotated or moved to different locations to identify in what areas it may be re-used. Performance indicator for ongoing analysis
Diameter (Nominal)	millimetre (mm)	FT	The nominal diameter may not match the internal or external (see definitions for internal and external diameter) diameter but is used a size name identification	Replacement of like-for like equipment which have been selected at time of design to comply with certain protection criteria for the installed environment, as well as when equipment is rotated or moved to different locations to identify in what areas it may be re-used. Performance indicator for ongoing analysis
Input voltage	Volt (v)	FT	The size of the electromotive force expressed in volt to power electrical equipment	To identify electrical power supply requirements of the asset. Power consumption analysis, replacement and equipment rotation
Input voltage Type (AC/DC)	Text - selection list	FT	Voltage is carried by the flow of current. The current can either be alternating current or direct current. The current type required to drive the equipment	To identify electrical power supply requirements of the asset. Power consumption analysis, replacement and equipment rotation
Output voltage	Volt (v)	FT	The size of the electromotive force expressed in volt that is output by the electrical equipment	To identify electrical power supply requirements of the asset. Power consumption analysis, replacement and equipment rotation

Asset Class	Instruments	Common /Feature field	Definitions	Attribute usage
			A device used directly or indirectly to measure and/or control a variable. The term does not apply to parts (e.g., a receiver bellows or a resistor) that are internal components of an instrument.	
Attribute name	Attribute unit			
Insulation Class	Alpha numeric - selection list	FT	The maximum allowable operating temperature classification of electrical componentry in accordance with IEC standards	Replacement of like-for like equipment which have been selected at time of design to comply with certain protection criteria for the installed environment, as well as when equipment is rotated or moved to different locations to identify in what areas it may be re-used. Performance indicator for ongoing analysis
External coating	Text - selection list	FT	Describes the protective corrosion or structural coating used on the exterior of the Asset.	Impacts on service life and maintenance scheduling
Internal lining	Text - selection list	FT	Describes the protective corrosion or structural coating used on the interior of the Asset.	Impacts on service life and maintenance scheduling
Jointing method	Text - selection list	FT	Describes the mechanical jointing method of the instrument to the parent system.	Replacement of like-for like equipment/maintenance planning
Length	metre (m)	FT	The end-to-end measurement of an asset (expressed in metres to three decimal places).	Geospatial awareness and cost valuation
Width	millimetre (mm)	FT	The extend measurement from side-to-side of an asset (expressed in millimetres).	Geospatial awareness and cost valuation
Height	millimetre (mm)	FT	The extend measurement from base-to-top of an asset (expressed in millimetres).	Geospatial awareness and cost valuation
depth	millimetre (mm)	FT	The extend measurement from top to the bottom (expressed in millimetres) and is used to expressed buried assets.	Geospatial awareness and cost valuation

Asset Class	Instruments	Common /Feature field	Definitions	Attribute usage
			A device used directly or indirectly to measure and/or control a variable. The term does not apply to parts (e.g., a receiver bellows or a resistor) that are internal components of an instrument.	
Attribute name	Attribute unit			
Ground level (GL)	metre (m)	FT	The level in relation to the asset (typically buried) in relation to a datum level	Geospatial reference
Mast base level above ground (IL)	metre (m)	FT	The level of the mast in relation to the ground level.	To assess signal degradation, benchmarking and replacement

4.9 Asset Class: Land

Asset Class	Land	Common /Feature field	Definitions	Attribute usage
			Earth surface not permanently covered by water vested or procured to secure access rights to water supply and treatment of large infrastructure	
Attribute name	Attribute unit			
Ownership	Text - selection list	C	The entity that that has financial and legislative responsibility of the asset	Future management of assets owned by others
Process	Text - selection list	C	The main media process stream i.e. Water or wastewater	Differentiate media process stream
Operational area	Text - selection list	C	The area where the asset is in operation as managed by the operational business unit	Differentiate operational process areas
Photo/3D model	PDF, Bitmap, Image, file link	C	A live colour photo of the installation or asset within its installed location. Alternative to a photo is a 3D drawing	Visual familiarisation and confirmation

Asset Class	Land	Common /Feature field	Definitions	Attribute usage
			Earth surface not permanently covered by water vested or procured to secure access rights to water supply and treatment of large infrastructure	
Attribute name	Attribute unit			
Equipment number	Alpha numeric, Watercare design generated number	C	A unique Watercare generated comprising of the facility, process area code, asset type and its sub-location as a parent asset or child asset within the system that it is installed at.	Unique identification. Reference number used between systems and field identification of assets
Coordinates (x)	Alpha numeric	C	Geographic coordinates used to define precise positions on the Earth's surface (where an Asset can be located). Coordinates come from the related GIS spatial representation of the Asset held within the GIS database - which currently is the COMPKEY or Equipment ID.	Geospatial awareness and area based analytics
Coordinates (y)	Alpha numeric	C	The x coordinate represents a point on an east-west axis (longitude). The y coordinate represents a point on a north-south axis (latitude).	
Coordinates (z)	Alpha numeric	C	The z coordinate indicates height or level above or below sea level (expressed in metres to two decimal places).	
Street Name	Text	C	Relationship to Address	Geospatial awareness and area based analytics
Suburb	Text	C	Relationship to Address	Geospatial awareness and area based analytics
District	Text	C	Relationship to Address	Geospatial awareness and area based analytics
Post Code	Numeric, no decimal	C	Relationship to Address	Geospatial awareness and area based analytics
acquisition value	Numeric, two decimals	C	The purchase price of the Asset (in NZ dollars).	Financial, service performance measure and replacement strategy
acquisition date	dd-mm-yyyy	C	The date that the Asset was purchased/acquired (by Watercare).	Required for valuation and warrantee purposes

Asset Class	Land	Common /Feature field	Definitions	Attribute usage
Attribute name	Attribute unit		Earth surface not permanently covered by water vested or procured to secure access rights to water supply and treatment of large infrastructure	
Area	square metre (m ²)	C	Surface extent	Geospatial awareness and cost valuation

4.10 Asset Class: Mechanical – Rotating

Asset Class	Mechanical Rotating	Common /Feature field	Definitions	Attribute usage
			Mechanical equipment that with the addition of kinetic energy can move other equipment, move material from one point to another, or to agitate media	
Attribute name	Attribute unit			
Sub-type	Alpha numeric - selection list	C	Breakdown of some assets types where required to distinguish asset types to a more granular level	
Sub-type feature	Alpha numeric - selection list	C	A distinguishing feature of a sub-type of asset	To describe a uniqueness or distinguishing feature of an asset sub-type that is important for analytical and functional purposes
Ownership	Text - selection list	C	The entity that that has financial and legislative responsibility of the asset	Future management of assets owned by others
Process	Text - selection list	C	The main media process stream i.e. Water or wastewater	Differentiate media process stream
Operational area	Text - selection list	C	The area where the asset is in operation as managed by the operational business unit	Differentiate operational process areas
Photo/3D model	PDF, Bitmap, Image, file link	C	A live colour photo of the installation or asset within its installed location. Alternative to a photo is a 3D drawing	Visual familiarisation and confirmation
Equipment number	Alpha numeric, Watercare design generated number	C	A unique Watercare generated comprising of the facility, process area code, asset type and its sub-location as a parent asset or child asset within the system that it is installed at.	Unique identification. Reference number used between systems and field identification of assets
Functional area	Alpha numeric	C	The systems and sub-process description of the area where the assets functions and is maintained	To identify the assets' physical location of functionality and where it is maintained in relationship to the plant/process.
Manufacturer/Constructor	Alpha numeric	C	The name of the company/organisation that built/manufactured the Asset.	Quality assurance and traceability. Manufacturer/contractor analysis across assets

Asset Class	Mechanical Rotating	Common /Feature field	Definitions	Attribute usage
			Mechanical equipment that with the addition of kinetic energy can move other equipment, move material from one point to another, or to agitate media	
Attribute name	Attribute unit			
Model/Class	Alpha numeric	C	The model id/number (assigned by the manufacturer) for this Asset.	Quality assurance and traceability. Model/class analysis across assets
Serial Nbr	Alpha numeric	C	The manufacturer's serial number allocated to this Asset.	Quality assurance and traceability
Year of Manufacture / construction	yyyy	C	The year that the Asset was built/manufactured.	Quality assurance, vendor liability and traceability of equipment changes from manufacturer
Weight	Kilogram (kg)	C	The weight of the Asset (expressed as a number of kilograms).	Design baseline (SiD), equipment handling for replacement and maintenance. Onsite material handling equipment or need to hire material handling equipment
Supplier/Vendor	Alpha numeric	C	The name of the company/organisation that sold/supplied the Asset.	Quality assurance and vendor liability
Warranty Start Date	dd-mm-yyyy	C	The effective start date of the warranty period for an Asset.	Quality assurance
Warranty End Date	dd-mm-yyyy	C	The effective end date of the warranty period for the Asset.	Quality assurance
Coordinates (x)	Alpha numeric	FT	Geographic coordinates used to define precise positions on the Earth's surface (where an Asset can be located). Coordinates come from the related GIS spatial representation of the Asset held within the GIS database - which currently is the COMPKEY or Equipment ID. The x coordinate represents a point on an east-west axis (longitude). The y coordinate represents a point on a	Geospatial awareness and area based analytics
Coordinates (y)	Alpha numeric	FT		Geospatial awareness and area based analytics

Asset Class	Mechanical Rotating	Common /Feature field	Definitions	Attribute usage
			Mechanical equipment that with the addition of kinetic energy can move other equipment, move material from one point to another, or to agitate media	
Attribute name	Attribute unit			
Coordinates (z)	Alpha numeric	FT	north-south axis (latitude). The z coordinate indicates height or level above or below sea level (expressed in metres to two decimal places).	Geospatial awareness and area based analytics
Street Name	Text	FT	Relationship to Address	Geospatial awareness and area based analytics
Suburb	Text	FT	Relationship to Address	Geospatial awareness and area based analytics
District	Text	FT	Relationship to Address	Geospatial awareness and area based analytics
Post Code	Numeric, no decimal	FT	Relationship to Address	Geospatial awareness and area based analytics
Locality	Text - selection list	C	Records the setting or placement of an Asset within its functional area.	Evaluation of deterioration and impact of the setting on the asset performance
Confined Space Located	Text - selection list	C	Indicates if the Asset is located in a confined space.	H&S to show when an asset or classed as a confined space
Hazardous area rating	Alpha numeric	C	The safety rating/specification of the Asset.	Replacement of like-for like equipment which have been selected at time of design to comply with certain protection criteria for the installed environment, as well as when equipment is rotated or moved to different locations to identify in what areas it may be re-used.
Linked Documents	Alpha numeric	C	Documents, warranties, specifications, plans/drawings ('as-built'), photos and videos relating to a particular Asset.	Traceability
acquisition value	Numeric, two decimals	C	The purchase price of the Asset (in NZ dollars).	Financial, service performance measure and replacement strategy
acquisition date	dd-mm-yyyy	C	The date that the Asset was purchased/acquired (by Watercare).	Required for valuation and warrantee purposes

Asset Class	Mechanical Rotating	Common /Feature field	Definitions	Attribute usage
			Mechanical equipment that with the addition of kinetic energy can move other equipment, move material from one point to another, or to agitate media	
Attribute name	Attribute unit			
Project reference	Alpha numeric	FT	The project ID, code or C-number of the project that the Asset was acquired/procured for.	Contractual links and business case documentation to capture decision making history
Start up date	dd-mm-yyyy	C	The date that the asset was first placed into operation	Some assets may be installed but have considerable delays before starting operation. Differential deterioration rates apply
asset designed life	Numeric, no decimal	C	The expected/designed lifetime of an Asset (expressed as a number of years).	Financial, service performance measure and replacement strategy
Service status	Alpha numeric - selection list	C	Asset lifecycle status codes that record the effective dates that an Asset was in a particular state (requires 'service status effective date' attribute as well).	Assets in-service or out of service status is used for analytical purposes on life expectancy as well as Watercare's ongoing liability towards assets that are no longer in used but are still installed.
Condition rating	Numeric, no decimal, selection list	C	Asset lifecycle status codes that record the effective dates that an Asset was in a particular state (requires 'service status effective date' attribute as well).	Analytical input to investment to maintain level of service
Criticality rating	Numeric, no decimal	C	An indicator of the criticality or importance (to the business, production, process, safety) of a particular Asset. Denotes the level of impact/consequence that will result from loss/breakdown of the Asset. If impact to Watercare's business, processes or reputation (of loss or breakdown of an Asset) is high/extensive the criticality rating will also be high.	Analytical input to investment to maintain level of service
Condition assessment date	dd-mm-yyyy	C	The date that the assessment was conducted/determined.	Tracking condition assessment

Asset Class	Mechanical Rotating	Common /Feature field	Definitions	Attribute usage
			Mechanical equipment that with the addition of kinetic energy can move other equipment, move material from one point to another, or to agitate media	
Attribute name	Attribute unit			
Assessed remaining life	Numeric, no decimal	C	An assessment of the remaining lifetime of an Asset (expressed as a number of years). The value is calculated based on physical evaluation, time in service and condition rating	Financial, service performance measure and replacement strategy
Functional output	Alpha numeric - selection list	FT	ISA 5 definition associated with instrumentation and mechanical equipment to identify the intended function that the equipment is to perform. This attribute is the output from the equipment e.g. transmitting, controlling, readout or alarm	To differentiate the type of equipment to its intended function. Some instruments and equipment may measure or perform a function other than its type definition affecting equipment analysis, maintenance and replacement considerations
Media Type Wtr/WWtr/chem/gas	Text - selection list	FT	Describes the substance that is contained in, processed by or transported by an Asset.	Evaluation of deterioration and impact of media on the asset performance
Material type (majority component)	Text - selection list	FT	Describes the (defining) material used to construct the external casing / majority component of the Asset.	Evaluation of deterioration
IP Rating	Alpha numeric - selection list	FT	Water and dust ingress protection rating for industrial equipment, electrical equipment and instruments	Replacement of like-for like equipment which have been selected at time of design to comply with certain protection criteria for the installed environment, as well as when equipment is rotated or moved to different locations to identify in what areas it may be re-used. Performance indicator for ongoing analysis
Installation Mounting (Wet/Dry)	Text - selection list	FT	An extension to the Locality field to the installation setting of certain equipment types	Specific identification of equipment and instruments in wet or dry conditions for performance monitoring

Asset Class	Mechanical Rotating	Common /Feature field	Definitions	Attribute usage
			Mechanical equipment that with the addition of kinetic energy can move other equipment, move material from one point to another, or to agitate media	
Attribute name	Attribute unit			
Installation Orientation	Text - selection list	FT	An extension to the Locality field to the installation setting of certain equipment types to identify how it has been specially orientated in the installed environments	Relates to bearing type applications on some equipment that places limitations/enabling an asset to operate under certain load conditions imposed by the installation orientation. Required for replacement, performance analysis and equipment rotation.
Nbr of Stages	Numeric, no decimal	FT	The number of stages in the pump/asset. [Fluid is discharged from an impeller and volute (called a stage) and immediately enters the next impeller and volute; the amount of pressure developed in a multi-stage pump depends on the diameter of the impellers, the number of stages used, and the speed at which the impellers are turning.]	Performance analysis stage equipment of the same asset type. Maintenance and replacement. The number of stages are not always concatenated in the supplier model number.
Body type	Text - selection list	FT	The main body configuration of the pump	Replacement of like-for like equipment which have been selected at time of design. Maintenance identification for spares and works methodology.
Shaft Coupling Type e.g. Close Coupled	Text - selection list	FT	The method by which the drive input shaft is connected to the motor output drive shaft	Performance analysis across coupling types. Maintenance identification for spares types and shaft alignment requirements.

Asset Class	Mechanical Rotating	Common /Feature field	Definitions	Attribute usage
			Mechanical equipment that with the addition of kinetic energy can move other equipment, move material from one point to another, or to agitate media	
Attribute name	Attribute unit			
Pressure Rating (kPa) static	kilo-pascal (kPa)	FT	The maximum pressure (expressed in kilopascals) that an Asset is designed to operate at (i.e. a pump) or withstand (i.e. pipes).	Replacement of like-for like equipment which have been selected at time of design to comply with certain protection criteria for the installed environment, as well as when equipment is rotated or moved to different locations to identify in what areas it may be re-used. Performance indicator for ongoing analysis
Max Designed flow	Litres per second (l/s)	FT	The maximum flow rate (expressed in litres per second) that the Asset was designed for / is capable of.	Replacement of like-for like equipment which have been selected at time of design to comply with certain protection criteria for the installed environment, as well as when equipment is rotated or moved to different locations to identify in what areas it may be re-used. Performance indicator for ongoing analysis
Min Designed flow	Litres per second (l/s)	FT	The minimum flow rate (expressed in litres per second) that the Asset was designed for.	Replacement of like-for like equipment which have been selected at time of design to comply with certain protection criteria for the installed environment, as well as when equipment is rotated or moved to different locations to identify in what areas it may be re-used. Performance indicator for ongoing analysis
Diameter (Nominal)	millimetre (mm)	FT	The nominal diameter may not match the internal or external (see definitions for internal and external diameter) diameter but is used a size name identification	Naming convention

Asset Class	Mechanical Rotating	Common /Feature field	Definitions	Attribute usage
			Mechanical equipment that with the addition of kinetic energy can move other equipment, move material from one point to another, or to agitate media	
Attribute name	Attribute unit			
Design Speed (rpm)	revolutions per minute (rpm)	FT	The maximum speed (expressed in revolutions per minute) that the Asset was designed for / is capable of.	Replacement of like-for like equipment which have been selected at time of design to comply with certain protection criteria for the installed environment, as well as when equipment is rotated or moved to different locations to identify in what areas it may be re-used. Performance indicator for ongoing analysis
Bearing Type	Text - selection list	FT	Describes the type of bearing used/associated to the Asset. [A bearing is a device to enable rotational or linear movement, while reducing friction and handling stress. Resembling wheels, bearings literally enable devices to roll, which reduces the friction between the surface of the bearing and the surface it's rolling over.]	The type of bearing selection places limitations/enabling an asset to operate under certain load conditions and installation orientation. Required for replacement, performance analysis and equipment rotation.
Input voltage	Volt (v)	FT	The size of the electromotive force expressed in volt to power electrical equipment	To identify electrical power supply requirements of the asset. Power consumption analysis, replacement and equipment rotation
Input voltage Type (AC/DC)	Text - selection list	FT	Voltage is carried by the flow of current. The current can either be alternating current or direct current. The current type required to drive the equipment	To identify electrical power supply requirements of the asset. Power consumption analysis, replacement and equipment rotation
Nbr of Phases	Numeric, no decimal, selection list	FT	The number of electrical supply phases	To distinguish between single phase and three phase equipment. Power consumption analysis, replacement and equipment rotation

Asset Class	Mechanical Rotating	Common /Feature field	Definitions	Attribute usage
			Mechanical equipment that with the addition of kinetic energy can move other equipment, move material from one point to another, or to agitate media	
Attribute name	Attribute unit			
Output voltage	Volt (v)	FT	The size of the electromotive force expressed in volt that is output by the electrical equipment	To identify electrical power supply requirements of the asset. Power consumption analysis, replacement and equipment rotation
Output voltage Type (AC/DC)	Text - selection list	FT	Voltage is carried by the flow of current. The current can either be alternating current or direct current. The current type that is delivered by the equipment	To identify electrical power supply requirements of the asset. Power consumption analysis, replacement and equipment rotation
Insulation Class	Alpha numeric - selection list	FT	The maximum allowable operating temperature classification of electrical componentry in accordance with IEC standards	Replacement of like-for like equipment which have been selected at time of design to comply with certain protection criteria for the installed environment, as well as when equipment is rotated or moved to different locations to identify in what areas it may be re-used. Performance indicator for ongoing analysis
Energy (Kw) Rating	Kilowatt (kW)	FT	The rate by which the equipment consumes electrical energy under the potential (voltage) and flow (current) to deliver work	To identify electrical power supply requirements of the asset. Power consumption analysis, replacement and equipment rotation
Frame Size	Alpha numeric	FT	The international standardised dimension of the base frame for connecting motor equipment. To match shaft dimensions and height.	Certain types of assets are standardised by frame size to allow replacement and rotation without the need to adjust mounting dimensions and connection height e.g. a motor base connecting mounted to the plinth (width and length) and having a standard height to connect the drive shaft.
Output current (A)	Amps (A)	FT	The size of the flow of current to deliver voltage	To identify electrical power supply requirements of the asset. Power consumption analysis, replacement and equipment rotation

Asset Class	Mechanical Rotating	Common /Feature field	Definitions	Attribute usage
			Mechanical equipment that with the addition of kinetic energy can move other equipment, move material from one point to another, or to agitate media	
Attribute name	Attribute unit			
Cooling System Fitted	Text - selection list	FT	Integral cooling system fitting to some mechanical equipment to cooling bearings or drive trains	To identify integrated systems to equipment that affects performance and maintenance. Equipment performance analysis
Impellor Type	Text - selection list	FT	Bladed equipment such as pumps and fans are designed using specific impellor type to displace media	Replacement of like-for like equipment which have been selected at time of design to comply with certain protection criteria for the installed environment, as well as when equipment is rotated or moved to different locations to identify in what areas it may be re-used. Performance indicator for ongoing analysis
Impellor Diameter	millimetre (mm)	FT	A straight line going through the centre of an impellor connecting two points on the external circumference	Replacement of like-for like equipment which have been selected at time of design to comply with certain protection criteria for the installed environment, as well as when equipment is rotated or moved to different locations to identify in what areas it may be re-used. Performance indicator for ongoing analysis. Identify if impellor can be increased without changing the complete asset to increase performance
Suction / inlet Diameter	millimetre (mm)	FT	A straight line going through the centre of the inlet connecting two points on the internal circumference	Replacement of like-for like equipment which have been selected at time of design to comply with certain protection criteria for the installed environment, as well as when equipment is rotated or moved to different locations to identify in what areas it may be re-used. Performance indicator for ongoing analysis

Asset Class	Mechanical Rotating	Common /Feature field	Definitions	Attribute usage
			Mechanical equipment that with the addition of kinetic energy can move other equipment, move material from one point to another, or to agitate media	
Attribute name	Attribute unit			
Discharge Diameter	millimetre (mm)	FT	A straight line going through the centre of the outlet connecting two points on the internal circumference	Replacement of like-for like equipment which have been selected at time of design to comply with certain protection criteria for the installed environment, as well as when equipment is rotated or moved to different locations to identify in what areas it may be re-used. Performance indicator for ongoing analysis
Torque (input rating)	Newton metre (Nm)	FT	Maximum into force to allow rotation to occur	Replacement of like-for like equipment which have been selected at time of design to comply with certain protection criteria for the installed environment, as well as when equipment is rotated or moved to different locations to identify in what areas it may be re-used. Performance indicator for ongoing analysis
Torque (output rating)	Newton metre (Nm)	FT	Maximum output force to allow rotation to occur	Replacement of like-for like equipment which have been selected at time of design to comply with certain protection criteria for the installed environment, as well as when equipment is rotated or moved to different locations to identify in what areas it may be re-used. Performance indicator for ongoing analysis
Stroke Controller Fitted	Text - selection list	FT	Used for dosing control to move the pump to deliver a precise volume of liquid	To identify integrated systems to equipment that affects performance and maintenance. Equipment performance analysis
External coating	Text - selection list	FT	Describes the protective corrosion or structural coating used on the exterior of the Asset.	Impacts on service life and maintenance scheduling

Asset Class	Mechanical Rotating	Common /Feature field	Definitions	Attribute usage
			Mechanical equipment that with the addition of kinetic energy can move other equipment, move material from one point to another, or to agitate media	
Attribute name	Attribute unit			
Internal lining	Text - selection list	FT	Describes the protective corrosion or structural coating used on the interior of the Asset.	Impacts on service life and maintenance scheduling
Length	metre (m)	C	The end-to-end measurement of an asset (expressed in metres to three decimal places). The length of pumps and fans are measured in the direction of the inlet and outlet volutes. e.g. a horizontal split case pump length is measured across the shaft whilst a vertical split pump length is measured along the length of the shaft. For vertically installed or cartridge cased pumps the length is the length is measured across the shaft	Geospatial awareness and cost valuation
Width	millimetre (mm)	FT	The extend measurement from side-to-side of an asset (expressed in millimetres). The width of pumps and fans are measured on the opposite axis of the inlet and outlet volutes. e.g. a horizontal split case pump width is measured along same axis as the shaft whilst a vertical split pump width is measured across the shaft.	Geospatial awareness and cost valuation
Height	millimetre (mm)	FT	The extend measurement from base-to-top of an asset (expressed in millimetres) in its installed orientation.	Geospatial awareness and cost valuation
Fuel type	Text - selection list	FT	Material such as gas or diesel that is burned in an engine or device to produce heat or power	Fuel type, cost and environmental footprint analysis

4.11 Asset Class: Mechanical – Static

Asset Class	Mechanical Static	Common /Feature field	Definitions	Attribute usage
			Mechanical equipment that is not used for rotation, movement or agitation. Static mechanical equipment is used to connect civil structures such as pipe fittings, supports a mechanical process, or is used as a physical interface with a mechanical machine.	
Attribute name	Attribute unit			
Sub-type	Alpha numeric - selection list	FT	Breakdown of some assets types where required to distinguish asset types to a more granular level	
Sub-type feature	Alpha numeric - selection list	FT	A distinguishing feature of a sub-type of asset	To describe a uniqueness or distinguishing feature of an asset sub-type that is important for analytical and functional purposes
Ownership	Text - selection list	C	The entity that that has financial and legislative responsibility of the asset	Future management of assets owned by others
Process	Text - selection list	C	The main media process stream i.e. Water or wastewater	Differentiate media process stream
Operational area	Text - selection list	C	The area where the asset is in operation as managed by the operational business unit	Differentiate operational process areas
Photo/3D model	PDF, Bitmap, Image, file link	C	A live colour photo of the installation or asset within its installed location. Alternative to a photo is a 3D drawing	Visual familiarisation and confirmation
Equipment number	Alpha numeric, Watercare design generated number	C	A unique Watercare generated comprising of the facility, process area code, asset type and its sub-location as a parent asset or child asset within the system that it is installed at.	Unique identification. Reference number used between systems and field identification of assets
Functional area	Alpha numeric	C	The systems and sub-process description of the area where the assets functions and is maintained	To identify the assets' physical location of functionality and where it is maintained in relationship to the plant/process.

Asset Class	Mechanical Static	Common /Feature field	Definitions	Attribute usage
			Mechanical equipment that is not used for rotation, movement or agitation. Static mechanical equipment is used to connect civil structures such as pipe fittings, supports a mechanical process, or is used as a physical interface with a mechanical machine.	
Attribute name	Attribute unit			
Manufacturer/Constructor	Alpha numeric	C	The name of the company/organisation that built/manufactured the Asset.	Quality assurance and traceability. Manufacturer/contractor analysis across assets
Model/Class	Alpha numeric	C	The model id/number (assigned by the manufacturer) for this Asset.	Quality assurance and traceability. Model/class analysis across assets
Serial Nbr	Alpha numeric	C	The manufacturer's serial number allocated to this Asset.	Quality assurance and traceability
Year of Manufacture / construction	yyyy	C	The year that the Asset was built/manufactured.	Quality assurance, vendor liability and traceability of equipment changes from manufacturer
Weight	Kilogram (kg)	C	The weight of the Asset (expressed as a number of kilograms).	Design baseline (SiD), equipment handling for replacement and maintenance. Onsite material handling equipment or need to hire material handling equipment
Supplier/Vendor	Alpha numeric	C	The name of the company/organisation that sold/supplied the Asset.	Quality assurance and vendor liability
Warranty Start Date	dd-mm-yyyy	C	The effective start date of the warranty period for an Asset.	Quality assurance
Warranty End Date	dd-mm-yyyy	C	The effective end date of the warranty period for the Asset.	Quality assurance
Coordinates (x)	Alpha numeric	C	Geographic coordinates used to define precise positions on the Earth's surface (where an Asset can be located). Coordinates come from the related GIS spatial representation of the Asset held within the GIS database - which currently is	Geospatial awareness and area based analytics
Coordinates (y)	Alpha numeric	C		Geospatial awareness and area based analytics
Coordinates (z)	Alpha numeric	C		Geospatial awareness and area based analytics

Asset Class	Mechanical Static	Common /Feature field	Definitions	Attribute usage
			Mechanical equipment that is not used for rotation, movement or agitation. Static mechanical equipment is used to connect civil structures such as pipe fittings, supports a mechanical process, or is used as a physical interface with a mechanical machine.	
Attribute name	Attribute unit			
			<p>the COMPKEY or Equipment ID.</p> <p>The x coordinate represents a point on an east-west axis (longitude).</p> <p>The y coordinate represents a point on a north-south axis (latitude).</p> <p>The z coordinate indicates height or level above or below sea level (expressed in metres to two decimal places).</p>	
Street Name	Text	C	Relationship to Address	Geospatial awareness and area based analytics
Suburb	Text	C	Relationship to Address	Geospatial awareness and area based analytics
District	Text	C	Relationship to Address	Geospatial awareness and area based analytics
Post Code	Numeric, no decimal	C	Relationship to Address	Geospatial awareness and area based analytics
Locality	Text - selection list	C	Records the setting or placement of an Asset within its functional area.	Evaluation of deterioration and impact of the setting on the asset performance
Confined Space Located	Text - selection list	C	Indicates if the Asset is in a confined space.	H&S to show when an asset or classed as a confined space
Hazardous area rating	Alpha numeric - selection list	FT	The safety rating/specification of the Asset.	Replacement of like-for like equipment which have been selected at time of design to comply with certain protection criteria for the installed environment, as well as when equipment is rotated or moved to different locations to identify in what areas it may be re-used.
Linked Documents	Alpha numeric	C	Documents, warranties, specifications, plans/drawings ('as-built'), photos and videos relating to a particular Asset.	Traceability

Asset Class	Mechanical Static	Common /Feature field	Definitions	Attribute usage
			<p>Mechanical equipment that is not used for rotation, movement or agitation. Static mechanical equipment is used to connect civil structures such as pipe fittings, supports a mechanical process, or is used as a physical interface with a mechanical machine.</p>	
Attribute name	Attribute unit			
acquisition value	Numeric, two decimals	C	The purchase price of the Asset (in NZ dollars).	Financial, service performance measure and replacement strategy
acquisition date	dd-mm-yyyy	C	The date that the Asset was purchased/acquired (by Watercare).	Required for valuation and warrantee purposes
Project reference	Alpha numeric	FT	The project ID, code or C-number of the project that the Asset was acquired/procured for.	Contractual links and business case documentation to capture decision making history
Start up date	dd-mm-yyyy	C	The date that the asset was first placed into operation	Some assets may be installed but have considerable delays before starting operation. Differential deterioration rates apply
asset designed life	Numeric, no decimal	C	The expected/designed lifetime of an Asset (expressed as a number of years).	Financial, service performance measure and replacement strategy
Service status	Alpha numeric - selection list	C	Asset lifecycle status codes that record the effective dates that an Asset was in a particular state (requires 'service status effective date' attribute as well).	Assets in-service or out of service status is used for analytical purposes on life expectancy as well as Watetrcare's ongoing liability towards assets that are no longer in used but are still installed.
Condition rating	Numeric, no decimal, selection list	C	Asset lifecycle status codes that record the effective dates that an Asset was in a particular state (requires 'service status effective date' attribute as well).	Analytical input to investment to maintain level of service

Asset Class	Mechanical Static	Common /Feature field	Definitions	Attribute usage
			<p>Mechanical equipment that is not used for rotation, movement or agitation. Static mechanical equipment is used to connect civil structures such as pipe fittings, supports a mechanical process, or is used as a physical interface with a mechanical machine.</p>	
Attribute name	Attribute unit			
Criticality rating	Numeric, no decimal	C	<p>An indicator of the criticality or importance (to the business, production, process, safety) of a particular Asset. Denotes the level of impact/consequence that will result from loss/breakdown of the Asset. If impact to Watercare's business, processes or reputation (of loss or breakdown of an Asset) is high/extensive the criticality rating will also be high.</p>	Analytical input to investment to maintain level of service
Condition assessment date	dd-mm-yyyy	C	The date that the assessment was conducted/determined.	Tracking condition assessment
Assessed remaining life	Numeric, no decimal	C	<p>An assessment of the remaining lifetime of an Asset (expressed as a number of years). The value is calculated based on physical evaluation, time in service and condition rating</p>	Financial, service performance measure and replacement strategy
Media Type Wtr/WWtr/chem/gas	Text - selection list	FT	Describes the substance that is contained in, processed by or transported by an Asset.	Evaluation of deterioration and impact of media on the asset performance
Material type (majority component)	Text - selection list	FT	Describes the (defining) material used to construct the external casing / majority component of the Asset.	Evaluation of deterioration
Calibration authority	Text	FT	The certified/registered 3rd party that completes calibration work	To identify 3rd party quality assurance and liability

Asset Class	Mechanical Static	Common /Feature field	Definitions	Attribute usage
			Mechanical equipment that is not used for rotation, movement or agitation. Static mechanical equipment is used to connect civil structures such as pipe fittings, supports a mechanical process, or is used as a physical interface with a mechanical machine.	
Attribute name	Attribute unit			
Calibration number	Alpha numeric	FT	The reference number of the certification issued with the calibration	To identify 3rd party quality assurance and liability
Calibration expiry date	dd-mm-yyyy	FT	The date by which calibration must be renewed	To identify when calibration needs to be updated
IP Rating	Alpha numeric - selection list	FT	Water and dust ingress protection rating for industrial equipment, electrical equipment and instruments	Replacement of like-for like equipment which have been selected at time of design to comply with certain protection criteria for the installed environment, as well as when equipment is rotated or moved to different locations to identify in what areas it may be re-used. Performance indicator for ongoing analysis
Installation Mounting (Wet/Dry)	Text - selection list	FT	An extension to the Locality field to the installation setting of certain equipment types	Specific identification of equipment and instruments in wet or dry conditions for performance monitoring
Nbr of Stages	Numeric, no decimal	FT	The number of stages in the pump/asset. [Fluid is discharged from an impeller and volute (called a stage) and immediately enters the next impeller and volute; the amount of pressure developed in a multi-stage pump depends on the diameter of the impellers, the number of stages used, and the speed at which the impellers are turning.]	Performance analysis stage equipment of the same asset type. Maintenance and replacement. The number of stages are not always concatenated in the supplier model number.

Asset Class	Mechanical Static	Common /Feature field	Definitions	Attribute usage
			Mechanical equipment that is not used for rotation, movement or agitation. Static mechanical equipment is used to connect civil structures such as pipe fittings, supports a mechanical process, or is used as a physical interface with a mechanical machine.	
Attribute name	Attribute unit			
Pressure Rating (kPa) static	kilo-pascal (kPa)	FT	The maximum pressure (expressed in kilopascals) that an Asset is designed to operate at (i.e. a pump) or withstand (i.e. pipes).	Replacement of like-for like equipment which have been selected at time of design to comply with certain protection criteria for the installed environment, as well as when equipment is rotated or moved to different locations to identify in what areas it may be re-used. Performance indicator for ongoing analysis
Stiffness rating (SN)	Nominal stiffness (SN), selection list	FT	A measurement of the crush resistance of a pipe or fitting as nominal stiffness (kN/m ²).	Evaluation of deterioration, fit for purpose and failure analysis. Replacement of like-for-like for maintenance purposes. SN rating is a design input.
Max Designed Flow	Litres per second (l/s)	FT	The maximum flow rate (expressed in litres per second) that the Asset was designed for / is capable of.	Replacement of like-for like equipment which have been selected at time of design to comply with certain protection criteria for the installed environment, as well as when equipment is rotated or moved to different locations to identify in what areas it may be re-used. Performance indicator for ongoing analysis
Min Designed Flow	Litres per second (l/s)	FT	The minimum flow rate (expressed in litres per second) that the Asset was designed for.	Replacement of like-for like equipment which have been selected at time of design to comply with certain protection criteria for the installed environment, as well as when equipment is rotated or moved to different locations to identify in what areas it may be re-used. Performance indicator for ongoing analysis

Asset Class	Mechanical Static	Common /Feature field	Definitions	Attribute usage
			Mechanical equipment that is not used for rotation, movement or agitation. Static mechanical equipment is used to connect civil structures such as pipe fittings, supports a mechanical process, or is used as a physical interface with a mechanical machine.	
Attribute name	Attribute unit			
Diameter (internal)	millimetre (mm)	FT	A straight line going through the centre of a pipe connecting two points on the external circumference	Hydraulic performance, future connectivity and evaluation of deterioration
Diameter (external)	millimetre (mm)	FT	A straight line going through the centre of a pipe connecting two points on the internal circumference	Future connectivity, repair sizing and evaluation of deterioration
Diameter (Nominal)	millimetre (mm)	FT	The nominal diameter may not match the internal or external (see definitions for internal and external diameter) diameter but is used a size name identification	Naming convention
Design Speed (rpm)	revolutions per minute (rpm)	FT	The maximum speed (expressed in revolutions per minute) that the Asset was designed for / is capable of.	Replacement of like-for like equipment which have been selected at time of design to comply with certain protection criteria for the installed environment, as well as when equipment is rotated or moved to different locations to identify in what areas it may be re-used. Performance indicator for ongoing analysis
Input voltage	Volt (v)	FT	The size of the electromotive force expressed in volt to power electrical equipment	To identify electrical power supply requirements of the asset. Power consumption analysis, replacement and equipment rotation
Input voltage Type (AC/DC)	Text - selection list	FT	Voltage is carried by the flow of current. The current can either be alternating current or direct current. The current type required to drive the equipment	To identify electrical power supply requirements of the asset. Power consumption analysis, replacement and equipment rotation

Asset Class	Mechanical Static	Common /Feature field	Definitions	Attribute usage
			Mechanical equipment that is not used for rotation, movement or agitation. Static mechanical equipment is used to connect civil structures such as pipe fittings, supports a mechanical process, or is used as a physical interface with a mechanical machine.	
Attribute name	Attribute unit			
Nbr of Phases	Numeric, no decimal, selection list	FT	The number of electrical supply phases	To distinguish between single phase and three phase equipment. Power consumption analysis, replacement and equipment rotation
Energy (Kw) Rating	Kilowatt (kW)	FT	The rate by which the equipment consumes electrical energy under the potential (voltage) and flow (current) to deliver work	To identify electrical power supply requirements of the asset. Power consumption analysis, replacement and equipment rotation
Suction / inlet Diameter	millimetre (mm)	FT	A straight line going through the centre of the inlet connecting two points on the internal circumference	Replacement of like-for like equipment which have been selected at time of design to comply with certain protection criteria for the installed environment, as well as when equipment is rotated or moved to different locations to identify in what areas it may be re-used. Performance indicator for ongoing analysis
Discharge Diameter	millimetre (mm)	FT	A straight line going through the centre of the outlet connecting two points on the internal circumference	Replacement of like-for like equipment which have been selected at time of design to comply with certain protection criteria for the installed environment, as well as when equipment is rotated or moved to different locations to identify in what areas it may be re-used. Performance indicator for ongoing analysis
Load rating (kN)	Kilo Newton (kN)	FT	The maximum load that the asset is rated to withstand	To identify design parameters for performance and replacement.

Asset Class	Mechanical Static	Common /Feature field	Definitions	Attribute usage
			Mechanical equipment that is not used for rotation, movement or agitation. Static mechanical equipment is used to connect civil structures such as pipe fittings, supports a mechanical process, or is used as a physical interface with a mechanical machine.	
Attribute name	Attribute unit			
External coating	Text - selection list	FT	Describes the protective corrosion or structural coating used on the exterior of the Asset.	Impacts on service life and maintenance scheduling
Internal lining	Text - selection list	FT	Describes the protective corrosion or structural coating used on the interior of the Asset.	Impacts on service life and maintenance scheduling
Jointing method	Text - selection list	FT	The mechanical method by which joints have been assembled	Evaluation of failure mode, servicing of mechanical joints and future connectivity
Length	metre (m)	FT	The end-to-end measurement of an asset (expressed in metres to three decimal places).	Geospatial awareness and cost valuation
Width	millimetre (mm)	FT	The extend measurement from side-to-side of an asset (expressed in millimetres).	Geospatial awareness and cost valuation
Height	millimetre (mm)	FT	The extend measurement from base-to-top of an asset (expressed in millimetres).	Geospatial awareness and cost valuation

4.12 Asset Class: Pipes and Conduits

Asset Class	Pipe and conduit	Common /Feature field	Definitions	Attribute usage
			A tube that conveys fluid or gas, or may be used for the protection of another service such as an electric cable	
Attribute name	Attribute unit			
Sub-type	Alpha numeric - selection list	C	Breakdown of some assets types where required to distinguish asset types to a more granular level	
Ownership	Text - selection list	C	The entity that that has financial and legislative responsibility of the asset	Future management of assets owned by others
Process	Text - selection list	C	The main media process stream i.e. Water or wastewater	Differentiate media process stream
Operational area	Text - selection list	C	The area where the asset is in operation as managed by the operational business unit	Differentiate operational process areas
Photo/3D model	PDF, Bitmap, Image, file link	C	A live colour photo of the installation or asset within its installed location. Alternative to a photo is a 3D drawing	Visual familiarisation and confirmation
Equipment number	Alpha numeric, Watercare design generated number	C	A unique Watercare generated comprising of the facility, process area code, asset type and its sub-location as a parent asset or child asset within the system that it is installed at.	Unique identification. Reference number used between systems and field identification of assets
Functional area	Alpha numeric	C	The systems and sub-process description of the area where the assets functions and is maintained	To identify the assets' physical location of functionality and where it is maintained in relationship to the plant/process.
Manufacturer/Constructor	Alpha numeric	C	The name of the company/organisation that built/manufactured the Asset.	Quality assurance and traceability. Manufacturer/contractor analysis across assets

Asset Class	Pipe and conduit	Common /Feature field	Definitions	Attribute usage
			A tube that conveys fluid or gas, or may be used for the protection of another service such as an electric cable	
Attribute name	Attribute unit			
Model/Class	Alpha numeric	C	The model id/number (assigned by the manufacturer) for this Asset.	Quality assurance and traceability. Model/class analysis across assets
Serial Nbr	Alpha numeric	C	The manufacturer's serial number allocated to this Asset.	Quality assurance and traceability
Year of Manufacture / construction	yyyy	C	The year that the Asset was built/manufactured.	Quality assurance, vendor liability and traceability of equipment changes from manufacturer
Supplier/Vendor	Alpha numeric	C	The name of the company/organisation that sold/supplied the Asset.	Quality assurance and vendor liability
Warranty Start Date	dd-mm-yyyy	C	The effective start date of the warranty period for an Asset.	Quality assurance
Warranty End Date	dd-mm-yyyy	C	The effective end date of the warranty period for the Asset.	Quality assurance
Coordinates (x)	Alpha numeric	C	Geographic coordinates used to define precise positions on the Earth's surface (where an Asset can be located). Coordinates come from the related GIS	Geospatial awareness and area based analytics

Asset Class	Pipe and conduit	Common /Feature field	Definitions	Attribute usage
Attribute name	Attribute unit			
Coordinates (y)	Alpha numeric	C	A tube that conveys fluid or gas, or may be used for the protection of another service such as an electric cable	Geospatial awareness and area based analytics
Coordinates (z)	Alpha numeric	C	spatial representation of the Asset held within the GIS database - which currently is the COMPKEY or Equipment ID. The x coordinate represents a point on an east-west axis (longitude). The y coordinate represents a point on a north-south axis (latitude). The z coordinate indicates height or level above or below sea level (expressed in metres to two decimal places).	Geospatial awareness and area based analytics
Street Name	Text	C	Relationship to Address	Geospatial awareness and area based analytics
Suburb	Text	C	Relationship to Address	Geospatial awareness and area based analytics
District	Text	C	Relationship to Address	Geospatial awareness and area based analytics
Post Code	Numeric, no decimal	C	Relationship to Address	Geospatial awareness and area based analytics
Locality	Text - selection list	C	Records the setting or placement of an Asset within its functional area.	Evaluation of deterioration and impact of the setting on the asset performance
Confined Space Located	Text - selection list	C	Indicates if the Asset is located in a confined space.	H&S to show when an asset or classed as a confined space
Linked Documents	Alpha numeric	C	Documents, warranties, specifications, plans/drawings ('as-built'), photos and videos relating to a particular Asset.	Traceability
acquisition value	Numeric, two decimals	C	The purchase price of the Asset (in NZ dollars).	Financial, service performance measure and replacement strategy

Asset Class	Pipe and conduit	Common /Feature field	Definitions	Attribute usage
			A tube that conveys fluid or gas, or may be used for the protection of another service such as an electric cable	
Attribute name	Attribute unit			
acquisition date	dd-mm-yyyy	C	The date that the Asset was purchased/acquired (by Watercare).	Required for valuation and warrantee purposes
Project reference	Alpha numeric	C	The project ID, code or C-number of the project that the Asset was acquired/procured for.	Contractual links and business case documentation to capture decision making history
Start up date	dd-mm-yyyy	C	The date that the asset was first placed into operation	Some assets may be installed but have considerable delays before starting operation. Differential deterioration rates apply
asset designed life	Numeric, no decimal	C	The expected/designed lifetime of an Asset (expressed as a number of years).	Financial, service performance measure and replacement strategy
Service status	Alpha numeric - selection list	C	Asset lifecycle status codes that record the effective dates that an Asset was in a particular state (requires 'service status effective date' attribute as well).	Assets in-service or out of service status is used for analytical purposes on life expectancy as well as Watercare's ongoing liability towards assets that are no longer in used but are still installed.
Condition rating	Numeric, no decimal, selection list	C	Asset lifecycle status codes that record the effective dates that an Asset was in a particular state (requires 'service status effective date' attribute as well).	Analytical input to investment to maintain level of service
Criticality rating	Numeric, no decimal	C	An indicator of the criticality or importance (to the business, production, process, safety) of a particular Asset. Denotes the level of impact/consequence that will result from loss/breakdown of the Asset. If impact to Watercare's business, processes or reputation (of loss or breakdown of an	Analytical input to investment to maintain level of service

Asset Class	Pipe and conduit	Common /Feature field	Definitions	Attribute usage
Attribute name	Attribute unit		A tube that conveys fluid or gas, or may be used for the protection of another service such as an electric cable	
			Asset) is high/extensive the criticality rating will also be high.	
Condition assessment date	dd-mm-yyyy	C	The date that the assessment was conducted/determined.	Tracking condition assessment
Assessed remaining life	Numeric, no decimal	C	An assessment of the remaining lifetime of an Asset (expressed as a number of years). The value is calculated based on physical evaluation, time in service and condition rating	Financial, service performance measure and replacement strategy
Media Type Wtr/WWtr/chem/gas	Text - selection list	C	Describes the substance that is contained in, processed by or transported by an Asset.	Evaluation of deterioration and impact of media on the asset performance
Material type (majority component)	Text - selection list	C	Describes the (defining) material used to construct the external casing / majority component of the Asset.	Evaluation of deterioration

Asset Class	Pipe and conduit	Common /Feature field	Definitions	Attribute usage
			A tube that conveys fluid or gas, or may be used for the protection of another service such as an electric cable	
Attribute name	Attribute unit			
Pressure Rating (kPa) static	kilo-pascal (kPa)	FT	The maximum pressure (expressed in kilopascals) that an Asset is designed to operate at (i.e. a pump) or withstand (i.e. pipes).	Replacement of like-for like equipment which have been selected at time of design to comply with certain protection criteria for the installed environment, as well as when equipment is rotated or moved to different locations to identify in what areas it may be re-used. Performance indicator for ongoing analysis
Stiffness rating (SN)	Nominal stiffness (SN), selection list	FT	A measurement of the crush resistance of a pipe or fitting as nominal stiffness (kN/m ²).	Evaluation of deterioration, fit for purpose and failure analysis. Replacement of like-for-like for maintenance purposes. SN rating is a design input.
Diameter (internal)	millimetre (mm)	C	A straight line going through the centre of a pipe connecting two points on the external circumference	Hydraulic performance, future connectivity and evaluation of deterioration
Diameter (external)	millimetre (mm)	C	A straight line going through the centre of a pipe connecting two points on the internal circumference	Future connectivity, repair sizing and evaluation of deterioration
Diameter (Nominal)	millimetre (mm)	C	The nominal diameter may not match the internal or external (see definitions for internal and external diameter) diameter but is used a size name identification	Naming convention
Construction method	Text - selection list	C	The construction industry methodology used to construct the asset (generally associated with civil works)	Failure mode analytics. Value engineering evaluations. Construction cost analysis
External coating	Text - selection list	C	Describes the protective corrosion or structural coating used on the exterior of the Asset.	Impacts on service life and maintenance scheduling

Asset Class	Pipe and conduit	Common /Feature field	Definitions	Attribute usage
			A tube that conveys fluid or gas, or may be used for the protection of another service such as an electric cable	
Attribute name	Attribute unit			
Internal lining	Text - selection list	C	Describes the protective corrosion or structural coating used on the interior of the Asset.	Impacts on service life and maintenance scheduling
Joining method	Text - selection list	C	The mechanical method by which joints have been assembled	Evaluation of failure mode, servicing of mechanical joints and future connectivity
Length	metre (m)	C	The end-to-end measurement of an asset (expressed in metres to three decimal places).	Geospatial awareness and cost valuation
Invert level (RL)	metre (m)	FT	The base interior level of a pipe, tunnel or civil structure in relation to the ground level	Geospatial awareness, also required for hydraulic modelling
Ground level (GL)	metre (m)	FT	The level in relation to the asset (typically buried) in relation to a datum level	Geospatial reference
earthquake Quake design lvl	Alpha numeric - selection list	C	The level of design actions undertaken for design as prescribed by structural design codes	Structural design safety factors for legislative compliance
Design resilience rating	Alpha numeric - selection list	FT	The ability of the designed asset to sustain a level of service and absorb or adapt to changing conditions when there is a failure in the system	Drives organisational response / capability to maintain levels of service

4.13 Asset Class: Retaining structures

Asset Class	Retaining structure	Common /Feature field	Definitions	Attribute usage
			A structure that holds back any material or fluid, typically to separate terrain or fluid at different elevations	
Attribute name	Attribute unit			
Sub-type	Alpha numeric - selection list	FT	Breakdown of some assets types where required to distinguish asset types to a more granular level	
Ownership	Text - selection list	C	The entity that that has financial and legislative responsibility of the asset	Future management of assets owned by others
Process	Text - selection list	C	The main media process stream i.e. Water or wastewater	Differentiate media process stream
Operational area	Text - selection list	C	The area where the asset is in operation as managed by the operational business unit	Differentiate operational process areas
Photo/3D model	PDF, Bitmap, Image, file link	C	A live colour photo of the installation or asset within its installed location. Alternative to a photo is a 3D drawing	Visual familiarisation and confirmation
Equipment number	Alpha numeric, Watercare design generated number	C	A unique Watercare generated comprising of the facility, process area code, asset type and its sub-location as a parent asset or child asset within the system that it is installed at.	Unique identification. Reference number used between systems and field identification of assets
Functional area	Alpha numeric	C	The systems and sub-process description of the area where the assets functions and is maintained	To identify the assets' physical location of functionality and where it is maintained in relationship to the plant/process.
Manufacturer/Constructor	Alpha numeric	C	The name of the company/organisation that built/manufactured the Asset.	Quality assurance and traceability. Manufacturer/contractor analysis across assets
Year of Manufacture / construction	yyyy	C	The year that the Asset was built/manufactured.	Quality assurance, vendor liability and traceability of equipment changes from manufacturer
Warranty Start Date	dd-mm-yyyy	C	The effective start date of the warranty period for an Asset.	Quality assurance

Asset Class	Retaining structure	Common /Feature field	Definitions	Attribute usage
			A structure that holds back any material or fluid, typically to separate terrain or fluid at different elevations	
Attribute name	Attribute unit			
Warranty End Date	dd-mm-yyyy	C	The effective end date of the warranty period for the Asset.	Quality assurance
Coordinates (x)	Alpha numeric	C	Geographic coordinates used to define precise positions on the Earth's surface (where an Asset can be located). Coordinates come from the related GIS spatial representation of the Asset held within the GIS database - which currently is the COMPKEY or Equipment ID. The x coordinate represents a point on an east-west axis (longitude). The y coordinate represents a point on a north-south axis (latitude). The z coordinate indicates height or level above or below sea level (expressed in metres to two decimal places).	Geospatial awareness and area based analytics
Coordinates (y)	Alpha numeric	C		Geospatial awareness and area based analytics
Coordinates (z)	Alpha numeric	C		Geospatial awareness and area based analytics
Street Name	Text	FT	Relationship to Address	Geospatial awareness and area based analytics
Suburb	Text	FT	Relationship to Address	Geospatial awareness and area based analytics
District	Text	FT	Relationship to Address	Geospatial awareness and area based analytics
Post Code	Numeric, no decimal	FT	Relationship to Address	Geospatial awareness and area based analytics
Linked Documents	Alpha numeric	C	Documents, warranties, specifications, plans/drawings ('as-builts'), photos and videos relating to a particular Asset.	Traceability
acquisition value	Numeric, two decimals	C	The purchase price of the Asset (in NZ dollars).	Financial, service performance measure and replacement strategy
acquisition date	dd-mm-yyyy	C	The date that the Asset was purchased/acquired (by Watercare).	Required for valuation and warrantee purposes

Asset Class	Retaining structure	Common /Feature field	Definitions	Attribute usage
			A structure that holds back any material or fluid, typically to separate terrain or fluid at different elevations	
Attribute name	Attribute unit			
Project reference	Alpha numeric	FT	The project ID, code or C-number of the project that the Asset was acquired/procured for.	Contractual links and business case documentation to capture decision making history
Start up date	dd-mm-yyyy	C	The date that the asset was first placed into operation	Some assets may be installed but have considerable delays before starting operation. Differential deterioration rates apply
asset designed life	Numeric, no decimal	C	The expected/designed lifetime of an Asset (expressed as a number of years).	Financial, service performance measure and replacement strategy
Service status	Alpha numeric - selection list	C	Asset lifecycle status codes that record the effective dates that an Asset was in a particular state (requires 'service status effective date' attribute as well).	Assets in-service or out of service status is used for analytical purposes on life expectancy as well as Watercare's ongoing liability towards assets that are no longer in used but are still installed.
Condition rating	Numeric, no decimal, selection list	C	Asset lifecycle status codes that record the effective dates that an Asset was in a particular state (requires 'service status effective date' attribute as well).	Analytical input to investment to maintain level of service
Criticality rating	Numeric, no decimal	C	An indicator of the criticality or importance (to the business, production, process, safety) of a particular Asset. Denotes the level of impact/consequence that will result from loss/breakdown of the Asset. If impact to Watercare's business, processes or reputation (of loss or breakdown of an Asset) is high/extensive the criticality rating will also be high.	Analytical input to investment to maintain level of service
Condition assessment date	dd-mm-yyyy	C	The date that the assessment was conducted/determined.	Tracking condition assessment

Asset Class	Retaining structure	Common /Feature field	Definitions	Attribute usage
			A structure that holds back any material or fluid, typically to separate terrain or fluid at different elevations	
Attribute name	Attribute unit			
Assessed remaining life	Numeric, no decimal	C	An assessment of the remaining lifetime of an Asset (expressed as a number of years). The value is calculated based on physical evaluation, time in service and condition rating	Financial, service performance measure and replacement strategy
Certification authority	Text	FT	The certified/registered 3rd party that completes calibration work	Legislative requirement
Certification number	Alpha numeric	FT	The reference number of the certification issued with the calibration	Legislative requirement
Certification expires	dd-mm-yyyy	FT	The date by which calibration must be renewed	Legislative requirement
Certification frequency	Text	FT	How often certification must be completed	Legislative requirement
Media Type Wtr/WWtr/chem/gas	Text - selection list	FT	Describes the substance that is contained in, processed by or transported by an Asset.	Evaluation of deterioration and impact of media on the asset performance
Material type (majority component)	Text - selection list	C	Describes the (defining) material used to construct the external casing / majority component of the Asset.	Evaluation of deterioration
Installation mounting	Text - selection list	FT	An extension to the Locality field to the installation setting of certain equipment types	Specific identification of equipment and instruments in wet or dry conditions for performance monitoring
Internal lining	Text - selection list	FT	Describes the protective corrosion or structural coating used on the interior of the Asset.	Impacts on service life and maintenance scheduling
Length	metre (m)	C	The end-to-end measurement of an asset (expressed in metres to three decimal places).	Geospatial awareness and cost valuation
Width	millimetre (mm)	C	The extend measurement from side-to-side of an asset (expressed in millimetres).	Geospatial awareness and cost valuation

Asset Class	Retaining structure	Common /Feature field	Definitions	Attribute usage
			A structure that holds back any material or fluid, typically to separate terrain or fluid at different elevations	
Attribute name	Attribute unit			
Height	millimetre (mm)	C	The extend measurement from base-to-top of an asset (expressed in millimetres).	Geospatial awareness and cost valuation
depth	millimetre (mm)	FT	The extend measurement from top to the bottom (expressed in millimetres) and is used to expressed buried assets.	Geospatial awareness and cost valuation
Area	square metre (m ²)	FT	Surface extent	Geospatial awareness and supply analytics
Volume/capacity	cubic metre (m ³)	FT	The maximum amount of fluid a dam or pond can contain before spilling	Supply analytics
Invert level (RL)	metre (m)	C	The base interior level of a pipe, tunnel or civil structure in relation to the ground level	Geospatial awareness, also required for hydraulic modelling
Ground level (GL)	metre (m)	C	The level in relation to the asset (typically buried) in relation to a datum level	Geospatial reference
earthquake Quake design lvl	Alpha numeric - selection list	C	The level of design actions undertaken for design as prescribed by structural design codes	Structural design safety factors for legislative compliance
Design resilience rating	Alpha numeric - selection list	C	The ability of the designed asset to sustain a level of service and absorb or adapt to changing conditions when there is a failure in the system	Drives organisational response / capability to maintain levels of service
Core type	Text - selection list	FT	The structural core type of the retaining or embankment structure	Structural integrity evaluation
Core material	Text - selection list	FT	The material that makes up the interior core of the dam	Structural integrity evaluation
Deck material	Text - selection list	FT	The material that makes up the surface surrounding the dam core material	Structural integrity evaluation
Crest length	metre (m)	FT	The length of the embankment	Structural integrity evaluation. Legislative compliance

Asset Class	Retaining structure	Common /Feature field	Definitions	Attribute usage
			A structure that holds back any material or fluid, typically to separate terrain or fluid at different elevations	
Attribute name	Attribute unit			
Crest height	metre (m)	FT	The height in relation to the base of the embankment to the top the embankment	Structural integrity evaluation. Legislative compliance
Spillway type	Text - selection list	FT	The structure that provides controlled release of flow from a dam	Structural integrity evaluation. Performance measurement
Energy dissipation	Text	FT	The mechanism that dissipates the energy of flow released from a spillway structure	Environmental impact assessment
Discharge capacity	cubic metre per second (m ³ /s)	FT	The average rate at which a vessel, container or pipe can be discharged	Required for system management when emptying services to calculate downtime of the asset
Overflow level	metre (m)	FT	The level at which a retaining or embankments structure will overflow	Management of compliance with environmental consent conditions
Inhibit level	metre (m)	FT	The level at which an imminent overflow is alarmed in order to prevent the overflow from occurring	Management of compliance with environmental consent conditions

4.14 Asset Class: Road/Bridge/Rail

Asset Class	Road/Bridge/Rail	Common /Feature field	Definitions	Attribute usage
			Transport corridor facilitating the transfer of goods and people by vehicle and/or the support of utility services along a designated infrastructure corridor	
Attribute name	Attribute unit			
Sub type	Alpha numeric - selection list	FT	A distinguishing feature of a sub-type of asset	To describe a uniqueness or distinguishing feature of an asset sub-type that is important for analytical and functional purposes
Ownership	Text - selection list	C	The entity that that has financial and legislative responsibility of the asset	Future management of assets owned by others
Process	Text - selection list	C	The main media process stream i.e. Water or wastewater	Differentiate media process stream
Operational area	Text - selection list	C	The area where the asset is in operation as managed by the operational business unit	Differentiate operational process areas
Photo/3D model	PDF, Bitmap, Image, file link	C	A live colour photo of the installation or asset within its installed location. Alternative to a photo is a 3D drawing	Visual familiarisation and confirmation
Equipment number	Alpha numeric, Watercare design generated number	C	A unique Watercare generated comprising of the facility, process area code, asset type and its sub-location as a parent asset or child asset within the system that it is installed at.	Unique identification. Reference number used between systems and field identification of assets
Functional area	Alpha numeric	C	The systems and sub-process description of the area where the assets functions and is maintained	To identify the assets' physical location of functionality and where it is maintained in relationship to the plant/process.
Manufacturer/Constructor	Alpha numeric	C	The name of the company/organisation that built/manufactured the Asset.	Quality assurance and traceability. Manufacturer/contractor analysis across assets
Year of Manufacture / construction	YYYY	C	The year that the Asset was built/manufactured.	Quality assurance, vendor liability and traceability of equipment changes from manufacturer

Asset Class	Road/Bridge/Rail	Common /Feature field	Definitions	Attribute usage
			Transport corridor facilitating the transfer of goods and people by vehicle and/or the support of utility services along a designated infrastructure corridor	
Attribute name	Attribute unit			
Warranty Start Date	dd-mm-yyyy	C	The effective start date of the warranty period for an Asset.	Quality assurance
Warranty End Date	dd-mm-yyyy	C	The effective end date of the warranty period for the Asset.	Quality assurance
Coordinates (x)	Alpha numeric	C	Geographic coordinates used to define precise positions on the Earth's surface (where an Asset can be located).	Geospatial awareness and area based analytics
Coordinates (y)	Alpha numeric	C	Coordinates come from the related GIS spatial representation of the Asset held within the GIS database - which currently is the COMPKEY or Equipment ID. The x coordinate represents a point on an east-west axis (longitude).	Geospatial awareness and area based analytics
Coordinates (z)	Alpha numeric	C	The y coordinate represents a point on a north-south axis (latitude). The z coordinate indicates height or level above or below sea level (expressed in metres to two decimal places).	Geospatial awareness and area based analytics
Street Name	Text	C	Relationship to Address	Geospatial awareness and area based analytics
Suburb	Text	C	Relationship to Address	Geospatial awareness and area based analytics
District	Text	C	Relationship to Address	Geospatial awareness and area based analytics
Post Code	Numeric, no decimal	C	Relationship to Address	Geospatial awareness and area based analytics
Linked Documents	Alpha numeric	C	Documents, warranties, specifications, plans/drawings ('as-built'), photos and videos relating to a particular Asset.	Traceability

Asset Class	Road/Bridge/Rail	Common /Feature field	Definitions	Attribute usage
			Transport corridor facilitating the transfer of goods and people by vehicle and/or the support of utility services along a designated infrastructure corridor	
Attribute name	Attribute unit			
acquisition value	Numeric, two decimals	C	The purchase price of the Asset (in NZ dollars).	Financial, service performance measure and replacement strategy
acquisition date	dd-mm-yyyy	C	The date that the Asset was purchased/acquired (by Watercare).	Required for valuation and warrantee purposes
Project reference	Alpha numeric	C	The project ID, code or C-number of the project that the Asset was acquired/procured for.	Contractual links and business case documentation to capture decision making history
Start up date	dd-mm-yyyy	C	The date that the asset was first placed into operation	Some assets may be installed but have considerable delays before starting operation. Differential deterioration rates apply
asset designed life	Numeric, no decimal	C	The expected/designed lifetime of an Asset (expressed as a number of years).	Financial, service performance measure and replacement strategy
Service status	Alpha numeric - selection list	C	Asset lifecycle status codes that record the effective dates that an Asset was in a particular state (requires 'service status effective date' attribute as well).	Assets in-service or out of service status is used for analytical purposes on life expectancy as well as WatetrCare's ongoing liability towards assets that are no longer in used but are still installed.
Condition rating	Numeric, no decimal, selection list	C	Asset lifecycle status codes that record the effective dates that an Asset was in a particular state (requires 'service status effective date' attribute as well).	Analytical input to investment to maintain level of service

Asset Class	Road/Bridge/Rail	Common /Feature field	Definitions	Attribute usage
			Transport corridor facilitating the transfer of goods and people by vehicle and/or the support of utility services along a designated infrastructure corridor	
Attribute name	Attribute unit			
Criticality rating	Numeric, no decimal	C	<p>An indicator of the criticality or importance (to the business, production, process, safety) of a particular Asset.</p> <p>Denotes the level of impact/consequence that will result from loss/breakdown of the Asset.</p> <p>If impact to Watercare's business, processes or reputation (of loss or breakdown of an Asset) is high/extensive the criticality rating will also be high.</p>	Analytical input to investment to maintain level of service
Condition assessment date	dd-mm-yyyy	C	The date that the assessment was conducted/determined.	Tracking condition assessment
Assessed remaining life	Numeric, no decimal	C	<p>An assessment of the remaining lifetime of an Asset (expressed as a number of years).</p> <p>The value is calculated based on physical evaluation, time in service and condition rating</p>	Financial, service performance measure and replacement strategy
Material type (majority component)	Text - selection list	FT	Describes the (defining) material used to construct the external casing / majority component of the Asset.	Evaluation of deterioration
Load rating (kN)	Kilo Newton (kN)	C	The proof load or design load rating of the asset is the loading vertical load that can be applied to the asset without causing permanent damage or deflection	Structural integrity the asset
Length	metre (m)	C	The end-to-end measurement of an asset (expressed in metres to three decimal places).	Geospatial awareness and cost valuation
Width	millimetre (mm)	C	The extend measurement from side-to-side of an asset (expressed in millimetres).	Geospatial awareness and cost valuation

Asset Class	Road/Bridge/Rail	Common /Feature field	Definitions	Attribute usage
			Transport corridor facilitating the transfer of goods and people by vehicle and/or the support of utility services along a designated infrastructure corridor	
Attribute name	Attribute unit			
Invert level (RL)	metre (m)	C	The base interior level of a pipe, tunnel or civil structure in relation to the ground level	Geospatial awareness, also required for hydraulic modelling
Ground level (GL)	metre (m)	C	The level in relation to the asset (typically buried) in relation to a datum level	Geospatial reference

4.15 Asset Class: Site service components

Asset Class	Site service components	Common /Feature field	Definitions	Attribute usage
			Ancillary site components that supports the infrastructure site functions such as access, security and office equipment	
Attribute name	Attribute unit			
Sub-type	Alpha numeric - selection list	FT	Breakdown of some assets types where required to distinguish asset types to a more granular level	
Sub-type feature	Alpha numeric - selection list	FT	A distinguishing feature of a sub-type of asset	To describe a uniqueness or distinguishing feature of an asset sub-type that is important for analytical and functional purposes
Ownership	Text - selection list	C	The entity that that has financial and legislative responsibility of the asset	Future management of assets owned by others
Process	Text - selection list	C	The main media process stream i.e. Water or wastewater	Differentiate media process stream
Operational area	Text - selection list	C	The area where the asset is in operation as managed by the operational business unit	Differentiate operational process areas

Asset Class	Site service components	Common /Feature field	Definitions	Attribute usage
			Ancillary site components that supports the infrastructure site functions such as access, security and office equipment	
Attribute name	Attribute unit			
Photo/3D model	PDF, Bitmap, Image, file link	C	A live colour photo of the installation or asset within its installed location. Alternative to a photo is a 3D drawing	Visual familiarisation and confirmation
Equipment number	Alpha numeric, Watercare design generated number	C	A unique Watercare generated comprising of the facility, process area code, asset type and its sub-location as a parent asset or child asset within the system that it is installed at.	Unique identification. Reference number used between systems and field identification of assets
Functional area	Alpha numeric	C	The systems and sub-process description of the area where the assets functions and is maintained	To identify the assets' physical location of functionality and where it is maintained in relationship to the plant/process.
Manufacturer/Constructor	Alpha numeric	C	The name of the company/organisation that built/manufactured the Asset.	Quality assurance and traceability. Manufacturer/contractor analysis across assets
Model/Class	Alpha numeric	FT	The model id/number (assigned by the manufacturer) for this Asset.	Quality assurance and traceability. Model/class analysis across assets
Serial Nbr	Alpha numeric	FT	The manufacturer's serial number allocated to this Asset.	Quality assurance and traceability
Year of Manufacture / construction	yyyy	C	The year that the Asset was built/manufactured.	Quality assurance, vendor liability and traceability of equipment changes from manufacturer
Supplier/Vendor	Alpha numeric	C	The name of the company/organisation that sold/supplied the Asset.	Quality assurance and vendor liability
Warranty Start Date	dd-mm-yyyy	C	The effective start date of the warranty period for an Asset.	Quality assurance
Warranty End Date	dd-mm-yyyy	C	The effective end date of the warranty period for the Asset.	Quality assurance

Asset Class	Site service components	Common /Feature field	Definitions	Attribute usage
			Ancillary site components that supports the infrastructure site functions such as access, security and office equipment	
Attribute name	Attribute unit			
Coordinates (x)	Alpha numeric	C	Geographic coordinates used to define precise positions on the Earth's surface (where an Asset can be located). Coordinates come from the related GIS spatial representation of the Asset held within the GIS database - which currently is the COMPKEY or Equipment ID. The x coordinate represents a point on an east-west axis (longitude). The y coordinate represents a point on a north-south axis (latitude). The z coordinate indicates height or level above or below sea level (expressed in metres to two decimal places).	Geospatial awareness and area based analytics
Coordinates (y)	Alpha numeric	C		Geospatial awareness and area based analytics
Coordinates (z)	Alpha numeric	C		Geospatial awareness and area based analytics
Street Name	Text	C	Relationship to Address	Geospatial awareness and area based analytics
Suburb	Text	C	Relationship to Address	Geospatial awareness and area based analytics
District	Text	C	Relationship to Address	Geospatial awareness and area based analytics
Post Code	Numeric, no decimal	C	Relationship to Address	Geospatial awareness and area based analytics
Linked Documents	Alpha numeric	C	Documents, warranties, specifications, plans/drawings ('as-built'), photos and videos relating to a particular Asset.	Traceability
acquisition value	Numeric, two decimals	C	The purchase price of the Asset (in NZ dollars).	Financial, service performance measure and replacement strategy
acquisition date	dd-mm-yyyy	C	The date that the Asset was purchased/acquired (by Watercare).	Required for valuation and warrantee purposes

Asset Class	Site service components	Common /Feature field	Definitions	Attribute usage
			Ancillary site components that supports the infrastructure site functions such as access, security and office equipment	
Attribute name	Attribute unit			
Project reference	Alpha numeric	FT	The project ID, code or C-number of the project that the Asset was acquired/procured for.	Contractual links and business case documentation to capture decision making history
Start up date	dd-mm-yyyy	C	The date that the asset was first placed into operation	Some assets may be installed but have considerable delays before starting operation. Differential deterioration rates apply
asset designed life	Numeric, no decimal	C	The expected/designed lifetime of an Asset (expressed as a number of years).	Financial, service performance measure and replacement strategy
Service status	Alpha numeric - selection list	C	Asset lifecycle status codes that record the effective dates that an Asset was in a particular state (requires 'service status effective date' attribute as well).	Assets in-service or out of service status is used for analytical purposes on life expectancy as well as Watercare's ongoing liability towards assets that are no longer in used but are still installed.
Condition rating	Numeric, no decimal, selection list	C	Asset lifecycle status codes that record the effective dates that an Asset was in a particular state (requires 'service status effective date' attribute as well).	Analytical input to investment to maintain level of service
Criticality rating	Numeric, no decimal	C	An indicator of the criticality or importance (to the business, production, process, safety) of a particular Asset. Denotes the level of impact/consequence that will result from loss/breakdown of the Asset. If impact to Watercare's business, processes or reputation (of loss or breakdown of an Asset) is high/extensive the criticality rating will also be high.	Analytical input to investment to maintain level of service
Condition assessment date	dd-mm-yyyy	C	The date that the assessment was conducted/determined.	Tracking condition assessment

Asset Class	Site service components	Common /Feature field	Definitions	Attribute usage
			Ancillary site components that supports the infrastructure site functions such as access, security and office equipment	
Attribute name	Attribute unit			
Assessed remaining life	Numeric, no decimal	C	An assessment of the remaining lifetime of an Asset (expressed as a number of years). The value is calculated based on physical evaluation, time in service and condition rating	Financial, service performance measure and replacement strategy
Material type (majority component)	Text - selection list	FT	Describes the (defining) material used to construct the external casing / majority component of the Asset.	Evaluation of deterioration
Calibration authority	Text	FT	The certified/registered 3rd party that completes calibration work	To identify 3rd party quality assurance and liability
Calibration number	Alpha numeric	FT	The reference number of the certification issued with the calibration	To identify 3rd party quality assurance and liability
Calibration expiry date	dd-mm-yyyy	FT	The date by which calibration must be renewed	To identify when calibration needs to be updated
Length	metre (m)	FT	The end-to-end measurement of an asset (expressed in metres to three decimal places).	Geospatial awareness and cost valuation
Width	millimetre (mm)	FT	The extend measurement from side-to-side of an asset (expressed in millimetres).	Geospatial awareness and cost valuation
Height	millimetre (mm)	FT	The extend measurement from base-to-top of an asset (expressed in millimetres).	Geospatial awareness and cost valuation

4.16 Asset Class: Tools

Asset Class	Tools	Common /Feature field	Definitions	Attribute usage
			Handheld devices or devices that are small enough to be moved by hand that aids in accomplishing a work task such as cutting, shaping, measuring or tightening	
Attribute name	Attribute unit			
Sub-type	Alpha numeric - selection list	C	Breakdown of some assets types where required to distinguish asset types to a more granular level	
Sub-type feature	Alpha numeric - selection list	C	A distinguishing feature of a sub-type of asset	To describe a uniqueness or distinguishing feature of an asset sub-type that is important for analytical and functional purposes
Ownership	Text - selection list	C	The entity that that has financial and legislative responsibility of the asset	Future management of assets owned by others
Process	Text - selection list	C	The main media process stream i.e. Water or wastewater	Differentiate media process stream
Operational area	Text - selection list	C	The area where the asset is in operation as managed by the operational business unit	Differentiate operational process areas
Photo/3D model	PDF, Bitmap, Image, file link	C	A live colour photo of the installation or asset within its installed location. Alternative to a photo is a 3D drawing	Visual familiarisation and confirmation
Equipment number	Alpha numeric, Watercare design generated number	C	A unique Watercare generated comprising of the facility, process area code, asset type and its sub-location as a parent asset or child asset within the system that it is installed at.	Unique identification. Reference number used between systems and field identification of assets
Functional area	Alpha numeric	C	The systems and sub-process description of the area where the assets functions and is maintained	To identify the assets' physical location of functionality and where it is maintained in relationship to the plant/process.
Manufacturer/Constructor	Alpha numeric	C	The name of the company/organisation that built/manufactured the Asset.	Quality assurance and traceability. Manufacturer/contractor analysis across assets

Asset Class	Tools	Common /Feature field	Definitions	Attribute usage
			Handheld devices or devices that are small enough to be moved by hand that aids in accomplishing a work task such as cutting, shaping, measuring or tightening	
Attribute name	Attribute unit			
Model/Class	Alpha numeric	C	The model id/number (assigned by the manufacturer) for this Asset.	Quality assurance and traceability. Model/class analysis across assets
Serial Nbr	Alpha numeric	C	The manufacturer's serial number allocated to this Asset.	Quality assurance and traceability
Year of Manufacture / construction	yyyy	C	The year that the Asset was built/manufactured.	Quality assurance, vendor liability and traceability of equipment changes from manufacturer
Weight	Kilogram (kg)	C	The weight of the Asset (expressed as a number of kilograms).	Design baseline (SiD), equipment handling for replacement and maintenance. Onsite material handling equipment or need to hire material handling equipment
Supplier/Vendor	Alpha numeric	C	The name of the company/organisation that sold/supplied the Asset.	Quality assurance and vendor liability
Warranty Start Date	dd-mm-yyyy	C	The effective start date of the warranty period for an Asset.	Quality assurance
Warranty End Date	dd-mm-yyyy	C	The effective end date of the warranty period for the Asset.	Quality assurance
Linked Documents	Alpha numeric	C	Documents, warranties, specifications, plans/drawings ('as-built'), photos and videos relating to a particular Asset.	Traceability
acquisition value	Numeric, two decimals	C	The purchase price of the Asset (in NZ dollars).	Financial, service performance measure and replacement strategy
acquisition date	dd-mm-yyyy	C	The date that the Asset was purchased/acquired (by Watercare).	Required for valuation and warrantee purposes
Project reference	Alpha numeric	FT	The project ID, code or C-number of the project that the Asset was acquired/procured for.	Contractual links and business case documentation to capture decision making history

Asset Class	Tools	Common /Feature field	Definitions	Attribute usage
			Handheld devices or devices that are small enough to be moved by hand that aids in accomplishing a work task such as cutting, shaping, measuring or tightening	
Attribute name	Attribute unit			
Start up date	dd-mm-yyyy	C	The date that the asset was first placed into operation	Some assets may be installed but have considerable delays before starting operation. Differential deterioration rates apply
asset designed life	Numeric, no decimal	C	The expected/designed lifetime of an Asset (expressed as a number of years).	Financial, service performance measure and replacement strategy
Service status	Alpha numeric - selection list	C	Asset lifecycle status codes that record the effective dates that an Asset was in a particular state (requires 'service status effective date' attribute as well).	Assets in-service or out of service status is used for analytical purposes on life expectancy as well as Watercare's ongoing liability towards assets that are no longer in used but are still installed.
Condition rating	Numeric, no decimal, selection list	C	Asset lifecycle status codes that record the effective dates that an Asset was in a particular state (requires 'service status effective date' attribute as well).	Analytical input to investment to maintain level of service
Criticality rating	Numeric, no decimal	C	An indicator of the criticality or importance (to the business, production, process, safety) of a particular Asset. Denotes the level of impact/consequence that will result from loss/breakdown of the Asset. If impact to Watercare's business, processes or reputation (of loss or breakdown of an Asset) is high/extensive the criticality rating will also be high.	Analytical input to investment to maintain level of service
Condition assessment date	dd-mm-yyyy	C	The date that the assessment was conducted/determined.	Tracking condition assessment

Asset Class	Tools	Common /Feature field	Definitions	Attribute usage
			Handheld devices or devices that are small enough to be moved by hand that aids in accomplishing a work task such as cutting, shaping, measuring or tightening	
Attribute name	Attribute unit			
Assessed remaining life	Numeric, no decimal	C	An assessment of the remaining lifetime of an Asset (expressed as a number of years). The value is calculated based on physical evaluation, time in service and condition rating	Financial, service performance measure and replacement strategy
Calibration authority	Text	FT	The certified/registered 3rd party that completes calibration work	To identify 3rd party quality assurance and liability
Calibration number	Alpha numeric	FT	The reference number of the certification issued with the calibration	To identify 3rd party quality assurance and liability
Calibration expiry date	dd-mm-yyyy	FT	The date by which calibration must be renewed	To identify when calibration needs to be updated
IP Rating	Alpha numeric - selection list	FT	Water and dust ingress protection rating for industrial equipment, electrical equipment and instruments	Replacement of like-for like equipment which have been selected at time of design to comply with certain protection criteria for the installed environment, as well as when equipment is rotated or moved to different locations to identify in what areas it may be re-used. Performance indicator for ongoing analysis
Fuel type	Text - selection list	FT	Material such as gas or diesel that is burned in an engine or device to produce heat or power	Fuel type, cost and environmental footprint analysis

4.17 Asset Class: Valves

Asset Class	Valves	Common /Feature field	Definitions	Attribute usage
			A device halting or controlling the passage of a fluid or gas through pipes, ducts and at the inlet or outlet of containment vessels	
Attribute name	Attribute unit			
Sub-type	Alpha numeric - selection list	C	Breakdown of some assets types where required to distinguish asset types to a more granular level	
Sub-type feature	Alpha numeric - selection list	C	A distinguishing feature of a sub-type of asset	To describe a uniqueness or distinguishing feature of an asset sub-type that is important for analytical and functional purposes
Ownership	Text - selection list	C	The entity that that has financial and legislative responsibility of the asset	Future management of assets owned by others
Process	Text - selection list	C	The main media process stream i.e. Water or wastewater	Differentiate media process stream
Operational area	Text - selection list	C	The area where the asset is in operation as managed by the operational business unit	Differentiate operational process areas
Photo/3D model	PDF, Bitmap, Image, file link	C	A live colour photo of the installation or asset within its installed location. Alternative to a photo is a 3D drawing	Visual familiarisation and confirmation
Equipment number	Alpha numeric, Watercare design generated number	C	A unique Watercare generated comprising of the facility, process area code, asset type and its sub-location as a parent asset or child asset within the system that it is installed at.	Unique identification. Reference number used between systems and field identification of assets
Functional area	Alpha numeric	C	The systems and sub-process description of the area where the assets functions and is maintained	To identify the assets' physical location of functionality and where it is maintained in relationship to the plant/process.
Manufacturer/Constructor	Alpha numeric	C	The name of the company/organisation that built/manufactured the Asset.	Quality assurance and traceability. Manufacturer/contractor analysis across assets

Asset Class	Valves	Common /Feature field	Definitions	Attribute usage
			A device halting or controlling the passage of a fluid or gas through pipes, ducts and at the inlet or outlet of containment vessels	
Attribute name	Attribute unit			
Model/Class	Alpha numeric	C	The model id/number (assigned by the manufacturer) for this Asset.	Quality assurance and traceability. Model/class analysis across assets
Serial Nbr	Alpha numeric	C	The manufacturer's serial number allocated to this Asset.	Quality assurance and traceability
Year of Manufacture / construction	YYYY	C	The year that the Asset was built/manufactured.	Quality assurance, vendor liability and traceability of equipment changes from manufacturer
Weight	Kilogram (kg)	C	The weight of the Asset (expressed as a number of kilograms).	Design baseline (SiD), equipment handling for replacement and maintenance. Onsite material handling equipment or need to hire material handling equipment
Supplier/Vendor	Alpha numeric	C	The name of the company/organisation that sold/supplied the Asset.	Quality assurance and vendor liability
Warranty Start Date	dd-mm-yyyy	C	The effective start date of the warranty period for an Asset.	Quality assurance
Warranty End Date	dd-mm-yyyy	C	The effective end date of the warranty period for the Asset.	Quality assurance
Coordinates (x)	Alpha numeric	C	Geographic coordinates used to define precise positions on the Earth's surface (where an Asset can be located). Coordinates come from the related GIS spatial representation of the Asset held within the GIS database - which currently is the COMPKEY or Equipment ID.	Geospatial awareness and area based analytics
Coordinates (y)	Alpha numeric	C	The x coordinate represents a point on an east-west axis (longitude).	Geospatial awareness and area based analytics

Asset Class	Valves	Common /Feature field	Definitions	Attribute usage
			A device halting or controlling the passage of a fluid or gas through pipes, ducts and at the inlet or outlet of containment vessels	
Attribute name	Attribute unit			
Coordinates (z)	Alpha numeric	C	The y coordinate represents a point on a north-south axis (latitude). The z coordinate indicates height or level above or below sea level (expressed in metres to two decimal places).	Geospatial awareness and area based analytics
Street Name	Text	C	Relationship to Address	Geospatial awareness and area based analytics
Suburb	Text	C	Relationship to Address	Geospatial awareness and area based analytics
District	Text	C	Relationship to Address	Geospatial awareness and area based analytics
Post Code	Numeric, no decimal	C	Relationship to Address	Geospatial awareness and area based analytics
Locality	Text - selection list	C	Records the setting or placement of an Asset within its functional area.	Evaluation of deterioration and impact of the setting on the asset performance
Confined Space Located	Text - selection list	C	Indicates if the Asset is located in a confined space.	H&S to show when an asset or classed as a confined space
Hazardous area rating	Alpha numeric - selection list	FT	The safety rating/specification of the Asset.	Replacement of like-for like equipment which have been selected at time of design to comply with certain protection criteria for the installed environment, as well as when equipment is rotated or moved to different locations to identify in what areas it may be re-used.
Linked Documents	Alpha numeric	C	Documents, warranties, specifications, plans/drawings ('as-built'), photos and videos relating to a particular Asset.	Traceability
acquisition value	Numeric, two decimals	C	The purchase price of the Asset (in NZ dollars).	Financial, service performance measure and replacement strategy
acquisition date	dd-mm-yyyy	C	The date that the Asset was purchased/acquired (by Watercare).	Required for valuation and warrantee purposes

Asset Class	Valves	Common /Feature field	Definitions	Attribute usage
			A device halting or controlling the passage of a fluid or gas through pipes, ducts and at the inlet or outlet of containment vessels	
Attribute name	Attribute unit			
Project reference	Alpha numeric	FT	The project ID, code or C-number of the project that the Asset was acquired/procured for.	Contractual links and business case documentation to capture decision making history
Start up date	dd-mm-yyyy	C	The date that the asset was first placed into operation	Some assets may be installed but have considerable delays before starting operation. Differential deterioration rates apply
asset designed life	Numeric, no decimal	C	The expected/designed lifetime of an Asset (expressed as a number of years).	Financial, service performance measure and replacement strategy
Service status	Alpha numeric - selection list	C	Asset lifecycle status codes that record the effective dates that an Asset was in a particular state (requires 'service status effective date' attribute as well).	Assets in-service or out of service status is used for analytical purposes on life expectancy as well as Watercare's ongoing liability towards assets that are no longer in used but are still installed.
Condition rating	Numeric, no decimal, selection list	C	Asset lifecycle status codes that record the effective dates that an Asset was in a particular state (requires 'service status effective date' attribute as well).	Analytical input to investment to maintain level of service
Criticality rating	Numeric, no decimal	C	An indicator of the criticality or importance (to the business, production, process, safety) of a particular Asset. Denotes the level of impact/consequence that will result from loss/breakdown of the Asset. If impact to Watercare's business, processes or reputation (of loss or breakdown of an Asset) is high/extensive the criticality rating will also be high.	Analytical input to investment to maintain level of service
Condition assessment date	dd-mm-yyyy	C	The date that the assessment was conducted/determined.	Tracking condition assessment

Asset Class	Valves	Common /Feature field	Definitions	Attribute usage
			A device halting or controlling the passage of a fluid or gas through pipes, ducts and at the inlet or outlet of containment vessels	
Attribute name	Attribute unit			
Assessed remaining life	Numeric, no decimal	C	An assessment of the remaining lifetime of an Asset (expressed as a number of years). The value is calculated based on physical evaluation, time in service and condition rating	Financial, service performance measure and replacement strategy
Functional output	Alpha numeric - selection list	C	ISA 5 definition associated with instrumentation and mechanical equipment to identify the intended function that the equipment is to perform. This attribute is the output from the equipment e.g. transmitting, controlling, readout or alarm	To differentiate the type of equipment to its intended function. Some instruments and equipment may measure or perform a function other than its type definition affecting equipment analysis, maintenance and replacement considerations
Media Type Wtr/WWtr/chem/gas	Text - selection list	C	Describes the substance that is contained in, processed by or transported by an Asset.	Evaluation of deterioration and impact of media on the asset performance
Material type (majority component)	Text - selection list	C	Describes the (defining) material used to construct the external casing / majority component of the Asset.	Evaluation of deterioration
Calibration authority	Text	FT	The certified/registered 3rd party that completes calibration work	To identify 3rd party quality assurance and liability
Calibration number	Alpha numeric	FT	The reference number of the certification issued with the calibration	To identify 3rd party quality assurance and liability
Calibration expiry date	dd-mm-yyyy	FT	The date by which calibration must be renewed	To identify when calibration needs to be updated

Asset Class	Valves	Common /Feature field	Definitions	Attribute usage
			A device halting or controlling the passage of a fluid or gas through pipes, ducts and at the inlet or outlet of containment vessels	
Attribute name	Attribute unit			
IP Rating	Alpha numeric - selection list	FT	Water and dust ingress protection rating for industrial equipment, electrical equipment and instruments	Replacement of like-for like equipment which have been selected at time of design to comply with certain protection criteria for the installed environment, as well as when equipment is rotated or moved to different locations to identify in what areas it may be re-used. Performance indicator for ongoing analysis
Installation mounting (Wet/Dry)	Text - selection list	C	An extension to the Locality field to the installation setting of certain equipment types	Specific identification of equipment and instruments in wet or dry conditions for performance monitoring
Pressure Rating (kPa) static	kilo-pascal (kPa)	C	The maximum pressure (expressed in kilopascals) that an Asset is designed to operate at (i.e. a pump) or withstand (i.e. pipes).	Replacement of like-for like equipment which have been selected at time of design to comply with certain protection criteria for the installed environment, as well as when equipment is rotated or moved to different locations to identify in what areas it may be re-used. Performance indicator for ongoing analysis
Max Designed Flow	Litres per second (l/s)	FT	The maximum flow rate (expressed in litres per second) that the Asset was designed for / is capable of.	Replacement of like-for like equipment which have been selected at time of design to comply with certain protection criteria for the installed environment, as well as when equipment is rotated or moved to different locations to identify in what areas it may be re-used. Performance indicator for ongoing analysis

Asset Class	Valves	Common /Feature field	Definitions	Attribute usage
			A device halting or controlling the passage of a fluid or gas through pipes, ducts and at the inlet or outlet of containment vessels	
Attribute name	Attribute unit			
Min Designed Flow	Litres per second (l/s)	FT	The minimum flow rate (expressed in litres per second) that the Asset was designed for.	Replacement of like-for like equipment which have been selected at time of design to comply with certain protection criteria for the installed environment, as well as when equipment is rotated or moved to different locations to identify in what areas it may be re-used. Performance indicator for ongoing analysis
Flow test result (l/s)	Litres per second (l/s)	FT	Flow test result for firefighting compliance testing	System analysis. Compliance monitoring
Residual pressure (kPa)	kilo-pascal (kPa)	FT	The residual pressure at the hydrant when tested under full flow conditions	System analysis. Compliance monitoring
Flow test date	dd-mm-yyyy	FT	The date when the flow testing was conducted	System analysis. Compliance monitoring
Diameter (Nominal)	millimetre (mm)	C	The nominal diameter may not match the internal or external (see definitions for internal and external diameter) diameter but is used a size name identification	Naming convention
Torque (input rating)	Newton metre (Nm)	FT	Maximum into force to allow rotation to occur	Replacement of like-for like equipment which have been selected at time of design to comply with certain protection criteria for the installed environment, as well as when equipment is rotated or moved to different locations to identify in what areas it may be re-used. Performance indicator for ongoing analysis
External coating	Text - selection list	C	Describes the protective corrosion or structural coating used on the exterior of the Asset.	Impacts on service life and maintenance scheduling

Asset Class	Valves	Common /Feature field	Definitions	Attribute usage
			A device halting or controlling the passage of a fluid or gas through pipes, ducts and at the inlet or outlet of containment vessels	
Attribute name	Attribute unit			
Internal lining	Text - selection list	C	Describes the protective corrosion or structural coating used on the interior of the Asset.	Impacts on service life and maintenance scheduling
Joining method	Text - selection list	C	The mechanical method by which joints have been assembled	Evaluation of failure mode, servicing of mechanical joints and future connectivity
Length	metre (m)	C	The end-to-end measurement of an asset (expressed in metres to three decimal places).	Geospatial awareness and cost valuation
Width	millimetre (mm)	C	The extend measurement from side-to-side of an asset (expressed in millimetres).	Geospatial awareness and cost valuation
Height	millimetre (mm)	C	The extend measurement from base-to-top of an asset (expressed in millimetres).	Geospatial awareness and cost valuation

4.18 Asset Class: Vehicles

Asset Class	Vehicles	Common /Feature field	Definitions	Attribute usage
			An asset used for the transportation of people or goods	
Attribute name	Attribute unit			
Sub-type	Alpha numeric - selection list	C	Bbreakdown of some assets types where required to distinguish asset types to a more granular level	
Sub-type feature	Alpha numeric - selection list	C	A distinguishing feature of a sub-type of asset	To describe a uniqueness or distinguishing feature of an asset sub-type that is important for analytical and functional purposes

Asset Class	Vehicles	Common /Feature field	Definitions	Attribute usage
			An asset used for the transportation of people or goods	
Attribute name	Attribute unit			
Ownership	Text - selection list	C	The entity that that has financial and legislative responsibility of the asset	Future management of assets owned by others
Process	Text - selection list	C	The main media process stream i.e. Water or wastewater	Differentiate media process stream
Photo/3D model	PDF, Bitmap, Image, file link	C	A live colour photo of the installation or asset within its installed location. Alternative to a photo is a 3D drawing	Visual familiarisation and confirmation
Equipment number	Alpha numeric, Watercare design generated number	C	Car registration number	Unique identification. Reference number
Manufacturer/Constructor	Alpha numeric	C	The name of the company/organisation that built/manufactured the Asset.	Quality assurance and traceability. Manufacturer/contractor analysis across assets
Model/Class	Alpha numeric	C	The model id/number (assigned by the manufacturer) for this Asset.	Quality assurance and traceability. Model/class analysis across assets
Serial Nbr	Alpha numeric	C	Vehicle VIN number	Traceability
Year of Manufacture / construction	yyyy	C	The year that the Asset was built/manufactured.	Quality assurance, vendor liability and traceability of equipment changes from manufacturer
Weight	Kilogram (kg)	C	The weight of the Asset (expressed as a number of kilograms).	Vehicle base data
Supplier/Vendor	Alpha numeric	C	The name of the company/organisation that sold/supplied the Asset.	Quality assurance and vendor liability
Warranty Start Date	dd-mm-yyyy	C	The effective start date of the warranty period for an Asset.	Quality assurance
Warranty End Date	dd-mm-yyyy	C	The effective end date of the warranty period for the Asset.	Quality assurance
Linked Documents	Alpha numeric	C	Documents, warranties, specifications, plans/drawings ('as-built'), photos and videos relating to a particular Asset.	Traceability

Asset Class	Vehicles	Common /Feature field	Definitions	Attribute usage
			An asset used for the transportation of people or goods	
Attribute name	Attribute unit			
acquisition value	Numeric, two decimals	C	The purchase price of the Asset (in NZ dollars).	Financial, service performance measure and replacement strategy
acquisition date	dd-mm-yyyy	C	The date that the Asset was purchased/acquired (by Watercare).	Required for valuation and warrantee purposes
Start up date	dd-mm-yyyy	C	The date that the asset was first placed into operation	Some assets may be installed but have considerable delays before starting operation. Differential deterioration rates apply
asset designed life	Numeric, no decimal	C	The expected/designed lifetime of an Asset (expressed as a number of years).	Financial, service performance measure and replacement strategy
Service status	Alpha numeric - selection list	C	Asset lifecycle status codes that record the effective dates that an Asset was in a particular state (requires 'service status effective date' attribute as well).	Assets in-service or out of service status is used for analytical purposes on life expectancy as well as Watetrcare's ongoing liability towards assets that are no longer in used but are still installed.
Condition rating	Numeric, no decimal, selection list	C	Asset lifecycle status codes that record the effective dates that an Asset was in a particular state (requires 'service status effective date' attribute as well).	Analytical input to investment to maintain level of service
Criticality rating	Numeric, no decimal	C	An indicator of the criticality or importance (to the business, production, process, safety) of a particular Asset. Denotes the level of impact/consequence that will result from loss/breakdown of the Asset. If impact to Watercare's business, processes or reputation (of loss or breakdown of an Asset) is high/extensive the criticality rating will also be high.	Analytical input to investment to maintain level of service
Condition assessment date	dd-mm-yyyy	C	The date that the assessment was conducted/determined.	Tracking condition assessment

Asset Class	Vehicles	Common /Feature field	Definitions	Attribute usage
Attribute name	Attribute unit		An asset used for the transportation of people or goods	
Assessed remaining life	Numeric, no decimal	C	An assessment of the remaining lifetime of an Asset (expressed as a number of years). The value is calculated based on physical evaluation, time in service and condition rating	Financial, service performance measure and replacement strategy
Fuel type	Text - selection list	FT	Material such as gas or diesel that is burned in an engine or device to produce heat or power	Fuel type, cost and environmental footprint analysis

5. Feature Selection Lists for metadata

Bearing type	Thrust	Radial				
Body type	Barrel	Split case	Axial split	Cartridge		
Circuit breaker feature HV	Air	Oil	Gas	Vacuum		
Circuit breaker feature LV	Moulded case	Withdrawable	Miniature			
Comms protocols	4-20mA	Serial	Digital Bus	FF (foundation field bus)	HART	
Condition rating	0-not assessed	1 - very good	2 - Good	3 - Moderate	4 - Poor	5 - Very poor
Confined space	No entry	Not valuated exercise caution	Permit required	Permit not required		
Construction method (pipe)	Tunnelling	Open-cut	Drilling	Re-lined		
Cooling system fitted	No	Yes				
Core type (dams)	Central on impervious foundation	Homogeneous on impervious foundation	Inclined on impervious foundation	Homogeneous on pervious foundation	Central on pervious foundation	Inclined on pervious foundation
Criticality rating	1 – Very low, negligible, no scheduled maintenance, Run to failure	2 – low, Reduced production, Planned preventative maintenance, calendar based	3 – Medium, Loss of production, Condition, predictive risk based maintenance,, design outs	4 – High, Non-compliance incident, Condition, predictive risk based maintenance, design outs	5 – Very high, H&S incident, Condition, predictive risk based maintenance, design outs	0- Not yet assessed
Dam material	Clay	Asphaltic concrete	Concrete	Rock		

Earthquake design function class	1-Low	2 - Moderate	3 - Critical	4 - Essential lifeline						
Energy dissipation	Stilling basin	Riprap	Concrete baffle	Stone lined channel						
External coating	Mortar	Paint (epoxy)	Plastic	Tar	Enamel	Tape	Galvanised	None		
Fall protection	No	Yes								
Frame Size	42C	42	48	48C	48H	56	56C	56H	56HZ	56J
	66	142AT	140T	143AT	143JM	143JP	143T	143TC	143TR	
	144AT	145AT	145JM	145JP	145T	145TC	145TR	146AT	146ATC	147AT
	148AT	149AT	1410AT	1411AT	1412AT	1412ATC	162AT	163AT	164AT	165AT
	166AT	167AT	169AT	168AT	1610AT	182	L182ACY	182AT	L182AT	182JM
	182JP	182T	182TC	182TR	183AT	184	184AT	184JM	184JP	184TC
	184T	184TR	185AT	186ACY	186AT	L186AT	186ATC	187AT	188AT	189AT
	189ATC	1810AT	204	203	213	213AT	213JM	213JP	213T	213TC
	213TR	214AT	215	215AT	215JM	215JP	215T	215TC	215TR	216AT
	217AT	218AT	219AT	219ATC	2110AT	2110ATC	224	225	253AT	254
	254AT	254T	254TR	254TC	254U	255AT	256AT	256T	256TC	256TR
	256U	257AT	258AT	259AT	283AT	284	284AT	284T	284TC	284TR
	284TC	284U	285AT	286AT	286T	286TC	286TR	286TS	286U	287AT
	288AT	289AT	324	323AT	324AT	324TR	324TS	324U	325AT	326
	326AT	326T	326TR	326TS	326U	327AT	328AT	329AT	363AT	364
364AT	364S	364T	364TR	364TS	364U	365	365AT	365T	324T	
365TR	365TS	366AT	365U	364AT	367AT	368AT	369AT			
fuel type	Diesel	Petrol	Electrical	Gas	None					

Functional area (pipe)	Drainage	Scour	Sampling	Process	Bridge	Pipework	Protective ducting	Domestic service connection	Commercial service connection	Fire suppression service connection
	Domestic and commercial service connection	Domestic and fire suppression service connection	Commercial and fire suppression service connection	Domestic, commercial and fire suppression service connection	Standard	Other (free text)				
Functional area (retaining structures)	Overflow	Discharge	Flow monitor	Other						
Functional output (FAN)	Fan supplying air	Fan extracting air	Blower							
Functional output (pump)	Process	Measured supply/dosing	Pressure/lift	Vacuum						
Functional output (valves)	I-isolation	B- bypass	R-Regulating	PR-Pressure reducing	PS- Pressure sustaining	RV-Pressure relief	FC- Flow control	L-Level control	D- draindown/ discharge	F-Firefighting
	BC-Burst control	FD- Flow direction	v- air/vacuum break	BFP- Backflow prevention						
Impellor Type	Closed channel	Semi-open	centrifugal screw	Propeller	Vortex	Macerator	Shredder			
Ingress protection rating	IP52	IP51	IP53	IP54	IP55	IP56	IP57	IP58	IP61	IP62
	IP63	IP64	IP65	IP66	IP67	IP68				
Installation mounting	Dry	Wet								
Installation Orientation	Vertical	Horizontal								
Insulation class	Class B	Class A	Class F	Class H						

Internal lining	Paint (epoxy)	Mortar (cementitious lining)	Enamel	Plastic	Galvanised	Polyvinyl Chloride (PVC)	Polyethylene (PE)	None		
Jointing method	Flanged	Welded	Mechanical restrained	Unrestrained	Socket	Threaded	Not stated			
Lid type (multi-option)	Safety grille fitted	Hinged	Locked	Bolt-down	Removable	None				
Locality	Indoor	Outdoor	Underground	Exposed						
Material type (civil)	Concrete	Clay	Earth	Reinforced concrete	Un-reinforced concrete	Steel	Rock	Plastic	Masonry	Wood
Material type (Mechanical and pipe)	Glass reinforced (GRP)	Concrete	Plastic	Masonry	Polyethylene (PE)	Concrete lined steel (CLS)	Epoxy lined steel (ELS)	Un-plasticised polyvinyl chloride (uPVC)	Modified polyvinyl chloride (PVC-M)	Oriented polyvinyl chloride (PVC-O)
	Ductile iron (DI)	Cast iron (CI)	Stainless steel	Asbestos cement (AC)	Brass	Aluminium	Fibreglass	Stainless steel	Fibreglass reinforced plastic	Mild steel
	Vitrified clay	Copper	Acrylonitrile butadiene chloride (ABS)	Polypropylene (PP)	Alkathene	Wood				
Measured output (Deviation element (gauge))	Pressure	Tipping	Temperature							
Measured output (instruments)	Cl - Chlorine Gas	H - Hydrogen Gas	CH4 - Methane	H2S - Hydrogen sulphide	C02 - Carbon dioxide	O2 - Oxygen	CP- Chlorine/pH Combined	DO - Dissolved Oxygen	F - Fluoride	MS - Moisture Content
	NH4 - Ammonia	N03 - Nitrates	N02 - Nitrites	PC - Particle Counter	pH - pH	SS - Suspended Solids	SC - Streaming Current	TB - Turbidity	TOC - Total Organic Content	TPH - Total Petro Hydrocarbons
	UVI - Ultra Violet Intensity	UVT - Ultra Violet Transmissivity								

Measured output (Water monitoring)	Surface water monitoring (metre)	Ground water monitoring (metre)	Derived values (Flow rate, storage volume, etc.)							
Measured output (Weather station)	Rain gauge (mm)	humidity (%)	wind direction (degrees)	air temperature (degC)	wind speed (km/hr)	wind gust (peak speed, km/hr)	wind run (average speed (km/hr)			
Media type	Hydrogen	Chlorine	Methane	Hydrogen sulphide	carbon dioxide	Oxygen	Fluoride	Ammonia	Potable water	Raw/untreated water
	Wastewater									
Nominal diameter	20mm	15mm	25mm	36mm	40mm	50mm	60mm	80mm	100mm	150mm
	250mm	200mm	300mm	350mm	400mm	450mm	500mm	600mm	700mm	750mm
	900mm	800mm	1000mm	1200mm	1400mm	1600mm	1800mm	2000mm	2200mm	2400mm
	3000mm	2800mm	3200mm							
Operational area	Headworks	Plant	Transmission	Local networks						
Overflow	Integrated with structure	Internal piped	Externally piped	Non-engineered	None					
Ownership	Other	Watercare								
Phases	Three	Single								
Process	Wastewater	Water	Multi-function							
Quality of radio path	1- very good	2- good	3- average	4-poor	5-very poor					
Resilience rating	2-Marginal, adaptive but with system constraints or reduced level of service	1-Poor, not adaptive, complete loss of level of service	3-Good, adaptive	4-Excellent, very adaptive/diverse with multiple redundancy options						
Service status	Entered	Acquired	Available	Operational	Abandoned	Disposed				

Shaft coupling type	Fixed	Flexible	Hydraulic	Magnetic	Disconnect	Belt	Close coupled
Spillway type	Chute	Ogee	Side channel	Shaft	Siphon	None	
Stroke controller fitted	Yes	No					
Sub type feature (Carbon filters)	Granular activated carbon	Powder activated carbon					
Sub type feature (Dampers)	Round type	Louvre/blade type					
Sub type feature (chambers and manholes)	Operator access only type	Operator and equipment access					
Sub type feature (containment structures)	Heated	Un-heated					
Sub type feature (Damper)	R-Round type	L- Louver/blade type					
Sub type feature (FAN)	Belt driven	Direct coupled					
Sub type feature (Marker)	Location indication	Movement indication	Survey/Set-out point				
Sub type feature (pump)	SUB-Submersible	VAC- Vacuum					
Sub type feature (submersible pressure transducer)	Vented	Non-vented					
Sub type feature (valves)	H - Operated by Hand	A - Air actuation	P-Hydraulic actuation	E- Electrical actuation			
Sub type feature (Water meter)	Magnetic	Mechanical	Ultrasonic				

Sub type feature (Water monitoring)	Vented	Non-vented
Sub type feature (Weather station)	Flexible mast,	Non-flexible mast

Sub-type feature (Antenna feeder cable)	RG178B/U	RG179	RG174/U	RG58C/U	CELLFOAM™	CELLFOIL™	LMR-195	LMR-200	10D-FB Type	RG8 Type
	RG142B/U	RG223/U	RG59B/U	RG62A/U	RG11/U	LMR-240	RG213/U	RG214/U		
	1/4" Superflex	3/8" Superflex	1/2" Superflex	LMR-400	1/4" HELIAX®	3/8" HELIAX®	1/2" HELIAX®	7/8" HELIAX®	1¼" HELIAX®	1½" HELIAX®
Sub-type feature (Antenna)	Horizontal polarisation	Vertical polarisation								
Sub-type feature (DCS/SCADA field cabinet) multi-selection of	Cabinet	Vent	Fan	Heater	Temperature monitor	Filter				
Sub-type feature (for gates)	Swing type	Slide gate	Motorised							
Sub-type feature (Radio) multi-selection of	Transceiver (transmitter /receiver)	Redundancy module feeder	Lightening arrestor	Hot standby unit						
Sub-type feature Software	Windows	MAC	Linux	Citech	Archestra	InTouch	DeltaV	Filter manager	Dosing control	Pump control
	Antivirus	PI datalink	(free text)							
Switch HV feature	Air	Gas	Oil							
Switchboard feature	Main power reticulation	Motor control centre								
Transformer feature	Air, natural	Air, forced	Oil							
Vegetation condition	1- very good	2- good	3- average	4-poor	5-very poor					
Voltage type	dc	ac								

Water monitoring submersed pressure transducer feature	Vented	Non-vented	
Weather station feature	Flexible mast	Non-flexible mast	

6. Dynamic data

Dynamic data comes from assets that are monitored through SCADA and DCS systems. The data is collected in the PI, InfoNet and Asset management databases. Dynamic data is the runtime and physical performance of the asset.

Runtime data includes the continual measurement of:

- Temperature
- Pressure
- Torque
- Noise/vibration level
- Speed
- Energy consumption
- Set points
- Alarms
- Run hours/time
- Levels/Overflows

7. External data sources

External data sources are data maintained in databases outside of Watercare that can be added or layered geospatially over assets in their installed environment for further performance analysis that includes effects of location such as ground conditions, coastal or inland setting or others such as population models. Data from these databases are assigned with a confidence rating.

The external data sources directly considered by Watercare are:

- Auckland geotechnical database
- NIWA Climate database
- MetService
- Auckland population database

Part C: Data preparation at design

1. Creating drawings

Engineering drawings shall be completed to the requirements of Watercare's Standard for producing CAD drawings.

In addition, drawings created for local network applications should be compiled to automate the as-built capturing process.

Note: Blackbox 22 is currently setup for use in Local networks only with Watercare internal contracts at a licencing fee. Transmission and other assets vested by developers are excluded from its use at this stage, but it is encouraged to use software to make this process easier and accurate.

2. Information on material selection

The design shall collect, at an early stage, the minimum data requirements as per material selected for its design purposes and further complete the data elements as procurement progresses through construction and delivery. The data collection shall include:

- The metadata of the material as described in Part B
- Maintenance schedules
- Installation manuals
- Product Operation and Maintenance manuals

3. Design data parameters

The design shall collect, at an early stage, the minimum data requirements for:

- Design specific parameters
- The metadata sets refer Part B, section 6
- Operational settings (Standard Operating Procedures and Functional description) refer Part D, section 3
- O&M manuals refer Part D, section 2

4. Equipment numbering

4.1 General principles

An equipment number is a unique identifier within Watercare to describe individual pieces of equipment.

Equipment numbers generated by this equipment numbering system applies to:

- Treatment facilities
- Transmission linear pipelines and associated facilities that include pump stations, reservoirs and booster plants. Network linear pipelines don't receive a number but are generated hierarchically the same by following the same allocation for facility name (zone or catchment) and the process area.
- Local network pump stations

Equipment numbering by this system does not apply to local network linear assets where a Component Key is assigned to the asset and there is no field labelling.

Assets are numbered in the field with an equipment number as identified on the P&ID drawings and within the asset management systems to allow traceability and the effective management of the asset. All process plants and medium to high impact linear infrastructure shall have an accompanying P&ID drawing(s) and numbered to this standard.

Based on the systems that Watercare is currently using the equipment number can only be up to 16 characters long:

- DELTA V – maximum 16 characters (lowest denominator)

- The AMIS – maximum 30 characters
- SCADA – maximum 40 characters

A representation of the integration with Watercare’s asset management systems is given below:

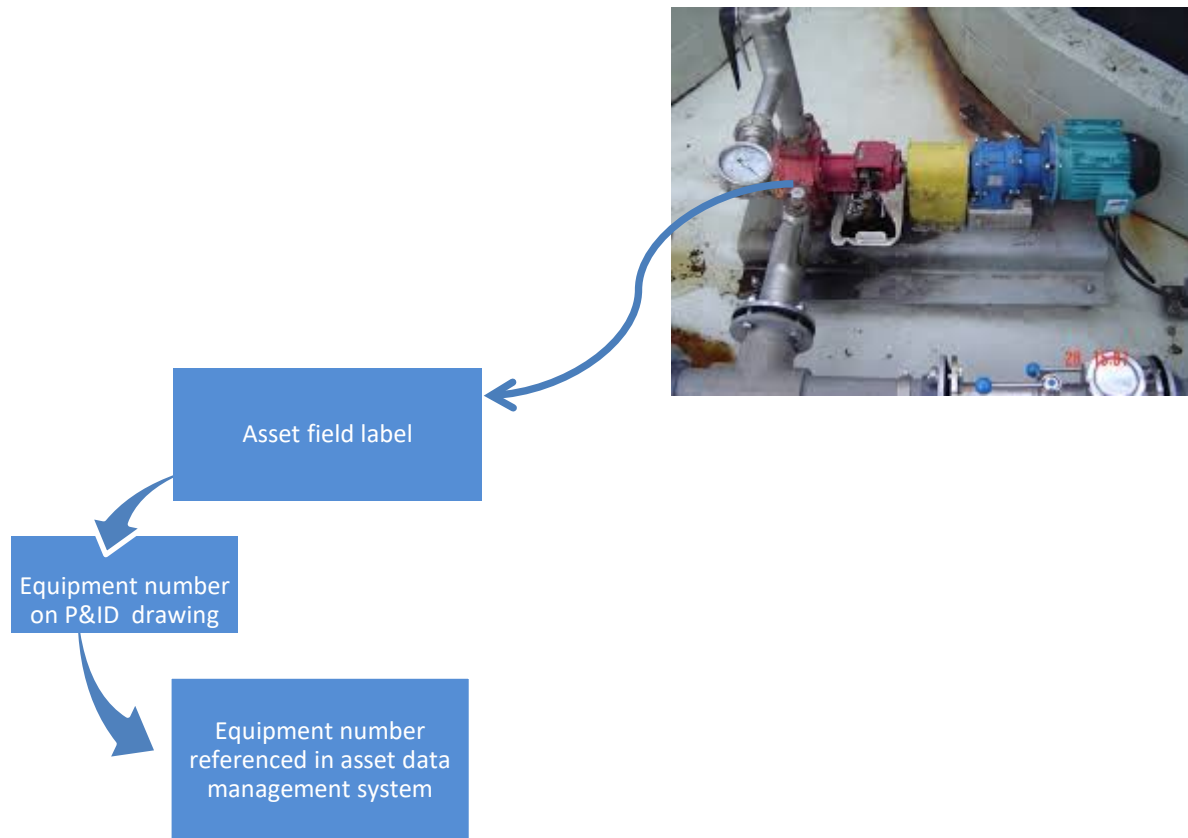

4.2 Equipment number hierarchy

The numbering system distinguishes between **primary equipment** and all other equipment associated with the primary equipment, the **secondary equipment** i.e. parent/child relationship.

Primary equipment related to processes will usually be equipment that stores a material, or changes the nature, pressure, temperature, or energy level of the material, and includes Tanks, Vessels, Filters, Pumps, and Compressors. The primary equipment will have associated equipment that monitors and controls parameters such as level, flow and pressure

The primary number is based on the functional location and within a specific process area. This enables a linkage to be made between a primary equipment item and its associated secondary equipment through sharing this unique number.

Examples:

STARD-54-TK-12

Ardmore Water Treatment Plant, Filtration, Tank 12

DTMAN-39-TK-01

Mangere Wastewater Treatment Plant, Blended Sludge, Tank 01

The numbering system establishes a sequence of primary equipment groups, increasing in the main process flow direction, as far as practical. This dictates the order in which sequential numbers are allocated amongst a range of equipment groups (group code) within a given process/functional area.

The secondary equipment number then derives from the primary equipment number. Secondary equipment for the above primary equipment example is shown below:

STARD-54-LIT-121 Ardmore Water Treatment Plant, Filtration, Tank 12, Level Transmitter 1

DTMAN-39-AAV-011 Mangere Wastewater Treatment Plant, Blended Sludge, Tank 01, Inlet Valve 1

Unless otherwise required by the loop and analyser numerical identifier rules (refer to section 4.5), the sequential number starts at 1 for the first associated equipment item of a particular type installed on a particular primary equipment item and increases by 1 for each successive associated equipment item of that type installed on that particular primary equipment item. Numbering starts at 1 again for each other type of associated equipment installed on the primary equipment item.

The primary equipment numbers are issued by the Watercare Operations at the preliminary design stage. The secondary equipment numbers are generated by the designer but must be reviewed with Watercare to ensure the correct hierarchy is followed.

4.3 Equipment number elements

The equipment number is made up of four nested parts, as per the following diagram.

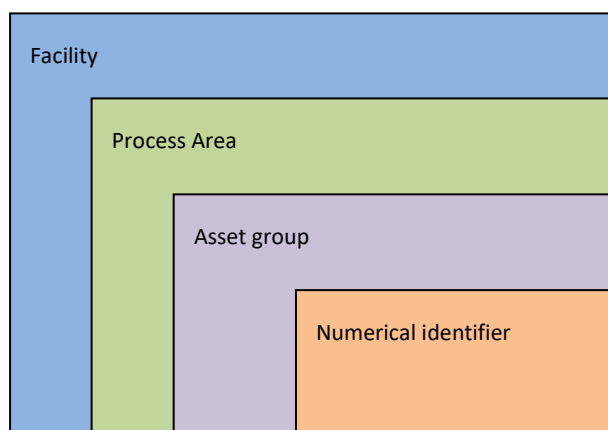

An example of primary number broken down to individual elements is shown below:

STARD-54-TK-12 Ardmore Water Treatment Plant, Filtration, Tank 12

Part	Description	Refer to Section
STARD	Facility Code	4.3.1
54	Process (Functional) Area	4.3.2 & 5.1

Part	Description	Refer to Section
TK	Asset Group Code	4.3.3 & 5.2
12	Numerical Identifier	4.3.4

4.3.1 Facility code

The facility codes lists are held internal to Watercare and provided after consultation with Watercare Operations. This is to avoid confusion in facility assignment and to ensure that new facilities such as a local network pump station is not already assigned.

Examples:

STARD-54-TK-12 **Ardmore Water Treatment Plant**, Filtration, Tank 12

WMHN3-91-LV-02 **Hunua No.3 Watermain**, Treated water, Line Valve Station 2

DTMAN-39-TK-01 **Mangere Wastewater Treatment Plant**, Blended Sludge, Tank 01

Equipment is assigned to the facility that it provides the service to. In explanation if equipment is located on one facility but serves another facility (exclusively), then the facility code used must be to the facility that it serves.

Example: Compressor located within the Huia village filter station is used **exclusively** for the Lower Huia dam aeration therefore the equipment is associated with the Lower Huia dam.

SDLHU-10-CM-31 **Lower Huia Dam**, Aeration, Air Compressor

Where equipment is shared between two or more facilities, then the facility code at which the equipment is located shall be used.

Example: The PLC physically located in the Khyber pump station is **shared** use with the pump station and all the Khyber reservoirs.

WPKHY-91-PLC-X01 **Khyber Pumping Station**, Treated Water, **multiple function area** (shared), PLC 01

4.3.2 Process area

The process area code provides a breakdown of the facility into groups of equipment, related by being part of the same process or functional area of a facility. The codes are determined by Watercare and from time-to-time amended or added to. Refer to section 5.1 for the process area code lists.

Examples:

STARD-**54**-TK-12 Ardmore Water Treatment Plant, **Filtration**, Tank 12

DTMAN-**39**-TK-01 Mangere Wastewater Treatment Plant, **Blended Sludge**, Tank 01

4.3.3 Asset group

The asset group identifies the type of equipment. The codes are determined by Watercare and from time-to-time amended or added to. Refer to section 5.2 for the asset group code lists.

Examples:

STARD-54-TK-12	Ardmore Water Treatment Plant, Filtration, Tank 12
DTMAN-39-TK-01	Mangere Wastewater Treatment Plant, Blended Sludge, Tank 01

4.3.4 Numerical identifier

The numerical identifier consists of the primary equipment identifier and in the case of secondary equipment the primary equipment identifier that the equipment is associated with and the sequential equipment digit.

4.3.4.1 Primary equipment identifier

The numerical identifier is a sequential number starting at the first of the **highest ranking** primary equipment type in a particular process (functional) area and increasing by 1 for each successive primary equipment item of this type in the process area. For primary equipment, the numerical identifier will have only two digits.

Examples:

STARD-54-TK-12	Ardmore Water Treatment Plant, Filtration, Tank 12
DTMAN-39-TK-01	Mangere Wastewater Treatment Plant, Blended Sludge, Tank 01

Ranking is used to identify fundamental equipment in the same process area.

Ranking	Primary Equipment Type
1 st	Equipment fundamental to the process area. Examples: Filters to filtration, clarifiers to clarification, thickening systems
2 nd	All other primary equipment numbered in the direction of process flow as far as is practicable. Examples: Bulk tanks, pumps, day tanks, dose pumps

Second ranking equipment is numbered in the direction of the process flow. Each group of equipment that performs the same function within a process area is allocated a block of 10 numbers (1 to 10, 11 to 20, 21 to 30 etc.).

Unit 1 of a group takes number 1 or 11 or 21, etc. Unit 2 of a group takes number 2 or 12 or 22 etc. Paired units are therefore 1 and 2, 11 and 12, 21 and 22 etc. For example, the equipment codes for a lime dosing system may be:

Bulk tank 1	TK-01
Bulk tank 2	TK-02
Transfer pump 1	PU-11

Transfer pump 2	PU-12
Dose tank 1	TK-21
Dose tank 2	TK-22
Pre-lime dose pump 1	PU-31
Pre-lime dose pump 2	PU-32
Post lime dose pump 1	PU-41
Post lime dose pump 2	PU-42

Appropriate gaps should be left for future expansion where it is known that an expansion will take place. For example, a plant where additional filters will be added may be:

Existing filters	TK-01 to TK-22
Future filters	TK-23 to TK-40
Backwash pumps 1 & 2	PU-41 & PU-42
Air scour blowers 1 & 2	PU-51 & PU-52

In this case, the filters are the highest-ranking primary equipment in this area so has been numbered first.

This procedure results in unique numerals for all primary equipment items in the same process area. This enables display of the linkage between primary equipment and its associated equipment through inclusion of the primary equipment numeral within the associated equipment numeral.

Plant specific records must be maintained to identify future available numbering gaps.

Equipment associated with multiple primary equipment, or with no primary equipment have an X in place of the primary equipment identifier (there being no primary number link) followed by the secondary equipment identifier.

Example:

WPKHY-91-PLC-X01 Khyber Pumping Station, Treated Water, multiple function area (shared), PLC 01

4.3.4.2 Secondary equipment identifier

Secondary equipment is identifiable by the presence of more than two-digit numerical identifiers. For secondary equipment, the numerical identifier will have three or four digits. It consists of the primary equipment numerical identifier as the first two digits, and a sequential number for the final digit.

Example:

STARD-54-AAV-121 Ardmore Water Treatment Plant, Filtration, associated primary equipment (Tank 12) Inlet Air Actuated Valve 1 (AAV-121 read as "AAV twelve-one")

DTMAN-39-LIT-011 Mangere Wastewater Treatment Plant, Blended Sludge, associated primary equipment (Tank 01), Level Transmitter 1 (LIT-011 reads as "LIT zero one-one")

The number of secondary equipment associated to primary equipment has a limit of up to 99. Where the equipment identifier becomes four digits long, the last three digits indicates the secondary equipment identifier.

Example:

DTMAN-39-HV-**0121**

Mangere Wastewater Treatment Plant, Blended Sludge, **associated primary equipment (Tank 01)**, hand valve **21**

4.4 Loop and instrument duplication rules

The sequential numbering of instruments, controllers and controlled equipment in the same loop is subject to rules for loop and analyser numbering and will have the same numerical identifier.

This identifier will be unique for any particular type of control loop (e.g. prefixes F, T, P, L, A) within a given process area.

Letters shall be used to differentiate between equipment with identical alphabetic codes that are part of the same control loop e.g. LCV-021A and LCV-021B, and duplicate instruments e.g. AIT-X13A and AIT-X13B.

Figure: Sample P&ID showing Equipment Numbers and Instrument Loops

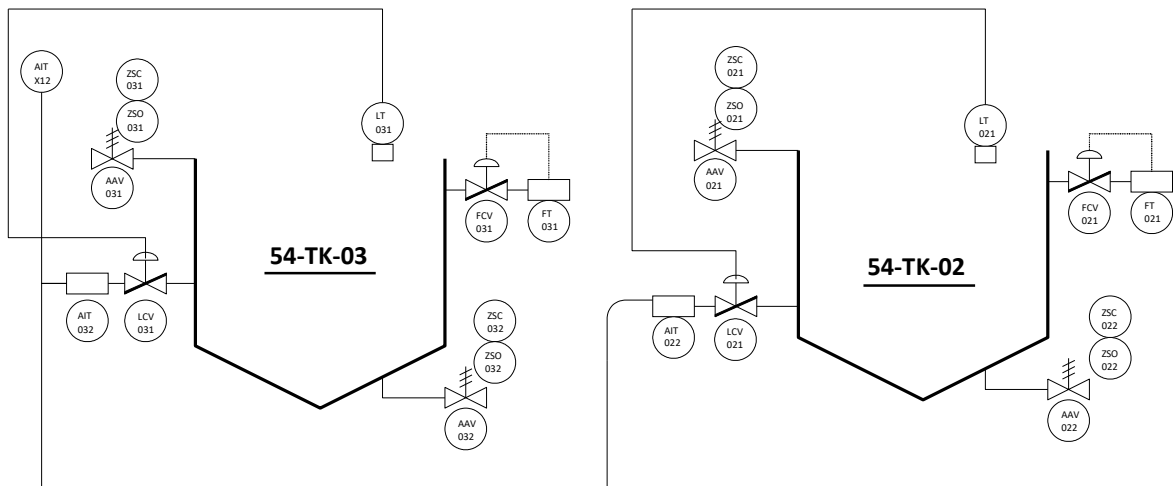

4.5 Process pipe (line) numbering

Process pipework numbering is made up of six elements nested as shown below:

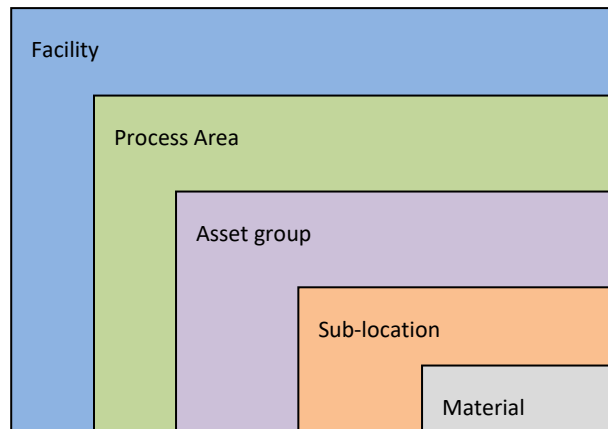

An example of a pipe line number broken down to individual elements is shown below:

STARD-49-PW-613-ELS-100

Ardmore Water Treatment Plant, PAC plant, Potable water line, sub-location 613, epoxy lined steel of 100mm diameter

Part	Description	Refer to Section
STARD	Facility Code	4.3.1
49	Process (Functional) Area	4.3.2 & 5.1
PW	Service Code	4.3.3 & 5.4
613	Sub-location	4.3.4
ELS	Line material	4.7.2.4 & 5.3
100	Size (mm - ISO nominal)	-

4.6 Water treatment specific requirements

4.6.1 Water Quality Analysers

To assist operators to differentiate between water analysers such as chlorine, turbidity and fluoride which are not differentiated by the ISA codes, the final digit of the identifier code shall be as follows for water quality analysers:

Streaming Current	AIT-xx 1 , AIC-xx 1
Turbidity	AIT-xx 2 , AIC-xx 2
Chlorine	AIT-xx 3 , AIC-xx 3
pH	AIT-xx 4 , AIC-xx 4
Fluoride	AIT-xx 5 , AIC-xx 5
Hydrocarbons	AIT-xx 6 , AIC-xx 6
UV Absorbance	AIT-xx 7 , AIC-xx 7
Particle Counter	AIT-xx 8

The primary numerical identifier is 'xx' if the analyser is associated with only one primary equipment item, or X when non-specific to a primary equipment item followed by a sequential number starting at 1 and sequentially for each successive analyser of the same type installed in the process area.

Example:

STARD-55-AIT-**X12** Ardmore Water Treatment Plant, Filtered Water, **Turbidity Analysing Indicating Transmitter 1**

4.7 Linear water assets specific numbering requirements

Transmission pipelines are operated as facilities. Local network linear assets are not operated as facilities but follows the same hierarchy principles for the top two tiers (see Part B, Section 2). Pump stations within networks and the associated instrumentation and electrical systems follow the same principles for sections 4.1 to 4.6 and 4.9.

For linear assets, primary equipment is defined as particular groupings of equipment that combine to perform a particular function that includes, scour valve installations, line valve stations, pressure control stations and flow metering stations.

Secondary equipment associated with the primary equipment is numbered in association with the primary equipment.

4.7.1 Pipeline sections

Pipeline sections are the segments of pipeline between valves, chambers, size changes, and pipe bridges or tunnels. The pipeline sections may have associated equipment such as; bypass pipes, scour pipes, air release valves, line valves and wet or dry chambers. The pipe section sub-location changes with each section.

The below example demonstrates the sub-location change from upstream to downstream of a dry chamber with line valve chamber.

Example: wastewater

DSWIN-82-01 Western interceptor, gravity pipes, [section 1](#)

Example: water

Upstream:

WMHN4-91-WM-01 Hunua no.4 watermain, treated water pumped, watermain, [section 1](#)

Downstream:

WMHN4-91-WM-02 Hunua no.4 watermain, treated water pumped, watermain, [section 2](#)

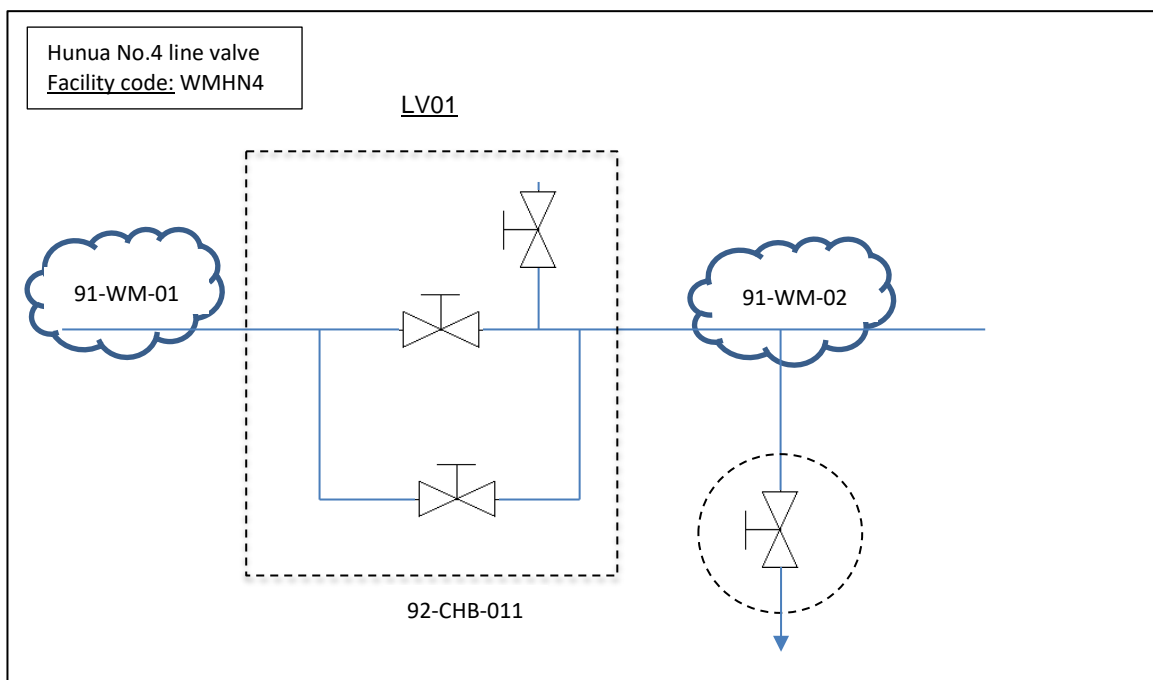

4.7.1.1 Pipeline cross connections

A cross connection connects one pipe to another. The cross connection numbering refers the facility code of the watermain from which the water is supplied under normal operation. Where there is no operational preference, the supply with the higher hydraulic height is used. The associated pipework shall start and end at the connections to the pipe.

A process area code identifies the cross connection.

Example:

WMWT1-96-FCV-XC01	Waitakere No1 Treated Watermain, Cross Connection , Flow Control Valve 1
-------------------	---

Note – where a branch main is connected from a cross connection, the cross connection become part of the branch main, refer to section 4.7.1.2.

4.7.1.2 Branch pipe mains

Branch mains are separate facilities that are branched off from a pipe facility to service a different area.

An example of this principle is the Mangere no.1 watermain that is branched off from the Hunua no.3 watermain at a line valve chamber. The numbering of the branch main will have a new facility code and numbering follows sequentially from the first valve connection with the supplying facility main.

Where a branch main is supplied from more than one watermain into, or from a cross connection, the branch main includes the connections off the individual mains and the cross-connecting valve layout. To identify the duplicated supplies, an alphabetic suffix is used following sequentially from the larger mains.

Example:

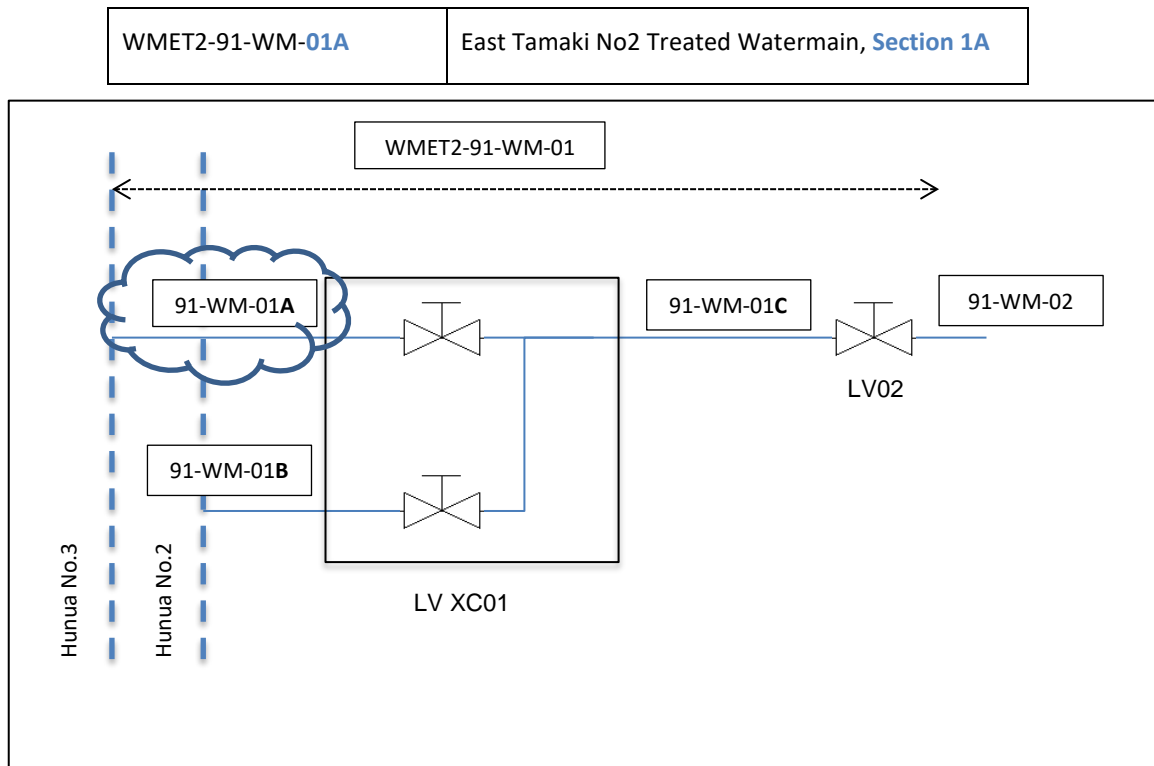

4.7.2 Line valve chambers

The line valve chamber and associated equipment follows the same principles as described under section 4.2 where the line valve chamber is the primary equipment. A line valve chamber with associated bypasses and chamber(s) therefore separates two sections of pipe main as per section 4.7.1. Note that pipe structures and equipment immediately associated with the line valve chamber function is included under the same location

Example: Line valve no. 1 on the Hunua No.4 watermain

Primary equipment location	
WMHN4-92-LV01	Hunua no.4 watermain, Line valve 1 - Note , for linear assets this is not an actual asset, but a functional location only to identify the structure in the asset system.
Equipment numbering	
WMHN4-92-CHB-011	Hunua no.4 watermain, Line valve 1, Chamber 1
WMHN4-92-HV-011	Hunua no.4 watermain, Line valve 1, Hand valve 1
WMHN4-92-HV-012	Hunua no.4 watermain, Line valve 1, Hand valve 2
WMHN4-92-PIPE-011	Hunua no.4 watermain, Line valve 1, Pipe 1
WMHN4-92-HV-013	Hunua no.4 watermain, Line valve 1, Hand valve 3
<i>Scour valve arrangement functionally associated with line valve 1</i>	
WMHN4-92-PIPE-012	Hunua no.4 watermain, Line valve 1, Pipe 2
WMHN4-92-HV-014	Hunua no.4 watermain, Line valve 1, Hand valve 4
WMHN4-92-CHB-012	Hunua no.4 watermain, Line valve 1, Chamber 2

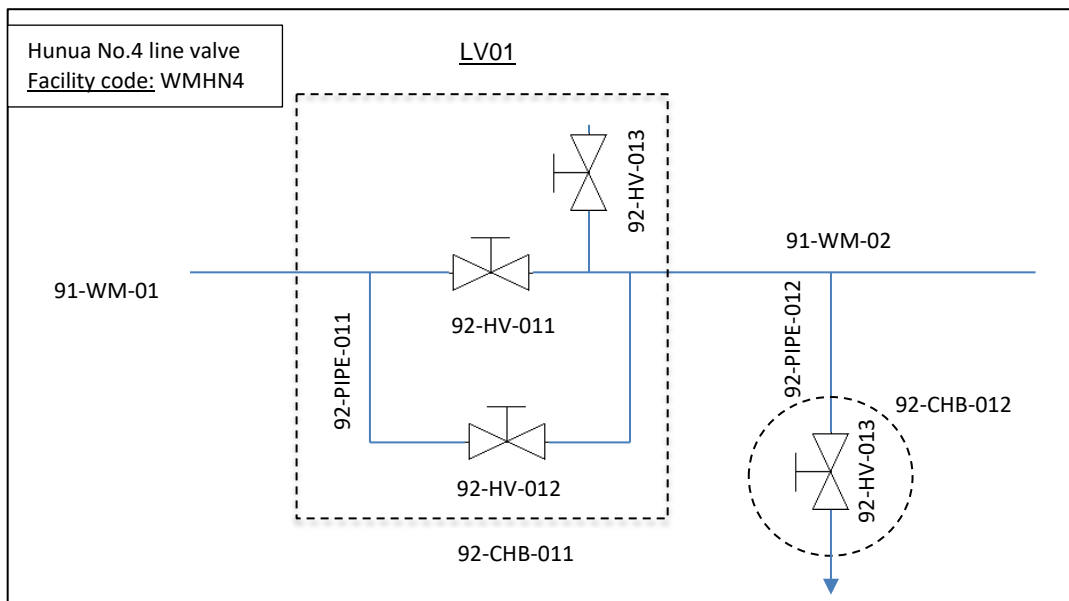

Numbering of line valves follow sequentially in the direction of flow from the first line valve chamber on the pipe main.

When additional line valve chambers are added within an existing scheme, the new line valve chamber is identified by adopting an alphabetic suffix to the asset group code.

Example: schematic representation of inserting new primary equipment

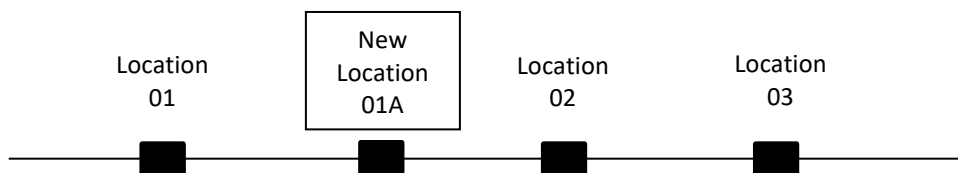

4.7.3 Water bulk supply points (SP)

A bulk supply point consists of all equipment inside the supply point chamber and the pipework to the supply point chamber from the watermain. Bulk supply points will typically have a meter installed but differs from flow metering stations and control stations in that the primary function is not to monitor flow through the pipe main, but to measure the flow supplied into local network from the supply point.

Example:

Primary equipment location

WMHN3-93-SP02

Hunua No.3 watermain, **Supply point 2** - **Note**, for linear assets this is not an actual asset, but a functional location only to identify the structure in the asset system.

Equipment numbering

WMHN3-93-STR-021 Hunua No.3 Treated Watermain, Supply point 2, **Strainer 1**

4.7.4 Flow metering station (FM)

A flow metering station consists of all equipment inside the flow metering chamber. Its primary function is to monitor the flow within a pipe main and may include associated equipment such as valves, meters and telemetry.

Primary equipment location

WMHN3-95-FM01 Hunua No.3 watermain, **Flow metering station 1 - Note**, for linear assets this is not an actual asset, but a functional location only to identify the structure in the asset system.

Equipment numbering

WMHN3-95-FIT-011 Hunua No.3 Treated Watermain, Flow Metering station 1, **Flow indicator transmitter 1**

4.7.5 Flow control station (FC)

A Flow Control Station consists of all equipment inside the flow control chamber. Its primary function is to control the flow within the reticulation system and may include associated equipment such as valves, meters and telemetry.

Example:

Primary equipment location

WMHN3-94-FC01 Hunua No.3 watermain, **Flow control station 1 - Note**, for linear assets this is not an actual asset, but a functional location only to identify the structure in the asset system.

Equipment numbering

WMHN3-94-FCV-011 Hunua No.3 Treated Watermain, Flow Control Station 1, Flow Control Valve 1

4.7.6 Wet chambers, manholes and wastewater pipelines

For wastewater there is a difference to water facilities in that manholes chambers have the same process area as the wastewater pipe that it is installed on.

Wastewater pipe:

DSWIN-82-01 Western interceptor, **gravity pipes, section 1**

Manhole:

DSWIN-82-MH-01 Western interceptor, gravity pipes, **manhole 1**

The numbering for wastewater pipe and manholes continue sequentially and the manhole number will be associated with the upstream pipe.

Example: Wastewater manhole number is associated with downstream pipe number and its direction.

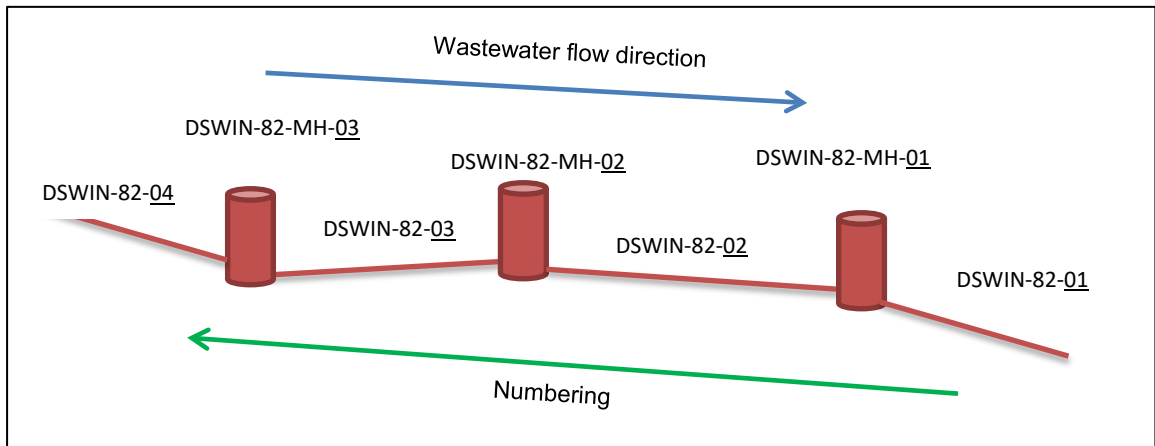

4.8 Electrical equipment specific requirements

The electrical equipment number is made up of four nested elements as shown below:

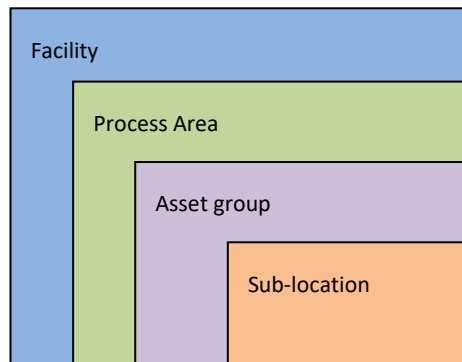

An example of an electrical equipment number broken down to individual elements is shown below:

STHUI-01-PLC-X02 Huia Water Treatment Plant PLC 2

Part	Description	Refer to Section
STHUI	Facility Code	4.3.1
01	Process (Functional) Area	4.3.2 & 5.1
PLC	Asset group Code	4.3.3 & 5.2
X02	Sub-location	4.3.4

4.8.1 Type 1 Electrical Equipment

The sub-location is split to include the associated primary equipment sub-location in the first two digits, with the final digit being a sequential number.

Equipment associated with multiple primary equipment, or with no primary equipment has an X in place of the primary sub-location.

The Process (functional) area code 02 in water and 06/07 in wastewater shall be used if the equipment is in a general plant area and unrelated to a particular process area. Where the electrical equipment is associated with a specific process only, then the equipment is listed under that process code and not code 02 in water and 06/07 in wastewater.

Examples:

STARD-05-FPS-X01	Ardmore Water Treatment Plant, Fire and security, Fire Protection System 1
STWKO-02-SWBD-X01	Waikato Water Treatment Plant, Electrical, Main Switchboard
STARD-54-FCAB-X01	Ardmore Water Treatment Plant Filtration Field Cabinet 1
STARD-54-FCAB-211	Ardmore Water Treatment Plant, Filtration, Filter 21 Field Cabinet 1
STARD-70-VSD-221	Ardmore Water Treatment Plant, Alum/PACL, Variable Speed Drive

4.8.2 Type 2 Electrical Equipment

Equipment such as terminal blocks, power supplies, and motor heaters are not allocated equipment numbers. However, items such as emergency stop buttons and isolation switches must be identified with labelling as required in the Watercare electrical design and construction standards.

5. Numbering Codes

5.1 Process area codes

The up -to-date codes list can be requested from assetinfo@water.co.nz or if access is provided to Watercare ProjectWise through this link: [Process Areas](#).

5.2 Group codes

The up -to-date code lists can be requested from assetinfo@water.co.nz or if access is provided to Watercare ProjectWise through this link: [Group Codes](#).

5.3 Line material codes

The up -to-date codes list can be requested from assetinfo@water.co.nz or if access is provided to Watercare ProjectWise through this link: [Lining material codes](#).

5.4 Service codes

The up -to-date codes list can be requested from assetinfo@water.co.nz or if access is provided to Watercare ProjectWise through this link: [Pipeline numbering service codes](#).

Part D: Operational Support Records

1. Supporting operational documents

Data management shall be carried through to be consistent with data in the field, whether available electronically or hard copy format. Any data changes are to be updated and outdated hardcopies destroyed.

2. Operation and maintenance (O&M) manuals

2.1 General requirements

All process areas must be detailed in a coherent and structured manner to provide the operator with adequate information on the objective of each particular process and how to run the facility.

Cover and Flysheet

Operations Manuals shall have a cover page containing the name of the manual, and a flysheet with the manual name, document control details and header and footer that are common to the entire manual.

A sample cover and flysheet are provided in Appendix 1, annotated with requirements for these pages.

Document Control

Revisions shall be named using consecutive alpha characters and include the word “Draft” until the document is accepted by Watercare as meeting all requirements. The first revision supplied to Watercare after acceptance of draft versions shall be named “Version 1”.

Table of Sections

Operations Manuals shall have a Table of Sections, with page numbers provided for every chapter of the manual. Appendices shall be named in a list. Each section shall have a table of contents

Headers

Headers are used to identify the document and section within the manual. Headers contain the words “Watercare Services Limited” and manual name and are left -justified. The Unit Process and Chapter name are provided right -justified.

Footers

Footers are used to identify the document page number, revision status and controlled document status.

Revision status and date are left –justified. The date of revision is manually input.

The words “CONTROLLED DOCUMENT” and “DESTROY UNBOUND COPIES AFTER USE” are centred. The page number is right –justified.

Page Numbers

Pages are numbered numerically

References to tables and graphs

All graphs and tables shall be numbered and correctly referenced in the text.

Font style

Font style shall be Arial type or similar derived style. Body text size 10pt. Heading text size 12pt.

2.2 O&M manual template

Table of Sections

- Section 1: Operations
- Section 2: Hazards and controls
- Section 3: Maintenance
- Section 4: Equipment lists (Pumps, valves and instruments)
- Section 5: Control system
- Section 6: Testing and commissioning records
- Section 7: Equipment data (manufacturer manuals etc.)
- Section 8: Consents, Land transfers and titles
- Section 9: Drawings

Version control

Revision	Description	By	Date

Section 1: Operations

Table of contents

1. Introduction
2. Overview (i.e. Catchment yields, system curve and flow tests – overview of the process, process theory etc.)
3. Facility elements
4. Functional description – level 1 (refer section 13.2 of this standard)
5. Standard operating procedures (SOP – refer section 13.3 of this standard)
6. Etc.

Note: Contents amended as applicable for the specific operation or facility

Section 2: Hazards and controls

(Hazards and controls register)

Section 3: Maintenance

Maintenance tables

1. Table of weekly tasks
2. Table of monthly tasks
3. Table of two monthly tasks
4. Table of four monthly tasks
5. Table of six monthly tasks

6. Table of annual tasks
7. Table of two yearly tasks
8. Table of three yearly tasks
9. Table of five yearly tasks

Note: Contents amended as applicable for the specific operation or facility components and system

Section 4: Equipment lists (Pumps, valves and instruments)

Cross referenced to P&ID drawing(s): [Insert indexed drawing number or list drawings below as bullet points]

Table 4. [xx]

Item	Size	Description	Serial No./ model code	Supplier
[e.g. FIT1]	[e.g. 300]	[e.g. Magnetic flowmeter]	[e.g. Magmaster]	[e.g. ABB]

Section 5: Control system

Table of contents

1. Introduction
2. Electrical
3. Instrumentation
4. Control
5. SCADA

Annexes:

- A. Design declaration of conformity
- B. PLC description

Note: Contents amended as applicable for the specific operation or facility components. This is a brief description of the control system, but not as detailed as the Functional Description

Section 6: Testing and commissioning records

(Electrical, I/O's, Pumps, rising main performance, odour control, vibration, noise, etc.)

Section 7: Equipment data

(Contains information specific to equipment, including supplier literature on operation, maintenance etc.)
{Provide links to supplier online information where available, or too large to include}

Section 8: Consents, Land transfers and titles

(Copies of final documents if applicable)

Section 9: Drawings

(As-built drawing sets for civil, mechanical and electrical & control)

3. Functional descriptions (FD)

3.1 General requirements

The FD style guide is available separate to this document.

3.2 FD template

[CODE e.g. DTMAN]

[NAME OF FACILITY]

LEVEL 1 FUNCTIONAL DESCRIPTION

[AREA CODE] – [FACILITY TYPE]

Functional Description Reference: [FACILITY CODE]_[AREA CODE]_FD_001					
Rev #	Date	Description	By	Checked	Approved

Table of Contents

[Insert standard Word TOC]

1 Process Overview and Theory

1.1 Process Overview

This functional description covers the following facility:

Facility Codes:	[FACILITY CODE], [Name], [Facility type]
Area Code:	[XX]
Alarm Groups:	[Operational area], [FACILITY CODE]_[AREA CODE]
Security Areas:	[XXX], (Operator), [XXX]_[SUPR] (Supervisor), [XXX]_[ENGR] (Engineer)
Region:	[Area]
Zone:	[XXXX]

The full name of all equipment in this document is [CODE]_[PP]_{[AAAA]_[VVV]}. Where PP is the Process Code, AAAA is the Equipment Type and VVV is the Equipment Number.

Note: asset was formerly referred to as [Previous name] (use if facility is renamed or amended with the project)

Plant Location and Access

Name, Facility type is located at the [Street address]. See Figures 1 through [#] for site maps, site photos and a GIS view of the site.

Directions from [Known landmark]:

[directions]

Directions from [Known landmark]:

[directions]

The site latitude and longitude are: - [XXXX], [YYYY]

Figure 1 Site location – map

[insert figure]

Figure 2 Site location – Street View.

[insert figure]

Figure 3 Auckland GIS topographical view showing the facility and connected infrastructure.

[insert figure]

Drawing and Document References

Drawing Set [drawing base number] [NAME], [Facility type] Electrical Drawings

Drawing [drawing full number] [NAME], [Facility type] P&ID

[FACILITY CODE]_[AREA CODE]_FD_002 [NAME], [Facility type] - Level 2 Functional Description

[Watercare standard number] Watercare Software Standard

1.2 Process Theory / Process Principles

A SCADA site view is provided in Figure 4 that details site equipment and process flow and the process information is listed in Table 1.

Figure 4 SCADA interface for [NAME] [Facility type] site (Provided by Watercare)

[insert figure]

[Process description paragraph(s)]

Table 1: [NAME] [Facility type] process information

1.3 Principles of Operation

Operation description paragraph(s) and tables

Process information		
[Process component e.g. Pump]	Number	[Number]
	Make, Model	[Make], [Model no.]
	Intake Diameter (mm)	[Number]
	Outlet diameter (mm)	[Number]
	Power rating	[Number]
	Motor speed	[Number]
	Pumps on variable speed drives	[Number]

	Duty pump minimum	[Number]
	Minimum threshold for high wet well alarm suppression	[Number]
Etc.		

Add e.g. Level Settings

Add e.g. Emergency Stop Operation

Etc.

2 Process Plant

2.1 Process Equipment

The facility consists of the following primary process equipment as detailed in Table 3.

Table 3: [Facility type] Equipment

Equipment Type & Number (Asset)	Equipment Description	Capacity/Range	Failsafe State	Control Module Type(s)	Notes
Mechanical Equipment					
Analogue Equipment					
Digital Equipment					

3 Routine Automatic Operation

3.1 Equipment operated (starts, interlocks, control range, control mode etc.)

[Description]

[Insert table(s)]

3.2 Equipment operated (starts, interlocks, control range, control mode etc.)

[Description]

[Insert table(s)]

3.4 (etc.)

[Description]

[Insert table(s)]

4 Failures

4.1 Equipment and/or Process (interlocks, conditions list, control failure etc.)

[Description]

4.2 Equipment and/or Process (interlocks, conditions list, control failure etc.)

[Description]

4.3 (etc.)

[Description]

5 Alarms

5.1 Process Alarms

The following table, Table 5, is a list of all the [Facility type] alarms for the [NAME] site.

Table 5: [Facility type] alarms with accompanying settings.

Alarm Trigger Description	Equipment No.	Units	Default	Delay (sec)	Priority	Control Action / Notes

[Description]

5.2 System Alarms

The following table, Table 6, is a list of all the [Facility type] alarms for the [NAME] site.

Table 6: [Facility type] alarms with accompanying settings.

Alarm Trigger Description	Equipment No.	Units	Default Setting	Alarm On Delay (sec)	Priority	Control Action / Notes

[Description]

6 Off-Normal Functions

6.1 Equipment and/or Process (operation other than remote)

[Description]

6.2 Equipment and/or Process (operation other than remote)

[Description]

6.3 (etc.)

7 Process Diversions/Overflows

Facility type overflow/diversion is from [Description of location] into [Description of location] pipe/facility discharging to [Description of location].

8 Shutdown Sequences

[Description]

9 External Inputs and Outputs

[Description]

10 Derived Variables

10.1 Facility

The following table, Table 7, is a list of all the [Facility type] derived variables, associated tag names, units and control modules that calculate the variable value for the [NAME] site.

Table 7: Derived variables with associated details.

Description	Equipment No(s).	Units	Capacity / Range	Control Type(s) Calculation	Module /	Name of HMI Display(s)

10.2 Other

{Example:}

Time to overflow and remaining tank volume is calculated using standard control modules.

Volume is calculated as indicated below in Table 8.

Table 8: Wet well volume lookup table

Wet well depth m	Volume m ³	Wet well depth m	Volume m ³
0.01	0.00	3.51	234.00
1.87	19.30	3.66	247.00
2.04	30.34	3.78	260.00
2.11	41.63	3.90	273.20
2.18	53.05	4.02	286.40
2.24	64.48	4.10	299.60

11 System Redundancy

11.1 Process Equipment

The following are the main process equipment with redundancy:

- PU_01 - Pump 1 with PU_02 - Pump 2

11.2 Control System

The following are the main control system equipment with redundancy:

- RTU Power supply – battery backed

12 Isolation Schemes

[Description of isolation scheme for the facility]

13 Operator Interface

13.1 Central SCADA

The primary control for this facility is via the central SCADA system via the following graphic(s):

Name	Description	Relevant P&ID
[CODE]_80.gfxSiteScreen	[CODE]_80 - NAME WW PS	XXXX

The central SCADA polls each of the site RTUs on a radio channel on a regular basis to receive RTU time stamped status updates and alarm events using **DNP3 over UHF radio ethernet**.

The RTU records alarm events and changes to instrument readings greater than a threshold in its on-board logs. During communication all new RTU logs are retrieved to populate the central SCADA trends and alarm and events history. Backfilling occurs if there has been a disruption in SCADA to RTU communication. In between SCADA update polls, critical alarms at any RTU are sent as unsolicited messages from the RTU to the SCADA to display as soon as possible on the alarm banner.

Duty Selection

Pump duties are normally selected by the central SCADA. Selecting a duty other than Auto Select has the effect of inhibiting the standby pump(s) from running.

13.2 Local SCADA

A local SCADA is located at the XXXX. The process graphics for the local SCADA are identical to the central SCADA. However only the local process information is available and no control is permitted from the graphics.

The local SCADA maintains a local historian and alarms. Alarms are not synchronised with the central SCADA

14 Control System Functionality

14.1 Standard Control Modules

Refer to *WSL Software Standard Specification* for software standards applied for this facility.

14.2 Time Synchronisation

The RTU requests a time synchronisation from the **DNP3 Master on power up and once per day at 3:15am**. The central SCADA's communication driver sends the control network time on next poll.

14.3 Control System Hardware

The facility is controlled by a **Kingfisher CP-30 RTU** connected to the central SCADA system via **Trio E-series radios**, photos of which are shown in Figures 5. Refer to the electrical drawings for RTU input/output modules and configuration.

Figure 5 Kingfisher RTUs and Trio E Series Radio

[insert figure]

14.3 Serial Communications

There are no RTU to serial device communications at this site.

14.3 Security System (05_SEC_X01)

The site is fitted with a **TECOM Challenger security panel**. Staff has to disarm the security system before entering the site and arm the site when leaving. There are five digital signals provided from the security panel to the site RTU:

- Intruder
- Authorised Entry
- Movement
- Smoke Detected
- Security Disarmed

There are two outputs from the RTU to the security panel to override or reset the system:

- Security Reset – This will arm the security system
- Security Disarm – This will disarm the security system

Central control room notifies the security company to check site if there is an intruder or smoke detected alarm.

15 Historical Process Data

The signals as logged in SCADA and RTU are detailed in the following table, Table 9.

Table 9: Signal tags with associated units, tag descriptions and triggers.

Tag	Units	Tag Description	Trigger
[CODE]_01_RTU_X01.CommsFailA		[CODE NAME] Comms Fail Alarm	
[CODE]_01_RTU_X01.CommsLost		[CODE NAME] Comms Lost	
[CODE]_01_RTU_X01.CommsLostA		[CODE NAME] Comms Lost Alarm	
[CODE]_01_RTU_X01.FailedReads.Roc.Rate		[CODE NAME] TOPServer Failed Reads	
[CODE]_01_RTU_X01.FailedWrites.Roc.Rate		[CODE NAME] TOPServer Failed Writes	

Tag	Units	Tag Description	Trigger
[CODE]_01_RTU_X01.PendingWrites		[CODE NAME] TOPServer Pending Reads	
[CODE]_01_RTU_X01.PendingReads		[CODE NAME] TOPServer Pending Writes	
[CODE]_01_RTU_X01.RxBytes.Roc.Rate		[CODE NAME] TOPServer Topic Rx Bytes	
[CODE]_01_RTU_X01.SuccessfulReads.Roc.Rate		[CODE NAME] TOPServer Successful Reads	
[CODE]_01_RTU_X01.SuccessfulWrites.Roc.Rate		[CODE NAME] TOPServer Successful writes	
[CODE]_01_RTU_X01.TxBytes.Roc.Rate		[CODE NAME] TOPServer Topic Tx Bytes	
[CODE]_01_RTU_X01.Watchdog		[CODE NAME] Comms Watch Dog	
[CODE]_05_SEC_X01.Intruder		[CODE NAME] Site Security Intruder Alarm	
[CODE]_06_EI_X02.PV		[CODE NAME] Battery Voltage Analogue present value	
[CODE]_06_EI_X02.PVAvg		[CODE NAME] Battery Voltage present value 15m average	

3.3 Standard operating procedures (SoP)

3.3.1 Wastewater Plant template



Operations
Wastewater
Treatment

Procedure Reference: [Plant]- [Process area]-
SOP-[SoP number XXX]

Document controller: [Administrator] -
[Operational area e.g. Southern]

Document Authoriser: [Operations controller]
- [Operational area e.g. Southern]

[Plant name/Process area/Type of work]

OBJECTIVE: [Objective of the standard operating procedure]

Isolations Required: [Yes/No]

PERSONNEL REQUIRED:

Confined Space Entry: [Yes/No]

JSWEP Applicable[Yes/No] (if no, refer to H&S page)

Prerequisites: [List training requirements and any special conditions or tools]

[Site Map / Process Area inserted here [picture size: height 12 cm, width 16 cm]]

Isolation completed: Signed: _____ Date: _____ Time: _____	Work all Completed: Signed: _____ Date: _____ Time: _____
---	--

Health and safety (Complete this section if JSWEP is not available)

Hazard	Consequence	Control
		Include diagrams if needed

General controls

- [Location of the MCC building]
- [Equipment normal operating mode (brief description)]
- [Associated document (example: Functional Description)]

Part	SOP contents
1	Preliminary checks
2	
[#]	[Emergency Procedure/Alarm Response (For Normal Operation SOP)]
[#]	[Troubleshooting (For Normal Operation SOP)]

Key

Activity	Font Convention
<p>Instructions</p> <p>[description, see below]</p> <p style="color: red;">What the SOP is instructing the operators to perform on:</p> <ul style="list-style-type: none"> - On the PLC/DCS. <p style="color: green;">e.g., <i>Select Pump X to [START]</i></p> <ul style="list-style-type: none"> - In the field. <p style="color: red;">e.g., Lock out Suction Manifold Penstock X in the field.</p>	<p style="color: green; font-style: italic;">Custom Green, Italic</p> <p style="color: red;">Calibri (Body)</p>

Steps	Instructions	Equipment Number				Diagram	Time
1	For any hazardous activities: Include *WARNING* and explain the hazards.					[Picture size (3.7cm height X 3.4cm width)]	[Time this step was completed]
2							
3							
4							
5							

Part-[#]

Emergency Procedures/Alarm Response

Equipment Number	Alarm/Trips	Automatic Actions	Operator Action

Part-[#]

Troubleshooting

Symptoms	Probable Causes	Action

Figure [Plant]- [Process area]-F[X]: [Title]

Example: GIS drawing, block flow diagram, PID etc. If required

Amendment Records

Amendment Number	Section Number	Date Inserted	Signature
	<p>[Procedures reference] [XXXXX] -SOP-[XXX] Page [X] of [X]</p>		

3.3.2 Water Plant template

	<p style="text-align: center;">Operations Water Supply</p>	<p style="text-align: center;"><i>Procedure Reference</i></p>
		<p style="text-align: center;">[Number]</p>
	<p style="text-align: center;">Standard Operating Procedure</p>	<p style="text-align: center;"><i>Document Controller</i></p>
		<p style="text-align: center;">[Name]</p>
		<p style="text-align: center;"><i>Document Authoriser</i></p>
		<p style="text-align: center;">[Name]</p>

WATER TREATMENT PLANT

Standard Operating Procedure

Unit Process **[AREA CODE]** – **[FACILITY NAME]**

PROCEDURE Reference							
Revision	Remarks	Developed By	Date	Reviewed By	Date	Authorised By	Date

1. Purpose

[Description]

2. Scope

[Description]

3. Relevant Authorities

[Description]

4. Associated Documentation

Document Title	Document Reference

5. Responsibility

[Description]

6. Prerequisites

[Description]

7. Hazard Analysis/Health and Safety

[Description]

8. Instructions/Technical Content

[Description]

9. Troubleshooting

[Description]

10. Reporting/Task Completion

[Description]

Part E: Field identification

1. As-built survey data for Geographic Information System (GIS)

Refer to the Watercare standard for creating CAD drawings. In general the minimum survey accuracy shall be 0.05m in the X, Y, and Z direction, but additionally for pipe invert levels to 0.01m in the Z direction.

2. Field identification and labelling of assets

2.1 Standards

The relevant parts of the following standards shall apply to the labelling of pipework and equipment:

NZS 5433 PARTS 1&2 Transport of dangerous goods on land - Parts 1 & 2

NZS 5807: Code of practice for industrial identification by colour, wording or other coding

2.2 General

All pipes (where exposed) and equipment shall be identified by a label.

Labels shall be engraved traffolyte (white background, black lettering) for electrical switchboards, FCABs and DBs, stamped stainless steel or anodised aluminium with Envirocoat. Also see Watercare's general electrical construction standard.

Labels on tanks can be of self-adhesive vinyl, if compatible with the tank material, so that the label will be permanent. All labels and the printing on these labels are to be UV stabilised where located outside. For attaching to concrete stainless steel billet plate shall be used with an epoxy fixing glue.

NB: For all Wastewater sites substitute anodised aluminium tags with 316 Stainless Steel – etched / black colour-filled labels.

Font shall be Arial. Font width may be compressed to 75% to enable letters to fit onto the label.

Labels comprise minimum of the asset number with an optional asset description under this, on one or two lines as needed, i.e. up to 3 lines. The asset number shall be on the top line. The optional description shall be used (e.g. chlorine analyser) when it is not clear in the field what the equipment is attached to or serves i.e. If a flow switch is remote from a pump and it is not obvious in the field that the switch serves the pump.

Labels shall be placed as close as practical to the equipment and where practical, attached to a permanent structure.

Installation and fastening shall be by either stainless steel fasteners (including rivets where appropriate), stainless steel wire looped around the equipment, through the label and crimped (typically used on instruments) or epoxy glue.

Instrument labels shall be double sided. Likewise, for instruments the fasteners should be reusable or easily replaced when serviced.

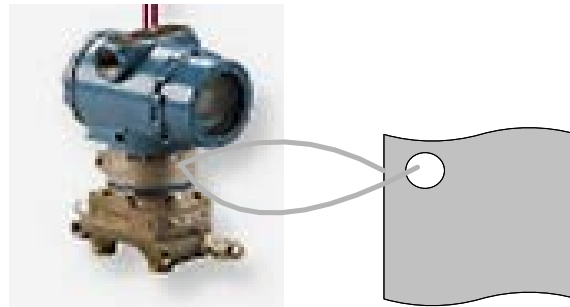

Typical stainless steel label attached to an Instrument

Labels shall be subject to the approval by Watercare prior to manufacture and installation.

Refer to the general mechanical construction standard for safety signage

Labels shall follow the examples given. However, the size of the label selected is to be in proportion to the equipment, i.e. small labels for small equipment and large labels for large equipment.

2.3 Abbreviations

Site equipment numbers shall be abbreviated to exclude the facility code as the equipment is located at the facility and where such abbreviation does not affect identification near the boundaries of facilities.

2.4 Examples

Type 1:

50mm x 10mm

E.g. limit switches

99-ZSO-013

5mm lettering

Type 2:

100mm wide

30mm High 3 lines

22mm High 2 lines

20-LSL-402
RAW WATER WET WELL
LOW LEVEL SWITCH

7mm lettering

5mm lettering

5mm lettering

Type 3:

150mm wide

50mm High 3 lines

35mm high 2 lines

51-PU-01
RAW WATER MAIN
RAPID MIX PUMP 1

10mm lettering

5mm lettering

5mm lettering

Type 4:

300mm wide

100mm high 3 lines

70mm high 2 lines

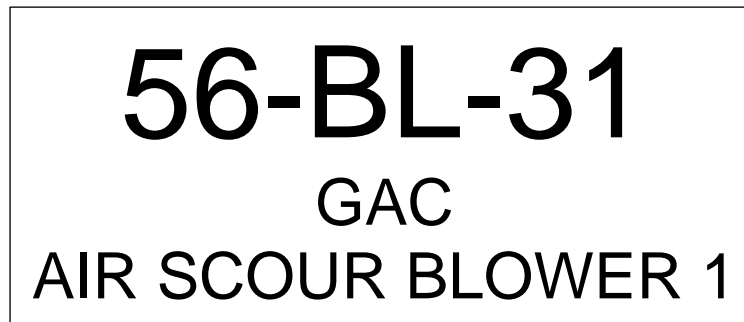

20mm lettering

15mm lettering

15mm lettering

Type 5:

Standard size 60mm x 200mm. Major lettering 60mm. Minor lettering 40mm



Type 6: Pipework

Standard sizes: 25mm x 200mm and 50mm x 400mm

Identification to comply with NZS5807.

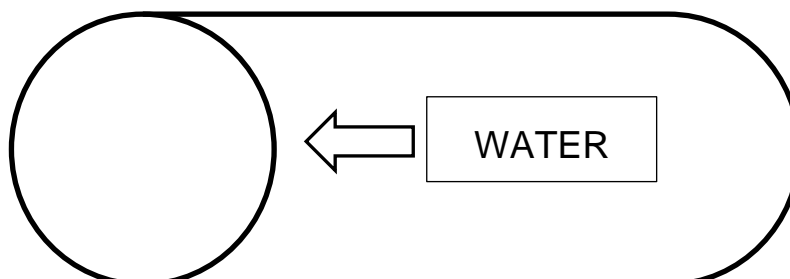

Part F: Condition assessment data – post construction

1. Asset inspections and data

1.1 Data collection

Procedure for updating inspection data:



1.2 Maintenance indicators – Equipment importance levels

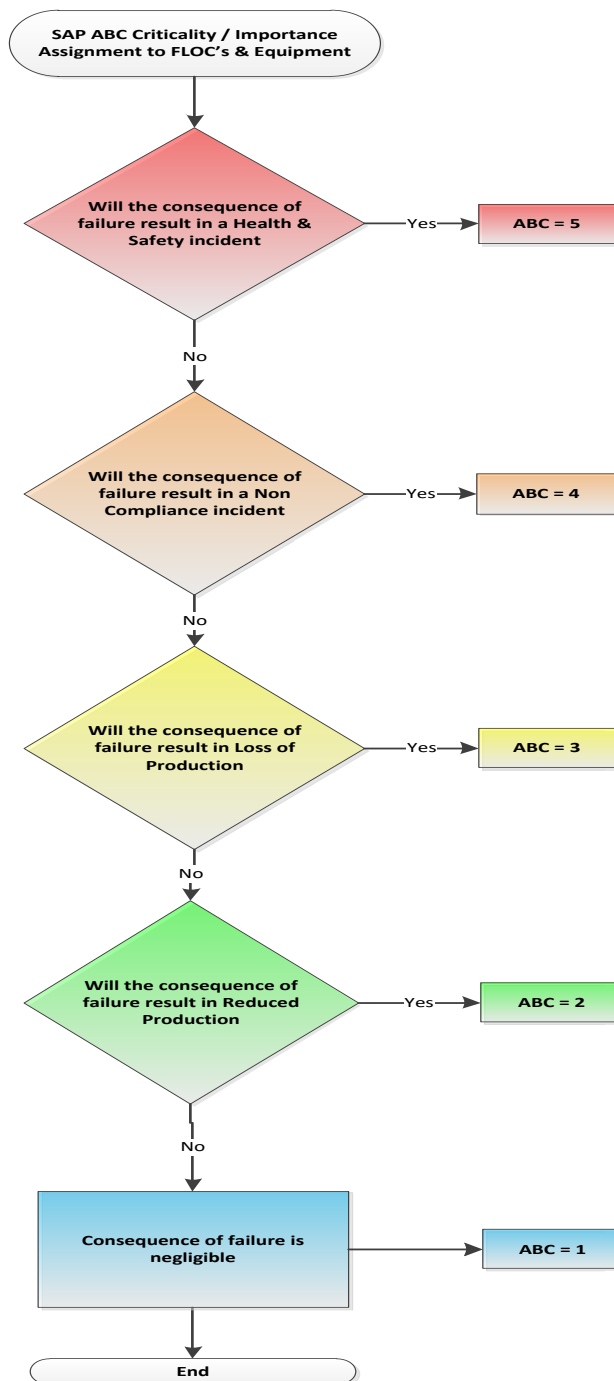

Equipment Importance Indicator			
Class	Score	Failure of Equipment Consequence	Typical Maintenance Requirement
Class 1 - Very Low	1	Negligible	No scheduled maintenance, Run to Failure (RTF)
Class 2 - Low	2	Reduction in production	RTF, Planned Preventative Maintenance (PPM), calendar based, hours run
Class 3 - Medium	3	Loss of production	PPM, Condition/Predictive/Risk Based Maintenance, Design Outs, Critical Spares
Class 4 - High	4	Non-compliance incident	PPM, Condition/Predictive/Risk Based Maintenance, Design Outs, Critical Spares
Class 5 - Very High	5	Health & Safety Incident	PPM, Condition/Predictive/Risk Based Maintenance, Design Outs, Critical Spares

1.3 Condition assessment

1.3.1 Overview

Condition grading is assets as measurement points. Grades are 0, 1 to 5 (0 = unmeasured, 1 = best, 5 = worst)

Grade	Classification	Definition	Action
0	Not Assessed	Assessment required	Assess
1	Very Good	No action required	No Action
2	Good	Do minor repairs. Monitor item to see if there are changes.	Monitor
3	Moderate	Do more extensive repairs. Consider specialist assessment to find the causes.	Review
4	Poor	Get specialist assessment for structural or important equipment items. Do repairs where possible.	Investigate
5	Very Poor	Replace or extensive refurbishment or repair.	Repair/Replace

1.3.2 Inspection criteria

Watercare has different inspection criteria for its assets. The grading system above in section 1.3.1 is used to complete the condition questions per asset and can be accessed by those with access rights to Watercare ProjectWise here: [Watercare Asset Type Condition Assessment Questions Final](#)

Alternatively, please contact: AssetIntegrityTeam@water.co.nz

1.3.3 Assessment strategy

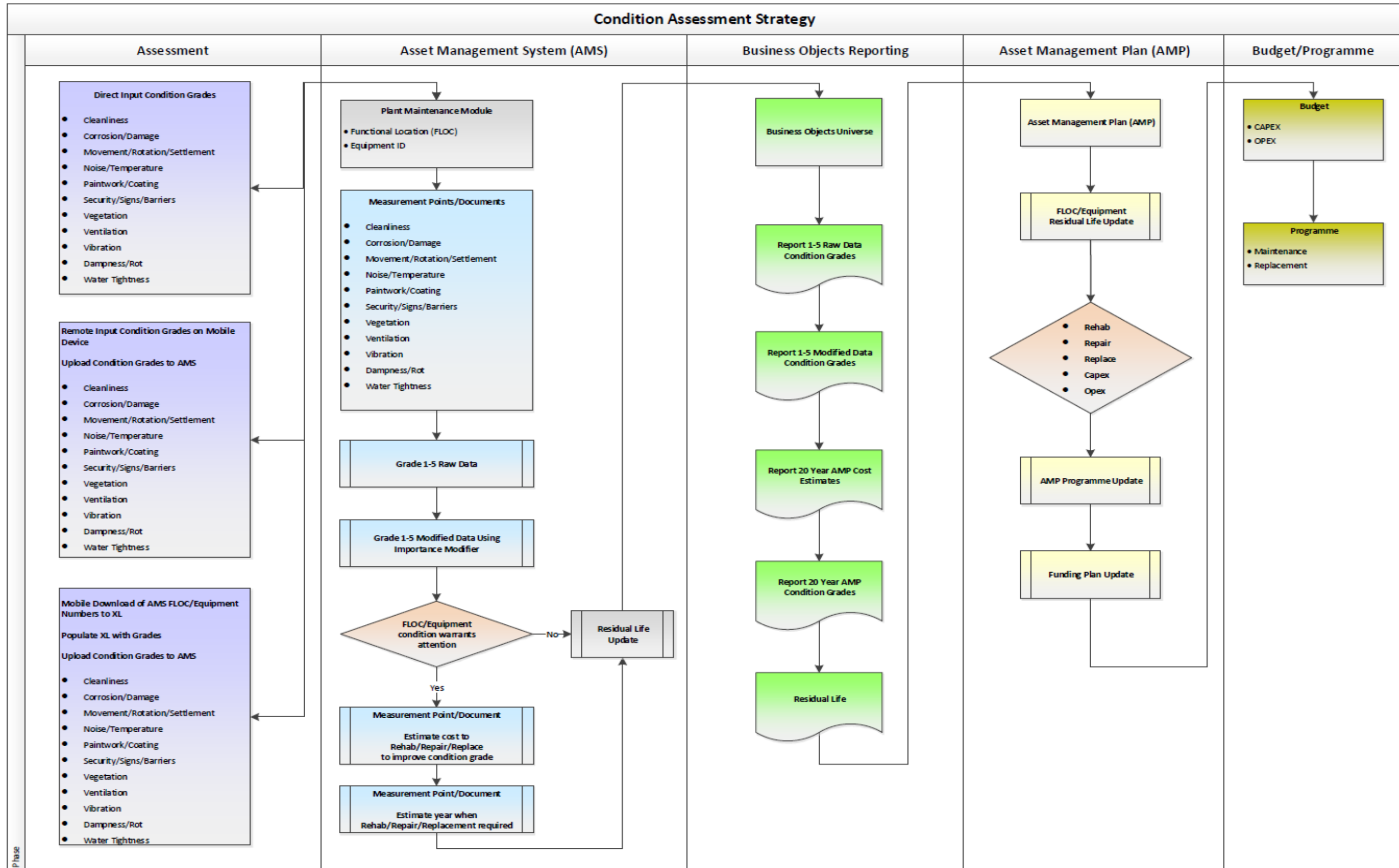

Grade measurement:

Condition Grades Aligned with NZWW Manual Visual Assessment of Utility Assets 2008 & NZS 4306-2005													
Grade	Classification	Action	Cleanliness	Corrosion/Damage	Movement/Rotation/Settlement	Noise/Temperature	Paint Work/Coating	Security/Signs/Barrier	Vegetation issues	Ventilation	Vibration	Dampness/Rot	Water tightness
1	Very Good	No action required	Clean and tidy	No signs of damage, insecurity, corrosion, degradation, cracking, spalling, or sag.	None evident	None evident	No deterioration, flaking or surface damage evident	No issues	No issues	No issues	None evident	No issues	No issues
2	Good	Do minor repairs. Monitor item to see if there are changes.	Minor tidying needed, no risk to building or equipment item use	Some minor signs of damage, insecurity, corrosion, degradation, cracking, spalling, or sag.	Minor problems showing.	Low level noise indicates there may be minor problems	Minor surface staining, wear or discoloration, no flaking. Minor dulling of surface evident	<ul style="list-style-type: none"> • Sign writing/pictures faded but still legible and easily read, no safety issues. • All Barriers sound and secure, minor signs of degradation, no safety or security issues. • Security system working, locks/chains/padlocks showing minor signs of degradation, no security issues. 	Vegetation location, type, may cause future growth problems	Minor problems showing.	Minor problems showing.	Minor dampness and moisture damage	Minor drips from glands, washers, connections. Dampness at structure joints, seals
3	Moderate	Do more extensive repairs. Consider specialist assessment to find the causes.	Building or equipment looking shoddy, condition may cause deterioration. Some indications of pest infestation (borer, ants, birds, rodents etc)	Signs of more extensive damage, insecurity, corrosion, degradation, cracking, spalling, or sag.	Item showing signs of stress. Misalignment of items.	Item showing signs of stress. Some discoloration at cable connections, couplings, bearings may indicate heat problems. Increased level of noise	Major surface staining, wear or severe discoloration. Damaged or incomplete coating, but surface not exposed, Cracking or blistering	<ul style="list-style-type: none"> • Sign writing/pictures faded or defaced. Potential minor safety issues caused by lack of clarity. • All Barriers secure, but signs of degradation, minor safety and/or security issues. • Security system working, locks/chains/padlocks showing signs of degradation, minor security issues. 	Vegetation location, type, growth starting to impact the structure, equipment item.	Minor odours evident, atmosphere warm and stuffy.	Item showing signs of stress. Get vibration test done immediately on important items.	Minor ponding, damp patches on walls, ceilings and timber frames. Lichen and moss growth	Glands, washers, connections leaking badly and causing minor ponding, damp patches on walls/ceilings
4	Poor	Get specialist assessment for structural or important equipment items. Do repairs where possible.	Very untidy. Dirt and debris accumulating, widespread insect and pest infestation (borer, ants, birds, rodents etc)	Numerous area of damage, insecurity, corrosion, degradation, cracking, spalling, or sag.	Movement, rotation or settlement is obvious and starting to threaten stability	Item under stress. Discolouration at cable connections, couplings, bearings indicating heat problems. Significant level of noise	Incomplete coating, flaking of coated material, surface exposed and showing deterioration	<ul style="list-style-type: none"> • Signs hard to find, writing too small to be read easily. Letters obscured by rust or badly faded, some safety issues. • Some Barriers insecure and unsound, others degraded. Some safety and or security issues. • Security system partially working, some locks/chains/padlocks missing or partially working some security issues. 	Vegetation location, type, growth causing damage, impeding access. Safety and functionality of embankments at risk.	Distinctly smelly, warm and stuffy	Level of vibration is high, affecting other equipment. Remove from service and repair ASAP.	Significant damp areas on walls and ceilings, rotting timbers, signs of ponding, major lichen and moss growth	Significant water loss from glands, washers, connections, flooding floors. Extensive damp areas on walls, ceilings
5	Very Poor	Replace or extensive refurbishment or repair.	Widespread mould, bird's nests, spider webs, rubbish, insect/pest infestation (borer, ants, birds, rodents etc)	Significant amount of damage, insecurity, corrosion, degradation, cracking, spalling, or sag is threatening the life or operability of the building or equipment item.	Significant misalignment. Item close to collapse or dangerous to use.	Item under such stress that noise and / or heat indicates imminent failure.	Split or detached coating, extensive flaking, perforation or major deterioration of coated material. Coating missing or clearly failed	<ul style="list-style-type: none"> • Signs effectively useless. Replace, major safety issues. • Some Barriers missing, others with major degradation, major safety and or security issues. • Security system not working, locks/chains/padlocks missing, major security issues. 	Vegetation location, type, growth causing severe damage, blocking access. Embankments at high probability of failure. Potential safety issues.	Overly warm/hot. Test for gas before entry.	Level of vibration is very high and there is a possibility of immediate failure. Take out of service immediately.	Functionality of item, structure or connections at risk. Possibility of immediate failure.	Functionality of item, structure or connections at risk. Possibility of immediate failure.

2. CCTV for pipe asset condition data collection

CCTV inspection shall be in accordance with the current New Zealand Pipe Inspection Manual.

Link: http://www.waternz.org.nz/Article?Action=View&Article_id=46

2.1 CCTV record template

All fields are compulsory

WSL Ref No. 9999	Sheet No. 01	Equip. ID 10004226	Date Started 17.12.08	Time Started 12.44 Completed 13.45			
Facility Name Branch 7B Sewer Mount Eden		Facility Code DSOB7B	Weather Showers	Flow Depth 0.1			
Contractor Auckland CCTV Ltd.		Operator Johnny Smith	Record No. B7B 17.12.08				
Node Type SMH	Upstream MH/Node No. DSOB7B005	Street No. 5	Street Name Ace Place, Mt Eden				
Node Type SMH	Downstream MH/Node No. DSOB7B004	Street No. Crn of	Street Name Alexander Street, Mt Eden				
Set-Up MH U/D U	Line Length (M) 160.91	Surveyed Length (M) 160.91	Diameter (MM) 300	Joint Spacing (M) 0.6	Material EW	Shape CP	Use F
Currency of Inspection CI CURRENT	Status of Pipe OC ORIGINAL	Inspection Completeness IC COMPLETE	Video Rec Format DVD	Date of Entry 17.12.08			

Comments

Job # 52346 - Various Cracks in line - 300mm PIPE

Condition Score

Video Reading	Distance From (m)	Condition Code	Severity	Position		Photo No.	Remarks
				from	to		
0:00:00	0	IS					Starts at DSOB7B005 Going downstream
	0.69	CC	S	1	9		
	5.93	CL	S	3			
	6.5	CL	S	1			
	9.02	ED	S	5			
	10.21	ED	S	5	6		
	12.67	CL	S	5			
	14.55	CM	S	4	5		
	17.55	CM	S	3	9		
	18.8	CM	S	10	1		
	20.13	CL	S	3			
	20.13	GP				9999_01_01.jpg	CONDITION PHOTO
	21.94	CL	S	1			
	23.46	CL	S	8			
	25	CL	S	3			
	25.6	CL	S	8			
	26.22	CM	S	3			
	40.2	GP				9999_01_02.jpg	CONDITION PHOTO
	56.22	GP				9999_01_03.jpg	CONDITION PHOTO

Part G: Asset type attribute As-built

1. Buildings

Asset Type	BUILDING			Feature selection table:
Sub type	R-Reinforced	NR-Not reinforced	P-Portable	
Ownership				Ownership
Process				Process
Operational area				Operational area
Material type (majority component)				Material type (Mechanical and pipe)
Photo/3D model				
Equipment number				
Functional area				
Manufacturer/Constructor				

Asset Type	BUILDING			Feature selection table:
Sub type	R-Reinforced	NR-Not reinforced	P-Portable	
Year of Manufacture / construction				
Warranty Start Date				
Warranty End Date				
Coordinates (x)	Node location of plant/facility, or coordinates of asset			
Coordinates (y)				
Coordinates (z)				
Street Name	Address location of plant/facility, or of closest node			
Suburb				
District				
Post Code				
Confined Space Located				Confined space

Asset Type	BUILDING			Feature selection table:
Sub type	R-Reinforced	NR-Not reinforced	P-Portable	
Linked Documents				
acquisition value				
acquisition date				
Project reference	If constructed under contract			
Start up date				
asset designed life				
Service status				Service status
Condition rating				Condition rating
Criticality rating				Criticality rating
Condition assessment date				

Asset Type	BUILDING			Feature selection table:
Sub type	R-Reinforced	NR-Not reinforced	P-Portable	
Assessed remaining life				
External coating				External coating
Length				
Width				
Height				
Ground level (GL)				
Area				
earthquake Quake design lvl				earthquake design function class
Design resilience rating				Resilience rating

2. Chambers and Manholes

Asset type	Chamber											Feature selection table	
Sub type	Drywell	Penstock	Wet well	Sump	Stilling well	Valve tower	Manhole	Valve chamber	Inspection point	Tunnel	Cable pit		
Sub type feature													Sub type feature
Ownership													Ownership
Process													Process
Operational area													Operational area
Media Type Wtr/WWtr/ chem/gas													Media type
Material type (majority component)													Material type (civils)
Photo/3D model													
Equipment number													
Functional area													

Asset type	Chamber											Feature selection table
	Drywell	Penstock	Wet well	Sump	Stilling well	Valve tower	Manhole	Valve chamber	Inspection point	Tunnel	Cable pit	
Manufacturer/Constructor												
Model/Class												
Serial Nbr												
Year of Manufacture / construction												
Weight												
Supplier/Vendor												
Warranty Start Date												
Warranty End Date												
Coordinates (x)	Node location of plant/facility, or coordinates of asset											
Coordinates (y)												
Coordinates (z)												

Asset type	Chamber											Feature selection table
Sub type	Drywell	Penstock	Wet well	Sump	Stilling well	Valve tower	Manhole	Valve chamber	Inspection point	Tunnel	Cable pit	
Street Name	Address location of plant/facility, or of closest node											
Suburb												
District												
Post Code												
Locality												Locality
Confined Space Located												Confined space
Linked Documents												
acquisition value												
acquisition date												
Project reference	If constructed under contract											
Start up date												
asset designed life												
Service status												Service status

Asset type	Chamber											Feature selection table
Sub type	Drywell	Penstock	Wet well	Sump	Stilling well	Valve tower	Manhole	Valve chamber	Inspection point	Tunnel	Cable pit	
Condition rating												Condition rating
Criticality rating												Criticality rating
Condition assessment date												
Assessed remaining life												
Diameter (internal)	If circular (not square shaped)											
Diameter (external)												
Diameter (Nominal)												Nominal diameter
Load rating (kN)												
Internal lining												Internal lining
Length	If square (not circular shape)											

Asset type	Chamber											Feature selection table
Sub type	Drywell	Penstock	Wet well	Sump	Stilling well	Valve tower	Manhole	Valve chamber	Inspection point	Tunnel	Cable pit	
Width												
Height												
depth												
Invert level (RL)												
Ground level (GL)												
Overflow												Overflow
Lid type												Lid type (multi-option)
Lid level (RL)												
Fall protection												Fall protection
Dropper fitted												Dropper fitted
earthquake Quake design lvl												earthquake design function class

Asset type	Chamber											Feature selection table
Sub type	Drywell	Penstock	Wet well	Sump	Stilling well	Valve tower	Manhole	Valve chamber	Inspection point	Tunnel	Cable pit	
Design resilience rating												Resilience rating

3. Civil

Asset type	DRAIN	FOOTPATH	HARD STANDING	SPILLWAY	SUPPORT STRUCTURE					Feature selection table:	
Sub type					Anchor block	Pier	Roller	Pad/Plinth	Pontoon		
Ownership											Ownership
Process											Process
Operational area											Operational area
Material type											Material type (civil)
Photo/3D model											
Equipment number											
Functional area											
Manufacturer/Constructor											
Model/Class											
Serial Nbr											
Year of Manufacture / construction											

Asset type	DRAIN	FOOTPATH	HARD STANDING	SPILLWAY	SUPPORT STRUCTURE					Feature selection table:
Sub type					Anchor block	Pier	Roller	Pad/Plinth	Pontoon	
Weight										
Supplier/Vendor										
Warranty Start Date										
Warranty End Date										
Coordinates (x)	Node location of plant/facility, or coordinates of asset									
Coordinates (y)										
Coordinates (z)										
Street Name	Address location of plant/facility, or of closest node									
Suburb										
District										
Post Code										
Locality										Locality
Confined Space Located										Confined space
Hazardous area rating										

Asset type	DRAIN	FOOTPATH	HARD STANDING	SPILLWAY	SUPPORT STRUCTURE					Feature selection table:
Sub type					Anchor block	Pier	Roller	Pad/Plinth	Pontoon	
Linked Documents										
acquisition value										
acquisition date										
Project reference	If constructed under contract									
Start up date										
asset designed life										
Service status										Service status
Condition rating										Condition rating
Criticality rating										Criticality rating
Condition assessment date										

Asset type	DRAIN	FOOTPATH	HARD STANDING	SPILLWAY	SUPPORT STRUCTURE					Feature selection table:	
Sub type					Anchor block	Pier	Roller	Pad/Plinth	Pontoon		
Assessed remaining life											
Diameter (internal)											
Diameter (external)											
Diameter (Nominal)											Nominal diameter
Load rating (kN)											
External coating											External coating
Length											
Width											
Height											
depth											
Invert level (RL)											

Asset type	DRAIN	FOOTPATH	HARD STANDING	SPILLWAY	SUPPORT STRUCTURE					Feature selection table:
Sub type					Anchor block	Pier	Roller	Pad/Plinth	Pontoon	
Ground level (GL)										
earthquake Quake design lvl										earthquake design function class
Design resilience rating										Resilience rating

4. Containment structures

Asset Type	AQUE DUCT	BUND	CHANNEL	POND, STORAGE	STORAGE UNIT				TANK		WELL		Feature selection table:
Sub type					Container	Skip	Hopper	Tipping bucket	Pressurised	Not pressurised	Borehole (exploration/monitoring)	Well (water extraction)	
Sub type feature													Sub type feature
Ownership													Ownership
Process													Process
Operational area													Operational area
Photo/3D model													
Equipment number													
Functional area													
Manufacturer /Constructor													
Model/Class													
Serial Nbr													
Year of Manufacture / construction													

Asset Type	AQUE DUCT	BUND	CHANNEL	POND, STORAGE	STORAGE UNIT				TANK		WELL		Feature selection table:
Sub type					Container	Skip	Hopper	Tipping bucket	Pressurised	Not pressurised	Borehole (exploration/monitoring)	Well (water extraction)	
Weight													
Supplier/Vendor													
Warranty Start Date													
Warranty End Date													
Coordinates (x)	Address location of plant/facility, or of closest node												
Coordinates (y)													
Coordinates (z)													
Street Name	Address location of plant/facility, or of closest node												
Suburb													
District													
Post Code													
Media Type													Media type

Asset Type	AQUE DUCT	BUND	CHANNEL	POND, STORAGE	STORAGE UNIT				TANK		WELL		Feature selection table:
Sub type					Container	Skip	Hopper	Tipping bucket	Pressurised	Not pressurised	Borehole (exploration/monitoring)	Well (water extraction)	
Material type (majority component)													Material type (Mechanical and pipe)
Locality													Locality
Confined Space Located													Confined space
Linked Documents													
acquisition value													
acquisition date													
Project reference	If constructed under contract												
Start up date													
asset designed life													

Asset Type	AQUE DUCT	BUND	CHANNEL	POND, STORAGE	STORAGE UNIT				TANK		WELL		Feature selection table:
					Container	Skip	Hopper	Tipping bucket	Pressurised	Not pressurised	Borehole (exploration/monitoring)	Well (water extraction)	
Service status													Service status
Condition rating													Condition rating
Criticality rating													Criticality rating
Condition assessment date													
Assessed remaining life													
Pressure Rating (kPa) static													
Stiffness rating (SN)													
Max Designed flow													
Min Designed flow													

Asset Type	AQUE DUCT	BUND	CHANNEL	POND, STORAGE	STORAGE UNIT				TANK		WELL		Feature selection table:
					Container	Skip	Hopper	Tipping bucket	Pressurised	Not pressurised	Borehole (exploration/monitoring)	Well (water extraction)	
Diameter (internal)													
Diameter (external)													
Diameter (Nominal)													Nominal diameter
Construction method													Construction method (pipe)
External coating													External coating
Internal lining													Internal lining
Jointing method													Jointing method
Length													
Width													
Height													
depth													
Volume/Capacity													

Asset Type	AQUE DUCT	BUND	CHANNEL	POND, STORAGE	STORAGE UNIT				TANK		WELL		Feature selection table:
Sub type					Container	Skip	Hopper	Tipping bucket	Pressurised	Not pressurised	Borehole (exploration/monitoring)	Well (water extraction)	
Invert level (RL)													
Ground level (GL)													
Area													
Lid type													Lid type (multi-option)
Lid level (RL)													
Fall protection													Fall protection
earthquake Quake design lvl													earthquake design function class
Design resilience rating													Resilience rating
Discharge capacity													
Overflow													Overflow

Asset Type	AQUE DUCT	BUND	CHANNEL	POND, STORAGE	STORAGE UNIT				TANK		WELL		Feature selection table:
Sub type					Container	Skip	Hopper	Tipping bucket	Pressurised	Not pressurised	Borehole (exploration/monitoring)	Well (water extraction)	
Overflow level													
Inhibit level													

Asset Type	ANTENNA							COMPUTER/SERVER/ELECTRONIC STORAGE					CONTROL COMPONENTS				DATA and TELECOMMUNICATION COMPONENTS										DCS/SCADA FIELD CABINET	PROGRAMMABLE LOGIC CONTROLLER/RTU	RADIO	SOFTWARE				POWER SUPPLY	Feature selection list:						
	Yagi	Phasing	BaseCoil	Whip	LowProfile	Dipole	Collinear	M-MONITOR	SR-Server	ES - Electronic	PR-Printer	KVM-Keyboard	WS-Workstation	CR - Controller	IO-I/O module	MP-Multiplexer	HMI - Human	AP - WIRELESS	FW-Firewall unit	MC Media	MW - Microwave	MD-Modem	NS-Network switch	PR-Protocol	PP - Patch panel	RT-Router				Antenna Feeder	Telephone	Operating system	User software system (app)			Configuration software	System software				
Condition assessment date																																									
Assessed remaining life																																									
IP Rating																																								Ingress protection rating	
Comms protocol																																								Comms protocols	
Instrument range																																									
Input voltage																																									
Input voltage Type (AC/DC)																																								Voltage type	
Output voltage																																									
Output voltage Type (AC/DC)																																									Voltage type
Insulation Class																																								Insulation class	
Energy (Kw) Rating																																									
Length																																									
Width																																									
Height																																									
depth																																									
Vegetation condition																																									Vegetation condition
Quality of radio path condition																																									Quality of radio path
Transmit Azimuth																																									

Asset Type	ANTENNA							COMPUTER/SERVER/ELECTRONIC STORAGE					CONTROL COMPONENTS				DATA and TELECOMMUNICATION COMPONENTS										DCS/SCADA FIELD CABINET	PROGRAMMABLE LOGIC CONTROLLER/RTU	RADIO	SOFTWARE				POWER SUPPLY	Feature selection list:						
	Yagi	Phasing	BaseCoil	Whip	LowProfile	Dipole	Collinear	M-MONITOR	SR-Server	ES - Electronic	PR-Printer	KVM-Keyboards	WS-Workstation	CR - Controller	IO-I/O module	MP-Multiplexer	HMI - Human	AP - WIRELESS	FW-Firewall unit	MC Media	MW - Microwave	MD-Modem	NS-Network switch	PR-Protocol	PP - Patch panel	RT-Router				Antenna Feeder	Telephone	Operating system	User software system (app)			Configuration software	System software				
Ground level (GL)																																									
Antenna base level above ground (IL)																																									
Forward Power Measured (dBm) at the Antenna Port																																									
Reverse Power Measured (dBm) at the Antenna Port																																									
Forward Power Measured (dBm) at the back of the Radio																																									
Reverse Power Measured (dBm) at the back of the Radio																																									
Configured Radio Transmit Power Left As (Watts)																																									

Asset Type	ANTENNA							COMPUTER/SERVER/ELECTRONIC STORAGE					CONTROL COMPONENTS				DATA and TELECOMMUNICATION COMPONENTS										DCS/SCADA FIELD CABINET	PROGRAMMABLE LOGIC CONTROLLER/RTU	RADIO	SOFTWARE					POWER SUPPLY	Feature selection list:				
	Yagi	Phasing	BaseCoil	Whip	LowProfile	Dipole	Collinear	M-MONITOR	SR-Server	ES - Electronic	PR-Printer	KVM-KeyBoard	WS-Workstation	CR - Controller	IO-I/O module	MP-Multiplexer	HMI - Human	AP - WIRELESS	FW-Firewall unit	MC Media	MW - Microwave	MD-Modem	NS-Network switch	PR-Protocol	PP - Patch panel	RT-Router				Antenna Feeder	Telephone	Operating system	User software system (app)	Configuration software			System software			
RSM Reference Frequency MHz																																								
RSM Bandwidth MHz																																								
RSM Licence Holder																																								

6. Electrical rotating

Asset Type	ALTERNATOR	MOTOR	GENERATOR	Feature selection list:
Ownership				Ownership
Process				Process
Operational area				Operational area
Photo/3D model				
Equipment number				
Functional area				
Manufacturer/Constructor				
Model/Class				
Serial Nbr				
Year of Manufacture / construction				
Weight				
Supplier/Vendor				
Warranty Start Date				

Asset Type	ALTERNATOR	MOTOR	GENERATOR	Feature selection list:
Warranty End Date				
Coordinates (x)	Node location of plant/facility, or coordinates of asset			
Coordinates (y)				
Coordinates (z)				
Street Name	Address location of plant/facility, or of closest node			
Suburb				
District				
Post Code				
Locality				Locality
Confined Space Located				Confined space
Hazardous area rating				
Linked Documents				
acquisition value				
acquisition date				
Project reference	When constructed under contract			

Asset Type	ALTERNATOR	MOTOR	GENERATOR	Feature selection list:
Start up date				
asset designed life				
Service status				Service status
Condition rating				Condition rating
Criticality rating				Criticality rating
Condition assessment date				
Assessed remaining life				
IP Rating				Ingress protection rating
Installation Method (Wet/Dry)				Installation mounting
Installation Orientation				Installation Orientation
Design Speed (rpm)				

Asset Type	ALTERNATOR	MOTOR	GENERATOR	Feature selection list:
Bearing Type				Bearing type
Input voltage				
Input voltage Type (AC/DC)				
Nbr of Phases				
Output voltage				Voltage type
Output voltage Type (AC/DC)				Phases
Insulation Class				Insulation class
Energy (Kw) Rating				
Frame Size				Frame Size
Output current (A)				
Cooling System Fitted				Cooling system fitted

Asset Type	ALTERNATOR	MOTOR	GENERATOR	Feature selection list:
Torque (output rating)				
Length				
Width				
Height				

Asset Type	AUTO TRANSFER SWITCH	WARNING HORN	AUTOMATIC VOLTAGE	BATTERY	BATTERY CHARGER	CABLE					CATHODIC PROTECTION					CIRCUIT BREAKER		CONTROL PANEL	CONTROL STATION	DISTRIBUTION BOARD	EARTHING		GENERATOR	HARMONIC FILTER	HEATER				HYPOCHLORITE	INVERTER	Isolator	JUNCTION BOX	LIGHTING		Ozone generator	POLE			Feature selection list		
Sub type	Mechanical Type	static type				Extra Low Voltage	Low voltage	High voltage	Fibre optic	Overhead power line	Anode bed	Corrosion rate coupon	Earth coupler	Reference electrode	Transformer rectifier/rectifier	test point	High Voltage	Low voltage				Electrode	Earth grid			Air Convection	Immersion	Trace heating	Fan heater					Emergency Lighting	General lightning and small power		Power	Light	CCTV tower	Antenna	
Project reference	If constructed under contract																																								
Start up date																																									
asset designed life																																									
Service status																															Service status										
Condition rating																															Condition rating										
Criticality rating																															Criticality rating										
Condition assessment date																																									
Assessed remaining life																																									
Calibration authority																																									
Calibration number																																									
Calibration expiry date																																									
IP Rating																															Ingress protection rating										

Asset Type	POWER FACTOR CORRECTION EQUIP	POWER SUPPLY UNIT, ELV/LV	RECTIFIER	RELAY, ELECTRICAL PROTECTION	NEUTRAL/EARTH RESISTOR	RING MAIN UNIT		SOLAR CELL	STARTER (ELECTRIC MOTOR)			SURGE ARRESTER	SWITCHBOARD		SWITCH, HIGH VOLTAGE (HV)			SWITCH, LOW VOLTAGE (LV)		ULTRAVIOLET (UV)		MIDGE SCREEN	UNINTERRUPTIBLE POWER SUPPLY (UPS)	TRANSFORMER			Feature selection list		
						GAS	Oil		Direct on-line	Soft starter	Variable speed drive		High Voltage	Low voltage	FUSED	No load break	FUSED	Load break	No load break	UV lamp module	UV Ballast				Current Transformer	Voltage transformer		Power	
Output current (A)																													
Cooling System Fitted																													
External coating																													
Length																													
Width																													
Height																													
depth																													

9. Land

Asset Type	LAND		Feature selection list:
Ownership			Ownership
Process			Process
Operational area			Operational area
Photo/3D model			
Equipment number			
Coordinates (x)			
Coordinates (y)			
Coordinates (z)			
Street Name			
Suburb			
District			
Post Code			
acquisition value			
acquisition date			
Area			

Asset Type	Actuator	AERATOR	Air conditioning unit	COMPRESSOR	CONVEYOR	DEWATERING UNIT	DRIVESHAFT	FANS and BLOWERS	SCREEN ROTATING	GEARBOX	CE- Combustion	TURBINE	MIXER	PUMP	SAMPLER	SCRAPER	SKIMMER (SCUM COLLECTOR)	Vibrator	Washpactor unit	GRIT CLASSIFIER UNIT	Feature selection list:																
Sub type	Air	electric	solenoid	Air	Gas	Belt type	Roller type	Screw Type	CENTRIFUGE	Press	Gravity belt	Axial	Centrifugal fan / Blower	Positive	Rotating mesh	Water turbine	Gas turbine	Wind Turbine	Agitation / SUBMERSIBLE	AXIAL	Mixed/Radial flow	Regenerative	GEAR	VANE	PROGRESSIVE	PERISTALTIC	DIAPHRAGM	RECIPROCATING/PI	Rake type	RUBBER BLADE TYPE							
Coordinates (z)	Address location of plant/facility, or of closest node																																				
Street Name																																					
Suburb																																					
District																																					
Post Code																																					
Locality		Locality																																			
Confined Space Located		Confined space																																			
Hazardous area rating																																					
Linked Documents																																					
acquisition value																																					
acquisition date																																					
Project reference	If constructed under contract																																				
Start up date																																					
asset designed life																																					

11. Mechanical static

Asset Type	AFTERCOOLER	HVAC - Air conditioning system/plant components						AIR LUBE UNIT	BAFFLE			BELLOWS						BOILER, INDUSTRIAL	RUPTURE DISC	CHLORINE CHLORINATOR	CONTAINMENT BOOM	CYCLONE UNIT	DAMPENER				Feature selection list:	
		CHILLER	DAMPER (HVAC)	DUCT-	HUMIDIFIER	LOUVRE			Curtain Type	Plate type	Baffle	Lateral	Single plane	Bi-planar	Hinged type	Angular	Universal/m						HYDRAULIC PISTON	Spring assisted	Counter balance weight	Vessel with pressurised bladder		
Sub type feature																											Sub type feature	
Ownership																												Ownership
Process																												Process
Operational area																												Operational area
Media Type War/Water/chemo /gas																												Media type
Material type (majority component)																												Material type (Mechanical and pipe)
Photo/3D model																												
Equipment number																												
Functional area																												
Manufacturer/Constructor																												
Model/Class																												
Serial Nor																												
Year of Manufacture / construction																												
Weight																												
Supplier/Vendor																												

Asset Type	MECHANICAL FITTINGS								WASHDOWN UNIT	MIXER STATIC	Feature selection list:
Sub type	VNT - Venturi	ORP - Orifice plate	NZ- Nozzle	JM- Bolted joint	JF- Joint (flexible)	Saddle joint	End cap	JI - Joint (Isolated)			
Sub type feature											Sub type feature
Ownership											Ownership
Process											Process
Operational area											Operational area
Media Type War/Water/chemo/gas											Media type
Material type (majority component)											Material type (Mechanical and pipe)
Photo/3D model											
Equipment number											
Functional area											
Manufacturer/Constructor											
Model/Class											
Serial Nor											
Year of Manufacture / construction											
Weight											
Supplier/Vendor											
Warranty Start Date											
Warranty End Date											
Coordinates (x)	Node location of plant/facility, or coordinates of asset										

Asset Type	MECHANICAL FITTINGS								WASHDOWN UNIT	MIXER STATIC		Feature selection list:
Sub type	VNT - Venturi	ORP - Orifice plate	NZ- Nozzle	JM- Bolted joint	JF- Joint (flexible)	Saddle joint	End cap	JI - Joint (Isolated)				
Coordinates (y)	Address location of plant/facility, or of closest node											
Coordinates (z)												
Street Name												
Suburb												
District												
Post Code												
Locality												Locality
Confined Space Located												Confined space
Hazardous area rating												
Linked Documents												
acquisition value												
acquisition date												
Project reference	If constructed under contract											
Start up date												
asset designed life												
Service status												Service status
Condition rating												Condition rating
Criticality rating												Criticality rating
Condition assessment date												
Assessed remaining life												

Asset Type	MECHANICAL FITTINGS								WASHDOWN UNIT	MIXER STATIC	Feature selection list:
Sub type	VNT - Venturi	ORP - Orifice plate	NZ- Nozzle	JM- Bolted joint	JF- Joint (flexible)	Saddle joint	End cap	JI - Joint (Isolated)			
Calibration authority											
Calibration number											
Calibration expiry date											
IP Rating											Ingress protection rating
Installation Method (Wet/Dry)											Installation mounting
Nor of Stages											
Pressure Rating (kappa) static											
Stiffness rating (SN)											
Max Designed flow											
Min Designed flow											
Diameter (internal)											
Diameter (external)											
Diameter (Nominal)											
Input voltage											
Input voltage Type (AC/DC)											Voltage type
Nor of Phases											Phases

Asset Type	MECHANICAL FITTINGS								WASHDOWN UNIT	MIXER STATIC		Feature selection list:
Sub type	VNT - Venturi	ORP - Orifice plate	NZ- Nozzle	JM- Bolted joint	JF- Joint (flexible)	Saddle joint	End cap	JI - Joint (Isolated)				
Energy (Kw) Rating												
Suction / inlet Diameter												
Discharge Diameter												
Load rating (ken)												
External coating												External coating
Internal lining												Internal lining
Jointing method												Jointing method
Length												
Width												
Height												

12. Pipe and conduit

Asset Type	Culvert	Pipe			Conduit	Feature selection list:
Sub type		Pressure rated	non-pressure rated	Pipe-tunnel		
Ownership						Ownership
Process						Process
Operational area						Operational area
Media Type Wtr/WWtr/chem/gas						Media type
Material type (majority component)						Material type (Mechanical and pipe)
Photo/3D model						
Equipment number						
Functional area						Functional area (pipe)

Asset Type	Culvert	Pipe			Conduit	Feature selection list:
Sub type		Pressure rated	non-pressure rated	Pipe-tunnel		
Manufacturer/Constructor						
Model/Class						
Serial Nbr						
Year of Manufacture / construction						
Supplier/Vendor						
Warranty Start Date						
Warranty End Date						
Coordinates (x)	Node location of plant/facility, or coordinates of asset					
Coordinates (y)						
Coordinates (z)						

Asset Type	Culvert	Pipe			Conduit	Feature selection list:
Sub type		Pressure rated	non-pressure rated	Pipe-tunnel		
Street Name	Address location of plant/facility, or of closest node					
Suburb						
District						
Post Code						
Locality						Locality
Confined Space Located						Confined space
Linked Documents						
acquisition value						
acquisition date	When constructed under contract					
Project reference						
Start up date						
asset designed life						

Asset Type	Culvert	Pipe			Conduit	Feature selection list:
Sub type		Pressure rated	non-pressure rated	Pipe-tunnel		
Service status						Service status
Condition rating						Condition rating
Criticality rating						Criticality rating
Condition assessment date						
Assessed remaining life						
Pressure Rating (kPa) static						
Stiffness rating (SN)						
Diameter (internal)						
Diameter (external)						
Diameter (Nominal)						

Asset Type	Culvert	Pipe			Conduit	Feature selection list:
Sub type		Pressure rated	non-pressure rated	Pipe-tunnel		
Construction method						Construction method (pipe)
External coating						External coating
Internal lining						Internal lining
Jointing method						Jointing method
Length						
Invert level (RL)	Level taken at node					
Ground level (GL)	Level taken at node					
earthquake Quake design lvl						earthquake design function class
Design resilience rating						Resilience rating

13. Retaining structure

Asset Type	ABUTMENT	DAM	WALL				WEIR	Feature selection list:
Sub type			Wing Wall	Retaining wall	Stop bank	Firewall		
Ownership								Ownership
Process								Process
Operational area								Operational area
Media type								Media type
Material type (majority component)								Material type (civils)
Photo/3D model								
Equipment number								
Functional area								Functional area (retaining structures)
Manufacturer/Constructor								
Year of Manufacture / construction								
Warranty Start Date								
Warranty End Date								
Coordinates (x)	Node location of plant/facility, or coordinates of asset							

Asset Type	ABUTMENT	DAM	WALL				WEIR	Feature selection list:
Sub type			Wing Wall	Retaining wall	Stop bank	Firewall		
Coordinates (y)	Address location of plant/facility, or of closest node							
Coordinates (z)								
Street Name								
Suburb								
District								
Post Code								
Linked Documents								
acquisition value								
acquisition date								
Project reference	If constructed under contract							
Start up date								
asset designed life								
Service status							Service status	
Condition rating							Condition rating	
Criticality rating							Criticality rating	
Condition assessment date								

Asset Type	ABUTMENT	DAM	WALL				WEIR	Feature selection list:
Sub type			Wing Wall	Retaining wall	Stop bank	Firewall		
Assessed remaining life								
Certification authority								
Certification number								
Certification expires								
Certification frequency								
Installation Mounting (Wet/Dry)								Installation mounting
Internal lining								Internal lining
Length								
Width								
Height								
depth								
Invert level (RL)								
Ground level (GL)								
Area								
volume Capacity								

Asset Type	ABUTMENT	DAM	WALL				WEIR	Feature selection list:
Sub type			Wing Wall	Retaining wall	Stop bank	Firewall		
earthquake Quake design lvl								earthquake design function class
Design resilience rating								Resilience rating
Core type								Core type (dams)
Core material								Dam material
Deck material								Dam material
Crest length								
Crest height								
Spillway type								Spillway type
Energy dissipation								Energy dissipation
Discharge capacity								
Overflow level								
Inhibit level								

14. Road, Rail, Bridge

Asset Type	BRIDGE				RAILWAY LINE & TRAMLINE	ROAD			Feature selection list:
	Pedestrian	Pipe support	Rail	Road		CONCRETE	Metal	Sealed	
Ownership									Ownership
Process									Process
Operational area									Operational area
Material type (majority component)									Material type (civil)
Photo/3D model									
Equipment number									
Functional area									
Manufacturer/Constructor									
Year of Manufacture / construction									
Warranty Start Date									
Warranty End Date									
Coordinates (x)	Node location of plant/facility, or coordinates of asset								
Coordinates (y)									
Coordinates (z)									
Street Name	Address of plant/facility, or applicable road corridor								

Asset Type	BRIDGE				RAILWAY LINE & TRAMLINE	ROAD			Feature selection list:
Sub type	Pedestrian	Pipe support	Rail	Road		CONCRETE	Metal	Sealed	
Suburb									
District									
Post Code									
Linked Documents									
acquisition value									
acquisition date									
Project reference	If constructed under contract								
Start up date									
asset designed life									
Service status									Service status
Condition rating									Condition rating
Criticality rating									Criticality rating
Condition assessment date									
Assessed remaining life									
Load rating (kN)									

Asset Type	BRIDGE				RAILWAY LINE & TRAMLINE	ROAD			Feature selection list:
Sub type	Pedestrian	Pipe support	Rail	Road		CONCRETE	Metal	Sealed	
Length									
Width									
Invert level (RL)									
Ground level (GL)									

Asset Type	Fence				Fire fighting equipment				Gate, access	Handrail	Hatch cover	Ladder	Office components							Platform	Safety equipment							Security components			Sign			Stairs	Feature selection list:				
Sub type	Wire and post	Panel and post	Barrier	Bollards	Fire Extinguisher	Fire hose reel	Gas suppression	Sprinkler	Fire alarm call unit					Fridge	Dishwasher	Oven	Microwave	Desk	Chair	Locker	Cabinet		Fall prevention	Fall prevention net	Eye wash	Emergency shower	Breathing	Personnel winch	First aid equipment	Fall prevention	Beacon	Card reader	Door/Window	CCTV camera	Safety	General	Marker		
Height																																							

16. Tools

Asset Type	TOOLS				Feature selection list:
Sub type	Mechanical		Electrical subject to testing	Instrument subject to calibration	
Sub-type feature	Hand tool	Engine powered tool			
Ownership					Ownership
Process					Process
Operational area					Operational area
Photo/3D model					
Equipment number					
Functional area					
Manufacturer/Constructor					
Model/Class					
Serial Nbr					
Year of Manufacture / construction					
Weight					
Supplier/Vendor					
Warranty Start Date					
Warranty End Date					

Asset Type	TOOLS				Feature selection list:
Sub type	Mechanical		Electrical subject to testing	Instrument subject to calibration	
Sub-type feature	Hand tool	Engine powered tool			
Linked Documents					
acquisition value					
acquisition date					
Project reference	If procured as part of project or construction				
Start up date					
asset designed life					
Service status					Service status
Condition rating					Condition rating
Criticality rating					Criticality rating
Condition assessment date					
Assessed remaining life					
Calibration authority					
Calibration number					
Calibration expiry date					

Asset Type	TOOLS					Feature selection list:
Sub type	Mechanical		Electrical subject to testing	Instrument subject to calibration		
Sub-type feature	Hand tool	Engine powered tool				
IP Rating						Ingress protection rating
Fuel type						fuel type

17. Valves

Asset Type	VALVE																												Feature selection list:						
Sub type	Auto flush	Air Release	Vacuum interface	Altitude	Butterfly	Backflow Preventer Dual	Backflow Preventer Double	Backflow Preventer RPZ	Vacuum break	Ball	Diaphragm	Ferrule	Float	Foot	Gate	Globe valve	Hydrant	Knife Gate	Lift Gate	Needle	Non Return / Reflux / Check	Penstock	Slide gate	Solenoid (position) valve	Pilot	Regulator	Sluice	Stop log	Plug	Tap	Trap (Condensate)	Pinch	Fixed cone		
Functional output																																		Functional output (valves)	
Sub type feature																																		Sub type feature (valves)	
Ownership																																		Ownership	
Process																																		Process	
Operational area																																		Operational area	
Media Type Wtr/WWtr/chem/gas																																		Media type	
Material type (majority component)																																		Material type (Mechanical and pipe)	
Photo/3D model																																			
Equipment number																																			
Functional area																																			
Manufacturer/Constructor																																			
Model/Class																																			
Serial Nbr																																			
Year of Manufacture / construction																																			
Weight																																			

Asset Type	VALVE																												Feature selection list:							
Sub type	Auto flush	Air Release	Vacuum interface	Altitude	Butterfly	Backflow Preventer Dual	Backflow Preventer Double	Backflow Preventer RPZ	Vacuum break	Ball	Diaphragm	Ferrule	Float	Foot	Gate	Globe valve	Hydrant	Knife Gate	Lift Gate	Needle	Non Return / Reflux / Check	Penstock	Slide gate	Solenoid (position) valve	Pilot	Regulator	Sluice	Stop log	Plug	Tap	Trap (Condensate)	Pinch	Fixed cone			
Criticality rating																																			Criticality rating	
Condition assessment date																																				
Assessed remaining life																																				
Calibration authority																																				
Calibration number																																				
Calibration expiry date																																				
IP Rating	If type is solenoid valve, or sub-type feature is or "electrical actuation"																												Ingress protection rating							
Installation Mounting (Wet/Dry)																																		Installation mounting		
Pressure Rating (kPa) static																																				
Max Designed flow																																				
Min Designed flow																																				
Flow test result (l/s)																																				
Residual pressure (kPa)																																				
Flow test date																																				
Diameter (Nominal)																																				
Torque (input rating)																																				

Asset Type	VALVE																												Feature selection list:							
Sub type	Auto flush	Air Release	Vacuum interface	Altitude	Butterfly	Backflow Preventer Dual	Backflow Preventer Double	Backflow Preventer RPZ	Vacuum break	Ball	Diaphragm	Ferrule	Float	Foot	Gate	Globe valve	Hydrant	Knife Gate	Lift Gate	Needle	Non Return / Reflux / Check	Penstock	Slide gate	Solenoid (position) valve	Pilot	Regulator	Sluice	Stop log	Plug	Tap	Trap (Condensate)	Pinch	Fixed cone			
External coating																																			External coating	
Internal lining																																			Internal lining	
Jointing method																																			Jointing method	
Length																																				
Width																																				
Height																																				

18. Vehicles

Asset Type	VEHICLES												Feature selection list:	
Sub type	MV - Motor vehicle				BT-Boat	LD- Locomotive, Engine drive unit	LR- Rail cars/coaches	OB- outboard	TR- Trailer	CV- Caravan	TRA- Tractor	MOW - Mower	FKL- Forklift	
Sub-type feature	Car	Ute	Truck	Bike or Quad bike										
ownership														Ownership
Operational area														Process
Photo/3D model														
Equipment number														
Manufacturer/Constructor														
Model/Class														
Serial Nbr														
Year of Manufacture / construction														
Weight														
Towbar ball hitch fitment date														
Supplier/Vendor														
Warranty Start Date														
Warranty End Date														
Linked Documents														

Asset Type	VEHICLES												Feature selection list:	
Sub type	MV - Motor vehicle				BT-Boat	LD- Locomotive, Engine drive unit	LR- Rail cars/coaches	OB- outboard	TR- Trailer	CV- Caravan	TRA- Tractor	MOW - Mower	FKL- Forklift	
Sub-type feature	Car	Ute	Truck	Bike or Quad bike										
acquisition value														
acquisition date														
Start up date														
asset designed life														
Service status														Service status
Condition rating														Condition rating
Criticality rating														Criticality rating
Condition assessment date														
Assessed remaining life														
Fuel type														fuel type