

## 5-Turn Analog Displacement Sensor P22 Redundant



### FEATURES

- Dual conductive plastic potentiometer technology 
- Infinite resolution
- Molded metal housing
- Stainless steel shaft
- Precious metal contacts
- Soldering terminal contacts
- Material categorization: for definitions of compliance please see [www.vishay.com/doc?99912](http://www.vishay.com/doc?99912)

### QUICK REFERENCE DATA

Sensor type	ROTATIONAL, multi turns conductive plastic
Output type	Output by turrets, wires, or connector
Market appliance	Transportation
Dimensions	51.1 mm x 30 mm

### ELECTRICAL SPECIFICATIONS

PARAMETER	
Theoretical electrical travel	1700° ± 15°
Independent linearity	± 1 %
Inter-linearity	± 2.5 %
Total resistance (R <sub>n</sub> )	2 x 2.2 kΩ
Tolerance on R <sub>n</sub>	± 20 %
Output smoothness	≤ 0.1 %
Power rating at 70 °C	1 W
Temperature coefficient	-300 ± 300 ppm/°C
Wiper current	≤ 1 mA
Recommended load impedance	≥ 100 R <sub>n</sub>
Insulation resistance	≥ 1 GΩ at 500 V <sub>DC</sub>
Dielectric strength	750 V <sub>RMS</sub> , 50 Hz, 1 min

### MECHANICAL SPECIFICATIONS

PARAMETER	
Mechanical rotation	Continuous
Running and starting torque	≤ 2 N cm
Panel tightening torque	≤ 250 N cm
Weight	100 g
Protection class	IP 50 to IP 66 (front face)
Backlash	< 14°

### PERFORMANCE

PARAMETER	
Operating temperature range	-30 °C to +70 °C
Life	100M cycles
Rotation speed (max.)	150 rpm

#### Note

- Nothing stated herein shall be construed as a guarantee of quality or durability



SAP PART NUMBERING GUIDELINES							
MODEL	FUNCTION	MOUNTING	TYPE	VALUE	LINEARITY	ANGLE	PACKAGING
P22	R = redundant	S = servo	R = ball bearing	222 = 2K2	A = 1 %	1700 # 5 turns	B = box

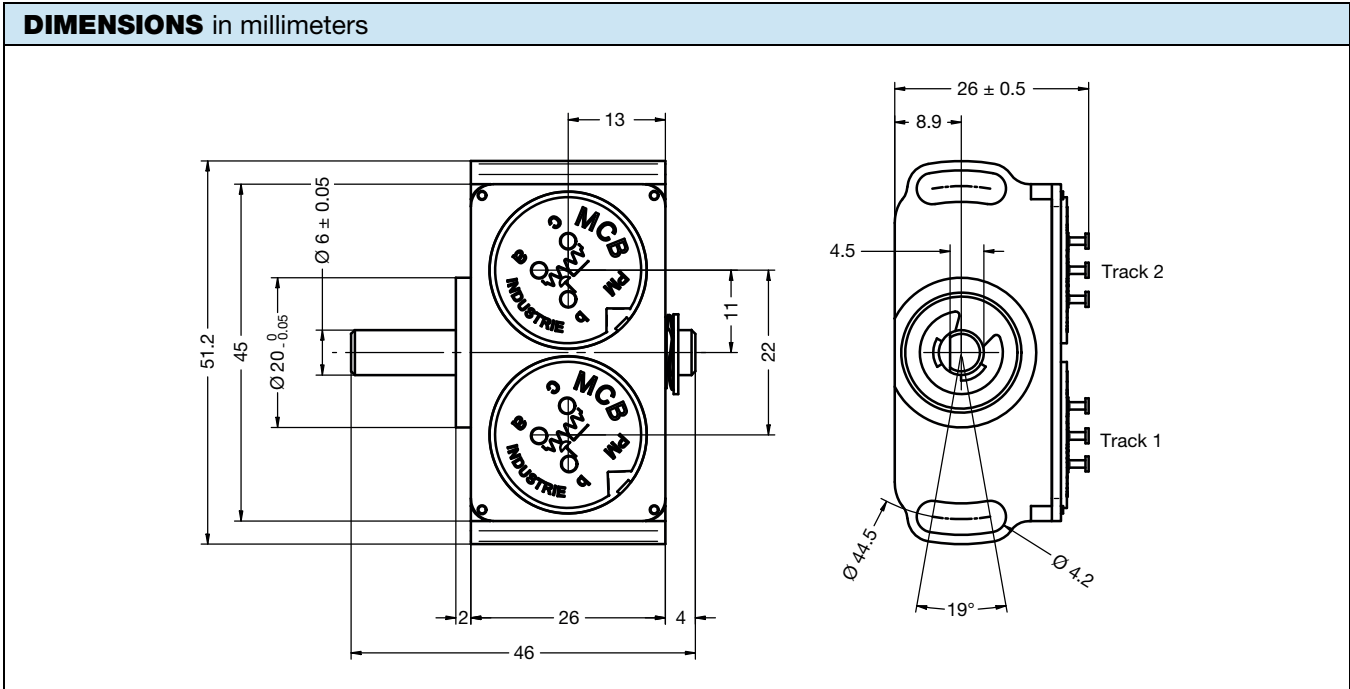

**ELECTRICAL DIAGRAM**

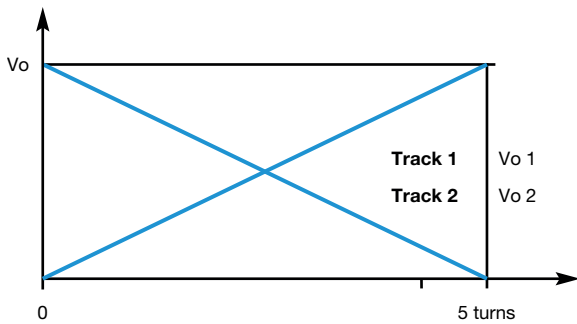

Clockwise rotation viewed from shaft side with identical wiring on both tracks

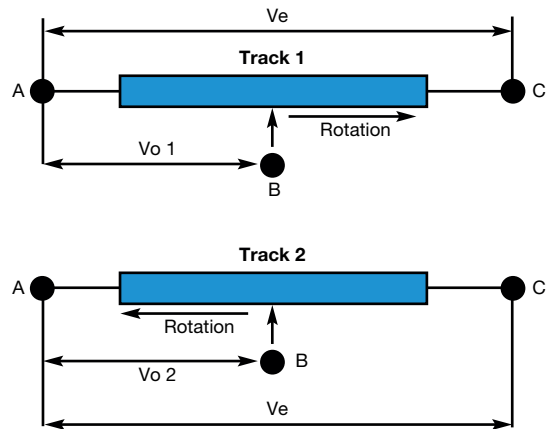



## OPTIONS (on request)

- Other total resistance ( $R_n$ )
- Other versions: 2.5 turns and 8 turns
- Option wire outputs or connector: in such case, between wires and turrets of sensor P22R, to protect against moisture and risk of short circuit, a potting is added on turrets to provide insulating function (to not confuse with mechanical stress / efforts applied on potting, to avoid such mechanical stress on potting / turrets)

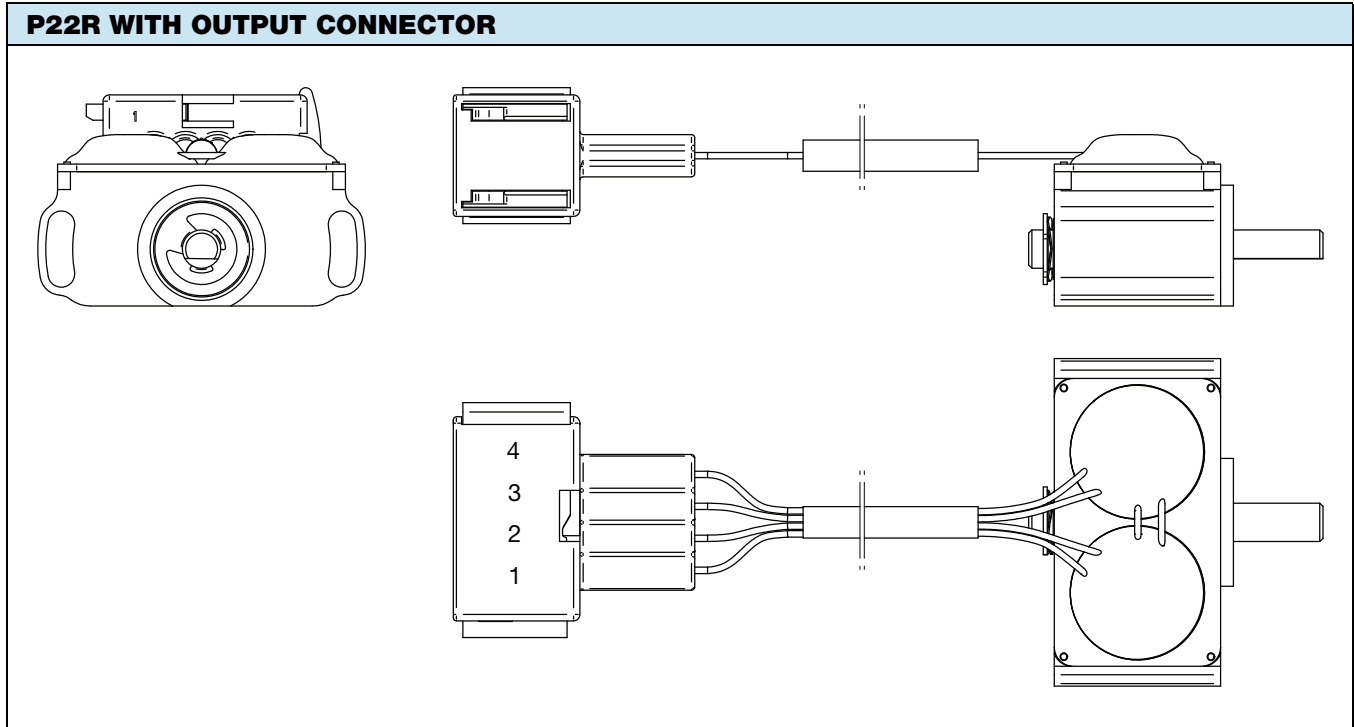



## Disclaimer

ALL PRODUCT, PRODUCT SPECIFICATIONS AND DATA ARE SUBJECT TO CHANGE WITHOUT NOTICE TO IMPROVE RELIABILITY, FUNCTION OR DESIGN OR OTHERWISE.

Vishay Intertechnology, Inc., its affiliates, agents, and employees, and all persons acting on its or their behalf (collectively, "Vishay"), disclaim any and all liability for any errors, inaccuracies or incompleteness contained in any datasheet or in any other disclosure relating to any product.

Vishay makes no warranty, representation or guarantee regarding the suitability of the products for any particular purpose or the continuing production of any product. To the maximum extent permitted by applicable law, Vishay disclaims (i) any and all liability arising out of the application or use of any product, (ii) any and all liability, including without limitation special, consequential or incidental damages, and (iii) any and all implied warranties, including warranties of fitness for particular purpose, non-infringement and merchantability.

Statements regarding the suitability of products for certain types of applications are based on Vishay's knowledge of typical requirements that are often placed on Vishay products in generic applications. Such statements are not binding statements about the suitability of products for a particular application. It is the customer's responsibility to validate that a particular product with the properties described in the product specification is suitable for use in a particular application. Parameters provided in datasheets and / or specifications may vary in different applications and performance may vary over time. All operating parameters, including typical parameters, must be validated for each customer application by the customer's technical experts. Product specifications do not expand or otherwise modify Vishay's terms and conditions of purchase, including but not limited to the warranty expressed therein.

Hyperlinks included in this datasheet may direct users to third-party websites. These links are provided as a convenience and for informational purposes only. Inclusion of these hyperlinks does not constitute an endorsement or an approval by Vishay of any of the products, services or opinions of the corporation, organization or individual associated with the third-party website. Vishay disclaims any and all liability and bears no responsibility for the accuracy, legality or content of the third-party website or for that of subsequent links.

Except as expressly indicated in writing, Vishay products are not designed for use in medical, life-saving, or life-sustaining applications or for any other application in which the failure of the Vishay product could result in personal injury or death. Customers using or selling Vishay products not expressly indicated for use in such applications do so at their own risk. Please contact authorized Vishay personnel to obtain written terms and conditions regarding products designed for such applications.

No license, express or implied, by estoppel or otherwise, to any intellectual property rights is granted by this document or by any conduct of Vishay. Product names and markings noted herein may be trademarks of their respective owners.