

FOR SPECIALIZED TRADE AND PLANNERS

CONVINCING ANSWERS FOR
MODERN HOME COMFORT

PRODUCT INFORMATION 2016

EXCERPT:
WATER HEATERS

AEG
HAUSTECHNIK

**WARM WATER
FOR ANY PURPOSE –
COST-EFFECTIVE,
CONVENIENT
AND RELIABLE**

AEG Haustechnik has been producing innovative water heaters for more than 100 years. The benefits of our products are mainly enjoyed in apartments and detached houses: low energy losses thanks to short pipe distances, high output and uncomplicated installation. In addition, our products also stand out for their individual comfort features

One example is the highly accurate temperature setting on our electronic instantaneous water heater. Not only will this keep showers pleasant and warm but compared with hydraulic units, it will cut energy consumption and deliver reduced energy costs of up to 140.- Euro a year because water is only heated to the set temperature and not a degree more.

Let's not forget the patented undersink hot water storage tank Huz 5 ÖKO DropStop, the open small storage water heater which doesn't drip when it heats up and saves up to 30.- Euro a year.

**The benefits of
AEG electric water heaters at a glance**

- Highly convenient as the water temperature can be set accurate to one degree
- An easy way to produce warm water wherever it's needed (all you need is a supply of cold water and electricity)
- Highly cost-effective through use of short pipes to point of use
- Low installation and maintenance costs
- High energy saving thanks to ThermoStop
- Simple cost calculation/billing via electricity meter

**GENERAL
CALCULATION
PRINCIPLES**

Required amount of heat Q		
in Wh	$Q = m \cdot c \cdot \Delta \vartheta$	How many Wh are required to heat 80 kg water from ϑ_1 10 °C to ϑ_2 55 °C? $Q = \frac{80 \text{ kg} \cdot 1.163 \text{ Wh} \cdot 45 \text{ K}}{\text{kg} \cdot \text{K}}$ $Q = 4187 \text{ Wh} \hat{=} 4.2 \text{ kW}$

Heat-up time t		
in h	$t = \frac{m \cdot c \cdot \Delta \vartheta}{P \cdot \eta}$	Required heat-up time for 80 kg of water heated from ϑ_1 10 °C to ϑ_2 55 °C with connected load of 2000 W $t = \frac{80 \text{ kg} \cdot 1.163 \text{ Wh} \cdot 45 \text{ K}}{2000 \text{ W} \cdot 0.98}$ $t = 2.1 \text{ h}$

Mixed water volume m _M		
in kg or l	$m_M = \frac{m_2 \cdot (\vartheta_2 - \vartheta_M)}{m_1 + m_2}$	How much mixed water at a temperature of ϑ_M 40 °C do you get by mixing cold water at ϑ_1 10 °C into 80 kg of DHW at ϑ_2 55 °C $m_M = \frac{80 \text{ kg} \cdot (55 \text{ °C} - 10 \text{ °C})}{40 \text{ °C} - 10 \text{ °C}}$ $m_M = 120 \text{ kg} \approx 120 \text{ l}$

Rule of thumb for the flow rate against time when raising the temperature as follows:		
28 K Δϑ (from 10 °C to 38 °C)	$m_D = \frac{\text{connected load in kW}}{2} = \text{approx. l/min}$	$\frac{21 \text{ kW}}{2} = 10.5 \text{ l/min}$

Rule of thumb for mixed water volume at a cold water temperature of 10 °C	
e. g. 80 litres heated to 65 °C	80 litres water volume at 65 °C · 2 $\hat{=} 160$ litres mixed water volume at around 37 °C

Household DHW demand		
Application	Water volume in litres	
	40 °C	60 °C
Personal hygiene		
Full-size bath tub	120 ... 150	72 ... 90
Shower	30 ... 50	18 ... 30
Washing hands	2 ... 5	1 ... 3
Washing hair (women)	10 ... 15	6 ... 9
Washing hair (men)	5 ... 10	3 ... 6
Household		
Cleaning water, 8 l per bucket		8
Washing-up water – 1 sinkful		8 ... 12
Washing-up water – daily demand for 2 persons		12
Washing-up water – daily demand for 3 persons		16
Washing-up water – daily demand for 4 persons		20
The average household DHW demand is 30 litres/person x day (45 °C) or 20 litres/person x da (60 °C). This represents a specific useful heat of 1.2 kWh/person x day or 400 kWh/person x year. These specific consumption values should be applied when calculating costs for the living space according to DIN VDI 2067 Part 4.		

Formula key		
Q = Amount of heat in Wh	c = Specific heat in $\frac{\text{Wh}}{\text{kg} \cdot \text{K}}$	$\Delta \vartheta$ = Temperature differential in K ($\vartheta_2 - \vartheta_1$)
m = Water volume in kg*		
P = Output in W	Water c 1.163 $\frac{\text{Wh}}{\text{kg} \cdot \text{K}}$	ϑ_2 = DHW temperature in °C
W = Energy demand in Wh		ϑ_M = Mixed water temperature in °C
t = Heat-up time in h	$\hat{=} 4.1868 \frac{\text{kJ}}{\text{kg} \cdot \text{K}}$	m_1 = Cold water volume in kg
η = Efficiency		m_2 = DHW volume in kg
* 1 kg $\hat{=} 1$ litres		m_M = Mixed water volume in kg

ErP

The efficiency label standardises the efficiency rating of energy related products (ErP) throughout Europe. .
Since 26/09/2015, it must be used on heat generators and water heaters.

It helps designer engineers and installers in their purchasing decisions because it makes it easy to compare the energy efficiency of different products. Energy efficiency should therefore become a key element in the purchasing decision and contribute to the transition of the market to energy efficient products.



ErP for electric water heaters

Small water heaters · Wall mounted water heaters · Floorstanding water heaters · Instantaneous water heaters

Name or trademark of the supplier

Load profile or draw-off profile

The draw-off profile is a measure of the potential DHW convenience of the appliance. The classes range from 3XS to 3XL and correspond to the standards-based user behaviour and output level of the appliance.

The higher the class, the greater the potential DHW draw-off and therefore convenience.

Important: When making a comparison therefore, the same draw-off profile should always be compared.

Sound power level

The sound power level is less important for electric water heaters and is measured at 15 dB. This value is virtually silent to the human ear.

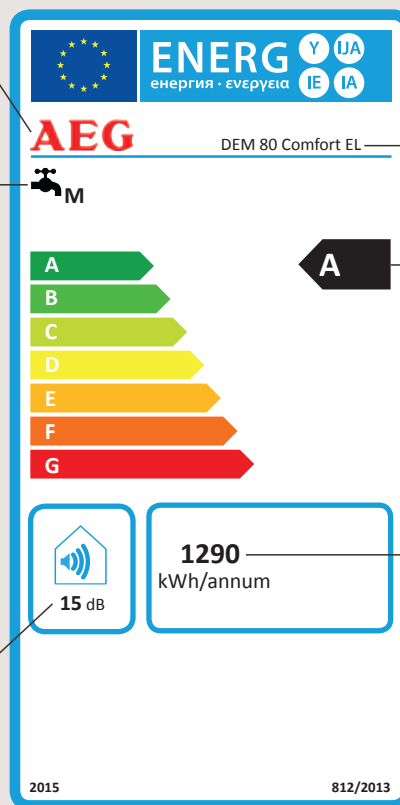

Model name

Energy efficiency class

An appropriate class for the appliance is determined based on the actual measured energy efficiency. For electric water heaters, the 7 classes range from A - G.

Annual power consumption

This field displays the annual power consumption in kWh per year in the specified load profile. Important parameters that produce this value are the amount of hot water heat drawn off and the heat loss of the appliance, for example.

AEG water heaters with ÖKO+

All AEG units featuring the ÖKO+ symbol are particularly energy and water efficient, which is good for the environment and your purse.

It's well worth comparing products! It's only when you take a look at operating costs that you can tell whether a cheap unit is actually the better choice.



DropStop

The Huz 5 ÖKO DropStop is the first small water storage heater not to drip when heating up. The special technology built into the inside of

the tank not only allows users to reap energy and water savings but also reduces limescale deposits on the fitting and basin.



ThermoStop

By using temperature control mixers, the ThermoStop in the Huz 5 ÖKO DropStop and Huz 5/10 ÖKO Comfort prevents heat

being lost through the fitting, saving up to 0.4 kWh of energy a day.



TIP FOR SAVING ENERGY

Modern small storage water heaters from AEG – the leading savings expert responsible for the patented DropStop system and ThermoStop technology.

When heating up, the expansion water is stored separately in the unit and when water is next drawn off, this is delivered. The temperature control mixer prevents the heat from circulating through the system.

REQUIREMENTS FOR CONNECTING TO THE ELECTRICITY SUPPLY

Power consumption of boiler [kW]	Rated current A	Fuse A	Comments
3.5	15.2	1 x 16	Connection to standard socket
4.4	19.1	1 x 20	Permanent connection, cable cross section, depends on type of laying, at least 2.5 mm ²
5.7	24.8	1 x 25	Permanent connection, cable cross section, depends on type of laying, at least 2.5 mm ²
6.5	2 x 16.3	2 x 16	Permanent connection, cable cross section, depends on type of laying, at least 1.5 mm ²
11	15.9	3 x 16	Permanent connection, cable cross section, depends on type of laying, at least 2.5 mm ²
12	17.3	3 x 20	AC connection, cable cross section, depends on type of laying, at least 2.5 mm ²
13.3	19.3	3 x 20	AC connection, cable cross section, depends on type of laying, at least 2.5 mm ²
18.0	26.0	3 x 32	AC connection, cable cross section, depends on type of laying, at least 4.0 mm ² (3 x 25 A suitable for old installations with 25 A)
21.0	31.0	3 x 32	AC connection, cable cross section, depends on type of laying, at least 4.0 mm ²
24.0	35.0	3 x 35	AC connection, cable cross section, depends on type of laying, at least 4.0 mm ²
18.0 / 21.0 / 24.0	29.0 / 31.0 / 35.0	3 x 35	AC connection, cable cross section, depends on type of laying, at least 4.0 mm ²
27.0	39.0	3 x 40	AC connection, cable cross section, depends on type of laying, at least 6.0 mm ²

Various connection requirements must be satisfied depending on the unit's power consumption. No extra consumers should be operated on power circuits for electric water heaters. The table contains the minimum fuses for each unit output.

INSTANTANEOUS WATER HEATERS	16
WATER BOILERS	31
SMALL WATER HEATERS	35
WALL MOUNTED WATER HEATERS	43
FLOORSTANDING WATER HEATERS	50



Annual energy costs



Calculation for 3-person household with individual water and energy requirement is in accordance with VDI 2067



Area of use

- To supply one or several nearby tap connections
- To supply washbasin/shower/kitchen sink/bath tub (bath tub 21 kW power or greater)
- Use in private or commercial sector

Components

- Elegant design, installation depth of just 93 mm
- Not sensitive to calcination as heating coils lie in the water itself
- Extensive fuse systems should problems arise
- Power supply with permanent connection

Installation

- Can be fitted directly in shower and bath tub area – water jet protection IP 25
- For oversink installation, with installation kit UT 104 also suitable for undersink installation
- Clever installation system:
 - universal installation plate with rotary fastener, fits on the drill holes of most other makes, everything is tight in just one turn
 - Cover installed from front, without screws
 - Electric connection from above or below
 - Universal water connection for remote and direct tap set-up
- Can also be installed in conjunction with plastic pipe systems (note details from manufacturer)

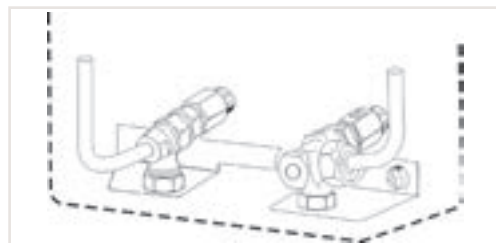

Remote tap set-up

- Cold water connection and warm water distribution via flush-mounted installation
- Warm water on left, cold water on right, pipe spacing of 100 mm, 1/2" thread connection



Direct tap set-up

- Special direct taps can be connected
- Can also be connected to a flush-mounted installation (remote tap) in parallel
- Cold water either supplied on unit or via the tap



Open water heaters

These units are used to supply a tap connection not far from the boiler (e.g. washbasin, sink) and are not subject to tap pressure. The tank is continually linked to the outside air via an open fitting.

If warm water is drawn off, the warm water valve opens the supply of cold water to the unit. The cold water flows into the tank at the bottom and forces the lighter warm water to rise towards the tap connection and flow out of the unit. An open unit can only ever supply one tap connection

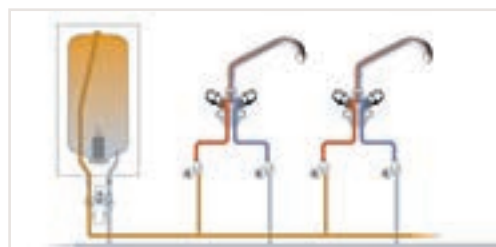

Closed water heaters

These units are used to supply several tap connections (e.g. bathroom with washbasin, shower and bath tub). Closed units are subject to tap pressure and the water heated is used downstream of the storage heater. The warm water is forced to the point of use by tap pressure.

Closed storage heaters need a safety valve combination which routes the expansion water to a separate discharge and protects the unit from overpressure when heating up. Closed instantaneous water heaters can be connected up directly to the water supply.

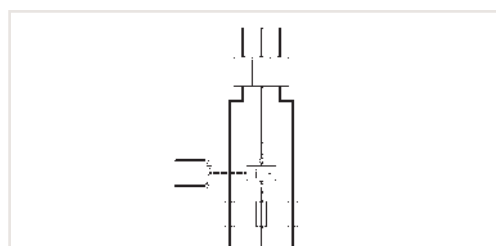

Priority switching in conjunction with storage heaters

- Priority switching in conjunction with heater e.g. electric storage heaters for instantaneous water heaters up to 27 kW
- A load shedding relay is needed for operation with priority switching (recommendation: fit LR 1-A in distribution, on request from AEG customer service, ELR relay 246 420)

- Check old installations and convert if necessary. Outer conductor L2 marked on mains connection terminal.

DDLE ÖKO THERMODRIVE

- Instantaneous water heaters with full electronic control for maximum temperature convenience and large amounts of water, e.g. rain showers
- Virtually constant outlet temperatures in the event of fluctuations in pressure, feed temperature and voltage
- Temperature selection (Off-Funktion) "0"-Position, 30 - 60 °C
- Temperature selection accurate to one degree using 2-colour backlit, clearly legible blue LCD display lighting (up to 42 °C, the colour changes to red at higher temperatures)
- Rapid control electronics for maximum showering comfort
- Processor-controlled motorised valve for water temperature accurate to the degree with maximum flow rate, suitable for rain shower heads
- Suitable for solar operation with feed temperatures of up to 60 °C, reheating of up to 45 °C
- Multi-function display with background lighting

- Temperature, flow rate, energy consumption or time can be displayed
- Two memory buttons for individually adjustable temperatures
- Comfort functions: ECO button, automatic water volume function, shower program
- Including wireless temperature button for setting the temperature once for the next drawing-off process
- Selectable output with the DDLE ÖKO TD 18/21/24 (at 18 kW, fuse min. 32 A)
- Electronic air bubble detection
- Wireless temperature button FBM Comfort, Dimension (H x W x D) 50 x 50 x 20 mm
- Childproofing: e.g. maximum temperature of 43 °C adjustable in the menu

ECO function for energy-saving operation:

- The ECO button is used to set the temperature and limit the flow rate to save energy and water
- The temperature and flow rate can be preselected individually



DDLE ÖKO TD



Wireless temperature button FBM Comfort

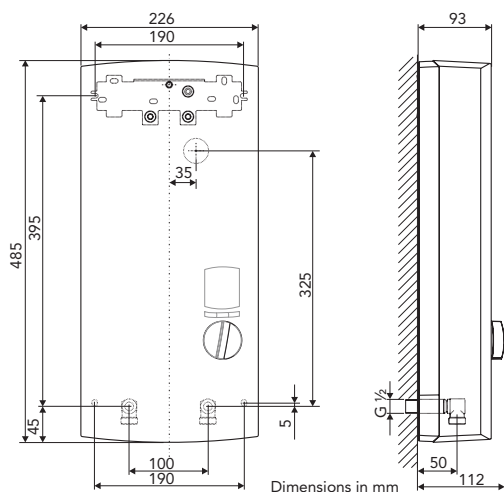

Model	DDLE ÖKO TD 18	DDLE ÖKO TD 18/21/24	DDLE ÖKO TD 27
EAN	40 41056 02280 2	40 41056 02282 6	40 41056 02283 3
E-Number	222 396	222 398	222 399
Technical Data			
Power supply	V	3/PE~400 50 Hz	3/PE~400 50 Hz
Connected load	kW	18	18/21/24
Rated current	A	26	29/31/35
Fuse protection	A	25	32/32/35
Temperature selection	°C	Off / 0.30 - 60	Off / 0.30 - 60
Minimum water flow volume	l/min	approx. 2.5	approx. 2.5
Max. flow rate	l/min	9.9	9.9/11.6/13.2
Mixed-water volume at Δ 26 K	l/min	9.9	9.9/11.6/13.2
Max. feed temperature	°C	60	60
Specific resistance of water	Ω cm	> 900	> 900
Energy efficiency category		A	A
Type of protection		IP 25	IP 25
Weight including water fill	kg	4.0	4.0

Only qualified contractors are permitted to install (water and electrical installations), commission and maintain DHW appliances in accordance with the operating instructions. · Palett: 24 items

DDLE LCD



DDLE LCD

- Electronically controlled instantaneous water heater with high temperature comfort
- Virtually constant outlet temperatures in the event of fluctuations in pressure, feed temperature and voltage
- Temperature selection accurate to one degree
- Dual colour display (blue/red); red illumination indicates risk of scalding (set temperature > 43 °C)
- Rapid control electronics for maximum showering comfort
- Suitable for solar operation with feed temperatures of up to 60 °C, reheating of up to 45 °C
- LC-Display
- Integrated diagnosis system
- Electronic air bubble detection
- Selectable output with the DDLE LCD 18/21/24 (at 18 kW, fuse protection min. 32 A)
- Temperature limit to max. 43 °C; can be set by a qualified contractor in the appliance. Temperature range 30 °C - 43 °C.

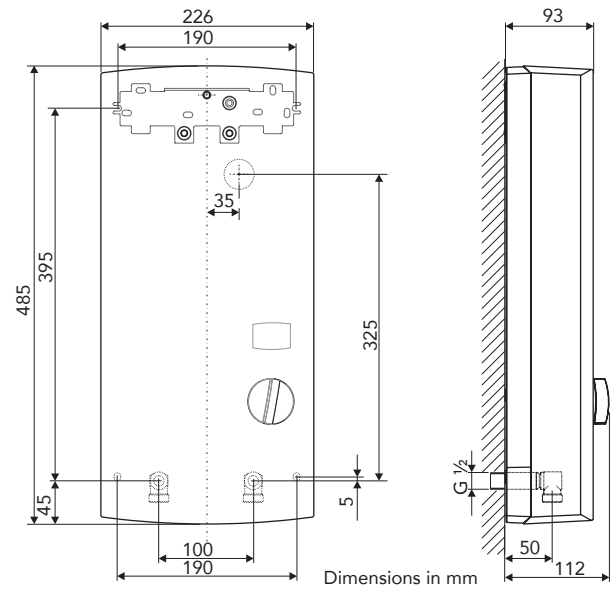

Model		DDLE LCD 18	DDLE LCD 18/21/24	DDLE LCD 27
EAN		40 41056 02276 5	40 41056 02278 9	40 41056 02279 6
E-Number		222 392	222 394	222 395
Technical Data				
Power supply	V	3/PE~400 50 Hz	3/PE~400 50 Hz	3/PE~400 50 Hz
Connected load	kW	18	18/21/24	27
Rated current	A	26	29/31/35	39
Fuse protection	A	25	32/32/35	40
Temperature selection	°C	30 - 60	30 - 60	30 - 60
Minimum water flow volume	l/min	approx. 2.5	approx. 2.5	approx. 2.5
Max. flow rate	l/min	8 *	8/8/9 *	9 *
Mixed-water volume at Δ 26 K	l/min	9.9	9.9/11.6/13.2	14.9
Max. feed temperature	°C	60	60	60
Specific resistance of water	Ω cm	> 900	> 900	> 900
Energy efficiency category		A	A	A
Type of protection		IP 25	IP 25	IP 25
Weight including water fill	kg	4.0	4.0	4.0

* with inserted volume limiter
Only qualified contractors are permitted to install (water and electrical installations), commission and maintain DHW appliances in accordance with the operating instructions. · Palett: 24 items

DDLE BASIS

- Electronically controlled instantaneous water heater with good temperature comfort
- Virtually constant outlet temperatures in the event of fluctuations in pressure and feed temperature
- Infinitely variable temperature setting with usage symbols
- Rapid control electronics for high level of temperature stability
- Electronic air bubble detection
- Selectable output with the DDLE Basis 18/21/24 (at 18 kW, Fuse protection min. 32 A)
- Suitable for solar operation with feed temperatures of up to 60 °C, reheating of up to 45 °C
- Temperature limit to max. 43 °C; can be set by a qualified contractor in the appliance. Temperature range 30 °C - 43 °C.



DDLE Basis

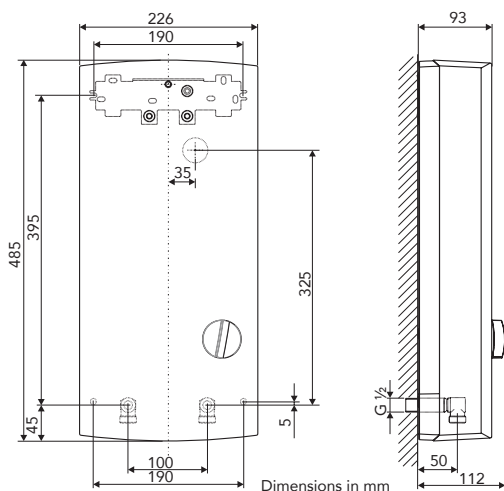

Model	DDLE Basis 11	DDLE Basis 13	DDLE Basis 18	DDLE Basis 18/21/24	DDLE Basis 27	
EAN	40 41056 02550 6	40 41056 02551 3	40 41056 02272 7	40 41056 02274 1	40 41056 02275 8	
E-Number	229 296	229 297	222 388	222 390	222 391	
Technical Data						
Power supply	V	3/PE~400 50 Hz	3/PE~400 50 Hz	3/PE~400 50 Hz	3/PE~400 50 Hz	
Connected load	kW	11	13.5	18	18/21/24	27
Rated current	A	16	19.5	26	29/31/35	39
Fuse protection	A	16	20	25	32/32/35	40
Temperature selection	°C	approx. 30 - 60	approx. 30 - 60	approx. 30 - 60	approx. 30 - 60	approx. 30 - 60
Minimum water flow volume	l/min	approx. 3.0	approx. 3.0	approx. 3.0	approx. 3.0	approx. 3.0
Max. flow rate	l/min	4.0 *	4.0 *	8 *	8/8/9 *	9 *
Mixed-water volume at Δ 26 K	l/min	5.9	7.2	9.9	9.9/11.6/13.2	14.9
Max. feed temperature	°C	60	60	60	60	60
Specific resistance of water	Ω cm	> 900	> 900	> 900	> 900	> 900
Energy efficiency category		A	A	A	A	A
Type of protection		IP 25	IP 25	IP 25	IP 25	IP 25
Weight including water fill	kg	4.0	4.0	4.0	4.0	4.0

* with inserted volume limiter
 Only qualified contractors are permitted to install (water and electrical installations), commission and maintain DHW appliances in accordance with the operating instructions. · Palett: 24 items

AS HERD FOR DDLE BASIS 11 AND DDLE BASIS 13

Special accessories: connection set for oven

- Connection set for electrical connection between DDLE Basis 11 or DDLE Basis 13 and oven junction box
- Recommended for electric ovens without electronics, clock and residual heat display
- For connecting of the DDLE Basis 11 or 13 and the electric cooker to the same power

supply. Priority control for the DDLE. When hot water is drawn, the cooker is disconnected from the mains for that period (load shedding)



AS Herd

Model	AS Herd
EAN	40 17212 23409 9
E-Number	223 409

DDLE KOMPAKT 11/13



DDLE KOMPAKT FB 11/13

- Electronically controlled compact instantaneous water heater for space saving installation below the kitchen sink, or below the washbasin or hand washbasin for greater convenience
- Virtually constant outlet temperatures in the event of fluctuations in pressure and feed temperature
- For sealed unvented/open vented operation
- Undersink installation
- Adjustable output, can be set internally to 11 or 13.5 kW
- Type of protection IP 24

- Rapid control electronics for high level of temperature stability
- Electronic air bubble detection
- Suitable for solar operation with feed temperatures of up to 70 °C, reheating of up to 55 °C feed temperature
- DDLE Kompakt FB 11/13 with remote control IP X7 protection against intermittent immersion
- Complete with connection accessories: pressure hose and tee
- As standard with 900 mm long flexible power cable



Readers of the trade magazine "Gebäudetechnik und Handwerk" assessed the DDL Kompakt as being "very good".

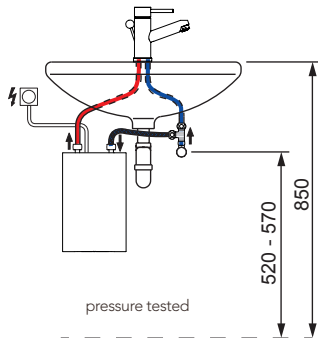

pressure tested

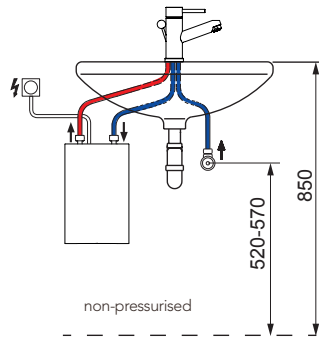

non-pressurised

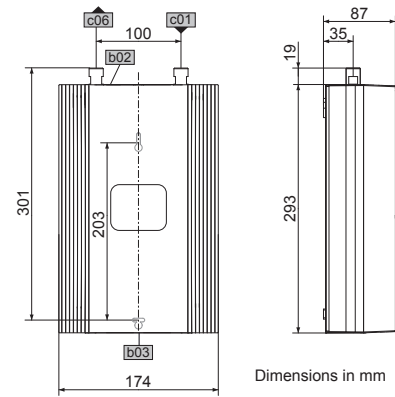

Dimensions in mm

b01: Electrical cable entry
c01: Cold water inlet, male thread G 3/8" A
c06: DHW outlet, male thread G 3/8" A

Model	DDLE Kompakt 11/13	
EAN	40 41056 02728 9	40 41056 02729 6
E-Number	230 768	230 769
Technical Data		
Power supply	V	3/PE~400 50 Hz
Connected load	kW	11/13.5
Rated current	A	15.9/18.8
Fuse protection	A	3 x 16/3 x 20
Temperature selection	°C	20 - 60 (factory setting 50)
Minimum water flow volume	l/min	2.5
Max. flow rate*	l/min	5.0
Mixed-water volume at Δ 26 K	l/min	5.4 / 6.4
Max. feed temperature **	°C	70
Specific resistance of water	V cm	≥ 900
Energy efficiency category		A
Type of protection		IP 24
Weight including water fill	kg	2.7

* with inserted volume limiter · ** DHW at 38 °C in litres per minute;; 12 °C feed temperature
Only qualified contractors are permitted to install (water and electrical installations), commission and maintain DHW appliances in accordance with the operating instructions. · Palett: 36 items

AS HERD KOMPAKT



AS Herd Kompakt

**Special accessories:
connection set for DDLE Kompakt 11/13**

- Connection set for electrical connection between DDLE Kompakt 11/13 or DDLE Kompakt FB 11/13 and oven junction box
- Recommended for electric ovens without electronics, clock and residual heat display

- For connecting of the DDLE Kompakt 11/13 or DDLE Kompakt FB 11/13 and the electric cooker to the same power supply. Priority control for the DDLE. When hot water is drawn, the cooker is disconnected from the mains for that period (load shedding)

Model	AS Herd Kompakt
EAN	40 17212 33048 7
E-Number	233 048

DDLE KOMPAKT OT 11/13

- Electronically controlled compact instantaneous water heater for oversink installation on sink or wash basin
- Variable temperature adjustment from 20 °C to 60 °C via rotary selector
- **G 1/2"** water connections for pressurised and non-pressurised systems from below
- Largely constant outlet temperature in the case of pressure or supply temperature fluctuations
- Oversink installation
- Adjustable output, can be set internally to 11 or 13.5 kW
- Type of protection IP 24
- Rapid control electronics for high level of temperature stability
- Electronic air bubble detection
- Suitable for solar operation with feed temperatures of up to 70 °C, reheating of up to 55 °C feed temperature
- Anti-scalding protection may be activated (limiting the outlet temperature to 43 °C)
- Flexible power cable, 900 mm long



DDLE KOMPAKT OT 11/13

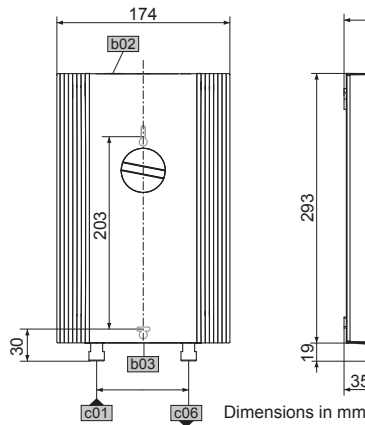

b02: Electrical cable entry
b03: Wall mounting
c01: DHW outlet, male thread G 1/2" A
c06: Cold water inlet, male thread G 1/2" A

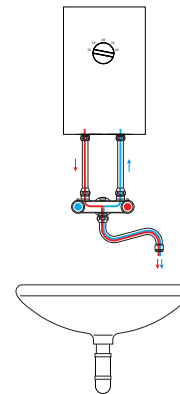

Readers of the trade magazine "Gebäudetechnik und Handwerk" assessed the DDL Kompakt as being "very good".

Model	DDLE Kompakt OT 11/13	
EAN	40 41056 03072 2	
E-Number	232 793	
Technical Data		
Power supply	V	3/PE~400 50 Hz
Connected load	kW	11/13.5
Rated current	A	15.9/18.8
Fuse protection	A	3 x 16/3 x 20
Temperature selection	°C	20 - 60
Minimum water flow volume	l/min	2.5
Max. flow rate*	l/min	5.0
Mixed-water volume at Δ 26 K	l/min	5.4 / 6.4
Max. feed temperature **	°C	70
Specific resistance of water	V cm	≥ 900
Energy efficiency category	A	
Type of protection	IP 24	
Weight including water fill	kg	2.7

* with inserted volume limiter · ** DHW at 38 °C in litres per minute;; 12 °C feed temperature
Only qualified contractors are permitted to install (water and electrical installations), commission and maintain DHW appliances in accordance with the operating instructions. · Palett: 36 items ·

OPEN VENTED WALL-MOUNTED MIXERS

AHo 50:

- Open vented two-hand wall-mounted mixer for oversink installation on sink or wash basin, complete with swivel spout



AHo 50

Model	AHo 50	
EAN	40 41056 02928 3	
E-Number	232 615	
Description	Open vented wall mounted two-hand mixer tap, oversink	

DDLE EASY



DDLE EASY

- Electronically controlled instantaneous water heater with good temperature convenience
- Virtually constant outlet temperatures in the event of fluctuations in pressure and feed temperatures
- Two fixed temperatures of 42 °C and 55 °C with usage symbols
- Rapid control electronics for high level of temperature stability
- Electronic air bubble detection

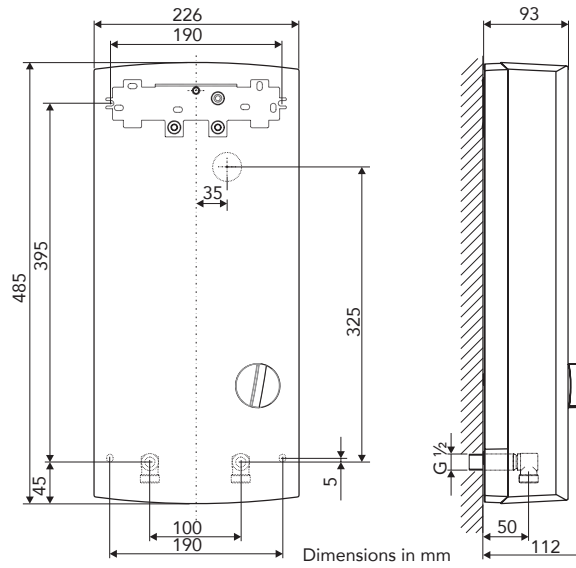

Model		DDLE EASY 18	DDLE EASY 21	DDLE EASY 24
EAN		40 41056 02507 0	40 41056 02508 7	40 41056 02509 4
E-Number		228 840	228 841	228 842
Technical Data				
Power supply	V	3/PE~400 50 Hz	3/PE~400 50 Hz	3/PE~400 50 Hz
Connected load	kW	18	21	24
Rated current	A	26	31	35
Fuse protection	A	25	32	35
Temperature selection	°C	approx. 42 / 55	approx. 42 / 55	approx. 42 / 55
Minimum water flow volume	l/min	approx. 3.0	approx. 3.0	approx. 3.0
Max. flow rate	l/min	8.0 *	8.0 *	9.0 *
Mixed-water volume at Δ 26 K	l/min	9.9	11.6	13.2
Max. feed temperature	°C	25	25	25
Specific resistance of water	V cm	> 900	> 900	> 900
Energy efficiency category		A	A	A
Type of protection		IP 25	IP 25	IP 25
Weight including water fill	kg	4.0	4.0	4.0

* with inserted volume limiter

Only qualified contractors are permitted to install (water and electrical installations), commission and maintain DHW appliances in accordance with the operating instructions. · Palett: 24 items

DDL T PINCONTROL

- Hydraulically controlled instantaneous water heater with mechanical temperature consistency control
- Virtually constant outlet temperature in the event of pressure fluctuations using PinControl
- 4 output stages – 2 can be selected manually, 2 switched hydraulically, depending on flow rate
- Pressure-controlled safety device



DDL T PinControl

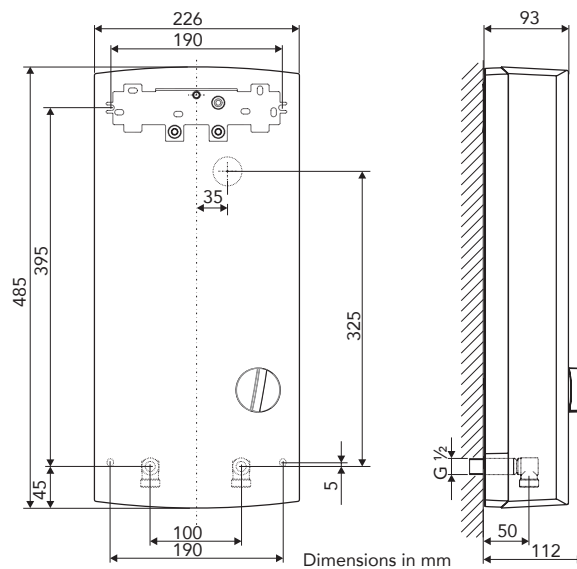

Model	DDL T PinControl 13	DDL T PinControl 18	DDL T PinControl 21	DDL T PinControl 24
EAN	40 41056 02268 0	40 41056 02269 7	40 41056 02270 3	40 41056 02271 0
E-Number	222 384	222 385	222 386	222 387
Technical Data				
Power supply	V	3/PE~400 50 Hz	3/PE~400 50 Hz	3/PE~400 50 Hz
Connected load	kW	13.5	18	21
Rated current	A	20	26	31
Fuse protection	A	20	25	32
Temperature selection	°C	up to around 60 (2 output stages)	up to around 60 (2 output stages)	up to around 60 (2 output stages)
Minimum water flow volume	l/min	2.4 / 3.9	3.0 / 4.9	3.5 / 5.6
Max. flow rate	l/min	4.7 *	5.9 *	7.0 *
Mixed-water volume at Δ 26 K	l/min	7.2	9.9	11.6
Max. feed temperature	°C	25	25	25
Specific resistance of water	V cm	> 900	> 900	> 900
Energy efficiency category		A	A	A
Type of protection		IP 25	IP 25	IP 25
Weight including water fill	kg	4.0	4.0	4.0

* when switching on 2nd level.

Only qualified contractors are permitted to install (water and electrical installations), commission and maintain DHW appliances in accordance with the operating instructions. · Palett: 24 items



UT 104



UNDERSINK INSTALLATION KIT

- For laying water connections on top of unit, thereby allowing for undersink installation
- For connection to existing corner valves
- Water connection with 12 mm compression fitting
- Not suited for DDLT PinControl



FBM Comfort

WIRELESS TEMPERATURE BUTTON FOR DDLE ÖKO THERMOTRIVE

- In the DDLE ÖKO ThermoDrive's normal mode, temperature can be set using all four buttons
- The temperature settings 38 °C and 55 °C are permanently programmed and can be individually adjusted with the +/- keys
- IP X7 protection against intermittent immersion
- In ECO mode, the ECO function is suspended for the next draw-off event when any key on the wireless remote control is pressed
- Range in buildings of around 25 m, and through 2 walls or one floor
- Up to 4 FBM can be operated with a single DDLE ÖKO TD
- Dimensions (W x H x D): 50 x 50 x 20 mm

Model	UT 104	FBM Comfort
EAN	40 14890 71432 5	40 41056 02446 2
E-Number	184 421	227 545
Description	Undersink installation kit	Wireless temperature button for ThermoDrive



ADEo 70 WD

FITTINGS FOR INSTANTANEOUS WATER HEATER

- Special direct drawing fitting for instantaneous water heater
- Twin-hand tap with bath tub/shower changeover, complete with 12 mm Ø, 300 mm long connection pipes, handheld shower head, shower hose and wall bracket
- Fitted directly under unit
- The support plate and connection plug needed for the connection are included in the fitting's scope of supply
- Protection rating: IP 24



AVR 1000-12

CONNECTION PIPES

- Connection pipes (pair)
- 1000 mm long
- can be individually trimmed to length
- Ø 12 mm

Model	ADEo 70 WD	AVR 1000-12
EAN	40 41056 02932 0	40 14890 74215 1
E-Number	232 619	184 549
Description	Single lever tap	Connection pipes (pair) 1000 mm long, can be individually trimmed to length, Ø 12 mm

MOUNTING FRAMES AND PIPE ASSEMBLIES

Mounting frame MR 110

- Universal mounting frame with back panel and wiring
- Particularly suitable for special installation conditions, such as the replacement of an instantaneous water heater with different connections
- The depth of the instantaneous water heater increases by around 30 mm
- Standard delivery: Universal mounting frame, extension cable, 2 tap extensions ½", cable grommet

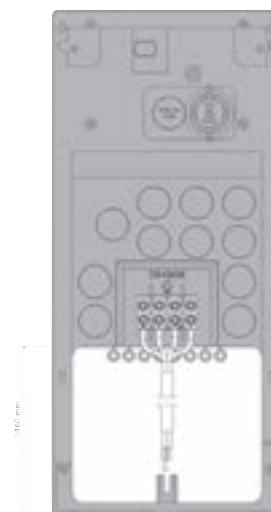

MR 110

Pipe assembly for offset installation MR 111

- Pipe assembly for offset installation incl. universal mounting frame
- Vertical offset of the appliance relative to the water connection by approx. 90 mm +/- 10 mm downwards
- The universal mounting frame creates the necessary space behind the appliance to accommodate the pipe assembly
- The depth of the instantaneous water heater increases by 30 mm
- Standard delivery: Universal mounting frame, 2 x ½" twin connectors each, fixing washers, pipe assemblies, ½" valve extensions and gaskets

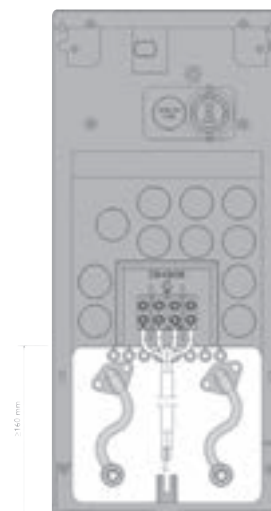

MR 111

Pipe assembly for gas water heater replacement MR 112

- Pipe assembly incl. universal mounting frame
- For installation on existing gas water heater connections (CW on the left, DHW on the right)
- The universal mounting frame creates the necessary space behind the appliance to accommodate the pipe assembly
- The depth of the instantaneous water heater increases by 30 mm
- Standard delivery: Universal mounting frame, ½" pipe assemblies and gaskets

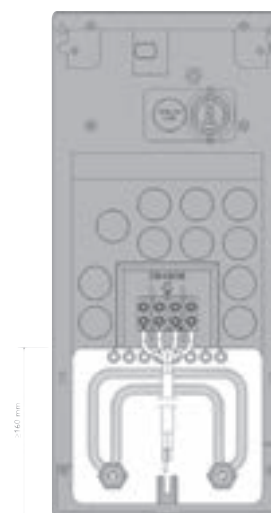

MR 112

Model	MR 110	MR 111	MR 112
EAN	40 41056 02455 4	40 41056 02456 1	40 41056 02457 8
E-Number	227 701	227 702	227 703
Description	Mounting frame instantaneous water heater	Pipe assembly for offset installation	Pipe assembly for gas water heater replacement



Area of use

- Electric small instantaneous water heaters for supplying warm water in energy- and water-saving manner.
- Cut energy consumption by up to 66 % energy and water consumption by up to 50 % water compared with other types of supply!
- Can be used in homes, holiday homes, guest WCs and toilet facilities
- With small instantaneous water heaters , the water volume and temperature are limited to around 2-3.3 l/min at approx. 35 °C. If higher water volumes and temperatures are needed, small storage tanks or instantaneous water heaters with power rates of 12 kW or more should be used

Components

- Very compact dimensions
- Bare wire heating system for rapid heating up, not susceptible to calcination

- MTE 350/440/570/650: open and closed operation
- MTD: closed unit, for pressure fittings
- MTH: open unit, for non-pressure fittings

Installation

- Jet water protection IP 25
- MTE: for undersink and oversink installation
- MTD: for undersink installation
- MTH: for undersink and oversink installation
- All you need to operate the MTE 350 and MTH 350 is a socket with a 16 A fuse and cold water supply
- For MTD 350, 440, 570, MTH 440, 570 and MTE 440/570, you need a permanent supply with a 16 A, 20 A or 25 A fuse
- With jet controller for adjusting standard fittings, MTD also with connection accessories, pressure hose and T-piece

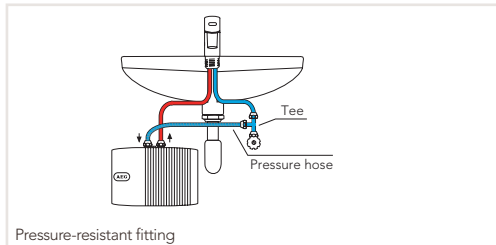

Fig. 1: AEG small instantaneous water heaters MTD and MTE 440/570/650 in undersink installation, with closed (pressure-resistant) fitting; T-piece and pressurised hose included in standard delivery; pressure fittings present can be adjusted using jet controller provided

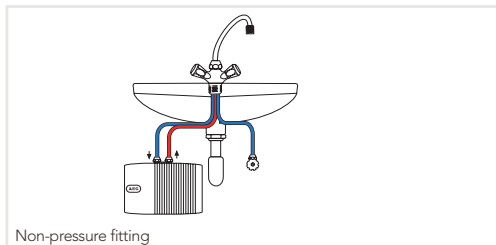

Fig. 2: AEG small instantaneous water heaters MTH and MTE 350 in undersink installation, with open, (non-pressure) fitting

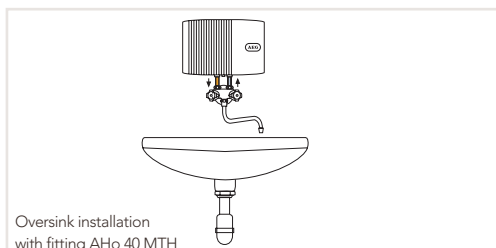

Fig. 3: AEG small instantaneous water heaters MTH and MTE in oversink installation; the special fitting AHo 40 MTH is needed for this



With new aerator for water saving tap outlet you get a pleasantly gentle water jet



Jet controller for adapting standard fittings

- The jet controller ensures that the comparatively low water volume of the small instantaneous water heater is well distributed at the water outlet and forms a good jet pattern
- The jet controller is provided with the units and is used in the fitting in place of the jet controller present
- Jet controller SR3 and SR5 with automatic flow control

- Jet Controller SR3 for small instantaneous water heaters: MTH 350, MTH 440, MTH 350 + UTE, MTH 350 + UT, MTH 350 + OT, For valves: AHEu 40 MTH, AHu 40 MTH, AHo 40 MTH Available as spare part (289 591)
- Jet Controller SR5 for small instantaneous water heater MTH 570/650 Available as spare part (270 582)

REQUIREMENTS FOR CONNECTING TO THE ELECTRICITY SUPPLY

Power consumption of boiler in kW	Rated current A	Fuse A	Comments
3.5	15.2	1 x 16	Connection to standard socket
4.4	19.1	1 x 20	Permanent connection, cable cross section, depends on type of laying, at least 2.5 mm ²
5.7	24.8	1 x 25	Permanent connection, cable cross section, depends on type of laying, at least 2.5 mm ²
6.5	2 x 16.3	2 x 16	Permanent connection, cable cross section, depends on type of laying, at least 1.5 mm ²

MTE (SEALED UNVENTED AND OPEN VENTED)

- Electronically controlled small instantaneous water heater for supplying a hand basin
- Electronics ensure constant outlet temperature, up to maximum capacity, in both summer and winter
- Outlet temperature can be set internally to 30...50 °C
- Suitable for solar operation up to 60 °C, reheating of up to 45 °C
- Maximum flow rate can be set internally
- Effective bare wire heating system
- Universal oversink or undersink installation
- **MTE 350:** with safety plug
- **MTE 440/570/650:** with permanent connection
- **MTE 350/ 440/570/650:** for non-pressure and pressure-resistant fittings, complete with connection accessories, pressure hose and T-piece
- Metal water connections
- Special jet controller with flow restrictor for M 2 internal thread and M 24 external thread
- **MTE 650:** 2-phase with connection 2/PE*~400 V 50 Hz
Fuse 2 x 16 A
Permanent connection, cable cross section, depends on type of laying, at least 1.5 mm²



MTE 350

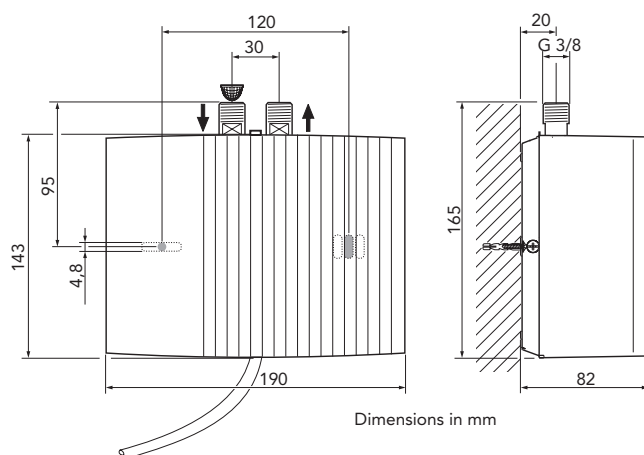
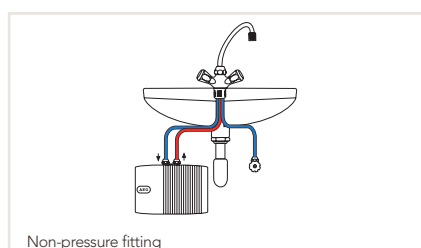
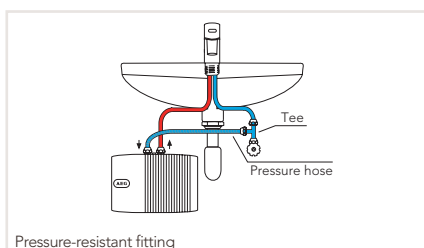

Model	MTE 350	MTE 440	MTE 570	MTE 650
EAN	40 41056 02740 1	40 41056 02741 8	40 41056 02774 6	40 41056 02945 0
E-Number	231 003	231 004	231 216	232 770
Technical Data				
Type closed/open	•/•	•/•	•/•	•/•
Power supply	V 1/N/PE~230 50 Hz	V 1/N/PE~230 50 Hz	V 1/N/PE~230 50 Hz	V 2/PE~400 50 Hz
Type of installation: undersink/oversink	•/•	•/•	•/•	•/•
Safety plug (S), Permanent connection (F)	S	F	F	F
Connected load	kW 3.5	kW 4.4	kW 5.7	kW 6.5
Flow rate at Δ 25 K	l/min 2.0	l/min 2.5	l/min 3.4	l/min 3.7
Temperature increase within the comfort range, approx.:	K 25	K 25	K 25	K 25
Temperature adjustment*:	°C 30 - 50	°C 30 - 50	°C 30 - 50	°C 30 - 50
Switch-on water volume	l/min 1.5	l/min 1.8	l/min 2.2	l/min 2.2
Energy efficiency category	A	A	A	A
Type of protection	IP 25	IP 25	IP 25	IP 25
Weight including water fill	kg approx. 1.5	kg approx. 1.5	kg approx. 1.5	kg approx. 1.5

* up to the output limit - depending on cold water inlet temperature and volume of water
Only qualified contractors are permitted to install (water and electrical installations), commission and maintain DHW appliances in accordance with the operating instructions. · Palett: 40 items

MTD (SEALED UNVENTED)



MTD 350

- Small instantaneous water heater for sealed unvented operation
- For undersink installation
- With new aerator for water-saving fitting outflow, pleasantly soft water jet
- Bare wire heating system for rapid heating up, not susceptible to calcination
- Complete with pressurised hose and T-piece connection accessories
- With permanent connection

- **MTD 350:** Connection cable with safety plug
- **MTD 650:** 2-phase with connection 2/PE*~400 V 50 Hz Fuse 2 x 16 A Permanent connection, cable cross section, depends on type of laying, at least 1.5 mm²

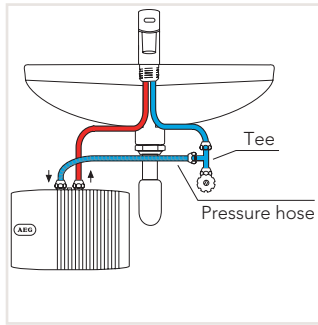

Pressure-resistant fitting

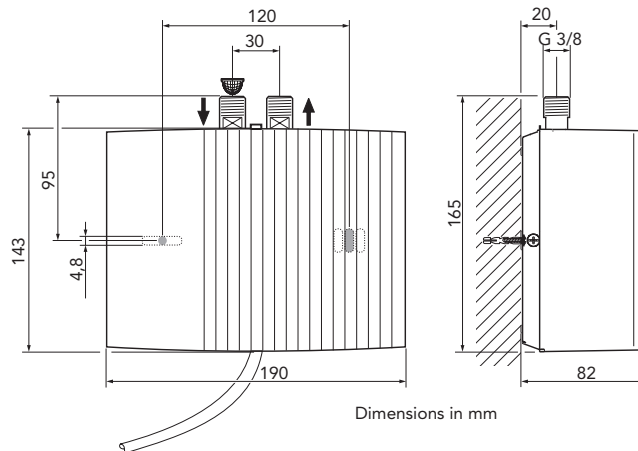

Dimensions in mm

Model	MTD 350	MTD 440	MTD 570	MTD 650
EAN	40 41056 02245 1	40 41056 02246 8	40 41056 02247 5	40 41056 02965 8
E-Number	222 120	222 121	222 122	232 790
Technical Data				
Type closed/open	-/•	-/•	-/•	-/•
Power supply	V 1/N/PE~230 50 Hz	V 1/N/PE~230 50 Hz	V 1/N/PE~230 50 Hz	V 2/PE~400 50 Hz
Type of installation: undersink/oversink	•/-	•/-	•/-	•/-
Safety plug (S), Permanent connection (F)	S	F	F	F
Connected load	kW 3.5	kW 4.4	kW 5.7	kW 6.5
Flow rate at Δ 25 K	l/min 2.0	l/min 2.5	l/min 3.3	l/min 3.7
Temperature increase within the comfort range, approx.:	K 25	K 25	K 25	K 25
Temperature adjustment*:	°C -	°C -	°C -	°C -
Switch-on water volume	l/min 1.6	l/min 2.0	l/min 2.6	l/min 2.6
Energy efficiency category	A	A	A	A
Type of protection	IP 25	IP 25	IP 25	IP 25
Weight including water fill	kg 1.4	kg 1.4	kg 1.4	kg 1.4

* up to the output limit - depending on cold water inlet temperature and volume of water
Only qualified contractors are permitted to install (water and electrical installations), commission and maintain DHW appliances in accordance with the operating instructions. · Palett: 40 items

MTH (OPEN VENTED)

- Small instantaneous water heater for open vented operation
- For undersink and oversink installation
- Bare wire heating system for rapid heating up, not susceptible to calcination
- With aerator for adapting existing fittings
- **MTH 350**: Connection cable with safety plug
- **MTH 440 and MTH 570**: Permanent connection
- Practical complete sets available with single lever fitting, 2-hand fitting or oversink fitting
- **MTH 350 + UTE**: With single-lever tap for washbasin
- **MTH 350 + UT**: With 2-hand fitting for washbasin
- **MTH 350 + OT**: With oversink fitting



MTH 350

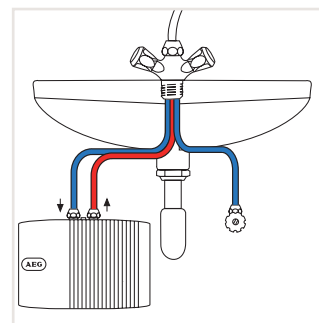

Pressure-less fitting

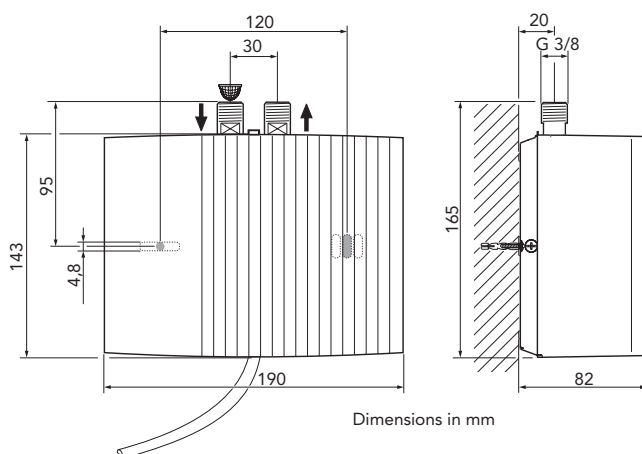

Model	MTH 350	MTH 440	MTH 570	MTH 350 + UTE	MTH 350 + UT	MTH 350 + OT
EAN	40 41056 01569 9	40 41056 02240 6	40 41056 02241 3	40 41056 01572 9	40 41056 01571 2	40 41056 01570 5
E-Number	189 554	189 555	222 116	189 557	189 631	189 556
Technical Data						
Type closed/open	•/–	•/–	•/–	•/–	•/–	•/–
Power supply	V 1/N/PE~230 50 Hz	1/N/PE~230 50 Hz	1/N/PE~230 50 Hz	1/N/PE~230 50 Hz	1/N/PE~230 50 Hz	1/N/PE~230 50 Hz
Type of installation: undersink/oversink	•/•	•/•	•/•	•/•	•/•	•/•
Safety plug (S), Permanent connection (F)	S	F	F	S	S	S
Connected load	kW 3.5	4.4	5.7	3.5	3.5	3.5
Flow rate at Δ 25 K	l/min 2.0	2.5	3.3	2.0	2.0	2.0
Temperature increase within the comfort range, approx.:	K 25	25	25	25	25	25
Temperature adjustment*:	°C –	–	–	–	–	–
Switch-on water volume	l/min 1.6	2.0	2.6	1.6	1.6	1.6
Energy efficiency category	A	A	A	A	A	A
Type of protection	IP 25	IP 25	IP 25	IP 25	IP 25	IP 25
Weight including water fill	kg 1.4	1.4	1.4	1.4	1.4	1.4

* up to the output limit - depending on cold water inlet temperature and volume of water
 Only qualified contractors are permitted to install (water and electrical installations), commission and maintain DHW appliances in accordance with the operating instructions. · Palett: MTH 350 – 570: 40 items, MTH Sets: 30 items

SENSOR FITTING FOR SMALL INSTANTANEOUS WATER HEATERS MTE AND MTD



ADS 40

- Sensor fitting (pressure) for zero-contact operation, with wall power supply
- Wash basin installation
- Valve body made from brass of low dezincification (MS 63)
- Mixing water temperature can be adjusted (permanent setting possible)
- Sensor sensitivity permanently self-calibrating
- Run-on time can be set between 0 and 5 seconds (factory setting of 1 second)
- 12- or 24-hour hygiene rinsing
- Connection cable length of wall power supply: 770 mm
- Flexible connection hose: 410 mm long
- Also suited to all instantaneous water heaters and pressure-resistant storage tanks

SENSOR FITTING FOR SMALL INSTANTANEOUS WATER HEATERS MTE AND MTH



AHS 50

- Sensor fitting (pressure) for zero-contact operation, with wall power supply
- Wash basin installation
- Valve body made from brass of low dezincification (MS 63)
- Mixing water temperature can be adjusted (permanent setting possible)
- 12 or 24 h hygiene flushing
- Rapid installation system
- Flexible connection hoses
- Dirt trap in inlet
- Connection cable length of wall power supply: 770 mm
- Flexible connection hose: 500 mm long

SINGLE-LEVER TAP FOR SMALL INSTANTANEOUS WATER HEATERS MTE AND MTH



AHEu 40 MTH

- Attractive open vented single-lever tap for washbasin
- With flexible connection hoses
- With pop-up waste set
- With water jet control SR3

2-HAND FITTING FOR SMALL INSTANTANEOUS WATER HEATERS MTE AND MTH



AHu 40 MTH

- 2-hand fitting for single-hole installation on washbasin
- Open vented single-hole mixer tap with swivel spout and flexible connection hoses.
- The left toggle opens the warm water valve and the right toggle the cold water valve
- With water jet control SR3

2-HAND FITTING FOR SMALL INSTANTANEOUS WATER HEATERS MTE AND MTH



AHo 40 MTH

- Open vented oversink fitting with swivel spout. The right toggle opens the warm water valve and the left toggle the cold water valve
- The cold water connection is at the rear on the fitting
- Suitable for MTH and MTE units. With special aerator
- With water jet control SR3

Model	ADS 40	AHS 50	AHEu 40 MTH	AHu 40 MTH	AHo 40 MTH
EAN	40 41056 02738 8	40 41056 02739 5	40 41056 01582 8	40 41056 01581 1	40 41056 01580 4
E-Number	230 958	230 959	189 634	189 633	189 632
Description	Sensor fitting for zero-contact operation	Sensor fitting for zero-contact operation	Open vented single-lever mixer tap	Single-hole mixer tap	Wall-mounted mixer for MTH and MDE

Area of use

- Water boiler for generating hot and boiling water to supply a kitchen sink
- Ideal for making instant meals, tea and coffee in the home, office, commerce, catering and much more

Components

- Heats water for between just one cup (0.2 l) and up to 5 litres
- Low-line design
- Stainless steel base plate, with heater underneath
- Temperature can be selected from between around 35 °C and boiling
- Automatic protection from running dry
- 3-hand fitting with swivel spout included in scope of supply
- 0.5 m connection cable with safety plug

Automatic further boiling function:

The ON/OFF indicator illuminates while the water is heated. The appliance switches off automatically as soon as the selected temperature has been reached. The ON/OFF indicator goes out. At the top end of the temperature range, once the boiling point has been reached the water is held at temperature by the automatic continuous reboil facility. An audible signal indicates that boiling water is available

Installation

- Unit is hung on the wall away from children
- Fitted directly above sink basin
- All you need for operation is a cold water connection and socket
- Cold water inlet from the back via the 3-lever tap



Simple to operate

- **“Warm” range:** Temperature of around 30-50 °C
- **“Hot” range:** Temperature of around 50-80 °C
- **“Boiling” range:** Temperature of around 80-100 °C
- On push-button: start the heating-up process
- Fitting:
 - Knob with white dot – fill tank
 - Knob with blue dot – draw off cold water
 - Knob with red dot – draw off warm water

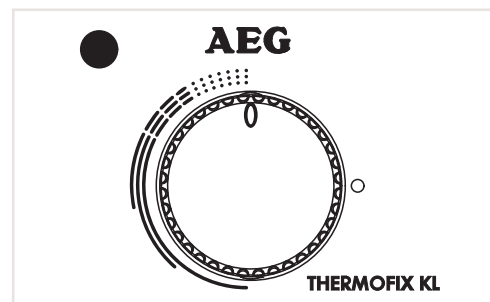

Simple to operate

- Temperature selector
Temperature selection 65 °C to HOT (around 97 °C)

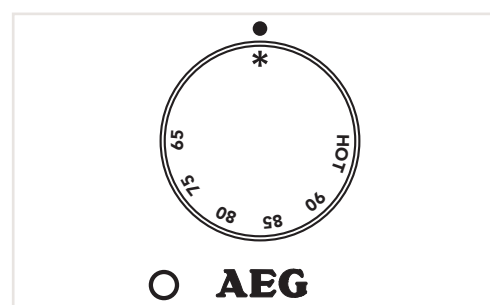

HOT 5

THERMOFIX KL



THERMOFIX KL

- For quickly generating hot water using a 2 kW connected load
- Automatic further boiling function with acoustic signal for boiling keeps boiling water hot
- Heats water for between just one cup and up to 5 litres
- Temperature can be set in continuously variable manner to between 35 °C and boiling
- Heat-up signalled by red indicator
- Quick and easy to install
- Plug-in variant
- Easy to replace without drilling through universal wall bracket
- Brass chrome-plated 3-hand fitting with swivel spout included in scope of supply

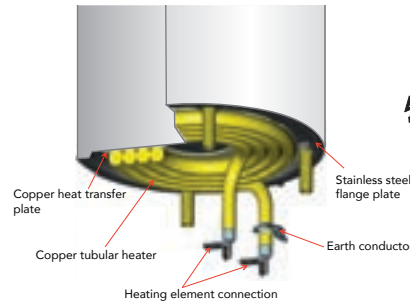

Long-life stainless steel heater outside the water under the base plate

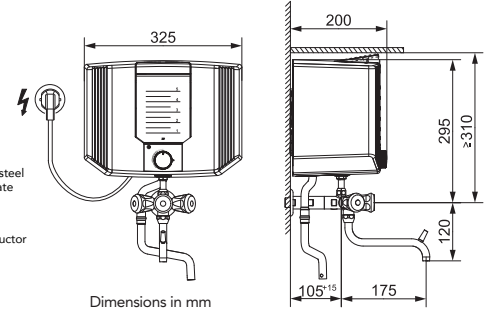

Model		THERMOFIX KL
EAN		40 41056 02532 2
E-Number		228 908
Technical Data		
Rated capacity	l	1 cup up to 5 litres
Power supply	V	1/N/PE ~230 50 Hz
Connected load	kW	2
Connection cable	m	0.75 with safety plug
Temperature selection	°C	approx. 35 up to boiling
Signal for boiling		•
Automatic further boiling function		•
Tank material		Plastic
Color		white
Fitting (as standard)		3-hand, chrome-plated
Type of protection		IP 24 D
Weight including water fill	kg	8.0
Only qualified contractors are permitted to install (water and electrical installations), commission and maintain DHW appliances in accordance with the operating instructions. · Palett: 16 items		



AT 30 ch

REPLACEMENT FITTING FOR THERMOFIX KL

- Special fitting for THERMOFIX KL, chrome valve body, chrome knob
- Supply pipe diameter: 1/2"

Model		AT 30 ch
EAN		40 17212 86253 7
E-Number		286 253
Description		3-hand fitting for THERMOFIX KL

HOT WATER SYSTEM HOT 5 WITH SPECIAL TAP – NEW – AND CHILD SAFETY FEATURE

- Hot water in 1 second
- Water drawn with little steam or splashing
- Push-turn feature on tap ensures child safety; system separation also prevents tap from getting hot
- Hot water system for connection to a central DHW supply system
- Including hot water tap AEuS HOT
- Suitable for the rapid preparation of hot drinks and food
- For use in kitchens, offices and surgeries
- Approximately 5 l of near-boiling water
- Flexible connection hoses
- High grade thermal insulation
- Hot water temperature adjustable from 65 °C to approx. 97 °C
- High safety level through high limit safety cut-out
- Connection with standard plug
- Type of protection IP 24
- We recommend operating the HOT 5 with a water filter



HOT 5



FITTING WILL NOT BECOME HOT

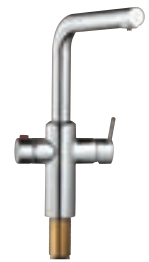

AEuS HOT

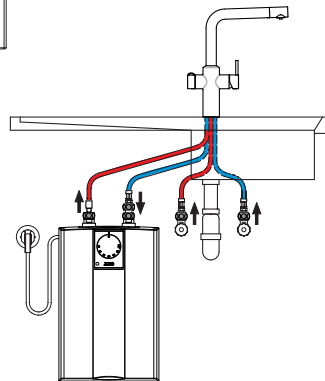
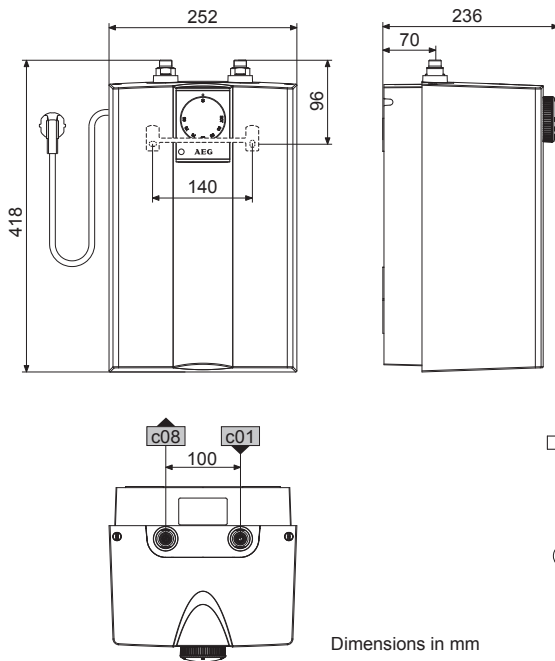

Model	HOT 5 + AEuS HOT	
EAN	40 41056 03073 9	
E-Number	234 238	
Technical Data		
Rated capacity	l	Up to 5 l of near-boiling water (approx. 97 °C)
Power supply	V	1/N/PE~230 50 Hz
Connected load	kW	2
Rated current	A	8.7
Standby power consumption / 24 h at 97 °C	kWh	0.53
Hot water temperature setting range	°C	65 to approx. 97
Max. hot water flow rate	l/min	2.1
Maximum permissible pressure	MPa	0 (non-pressurised)
Type of protection	IP 24	
Color	White	
Weight (without water fill)	kg	3
Hot water tap AEuS HOT		
Type of installation	Mono block mixer tap, sink	
Application	sink	
Type of design	open / closed	
Max. hot water flow rate	l/min	2.1
Max. cold water/DHW flow rate	l/min	12
Finish	Polished chrome	
Outlet height	mm	287
Reach	mm	210

Only qualified contractors are permitted to install (water and electrical installations), commission and maintain DHW appliances in accordance with the operating instructions. · Palett: 12 Items



HOT WATER TAP AEU S HOT PART OF THE STANDARD DELIVERY

- One handle for drawing hot water from the water heater and a mixing lever for cold and hot water from the central DHW system
- Separate heating water routing inside the tap (surface is safe to touch)
- **Child safety feature:** safety push-turn mechanism
- Water drawn with little steam or splashing
- After drawing hot water, the water that remains inside the tap is returned to the water heater



AEuS HOT



AEuS HOT special aerator

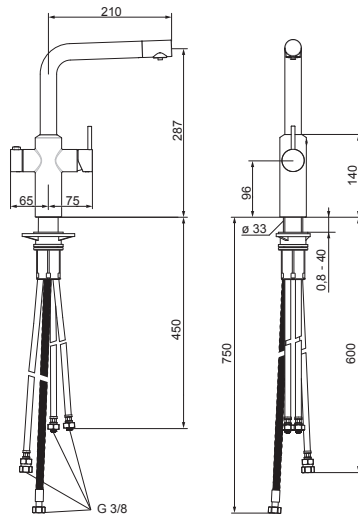

Child safety feature with red safety button (push-turn lock), water drawn with little steam or splashing

ANTI-SCALING FILTER · RECOMMENDED ACCESSORIES

- **Anti-scaling filter:** Recommended for soft water areas (1 – soft); required for medium and hard water areas
- Installation on the cold water inlet of the hot water system
- 500 to 1000 l capacity, depending on water hardness
- **FKC Filter Starter-Kit Comfort**
- Includes flow rate measuring device for filter monitoring
- Connection hose and flow sensor with LED indicator of current filter capacity
- Test strip for determining the water hardness

Hardness range – millimol calcium carbonate per litre	
soft	below 8.4 °dH
medium	8.4 to 14 °dH
hard	above 14 °dH

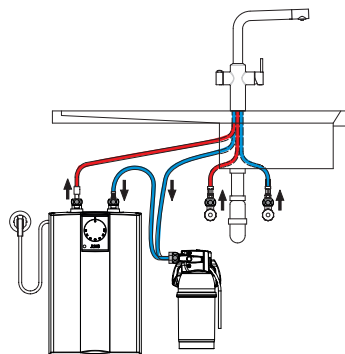

FKB-Filter

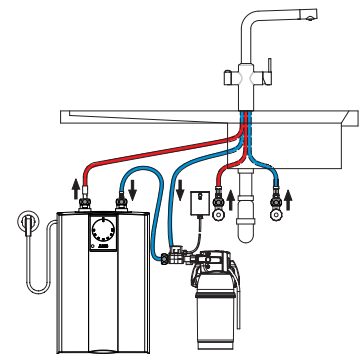

FKC-Filter

Model	FKB Filter	FKC Filter	FK Filter Kartusche
EAN	40 17212 33231 3	40 17212 33232 0	40 17212 33232 0
E-Number	233 231	233 232	233 230
Description	Starter-Kit Basis	Starter-Kit Comfort	Filter cartridge

Area of use

- Energy-saving and cost-effective way of supplying a tap connection with warm water
- Virtually unlimited uses in private and commercial sectors: kitchen sink, washbasin, work room, toilet, workshop, catering, making tea, doctors' practices and much more besides.
- Open vented small storage water heater for undersink installation (Huz) or oversink installation (Hoz)

Components

- 5-litres ÖKO storage tank with ThermoStop. This prevents energy from being lost through the fitting during standby operation
- Huz 5 ÖKO DropStop: the first small storage water heater which doesn't drip when heating up
- Quality benefit from a brand manufacturer:

high-quality thermal insulation for low standby energy consumption

- Considerably lower operating costs than from cheap manufacturers with insufficient thermal insulation. The difference in price is paid off in just a few months of use.
- Quality benefit from a brand manufacturer: large volume of warm water or mixed water can be drawn off thanks to special boiler geometry
- Temperature can be selected in continuously variable manner between approx. 35 °C and 85 °C
- Corrosion-resistant inner tank made from polypropylene, with copper heating flange
- Protection rating: IP 24

Installation

- All that is needed for operation is a grounding receptacle with 10 A fuse and cold water connection
- Simple to fit on wall with separate wall bracket



Outlet temperature barely varies for approx. 90 % of the cylinder content

Overflow curve for AEG 5 litre small water heater Mixed water volume at 65 °C set temperature	
65 °C	approx. 5 litre
53 °C	approx. 6 litre
45 °C	approx. 7.5 litre
30 °C	approx. 9 litre

Approx. 95 % of the cylinder content is available at a practically unvarying outlet temperature (tolerance < 2.5 K)

The average cylinder temperature falls by only 1.2 K when the entire cylinder content is drawn

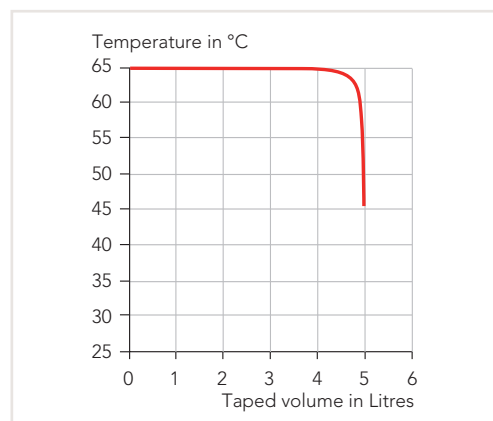

Quality symbol for electrical appliances designed for quiet operation.



Heating up time depending on the temperature set

- Heating up time after drawing off the entire storage tank contents.
- Example: Temperature setting chosen 65 °C, unit: Huz 5 – the heating up time is around 9 minutes

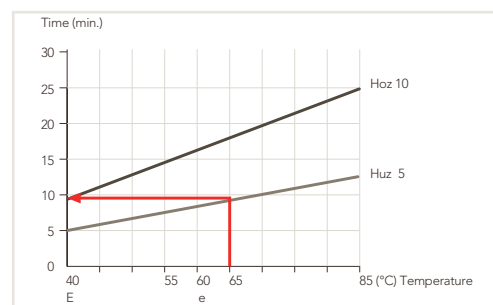

Mixed water volume at 40 °C depending on temperature set

- The mixed water volume is the maximum water volume which can be drawn off at a particular temperature by adding cold water.
- Example: The storage tank temperature is 65 °C, the feed temperature is 15 °C, the water temperature required is 40 °C. The Huz 5 ÖKO Comfort can therefore deliver 10 l of water at a temperature of 40 °C.

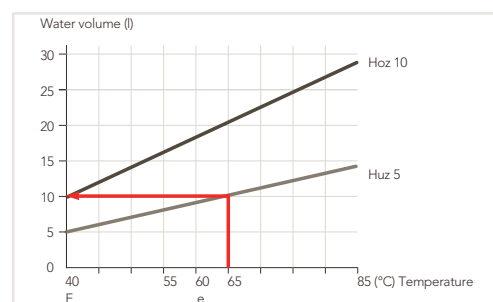

HUZ 5 ÖKO DROPSTOP



HUZ 5 ÖKO DropStop

- Small storage water heater, volume of 5 litres, for undersink installation
- DropStop: open vented small storage water heater which doesn't drip when heating up
- Huz 5 ÖKO DropStop with ThermoStop technology
- Modern, attractive design
- Temperature can be selected in continuously variable manner between approx. 35 °C and 85 °C
- Temperature can be limited to 45 °C / 55 °C / 65 °C using the rotating knob
- Outstanding thermal insulation, standby power consumption of just 0.20 kWh/24 hours
- Metal water connections
- Safety temperature limiter can be reset by disconnecting the mains plug
- Connection cable with safety plug, around 0.6 m

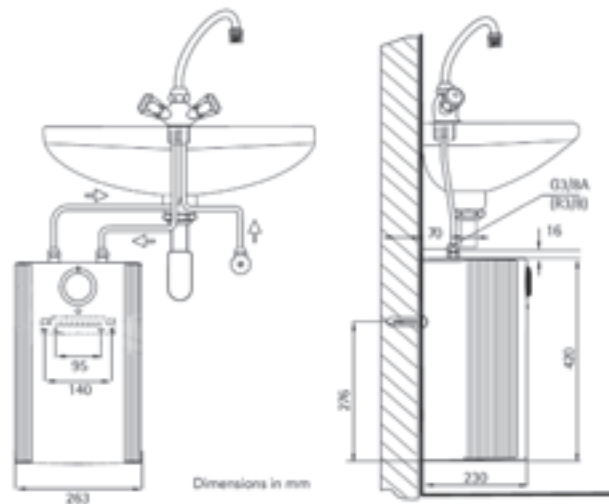

Model	HUZ 5 ÖKO DropStop	
EAN	40 41056 02315 1	
E-Number	222 167	
Technical Data		
For one tap connection (open vented unit)		•
Rated capacity	l	5
For undersink installation		•
With ThermoStop		•
Power supply	V	1/N/PE-230 50 Hz
Connected load	kW	2
Standby power consumption *	kWh/24 hrs	0.2
Safety Plug (S), Permanent connection (F)		S
Temperature selection	°C	approx. 35 – 85
Temp. of selector lever can be limited to:	°C	45 / 55 / 65
Thermal fuse / can be switched back on		• / •
Energy efficiency category		A
Type of protection		IP 24 D
Weight including water fill	kg	8.3

* The standby power consumption states the amount of energy needed in 24 hours to maintain a storage tank temperature of 65 °C (not drawing off any warm water).
The standby power consumption is a measure of the quality of the storage tank's thermal insulation
Only qualified contractors are permitted to install (water and electrical installations), commission and maintain DHW appliances in accordance with the operating instructions. · Palett: 24 items

HUZ 5 ÖKO COMFORT AND HOZ 5 COMFORT

- Small storage water heater, content of 5 litres, for undersink installation (Huz) or oversink installation (Hoz)
- Huz 5 ÖKO Comfort with ThermoStop technology
- Modern, attractive design
- Continuously variable temperature selection between around 35 °C and 85 °C with energy-saving setting "E" at 40 °C and "e" at 60 °C
- Temperature can be limited to 45 °C / 55 °C / 65 °C using the rotating knob
- High-quality thermal insulation, standby power consumption of just 0.22 kWh /24 hours
- Safety temperature limiter can be reset by disconnecting the mains plug
- Metal water connections
- Connection cable with safety plug, around 0.6 m
- Flow rate approx.. 5 litres per minute



Huz 5 ÖKO Comfort

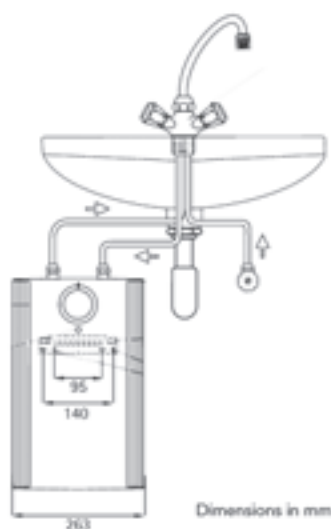

Dimensions in mm

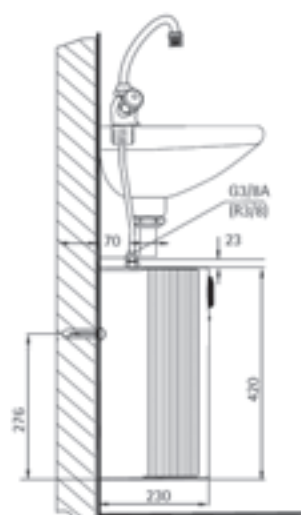

Huz 5 ÖKO Comfort

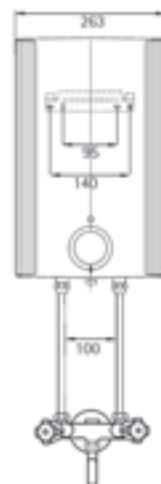

Hoz 5 ÖKO Comfort

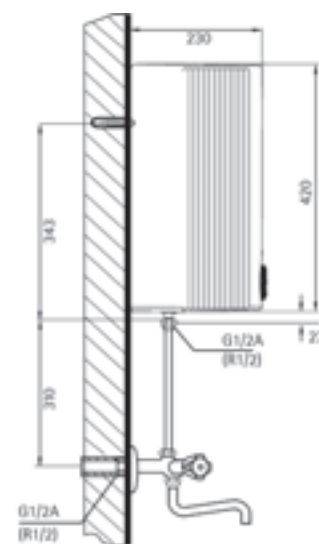

Model		Huz 5 ÖKO Comfort	Hoz 5 Comfort
EAN		40 41056 02313 7	40 41056 02307 6
E-Number		222 164	222 154
Technical Data			
For one tap connection (open vented unit)		•	•
Rated capacity	l	5	5
For oversink installation		–	•
For undersink installation		•	–
With ThermoStop		•	–
Power supply	V	1/N/PE~230 50 Hz	1/N/PE~230 50 Hz
Connected load	kW	2	2
Standby power consumption *	kWh/24 hrs	0.22	0.22
Safety Plug (S), Permanent connection (F)		S	S
Temperature selection	°C	approx. 35 – 85	approx. 35 – 85
Temp. of selector lever can be limited to	°C	45 / 55 / 65	45 / 55 / 65
Thermal fuse / can be switched back on		• / •	• / •
Energy efficiency category		A	A
Type of protection		IP 24 D	IP 24 D
Weight including water fill	kg	8.2	8.2

* The standby power consumption states the amount of energy needed in 24 hours to maintain a storage tank temperature of 65 °C (not drawing off any warm water).
The standby power consumption is a measure of the quality of the storage tank's thermal insulation
Only qualified contractors are permitted to install (water and electrical installations), commission and maintain DHW appliances in accordance with the operating instructions. · Palett: 24 items

HUZ 5 BASIS AND HOZ 5 BASIS



Huz 5 Basis

- Small storage water heater, content of 5 litres, for undersink installation (Huz) or oversink installation (Hoz)
- Temperature can be selected in continuously variable manner between approx. 35 °C and 85 °C

- Safety temperature limiter can be reset by disconnecting the mains plug
- Standby power consumption of just 0.24 kWh / 24 hours
- Connection cable with safety plug, around 0.6 m
- Huz 5 Basis + A: Single hole mixer tap
- Huz 5 Basis + AS: Single-lever tap for sink
- Huz 5 Basis + AW: Single-lever tap for washbasin



A: Single hole mixer tap



AS: Single-lever tap for sink



AW: Single-lever tap for washbasin

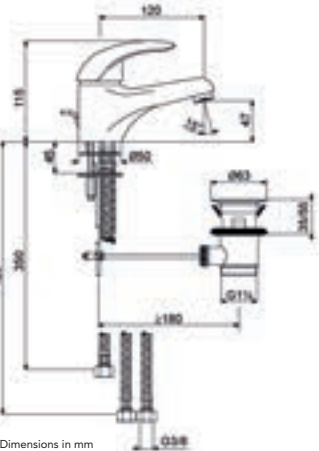
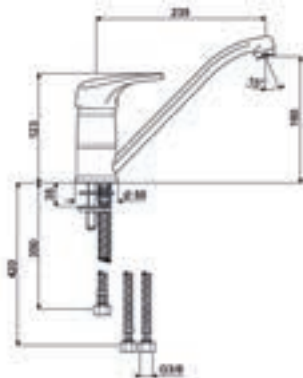

Dimensions in mm

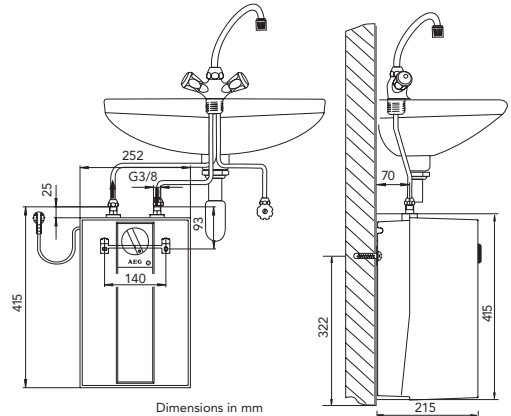

Huz 5 Basis

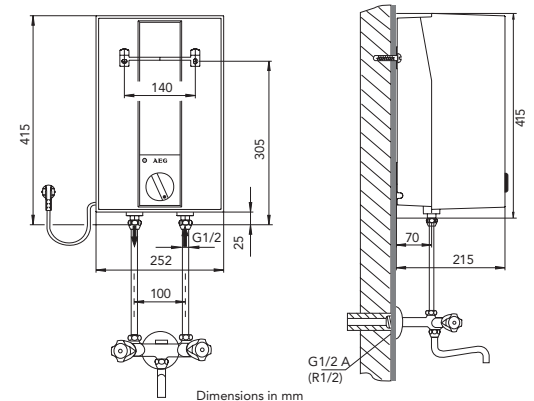

Hoz 5 Basis

Model	Huz 5 Basis	Huz 5 Basis + A	Huz 5 Basis + AS	Huz 5 Basis + AW	Hoz 5 Basis
EAN	40 41056 02311 3	40 41056 02544 5	40 41056 02943 6	40 41056 02944 3	40 41056 02306 9
E-Number	222 162	229 287	232 752	232 753	221 117
Technical Data					
For one tap connection (open vented unit)	•	•	•	•	•
Rated capacity	l	5	5	5	5
For oversink installation	-	-	-	-	•
For undersink installation	•	•	•	•	-
Power supply	V	1/N/PE~230 50 Hz	1/N/PE~230 50 Hz	1/N/PE~230 50 Hz	1/N/PE~230 50 Hz
Connected load	kW	2	2	2	2
Standby power consumption *	kWh/24 hrs	0.24	0.24	0.24	0.24
Safety Plug (S), Permanent connection (F)		S	S	S	S
Temperature selection	°C	approx. 35 – 85	approx. 35 – 85	approx. 35 – 85	approx. 35 – 85
Temp. of selector lever can be limited to	°C	45 / 55 / 65	45 / 55 / 65	45 / 55 / 65	45 / 55 / 65
Thermal fuse / can be switched back on		• / •	• / •	• / •	• / •
Energy efficiency category		A	A	A	A
Type of protection		IP 24 D	IP 24 D	IP 24 D	IP 24 D
Weight including water fill	kg	8.2	8.2	8.2	8.2

* The standby power consumption states the amount of energy needed in 24 hours to maintain a storage tank temperature of 65 °C (not drawing off any warm water).
The standby power consumption is a measure of the quality of the storage tank's thermal insulation
Only qualified contractors are permitted to install (water and electrical installations), commission and maintain DHW appliances in accordance with the operating instructions. - Palett: Huz 5 Basis 24 items, Huz 5 Basis + A 18 Items, Hoz 5 Basis 24 items

HUZ 10 ÖKO AND HOZ 10

- For supplying hot water to a single draw-off point with high DHW demand, i.e. in the kitchen or utility room
- Small storage water heater for undersink installation (Huz 10 Öko) or oversink installation (Hoz 10)
- Huz 10 ÖKO with ThermoStop technology
- Excellent thermal insulation and small external dimensions
- Continuously variable temperature selection between around 35 °C and 85 °C with optional range limiting
- Safety temperature limiter can be reset by disconnecting the mains plug
- Connection cable with safety plug, around 0.6 m



Huz 10 ÖKO

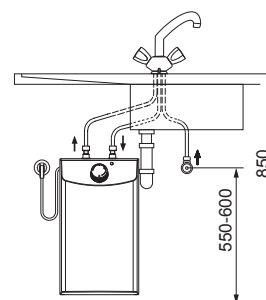

Huz 10 ÖKO

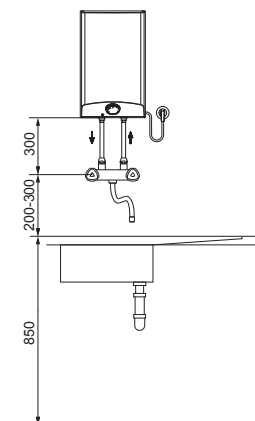

Hoz 10

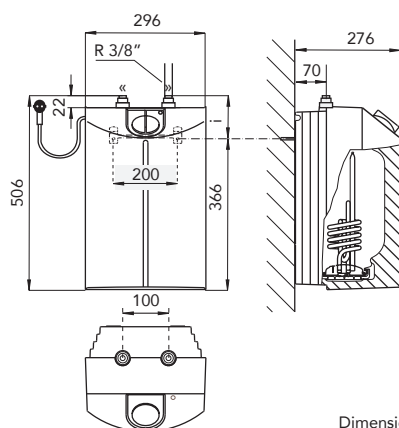

Huz 10 ÖKO

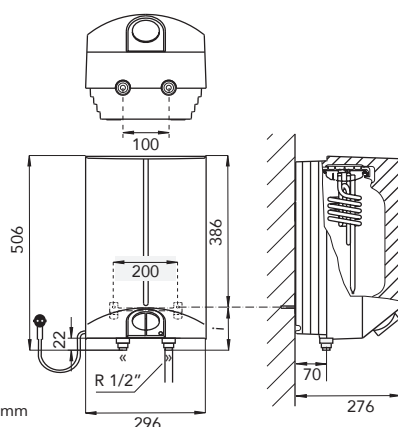

Hoz 10

Dimensions in mm

Model	Huz 10 ÖKO	Hoz 10
EAN	40 41056 02582 7	40 41056 02584 1
E-Number	229 486	229 488
Technical Data		
For one tap connection (open vented unit)	•	•
Rated capacity	l 10	10
For oversink installation	–	•
For undersink installation	•	–
With ThermoStop	•	–
Power supply	V 1/N/PE~230 50 Hz	1/N/PE~230 50 Hz
Connected load	kW 2	2
Standby power consumption *	kWh/24 hrs 0.32	0.31
Safety Plug (S), Permanent connection (F)	S	S
Temperature selection	°C approx. 32 – 85	approx. 32 – 85
Temp. of selector lever can be limited to	°C 38 / 45 / 55 / 65	38 / 45 / 55 / 65
Thermal fuse / can be switched back on	• / •	• / •
Energy efficiency category	A	A
Type of protection	IP 24 D	IP 24 D
Weight including water fill	kg 16	16

* The standby power consumption states the amount of energy needed in 24 hours to maintain a storage tank temperature of 65 °C (not drawing off any warm water).
The standby power consumption is a measure of the quality of the storage tank's thermal insulation
Only qualified contractors are permitted to install (water and electrical installations), commission and maintain DHW appliances in accordance with the operating instructions. · Palett: 15 items

SENSOR FITTING FOR OPEN STORAGE WATER HEATERS



AHS 50

- Sensor fitting (non-pressure) for zero-contact operation, with wall power supply
- Wash basin installation
- Valve body made from brass of low dezincification (MS 63)
- Mixing water temperature can be adjusted (permanent setting possible)
- 12 or 24 h hygiene flushing
- Rapid installation system
- Flexible connection hoses
- Dirt trap in inlet
- Connection cable length of wall power supply: 770 mm
- Flexible connection hose: 500 mm long

OPEN VENTED SINGLE-LEVER TAP



AHEu 50 WT



AHEu 50 S

AHEu 50 WT:

- Attractive open vented single-lever tap for washbasin. With pop-up waste set and flexible connection hoses

AHEu 50 S:

- Attractive open vented single-lever tap for sink. With swivel spout and flexible connection hoses
- Copper pipe chrome-plated

OPEN VENTED TEMPERATURE CONTROL MIXER



AHu 50



AHu 51

AHu 50:

- Open vented single-hole temperature control mixer with swivel spout. The left toggle is used to set the temperature and the right toggle to open the water valve
- For washbasin and sink
- Copper pipe diameter of 8 mm
- Flexible connection hoses

AHu 51:

- 2-hand fitting for single-hole installation on washbasin
- Open vented single-hole mixer tap with swivel spout and flexible connection hoses. The left toggle opens the warm water valve and the right toggle the cold water valve

Model	AHS 50	AHEu 50 WT	AHEu 50 S	AHu 50	AHu 51
EAN	40 41056 02739 5	40 41056 02931 3	40 41056 02930 6	40 14890 74207 6	40 14890 74867 2
E-Number	230 959	232 618	232 617	183 918	184 545
Description	Sensor fitting for zero-contact operation	Open vented single-lever washbasin fitting with pop-up waste set	Open vented single-lever sink fitting	Temperature control mixer with swivel spout	Single-hole mixer tap

OPEN VENTED WALL-MOUNTED MIXERS



AHo 50



AHo 50 WD



AVR 1000-16

AHo 50:

- Open vented two-hand wall-mounted mixer for oversink installation on sink or wash basin
- Complete with swivel spout

AVR 1000-16:

- With connection pipes 16 mm Ø, 1000 mm long
- Can be individually trimmed to length

AHo 50 WD:

- Open vented wall-mounted mixer with bath tub/shower head changeover
- Complete with handheld shower head and shower head hose

Model	AHo 50	AHo 50 WD	AVR 1000-16
EAN	40 41056 02928 3	40 41056 02929 0	40 14890 74232 8
E-Number	232 615	232 616	184 553
Description	Open vented two-hand mixer tap, oversink Ø 16 mm	Open vented two-hand bath tub/shower fitting Ø 16 mm	Connection pipes (pair) 1000 mm long, can be individually trimmed to length, Ø 16 mm

Area of use

- Small water heater for supplying hot water to one or several draw-off points, such as a twin washbasin, shower and single washbasin, or sinks in restaurants etc.

Components

- Quality benefit from a brand manufacturer: high-quality thermal insulation for low standby energy consumption – considerably lower operating costs than from cheap manufacturers with insufficient thermal insulation. The difference in price is paid off in just a few months of use.

- Quality benefit from a brand manufacturer: large volume of warm water or mixed water can be drawn off thanks to special boiler geometry
- Temperature can be selected in continuously variable manner between approx. 35 °C and 85 °C
- Pressure-resistant inner tank made from steel, with copper heating flange
- Protection rating: IP 24

Installation

- Simple to fit on wall with separate wall bracket
- Special valve combinations are required to provide the water connection



Heating up time

- Heating up time depending on the temperature set

- Heating up time after drawing off the entire storage tank.
Cold water temperature of 15 °C
Example: Temperature setting chosen 65 °C.
Unit: DKu 10. The heating up time is around 8 minutes

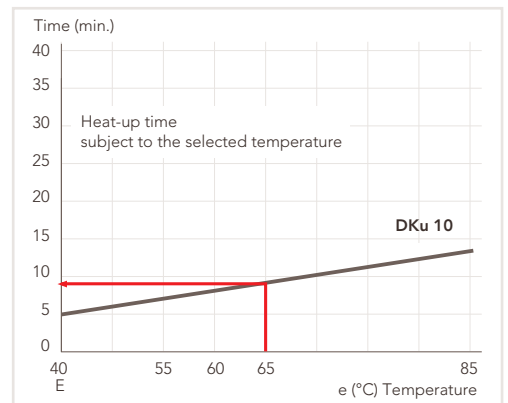

Mixed water volume

- Mixed water volume at 40 °C depending on temperature set
- The mixed water volume is the maximum water volume which can be drawn off at a particular temperature by adding cold water.

Example:
The storage tank temperature is 65 °C, the feed temperature is 15 °C, the water temperature required is 40 °C.
The DKu 10 can therefore deliver 20 l of water at a temperature of 40 °C.

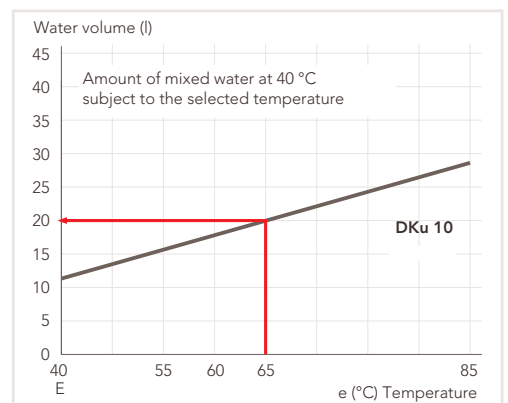

DKU 10



DKu 10

- Sealed unvented small water heater for supplying two draw-off points that are close to each other, such as a twin washbasin
- Temperature can be selected in continuously variable manner between approx. 35 °C and 85 °C with optional range limiting
- Highly efficient
- Safety temperature limiter
- Connection cable with safety plug

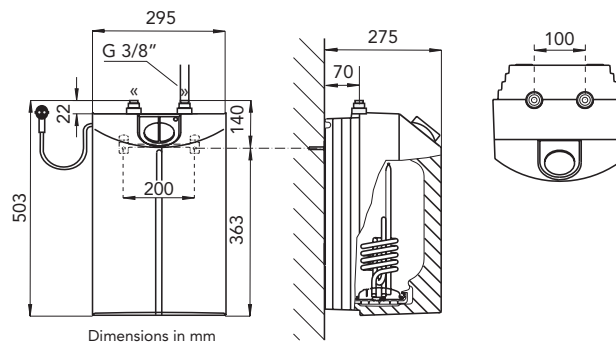

DKu 10

Model	DKu 10	
EAN	40 41056 02577 3	
E-Number	229 481	
Technical Data		
For one or more tap connections (sealed unvented unit)		•
Rated capacity	l	10
For undersink installation		•
Power supply	V	1/N/PE~230 50 Hz
Connected load	kW	2
Standby power consumption *	kWh/24 hrs	0.36
Safety Plug (S), Permanent connection (F)		S
Temperature selection	approx. °C	35 - 82
Temp. of selector lever can be limited to		•
Thermal fuse / can be switched back on		•/•
Energy efficiency category		A
Type of protection		IP 24 D
Weight including water fill	kg	19

* The standby power consumption states the amount of energy needed in 24 hours to maintain a storage tank temperature of 65 °C (not drawing off any warm water). The standby power consumption is a measure of the quality of the storage tank's thermal insulation. Only qualified contractors are permitted to install (water and electrical installations), commission and maintain DHW appliances in accordance with the operating instructions. · Palett: 15 items

CONNECTION ACCESSORY FOR DKU 10 – NEW –



SVMT

SVMT

- Combined connection facility complete with 7 bar safety valve, drain outlet with backpressure stop

Model	SVM1	
EAN	40 172100 73499 7	
E-Number	073 499	
Description	Combined connection facility for DKu 10	

Area of use

- To supply one or several nearby tap connections
- To supply washbasin/shower/kitchen sink/bath tub
- Use in private or commercial sector

Components

- Continuously variable temperature selection
- Rapid heating button in the event of increased demand for warm water
- Available ECO functions for high energy efficiency
- For single and double circuit, power and voltage can be switched
- Control panel with telltale

- Steel inner tank with special enamelling and magnesium protective anode, maintenance-free impressed current anode for DEM Comfort EL
- With flanged stainless steel heater, DEM Comfort with flanged copper immersion heater
- Protection rating
IP 24 (EWH Universal horizontal installation, DEM Comfort),
IP 25 (EWH Trend, EWH Universal vertical installation, EWH Comfort, DEM Comfort EL)

Installation

- Simple wall bracket mounting
- Permanent connection
- A combination of safety valves is needed for the water connection



Quality symbol for electrical appliances designed for quiet operation.



Single circuit operation

- In a single-circuit operation the storage tank's temperature is only controlled by the inbuilt temperature controller
- The temperature controller maintains the set temperature around the clock

Dual circuit operation

- The storage tank is heated up in the cheap low rate period. The storage tank volume should be dimensioned such that the volume of water can last until the next low-rate period
On days when there is increased demand for hot water, the rapid heating button can be used to provide additional heating in the high rate periods
- The dual circuit should always be selected if using a dual rate connection

Heating up period

- The heating up period for storage tanks with different capacities depends on the power rating set and can be seen in the graphic
- Example:
A storage tank with a capacity of 80 l needs around 1 hour at 6 kW heating capacity to heat to 65 °C (starting temperature of 15 °C)

Boiler circuit operation(only EWH ... Universal, EWH ... Comfort and DEM ... Comfort, DEM ... Comfort EL)

- With the boiler circuit, heating takes place once when the rapid heating button is pressed and lasts until the temperature set on the temperature selector is reached
- The boiler circuit should be selected for units only used occasionally

**SINGLE CIRCUIT,
DUAL CIRCUIT,
BOILER CIRCUIT**

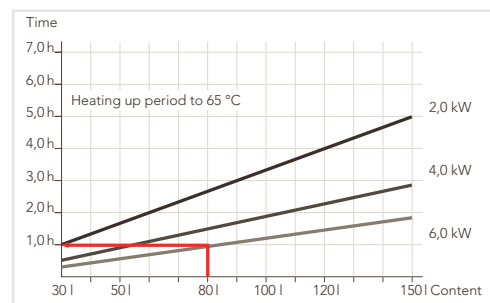

EWH UNIVERSAL EL 30 TO 150 LITRES



EWH 30 Universal EL
(vertical wall-mounted)

- Angular wall mounted sealed unvented DHW cylinder with directly applied foam insulation and enamelled internal steel cylinder
- Flanged immersion heater with protective anode
- ECO Comfort function (temperature setback from 85 °C to 60 °C)
- ECO Plus function (60 °C set temperature and 60 % charging level)
- ECO Dynamic function (intelligent dynamic matching to the draw-off pattern)
- Intelligent self-learning electronics
- Contemporary design with intuitive user interface
- Integral key lock
- Additional function temperature limiter from 40 °C - 60 °C
- Protected ceramic heating element (replaceable without draining)
- Vertical or horizontal installation



EWH 30 Universal EL
(horizontal wall-mounted)

Model	EWH 30 Universal EL	EWH 50 Universal EL	EWH 80 Universal EL	EWH 100 Universal EL	EWH 120 Universal EL	EWH 150 Universal EL	
EAN	40 41056 02769 2	40 41056 02770 8	40 41056 02771 5	40 41056 02772 2	40 41056 02821 7	40 41056 02773 9	
E-Number	231 193	231 194	231 195	231 196	231 647	231 197	
Dimensions in mm							
Height	mm	676	931	893	1045	1200	1435
Width	mm	380	380	475	475	475	475
Depth	mm	380	380	475	475	475	475
Technical Data							
Rated capacity	l	30	50	80	100	120	150
Power supply	V	1/N/PE~230 50 Hz	1/N/PE~230 50 Hz	1/N/PE~230 50 Hz	1/N/PE~230 50 Hz	1/N/PE~230 50 Hz	1/N/PE~230 50 Hz
Connected load	kW	2.6	3.0	3.0	3.0	3.0	3.0
Single circuit operating mode		•	•	•	•	•	•
Dual circuit operating mode		•	•	•	•	•	•
Manual rapid heat-up operating mode		•	•	•	•	•	•
Heating up time (15 °C / 60 °C)	hrs	0.61	0.88	1.42	1.77	2.13	2.66
Standby power consumption ¹⁾ – vertical	kWh/24 hrs	0.57	0.78	0.88	1.05	1.19	1.29
Standby power consumption ¹⁾ – horizontal	kWh/24 hrs	0.83	0.94	0.99	1.26	1.43	1.57
Mixed water volume at 40 °C ²⁾ – vertical	l	50	92	136	183	217	273
Mixed water volume at 40 °C ²⁾ – horizontal	l	42	76	111	153	173	194
Permissible operating pressure – DHW	MPa	0.6	0.6	0.6	0.6	0.6	0.6
Max. throughput	l/min	23.5	23.5	23.5	23.5	23.5	23.5
Available temperature range	°C	7 – 85	7 – 85	7 – 85	7 – 85	7 – 85	7 – 85
Cylinder version		wall-mounted	wall-mounted	wall-mounted	wall-mounted	wall-mounted	wall-mounted
Container material		Steel, enamelled	Steel, enamelled	Steel, enamelled	Steel, enamelled	Steel, enamelled	Steel, enamelled
Heater type		Ceramic heater	Ceramic heater	Ceramic heater	Ceramic heater	Ceramic heater	Ceramic heater
Type		closed	closed	closed	closed	closed	closed
Type of protection (vertical)		IP 25	IP 25	IP 25	IP 25	IP 25	IP 25
Type of protection (horizontal)		IP 24	IP 24	IP 24	IP 24	IP 24	IP 24
Water connection		G ½"	G ½"	G ½"	G ½"	G ½"	G ½"
Weight (dry)	kg	22	28	34	38	43	52
Weight (wet)	kg	52	78	114	138	163	202
Power cable / power cable length	– / m	• / 1	• / 1	• / 1	• / 1	• / 1	• / 1
Energy efficiency category		B	B	C	C	C	C

¹⁾ The standby power consumption states the amount of energy needed in 24 hours to maintain a storage tank temperature of 65 °C (not drawing off any warm water).

The standby power consumption is a measure of the quality of the storage tank's thermal insulation

²⁾ The mixed water volume at a usage temperature of 40 °C results from adding cold water (15 °C) to the storage tank water of 65 °C, in relation to the ready-for-use condition

Only qualified contractors are permitted to install (water and electrical installations), commission and maintain DHW appliances in accordance with the operating instructions. - Palett: EWH 30 - 100 Universal EL: 8 items, EWH 120 - 150 Universal EL: 4 items

EWH COMFORT EL 30 TO 150 LITRES

- Angular wall mounted sealed unvented DHW cylinder with directly applied foam insulation and enamelled internal steel cylinder.
- Flanged immersion heater with protective magnesium anode
- ECO Comfort function (temperature setback from 85 °C to 60 °C)
- ECO Plus function (60 °C set temperature and 60 % charging level)
- ECO Dynamic function (intelligent dynamic matching to the draw-off pattern)
- Intelligent self-learning electronics
- Contemporary design with intuitive user interface
- Integral key lock
- Protected heating element (replaceable without draining)
- CoPro special enamel coating
- Vertical installation



EWH 30 Comfort EL

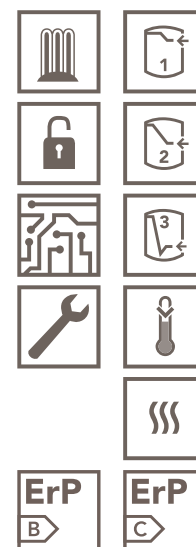

Model	EWH 30 Comfort EL	EWH 50 Comfort EL	EWH 80 Comfort EL	EWH 100 Comfort EL	EWH 120 Comfort EL	EWH 150 Comfort EL
EAN	40 41056 02763 0	40 41056 02764 7	40 41056 02765 4	40 41056 02766 1	40 41056 02822 4	40 41056 02767 8
E-Number	231 188	231 189	231 190	231 191	231 650	231 192
Dimensions in mm						
Height	mm	676	931	893	1045	1200
Width	mm	380	380	475	475	475
Depth	mm	380	380	475	475	475
Technical Data						
Rated capacity	l	30	50	80	100	120
Power supply	V	1/N/PE~230 50 Hz	1/N/PE~230 50 Hz	1/N/PE~230 50 Hz	1/N/PE~230 50 Hz	1/N/PE~230 50 Hz
Connected load	kW	1.8	1.8	1.8	1.8	2.4
Single circuit operating mode		•	•	•	•	•
Dual circuit operating mode		•	•	•	•	•
Manual rapid heat-up operating mode		•	•	•	•	•
Heating up time (15 °C / 60 °C)	hrs	0.88	1.48	2.37	2.96	3.55
Standby power consumption	kWh/24 hrs	0.57	0.8	0.82	0.97	1.08
Standby power consumption at 65 °C ¹⁾	kWh/24 hrs	0.55	0.71	0.89	1.04	1.29
Mixed water volume at 40 °C ²⁾	l	56	102	145.5	191	229
Permissible operating pressure – DHW	MPa	0.6	0.6	0.6	0.6	0.6
Max. throughput	l/min	23.5	23.5	23.5	23.5	23.5
Available temperature range	°C	7 – 85	7 – 85	7 – 85	7 – 85	7 – 85
Cylinder version		wall-mounted	wall-mounted	wall-mounted	wall-mounted	wall-mounted
Container material		Steel, enamelled	Steel, enamelled	Steel, enamelled	Steel, enamelled	Steel, enamelled
Heater Type		Protected heater	Protected heater	Protected heater	Protected heater	Protected heater
Type		closed	closed	closed	closed	closed
Type of protection		IP 25	IP 25	IP 25	IP 25	IP 25
Water connection		G ½"	G ½"	G ½"	G ½"	G ½"
Weight (dry)	kg	18	24	30	34	40
Weight (wet)	kg	48	74	110	134	198
Weight	kg	21.5	27	33	38	42.5
Power cable / power cable length	- / m	• / 1	• / 1	• / 1	• / 1	• / 1
Energy efficiency category		B	B	C	C	C

¹⁾ The standby power consumption states the amount of energy needed in 24 hours to maintain a storage tank temperature of 65 °C (not drawing off any warm water).

The standby power consumption is a measure of the quality of the storage tank's thermal insulation

²⁾ The mixed water volume at a usage temperature of 40 °C results from adding cold water (15 °C) to the storage tank water of 65 °C, in relation to the ready-for-use condition

Only qualified contractors are permitted to install (water and electrical installations), commission and maintain DHW appliances in accordance with the operating instructions. · Palett: EWH 30 - 100 Comfort EL: 8 items, EWH 120 - 150 Comfort EL: 4 items

EWH TREND 30 TO 200 LITRES

EWH 80 Trend

- Energy efficient
- Excellent thermal insulation (48 mm)
- Low standby losses
- ErP ready
- Quick, straightforward installation
- Universal wall mounting
- Ergonomic recessed grips
- 1 m power cable
- Particularly long service life
- CoPro special enamel coating
- Protective anode to DIN 4753
- Low scaling stainless steel heating element
- Convenient, easy operation
- Infinitely variable temperature selection 35 – 75 °C
- Quick capture temperature indicator
- Single circuit operation for hot water around the clock
- Easy to service and maintain
- Large flanged aperture (110 mm)
- Replaceable stainless steel heating elements
- Five-point protection
- Safety thermostat
- Frost protection
- Overheating protection with reset function
- Safety valve
- Type of protection IP 25

Model		EWH 30 Trend	EWH 50 Trend	EWH 80 Trend	EWH 100 Trend	EWH 120 Trend	EWH 150 Trend	EWH 200 Trend
EAN		40 41056 02869 9	40 41056 02870 5	40 41056 02871 2	40 41056 02872 9	40 41056 02873 6	40 41056 02874 3	40 41056 02875 0
E-Number		232 087	232 088	232 089	232 090	232 091	232 092	232 093
Dimensions in mm								
Height	mm	635	890	860	1.015	1.170	1.400	1.705
Width	mm	405	405	510	510	510	510	510
Depth	mm	410	410	420	420	420	420	420
Technical Data								
Rated capacity	l	30	50	80	100	120	150	200
Power supply	V	1/N/PE~220-240 50/60 Hz	1/N/PE~220-240 50/60 Hz	1/N/PE~220-240 50/60 Hz	1/N/PE~220-240 50/60 Hz	1/N/PE~220-240 50/60 Hz	1/N/PE~220-240 50/60 Hz	1/N/PE~220-240 50/60 Hz
Connected load	kW	2.0	2.0	2.0	2.0	2.0	2.0	3.0
Standby power consumption at 65 °C ¹⁾	kWh/24hrs	0.53	0.72	0.79	0.97	1.14	1.32	1.61
Mixed water volume at 40 °C ²⁾	l	52	99	142	186	224	288	376
Permissible operating pressure – DHW	MPa	0.6	0.6	0.6	0.6	0.6	0.6	0.6
Available temperature range	°C	7 – 70	7 – 70	7 – 70	7 – 70	7 – 70	7 – 70	7 – 70
Cylinder version		wall-mounted	wall-mounted	wall-mounted	wall-mounted	wall-mounted	wall-mounted	wall-mounted
Container material		Steel, enamelled	Steel, enamelled	Steel, enamelled	Steel, enamelled	Steel, enamelled	Steel, enamelled	Steel, enamelled
Type		Inox direct	Inox direct	Inox direct	Inox direct	Inox direct	Inox direct	Inox direct
Type of protection		IP 25	IP 25	IP 25	IP 25	IP 25	IP 25	IP 25
Water connection		G ½" A	G ½" A	G ½" A	G ½" A	G ½" A	G ½" A	G ½" A
Weight (dry)	kg	16.4	21.4	28.2	33.6	39.1	46.2	56.3
Connection cable		•	•	•	•	•	•	•
Energy efficiency category		C	C	C	C	C	C	C

¹⁾ The standby power consumption states the amount of energy needed in 24 hours to maintain a storage tank temperature of 65 °C (not drawing off any warm water).

The standby power consumption is a measure of the quality of the storage tank's thermal insulation

²⁾ The mixed water volume at a usage temperature of 40 °C results from adding cold water (15 °C) to the storage tank water of 65 °C, in relation to the ready-for-use condition

Only qualified contractors are permitted to install (water and electrical installations), commission and maintain DHW appliances in accordance with the operating instructions.

DEM COMFORT EL 30 TO 150 LITRES

- **Energy efficiency category B (up to 80 l)**
- Comfort wall-mounted hot storage water heater, for sealed unvented or open vented operation
- Contemporary design with intuitive user interface
- Intelligent self-learning electronics
- High energy efficiency with 3 available ECO-functions: ECO Comfort, ECO Plus, ECO Dynamic
- For single circuit, dual circuit and manual rapid heat-up

- Precise temperature selection from approx. 20 °C to 85 °C
- Quick heat-up key for higher DHW demand
- Maintenance-free impressed current anode
- Internal steel cylinder with high grade special direct enamel coating
- Heating element made from high grade stainless steel
- High grade thermal insulation with low standby energy consumption
- Quick and easy installation through universal wall mounting bracket – straightforward replacement of all common wall mounted water heaters.
- Installation also in connection with plastic pipework systems (observe manufacturer's details)



DEM 80 Comfort EL

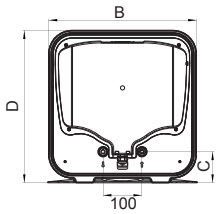

80 l accessory mounting bracket spare
E-number: 235 095

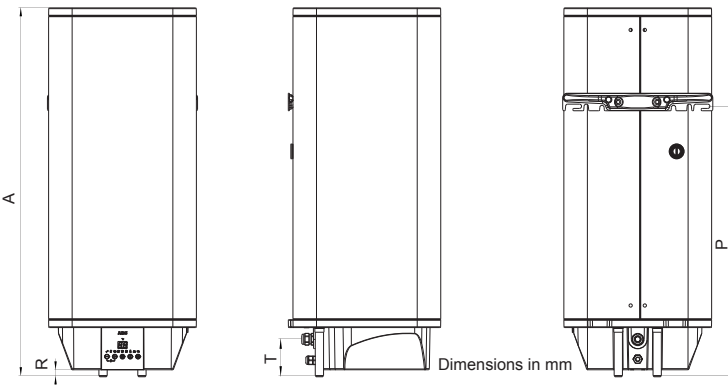

Model	DEM 30 Comfort EL	DEM 50 Comfort EL	DEM 80 Comfort EL	DEM 100 Comfort EL	DEM 120 Comfort EL	DEM 150 Comfort EL	
EAN	40 41056 03059 3	40 41056 03060 9	40 41056 03061 6	40 41056 03062 3	40 41056 03063 0	40 41056 03064 7	
E-Number	234 190	234 191	234 192	234 193	234 194	234 195	
Dimensions							
A - Overall height	mm	696	951	893	1045	1200	1435
B - Width excluding wall mounting bracket	mm	380	380	475	475	475	475
C - Clearance wall to water connection	mm	80	80	85	85	85	85
D - Depth including wall mounting bracket	mm	392	392	492	492	492	492
P - Wall mounting bracket water connection	mm	465	620	800 **	920	920	1120
R - Water connector height	mm	20	20	0	0	0	0
T - Cable entry to the water connector	mm	98.5	98.5	78.5	78.5	78.5	78.5
Technical Data							
Rated capacity	l	30	50	80	100	120	150
Mixed water volume at 40 °C ¹⁾	l	53	99	135	178	223	294
To supply one bath tub		-	-	•	•	•	•
Switchable output for single-circuit operation							
At voltage of 1/N/PE-230 V 50 Hz	kW	2 or 4	2 or 4	2 or 4	2 or 4	2 or 4	2 or 4
At voltage of 2/N/PE-400 V 50 Hz	kW	4	4	4	4	4	4
At voltage of 3/N/PE-400 V 50 Hz	kW	6	6	6	6	6	6
Switchable output for dual-circuit operation							
At voltage of 1/N/PE-230 V 50 Hz	kW	2 / 4	2 / 4	2 / 4	2 / 4	2 / 4	2 / 4
At voltage of 2/N/PE-400 V 50 Hz	kW	2 / 4	2 / 4	2 / 4	2 / 4	2 / 4	2 / 4
At voltage of 3/N/PE-400 V 50 Hz	kW	2 / 6	2 / 6	2 / 6	2 / 6	2 / 6	2 / 6
Switchable output for boiler-circuit operation							
At voltage of 1/N/PE-230 V 50 Hz	kW	2 or 4	2 or 4	2 or 4	2 or 4	2 or 4	2 or 4
At voltage of 2/N/PE-400 V 50 Hz	kW	4	4	4	4	4	4
At voltage of 3/N/PE-400 V 50 Hz	kW	6	6	6	6	6	6
Standby power consumption ²⁾	kWh/24 h	0.51	0.67	0.73	0.83	0.92	1.1
Temperature selection (plus/minus 5K)	ca. °C	Regulator 30 - 85	Regulator 30 - 85	Regulator 30 - 85	Regulator 30 - 85	Regulator 30 - 85	Regulator 30 - 85
Tank/boiler material		Steel enamelled/stainless steel					
Protective anode		External power anode					
Thermal fuse / can be switched back on		• / •	• / •	• / •	• / •	• / •	• / •
Type of protection		IP 25	IP 25	IP 25	IP 25	IP 25	IP 25
Weight including water fill	kg	49	75	111	135	161	199
Energy efficiency category		B	B	B	C	C	C

¹⁾ The mixed water volume at a usage temperature of 40 °C results from adding cold water to the storage tank water of 65 °C, in relation to the ready-for-use condition

²⁾ The standby power consumption states the amount of energy needed in 24 hours to maintain a storage tank temperature of 65 °C (not drawing off any warm water).

The standby power consumption is a measure of the quality of the storage tank's thermal insulation

** With wall mounting bracket that can be ordered separately = 920 mm

Only qualified contractors are permitted to install (water and electrical installations), commission and maintain DHW appliances in accordance with the operating instructions. · Palett: DEM 30 to 80 Comfort EL: 8 items, DEM 100 to 150 Comfort EL: 4 items

DEM COMFORT 30 TO 150 LITRES



DEM 80 Comfort

- Comfort wall-mounted hot storage water heater, for sealed unvented or open vented operation
- Quality benefit from a brand manufacturer: steel inner tank, with high-quality special direct enamel coating – considerably longer service life than from cheap makes
- High-quality thermal insulation with low standby power consumption – considerably lower operating costs than from cheap makes with insufficient thermal insulation. The difference in price is paid off in just a few months of use.
- Magnesium protective anode and potential compensation
- Anode wear display on the front cover
- With telltale
- For single circuit, dual circuit and boiler circuit
- Rapid heating button in the event of increased demand for water
- Temperature can be selected in continuously variable manner between approx. 35 °C and 82 °C
- Can also be installed in conjunction with plastic pipe systems (note details from manufacturer)
- Mounting bracket, spacer and installation template are part of the standard delivery

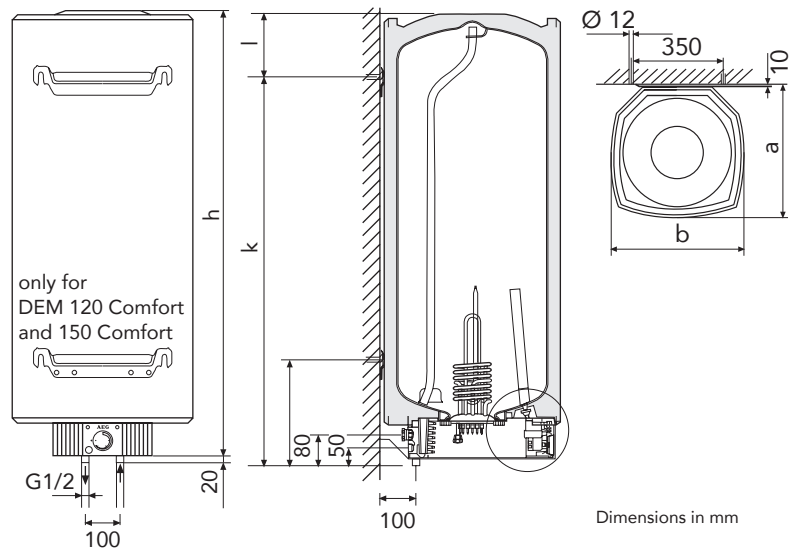

Dimensions in mm

Model	DEM 30 Comfort	DEM 50 Comfort	DEM 80 Comfort	DEM 100 Comfort	DEM 120 Comfort	DEM 150 Comfort
EAN	40 41056 00945 2	40 41056 00946 9	40 41056 00947 6	40 41056 00948 3	40 41056 00949 0	40 41056 00950 6
E-Number	182 232	182 233	182 234	182 235	182 236	182 237
Dimensions						
Depth	a (mm)	420	510	510	510	510
Width	b (mm)	410	510	510	510	510
Height, not including water connection	h (mm)	750	720	955	955	1080
Bottom wall bracket – water connection	i (mm)	–	–	–	–	300
Top wall bracket – water connection	k (mm)	700	600	900	900	1100
Top wall bracket – top edge	l (mm)	70	140	75	75	200
Technical Data						
Rated capacity	l	30	50	80	100	120
Mixed water volume at 40 °C ¹⁾	l	58	90	158	197	226
To supply one bath tub		–	–	•	•	•
Switchable output for single-circuit operation						
At voltage of 1/N/PE~230 V 50 Hz	kW	2 or 4	2 or 4	2 or 4	2 or 4	2 or 4
At voltage of 2/N/PE~400 V 50 Hz	kW	4	4	4	4	4
At voltage of 3/N/PE~400 V 50 Hz	kW	6	6	6	6	6
Switchable output for dual-circuit operation						
At voltage of 1/N/PE~230 V 50 Hz	kW	2 / 4	2 / 4	2 / 4	2 / 4	2 / 4
At voltage of 2/N/PE~400 V 50 Hz	kW	2 / 4	2 / 4	2 / 4	2 / 4	2 / 4
At voltage of 3/N/PE~400 V 50 Hz	kW	2 / 6	2 / 6	2 / 6	2 / 6	2 / 6
Switchable output for boiler-circuit operation						
At voltage of 1/N/PE~230 V 50 Hz	kW	2 or 4	2 or 4	2 or 4	2 or 4	2 or 4
At voltage of 2/N/PE~400 V 50 Hz	kW	4	4	4	4	4
At voltage of 3/N/PE~400 V 50 Hz	kW	6	6	6	6	6
Standby power consumption ²⁾	kWh/24 hrs	0.46	0.54	0.75	0.9	0.93
Temperature selection	approx. °C	35 - 82	35 - 82	35 - 82	35 - 82	35 - 82
Tank/boiler material		Steel enamelled / copper	Steel enamelled / copper	Steel enamelled / copper	Steel enamelled / copper	Steel enamelled / copper
Magnesium protective anode		•	•	•	•	•
Thermal fuse / can be switched back on		• / •	• / •	• / •	• / •	• / •
Type of protection		IP 24 D	IP 24 D	IP 24 D	IP 24 D	IP 24 D
Weight including water fill	kg	54	80	124	145	170
Energy efficiency category		C	C	C	C	C

¹⁾ The mixed water volume at a usage temperature of 40 °C results from adding cold water to the storage tank water of 65 °C, in relation to the ready-for-use condition

²⁾ The standby power consumption states the amount of energy needed in 24 hours to maintain a storage tank temperature of 65 °C (not drawing off any warm water).

The standby power consumption is a measure of the quality of the storage tank's thermal insulation

Only qualified contractors are permitted to install (water and electrical installations), commission and maintain DHW appliances in accordance with the operating instructions. • Palett: DEM 30 Comfort: 9 items, DEM 50-150 Comfort: 6 items

OPEN VENTED 2-HAND WALL-MOUNTED MIXER

AHo 50 WD:

- Open vented two-hand wall-mounted mixer with bath tub/shower changeover, with connection pipes (Ø 16 mm, 300 mm long), handheld shower wall bracket and shower hose 1.5 m

AHo 50:

- Open 2-handle wall mounted mixer tap for oversink installation at a sink or washbasin
- Complete with pivoting spout

AVR 1000-16:

- Connection pipes (pair) 1000 mm long, can be individually trimmed to length, Ø 16 mm

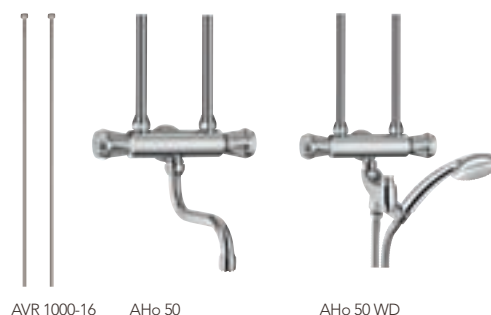

AVR 1000-16

AHo 50

AHo 50 WD

VALVE COMBINATIONS / SAFETY ASSEMBLIES FOR SMALL STORAGE WATER HEATERS (SEALED UNVENTED)

Flush-mounted valve combination AD 786:

- For tap water pressure of up to 0.48 MPa on device connection, G 1/2" (R 1/2"), activation pressure 0.6 MPa



AD 786

Flush-mounted valve combination AD 796:

- For tap water pressure of up to 1 MPa on device connection, G 1/2" (R 1/2"), activation pressure 0.6 MPa, with pressure reducer



AD 796

Surface-mounted valve combination ADA 787:

- Surface-mounted valve combination for sealed unvented wall mounted water heaters
- For vertical or horizontal installation
- Safety valve, 0.6 MPa contact pressure
- Surface: brass
- Adjustable drip connection G1
- Test mark PA –IX 7926/I



ADA 787

Model	AHo 50	AHo 50 WD	AVR 1000-16	AD 786	AD 796	ADA 787
EAN	40 41056 02928 3	40 41056 02929 0	40 14890 74232 8	40 41056 03026 5	40 41056 03027 2	40 41056 02725 8
E-Number	232 615	232 616	184 553	233 716	233 717	230 765
Description	Open 2-handle wall mounted mixer tap, for oversink installation, Ø 16 mm	Open vented two-hand bath tub/shower fitting, Ø 16 mm	Connection pipes (pair) 1000 mm long, can be individually trimmed to length, Ø 16 mm	up to 4.8 bar	up to max. 10 bar	up to 4.8 bar



Area of use

- For central warm water supply for detached and semi-detached homes and commercial ventures

Components

- Continuously variable temperature selection of 35-82 °C, with energy-saving settings
- For single and double circuit, power and voltage can be switched
- Rapid heating function in dual-circuit operation

- Connection for circulation line
- Protection rating: IP 24

Installation

- For installation on the floor
- Can also be installed in conjunction with plastic pipe systems (note details from manufacturer)
- A combination of valves is needed for the water connection

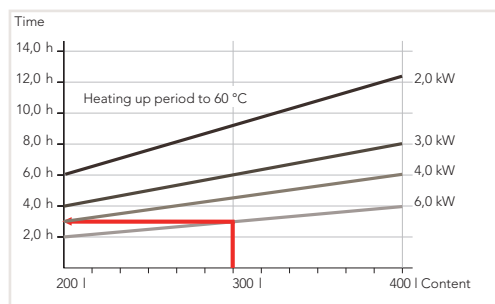

Heating up period

- The heating up period for storage tanks with different capacities depends on the power rating set and can be seen in the graphic
- Example: A storage tank with a capacity of 300 l needs around 3 hours at 6 kW heating capacity to heat to 60 °C (starting temperature of 15 °C)

STM 20 - 40

- Sealed unvented special enamelled inner tank with magnesium protective anode
- Low standby energy consumption thanks to outstanding thermal insulation
- For single-circuit and dual-circuit
- Rapid heating function in dual-circuit operation
- External power anode can be fitted (special accessory)
- With safety temperature limiter
- Color: white



STM 20

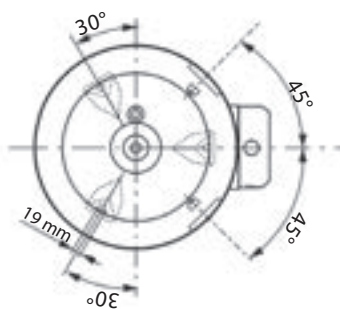
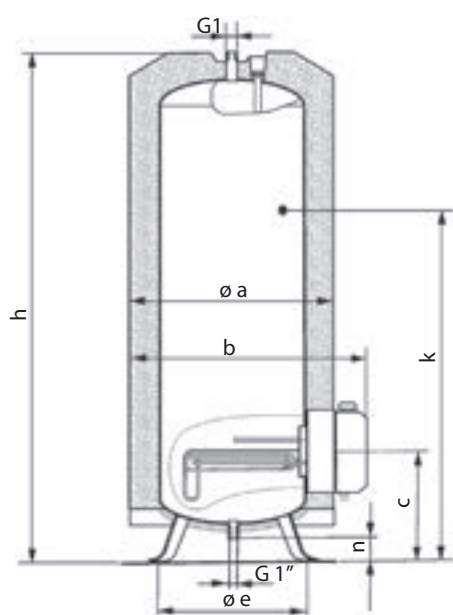

Dimensions in mm

Model	STM 20	STM 30	STM 40	
EAN	40 41056 00957 5	40 41056 00958 2	40 41056 00959 9	
E-Number	182 239	182 240	182 241	
Dimensions				
Diameter with thermal insulation	ø a (mm)	630	700	750
Depth	b (mm)	730	815	865
Stand foot – centre – flange	c (mm)	340	365	375
Pitch circle diameter on heating flange	ø e (mm)	430	490	540
Height	h (mm)	1570	1585	1755
Height up to thermometer neck	k (mm)	1035	1040	1160
Spacing between KW connection and storage space	n (mm)	80	75	75
Technical Data				
Rated capacity	l	200	300	400
Mixed water volume at 40 °C ¹⁾	l	397	590	780
Power supply (switchable to)	V	3/N/PE~400 50 Hz (1/N/PE~230 50 Hz)	3/N/PE~400 50 Hz (1/N/PE~230 50 Hz)	3/N/PE~400 50 Hz (1/N/PE~230 50 Hz)
Switchable output for dual-circuit operation	kW	3/N/PE~400 V: 2/6, 3/6, 4/6, 6/6 1/N/PE~230 V: 2/4, 4/4	3/N/PE~400 V: 2/6, 3/6, 4/6, 6/6 1/N/PE~230 V: 2/4, 4/4	3/N/PE~400 V: 2/6, 3/6, 4/6, 6/6 1/N/PE~230 V: 2/4, 4/4
Switchable output for single-circuit operation (rapid heating up)	kW	3/N/PE~400 V: 2 (6), 3 (6), 4 (6), 6 (6) 1/N/PE~230 V: 2 (4), 4 (4)	3/N/PE~400 V: 2 (6), 3 (6), 4 (6), 6 (6) 1/N/PE~230 V: 2 (4), 4 (4)	3/N/PE~400 V: 2 (6), 3 (6), 4 (6), 6 (6) 1/N/PE~230 V: 2 (4), 4 (4)
Standby power consumption ²⁾	kWh/24 hrs	1.6	2.0	2.35
Temperature selection	approx. °C	35 - 82	35 - 82	35 - 82
Tank/boiler material		Steel enamelled/copper	Steel enamelled/copper	Steel enamelled/copper
Magnesium protective anode		•	•	•
Connection for circulation line		•	•	•
Thermal fuse / can be switched back on		•/•	•/•	•/•
Warm/cold water connections:		G 1" AG	G 1" AG	G 1" AG
Circulation line connection		G ½" AG	G ½" AG	G ½" AG
Type of protection		IP 24	IP 24	IP 24
Weight including water fill	kg	275	395	526
Energy efficiency category		C	C	C

¹⁾ The mixed water volume at a usage temperature of 40 °C results from adding cold water to the storage tank water of 65 °C, in relation to the ready-for-use condition

²⁾ The standby power consumption states the amount of energy needed in 24 hours to maintain a storage tank temperature of 65 °C (not drawing off any warm water).

The standby power consumption is a measure of the quality of the storage tank's thermal insulation

Only qualified contractors are permitted to install (water and electrical installations), commission and maintain DHW appliances in accordance with the operating instructions. · Palett: 1 item

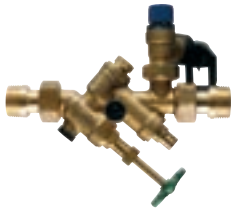

ZH1



DMV/ZH1

SAFETY ASSEMBLIES FOR FLOORSTANDING WATER HEATERS – NEW –

ZH1

- Valve combination ZH1 for sealed unvented electric floorstanding water heaters up to 1000 litres. Pressure reducing valve DMV/ZH1 may be retrofitted. Brass casing, threaded fittings.

DMV/ZH1

- Safety valve 0.6 MPa (6 bar) fitted as standard; replacement cartridge supplied 1.0 MPa (10 bar).
- Test symbol PA-IX 1794/I
- Applicable to STM 20 to STM 40



ZT2/ZT34

INDICATOR THERMOMETER

- Indicator thermometer for fitting in AEG floor-mounted storage water heater
- Indicates the water temperature in the top third of the floor-mounted storage water heater

Model	ZH1	DMV/ZH1	ZT 2	ZT 34
EAN	40 17210 74370 8	40 17210 74371 5	40 41056 01007 6	40 41056 01009 0
E-Number	074 370	074 371	185 982	185 983
Description	Safety assembly for floorstanding water heaters G 3/4" A	Pressure reducing valve G1 as a supplement to ZH1	for STM 20	for STM 30 and 40

1. Applicability

- 1.1. All our supplies – also in the future – exclusively take place on the basis of these Terms and Conditions of Delivery and Payment. They are accepted by the Customer at the latest with placing the order however with the acceptance of the first supply, and shall apply for the entire duration of the business relationship. We hereby expressly contradict to any opposing business and purchasing conditions of the Customer. Deviations from our terms/conditions shall be effective only if confirmed by us in writing
- 1.2. General terms and conditions of the customer apply only to that extent, when we agreed them expressly in writing. This written-form requirement cannot be waived.

2. Prices, packaging, terms of payment, set-off, right of retention

- 2.1. Our offers are non-binding. The agreement is formed only through our written confirmation or through delivery.
- 2.2. The invoice for orders for which no individual fixed price is agreed on is issued on the basis of the list prices applicable on the day of delivery.
- 2.3. Prices and discounts quoted verbally shall be effective only if confirmed by us in writing.
- 2.4. All prices are understood free carrier (FCA) our factories in Holzminden, Eschwege, Poprad, Ayut-thaya and Tianjin including cardboard packaging, or free on board (FOB) at a German port (Incoterms 2010). Should the need for special packaging arise, we reserve the right to charge for this separately and additionally.
- 2.5. Unless otherwise agreed in writing, our invoices shall be paid against prepayment in the currency indicated in the invoice. Unless otherwise agreed in writing, payment in Euros shall be deemed agreed on.
- 2.6. If the products are exported, the Customer will comply with the German export rules and regulations, and point out to its buyers that German export rules and regulations are applicable in the case of an exportation of products. The Customer undertakes to provide the information necessary to obtain an (import) export permit already when the Customer places the order. If at the Customer's request deliveries are passed on without customs clearance, the Customer shall be liable for any additional or extra payments demanded by the German customs authorities. If the exportation of the goods is prohibited or not permitted by the German authorities although such a permit is required, the Customer cannot derive any claims against us from this. The same shall apply if, for reasons that we are not responsible for, the importation of the goods into the country of destination is prevented or delayed by the authorities there.
- 2.7. The Customer is entitled to set off or retain claims only if they are undisputed or have been ascertained legally binding. The Customer shall have a right of retention only if its counterclaims are based on the same contractual relationship.

3. Delivery/acceptance/impossibility performance/delay/take-back

- 3.1. A delivery period specified in the order shall be binding only if confirmed by us in writing. Delivery shall be deemed to have been made within an agreed delivery period if the goods to be delivered have left our plant before the end of the delivery period, or if the Customer is obliged to notify us prior to delivery of his readiness to collect or take delivery of the goods, but has not done so, and we notify the Customer of our readiness to make shipment. In the latter case, delivery shall be deemed to be made when the written notification of readiness to make shipment is mailed by us.
- 3.2. The delivery period shall be extended in a reasonable way if the Customer subsequently requests changes or additions. The same shall apply in the event of the occurrence of unforeseen difficulties

beyond our control, e.g. force majeure, lawful labour disputes, disruptions of business affecting us or our suppliers.

- 3.3. All delivery obligations are subject to timely and proper delivery to us, also of suppliers' parts, if delivery is impossible within the agreed delivery period because of such circumstances or, if no such delivery period is agreed on, within three months of receipt of the order, we can cancel the agreement. The Customer shall not have any claims against us whatsoever in any of these cases, especially no claims to compensation for default damage and no damage claims.
- 3.4. Compensation for any default damage can be demanded by the Customer only in the event of wilful act or gross negligence on our part. This shall not apply if we commit to a binding delivery date in the confirmation of order and culpably fail to deliver on or before such date. In any case of default, our liability shall be limited to the foreseeable loss which typically arises, unless we intentionally violate the agreement or such breach of contract is attributable to us. The foreseeable loss which typically arises will generally not exceed the double amount of the order value affected by default.
- 3.5. In the event of default, we shall have the right to fix a reasonable deadline for the Customer to declare whether he wishes to cancel the agreement and/or demand damages instead of performance. If the Customer does not make a statement within that deadline, his right to cancel the agreement or to demand damages instead of performance shall lapse.
- 3.6. Goods are always shipped for the Customer's account and at the Customer's risk. All risks shall pass over to the Customer as soon as the goods are handed over to the carrier or leave our warehouse for shipment. In all other respects, the Incoterms 2010 shall be applicable.
- 3.7. The fulfilment of this contract has the reservation that no obstacle in form of German, US-American or other applicable national, EU or international provisions of foreign trade legislation and no embargos or sanctions are in force.
- 3.8. If the ordering party has the desire to return defect-free and correctly delivered goods, the ordering party can apply for a take-back. It is in our free discretion to take back or not to take-back the goods in question, especially after verification of age (not older than 6 months) and condition, against a markdown of at least 20% of the value of the goods. The ordering party has to bear all costs related to the take-back

4. Customer's obligation to complain, liability for defects

- 4.1. Our Customer shall not have any claims because of defects of the goods unless the Customer properly performed all of his obligations to inspect the goods and to complain of defects pursuant to sec. 377 HGB (German Commercial Code).
- 4.2. Any transportation or shipping damage is to be reported in writing by the Customer to the carrier immediately upon receipt of the goods. In addition, we are to be informed without undue delay about the damage, if possible by telefax. The Customer shall bear any damage or any loss of rights incurred by the carrier or by us in consequence of failure to make an immediate report.
- 4.3. If a defect which we are responsible for existed already at the time of the passing of the risk, we shall be obliged to remedy the

defect or, at our option, to make substitute delivery. If we are not prepared or able to do so, in particular if this is delayed unreasonably for reasons that we are responsible for, or if remedial action/substitute delivery fails in some other way, the Customer shall have the right – subject to clause 5 of these General Terms of Payment and Delivery – to assert the rights otherwise provided for by law in the event of a defect.

- 4.4. If we remedy a defect, our obligation also includes payment of all expenses to remedy the defect, especially transportation, forwarding, labour and material costs, unless they are increased due to the fact that the defective goods were taken to a different place than the place of performance.
- 4.5. The limitation period for all rights pertaining to defects shall be two years but for use in commercial companies, craft businesses, industrial companies or comparable activities the limitation period shall be one year; in other respects, the statutory provisions shall apply. Any other more extensive statutory warranty rights shall be unaffected by this.
- 4.6. However, the Customer shall have rights of recourse only to the extent that he did not make any agreement with his buyer which goes beyond the statutory rights in the event of a defect

5. Damages

For damage which is not caused to the actual object of delivery itself, we shall be liable on whatever legal basis only:

1. in the full amount of the damage in the case of wilful intent and the case of gross negligence on the part of management and/or executive staff, and also
2. subject to subparagraph 4 in any case of culpable violation of essential contractual obligations and
3. outside such obligations and subject to subparagraph 4 also for gross negligence on the part of persons employed by us for the performance of our contractual obligations, unless we can exonerate ourselves by virtue of trade customs,
4. in the two cases of subparagraph 2 and 3 above, limited to the amount of damage foreseeable and typical for the contract in question,
5. for defects of the goods which were maliciously concealed by us or whose absence was guaranteed by us,
6. for defects of the goods to the extent that the Product Liability Act provides for liability for personal injury or damage to privately used things,
7. in case of any liability based on an injury of life, body or health.

Further claims shall be excluded.

6. Retention of title

- 6.1. We retain title to all goods delivered until all of our current and future claims against the Customer have been discharged.
- 6.2. Any processing or transformation by the Customer of the goods delivered shall always be done for us. If the goods are processed with other things not belonging to us, we acquire co-ownership of the new thing in the proportion of the value of the goods delivered and transformed or processed (final invoice amount including VAT) to the other processed things at the time of processing. In all other respects, the same shall apply to the thing created through processing as to the object of purchase delivered subject to retention of title.

6.3. If the goods delivered are mixed inseparably with other things not belonging to us, we shall acquire co-ownership to the new thing in the proportion of the value of the object of the purchase (final invoice amount including VAT) to the other mixed things at the time of intermixture. If intermixture takes place in such a way that the Customer's thing is to be regarded as the main thing, it is agreed that the Customer shall transfer co-ownership to us on a pro rate basis. The Customer shall safekeep for us the sole ownership or co-ownership thus created.

The Customer assigns to us by way of security especially also those claims which he obtains against a third party through the combination of the goods delivered with a piece of real estate. This claim shall be subject analogously to the above provisions.

6.4. Any pledge and any transfer of title by way of security is inadmissible as long as we retain title. The Customer must inform us promptly of any pledge or other thirdparty seizure of the goods title to which is retained by us or of the assigned claims, and must assist us in every way in the intervention.

6.5. The customer may sell the goods title to which we retain, in the ordinary course of business, but only for immediate payment on delivery or subject to retention of title. The claims arising from the resale or from any other legal reason (insurance, tort, etc.) with respect to the goods title to which we retain (including all claims to payment of the balance on a current account) are hereby assigned already by the Customer with all ancillary claims to us.

6.6. The Customer is obliged at our request to inform the buyers in writing of the assignment and to give us all information necessary to assert our rights against the buyers, to provide documents and to hand over bills of exchange. For this purpose the Customer must allow us to inspect his records in this respect, if necessary.

6.7. The Customer shall have the right until further notice to collect the claims assigned to us. Any assignment or pledge of these claims is admissible only with our written consent. In the event of the discontinuation of payments, failure to honour a check or a bill of exchange made out by the Customer, an application for the institution of insolvency proceedings, or the institution of such proceedings, or in the case of a foreign customer if proceedings similar to insolvency proceedings or judicial or out-of-court composition proceedings are opened, the right to resell the goods and to collect the assigned claims shall end.

6.8. Under any of the circumstances described in clause 6.7, the Customer must give us access to the goods still in his possession, send us an exact list of the goods, separate the goods and hand over the goods to us. We also have the right to demand the assignment of the Customer's claims for possession against third parties or to cancel the agreement. In either case, whether we take back the goods or assert our rights of retention, we need not cancel the agreement. Neither any of these acts nor a pledge of the goods title to which is retained shall constitute a cancellation of the agreement unless this is expressly declared by us.

6.9. If the value of the security existing for us exceeds our total claims by more than 20%, we will at the Customer's written request release an appropriate part of such security at our option.

6.10. The costs for the performance of the co-operation duties set out in clause 6.4 and clause 6.6 in connection with all rights arising from the retention of title and all costs for preserving and storing the goods shall be borne by the customer

7. Labelling of goods, patent guarantee, redemption and environment friendly disposal of electronic devices

Any change in the goods, the removal of device numbers and type designations as well as labels which constitute a designation of origin for the Customer or a third party or could create the impression that the product is a special product are inadmissible unless expressly agreed on in writing by the parties.

Per the EU guideline 2002/96/EC dated January 27, 2003 (Directive of the European Parliament and of the Council on Waste Electrical and Electronic Equipment) and the county-specific regulations released due to this regulation the purchaser as importer / manufacturer according to law inside the member States of the European Union is obliged to disposal or to let disposal the devices, stated in EU-Guideline and in the country-specific regulations, at his own expenses.

8. Place of performance/jurisdiction

The place of jurisdiction and of performance for all mutual services is Holzminden. However, we also have the right to sue at the Customer's domicile. German law is applicable. The applicability of the provisions of the United Nations Convention on the International Sale of Goods (CISG) is expressly excluded

Stiebel Eltron International GmbH,
Limited Liability Company
Registered Office: Holzminden
Register Court: Hildesheim HRB 110397
Management Board:
Rudolf Sonnemann, Karlheinz Reitze,
Dr. Marc-Jan Schutte

Version: 04/2012

www.aeg-haustechnik.com

The current terms and conditions of sale and delivery (domestic) apply.

Despite the information in this product information being put together with great care, we cannot rule out the possibility of mistakes. Statements on the equipment and equipment features are not binding. The equipment features described in this product information are not the agreed properties of our products. Our products are developed on an ongoing basis. Individual equipment features may have since changed or been removed. Please contact our consultants for details of the current equipment features. The photos in the brochure are only examples of use. The photos also contain installation parts, accessories and special equipment which are not supplied as standard. The publisher's consent must be obtained for reprints, even extracts hereof.

The installation of appliances that require wiring on site must be installed by the relevant power supply utility or an authorised electrician, who will also be able to assist you with obtaining any permits required from the respective power supply utility prior to the installation of the appliance.

AEG is a registered trademark under the license from AB Electrolux (publ).

AEG Haustechnik
– International Sales –
c/o Stiebel Eltron International GmbH
Dr.-Stiebel-Straße
D-37603 Holzminden
Telephone: +49 5531 702-0
Telefax: +49 5531 702-95479
info@stiebel-eltron.com
www.aeg-haustechnik.com

Information and sales

AEG
HAUSTECHNIK