



Agilent InfinityLab LC Series
Multisamplers

User Manual



Notices

Document Information

Document No: SD-29000238 Rev. J
Edition: 11/2022

Copyright

© Agilent Technologies, Inc. 2014-2022

No part of this manual may be reproduced in any form or by any means (including electronic storage and retrieval or translation into a foreign language) without prior agreement and written consent from Agilent Technologies, Inc. as governed by United States and international copyright laws.

Agilent Technologies
Hewlett-Packard-Strasse 8
76337 Waldbronn, Germany

Warranty

The material contained in this document is provided "as is," and is subject to being changed, without notice, in future editions. Further, to the maximum extent permitted by applicable law, Agilent disclaims all warranties, either express or implied, with regard to this manual and any information contained herein, including but not limited to the implied warranties of merchantability and fitness for a particular purpose. Agilent shall not be liable for errors or for incidental or consequential damages in connection with the furnishing, use, or performance of this document or of any information contained herein. Should Agilent and the user have a separate written agreement with warranty terms covering the material in this document that conflict with these terms, the warranty terms in the separate agreement shall control.

Technology Licenses

The hardware and/or software described in this document are furnished under a license and may be used or copied only in accordance with the terms of such license.

Restricted Rights Legend

U.S. Government Restricted Rights. Software and technical data rights granted to the federal government include only those rights customarily provided to end user customers. Agilent provides this customary commercial license in Software and technical data pursuant to FAR 12.211 (Technical Data) and 12.212 (Computer Software) and, for the Department of Defense, DFARS 252.227-7015 (Technical Data - Commercial Items) and DFARS 227.7202-3 (Rights in Commercial Computer Software or Computer Software Documentation).

Safety Notices

CAUTION

A **CAUTION** notice denotes a hazard. It calls attention to an operating procedure, practice, or the like that, if not correctly performed or adhered to, could result in damage to the product or loss of important data. Do not proceed beyond a **CAUTION** notice until the indicated conditions are fully understood and met.

WARNING

A **WARNING** notice denotes a hazard. It calls attention to an operating procedure, practice, or the like that, if not correctly performed or adhered to, could result in personal injury or death. Do not proceed beyond a **WARNING** notice until the indicated conditions are fully understood and met.

In This Guide

This manual covers the following InfinityLab LC Series Multisamplers:

- Agilent 1290 Infinity II Multisampler (G7167B),
- Agilent 1260 Infinity II Multisampler (G7167A),
- Agilent 1290 Infinity II Bio Multisampler (G7137A), and
- Agilent 1260 Infinity II Bio-Inert Multisampler (G5668A)

1 Introduction

This chapter gives an introduction to the Multisampler.

2 Site Requirements and Specifications

This chapter provides information on environmental requirements, physical and performance specifications.

3 Using the Module

This chapter explains the essential operational parameters of the module.

4 Preparing the Module

This chapter explains the operational parameters of the module.

5 Optimizing Performance

This chapter gives hints on how to optimize the performance or use additional devices.

6 Troubleshooting and Diagnostics

This chapter gives an overview about the troubleshooting and diagnostic features and the different user interfaces.

7 Error Information

This chapter describes the meaning of error messages, and provides information on probable causes and suggested actions how to recover from error conditions.

8 Test Functions and Calibration

This chapter describes the built in test functions.

9 Maintenance

This chapter describes the maintenance of the Multisampler

10 Parts for Maintenance and Upgrade or Options

This chapter provides information on parts material required for the module.

11 Identifying Cables

This chapter provides information on cables used with the modules.

12 Hardware Information

This chapter describes the module in more detail on hardware and electronics.

13 LAN Configuration

This chapter provides information on connecting the detector to the Agilent ChemStation PC.

14 Appendix

This chapter provides addition information on safety, legal and web.

Contents

1	Introduction	10
	Product Description (G7167B)	11
	Features (G7167B)	12
	Product Description (G7167A)	13
	Features (G7167A)	14
	Product Description (G5668A)	15
	Features (G5668A)	16
	Product Description (G7137A)	17
	Features (G7137A)	18
	Overview of the Module	19
	Single Needle Setup	21
	Injection Sequences	23
	System Overview	37
2	Site Requirements and Specifications	45
	Site Requirements	46
	Physical Specifications	50
	Performance Specifications	54
	Specifications of the Sample Cooler	62
	Specifications of the Sample Thermostat	64
3	Using the Module	67
	Magnets	68
	Turn on/off	69
	Status indicators	71
	Drawer Status Indicator	72
	Insert vial trays/wellplates	73
	Remove vial trays/wellplates	74
	Installing the Optional Sample Cooler/Thermostat	75
	Using the Optional Sample Cooler/Sample Thermostat	85
	Transporting the Sampler	95
	Solvent Information	100
	Reset the Multisampler in Case of an Error	112
	Agilent Local Control Modules	115

4	Preparing the Module	116
	Leak and Waste Handling	117
	Preparing the Multisampler	118
	Recommended Mats and Vials	119
	Configure Well Plate Types	122
	Capillary Coding Guide	125
	Installing Capillaries	127
	Flow Connections to the Washport (Standard)	131
	Flow Connections to the Washport (Dual Needle)	133
	Installing the Bypass Capillary (Dual Needle)	135
	Flow Connections to the Washport (Multiwash)	138
	Setting up the Autosampler with OpenLab ChemStation	140
	Setting up the Dual-Needle System with OpenLab ChemStation	147
5	Optimizing Performance	161
	Delay Volume and Extra-Column Volume	162
	How to Configure the Optimum Delay Volume	163
	How to Achieve Higher Injection Volumes	167
	How to Achieve High Throughput	169
	How to Achieve Higher Resolution	170
	How to Achieve Higher Sensitivity	173
	How to Achieve Lowest Carryover	174
	Best Practices for Multiwash	176
6	Troubleshooting and Diagnostics	178
	User Interfaces	179
	Agilent Lab Advisor Software	180
7	Error Information	181
	What Are Error Messages	183
	General Error Messages	184
	Sampler Error Messages	192
	Sample Cooler/Sample Thermostat Error Messages	203

8	Test Functions and Calibration	209
	Introduction	210
	System Pressure Test	211
	Auto Referencing	214
	Maintenance Positions	216
	Injector Steps	220
	Sample Cooler Function Test	222
	Sampler Leak Test	223
9	Maintenance	224
	Introduction to Maintenance	225
	Warnings and Cautions	227
	Overview of Maintenance	229
	Clean the Module	230
	Removal and Installation of the Front Door	231
	Remove the Needle Assembly	234
	Install the Needle Assembly	239
	Exchange the Needle Seat	243
	Replace the Rotor Seal	246
	Replace the Injection Valve	252
	Remove the Metering Seal	257
	Install the Metering Seal	262
	Replace the Peristaltic Pump Cartridge	269
	Replace the Flushhead Seal	272
	Remove the Sample Loop-Flex	276
	Installing the Sample Loop-Flex	280
	Replace the Dummy Drawer	285
	Replace the Sample Cooler/Sample Thermostat	293
	Replace the Module Firmware	298

10	Parts for Maintenance and Upgrade or Options	299
	Standard Parts	300
	Hotel Drawer	303
	Analytical Head Assembly 40 μ L	304
	Bio-Compatible Analytical Head Assembly 40 μ L	305
	Analytical Head Assembly 100 μ L	307
	Bio-inert Analytical Head Assembly 100 μ L (600 bar)	308
	Bio-Compatible Analytical Head Assembly 100 μ L	310
	Analytical Head Assembly 900 μ L	312
	Flush Head Assembly 500 μ L	313
	Bio Flush Head Assembly 500 μ l	315
	2-Position/6-Port Injection Valve VICI	317
	Bio-Compatible 2-Position/6-Port Injection Valve VICI	318
	2-Position/6-Port Injection Valve IDEX	319
	2-Position/6-Port Injection Valve Bio-inert IDEX	320
	Injection Valve with Actuator	321
	Sample Loops and Capillaries (Dual Needle)	322
	3-Position/6-Port Peripheral Valve Dual Needle	324
	2-Position/8-Port Injection Valve Dual Needle	325
	Needle Port Assembly	326
	Door Assy	327
	Accessory Kit	328
	Bottles	330
	Tubing Kit Sampler Standard	331
	Tubing Kit Sampler Multi-Wash	333
	Multi Draw Kit	334
	Bio-Inert Multi-Draw Kit	335
	Upgrade Kits	336
	Leak System Parts	337
	Sample Thermostat	338

11	Identifying Cables	339
	Cable Overview	340
	Analog Cables	342
	Remote Cables	344
	CAN/LAN Cables	348
	Agilent Module to PC	349
	USB	350
12	Hardware Information	351
	Firmware Description	352
	Electrical Connections	355
	Interfaces	358
	Setting the 6-bit Configuration Switch	366
	Instrument Layout	368
	Early Maintenance Feedback	369
13	LAN Configuration	370
	Setting up the module in a LAN environment	371
14	Appendix	372
	General Safety Information	373
	Waste Electrical and Electronic Equipment (WEEE) Directive	379
	Refrigerant	380
	Radio Interference	383
	Sound Emission	384
	Solvent Information	385
	Installation of Stainless Steel Cladded PEEK Capillaries	386
	Agilent Technologies on Internet	392

1

Introduction

Product Description (G7167B)	11
Features (G7167B)	12
Product Description (G7167A)	13
Features (G7167A)	14
Product Description (G5668A)	15
Features (G5668A)	16
Product Description (G7137A)	17
Features (G7137A)	18
Overview of the Module	19
Single Needle Setup	21
Injection Sequences	23
System Overview	37
Leak and Waste Handling	37
Leak and Waste Handling in a Mixed Configuration	43

This chapter gives an introduction to the Multisampler.

Product Description (G7167B)

The Agilent 1290 Infinity II Multisampler can handle both vials and microtiter plates with ease and efficiency up to 1300 bar system pressure, optimized on chromatographic performance.

In fact, this compact module has the capacity to house up to 6144 samples, all inside the Agilent stack footprint and the robotics to smoothly inject each into the chromatograph in turn.

With the multi-wash capability, you can reduce carryover to less than 9 parts per million.

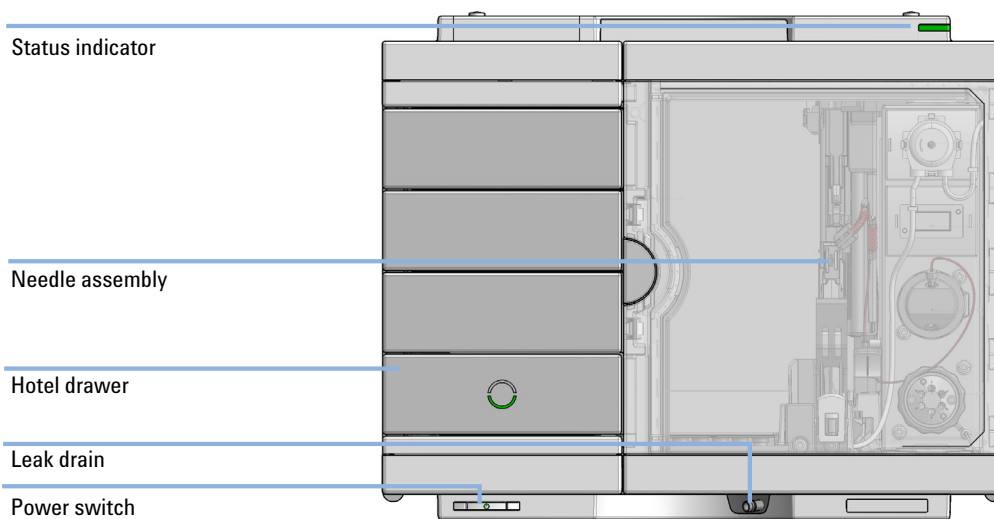

Figure 1 Overview of the Multisampler

Features (G7167B)

- *Unmatched flexibility* – You choose how you want to introduce samples for injection, whether you prefer vials, microtiter plates, or any combination of formats. Sample drawers are available in three heights, and you can mix shallow drawers with deeper ones to accommodate different sample sizes.
- *High capacity* – Using shallow well-plate drawers, the 1290 Infinity II Multisampler takes a maximum load of 16 microtiter plates and up to 6144 samples—the most of any single system.
- *Seamless automation* – Internal robotics move microtiter plates and other sample containers from the sample hotel to the central workspace for sample processing steps and injections.
- *Dual-needle injection* – By running samples alternately through one or the other injection path, you can reduce cycle times to mere seconds, virtually eliminating conventional wait times—whether for large volume loadings or flushing procedures.
- *Scalable injection volumes* – The Agilent unique dual-needle setup also enhances flexibility by providing two differently optimized injectors in a single instrument. You can, for example, optimize one path for large volume injections and the other for low delay volumes.
- *Ultralow carryover* – The 1290 Infinity II Multisampler is designed for low carryover, but you can take clean to a whole new level with our multi-wash capability, cleaning all relevant injection parts between runs. This sophisticated, integrated feature flushes the injection needle outside with three solvents, and uses seat backflush procedures to reduce carryover to less than 9 ppm.
- *Integrated sample thermostat* – available as option or upgrade, providing cooling and heating in the range from 4 °C - 40 °C.
- *Instant information* – Lights on each drawer tell you all you need to know about loading status, current activity, and accessibility.

Product Description (G7167A)

The Agilent 1260 Infinity II Multisampler can handle both vials and microtiter plates with ease and efficiency up to 800 bar system pressure, optimized on high flexibility.

This compact module can house up to 6144 samples, all inside the Agilent stack footprint and the robotics to inject each into the chromatograph in turn.

With the multi-wash capability, you can reduce carryover to less than 9 parts per million.

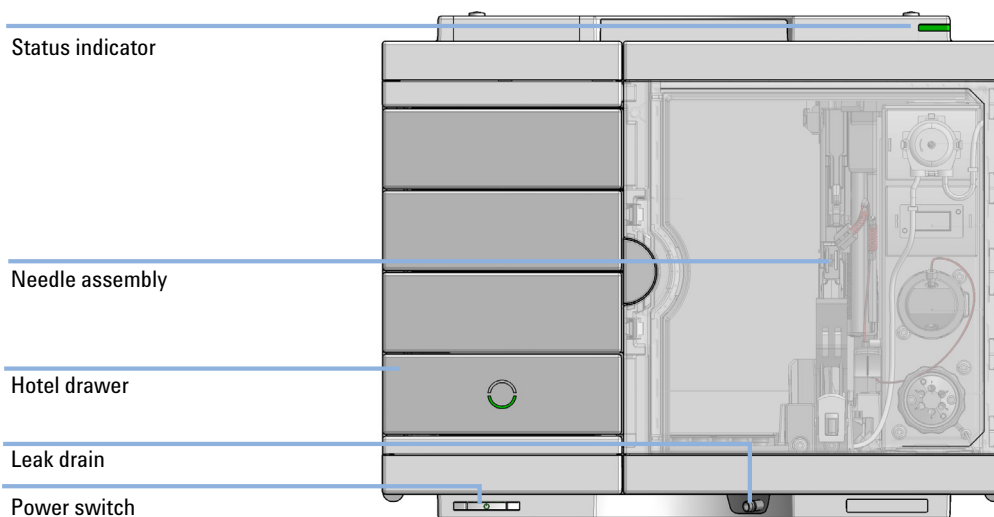

Figure 2 Overview of the Multisampler

Features (G7167A)

- *Unmatched flexibility* – You can choose how you want to introduce samples for injection, whether you prefer vials, microtiter plates, or any combination of formats. Sample drawers are available in three heights, and you can mix shallow drawers with deeper ones to accommodate different sample sizes.
- *High capacity* – Using shallow well-plate drawers, the 1260 Infinity II Multisampler takes a maximum load of 16 microtiter plates and up to 6144 samples—the most of any single system.
- *Seamless automation* – Internal robotics move microtiter plates and other sample containers from the sample hotel to the central workspace for sample processing steps and injections.
- *Dual-needle injection* – By running samples alternately through one or the other injection path, you can reduce cycle times to mere seconds, virtually eliminating conventional wait times—whether for large volume loadings or flushing procedures.
- *Scalable injection volumes* – The Agilent dual-needle setup enhances flexibility by providing two differently optimized injectors in a single instrument. You can, for example, optimize one path for large volume injections and the other for low delay volumes.
- *Ultralow carryover* – The 1260 Infinity II Multisampler has a low carryover, and a multi-wash capability, cleaning all relevant injection parts between runs. This integrated feature flushes the injection needle outside with three solvents, and uses seat backflush procedures to reduce carryover to less than 9 ppm.
- *Efficient temperature control* – For temperature-sensitive samples, add Agilent's compressor-based cooling system. It maintains temperature control on all vials and plates inserted into the 1260 Infinity II Multisampler.
- *Instant information* – Lights on each drawer tell you about loading status, current activity, and accessibility.

Product Description (G5668A)

Agilent 1260 Infinity II Bio-Inert Multisampler features a 100 % metal-free sample flow path and is therefore the ideal injector for all biorelated applications, including analysis of mAbs, proteins in general and oligonucleotides. The ceramic needle, PEEK needle seat, and stainless steel-clad PEEK capillaries ensure highest injection accuracy and precision and are rated for a maximum system pressure of 600 bar allowing the use of highest performance columns. With multiwash capability, you can reduce carryover to less than 9 ppm. This design offers highest flexibility by handling both vials and microtiter plates and can house up to 6144 samples. For temperature-sensitive samples, simply add Agilent's highly efficient compressor-based thermostating system. It allows you to maintain perfect temperature control on all vials and plates inserted.

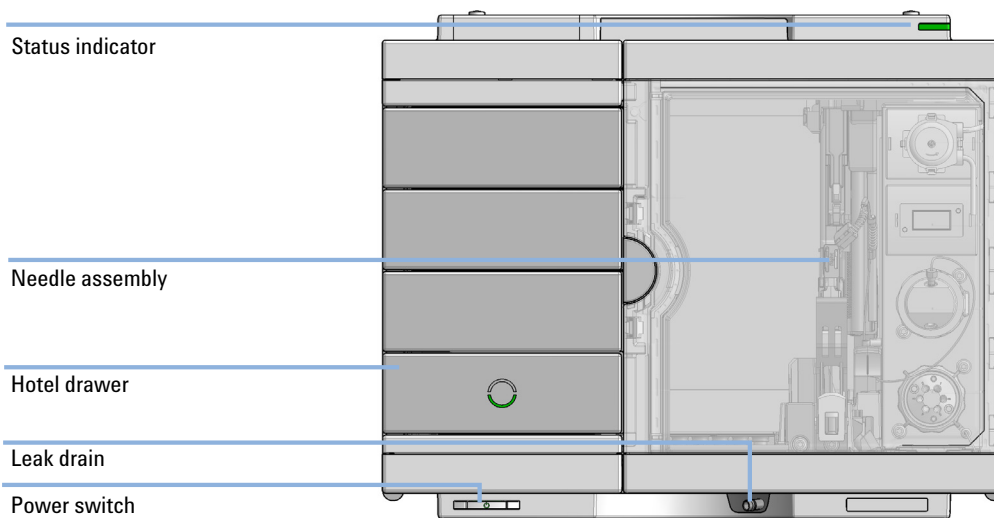

Figure 3 Overview of the Bio-inert Multisampler

Features (G5668A)

- *Reliable analysis of biological samples* – the metal-free sample flow path at 600 bar means that none of your precious sample touches metal surfaces.
- *Maintain perfect temperature control* - for temperature-sensitive samples, simply add Agilent's new highly efficient compressor-based thermostating system. It allows you to efficiently control the temperature of all vials and plates inserted into the 1260 Infinity II Multisampler, providing cooling and heating in the range from 4 – 40 °C.
- *Ultralow carryover* - the 1260 Infinity II Multisampler is designed for low carryover. But you can take clean to a whole new level with our multiwash capability, cleansing all relevant injection parts between runs. This sophisticated, integrated feature flushes the injection needle outside with three solvents, and uses seat backflush procedures to reduce carryover to less than 9 ppm.
- *Unmatched flexibility* - you choose how you want to introduce samples for injection, whether you prefer vials, microtiter plates, or any combination of formats. Sample drawers are available in three heights, and you can mix shallow drawers with deeper ones to accommodate different sample sizes
- *High capacity* - using shallow well-plate drawers, the 1260 Infinity II Multisampler takes a maximum load of 16 microtiter plates and up to 6144 samples. The most of any single system.
- *Seamless automation* - internal robotics move microtiter plates and other sample containers from the sample hotel to the central workspace for sample processing steps and injections.

Product Description (G7137A)

The Agilent 1290 Infinity II Bio Multisampler, with its biocompatible sample flow path, is perfectly suited for biomolecule analysis, ensuring integrity of biomolecules and minimizing unwanted surface interaction. For temperature-sensitive samples, a compressor-based thermostating device can be added.

Injecting at pressures up to 1300 bar, the Bio Multisampler is a compact module with a capacity of up to 6144 samples, all within the footprint of an Agilent LC stack. It is a multipurpose autosampler that handles vials and microplates, and is optimized for highest chromatographic performance.

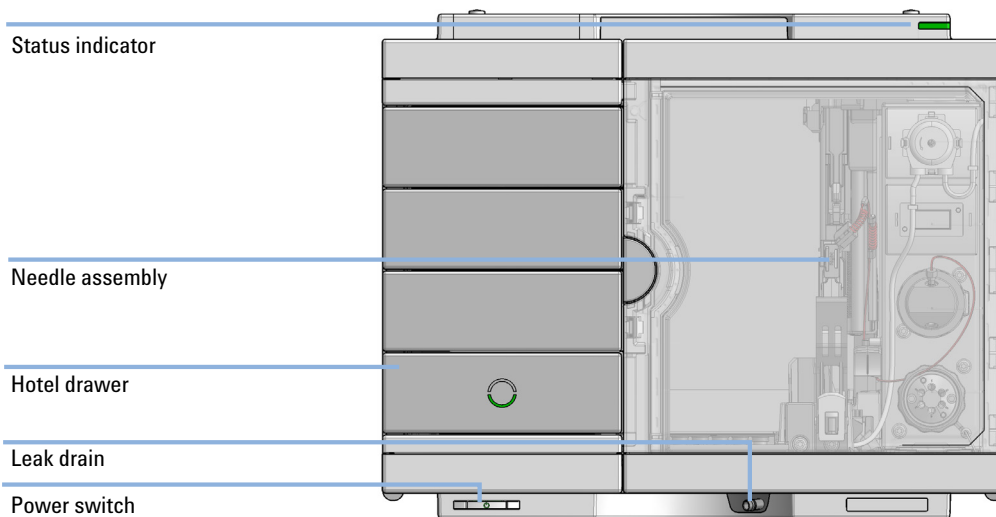

Figure 4 Overview of the Multisampler

Features (G7137A)

- Biocompatible sample flow path ensures integrity of biomolecules and minimize unwanted surface interaction.
- Integrated sample thermostat, available as option or upgrade, provides cooling and heating from 4 – 40 °C, allowing samples to be handled under certain temperature conditions and preventing degradation of temperature-sensitive samples.
- Sample drawers are available in three heights to accommodate any combination of sample containers for maximum flexibility.
- Shallow microplate drawers take a maximum load of 6144 samples for unmatched sample capacity.
- Optional multiwash capability flushes the outside surface of the injection needle and uses seat backflush procedures to reduce carryover to less than 9 ppm.
- Robotics move microtiter plates and other sample containers from sample hotel to central workspace for seamless automation during sample processing steps and injections.

Overview of the Module

The Multisampler transport mechanism uses a Cartesian robot. The X-Y drive together with the Z drive optimize the grabbing and positioning for the sample trays and the needle handling inside of the Multisampler. The sample coupler moves the sample container from the sample hotel which stores all the samples and place it on the central workspace. Then the needle coupler of the Z drive takes over and grabs the needle assembly from the needle station and performs the analytical procedures inside of the Multisampler. Due the uncoupled needle design, the robot can do other liquid handling jobs during the analysis.

The multisampler employs an active vial/plate pusher mechanism to hold down the vial or the plate while the needle is drawn back from the sample vessel (a must in the case a septum is used). This active vial/plate pusher employs a sensor to detect the presence of a plate and to ensure accurate movement regardless of plate used. All axes of the transport mechanism are driven by very fast BLCD motors. Optical encoders ensure the correct operation of the movement.

The standard configuration of the Multisampler uses either a 40 μL or a 100 μL metering device. With this instrument setup, it is possible to inject a maximum volume of 20 μL or 100 μL . For higher injection volumes, additional hardware modifications are required. For minimum internal carryover, the entire injection flowpath is always flushed by the mobile phase.

In addition, you have two different possibilities to reduce the carryover. The first is the external needle wash. In the Standard configuration, the needle flush station is equipped with a peristaltic pump to wash the outside of the needle. This reduces already low carryover for very sensitive analysis. The bottle containing the mobile phase for the wash procedure will be located in the solvent bottle cabinet. Produced waste during this operation is channeled safely away through a waste drain. In the Multi-Wash configuration, the external needle wash will be done by a micro piezo pump combined with a solvent selection valve, where you can select between three different solvents. If this is not sufficient to reduce the carryover, there is an additional and perfect way to achieve the lowest carryover in the Multi-Wash configuration by using the integrated flush pump. This high-pressure pump can also select between three different solvents and is capable of reducing the carryover to a minimum by using the seat backflushing. The flush pump outlet capillary is connected to port 4 of the Multisampler's injection valve, which normally holds the waste line. If the Multisampler is in bypass mode, the flush pump connects to the needle seat and can flush backwards through the needle seat into the waste line attached to the needle seat outlet port.

Introduction

Overview of the Module

The six-port (only 5 ports are used) injection valve unit is driven by a high-speed hybrid stepper motor. During the sampling sequence, the valve unit bypasses the Multisampler, and connects flow from the pump to the column directly. During injection and analysis, the valve unit directs the flow through the Multisampler which ensures that all of the sample is injected onto the column, and that the metering unit and needle are always free of sample residue before the next sampling sequence begins.

The Cooling Control of the vial/plate temperature in the Multisampler is achieved using an additional Agilent Sample Cooler or Sample Thermostat module. The chiller unit is a micro compressor-based refrigerator. A fan draws air from the central workstation above the sample container of the Multisampler. It is then blown through the fins of the cooling module, where it is cooled according to the temperature setting. The cooled air enters the Sampler Hotel through a recess underneath the special designed base plate. The air is then distributed evenly through the Sample Hotel ensuring effective temperature control, regardless of how many sample containers are in the drawer. In cooling mode, condensation is generated on the cooled side of the Sample Cooler or Sample Thermostat. This condensed water is safely guided into a waste bottle for condensed water that is located underneath the working bench.

Single Needle Setup

The movements of the Multisampler components during the sampling sequence are monitored continuously by the Multisampler processor. The processor defines specific time windows and mechanical ranges for each movement. If a specific step of the sampling sequence is not completed successfully, an error message is generated. Solvent is bypassed from the Multisampler by the injection valve during the sampling sequence. After the required sample container was automatically loaded from the sample hotel and placed on the central workspace. The needle assembly moves via robot to the desired sample position and is lowered into the sample liquid in the sample to allow the metering device to draw up the desired volume by moving its plunger back a certain distance. The needle assembly is then raised again and moved to the needle park station onto the seat to close the sample loop. Sample is applied to the column when the injection valve returns to the mainpass (main path) position at the end of the sampling sequence.

Introduction

Single Needle Setup

The standard sampling sequence occurs in the following order:

- 1 The robot loads the required sample container on the central workspace
- 2 The injection valve switches to the bypass position.
- 3 The plunger of the metering device moves to the initialization position, pushing out clean eluent through the waste tube (port 4) for a standard or through the needle for a Multiwash system.
- 4 The robot couples into the needle assembly from the needle parkstation.
- 5 The robot unlocks the needle assembly and moves up.
- 6 The coupled needle assembly/robot moves to the desired sample vial (or well plate) position on the central workstation.
- 7 The needle lowers into the sample vial (or well plate).
- 8 The metering device draws the preset sample volume.
- 9 The needle lifts out of the sample vial (or well plate).
- 10 The coupled needle assembly/robot is then moved to the park station onto the seat to close the sample loop.
- 11 The needle assembly is locked into the park station and moves down.
- 12 The injection cycle is completed when the injection valve switches to the mainpass (main path) position.
- 13 The robot moves the sample container back into the sample hotel if the sampling sequence is done. If needle wash is required, it will be done between step 9 and 10.

NOTE

For the needle seat backflush the Multisampler must be in bypass mode.

If an additional needle seat backflush is required this step must also be done between step 5 and 9.

Injection Sequences

Injection Sequence for a Single-needle System

Preparing for Sample Drawing

Before the start of an injection sequence or during an analysis, the injection valve is in the mainpass (main path) position. In this position, the mobile phase passes through all flow path components in contact with the sample, such as the loop capillary, to ensure that they are constantly flushed by the flow, minimizing carry over.

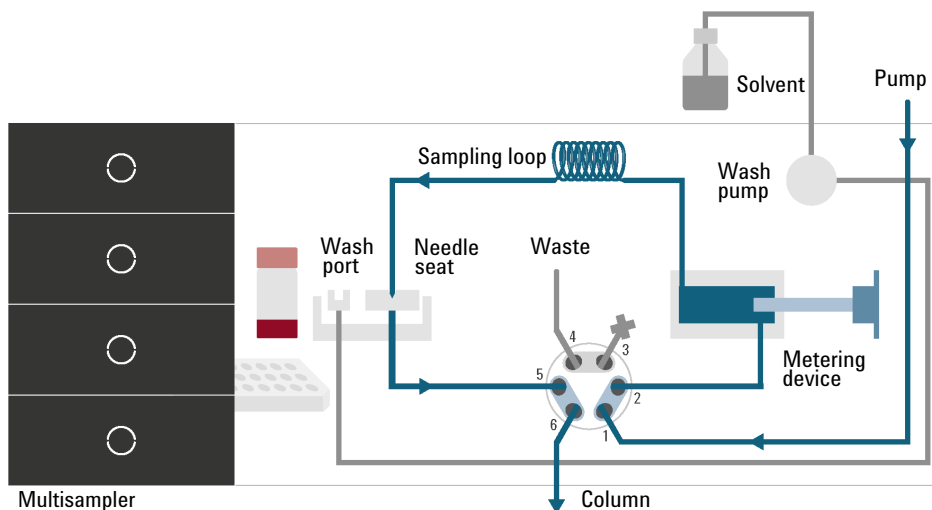

Figure 5 Valve in mainpass (main path), flow through

Introduction

Injection Sequences

The injection sequence begins with the injection valve switching to the bypass position, which diverts the flow from the pump directly towards the column (from port 1 to port 6), while leaving out the components of the sample introduction system.

For a standard wash system, the seat capillary is then connected to the waste line (from port 5 to port 4). Thus, when the metering plunger moves forward to return to the home position, some eluent is pushed out through the waste tube towards the waste handling system. The volume of the ejected liquid equals the injection volume of the previous run.

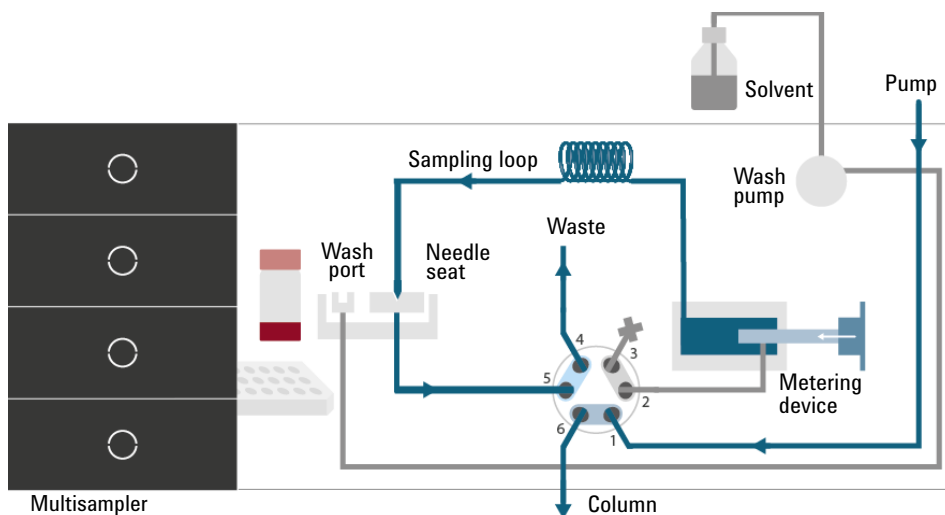

Figure 6 Valve in bypass, standard wash system

Introduction

Injection Sequences

For a Multiwash system, the seat capillary is not connected to the waste line but to the flush pump of the needle seat backflush system (from port 5 to port 4) when the injection valve is in the bypass position. To allow the escape of the eluent pushed out when the metering plunger returns to the home position, the needle lifts by a couple of millimeters above the needle seat. The ejected liquid might build a droplet on the needle seat depending on its volume, which equals the injection volume of the previous run.

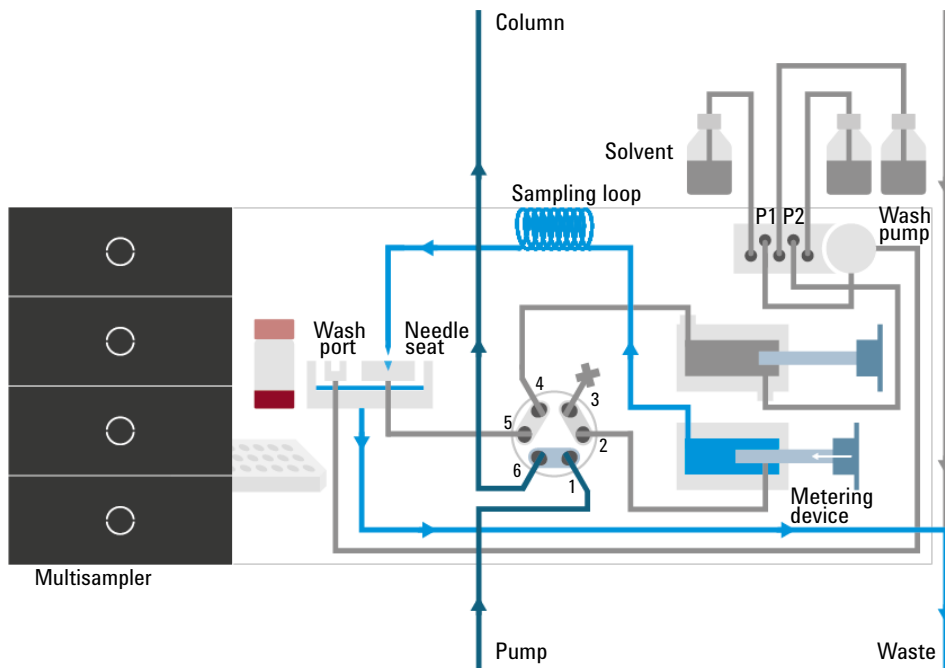

Figure 7 Valve in bypass, Multiwash system

NOTE

When the Multiwash option is installed, it must be used to wash away droplets created on the needle seat after each injection.

Introduction

Injection Sequences

Sample Drawing

As soon as the metering plunger is back in the home position, the robotic arm lifts the needle assembly from the park station, moves it to the central workstation, and lowers it into the vial or wellplate with the sample of interest. The metering plunger then starts to move back, drawing the sample into the loop capillary. Finally, the robotic arm moves the needle assembly back to the park station and lowers it into the needle seat to close the flow path. In the case of an injector program, the system might perform additional sample preparation steps at this point, such as mixing or standard addition.

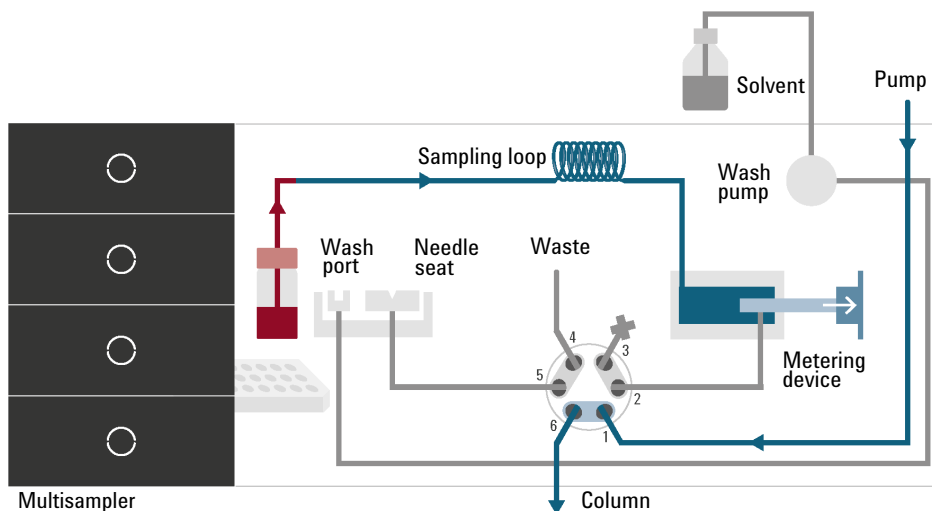

Figure 8 Valve in bypass, drawing sample

Introduction

Injection Sequences

Flushing the Needle (Standard Wash)

When high sensitivity is needed, the outer surface of the needle can be rinsed in the flush port located behind the injector port before the injection of the sample to reduce carryover.

At the start of the wash process, a small air plug is introduced into the needle tip to prevent any undesired sample loss. Then, the needle moves into the flush port, and the peristaltic pump starts delivering wash solvent for a predefined time at a rate of 5 mL/min. The fresh wash solvent enters through the inlet port at the bottom, whereas the exhausted solvent leaves at the top edge of the flush port towards the waste handling system. This concept ensures that the needle tip is constantly exposed to clean wash solvent. At the end of the wash procedure, the needle returns to the needle seat

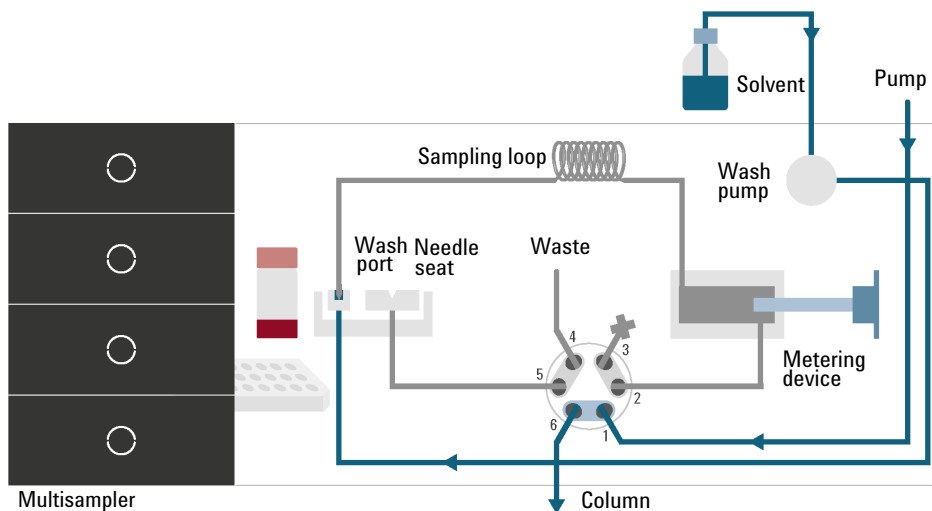

Figure 9 Valve in bypass, washing needle (standard wash)

Introduction

Injection Sequences

Flushing the Needle (Multiwash)

With the Multiwash option, the outer surface of the needle can be rinsed with not one but three different wash solvents, reducing the carryover to as low as the level of 9 ppm, which ultimately allows for ultra-low sensitivity analyses.

At the start of the wash process, a small air plug is introduced into the needle tip to prevent any undesired sample loss. Then, the needle moves into the flush port, and the piezo pump starts delivering wash solvent for a predefined time at a rate of 5 mL/min. The solvent selection valve enables the system to switch between three different wash solvents during the wash procedure in a user-defined order. The fresh wash solvent enters through the inlet port at the bottom, whereas the exhausted solvent leaves at the top edge of the flush port towards the waste handling system.

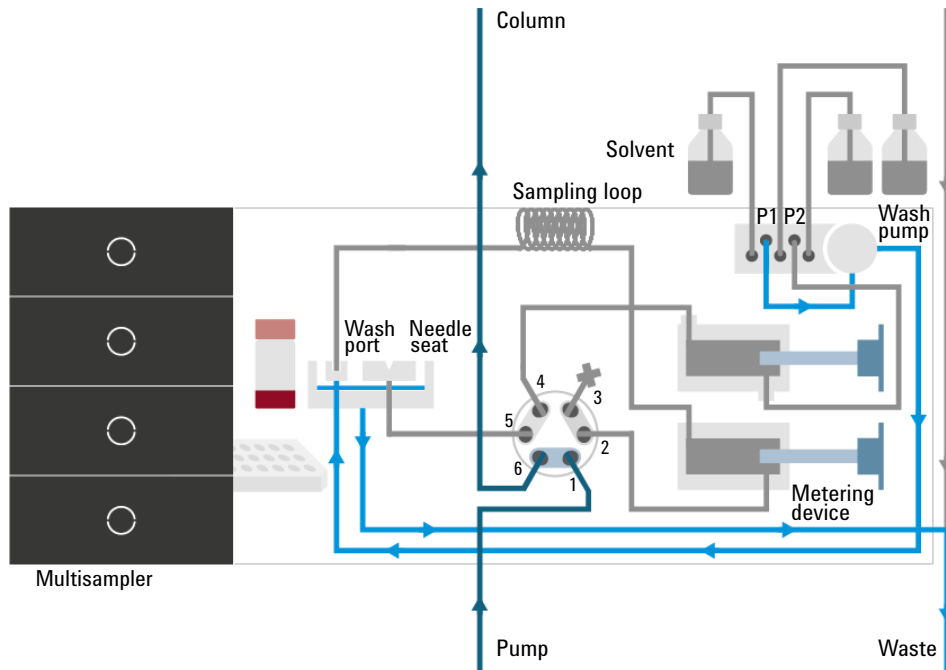

Figure 10 Valve in bypass, washing needle (Multiwash)

Inject-and-Run

During the inject-and-run step, the six-port valve switches to the mainpass (main path) position and directs the flow towards the sample loop, which marks the beginning of the run in the chromatography data system (CDS). The eluent then transports the sample from the loop capillary onto the column, where the separation begins. Thanks to the flow-through design of the injection system, the components of the flow path are constantly flushed by the solvent flow, reducing carryover significantly. For standard applications, no additional flushing procedure is required.

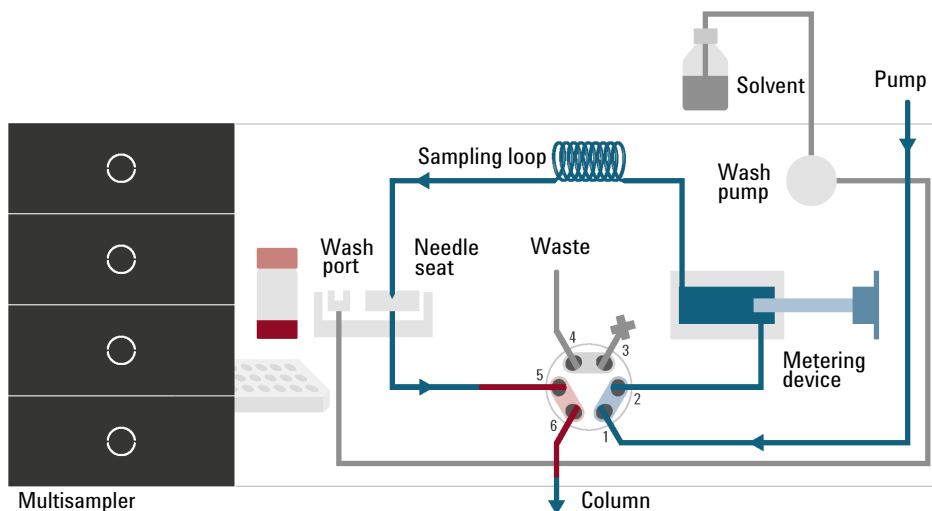

Figure 11 Valve in mainpass (main path), sample injected

NOTE

When the Multiwash option is installed, it must be used to wash away droplets created on the needle seat after each injection.

Introduction

Injection Sequences

Needle seat back flush

With the Multiwash option, the system can backflush the needle seat capillary with the help of a dedicated flush pump at the end of each injection cycle, which has paramount importance when high sensitivity is needed.

After the injection valve switches into the bypass position, the solvent selection valve diverts the wash solvent stream towards the flush pump, allowing the system to use the same three solvents available for needle wash. The flush pump then presses the wash solvent through the needle seat capillary via the injection valve (from port 4 to port 5) in the reverse direction to remove any contamination that may reside there. The exhausted wash solvent leaves through the inlet port of the needle seat and drains through the leak system of the needle wash port. During the seat backflush procedure, the solvent selection switches between the different wash solvents in a user-defined order.

Multi-wash					
Step	Solvent	Time [s]	Seat Back Flush	Needle Wash	Comment
1	Off		<input type="checkbox"/>	<input type="checkbox"/>	
2	Off		<input type="checkbox"/>	<input type="checkbox"/>	
3	Off		<input type="checkbox"/>	<input type="checkbox"/>	
Start Cond.	S1		<input checked="" type="checkbox"/>	<input type="checkbox"/>	

Figure 12 Needle Seat Back Flush settings

It is recommended to use the starting mobile phase composition as the wash solvent in the last rinsing step to avoid any undesired solvent interaction with your chromatography.

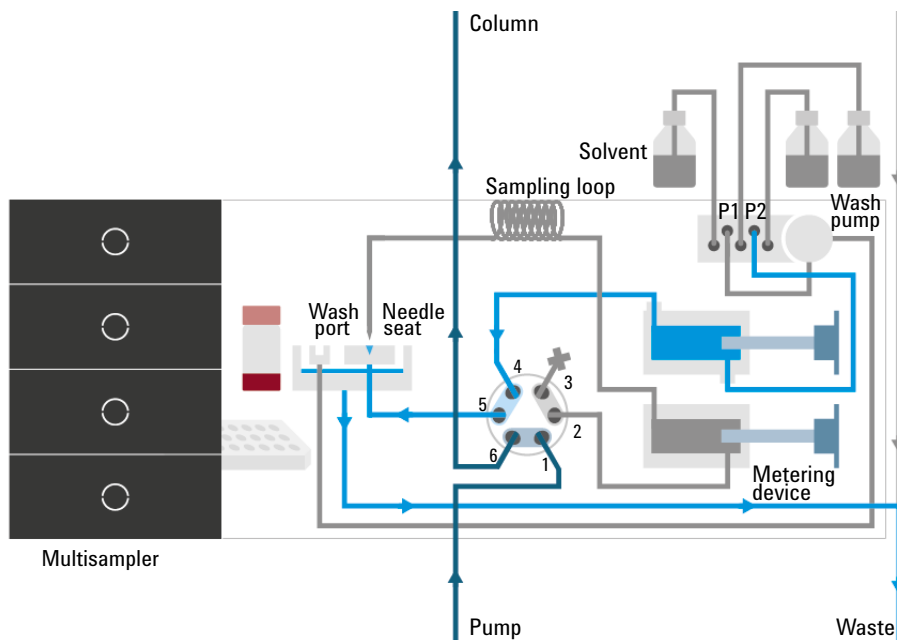

Figure 13 Valve in bypass, needle seat backflush (Multiwash)

NOTE

It takes approximately 30 s to fully exchange one solvent for another in the flush port, and 18 s in the seat. Also, it is recommended to use the autoclean function (right-click the dashboard and select **Auto-clean**) to flush the multisampler regularly with all installed solvents.

NOTE

If **Seat Back Flush** and **Needle Wash** are both activated at the same time, they must use the same solvent.

NOTE

It is recommended to always activate **Start Cond.** as the last step of the washing procedure. The flow path is then filled with the appropriate starting solvent conditions for the next sample.

NOTE

It is not recommended to use buffers and solvents with high salt content as the last step of the washing procedure. This might cause formation of salt crystals on the needle seat.

NOTE

Due to the flow path of the Multiwash hydraulic box (see [Figure 13](#) on page 31), when the metering device moves to home position before an injection, a droplet of clean mobile phase will come out from the needle tip and might fall into the seat. This is an expected behavior, independent of the **Injection Path Cleaning** settings, and does not indicate leakage.

To avoid salt build-up on the needle and the seat when using buffers and solvents with high salt content as mobile phase, follow these recommendations:

- Purge the Multisampler daily with water for 15 min.
 - Visually inspect the needle and seat.
-

Injection Sequence for dual needle (alternating mode)

Flushing the system

The Start of the pump or changes in solvent composition trigger the purge routine of the multisampler. The purge routine flushes the hydraulic setup of the multisampler with fresh mobile phase (for example metering device, sample loops, and needles). This ensures cleanness of the flowpath.

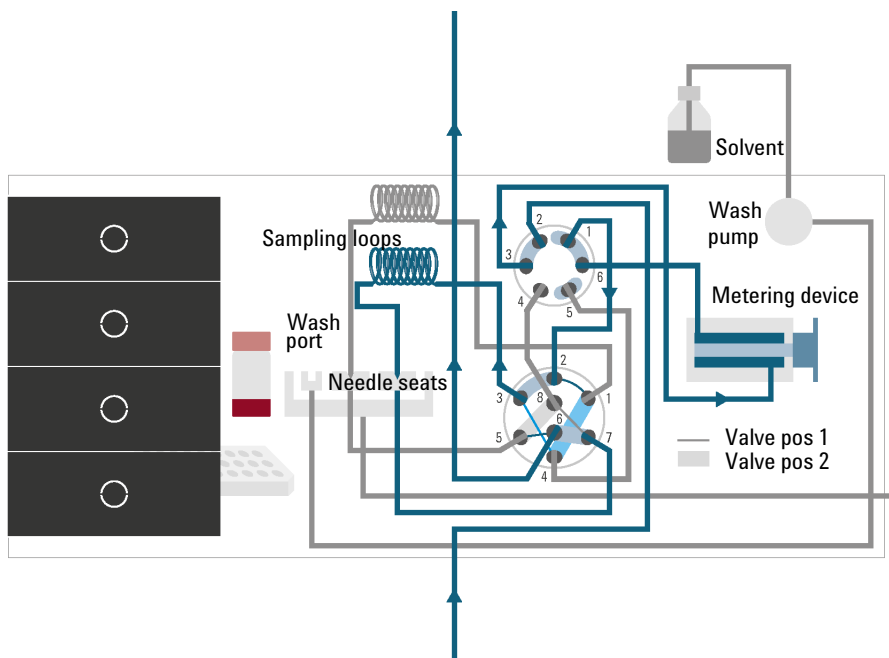

Figure 14 Valve in mainpass (main path) (right), metering device purged, and alternate dual-needle injection prepared

NOTE

For pumps with a manual purge valve, it is mandatory to start the purge routine before a run or sequence. This will guarantee that the complete flow path of the dual-needle setup is flushed with fresh mobile phase.

The robot moves the wellplates or vial trays from the sample hotel to the central workspace. The injection valve unit switches to the mainpass (main path) (left) position. Then the sampling process starts. Solvent from the pump enters the peripheral valve at port 2, and flows through port 1 directly to the injection valve. The solvent enters the injection valve at port 2, flows via port 1 through the sample loop (left), the needle (left), the needle seat (left), port 5 and port 6 to the column.

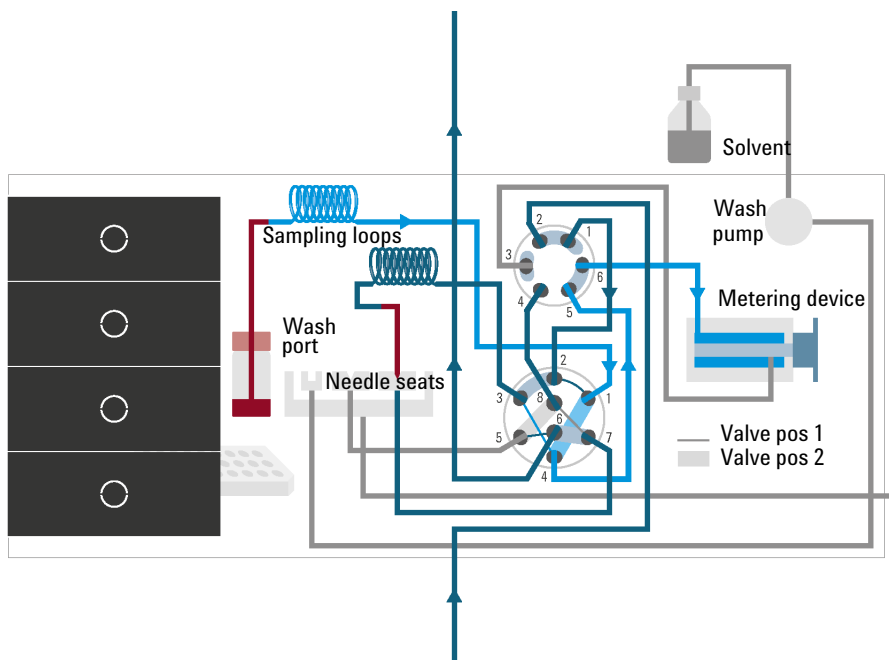

Figure 15 Valve in mainpass (main path) (right), drawing sample with left needle

Drawing sample (right)

Then the needle assembly (right) moves to the desired sample position and immerses into the sample. The plunger of the metering device moves back and draws up the desired volume. Then the needle assembly (right) raises and moves to the needle park station on the needle seat (right). This closes the sample loop (right).

Flush the Needle (if selected)

To reduce carryover, the outside of the left or the right needle can be washed in the flush port that is located behind the needle park station. As soon as the needle is on the flush port, a wash pump flushes the outside of the needle for a defined time (defined for example in the method). After this process the needle assembly returns to the appropriate needle park station. This closes the sample loop (right).

Introduction

Injection Sequences

Alternating Dual-needle Inject and Run (Right needle)

The eight port valve switches to the mainpass (main path) (right) position. Now Port 2 and 3 and Port 7 and 6 of the injection valve are connected. This directs the flow through the sample loop (right) and the solvent transports the sample to the column. Separation and analysis starts. In the meantime, the flow path (right) is flushed internally by the solvent.

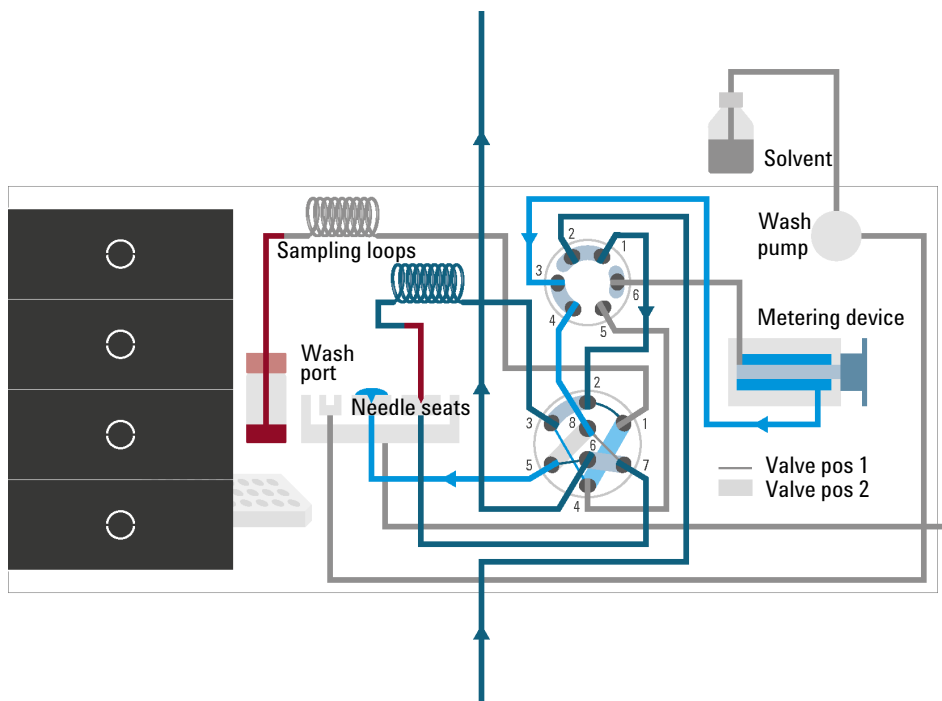

Figure 16 Valve in mainpass (main path) (right), metering home (multi-load position of the peripheral valve)

Introduction

Injection Sequences

Prepare Inject and Run of the alternating dual needle (left needle)

The sample container is in the central sample work space. The robot detaches the needle assembly (left) from the needle port. The metering device drives to the home position. Then the needle assembly (left) is moved to the desired sample position and immerses into the sample. The plunger of the metering device moves back and draws up the desired volume. Then the needle assembly (left) raises and moves to the needle park station on the needle seat (left). This closes the sample loop (left).

The left needle can be flushed as the right needle, see description above.

The eight port valve switches to the mainpass (main path) (left) position. Now Port 2 and 1 and Port 5 and 6 of the injection valve are connected. This directs the flow through the sample loop (left) and the solvent transports the sample to the column. Separation and analysis starts. In the meantime, the flow path (left) is flushed internally by the solvent.

The alternating flush and injection cycles minimize injection cycle times and ensure maximal cleanness of the hardware.

Multi-load with Dual needle (left needle)

In the multi-load mode, the peripheral valve switches in different positions while the plunger of the metering device moves back and forward. At the same time, the needle remains in the sample vial or well. That way the multi-load technique allows to draw multiple times and inject large sample volumes. This multi-load technique is completely different from the multi-draw technique that is used in other autosamplers.

Injection Sequence for dual needle (bypass mode)

This corresponds to the injection sequence for single needles, see [“Injection Sequence for a Single-needle System”](#) on page 23. Only one flow path is used on a regular basis, and a defined bypass capillary replaces either the left or the right dual-needle sample loop. This bypass capillary shortcuts one path to allow faster reconditioning.

System Overview

Leak and Waste Handling

The Agilent InfinityLab LC Series has been designed for safe leak and waste handling. It is important that all security concepts are understood and instructions are carefully followed.

The solvent cabinet is designed to store a maximum volume of 8 L solvent. The maximum volume for an individual bottle stored in the solvent cabinet should not exceed 2 L. For details, see the usage guideline for the Agilent Infinity II Solvent Cabinets (a printed copy of the guideline has been shipped with the solvent cabinet, electronic copies are available on the Internet).

All leak plane outlets are situated in a consistent position so that all Infinity and Infinity II modules can be stacked on top of each other. Waste tubes are guided through a channel on the right hand side of the instrument, keeping the front access clear from tubes.

The leak plane provides leak management by catching all internal liquid leaks, guiding them to the leak sensor for leak detection, and passing them on to the next module below, if the leak sensor fails. The leak sensor in the leak plane stops the running system as soon as the leak detection level is reached.

Solvent and condensate is guided through the waste channel into the waste container:

- from the detector's flow cell outlet
- from the Multisampler needle wash port
- from the Sample Cooler or Sample Thermostat (condensate)
- from the pump's Seal Wash Sensor (if applicable)
- from the pump's Purge Valve or Multipurpose Valve

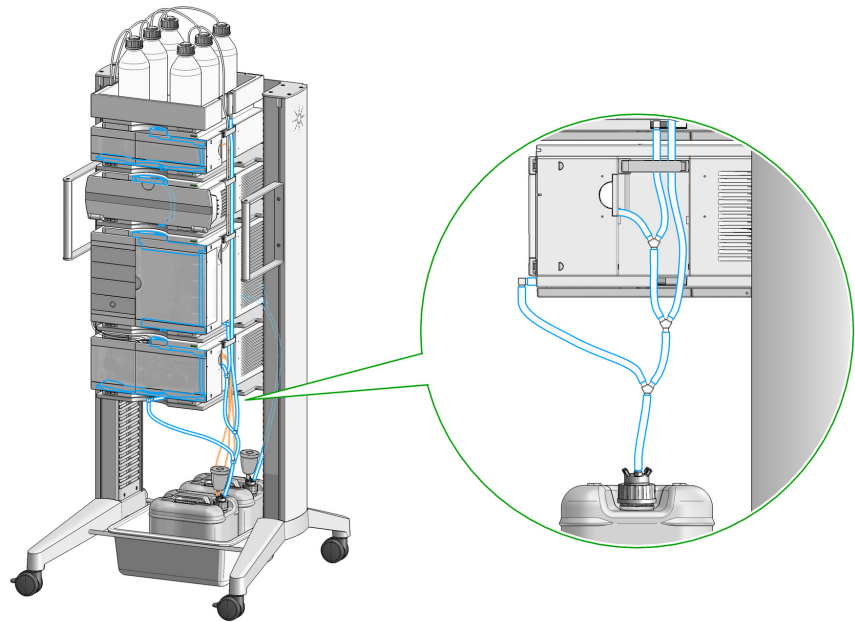

Figure 17 Infinity II Leak Waste Concept (Flex Bench installation)

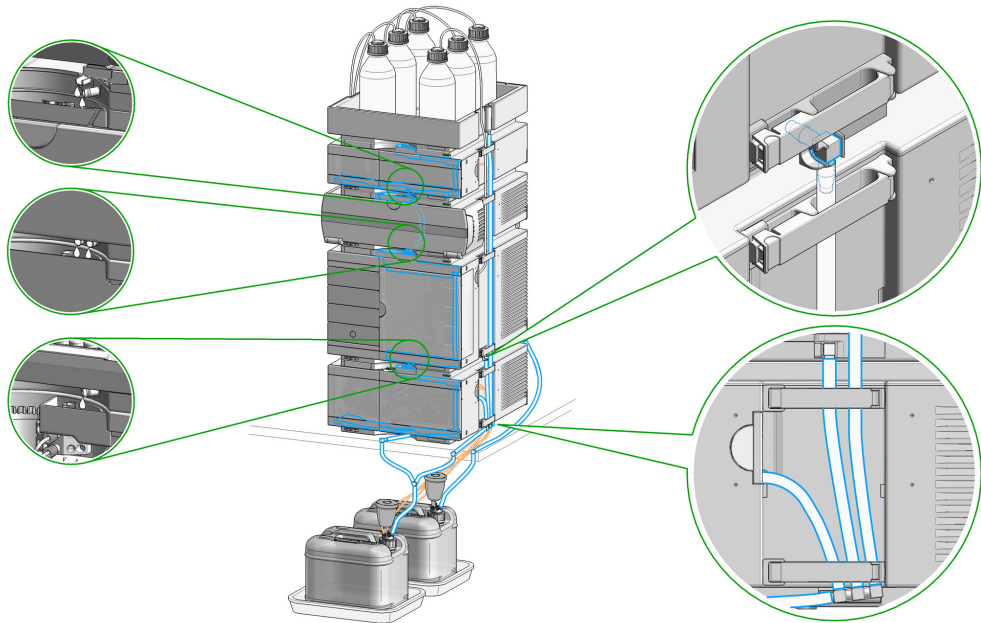

Figure 18 Infinity II Single Stack Leak Waste Concept (bench installation)

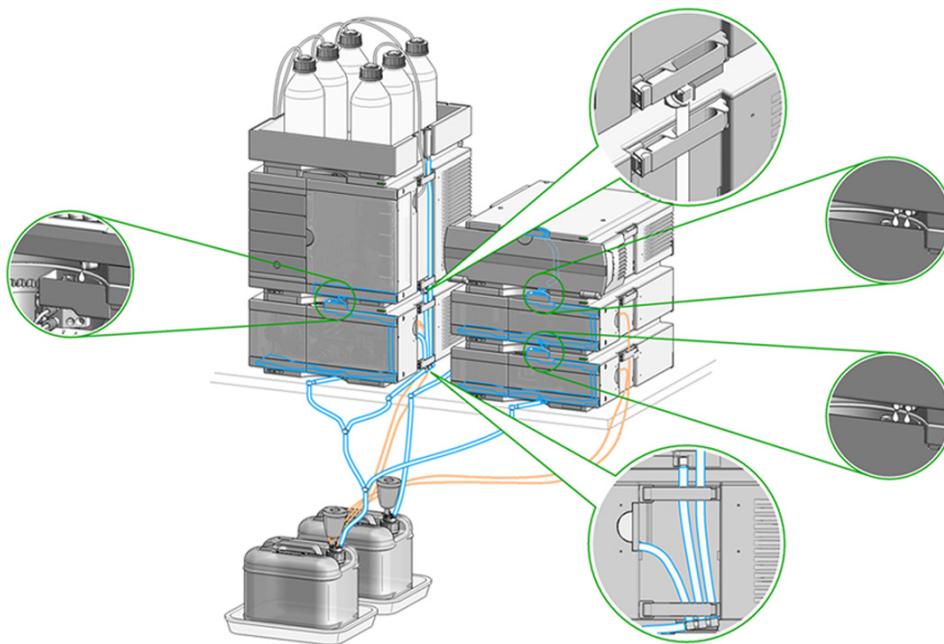

Figure 19 Infinity II Two Stack Leak Waste Concept (bench installation)

The waste tube connected to the leak plane outlet on each of the bottom instruments guides the solvent to a suitable waste container.

Leak Sensor

CAUTION

Solvent incompatibility

The solvent DMF (dimethylformamide) leads to corrosion of the leak sensor. The material of the leak sensor, PVDF (polyvinylidene fluoride), is incompatible with DMF.

- ✓ Do not use DMF as mobile phase.
- ✓ Check the leak sensor regularly for corrosion.

Waste Guidance

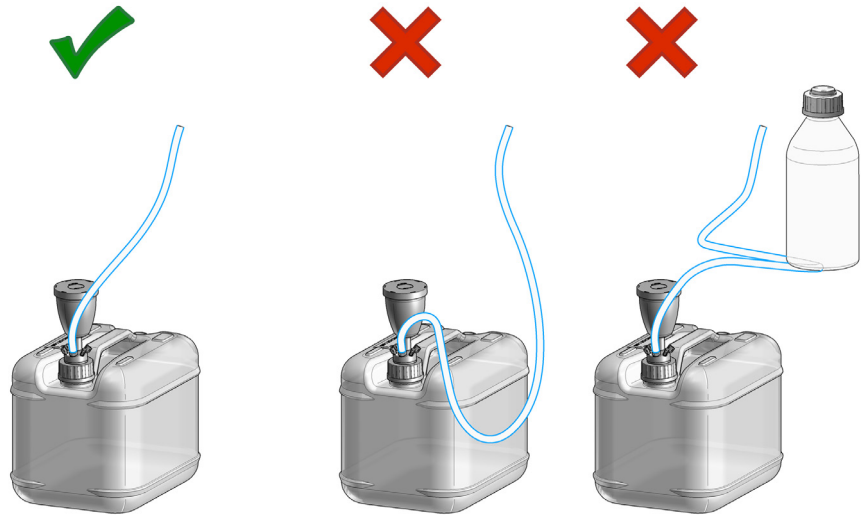

NOTE

The waste drainage must go straight into the waste containers. The waste flow must not be restricted at bends or joints.

Waste Concept

- 1 Agilent recommends using the 6 L waste can with 1 Stay Safe cap GL45 with 4 ports (5043-1221) for optimal and safe waste disposal. If you decide to use your own waste solution, make sure that the tubes don't immerse in the liquid.

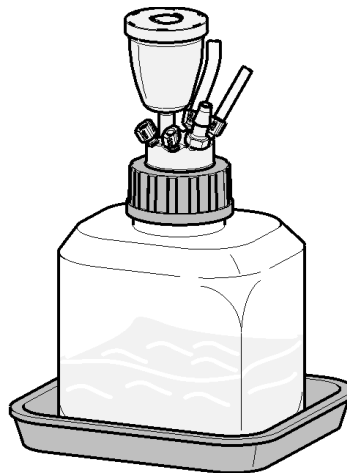

Leak and Waste Handling in a Mixed Configuration

Leak and Waste Handling in a Mixed Configuration

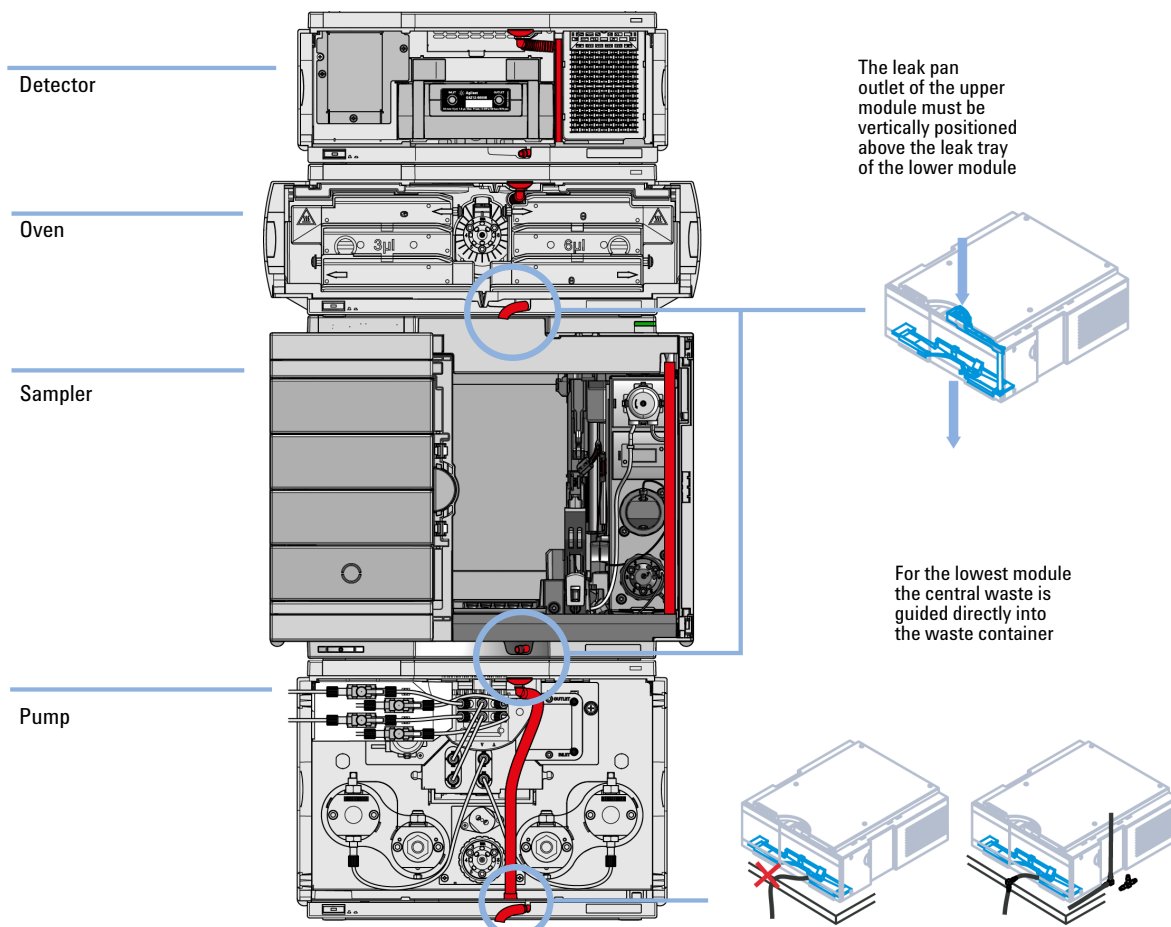

Figure 20 Leak and waste handling with multisampler in a mixed configuration as an example

NOTE

Flush solvent from the washport of the multisampler is guided out to the right of the instrument.

Multisampler

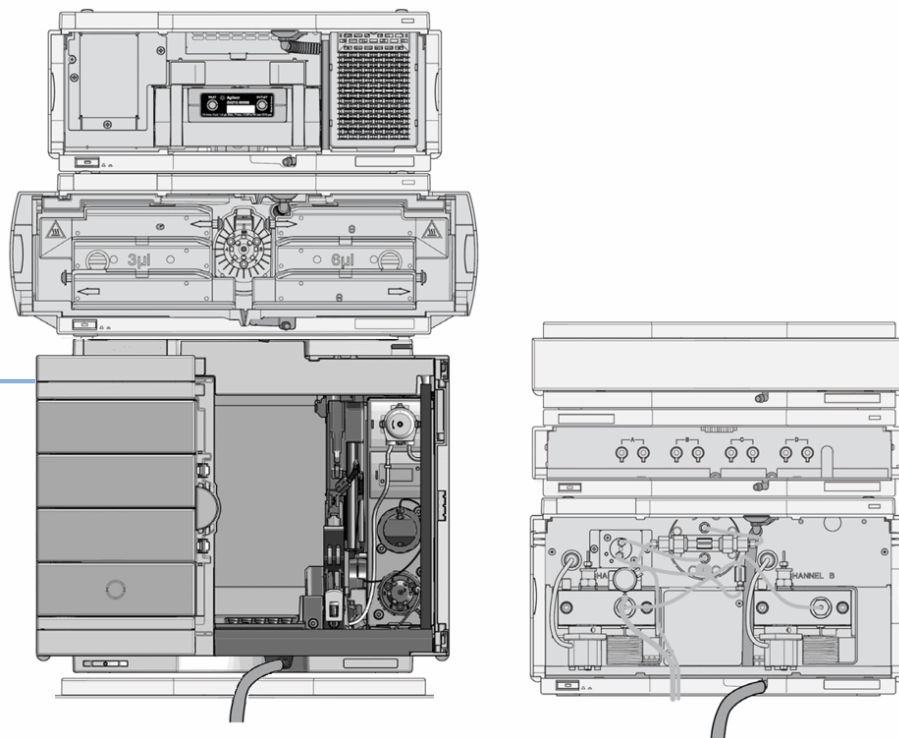

Figure 21 Leak and waste handling with multisampler in a mixed configuration as an example (two stack configuration)

NOTE

Do not place the multisampler directly on the bench if a sample cooler or sample thermostat is installed.

2

Site Requirements and Specifications

Site Requirements 46

Physical Specifications 50

Physical Specifications Agilent 1290 Infinity II Multisampler (G7167B) 50

Physical Specifications Agilent 1260 Infinity II Multisampler (G7167A) 51

Physical Specifications Agilent 1290 Infinity II Bio Multisampler (G7137A) 52

Physical Specifications Agilent 1260 Infinity II Bio-inert Multisampler (G5668A) 53

Performance Specifications 54

Performance Specifications (G7167B) 54

Performance Specifications (G7167A) 56

Performance Specifications (G7137A) 58

Performance Specifications G5668A 60

Specifications of the Sample Cooler 62

Specifications of the Sample Thermostat 64

This chapter provides information on environmental requirements, physical and performance specifications.

Site Requirements

A suitable environment is important to ensure optimal performance of the instrument.

Power Considerations

The module power supply has wide ranging capability. It accepts any line voltage in the range described in [Table 1](#) on page 50. Consequently there is no voltage selector in the rear of the module. There are also no externally accessible fuses, because automatic electronic fuses are implemented in the power supply.

WARNING

Hazard of electrical shock or damage of your instrumentation can result, if the devices are connected to a line voltage higher than specified.

- ✓ Connect your instrument to the specified line voltage only.

WARNING**Electrical shock hazard**

The module is partially energized when switched off, as long as the power cord is plugged in.

The cover protects users from personal injuries, for example electrical shock.

- ✓ Do not open the cover.
- ✓ Do not operate the instrument and disconnect the power cable in case the cover has any signs of damage.
- ✓ Contact Agilent for support and request an instrument repair service.

WARNING**Inaccessible power plug.**

In case of emergency it must be possible to disconnect the instrument from the power line at any time.

- ✓ Make sure the power connector of the instrument can be easily reached and unplugged.
- ✓ Provide sufficient space behind the power socket of the instrument to unplug the cable.

Power Cords

Country-specific power cords are available for the module. The female end of all power cords is identical. It plugs into the power-input socket at the rear. The male end of each power cord is different and designed to match the wall socket of a particular country or region.

Agilent makes sure that your instrument is shipped with the power cord that is suitable for your particular country or region.

WARNING**Unintended use of power cords**

Using power cords for unintended purposes can lead to personal injury or damage of electronic equipment.

- ✓ Never use a power cord other than the one that Agilent shipped with this instrument.
- ✓ Never use the power cords that Agilent Technologies supplies with this instrument for any other equipment.
- ✓ Never use cables other than the ones supplied by Agilent Technologies to ensure proper functionality and compliance with safety or EMC regulations.

WARNING**Absence of ground connection**

The absence of ground connection can lead to electric shock or short circuit.

- ✓ Never operate your instrumentation from a power outlet that has no ground connection.

WARNING**Electrical shock hazard**

Solvents may damage electrical cables.

- ✓ Prevent electrical cables from getting in contact with solvents.
 - ✓ Exchange electrical cables after contact with solvents.
-

Room Size and Ventilation

WARNING

Flammable refrigerant

Formation of flammable gas-air mixtures inside the Sample Thermostat and laboratory.

- ✓ Keep open fire or sources of ignition away from the device.
 - ✓ Ensure a room size of 4 m³ (1 m³ for every 8 g of R600a refrigerant inside of the Sample Thermostat).
 - ✓ Ensure adequate ventilation: typical air exchange of 25 m³/h per m² of laboratory floor area.
 - ✓ Keep all ventilation openings in the enclosure clear of obstructions. Do not block the openings on the circumference of the Sample Thermostat.
-

Bench Space

The module dimensions and weight (see [Table 1](#) on page 50) allow you to place the module on almost any desk or laboratory bench. It needs an additional 2.5 cm (1.0 inches) of space on either side and approximately 8 cm (3.1 inches) in the rear for air circulation and electric connections.

If the bench shall carry a complete HPLC system, make sure that the bench is designed to bear the weight of all modules.

The module should be operated in a horizontal position, especially if a Sample Cooler or Sample Thermostat is installed. Use a bubble level to check the leveling of the sampler.

NOTE

Agilent recommends that you install the HPLC instrument in the InfinityLab Flex Bench rack. This option helps to save bench space as all modules can be placed into one single stack. It also allows to easily relocate the instrument to another laboratory.

WARNING

Heavy weight

The module is heavy.

- ✓ Carry the module at least with 2 people.
- ✓ Avoid back strain or injury by following all precautions for lifting heavy objects.
- ✓ Ensure that the load is as close to your body as possible.
- ✓ Ensure that you can cope with the weight of your load.

Condensation

CAUTION

Condensation within the module

Condensation can damage the system electronics.

- ✓ Do not store, ship or use your module under conditions where temperature fluctuations could cause condensation within the module.
- ✓ If your module was shipped in cold weather, leave it in its box and allow it to warm slowly to room temperature to avoid condensation.

Physical Specifications

Physical Specifications Agilent 1290 Infinity II Multisampler (G7167B)

Table 1 Physical Specifications

Type	Specification	Comments
Weight	22 kg (48.5 lbs)	w/o sample thermostat
Dimensions (height x width x depth)	320 x 396 x 468 mm (12.6 x 15.6 x 18.4 inches)	
Line voltage	100 – 240 V~, ± 10 %	Wide-ranging capability
Line frequency	50 or 60 Hz, ± 5 %	
Power consumption	180 VA, 180 W	
Ambient operating temperature	4 - 40 °C (39 - 104 °F)	
Ambient non-operating temperature	-40 – 70 °C (-40 – 158 °F)	
Humidity	< 95 % r.h. at 40 °C (104 °F) ¹	Non-condensing
Operating altitude	Up to 3000 m (9842 ft)	
Safety standards: IEC, EN, CSA, UL	Overvoltage category II, Pollution degree 2	For indoor use only
ISM Classification	ISM Group 1 Class B	According to CISPR 11
Permitted solvents	Boiling point ≥56 °C (133 °F). Auto-ignition temperature ≥200 °C (392 °F).	

¹ If a sample thermostat is included the upper value for humidity can be reduced. Please check your lab conditions to stay beyond dew point values for non-condensing operation.

Physical Specifications Agilent 1260 Infinity II Multisampler (G7167A)

Table 2 Physical Specifications

Type	Specification	Comments
Weight	22 kg (48.5 lbs)	w/o sample thermostat
Dimensions (height x width x depth)	320 x 396 x 468 mm (12.6 x 15.6 x 18.4 inches)	
Line voltage	100 – 240 V~, ± 10 %	Wide-ranging capability
Line frequency	50 or 60 Hz, ± 5 %	
Power consumption	180 VA, 180 W	
Ambient operating temperature	4 - 40 °C (39 - 104 °F)	
Ambient non-operating temperature	-40 – 70 °C (-40 – 158 °F)	
Humidity	< 95 % r.h. at 40 °C (104 °F) ¹	Non-condensing
Operating altitude	Up to 3000 m (9842 ft)	
Safety standards: IEC, EN, CSA, UL	Overvoltage category II, Pollution degree 2	For indoor use only
ISM Classification	ISM Group 1 Class B	According to CISPR 11
Permitted solvents	Boiling point ≥56 °C (133 °F). Auto-ignition temperature ≥200 °C (392 °F).	

¹ If a sample thermostat is included the upper value for humidity can be reduced. Please check your lab conditions to stay beyond dew point values for non-condensing operation.

Physical Specifications Agilent 1290 Infinity II Bio Multisampler (G7137A)

Table 3 Physical Specifications G7137A

Type	Specification	Comments
Weight	22 kg (48.5 lbs)	w/o sample thermostat
Dimensions (height x width x depth)	320 x 396 x 468 mm (12.6 x 15.6 x 18.4 inches)	
Line voltage	100 – 240 V~, ± 10 %	Wide-ranging capability
Line frequency	50 or 60 Hz, ± 5 %	
Power consumption	180 VA, 180 W	
Ambient operating temperature	4 - 40 °C (39 - 104 °F)	
Ambient non-operating temperature	-40 – 70 °C (-40 – 158 °F)	
Humidity	< 95 % r.h. at 40 °C (104 °F) ¹	Non-condensing
Operating altitude	Up to 3000 m (9842 ft)	
Safety standards: IEC, EN, CSA, UL	Overvoltage category II, Pollution degree 2	For indoor use only
ISM Classification	ISM Group 1 Class B	According to CISPR 11
Permitted solvents	Boiling point ≥56 °C (133 °F). Auto-ignition temperature ≥200 °C (392 °F).	

¹ If a sample thermostat is included the upper value for humidity can be reduced. Please check your lab conditions to stay beyond dew point values for non–condensing operation.

Physical Specifications Agilent 1260 Infinity II Bio-inert Multisampler (G5668A)

Table 4 Physical Specifications

Type	Specification	Comments
Weight	22 kg (48.5 lbs)	w/o sample thermostat
Dimensions (height x width x depth)	320 x 396 x 468 mm (12.6 x 15.6 x 18.4 inches)	
Line voltage	100 – 240 V~, ± 10 %	Wide-ranging capability
Line frequency	50 or 60 Hz, ± 5 %	
Power consumption	180 VA, 180 W	
Ambient operating temperature	4 - 40 °C (39 - 104 °F)	
Ambient non-operating temperature	-40 – 70 °C (-40 – 158 °F)	
Humidity	< 95 % r.h. at 40 °C (104 °F) ¹	Non-condensing
Operating altitude	Up to 3000 m (9842 ft)	
Safety standards: IEC, EN, CSA, UL	Overvoltage category II, Pollution degree 2	For indoor use only
ISM Classification	ISM Group 1 Class B	According to CISPR 11
Permitted solvents	Boiling point ≥56 °C (133 °F). Auto-ignition temperature ≥200 °C (392 °F).	

¹ If a sample thermostat is included the upper value for humidity can be reduced. Please check your lab conditions to stay beyond dew point values for non-condensing operation.

Performance Specifications

Performance Specifications (G7167B)

Table 5 Performance Specifications G7167B

Type	Specification	Comments
Injection range for <i>Single-needle</i> instruments	Default: 0.1 – 20 µL in 0.1 µL increments; optional: 40 µL or 100 µL (using 100 µL analytical head)	Up to 1300 bar using 40 µL (default) or optional 100 µL analytical head
	0.1 – 500 µL or 900 µL in 0.1 µL increments (using 900 µL analytical head)	Pressure range up to 400 bar due to 900 µL analytical head
	0.1 – 120 µL in 0.1 µL increments with 1290 Infinity II large volume injection kit (hardware modification required) G4216-68711 0.1 – 500 µL or 1500 µL in 0.1 µL increments with 100 µL upgrade kit (hardware modification required) G7167-68711	Pressure range up to 1300 bar Multi-draw mode (Injection into needle-seat capillary)
Injection range for <i>Dual-needle</i> instruments	Default: 0.1 – 20 µL in 0.1 µL increments; optional: 40 µL or 100 µL	Up to 1300 bar using 100 µL analytical head
	Up to 500 µL in 0.1 µL increments depending on installed loop size	Up to 1300 bar using 100 µL analytical head + Multi-load
Injection precision for <i>Single-needle</i> instruments	<0.15 % RSD or SD <10 nL, whatever is greater	Measured caffeine
Injection precision for <i>Dual-needle</i> instruments	<0.2 % RSD or SD <10 nL, whatever is greater	Measured caffeine
Injection linearity	0.9999 in the range of 0.1 – 100 µL	Measured caffeine
Pressure range	Up to 1300 bar	Max pressure for basic instrument
Sample viscosity range	0.2 – 5.0 cP	
Sample capacity	1H Drawer up to 8 drawers and 16 positions Shallow well plates (MTP)	Max. 6144/1536 samples (384 MTP/96)
	2H Drawer up to 4 drawers and 8 positions MTP, deep well plates, vials, Eppendorf	3072 samples, 432 vials (2 mL)
	3H Drawer up to 2 drawers and 4 positions MTP, deep well plates, vials up to 6 mL, Eppendorf	1536 samples, 60 vials (6 mL), 384 vials (1 mL), 216 vials (2 mL)

Table 5 Performance Specifications G7167B

Type	Specification	Comments
Injection cycle time	<10 s using following standard conditions: Default draw speed: 100 µL/min Default eject speed: 400 µL/min Injection volume: 1 µL	Time between 2 injections is not mechanically limited, time delay depends on communication speed of software, OS or network connections
Carryover	<0.003 % (30 ppm) Multisampler Standard and Dual Needle <0.0009 % (9 ppm) Multisampler Multiwash	Sample: Chlorhexidine
Multiwash	Outer needle wash and seat backflush for carryover reduction with up to 3 different solvents	
Instrument Control	LC & CE Drivers A.02.10 or above Instrument Control Framework (ICF) A.02.03 or above Instant Pilot (G4208A) with firmware B.02.19 or above Lab Advisor B.02.06 or above	For details about supported software versions refer to the compatibility matrix of your version of the LC and CE Drivers
Communication	Controller Area Network (CAN), Local Area Network (LAN) ERI: ready, start, stop and shut-down signals	
Maintenance and safety-related features	Extensive diagnostics, error detection and display with Agilent Lab Advisor software Leak detection, safe leak handling, leak output signal for shutdown of pumping system, and low voltages in major maintenance areas	
GLP features	Early maintenance feedback (EMF) for continuous tracking of instrument usage with user-settable limits and feedback messages. Electronic records of maintenance and errors.	
Housing	All materials recyclable.	

Performance Specifications (G7167A)

Table 6 Performance Specifications G7167A

Type	Specification	Comments
Injection range for <i>Single-needle</i> instruments	Default: 0.1 – 100 µL in 0.1 µL increments optional: 20 µL or 40 µL (using optional 40 µL analytical head)	Up to 800 bar using the 100 µL (default) or optional 40 µL analytical head
	0.1 – 500 µL or 900 µL in 0.1 µL increments (using 900 µL analytical head)	Pressure range up to 400 bar due to 900 µL analytical head
	0.1 – 120 µL in 0.1 µL increments with 1290 Infinity II large volume injection kit (hardware modification required) G4216-68711 0.1 – 500 µL or 1500 µL in 0.1 µL increments with 100 µL upgrade kit (hardware modification required) G7167-68711	Pressure range up to 800 bar Multi-draw mode (Injection into needle-seat capillary)
Injection range for <i>Dual-needle</i> instruments	Default: 0.1 – 100 µL in 0.1 µL increments; optional: 20 µL or 40 µL (using 100 µL analytical head)	Up to 800 bar using 100 µL analytical head
	Up to 900 µL in 0.1 µL increments depending on installed loop size	Up to 800 bar using 100 µL analytical head
Injection precision for <i>single-needle</i> instruments	<0.15 % RSD or SD <10 nL, whatever is greater	Measured caffeine
Injection precision for <i>dual-needle</i> instruments	<0.2 % RSD or SD <10 nL, whatever is greater	Measured caffeine
Injection linearity	0.9999 in the range of 0.1 – 100 µL	Measured caffeine
Pressure range	Up to 800 bar	Max pressure for basic instrument Feature is available for instruments manufactured in Sep 2017 or later. Requires LC and CE Drivers A.02.17 or later.
Sample viscosity range	0.2 – 5.0 cP	
Sample capacity	1H Drawer up to 8 drawers and 16 positions Shallow well plates (MTP)	Max. 6144/1536 samples (384 MTP/96)
	2H Drawer up to 4 drawers and 8 positions MTP, deep well plates, vials, Eppendorf	3072 samples, 432 vials (2 mL)
	3H Drawer up to 2 drawers and 4 positions MTP, deep well plates, vials up to 6 mL, Eppendorf	1536 samples, 60 vials (6 mL), 384 vials (1 mL), 216 vials (2 mL)

Table 6 Performance Specifications G7167A

Type	Specification	Comments
Injection cycle time	<10 s using following standard conditions: Default draw speed: 100 µL/min Default eject speed: 400 µL/min Injection volume: 1 µL	Time between 2 injections is not mechanically limited, time delay depends on communication speed of software, OS or network connections
Carryover	<0.003 % (30 ppm) Multisampler Standard and Dual Needle <0.0009 % (9 ppm) Multisampler Multiwash	Sample: Chlorhexidine
Multiwash	Outer needle wash and seat backflush for carryover reduction with up to 3 different solvents	
Instrument Control	LC and CE Drivers A.02.10 or above Instrument Control Framework (ICF) A.02.03 or above Instant Pilot (G4208A) with firmware B.02.19 or above Lab Advisor B.02.06 or above	For details about supported software versions refer to the compatibility matrix of your version of the LC and CE Drivers
Communication	Controller Area Network (CAN), Local Area Network (LAN) ERI: ready, start, stop and shut-down signals	
Maintenance and safety-related features	Extensive diagnostics, error detection and display with Agilent Lab Advisor software Leak detection, safe leak handling, leak output signal for shutdown of pumping system, and low voltages in major maintenance areas	
GLP features	Early maintenance feedback (EMF) for continuous tracking of instrument usage with user-settable limits and feedback messages. Electronic records of maintenance and errors.	
Housing	All materials recyclable.	

Performance Specifications (G7137A)

Table 7 Performance Specifications G7137A

Type	Specification	Comments
Injection range	Default 0.1 – 20 μ L in 0.1 μ L increments optional: 40 μ L or 100 μ L (using optional 100 μ L analytical head)	Up to 1300 bar using the 40 μ L (default) or optional 100 μ L analytical head
	0.1 – 500 μ L or 1500 μ L in 0.1 increments with 100 μ L upgrade kit (hardware modification required G7137-68711)	Pressure range up to 1300 bar Multidraw mode (injection into needle-seat capillary)
Injection precision	< 0.15 % RSD or SD < 10 nL, whatever is greater	Measured caffeine
Injection linearity	> 0.9999	Measured caffeine
Pressure range	Up to 1300 bar	Max pressure for basic instrument.
Sample viscosity range	0.2 – 5.0 cP	
Sample capacity	<i>1H Drawer</i> up to 8 drawers and 16 positions shallow well plates (MTP)	Max. 6144/1536 samples (384 MTP/96)
	<i>2H Drawer</i> up to 4 drawers and 8 positions MTP, deep well plates, vials, Eppendorf	3072 samples, 432 vials (2)
	<i>3H Drawer</i> up to 2 drawers and 4 positions MTP, deep well plates, vials up to 6 mL, Eppendorf	1536 samples, 60 vials (6), 384 vials (1 mL), 216 vials (2 mL)
Injection cycle time	< 10 s using following standard conditions: Default draw speed: 100 μ L/min Default eject speed: 400 μ L/min Injection volume: 1 μ L	Time between 2 injections is not mechanically limited, time delay depends on communication speed of software, OS or network connections
pH Range	pH 1 – 12.5, short term pH 13 (for flushing)	
Carryover	< 0.003 % (30 ppm) Multisampler Standard < 0.0009 % (9 ppm) Multisampler Multiwash	Sample: Chlorhexidine
Multiwash	Outer needle wash and seat backflush for carryover reduction with up to 3 different solvents	
Materials in the flow path	MP35N, Gold, PEEK, UHMW-PE	

Table 7 Performance Specifications G7137A

Type	Specification	Comments
Instrument control	LC & CE Drivers Rev. 3.3 or above Instrument Control Framework (ICF) A.02.03 or above, available in emulation mode LC Instrument Firmware Rev. D.07.33 or above Lab Advisor B.02.16 or above	For details about supported software versions refer to the compatibility matrix of your version of the LC & CE Drivers
Communication	Controller Area Network (CAN), Local Area Network (LAN), ERI: ready, start, stop and shut-down signals	
Maintenance and safety-related features	Extensive diagnostics, error detection and display with Agilent Lab Advisor software. Leak detection, safe leak handling, leak output signal for shutdown of pumping system, and low voltages in major maintenance areas.	
GLP features	Early maintenance feedback (EMF) for continuous tracking of instrument usage with user-settable limits and feedback messages. Electronic records of maintenance and errors.	
Housing	All materials recyclable	

Performance Specifications G5668A

Table 8 Performance Specifications G5668A

Type	Specification	Comments
Injection range	Default: 0.1 – 100 µL in 0.1 µL increments	Up to 600 bar using the 100 µL analytical head
	0.1 – 250 µL or 1000 µL in 0.1 µL increments with Multidraw upgrade kit (Bio-inert) (G5667-68711) (hardware modification required)	Pressure range up to 275 bar Multidraw mode, depending on solvent used (Injection into needle seat capillary)
Injection precision	<0.15 % RSD or SD <10 nL, whatever is greater	Measured caffeine
Injection linearity	0.9999 in the range of 0.1 – 100 µL	Measured caffeine
Pressure range	Up to 600 bar	Max pressure for basic instrument
Sample viscosity range	0.2 – 5.0 cP	
Sample capacity	1H Drawer up to 8 drawers and 16 positions Shallow well plates (MTP)	Max. 6144/1536 samples (384MTP/96)
	2H Drawer up to 4 drawers and 8 positions MTP, deep well plates, vials, Eppendorf	3072 samples, 432 vials (2 mL)
	3H Drawer up to 2 drawers and 4 positions MTP, deep well plates, vials up to 6 mL, Eppendorf	1536 samples, 60 vials (6 mL), 384 vials (1 mL), 216 vials (2 mL)
Injection cycle time	<10 s using following standard conditions: Default draw speed: 100 µL/min Default eject speed: 400 µL/min Injection volume: 1 µL	Time between 2 injections is not mechanically limited, time delay depends on communication speed of software, OS or network connections
Carryover	<0.003 % (30 ppm) Multisampler Standard <0.0009 % (9 ppm) Multisampler Multiwash	Sample: Chlorhexidine
Multiwash	Outer needle wash and seat backflush for carryover reduction with up to 3 different solvents	
Instrument Control	LC and CE Drivers A.02.14 or above Instrument Control Framework (ICF) A.02.04 or above Instant Pilot (G4208) with firmware B.02.20 or above Lab Advisor B.02.08 or above	For details about supported software versions refer to the compatibility matrix of your version of the LC and CE Drivers
Communication	Controller Area Network (CAN), Local Area Network (LAN), ERI: ready, start, stop and shut-down signals	

Table 8 Performance Specifications G5668A

Type	Specification	Comments
Maintenance and safety-related features	Extensive diagnostics, error detection and display with Agilent Lab Advisor software Leak detection, safe leak handling, leak output signal for shutdown of pumping system, and low voltages in major maintenance areas	
GLP features	Early maintenance feedback (EMF) for continuous tracking of instrument usage with user-settable limits and feedback messages. Electronic records of maintenance and errors.	
Housing	All materials recyclable.	

Specifications of the Sample Cooler

The Agilent Infinity II Sample Cooler is a vapor-compression refrigeration system that uses a fluorinated greenhouse gas (HCF-134a) as the refrigerant. For information on carbon dioxide equivalency (CDE) and global warming potential (GWP), see the instrument label.

Table 9 Physical Specification of the Sample Cooler

Type	Specification	Comment
Weight	< 6 kg (< 13.2 lbs)	
Dimensions (height × width × depth)	205 × 340 × 370 mm (8.1 × 13.4 × 14.6 inches)	
Refrigerant gas	HFC-134a (0.042 kg)	Ozone depletion potential (ODP) = 0
Supply voltage	24 VDC	
Current	10 A max.	
Ambient operating temperature	4 – 40 ° C (39 – 104 ° F)	
Ambient non-operating temperature	-40 – 70 ° C (-40 – 158 ° F)	
Humidity	< 95 % r.h. at 40 ° C (104 ° F)	Non-condensing
Operating altitude	Up to 3000 m (9842 ft)	
Safety standards: IEC, EN, CSA, UL	Installation category II, Pollution degree 2	For indoor use only
ISM Classification	ISM Group 1 Class B	According to CISPR 11

CAUTION

General hazards and improper disposal

Improper disposal of the media and components used pollutes the environment.

- ✓ The disposal or scrapping of the Sample Cooler or the Sample Thermostat must be carried out by a qualified disposal company.
- ✓ All media must be disposed of in accordance with national and local regulations.
- ✓ Please contact your local Agilent Service Center in regard to safe environmental disposal of the appliance or check www.agilent.com for more info.

Table 10 Performance Specifications of the Sample Cooler

Type	Specifications
Operating principle	High performance, low-energy consumption micro-compressor based cooler with ozone-friendly HFC-134a coolant (42 g), user-upgradable.
Temperature range	from 4 °C to 5 °C below ambient
Temperature settable	from 4 – 40 °C in 1 ° increments
Temperature accuracy (<25 °C, <50 % r.H.)	2 °C to 6 °C at a setpoint of 4 °C

NOTE

The Agilent Infinity II Sample Cooler is not available for trade sales anymore and has been replaced by the Agilent InfinityLab Sample Thermostat.

Specifications of the Sample Thermostat

The Agilent InfinityLab Sample Thermostat is the combination of an electric heater and a vapor-compression refrigeration system. It uses isobutane as a non-Freon refrigerant, which is harmless to the environment and does not affect the ozone layer and global warming, but it is combustible. Please adhere to the warnings listed in the manual.

Table 11 Physical Specifications of the Sample Thermostat (G7167-60101 and G7167-60201)

Type	Specification	Comments
Weight	<6 kg (< 13.2 lbs)	
Dimensions (height x width x depth)	205 x 340 x 370 mm (8.1 x 13.4 x 14.6 inches)	
Refrigerant gas	R600a (max. 0.030 kg)	Ozone depletion potential (ODP) =0 Global warming potential (GWP) =3
Supply voltage	24VDC	
Current	10 A max.	
Ambient operating temperature	4 °C to 40 °C (39 °F to 104 °F)	For sample cooling, ambient temperature ≥10 °C
Ambient non-operating temperature	-40 °C to +70 °C (-40 °F to +158 °F)	
Humidity	< 95 % r.h. at 40 °C (104 °F)	Non-condensing
Operating altitude	Up to 3000 m (9842 ft)	
Safety standards: IEC, EN, CSA, UL	Pollution degree 2	For indoor use only
ISM Classification	ISM Group 1 Class B	According to CISPR 11

CAUTION

General hazards and improper disposal

Improper disposal of the media and components used pollutes the environment.

- ✓ The disposal or scrapping of the Sample Cooler or the Sample Thermostat must be carried out by a qualified disposal company.
- ✓ All media must be disposed of in accordance with national and local regulations.
- ✓ Please contact your local Agilent Service Center in regard to safe environmental disposal of the appliance or check www.agilent.com for more info.

Table 12 Performance Specifications for the Sample Thermostat (G7167-60101 and G7167-60201)

Type	Specifications
Operating principle	High performance, low-energy consumption micro-compressor based cooler with natural R600a coolant (Isobutane max. 0.030 kg), user-upgradable
Temperature range	from 4 °C to 40 °C
Temperature settable	from 4 °C to 40 °C in 1 ° increments
Temperature accuracy (<25 °C, <50 % r.H.)	2 °C to 6 °C at a setpoint of 4 °C

Table 13 Minimum System Requirements for the G7167-60101 Sample Thermostat

Type	Specification
LC & CE Drivers	A.02.14, (A.02.18) ¹ or above
Instrument Control Framework (ICF)	A.02.04, (A.02.05) ¹ or above
Lab Advisor Software	B.02.11 or above
Firmware	D.07.22 or above

¹ Minimum version for full thermostat functionality.

Site Requirements and Specifications

Specifications of the Sample Thermostat

Table 14 Minimum System Requirements for the G7167-60201 Sample Thermostat

Type	Specification
LC & CE Drivers	A.02.14, (A.02.18) ¹ or above
Instrument Control Framework (ICF)	A.02.04, (A.02.05) ¹ or above
Lab Advisor Software	2.19 or above
Firmware	D.07.37 or above

¹ Minimum version for full thermostat functionality.

3 Using the Module

Magnets	68
Turn on/off	69
Status indicators	71
Drawer Status Indicator	72
Insert vial trays/wellplates	73
Remove vial trays/wellplates	74
Installing the Optional Sample Cooler/Thermostat	75
Unpacking the Unit	75
Install the Sample Cooler/Sample Thermostat	76
Using the Optional Sample Cooler/Sample Thermostat	85
Dashboard	86
Control Interface	87
Control	88
Temperature Mode	90
Online Signal Monitor	91
Reporting Sample Temperature	92
Operation Information	93
Transporting the Sampler	95
Prepare a Sampler Without Cooler/Thermostat for Transportation	95
Prepare a Sampler with Cooler/Thermostat for Transportation	96
Install the Transport Protection Foam	98
Solvent Information	100
Materials used in the 1260 Infinity II Bio-inert System	102
Materials used in the 1290 Infinity II Bio LC System	104
Material Information	106
Reset the Multisampler in Case of an Error	112
Agilent Local Control Modules	115

This chapter explains the essential operational parameters of the module.

Magnets

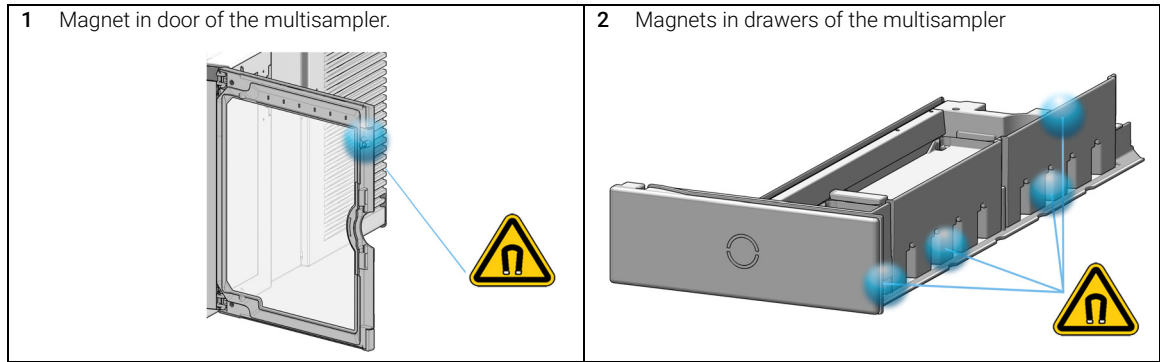

Turn on/off

This procedure exemplarily shows an arbitrary LC stack configuration.

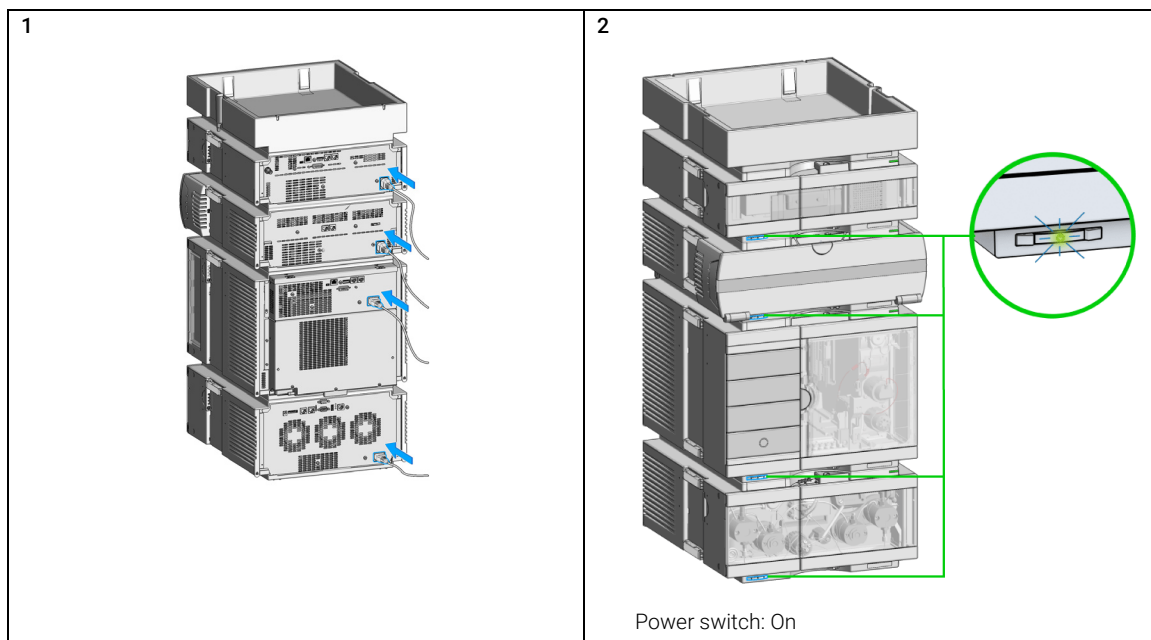

Using the Module

Turn on/off

3 Turn instrument **On/Off** with the control software.

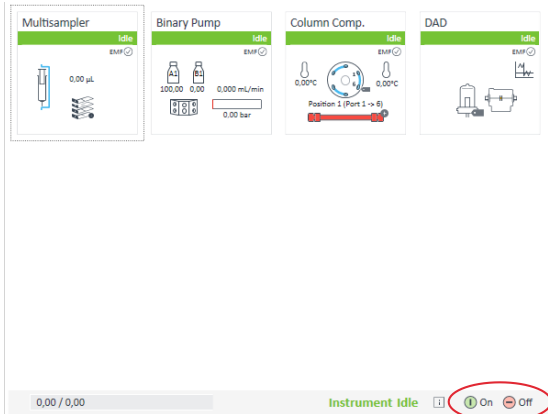

4

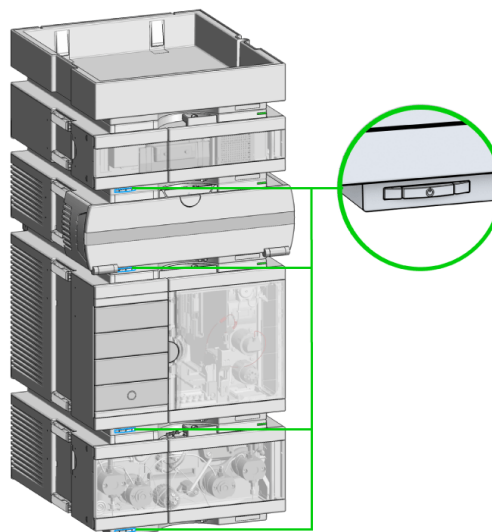

Power switch: Off

5

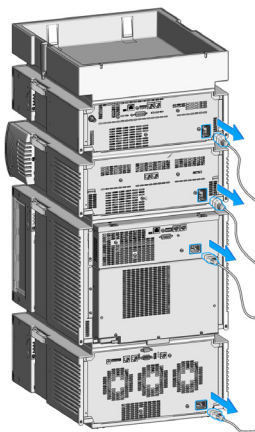

Status indicators

This procedure exemplarily shows an arbitrary LC stack configuration.

- 1 The module status indicator indicates one of six possible module conditions:

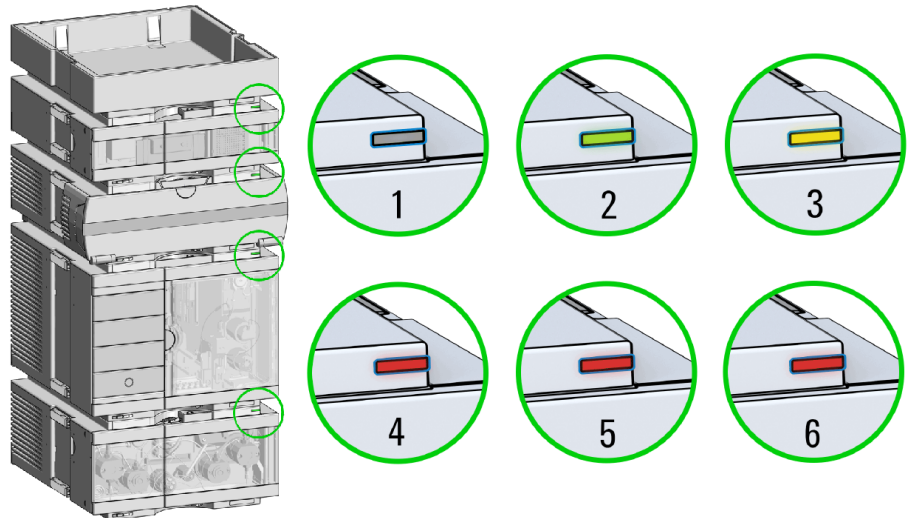

Status indicators

1. Idle
2. Run mode
3. Not-ready. Waiting for a specific pre-run condition to be reached or completed.
4. Error mode - interrupts the analysis and requires attention (for example, a leak or defective internal components).
5. Resident mode (blinking) - for example, during update of main firmware.
6. Bootloader mode (fast blinking). Try to re-boot the module or try a cold-start. Then try a firmware update.

Drawer Status Indicator

The module status indicator indicates one of three possible module conditions:

- When the status indicator is *OFF* no sample containers are loaded.
- When the upper, lower or both semi circle status indicators are *ON*, indicates the rear or front position of the drawer or both positions are loaded with a sample containers.
- When semi circle indicators are *blinking* the robot interacts with a drawer.

NOTE

Do not open the drawers when the drawer status indicator is blinking.

Drawer status indicator

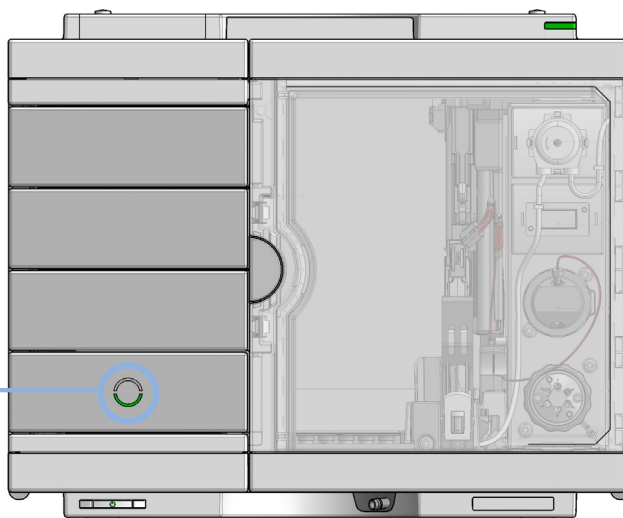

Insert vial trays/wellplates

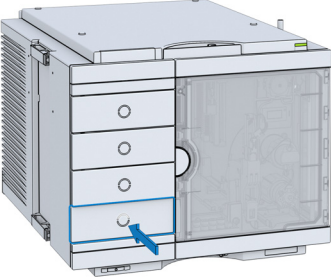
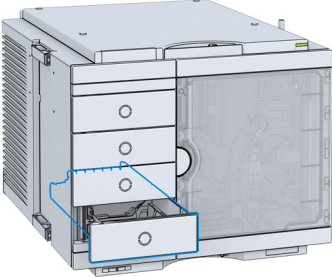
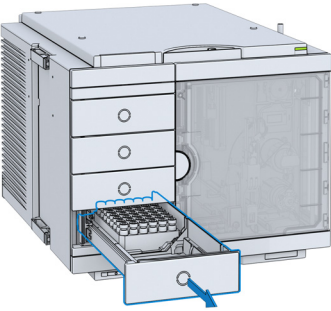
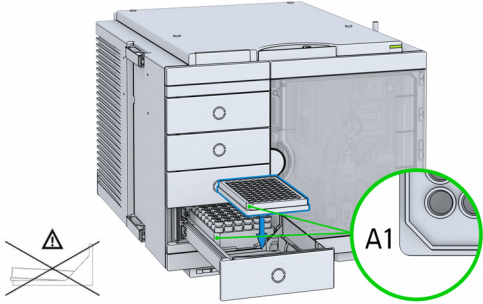
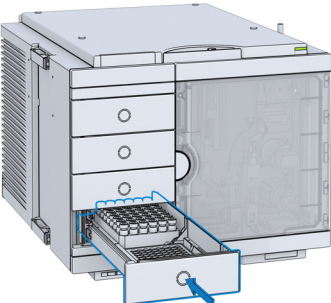
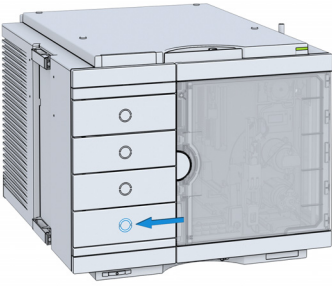
<p>1</p> 	<p>2</p> 
<p>3</p> 	<p>4 Check the orientation of the vial tray/wellplates and ensure correct seat by pressing down the plate. When the lever sensor has detected the plate correctly the front LED lights up and the device recognizes the assignment.</p> 
<p>5</p> 	<p>6</p> 
<p>7 Configure the vial tray/wellplate type in the chromatographic data system (see Table 29 on page 141).</p>	

Remove vial trays/wellplates

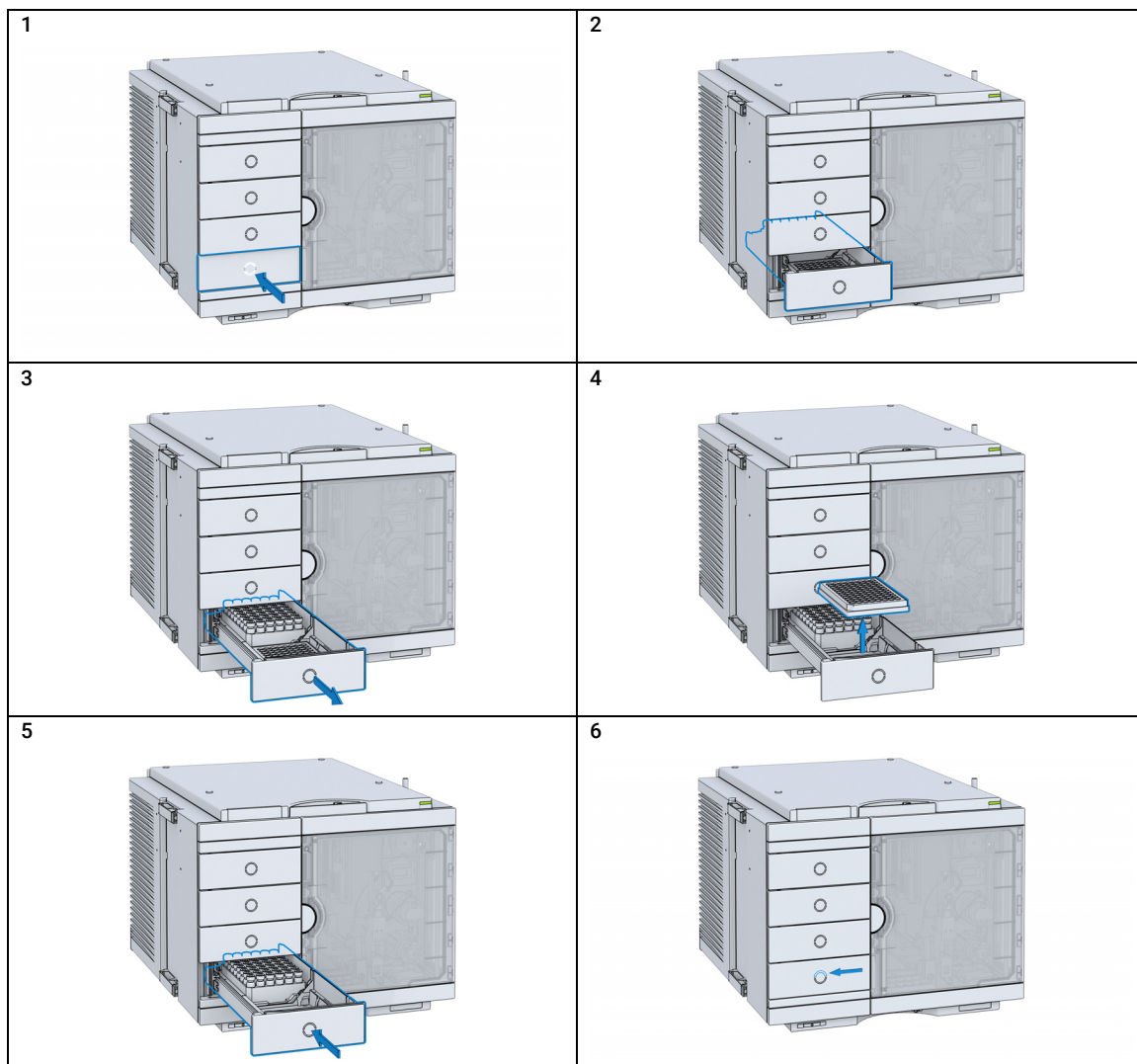

Installing the Optional Sample Cooler/Thermostat

Unpacking the Unit

Damaged Packaging

If the delivery packaging shows signs of external damage, please call your Agilent Technologies sales and service office immediately. Inform your service representative that the instrument may have been damaged during shipment.

CAUTION

"Defective on arrival" problems

If there are signs of damage, please do not attempt to install the module. Inspection by Agilent is required to evaluate if the instrument is in good condition or damaged.

- ✓ **Notify your Agilent sales and service office about the damage.**
- ✓ **An Agilent service representative will inspect the instrument at your site and initiate appropriate actions.**

Delivery Checklist

Ensure that all parts and materials have been delivered with your module. The delivery checklist is shown below. For parts identification, please check the illustrated parts breakdown in "Sample Thermostat" on page 338. Please report any missing or damaged parts to your local Agilent Technologies sales and service office.

Table 15 Delivery checklist for the Sample Thermostat

Description	Quantity
Sample Thermostat (G7167-60201)	1
Condensate Drainage Kit (5067-6208)	1
Declaration of Conformity	1
Customer Letter	1

NOTE

The Agilent Infinity II Sample Cooler is not available for trade sales anymore and has been replaced by the Agilent InfinityLab Sample Thermostat.

Install the Sample Cooler/Sample Thermostat

Tools required	p/n	Description
	8710-0899 📄	Screwdriver Pozidrive Shaft (for the Sample Cooler)
	5182-3466 📄	Torx screwdriver T10 (for the Sample Thermostat)
OR	5023-3089 📄	Torx key set (part of the G7120-68708 InfinityLab LC Series Tool Kit)

Parts required	#	p/n	Description
	1		Multisampler
	1	G7167-60005 📄	Sample Cooler
OR	1	G7167-60101 📄	Sample Thermostat
OR	1	G7167-60201 📄	Sample Thermostat
	1		Power cord
	1	5067-6208 📄	Condensate Drainage Kit

Preparations

- The hosting sampler is installed in the HPLC stack.
- If needed, update the firmware of the hosting sampler to ensure that it supports the type of thermostat you are about to install, see "Specifications of the Sample Thermostat" on page 64.

NOTE

Visit <https://www.agilent.com/> for a video tutorial on installing the Agilent InfinityLab Sample Thermostat. Find the video by the following options:

- Enter the link <https://www.agilent.com/search/?Ntt=install-infinitylab-sample-thermostat>.
- Alternatively, the video is available on the landing page of any compatible Agilent Infinity II autosampler under the section **Videos**.

WARNING

Flammable refrigerant

Formation of flammable gas-air mixtures inside the Sample Thermostat and laboratory.

- ✓ Keep open fire or sources of ignition away from the device.
- ✓ Ensure a room size of 4 m³ (1 m³ for every 8 g of R600a refrigerant inside of the Sample Thermostat).
- ✓ Ensure adequate ventilation: typical air exchange of 25 m³/h per m² of laboratory floor area.
- ✓ Keep all ventilation openings in the enclosure clear of obstructions. Do not block the openings on the circumference of the Sample Thermostat.

WARNING

Flammable refrigerant used

- ✓ When handling, installing and operating the Sample Thermostat, care should be taken to avoid damage to the refrigerant tubing or any part of the Sample Thermostat.

CAUTION

Routing of the condensation tubing

Proper routing of the condensation tubing is critical for correct condensate drainage.

- ✓ Do not place the sampler directly on the bench.

CAUTION

Condensate inside the Sample Cooler/Sample Thermostat

Damage to the electronics of the module

- ✓ After installation of the Sample Cooler/Sample Thermostat, wait at least 30 min before switching on the module.
- ✓ Make sure there is no condensate inside the module.

WARNING

In the event of a damage

- ✓ Keep open fire or sources of ignition away from the device.
- ✓ Ventilate the room for several minutes.
- ✓ Do not use the Sample Thermostat any more.

Using the Module

Installing the Optional Sample Cooler/Thermostat

NOTE

If the sample cooler or thermostat is disconnected from the power supply, you should wait for at least five minutes before replugging and switching on the compressor again.

NOTE

Even under average humidity conditions, a significant amount of condensed water gathers every day. A suitable container must be provided and emptied regularly in order to avoid overflow.

NOTE

For best cooling performance of the thermostat, the 2H drawer must be installed in the lowest position. Use the dummy drawers (G4267-60024) if no full hotel configuration is needed.

NOTE

For the Sample Cooler installation in a sampler, the serial number of the Sample Cooler must be DEBAT02001 or higher.

NOTE

Depending on the ambient conditions in the lab, the amount of condensate can vary from 200 mL to 2 L per day. Do not fill waste containers for the condensate to the top. Regularly empty the waste container.

NOTE

The setup with the condensate collector funnel is suitable for bench installations only. For installations on an InfinityLab Laboratory Instrument Bench, use the alternative installation described in the *Installation of the Infinity II Cooler/Thermostat Condensate Drainage Tubing Kit Technical Note*. Enter the link <https://www.agilent.com/search/?Ntt=Installation-of-the-Infinity-II-Cooler/Thermostat-Condensate-Drainage-Tubing-Kit-Technical-Note> to locate the TechNote on <https://www.agilent.com/>.

Using the Module

Installing the Optional Sample Cooler/Thermostat

- 1 Ensure that the power switch on the front of the module is OFF (switch stands out).

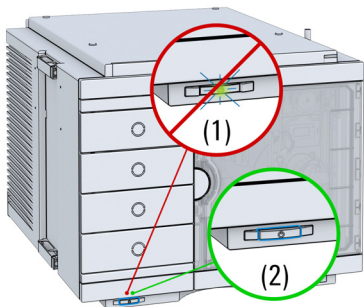

- 2 Disconnect the power cable from the sampler.

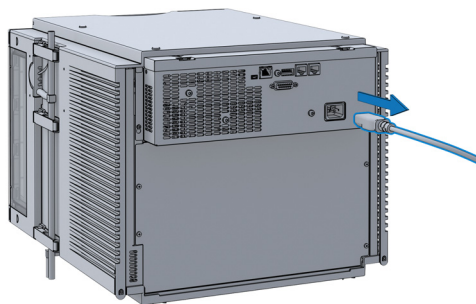

- 3 Loosen the four screws on the rear of the module.



- 4 Remove the sheet metal back cover of the sampler.

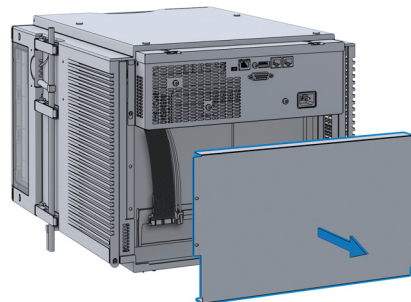

Using the Module

Installing the Optional Sample Cooler/Thermostat

- 5 Slide the Sample Cooler/Sample Thermostat halfway into the sampler.

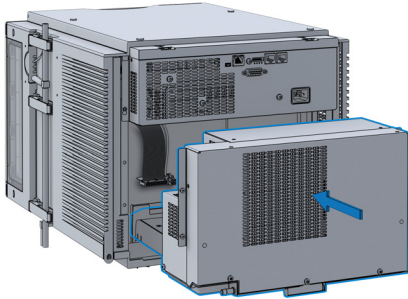

WARNING

Module is partially energized when switched off, as long as the power cord is plugged in. Repair work at the module can lead to personal injuries, e.g. shock hazard, when the cover is opened and the module is connected to power.

- ✓ Make sure that it is always possible to access the power plug.
- ✓ Do not use the Sample Cooler/Sample Thermostat if it is not operating correctly or has been damaged. Disconnect it from the power supply and call your local service center.
- ✓ Remove the power cable from the module before opening the cover.
- ✓ Do not connect the power cable to the module while the covers are removed.
- ✓ If the Sample Cooler/Sample Thermostat is disconnected from the power supply, you should wait for at least five minutes before switching on the compressor.

CAUTION

Damaged electronics

- ✓ To avoid damages of the electronics of the module make sure the power cords are unplugged before disconnecting or reconnecting the sampler to the Sample Cooler/Sample Thermostat cables.

- 6 Connect the power cable and the data cable to the cooler/thermostat.

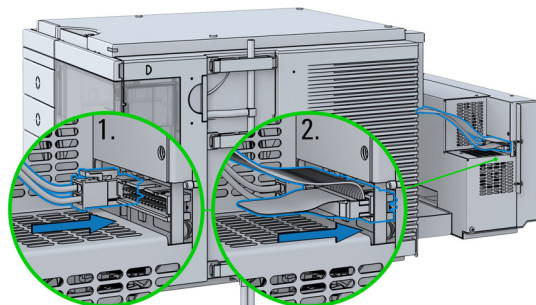

CAUTION

Damage to the cables

- ✓ Do not bend or pinch the cables.
 - ✓ Make sure that the Sample Cooler/Sample Thermostat fits perfectly in the sampler.
- 7 Slide the Sample Cooler/Sample Thermostat all the way into the sampler.

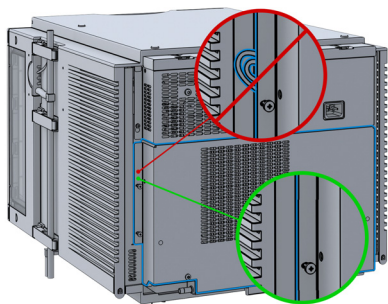

- 8 Fix the Sample Cooler/Sample Thermostat with the four screws.

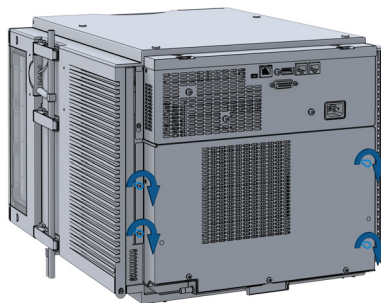

- 9 Use a bubble level to check the leveling of the sampler.

NOTE

To ensure adequate drainage for condensate, the module should be operated in a proper horizontal position.

- 10 Attach the condensate tube to the outlet port of the condensate collector funnel.

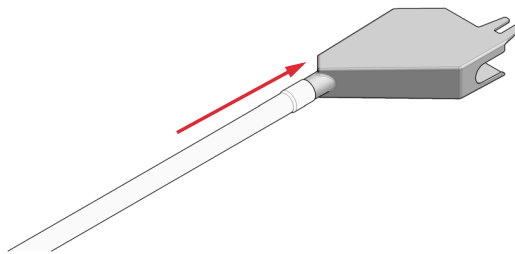

Using the Module

Installing the Optional Sample Cooler/Thermostat

11 Mount the drain connector on the condensate drainage outlet tube. Ensure the correct orientation of the spout.

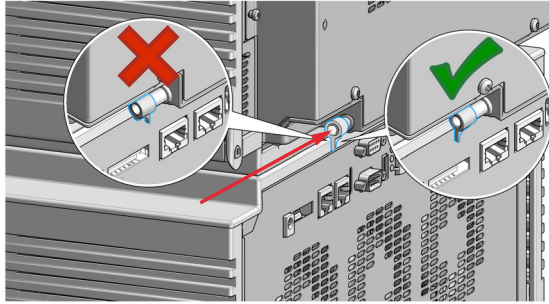

12 Remove the screw situated above the condensate drainage outlet tube.

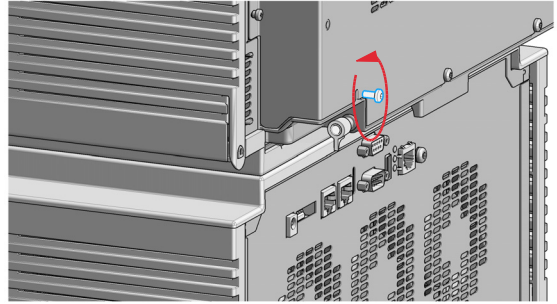

13 Place the washer over the thread of the screw (1). Screw the screw and washer halfway into the hole in the back of the cooler/thermostat (2).

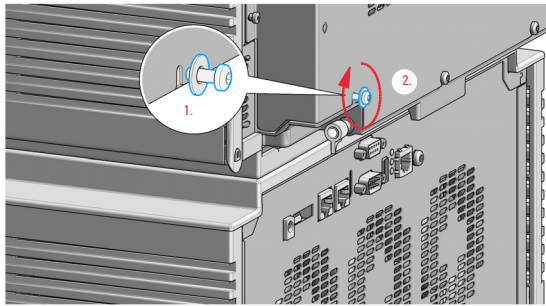

14 Position the condensate collector funnel underneath the condensate drainage outlet tube (1) and fix it to the back of the cooler/thermostat by tightening the screw (2). Ensure correct orientation and avoid overtightening the screw.

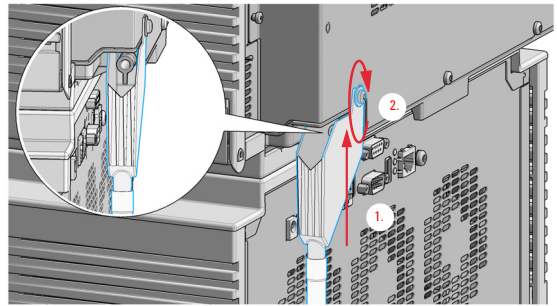

Using the Module

Installing the Optional Sample Cooler/Thermostat

- 15** Shorten the condensate tube so that it runs straight into the waste container without any unnecessary detour (1). If needed, use the 90° tubing connector provided in the kit to eliminate uphill sections, which might occur at the edge of the bench (2). Agilent recommends the use of a separate canister for condensate collection to avoid drainage problems (3).

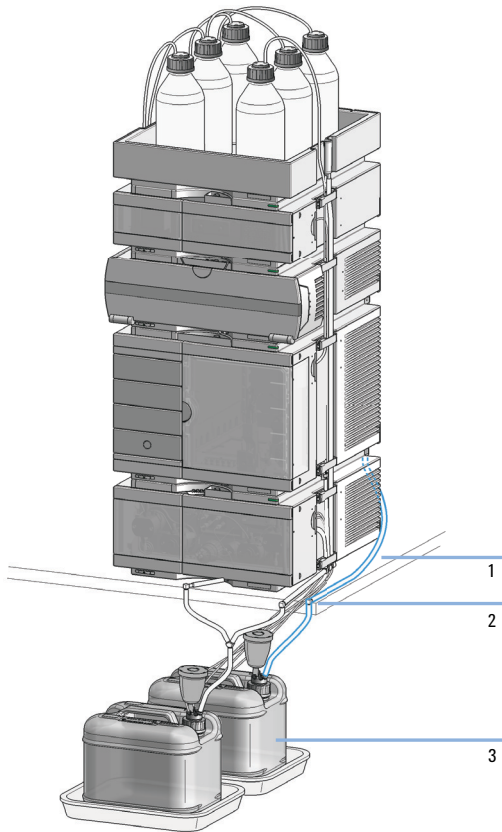

- 16** Ensure that the tubing runs straight into the waste canister without any bends or joints and it is not hindered by any mechanical obstacle. Agilent recommends using a 6 L waste canister equipped with a suitable InfinityLab Stay Safe cap for optimal condensate handling. If you decide to use your own waste solution, make sure that the tubes don't immerse in the liquid.

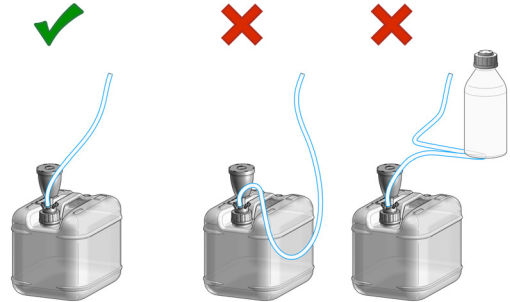

NOTE

For more information, see "Leak and Waste Handling" on page 37.

NOTE

Depending on the ambient conditions in the lab, the amount of condensate can vary from 200 mL to 2 L per day. Do not fill the waste container for the condensate to the top. Regularly empty the waste container.

CAUTION**Damage to the Sample Cooler/Sample Thermostat**

- ✓ Wait at least 30 min before switching on the compressor of the cooler/thermostat.
 - ✓ This allows the refrigerant and system lubrication to reach equilibrium.
- 17 Connect the power cable to the power connector at the rear of the module.

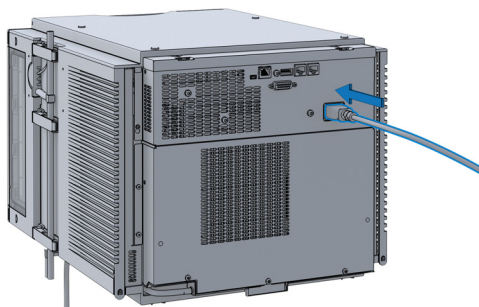

- 18 Configure the Sample Cooler/Sample Thermostat in the CDS.

Using the Optional Sample Cooler/Sample Thermostat

The following section describes how to operate the Agilent Infinity II Sample Cooler and the Agilent InfinityLab Sample Thermostat using the Multisampler as an example for the hosting sampler. The operation principle is the same for any other Infinity II sampler type.

Dashboard

The status indicator of the Sample Cooler/Sample Thermostat is incorporated in the graphical user interface (GUI) of the hosting sampler, which appears automatically when the unit is configured in the chromatography data system (CDS). When the cooler/thermostat is turned on, the set temperature and the actual temperature are also displayed.

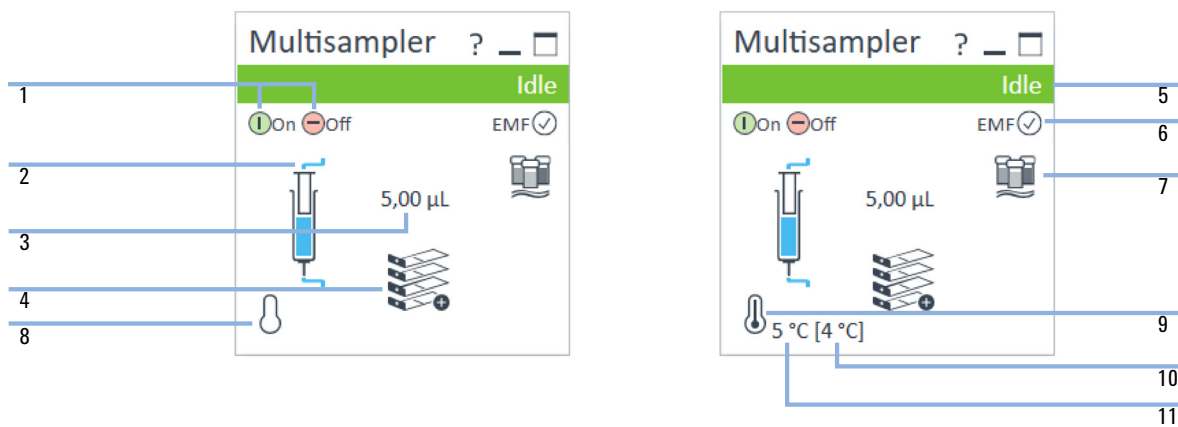

1	Sampler: Turn On/Off
2	Sampler: Analytical head configuration
3	Sampler: Injection volume
4	Sampler: Hotel configuration
5	Sampler: Status indicator
6	Sampler: Early Maintenance Feedback (EMF) status
7	Sampler: Multiwash installed
8	Cooler/Thermostat: Status indicator (Off)
9	Cooler/Thermostat: Status indicator (On)
10	Cooler/Thermostat: Set temperature
11	Cooler/Thermostat: Actual temperature

NOTE

The actual temperature may deviate from the set temperature by up to 3 °C, depending on the temperature setting and ambient conditions.

NOTE

If the actual temperature differs by more than ± 2 °C from the set temperature, a yellow highlight is visible around the temperature reading. This, however, will not prevent the system from starting a new analysis, unless the **Enable Analysis > Temperature within +/- 2 °C function** is selected.

Control Interface

Right-clicking the sampler GUI will prompt the control interface, where control and method parameters can be edited, configuration modified, and special commands executed.

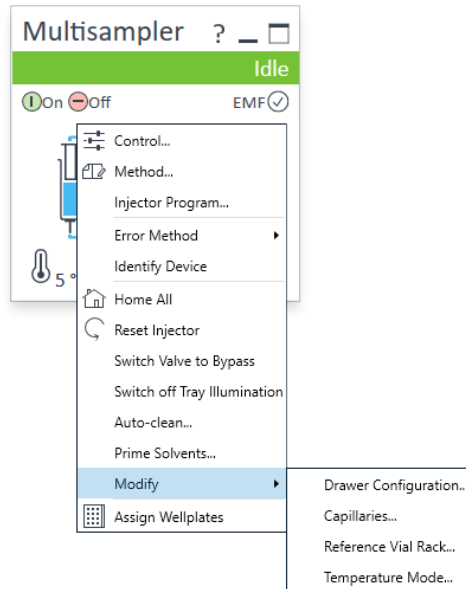

Control

With the Sample Cooler/Sample Thermostat installed, the **Control** dialog box of the hosting Infinity II sampler will include the following cooler/thermostat-specific control options:

- **At Power On:**
 - **Turn On Thermostat:** The cooler/thermostat turns on automatically upon powering on the sampler.
- **Thermostat:**
 - **On:** The cooler/thermostat turns on and the system starts to regulate the temperature inside the sample space towards the setpoint.

NOTE

For the Sample Cooler, the set temperature must be at least 5 °C below ambient for proper temperature control.

- **Off:** The cooler/thermostat turns off.
- **Enable Analysis**

NOTE

The **Enable Analysis** control setting is available since LC & CE drivers A.02.19.

- **With any temperature:** The analysis starts regardless of the actual temperature inside the sampler.
- **Temperature within +/- 2 °C:** The analysis starts only when the actual temperature is within the ± 2 °C range of the setpoint temperature.

NOTE

The **Temperature within +/- 2 °C** option is only available for the Sample Thermostat.

Using the Module

Using the Optional Sample Cooler/Sample Thermostat

The screenshot shows a software dialog box titled "Control" with a standard Windows window border. The dialog is organized into several sections:

- Missing Vessel:** Contains a checkbox labeled "Ignore missing vessel".
- Illumination:** Contains two radio buttons: "On" (selected) and "Off".
- At Power On:** Contains a checkbox labeled "Turn on Thermostat".
- Thermostat:** Contains two radio buttons: "On" (selected) and "Off". Next to the "On" radio button is a temperature input field showing "4" and a degree Celsius symbol.
- Automatic Turn On:** Contains a checkbox labeled "Turn on at" and a date/time dropdown menu showing "Wednesday, 30 October 2019 02:00:00".
- Pump connected to Sampler:** Contains a dropdown menu showing "not linked".
- Clear Workspace:** Contains a dropdown menu showing "At End of Analysis".
- Enable Analysis:** Contains two radio buttons: "With any temperature" (selected) and "Temperature within +/- 2 degrees Celsius".

At the bottom right of the dialog are three buttons: "Ok", "Cancel", and "Help".

Temperature Mode

Selecting **Modify >Temperature Mode** in the **Control Interface** will prompt a dialog box, where the temperature control mode can be switched between being a method parameter or a system (control) setting:

- **Constant Temperature Mode:** The temperature control mode is defined as a system (control) setting, meaning that the temperature setting is independent of the method parameters. The temperature stays constant for all methods within a given sequence. This control mode is the default option and recommended for most applications.
- **Variable Temperature Mode:** The temperature control mode is defined as a method parameter, meaning that the temperature setting is part of the method parameters. The temperature can change from method to method within a given sequence. This control mode is not recommended for most analytical workflows but might be used for some special applications, such as degradation studies.

NOTE

For modifying the temperature mode, LC & CE drivers A.02.12 or higher are required. If the system is run on an earlier driver version, the temperature mode is defined as a system setting.

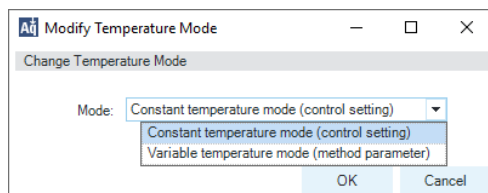

Figure 22 Modify Temperature Mode screen

Before using the **Variable Temperature Mode** setting, here are some hints and tips to consider:

- Changing the temperature setting from one method to another will affect all samples inside the sampler.
- Depending on the extent of the temperature change, it could take up to a couple of hours until the sample temperature stabilizes at the new setpoint (for example, from 4 to 40 °C or vice versa).
- It might be beneficial to use the **Temperature within +/- 2 °C** function; otherwise, the next run will start without waiting for the new setpoint being reached.

Online Signal Monitor

In the **Online Signals** tab of the CDS, the actual temperature of the sample space can be configured and plotted together with the other instrument actuals. This enables the user to have a better overview of how the temperature changes over time.

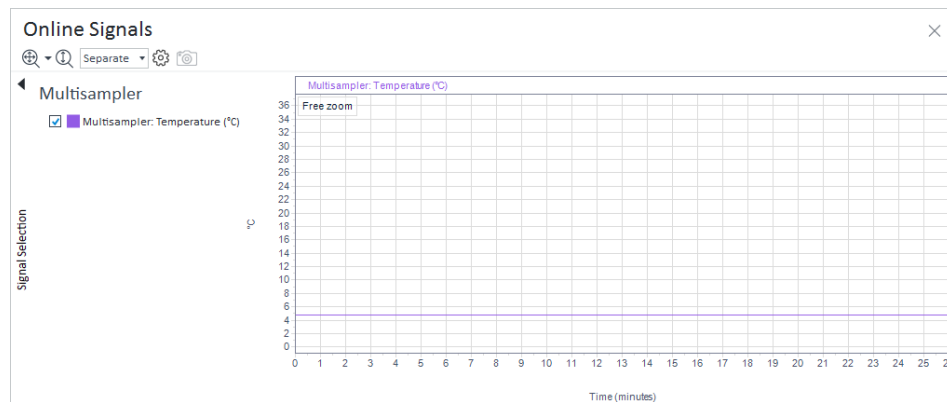

Reporting Sample Temperature

The actual and setpoint temperature can be included in the analysis report. For this, the **Samples >Advanced Run Information** field must be included in the report template.

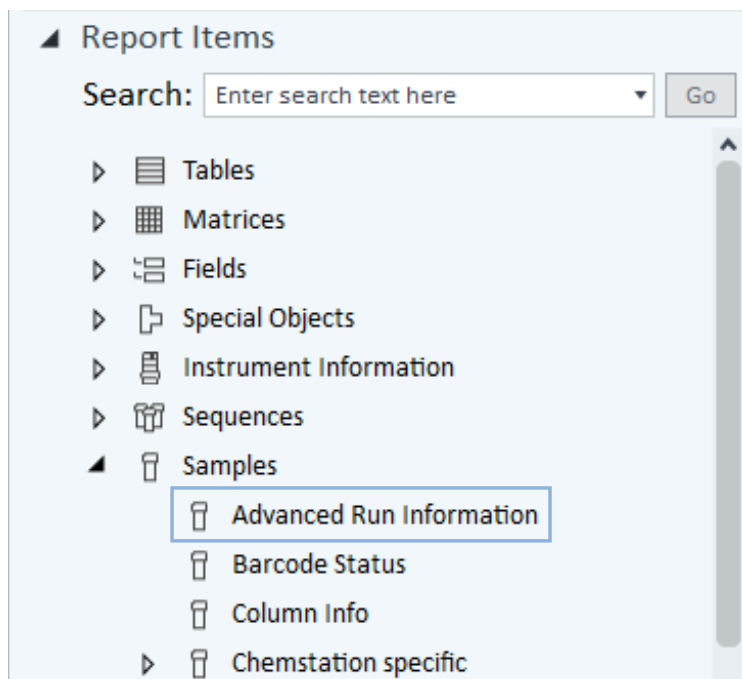

Figure 23 Finding the Advanced Run Information setting in OpenLab CDS 2.4.

Method Events

Module	Name	Value
Sampler	Run start - Temperature	5 °C
Sampler	Run start - Temperature setpoint	4 °C
Sampler	Run stop - Temperature	5 °C
Sampler	Run stop - Temperature setpoint	4 °C

Figure 24 Reporting actual and setpoint temperature using the Advanced Run Information setting.

NOTE

For OpenLab CDS ChemStation, this option is only available in Intelligent Reporting.

Operation Information

Reaching Setpoint Temperature

Depending on the ambient conditions and the sampler configuration (for example, hotel configuration for the Multisampler), reaching the setpoint temperature can take from 30 min up to a couple of hours.

NOTE

Reaching the 4 °C setpoint from an ambient temperature of 22 °C takes about 45 min for the Vialsampler (G7129A/B/C or G7157A), as well as for the Multisampler (G7167A/B, G5668A, G7137A, or G4767A), and the Online Sample Manager (G3167A) with a single 2H drawer installed.

NOTE

This relatively slow ramping down of the temperature is necessary to avoid ice formation.

NOTE

For the best performance of the Sample Cooler/Sample Thermostat, all drawers must be installed in the sampler. For the Multisampler, use dummy drawers if no full hotel configuration is needed.

Condensate Formation

Operating the cooler/thermostat at temperatures below ambient results in condensate formation. This condensed water is collected in the base plate of the cooler/thermostat and drained through the drainpipe at the back of the unit. The container for condensate collection should be regularly emptied to ensure the proper functioning of the system.

NOTE

If the container is overfilled or the condensate tubing is blocked, the condensate sensor is triggered, rendering the HPLC system to enter the error state (see [“Sample temperature control switched off due to condensate”](#) on page 203).

NOTE

Depending on the ambient conditions in the lab, the amount of condensate can vary from 200 mL to 2 L per day. Waste containers for the condensate should not be filled to the top. The waste container must be emptied regularly.

Dew Formation

Setting the cooler/thermostat from a lower to a higher temperature setpoint, or just simply turning it off, can result in dew formation on the internal surfaces of the sampler. This is normal and should cease after a couple of hours at the most.

Frequent Door/Drawer Opening

Opening the door(s) and/or the sample drawers frequently can compromise the temperature stability, as fresh warm and humid air will enter each time. In a highly humid environment, this could also lead to the formation of significant amounts of condensate on the internal surfaces of the sampler.

Ice Formation

The Sample Cooler/Sample Thermostat was designed to operate without the risk of icing. In an unlikely event of ice formation, turn off the cooler/thermostat and wait until it defrosts.

NOTE

Do not use mechanical devices or other means to accelerate the defrosting process.

Shutting Down

When the Sample Cooler/Sample Thermostat needs to be turned off for the night or a longer period, the following best practices are recommended:

- Remove all sample containers and/or vials from the sampler.
- Let the system reach the ambient temperature. Opening the door(s) of the sampler facilitates this process.
- Remove any condensate that might appear on the sample drawers or the internal surfaces of the sampler.
- Make sure that all condensate is removed from the cooler/thermostat.

NOTE

Gently tapping on the sides of the sampler facilitates the condensate removal. Tilting the module towards its right back corner is not recommended as it can damage the internal parts.

Transporting the Sampler

Prepare a Sampler Without Cooler/Thermostat for Transportation

When The module needs to be transported or relocated.

WARNING

Heavy weight

The module is heavy.

- ✓ Carry the module at least with 2 people.
- ✓ Avoid back strain or injury by following all precautions for lifting heavy objects.
- ✓ Ensure that the load is as close to your body as possible.
- ✓ Ensure that you can cope with the weight of your load.

CAUTION

Unsecured transportation

Mechanical damage

- ✓ Secure the sampler handler assembly before transporting the sampler.

- 1 Remove all sample containers from the sample hotel.
- 2 Move the robot arm to the park position using Instant Pilot or Lab Advisor, see “[Arm Position](#)” on page 218.
- 3 Turn off the sampler.
- 4 Install all parts of the Transport Protection, see “[Install the Transport Protection Foam](#)” on page 98.

Prepare a Sampler with Cooler/Thermostat for Transportation

When The module needs to be transported or relocated.

WARNING

Heavy weight

The module is heavy.

- ✓ Carry the module at least with 2 people.
- ✓ Avoid back strain or injury by following all precautions for lifting heavy objects.
- ✓ Ensure that the load is as close to your body as possible.
- ✓ Ensure that you can cope with the weight of your load.

CAUTION

Condensate inside the cooler or thermostat

Damage to the electronics

- ✓ Unplug the power cords.
- ✓ Drain off all condensate before dismounting the sample cooler or thermostat.
- ✓ Make sure that there is no condensate left.

CAUTION

Unsecured transportation

Mechanical damage

- ✓ Secure the sampler handler assembly before transporting the sampler.

NOTE

Moving the sampler with the Sample Cooler/Sample Thermostat installed is possible for short distances (for example, from one workbench to another). For longer transportation, remove the cooler/thermostat from the sampler and handle the units separately.

Using the Module

Transporting the Sampler

- 1 Remove condensate.
 - a Place a suitable container underneath the outlet pipe.
 - b Remove the drainage tube.
 - c Gently tap the sides of the sampler several times to facilitate the drainage of the condensate from the system.

NOTE

Do not tilt the module to avoid damage to the internal parts.

- 2 Remove all sample containers from the sample hotel.
- 3 Move the robot arm to the park position using Instant Pilot or Lab Advisor, see [“Arm Position”](#) on page 218.
- 4 Turn off the sampler.
- 5 Install all parts of the Transport Protection, see [“Install the Transport Protection Foam”](#) on page 98.
- 6 Remove the Sample Cooler/Sample Thermostat from the sampler if needed, see [“Replace the Sample Cooler/Sample Thermostat”](#) on page 293.

Install the Transport Protection Foam

When To secure the transport arm before transporting or shipping the sampler.

Parts required	p/n	Description
	G4267-40033 	Transport Protection

Preparations

- All sample containers are removed from the sample hotel.
- Module is switched off.

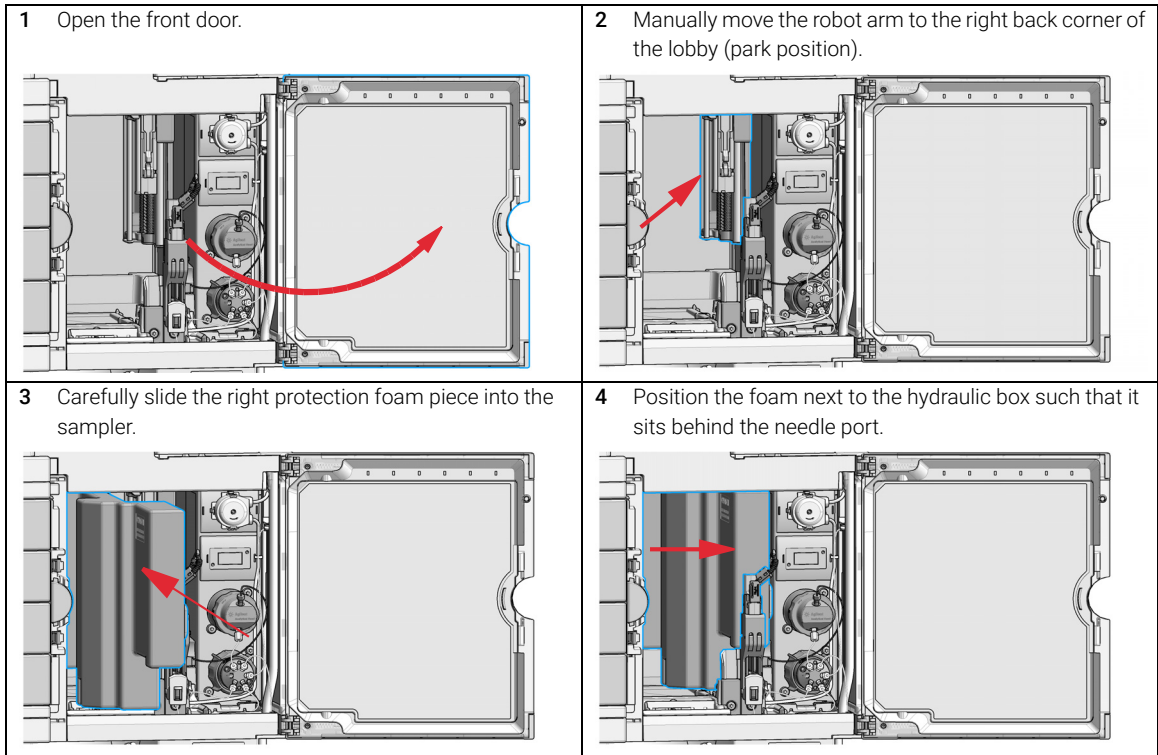

3

Using the Module Transporting the Sampler

5 Slide the left protection foam piece into the sampler.

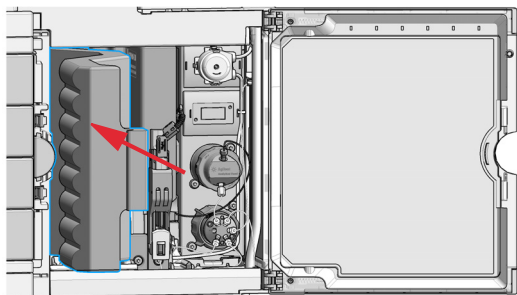

6 Firmly push it into place until it snaps in behind the hotel support frame.

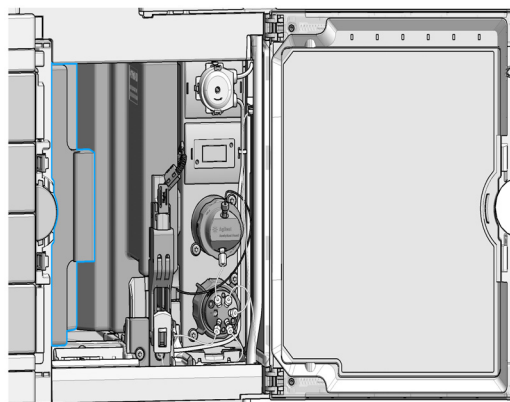

7 Place the protection foam of the hydraulic box in a way that it snaps onto the analytical head.

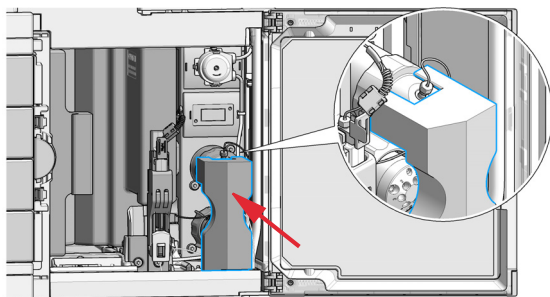

8 Verify that all three protection foams are in the correct position.

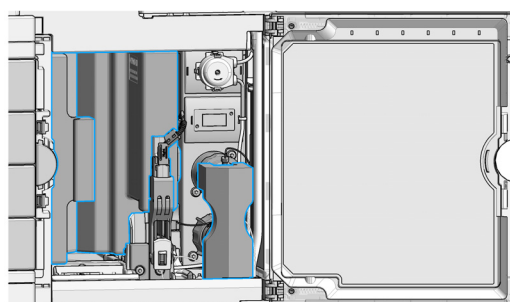

9 Close the front door.

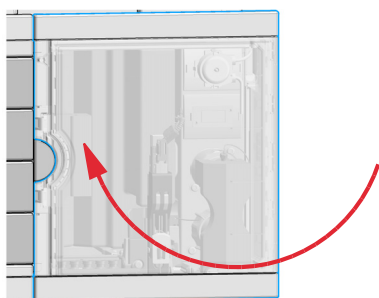

Solvent Information

Observe the following recommendations on the use of solvents.

- Follow the recommendations for avoiding the growth of algae, see the pump manuals.
- Small particles can permanently block capillaries and valves. Therefore, always filter solvents through 0.22 µm filters.
- Avoid or minimize the use of solvents that may corrode parts in the flow path. Consider specifications for the pH range given for different materials such as flow cells, valve materials etc. and recommendations in subsequent sections.

Recommended Wash Solvents

- water
- ethanol
- methanol
- water/acid (especially for basic compounds)
- water/base (especially for acidic compounds)
- water/acetonitrile

NOTE

For different wash solvents as mentioned above, verify that the wash solvent is suitable for the silicone wash tubing.

Solvent Compatibility of Tubings for Peristaltic Pumps

The table shows the chemical resistance properties of Silicone and PharMed tubing to different needle wash solvents:

Table 16 Solvent Compatibility of Silicone and PharMed Tubing

	Silicone	PharMed
Acids		
• weak	• good	• very good
• medium	• unsatisfactory	• good
• strong	• not recommended	• not recommended
Alkaline solution		
• weak	• good	• very good
• medium	• unsatisfactory	• very good
• strong	• not recommended	• good
Hydrocarbons		
• aliphatic		•not recommended
• aromatised		•not recommended
• halogenated		•not recommended

Materials used in the 1260 Infinity II Bio-inert System

For the Bio-inert LC system, Agilent Technologies uses highest-quality materials in the flow path (also referred to as wetted parts), which are widely accepted by life science scientists, as they are known for optimum inertness to biological samples and ensure best compatibility with common samples and solvents over a wide pH range. Explicitly, the complete flow path is free of stainless steel and free of other alloys containing metals such as iron, nickel, cobalt, chromium, molybdenum, or copper, which can interfere with biological samples. The flow downstream of the sample introduction contains no metals whatsoever.

Table 17 Used Bio-inert materials

Module	Materials
Agilent 1260 Infinity II Bio-inert Pump (G5654A)	Titanium, gold, platinum-iridium, ceramic, ruby, PTFE, PEEK
Agilent 1260 Infinity II Bio-inert Multisampler (G5668A)	Upstream of sample introduction: <ul style="list-style-type: none"> • Titanium, gold, PTFE, PEEK, ceramic Downstream of sample introduction: <ul style="list-style-type: none"> • PEEK, ceramic
Agilent 1260 Infinity II Bio-inert Manual Injector (G5628A)	PEEK, ceramic
Agilent 1260 Infinity II Bio-inert Analytical Fraction Collector (G5664B)	PEEK, ceramic, PTFE
Bio-inert Flow Cells:	
Standard flow cell bio-inert, 10 mm, 13 μ L, 120 bar (12 MPa) for MWD/DAD, includes 0890-1763 – 0.18 x 1500 mm PEEK capillary and 5063-6591 – PEEK fittings (G5615-60022) (for Agilent 1260 Infinity II DAD G7115A, and MWD G7165A)	PEEK, ceramic, sapphire, PTFE
Bio-inert flow cell, 8 μ L, 20 bar (pH 1–12), includes and PEEK fittings (G5615-60005) (for Agilent 1260 Infinity II FLD G7121A/B)	PEEK, fused silica, PTFE
Bio-inert Heat Exchangers, Valves and Capillaries:	
Quick Connect Heat Exchanger Bio-inert (G7116-60041) (for Agilent 1260 Infinity II Multicolumn Thermostat G7116A)	PEEK (steel-cladded)
Bio-inert Valve heads (G4235A, G5631A, G5632A, G5639A)	PEEK, ceramic (Al ₂ O ₃ based)
Bio-inert Connection capillaries	Upstream of sample introduction: <ul style="list-style-type: none"> • Titanium Downstream of sample introduction: <ul style="list-style-type: none"> • Agilent uses stainless-steel-cladded PEEK capillaries, which keep the flow path free of steel and provide pressure stability up to 600 bar.

NOTE

To ensure optimum biocompatibility of your Agilent 1260 Infinity II Bio-inert LC system, do not include non-inert standard modules or parts to the flow path. Do not use any parts that are not labeled as Agilent “Bio-inert”. For solvent compatibility of these materials, see “Material Information” on page 106.

Materials used in the 1290 Infinity II Bio LC System

For the 1290 Infinity II Bio LC System, Agilent Technologies uses highest quality materials in the flow path (also referred to as wetted parts). Life scientists accept these materials, as they are known for optimum inertness to biological samples and ensure best compatibility with common samples and solvents over a wide pH range. To enable chromatography at very high pressures, while maintaining inertness the metal alloy MP35N is used instead of stainless steel throughout the system.

The MP35N is a nonmagnetic, nickel-cobalt-chromium-molybdenum alloy with an excellent resistance to sulfation, oxidation, saline solutions, and most mineral acids. Its superior properties guaranty reliable performance, even under UHPLC conditions.

Table 18 Used Bio-compatible materials

Module	Materials
Agilent 1290 Infinity Bio High-Speed Pump (G7132A)	MP35N, gold, ceramic, ruby, PTFE, PEEK, UHMW-PE, tantalum, TFE/PDD copolymer, PFA, FEP, FFKM, ETFE, DLC coated MP35N
Agilent 1290 Infinity Bio Flexible Pump (G7131A)	MP35N, gold, ceramic, ruby, PEEK, UHMW-PE, tantalum, TFE/PDD copolymer, PFA, FEP, titanium, DLC coated MP35N, FFKM, ETFE
Agilent 1290 Infinity Bio Multisampler (G7137A)	Standard: MP35N, gold, DLC coated MP35N, PEEK, UHMW-PE Multi Wash: PEEK, FFKM, titanium, PTFE, PPS, MP35N, gold, DLC coated MP35N, UHMW-PE
Bio-compatible Flow Cells:	
Max-Light Cartridge Cell LSS (10 mm) (G7117-60020) (for Agilent 1290 Infinity II DAD (G7117A/B))	MP35N, fused silica, PEEK
Bio standard flow cell VWD, 10 mm, Cell Vol. 14 µl, Sapphire, MP35N (G1314-60188) (for Agilent 1290 Infinity II VWD (G7114B))	Sapphire, MP35N, FEP
Bio micro flow cell VWD, 3 mm, Cell Vol. 2 µl, Sapphire, MP35N (G1314-60189) (for Agilent 1290 Infinity II VWD (G7114B))	Sapphire, MP35N, FEP
Bio-compatible Heat Exchangers, Valves and Capillaries:	
Quick Connect Bio Heat Exchanger Standard Flow (G7116-60071), Quick Connect Bio Heat Exchanger High Flow (G7116-60081), Quick Connect Bio Heat Exchanger Ultra Low Dispersion (G7116-60091) (for Agilent 1290 Infinity II Multicolumn Thermostat (G7116B))	MP35N
2-position/10-port valve, bio 1300 bar (G5641A)	MP35N coated with DLC, PEEK
12ps/13pt valve, bio-inert (G4235A)	PEEK, ceramic (Al ₂ O ₃ based)
Bio connection capillaries	MP35N

NOTE

To ensure optimum bio-compatibility of your Agilent 1290 Infinity II Bio LC System, do not include non-Bio standard modules or parts to the flow path. Do not use any parts that are not labeled as Agilent "Bio". For solvent compatibility of these materials, see "Material Information" on page 106

Material Information

Materials in the flow path are carefully selected based on Agilent's experiences in developing highest-quality instruments for HPLC analysis over several decades. These materials exhibit excellent robustness under typical HPLC conditions. For any special condition, please consult the material information section or contact Agilent.

Disclaimer

Subsequent data was collected from external resources and is meant as a reference. Agilent cannot guarantee the correctness and completeness of such information. Data is based on compatibility libraries, which are not specific for estimating the long-term life time under specific but highly variable conditions of UHPLC systems, solvents, solvent mixtures, and samples. Information also cannot be generalized due to catalytic effects of impurities like metal ions, complexing agents, oxygen etc. Apart from pure chemical corrosion, other effects like electro corrosion, electrostatic charging (especially for nonconductive organic solvents), swelling of polymer parts etc. need to be considered. Most data available refers to room temperature (typically 20 – 25 °C, 68 – 77 °F). If corrosion is possible, it usually accelerates at higher temperatures. If in doubt, please consult technical literature on chemical compatibility of materials.

MP35N

MP35N is a nonmagnetic, nickel-cobalt-chromium-molybdenum alloy demonstrating excellent corrosion resistance (for example, against nitric and sulfuric acids, sodium hydroxide, and seawater) over a wide range of concentrations and temperatures. In addition, this alloy shows exceptional resistance to high-temperature oxidation. Due to excellent chemical resistance and toughness, the alloy is used in diverse applications: dental products, medical devices, nonmagnetic electrical components, chemical and food processing equipment, marine equipment. Treatment of MP35N alloy samples with 10 % NaCl in HCl (pH 2.0) does not reveal any detectable corrosion. MP35N also demonstrates excellent corrosion resistance in a humid environment. Although the influence of a broad variety of solvents and conditions has been tested, users should keep in mind that multiple factors can affect corrosion rates, such as temperature, concentration, pH, impurities, stress, surface finish, and dissimilar metal contacts.

Polyphenylene Sulfide (PPS)

Polyphenylene sulfide has outstanding stability even at elevated temperatures. It is resistant to dilute solutions of most inorganic acids, but it can be attacked by some organic compounds and oxidizing reagents. Nonoxidizing inorganic acids, such as sulfuric acid and phosphoric acid, have little effect on polyphenylene sulfide, but at high concentrations and temperatures, they can still cause material damage. Nonoxidizing organic chemicals generally have little effect on polyphenylene sulfide stability, but amines, aromatic compounds, and halogenated compounds may cause some swelling and softening over extended periods of time at elevated temperatures. Strong oxidizing acids, such as nitric acid (> 0.1 %), hydrogen halides (> 0.1 %), peroxy acids (> 1 %), or chlorosulfuric acid degrade polyphenylene sulfide. It is not recommended to use polyphenylene sulfide with oxidizing material, such as sodium hypochlorite and hydrogen peroxide. However, under mild environmental conditions, at low concentrations and for short exposure times, polyphenylene sulfide can withstand these chemicals, for example, as ingredients of common disinfectant solutions.

PEEK

PEEK (Polyether-Ether Ketones) combines excellent properties regarding biocompatibility, chemical resistance, mechanical and thermal stability. PEEK is therefore the material of choice for UHPLC and biochemical instrumentation.

It is stable in the specified pH range (for the Bio-Inert LC system: pH 1 – 13, see bio-inert module manuals for details), and inert to many common solvents.

There are still some known incompatibilities with chemicals such as chloroform, methylene chloride, THF, DMSO, strong acids (nitric acid > 10 %, sulfuric acid > 10 %, sulfonic acids, trichloroacetic acid), halogens or aqueous halogen solutions, phenol and derivatives (cresols, salicylic acid, and so on).

When used above room temperature, PEEK is sensitive to bases and various organic solvents, which can cause it to swell. Under such conditions, normal PEEK capillaries are sensitive to high pressure. Therefore, Agilent uses stainless steel clad PEEK capillaries in bio-inert systems. The use of stainless steel clad PEEK capillaries keeps the flow path free of steel and ensures pressure stability up to 600 bar. If in doubt, consult the available literature about the chemical compatibility of PEEK.

Polyimide

Agilent uses semi-crystalline polyimide for rotor seals in valves and needle seats in autosamplers. One supplier of polyimide is DuPont, which brands polyimide as Vespel, which is also used by Agilent.

Polyimide is stable in a pH range between 1 and 10 and in most organic solvents. It is incompatible with concentrated mineral acids (e.g. sulphuric acid), glacial acetic acid, DMSO and THF. It is also degraded by nucleophilic substances like ammonia (e.g. ammonium salts in basic conditions) or acetates.

Polyethylene (PE)

Agilent uses UHMW (ultra-high molecular weight)-PE/PTFE blends for yellow piston and wash seals, which are used in 1290 Infinity pumps, 1290 Infinity II pumps, the G7104C and for normal phase applications in 1260 Infinity pumps.

Polyethylene has a good stability for most common inorganic solvents including acids and bases in a pH range of 1 to 12.5. It is compatible with many organic solvents used in chromatographic systems like methanol, acetonitrile and isopropanol. It has limited stability with aliphatic, aromatic and halogenated hydrocarbons, THF, phenol and derivatives, concentrated acids and bases. For normal phase applications, the maximum pressure should be limited to 200 bar.

Tantalum (Ta)

Tantalum is inert to most common HPLC solvents and almost all acids except fluoric acid and acids with free sulfur trioxide. It can be corroded by strong bases (e.g. hydroxide solutions > 10 %, diethylamine). It is not recommended for the use with fluoric acid and fluorides.

Stainless Steel (SST)

Stainless steel is inert against many common solvents. It is stable in the presence of acids and bases in a pH range of 1 to 12.5. It can be corroded by acids below pH 2.3. It can also corrode in following solvents:

- Solutions of alkali halides, their respective acids (for example, lithium iodide, potassium chloride) and aqueous solutions of halogens.
- High concentrations of inorganic acids like nitric acid, sulfuric acid, and organic solvents especially at higher temperatures (replace, if your chromatography method allows, by phosphoric acid or phosphate buffer, which are less corrosive against stainless steel).
- Halogenated solvents or mixtures, which form radicals and/or acids, for example:

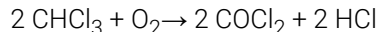

This reaction, in which stainless steel probably acts as a catalyst, occurs quickly with dried chloroform if the drying process removes the stabilizing alcohol.

- Chromatographic grade ethers, which can contain peroxides (for example, THF, dioxane, diisopropyl ether). Such ethers should be filtered through dry aluminum oxide, which adsorbs the peroxides.
- Solutions of organic acids (acetic acid, formic acid, and so on) in organic solvents. For example, a 1 % solution of acetic acid in methanol will attack steel.
- Solutions containing strong complexing agents (for example, EDTA, ethylenediaminetetraacetic acid).
- Mixtures of carbon tetrachloride with isopropanol or THF.

Titanium (Ti)

Titanium is highly resistant to oxidizing acids (for example, nitric, perchloric and hypochlorous acid) over a wide range of concentrations and temperatures. This is due to a thin oxide layer on the surface, which is stabilized by oxidizing compounds. Non-oxidizing acids (for example, hydrochloric, sulfuric and phosphoric acid) can cause slight corrosion, which increases with acid concentration and temperature. For example, the corrosion rate with 3 % HCl (about pH 0.1) at room temperature is about 13 $\mu\text{m}/\text{year}$. At room temperature, titanium is resistant to concentrations of about 5 % sulfuric acid (about pH 0.3). Addition of nitric acid to hydrochloric or sulfuric acids significantly reduces corrosion rates. Titanium is sensitive to acidic metal chlorides like FeCl_3 or CuCl_2 . Titanium is subject to corrosion in anhydrous methanol, which can be avoided by adding a small amount of water (about 3 %). Slight corrosion is possible with ammonia > 10 %.

Diamond-Like Carbon (DLC)

Diamond-Like Carbon is inert to almost all common acids, bases, and solvents. There are no documented incompatibilities for HPLC applications.

Fused silica and Quartz (SiO_2)

Fused silica is used in Max Light Cartridges. Quartz is used for classical flow cell windows. It is inert against all common solvents and acids except hydrofluoric acid and acidic solvents containing fluorides. It is corroded by strong bases and should not be used above pH 12 at room temperature. The corrosion of flow cell windows can negatively affect measurement results. For a pH greater than 12, the use of flow cells with sapphire windows is recommended.

Gold

Gold is inert to all common HPLC solvents, acids, and bases within the specified pH range. It can be corroded by complexing cyanides and concentrated acids like aqua regia.

Using the Module

Solvent Information

Zirconium Oxide (ZrO_2)

Zirconium Oxide is inert to almost all common acids, bases, and solvents. There are no documented incompatibilities for HPLC applications.

Platinum/Iridium

Platinum/Iridium is inert to almost all common acids, bases, and solvents. There are no documented incompatibilities for HPLC applications.

Fluorinated polymers (PTFE, PFA, FEP, FFKM, PVDF)

Fluorinated polymers like PTFE (polytetrafluorethylene), PFA (perfluoroalkoxy), and FEP (fluorinated ethylene propylene) are inert to almost all common acids, bases, and solvents. FFKM is perfluorinated rubber, which is also resistant to most chemicals. As an elastomer, it may swell in some organic solvents like halogenated hydrocarbons.

TFE/PDD copolymer tubings, which are used in all Agilent degassers except G1322A/G7122A, are not compatible with fluorinated solvents like Freon, Fluorinert, or Vertrel. They have limited life time in the presence of hexafluoroisopropanol (HFIP). To ensure the longest possible life with HFIP, it is best to dedicate a particular chamber to this solvent, not to switch solvents, and not to let dry out the chamber. For optimizing the life of the pressure sensor, do not leave HFIP in the chamber when the unit is off.

The tubing of the leak sensor is made of PVDF (polyvinylidene fluoride), which is incompatible with the solvent DMF (dimethylformamide).

Sapphire, Ruby, and Al_2O_3 -based ceramics

Sapphire, ruby, and ceramics based on aluminum oxide Al_2O_3 are inert to almost all common acids, bases, and solvents. There are no documented incompatibilities for HPLC applications.

Reset the Multisampler in Case of an Error

When

In some cases the multisampler has to be reset by the user in order for the system to resume working in normal operation mode.

WARNING**Risk of injury by uncovered needle**

An uncovered needle is a risk of harm to the operator.

- ✓ Open the safety lock of the needle assembly *only* on the sample handler and for this particular procedure.
 - ✓ Be careful working at the z-robot.
 - ✓ Wear safety gloves when removing the needle assembly.
-

Resetting the Multisampler

- 1 Check the condition of the needle assembly and the sample loop. Replace them if necessary, see "Remove the Needle Assembly" on page 234 and "Remove the Sample Loop-Flex" on page 276

NOTE

Take care that the needle is installed properly. The plastic adapter must be installed correctly and the sample loop should not be kinked.

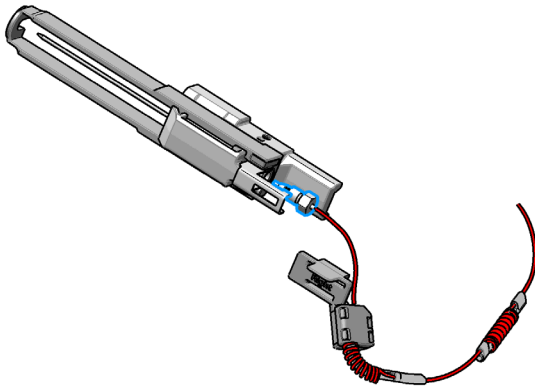

WARNING

Risk of injury by uncovered needle

An uncovered needle is a risk of harm to the operator.

- ✓ Open the safety lock of the needle assembly *only* on the sample handler and for this particular procedure.
- ✓ Be careful working at the z-robot.
- ✓ Wear safety gloves when removing the needle assembly.

- 2 Unlock the needle.

NOTE

This procedure is completely different than the standard PM replacement of the needle assembly in Lab Advisor. The safety lock of the needle assembly has to be released by carefully sliding the pusher upwards.

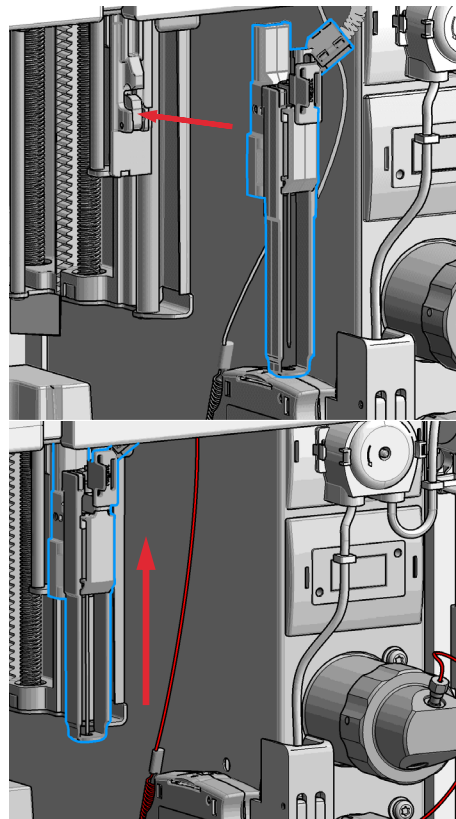

- 3** Verify that the needle assembly is unlocked after installation.

Needle unlocked

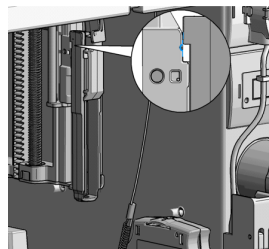

Needle locked

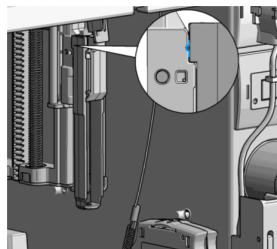

- 4** Reset the sampler (using the instrument control) or turn the instrument Off/On again to start the initialization.

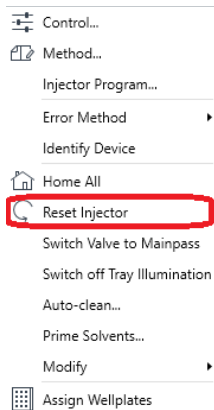

Next Steps:

- 5 Close the front door.
- 6 Wait until the initialization of the sampler is completed.
- 7 If the error persists, contact your local service representative.

Agilent Local Control Modules

Agilent InfinityLab Companion G7108AA

The Agilent InfinityLab Companion gives you complete control, system monitoring, signal plotting, and diagnostic capabilities for a wide range of LC system modules.

The instrument control solution is available as full package including all hardware and accessories, but can also be used on your own mobile devices like tablets, mobile phones and other electronic equipment.

Combining the conveniences of the Agilent Instant Pilot features with state-of-the-art mobile technology, the Agilent InfinityLab Companion gives you maximum flexibility and ease of use to control and monitor your LC system modules.

Features:

- Complete local control and monitoring of Agilent Infinity II LC modules
- Excellent usability and ease of use through a user interface specifically tailored for mobile devices - simple, intuitive touch-enabled, and visual controllable.
- High flexibility through a modern “Bring your own device” approach. Connection between LC module and mobile device either wireless via Wi-Fi or wired over USB cable (with full package).
- Convenient, ergonomic operation either handheld or attached to a module at the stack with newly developed, secure tablet holder (included in the full package).
- Preconfigured tablet with all required software already installed (included in the full package).
- Centerpiece of the solution is a USB dongle that activates the complete intelligence of the InfinityLab Companion on the instrument stack.

The InfinityLab Companion provides:

- fast and direct control in front of the instrument
- a clear overview of the system status
- control functionalities
- access to method parameters and sequences
- a logbook showing events from the modules
- diagnostic tests

4 Preparing the Module

Leak and Waste Handling	117
Preparing the Multisampler	118
Recommended Mats and Vials	119
Configure Well Plate Types	122
Capillary Coding Guide	125
Syntax for Capillary Description	125
At-a-Glance Color-Coding Keys	126
Installing Capillaries	127
Flow Connections to the Washport (Standard)	131
Flow Connections to the Washport (Dual Needle)	133
Installing the Bypass Capillary (Dual Needle)	135
Flow Connections to the Washport (Multiwash)	138
Setting up the Autosampler with OpenLab ChemStation	140
Control Settings	142
Method Parameter Settings	144
Module Configuration View for Single Needle	146
Setting up the Dual-Needle System with OpenLab ChemStation	147
Instrument Configuration View for Dual Needle	151
Method Setup	156
Sequence Parameters	160

This chapter explains the operational parameters of the module.

Leak and Waste Handling

WARNING

Toxic, flammable and hazardous solvents, samples and reagents

The handling of solvents, samples and reagents can hold health and safety risks.

- ✓ When working with these substances observe appropriate safety procedures (for example by wearing goggles, safety gloves and protective clothing) as described in the material handling and safety data sheet supplied by the vendor, and follow good laboratory practice.
- ✓ Do not use solvents with an auto-ignition temperature below 200 °C (392 °F). Do not use solvents with a boiling point below 56 °C (133 °F).
- ✓ Avoid high vapor concentrations. Keep the solvent temperature at least 40 °C (72 °F) below the boiling point of the solvent used. This includes the solvent temperature in the sample compartment. For the solvents methanol and ethanol keep the solvent temperature at least 25 °C (45 °F) below the boiling point.
- ✓ Do not operate the instrument in an explosive atmosphere.
- ✓ Do not use solvents of ignition Class IIC according IEC 60079-20-1 (for example, carbon disulfide).
- ✓ Reduce the volume of substances to the minimum required for the analysis.
- ✓ Never exceed the maximum permissible volume of solvents (8 L) in the solvent cabinet. Do not use bottles that exceed the maximum permissible volume as specified in the usage guideline for solvent cabinet.
- ✓ Ground the waste container.
- ✓ Regularly check the filling level of the waste container. The residual free volume in the waste container must be large enough to collect the waste liquid.
- ✓ To achieve maximal safety, regularly check the tubing for correct installation.

NOTE

For details, see the usage guideline for the solvent cabinet. A printed copy of the guideline has been shipped with the solvent cabinet, electronic copies are available in the Agilent Information Center or via the Internet.

For details on correct installation, see separate installation documentation.

Preparing the Multisampler

For best performance of the Multisampler

- When using the Multisampler in a system with a vacuum degassing unit, shortly degas your samples before using them in the Multisampler.
- Filter samples before use in an InfinityLab LC Series system. Use 1290 Infinity II inline filter (0.3 µm) (5067-6189) for inline filtering.

NOTE

This inline filter contains stainless steel and is not indicated for use in bio-inert or biocompatible systems.

- When using buffer solutions, flush the system with water before switching it off.
- Check the Multisampler plungers for scratches, grooves, and dents when changing the piston seal. Damaged plungers cause micro leaks and will decrease the lifetime of the seal.
- Solvent Information: Observe recommendations on the use of solvents, see “Solvent Information” on page 100.
- Priming and purging the system: When the solvents have been exchanged or the system has been turned off for a certain time (for example, overnight) oxygen will re-diffuse into the solvent channel. Therefore priming and purging of the system is required before starting an application.

Table 19 Choice of Priming Solvents for Different Purposes

Activity	Solvent	Comments
After an installation	Isopropanol	Best solvent to flush air out of the system
When switching between reverse phase and normal phase (both times)	Isopropanol	Best solvent to flush air out of the system
After an installation	Ethanol or methanol	Alternative to isopropanol (second choice) if no isopropanol is available
To clean the system when using buffers	Bidistilled water	Best solvent to re-dissolve buffer crystals
After a solvent change	Bidistilled water	Best solvent to re-dissolve buffer crystals

Recommended Mats and Vials

Table 20 Recommended plates and closing mats

Description (Part Number)	Rows	Columns	Plate height (mm)	Volume (μL)	Package	Closing mat compatibility
384Agilent (5042-1388)	16	24	14.4	80	30	
384Corning (No Agilent PN)	16	24	14.4	80		
384Nunc (No Agilent PN)	16	24	14.4	80		
96 well plate 0.5 ml, PP (pack of 10) (5042-1386)	8	12	14.3	500	10	1
96 well plate 0.5 ml, PP (pack of 120) (5042-1385)					120	1
96Agilent conical (5042-8502)	8	12	17.3	150	25	1
96CappedAgilent (5065-4402)	8	12	47.1	300	1	1
96Corning (No Agilent PN)	8	12	14.3	300		
96CorningV (No Agilent PN)	8	12	14.3	300		
96DeepAgilent31mm (5042-6454)	8	12	31.5	1000	50	1
96DeepNunc31mm (No Agilent PN)	8	12	31,5	1000		
96DeepRitter41mm (No Agilent PN)	8	12	41.2	800		
96Greiner (No Agilent PN)	8	12	14.3	300		
96GreinerV (No Agilent PN)	8	12	14.3	250		
96Nunc (No Agilent PN)	8	12	14.3	400		
96 Well plate, square wells, U shape, PP (5043-9300)	8	12	41	2200	30	2
96 Well plate, round wells, U shape, PP (5043-9302)	8	12	45.3	2000	30	3
96 Well plate, round wells, U shape, PP (5043-9305)	8	12	32	1000	50	3
96 Well plate, round wells, U shape, PP (5043-9308)	8	12	27	1200	25	3

Table 20 Recommended plates and closing mats

Description (Part Number)	Rows	Columns	Plate height (mm)	Volume (µL)	Package	Closing mat compatibility
96 Well plate, round wells, U shape, PP (5043-9309)	8	12	27	1200	50	3
96 Well plate, round wells, U shape, PP (5043-9310)	8	12	14	500	30	3
96 Well plate, round wells, U shape, PP (5043-9311)	8	12	14	500	120	3
96 Well plate, round wells, V shape, PP (5043-9312)	8	12	14	330	25	3
96 Well plate, round wells, V shape, PP (5043-9313)	8	12	14	330	50	3
96 Well plate, round wells, V shape, PP (5043-9314)	8	12	14	330	100	3
384 Well plate, square wells, V shape, PP (5043-9315)	16	24	22	190	25	4

¹ Closing mat for all 96 Agilent plates (5042-1389)

² Mat 96 wells, square, pierceable, silicone 50/pk (5043-9319)

³ Mat 96 wells, round, pierceable, silicone 50/pk (5043-9317), Mat 96 wells, round, pierceable, silicone 100/pk (5043-9318)

⁴ Mat 384 wells, square, pierceable, silicone 50/pk (5043-9320)

Table 21 Recommended vial plates

Description (part number)	Rows	Columns	Plate height (mm)	Volume (µL)	Package
Vial plate for 54 x 2 mL vials (6/pk) (G2255-68700)	6	9	36	2000	6
Vial plate 40 x 2 mL vials (5023-2471)	5	8	43	2000	1
Vial plate for 15 x 6 mL vials (1/pk) (5022-6539) only compatible with 3H drawers	3	5	42	6000	1
Vial plate for 27 Eppendorf tubes (1/pk) (5022-6538)	3	9	40	500 – 2000	1

NOTE

For good chromatographic results the maximum filling should not exceed 3/4 of the total volume of the vial.

NOTE

Agilent Technologies recommends to use preslit septa.

NOTE

Bottom sensing is a feature to detect the depth of vials or plates via the software. If the bottom sensing feature is used, the bottom of the plates and vials must resist the needle. Make sure that the material supports this feature. Inserts with flexible support should not be used.

NOTE

The default needle height offset value (0 mm) equates to an approximate distance of 2 mm above the bottom of a wellplate or a standard 2 mL vial at the reference bar, whereas it corresponds to an approximate distance of 5 mm above the bottom of a standard 2 mL vial in a vial tray. Using vial inserts or high recovery vials will impact the apparent distance between the needle tip and the bottom of the vessel.

NOTE

In case of custom-made wellplates or vials, please keep in mind the physical limitations of each drawer.

The maximum total height allowed (including sample container and vial caps, if present) is:

- 1H: 19 mm
- 2H: 45 mm
- 3H: 50 mm

NOTE

Adhesive foils are not recommended to seal wellplates. Alternatively, plates can be sealed with a Pierceable aluminium foil (06644-001).

Configure Well Plate Types

If the plate you are using is not found on the “Recommended Mats and Vials” on page 119 you may configure a custom plate. Measure the exact dimensions of the plate as marked below and enter the values in the plate configuration table of the chromatographic data system.

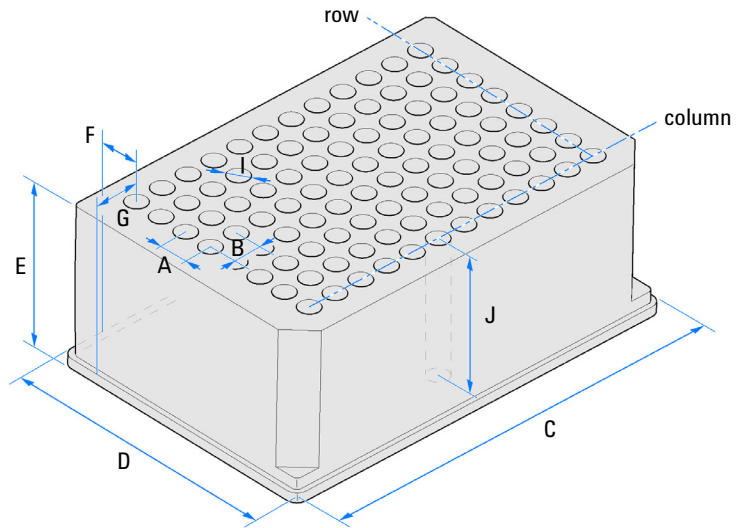

Figure 25 Well Plate Dimensions (straight)

Preparing the Module

Configure Well Plate Types

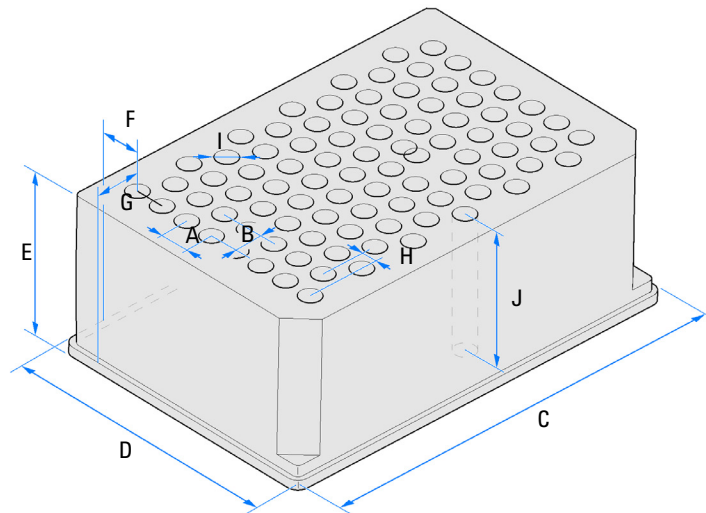

Figure 26 Well Plate Dimensions (staggered)

Table 22 Well Plate Dimensions

Location	Description	Definition	Limits
	Rows	Number of rows on the plate	up to 16
	Columns	Number of columns on the plate	up to 24
	Volume	Volume (in μl) of a sample vessel	
A	Row distance	Distance (in mm) between the center of two rows	
B	Column distance	Distance (in mm) between the center of two columns	
C	Plate length	X size (in mm) at the bottom of the plate	127.75 \pm 0.25 mm (SBS Standard)
D	Plate width	Y size (in mm) at the bottom of the plate	85.50 \pm 0.25 mm (SBS Standard)
E	Plate height	Size (in mm) from the bottom to the top of the plate	up to 47 mm
F	Row offset	Distance (in mm) from the back edge (bottom) to the center of the first hole (A1)	
G	Column offset	Distance (in mm) from the left edge (bottom) to the center of the first hole (A1)	
H	Column shift	Offset (in mm) to Y when the rows are not straight but staggered	
I	Well diameter	Diameter (in mm) of the well	at least 4 mm
J	Well depth	Distance (in mm) from the top of the plate to the bottom of the well	up to 45 mm

NOTE

The distances need to be measured with high precision. It is recommended to use calipers.

Capillary Coding Guide

Syntax for Capillary Description

The tables below are your guide to identifying the proper specifications for your capillary. On all capillaries, dimensions are noted in id (mm), length (mm) and, where applicable, volume (μL). When you receive your capillary, these abbreviations are printed on the packaging.

Using the guide: This fitting is coded as *SPF*, for Swagelok, PEEK, Fingertight.

Table 23 Capillary coding guide

Type The type gives some indication on the primary function, like a loop or a connection capillary.		Material The material indicates which raw material is used.		Fitting left/fitting right The fitting left/right indicate which fitting is used on both ends of the capillary.			
Key	Description	Key	Description	Key	Description		
Capillary	Connection capillaries	ST	Stainless steel	W	Swagelok + 0.8 mm Port id		
Loop	Loop capillaries	Ti	Titanium	S	Swagelok + 1.6 mm Port id		
Seat	Autosampler needle seats	PK	PEEK	M	Metric M4 + 0.8 mm Port id		
Tube	Tubing	FS/PK	PEEK-coated fused silica ¹	E	Metric M3 + 1.6 mm Port id		
Heat exchanger	Heat exchanger	PK/ST	Stainless steel-coated PEEK ²	U	Swagelok union		
				PFFE	PTFE	L	Long
				FS	Fused silica	X	Extra long
				MP35N	Nickel-cobalt-chromium-molybdenum alloy	H	Long head
						G	Small head SW 4
						N	Small head SW 5
						F	Finger-tight
						V	1200 bar
						B	Bio
				P	PEEK		
				I	Intermediate		

¹ Fused silica in contact with solvent

² Stainless steel-coated PEEK

At-a-Glance Color-Coding Keys

The color of your capillary will help you quickly identify the capillary id.

Table 24 Color-coding key for Agilent capillary tubing

Internal diameter in mm		Color code
0.015		 Orange
0.025		 Yellow
0.05		 Beige
0.075		 Black
0.075	MP35N	 Black with orange stripe
0.1		 Purple
0.12		 Red
0.12	MP35N	 Red with orange stripe
0.17		 Green
0.17	MP35N	 Green with orange stripe
0.20/0.25		 Blue
0.20/0.25	MP35N	 Blue with orange stripe
0.3		 Grey
0.50		Bone White

HINT

As you move to smaller-volume, high efficiency columns, you'll want to use narrow id tubing, as opposed to the wider id tubing used for conventional HPLC instruments.

Installing Capillaries

Capillaries and connections depend on which system is installed.

Table 25 Capillary connections for 1260 Infinity II systems

p/n	From	To
Bottle Head Assembly (G7120-60007)	Solvent Bottle	Infinity II Pump
Capillary ST 0.17 mm x 500 mm SI/SI (5500-1246)	Pump	Sampler
Capillary, ST, 0.17 mm x 900 mm SI/SX (5500-1217)	Pump	Vialsampler with ICC
Capillary ST 0.17 mm x 500 mm SI/SI (5500-1246)	Multisampler	MCT Valve/Heat Exchanger
Capillary, ST, 0.17 mm x 400 mm SL/SL (5500-1252)	Vialsampler	MCT Valve/Heat Exchanger
Capillary ST 0.17 mm x 105 mm SL/SL (5500-1240)	Vialsampler	ICC Heat Exchanger
Capillary, ST, 0.17 mm x 120 mm SL/SL, long socket (5500-1250)	ICC Heat Exchanger	Column
InfinityLab Quick Turn Capillary ST 0.17 mm x 105 mm, long socket (5500-1193)	MCT Heat Exchanger	Column
InfinityLab Quick Turn Capillary ST 0.12 mm x 280 mm, long socket (5500-1191)	Column/MCT Valve	Detector
Waste accessory kit (5062-8535)	VWD	Waste
Tube PTFE 0.7 mm x 5 m, 1.6 mm od (5062-2462)	DAD/FLD	Waste
Analytical tubing kit 0.25 mm i.d. PTFE-ESD (G5664-68712)	Detector	Fraction Collector

Table 26 Capillary connections for 1290 Infinity II systems

p/n	From	To
Bottle Head Assembly (G7120-60007)	Solvent Bottle	Infinity II Pump
Capillary ST 0.17 mm x 400 mm SI/SI (5500-1245)	Pump	Sampler
Capillary, ST, 0.17 mm x 900 mm SI/SX (5500-1217)	Pump	Vialsampler with ICC
Capillary ST 0.12 mm x 500 mm SL/S (5500-1157)	Multisampler	MCT Valve/Heat Exchanger
Capillary ST 0.12 mm x 400 mm SL/SL (5500-1251)	Vialsampler	MCT Valve/Heat Exchanger
Capillary ST 0.12 mm x 105 mm SL/SL (5500-1238)	Vialsampler	ICC Heat Exchanger
Capillary ST 0.12 mm x 120 mm SL/SL, long socket (5500-1249)	ICC Heat Exchanger	Column
Capillary ST 0.12 mm x 105 mm SL (5500-1201)	MCT Heat Exchanger	Column
InfinityLab Quick Turn Capillary ST 0.12 mm x 280 mm, long socket (5500-1191)	Column/MCT Valve	Detector
Waste accessory kit (5062-8535)	VWD	Waste
Tube PTFE 0.7 mm x 5 m, 1.6 mm od (5062-2462)	DAD/FLD	Waste
Analytical tubing kit 0.25 mm i.d. PTFE-ESD (G5664-68712)	Detector	Fraction Collector

Table 27 Capillary connections for 1260 Infinity II Bio-inert LC

p/n	From	To
Bottle Head Assembly (G7120-60007)	Solvent Bottle	Infinity II Pump
Capillary Ti 0.17 mm x 500 mm, SL/SLV (5500-1264)	Pump	Multisampler
Capillary PK/ST 0.17 mm x 500 mm, RLO/RLO (Bio-inert) (G5667-81005)	Multisampler	MCT
ZDV union (Bio-inert) (5067-4741)	Capillary	Bio-inert Heat Exchanger
Quick Connect Heat Exchanger Bio-inert (G7116-60041)		
Capillary PEEK 0.18 mm x 1.5 m (0890-1763) and PEEK Fittings 10/PK (5063-6591)	Column/MCT Valve	Detector
Waste accessory kit (5062-8535)	VWD	Waste
Tube PTFE 0.7 mm x 5 m, 1.6 mm od (5062-2462)	DAD/FLD	Waste
Analytical tubing kit 0.25 mm i.d. PTFE-ESD (G5664-68712)	Detector	Fraction Collector

Table 28 Capillary connections for 1290 Infinity II Bio LC

p/n	From	To
Bottle Head Assembly (G7120-60007)	Solvent Bottle	Infinity II Pump
Capillary MP35N 0.17 mm x 500 mm, SI/SI (5500-1419)	Pump	Multisampler
Capillary MP35N 0.12 mm x 500 mm SI/SI (5500-1279)	Multisampler	MCT
Quick Connect Capillary MP35N 0.12 mm x 105 mm (5500-1578)	MCT Heat Exchanger	Column
Quick Turn Capillary MP35N 0.12 mm x 280 mm (5500-1596)	Column/MCT Valve	Detector (DAD)
Quick Turn Capillary MP35N 0.12 mm x 500 mm (5500-1598)	Column/MCT Valve	Detector (VWD)
Waste accessory kit (5062-8535)	VWD	Waste
Tube PTFE 0.7 mm x 5 m, 1.6 mm od (5062-2462)	DAD/FLD	Waste
Analytical tubing kit 0.25 mm i.d. PTFE-ESD (G5664-68712)	Detector	Fraction Collector

For correct installation of capillary connections it's important to choose the correct fittings, see ["Syntax for Capillary Description"](#) on page 125.

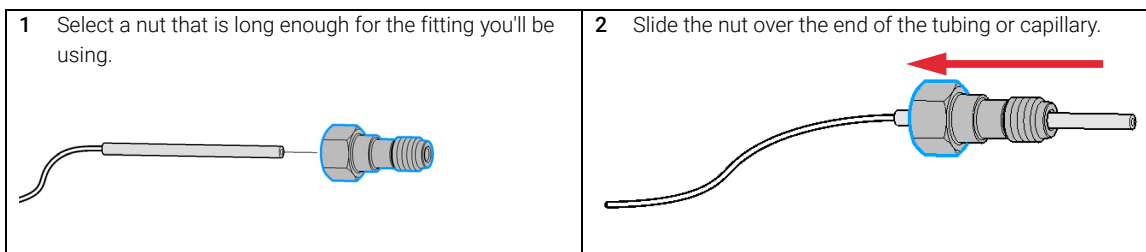

- 3 Carefully slide the ferrule components on after the nut and then finger-tighten the assembly while ensuring that the tubing is completely seated in the bottom of the end fitting.

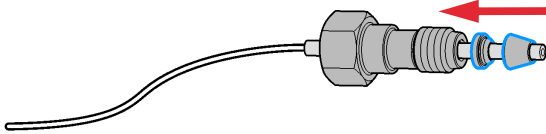

- 4 Use a column or injection valve to gently tighten the fitting, which forces the ferrule to seat onto the tubing or capillary.

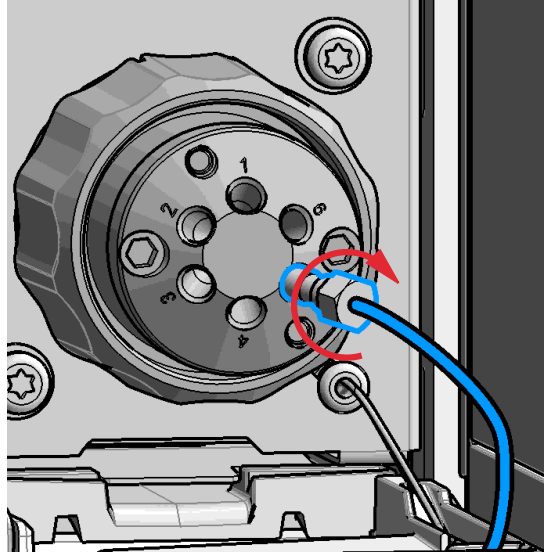

NOTE

Don't overtighten. Overtightening will shorten the lifetime of the fitting.

- 5 Loosen the nut and verify that the ferrule is correctly positioned on the tubing or capillary.

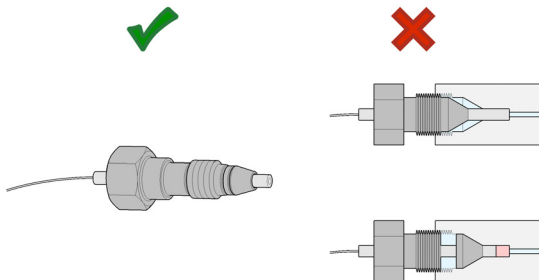

NOTE

The first time that the Swagelok fitting is used on a column or an injection valve, the position of the ferrule is permanently set. If changing from a column or an injection valve to another, the fitting may leak or decrease the quality of the separation by contributing to band broadening.

Flow Connections to the Washport (Standard)

Preparations

Module is installed in the system.

Use an appropriate solvent based on the sample and mobile phase chemistries.

The composition of the wash solvent should be the most solubilizing compatible solvent (your strongest diluent). Selecting the wash solvent is part of the method development.

A mixture of 50 % up to 100 % organic solvent in distilled water is a good choice for many applications.

NOTE

The silicone waste drainage is suitable for the most common wash solvents. For critical wash solvents, it may be necessary to replace the silicone tube with a PE tube (Tubing, PE, 1.5 m (5042-9974))

- 1 Place a needle wash solvent reservoir into the solvent cabinet.
- 2 Connect the a Bottle Head Assembly to the solvent reservoir and close the bottle.
- 3 Guide the tube of the Needle Wash Bottle Head Assembly through the cover opening and connect it to the peristaltic pump (use a TEFZEL union 0100-1846 and the FEP tubing 0890-1760 from the Standard Tubing kit).
- 4 Route the drainage of the washport outlet to the waste container.
- 5 Prime or auto clean the wash solvent tubings.
- 6 Check setting up the autosampler with OpenLAB Chemstation.

Preparing the Module

Flow Connections to the Washport (Standard)

Flow Connections to the Multisampler (Standard)

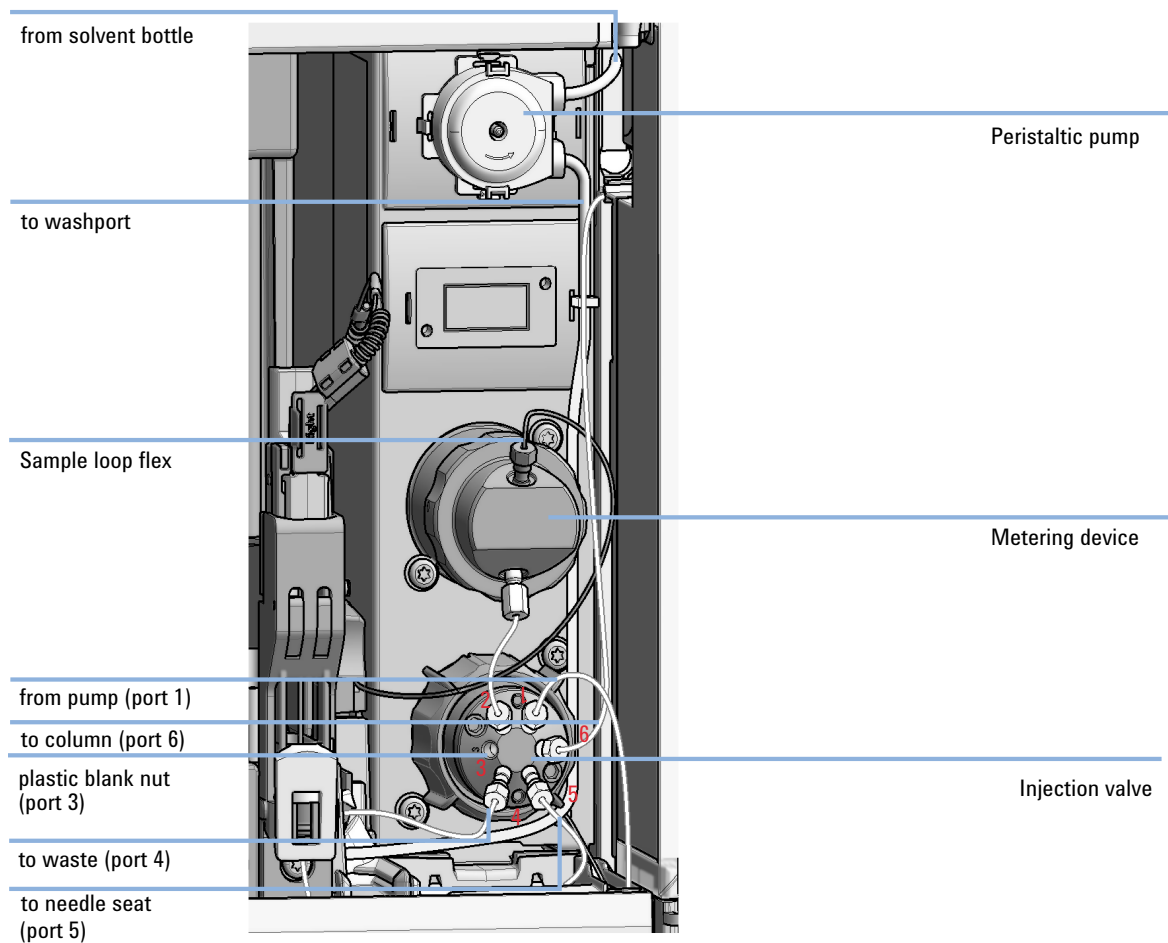

Figure 27 Capillary connections (Standard)

Flow Connections to the Washport (Dual Needle)

Preparations

Module is installed in the system.

Use an appropriate solvent based on the sample and mobile phase chemistries.

The composition of the wash solvent should be the most solubilizing compatible solvent (your strongest diluent). Selecting the wash solvent is part of the method development.

A mixture of 50 % up to 100 % organic solvent in distilled water is a good choice for many applications.

NOTE

The silicone waste drainage is suitable for the most common wash solvents. For critical wash solvents, it may be necessary to replace the silicone tube with a PE tube (Tubing, PE, 1.5 m (5042-9974))

- 1 Place a needle wash solvent reservoir into the solvent cabinet.
- 2 Connect the a Bottle Head Assembly to the solvent reservoir and close the bottle.
- 3 Guide the tube of the Needle Wash Bottle Head Assembly through the cover opening and connect it to the peristaltic pump (use a TEFZEL union 0100-1846 and the FEP tubing 0890-1760 from the Standard Tubing kit).
- 4 Route the drainage of the washport outlet to the waste container.
- 5 Prime or auto clean the wash solvent tubings.
- 6 Check setting up the autosampler with OpenLAB Chemstation.

Preparing the Module

Flow Connections to the Washport (Dual Needle)

Flow Connections to the Multisampler (Dual Needle)

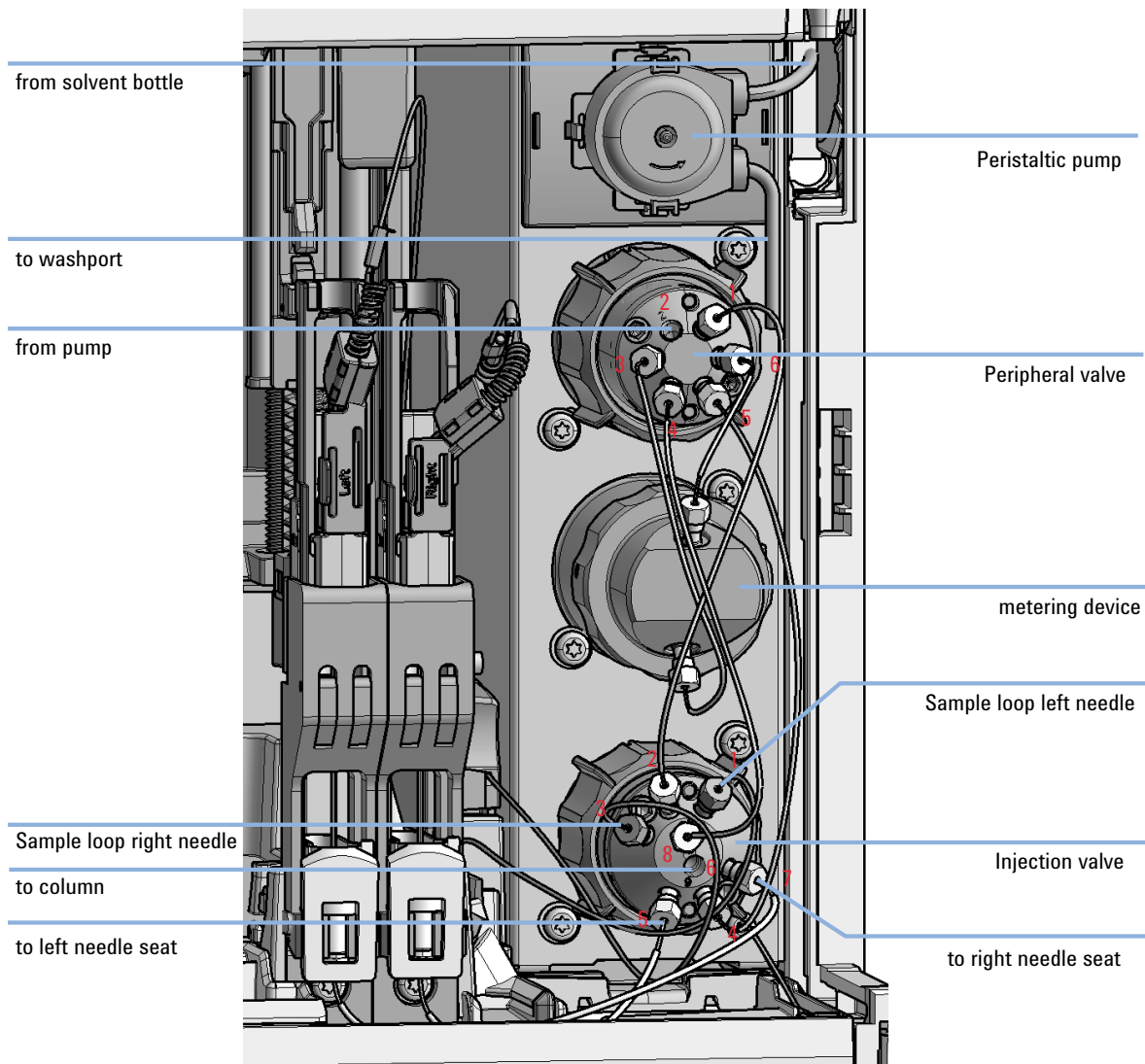



Figure 28 Capillary connections (Dual Needle)

Installing the Bypass Capillary (Dual Needle)

When When the dual-needle configuration has to be used in single-path mode. The bypass capillary allows the configuration of a minimized injection path to reduce flush times. In this case, the needle where the bypass is installed is no longer available for injection.

Tools required	p/n	Description
	8710-0510 	Open-end wrench 1/4 – 5/16 inch

Parts required	p/n	Description
	5500-1238 	Capillary ST 0.12 mm x 105 mm SL/SL

Preparations Finish any pending acquisition job and return any plate on the workspace back to the hotel. Remove the Sample Loop-Flex that will be replaced by the bypass capillary. Store the unused sample loop in a safe place.

WARNING

Risk of injury by uncovered needle

An uncovered needle is a risk of harm to the operator.

- ✓ Do not open the safety lock of the needle assembly
- ✓ Be careful working at the z-robot.
- ✓ Wear safety goggles, when removing the needle assembly.

CAUTION

Mismatching sample loop configuration

Damage to the system

- ✓ Make sure, that the sample loop configuration matches to the hardware installed.

NOTE

If you have changed the bypass capillary, verify that the correct sample loop and bypass capillary is configured in the CDS (see “Setting up the Autosampler with OpenLab ChemStation” on page 140).

NOTE

For details on the setup of the dual-needle system, see “Modify Capillaries” on page 150.

Preparing the Module

Installing the Bypass Capillary (Dual Needle)

- 1 Install the bypass capillary to the left or right flow path.

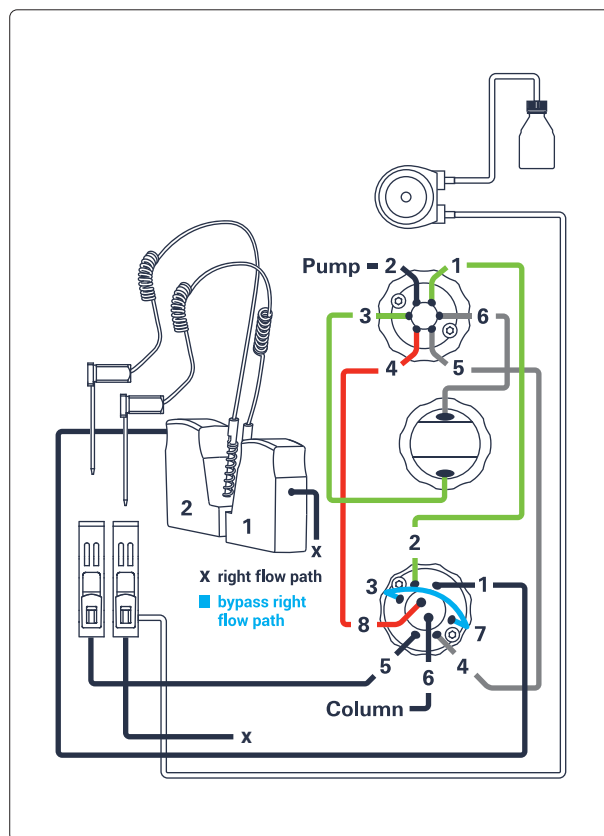

Figure 29 The right bypass capillary is installed

NOTE

Either connect the bypass capillary from port 1 to port 5 in the left flow path or connect the bypass capillary from port 3 to port 7 for the right flow path.

Preparing the Module

Installing the Bypass Capillary (Dual Needle)

- To set up the bypass capillary in the CDS, right-click into the active area, then select **Modify >Capillaries** from the context menu.

Capillary Setup

Section	Capillary Type	Physical Volume (μL)	Injection Volume (μL)
Loop Capillary Left	G4267-60301 : Loop 20 μL left Dual-Needle	40.00	20.00
Loop Capillary Right	G4267-60300 : Sample Loop-Flex 20 μL right	33.00	20.00
Seat Capillary Left	G4267-87012 : Seat assembly 0.12 mm 1290 Infini	1.50	0.00
Seat Capillary Right	G4267-87012 : Seat assembly 0.12 mm 1290 Infini	1.50	0.00
Bypass capillary	None		

- Select **Right** or **Left** from the **Bypass capillary** dropdown menu, depending on which flow path you want to bypass.

Bypass capillary

Right

In the active area, you will see that one syringe icon is greyed out, indicating that only one flow path is active. Click **Assign**.



Flow Connections to the Washport (Multiwash)

Preparations

Module is installed in the system.

Use an appropriate solvent based on the sample and mobile phase chemistries.

The composition of the wash solvent should be the most solubilizing compatible solvent (your strongest diluent). Selecting the wash solvent is part of the method development.

A mixture of 50 % up to 100 % organic solvent in distilled water is a good choice for many applications.

NOTE

The silicone waste drainage is suitable for the most common wash solvents. For critical wash solvents, it may be necessary to replace the silicone tube with a PE tube (Tubing, PE, 1.5 m (5042-9974))

- 1 Place solvent reservoirs for needle wash and needle seat flushing into the solvent cabinet.
- 2 Connect the Bottle Head Assemblies to the solvent reservoirs and close the bottles.
- 3 Guide the tubes of the Wash Bottle Head Assemblies through the cover opening and connect it to the ports S1, S2, and S3 of the solvent selection valve.
- 4 Route the drainage of the washport outlet to the waste container.
- 5 Prime or auto clean the wash solvent tubings.
- 6 Check setting up the autosampler with OpenLAB Chemstation.

Flow Connections to the Multisampler (Multiwash)

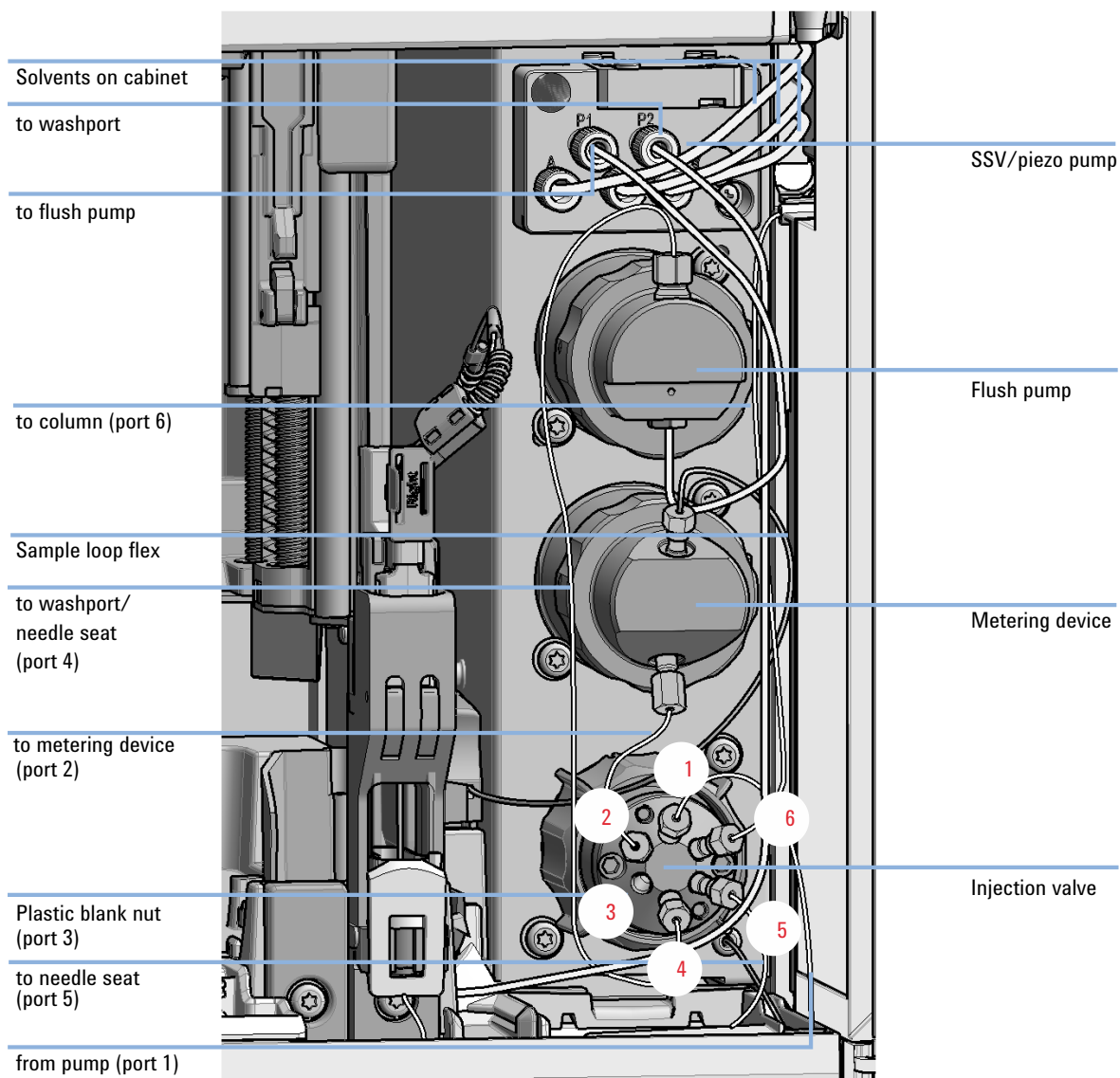

Figure 30 Capillary connections (Multiwash)

Setting up the Autosampler with OpenLab ChemStation

The setup of the Multisampler is shown with the Agilent OpenLab CDS ChemStation Edition C.01.06. Depending on the controller (e.g. Local Controller, OpenLab CDS EZChrom Edition, Masshunter) the screens look different.

NOTE

This section describes the autosampler settings only. For information on Agilent OpenLab CDS ChemStation Edition or other InfinityLab LC Series modules refer to the corresponding documentation.

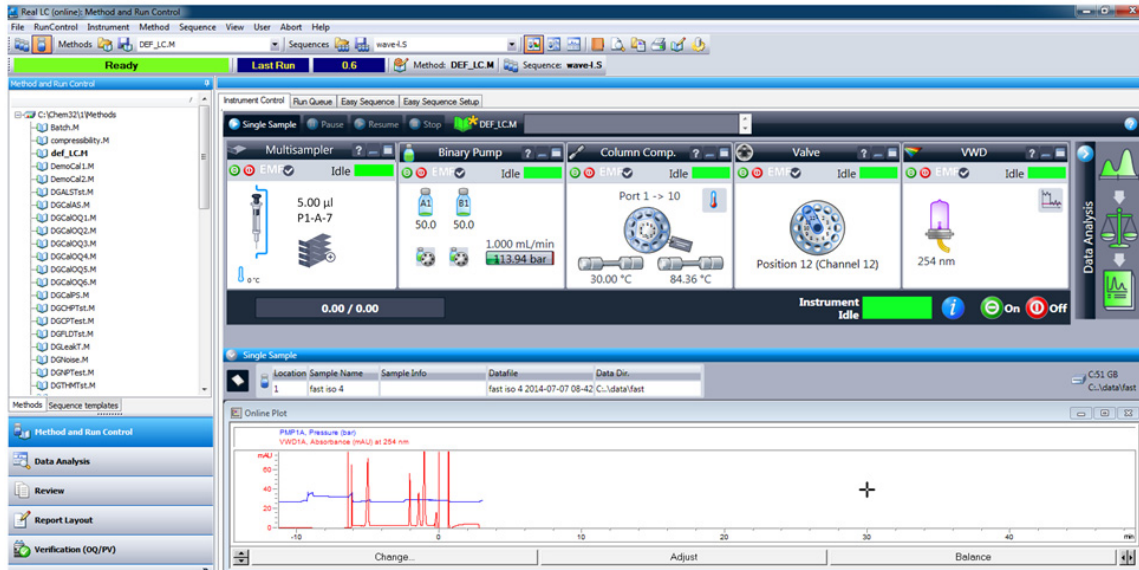
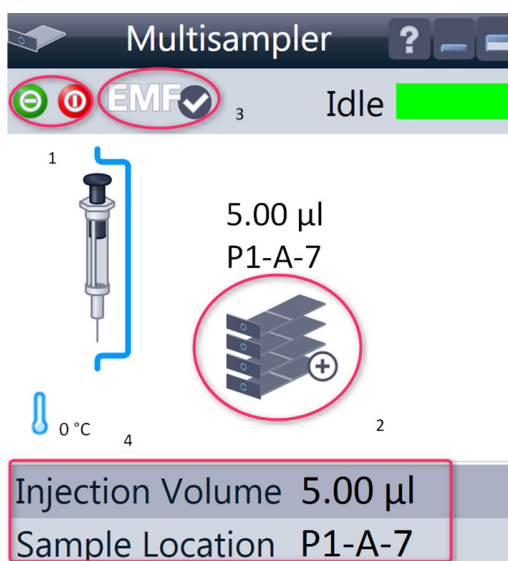

Figure 31 ChemStation Method and Run Control

After successful load of the OpenLab CDS ChemStation Edition, you should see the module as an active item in the graphical user interface (GUI).

Table 29 The Autosampler User Interface



Within the Multisampler user interface, there are active areas. If you move the mouse cursor across the icons (tray, EMF button), the cursor will change and you may click on the icon to

- 1 Turn on/off the autosampler
- 2 Configure the sample hotel
- 3 Get the status of the **EMF** (Early Maintenance Feature)
- 4 Sample Cooler/Thermostat Temperatur

Current instrument information on:

- **Injection volume**
- **Sample location**

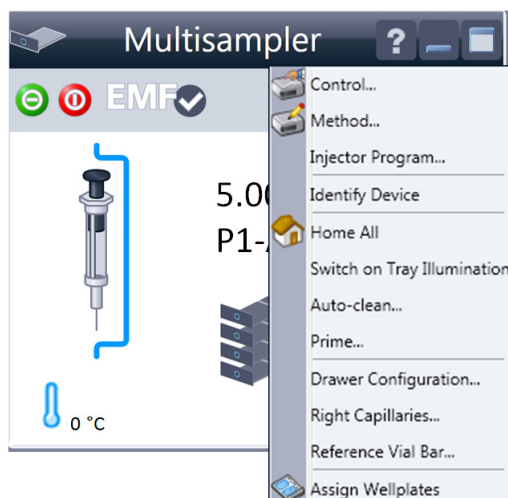

A right-click into the Active Area will open a menu to

- Show the **Control** User Interface (special module settings)
- Show the **Method** User interface (same as via menu **Instrument >Set up Instrument Method >Setup G7167B)**
- **Injector Program**

When you activate a pretreatment/injector program, it replaces the standard injection cycle.

- **Identify Device**
- **Home All**
- **Switch on Tray Illumination**
- **Auto Clean**
- **Prime**
- **Modify**
 - **Drawer Configuration**
Changing the load capacity of the Sample Hotel
 - **Capillaries**
Changing Sample Loop, Needle Seat, and bypass capillary configuration
 - **Reference Vial Rack**
- **Assign Wellplates**
Wellplate Configuration (same as click on the Tray icon)

NOTE

For customizing a wellplate in the CDS, click on **Define Sample Containers** in the instrument configuration view.

Table 29 The Autosampler User Interface

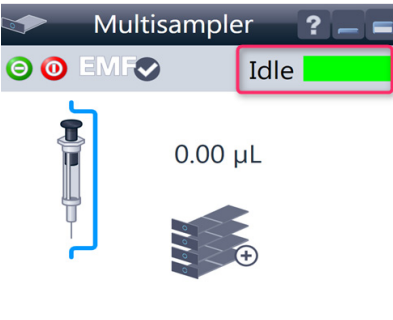
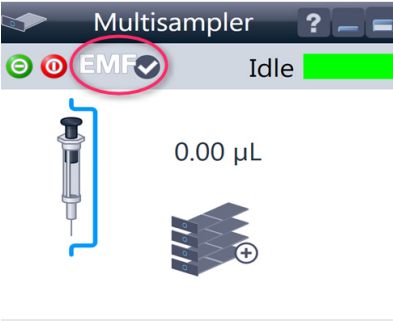
	<p>Module Status shows Run / Ready / Error state and “Not Ready text” or “Error text”</p> <ul style="list-style-type: none"> • Error (Red) • Not ready (yellow) • Ready (green) • Pre run, Post run (purple) • Run (blue) • Idle (green) • Offline (dark gray) • Standby (light gray)
<p>Injection Volume 0.00 µL Sample Location</p>	<p>EMF Status shows Run / Ready / Error state and “Not Ready text” or “Error text”</p> <ul style="list-style-type: none"> • Offline (gray) • Ok • No Maintenance required (green) • EMF warning. Maintenance might be required (yellow) • EMF warning. Maintenance required (red)
	<p>EMF Status shows Run / Ready / Error state and “Not Ready text” or “Error text”</p> <ul style="list-style-type: none"> • Offline (gray) • Ok • No Maintenance required (green) • EMF warning. Maintenance might be required (yellow) • EMF warning. Maintenance required (red)
<p>Injection Volume 0.00 µL Sample Location</p>	

NOTE

The multisampler configuration is done in the module dashboard context menu, not in the instrument configuration.

Control Settings

The control settings are available via right click on the active area of the graphical user interface, see “Setting up the Autosampler with OpenLab ChemStation” on page 140.

Table 30 Control settings
Figure 32 Control settings

The Sampler control parameters are in the following sections:

- Missing Vial**
 Mark the **Ignore missing vial** check box to specify that, if a vial is missing, the injector ignores it and continues with a 6-second dummy run. The message "Missing vial <x>" is logged, and the system continues with the next injection.
- Illumination**
 Toggles the illumination of the sample area, On or Off.
- At Power On**
 The section is available when a cooler/thermostat is installed and configured. Mark the **Turn on Thermostat** check box to specify that the cooler/thermostat is switched on automatically when the instrument is switched on.
- Thermostat**
 The section is available when a cooler/thermostat is installed and configured and the Constant temperature mode is selected. Select **On** to switch on the cooler/thermostat. Specify the required temperature in the adjacent field. The specified temperature must be at least 5 °C below ambient for proper temperature control. Select **Off** to switch off the cooler/thermostat.
- Automatic Turn On**
 You can set a date and time at which the cooler/thermostat switches on automatically.
- Pump connected to Sampler**
 Use this section to specify the pump that is used with the Sampler. If more than one pump is configured, display the drop-down list and select the appropriate pump from the list.
- Clear Workspace**
Immediately Returns the sample container on the workspace to its position in the sample hotel immediately after the injection has been completed. This allows you to quickly retrieve the sample container for further processing.
At End of Analysis Returns the sample container on the workspace to its position in the sample hotel after the current run or sequence/worklist has been completed. This is the default setting.
Never Leaves the sample container on the workspace until a different sample container is required to replace it.
- Enable Analysis**
 This feature requires LC & CE Drivers A.02.19 or newer and is only available for the Sample Thermostat. With this function, you can specify if the analyses should start **With any temperature** or only when the **Temperature is within ± 2 °C** range of the setpoint temperature.

NOTE

The Enable Analysis section is disabled when Not controlled is selected in the Temperature section.

NOTE

For additional help and support, highlight the desired area and press the **F1** key. A help screen will open with additional information and documentation about the topic.

Method Parameter Settings

These settings are available via **Menu >Instrument >Set up Instrument Method Multisampler** or via right click on the Active area.

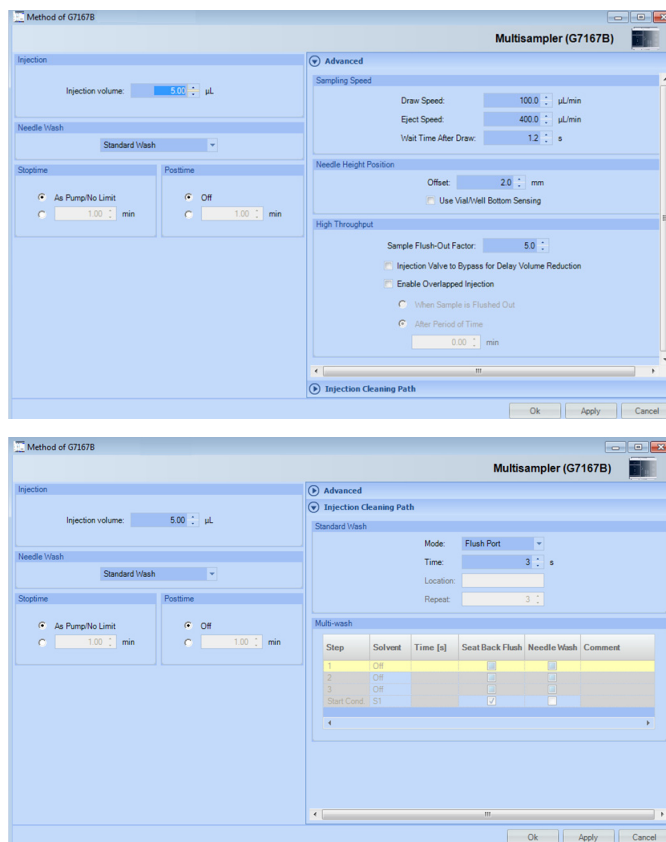

Figure 33 Method parameter settings

NOTE

The default needle height offset value (0 mm) equates to an approximate distance of 2 mm above the bottom of a wellplate or a standard 2 mL vial at the reference bar, whereas it corresponds to an approximate distance of 5 mm above the bottom of a standard 2 mL vial in a vial tray. Using vial inserts or high recovery vials will impact the apparent distance between the needle tip and the bottom of the vessel.

NOTE

For additional help and support. Highlight the desired cell and press the **F1** key. A help screen will open with additional information and documentation about the topic.

Injection
Injection volume: 5.00 µL

Needle Wash
Standard Wash

Advanced
Injection Cleaning Path

Standard Wash
Mode: Flush Port
Time: 3 s
Location:
Repeat: 3

Multi-wash

Step	Solvent	Time [s]	Seat Back Flush	Needle Wash	Comment
1	Off		<input type="checkbox"/>	<input type="checkbox"/>	
2	Off		<input type="checkbox"/>	<input type="checkbox"/>	
3	Off		<input type="checkbox"/>	<input type="checkbox"/>	
Start Cond.	S1		<input checked="" type="checkbox"/>	<input type="checkbox"/>	

Multi-wash

Step	Solvent	Time [s]	Seat Back Flush	Needle Wash	Comment
1	Off		<input type="checkbox"/>	<input type="checkbox"/>	
2	Off		<input type="checkbox"/>	<input type="checkbox"/>	
3	Off		<input type="checkbox"/>	<input type="checkbox"/>	
Start Cond.	S1		<input checked="" type="checkbox"/>	<input type="checkbox"/>	

Injection Mode/ Needle Wash

The settable **Injection volume** is depending on what kind of configuration is installed. Default configuration 0.1 – 20 µL. It is possible to select between using the **Standard Wash** or **Standard Wash off**. Using needle wash is one option to obtain minimum carryover.

The Injection cleaning section allows you to select between the **Standard Wash** option and the **Multi-wash** option. With the **Standard Wash** (default configuration) you can choose between two modes the Flush port or Wash Vial. If the **Multi-Wash** option is installed (additional hardware is required) you can use **Needle Wash** and **Seat Back Flush** together to obtain the lowest carryover.

Multi-wash (Multisampler Injection Cleaning)

The Multi-wash table allows you to specify up to four steps that will be used to clean the system.

The Start Cond. step is not always executed. Therefore it is recommend to check the box to ensure that, at the end of the cleaning procedure, the flow path of the sampler is filled with the starting solvent conditions for the next sample.

For each cleaning step, Click the Solvent down arrow and select the solvent to use (S1, S2, S3) or switch the step Off.

Specify a duration (in seconds) in the Time [s] field.

Mark the check boxes for **Seat Back Flush** and/or **Needle Wash** to include these actions. If both are selected, they are carried out simultaneously; if neither is selected, the step is ignored (equivalent to selecting **Off**). Add a comment in the **Comment** column, if necessary.

NOTE

If the Multiwash feature is installed, it is strongly recommended to use it for each analysis to prevent carryover and achieve the highest possible performance.

Stoptime
 As Pump/No Limit
 1.00 min

Posttime
 Off
 1.00 min

Stoptime/Posttime

A Multisampler **Stoptime** can be set. For equilibration of the Multisampler a **Posttime** can be set.

NOTE

It takes approximately 30 s to fully exchange one solvent for another in the flushport. To flush and exchange the solvent in the needle seat it takes 18 s.

Additionally it is strong recommended to use Auto-Clean function to flush the module regularly with all installed solvents.

Module Configuration View for Single Needle

The settings are available via menu **Instrument > Instrument Configuration > Multisampler Configuration**.

- **Device name:** based on the module.
- **Type ID:** based on the module (product number). Some modules may allow changing the type based on hardware/firmware. This results in a change of features and functions.
- **Serial number:** based on the module.
- **Firmware revision:** based on the module.
- **Options:** lists installed options.

Figure 34 Configuration view (single needle)

NOTE

Changes in the sampler configuration can only be done in the online view of the CDS system, see [Table 29](#) on page 141.

Setting up the Dual-Needle System with OpenLab ChemStation

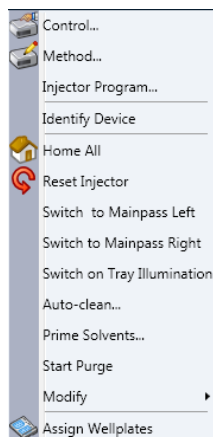

A right-click into the Active Area will open a menu to

- Show the **Control** User Interface (special module settings)
- Show the **Method** User interface (same as via menu **Instrument >Set up Instrument Method >Setup G7167B**)
- **Injector Program**
When you activate a pretreatment/injector program, it replaces the standard injection cycle.
- **Identify Device**
- **Home All**
- **Reset Injector**
- **Switch to Mainpass (main path) Left** (needle loop left is connected to the pump device)
- **Switch to Mainpass (main path) Right** (needle loop right is connected to the pump device)
- **Switch on Tray Illumination**

- **Auto-clean**

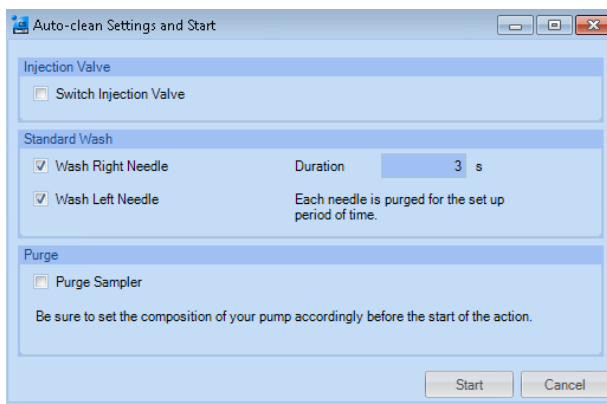

- **Prime Solvents**

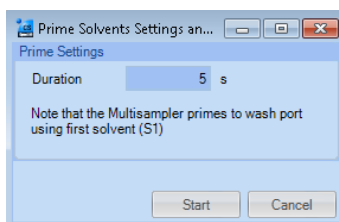

- **Start Purge:**

Manual start of the purge routine, duration defined by hydraulic setup.

See "Purge" on page 149 for further information on purge.

- **Modify**

- **Drawer Configuration:** Changing the load capacity of the Sample Hotel
- **Capillaries Setup:** for the sample loops, needle seat, and bypass capillaries for dual-needle option
- **Reference Vial Bar**

- **Assign Wellplates**

Wellplate Configuration (same as click on the Tray icon)

NOTE

For customizing a wellplate in the CDS, click on **Define Sample Containers** in the instrument configuration view.

Preparing the Module

Setting up the Dual-Needle System with OpenLab ChemStation

Purge

Typical time for purge:

- 1290 Binary pump, 2x 20 μ L setup, flow rate: 0.5 mL/min ~ 125 s
- 1290 Binary pump, 2x 20 μ L setup, flow rate: 1.0 mL/min ~ 85 s

Other configurations (especially large volume setups) will last longer.

In order to get information about remaining purge time, expand the window in the user interface:

The screenshot shows the 'Multisampler' software window. At the top, there is a status bar with a green 'EVI' icon and a yellow 'Not Ready' indicator. Below this is a diagram of the multisampler hardware with a blue arrow pointing to the right needle, labeled 'Bypass capillary installed (needle right)'. The injection volume is set to 20.00 μ L. Below the diagram is a table with the following data:

Injection Volume	20.00 μ L
Sample Location	
Prime Status	Idle
Auto-clean Status	Idle
Purge Status	107 s
Active Tray	None

Text labels on the right side of the screenshot point to the status bar ('Not ready condition: Cleaning') and the 'Purge Status' value ('Remaining time for purge').

NOTE

The start of the pump or changes in solvent composition trigger the purge routine of the multisampler. The purge routine flushes the hydraulic setup of the multisampler with fresh mobile phase (for example metering device, sample loops, and needles). This ensures cleanness of the flowpath.

NOTE

For pumps with a manual purge valve, it is mandatory to start the purge routine before a run or sequence. This will guarantee that the complete flow path of the dual-needle setup is flushed with fresh mobile phase.

NOTE

The only way to speed up the purge routine is to increase flow rate. Best practices is to write a purge method in the sequence table. The purge method includes a column switching valve that switches at high flow rate into the waste position.

Modify Capillaries

The screenshot shows the 'Capillary Setup' dialog box with the following configuration:

Section	Capillary Type	Physical Volume (μL)	Injection Volume (μL)	Inner Diameter (mm)	Length (mm)
Loop Capillary Left	G4267-60301 : Loop 20 μL left Dual-Needle	40.00	20.00	0.20	1040.00
Loop Capillary Right	G4267-60311 : Loop 20 μL right Dual-Needle	40.00	20.00	0.20	1040.00
Seat Capillary Left	G4267-87012 : Seat assembly 0.12 mm 1290 Infini	1.50	0.00	0.12	150.00
Seat Capillary Right	G4267-87012 : Seat assembly 0.12 mm 1290 Infini	1.50	0.00	0.12	150.00
Bypass capillary	None				

Figure 35 Capillary Setup for the Multisampler

NOTE

To avoid damage of the system, the configuration of the dual-needle system must match to the installed hardware, especially the sample loops.

NOTE

Only the listed capillary PN 5500-1238 can be used as bypass capillary (either left or right).

Instrument Configuration View for Dual Needle

Communication

Device name: Multisampler
Type ID: G7167B
Serial number: DEBAR00101
Firmware revision: D.06.75
Connection settings...

Options | Drawer

i These options are for information only or configuring an offline system. Please see help for instructions how to change the configuration.

Metering: G4267-60043: 100 μ L Analytical Head

Left needle installed Alternating needle usage possible

Left needle	Right needle
Loop: G4267-60301: Loop 20 μ L left Dual-Needle	Loop: G4267-60311: Loop 20 μ L right Dual-Needle
Seat: G4267-87012: Seat assembly 0.12 mm 1290 Infinity LC Max. Injection Volume: 20 μ L (Multi-draw disabled)	Seat: G4267-87012: Seat assembly 0.12 mm 1290 Infinity LC Max. Injection Volume: 20 μ L (Multi-draw disabled)

Cooler installed Multi-wash installed

Mode: Constant temperature mode (control setting)

Reference vial rack: G4267-40071: Reference vial rack (5)

Bypass capillary: None

Define Sample Containers...

Figure 36 Configuration view for alternating dual needle with two 20 μ L Sample Loops

Figure 37 Configuration view for dual needle with non-identical flow paths (e.g a 20 µL and a 500 µL Sample Loop)

NOTE

In this view it is not possible to change the online configuration of the sample loops or the seat capillaries.

Shows the currently installed devices and status.

Preparing the Module

Setting up the Dual-Needle System with OpenLab ChemStation

Table 31 Instrument configuration view for dual needle

Communication	<ul style="list-style-type: none"> • Device name: Multisampler • Type ID: G7167A/B • Serial number: DEBAR00101 • Firmware revision: D.06.75 • Connection settings: LAN connection or hostname
Options	<p>Metering: G4267-60043 100 µL Analytical Head</p> <p style="text-align: center;">NOTE</p> <p>For dual needle only the 100 µL metering device is available.</p> <p>For single needle you can use 40 µL, 100 µL or 900 µL metering devices</p>
Left Needle installed	<p>This check box is marked to indicate that your system is equipped with a dual-needle option. When the check box is marked, the Left Needle section is enabled.</p> <p style="text-align: center;">NOTE</p> <p>If the Left Needle parameters are equivalent to the Right Needle parameters, then Alternating Needle Usage is possible, which increases sampling efficiency.</p> <p style="text-align: center;">NOTE</p> <p>If dual-needle option is installed, the system will use multi-load instead of multi-draw for larger sample volumes. For multi-wash and an installed dual-needle option, multi-draw is not available.</p>
Left Needle	<p>This section is enabled only when the Left Needle installed check box is marked.</p>
Loop	<p>Shows the currently installed loop capillary.</p> <p style="text-align: center;">NOTE</p> <p>It is mandatory that the configuration of the dual-needle system, especially sample loops, match to the installed hardware to avoid damage to the system.</p>
Seat	<p>Shows the currently installed seat capillary.</p>
Right Needle	<p>This section is always enabled.</p>

Table 31 Instrument configuration view for dual needle

Loop	Shows the currently installed loop capillary.
	<div style="background-color: #cccccc; padding: 5px; display: inline-block;">NOTE</div> <p>For the dual-needle setup, only the correct dual-needle sample loops must be configured and used, for instance Sample Loop 20 µL right Dual needle (G4267-60311). These sample loops are manufactured especially for dual-needle systems.</p>
Seat	Shows the currently installed seat capillary. The needle seat capillary volume is used for the Automatic Delay Volume Reduction option and ISET.
Thermostat installed	This check box is marked to show that a sample cooler or sample thermostat is installed.
Mode	Select Constant temperature mode to set the temperature using the Thermostat section of the Multisampler Control parameters. Use this mode to store samples at a constant temperature across multiple runs. This is the default mode, which is recommended in most cases. Select Variable temperature mode to set the temperature using the Thermostat section of the Advanced Method Setup parameters. In this mode, the temperature can be varied from run to run.
Multi-wash installed	This check box is marked to show that the multi-wash option is installed, and the Multi-wash option in the Needle Wash section of the Method parameters is available (<i>Not available for dual needle</i>).
Reference vial rack	Click the down-arrow and select the reference vial rack that is installed in your multisampler from the drop-down list.

Table 31 Instrument configuration view for dual needle

Bypass capillary	<p>Click the down arrow and select where the bypass capillary is installed (if any).</p> <p>When installed, the bypass capillary allows the configuration of a minimized injection path to reduce flush times and allows the dual-needle configuration to be used in single-path mode. In this case, the needle where the bypass is installed is no longer available for injection.</p>
-------------------------	---

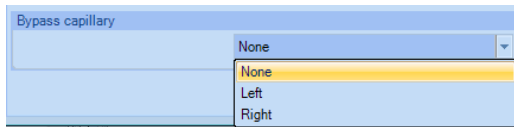

NOTE

Bypass capillary either installed left or right: only the listed capillary (p/n 5500-1238) can be used as bypass capillary.

Define Sample Containers	<p>Displays the Define and edit Wellplates configuration dialog box, which contains a list of standard preconfigured wellplates plus any custom wellplates that have been added.</p>
---------------------------------	---

NOTE

For the dual-needle setup, only the correct hardware must be configured and used, for instance the Capillary ST 0.12 mm x 105 mm SL/SL (5500-1238) or Sample Loop 20 μ L right Dual needle (G4267-60311).

Method Setup

Method of G7167B (DEBAR00101) Multisampler (G7167B)

Injection

Injection volume: 5.00 µL
Needle selection: Alternating Needle

Needle Wash

Standard Wash

Stoptime **Posttime**

As Pump/No Limit Off
 1.00 min 1.00 min

Advanced

Sampling Speed

Draw Speed: 100.0 µL/min
Eject Speed: 400.0 µL/min
Wait Time After Draw: 1.2 s

Needle Height Position

Offset: 0.0 mm
 Use Vial/Well Bottom Sensing

Smart Overlap

Enable Smart Overlap
After Period of Time: 0.00 min

Injection Path Cleaning

Ok Apply Cancel

Figure 38 Method setup screen for Dual-Needle option

Preparing the Module

Setting up the Dual-Needle System with OpenLab ChemStation

Table 32 Method setup parameters (DN)

Injection	The Injection section allows you to specify the Injection volume and to select the needle
Needle selection	 <ul style="list-style-type: none"> • Alternating Needle: Needles will be toggled (only possible if the both flowpaths of are configured identically) • Right Needle: only the right needle will be used • Left Needle: only the left needle will be used
Needle Wash	The needle is washed in accordance with the parameters set up in the Standard Wash section of the Injection Path Cleaning section of the Method.
Stoptime	The Stoptime enables you to set the time that the analysis stops. Limits: 0.01 to 99999 min or As Pump/No Limit .
Posttime	You can set the Posttime so that your Multisampler remains in a post-run state during the Posttime to delay the start of the next analysis. A Posttime period can be used to allow your column to equilibrate after changes in solvent composition (for example after gradient elution). Limits: 0.01 to 99999 min or Off (0.0 min).
Sampling Speed	<ul style="list-style-type: none"> • Draw Speed: determines the rate at which the plunger draws sample from the vial. Set the speed to an appropriate value for your sample. For viscous samples, use a slow Draw Speed. • Eject Speed: determines the rate at which the plunger ejects sample from the metering device. If you are injecting large volumes of sample, setting a high Eject Speed will shorten the time needed for an injection cycle. For viscous samples, use a slow Eject Speed. • Wait Time After Draw: this time ensures that the temporary vacuum, which originates from the drawing of liquid from the sample vial, dissipates. The needle first stays on the seat for the specified time, then after drawing sample from the vial remains there for the specified time.

Table 32 Method setup parameters (DN)

<p>Needle Height Position</p>	<ul style="list-style-type: none"> • Offset: this is a vertical offset that enables you to position the needle a specific distance (in mm) away from its standard position. The Offset function is useful when analyzing very small sample volumes, or when only a specific part of the sample is required, for example, the top layer. Usually default draw offset = 0 equates to 2 mm above the wellplate bottom. • Use Vial/Well Bottom Sensing: this feature allows the needle to detect non-uniform well bottoms, and adjusts the depth of the needle position to 2 mm (default value) above the detected bottom of the vial or well. You can use Vial/Well Bottom Sensing in combination with the Offset to customize the draw position of the needle. To turn on Vial/Well Bottom Sensing, mark the check box. The default setting is cleared. You may want to turn off Vial/Well Bottom Sensing to increase speed of injection, or to avoid the needle touching the bottom of the well if a sample precipitate could clog it.
<p>Smart Overlap</p>	<ul style="list-style-type: none"> • Enable Smart Overlap: Overlapped injection provides faster throughput of samples by allowing the preparation of the next injection while the current injection is in the mainpass (main path). This section is available only for a dual-needle Multisampler with identical left and right flow paths (Seat capillary and Loop capillary), and Alternating Needle selected in the Injection section of the method setup. • After Period of Time: specifies the time (in minutes) that the Multisampler waits after injection of a sample before taking up and injecting the next sample.

NOTE

It is important to calculate the time close to the start point of the next run to avoid waiting time with filled sample loop.

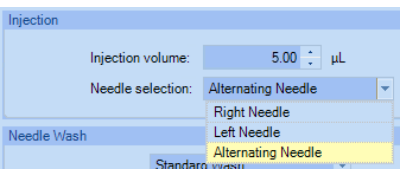
High Throughput

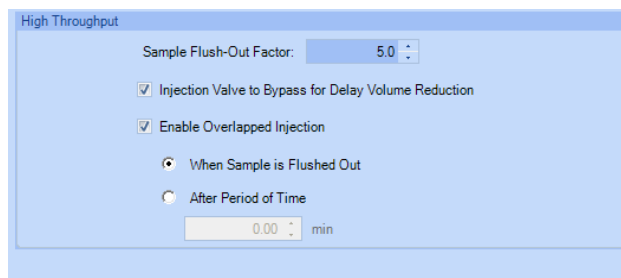

NOTE

This section is available only for a dual-needle Multisampler with different seat-capillary and loop-capillary volumes, and either **Right Needle** or **Left Needle** selected in the **Injection** section of the method setup.

Table 33 High throughput

Sample Flush-Out Factor	<p>The Sample Flush-Out Factor ensures that the sample is thoroughly flushed out of the sample loop and needle after switching into the mainpass (main path). The factor is part of the flush-out volume formula, which is calculated by the Multisampler firmware.</p> <p>The volume is calculated as: factor x (injection volume + seat capillary volume + valve volume).</p> <p>The Sample Flush-Out Factor is preset to 5.0 at the factory.</p> <p>The preset Sample Flush-Out Factor is correct for most methods. However, for unusually viscous samples, you should increase the Sample Flush-Out Factor to obtain the desired degree of flushing in order to prevent sample carryover.</p>
Injection Valve to Bypass for Delay Volume Reduction	<p>This parameter is used to switch the flow from the injector from mainpass (main path) to bypass after injection has taken place. This reduces the delay volume for low volume techniques. You can specify the point during the analyses when the valve switches to bypass. This is done by setting the Sample Flush-out Factor.</p>
Enable Overlapped Injection	<p>Overlapped injection provides faster throughput of samples by allowing the preparation of the next sample during analysis of the injected sample.</p>

Sequence Parameters

Sequence Parameters [Current Sequence:]

Sequence parameters | Sequence output

Data file

Path: C:\Chem32\1\Data\

Subdirectory: DEBAR00002

Auto Prefix: Counter:

Prefix/Counter SIG1 000001

Name Pattern

<SeqLine>:<SampleLoc>:<SampleName>

042-P1-A1-Example.D

Operator Name

SYSTEM

ChemStore

Transfer Settings...

Part of method to run

Acquisition Only

Use sequence table information

Wait: 0.00 minutes after loading a new method.

Bar code reader

Use in sequence On barcode mismatch don't inject

Update master method (data analysis parameters)

Sequence comment:

Shutdown

Post-Sequence command/macro

PUMPALL OFF

Not ready timeout: 0.00 minutes.

Fraction information

Fraction start location:

OK Cancel Help

Not ready timeout: the time in minutes has to be longer than the purge routine lasts - otherwise the run will be aborted before start.

5

Optimizing Performance

Delay Volume and Extra-Column Volume	162
Delay Volume	162
How to Configure the Optimum Delay Volume	163
How to Achieve Higher Injection Volumes	167
How to Achieve High Throughput	169
How to Achieve Higher Resolution	170
How to Achieve Higher Sensitivity	173
How to Achieve Lowest Carryover	174
Best Practices for Multiwash	176

This chapter gives hints on how to optimize the performance or use additional devices.

Delay Volume and Extra-Column Volume

The *delay volume* is defined as the system volume between the point of mixing in the pump and the front of the column.

The *extracolumn volume* is defined as the volume between the injection point and the detection point, excluding the volume in the column.

Delay Volume

In gradient separations, this volume causes a delay between the mixture changing in the pump and that change reaching the column. The delay depends on the flow rate and the delay volume of the system. In effect, this means that in every HPLC system there is an additional isocratic segment in the gradient profile at the start of every run. Usually the gradient profile is reported in terms of the mixture settings at the pump and the delay volume is not quoted even though this will have an effect on the chromatography. This effect becomes more significant at low flow rates and small column volumes and can have a large impact on the transferability of gradient methods. It is important, therefore, for fast gradient separations to have small delay volumes, especially with narrow bore columns (e.g., 2.1 mm i.d.) as often used with mass spectrometric detection.

How to Configure the Optimum Delay Volume

For fast gradients over 0.5 min, the delay volume of the system can be easily reduced without changing the physical configuration of the system. The change is achieved by changing the behavior of the multisampler. The delay volume of the autosampler is due to the flow path from the injection valve through the metering device, needle, needle seat, and connecting capillaries back to the injection valve (see [Table 34](#) on page 164). For a 1290/1260 Infinity II Multisampler, the delay volume equates approximately to 78 μL (G7167B) or 265 μL (G7167A). To make an injection, the valve switches from mainpass (main path) to bypass so that the metering device can draw the sample into the needle capillary. The injection is made when the valve switches back to mainpass (main path) and the sample is flushed onto the column. The valve remains in this position during analysis so that the autosampler is continually flushed and hence the gradient has to flow through this delay volume to reach the column. This can be eliminated by switching the injection valve from mainpass (main path) to bypass after the injection has been made and the injected sample has been flushed onto the column. In practice, this can be done a few seconds after injection by selecting the **Automatic Delay Volume Reduction (ADVR)** function in the autosampler setup menu. The Flush-out Factor (typically five times injection volume) ensures that enough time is allowed to flush the sample out of the injector before switching to bypass. For instance, a 1 μL injection under standard conditions effectively reduces the system delay volume by approximately 50 μL or 240 μL , depending on the installed Multisampler.

Table 34 Schematic of injection steps in the Multisampler (Single needle)

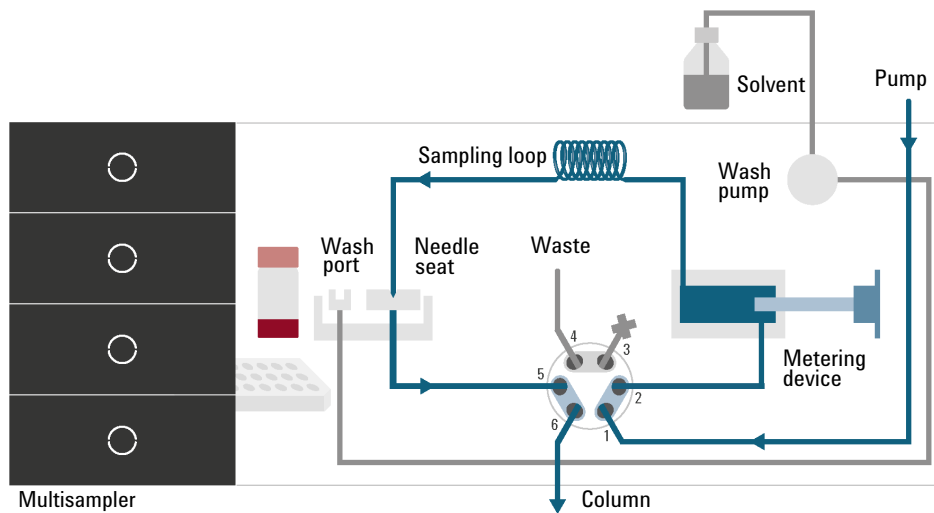

Figure 39 Valve in mainpass (main path), flow through

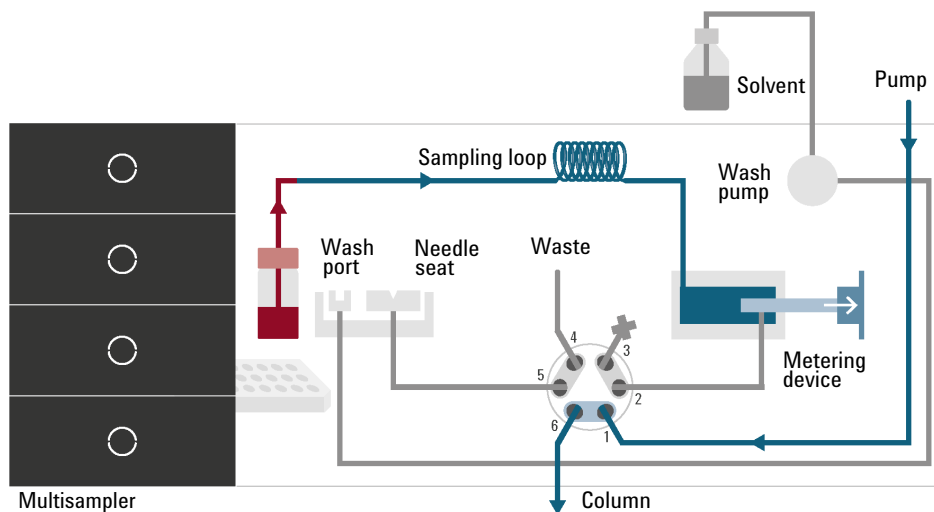

Figure 40 Valve in bypass, drawing sample

Optimizing Performance

How to Configure the Optimum Delay Volume

Table 34 Schematic of injection steps in the Multisampler (Single needle)

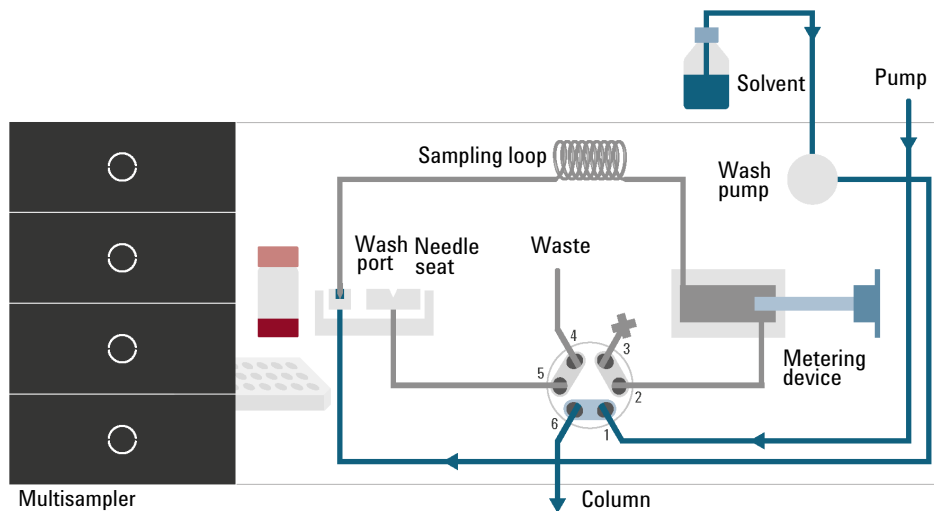

Figure 41 Valve in bypass, washing needle (standard wash)

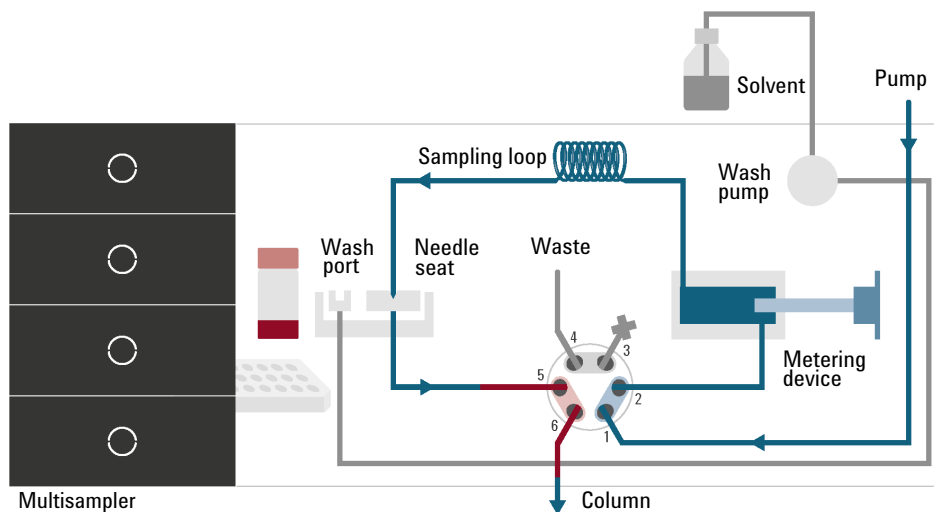

Figure 42 Valve in mainpass (main path), sample injected

Table 34 Schematic of injection steps in the Multisampler (Single needle)

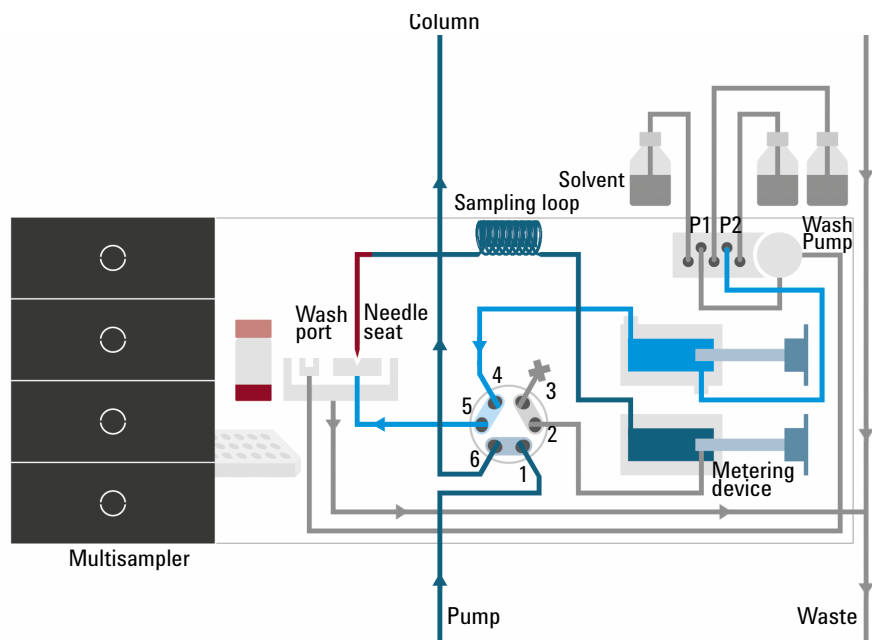

Figure 43 Valve in bypass, needle seat backflush (Multiwash)

When using ADVR, it should be noted that the gradient has already started at the pump at the instant of injection. The question should be asked whether the gradient has already reached the autosampler, in which case a small step in the gradient results. This happens when the delay volume is less than the flush-out volume and is not necessarily a problem but may be a factor to be considered in a method transfer. With a flush-out factor of 5 and an injection volume of 10 μL , the autosampler allows 50 μL to pass through before switching to bypass which, with a delay volume of 50 μL , means that the gradient just reached the injection valve. Smaller injection volumes have no effect, but for larger injection volumes this introduces a small step in the gradient. The flow rate in use also has an impact on the decision to use ADVR or not. At a 0.2 mL/min the delay time saved is 21 seconds, while at 1.0 mL/min it is 4 seconds.

The ADVR function is unlikely to be suitable for applications involving compounds that are known to cause carryover problems. The best way to reduce the delay volume is to install the 40 μL Analytical Head and the 20 μL Loop. To get the best results, it is also recommended to order the Low Dispersion Heat Exchanger and the micro flow cell for UV. This reduces the delay volume by 60 μL or 250 μL .

How to Achieve Higher Injection Volumes

The standard configuration of the Multisampler can inject a maximum volume of 20 μL (G7167B and G7137A) or 100 μL (G7167A and G5668A) with the standard loop capillaries. To increase the injection volume, a Multidraw Kit can be used, where extra volume is created by installing an extension capillary between the needle seat and the injection valve. Four different kits are available: the Large Volume Injection Kit (G4216-69711, providing 80 μL of extra volume) and the Multidraw Kit (G7167-68711, providing either 400 or 1400 μL of extra volume) for use with G7167A and G7167B; the Bio-inert Multidraw kit (G5667-68711, providing either 250 or 1000 μL of extra volume) for use with G5668A; and the Infinity II Bio LC Multidraw kit (G7137-68711, providing either 400 or 1400 μL of extra volume) for use with G7137A.

For higher injection volumes, larger analytical heads and sample loops can also be installed: 100 μL Analytical Head with 40 or 100 μL loops (for G7167B), and 900 μL Analytical Head with 500 or 900 μL loops (for G7167A and G7167B).

The 900 μL analytical head can also be combined with the 1400 μL Multidraw Extension Seat Capillary Kit for achieving the maximum volume of 1800 μL . In this configuration, the pressure limit is 400 bar.

NOTE

The multidraw mode only allows the storage of integer multiples of the analytical head volume in the seat capillary.

NOTE

Installing a seat extension capillary increases both the delay volume and the dead volume of the system, which might impact the chromatographic performance due to delayed gradient response and peak broadening. Therefore, re-evaluation of method parameters might be required.

NOTE

To calculate the delay volume of the Multisampler when using the Multidraw Kit, double the volume of the extended capillary. The system delay volume due to the Multisampler will increase accordingly.

NOTE

The Multiwash option is incompatible with multidraw.

Whenever a method is scaled down from a larger column to a smaller column it is important that the method translation allows for reducing the injection volume in proportion to the volume of the column to maintain the performance of the method. This keeps the volume of the injection at the same percentage volume with respect to the column.

This is particularly important if the injection solvent is stronger (more eluotropic) than the starting mobile phase and any increase will affect the separation particularly for early running peaks (low retention factor). Sometimes, it is the cause of peak distortion and the general rule is to keep the injection solvent the same or weaker than the starting gradient composition. This has a bearing on whether, or by how much, the injection volume can be increased. The user should check for signs of increased dispersion (wider or more skewed peaks and reduced peak resolution) when trying to increase the injection size. If an injection is made in a weak solvent, the volume can probably be increased further because the effect will be to concentrate the analyte on the head of the column at the start of the gradient. Conversely if the injection is in a stronger solvent than the starting mobile phase, then increased injection volume will spread the band of analyte down the column ahead of the gradient resulting in peak dispersion and loss of resolution.

Perhaps the main consideration in determining injection volume is the diameter of the column as this has a big impact on peak dispersion. Peak heights can be higher on a narrow column than with a larger injection on a wider column because there is less peak dispersion. With 2.1 mm i.d. columns typical injection volumes might range up to 5 to 10 μL but it is very dependent on the chemistry of the analyte and mobile phase as discussed earlier. In a gradient separation, injection volumes of about 5 % of the column volume might be achieved while maintaining good resolution and peak dispersion. One way to achieve larger injections is to use a trapping column selected by a switching valve to capture and concentrate the injection before switching it, i.e. injecting it, onto an analytical column, see “[Sample Enrichment](#)” on page 168. The valve can be conveniently located in the Multicolumn Thermostat.

Sample Enrichment

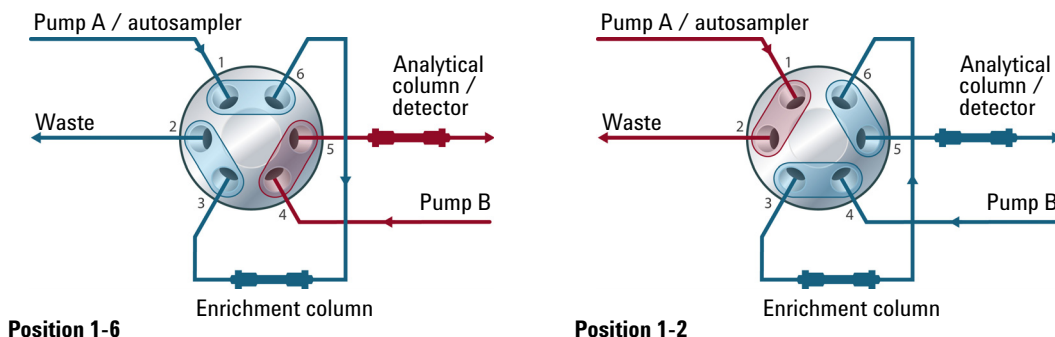

How to Achieve High Throughput

The injection can be optimized for speed remembering that drawing the sample too fast can reduce the reproducibility. Marginal gains are to be made here as the sample volumes used tend towards the smaller end of the range in any case. A significant portion of the injection time is the time taken with the needle movements to and from the vial and into the flush port. These manipulations can be performed while the previous separation is running. This is known as *overlapped injection* and it can be easily turned on from the sampler setup screen in the control software. The sampler can switch the flow to bypass after the injection has been made and then after, for example, 3 minutes into a 4 minutes run, start aspirating the next sample and preparing for injection. This can typically save 0.5 to 1 minute per injection.

How to Achieve Higher Resolution

Increased resolution in a separation will improve the qualitative and quantitative data analysis, allow more peaks to be separated or offer further scope for speeding up the separation. This section explains how resolution can be increased by examining the following points:

- Optimize selectivity
- Smaller particle-size packing
- Longer columns
- Shallower gradients, faster flow

Resolution between two peaks is described by the resolution equation:

$$R_s = \frac{1}{4} \sqrt{N} \frac{(\alpha - 1)}{\alpha} \frac{(k_2 + 1)}{k_2}$$

where

- R_s =resolution,
- N =plate count (measure of column efficiency),
- α =selectivity (between two peaks),
- k_2 =retention factor of second peak (formerly called capacity factor).

The term that has the most significant effect on resolution is the selectivity, α . In practice, varying this term involves changing the type of stationary phase (C18, C8, phenyl, nitrile etc.), the mobile phase, and temperature to maximize the selectivity differences between the solutes to be separated. This is a substantial piece of work that is best done with an automated method development system, which allows assessment of a wide range of conditions on different columns and mobile phases in an ordered scouting protocol. This section considers how to get higher resolution with any chosen stationary and mobile phases. If an automated method development system was used in the decision on phases, it is likely that short columns were used for fast analysis in each step of the scouting.

The resolution equation shows that the next most significant term is the plate count or efficiency, N , which can be optimized in several ways. N is inversely proportional to the particle size and directly proportional to the length of a column. Smaller particle size and a longer column thus result in a higher plate number. The pressure rises with the inverse square of the particle size and proportionally with the length of the column. This is the reason that the 1290

Infinity II LC System was designed to go to 1300 bar so that it can run sub-2-micron particles and column length can be increased to 100 mm or 150 mm. There are even examples of 100 mm and 150 mm columns linked to give 250 mm length. Resolution increases with the square root of N so doubling the length of the column will increase resolution by a factor of 1.4. What is achievable depends on the viscosity of the mobile phase as this relates directly to the pressure. Methanol mixtures will generate more backpressure than acetonitrile mixtures. Acetonitrile is often preferred because peak shapes are better and narrower in addition to the lower viscosity but methanol generally yields better selectivity (certainly for small molecules less than about 500 Da). The viscosity can be reduced by increasing the temperature but it should be remembered that this can change the selectivity of the separation. Experiment will show if this leads to increase or decrease in selectivity. As flow and pressure are increased, it should be remembered that frictional heating inside the column will increase and that can lead to slightly increased dispersion and possibly a small selectivity change both of which could be seen as a reduction in resolution. The latter case might be offset by reducing the temperature of the thermostat by a few degrees and again experiment will reveal the answer.

The van Deemter curve shows that the optimum flow rate through an STM column is higher than for larger particles and is fairly flat as the flow rate increases. Typical, close to optimum, flow rates for STM columns are: 2 ml/min for 4.6 mm i.d.; and 0.4 ml/min for 2.1 mm i.d. columns.

Optimizing Performance

How to Achieve Higher Resolution

In isocratic separations, increasing the retention factor, k , results in better resolution because the solute is retained longer. In gradient separations the retention is described by k^* in the following equation:

$$k^* = \frac{t_G}{\Delta\%B} \cdot \frac{F}{V_m} \cdot \frac{100}{S}$$

where:

- k^* = mean k value,
- t_G = time length of gradient (or segment of gradient) (min),
- F = flow (mL/min),
- V_m = column delay volume,
- $\Delta\%B$ = change in fraction of solvent B during the gradient,
- S = constant (ca. 4 – 5 for small molecules).

This shows that k and hence resolution can be increased by having a shallower gradient (2 to 5 %/min change is a guideline), a higher flow rate, and a smaller column volume. This equation also shows how to speed up an existing gradient – if the flow is doubled but the gradient time is halved, k^* remains constant, and the separation looks the same but happens in half the time. Recently published research has shown how a shorter STM column (at temperatures above 40 °C) can generate higher peak capacity than a longer STM column by virtue of running it faster. (See *Petersson et al., J.Sep.Sci, 31, 2346-2357, 2008, Maximizing peak capacity and separation speed in liquid chromatography.*)

How to Achieve Higher Sensitivity

The sensitivity of a separation method is linked to the choice of stationary and mobile phases as good separation with narrow peaks and a stable baseline with minimal noise are desirable. The choice of instrument configuration will have an effect and a major impact is the setup of the detector. This section considers how sensitivity is affected by:

- Pump mixer volume
- Narrower columns
- Detector flow cell
- Detector parameters

In addition, the discussion on detector parameters also mentions the related topics of selectivity and linearity.

Columns

Sensitivity is specified as a signal-to-noise ratio (S/N) and hence the need to maximize peak height and minimize baseline noise. Any reduction in peak dispersion will help to maintain peak height and so extra-column volume should be minimized by use of short, narrow internal diameter, connection capillaries and correctly installed fittings. Using smaller inner diameter columns should result in higher peak height and is therefore ideal for applications with limited sample amounts. If the same sample amount can be injected on a smaller i.d. column, then the dilution due to column diameter will be less and the sensitivity will increase. For example, decreasing the column i.d. from 4.6 mm to 2.1 mm results in a theoretical gain in peak height of 4.7 times due to the decreased dilution in the column. For a mass spectrometer detector, the lower flow rates of narrow columns can result in higher ionization efficiencies and therefore higher sensitivity.

How to Achieve Lowest Carryover

Carryover is measured when residual peaks from a previous active-containing injection appear in a subsequent blank solvent injection. There will be carryover between active injections, which may lead to erroneous results. The level of carryover is reported as the area of the peak in the blank solution expressed as a percentage of the area in the previous active injection. The Multisampler is optimized for lowest carryover by careful design of the flow path and use of materials in which sample adsorption is minimized. A carryover figure of 0.001 % should be achievable even when a triple quadrupole mass spectrometer is the detector. Operating settings of the Multisampler allow the user to set appropriate parameters to minimize carryover in any application involving compounds liable to stick in the system. The following functions of the Multisampler can be used to minimize carryover:

- Internal needle wash
- External needle wash
- Needle seat backflush
- Injection valve cleaning

The flow path, including the inside of the needle, is continuously flushed in normal operation, providing good elimination of carryover for most situations. Automated delay volume reduction (ADVR) reduces both the delay volume and the flushing of the standard Multisampler and should not be used with analytes where carryover might be a problem.

The outside of the needle can be washed using a wash vial in a specific location or the flush port. If a wash vial is chosen, then this vial should have no septum and should contain a solvent suitable for washing the sample from the needle. The septum is not used to avoid wiping contamination off the needle on the downstream only to re-apply it on the upstroke. The needle can be dipped into the vial multiple times. This will be effective in removing a small degree of carryover, but for more effective external needle wash, use the flush port.

The flush port is located above and behind the needle seat, and in the standard hardware configuration a peristaltic pump delivers the wash solvent. It has a volume of 0.68 mL and the peristaltic pump delivers 5 mL/min, which means the flush port volume is completely refilled with fresh solvent in 7 s.

If the flush port is selected, the user can set how long the outside of the needle is to be washed with fresh solvent. This can last from 2 – 3 s in routine situations where carryover is less of a problem, to 10 – 20 s for complete washing.

It is recommended that the external needle wash in the flush port should be standard procedure to avoid contaminating the needle seat. If the needle seat becomes contaminated, it must be back-flushed. In the standard setup, this task can be done manually by changing the flow connections, or it can be automated using the Flexible Cube (G4227A). In the Multiwash setup (G4757A), the needle seat back-flush is automated and can be performed with up to three different solvents.

The flush port and its solvent delivery pump and tubing should be regularly flushed to ensure the lowest carryover. For example, before using the system each day, prime the flush pump for three minutes with appropriate solvent.

When other measures have failed to eliminate carryover, it might be that analyte is adsorbing to the inner surfaces of the injection valve. In this case, the auto clean feature in the CDS can be activated, and the valve will make additional switching movements to clean out the flow path. If the problem compounds need a high percentage of organic phase for elution, it is recommended to switch the injection valve at the high percentage of organic phase after the last peak has eluted. It is also recommended to switch the injection valve again after the initial conditions for the mobile phase have stabilized. This ensures that the bypass groove in the rotor seal of the valve contains the gradient start conditions, which is especially important for flow rates below 0.5 mL/min. For samples where the outside of the needle cannot be cleaned sufficiently with water or alcohol from the flush pump, use wash vials with an appropriate solvent. With an injector program, several wash vials can be used for cleaning.

The optimum carryover performance of the Multisampler is achieved after a run-in period of new instruments or after the exchange of consumable parts (like needle, needle seat and valve parts). During injections in this period, surfaces of these parts adjust to each other. After this period, we recommend back-flushing the needle seat to get the sealing areas between needle and needle seat clean. Regular preventive maintenance service is recommended as the carryover performance of the autosampler depends on the integrity of these consumable parts.

Best Practices for Multiwash

Multiwash option is designed for the low carryover and can be installed in any Agilent Multisampler.

This option reduces carryover for critical samples by allowing:

- External needle wash with up to three different solvents
- Seat backflush with up to three different solvents

The use of the Multiwash option is not recommended with salt-containing mobile phases, as salt will crystallize on the needle and needle seat. Due to the flow path of the Multiwash hydraulic box, when the metering device moves to the home position before injection, the mobile phase will come out from the needle tip and might fall into the seat. This is expected behavior, independent of the Injection Path Cleaning settings, and does not indicate leakage.

If the Multiwash is installed on the system with salt-containing mobile phases, to avoid salt build-up on the needle and the seat, it is recommended to flush the Multisampler daily with water for 15 min and visually inspect the needle and seat. If necessary, use a lint-free tissue with distilled water to manually clean the needle, seat, and other parts that still contain salt residue.

When should the Multiwash option be used?

- If the system is intended for reversed-phase applications only and no precipitating compounds are present in the mobile phase.
- If the system is intended for applications with salt-containing mobile phases, the Multiwash option is not recommended. If the option is however installed, crystallization on the needle and the seat can take place. The following practices should be followed:
 - Perform daily a 15 min flushing with water to remove salt residue.
 - Perform external needle wash and seat backflush.
 - Visually control needle/seat/washport for salt residue.
 - Manually clean needle/seat/washport if necessary.

NOTE

If these procedures are not followed, it will lead to needle and seat blockages.

- If the system is intended for alternating applications with salt-containing mobile phases AND reversed-phase applications, Multiwash option is not supported. There is a high risk that salt residue will be continuously released and either interfere with reversed-phase chromatography or even cause clogging of the system.

A considerable amount of solvent is aging in the lines of the Multiwash flow paths, which could lead to elevated background in highly sensitive UV and MS measurements. To mitigate this, it is recommended to prime solvents in each Multiwash line in use to the wash port and S1 line (initial chromatographic condition) to the seat for at least 5 minutes before actual LC analysis is started.



6 Troubleshooting and Diagnostics

User Interfaces	179
Agilent Lab Advisor Software	180

This chapter gives an overview about the troubleshooting and diagnostic features and the different user interfaces.

User Interfaces

- Depending on the user interface, the available tests and the screens/reports may vary.
- The preferred tool for troubleshooting and diagnostics should be Agilent Lab Advisor Software, see [“Agilent Lab Advisor Software”](#) on page 180.
- The Agilent OpenLab ChemStation C.01.03 and above do not include any maintenance/test functions.
- Screenshots used within these procedures are based on the Agilent Lab Advisor Software.

Agilent Lab Advisor Software

The Agilent Lab Advisor Software (basic license, shipped with an Agilent LC pump) is a standalone product that can be used with or without a chromatographic data system. Agilent Lab Advisor helps to manage the lab for high-quality chromatographic results by providing a detailed system overview of all connected analytical instruments with instrument status, Early Maintenance Feedback counters (EMF), instrument configuration information, and diagnostic tests. With the push of a button, a detailed diagnostic report can be generated. Upon request, the user can send this report to Agilent for a significantly improved troubleshooting and repair process.

The Agilent Lab Advisor software is available in two versions:

- Lab Advisor Basic
- Lab Advisor Advanced

Lab Advisor Basic is included with every Agilent 1200 Infinity Series and Agilent InfinityLab LC Series instrument.

The Lab Advisor Advanced features can be unlocked by purchasing a license key, and include real-time monitoring of instrument actuals, all various instrument signals, and state machines. In addition, all diagnostic test results, calibration results, and acquired signal data can be uploaded to a shared network folder. The Review Client included in Lab Advisor Advanced allows to load and examine the uploaded data no matter on which instrument it was generated. This makes Data Sharing an ideal tool for internal support groups and users who want to track the instrument history of their analytical systems.

The optional Agilent Maintenance Wizard Add-on provides an easy-to-use, step-by-step multimedia guide for performing preventive maintenance on Agilent 1200 Infinity LC Series instrument.

The tests and diagnostic features that are provided by the Agilent Lab Advisor software may differ from the descriptions in this manual. For details, refer to the Agilent Lab Advisor software help files.

7

Error Information

What Are Error Messages	183
General Error Messages	184
Timeout	184
Shutdown	185
Remote Timeout	186
Lost CAN Partner	186
Leak Sensor Short	187
Leak Sensor Open	188
Compensation Sensor Open	188
Compensation Sensor Short	189
Fan Failed	190
Leak	191
Sampler Error Messages	192
Draw command aborted	192
Sample container vessel missing	192
Initialization failed	193
Injection valve initialization failed	194
Sampler alignment procedure command failed	194
Sampler transport initialization failed	195
Front door error	195
Alignment procedure: needle command failed	196
Needle hit the vessel bottom	197
Robot drive current too high	198
Robot drive hardware overcurrent	198
Cleaning Procedure Failed	199
Metering Device Initialization Failed	199
Flush Pump Device Initialization Failed	199
Peripheral Valve Initialization Failed	200
Seat Back Flushing Failed	200
Move Needle to Parkstation Failed	200
Taking Needle from Parkstation Failed	201
Taking sample tray from hotel position failed	201
Transport Motor Index Missing	201
Transport Motor Tag cannot be read	202
Peristaltic Pump Movement Failed	202

Sample Cooler/Sample Thermostat Error Messages	203
Sample temperature control voltage too low, check fuses and wires	203
Sample temperature control switched off due to condensate	203
Sample temperature control switched off due to overpressure	204
Sample temperature control sensor electronics calibration failed	204
Sample temperature control switched off due to supply voltage drop	205
Cooler condensate sensor defect	205
Cooler PCB is in error mode	205
Cooler condenser fan failed	206
Thermostat communication error	206
Heater defect	206
Heater in operating error	207
Heater has power supply failure	207
Thermostat sensor defect	207
Compressor has error	208
Sample Thermostat type unknown, update firmware	208
Thermostat fan defect	208

This chapter describes the meaning of error messages, and provides information on probable causes and suggested actions how to recover from error conditions.

What Are Error Messages

Error messages are displayed in the user interface when an electronic, mechanical, or hydraulic (flow path) failure occurs which requires attention before the analysis can be continued (for example, repair, or exchange of consumables is necessary). In the event of such a failure, the red status indicator at the front of the module is switched on, and an entry is written into the module logbook.

If an error occurs outside a method run, other modules will not be informed about this error. If it occurs within a method run, all connected modules will get a notification, all LEDs get red and the run will be stopped. Depending on the module type, this stop is implemented differently. For example, for a pump the flow will be stopped for safety reasons. For a detector, the lamp will stay on in order to avoid equilibration time. Depending on the error type, the next run can only be started, if the error has been resolved, for example liquid from a leak has been dried. Errors for presumably single time events can be recovered by switching on the system in the user interface.

Special handling is done in case of a leak. As a leak is a potential safety issue and may have occurred at a different module from where it has been observed, a leak always causes a shutdown of all modules, even outside a method run.

In all cases, error propagation is done via the CAN bus or via an APG/ERI remote cable (see documentation for the APG/ERI interface).

General Error Messages

General error messages are generic to all Agilent series HPLC modules and may show up on other modules as well.

Timeout

Error ID: 0062

The timeout threshold was exceeded.

Probable cause	Suggested actions
1 The analysis was completed successfully, and the timeout function switched off the module as requested.	Check the logbook for the occurrence and source of a not-ready condition. Restart the analysis where required.
2 A not-ready condition was present during a sequence or multiple-injection run for a period longer than the timeout threshold.	Check the logbook for the occurrence and source of a not-ready condition. Restart the analysis where required.

Shutdown

Error ID: 0063

An external instrument has generated a shutdown signal on the remote line.

The module continually monitors the remote input connectors for status signals. A LOW signal input on pin 4 of the remote connector generates the error message.

Probable cause	Suggested actions
1 Leak detected in another module with a CAN connection to the system.	Fix the leak in the external instrument before restarting the module.
2 Leak detected in an external instrument with a remote connection to the system.	Fix the leak in the external instrument before restarting the module.
3 Shut-down in an external instrument with a remote connection to the system.	Check external instruments for a shut-down condition.
4 The degasser failed to generate sufficient vacuum for solvent degassing.	Check the vacuum degasser for an error condition. Refer to the <i>Service Manual</i> for the degasser or the pump that has the degasser built-in.

Remote Timeout

Error ID: 0070

A not-ready condition is still present on the remote input. When an analysis is started, the system expects all not-ready conditions (for example, a not-ready condition during detector balance) to switch to run conditions within one minute of starting the analysis. If a not-ready condition is still present on the remote line after one minute the error message is generated.

Probable cause	Suggested actions
1 Not-ready condition in one of the instruments connected to the remote line.	Ensure the instrument showing the not-ready condition is installed correctly, and is set up correctly for analysis.
2 Defective remote cable.	Exchange the remote cable.
3 Defective components in the instrument showing the not-ready condition.	Check the instrument for defects (refer to the instrument's documentation).

Lost CAN Partner

Error ID: 0071

During an analysis, the internal synchronization or communication between one or more of the modules in the system has failed.

The system processors continually monitor the system configuration. If one or more of the modules is no longer recognized as being connected to the system, the error message is generated.

Probable cause	Suggested actions
1 CAN cable disconnected.	<ul style="list-style-type: none"> Ensure all the CAN cables are connected correctly. Ensure all CAN cables are installed correctly.
2 Defective CAN cable.	Exchange the CAN cable.
3 Defective mainboard in another module.	Switch off the system. Restart the system, and determine which module or modules are not recognized by the system.

Leak Sensor Short

Error ID: 0082

The leak sensor in the module has failed (short circuit).

The current through the leak sensor is dependent on temperature. A leak is detected when solvent cools the leak sensor, causing the leak sensor current to change within defined limits. If the current increases above the upper limit, the error message is generated.

Probable cause	Suggested actions
1 Defective leak sensor.	Please contact your Agilent service representative.
2 Leak sensor incorrectly routed, being pinched by a metal component.	Please contact your Agilent service representative.
3 Power switch assembly defective.	Please contact your Agilent service representative.
4 Cable or contact problem.	Please contact your Agilent service representative.

Leak Sensor Open

Error ID: 0083

The leak sensor in the module has failed (open circuit).

The current through the leak sensor is dependent on temperature. A leak is detected when solvent cools the leak sensor, causing the leak sensor current to change within defined limits. If the current falls outside the lower limit, the error message is generated.

Probable cause	Suggested actions
1 Leak sensor not connected to the power switch board.	Please contact your Agilent service representative.
2 Defective leak sensor.	Please contact your Agilent service representative.
3 Leak sensor incorrectly routed, being pinched by a metal component.	Please contact your Agilent service representative.
4 Power switch assembly defective.	Please contact your Agilent service representative.

Compensation Sensor Open

Error ID: 0081

The ambient-compensation sensor (NTC) on the power switch board in the module has failed (open circuit).

The resistance across the temperature compensation sensor (NTC) on the power switch board is dependent on ambient temperature. The change in resistance is used by the leak circuit to compensate for ambient temperature changes. If the resistance across the sensor increases above the upper limit, the error message is generated.

Probable cause	Suggested actions
1 Loose connection between the power switch board and the mainboard.	Please contact your Agilent service representative.
2 Defective power switch assembly.	Please contact your Agilent service representative.

Compensation Sensor Short

Error ID: 0080

The ambient-compensation sensor (NTC) on the power switch board in the module has failed (open circuit).

The resistance across the temperature compensation sensor (NTC) on the power switch board is dependent on ambient temperature. The change in resistance is used by the leak circuit to compensate for ambient temperature changes. If the resistance across the sensor falls below the lower limit, the error message is generated.

Probable cause	Suggested actions
1 Defective power switch assembly.	Please contact your Agilent service representative.
2 Loose connection between the power switch board and the mainboard.	Please contact your Agilent service representative.

Fan Failed

Error ID: 0068

The fan in the autosampler module or in the Sample Cooler/Sample Thermostat has failed.

- Error ID: 68,0 → Sampler fan defect
- Error ID: 68,1 → Evaporator fan defect
- Error ID: 68,2 → Condenser fan defect

The hall sensor on the fan shaft is used by the mainboard to monitor the fan speed. If the fan speed falls below a certain limit for a certain length of time, the error message is generated.

This limit is given by 2 revolutions/second for longer than 5 seconds.

Depending on the module, assemblies (e.g. the lamp in the detector) are turned off to assure that the module does not overheat inside.

Probable cause	Suggested actions
1 Fan cable disconnected.	Please contact your Agilent service representative.
2 Defective sampler fan.	Please contact your Agilent service representative.
3 Defective evaporator fan.	Please contact your Agilent service representative.
4 Defective condenser fan.	Please contact your Agilent service representative.
5 Blown fuses.	Please contact your Agilent service representative.
6 Defective mainboard.	Please contact your Agilent service representative.

Leak

Error ID: 0064

A leak was detected in the module.

The signals from the two temperature sensors (leak sensor and board-mounted temperature-compensation sensor) are used by the leak algorithm to determine whether a leak is present. When a leak occurs, the leak sensor is cooled by the solvent. This changes the resistance of the leak sensor which is sensed by the leak sensor circuit on the main board.

Probable cause	Suggested actions
1 Loose fittings.	Ensure all fittings are tight.
2 Broken capillary.	Exchange defective capillaries.
3 Leaking rotor seal or needle seat.	Exchange the rotor seal or seat capillary.
4 Defective metering seal.	<ul style="list-style-type: none">• Exchange the metering seal.• <i>Make sure the leak sensor is thoroughly dry before restarting the autosampler.</i>
5 Leaking peristaltic pump.	Exchange the peristaltic pump.

Sampler Error Messages

NOTE

Please verify the first errors in the list. The last error message could be a subsequent error.

Draw command aborted

Error ID: 25478

The robot (sample handler) failed to move correctly during injection sequence.

Probable cause	Suggested actions
1 Missing vessel.	Check if the sample vial is installed in the correct position, or edit the method or sequence accordingly.
2 Needle command failed.	Check the status of the needle assembly. Perform an autoreferencing.

Sample container vessel missing

Error ID: 25471

No vial was found in the position defined in the method or sequence. When the needle carrier moves to a vial and the needle lowers into the vial, the position of the needle is monitored by an encoder behind the vial pusher. If no vial is present, the encoder detects an error and the message "missing vial" is generated.

Probable cause	Suggested actions
1 No vial in the position defined in the method.	<ul style="list-style-type: none"> Install the sample vial in the correct position. Edit the method or sequence accordingly.
2 Defective needle assembly.	Exchange the needle assembly.
3 Sample container missing or not correctly installed.	Install the sample container correctly on the tray.

Initialization failed

Error ID: 25120

The autosampler failed to complete initialization correctly. The autosampler initialization procedure moves the robot to its reference positions in a predefined routine. During initialization, the processor monitors the position sensors and motor encoders to check for correct movement. During initialization the system also checks the status of the sample hotel and the hydraulic box. If one or more of the movements or the status information of the subparts is not read out successfully, the error message is generated.

Probable cause	Suggested actions
1 Front door not installed correctly.	<ul style="list-style-type: none"> • Check if the front door is installed correctly. • Check if the magnet is in place in the front door.
2 Sample handler not aligned correctly.	Do an autoreferencing.
3 Mechanical obstruction of the sample handler.	Ensure unobstructed movement.
4 Defective sample handler motors.	Please contact your Agilent service representative.
5 Loose connection between hydraulic box and adapter board.	Please contact your Agilent service representative.
6 Defective sample hotel electronic.	Please contact your Agilent service representative.
7 Defective specific main board or fusion board.	Please contact your Agilent service representative.

Injection valve initialization failed

Error ID: 25123

The autosampler failed to complete initialization correctly. The autosampler initialization procedure can recognize and move the injection valve to its reference positions in a predefined routine. During initialization, the processor monitors the position sensor, tag sensors, and actuator motor to check for correct movement. If one or more of the movements or the status information of the subparts is not read out successfully, the error message is generated.

Probable cause	Suggested actions
1 Injection valve not installed correctly.	Check if the injection valve is installed correctly.
2 TAG and TAG reader not aligned correctly.	Check if the TAG or the TAG Reader are aligned correctly.
3 Electrical connection or components are defective.	Please contact your Agilent service representative.

Sampler alignment procedure command failed

Error ID: 25034

The autosampler failed to complete the alignment correctly.

Probable cause	Suggested actions
1 Mechanical obstruction of the sample handler.	Ensure unobstructed movement.
2 Defective sample handler motors.	Please contact your Agilent service representative.

Sampler transport initialization failed

Error ID: 25121

The autosampler failed to complete initialization correctly. The autosampler initialization procedure moves the robot to its reference positions in a predefined routine. During initialization, the processor monitors the position sensors and motor encoders to check for correct movement. During initialization, the processor monitors the position sensor, tag sensors, and actuator motor to check for correct movement. If one or more of the movements or the status information of the subparts is not read out successfully, the error message is generated.

Probable cause	Suggested actions
1 Sample handler not aligned correctly.	Switch off the instrument and do an autoreferencing.
2 Mechanical obstruction of the sample handler.	Ensure unobstructed movement.
3 Defective sample handler motors.	Please contact your Agilent service representative.

Front door error

Error ID: 25051, 25049

During initialization, the autosampler recognizes the position of the front door. If the front door is open, this error message is displayed.

Probable cause	Suggested actions
1 Front door is not closed properly.	Check if the front door is closed or if the magnet is missing.

Alignment procedure: needle command failed

Error ID: 25095

During the parking or movements of the needle assembly, the status information of the subparts is not read out successfully and the error message is generated.

Probable cause	Suggested actions
1 The sample loop capillary was squeezed in the needle parkstation.	<ul style="list-style-type: none">• Check if the sample loop is installed correctly.• Do an autoreferencing afterwards (needle assembly must be installed in the needle parkstation during this procedure).
2 The needle assembly was not installed correctly in the needle parkstation.	<ul style="list-style-type: none">• Check if the needle assembly is installed correctly.• Install the needle assembly on the sample handler.• Do a reset of the sample handler.• Do an autoreferencing (the needle assembly must be installed in the needle parkstation during this procedure).• If this will not help: Please contact your Agilent service representative.
3 Needle parkstation is loose.	Carefully tighten the needle parkstation.
4 For G5668A (Bio-inert Multisampler): Ceramic part of the needle is broken.	Replace the needle assembly.

Needle hit the vessel bottom

Error ID: 25226

The autosampler failed to complete injection sequence correctly. The autosampler can move and draw sample from the draw position and generates the error message.

Probable cause	Suggested actions
1 Sample container is not installed correctly in the pallet.	Check if the sample container is installed correctly.
2 Sample container definition in the CDS is not correct.	<ul style="list-style-type: none">• Check if the correct sample container is selected in the CDS.• Verify if the dimension of the sample container match the database of your CDS.
3 Sample handler not aligned correctly.	<ul style="list-style-type: none">• Check if the sample handler can move freely.• Do an auto referencing (needle assembly must be installed in the needle parkstation during this procedure).• If this will not help: Please contact your Agilent service representative.

Robot drive current too high

Error ID: 25409

The autosampler failed to complete initialization correctly. The autosampler initialization procedure can not move the motors inside of the sample handler to their reference positions in a predefined routine. During initialization, the processor monitors the position sensor and encoders to check for correct movement. If one or more of the movements or the status information of the subparts is not read out successfully, the error message is generated.

Probable cause	Suggested actions
1 Sample handler is blocked.	<ul style="list-style-type: none"> • Check if the sample handler can move freely. • Switch off the instrument. • Do an auto referencing (needle assembly must be installed in the needle parkstation during this procedure).
2 Defective sample handler motors.	Please contact your Agilent service representative.

Robot drive hardware overcurrent

Error ID: 25411

The autosampler failed to complete initialization correctly. The autosampler electronic has detected a increasing of the internal limits and has generated the error message.

Probable cause	Suggested actions
1 Bad electronic connections.	Please contact your Agilent service representative.
2 Defective mainboard/fusion board.	Please contact your Agilent service representative.

Cleaning Procedure Failed

Error ID: 25400, 1-4

Cleaning procedure failed. Parameter shows what kind of cleaning procedure has failed: 1 = Wash, 2 = Prime, 3 = Autoclean, 4 = Clogged seat.

Probable cause	Suggested actions
1 Solvent lines not installed correctly (valve block or flushpump).	Check status of the solvent lines. Use isopropanol for verification.
2 Clogged needle seat.	Replace the needle seat.

Metering Device Initialization Failed

Error ID: 25122

Probable cause	Suggested actions
1 Hydraulic box not in place.	Please contact your Agilent service representative.
2 Metering device not properly installed.	Check the correct positioning of RFID tag and tag reader.

Flush Pump Device Initialization Failed

Error ID: 25124

Probable cause	Suggested actions
1 Hydraulic box not in place.	Please contact your Agilent service representative.
2 Flush pump not properly installed.	Check the correct positioning of RFID tag and tag reader.

Peripheral Valve Initialization Failed

Error ID: 25125

Probable cause	Suggested actions
1 Hydraulic box not in place.	Please contact your Agilent service representative.
2 Valve not properly installed.	Check the correct positioning of RFID tag and tag reader.

Seat Back Flushing Failed

Error ID: 25119

Probable cause	Suggested actions
1 Clogged needle seat.	Replace the needle seat.

Move Needle to Parkstation Failed

Error ID: 25106

Probable cause	Suggested actions
1 Autoreferencing values missing or outdated.	Manually install the needle into the parkstation, clear current autoreferencing values (use Clear data on Lab Advisor), power cycle the module and perform autoreferencing.

Taking Needle from Parkstation Failed

Error ID: 25105

Probable cause	Suggested actions
1 Parkstation is loose.	Carefully tighten the parkstation. Avoid overtightening, as this could damage the baseplate of the module.
2 Needle assembly is defective.	Replace the needle assembly.
3 Autoreferencing needed.	Manually install the needle into the parkstation, clear current autoreferencing values (use Clear data on Lab Advisor), power cycle the module and perform autoreferencing.

Taking sample tray from hotel position failed

Error ID: 25104

Probable cause	Suggested actions
1 Mechanical obstruction of the sample handler by reference vial holder.	Please contact your Agilent service representative.

Transport Motor Index Missing

Error ID: 25235

The index of a transport motor cannot be found. The motor ID is given in the event parameter: 0=A, 1=B, 2=Z1, 3=Z2.

Probable cause	Suggested actions
1 Defective fuse.	Please contact your Agilent service representative.
2 Defective mainboard.	Please contact your Agilent service representative.

Transport Motor Tag cannot be read

Error ID: 25236

The tag data of a transport motor cannot be read. The motor ID is given in the event parameter: 0=A, 1=B, 2=Z1, 3=Z2.

Probable cause	Suggested actions
1 One of the sample handler cables is not properly connected.	Please contact your Agilent service representative.
2 One of the sample handler cables is damaged (corroded or chipped off).	Please contact your Agilent service representative.
3 Defective mainboard.	Please contact your Agilent service representative.

Peristaltic Pump Movement Failed

Error ID: 25463

Probable cause	Suggested actions
1 Pump tubing blocked.	Verify that the solvent tubing is not blocked.
2 Pump motor is defective.	Replace the pump motor.
3 Pump is defective.	Replace the peristaltic pump.

Sample Cooler/Sample Thermostat Error Messages

Sample temperature control voltage too low, check fuses and wires

Error ID: 30713

The compressor voltage is below the lower threshold value.

Probable cause	Suggested actions
1 Potential hardware error.	Please contact your Agilent service representative.

Sample temperature control switched off due to condensate

Error ID: 30715

The cooler/thermostat was switched off due to a condensate event.

Probable cause	Suggested actions
1 Overfilled container.	Empty the condensate container. Verify that the open end of the tubing doesn't immerse in the liquid.
2 Drainage issues.	<ul style="list-style-type: none"> • Verify the correct plumbing of the condensate drainage system. • Make sure that no kinks or mechanical blocks are present in the drainage system. • Avoid the formation of the siphoning effect. • Make sure that the hosting sampler is level.

Sample temperature control switched off due to overpressure

Error ID: 30716

The pressure in the refrigerant circuit exceeded the maximum allowed level. To prevent any damage to the system, the compressor was turned off.

Probable cause	Suggested actions
1 Overheated condenser.	Turn off the cooler/thermostat and wait for 15 min to allow the system to cool down. Verify if there is enough space around the sampler for adequate ventilation and the cooler/thermostat is not exposed to direct sunlight.
2 Potential hardware error.	Please contact your Agilent service representative.

Sample temperature control sensor electronics calibration failed

Error ID: 30717

The system is in an error state because the calibration of the analog temperature sensor has failed.

Probable cause	Suggested actions
1 Sampler incompatibility.	If the hosting sampler is a Vialsampler, verify its compatibility with the Sample Cooler installed. Units with the serial number DEBAT02000 or below are equipped with an analog temperature sensor that is not compatible with the Vialsampler.
2 Potential hardware error.	Please contact your Agilent service representative.

Sample temperature control switched off due to supply voltage drop

Error ID: 30718

The compressor is turned off due to an unexpected drop in the supply voltage.

Probable cause	Suggested actions
1 Potential hardware error.	Please contact your Agilent service representative.

Cooler condensate sensor defect

Error ID: 30719

The condensate sensor of the cooler/thermostat is not working properly.

Probable cause	Suggested actions
1 Potential hardware error.	Please contact your Agilent service representative.

Cooler PCB is in error mode

Error ID: 30725

The system is in an error state because the compressor control board has encountered an unexpected error.

Probable cause	Suggested actions
1 Potential hardware error.	Please contact your Agilent service representative.

Cooler condenser fan failed

Error ID: 30726

The condenser fan of the cooler is not working properly.

Probable cause	Suggested actions
1 Potential hardware error.	Please contact your Agilent service representative.

Thermostat communication error

Error ID: 30738

The system is in an error state because the communication between the sampler and the thermostat has failed.

Probable cause	Suggested actions
1 Potential hardware error.	Please contact your Agilent service representative.

Heater defect

Error ID: 30739

One of the heating elements is malfunctioning or broken.

Probable cause	Suggested actions
1 Potential hardware error.	Please contact your Agilent service representative.

Heater in operating error

Error ID: 30744

The system is in an error state because the thermostat heater has encountered an unexpected error.

Probable cause	Suggested actions
1 Potential hardware error.	Please contact your Agilent service representative.

Heater has power supply failure

Error ID: 30745

The voltage measured at the electric amplifier is below the expected level.

Probable cause	Suggested actions
1 Potential hardware error.	Please contact your Agilent service representative.

Thermostat sensor defect

Error ID: 30751

One of the digital temperature sensors of the cooler/thermostat is not working properly.

Probable cause	Suggested actions
1 Potential hardware error.	Please contact your Agilent service representative.

Compressor has error

Error ID: 30756

The system is in an error state because the control board of the compressor has encountered an unexpected error.

Probable cause	Suggested actions
1 Potential hardware error.	Please contact your Agilent service representative.

Sample Thermostat type unknown, update firmware

Error ID: 30768

The system is in an error state because the type of the thermostat is unsupported by the current firmware revision.

Probable cause	Suggested actions
1 Potential hardware error.	Please contact your Agilent service representative.

Thermostat fan defect

Error ID: 30771

One of the cooling fans of the cooler/thermostat is not working properly.

Probable cause	Suggested actions
1 Potential hardware error.	Please contact your Agilent service representative.



8 Test Functions and Calibration

Introduction	210
System Pressure Test	211
System Pressure Test Evaluation	213
Auto Referencing	214
Maintenance Positions	216
Change Needle Assembly	217
Change Sample Loop Capillary	218
Arm Position	218
Change Metering Device	219
Injector Steps	220
Sample Cooler Function Test	222
Sampler Leak Test	223

This chapter describes the built in test functions.

Introduction

All tests are described based on the Agilent Lab Advisor Software B.02.06 or above. Other user interfaces may not provide any test or just a few. For details on the use of the interface refer to the interface documentation.

Table 35 Interfaces and available test functions

Interface	Comment	Available Function
Agilent Lab Advisor	All tests are available Adding of pressure to chromatographic signals possible	<ul style="list-style-type: none"> • System Pressure test • Maintenance • Drawer Detection/Auto Referencing • Sample Cooler Function Test • Sample Thermostat Function Test • Sample Handler Function Test
Agilent ChemStation	No tests available Adding of pressure to chromatographic signals possible	<ul style="list-style-type: none"> • Drawer Detection/Auto Referencing • Temperature mainboard • Pressure/Pressure ripple

For details on the use of the interface refer to the interface documentation.



System Pressure Test

The test determines the leak rate of the system between pump outlet valves and a blank nut. The blank nut can be positioned at different locations in the system before the flow cell, to determine and verify the leak rate of individual modules and components. The test allows for setting the pressure at which the test is performed. The leak rate of high pressure parts is not always a linear function and therefore it is recommended to perform the test at a pressure that corresponds to the normal operating pressure of the system.

When

- In case of a suspected leak
- To verify successful execution of maintenance

Parts required

	#	p/n	Description
	1	5067-6127 	Blank Nut SL For 1290 Infinity II Multisampler, use the Blank Nut SL which fits the special port size of the VICI valve. This Blank Nut is backward compatible and can be used for the 1260 Infinity II Multisampler as well.
OR	1	5043-0277 	Blank nut long 10-32, PEEK For Bio-inert or 1290 Bio systems

Test Functions and Calibration

System Pressure Test

- 1 Run the System pressure test with the Agilent Lab Advisor (for further information see Online-Help of user interface).

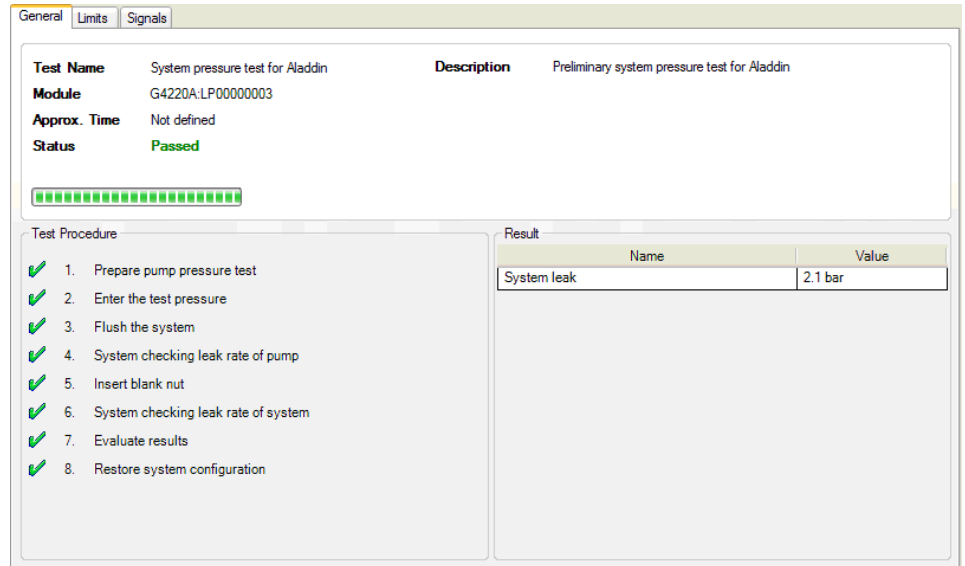

Figure 44 System Pressure Test – Result

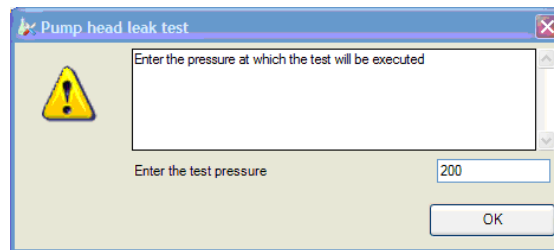

Figure 45 System Pressure Test – Dynamic pressure input

System Pressure Test Evaluation

Test Failed

Probable cause	Suggested actions
1 Damaged blank nut (poorly shaped from over tightening).	Before investigating any other possible sources of failure make sure that the blank nut you are using is in a good condition and properly tightened.
2 Pump leakage.	Perform the Pump Head Leak test.
3 Loose or leaky fittings.	Tighten the fittings or replace capillaries.
4 Autosampler leakage.	Perform the Autosampler Leak test.
5 Thermostatted Column Compartment valve leakage.	Replace the TCC valve rotor seal.

NOTE

Notice the difference between *error* in the test and a *failed* result! An *error* is caused by an abnormal termination during the operation of the test, whereas a *failed* result indicates that the test result were not within the specified limits.

Auto Referencing

The sampler auto referencing uses predefined positions on the base plate and the sample hotel to calibrate the positioning of the needle parkstation and the sample hotel. The auto referencing is required to compensate deviations in positioning the needle assembly and the sample tray. The auto referencing is required after disassembling the system or when you exchange the sample handler, the sample hotel, the needle parkstation, the needle assembly or one of the main boards. This function is implemented in the drawer detection and in the needle exchange routine.

When

After disassembling the module or an exchange of the needle assembly.

Preparations

- Workspace of the sampler is empty
- All drawers are closed properly
- All drawers have two sample trays installed, but no sample containers
- All drawers have been properly configured
- Needle assembly is installed in the needle parkstation

Test Functions and Calibration

Auto Referencing

- 1 Open the Agilent chromatography data system of the instrument.
A right-click into the Active Area of the sampler will open a menu to modify
 - drawer configuration
 - capillaries
 - Reference Vial Bar

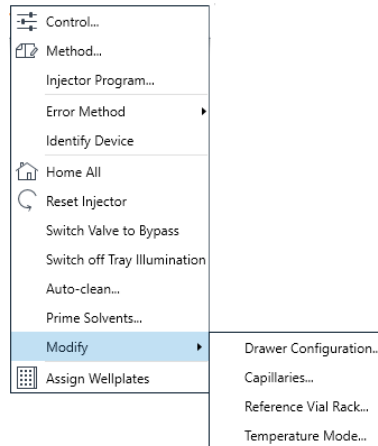

- 2 Use drawer configuration and follow the software instructions.
Auto referencing is done.
- 3 Click the **Back** button to leave the **Service & Diagnosis** menu.

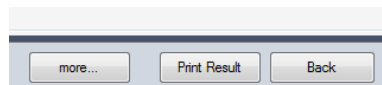

NOTE

For auto referencing, you can alternatively use the Local Controller.

Maintenance Positions

Some maintenance procedures require the needle assembly, the sample loop flex, the metering device and the needle seat to be moved to specific positions to enable easy access to components. The maintenance functions move these assemblies into the appropriate maintenance position. In the Agilent Lab Advisor Software the maintenance positions can be selected in the **Service & Diagnostics** view.

When

Performing maintenance on the module

- 1 Run the Maintenance Positions in the **Service & Diagnostics** View in the Agilent Lab Advisor (for further information see Online-Help of user interface).

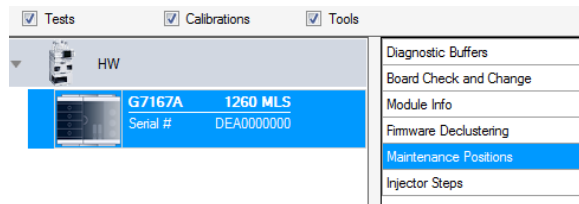

Figure 46 Maintenance Positions

Change Needle Assembly

The Sample handler is positioning the needle assembly so that there is easy access for changing needle assembly or needle seat. The position is far to the left of the needle parkstation, and the current to the motors are off, so that the Z-drive of the robot can be moved while servicing the module.

NOTE

For safety reason you have to lock the needle assembly before you detach the needle from the robot. Refer to “[Remove the Needle Assembly](#)” on page 234 and “[Install the Needle Assembly](#)” on page 239.

NOTE

During normal operation the needle assembly has to be unlocked.

The screenshot shows a software interface titled "Maintenance Positions". Under "Task Selection", there are two groups of dropdown menus. The first group includes "Change Rotor Seal" (set to No), "Change Loop" (set to No), and "Change Metering Device" (set to No). The second group includes "Change Seat" (set to Yes) and "Change Needle" (set to Yes). To the right of these menus is a "Start >>" button. Below the button is a yellow information box with an 'i' icon and the text "Press the [Start >>] button in order to begin." At the bottom right, under "Procedure", a list of steps is shown: "Change the seat", "Change the needle", "Leave the service mode", "Perform auto referencing", and "Reset EMF Counters".

Figure 47 Change Needle Assembly

Change Sample Loop Capillary

The **Change Loop** command positions the Z-drive of the robotarm far to the left of the needle parkstation to enable easy exchange of the sample loop cartridge.

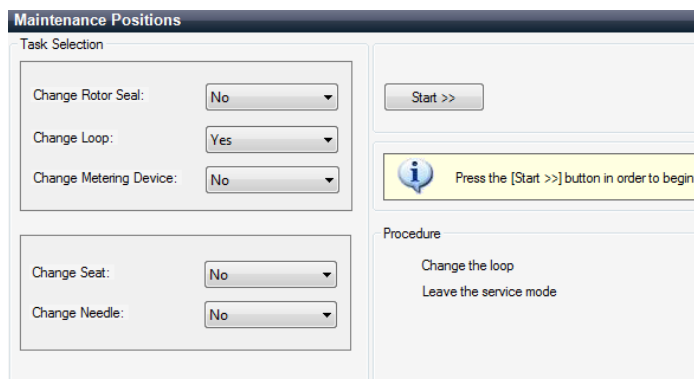

Figure 48 Change Sample Loop Capillary

Arm Position

The home position of the sampler ensures a better access to the workspace. When transporting the module it is highly recommended to use the **Instrument Control >Park Position** command, in order to place the Sample Handler in a position for safe transport.



Figure 49 Park Position Button

NOTE

If the transport assembly is not parked and not protected by the transport foam, the module could be damaged due to excessive shock of the shipping container during transport.

Change Metering Device

When removing the metering device is necessary (by exchanging the metering seal for instance), the metering drive needs to be moved to a position at the far back, in order to prevent seal and/or piston damage.

The screenshot shows a software interface titled "Maintenance Positions". Under the "Task Selection" section, there are two groups of dropdown menus. The first group includes "Change Rotor Seal:" (set to "No"), "Change Loop:" (set to "No"), and "Change Metering Device:" (set to "Yes"). The second group includes "Change Seat:" (set to "No") and "Change Needle:" (set to "No"). To the right of these menus is a "Start >>" button. Below the button is a yellow information box with an 'i' icon and the text "Press the [Start >>] button in order to begin." At the bottom right, under the "Procedure" section, the steps are listed as "Change the metering device" and "Leave the service mode".

Figure 50 Change Metering Device

Injector Steps

Each movement of the sampling sequence can be done under manual control. This is useful during troubleshooting, where close observation of each of the sampling steps is required to confirm a specific failure mode or verify successful completion of a repair. Each injector step command actually consists of a series of individual commands that move the multisampler components to predefined positions, enabling the specific step to be done.

- 1 Run the **Injector Steps** in the **Service & Diagnostics** View in the Agilent Lab Advisor (for further information see Online-Help of user interface).

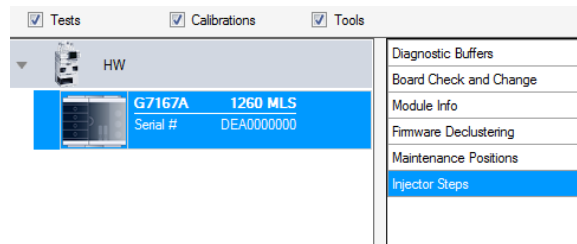

Test Functions and Calibration

Injector Steps

- 2 Select the individual step command like needle selection and needle position (for further information see Online-Help of user interface).

Action	Result
User interaction	Take tray from drawer 1 (Front)
Device command accepted	Ok
User interaction	Take needle 2
Device command accepted	Ok
User interaction	Needle Into Sample
Device command accepted	Ok
User interaction	Draw (Volume=1 µl)
Device command accepted	Ok
User interaction	Needle To Home
Device command accepted	Ok
Device command accepted	Ok
User interaction	Move tray back into drawer
Device command accepted	Ok
User interaction	Mainpass
Device command accepted	Ok

NOTE

Follow a logical order to use the injector steps function.

Sample Cooler Function Test

The **Sample Cooler Function Test** is a diagnostic test to verify the correct functioning of the Sample Cooler/Sample Thermostat. The test takes up to 15 min to complete and returns a pass/fail type result. If the test failed or was aborted by the system, the final report will include some information on the possible root causes.

Before the test starts, the compressor is turned off to allow the system to reach the initial conditions. The test starts with acquiring data from the evaporator temperature sensor. If the reading is stable for at least 10 s ($\Delta T < 0.5\text{ }^{\circ}\text{C}$), the compressor turns on and the temperature inside the cooler/thermostat starts to drop.

For the test to succeed, the system must pass three temperature checkpoints in a timely manner. These checkpoints are the following:

- Checkpoint 1: The temperature drops by 1/3 of the difference between the starting temperature and 5 °C.
- Checkpoint 2: The temperature drops below 5 °C.
- Checkpoint 3: The temperature stabilizes at a value below 5 °C and stays stable for at least 60 s ($\Delta T < 1.0\text{ }^{\circ}\text{C}$).

For a Sample Thermostat, the heater resistance of the heating elements will also be tested and checked if the measured value is within the acceptance range (5 – 9 Ohm).

NOTE

Lab Advisor B.02.11 or higher is needed for testing the heater resistance of the G7167-60101 Sample Thermostat.

NOTE

Lab Advisor 2.19 or higher is needed to execute the Sample Cooler Function Test for the G7167-60201 Sample Thermostat.

Sampler Leak Test

The **Sampler Leak Test** determines the specific leak rates of injection valve, metering device, needle/seat, and system. The test requires that a blank nut gets installed at port 6 (outlet) of the injection valve. The test allows for setting the pressure at which it should be performed (maximum pressure allowed: 1000 bar), and it is recommended to use a pressure that corresponds to the normal operation of the system.

The test proceeds as follows:

- 1 A pump head leak test is carried out on the selected channel.
- 2 A **Pressure Test** is carried out in the bypass position.
- 3 A **Pressure Test** is carried out in the main pass position.
- 4 A **Pressure Test** is carried out in the main pass position with the needle at the blocked seat position.



The values obtained are then used to calculate the injection valve, metering device, and needle/seat leak rates.

At the end of the test, the results are evaluated automatically.

When

- In case of a suspected leak
- To verify successful execution of maintenance

Parts required

p/n	Description
5067-6127 	Blank Nut SL
5043-0277 	Blank nut long 10-32, PEEK
8710-0510 	Open-end wrench 1/4 – 5/16 inch

Preparations

Place a bottle of solvent in the channel that shall be tested. The type of solvent is not important.

- 1 Run the **Sampler Leak Test** with the Agilent LabAdvisor and follow the provided instructions.

NOTE

The **Sampler Leak Test** is only available for Standard or Multiwash Multisamplers and the Online Sample Manager. For Dual-Needle Multisamplers, perform the **System Pressure Test** instead.

9

Maintenance

Introduction to Maintenance	225
Warnings and Cautions	227
Overview of Maintenance	229
Clean the Module	230
Removal and Installation of the Front Door	231
Remove the Needle Assembly	234
Install the Needle Assembly	239
Exchange the Needle Seat	243
Replace the Rotor Seal	246
Replace the Injection Valve	252
Remove the Metering Seal	257
Install the Metering Seal	262
Replace the Peristaltic Pump Cartridge	269
Replace the Flushhead Seal	272
Remove the Sample Loop-Flex	276
Installing the Sample Loop-Flex	280
Replace the Dummy Drawer	285
Optional Configurations	285
Installing and Replacing of Drawers (Upgrade Drawer Kit)	286
Configuration of the Hotel Drawers	290
Replace the Sample Cooler/Sample Thermostat	293
Replace the Module Firmware	298

This chapter describes the maintenance of the Multisampler

Introduction to Maintenance

Figure 51 on page 225 shows the main user accessible assemblies of the multisampler. These parts can be accessed from the front (simple repairs) and don't require to remove the multisampler from the system stack.

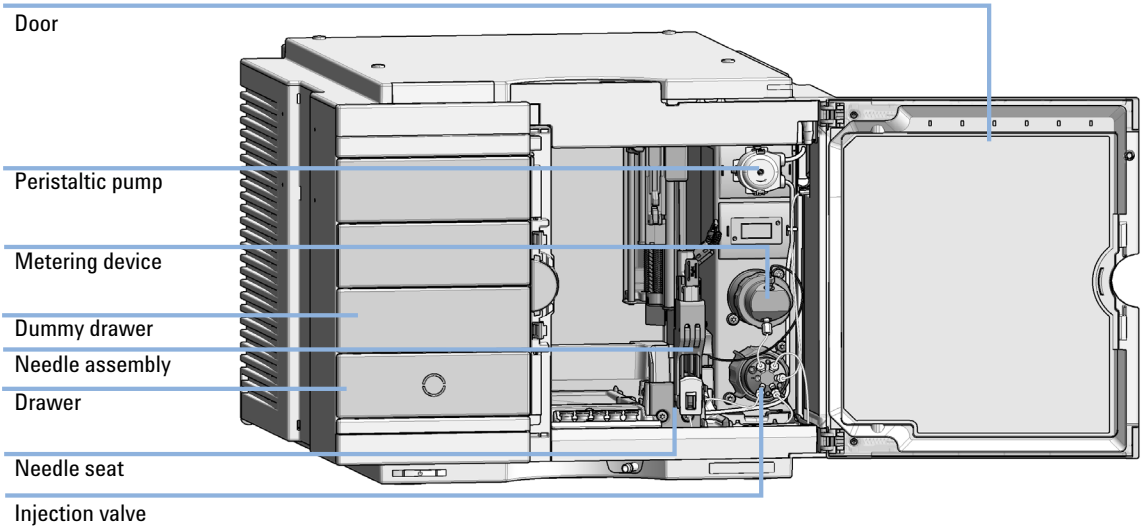

Figure 51 Main user accessible assemblies (standard)

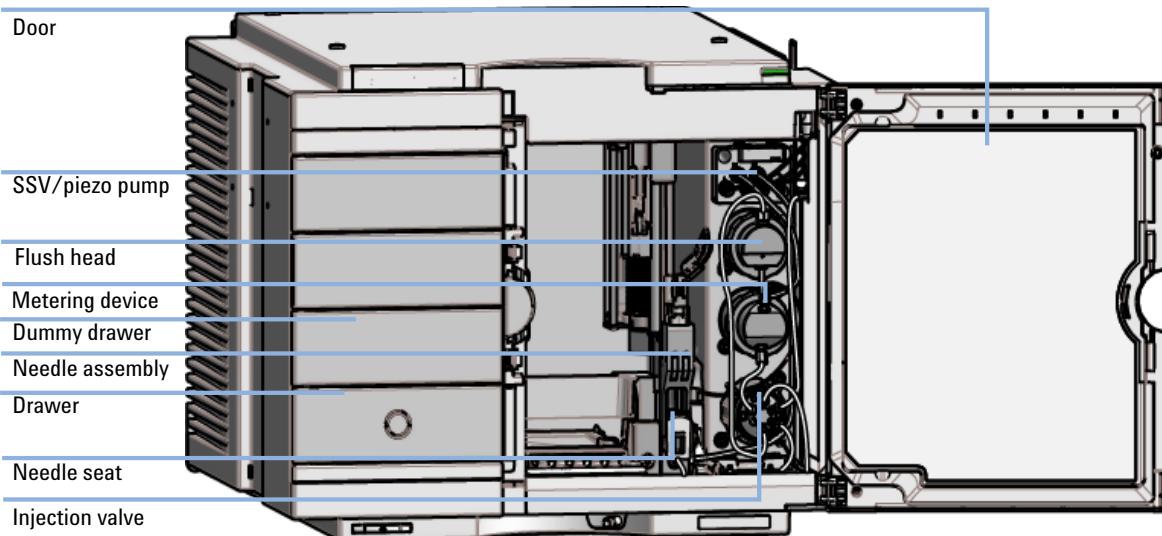

Figure 52 Main user accessible assemblies (multiwash)

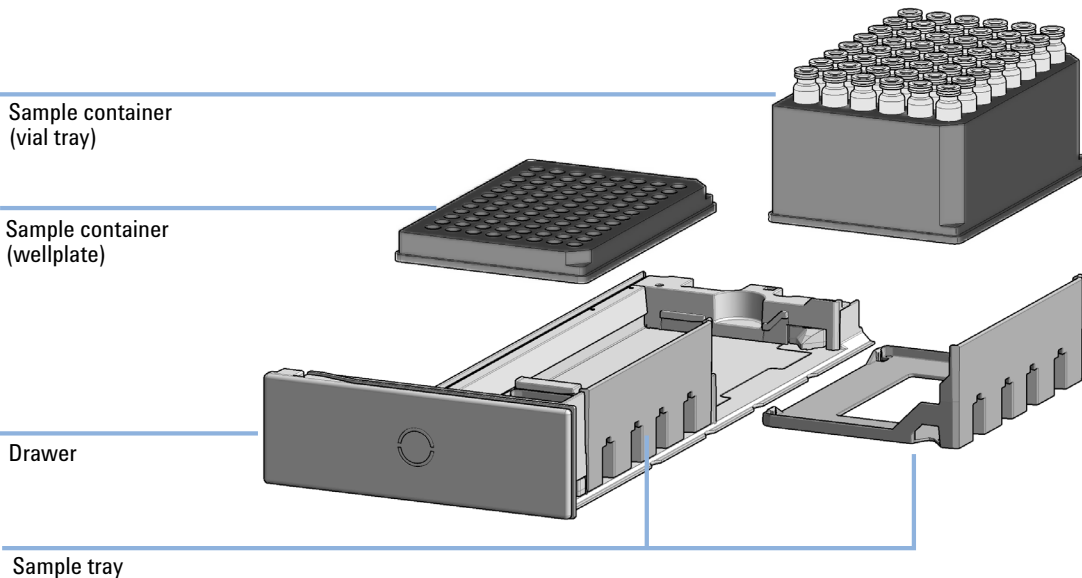

Figure 53 Overview of drawer, sample tray and sample container

Warnings and Cautions

WARNING**Personal injury or damage to the product**

Agilent is not responsible for any damages caused, in whole or in part, by improper use of the products, unauthorized alterations, adjustments or modifications to the products, failure to comply with procedures in Agilent product user guides, or use of the products in violation of applicable laws, rules or regulations.

- ✓ Use your Agilent products only in the manner described in the Agilent product user guides.
-

WARNING**Electrical shock**

Repair work at the module can lead to personal injuries, e.g. shock hazard, when the cover is opened.

- ✓ Do not remove the cover of the module.
 - ✓ Only certified persons are authorized to carry out repairs inside the module.
-

WARNING**Sharp metal edges**

Sharp-edged parts of the equipment may cause injuries.

- ✓ To prevent personal injury, be careful when getting in contact with sharp metal areas.
-

WARNING

Toxic, flammable and hazardous solvents, samples and reagents

The handling of solvents, samples and reagents can hold health and safety risks.

- ✓ When working with these substances observe appropriate safety procedures (for example by wearing goggles, safety gloves and protective clothing) as described in the material handling and safety data sheet supplied by the vendor, and follow good laboratory practice.
 - ✓ The volume of substances should be reduced to the minimum required for the analysis.
 - ✓ Do not operate the instrument in an explosive atmosphere.
-

CAUTION

Safety standards for external equipment

- ✓ If you connect external equipment to the instrument, make sure that you only use accessory units tested and approved according to the safety standards appropriate for the type of external equipment.
-

CAUTION

Sample degradation and contamination of the instrument

Metal parts in the flow path can interact with the bio-molecules in the sample leading to sample degradation and contamination.

- ✓ For bio applications, always use dedicated bio parts, which can be identified by the bio-inert symbol or other markers described in this manual.
 - ✓ Do not mix bio, and non-bio modules or parts in a bio system.
-

Overview of Maintenance

It is necessary to perform periodic inspection of this instrument to ensure its safe use. It is possible to have these periodic inspections performed by Agilent service representatives on a contractual basis. For information regarding the maintenance inspection contract, contact your Agilent representative.

The following pages describe the maintenance (simple repairs) of the module that can be carried out without opening the main cover.

Table 36 Overview of maintenance

Procedure	Typical interval (minimum)
Change needle/needle seat	30000 needle into seat movements
Change peristaltic pump cartridge	3000 h on time
Change rotor seal	As needed
Change metering seal	30000 injections

Clean the Module

To keep the module case clean, use a soft cloth slightly dampened with water, or a solution of water and mild detergent. Avoid using organic solvents for cleaning purposes. They can cause damage to plastic parts.

WARNING

Liquid dripping into the electronic compartment of your module can cause shock hazard and damage the module

- ✓ **Do not use an excessively damp cloth during cleaning.**
- ✓ **Drain all solvent lines before opening any connections in the flow path.**



NOTE

A solution of 70 % isopropanol and 30 % water might be used if the surface of the module needs to be disinfected.

Removal and Installation of the Front Door

When The instrument doors or the hinges are broken.

Tools required **Description**
Flathead screwdriver

Parts required	#	p/n	Description
	1	5067-5415 	Door Assy
OR	1	G7167-68718 	Light Protection Kit

Preparations Finish any pending acquisition job and return any plate on the workspace back to the hotel.

NOTE

For detailed information on position of the magnets, refer to “Magnets” on page 68

CAUTION

Magnetic fields

Magnets produce a far-reaching, strong magnetic field.

You can damage for example televisions, laptops, computer harddisks, credit cards, magnetic cards may be damaged as well.

- ✓ Keep magnets at least 25 mm away from devices and objects that could be damaged by strong magnetic fields.

WARNING

Heart pacemakers

Magnets could affect the functioning of pacemakers and implanted heart defibrillators.

A pacemaker could switch into test mode and cause illness.

A heart defibrillator may stop working.

- ✓ Bearers of heart pacemakers or implanted defibrillators must stay off at least 55 mm from the magnets.

1 Open the front door.

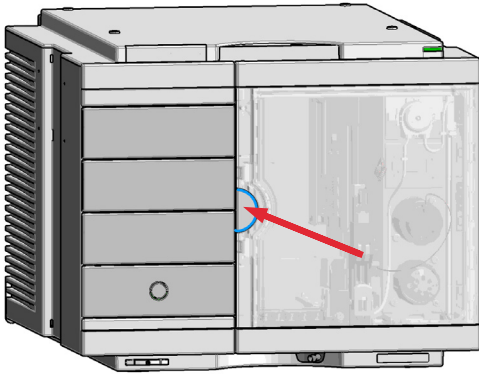

2 Press the release buttons and pull the front door out.

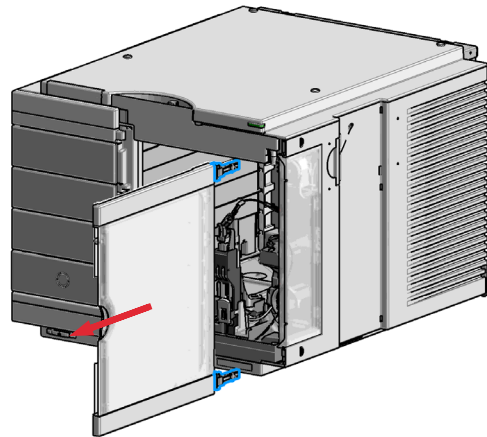
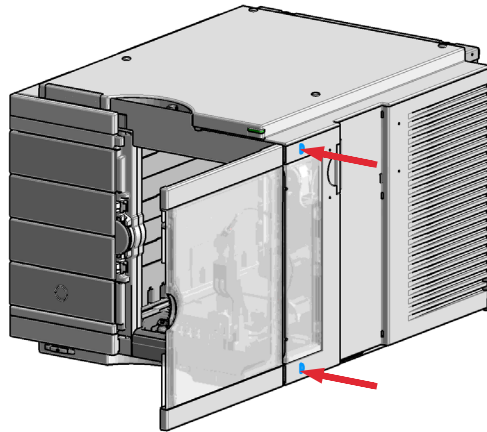

- 3 For the installation of the front door. Insert the hinges into their guides and move the door in until the release buttons click into their final position.

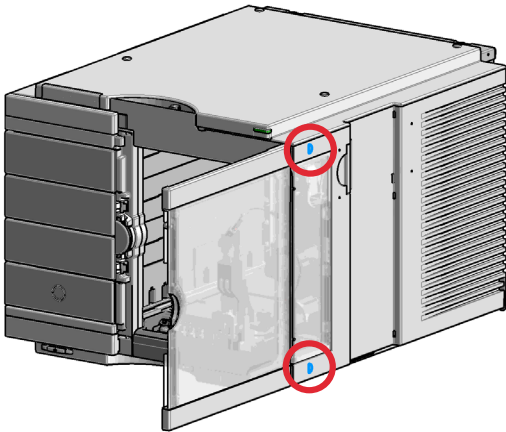
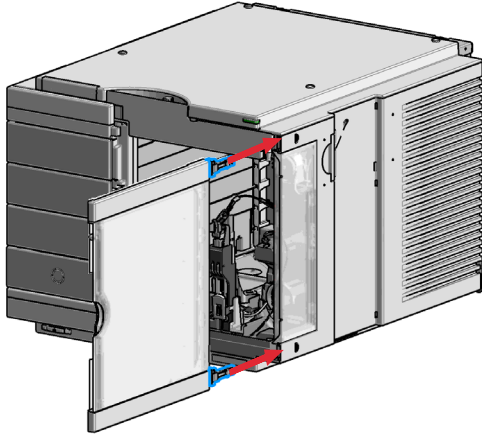

Remove the Needle Assembly



For bio-inert modules use bio-inert parts only!



For 1290 Infinity II Bio LC modules, use bio / biocompatible parts only.

Do not mix parts between 1260 Infinity II Bio-Inert LC modules and 1290 Infinity II Bio LC modules.

When

- The needle is visibly damaged.
- Leaks or blockages are observed.
- The limit for the needle interaction EMF counter is exceeded.
- The needle needs to be replaced as part of the yearly maintenance.

Tools required

p/n	Description
8710-0510 📄	Open-end wrench 1/4 – 5/16 inch

Parts required

#	p/n	Description
1	G4267-87201 📄	Needle Assembly
OR	1	G4267-87210 📄 Needle Assembly (slotted) for high injection volumes
1	G5668-87200 📄	Needle Bio-Sampler (for G5668A)
1	G7137-87201 📄	Needle Biocompatible (for G7137A)

Preparations

- Finish any pending acquisition job.
- Stop the flow at the pump and remove the solvent lines from the eluent bottles to avoid spilling solvent.
- Close the shutoff valves at the pump if available.

WARNING

Risk of injury by uncovered needle

An uncovered needle is a risk of harm to the operator.

- ✓ Do not open the safety lock of the needle assembly
- ✓ Be careful working at the z-robot.
- ✓ Wear safety goggles, when removing the needle assembly.

WARNING

Toxic, flammable and hazardous solvents, samples and reagents

The handling of solvents, samples and reagents can hold health and safety risks.

- ✓ When working with these substances observe appropriate safety procedures (for example by wearing goggles, safety gloves and protective clothing) as described in the material handling and safety data sheet supplied by the vendor, and follow good laboratory practice.

NOTE

It is recommended to always exchange the needle assembly and the needle seat at the same time to prevent premature leakage.

1 In the Agilent Lab Advisor software select **Service & Diagnostics >Maintenance Positions >Change Needle, Loop and Seat**, click **Start** and wait until the needle assembly is in maintenance position.

OR

In the Local Controller start the maintenance mode and select **Change Needle, Loop and Seat** function.

2 Open the front door.

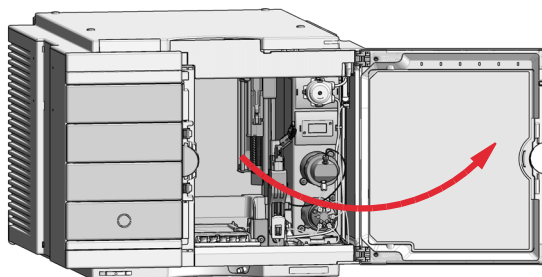

Maintenance

Remove the Needle Assembly

- 3 Lock the needle in the safety position.

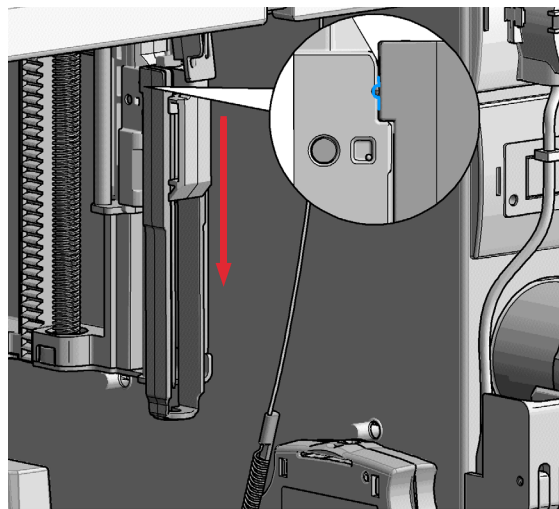

NOTE

During normal operation of the Multisampler the needle assembly has to be unlocked.

WARNING

Sharp needle
Uncovered needles may cause injuries

- ✓ Make sure the needle is in the safety lock position.
- 4 Remove the needle assembly by slightly pulling the needle cartridge.

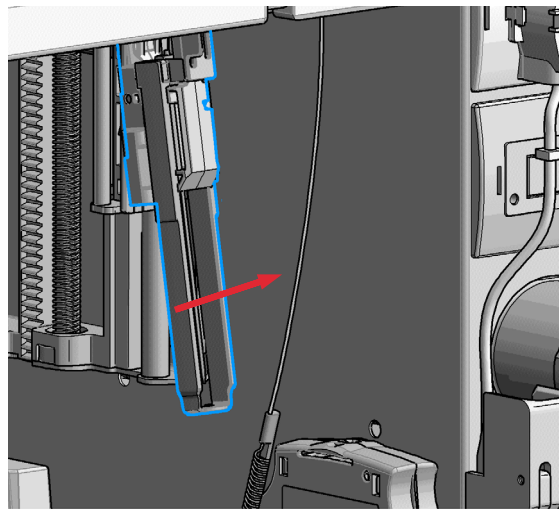

Maintenance

Remove the Needle Assembly

5 Z-Robot (Z-arm coupler) without the needle assembly.

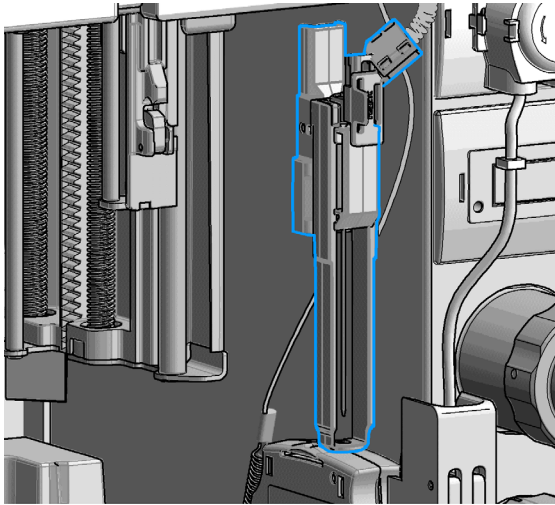

CAUTION

Damage of the loop

The loop shape may be damaged if the loop is stretched or bent too far.

- ✓ Avoid to change the loop shape.
- ✓ Do not pull or bend the loop too far.

6 The needle assembly is still connected to the loop capillary.

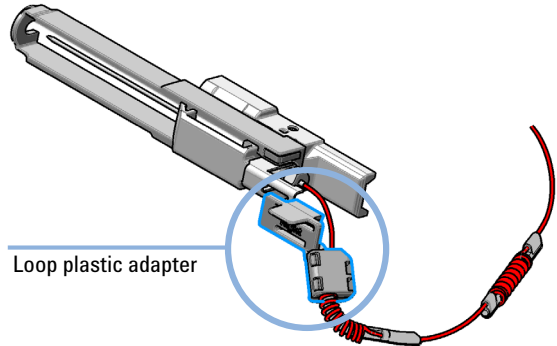

7 Remove the loop plastic adapter.

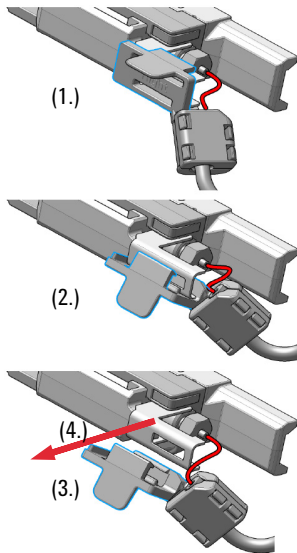

NOTE

Do not open the rear plastic clamp.

NOTE

If the plastic adapter is damaged the sample loop has to be replaced.

8 Use a 1/4 inch wrench to loosen the fitting of the loop capillary.

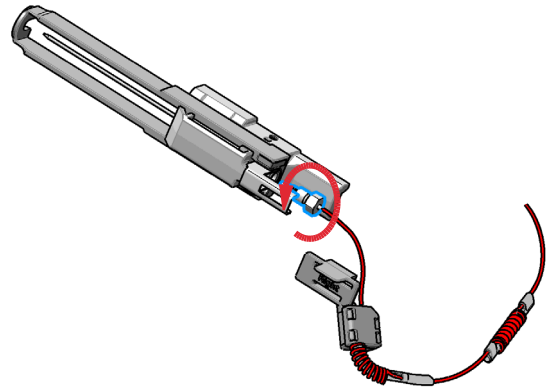

9 Remove the needle assembly.

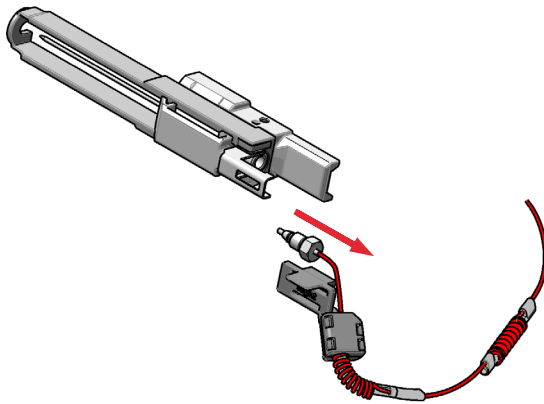

Install the Needle Assembly



For bio-inert modules use bio-inert parts only!



For 1290 Infinity II Bio LC modules, use bio / biocompatible parts only.
Do not mix parts between 1260 Infinity II Bio-Inert LC modules and 1290 Infinity II Bio LC modules.





When

- The needle is visibly damaged.
- Leaks or blockages are observed.
- The limit for the needle interaction EMF counter is exceeded.
- The needle needs to be replaced as part of the yearly maintenance.

Tools required

p/n	Description
8710-0510 	Open-end wrench 1/4 – 5/16 inch

Parts required

#	p/n	Description
1	G4267-87201 	Needle Assembly
OR	1	G4267-87210 
	1	G5668-87200 
	1	G7137-87201 

Preparations

- Finish any pending acquisition job.
- Stop the flow at the pump and remove the solvent lines from the eluent bottles to avoid spilling solvent.
- Close the shutoff valves at the pump if available.

WARNING**Risk of injury by uncovered needle**

An uncovered needle is a risk of harm to the operator.

- ✓ Do not open the safety lock of the needle assembly
- ✓ Be careful working at the z-robot.
- ✓ Wear safety goggles, when removing the needle assembly.

NOTE

It is recommended to always exchange the needle assembly and the needle seat at the same time to prevent premature leakage.

- 1** Install the loop capillary on top of the needle cartridge (1.) and tighten the fitting hand tight (2.).

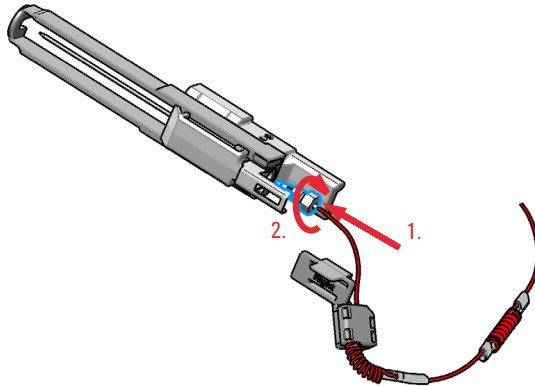
**NOTE**

If the sample loop is changed, we recommend changing the needle as well.

CAUTION**Blockages inside of the needle assembly union**

- ✓ Do not overtighten the fitting. A quarter turn should be sufficient.
- 2** Use a 1/4 inch wrench to tighten the fitting of the loop capillary.

Maintenance

Install the Needle Assembly

3 Install loop plastic adapter.

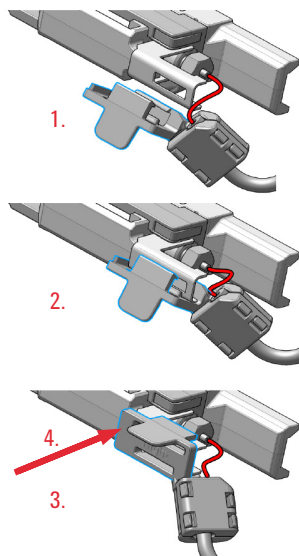

NOTE

Verify the sample loop info on the plastic adapter. A left or a right sample loop must be installed in the correct slot of the needle parkstation. For single needle, the default position is on the right.

NOTE

If the plastic adapter is damaged the sample loop has to be replaced.

4 Pinch and reinsert the needle assembly and the connected loop capillary into the z-arm coupler.

NOTE

Check the tension of the loop capillary. This must be forced and guided to the hydraulic box to prevent it from being caught by the Z-drive.

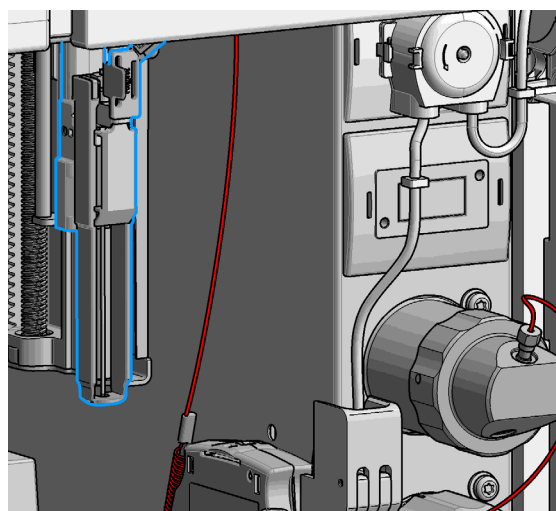
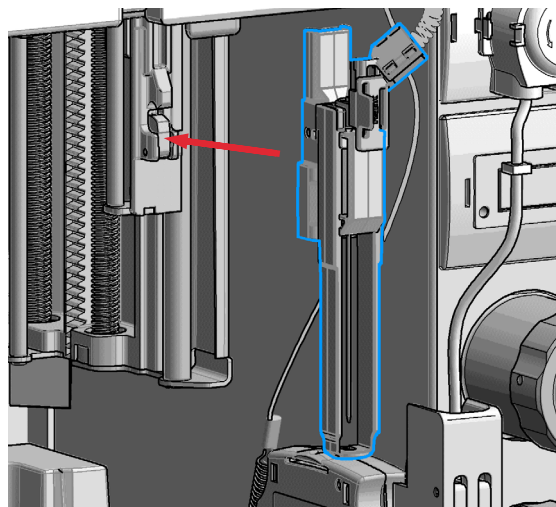

Maintenance

Install the Needle Assembly

- 5 Close the front door.

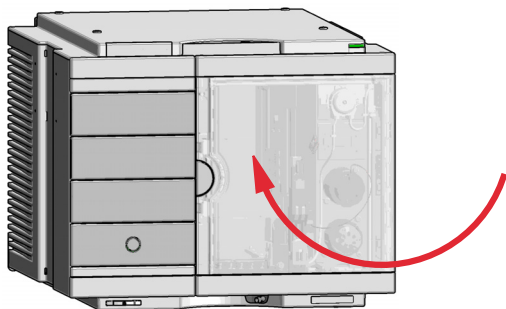

Next Steps:

- 6 In the Local Controller close **Change needle /seat**.
OR
In the Agilent Lab Advisor software **Change needle/loop**, click **Back** and wait until the needle assembly is in the needle park station.
- 7 Perform a **Pressure Test**.

Exchange the Needle Seat



For bio-inert modules use bio-inert parts only!



For 1290 Infinity II Bio LC modules, use bio / biocompatible parts only.
Do not mix parts between 1260 Infinity II Bio-Inert LC modules and 1290 Infinity II Bio LC modules.

When When seat is visibly damaged, blocked or leaks.

Tools required

p/n	Description
8710-0510 📄	Open-end wrench 1/4 – 5/16 inch

Parts required

#	p/n	Description
1	G4267-87012 📄	High Pressure Needle Seat, 0.12 mm (PEEK)
OR	1	G4267-87020 📄 High Pressure Seat Assembly 0.075 mm (PEEK)
OR	1	G5668-87017 📄 Bio Seat ID 0.17 (for G5668A)
1	G7137-87012 📄	High pressure seat assembly 0.12 mm Biocompatible (for G7137A)

Preparations

- Finish any pending acquisition job.
- Stop the flow at the pump and remove the solvent lines from the eluent bottles to avoid spilling solvent.
- Close the shutoff valves at the pump if available.

WARNING

Risk of injury by uncovered needle

An uncovered needle is a risk of harm to the operator.

- ✓ Do not open the safety lock of the needle assembly
- ✓ Be careful working at the z-robot.
- ✓ Wear safety goggles, when removing the needle assembly.

NOTE

Refer the Agilent 1290 Infinity II Ultra Low Dispersion Kit Technical Note (p/n 01200-90105) for further details.

- 1** In the Local Controller start the maintenance mode and select **Change needle/seat** function.

OR

In the Agilent Lab Advisor software select **Service & Diagnostics** in the system screen **Maintenance Positions >Change Needle**, click **Start** and wait until the needle assembly is in maintenance position.

- 2** Open the front door.

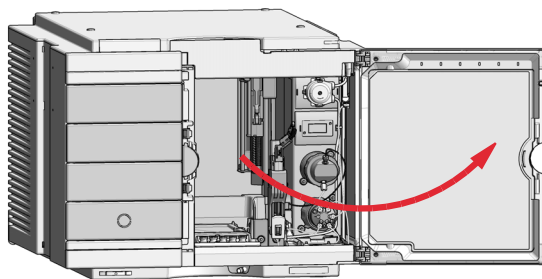

- 3** Disconnect the seat capillary from the Injection valve.

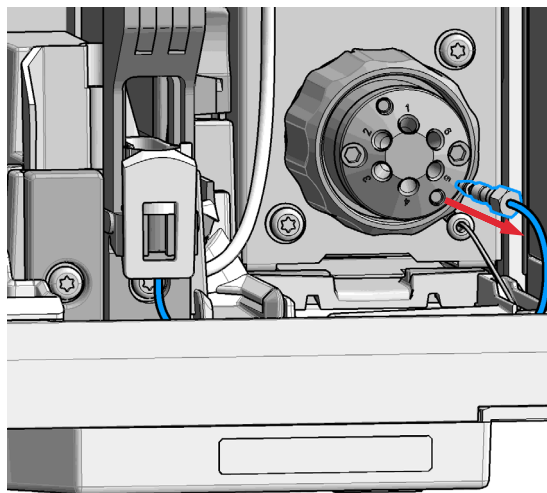

- 4** Slightly pull (1.) the front clip which holds the needle seat in position. Then carefully lift up (2.) the complete leak tube needle assembly from the holder.

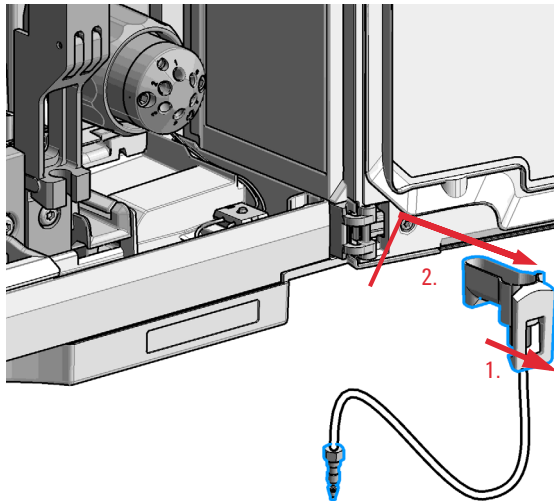

Maintenance

Exchange the Needle Seat

- 5 Insert the new Needle seat (1.). Press it firmly in position (2.).

NOTE

Verify that the needle seat clip is locked in the needle park station.

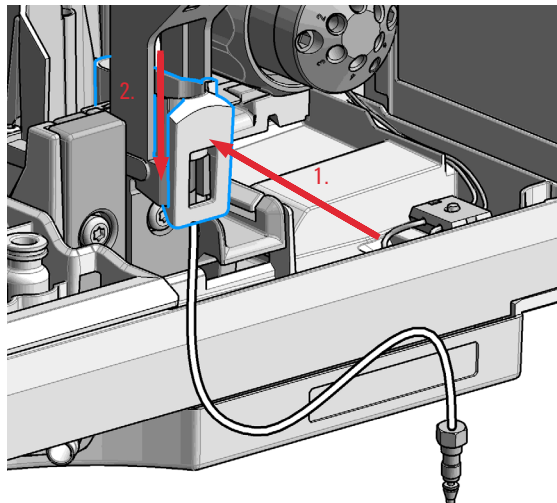

- 6 Reconnect the seat capillary to the injection valve.

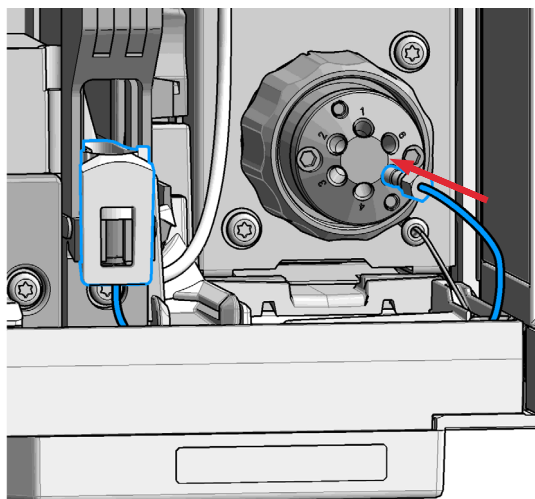

- 7 Close the front door.

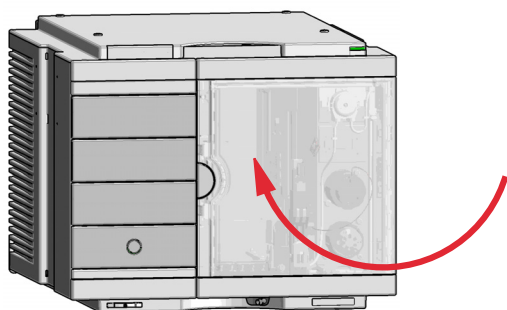

Next Steps:

- 8 In the Local Controller close **Change needle /seat**.
OR
In the Agilent Lab Advisor software **Change needle** click **End** and wait until the needle assembly is in the needle park position.
- 9 Perform a **Pressure Test**.

NOTE

Always flush the sampler with fresh solvent and perform a pressure test before using the **Auto Clean** or **Prime** function after exchanging a needle seat.

Replace the Rotor Seal



For bio-inert modules use bio-inert parts only!



For 1290 Infinity II Bio LC modules, use bio / biocompatible parts only.
 Do not mix parts between 1260 Infinity II Bio-Inert LC modules and 1290 Infinity II Bio LC modules.

When

- Injection volume reproducibility problems are observed.
- Leaks or blockages are observed.
- The limit for the rotor seal EMF counter is exceeded.
- The rotor seal needs to be replaced as part of the yearly maintenance.

Tools required

p/n	Description
8710-0510 📄	Open-end wrench 1/4 – 5/16 inch
8710-2394 📄	Hex key 9/64 inch 15 cm long T-handle
05980-60051 📄	Cloths, clean, lint-free 15/pk Isopropanol or any other appropriate solvent

Parts required

#	p/n	Description
1	5068-0198 📄	Rotor Seal 1300 bar (PEEK) for 1290 Infinity II Injection Valve
1	5068-0209 📄	Rotor Seal (PEEK) for 1260 Infinity II Injection Valve and Bio-inert injection valve
1	5068-0229 📄	Rotor Seal (PEEK) for 3Pos/6Port Peripheral Valve Dual Needle
1	5068-0232 📄	Rotor Seal (PEEK) for 2Pos/8Port Injection Valve Dual Needle
1	5320-0010 📄	Rotor Seal 1300 bar (PEEK) for 1290 Infinity II Bio Injection valve

CAUTION

Reduced life time of the injection valve
Component cleanliness is crucial for the life time of the injection valve.

- ✓ Replace the rotor seal in a clean environment.

NOTE

Please bear in mind that depending on which valve you have installed the images may slightly differ from the actual item.

- 1 Open the front door.

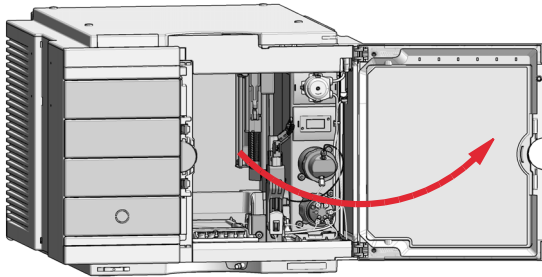

- 2 Remove all capillaries from the injection valve with a 1/4 inch wrench.

NOTE

Remember the correct plumbing.

Check the drawing on the side cover of the hydraulic box for correct plumbing.

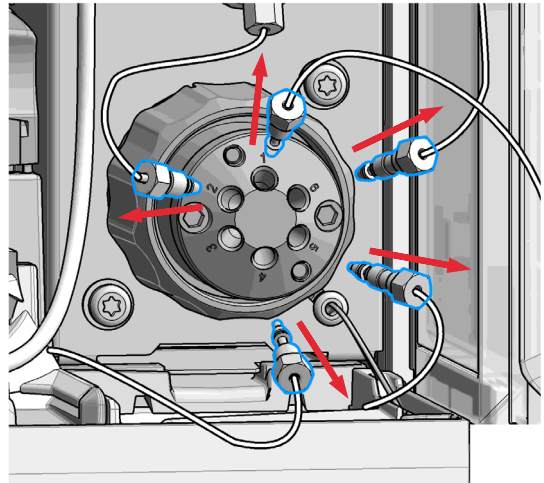

Maintenance

Replace the Rotor Seal

- 3 Use a 9/64 inch hex driver to unscrew the two socket screws which hold the stator head in place.

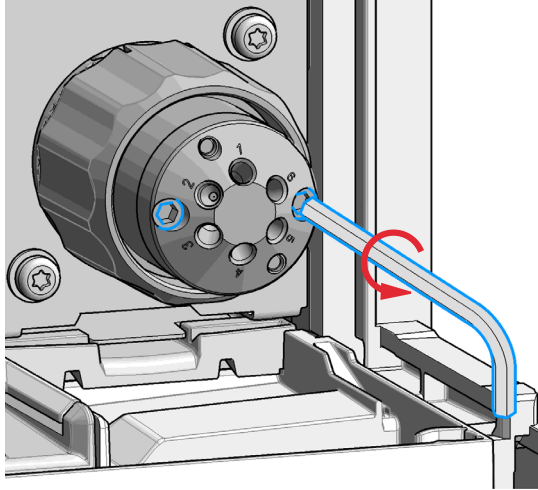

CAUTION

Damage to the stator head

The polished sealing surface of the stator head contains six ports that access handling can easily damage.

- ✓ Avoid touching the polished surface of the stator head.
- ✓ Never place the polished surface on a hard surface.

- 4 Carefully remove the stator head. To ensure that the sealing surface of the stator head is not damaged, place it on its outer face.

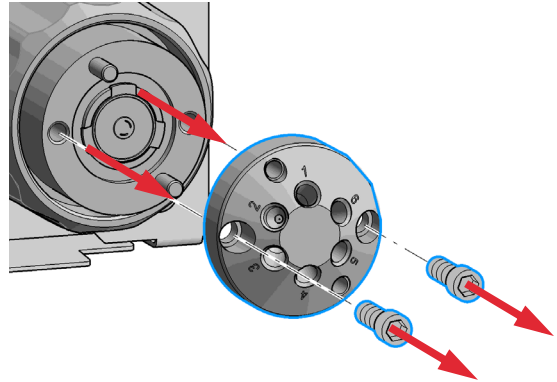

Maintenance

Replace the Rotor Seal

5 Remove the rotor seal.

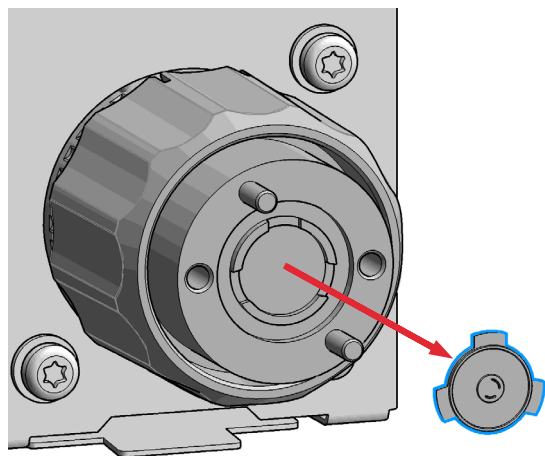

NOTE

Remove the rotor seal with a small tool, gently pry the rotor seal away from the drive.

Examine the rotor sealing surface for scratches and nicks.

- If scratches are visible the rotor seal must be replaced.
- If no scratches are visible clean all the parts with an appropriate solvent, taking care that no surfaces get scratched.

CAUTION

Damage to the rotor seal and cross-port leaks

- ✓ Before you replace the rotor seal, clean the stator.
- ✓ Inspect the stator head and swab it with the appropriate solvent. If more stringent cleaning is required, use a sonicator. Inspect the remaining valve components for contamination. Clean them as necessary.
- ✓ If the stator head is scratched, replace it.

6 Install new rotor seal.

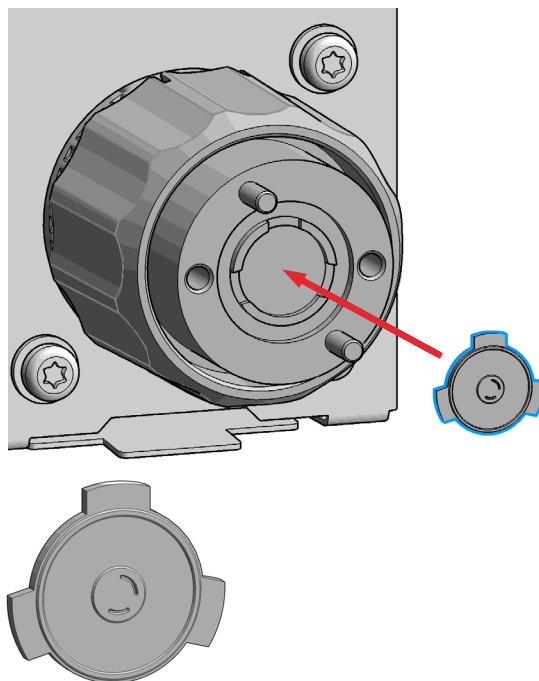

NOTE

Make sure that the rotor sealing surface with its engraved flow passages is facing out. The pattern is asymmetrical to prevent improper placement.

NOTE

The Bio-inert injection valve additionally has a stator face installed.

Maintenance

Replace the Rotor Seal

- 7 Reinstall the stator head. The index pins on the drive and the stator head must engage in the corresponding holes. Insert the two socket head screws.

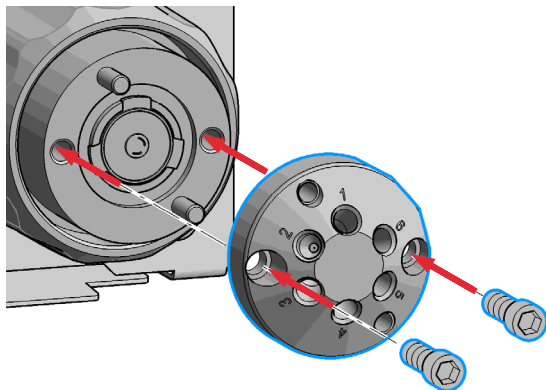

- 8 Using a 9/64 in. L-Hex wrench, tighten each screw gently until you feel resistance (approximately fingertight). Tighten each screw by 1/8 turn, and then tighten each screw again, until the stator is secured to the driver.

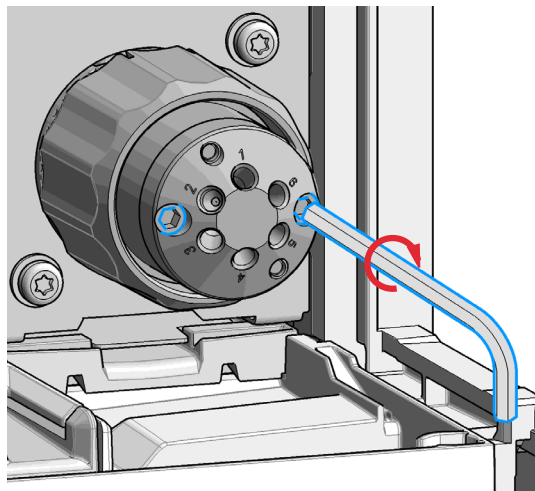

NOTE

Do not over-tighten the screws. The screws hold the assembly together and do not affect the sealing force. The sealing force is automatically set as the screws close the stator head against the valve body.

Maintenance

Replace the Rotor Seal

9 Reconnect all capillaries to the proper injection valve ports with a 1/4 inch wrench

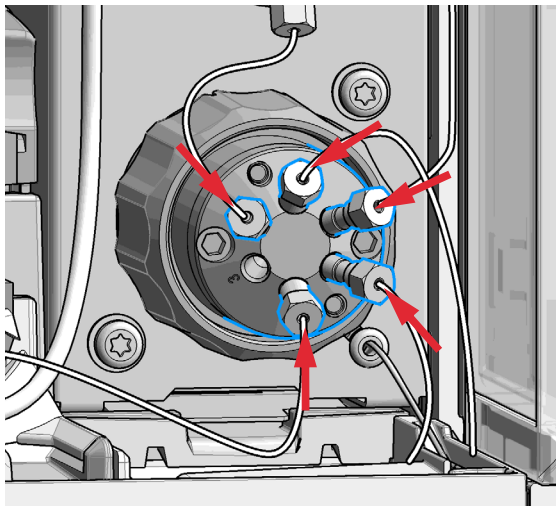

10 Install the waste line.

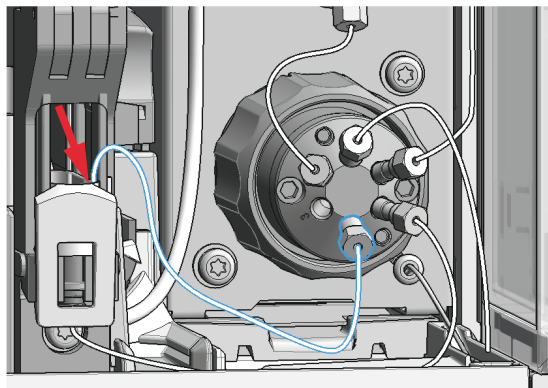

11 Close the front door.

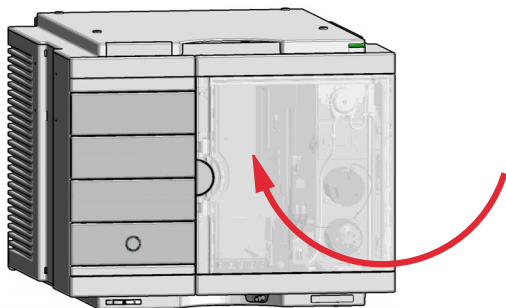

12 Perform a **Pressure Test**.

Replace the Injection Valve



For bio-inert modules use bio-inert parts only!







For 1290 Infinity II Bio LC modules, use bio / biocompatible parts only.
 Do not mix parts between 1260 Infinity II Bio-Inert LC modules and 1290 Infinity II Bio LC modules.

When Add new injection valve or replace defective injection valve.

Tools required

p/n	Description
8710-0510 	Open-end wrench 1/4 – 5/16 inch

Parts required

#	p/n	Description
1	5067-4232 	2-position/6-port Injection Valve (VICI) 1300 bar 1300 bar (G7167B)
1	5067-6698 	2-position/6-port RC Injection Valve 800 bar 800 bar (G7167A)
1	5067-4260 	2-position/8-port Injection Valve Dual Needle 1300 bar
1	5067-4263 	2-position/6-port Injection Valve Bio-inert 600 bar for bio inert solution
1	5067-6739 	2-position/6-port injection valve Bio 1300 bar (G7137A)

Preparations Switch off the power of the Multisampler

NOTE

Please bear in mind that depending on which valve you have installed the images may slightly differ from the actual item.

Maintenance

Replace the Injection Valve

- 1 Disconnect the capillaries.

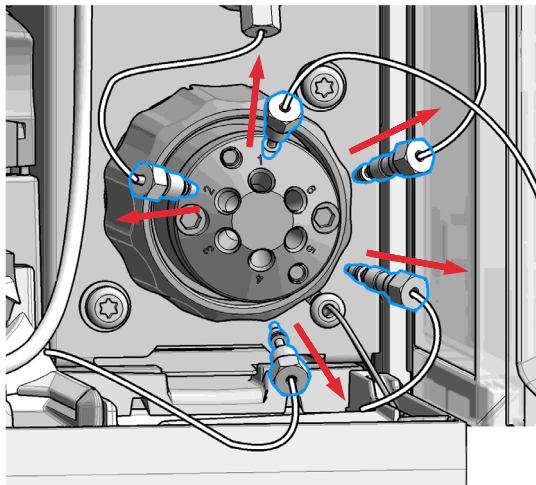

- 2 Turn the spanner nut counter clockwise until the injection valve head detaches from the hydraulic box (Do not use wrenches on the spanner nut).

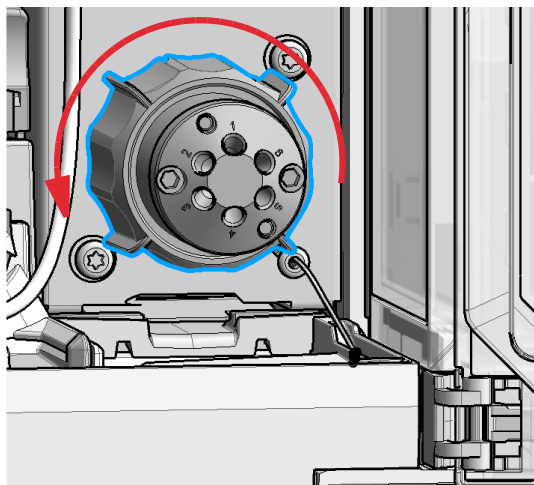

Maintenance

Replace the Injection Valve

- 3 Remove the spanner nut from the injection valve head.

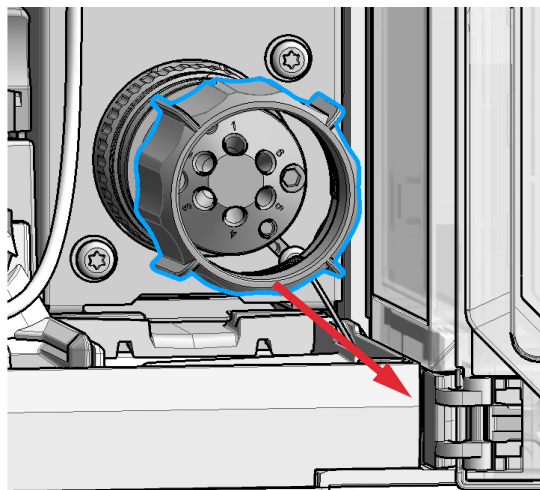

- 4 Take the replacement injection valve head and insert it into the open actuator slot of the hydraulic box. Rotate until the unions at the base of the replacement injection valve head and the valve actuator engage

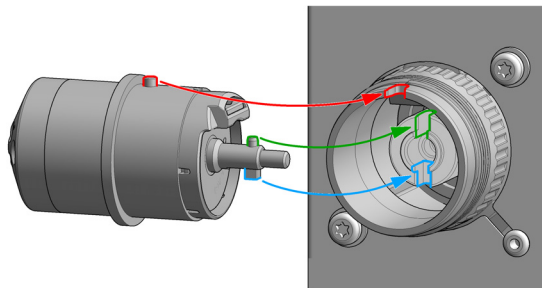

OR

If the outside pin does not fit into the outside groove, you have to turn the valve head until you feel that the two pins snap into the grooves. Now you should feel additional resistance from the valve drive while continue turning the valve head until the pin fits into the groove.

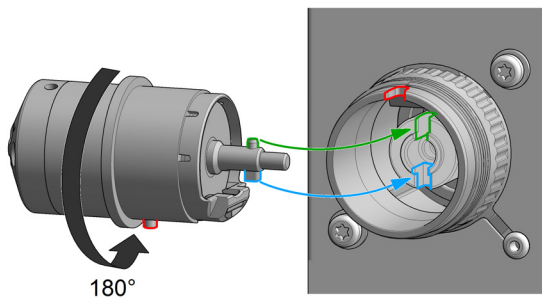

NOTE

Check the orientation of the rear side.

Verify the correct position of the Valve TAG.

Maintenance

Replace the Injection Valve

- 5 Continue to rotate until the clocking pin in the injection valve head align with the notch in the housing and press the replacement injection valve head into the actuator.

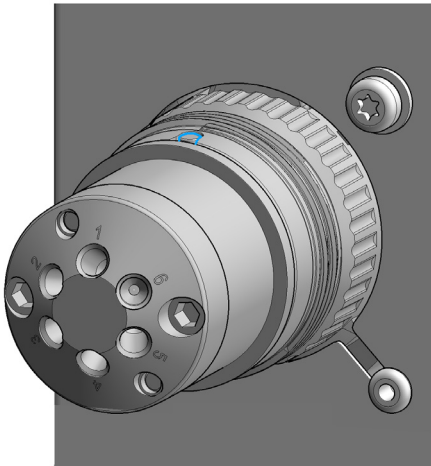
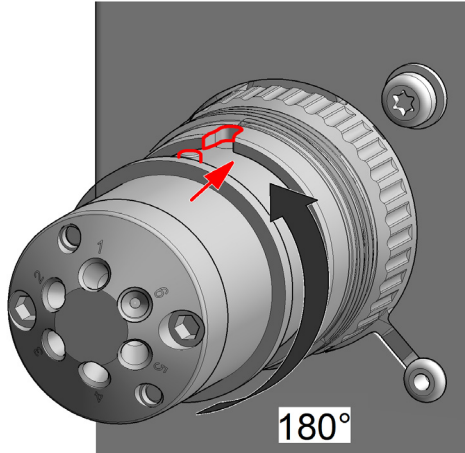

- 6 Replace the spanner nut (1.) and tighten clockwise (2.) (Hand tighten only, do not use wrenches on the spanner nut).

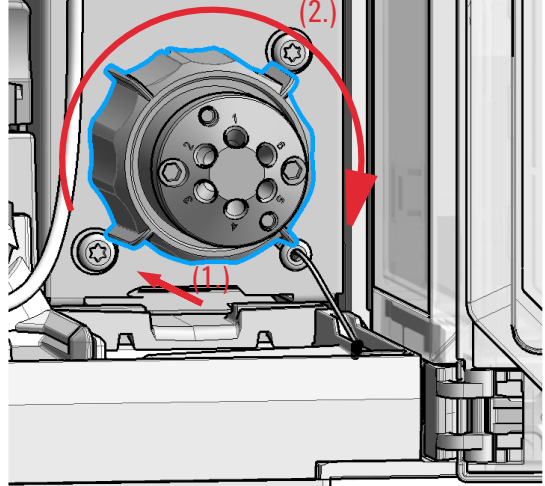

Maintenance

Replace the Injection Valve

7 Reconnect the capillaries

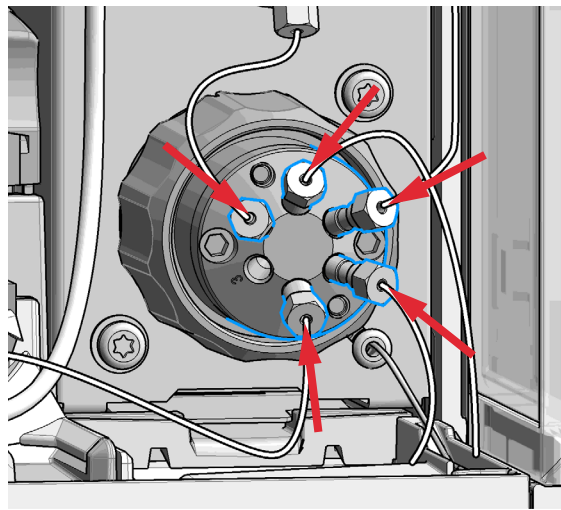

Remove the Metering Seal







For bio-inert modules use bio-inert parts only!



For 1290 Infinity II Bio LC modules, use bio / biocompatible parts only.
Do not mix parts between 1260 Infinity II Bio-Inert LC modules and 1290 Infinity II Bio LC modules.

When When poor injection volume reproducibility or when metering device / analytical head is leaking.

Tools required

p/n	Description
8710-0510 	Open-end wrench 1/4 – 5/16 inch
5023-2524 	Hex Key Set (part of the G7120-62708 InfinityLab LC Series Tool Kit)
01018-23702 	Insert tool
OR	
G4226-43800 	Seal insert tool for 100 µL or 40 µL

Maintenance

Remove the Metering Seal

Parts required	#	p/n	Description
	1	0905-1717 📄	Metering Seal, 40 µL
	1	0905-1719 📄	Metering Seal, 100 µL
	1	G5611-21503 📄	Metering Seal PTFE (Bio-inert) for bio inert solution
	1	G7137-20003 📄	Metering seal 1290 Bio 2 mm piston, 40 µL
	1	0905-1294 📄	Metering Seal, 900 µL
	1	5067-5920 📄	Piston, 40 µL, Zirconium oxide If previous piston is scratched (for 40 µL analytical head)
	1	5067-5678 📄	Piston, 100 µL, Zirconium oxide If previous piston is scratched (for 100 µL analytical head)
	1	G4267-60462 📄	Piston, 900 µL, Sapphire If previous piston is scratched (for 900 µL analytical head)

1 In the Local Controller start the maintenance mode and select **Service Position**.

OR

In the Agilent Lab Advisor software select **Service & Diagnostics** in the system screen (**Tools**) **>Maintenance Positions >Change Metering Device**, click start and wait until the metering device is in maintenance position.

2 Open the front door.

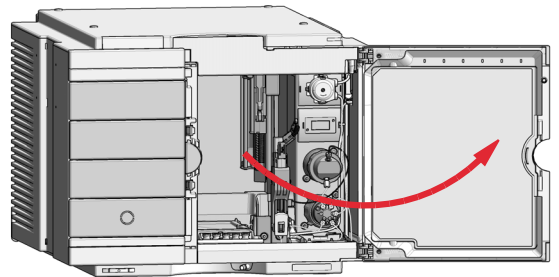

Maintenance

Remove the Metering Seal

3 Disconnect all capillaries from the metering device.

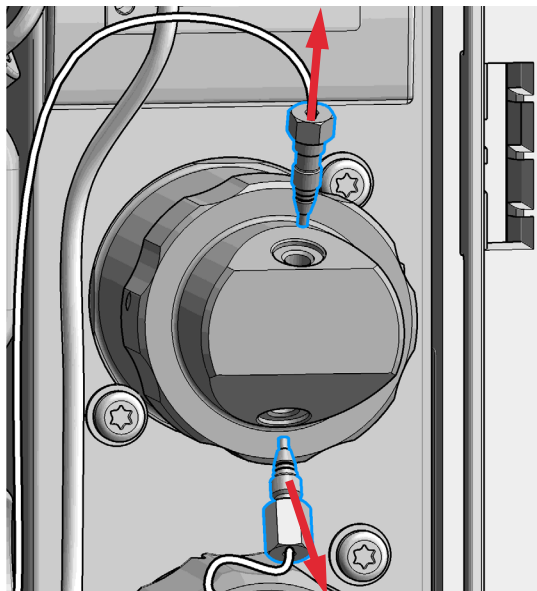

4 To release the bayonet lock, push (1.) and rotate (2.) the analytical head a quarter left. Then you can pull and detach the analytical head assembly from the actuator (3.).

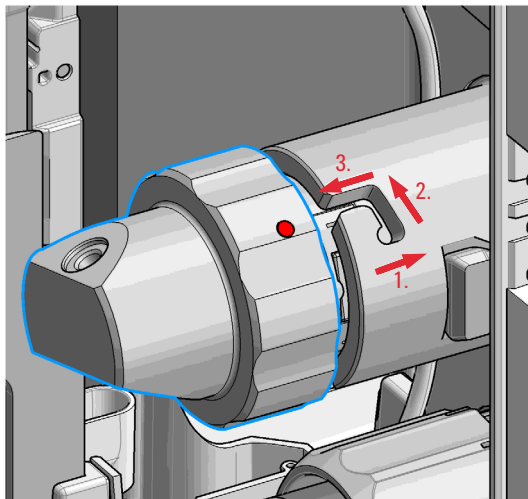

5 Remove the metering device.

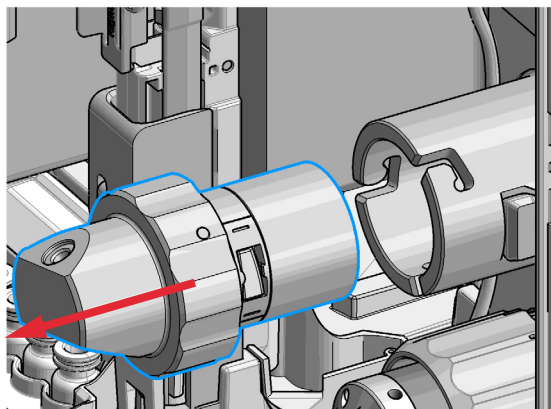

6 Take the metering device. Push against the rear side of the metering device and rotate a quarter left to release the bayonet lock.

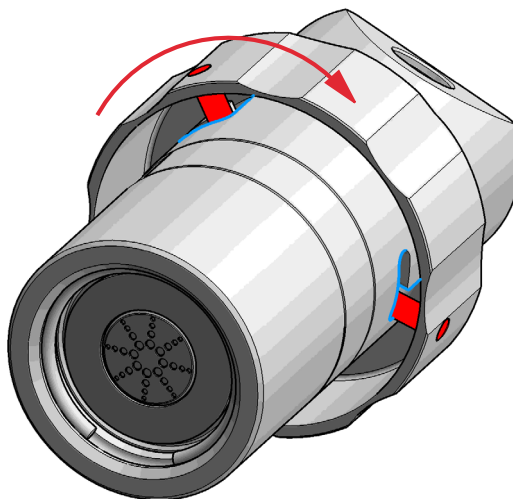

7 Now you can separate the analytical head and head body.

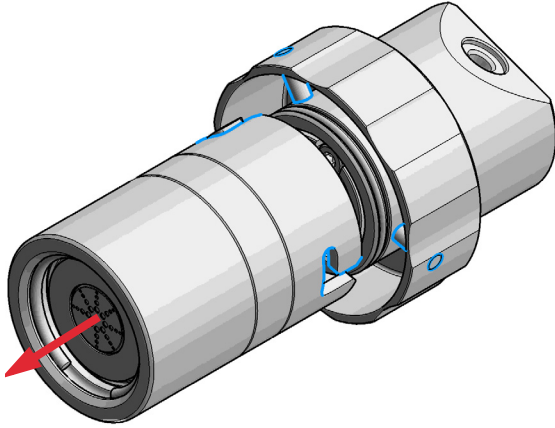

8 Remove the piston out of the head body.

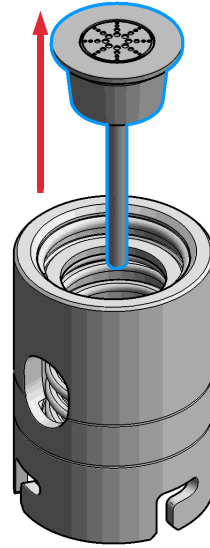

9 Inspect the piston for cleanliness and scratches.

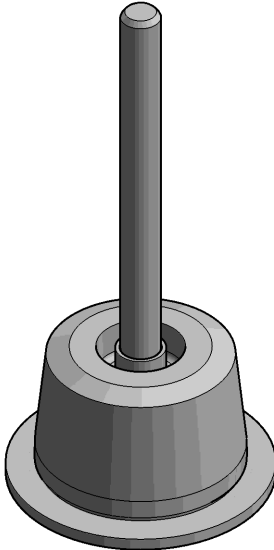

- If dirty:
Clean the piston with an appropriate solvent.
- If scratched:
Replace the piston by a new one.

10 Take the analytical head and remove the three screws on the rear side, which holds the support ring in place. Check the support ring for any damages.

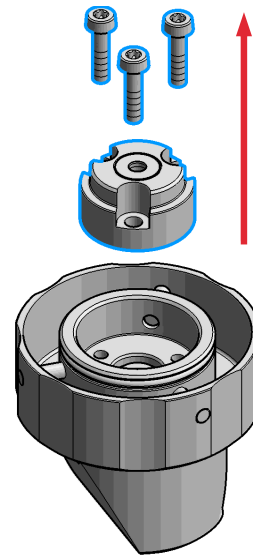

Maintenance

Remove the Metering Seal

- 11** Carefully remove the metering seal using the steel side of the insert tool. Clean the chamber with an appropriate solvent and ensure that all particulate matter is removed.

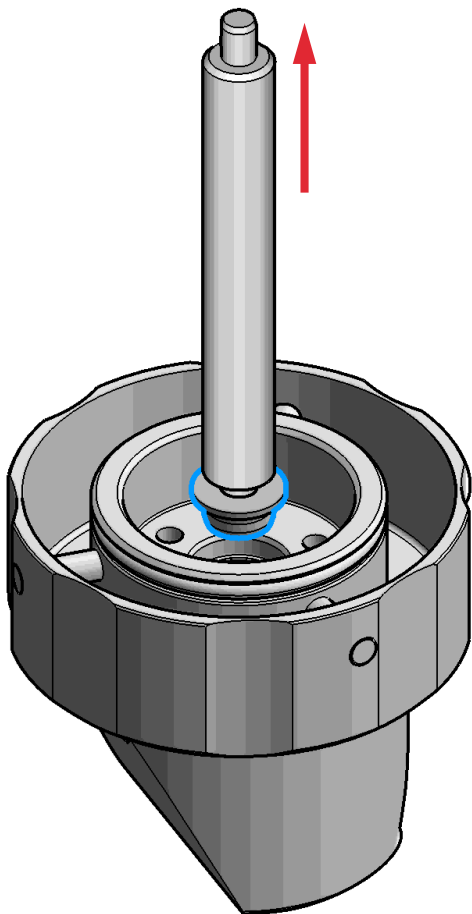

Install the Metering Seal







For bio-inert modules use bio-inert parts only!



For 1290 Infinity II Bio LC modules, use bio / biocompatible parts only.
Do not mix parts between 1260 Infinity II Bio-Inert LC modules and 1290 Infinity II Bio LC modules.

When After removing the metering seal.

Tools required

	p/n	Description
	8710-0510 	Open-end wrench 1/4 – 5/16 inch
	5023-2524 	Hex Key Set (part of the G7120-62708 InfinityLab LC Series Tool Kit)
	01018-23702 	Insert tool (for 100 µL seals)
OR	G4226-43800 	Seal insert tool (for 40 µL seals)
		Cleaning tissue and appropriate solvent like isopropanol or methanol

Maintenance

Install the Metering Seal

Parts required	#	p/n	Description
	1	0905-1717 📄	Metering Seal, 40 µL
	1	0905-1719 📄	Metering Seal, 100 µL
	1	G5611-21503 📄	Metering Seal PTFE (Bio-inert) for bio inert solution
	1	G7137-20003 📄	Metering seal 1290 Bio 2 mm piston, 40 µL
	1	0905-1294 📄	Metering Seal, 900 µL
	1	5067-5920 📄	Piston, 40 µL, Zirconium oxide If previous piston is scratched (for 40 µL analytical head)
	1	5067-5678 📄	Piston, 100 µL, Zirconium oxide If previous piston is scratched (for 100 µL analytical head)
	1	G4267-60462 📄	Piston, 900 µL, Sapphire If previous piston is scratched (for 900 µL analytical head)

Preparations Removing the metering seal, see ["Remove the Metering Seal"](#) on page 257

Maintenance

Install the Metering Seal

- 1 Install the new metering seal using the plastic side of the insert tool. Press it firmly into position. Avoid any offset angle as it might deform the seal.

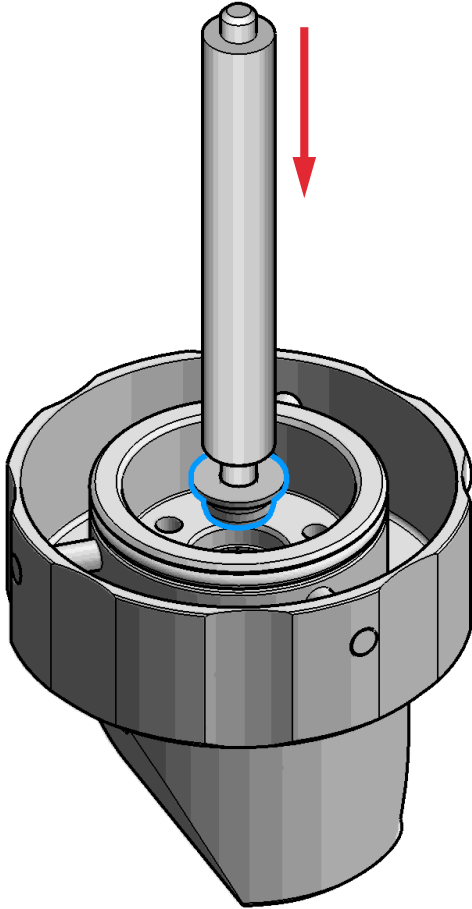

- 2 Reassemble the support ring.

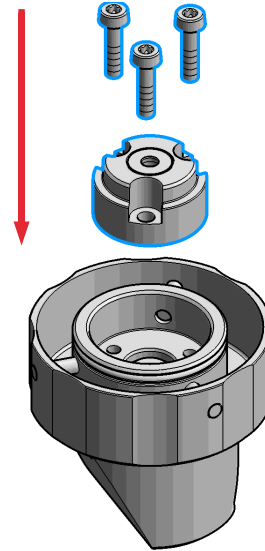

Maintenance

Install the Metering Seal

- 3** Make sure to comply to the following order of actions:
- a** Tighten the three screws fingertight, then
 - b** Tighten the screws a little at a time to keep the support ring surface *parallel* (important!) to the surface of the analytical head.

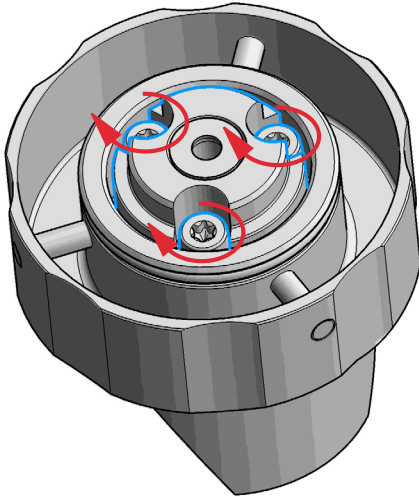

- 4** Use the twist and lock bayonet mechanism to reassemble the analytical head assembly. Push the two parts together to couple the head body with the analytical head. Once the pin reaches the bottom of the slot, one or both parts are rotated so that the pin slides along the horizontal arm of the L until it reaches the *serif*. The spring then pushes the male connector up into the *serif* to keep the pin locked into place.

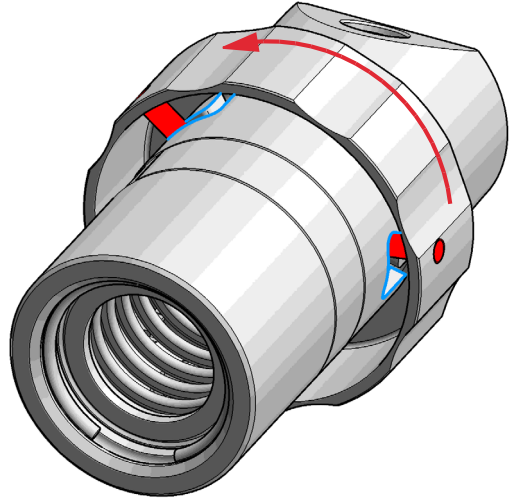

Maintenance

Install the Metering Seal

- 5 Press the piston carefully into the housing of the head body and the seal.

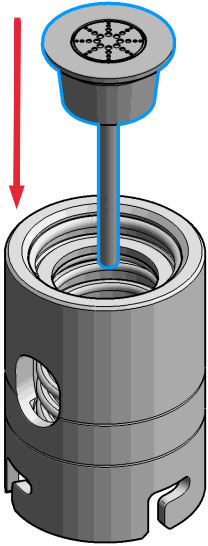

- 6 Reinstall the complete analytical head with the actuator housing

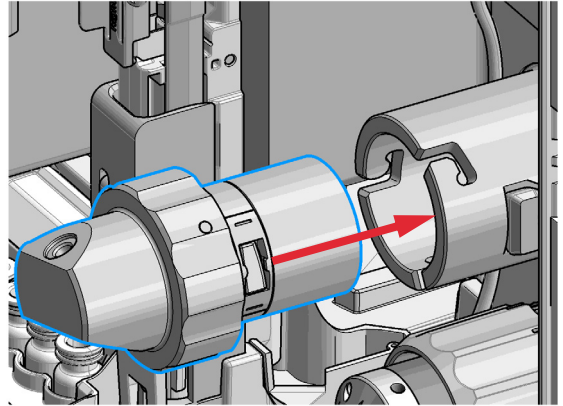

NOTE

For proper installation, check the correct position of the tag.

Maintenance

Install the Metering Seal

- 7 Fix the analytical head by pushing (1.) and rotating (2.) via twist and lock bayonet mechanism.

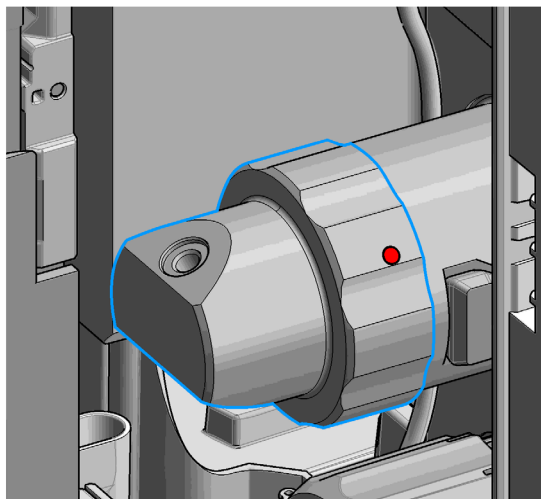
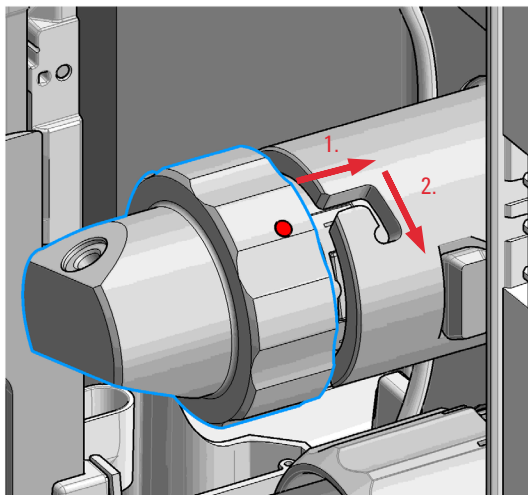

- 8 Reconnect the capillaries.

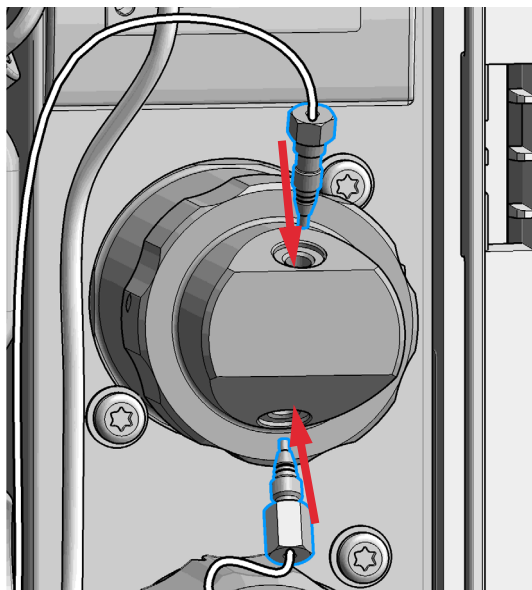

Maintenance

Install the Metering Seal

9 Close the front door.

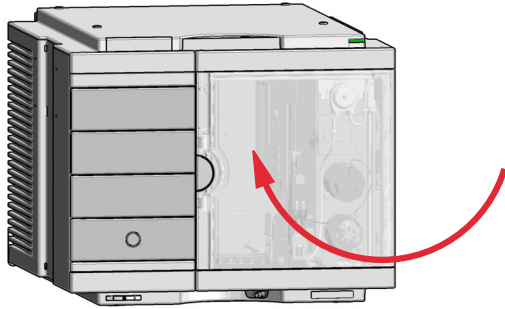

Next Steps:

10 In the Local Controller exit the maintenance mode and select **Change metering device** function.

OR

In Agilent Lab Advisor software system screen exit **Service & Diagnostics (Tools) >Maintenance Positions >Change Metering Device** click **End** and wait until the metering device is in **Home** position.

11 Perform a **Pressure Test**.

Replace the Peristaltic Pump Cartridge

- When**
- The tubing is blocked or damaged.
 - The peristaltic cartridge needs to be replaced as part of the yearly maintenance.

Parts required	#	p/n	Description
	1	5065-4445 E	Peristaltic pump with PharMed tubing (default)
OR	1	5042-8507 E	Peristaltic pump cartridge, silicone tubing
OR	1	5065-9952 E	Peristaltic pump with Chemsure tubing

- Preparations**
- Finish any pending acquisition job.
 - Remove the solvent line from the wash bottle to avoid spilling solvent.

WARNING

When opening capillary or tube fittings solvents may leak out.

The handling of toxic and hazardous solvents and reagents can hold health risks.

- ✓ **Please observe appropriate safety procedures (for example, goggles, safety gloves and protective clothing) as described in the material handling and safety data sheet supplied by the solvent vendor, especially when toxic or hazardous solvents are used.**

NOTE

The peristaltic pump cartridge is a replaceable unit. The tubing inside the pump is not replaceable.

Replace the Peristaltic Pump Cartridge

1 Open the front door.

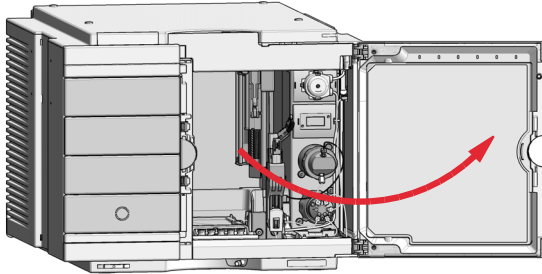

2 Press the two clips on the front of the peristaltic pump cartridge.

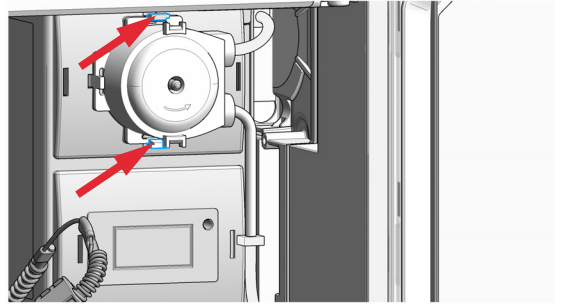

3 Pull the cartridge forward off the motor shaft.

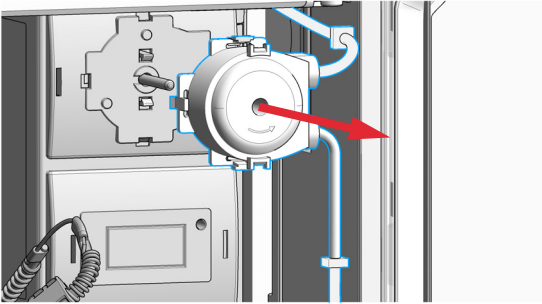

4 Disconnect the tubing coupler leading to the wash port and the tubing coupler coming from the solvent bottle.

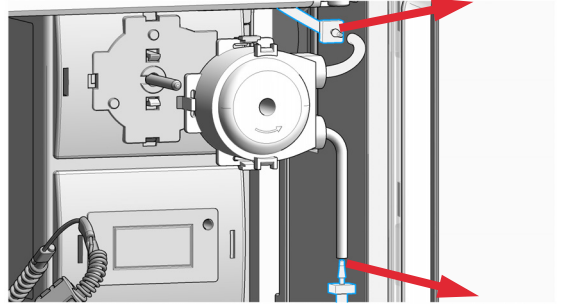

5 Push the new cartridge onto the motor shaft until the clips click into place.

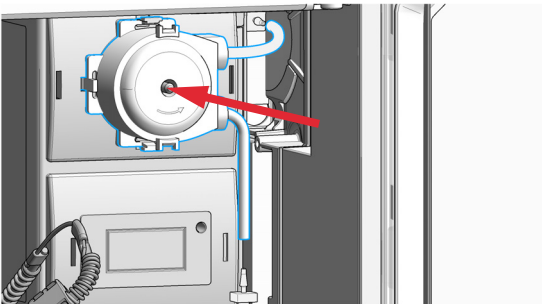

6 Connect the wash port tubing to the upper tubing of the new cartridge (use sand paper to get a good grip on the tubing).

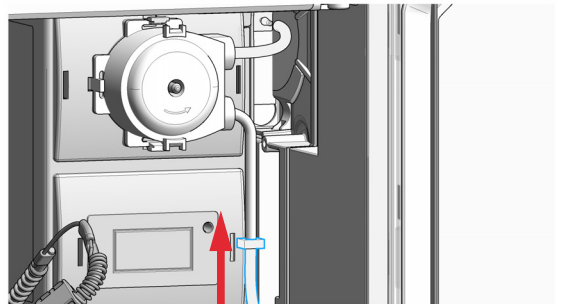

Replace the Peristaltic Pump Cartridge

- 7 Connect the inlet filter of the solvent bottle again. Use the syringe to draw enough solvent for completely filling of the peristaltic pump tubing before continuing to prime the peristaltic pump.

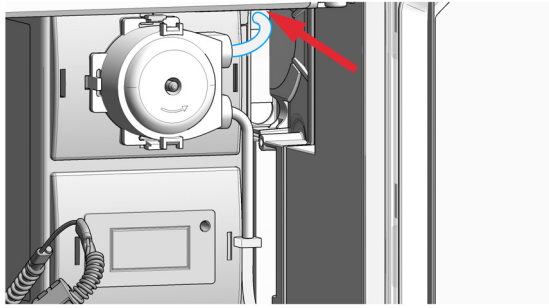

- 8 Close the front door.

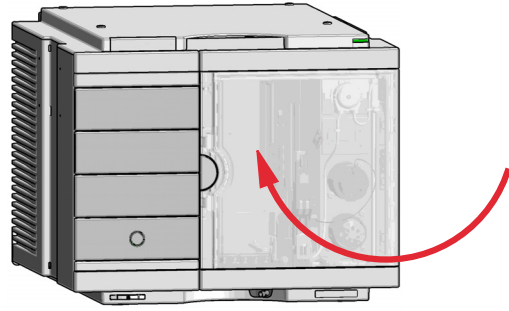

Replace the Flushhead Seal



For bio-inert modules use bio-inert parts only!

When Flush head is leaking

Tools required	p/n	Description
	8710-0510	Open-end wrench 1/4 – 5/16 inch
	8710-2392	Hex key 4 mm15 cm long T-handle

Parts required	p/n	Description
	5067-5918	Flush Head Seal 500 µL
	G5668-60494	Seal 500 µL Bio for bio inert solution

Preparations

- Cleaning tissue
- Appropriate solvent like isopropanol or methanol

1 In the Local Controller start the maintenance mode and select **Service Position**.

OR

In the Agilent Lab Advisor software select **Service & Diagnostics** in the system screen (**Tools**) >**Maintenance Positions** >**Change Metering Device**, click start and wait until the metering device is in maintenance position.

2 Open the front door.

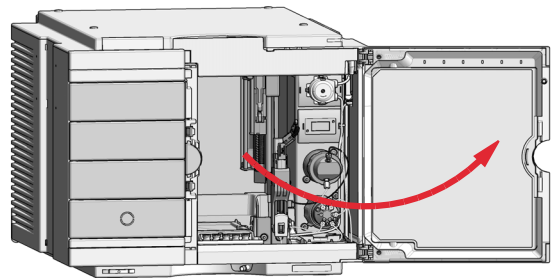

Maintenance

Replace the Flushhead Seal

3 Remove capillaries and valves from the flush head.

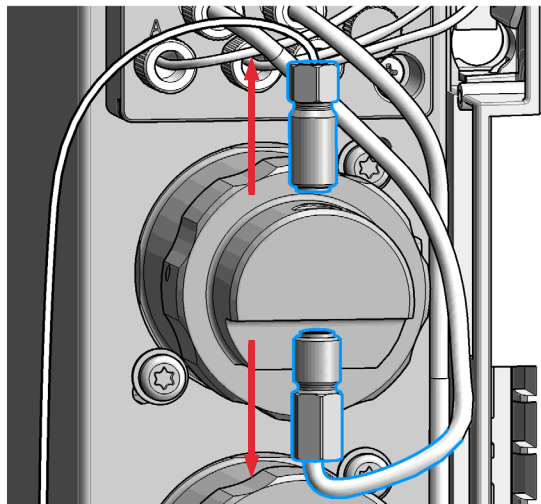

4 Press and turn the Flush Head a quarter left (bayonet fitting) and detach the metering device from the actuator.

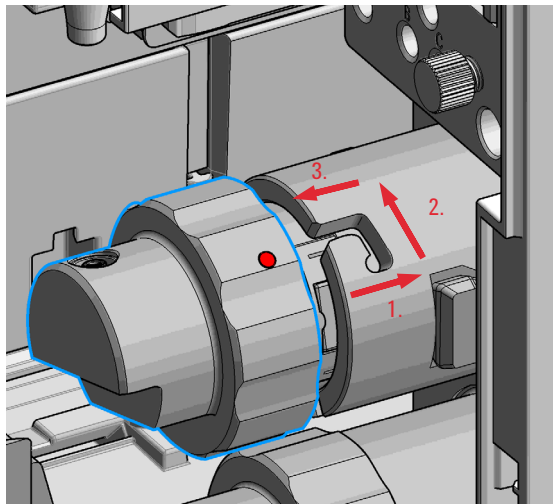

5 Pull the flush head away from the hydraulic box

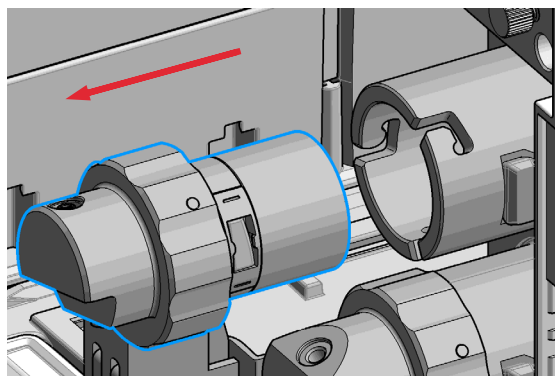

6 Press against the rear side of flush head and turn a quarter left (bayonet fitting) and separate the flush head, head body and the piston.

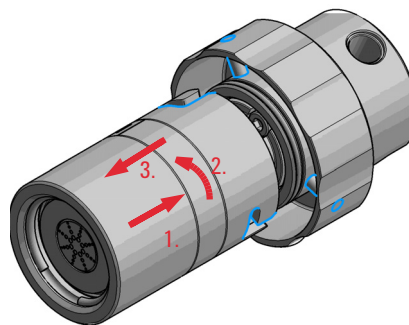

NOTE

Be careful not to break the piston.

Maintenance

Replace the Flushhead Seal

7 Remove the piston from the head body.

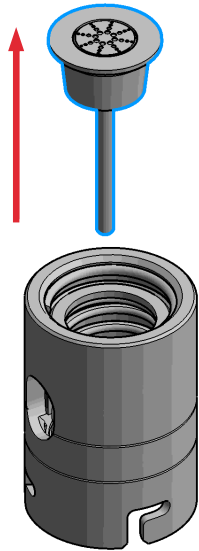

8 Carefully remove the seal from the tip of the piston.

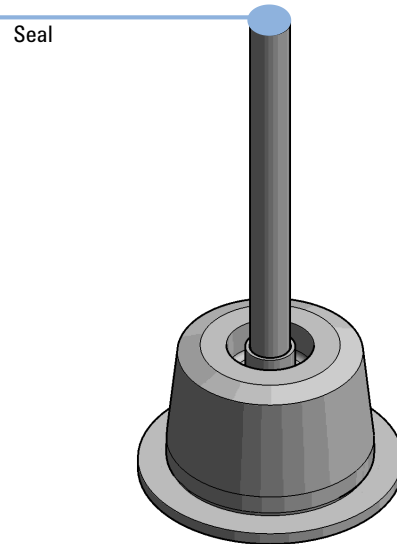

9 Reassemble the flush head and the head body (without piston).

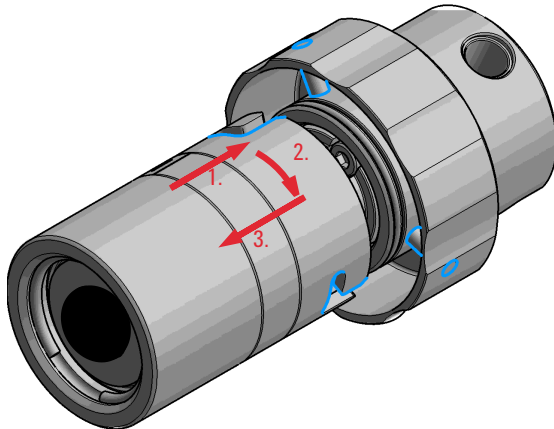

10 Carefully insert the piston with the new metering seal into the flush head assembly.

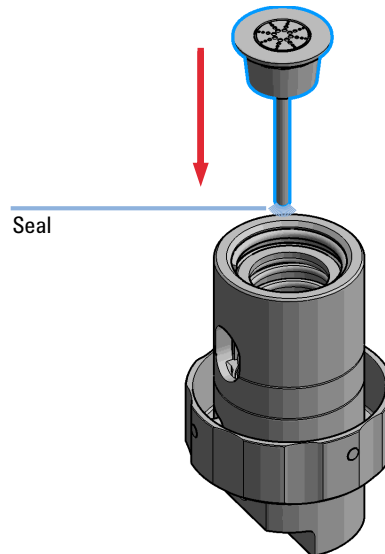

Maintenance

Replace the Flushhead Seal

11 Reinstall the flush head to the actuator housing.

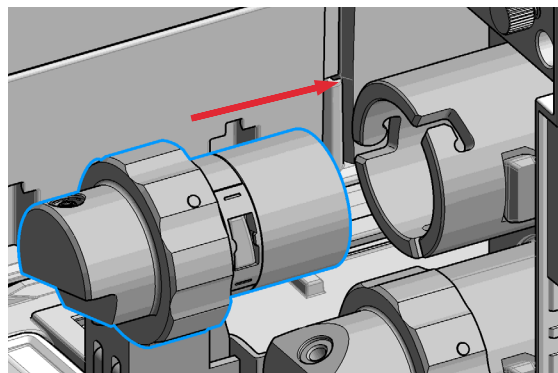

NOTE

For proper installation, check the correct position of the tag.

12 Fix the flush head.

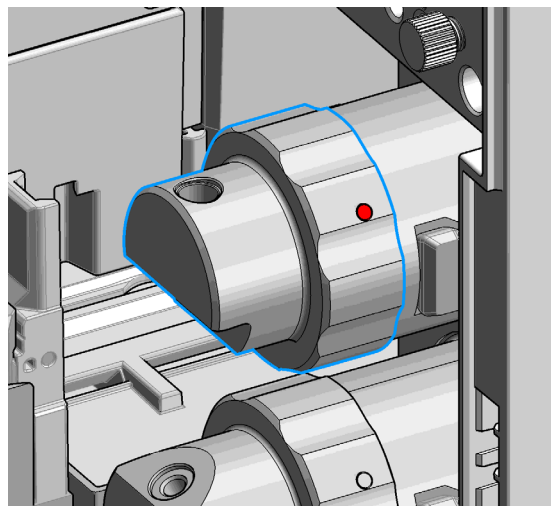

13 Connect the capillaries.

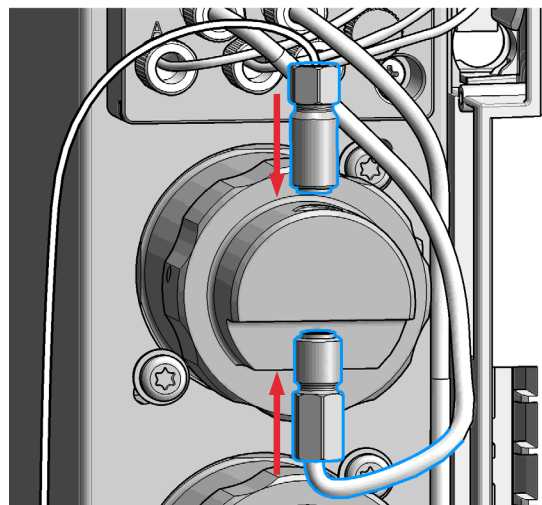

14 Close the front door.

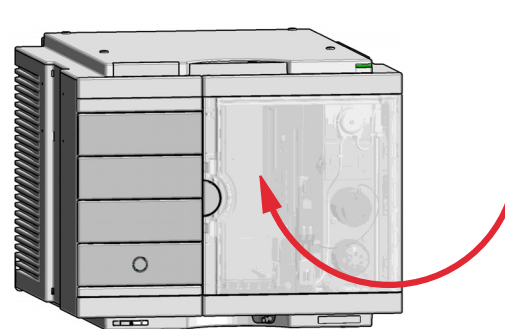

Remove the Sample Loop-Flex











For bio-inert modules use bio-inert parts only!



For 1290 Infinity II Bio LC modules, use bio / biocompatible parts only.
Do not mix parts between 1260 Infinity II Bio-Inert LC modules and 1290 Infinity II Bio LC modules.

When If the sample loop flex is defective or damaged.

Tools required	p/n	Description
	8710-0510 	Open-end wrench 1/4 – 5/16 inch

Parts required	p/n	Description
	G4267-60300 	Sample Loop Flex 20 µL, right (red coded)
	G4267-60400 	Sample Loop Flex 40 µL, right (green coded)
	G4267-60500 	Sample Loop Flex 100 µL, right (blue coded)
	G7167-68500 	Sample Loop Cartridge 500 µL right
	G7167-68900 	Sample Loop Cartridge 900 µL right
	G5668-60500 	Bio-inert Sample Loop 100 µL (for G5668A)
	G7137-60300 	Sample Loop MP35N 20 µL, right (red/orange coded)
	G7137-60400 	Sample Loop MP35N 40 µL, right (green/orange coded)
	G7137-60500 	Sample Loop MP35N 100 µL, right (blue/orange coded)

Further sample loops for the Dual-Needle option are available, see “Sample Loops and Capillaries (Dual Needle)” on page 322.

Preparations Finish any pending acquisition job and return any plate on the workspace back to the hotel.

WARNING

Risk of injury by uncovered needle

An uncovered needle is a risk of harm to the operator.

- ✓ Do not open the safety lock of the needle assembly
- ✓ Be careful working at the z-robot.
- ✓ Wear safety goggles, when removing the needle assembly.

1 In the Agilent Lab Advisor software select **Service & Diagnostics >Maintenance Positions >Change Needle, Loop and Seat**, click **Start** and wait until the needle assembly is in maintenance position.

OR

In the Local Controller start the maintenance mode and select **Change Needle, Loop and Seat** function.

2 Open the front door.

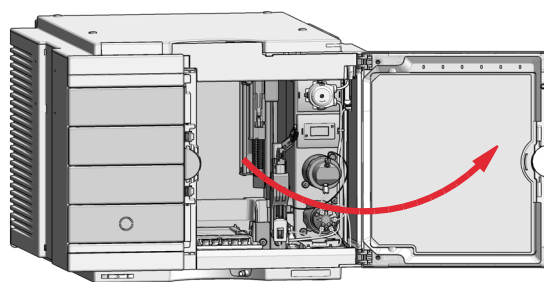

3 The needle assembly is still connected to the loop capillary. Use a 1/4 inch wrench to loosen the fitting of the loop capillary connected to the analytical head.

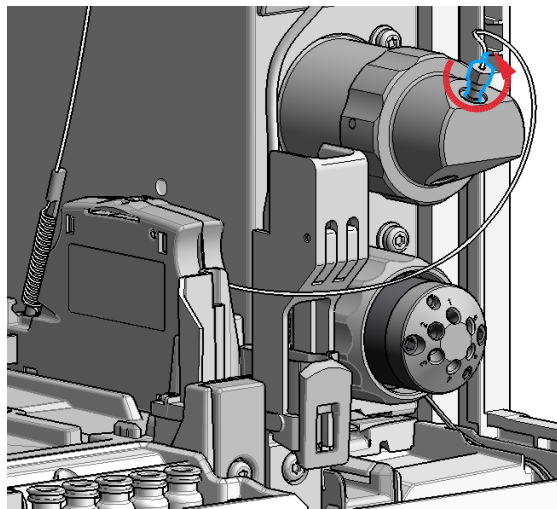

4 Lock the needle in the safety position.

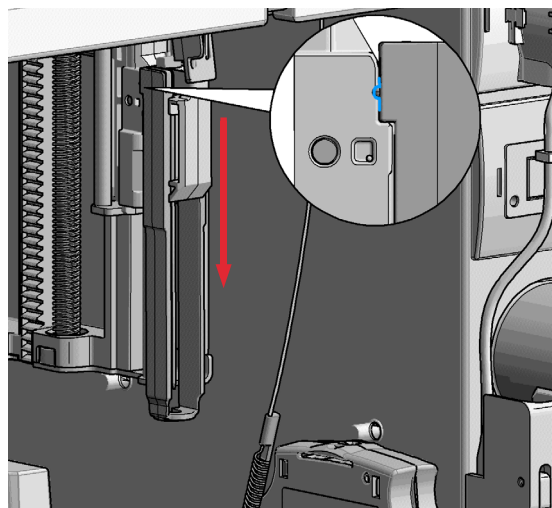

NOTE

During normal operation of the Multisampler the needle assembly has to be unlocked.

CAUTION

Damage of the loop

The loop shape may be damaged if the loop is stretched or bent too far.

- ✓ Avoid to change the loop shape.
- ✓ Do not pull or bend the loop too far.

WARNING

Sharp needle

Uncovered needles may cause injuries

- ✓ Make sure the needle is in the safety lock position.

- 5 Remove the needle assembly by slightly pulling the needle cartridge.

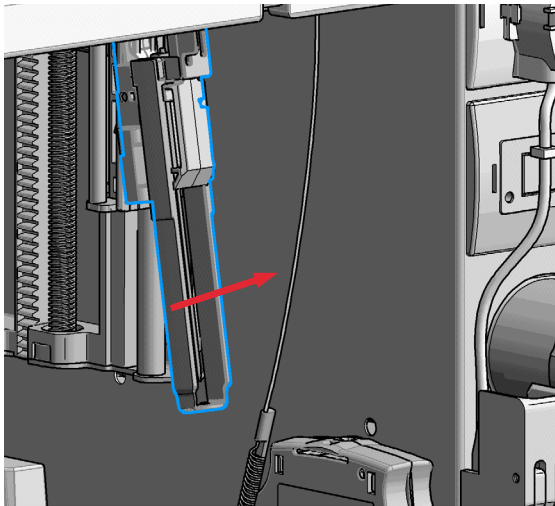

- 6 Remove the cartridge out of its proper position. By gently tilting and pulling it out of the work space of the multisampler.

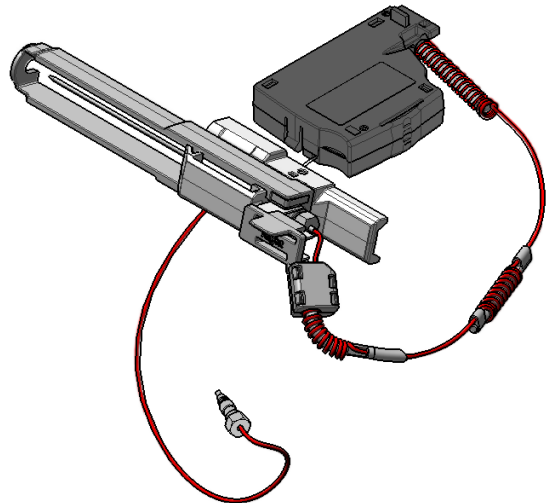
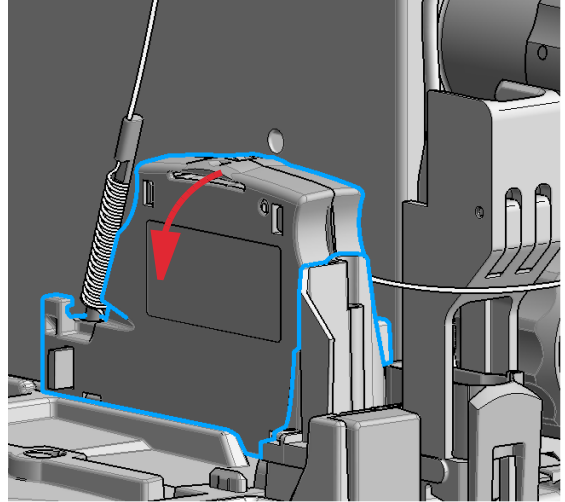

Maintenance

Remove the Sample Loop-Flex

7 Remove the loop plastic adapter.

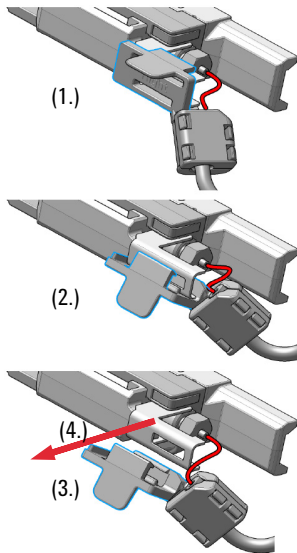

NOTE

Do not open the rear plastic clamp.

NOTE

If the plastic adapter is damaged the sample loop has to be replaced.

8 Use a 1/4 inch wrench to loosen the fitting of the loop capillary.

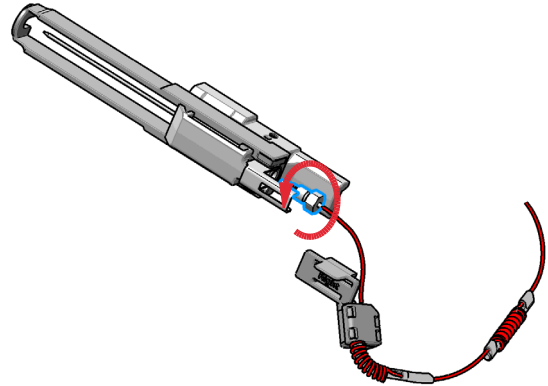

9 Remove the needle assembly.

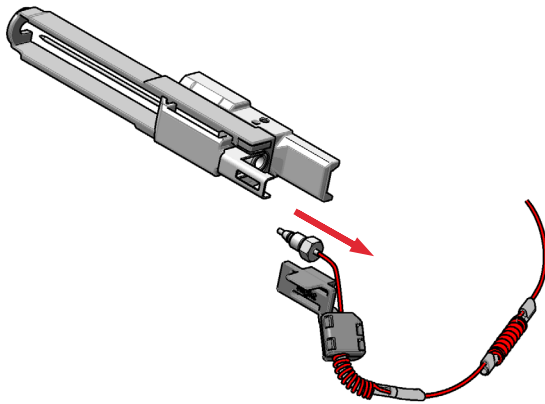

Installing the Sample Loop-Flex



For bio-inert modules use bio-inert parts only!











For 1290 Infinity II Bio LC modules, use bio / biocompatible parts only.
Do not mix parts between 1260 Infinity II Bio-Inert LC modules and 1290 Infinity II Bio LC modules.

When If the sample loop flex is defective or damaged.

Tools required

p/n	Description
8710-0510 	Open-end wrench 1/4 – 5/16 inch

Parts required

p/n	Description
G4267-60300 	Sample Loop Flex 20 µL, right (red coded)
G4267-60400 	Sample Loop Flex 40 µL, right (green coded)
G4267-60500 	Sample Loop Flex 100 µL, right (blue coded)
G7167-68500 	Sample Loop Cartridge 500 µL right
G7167-68900 	Sample Loop Cartridge 900 µL right
G5668-60500 	Bio-inert Sample Loop 100 µL (for G5668A)
G7137-60300 	Sample Loop MP35N 20 µL, right (red/orange coded)
G7137-60400 	Sample Loop MP35N 40 µL, right (green/orange coded)
G7137-60500 	Sample Loop MP35N 100 µL, right (blue/orange coded)

Further sample loops for the Dual-Needle option are available, see “Sample Loops and Capillaries (Dual Needle)” on page 322.

Preparations Finish any pending acquisition job and return any plate on the workspace back to the hotel.

WARNING**Risk of injury by uncovered needle**

An uncovered needle is a risk of harm to the operator.

- ✓ Do not open the safety lock of the needle assembly
- ✓ Be careful working at the z-robot.
- ✓ Wear safety goggles, when removing the needle assembly.

CAUTION**Mismatching sample loop configuration**

Damage to the system

- ✓ Make sure, that the sample loop configuration matches to the hardware installed.

NOTE

If you have changed the sample loop, verify that the correct sample loop is configured in the CDS (see [“Setting up the Autosampler with OpenLab ChemStation”](#) on page 140).

NOTE

For details on the setup of the dual-needle system, see [“Modify Capillaries”](#) on page 150.

Maintenance

Installing the Sample Loop-Flex

- 1 Install the loop capillary on top of the needle cartridge (1.) and tighten the fitting hand tight (2.).

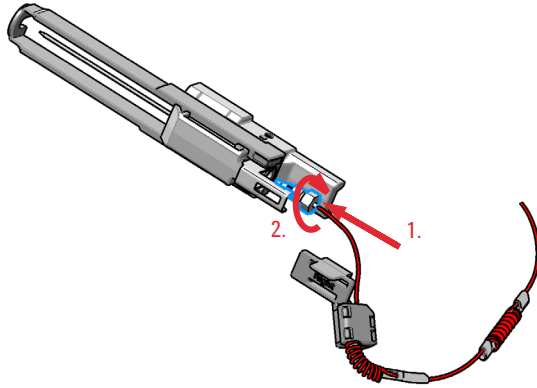

NOTE

If the sample loop is changed, we recommend changing the needle as well.

CAUTION

Blockages inside of the needle assembly union

- ✓ Do not overtighten the fitting. A quarter turn should be sufficient.
- 2 Then use a 1/4 inch wrench to tighten the fitting of the loop capillary.

3 Install loop plastic adapter.

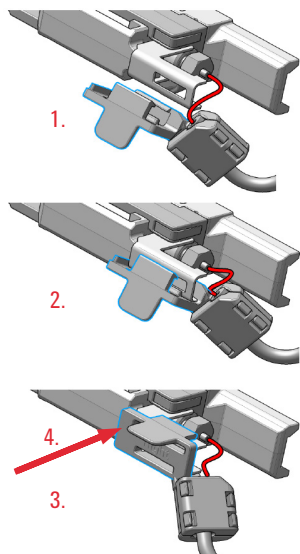

NOTE

Verify the sample loop info on the plastic adapter. A left or a right sample loop must be installed in the correct slot of the needle parkstation. For single needle, the default position is on the right.

NOTE

If the plastic adapter is damaged the sample loop has to be replaced.

4 Click the sample loop cartridge in the designated location and keep the right orientation.

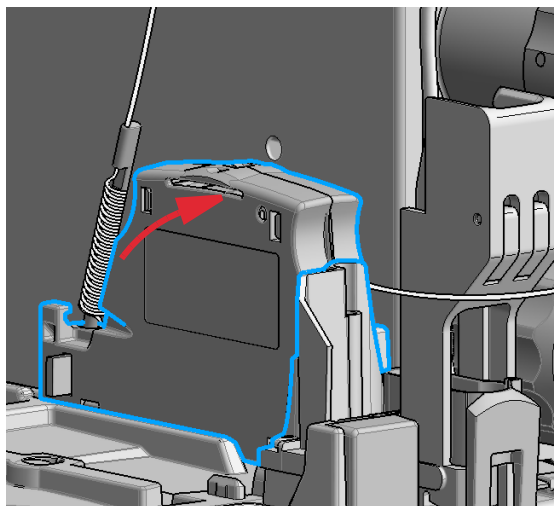

Maintenance

Installing the Sample Loop-Flex

- 5 Install the shorter capillary of the sample loop cartridge to the analytical head.

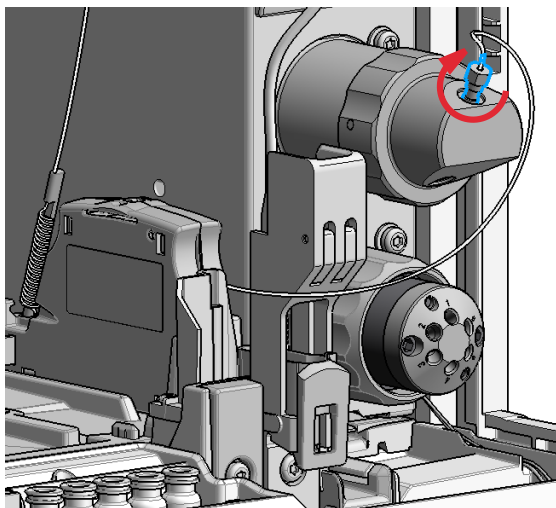

- 6 Pinch and reinsert the needle assembly and the connected sample loop capillary into the z- arm coupler.

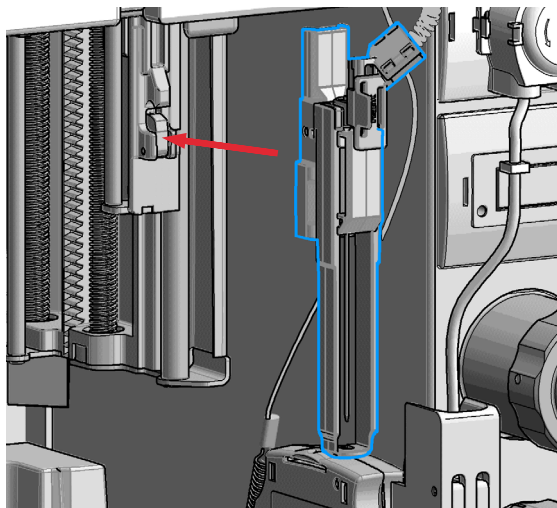

NOTE

Check the tension of the loop capillary. This must be forced and guided to the hydraulic box to prevent it from being caught by the Z-drive.

- 7 Close the front door.

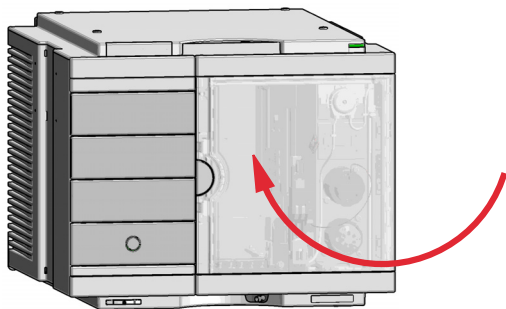

Next Steps:

- 8 In the Local Controller close **Change needle /seat**.
OR
In Agilent Lab Advisor software **Change needle/loop**.
Click **NEXT** and wait until the needle is in the needle park station.
Click **Back** to leave the Maintenance window.

NOTE

If you need an autoreferencing step included you must choose the change needle procedure



NOTE

If you have changed the sample loop, verify that the correct sample loop is configured in the CDS (see "Setting up the Autosampler with OpenLab ChemStation" on page 140).

Replace the Dummy Drawer

Optional Configurations

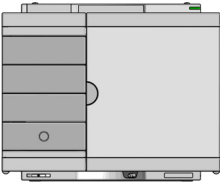
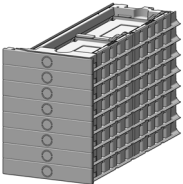
Table 37 Overview on optional configurations (examples for uniform types)

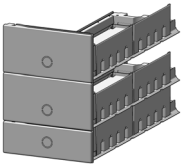
	1H	2H	3H	Dummy-Drawer
 <p>Delivery Status</p>	-	G7167-60020 1x	-	G4267-60024 3x
 <p>Up to 8 single height drawers 16 positions Shallow wellplates and MTP Max Sample capacity 1536 / 6144 samples (96 Shallow Wellplates / 384 MTP)</p>	G7167-60021 8x	-	-	-
 <p>Up to 4 Dual Height drawers 8 positions Vials (2 mL), deep well plates, MTP, Eppendorf Max Sample capacity 432 / 3072 samples (2 mL Vials/ 384 MTP)</p>	-	G7167-60020 4x	-	-
 <p>Up to 2 Drawers Triple Height 4 positions (2H or 2*1H option left over) Vials (6 ml), deep well plates, MTP, Eppendorf Max Sample capacity 60 / 216/ 1536 samples (6 mL Vials/ 2 mL Vials/ 384 MTP)</p>	-	G7167-60020 1x	G7167-60022 2x	-

NOTE

Mixed configurations are possible (for example 1x3H- with 1x2H- and 3x1H-drawer).

All positions in the Sample Hotel must be filled either with dummies or drawers. The drawers must be installed from bottom to top.

Installing and Replacing of Drawers (Upgrade Drawer Kit)

Tools required

Description

Screwdriver

Parts required

p/n

Description

G7167-60020  Drawer 2H

G7167-60021  Drawer 1H

G7167-60022  Drawer 3H

NOTE

Before you start the new drawer installation you have to remove the lower drawer (2H drawer = default configuration) from the Sample Hotel.

NOTE

For best cooling performance the 2H drawer must be installed in the lowest position.

NOTE

More detailed video information is available on the Agilent Information Center.

1 Open the drawer.

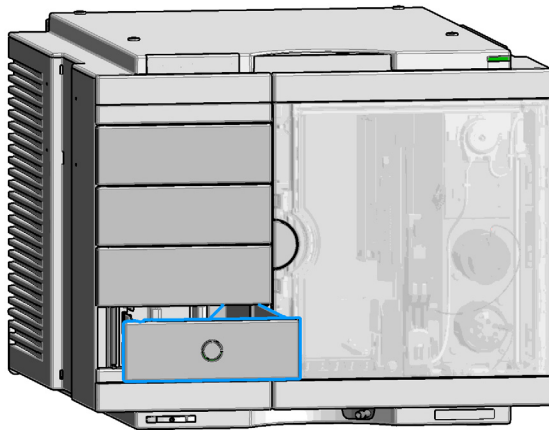

2 Pull the drawer completely out.

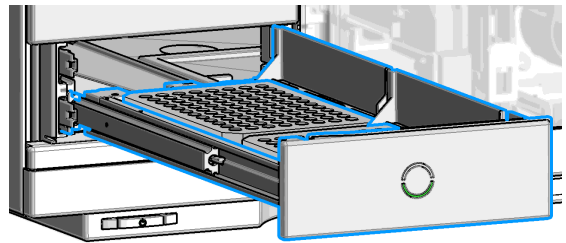

Maintenance

Replace the Dummy Drawer

- 3** Unlatch the drawer: Use a screwdriver to press the clamping lever lightly to the left.

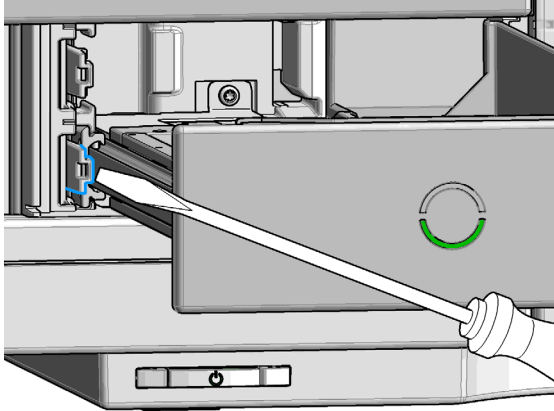

- 4** Remove the drawer from the rail guide.

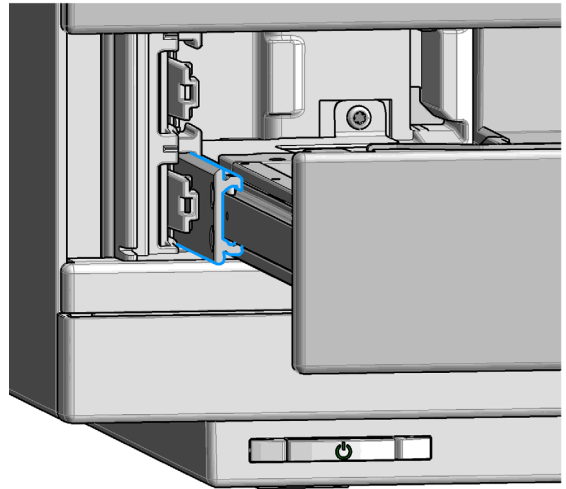

The drawer is now out of the hotel.

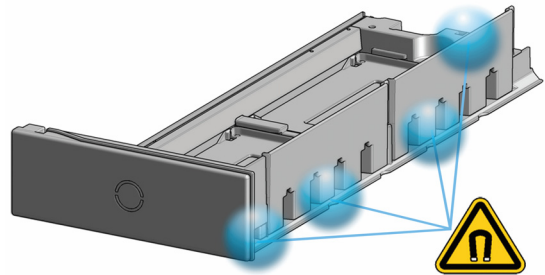

Maintenance

Replace the Dummy Drawer

- 5 Grab in the recession below the dummy drawer front panel (1.) and lift the left side (2.).

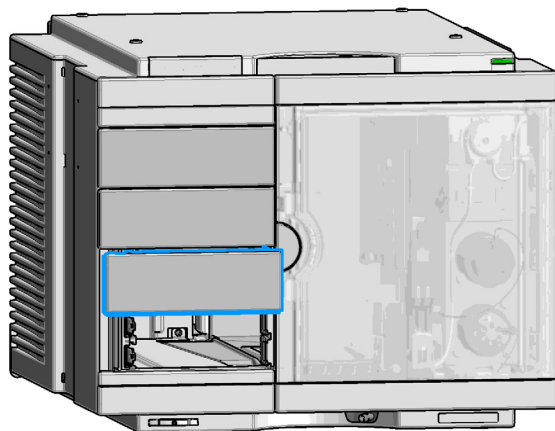

- 6 Remove the dummy drawer.

NOTE

At this stage remove all other dummies that will be replaced by hotel drawers.

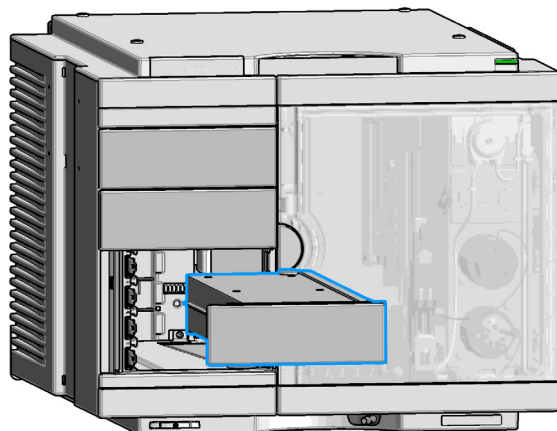

Maintenance

Replace the Dummy Drawer

- 7 Place the new drawer horizontally into the sample hotel. Check that the drawer matches the middle bracket of the sample hotel.

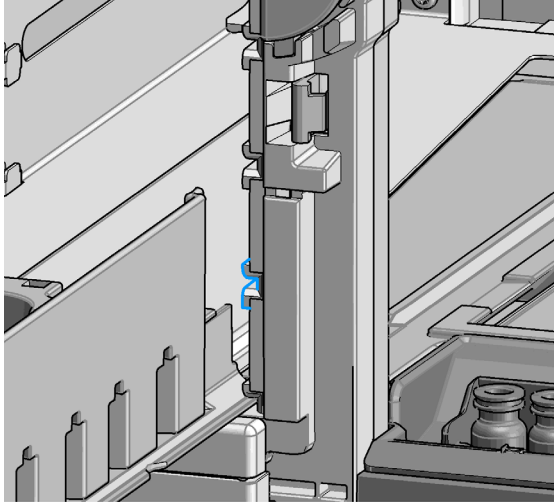

- 8 Push until the complete drawer locks in place.

NOTE

Take care that the clamping lever locks.

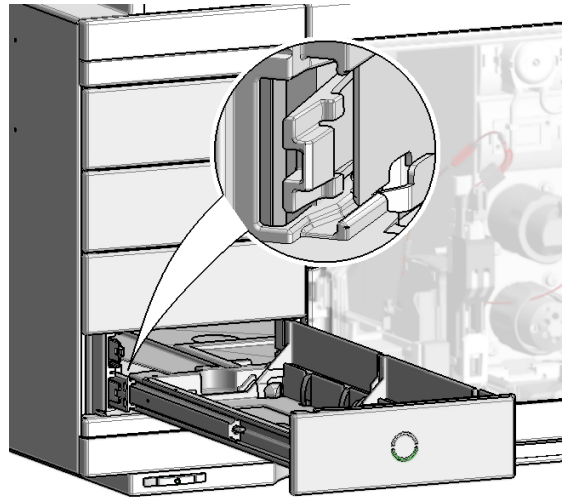

NOTE

Always fill sample hotel completely (no empty drawer slots). Otherwise the drawers can't be configured in the software.

- 9 Configure the hotel drawers in the controller software (see the Online Help of the software for details).

Configuration of the Hotel Drawers

The configuration of your drawers is necessary to detect the new drawer configuration for your CDS system. When a wrong configuration is detected there will be a mismatch in your CDS system and you are not able to use the new drawers. The new drawer configuration is active and stored after you have done the Drawer Configuration.

Configure the Hotel Drawers in the Control Software

Software required OpenLab CDS (A.02.01 or above)
LC driver (A.02.10 or above)

Preparations

- Stop the acquisition run.
- Remove the sample containers (trays and well plates) from workspace.
- Complete the drawer installation.
- Remove the sample containers (trays and well plates) from the drawers.
- Verify that all sample trays (palettes) are installed in their drawers.
- All open drawers and dummies have to be closed and installed properly.

- 1 Start the Agilent chromatography data system.
- 2 Right-click on the **Sampler** GUI (example shows a Multisampler).

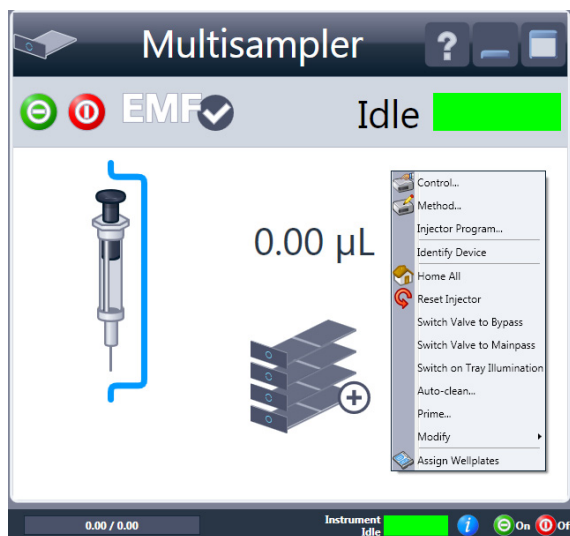

Maintenance

Replace the Dummy Drawer

- 3 Select **Modify >Drawer Configuration** in the GUI screen.

NOTE

For correct detection, it is necessary to remove all sample containers (for example 54 vial tray or well plates).

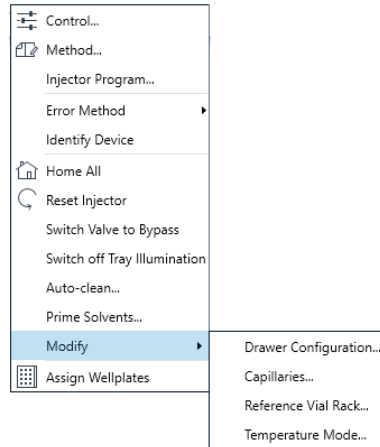

- 4 Follow the Setup or Change configuration screen.
- 5 System is ready after the robot has done Auto Referencing (see “Auto Referencing” on page 214).

Configure the Hotel Drawers in Lab Advisor

Software required Lab Advisor (B.02.05 or above)

Preparations

- Stop the acquisition run.
- Remove the sample containers (trays and well plates) from workspace.
- Complete the drawer installation.
- Remove the sample containers (trays and well plates) from the drawers.
- Verify that all sample trays (palettes) are installed in their drawers.
- All open drawers and dummies have to be closed and installed properly.

- 1 Start the Lab Advisor Software.
- 2 Connect the instrument and select **Instrument Control** in the system screen.
- 3 Switch In the **Configuration** menu of the Multisampler. Select **Detect Drawers** in the **Hotel Configuration**.

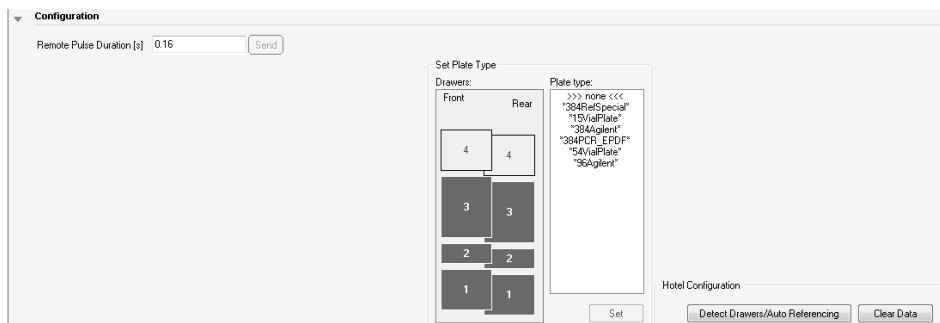

- 4 Follow the Detect Hotel Configuration screen to detect the physically available drawers.



NOTE



For correct detection, it is necessary to remove all sample containers (for example 54 vial tray or well plates).

- 5 System is ready after the robot has done Auto Referencing (see "Auto Referencing" on page 214).

Replace the Sample Cooler/Sample Thermostat

When The Sample Cooler/Sample Thermostat is damaged or defective.

Tools required	p/n	Description
	8710-0899 	Screwdriver Pozidrive Shaft (for the Sample Cooler)
	5182-3466 	Torx screwdriver T10 (for the Sample Thermostat)
OR	5023-3089 	Torx key set (part of the G7120-68708 InfinityLab LC Series Tool Kit)

Parts required	#	p/n	Description
	1	G7167-60005 	Sample Cooler
OR	1	G7167-60101 	Sample Thermostat
OR	1	G7167-60201 	Sample Thermostat

Preparations If needed, update the firmware of the hosting sampler to ensure that it supports the type of thermostat you are about to install, see “Specifications of the Sample Thermostat” on page 64.

WARNING

Flammable refrigerant

Formation of flammable gas-air mixtures inside the Sample Thermostat and laboratory.

- ✓ Keep open fire or sources of ignition away from the device.
- ✓ Ensure a room size of 4 m³ (1 m³ for every 8 g of R600a refrigerant inside of the Sample Thermostat).
- ✓ Ensure adequate ventilation: typical air exchange of 25 m³/h per m² of laboratory floor area.
- ✓ Keep all ventilation openings in the enclosure clear of obstructions. Do not block the openings on the circumference of the Sample Thermostat.

WARNING

Flammable refrigerant used

- ✓ When handling, installing and operating the Sample Thermostat, care should be taken to avoid damage to the refrigerant tubing or any part of the Sample Thermostat.
-

WARNING

In the event of a damage

- ✓ Keep open fire or sources of ignition away from the device.
 - ✓ Ventilate the room for several minutes.
 - ✓ Do not use the Sample Thermostat any more.
-

WARNING

Heavy weight

The module is heavy.

- ✓ Carry the module at least with 2 people.
 - ✓ Avoid back strain or injury by following all precautions for lifting heavy objects.
 - ✓ Ensure that the load is as close to your body as possible.
 - ✓ Ensure that you can cope with the weight of your load.
-

CAUTION

Routing of the condensation tubing

Proper routing of the condensation tubing is critical for correct condensate drainage.

- ✓ Do not place the sampler directly on the bench.
-

CAUTION

Condensate inside the cooler or thermostat

Damage to the electronics

- ✓ Unplug the power cords.
 - ✓ Drain off all condensate before dismounting the sample cooler or thermostat.
 - ✓ Make sure that there is no condensate left.
-

Replace the Sample Cooler/Sample Thermostat

- 1 Ensure that the power switch on the front of the module is OFF (switch stands out).

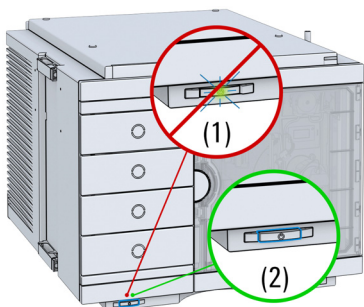

- 2 Disconnect the power cable from the sampler.

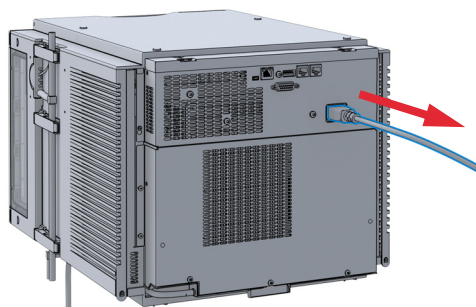

- 3 Ensure that no condensate remains inside the cooler/thermostat before proceeding forward.

NOTE

Gently tapping on the sides of the sampler can help to remove the last traces of condensate from the system.

- 4 Loosen the screw (1) and remove the condensate funnel (2) from the back of the cooler/thermostat.

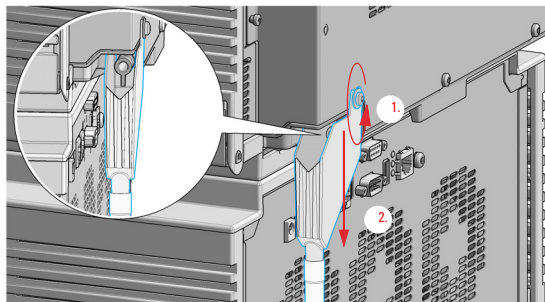
**NOTE**

If there is still some condensate inside the cooler/thermostat, place a suitable container underneath the outlet tube, and keep tapping on the sides of the sampler until no more water comes out.

- 5 Remove the fixation screws on the back of Sample Cooler/Sample Thermostat.

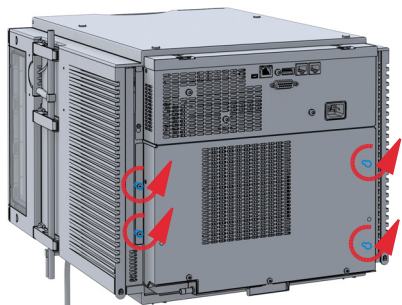

- 6 Pull the cooler/thermostat halfway out, disconnect the power and the data cable and then remove the unit completely from the sampler.

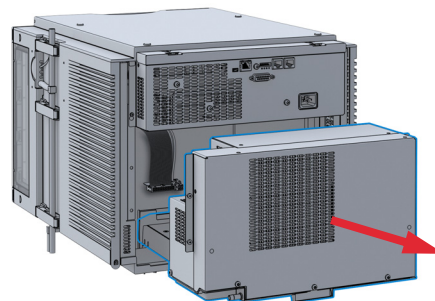

Replace the Sample Cooler/Sample Thermostat

- 7 Slide the new cooler/thermostat halfway into the sampler and connect the power and the data cable.

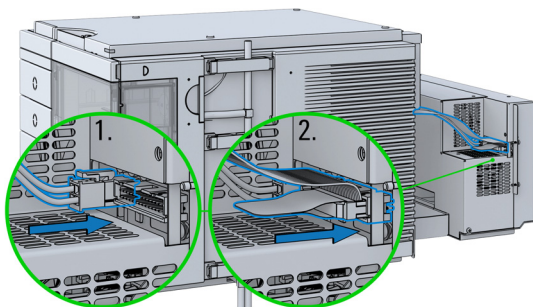
**CAUTION****Damage to the cables**

- ✓ Do not bend or pinch the cables.
 - ✓ Make sure that the Sample Cooler/Sample Thermostat fits perfectly in the sampler.
- 8 Slide the cooler/thermostat all the way into the sampler, making sure that the cables don't get jammed between the metal parts.

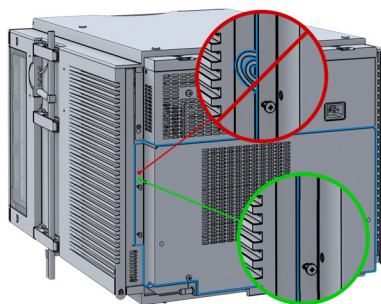

- 9 Fix the unit with the four screws.

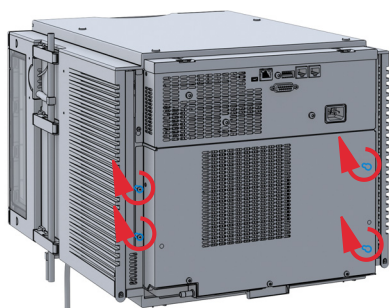

- 10 Position the condensate collector funnel underneath the condensate drainage outlet tube (1) and fix it to the back of the cooler/thermostat by tightening the screw (2). Ensure correct orientation and avoid overtightening the screw.

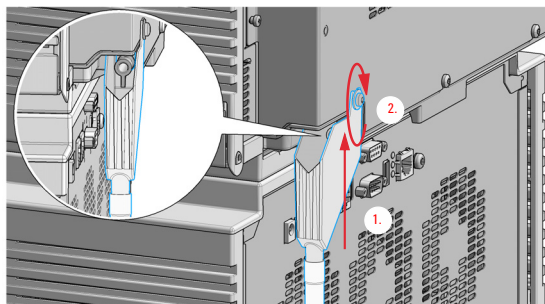
**NOTE**

For information on proper condensate handling, see "Install the Sample Cooler/Sample Thermostat" on page 76.

Replace the Sample Cooler/Sample Thermostat

- 11 Connect the power cable to the power connector at the rear of the module.

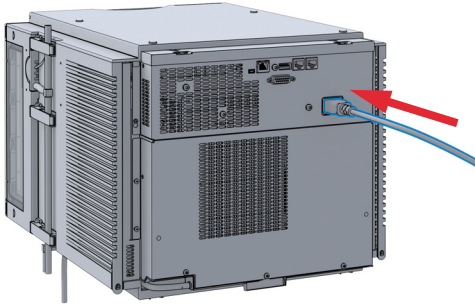
**CAUTION****Damage to the Sample Cooler/Sample Thermostat**

- ✓ Wait at least 30 min before switching on the compressor of the cooler/thermostat.
 - ✓ This allows the refrigerant and system lubrication to reach equilibrium.
- 12 Switch on the sampler and perform the **Sample Cooler Function Test** to verify the correct functioning of the new cooler/thermostat (see "Sample Cooler Function Test" on page 222).

Replace the Module Firmware

When

The installation of newer firmware might be necessary

- if a newer version solves problems of older versions or
- to keep all systems on the same (validated) revision.

The installation of older firmware might be necessary

- to keep all systems on the same (validated) revision or
- if a new module with newer firmware is added to a system or
- if third party control software requires a special version.

Tools required

Description

Agilent Lab Advisor software

Parts required

Description

- | # | Description |
|---|---|
| 1 | Firmware, tools and documentation from Agilent web site |

Preparations

Read update documentation provided with the Firmware Update Tool.

To upgrade/downgrade the module's firmware carry out the following steps:

- 1 Download the required module firmware, the latest FW Update Tool and the documentation from the Agilent web.
<https://www.agilent.com/en-us/firmwareDownload?whid=69761>
- 2 For loading the firmware into the module follow the instructions in the documentation.

Module Specific Information

There is no specific information for this module.

10















Parts for Maintenance and Upgrade or Options

Standard Parts	300
Hotel Drawer	303
Analytical Head Assembly 40 μ L	304
Bio-Compatible Analytical Head Assembly 40 μ L	305
Analytical Head Assembly 100 μ L	307
Bio-inert Analytical Head Assembly 100 μ L (600 bar)	308
Bio-Compatible Analytical Head Assembly 100 μ L	310
Analytical Head Assembly 900 μ L	312
Flush Head Assembly 500 μ L	313
Bio Flush Head Assembly 500 μ L	315
2-Position/6-Port Injection Valve VICI	317
Bio-Compatible 2-Position/6-Port Injection Valve VICI	318
2-Position/6-Port Injection Valve IDEX	319
2-Position/6-Port Injection Valve Bio-inert IDEX	320
Injection Valve with Actuator	321
Sample Loops and Capillaries (Dual Needle)	322
3-Position/6-Port Peripheral Valve Dual Needle	324
2-Position/8-Port Injection Valve Dual Needle	325
Needle Port Assembly	326
Door Assy	327
Accessory Kit	328
Bottles	330
Tubing Kit Sampler Standard	331
Tubing Kit Sampler Multi-Wash	333
Multi Draw Kit	334
Bio-Inert Multi-Draw Kit	335
Upgrade Kits	336
Leak System Parts	337
Sample Thermostat	338

This chapter provides information on parts material required for the module.

Standard Parts

Standard Parts

p/n	Description
G4267-87201 	Needle Assembly
G4267-87210 	Needle Assembly (slotted) for high injection volumes
G4267-87012 	High Pressure Needle Seat, 0.12 mm (PEEK)
5068-0198 	Rotor Seal 1300 bar (PEEK) for 1290 Infinity II Injection Valve (Single Needle)
5068-0209 	Rotor Seal (PEEK) for 1260 Infinity II Injection Valve (Single Needle)
5068-0232 	Rotor Seal (PEEK) for Dual-needle Injection Valve
5068-0229 	Rotor Seal (PEEK) for Dual-needle Peripheral Valve
G4267-60300 	Sample Loop Flex 20 µL, right (red coded)
G4267-60400 	Sample Loop Flex 40 µL, right (green coded)
G4267-60500 	Sample Loop Flex 100 µL, right (blue coded)
G7167-68500 	Sample Loop Cartridge 500 µL right
G7167-68900 	Sample Loop Cartridge 900 µL right
G7167-60300 	Extension Sample Loop-Flex 500 – 900 µL Right Single Needle
G4267-40033 	Transport Protection





NOTE

For using the 500 µL or 900 µL Sample loop cartridge in a single needle system, install a 900 µL analytical head.

Standard Parts used in the 1260 Infinity II Bio-inert System



For bio-inert modules use bio-inert parts only!







p/n	Description
G5668-87200 	Needle Bio-Sampler (G5668A)
5068-0209 	Rotor Seal (PEEK) (G5668A)
G5668-87017 	Bio Seat ID 0.17 (G5668A)
G5668-60500 	Bio-inert Sample Loop 100 μ L

Standard Parts used in the 1290 Infinity II Bio LC System



For 1290 Infinity II Bio LC modules, use bio / biocompatible parts only.

Do not mix parts between 1260 Infinity II Bio-Inert LC modules and 1290 Infinity II Bio LC modules.

p/n	Description
G7137-87201 	Needle Biocompatible
5320-0010 	Rotor Seal 1300 bar (PEEK)
G7137-87012 	High pressure seat assembly 0.12 mm Biocompatible
G7137-60300 	Sample Loop MP35N 20 µL, right (red/orange coded)
G7137-60400 	Sample Loop MP35N 40 µL, right (green/orange coded)
G7137-60500 	Sample Loop MP35N 100 µL, right (blue/orange coded)

Hotel Drawer

Item	p/n	Description
1	G7167-60021 E	Drawer 1H (including 2*G4267-60206 Sample Tray (Palette)) ¹
2	G7167-60020 E	Drawer 2H (including 2*G4267-60205 Sample Tray (Palette)) ¹
3	G7167-60022 E	Drawer 3H (including 2*G4267-60205 Sample Tray (Palette)) ¹
	G4267-60024 E	Dummy Drawer (not shown)

¹ Note: This partnumber should only be used for repairs. For increasing the capacity in the Sample Hotel please order a pair of drawers via ELSA http://wadnts02.germany.agilent.com/csc/tools/web_elsa/elsa.htm.

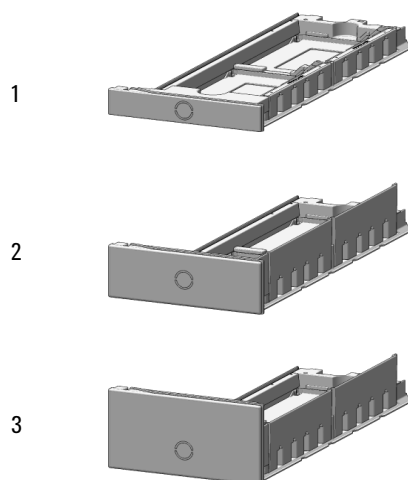

Figure 54 Hotel drawer

Analytical Head Assembly 40 μ L

Item	p/n	Description
	G4267-60042 [E]	Analytical Head, 40 μ L
1	G4267-60423 [E]	Head Assembly, 40 μ L
2	0905-1717 [E]	Metering Seal, 40 μ L
3	G4267-60422 [E]	Seal Support Assembly, 40 μ L
4	0515-1052 [E]	Screw
5	G4267-60432 [E]	Spring Adapter Assembly
6	5067-5920 [E]	Piston, 40 μ L, Zirconium oxide
7	G4267-40430 [E]	RFID Clamp (not including the RFID Tag)
	5043-1000 [E]	O-Ring (not shown)
	5500-1159 [E]	Capillary ST 0.17 mm x 100 mm SX/S-2.3 Capillary from the metering device to the injection valve (not shown)

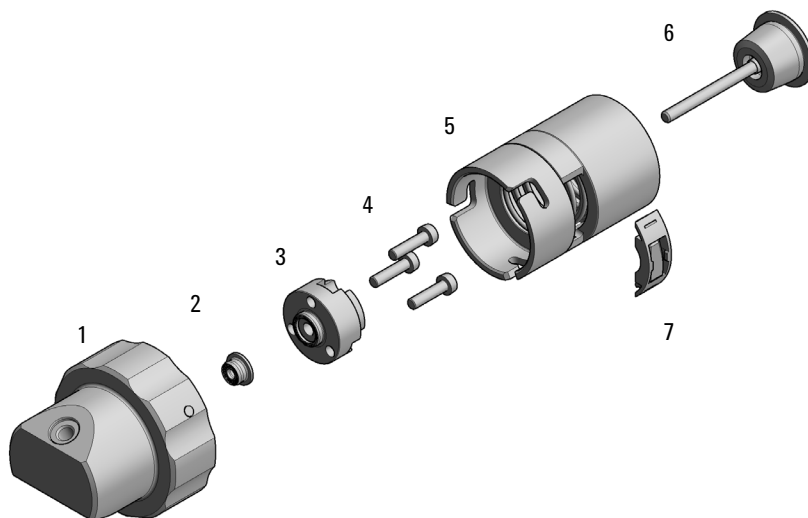

Figure 55 Analytical head assembly, 40 μ L

Bio-Compatible Analytical Head Assembly 40 μ L



For 1290 Infinity II Bio LC modules, use bio / biocompatible parts only.
 Do not mix parts between 1260 Infinity II Bio-Inert LC modules and 1290 Infinity II Bio LC modules.

Item	p/n	Description
	G7137-60042 📄	Bio-compatible head 40 μ L for G7137A
1	G7137-60000 📄	Bio-compatible head assembly, 40 μ L
2	G7137-20003 📄	Metering seal 1290 Bio 2 mm piston, 40 μ L
3	G4267-60422 📄	Seal Support Assembly, 40 μ L
4	0515-1052 📄	Screw, ST, M3x0.5, 12 mm, Hex 2.5 mm
5	G4267-60432 📄	Spring Adapter Assembly
6	5067-5920 📄	Piston, 40 μ L, Zirconium oxide
7	G4267-40430 📄	RFID Clamp (not including the RFID Tag)
	5043-1000 📄	O-Ring (not shown)
	5500-1278 📄	Capillary MP35N 0.17 mm x 100 mm SL/SL Capillary from the metering device to the injection valve (not shown)

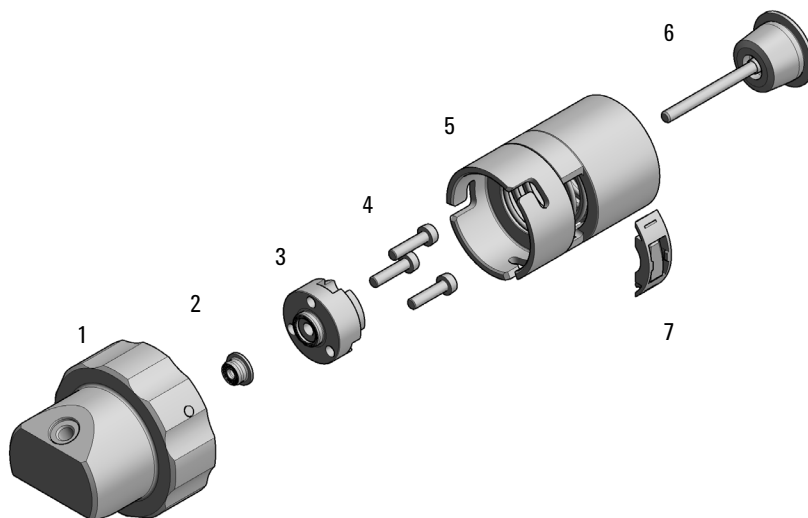

Figure 56 Analytical head assembly, 40 μ L

Analytical Head Assembly 100 μ L

Item	p/n	Description
	G4267-60043 [E]	Analytical Head, 100 μ L for G7167A, G7167B
1	G4267-60433 [E]	Head Assembly, 100 μ L
2	0905-1719 [E]	Metering Seal, 100 μ L
3	G4267-60434 [E]	Seal Support Assembly, 100 μ L
4	0515-1052 [E]	Screw, ST, M3x0.5, 12 mm, Hex 2.5 mm
5	G4267-60432 [E]	Spring Adapter Assembly
6	5067-5678 [E]	Piston, 100 μ L, Zirconium oxide
7	G4267-40430 [E]	RFID Clamp (not including the RFID Tag)
	5043-1000 [E]	O-Ring (not shown)
	5500-1159 [E]	Capillary ST 0.17 mm x 100 mm SX/S-2.3 Capillary from the metering device to the injection valve (not shown)

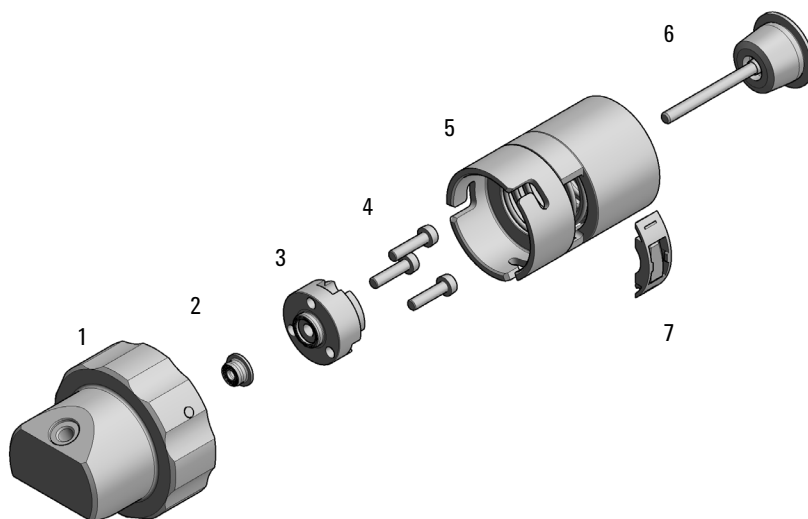

Figure 57 Analytical head assembly, 100 μ L

Bio-inert Analytical Head Assembly 100 μ L (600 bar)



For bio-inert modules use bio-inert parts only!

Item	p/n	Description
	G5668-60043 [E]	Bio-Inert Analytical Head 100 μ L for G5668A
1	G5668-60433 [E]	BIO Analytical Head 100 μ L
2	G5611-21503 [E]	Metering Seal PTFE (Bio-inert)
3	G4267-60434 [E]	Seal Support Assembly, 100 μ L
4	0515-1052 [E]	Screw, ST, M3x0.5, 12 mm, Hex 2.5 mm
5	G4267-60432 [E]	Spring Adapter Assembly
6	5067-5678 [E]	Piston, 100 μ L, Zirconium oxide
7	G4267-40430 [E]	RFID Clamp (not including the RFID Tag)

Capillary from the metering device to the injection valve (not shown)

Parts for Maintenance and Upgrade or Options
Bio-inert Analytical Head Assembly 100 μ L (600 bar)

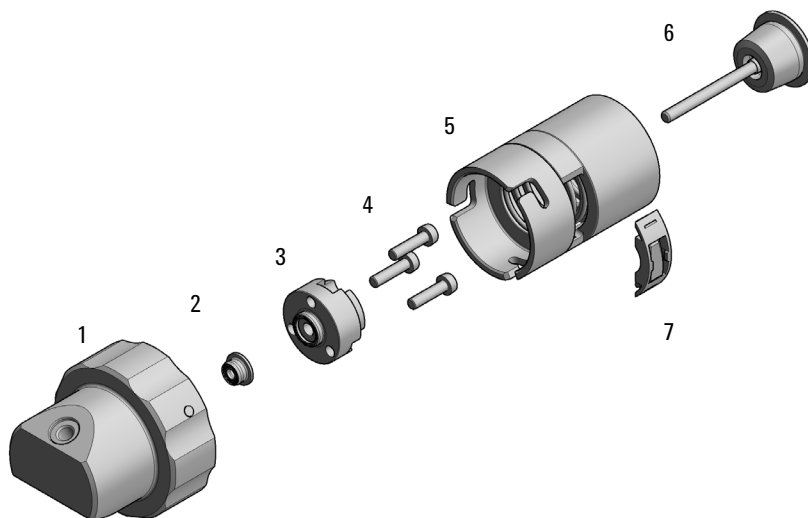

Figure 58 Analytical head assembly, 100 μ L

Bio-Compatible Analytical Head Assembly 100 μ L



For 1290 Infinity II Bio LC modules, use bio / biocompatible parts only.
Do not mix parts between 1260 Infinity II Bio-Inert LC modules and 1290 Infinity II Bio LC modules.

Item	p/n	Description
	G7137-60043 [i]	Bio-compatible Head 100 μ L for G7137A
1	G7137-60001 [i]	Bio-compatible head assembly, 100 μ L
2	G7131-20009 [i]	Metering Seal PTFE (Bio), 100 μ L
3	G4267-60434 [i]	Seal Support Assembly, 100 μ L
4	0515-1052 [i]	Screw
5	G4267-60432 [i]	Spring Adapter Assembly
6	5067-5678 [i]	Piston, 100 μ L, Zirconium oxide
7	G4267-40430 [i]	RFID Clamp
8	0960-2971 [i]	RF Transponder
	5043-1000 [i]	O-Ring (not shown)
	5500-1278 [i]	Capillary MP35N 0.17 mm x 100 mm SL/SL Capillary from the metering device to the injection valve (not shown)

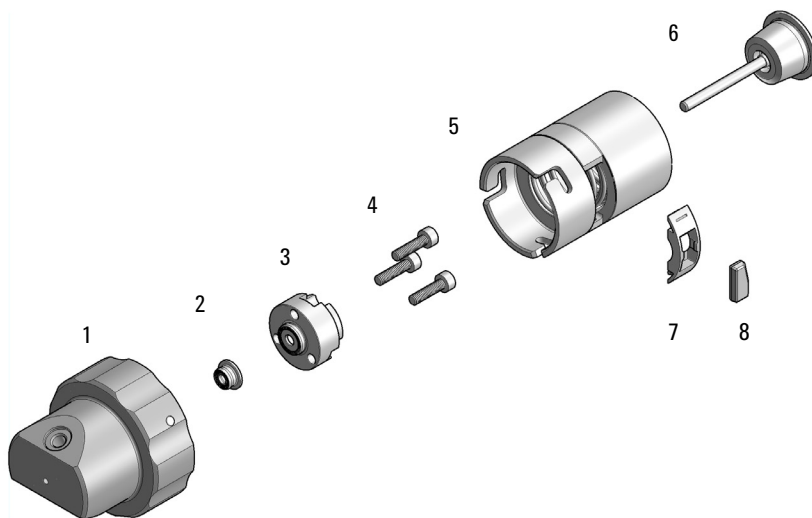

Figure 59 Analytical head assembly, 100 μ L

Analytical Head Assembly 900 μ L

Item	p/n	Description
	G4267-60046 [E]	Analytical head, 900 μ L, 400 bar
1	G4267-60461 [E]	Head Assembly, 900 μ L
2	0905-1294 [E]	Metering Seal, 900 μ L
3	G4267-60463 [E]	Seal Support Assembly, 900 μ L
4	SCREW-SKT [E]	SCREW-SKT HD CAP M2.5 X 0.45 10MM LG (not available)
5	G4267-60432 [E]	Spring Adapter Assembly
6	G4267-60462 [E]	Piston, 900 μ L, Sapphire
7	G4267-40430 [E]	RFID Clamp (not including the RFID Tag)
	5043-1000 [E]	O-Ring (not shown)
	5500-1159 [E]	Capillary ST 0.17 mm x 100 mm SX/S-2.3 Capillary from the metering device to the injection valve (not shown)

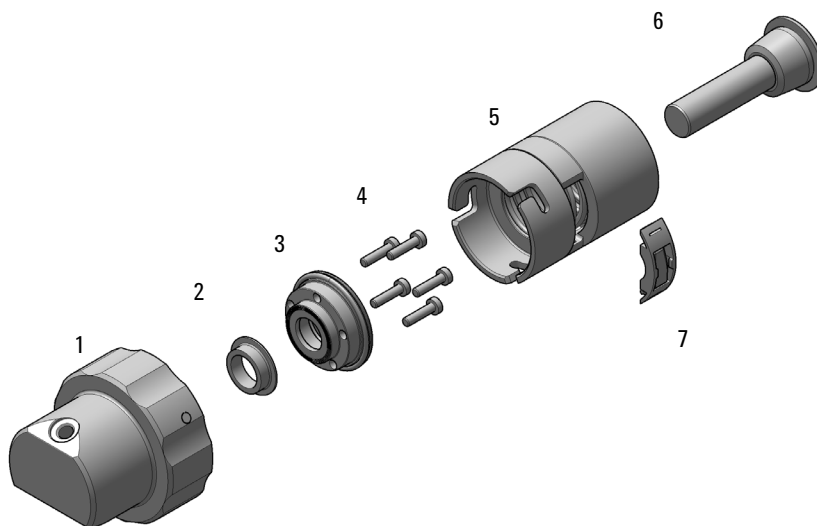

Figure 60 Analytical head assembly, 900 μ L

Flush Head Assembly 500 μ L

Item	p/n	Description
	G4267-60049 📄	Flush head, 500 μ L
1	G4267-60491 📄	Flush Head Assembly, 500 μ L
2	5023-2473 📄	Sealing Plate 500 μ L
3	G4267-60482 📄	Cylinder Assembly, 500 μ L
4	5067-5918 📄	Flush Head Seal 500 μ L
5	0515-5167 📄	Screw
6	1410-1881 📄	Bearing-Sleeve 8 mm-ID 10 mm-OD 10 mm-LG PI
7	G4267-60432 📄	Spring Adapter Assembly
8	5067-5919 📄	Piston Assembly 500 μ L
9	G4267-60451 📄	Pump Valve IN
10	G4267-60452 📄	Pump Valve Out
	5043-1000 📄	O-Ring (not shown)
	5500-1167 📄	Capillary ST 0.17 mm x 250 mm SL-SL Capillary from the flush head to the injection valve (not shown)

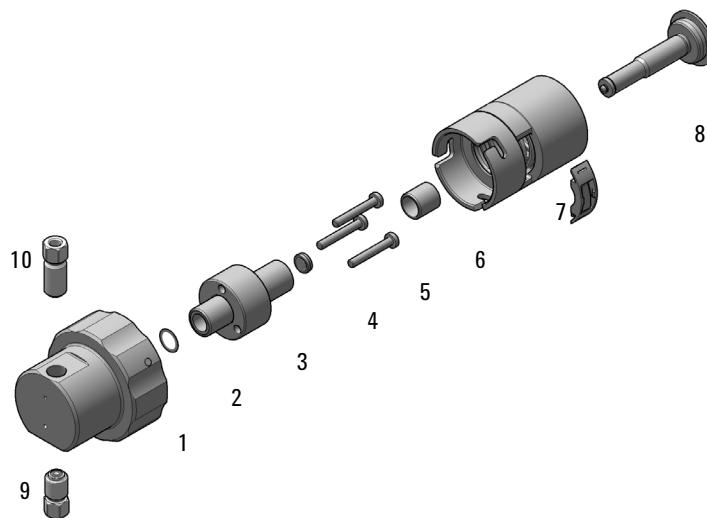

Figure 61 Flush head assembly, 500 μ L

Bio Flush Head Assembly 500 µl



For bio-inert modules use bio-inert parts only!

Item	p/n	Description
	G5668-60049 📄	Flush Head Bio 500 µL
1	G5668-60491 📄	Flush Head Bio Assembly, 500 µL
2	5023-2473 📄	Sealing Plate 500 µL
3	G4267-60482 📄	Cylinder Assembly, 500 µL
4	G5668-60494 📄	Seal 500 µL Bio
5	0515-5167 📄	Screw
6	1410-1881 📄	Bearing-Sleeve 8 mm-ID 10 mm-OD 10 mm-LG PI
7	G4267-60432 📄	Spring Adapter Assembly
8	5067-5919 📄	Piston Assembly 500 µL
9	G5668-60492 📄	Pump Valve IN
10	G5668-60493 📄	Pump Valve Out

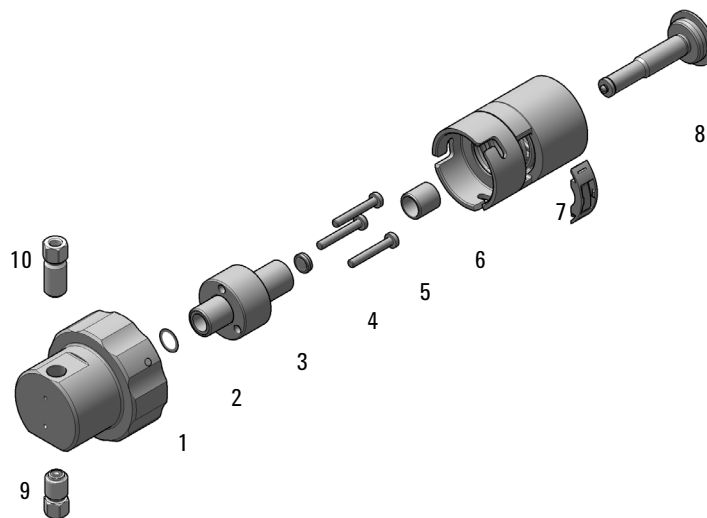

Figure 62 Flush head assembly, 500 μ L

2-Position/6-Port Injection Valve VICI

Item	p/n	Description
	5067-4232 📄	2-position/6-port Injection Valve (VICI) 1300 bar 1300 bar (G7167B)
1	5068-0210 📄	Stator screws
2	5068-0197 📄	Stator head
3	5068-0198 📄	Rotor Seal 1300 bar (PEEK)
	5500-1159 📄	Capillary ST 0.17x100 SX/S-2.3 Metering Device to Injection Valve
	5500-1246 📄	Capillary ST 0.17 mm x 500 mm SI/SI
	5500-1157 📄	Capillary ST 0.12 mm x 500 mm SL/S Sampler to column compartment
	5067-6127 📄	Blank Nut SL

NOTE

For the VICI Valve SL, SX, or SI fittings are mandatory.

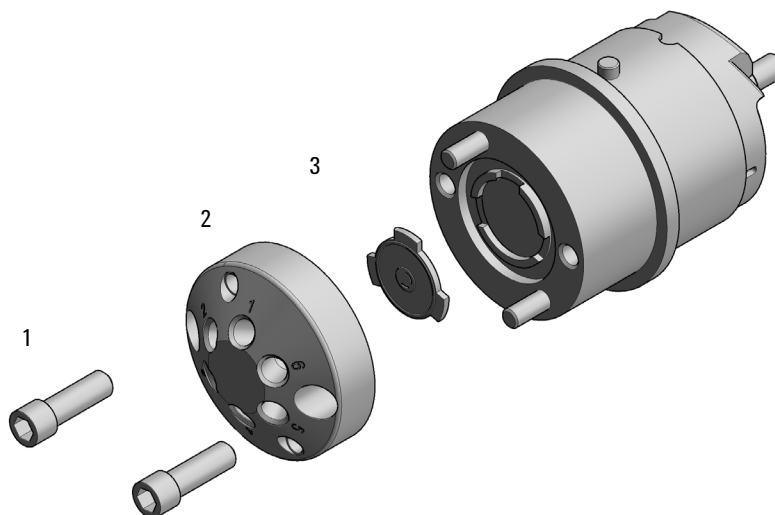

Figure 63 Injection valve assembly (VICI)

Bio-Compatible 2-Position/6-Port Injection Valve VICI



For 1290 Infinity II Bio LC modules, use bio / biocompatible parts only.
 Do not mix parts between 1260 Infinity II Bio-Inert LC modules and 1290 Infinity II Bio LC modules.

p/n	Description
5067-6739 	2-position/6-port injection valve Bio 1300 bar for G7137A
5428-0006 	Stator screws biocompatible
5320-0010 	Rotor Seal 1300 bar (PEEK)
5500-1278 	Capillary MP35N 0.17 mm x 100 mm SL/SL Metering device to injection valve
5500-1279 	Capillary MP35N 0.12 mm x 500 mm SI/SI Sampler to column compartment
5500-1419 	Capillary MP35N 0.17 mm x 500 mm, SI/SI Pump to sampler
5043-0277 	Blank nut long 10-32, PEEK
5068-0281 	Stator face, MP35N

2-Position/6-Port Injection Valve IDEX

Item	p/n	Description
	5067-6698 📄	2-position/6-port RC Injection Valve 800 bar
1	1535-4857 📄	Stator screws
2	5068-0208 📄	Stator head
3	5068-0120 📄	Stator ring
4	5068-0209 📄	Rotor Seal (PEEK)
5	1535-4045 📄	Bearing ring

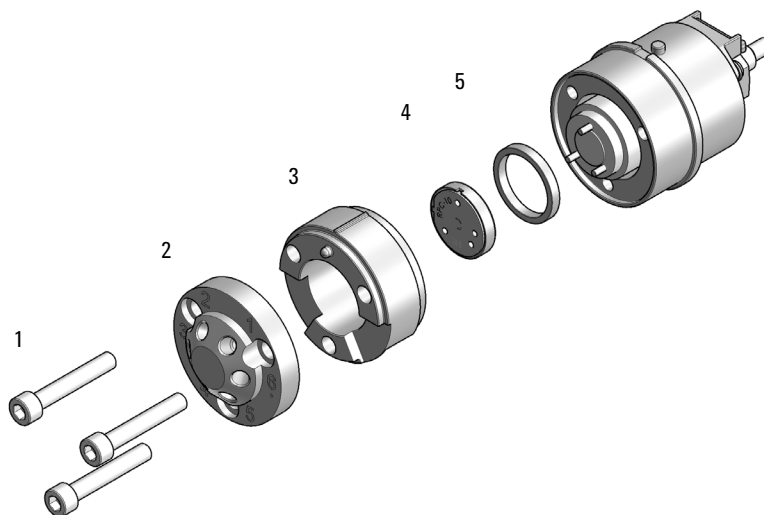
**Figure 64** Injection valve assembly (IDEX)

2-Position/6-Port Injection Valve Bio-inert IDEX

**BIO
INERT**

For bio-inert modules use bio-inert parts only!

Item	p/n	Description
	5067-4263 📄	2-position/6-port Injection Valve Bio-inert 600 bar (G5668A)
1	1535-4857 📄	Stator screws
2	5068-0060 📄	Bio-inert stator head
3	5068-0120 📄	Stator ring
4	5068-0209 📄	Rotor Seal (PEEK)
5	1535-4045 📄	Bearing ring
	5043-0277 📄	Blank nut long 10-32, PEEK

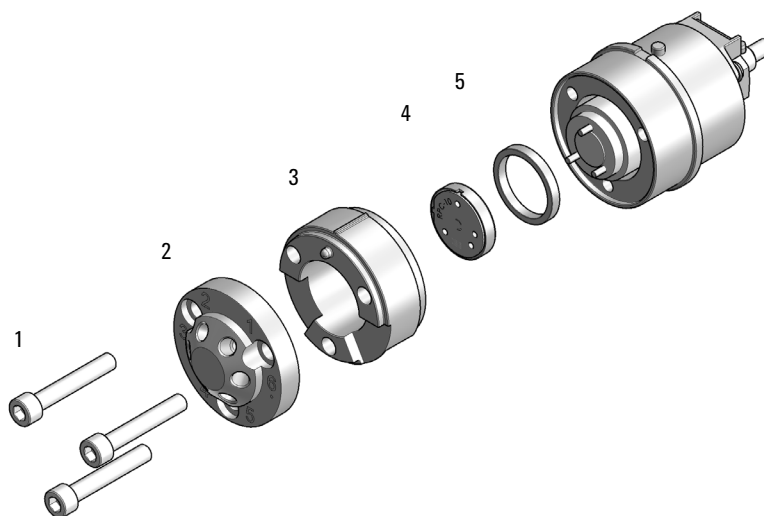

Figure 65 Injection valve assembly (IDEX)

Injection Valve with Actuator

Item	p/n	Description
1	5067-4232 📄	2-position/6-port Injection Valve (VICI) 1300 bar (G7167B)
OR	5067-6698 📄	2-position/6-port RC Injection Valve 800 bar
2	5043-0291 📄	Lock Nut
3	5188-8030 📄	Tag Reader
4	5067-4162 📄	Direct-Actuator-50 Assembly

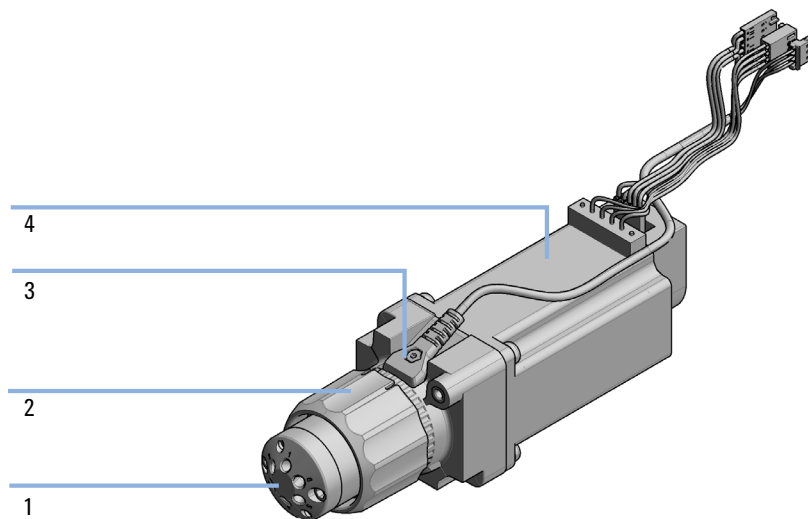

Figure 66 Injection valve with actuator

Sample Loops and Capillaries (Dual Needle)

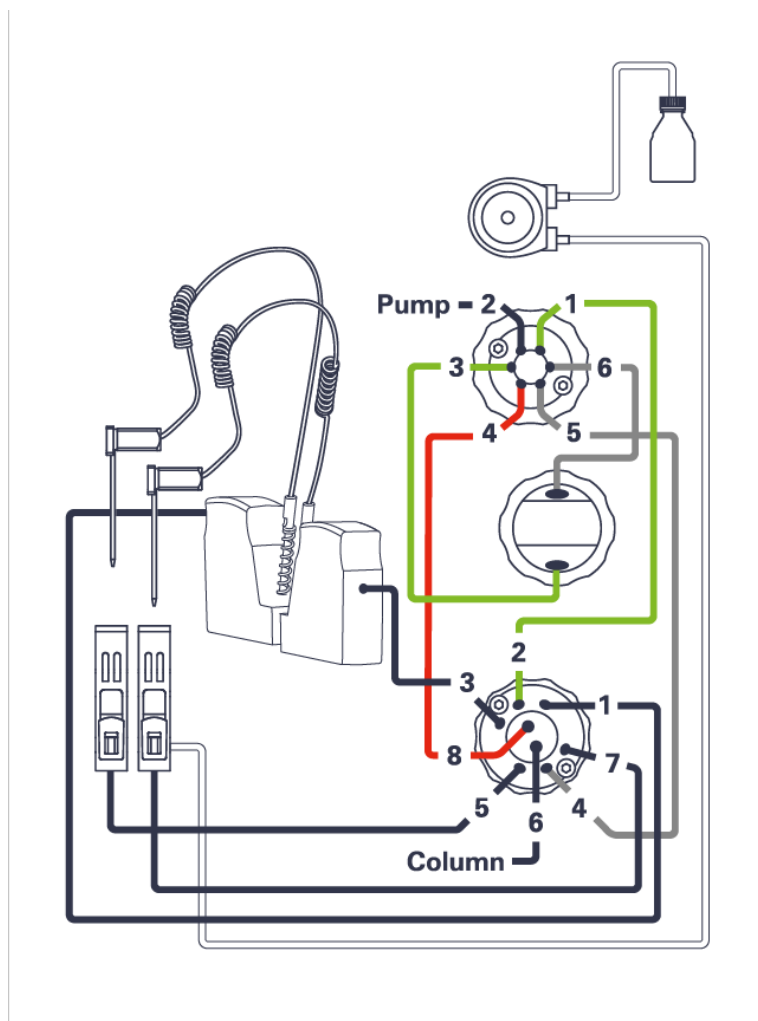

Figure 67 Capillary connections (Dual-Needle Option)

NOTE

Important for precision and avoiding of retention time shifts: only these sample loops must be used for the dual-needle option.







NOTE

It is mandatory that the configuration of the dual-needle system, especially sample loops, must match to the installed hardware to avoid damage to the system.







Parts for Maintenance and Upgrade or Options

Sample Loops and Capillaries (Dual Needle)







Dual-needle Sample Loops right

p/n	Description
G4267-60311 	Sample Loop 20 µL right Dual needle
G4267-60411 	Sample Loop 40 µL right Dual needle
G4267-60511 	Sample Loop 100 µL right Dual needle
G7167-68511 	Sample Loop 500 µL right Dual needle
G7167-68911 	Sample Loop 900 µL right Dual needle
G7167-60311 	Extension Sample Loop-Flex 500 – 900 µL Right Dual Needle



Dual-needle Sample Loops left

p/n	Description
G4267-60301 	Sample loop 20 µL left Dual needle
G4267-60401 	Sample loop 40 µL left Dual needle
G4267-60501 	Sample loop 100 µL left Dual needle
G7167-68501 	Sample Loop 500 µL left Dual needle
G7167-68901 	Sample Loop 900 µL left Dual needle
G7167-60301 	Extension Sample Loop-Flex 500 – 900 µL Left Dual Needle

Capillaries for the Dual-Needle Option

p/n	Description
5500-1225 	Capillary ST 0.12 mm x 180 mm SL-SL Port 4 Peripheral Valve/Port 8 Injection Valve
5500-1226 	Capillary ST 0.17 mm x 180 mm SL-SL Port 2 Injection Valve/ Port 1 Peripheral Valve
5500-1227 	Capillary ST 0.17 mm x 150 mm SL-SL Port 3 Peripheral Valve/Metering Device bottom
5500-1228 	Capillary ST 0.3 mm x 80 mm SL-SL Metering Device Top/Port 6 Peripheral Valve
5500-1229 	Capillary ST 0.3 mm x 180 mm SL-SL Port 4 Injection Valve/Port 5 Peripheral Valve
5500-1238 	Capillary ST 0.12 mm x 105 mm SL/SL

3-Position/6-Port Peripheral Valve Dual Needle

p/n	Description
5067-4256 	3-position/6-port Peripheral Valve DN 1300 bar
5068-0229 	Rotor Seal (PEEK)
5068-0197 	Stator head

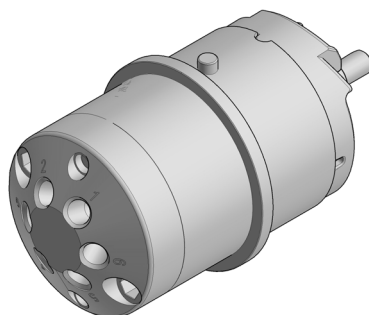

Figure 68 Peripheral valve (dual needle)

2-Position/8-Port Injection Valve Dual Needle

Item	p/n	Description
	5067-4260 📄	2-position/8-port Injection Valve Dual Needle 1300 bar
1	5068-0231 📄	Stator
2	5068-0232 📄	Rotor Seal (PEEK)

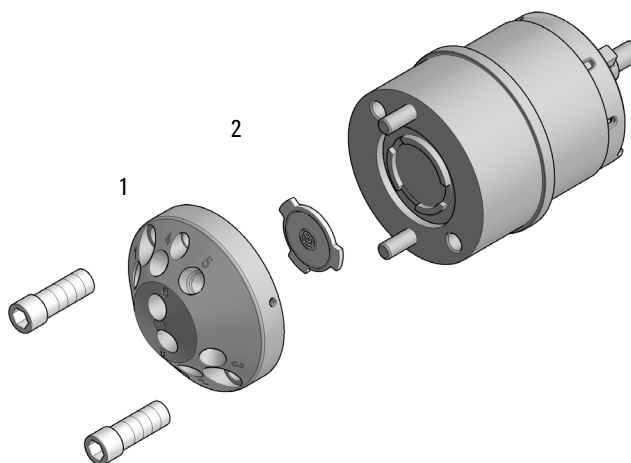

Figure 69 Injection valve (dual needle)

Needle Port Assembly

Item	p/n	Description
1	G4267-60044 E	Needle Port Assembly Station
2	G4267-40045 E	Needle port Adapter

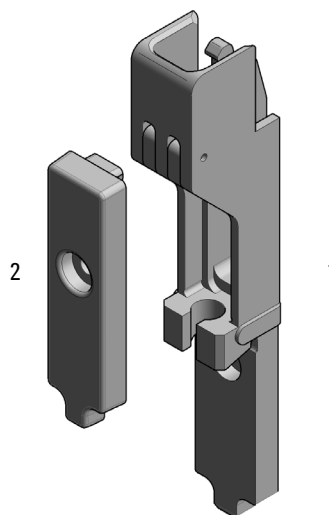

Figure 70 Needle port assembly

Door Assy

Item	#	p/n	Description
	1	5067-5415 [E]	Door Assy
1	1	5021-1879 [E]	Permanent Magnet
2	1		Pressure Spring (not available)
3	2	5067-5412 [E]	Hinge for Infinity II Instrument Doors
	1	G7167-68718 [E]	Light Protection Kit (not shown)

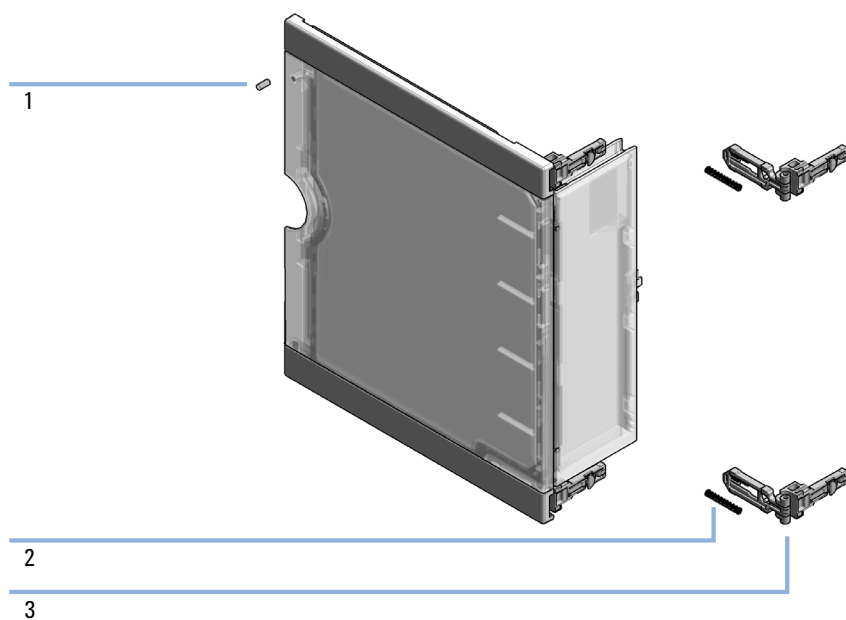

Figure 71 Door assy

Accessory Kit

Item	p/n	Description
	G4267-68705 📄	Accessory Kit (for G7167B)
	G7167-68715 📄	Accessory Kit (for G7167A)
	G5668-68705 📄	Accessory Kit Bio-inert Multisampler (for G5668A)
	G7137-68705 📄	Accessory Kit (for G7137A)
1	G4220-60007 📄	Bottle Head Assembly (not included in the accessory kit)
2	5063-6527 📄	Tubing, Silicon Rubber, 1.2 m, ID/OD 6/9 mm
3	5500-1157 📄	Capillary ST 0.12 mm x 500 mm SL/S (for G7167B)
OR	5500-1246 📄	Capillary ST 0.17 mm x 500 mm SI/SI (for G7167A)
OR	5500-1279 📄	Capillary MP35N 0.12 mm x 500 mm SI/SI (for G7137A)
OR	G5667-81005 📄	Capillary PK/ST 0.17 mm x 500 mm, RLO/RLO (Bio-inert) (for G5668A)
4	5043-1013 📄	Tubing Clip IF-II
5	5181-1519 📄	CAN cable, Agilent module to module, 1 m
	5067-5967 📄	Tubing Clip Tube Connector
	0100-1846 📄	UNION-TEFZEL
	5182-0716 📄	Screw Cap Vial, 2 mL, amber glass, write-on spot, 100/Pack
	5190-7024 📄	Screw Cap, PTFE/silicone, 100/pk

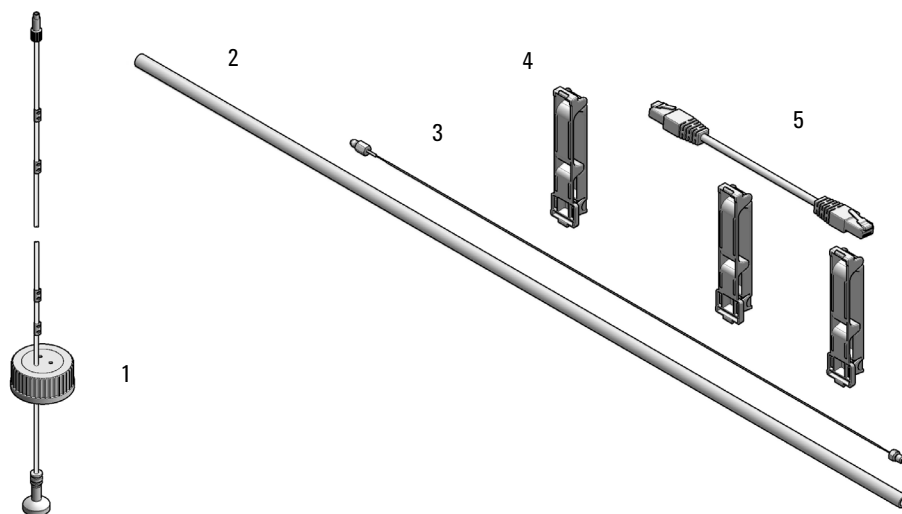

Figure 72 Accessory kit (standard)

Tools

Item	p/n	Description
1	0100-1710 [E]	Mounting Tool for Tubing Connections
2	5023-2533 [E]	Mounting tool

Tubing Connector Leak Kit (5067-6137)

p/n	Description
5067-6137 [E]	Tubing Connector Leak Kit



Figure 73 Tubing connector Leak Kit

Bottles

p/n	Description
9301-6524 📄	Solvent bottle, clear, 1000 mL
9301-6528 📄	Solvent bottle, clear, 1000 mL with cap
9301-6342 📄	Solvent bottle, clear 2 L
9301-6526 📄	Solvent bottle, amber, 1000 mL
9301-6341 📄	Solvent bottle, amber 2 L

Tubing Kit Sampler Standard

p/n	Description
G4267-60061 📄	Tubing-Kit-Sampler-Standard contains:
0890-1760 📄	Tubing Flexible 1 ea / 1 meter
5042-6422 📄	Tubing Connector, PP
0100-1708 📄	Nut 1/8 PPS
0100-1700 📄	FERRULE-AY-18IN
5500-1155 📄	Tube Connector, 90 degree, ID 6.4
5042-9917 📄	Flex Tubing
5043-1394 📄	Ferrule
5043-1395 📄	Nut
5043-1377 📄	FEP Tubing OD 0.0625 in x ID 0.02 in

NOTE

The components of the kit are not orderable separately.

Accessories not included in the kit, orderable separately:

Item	p/n	Description
1	5042-9974 📄	Tubing, PE, 1.5 m
2	0100-1846 📄	UNION-TEFZEL
3	5067-5967 📄	Tubing Clip Tube Connector

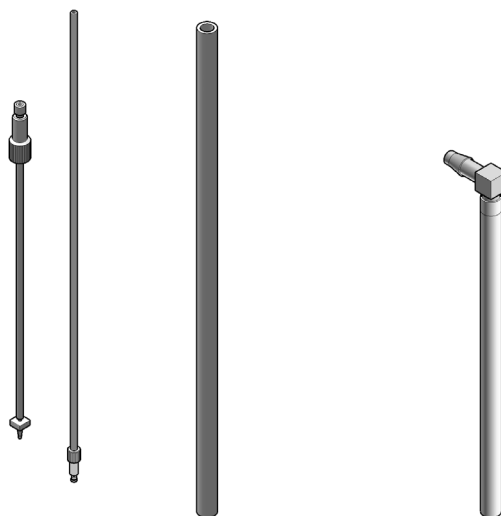

Figure 74 Tubing kit sampler standard

Tubing Kit Sampler Multi-Wash

Item	p/n	Description
	G4267-60081 E	Tubing-Kit-Sampler-Multi-Wash Contains:
1		Flex-Tubing
2		Flex-Tubing with tube connector 90 °
3		FEP Tubing OD 0.0625 with Ferrule/Nut for washport
4		FEP Tubing OD 0.0625 with Ferrule/Nut for flushpump

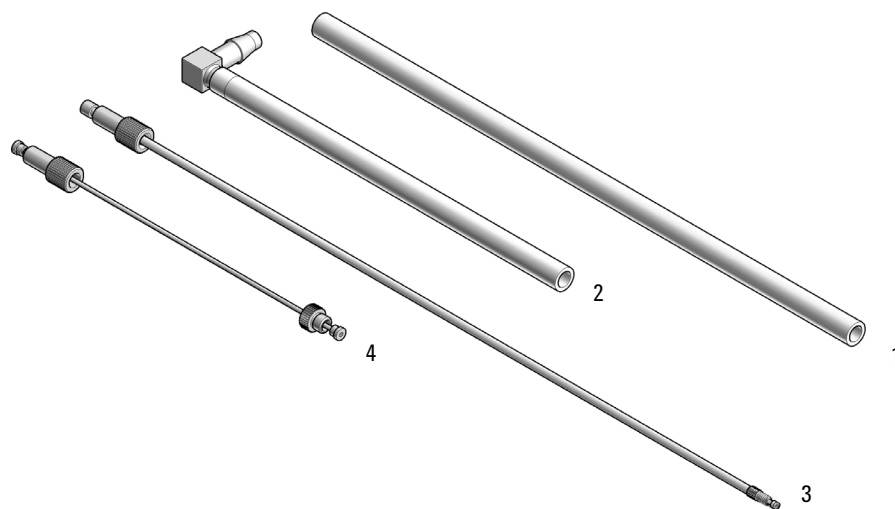

Figure 75 Tubing kit sampler multi-wash

Multi Draw Kit

NOTE

At the moment, multidraw is only possible with the Standard Multisampler.

Item	p/n	Description
	G7167-68711 [E]	Multidraw Kit for 1260 Infinity II samplers Contains:
1	0100-0900 [E]	Union
2	G1313-87307 [E]	Seat Capillary, ST, 500 μ L, ID 0.5 mm
3	G1313-87308 [E]	Seat Capillary, ST, 1500 μ L, ID 0.94 mm

p/n	Description
G4216-68711 [E]	Large Volume Injection Kit for 1290 Infinity II samplers Contains: Extension Seat Capillary, 80 μ L, 0.5 mm ID (0.9 mm OD)

Bio-Inert Multi-Draw Kit

Multidraw upgrade kit (Bio-inert) (G5667-68711) contains:



For bio-inert modules use bio-inert parts only!

p/n	Description
5067-4741 📄	ZDV union (Bio-inert)
0101-1234 📄	Sample loop 2 mL, PEEK
0101-1236 📄	Sample loop 500 µL, PEEK

NOTE

The PEEK Sample Loops present in this Multi-draw upgrade kit have lower pressure limit compared to the stainless-steel clad PEEK capillaries installed in other parts of the Agilent 1260 Infinity II Bio-Inert Multisampler. The pressure limits depend on the solvent and are listed in the following.

Table 38 Pressure limit of PEEK Sample Loops in G5667-68711

Solvent	Pressure Limit
Acetonitrile	200 bar
Water	240 bar
Isopropanol	275 bar

Upgrade Kits

p/n	Description
G4757A 📄	Multi-wash upgrade kit
G4758A 📄	G71767A Dual-needle upgrade kit
G4759A 📄	G71767B Dual-needle upgrade kit

NOTE

For instructions on how to install the Upgrade Kits, please refer to the respective Installation Notes:

- Agilent Infinity II Series Multi-wash Upgrade Kit Installation Note (G7167-90210)
- Dual-Needle Infinity II Upgrade Kit Installation Note (G7167-90220)

Leak System Parts

Item	p/n	Description
	G4267-68708 [E]	Drain management contains:
1	G4267-40013 [E]	Leak Plane
2		Ref Vial Holder (not orderable as one part)
3		Wash Port Assembly (not orderable as one part)
	5043-1357 [E]	Seal silicone rubber (Washport; not shown)
	G4267-60060 [E]	Blind seat (not shown)
	5042-9974 [E]	Tubing, PE, 1.5 m (not shown)

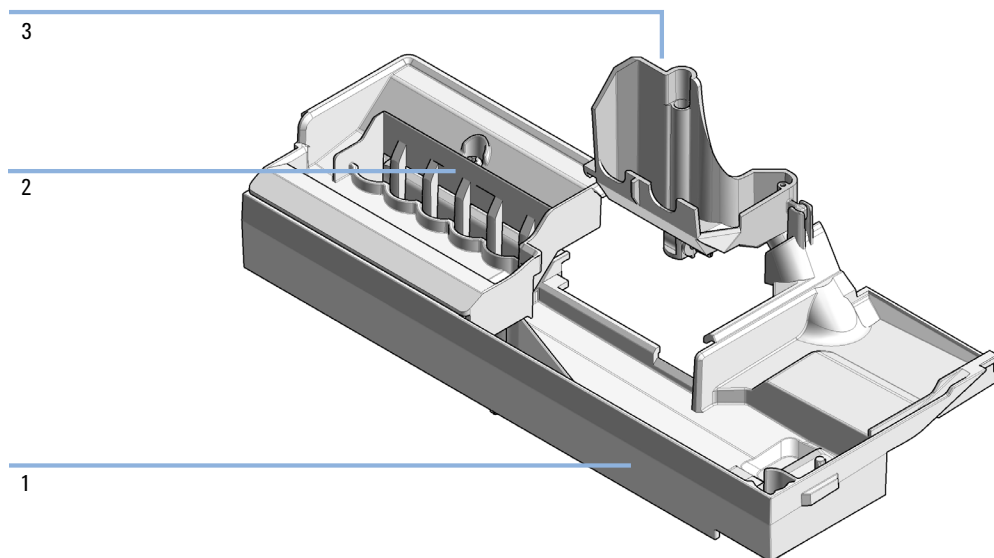

Figure 76 Drain management kit

Sample Thermostat

p/n	Description
G4761A E	InfinityLab Sample Thermostat Upgrade Kit contains:
G7167-60201 E	Sample Thermostat
5067-6208 E	Condensate Drainage Kit (not shown)

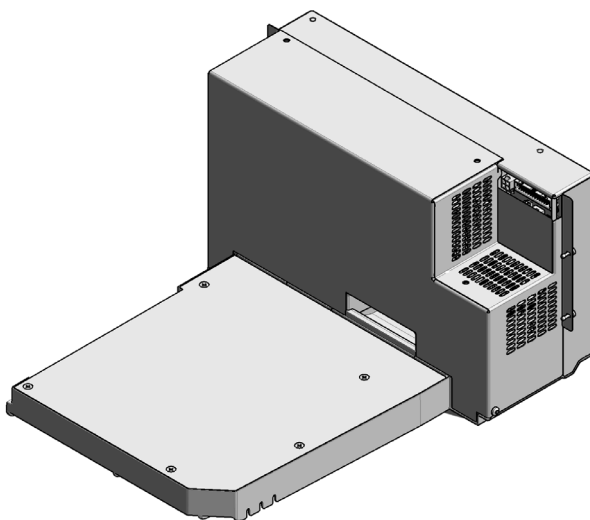

Figure 77 Sample Thermostat

NOTE

The Sample Thermostat contains flammable refrigerant R600a. Please check further details for installation.



11

Identifying Cables

Cable Overview	340
Analog Cables	342
Remote Cables	344
CAN/LAN Cables	348
Agilent Module to PC	349
USB	350

This chapter provides information on cables used with the modules.

Cable Overview

NOTE

Never use cables other than the ones supplied by Agilent Technologies to ensure proper functionality and compliance with safety or EMC regulations.



Analog cables

p/n	Description
35900-60750 📄	Agilent 35900A A/D converter
01046-60105 📄	Analog cable (BNC to general purpose, spade lugs)



Remote cables

p/n	Description
5188-8029 📄	ERI to general purpose
5188-8044 📄	Remote Cable ERI – ERI
5188-8045 📄	Remote Cable APG – ERI
5188-8059 📄	ERI-Extension-Cable 1.2 m
5061-3378 📄	Remote Cable to 35900 A/D converter
01046-60201 📄	Agilent module to general purpose
5188-8057 📄	Fraction Collection ERI remote Y-cable



CAN cables

p/n	Description
5181-1516 	CAN cable, Agilent module to module, 0.5 m
5181-1519 	CAN cable, Agilent module to module, 1 m



LAN cables

p/n	Description
5023-0203 	Cross-over network cable, shielded, 3 m (for point to point connection)
5023-0202 	Twisted pair network cable, shielded, 7 m (for point to point connection)

**RS-232 cables
(not for
FUSION board)**

p/n	Description
RS232-61601 	RS-232 cable, 2.5 m Instrument to PC, 9-to-9 pin (female). This cable has special pin-out, and is not compatible with connecting printers and plotters. It is also called "Null Modem Cable" with full handshaking where the wiring is made between pins 1-1, 2-3, 3-2, 4-6, 5-5, 6-4, 7-8, 8-7, 9-9.
5181-1561 	RS-232 cable, 8 m

USB cables

p/n	Description
5188-8050 	USB A M-USB Mini B 3 m (PC-Module)
5188-8049 	USB A F-USB Mini B M OTG (Module to Flash Drive)

Analog Cables

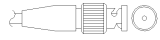

One end of these cables provides a BNC connector to be connected to Agilent modules. The other end depends on the instrument to which connection is being made.

Agilent Module to 35900 A/D converters

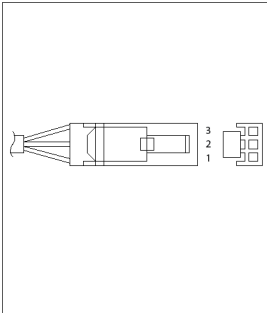
p/n 35900-60750	35900	Pin Agilent module	Signal Name
	1		Not connected
	2	Shield	Analog -
	3	Center	Analog +

Identifying Cables
Analog Cables

Agilent Module to BNC Connector

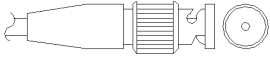
p/n 8120-1840	Pin BNC	Pin Agilent module	Signal Name
	Shield	Shield	Analog -
	Center	Center	Analog +

Agilent Module to General Purpose

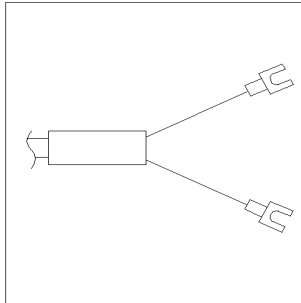
p/n 01046-60105	Pin	Pin Agilent module	Signal Name
	1		Not connected
	2	Black	Analog -
	3	Red	Analog +

Remote Cables

ERI (Enhanced Remote Interface)

- 5188-8029 ERI to general purpose (D-Sub 15 pin male - open end)
- 5188-8044 ERI to ERI (D_Sub 15 pin male - male)
- 5188-8059 ERI-Extension-Cable 1.2 m (D-Sub15 pin male / female)

p/n 5188-8029	pin	Color code	Enhanced Remote	Classic Remote	Active (TTL)
<p>D-Sub female 15way user's view to connector</p>	1	white	IO1	START REQUEST	Low
	2	brown	IO2	STOP	Low
	3	green	IO3	READY	High
	4	yellow	IO4	PEAK DETECT	Low
	5	grey	IO5	POWER ON	High
	6	pink	IO6	SHUT DOWN	Low
	7	blue	IO7	START	Low
	8	red	IO8	PREPARE	Low
	9	black	1wire DATA		
	10	violet	DGND		
	11	grey-pink	+5V ERI out		
	12	red-blue	PGND		
	13	white-green	PGND		
	14	brown-green	+24V ERI out		
	15	white-yellow	+24V ERI out		
	NC	yellow-brown			

NOTE

Configuration is different with old firmware revisions.

The configuration for IO4 and IO5 is swapped for modules with firmware lower than D.07.10.

NOTE

Peak Detection is used for LCMS systems connected with the Fraction Collection Remote Y-Cable (5188-8057).

- 5188-8045 ERI to APG (Connector D_Subminiature 15 pin (ERI), Connector D_Subminiature 9 pin (APG))

p/n 5188-8045	Pin (ERI)	Signal	Pin (APG)	Active (TTL)
	10	GND	1	
	1	Start Request	9	Low
	2	Stop	8	Low
	3	Ready	7	High
	5	Power on	6	High
	4	Future	5	
	6	Shut Down	4	Low
	7	Start	3	Low
	8	Prepare	2	Low
	Ground	Cable Shielding	NC	

- 5188-8057 ERI to APG and RJ45 (Connector D_Subminiature 15 pin (ERI), Connector D_Subminiature 9 pin (APG), Connector plug Cat5e (RJ45))

Table 39 5188-8057 ERI to APG and RJ45

p/n 5188-8057	Pin (ERI)	Signal	Pin (APG)	Active (TTL)	Pin (RJ45)
	10	GND	1		5
	1	Start Request	9	High	
	2	Stop	8	High	
	3	Ready	7	High	
	4	Fraction Trigger	5	High	4
	5	Power on	6	High	
	6	Shut Down	4	High	
	7	Start	3	High	
	8	Prepare	2	High	
	Ground	Cable Shielding	NC		



One end of these cables provides an Agilent Technologies APG (Analytical Products Group) remote connector to be connected to Agilent modules. The other end depends on the instrument to be connected to.

Identifying Cables

Remote Cables

Agilent Module to Agilent 35900 A/D Converters

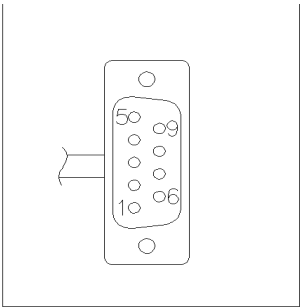
p/n 5061-3378	Pin 35900 A/D	Pin Agilent module	Signal Name	Active (TTL)
	1 - White	1 - White	Digital ground	
	2 - Brown	2 - Brown	Prepare run	Low
	3 - Gray	3 - Gray	Start	Low
	4 - Blue	4 - Blue	Shut down	Low
	5 - Pink	5 - Pink	Not connected	
	6 - Yellow	6 - Yellow	Power on	High
	7 - Red	7 - Red	Ready	High
	8 - Green	8 - Green	Stop	Low
	9 - Black	9 - Black	Start request	Low

Agilent Module to General Purpose

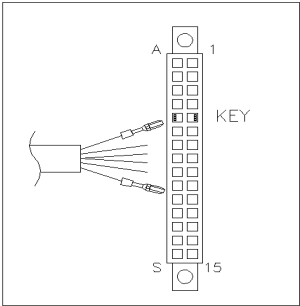
p/n 01046-60201	Wire Color	Pin Agilent module	Signal Name	Active (TTL)
	White	1	Digital ground	
	Brown	2	Prepare run	Low
	Gray	3	Start	Low
	Blue	4	Shut down	Low
	Pink	5	Not connected	
	Yellow	6	Power on	High
	Red	7	Ready	High
	Green	8	Stop	Low
	Black	9	Start request	Low

CAN/LAN Cables

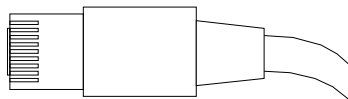

Both ends of this cable provide a modular plug to be connected to Agilent modules CAN or LAN connectors.



CAN Cables

p/n	Description
5181-1516 📄	CAN cable, Agilent module to module, 0.5 m
5181-1519 📄	CAN cable, Agilent module to module, 1 m

LAN Cables

p/n	Description
5023-0203 📄	Cross-over network cable, shielded, 3 m (for point to point connection)
5023-0202 📄	Twisted pair network cable, shielded, 7 m (for point to point connection)

Agilent Module to PC

p/n	Description
RS232-61601 	RS-232 cable, 2.5 m Instrument to PC, 9-to-9 pin (female). This cable has special pin-out, and is not compatible with connecting printers and plotters. It is also called "Null Modem Cable" with full handshaking where the wiring is made between pins 1-1, 2-3, 3-2, 4-6, 5-5, 6-4, 7-8, 8-7, 9-9.
5181-1561 	RS-232 cable, 8 m

USB

To connect a USB Flash Drive use a USB OTG cable with Mini-B plug and A socket.

p/n	Description
5188-8050 📄	USB A M-USB Mini B 3 m (PC-Module)
5188-8049 📄	USB A F-USB Mini B M OTG (Module to Flash Drive)



12 Hardware Information

Firmware Description	352
Electrical Connections	355
Rear view of the module	356
Information on Instrument Serial Number	357
Interfaces	358
Overview Interfaces	360
ERI (Enhanced Remote Interface)	363
USB (Universal Serial Bus)	365
Setting the 6-bit Configuration Switch	366
Instrument Layout	368
Early Maintenance Feedback	369

This chapter describes the module in more detail on hardware and electronics.

Firmware Description

The firmware of the instrument consists of two independent sections:

- a non-instrument specific section, called *resident system*
- an instrument specific section, called *main system*

Resident System

This resident section of the firmware is identical for all Agilent 1100/1200/1220/1260/1290 series modules. Its properties are:

- the complete communication capabilities (CAN, LAN, USB and RS- 232)
- memory management
- ability to update the firmware of the 'main system'

Main System

Its properties are:

- the complete communication capabilities (CAN, LAN, USB and RS- 232)
- memory management
- ability to update the firmware of the 'resident system'

In addition the main system comprises the instrument functions that are divided into common functions like

- run synchronization through APG/ERI remote,
- error handling,
- diagnostic functions,
- or module specific functions like
 - internal events such as lamp control, filter movements,
 - raw data collection and conversion to absorbance.

Firmware Updates

Firmware updates can be done with the Agilent Lab Advisor software with files on the hard disk (latest version should be used).

Required tools, firmware and documentation are available from the Agilent web: <https://www.agilent.com/en-us/firmwareDownload?whid=69761>

The file naming conventions are:

PPPP_RVVV_XXX.dlb, where

- PPPP is the product number, for example, 1315B for the G1315B DAD,
- R the firmware revision, for example, A for G1315B or B for the G1315C DAD,
- VVV is the revision number, for example 650 is revision 6.50,
- XXX is the build number of the firmware.

For instructions on firmware updates refer to section *Replacing Firmware* in chapter "Maintenance" or use the documentation provided with the *Firmware Update Tools*.

NOTE

Update of main system can be done in the resident system only. Update of the resident system can be done in the main system only.

Main and resident firmware must be from the same set.

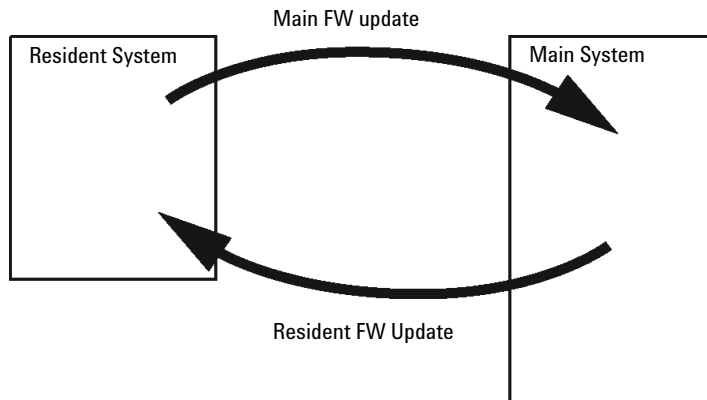

Figure 78 Firmware Update Mechanism

NOTE

Some modules are limited in downgrading due to their mainboard version or their initial firmware revision. For example, a G1315C DAD SL cannot be downgraded below firmware revision B.01.02 or to a A.xx.xx.

Some modules can be re-branded (e.g. G1314C to G1314B) to allow operation in specific control software environments. In this case, the feature set of the target type is used and the feature set of the original one is lost. After re-branding (e.g. from G1314B to G1314C), the original feature set is available again.

All this specific information is described in the documentation provided with the firmware update tools.

The firmware update tools, firmware and documentation are available from the Agilent web.

- <https://www.agilent.com/en-us/firmwareDownload?whid=69761>

Electrical Connections

- The CAN bus is a serial bus with high-speed data transfer. The two connectors for the CAN bus are used for internal module data transfer and synchronization.
- The ERI/REMOTE connector may be used in combination with other analytical instruments from Agilent Technologies if you want to use features such as start, stop, common shutdown, prepare, and so on.
- With the appropriate software, the LAN connector may be used to control the module from a computer through a LAN connection. This connector is activated and can be configured with the configuration switch.
- With the appropriate software, the USB connector may be used to control the module from a computer through a USB connection.
- The power input socket accepts a line voltage of 100 – 240 VAC \pm 10 % with a line frequency of 50 or 60 Hz. Maximum power consumption varies by module. There is no voltage selector on your module because the power supply has wide-ranging capability. There are no externally accessible fuses because automatic electronic fuses are implemented in the power supply.

NOTE

Never use cables other than the ones supplied by Agilent Technologies to ensure proper functionality and compliance with safety or EMC regulations.

Rear view of the module

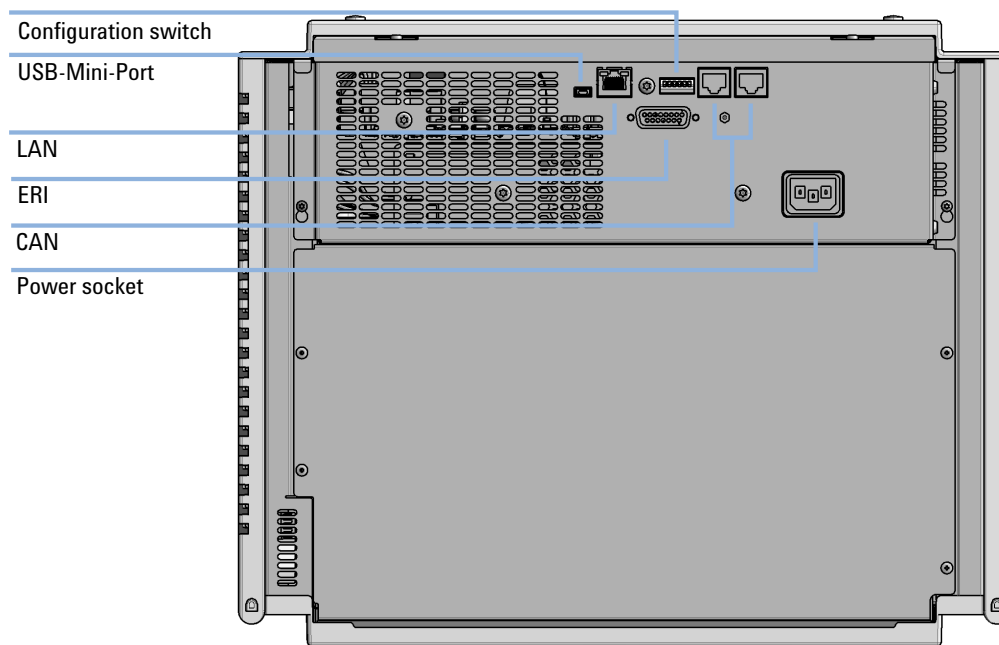

Figure 79 Rear view of multisampler - electrical connections and label

Information on Instrument Serial Number

Serial Number Information 1200 Series and 1290 Infinity

The serial number information on the instrument labels provide the following information:

CCYWWSSSSS	Format
CC	country of manufacturing <ul style="list-style-type: none"> • DE = Germany • JP = Japan • CN = China
YWW	year and week of last major manufacturing change, e.g. 820 could be week 20 of 1998 or 2008
SSSSS	real serial number

Serial Number Information 1260/1290 Infinity

The serial number information on the instrument labels provide the following information:

CCXZZ00000	Format
CC	Country of manufacturing <ul style="list-style-type: none"> • DE = Germany • JP = Japan • CN = China
X	Alphabetic character A-Z (used by manufacturing)
ZZ	Alpha-numeric code 0-9, A-Z, where each combination unambiguously denotes a module (there can be more than one code for the same module)
00000	Serial number

Interfaces

The Agilent InfinityLab LC Series modules provide the following interfaces:

Table 40 Agilent InfinityLab LC Series Interfaces

Module	CAN	USB	LAN (on-board)	RS-232	Analog	APG (A) / ERI (E)	Special
Pumps							
G7104A/C	2	No	Yes	Yes	1	A	
G7110B	2	Yes	Yes	No	No	E	
G7111A/B, G5654A	2	Yes	Yes	No	No	E	
G7112B	2	Yes	Yes	No	No	E	
G7120A, G7132A	2	No	Yes	Yes	1	A	
G7161A/B	2	Yes	Yes	No	No	E	
Samplers							
G7129A/B/C	2	Yes	Yes	No	No	E	
G7167A/B, G7137A, G5668A, G3167A	2	Yes	Yes	No	No	E	
G7157A	2	Yes	Yes	No	No	E	
Detectors							
G7114A/B	2	Yes	Yes	No	1	E	
G7115A	2	Yes	Yes	No	1	E	
G7117A/B/C	2	Yes	Yes	No	1	E	
G7121A/B	2	Yes	Yes	No	1	E	
G7162A/B	2	Yes	Yes	No	1	E	
G7165A	2	Yes	Yes	No	1	E	

Table 40 Agilent InfinityLab LC Series Interfaces

Module	CAN	USB	LAN (on-board)	RS-232	Analog	APG (A) / ERI (E)	Special
Fraction Collectors							
G7158B	2	Yes	Yes	No	No	E	
G7159B	2	Yes	Yes	No	No	E	
G7166A	2	No	No	No	No	No	Requires a host module with on-board LAN with minimum FW B.06.40 or C.06.40, or with additional G1369C LAN Card
G1364E/F, G5664B	2	Yes	Yes	No	No	E	THERMOSTAT for G1330B
Others							
G1170A	2	No	No	No	No	No	
G7116A/B	2	No	No	No	No	No	Requires a host module with on-board LAN or with additional G1369C LAN Card.
G7122A	No	No	No	Yes	No	A	
G7170B	2	No	No	No	No	No	Requires a host module with on-board LAN with minimum FW B.06.40 or C.06.40, or with additional G1369C LAN Card

NOTE

The detector (DAD/MWD/FLD/VWD/RID) is the preferred access point for control via LAN. The inter-module communication is done via CAN.

- CAN connectors as interface to other modules
- LAN connector as interface to the control software
- RS-232C as interface to a computer
- USB (Universal Series Bus) as interface to a computer
- REMOTE connector as interface to other Agilent products
- Analog output connector(s) for signal output

Overview Interfaces

CAN

The CAN is inter-module communication interface. It is a 2-wire serial bus system supporting high speed data communication and real-time requirement.

LAN

The modules have either an interface slot for a LAN card (e.g. Agilent G1369B/C LAN Interface) or they have an on-board LAN interface (e.g. detectors G1315C/D DAD and G1365C/D MWD). This interface allows the control of the module/system via a PC with the appropriate control software. Some modules have neither on-board LAN nor an interface slot for a LAN card (e.g. G1170A Valve Drive or G4227A Flexible Cube). These are hosted modules and require a Host module with firmware B.06.40 or later or with additional G1369C LAN Card.

NOTE

If an Agilent detector (DAD/MWD/FLD/VWD/RID) is in the system, the LAN should be connected to the DAD/MWD/FLD/VWD/RID (due to higher data load). If no Agilent detector is part of the system, the LAN interface should be installed in the pump or autosampler.

USB

The USB interface replaces the RS-232 Serial interface in new FUSION generation modules. For details on USB refer to “USB (Universal Serial Bus)” on page 365.

Analog Signal Output

The analog signal output can be distributed to a recording device. For details refer to the description of the module’s mainboard.

Remote (ERI)

The ERI (Enhanced Remote Interface) connector may be used in combination with other analytical instruments from Agilent Technologies if you want to use features as common shut down, prepare, and so on.

It allows easy connection between single instruments or systems to ensure coordinated analysis with simple coupling requirements.

The subminiature D connector is used. The module provides one remote connector which is inputs/outputs (wired- or technique).

To provide maximum safety within a distributed analysis system, one line is dedicated to **SHUT DOWN** the system's critical parts in case any module detects a serious problem. To detect whether all participating modules are switched on or properly powered, one line is defined to summarize the **POWER ON** state of all connected modules. Control of analysis is maintained by signal readiness **READY** for next analysis, followed by **START** of run and optional **STOP** of run triggered on the respective lines. In addition **PREPARE** and **START REQUEST** may be issued. The signal levels are defined as:

- standard TTL levels (0 V is logic true, + 5.0 V is false),
- fan-out is 10,
- input load is 2.2 kOhm against + 5.0 V, and
- output are open collector type, inputs/outputs (wired- or technique).

NOTE

All common TTL circuits operate with a 5 V power supply. A TTL signal is defined as "low" or L when between 0 V and 0.8 V and "high" or H when between 2.0 V and 5.0 V (with respect to the ground terminal).

Table 41 ERI signal distribution

Pin	Signal	Description
1	START REQUEST	(L) Request to start injection cycle (for example, by start key on any module). Receiver is the autosampler.
2	STOP	(L) Request to reach system ready state as soon as possible (for example, stop run, abort or finish and stop injection). Receiver is any module performing run-time controlled activities.
3	READY	(H) System is ready for next analysis. Receiver is any sequence controller.
4	POWER ON	(H) All modules connected to system are switched on. Receiver is any module relying on operation of others.
5		Not used
6	SHUT DOWN	(L) System has serious problem (for example, leak: stops pump). Receiver is any module capable to reduce safety risk.
7	START	(L) Request to start run / timetable. Receiver is any module performing run-time controlled activities.
8	PREPARE	(L) Request to prepare for analysis (for example, calibration, detector lamp on). Receiver is any module performing pre-analysis activities.

Special Interfaces

There is no special interface for this module.

ERI (Enhanced Remote Interface)

ERI replaces the AGP Remote Interface that is used in the HP 1090/1040/1050/1100 HPLC systems and Agilent 1100/1200/1200 Infinity HPLC modules. All new InfinityLab LC Series products using the FUSION core electronics use ERI. This interface is already used in the Agilent Universal Interface Box 2 (UIB2)

ERI Description

The ERI interface contains eight individual programmable input/output pins. In addition, it provides 24 V power and 5 V power and a serial data line to detect and recognize further add-ons that could be connected to this interface. This way the interface can support various additional devices like sensors, triggers (in and out) and small controllers, etc.

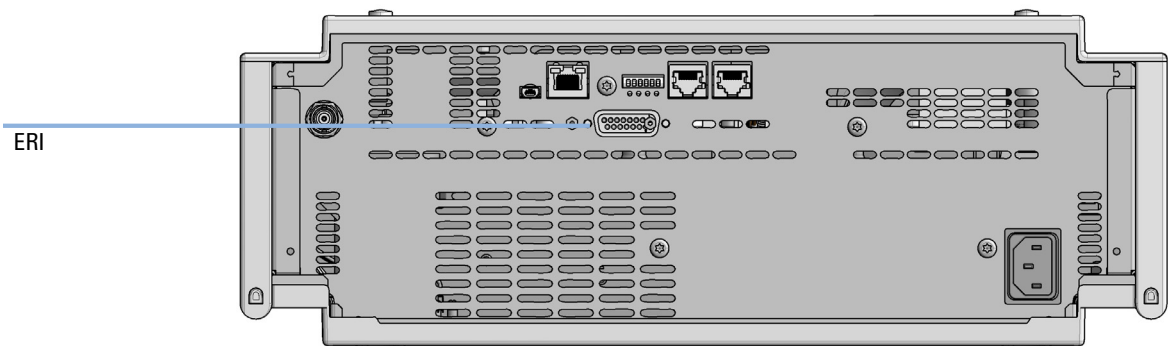

Figure 80 Location of the ERI interface (example shows a G7114A/B VWD)

	Pin	Enhanced Remote
<p>D-Sub female 15way user's view to connector</p> <p>IO1 IO2 IO3 IO4 IO5 IO6 IO7 IO8</p> <p>1 8 15 9</p> <p>1WEprom DGND +5V PGND PGND +24V +24V</p>	1	IO 1 (START REQUEST)
	2	IO 2 (STOP)
	3	IO 3 (READY)
	4	IO 4 (POWER ON)
	5	IO 5 (NOT USED)
	6	IO 6 (SHUT DOWN)
	7	IO 7 (START)
	8	IO 8 (PREPARE)
	9	1 wire DATA
	10	DGND
	11	+5 V ERI out
	12	PGND
	13	PGND
	14	+24 V ERI out
	15	+24 V ERI out

IO (Input/Output) Lines

- Eight generic bi-directional channels (input or output).
- Same as the APG Remote.
- Devices like valves, relays, ADCs, DACs, controllers can be supported/controlled.

1-Wire Data (Future Use)

This serial line can be used to read out an EPROM or write into an EPROM of a connected ERI-device. The firmware can detect the connected type of device automatically and update information in the device (if required).

5V Distribution (Future Use)

- Available directly after turning on the hosting module (assures that the firmware can detect certain basic functionality of the device).
- For digital circuits or similar.
- Provides 500 mA maximum.
- Short-circuit proof with automatic switch off (by firmware).

24V Distribution (Future Use)

- Available by firmware command (defined turn on/off).
- For devices that need higher power
 - Class 0: 0.5 A maximum (12 W)
 - Class 1: 1.0 A maximum (24 W)
 - Class 2: 2.0 A maximum (48 W)
- Class depends on hosting module's internal power overhead.
- If a connected device requires more power the firmware detects this (overcurrent detection) and provides the information to the user interface.
- Fuse used for safety protection (on board).
- Short circuit will be detected through hardware.

USB (Universal Serial Bus)

USB (Universal Serial Bus) - replaces RS232, supports:

- a PC with control software (for example Agilent Lab Advisor)
- USB Flash Disk

Setting the 6-bit Configuration Switch

The 6-bit configuration switch is located at the rear of the module with FUSION electronics. Switch settings provide configuration parameters for LAN and instrument specific initialization procedures.

All modules with FUSION electronics:

- Default is ALL switches DOWN (best settings).
 - Default IP address for LAN 192.168.254.11
- For specific LAN modes switches 4-5 must be set as required.
- For boot resident/cold start modes switches 1+2 or 6 must be UP.

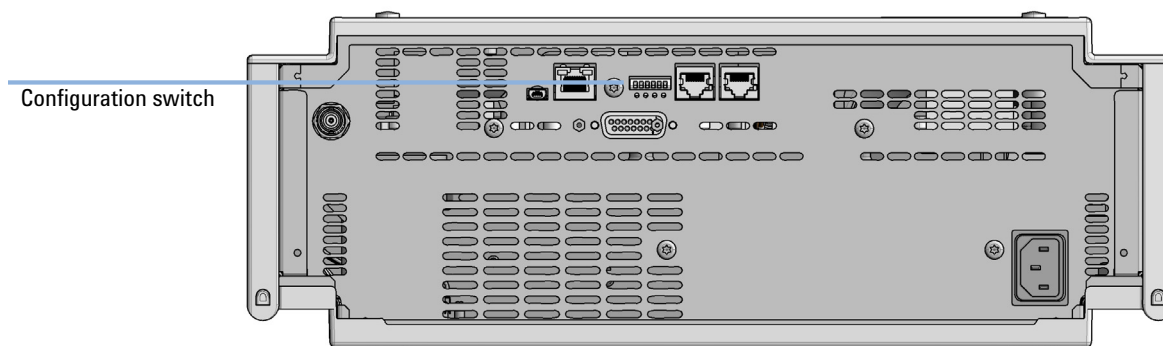

Figure 81 Location of Configuration switch (example shows a G7114A/B VWD)

Table 42 6-bit Configuration Switch

	Mode	Function/Setting				
	Switch 1	Switch 2	Switch 3	Switch 4	Switch 5	Switch 6
COM ¹	0	n.a. ²	n.a.	LAN Init Mode		n.a.
Use Default IP Address ³		0	0	0	0	0
Use Stored IP Address		0	0	0	1	0
Use DHCP to request IP Address ⁴		0	0	1	0	0
Test	1	System	n.a.	n.a.	n.a.	ColdStart
Boot Main System / Keep Data		0	0	0	0	0
Boot Resident System / Keep Data		1	0	0	0	0
Boot Main System / Revert to Default Data		0	0	0	0	1
Boot Resident System / Revert to Default Data		1	0	0	0	1

¹ When selecting mode COM, settings are stored to non-volatile memory. When selecting mode Test, COM settings are taken from non-volatile memory.

² not assigned - Always keep these switches on position '0' (off)

³ Default IP Address is 192.168.254.11

⁴ Host Name will be the MAC address.

Instrument Layout

The industrial design of the module incorporates several innovative features. It uses Agilent's E-PAC concept for the packaging of electronics and mechanical assemblies. This concept is based upon the use of expanded polypropylene (EPP) layers of foam plastic spacers in which the mechanical and electronic boards components of the module are placed. This pack is then housed in a metal inner cabinet which is enclosed by a plastic external cabinet. The advantages of this packaging technology are:

- virtual elimination of fixing screws, bolts or ties, reducing the number of components and increasing the speed of assembly/disassembly,
- the plastic layers have air channels molded into them so that cooling air can be guided exactly to the required locations,
- the plastic layers help cushion the electronic and mechanical parts from physical shock, and
- the metal inner cabinet shields the internal electronics from electromagnetic interference and also helps to reduce or eliminate radio frequency emissions from the instrument itself.

Early Maintenance Feedback

Maintenance requires the exchange of components that are subject to wear or stress. Ideally, the frequency at which components are exchanged should be based on the intensity of use of the module and the analytical conditions, and not on a predefined time interval. The early maintenance feedback (EMF) feature monitors the use of specific components in the instrument, and provides feedback when the user-selectable limits have been exceeded. The visual feedback in the user interface provides an indication that maintenance procedures should be scheduled.

EMF Counters

EMF counters increment with use and can be assigned a maximum limit which provides visual feedback in the user interface when the limit is exceeded. Some counters can be reset to zero after the required maintenance procedure.

Using the **EMF Counters**

The user-settable **EMF** limits for the **EMF Counters** enable the early maintenance feedback to be adapted to specific user requirements. The useful maintenance cycle is dependent on the requirements for use. Therefore, the definition of the maximum limits need to be determined based on the specific operating conditions of the instrument.

Setting the **EMF Limits**

The setting of the **EMF** limits must be optimized over one or two maintenance cycles. Initially the default **EMF** limits should be set. When instrument performance indicates maintenance is necessary, take note of the values displayed by the **EMF counters**. Enter these values (or values slightly less than the displayed values) as **EMF** limits, and then reset the **EMF counters** to zero. The next time the **EMF counters** exceed the new **EMF** limits, the **EMF** flag will be displayed, providing a reminder that maintenance needs to be scheduled.



13 LAN Configuration

Setting up the module in a LAN environment 371

This chapter provides information on connecting the detector to the Agilent ChemStation PC.

Setting up the module in a LAN environment

It is not recommended to connect a system via an autosampler. The detector is producing the most data in the stack, followed by the pump, and it is therefore highly recommended to use either of these modules for the LAN connection.

General Safety Information	373
General Safety Information	373
Safety Standards	373
General	373
Before Applying Power	374
Ground the Instrument	374
Do Not Operate in an Explosive Atmosphere	375
Do Not Remove the Instrument Cover	375
Do Not Modify the Instrument	375
In Case of Damage	375
Solvents	376
Symbols	377
Waste Electrical and Electronic Equipment (WEEE) Directive	379
Refrigerant	380
Radio Interference	383
Sound Emission	384
Solvent Information	385
Installation of Stainless Steel Cladded PEEK Capillaries	386
First Step: Finger-tight Fitting	387
Second Step: Installation to Connector	387
Removing Capillaries	391
Agilent Technologies on Internet	392

This chapter provides addition information on safety, legal and web.

General Safety Information

General Safety Information

The following general safety precautions must be observed during all phases of operation, service, and repair of this instrument. Failure to comply with these precautions or with specific warnings elsewhere in this manual violates safety standards of design, manufacture, and intended use of the instrument. Agilent Technologies assumes no liability for the customer's failure to comply with these requirements.

WARNING

Ensure the proper usage of the equipment.

The protection provided by the equipment may be impaired.

- ✓ **The operator of this instrument is advised to use the equipment in a manner as specified in this manual.**

Safety Standards

This is a Safety Class I instrument (provided with terminal for protective earthing) and has been manufactured and tested according to international safety standards.

General

Do not use this product in any manner not specified by the manufacturer. The protective features of this product may be impaired if it is used in a manner not specified in the operation instructions.

Before Applying Power

WARNING

Wrong voltage range, frequency or cabling
Personal injury or damage to the instrument

- ✓ Verify that the voltage range and frequency of your power distribution matches to the power specification of the individual instrument.
- ✓ Never use cables other than the ones supplied by Agilent Technologies to ensure proper functionality and compliance with safety or EMC regulations.
- ✓ Make all connections to the unit before applying power.

NOTE

Note the instrument's external markings described under "Symbols" on page 377.

Ground the Instrument

WARNING

Missing electrical ground
Electrical shock

- ✓ If your product is provided with a grounding type power plug, the instrument chassis and cover must be connected to an electrical ground to minimize shock hazard.
- ✓ The ground pin must be firmly connected to an electrical ground (safety ground) terminal at the power outlet. Any interruption of the protective (grounding) conductor or disconnection of the protective earth terminal will cause a potential shock hazard that could result in personal injury.

Do Not Operate in an Explosive Atmosphere

WARNING

Presence of flammable gases or fumes

Explosion hazard

- ✓ Do not operate the instrument in the presence of flammable gases or fumes.
-

Do Not Remove the Instrument Cover

WARNING

Instrument covers removed

Electrical shock

- ✓ Do Not Remove the Instrument Cover
 - ✓ Only Agilent authorized personnel are allowed to remove instrument covers. Always disconnect the power cables and any external circuits before removing the instrument cover.
-

Do Not Modify the Instrument

Do not install substitute parts or perform any unauthorized modification to the product. Return the product to an Agilent Sales and Service Office for service and repair to ensure that safety features are maintained.

In Case of Damage

WARNING

Damage to the module

Personal injury (for example electrical shock, intoxication)

- ✓ Instruments that appear damaged or defective should be made inoperative and secured against unintended operation until they can be repaired by qualified service personnel.
-

Solvents

WARNING

Toxic, flammable and hazardous solvents, samples and reagents

The handling of solvents, samples and reagents can hold health and safety risks.

- ✓ When working with these substances observe appropriate safety procedures (for example by wearing goggles, safety gloves and protective clothing) as described in the material handling and safety data sheet supplied by the vendor, and follow good laboratory practice.
- ✓ Do not use solvents with an auto-ignition temperature below 200 °C (392 °F). Do not use solvents with a boiling point below 56 °C (133 °F).
- ✓ Avoid high vapor concentrations. Keep the solvent temperature at least 40 °C (72 °F) below the boiling point of the solvent used. This includes the solvent temperature in the sample compartment. For the solvents methanol and ethanol keep the solvent temperature at least 25 °C (45 °F) below the boiling point.
- ✓ Do not operate the instrument in an explosive atmosphere.
- ✓ Do not use solvents of ignition Class IIC according IEC 60079-20-1 (for example, carbon disulfide).
- ✓ Reduce the volume of substances to the minimum required for the analysis.
- ✓ Never exceed the maximum permissible volume of solvents (8 L) in the solvent cabinet. Do not use bottles that exceed the maximum permissible volume as specified in the usage guideline for solvent cabinet.
- ✓ Ground the waste container.
- ✓ Regularly check the filling level of the waste container. The residual free volume in the waste container must be large enough to collect the waste liquid.
- ✓ To achieve maximal safety, regularly check the tubing for correct installation.

NOTE



For details, see the usage guideline for the solvent cabinet. A printed copy of the guideline has been shipped with the solvent cabinet, electronic copies are available in the Agilent Information Center or via the Internet.

Symbols

Table 43 Symbols

	The apparatus is marked with this symbol when the user shall refer to the instruction manual in order to protect risk of harm to the operator and to protect the apparatus against damage.
	Indicates dangerous voltages.
	Indicates a protected ground terminal.
	The apparatus is marked with this symbol when hot surfaces are available and the user should not touch it when heated up.
	Sample Cooler unit is designed as vapor-compression refrigeration system. Contains fluorinated greenhouse gas (refrigerant) according to the Kyoto protocol. For specifications of refrigerant, charge capacity, carbon dioxide equivalent (CDE), and global warming potential (GWP) see instrument label.
	Flammable Material For Sample Thermostat which uses flammable refrigerant consult Agilent Information Center / User Manual before attempting to install or service this equipment. All safety precautions must be followed.
	Confirms that a manufactured product complies with all applicable European Community directives. The European Declaration of Conformity is available at: http://regulations.corporate.agilent.com/DoC/search.htm
	Manufacturing date.
	Power symbol indicates On/Off. The apparatus is not completely disconnected from the mains supply when the power switch is in the Off position
	Pacemaker Magnets could affect the functioning of pacemakers and implanted heart defibrillators. A pacemaker could switch into test mode and cause illness. A heart defibrillator may stop working. If you wear these devices keep at least 55 mm distance to magnets. Warn others who wear these devices from getting too close to magnets.

Table 43 Symbols

	<p>Magnetic field</p> <p>Magnets produce a far-reaching, strong magnetic field. They could damage TVs and laptops, computer hard drives, credit and ATM cards, data storage media, mechanical watches, hearing aids and speakers. Keep magnets at least 25 mm away from devices and objects that could be damaged by strong magnetic fields.</p>
	Indicates a pinching or crushing hazard
	Indicates a piercing or cutting hazard.

WARNING

A WARNING

alerts you to situations that could cause physical injury or death.

- ✓ Do not proceed beyond a warning until you have fully understood and met the indicated conditions.

CAUTION

A CAUTION

alerts you to situations that could cause loss of data, or damage of equipment.

- ✓ Do not proceed beyond a caution until you have fully understood and met the indicated conditions.

Waste Electrical and Electronic Equipment (WEEE) Directive

This product complies with the European WEEE Directive marking requirements. The affixed label indicates that you must not discard this electrical/electronic product in domestic household waste.



NOTE

Do not dispose of in domestic household waste

To return unwanted products, contact your local Agilent office, or see <https://www.agilent.com> for more information.

Refrigerant

The refrigerant HFC-134a is used only in the Agilent Infinity II Sample Cooler.

Table 44 Physical properties of refrigerant HFC-134a

Molecular weight	102
Critical temperature	101.1 °C
Critical pressure	40.6 bar
Boiling point	-26.5 °C

Table 45 Physical properties of refrigerant R600a (isobutane)

Molecular weight	58.12
Critical temperature	134.98 °C
Critical pressure	36.6 bar
Boiling point	-11.7 °C

WARNING

Refrigerant



Refrigerant HFC-134a is known as a safe refrigerant, however accidents can occur if it is handled incorrectly. For this reason, the following instructions must be observed:

- ✓ Avoid contact with liquid refrigerant HFC-134a. At atmospheric pressure HFC-134a evaporates at approximately -26 °C and causes frost bite.
 - ✓ After skin contact, rinse the affected area with water.
 - ✓ After eye contact, rinse the eye(s) with plenty of water for at least 15 minutes and consult a doctor.
 - ✓ HFC-134a must not be allowed to escape in enclosed areas. Although HFC-134a is not toxic, there is a danger of suffocation as gaseous refrigerant is heavier than air.
 - ✓ Please observe the following first aid instructions. After inhalation, move the affected person to fresh air, keep him warm and allow him to rest. If necessary, he should be supplied with oxygen. If he has stopped breathing or is breathing erratically, he should be given artificial respiration. In the case of cardiac arrest, carry out heart massage. Send for a doctor immediately.
 - ✓ Moreover, it must be noted that HFC-134a must always be extracted from the system and collected. It must never be discharged into the atmosphere on environmental grounds (greenhouse effect).
-

CAUTION**General hazards and improper disposal**

Improper disposal of the media and components used pollutes the environment.

- ✓ The disposal or scrapping of the Sample Cooler or the Sample Thermostat must be carried out by a qualified disposal company.
 - ✓ All media must be disposed of in accordance with national and local regulations.
 - ✓ Please contact your local Agilent Service Center in regard to safe environmental disposal of the appliance or check www.agilent.com for more info.
-

CAUTION**Risk of fire or explosion**

- ✓ Dispose of properly in accordance with federal or local regulations. Flammable Refrigerant Used.
 - ✓ Do not dispose of in domestic household waste.
 - ✓ To return unwanted products, contact your local Agilent office, or see <http://www.agilent.com> for more information.
-

Radio Interference

Never use cables other than the ones supplied by Agilent Technologies to ensure proper functionality and compliance with safety or EMC regulations.

Test and Measurement

If test and measurement equipment is operated with equipment unscreened cables and/or used for measurements on open set-ups, the user has to assure that under operating conditions the radio interference limits are still met within the premises.

Sound Emission

Sound pressure

Sound pressure $L_p < 70$ db(A) according to DIN EN ISO 7779

Schalldruckpegel

Schalldruckpegel $L_p < 70$ db(A) nach DIN EN ISO 7779

Solvent Information

Observe the following recommendations on the use of solvents.

- Brown glass ware can avoid growth of algae.
- Avoid the use of the following steel-corrosive solvents:
 - solutions of alkali halides and their respective acids (for example, lithium iodide, potassium chloride, and so on),
 - high concentrations of inorganic acids like sulfuric acid and nitric acid, especially at higher temperatures (if your chromatography method allows, replace by phosphoric acid or phosphate buffer which are less corrosive against stainless steel),
 - halogenated solvents or mixtures which form radicals and/or acids, for example:
$$2\text{CHCl}_3 + \text{O}_2 \rightarrow 2\text{COCl}_2 + 2\text{HCl}$$

This reaction, in which stainless steel probably acts as a catalyst, occurs quickly with dried chloroform if the drying process removes the stabilizing alcohol,
 - chromatographic grade ethers, which can contain peroxides (for example, THF, dioxane, diisopropyl ether) should be filtered through dry aluminium oxide which adsorbs the peroxides,
 - solvents containing strong complexing agents (e.g. EDTA),
 - mixtures of carbon tetrachloride with 2-propanol or THF.
- Avoid the use of dimethyl formamide (DMF). Polyvinylidene fluoride (PVDF), which is used in leak sensors, is not resistant to DMF.

Installation of Stainless Steel Cladded PEEK Capillaries

NOTE

This installation procedure applies for capillaries and corresponding fittings used in modules delivered before January 2013.

The 1260 Infinity Bio-inert LC system uses PEEK capillaries that are clad with stainless steel. These capillaries combine the high-pressure stability of steel with the inertness of PEEK. They are used in the high-pressure flow path after sample introduction (loop/needle seat capillary) through the thermostatted column compartment/heat exchangers to the column. Such capillaries need to be installed carefully in order to keep them tight without damaging them by over-tightening.

The installation consists of two steps. In the first step, the fitting is installed finger-tight without using tools. Finger-tight means that the fitting will grip and hold the capillary. This brings the fitting to the appropriate start position (marked as 0 ° below) for the second step.

First Step: Finger-tight Fitting

- 1 Tighten the fitting using your fingers.

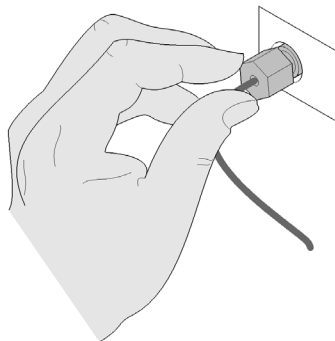

Second Step: Installation to Connector

In the second step (“[Second Step: Installation to Hard Connectors](#)” on page 387 or “[Second Step: Installation to Soft Connectors](#)” on page 389), a wrench is used to rotate the fitting relative to the finger-tight position by a defined angle. For each of the cases mentioned above, there is a recommended range in which the fitting is tight.

Staying below this range could create a leak, either a visible one or a micro-leak, potentially biasing measurement results. Exceeding the recommended range could damage the capillary.

Alternatively, a torque wrench may be used. The target torque for all connections is about 0.7 Nm. When using a torque wrench, read instructions for that tool carefully, as wrong handling may easily miss the correct torque.

Second Step: Installation to Hard Connectors

Use this procedure for hard connectors made from metal (titanium) or ceramics. In the system, these are connections to and from the analytical head of the autosampler (connections to injection valve and needle), and to a metal column.

First installation of a capillary to a hard connector

- 1 When tightening a fitting for the first time, start from the finger-tight position (which is not necessarily a vertical wrench position) and rotate the wrench by $135 - 180^\circ$. Staying below 135° (grey arrow) will be insufficiently tight, more than 180° (red arrow) could damage the capillary.

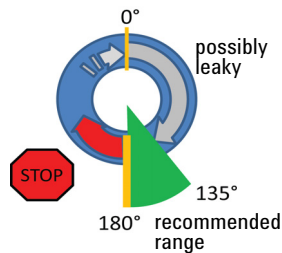

Second and subsequent installations of a capillary to a hard connector

- 1 When tightening the fitting for the second and subsequent times, again start from the finger-tight position (which is not necessarily a vertical wrench position) and rotate the wrench by $90 - 135^\circ$. Staying below 90° (grey arrow) could be insufficiently tight, more than 135° (red arrow) could damage the capillary.

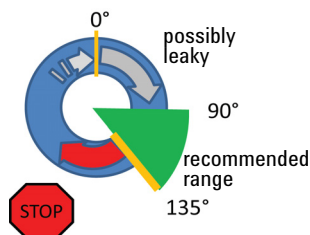

Second Step: Installation to Soft Connectors

Use this procedure for soft connectors, which are typically made from PEEK. These are the following connections:

- to and from all bio-inert valves (injection valve in the autosampler and valves in the thermostatted column compartment and 1290 Infinity Valve Drive),
- bio-inert ZDV unions (detector flow cells, multidraw upgrade kit, capillary to capillary connections, for example, for heat exchangers),
- to the autosampler needle and
- to PEEK columns (like many bio-inert columns).

For the installation of bio-inert ZDV unions, see the Technical Note *"Installation of stainless steel cladded PEEK capillaries"* (p/n G5611-90120).

First installation of a capillary to a soft connector

- 1 When tightening a fitting for the first time, start from the finger-tight position (which does not necessarily need to be a vertical wrench position) and rotate the wrench by 180 – 210°. Staying below 180° (grey arrow) will not be sufficiently tight, more than 210° (red arrow) could damage the capillary.

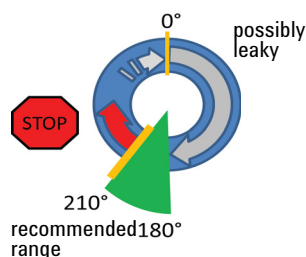

Second and subsequent installations of a capillary to a soft connector

- 1 When tightening the fitting for the second and subsequent times, again start from the finger-tight position (which is not necessarily a vertical wrench position) and rotate the wrench by 135 – 180°. Staying below 135° (grey arrow) could be insufficiently tight enough, more than 180° (red arrow) could damage the capillary.

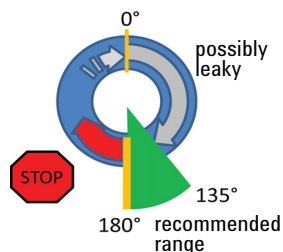

Summary for Second Step

Table 46 Summary for second step

2 nd Step	First installation	Subsequent installations
Hard connectors		
Soft connectors		

Removing Capillaries

CAUTION**Potential damage of capillaries**

- ✓ Do not remove fittings from used capillaries.

To keep the flow path free of stainless steel, the front end of the capillary is made of PEEK. Under high pressure, or when in contact with some solvents, PEEK can expand to the shape of the connector where the capillary is installed. If the capillary is removed, this may become visible as a small step. In such cases, do not try to pull the fitting from the capillary, as this can destroy the front part of the capillary. Instead, carefully pull it to the rear. During installation of the capillary, the fitting will end up in the correct position.

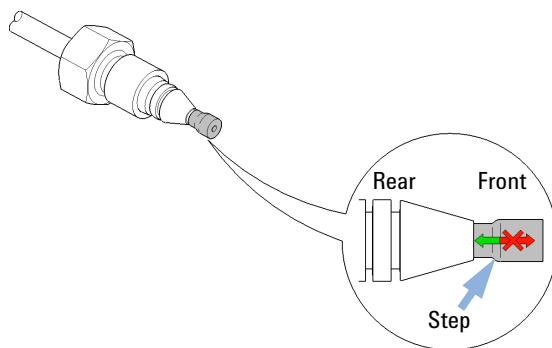

Figure 82 Capillary fitting

Agilent Technologies on Internet

For the latest information on products and services visit our worldwide web site on the Internet at:

<https://www.agilent.com>

In This Book

This manual contains technical reference information about the Agilent 1290 Infinity II Multisampler (G7167B), Agilent 1260 Infinity II Multisampler (G7167A), Agilent 1290 Infinity II Bio Multisampler (G7137A), and Agilent 1260 Infinity II Bio-Inert Multisampler (G5668A).

The manual describes the following:

- Introduction,
- Site requirements and specifications,
- Using the module,
- Preparing the module,
- Optimizing performance,
- Troubleshooting and diagnostics,
- Error information,
- Test functions,
- Maintenance,
- Parts,
- Hardware information,
- LAN configuration,
- Safety and related information.

www.agilent.com

© Agilent Technologies Inc. 2014-2022
Edition: 11/2022

Document No: SD-29000238 Rev. J

