

Arkansas Department of Agriculture – Apiary Section Information Packet

Why honeybees are not just good for the beekeeper...

Why should the public care about honey bees?

Bee pollination is responsible for \$15 billion in added crop value, particularly for specialty crops such as almonds and other nuts, berries, fruits, and vegetables. About one mouthful in three in the diet directly or indirectly benefits from honey bee pollination. While there are native pollinators (honey bees came from the Old World with European colonists), honey bees are more prolific and the easiest to manage for the large scale pollination that U.S. agriculture requires. In California, the almond crop alone uses 1.3 million colonies of bees, approximately one half of all honey bees in the United States, and this need is projected to grow to 1.5 million colonies by 2010.

The number of managed honey bee colonies has dropped from 5 million in the 1940s to only 2.5 million today. At the same time, the call for hives to supply pollination service has continued to climb. This means honey bee colonies are trucked farther and more often than ever before.

Honey bee colony health has also been declining since the 1980s with the advent of new pathogens and pests. The spread into the United States of varroa and tracheal mites, in particular, created major new stresses on honey bees.

Is there currently a crisis in food production because of CCD?

While CCD has created a very serious problem for beekeepers and could threaten the pollination industry if it becomes more widespread, fortunately there were enough bees to supply all the needed pollination this past spring. But we cannot wait to see if CCD becomes an agricultural crisis to do the needed research into the cause and treatment for CCD.

The cost of hives for pollination has risen this year. But much of that is due to growing demand. Some of the price increase may also be due to higher cost of gas and diesel and other increases related to energy and labor costs. Commercial beekeepers truck hives long distances to provide pollination services, so in particular they must deal with rising expenses.

Apiary Section

Mission

To protect honeybees in order to maintain viable honeybee populations for the purpose of pollination in Arkansas

Methods:

- 1) By equitably administering laws and regulations in order to minimize and slow the spread and negative effects of diseases, harmful pests and unwanted species.**
- 2) By educating beekeepers in modern apicultural techniques and the citizens of Arkansas of the importance of honeybees.**

The Apiary Section is part of the Plant Industry Division of the Arkansas Department of Agriculture. The Apiary Section is a regulatory agency that will follow and enforce the Apiary Laws and Regulations stated in Circular 5. We provide a useful service to help protect honeybees in Arkansas. Through this service we also help educate beekeepers through our inspections, presentations, newsletters, and other services. The Apiary Section consists of four full time employees and some seasonal help. Please call the office at 501-225-1598 if you have any questions or comments.

The full time employees are:

Zac Wellman, Apiary Manager - Zac.Wellman@agriculture.arkansas.gov
Lexie Felton, Apiary Secretary - Lexie.Felton@agriculture.arkansas.gov
John Martin, Apiary Inspector for Southern half of state - 501-590-2259
Jacob Bates, Apiary Inspector for Northern half of state - 501-231-0537

The Apiary Section handles all regulatory issues concerning the Honeybee. We provide free inspection services for beekeepers that want to sell, or move their bees, or if you are having a problem and just want an inspection. In the past we provided educational programs. Now educational programs and research is handled through extension services. However, we will still help out in that area upon request.

If you are interested in beekeeping there are a few things you will need to know, and hopefully they are all provided to you in this information. If you do become a beekeeper the first thing you will need to do is register your Apiary Location. The registration application is provided on this disc. Registering your location will let the Apiary Section know where your bees are located if we need to contact you about any bee-related problems in your area, and it will also put you on our newsletter list. The Apiary Section sends out a quarterly newsletter that will contain various types of information. We will also be able to notify you of meetings in your area.

Current Apiary Laws, Forms & Required Documents

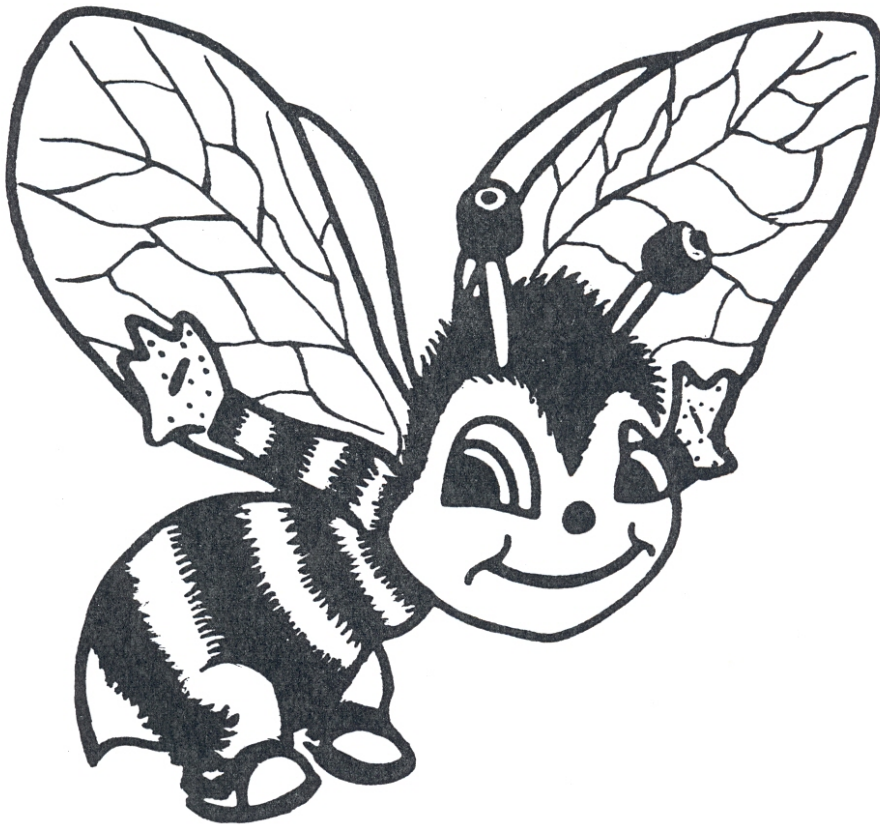

*"Where would
Agriculture be without
the work of the honeybee?"*

AFRICANIZED HONEYBEES FREQUENTLY ASKED QUESTIONS

Q. I have noticed a strange looking bee around my home. How can I find out if it is the Africanized honeybee that I've heard so much about?

A. The answer depends on where you live in Arkansas.

You can contact your local county Cooperative Extension Service agent for assistance in getting information on identification of bees and other stinging insects.

If the bees are aggressive and threatening you may contact the Apiary Section of The Arkansas State Plant Board at (501) 225-1598, to report any aggressive bee swarms.

Q. What is the scientific name for Africanized honeybees and can they mate with other honeybees?

A. The Africanized Honeybee is a hybrid of a strain of honeybees from Africa, *Apis mellifera scutellata*, and basically any other honeybee that it can mate with and produce viable off-spring. In the United States this could be *Apis mellifera ligustica* (Italian honeybee), *Apis mellifera carnica* (Carniolian honeybee), *Apis mellifera caucasica* (Caucasian honeybee), and *Apis mellifera mellifera* (Dark honeybee).

Q. There are bees building a hive near our home. We walk past their hive a lot and them seem very calm and not dangerous at all, so they probably are not the Africanized honeybees, right?

A. While bees are building a hive, they are not likely to sting. That is because they are busy building the home and do not have anything in it that they feel they must defend. Typically, honeybees only sting when they feel that something is threatening their baby bees and honey. So, until the hive is built and full, the honeybees will seem very docile or calm. That is true of both regular European honeybees and Africanized honeybees. The only way to find out if honeybees are European or Africanized is to have a sample analyzed. But you should go ahead and have a trained pest control person remove the hive that is under construction before the bees set up house and become defensive.

Q. A hive of bees seems to be building a hive in the outside wall of our house. Since they're in the wall, they probably won't bother us. Is it alright to let them live there or should we think about having them removed?

A. Bees should never be allowed to build or remain in the walls of a structure. For one thing, they will become very defensive of their hive once they have made honey and begun to develop baby bees. That means people and pets that happen by the hive could be stung by the defensive bees. But bees in walls also cause a problem with the building structure because of the massive amounts of honeycomb and honey that can be stored. Killing the bees from such a hive is extremely difficult to do without completely tearing into the wall. Also, all the honeycomb and honey has to be removed or it can become rank and attract other pests. The best thing to do is to never allow bees to build in the walls. Make a check of your home and other structures on your property to see that they are no holes that bees can enter. If you find that bees already are building in a wall, call a pest control operator immediately to get them removed.

Q. We recently found out that bees are living in the wall of our garage and want them removed. Can we kill them by spraying the hole where they enter or is there a better way?

A. No, simply spraying the hole of an entryway into any hive will not kill all the insects that are inside. Call a pest control operator who is knowledgeable about bee removal for assistance.

Q. I heard that soapy water is a simple way to kill bees. Why is that and how can I do it?

A. Soapy water is one approved way to kill bees, but it has to be done with caution. The reason that soapy water kills bees is that the outer body of the bee has a waxy coating. In just the way that some commercials show soap cutting through grease on a dirty pan, the soap works through the waxy body and allows the water to enter, in effect drowning the bee. But it has to be done with caution, because enough soapy water has to be applied at once to all the bees or they will get mad and begin to sting before the effect can take place. If most of the bees are unreachable in a hive, therefore, spraying soapy water on the few bees that can be seen outside of the hive will not have much of an impact.

Q. I was out in the yard behind my home and noticed a huge mass of bees all balled up in a tree. I've never seen a swarm like that and I'm afraid that they are going to attack my family and pets. How can I make them leave?

A. Swarms of bees is a phenomena that is most likely in the spring and fall each year. Swarms develop when a hive gets too full or crowded. The bees in the old hive make a new queen and she flies off with most of the younger bees of the colony to find a new place to live. The swarm lands on something that will enable them to stay huddled together while a few scout bees fly on to try to locate a suitable place to build a new hive. Because a swarm is in essence a group of homeless bees, they have nothing to protect. So, they are not likely to sting anything because they do not feel defensive. As for making them leave, it is best to let them stay put. Swatting at them could anger them and make them feel threatened into stinging. But just make sure that you have secured your property so that they do not feel like it would be a good place to build. And keep a watch while the swarm is near to see that the scouts haven't located a place near where people and pets will be. That way, the scout bees will keep looking until they find a place further away that is less likely to be disturbed by people and animals.

Q. My child was just stung by a bee and I'm afraid that it might have been Africanized. What should we do, and how can we find out what type of bee it is?

A. First of all, make sure to remove the stinger. Scrape it out sidewise so that you don't pinch the venom sack and make it squirt more venom into your child. Refer to our First Aid page to find out more. Treatment for honeybee stings is the same regardless of whether the bees are Africanized. Refer to the information above on how to have bee samples analyzed.

Q. My friend and I are having a disagreement. Are Africanized honeybees bigger than regular honeybees? Please settle our argument.

A. Africanized honeybees actually are smaller, slightly, than regular honeybees. It is not possible to tell them apart just from looking at them with the naked eye. The bees must be analyzed in a lab through a process of dissection and measuring various body parts that are then compared against a huge database of measurements to determine if the bees fall into the range of bees that have proven in the past to be Africanized.

Q. Is the venom from an Africanized honeybee more poisonous than a regular honeybee?

A. No, the venom from both honeybees is chemically the same. And, because the Africanized honeybee is slightly smaller than the regular honeybee, it actually has slightly less venom.

Q. Can Africanized honeybees sting more than once?

A. No, worker honeybees, whether Africanized or regular European, only sting once. That is because the edges of their stinger are jagged. So, when a worker honeybee penetrates the skin with its stinger, the jagged edges get caught and can not be pulled back out. The worker honeybee tries and tries to free herself anyway and eventually she pulls her body away from the stinger. That means that she "bleeds" to death while the stinger remains in the body attached to a muscle and venom sac that continues to pump venom until it is empty or the stinger removed.

R. We're thinking about buying some property in Arkansas. I heard that the Africanized honeybees have been found there. Should we buy there or consider some other place where the bees haven't migrated?

A. Bees first migrated to Texas from Mexico in 1990. In that time, the people who live along the border have learned how to live there and avoid being stung. They are an example for the rest of us. Africanized bees now have spread to more than one fourth of Oklahoma and into parts of Texas, New Mexico, Arizona and California. In those states, too, people have learned how to avoid being stung by honeybees. So, go ahead and purchase property wherever you want, but be sure to learn how to avoid all kinds of stinging insects.

S. How many people have died from Africanized honeybee stings?

A. From 1990 to present there have been an average of 1 fatality in the United States from Africanized honeybee stings. No one has died in Arkansas from Africanized honeybee stings.

T. I'm doing a paper for school on Africanized honeybees. Can you send me all the information you have on them?

A. Additional information Africanized honeybees can be found at the following links:

AFRICANIZED BEES – GENERAL

Texas A&M University "Bee Alert: What is the Africanized Honeybee?" Home Page
Smithsonian Institution - Encyclopedia Smithsonian "Bug Info"
US Department of Interior, National Biological Services & USDA's Africanized Bees in North America
USDA-ARS National Programs concerning Africanized Bees
Insecta Inspecta World - Killer Bees
Information on the Africanized /African Honeybees: Malcolm T. Sanford, University of Florida
National Biological Information Infrastructure - ivasivespecies.gov
Ohio State University Extension - Africanized Honeybee
Center for Environmental Research and Conservation at Columbia University
Bee Alert - Africanized Honeybee Facts
Meter Reader Safety Committee AHB Page
<http://ourworld.compuserve.com/homepages/Beekeeping/weblinks.htm>

Q. Why are Africanized honeybees called 'killer bees'?

A. The name "killer" was first used in a news magazine report several decades ago when it was reported that several people died after having been stung by the bees. The name was only used once at that time and was greatly exaggerated. A B-grade movie then was made in which the "killer" bees attacked Houston and caused a lot of death and destruction in that city. Though the movie was complete fiction, the widespread perception of the Africanized honeybees being killers was launched.

Q. Why don't researchers think of a way to kill all the Africanized honeybees?

A. Africanized honeybees, like their cousins the regular European honeybee, actually are useful in helping to pollinate plants. Scientists still are trying to learn more about the value of Africanized honeybees, and in some South and Central American countries and in their native African, these bees are maintained for honey production. Even if they never are used for honey production in the United States, it would not be possible to kill one kind of honeybee without killing other types. And because the population of regular honeybees has been greatly harmed by a deadly mite in recent years, honeybees are desperately needed to pollinate our crops and flowers.

Q. My friend says that honeybees are actually good to have around, but I am afraid of them. How can they be good for us when they are so likely to sting?

A. Honeybees are the best pollinators of our crops and flowers. Without honeybees, we will have inferior fruit and vegetable crops, both commercially and in our home gardens. History has shown us that we can learn to live with honeybees safely.

Q. How does temperature and altitude affect Africanized honeybees? Do they hibernate? Can they live in cold climates?

A. It is not known how far north AHB can live in the US. They have been found to be able to live in the Andes Mountains in South America. The limiting factor seems to be that they tend to not store food as other honeybees do. So, when it becomes winter and there are not flowers blooming from which to make honey, they starve to death.

Q. Are bee stings acidic or alkaline? What about wasp stings?

A. Bee and wasp venoms consist of complex mixtures of biogenic amines, protein (polypeptide) toxins and enzymes. The stinging effects are not due to the acidity or alkalinity of the venom per se.

Q. What is the genus, species, etc (proper science classification) for killer bees?

A. The Africanized honeybee is a hybrid of a strain of honeybees from Africa, *Aphis mellifera scutellata*, and basically any other honeybee that it can mate with and produce viable off-spring. In the United States this could be *Aphis mellifera ligustica* (Italian honeybee), *Aphis mellifera carnica* (Carniolian honeybee), *Aphis mellifera caucasica* (Caucasian honeybee), and *Aphis mellifera mellifera* (Dark honeybee).

Q. How do I collect a sample for identification?

A. YOU DON'T!!

Because of the aggressive nature of AHB (or honey bees in general) it takes specialized equipment to safely collect a sample. You can report suspect bee colonies to the Arkansas State Plant Board office and they will be able to determine if it is a wild swarm or possibly some other type of stinging insect. Please call Mr. Mark Stoll at (501) 225-1598 to report any aggressive bee swarms.

Commonly Used Pesticides Grouped by their Relative Toxicity to Honeybees

Group 1 *[Hazardous]*

Aldrin	Aminocarb (Matacil)	Arsenicals	Azinphosethyl (Ethyl Guthion*)
Azinphosmethyl (Guthion*)	Benzene hexachloride (BHC)	Boml*	Carbanolate (Banol)
Carbarrl (Sevin*)	Chlordane	Crotoxyphos	Siazinon
Dieldrin	Dicaphon	Dichlorvos (DDVP)	Dicrotophos (Bidrin)
Dimethoate (Cygon)	Dinitrobutylphenol	EPN	Famphur (Famophos*)
Fenitruthion (Sumithion*)	Fenthion	Gardona	Heptachlor
Imidan*	Isobenzan (Telodrin*)	Isodrin	Lindane
Malathion	Malathion ULV	Methomyl (Lannate*)	Mevinphos (Phosdrin*) ²
Monocrotophos (Azodrin)	Naled (Dibrom*) ²	Parathion	Phosphamidon
Propoxon (Baygon*)	Pyramat*	Sabadilla ³	Tepp ²
Zectran*	Zinophos*		

Group 2 *[Moderately Hazardous]*

Cacodylic Acid	Carbophenothion (Trithion*)	Coumophos (Co-Ral*)	DDT
Dimethilan	Disulfoton (Di-Syston*)	DSMA	Endosulfan (Thiodan*)
Endothion	Endrin	Fundal* (Galecron*)	Hexaflurate
MAA	Methyldemeton	Mirex	MSMA
Paraquat	Perthane*	Phorate (Thimet*)	Phosalone
Ronnel	Tartar emetic		

* Relatively non-toxic on next page

Commonly Used Pesticides Grouped by their Relative Toxicity to Honeybees (Continued)

Group 3 [Relatively non-toxic]

Allethrin	Amitrole	Aramite*	Bacillus thuringiensis
Binapacryl (Morocide*)	Bordeaux mixture	Bromoxynil	Captan
CDA (Radox*)	CDEC (Vege dex*)	Chloramben	Chlorbenside (Mitox*)
Chlorobenzilate	Copper oxychloride sulphate	Copper 8-quinolinolate	Copper sulphate (monohydrated)
Cryolite	Cuprous oxide	Dalapon	Dazomet (Mylone)
Dmeton (Systox*)	Dexon*	Dicambra (Banvel D*)	Dichlone (Phygon*)
Dicofol (Kelthan*)	Delan*	Dimite* (DMC)	Dinitrocyclohexylphenol (DNOCHP)
Dinocap (Karathane*)	Dioxathion (DInav*)	Diquat	Dodine (Cyprex*)
Dyrene*	Endothall	EPTC (Eptam*)	Ethion
EXD (Herisan *)	Fenson	Ferbam	Focid (Difolatan*)
Fopet (Phaltan*)	Genite 923*	Glyodin (Glyoxide*)	Kepone*
Maneb	MCPA	Menazon	Methoxychlor
Monuron (Telular)	Nabam (Parzate*)	Nemogon*	Neotran*
Nicotine Sulfate	Olancha Clay	Ovex (Ovatran*)	Oxythioquinox (Morestan*)
Pentac*	Pyrethrins	Pyrolite	Rotenone
Ryania	Schradan (OMPA)	Sesamin	Sesone
Sillica gel (SG-78)	Silvex	Simazine (Princep)	Strobane*
Sulfur	Sulphenone*	TDE (Rhothane*)	Tetradiforn (Tedion*)
Tetram*	Thioquinox (Eradex*)	Thiram (Araxan*)	Toxaphene
Trichlorfon (Dylox*, Dipterex*)		Zineb	Ziram
2,3,6-TBA (Trybsen*)	2, 4-D	2, 4-DB	2,4, 5-T

NOTES:

- ✓ Terms followed by an asterisk (*) are trade names of proprietary products.
- ✓ Mevinphos (Phosdrin*), naled (Diborn*), and tepp have short residual activity and kill only the bees contacted at the time of treatment or shortly thereafter. They are usually safe to use when bees are not in flight; they are not safe to use around colonies.
- ✓ Usually, losses to sabadilla are low enough to be no problem. Sabadilla should not be applied to open flowers that are freely visited by bees.

EXTENDER PATTY METHOD

- ❖ Terramycin can also be mixed in extender patties and one patty can be used in place of the 3 treatments. In such a case, use the equivalent of 3 treatments of Terramycin in each patty.
- ❖ May not want to use if you have SHB – due to the fact that the adult beetle will lay eggs in the patty. They are drawn to the pollen.

NOTE: USE AS A PREVENTATIVE OF FOULBROODS.

AMERICAN FOULBROOD CANNOT BE CURED!

Diseases, Parasites and Their Non-Chemical Controls *

Disease or Parasite	Prevention or Control	Dosage	Method	Timing
American Foulbrood	Prevention		Annual replacement of brood combs. (Prevention only)	Early Spring or late Fall
American Foulbrood	Control and Prevention		Burning infected colonies	When found
European Foulbrood	Prevention or Control		Annual replacement of brood combs (Prevention but can be a control)	Early Spring or late Fall or when detected
Tracheal Mites	Control		Using resistant stock	
Tracheal Mites	Grease Patties (control)	2 parts table sugar w/ 1 part pure, vegetable shortening	Placed on top bars of frames where bees have ready access	8 oz. Patty kept in the hive at all times
Varroa Mites	Control		Using resistant stock	
Varroa Mites	Control		Trapping mites in drone brood and destroying, repetition	
Varroa Mites	Control		Screened bottom board	Year round
Varroa Mites	Control	½ cup	Powdered sugar dusting	2X / week for at least 3 weeks
Varroa Mites	Control		Sucroicide	As per label instructions
Small Hive Beetle	Control		In or below hive traps	During warm seasons
Small Hive Beetle	Control	Nematodes	Watered in ground around hives and honey house	During warm seasons
Nosema	Control	15 drops Nosevit	Mixed in sugar syrup, sprayed on bees or fed	2X in Spring and Fall

* These methods are only ways of reducing the chemical controls at this time. They are not intended to totally replace the need for chemical controls but just to reduce the dependence of them.

* Measuring levels of Varroa mite infestations is critical for knowing if a chemical treatment can be skipped or if it is, in fact, necessary to treat as soon as possible. Methods used to check levels of infestations include, in order of accuracy:

- Drone scans,
- Sugar shakes, wash or ether roll,
- Sticky bottom board with 72 hour, natural fall,

For all of these methods, timing is critical and factors that must be taken into consideration when measuring should include colony strength, time of year and amount of brood.



Wax Moth

Wax moths can be a terrible problem to bee hives if allowed to get out of hand and will destroy brood comb in a very short time if unchecked. There are some simple steps to prevent the damage, but first it might be simpler to discuss the life cycle to understand where the problem comes from.

A normal healthy hive will keep wax moth under control by ejecting the larvae, but weakened hives with small populations can be overcome by wax moth infestations destroying the brood comb, ultimately destroying the hive.

There are two varieties of moth which take delight in dining on wax the 'Greater' and also the 'Lesser' Wax Moth the greater wax moth is a mottled grey in colour approx 1 -1 1/2 inches in length while the lesser is smaller and slimmer approx 1/2 inch in length and white/silver. As all moths, they prefer night time to mate and lay eggs. (Photos are available in our picture gallery.)

Most wax moths are seen in early summer in our area, and we see them under the overhang of hive roofs, out of the daylight, when the hive is disturbed they take off quickly and disappear into the trees.

Preferring to work in the dark the moths enter the hive through top entrances left unscreened and unguarded by the bees, perhaps a sudden cold snap making the bees cluster, and lay eggs in cracks unavailable to the bees. These hatch in due course and the grey larvae begin feeding on wax and hive debris, tunneling just under the cell caps and feeding on the discarded cocoons left by the bees, leaving behind an extremely sticky white web, similar to spiders web but almost impossible to pull apart. So perhaps they are misnamed and should be called Cocoon moths?

With a little care wax moth can be outwitted and the damage they do can be prevented.

First, the practice of top entrances should be examined, provided they have screening then there will be no problem. Leaving a big hole in the inner cover, then a badly fitting roof, is just asking for trouble. Or even worse those holes drilled in the top of boxes allowing the bees a second entrance are a real problem. Apart from pollen in the honey, a cold evening and the bees pull down and form a cluster leaving that entrance unguarded, easy pickings for the wax moth, as they will fly in cooler conditions than bees.

They do say that prevention is better than cure. I have already given one way, using screening to prevent wax moth entering the hive top. The second point could be to use a trap to draw the moths away from the hive area. There are, to my knowledge, no commercial wax moth traps, but we use a country cure which works extremely well and I would recommend to all.

Take a 2 litre plastic pop bottle and drill a 1 inch hole just below the slope on the neck, then add 1 cup water, 1 cup sugar, 1 half cup vinegar and finally 1 banana peel. Wait a few days till it starts to ferment, then tie it into a tree close to the hives. This trap will draw the wax moth, they enter the hole can't get out and drown in the liquid, this will even draw in and kill the bald faced hornet.

Assuming you have followed the above instructions, then you should be able to prevent damage, but what to do if you have already a problem of wax moth?

Extensive damage, evidenced by the white webs, might be simpler to burn and start again. In cases of minor infestations pull out any larvae you can see and clean out all webs. Freezing is a very good way of killing larvae and eggs, so storage in an outside unheated shed during the winter can be useful. Boxes should have a screen top and bottom to prevent mouse damage and allow light to filter down as wax moth prefer the dark.

A treatment is placed onto the stacked pile of boxes during storage and consists of ParadiChlorBenzene crystals. These are used over newspaper in the stack, needs airing out before use.

Contrary to public opinion wax moth can be controlled, but I stress that prevention is better than cure, and the simplest way is to prevent wax moth getting into the hive through gaps and spaces.



Varroa Destructor Mite

scientific name: *Varroa destructor* Anderson & Trueman

(Arachnida: Acari: Varroidae)

Introduction

The varroa mite, *Varroa destructor* Anderson & Trueman, an ectoparasite of honey bees, was first described as *Varroa jacobsoni* by Oudemans (1904) from Java on *Apis cerana*. However, Anderson and Trueman (2000), after studying mtDNA Co-I gene sequences and morphological characters of many populations of *V. jacobsoni* from around the world split it into two species. *Varroa jacobsoni* s.s. infests *Apis cerana* F. in the Malaysia-Indonesia region. *Varroa destructor* Anderson & Trueman, 2000 infests its natural host *A. cerana* on mainland Asia and also *A. mellifera* L. worldwide (Zhang 2000).

In 1951, varroa mite was found in Singapore. In 1962-63, the mite was found on *Apis m. mellifera* in Hong Kong and the Philippines (Delfinado 1963) and spread rapidly from there. Adaption to a new host (*Apis m. mellifera*), the importation of queen bees from infested areas, and the movement of infested colonies of bees for pollination led to the rapid spread of this mite. Following the find of a single varroa mite in Maryland in 1979, the Division of Plant Industry and H.L. Cromroy, University of Florida, made an inspection of Florida bees in 1984. The varroa mite was not found at that time, but in 1987 it was detected in Wisconsin and Florida. It remains unknown how or when the varroa mite was introduced into the continental U.S.A. In Florida, the varroa mite has been found on flower feeding-insects [Bombus pennsylvanicus](#) (Hymenoptera: Apidae), *Palpada vinetorum* (Diptera: Syrphidae), and *Phanaeus vindex* (Coleoptera: Scarabaeidae) (Kevan et al. 1990). Although the varroa mite cannot reproduce on other insects, its presence on them may be a means by which it spreads short distances.



[bee with varroa mite](#)

Distribution

The varroa mite is now cosmopolitan, being found in Indonesia (Oudemans 1904), Singapore (Gunther 1951), and USSR (Breguetova 1953); it was found on *Apis m. mellifera* in Hong Kong (Delfinado 1963) and Philippines (Delfinado 1963). It quickly spread to the Peoples Republic of China (Ian Tzien-He 1965), India (Phadke et al. 1966), North Korea (Tian Zai Zai Soun 1967), Cambodia (Ehara 1968), Japan (Ehara 1968), Vietnam (Stephen 1968), Thailand (Laigo and Morse 1969), Czechoslovakia (Samsinak and Haragsim 1972), Bulgaria (Velitchkov and Natchev 1973), South Korea (Delfinado and Baker 1974), Paraguay (Orosi-Pal 1975), Taiwan (Akranakul and Burgett 1975), Argentina (Montiel and Piola 1976), Poland (Koivulehto 1976) Romania (Orosi-Pal 1975), Uruguay (Grobov 1976), Germany (Ruttner 1977), Bangladesh (Marin 1978), Brazil (Alves et al. 1975) Myanmar (Marin 1978), Hungary (Buza 1978), Tunisia (Hicheri 1978), Greece (Santas 1979), Iran (Crane 1979), Libya (Crane 1979), Turkey (Crane 1979), Yugoslavia (Santas 1979), Lebanon (Popa 1980), and likely other countries. Again, the mite was first detected in the USA in 1987 and has spread to most of North America. A full description of varroa's introduction, spread and economic impact has recently been published (Sanford 2001).

Description

Adult female mites are brown to dark brown, shaped like a crab, measuring 1.00 to 1.77 mm long and 1.50 to 1.99 mm wide. Their curved bodies fit into abdominal folds of the adult bee and are held there by the shape and arrangement of ventral setae. This protects them from the bee's normal cleaning habits. Adult males are yellowish with lightly tanned legs and spherical body shape measuring 0.75 to 0.98 mm long and 0.70 to 0.88 mm wide. The male chelicerae are modified for transferring sperm. The protonymph and deutonymph stages were described by Delfinado-Baker (1984).



[adult female, ventral and dorsal views](#)



[adult female, anterior view](#)



[adult female, dorsal view](#)

Life Cycle

The life cycle of the varroa mite is synchronized with that of its honey bee host; it may be that hormones or pheromones of honey bees are necessary for the mite to complete its development (see graphic). The female lays eggs in bee brood cells. Developing mites feed on developing honey bee larvae. Males and females copulate in the cell. The male dies, but pregnant females emerge from the cell along with their bee host and seek another cell to repeat the cycle. It is thought the length of the postcapping period in honey bees is an important indicator of eventual infestation. The longer the postcapping time, the more time there is for more female mites to develop.

Development of the bee brood	Day	Development of the varroa mite
Queen lays egg	1	
Egg phase	2	
	3	
Larva phase	4	
	5	
	6	
(uncapped brood)	7	Mite lays 4 eggs in the brood cell: 1st egg 2.5 days after entering cell 2nd egg 1.25 days later 3rd egg 1.25 days later 4th egg 1.25 days later
	8	
	9	
Pupa phase	10	
	11	
	12	
(capped brood)	13	Damage to the brood
	14	
	15	
	16	
Emergence of worker bees	17	Mites emerge with bees or die
	18	
	19	
	20	
	21	



[varroa mites](#)



[young bee with varroa mite](#)

Hosts

Among the bees that serve as hosts of the varroa mite are *Apis cerana*, *A. koschevnikovi*, *A. mellifera mellifera*, *A. m. capensis*, *A. m. carnica*, *A. m. iberica*, *A. m. intermissa*, *A. m. ligustica*, *A. m. macedonica*, *A. m. meda*, *A. m. scutellata*, and *A. m. syriaca*.

Economic Importance

The varroa mite is one of the most serious pests known for *Apis mellifera*, principally because it is an introduced and therefore exotic organism on *Apis mellifera*. It feeds on the haemolymph of the developing honey bee larva, pupa, and the adult bee. Heavily infested colonies usually have large numbers of unsealed brood cells. Dead or dying newly emerged bees with malformed wings, legs, abdomens, and thoraxes may be present at the entrance of affected colonies. If left unchecked, mites can cause loss of most affected colonies. It is reported in Europe that weak colonies are subject to being robbed by stronger colonies and may die within three to four years from the lack of worker bees to manage the brood and gather nectar. In Florida, infested colonies have died within seven months, probably due to the ideal weather conditions for mite development. Because varroa mites usually cause the death of a colony of *Apis mellifera*, it has been suggested that the development of this particular host/parasite relationship is still incomplete. The original host, *Apis cerana*, supports populations of mites without collapsing and *Apis m. scutellata* (the African or Africanized honey bee) seems to have some [resistance or tolerance](#) to varroa mite (Ritter 1981).

Survey and Detection

Ether Roll: The most widely used technique involves shaking 300 to 500 bees (1/4 to 1/3 pint) from the center frame of the brood nest into a pint jar. Spray automotive ether starting fluid for about two seconds onto bees. Close jar and shake vigorously for 10 to 15 seconds, then roll slowly. Mites can be seen stuck to the jar's interior.

Sugar Shake: Rather than starting fluid, which kills the bees, one can use powdered sugar as a substitute. Place a few table spoons of powdered sugar in a mason jar. Next, scoop up about ½ cup of bees (about 300) and dump them in the jar. Replace the lid with #8 hardware cloth and screw it onto the jar using the band. Now gently “slosh” the bees around in the sugar to ensure they are fully coated. The sugar dislodges the mites which can then be shaken through the screen to be counted.

Sticky Paper: Place a sheet of white paper coated with cooking oil (i.e., Pam®) on the hive bottom and cover with #8 hardware cloth. Check the "sticky board" after 3 days for mites and do not replace. Sticky boards are commercially available for this purpose. Do not use during honey flow.



[sticky paper trap](#)

Shake and Wash: Shake 1/4 of bees from the brood nest into a jar. Cover with 70% isopropyl alcohol and place on shaker for 15 to 30 minutes. Pour contents through a 8 mesh screen to count the mites. Replace bees in pint jar and preserve with alcohol, if planning to send a sample to a lab. Count bees in white enamel pan and reshake sample a second time to recover any additional mites.

Selected References

- Anderson D, Trueman JWH. (2000) *Varroa jacobsoni* (Acari: Varroidae) is more than one species. *Experimental & Applied Acarology*, 24: 165-189.
- Aratanakul P, Burgett M. 1975. *Varroa jacobsoni*: A prospective pest of honeybees in many parts of the world. *Bee World* 56: 119-121.
- Alves SB, Flechtmann CH, Rosa AE. 1975. *Varroa jacobsoni* Oudemans, 1904 (Acari: Mesostigmata, Varroidae) also in Brazil. *Ecosistema* 3: 78-79.
- Breguetova NG. 1953. [The mite fauna of the Far East.] *Parazitologicheskii Zbornik ZIN AN SSR*. 15: 302-338. (In Russian).
- Buza L. 1978. Control of varroa disease in Hungary. *Apiacta* 13: 176-177.
- Crane E. 1979. Fresh news on the varroa mite. *Bee World*. 608: 8.
- Cromroy HL. 1984. The Asian honeybee mite, a new threat to American beekeepers. Florida Extension Service. EYN-48. 4 p.
- Delfinado MD. 1963. Mites of the honeybee in Southeast-Asia. *Journal of Apicultural Research* 2: 113-114.
- Delfinado MD, Baker EW. 1974. Varroidae, a new family of mites on honeybees (Mesostigmata: Acarina). *Journal of the Washington Academy of Science* 64: 4-10.
- Delfinado-Baker M. 1984. The nymphal stages and male of *Varroa jacobsoni* Oudemans, a parasite of honeybees. *International Journal of Acarology* 10: 75-80.
- Denholm C. (unknown) *Varroa* WWW Hub. *Plant and Invertebrate Ecology*. <http://www.rothamsted.bbsrc.ac.uk/pie/BrianGrp/VarroaHub.html> (8 April 2004).
- Ehara S. 1968. On two mites of economic importance in Japan (Arachnida: Acarina). *Applied Entomology and Zoology* 3: 124-129.
- Grobov OF. 1976. Varroasis in bees. *In: Varroasis, a honey bee disease*. Apimondia Publishing House, Bucharest. 46-70.
- Gunther CEM. 1951. A mite from a beehive on Singapore Island (Acarina: Laelapidae). *Proceedings of the Linnean Society of New South Wales*. 76: 155.
- Hicheri LK. 1978. *Varroa jacobsoni* in Africa. *Apiacta* 13: 178.
- Kevan PG, Laverty TM, Denmark HA. 1990. Association of *Varroa jacobsoni* with organisms other than honey bees and implications for its dispersal. *Bee World* 7: 119-121.
- Koivulehto K. 1976. *Varroa jacobsoni*, a new mite infesting honeybees in Europe. *British Bee Journal* 104: 16-17.

- Laigo FM, Morse RA. 1969. Control of the bee mites, *Varroa jacobsoni* Oudemans and *Tropilaelaps clareae* Delfinado and Baker with chlorobenzilate. Philippine Entomologist 1: 144-148.
- Marin M. 1978. World spread of varroa disease. Apiacta 13: 163-166.
- Montiel JC, Piola GA. 1976. A new enemy of bees. Campo Moderno and Chacra, Oct. 1976:36-37. English translation *In* Varroasis, a honey bee disease. Apimondia Publishing House, Bucharest. 36-38.
- Orosi-Pal Z. 1975. [Varroa in America]. Mehezset. 23: 123. (In Hungarian).
- Oudemans AC. 1904. On a new genus and species of parasitic acari. Notes. Leyden Museum 24: 216-222.
- Phadke KG, Bisht DS, Sinha RBP. 1966. Occurrence of the mite *Varroa jacobsoni* Oudemans in the brood cells of the honey bee, *Apis indica* F. Indian Journal of Entomology 28: 411-412.
- Popa A. 1980. Agriculture in Lebanon. American Bee Journal 120: 336-367.
- Ritter W. 1981. Varroa disease of the honeybee *Varroa mellifera*. Bee World 62: 141-153.
- Ruttner F. 1977. [Interim report on the cause of varroa infection.] Die Biene. 13: 353-354. (In German).
- Samsinak K, Haragsim O. 1972. [The mite *Varroa jacobsoni* imported into Europe.] Vcelarstvi. 25: 268-269.
- Sanford MT. 2001. Introduction, spread and economic impact of *Varroa* mites in North America. *In*: Mites of the Honey Bee. Hamilton, Illinois: Dadant & Sons. pp. 149-162.
- Sanford MT. (1997). A history of varroa mite in Florida, with discussion of controls. *APIS* <http://apis.ufl.edu/threads/varroa.htm> (May 2000).
- Santas LA. 1979. Problems of honey bee colonies in Greece. Apiacta 14: 127-313.
- Stephen WA. 1968. A beekeeping problem in Vietnam and India. Bee World 49: 119-120.
- Tian ZS. 1967. [The disease of bees caused by the mite *Varroa jacobsoni*.] Monop Kvahaiboi Karmo. 4: 30-31. (In Korean).
- Tzien-He I. 1965. The biological peculiarities of the acarine mite *Varroa jacobsoni* Oudemans. Kounchong Zhishi. 9: 40-41. (In Chinese).
- Velitchkov V, Natchev P. 1973. Investigation about the *Varroa jacobsoni* disease - Oud. in Bulgaria. *In* Proceedings of the XXIV In. Apic. Congr. Buenos Aires, Argentina. 375-377.
- Zhang Z-Q. 2000. Notes on *Varroa destructor* (Acari: Varroidae) parasitic on honeybees in New Zealand. Systematic & Applied Acarology Special Publications 5: 9-14

Authors: [M.T. Sanford](#), University of Florida; H.A. Denmark, Florida Department of Agriculture and Consumer Services (FDACS), Division of Plant Industry; H.L. Cromroy, University of Florida; and L. Cutts, FDACS, Division of Plant Industry
Originally published as DPI Entomology Circular [347](#). Updated for this publication.

Photographs: FDACS - Division of Plant Industry; and [Scott Bauer, Peggy Greb](#)

[and Stephen Ausmus](#), USDA

Project Coordinator: [Thomas R. Fasulo](#), University of Florida

Publication Number: EENY-37

Publication Date: July 1998. Latest revision: May 2007.

Copyright 1998-2007 [University of Florida](#)

VARROA JACOBSONI OR VARROA MITE

- BIOLOGY -** The adult mite is between the size of a yearling tick and a seed tick and is reddish brown in color. They cling to the adult bee they are feeding on. They ingest small quantities of blood which weakens the bee and leave wounds for infections. The adult bee is only an intermediate host and a means of transport. The female mite enters a brood cell shortly before it is capped. She lays 2 to 6 eggs on the larvae and they hatch after 24 hours. Complete development of the mite takes 8 to 10 days (6 to 7 for the smaller, yellowish male). The young mites mate in the capped cells and emerge on the adult bee. The females seek a brood cell again after 4 to 13 days. They live about 2 months in the summer and 5 to 8 months in the winter.
- SPREAD -** Can spread through queen and bee sales. Spreads rapidly from bees in close proximity. (Bees meeting at water & nectar sources). Also, keep in mind that drones and even workers can drift from hive to hive. Very rapid from yards within 1.6 miles has been verified.
- DETECTION -** The dwindling of the colony is reason to suspect mites. Also, watch for a low incidence of flying. There are several methods for detecting Varroa mites. The easiest are the ether roll test, sugar shake or the drone scrapping methods.
- TREATMENT -** See medications section.

THE SMALL HIVE BEETLE

The small hive beetle (SHB), *Aethina tumida* Murray (Coleoptera: Nitidulidae), was identified from honey bee colonies (*Apis mellifera*) in Florida by M.C. Thomas of the Florida Department of Agriculture, June 1998. This was the first report of this insect in the Western Hemisphere; it was previously known only in sub-Saharan Africa. Adult beetles are 5mm long, dark brown to black and can be found within honey bee colonies. Eggs are laid in concealed areas and empty cells and larvae seek out pollen bee brood and honey to feed upon. The feeding of larvae causes honey to drip from the cells and often ferment, leaving a repellent on combs that can cause adult bees to abandon the comb and leave the hive. Beetle larvae complete their feeding on bee combs and then migrate outside to pupate in the soil. Development from egg to adult beetle takes 30-80 days. Reports from South Africa suggest that the beetle is rarely a significant pest with African bees. However, since beekeepers in the United States manage a different race of honey bee than in South Africa, the effects of this pest on U.S. beekeeping are largely unknown.

Distribution in the United States: The small hive beetle has been found in over 35 states, as of February 2010. Migratory beekeepers transport bee colonies from areas known to be infested with the small hive beetle and the probability that this pest is more widespread is very real due to the migratory pollination demands within the U. S.

Nature of the problem: The small hive beetle is considered a secondary pest in South Africa, attacking small or weak hives but rarely affecting strong hives. The honey bees in South Africa are primarily *Apis mellifera scutellata*, an aggressive bee that has excellent housecleaning and defensive traits. In contrast, the bees kept in North America are predominately *A. m. ligustica* or *A. m. carnica* and differ in behavior from African bees. The difference between races of bees coupled with different climatic and colony management styles between South Africa and the United States make it difficult to predict the impact of this new pest on the U. S. beekeeping industry. Reports from states with SHB have indicated occasional problems with beetles infesting and destroying hives in the apiary. However, more problems have been reported from damage by SHB to stored honey.

Damage to colonies and stored honey: Small hive beetle larvae affect combs of stored honey and pollen and will also infest brood combs. During the feeding action by larvae an associated repellent sticky substance is laid down on the combs and this can result in bees abandoning the hive. When honeycombs are removed from colonies, bees then no longer protect the combs allowing larvae to feed uninhibited. The management practice of removing honey and then storing it in warehouses prior to extraction will need to be changed with the introduction of this beetle. Additionally, the handling of wax cappings and honey in areas known to have the small hive beetle will require increased sanitation. Our research has shown that reducing relative humidity below 50% where honey is stored will inhibit SHB eggs from hatching and thus reduce or eliminate larval damage in honey.

HONEY BEE TRACHEAL MITE -

Acarapis woodi

The honey bee tracheal mite, *Acarapis woodi*, or acariosis as the disease is known in Europe, afflicts only adult honey bees. The parasite was first described in 1921 in bees in Great Britain. This discovery and concern over the potential impact that this mite would have on beekeeping in the United States led to the enactment of the Honeybee Act of 1922, which restricted the importation of honey bees from countries where this mite was known to exist.

There are three *Acarapis* species associated with adult honey bees: *A. woodi*, *A. externus*, and *A. dorsalis*. These mites are difficult to detect and differentiate due to their small size and similarity; therefore, they are frequently identified by location on the bee instead of morphological characteristics. However, only *A. woodi* can be positively diagnosed solely on habitat; the position of other species on the host is useful, but not infallible. *Acarapis woodi* lives exclusively in the prothoracic tracheae; *A. externus*, being external, inhabits the membranous area between the posterior region of the head and thorax or the ventral neck region and the posterior tentorial pits; and *A. dorsalis* is usually found in the dorsal groove between the mesoscutum and mesocutellum and the wing bases.

The *A. woodi* female is 143-174 um in length and the male 125- 136 um. The body is oval, widest between the second and third pair of legs, and is whitish or pearly white with shining, smooth cuticle; a few long hairs are present on the body and legs. It has an elongate, beak-like gnathosoma with long, blade-like styles (mouthparts) for feeding. When over 30 percent of the bees in a colony become parasitized by *A. woodi*, honey production may be reduced and the likelihood of winter survival decreases with a corresponding increase in infestation. Individual bees are believed to die because of the disruption to respiration due to the mites clogging the tracheae, the damage caused by the mites to the integrity of the tracheae, microorganisms entering the hemolymph (blood) through the damaged tracheae, and from the loss of hemolymph.

The tracheal mite has now been reported on every continent except Australia. Initial detections of *A. woodi* were reported in Brazil in 1974, in Mexico in 1980, and in Texas in 1984. The mites are transmitted bee to bee within a colony by queens, drones and workers. In addition, the movement of package bees and queens, as well as established colonies, has resulted in the dissemination of this mite throughout much of the United States.

One of the first problems that became apparent when the tracheal mite was detected in the United States was the lack of agreement on their economic impact. The literature from Europe did not always agree and beekeepers, research scientists and regulatory officials had differing opinions on the interpretation of the data. However, it soon became evident that the mites were having a serious impact on beekeeping and spreading faster than predicted. The level of infestation within colonies was higher than expected. It is apparent that the tracheal mite found an extremely susceptible honey bee host in the United States.

The population of *A. woodi* in a colony may vary seasonally. During the period of maximum bee population, the percentage of bees with mites is reduced. The likelihood of detecting tracheal mites is highest in the fall and winter. No one symptom characterizes this disease; an affected bee could have disjointed wings and be unable

to fly, or have a distended abdomen, or both. Absence of these symptoms does not necessarily imply freedom from mites. Positive diagnosis can only be made by microscopic examination of the tracheae; since only *A. woodi* is found in the bee tracheae, this is an important diagnostic feature.

In sampling for *A. woodi*, collect moribund bees that may be crawling near the hive entrance or bees at the entrance as they are leaving or returning to the hive. These bees should be placed in 70% ethyl or methyl alcohol as they are collected. Bees that have been dead for an indeterminate period are less than ideal for tracheal mite diagnosis.

Menthol is the only material that is currently approved by the Environmental Protection Agency (EPA) for the control of these mites in the United States. Beekeepers can minimize the impact of tracheal mites by intensive management practices to maintain populous colonies and by using menthol.

Colonies can be treated with menthol when there is no heavy nectar flow and daytime temperatures are expected to reach at least 60 F. The best time being in the spring when the weather is warm, and in the late summer or fall of the year immediately after removing the surplus honey.

Directions for Using Menthol: Fifty grams (1.8 ounce) of crystalline menthol should be enclosed in a 7" x 7" plastic screen bag or equally porous material and placed inside a colony for 20-25 days. Menthol placed on the top bars is the preferred method of treatment provided the daytime temperature does not exceed 80 degrees F. During hot weather, the menthol should be placed on the bottom board of the colony. There should be no honey supers on the hive during the treatment, and the menthol should be taken out of a colony at least one month before any anticipated flow. Before using menthol, read and follow the approved label carefully.

Integrated Pest Management in Beekeeping, A general concept & specifics for Varroa control

Ed Levi, Arkansas State Plant Board

As more and more problems seem to besiege the honeybees, it becomes incumbent on the bee's guardians to become better beekeepers. While chemical controls of these problems have their place, and in many ways have served us well, they are not the only solutions. In fact, as we see more and more problems with the chemicals we've employed, we learn they are only stop-gap solutions that need to be employed very prodigiously and, at best, only on an emergency basis.

Continued use of chemicals has caused uncounted problems in the hive. Queen and drone fertility has been documented from chemical residues and bee viability is suspect. We have watched as the diseases and pests have gained tolerance and/or resistance to the chemicals we've employed for their control. We have chosen to tolerate levels of contamination in a food product that sells largely because of the concept that it is "pure and natural." If used carelessly, use of chemicals can put at risk the very product that is the end product of our endeavors; honey.

The concept of Integrated Pest Management (IPM) in beekeeping serves purposes on a few levels. It strives for the long solution, it minimizes the use of chemicals that can damage the "pure and natural" image of honey, it minimizes the negative effects of chemicals in the hive, and it safeguards the usefulness of the chemicals for when they are most needed. These advantages have a price; they can be more labor intensive. At the same time, they can save.

IPM is not the changing from chemical controls to some other method. It is the educated integrated use of methods as needed. This requires knowledge of the pest or disease and the level of infestation. This requires a knowledge of all the tools available in combating the pest or disease and what they do both in the combating the problem as well as the unintended "damage" they can cause. It's long term goal should be to aid the honey bee colony in acquiring self defenses so that it can handle its own problems. Basically it is helping where needed while doing as little damage as possible. Like raising kids, the goal is the bees' self-reliance. Unfortunately, honey bee colonies in today's modern world seem to be constantly attacked from the environment to which they are exposed.

There are four steps to IPM in Beekeeping:

- Genetics
- Mechanics
- Measuring
- Chemicals

For proper employment of IPM in Beekeeping, these should be used in the order they are listed above:

1. Genetics, while it is not a quick fix, it is the real, long-term solution. We are blessed with those who have scientifically worked to come up with bees that demonstrate resistance to various problems. We should take advantage of these traits. We can also be doing our own selection of traits in the areas of hygienic behavior and disease resistance. At any rate, we should be working toward the goal of having bees that take care of the problems themselves without the aid of systematic drug therapies.
2. While working on the genetics, mechanical controls of bee diseases and pests should be employed. Some of these are clearly labor intensive but will not only save money, they will add to the general well being of the bees and purity of the honey. In fact, some of these methods are not so labor intensive, but all of these methods should be considered as a method of using fewer chemicals while working on the long-term solutions of genetic controls.

The concept of using mechanical controls and genetic traits to minimize the detrimental effects of diseases and pests has given us tools for long term solutions and, in the meantime, given us the ability to stretch out the time between chemical treatments.

3. In order for you know when you can skip a chemical or, for that matter, any treatment or when it is necessary to employ such controls, the beekeeper needs to monitor levels of infestation. Inspecting the brood for diseases is considered normal in most operations. It should also be normal practice to measure mite load levels and keep an eye on beetle infestations. Once the mite levels are determined, they can then be compared with levels that are considered to be “economic threshold” levels to determine if chemical treatments can be skipped or are necessary at the time, or if other means might be called for. Measuring also tells when we can use alternative or mechanical methods and should be used to measure the efficacy of the various treatments employed.

Measuring levels of Varroa mite infestations is critical for knowing if a chemical treatment can be skipped or if it is, in fact, necessary to treat as soon as possible. For all of these methods, timing is critical and factors, which must be taken into consideration include: climate of the area of concern, time of year, colony strength and amount of brood. Methods used to check levels of infestations include, in order of accuracy:

- a. Drone scans
 - A quick method for detection of infestation but of little value in measuring levels.
 - b. Sugar shakes (or ether-roll or mite wash methods)
 - Best if a consistent level of approximately 300 bees are used in sample
 - Bees must come from brood area
 - Depending on time of year, 12 – 25 mites found in 300 bees is a conservative threshold
 - c. Sticky bottom board with 3 day, natural fall,
 - Assuming brood is available, 150 mites would be considered a conservative threshold. (50 mites per day)
4. Chemicals or drugs that are labeled for specific use in beehives for the control of specific infections or infestations should be employed by closely following label instructions when threshold levels are reached and when it's felt that other methods will not be effective enough. It has been demonstrated that the frequency of use is being minimized through genetic advances and mechanical techniques. Using the chemicals as little as possible and correctly, when necessary, will maximize their benefits and make for advances in both the beekeepers operation and in beekeeping in general. When chemicals are needed, beekeepers should consider not using the same one over and over. Alternating each time or every third time will extend the efficacy of the chemicals. That said, it should be understood that the alternating of the harder chemicals, while limiting mite resistance, actually leaves the individual bee more susceptible to other problems and shortens its life.

There are new chemicals being developed all the time. For many years we only had one chemical to control Varroa mites. As efficacy diminishes due to resistance, others are developed. Today there are several. Some of these can be called “hard” chemicals while others could be considered as “soft” chemicals. No matter which chemicals you choose to use to control the specific problem you're targeting, it is required by law to follow the label directions. Likewise, it is not legal to use products or formulations that are not labeled to control the specific pest being targeted.

For a chart of “**Chemical and Non-Chemical Controls for Bee Ailments**”, see “**Medications**” section.

Honey Bee Pests

Full name	Description	Description	Description	Where found	Symptoms	Further Symptoms	Results
Varroa destructor anderson. an external mite	Dark brown, pencil-lead size spider	Found walking around but most in brood cells	Can be found with drone scans, sugar shakes & sticky bottom boards	Mostly in drone cells, in sealed worker cells when heavily infected	dead larvae decay; surviving adults often have deformed wings	Not always scattered brood pattern; infestation greatest in drone brood	Shortens bees' life, kills entire colonies, causes secondary viral infections
Acapis woodi. An internal mite	Microscopic, semi-transparent			With dissection and microscope, found in tracheal tubes of older bees	Most common in late-Winter to early-Spring. After closed-in season, bees appear to starve with feed in the combs	Bees often have "K-wing", Some bees can't fly and appear disoriented When warm, bees found walking on combs or outside hive	Shortens bees' life, kills entire colonies.
Aethina Tumida Murray.	Adults: Reddish-brown, pin-head sized, round beetle	Larvae: walking around on frames, comb, bottom boards. Fore-legs only & small horns on rear. No webbing.	Found on bottom boards and in cracks and crevices. Adults hide from light while larvae attracted to light	Walking around, slimy honey, trash on bottom board	Visual	Slimed honey, slimy honey on bottom board. Bees won't eat honey or feed touched by beetle larvae.	Kills small colonies. Can make a mess in honey house.
Achroia grisella & Galleria mellonella	Adults: Moths which lay eggs in hives	Larvae: maggot-like, makes webbing, and spins cocoons, walks with fore and hind legs.	Not a true parasite	In or on combs in dead or weak colonies.	Visual	Destroys combs and scars wooden ware.	Finishes colonies weal or dying from some other cause

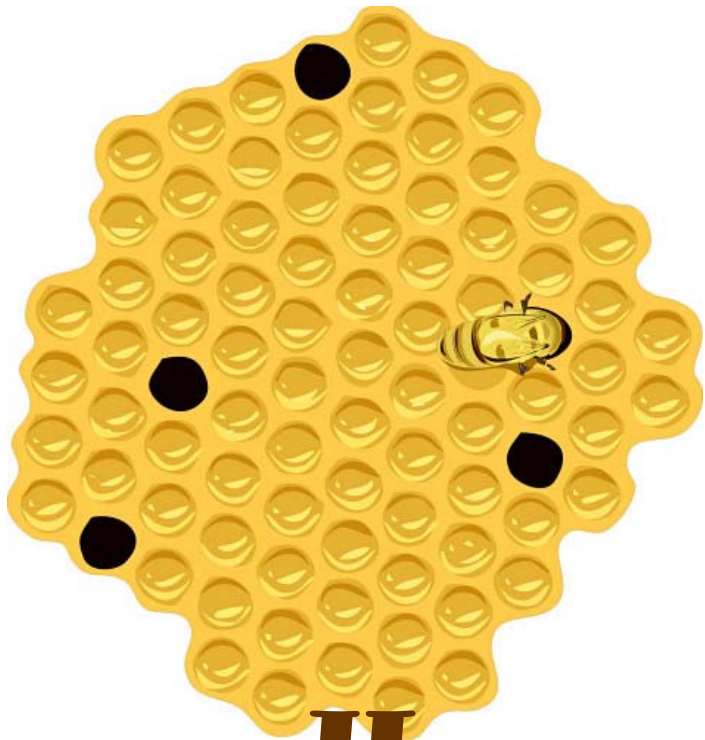

Honey Bee Pests

Contents:

1. Honeybee Pest Chart
2. Varroa Destructor
3. Varroa Jacobsoni
4. Tracheal Mites
5. Small Hive Beetle
6. Picture of Hive Beetle – Larvae in Frame
7. Picture of Hive Beetle – Adult Hive Beetle
8. Wax Moth
9. IPM

SACBROOD DISEASE OF THE HONEY BEE

Cause: A virus.

Effect: Sacbrood is a widely distributed disease, but it usually does not cause serious losses. However, the beekeeper should learn to recognize Sacbrood so it will not be mistaken for the more serious foulbrood diseases. Sacbrood may appear at any time during the brood-rearing season, but it is most common during the first half of the season. Usually it subsides after the main honey flow starts.

Symptoms: Scattered among the healthy brood are cells containing dead brood. Their cappings are dark and may be punctured or partly removed by the adult bees. About the time the cell is sealed, the larva dies. When it does, the head end turns up like the end of a gondola and remains in that position; also the pearly white color begins to darken, and the skin then becomes tough and the contents watery. At that stage, the larva, which resembles a liquid-filled sac, can be removed from the cell intact; hence, the name Sacbrood. The dead larva then continues to dry and harden until the dried-down scale is almost black. The head end is usually the darkest. Scales of larvae dead of Sacbrood can be removed from the cell easily.

Transmission: The virus is probably fed to the young larva by the nurse bees in the brood food. It multiplies rapidly within the larva until it causes death. Then the house bees cleaning out the cells probably distribute the virus to other larvae within the hive. The disease is usually limited to one or a few colonies in an apiary.

PRECAUTIONS AGAINST THE SPREAD OF BROOD DISEASES

- Keep the apiary clean and tidy. Do not throw propolis or burr comb on the ground where it may be robbed. Place it in a suitable container and remove from the apiary.
- Do not buy colonies of bees except from disease-free apiaries. Do not accept swarms of unknown origin. It is good to make sure the bees have been officially inspected before buying.
- Do not buy old combs without knowing the disease history.
- Disinfect secondhand equipment before use.
- Do not feed honey or pollen from doubtful sources.
- If a colony dies, close the hive pending an examination to prevent remaining stores from being robbed.
- Do not exchange brood or super combs unless they are from disease-free colonies.
- Prevent robbing at all times.
- Minimize drifting as much as possible.
- Inspect your own colonies for disease, do not wait for someone else to do it for you.
- Always keep a careful watch for signs of disease. If you see suspicious signs of diseases, call upon your apiary inspector for advice and assistance.

NOSEMA CERANAE

One of two known Nosema Diseases in Honey Bees

Nosema ceranae - a new threat to Apis mellifera honey bees

Posted 24 February, 2007

***Nosema ceranae* - a new threat to *Apis mellifera* honey bees**

Robert J Paxton, School of Biological Sciences, Queen's University Belfast, UK

(originally published in *Bees for Development Journal* 81)

History

Nosema is considered one of the most prevalent and economically damaging of honey bee diseases. Yet it often goes unnoticed because the causative agent, a microsporidium, is microscopic in size and therefore invisible to the naked eye, and because the disease rarely leads to the death of a diseased colony. At the beginning of the 20th Century, the great German bee scientist Zander first described *Nosema apis* as 'the microsporidium responsible for *Nosema* disease'. Subsequently, all reports of microsporidia in honey bees, in both the western hive bee *Apis mellifera* and the eastern hive bee *Apis cerana*, were attributed to *Nosema apis*.

Disturbing developments

In 1995, Professor Ingemar Fries of the Swedish Agricultural University, Uppsala and an expert on *Nosema* in bees, visited China where he described a new microsporidium, *Nosema ceranae*, in indigenous honey bees *Apis cerana* (Fries *et al.* 1996). The differences between the two microsporidia, *Nosema apis* and *Nosema ceranae*, lie in their ultrastructure and genetics (see Fries *et al.* 2006). Though Professor Fries subsequently demonstrated in experiments that *Nosema ceranae* is infective for the western honey bee, little more was made of the observations until the spring of 2005, when I was contacted by Dr Dinh Quyet Tam of the Bee Research and Development Centre (BRDC) in Hanoi, Vietnam, whose honey bees (*Apis cerana* and *Apis mellifera*) were suffering from *Nosema* disease. Julia Klee and Andrea Besana, working with me at Queen's University, Belfast, then developed a rapid and accurate molecular genetic detection system to differentiate *Nosema apis* from *Nosema ceranae* and found the Vietnamese honey bees to be infected exclusively with *Nosema ceranae*. In summer 2005, a group of Taiwanese researchers also found *Nosema ceranae* in Taiwanese *Apis mellifera* (Huang *et al.* 2006). It might have been anticipated that the western honey bee would acquire *Nosema ceranae* if kept in Asia, where *Apis cerana* and its parasite *Nosema ceranae* are endemic.

A group of bee pathologists in Spain, led by Dr Mariano Higes, subsequently discovered *Nosema ceranae* to be widespread in Spanish honey bees *Apis mellifera*, as of 2005 (Higes *et al.* 2006), indicating that the parasite had moved out of Asia. Dr Higes' group have subsequently reported the disease in France, Germany and Switzerland (2nd EurBee Conference, Prague, September 2006). More worryingly still has been the massive colony losses in Spain over the winter of 2005/2006, some of which have been linked to *Nosema* disease.

Wide ranging analysis

Given the potential threat posed to beekeeping by *Nosema ceranae*, we contacted bee scientists and government agencies across the world for samples of *Nosema*, both old and new, that Julia and Andrea analysed using their genetic marker system. Our results have been submitted to the *Journal of Invertebrate Pathology* for peer-reviewed publication. In short, we demonstrate that *Nosema ceranae* probably jumped host from *Apis cerana* to *Apis mellifera* within the last decade and that it has spread remarkably rapidly. It is found nowadays in the western honey bee in North and South America, the Caribbean, across Europe (from south to north and west to east) and Asia. Only on the islands of Ireland and New Zealand have we looked but found only *Nosema apis*. We lack samples from Africa, Australia and the UK to state anything about those locations. However, given its rate of spread and occurrence even on isolated islands of the Danish archipelago, it is quite possible that *Nosema ceranae* is, or will soon be, spread worldwide.

Warning for beekeepers

The implications for beekeeping with the western honey bee *Apis mellifera* are profound. First, we need to understand how virulent *Nosema ceranae* is in its new host *Apis mellifera*. Currently, there is a correlation between *Nosema ceranae* and colony mortality, but this does not of course mean that *Nosema ceranae* was the cause of the colony mortality. Other factors such as *Varroa* mites or pesticide misuse could account for the Spanish colony losses, and *Nosema ceranae* might have then multiplied in the dying colonies. There may however be a synergistic relationship between *Nosema ceranae* and other factors, leading to increased colony mortality. Studies are needed on how to control *Nosema ceranae*, if it proves to be highly virulent. Dr Higes' group are looking into some of these issues; more needs to be done now. I hope the relevant authorities and beekeepers take note. Forewarned is forearmed.

Acknowledgements

I thank the EU (projects Pollinator Parasites: QLK5-CT-2002-00741, and BeeShop: FOOD-CT-2006-022568) and the Institute of Apiculture (Robert S Pickard) for financial support of our work on the genetics of bee diseases.

References

- Fries, I., Feng, F., Silva, A. d., Slemenda, S. B. & Pieniazek, N. J. (1996) *Nosema ceranae* n. sp. (Microspora, Nosematidae), morphological and molecular characterization of a microsporidian parasite of the Asian honey bee *Apis cerana* (Hymenoptera, Apidae). *European Journal of Protistology* 32, 356-365.
- Fries, I., Martín R., Meana, A., García-Palencia P. & Higes, M. (2006) Natural infections of *Nosema ceranae* in European honey bees. *Journal of Apicultural Research*. *In press*.
- Higes, M., Martín, R. & Meana, A. (2006) *Nosema ceranae*, a new microsporidian parasite in honey bees in Europe. *Journal of Invertebrate Pathology* 92, 93-95.
- Huang, W.-F., Jiang, J.-H., Chen, Y.-W., Wang, C.-H. (2006) A *Nosema ceranae* isolate from the honey bee *Apis mellifera*. *Apidologie*. *In press*.
- Klee, J., Besana, A. M., Genersch, E., Gisder, S., Nanetti, A., Tam, D. Q., Chinh, T. X., Puerta, F., Ruz, J. M., Kryger, P., Message, D., Hatjina, F., Korpela, S., Fries, I. & Paxton, R. J. (2006) Widespread dispersal of the microsporidium *Nosema ceranae*, an emergent pathogen of the western honey bee, *Apis mellifera*. *Journal of Invertebrate Pathology*. *Under review*.

NOSEMA APIS DISEASE OF THE HONEY BEE

Cause: *Nosema apis*, a fungus.

Effect: Nosema disease is widespread and can cause extensive losses of adult bees. It may also be responsible for some supersedure of queens.

Symptoms: *Nosema apis* has some fairly clear symptoms compared to *Nosema Ceranae*. Inability of bees to fly, excreta on combs or lighting boards, and a pile of dead or dying bees on the ground in front of the hive may be manifestations of Nosema infection, and K-wing, distended abdomens, supercedures, and dwindling but they may also be caused by other abnormal conditions. The disease may be present without any obvious signs. However, if crawling bees or unusual numbers of dead bees are seen or if a colony fails to build up properly in the spring, Nosema disease should be suspected and your apiary inspector should be contacted for advice and assistance.

Transmission: The spores of *Nosema apis* enter the body of the adult bee through the mouth and germinate in the gut. After germination, the active phase of the organism enters the digestive cells that line the midgut where it multiplies rapidly; the contents of these cells are used as its food supply until reproduction ceases and new spores are formed. The cell then ruptures and sheds the new spores into the midgut where they pass down through the small intestine to the rectum. Here they accumulate and are voided in the excreta of the bee. The cycle begins over again when the spores contaminate the food of other bees. Spores will remain viable for many months in dried spots of excreta on brood combs. Near the end of winter, combs are often soiled with excreta from infected workers. Other bees become infected when they pick up the spores in the excreta as they clean the soiled combs during the spring expansion of the brood nest. Thus, the disease within the colony increases rapidly for a time, and a colony may dwindle in the spring because of the premature death of the overwintered bees. Usually, the colony survives and the proportion of infected bees begins to decline rapidly. This decline occurs because the excreta are normally voided away from the hive when regular flights become possible in spring. Since the old bees now die off and are replaced by healthy bees emerging from the brood combs, the disease may not be detectable in the colony by the end of the season. However, enough spores remain on the combs from the previous winter to infect a few bees in the cluster that forms when winter sets in again. These infected bees then form the nucleus for a repetition of the cycle. The disappearance of the infection during the summer seems to indicate that outside agencies such as drinking water, flowers, or vegetation are not important in the spread of the disease. Also, the honey is probably not contaminated to any significant degree, since excreta are not deposited on the honey combs during the honey flow. The spread of Nosema disease occurs chiefly because of the use of contaminated equipment and the robbing of infected hives, through infected package bees, infected queens, and her attendant workers.

Honey Bee Brood Disorder Chart

Brood Disease or Condition	Cause	Symptoms	Further Symptoms	Further Symptoms	Further Symptoms	Scales	Odor
Healthy Brood		pattern of sealed cells	light brown color, convex cappings	none	plump, white, mother-of-pearl appearance	none	none or fresh
American Foulbrood	bacillus larvae-bacterium, sporeforming	scattered brood pattern	sunken, perforated, discolored, greasy appearance	flat on bottom of cell	light brown, dull white, dark brown, eventually coffee to dark brown,; sticky to ropey	black-brown and rough, removed by bees with difficulty; lies flat on lower side of cell	unpleasant glue-like
European foulbrood, advanced infection	Streptococcus pluton, a bacterium	scattered brood pattern, often pepperbox in appearance	discolored, sunken, perforated	in unsealed and sealed cells, in twisted positions, sometimes stretched out on the ventral side of the cell	black-brown, viscous and sticky	rubbery, black-brown and smooth, are removed by bees	unpleasant, sour
Chalkbrood	Acosphaera apis, a fungus	scattered	light or dark, convex, any perforated	most often in sealed or perforated cells	white and mouldy, later grey-black, hard and chalk-like	none	normal
Chilled brood	sudden or prolonged low temperature	few or many dead larvae in cells at edge of broodnest	light or dark sunken and discolored over time	mostly in unsealed cells	dark or black, dry quickly	remnants are removed by bees easily	normal, rotten odor in severe cases

Brood Disease or Condition	Cause	Symptoms	Further Symptoms	Further Symptoms	Further Symptoms	Scales	Odor
Drone brood in worker cells	unfertilized or laying worker eggs in worker cells	predominantly drone brood	bullet-like	none or few	normal	none	normal
Sacbrood	a virus	scattered, often with many unsealed cells	often dark and sunken, many perforated	most often with head raised	greyish to black, watery and granular; skin has a sack-like appearance	head predominantly curled up; yellow-brown or dark grey; removed by bees with ease	none to sour
Stonebrood	Aspergillus flavus, a fungus	affected cells have a greenish, mouldy appearance	some perforated and covered with a greenish layer	in unsealed and sealed cells	green-yellow, hard and shrunken	none	mouldy in advanced stage

EUROPEAN FOULBROOD DISEASE OF THE HONEY BEE

Cause: *Melissococcus pluton*, a bacterium.

Effect: European foulbrood is most common in the spring when brood rearing is at its height, though usually the earliest reared brood is not affected. Sometimes the disease appears suddenly and spreads rapidly within infected colonies; at other times it spreads slowly and does little damage. As a rule, it subsides by mid-summer, but occasionally it continues to be active during summer and fall or may reappear in the fall. A good honey flow seems to hasten recovery.

Symptoms: Combs containing larvae infected with European foulbrood usually present a rather uniform appearance because the cells are not sealed. Larvae diseased by European foulbrood move restlessly within their cells and, therefore, when they die, are usually twisted in the cells or die while in the "C" stage at the bottom of the cell. However, some larvae may be stretched out lengthwise from the mouth to the base. In some cases, the larva collapses as though it had been melted, turns yellowish brown, and eventually dries to form a loosely attached brown scale. The consistency of recently dead larvae varies but it is not ropy. The odor of the larval remains also varies. The scale remains of larva dead from European foulbrood disease can be removed readily.

Transmission: The organism becomes mixed with the brood food fed to the young larva by the nurse bees, multiplies rapidly within the gut of the larva, and causes death within 4 days after egg hatch. House bees cleaning out the dead larvae from the cells distribute the organism throughout the hive. Since the honey of infected colonies and the beekeeper's equipment are undoubtedly contaminated, subsequent spread of the disease is accomplished by robber bees, exposure of contaminated honey by the beekeeper, interchange of contaminated equipment among colonies, and perhaps, to some extent, by drifting bees.

COMPARING FOULBROOD

AMERICAN FOULBROOD BACILLUS LARVAE

Suspect

dirty landing board,
not flying like others

Examining brood

often, before using equipment
on other hives

Look for:

good pattern vs shot-gun pattern
convex cell caps vs sunken ones
holes in cell caps
bright white, glossy larvae

OTHER SYMPTOMS (clues)

affects only worker caste
attacks larva after cell is closed
melts to bottom of cell
stays opaque
turns brown
soft & sticky and can't be completely
removed from cell - ropy
can smell (glue-pot)
scales adhere tightly on bottom

EUROPEAN FOULBROOD MELISSOCOCCUS PLUTON

Suspect

dirty landing board,
not flying like others

Examining brood

often, before using equipment
on other hives

Look for:

good pattern vs shot-gun pattern
convex cell caps vs sunken ones
holes in cell caps
bright white, glossy larvae

OTHER SYMPTOMS (clues)

affects all castes
attacks larva before cell is closed
twists to back of cell
becomes sort of transparent
turns brown
soft & watery isn't sticky and can be
removed from cell
can smell (sour odor)
scales twist, rubbery, doesn't adhere

CHALKBROOD DISEASE OF THE HONEY BEE

Cause: *Ascosphaera apis*, a fungus.

Effect: Chalkbrood disease affects only the brood. The diseased larvae are usually found on the outer edges of the brood nest. Workers, drones, and queens are all susceptible to the disease.

Symptoms: The affected larvae are usually found on the outer fringes of the brood area. Brood cells can either be sealed or unsealed. Diseased larvae are stretched out in their cells in an upright condition. Typically, larvae dead from chalkbrood disease are chalk white, hence the name chalkbrood. Sometimes the diseased larvae can be mottled with brown or black spots, especially on the ventral sides. The color variation is from the brown to black color of the fruiting bodies (spore cysts).

Transmission: The spores of *Ascosphaera apis* are ingested with the brood food provided by the nurse bees. The germination of the spores and proliferation of the fungus covers the larva with a white mycelium. Spores of *Ascosphaera apis* remain viable for years. Consequently, the infection source could be present in the cells used to rear brood. Chalkbrood appears to be most prevalent in the spring when the brood area is increasing. Chalkbrood normally does not destroy a colony. However, it can prevent normal population build-up when the disease is serious. No treatment is presently available for the control of chalkbrood. The disease usually disappears or is reduced as the air temperature increases in the summer.



American Foulbrood

Cause: *Paenibacillus* (=Bacillus) larvae, a spore-forming bacterium.

Effect: American foulbrood is one of the most widespread and the most destructive of the honey bee brood diseases. At first, the population of an infected colony is not noticeably decreased and only a few dead larvae or pupae may be present. The disease may not develop to the critical stage where it seriously weakens the colony until the following year, or it may advance rapidly and seriously weaken or kill the colony the first season.

Symptoms: First the capping of the diseased cell becomes moist and darkens in color. Then as the larva shrinks, the capping is drawn down into the mouth of the cell so the normal convex capping becomes concave. Worker bees may puncture this sunken capping and eventually remove it altogether. Death of an infected larva takes place after the cell has been sealed and the cocoon has been spun. At death, the diseased larva changes from a normal pearly white color to a creamy brown, then gradually darkens. These larval remains can be drawn out into a brown thread or rope. As the larva dries, it becomes dark brown. The final state is a very dark brown scale that lies uniformly on the lower side of the cell and extends from just below the mouth of the cell down to the base. These scales adhere very tightly to the cell and can be removed only with great difficulty. (If death occurs at the pupal stage, the tongue of the pupa may protrude from the scale.) The overall appearance of a comb infected with American foulbrood disease is patchy because of the mixture of diseased and healthy brood cells and also because the remains vary from the ropy moist larvae in cells with dark sunken or perforated cappings to the dry scales lying in open cells whose cappings have been chewed away completely by the bees.

Transmission: The spores are fed to young larvae by the nurse bees. They then germinate in the gut of the larva and multiply rapidly, causing the larva to die soon after it has been sealed in its cell. By the time of death of the larva, the new spores have formed. When the house bees clean out the cell containing the dead larva, these spores are distributed throughout the hive and more and more larvae become infected. The honey in an infected colony can become contaminated with spores and can be a source of infection for any bee that gains access to it. For example, as a colony becomes weak, it cannot defend itself from attacks by robber bees from strong nearby colonies; these robbers take back the contaminated honey to their own colony, continuing the cycle of infection. The beekeeper also may inadvertently spread the disease by exposing contaminated honey to other bees or by the interchange of infected equipment. Moreover, drifting bees or swarms issuing from an infected colony may spread the disease.



Honeybee Diseases

CONTENTS:

1. Honeybee Brood Diseases
2. Adult Bee Disorder Chart
3. Precautions Against the Spread of Brood Diseases
4. American Foulbrood
5. European Foulbrood
6. Comparing Foulbrood
7. Nosema Ceranae
8. Nosema Apis
9. Parasitic Mite Syndrome
10. Chalkbrood
11. Sacbrood



HONEYBEE ANATOMY & LIFE CYCLE

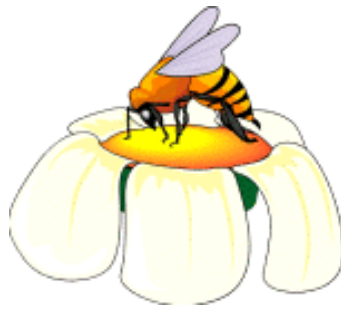

Contents:

1. The Anatomy of a Bee
2. The Anatomy of a Bee Diagram
3. Honey Bee Life Cycle

Diseases, Parasites and Their Chemical Controls *

Disease or Parasite	Prevention or Control	Dosage	Method	Timing	Cautions
American Foulbrood	Terramycin (Prevention Only)	9:1 (powdered sugar to TM25) 1 Tablespoon, 3 times, 1 week apart.	Dusted on ends of top bars of brood frames	Early Spring and Fall	Never to be in hive during honey production. Finish at least 30 days prior to super placement
American Foulbrood	Tylan (Tylosin) (Not a preventative nor a cure)	As per directions	Mixed with powdered sugar and dusted on ends of top bars	Early Spring and in the Fall	Never to be used when supers are present. Residues are likely and are not tolerated.
European Foulbrood	Terramycin (prevention but can be a control)	Same as above	Same as above	Same as above	Never to be in hive during honey production. Finish at least 30 days prior to super placement
Nosema	Fumidil-B (control)	2 teaspoons to two gallons of syrup. Or to one gallon of syrup	Feed in syrup	In the Fall or in the Spring	Never to be in the hive during honey production.
Tracheal Mites	Menthol crystals (control)	One packet	Placed in hive in temperature ranging from 60 to 80 degrees	In the Fall &/or in the Spring. (Ideally, 21 days of vapors)	Never to be in the hive during honey production.
Tracheal Mites	Grease Patties (control)	2 parts table sugar w/ 1 part pure, vegetable shortening	Placed on top bars of frames where bees have ready access	8oz. Patty kept in the hive at all times	
Tracheal Mites	MiteAway II (control)	1 pack for 2 story hive	Placed on top bars	Spring &/or Fall (alternate with other treatments)	Never to be in hive during honey production. Not to be used with supes in place.
Tracheal Mites	ApiGuard (control)	1 pack for each hive body	Placed on top of the frames	Fall and Spring (alternate with other treatments)	Never to be used during honey production. Wear protective gear.
Varroa Mites	Apistan (control)	1 strip in brood area for each 5 frames of bees	Hung in between frames in brood area	Fall and Spring (alternate with other treatments)	Never to be in hive during honey production. Not to be used with supes in place.
Varroa Mites	Checkmite+ (Bayer Bee Strips) (Control) Section 3	1 strip in brood area for each 5 frames of bees	Hung in between frames in brood area	Fall and Spring (alternate with other treatments)	Never to be in hive during honey production. To be removed 15 days prior to placing supers.
Varroa Mites	MiteAway II (control) (Formic Acid gel pack)	1 packette	Placed on top of frames	Fall and Spring (alternate with other treatments)	Never to be used during honey production. Wear protective gear.
Varroa Mites	MAQS (control)	2 strips	On top of frames	7 day treatment	Anytime
Varroa Mites	ApiLife Var	Packette	Placed on top of frames	Fall and Spring (alternate with other treatments)	Never to be used during honey production. Wear protective gear.
Varroa Mites	ApiGuard	Packet or bulk	Placed on top of frames	Fall and Spring (alternate with other treatments)	Never to be used during honey production. Wear protective gear.
Varroa Mites	Hivastan (control) Section 3	8 oz.	Patty on top of brood frames	Fall and Spring (alternate with other treatments)	
Varroa Mites	Sucrocide	Diluted in water	Sprayed on or between frames	Fall and Spring	Not to be used during honey flow.
Small Hive Beetle	GardStar	Ground drench	Around hives and honey house	Every six weeks during warm weather	Follow label instructions
Small Hive Beetle	Checkmite+ (Bayer Bee Strips) (Control) Section 3	1 strip cut in half	Stapled under corrugation cardboard placed on bottom board	Fall and Spring but only when bees are not clustered.	Never to be in hive during honey production. To be removed 15 days prior to placing supers.

* Follow all label instructions

* Illegal to use products not labeled for use in beehives.

Races of Bees

race/variety	scientific name	appearance	temperament/ behavior	honey production	propolis	disease/pests	brood production	overwintering	swarming	comments	origin
Italian	<i>Apis mellifera</i> linguistica	a classic golden yellow with black bands on the abdomen	very gentle, easy to work; prone to robbing and drifting, stay on combs during inspections; keep clean hives	very good under good conditions	moderate	fair resistance to European foulbrood and wax moths; robbing and drifting promote spread of diseases/pests	rapid spring build-up; maintains large brood area regardless of food supply, thus large portion of resources consumed for brood rearing	overwinter with large population, thus require large food supply for winter; can starve if food stores are exhausted	moderate	somewhat prone to drifting and robbing, but good mixture of characteristics makes the Italian a good choice for beginners; by far the most popular bee in the U.S.; queens are fairly easy to locate; these bees do well in temperate or warm climates, over long warm seasons with abundant forage and good weather, not as well during cold wet springs or hot dry summers;	Apennine Peninsula of Italy
Carniolan	<i>Apis mellifera</i> carnica	dark brown to gray or black, largest of domestic bee races	gentle, non-aggressive not prone to robbing, construct new comb slowly; forage earlier in the morning	reputed slightly less than Italians, but can do well in adverse climates	little	-	slow spring starters, but then build up very fast; brood production slows in times of nectar or pollen dearth, stops in fall	fly in cooler weather, overwinter in smaller clusters, efficient users of winter food stores, good choice for colder climates	can be very prolific, prone to excessive swarming	can be difficult to find the queen; does well in long cold winters, short springs and hot summers; better suited to northern climates than in the south; said to cross well with other races; best traits have been bred into "New World Carniolan" queens	alpine regions of Austria, Slovenia, Yugoslavia, and Danube Valley
Caucasian	<i>Apis mellifera</i> caucasica	silver-gray to dark brown or yellow; has longest tongue of domestic bee strains (can work flowers other bees can't reach)	very gentle; somewhat prone to robbing; forages earlier and on colder days; once alarmed, can be difficult to calm	fair to good, especially in wet climates	excessive, very sticky; also produces burr comb	susceptible to disease, especially noseema	slower build-up than Italians; becomes large and stong; can adjust boor rearing to current conditions; stops prd in fall	maintain good overwintering stores	low	difficult to locate queen; do well in both warm/humid and cold/damp climates; can fly in poor weather;	Caucasian mountains between the Black Sea and Caspian Sea; pure-breeds not widely available in U.S.
German / English ("black bees")	<i>Apis mellifera</i> mellifera	dark brown to black	tend to be runny (run all over combs during inspection); often described as "excitable" or "mean" or "irritable"	can be good	lots	prone to diseases, especially EFB, don't defend well against wax moths	build up slowly in the spring	well-adapted to cold, damp climates	moderate to high	The bees originally brought ot America by early colonists, later fell out of favor when Italians became available	northern Europe
Russian	<i>Apis mellifera</i> caucasica	a sub-type of Caucasian	aggressive/defensive of hives, often observed to head-butt before stinging,	moderate to good	excessive, very sticky; also produces burr comb	able to remove some varroa mites/tolerate more mites in nest than other types	brood production slows/stops in times of nectar dearth	overwinter well with small stores	moderate to high; always keeps some swarm cells ready	swarming unpredictable; can be expensive	a type of hybrid, bred from Caucasian bees originally brought to U.S. from eastern Russia for its increased ability to resist/tolerate Varroa mites
Cordovan	not a true race, but a color due to a recessive genetic trait; often found in Italians, but can be found in other races	yellow bodies; reddish brown legs, head	very gentle; prone to robbing; excellent comb builders	good	little	fair	fair	consumes large volume of honey in winter	-	Color makes queen easy to locate; may perform poorly under cold, wet conditions; cordovan color can be bred into any line of bees, thus making it useful for open-mated breeding programs	technically term refers a color, not a true race, so could be found in any type of bee, but usually of Italians
Buckfast	hybrid of many races	golden to light grayish-brown	fairly gentle, low instinct to sting; can be defensive when disturbed; inclined to rob	excellent	little	highly resistant to tracheal mites and chalkbrood, other common ailments; very hygienic	start later, but build up fast in spring, makes them pslow down in fall for small clusters, survive cold winters and cool damp springs	require less than Italians, but more than Carniolans	low	A hybrid developed by Brother Adam of Buckfast Abbey, a mixture of many races of bees; an excellent choice for beginners.	bred from bee races collected from all over

Races of Bees

Minnesota-Hygeinic	hybrid of mainly Italians	yellow with black bands	exceptionally hygienic	good	moderate	bred to be very resistant to American Foul Brood and other diseases	similar to Italians	similar to Italians	moderate	selected for ability to detect, uncap, and remove diseased brood before they became contagious to the colony; some report that hygienic behavior is lost or reduced after queen replacement.	developed as a result of research by Dr. Marla Spivak at the University of Minnesota,
Starline	hybrid line of Italian bees	similar to Italians	gentle	excellent under good conditions (especially suited for clover)	minimal	-	prolific brood producers; fast spring build-up	overwinter poorly; due to large population, needs large food reserve	moderate; large populations may require attention to prevent	queens resulting from swarm/supercedure do not have same traits as mother; require requeening each year	hybrid produced by crossign two unrelated lines of Italians, produced for hobbyists, not suitable for commercial operations
Midnite	(hybrid) <i>Apis mellifera caucasia</i> X <i>carnica</i>	varies, generally darker	very gentle	fair to good	moderate	-	-	-	-	queens resulting from swarm/supercedure do not have same traits as mother; require requeening each year	hybrid of Caucasian and Carniolan bees
Africanized Honey Bee (AHB)	(hybrid) <i>Apis mellifera linguistica</i> X <i>scutelata</i>	much like Italians, very accurate morphometrics or DNA sample needed to determine AHB prevalence	extremeny defensive of hive territory, occasionally dangerous; prone to absconding	generally have smaller colonies, so collect less honey per hive	-	resistance to varroa mites reported	maintain smaller colonies than Italians	lack ability to cluster, have not established in colder climates; well-suited for tropical climates	high	because of their defensive nature, these bees should not be kept near human dwellings or around tethered/penned livestock; hives should be spaced apart to prevent alarm pheromone from one colony spreading to another	The result of accidental release from a Brazilian breeding program bewteen African bees and European bees, attempting to produce a vigorous honey producer adapted to the tropics. Arrived in U.S. in 1990.
Yugo	sub-type of Carniolan	-	-	-	-	tracheal mite resistant; varroa tollerant	-	overwinter well	low	crosses usually produce queens with hybrid vigor	-
All American	strain of Italian	darker than normal Italian	gentle; don't run on the combs	good	moderate	resistant to tracheal mites	prolific and build up quickly	generally keep an open brood nest, but will store honey below if crowded down in time	low	adapt well to most North American climates, but do best in warmer regions, especially in the southwest	a strain of Italians that have been selected over many years in the US for desitreable characteristics

WE NEED BEEES!



AMERICAN BEEKEEPING NEEDS YOUR SUPPORT:

Due to increased urbanization, changing farm land use patterns and increased herbicide use to control weeds, the total quantity of honeyplants has been reduced: **HELP** by reducing herbicide use for “cosmetic” weed control situations. Pesticides take a great toll on bees. Use extreme caution in the use of these products, especially such common pesticides as Sevin and Malathion. **ALWAYS USE EXTREME CAUTION WITH THESE CHEMICALS.**

Contents:

1. Bees are Important to Everyone
2. Our State Insect
3. Landscape Planting for Bees
4. Selecting the Apiary Site
5. Composition of Honey
6. Pesticides Relative Toxicity to Honey Bees
7. Races of Bees
8. Recipes for Healthy Bees

Normal and allergic reactions to insect stings

- I. Normal, non-allergic reactions at the time of the sting
Pain, sometimes sharp and piercing
Burning, or itching
Redness (erythema) around the sting site
A white area (wheal) immediately surrounding the sting puncture mark
Swelling (edema)
Tenderness to touch
- II. Normal, non-allergic reactions hours or days after the sting
Itching
Residual redness
A small brown or red damage spot at the puncture site
Swelling at the sting site
- III. Large local reactions
Massive swelling (angioedema) around the sting site extending over an area of 10 cm or more and frequently increasing in size for 24 to 72 hours, some times lasting up to a week in duration.
- IV. Cutaneous allergic reactions
Urticaria (hives, nettle rash) anywhere on the skin
Angioedema (massive swelling) remote from the sting site
Generalized pruritus (itching) of the skin
Generalized erythema (redness) of the skin remote from the sting site
- V. Non life-threatening systemic allergic reactions
Allergic rhinitis or conjunctivitis
Minor respiratory symptoms
Abdominal cramps
Severe gastrointestinal upset
Weakness
Fear or other subjective feelings
- IV. Life-threatening systemic allergic reactions.
Shock
Unconsciousness
Hypotension or fainting
Respiratory distress (difficulty in breathing)
Laryngeal blockage (massive swelling in the throat)

HOW TO SUBDUE ATTACKING EUROPEAN or AFRICANIZED HONEYBEES

A Guide for Fire Fighters and Rescue Personnel

This guide was prepared in July 1992 by Dr. Eric H. Erickson and Capt. John B. Estes. Dr. Erickson is Director, Carl Hayden Bee Research Center, Agricultural Research Service, USDA, 2000 E. Alien Road, Tucson, Ariz. 85719. Phone: (602) 670-6380. John B. Estes is Captain, Northwest Fire District, Station #60, Tucson, Ariz. 85741.

The use of trade names does not constitute endorsement of a product by the U.S. Department of Agriculture.

Africanized honey bees (ABH) are spreading in 9 US States. Their attacks can be a life-threatening emergency. Fortunately, rescue personnel can help people under attack by using — with slight modification — equipment and materials common on fire trucks, ambulances and hazardous materials response vehicles.

This guide can also be used to protect people from swarms of wasps and domestic honey bees, which to the naked eye are indistinguishable from the AHB.

PROTECTIVE CLOTHING

Conventional heavy turnout gear worn by most fire fighters protects all areas of the body except the head and neck. Consequently, veils are essential, but they must be adapted to the headgear worn. Bee veils are available from beekeeping supply houses. Mosquito veils can be obtained from military surplus and sporting goods stores. Seal the veil at the top and bottom with string or duct tape. Tape should also be used around the waist, wrists and ankles and to close any other gaps. Leather areas of turnout gear, such as gloves, may antagonize the bees. Plastic or rubber gloves are best.

Disposable hazardous materials suits, such as those made of Chemrel R, Saranex R or Tyvek R, provide good protection, especially if worn over street clothing or uniforms.

Reflective aluminum suits work but may limit movement, and veils and duct tape are needed.

WETTING AGENTS

Bees are easily immobilized and killed by wetting agents (surfactant) — including commercial liquid dishwashing detergent. Non-foaming fire control chemicals and fire fighting foams with surfactant characteristics such as the aqueous film-forming foams (AFFF) also work.

Not all commercially available products have been tested, but most such wetting agents should be equally effective. Chemicals tested so far include: original Palmolive dishwashing liquid, 9-55 R fire control chemical, Silv-ex R foam concentrate and FC-600 Light Water brand ATC/AFFF. All had a light but distinctive odor. A one percent solution was sufficient to immediately immobilize honey bees and apparently kill them within 60 seconds.

If there is doubt whether a particular chemical will work, rescue personnel should enlist the aid of a local beekeeper. Clearly, human and animal safety must be the most important consideration. The U.S. Environmental Protection Agency has conditionally approved detergents for use against AHB's.

VICTIM RESCUE

After arriving at a site, rescue personnel first should assess the situation from within their vehicles. Then they should retreat several hundred yards, put on protective clothing and move any onlookers to safe distance.

Each situation is unique, but to rescue a victim, two things must be done as quickly as possible: establish an adequate insect barrier, and neutralize the insects' alarm odor — which consists of chemical components of venom that enable more bees to find and attack the victim.

Fire and rescue units responding with standard fire fighting equipment can quickly accomplish both objectives by using water plus a non-toxic wetting agent.

Using standard fire fighting procedures, set up a line with an educator capable of delivering a one to three percent spray of one of the foaming/wetting agents and a nozzle capable of delivering a wide fan pattern. A light initial application to the victim will stop the attack by most of the insects on or near the victim within 60 seconds. These insects, unable to fly, will begin to suffocate and can be quickly brushed aside.

If an obvious line of insect flight can be determined, a vertical wall of spray 20 to 30 feet in the air should intercept further flight activity. Or, the nozzle can be inverted near the victim to provide a curtain of safety.

Rescuers wearing proper protective gear then can carry a victim into a house, van or ambulance for treatment and transport. Many bees, however, will follow to continue their attack. In a house, vacuum up bees attracted to windows by light. In a rescue vehicle, drive away and then roll down the windows and chase the insects out.

STING REMOVAL

Once the victim is protected, remove stings as quickly as possible. Otherwise, the white, translucent, venom sac — with its nerves and muscles attached — will continue to pump venom into the wound for a minute or more. Removing the victim's outer layer of garments may help because stings embedded through the fabric will be dislodged in the process.

The best way to remove stings is to simply scrape them away with a fingernail, credit card or similar instrument. Never pinch, tweeze or otherwise attempt to pull stings out, as this will simply inject the remaining contents of the venom sacs.

TRAINING

Fire and rescue personnel should familiarize themselves with normal activities of stinging social insects in their area. Local bee experts or beekeepers can provide extremely valuable advice and assistance, particularly when unusual situations arise. All states have active beekeeper organizations, as do many local communities, and they usually welcome requests for assistance.

Most beekeeper groups would welcome an invitation to help develop training exercises, where bees would be used to simulate an actual attack and allow rescuers an opportunity to practice their skills.

Background Information on Africanized Honeybees

In order to understand Africanized Honeybees (AHB), it is important to have some understanding of Honeybees in general.

Honeybees live in a very sophisticated, social structure. They are not aggressive but have variable degrees of defensiveness – they protect their “families and homes”.

How they got here:

Honeybees were not native in either the north or south American continents but were brought to both continents by European colonists as valuable assets for the products they produce. The European Honeybees (EFB) brought to the northern continent were well adapted on arrival due to similar climates and flora in Europe and North America. Conversely, the European bees never really adapted to the more tropical conditions of South America.

In the 1950's, researchers in Brazil came to the conclusion that importing bees from South Africa to interbreed with the bees already present in Brazil would help them to take better advantage of the resources there. This has been proven to be true, in South America beekeepers who've adapted to the behaviors of the AHB have created a booming industry out of what had been very marginal before the introduction.

Both bees European and African bees are *Apis mellifera* but there are differences in sub-species. It was known that the South African bee had tendencies to be more defensive due to the number and variety of predators. To the unaided eye, there are no differences. Individual stings are also virtually the same but Africanized honeybees react in greater numbers. This can result in a greater number of stings.

The introduction of a new sub-species was to be done under controlled conditions while studies were being conducted. Unfortunately a yard keeper released the bees not knowing why they were confined.

Quite rapidly the genetics of the African Honeybees spread into the European stock and therefore became known as “Africanized”. The term “killer bee” was actually due to a mistranslation of a misunderstanding. It was originally thought that the bees assassinated the European queens. The Portuguese word for “assassin” is the same as the word for “killer”. But this misunderstanding and the mistranslation that followed stuck because Hollywood and the press found it to be a good “seller”. This is unfortunate on many levels. It blurs the facts while creating exaggerated fears.

Since the introduction of the African bees to Brazil, the cross with the European bees has been very successful. The resulting Africanized Honeybees have spread in all directions mostly due to their swarming and mixing with the already present European bees. Many of the traits, including their defensiveness, are genetically dominant and don't seem to dilute. While they were in South and Central America they moved an average of 200 to 300 miles per year toward warmer climates. At the same time, they moved much slower toward the south and into higher elevations.

This rate of movement was observed for many years until, in 1990, when they reached Texas. Due to droughts and parasites their spread seemed to slow considerably. Also it was noticed that they tended to stick to paths where water and forage was most readily available. It took nearly a decade for them to be established in the vast majority of Texas counties. A few years after entering Texas, they entered New Mexico and Arizona and later yet, they entered California and

Nevada. In 2004 they were found in Oklahoma and during that year were found in several counties in that state. This year they've been found in several more Oklahoma counties and in June of 2005 were found in a county bordering Arkansas.

Honeybees are Extremely Beneficial

Honeybees are extremely beneficial insects and must be protected. In the U.S., approximately \$225 million of honey and other products from the bees are produced annually. While that's a significant amount, it's less than 1/50 of the value of the crops made possible because of the pollination done by the honeybees. According to studies done by Cornell University for USDA, the US agricultural product is increased by \$14.2 billion every year due to the work of the bees. Nearly one third of the food we eat is made possible by the pollination the bees do while they're collecting nectar and pollen from the flowers.

This doesn't even take into account the added beauty and life the bees add to our flora and fauna.

What to do Around Bees

Bees have a tendency to protect themselves and their homes. For that reason people should respect their space by not approaching where they're nesting. Any harassment of a bee nest can create a stinging situation. Trying to kill a colony of bees by spraying an insecticide can be both ineffective and dangerous. There are few circumstances when bees should be killed. Remember, most honeybees are good to have around.

If bees are flying around you, don't swat at them or try to kill them. Swatting at bees can appear that you are an aggressor. Squashing a bee can also put out an alarm odor that can attract more bees to the defense. The best thing to do is to rapidly walk away. If several bees are stinging you, you should run to safety. Protect your eyes, head and neck while getting to a safe place. Safety would be into a house or vehicle where you can be protected until the incident is over. Hiding under water is not a good idea.

If you get stung remove the stinger by scraping it with a stiff card or the back of a knife. Don't grab the stinger to pull it out, as you'll be putting more venom into your body.

How to get a Sample for Testing?

Don't! If you suspect that some bees in your area may be Africanized, call the Arkansas State Plant Board. The number is 501-225-1598.

Africanized Honeybee Map of Arkansas

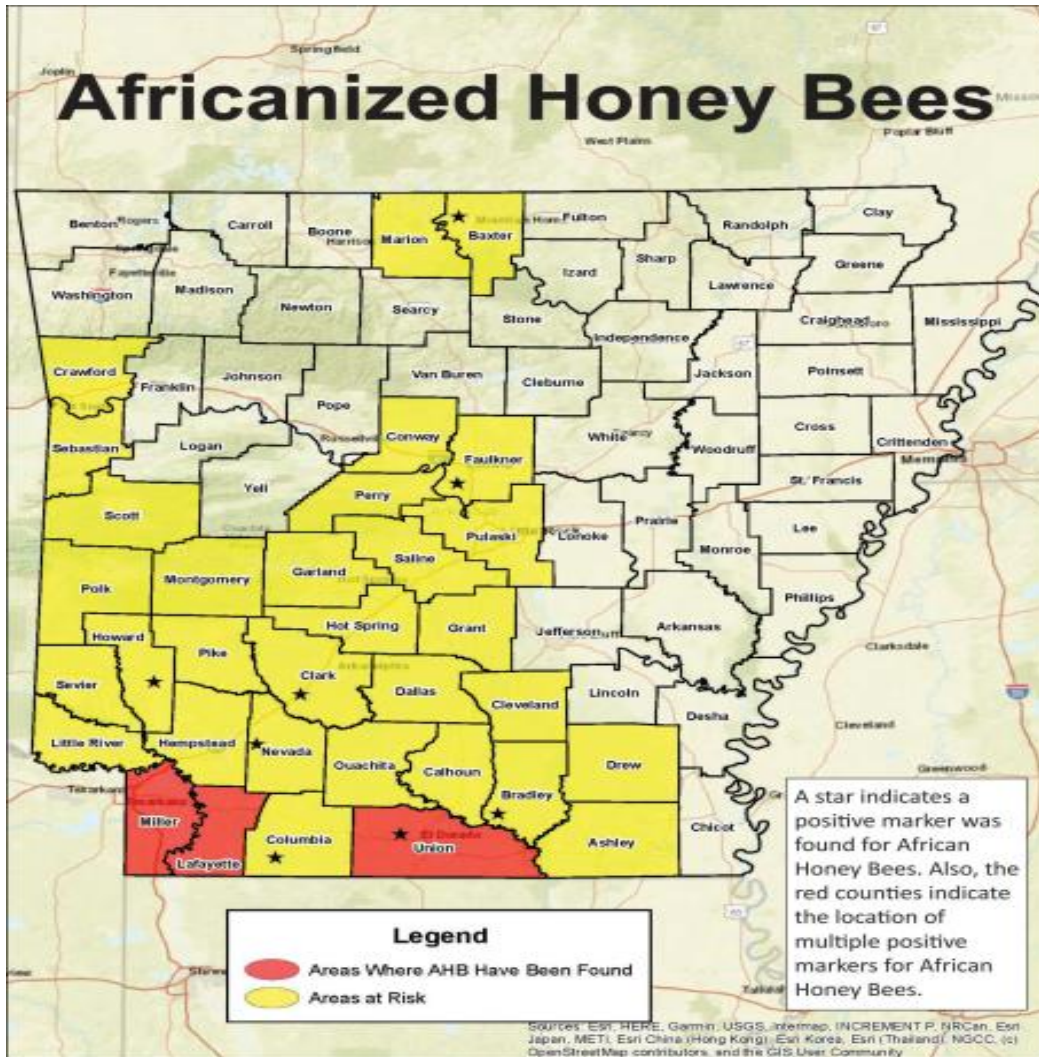



Africanized Honey Bees

Contents:

1. State Map Including Africanized Honeybee Finds
2. Background Information about the Africanized Bee
3. How to Subdue Attacking Bees
4. Normal and Allergic Reactions to Bee Stings
5. Africanized Honeybee Frequently Asked Questions



COLONY COLLAPSE DISORDER

Contents:

1. Colony Collapse Disorder Explanation
2. CCD Frequently Asked Questions

Selecting the Apiary Site

D. F. Peer, Nipawin, Sask.

The selection of apiary locations can be one of the most time consuming yet most important field operations performed by the beekeeper. Too often yards are selected on a hit and miss basis or else a particular crop such as alfalfa is found and the colonies located thereon or nearby. Several selection factors should be taken into consideration while choosing apiary locations if maximum average production is to be attained.

Where package colonies are employed, the first prerequisite of an installation yard is wind protection especially at ground level. Trees or hedges around a yard or at least in the direction of prevailing winds are a must. In Western Canada, sunlight is an important factor, so do not over shade colonies. It has been found that colonies build up better in pine and/or poplar treed areas rather than in those treed by spruce, with the exception where spruce is used for wind breaks. Furthermore, experience has shown that long dead grass is warmer and subsequently allows for faster colony development than tilled or smooth terrain. Sandy and sparse vegetation areas under and around pine trees are the exception here.

Adequate spring sources of nectar and particularly pollen from such sources as willow, fruit bloom and dandelions are helpful for colony build-up. The more nectar that colonies bring in during build-up the less feeding will be required, either of combs of honey or syrup, and far greater savings than is usually considered will result.

It goes without saying that all-weather accessibility is another prerequisite of any bee yard and it must be kept in mind that sites should not be selected where flooding is a possibility. Anyone that has lost colonies in a flood or has had colonies even partially flooded will not soon forget the productive loss as well as the damage caused by mudding of the equipment especially the combs.

It is wise to keep in mind, too, that the particular location must be of such size as to allow for the proper arrangement of an economic number of colonies. If it is felt that 40 colonies per location is an economic number, then the selection of a site that will take only 30 colonies, say, would be unwise. From the production standpoint most summer locations and areas will support far greater numbers of colonies than are usually allocated. The limiting factors on colony numbers per location are (a) the amount of spring pasture, including both nectar and particularly pollen for build-up, and (b) the number of colonies that can be worked without inciting robbing. During a maximum honey flow it would appear that only rarely do the bees in an area keep up with the nectar that is produced. In most cases production increase by the use of few colonies per yard is an old wives tale.

Apiary locations that may be molested by cattle or bears or in some cases humans are not to be recommended. While yards can be fenced from cattle and electric fences can be used to deter bears, they are costly to install and to some extent time consuming to keep in working order and to work within. A good axiom in yarding is "build as few fences and go through as few gates as possible." Though it may seem to be an unfriendly attitude, the passing through farmer's yards is a time consuming and thus uneconomic proposition because, of course, of the necessity of opening and closing gates and time spent being neighborly.

Where commercial operations are concerned, that is, where the operator has many locations and one of his major costs is the travel to and from yards, it is to be recommended that the yards be located as much as possible in zigzag lines in such a way that excess time and vehicle costs are not expanded in traveling out and back from the home base like traveling along the spokes of a wheel. In short, reduce dead-heading mileage to the minimum. In this connection, too, it is far better to locate a number of yards in an area that will allow for a day's work checking, supering, and so on and not have such a number of yards that will require part-day operations in a given area.

Over a period of years it would be far better to work for relatively uniform economic averages rather than have years of high and low averages. Thus, it is to be suggested that yards be located in varying soil types, different elevations, different agricultural crop situations, as well as areas of different rainfall potential where possible. It is surprising how production will change from year to year in a given area due to these factors and, therefore, the operator must guard against overloading on area because the colonies there produced the big crop the year before.

Because of local factors most beekeepers have some of their areas that enter major honey flows sooner than others. This situation can be used to advantage over and above helping to stagger peak work periods. Where moving is practiced the strongest colonies (yards) should be moved to the earliest flow areas and the weakest colonies to the latest flow areas. Furthermore, rigorous selection of summer yards is of extreme importance and too often not given proper attention. First, provide adequate wind protections. To reduce drift do not set yards out in long rows or solid uniform blocks – the shotgun method is strongly recommended. The painting of colony entrances different colors, namely – black, blue, yellow and white or aluminum, will help to reduce drift also. Face colony entrances in several directions and where possible use landmarks such as shrubs, trees, stumps, etc., between colonies. Yards that are relatively uniform, population-wise, are easier to work and will out-average yards with great variation in colony strength.

Studies have shown that bees will readily forage a mile and a half to two miles from the colony, that individual colonies will forage at many locations and on several plant species on a given day. With this in mind, where two fields of pasture are, say, three miles apart, it would be better to locate the yard between the two fields, that is, a mile and one-half from each, rather than locate the yard on or near one or the other of the fields. In this way the colonies have two potential sources, especially if the two fields or areas are of different plant species. If the bees are unable to obtain nectar from the one, perhaps they can from the other. Also, if both sources yield at different periods, a larger average can be expected than from colonies located on the one crop and which have to fly perhaps three miles to the second crop. In short, then, apiary locations should be selected between fields and the more fields, the better. The operator should, wherever possible, locate in areas which have as many different plant species as possible because if one species fails to yield due to insect damage, too much or too little moisture, too cold or too hot, etc., often one or more the other species will yield during these situations.

In summary, yards should be selected of adequate size, with proper windbreaks especially ground wind protection, with ease of accessibility, with numerous nectar, pollen and water sources for build-up, and between several major honey producing areas.

Recipes For Bees

FEEDS

Sugar syrup:

Stimulant feed

1 pound sugar for each pound of water (4 lbs sugar with ½ gallon of water)

Sustenance feed

2 pounds sugar for each pound of water (8 lbs sugar with 2 quarts water)

Candy:

Sustenance feed

made in a tray (20 x 16" with trim)

2 cups water with 5 lbs sugar brought to "hard ball" stage while stirring

pour in tray and let harden

Grease patties:

2 parts table sugar for each part pure vegetable shortening (6 lbs sugar with 3 lbs Crisco shortening)

OUR STATE INSECT



The honeybee was adopted as the Arkansas State Insect by the General Assembly of 1973. Honeybees carry pollen from flower to flower. The bees also produce honey which is collected and sold by beekeepers. An old fashioned dome beehive is one of the symbols on the Great Seal of Arkansas.

Landscape Planting for Bees

Prepared by:

S. Bambara, Extension Specialist

Dated 1/93

Placed on the Web 3/95 by the Center for Integrated Pest Management

Increased urbanization of our rural areas has destroyed native forage vegetation in many places. In addition, many of our hobby beekeepers living in the suburbs enjoy watching bees work the flowers. With this in mind and because honey bees are so important for pollinating agricultural, horticultural, and wild plants, there is at least one small thing we can do to support our state insect.

Most houses and yards are landscaped, so by merely making certain choices, nectar or pollen producing plants can be used with little or no additional cost. Though they have only a tiny effect on a single hive, every little bit contributes and the more people use these plants, the more significant will be the total benefit. Below are listed some plant material which can be used around homes, parks or city streets. All are highly attractive to bees except where noted. Attractiveness may vary in different regions. Most of the berry and seed bearing plants also produce good forage for birds.

This list is not complete and all plants may not thrive in all parts of the state. Consult any reference on landscape plants or your Cooperative Extension agent for further information about how to use some of these. You may also want to visit local gardens or plantings for ideas.

Ground Covers

- Ladino clover - blooms late spring-summer
- Crimson clover - blooms late spring
- Ajuga - blooms spring
- Graph Hyacinth - blooms spring
- Strawberry - blooms spring
- *Ampelopsis brevipedunculosa* - blooms late spring

Shrubs

- Barberry (*Berberis* sp.) - blooms spring; evergreen*
- Vitex - blooms most of summer; deciduous
- Privet (*Ligustrum*) - blooms late spring; may produce bitter nectar
- Abelia - blooms summer/fall; evergreen; mildly attractive
- Quince (*Chaenomeles*) - blooms spring
- Blueberry (*Vaccinium*) - blooms spring
- Silverberry (*Eleagnus*) - blooms late spring; deciduous; fragrant*
- Nandina - blooms summer; mildly attractive
- Pieris (*Pieris japonica*) - blooms spring; evergreen
- Holly (*Ilex*) especially *I. burfordi*, *I. cornuta*, *I. rotunda*; blooms spring; almost all species excellent nectar source; may require pruning*
- Euonymus - blooms summer; variable attractiveness among species
- Silverling (*Baccharis halimifolia*) - blooms fall; native aster shrub in coastal plain and piedmont
- Pepperbush (*Clethra alnifolia*) - blooms late spring; native coastal plain shrub, survives piedmont; evergreen*

Small Trees

- Red Bud (*Cercis*) - blooms early spring; native or cultivated varieties
- Apple, Crabapple (*Malus*) - blooms early spring; usually requires pruning*
- Pussy Willow (*Salix*) - blooms early spring; most *Salix* spp. good
- Golden Rain Tree (*Koelreuteria paniculata*) - blooms summer
- Sourwood (*Oxydendron arboreum*) - blooms midsummer; irregular nectar production
- Sumac (*Rhus*) - blooms summer/fall; shrub or small tree; deciduous*
- Holly (*Ilex*) - blooms spring; many species achieve tree status if unpruned*
- Beebee Tree (*Evodia danielli*) - blooms late summer
- Hercules Club (*Aralia spinosa*) - blooms late summer

Large Trees

Maple (*Acer* spp.), especially *A. rubrum*, *A. ginnala* - blooms early spring; good nectar production

- Linden, Basswood (*Tilia*) - blooms in spring; excellent nectar production
- Black Locust (*Robinia pseudoacacia*) - blooms spring; inconsistent nectar production
- Tulip, Yellow Poplar (*Liriodendron tulipifera*) - blooms spring; fast growing; excellent nectar production
- Black Gum, Tupelo (*Nyssa*) - blooms spring; Tupelo requires moist soil
- Persimmon (*Diospyros*) - blooms late spring

*Also provides food/cover for birds.

Suggested References

Honey Plants Manual. H.B. Lovell. 1966. A.I. Root Co., Medina, OH 44256.

American Honey Plants. F.C. Pellett. 1947. Orange Judd, NY.

"Bee Forage of North America." Ayers & Harman, in *Hive and Honey Bee*. 1922. Dadant & Sons, Hamilton, IL.

Composition of Honey

Honey is composed mainly of a variety of sugars, traces of pollen and water. There are also enzymes present. The following from 490 samples of largely uncrystallized honeys...

Moisture(%)	17.2
Levulose(%)	38.19
Dextrose(%)	31.28
Sucrose(%)	1.31
Maltose(%)	7.31
Higher sugars(%)	1.50
Undetermined(%)	3.1
pH	3.91
Free Acidity	22.03
Lactone	7.11
total Acidity	29.12
Lactone/Free Acid	0.335
Ash(%)	0.169
Nitrogen(%)	0.041
Diastase	20.8



U. S. Dept. of Agriculture Technical bulletin 1261, "Composition of American Honeys" by J.W. White Jr., M. L. Reithof, M. H. Subers, and I. Kushnir, 1962.

BEES ARE IMPORTANT TO EVERYONE!!!

Bees, particularly honeybees, are greatly valued in American Agriculture. They pollinate many important crops which provide seed used grow food for both man and livestock.

BEES CONTRIBUTE TO - OR - ARE TOTALLY RESPONSIBLE FOR POLLINATION OF THE FOLLOWING CROPS:

apples	grape	cucumbers	buckwheat
apricots	huckleberries	gourds	flax
blackberries	peaches	chestnuts	lettuce
black currants	pears	plums	linseed
blueberries	raspberries	pumpkins	rhubarb
cherries	red currants	squash	safflower
dewberries	strawberries	watermelon	sunflower
gooseberries	cantalopes	beets	almonds

THE FOLLOWING PLANTS RELY UPON FOR SEED PRODUCTION:

alfalfa	vetch	brussel sprouts	mustard
clovers	asparagus	cabbage	radish
field bean	chive	cauliflower	rape
broad bean	garlic	chinese cabbage	rutabaga
lespedeza	leek	collard	turnip
lima bean	onion	horseradish	carrot
sainfoin	okra	kale	celery
trefoil	broccoli	kohlrabi	parsley

SOYBEAN YIELD HELPED BY BEES:

USDA research has shown that up to a 16% increase in soybean yield is possible in certain varieties when bees were used for pollination. More research is needed, but growers are stating that bees are helping their production.

THE DOLLAR VALUE OF BEES HARD TO DETERMINE:

The value of bee pollination and the crops which rely partially or totally on bees for pollination equal approximately one third of all the U. S. agricultural production annually.

BEES HELP THE ENVIRONMENT:

Bees contribute to the overall environmental balance by pollinating many seeds, berries and fruits used in the food chains of wildlife, both animal and insect.

ARKANSAS STATE PLANT BOARD
APIARY SECTION - PHONE # 501-225-1598
#1 NATURAL RESOURCES DRIVE
LITTLE ROCK, AR 72205

HONEYBEE PARASITIC MITE SYNDROME

“BPMS is devastating to the entire colony; both adult bees and brood are affected. Symptoms can occur at any time of the year, although we are seeing more samples from mid-summer into fall. Some of the symptoms that we have found associated with BPMS are listed below. It is important to note that not all the symptoms may be evident in any one colony at a given time.

ADULT SYMPTOMS

1. Varroa destructor is present.
2. Reduction in adult bee population.
3. Evacuation of hive by crawling adult bees.
4. Queen supersedure
5. Acarapis woodi (Tracheal mites) may or may not be present

BROOD SYMPTOMS (More puzzling aspects of this syndrome are observed in the affected brood)

1. Varroa destructor is present.
2. Spotty brood pattern
3. Symptoms resembling EFB, AFB, and sacbrood disease may be present. (These symptoms may disappear following feeding of oxytetracycline, sugar syrup and the use of fluvalinate)
4. Individual larva may appear in the “C” stage larva to prepupa. As a result the affected brood may be seen anywhere on the comb.
5. Individual larva may appear in the “C” stage, twisted in the cell, “molten” to the bottom of the cell, light brown in color as in the early stages of AFB.
6. The affected individuals do not display any ropiness.
7. Some scale formation has been noted, scales are not brittle as with AFB.
8. Not typical odor can be associated with the syndrome.
9. Microscopically, the affected larva has not characteristic microbial flora.
10. To date, no known bee pathogen has been isolated from the affected brood with BPMS.”

At this point, it is believed that the best control of BPMS is by effectively keeping Varroa mite infestations at low levels and using Terramycin® for the control of bacteria on a regular schedule. There are no specific medications which controls this syndrome. Keeping up the general health of the bees and keeping down the mite infestation levels is the best you can do to combat it.

MEDICATIONS

- ALL MEDICATIONS SHOULD BE USED WITH EXTREME CAUTION, LABEL INSTRUCTIONS SHOULD BE FOLLOWED AND ***NO MEDICATIONS*** SHOULD BE IN HIVES ***WHEN HONEY SUPERS ARE PRESENT***

Adult Bee Disorder Chart

DISORDER	CAUSE	SYMPTOMS	MORE SYMPTOMS	MORE SYMPTOMS	MORE SYMPTOMS	RESULTS
Deformed Wing Virus	A virus related to mite infestations	Wings of bees often look deformed or undeveloped	Bees can't fly	Walking on combs or outside hive		shortened life
Paralysis	3 major varieties of this virus	extended wings	shaky, shiny, hairless			shortened life
Nosema apis	a microsporidian now considered a fungus	hive "spotting"; dysentari-like	dystended abdomens & crawling bees	queen supercedures	most evident in early spring	shortened life
Nosema ceranae	a microsporidian now considered a fungus	a "dry" nosema	can have crawling bees but not necessarily	very damaging to colony	year round	shortened life
Pesticide Poisoning	can be from the field, directly at colony or drift	Piles of dead or dying, twitching bees on hive bottom or in front	can just deminish field force, suddenly kill entire colony or slowly hurt entire population			
Colony Collapse Disorder	Stress coming from nutrition, management & parasites (no single cause known)	a sudden decline of adult bee population	ratio reverses from 2 adults per brood cell to 2 brood cells per adult bee	Forager are gone without presence of carcuses (queen and a couple hundred bees are often last to die)	Robber bees, wax moths and SHBs are hesitant to go in	kills colony, nearby colonies follow and equipment seems "infected"

Honey bee (*Apis mellifera*) life cycle

The three types of bee

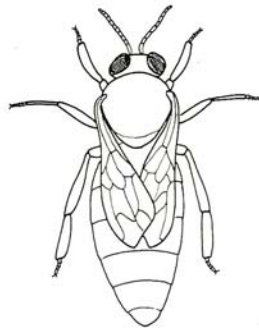

Queen

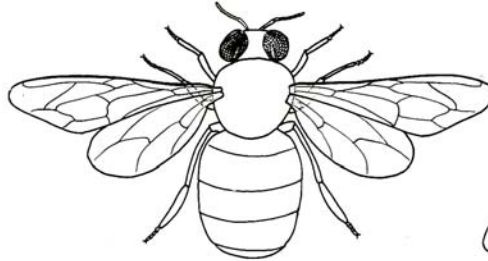

Drone

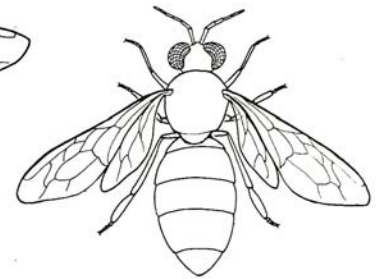

Worker

The queen is a fertile female. There is only one queen in a hive and only she can lay eggs.

Drones are males. There may be several hundred in a hive. Their function is to fertilize the queen

Workers are sterile females. There may be 20,000 to 80,000 in a hive. They do all the work of building the combs, collecting and storing nectar and pollen, feeding the larvae and cleaning the hive.

The workers build three types of wax cell, differing in size or shape. The queen lays eggs in each of the cells and the eggs hatch into larvae. The workers feed the larvae until they are ready to pupate and then they put a wax capping over the cell. After 10-11 days the capping is bitten off and the adult bee emerges

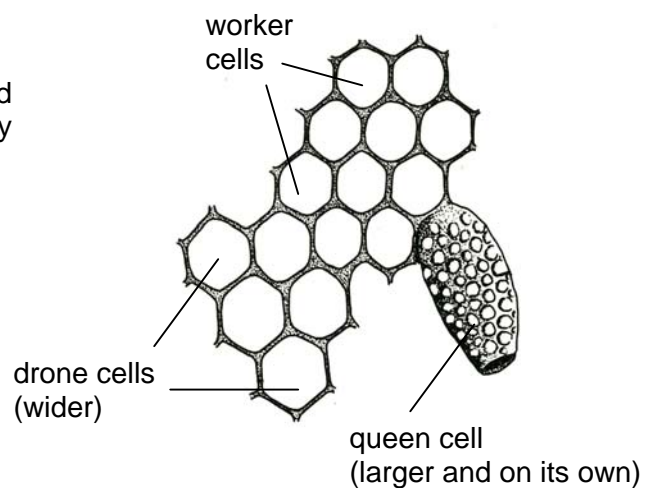
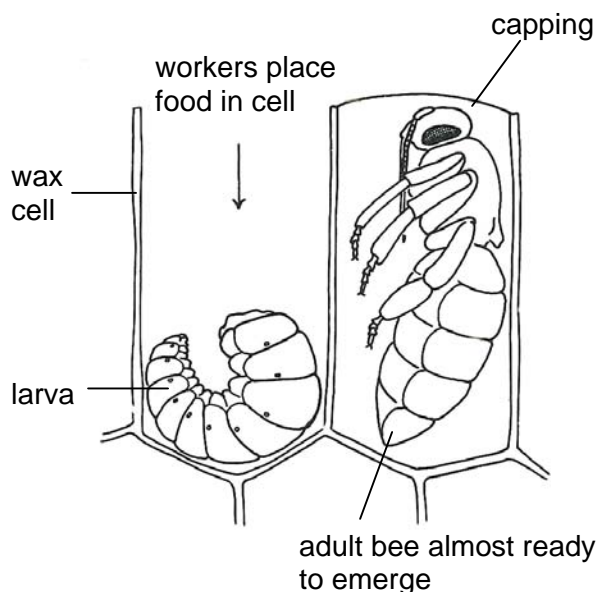

The eggs laid in the drone cells are unfertilized and develop into males. The eggs laid in the worker cells and queen cells are fertilized but the queen larvae are fed a different diet from that of the larvae in the worker cells. The difference in diet causes the workers to be sterile and the queen to be fertile.

Beekeeping Classes and Education

The University of Arkansas Cooperative Extension Service created a new position to work specifically with honey bees and projects in apiculture for both beekeepers and the general public, with the goal of promoting beekeeping as a hobby and an industry.

Mr. Jon Zawislak will work with other Arkansas Entomologists and the Department of Agriculture to provide accurate, science-based information on apiculture to the state's beekeepers', the public and the media. To inquire about beekeeping classes, please contact:

Jon Zawislak,
Cooperative Extension Service
P. O. Box 391
Little Rock, AR 72203
(501)671-2222
Jzawislak@uaex.edu

GOOD PUBLIC RELATIONS FOR HOBBY BEEKEEPERS

On a fair summer's day, a typical suburban lot may contain thousands of honey bees going quietly about their business, foraging for nectar and pollen and pollinating food-producing plants and chances are the homeowner doesn't even know the bees are there. However, because of the sensationalized publicity surrounding "scare" movies and the "African" bee, the appearance of a bee hive in your backyard may unnecessarily alarm your neighbors. **Backyard beekeeping means that every beekeeper must practice good public relations as well as good beekeeping.**

1. **Before you start** – Check local ordinances to make sure you're allowed to keep bees on your property. Talk to your neighbors, find out if anyone has an extreme sensitivity to bee stings, and stress the positives of beekeeping, fresh wholesome honey, increased pollination, and the fascination of your beekeeping hobby.
2. **Start with one or two colonies of gentle bees.** – Requeen as needed to keep the bees working and gentle. Stay small the first year. At the end of the first year you'll be able to judge neighbor reactions to expansion or changes. Perhaps expansion of your new business requires an out-of-town beeyard.
3. **Locate the bees carefully** – away from patios, play areas, swimming pools, confined pets, and neighboring doorways and driveways. Direct bee flight upwards by locating hives behind shrubbery, fences, or in the light shade of open trees so that flight is at least 7 feet above the ground at boundary lines. "Out of sight, Out of mind" is a good policy. Locating hives in quiet areas will calm bees, avoid the danger of vandalism and calm everybody's imagination. Always provide a continuous source of water such as a hydrant slowly dripping onto a board. Don't let bees get started using your neighbor's dog's water dish.
4. **Keep your bees calm** – If possible, work the bees when there is little or no neighborhood activity. Open hives only on warm sunny days when there is some nectar flow to prevent robbing which can irritate the bees. Wear protective clothing and use your smoker to calm the bees. Work carefully with no sudden movements. Remember, your calm attitude toward bees will also calm anxious neighbors who will be watching.
5. **Prevent swarming** – Beekeepers know that swarming is a safe and perfectly natural occurrence, but neighbors may be reminded of sensationalized special effects in "scare" movies. Be prepared to handle swarms as quietly and efficiently as possible. Don't try to compete with the movies and other spectacular publicity – your first obligation is to be a good neighbor.
6. **Share your hobby** – Giving an occasional jar of honey to the neighbors is good for public relations. Read and keep informed so you can talk about your bees in an informative and down-to-earth manner. Chances are you'll be invited to share your hobby with various groups. Use these opportunities to point out the value and importance of bees and beekeeping.
7. **Remember** – Sometimes one small incident can create a lot of bad publicity.

(Taken from "Tips from Dadants")

Constructing a Bee Hive

If all dimensions are accurate, a homemade bee hive can be as satisfactory as a commercial hive. It is especially important that the *inside* dimensions of the hive bodies and the size of the frames provide for the proper bee space – the space that bees keep free of comb and propolis. If those dimensions are wrong, the movable frames quickly become immovable and difficult to manipulate when filled with bees. The construction plan (page 3) shows the inside dimensions for the deep hive body only. Those for the other hive bodies differ only in the depth, which is the same inside and out. The external dimensions given are suitable only for equipment constructed from $\frac{3}{4}$ inch thick lumber. Adjust the dimensions if you use wood of any other thickness.

Western pine is the best wood to use for hive bodies, supers, covers, and frames. However, hive bottoms made of cedar, cypress, or redwood will generally last longer than those made of pine or similar woods. Regardless of the wood used, hive bottoms resist moisture and decay better if treated with a wood preservative or with boiled linseed oil.

Bee equipment may be assembled with nails or power-driven staples. Seven-penny box nails, cement – or resin-coated, are a good size to use for hive bodies. The corners of the bodies should be cross-nailed for greatest strength. Galvanized nails are good for assembling bottoms and for use with redwood lumber. Coated box nails, 1 $\frac{1}{4}$ inches long, are suitable for nailing frames. Glue makes all wooden equipment stronger and longer lasting.

If you prefer, you can make the cover of exterior plywood without cleats. Or you can lengthen the cover to accommodate a $\frac{3}{4}$ x 2 inch cleat extending downward at each end of the lid. The smooth top of this lid can be covered with metal – preferably aluminum – to increase its weather resistance and to reflect the sun's rays in summer.

When making hive bodies, you have the option of dadoing the handholds into them, about 2 inches below the top, or of the nailing a $\frac{3}{4}$ x 2 inch cleat at the same level on each end of the hive bodies. It is much easier to handle heavy supers of honey by grasping cleats than by grasping handholds.

The hive bottom shown in this plan provides a $\frac{3}{8}$ inch deep entrance. To make a deeper entrance, cut the spacer strips to the height you desire, such as $\frac{3}{4}$ or $\frac{7}{8}$ inch. Bottoms with 2 x 2 inch cleats rather than $\frac{3}{4}$ x 4 inch cleats make it a little easier to pick up the hive and may also help to keep the hive a little drier.

The hive pattern can be adapted to make nuc boxes by narrowing the hive width to provide room for 3 or 5 frames rather than 10.

To make pallets for use in handling and storing stacks of hive bodies, follow the pattern for the hive cover and add a rim of spacer strips around the outer edge of the flat side of the lid. These will help to catch and confine honey and bits of wax that fall from combs.

Making Frames requires many saw cuts and can be dangerous if you do not use special equipment and techniques. It is usually better to buy frames than to risk a serious accident. However, if you decide to make them, use the pattern for frames with straight-sided end bars. These are easier to cut out and are accepted by the bees as easily as frames with tapered or indented end bars.

Paint all exposed surfaces of the hive bodies, supers, and covers. Bottoms can be painted after being treated with wood preservative or preferably, sealed with a few coats of boiled linseed oil. Frames do not need any preservative treatment.

INTRODUCTION:

Beginning Beekeepers Information

CONTENTS:

1. CONSTRUCTING A BEEHIVE
2. 10-FRAME BEEHIVE CONSTRUCTION DIAGRAM
3. GOOD PUBLIC RELATIONS FOR HOBBY BEEKEEPERS
4. ARKANSAS DEPARTMENT OF AGRICULTURE APIARY SECTION
AND CONTACT INFORMATION
5. BEEKEEPING CLASSES/EDUCATION PROVIDED BY JON ZAWISLAK,
ARKANSAS COOPERATIVE EXTENSION OFFICE
6. ARKANSAS LOCAL BEEKEEPING ASSOCIATIONS

Small Hive
Beetle Larvae



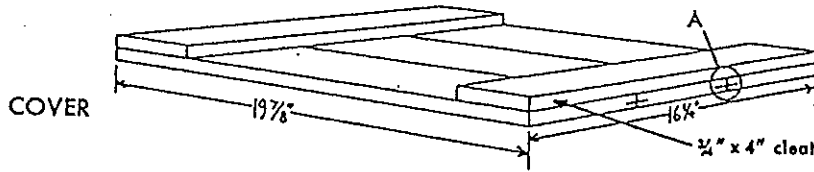
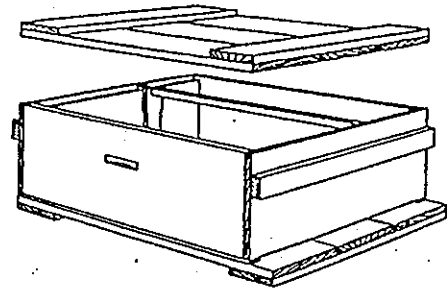

Figure 1. *Aethina tumida* Murray, adult, dorsal view. Beetle is somewhat distended.

[Top of Page](#) | [Back to Aethina Page](#) | Last updated 25-May-1999

CONSTRUCTION DETAILS FOR A 10-FRAME BEE HIVE

($\frac{3}{4}$ -inch-thick lumber)



(A) DETAIL OF COVER AND BOTTOM

Saw kerfs (cuts) with tin or roofing paper strip set in before nailing and gluing.

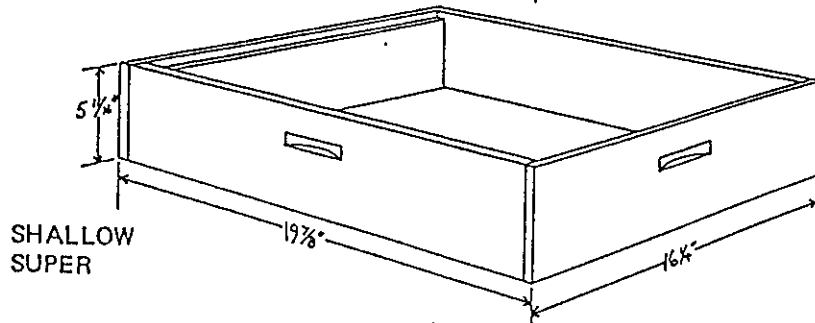
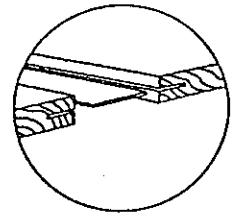

SHALLOW FRAME

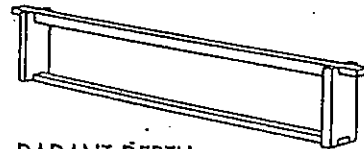

As below, but 5 $\frac{1}{4}$ " deep.

DADANT-DEPTH FRAME

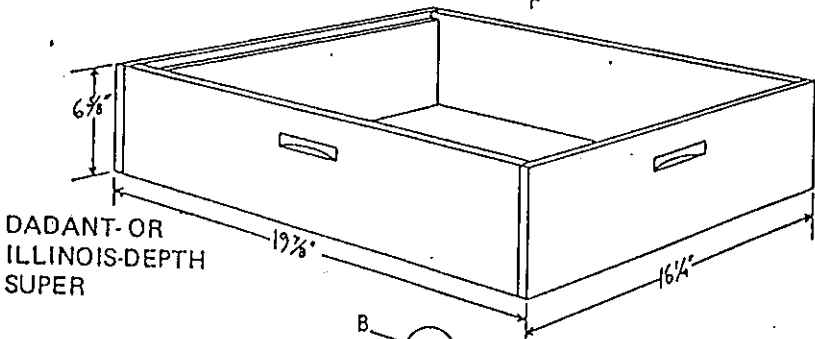
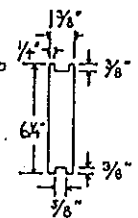

DEEP FRAME

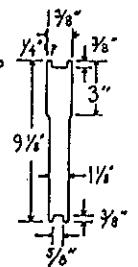
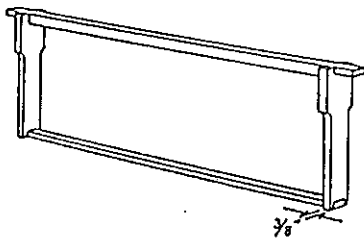

SIDE VIEW OF TOP BAR

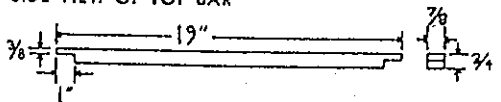

SIDE VIEW OF BOTTOM BAR

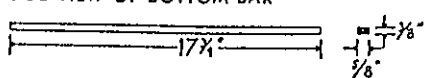

(B) DETAIL OF FRAME REST

Rabbeted corners, not dovetailed.

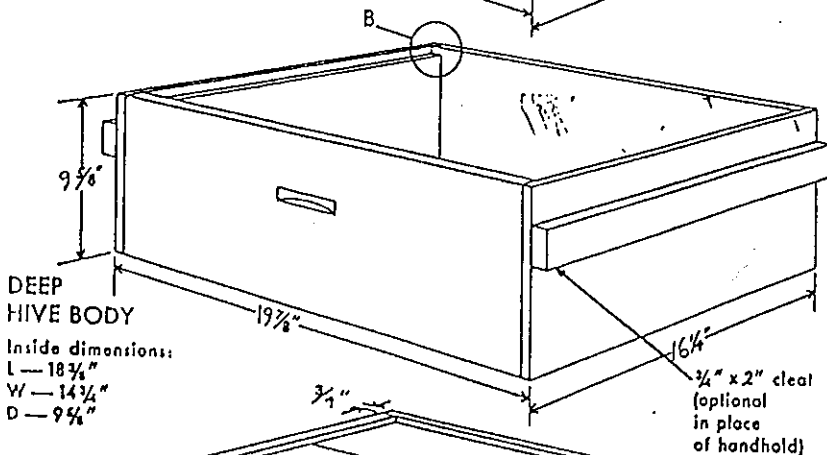
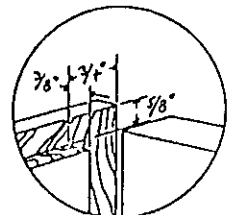

Inside dimensions:
L — 18 $\frac{3}{4}$ "
W — 14 $\frac{3}{4}$ "
D — 9 $\frac{3}{4}$ "

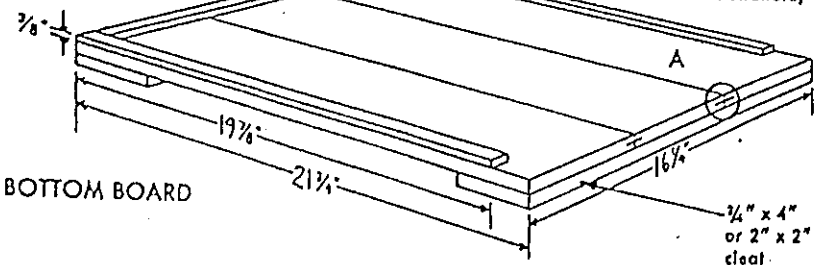

THE HONEY BEE

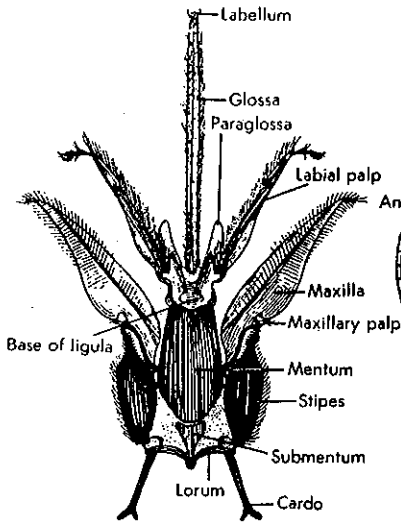

Mouth parts

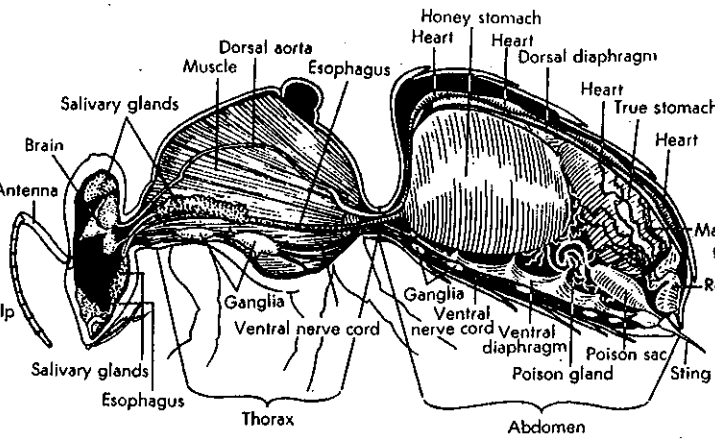

Lateral section

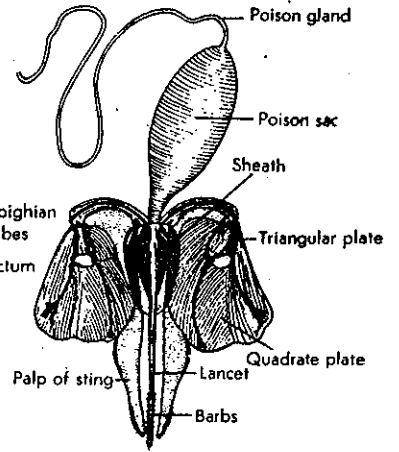

Sting

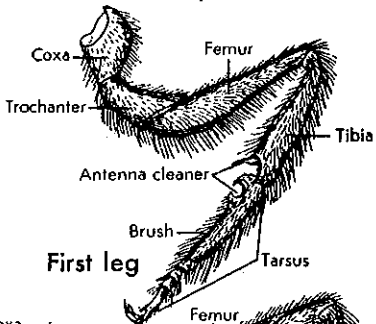

First leg

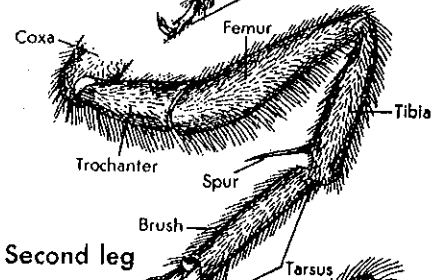

Second leg

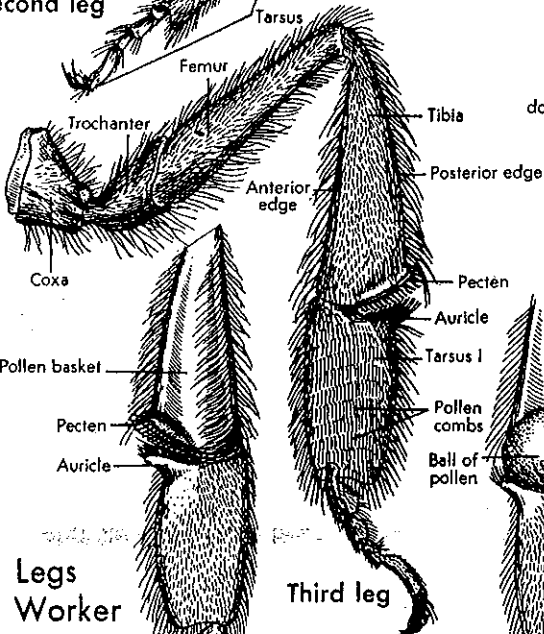

Legs of Worker

Detail of pollen basket

Third leg

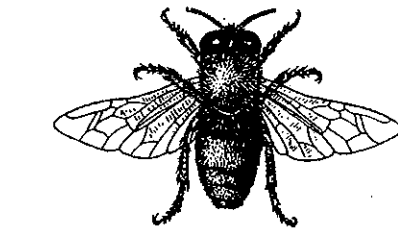

Drone
dorsal and lateral view

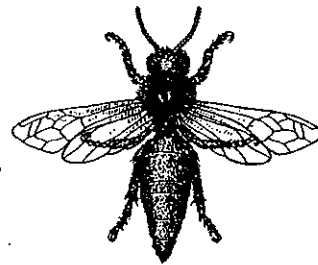

Queen
dorsal and lateral view



Worker
dorsal and lateral view

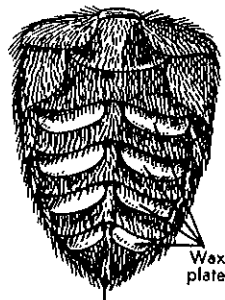

Ventral view of abdomen of worker

Pollen in pollen basket

HERMAN KOLB, *Bee Hobbyist*,

Developer of See-Thru Observation Bee Hives

STUDYING BEES: A nature study that can lead to practical usefulness.

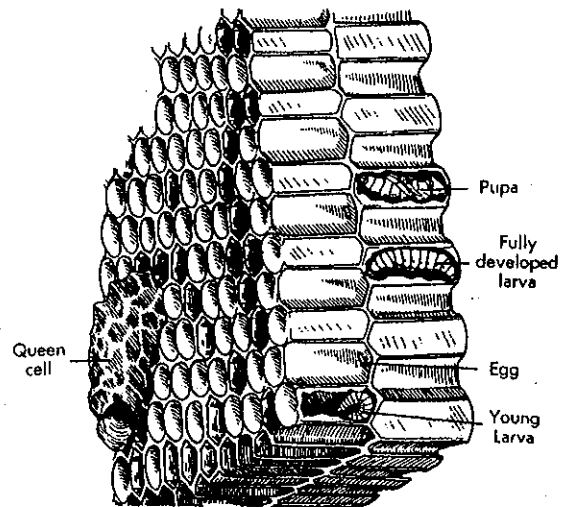

Section of Comb

Colony Collapse Disorder
Ed Levi
Oct. 2009

Explaining what's known about Colony Collapse Disorder is not a simple matter. Part of the problem with discussing CCD is that, like many things, people want simple answers so that they can both understand it and hope for a simple solution. In CCD, as in many things, it's just not simple.

The implications of a continued CCD can become huge as far as our food supply and general environment is concerned. In the US, depending on who you're quoting, somewhere between, \$15.8 and \$18 billion of our agricultural crop is due to the pollination done by honeybees. Virtually one out of every three bites we eat is due to the inadvertent pollination by the bees while they collect pollen and nectar. More than 90 of our food crops are either fully or partially dependent on pollination done by our bees. Beyond all that, our fauna also rely on honeybee pollination for nuts and berries that are consumed by mammals and birds. The chain can be followed from there.

The last 3 years of the incidence of CCD has been studied by a survey sponsored by the USDA and done by the Apiary Inspectors of America. Over those 3 years we have shown that approximately (varies by year) 30%/annum of our bees have been lost to this disorder. The loss declined a bit this last year. Of course part of this loss is made up annually through the beekeeper management techniques but overall, we are losing our bees at an alarming rate.

Beyond all that, we have to wonder if the losses of species of birds, bats and frogs aren't also results of some of the same causes.

There have been many explanations of what causes CCD that range all the way from alien influences and cell phones to ribosomal damage. (Ribosomes are responsible for manufacturing proteins and proteins are the tools bees use to fight off pathogens, detoxify pesticides, repair cells and other challenges they encounter in the world today.) This theory of damaged Ribosomes as being the cause of CCD has recently been published by a team of scientists from the Univ. of IL. That would be a single, albeit not simple cause but some scientists question whether this is the cause or merely another result of the problem/s. In other words, it reminds some researchers of the old Chicken & Egg question.

Often we are asked with a limited amount of time to explain CCD and are therefore forced to respond in rather simple terms.

First of all, since there are no specific "biological markers" it is therefore a syndrome rather than a disease. Thus, there are criteria that have to be observed in order to diagnose it. This is important for beekeepers to understand that there are many things that cause bee colonies to die. Dead colonies does not mean it's CCD.

The following conditions indicate the disorder:

1. A large number of the older or forage bees are just missing;
2. Often there is a lot of brood left in the colony which indicates that there had been recently a large population;
3. There are often, if not already dead, a small number of young bees left;
4. In this condition, the queen is often present;
5. Common, post-mortem parasites as well as 'robber bees' are slow and hesitant to enter the hive.

As mentioned earlier, there have been many theories over the last few years. While some have been disproved, the rumors persist. Some are less concrete than others too; making them harder to prove or disprove. Falling into this last camp would be things like the receding size of the genetic pool for bees. (ie; both lack of diversity as well as lack of source) The more concrete things that have been disproved include things like materials used for feeding bees. (ie; honey, sugars or HFCS) (HFCS which is most often used by commercial beekeepers can become toxic to bees when stored in warm or heated conditions like silos in the sun...often common.) Another disproved speculation includes cell phones and microwave towers. Of course, aliens, Russians and terrorists have all been suspected but those theories have not been proven either.

Now, rather briefly, CCD comes from stress factors that probably come from multiple sources. A list of the stress sources are highly implicated in scientific studies but none have been proven to be THE cause and therefore it is thought to come from synergy of several stressors, at this time Implicated in this list and placed into three categories are:

Environmental (Scary stuff)

Honeybees are virtually environmental dust mops. They have tiny hairs on their body which are important in the pollination process. But those hairs along with the static electric charge inherent cause them to pick up micro samples of all the things out in the environment and bring them back to their hive and colony. A team at the Penn State U have been studying those elements in stored pollen, bees themselves (and secondary effects on bee larvae thru feeding) and in wax. Wax is basically a fatty tissue which is "great" for storing many trace elements. The Penn State team has found an alarming number of pesticides, metabolites and fungicides in the hives. Some of these are known to cause learning and memory losses and have been shown by some researchers to cause bees to get lost when out foraging. Because of this, several countries (France, Germany, Italy, Denmark, Slovenia, etc.) have outlawed the use of some implicated pesticides that are still commonly used in this country. Not only are these affecting the adult bees but becomes a part of the diet of the bee larvae during development. Residues of chemicals are even found in newly manufactured foundation.

Mono-cultural farming not only requires more "icides" but creates another problem for bees in their dietary needs. Bees placed on large monoculture acreage, whether for honey production or pollination, eat what's available to them and make food for the

offspring from the same. This gives them long periods of time when they might be eating from a decent food source but with little variety. (It's sort of like if you were to eat some good yogurt and nothing from yogurt. While yogurt may be good for you, your body is going to be lacking in other nutrients not found in yogurt and eventually you'll suffer.)

Also in this category but not at all proven either way is the effects of global warming.

Pathological

This is a complex category as bees are besieged by many pathogens: bacterial, viral, fungal and parasitic. Mainly with CCD we are looking at the last three and they are showing up in amazing numbers and many are heretofore hardly known.

To start with, a parasitic mite known as Varroa destructor jumped on our western Honeybees, entered the US and much of the world (originating as a parasite on an Asian honeybee) starting in the late 70s and getting into the US in the latter half of the 80s. Until fairly recently we were mostly concerned with the direct damage it was causing but recently we've found that it has both "woken" viruses which have seemed to be "sleeping giants" and, very recently, have discovered that while doing "its thing" is also injecting the bees with a substance which lowers the resistance of bees to many pathogens. Hence, the bees are having HIV-like symptoms and a whole host of not often seen pathogens seem to be appearing in force.

There is also a bee disease that has become sited as being a cause called Nosema which used to be considered a protozoa but is now known as a fungus. We have had a variety of Nosema for years which is called Nosema apis but a new species of Nosema has made itself known and, again, originated on the Asian honeybee. It is called Nosema ceranae and it has been found around the country including Arkansas. In Spain, when CCD hit them, they found and still believe to a large extent that Nosema ceranae is the cause. Unlike the Nosema apis, N.c. kills faster, kills all through the summer, attacks more organs, etc. Nosema c. seems to be more virulent against the bees but is also pushing N.a. off the map. N.c. does not show obvious symptoms.

Like Nosema, we have known various Paralysis Viruses for a while but recently a new one has made its debut. It is known as Israeli Acute Paralysis Virus (IAPV) and, of all the pathogens found in colonies which have CCD symptoms, it shows up the most yet, not all the time.

Managerial

CCD shows up in mostly but not solely commercial beekeeping operations.

Many commercial operations have moved from honey as being their main source of revenue to pollination contracts to bring in the money. This has several implications:

As mentioned above, their bees are often placed on monocultures.

Their bees are exposed to other bees in close proximity who may have new and unknown pathogens. It should be clearly noted here that bees in close proximity to others suffering with Colony Collapse Disorder are at a much higher risk of contracting the disorder.

Their bees don't get a winter season to rest as our western bee is used to.

These bees are often on the road and are transported thousands of miles at a time and multiple times a year.

Most, although not all, beekeepers have changed from fearing the effects of pesticides on their bees to relying on pesticides in their hives to help control the parasites that are harming their bees. These pesticides used by the beekeepers, while helping to control problems are, in fact, creating other ones. Because of this practice, beekeeper used pesticides are the residues most often found and in the largest quantity in wax and pollen.

While a short and simple cause for Colony Collapse Disorder would be nice and might indicate a short and simple remedy, this is not the case. Unfortunately there just isn't a short, easy answer. Beekeepers need to do the best they can in caring for their bees in a holistic manner. We need to be on our toes and be on the watch-out for those factors which stress our bees and avoid them when we can.

FAQ's Colony Collapse Disorder

What is CCD? Colony Collapse Disorder (CCD) is the name that has been given to the latest, and what seems to be the most serious, die-off of honey bee colonies across the country. It is characterized by, sudden colony death with a lack of adult bees in/in front of the dead-outs. Honey and bee bread are usually present and there is often evidence of recent brood rearing. In some cases, the queen and a small number of survivor bees may be present in the brood nest. It is also characterized by delayed robbing and slower than normal invasion by common pests such as wax moth and small hive beetles.

What causes CCD? Although there is much attention being given to this situation, it is not yet clear what is causing the die-off. From two intensive surveys of many of the beekeepers involved, some potential causes have been eliminated (see below) and others have been identified as important to investigate (see below). However, at this point it does seem likely that a number of factors may be involved.

Who is being impacted? As of February 2007, many of the beekeepers reporting heavy losses associated with CCD are large commercial migratory beekeepers, some of who have lost 50-90% of their colonies. Surviving colonies are often so weak that they are not viable pollinating or honey producing units. Losses have been reported in migratory operations wintering in CA, FL, OK and TX. However, late in February some larger non-migratory beekeepers, particularly from the mid-Atlantic region and the Pacific Northeast have reported significant losses of >50%.

When was it first discovered and how long has it been going on? The first "report" of CCD was made in mid-November 2006 by a Pennsylvania beekeeper overwintering in Florida. Soon after the initial report, other migratory beekeepers reported heavy losses of colonies under similar circumstances. In subsequent conversations with beekeepers from across the country, it appears that a number of large beekeepers have been discovering higher than normal losses compared to the past few years (although heavy overwintering losses were reported in 2003-2004 for many northern beekeepers). These losses may or may not be related to CCD, but it is likely that there may be some relationship.

Is honey from CCD colonies safe to eat? To date there is no evidence that CCD affects honey. The impact of CCD appears to be limited to adult bees.

The beekeeping industry has experienced heavy losses of colonies in the past. Is this something new? Symptoms similar to CCD have been described in the past, and heavy losses have been documented. The condition has received many different names over the years including autumn collapse, May disease, spring dwindle, disappearing disease, and fall dwindle disease. Whether or not the current die-off is being caused by the same factors that caused heavy losses in the past or if new factors are involved is not yet clear.

Why is it called Colony Collapse Disorder rather than disappearing or spring/fall dwindling/disease? References to the season are inappropriate as there are increasing reports that the condition manifests itself throughout the year. “Dwindle” implies a gradual decline of colony population whereas we are seeing a rapid collapse. While the actual rate of adult bee loss in populations have not been recorded, it is clear that otherwise strong colonies can quickly lose their entire workforce in a matter of a few weeks or even a few days. “Disappearing” has been used to refer to a host of other conditions that do not necessarily share the same symptoms as those presently being described. The term “disease” is commonly associated with a pathogenic agent. While the definition of disease does have a broader meaning (i.e. coronary disease), until (or if) such an agent is found the use of the word “disease” would be misleading. Should a biological or other agent(s) be isolated as the cause, the name of this condition will likely be reconsidered.

How do I know if a colony has CCD? Colonies impacted by CCD have the following characteristics:

- The complete absence of adult bees in the hive, (in some cases the queen and a small number of survivor bees are present in the brood nest) with no or little build-up of dead bees in the hive or at the hive entrances.
- The presence of capped brood.
- The presence of food stores, both honey and bee bread, which is not immediately robbed by other bees. Invasion of common hive pests such as wax moth and small hive beetle is noticeably delayed in dead-out equipment left in the field.

What are the early signs of CCD? In cases where the colony appears to be actively collapsing:

- There is an insufficient workforce to maintain the brood that is present.
- The workforce seems to be made up of young adult bees.
- The queen is present, appears healthy and is usually still laying eggs.
- The cluster is reluctant to consume feed provided by the beekeeper, such as sugar syrup and protein supplement.
- Foraging populations are greatly reduced/non-existent.

What should a beekeeper do if he or she has CCD? See the CCD information on recommendation (separate document).

What can I do to reduce the likelihood of getting CCD?

- Keep colonies strong by practicing best management practices.
- Don't stack dead or weak colonies on strong colonies.
- Feed colonies fumigillin in the spring.

Is it safe to reuse the equipment from colonies that have been lost during the winter? If it can be determined that bees starved or died due to other reasons associated with typical winter loss, it does appear safe to reuse equipment, including honey stores and pollen, but caution is advised and equipment probably needs to be aired thoroughly. Also you should seriously consider replacing old comb with new foundation on a regular

basis. However if your colonies died from what appears to be CCD (see description above), reusing equipment is not advised since we do not yet know the cause of this condition. Members of the CCD working group have initiated experiments that will look at various comb sterilization techniques for suggestions in the future.

Who is working on this problem? A group of researchers, apiculture extension specialists and government officials from a number of different institutions across the country have come together to work on this problem and share information with beekeeper and the public. This group is called the CCD Working Group. For a complete list of the institutions and individuals involved please visit the CCD page on the Website: MAAREC.org.

What has been eliminated as a potential cause of CCD? These results are based on in-depth interviews with beekeepers impacted by CCD and surveys of beekeepers responding to our request for information. While these items have been removed from our list of “causes” they may increase the risk of developing CCD. For instance, wearing wet clothes will not give you a cold, but it does increase your chances of catching a cold.

Feeding: The practice of feeding was common to most of the beekeepers interviewed and surveyed who experienced CCD. Some feed HFCS, others sucrose however, some did not feed. Most beekeepers interviewed did not feed protein but some used pre-made protein supplement.

Chemical use: While most used antibiotics, the type, frequency of application, and method varied. Most beekeepers had applied a miticide treatment during 2006. The products used and method of application varied.

Use of bees: Some beekeepers reported that their bees were used primarily for the production of honey, while others received most of their income from pollination contracts. Some produced honey and used their colonies for pollination.

Queen Source: All beekeepers purchased at least some queens throughout the year. Some beekeeper reared the majority of their own cells, but most bought either mated queens or queen cells. Queens were bought from at least 5 different states (Florida, California, Texas, Georgia, Hawaii) and 2 foreign countries (Canada and Australia).

What potential causes of CCD is the Working Group investigating? The current research priorities under investigation by various members of the CCD working group, as well as other cooperators include, but is not limited to:

- Chemical residue/contamination in the wax, food stores and bees
- Known and unknown pathogens in the bees and brood
- Parasite load in the bees and brood
- Nutritional fitness of the adult bees
- Level of stress in adult bees as indicated by stress induced proteins
- Lack of genetic diversity and lineage of bees

For a more complete description of the research priorities, please visit CCD page found on the MAAREC.org website.

What are examples of topics that the CCD working group is not currently investigating? GMO crops: Some GMO crops, specifically Bt Corn have been suggested as a potential cause of CCD. While this possibility has not been ruled out, CCD symptoms do not fit what would be expected in Bt affected organisms. For this reason GMO crops are not a “top” priority at the moment.

Radiation transmitted by cell towers: The distribution of both affected and non-affected CCD apiaries does not make this a likely cause. Also cell phone service is not available in some areas where affected commercial apiaries are located in the west. For this reason, it is currently not a top priority.

What can beekeepers/beekeeper groups do to help with discovering the cause of CCD?

- Please fill out an online survey at: www.beesurvey.com
- Consider giving to one of the foundations collecting monies to help fund research in these activities:

The Foundation for the Preservation of Honey Bees, Inc.
Troy Fore - Executive Director
PO Box 1337 – Jesup, Georgia 31598-1337
PH. 912-427-4233 – Fax 912-427-8447
E-mail: beefoundation@bellsouth.net

Project Apis m (PAMs)
Christi M. Heintz - Project Director
1750 Dayton Rd
Chico, CA 95928
PH. 520-829-6754
E-mail: Christih@cox.net

In the “Memo” line, write “CCD” if you wish to donate to the overall group effort, or “CCD-Bee Alert”, if they wish to donate to the work being done by Bee Alert Technologies Inc.

Or give directly to a university or research institution:

A special fund has been set up at Penn State University for individuals or beekeeping organizations that want to contribute to the research effort on CCD at this institution. Checks can be made out to Penn State University and need to be accompanied by a letter that states that the funds are a gift given to the Department of Entomology in support of the work on CCD. These can be sent:

Department of Entomology
Penn State University
501 ASI Building
University Park, PA 16802.

The Pennsylvania Department of Agriculture cannot directly receive donations, however they should be submitted to Penn State.

Gifts to the University of North Carolina in support of the work Dr. Dave Taryp is conducting on CCD can be sent to:

Dr. Dave Taryp

NCU Apiculture Program

Campus Box 7613

North Carolina State University

Raleigh, NC 27695-7613

And should be accompanied by a letter stating the following:

We are pleased to donate \$\$\$\$ as an unrestricted gift in support of the NC State Apiculture Program. The check is enclosed and endorsed to the NC Agricultural Foundation. Please deposit the monies into the Entomology Enhancement Fund of the North Carolina Agricultural Foundation, Inc. so that you may continue your work on honey bee biology and apicultural science.

*Prepared by M. Frazier, D. vanEngelsdor, and D. Caron,
Edited by the CCD working group*

APPLICATION FOR BEEYARD REGISTRATION

ARKANSAS DEPARTMENT OF AGRICULTURE

(PRINT ONLY PLEASE)

APIARY SECTION
 P. O. Box 1069
 Little Rock, AR 72203
 Phone: (501) 225-1598
 Fax: (501) 225-3590

NAME: _____

ADDRESS: _____

PHONE NUMBER: [] _____

CITY: _____ STATE: _____ ZIP: _____

EMAIL: _____

PLEASE CHECK ONE: REGISTERED BEEKEEPER: NEW BEEKEEPER:

	COUNTY	QUARTER SECTION	SECTION NUMBER	TOWNSHIP NUMBER	RANGE NUMBER	NUMBER OF COLONIES	CIRCLE THE TYPE OF YARD	OWNER OF LAND	APIARY NAME OR NUMBER	<u>FOR OFFICE USE ONLY</u>
1.							PERMANENT, TEMP, OR SEASONAL			
	GPS: IN DEGREES DECIMAL	LAT:			LONG:					
2.							PERMANENT, TEMP, OR SEASONAL			
	GPS: IN DEGREES DECIMAL	LAT:			LONG:					
3.							PERMANENT, TEMP, OR SEASONAL			
	GPS: IN DEGREES DECIMAL	LAT:			LONG:					
4.							PERMANENT, TEMP, OR SEASONAL			
	GPS: IN DEGREES DECIMAL	LAT:			LONG:					
5.							PERMANENT, TEMP, OR SEASONAL			
	GPS: IN DEGREES DECIMAL	LAT:			LONG:					

OFFICE USE ONLY BELOW:

Apiary Section Head _____

Date _____

Registration Number: _____



PLANT INDUSTRIES DIVISION

How Bees Work Anatomy

©2007 HowStuffWorks

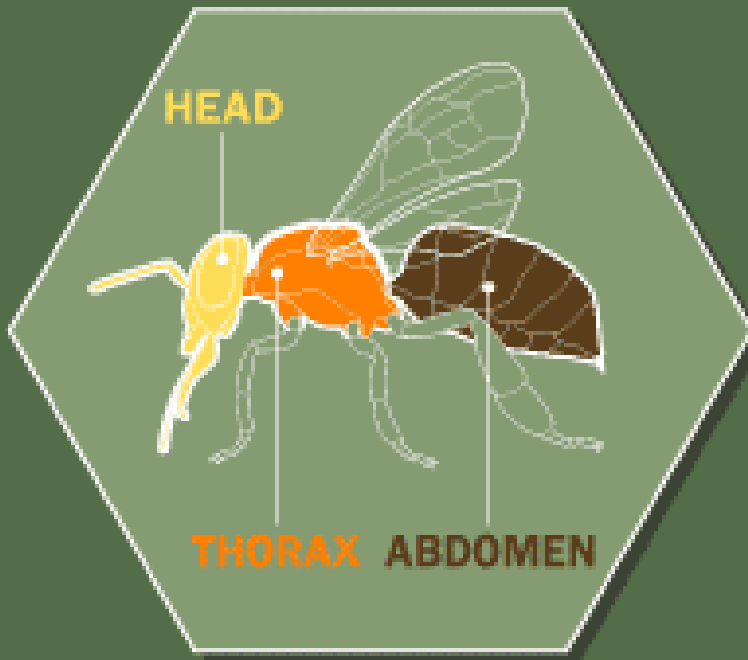
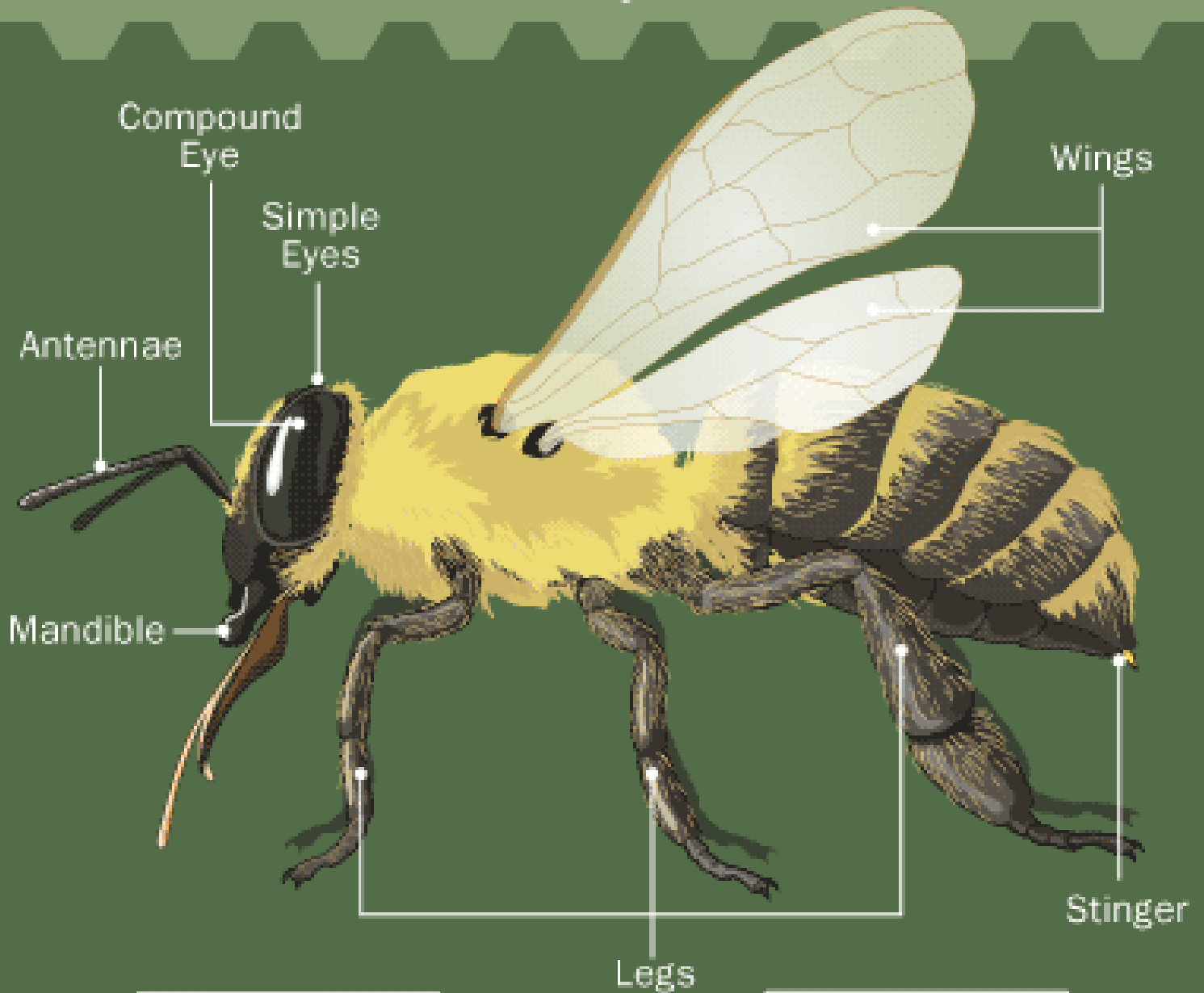

Body Structure

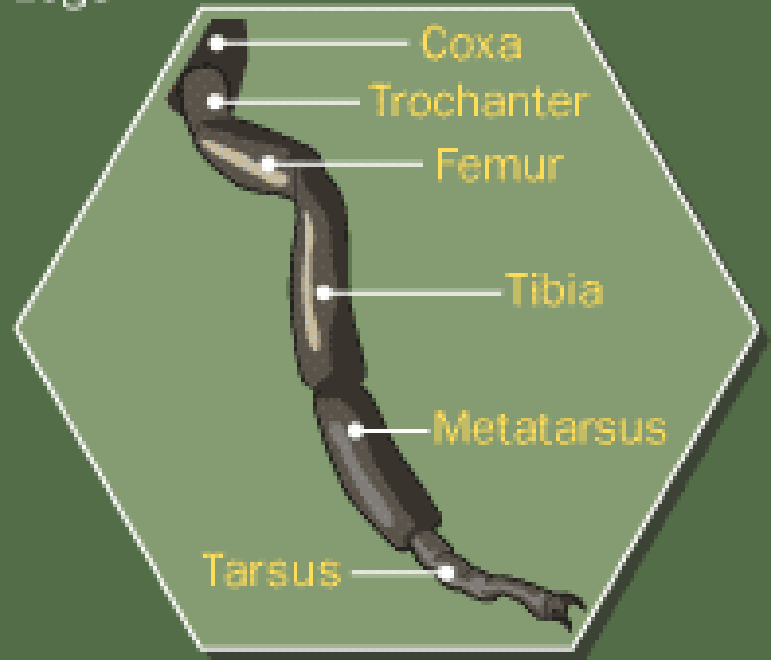

Leg Structure

CIRCULAR 5

THE ARKANSAS APIARY LAW AND REGULATIONS

A handbook for Apiarists issued October 1, 1979 under Act 161 of 1977 by the **State Plant Board**, Box 1069, Little Rock, Arkansas 72203, **Mark Stoll**, Head, Apiary Section.

ARKANSAS APIARY LAW (Act 161 of 1977 as Amended by Act 149 of 1979)

Section 1. **Enforcement, Administration, and Personnel.** The State Plant Board, hereinafter referred to as the Board, is hereby vested with the authority to carry out provisions of this Act through the Director, State Apiarist, Section Head, and Deputies. The State Apiary Board created by Act 59 of 1945, as amended, is hereby abolished and all records, supplies, equipment, and personnel existing under the authority of Act 59 of 1945, as amended, are hereby transferred to the Board for use in carrying out the provisions of this Act. Hereafter, the State Apiary program shall be continued in accordance with the provisions of this Act.

Section 2. **Definitions.** The terms used in this Act, unless the context otherwise requires, shall mean:

- A. "Abandoned apiary"; an apiary to which the owner or operator fails to provide such reasonable and adequate attention to each hive during the year as to jeopardize the welfare of neighboring colonies;
- B. "Apiary"; any place where one or more colonies of bees are kept;
- C. "Appliance"; any apparatus, tools, machines or other devices, used in the handling and manipulation of bees, honey, wax and hives. The term includes containers of honey and wax which may be used in an apiary or in transporting bees and their products and apiary supplies;
- D. "Bees"; any stage of the common honeybee (**Apis mellifera**);
- E. "Bee disease"; American and European foulbrood, sacbrood, bee paralysis, or any other disease or abnormal condition of the egg, larval, pupal or adult stages of bees;
- F. "Apiary equipment"; hives, supers, frames, veils, gloves, or any other equipment used in the handling and manipulation of bees, honey, wax, and hives;

- G. "Colony"; the bees in any hive including queens, workers, and drones;
- H. "Hive"; a frame hive, box hive, box, barrel, logs, gum skep or any other receptacle or container, natural or artificial, or any part thereof which may be used as a domicile for bees;
- I. "Nucleus"; any division or portion of a hive that contains comb;
- J. "Package"; an indefinite number of bees in a bee-tight container, with or without a queen, without comb;
- K. "Pollination"; the use of bees for the transfer of pollen in the production of agricultural crops;
- L. "Director"; the Director of the Arkansas State Plant Board;
- M. "State Apiarist"; the Director of the Division of Plant Industries of the State Plant Board;
- N. "Section Head"; the Head of the Apiary Section of the Division of Plant Industries.

Section 3. **Registration.** A. Every person owning, leasing or possessing bees shall, before July 1, of 1979, or thereafter within ten (10) days after coming into ownership or possession of bees, or before moving bees from outside the State of Arkansas, file with the Board an application for registration. The application shall set forth the exact location by legal description of the premises, together with the name of owner or possessor or such apiary, the number of colonies of bees in each apiary owned by him or in his possession or under his control, together with such other information as may be required by the Board. The beekeeper may register one location for each ten (10) colonies for the first one thousand (1,000) colonies and may register one location for each twenty (20) colonies thereafter. A new registration is required when any significant change occurs in the location or operation of the beekeeper. All applications for registration shall be approved or rejected by the Board so as to effectuate compliance with the Act or rules and regulations promulgated pursuant hereto.

B. No person can place bees on property other than his own within three miles of a previously registered area without the written permission of the registrant; PROVIDED, however, that upon written complaint made to the Board by any beekeeper or any land owner whose land is in the registered area, that the registrant or any other person claiming prior bee pasturage rights is not properly covering the area so registered, then the Apiary Board shall be authorized to permit the placing in such area other bees or bee yards as in its judgment shall be sufficient.

C. Nonresidents of this State who desire to locate their colonies of bees in Arkansas shall register

their bees and the locations they desire as required in subsection A above, provided that such registration shall be required annually. If such nonresident beekeeper fails to place his bees in an area registered by him during the registration period, such beekeeper shall forfeit his rights to such area and shall not be allowed to apply for such area until one year after the forfeiture.

Section 4. **Inspection.** The Board shall establish minimum competency standards for persons to be employed as inspectors. These requirements are to include demonstrated ability to properly handle hives and bees in addition to proficient performance on a written test measuring knowledge pertinent to the job of inspector.

A. It shall be the duty of all persons engaged in beekeeping to provide movable frames in all hives used by them to contain bees, and to cause the bees in such hives to construct brood combs in such frames so that any of said frames may be removed from the hive without injuring other combs in such hive. Beekeepers shall change newly acquired bees from their natural habitat to hives as soon as possible, but in no case shall a period of more than twelve (12) months elapse between date of acquiring new bees and transferring the same to hives.

B. Immediately upon detection of disease, anyone keeping bees shall treat and disinfect, or burn and bury in places where they shall remain undisturbed, combs and frames taken from diseased colonies or, until salvaged, combs and frames shall be placed in tight receptacles so constructed that it shall be impossible for bees to gain access to combs, or for honey or any other liquid to leak out where bees can gain access to it.

C. Anyone exposing comb, honey, frames, empty hives, covers or bottomboard, or tools or other appliances contaminated by infected material from diseased colonies, shall upon conviction thereof, be punished as provided in this Act.

D. Whenever an apiary has been inspected and found apparently free from American foulbrood or other dangerous, contagious or infectious bee diseases, and all other provisions of this Act have been complied with, a certificate of inspection shall be issued. The certificate of inspection shall be valid for a period of one year following the date of its issuance. A valid certificate of inspection shall be deemed as a blanket permit to move the hives from place to place within the State.

E. Should upon inspection or laboratory analysis, any of the diseases described in Sub-Section L be determined to exist in an apiary it shall be the duty of the Board to cause to be treated or disinfected or to destroy or cause to be destroyed by fire the colony, including the hives, frames, honey, wax, and brood.

F. If an abandoned apiary is found, upon inspection, to be diseased, the Board shall cause it to be immediately destroyed by burning. An apiary may be considered abandoned only after reasonable attempts have been made to determine ownership. Such attempts are to at least include the questioning of the owner, lessee or renter of the land on which the apiary is discovered.

G. After inspection of infected bees or fixtures or handling diseased bees, the Apiary Inspector

shall, before leaving the premises or proceeding to any other apiary, take such measures as shall prevent the spread of the disease by infected material adhering to his person or clothing or to any tools or appliances used by him, which have come in contact with infected materials.

H. All apiaries, bees, bee equipment, bee products, buildings, premises and appliances wherein or on which American and/or European foulbrood is known to exist are hereby declared to be under quarantine. The removal of any and all bees, queen bees, bee products, colonies, nuclei, combs and apiary appliances and bee fixtures is prohibited except under such cases as the Board may permit or approve. Such quarantines shall exist until the Board shall determine and declare the premises or material are apparently free from American and/or European foulbrood. The imposed quarantine shall cease to be in effect if the Board has not verified the existence of American or European foulbrood within thirty days after appeal by the beekeeper.

I. No person shall sell, offer for sale, give away or otherwise transfer ownership of any colony of bees, bees, or queen bees without first receiving from the Board a certificate of health issued not more than six (6) months prior to the disposition. A copy of the certificate shall be issued by the seller or given to the purchaser or person receiving the colony at the time of delivery.

J. Upon request, additional inspections shall be made, by the Apiary Inspector, of colonies of bees, bees, queen bees and their attendants or hives, supers, or other equipment used in bee culture.

K. It shall be unlawful for any person to give false information or incomplete information in any matter pertaining to this Act, or to resist, impede, or hinder the Apiary Inspector in the discharge of his duties.

L. For the enforcement of this Act, the Apiary Inspector shall have, where any apiary is located or any bees, combs or apiary appliances are kept, the authority to enter upon any private or public premises with right of access, ingress and egress for the purpose of ascertaining the existence of the disease known as American foulbrood or European foulbrood or any other disease which is infectious or contagious and injurious to bees in their egg, larval, pupal or adult stages. However, prior to exercising that authority, the Apiary Inspector must afford the beekeeper the opportunity to be present during the inspection by serving notice of the date and time of inspection at least five (5) days prior to the inspection. The five-day period may be abbreviated upon the mutual consent of the Apiary Inspector and the beekeeper.

M. Beekeepers aggrieved by the actions of an Apiary Inspector may appeal the Inspector's action to the Board at the Board's next meeting.

Section 5. **Transportation.** A. All bees in used hives or other apiary equipment which may be brought into the State from other states or other countries must be accompanied by a certificate of health issued by the official inspector of the state or country from whence they came. The transportation of bees in used hives or other apiary equipment into this State without said certificate of health by any person or persons or by common carriers is expressly prohibited.

B. The certificate of health shall certify to the apparent freedom from foulbrood or any other contagious or infectious bee disease, and shall be based on actual inspection of bees and material within ninety (90) days of the date of shipment.

C. A person transporting bees within the State to a location not previously approved shall notify the Apiary Board of the Action at least twenty (20) days before the move, however, under emergency conditions, such as fires, crop dusting and natural disasters, the bees may be moved without prior notice provided that the Apiary Board is notified within five (5) days of the move and informed of the circumstances necessitating the emergency move. No notification shall be required for the movement of disease-free bees between previously registered locations.

Section 6. **Rules and Regulations.** The Board may promulgate such rules and regulations, not inconsistent herewith, as it shall deem necessary for the proper enforcement of this Act. Such rules and regulations shall be promulgated, issued, and enforced in accordance with the Administrative Procedures Law of the State, Act 434 of 1967, as amended. Any person violating the provisions of this Act shall be guilty of a class 'C' misdemeanor and shall be punished accordingly.

Section 7. **Severability.** The provisions of this Act are severable. If any section or other part thereof is declared unconstitutional or invalid, such declaration shall not affect the part that remains.

Section 8. **Repeal of Conflicting Laws.** All laws and parts of laws in conflict with this Act are hereby repealed, specifically Act 59 of 1945, as amended, and that part of Section 16 of Act 38 of 1971, as amended, that pertains to the State Apiary Board.

APIARY REGULATIONS OF THE STATE PLANT BOARD

The following regulations have been promulgated and adopted under authority of Act 161 of 1977 as amended by Act 149 of 1979 and in conformance with Act 434 of 1967 as amended, the Administrative Procedures Act.

The State Plant Board recognizes the importance of the honeybee to Arkansas agriculture through its pollination of crops and the value of the honey it produces. The Board will, therefore, strive to preserve the honeybee, promote beekeeping and strengthen apiary functions in Arkansas through the considerate and judicious application of Act 161 of 1977, as amended by Act 149 of 1979, and these regulations.

Regulation I. Registration

Registering Apiaries. Each apiary in the state shall be registered. Apiaries may be registered at permanent or temporary locations. Temporary locations shall be occupied by active colonies of bees during the honey producing season, subject to pasturage rights specified in Section 3B of Act 161, or registration will be canceled. Registration shall be on forms provided by the Board and shall include the following information: 1. Name and complete mailing address of the owner, 2. Legal description of each location by Quarter section, Section, Township and Range, 3. A notation whether each location is permanent or temporary, 4. The name of the owner of the land where each apiary is located, and 5. The number of colonies at each location. Registration may be amended anytime as new colonies are added to an apiary by purchase, division or the capture of swarms, or when any significant change occurs in the location or operation of a beekeeper. Any person who purchases colonies of bees from a beekeeper with registered apiary locations (bee yards) shall have the first option to register said locations in his own name, provided such action is agreeable to the owner of the land whereon the apiaries are located.

Apiary Identification. Each apiary location, whether permanent or temporary, shall be identified by prominently displaying the owner's Registration Number at the site. This number may be displayed on one or more hives or on a readily visible sign placed within 10 feet of the hives.

Regulation II. Inspection.

Minimum Competency Standards For Inspector, Education and Experience.

Two years college with at least one course in beekeeping, or high school diploma with two years experience as a beekeeper or equivalent.

Training.

A minimum of one week on-the-job training with the Head of the Apiary Section or the Chief Inspector or the Apiary Specialist where the beginning inspector shall demonstrate ability to properly handle hives and bees, to identify bee diseases and to execute required forms and paperwork.

Examination.

The prospective inspector shall make a passing grade of 70% on a written examination designed to measure his knowledge pertinent to the job before entering into the required training.

Hives With Movable Frames Required. A person may not keep bees in a hive which does not have movable frames. Movable frames permit thorough examination of every brood comb in a hive to determine the presence of disease. If a hive without movable frames is found the inspector will notify the owner or persons responsible for the hive of the condition in writing. The written notice shall require that the bees be moved into a hive with movable frames as soon as possible, but in no case more than 12 months from the date of the notice. If the owner or person responsible for the hive wishes to do so he may, after it is inspected, sell or give it to a second party who will house the bees properly. If he refuses or fails to provide proper housing himself or by a second party the hive or receptacle shall be condemned and destroyed. Hives condemned for destruction will be destroyed in the manner described for American foulbrood disease.

Inspection Frequency. The frequency of inspection of each apiary will be determined by the Board. Inspections may be made annually or at more frequent or less frequent intervals depending upon the disease history of the apiary and the surrounding area.

Owner Participation Weather Conditions. Owner participation during inspection is helpful to the owner as well as to the inspector and is encouraged. The apiary inspector will afford the beekeeper the opportunity to be present during the inspection by serving notice of the date and time at least five days prior to the inspection. The five-day period may be abbreviated upon the mutual consent of the apiary inspector and the beekeeper. Inspections will not be made when weather conditions are such that inspections may be seriously detrimental to the bees. Weather determinations will be made by mutual agreement between the owner or the person in charge and the inspector.

Notice of Disease; Quarantine; Appeal. If a bee disease is found to exist in any degree in an apiary the inspector will notify the owner or person responsible for the apiary in writing at the conclusion of the inspection. The notice will state which disease(s) is present, the number of colonies infected, how the diseased colonies are marked, the manner in which the disease(s) shall be eradicated and the length of time in which eradication shall be accomplished. The written notice shall also be considered a notice of quarantine if American foulbrood or European foulbrood is found in an apiary. The owner or person responsible for a quarantined apiary may appeal the findings of the inspector to the Head of the Apiary Section or the State Apiarist within 3 days. At the owner's option, confirmation or denial of the inspector's findings may be based upon reinspection of the apiary by the Head of the Apiary Section or the State Apiarist, or upon the findings of the USDA Bee Disease Investigative Laboratory. If the latter option is chosen the apiary inspector will, in the presence of the beekeeper, collect and identify samples to be sent to the laboratory. Based upon reinspection or laboratory findings, the determination of the Plant Board shall be final unless otherwise determined by a court of proper jurisdiction. The quarantine shall cease to be in effect if the Board has not verified the existence of American or European foulbrood within thirty days

after appeal by the beekeeper.

Disease Eradication:

American Foulbrood. If American foulbrood disease is found to exist in any degree in an apiary, after written notice to the owner or person responsible for the apiary and after a final determination is made, the inspector shall destroy or cause to be destroyed the diseased colonies and contaminated equipment in the following manner:

(a) By killing the bees in infected hives and burning the bees, combs, frames and honey in a pit and burying the ashes at least 1 foot below the surface of the ground.

(b) By scorching with fire or boiling in lye solution (one pound lye per 10 gallons of water) for not less than 30 minutes the hive bodies, bottom boards, covers, supers, or other equipment associated with the infected colonies.

The quarantine which is placed on an apiary when American foulbrood disease is found shall not be lifted until these eradication measures have been carried out to the satisfaction of the inspector and subsequent inspections reveal no American foulbrood disease in the apiary.

European Foulbrood. If European foulbrood disease is found to exist in any degree in an apiary, written notice and opportunity for appeal as described previously herein will be given to the owner or person responsible for the apiary. The written notice shall require that in each infected colony: (a) The queen shall be killed immediately, (b) An approved antibiotic shall be fed immediately and once per week for at least 3 weeks thereafter, and (c) After 10 days a new queen shall be introduced into the colony. If the owner or person responsible for the apiary refuses or fails to carry out the prescribed eradication procedures the infected colonies shall be destroyed by the inspector in the manner described for American foulbrood disease.

The quarantine which is placed on an apiary when European foulbrood disease is found shall not be lifted until these eradication measures have been carried out to the satisfaction of the inspector and subsequent inspections reveal no European foulbrood disease in the apiary.

Other Bee Diseases. If sacbrood, chalkbrood, bee paralysis or other bee disease are found to exist in any degree in an apiary the inspector will require such treatment as may be specified by the State Apiarist.

Regulation III. **Transporting.**

Transporting Bees, Apiary Equipment; Emergencies. A person may not transport or cause to be transported into or within this state bees on combs, used hives or other used apiary equipment or appliances without a current certificate of inspection covering the bees and equipment to be moved. With such a certificate bees may be moved between registered locations at will without

prior notice to the Plant Board. A person who does not possess a current certificate of inspection who wishes to move bees, or a person who wishes to move to a location which he has not registered, shall notify the Plant Board at least 20 days prior to the anticipated moving date. Within this 20-day period the Apiary Section shall inspect the apiary(ies) to be moved, conduct necessary investigations, determine prior pasturage rights and approve or reject the move.

Emergency moves made necessary by such things as fires, crop dusting and natural disasters may be made without prior notice provided that the Plant Board is notified within five days of the move and informed of the circumstances necessitating the emergency move.