

HEAD

TYROLIA®



**TECHNICAL
MANUAL**

ALPINE SKI BINDINGS

ONLY PERFECTION PROVIDES SAFETY.

2020 / 2021

www.tyrolia.com

TABLE OF CONTENT

NEWS

THE TYROLIA MISSION	3
TYROLIA HISTORY	4
TYROLIA NEWS 2020.21	5
BOOT AND BINDING COMPATIBILITY 2020.21	6

TECHNICAL INFORMATION

REFERENCE PARTS - RETAIL	8
REFERENCE PARTS - AAA-SERIES	9
HEAD BINDING LINE 2020.21 - DATASHEET	10
TYROLIA BINDING LINE 2020.21 - DATASHEET	12
TYROLIA INSIDE BINDING LINE 2020.21 - DATASHEET	14
REFERENCE PARTS - RENTAL	16
TYROLIA RENTAL SYSTEMS	18
TYROLIA RENTAL LINE 2020.21- DATASHEET	20
DEALER ONLINE SUPPORT	22
HEAD/TYROLIA BRAKE LINE 2020.21	24

MOUNTING BINDINGS & PLATES

WORKSHOP TOOLS AND AIDS	28
DRILL TEMPLATE SELECTION	29
DRILL TEMPLATE 92W & 92 FAT	33
DRILL TEMPLATE AMBITION	37
DRILL TEMPLATE ADRENALIN	41
DRILL TEMPLATE ATTACK DEMO	45
DRILL TEMPLATE BASES & PLATES	48
DRILL TEMPLATE RACEPLATE WCR SHORT/TEAM	53
DRILL TEMPLATE RACEPLATE 09	55
DRILL TEMPLATE SLR PRO	57
DRILL TEMPLATE 94W	59
DRILL TEMPLATE FREEFLEX DEMO	61
DRILL TEMPLATE SP 2003 W	63
DRILL TEMPLATE SR 2003 W	65
BOOT SOLE TYPES - ISO STANDARDS	67
BOOT HANDLING AND TESTING	69
MAINTENANCE AND SERVICE	70
TROUBLESHOOTING (INCL. RENTAL)	74

ADJUSTMENT

CLASSIFY YOURSELF	78
RELEASE/RETENSION ADJUSTMENT TABLE	79
TROUBLESHOOTING RELEASE/RETENSION PROBLEMS	80
RENTAL-TEST AND INSPECTION PROCEDURES	81

DEALER SERVICE INFORMATION

HEAD/TYROLIA CERTIFICATION REQUIREMENTS	86
HEAD/TYROLIA RETAILER INDEMNITY PROGRAM	88
HEAD/TYROLIA LIMITED WARRANTY	90
RISK MANAGEMENT	91
USE OF NON RECOMMENDED SETTINGS	93
POST ACCIDENT INSPECTION REPORT	94
SYSTEM PERFORMANCE REPORT	95
USED BINDING/SKI/BOOT CHECKLIST	96

T H E T Y R O L I A M I S S I O N

ONLY PERFECTION PROVIDES SAFETY

The reliability of quality technology and know-how, continual innovation and a proven safety record have defined TYROLIA for decades. For more than 90 years, TYROLIA has been the epitome of top-of-the-line research and development in the ski binding industry. And, due to rapid developments in the winter sports sector, increased safety has become critical. A ski binding is much more than just the link between a ski and a boot. It is the most important safety and performance component. TYROLIA provides a high-tech product with unique safety features, thanks to continual improvement and high-quality service.

SUSTAINABILITY AND CLIMATE PROTECTION

In recent years TYROLIA has already implemented at the Schwechat location a number of different measures to produce sustainably and protect the environment. Among other things, the electroplating and molding division works with heat-recovering systems. Another initiative is to discontinue the use of plastic in the packaging of our ski bindings. TYROLIA cares about sustainability and protection for nature where we all hope to enjoy our passion for skiing for generations to come!

VISION – ACCESS ALL AREAS

TYROLIA offers ski bindings for every type of skier, every terrain and every type of skiing performance. Ski bindings ranging from Competition, Racing, All Mountain, Junior to Rental products provide access to all the skiing areas of a mountain. With confidence in a reliable product, go out and enjoy the outdoor experience of skiing or alpine touring and gain access to all areas!

MARKET LEADER IN THE ALPINE SKI BINDING SECTOR

The company located in Schwechat, Austria, was founded in 1847 as "Wiener Metalwaren-, Schnallen- und Maschinenfabrik GmbH". The first ski binding was manufactured in 1928. Ten years later, industrial production started and in 1949 the first TYROLIA branded ski binding was produced. Continued advances in research and development, unparalleled performance and high-quality service guarantee a high-tech product renowned throughout the entire winter sports industry. Today, TYROLIA has secured a strong leadership position with more than 1.2 million bindings produced every year plus numerous podiums in World Cup Racing and the growing freeski segment. One out of every three bindings sold worldwide is designed, developed, and mounted by TYROLIA. Exporting 90 percent of its capacity, TYROLIA delivers its bindings to subsidiaries and dealers worldwide.

PRODUCT LINE

TYROLIA's wide product range offers the perfect ski binding for every type of skier. You now have a complete binding selection to explore every part of a mountain: whether you enjoy the unlimited freedom of freeriding and touring (TYROLIA AAA-Series), high performance at top speed (TYROLIA Racing Bindings), regular skiing including on-snow demoing or rental (TYROLIA PowerRail, SuperLiteRail and TYROLIA Rental Bindings) or outfitting kids with maximum fun and safety in mind (TYROLIA Junior) – simply Access All Areas with TYROLIA bindings.



www.tyrolia.com



www.facebook.com/tyroliabindings



www.youtube.com/user/tyroliabindings



www.instagram.com/tyroliabindings

TYROLIA HISTORY

1847	The "Wiener Metallwaren, Schnallen und Maschinenfabrik GmbH" was founded in Schwechat/Austria	2015	TYROLIA Freeflex EVO TYROLIA AAAmbition Carbon TYROLIA AAAAttack 18 X TYROLIA AAAAttack 11 TYROLIA POWER Brake ²
1928	First ski binding produced in the Schwechat factory	2016	SuperLiteRail II RX – Performance AAAAttack 14 AT AAAAttack 11 Demo
1949	First TYROLIA branded ski binding	2017	AAAAttack ² GW/AT/AT DEMO MBS - Multi Boot Standard Official GripWalk Partner
1953	World's first safety fore-clamp - TYROLIA Ski Master	2018	GripWalk compatibility in all HEAD/TYROLIA Adult System Bindings and Adult Sympro Rental Bindings
1962	TYROLIA Rocket – World's first automatic heel	2019	GripWalk and GripWalk Junior compatibility in all HEAD/TYROLIA bindings
1964	TYROLIA Clix Heel	2020	TYROLIA Freeflex ST
1973	TYROLIA Diagonal Heel		
1979	TYROLIA 60 series		
1986	4-roller Spring Pincer System		
1989	Freeflex System		
1996	ABS – Anti Blocking System		
1999	Freeflex Plus		
2000	TYROLIA becomes world market leader		
2001	ISO-Certification 9001:2000 TYROLIA is the first company in the binding industry to be certified according to the ISO 9001:2000 standard. The TÜV has certified that TYROLIA meets the highest standards for quality consciousness and international corporate structure.		
2002	Railflex System		
2008	Freeflex Pro & Race Pro Heel		
2009	Literail and TYROLIA Carbon Prestige		
2010	Powerrail		
2011	SX Product Line (New Toe and Heel)		
2012	LX Toe, SX Junior & SX Kid Product Line, AAADRENALIN Freeride AT Binding		
2013	TYROLIA AAA-Series (AAAMBITION, AAATTACK, AAADRENALIN)		
2014	AAATTACK DEMO, SLR - SuperLiteRail, TRIFLEX		

PARTNER – EVERYTHING UNDER ONE ROOF!

TYROLIA responds as rapidly as possible to the needs of the market and its customers, enabled by a wide vertical range of manufacturing processes and a faster time to market for development of new products. Well-known brands like HEAD, FISCHER and ELAN have entrusted the market leader TYROLIA for many years and recognize its competence. Moreover, small and independent ski manufacturers choose TYROLIA bindings as the perfect partner for their skis, e. g. Kästle, Kessler, Liberty, Amplid, Sporten, Original+ and Blossom.



NEWS





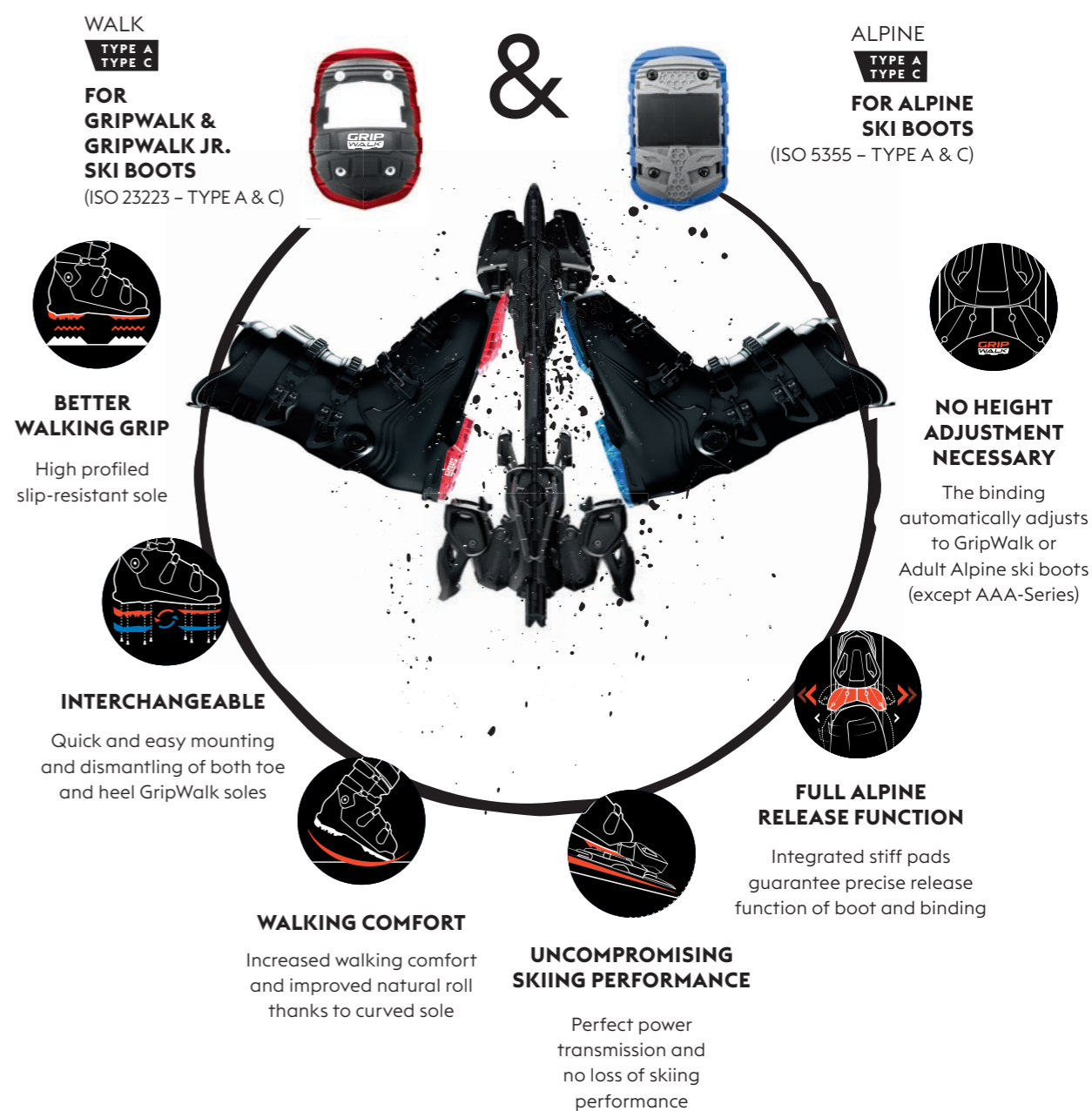

GRIPWALK COMPATIBILITY

TYROLIA is an official GripWalk partner. The entire TYROLIA 2020/21 line (except racing retail) is GripWalk compatible and can be used with Alpine ski boots (ISO 5355 – TYPE A) plus GripWalk ski boots (ISO 23223 – TYPE A). Additionally, the entire Junior 2020/21 line can be used with Alpine Adult and Children ski boots (ISO 5355 – TYPE A & C), as well as with GripWalk and GripWalk Junior ski boots (ISO 23223 – TYPE A & C).





BOOT AND BINDING COMPATIBILITY

	ALPINE SKI BOOTS (ISO 5355)		WALK SKI BOOTS (ISO 23223)		TOURING SKI BOOTS (ISO 9523)
	TYPE A	TYPE C	(TYPE A) 	(TYPE C) 	
* marking can be found in the product name and partly also on the binding					
Binding without any indication*	●				
Binding marked „GW AC“ 	●	●	●	●	
Binding marked „GW“ 	●		●		
Binding marked „AT“ 	●		●		●



TECHNICAL INFORMATION

REFERENCE PARTS - RETAIL

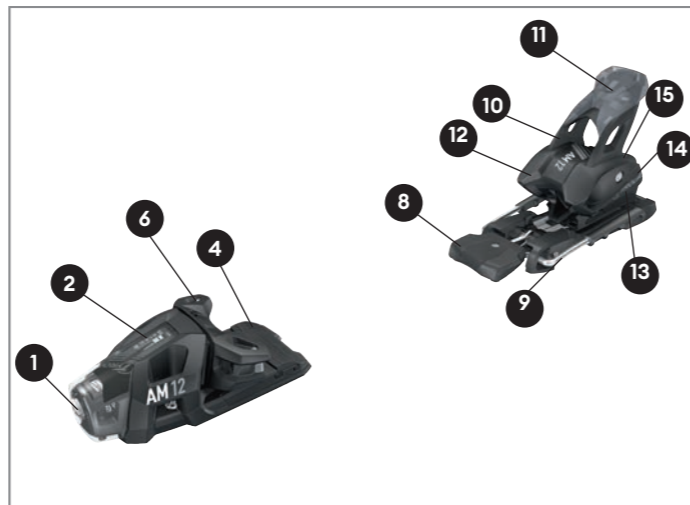
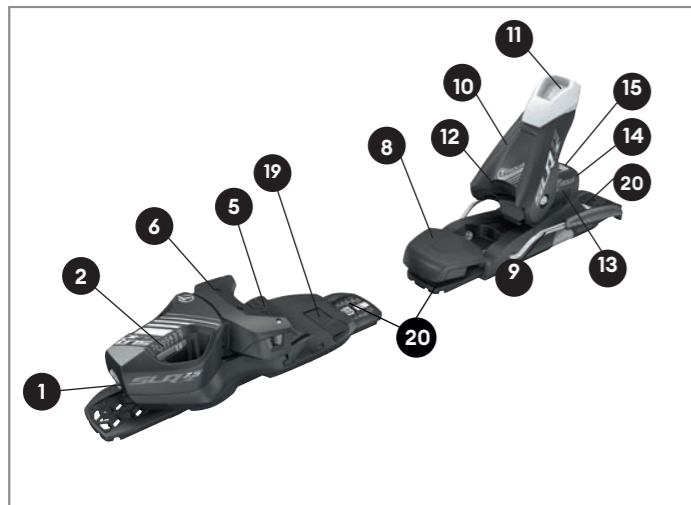
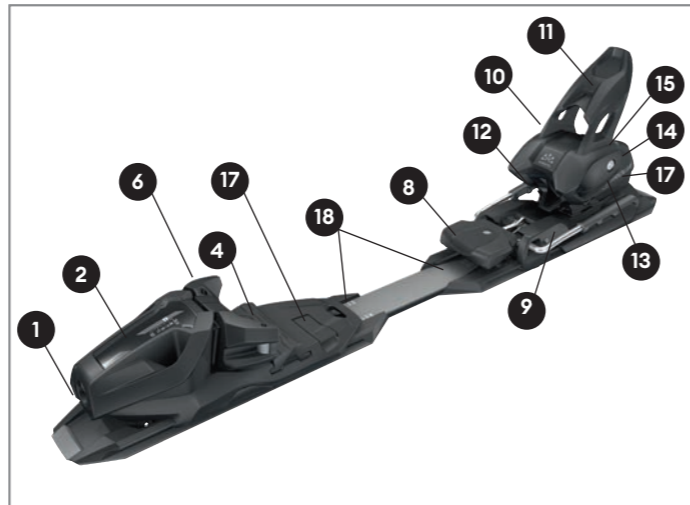
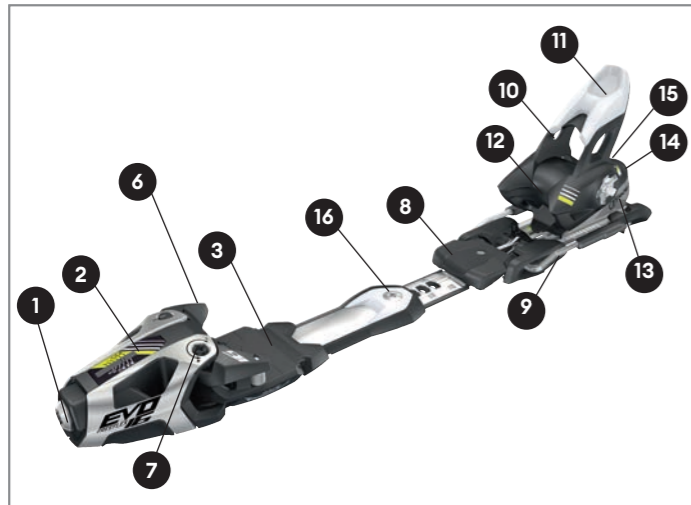

REFERENCE PARTS - AAA-SERIES

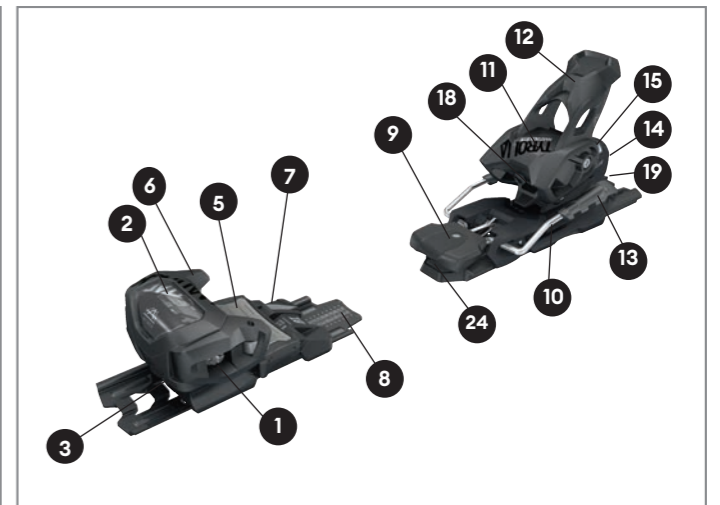
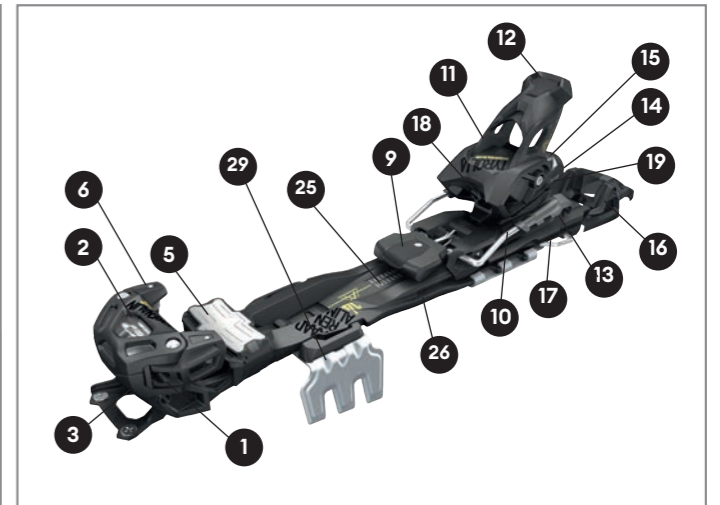
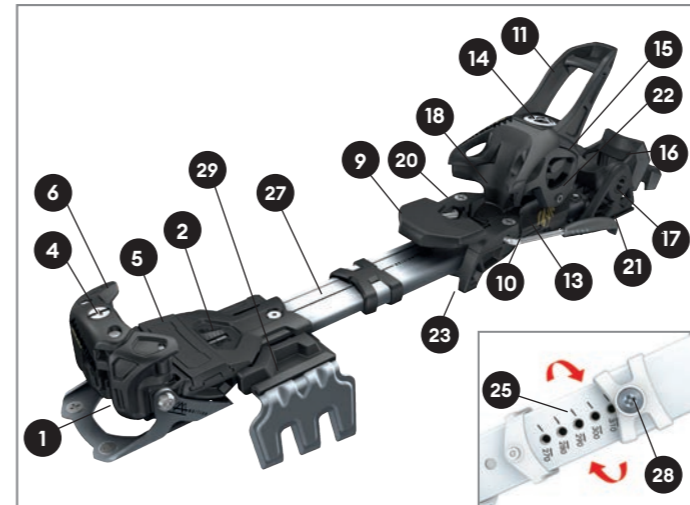

TOE PIECE

- 1 Adjustment screw
- 2 Visual indicator
- 3 Race AFD
- 4 GripWalk - AFS
- 5 GripWalk Junior - AFS
- 6 Wings
- 7 Adjustment screw - sole height

HEEL PIECE

- 8 Brake pedal
- 9 Brake arms
- 10 Heel lever
- 11 Heel cover
- 12 Sole lug
- 13 Heel housing
- 14 Adjustment screw
- 15 Visual indicator

MID PARTS

- 16 Freeflex PRO
- 17 PR lever
- 18 PR scale
- 19 SLR lever
- 20 SLR scale

TOE PIECE

- 1 Adjustment screw
- 2 Visual indicator
- 3 Adjustment screw - AFS/AFD
- 4 Adjustment screw - sole height
- 5 AFS/AFD
- 6 Wings
- 7 Toe lever
- 8 Attack Demo scale

HEEL PIECE

- 9 Brake pedal
- 10 Brake arms
- 11 Heel lever

HEEL COVER

- 12 Heel cover
- 13 Heel housing
- 14 Adjustment screw
- 15 Visual indicator
- 16 Ascender look
- 17 Climbing aid
- 18 Sole lug
- 19 Heel adjustment lever
- 20 Heel base plate
- 21 Demo Track
- 22 Length adjustment screw
- 23 Dampener
- 24 Attack Demo scale

MID PARTS

- 25 Boot sole length scale
- 26 Walking platform
- 27 Telescopic tube
- 28 Length adjustment screw
- 29 Crampon

HEAD BINDING LINE 20.21

DATASHEET

Model	Ramp angle	Z - DIN	kg	lbs	Set-Weight [g]	Drill Template	FEATURE	Toe					Heel					Boot Sole		
								Type	System	AFD	Stand Height [mm]	Length Adj. Range [mm]	Type	Heel System	Brake [Code]	Stand Height [mm]	Length Adj. Range [mm]	Length [mm]	DIN/ISO Standard	
COMPETITION																				
FREEFLEX ST 20 X RD Brake 85 [A]	3,5	10,5-20	from 97	from 209	3150	92 W / 92 FAT	FREEFLEX Pro Wide Track	STREAM	---		AFD ST POM (X)	12,5	---	RACE PRO RD	Standard	PB ² Race Pro 16-85 [A]	16,0	32	255 - 375	A
FREEFLEX ST 20 X RS Brake 85 [A]	3,5	10,5-20	from 97	from 209	3150	92 W / 92 FAT	FREEFLEX Pro Wide Track	STREAM	---		AFD ST POM (X)	12,5	---	RACE PRO RS	Standard	PB ² Race Pro 16-85 [A]	16,0	32	255 - 375	A
FREEFLEX ST 16 X RD Brake 85 [A]	3,5	10,5-16	from 97	from 209	3130	92 W / 92 FAT	FREEFLEX Pro Wide Track	STREAM	---		AFD ST POM (X)	12,5	---	RACE PRO RD	Standard	PB ² Race Pro 16-85 [A]	16,0	32	255 - 375	A
RACING																				
FREEFLEX ST 16 Brake 85 [A]	4,5	5-16	from 49	from 109	2650	92 W / 92 FAT	FREEFLEX Pro Wide Track	STREAM	---		AFD ST TEFLON	12,5	---	RACE PRO	Standard	PB ² Race Pro 17-85 [A]	17,0	32	255 - 375	A
FREEFLEX ST 14 Brake 85 [A]	4,5	4-14	from 42	from 92	2470	92 W / 92 FAT	FREEFLEX Pro Wide Track	STREAM	---		AFD ST TEFLON	12,5	---	NX Wide Track	Diagonal	PB ² Race Pro 17-85 [A]	17,0	32	255 - 375	A
FREEFLEX 14 Brake 85 [D]	4,0	4-14	from 42	from 92	2330	92 W / 92 FAT	FREEFLEX Pro	RX	Full Diagonal		ABS	17,0	---	D-RX	Diagonal	Power Brake ² LD 85 [D]	21,0	24	257-372	A
FREEFLEX 11 Brake 85 [D]	4,0	3-11	from 31	from 67	2260	92 W / 92 FAT	FREEFLEX Pro	RX	Full Diagonal		ABS	17,0	---	NX	Standard	Power Brake ² LD 85 [D]	21,0	24	257-372	A
FREEFLEX DEMO 14 GW Brake 85 [D]	1,5	4-14	from 42	from 92	2650	FREEFLEX DEMO	FREEFLEX DEMO	RX	Full Diagonal		AFS GW	19,5	60	NX	Standard	Power Brake ² LD 85 [D]	21,0	60	263-386	A / GW
SYSTEM																				
PRD 14 GW Brake 85 [F]	5,5	4-14	from 42	from 92	2090	Bases & Plates	PowerRail	RX	Full Diagonal		AFS GW	28,0	60	D-RX	Diagonal	Powerrail Brake ² LD 85 [F]	33,5	60	255-378	A / GW
PRD 12 GW Brake 85 [F]	5,5	3,5-12	from 36	from 79	2000	Bases & Plates	PowerRail	RX	Full Diagonal		AFS GW	28,0	60	D-RX	Diagonal	Powerrail Brake ² LD 85 [F]	33,5	60	255-378	A / GW
PRD 12 GW Brake 95 [F]	5,5	3,5-12	from 36	from 79	2000	Bases & Plates	PowerRail	RX	Dull Diagonal		AFS GW	28,0	60	D-RX	Diagonal	Powerrail Brake ² LD 95 [F]	33,5	60	255-378	A / GW
PR 11 GW Brake 78 [G]	3,0	3-11	from 31	from 67	1790	Bases & Plates	PowerRail	SX	Full Diagonal		AFS GW	28,0	60	SX FR	Standard	Powerrail Brake SL 78 [G]	31,0	60	255-378	A / GW
PR 11 GW Brake 85 [G]	3,0	3-11	from 31	from 67	1790	Bases & Plates	PowerRail	SX	Full Diagonal		AFS GW	28,0	60	SX FR	Standard	Powerrail Brake SL 85 [G]	31,0	60	255-378	A / GW
PR 11 GW Brake 90 [G]	3,0	3-11	from 31	from 67	1790	Bases & Plates	PowerRail	SX	Full Diagonal		AFS GW	28,0	60	SX FR	Standard	Powerrail Brake SL 90 [G]	31,0	60	255-378	A / GW
SLR 7.5 GW AC Brake 78 [H]	1,5	2-7,5	22-84	48-187	1390	SLR PRO	SLR PRO	SX Jr.	Full Diagonal		AFS GW Jr.	25,5	60	SX Jr.	Standard	SL Brake LR 78 [H]	27,0	60	XS:183 - 307/ XM:215 - 339/ XL:239 - 363	A/C/GW GW Jr.
SLR 4.5 GW AC Brake 80 [I]	1,5	0,75-4,5	10-48	22-105	1290	SLR PRO	SLR PRO	SX Kid	Full Diagonal		AFS GW Jr.	25,5	60	SX Kid	Standard	SX Kid Brake SLR 80 [I]	27,0	60	XS:183 - 307/ XM:215 - 339/ XL:239 - 363	A/C/GW GW Jr.
WOMEN																				
JOY 12 GW PRD Brake 85 [F]	5,5	3,5-12	from 36	from 79	2000	Bases & Plates	PowerRail	RX	Full Diagonal		AFS GW	28,0	60	D-RX	Diagonal	Powerrail Brake ² LD 85 [F]	33,5	60	255-378	A / GW
JOY 11 GW SLR Brake 78 [H]	2,0	3-11	from 31	from 67	1800	SLR PRO	SLR PRO	RX	Full Diagonal		AFS GW	26,0	60	NX	Standard	SL Brake LR 78 [H]	28,0	60	XS:183 - 307/ XM:215 - 339/ XL:239 - 363	A / GW
JOY 11 GW SLR Brake 90 [H]	2,0	3-11	from 31	from 67	1800	SLR PRO	SLR PRO	RX	Full Diagonal		AFS GW	26,0	60	NX	Standard	SL Brake LR 90 [H]	28,0	60	XS:183 - 307/ XM:215 - 339/ XL:239 - 363	A / GW
JOY 9 GW SLR Brake 78 [H]	2,0	2,5-9	from 26	from 57	1420	SLR PRO	SLR PRO	SX Lite	Full Diagonal		AFS GW	26,0	60	SXG Lite	Standard	SL Brake LR 78 [H]	28,0	60	XS:183 - 307/ XM:215 - 339/ XL:239 - 363	A / GW
JOY 9 GW SLR Brake 85 [H]	2,0	2,5-9	from 26	from 57	1420	SLR PRO	SLR PRO	SX Lite	Full Diagonal		AFS GW	26,0	60	SXG Lite	Standard	SL Brake LR 85 [H]	28,0	60	XS:183 - 307/ XM:215 - 339/ XL:239 - 363	A / GW
JUNIOR																				
EVO 9 GW AC Brake 78 [J]	3,0	2,5-9	from 26	from 57	1510	92 W / 92 FAT	---	SX Lite	Full Diagonal		AFS GW Jr.	18,0	-	SX Lite	Standard	SL Brake 78 [J]	21,0	32 (-8/+24)	---	A/C/GW GW Jr.

TECHNICAL INFORMATION

TECHNICAL INFORMATION

TYROLIA BINDING LINE 2020.21

DATASHEET

Model	Ramp angle	Z - DIN	kg	lbs	Set-Weight [g]	Drill Template	FEATURE	Toe					Heel					Boot Sole		
								Type	System	AFD	Stand Height [mm]	Length Adj. Range [mm]	Type	Heel System	Brake [Code]	Stand Height [mm]	Length Adj. Range [mm]	Length [mm]	DIN/ISO Standard	
RACING																				
FREEFLEX ST 16 Brake 85 [A]	4,5	5-16	from 49	from 109	2650	92 W / 92 FAT	FREEFLEX Pro Wide Track	STREAM	---		AFD ST TEFLON	12,5	---	RACE PRO	Standard	PB² Race Pro 17-85 [A]	17,0	32	255 - 375	A
FREEFLEX Pro 11 Brake 85 [D]	7,0	3-11	from 31	from 67	2250	92 W / 92 FAT	FREEFLEX Pro	SX	Full Diagonal		ABS	14,0	---	RACE Lite	Standard	Power Brake² LD 85 [D]	21,0	24	257 - 372	A
FREEFLEX DEMO 14 GW Brake 85 [D]	1,5	4-14	from 42	from 92	2650	FREEFLEX DEMO	FREEFLEX DEMO	RX	Full Diagonal		AFS GW	19,5	60	NX	Standard	Power Brake² LD 85 [D]	21,0	60	263-386	A / GW
AAA-SERIES																				
ADRENALIN 14 AT short W/O Brake [F]	4-10,5	4-13	from 42	from 92	2720*	Adrenalin	Hiking platform	FR PRO	---		AFS metal	28,5-35,0	---	NX FR	Standard	w/o Brake [F]	39,0	60	270-330	A / T
ADRENALIN 14 AT long W/O Brake [F]	4-10,5	4-13	from 42	from 92	2740*	Adrenalin	Hiking platform	FR PRO	---		AFS metal	28,5-35,0	---	NX FR	Standard	w/o Brake [F]	39,0	60	300-360	A / T
AMBITION 12 AT W/O Brake [C]	1(*5)	4-12	from 42	from 92	1980*	Ambition	Telescopic tube	AT	---		AFS	37,0	---	AT	Standard	w/o Brake [C]	38 (*42)	14	260-350	A / T
AMBITION 10 AT W/O Brake [C]	1(*5)	3-10	from 31	from 67	1960*	Ambition	Telescopic tube	AT	---		AFS	37,0	---	AT	Standard	w/o Brake [C]	38 (*42)	14	260-350	A / T
ATTACK² 18 X GW W/O Brake [A]	2-5	8-18	from 79	from 175	2430*	92 W / 92 FAT	---	FR PRO²	---		AFD metal	12-15	---	RACE PRO FR	Standard	w/o Brake [A]	17,0	32	---	A / GW
ATTACK² 16 GW W/O Brake [A]	2-5	5-16	from 49	from 109	2240*	92 W / 92 FAT	---	FR PRO²	---		AFD metal	12-15	---	RACE PRO FR	Standard	w/o Brake [A]	17,0	32	---	A / GW
ATTACK² 14 AT W/O Brake [A]	2-7	4-14	from 42	from 92	2230*	92 W / 92 FAT	---	FR PRO² AT	---		AFS metal	17-22	---	NX FR	Standard	w/o Brake [A]	24,0	32	---	A / T
ATTACK² 13 GW W/O Brake [A]	2-5	4-13	from 42	from 92	2070*	92 W / 92 FAT	---	FR PRO²	---		AFD metal	12-15	---	NX FR	Standard	w/o Brake [A]	17,0	32	---	A / GW
ATTACK² 13 GW Brake 85 [A]	2-5	4-13	from 42	from 92	2070	92 W / 92 FAT	---	FR PRO²	---		AFD metal	12-15	---	NX FR	Standard	PB² Race Pro 17-85 [A]	17,0	32	---	A / GW
ATTACK² 13 GW Brake 95 [A]	2-5	4-13	from 42	from 92	2070	92 W / 92 FAT	---	FR PRO²	---		AFD metal	12-15	---	NX FR	Standard	PB² Race Pro 95 [A]	17,0	32	---	A / GW
ATTACK² 13 GW Brake 110 [A]	2-5	4-13	from 42	from 92	2070	92 W / 92 FAT	---	FR PRO²	---		AFD metal	12-15	---	NX FR	Standard	PB² Race Pro 110 [A]	17,0	32	---	A / GW
ATTACK² 12 GW Brake 85 [A]	2-5	3,5-12	from 36	from 79	2070	92 W / 92 FAT	---	FR PRO²	---		AFD metal	12-15	---	NX FR	Standard	PB² Race Pro 17-85 [A]	17,0	32	---	A / GW
ATTACK² 12 GW Brake 95 [A]	2-5	3,5-12	from 36	from 79	2070	92 W / 92 FAT	---	FR PRO²	---		AFD metal	12-15	---	NX FR	Standard	PB² Race Pro 95 [A]	17,0	32	---	A / GW
ATTACK² 12 GW Brake 110 [A]	2-5	3,5-12	from 36	from 79	2070	92 W / 92 FAT	---	FR PRO²	---		AFD metal	12-15	---	NX FR	Standard	PB² Race Pro 110 [A]	17,0	32	---	A / GW
ATTACK² 11 GW W/O Brake [L]	6-9	3-11	from 31	from 67	1800*	92 W / 92 FAT	---	FR PRO²	---		AFD metal	12-15	---	SX FR	Standard	w/o Brake [L]	21,0	32	---	A / GW
ATTACK² 11 GW Brake 90 [L]	6-9	3-11	from 31	from 67	1800	92 W / 92 FAT	---	FR PRO²	---		AFD metal	12-15	---	SX FR	Standard	SL Brake FS 90 [L]	21,0	32	---	A / GW
ATTACK² 11 GW Brake 100 [L]	6-9	3-11	from 31	from 67	1800	92 W / 92 FAT	---	FR PRO²	---		AFD metal	12-15	---	SX FR	Standard	SL Brake FS 100 [L]	21,0	32	---	A / GW
ATTACK² 13 AT DEMO W/O Brake [F]	3-7	4-13	from 42	from 92	2550*	Attack Demo	Attack Demo PR	FR PRO² AT	---		AFS metal	25-29	60	NX FR	Standard	w/o Brake [F]	32,0	60	259-382	A / T
ATTACK² 13 AT DEMO Brake 95 [F]	3-7	4-13	from 42	from 92	2550	Attack Demo	Attack Demo PR	FR PRO² AT	---		AFS metal	25-29	60	NX FR	Standard	Powerrail Brake² LD 95 [F]	32,0	60	259-382	A / T
ATTACK² 13 AT DEMO Brake 110 [F]	3-7	4-13	from 42	from 92	2550	Attack Demo	Attack Demo PR	FR PRO² AT	---		AFS metal	25-29	60	NX FR	Standard	Powerrail Brake² LD 110 [F]	32,0	60	259-382	A / T
ATTACK² 11 AT DEMO W/O Brake [G]	0,5-4,5	3-11	from 31	from 67	2430*	Attack Demo	Attack Demo PR	FR PRO² AT	---		AFS metal	25-29	60	SX FR	Standard	w/o Brake [G]	29,5	60	259-382	A / T
ATTACK² 11 AT DEMO Brake 90 [G]	0,5-4,5	3-11	from 31	from 67	2430	Attack Demo	Attack Demo PR	FR PRO² AT	---		AFS metal	25-29	60	SX FR	Standard	Powerrail Brake SL 90 [G]	29,5	60	259-382	A / T
ATTACK² 11 AT DEMO Brake 100 [G]	0,5-4,5	3-11	from 31	from 67	2430	Attack Demo	Attack Demo PR	FR PRO² AT	---		AFS metal	25-29	60	SX FR	Standard	Powerrail Brake SL 100 [G]	29,5	60	259-382	A / T
SYSTEM																				
PRW 12 GW Brake 85 [F]	5,5	3,5-12	from 36	from 79	2000	Bases & Plates	PowerRail	AM	Full Diagonal		AFS GW	28,0	60	D-RX	Diagonal	Powerrail Brake² LD 85 [F]	33,5	60	255-378	A / GW
PRD 12 GW Brake 85 [F]	5,5	3,5-12	from 36	from 79	2000	Bases & Plates	PowerRail	RX	Full Diagonal		AFS GW	28,0	60	D-RX	Diagonal	Powerrail Brake² LD 85 [F]	33,5	60	255-378	A / GW
PRD 11 GW Brake 85 [F]	5,5	3-11	from 31	from 67	1980	Bases & Plates	PowerRail	SX	Full Diagonal		AFS GW	28,0	60	D-RX	Diagonal	Powerrail Brake² LD 85 [F]	33,5	60	255-378	A / GW
PRW 11 GW Brake 85 [G]	3,0	3-11	from 31	from 67	1840	Bases & Plates	PowerRail	AM	Full Diagonal		AFS GW	28,0	60	SX FR	Standard	Powerrail Brake SL 85 [G]	31,0	60	255-378	A / GW
PR 11 GW Brake 85 [G]	3,0	3-11	from 31	from 67	1790	Bases & Plates	PowerRail	SX	Full Diagonal		AFS GW	28,0	60	SX FR	Standard	Powerrail Brake SL 85 [G]	31,0	60	255-378	A / GW
PR 11 GW Brake 90 [G]	3,0	3-11	from 31	from 67	1790	Bases & Plates	PowerRail	SX	Full Diagonal		AFS GW	28,0	60	SX FR	Standard	Powerrail Brake SL 90 [G]	31,0	60	255-378	A / GW
SLR 10 GW Brake 85 [H]	2,0	3-10	from 31	from 67	1800	SLR PRO	SLR PRO	RX	Full Diagonal		AFS GW	26,0	60	NX	Standard	SL Brake LR 85 [H]	28,0	60	XS:183 - 307/ XM:215 - 339/ XL:239 - 363	A / GW
SLR 9.0 GW Brake 85 [H]	2,0	2,5-9	from 26	from 57	1420	SLR PRO	SLR PRO	SX Lite	Full Diagonal		AFS GW	26,0	60	SXG Lite	Standard	SL Brake LR 85 [H]	28,0	60	XS:183 - 307/ XM:215 - 339/ XL:239 - 363	A / GW
SLR 9.0 GW Brake 90 [H]	2,0	2,5-9	from 26	from 57	1420	SLR PRO	SLR PRO	SX Lite	Full Diagonal		AFS GW	26,0	60	SXG Lite	Standard	SL Brake LR 90 [H]	28,0	60	XS:183 - 307/ XM:215 - 339/ XL:239 - 363	A / GW
SLR 9.0 GW Brake 100 [H]	2,0	2,5-9	from 26	from 57	1420	SLR PRO	SLR PRO	SX Lite	Full Diagonal		AFS GW	26,0	60	SXG Lite	Standard	SL Brake LR 100 [H]	28,0	60	XS:183 - 307/ XM:215 - 339/ XL:239 - 363	A / GW
SLR 7.5 GW AC Brake 78 [H]	1,5	2-7,5	22-84	48-187	1390	SLR PRO	SLR PRO	SX Jr.	Full Diagonal		AFS GW Jr.	25,5	60	SX Jr.	Standard	SL Brake LR 78 [H]	27,0	60	XS:183 - 307/ XM:215 - 339/ XL:239 - 363	A/C/GW GW Jr.
SLR 7.5 GW AC Brake 90 [H]	1,5	2-7,5	22-84	48-187	1390	SLR PRO	SLR PRO	SX Jr.	Full Diagonal		AFS GW Jr.	25,5	60	SX Jr.	Standard	SL Brake LR 90 [H]	27,0	60	XS:183 - 307/ XM:215 - 339/ XL:239 - 363	A/C/GW GW Jr.
SLR 4.5 GW AC Brake 80 [I]	1,5	0,75-4,5	10-48	22-105	1290	SLR PRO	SLR PRO	SX Kid	Full Diagonal		AFS GW Jr.	25,5	60	SX Kid	Standard	SX Kid Brake SLR 80 [I]	27,0	60	XS:183 - 307/ XM:215 - 339/ XL:239 - 363	A/C/GW GW Jr.

TECHNICAL INFORMATION

TECHNICAL INFORMATION

* Weight with Brake

A: Alpine Adults, A/C: Alpine Adults and Alpine Children, A/GW: Alpine Adults and GripWalk, A/C/GW/GWJr.: Alpine Adults, GripWalk, Alpine Children and GripWalk Jr., A/T: Alpine Adults and Touring T

TYROLIA BINDING LINE 2020.21

DATASHEET

Model	Ramp angle	Z - DIN	kg	lbs	Set-Weight [g]	Drill Template	FEATURE	Toe					Heel					Boot Sole			
								Type	System	AFD	Stand Height [mm]	Length Adj. Range [mm]	Type	Heel System	Brake [Code]	Stand Height [mm]	Length Adj. Range [mm]	Length [mm]	DIN/ISO Standard		
LIGHT DIAGONAL																					
AM 12 GW Brake 85 [D]	5,5	3,5-12	from 36	from 79	1980	92 W / 92 FAT	---	AM	Full Diagonal		AFS GW	15,5	---	D-RX	Diagonal	Power Brake ² LD 85 [D]	21,0	24	---	A / GW	
AM 12 GW Brake 95 [D]	5,5	3,5-12	from 36	from 79	1980	92 W / 92 FAT	---	AM	Full Diagonal		AFS GW	15,5	---	D-RX	Diagonal	Power Brake ² LD 95 [D]	21,0	24	---	A / GW	
AM 12 GW Brake 110 [D]	5,5	3,5-12	from 36	from 79	1980	92 W / 92 FAT	---	AM	Full Diagonal		AFS GW	15,5	---	D-RX	Diagonal	Power Brake ² LD 110 [D]	21,0	24	---	A / GW	
RX 12 GW Brake 85 [D]	5,5	3,5-12	from 36	from 79	1980	92 W / 92 FAT	---	RX	Full Diagonal		AFS GW	15,5	---	D-RX	Diagonal	Power Brake ² LD 85 [D]	21,0	24	---	A / GW	
SUPERLIGHT																					
SX 10 GW Brake 78 [J]	9,5	3-10	from 31	from 67	1650	92 W / 92 FAT	---	SX	Full Diagonal		AFS GW	11,5	---	SX	Standard	SL Brake 78 [J]	21,0	32 (-8/+24)	---	A / GW	
D 12 GW W/O Brake [D]	9,5	3,5-12	from 36	from 79	1790	92 W / 92 FAT	---	SX	Full Diagonal		AFS GW	11,5	---	NX	Standard	w/o Brake [D]	21,0	24	---	A / GW	
D 11 GW W/O Brake [J]	9,5	3-11	from 31	from 67	1650	92 W / 92 FAT	---	SX	Full Diagonal		AFS GW	11,5	---	SX	Standard	w/o Brake [J]	21,0	32 (-8/+24)	---	A / GW	
JUNIOR																					
SX 7.5 GW AC Brake 78 [J]	7,5	2-7,5	22-84	48-187	1410	92 W / 92 FAT	---	SX Jr.	Full Diagonal		AFS GW Jr.	13,5	---	SX Jr.	Standard	SL Brake 78 [J]	21,0	32 (-8/+24)	---	A/C/GW GW Jr.	
SX 7.5 GW AC Brake 90 [J]	7,5	2-7,5	22-84	48-187	1410	92 W / 92 FAT	---	SX Jr.	Full Diagonal		AFS GW Jr.	13,5	---	SX Jr.	Standard	SL Brake 90 [J]	21,0	32 (-8/+24)	---	A/C/GW GW Jr.	
SX 4.5 GW AC Brake 80 [K]	1,5	0,75-4,5	10-48	22-105	1200	94 W	---	SX Kid	Full Diagonal		AFS GW Jr.	13,5	---	SX Kid	Standard	SX Kid Brake 80 [K]	15,0	44	---	A/C/GW GW Jr.	
D 4.5 GW AC Brake 80 [K]	1,5	0,75-4,5	10-48	22-105	1200	94 W	---	SX Kid	Full Diagonal		AFS GW Jr.	13,5	---	SX Kid	Standard	SX Kid Brake 80 [K]	15,0	44	---	A/C/GW GW Jr.	
PROMO																					
PR 10 GW Promo Brake 85 [G]	3,0	3-10	from 31	from 67	1770	Bases & Plates	PowerRail	SX	Full Diagonal		AFS GW	28,0	60	SX	Standard	Powerrail Brake SL 85 [G]	31,0	60	255-378	A / GW	
SRM 10 GW Brake 85 [D]	6,5	2,5-10	from 26	from 57	2200	SR 2003 W yellow arrow	SYMRENT	SX	Full Diagonal		AFS GW	15,5	---	RENT	Rental	Power Brake ² LD 85 [D]	22,0	84	263-351	A / GW	
SX 10 GW Promo Brake 78 [J]	9,5	3-10	from 31	from 67	1650	92 W / 92 FAT	---	SX	Full Diagonal		AFS GW	11,5	---	SXG	Standard	SL Brake 78 [J]	21,0	32 (-8/+24)	---	A / GW	
SX 10 GW Promo Brake 90 [J]	9,5	3-10	from 31	from 67	1650	92 W / 92 FAT	---	SX	Full Diagonal		AFS GW	11,5	---	SXG	Standard	SL Brake 90 [J]	21,0	32 (-8/+24)	---	A / GW	

TYROLIA INSIDE LINE 2020.21

DATASHEET

Model	Ramp angle	Z - DIN	kg	lbs	Set-Weight [g]	Drill Template	FEATURE	Toe					Heel					Boot Sole			
								Type	System	AFD	Stand Height [mm]	Length Adj. Range [mm]	Type	Heel System	Brake [Code]	Stand Height [mm]	Length Adj. Range [mm]	Length [mm]	DIN/ISO Standard		
AAA-SERIES																					
K13 ATTACK ² GW W/O Brake [A] (Kästle)	2-5	4-13	from 42	from 92	2070*	92 W / 92 FAT	---	FR PRO ²	---		AFD metal	12-15	---	NX FR	Standard	w/o Brake [A]	17,0	32	---	A / GW	
K13 ATTACK ² AT DEMO W/O Brake [F] (Kästle)	3-7	4-13	from 42	from 92	2550*	Attack Demo	Attack Demo PR	FR PRO ² AT	---		AFS metal	25-29	60	NX FR	Standard	w/o Brake [F]	32,0	60	259-382	A / T	
COMP. / RACING																					
K14 FREEFLEX EVO Brake 85 [D] (Kästle)	7,0	4-14	from 42	from 92	2330	92 W / 92 FAT	FREEFLEX PRO	RX	Full Diagonal		ABS	14,0	---	D-RX	Standard	Power Brake ² LD 85 [D]	21,0	24	257-372	A	
SYSTEM																					
K12 TRI GW W/O Brake [F] (Kästle)	5,5	3,5-12	from 36	from 79	2000	Bases & Plates	PowerRail	RX	Full Diagonal		AFS GW	28,0	60	D-RX	Diagonal	w/o Brake [F]	33,5	60	255-378	A / GW	
K12 PRW GW Brake W/O Brake [F] (Kästle)	5,5	3,5-12	from 36	from 79	2000	Bases & Plates	PowerRail	RX	Full Diagonal		AFS GW	28,0	60	D-RX	Diagonal	w/o Brake [F]	33,5	60	255-378	A / GW	
K10 SLR GW Brake 85 [H] (Kästle)	2,0	3-10	from 31	from 67	1800	SLR PRO	SLR PRO	RX	Full Diagonal		AFS GW	26,0	60	NX	Standard	SL Brake LR 85 [H]	28,0	60	XS:183 - 307/ XM:215 - 339/ XL:239 - 363	A / GW	
K7.5 GW AC SLR Brake 85 [H] (Kästle)	1,5	2-7,5	22-84	48-187	1390	SLR PRO	SLR PRO	SX Jr.	Full Diagonal		AFS GW Jr.	25,5	60	SX Jr.	Standard	SL Brake LR 78 [H]	27,0	60	XS:183 - 307/ XM:215 - 339/ XL:239 - 363	A/C/GW GW Jr.	
K4.5 GW AC SLR Brake 80 [I] (Kästle)	1,5	0,75-4,5	10-48	22-105	1290	SLR PRO	SLR PRO	SX Kid	Full Diagonal		AFS GW Jr.	25,5	60	SX Kid	Standard	SX Kid Brake SLR 80 [I]	27,0	60	XS:183 - 307/ XM:215 - 339/ XL:239 - 363	A/C/GW GW Jr.	
PROMO																					
SRM 4.5 GW AC Brake 80 [K] (Decathlon)	0	0,75-4,5	10-48	22-105	1330	SR 2003 W red arrow (green arrow)	SYMRENT	SX Kid	Full Diagonal		AFS GW Jr.	15,0	---	SX Kid OT	Rental	SX Kid Brake 80 [K]	15,0	52	199 - 255	A/C/GW GW Jr.	

* Weight with Brake

A: Alpine Adults, A/C: Alpine Adults and Alpine Children, A/GW: Alpine Adults and GripWalk, A/C/GW/GW Jr.: Alpine Adults, GripWalk, Alpine Children and GripWalk Jr., A/T: Alpine Adults and Touring T

RENTAL

FOR ALL TYPES OF DAILY USE ON SNOW

Special features make the TYROLIA Rental bindings extremely long lasting and especially durable, but at the same time easier to handle – ideally suited for long-term use and abuse in the rental sector.

REFERENCE CHART - RENTAL

TECHNICAL INFORMATION

TOE PIECE

- 1 Adjustment screw
- 2 Visual indicator
- 3 AFS GW
- 4 Colored base plate (BYS)
- 5 One Touch lever
- 6 Base plate
- 7 Bar code area
- 8 Single code scale
- 9 Wings

HEEL PIECE

- 10 Brake pedal
- 11 Brake arms
- 12 Heel lever
- 13 Heel cover
- 14 Sole lug
- 15 Visual indicator
- 16 Heel housing
- 17 Adjustment screw
- 18 Single code scale
- 19 One touch lever

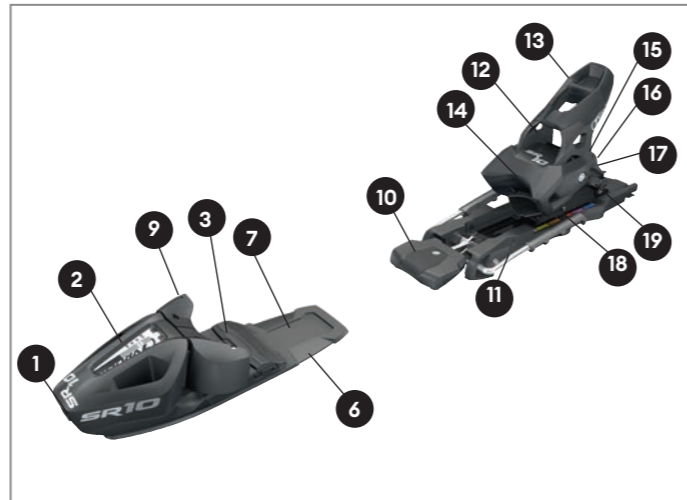
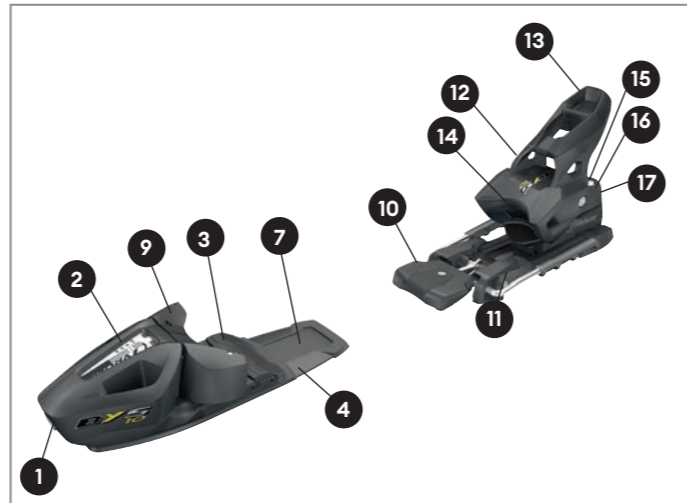
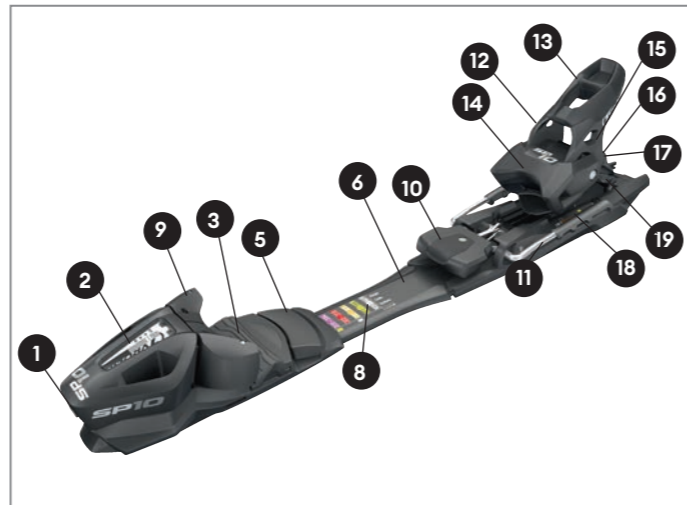

RENTAL TECHNOLOGY

GripWalk COMPATIBILITY

The complete TYROLIA Rental binding range is GripWalk and GripWalk Junior compatible. All bindings can be used with Alpine (ISO 5355 TYPE A & C) and GripWalk ski boots (ISO 23223 TYPE A & C).

TYROLIA ONE-TOUCH-SYSTEM

The innovative One-Touch-System used for the TYROLIA Rental bindings ensures the simplest possible operation and length adjustment of toes and heels. Because – especially in the Rental sector – time is also money!

TYROLIA SYMPRO SYSTEM

The TYROLIA SYMPRO (SP) bindings are for any rental ski without integrated system. The length of the toe and heel can be adjusted with only a few easy steps for fast on-hill adjustment.

TYROLIA SYMRENT SYSTEM

The TYROLIA SYMRENT (SR) bindings are ideal for mounting on any rental ski. The mobile heel can be adjusted simply and very quickly to almost any size of a boot.

BARCODE HOLDER

The TYROLIA SLR 7.5 GW AC Pro Set and SLR 4.5 GW AC Pro Set come with a barcode holder. An additional barcode holder can be retrofitted to all other SLR Pro Bases.

TYROLIA RENT HEEL AND SX TOE

The TYROLIA Rent heel features improved ergonomics, resistance and better protection against abrasion plus an optimized scale window – thus combining visual quality with safety and stability. Most of the Rental binding models are equipped with the SX toe with improved kinematics and the proven Rent One-Touch-System, optimized and much appreciated for rental purposes.

TYROLIA Single Code

The TYROLIA Single Code guarantees that rental agreements are processed in record time. There is only one unit of size in the form of clearly color-coded letters. This enables, toe, heel and boot to be adjusted very quickly.

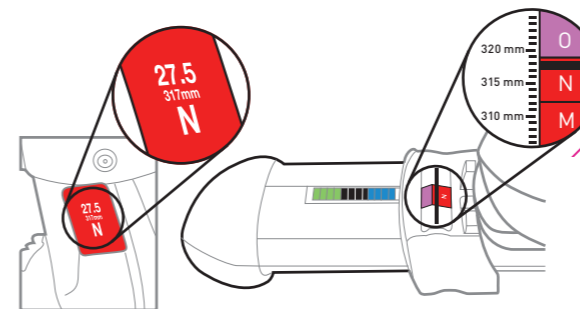

DETERMINE

If the boot is already color-coded you can use the single code – if not, measure the boot with the measuring tool to determine the single code.

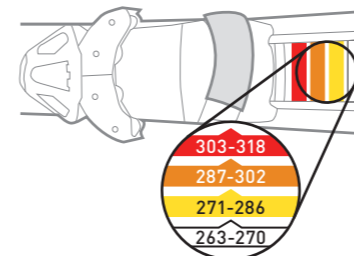

ADJUST

Adjust the toe to the desired single code position (color-coded area), which is shown on the boot (N/red).

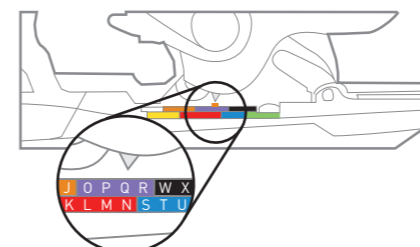

READY

Set the heel to the desired single code position (letter), which is shown on the boot as well (N/red). The system is extremely accurate so no further checks are needed.

TECHNICAL INFORMATION

TYROLIA RENTAL SYSTEMS - SP, SR & SLR PRO

The performance of a rental binding is not judged only by what happens on the hill. A key measure of a product's quality is its ease of adjustment and maintenance throughout the course of many seasons.

THE TYROLIA'S SHOP-FRIENDLY RENTAL DESIGN FEATURES:

- Easy mounting: This means fewer mistakes and a shorter set-up time.
- Easy pre-season testing, low drop-out rate. The automatic sole lug design and the precise centering of the toe pincer system mean fewer correction factors will be needed and less time spent testing.
- The SINGLE CODE system gives you a super fast option for binding-to-boot adjustment: set the heel length using the special sole length scale. Forward pressure will be right on, first time, every time.
- All models have automatic lug height adjustment which accommodate standard differences in boot sole-height.
- Easy, hand-lever "ONE TOUCH"- set up. One-tool adjustment, easy-to-turn adjustment screw, "easy-in" boot feature
- Almost maintenance-free: easy to change the AFD, clean and lubricate the heel track. TYROLIA made the commitment to offer a comprehensive product and service program.

THE TYROLIA RENTAL BINDINGS

No single rental binding can ever fulfill all the needs of all types of shops. We therefore offer the following line of rental/demo models.

SYMPRO:

THE BINDINGS THAT HELP YOUR HIGH PERFORMANCE SKI SET-UP:

SP 10 GW

- Hand lever adjusted heel (60 mm) and toe (64 mm)
- 7 toe positions
- DIN ranges from 2.5 up to 10 that accommodate even high-level skiers
- Short, lightweight heel track, while offering a wide adjustment range
- SINGLE CODE: "A-6" for ski boots with sole lengths from 263 to 391 mm
- Replaceable Brake
- Diagonal toe
- Optimal for carving, minimized deviation between ski and boot mounting point
- Fully GripWalk compatible - no further height adjustment necessary

SLR PRO:

SLR 7.5 GW AC PRO SET SLR 4.5 GW AC PRO SET

A child and junior model, super convenient, "parent-free" operation.

- Automatic toe and heel pieces accept child and adult boot sole dimensions, giving you full use of your child/junior ski inventory
 - SINGLE CODE
 - "a-L" for ski boots with sole lengths from 183 to 307mm (SLR 4.5 GW AC PRO SET) and
 - "f-T" for ski boots with sole lengths from 215-339 mm (SLR 7.5 GW AC PRO SET)
- A lowercase letter Single Code refers to children's boots, an uppercase letter code to TYPE A boots (Adult)
- „ONE TOUCH" hand lever adjustment for toe and heel
 - Replaceable Brake
 - Diagonal Toe
 - Bar Code Holder
 - For ski groups G3 and G4
 - DIN range 0.75 up to 7.5
 - Fully GripWalk Junior compatible - compatible with adult alpine and GripWalk ski boots as well as children's alpine and GripWalk Junior ski boots, no height adjustment necessary

SYMRENT:

SR 10 GW SRM 10 GW

A technically proven workhorse for the discerning skier who rents

- DIN range of 2.5 up to 10
- Diagonal toe
- Large 84 mm heel adjustment range
- SINGLE CODE "A-V"
- Automatic toe and heel height adjustment
- "ONE TOUCH" hand lever adjustment for the heel
- Replaceable Brake
- Fully GripWalk compatible - no further height adjustment necessary

SR 4.5 GW AC SRM 4.5 GW AC

A child and junior model, super convenient, "parent-free" operation.

- Automatic toe and heel pieces accept child and adult boot sole dimensions, giving you full utilization of your child/junior ski inventory
- SINGLE CODE
 - "b-o" (199-255 mm) standard, or
 - "j-w/F" (231-287 mm) with spare part 162970
- "ONE TOUCH" hand lever adjustment of the heel
- Replaceable Brake
- Easy to open, easy to close
- For ski groups G3 and G4
- DIN range 0.75 up to 4.5
- Fully GripWalk Junior compatible - compatible with adult Alpine and GripWalk ski boots as well as children's Alpine and GripWalk Junior ski boots, no height adjustment necessary

TYROLIA RENTAL SYSTEMS - BYS & HRS

RENTAL REVOLUTION

When customers enter your shop to rent gear they have only one thing in mind: enjoying the snowy mountains outside your window. Nothing against you or your shop, skiing down slopes is just way more fun than waiting in line for equipment. Calibrating, mounting and fitting can take ages, unless you've got HEAD'S RENTAL System, not only speeding up your rental business, but also putting smiles on the faces of your customers and getting them out on the snow.

SIMPLICITY RULES

The breakdown. Fitting, mounting and adjusting is extremely time consuming. With the variables of ski length, boot size, weight, height and riding style the possible combinations amount to over 2.500 set ups per season in a typical rental operation. With BYS you can break that number down to less than 100. How? through simplification: HEAD BYS boots are reduced to three fixed sole-lengths per size-run, each perfectly fitting into corresponding pre-adjusted bindings.

1, 2, SKI

Add some color to your life. HEAD'S BYS system categorizes all rental gear into three clear segments by coding them with the colors black, yellow and silver. In just two simple steps, customers will be walking out of your shop and hitting the slopes with the right equipment. All they have to do is 1) choose a boot and 2) choose the matching ski with the same color tag. That's safe, easy and time efficient rental gear handling.

FACTORY SEALED AND PRE-SET

It just keeps getting better and better: Start replenishing your boot fleet with BYS boots. The more, the better. For maximum savings convert your entire fleet - boots and skis. HEAD RENTAL BYS is a pre-set and pre-mounted system. All skis are shipped with ready-to-go installed bindings, nicely shrink-wrapped along with a pre-season inspection certificate. Forget about all the hassles of mounting and pre-season calibrations. All you have to do is open the box and make customers happy. It's an easy job with the BYS Rental System.

BINDINGS:

BY 10 GW

- Features:** Fitted and ready to go
Non-adjustable length
No rental track
Each pair is 1 kg (2.2 pounds) lighter than similar traditional bindings
Color coded barcode holder
Fully GripWalk compatible
- Setting:** Each skier has only 3 possible DIN settings depending on the color coding.
The value of the binding setting does not need to be changed if a boot is used with a different size within the same color code.
- Sizes:** DIN 2.5 - 10



SX 4.5 R GW AC

- Features:** Fitted and ready to go
Non-adjustable length
No rental track
Each pair is 0,5 kg (more than a pound) lighter than similar traditional bindings
Color coded barcode holder
GripWalk Junior compatible
- Setting:** Each skier has only 4 possible DIN settings depending on the color coding. The value of the binding setting does not need to be changed if a boot is used with a different size within the same symbol-color code.
- Sizes:** DIN 0.75 - 4.5



HEAD/TYROLIA RENTAL LINE 2020.21

DATASHEET

Model	Ramp angle	Z - DIN	kg	lbs	Set-Weight [g]	Drill Template	Feature	Toe					Heel					Boot Sole					
								Type	System	AFD	Stand Height [mm]	Length Adj. Range [mm]	Type	Heel System	Brake [Code]	Stand Height [mm]	Length Adj. Range [mm]	Single Code	Mondo - point	Length [mm]	DIN/ISO Standard		
RACING																							
FREEFLEX DEMO 14 GW Brake 85 [D]	1,5	4-14	from 42	from 92	2650	FREEFLEX DEMO	FREEFLEX DEMO	RX	Full Diagonal		AFS GW	19,5	60	NX	Standard	Power Brake ² LD 85 [D]	21,0	60	A - 5	22 - 35	263-386	A / GW	
AAA-SERIES																							
ATTACK ² 13 AT DEMO W/O Brake [F]	3-7	4-13	from 42	from 92	2550*	Attack Demo	Attack Demo PR	FR PRO ² AT	---		AFS metal	25-29	60	NX FR	Standard	w/o Brake [F]	32,0	60	q - 5	22 - 34	259-382	A / T	
ATTACK ² 13 AT DEMO Brake 95 [F]	3-7	4-13	from 42	from 92	2550	Attack Demo	Attack Demo PR	FR PRO ² AT	---		AFS metal	25-29	60	NX FR	Standard	Powerrail Brake ² LD 95 [F]	32,0	60	q - 5	22 - 34	259-382	A / T	
ATTACK ² 13 AT DEMO Brake 110 [F]	3-7	4-13	from 42	from 92	2550	Attack Demo	Attack Demo PR	FR PRO ² AT	---		AFS metal	25-29	60	NX FR	Standard	Powerrail Brake ² LD 110 [F]	32,0	60	q - 5	22 - 34	259-382	A / T	
ATTACK ² 11 AT DEMO W/O Brake [G]	0,5-4,5	3-11	from 31	from 67	2430*	Attack Demo	Attack Demo PR	FR PRO ² AT	---		AFS metal	25-29	60	SX FR	Standard	w/o Brake [G]	29,5	60	q - 4	22 - 34	259-382	A / T	
ATTACK ² 11 AT DEMO Brake 90 [G]	0,5-4,5	3-11	from 31	from 67	2430	Attack Demo	Attack Demo PR	FR PRO ² AT	---		AFS metal	25-29	60	SX FR	Standard	Powerrail Brake SL 90 [G]	29,5	60	q - 4	22 - 34	259-382	A / T	
ATTACK ² 11 AT DEMO Brake 100 [G]	0,5-4,5	3-11	from 31	from 67	2430	Attack Demo	Attack Demo PR	FR PRO ² AT	---		AFS metal	25-29	60	SX FR	Standard	Powerrail Brake SL 100 [G]	29,5	60	q - 4	22 - 34	259-382	A / T	
SYSTEM																							
PR 11 GW Brake 85 [G]	3,0	3-11	from 31	from 67	1790	Bases & Plates	PowerRail	SX	Full Diagonal		AFS GW	28,0	60	SX FR	Standard	Powerrail Brake SL 85 [G]	31,0	60	q - 3	21 - 34	255-378	A / GW	
SLR 9.0 GW Brake 85 [H]	2,0	2,5-9	from 26	from 57	1420	SLR PRO	SLR PRO	SX Lite	Full Diagonal		AFS GW	26,0	60	SXG Lite	Standard	SL Brake LR 85 [H]	28,0	60	a - L f - T l - Z	14 - 26 17 - 30 18 - 34	XS:183 - 307/ XM:215 - 339/ XL:239 - 363	A / GW	
SLR 7.5 GW AC Brake 78 [H]	1,5	2-7,5	22-84	48-187	1390	SLR PRO	SLR PRO	SX Jr.	Full Diagonal		AFS GW Jr.	25,5	60	SX Jr.	Standard	SL Brake LR 78 [H]	27,0	60	a - L f - T l - Z	14 - 26 17 - 30 18 - 34	XS:183 - 307/ XM:215 - 339/ XL:239 - 363	A/C/GW GW Jr.	
SLR 4.5 GW AC Brake 80 [I]	1,5	0,75-4,5	10-48	22-105	1290	SLR PRO	SLR PRO	SX Kid	Full Diagonal		AFS GW Jr.	25,5	60	SX Kid	Standard	SX Kid Brake SLR 80 [I]	27,0	60	a - L f - T l - Z	14 - 26 17 - 30 18 - 34	XS:183 - 307/ XM:215 - 339/ XL:239 - 363	A/C/GW GW Jr.	
SYMPRO																							
SP 13 GW W/O Brake [F]	5,0	4-13	from 42	from 92	2620	SP 2003 W yellow bushings	SYMPRO	RX	Full Diagonal		AFS GW	26,0	64	RENT	Rental	w/o Brake [D]	31,0	60	A - 6	22 - 36	263 - 391	A / GW	
SP 10 GW Brake 85 [D]	5,0	2,5-10	from 26	from 57	2580	SP 2003 W yellow bushings	SYMPRO	SX	Full Diagonal		AFS GW	26,0	64	RENT	Rental	Power Brake ² LD 85 [D]	31,0	60	A - 6	22 - 36	263 - 391	A / GW	
SP 10 GW Brake 95 [D]	5,0	2,5-10	from 26	from 57	2580	SP 2003 W yellow bushings	SYMPRO	SX	Full Diagonal		AFS GW	26,0	64	RENT	Rental	Power Brake ² LD 95 [D]	31,0	60	A - 6	22 - 36	263 - 391	A / GW	
SP 10 GW W/O Brake [D]	5,0	2,5-10	from 26	from 57	2580*	SP 2003 W yellow bushings	SYMPRO	SX	Full Diagonal		AFS GW	26,0	64	RENT	Rental	w/o Brake [D]	31,0	60	A - 6	22 - 36	263 - 391	A / GW	
SP 10 GW (6mm screws)	5,0	2,5-10	from 26	from 57	2580	SP 2003 W yellow bushings	SYMPRO	SX	Full Diagonal		AFS GW	26,0	64	RENT	Rental	---	31,0	60	A - 6	22 - 36	263 - 391	A / GW	
SYMRENT																							
SR 10 GW Brake 85 [D]	6,5	2,5-10	from 26	from 57	2200	SR 2003 W yellow arrow	SYMRENT	SX	Full Diagonal		AFS GW	15,5	-	RENT	Rental	Power Brake ² LD 85 [D]	22,0	84	A - V	22 - 31	263 - 351	A / GW	
SR 4.5 GW AC Brake 80 [K]	0	0,75-4,5	10-48	22-105	1330	SR 2003 W red arrow (green arrow)*	SYMRENT	SX Kid	Full Diagonal		AFS GW Jr.	15,0	-	SX Kid	Rental	SX Kid Brake 80 [K]	15,0	52	b - o J - w/F	15 - 21	199 - 255 (231 - 287)*	A/C/GW GW Jr.	
BYS / HRS																							
BYS 10 GW Brake 85 [D]	5,5	2,5-10	from 26	from 57	1890	92 W / 92 FAT	BYS	SX	Full Diagonal		AFS GW	15,5	-	RENT	Standard	Power Brake ² LD 85 [D]	21,0	---	Black Yellow Silver	23.5 - 26.5 27.5 - 30.5 31.0 - 34.0	289 329 365	A / GW	
SX 4.5 R GW AC Brake 74 [K]	0	0,75-4,5	10-48	22-105	1220	94 W	94W	SX Kid	Full Diagonal		AFS GW Jr.	15,0	-	SX Kid	Standard	SX Kid Brake 74 [K]	15,0	---	red triangle blue square black diamond white circle	15.5 - 16.5 17.5 - 18.5 19.5 - 20.5 21.5 - 22.5	205 225 245 265	A/C/GW GW Jr.	
PROMO																							
SRM 10 GW Brake 85 [D]	6,5	2,5-10	from 26	from 57	2200	SR 2003 W yellow arrow	SYMRENT	SX	Full Diagonal		Teflon	15,5	-	RENT	Rental	Power Brake ² LD 85 [D]	22,0	84	A - V	22 - 31	263 - 351	A / GW	

TECHNICAL INFORMATION

TECHNICAL INFORMATION

ONLINE SUPPORT

oms.head.com

SEARCHING FOR SPARE PARTS AND TECHNICAL DATA AS SIMPLE AS POSSIBLE

The Spare Part Management offers all relevant information about ski bindings, technical data and their (spare) parts at a glance. Extensive information is available: Starting with the appropriate drill template right up to screws and spare parts related to a specific binding model, for example different Brake types – plus, all parts can be directly identified by model. Pictures and colored marks provide simple navigation tools and easy recognition of selected parts.

LOGIN User: **spare_tyrolia**
Password: **omsnew**

JUST ONE CLICK

You may navigate through the Spare Parts OMS via two different "views":

1. Product view
2. Spare part view

With the "product view" mode, all existing spare parts related to a specific binding model can be identified. With the "spare part view" mode, all spare parts are listed with their designated use.

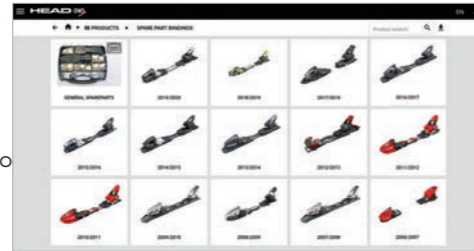

SPARE PART VIEWER

The "spare part viewer" explains all spare parts in detail (text and pictures) and shows the appropriate item number, description and order quantity.

Colored bars and marks of the requested part make navigation extremely simple and easy.

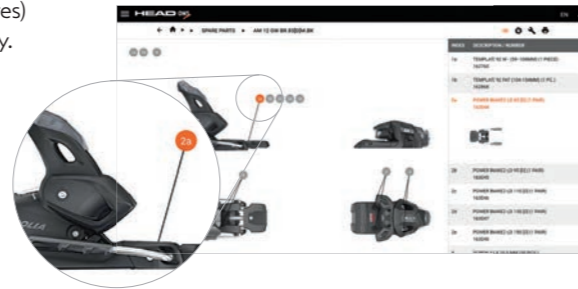

TECHNICAL DATA

In the "product view" mode, technical data is available as additional information. You may access this data by clicking on the spanner symbol. You will find this symbol in the spreadsheet between the picture preview symbol and the symbol which opens the spare part viewer (the toothed wheel symbol). You can access the technical data sheet of one specific binding model, or open the technical data catalog for all models per line and season. Technical Data for all lines (HEAD and TYROLIA) from season 2004/2005 up to the current line is available online.



ONLINE HELP

A HELP Document is also available online. You will find it in the OMS in the top right corner.

CALCULATOR APP

The Calculator App is designed to make the DIN setting process as easy as possible. You will find the app for your operating system in the appropriate App Store for IOS or Android. Search for HEAD TYROLIA CALCULATOR, accept the terms and start the download. Use „din_setting“ as the unlock code for installation. After downloading the App to your mobile device, enter all the required information and the appropriate DIN setting will appear on your smartphone screen.

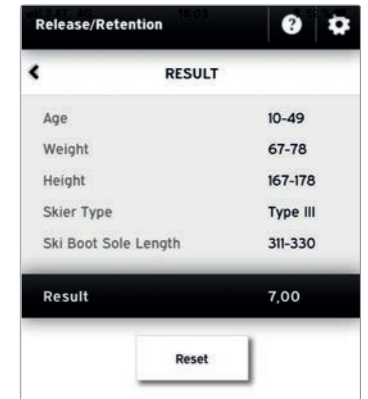

ONLY CERTIFIED HEAD/TYROLIA SKI MECHANICS ARE ALLOWED TO USE THIS APPLICATION. IT IS FOR INFORMATION PURPOSES ONLY AND MAY NOT BE FORWARDED OR OFFERED TO OTHERS.

ONLINE TYROLIA

Obsession on www.tyrolia.com

On Facebook

On Instagram

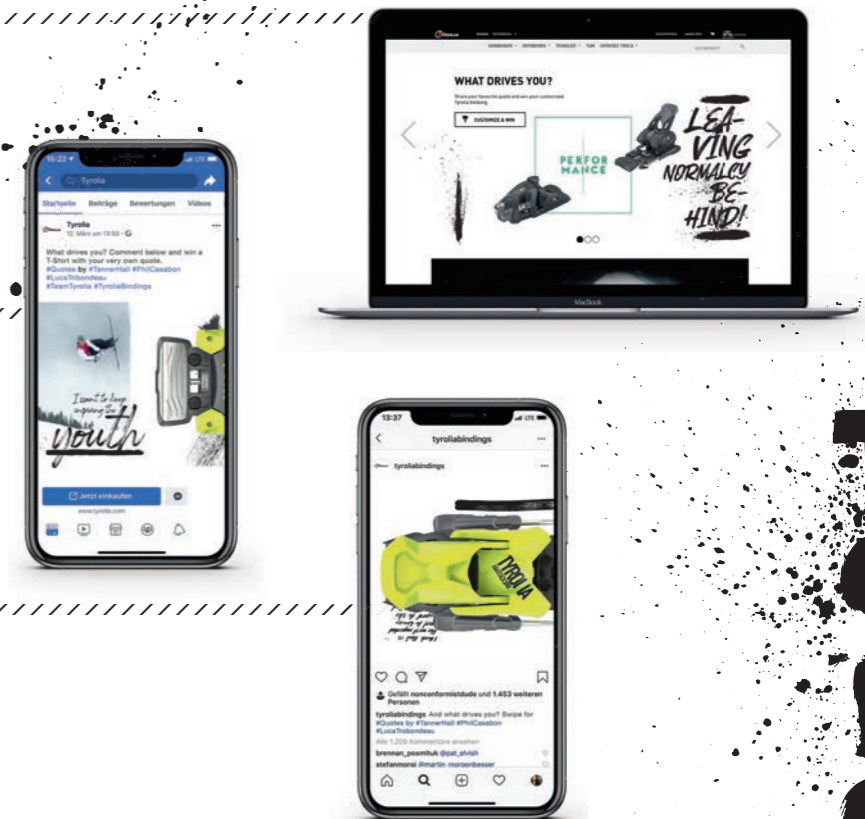

TYROLIA

HEAD/TYROLIA BRAKE LINE 2020.21

1. POWER BRAKE² FOR [A],[B],[D] AND [F]

HEAD/TYROLIA introduced the Power Brake² with a better retraction up to 30 mm in comparison to former Brakes. These Brakes retract completely to the heel housing. HEAD/TYROLIA reduces the amount of Brake models in PB segments [A],[B],[D] and [F] due to new width split – 85/95/110/130/150 (from 26 to 19 models). Power Brake² feature a fully compatibility – new Brakes match with old bindings and old Brakes match with new bindings.

85/95/110/130/150mm



2. IDENTIFICATION AND NAMING SYSTEM

To make the Brake-binding allocation as easy as possible, we are using a color coding system. In addition to the standard product labels of the spare Brakes, a color-letter code is affixed on the Brake boxes (single and master packaging).

All bindings packaged without Brakes will come with a similar sticker. Matching Brakes and bindings has become fast and easy. For a binding with a red sticker [A], the dealer just has to look for a Brake with a red sticker [A] in the proper width. The segmentation and colorcoding system can be found in the HEAD/TYROLIA Brake line on the next page.

Also the nomenclature of all HEAD/TYROLIA Brakes is standardized and includes all basic information. These nomenclature consist of a clear name, a number, what defines the maximum ski width at the mounting point and a letter, what specifies the Brake cluster.

3. W/O BRAKE BINDING MODELS

HEAD/TYROLIA is offering some binding models without Brakes, (marked "w/o Brake") to avoid Brake exchanges later on and to provide suitable Brakes for different ski widths. For these models you need to order appropriate Brakes separately. Please find all available spare Brakes in the HEAD/TYROLIA Brake line overview on page 25.

HEAD/TYROLIA BRAKE LINE 2020.21

Brake Code	HEAD	TYROLIA	TYROLIA INSIDE	ART. NO.	Brake MODEL / WIDTH
A	FREEFLEX ST 20 X RD	FREEFLEX ST 16	K13 ATTACK ² GW	163033	Power Brake ² Race PRO 17-85 [A]
	FREEFLEX ST 20 X RS	ATTACK ² 18 X GW		163035	Power Brake ² Race PRO 95 [A]
	FREEFLEX ST 16 X RD	ATTACK ² 16 GW		163036	Power Brake ² Race PRO 110 [A]
	FREEFLEX ST 16	ATTACK ² 14 AT		163037	Power Brake ² Race PRO 130 [A]
	FREEFLEX ST 14	ATTACK ² 13 GW		163038	Power Brake ² Race PRO 150 [A]
				*use only for competition (X) bindings	
				163032	Power Brake ² Race PRO 16-85 [A]*
				163034	Power Brake ² Race PRO 18-85 [A]*
B				163040	Power Brake ² FR PRO 95 [B]
				163041	Power Brake ² FR PRO 110 [B]
				163042	Power Brake ² FR PRO 130 [B]
C		AMBITION 12 AT		163003	Brake Ambition 85 white [C]
		AMBITION 10 AT		163016	Brake Ambition 95 white [C]
				163004	Brake Ambition 105 white [C]
				163005	Brake Ambition 125 white [C]
				163098	Brake Ambition 85 black [C]
				163099	Brake Ambition 95 black [C]
			163100	Brake Ambition 105 black [C]	
			163101	Brake Ambition 125 black [C]	
D	FREEFLEX 14	FREEFLEX PRO 11	K14 FREEFLEX EVO	163044	Power Brake ² LD 85 [D]
	FREEFLEX 11	FREEFLEX DEMO 14 GW		163045	Power Brake ² LD 95 [D]
	FREEFLEX DEMO 14 GW	RX 12 GW		163046	Power Brake ² LD 110 [D]
		AM 12 GW		163047	Power Brake ² LD 130 [D]
		D12 GW		163048	Power Brake ² LD 150 [D]
		SP 10 GW			
		BYS 10 GW			
		SR 10 GW			
		SRM 10 GW			
F	PRD 14 GW	ADRENALIN 14 AT	K13 ATTACK ² AT DEMO	163050	Powerrail Brake ² LD 85 [F]
	PRD 12 GW	ATTACK ² 13 AT DEMO	K12 TRI GW	163051	Powerrail Brake ² LD 95 [F]
	JOY 12 GW PRD	PRW 12 GW	K12 PRW GW	163052	Powerrail Brake ² LD 110 [F]
		PRD 12 GW		163053	Powerrail Brake ² LD 130 [F]
		PRD 11 GW			
G	PR 11 GW	ATTACK ² 11 AT DEMO		162943	Powerrail Brake SL 78 [G]
		PRW 11 GW		163084	Powerrail Brake SL 85 [G]
		PR 11 GW		162944	Powerrail Brake SL 90 [G]
		PR 10 GW PROMO		163078	Powerrail Brake SL 100 [G]
				162985	Powerrail Brake SL 115 [G]
H	JOY 11 GW SLR	SLR 10 GW	K10 SLR GW	162942	SL Brake LR 78 [H]
	JOY 9 GW SLR	SLR 9.0 GW	K 7.5 GW AC SLR	163085	SL Brake LR 85 [H]
	SLR 7.5 GW AC	SLR 7.5 GW AC		162949	SL Brake LR 90 [H]
				163079	SL Brake LR 100 [H]
I	SLR 4.5 GW AC	SLR 4.5 GW AC	K 4.5 GW AC SLR	163110	SX Kid Brake LR 80 [I]
J	EVO 9 GW AC	SX 10 GW	TW 75 GW AC	163058	SL Brake 78 [J]
		SX 7.5 GW AC		162776	SL Brake 90 [J]
		D 11 GW		163067	SL Brake 100 [J]
				163068	SL Brake 115 [J]
K		SX 4.5 GW AC	SRM 4.5 AC	163111	SX Kid Brake 80 [K]
		SR 4.5 GW AC			
		SX 4.5 R GW AC			
		D 4.5 GW AC			
L		ATTACK ² 11 GW		163027	SL Brake FS 78 [L]
				163028	SL Brake FS 90 [L]
				163029	SL Brake FS 100 [L]
				163030	SL Brake FS 115 [L]

NOTES:

TECHNICAL INFORMATION



MOUNTING BINDINGS & PLATES

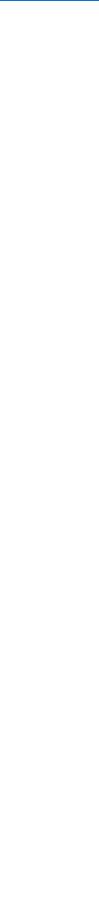

WORKSHOP TOOLS AND AIDS

To make your work easier, HEAD/TYROLIA provides a variety of workshop tools and aids. Find the whole product range below. Furthermore HEAD/TYROLIA offers different templates for all available HEAD/TYROLIA ski bindings and plates. Find the overview of the drill template selection on next pages. Referring to this overview you are able to determine easily which template should be used with which binding. Also find this information on the removable bench chart which is located inside the back cover of this Technical Manual or at the label on the binding box. For earlier lines, refer to the corresponding Technical Manuals or use the Online Spare Parts OMS to search for specific information.

PICTURE	ITEM	PACKED	Art.No.
	<ul style="list-style-type: none"> Drill Template Adapter-Set (adapter for TYROLIA-Templates) 	per set	162569
	<ul style="list-style-type: none"> Drill 4.1 Ø x 7.0 mm long Drill 4.1 Ø x 9.0 mm long Drill 3.5 Ø x 7.0 mm long Drill 3.5 Ø x 9.0 mm long Drill-set complete 	per piece per piece per piece per piece per set	162772 162773 162770 162771 162774
	<ul style="list-style-type: none"> Screwdriver flat Screwdriver incl. Pozidrive #3 Bit (160805) Handy Ratchet incl. bits (162575 + 162576) Slotted Screw Bit for Handy Ratchet Pozidrive #3 Bit for Handy Ratchet Pozidrive #3 Bit for Screwdriver 162800 and electric drivers hexagon. 1/4" (6.35 mm) Pozidrive #3 Bit for electric driver (Black & Decker, Skill, Thor, Atlas-Copco, Virax, Consolidated, Bosch, Ingersoll-Rand), hexagon. 1/4" (6.35 mm) Pozidrive #3 Bit for electric driver (Bosch, Metabo, AEG), hexagon. 1/4" (5.5 mm) Torx bit 25/50 - 1/4 inch 	per piece per piece per piece per piece per piece per piece per piece per piece	160806 162800 162574 162575 162576 160805 160805 160802
	<ul style="list-style-type: none"> Special set for repairs (drill bit and plugs) Drill bit for repair set Special plastic plugs for repair set 	per set per piece 1 set = 50 pieces	162127 162128 162129
	<ul style="list-style-type: none"> Plastic plugs mixed Plastic plugs silver 	500 pieces 500 pieces	160857 162856
	<ul style="list-style-type: none"> Service-Grease-Spray (500 ml) TYROLIA Grease TYROLIA Glue 	per piece per piece per piece	162779 160052 160858
	<ul style="list-style-type: none"> Rubber band for Brake 	10 pieces	162562
	<ul style="list-style-type: none"> Rental Boot Indicator (Single Code, mm) Slide (replacement) for Rental Boot Indicator 	per piece per piece	162617 162518
	<ul style="list-style-type: none"> SINGLE CODE Rental Boot Stickers (5 sheets) 	per set	162561
	<ul style="list-style-type: none"> Height Adjustment Tester for AAA-Series and Freeflex EVO 	per piece	162983

DRILL TEMPLATE SELECTION

All HEAD/TYROLIA templates are equipped with extended clamping jaws and a larger range of the fastening mechanism. The STANDARD fastening mechanism ranges from 59 to 108 mm, the ADRENALIN, AMBITION and ATTACK DEMO mechanism from 75 to 125 mm and the FAT mechanism from 104 to 154 mm. For more versatility HEAD/TYROLIA offers a template adapter set to adapt the mounting range of your template (see page 70/71).

DRILL TEMPLATE 92 W (162760) for ski widths from 59 to 108 mm DRILL TEMPLATE 92 FAT (162868) for ski widths from 104 to 154 mm



HEAD
FREEFLEX ST 20 X RD, FREEFLEX ST 20 X RS, FREEFLEX ST 16 X RD, FREEFLEX ST 16, FREEFLEX ST 14, FREEFLEX 14, FREEFLEX 11, EVO 9 GW AC

TYROLIA
FREEFLEX ST 16, FREEFLEX PRO 11, ATTACK² 18 X GW, ATTACK² 16 GW, ATTACK² 14 AT, ATTACK² 13 GW, ATTACK² 12 GW, ATTACK² 11 GW, AM 12 GW, RX 12 GW, SX 10 GW, SX 10 GW PROMO, D 12 GW, D 11 GW, SX 7.5 GW AC, BYS 10 GW

TYROLIA INSIDE
K14 FREEFLEX EVO, K13 ATTACK² GW

DRILL TEMPLATE AMBITION (163000) for ski widths from 75 to 125 mm PLASTIC FOIL TEMPLATE AMBITION (163011)



TYROLIA
AMBITION 12 AT, AMBITION 10 AT

DRILL TEMPLATE ADRENALIN (162976) for ski widths from 75 to 125 mm PLASTIC FOIL TEMPLATE ADRENALIN (163010)



TYROLIA
ADRENALIN 14 AT short, ADRENALIN 14 AT long

DRILL TEMPLATE ATTACK DEMO (163009) for ski widths from 75 to 125 mm
PLASTIC FOIL TEMPLATE ATTACK DEMO (163015)



TYROLIA
 ATTACK² 13 AT DEMO, ATTACK² 11 AT DEMO

TYROLIA INSIDE
 K13 ATTACK² AT DEMO

DRILL TEMPLATE BASES & PLATES (162865) for ski widths from 59 to 108 mm



HEAD
 Superflex PR high Base, Superflex PR low Base, LYT PR Base, MultiFlex PR Base, Twin PR Base, Allride PR Base, PowerPro Plate 9

TYROLIA
 Multiflex PR Base, Allride PR Base, Twin PR Base, PowerPro Plate 9

TYROLIA INSIDE
 TriFlex PR Base

DRILL TEMPLATE RACE PLATE 09 (162902) for ski widths from 59 to 108 mm

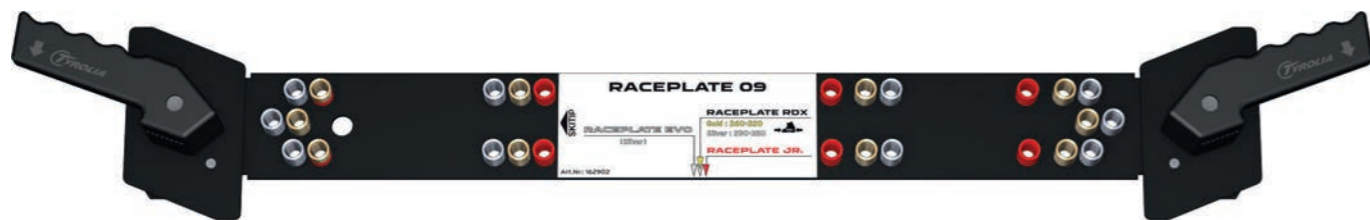

HEAD
 RACEPLATE EVO 14

TYROLIA
 RACEPLATE EVO 14

DRILL TEMPLATE SLR PRO (163104) for ski widths from 59 to 108 mm



HEAD
 SLR PRO Base XS/XM/XL, JOY SLR Base XS/XM/XL

TYROLIA
 SLR PRO Base XS/XM/XL

DRILL TEMPLATE 94 W (162761) for ski widths from 59 to 108 mm



TYROLIA
 SX 4.5 GW AC, D 4.5 GW AC, SX 4.5 R GW AC

DRILL TEMPLATE SP 2003 W (162763) for ski widths from 59 to 108 mm



TYROLIA
 SP 10 GW

DRILL TEMPLATE SR 2003 W (162762) for ski widths from 59 to 108 mm



TYROLIA
 SR 10 GW, SR 4.5 GW AC, SRM 10 GW

TYROLIA INSIDE
 SRM 4.5 GW AC

MOUNTING

MOUNTING

DRILL TEMPLATE RACEPLATE WCR SHORT/TEAM (165253) for ski widths from 59 to 108 mm



HEAD
RACEPLATE WCR SHORT

DRILL TEMPLATE FREEFLEX DEMO (163013) for ski widths from 59 to 108 mm



HEAD
FREEFLEX DEMO 14 GW

TYROLIA
FREEFLEX DEMO 14 GW

DRILL TEMPLATE 92W & 92FAT

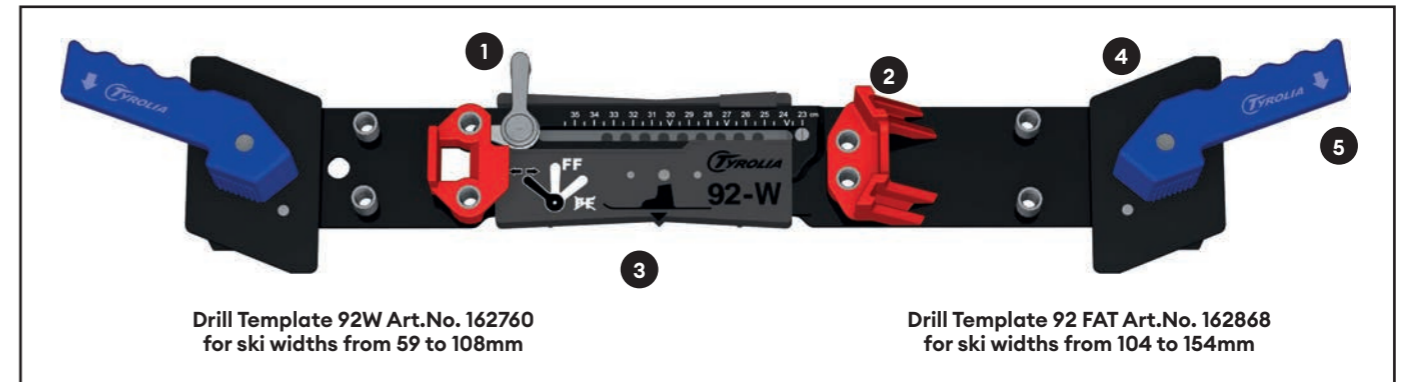

Drill Template 92W Art.No. 162760 for ski widths from 59 to 108mm

Drill Template 92 FAT Art.No. 162868 for ski widths from 104 to 154mm

1. COMPATIBILITY

Presently the drill template 92 W & drill template 92 FAT can be used for:

HEAD:	
FREEFLEX ST 20 X RD	FREEFLEX ST 14
FREEFLEX ST 20 X RS	FREEFLEX 14
FREEFLEX ST 16 X RD	FREEFLEX 11
FREEFLEX ST 16	EVO 9 GW AC

TYROLIA:	
FREEFLEX ST 16	ATTACK ² 18 X GW
FREEFLEX PRO 11	ATTACK ² 16 GW
RX 12 GW	ATTACK ² 14 AT
SX 10 GW / SX 10 GW PROMO	ATTACK ² 13 GW
D12 GW	ATTACK ² 12 GW
D11 GW	ATTACK ² 11 GW
SX 7.5 GW AC	BYS 10 GW

TYROLIA INSIDE
KÄSTLE:
K14 FREEFLEX EVO
K13 ATTACK ² 13 GW

All HEAD/TYROLIA adult bindings come with screws with a penetration depth of 8 mm for ski groups G1 and G2. If recommended by the ski manufacturer use shorter screws with a penetration depth of 6 mm. The junior bindings are delivered with screws with a penetration depth of 6 mm. For mounting junior bindings on plates or on ski groups G1 and G2, replace them by longer screws.

Drill template 92 W can be used for ski widths from 59 mm to 108 mm, whereas the Drill template 92 FAT fits ski widths from 104 mm to 154 mm. For other skis use the template adapter set (Art. No. 162569). With this adapter set, you can mount skis from 45 mm to 132 mm with the standard drill template 92 W, as well as skis from 90 mm to 178 mm with Drill Template 92 FAT.

NOTE: HEAD/TYROLIA offers different types of Brakes. Refer to the Brake overview on page 25 for Brake and binding compatibility. The description of the Brakes always includes a number and a color-letter code. This number stands for the maximum ski width in the Brake area and not in the ski center! The color letter code defines the Brake segment.

2. ADJUSTING THE DRILL TEMPLATE

To adjust the template unlock the locking lever (1) by rotating it counter-clockwise to the far left position.

FREEFLEX ST

NOTE: Due to the center piece these bindings are limited to ski boots with sole lengths from 257 to 372 mm. Place the ski boot in the template and push the template together until the stops (2) come against the ski boot sole. Take the boot out of the template. Position the locking lever (1) in the mid position, then open or close the template to the nearest centimeter mark.

FOR TWO-PIECE AND AAATTACK BINDINGS

Place the ski boot in the template and push the template together until the stops (2) come against the ski boot sole. Lock the lever to the far right position to prevent length change, and then take the boot out of the template.

3. POSITIONING OF THE DRILL TEMPLATE

Open the clamping jaws (4) of the template by rotating the clamping handles (5) and then place the template correctly on the ski, with the boot midsole indicator (3) aligned with the mounting mark on the ski. Be sure the template is evenly seated against the ski's top surface. Release clamping handles to attach the template to the ski. Check the boot midsole mark with template mark. If they are not the same use the boot midsole mark to align the template with the ski mounting mark.

NOTE: Keep in mind that some ski manufacturers do not use the center of boot sole location method. Always follow their instructions.

4. DRILLING THE HOLES

If not otherwise specified by the ski manufacturer, use a 4.1 Ø x 9.0mm drill bit. Use a 4.1 Ø x 7.0 mm drill bit for skis, group G3 & G4. Drill the holes using the appropriate drill bit. If required by the ski manufacturer, tap the holes. After drilling place a drop of HEAD/TYROLIA glue in each hole.

5. MOUNTING

5.1. FOR FREEFLEX ST

Place the pre-assembled heel over the prepared holes (Pict. 1) and tighten the screws in a cross pattern (min. 5 Nm).

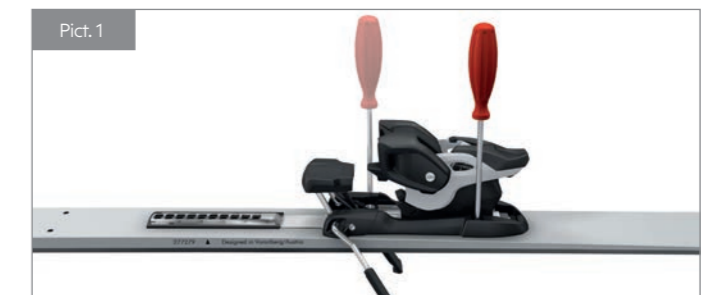

Then attach the AFD to the toe and check if the AFD has snapped in, in its specific position (Pict. 2).

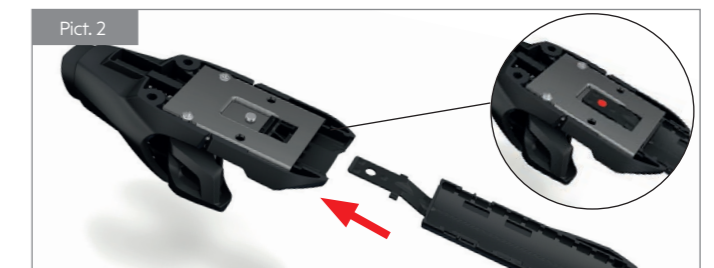

Then you have to place the pre-assembled toe over the holes (Pict.3).



ATTENTION: First you have to tighten the screw in the center – the number has to correspond to the centimeter mark from the template (Pict. 4). To fix it you have to hold the bands together and tighten the screw carefully!

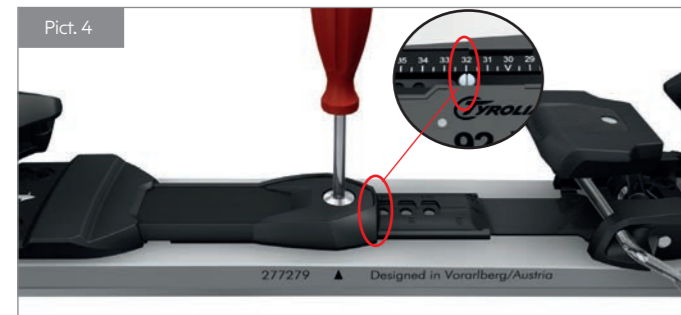

After this align the toe over the holes and fasten the screws in a cross pattern (min. 5Nm). (Pict 5)



5.2. FOR TWO-PIECE BINDINGS

Hook the Brake into heel housing and place the binding over the predrilled holes and tighten the screws in a cross pattern.

5.2.1. BINDINGS WITH AFS JUNIOR - GW AC MODELS

All binding models marked with GW AC are suitable for Adult Alpine (ISO 5355 TYPE A), GripWalk (ISO 23223 TYPE A), Children Alpine (ISO 5355 TYPE C) and GripWalk Junior (ISO 23223 TYPE C) ski boots: the innovative mechanical Anti Friction Slider (AFS Jr.) automatically adjusts to the boot sole height, A/C standards as well as height differences due to icing up, dirt or boot wear (Pict. 6).



If you want to increase the stability of your junior binding in combination with children (TYPE C) boots, e.g. for junior racing, you can replace the standard AFS with a vertically blocked AFS (Art. No. 163113), which is for children (TYPE C) boots ONLY. All you have to do is to separate the standard slider from the base plate and you can simply click in the spare slider (Pict. 7).



MOUNTING OF JUNIOR BINDINGS ON PLATES AND ON SKIS GROUPS G1 AND G2

For mounting junior bindings on plates or on skis, group G1 & G2, replace the pre-mounted screws by 8 mm penetration depth screws. Only with these screws the right pullout strength guaranteed.

5.3. FOR ATTACK² BINDINGS

For mounting the toe unit at Attack² bindings, place the mounting part over the front 2 drilled holes and tighten the screws. Now slide the toe unit from the rear over the mounting part and fasten the screws. Go on by mounting the heel unit. Hook the Brake into heel housing and place the heel unit over the predrilled holes and tighten the screws in a cross pattern (Pict.8).



5.3.1. SOLE HEIGHT ADJUSTMENT

The new Attack² GW is designed for use with Alpine (TYPE A) and GripWalk soles. The Attack² 14 AT provides full AT adjustability for Alpine, Walk (GripWalk) and Touring boots.

	ISO 5355	ISO 23223	ISO 9523
	Alpine Adult (A)	GripWalk (GW)	Touring (T)
Attack ² GW (18x,16,13,12,11)	●	●	-
Attack ² AT (14)	●	●	●

●...suitable -...not suitable

For proper function the height of the AFD must be adjusted to the height of the boot sole. HEAD/TYROLIA recommends using the "TYROLIA boot height adjustment tester" (Art. No. 162983) to get the ideal distance of 0.5 mm between boot and AFD. For Attack² 14 AT please use the A/GW (Alpine and GripWalk) and T (Touring) markings for rough adjustment. (Pict. 9)

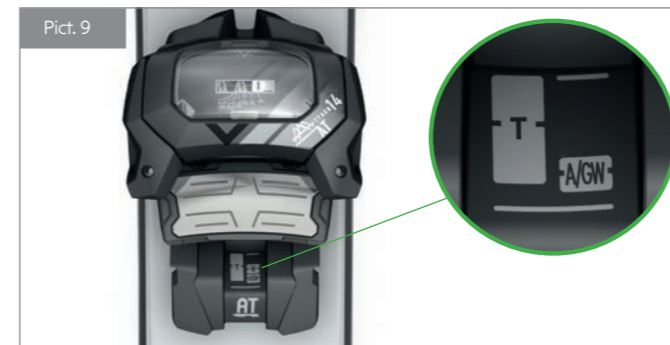

Turning the adjustment screw at the toe moves the AFD up or down. Place the tester on the AFD and enter the boot in the binding. Lift the tip of the boot to take out the play of the toe. (Pict. 10)



Adjust the AFD with the screw in the front so that the tester is still moveable but with a slight resistance. In this case, you reached a gap of 0.5 mm between AFD and the boot (Pict. 11).

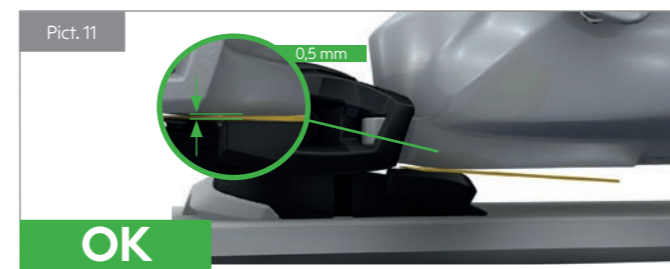

If the tester is not moveable, the gap is smaller than 0,5 mm, if you feel no resistance the gap is more than 0.5 mm. In both cases you need to re-adjust the AFD. (Pict.12)

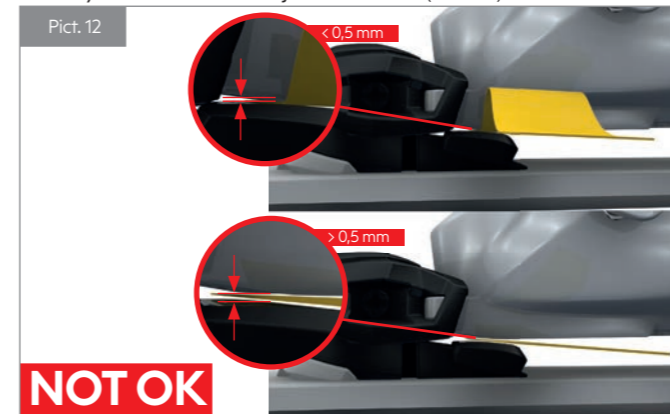

6. ADJUSTING THE RELEASE VALUES

The release values of the toe and heel should be determined by height and body weight (ISO/ASTM) method. Set the binding accordingly with the adjustment screws at heel and toe unit. HEAD/TYROLIA recommends adjusting these settings with a manual screwdriver. **Do NOT use a screw shooter!**

We also recommend the use of a calibrated testing device and that you keep a written record of whether the system passes or fails (requirement in the US).

NOTE: Release/retention settings above a release moment of 105 Nm at the toe and 452 Nm at the heel are higher than the international standards recommend and are used solely at the skier's own risk!

7. FORWARD PRESSURE

Make sure that the boot meets international standards and is not damaged. Place the boot in the binding and close it. The indicating pointer should rest within the marked area (Pict. 13) if not, you have to adjust the forward pressure.



DON'T OPEN THE LENGTH ADJUSTMENT LOCK AS LONG AS A SKI BOOT IS FIXED IN THE BINDING!

Place the ski boot in the open binding and rest the boot heel on the Brake pedal. Lift the length adjustment lock with a screwdriver and slide the heel until the heel cup just touches the boot. Lock the length adjustment by pushing it down. Latch the boot in the binding and check forward pressure again. The toe pincers should not be pressed open and the indicating pointer should rest within the marked area.

8. FUNCTION CHECK

ENTRY/EXIT: Check to make sure that the boot does not catch on the heel hold down lug.

Brake: press the Brake pedal down by hand (1). The Brake arms (2) must automatically return to the braking position when the pedal is released (Pict. 14).

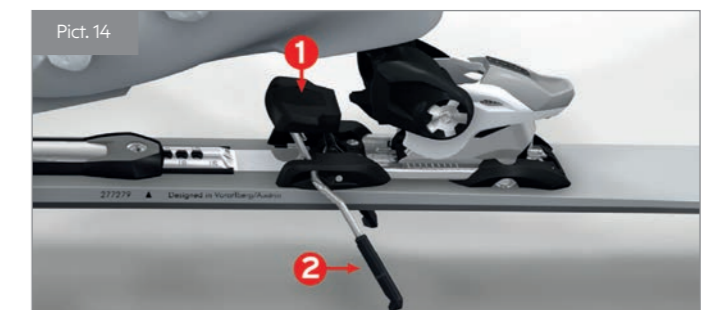

LATERAL ELASTICITY OF THE TOE

Press the boot laterally outward. The binding must re-center the boot easily and quickly from a 15 mm lateral displacement (junior bindings – 10 mm).

9. FINAL CHECK

- Has the proper mounting point been selected?
- Functional Brake test passed?
- Have all screws been fastened tightly?
- Was the boot sole height adjusted correctly?
- Has the forward pressure been properly set?
- Are the release values of the toe and heel properly determined and set?
- Is the instruction for use booklet ready to be handed over to the consumer?

DRILL TEMPLATE AMBITION

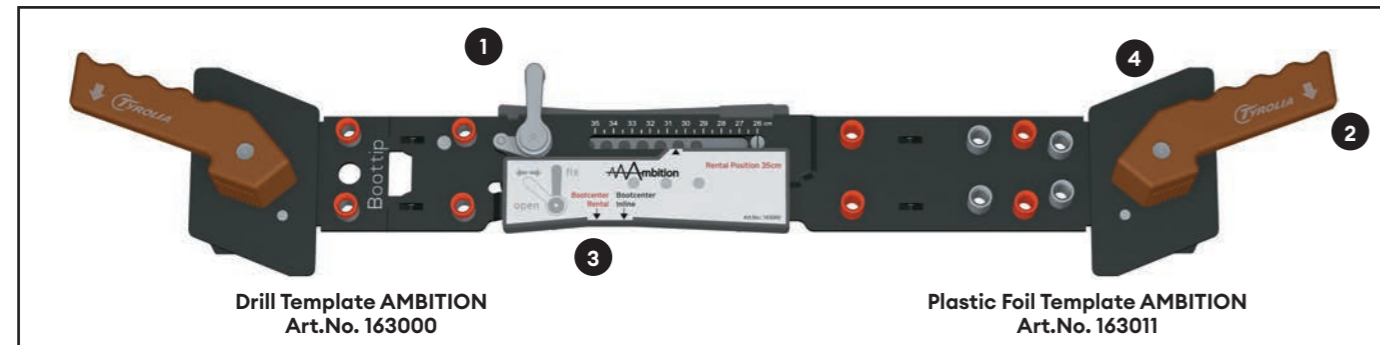

1. COMPATIBILITY

Presently the drill template AMBITION can be used for:

TYROLIA:
AMBITION 12 AT
AMBITION 10 AT

All Ambition bindings come with 8 mm penetration screws and can be used with skis of groups G1 and G2. If recommended by the ski manufacturer use shorter screws with a penetration depth of 6 mm. Therefore use the spare part "Ambition Screw Set - G3 and G4 (6 mm) Art. No. 163055.

Drill template Ambition can be used for ski widths from 75 to 125 mm. For other skis use the template adapter set (Art. No. 162569). With this adapter set, skis from 61 to 149 mm can be mounted. Alternatively, the use of the attached plastic foil template is also an option.

NOTE: HEAD/TYROLIA offers different types of Brakes. Refer to the Brake overview on page 25 for Brake and binding compatibility. The description of the Brakes always includes a number and a color-letter code. This number stands for the maximum ski width in the Brake area and not in the ski center! The color letter code defines the Brake segment.

2. POSITIONING OF THE TEMPLATE

There are two ways to mount Ambition bindings. Either with the solid jig (Art. No. 163000) or with the plastic foil template (Art. No. 163011), which is included in the packaging of each binding. We will show both procedures. First of all, make sure that the boot is satisfying the international standards and has no functional damage. Determine the boot sole length with the HEAD/TYROLIA rental caliper (Art. No. 162617).



NOTE: Keep in mind that some ski manufacturers do not use the center of boot sole location method. Always follow their instructions.

2.1. DRILL TEMPLATE

Adjust the boot sole length on the template - open it by pulling the locking lever (1) to the left position. Slide the template to the right length position and push the locking lever (1) to middle position. Slide the template to closest centimeter mark, until it snaps into position.

Please use the following length markings for the Rental version:

VERSION	LENGTH POSITION
Ambiton Rental	35 cm

Place the template on the ski and center the jig. Therefore open the clamping jaws (2) by rotating the clamping handles (3) and then place the template on the ski. Select the right midsole indicator on the template (Black for RETAIL or Red for RENTAL version), align the indicator with the midsole mounting mark on the ski.



Release the handles and ensure that the template is evenly seated against the ski's top surface. Select the right holes! The front holes are identical for all versions (Retail and Rental - red-silver bushings). You just have to select the right bushings for the rear holes:

VERSION	COLOR OF BUSHINGS/INDICATORS
Ambiton Retail	silver
Ambition RENTAL	red

2.2. PLASTIC FOIL TEMPLATE

Follow the same procedure with the plastic foil template - place it on the ski, align the correct boot mid sole mark with the ski mounting mark. Fix it with a sticky tape and ensure that the template is centered and evenly seated against the ski's top surface.

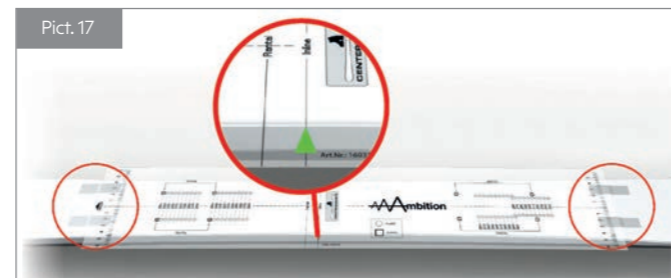

After that, you can mark the correct positions with a punch (Pict. 18) for front and rear position. Remove the plastic foil template from the ski surface.

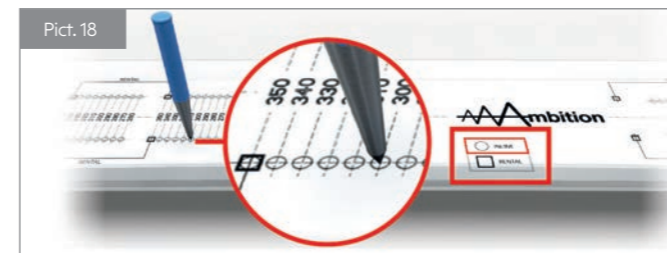

3. DRILLING THE HOLES

If not otherwise specified by the ski manufacturer, use a 4.1 Ø x 9 mm drill bit for the toe and the heel track (8 holes) if required by the ski manufacturer, tap the holes. After drilling, place a drop of TYROLIA glue into the holes. It lubricates the screws and seals the holes.

4. MOUNTING

Just start with mounting the heel unit of the binding depending on the version.

4.1. HEEL UNIT

4.1.1. RETAIL VERSION - HEEL UNIT

Place the heel unit over the rear holes and fasten all screws in a cross pattern and continue at 4.2. (Pict. 19)



4.1.2. RENTAL VERSION - HEEL UNIT

Start with placing the Demo Track over the holes and fasten all screws in a cross pattern. Use the screws provided with the binding. (Pict.20)

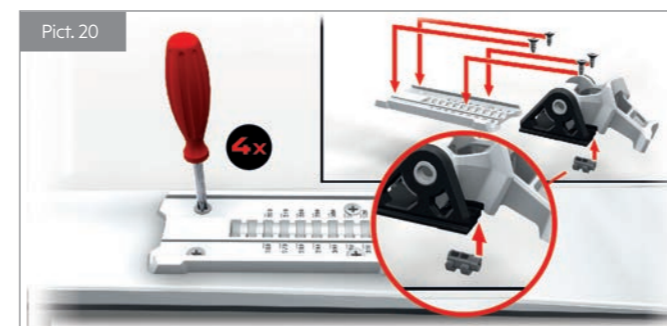

Insert the screw in the bottom side of the heel unit, and slide the whole unit to the closest mounting position on demo track and fix it with the screw.

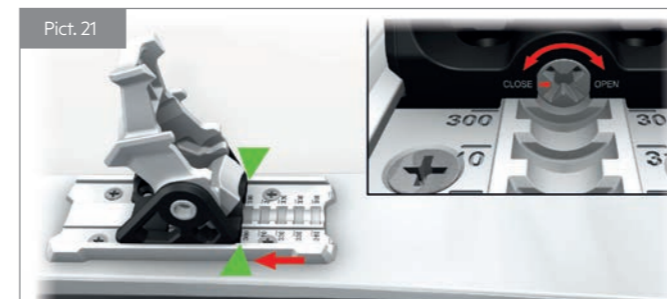

4.2. MOUNTING OF THE TOE UNIT

If you are mounting the RENTAL version, the dampener has to be changed.

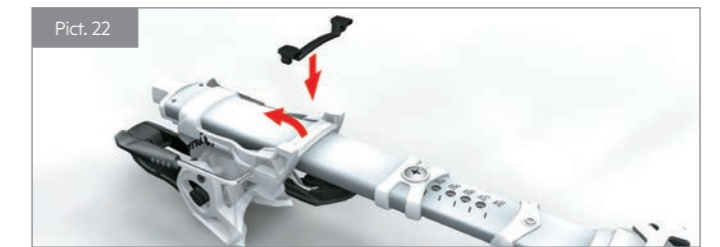

From now on the mounting is the same in RETAIL and RENTAL version. Start with the Adjustment of the telescopic tube to the closest mounting position and fix it with the screw.

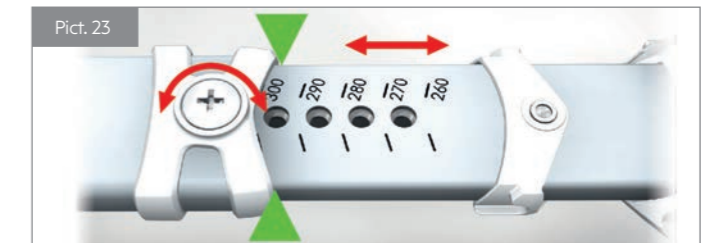

Close the ascender lock and slide the binding into the closed position in all versions.

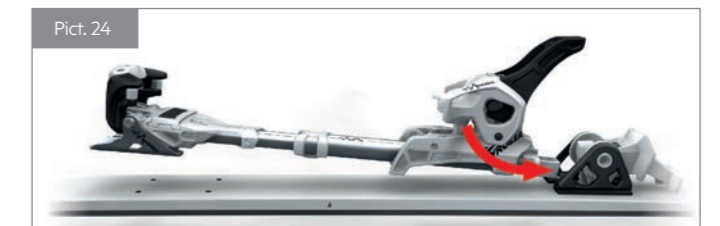

Place the toe unit assembly over the front holes and fasten the two front screws.



Open the ascender lock and tighten the other two screws of the toe unit.

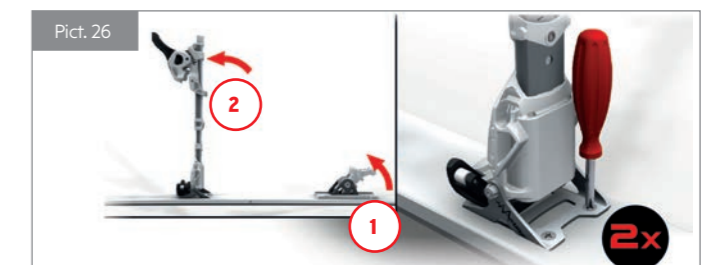

!!!ATTENTION!!! Ambition bindings are sold without Brakes. Please choose the proper Brake width for your ski and mount it on the binding. You can also use it to ride and hike with the appropriate powder straps. It is required to use one of these options (in reference to ISO 11088)!!

A.No	SPAREPARTS
163003	Brake AMBITION 85 white (C) (1 pair)
163016	Brake AMBITION 95 white (C) (1 pair)
163004	Brake AMBITION 105 white (C) (1 pair)
163005	Brake AMBITION 125 white (C) (1 pair)
163098	Brake AMBITION 85 black (C) (1 pair)
163099	Brake AMBITION 95 black (C) (1 pair)
163100	Brake AMBITION 105 black (C) (1 pair)
163101	Brake AMBITION 125 black (C) (1 pair)
162981	AAA-Series Powder Strap (1 pair)

4.3 MOUNTING OF THE BRAKES

Remove the heel base plate – therefore remove both screws completely. Pop out the plate with a flat screwdriver.

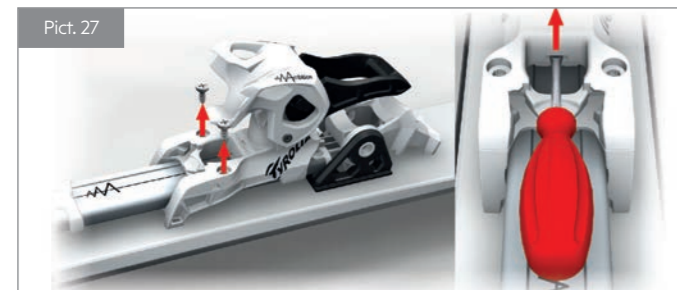

Take the Ambition Brake arm, press it together and clap the Brake pedal to a horizontal position. First click right then left side into place.



Check the right position of the Brake.



Place the Brake to its position on the heel unit, push the plate to lock on binding. Fix the plate with the two screws. Ready!!!



5. SOLE HEIGHT ADJUSTMENT

The Ambition is designed to accommodate Alpine ski boots (ISO 5355 TYPE A), Walk ski boots (ISO 23223 TYPE A) and Touring boots (ISO 9523). For proper function the height of the toe unit must be adjusted to the height of the boot sole. HEAD/TYROLIA recommends to use the "TYROLIA boot height adjustment tester" (Art. No. 162983) to get the ideal distance of 0.5 mm between boot and AFS. Turning the adjustment screw at the toe moves the unit up or down. Place the tester on the AFS and enter the boot in the binding. Lift the tip of the boot to take out the play of the toe.

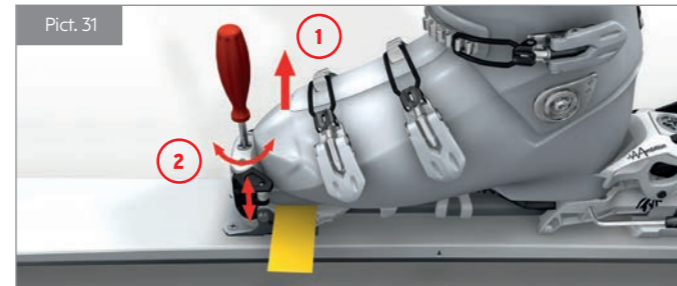

Adjust the AFS with the screw in the front so that the tester is still moveable but with a slight resistance. In this case, you reached a gap of 0.5 mm between AFS and the boot.

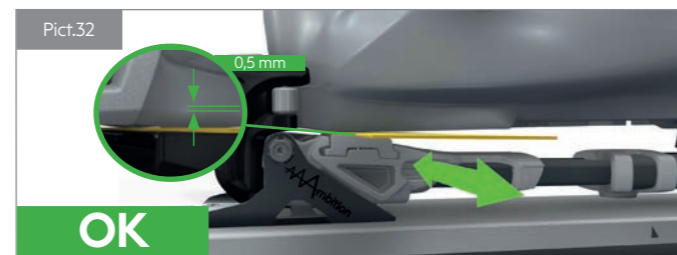

If the tester is not moveable, the gap is smaller than 0,5 mm, if you feel no resistance the gap is more than 0.5 mm. In both cases you need to re-adjust the AFS.

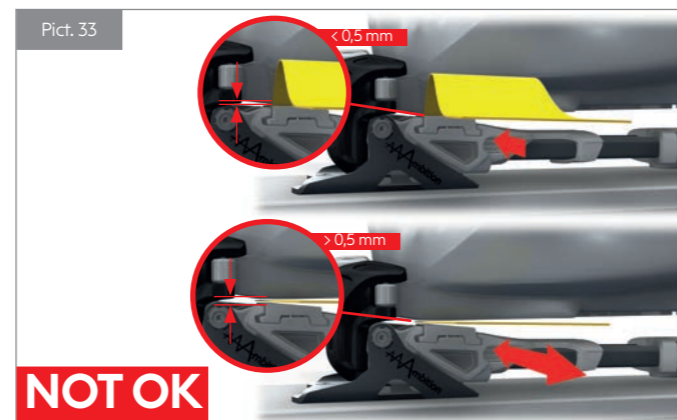

6. ADJUSTMENT OF THE RELEASE VALUES

The release values of the toe and heel should be determined by height and body weight (ISO/ASTM) method. Set the binding accordingly with the adjustment screws at heel and toe unit. HEAD/TYROLIA recommends adjusting these settings with a manual screwdriver. Do NOT use a screw shooter. We also recommend the use of a calibrated testing device and that you keep a written record of whether the system passes or fails (requirement in the US).

NOTE: Release/ Retention settings above a release moment of 105 Nm at the toe and 452 Nm at the heel are higher than the international standards recommend and are used solely at the skier's own risk!

7. FORWARD PRESSURE

Check the forward pressure, by placing a boot into the binding. If you have followed all mounting steps correctly, the indicator and the heel housing should be on a flat surface. If you have too much or not enough forward pressure, check the settings and if necessary re-adjust the heel.

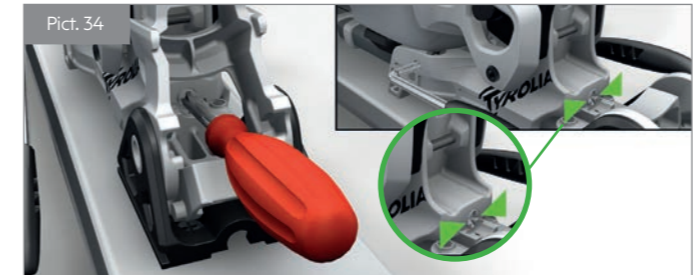

8. FUNCTION CHECK

Check the function of the heel. Make sure that the boot does not catch on the heel during entry and exit. Check the Brake function (Pict. 35) by pressing down the Brake pedal (1) by hand. The Brake arms (2) must open to the braking position when the Brake pedal is released. Check the elasticity and retention of the toe by pushing the boot inward and outward. The binding must recenter the boot easily and quickly from a 15 mm lateral displacement.

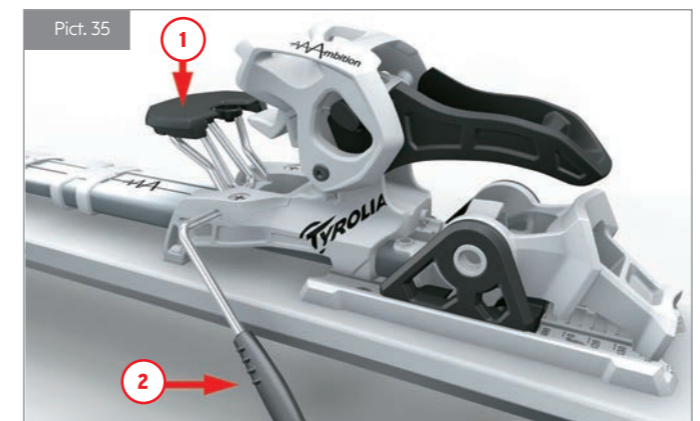

9. ADDITIONAL EQUIPMENT AND SPARE PARTS FOR AMBITION:

9.1. AMBITION CRAMPONS

HEAD/TYROLIA is offering additional crampons for AMBITION Bindings. Use the crampons in icy and hard snow conditions to provide safe climbing and a secure stance in any situation. Be sure to use the right width - 90 mm (Art.No. 163006), 105 mm (Art.No. 163007) or 120 mm (Art.No. 163008).

MOUNTING: Open the climbing aid and swing open the binding. Take the crampon and slide it to the fixing- position on the bottom of the telescopic tube. Consider the right position as shown in pict. 36. Lock the crampon with the lever- ready!

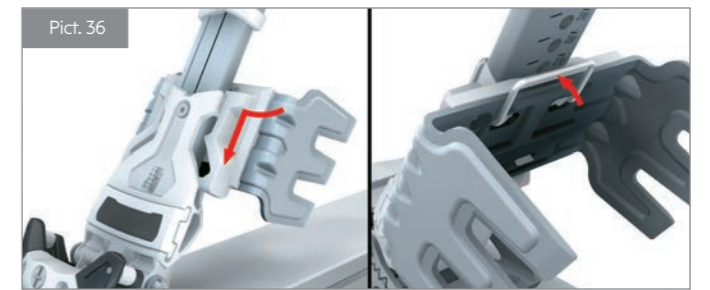

To remove just unlock the crampon with the lever and take off the crampon from the telescopic tube (Pict. 37).

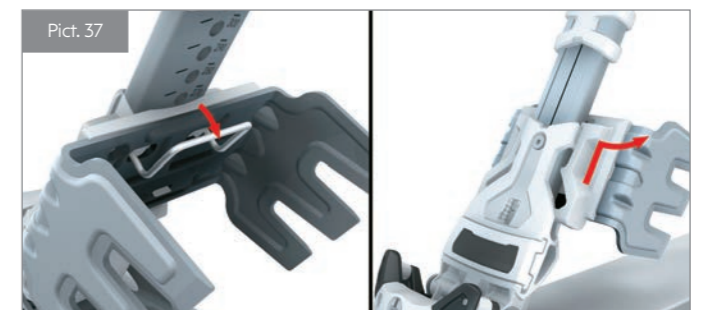

9.2. AAA-SERIES POWDER STRAP

Instead of Brakes it is also possible to use the AAA-Series powder strap for riding and hiking. At Ambition bindings it is required to use either Brakes or powder strap! To fix the strap on your binding take the hanger from the strap and fix it on the heel lever as shown in pict. 38.



Fix the strap with the Velcro fastener on your leg and use the carabiner to connect strap and hanger again.

10. FINAL CHECK

- Has the proper mounting point selected?
- Brake or Powder Strap mounted?
- Functional Brake test passed?
- Are all screws fastened tightly?
- Was the boot sole height adjusted correctly?
- Is the forward pressure properly adjusted?
- Are the release values of the toe and heel properly determined and set?
- Is the instruction for use booklet ready to be handed over to the consumer?

DRILL TEMPLATE ADRENALIN

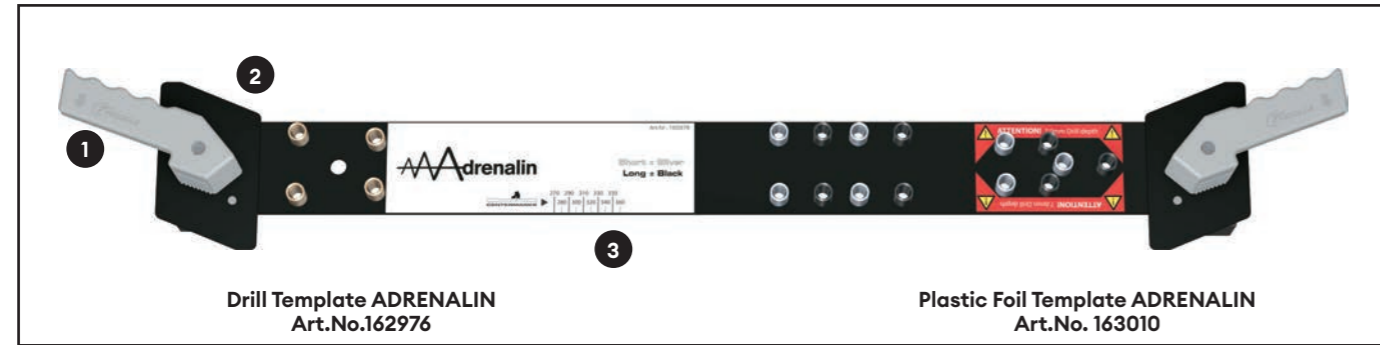

1. COMPATIBILITY

Presently the drill template ADRENALIN can be used for:

TYROLIA
ADRENALIN 14 AT long ADRENALIN 14 AT short

All Adrenalin bindings come with 8 mm penetration screws (except the screws for the locking mechanism, which have only 6 mm penetration) and can be used with skis of groups G1 and G2. Drill template Adrenalin can be used for ski widths from 75 to 125 mm. For other skis use the template adapter set (Art. No. 162569). With this adapter set, skis from 61 to 149 mm can be mounted.

NOTE: HEAD/TYROLIA offers different types of Brakes. Refer to the Brake overview on page 25 for Brake and binding compatibility.

The description of the Brakes always includes a number and a color-letter code. This number stands for the maximum ski width in the Brake area and not in the ski center! The color letter code defines the Brake segment.

2. POSITIONING OF THE TEMPLATE

There are two ways to mount Adrenalin bindings. Either with the solid jig (Art. No. 162976) or with the plastic foil template (Art.No. 163010), which is included in the packaging of each binding. We will show both procedures.

First of all, make sure that the boot is satisfying the international standards and has no functional damage. Determine the boot sole length with the HEAD/TYROLIA rental caliper (Art. No. 162617).



NOTE: Keep in mind that some ski manufacturers do not use the center of boot sole location method. Always follow the ski manufacturer's instructions.

2.1. DRILL TEMPLATE

Open the clamping jaws (2) by rotating the clamping handles (1) and then place the template on the ski. Align the boot midsole indicator (3) for the appropriate boot sole length with the midsole mounting mark on the ski. Release the handles and ensure that the template is evenly seated against the ski's top surface.

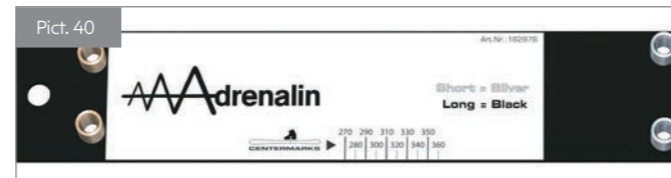

The front holes are identical for both versions (gold bushings). You just have to select the right bushings for the rear holes:

VERSION	COLOR OF BUSHINGS
Adrenalin short 270-330 mm	silver
Adrenalin long 300-360 mm	black

2.2. PLASTIC FOIL TEMPLATE

Align the boot midsole indicator for the appropriate boot sole length with the midsole mounting mark on the ski. Fix it with a sticky tape and ensure that the template is centered and evenly seated against the ski's top surface. After that you can mark the correct indicators with a punch.

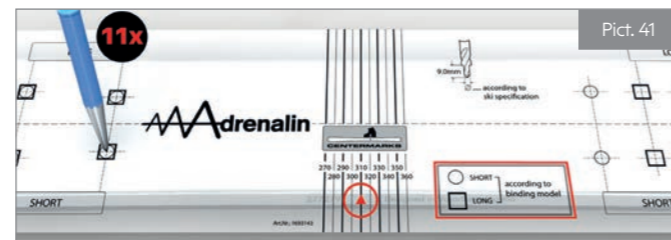

The front holes are identical for both versions. You just have to select the right indicator for the rear holes.

VERSION	SYMBOL OF BUSHINGS
Adrenalin short 270-330 mm	○
Adrenalin long 300-360 mm	□

Remove the plastic foil template from the ski surface.

3. DRILLING THE HOLES

If not otherwise specified by the ski manufacturer, use a 4.1 Ø x 9mm drill bit for the holes for the toe and the heel track and a 4.1 Ø x 7mm drill bit for the holes for the locking mechanism. If required by the ski manufacturer, tap the holes.



After drilling, place a drop of TYROLIA glue into the holes. It lubricates the screws and seals the holes.

4. MOUNTING

Place the heel track assembly over the holes and fasten all screws in a cross pattern.

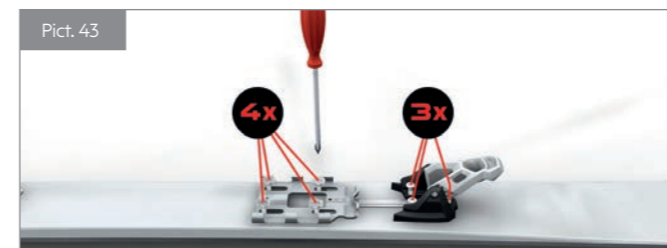

Then you can place the toe assembly over the holes and fasten the two front screws lightly. (1-2 turns).



After that you have to close the platform with the ascender lock and then tighten the front screws.



Open the lock again and tighten the other two screws of the toe piece.

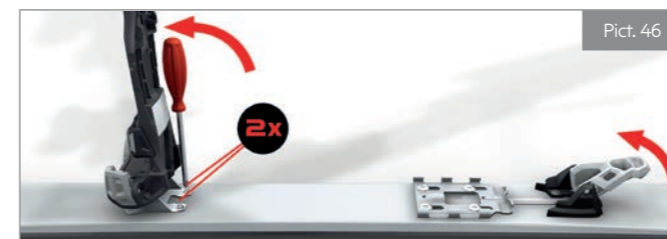

Now you can mount the heel. Therefore hook the Brake into the heel housing (Pict. 47), slide the heel on the platform from the back and lock it at the appropriate boot sole marking (Pict. 48).



After that you can close the ascender lock and you are ready for the final adjustments.



5. SOLE HEIGHT ADJUSTMENT

The Adrenalin is designed to accommodate Alpine ski boots (ISO 5355 TYPE A), Walk ski boots (ISO 23223 TYPE A) and Touring boots (ISO 9523). Please use the A (Alpine) and T (Touring) markings for rough adjustment (Pict. 50).



For proper function the height of the AFS must be adjusted to the height of the boot sole. HEAD/TYROLIA recommends to use the "TYROLIA boot height adjustment tester" (Art. No. 162983) to get the ideal distance of 0.5 mm between boot and AFS. Turning the adjustment screw at the toe moves the AFS up or down. Place the tester on the AFS and enter the boot in the binding. Lift the tip of the boot to take out the play of the toe.

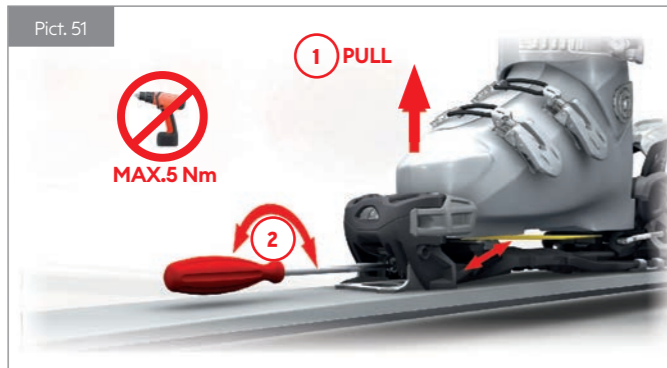

Adjust the AFS with the screw in the front so that the tester is still moveable but with a slight resistance. In this case, you reached a gap of 0.5 mm between AFS and the boot.

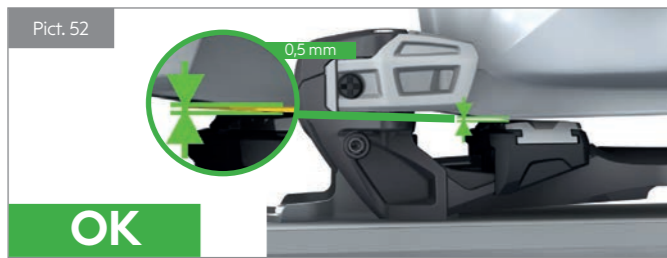

If the tester is not moveable, the gap is smaller than 0,5 mm, if you feel no resistance the gap is more than 0.5 mm. In both cases you need to re-adjust the AFS.

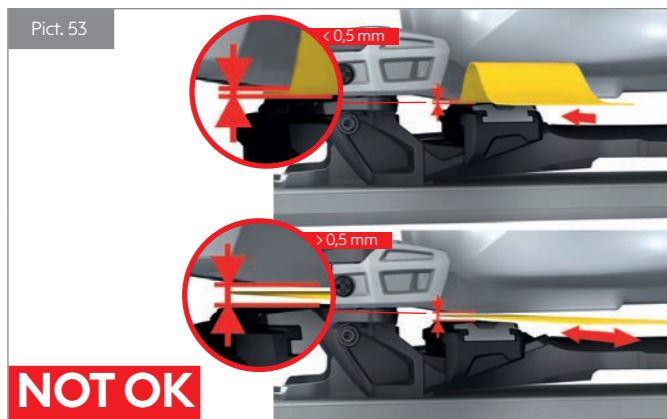

6. ADJUSTMENT OF THE RELEASE VALUES

The release values of the toe and heel should be determined by height and body weight (ISO/ASTM) method.

Set the binding accordingly with the adjustment screws at heel and toe unit. HEAD/TYROLIA recommends adjusting these settings by hand with a manual screwdriver. We also recommend the use of a calibrated testing device and that you keep a written record of whether the system passes or fails (requirement in the US).

NOTE: Release/Retention settings above a release moment of 105 Nm at the toe and 452 Nm at the heel are higher than the international standards recommend and are used solely at the skier's own risk!

7. FORWARD PRESSURE

Check the forward pressure, by placing a boot into the binding. If you have followed all mounting steps correctly, the indicator should rest in the marked area and you are ready to go.



If you have too much or not enough forward pressure, check the settings and if necessary re-adjust the heel. Then close the lever and check the forward pressure again. Now it should be okay.

8. FUNCTION CHECK

Check the function of the heel. Make sure that the boot does not catch on the heel during entry and exit. Check the Brake function by pressing down the Brake pedal (1) by hand. The Brake arms (2) must open to the braking position when the Brake pedal is released.



Check the elasticity and retention of the toe by pushing the boot inward and outward. The binding must recenter the boot easily and quickly from a 15 mm lateral displacement.

9. ADDITIONAL EQUIPMENT AND SPARE PARTS FOR ADRENALIN

9.1. ADRENALIN CRAMPONS

HEAD/TYROLIA is offering additional crampons for ADRENALIN Bindings. Use the crampons in icy and hard snow conditions to provide safe climbing and a secure stance in any situation. Be sure to use the right width - 90 mm (Art.No. 162977), 105 mm (Art.No. 162978) or 120 mm (Art.No. 162979).

MOUNTING: Open the climbing aid and lift the binding. Take the crampon and slide it to the fixing- position on the bottom of the hiking platform. Consider the right position as shown in pict. 56. Lock the crampon with the lever- ready!



To remove just unlock the crampon with the lever and take off the crampon from the platform (Pict. 57).



9.2. AAA-SERIES POWDER STRAP

Instead of Brakes it is also possible to use the AAA-Series powder strap for riding and hiking. At Adrenalin bindings it is required to use either Brakes or powder strap! To fix the strap on your binding take the hanger from the strap and fix it on the heel lever as shown in pict. 58.



9.3. SPARE PARTS FOR ADRENALIN

Changing AFS Metal Pro Art. No.162984

Slide the AFS by turning the adjustment screw to highest position. Take off the old AFS.



Bring the new slider in position. Make sure that AFS is positioned on the two side rails and the guide screw of the binding matches the screw-nut at AFS. Therefore press the screw from the bottom up and slide the AFS to rails at once.



Make a readjustment of your sole height as described before.

Changing the climbing aid set Art. No.162892

The climbing aid includes 1 wrench, 2 screws, 2 fixing parts and 2 climbing levers. First open the ascender lock and slide the heel housing from the platform. Remove the fixing screw with the added wrench on the top of the platform and furthermore the fixing part and the climbing lever from the bottom.



Put the binding to a straight position. Insert and click the new parts as show in picture 62 into position - use the 13° climbing position. Picture 62 shows the right position of the lever (the flatten part indicator has to be on the bottom side).

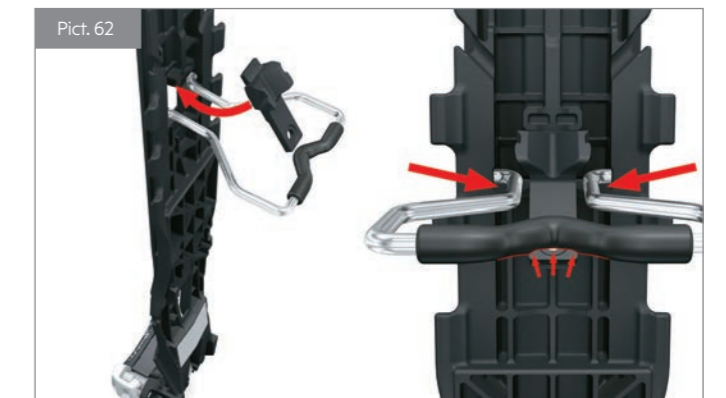

Fasten the screw and check the all 3 climbing positions. Slide the heel housing with the Brake from the back and lock it at the appropriate boot sole marking.

10. FINAL CHECK

- Is the proper mounting point selected?
- Is the Brake mounted?
- Functional Brake test passed?
- Are all screws fastened tightly?
- Was the boot sole height adjusted correctly?
- Is the forward pressure properly adjusted?
- Are the release values of the toe and heel properly determined and set?
- Is the instruction for use booklet ready to be handed over to the consumer?

DRILL TEMPLATE ATTACK DEMO

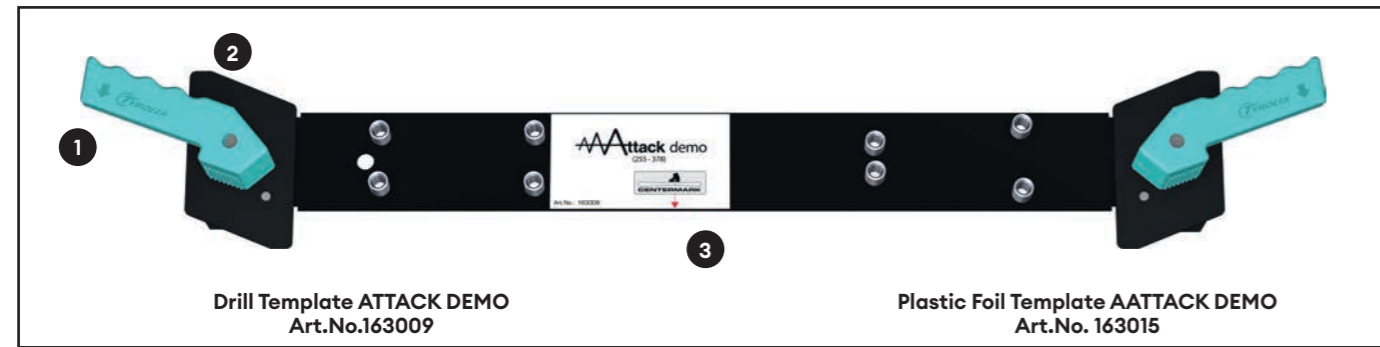

1. COMPATIBILITY

Presently the drill template ATTACK DEMO can be used for:

TYROLIA:
ATTACK² 13 AT DEMO
ATTACK² 11 AT DEMO

TYROLIA INSIDE:
KÄSTLE:
K13 ATTACK² AT DEMO

All Attack² AT Demo bindings come with 8 mm penetration screws and can be used with skis of groups G1 and G2. If recommended by the ski manufacturer use shorter screws with a penetration depth of 6 mm. Therefore use the spare part "Screw Set Attack 11/13 AT Demo - G3 and G4 (6 mm)" (Art. No. 163091).

Drill template Attack Demo can be used for ski widths from 75 to 125 mm. For other ski widths please use the template adapter set (Art. No. 162569). With this adapter set skis from 61 to 149 mm can be mounted.

NOTE: HEAD/TYROLIA offers different types of Brakes. Refer to the Brake overview on page 25 for Brake and binding compatibility.

The description of the Brakes always includes a number and a color-letter code. This number stands for the maximum ski width in the Brake area and not in the ski center! The color letter code defines the Brake segment.

2. POSITIONING OF THE TEMPLATE

There are two ways to mount Attack Demo bindings. Either with the solid jig (A.No. 163009) or with the plastic foil template (this is included in the packaging of each binding and also available as a spare part A.No. 163015). We will show both procedures.

NOTE: Keep in mind that some ski manufacturers do not use the center of boot sole location method. Always follow the ski manufacturer's instructions.



2.1. DRILL TEMPLATE

Open the clamping jaws (2) by rotating the clamping handles (1) and then place the template on the ski. Align the boot midsole indicator (3) with the midsole mounting mark on the ski. Release the handles and ensure that the template is evenly seated against the ski's top surface.

2.2. PLASTIC FOIL TEMPLATE

Align the boot midsole indicator with the midsole mounting mark on the ski. Fix it with a sticky tape and ensure that the template is centered and evenly seated against the ski's top surface. After that you can mark the indicators (8x) with punch and remove the plastic foil template from the ski surface.

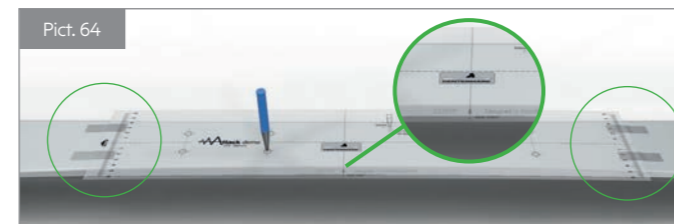

3. DRILLING THE HOLES

If not otherwise specified by the ski manufacturer use a 4.1 Ø x 9 mm drill bit for all holes (8x) for the toe and the heel track.



After drilling place a drop of HEAD/TYROLIA glue into the holes. It lubricates the screws and seals the holes.

4. MOUNTING

First of all, make sure that the boot is satisfying the international standards and has no functional damage. Determine the boot sole length with the HEAD/TYROLIA rental caliper (A.No. 162 617).



Go on with placing the toe track over the holes and fasten all screws in a cross pattern.

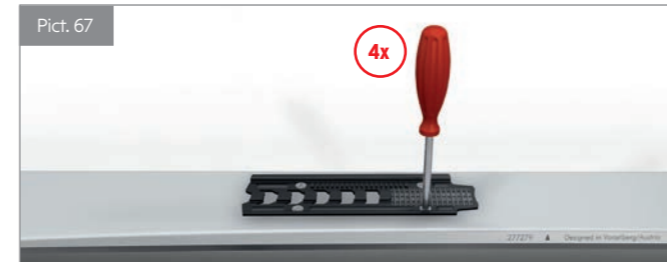

Open the one-touch lever and slide the toe unit from the front on the track and lock it at the appropriate boot sole marking.

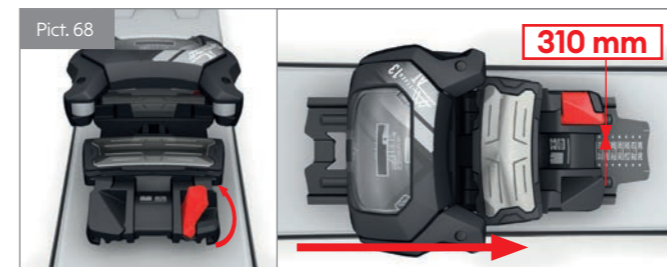

Now you can mount the heel unit. Place the heel track over the holes and fasten all screws in a cross pattern.



Now hook the Brake into the heel, open the one touch lever, slide the heel unit from the back to the track and lock it at the appropriate boot sole marking.



5. SOLE HEIGHT ADJUSTMENT

The new Attack² AT DEMO provides full AT adjustability for Alpine ski boots (ISO 5355 TYPE A), Walk ski boots (ISO 23223 TYPE A) and Touring boots (ISO 9523).

	ISO 5355	ISO 23223	ISO 9523
	Alpine Adult (A)	GripWalk (GW)	Touring (T)
Attack ² AT DEMO	●	●	●

●...suitable □...not suitable

For proper function the height of the AFS must be adjusted to the height of the boot sole. HEAD/TYROLIA recommends using the "TYROLIA boot height adjustment tester" (Art. No. 162983) to get the ideal distance of 0.5 mm between boot and AFS. Turning the adjustment screw at the toe moves the AFS up or down. Place the tester on the AFS and enter the boot in the binding. Lift the tip of the boot to take out the play of the toe. Adjust the AFS with the screw in the front so that the tester is still moveable but with a slight resistance.

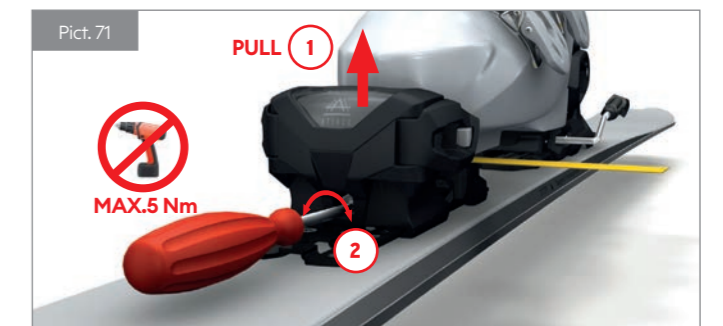

In this case, you reach a gap of 0.5mm between AFS and the boot.

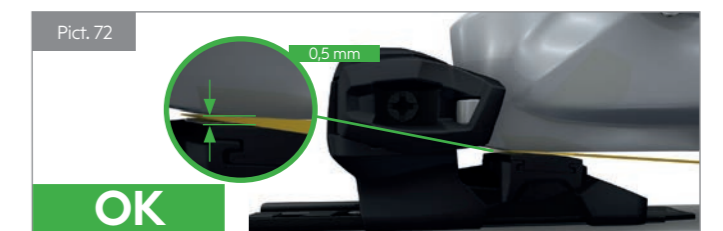

If the tester is not moveable, the gap is smaller than 0,5 mm, if you feel no resistance the gap is more than 0.5 mm. In both cases you need to re-adjust the AFS.

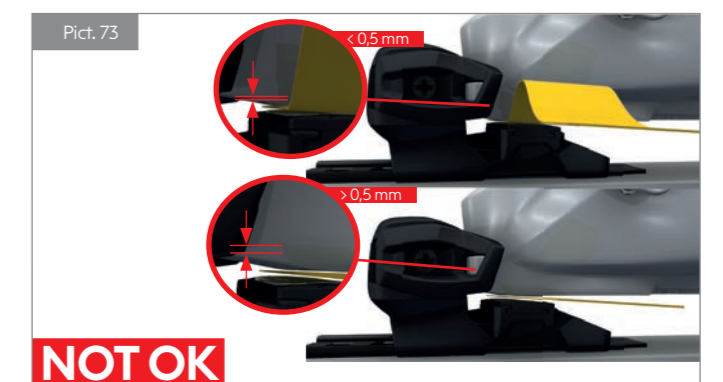

6. ADJUSTMENT OF THE RELEASE VALUES

The release values at toe and heel should be determined by height and body weight (ISO/ASTM) method. Set the binding accordingly with the adjustment screws. We recommend the use of a calibrated testing device and that you keep a written record of whether the system passes or fails (requirement in the US).

NOTE: Release/ Retention settings above a release moment of 105 Nm at the toe and 452 Nm at the heel are higher than the international standards recommend and are used solely at the skier's own risk!

7. FORWARD PRESSURE

Check the forward pressure, by placing a boot into the binding. If you have followed all mounting steps correctly, the indicator should rest in the marked area and you are ready to go.



If you have too much or not enough forward pressure, check the settings and if necessary re-adjust the heel. Then close the lever and check the forward pressure again. Now it should be okay!

8. FUNCTION CHECK

Check the function of the heel. Make sure that the boot does not catch on the heel during entry and exit. Check the Brake function by pressing down the Brake pedal (1) by hand. The Brake arms (2) must open to the braking position when the Brake pedal is released.



Check the elasticity and retention of the toe by pushing the boot inward and outward. The binding must recenter the boot easily and quickly from a 15 mm lateral displacement.

9. FINAL CHECK

- Was the proper mounting point selected?
- Did it pass the functional Brake test?
- Are all screws fastened tightly?
- Was the boot sole height adjusted correctly?
- Is the forward pressure properly adjusted?
- Are the release values of the toe and heel properly determined and set?
- Is the instruction for use booklet ready to be handed over to the consumer?

DRILL TEMPLATE BASES & PLATES

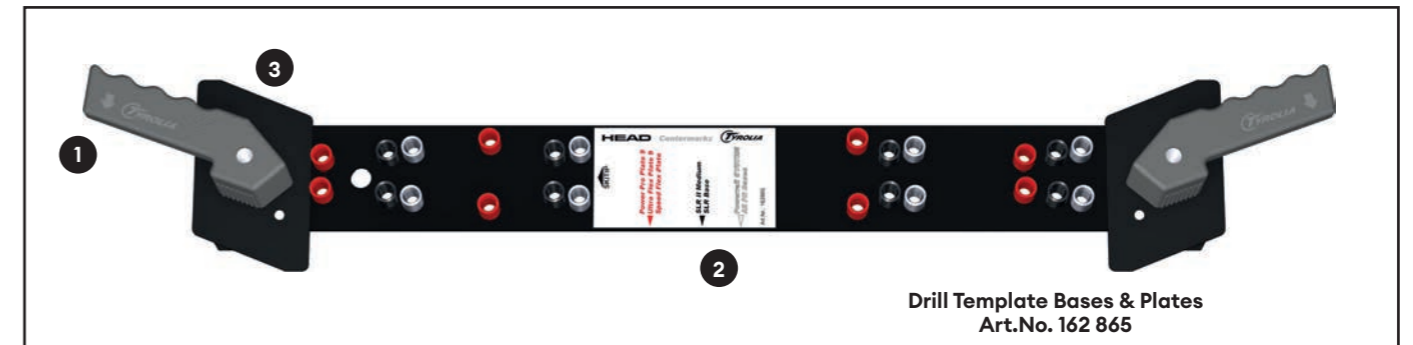

1. COMPATIBILITY

Presently the drill template Bases & Plates can be used for:

HEAD:	
SUPERFLEX PR BASE LOW	SUPERFLEX PR BASE HIGH
MULTIFLEX PR BASE	TWIN PR BASE
LYT PR BASE	ALLRIDE PR BASE
POWERPRO PLATE 9	

TYROLIA:	
MULTIFLEX PR BASE	TWIN PR BASE
ALLRIDE PR BASE	
POWERPRO PLATE 9	

TYROLIA INSIDE:	
KÄSTLE:	
TRIFLEX PR BASE	

Drill template BASES & PLATES is for mounting of all types of plates and POWERRAIL bases, except the RACEPLATES. All bases and plates come with 8 mm penetration depth screws. Drill template BASES & PLATES can be used for ski widths from 59 to 108 mm. For other skis use the template adapter set (Art. No. 162569). With this adapter set skis from 45 to 132 mm can be mounted.

The following chart shows which HEAD/TYROLIA bases and plates are suitable for the different ski-groups (G1-G4).

MODEL	G1	G2	G3	G4
SUPERFLEX PR BASE	●	●	●	-
ALLRIDE PR BASE	●	●	●	-
MULTIFLEX PR BASE	●	●	●	-
TWIN PR BASE	●	●	●	-
LYT PR BASE	●	●	●	-
TRIFLEX PR BASE	●	●	●	-
POWERPRO PLATE 9	●	●	●	-

●...suitable - ...not suitable

If bases and plates are mounted on other ski groups, the penetration depth and the torque moment of the screws have to be verified.

2. POSITIONING OF THE DRILL TEMPLATE

Open the clamping jaws (3) by rotating the clamping handles (1) and then place the template on the ski. Align the boot midsole indicator (2) for the appropriate model with the midsole mounting mark on the ski. Be sure the template is evenly seated against the ski's top surface. Release clamping handles.

NOTE: Keep in mind that some ski manufacturers do not use the center of boot sole location method. Always follow the ski manufacturer's instructions.

3. DRILLING THE HOLES

If not otherwise specified by the ski manufacturer, for all bases use a 4.1 Ø x 9.0 mm drill bit for ski groups G1 and G2. For skis of groups G3 and G4, use a 4.1 Ø x 7.0mm drill bit.

DRILL THROUGH THE APPROPRIATE BUSHINGS

MODEL	COLOR OF BUSHINGS/INDICATORS
POWERPRO PLATE 9	red
SUPERFLEX PR BASE ALLRIDE PR BASE MULTIFLEX PR BASE TWIN PR BASE TRIFLEX PR BASE LYT PR BASE	white

After drilling place a drop of TYROLIA glue into the holes. It lubricates the screws and seals the holes.

4. PLATES

4.1. MOUNTING - PLATES

The compatible binding-plate combinations can be found in the compatibility chart (see next page). Place the front part of the plate over the holes and fasten the screws. Then place the back part over the holes and fasten the screws.



4.2. MOUNTING - BINDING ON PLATES

For mounting junior bindings on HEAD/TYROLIA PLATES, you have to replace the pre-mounted screws by screws of 8mm penetration depth. The right pullout strength can only be ensured with these screws.

NOTE: Use only the pre-drilled holes for installation – do not drill holes into the plate to mount bindings of other manufacturers. Determine the boot sole length with the HEAD/TYROLIA Rental boot caliper and place the binding on the plate corresponding with the appropriate printed length markings. Mount the binding in accordance with the procedures in this manual.

MOUNTING HEAD/TYROLIA BINDINGS ON RAISED PLATFORMS:

Please refer to the HEAD/TYROLIA Brake-matrix on page 49. There you will find a classification of all our Brakes depending on stand height and weight. A Brake is permitted, if the combination of stand height and weight hits the sector under the relevant curve. If not the Brake has to be changed by a stronger one of a higher category.



At all current HEAD ski sets with HEAD/TYROLIA binding-plate-systems the included Brakes fit these requirements. If you are combining HEAD/TYROLIA bindings and plates with product of other manufacturer please check the technical requirements of the ski - plate - binding - combination at the HEAD/TYROLIA Brake matrix on next page. There you will find out, if the desired combination of ski- plate-binding is accepted.

BINDING-PLATE COORDINATION

BINDING	POWERPRO PLATE 9 HEIGHT: 9 MM	
	MOUNTING RANGE [MM]	STANDHEIGHT [MM]
Freeflex ST 16 Freeflex ST 14	258 - 372	26,0
Freeflex 14 Freeflex 11 Freeflex PRO 11 Freeflex DEMO 14 GW RX 12 GW D12 GW / D11 GW	258 - 372	30,0
EVO 9 GW AC SX 10 GW SX 7.5 GW AC	261 - 384	30,0
SP 10 GW	263 - 391	40,0
SR 10 GW SRM 10 GW	263 - 391	31,0

FOLLOW THE PROCEDURE BELOW:

1. Add the weight of the components you want to mount (ski + plate + binding).
2. Add the thickness of the components you want to mount (ski + plate + binding).
3. Find the value on the vertical axis which corresponds to the sum of the addition for the stand height.
4. Follow the horizontal axis on the matrix to the right until you find the value which corresponds to the total weight on the horizontal axis.
5. Use the lists at chapter "Technical Information" (page 9 et seqq.), determine the standard HEAD/TYROLIA Brakes of the binding and based on this information select the right curve at the matrix.
6. If the point of intersection of the weight and stand height lies below the respective curve, the Brake will work properly.
7. If the point of intersection lies above the curve the Brake must be replaced with the next stronger one.
8. If the point of intersection lies above the highest curve this combination of ski + binding + plate is not recommended. In this case, you have the following possibilities to come within the permitted range:

- a) Reduce the total thickness through:
 - a thinner plate
 - a HEAD/TYROLIA binding with less stand height
- b) Reduce the total weight to
 - a lighter plate
 - a HEAD/TYROLIA binding with less weight
 - a lighter ski
- c) Use a combination of a) + b)

Have a look at all technical specifications about HEAD/TYROLIA bindings and plates in chapter "Technical Information" - this will help you in finding an accepted combination.

4.3. HEAD/TYROLIA BRAKE MATRIX 2020.21

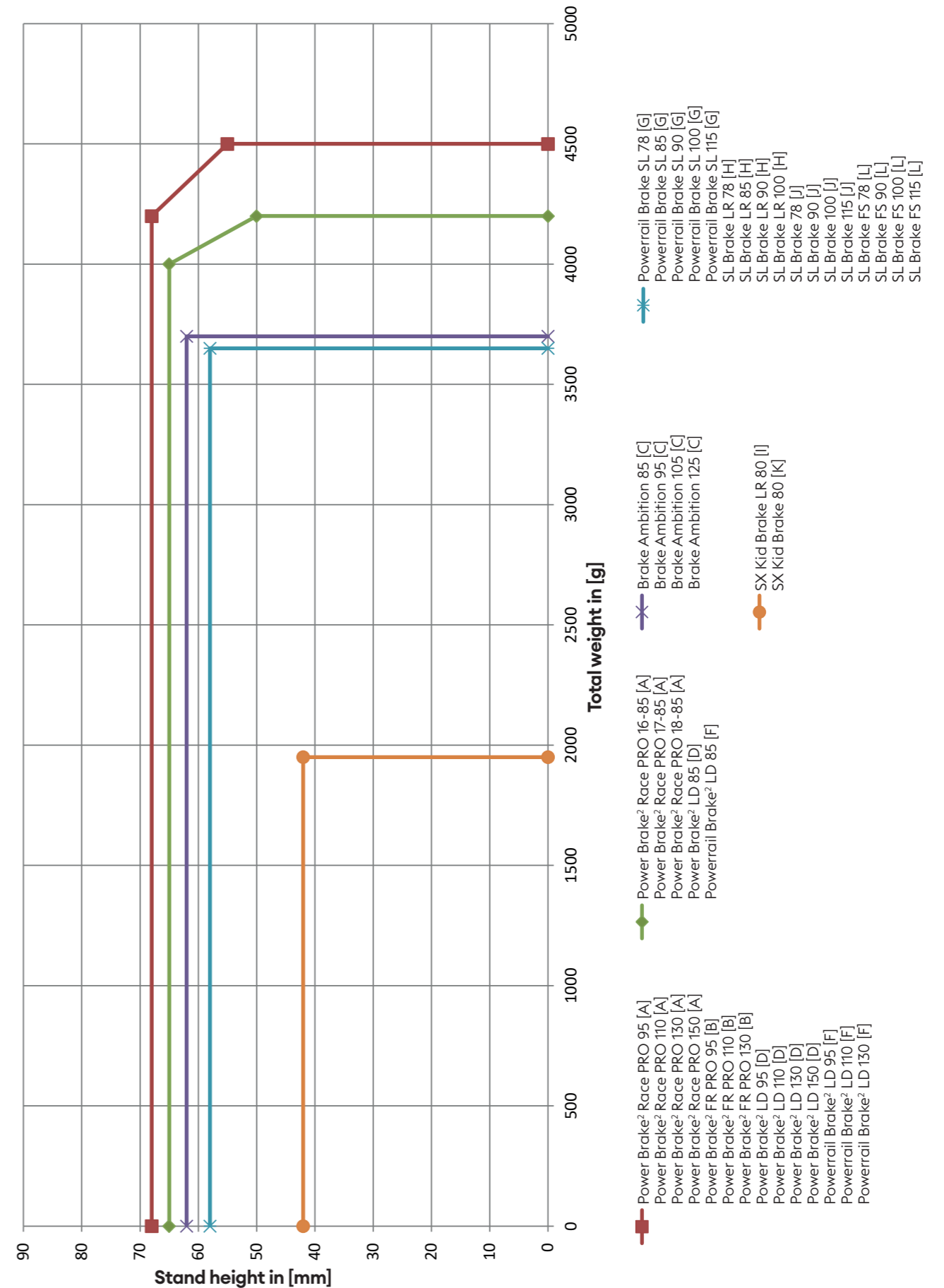

5. POWERRAIL SYSTEM

The POWERRAIL system meets the demands of adult skiers, while being perfectly suited for both retail and rental sectors! HEAD/TYROLIA offers different types of bases. All of them are indicated with a PR in their name. All PRD, PRW and PR bindings can be combined with all types of Powerrail bases:

HEAD:	
PRD 14 GW	
PRD 12 GW	
PR 11 GW	

TYROLIA:	
PRW 12 GW	PRD 12 GW
PRW 11 GW	PR 11 GW
PRD 11 GW	PR 10 GW PROMO

TYROLIA INSIDE:	
KÄSTLE:	
K12 TRI GW	

NOTE: HEAD/TYROLIA offers different types of Brakes for POWERRAIL bindings. Refer to the Brake overview on page 25 for Brake and binding compatibility.

The description of the Brakes always includes a number and a color-letter code. This number stands for the maximum ski width in the Brake area and not in the ski center! The color letter code defines the Brake segment.

5.1. MOUNTING - BASE

If the base is not already pre-mounted on the ski, you have to use the template Bases & Plates to mount it. Just select the right mounting mark and the appropriate bushings – as listed on page 47: the white mark and the silver bushings for POWERRAIL System.

MODEL	BOOTSOLE RANGE
ALLRIDE PR BASE	255 - 378 mm
MULTIFLEX PR BASE	255 - 378 mm
TWIN PR BASE	255 - 378 mm
TRIFLEX PR BASE	255 - 378 mm
LYT PR BASE	259 - 382 mm
SUPERFLEX PR BASE	259 - 382 mm

The procedure is similar as for plates - just follow the instructions in this manual. After drilling, cleaning, tapping and lubricating you can put on the base. Place it over the holes and tighten all screws (Pict. 78). Finally, you can snap in the appropriate cover if needed.

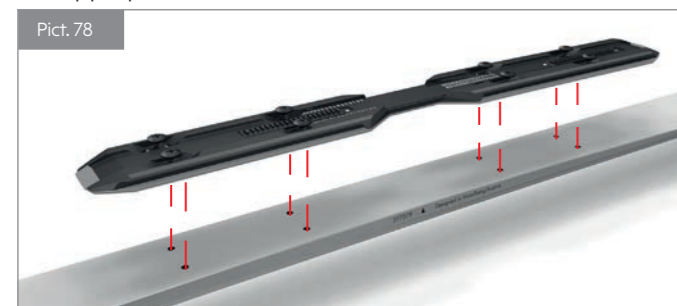

5.2. MOUNTING - BINDINGS

Make sure that the boot is satisfying the international standards and has no functional damage. Take the binding parts out of the box and follow the steps on the instruction leaflet. Determine the boot sole length with the HEAD/TYROLIA rental caliper (Art. No. 162617).



FIRST INSTALLATION

Open the toe-lever and slide the toe on the rail from the front. Lock at the appropriate boot sole length and close the lever.

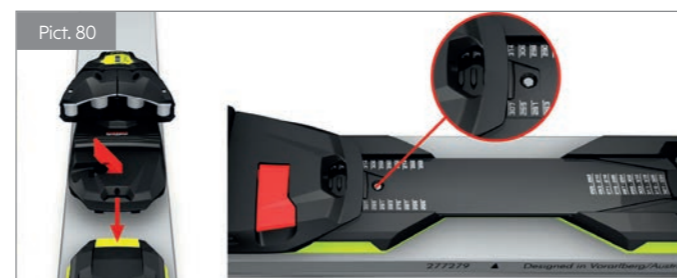

Now hook the Brake into the heel housing.



Then open the heel lever, slide the heel on the rail from the back and lock it at the appropriate boot sole marking. Don't forget to check that the lever is closed again.



Finally, check the forward pressure, by placing a boot into the binding. If you have followed all steps correctly, the indicator should rest in the marked area.

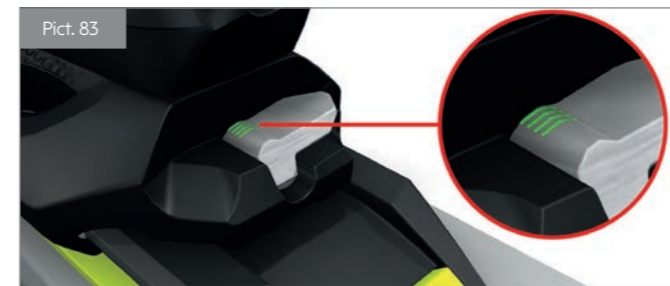

If you have too much or not enough forward pressure, check the settings and if necessary, adjust slightly at the heel and the toe. Then close the levers and check the forward pressure again. Now it should be okay.

ADAPTATION:

Once the binding is mounted onto a ski it is very easy to adjust it to another boot sole length. Just open the levers and slide toe and heel to the desired length mark. Finally close the levers and check forward pressure as described before.

6. ADJUSTMENT OF THE RELEASE VALUES

The release values of the toe and heel should be determined by height and body weight (ISO/ASTM) method. Set the binding accordingly with the adjustment screws at heel and toe unit. HEAD/TYROLIA recommends adjusting these settings with a manual screwdriver. Do NOT use a screw shooter. We also recommend the use of a calibrated testing device and that you keep a written record of whether the system passes or fails (requirement in the US).

NOTE: Release/Retention settings above a release moment of 105 Nm at the toe and 452 Nm at the heel are higher than the international standards recommend and are used solely at the skier's own risk!

7. FUNCTION CHECK

Check the function of the heel. Make sure that the boot does not catch on the heel during entry and exit. Check the Brake function by pressing down the Brake pedal (1) by hand. The Brake arms (2) must open to the braking position when the Brake pedal is released (Pict. 84).

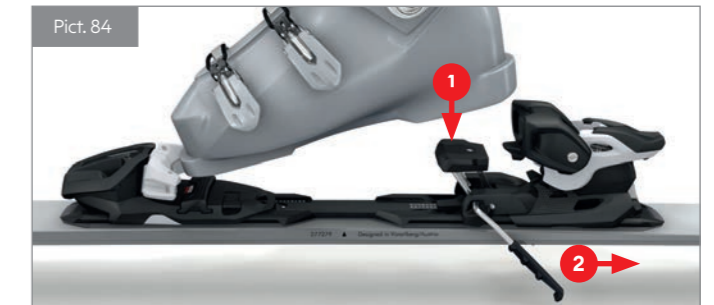

Check the elasticity and retention of the toe by pushing the boot inward and outward. The binding must recenter the boot easily and quickly from a 15 mm lateral displacement.

8. FINAL CHECK

- Is the proper mounting point selected?
- Functional Brake test passed?
- Have all screws been fastened tightly?
- Is the forward pressure properly adjusted?
- Are the release values of toe and heel properly determined and set?
- Is the Instruction for use booklet ready to be handed over to the customer?

DRILL TEMPLATE RACEPLATE WCR SHORT/TEAM

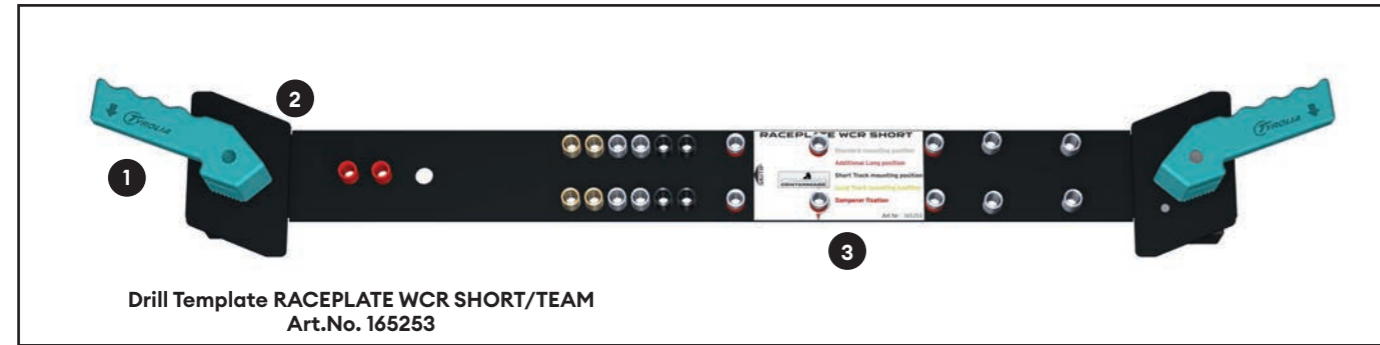

1. COMPATIBILITY

Presently the drill template Raceplate WCR/TEAM can be used for:

HEAD:

RACEPLATE WCR SHORT
RACEPLATE WCR TEAM

The Raceplate WCR SHORT comes with 8 mm penetration screws and can be used with ski groups G1 and G2.

Drill template Raceplate WCR SHORT/TEAM can be used for ski widths from 59 to 108 mm. For other skis use the template adapter set (Art. No. 162569). With this adapter set ski widths from 45 to 132 mm can be mounted.

2. POSITIONING THE DRILL TEMPLATE

Open the clamping jaws (2) by rotating the clamping handles (1) and then place template on the ski. Align the boot midsole indicator (3) with the midsole mounting mark on the ski. Be sure the template is evenly seated against the ski's top surface. Release clamping handles (1) and attach the template firmly to the ski.

NOTE: Some ski manufactures do not use the center of boot sole location method. Always follow the ski manufacturer's instructions.

3. DRILLING THE HOLES

If not otherwise specified by the ski manufacturer, use a 4.1 Ø x 9.0 mm drill bit for ski groups G1 and G2.

Use the silver bushings for the standard mounting position (Pict. 84). Use the black bushings for the short track mounting position and the golden bushings for the long track mounting position. Use the red/silver bushings for the additional long position. Use the red bushings only if you want to mount the optional logo plate or the interchangeable dampener kit (Art. No. 163082).

If required by the ski manufacturer, tap the hole. After drilling place a drop of TYROLIA glue into the holes. It lubricates the screws and seals the holes.



4. MOUNTING

4.1. MOUNTING - PLATE

Place the mounting rail onto the prepared holes and fasten the screws in a cross pattern (Pict. 86).

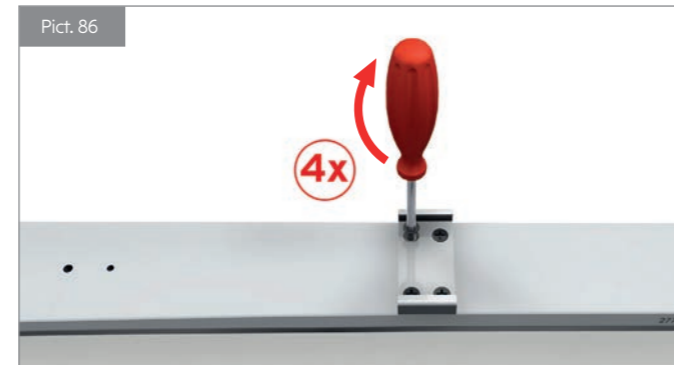

Slide in the plate until the midsole indicator aligns with the midsole mounting mark on the ski (Pict. 87).

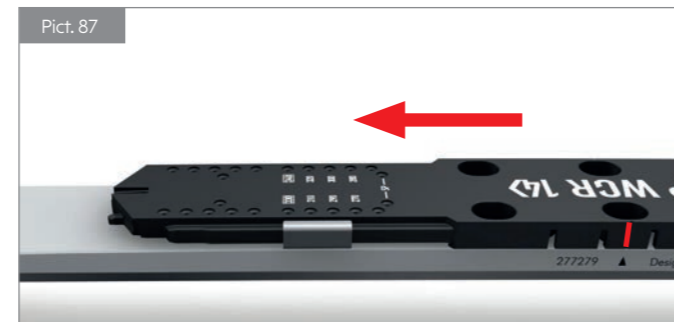

Check if the holes align with the prepared holes in the ski and fasten the screws as shown below (Pict. 88).

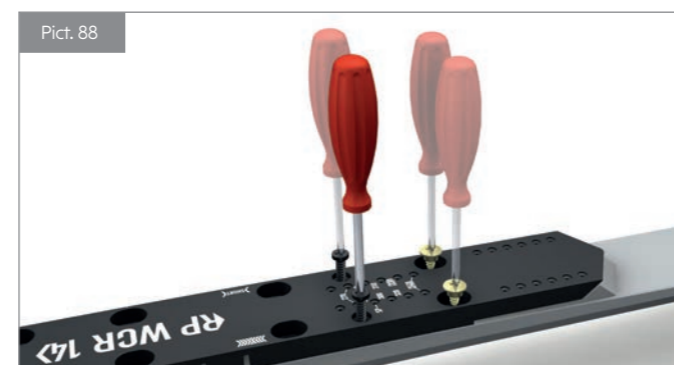

Slide on the cap and place the logo plate (optional) onto the prepared holes and fasten the screws. To fasten the fixing screw of the cap it is not recommended to use a screw shooter as it is possible to overturn the screw (Pict. 89).

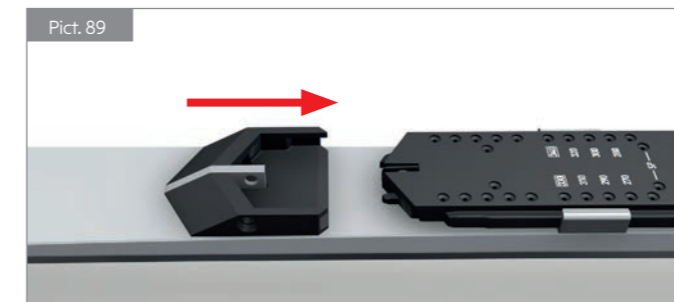

4.2. MOUNTING - BINDING

Use only the pre-drilled holes for installation – do not drill holes into the plate to mount bindings of other manufacturers.

Determine the boot sole length with the HEAD/TYROLIA Rental boot caliper and place the binding on the plate corresponding with the appropriate printed length markings. Mount the binding in accordance with the procedures in this manual.



BINDING-PLATE COORDINATION

BINDING	RACEPLATE WCR SHORT/TEAM HEIGHT: 14 MM	
	MOUNTING RANGE [MM]	STAND HEIGHT [MM]
Freeflex ST 16 Freeflex ST 14	258 - 372	31,0
Freeflex 14 Freeflex 11 Freeflex PRO 11 Freeflex DEMO 14 GW RX 12 GW / D11 GW	258 - 372	35,0
EVO 9 GW AC SX 10 GW SX 7.5 GW AC	261 - 384	35,0
SP 10 GW	263 - 391	45,0

5. FINAL CHECK

- Have the proper mounting points been selected?
- Have all screws been fastened tightly?
- Does the midsole mark of the plate align with the midsole mark of the ski?

DRILL TEMPLATE RACEPLATE 09

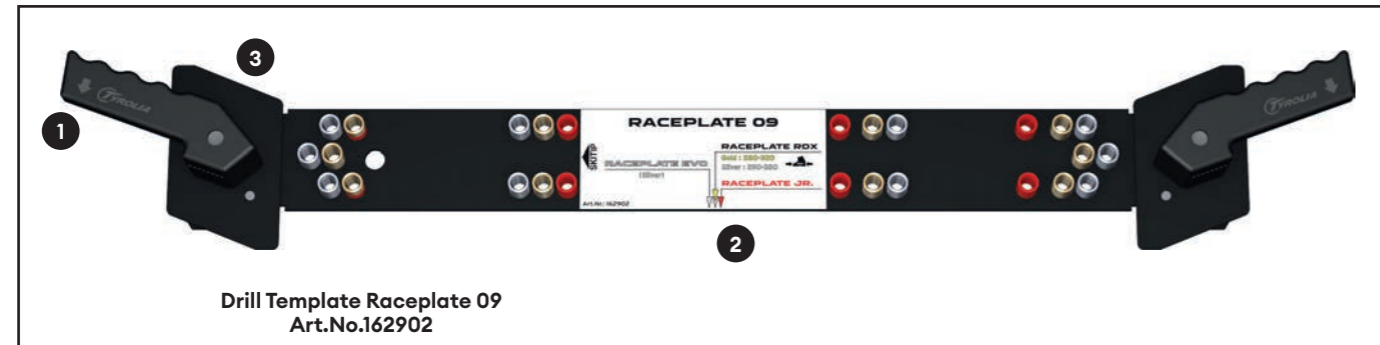

1. COMPATIBILITY

Presently the drill template RACEPLATE 09 can be used for:

HEAD: RACEPLATE EVO
TYROLIA: RACEPLATE EVO

Drill template RACEPLATE 09 is for mounting of the RACEPLATE EVO. It can be used for ski widths from 59 mm to 108 mm. For other skis use the template adapter set (Art. No. 162569). With this adapter set, you can mount skis from 45 mm to 132 mm.

The following chart shows which HEAD/TYROLIA bases and plates are suitable for the different ski-groups (G1-G4).

MODEL	G1	G2	G3	G4
RACEPLATE EVO 14	●	●	●	-

●...suitable - ...not suitable

If bases and plates are mounted on other ski groups, the penetration depth and the torque moment of the screws have to be verified.

2. POSITIONING THE DRILL TEMPLATE

Open the clamping jaws (3) by rotating the clamping handles (1) and then place the template on the ski. Align the boot midsole indicator (2) for the appropriate model with the midsole mounting mark on the ski. Be sure the template is evenly seated against the ski's top surface. Release clamping handles.

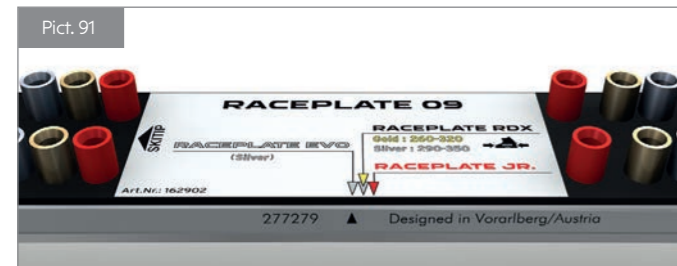

NOTE: Keep in mind that some ski manufacturers do not use the center of boot sole location method. Always follow the ski manufacturer's instructions.

3. DRILLING THE HOLES

If not otherwise specified by the ski manufacturer, use a 4,1 Ø x 9,0 mm drill bit for RACEPLATE EVO, as it comes with 8 mm penetration screws.

DRILL THROUGH THE APPROPRIATE BUSHINGS

VERSION / BOOT SOLE LENGTH	COLOR OF BUSHINGS / INDICATORS
RACEPLATE EVO (261 - 372 mm)	silver

After drilling place a drop of TYROLIA glue into the holes. It lubricates the screws and seals the holes.

4. MOUNTING - RACEPLATE EVO

4.1. MOUNTING - PLATE

First place the metal base plate over the two front holes and tighten the screws (Pict. 92). Then place the second metal base plate over the two back holes and tighten the screws (Pict. 93). Slide in the front plate into the metal base plate in the front



until the holes in the plate align with the holes in the ski. Do the same also for the back part of the plate (Pict. 94).



Now you can fasten the plate. Just tighten the screws – the special golden screws in the oblong holes and the standard black screws in the normal holes (Pict 95).



Finally place the central part metal plate between the plates in the front and back so the holes align and tighten the screws (Pict 96).

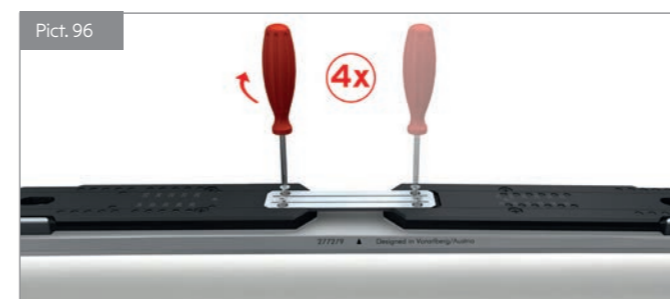

4.2. MOUNTING - BINDING ON PLATE

The Raceplate EVO is suited for all HEAD/TYROLIA two-piece bindings, Freeflex bindings and rental bindings for boot sole lengths from 261 to 372mm.

Simply mount the binding by placing the binding over the holes indicating the appropriate boot sole length and tighten the screws (Pict. 97).

NOTE: Use only the pre-drilled holes for installation – do not drill holes into the plate to mount bindings of other manufacturers.

Other than those two points, the mounting is the same as the method described in this manual in the section about the 92W template!



DRILL TEMPLATE SLR PRO

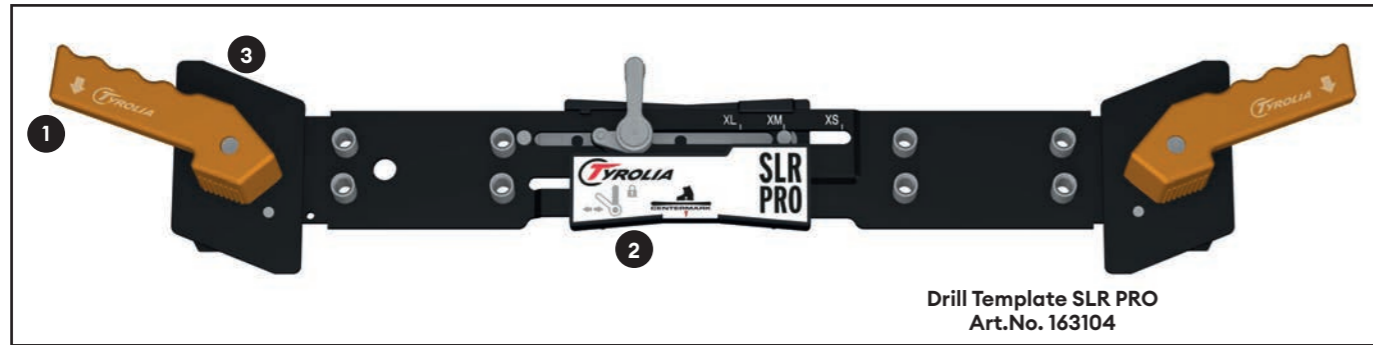

1. COMPATIBILITY

Presently the drill template SLR PRO can be used for:

HEAD:

SLR PRO Base (XS / XM / XL)
JOY SLR PRO Base (XS / XM / XL)

TYROLIA:

SLR PRO Base (XS / XM / XL)

Drill template SLR PRO can be used for ski widths from 59 to 108 mm to mount SLR PRO Bases and JOY SLR PRO Bases. For other skis use the template adapter set (Art. No. 162569). With this adapter set ski widths from 45 mm to 132 mm can be mounted.

The SLR PRO Bases are available in three sizes and cover sole lengths ranging from 183 to 363 mm. All SLR Bindings are compatible with both bases – SLR PRO and JOY SLR PRO bases.

MODEL	BOOT SOLE RANGE
SLR PRO Base (XS)	183 - 307 mm
SLR PRO Base (XM)	215 - 339 mm
SLR PRO Base (XL)	239 - 363 mm

Depending on the ski specification the appropriate screws for the SLR PRO and JOY SLR PRO base have to be used. The following chart shows which HEAD/TYROLIA bases and plates are suitable for the different ski groups (G1-G4).

MODEL	G1	G2	G3	G4
SLR PRO Base (XS)	●	●	●	-
SLR PRO Base (XM)	●	●	●	-
SLR PRO Base (XL)	●	●	●	-

●...suitable - ...not suitable

If bases and plates are mounted on other ski groups, the penetration depth and the torque moment of the screws have to be verified.

2. POSITIONING THE DRILL TEMPLATE

Move the adjustment lever to the left and move the clamping jaws so the silver indicator aligns with the correct size indicator on the template (XS, XM or XL). After that, move the lever back to the locking position.

Open the clamping jaws (3) by rotating the clamping handles (1) and then place the template on the ski. Align the boot midsole indicator (2) for the appropriate model with the midsole mounting mark on the ski. Be sure the template is evenly seated against the ski's top surface. Release clamping handles.

NOTE: Keep in mind that some ski manufacturers do not use the center of boot sole location method. Always follow the ski manufacturer's instructions.

3. DRILLING THE HOLES

If not otherwise specified by the ski manufacturer use for all bases a 4.1 Ø x 9.0 mm drill bit for ski groups G1 and G2. For skis of groups G3 and G4, use a 4.1 Ø x 7.0 mm drill bit. After drilling place a drop of TYROLIA glue into the holes. It lubricates the screws and seals the holes.

4. SLR PRO 4.1. MOUNTING - SLR PRO BASES

After drilling, cleaning and lubrication, you can put on the base. Place it over the holes and tighten all screws in a cross pattern (Pict. 98). Finally, snap in the cover on the base (only for JOY SLR PRO base).



4.2. MOUNTING - BINDINGS

Mounting and adjusting the SLR bindings is extremely simple and can be done without any additional tool.

Make sure that the boot meets the international standards and is free of any functional damage. Take the binding parts out of the box and follow the steps on the instruction leaflet. Determine the boot sole length with the HEAD/TYROLIA rental caliper (Art. No. 162617).



First you have to open the toe-lever and slide the toe on the rail from the front. Lock at the appropriate boot sole length and close the lever.



Now hook the Brake into the heel housing (Pict. 101).



Then you can open the lever and slide the heel on the rail from the back! Simply lock it at the appropriate boot sole marking by closing the lever - and you are ready to go!



Finally, check the forward pressure, by placing a boot into the binding. If you have followed all steps correctly, the indicator should rest in the marked area.



If you have too much or not enough forward pressure, check the settings at first. If necessary, adjust slightly at the heel and the toe.

Then check the forward pressure again. Now it should be okay.

5. AFS GW JUNIOR ON DIN 7.5 GW AC AND DIN 4.5 GW AC MODELS

The SX Junior and SX Kid lines are suitable for both Adult (ISO 5355 TYPE A) and Children (ISO 5355 TYPE C) boots as well as GripWalk (ISO 23223 TYPE A) and GripWalk Junior (ISO 23223 TYPE C) boots: the innovative mechanical Anti Friction Slider (AFS GW Jr.) automatically adjusts to the boot sole height, A/C standards, GripWalk standards as well as height differences due to icing up, dirt or boot wear (Pict. 104).



If you want to increase the stability of your junior binding in combination with Children (TYPE C) boots, you can replace the standard AFS with a vertically blocked AFS (Art. No. 163113), which is for Children boots and GripWalk Junior boots ONLY. All you have to do is to separate the standard slider from the base plate. Afterwards you can simply click in the spare slider.

6. ADJUSTMENT OF THE RELEASE VALUES

The release values of the toe and heel should be determined by height and body weight (ISO/ASTM) method.

Set the binding accordingly with the adjustment screws at heel and toe unit. HEAD/TYROLIA recommends adjusting these settings with a manual screwdriver. Do NOT use a screw shooter. We also recommend the use of a calibrated testing device and that you keep a written record of whether the system passes or fails (requirement in the US).

NOTE: Release/Retention settings above a release moment of 105 Nm at the toe and 452 Nm at the heel are higher than the international standards recommend and are used solely at the skier's own risk!

7. FUNCTION CHECK

Check the function of the heel. Make sure that the boot does not catch on the heel during entry and exit. Check the Brake function by pressing down the Brake pedal by hand.

The Brake arms must open to the braking position when the Brake pedal is released.



Check the elasticity and retention of the toe by pushing the boot inward and outward. The binding must recenter the boot easily and quickly from a 15 mm lateral displacement (SLR 7.5 GW AC, SLR 4.5 GW AC - 10 mm).

8. FINAL CHECK

- Is the proper mounting point selected?
- Functional Brake test passed?
- Have all screws been fastened tightly?
- Is the forward pressure properly adjusted?
- Are the release values of toe and heel properly determined and set?
- Is the Instruction for use booklet ready to be handed over to the customer?

DRILL TEMPLATE 94W

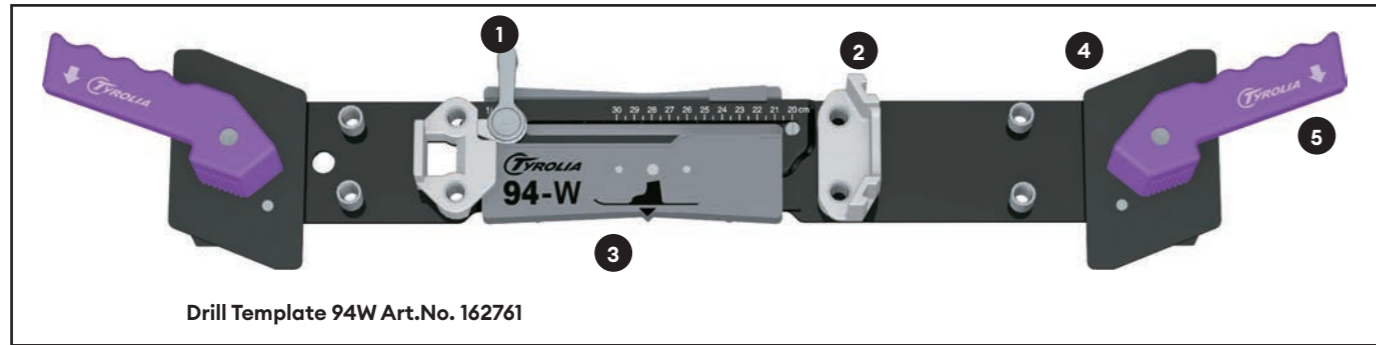

1. COMPATIBILITY

Presently the drill template 94 W can be used for:

TYROLIA:
SX 4.5 GW AC
D 4.5 GW AC
SX 4.5 R GW AC

Drill template 94 W can be used for ski widths from 59 mm to 108 mm. For other skis use the template adapter set (Art. No. 162569).

The SX 4.5 GW AC binding comes with 6 mm penetration depth screws and can be used for ski groups G3 and G4. The standard Brake, the SX KID Brake 80 [K], can be used for skis up to 80 mm.

NOTE: HEAD/TYROLIA offers different types of Brakes. Refer to the Brake overview on page 25 for Brake and binding compatibility.

The description of the Brakes always includes a number and a color-letter code. This number stands for the maximum ski width in the Brake area and not in the ski center! The color letter code defines the Brake segment.

2. ADJUSTING THE DRILL TEMPLATE

Unlock the locking lever (1) by rotating it counter-clockwise. Place the template on the ski. Place the ski boot in the template. Push the template together until the stops are against the sole (2). Lock the lever (1) to prevent length change and take the boot out of the template.

3. POSITIONING OF THE DRILL TEMPLATE

Align the boot midsole indicator (3) with the midsole mounting mark on the ski. Be sure the template is evenly seated against the ski's top surface. Release clamping handles to attach the template to the ski.

Check the boot midsole mark with template mark. If they are not the same use the boot midsole mark to align the template with the ski mounting mark.

NOTE: Some ski manufacturers do not use the center of boot sole location method. Always follow the ski manufacturer's instructions.

4. DRILLING THE HOLES

If not otherwise specified by the ski manufacturer, use a 4.1 Ø x 7.0 mm drill bit, which is the right bit for ski groups G3 and G4. Drill the holes using an appropriate TYROLIA drill. If required by the ski manufacturer, tap the holes. Place a drop of TYROLIA glue into the holes. It lubricates the screws and seals the ski (Pict. 106).

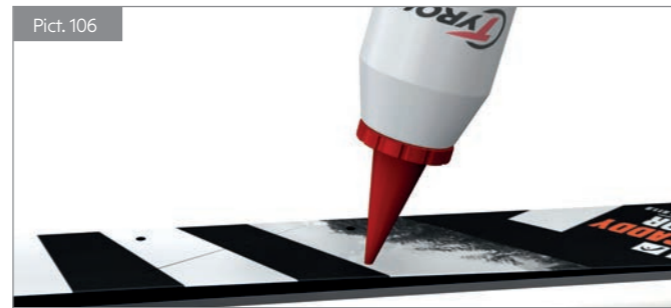

5. MOUNTING

Place the toe unit over the holes and fasten the screws in an cross-pattern. Then do the same for the heel (Pict. 107).

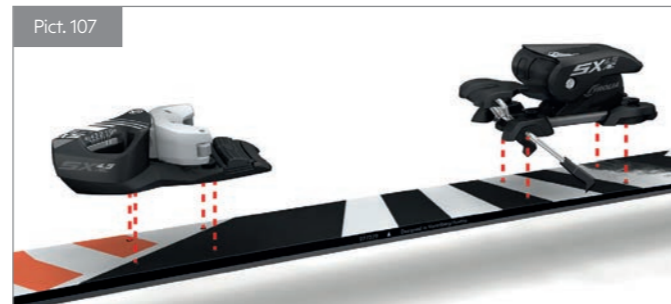

6. ADJUSTMENT

Use the TYROLIA Rental Caliper to check and make sure that the boot meets international standards and is not damaged.



AFS GW JUNIOR

The SX Junior and SX Kid lines are suitable for both Adult (ISO 5355 TYPE A) and Children (ISO 5355 TYPE C) boots as well as GripWalk (ISO 23223 TYPE A) and GripWalk Junior (ISO 23223 TYPE C) boots: the innovative mechanical Anti Friction Slider (AFS GW Jr.) automatically adjusts to the boot sole height, A/C standards, GripWalk standards as well as height differences due to icing up, dirt or boot wear (Pict. 109).



If you want to increase the stability of your junior binding in combination with Children (TYPE C) boots, you can replace the standard AFS with a vertically blocked AFS (Art. No. 163113), which is for Children (TYPE C) boots and GripWalk Junior boots ONLY. All you have to do is to separate the standard slider from the base plate. Afterwards you can simply click in the spare slider (Pict. 110).



ADJUSTING THE RELEASE VALUES

The release values of the toe and heel should be determined by height and body weight (ISO/ASTM) method.

Set the binding accordingly with the adjustment screws at heel and toe unit. HEAD/TYROLIA recommends adjusting these settings with a manual screwdriver. Do NOT use a screw shooter! We also recommend the use of a calibrated testing device and that you keep a written record of whether the system passes or fails (requirement in the US).

7. FORWARD PRESSURE

Place the boot in the binding and close it. The indicating pointer should rest within the marked area (Pict. 111), if not you have to adjust the forward pressure.

DON'T OPEN THE LENGTH ADJUSTMENT LOCK AS LONG AS A SKI BOOT IS FIXED IN THE BINDING.

Place the ski boot in the open binding and rest the boot heel on the Brake pedal. Lift the length adjustment lock (1) with a screwdriver and slide the heel until the heel cup just touches the boot. Lock the length adjustment by pushing it down. Latch the boot in the binding and check forward pressure again. The toe pincers should not be pressed open and the indicating pointer should rest within the marked area (Pict. 111).



8. FUNCTION CHECK

ENTRY/EXIT: Check to make sure that the boot does not catch on the heel hold down lug.

Brake: Press the Brake pedal (1) down by hand. The Brake arms (2) must automatically return to the braking position when the treadle is released (Pict. 112).



LATERAL ELASTICITY OF THE TOE

Press the boot laterally outward. The binding must re-center the boot easily and quickly from a 10 mm lateral displacement.

9. FINAL CHECK

- Has the proper mounting point been selected?
- Functional Brake test passed?
- Have all screws been fastened tightly?
- Has the forward pressure been properly set?
- Are the release values of the toe and heel properly determined and set?
- Is the instruction for use booklet ready to be handed over to the consumer?

DRILL TEMPLATE FREEFLEX DEMO

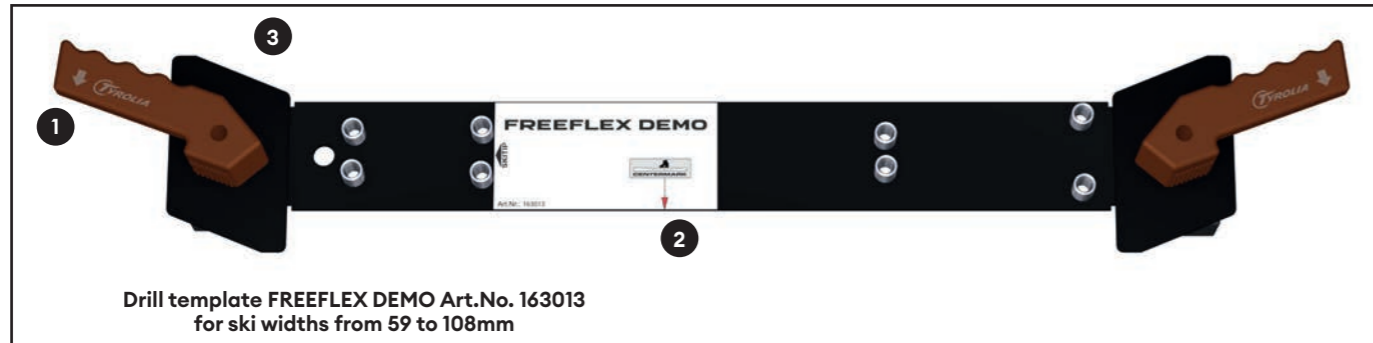

1. COMPATIBILITY

Presently the drill template FREEFLEX DEMO can be used for:

HEAD:
FREEFLEX DEMO 14 GW

TYROLIA:
FREEFLEX DEMO 14 GW

All TYROLIA adult bindings come with 8 mm penetration screws and can be used with skis of groups G1 and G2.

The FREEFLEX DEMO 14 GW bindings are fully GripWalk compatible and can be used with Adult Alpine ski boots (ISO 5355 TYPE A) and GripWalk ski boots (ISO 23223 TYPE A)*. No further adjustment to the boot sole type is necessary. Every GripWalk compatible binding is indicated with the GripWalk logo on the AFS and also in the Product name with "GW".

Drill template FREEFLEX DEMO can be used for ski widths from 59 mm to 108 mm. For other skis use the template adapter set (Art. No. 162569). With this adapter set, you can mount skis from 45 mm to 132 mm.

NOTE: TYROLIA offers different types of Brakes. Refer to the Brake overview on page 25 for Brake and binding compatibility.

The description of the Brakes always includes a number and a color-letter code. This number stands for the maximum ski width in the Brake area and not in the ski center! The color letter code defines the Brake segment.

2. MOUNTING

2.1. MOUNTING ON FLAT SKIS

POSITIONING THE DRILL TEMPLATE

Open the clamping jaws (3) by rotating the clamping handles (1) and then place the template on the ski. Align the boot midsole indicator (2) for the appropriate binding model with the midsole mounting mark on the ski. Be sure the template is evenly seated against the ski's top surface. Release the clamping handles (1) and attach the template firmly to the ski.

NOTE: Some ski manufactures do not use the center of boot sole location method. Always follow the ski manufacturer's instructions.

DRILLING THE HOLES

If not otherwise specified by the ski manufacturer, for all FREEFLEX DEMO models use a 4.1 Ø x 9.0 mm drill bit for ski groups G1 and G2.



If required by the ski manufacturer, tap the hole. After drilling place a drop of TYROLIA glue into the holes. It lubricates the screws and seals the holes.

MOUNTING

Place the metal toe track over the front holes and fasten the two front screws (Pict. 114).



Place the heel unit with its Brake, guide and track over the holes, connect the Freeflex band with the metal toe track and tighten the screws in a cross pattern (Pict. 115).



2.2. MOUNTING ON PLATES

MOUNTING

If you want to mount the Freeflex Demo bindings onto a HEAD/TYROLIA plate, you don't need a drill template and drill holes.

NOTE: For mounting the Freeflex Demo bindings onto the Raceplate WCR SHORT remove the front dampener of the metal toe track.

Simply place the metal toe track over the holes indicated with the SP / DEMO marking. Tighten the two front screws. Place the heel unit over the holes with the SP / DEMO markings, connect the Freeflex band with the metal toe track and tighten the remaining screws in a cross pattern (Pict. 116).



3. ADJUSTMENT

Make sure that the boot meets the international standards and is free of any functional damage. Determine the boot sole length with the HEAD/TYROLIA rental caliper (Art. No. 162617).

Open the one-touch latch and slide the toe piece on from the front. Adjust the toe piece to the desired position and close the latch. Push the one-touch lever of the heel forward and slide the heel into the correct position. Let go of the lever and make sure that the heel snaps into position (Pict. 117).



4. FORWARD PRESSURE CONTROL

Place a suitable reference boot in the binding using the mm-scale for length adjustment and close it (Pict. 118). Then check the indicator located at the rear end of the heel piece. With the boot inserted, the pointer should rest in the middle of the marked area. The Freeflex Demo 14 GW binding is fully GripWalk compatible, no further height adjustment is necessary.

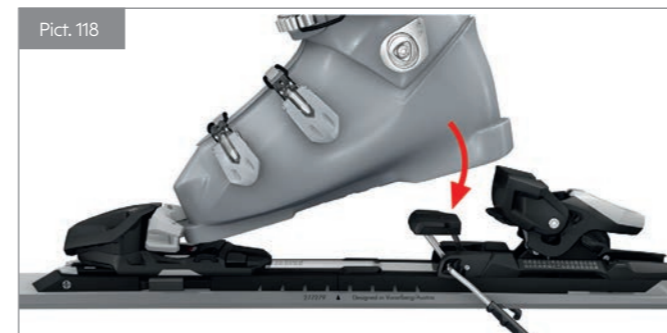

NOTE: Always remove the boot from the binding before adjusting.



5. FUNCTION CHECK

Before the newly mounted ski equipment is rented, perform a complete functional check.

NOTE: In some countries rental equipment needs to pass a Pre-Season Test (See the Rental section of this manual). The boot should not catch on the sole hold-down of the heel as it opens and closes.

Brake

Press the step-on plate down by hand. The Brake arms must close and open automatically to the braking position when the step-on plate is released.

LATERAL ELASTICITY OF THE TOE

Press the boot laterally outward. The binding must re-center the boot easily and quickly from a 15mm lateral displacement.

6. FINAL CHECK

- Has the proper mounting point been selected?
- Have all screws been fastened tightly?
- Has the forward pressure setting been adjusted?
- Has at least one full adjustment been made using a representative reference boot, including Release-Retention setting and momentum test?
- Was the functional check successfully completed?
- Was the functional Brake test successfully completed?

DRILL TEMPLATE SP 2003 W

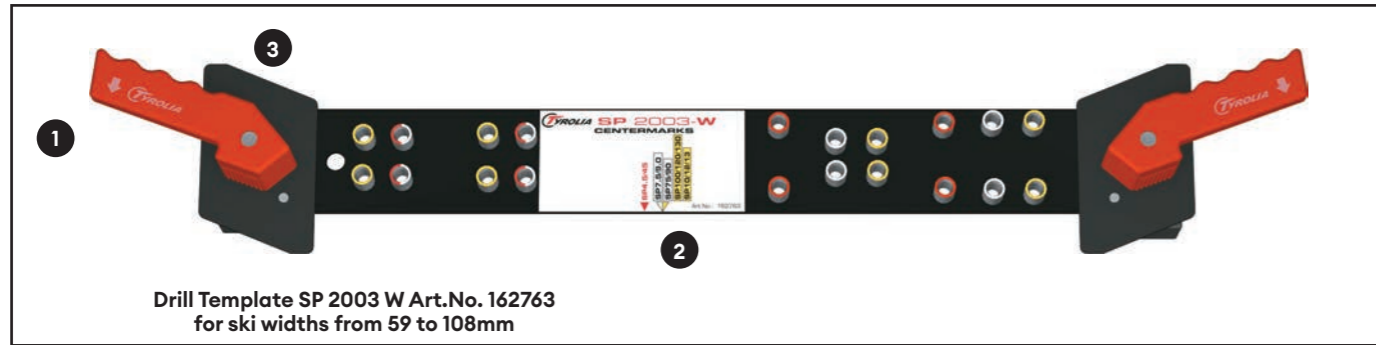

1. COMPATIBILITY

Presently the drill template SP 2003 W can be used for:

TYROLIA:
SP 10 GW

All TYROLIA adult bindings come with 8 mm penetration screws and can be used with skis of groups G1 and G2, except the SP 10 GW (screws 6mm-G3/G4) (Art. No. 114395) model which is delivered with 6 mm penetration screws for G3 and G4 skis.

The TYROLIA SP 10 GW Bindings are now fully GripWalk compatible and can be used with Adult Alpine ski boots (ISO 5355 TYPE A) and GripWalk ski boots (ISO 23223 TYPE A). No further adjustment to the boot sole TYPE is necessary. Every GripWalk compatible binding is indicated with the GripWalk Logo on the AFS and also in the Product name with "GW".

Drill Template SP 2003 W can be used for ski widths from 59 mm to 108 mm. For other skis use the template adapter set (Art. No. 162569). With this adapter set, you can mount skis from 45 mm to 132 mm with the standard SP 2003 W drill template.

NOTE: TYROLIA offers different types of Brakes. Refer to the Brake overview on page 25 for Brake and binding compatibility.

The description of the Brakes always includes a number and a color-letter code. This number stands for the maximum ski width in the Brake area and not in the ski center! The color letter code defines the Brake segment.

2. POSITIONING THE DRILL TEMPLATE

Open the clamping jaws (3) by rotating the clamping handles (1) and then place the template on the ski. Align the boot midsole indicator (2) for the appropriate binding model with the midsole mounting mark on the ski. Be sure the template is evenly seated against the ski's top surface. Release the clamping handles (1) and attach the template firmly to the ski.

NOTE: Some ski manufactures do not use the center of boot sole location method. Always follow the ski manufacturer's instructions.

3. DRILLING THE HOLES

If not otherwise specified by the ski manufacturer, for all SYMPRO adult models use a 4.1 Ø x 9.0 mm drill bit for ski groups G1 and G2.

MODEL	COLOR OF BUSHINGS / INDICATORS
SP 10 GW	yellow



If required by the ski manufacturer, tap the hole. After drilling place a drop of TYROLIA glue into the holes. It lubricates the screws and seals the holes.

4. MOUNTING

MOUNTING THE TOE

Connect the plastic mid section with the metal toe track. Place the assembled toe track over the holes and tighten the screws. Open the one touch latch and slide the toe piece on from the front. Adjust the toe piece to the desired SINGLE CODE position and close the latch (Pict. 121).



Make sure that the lever snaps in place completely (it may be necessary to slide the toe forward and backwards slightly and to close the lever actively by hand).

MOUNTING THE HEEL

Place the heel unit with its Brake, guide and track over the holes. Tighten the screws in a cross-pattern.

5. ADJUSTMENT

FOR ALL MODELS

Find adjustment ranges and some handling hints in the "SYMPRO SYMPRO" section of the Technical Manual. Take at least one reference boot satisfying all standards and free of functional damages to perform test adjustments with the binding.

USING THE SINGLE CODE

Adjust the heel to the corresponding alpha-settings (SINGLE CODE) of the ski boot.



IF A BOOT OF UNKNOWN SIZE IS USED PROCEED AS FOLLOWS:

Place the boot in the toe cup. Slide the heel piece forward until it just touches the boot. Close the binding and check the forward pressure.

ADJUSTING THE RELEASE VALUES

The release values of the toe and heel should be determined by height and body weight (ISO/ASTM) method. Set the binding accordingly with the adjustment screws at heel and toe unit. HEAD/TYROLIA recommends adjusting these settings with a manual screwdriver. Do NOT use a screw shooter. We also recommend the use of a calibrated testing device and that you keep a written record of whether the system passes or fails (requirement in the US).

NOTE: Release/Retention settings above a release moment of 105 Nm at the toe and 452 Nm at the heel are higher than the international standards recommend and are used solely at the skier's own risk!

6. FORWARD PRESSURE CONTROL

Place a suitable reference boot in the binding using the SINGLE CODE for length adjustment and close it. Then check the indicator (see Pict. 123) located at the rear end of the heel piece. With boot inserted the pointer should rest in the middle of the marked area.

NOTE: There is no need to insert a boot and check forward pressure in the adjustment process if SINGLE CODE is used (HEAD boots with single code marking or all types of boots measured and marked with spare single code stickers).



If necessary, re-adjust the boot sole length, check the SINGLE CODE.

NOTE: Always remove the boot from the binding before adjusting.

7. FUNCTION CHECK

Before the newly mounted ski equipment is rented perform a complete functional check.

NOTE: In some countries rental equipment has to pass a Pre-Season Test (See the Rental section of this manual). The boot should not catch on the sole hold-down of the heel as it opens and closes.

Brake

Press the step-on plate (1) down by hand. The Brake arms (2) must close and open automatically to the braking position when the step-on plate is released (Pict. 124).



LATERAL ELASTICITY OF THE TOE

Press the boot laterally outward. The binding must re-center the boot easily and quickly from a 15mm lateral displacement.

8. FINAL CHECK

- Has the proper mounting point been selected?
- Have all screws been fastened tightly?
- Has the forward pressure setting been controlled?
- Has at least one full adjustment been made using a representative reference boot including Release- / Retention setting and momentum test?
- Has the functional check been passed successfully?
- Functional Brake test passed?

DRILL TEMPLATE SR 2003 W

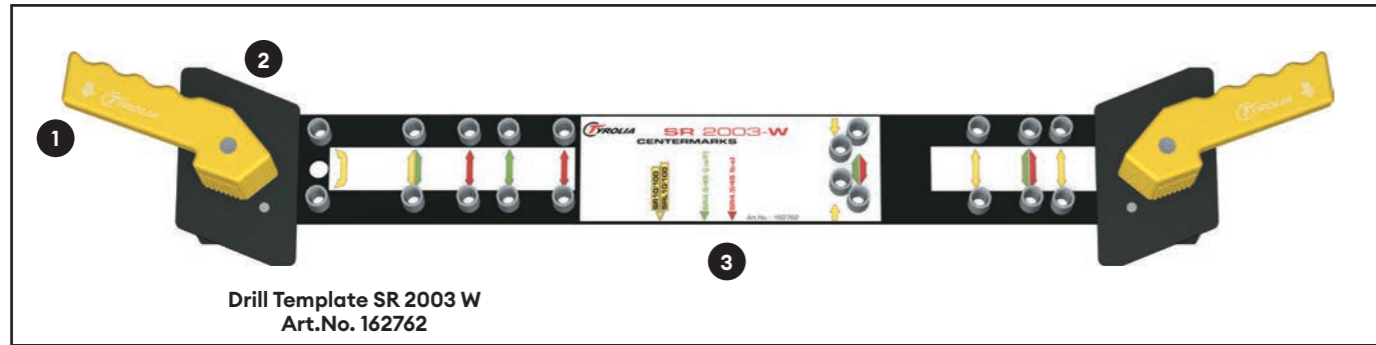

1. COMPATIBILITY

Presently the drill template SR 2003 W can be used for:

TYROLIA:	
SR 10 GW	SRM 10 GW
SR 4.5 GW AC	SRM 4.5 GW AC

SR 10 GW and SRM 10 GW come with 8 mm penetration screws and can be used with ski groups G1 and G2.

SR 4.5 GW AC and SRM 4.5 GW AC come with 6 mm penetration screws and is only for ski groups G3 and G4.

Drill template SR 2003 W can be used for ski widths from 59 to 108 mm. For other skis use the template adapter set (Art. No. 162569). With this adapter set, bindings on ski widths from 45 to 132 mm can be mounted.

NOTE: TYROLIA offers different types of Brakes. Refer to the Brake overview on page 25 for Brake and binding compatibility. The description of the Brakes always includes a number and a color-letter code. This number stands for the maximum ski width in the Brake area and not in the ski center! The color letter code defines the Brake segment.

2. POSITIONING THE DRILL TEMPLATE

Open the clamping jaws (2) by rotating the clamping handles (1) and then place template on the ski. Align the boot midsole indicator (3) for the appropriate binding model with the midsole mounting mark on the ski. Be sure the template is evenly seated against the ski's top surface. Release clamping handles (1) and attach the template firmly to the ski.

NOTE: Some ski manufactures do not use the center of boot sole location method. Always follow the ski manufacturer's instructions.

3. DRILLING THE HOLES

If not otherwise specified by the ski manufacturer, for all SYMRENT adult models use a 4.1 Ø x 9.0 mm drill bit for ski groups G1 and G2. For SR 4.5 GW AC use a 4.1 Ø x 7.0 mm for ski groups G3 and G4, if not otherwise recommended.

DRILL THROUGH THE APPROPRIATE BUSHINGS

MODEL	COLOR OF BUSHINGS / INDICATORS
SR 10 GW	yellow
SRM 10 GW	yellow
SR 4.5 GW AC (standard)	red (b-o)
SR 4.5 GW AC (sparepart)	green (j-w/F)
SRM 4.5 GW AC	red (199-255mm)

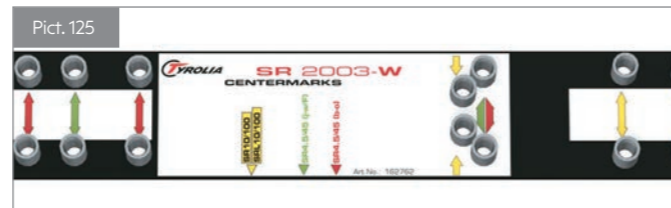

If required by the ski manufacturer, tap the hole. After drilling place a drop of TYROLIA glue into the holes. It lubricates the screws and seals the holes.

4. MOUNTING

MOUNTING THE TOE

Place toe piece on the prepared holes and drive the screws.

MOUNTING THE HEEL

Place the heel unit with its Brake, guide and track over the holes. Tighten the screws in a cross pattern.



5. ADJUSTMENT

FOR ALL MODELS

Find adjustment ranges and some handling hints in the SYMPRO/SYMRENT section of the Technical Manual. Take at least one reference boot satisfying all standards and free of functional damages to perform test adjustments with the binding.

USING THE SINGLE CODE

Adjust the heel to the corresponding alpha-setting (SINGLE CODE) of the ski boot (Pict. 127).



IF A BOOT OF UNKNOWN SIZE IS USED PROCEED AS FOLLOWS:

Place the boot in the toe cup. Slide the heel piece forward until it just touches the boot. Close the binding and check the forward pressure.

ADJUSTING THE RELEASE VALUES

The release values of the toe and heel should be determined by height and body weight (ISO/ASTM) method. Set the binding accordingly with the adjustment screws at heel and toe unit. HEAD/TYROLIA recommends adjusting these settings with a manual screwdriver. Do NOT use a screw shooter. We also recommend the use of a calibrated testing device and that you keep a written record of whether the system passes or fails (requirement in the US).

NOTE: Release/ Retention settings above a release moment of 105 Nm at the toe and 452 Nm at the heel are higher than the international standards recommend and are used solely at the skier's own risk!

6. FORWARD PRESSURE CONTROL

Place a suitable reference boot in the binding using the SINGLE CODE for length adjustment and latch it. Then check the indicator (see Pict. 128) located at the rear end of the heel piece. With boot inserted the pointer should rest in the middle of the marked area.

NOTE: There is no need to insert a boot and check forward pressure in the adjustment process if SINGLE CODE is used (HEAD boots with single code marking or all types of boots measured and marked with spare single code stickers).



NOTE: If the forward pressure is not correct, readjust the boot sole length and check the SINGLE CODE. Please make sure that no boot is placed in the binding during adjusting!

7. FUNCTION CHECK

Before newly mounted ski equipment is rented perform a complete functional check.

NOTE: In some countries rental equipment has to pass a Pre-Season Test (See the Rental section this manual).

The boot should not catch on the sole hold-down of the heel as it opens and closes.

Brake

Press the step-on plate (1) down by hand. The Brake arms (2) must close and open automatically to the braking position when the step-on plate is released (Pict. 129).



LATERAL ELASTICITY OF THE TOE

Press the boot laterally outward. The binding must recenter the boot easily and quickly from a 15 mm lateral displacement. (Model SR 4.5 GW AC and SRM 4.5 GW AC – 10 mm).

8. FINAL CHECK

- Has the proper mounting point been selected?
- Have all screws been fastened tightly?
- Has the forward pressure setting been controlled?
- Has at least one full adjustment been made using a representative reference boot including Release- / Retention setting and momentum test?
- Has the functional check been passed successfully?
- Functional Brake test passed?

BOOT SOLE TYPES - STANDARDS

1. BOOT STANDARDS

Actually there are three different boot sole standards on the market. The ISO 5355 (corresponding to binding standard ISO 9642) defines Alpine boots for adults and children, the ISO 23223 defines Alpine boots with improved walking soles (GripWalk and GripWalk Junior) and the ISO 9523 (corresponding to binding standard ISO 13992) defines a wide range of touring ski boots.

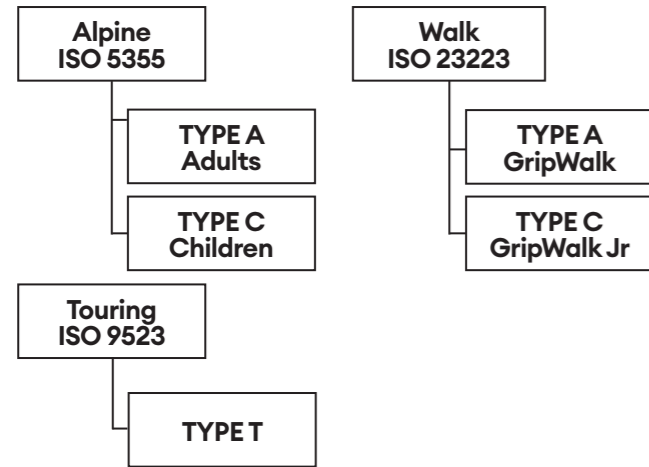

The new sub category (Walk) tries to combine the advantages of both previously existing standards:

- To offer more grip and better walkability compared to Alpine boots. A profiled sole made of softer material offers a superior walking grip and is less slippery than a standard ski boot sole. A rockered sole offers a more comfortable natural roll motion.
- To also offer better skiability and increased safety compared to Touring boots (hard contact area, stiffer material, Alpine boot design) and the same safe release function and power transmission as an alpine boot.

2. BOOT IDENTIFICATION

In general, all boots should be marked with the corresponding standard. In most cases you will find the indication on the sole pads of the boot.

ALPINE BOOTS ISO 5355



TOURING BOOTS ISO 9523

In case there is no other marking, in addition to ISO 9523, the boot is a regular Touring boot. The boot will only work in bindings with AT compatibility.



ALPINE BOOTS ISO 23223 TYPE A - GripWalk

To help identify a GripWalk boot the GripWalk icon and ISO marking (ISO 23223, but can be also ISO 9523 on older boots) are incorporated in the sole.



ALPINE BOOTS ISO 23223 TYPE C - GripWalk Junior

To help identify a GripWalk Junior boot, the GripWalk Junior logo and ISO marking (ISO 23223, can be missing on older boots) are incorporated in the sole pads.

NOTE: The boot is also marked with a sticker placed in the toe area. (pict 133 - right side). The sticker comes from the factory on boots with pre-mounted GripWalk soles or it needs to be placed in the toe area if the pads are retrofitted.



GripWalk Junior logo embossed in the front and rear sole pads

3. BOOT-BINDING COMPATIBILITY

In case of uncertainty, the dealer should check the instructions of use of the binding. It lists all compatible boot types:

Example for an Attack ² GW	Example for an Attack ² AT	Example for a GW AC model
This binding model can be used with ski boots that meet the following current industry standards - ALPINE TYPE A (ISO 5355) and WALK TYPE A (ISO 23223).	This binding model can be used with ski boots that meet the following current industry standards - ALPINE TYPE A (ISO 5355), WALK TYPE A (ISO 23223) and TOURING TYPE T (ISO 9523).	This binding model can be used with ski boots that meet the following current industry standards - ALPINE TYPE A and ALPINE TYPE C (ISO 5355), WALK TYPE A (GripWalk) (ISO 23223) WALK TYPE C (GripWalk Junior) (ISO 23223)

BOOT - BINDING - COMPATIBILITY - CHART

The following chart shows the boot-binding compatibility of the current HEAD/TYROLIA binding line:

BOOT AND BINDING COMPATIBILITY

TYROLIA®	ALPINE SKI BOOTS (ISO 5355)		WALK SKI BOOTS (ISO 23223)		TOURING SKI BOOTS (ISO 9523)
	TYPE A	TYPE C	(TYPE C) GRIP WALK	(TYPE A) GRIP WALK JUNIOR	
* marking can be found in the product name and partly also on the binding					
Binding without any indication*	●	△	△	△	△
Binding marked „GW AC“	●	●	●	●	△
Binding marked „GW“	●	△	●	△	△
Binding marked „AT“	●	△	●	△	●

BOOT-HANDLING AND TESTING

VISUAL INSPECTION OF SKI BOOTS

In assembling a system for the skier, it is the responsibility of the shop to inspect and evaluate each equipment component. This inspection checklist should be followed before any mounting or adjusting is performed.

Ideally, they should be posted and used on the sales floor while the customer is still in the shop so that any deficiencies can be explained on the spot.

In retail, boots must pass all four points of this inspection before being accepted for use. In rental, this inspection is the first step in the "preseason boot test procedure".

1. CHECK TYPE, SIZE AND OVERALL CONDITIONS

- Is the performance level appropriate for the skier?
- Is the size correct (SINGLE CODE, boot sole length)?
- Is all hardware intact and in working order?
- Is the boot free of excessive or asymmetric wear?
- Is the boot free of dirt or sole warp?

2. CHECK MATERIAL

- Binding contact surfaces require a high quality hard, low-friction material. Check both lower shell and any separately attached inserts.
- If you can easily scratch the surface of the sole with your fingernail, that's an indication of extremely soft material that can degrade system performance.

3. CHECK CONDITION OF BINDING CONTACT SURFACES, TOE AND HEEL

- Any scratches or other roughness should not be deeper than 1 mm.
- Check for any rocks, gum, or other foreign matter stuck to the sole.

4. VERIFY BOOT SOLE DIMENSIONS

- Ski boots must meet international standard specifications.
- Use the HEAD/TYROLIA Boot Rental Indicator to determine whether wear is excessive. The most critical dimension for HEAD/TYROLIA bindings is the front surface and height of the boot toe. Any boots worn past the indicated amounts should be repaired or not used with HEAD/TYROLIA bindings.



THE HEAD/TYROLIA BOOT INDICATOR Art. No. 162617

This TYROLIA rental boot device is a multifunction-tool:

1. Sole length: Put the boot in the device and slide the toe stop up to the boot toe. Read sole length in the window, used for TYROLIA rental bindings: the SINGLE CODE. Boot sole wear: The standardized interfaces (contact boot sole with sole lugs) are important in the functioning of HEAD/TYROLIA bindings.
3. Boot toe bottom: Excessive wear is indicated if the lower edge of the front surface is at or above the bottom step on the appropriate child (C 2), adult (A 2) or touring (T 2) post (see Pict. 138).
4. Boot toe ledge height: With the toe stop against the boot toe, the level of the toe ledge should be at or above the top of the appropriate post, "Child" (C 1), "Adult" (A1) or "Touring" (T 1) (see Pict. 138). Replace toe pads if worn.

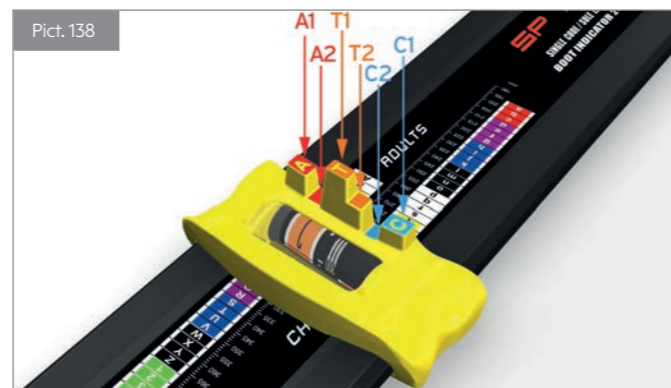

5. Heel height and wear: Check this boot standard with the same procedure used for the toe. The heel posts (A 3 + C 3) are located at the rear of the device (see Pict. 139).
6. The marks "A/C" help to select a "Child" boot from an "Adult" by indicating the standardized sole width.



NOTE:

Any boot which passes points 3, 4 and 5, as well as conforming to the Visual Inspection Checklist, may be accepted for use with TYROLIA bindings.

Boots which fail any point should be repaired or replaced. These checks apply only to boots used with TYROLIA bindings. Consult other binding manufacturers for their used boot specifications.

MAINTENANCE & SERVICE

1. VISUAL INSPECTION OF THE BINDING

In assembling a system for the skier, it is the responsibility of the shop to inspect and evaluate each equipment component. This inspection checklist should be followed before any mounting or adjusting is performed. Ideally, they should be posted and used on the sales floor while the customer is still in the shop so that any deficiencies can be explained on the spot.

2. CHECK SUITABILITY

- Is the binding model appropriate for the skier's ability?
- The binding must be compatible with the customer's boot/ski.
- The skier's release/retention setting should fall within the binding's adjustment range. Additionally, we recommend that the skier's setting should not be closer than one number from the minimum or maximum settings on the binding in order to allow for future readjustment.
- Are the mounting screw lengths appropriate for the ski being used?

3. CHECK THE CONDITION OF BINDING

- Are all parts present and in working order?
 - Is the AFD surface smooth and secure? If not, it should be replaced.
 - Are all mounting screws present or tight?
 - Does the binding show signs of contamination?
 - Has proper periodic lubrication been performed?
- Dried out or corroded bindings can function improperly.

4. RETAIL TESTING

Completion and documentation of the following Retail Test Procedures is recommended for U.S.: required under the terms of the HEAD/TYROLIA Dealer Indemnity Program. These tests should be conducted any time work is performed on a ski/boot/binding system that may affect its release values. The procedure applies to all HEAD/TYROLIA alpine bindings, new as well as used.

CLEAN VS. LUBRICATED SKI BOOT TEST

This test is designed to determine the influence of a given boot on the release characteristic of a binding. It should be performed on boots not meeting all the points of the HEAD/TYROLIA boot visual inspection criteria, or if measured release values fall outside the system "inspection" tolerance. It is seen as the "last chance" for a boot to qualify before getting eliminated from inventory.

1. Clean the boot(s) to be tested with soap and water. Allow to dry.
2. Select an appropriate HEAD/TYROLIA "reference" binding that has displayed release values within the inspection tolerance on the TYROLIA Adjustment Chart. Clean the binding's boot contact surfaces with soap and water and allow to dry.
3. Test the binding and boot in Twist and Forward Lean at a mid-scale indicator value (Only one direction of twist is required).
4. In a further test run lubricate all boot/binding contact areas with soapy water. Retest in Twist and Forward Lean.
5. Results of each lubricated test should be within 20% of the corresponding results when tested clean.

Any boot which fails this test should not be used with a HEAD/TYROLIA binding.

1. Follow HEAD/TYROLIA procedures for inspection, mounting, adjustment, and maintenance as appropriate.
2. Confirm that toe and heel indicator values match those specified on the actual HEAD/TYROLIA Adjustment Chart.
3. Using a calibrated testing device, according to its instructions for use, "exercise" the binding by releasing it at least once in each direction (clock-wise and counter clockwise at the toe, vertically at the heel). Then measure Twist and Forward Lean Torque Values. The middle quantitative value of 3 releases in each direction should be used as the test result.
4. Compare Twist and Forward Lean test results with the System Inspection Ranges on the actual HEAD/TYROLIA Adjustment Chart.
5. If any test results fall outside the System Inspection Range, consult HEAD/TYROLIA Troubleshooting Procedures which follow this section.
6. With testing complete, the HEAD/TYROLIA Certified Mechanic must complete and sign the workshop ticket. Be sure the Final Indicator Settings are correctly shown there.

The workshop ticket should simply reflect that the system has "passed all tests" or that "all manufacturer's procedures have been completed".

5. REPLACING THE BRAKE

If the Brake feels too hard or blocks during the hand test, if the Brake arms are damaged, if the pedal is worn out or if a wider Brake is necessary then the Brake should be replaced immediately. HEAD/TYROLIA offers different Brakes for almost every binding. Refer to the Brake overview on page 25 for Brake and binding compatibility. To change the Brake, all you have to do is to unscrew the old Brake and replace it with the proper Brake previously selected for the binding. In order to fix the Brake, tighten the screws. On rail-bindings, the Brake is hooked into the heel housing and not fixed with screws. Slide the heel off from the rails and replace the Brake (Pict. 140).



6. REPLACING THE GLIDE INSERTS POWERRAIL BINDINGS

To provide unaffected long-term performance of the new POWERRAIL binding models, the toe and heel guides can be exchanged or retrofitted. These features ensure that steady function is guaranteed, even after massive use in rental.

Art.No. - 162950 Play Compensator PR TOE ABS
Art.No. - 162955 Play Compensator PR TOE AFS
Art.No. - 162951 Play compensator PR HEEL

To change the inserts just slide toe and heel off the rails and replace them with new ones (Pict. 141). Lubricate the new inserts with HEAD/TYROLIA grease, clean the track, and slide toe and heel back in its original position on the rails.



HEEL INSERTS FOR RACE PRO HEEL

Open the heel-locking lever and pull off the heel backwards. Remove the inserts and mount the new ones - Art. No. 162803 (Pict. 142).



Lubricate the new inserts with HEAD/TYROLIA grease, clean the heel track, and slide the heel back into the track. Lock the locking lever into the same position it was before.

7. LONG & SHORT SCREWS

Junior Bindings (DIN 7.5) are delivered with screws for ski groups G3 and G4 (penetration depth 6 mm). If they are mounted on ski groups G1 and G2 then the screws have to be replaced with longer screws. (penetration depth 8 mm).

8. TAPPING

HEAD/TYROLIA recommends tapping the drilled binding holes of any ski before mounting. Of course, there is a never ending discussion among the mechanics if this is really necessary. But the pros are convincing:

- smooth and easy mounting
- reduced risk of stripping a screw
- same momentum adjustment of the screwdriver regardless of the ski material
- increased mounting quality/precision
- fewer pull outs.

9. TEMPLATE "ADAPTER SET"

Compatible to all TYROLIA-Templates. By using the template Adapter Set (Art. No. 162569) the mounting range of your template can be adapted depending on how you position the adapters on the drill template.

WARNING: Avoid dropping of the template. The clamping jaws could be damaged.

YOU HAVE 3 POSSIBLE OPTIONS

1. For raised mounting position:

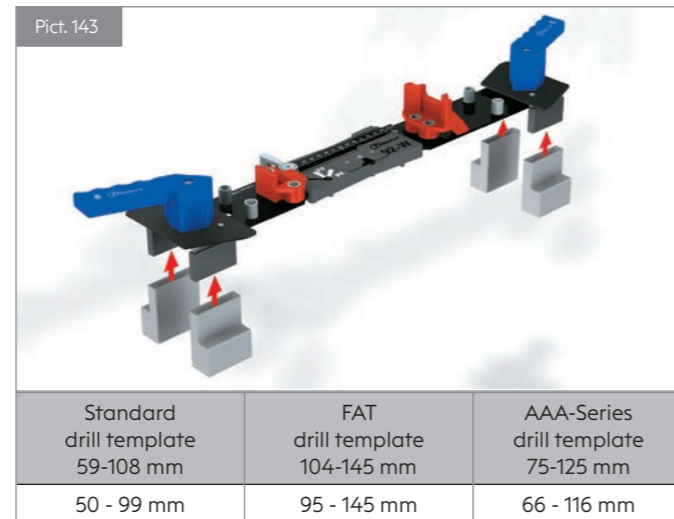

2. For wider mounting position:

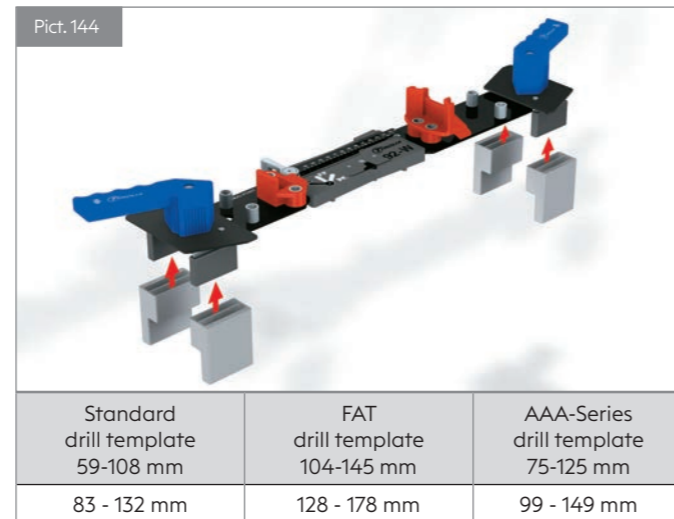

3. For narrower mounting position:

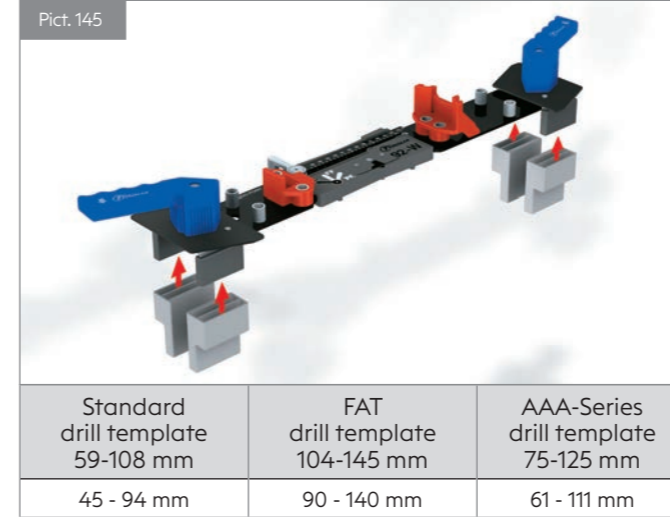

10. RACING (X) - BINDINGS

Certain binding models are produced by HEAD/TYROLIA each year for the exclusive use of qualified competitors under the supervision of HEAD/TYROLIA Technical Specialists.

Racing bindings offer release/retention settings outside of those on the HEAD/TYROLIA Release/Retention Adjustment Table, which is based upon ISO/ASTM Safety Standards. These bindings can be serviced under the Dealer Indemnity Program if proper procedures are followed.

We recommend you decline to service them and that you warn against their use unless you have training or experience as a race technician and your customer is a high-level competitor who clearly states a need for these bindings. The customer is to be warned that using these bindings significantly increases the risk of injury due to non-release, and that settings exceeding the recommended range are made at the skier's own risk. If you do service racing bindings, you must follow the same procedures described above for making specific comments on the standard workshop form in addition to completing the form on this page to be signed by the skier.

11. CLEANING AND LUBRICATING

Ski bindings need regular maintenance. Proper function is no longer assured if this procedure is not followed periodically.

- Please use only HEAD/TYROLIA recommended lubrication: 160052 - TYROLIA grease 162779 - TYROLIA service-grease-spray Both have the same content, but the grease tube is for more precise lubrication and the spray is suited for spots which are hard to reach with the tube.
- Clean the surfaces with a dry rag or warm water and mild soap.
- Avoid any contact with aggressive solvents or degreasers!
- Don't use cleansers!
- High pressure cleaning is not recommended. It might have the negative side effect of washing away the lubricating films.

11.1. LUBRICATING THE TOE PIECE

ALL SYMPRO/SP TOES

- In case of friction in the track system: Mark the toe position, open the SP hand lever and slide the toe piece off.
- Dry clean the track and the toe guide base gently using a plastic brush.
- Then lubricate the locking mechanism at both sides of the toe guide base.
- Lubricate also both sides of the track guide over the entire length.



11.2. LUBRICATING THE HEEL

ALL RENTAL BINDINGS

- Mark heel position, open the hand lever and slide the heel off backwards. At the SR 10 GW the guide lock has to be opened with a screwdriver (Pict. 147) to get the binding off.



LUBRICATE

- the edge of the release cam under the heel lug



- both sides of the heel track (inside) over the entire length
- the bearings of the opened hand lever on both sides



- the guiding channel of the release setting adjustment screw.

After finishing the heel lubrication slide on the heel and lock it in its original position.

11.3. SR 4.5 GW AC

LUBRICATE

- the contact areas between housing and the release cam on the frontside and the backside as shown in Pict. 150 and 151.

- both sides of the heel track (inside) over the entire length.
- the guiding channel of the release setting adjustment screw (Pict. 151)



After finishing the heel lubrication slide on the heel and lock it in its original position.

11.4. NOT TO BE LUBRICATED

The locking element and the corresponding holes in the heel track should be cleaned but not lubricated. This should prevent dirt accumulation in this area, which could interfere with the ease of handling.

12. TEST YOUR DRILL TEMPLATE

A worn or damaged drill template could create a lot of trouble. Please check your templates periodically:

1. Position the fully extended drill template on a discarded ski.
2. Turn the clamping lever to open the clamping jaws of the mounting template.
3. Position the template properly on the ski so that the boot center marking is aligned with the mounting point described on the ski.
4. Let go of the clamping lever. The template clamps automatically.
5. Drill all the holes.
6. Remove the mounting template and clean the ski.
7. Measure the holes with a slide gauge.
8. The distance of the screw holes to the edge of the ski must be equal for each pair of related holes. The deviation must not be more than 1 mm.
9. Repeat the test, if greater deviations occur.
10. The mounting template must be discarded if greater deviations occur again!

13. REPAIR OF DAMAGED MOUNTING HOLES OR BROKEN SCREWS

For repairing damaged holes, we suggest our special "Repair Set" – Art. No. 162127. It consists of a hollow drill bit and plastic inserts (Pict. 152).



You can extract broken screws too. Remove the binding from the ski. Drill with the hollow drill through the bushing of the appropriate drill template and drive in the plastic insert. Mount the binding again.

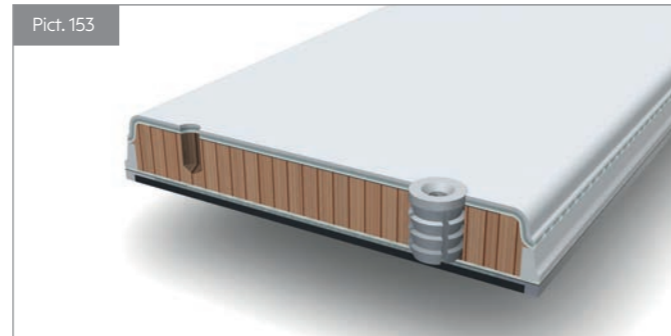

14. SEALING OLD MOUNTING HOLES

For sealing old holes you can use wood- or plastic plugs (Art. No. 160857), if not otherwise specified by the ski manufacturer.



TROUBLESHOOTING (INCLUDING RENTAL)

PROBLEM	POSSIBLE REASON	SOLUTION
Difficulty when stepping in	Non-standard boot sole	Test and select a new boot
	Forward pressure too high	Readjust according to instructions
	Brake jams	Clean, lubricate or replace
Brake does not retract	Obstruction under the Brake	Remove, clean, lubricate
	Brake arm bent	Replace Brake
	Ski obstructs Brake	Replace the standard Brake with a wider Brake, accordingly to the ski width.
Boot fails pre-season test	Low-quality boot material	Replace boot
	Excessive wear or contamination	Clean, repair or replace boot
	Reference binding worn	Recheck reference binding with a boot that has passed
	Boot does not meet ISO 5355	Replace boot
	Improper use of testing device	Check calibration and operating technique
Excessive in-season class 1 or class 2 deviations	Excessive boot sole wear or contamination	Clean, repair or replace boot
	Inadequate binding service/lubrication	Conduct recommended maintenance every 15–20 days of use
	Improper use of testing device	Check calibration and operating technique
	Indicator correction factor needed	Test system according to pre-season testing. Define indicator correction factor for subsequent adjustments
SINGLE CODE on binding interferes SINGLE CODE on boot	Incorrect template adjustment used when mounting	Set template to proper length and remount heel
	Incorrect track guide scale chosen for given mounting position	Choose binding according to given mounting position

TROUBLESHOOTING (INCLUDING RENTAL)

PROBLEM	POSSIBLE REASON	SOLUTION
SYMPRO toe wobbles in this track	Toe locking lever not properly engaged in locking holes	Remove toe, clean track. Be sure toe piece locks into place
FREEFLEX-drill pattern not fitting	Toe / equalizing bridge in wrong position	Dismount, place toe in correct position
	Drill template not locked	Re-adjust, drill new holes
Heel slides backwards when customer steps in	Rear locking lever not fully closed or boot length exceeds adjustment range	Lever should fully engage locking teeth in slots on track or boot sole length exceeds binding range
Binding fails pre-season test: release values too high or too low	Reference boot contaminated or worn	Clean or replace boot as indicated by clean vs. lube test result
	Forward pressure set incorrectly	Re-adjust to TYROLIA recommendations
	Incorrect or off-center-mounting	Check the template. Remount using template correctly
	Improper use of testing device	Check calibration and operating technique
Adult bootsole does not fit into Junior toe lug	Boot sole exceeds the standard tolerance	Clean AFD and boot sole, check standard tolerance, change boot
RACE PRO or POWERRAIL heel wobbles in the track	Heel glide inserts worn	Remove heel and replace plastic heel guides



ADJUSTMENT

ADJUSTMENT

CLASSIFY YOURSELF

DETERMINING YOUR SKIER TYPE IS YOUR RESPONSIBILITY!

The factors that determine the release setting on your ski bindings include your height, weight, age, boot sole length and your personal release preference. You are responsible for determining your own release preference based upon the chart below and for informing the ski shop technician of your preference. Your ski shop technician cannot make this determination for you. Be sure to provide accurate information regarding your height, weight, age and personal release preference. Errors may increase your risk of injury.

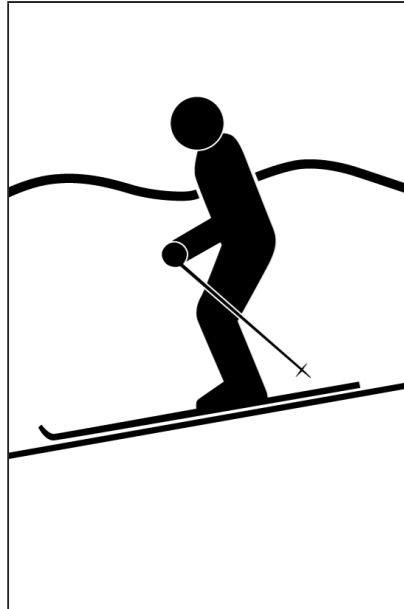

TYPE I
Cautious skiing on smooth slopes of gentle to moderate pitch.

Entry-level skiers and skiers who designate themselves as TYPE I receive lower than average release settings. This corresponds to easier binding release in a fall. Entry-level skiers or skiers who are uncertain of their preference.

SKIERS NOT CLASSIFIED AS TYPES I OR III

TYPE II

Skiers who designate themselves as TYPE II receive average release settings appropriate for most recreational skiing. Most skiers are satisfied with a TYPE II setting.



TYPE III
Fast skiing on slopes of moderate to steep pitch.

Skiers who designate themselves as TYPE III receive higher than average release settings. This corresponds to decreased risk of inadvertent binding release. TYPE III settings should not be used by skiers of less than 21 kg/47 lbs.

If from experience, you have been dissatisfied with the release settings that result from your release preference, mention this to your binding ski shop technician.

NOTE: If the skier reports release/retention problems see the chapter "trouble shooting release/retention problems", page 80 in the manual. Skiers who desire release/retention settings lower than **TYPE I** may designate themselves (I-). **TYPE I-** is inappropriate for skiers 17 kg/38 lbs or less. **TYPE I-**: Move up the table one skier code.

Skiers who desire release/retention settings higher than TYPE III may designate themselves (III+). **TYPE III+**: Move down the table three skier codes.

Skiers may select skier TYPE designations that are different for twist and forward lean. In such a case, the selection shall be indicated by a slash separating twist and forward lean selections, in that order (for example, K/L, K for the toe and L for the heel).

RELEASE/RETENTION ADJUSTMENT TABLE

NOTE: The initial indicator values found in this table are only the starting point in the binding setting process. The initial values may need to be modified in order to achieve the correct measured release values.



kg (lbs)	cm (ft 'in")	Skier Code	Mz (Nm)	My (Nm)	Single Code							
					a-i	j-n	o-s/B	t/C-G	H-L	M-Q	R-V	V-6
					≤ 230	231-250	251-270	271-290	291-310	311-330	331-350	≥ 351
					5°	18°						
10-13 kg (22-29 lbs)		A	8	29	0,75	0,75	0,75					
14-17 kg (30-38 lbs)		B	11	40	1,00	0,75	0,75	0,75				
18-21 kg (39-47 lbs)		C	14	52	1,50	1,25	1,25	1,00				
22-25 kg (48-56 lbs)		D	17	64	2,00	1,75	1,50	1,50	1,25			
26-30 kg (57-66 lbs)		E	20	75	2,50	2,25	2,0	1,75	1,50	1,50		
31-35 kg (67-78 lbs)		F	23	87	3,00	2,75	2,50	2,25	2,00	1,75	1,75	
36-41 kg (79-91 lbs)		G	27	102		3,50	3,00	2,75	2,50	2,25	2,00	
42-48 kg (92-107 lbs)	≤ 148 cm (≤ 4'10")	H	31	120			3,50	3,00	3,00	2,75	2,50	
49-57 kg (108-125 lbs)	149-157 cm (4'11"-5'1")	I	37	141			4,50	4,00	3,50	3,50	3,00	
58-66 kg (126-147 lbs)	158-166 cm (5'2"-5'5")	J	43	165			5,50	5,00	4,50	4,00	3,50	
67-78 kg (148-174 lbs)	167-178 cm (5'6"-5'10")	K	50	194			6,50	6,00	5,50	5,00	4,50	
79-94 kg (175-209 lbs)	179-194 cm (5'11"-6'4")	L	58	229			7,50	7,00	6,50	6,00	5,50	
≥ 95 kg (≥ 210 lbs)	≥ 195 cm (≥ 6'5")	M	67	271				8,50	8,00	7,00	6,50	
		N	78	320				10,00	9,50	8,50	8,00	
		O	91	380				11,50	11,00	10,00	9,50	
		P	105	452						12,00	11,00	
			121	520							10,50	
			137 ^b	588 ^b								

a...Lowermost tolerance limit
b...Uppermost tolerance limit

HOW TO USE THE RELEASE/ RETENTION ADJUSTMENT TABLE:

- Determine the Skier Code by locating the skier's weight in the first column and the skier's height in the second column. If the height and weight are not on the same line select the Skier Code closer to the top of the chart.
- The Skier Code found in step 1 is for TYPE I skiers. For TYPE II skiers move down the chart toward the bottom one Skier Code. For TYPE III skiers move down two Skier Codes.
 - If the skier is age 50 or older or under 10 move up the chart one Skier Code toward the top. For skiers 13 kg/ 29 lbs and under, no further correction is required.
- Find the column that corresponds to the skier's boot sole measurement in millimeters.
- The value where the Skier Code and the boot sole measurement intersect is the initial indicator setting for the skier.
If the intersection of the row and column falls in a blank box, do not move up or down the chart. Move sideways on the same row to the nearest box showing a visual indicator setting.
- This value should be recorded on the workshop form under Initial Indicator Settings.

MECHANICAL SYSTEM TESTING

1. Adjust the bindings toe and heel indicators to the Initial Indicator Setting.
2. Use a calibrated torque measuring device according to the instructions provided by the supplier.
3. Test that binding by releasing it at least once in all directions.
4. Three tests are required in each direction. The middle quantitative value of the three releases should be used as the test result.
5. Using the previously determined Skier Code slide across the chart to the column representing twist torque reference values.
6. If the test result is within one torque value above to one torque value below the reference value, it is in the Inspection Range. These results are acceptable and no further adjustment is necessary.
7. If the test result is within two torque values above to two torque values below the reference value, it is in the In-Use Range. The indicator value should be readjusted and the system retested so that it falls in the Inspection Range. Record the corrected indicator value in the box for final release/retention settings.
8. If the test result value falls out of the In-Use Range the system should be thoroughly inspected for the following:
 1. Correct forward pressure
 2. Correct Sole-hold down adjustment
 3. Worn or contaminated AFD's
 4. Out of standard boot solesNo work can be performed on the system until these problems are corrected.
9. Check the heel for forward lean the same way, determining the middle quantitative value of three vertical releases. Adjust if necessary.
10. Record final indicator settings on the workshop form in the area for final release/retention settings.

TROUBLESHOOTING RELEASE/RETENTION PROBLEMS

IF THE SKIER REPORTS A RELEASE OR RETENTION PROBLEM:

- Re-inspect the equipment to make sure that all components are in good condition and function properly.
- Test the system to make sure that it is calibrated properly.
- Have the skier use the "Classify Yourself" materials to make certain that the correct Skier type has been selected.

If component inspections and a calibration check do not reveal a problem the skier may be requesting discretionary settings.

INFORMATION FOR SKIERS REQUESTING DISCRETIONARY SETTINGS.

1. Your normal release/retention settings comply with ISO/ASTM standards. Although these guidelines may be inappropriate for some types of competitive skiing or competition training, they are believed to provide an effective compromise between the release and retention needs of most recreational skiers.
2. Adhering to these guidelines may help to reduce the risk of injuries resulting from improper release/retention setting selection. However, skiing involves inherent risks. Injury can result from simply falling down, impact with an object, or from many other actions. Many injuries are unrelated to the function of the release system. Furthermore, even a properly adjusted binding cannot protect the skier in all situations.
3. Difficulties with release or retention may be unrelated to release/retention settings and can result from your skiing style, the incompatibility of your boots and bindings, or wear, damage, or contamination of a component of the release system. Be sure to describe your circumstances to the shop technician and to authorize recommended inspections and repairs before proceeding.

4. If you have been dissatisfied with the release/retention settings that result from your normal skier classification, you may wish to consider changing your skier classification, or designating skier type classifications that are different for twist and forward lean. You may even request discretionary release/retention settings that are outside of your setting range.

If you believe that you require higher release/retention settings but are unsure if the increase should be applied to twist or forward lean settings, request that the increase be applied to forward lean settings before experimenting with higher twist settings. Similarly if you believe that you require lower release/retention settings but are unsure if the decrease should be applied to twist or forward lean settings, request that the decrease be applied to twist settings before experimenting with lower forward lean settings.

Lower settings correspond to an increase in the risk of inadvertent binding release in order to gain increased releasability in a fall.

Higher settings correspond to a decrease in releasability in a fall in order to gain a decreased risk of inadvertent binding release.

5. Although the shop technician may help you to record your choice on the appropriate form, the final decision on your release/retention settings is yours.

RENTAL-TEST AND INSPECTION PROCEDURES

PREPARING AND CHECKING RENTAL SYSTEMS

Customers usually don't treat rental equipment as gently and carefully as they would handle their private property. In order to keep your rental fleet as functional and appealing as possible, a systematic maintenance program is a must.

The best results are obtained with an ongoing program that constantly checks boots, bindings and skis. To keep the equipment in good condition while minimizing liability we recommend the following program (this is a requirement in the U.S.). In order to produce a truly efficient rental inventory some pre-season setup is required.

SINGLE CODING

This enables a quick binding to boot adjustment even during the rush hours of rental business.

TYROLIA offers self-adhesive color stickers (Art. No. 162561) with the SINGLE CODE to be applied before season.

You simply check the boot's SINGLE CODE and adjust the binding accordingly.

In order to gain the efficiencies of SINGLE CODE, all you need to do is follow our simple procedure.

1. Mount all bindings according to the TYROLIA manual. Pick a mounted sample binding of each model.
2. Place a boot of each size in the binding and adjust forward pressure until correct.
3. Open the heel and remove boot.
4. Record the SINGLE CODE from the track on the side of the heel housing. (The boot must not be in the binding when you read the code).
5. Check each code again before marking all boots of this size with their SINGLE CODE (Pict. 155)!

You can get SINGLE CODE stickers as a spare part. "SINGLE CODE" sticker set Art. No. 162561.

For this procedure the TYROLIA Rental Boot Indicator (Art. No. 162617) can be used.



RENTAL INSPECTION SUMMARY

Since it is impractical to perform a full inspection each time a system is rented, a routine of preseason and in-season inspections has been developed to verify release indicator accuracy, confirm correct equipment function, and assure proper assembly and adjustment procedures by the rental shop staff.

Fully implemented, the procedures that follow provide rental shop customers a standard of care equivalent to that provided retail shop customers under current ISO and ASTM standards. The program is based on standards: ISO 13993 and ASTM F1064.

The rental procedure is not applicable for complete and incomplete alpine ski-binding-boot systems which are rented 15 days or more and for alpine touring ski-binding-boot systems.

PRE-SEASON INSPECTION

Prior to the beginning of each season and whenever new inventory is added, an inspection should be made of the components of the release/retention system (binding-boot) in accordance with the procedure described in this manual (Page 79-82).

Bindings that fail go through a troubleshooting procedure (see page 73/74) to identify and correct the deviation or malfunction. If this procedure does not correct the problem, the binding is removed from inventory (Page 79-82).

All rental boots, new and used, are visually inspected for damage, wear, contamination, broken or missing parts, or inferior materials at contact points with the binding. If a boot fails, a 16 system (or less if 16 systems are not available) random sample is also tested. If any boot in this sample creates a deviation greater than the inspection tolerance all boots from that cell are then tested. Boots that fail and cannot be repaired are removed from inventory.

IN-SEASON INSPECTION

At regular intervals during the season, samples are taken from the rental inventory and evaluated in accordance with the procedures described in this manual (Page 81-82). In-season inspections are performed on complete rental systems to ensure that the equipment is adjusted appropriately and continues to function correctly.

IMPORTANT TERMS

CORRECTION FACTOR

The value that must be added or subtracted from the initial visual indicator setting to bring the result within the Inspection Tolerance (or Inspection Range).

DIRECTIONS OF RELEASE

Unless otherwise specified (see In season Inspection), the directions of release to be tested are forward lean, clockwise and counter clockwise in twist.

TEST DEVICE

A device which meets ISO standard 11110 or ASTM standard F1061 and has been checked and maintained in the manner specified by the device manufacturer.

TEST RESULT OR RELEASE TORQUE

The middle quantitative value of three tests made in the same direction.

SYSTEM BINDING

A binding that is slid onto a pre-mounted or integrated track without drilling.

PRE-MOUNTED BINDING

A binding that is already mounted on the ski before being delivered to the shop.

PRE-SEASON TEST

PRE-SEASON BINDING SAMPLING

All bindings, new or used are visually inspected.

1. For factory new pre-mounted or sealed system bindings (PR, SLR and SP PM) a 5% sample (not less than 16 nor more than 80 systems) of each "cell" is tested using a specially selected reference boot. A cell is all bindings of the same make, model and year. Although sampling eliminates the need to test every binding before the season starts, the sample chosen must be representative of the inventory.
2. For any other new bindings and all used bindings, all bindings of the inventory are inspected.

REFERENCE BOOT SELECTION

The Reference Boot is a boot of a designated sole length which is otherwise typical of the boot inventory. Use the procedure below if the boot inventory includes several models and a representative boot cannot easily be identified.

- Select five single boots with sole lengths as specified in Table [A] for the binding type to be tested: adult, junior, child, BYS or HRS.
- Clean all five boots with a mild detergent and water.
- Adjust a rental binding to the release indicator setting specified in Table [A] for the binding type.
- Fit the binding to the boot and determine the Release Torque in all three directions of release (forward lean and both directions in twist-three releases in each direction).
- Average the Release Torque for CW (clockwise) and CCW (counter clockwise) twist release.
- Reject and replace any boot with a CW to CCW difference of more than 6 Nm for adult boots or 4 Nm when testing child boot types.
- Rank the five twist results and select, as the Reference Boot for twist, the middle boot.
- Rank the five forward lean results and select, as the Reference Boot for forward lean, the middle boot.
- With the Ski Binding Test Device determine the Release Torque for each direction of release (forward lean and both directions in twist).
- Record "PASS" in the bindings maintenance record if test results are within the Inspection Tolerance provided in Table [A].
- a. If the test results of any binding from the before taken sample for factory pre-mounted or sealed system bindings is outside the Inspection Tolerance in Table [A], every binding of the same cell is tested.
b. Set aside the binding if the test result in any directions of release is outside the Inspection Tolerance in Table [A].
- Follow Troubleshooting Procedure on page 73/74 for units which have been set aside and retest if changes in the unit's condition or adjustment are made.
- Record "FAIL" in the binding's maintenance record if, after troubleshooting, test results in any direction of release are outside the In-Use Range. Replace the "failed" unit and retest before returning the ski to service.
- If after troubleshooting, test results are outside the Inspection Tolerance but within the In-Use Range, apply a Correction Factor to the unit and note the Correction Factor for that unit in the binding's maintenance record.
- If many bindings fail, check the test device and reinspect the Reference Boot. If necessary, select another boot and retest the bindings.

PRE-SEASON BINDING INSPECTION

The procedure that follows is an integral part of pre-season maintenance. It is also a good way to determine if maintenance was successful and which units have outlived their usefulness and must be removed from inventory.

- Clean areas of the bindings that contact the boot and perform all preseason binding maintenance.
- Visually or manually check:
 - AFD condition.
 - Brakes function.
 - Release indicator readability and travel
 - Screw tightness.
- Adjust each binding with the reference boot, then adjust the release value indicators to the specified value found in table [A]. Due to the fixed length of BYS bindings there are adapted tables for all BYS and HRS system bindings (table [B], [C]).
- Check that the heel track and toe track Single Code agree with the sole length Single Code of the reference boot.
- With the Reference Boot in the binding, verify elastic travel of the toe piece by striking the boot toe with a mallet or dead hammer and checking that the toe piece returns the boot quickly and completely to center.
- Verify elastic travel of the heel piece by lifting the boot while depressing the heel piece cocking lever and checking that the heel piece returns the boot quickly and completely to the latched position.
- Manually release the binding 3 times in each direction.
- Lubricate all boot/binding interfaces with a mild liquid detergent and water solution.

Skier Code	Binding type	Boot sole length [mm]	Release Indicator Setting	Reference Torque Twist [Nm]	Reference Torque Forward [Nm]	Twist Inspector Tolerance [Nm]	Forward Inspector Tolerance [Nm]	Twist In-Use Range [Nm]	Forward In-Use Range [Nm]
F	Children	260	2.5	23	87	20-27	75-102	17-31	64-120
J	Junior	300	4.5	43	165	37-50	141-194	31-58	120-229
L	Adult	320	6.0	58	229	50-67	194-271	43-78	165-320

Table [A] Pre-season binding inspection

Color Code	Boot sole length [mm]	Release Indicator Setting	Reference Torque Twist [Nm]	Reference Torque Forward [Nm]	Twist Inspector Tolerance [Nm]	Forward Inspector Tolerance [Nm]	Twist In-Use Range [Nm]	Forward In-Use Range [Nm]
Black	289	5.0	43	165	37-50	141-194	31-58	120-229
Yellow	329	6.0	58	229	50-67	194-271	43-78	165-320
Silver	365	6.0	67	271	58-78	229-320	50-91	194-380

Table [B] Pre-season binding inspection for BYS 10 GW

Color Code	Boot sole length [mm]	Release Indicator Setting	Reference Torque Twist [Nm]	Reference Torque Forward [Nm]	Twist Inspector Tolerance [Nm]	Forward Inspector Tolerance [Nm]	Twist In-Use Range [Nm]	Forward In-Use Range [Nm]
red triangle	205	1.0	11	40	8-14	29-52	5-17	18-64
blue square	225	1.5	14	52	11-17	40-64	8-20	29-75
black diamond	245	2.25	20	75	17-23	64-87	14-27	52-102
white circle	265	3.0	27	102	23-31	87-120	20-37	75-141

Table [C] Pre-season binding inspection for SX 4.5 R GW AC - HRS Junior

- Remove from inventory all boots that have failed the visual check.
- contact the binding or AFD the boot may be incompatible with the binding.
f.) Mold flashings. Flashing which can be seen or felt at contact points with the binding, Brake, or AFD must be carefully removed.

PRE-SEASON BOOT SAMPLING

Although sampling eliminates the need to test every boot before the season starts, the sample chosen must be representative of the inventory.

- For boots that are new to inventory or have never been inspected, take a single boot from each cell (a cell is all boots of the same make, model, year, and shell size).
- For used boots, take a 5% (but not less than 16 or more than 80) random sample of the entire inventory, see Table [D]. Make sure that there is at least one boot from each cell in the sample.

PRE-SEASON BOOT INSPECTION

The procedure that follows helps to assure boot/binding compatibility and boot interchangeability.

NOTE: when using Table [A], [B], [C] in the Boot Inspection procedures that follow, the Sole Length and release Indicator Setting columns should be ignored.

- Randomly select a pair of bindings that have passed the preseason inspection from each binding type: adult, junior, child.
- Lubricate all boot/binding contact points with a mild liquid detergent.
- Without regard to whether the boot is new or used, sort the sample by sole type and length according to the 20 mm Sole Length Categories defined by the Release/Retention Adjustment Chart.
- In each Sole Length Category rank the boots by sole length and select the middle boot.
- In each Sole Length Category fit the appropriate reference bindings to this "typical" boot and adjust the two bindings to release as close as practical to the Reference Torque in Table [A], [B], [C]. Use the Reference Torque corresponding to Skier Code [L] for the Adult binding, [J] for Junior binding, and [F] for the Child binding. (Reference [B]- black, yellow, silver; [C] - red triangle, blue square, black diamond, white circle)
- Rinse the lubricant from one binding and mark it "clean". Mark the other "lubricated".
- Test each boot in the Sole Length Category with the clean Reference Binding and then the lubricated Reference Binding in both twist and forward lean (only one direction in twist is required for the clean binding).
- Set aside any boots for which the lubricated Test Result is more than 20% less than the clean Test Result in the same di-

rection of release or the lubricated Test Result in any direction of release is outside of the Inspection Tolerance provided in Table [A], [B], [C] for Skier Code used to set up the Reference Binding (Reference [A] - F, J or L; [B]- black, yellow, silver; [C] - red triangle, blue square, black diamond, white circle).

- For a new boot that fails, check a 16 system (or less if 16 are not available) random sample of the boots of the same cell (make, model, year, and shell size) as those that failed. If any boot of these samples creates a deviation greater than the Inspection Tolerance, check all other boots from the same cell.
- For used boots, if any boot of the sample creates a deviation greater than the Inspection Tolerance, check all other boots from the same cell.
- Repeat the Visual check on all boots that have been set aside, correct any defects noted, and retest. Remove from inventory boots that fail the retest.

NOTE: On completion of the preseason inspection, clean the liquid detergent from equipment and lubricate the binding before returning it to service.

INSEASON SAMPLING AND INSPECTION

The in-season Inspection is a test of complete systems and all the procedures used by the rental staff to assemble and adjust the system. The program uses random samples of rental inventory taken at routine intervals. Any sampling program that gives every unit of inventory the same chance as every other of being picked is valid.

SAMPLE FREQUENCY

Random sampling is conducted throughout the entire season. Frequency is as follows:

- After 7 days of operation.
- If the sample passes the next sampling is taken after another 7 days operation.
- If two consecutive samples pass, sampling frequency is increased to 14 days (reduced sampling schedule).
- If a sample fails at any time, daily sampling is instituted until two consecutive samples pass, at which point weekly sampling resumes.

Facilities that have an average daily output of fewer than 160 rental skier days/day (averaged on a weekly basis) may adopt an alternate procedure and sample, over the sampling interval, 5% of average daily output, and delay evaluation of the inspection results until a total of 16 sampled units is detected at any time, corrective action should be taken. This alternative method is used with a normal (weekly) or daily sampling schedule but is inappropriate for a reduced schedule.

SAMPLE SIZE

Sample size is 5% of inventory but not less than 16 nor more than 80 units as noted in Table [D]. Sample size may be based on average daily output if rental output drops below 50% of capacity over the sampling period. The sample is taken at any time during the sampling interval or may be spread over the period. The sample represents both inventory available for rental and equipment in the condition in which it is returned, with an equal number of units drawn of each group. All units within such sample should be selected randomly.

INSEASON INSPECTION

1. Take a random sample of the rental inventory as determined by Table [D]. Take half the sample from inventory as it is either rented or returned and the remainder from inventory available for rental.
2. The returned samples are tested with the last customer's data, the other samples adjust to randomly selected skier data. Consider already applied Correction Factors.
3. Wipe the boot clean and cycle the boot/binding systems at least once in each direction.
4. Test sample units in Twist (one direction only) and Forward Lean.
5. Compare the Test Results with the Inspection Tolerance for the appropriate Skier Code, see ISO 11088 Release/ Retention Adjustment Chart (page 81).
6. If the results are within the Inspection Tolerance, one value above to one value below the reference value, the unit passes.
7. If the results are outside Inspection Tolerance but within the In-Use Range, two values above to two values below the reference value, count the unit as a range class I deviation.
8. If the results are outside the In-Use Range, count the unit as a range class II deviation.

9. Check elastic travel and visually inspect the ski Brake function, interface areas between boot and binding, including AFD, lug height adjustment (if appropriate), and forward pressure. Count any deficiencies as range class I deviation.
10. If more than the maximum number of range class I deviations given in Table [D] are found in the sample, or a single range class II deviation is detected the sample fails and daily sampling must be conducted until the problem which led to the failed sample is found and corrected. See pages 80/81 for Troubleshooting Procedures following a Failed In season Inspection.
11. Record the date the sample was tested, the number of units tested the number of range class I and range class II deviations, whether the sample passed or failed and any actions taken. There is no need to record the identity of units tested or actual Test Results.

	min.						max.			
Inventory Size - pairs	50	100	200	300	400	500	600	700	800	900
Inventory Size - units (half pairs)	100	200	400	600	800	1000	1200	1400	1600	1800
Sample Size - units (half pairs)	16	16	20	30	40	50	60	70	80	80
Max. Class 1 dev.	3	3	4	6	8	10	12	14	16	16

Table [D]

RENTAL/DEMO OF PARTIAL SYSTEMS

Many shops rent their customers partial ski equipment systems. Boots only if customers own their own skis with bindings, or skis and bindings if the customers own their own boots. Additionally some shops utilize on-hill "demo days" as a means by which new products can be tested and evaluated by potential buyers.

In order to offer these skiers the same level of care as that afforded under the preceding procedures, the following guidelines should be used:

RENTAL OF SKIS/BINDING ONLY CUSTOMER - OWNED BOOTS

Although the retail test procedure may be applied in this case, it is often impractical to require actual system testing, especially in on-hill situations. In lieu of retail testing, the following procedures may be employed:

1. The ski/binding system to be rented or demoed should be tested "pre-season" using a boot which passes the TYROLIA Boot Visual Inspection.

2. The skier's boot should also pass the Visual Inspection. If any questions exist regarding the quality of the boot, or if only the boot is rented retail-type testing should be used.
3. The binding should be adjusted and its indicators set per current TYROLIA recommendation.
4. A full record noting appropriate customer information and binding settings should be kept by the individual or organization responsible for the adjustment.
5. After seven days of use, the ski/binding system should be tested according to the In-Season Inspection Procedures previously described.

NOTE for US and Canada

Signatures of both the customer and HEAD/TYROLIA Certified Mechanic are required on all shop forms to qualify for the HEAD/TYROLIA Dealer Indemnity Program.



DEALER SERVICE INFORMATION

HEAD/TYROLIA CERTIFICATION REQUIREMENTS

This section must be read, and thoroughly understood, prior to completion of HEAD/TYROLIA's Employee Training Documentation Form and viewing the current HEAD/ TYROLIA Certification Video.

At TYROLIA we realize that the quality added to our products in your shop is every bit as important as the quality we build in at the factory. The HEAD/TYROLIA Retailer Indemnity Program, which includes in depth technical training, is a key element of maintaining consistent quality.

TECHNICAL INFORMATION

Procedures for installation, release/retention adjustment, testing, troubleshooting and record keeping should always be taken from the current season's HEAD/TYROLIA Technical Manual.

EMPLOYEE TRAINING

This manual provides a depth of information unprecedented in the industry, it is here to help you fulfill the shop's responsibility to bring new employees to a basic level of competence. It also addresses our desire to provide information specific to selling, installing, function checking, and maintaining HEAD/TYROLIA products. Last but perhaps most important, we produced it to help you understand why HEAD/TYROLIA represents the state of the art in bindings. We hope you will use it as part of a well-planned and professional employee training program which goes far beyond properly installing bindings. Done well it will translate into consistent quality and the high level of satisfaction your customers deserve. Look at it as one of the first steps in your Total Quality Management program.

NOTE: Hands on training is the best training – An ideal task that can be incorporated into the training is preseason testing. This will give your trainees hands on experience operating a testing device and adjusting ski/boot/binding systems. Other tasks, such as routine rental maintenance, can also be done during the training period.

SHOP REQUIREMENTS

Each retail location must have:

- A current HEAD/TYROLIA Authorized Retailer Agreement on file with HEAD USA INC. / HEAD CANADA INC.
- A current HEAD/TYROLIA Binding Indemnification Agreement on file with HEAD USA INC. / HEAD CANADA INC.
- At least one HEAD/TYROLIA Certified Technician employed per location.
- The required equipment for installing and testing HEAD/ TYROLIA bindings. All Agreements and Certifications must be valid for the current season.

REQUIRED SERVICE SHOP TOOLS

This list is the bare minimum a shop can survive with.

- Tape Measure
- HEAD/TYROLIA Templates
 - Drill template 92 W or 92 FAT
 - Drill template AMBITION
 - Drill template ADRENALIN
 - Drill template ATTACK DEMO
 - Drill template BASES & PLATES
 - Drill template Raceplate WCR SHORT/TEAM
 - Drill template RACEPLATE 09
 - Drill template SLR PRO
 - Drill template 94 W
 - Drill template Freeflex Demo
 - Drill template SP 2003 W
 - Drill template SR 2003 W
- Variable speed, reversible electric drill
- HEAD/TYROLIA Step Drill Bits (or equivalent)
 - 4.1 Ø x 9.0 mm
 - 4.1 Ø x 7.0 mm

- 3.5 Ø x 9.0 mm
- 3.5 Ø x 7.0 mm
- Tap, Tap Brace and Tap Guide
- HEAD/TYROLIA Pozidrive No. 3 screwdriver (or equivalent)
- HEAD/TYROLIA Torx-Bit TX25/50 - 1/4inch
- HEAD/TYROLIA large slot screwdriver
- Current HEAD/TYROLIA retention/release adjustment table
- Approved mechanical testing device
- Screw extractor
- Tap extractor
- Hole plugs, plastic & wood
- HEAD/TYROLIA threaded plastic ski inserts
- Chisel
- Hammer

CREATING AN INFORMED CONSUMER

Customers, whether rental or retail, come to your shop with all levels of knowledge. The range extends from true experts who really know the sport and their equipment needs, to never-ever skiers who know they must rely totally on your expertise.

A key role played by a good shop, and a requirement in the US and Canada under the "HEAD/TYROLIA Retailer Indemnity Program", is providing information, guidance and instruction to all customers.

SPECIFICALLY THIS MEANS:

Providing product and suitability information to help customers make an informed choice on which equipment models are right for them. The amount and type of advice given will naturally be different for each customer.

- The shop's responsibility is to be sure that each product sold or serviced is appropriate for the needs of its user.
- The shop must provide accurate information about the nature of the sport, and what equipment can and cannot do. Inform customers that there are risks inherent in the sport of skiing that no binding can protect against. It is imperative that each customer be informed there are limitations to the protection their equipment can afford and that injuries can and do occur in the normal course of skiing.
- Under no circumstances should you make any warranties or assertions about the customers safety on the hill. Speaking simply, no binding is "absolutely safe". Well designed shop record forms address the disclosure and agreement subject very directly and professionally. Use them to your advantage by making sure customers read and understand the form before signing it. The following points must be explained to all customers (rental or retail) before they leave the shop with their equipment (consumer awareness checklist).
- Go through your workshop ticket and fully explain each task that has been performed by the shop.
- Explain how to use bindings and equipment. Let customers put on their boots and step in and out of the binding if need be.
- Remind skiers to clean their boots and bindings each time before stepping in. Tell them that they should always walk through clean snow before entering the bindings.
- Deliver the "Instructions For Use" booklet to retail customers. It is an important document and is essential for warranty service.
- Advise the customers to return to your shop periodically for maintenance and a system inspection. The service interval is once each 15–20 days of skiing, or annually, whichever comes first. Failure to adhere to this service interval will void the HEAD/TYROLIA Limited Warranty.
- Recommend care in transport: heels closed, bindings covered.
- Recommend care in storage: dry, moderate temperature, heels closed, boots not in bindings.
- Explain that bindings and boots must be kept clean for optimal function.

- Skiers should make a visual inspection of their system before each use, including the AFD pad which should be checked for wear, damage or loss. It is also wise to visually verify the release indicator value.

NOTE:

- The workshop ticket must be read, initialed and signed by the customer. If the customer is a minor, his or her signature should be obtained, along with that of the parent or guardian. If a parent or guardian is not available, the equipment should only be released if the proper signatures have been obtained.
- Remember, the customer's signature is required in two places under the terms of the HEAD/TYROLIA Retailer Indemnity Program. In order to avoid misunderstandings with the customer, please inform them of this requirement when equipment is taken in for service.
- If the customer is not the end user, every attempt should be made to make certain all aspects of the system are explained to the user, and to obtain his/her signature on the workshop ticket.

ABOUT TESTING

Testing is required for all HEAD/TYROLIA retail and rental systems as specified in this manual. Many consumers view system testing as a valuable service provided by professional shops. They expect their equipment will be properly tested, and are willing to pay for it. On the other hand, some customers may be reluctant to accept any additional costs. They may be especially resistant to charges made by the shop for testing and inspections of equipment which is being serviced. Following are some communication techniques that have been found to be helpful:

- Post your shop's testing policy. A clear statement, prominently displayed, will reassure customers that they're all receiving the same treatment. Consider a text similar to the following:
"Industry standards have defined shop testing procedures for your ski/boot/binding system. We're proud to offer this service since it is in your best interest. While even the best ski equipment cannot eliminate all risks of injury, we strive to maximize your enjoyment of the sport by verifying the settings and function of your equipment. The extra time and expense of system testing will pay off for you in a better skiing experience."
- Make your service shop a showplace. Place your testing bench in a prominent location. Many customers like to know what kind of work you're doing for them. If you get a question, offer to let the skier watch.
- Proudly display diplomas and certificates received by your mechanics. Make their expertise known to your customers.
- Above all, don't apologize for testing. It's a valuable and necessary service well worth the cost.

ABOUT TESTING DEVICES

ASTM and ISO have defined specifications for ski equipment system testing devices. Only those devices that meet these recognized performance standards should be used to test systems that include HEAD/TYROLIA bindings. You should make it the responsibility of your testing device supplier to verify that their device fulfills all ASTM/ISO requirements.

Each device has its own unique features and some will fit your shop's needs better than others. Therefore, we can't recommend a single device as universally "the best".

The following points, however, can be used as a guideline to getting the most out of your choice:

- Training is very important in the use of any device. Read the instructions thoroughly, and practice!
- To insure reproducibility from one technician to another a "Multiple Operator Reproducibility Test" should be performed by all users of the testing device. This simply requires that all technicians join in a "round robin" exercise where each tests the same system with the same test device. The goal is to verify that the testing techniques are the same and that all test results are comparable. Speak with your testing device supplier for the details on how to conduct this program.
- Beware of "black box" calculations that may be performed by some electronic testers, the calculations performed to arrive at an indicator value or determine an appropriate Torque Range could be based on old standards. Check the current HEAD/TYROLIA Adjustment Chart for applicable values.
- Periodic calibration of these devices is important, and this information should be documented in your shop records.
- Most important, never blindly trust the values given by any test device. This is just one tool to use in your evaluation of a complete release/retention system.

MAINTENANCE

Inform every customer of the simple fact that periodic maintenance is needed. If they don't bring their gear back for regular function checks, it is unreasonable to expect it to work as designed. Studies have shown that binding systems which have not been properly maintained have serious injury rates very much higher than those which have.

Following this simple, logical guideline is the single most effective way to decrease serious injuries dramatically. Have the system serviced by a HEAD/TYROLIA certified technician once each 15–20 days of skiing, or annually, whichever comes first.

HEAD/TYROLIA RETAILER INDEMNITY PROGRAM

Today's equipment may help reduce certain hazards involved in the sport, but the risk of injury remains. The HEAD/TYROLIA Retailer Indemnity Program is designed to help formalize service procedures and minimize the risks to both you and your customer. Under the plan, HEAD/TYROLIA will defend and indemnify the Authorized Retailer in bodily injury claims when certain conditions are met, including following all HEAD/TYROLIA required procedures.

The program benefits are not without limits, indemnification is not insurance, and it does not eliminate the need for a shop to have adequate insurance of its own. But, for the shop willing to make the investment in doing a quality job as an assembler of equipment systems from components, it is a key element in their risk management plan.

This is only a summary of the HEAD/TYROLIA Retailer Indemnity Program, complete requirements are listed in the current HEAD/TYROLIA Binding Indemnification Agreement. You should read this Agreement carefully.

Retailer benefits under the terms of the plan are based, in part, on the adequacy of the service work performed by the mechanic. For this reason, thorough employee training is essential. This manual, a tech video and technical seminars are presented by HEAD/TYROLIA to help define appropriate shop procedures.

It is the responsibility of the HEAD/TYROLIA Authorized Retailer to see that all technical and product information materials provided by HEAD USA / HEAD CANADA INC. are ordered and available in their shop. This should be done with the aid of your HEAD/TYROLIA Representative while placing your TYROLIA pre-season binding order.

Competition bindings are intended only for high level competitors who have special requirements that do not apply to recreational skiers. Any transaction involving competition bindings must include a warning and assumption of risk agreement signed by the skier that acknowledges the increased risk of using this equipment. See the section in this manual regarding Use of Non-Recommended Settings (page 91).

THE HEAD/TYROLIA RETAILER INDEMNITY PROGRAM APPLIES ONLY TO THE FOLLOWING BINDINGS:

HEAD:

COMPETITION

- FREEFLEX ST 20 X RD, FREEFLEX ST 20 X RS, FREEFLEX ST 16 X RD
- FREEFLEX EVO 20 X RD, FREEFLEX EVO 20 X RS, FREEFLEX EVO 18 X, FREEFLEX EVO 16 X RD, FREEFLEX EVO 14X
- FREEFLEX PRO 20 X RD, FREEFLEX PRO 20 X RS, FREEFLEX PRO 18 X, FREEFLEX PRO 16 X RD, FREEFLEX PRO 16 X RD STIFF, FREEFLEX PRO 16 X RD/EP

RACING

- FREEFLEX ST 16, FREEFLEX ST 14, FREEFLEX 14, FREEFLEX 11
- FREEFLEX EVO 16, FREEFLEX EVO 14, FREEFLEX EVO 11
- FREEFLEX PRO 16, FREEFLEX PRO 14, FREEFLEX PRO 12
- FREEFLEX DEMO 14 GW
- GTO 15

AAA-SERIES

- ADRENALIN 16

PARK & POWDER

- MOJO 20 X, MOJO 18 X, MOJO 15, MOJO 12, MOJO 11, MOJO 7.5 AC, MOJO 7.5, MOJO 4.5 AC

SYSTEMS

- PRD 14 GW, PRD 12 GW, PRD 14 S, PRD 14, PRD 12, PRD 12 MBS
- PRX 12, PRX 12 S, PRX 11
- PR 11 GW, PR 11, PR 11 MBS
- SLR 7.5 GW AC, SLR 7.5 AC, SLR 4.5 GW AC, SLR 4.5 AC
- JOY 4.5 AC LRX, LRX 7.5 AC, LRX 4.5 AC, LR 7.5, LR 4.5

LIGHT DIAGONAL & SUPERLIGHT

- LX 12, SX 10
- SL 100

WOMEN

- JOY 12 GW PRD
- JOY 11 GW SLR, JOY 9 GW SLR, JOY 11 SLR, JOY 9 SLR
- MYA 12 PRD, MYA 12 LX, MYA 10 PR, MYA 9 LRX, MYA 9 LR

JUNIOR

- EVO 9 GW AC, EVO 9 AC
- SX 9 JR, RACE, SX 7.5 GW AC, SX 7.5 AC, SX 4.5 GW AC, SX 4.5 AC
- SL 90 ABS JR RACE, SL 75 ABS, SL 75, SL 70 AC, SL 45

TYROLIA:

COMPETITION

- FREEFLEX EVO 18 X
- FREEFLEX PRO 18 X

RACING

- FREEFLEX ST 16
- FREEFLEX EVO 16, FREEFLEX EVO 14
- FREEFLEX PRO 17, FREEFLEX PRO 15, FREEFLEX PRO 14
- FREEFLEX PRO 11
- FREEFLEX DEMO 14 GW
- RACE EVO 16, RACE EVO 14

AAA-SERIES

- ADRENALIN 14 AT, ADRENALIN 16 AT, ADRENALIN 13 AT, ADRENALIN 16, ADRENALIN 13
- AMBITION 12 AT, AMBITION 12 AT CARBON, AMBITION 10 AT, AMBITION 12, AMBITION 12 CARBON, AMBITION 10
- ATTACK² 18 (X) GW, ATTACK² 16 GW, ATTACK² 14 AT, ATTACK² 13 GW, ATTACK² 12 GW, ATTACK² 11 GW, ATTACK² 13 AT DEMO, ATTACK² 11 AT DEMO
- ATTACK 18 X, ATTACK 16, ATTACK 14 AT, ATTACK 13, ATTACK 13 DEMO, ATTACK 12, ATTACK 13 LT, ATTACK 11 DEMO, ATTACK 11

PARK & POWDER

- PEAK 20 X, PEAK 18 X, PEAK 15, PEAK 12, PEAK 11, PEAK 7.5 AC, PEAK 7.0 AC, PEAK 4.5 AC

SYSTEMS

- PRW 12 GW, PRD 12 GW, PRD 11 GW, PRD 12, PRD 12 MBS, PRD 11
- PRW 11 GW, PR 11 GW, PR 10 GW, PR 11, PR 11 MBS, PR 10, PR 10 PROMO
- SLR 11 GW, SLR 10 GW, SLR 9.0 GW, SLR 10, SLR 9 AC, SLR 9.0, SLR 7.5 GW AC, SLR 7.5 AC, SLR 4.5 GW AC, SLR 4.5 AC,
- LRX 10, LRX 9.0, LRX 7.5 AC, LRX 4.5 AC
- LR 10, LR 9, LR 7.5, LR 7.0 AC, LR 4.5

LIGHT DIAGONAL

- AM 12 GW, RX 12 GW, RX 12, LX 12, LD 12

SUPER LIGHT

- SX 10 GW, SX 10, D12 GW, D12, D11 GW, D11
- SL 100

JUNIOR

- FREEFLEX JUNIOR RACE 11
- SX 7.5 GW, AC, SX 7.5 AC, SX 4.5 GW AC, SX 4.5 AC, D 7 AC, D 4.5 GW AC, D 4.5 AC
- SL 70 ABS, SL 70, SL 70 AC, SL 45

RENTAL

- FREEFLEX DEMO 14 GW
- SP 13 GW, SP 10 GW, SP 10 GW PM, SP 7.5 AC PM, SP 13 ABS
- SP 130 ABS, SP 130 ABS DEMO AERO, SP 12 ABS, SP 120 ABS, SP 10 ABS, SP 100 ABS, SP 90 ABS, SP 75 ABS, SP 70 ABS, SP 7.5 AC, SP 4.5 AC, SP 45
- SRM 10 GW, SRM 10, SR 10 GW, SR 10, SR 100, SR 70, SR 4.5 AC, SRM 4.5 AC
- SR 4.5 GW AC, SR 45, SRL 100
- BYS 10 GW, BYS 10, BYS 100, BYS 100 B, BYS 100 Y, BYS 100 S, BYS 7.5 AC, BYS 75 JUNIOR
- SX 4.5 R GW AC, SX 4.5 SX 4.5 R AC, B2YS 4.5 AC, B2YS 45

TYROLIA INSIDE:

4FRNT

- ADRENALIN 16 AT, ADRENALIN 16
- ATTACK² 18 (X) GW, ATTACK² 16 AT, ATTACK² 13 GW
- ATTACK 18 X, ATTACK 16, ATTACK 13, ATTACK 11
- DEADBOLT 18, DEADBOLT 15, DEADBOLT 13 DEMO, DEADBOLT 13, DEADBOLT 12
- PADLOCK 11, PADLOCK 7

KAESTLE

- K14 FREEFLEX EVO
- K13 ATTACK² GW, K13 ATTACK² AT DEMO
- K16 ATTACK, K13 ATTACK, K13 ATTACK DEMO
- K18 TI, K12 PRW GW, K12 TRI GW, K10 SLR GW, K12 TI, K11 TI, K12 CTI PRO, K11 CTI PRO, K10 SLR PRO
- K7.5 GW AC SLR, K4.5 GW AC SLR

LIBERTY

- ADRENALIN 16
- ATTACK² 13 GW, ATTACK² 13 AT DEMO
- ATTACK 16, ATTACK 13, ATTACK 13 DEMO
- LIBERTY 15

RETAILER AGREEMENTS AND INDEMNIFICATION AGREEMENTS

Both Agreements must be completed annually. This year's Retailer and Indemnification Agreements should already be completed, if not please contact customer service or your sales rep. Completed Retailer Agreements, Indemnification Agreements and Employee Training Documentation Forms should be received at HEAD USA INC. / HEAD CANADA INC. no later than December 31, 2020.

An administrative fee of \$15 Cdn per year for each Certified Mechanic (maximum \$ 75 Cdn per location) will be charged by TYROLIA in Canada and \$30 US per location in the USA. If a retailer loses his only TYROLIA Certified Mechanic, he must notify HEAD USA INC. / HEAD CANADA INC. in writing within 48 hours.

SUMMARY OF REQUIREMENTS

These basic requirements help assure that the end product which is delivered to the customer is appropriate.

- Signed, current copies of the HEAD/TYROLIA Authorized Retailer Agreement and the HEAD/TYROLIA Bindings Indemnification Agreement must be on file with HEAD USA INC. / HEAD CANADA INC.
- The shop must adhere to 2020.21 HEAD/TYROLIA procedures for selection, mounting, adjusting, testing and/or servicing of system components as detailed in this manual.
- The actual HEAD/TYROLIA retention/release adjustment, or its equivalent, must be used.
- A HEAD/TYROLIA Certified Mechanic must properly mount, inspect, adjust and/or service system components and/or check to make sure all service, adjustments, testing and record keeping were properly completed.
- Mechanics must receive full training, including hands-on practice in the use of system testing devices, as provided by the testing device supplier. A multiple operator reproducibility test should be completed and results documented by the shop each season.
- The shop must maintain records of all retail/rental testing and/or service work for 5 years or for the length of the statute of limitations in the state where your business resides, whichever is longer. Bear in mind that the statute of limitations for minors begins only when they come of legal age.

PAPERWORK REQUIREMENTS

TYROLIA Retail/Rental Workshop tickets have proven their importance in the legal system, and we strongly recommend their use (see elsewhere in this manual). At the very minimum, records must contain the following information:

- Identification of shop and customer: name, address, phone.
- Date of transaction or work.
- Information on which binding settings are based: skier height, weight, skier type, age, boot sole type and length.

- A full description of the equipment being serviced or rented (skis/boots/bindings), including but not limited to brand, model, size and serial numbers.
- Skier code, "Initial" binding release/retention settings, and final settings.
- Signed, dated statement from the HEAD/TYROLIA Certified Mechanic that all manufacturer's procedures have been completed, and the signature of the mechanic who performed the service (if they are different individuals).
- An agreement dated and signed by the customer, the language of which is substantially similar to the current HEAD/TYROLIA form. This agreement must include the following points:
 - User verification of skier information.
 - WARNING that there are risks of injury inherent in the sport of skiing and that the customer accepts those risks.
 - DISCLOSURE of the equipment's limitations, that it will not release, retain or prevent injury under all circumstances, and is no guarantee of the user's safety.
 - RELEASE language whereby the user releases the retailer, manufacturer and distributor from liability and damages, to the fullest extent allowed by law.
 - STATEMENT that no warranties of any kind are offered by the shop beyond those offered by HEAD/TYROLIA.
 - AGREEMENT that instruction in the use of the equipment has been received, that the skier height, weight, skier type, age, boot sole type and length, as well as the settings on the binding match those on the record form, and that the skier will inspect the system, including the binding's AFD, before each use.
 - Signatures by both the customer and HEAD/TYROLIA Certified Mechanic are required by for the HEAD/TYROLIA Retailer Indemnity Program.

NOTE:

- Any changes in documentation requirements must be authorized in writing by HEAD USA INC. / HEAD CANADA INC. POST-ACCIDENT REPORT (SEE SAMPLE IN APPENDIX). In addition to the above information on the system's performance, fill out a Post Accident Report when you become aware that an injury has occurred. Keep this document for 5 years or the duration of the statute of limitations for minors, whichever is longer.

IN THE EVENT OF AN INJURY CLAIM

- The retailer must give written notice to HEAD USA INC. / HEAD CANADA INC. of any bodily injury claim (which includes any lawsuit, letter from a lawyer, statement from the customer, their family or others alleging wrongdoing or seeking compensation, or other similar circumstances), on or before the tenth calendar day from the date on which the retailer first received notice of any claim for which indemnity will or could be sought under the applicable HEAD/Tyrolia indemnity agreement. The retailer must also notify his/her own attorney and insurance carrier, and must cooperate with HEAD USA INC. / HEAD CANADA INC. and respond to their requests for information, documents and other materials.
- In the event of an injury involving HEAD/Tyrolia equipment (whether or not a claim has been made), a Post-Accident Report must be completed and retained to the extent information and the equipment are available to the retailer. If the entire system is not available for testing that fact should be noted and all available information such as equipment condition, visual indicator settings, and any equipment abnormalities, as well as pertinent statements from the customer or witnesses, should be recorded.
- When filling out a Post-Accident Report, record the numerical test results, not just pass/fail. Fill out the report accurately and completely, without editorial comment. Use quotes if you are taking down exactly what someone has told you. If part of the information called for in the report is unavailable, enter "not available" or another reason why the information has not been written down. This document may become part of a legal case years later,

when personal recollections are not as strong, so it is important to collect and record accurate and complete information while it is fresh.

- In a rental situation where there has been a reported injury but no claim has been made, equipment may be returned to service upon passing a post-accident test/inspection. If a claim is received regarding this equipment, however, any involved equipment must be set aside and preserved intact, even if time has passed and the equipment was used by others after the incident.
- Skiing is a hazardous sport with inherent risks of injury, and not every injury or accident constitutes a "claim" that must be reported within ten days, but the following is a non-exclusive list of the situations that should be handled as a claim that requires reporting to HEAD/Tyrolia and setting aside the involved equipment:
 - Filing or receipt of any lawsuit or any preliminary notice regarding a legal action;

HEAD/TYROLIA LIMITED WARRANTY

In the case of direct sales from the HEAD/TYROLIA web shop, HEAD/TYROLIA itself warrants, otherwise HEAD/TYROLIA'S authorized distributor in the country in which this product was first sold at retail, warrants to the first retail purchaser or user, that this product shall be free from defects in materials and workmanship. This limited warranty, as well as any implied warranty, shall expire two years from date of the initial retail purchase. For warranty claims or service, the product must be returned at the consumer's expense, in the case of direct sales from the HEAD/TYROLIA web shop, to the customer service address stated in the web shop or otherwise to the place of purchase, or to another authorized TYROLIA dealer or to the authorized TYROLIA distributor in the country of purchase. This "Instructions for Use" booklet, the proof of purchase, and proof of periodic service must accompany all bindings returned under warranty.

LIMITATION OF LIABILITY

Cosmetic damage that does not affect function, and any damage caused by abuse or improper use, are not covered. Parts subject to normal wear and tear, such as AFD's, Brakes, windows, plastic or metal tracks, are not covered.

Your sole remedy under the Limited Warranty or any implied warranty shall be limited to the repair or replacement, at HEAD/TYROLIA's and its distributor's sole option, of the subject product or parts thereof. In no event shall HEAD/TYROLIA or its agents be liable for incidental or consequential damages or for any cost of transporting or shipping the product, whether the claim is based upon contract, warranty, negligence or product liability, including, without limitation, loss to property other than the bindings, loss of use of any property, or other economic losses. Neither HEAD/TYROLIA nor any distributor or dealer shall be liable for contribution or indemnification, whatever the cause. This warranty may not be assigned or transferred. HEAD/TYROLIA's obligations under any warranty shall be limited, to the greatest extent allowed by law, as provided in this Limited Warranty. Some states do not allow limitations on implied warranties or on certain damages or remedies, so some or all of these limitations may not apply to you. This Limited Warranty gives you specific legal rights, and you may also have other rights which vary in different states, provinces and countries.

SERVICE UNDER THE HEAD/TYROLIA WARRANTY

Products requiring service under the terms of the warranty should be dealt with as follows:

- Send the complete binding set to the authorized distributor where evaluation will be made and warranty action taken if required.

- Any letter, call or other communication from a lawyer's office, even if the lawyer says that they are simply "investigating" an incident;

- Statements by the customer, family, friends or representatives that any equipment was defective or broken, that it caused someone's injury, that the retailer was at fault, or that the retailer or manufacturer should pay; or

- An incident that has involved investigation by law enforcement authorities, news reports, or other circumstances that would cause a reasonable person to believe that a legal claim is likely.

- Read the applicable HEAD/Tyrolia indemnity agreement for full details regarding claims, indemnity and related matters.

- If a clear warranty situation exists, and the shop wishes to replace the pair of bindings products out of stock for a customer, the shop may do so after the approval of the ski warranty department of your HEAD/TYROLIA distributor. Be sure to check suitability and mounting hole pattern before making a change of model.
- When possible, the replacement should be of the same model as the returned product.
- If the same model is not available, the shop should contact the authorized HEAD/TYROLIA distributor warranty department for authorization before a more expensive model is selected for replacement.
- If a replacement is made from retailer stock, the complete binding set should be returned to the authorized HEAD/TYROLIA distributor as soon as possible. The packing list must clearly state which model was used for replacement.
- The "Instructions for Use" booklet (warranty), and proof of purchase must accompany all products returned for consideration.
- No credits will be issued..
- The authorized HEAD/TYROLIA distributor reserves the right to deny replacement to the retailer if the alleged problem is not verified or if products are returned without the "Instructions for Use" booklet and proof of purchase.
- Replacement bindings are covered by the warranty stated above.
- Any bindings returned to the authorized HEAD/TYROLIA distributor due to inappropriate release values (i.e. values which fall outside the "In-Use" tolerance range on the current HEAD/TYROLIA Adjustment Chart) must be accompanied by a completed System Performance Report.
- The report form is printed in this manual; no warranty action will be taken on release value related claims unless this report accompanies the returned bindings.

DISTRIBUTOR ADDRESSES:

HEAD USA INC. 3125 Sterling Circle Suite 101 Boulder, CO 80301 USA Phone: 800-874-3235 720-708-6400 Fax: 720-708-6419 www.tyrolia.com	HEAD CANADA INC. P.O. Box 3620, Station Main Guelph Ontario N1H 7H1 Canada Phone: 800-265-7257 519-822-1576 Fax: 519-822-2202 www.tyrolia.com
--	--

HEAD/TYROLIA RISK MANAGEMENT

Indemnification, Insurance, and your liabilities.

INDEMNIFICATION

Indemnification simply means that someone agrees to reimburse you for certain costs. In the ski industry it normally means that provided you fully follow the manufacturer's requirements and install and adjust the binding system correctly, the manufacturer or distributor will provide a defense and pay any judgment which may be entered against you if you are the subject of a claim or suit by a customer who claims to have suffered bodily injury as a result of using certain equipment. The key here is you must be able to prove that you did your job properly in order to qualify. If you do not, you will not be entitled to a defense or indemnification in the event of a claim.

YOUR PERSONAL LIABILITY

It's simple: If you make a mistake which causes harm to another, you can be held liable for it.

Be very careful not to make verbal warranties that extend beyond those made by HEAD/TYROLIA. Read the manufacturer's literature and warranties carefully. If a feature or benefit is not mentioned there, don't mention it to the customer.

SHOP LIABILITY INSURANCE

No indemnification program is a substitute for liability insurance. Common sense dictates that you should have an insurance policy that covers your shop and employees for commercial general liability and completed operations. Check with your insurance broker.

SHOP PROCEDURE TO REDUCE LEGAL EXPOSURE

Risk Management has become a very important area in virtually every industry. In today's world it is more important than ever to do as much as possible to recognize how and where we might be exposing ourselves to a potentially serious problem. HEAD/TYROLIA has been the leader in molding valuable risk management concepts into a program that virtually the entire ski industry follows today. HEAD/TYROLIA has defined proper shop practices and how shop personnel and customers need to interact in order to maximize skiing enjoyment while lowering the risks of liability. If these procedures are followed properly, both the skier and the industry are well served. In the event of a mishap, the programs documentation and record keeping system will provide strong evidence of work performed.

YOUR OBLIGATIONS UNDER THE HEAD/ TYROLIA RETAILER INDEMNITY PROGRAM

Selecting equipment for your customer.

- Make sure the products are suitable for the skiers height, weight, ability, shoe size and level of ability.
- Always make sure your recommendations are consistent with the manufacturer's.

BINDINGS SELECTION

Generally, the idea that top of the line products offer the greatest margins for safety as well as performance and durability is correct – provided the skier fits the weight range of the product. Combine this knowledge with our weight and ability recommendations for the skier when selecting a binding.

Avoid selling a product with the idea that the customer will grow into it. If a product is not suitable for their current requirements make another choice. Avoid the temptation to do the customer a favor by re-writing the rules. More often than not, all you will do is cause problems. At the time of delivery to the customer, the bindings must be accompanied by all the informational materials supplied by the manufacturer, i. e., pamphlets, forms, etc. The product must be fully demonstrated to either the intended user

or their parent or legal guardian if the child is a minor. This includes instructions on inspecting the low friction surfaces, cleaning the boot sole, entry of the binding, reentry after releasing on the hill and exiting the system. You must also explain what care and maintenance the skier is responsible for, as well as when to return the equipment to your shop for a thorough function check. Routine maintenance is the most cost effective thing a skier can do to protect their wellbeing.

RACING (X) BINDINGS

Certain binding models are produced by HEAD/TYROLIA each year for the exclusive use of qualified competitors under the supervision of HEAD/TYROLIA Technical Specialists.

Racing bindings offer release/retention settings outside of those on the HEAD/TYROLIA Release/Retention Adjustment Table, which is based upon ISO/ASTM Safety Standards. These bindings can be serviced under the Dealer Indemnity Program if proper procedures are followed.

We recommend you decline to service them and that you warn against their use unless you have training or experience as a race technician and your customer is a high-level competitor who clearly states a need for these bindings. The customer is to be warned that using these bindings significantly increases the risk of injury due to non-release, and that settings exceeding the recommended range are made at the skier's own risk. If you do service racing bindings, you must follow the same procedures described above for making specific comments on the standard workshop form in addition to completing the form on this page to be signed by the skier.

BOOT SELECTION

Make sure the customer's boot choice is consistent with their level of skiing and that the boots meet all current DIN or ISO standards.

SKI SELECTION

Take care to ensure that the skier's intended use of the chosen equipment is consistent with the manufacturer's recommendation for the skier's weight and level of skiing. This is another area where regular maintenance is critical. It is only logical that skis which help keep your customer upright reduce their overall chance of injury.

COMPLETING THE WORK ORDER WITH THE CUSTOMER

It is critical that certain basic information be included on all shop work orders. While we do not require it, the easiest way to make sure the form you use fits HEAD/TYROLIA's requirements is to use ours.

Once the customer has selected equipment or described the repair or service to be performed, the technician must ask the customer to complete a portion of the Work Order Form which includes their Name, Address, Phone number, Weight, Height, Age, Sex, and Skiing ability.

There are few things more embarrassing than having a customer come in to pick up a pair of skis that could not be serviced due to an improperly filled out form, or an unforeseen technical problem.

The best way to avoid this is to have a HEAD/TYROLIA Certified technician thoroughly inspect all incoming work, and check the paperwork. The skier must then sign indicating that they have read, understood, and agreed to the terms of your Rental/Repair agreement (this agreement must comply with HEAD/TYROLIA Dealer Indemnity Program requirements).

It is also important that the customer be informed that they will be expected to verify in writing that the indicator settings agree with what is written on the form, and that they have been instructed in the use and maintenance of their equipment, and fully understand it.

This procedure must be completed before the transaction is consummated. Remember, the customer has the option of going to another store if the terms of the contract are not acceptable to them, and under no circumstances should the transaction go any further without their signature. The end user, or their agent, must sign the incoming work order.

SHOP PROCEDURES SUMMARY

For in depth details, see the "Binding Installation" section of this manual.

- Follow HEAD/TYROLIA procedures for inspection, mounting, adjustment and maintenance as appropriate.
- Confirm that toe and heel indicator values match those specified on the actual HEAD/TYROLIA Adjustment Chart.
- Using a calibrated testing device, according to the manufacturer's instructions for use, "exercise" the binding by releasing it at least once in each direction (clockwise and counter-clockwise at the toe, vertically at the heel). Then measures Twist and Forward Lean Torque Values. The middle quantitative value of 3 releases in each direction should be used as the test result.
- Compare Twist and Forward Lean test, results with the System Inspection Ranges on the actual HEAD/TYROLIA Adjustment Chart.
- After the equipment is adjusted to the skier's needs according to the manufacturer's standards, the certified technician signs the form indicating that the work has been completed according to the manufacturer's specifications.
- With testing complete, the HEAD/TYROLIA Certified Technician must complete and sign the workshop ticket. Be sure the Final Indicator Settings are correctly shown there. The workshop ticket should simply reflect that the system has "passed all tests" or that "all manufacturer's procedures have been completed".

PROCEDURES FOR RETAIL CUSTOMER PICK-UP

When the Retail Customer or his representative comes in to pick-up the equipment, the store employee has a fantastic opportunity to improve the skier's safety and enjoyment, while minimizing the risk of a lawsuit later on. All that's involved is properly informing the skier about the realities of skiing and ski equipment.

- Explain the function and operation of the binding, including a review of the manufacturer's pamphlet.
- Explain the settings that show in the release setting windows and how they were derived by referring to the manufacturer's release adjustment charts.
- Explain how much proper maintenance of the entire system (boots, bindings and skis) can improve their enjoyment and margins for safety. Also make it clear that skiing, like any sport, has its risks, and equipment cannot eliminate them.
- Have the customer sign the form again indicating that they have been instructed on the use of the equipment and that they verified that the visual release indicators on the bindings correspond to the manufacturer's recommended settings shown on the work order ticket.

ARCHIVING RECORD

Should you become one of the few that must defend against a law suit you will soon find out that the very best defense is made of paper. For this reason we recommend that you start out each ski season with a huge, brand new, manila envelope. Over the course of the season you should fill it with the following items:

- Collect a copy of the technical manual for each and every binding, boot and ski on the market. Be especially diligent with those you carry or work on regularly.
- Copies of the manufacturer's customer instruction booklets.
- Technician employment applications. Make sure they have the address of someone who will always know where they can be found, and is likely to stay put - Moms are good. This can be invaluable if you need the technician as a witness.
- A listing of all technician certifications and their dates. Keep all certification records as well.
- Copies of any pertinent wall charts, customer information posters etc.
- A copy of your shop procedures, including training materials, rental and repair shop practices, and binding setting charts.
- Copies of rental fleet test data.

This type of supporting documentation can be tremendously useful for your lawyer.

STORAGE OF FORMS

All forms containing the customer's signature must be kept for a minimum of five years or the term of the statute of limitations in the state where the injury occurs, or your state, whichever is longer. As a practical matter you have no idea where or when your customer may sustain an injury on this equipment.

Naturally, should an injury occur to either an adult or a child, keep the original form in a safe place until the case is completely resolved.

Risk Management is really just common sense. Do your job well, have integrity, keep your customers well informed, and keep proper records. Follow these simple rules and you will have very few problems.

USE OF NON-RECOMMENDED SETTINGS

SKIERS REQUESTING SETTINGS NOT RECOMMENDED BY HEAD/ TYROLIA

The 2020.21 HEAD/TYROLIA Release/Retention Adjustment Table is the only adjustment chart recommended for use by HEAD/TYROLIA dealers during the 2020.21 season.

Some skiers may request settings different from those in the HEAD/TYROLIA Release/Retention Adjustment Table. Most of these concerns can be addressed by following the procedures for reclassifying skier type and for troubleshooting which follow the instructions for using the HEAD/TYROLIA Release/Retention Adjustment Table.

HEAD/TYROLIA and the ISO/ASTM standards organizations do not recommend the use of release/retention settings outside of these tolerances, but skiers occasionally may request such settings. HEAD/TYROLIA recognizes a skier's right to choose other settings, but if the skier requests settings outside of those derived from the normal procedures for reclassifying skier type and for troubleshooting, the shop may either:

1. Adjust the system to the setting derived from HEAD/TYROLIA Release/Retention Adjustment Table and instruct the skier on how to change the setting (if this is done, make a note to this effect on the workshop or rental form), **or**
2. Adjust the system to the skier's individual request, but only if the technician notes on the workshop or rental form the skier's stated reason for requesting the higher or lower setting.
3. In either case, the customer must verify the request for the higher or lower settings by signing and dating the workshop or rental form by the reason noted next to the setting request, and in addition to making comments on the workshop or rental form, the skier must also read and sign a supplemental warning, release and indemnity agreement identical to the one printed on this page. In such cases, the system will only be indemnified if all other conditions of indemnification are met and the supplemental signed warning, release and indemnity agreement are attached to the completed workshop or rental form.

RACING (X) BINDINGS

Certain binding models are produced by HEAD/TYROLIA each year for the exclusive use of qualified competitors under the supervision of HEAD/TYROLIA Technical Specialists.

Racing bindings offer release/retention settings outside of those on the HEAD/TYROLIA Release/Retention Adjustment Table, which is based upon ISO/ASTM Safety Standards. These bindings can be serviced under the Dealer Indemnity Program if proper procedures are followed.

We recommend you decline to service them and that you warn against their use unless you have training or experience as a race technician and your customer is a high-level competitor who clearly states a need for these bindings. The customer is to be warned that using these bindings significantly increases the risk of injury due to non-release, and that settings exceeding the recommended range are made at the skier's own risk. If you do service racing bindings, you must follow the same procedures described above for making specific comments on the standard workshop form in addition to completing the form on this page to be signed by the skier.

WARNING, LIABILITY RELEASE AND INDEMNITY AGREEMENT FOR NON-RECOMMENDED RELEASE/RETENTION SETTINGS OR RACING BINDINGS

I, _____ hereby acknowledge that I have been advised by the _____ rental shop, sales department, etc.) that settings which I have requested for my bindings (Model _____) is not the setting recommended by the manufacturer of the bindings for a skier of my height, weight, age and skier type. I understand and acknowledge that there may be an increased risk of injury or death to me as a result of my own personal preference for these binding settings.

To the fullest extent allowed by law, I RELEASE this shop, all manufacturers, distributors, retailers and other providers of this equipment, all persons who service this equipment, the resort and property owners where this equipment is used, serviced or sold, and all of their agents, employees, officers, directors, owners, sponsors and affiliated persons and companies ("Released Parties"), from ANY AND ALL RESPONSIBILITY OR LEGAL LIABILITY for any injuries, damages or death to any user of this equipment, whether caused by NEGLIGENCE or any other cause. I further agree that I WILL NEVER SUE the Released Parties, and that I WILL DEFEND AND INDEMNIFY the Released Parties if any claim or action is pursued for any injuries, damages or death involving the use of this equipment.

If I am using Competition Bindings, such as HEAD/TYROLIA (X) bindings, my doing so is based entirely upon my personal decision to use them. Competition bindings are not intended for use by recreational skiers because they have release and retention features that do not comply with national and international safety standards. I understand and acknowledge that competition bindings are made for high level competitors who, based upon their personal experience, have decided that they have special retention requirements that exceed the capabilities of recreational ski equipment and the standards that apply to recreational ski equipment. I understand and agree that any use of this equipment may significantly increase the risk of injury due to non-release or other events, and I assume all risk of injury or death that may result from using competition equipment.

I, the undersigned, have read and understand this liability release and indemnity agreement, and agree that it is binding upon me, my heirs, family, guardians, administrators, assigns, and legal representatives. If any part of this agreement is held to be invalid or unenforceable, the remainder shall be given full force and effect.

Skier's Signature
(or that of the skier's parent or guardian)

Shop Manager's Signature

USED BINDING CHECKLIST

1. Customer concerns
2. Service bulletins – maintenance
3. Suitability
4. Availability – parts/tools/technical info
5. Boot/binding compatibility
6. Compatibility of under-binding options
7. Defects:
 - a) parts – cracked/corroded/missing
 - b) boot contact area – worn/damaged
 - c) boot contact area – contaminated
 - d) screws – missing/protruding
 - e) Brake/rollers/AFD – malfunctioning
 - f) positioning/alignment – incorrect
8. Binding to boot adjustments
9. INITIAL ASSESSMENT
10. Tests:
 - a) screw tightness
 - b) antishock travel
 - c) compatibility (if indicated)
 - d) release indicator verification
 - e) accelerated life cycle (with permission)
11. FINAL ASSESSMENT

USED SKI CHECKLIST

1. Customer concerns
2. Service bulletins – tuning requirements
3. Suitability
4. Defects:
 - a) delaminated
 - b) edge pulled out
 - c) cracked side wall
 - d) warped, bent, twisted
 - e) damaged tip / tail protector
 - f) lost camber
5. INITIAL ASSESSMENT
6. Base/edge condition / thickness
7. Base/edge profile
8. FINAL ASSESSMENT

USED BOOT CHECKLIST

1. Customer concerns
2. Service bulletins – fitting requirements
3. Suitability
4. ISO sole dimensions – Adult/Child
5. Sole hardness/material
6. Defects:
 - a) sole – warped
 - b) contact area – damaged/worn
 - c) contact area – contaminated
 - d) shell/liner/buckle – damaged
7. Type/position of foot bed/fitting aids
8. INITIAL ASSESSMENT
9. Fit:
 - a) foot anomalies
 - b) foot/boot size comparison
 - c) foot in boot evaluation
10. Performance adjustments
11. FINAL ASSESSMENT

NOTES:



HEAD



TYROLIA



head.com

HEAD Sport GmbH

Wuhrkopfweg 1
A-6921 Kennelbach
Tel.: +43-5574-608-0
FAX: +43-5574-608-130



tyrolia.com

HEAD Sport GmbH
Branch Schwechat
Tyroliaplatz 1
A-2320 Schwechat
Tel.: +43-1-701 79-0
FAX: +43-1-701 79-334