

Model Specific Operation Manual

Clubmax series

CM-800 | CM-1000 | CM-1800 | CM-2000
CM-3000 | CM-3400 | CM-6000 | CM-6800

KVANT[®]
www.kvantlasers.sk



Table of Contents

| | |
|--|-----------|
| Introduction | 1 |
| General Information | 2 |
| What is a laser and how does it work? | 4 |
| Laser Safety First! | 6 |
| Installation of the System | 7 |
| Control System | 8 |
| Scanning System | 9 |
| Connection Diagram | 11 |
| Multiple System Interlock | 12 |
| Switching ON sequence and User Interlock | 13 |
| Maintenance | 16 |
| Item Checklist | 17 |
| Optional Accessories | 19 |
| System Overview | 20 |
| Front View | 21 |
| Rear View | 22 |
| Beam Alignment | 25 |
| Beam Alignment [CM-800; CM-1000] | 27 |
| Beam Alignment [CM-1800; CM-2000] | 29 |
| Beam Alignment [CM-3000] | 31 |
| Beam Alignment [CM-3400] | 34 |
| Beam Alignment [CM-6000] | 37 |
| Beam Alignment [CM-6800] | 41 |
| Technical Specifications | 45 |
| Technical Specification [CM-800] | 46 |
| Technical Specification [CM-1000] | 47 |
| Technical Specification [CM-1800] | 48 |
| Technical Specifications [CM-2000] | 49 |
| Technical Specification [CM-3000] | 50 |
| Technical Specification [CM-3400] | 51 |
| Technical Specification [CM-6000] | 52 |
| Technical Specification [CM-6800] | 53 |

Introduction

Thank you for purchasing this KVANT product.

To ensure proper operation, please read this manual carefully before using the product.
After reading it, keep it in a safe place for future reference.

General Information

* The following chapters explain important information about lasers in general, basic **laser safety** and some tips about how to use this device correctly. Please spend some time reading these information as some of them are critical for safe and efficient operation of this laser display system.



LASER RADIATION
AVOID EYE OR SKIN EXPOSURE TO
DIRECT OR SCATTERED RADIATION
CLASS 4 LASER PRODUCT
IEC 60825-1



DANGER

LASER RADIATION
AVOID EYE OR SKIN EXPOSURE
TO DIRECT OR SCATTERED RADIATION
CLASS IV LASER PRODUCT

 **Diode Laser**

___ W MAX OUTPUT AT ___ nm
___ W MAX OUTPUT AT ___ nm
___ W MAX OUTPUT AT ___ nm
TOTAL MAX OUTPUT
W AT ___ nm

IEC 60825 - 1:2007

| | | |
|---|---|---|
|  | CAUTION RISK OF ELECTRIC SHOCK DO NOT OPEN |  |
|---|---|---|

CAUTION: TO REDUCE THE RISK OF ELECTRIC SHOCK,
DO NOT REMOVE COVER OR BACK PANEL.
SERVICEABLE PARTS INSIDE. REFER SERVICING TO
QUALIFIED SERVICE PERSONNEL.

CAUTION

LASER LIGHT IS BRIGHT AND
BLINDING DO NOT SHINE AT
AIRCRAFT OR VEHICLES AT
ANY DISTANCE

CAUTION

CLASS 4 VISIBLE
LASER RADIATION WHEN OPEN
AND INTERLOCKS DEFEATED

AVOID EYE OR SKIN EXPOSURE TO
DIRECT OR SCATTERED RADIATION

Caution

! This laser entertainment system is rated as a **Class IV laser product** and manufactured in accordance to **EN 60825-1:2007**. Avoid eye or skin exposure to direct or scattered radiation. Wear protective goggles of suitable optical density if necessary.

! If the laser is operated in a situation where health or property injury may occur the operation must be stopped immediately.

! The manufacturer and its distributors cannot be held responsible for any damages caused by improper use or misuse of this KVANT laser system. The owner/user is fully responsible for using this product in accordance to laser safety regulations of the country or state where the system is being used.

Please note that some other optical devices such as cameras, camcorders, video projector etc. can be damaged if exposed to excessive laser radiation.

Handling precautions

This laser system is a precision device that contains some sensitive opto-electronics components. DO NOT drop it or subject it to physical shock.

This laser system is not waterproof or dust-proof. Make sure to use an appropriate cover or enclosure if it is used in the rain, snow or similar severe environment conditions.

Do not leave the laser system in excessive heat such as in a car whilst in direct sunlight. High temperatures could cause some serious damage to the system.

The laser system contains precision electronic circuitry. Never attempt to disassemble the laser yourself.

If the laser is suddenly brought in from the cold into a warm room, condensation may form on the laser and internal parts. If condensation forms on the laser body, do not use the laser as this may damage the laser system. If there is condensation, wait until it has evaporated before using it.

What is a laser and how does it work?

What is a LASER?

The laser is a bunch of energy waves (streams of photons called radiation) with the same amplitude and phase that are flowing in the same direction; meaning they are coherent – they stick together and form a laser beam.

The width of a single wave is measured in nano-meters and defines the colour and visibility of the laser beam. The visible spectrum of the human eye is roughly between 400nm and 700nm, going from violet to a dark red colour. A human eye is most sensitive to a green light of around 555nm, meaning that a 1W of green laser will always appear more visible than 1W of any other colour laser. 1W of quality laser light is very powerful and although it doesn't sound like much it can burn eye retinas, skin and clothes or even start a fire!

What makes the laser visible?

Mainly it is the particles of dust in the air that the laser beam hits on its path. That's why we "laserists" use haze or smoke machines to make lasers more visible. Too much of the haze or smoke will kill it, but the right amount will make all the difference between no show and a great show.

When outdoors, lasers mainly reflect off dust and mist in the air but due to unpredictable wind conditions we can never make sure the hazers or smoke machines will be effective enough. And that's why we use high power lasers for outdoor shows – to substitute for the lack of dust, haze and smoke.

How far does it go?

Depending on the power output of the system and weather conditions, the laser can be visible for miles – that is why we need to be cautious about aircrafts when performing outdoor shows. And if you get a system that is powerful enough then yes, it can reach the Moon.

Colours

Standard full colour analogue lasers use three primary colours: Red, Green and Blue. By mixing those together you can pretty much get any secondary colour:

Red + Blue = Magenta

Red + Green = Yellow

Green + Blue = Cyan

Red + Green + Blue = White

Of course the number and precision of the colours is determined by the modulation, stability and linearity of the system. If the system is not stable enough, it will produce different colours every time it is used, making it virtually impossible to match the colours of two systems at any one time. This is very often the

case with systems from far east manufacturers and with re-branded lasers that are being presented as European makes.

Scanning System

A scanning system is essentially two tiny mirrors, each moving on X or Y axis. By working together they can “scan” the laser beam in all directions. Once a shape is scanned more than 20 times per second, it appears static to the human eye. So any shape drawn by a laser is actually produced by one single laser beam running around like crazy. Every scanning system has a mechanical limit of how fast it can move its mirrors and therefore how many points it can display at any one second and that is usually represented in Points Per Second at a certain scanning angle, i.e. 8 degrees.

Laser Safety First!

! Before proceeding any further, please read the following safety page very carefully. It could help you avoid dangerous and hazardous situations which could lead to serious injury or property damage.

! Any laser system classified as a **Class 4** laser must be used with caution. If you are not an experienced laser operator we would strongly recommend that you attend a laser display safety course as soon as possible, and ideally before this laser system is used in public areas. There are various places in Europe where you can attend quality training and even a one day course will give you a good amount of valuable information to safely start with.

Unless you are very competent with the use of lasers and about the laser safety, make sure you **at least** follow these basic laser safety rules:

1. Never look directly into a laser beam.
2. Never look directly into laser aperture if the laser system is switched on.
3. Be aware that lasers can burn the eye retina, skin or cause fires if not used correctly.
4. Never perform Audience Scanning – that's when laser beams and effects hit an audience directly. Always project with the laser above audience head level – at least 3m above floor level.
5. When performing outdoors, avoid pointing the laser at aircrafts, buses, trains, etc.
6. Never leave the laser system unattended when it's switched on.
7. Always check for reflective surfaces within the laser range – these can be very dangerous (i.e. mirror behind the bar in a club could bounce the beam into bar attendant's eye).
8. Never hesitate to use the Emergency STOP if you think there's a fault within the laser system or a potential danger to a person/object caused by the laser performance.

Installation of the System

! The manufacturer is not liable for damages or a injury caused by improper installation of the system.
The installation should be carried by a qualified installer who should follow the Laser Safety Regulations of respective country.

Please follow these rules during the installation:

1. Do not connect the device to power supply during the installation.
2. Mount the system only to mounting point that is strong, secure and away from places where non-authorized person could get an access to.
3. Always make sure the system is properly tighten down and that it cannot get loose and move as a result of sound vibrations, cable pull or similar.
4. Always use a safety rope.
5. Ensure that all the cables have enough leverage just in case they get caught.
6. Ensure that the system is placed at least 20cm away from walls or any other objects including drapes etc.
7. Ensure that the system is placed well away from any heat sources including spotlights, moving heads, radiators, etc. Make sure there is a sufficient air-flow around the laser system.
8. It is essential that the fan openings are never covered during the laser operation.
9. Always follow the Laser Safety Regulations of respective country where the laser is being used.

Control System

The overall performance of any KVANT laser system is also dependent on the control system that you use for operating the laser as well as the correct device configuration in the laser control software. Please make sure all the laser settings in your control system are set correctly before you start using your Kvant laser display system.

Scanning System

The product warranty does not cover the damages to the scanning system caused by improper use of the scanning system or by incorrect programming. Therefore it is essential to understand how the scanning works and where are the limits of it. In this manual we will explain only the basics of it but it is the responsibility of every user to educate themselves so they can avoid damage being caused to the scanning system and costly repairs.

A laser beam comes from a laser module and hits the two moving mirrors of the scanning system. These mirrors are mounted on the scanner shafts and are moved by the scanner rotors, one on X and one on Y axis.

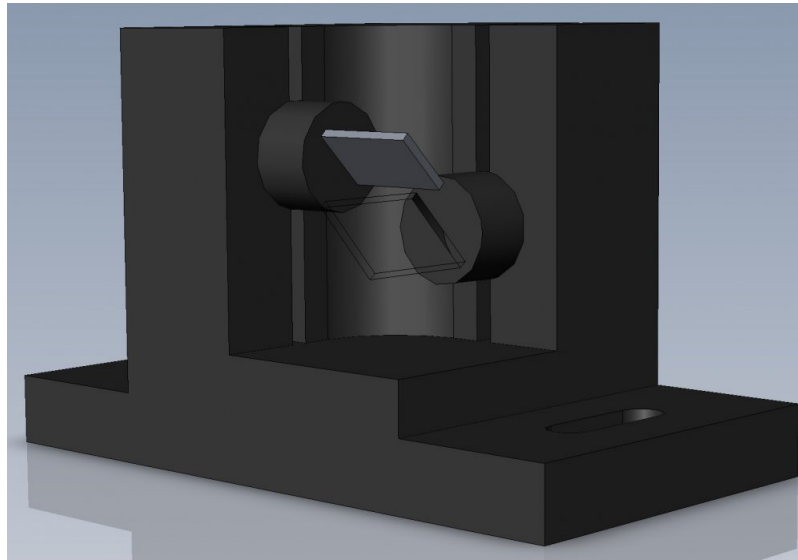

An effect such as tunnel (circle) is displayed by a repetitive mechanical movement of the scanners. For each scanning system and effect, there's a maximal scan rate that is defined by mechanical load, scanner mirror size and weight, complexity of displayed picture and size of the projection (an angle under the laser beam is being projected). A different scanning systems have different scan- rate limits. It is essential to operate the scanning system at scan-rates within its maximal limit at all times to prevent it from overload damage.

How to establish correct Scan-rate and maximal number of points in an effect

Each effect (picture) contains a different number of graphical points which defines the actual shape of the effect. The more points an effect contains, the lower the maximum scan rate will be in relation to the scanning angle.

As an example we'll work with the star effect shown below and with the parameters of quality scanning system:

Let's say the star effect is made of 300 graphical points (including non-visible blanking points) and we know that the maximal scan-rate of our scanning system is 35kpps @ 8 degrees (= 35.000 points per second at 8 degrees projection angle). We also know that we display the star 35 times per second which is a default frame rate of the control software we are using.

So we need to display 300 points 35 times per second = 10.500 pps. This means that we could display 3 of these stars beside each other within one single laser effect and that it would be quite close to the scanner limit ($3 \times 10.500 = 31.500$ pps). This however applies ONLY if the scanning angle is not more than 8 degrees on both axes! If we start to increase the size of the projection (scanning angle) it is necessary to either lower the number of points within the effect or drop down the scan-rate in the control software (FPS) to a safe level – which may result in flicker.

From the example above we can also determine how many points this scanning system is able to project if the scanning angle is not more than 8 degrees:

$35.000 \text{ points} / 35 \text{ Frames Per Second} = 1.000 \text{ pps}$. This is the absolute maximum of how many points we should be using when programming an effect if the scanning angle is not more than 8 degrees.

In the following pictures you see the same star effect scanned at different scan rates at full scanning angle (60 degrees).

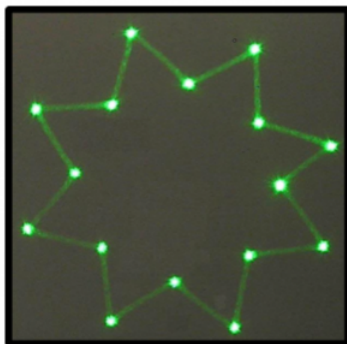

picture 1

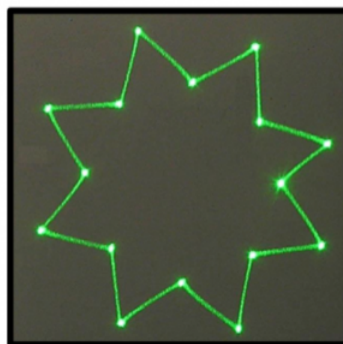

picture 2

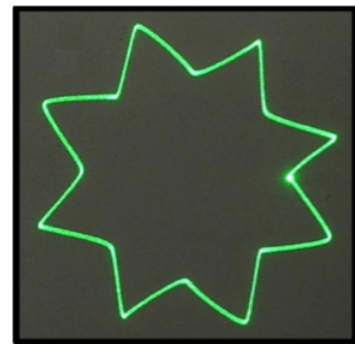

picture 3

Picture 1: the scan rate and/or number of points is too low. The corner points are more visible than the lines between them and the whole effect flickers. The scan-rate and/or number of points needs to be increased.

Picture 2: the scan-rate and/or number of points is about right. The whole effect has more or less the same intensity and does not flicker.

Picture 3: further increasing of the scan-rate and/or number of points results in the effect starting to distort, firstly around corners only. This indicates that you are exceeding the maximal scan rate of the scanning system! If you operate the scanning system at scan-rates higher than the maximum scan-rate of the scanning system the scanners will get damaged irreversibly due to overheated coils damaging rotor magnets.

Connection Diagram

Please check that all the signal and power leads are correctly installed and that the safety keys are inserted in all necessary positions.

Basic connection diagram

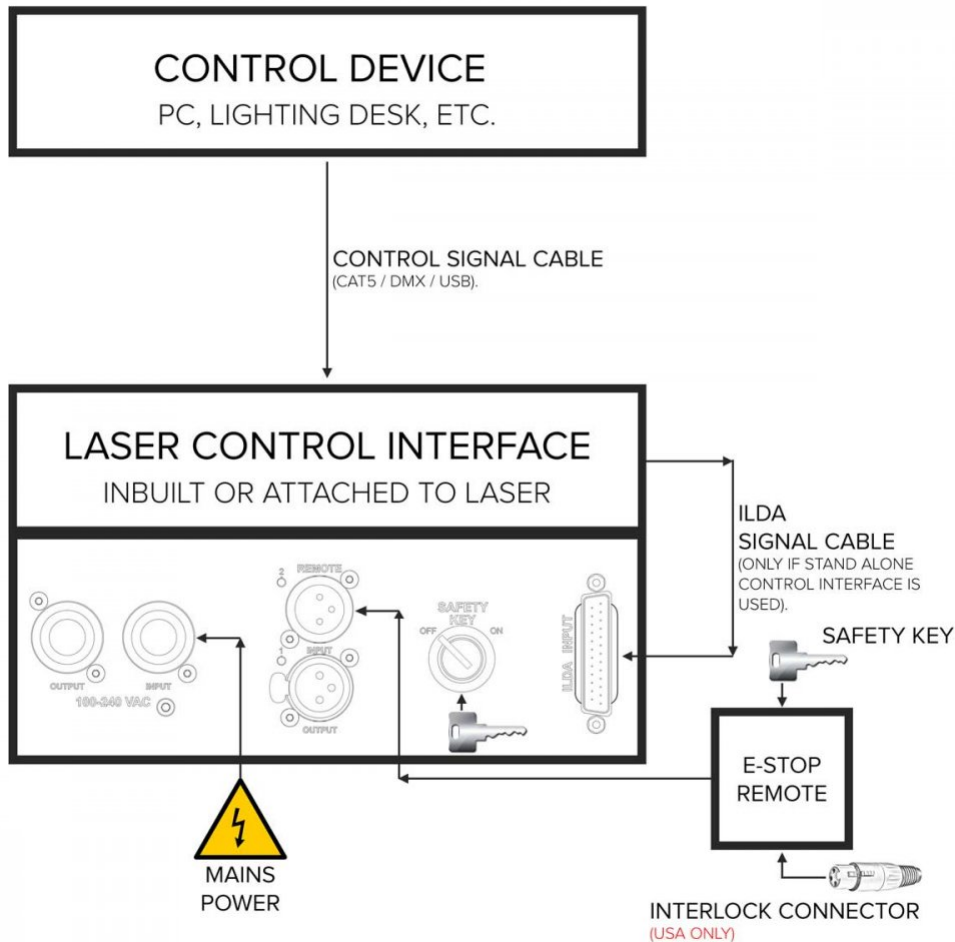

* Both E-STOP Remote safety key and laser system safety key must be inserted and switched to ON position in order to disable the interlock.

! USA ONLY: Interlock Connector must be inserted in the E-STOP Remote as well in order to disable the interlock.

Multiple System Interlock

Multiple laser projectors may be daisy chained and controlled by a single E-STOP Remote. Any event which enables the Interlock on any laser projector in the daisy chain will trigger the safety Interlock for all the systems. After the event has been corrected the START button on the E-STOP Remote must be pressed by the operator to disable the Interlock. After an Emission Delay period the laser projectors will be ready for use.

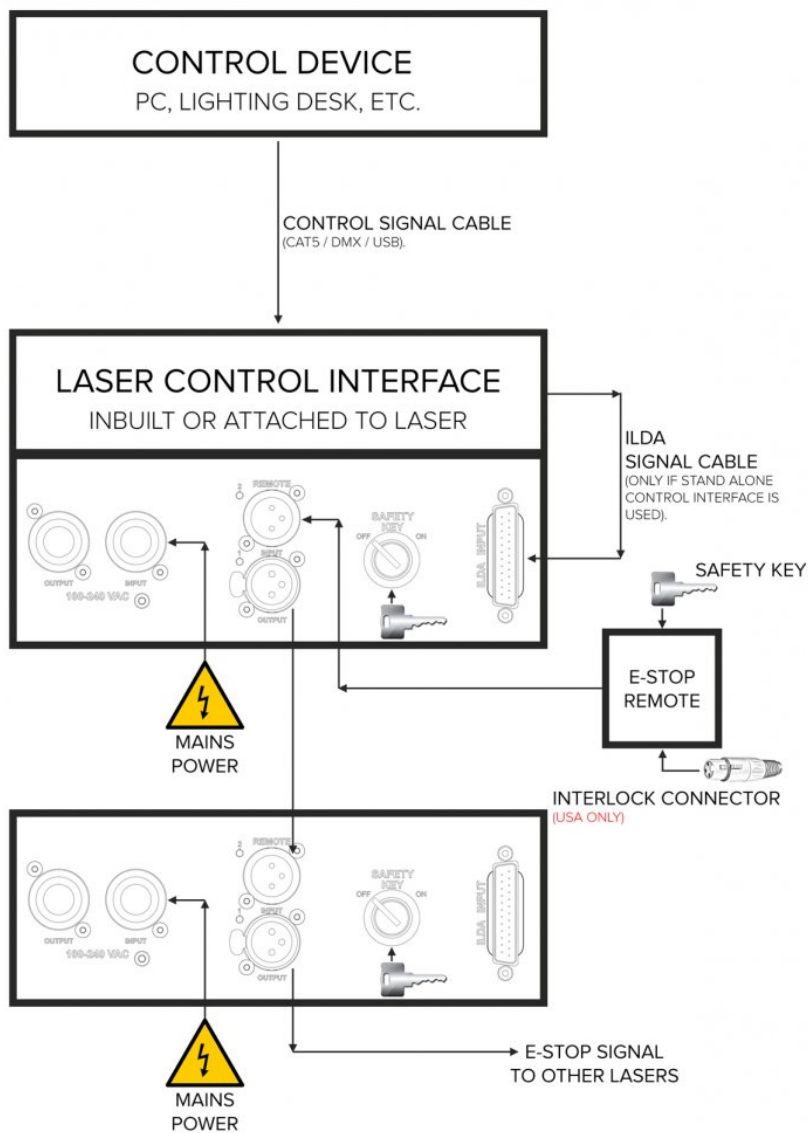

Switching ON sequence and User Interlock

! Please make sure that all laser display safety requirements are fulfilled in accordance with laws of the country where this KVANT laser system is being used before switching the system ON.

1. Connect the system as showed on [Connection Diagram](#).
2. Turn both E-STOP Remote and laser system safety keys to ON position.
3. Release the E-STOP button by pulling it upwards.
4. Open the aperture window by loosening the two bolts at the bottom of the aperture, adjust the masking plate to desired position and tighten the bolts to secure it.
5. Press the Main Power switch located at the back panel.
6. Press the RESTART button on the E-STOP Remote.

What happens next?

1. The laser system starts up and performs a self-check during which you may hear the initial spin of the cooling fans.
2. ScanFail safety indicator starts flashing and flashes for 60 seconds which indicates the Emission Delay period.
3. The Interlock indicator stays switched off if the Interlock Connector or the E-STOP Remote are connected correctly.
4. After 60 second Emission Delay period the laser system is ready to start output laser radiation. Depending on chosen ScanFail safety mode and an effect in the control software the laser CAN start the laser emission immediately after the initial 60 Emission Delay period – always keep this in mind!

Interlock Enabled, Laser Output Terminated

The Interlock is latched enabled and the laser projector's beam output will be terminated if any of the following events happen:

1. Power loss lasting greater than 2 seconds.
2. Mushroom emergency switch depressed.
3. #2 Key Switch on E-STOP Remote turned to OFF position.
4. #1 Key Switch on laser projector turned to OFF position.
5. Any other interruption to line No.1 of the cable leading to the E-STOP Remote. This includes any user interlocks connected in series in the line No. 1 of this cable. Refer to Connection Drawing below.

Interlock Connection Diagram

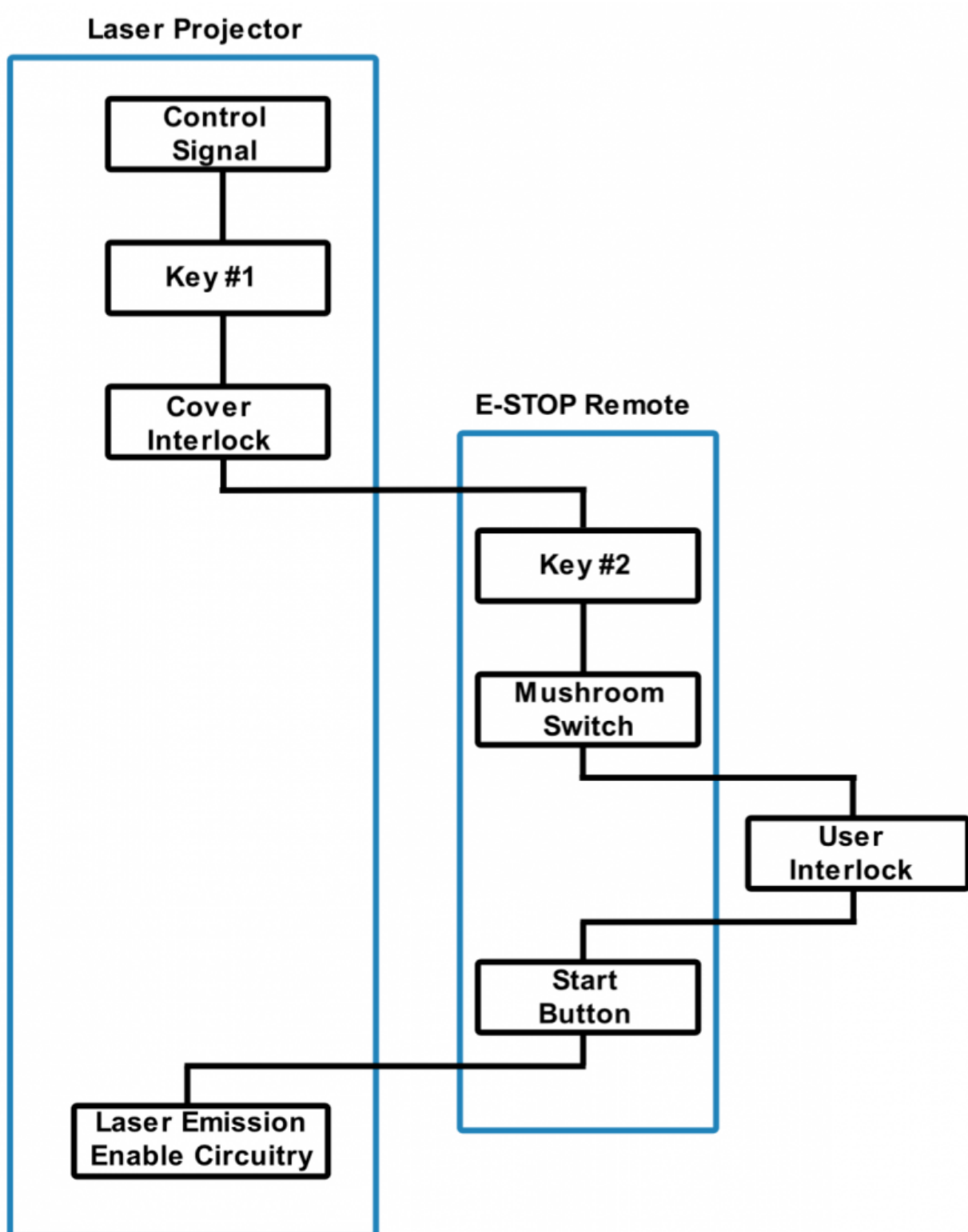

E-STOP Connection Drawing including User Interlock option

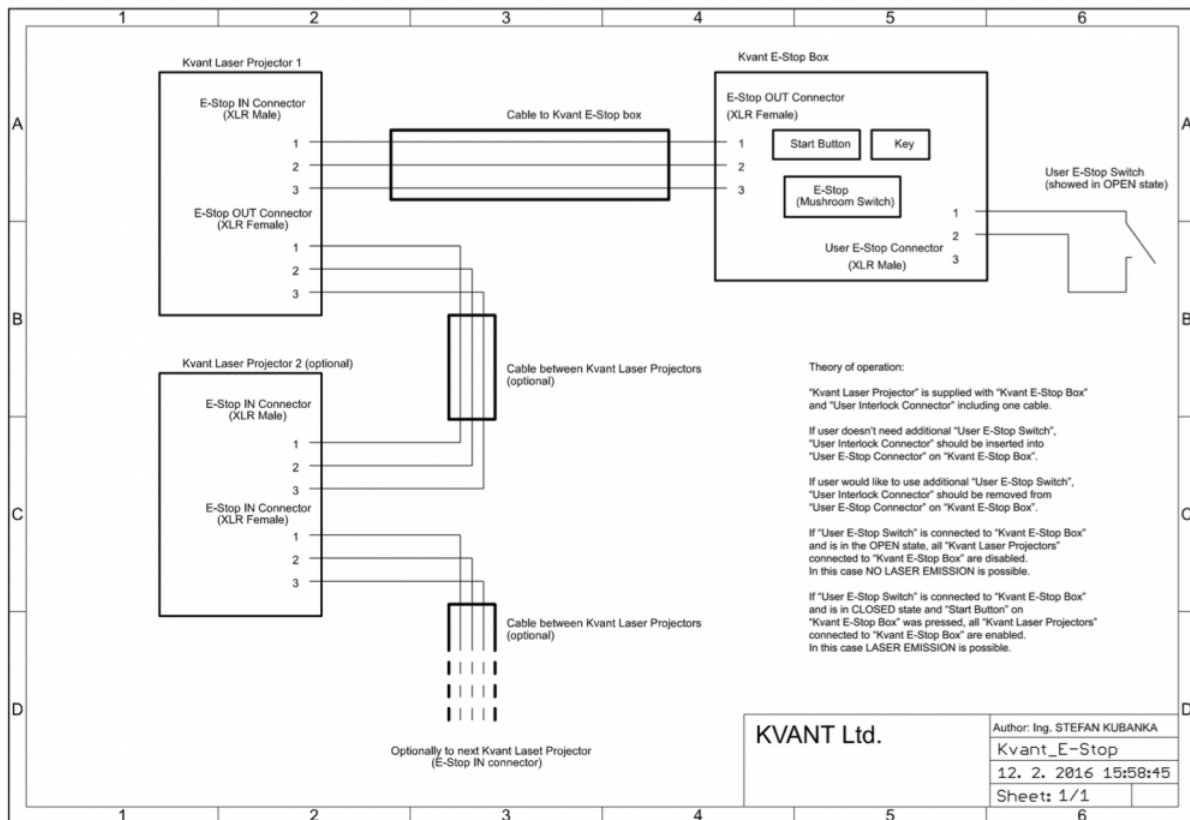

After the event has been corrected the START button on the E-STOP Remote must be pressed by the operator to disable the Interlock and after an Emission Delay period the laser projector will be ready for use.

Maintenance

Aperture Window

To clean the aperture output window use a soft cloth and medical grade isopropyl alcohol. If necessary, you can remove the aperture output window by loosening the 4 socket bolts and clean the inside of the window as well.

Cooling Fans

Use compressed air for cleaning the bottom part of the laser system. There are cooling fans located at the bottom of the heat sink and they are vital for correct operation of the laser system. Please always ensure that they are spinning freely.





You should perform this service every 2 months if the laser is used regularly or even more often if it is used in dusty conditions.



Internal Optics

The cleaning of the internal optical components should be performed by an authorised technician only. Incorrect techniques or wrong choice of chemicals used for cleaning could cause serious damage to the laser system. Due to the fact that the optical compartment is split and sealed from the rest of the laser system it shouldn't be necessary to perform this procedure more often than once a year.

Item Checklist

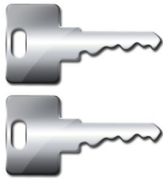





Before starting, check that all the following items have been included with your laser system. If anything is missing, contact your supplier.

| Item | Number of units | Description |
|---|-----------------|--|
|  | 1 | KVANT Clubmax Laser Display System |
|  | 1 | Emergency STOP Remote |
|  | 1 | 3-pin XLR Emergency STOP Remote cable |
|  | 1 | AC Power cable |
|  | 1 | Interlock Connector (for servicing only) |
|  | 2 | Set of Safety Keys |

| | | |
|---|---|--|
|  | 1 | ILDA Signal Cable |
|  | 1 | User manual CD |
|  | 1 | Heavy duty flight case (*not included with CM-800 & CM-1800) |

Optional Accessories

Here is a list of optional accessories that are compatible with Clubmax laser system.

| Item | Description |
|---|--|
|  | SafetyScan lens attachment bracket (lens is not included) |
|  | DiscoScan lens attachment bracket (lens is not included) |
|  | 4-way masking plate |
|  | FB4-MAX QS Quick Connect laser control interface with software |
|  | Moncha.NET Quick Connect laser control interface with software |
|  | Heavy Duty Flight Case |

System Overview

KVANT Clubmax is a full colour, semiconductor diode laser system designed for professional laser displays.

When operated correctly and in the right conditions the Clubmax laser system is able to deliver a strong performance in venues with up to 6000 people (CM-6800). The Clubmax can display virtually any colour within the basic RGB palette and its secondary mixed colours including white.

The system is air-cooled and designed so that there is no airflow going through the optical compartment of the system. This ensures that all important optical parts of the system stay clean for longer, keeping the maintenance time down to a minimum. This is a real advantage for all the venues where lots of smoke or haze is used on a daily basis.

This laser is IP rated to IP54, meaning that it is splash-proof. It is however important to understand that this system was designed for indoor use and therefore it must not be exposed to rain, snow or excessive amounts of dust.

Front View

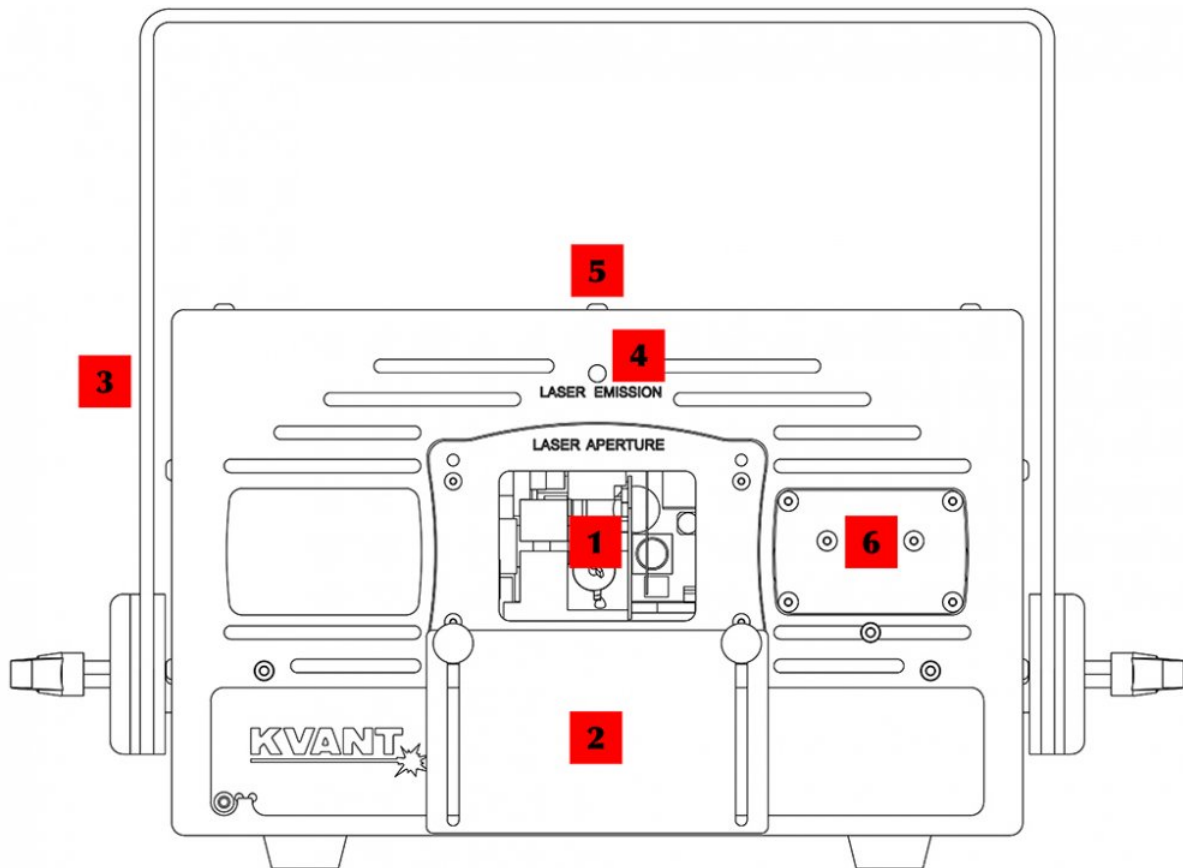

1. **Laser aperture plate.** To clean the laser aperture window from inside or to swap the aperture plate for different type of aperture (i.e. DiscoScan lens attachment bracket), remove the four socket bolts that hold the laser aperture plate in place.
2. **Aperture masking plate.** This metal masking plate can be moved up and down when two locking bolts are loosened. This useful safety feature gives you an option to limit the bottom of the laser output area if necessary (for example to avoid audience scanning). If it is required to limit the output from the top, the masking plate can also be attached to the top of the aperture.
3. **Attachment bracket.** The attachment bracket spins 360 degrees around the laser body whilst it can be locked in desired position by two small locking handles on sides. Due to a sophisticated locking mechanism there's no need to use excessive force when locking the system in position.
4. **Laser emission indicator.** When this indicator is lit up the laser system is ready to emit the laser radiation as soon as it receives instructions from control software.
5. **Optical compartment cover bolts.** To access the optical compartment of the laser system undo 18 button hex bolts and carefully remove the cover.
6. **RGB colour alignment mechanism.** To access the colour alignment mechanism undo 2 silver bolts and remove the cover. (*CM-800 and CM-1800 models only)

Rear View

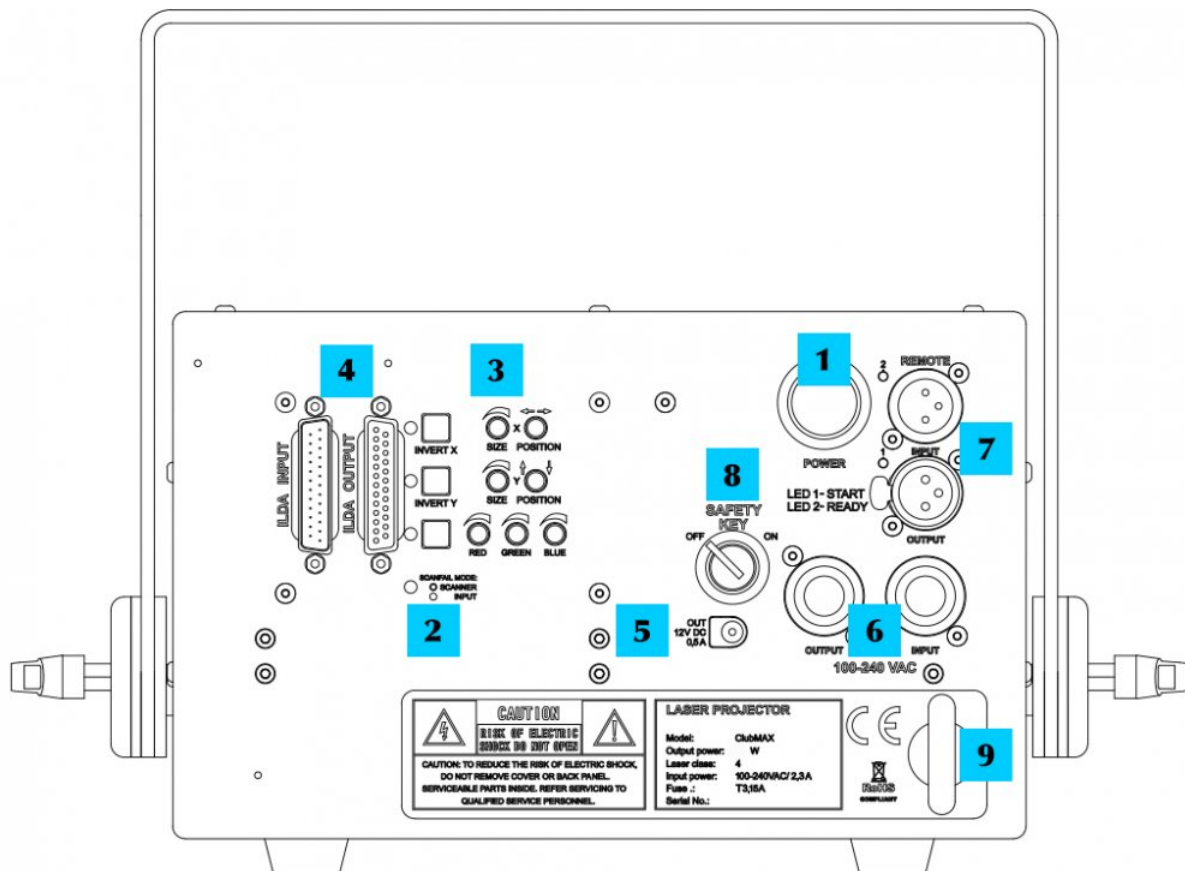

1. Mains power switch.
2. Scan-fail safety mode selector and Scan-fail status indicator.

There are two modes in which the Scan-fail detection system works:

- **SCANNER** – the system controls the movement of both scanners. If there is no movement it switches the laser emission off and keeps it off until there is a movement on both scanners detected.
- **INPUT** – the system checks for a difference between the input signal that goes into the laser system and the movement of the galvo motors. If the system detects that there's a difference between these two signals (meaning that scanning system is faulty), it will switch the laser emission off.

Please note, in the INPUT mode the safety circuit sometimes kicks in if the scanned effect is too small.

- **SCAN-FAIL STATUS INDICATOR** – This indicates the state of the Scan-fail safety circuit of the Emission Delay function. After every switch ON, this indicator will flash for about 60 seconds

during which the laser will not emit any laser radiation. After this initial period the light will turn itself off and only light up again when there is a problem with the scanning system or input signal.

3. **Main controls.** If necessary, you can use these control pots to adjust the size and position of the master projection zone. An output of each of the three basic colours (RGB) can be manually adjusted by turning corresponding pot to the left or right. Normally, all the colours are adjusted in the laser control software and these pots are mainly used when taking measurements or when performing the beam alignment procedure.
4. **ILDA INPUT/OUTPUT.** Use the input connector for the control signal input from your external control interface. The output connector is used to daisy chain the control signal between multiple laser systems.
5. **Quick Connect interface power connector.** This is used to directly power supply the Quick Connect interface which can be purchased separately.
6. **Mains power INPUT/OUTPUT.** Use supplied blue Neutrik Powercon power cable to connect the laser system to mains power supply using the INPUT connector. The OUTPUT connector is used to daisy chain power between multiple laser systems for quick and easy installation.
7. **E-STOP Remote connector, Interlock status indicator and User Interlock.** In order to use the laser system, the Interlock must be closed circuit. This is done by connecting the Emergency STOP Remote to the XLR INPUT Remote socket on the projector using the supplied cable and plugging in the User Interlock Connector into the Remote's XLR "User E-STOP Connector".

The User Interlock Connector may be replaced by the user's own interlock system using a switch or dry relay closure to connect pins 1 and 2. With pins 1 and 2 shorted, Laser Emission is possible, provided all other interlocks are closed circuit. With pins 1 and 2 open, NO Laser Emission is possible.

The Interlock status indicator goes off when the Interlock is closed circuit and the Interlock key is in the ON position. All above must be done correctly to allow laser emission from the system.

The projector's REMOTE Output is used to daisy-chain the Remote signal when you want to use a single Emergency STOP Remote to control multiple systems.

After a power failure or interlock failure (open circuit) has occurred and been corrected you need to manually reset laser emission by pressing the START button on the E-STOP Remote. Laser emission will then be available after a 60 second delay.



Please note that in most countries it is required by law to have a fully working Emergency STOP in place for every laser system used. If you use supplied interlock connector to defeat the safety interlock you must have another method in place to be able to kill the laser output instantly in case of emergency.

8. **Safety key switch.** The Safety key must be inserted and turned to ON position in order to enable the system to operate.
9. **Safety eyelet.** Use this together with appropriate safety wire to secure the system against unexpected fall.

Beam Alignment

It is possible that due to transportation, rigging, moving around or vibrations caused by various elements during a set up or laser performance some of the internal optical parts can move slightly resulting in colour misalignment.

The colour misalignment is when two or more colours (red, green and blue) physically do not overlay each other properly like on the picture below. This makes it impossible to get nicely mixed colours like yellow, cyan, magenta and white (including all their shades). If this occurs it is necessary to carry out the beam alignment procedure.

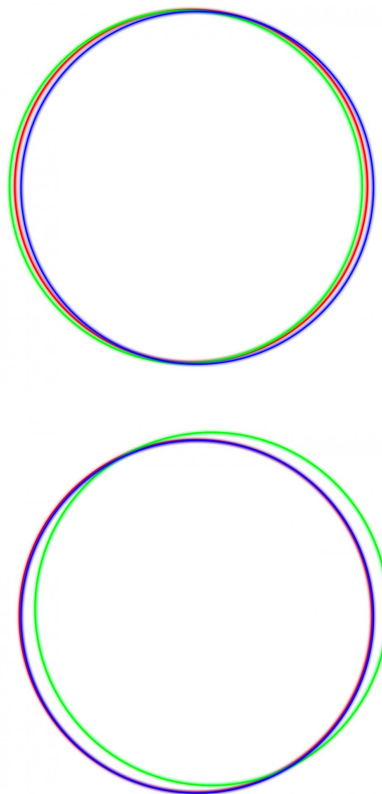

Be cautious when aligning the beams and wear sufficient laser safety protection to avoid accidental exposure to Class 4 laser radiation.

Beam alignment principle.

There are three laser modules within this system where each module produces one of the basic RGB colours (red, green or blue).

The goal of the alignment procedure is to align all three beams (colours) so they overlay each other

nicely while they hit exact centre of the bottom scanning mirror.

An easiest way to do the alignment is to project a full size circle onto a wall (or any another suitable projection surface), change its colour as necessary and check the alignment of individual colours on both X and Y axes.



Remember that greater is the distance between the laser system and the projection surface during the alignment, more precise the alignment will be.

When doing the alignment on long distances it is always good to have someone with you who can point you in the right direction. Alternatively you can use binoculars.

Beam Alignment [CM-800; CM-1000]

1. Loosen 2 silver bolts that hold down the colour alignment mechanism cover and remove the cover.

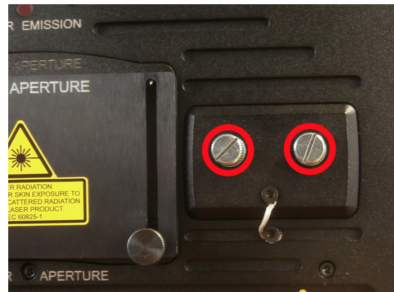

2. Power up the system as normal.
3. Firstly, it is necessary to align a colour with the longest beam path between the laser module output and the scanning system in a way so it hits the exact centre of the bottom scanning mirror – in this case it is the blue laser beam.

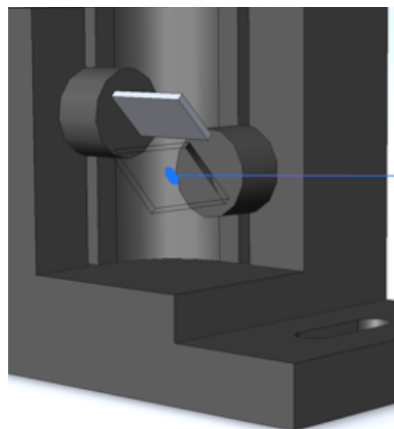

Create a blue beam effect (point) and check visually whether the beam hits the exact centre of the bottom scanning mirror.

If not, follow the diagram below to adjust the beam path accordingly (step 1 on the diagram below).

Colour alignment mechanism (front view)

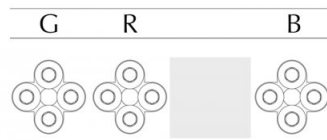

Use vertical adjusters for moving the beam left and right.

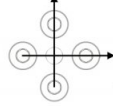

Use horizontal adjusters for moving the beam up and down.

One of the two adjusters must be always loosen first before the other one is tighten up. The order depends on desired beam movement direction.

Correct order of the colour (beam) alignment:

- 1) B : blue beam hits the centre of the bottom scanning mirror
- 2) R : align red beam to blue beam for unified magenta beam
- 3) G : align green beam to red beam for unified yeallow beam

4. Create a full size magenta circle (static tunnel effect) and check whether the red circle overlays the blue circle all the way around the shape.
If not, adjust the beam path of the green circle accordingly (step 2 on the diagram above).
5. Create a full size yellow circle (static tunnel effect) and check whether the green circle overlays the red circle all the way around the shape.
If not, adjust the beam path of the red circle accordingly (step 3 on the diagram above).
6. Finally create a full size white circle (static tunnel effect).
If the alignment procedure was done successfully you can see all the colours nicely overlaying each other, resulting in even, bright and sharp circle like the one on the picture below.

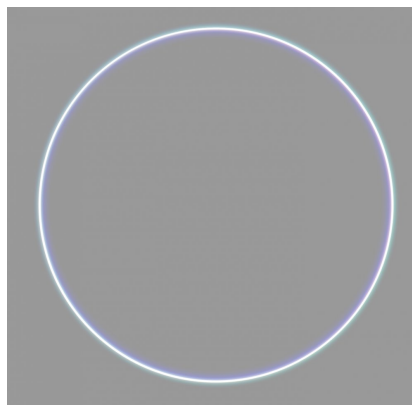

Beam Alignment [CM-1800; CM-2000]

1. Loosen 2 silver bolts that hold down the colour alignment mechanism cover and remove the cover.

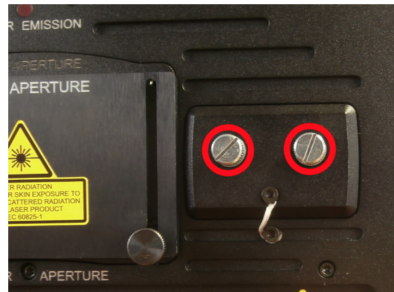

2. Power up the system as normal.
3. Firstly, it is necessary to align a colour with the longest beam path between the laser module output and the scanning system in a way so it hits the exact centre of the bottom scanning mirror – in this case it is the blue laser beam.

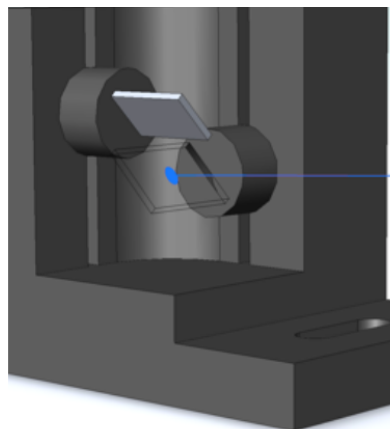

Create a blue beam effect (point) and check visually whether the beam hits the exact centre of the bottom scanning mirror.

If not, follow the diagram on the next page to adjust the beam path accordingly (step 1 on the diagram below).

Colour alignment mechanism (front view)

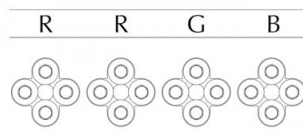

Use vertical adjusters for moving the beam left and right.

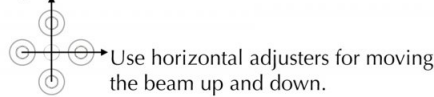

One of the two adjusters must be always loosen first before the other one is tighten up. The order depends on desired beam movement direction.

Correct order of the colour (beam) alignment:

- 1) B : blue beam hits the centre of the bottom scanning mirror
- 2) G : align green beam to blue beam for unified cyan beam
- 3) R1 : align red (R1) beam to green beam for unified yellow beam
- 4) R2 : align red (R2) beam to red (R1) beam for unified red beam

4. Create a full size cyan circle (static tunnel effect) and check whether the green circle overlays the blue circle all the way around the shape.
If not, adjust the beam path of the green circle accordingly (step 2 on the diagram above).
5. Create a full size yellow circle (static tunnel effect) and check whether the red circle overlays the green circle all the way around the shape.
If not, adjust the beam path of the red circle accordingly (step 3 on the diagram above).
6. Create a full size red circle (static tunnel effect) and check whether the 2nd red circle overlays the 1st red circle all the way around the shape.
If not, adjust the beam path of the 2nd red circle accordingly (step 4 on the diagram above).
7. Finally create a full size white circle (static tunnel effect).
If the alignment procedure was done successfully you can see all the colours nicely overlaying each other, resulting in even, bright and sharp circle like the one on the picture below.

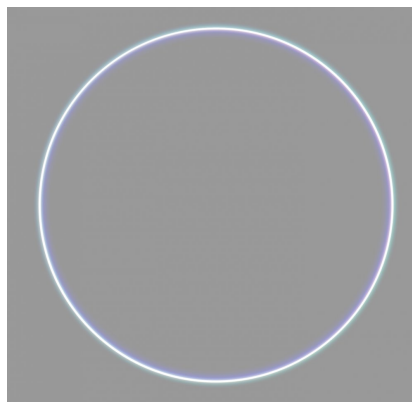

Beam Alignment [CM-3000]

! Although KVANT uses the latest technology to protect all the critical components inside this laser system against Electrostatic Discharge, the semiconductor laser diodes within this system are extremely vulnerable to it. This is due to some of the electronic components being exposed when the top cover is taken off.

If you decide to proceed with the Beam Alignment process yourself, it is absolutely essential that all the common ESD protection rules are strictly followed.

We don't accept any responsibility for Electrostatic Discharge damages to laser diodes caused by customer.

1. Loosen and remove 18 button hex bolts that hold down the top cover.
2. Slowly remove the cover – **detach the GND wire** that is attached to the top cover from the inside of the system! To detach the wire gently pull it out from the connector.
3. Removal of the cover will show the two internal defeatable magnetic interlocks. You must flip over the right side of the magnetic interlock until it touches the other side. You will be able to read the warning label “Interlock Defeated”.



* In the defeated position the label “INTERLOCK DEFEATED” becomes visible as shown in the image.

* Placing the magnetic interlock in the defeated position raises the interlock higher than the edge of the housing which will not allow the cover to be installed.

4. Power up the system as normal.
5. Firstly, it is necessary to align a colour with the longest beam path between the laser module output and the scanning system in a way so it hits the exact centre of the bottom scanning mirror – in this case it is the red laser beam (made of 4 individual red beams R4 – R1).

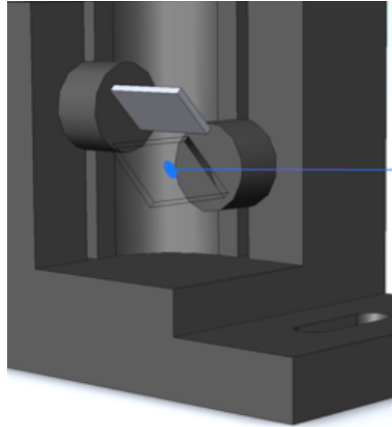

Create a red beam effect (point) and check visually whether the beam hits the exact centre of the bottom scanning mirror.

If not, use dichroic mount DF1 to adjust the beam path accordingly (showed on the picture below). To adjust the dichroic mount use the two adjustment knobs – each one works for one axis.

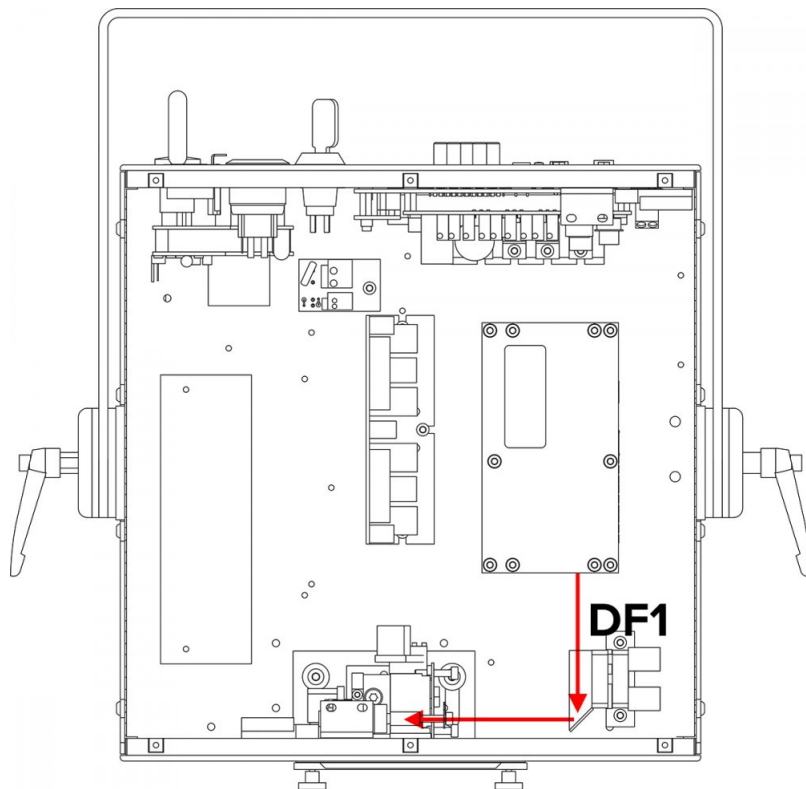

6. Create a full size red circle (static tunnel effect) and check whether the red circles of all R4, R3, R2 and R1 overlay each other all the way around the shape.
If not, follow the diagram below to adjust the beam path accordingly (step 1 & 2 on the diagram).

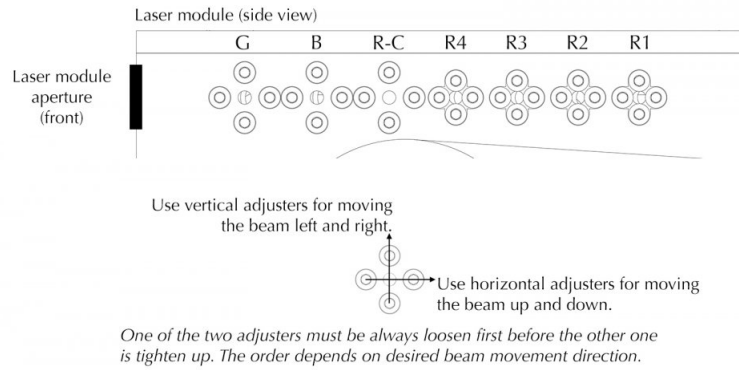

Correct order of the colour (beam) alignment:

- 1) R1 - R4 : align four red beams to pairs; R1 with R2 and R3 with R4
- 2) R-C : combine paired beams (R1&R2 with R3&R4) for unified main red beam
- 3) B : align blue beam to red beam for unified magenta beam
- 4) G : align green beam to magenta beam for unified white beam

7. Create a full size magenta circle (static tunnel effect) and check whether the blue circle overlays the red circle all the way around the shape.
If not, follow the diagram above to adjust the beam path accordingly (step 3 on the diagram above).
8. Create a full size yellow circle (static tunnel effect) and check whether the green circle overlays the red circle all the way around the shape.
If not, follow the diagram above to adjust the beam path accordingly (step 4 on the diagram above).
9. Finally create a full size white circle (static tunnel effect).
If the alignment procedure was done successfully you can see all the colours nicely overlaying each other, resulting in even, bright and sharp circle like the one on the picture below.

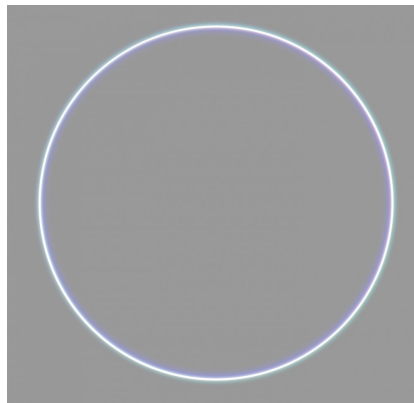

Beam Alignment [CM-3400]

! Although KVANT uses the latest technology to protect all the critical components inside this laser system against Electrostatic Discharge, the semiconductor laser diodes within this system are extremely vulnerable to it. This is due to some of the electronic components being exposed when the top cover is taken off.

If you decide to proceed with the Beam Alignment process yourself, it is absolutely essential that all the common ESD protection rules are strictly followed.

We don't accept any responsibility for Electrostatic Discharge damages to laser diodes caused by customer.

1. Loosen and remove 18 button hex bolts that hold down the top cover.
2. Slowly remove the cover – **detach the GND wire** that is attached to the top cover from the inside of the system! To detach the wire gently pull it out from the connector.
3. Removal of the cover will show the two internal defeatable magnetic interlocks. You must flip over the right side of the magnetic interlock until it touches the other side. You will be able to read the warning label “Interlock Defeated”.



* In the defeated position the label “INTERLOCK DEFEATED” becomes visible as shown in the image.

* Placing the magnetic interlock in the defeated position raises the interlock higher than the edge of the housing which will not allow the cover to be installed.

4. Power up the system as normal.
5. Firstly, it is necessary to align a colour with the longest beam path between the laser module output and the scanning system in a way so it hits the exact centre of the bottom scanning mirror – in this case it is the red laser beam (made of 6 individual red beams R6 – R1).

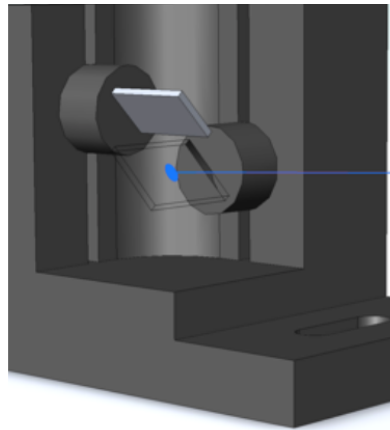

Create a red beam effect (point) and check visually whether the beam hits the exact centre of the bottom scanning mirror.

If not, use dichroic mount DF1 to adjust the beam path accordingly (showed on the picture below). To adjust the dichroic mount use the two adjustment knobs – each one works for one axis.

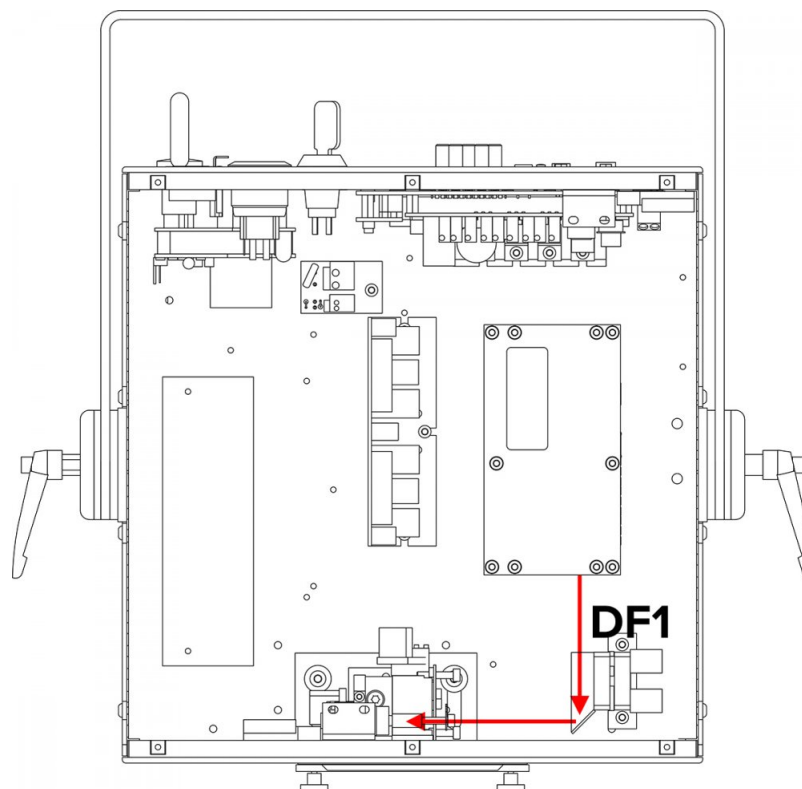

6. Create a full size red circle (static tunnel effect) and check whether the red circles of all R6, R5, R4, R3, R2 and R1 overlay each other all the way around the shape.
If not, follow the diagram below to adjust the beam path accordingly (step 1 on the diagram below).

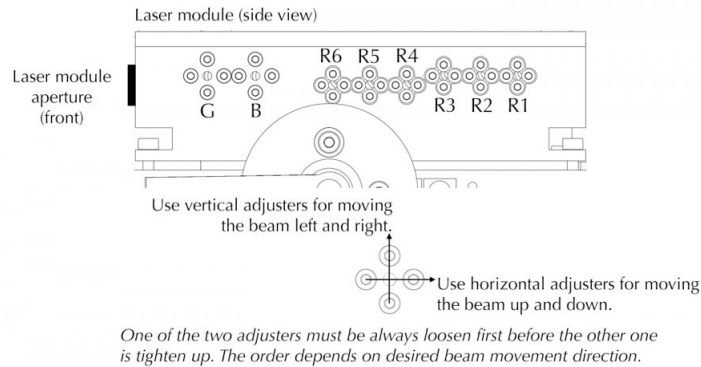

Correct order of the colour (beam) alignment:

- 1) R1 - R6 : align six red beams for unified main red beam
- 2) B : align blue beam to red beam for unified magenta beam
- 3) G : align green beam to magenta beam for unified white beam

7. Create a full size magenta circle (static tunnel effect) and check whether the blue circle overlays the red circle all the way around the shape.
If not, follow the diagram above to adjust the beam path accordingly (step 2 on the diagram above).
8. Create a full size yellow circle (static tunnel effect) and check whether the green circle overlays the red circle all the way around the shape.
If not, follow the diagram above to adjust the beam path accordingly (step 3 on the diagram above).
9. Finally create a full size white circle (static tunnel effect).
If the alignment procedure was done successfully you can see all the colours nicely overlaying each other, resulting in even, bright and sharp circle like the one on the picture below.

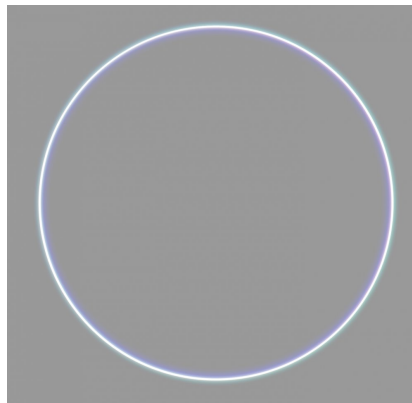

Beam Alignment [CM-6000]

! Although KVANT uses the latest technology to protect all the critical components inside this laser system against Electrostatic Discharge, the semiconductor laser diodes within this system are extremely vulnerable to it. This is due to some of the electronic components being exposed when the top cover is taken off.

If you decide to proceed with the Beam Alignment process yourself, it is absolutely essential that all the common ESD protection rules are strictly followed.

We don't accept any responsibility for Electrostatic Discharge damages to laser diodes caused by customer.

1. Loosen and remove 18 button hex bolts that hold down the top cover.
2. Slowly remove the cover – **detach the GND wire** that is attached to the top cover from the inside of the system! To detach the wire gently pull it out from the connector.
3. Removal of the cover will show the two internal defeatable magnetic interlocks. You must flip over the right side of the magnetic interlock until it touches the other side. You will be able to read the warning label “Interlock Defeated”.



* In the defeated position the label “INTERLOCK DEFEATED” becomes visible as shown in the image.

* Placing the magnetic interlock in the defeated position raises the interlock higher than the edge of the housing which will not allow the cover to be installed.

4. Power up the system as normal.
5. Firstly, it is necessary to align a colour with the longest beam path between the **Laser Module 2 (LM2)** output and the scanning system in a way so it hits the exact centre of the bottom scanning mirror – in this case it is the red laser beam (made of 4 individual red beams R4 – R1).

6. Cover the laser aperture of **Laser Module 1 (LM1)** with a small metal plate of some sort – this will allow you to work with the beams from **Laser Module 2 (LM2)** only.
7. Create a red beam effect (point) and check visually whether the beam hits the exact centre of the bottom scanning mirror.

If not, use dichroic mount **DF1** to adjust the beam path accordingly (showed on the picture below). To adjust the dichroic mount use the two adjustment knobs – each one works for one axis.

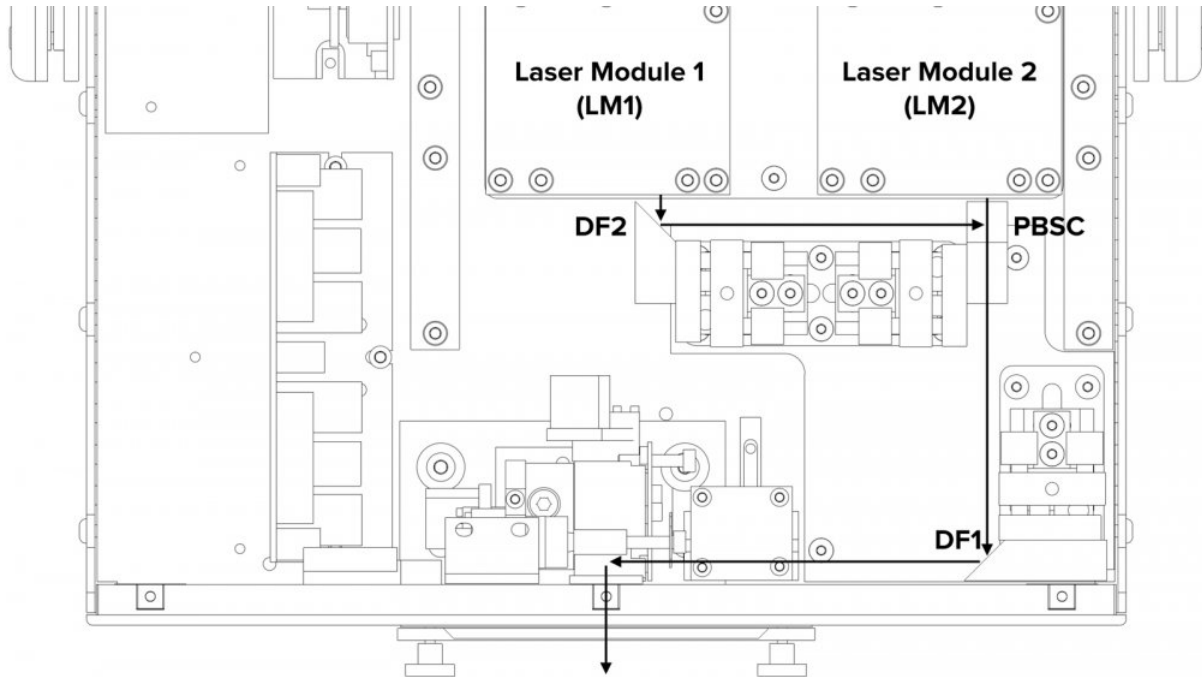

8. Create a full size red circle (static tunnel effect) and check whether the red circles of all R4, R3, R2 and R1 overlay each other all the way around the shape. If not, follow the diagram below to adjust the beam path accordingly (step 1 on the diagram below).

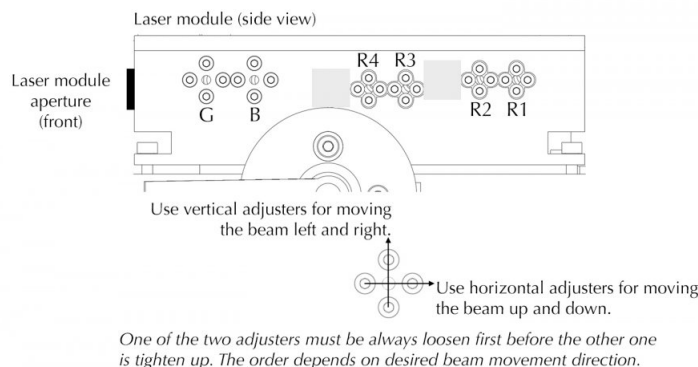

Correct order of the colour (beam) alignment:

- 1) R1 - R4 : align four red beams for unified main red beam
- 2) B : align blue beam to red beam for unified magenta beam
- 3) G : align green beam to magenta beam for unified white beam

9. Create a full size magenta circle (static tunnel effect) and check whether the blue circle overlays the red circle all the way around the shape.
If not, follow the diagram above to adjust the beam path accordingly (step 2 on the diagram above).
10. Create a full size yellow circle (static tunnel effect) and check whether the green circle overlays the red circle all the way around the shape.
If not, follow the diagram above to adjust the beam path accordingly (step 3 on the diagram above).
11. Finally create a full size white circle (static tunnel effect).
If the alignment procedure was done successfully you can see all the colours nicely overlaying each other, resulting in even, bright and sharp circle like the one on the picture below.

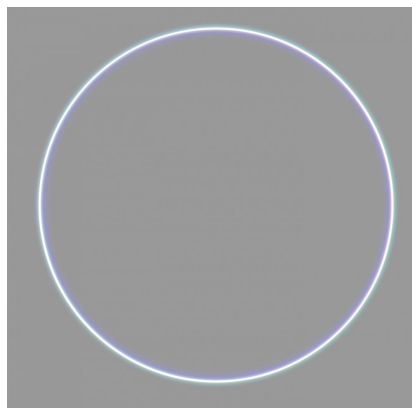

The next step is to align the colours of **Laser Module 1 (LM1)**.

1. Cover the laser aperture of **Laser Module 2 (LM2)** with a small metal plate of some sort – this will allow you to work with the beams from **Laser Module 1 (LM1)** only.
2. Create a full size red circle (static tunnel effect) and check whether the red circles of all R4, R3, R2 and R1 overlay each other all the way around the shape.
If not, follow the diagram above to adjust the beam path accordingly (step 1 on the diagram above).
3. Create a full size magenta circle (static tunnel effect) and check whether the blue circle overlays the red circle all the way around the shape.
If not, follow the diagram above to adjust the beam path accordingly (step 2 on the diagram above).
4. Create a full size yellow circle (static tunnel effect) and check whether the green circle overlays the red circle all the way around the shape.
If not, follow the diagram above to adjust the beam path accordingly (step 3 on the diagram above).
5. Finally create a full size white circle (static tunnel effect).
If the alignment procedure was done successfully you can see all the colours nicely overlaying each other, resulting in even, bright and sharp circle like the one on the picture below.

Finally we have to align the beams of both **LM1** and **LM2** together.

1. Create a full size white circle (static tunnel effect) and check whether the white beam from **LM1** joins the white beam from **LM2** at exactly the same point inside the **Polarisation Beam Splitter Cube (PBSC)**.
If not, use dichroic mount **DF2** to adjust the beam path accordingly.
2. Once both beams are joined together in **PBSC**, check whether the both white circles overlay each other all the way around the shape.
3. If not, use **PBSC** mount to adjust the beam path of **LM1** accordingly.
If the alignment procedure was done successfully you can see both white circles nicely overlaying each other, resulting in even, bright and sharp circle like the one on the picture below.

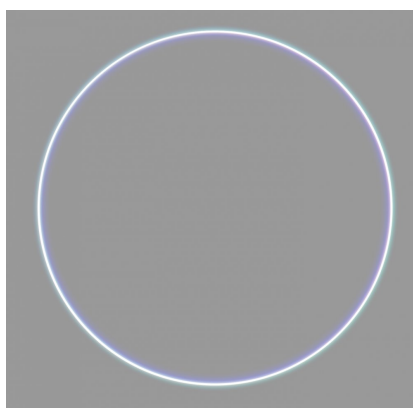

Beam Alignment [CM-6800]

! Although KVANT uses the latest technology to protect all the critical components inside this laser system against Electrostatic Discharge, the semiconductor laser diodes within this system are extremely vulnerable to it. This is due to some of the electronic components being exposed when the top cover is taken off.

If you decide to proceed with the Beam Alignment process yourself, it is absolutely essential that all the common ESD protection rules are strictly followed.

We don't accept any responsibility for Electrostatic Discharge damages to laser diodes caused by customer.

1. Loosen and remove 18 button hex bolts that hold down the top cover.
2. Slowly remove the cover – **detach the GND wire** that is attached to the top cover from the inside of the system! To detach the wire gently pull it out from the connector.
3. Removal of the cover will show the two internal defeatable magnetic interlocks. You must flip over the right side of the magnetic interlock until it touches the other side. You will be able to read the warning label “Interlock Defeated”.



* In the defeated position the label “INTERLOCK DEFEATED” becomes visible as shown in the image.

* Placing the magnetic interlock in the defeated position raises the interlock higher than the edge of the housing which will not allow the cover to be installed.

4. Power up the system as normal.
5. Firstly, it is necessary to align a colour with the longest beam path between the **Laser Module 2 (LM2)** output and the scanning system in a way so it hits the exact centre of the bottom scanning mirror – in this case it is the red laser beam (made of 6 individual red beams R6 – R1).

6. Cover the laser aperture of **Laser Module 1 (LM1)** with a small metal plate of some sort – this will allow you to work with the beams from **Laser Module 2 (LM2)** only.
7. Create a red beam effect (point) and check visually whether the beam hits the exact centre of the bottom scanning mirror.

If not, use dichroic mount **DF1** to adjust the beam path accordingly (showed on the picture below). To adjust the dichroic mount use the two adjustment knobs – each one works for one axis.

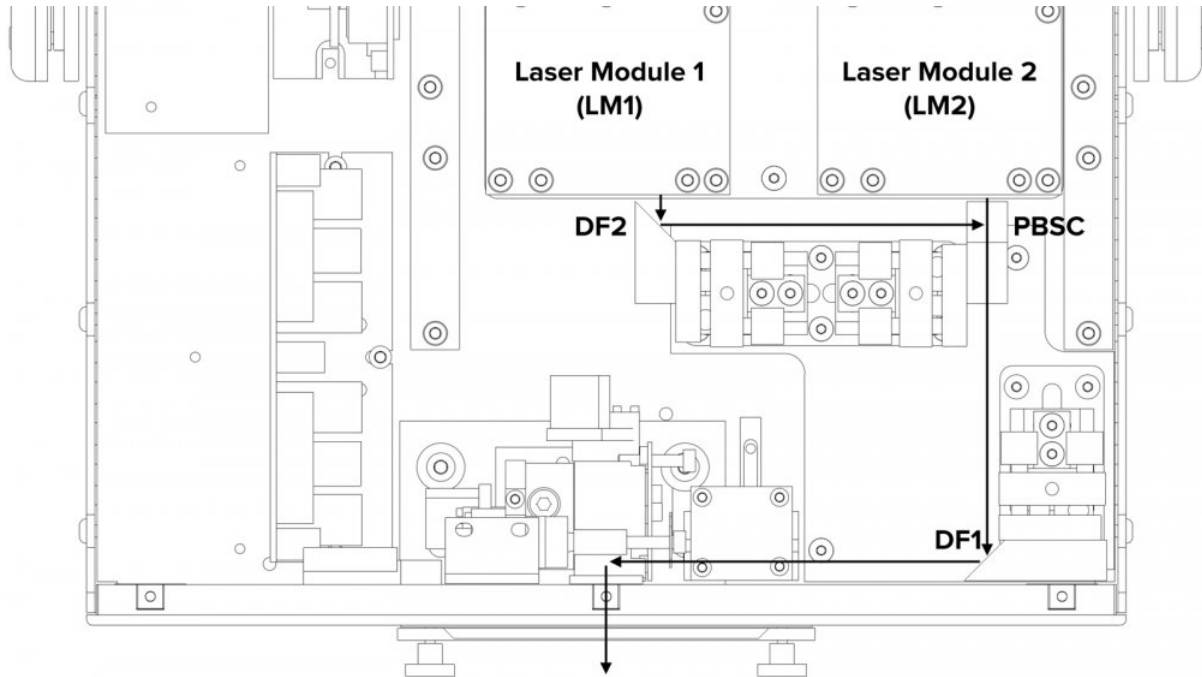

8. Create a full size red circle (static tunnel effect) and check whether the red circles of all R6, R5, R4, R3, R2 and R1 overlay each other all the way around the shape.
- If not, follow the diagram below to adjust the beam path accordingly (step 1 on the diagram below).

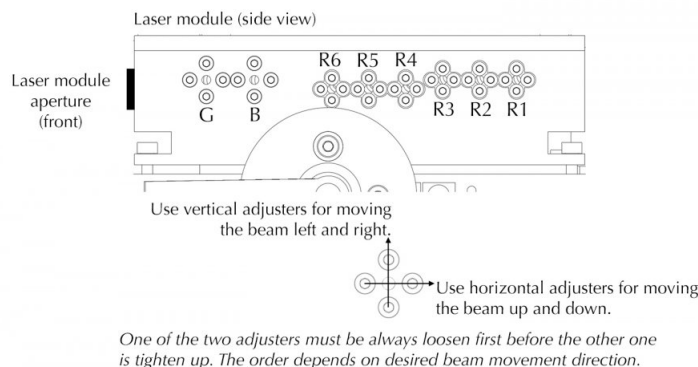

Correct order of the colour (beam) alignment:

- 1) R1 - R6 : align six red beams for unified main red beam
- 2) B : align blue beam to red beam for unified magenta beam
- 3) G : align green beam to magenta beam for unified white beam

9. Create a full size magenta circle (static tunnel effect) and check whether the blue circle overlays the red circle all the way around the shape.
If not, follow the diagram above to adjust the beam path accordingly (step 2 on the diagram above).
10. Create a full size yellow circle (static tunnel effect) and check whether the green circle overlays the red circle all the way around the shape.
If not, follow the diagram above to adjust the beam path accordingly (step 3 on the diagram above).
11. Finally create a full size white circle (static tunnel effect).
If the alignment procedure was done successfully you can see all the colours nicely overlaying each other, resulting in even, bright and sharp circle like the one on the picture below.

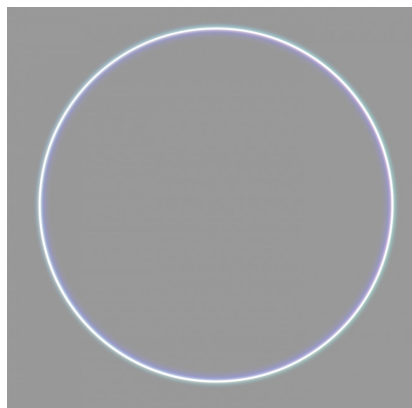

The next step is to align the colours of **Laser Module 1 (LM1)**.

1. Cover the laser aperture of **Laser Module 2 (LM2)** with a small metal plate of some sort – this will allow you to work with the beams from **Laser Module 1 (LM1)** only.
2. Create a full size red circle (static tunnel effect) and check whether the red circles of all R6, R5, R4, R3, R2 and R1 overlay each other all the way around the shape.
If not, follow the diagram above to adjust the beam path accordingly (step 1 on the diagram above).
3. Create a full size magenta circle (static tunnel effect) and check whether the blue circle overlays the red circle all the way around the shape.
If not, follow the diagram above to adjust the beam path accordingly (step 2 on the diagram above).
4. Create a full size yellow circle (static tunnel effect) and check whether the green circle overlays the red circle all the way around the shape.
If not, follow the diagram above to adjust the beam path accordingly (step 3 on the diagram above).
5. Finally create a full size white circle (static tunnel effect).
If the alignment procedure was done successfully you can see all the colours nicely overlaying each other, resulting in even, bright and sharp circle like the one on the picture below.

Finally we have to align the beams of both **LM1** and **LM2** together.

1. Create a full size white circle (static tunnel effect) and check whether the white beam from **LM1** joins the white beam from **LM2** at exactly the same point inside the **Polarisation Beam Splitter Cube (PBSC)**.

If not, use dichroic mount **DF2** to adjust the beam path accordingly.

2. Once both beams are joined together in **PBSC**, check whether the both white circles overlay each other all the way around the shape.

3. If not, use **PBSC** mount to adjust the beam path of **LM1** accordingly.

If the alignment procedure was done successfully you can see both white circles nicely overlaying each other, resulting in even, bright and sharp circle like the one on the picture below.

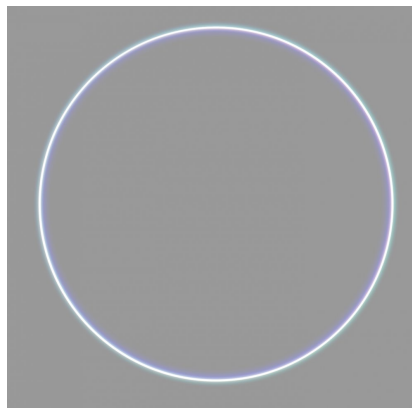

Technical Specifications

All the technical specifications are subject to change without prior notice.

Technical Specification [CM-800]

KVANT Clubmax 800 – full colour, semiconductor diode laser system

Total Optical Power (installed): 0.97W

Total Optical Power (guaranteed): 0.8W*

Maximum Output Power: 1.27W

**Due to Advanced Optical Correction technology used in our laser systems the optical power output of each laser colour within the system may slightly differ from the specification of respective laser module(s) installed. This does not affect the guaranteed total power output.*

| Colour | Wavelength | Output |
|--------|------------|--------|
| Red | 637nm | 170mW |
| Green | 520nm | 100mW |
| Blue | 445nm | 700mW |

NOHD (Nominal Ocular Hazard Distance): 275m

Beam diameter at laser aperture: 3.5mm

Beam divergence: <1mrad (full angle)

Modulation: 0-5V analog, up to 50kHz

Module cooling: TEC

Scanning System:

ScannerMAX 506 Compact, 40kpps@8°, max. scanning angle 60° on both axes

Saturn 1, 90kpps@7°, max. scanning angle 60° on both axes (optional)

Control signal: ILDA, [Ethernet, ArtNet and SD Auto Quick Connect interface is optional)

Power requirements: 100-240V/50Hz (±5%)

Consumption: 250VA/100-240V

Operation temperature: 10-40°C

Ingress protection rating: IP54

Dimensions (WxDxH): 255 × 207 × 168mm

Weight: 6kg

Laser safety features: Keyed interlock, emission delay, magnetic interlock, scan-fail safety, V-RAD 506 mechanical shutter | reaction time <20ms, adjustable aperture masking plate.

This laser system fully complies with the latest EN 60825-1, FDA regulations and TUV Laser Safety.

Technical Specification [CM-1000]

KVANT Clubmax 1000 – full colour, semiconductor diode laser system

Total Optical Power (installed): 1.03W

Total Optical Power (guaranteed): 1W*

Maximum Output Power: 1.08W

**Due to Advanced Optical Correction technology used in our laser systems the optical power output of each laser colour within the system may slightly differ from the specification of respective laser module(s) installed. This does not affect the guaranteed total power output.*

| Colour | Wavelength | Output |
|--------|------------|--------|
| Red | 637nm | 170mW |
| Green | 520nm | 110mW |
| Blue | 445nm | 750mW |

NOHD (Nominal Ocular Hazard Distance): 285m

Beam diameter at laser aperture: 3.5mm

Beam divergence: <1mrad (full angle)

Modulation: 0-5V analog, up to 50kHz

Module cooling: TEC

Scanning System:

ScannerMAX 506 Compact, 40kpps@8°, max. scanning angle 60° on both axes

Saturn 1, 90kpps@7°, max. scanning angle 60° on both axes (optional)

Control signal: ILDA, [Ethernet, ArtNet and SD Auto Quick Connect interface is optional)

Power requirements: 100-240V/50Hz (±5%)

Consumption: 250VA/100-240V

Operation temperature: 10-40°C

Ingress protection rating: IP54

Dimensions (WxDxH): 255 × 207 × 168mm

Weight: 6kg

Laser safety features: Keyed interlock, emission delay, magnetic interlock, scan-fail safety, V-RAD 506 mechanical shutter | reaction time <20ms, adjustable aperture masking plate.

This laser system fully complies with the latest EN 60825-1, FDA regulations and TUV Laser Safety.

Technical Specification [CM-1800]

KVANT Clubmax 1800 – full colour, semiconductor diode laser system

Total Optical Power (installed): 2W

Total Optical Power (guaranteed): 1.8W*

Maximum Output Power: 2.4W

**Due to Advanced Optical Correction technology used in our laser systems the optical power output of each laser colour within the system may slightly differ from the specification of respective laser module(s) installed. This does not affect the guaranteed total power output.*

| Colour | Wavelength | Output |
|--------|------------|--------|
| Red | 637nm | 300mW |
| Green | 520nm | 600mW |
| Blue | 445nm | 1100mW |

NOHD (Nominal Ocular Hazard Distance): 297m

Beam diameter at laser aperture: 3.5mm

Beam divergence: <1mrad (full angle)

Modulation: 0-5V analog, up to 50kHz

Module cooling: TEC

Scanning System:

ScannerMAX 506 Compact, 40kpps@8°, max. scanning angle 60° on both axes

Saturn 1, 90kpps@7°, max. scanning angle 60° on both axes (optional)

Control signal: ILDA, [Ethernet, ArtNet and SD Auto Quick Connect interface is optional)

Power requirements: 100-240V/50Hz (±5%)

Consumption: 250VA/100-240V

Operation temperature: 10-40°C

Ingress protection rating: IP54

Dimensions (WxDxH): 255 × 207 × 168mm

Weight: 6kg

Laser safety features: Keyed interlock, emission delay, magnetic interlock, scan-fail safety, V-RAD 506 mechanical shutter | reaction time <20ms, adjustable aperture masking plate.

This laser system fully complies with the latest EN 60825-1, FDA regulations and TUV Laser Safety.

Technical Specifications [CM-2000]

KVANT Clubmax 2000 – full colour, semiconductor diode laser system

Total Optical Power (installed): 2.07W

Total Optical Power (guaranteed): 2W*

Maximum Output Power: 2.28W

**Due to Advanced Optical Correction technology used in our laser systems the optical power output of each laser colour within the system may slightly differ from the specification of respective laser module(s) installed. This does not affect the guaranteed total power output.*

| Colour | Wavelength | Output |
|--------|------------|--------|
| Red | 637nm | 340mW |
| Green | 520nm | 630mW |
| Blue | 445nm | 1100mW |

NOHD (Nominal Ocular Hazard Distance): 306m

Beam diameter at laser aperture: 3.5mm

Beam divergence: <1mrad (full angle)

Modulation: 0-5V analog, up to 50kHz

Module cooling: TEC

Scanning System:

ScannerMAX 506 Compact, 40kpps@8°, max. scanning angle 60° on both axes

Saturn 1, 90kpps@7°, max. scanning angle 60° on both axes (optional)

Control signal: ILDA, [Ethernet, ArtNet and SD Auto Quick Connect interface is optional)

Power requirements: 100-240V/50Hz (±5%)

Consumption: 250VA/100-240V

Operation temperature: 10-40°C

Ingress protection rating: IP54

Dimensions (WxDxH): 255 × 207 × 168mm

Weight: 6kg

Laser safety features: Keyed interlock, emission delay, magnetic interlock, scan-fail safety, V-RAD 506 mechanical shutter | reaction time <20ms, adjustable aperture masking plate.

This laser system fully complies with the latest EN 60825-1, FDA regulations and TUV Laser Safety.

Technical Specification [CM-3000]

KVANT Clubmax 3000 – full colour, semiconductor diode laser system

Total Optical Power (installed): 3.04W

Total Optical Power (guaranteed): 3W*

Maximum Output Power: 3.5W

**Due to Advanced Optical Correction technology used in our laser systems the optical power output of each laser colour within the system may slightly differ from the specification of respective laser module(s) installed. This does not affect the guaranteed total power output.*

| Colour | Wavelength | Output |
|--------|------------|--------|
| Red | 637nm | 650mW |
| Green | 520nm | 890mW |
| Blue | 445nm | 1500mW |

NOHD (Nominal Ocular Hazard Distance): 350m

Beam diameter at laser aperture: 3.5 × 4mm

Beam divergence: <1mrad (full angle)

Modulation: 0-5V analog, up to 50kHz

Module cooling: TEC

Scanning System:

ScannerMAX 506 Compact, 40kpps@8°, max. scanning angle 60° on both axes

Saturn 1, 90kpps@7°, max. scanning angle 60° on both axes (optional)

Control signal: ILDA, [Ethernet, ArtNet and SD Auto Quick Connect interface is optional)

Power requirements: 100-240V/50Hz (±5%)

Consumption: 350VA/100-240V

Operation temperature: 10-40°C

Ingress protection rating: IP54

Dimensions (WxDxH): 255 × 225 × 168mm

Weight: 8.8kg

Laser safety features: Keyed interlock, emission delay, magnetic interlock, scan-fail safety, V-RAD 506 mechanical shutter | reaction time <20ms, adjustable aperture masking plate.

This laser system fully complies with the latest EN 60825-1, FDA regulations and TUV Laser Safety.

Technical Specification [CM-3400]

KVANT Clubmax 3400 – full colour, semiconductor diode laser system

Total Optical Power (installed): 3.41W

Total Optical Power (guaranteed): 3.4W*

Maximum Output Power: 3.82W

**Due to Advanced Optical Correction technology used in our laser systems the optical power output of each laser colour within the system may slightly differ from the specification of respective laser module(s) installed. This does not affect the guaranteed total power output.*

| Colour | Wavelength | Output |
|--------|------------|--------|
| Red | 637nm | 920mW |
| Green | 520nm | 890mW |
| Blue | 445nm | 1600mW |

NOHD (Nominal Ocular Hazard Distance): 409m

Beam diameter at laser aperture: 3.5 × 4mm

Beam divergence: <1mrad (full angle)

Modulation: 0-5V analog, up to 50kHz

Module cooling: TEC

Scanning System:

ScannerMAX 506 Compact, 40kpps@8°, max. scanning angle 60° on both axes

Saturn 1, 90kpps@7°, max. scanning angle 60° on both axes (optional)

Control signal: ILDA, [Ethernet, ArtNet and SD Auto Quick Connect interface is optional)

Power requirements: 100-240V/50Hz (±5%)

Consumption: 350VA/100-240V

Operation temperature: 10-40°C

Ingress protection rating: IP54

Dimensions (WxDxH): 255 × 225 × 168mm

Weight: 8.8kg

Laser safety features: Keyed interlock, emission delay, magnetic interlock, scan-fail safety, V-RAD 506 mechanical shutter | reaction time <20ms, adjustable aperture masking plate.

This laser system fully complies with the latest EN 60825-1, FDA regulations and TUV Laser Safety.

Technical Specification [CM-6000]

KVANT Clubmax 6000 – full colour, semiconductor diode laser system

Total Optical Power (installed): 6.1W

Total Optical Power (guaranteed): 6W*

Maximum Output Power: 6.6W

**Due to Advanced Optical Correction technology used in our laser systems the optical power output of each laser colour within the system may slightly differ from the specification of respective laser module(s) installed. This does not affect the guaranteed total power output.*

| Colour | Wavelength | Output |
|--------|------------|--------|
| Red | 637nm | 1300mW |
| Green | 520nm | 1800mW |
| Blue | 445nm | 3000mW |

NOHD (Nominal Ocular Hazard Distance): 545m

Beam diameter at laser aperture: 3.5 × 4mm

Beam divergence: <1mrad (full angle)

Modulation: 0-5V analog, up to 50kHz

Module cooling: TEC

Scanning System:

ScannerMAX 506 Compact, 40kpps@8°, max. scanning angle 60° on both axes

Saturn 1, 90kpps@7°, max. scanning angle 60° on both axes (optional)

Control signal: ILDA, [Ethernet, ArtNet and SD Auto Quick Connect interface is optional)

Power requirements: 100-240V/50Hz (±5%)

Consumption: 350VA/100-240V

Operation temperature: 10-40°C

Ingress protection rating: IP54

Dimensions (WxDxH): 255 × 359 × 168mm

Weight: 11.6kg

Laser safety features: Keyed interlock, emission delay, magnetic interlock, scan-fail safety, V-RAD 506 mechanical shutter | reaction time <20ms, adjustable aperture masking plate.

This laser system fully complies with the latest EN 60825-1, FDA regulations and TUV Laser Safety.

Technical Specification [CM-6800]

KVANT Clubmax 6800 – full colour, semiconductor diode laser system

Total Optical Power (installed): 6.8W

Total Optical Power (guaranteed): 6.8W*

Maximum Output Power: 7.3W

**Due to Advanced Optical Correction technology used in our laser systems the optical power output of each laser colour within the system may slightly differ from the specification of respective laser module(s) installed. This does not affect the guaranteed total power output.*

| Colour | Wavelength | Output |
|--------|------------|--------|
| Red | 637nm | 2000mW |
| Green | 520nm | 1800mW |
| Blue | 445nm | 3000mW |

NOHD (Nominal Ocular Hazard Distance): 580m

Beam diameter at laser aperture: 3.5 × 4mm

Beam divergence: <1mrad (full angle)

Modulation: 0-5V analog, up to 50kHz

Module cooling: TEC

Scanning System:

ScannerMAX 506 Compact, 40kpps@8°, max. scanning angle 60° on both axes

Saturn 1, 90kpps@7°, max. scanning angle 60° on both axes (optional)

Control signal: ILDA, [Ethernet, ArtNet and SD Auto Quick Connect interface is optional)

Power requirements: 100-240V/50Hz (±5%)

Consumption: 350VA/100-240V

Operation temperature: 10-40°C

Ingress protection rating: IP54

Dimensions (WxDxH): 255 × 359 × 168mm

Weight: 11.6kg

Laser safety features: Keyed interlock, emission delay, magnetic interlock, scan-fail safety, V-RAD 506 mechanical shutter | reaction time <20ms, adjustable aperture masking plate.

This laser system fully complies with the latest EN 60825-1, FDA regulations and TUV Laser Safety.