

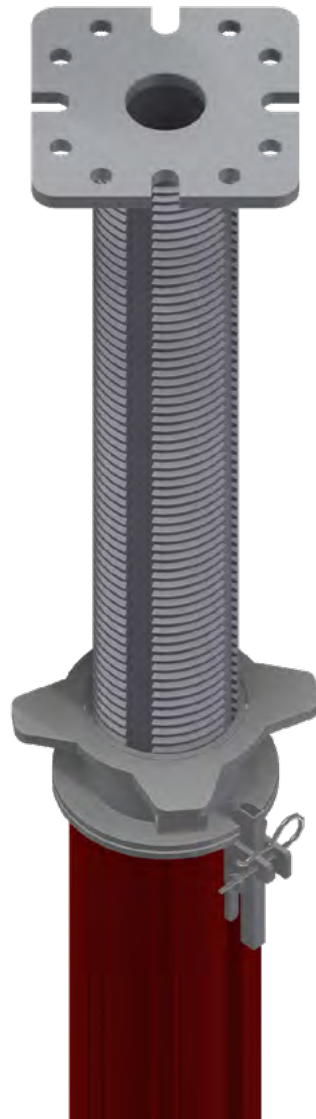

COFFRAGE
& ÉTAIEMENT
LOCATION
VENTE
MONTAGE



EASY UP SHORING

INFORMATIONS

This document is intended for all persons working with the Altrad Coffrage & Etaisement product described and contains information on the installation and use of the system in accordance with the guidelines.

All persons who work with these various products must be fully familiar with the contents of these documents and their safety information.

The use of our products is subject to compliance with the laws and regulations, in their current version, in France. The safety instructions and load specifications must be strictly adhered to.

This document can also be used as generally applicable installation and operating instructions or as part of site-specific installation and operating instructions.

Altrad reserves the right to make changes for the purpose of technical optimisation.

Errors, typographical and printing errors excepted.



Édition : 05 - 2023

Altrad Coffrage & Etaisement
contact@altrad-coffrage.com
www.altrad-coffrage.com

SOMMAIRE

PRESENTATION	4
Caracteristiques.....	4
Components.....	5
Individual prop loading capacity.....	6
Aluminium prop extension (1m ou 1,5m).....	7
Defintion of the capacity loads.....	8
INSTRUCTION ASSEMBLY	12
Prop and tower assembly.....	12
Détail du préréglage rapide en hauteur.....	14
Use of the tower	15
SAFETY & MAINTENANCE	18
Safety rules	18
Maintenance	19

PRESENTATION

Characteristiques



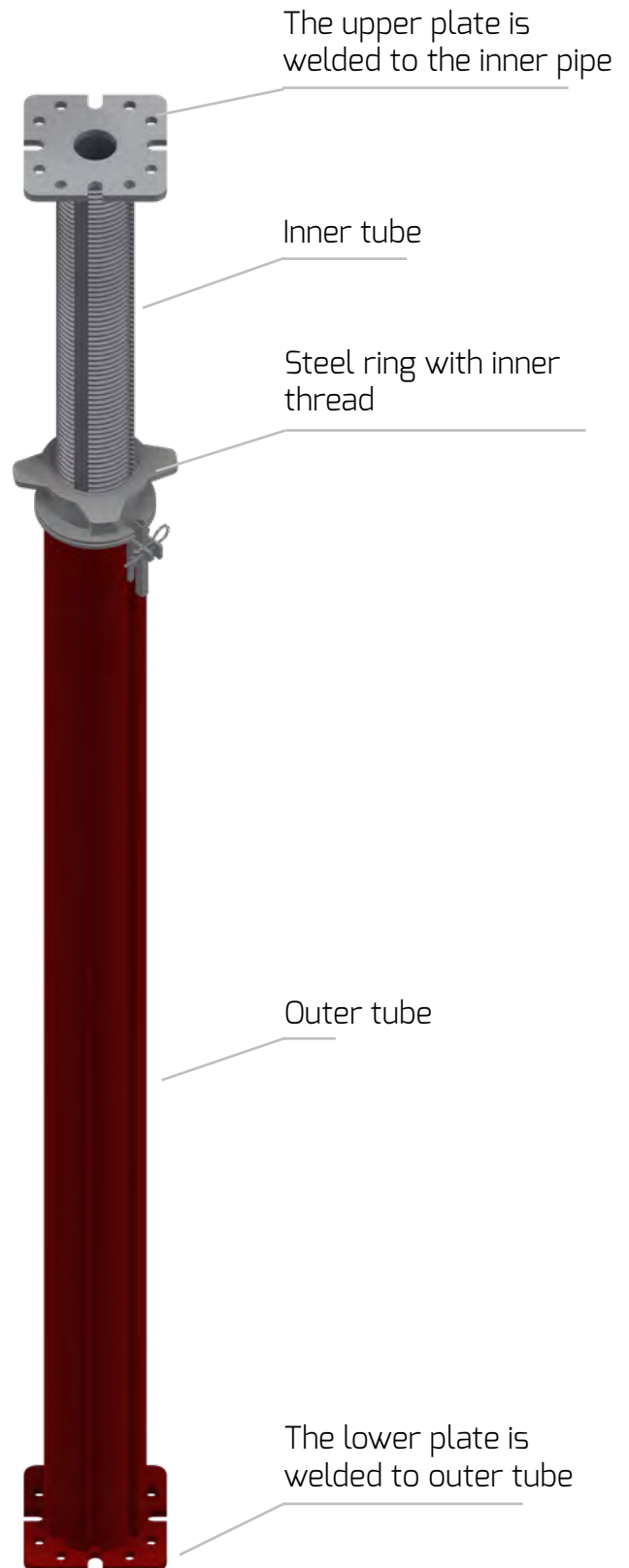
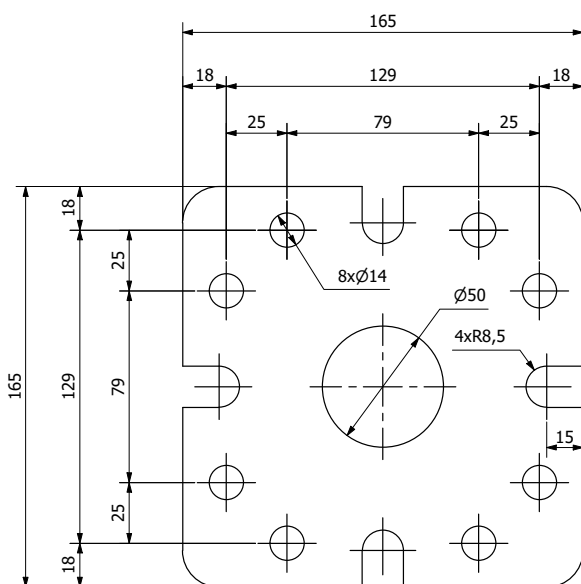

The EASY UP is an **aluminum prop**, robust and light to handle, with high load capacity. This prop can be used in particular for underpinning. This type of shoring allows the implementation of a **heavy shoring**, combining both power and high productivity on your site, at a controlled cost.

- The outer tube is red painted and in aluminium alloy,
- The inner tube is fully threaded,
- The ring nut can be set free from the outer element,
- The plates on the borders are provided with different holes, suitable to be connected with various accessories.

Possibility of superimposing two props with bolts or connecting mesh.

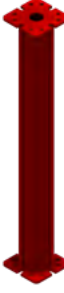

Components

Ref. prod.	Weight (Kg)	Caracteristiques	Item
STRUCTURE COMPONENTS			
137-0300 137-0400 137-0500 137-0600	18.4 24 28 33	PROP J300 (178CM/300CM) PROP J400 (278CM/400CM) PROP J500 (378CM/500CM) PROP J600 (505CM/625CM)	
137-2100 137-2150	5.6 6	PROP EXTENSION 100CM PROP EXTENSION 150CM	
STABILITY COMPONENTS			
137-1075 137-1150	9 14	STABILITY FRAME 75CM STABILITY FRAME 150CM	
137-0900	10.5	TRIPOD FOR ALU PROP	
ACCESSORIES COMPONENTS			
137-0902	2	ALU PROP FORK	
521-0750	11.50	SFM PROP BASKET 50 U GV MES Basics dimensions : 155 x 90 cm Height dimensions : 85 cm Storage capacity : 50 props Ø57	

Individual prop loading capacity

EASY UP	Easy Up 300		Easy Up 400		Easy Up 500		Easy Up 625	
Weight (kg)	18,4		24		28		36	
Extension (m)	<i>Ref. 137-0300</i>		<i>Ref. 137-0400</i>		<i>Ref. 137-0500</i>		<i>Ref. 137-0600</i>	
	Load table in KN		Load table in KN		Load table in KN		Load table in KN	
	Inner tubes toward the top	Inner tubes toward the bottom	Inner tubes toward the top	Inner tubes toward the bottom	Inner tubes toward the top	Inner tubes toward the bottom	Inner tubes toward the top	Inner tubes toward the bottom
1,78	75	88,2						
1,8	73,5	85,9						
1,9	71,9	83,6						
2	70,4	81,3						
2,1	68,9	80,2						
2,2	67,4	79,2						
2,3	65,8	76,3						
2,4	64,3	72,6						
2,5	62,8	70,2						
2,6	61,2	68,5						
2,7	59,7	64,8						
2,8	58,2	62,5	77,2	85,3				
2,9	56,6	59,8	73,8	81,2				
3	55	58,2	70,3	78,2				
3,1			66,9	73,2				
3,2			63,5	70,1				
3,3			60	64,5				
3,4			56,6	61,1				
3,5			53,2	57,5				
3,6			49,7	55,6				
3,7			46,3	48,8				
3,8			42,9	45,8	44,5	49,2		
3,9			39,4	41,9	43,5	47,1		
4			36	38,5	42,6	46,2		
4,1					41,6	44,1		
4,2					40,7	43,3		
4,3					39,7	42,3		
4,4					38,7	41,2		
4,5					37,8	40,1		
4,6					36,8	39,4		
4,7					35,9	37,5		
4,8					34,9	38		
4,9					33,9	36,5		
5					32,9	35		
5,05							41	43,2
5,15							40	42
5,25							38,1	40,2
5,35							36,3	38,4
5,45							34,4	36,6
5,55							32,5	34,5
5,65							30,7	32,7
5,75							29,1	31
5,85							27,5	29
5,95							26	28,1
6,05							24,8	26,6
6,15							23,6	25,6
6,25							22,4	24,4

Aluminium prop extension (1m ou 1,5m)

Extension (cm)	Easy Up 3m + 1m	Easy Up 3m + 1.5m	Easy Up 4m + 1m	Easy Up 4m + 1.5m	Easy Up 5m + 1m	Easy Up 5m + 1.5m	Easy Up 6m + 1m
	Load table (KN)	Load table (KN)	Load table (KN)	Load table (KN)	Load table (KN)	Load table (KN)	Load table (KN)
270	75.0						
280	73.5						
290	72.5						
300	69.0						
310	65.0						
320	62.0						
330	59.0	44.5					
340	55.0	43.5					
350	52.0	42.6					
360	48.0	41.6					
370	45.0	40.7					
380	41.5	39.7	43.5				
390	38.5	38.7	43.0				
400	35.0	37.0	41.6				
410		35.6	40.5				
420		34.0	39.5				
430		32.6	38.7	40.0			
440		31.2	37.5	38.7			
450		30.0	36.0	37.9			
460			35.0	37.0			
470			34.0	36.5			
480			33.0	35.5	42.0		
490			32.0	34.0	40.0		
500			31.0	33.0	38.8		
510				31.5	37.2		
520				30.0	35.4		
530				29.0	34.0	35.0	
540				27.5	32.7	33.5	
550				26.0	31.0	32.0	
560					29.5	31.0	
570					28.0	30.0	
580					26.8	28.5	
590					25.6	27.0	
600					24.0	26.0	
610						25.0	20.5
620						24.0	20.5
630						23.0	20.5
640						22.0	20.5
650						21.0	20.5
655							20.5
665							20
675							19
685							18.1
695							17.2
705							16.3
715							15.4
725							14.5

SHORING

Aluminium shoring · EASY UP

Defintion of the capacity loads



The bearing capacities are calculated without the presence of the lateral thrust caused by the wind ; in windy conditions the lateral thrust reduces the load by 10%.

TOWERS WITH A SERIE OF LATTICE GIRDERS H=3 ML - EASY UP PROP MAXIMUM EXTENSION 3M

Tower H	Max. bearing capacity
1.78 ml	112.5 kn
1.80 ml	110.3 kn
1.90 ml	107.9 kn
2.0 ml	105.6 kn
2.10 ml	103.4 kn
2.20 ml	101.1 kn
2.30 ml	98.7 kn
2.40 ml	96.5 kn
2.50 ml	94.2 kn
2.60 ml	91.8 kn
2.70 ml	89.6 kn
2.80 ml	97.3 kn
2.90 ml	84.9 kn
3.00 ml	82.5 kn

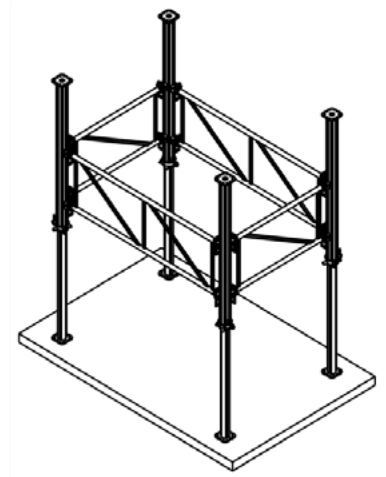
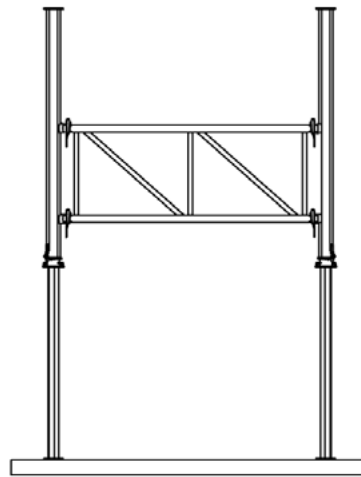

N.B.: Maximum bearing capacity for towers with the following dimensions : 2300 x 1500mm and 1500 x 1500mm.

TOWERS WITH A SERIE OF LATTICE GIRDERS H=4ML - EASY UP PROP MAXIMUM EXTENSION 4M

Tower H	Max. bearing capacity
2.80 ml	115.8 kn
2.90 ml	110.7 kn
3.00 ml	105.5 kn
3.10 ml	100.4 kn
3.20 ml	95.3 kn
3.30 ml	90.0 kn
3.40 ml	84.9 kn
3.50 ml	79.8 kn
3.60 ml	74.6 kn
3.70 ml	69.5 kn
3.80 ml	64.4 kn
3.90 ml	59.1 kn
4.00 ml	54.0 kn

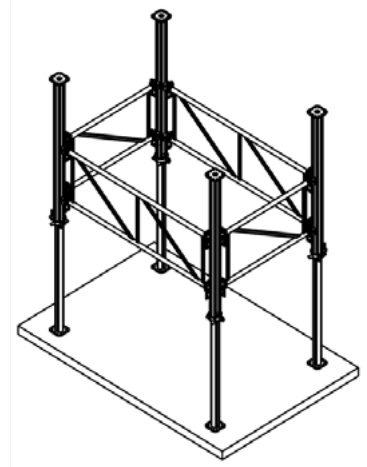
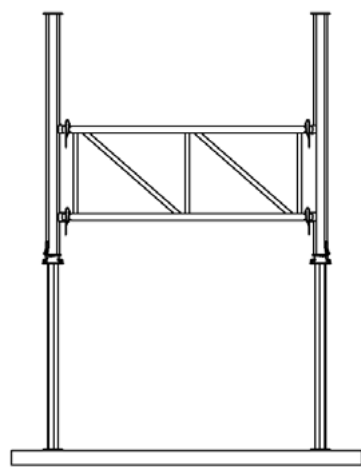

N.B.: Maximum bearing capacity for towers with the following dimensions : 2300 x 1500mm and 1500 x 1500mm.

TOWERS WITH TWO SERIES OF LATTICE GIRDERS H = 4ML - EASY UP PROP MAXIMUM EXTENSION 4M

Tower H	Max/ bearing capacity
2.80 ml	123.5 kn
2.90 ml	118.1 kn
3.00 ml	112.5 kn
3.10 ml	107.0 kn
3.20 ml	101.6 kn
3.30 ml	96.0 kn
3.40 ml	90.6 kn
3.50 ml	85.1 kn
3.60 ml	79.5 kn
3.70 ml	74.1 kn
3.80 ml	68.6 kn
3.90 ml	63.0 kn
4.00 ml	57.6 kn

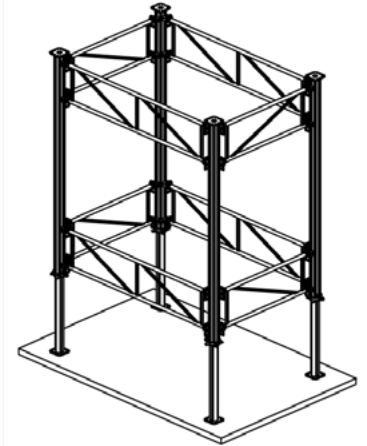
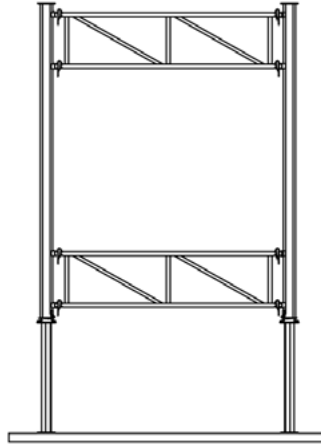

N.B.: Maximum bearing capacity for towers with the following dimensions : 2300 x 1500mm and 1500 x 1500mm.

TOWERS WITH TWO SERIES OF LATTICE GIRDERS H = 5ML - EASY UP PROP MAXIMUM EXTENSION 5M

Tower H	Max. bearing capacity
3.80 ml	71.2 kn
3.90 ml	69.6 kn
4.00 ml	68.2 kn
4.10 ml	66.6 kn
4.20 ml	65.1 kn
4.30 ml	63.5 kn
4.40 ml	61.9 kn
4.50 ml	60.5 kn
4.60 ml	58.9 kn
4.70 ml	57.4 kn
4.80 ml	55.8 kn
4.90 ml	54.2 kn
5.00 ml	52.6 kn

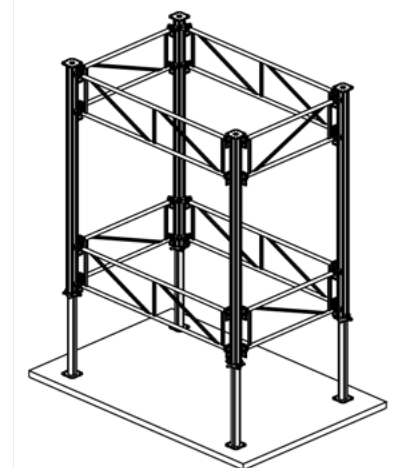
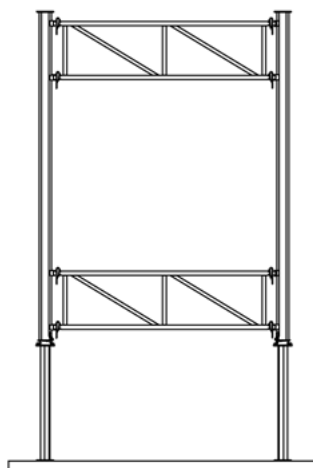

N.B.: Maximum bearing capacity for towers with the following dimensions : 2300 x 1500mm and 1500 x 1500mm.

TOWER WITH TREE SETS OF LATTICE GIRDERS - UPRIGHTS MADE WITH OPPOSED EASY UP PROPS

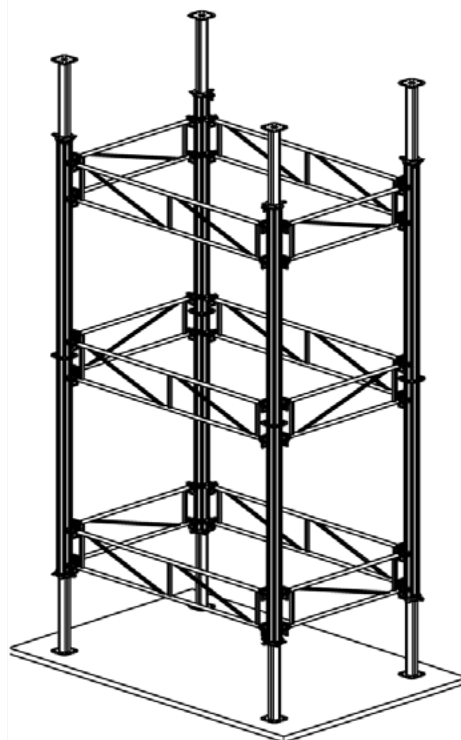
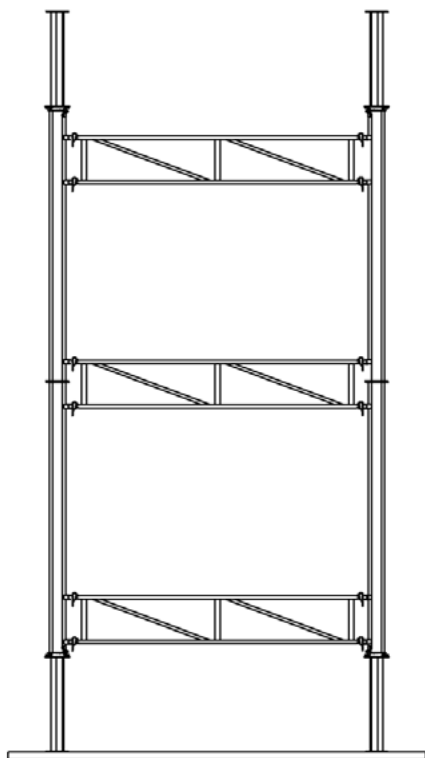

Tower H	Max. bearing capacity end post
3.56 m	120.0 kn
3.60 m	117.6 kn
3.80 m	115.0 kn
4.00 m	112.6 kn
4.20 m	110.2 kn
4.40 m	107.8 kn
4.60 m	105.3 kn
4.80 m	102.9 kn
5.00 m	100.5 kn
5.20 m	97.9 kn
5.40 m	95.5 kn
5.60 m	93.1 kn
5.80 m	90.6 kn
6.00 m	88.0 kn

Tower H	Max. bearing capacity end post
5.60 m	123.5 kn
5.80 m	118.1 kn
6.00 m	112.5 kn
6.20 m	107.0 kn
6.40 m	101.6 kn
6.60 m	96.0 kn
6.80 m	90.6 kn
7.00 m	85.1 kn
7.20 m	79.5 kn
7.40 m	74.1 kn
7.60 m	68.6 kn
7.80 m	63.0 kn
8.00 m	57.6 kn

Tower H	Max. bearing capacity end post
7.60 m	71.2 kn
7.80 m	69.6 kn
8.00 m	68.2 kn
8.20 m	66.6 kn
8.40 m	65.1 kn
8.60 m	63.5 kn
8.80 m	61.9 kn
9.00 m	60.5 kn
9.20 m	58.9 kn
9.40 m	57.4 kn
9.60 m	55.8 kn
9.80 m	54.2 kn
10.00 m	52.6 kn



INSTRUCTION ASSEMBLY

Prop and tower assembly

General Guidelines

Before erecting the towers the bearing surface must be verified as capable of supporting the loads transmitted to the tower bearing points.

The following conditions must be verified to determine the suitability of the bearing surface :

■ Flatness of the surface :

the surface must be flat and free from any irregularities such as indentations, etc.... If necessary, load distribution planking having a minimum thickness of 40 mm and a minimum width of 400 mm should be placed on the bearing surface to guarantee suitable planarity.

■ Resistance of the bearing surface suitable for the transmitted loads :

the pressure at the base is distributed to the surface of the bearing plate and therefore creates a concentrated load condition. A concrete slab with a suitable thickness to distribute the load to the ground below without causing any sagging is considered suitable for distribution of the load (min.15-20 cm). For loads that are not particularly heavy, a bearing surface could also be made on a suitably compacted and stabilised scree surface (the load per foot must be compatible with the ground bearing capacity).

■ Uniformity of rigidity and strength of the bearing surface :

the bearing surface must not comprise elements with different rigidity (for example, pebbles).

■ No possibility of differential or uniform sagging of the bearing surface :

the bearing surface must not be subjected to notable yielding, caused by the applied loads, that could affect the capacity of the towers or the load distribution.



The quality of the bearing directly influences the capacity of the towers, the greater the applied load the greater the care required to ensure rigid and stable bearing conditions.

The towers can be stabilised, in the following phases, in several ways :

1. By connecting the tower to the ground at various heights as it grows upwards with ropes or tube and coupler, in an adequate number of directions to guarantee its stability.

2. By connecting the towers to pre-existing structures that are strong enough to stabilize the towers.

3. By connecting several towers together as they grow upwards simultaneously to guarantee :

- During the construction of the towers extension in both directions simultaneously with the upward extension
- Connection between towers with tube and coupler or with longitudinal and diagonal braces to

create triangular shapes that are always extended in both directions on the plane. Connecting the towers with horizontal braces without using diagonal elements is totally ineffective.



If the towers are erected on a slab or floor the user must verify the static suitability of the floor for the loads applied by the load-holding towers.

The following controls must be verified before a load can be applied to the towers :

- Ensure that all the main and secondary elements have been positioned for a correct erection of the towers
- Ensure that all the bracing has been added to guarantee stability of the towers
- Ensure that the bearing surface is uniformly resistant and capable of supporting the loads transmitted by the towers without deforming.
- Ensure the verticality of all the towers in all directions and the horizontality of the lattices.
- Ensure that all diagrams or integrating instructions provided by the manufacturer or designer have been observed in full.

The load-holding towers are used predominantly to support the load exerted by a concrete slab pour. The instructions below refer to this type of use.

Use of the holding towers to support loads other than the application of a uniform concrete pour is not considered in this manual and must be verified beforehand.

When pouring the concrete take care to :

1. Avoid eccentric loads applied only to some end posts.
2. Avoid accumulation of concrete in some points of the slab, the accumulation could affect the strength of the concrete but also the stability of the towers.
3. Proceed with uniform thin layers and respecting any instructions concerning pour times.
4. Distribute the concrete in such a way that the load configuration is always stable.



The composition of several towers to create scaffold decks must be resistant to actions arriving from all directions. To stabilise the composition of several towers they must be connected to each other with longitudinal and diagonal braces or with tube and coupler in order to assemble suitable bracing.

Détail du préréglage rapide en hauteur

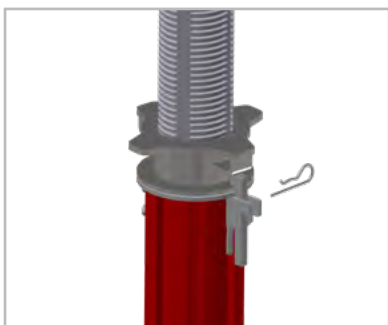

1 Extraction of the folding pin reassuring securing the bolt.

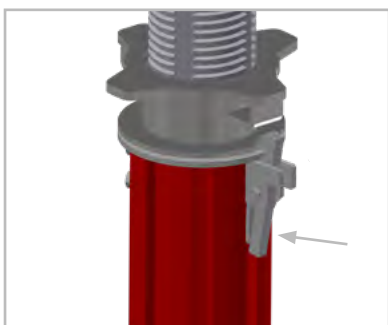

2 Pressure on the spring bolt for liberation of the nut.

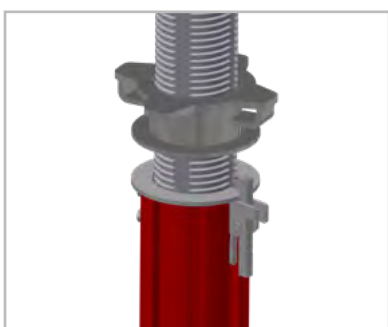

3 Extraction of the wing and unscrewing fall for fast preregulation of the nut

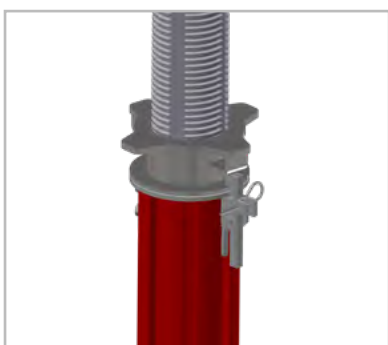

4 To put back hand in contact the nut on the wing ,the bolt automatically closes to replace the folding pin in its initial position to reassure secure the locking the girder is ready to use with a fine regulation.

Use of the tower

EXTENDING PROP

Before using the props, it is advisable to prepare them by extending them to the required size by carrying out the following simple actions :

- Place the prop in a horizontal position at a height from the ground that is suitable for the person carrying out the operation.
- Press the lever positioned under the ring lock to disengage it from the shaft.
- Slide out the internal prop tube to the desired size.
- Rotate the ring until it makes contact with the shaft and locks onto the lever.
- Straighten the prop and use as required.

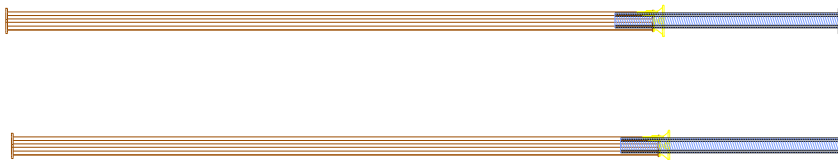

- 1** Begin by laying the EASY UP Props on the ground.

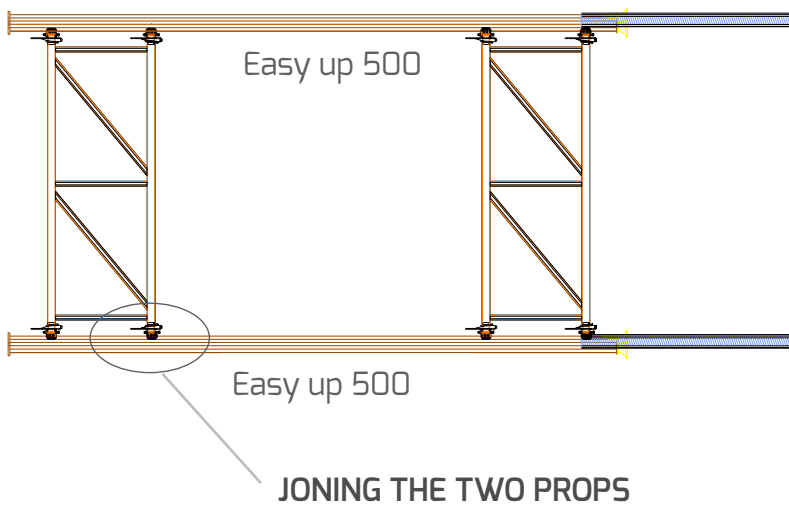

- 2** Join the first two props laid on the ground with the lattice girders

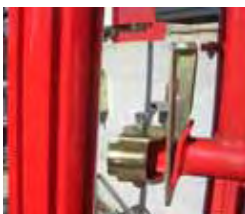

1 - Tightening by keys to be struck. No specific equipment a simple hammer or coffering is enough



2 - Mettre en contact les rainures du fût de l'étais avec les mâchoires à ressort du cadre treillis.



3 - Frapper sur la clavette de serrage par l'usage modéré d'un marteau de coffreur.

SHORING

Aluminium shoring · EASY UP

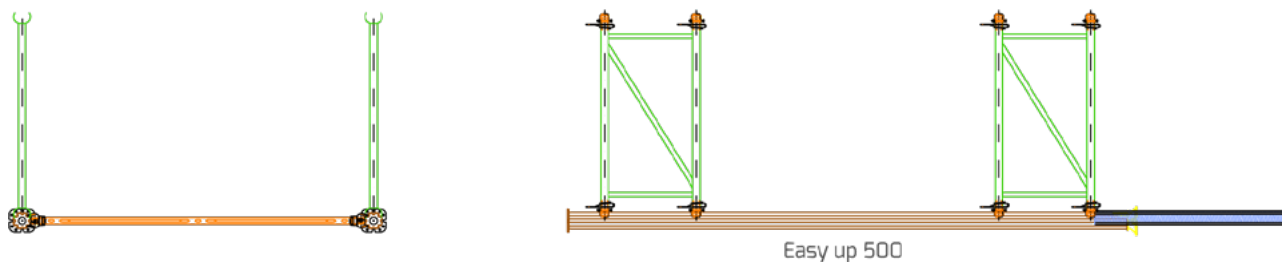

- 3** Installation of the lateral lattice girders
Now install the side lattice girders in the base configuration.

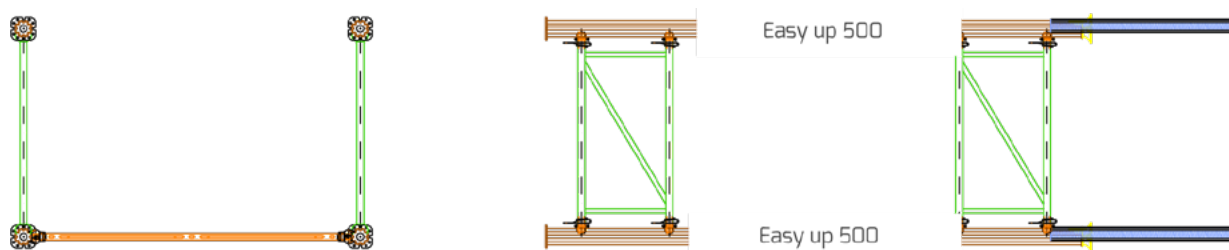

- 4** The second pair of easy props
Position the props on the lattice girder heads and fasten them.

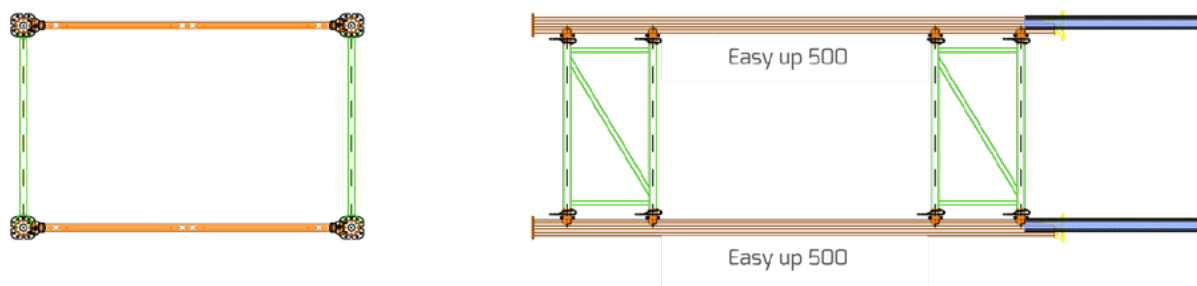

- 5** Forming the tower
Now install the lattice girders to complete the rectangular shape of the tower.

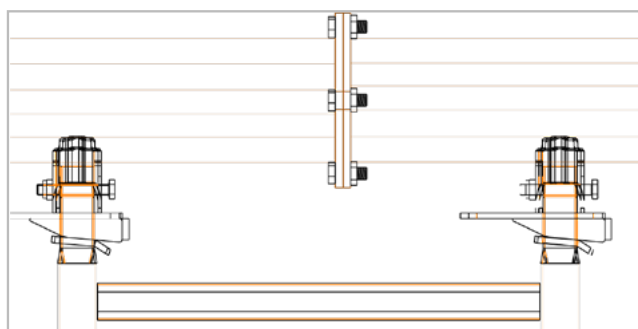

6

Joining several props

To reach the desired heights join two or more props lengthwise using bolts and nuts M12x40.

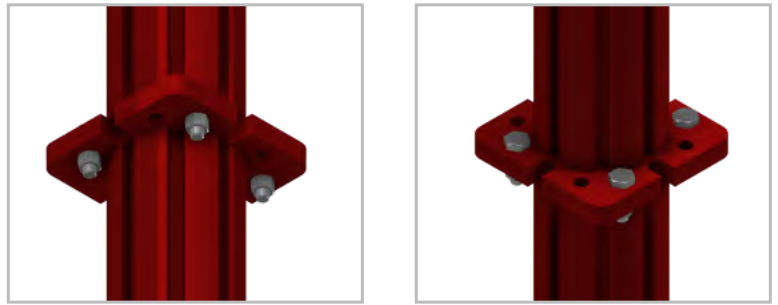

7

Lifting the tower to an upright position

At this point the tower has been constructed. Now attach it to the crane with ropes or chains and lift to an upright position and place in the required position.

8

Others towers

To realize the other necessary towers, it is enough to repeat the accomplished shares up to here, until the realization of all the towers necessary for the work.

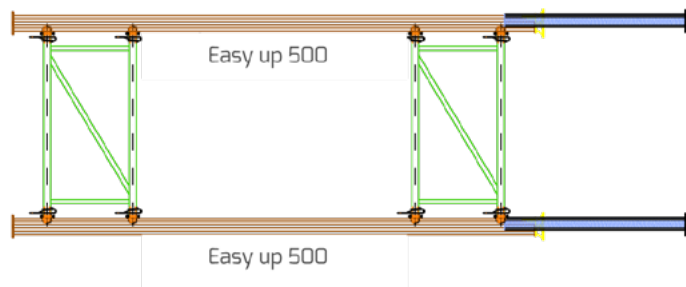

9

Joining the towers

Depending on the complexity of the works, in some cases it may be necessary to connect the load-holding towers using lattice girders.

SAFETY & MAINTENANCE

Safety rules

Do not use accessories that show obvious signs of damage.

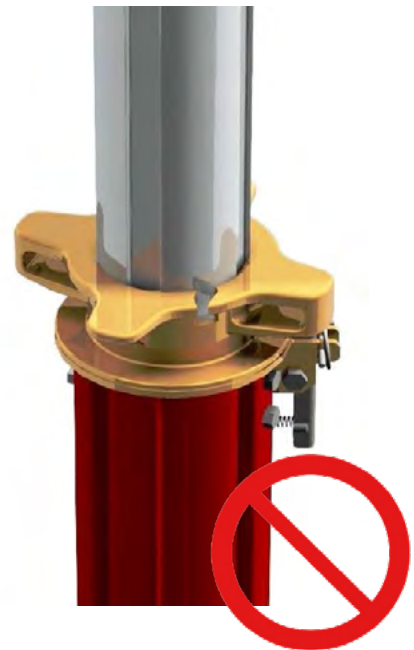

Avoid uneven and dangerous surfaces.

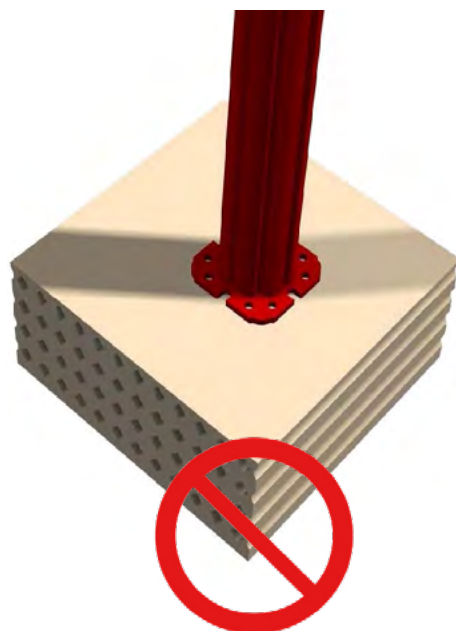
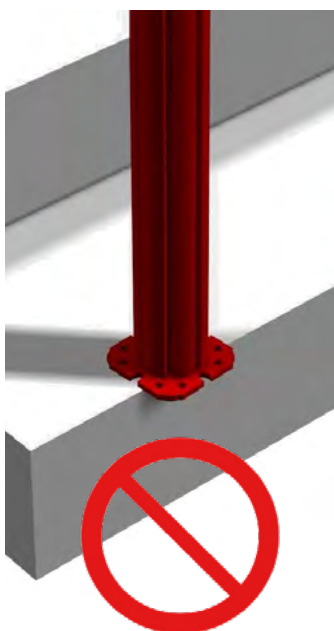

Maintenance

Handle props with appropriate handling equipment and systems.

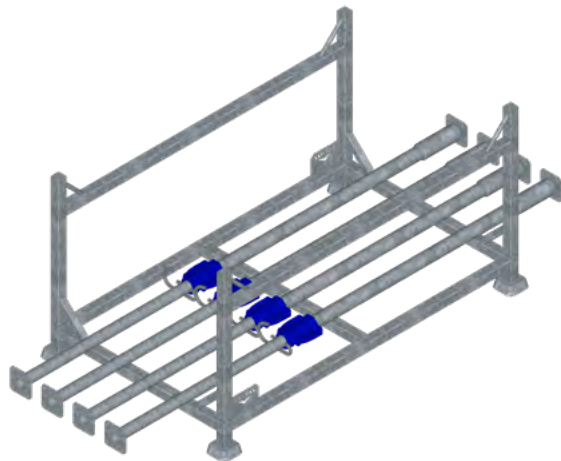

SFM PROP BASKET

Weight : 53 kg

Ref. : 138-8010

- Galvanized steel
- Top lift system
- **SWT per basket** : 1,5T evenly distributed on the side rail.
- **Dimensions** : base 155 x 90 cm - height 85 cm
- **Storage capacity** : 50 props Ø57

See the Storage
Baskets
documentation





+40 countries
where we have already worked



HEAD OFFICE & EXPORT

Parc d'activités de la Verdrière II
13880 Velaux - FRANCE
+33 (0)4 42 10 84 15
export@altrad-coffrage.com



www.altrad-coffrage.com