

JOURNAL
of the
AMERICAN VIOLA SOCIETY

Section of
THE INTERNATIONAL VIOLA SOCIETY
Association for the Promotion of Viola Performance and Research

Vol. 14 No. 3

1998



FEATURES

- 15 Rochberg's Sonata for Viola and Piano
*Interview of Joseph de Pasquale and
discussion of Sonata*
By LeeAnn Morgan
- 31 William Primrose: A Life Recorded
By Tully Potter
- 39 New PIVA and Primrose Rooms at BYU
- 49 Music Insert: *Six Bagatelles for
Solo Viola*
By Henry Lazarof

American Viola Society

OFFICERS

Peter Slowik
President
School of Music
Northwestern University
Evanston, IL 60201
(847) 491-3826
pjs279@nwu.edu

William Preucil
Vice President
317 Windsor Dr.
Iowa City, IA 52245

Catherine Forbes
Secretary
1128 Woodland Dr.
Arlington, TX 76012

Ellen Rose
Treasurer
2807 Lawtherwood Pl.
Dallas, TX 75214

Thomas Tatton
Past President
7511 Parkwoods Dr.
Stockton, CA 95207

BOARD

Victoria Chiang
Donna Lively Clark
Paul Coletti
Ralph Fielding
Pamela Goldsmith
Lisa Hirschmugl
John Graham
Jerzy Kosmala
Jeffrey Irvine
Karen Ritscher
Christine Rutledge
Pamela Ryan
Juliet White-Smith

EDITOR, JAVS

David Dalton
Brigham Young University
Provo, UT 84602

PAST PRESIDENTS

Myron Rosenblum (1971–1981)
Maurice W. Riley (1981–1986)
David Dalton (1986–1990)
Alan de Veritch (1990–1994)

HONORARY PRESIDENT

William Primrose (deceased)



The *Journal of the American Viola Society* is a peer-reviewed publication of that organization and is produced at
Brigham Young University, ©1985, ISSN 0898-5987.
JAVS welcomes letters and articles from its readers.

Editorial Office:
School of Music
Harris Fine Arts Center
Brigham Young University
Provo, UT 84602
(801) 378-4953
Fax: (801) 378-5973
david_dalton@byu.edu

Editor: David Dalton
Associate Editor: David Day
Assistant Editor for Viola Pedagogy: Jeffrey Irvine
Assistant Editor for Interviews: Thomas Tatton
Production: Ben Dunford & Nancy Wakefield
Advertising: Jeanette Anderson

Advertising Office:
Crandall House West (CRWH)
Brigham Young University
Provo, UT 84602
(801) 378-4455
humanities-pubcenter@email.byu.edu

JAVS appears three times yearly. Deadlines for copy and artwork are 1 March, 1 July, and 1 November; submissions should be sent to the editorial office.

Ad rates: \$125 full page, \$80 half page, \$45 one-fourth page.

Classifieds: \$30 for 30 words including address; \$50 for 31–60 words.

Advertisers will be billed after the ad has appeared.

Payment to the American Viola Society should be remitted to the advertising office.

Margin graphics courtesy of *Basic String Repairs*, by Arthur Burgan (London: Oxford University Press, 1974) and *The Origins of Bowing*, by Werner Bachmann (London: Oxford University Press, 1969).

TABLE OF CONTENTS

Winter 1998, Volume 14 Number 3

From the President	5
Announcements	7
Rochberg's Sonata for Viola and Piano	15
<i>LeeAnn Morgan, freelance violist and teacher, interviews Joseph de Pasquale, discusses Rochberg's aesthetics, and analyzes the sonata.</i>	
William Primrose: A Life Recorded	31
<i>Author and music critic, Tully Potter highlights William Primrose's recordings at the XXVI International Viola Congress at Glasgow.</i>	
New PIVA and Primrose Rooms at BYU	39
<i>Preview of the Primrose International Viola Archives</i>	
Music Insert: Henry Lazarof, <i>Six Bagatelles for Solo Viola</i>	49
Of Interest	57
About Violists	59
AVS Chapters	67
New Works	69
Viola Connotations	70
Recordings	71
Competitions	75
American Viola Society Directory	81

Bein & Fushi *inc.*

Fine stringed instruments and bows
Expert appraisals

Member: Appraisers Association of America

Hours 10 - 5:30 Tuesday - Saturday
410 South Michigan Avenue
Chicago, Illinois 60605

Phone (312) 663-0150

FAX (312) 663-0873

E-mail mail@beinfushi.com

FROM THE PRESIDENT

In the next year members of AVS will have two significant opportunities to build a legacy to aid future generations of violists: the campaign to reach an AVS membership of 2000 by the year 2000, and a fundraising campaign to support construction of rooms at the Primrose International Viola Archive in Provo. I'd like to discuss the importance of these two worthwhile efforts and urge each of us to participate.

It may seem like a stretch to assert that the "2000 for 2000" campaign will have historical significance. Consider, however, that AVS has maintained its excellent publications, congresses, and scholarship competition with a membership that in recent years has hovered near 1000. A significant increase in membership would free discretionary funds in the AVS budget. These funds could be used for a variety of useful projects: commissioning new works for the viola, publication of "lost gems" from the repertoire, additional support of scholarship competitions, to name a few. To me, these activities should be part of the essential mission of AVS—to help support and shape the future of the instrument in addition to serving the needs of today's players and teachers.

The AVS Board is counting on each of you to help the "2000 for 2000" effort in two ways:

- 1) Bring a new member to AVS in the coming year—a friend, standpartner, or student. If we each bring a new member to AVS we will easily reach our goal.
- 2) Assist Bill Preucil and his committee on AVS chapters as they work to achieve their goal of providing each AVS member with an accessible local chapter. At the end of their first six months, two of the newest AVS local chapters (Chicago and Los Angeles) were comprised of 80% new AVS members. Active local chapters will help retain these members as a new base for AVS growth. If you live in an area not served by a local AVS chapter (New England, Florida, Minnesota, Texas, for instance) consider contacting Bill Preucil to receive AVS financial and logistical assistance in planning a chapter-forming meeting. Starting a chapter needn't carry a long-term commitment for any one individual, as officers are elected from violists that attend the first chapter event.

If your area is already served by an active local chapter, think of energetic, well-connected viola friends in different parts of the country who could develop local chapters. Contact them yourself and encourage them to start a chapter, refer their name to Bill Preucil, or better yet, do both!

A more tangible way we can build a legacy for violists of the next millennium is to support a construction project about to take place at the Primrose International Viola Archive. In this and future issues of the Journal you will read of this visionary project to bring together the resources of PIVA in easily accessible library stacks and an inspiring and technologically up-to-date reading room. Last summer's AVS board meetings in Provo gave me my first opportunity to look through the PIVA collection. I wish I had had a month to browse and study, instead of just an afternoon! The construction project will bring all of the archive's collection together and allow for easier access to recorded performances. Please consider supporting this worthwhile project with a contribution.

Thanks for doing your part for the future, and for all of the beautiful music you are creating in alto-clef land in the present! May the new year be one of growth for you as well as for our organization!



Peter Slowik

Peter Slowik



ANNOUNCEMENTS

1998 International Viola Society Election Results

(three-year term until 2001)

President:	David Dalton (America)
Vice-President:	Emile Cantor-Samama (Germany)
Secretary:	Ronald Schmidt (Germany)
Treasurer:	Ann Frederking (Canada)
Executive Secretary:	Dwight Pounds (America)
Ass't Executive Secretary:	Uta Lenkewitz-von Zahn (Germany)

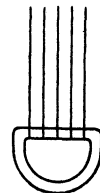

The long labor in behalf of the IVS on the part of Pres. Günter Ojsteršek and other members of the IVS presidency, Wolfgang Sawodny, Heinz Berck, and Emile Cantor-Samama, is recognized and appreciated. Congratulations and well wishes are offered the new IVS presidency. Appreciation is also expressed to AVS past-president Thomas Tatton, and others, who worked toward an increased international representation in the IVS presidency.

JAVS Editor Resigns

David Dalton, longtime editor of the *Journal of the American Viola Society*, announced his resignation no later than *JAVS* Vol. 15 No. 1, 1999, at the AVS Board Meeting in July. A search is now underway for his replacement.

JAVS editor is a paid position.

JAVS is published three times yearly.

Editorial subcommittees to assist the *JAVS* editor.

Candidates must submit applications before 15 March 1999.

Send notification of interest and request for job description to

Prof. Peter Slowik, AVS President
 School of Music, Northwestern University
 Evanston, IL 60201
 Tel. (847) 480-4670
 e-mail: pjs279@nwu.edu

ANNOUNCEMENT

Khan Management now offers free employment information on its website, www.khanmusic.com. Currently, the site lists various orchestral vacancies throughout the United States and Canada. If you would like to place a free ad on their website, please contact Khan Management at khan@khanmusic.com.

THE COMPLETE BLUES

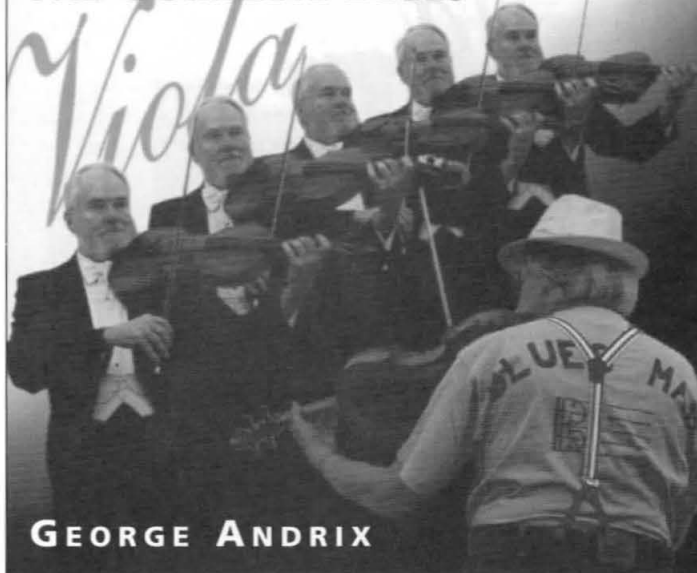

GEORGE ANDRIX

A UNIQUE LISTENING EXPERIENCE

Blues and Blues derived music ranging from the big band sound to solo viola. All played on the viola (with vocals and drums) by George Andrix.

CD available at:
The Gramophone, 10180 - 101 Street
Edmonton, Alberta, Canada, T5J 3S4
Telephone: 403-428-2356
Toll-free in Canada: 1-800-231-7594
Email: gphone@planet.eon.net

MOES & MOES

VIOLIN MAKERS



New Instruments
made by
Peter & Wendela Moes

Sound Adjustments
(by appointment)
Instrument Repair

134 Brooksdale Road
Stamford, CT 06903

Phone (203) 461-9560

FAX (203) 461-9562

Be sure to check out our web site!
e-mail: moes@connix.com
www.chamfer.com/moes



SHEET MUSIC

North America's most complete source of

Chamber Music for Strings

Call for your free string sheet music catalog, or view it on the Web.*

Toll-Free: (800) 248-SHAR
or (734) 665-7711

Also available - our free 64-page color catalog including strings, accessories, rare, contemporary & student instruments and bows, cases, and more.

Shar Products ■ P.O. Box 1411 ■ Ann Arbor, MI 48104
Fax: (734) 665-0829 ■ E-Mail: sharnet@sharmusic.com

*Order on the World Wide Web: <http://www.sharmusic.com>

Faculty Position Vacancy

University Viola Faculty Vacancy at Brigham Young University

Appointment: 23 August 1999 (Applications now being reviewed)

Rank & Salary: Negotiable depending on qualifications and experience

Qualifications: Doctorate or equivalent professional experience in performing and teaching

Responsibilities:

1. Teach viola, direct viola studies
2. Continue involvement in performance, research, and professional service
3. Teach additional related music courses
4. Administrative duties and service on committees as assigned

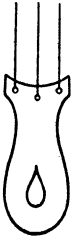

The School of Music at BYU is accredited by the National Association of Schools of Music and has approximately 750 majors enrolled in its undergraduate and graduate programs. There are 48 full-time and 45 part-time faculty members.

Apply to: David M. Randall, Director
BYU School of Music, C-550 HFAC
Provo, UT 84602

TEL (801) 378-6304

FAX (801) 378-5973

THOMASTIK DOMINANT

THE NEW STANDARD OF EXCELLENCE

WHEN great artists like Pinchas Zukerman, Itzhak Perlman and the Fine Arts Quartet choose their strings, they choose the best. That's why they use 'Dominant' strings for violin, viola, and cello. They have a rich powerful tone, unmatched response and they stay in tune unlike old-fashioned gut strings. They last far longer and are the closest thing to a perfect string ever made.

Now available in Full, 3/4, 1/2, 1/4, 1/8 and 1/16 sizes.
Sold in Better Music Stores

For further information or the name of your nearest
dealer contact the exclusive U.S. Importer

JOHN M. CONNOLLY & CO., INC.
P.O. BOX 93 • NORTHPORT, NEW YORK 11768



Chicago

MUSICAL COLLEGE

Richard Ferrin and Li-Kuo Chang, CMC Viola Faculty

Li-Kuo Chang, appointed assistant principal viola of the Chicago Symphony Orchestra by Sir Georg Solti in 1988, held similar positions in China, Europe, and the United States, including assistant principal viola of the Denver Symphony Orchestra. A graduate of the Shanghai Conservatory, he was the first violist to win the Young Artist Competition in Shanghai. In the United States he studied with Francis Tursi at the Eastman School of Music, and with Milton Thomas, Donald McInnes, Paul Doktor and William Magers.

Li-Kuo Chang has appeared as soloist with the Chicago Symphony Orchestra, Phoenix Symphony, and the Shanghai Symphony Orchestra; in chamber music performances at the Los Angeles Music Center, at Le Gesse Festival in France and the Taipei Music festival in Taiwan, to just name a few. He has taught and performed at the Affinis Music Festival in Japan since 1992.

Richard Ferrin, violist with the Chicago Symphony Orchestra since 1967, has enjoyed a distinguished career as soloist, chamber musician, symphony member and teacher. Concertmaster of the Interlochen World Youth Symphony as a teen, he studied viola and violin at Eastman and the University of Southern California, at the Sibelius Academy in Helsinki, and visited the Soviet Union in 1962 to study pedagogy in Leningrad, Moscow, Kiev and Odessa.

Richard Ferrin has been soloist with the Chicago Symphony Orchestra, Eastman-Rochester Symphony Orchestra, the Finnish Radio Orchestra, and the Houston Symphony, and in 1986 gave the first performances of the Bartok *Viola Concerto* with the Shanghai Symphony Orchestra and the Central Philharmonic Orchestra in Beijing. As a violist of Chicago Pro Musica, he has performed at international festivals in Japan, Australia, Spain, Germany, and the former Soviet Union.

Mr. Ferrin and Mr. Chang's string faculty colleagues at Chicago Musical College include violinists Cyrus Forough, Joseph Golan, Yuko Mori (in 1999), and Albert Wang, cellist Natalia Khoma and John Sharp, and bassist Stephen Lester.

To find out more about the Orchestral Studies Program, write or call Mr. Bryan Shilander, Assistant Dean, College of the Performing Arts, Roosevelt University, 430 South Michigan Avenue, Chicago, IL 60605; 312-341-3789.

*Scholarship Auditions; February 5, 6, 7 and 19, 20, 21 and March 5, 6, 7.
Additional dates by appointment or by audition tape.*



Li-Kuo Chang



Richard Ferrin

ROOSEVELT
UNIVERSITY

The Primrose International Viola Archive

PIVA is the official archive of the International and the American Viola societies. We wish to be user-friendly and to aid you in your needs regarding the viola repertoire.

Holdings of PIVA now consist of approximately 5,000 scores that feature the viola. Some of the older editions and manuscript scores can be photocopied for a modest fee. Although many scores are protected by copyright and may not be photocopied, PIVA is able to loan these materials through interlibrary loan. The process of interlibrary loan is simple—inquire at your local public or academic library; ask them to send your request to the following address:

Interlibrary Loan
Attn: Maria Childers
Harold B. Lee Library
Brigham Young University
Provo, UT 84602

TEL: (801) 378-4155
FAX: (801) 378-6347
e-mail: maria_childers@byu.edu

If the request is sent by regular mail, please ask your library to use their official library letterhead. The response time for these requests varies, depending mostly on how quickly your library can process the request. There is no charge for loans from our library.

At present, other materials collected by PIVA, such as sound recordings and archival documents, cannot be loaned. If you have research needs or other inquiries related to these materials, please contact David Day at the following address:

David A. Day
Curator
The Primrose International Viola Archive
Brigham Young University
Provo, UT 84602

TEL: (801) 378-6119
FAX: (801) 378-6708
e-mail: david_day@byu.edu

For general information concerning PIVA, visit our website at
<http://www.lib.byu.edu/~music/PIVA/WP.html>

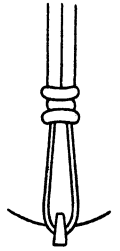

An Estimate of Yearly Financial Support from the Harold B. Lee Library at BYU for PIVA

Acquisition of new scores and recordings	\$5,000
Binding of scores (based on 200 titles per year)	3,000
Cataloging and processing of scores and recordings	25,000
Storage, shelving, building maintenance	3,000
Reference and selection of materials	10,000
Interlibrary Loan	3,000
Internet and on-line catalog computer support (system use only)	1,000
<hr/>	
Subtotal	\$50,000
Student assistant (beginning 1999)	2,500
10-year life cycle of computer, audio, and video equipment	7,500
<hr/>	
Subtotal	\$10,000
Grand Total	\$60,000

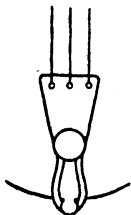

XXVII International Viola Congress (1999)

The International Viola Congress XXVII will be held June 9–12 in Guelph, Ontario, Canada. Guelph is a university community about 40 minutes by car from Toronto's Pearson International Airport.

The final rounds of the Primrose Memorial Scholarship Competition will also be held in Guelph on Tuesday, June 8. For more information about the competition, contact Lisa Hirschmugl at 1 S. 229 Pine Lane, Lombard, IL 60148, or check the web site of the Competition—<http://www.viola.com/congress99/prim99.html>.

The Congress registration will begin on Tuesday evening, June 8, and opening ceremonies will begin at 10:00 a.m., June 9. The Congress will feature full-length recitals by Rivka Golani and by the Belgium-based Russian violist Michael Kugel, whose performance at the recent Congress in Glasgow was enthusiastically received. There will be the usual luthiers' exhibits, and Steve Larson, second-place winner of the 1997 Tertis Competition, will play the instruments in the luthiers' demonstration.

Mixed recitals will feature young talent, the viola in chamber music, and the viola and electronics. Michael Kugel and Ralph Fielding will hold master classes. Lectures will vary from "Tertis and the English School of Viola Playing" to "Making, Repair, and Adjustment of the Viola Bow." Barbara Paulls will present a lecture demonstration on "Human Physiology and String Playing" and will follow up with two working sessions for all those interested. Teachers Jutta Puchhammer-Sedillot and Thomas Tatton will work with young violists to prepare multiple viola pieces for a recital program. A competition to select these young violists will be held early in 1999. There will be opportunities to play in viola jam sessions and there will be forays into the realm of the viola in Blues and Klezmer music.

One afternoon will be devoted to exploring Niagara Falls, Toronto, or the well-known Guelph micro-breweries. That afternoon will be followed by the gala banquet and awards dinner.

BE A CONTRIBUTOR TO OR BENEFACTOR OF THE AVS

Your contributions are tax-deductible
and are greatly appreciated.

(SEE MEMBERSHIP ENROLLMENT FORM IN THIS ISSUE—page 94)

IF YOU LOVE THE VIOLA AND FEEL WARMLY
TOWARD THE SOCIETY OF VIOLISTS, WHO WOULD YOU NAME
AS A BENEFICIARY OF YOUR ESTATE?

*The AVS Endowment? or
The Primrose International Viola Archive? or
The Primrose Memorial Scholarship Fund?*

The Congress will use the facilities of the River Run Centre in Guelph. Housing will be available at a reasonable price in university dormitories or in local hotels. "Members" are those who belong to any section of the International Viola Gesellschaft such as the AVS, CVS, or other. The Congress rates are as follows:

Full Congress fees in CANADIAN dollars

	Regular	Student	Spouse
Members	\$250	150	150
Non-members	\$300	180	n/a

All registrations postmarked after April 1 are subject to a \$25 late handling charge. (Dormitory rooms MAY NOT be available with late registrations.)

Daily Registration fees in CANADIAN dollars

	Regular	Student	Spouse
Members	\$ 80	50	50
Non-members	\$100	60	n/a

*The Canadian dollar is presently valued at about 65 cents U.S.

Brochures about the Congress will be available early in 1999 and entry forms will be available on the Congress website at - <http://www.viola.com/congress99/>.

For more information, please contact:
Ann Frederking, Business Manager
2030 Woodglen Crescent
Gloucester, Ontario K1J 6G4 Canada
fredrkng@trytel.com

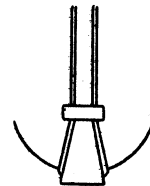

... maker of
fine string instruments

By appointment
(980) 356-3712

15-A North Road
Warren, New Jersey 07059



ORFORD ARTS CENTRE

Advanced Music Studies

June 28 to August 14, 1999

A wide selection of programs to choose from...
To assist you in the preparation of your career, our school not only offers you its regular program of **master classes**, it also offers you the following programs:

- **Orchestral Repertoire and Preparation for Orchestral Auditions;**
- **Orchestral Training;**
- **Chamber Music for String and Wind Instruments;**

Orford Arts Centre master teachers are also section leaders or soloists with some of the most famous orchestras in North America and Europe.

REGISTRATION DEADLINE:
April 30, 1999

To receive our brochure, write or call

ORFORD ARTS CENTRE
3165 ch. du Parc, Canton d'Orford (Québec)
CANADA J1X 3W3
Tel: (819) 843-3981
Fax: (819) 843-7274
arts.orford@sympatico.ca
www3.sympatico.ca/arts.orford



WHEN IS "GOOD" JUST NOT GOOD ENOUGH?

When your insurance agent tells you that your current musical instrument policy provides the same coverage as the **NEW CLARION Insurance Program** but the policy itself does not include these important coverages:

- *Thirty days free coverage for borrowed instruments.*
- *The right to keep undamaged parts of any instrument suffering a loss.*
- *Right of repurchase - permitting you to re-purchase recovered instruments at the price paid for the claim (regardless of the increases market value of the instrument in the interim.)*
- *Loss of Market Value - pays you the difference in market value for instruments that have been damaged and repaired.*
- *No exclusion for instruments in a motor vehicle.*
- *Inflation Guard providing insurance beyond policy limits.*
- *Free coverage for replacement instruments while yours is being repaired for a claim.*

Call 1- 800- VIVALDI
for information or an
immediate quote.

CLARION ASSOCIATES, INC.
MUSICAL INSTRUMENT INSURANCE

1 • 800 • VIVALDI

E-Mail: clarion @ villagenet.com

ROCHBERG'S SONATA FOR VIOLA AND PIANO

An Interview and Analysis
by LeeAnn J. Morgan

INTRODUCTION & INTERVIEW

George Rochberg's Sonata for Viola and Piano is a beautiful neo-Romantic work which contrasts long flowing lines with sections of sharp articulation. There are elements of surprise, as in the second movement with the use of jazz harmonies. The Sonata presents many technical demands on the violist and it takes an experienced performer to execute it well. It is a wonderful contribution to the viola repertoire and well worth taking the time to explore.

The Sonata was commissioned to commemorate the 75th birthday of violist William Primrose.¹ In 1979 Joseph de Pasquale and Vladimir Sokoloff premiered the work at the VII International Viola Congress held at Brigham Young University.² This article will focus on three major sections: an interview with de Pasquale, Rochberg's aesthetics and an analysis of the Sonata.

At the XXV International Viola Congress, held in Austin, I was privileged to meet Joseph de Pasquale, who graciously consented to an interview about his premiere of the Sonata.

Morgan: What were the circumstances surrounding your giving the premiere?

de Pasquale: Primrose called me on the phone and said, "Joe, I want you to play the first performance of the Rochberg." I was busy with the Philadelphia Orchestra and did not know how I could do it. Rochberg writes difficult music, and I was concerned about whether I had the time to work on it and to perform it at the congress, which commemorated Primrose's 75th birthday. So I said, "I would rather you get someone else because I just don't have the time to work on it." Primrose said, "I want you to play it!" He was pretty insistent. Finally, I said, "Ok. Fine." It is a difficult piece, but it is also a beautiful piece.

Morgan: After the Sonata was complete, did you do the editing?

de Pasquale: Yes, and I worked closely with Vladimir Sokoloff, the pianist who premiered the Sonata. We also played it for Rochberg for any suggestions he had.

Some people asked why I indicated slides between the notes. That is the way I felt it when I learned it. It is my interpretation of this basically Romantic piece.

Morgan: Having heard a tape recording of the premiere, I appreciated your interpretation of this neo-Romantic work. What approach did you use to create this interpretation?

de Pasquale: After working on it, you hear the harmonies and you decide the musical content of it through those harmonies and your part. That is how I went about interpreting it.

Morgan: How do you prepare a work for a world premiere, compared to performing a well-known piece? Are there differences and what are they?

de Pasquale: One difference between a premiere and a well-known piece is that with a new piece I have to put in the fingerings. Also, I may disagree with some of the legato or slurred markings of the composer. I ironed these concerns out with Rochberg saying, "I would like to do this and I would like to do that." For example, in measures 74 and 75 I think those notes should be separated. I told him I am going to do it this way and he said, "Why not? As long as it sounds legato. You don't want to make it sound too detached." As long as it sounds legato, it gives you more breadth in phrasing when you change your bow from slur to separate.

Morgan: That's such a dramatic part there, too, the *molto espressivo*.

de Pasquale: That's right. And after the third bar when you go from the F to the E, you need to take another bow. Rochberg was very receptive, and we did play the Sonata for him many times. I naturally had to dissect and figure out the notes. If it is something I know, I don't have to do that. But this really had to be dissected. At the first hearing there are strange notes. That is another problem with a new work, seeing that you play the right notes. You do not want to learn





The
Cleveland
Institute
of Music

DAVID CERONE
President

VIOLA STUDIES

ROBERT VERNON

Principal Viola, The Cleveland Orchestra

CHAUNCEY PATTERSON

The Miami String Quartet

LISA BOYKO

CIM Alumna, member of The Cleveland Orchestra

"Talented students develop into the best musicians when they receive excellent teaching that instills self-discipline and nurtures their spirits in a caring atmosphere."

The viola faculty at The Cleveland Institute of Music includes Robert Vernon, Head of the department, Lisa Boyko, Mark Jackobs, Lucien Joel, and Stanley Konopka, all members of The Cleveland Orchestra, Edward Ormond, and Chauncey Patterson, Visiting Professor.

Bachelor of Music
Master of Music
Doctor of Musical Arts
Artist Certificate
Artist Diploma
Professional Studies

For further information, contact William Fay, Director of Admission
The Cleveland Institute of Music
11021 East Boulevard
Cleveland, Ohio 44106
(216) 795-3107
Web Site: www.cim.edu

the wrong ones. You have to follow the dynamics very closely and the phrasings, and you need to invent fingerings that suit the passage.

There are all sorts of differences compared to playing a well-known piece. I still make changes in the well-known pieces—I change my fingerings in the Walton Concerto, the Hindemith Concerto, the Bartók Concerto. I am still experimenting—which is good. I see students who do things they shouldn't, but then I like some of the things that they do. I say, "That's a very good fingering, very good. I don't use it, but it sounds good, so use it."

Morgan: I have known of accomplished musicians who have avoided performing the Rochberg Sonata because of its difficulty. What did you find challenging about this piece?

de Pasquale: Well, if you play Rochberg's tempo marks, it is not easy. Some people slow down if it is too difficult. You have to have technique, naturally, to perform it. If you don't, I don't think you should perform it. One should not play it slower than it should be, because if it is played slower, it lacks brilliance. You cannot play it on the slow side.

Both the technique and the musicality are challenging. It has to be played very musically, very expressively. There are strange and large intervals that require wide leaps, plus a brilliant technique. But it was wonderful going through this piece, bowing and fingering it. I found the thought of it very challenging because I imagined Rochberg was going to write music of the Rochberg years ago. But this music was much different than that earlier period.

Morgan: Yes. I actually discovered that in doing my research. He went through three phases. In this last phase he is calling for a rebirth of tonal harmonies.

de Pasquale: That's right. This work is very tonal. There are some striking harmonies, but, on the whole, it is very melodic and beautiful. I still play it and use it often as it is a wonderful contribution to the viola repertoire.

It was a wonderful day, that day I premiered it. Primrose was in the audience and it was overwhelming. A new piece and Primrose on the front row. He wrote me a beautiful note on the music . . . "To my very dear Joe. Many thanks for a moving and great performance. William Primrose."

Morgan: That is a treasure.

de Pasquale: Yes it is. You won't get that signature any more. And there is a very nice inscription by David Dalton, who had a lot to do with having the work commissioned . . . "I was deeply touched by this performance." That is very complimentary from another viola player.

ROCHBERG'S AESTHETICS

George Rochberg's writings are prolific, with some of the main aesthetic points summarized here. In the 1970s George Rochberg emerged as an influential figure in American music, both as a journalist and as a composer. His essays explore aesthetic problems and his musical works reflect engagements with major aesthetic issues.

Rochberg's music in the late 1940s resembled Stravinsky's, Hindemith's and Bartók's (especially in the *Capriccio* and the *First String Quartet*). In the 1950s he adopted twelve-tone serialism and felt his imagination liberated. At this time Rochberg perceived serialism to be the culmination of historical developments and felt that its strict parameters gave him freedom. Works stemming from this time include the *Twelve Bagatelles* for piano, the *Chamber Symphony* and the *Symphony No. 2*.³

Growing dissatisfied with atonal serialism, Rochberg took a decidedly different direction in the early 1960s:

The freedom I had felt in 1952 turned into a trap by 1963. I saw serialism as a means of projecting only the strange peripheral areas of human feeling while the old music now seemed to cover the central core of it.⁴



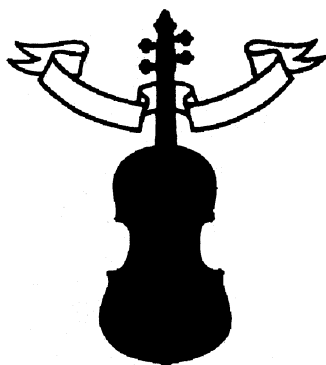

William Moennig & Son, Ltd.

Locust Street, Philadelphia, PA 19103

***Since 1892,
Dealers, Restorers, and Appraisers in Rare
Violins, Violas, Cellos, and Bows***

MEMBER: ENTENTE INTERNATIONALE DES MAITRES
LUTHIERS ET ARCHETIERS D'ART

ART AND ANTIQUE DEALERS OF AMERICA, INC.

APPRAISERS ASSOCIATION OF AMERICA

FOUNDING MEMBER, AMERICAN FEDERATION OF VIOLIN
AND BOW MAKERS

VIOLIN SOCIETY OF AMERICA

Officers: William H. Moennig,
William R. Moennig, Pamela J. Moennig

Associates: Philip J. Kass, Richard Donovan

(215) 567-4198, (800) 523-4051, Fax (215) 567-4175
e-mail: PJKASS@worldnet.att.net

After this time, he expanded his compositional range to include tonal idioms and worked to assimilate traditional elements. Rochberg also included quotation of tonal repertory (from composers such as Beethoven and Mahler) to affirm his integration of traditional with contemporary elements. An example of this type of work is his String Quartet No. 3 (which will be discussed later).⁵

What is the aim of Rochberg's reactionary music? His writings give us the answer. They focus on two subjects regularly: serialism and modernism. While Rochberg finds no fault with Schoenberg he rejects the perversions spawned by serialism. Of serialism and the twelve-tone method, Rochberg writes:

It is the method itself which is the point of real break. It helped spawn all the aberrations, perversions, and distortions which go by the name of contemporary music: aleatory music, pointillism, total serialism . . . a whole Pandora's box.⁶

Rochberg views modernism as a reactionary movement in the European culture; a way of expressing freedom from regimented political systems, social classes, and human injustices. He believes modernism compelled composers to reject the past and neglect their musical heritage.

Viewing the effects of serialism and modernism Rochberg made two conclusions: music should encompass the past and the present, and music must have an era of renewal. (Since Rochberg's writings in these two areas are prolific, the following material represents only a sample of his thought.)

Rochberg argues against discarding the past in order to create something "new," asserting that ancestral ties can rejuvenate music:

All acts of renewal through uses of the past renew both that past drawn upon and that present in which the act occurs. Far from being acts of weakness or signs of the depletion of creative energy, they reveal a profound wisdom about paradox of time, which does not consume itself and its products as if it were fire, but gathers up into itself everything which has occurred in it, preserving everything as the individual mind preserves its individual memories.⁷

One of Rochberg's most assertive works is the Third String Quartet. In this work Rochberg makes a strong statement that the old and the new can coexist. Rochberg views the Third Quartet as "a multi-gestural work . . . which denies neither the past nor the present."⁸

The Quartet's fascinating idea is the confrontation of styles, the (not always peaceful) co-existence of tonality and atonality, the mixture of gestures toward different pasts. The confrontation of recognizable new and old idioms is what makes this music modernist. It does not have a modern sound, which would be superficial, but its conception is thoroughly modernist—for the first time in Rochberg's career.⁹

Along with evoking the past, Rochberg's writings contain these additional proposals:

First, music should not be created and analyzed solely for cerebral purposes. Rochberg asserts that those dissecting works solely for cerebral purposes often overlook the real meaning of music:

It is curious that *Le Sacre* is the subject of rhythmic analysis, *Wozzeck* of structural analysis, and more recently *Lulu* of harmonic and intervallic analysis, not to speak of rhythmic and metric analysis. They are treated as though the balletic and theatrical impulses which brought them to life are as nothing compared with the formal designs and patterns which articulate their audible surfaces. The passions of man, which are the very heart of theater and theater music, seem to escape or to embarrass those who write about music today. They [composer-theorists] . . . are lost in the labyrinth of academic abstractions.¹⁰

Second, music should be affirmative. As Rochberg draws from the past, he experiences a resurgence of affirmative energy:



I used to feel hemmed in, now, I feel free. I used to feel uncertain and dissatisfied; today I have incredible energy. For the first time in my life I'm saying what I feel.¹¹

Rochberg believes that in order to survive, music must experience a rebirth, an era of renewal:

We must stop torturing sound in the name of music and begin to sing again, to dance again, to let music be again what it once was and can be once more—a source of joy, a vehicle of human passions, a channel through which we vivify our existence.¹²

The Sonata for Viola and Piano exemplifies an era of renewal that champions passionate music which draws from traditional tonality:

The task for me and I believe for other composers as well is very clear but also extremely difficult: to reexamine the present in the light of the past and the past in the light of the present; to rejoin tradition and extend it in the light of the experience of the 20th century. Among other things, this means relearning the language of tonality and its forms, as well as subjecting 20th-century aesthetics to a searching critical examination of what is worth continuing.¹³

ANALYSIS

The Sonata is a neo-Romantic work. Generally the harmony functions around specific notes rather than around specific keys. The work is different from Rochberg's "multi-gestural" works in that it is more consistent in its musical language. While both the Viola Sonata and the Third String Quartet incorporate more than one style, they do it in different ways. The Quartet uses abrupt style juxtaposition; the Sonata uses a more subtle style combination, blending traditional formal structures with untraditional harmonic devices.

First Movement

Exposition. The first movement is cast in a traditional sonata-allegro form. The exposition presents three themes, the development reworks the themes and the recapitulation restates the materials from the exposition, thus following a traditional formal structure. The viola introduces the Romantic melodic line of the first theme (mm. 1–26) (Example 1). Long flowing phrases and smooth articulation define the theme's personality. The two-measure rhythmic motive serves as the foundation of the melody (mm. 1–2, 3–4, 5–6, 18–19, 20–21) (Example 2).

Example 1. Main theme, measures 1–11.

Allegro moderato (♩ = ca. 112)

The musical score shows the first eleven measures of the main theme. The Viola part (top staff) features a long, flowing melodic line with a dynamic marking of *f espr.* The Piano part (bottom staff) provides a harmonic accompaniment with a two-measure rhythmic motive. The score includes dynamic markings, articulation marks, and a key signature of one sharp (F#).

⑤
cresc.
cresc.

più f *dim.* *poco rit.* ⑩ *a tempo* *p*
più f *dim.* *p dolce*

Example 2. Main theme rhythmic motive, measures 1, 2, 18, 19, 20, 21, viola.

f espr.
p dolciss.
 ②

The first theme ends quietly and the second theme, fugal in character, enters with sharp, staccato articulation (Example 3).



San Francisco Conservatory of Music

Viola Faculty



Don Ehrlich, Assistant Principal Viola of the San Francisco Symphony, has been a frequent soloist and chamber musician in the Bay Area and around the world in such groups as the Aurora String Quartet and Stanford String Quartet, and on such series as Chamber Music West, Chamber Music Sundaes, and the Mendocino Music Festival. He received his B.M. from the Oberlin Conservatory, his M.M. from the Manhattan School of Music and his D.M.A from the University of Michigan.

A native of Russia, **Leonid Gesin** studied with A.G. Sosin at the Leningrad State Conservatory, where he later served as a member of the faculty. He performed for 17 years with the Leningrad State Philharmonic. He also taught viola and violin for five years at the Rimsky-Korsakov Special Music School in Leningrad, then emigrated to the U.S. in 1978. Gesin is a member of the San Francisco Symphony and of the Navarro String Quartet. He appears in Chamber Music Sundaes and performs with the Sierra Chamber Society.



Paul Hersh, former violist and pianist of the Lenox Quartet, studied viola with William Primrose. He is former faculty member of the Grinnell College and SUNY at Binghamton, and has been artist-in-residence and visiting faculty at the University of California at Davis, Temple University, Oregon State University, University of Western Washington, Berkshire Music Festival, Aspen Music Festival, and the Spoleto (Italy) Festival of Two Worlds. He has performed with the San Francisco Symphony, the San Francisco Chamber Orchestra and many other groups.

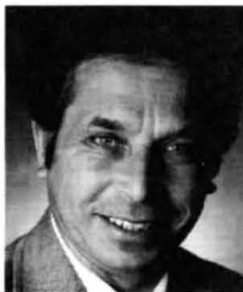

For more information, contact:
Office of Student Services
San Francisco Conservatory of Music
1201 Ortega Street
San Francisco, CA 94122-4498
[415] 759-3431 tel; [415] 759-3499 fax
jog@sfc.edu
<http://www.sfc.edu>

Founded 1917
Colin Murdoch, President
Deborah Berman, Dean

Affirmative Action/Equal Opportunity Employer

Offering the Music Diploma, Bachelor of Music, and Master of Music.

Students from around the world come to the San Francisco Conservatory of Music for several reasons:

- A student-teacher ratio of 6-to-1.
- The opportunity to study with an exceptional faculty in one of the world's most diverse and exciting cultural centers.
- Extensive performance opportunities both on campus and around the city. Concerts and recitals are presented at the Conservatory's Hellman Hall nearly everyday of the school year.

We have a faculty for great music.

Example 3. Theme II, measures 26–32.

The third theme also employs sharp, short articulation but uses different rhythmic material (Example 4). The ostinato in the piano provides the foundation for an active melody.

Example 4. Theme III, measures 52–55.

Although the exposition material is diverse rhythmically, texturally, harmonically, and dynamically, there are relationships (compare underlying intervallic content, articulation, and similar basic rhythmic units).

Development. There is a clear-cut section of development in which Rochberg employs recombinations of the main themes to give continuous growth, change and synthesis to those materials (mm. 68–154) (Example 5). This section is mostly free and cadenza-like.

Example 5. Development – Themes I, II and III.

Musical score for Example 5, Development – Themes I, II and III. The score is in 3/4 time and consists of three systems. The first system starts at measure 70. The top staff is for the violin, the middle for the piano, and the bottom for the bass. The violin part features a melodic line with dynamics like *più sf*, *arco*, *pizz.*, and *più mollo espr.*. The piano part has a rhythmic accompaniment with dynamics like *più sf* and *ben marcato*.

Recapitulation. In the recapitulation, themes I, II and III come back with more melodic elaboration and more textural depth (Example 6). This is not an uncommon traditional practice.

Example 6. Theme I in Recapitulation, measures 155–158.

Musical score for Example 6, Theme I in Recapitulation, measures 155–158. The score is in 3/4 time and consists of three systems. The top staff is for the violin, the middle for the piano, and the bottom for the bass. The violin part starts with *Tempo I* and features a melodic line with dynamics like *f*, *cresc.*, and *f espr.*. The piano part has a rhythmic accompaniment with dynamics like *mf*, *poco espr.*, and *f espr.*.

Unlike the solo entrance of the second theme in the exposition, a viola figure accompanies the second theme's return in the recapitulation (Example 7).

Example 7. Theme II in Recapitulation, measures 188–191.

a tempo, energico e risoluto
sempre brusco

sempre brusco! molto secco

Coda. The coda begins with the viola playing the first theme (m. 231). As the notes relax towards a peaceful ending, an unobtrusive memory of the second theme brings the movement to a close.

Untraditional Harmonic Devices. There is nothing shockingly new or unexpected in the form of the Viola Sonata. However, the harmonic materials are non-traditional. If Rochberg is not using traditional harmonies, how is he able to create a functional sonata-allegro form? One answer is the use of dissonance to create tension and release (a technique used by Hindemith). The climactic point of the development (mm. 171–178) uses extremely dissonant chords to intensify the formal apex (Example 8). Another answer is Rochberg's use of a sonata form based on specific pitches rather than on definite keys.

Example 8. Developmental climax, measures 173–175.

f *ff* *più ff*

(8va)

f

Quartal harmony is structurally significant in the Viola Sonata, in which the perfect fourth is the foundation of both the primary harmonic and the melodic materials. Quartal material appears in the opening notes of the viola and gives cohesion to the main theme. The transitional passage from theme I to theme II (mm. 18–25) is a succession of fourths. Also, the fourth provides the harmonic base in the fugue as the piano plays inverted quartal chords (Example 4). In addition, the overall form of the movement points to the importance of the fourth, as the second theme in the recapitulation returns in B-flat (a perfect fourth above the tonic F) instead of the traditional return in the tonic.

Rochberg also employs tertial chords, but they are used in a nontraditional way. Tertially based chords alternating with dissonant harmonies arpeggiate above the chromatic bass pedal in the opening measures creating a sense of tonal instability (Example 1). Dynamic contrast occurs frequently (sometimes up to five dynamic markings within one measure) with alternating subito piano and forté (Example 9).

Example 9. Theme II fugue entrance, measures 32–34.

Second Movement

The form of the second movement is a traditional A B A B A with free and varied statements of each theme as it returns (examples 10 and 11). The B theme comes directly from the second theme of the first movement (compare examples 3 and 11).

Example 10. The A theme, movement two, measures 1–6, viola.

Example 11. The B theme, movement two, measures 28–30, piano.

The opening measures have a hint of jazz blues harmonies (Example 12). There is a brief viola *cadenza* interpolated within the middle A theme. Rochberg creates color changes within the movement by using contrasting dynamics, pizzicato and flautando.

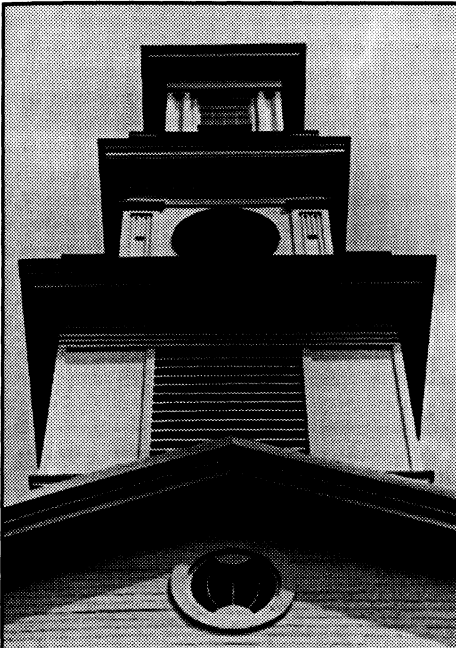

ENCORE celebrates fifteen years of collaboration between dedicated students and an exceptional faculty. The tranquil setting found at ENCORE allows students to meet the challenges and goals they have set for the mastery of their instrument through the performance of solo and chamber music repertoire. The result is an unforgettable musical experience and tremendous personal and artistic growth. Join us for a summer you won't soon forget!

David Cerone, Director

Illustrious ENCORE alumni:

Ivan Chan, first violinist of the Miami String Quartet.

Judith Ingolfsson, winner of the 1998 International Violin Competition of Indianapolis.

Lara St. John, a celebrated concert and recording artist.

Soovin Kim, winner of the 1996 Paganini International Violin Competition and the 1997 Henryk Szeryng Foundation Career Award.

Jasper Wood, winner of the Eckhardt-Grammaté National Music Competition and top prize in the Canada Council Competition.

Sheryl Staples, Principal Associate Concertmaster of The New York Philharmonic.

Richard Aaron, cello; Lisa Boyko, viola; David Cerone, violin; Linda Sharon Cerone, violin; Ivan Chan, violin; Orlando Cole, cello; Victor Danchenko (on leave), violin; Erich Eichhorn, chamber music; Stephen Geber, cello; Marshall Griffith, comprehensive music skills; Jeffrey Irvine, viola; Mark Jackobs, viola; Stanley Konopka, viola; Jun-Ching Lin, chamber music; Robert Lipsett, violin; Dorothy Mauney, violin, chamber music; Chauncey Patterson, viola, chamber music; William Preucil, violin and chamber music; David Russell, violin; Laura Russell, chamber music; Carol Ruzicka, scale techniques; Bruce Uchimura, cello, chamber music; David Updegraff, violin; Robert Vernon, viola; Christopher von Baeyer, cello, chamber music; Heather Walker, chamber music; Metta Watts, cello.

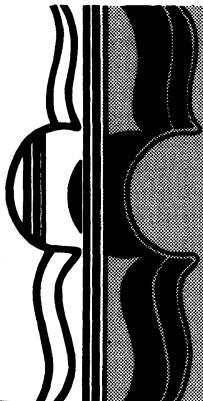

ENCORE School for Strings

June 20 - July 31, 1999

located at Western Reserve Academy, Hudson, Ohio.

For information, contact: ENCORE School for Strings
The Cleveland Institute of Music
11021 East Boulevard, Cleveland, Ohio, 44106
216-791-5000 Web Site: www.cim.edu

Example 12. Jazz blues influence, measures 1–5, piano.

Adagio lamentoso (♩ = ca. 63)

Viola *arco* *sempre cantando* *mp* ⑤

Piano *mp* *mp* *p* *sim.* *sim.* *sim.*

Third Movement

The third movement is an epilogue in fantasia form (Example 13). The first movement generates material for the whole sonata, which is especially evident in the third movement (where themes I and III recur), and the concept of development and change is not limited to a “development section” but encompasses the whole work (examples 14 and 15).

Example 13. Opening of third movement, measures 1–4.

Allegro moderato; ma un poco parlando *poco incalzando*

Viola *f* *più espr.* *sub. p* *cresc.*

Piano *più ben tenuto* *f* *sub. p* *cresc.*

Example 14. Theme I in the third movement, measures 6–9.

Example 15. Theme III in the third movement, measures 25–26.

Many of the same dissonances in the first movement also occur in the third (examples 14 and 15). Yet the tension is condensed and intensified. Also, the excerpts taken from themes I and II are greatly shortened and end without resolution.

CONCLUSION

According to Rochberg, in reaching the apex of renewal, composers must use all available resources. The result would be eclectic; it would draw upon the fullest use of human imagination. Here is Rochberg's formula for renewal:

Translated into practice, this would mean the use of every device and every technique appropriate to its specific gestural repertory in combination with every other device and technique until theoretically all that we are and all that we know is bodied forth in the richest, most diverse music ever known to man, *ars combinatoria*.¹⁴

Regarding Rochberg's utopian *ars combinatoria* music, is it possible to create a music with all these parameters? Has the music of Rochberg led us to this Utopia? Rochberg's works do evoke past melodies, harmonies and forms which are integrated with contemporary devices. And his writings and music have inspired many to support a renewal of music. To this end he has reached his goal.

In the Sonata for Viola and Piano he has presented violists a work of sound craftsmanship, romantically arching melodies sometimes underscored with acerbic dissonance; a music accessible to audiences, and challenging to performers. It is a small wonder that the sonata has had little difficulty in establishing itself in the viola repertoire since its premiere twenty years ago.

LeeAnn J. Morgan received her master's degree in performance from Brigham Young University. She is a teacher and free lance violist in the Seattle area. Her writings on the pedagogical works of Maurice Vieux appeared in JAVS, Vol. 7 nos. 2 & 3.

¹ The printed edition of the Sonata reads, "Commissioned by Friends of William Primrose, The American Viola Society and Brigham Young University in honor of William Primrose on his 75th Birthday." The rough score manuscript and the master tissues sent to the publisher (again in manuscript) are held in the Primrose International Viola Archive at Brigham Young University along with the recording of the Sonata's premiere by de Pasquale and Sokoloff.

² Myron Rosenblum, "'You've Come a Long Way Baby!' A Report on the VII International Viola Congress, Provo, Utah, July 12-14, 1979," *Journal of the Violin Society of America* 5 no. 1 (1978-79): 92.

³ Stanley Sadie, ed. *The New Grove Dictionary of Music and Musicians* (London: Macmillan, 1980), s.v. "Rochberg, George," by Austin Clarkson.

⁴ Freedman, "Metamorphosis of a 20th-Century Composer," *Music Journal* 34 (March 1976): 12.

⁵ Sadie, ed. *New Grove Dictionary of Music*.

⁶ Freedman, "Metamorphosis."

⁷ George Rochberg, "Reflections on the Renewal of Music," *Current Musicology* 13 (1972): 76.

⁸ Quote of George Rochberg from record jacket: George Rochberg, String Quartet No. 3 performed by the Concord String Quartet. Nonesuch H-1283 (1973).

⁹ Jonathan D. Kramer, "Can Modernism Survive George Rochberg?" *Critical Inquiry* (December 1984): 350.

¹⁰ George Rochberg, "Reflections on the Renewal of Music," *Current Musicology* 13 (1972): 79.

¹¹ S.H., "George Rochberg," *Newsweek* 19 February 1979, 73.

¹² L. Foss, "George Rochberg," *Music and Artists* (June-July 1972): 13.

¹³ Roger Scanlan, "Spotlight on Contemporary American Composers," *NATS Bulletin* (October 1976): 49.

¹⁴ George Rochberg, "Reflections on the Renewal of Music," *Current Musicology* 13 (1972): 81.

JOHN- BRASIL

The NAME in
QUALITY PERNAMBUCO
WOODS and BOWS

1993
45 LOBBY EXHIBITIONS
INTERNATIONAL
ON 5 CONTINENTS

Horst John & Cia. Ltda
Box 606 - Rio de Janeiro
BRAZIL

Reference:
Bischofberger Violins
1314 East John
Seattle, WA 98102
Tel: (206) 324-3119



dampit®
Pat No 3 407 700

**the sensational
humidifier for
VIOLIN • VIOLA • CELLO • BASS**

GUARNERI QUARTET
We recommend the Dampit enthusiastically.

dampit provides perfect protection
against damage from a dry atmosphere.

dampit proved itself 100% effective in
scientific sensor measurements.

FREE Room Humidity Indicator with
each **dampit**.

Violin	\$8.95	●	Viola	\$9.50
Little Violin	\$7.95	●	Cello	\$11.50
Bass	\$12.50			

AVOID FAKES. AVOID MISTAKES.

A genuine Dampit has the Dampit name on the black top.

Air postage and handling outside USA and Canada \$1.00 per unit.
In USA and Canada please add \$.85 per unit.
Box 483, Radio City Station NY, NY 10101.

WILLIAM PRIMROSE: A LIFE RECORDED

by Tully Porter

The viola has never before enjoyed the high profile it does today. A handful of mighty soloists are placing the viola on the same level as the violin and cello, and the music being written for it by composers such as Ligeti and Schnittke makes no concessions to the player. Yet it is doubtful whether any of the star viola virtuosi of the 1990s has outstripped the achievement of that characterful Scots pioneer William Primrose. He was not the first great modern violist; before him came Oskar Nedbal, who also had careers as conductor and composer; Lionel Tertis, who showed that Kreisler's new technique of continuous vibrato could be even more effective on the viola; and Maurice Vieux, whose playing was the quintessence of French style. Primrose's contribution was to advance viola virtuosity even further, appearing on equal terms with such colleagues as Jascha Heifetz, Isaac Stern, Arthur Grumiaux, Szymon Goldberg, Emanuel Feuermann, and Gregor Piatigorsky. Apart from his sheer dexterity, he drew a veritable rainbow of colors from the instrument, exploiting its plangent middle register in a subtler way than his predecessors. These qualities, backed by a fine temperament, also made him an astounding recording artist, providing us with many performances to remember him by.

It was on the violin that Bill Primrose made his early reputation. Coming across mentions of his fiddle playing in periodicals of the 1920s, it is intriguing to realize that if his career had taken a different turn, he would be remembered as the successor not of Lionel Tertis but of Albert Sammons.

He was born on 23 August 1904 in Glasgow, the son of John Primrose, an orchestral violinist and violist and a connoisseur of string playing and instruments. John owned a 1735 Niccolò Gagliano, which Bill used in his early career. There was music on his mother's side of the family too: her brother,

Samuel Whiteside, a distinguished Glaswegian violinist, played several other instruments, but sadly he drowned when Bill was still very young. The lad began violin lessons at the age of four with Camillo Ritter, a pupil of Joachim and Ševčík, and would have gone on to study with the latter, had it not been for World War I. Primrose was playing in public at twelve and, with Sir Landon Ronald's help, was at the Guildhall School in London at the age of fifteen. He studied there with Max Mossel and made his Queen's Hall debut with Ronald conducting in June 1923, playing Lalo's *Symphonie Espagnole* and Elgar's Concerto on the borrowed Betts Stradivarius.

But he gained most from Ysaÿe, with whom he spent several summers from 1926, and it was the Belgian master who first suggested he might turn to the viola. Had Ysaÿe heard something altoish in the young man's tone, or was he hoping to revive his quartet with Primrose as its violist? Primrose himself was never quite sure, but in 1928 he played Mozart's *Sinfonia Concertante* in Paris with Lionel Tertis and this was the crucial event in his career—though he subsequently tended to skate over the Tertis connection, perhaps because of their basic disagreements on the vexed questions of viola tone and vibrato, as well as the ideal size of the instrument. Primrose had always had a soft spot for the viola but Tertis's huge, warm tone showed him the real possibilities of the instrument. By 1930 he was playing the viola in the London String Quartet and by 1935 he was making viola records. He joined Toscanini's NBC Symphony Orchestra in New York as coprinicipal viola in 1937 and went solo in 1941, touring with the lyric tenor Richard Crooks. For a few years he organized the Primrose Quartet (with young Oscar Shumsky, a pupil of Auer and Zimbalist, Ysaÿe disciple Josef Gingold, and Harvey Shapiro, whose teachers had included Diran Alexanian). He had a long collaboration



Help Stop the Domino Effect... Refuse to use illegally copied music.

"just for a few students"

"...just for church"

"just for
the words"

"just for a non-profit
organization"

What does it take to get a piece of music in print?

- Composer
- Publisher
- Music Editor
- Engraver
- Marketing
- Copyright and legal fees
- Operating overhead
- Music Dealer

What does it take to put a piece of music perma- nently out of print?

- Decreased sales

Every illegally copied piece of music means a lost sale and lost income to everyone involved in putting a piece of music in print.

What can you do to as- sure quality music re- mains in print?

- Refuse to use illegally photocopied music
- Report offenders to:

The Music Publishers' Association
1353 River Road
Teaneck, NJ 07666
email: webmaster@mpa.org



Pushing the photocopy button is the same as pushing over the first domino. All it takes to stop the domino effect is to prevent that photocopy button from being pushed.



with Jascha Heifetz and Gregor Piatigorsky, and during the late 1950s and early 1960s he took part in the magnificent Festival Quartet (with Szymon Goldberg, violin, Nikolai Graudan, cello, and Victor Babin, piano). Among the works he inspired or commissioned were Britten's *Lachrymae* and the Bartók, Rubbra, Fricker, and Milhaud (Second) concertos.

In private life he enjoyed billiards, cricket, and swimming. After a long illness he died in Provo, Utah, on 1 May 1982. Primrose taught a good deal in his last years, when his health and his hearing were impaired; and he left a fair amount of teaching material, the most accessible being *Playing the Viola* (1988) and the *Yehudi Menuhin Music Guide to the Violin and Viola* (1976). He also wrote a delightful autobiography, *Walk on the North Side*.

First Modern Violist

Primrose is regarded as the first really modern violist. His technique was such that he could play virtually anything put in front of him at sight. On the rare occasions when he was defeated, he would work all night at the piece and present himself the next morning, fully in command.

His career fell into three periods, corresponding with his choice of instrument: the violin phase; the first viola phase, lasting until just after World War II, in which he played his father's Brothers Amati with its warm, deep tenorish sonority; and the second viola phase, when he switched to a slightly bigger but more alto-sounding Andrea Guarneri and was unduly influenced by Heifetz. Between the two viola phases he experimented with a new instrument of William Moennig and also had use of the Macdonald Strad, with its wonderful tone and instantly recognizable diagonal-grained back. Later this instrument would be heard in the Amadeus Quartet in the hands of Peter Schidlof; if you want to hear Primrose play it, turn to his recording of *Harold in Italy* with Koussevitzky (Biddulph or Dutton Laboratories). A live 1939 *Harold* with Toscanini, on the Music and Arts label, taken from crunchy broadcast acetate discs is a very exciting recording with the solo part played on the Amati (ATRA-614).

Similarly one can roughly divide Primrose's recordings into three groups. The first, and least significant, is the series he made for Columbia and HMV in the 1920s as a violinist, using his father's Niccolo Gagliano. These discs show that he was an excellent fiddler with a fine bow arm but not, perhaps, the virtuoso he became. Judge for yourself by hearing the Bach *Andante*, recorded acoustically in 1924 and included in Volume II of the Pearl anthology *The Recorded Violin* (BVA II, three CDs). The second group covers his first decade of recording as a violist, roughly 1935 to 1945, when he was still under the influence of Ysaÿe and was using some sonorous violas. He announced himself with an epoch-making Columbia disc including Paganini's 5th and 13th *Caprices*, cut slightly but so stunningly played that the performance influenced a generation of players such as Emanuel Vardi, who was inspired by them to take up the viola. And no wonder. Viola players usually have something of the crusader about them, and Primrose had found a burning zeal for his instrument which had turned him from a good violinist into a great violist. Other highlights of his Columbia sojourn were a meandering but beautifully played Bax Sonata, the Bloch Suite, Paganini's 17th *Caprice* (with piano) and *La Campanella*, and Kreisler's *Liebesfreud*. All are included on a Pearl CD (GEMM CD 9453). For Columbia Primrose also made the first of two recordings of the "Händel" Concerto by Casadesu, which served to display his easeful articulation and rhythmic flair. Although on the later RCA recording the conductor Frieder Weissmann, did not match the vigor of Walter Goehr on the Columbia version, the Victor recording showed off the soloist's tone better. The Columbia version is on a Biddulph CD (LAB 088) with two Victor recordings: the Beethoven "Eyeglass" Duo with Feuermann and the best of Primrose's renderings of Mozart's *Sinfonia Concertante*, in which he is partnered by a fellow Ysaÿe admirer, Albert Spalding. Another Biddulph CD (LAB 011) includes the 1937 HMV version of Brahms's E-flat Sonata; Gerald Moore's deep purple piano sound is well captured by the engineers, as is the tone of the Amati. Brahms's F-minor

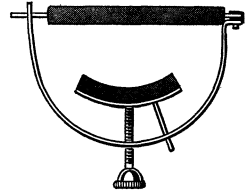

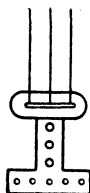

Sonata, waxed in 1939 but unpublished on 78rpm discs, is the jewel of a STRAD CD, the first of three Primrose recordings and the only one in which he plays the Amati; his partner is the distinguished Puerto Rican pianist Jesús María Sanromá and the interpretation, subtle. He recorded somewhat fleetier interpretations of both sonatas with Rudolph Firkusny in the LP era but the 78rpm versions are wonderfully autumnal in the true late Brahmsian manner. The published 78rpm F-minor Sonata is notable for being among the few records made by the brilliant American pianist William Kapell (1922–1953), who perished in an air crash; this version has more overall cohesion than the 1939 one with Sanromá.

Also on the STRAD disc is the Mozart G-major Quartet, K387, featuring the Primrose Quartet, which arose from the ranks of the NBC Symphony in 1938 and broke up in 1942. Although Primrose's three colleagues were all significant virtuosos, the quartet did not have time to become a great ensemble. It was a very good one, however, as this performance demonstrates. The group's other four recordings—a disappointing Schumann Quintet (with Sanromá), a fair Smetana E-minor and superb accounts of Brahms's B-flat and Haydn's *Seven Last Words*—are on Biddulph set (LAB 052/3, two discs). A wonderful Dohnányi *Serenade* with Heifetz and Feuermann is on Biddulph (LAB 074), along with a tightly controlled Handel/Halvorsen *Pasacaglia* and some Heifetz-slick Mozart. Available from Biddulph (LAB 150) are songs with the great contralto Marian Anderson, including Brahms's Op. 91 set. Not yet on CD are such gems as the Hindemith Sonata, Op. 11 No. 4, with Sanromá.

Primrose enjoyed playing short pieces such as *Jamaican Rumba* by Australian-born Arthur Benjamin, and when he asked for a work from Benjamin, he was rewarded with a splendid triptych for viola and orchestra, ideal for slotting into a recital in its piano-accompaniment form. He had similar luck when he got to know the American composer Roy Harris in 1938, receiving a suite and the *Soliloquy and Dance*. The Benjamin and Harris performances are definitive—the latter has the additional attraction of featuring

the composer's wife Johana, a committed interpreter of her husband's music and an occasional recital partner of Primrose's. Both are on a Pearl CD (GEMM CD 9253) along with the Brahms Sonatas (Moore and Kappell versions) and Kreisler's *Praeludium* and *Allegro*. The *Praeludium* has one or two uncharacteristic intonation slips and one assumes Primrose chose this 'take' because he played the *Allegro* so brilliantly. His bowing here would be a tour de force on the violin, let alone the viola.

Post-World War II Recordings

Our third group takes in a mass of post-war recordings. Primrose had always employed an unusually fast vibrato, leading the Tertis faction to say that he played "like a fiddler"; and in later years, while he still commanded a wide range of color, his tone was more mezzo-soprano in quality than the contralto or tenor that it had been. Two 1946 recordings on an EMI disc (CDH 7638282, also on Pearl) showed him still in sonorous form: Walton's Concerto, with composer conducting, and Vaughan Williams's gentle *Flos Campi* with Boult. To the Walton, Primrose brought a new dimension of virtuosity; and although Walton, who had made a still unsurpassed recording with Frederick Riddle eight years earlier, could not raise his own rather moderate game to that of his 1946 soloist, the performance had marvelous moments, not least from the Philharmonic wind soloists. *Flos Campi* was another matter. With the incomparable Adrian Boult in charge, this inspired piece received a rapturous performance, right down to the difficult closing bars.

Primrose was clearly using either the Andrea Guarneri viola or his Moennig for the 1947 sessions with his longtime accompanist David Stimer which round out the STRAD disc. Only three of these tracks, Boris Myronoff's unpublished *Caprice* and Heifetz's Latin American arrangements—*Huella* by Aguirre and *Ao Pe da Fogueira* by Valle—were issued by RCA Victor, on two 45rpm discs coupled with Saint-Saëns' *The Swan* and Bach's *Air* (omitted from the CD for space reasons, along with an impatiently played Tchaikovsky-Kreisler *Andante cantabile*). Milhaud's First Sonata was then a new work. It is

good to have Primrose's incisive performance, even with a few tiny flaws and some ineradicable extraneous noise during the muted *Air*. Then there are the encores. Like Tertis, Primrose generally based his transcriptions on previous adaptations for the violin: examples here (apart from the Heifetz trifles) are *Lema* and *Ipanema* from Claude Levy's version of Milhaud's early piano cycle *Saudades do Brasil*; and Mendelssohn's *May Breeze* transcribed by Kreisler. A pair of the latter's Viennese delights—*Schön Rosmarin* and a convincing *Liebeslied*—complete a program which should please connoisseurs of string playing. Also of interest are the fill-ups to the Pearl edition of the Walton Concerto and *Flos Campi*: the coupling of Bach's *Come, Sweet Death* (No. 42 in the *Schemeligesangbuch*) and Schubert's *Litanei*. The Schubert piece is Primrose's most Tertis-like 78rpm disc; indeed, his manner of attacking the Bach suggests he knew Tertis's record of it, and although Tertis never recorded this Schubert song, transcriptions of other Schubert lieder were featured in his programs. The effective combination of viola

and organ was one that Primrose would return to, but of his major colleagues only Paul Doktor emulated this instrumental combination. The final two tracks on the CD made up Primrose's most popular 78; how sweetly and yet how un sentimentally he could sing even such a hackneyed tune as Dvořák's *Humoresque* or Ethelbert Nevin's best-selling religious ballad *The Rosary*.

In the 1950s Primrose recorded for American Columbia Walton's Concerto and Hindemith's *Der Schwanendreher*, which have not been seen since an Odyssey LP reissue, but the expansive Mozart *Sinfonia Concertante* with Stern and Casals has reappeared (Sony SMK 58953), as has the trim *Harold* with Beecham (Sony MPK 47679). He also made a couple of LPs for Capitol; a Bloch program has disappeared but the Brahms Sonatas with Firkusny are available in America and Europe (EMI 66065) and in Japan (EMI ORG 3002). Primrose's official recording of the Bartók Concerto, which he commissioned, was done for Peter Bartók's label; but it is not available on CD. Two other versions are on

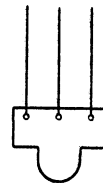

Robertson & sons Violin shop INCORPORATED

Fine Quality Instruments and Bows / Repairs / Rentals / Accessories / Sheet Music

FOR ALL YOUR BOWED INSTRUMENT NEEDS

established 1971

Mail Orders Processed Promptly

(505) 889-2999 • (800) 284-6546

3201 Carlisle, NE Albuquerque, New Mexico 87110

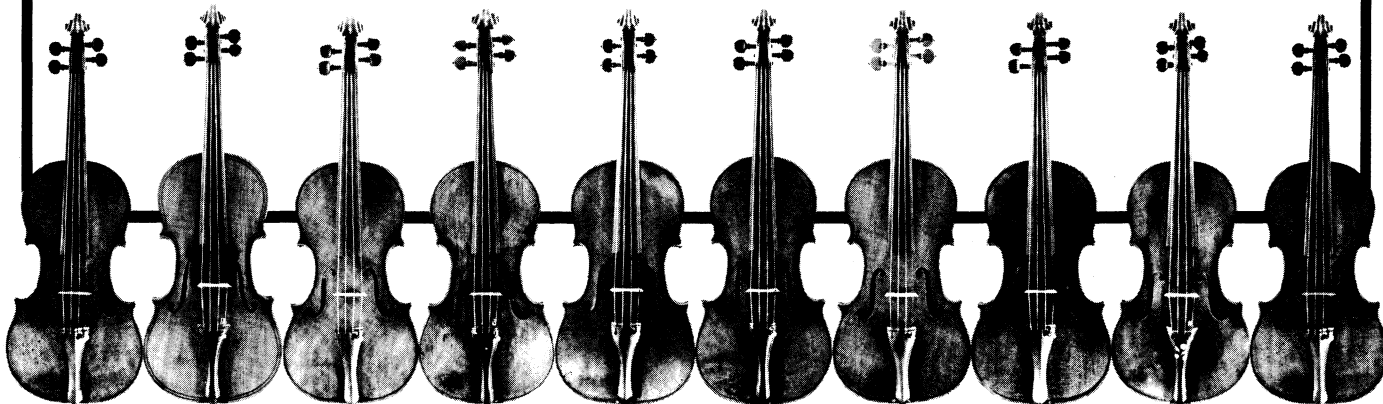



CD: the one with Ernst Bour on Vogue is well played but poorly recorded and I prefer that with Klemperer on Music and Arts (CD-752). Most of Primrose's late work was done for RCA Victor. Sadly, the best chamber group in which he played, the Festival Quartet, is not represented on CD. Among its finest records were the Beethoven and Schumann E-flat quartets, the Brahms C-minor (all three Brahms piano quartets were done) and the Faure G-minor. RCA has re-released a heartless Mozart *Concertante* with Heifetz; but it is better to go for Arthur Benjamin's *Romantic Fantasy*, in which their collaboration really strikes sparks in the Heifetz Edition. All the chamber music with Heifetz and Piatigorsky is available, which will please those that like surface gloss, oily tone, and brutally fast tempi. The late Primrose is well represented by some 1959 Mozart Quintets with the Griller Quartet on Vanguard (08 802471 and 08 802571), though I prefer to think of Primrose playing in the slow movement of Beethoven's Piano Quartet with the Festival Quartet, which was the essence of

bel canto. RCA should reissue that performance without delay.

Primrose's last records documented his approach to the first five of Bach's six cello suites—he did not believe the *Sixth Suite* was suitable for playing on the viola. The recording process was fraught with difficulties due to the great violist's deafness, but with the devoted help of Dr. David Dalton, who acted as producer, it was possible to set down at least a template of what might have been had Primrose tackled such a project ten or twenty years earlier. The results—on a two-CD set (Biddulph LAB 131/2) with selected performances from 78rpm discs including all of Primrose's fine obbligati to Marian Anderson's rich singing—do not always make comfortable listening, but viola enthusiasts and students will find the performances absorbing for their rhythmic acuity, interpretative penetration, and expressive power.

William Primrose belonged to no school of playing, although he displayed the best aspects of the Sevcik school and the Franco-Belgian tradition in the way he handled the viola. As

USC
UNIVERSITY
OF SOUTHERN
CALIFORNIA

**UNIVERSITY OF SOUTHERN CALIFORNIA
SCHOOL OF MUSIC**

VIOLA FACULTY
Pamela Goldsmith
Donald McInnes

Degrees offered: BM, MM, DMA
Advanced Studies Certificate

For further information, contact:
USC School of Music
Los Angeles, Ca 90089-0851
(800)872-2213
e-mail: uscmusic@usc.edu
www.usc.edu

with Tertis before him, there simply was no one of sufficient stature from whom he could learn how to realize his ideal sound. He was as much a "one-off," self-taught phenomenon as Tertis, although he made rather less fuss about it. His straightforward, businesslike attitude was as much a part of his British inheritance as Tertis's more demonstrative behavior was a product of his East European ancestry. The Scots have long been famed for hiding a highly sensitized, fantastical imagination behind a confident exterior. Looked at this way Primrose was not just a typical Scot but a great one—in the sublime inner tension of his cantilena spoke a true poet's voice.

Article taken, courtesy of the author, from the Programme of the XXVI International Viola Congress at Glasgow.

Tully Potter is a well-known London author and critic on music subjects. His writings in newspapers and journals, such as The Strad, and his liner notes in CD's for recording companies are many. He has compiled an eight-CD set for the Pearl label entitled "The Recorded Viola." Potter professes the viola to be his favorite instrument.



Bearden Violin Shop

INCORPORATED

DEALERS AND MAKERS

of *Rare and Contemporary*
Violins - Violas - Cellos - Bows

Expert Restorations, Repairs, and Appraisals

Instruments and bows shipped on approval
with liberal, ten-day trial period
Generous discount on all strings and accessories



Established in and serving the U.S.A. since 1942
Member of Appraisers Association of America &
International Society of Violin and Bow Makers

L. Gene Bearden, President
Gregory Bearden

Call or write for our free brochure
10:00 A.M. - 6:00 P.M., Monday - Friday
9:00 A.M. - 4:00 P.M., Saturday
1-800-929-2327 (314) 427-7570
8787 Lackland St. Louis, MO 63114

Boston University School for the Arts

STRING PERFORMANCE

IN RESIDENCE: The Muir String Quartet

BM, MM, DMA, Artist Diploma

FACULTY

Steven Ansell, *Viola* †*
Edwin Barker, *Bass* *
Lynn Chang, *Violin*
Iseut Chuat, *Cello*
Andres Diaz, *Cello*
Jules Eskin, *Cello* *
Bayla Keyes, *Violin*
Michelle LaCourse, *Viola*
Carol Lieberman, *Violin*
Lucia Lin, *Violin* †*
Malcolm Lowe, *Violin* *
Dana Mazurkevich, *Violin*
Yuri Mazurkevich, *Violin*

Ikuko Mizuno, *Violin* *
George Neikrug, *Cello*
James Orleans, *Bass* *
Leslie Parnas, *Cello*
Michael Reynolds, *Cello* †
Todd Seeber, *Bass* *
John Stovall, *Bass* *
Roman Totenberg, *Violin*
Lawrence Wolfe, *Bass* *
Michael Zaretsky, *Violin* *
Peter Zazofsky, *Violin* †

†Muir String Quartet member

*Boston Symphony Orchestra member

For information on summer programs for high school students at Tanglewood in conjunction with the Boston Symphony Orchestra, call 617/353-3341 or 617/353-3386. *An equal opportunity, affirmative action institution.*

For More Information contact:
Halley Shefler, Director of Admissions
School for the Arts, Music Division
855 Commonwealth Avenue,
Boston, MA 02215
617/353-3341 • 800/643-4796

Bruce MacCombie, *Dean, School for the Arts*
Phyllis Elhady Hoffman, *Director, Music Division*



SCHOOL FOR THE
ARTS

Music • Theatre Arts • Visual Arts

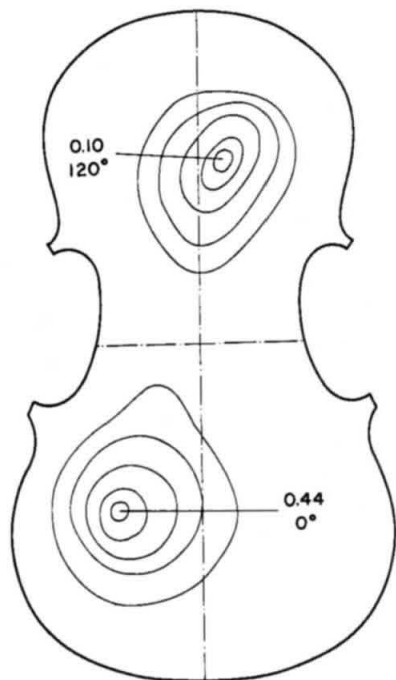

- *Violas made in the style of the great Classical makers*
- *Awarded for tone and workmanship*

William Robert Scott
Violinmaker

2865 Valle Vista Street
Minneapolis, MN 55427
Tel. 612-544-1021
www.delgesu.com

Member:
*American Federation of
Violin and Bow Makers*

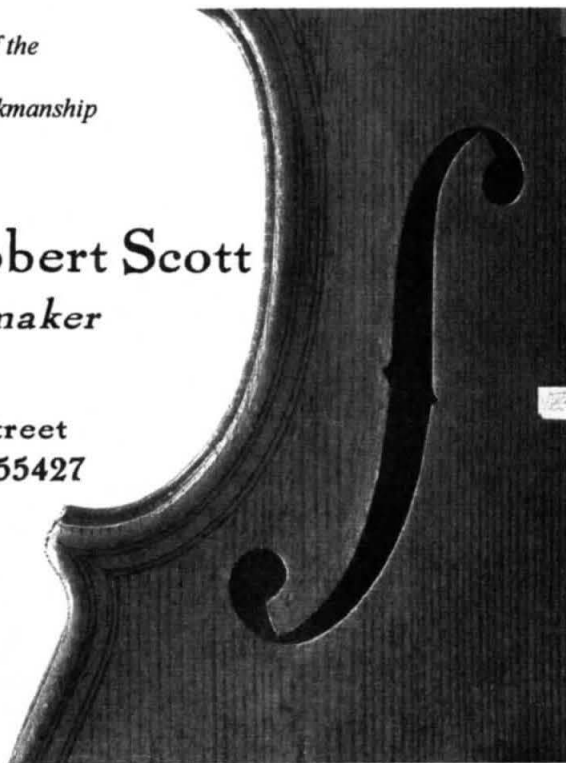

NEW PIVA AND PRIMROSE ROOMS



rimrose International Viola Archive

What an extraordinary collection! It was a great thrill to be able to spend time there, and I have no doubts that the new facilities will bring PIVA to the true international prominence it deserves.

—*Joanna Pieters, editor THE STRAD*

Dear Member of the American Viola Society, Friend & Colleague,

By year 2000 an aspiration of twenty-five years ago, shared by William Primrose, myself, and a few others, will have been fulfilled. A self-contained space—elegantly designed, constructed, and adorned—will house the diverse elements of the Primrose International Viola Archive. One room will be a repository of musical and intellectual significance to the instrument, the other, a pantheon celebrating the human effort of those who brought, and bring, our alto sound to life. You are invited to add your name to the register of contributing supporters by donating in any amount.

—*David Dalton, president of the International Viola Society and PIVA archivist*

For violists, I can think of no more important collection than that of the Primrose International Viola Archive and Primrose Room. We must preserve and enhance the knowledge of our wonderful instrument.

—*Pamela Goldsmith, University of Southern California and Hollywood studio musician*

This invaluable new enterprise of preserving the legacy of the remarkable William Primrose by Brigham Young University should be applauded and supported by musicians, scholars, and the general public.

—*Paul Neubauer, distinguished viola soloist and former principal, New York Philharmonic*

Primrose was the single most important contributor to me as a violist, soloist, and teacher, and PIVA is the most important center to perpetuate his memory.

—*Joseph de Pasquale, Curtis Institute, and principal emeritus, The Philadelphia Orchestra*

Violists around the world have been grateful for PIVA, and I was delighted to receive the news about its further expansion. BYU should be congratulated for this remarkable undertaking.

—*Günter Ojsteršek, past president of the International Viola Society*

My recent visit to PIVA was a fascinating and inspiring journey through the history of the instrument. Whatever your interest—discovering new repertoire, getting to know the viola's legendary performers through their memorabilia, or enjoying brilliant recorded performances—it's all here, in one convenient center.

—*Peter Slowik, Northwestern University and president of the American Viola Society*

PIVA is the embodiment of one of the major principles on which the International Viola Society was founded. The rooms will house the essence of our instrument and elegantly display and facilitate the use of viola music, books, recordings, memorabilia, and artifacts for performers, scholars, and enthusiasts around the world.

—*Thomas Tatton, past president of the American Viola Society*

The Primrose International Viola Archive is not only a most fitting and wonderful tribute to one of the greatest gentlemen and musical personalities of all time, it will serve as a true inspiration to all performers, teachers, and protagonists of the viola for many generations to come.

—*Alan de Veritch, Indiana University and past president of the American Viola Society*

Carleen M. Hutchins

DOYENNE OF AMERICAN VIOLIN MAKERS

—New York Times, June 14, 1994

VIOLAS played in the Cleveland, Juilliard, Kröll, Laurentian, Shanghai, and Vanbrugh Quartets, and in the symphony orchestras of Boston, Columbus (Principal), Detroit, Edinburgh (Principal) Hamilton, Ontario (Principal), Israel, New Jersey, New York, Newcastle (Principal and second), Northern Illinois (Principal), Portland Oregon (Principal), among others.

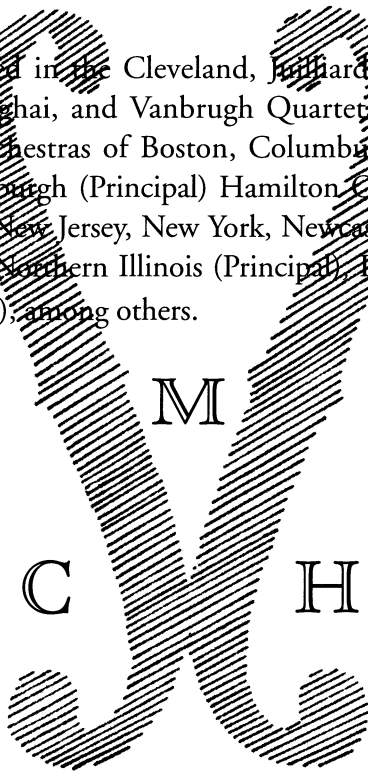

COMMENTS:

"My Hutchins viola creates a sensation wherever I play it. People want to know how to get that tone quality. At the Spoleto Festival they wouldn't believe it."

David Mankovitz, 1962, Kröll Quartet

"Thank you for my marvelous viola."

Simon Aspell, 1992, Vanbrugh Quartet

"Perhaps the most beautiful sounding viola I ever played. I would be proud to own it if I needed one on a regular basis."

Paul Zukofsky, 1994, Concert Violist

112 Essex Avenue (201) 744-4029
Montclair, NJ 07042 Fax (201) 744-9197

The History of the Viola

Volume I (with Supplement)

Revised 1993

(out of print since 1987)

and

Volume II, 1991

Both available NOW

Hard and Soft Cover
\$29.50 and \$24.50 each;
plus Shipping and Handling:
USA \$3.00; Canada \$35.0;
Foreign, USD \$4.00; each

Dr. Maurice W. Riley

Author/Publisher

512 Roosevelt Blvd.

Ypsilanti, MI 48197

Phone: (313) 482-6288

CLAIRE GIVENS VIOLINS, INC.

VIOLAS

Joseph Hel, Lille 1888
Jago Peternella, Venice 1957
Arthur Toman, Boston 1996
Mark Anton Hollinger, Missoula 1991
Michael Scoggins, Salt Lake City 1998
David Polstein, Boston 1997
Lothar Meisel, Owatonna 1979
Scott Zumberge, Minneapolis 1978
G. Garavaglia, Chicago 1985
Reinhold Schnabl, Germany 1976
John Tartaglia, Minneapolis 1995

EARLY VIOLAS & BOWS

Edward Dodd transitional bow

VIOLA BOWS

L. Gillet
C. N. Bazin
Mirecourt, 19th c.
Collin-Mezin
Lee Guthrie
R. Zabinski, Mpls.
Dodd
F. K. Mueller
Bradley Taylor
R. Dotschkail
Jean Bouvin
K. Gerhard Penzel
A. Moinier, Mirecourt
D. A. Seppelfrick

1004 Marquette Avenue, Minneapolis, MN 55403
(612) 375-0708 or (800) 279-4323
www.givensviolins.com cgivens@ix.netcom.com

The
P.
rimrose

International Viola Archive (PIVA)
& Primrose Endowment



at Brigham Young University



William Primrose and the Viola

"If Lionel Tertis was the first protagonist, Bill Primrose was certainly the first star of the viola."

—Yehudi Menuhin
Celebrated violinist

Renowned Belgian violinist Eugene Ysaÿe was among the first to recognize the viola as a concertizing instrument. "We must not overlook the viola either . . .," he cautioned. "My friend Tertis is doing much missionary work for the viola, and I have had a young man from Scotland who will blaze new paths in the years to come."

William Primrose, the legendary virtuoso violist, was Ysaÿe's "young man from Scotland."

Primrose's career spanned virtually the entire genre of musical professionalism. He was affiliated with the London String Quartet, the Primrose Quartet, the Festival Piano Quartet, and the

Heifetz-Primrose-Piatigorsky Trio. After four seasons with the NBC Symphony, Primrose embarked on a solo career that brought him international acclaim. He performed as soloist under such conductors as Sir Thomas Beecham, Serge Koussevitsky (who called Primrose the world's greatest violist), and Arturo Toscanini. Primrose also recorded extensively.

A noted pedagogue, Primrose served on the faculties of the Curtis Institute of Music, University of Southern California, Indiana University, Tokyo University, and, for his last three years, Brigham Young University. He passed away in 1982.

In collaboration with BYU faculty violist Dr. David Dalton, Primrose produced a memoir, *Walk on the North Side*, and the book *Playing the Viola: Conversations with William Primrose*, published by Oxford University Press. His artistry inspired many composers to write for him, the most notable work being, perhaps, the Bartók Viola Concerto, the composer's final opus. Primrose set a remarkable and elusive technical and artistic standard for all violists to emulate.



Design and construction by Artisans du Bois, San Diego, California.

Primrose Room



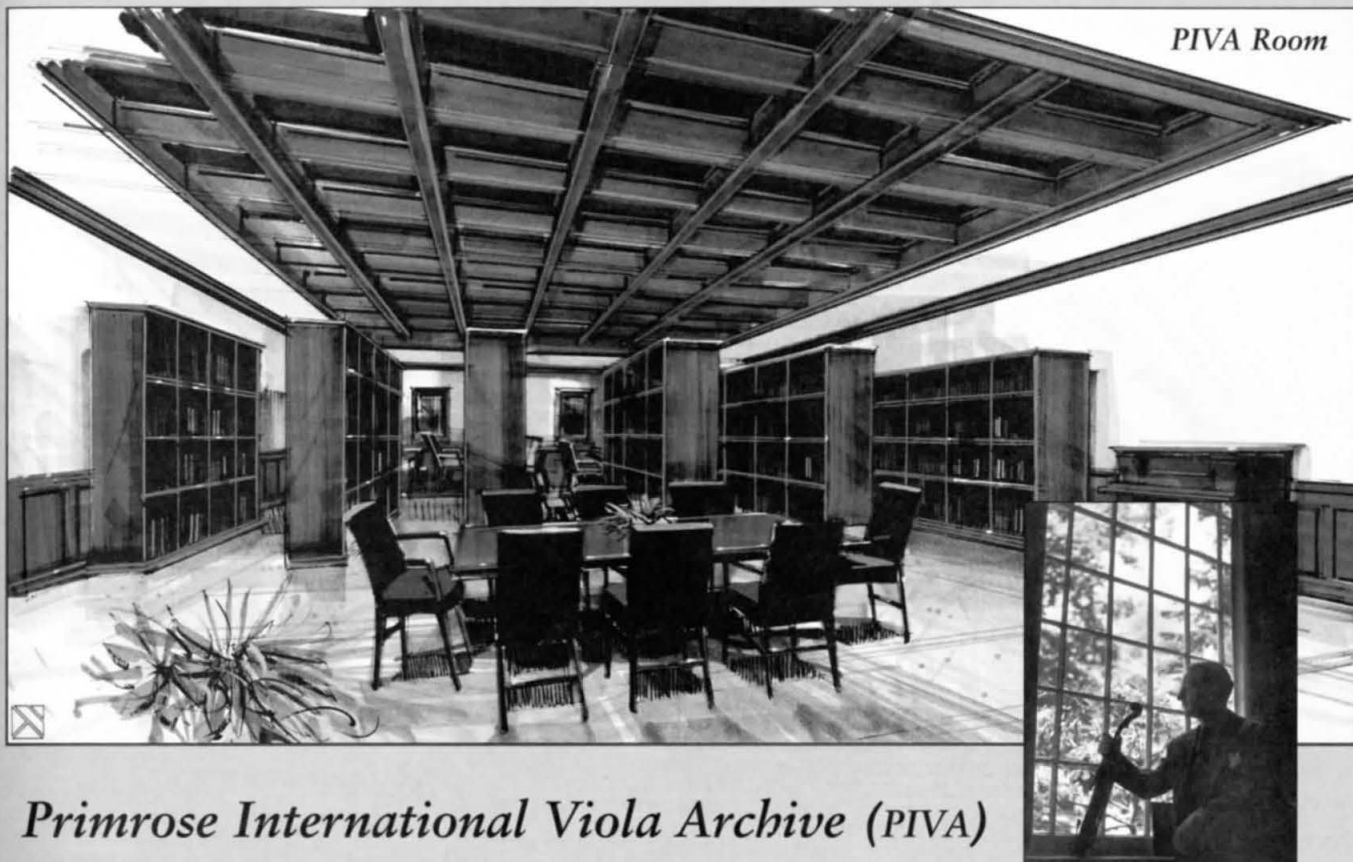

Primrose International Viola Archive (PIVA)

The singular legacy that Primrose left as a musician, recording artist, and articulate exponent of his instrument has prompted BYU to honor his legacy. Thus, in 1974 Primrose, Dalton, and officials of the Harold B. Lee Library at BYU established a viola music archive that has become a resource center for students, professional and amateur violists, and scholars. The core of the archive is Primrose's own library of annotated scores, manuscripts, recordings, and memorabilia. It also contains a collection of all currently available viola scores, recordings by other violists, books, treatises, and articles pertaining to viola pedagogy and history.

Two documentaries featuring Primrose produced by KBYU-TV are also part of the collection. They are *A Violist's Legacy* and *William Primrose, Violist*, both distributed by Shar, Inc.

The acquisition in 1981 of the International Viola Society's extensive archive, formerly housed in the Mozarteum in Salzburg, spurred an increased effort to expand BYU's holdings. Since 1983, PIVA has persuaded music publishers worldwide to contribute viola music and has

placed standing orders with several international library suppliers to enhance the Primrose Archive. The library was also fortunate enough to acquire the personal collections of late eminent violists Ernst Wallfisch and Paul Doktor, and those of Jan Albrecht, Walter Lebermann, and Rudolf Tretzsch; François de Beaumont's phonodisc collection; and the library of Franz Zeyringer, the largest private collection yet donated to PIVA. Zeyringer was the founder and longtime president of the International Viola Society.

PIVA is now the largest repository of materials relating to the viola in the world. Moreover, creation of a separate Primrose Room to house and service the varied dimensions of PIVA is underway. Contribution of materials to PIVA are invited and welcome. Inquiries should be made to its curator, David A. Day, 5222 Harold B. Lee Library, Brigham Young University, P.O. Box 26897, Provo, UT 84602 USA; by e-mail to david_day@byu.edu, or by phone: 801/378-6119.

PIVA welcomes students, performers, and scholars from around the world.

Opportunities available for your participation:

Primrose Room

Furnishing and finishing a violists' pantheon, an *exhibition space* dedicated to honoring and celebrating William Primrose and other violists, and the viola.

Overall Goal: \$64,000

PIVA Room

Interior finishing of a *library and reading room* containing the open stacks of viola scores uniformly bound.

Overall Goal: \$36,000

Primrose Endowment

Earnings from the endowment will be used for the following:

- Expand PIVA website to include 5,000 viola scores and unpublished works;
- Complete the Zeyringer lexicon *Literatur für Viola*;
- Complete and publish *Viola Discography*, and publish *The Violists' Biographies*;
- Commission new works for the viola and promote unpublished works via the Internet or PIVA website;
- Purchase out-of-print, rare, and microfilm copies of viola scores not yet in PIVA, and collections and other archive of viola music;
- Purchase supplies necessary to process archival collection;
- Hire student assistant for reference and copy requests;
- Video record all International Viola Congresses;
- Fund the annual Primrose Memorial Concert and Master Class, conducted by a prominent violist, now in its 16th

Overall Goal: \$500,000



Circles of Giving

William Primrose Circle	\$100,000	and above
Lionel Tertis Circle	\$ 50,000	to \$99,999
Paul Hindemith Circle	\$ 25,000	to \$49,999
Vadim Borissowsky Circle	\$ 10,000	to \$24,999
Maurice Vieux Circle	\$ 5,000	to \$ 9,999
Carl Stamitz Circle	\$ 1,000	to \$ 4,999
Alessandro Rolla Circle	\$ 100	to \$ 999

Construction in 1999

Donors at the Borissowsky Circle level (\$10,000) will receive a bronze of the "Primrose Hands" statuary.



(12"x12" base,
11" vertical)

Your tax deductible contribution to the Primrose project will be greatly appreciated.

Please make checks payable to

BYU, Primrose Account
 BYU Development Office
 C-389 ASB
 Brigham Young University
 Provo, UT 84602, USA
 Or call 1-800/525-8074 for information.

The Harold B. Lee Library

Completion of the Harold B. Lee Library's new underground expansion in 2000 will mark a major remodeling of the current facilities at Brigham Young University located in Provo, Utah. The combined \$50 million project will bring the library's square footage to 665,000 on six floors. Among the new "residents" of the refurbished area will be the Primrose Room and the Primrose International Viola Archive.

With nearly 3,000,000 volumes, the Lee Library is one of the largest in the Intermountain West, with extensive collections in business, western U.S. history, art, and especially music. It has one of the most significant music collections in the United States. It is rich in early-American film and sheet music, radio manuscripts and vaudeville music from the early-to mid-twentieth century, and scores for ballets and French opera.

Complementing these extensive collections are the archives of Gina Bachauer and, of course, William Primrose with near-comprehensive scores for viola and also the harp.

The expanded library serves a professionally recognized music faculty and more than 700 School of Music student-musicians as a research and learning cen-

Brigham Young University

During its approximately 130-year history, BYU has amplified its unique capacity to equip students with a world-class, values-centered education. Thus, BYU has been listed on the

John Templeton Foundation's honor roll of colleges and universities that adhere to high moral values, and consistently receives national recognition for its strong undergraduate and graduate programs and high-quality teaching. It regularly ranks near the top in enrollment of freshman Merit Scholars and in advanced Placement scores sent to the school.

Furthermore, BYU is also one of the very few universities that encourage undergraduates to become heavily involved in professional research in all disciplines and to serve as teaching and laboratory assistants. Acquisition of these skills superbly prepares students for success in the finest graduate and professional schools and programs.

The arts also are among the university's major strengths, with some 10,000 students participating. Fifteen traveling performing groups, made up of approximately 650 students, tour internationally on a regular basis, presenting some 190 concerts in more than 30 countries annually, making friends and bringing hope to tens of thousands worldwide. Many of these groups regularly win international competitions.

Now, creation of the Primrose Room, the Primrose International Viola Archive room, and the Primrose Endowment will elevate the quality of BYU's already internationally acclaimed music programs, ensure the highest quality professional collection of viola music, and encourage the continued development of music for this instrument.

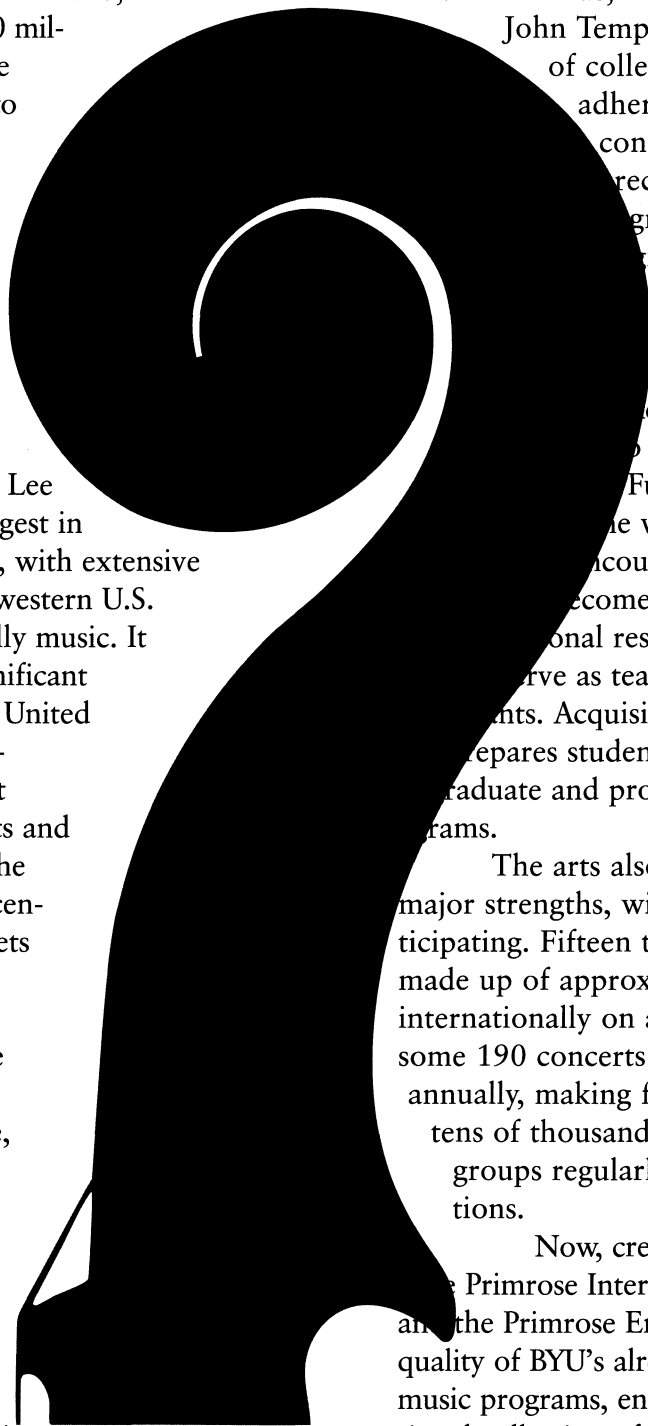

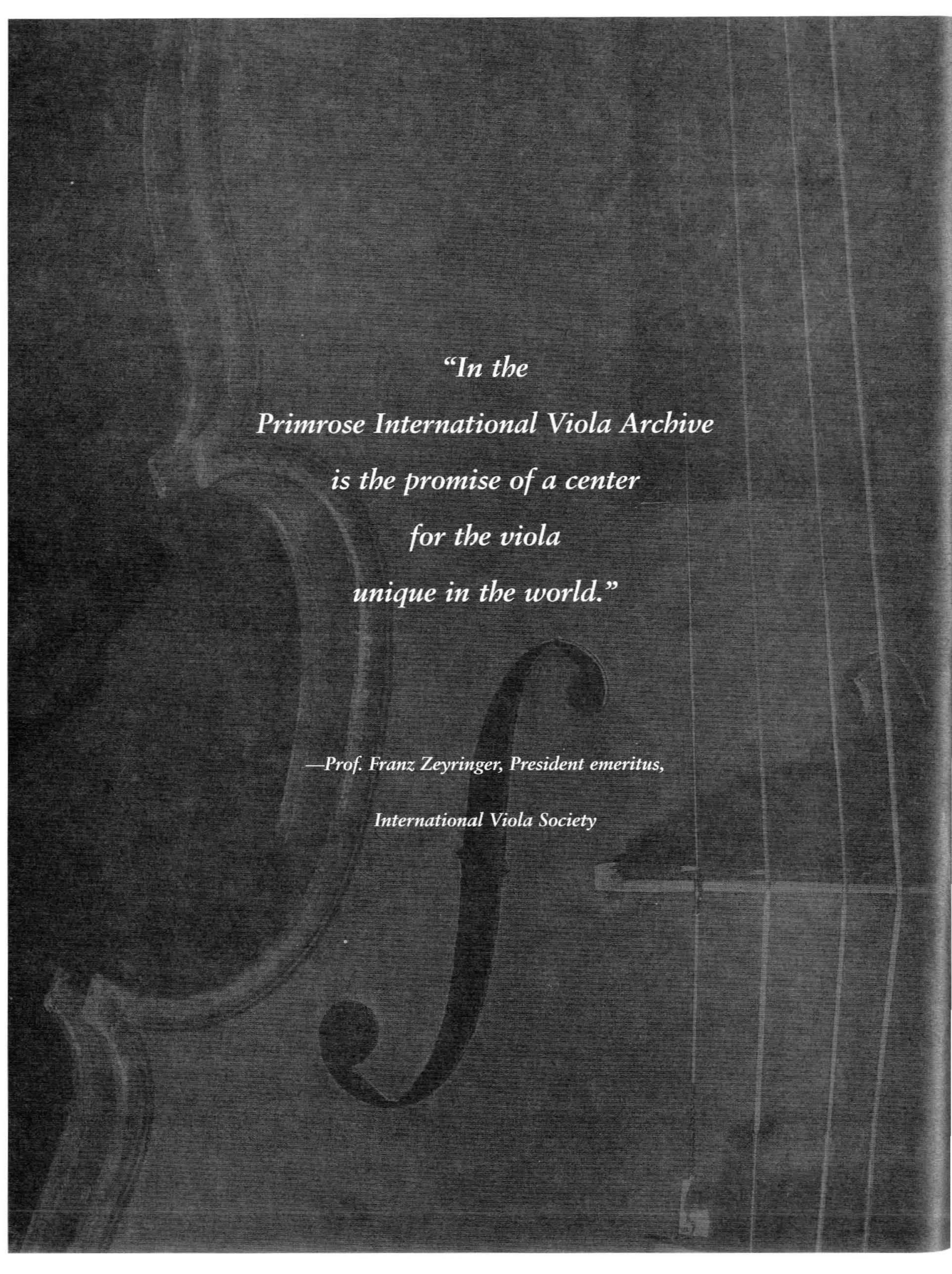

*“In the
Primrose International Viola Archive
is the promise of a center
for the viola
unique in the world.”*

*—Prof. Franz Zeyringer, President emeritus,
International Viola Society*



MUSIC PUBLISHERS

RBP is pleased to announce a unique new line of exceptional arrangements for viola, transcribed and edited by ROBERT BRIDGES. This collection has been thoughtfully crafted to fully exploit the special strengths and sonorities of the viola. We're confident these arrangements will be effective and useful additions to any violist's recital library.

1001 Biber Passacaglia (violin)	\$ 5.75
1002 Beethoven Sonata op.5 #2 (cello)	\$ 9.25
1003 Debussy Rhapsody (saxophone)	\$14.25
1004 Franck Sonata (violin)	\$10.75
1005 Telemann Solo Suite (gamba)	\$ 6.75
1006 Stravinsky Suite for Via and piano	\$28.00
1007 Prokofiev "Cinderella" Suite for Viola and Harp	\$25.00

Include \$1.50/item for shipping and handling

*To order, send your check or money order to:

send for
our FREE
catalogue!

RBP Music Publishers
2615 Waugh Dr., Suite 198
Houston, Texas 77006

IRA B. KRAEMER & Co.

Fine Violins, Violas, Cellos and Bows
Expert Repairs, Restorations, Appraisals
and Accessories

Est. 1967

A selection of Violas for the well advanced student and professional player. Hand made from the finest materials and expertly adjusted in our shop.

Also featuring the violas of the master viola maker Otto Erdesz which are available in limited quantities.

467 Grant Avenue
Scotch Plains, New Jersey 07076

Ph. (908) 322-4469 Fax: (908) 322-8613

NOW APPEARING...



ON A SCREEN NEAR YOU.

Customer-friendly ordering is now available 24 hours a day via our new web-site. It has never been easier to purchase:

- Instruments
- Bows
- Strings
- Accessories
- Cases

And try our
EXPRESS ORDERING SERVICE
for Strings

COME SEE FOR YOURSELF:
www.musiccitystrings.com

And, as always, our informed, courteous sales representatives are available to serve you.

Just call:
1-800-336-1980

Music City
STRINGS

P.O. Box 381 • Rockport, MA 01966
email: musiccitystrings@worldnet.att.net
fax: 888-875-7660



Csaba Erdélyi and his 1991 Joseph Curtin viola.

*"In a sense it was a premiere for the Bartók Concerto...
and for my Joseph Curtin viola."*

In January of 1992, violist Csaba Erdélyi returned to his native Hungary for a concert to be broadcast live from the Budapest Opera.

"It was a double premiere," says Erdélyi. "I spent ten years restoring Bartók's viola concerto from his original manuscript, and this was its debut. It was also the first concerto performance for my Joseph Curtin viola. Both were praised highly."

Csaba Erdélyi established his presence in the music world with another first. In 1972 he became the only viola player ever to win the prestigious Carl Flesch International Violin Competition. He went on to serve as principal of the Philharmonia Orchestra and violist in the Chilingirian Quartet,

reaching a wider audience as the solo viola player in the film score *Amadeus*.

"It's a rare treat to own an instrument that has a strong, mature, even, rich tone in all its registers, *and* the perfect health of a young instrument. It has blended beautifully with Strad and Guarneri violins, as well as Goffriller and Montagnana cellos. I've trusted it in extreme climates from Brazil to Alaska. When I premiered the Bartók, it was just six months old. Yehudi Menuhin, my mentor and frequent concert partner, tried it and immediately ordered a violin from Joseph."

Erdélyi can be heard on his most recent recording, *Liszt and the Viola*, with pianist Ian Hobson [Hungaroton HCD 31724]. Says Tully Potter, writing for

Strad Magazine, "you will have to go a long way to hear any of this material better played...and Erdélyi draws a wonderfully warm tone from his 1991 Joseph Curtin instrument."

After 12 years with Curtin & Alf, Joseph Curtin has opened his own studios, where he designs and builds concert violins and violas for an international clientele. For further information, including current prices and a free color brochure, please contact us:

205 North Main Street
Ann Arbor, MI 48104
(734) 665-1303 • Fax 665-1305
violins@jcastudios.com
<http://www.msen.com/~violins>

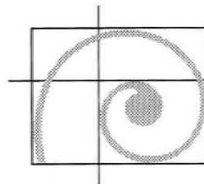

CONCERT VIOLINS & VIOLAS
JOSEPH CURTIN STUDIOS

Henry Lazarof

Six Bagatelles

for Solo Viola

HENRI LAZAROF

Distinguished composer and educator Henri Lazarof received his musical training in both Europe and the United States. In 1959 he joined the faculty of the University of California, Los Angeles, where he is currently a Professor Emeritus of Music.

Lazarof has been awarded numerous prizes for his compositions including first prize, International Competition of Monaco (1962), and first international Prize, City of Milan, La Scala Award (1966). He is the recipient of commissions from the Berlin Philharmonic; the Baltimore, Houston, Seattle, and Utah symphonies; the Los Angeles Chamber Orchestra, London Sinfonietta; and the Chamber Symphony of San Francisco, among others. He has composed prolifically in many media, and his music is widely performed. His works have been recorded on the Delos, CRI, Everest, Laurel, Desto, Vanguard, Vox, and Crystal labels.

MERION MUSIC, INC.

Theodore Presser Company, Sole Representative
1 Presser Place, Bryn Mawr, Pennsylvania 19010
<http://www.presser.com>

REPRINTED BY PERMISSION OF THE PUBLISHER

for Marcus Thompson

Six Bagatelles for Solo Viola

Duration: c. 13' 30"

HENRI LAZAROF
(1996)

$\text{♩} = 56^*$
Molto rubato (quasi una improvvisazione)

I

f mp f mp mf p *espr.* mp
 3 3 3 3 3 3 3 3
 poco accel. Tempo I
 mf f mp mf p
 sul tasto ord. $sub. pp$ p mp
 mp mf mp
 f mp mf p
 mp mf mp p *pizz.* mp

* $\text{♩} = 56$ means only a basic tempo to be interpreted with great freedom.

II

$\text{♩} = 84$ (rubato) mf mp pp *allarg.* $\text{♩} = 63$
 $\text{♩} = 76$ sul tasto p mf p mp $\text{♩} = 63$ ord. $\text{♩} = 60$

The bagatelles may be played in any order.

In contrapuntal passages, phrase marks which appear to conflict may be interpreted at the performer's discretion.

© 1997 by Merion Music, Inc., Bryn Mawr, Pa.
Theodore Presser Co., Sole Representative
144-40286

All Rights Reserved
Printed in U.S.A.

International Copyright Secured

Unauthorized copying, arranging, adapting, recording, or digital storage or transmission is an infringement of copyright. Infringers are liable under the law.

Musical staff 1: Treble clef, key signature of one sharp (F#). The staff contains a sequence of notes with dynamic markings: *mf*, *mp*, *pp*, *mp*, *mf*, and *p*. There are accents over the first and fourth measures.

Musical staff 2: Treble clef. The staff contains a sequence of notes with dynamic markings: *mf*, *f*, *mp*, and *p*. It includes a triplet of eighth notes with a '3' above it. There are accents over several notes and a tempo marking $\text{♩} = 60$.

Musical staff 3: Treble clef. The staff contains a sequence of notes with dynamic markings: *mf*, *f*, and *ff*. It includes a triplet of eighth notes with a '3' above it. There are accents over several notes and a tempo marking $\text{♩} = 76$. The instruction *accel.* is written above the staff.

Musical staff 4: Treble clef. The staff contains a sequence of notes with dynamic markings: *ff*. It includes a triplet of eighth notes with a '3' above it. There are accents over several notes and a tempo marking $\text{♩} = 84$. The instruction *accel.* is written above the staff.

Musical staff 5: Treble clef. The staff contains a sequence of notes with dynamic markings: *ff*. It includes a triplet of eighth notes with a '3' above it. There are accents over several notes and a tempo marking $\text{♩} = 96$.

Musical staff 6: Treble clef. The staff contains a sequence of notes with dynamic markings: *ff* and *mf*. It includes a triplet of eighth notes with a '3' above it. There are accents over several notes and a tempo marking $\text{♩} = 112$.

Musical staff 7: Treble clef. The staff contains a sequence of notes with dynamic markings: *mf*. It includes a triplet of eighth notes with a '3' above it. There are accents over several notes and a tempo marking $\text{♩} = 80$. The instruction *poco a poco calmando* is written below the staff.

Musical staff 8: Treble clef. The staff contains a sequence of notes with dynamic markings: *mp*. It includes a triplet of eighth notes with a '3' above it. There are accents over several notes and a tempo marking $\text{♩} = 69$.

Musical staff 9: Treble clef. The staff contains a sequence of notes with dynamic markings: *p*. It includes a triplet of eighth notes with a '3' above it. There are accents over several notes.

Musical staff 10: Treble clef. The staff contains a sequence of notes with dynamic markings: *mp*, *p*, and *ord.*. It includes a triplet of eighth notes with a '3' above it. There are accents over several notes and a tempo marking $\text{♩} = 52$. The instruction *pizz.* is written above the staff.

III

♩ = 60
con sord.

mp molto cantabile

Measures 1-18 of section III. The music is in 3/4 time with a tempo of 60. It begins with a treble clef and a bass clef. The first staff (treble) starts with a half note G4, followed by quarter notes A4, B4, and C5. The second staff (bass) starts with a half note G3, followed by quarter notes F3, E3, and D3. The score includes several triplet markings (3) and dynamic markings: *mp*, *poco f*, *mf*, *p*, *f*, *ff*, *f*, *mp*, *p*, *mf*, *p*, *f*, *pp*, *pp*, *mp*, and *poco f*. Performance instructions include *molto cantabile*, *poco rit.*, *a tempo*, *sul pont.*, and *poco accel.*

IV

♩ = 92
senza sord.

mf-f (at will)

Measures 1-2 of section IV. The music is in 3/4 time with a tempo of 92. It begins with a treble clef and a bass clef. The first staff (treble) starts with a half note G4, followed by quarter notes A4, B4, and C5. The second staff (bass) starts with a half note G3, followed by quarter notes F3, E3, and D3. The score includes triplet markings (3) and dynamic markings: *mf-f* (at will), *ff*, *mf*, and *f*. Performance instructions include *rit.*, *a tempo*, *poco a poco rit.*, *sul tasto*, and *lunga*.

Musical staff 1: Treble clef, 3/8 time signature. Starts with a triplet of eighth notes. Dynamics: *mf* to *f*. Includes a triplet of eighth notes and a slur over a group of notes.

Musical staff 2: Treble clef. Dynamics: *mf*. Includes a triplet of eighth notes and a slur over a group of notes.

Musical staff 3: Treble clef. Dynamics: *f*. Includes a triplet of eighth notes and a slur over a group of notes.

Musical staff 4: Treble clef. Dynamics: *mp*. Includes a slur over a group of notes.

Musical staff 5: Treble clef. Dynamics: *f*. Includes a triplet of eighth notes and a slur over a group of notes.

Musical staff 6: Treble clef. Dynamics: *ff*. Includes a slur over a group of notes.

Musical staff 7: Treble clef. Includes triplets of eighth notes and a slur over a group of notes.

Musical staff 8: Treble clef. Includes a triplet of eighth notes and a slur over a group of notes.

Musical staff 9: Treble clef. Tempo marking: $\text{♩} = 46$. Dynamics: *p* to *pp*. Includes a slur over a group of notes.

V

♩=48
(heavy sord. - optional)

mp cantabile

mf

mp

mf

pp

mf

p

pp

mf

p

mp

mp

ord.

♩=58

mf

p

p

mp

pp

♩=40

ppp

sul tasto

(tremolo begins here)

VI

♩=92

f

ff

f

mf

mp

p

mp

l.h. pizz.

mf mp sfz ff

poco a poco calmando

sub.p mp p $\text{♩} = 63$

mp mf f

ff

mp $\text{♩} = 92$

mf ff pizz.

arco mp mf f ff pizz.

arco mf f ff mp $\text{♩} = 84$

poco a poco allargando

p f ff $\text{♩} = 104$

f mf p pp mp p pp $\text{♩} = 63$ $\text{♩} = 50$

D'Addario
Helicore
VIOLA STRINGS

Set H410

"Helicore strings offer flexibility, ease, sheen, clarity of pitch, and power throughout the entire tonal and dynamic range. Response both to bow and left hand pressures is amazingly consistent; the tone flows up and down the fingerboard."

-Bernard Zaslav

Mr. Zaslav played Helicore viola strings while recording the Zaslav Duo's two latest releases, "Ernest Bloch: Music for Viola & Piano" and "Dvorák's Viola," on the Music & Arts Programs of America label.

J. D'Addario & Company, Inc. • PO Box 290 • Farmingdale, NY 11735 USA
E-Mail: strings@daddario.com • Home Page: <http://www.daddario.com>

OF INTEREST

Internet sites of possible interest to AVS members:

Information from the Viola Fan Club in Japan. The CD list was updated 23 October 1998.

The URL of Additional CD list page is:

<http://www1.nisiq.net/~viola/vfc/vfcenglish.html>

VIOLIST & CD Number - Alphabetical Listing is:

<http://www1.nisiq.net/~viola/VCD/violistindex.html#english>

COMPOSER & COMPOSITION - Alphabetical Listing is:

<http://www1.nisiq.net/~viola/cdlist/vfccdlist.comp.html#english>

Thank you very much for your CD information.

Rumi Takano / Office of Viola Fan Club

E-mail: viola@nisiq.net



Steven McCann

Maker of Violas • Violins • Cellos

Available at
Guarneri House
 221 John Street NE
 Grand Rapids, MI 49503
 (616) 451-4960

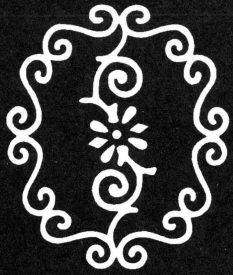

Stamell

STRINGED
INSTRUMENTS

A Full Service
Violin Shop

Inquiries:

(800) 766-0936

info@stamellstring.com

www.stamellstring.com

18 Kellogg Ave.
Amherst, MA 01002
U.S.A.

VIOLAS FOR CHILDREN

Entirely Hand Crafted
by **Philippe Raynaud**

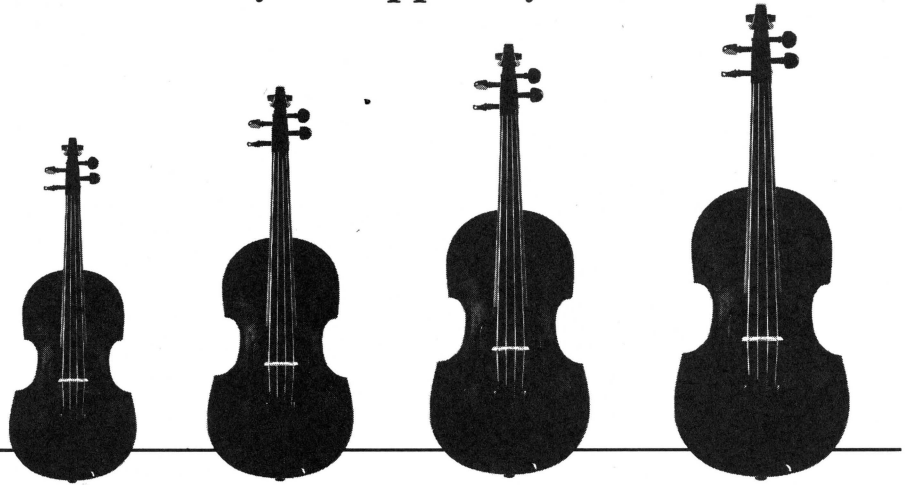

11"

12"

13"

14"

Unique, Affordable, Heirloom Quality
Exclusively for *Stamell Stringed Instruments*

VIOLIN MAKERS • DEALERS • APPRAISERS • RESTORERS

Helen Callus, *viola*

Artist in Residence at the University of Washington, Seattle



"Impeccable sensibilities. [Her sound] is soft-edged, rich, gorgeous and relaxed... A consummate chamber music player, her tone is easy and mellow, with depth, and her technique is unobtrusively excellent."

*—Seattle Post
Intelligencer*

Information: Advising Office
University of Washington School of Music, Box # 353450
Seattle, WA 98195-3450.
Telephone: (206) 543-1239 (undergrad.); 543-8273 (grad.)

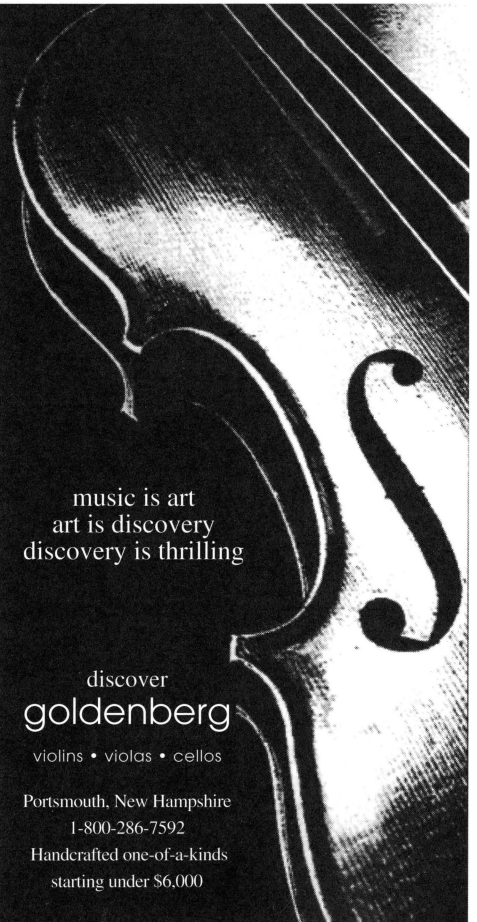

music is art
art is discovery
discovery is thrilling

discover
goldenberg

violins • violas • cellos

Portsmouth, New Hampshire

1-800-286-7592

Handcrafted one-of-a-kinds
starting under \$6,000

ABOUT VIOLISTS

Primrose and the American Connection: A paper read at the XVI International Viola Congress, Glasgow, 1998

by Myron Rosenblum

William Primrose's accomplishments as soloist, chamber musician, and teacher during his many years in America are legendary and well documented. In a short article by James Wilson, a cousin of Primrose, Wilson mentions that he established contact with Primrose in Boston in 1964, where Primrose had been consulting with a doctor about his heart condition. This serious medical situation caused Primrose to curtail his solo concert schedule and focus more on chamber music performances and teaching. Teaching constituted an important part of his musical life and I am convinced that he took great pleasure in it, learned from it, and used it to further analyze violistic and string problems and come to possible solutions. I well recall my very first lesson with this amazing musician. He pulled out his books of Ševčík finger and shifting exercises and my heart sank a bit with memories of childhood drudgery and boredom on these violin staples. But Primrose was excited about them and their inherent worth to violists and quickly transmitted this enthusiasm to me, a twenty-two-year-old string player on the verge of pursuing a viola career.

Henri Temianka, the first violinist of the Paganini Quartet, who often performed with Primrose, wrote of his teaching: "It is probably true to say that Primrose accomplished his most important work as a teacher after he had concluded his career as a performer. Also, there were his many superb recordings to guide and inspire his students."

During his years in America, Primrose was affiliated with some outstanding music schools and conservatories, such as the Curtis Institute in Philadelphia; the Juilliard School of Music in New York; the School of Music at Indiana University, Bloomington, Indiana; the University of Southern California; the Eastman School of Music; and the Aspen Music School and Festival in Colorado.

His fine pragmatic and analytical teaching

touched many violists and produced players that can be counted among the best in the world today. I will highlight seven violists who were his pupils in America—some who will be known to you, and some who may not be so well known. The outstanding musical and technical standards, demanded by their mentor, were instrumental and inspirational in putting each on the track to great viola artistry.

I will follow a more or less chronological order, starting with Joseph de Pasquale, the oldest, and concluding with Paul Neubauer, young perhaps in years but by no means in musical powers.



Joseph de Pasquale

JOSEPH DE PASQUALE was born in Philadelphia in 1919. He is a graduate of the Curtis Institute, where he studied with Primrose from 1943 to 1946. After army service he joined the American Broadcasting Orchestra in New York and then became principal violist of the Boston Symphony Orchestra in



Violists
Please Visit the
Four Seasons Orchestra
Website



To Discover
Beautiful
Alto-Clef Logo Gifts



[@www.fourseasonsorchestra.org](http://www.fourseasonsorchestra.org)

or write to Carolyn Broe @
4972 E. Paradise Lane
Scottsdale, AZ 85254

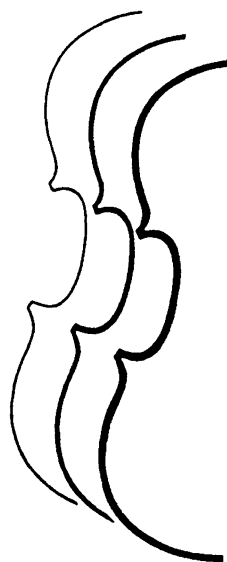

GEOFFREY OVINGTON

MAKER OF VIOLINS,
VIOLAS AND CELLI

Instruments of Distinction
Played Internationally

GEOFFREY OVINGTON VIOLINS

STANTON ROAD
SHUSHAN, NY 12873
U.S.A.

518-854-3648

VIENNA PHILHARMONIC (PR. VLA.)
ALBAN BERG STRING QUARTET
DEUTSCHE KAMMERPHILHARMONIE
NEW YORK PHILHARMONIC
JOACHIM-KOECHERT QUARTET

LOS ANGELES CHAMBER ORCHESTRA
BUFFALO PHILHARMONIC
LAFAYETTE QUARTET
BAVARIAN RADIO SYMPHONY (PR. VLA.)
ST. CECILIA CHAMBER ORCHESTRA

OPERA ORCHESTRA OF LA SCALA (PR. VLA.)
OSLO PHILHARMONIC
VIENNA RADIO SYMPHONY
NORWEGIAN CHAMBER ORCHESTRA
GÖTEBORG SYMPHONY

1947 under Serge Koussevitsky. During his seventeen years there he gave the first Boston performances of the Walton and Milhaud viola concerti and premiered the Walter Piston viola concerto.

De Pasquale was the principal violist of the Philadelphia Orchestra from 1964 to 1996. In the late 1960s, he appeared in concerts with Jascha Heifetz and Gregor Piatigorsky in New York and subsequently recorded the Françaix Trio and Dvorák Piano Quintet with them. He was on the faculty of Indiana University from 1990 to 1992, a position previously held by Primrose.

Recently, de Pasquale was the dedicatee of the XV International Viola Congress, sponsored by the American Viola Society. Currently he is on the faculties of the Curtis and Peabody institutes.



Photo by Christian Steiner

Myra Kestenbaum

MYRA KESTENBAUM studied with Primrose from 1955–58 while a student at the Juilliard School. She played with the Los Angeles Philharmonic for five years and also performed in the California Chamber Symphony. She appeared as viola soloist in many concerts in Los Angeles and San Francisco and in a multitude of movie scores in Hollywood.

In 1971 she became the principal violist of the Los Angeles Chamber Orchestra under Sir Neville Marriner and was the violist in the Los Angeles Piano Quartet, a satellite of that orchestra. She resigned her position in 1979 to pursue a career as viola soloist and appeared throughout the USA, Canada, Europe, Australia, New Zealand, Mexico and Russia. She has taught in many schools and appeared in many music festivals.

Sadly, a serious injury in 1992 put an abrupt stop to her career as a performer. She has since concentrated on composition and has written some fine music, including a string trio and a sonata for viola and percussion. When she left the Los Angeles Chamber Orchestra, Sir Neville Marriner wrote of her: "She is unique as a dazzling protagonist of the viola in the 20th century and has given me more pleasure as a soloist than any other performer." She is currently teaching in the Los Angeles area.



Donald McInnes

DONALD McINNES was born in 1939 in San Francisco and studied with Primrose from 1965–66 at the University of Southern California. He continued taking private lessons with Primrose while Primrose was at Indiana University. He has given many recitals and has appeared as a soloist with major orchestras and in many chamber concerts. He is also well known for his superior master classes.

McInnes has been on the faculties of the University of Michigan, the Cincinnati



Latham Music Enterprises

*Specializing in
Music for Strings*

• Free Catalog •

New Website:

www.latham-music.com

• Last chance! Close out! •
Viola Power T-Shirt - \$11.00

1327 Beaman Pl. #214 Greensboro, NC 27408
(800)645-7022 (US) or (336)273-1499 (FAX)



Mark Anton Hollinger

Award Winning Instruments
VIOLIN • VIOLA • CELLO
CONTEMPORARY & BAROQUE

EXPERT REPAIRS, ACCOUSTICAL ADJUSTMENTS
BOWS & ACCESSORIES

5075 LUPINE ROAD
MISSOULA, MONTANA 59803
406-542-2012

Member AFVBM

Conservatory, and the University of Washington. In 1985 he was appointed Professor of Viola at the University of Southern California, a position formerly held by Primrose.

He has appeared as viola soloist with the New York Philharmonic, the Boston Symphony Orchestra, the Orchestre Nationale de France, the Pittsburgh Symphony, the Zürich Chamber Orchestra, CBC Radio Orchestra and others. Among artists he has performed with are Leonard Bernstein, Yehudi Menuhin, Lynn Harrell, Yo-Yo Ma, and Janos Starker. He has recorded extensively and premiered numerous viola works by American composers. His students have won many major competitions and prizes.



Photo by Louis Ouzier

Martha Strongin Katz

MARTHA STRONGIN KATZ was the founding violist of the Cleveland String Quartet, one of America's premier chamber ensembles for many years. Her years with the Cleveland Quartet were from 1964-80, when she left to raise a family. She studied at the Curtis Institute, Juilliard, and the University of Southern California. She has taught at the Eastman School; the Cleveland Institute; the Yale Summer Music School; the Guildhall School of Music, London; the Banff Centre; and the Aspen Music School. Her many honors include prizes at the Munich International

Competition (with the Cleveland Quartet), the Geneva Viola Competition (1968) and the Max Reger Award, also in 1968.

She was featured at the 1989 International Viola Congress and has performed as soloist with the Orchestre de la Suisse Romande and the Mozarteum Orchester. She now teaches at the Shephard School of Music at Rice University.

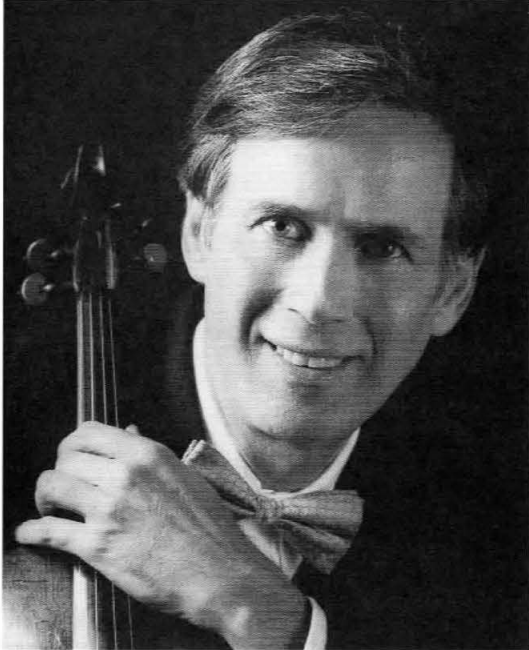

Yizhak Schotten

YIZHAK SCHOTTEN, born in Israel, was discovered and brought to America by Primrose. Schotten studied under Primrose at the University of Southern California and Indiana University. He has performed as soloist with Seiji Ozawa, Thomas Schippers, Sergio Commissiona, and others and has performed widely in Israel, Japan, Taiwan, Malaysia, Holland, Austria, Mexico, England, Canada and the U.S. He was a member of the Boston Symphony Orchestra and was principal violist in the Cincinnati and Houston Symphony orchestras. Schotten hosted the XIV International Viola Congress at the University of Michigan. He has given master classes in the U.S. and Europe and has made several recordings of viola works by Bloch, Hindemith and others. Among his recitals and master classes have been those at the Menuhin School in Surrey, the Guildhall School, and the Royal

College of Music in London. He was a judge in the 1997 Tertis Viola Competition and was recently featured in *The Strad* magazine as one of America's finest violists.



Alan de Veritch

ALAN DE VERITCH was born in 1947 in New Jersey but lived most of his life in California. He was co-principal violist in the Los Angeles Philharmonic under Zubin Mehta from 1970–79, where de Veritch also appeared as a soloist. He has recorded hundreds of sound tracks and recorded for every major record label in the U.S. He has been on the faculties of the California Institute of the Arts, California State University, and the University of Southern California, among others. From 1990–94 he served as president of the American Viola Society and also established the De Veritch Institute for Viola Studies. In June 1995, he hosted the XXIII International Viola Congress at Indiana University. He also was the recipient of an award from the American Viola Society for his outstanding achievements and personal contributions to the legacy of the viola.

De Veritch is now a professor of music and chair of the String Department at the School of Music at Indiana University.

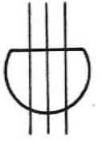

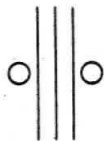

Photo by J. Henry Fair

Paul Neubauer

PAUL NEUBAUER comes from Los Angeles and is a graduate of the Juilliard School. He studied with Primrose late in Primrose's life. At age twenty-one, he was appointed principal violist of the New York Philharmonic, the youngest principal string player in its history. He replaced Walter Trampler as the violist in the Lincoln Center Chamber Music Players, a prestigious position. He has performed widely in the U.S. and as a soloist

and in festivals in Europe and Asia. With Peter Bartók, he recently made a revised version of the Bartók Viola Concerto.

Neubauer has appeared in many radio and television concerts in New York, Argentina, Brazil, Mexico, Canada, England, Germany, Hungary, Norway and Yugoslavia. With the New York Philharmonic, he was soloist in the New York première of Penderecki's Viola Concerto, with the composer conducting.

Paul has performed with many orchestras, including the Los Angeles Philharmonic, the National Symphony, the Orchestra of St. Luke's, the San Francisco Symphony, the St. Louis Symphony, the Bavarian State Radio Orchestra, the English Chamber Orchestra (where he gave the world premiere of Gordon Jacob's Viola Concerto No. 2) and the Bournemouth Symphony.

He has recorded extensively and his CD of the Walton Viola Concerto with the Bournemouth Symphony and Andrew Litton will be released soon. His awards are many, including first prize at the Tertis International Viola Competition.

These are but seven of the many fine and talented violists who were touched by William Primrose. To quote Henri Temianka once again: "Through his teaching, Primrose left a tremendous legacy."

I have thought back to my own lessons with William Primrose. They were special moments in my music education. I instinctively pulled out some old recordings and after listening to much extraordinary playing, I thought of an old review which appeared in the 1950s in *High Fidelity* magazine of Primrose's recording of the Walton Viola Concerto and Hindemith's *Der Schwandreher*. The reviewer started by asking something to the effect: "Is William Primrose the Greatest String Player of All?" That's a tough one to answer, but he is certainly up there with the very best of this century's most gifted artists, and some of his former students are right behind him.

KENNETH STEIN VIOLINS

Expert Repairs & Restorations

Large selection of
fine Violins, Violas, Cellos and Bows

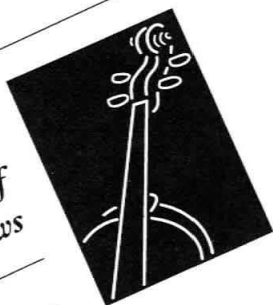

(847)491-9550
1320 Sherman Avenue.
Evanston, IL
60201



Kagan & Gaines Company, Inc.

"From Strings to Strads"

Fine violins, violas, cellos, bows

Specialists in violas

Instruments appropriate for amateur and professional use

Excellent modern Italian violins and violas

We will work with you to commission instruments
from gold medal winning luthiers in America
and Europe

Good selection of student instruments

Appraisals, insurance evaluations, certificates on
select instruments

Kagan & Gaines: Your connection to masterpieces

For assistance with instruments and bows please call:

Eric Chapman
Director, Strings Department
312.849.3003

The most talked about innovation for bowed instruments at a most affordable price.

C. F. Durre Bows

A Durro carbon fibre composite bow feels and handles like a fine pernambuco bow at a fraction of the cost. The big clear and focused sound will astonish you.

Available weights:
violin 58 to 62 grams
viola 66 to 70 grams

Prices starting at \$300.

EXCLUSIVE WORLDWIDE DISTRIBUTION

Ideal Musical Merchandise Company
53 West 23rd Street
New York, NY 10010

TEL 212.675.5050 . FAX 212.989.9275

AVS CHAPTERS

Editor's Note: Each president of the various AVS chapters is requested to send chapter news to the editor of JAVS.

Utah Viola Society

The Utah Viola Society will cosponsor ViolaFest March 9–13, 1999. The guest artist is Paul Neubauer. A master class will be held at Brigham Young University on Tuesday, March 9, and the annual Primrose Memorial Concert will be on Wednesday the 10th. Friday and Saturday evenings, Mr. Neubauer will

play Walton with the Utah Symphony under the direction of Joseph Silverstein at Abravanel Hall in Salt Lake City. Saturday, March 13, Mr. Neubauer will participate in another viola activity in the Utah Capitol Building. For information contact UVS president Leslie Harlow (435) 649-5909.

Arizona Viola Society

William Magers, the AVS president, reports that "Virtuoso Violas" took place at Tempe last October in which over one hundred viola students between grades 3–12 par-

ticipated. Also, residency by the Cavani String Quartet at Arizona State University with a master class by its violist Kirsten Docter highlighted viola activities of the month.

Rocky Mountain Viola Society

Visiting viola artist, Simon Rowland-Jones, appeared with the University of Northern Colorado Symphony Orchestra in a performance of the Suite for viola by Ernest Bloch. Rowland-Jones is professor of viola at the

Royal College of Music in London and founding member of the Chilingirian String Quartet. He offered two master classes at the University of Northern Colorado.

Music of Alfred Loeffler

Sonata for Viola and Piano \$21.00

Toccata III for Viola and Percussion \$18.50

String Quartet \$54.50

Four Appalachian Melodies for Four Violins \$12.00

(Appropriate for intermediate students)

Also of interest:

J. S. Bach: Suite in G for Viola Solo

(Arranged by Alfred Loeffler after the Cello Suite No. 6 in D)

To order, send payment (check or purchase order) plus \$2 shipping for one item and \$0.50 for each additional item. CA residents add 7.25% sales tax.

Avera Music Press

(())(())(())(())(())

308 Mission Serra Terrace

(())(())(())(())(())

Chico, California 95926

530/345-3772

Free brochure on request. Score samples available on the World Wide Web: <http://www.now2000.com/avera>

Ever felt like something was missing in your viola?



ALF STUDIOS

Pre-purchase consultation
Prompt delivery on custom orders
After-sale service plan
Financing plan
Assorted price ranges
Instrument care instruction
Referrals to other makers
Free insurance updates

Gregg T. Alf, Violamaker
1221 Prospect Avenue, Ann Arbor, MI 48104
tel: (734) 665-2012 fax: (734) 665-4623
email: violas@alfstudios.com
www.alfstudios.com

PRACTICE VIOLAS

Have you sometimes wanted to practice late at night without disturbing others, either at home or in a hotel room? Or wished for an instrument that could be packed into your suitcase? Or one that could safely be taken to the beach cottage and other places where you don't want to take your good viola?

One of our **take-apart** practice/travel instruments may be just the thing. They have a subdued and pleasant tone. They will fit even into a backpack. Take-apart bows are also available.

We also make practice/travel violins and cellos.

Ernest Nussbaum
6009 Johnson Ave.
Bethesda, MD 20817

Tel 301/530-7316
Fax 301/493-4867

E-mail: cellist@compuserve.com

Send for your FREE CATALOG!

from Theodore Presser Co. & affiliates

Highlights include:

- Samuel Adler** (Theodore Presser Co.)
Sonata *Vla. & Pno.* (114-40445) \$18.50
- Atar Arad** (Israel Music Institute)
Sonata *Vla., unacc.* (514-02612) \$8.00
- Philippe Hersant** (Durand S.A.)
Eight Duos *Vla. & Bsn.* (554-01049) \$24.75
- Robert Mann** (Merion Music, Inc.)
Invocation *Vln. & Vla.* (144-40225) \$4.50
- Louis Marischal** (Éditions Robert Martin)
Sonate, Op. 52 *Vla. & Pno.* (514-02651) \$28.00
- Alexandre Tansman** (Éditions Billaudot)
Alla Polacca *Vla. & Pno.* (514-02816) \$6.95
- Yoshihisa Taïra** (Éditions Musicales Transatlantiques)
Pénombres 5 *Vla. & Pno.* (514-02761) \$42.50
- Ward/Downing** (Dr. Downing Books)
Violin and Viola Technique Doctor (578-00345) \$5.95

Prices subject to change.

Available through dealers.

For FREE catalog and quarterly updates, send your request to:

THEODORE PRESSER CO. • Dept. 9VA
1 Presser Pl. • Bryn Mawr, PA • 19010
or: E-mail presser@presser.com

NEW WORKS

—*Courtesy Canadian Viola Society Newsletter*

Extracted from *American String Teacher*, Winter 1998. Comments by Jeffrey Showell, associate professor of viola and assistant director of the School of Music at the University of Arizona.

Orchesterstudien, Vols. 3 (Elektra) and 4 (Rosenkavalier). Richard Strauss/August Gentz. Fuerstner, 1987, \$27 U.S./vol. A reissue of the venerable 1912 edition. Extensive excerpts rather than entire works. Have occasional bowings and fingerings. Probably less expensive to buy complete parts.

Poem for Viola and Orchestra (viola/organ). Leo Sowerby. H. W. Gray/Presser, 199[?], \$18 U.S. A reprint of the 1947 edition. An eclectic, solid work, quite typical of that period of American composition. Moderately difficult.

The North Shore (viola/piano). Gavin Gryars. Schott, 1995. Short, repetitive with motivic repetition. Dissonant, but shows off the viola tone well. Medium difficulty.

Sonate pour alto seul. Georges Migot/Marc Honegger. SEDIM, 1996. Written in 1952. Relatively conservative. Four long movements. Consonant, although not traditionally tonal. Fairly difficult.

Twenty-Four Caprices (solo viola). Casimir Frédéric Lainé, Billadout, 1996, \$30 U.S. Written 1849 and surprisingly difficult for the period.

Premier Voyage, 2 vols. (viola/piano). Yvette Voirpy/Alain Voirpy. Lemoine, 1996, \$25/vol. European folk songs adapted for the first-year violist. A more demanding piano part.

Pièces Classiques. Frédéric Lainé. Billadout, 1996, \$11.50 U.S. The first of five volumes of progressive difficulty. Twelve short, very easy arrangements of compositions by Classical and Romantic composers.

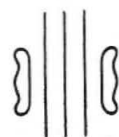

HARID

Setting the Stage for the Future

The Harid Conservatory's Bachelor of Music-Performance, Professional Studies, and Performer's Certificate programs offer performance training at the highest level:

- ◆ Comprehensive curriculum
- ◆ Intensive orchestral and chamber music performance training
- ◆ Select studio classes
- ◆ Vigorous solo training
- ◆ Career development and performance opportunities

Auditions for Fall 1999 enrollment will be held February 14–19 and March 14–19, 1999. Preliminary tapes are encouraged by January 15, 1999.

All students accepted receive full-tuition scholarships.



Artist Faculty Michael McClelland coaches a HARID viola student

The Harid Conservatory is an accredited institutional member of the National Association of Schools of Music.

Harid Conservatory of Music, Inc. is an equal opportunity institution and does not discriminate against anyone on the basis of race, color, sex, religion, national or ethnic origin, or other protected status.

MUSIC DIVISION 1998–99

Kate Ransom, Director
 Sergiu Schwartz, Violin
 Michael McClelland, Viola
 Johanne Perron, Cello
 Shigeru Ishikawa, Double Bass
 Laura Gilbert, Flute
 John Dee, Oboe
 Paul Green, Clarinet
 Arthur Weisberg, Bassoon / Conductor
 Gregory Miller, French Horn
 Richard Stoelzel, Trumpet
 Stephen Rawlins, Trombone
 Matthew K. Brown, Tuba
 Michael Parola, Percussion
 Roberta Rust, Piano
 Thomas McKinley, Music Theory

**The Harid Conservatory
 Music Division
 2285 Potomac Road
 Boca Raton, FL 33431-5518
 Phone: 561-997-2677**

VIOLA CONNOTATIONS

Please submit your informative photos of license plates, commercial products,
and unusual associations that keep our name before the public.

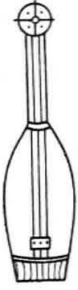

Monsieur Viola Player?

Submitted by Donna Dalton
Provo, Utah

JAVS Special Offer to AVS Members!

A good gift to students and friends. \$3.00 for any of the following back issues
of the *Journal of the American Viola Society*.

April 1987, Vol. 3 No. 1 _____

Nov. 1987, Vol. 3 No. 3 _____

Spring 1989, Vol. 5 No. 1 _____

Summer 1989, Vol. 5 No. 2 _____

Fall 1989, Vol. 5 No. 3 _____

Summer 1990, Vol. 6 No. 2 _____

Fall 1990, Vol. 6 No. 3 _____

Fall 1991, Vol. 7 No. 2 _____

Winter 1991, Vol. 7 No. 3 _____

Vol. 8 No. 2, 1992 _____

Vol. 9 No. 1, 1993 _____

Vol. 10 No. 1, 1994 _____

Vol. 10 No. 2, 1994 _____

Vol. 10 No. 3, 1994 _____

Vol. 11 No. 1, 1995 _____

Vol. 11 No. 2, 1995 _____

Vol. 11 No. 3, 1995 _____

Vol. 12 No. 1, 1996 _____

Vol. 12 No. 2, 1996 _____

Vol. 12 No. 3, 1996 _____

Vol. 13 No. 1, 1997 _____

Vol. 14 No. 1, 1998 _____

Vol. 14 No. 2, 1998 _____

The Viola, Vol. 6 _____

The Viola, Vol. 7 _____

The Viola, 1985/86 _____

Name _____ Telephone _____

Address _____

City _____ State _____ Zip _____

Make check payable to the American Viola Society and submit to
David Dalton, Editor *JAVS*, BYU Music HFAC, Provo, UT 84602

RECORDINGS

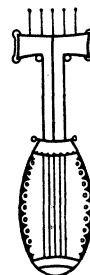

J. S. Bach: Sonatas for Viola da Gamba and Harpsichord (Arranged for viola and piano); **Verebes**, viola; Lagace, piano; Sne 564 (Allegro)

J. S. Bach: Sonatas for Viola da Gamba and Harpsichord (Arranged for viola and piano); W. F. Bach: Sonata for Viola and Harpsichord; C. P. E. Bach: Sonata for Viola da Gamba and Harpsichord (Arranged for viola and piano); **Nobuko Imai**, viola; Roland Poentinen, piano; Phillips 454449-2

Bartók: Concerto for Viola (Serly 1949 version); **Bartók:** Concerto for Viola (Peter Bartók 1995 version); **Bartók:** *Two Pictures*; Serly: *Rhapsody for Viola*; **Hong-Mei Xiao**, viola; Budapest Philharmonic Orchestra; Kovacs, con; Naxos 8.554183

Brotons: Sonata for Viola; Benejam: *Moment Musicals*; Grignon: *Scherzino*; Bonte: *Sonatina*; **Paul Cortese**, viola; Soler, piano; Edition Albert Moraleda EAM 7373

Bruch: Concerto for Clarinet and Viola; Concerto for Violin No. 2; Romance for Violin; *Adagio Appassionato*; **Donatius Katkus**, viola; Jacques Israelovich, violin; Guy Chadash, clarinet; St. Christopher Chamber Orchestra of Lithuania; Arie Lipsky, conductor; Fleur de son FDS 925

Clarke: Sonata for Viola; Landry: *Three Poems*; Gougeon: *Alto Neptune*; Rubenstein: Sonata for Viola; **Chantal Masson-Bouque**, viola; Mariko Sato, piano; Sne 199654

Colgrass: Variations for Four Drums and Viola; McIntosh: *Nanuk*; Hiscott: *Romantic Nights*; Harmon: Sonata for Viola; **Rivka Golani**, viola; Huang, percussion; Scott, percussion; Clarke, piano; Centrediscs CMCCD 5798

Debussy: Sonata for Flute, Viola and Harp; La Flute de Pan (Syrinx); *Les Chansons de Bilitis*; *Prelude to the Afternoon of a Faune*; **Gerard Caussé**, viola; Isabelle Moretti, harp; Irene Jacob, narrator; Hermonia Mundi HMC 90.1647

Dohnányi: *Serenade*; Fuchs: String Trio; Kodály: String Trio; Berlin String Trio; Arte Nova classics 74321 4845-2

Viola Transcriptions: Falla; Kreisler; Benjamin; Ravel; Bach; Tchaikovsky; Sarasate; Rachmaninoff; Paganini; **Defant**, viola; Waterhouse, piano; Symposium 0101

Franck: Sonata for Viola; Vieuxtemps: Sonata for Viola; *Elegie Capriccio*; **Lars Andes Tomter**, viola; Havard Gimse, piano; Simax PSC 1126

Hindemith: Sonata op. 11 No. 4; Britten: *Lachrymae*; Shostakovich: Sonata for Viola; **Yuri Bashmet**, viola; Sviatislav Richter, piano (Recorded in 1985); Olympia 625 (Allegro)

Hindemith: Sonatas for Viola op. 11 No. 4, No. 5; Op. 25 No. 1, No. 4; **Verebes**, viola; Bartlett, piano; 2 SNE 546

Hyde: 12 works include Sonatas for Viola; Sydney Chamber Orchestra; Walsingham Classics 2 WAL 8036

Loeffler: *Forgotten Songs*; **Noah Chaves**, viola; Deidra Palmer, mezzo-soprano; Noel Lester, piano; RoseAnn Markow, piano; Koch 3 3-7248-2HI

Lopez-Garcia: Concertino for Viola; concertino for Piano; *Divertimento*; **Ana Bela Chaves**, viola; Helena Sae Costa, piano; Strauss Portugalsom SP 4129

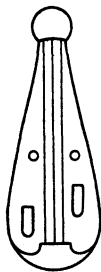

Schubert: The Viennese Guitar Quartet for Flute, Viola, Guitar and Cello; Kreutzer: Grand Trio; Beethoven: Serenade for Flute, Clarinet, and Guitar (Arranged by Mattiegka); **Paul Neubauer**, viola; Falleta, guitar; Still, flute; Thomas, cello; Koch 199667

Schumann: *Märchenbilder*; Glinka: Sonata for Viola; Debussy: Sonata for Flute, Viola and Harp; Milhaud: Sonata No. 2 for Viola; **Serge Collot**, viola; Keiko Toyama, piano; Aurele Nicolet, flute; Ayako Shinozaki, harp; Camerata 30 CM-462 (Albany)

Schumann: *Märchenerzählungen*; Adagio and Allegro; *Fantasiestücke*; *Märchenbilder*; Kurtág: Hommage à Robert Schumann; **Philip Dukes**, viola; Robert Plane, clarinet; Sophie Ramin, piano; ASV CD QS 6221

Schumann: *Märchenerzählungen*; *Märchenbilder*; Romances; *Fantasiestücke*; **Carbonare**, viola; et al.; Agora AGO 043

Telemann: Concerto for Viola; Concerto for Recorder and Bassoon; Suite in A; **David Miller**, viola; Dennis Godburn, bassoon; Elissa Beradi, recorder; Philomel Baroque Orchestra (period instruments); Centaur CRC 2366

Note:

In trying to get some further information I selected a search engine on my computer because the name of an Australian record company fascinated me. The name of the company is Tall Poppies. I selected it, and a wonderful website came on the screen that should be a model for all companies and artists. I clicked on the name of violist, Patricia Pollett and a most attractive picture of the artist popped up with her discography on which you could continue for more detailed information. Pollett has two solo recordings on Tall Poppies; the cost of the recordings were mentioned as well as how to order them.

The experience reminded me of another—several years ago I met a violist with

the New York Philharmonic who at his own expense had a CD made of his solo performances. I suggested he send one to a couple of people who might have been in a position to help promote his work. One was an artist representative of Naxos Records who had written me about suggesting viola works to record. The next thing I heard was that the two gentlemen had gotten together to discuss the possibility of making some records.

Violists, if you don't promote yourself, who will? The computer should be your friend and advertising companion.

Grainger: *Arrival Platform Humlet*; Sutherland: Viola Sonata; Edwards: *Enyato 11*; Sabin: *Resting Point*; Davidson: Arch for 3 Violas; Sculthorpe: Sonata for Viola and Percussion; Schultz: *Attack*; *Duo Variations* (All the composers are Australian); **Patricia Pollett**, viola; Jenni Fleming, piano; Colin Spiers, piano; Michael Askill, percussion; Tall Poppies TP098

Review:

In this CD, Entitled "Viola Power," Australian composer Robert Davidson is represented—with an original composition for three violas (all played by Pollett). Its title, "Arch," stems from the Italian word for both bows, *archi*, and the basic form of the piece. It is delightful and when I was sitting in front of the speakers I could easily discern the three distinctly different standing positions Pollett used when recording the different parts. I've already played this 6.42 minute composition on my radio program and have received quite a positive response from listeners. All the compositions are quite varied and enjoyable. Schultz's 18 minute composition seemed at first rather fragmentary but then became more interesting when the variation form became more discernible.

Brahms (Orch. Berio): Op. 120 No. 1 for Viola and Piano; Bruch: Romance; Schubert (Orch. Davidson): Sonata for Viola and Piano (*Arpeggione*); Sabin: *New York Souvenir*;

Patricia Pollett, viola; Queensland Philharmonic Orchestra; Werner Andreas Albert, conducting; Tall Poppies TP084

Review:

This disk (with the remarkable Queensland Philharmonic Orchestra which comprises 31 musicians yet sounds like it has more than twice that number) also shows off the wonderful talents of Patricia Pollett—a young virtuoso who is willing to take chances with old favorites and present a new composition by a little known (at least in this country) Australian composer, Nigel Sabin. It may be disconcerting to some to hear the familiar sonatas of Brahms and Schubert with orchestral accompaniment, but I rather enjoyed them. The arrangements were made by Luciano Berio and Robert Davidson. Shorter compositions by Bruch and Nigel Sabin admirably fill out the disc. Pollett has wonderful technique and the ability to change her tone quality in order to fit the mood of the music.

I recommend both disks wholeheartedly and commend Pollett for her daring, her imagination, and her innate musicianship. She is a violist of international quality and I eagerly await her future endeavors.

—David O. Brown, Brentwood, New York

From journals (*The Strad*):

Bruni: Viola Sonatas op. 27; **Farulli, Antonello**, viola; Francesco Dillon, cello; Gabriele Micheli, harpsichord and fortepiano; Dynamis S 2005

Beach: Music for violin/viola and piano; **Klugherz, Laura**, viola; Jill Timmons, piano; Centaur CRC 2312

Viola Pieces by Violin Virtuosi: rarely heard works by Wieniawski, Joachim, Vieuxtemps and Hubay; **Xuereb, Pierre-Henri**, viola; Luc Devos, piano; Classic Talent DOM 2910 12

The Strad also lists two complete discographies in recent issues. The June 1998 issue includes a list of recordings by Pinchas Zukerman on pp. 654–668. The September issue lists

the recordings of Yehudi Menuhin on pp. 994–1006.

Recommendations from the Viola Internet list:

L'Alto Romantique - The Romantic Viola I Laurent Verney. Release Date: 02/94 Num of Discs: 1 Length: 60 minutes; Label Pierre Verany (FRA) PV793121 SPARS code: DDD (It is on CDNow at: <http://www.cdnnow.com>)

This CD has *Andante and Rondo Ungarese* for Viola and Orchestra in C, Carl Maria von Weber; *Märchenbilder* for Viola and Piano, op. 113, Robert Schumann; *Potpourri* for Viola and Orchestra in G-minor, op. 94 *Fantasia*, Johann Nepomuk Hummel; *Pièce* for Viola and Piano in C-major, op. 39, Ernest Chausson; *Elegie* for Viola and Piano, op. 30, Vieuxtemps; *Élegie* for Viola and Piano in G-minor, op. 44, Glazunov (1856–1936); *Après un reve*, op. 7 no. 1, Gabriel Fauré.

—Ronald Schmidt, Germany

Hummel *Fantasia* recording

I have a recording of this played by Gerard Caussé on viola. The Hummel fantasy is fine, but I'm really wowed by a Joseph Schubert viola concerto on same CD, both the playing and composing are—wow!! What an amazingly lovely piece and impressive playing.

If I may put in another plug for Gerard Caussé—he recorded the string trio version of J. S. Bach's Goldberg Variations (transcribed to string trio by Dimitri Sitovetsky)—Dimitri on violin, **Gerard** on viola, (I've forgotten who was on violincello). Identification is Orfeo OYF138852 and it's an utter jewel. I prefer it a thousand times to any keyboard version (and am sure it must be crisper sound than the washy-full orchestra version). Of course, purists will object in howls. Bah.

—P. Winslowe Laccess, Calgary, Canada

I recently discovered an excellent CD in the "orchestra_pro_series" of Summit Records (DCD 217, 1997): Orchestral excerpts for viola with spoken commentary by Robert Vernon, principal violist of the Cleveland Orchestra.

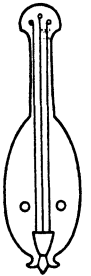

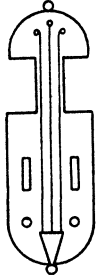

Included are excerpts from 20 different works, each performed by Vernon and preceded by his insightful and practical comments. I would recommend it highly to every violist and teacher of violists.

—Michael Kimber

J. S. Bach: The Sonatas and Partitas for Solo Violin and The Unaccompanied Partita for Flute, performed on viola. **Scott Slapin,**

viola; 2 CD set: The Stewart Society for the Recorded Sound; SSRS 42773-2

This is impressive playing of difficult music by a young, talented violist, Scott Slapin.

—Myron Rosenblum, New York

Courtesy of the *Newsletter*, Canadian Viola Society.

July 3 to 26, 1999

A festival for talented young musicians in an inspired setting

California Summer Music

— at the —
Robert Louis Stevenson School at Pebble Beach

Ages 12 through 23

Lessons, chamber music and performance for strings and piano. Composition and premieres for composers.

Information
email csm@dnai.com
web www.csmusic.org

Applications
236 W. Portal Ave., #104
San Francisco, CA 94124
t 415 753 8920
f 415 753 8934

In co-operation with the American String Teachers Assoc.



THE FACULTY

Timothy Bach
piano
Susan Bates
viola
Kathryn Brown
piano
Andrew Tuchansky
cello
Zaven Melikian
violin
Jan Repko
violin
Irene Sharp
cello
Wendy Sharp
violin
Basil Vendryes
viola

GUEST ARTISTS

Gilbert Kalish
piano
Paul Katz
cello
Irene Sharp
Artistic Director
Susan Bates
Program Director

Auditions

Live or taped auditions.
Call for dates and locations

Deadline: April 9, 1999

DEALERS, MUSICIANS, COLLECTORS, MAKERS ...

Specialized Insurance Coverage for the Classical & Vintage Musical Instrument Trade

- The most comprehensive protection at reasonable cost.
- Underwritten by a financially sound A-rated company.
- Call Toll Free today for information and quotation.

ELLIS W. HERSHMAN
Heritage Insurance Services, Inc.
826 Bustleton Pike, Suite 203
Feasterville, PA 19053

800-289-8837

FAX: 215-322-5854



COMPETITIONS

Irving M. Klein String Competition

The Irving M. Klein String Competition, 12–13 June 1999, ages 15–23. \$15,000 prize money. Entries by February 1999. Telephone (415) 338-7618.

Fischhoff Chamber Music Competition

7–9 May 1999 at South Bend, Indiana. Entry deadline 3 March 1999. Contact

PO Box 1303
South Bend, IN 46624
tel. (219) 237-4871
email: info@fischhoff.org
website: <http://fischhoff.org>

1999 Primrose Memorial Scholarship Competition

Eligibility: Applicants must meet the following criteria:

Have not yet reached their 28th birthday by 3 June 1999, and
Must be a current member, or presently studying with a current member, of the any of the branches of the International Viola Society (AVS, CVS, etc.)

N.B.: If you are not currently a member of the AVS and wish to join, please see application form for details.

Prizes:

- 1st Prize: \$2000, a Mini-Recital at the XXVII Congress, and an invitation to make a featured appearance at the XXVIX International Viola Congress.
- 2nd Prize: \$1000 and a Performance in a Master Class at the Congress.
- 3rd Prize: \$500 and a Performance in a Master Class at the Congress.

THE COMPETITION

REPERTOIRE: General Information

There are four categories of repertoire: (1) Work with Orchestra, (2) Work with Piano, (3) Un-accompanied Work, and (4) Virtuoso Primrose Transcriptions. Candidates must prepare one complete work from each category, one of which must be selected from the Contemporary Selections by Pendereski, Schnittke, or Takimitsu.

Work with Orchestra: Walton Concerto; Bloch Suite (1919)
Contemporary Selections: Pendereski Concerto; Schnittke Concerto

Work with Piano: Brahms Sonata (E \flat or F minor); Hindemith Op. 25, No. 4; Clarke Sonata, Shostakovich Sonata
Contemporary Selection: Takimitsu *A Bird Came down the Walk* (Published by Sharp)

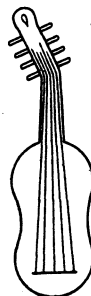

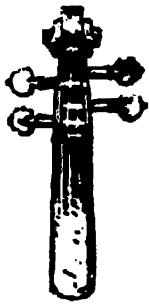

Miller & Fein

STRINGED INSTRUMENTS

*Makers, Restorers and Dealers of
Violins, Violas, Cellos and Bows*

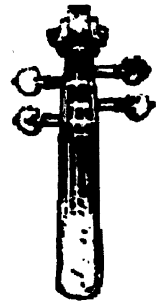

We offer a fine selection of instruments and bows in a wide range of prices, including master-crafted instruments from several European countries and eras, and restored instruments from some of the finer ateliers of France and Germany.

Advancing Students need high quality instruments with excellent projection and a warm, clear tone. Miller & Fein presents an outstanding selection in the \$1,000 to \$4,000 price range.

We feature handmade instruments and bows by some of the finest makers from around the world, including Tambovsky and Krutz, Amnon Weinstein, Whitney Osterud, Joseph Krosnowski, K. Gerhard Penzel, Nicolas Delaune, F. Vincent a Lyon, Andrew Fein and many others. Handcrafted bows priced from \$1,200. Master-made instruments priced from \$5,000.

Our Hours: Monday, Wednesday and Friday 10–6
Tuesday and Thursday 10–8
Saturday 10–4
Closed Sunday

Please make appointments to try instruments or bows.

Every virtuoso was a beginner once. . . . that's why they're important to us.

Ask about our great rental instrument plan.

In St. Paul's Historic Cathedral Hill District
The Blair Arcade, at Selby & Western Avenues
165 Western Avenue North, Saint Paul, MN 55102

612/228-0783 800/347-9172

Unaccompanied Work: Hindemith Sonata (any); Bach Suite (any); Reger (any)
Contemporary Selection: Pendereski Cadenza

Virtuosic Primrose Transcription: Benjamin *Jamaican Rhumba*; Borodin Scherzo; Benjamin *Le Tombeau de Ravel*; Paganini *La Campanella*; Paganini 24th Caprice (Viola and Piano); Sarasate-Zimbalist Tango, Polo, Maleguena, or Zapateado (from "Sarasateana")

FIRST ROUND:

The first round is recorded and submitted on audio cassette tape, which will then be auditioned by a jury. Candidates chosen from the taped round to compete in the final round(s) on 9–12 June 1999 in Guelph, Canada, will be notified by 15 April 1999.

In order to assure anonymity, the applicant's name and address should appear only on the applicant's outer package. There should be no personal identification on the tape or its container. Tapes will be coded before being sent to the adjudicating committee. Tapes will not be returned.

Applicants should understand that the quality of the recording may influence the judges; therefore, a new tape of a high quality should be used.

Repertoire for the First Round:

The cassette tape must include the applicant performing the following in accordance with the Repertoire General Information above:

- The first movement of a **Work with Orchestra**;
- An excerpt (c. 5 minutes) from the **Work with Piano**;
- An excerpt (c. 5 minutes) of an **Unaccompanied Work**.

N.B.: One of the selections must be from the list of Contemporary Selections, and candidates may not change repertoire between the First and Final round(s).

FINAL ROUND(S):

The Final Round(s) will take place in Guelph, Ontario, Canada, in conjunction with the XXVII International Viola Congress, 9–12 June 1999 at the _____.

Each of the finalists will be asked to perform (from memory, unless noted)

- The entire Work with Orchestra from the first round
- The entire Unaccompanied Work from the first round
- The entire Work with Piano from the first round (need not be memorized)
- A complete Virtuosic Primrose Transcription from the list above.

Finalists will receive discounted lodging and a waiver of the registration fees during the Congress. An accompanist will be provided if requested. The Jury for the Final Round(s) will be selected from those artists participating in the 1999 Congress who do not have a student invited to the Final Round(s). No screens will be used. Finalists are responsible for their own transportation expenses.

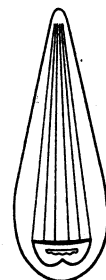



William Harris Lee & Company, Inc.
Makers of fine Violins, Violas and Cellos

Making instruments that meet the needs
of a new generation of players.

Call or write for further information:

William Harris Lee & Company, Inc.
410 South Michigan Avenue
Chicago, Illinois 60605
Telephone (312)786-0459 * (800)447-4533
Fax (312)786-9615

PRIMROSE MEMORIAL SCHOLARSHIP COMPETITION
Application Form

Name: _____ Birthdate: _____

Address: _____ Telephone: _____

Current Teacher, if any: _____

Please check the appropriate items:

I am or my teacher is currently a member of the American Viola Society,
 Canadian Viola Society, International Viola Society.

OR

I am not currently a member and wish to join the AVS.

If you wish to join the AVS, please enclose a SEPARATE check (made payable to the AVS), in the amount of \$15.00 (student member) or \$30.00 (regular member), along with your filled-out entry form, tape, and competition application fee.

Enclosed is my nonrefundable application fee of \$25.00, in the form of a check made out to the Primrose Memorial Scholarship Competition—AVS, and my unmarked audition tape. I have read the Competition Rules and Repertoire Lists and certify that I am eligible to participate in this year's Primrose Memorial Scholarship Competition. I am enclosing a photocopy of proof of my age (passport, driver's license) and proof of my or my teacher's membership in one of the branches of the International Viola Society.

Signature Required:

_____ Date: _____

SEND COMPLETED APPLICATION, TAPE, AND APPLICATION FEE TO

Lisa L. Hirschmugl
Primrose Competition
1 S. 229 Pine Lane
Lombard, IL 60148

APPLICATION AND SUPPORTING MATERIALS MUST BE POSTMARKED NO LATER THAN 15 MARCH 1999.



**Nowhere else
in the world
can you ...**

- ... study privately with today's leading professionals, studio musicians and freelance artists
- ... be part of a unique orchestral experience performing symphonic jazz and chamber music
- ... work with renowned composers and conductors from the film & music industry
- ... better prepare for your professional musical career



Jack Elliott, Music Director

August 1 - 28, 1999
UCLA
Faculty
(currently scheduled)



Jack Elliott conducts HMI Orchestra with the Turtle Island String Quartet

Carole Mukogawa (viola) Served as principal violist with Los Angeles Chamber Orchestra and Joffrey Ballet • Recorded with Henry Mancini, Frank Sinatra, and Mel Tormé

James (Jimbo) Ross (viola) Classical, blues, jazz and rock violist
• Recorded with Rod Stewart, Tori Amos • Featured soloist with the Don Ellis Orchestra

Bert Turetzky (bass) Author of "The Contemporary Contrabass" • Performed as soloist throughout the world • Professor of music at University of California, San Diego

Antony Cooke (cello) Performed as soloist under Sir Colin Davis • Former principal cellist of London Mozart Players • Leading studio musician in the Hollywood recording industry

Roger Lebow (cello) Principal cellist of the LA Mozart Orchestra • Founding member of the new-music group XTET • Leading studio musician

Jeremy Cohen (violin) Former member of Turtle Island String Quartet • Concertmaster on Linda Ronstadt's latest recording • Soloist with various U.S. orchestras

Irving Geller (violin) Former associate concertmaster of the Los Angeles Philharmonic • Currently with Hollywood Bowl Orchestra

Richard Greene (violin) Leading bluegrass, jazz, and folk violinist • Recorded and performed with Jerry Garcia, Herbie Hancock and Bruce Springsteen

Lesa Terry (violin) Former member of Atlanta Symphony Orchestra • Co-founder of the Uptown String Quartet • Performed with Ella Fitzgerald, Max Roach and Joe Williams

Previous guest artists

Ray Brown • Dave Grusin • Roy Hargrove • Tom Scott
Turtle Island String Quartet • Ernie Watts



HMI soloist performs with orchestra

**Full fellowships awarded to
all participants**
Violists encouraged

Henry Mancini Institute

Designed for college and post-college aged musicians seeking a career in music.

**HMI alumni include
graduates of:**

Berklee College of Music • Cleveland Institute of Music
Eastman School of Music • The Juilliard School
Manhattan School of Music • University of Miami • University
of North Texas • University of Southern California • UCLA

Catalog/Application
310.845.1903

also visit our Web site: www.amjazzphil.org

AMERICAN VIOLA SOCIETY DIRECTORY

Membership Report of the American Viola Society December 1, 1998

Regular members 781; Student members 286; International members 63; Complimentary members 22;
Joint AVS/CVS members 20; Institutions/Organizations 69; Total members 1241

A Message from Your Secretary:

I would like to take this opportunity to thank you for expressing your confidence in me by electing me as a new officer. I am honored to serve as your secretary for this term and I am enthusiastic about participating in the promising future of our American Viola Society. Welcome to all the new members who have joined this year! If you paid your membership during the last trimester of 1998 you are in good standing through January 1, 2000. Dues reminders should have arrived before January 1, 1999, for those of you needing to renew for 1999. Please be sure to notify me of any errors listed below.

Catherine Forbes, Secretary 817-261-5211
1128 Woodland Drive cforbes@uta.edu
Arlington, Texas 76012

Aagaard, Kathie J., 4018 N. Central Av, Tampa, FL 33603
Abel, Colette Grossman, 3227 Pennsylvania St, Indianapolis, IN, 46205
Adams, Julia, 15 Seeley Ave, Portland, ME, 04103
Adams, Jacob, 3532 Herschel View St, Cincinnati, OH, 45208
Adkins, Loretta C., 1981 State Rt 571 W, Greenville, OH, 45331
Agent, Betty, 11024 27th Ave NE, Seattle, WA, 98125
Ahlquist, Cigale, 217-C Presidential Dr, Greenville, DE, 19807
Akkerman, Kathleen, 17303 Herrnhut Dr, Webster, TX, 77598
Alban, Marcia, 3410 Woodland, Olympia Fields, IL, 60461
Albright, Chrissy, 2220 Palos Verdes, Carrollton, TX, 75006
Aldcroft, Margot, 5903 Gleam Ct, Agoura, CA, 91301
Alf, Gregg, 1221 Prospect St, Ann Arbor, MI, 48104
Ali, Shauncey, 1220 Fairlane Ave, Brookfield, WI, 53005
Allcott, David, 20800 Valley Green Dr #427, Cupertino, CA, 95014
Altmiller, William, 280 North & South Rd, Sullivan, MO, 63080
Altobelli, Rachel, 4023 Mackland NE, Albuquerque, NM, 87110
Andersen, Rebecca, 8049 S 1475 E, Sandy, UT, 84093
Anderson, Stella, 4744 Lyndale Ave S, Minneapolis, MN, 55409
Anderson, Christopher, 4807 Enchanted Rock Ln, Spring, TX, 77388
Anderson, Kathleen, 4474 South Crest Oak Dr, Salt Lake City, UT, 84124
Andrix, George, 10217-88th Street, Edmonton, Alberta, T5H 1PH, CANADA
Andrusco, Ronn, 28 Barbara Crescent, Toronto, Ont, M4C 3B2, CANADA
Angel, Eleanor, 3454 Ashton Ct, Palo Alto, CA, 94306
Antonik, John, 1060 Oldstone Rd, Allentown, PA, 18103
Appel, Toby, 164 West 79th St, New York, NY, 10024
Apperson, Laura, 15420 S 38th St, Phoenix, AZ, 85044
Arad, Atar, 710 Chaudin Ct, Bloomington, IN, 47401
Arlin, Mary, 623 Utica St, Ithaca, NY, 14850
Armbrust, Kyle, 5N648 Dunham Rd, Wayne, IL, 60184
Armbrust, Rose, 5N648 Dunham Rd, Wayne, IL, 60184
Arnold, Jennifer, 8521 Yorkview E. Drive, North Royalton, OH, 44133
Arnott, J, 331 N Main, Lindsborg, KS, 67456
Aronchick, Melissa, 4816 Clark, Montreal, Que, H2T 2T5, CANADA
Artley, Nathan, 150 Homeplace Dr, Fayetteville, NC, 28311
Asbell, Stephanie Ames, 208 West 31st Street #A, Austin, TX, 78705
Ast, Fatima, 1756 N. Sedgwick, Chicago, IL, 60614
Austin, John, 329 W 108th St, New York, NY, 10025
Austin, Krista, 4954 Foothill Blvd, San Diego, CA, 92109
Axelrod, Lisa, 2288 E Sunset Drive, Layton, UT, 84040-8165
Ayres, Carol, Rt 1 Box 812, Newton, TX, 75966
Ayres, Damara, 922 S Cleveland, Denton, TX, 76201
Baca, Sally, Theresa Ln Unit 1, Box 6, Espanola, NM, 87532
Bailey, Bill, 355 Staten Ave, Oakland, CA, 94610
Baker, Jennifer, 446 Conrad St, Tallahassee, FL, 32304
Baker, Marilyn, 1630 S Garth Ave, Los Angeles, CA, 90035
Baldwin, Maria, 4873 E Half Moon, Flagstaff, AZ, 86004
Balija, Ayn, 900 N Goodwin Dr, Park Ridge, IL, 60068
Balmforth, Alan, 1865 NE 171st, Seattle, WA, 98155
Banducci, Brett, 912 Haverhill Dr, Modesto, CA, 95356
Banerdt, Brendan, 20883 Kelvin Pl., Woodland Hills, CA, 91367
Barela, Robert, 5711 Simpson Ave, North Hollywood, CA, 91607
Barker, Lena, 2411 Johnstone Cir, Huntsville, AL, 35803
Barnes, Darrel, 18 Fall Creek Dr Apt. 3, Branson, MO, 65616
Barron, Virginia, 820 S Humphrey, Oak Park, IL, 60304
Barta, Claire, PO Box 758, Evans, CO, 80620
Barthe, Emmanuelle, 124 rue de Turenne, 75003, Paris, FRANCE
Bartow, George, 2320 Cherrybrook Ln, Pasadena, TX, 77502
Bartruff, William, 3329 1st Ave South, Minneapolis, MN, 55408
Bashmet, Yuri, c/o 26 Wadham Rd, London, SW15 2LR, UK
Basrak, Cathy, 1331 North Vail Ave, Arlington Heights, IL, 60004
Bass, Jonna, 3804 Deann, Amarillo, TX, 79121
Bates, Tara, 1335 W Warner, Fresno, CA, 93711
Bates, Susan, 1530 7th Ave, San Francisco, CA, 94122
Bauer, LeRoy, 242 Circle Dr, Moscow, ID, 83843
Bautista, Aladino, 589 Rocca Ave, South, CA, 94080
Bea, Karen, 5562 Hobart St, Pittsburgh, PA, 15217
Beaudette, Eileen, 732 Centre St, Kingston, Ont, K7M 5E4, CANADA
Beauregard, Lou, 1014 Delaware Ave, Butte, MT, 59701
Beck, Wanda, 28106 Meadowlark Dr, Golden, CO, 80401
Becker, Robert L., 2105 N. Louise, Santa Ana, CA, 92706
Becker, Leslie Van, 539 Paris St SE, Grand Rapids, MI, 49503
Beckstrom, Christine, 817 E Orangeburg, Modesto, CA, 95350
Behizadeh, Susan, 3184 Creek Dr, Marietta, GA, 30062
Bell, Nathem, 7211 Foothill Dr, Anchorage, AK, 99504

Bell, James, 8380 Waring Ave #102, Los Angeles, CA, 90069
 Beltzner, Gail, PO Box 4427, Allentown, PA, 18105
 Benjamin, Adria, 16 West 16th 4EN, New York, NY, 10011
 Benoit, Jimmie, 906 Kim Dr, Lafayette, LA, 70503
 Benson, Wilma, 6610 St Mary's Rd, Floyds Knobs, IN, 47119
 Benti, Diana, 858 Milwaukee Rd, Beloit, WI, 53511
 Beranger, Vinciane, 57 rue des Martyrs, Paris, F-75 009, FRANCE
 Berg, Robert, 5745 Friats Rd #74, San Diego, CA, 92110
 Berger, Madeline, 2 Mac Irvin Dr, Newport News, VA, 23606
 Bergman, Claire, 854 W 181 St Apt. 6B, New York, NY, 10033
 Bergman, Sam, 74 Groveland St, Oberlin, OH, 44074
 Berk, Annabel, 6971 E Calle Cavalier, Tucson, AZ, 85715
 Berkowitz, Lori, 170 Second Ave, New York, NY, 10003
 Berlet, Patricia, 992 Ash St, Winnetka, IL, 60093
 Besser, Idalynn, 2017 Benjamin Ave, Nashville, TN, 37206
 Betancourt, Cindy, 552 Summit St, Memphis, TN, 38104
 Betson, Nicholas, 944 Riverside Dr, South Bend, IN, 46619
 Bettigole, Marcia, 53 Wiltshire Rd, Williamsville, NY, 14221
 Betts, Alison, 723 N. Scott, Wheaton, IL, 60187
 Bidwell, Molly, 196 Jerusalem Rd, Bristol, VT, 05443
 Bienkowski, Barbara, 7005 Youpon, Galveston, TX, 77551
 Bigelow, Claudine, 815 S 18th St, Arlington, VA, 22202
 Bill, Susan, 10 Clive St, N Quincy, MA, 02171
 Bilyeu, Keith, 308 E College Ave, Appleton, WI, 54911
 Bingham, Sharon, 7112 Tolliver St, Alexandria, VA, 22306-3501
 Birmingham, Meghan, 9403 W 116th Terr, Overland Park, KS, 66210
 Bisha, Norma Lee, 507 Chebucto Head Rd, Duncan's Cove, Nova Scotia, B3V 1K4, CANADA
 Black, Katherine, PO Box 25089, Tempe, AZ, 85285-5089
 Blair, Harold, 80 Hunters Ln, Morehead, KY, 40351
 Blalock, Karen, 1098 East 500 S, Pleasant Grove, UT, 84062
 Blanchard, Maren, 525 N 600 E, Payson, UT, 84657
 Blankleder, Jose, 1240 Ala Kapuna #409, Honolulu, HI, 96819
 Blom, Rebecca, 1072 North Creek Rd, Porter Corners, NY, 12859
 Blumberg, Kira, 230 W. 7th Street, Claremont, CA, 91711
 Boaird, Dmitri, 10225 Scenario Ln, Los Angeles, CA, 90077
 Boc, Katherine, 2819 Rio Grande No. 320, Austin, TX, 78705
 Bochonko, Coca L., 218 4th Ave S Apt.D6, St Cloud, MN, 56301
 Boden, Kevin, 5018 N Evergreen, Spokane, WA, 99216
 Bodman, Alan, 338 Castle Blvd, Akron, OH, 44313-6504
 Bogin, Masako, 838 West End Ave Apt 2B2, New York, NY, 10025-5351
 Bolles, Emily, 30625 132 Ave SE, Auburn, WA, 98092
 Bollschweiler, Hugo, Eisengasse 40, 5600 Lenzburg, SWITZERLAND
 Bootz, Melinda, 1001 N Alford Blvd, Evansville, IN, 47711-4801
 Borchelt, Sarah E., 6 Stonebriar Ct, Ballwin, MO, 63011-2738
 Bottge, Karen, 3508 12th Ave SE, St Cloud, MN, 56304
 Bowers, Melissa, 5226 Don Pio Dr, Woodland Hills, CA, 91364
 Bradford, Lawrence, 426 18th St NW, Canton, OH, 44703
 Bradley, Lynda, 1502 Madison St NE, Minneapolis, MN, 55413
 Bram-MacPhill, Marjorie, 3614 22nd Ave West, Bradenton, FL, 34205
 Bramble, Marcia, 235 A. St, Salt Lake City, UT, 84103
 Brandfonbrener, Amy, 1575 Marilyn Ave, W. Lafayette, IN, 47906
 Braunstein, Mark, 71 E. Divison #1904, Chicago, IL, 60610
 Bravar, Mimi, 252 Joppa Hill Rd, Bedford, NH, 03110
 Bregman, Ann, 1835 Hinman Ave 0525, Evanston, IL, 60201
 Brown, Emily, SMU Box 751611, Dallas, TX, 75275
 Brown, David O., 9 Grouse Drive, Brentwood, NY, 11717-1315
 Brown, Karin, 308 Trevethan Ave, Santa Cruz, CA, 95062
 Brown, Rebecca, 8527 Rhoads Cir, Fountain Valley, CA, 92708
 Brown, Richard, BYU, Provo, UT, 84604
 Brown, Monica, 3939 W Windmills Blvd Apt. 1137, Chandler, AZ, 85226
 Brown, Susan, 308 Trevethan Ave, Santa Cruz, CA, 95062
 Brown, Dwight, 317 Inspiration Way, Del Rio, TX, 78840
 Brown, Louise, 440 Vetran Ave #101, Los Angeles, CA, 90024
 Browne, Laurel, 2130 Ridge Dr, Minneapolis, MN, 55416
 Browne, Sheila, 536 W Addison, Chicago, IL, 60613
 Bruderer, Conrad, 8147 Fairview Ave, La Mesa, CA, 91941
 Buchlu, Ezra, c/o Ami Radunskaya 1515 Bates Pl, Claremont, CA, 91711
 Buck, Nancy, 18 Augusta Drive, Bowling Green, OH, 43402
 Buckley, Christopher, 12 Kent St, Fairvale, NB, E2E 3L6, CANADA
 Buckley, Diedre, 1429 E Johnson St, Madison, WI, 53703-1728
 Buffum, Denyse, 8823 Shoshone Ave, Northridge, CA, 91325
 Bugaj, Katarzyna A., 24 Camden St, Morgantown, WV, 26505
 Bukstein, Katherine, 790 Clydesdale Dr, Hillsborough, CA, 94010
 Bunner, Bryce, 718 Mels Dr, Evansville, IN, 47712
 Burgess, Laura L., 19 Summit Ave, Everett, MA, 02149
 Burke, Dennis, R.R. 1Box 43D, Bayfield, WI, 54814
 Burke, Gertrude, 6100 West Friendly Ave, Greensboro, NC, 27410
 Burkholder, Polly, 222 3rd Ave, Santa Cruz, CA, 95062
 Burnett, Karen, 122 Cedar Creek Rd, Central, SC, 29630
 Burton, Natalie, 2375 E 3510 S, Salt Lake City, UT, 84109
 Busch, Cynthia, 8209 Thompson Run Rd, Pittsburgh, PA, 15237
 Butler, Jessica, 1035 E 550 S, Pleasant Grove, UT, 84062
 Buttemer, Anita, 30-S90 Bearuinger Rd, Waterloo, Ontario, N2L GC4, CANADA
 Buttery, Margaret, 268 Parkway Dr, Westbury, NY, 11590
 Butters, Ellen, 27 1/2 W College St, Oberlin, OH, 44074
 Bynog, David Michael, 1420 Richmond Ave #3035, Houston, TX, 77006
 Cabansag, Clifford, 1525 W Avon Blvd, Avon Park, FL, 33825
 Caddell, Heather, 7619 E Cordova Club Dr, Cordova, TN, 38018
 Cain, Donna, 755 Vanessa Ln, Neshanic Station, NJ, 08853
 Caldwell, Brenton, 5109 Katie Dr, Tyler, TX, 75703
 Callus, Helen, 8535 Nesbit Ave N, Seattle, WA, 98103
 Caputo, Janette, 5651 North Luce Rd, Alma, MI, 48801
 Carapetyan, Martha, 2005 Bowman Ave, Austin, TX, 78703
 Carey, Colleen M., 42 Beth Ellen Dr, Lewisburg, PA, 17837
 Carhart, Jane, 25 Alden Terrace, Millbrook, NY, 12545
 Carreon, Alexis, 6163 Case Ave, North Hollywood, CA, 91606
 Cassidy, Marcia, PO Box 711, Norwich, VT, 05055
 Castillo, Carole, 5719 Loma Ave, Temple City, CA, 91780
 Castledine, Melissa, 738 Danbury Rd, Cincinnati, OH, 45240
 Castleman, Heidi, 3330 Warrensville Ctr Rd #706, Shaker Heights, OH, 44122
 Cease, Dr Wesley, PO Box 159, La Canada-Flintridge, CA, 91012
 Cerf, Kelly, 1315 Lore Ln, Lombard, IL, 60148
 Chamberlain, Jeron, 910 N 900 E, Provo, UT, 84604
 Chang, Michael, 1452 Ripchak Rd, Corona, CA, 91719
 Chang, Li-Quo, 360 E. Randolph #307, Chicago, IL, 60601
 Chapman, Eric, 30 E. Adams St (8th Floor), Chicago, IL, 60603
 Charlap-Evans, Valentina, 114 Prospect St, Newburgh, NY, 12550
 Chase-Salerno, Erica, 12 Main Street Apt. #2, New Paltz, NY, 12561
 Chen, Qing, 161 W. 78th St #13, NY, NY, 10024
 Chen, Ko-Ting Jack, 2727 Ellendale Place Apt 56, Los Angeles, CA, 90007-2255
 Chen, Youming J., PO Box 1703, Bloomington, IN, 47402
 Chen, Ching, 1429 Locust St, Philadelphia, PA, 19102
 Chestnut, S. Louise, 801 Bradford Ave, Arnold, MD, 21012
 Cheung, Anthony, 39544 Squire Dr, Novvi, MI, 48375
 Chiang, Victoria, 6 Hawick Ct, Owings Mills, MD, 21117
 Chipman, Lauren, 811 N. Sheridan Rd, Lake Forest, IL, 60045
 Chisholm, Sally, 5605 Old Middleton Rd, Madison, WI, 53705
 Cho, Jennifer, 1277 Calle de Secilla, Pacific Palisades, CA, 90272
 Chouinard, Paul, 2105 Birchwood, Wilmette, IL, 60091
 Christian, Amy J., 80 Woodhills Dr Apt #7, Gashen, NY, 10924
 Christopher, Zara, 488 N 100 E, Provo, UT, 84606
 Clark, Donna Lively, 4480 Manning Rd, Indianapolis, IN, 46228
 Clark, Jennifer, 373 Meng Rd, Bowling Green, KY, 42104
 Clarke, Jean, 9 Phillips Trail, Greenville, SC, 29609

Clarke, Mary, 13535 83rd Street, Edmonton, Alberta, T5E 2X4, CANADA
 Cluxton, Everett, 408 S Oak Park Ave #375, Oak Park, IL, 60302
 Cobb, Mary, Barnes Ln, Plymouth, MA, 02360
 Coe, Russell, 3800 E 300 S, Albion, IN, 46701
 Cohen, Jill, 3213 Ramona St, Palo Alto, CA, 94306
 Colburn, Richard, 1120 La Collina, Beverly Hills, CA, 90210
 Cole, Alfred, 3835 South Crosswell, Freemont, MI, 49412
 Cole, Wesley, 3547 Cottage St, Jackson, MS, 39213
 Coletti, Paul, 103 E 86th St Apt. 6D, New York, NY, 10028
 Collin, Paul, 9 Rue Rameau, Le Barcares, F-66420, FRANCE
 Collins, W Ovid Jr., 4400 Belmont Pk Terr No.164, Nashville, TN, 37215
 Compertino, Richard, 735 Jaques Berthiaume, Ste-Foy, Québec, G1V 3T2,
 CANADA
 Conant, Keith, 3317 W. Palmer St Apt. 7896, Chicago, IL, 60647
 Connolly, Suzanne, 232 Peppertree Ct, Lake Mary, FL, 32746
 Conrad II, Joseph, 15 A North Rd, Warren, NJ, 07059
 Cook, Emily, 16703 Glenburn Ave, Torrance, CA, 90504
 Coppenhaver, Dorian, 1309 Plantation Dr, Dickinson, TX, 77539
 Corbato, Barbara, 808 Northlawn NE, Grand Rapids, MI, 49505
 Cordell, Krista, 1412 Cardiff Ln, High Point, NC, 27409
 Cornish, Wendy, 646 Georgia Ave, Palo Alto, CA, 94306
 Corsat, Merryn, 3970 San Bernardo Dr, Jacksonville, FL, 32217-4611
 Cosand, Patricia, 117 E. Ellis Dr, Temple, AZ, 85282
 Cosart, Jann, 1915 E Maxwell Ln, Bloomington, IN, 47401
 Cosgrove, Amanda, 390 Norhurst Rd, York, PA, 17402
 Cote, Sarah, 333 E Rosewood, San Antonio, TX, 78212
 Council-Phelan, Elizabeth, 1945 Lehigh, Cincinnati, OH, 45230
 Covington, Cynthia, 669 E 800 N, Provo, UT, 84606
 Cowell, Myron, 3150 E 8th, Casper, WY, 82609
 Crane, Patricia, 9827 Meadow Valley Dr, Vienna, VA, 22181
 Cruden, Nathalie, 1638 Morningside Dr, Iowa City, IA, 52245
 Crumine, Sarah, 1621 Sunvale Dr, Olathe, KS, 66062
 Cuneo, Monica, Via Mazzini 10, 26010 Vaiano Cremona CR, Milano,
 26010, ITALY
 Curtin Studios, Joseph, 205 North Main Street, Ann Arbor, MI, 48104
 Curtis, Robyn, 1817 Elaine St, Billings, MT, 59105
 Curtiss, Sidney, 618 Spruce St, Philadelphia, PA, 19106
 D'Alexander, Christine, 954 S. Kent, Elmhurst, IL, 60126
 D'Andrea, Daria, 724 Brunswick St, San Francisco, CA, 94112
 Dakin, Deborah, 206 2nd Ave N, Mt. Vernon, IA, 52314
 Dalton, David, BYU Music-HFAC, Provo, UT, 84602
 Daniels, Karen, 926 Meadowlark Ln, Glenview, IL, 60025
 Danis, Ann, 138 Lyndon Rd, Cranston, RI, 02905
 Danks, Harry, 12 Beverly Gardens, Wembley Pk, Middlesex, HA9 3QZ, UK
 Darling, Sarah, 6 West St, Carlisle, MA, 01741
 Darrow, Kristin, 1500 Royal Crest, Austin, TX, 78741
 Dastrup, Benjamin, 598 S. 560 W., Orem, UT, 84058
 Dattner, Joan, 10400 Golden Quail Dr, Austin, TX, 78758
 Davidowitz, Joshua, 29-50 137 St, Flushing, NY, 11354
 Davies, Brannon, 1543 W Griffith, Fresno, CA, 93705
 Davis, Leonard, 185 West End Ave, New York, NY, 10023
 Dawkins, Allyson, 107 Eaton St, San Antonio, TX, 78209
 Day, David, 50 E 2050 N, Provo, UT, 84604
 de Jonge, Frits, 817 Gregg St, Columbia, SC, 29201
 De Luca, Thomas, 5275 Ormond Rd, Davisburg, MI, 48350
 de Olano, Harkaitz Mendi, "Herriko Plaza 2,2 48160", Derio, SPAIN
 de Pasquale, Joseph, 532 Lafayette Rd, Merion Station, PA, 19066
 De Queiroz, Marilyn, 4985 Grove St, Denver, CO, 80221
 de Veritch, Alan, 2711 Brigs Bend, Bloomington, IN, 47401
 Dee, Connie, 15492 Hitchcock, Chesterfield, MO, 63017
 Degraw, Diantha, 7902 Lantern Rd, Indianapolis, IN, 46256
 Deighton, Tim, 2024 Fariwood Lane, State College, PA, 16803
 Denbina, Devon, 3415 Fir Forest Dr, Spring, TX, 77388
 DerHovsepian, Joan, 5101 N Ave A 200, Midland, TX, 79705
 Dey, Kathryn, 217A E Earle St, Greenville, SC, 29609
 Dharamraj, Noemie, 2850 Renatta Dr, Largo, FL, 34640
 Diaz, Roberto, 135 S. 19th St #803, Philadelphia, PA, 19103
 Dicterow-Vaj, E. Marcy, 1045 Palms Blvd, Venice, CA, 90291
 Didrickson, Sally, 2115 Ridge Ave, Evanston, IL, 60201
 Dimond, Valerie, 465 So. Madison Apt. 301, Pasadena, CA, 91101
 Dinerchtein, Viacheslav, Peabody Conservatory Campus Box 498, 606 St
 Paul Street, Baltimore, MD, 21202
 Dirks, Karen M., 9684 Wayfarer Dr, La Mesa, CA, 91942
 Dixon, Katherine, 3117 Leverett, Alton, IL, 62002
 Dong, Li Xu, #401#8-5 Bao Yun Yi Dong Chuan Rd, Guangzhou, 510100,
 CHINA
 Donnell, Carolyn, 5684 Chesbro Ave, San Jose, CA, 95123
 Donnelly, John, 48 Lowcrest Blvd, Scarborough, ONT, M1T 1K5, CANADA
 Dott, Christian, 15 rue du Faubourg St Denis, Paris, F-75010, FRANCE
 Dowd, Andrew, 909 Lind, Joliet, IL, 60432
 Drew, Patricia, 1904-G Generation Dr, Raleigh, NC, 27612
 Drorbaugh, Wilma, 1058 E Raymond Rd, Fruit Heights, UT, 84037
 Duba, Joseph, 8 W Main St, Shortsville, NY, 14548
 Dubois, Susan, 3232 N. Locust St #113, Denton, TX, 76207
 Dudeck, Bianca, 1714 W 51st, Indianapolis, IN, 46228
 Dudreck, Kristen, 904 Norwood Ct, Naperville, IL, 60540
 Due, Christine, 7319 N Bell Ave, Chicago, IL, 60645-2005
 Duff, Michael, PO Box 6235, Bloomington, IN, 47407
 Dunetz, Nancy S., 750 Kappock St #210, Bronx, NY, 10463-4613
 Dunham, James, 18 Hillcrest Rd, Needham, MA, 02492-4214
 Dupuy, Kendra, 3120 177th Pl SW, Lynnwood, WA, 98036
 Durham, Andra, 823 Shland Ave, Wilmette, IL, 60091
 Durham, Emily, 123 Crandon Cir, Beaver, PA, 15009
 Dutt, Hank, 377 Mangels Ave, San Francisco, CA, 94127
 Dutton, Harry, PO Box 229, Deer Lodge, MT, 59722
 Dyer, Alisa, 1384 West Wind Circle, Carmel, IN, 46032
 Eastham, Glynn, 10555 Ridgeview Ct, Cupertino, CA, 95014
 Eberle, Karen, 114 Bradley Blvd, Travis AFB, CA, 94535
 Eckert, Erika, U. of Colorado Campus Box 301, Boulder, CO, 80309
 Edmonds, Eugenie, 606 Jessie, Austin, TX, 78704
 Edwards, Stephen, 800 Ethel St, Austin, TX, 78704
 Edwards, Alison, 718 11th St, Wilmette, IL, 60091
 Ehrlich, Don, 806 Shrader St, San Francisco, CA, 94117
 Eisenschirn, Betsy, 609 Elmdale Rd, Glenview, IL, 60025
 Ekholm, Susan, 8415-105 St, Edmonton, Alberta, T6E 4H6, CANADA
 Elaine, Karen, 208 Welling Way, San Diego, CA, 92114-5947
 Ellenwood, Elisabeth, 5602 Weslo Willow Cr, Greensboro, NC, 27409
 Eilersick, Joan, 21 Pequossette St, Watertown, MA, 02172
 Emmons, Marilyn C., 1408 W Oak St, Fort Collins, CO, 80521
 Epstein, Herbert, 199 Coolidge Ave, Watertown, MA, 02172-1521
 Erdelyi, Csaba, 2420 Boston Rd, Bloomington, IN, 47401
 Erlanson, Carol, RD #1 Box 98, Walton, NY, 13856
 Evans, Carole, 6710 McVey Blvd, West Worthington, OH, 43235
 Evans, Stanley, 188 Lois Lane, Palo Alto, CA, 94303
 Everett, William, 803 W. 87th Terrace, Kansas City, MO, 64114
 Everts, Chip, 4199 Anderson Mill Rd, Spartanburg, SC, 29301
 Ewing-Wood, Nancy, 16754 Brewer Rd, Grass Valley, CA, 95949
 Fabrizio, Scalabrin, via Bariero 75, Mogliano Veneto, Treviso, 31021, ITALY
 Falck, Suzanne, 2881 Blue Spruce Dr, Salt Lake City, UT, 84117
 Falkove, Albert, 2 Franklin Town Blvd, Philadelphia, PA, 19103
 Fall, Helen, 4318 Argonne Dr, Fairfax, VA, 22032
 Farr, Keanen, 1547 N 4700 W, Plain City, UT, 84404
 Fedotov, Igor, 6124 Merlot Court, Portage, MI, 49024
 Feltner, David, 263 Commonwealth Ave #7, Boston, MA, 2116
 Feres-Lloyd, Sonia, 3003 River Road Apt. C-107, Baton Rouge, LA, 70802
 Ferrian, Jennifer, 307 E. Lawrence #215, Appleton, WI, 54911
 Ferrin, Richard R., 28 Cumberland Dr, Lincolnshire, IL, 60069
 Fetsch, Nicholette, 7557 Andrea Ave, Stockton, Ca, 95207

Fiaca, Anna, 221 Indiana Cabin Rd, Home Valley, WA, 98648
 Field, Richard, 14906 Dunstan Ln, Monkton, MD, 21111
 Fielding, Ralph, 465 S. Madison #301, Pasadena, CA, 91101
 Fine, Marshall, 38 N Highland St, Memphis, TN, 38111
 Fine, Michelle, 38 N Highland St, Memphis, TN, 38111
 Finney, Amy, 9940 SW Taylor, Portland, OR, 97225
 Fisch, Burt, 5030 Mycenae Way, Oceanside, CA, 92056
 Fisher, Marlow, 242 Entrada Dr, Santa Monica, CA, 90402
 Fisher, Julian, 303-14 Deer Park Cres., Toronto, Ontario, M4V 2C2,
 CANADA
 Fitchuk, John, ON780 Woodlawn, Wheaton, IL, 60187
 Fletcher, Kristen, 4785 NW 177th Pl, Portland, OR, 97229
 Foerstel, Gunnar, 6-718 Churchhill Ave N, Ottawa, Ont, K1Z T3A 0B6,
 CANADA
 Fogg, Cynthia, 1649 Lowell Ave, Claremont, CA, 91711
 Forbes, Catherine, 1128 Woodland Dr, Arlington, TX, 76012
 Forbes, Leona, 336 Vincent St, Syracuse, NY, 13210
 Forsythe, Georgia, 5840 O'Malley Rd, Anchorage, AK, 99516
 Fort Manero, Abili, "Diputacio, 327 3-1", 08009 Barcelona, SPAIN
 Foster, Daniel, 3945 Connecticut Ave NW, Washington, D.C., 20008
 Foster, William L., 7717 14th St NW, Washington, D.C., 20012
 Fouse, Kathryn, 4967 E. Fair Dr, Littleton, CO, 80121
 Fox, Theresa, 2322 Newton St, Greensboro, NC, 27406
 Franson, Marta, R.R. 3 Box 3184, Farmington, ME, 04938
 Fredenburgh, Kimberly A., PO Box 1646, Tempe, AZ, 85280
 Frederking, Ann, 2030 Woodglen Cres, Ottawa, Ont, K1J 6G4, CANADA
 Freeman, Phyllis, 11 East Second St, Frederick, MD, 21701
 Freund-Striplen, Pamela, 3282 Helen Ln, Lafayette, CA, 94549
 Frieman, James R., 3476 Waverly St, Palo Alto, CA, 94306
 Frisk, Nora, 1286 Lake Charles Ave, Porter, IN, 46304
 Fugate, Sharon, 55 Old Stagecoach Rd, West Redding, CT, 06896
 Furness, Keiko, 3315 Sweetwater Dr, Cumming, GA, 30131
 Furtwangler, Angelika, 1 Cliff St #2, Norwich, VT, 05055
 Gaither, Jamie, 1924 S 11th St No. 4, Waco, TX, 76706
 Galaganov, Misha, 1503 Bissonnet, Houston, TX, 77005
 Gallent, John, 125 Comanche Dr, Pineville, LA, 71360
 Ganea, Andrei, 358 W California Blvd, Pasadena, CA, 91105
 Garber, Alan, 1240 N Lake Shore Dr, Chicago, IL, 60610-2358
 Gardner, Maurice, 5640 Collins Ave, Miami Beach, FL, 33140
 Gardner, Edythe, 2624 N. Terrace St, Mesa, AZ, 85203
 Gartner, Ellen, 324 S. Knight, Park Ridge, IL, 60068
 Gaudio, Edith, 7048 N Mankato, Chicago, IL, 60646
 Gaul, Gerald, 525 Reeves Dr, Grand Forks, ND, 58201
 Gerard, Mary, 1414 Galveston St, San Diego, CA, 92110
 Gerhard, Jennifer, 1140 Nineteen North Dr, Pittsburgh, PA, 15237
 Gersh, Igor, 2745 Arlington Ave, Highland Pk, IL, 60035
 Gianotti, Joseph, 1701 Thuja Ave, Anchorage, AK, 99507
 Gibson, Craig, 305 17th St, Seal Beach, CA, 90740
 Gillespie-Heinis, Andrea, 3714 Drakewood Dr, Cincinnati, OH, 45209
 Gingras-Ray, Marylene, 909 Bellaire Ave, Pittsburgh, PA, 15226
 Giordano, Suzanna, 1323 Berkeley St, Apt. B, Santa Monica, CA, 90404
 Glazer, Robert, 16 Moos Ln, Bergenfield, NJ, 07621
 Glick, Jacob, RR1 Box 80-S, North Bennington, VT, 05257
 Goldblatt, David, 5750 Lombardy Dr, Osgoode, ONT, KOA 2W0, CANADA
 Goldenberg, Isabella, 56-32 Bell Blvd, Bayside, NY, 11364
 Goldsmith, Pamela, 14601 Mulholland Dr, Los Angeles, CA, 90077
 Gomez, Alvaro, 17 Tymber Cove, De Land, FL, 32724
 Good, Jody, 438 Long Ln, East Earl, PA, 17519-9755
 Goodman, Lauren, 7437 Stony River Ct, Bloomfield Hills, MI, 48301
 Goodwin, William, 209 Shamrock Lane Apt. 1, Richmond, KY, 40478
 Gossage, Kathryn, 7525 Ridge Blvd, Chicago, IL, 60645
 Goward, Marion, Box 22, Melstone, MT, 59054-0022
 Graddy, Damon, PO Box 8422, Calabassas, CA, 91302
 Graham, John, 291 Barrington St, Rochester, NY, 14607
 Granat, Miriam, 11780 Moorpark St Apt.# E, Studio City, CA, 91604
 Granat, J Wolfgang, 4738 Osage Ave, Philadelphia, PA, 19143
 Grand, Louis, 202 Plutarch Rd, Highland, NY, 12528
 Grants, Lynn, 12421 Landale St, Studio City, CA, 91604
 Gray-Lion, Julia, 258 Harrison, Chelsea, MI, 48118
 Greeman, Sherri, 53 Granburg Cir, San Antonio, TX, 78218
 Green, David, 344 Stewart Dr, El Paso, TX, 79915
 Green, Linda, 1950 Calumet Ave, Toledo, OH, 43607
 Greene, Kenneth, 1207 Timber Bay, San Antonio, TX, 78232
 Greene, Keith, 20569 Cheney Dr, Topanga, CA, 90290
 Greer, G, 701 W Rochelle No. 2099, Irving, TX, 75062
 Gregory, Myra, PO Box 130041, Brooklyn, NY, 11213-0001
 Gregory, Michael, RR #1, Mount Uniacke, NS, B0N 1Z0, CANADA
 Griebing, Karen, 1600 Washington Ave, Conway, AR, 72032
 Grishkoff, Lindy, 15152 Normandie Ave, Irvine, CA, 92604
 Grohs, Carol, 214 Lake Ave, Ithaca, NY, 14850
 Guenter, Monica, 33 Waterford Bay, Winnipeg, Man, R3T 1H6, CANADA
 Gullerud, Lois, 1208 W Daniel, Champaign, IL, 61821-4514
 Gundersen, Bjarke, 300 W Royal Palm Rd, Boca Raton, FL, 33432
 Gunderson, Douglas, 760 Dodge Dr, La Jolla, CA, 92037
 Gunn, Michele, 10722 Valley Hills Dr, Houston, TX, 77071
 Gurzynski, John, 1014 Delaware Ave, Butte, MT, 59701
 Gustavsson, Marka, 523 W 112th St, New York, NY, 10025
 Hager, Carla, 913 Sailor's Reef, Ft. Collins, CO, 80525
 Halen, Walter, 410 Mill Cir SW, Lee's Summit, MO, 64081
 Hall, Michael, 5646 W Market St, Greensboro, NC, 27409
 Hall, Susan, PO Box 162594, Sacramento, CA, 95816
 Hall, Thomas, 3843 East Kirkwood Ave, Orange, CA, 92669
 Hall-Reinhard, Esther, PO Box 1298, Somis, CA, 93066
 Halleck, Mahlon, 910 Lakeridge Ave, Stillwater, OK, 74075
 Halverson, Lawrence, 2441 S New York St, Denver, CO, 80210
 Hamilton, Barbara, 1059 Monaco Pkwy, Denver, CO, 80220
 Hamilton, Kate, 30 Knollcrest Ct, Normal, IL, 61761
 Hammelman, Eric, 3149 Broadway, New York, NY, 10027
 Hamsen, Susie, 392 Compon Vista Dr, Los Angeles, CA, 90065
 Hanks, Alison A., 190 John Henry Cr., Folsom, CA, 95630
 Hanna, James, 963 Cutlin St, Simi Valley, CA, 93065
 Hansen, Dennis, 279 E 300 N, Ephraim, UT, 84627
 Hansen, Jo Plum, 619 Hobbs Rd, Greensboro, NC, 27403
 Hansen, Sharon, 3331 Green Meadows Ln, Racine, WI, 53405
 Hansen, Jennie, 19433 Pacific Coast Hwy., Malibu, CA, 90265-5411
 Hard, Wallace, 6514 Sorrento Ct, Dayton, OH, 45459
 Hardie, Julia, PO Box 23, Waco, TX, 76703
 Hardin, Burton, 3780 Peak View Blvd, Monument, CO, 80132
 Hardy, Frank, 462 Ridge Rd, Westminster, MD, 21157
 Harlow, Leslie, 1420 West Meadowloop Rd, Park City, UT, 84060
 Harman, Charles E., PO Box 4031, Brookings, OR, 97415
 Harper, L. Alexander, 144 Gillies Ln, Norwalk, CT, 06854-1009
 Harris, Mary, 5846 K-Bell St, Oxford, OH, 45056
 Harrison, Lucretia, 99 Bayview Ave, Port Washington, NY, 11050
 Harrison, Campbell, 10770 Wanda Ln, Northglenn, CO, 80234
 Hatch, Peter, 3803 Udell Ct, Los Angeles, CA, 90027
 Haussler, Lawrence, 3357 South Ct, Palo Alto, CA, 94306
 Haviland, Margaret, 1698 Minnehaha Ave W Apt. 2, St Paul, MN, 55104
 Hayes, Karen, 419 S Lilly, Moscow, ID, 83843
 Hayman, Helene, 146 Lakeside-Pine Lakes, Prescott, AZ, 86301
 Haynes, Courtney, 2901 Blossom Ln, Evansville, IN, 47711
 Hedin, Keith, 13 Old Town Rd, Newtown, CT, 06470-2521
 Heimberg, Thomas, 1656 Ocean View Ave, Kensington, CA, 94707
 Heise, David, 535 Dawes Ave, Glen Ellyn, IL, 60137
 Heller, Patricia, 49 Pinehaven Dr, Daly City, CA, 94015-3545
 Hemsath, Alex, 518 June St, Endicott, NY, 13760
 Henderson, David, 8740 Potts Ct, Orangevale, CA, 95662
 Henry, Rebecca, 3107 Shannon Dr, Baltimore, MD, 21213

Henry, Rebecca, 1317 Lockhill Selma Rd, San Antonio, TX, 78213
Herbert, Kristen, 1612 Springmill Ponds Cir, Carmel, IN, 46032
Herman, Deanna, 444 Glendenning PL., Waukegan, IL, 60087
Hernandez, Teresa, PO Box 31481, El Paso, TX, 79931
Herrick, Jennifer, 1367 E 3090 N, North Ogden, UT, 84414
Higham, Ellen, 1051 Whitney Ave, Hamden, CT, 06517
Hildwein, Jeneen, 2738 N. Pine Grove Apt.1006, Chicago, IL, 60614
Hinson, Christine, 1316 Grand Ave F, Edwardsville, IL, 62025
Hirschmugl, Lisa, 1S229 Pine Ln, Lombard, IL, 60148
Hirtzel, Robert, 123 W 37th St, Vancouver, WA, 98660
Ho, Wing, College of Charleston, Charleston, SC, 29424
Hoeschen, Kevin, 3515 E 3rd St, Duluth, MN, 55804
Hoffman, Mary Kay, 30 Elm St, Glenview, IL, 60025
Hofman, Jamie, 3363 N. 51st Blvd, Milwaukee, WI, 53216
Hogg, James M., PO Box 17207, Fountain Hills, AZ, 85269
Hokanson, Tyler, 2591 N 850 W, Provo, UT, 84604
Holian, Michael, 1825 N 78th Ct, Elmwood Park, IL, 60707
Hollinger, Mark, 5075 Lupine Rd, Missoula, MT, 59803
Hollis, Andrew, 505 Queen Anne's Rd, Greenville, NC, 27858
Holmes, Marsha, 2360 Kearney St, Denver, CO, 80207
Holvik, Martha, 1723A W 18th St, Cedar Falls, IA, 50613
Homb, Sandra, 1453 Greenock Ln, Ventura, CA, 93001
Hook, Sara Anne, 7340 Railhear Ct, Indianapolis, IN, 46256
Hook, Claudia, 6544 Crabapple Drq, Troy, MI, 48098
Hoolihan, Carolyn, 16310 Dahl Rd, Laurel, MD, 20707
Horcasitas, Rafael, 2489 Whipporwill Ln, Las Vegas, NV, 89121
Horn, Patrick, 429 Lee 35, Evanston, IL, 60202
Horowitz, Hank, 175 Adams St, Brooklyn, NY, 11201
Horst, John & Cia, "Caixa Postal, 606", Rio de Janeiro, 20001, BRAZIL
Hos, Wilma, "4 Varbow Pl., N.W.", Calgary, Alberta, T3A 0B6, CANADA
Houser, Rebecca, 202 WSU Residence Halls, Ogden, UT, 84408
Houston, Ronald, 400 Crestover Cir, Richardson, TX, 75080
Howard, James, PO Box 160184, Austin, TX, 78716-0184
Howard, Sarah, PO Box 160184, Austin, TX, 78716-0184
Howson, Louise Zeitlin, 240 E. College St, Oberlin, OH, 44074
Hoy, Victoria, 545 S Valley View Dr #73, St George, UT, 84770
Huang, Lin-Chuan, 110 W Adams Blvd, Los Angeles, CA, 90007
Huang, Shu-Ling, 1326 Spruce St, Philadelphia, PA, 19107
Hult, David, 20 S Landing Rd, Rochester, NY, 14610
Humbert, Samara, 2749 S. Los Altos, Mesa, AZ, 85202
Humphreys, Megan, 2255 Shasta Wat N.E., Atlanta, GA, 30345
Hunter, Carolyn, 155 Bardet Rd, Woodside, CA, 94062
Hurd, William, 6361 N. Berkeley Blvd, Milwaukee, WI, 53217
Hurley, James, 2737 Forest Ave Apt. 301, Berkeley, CA, 94705
Hustis, Barbara, 3456 Mockingbird Ln, Dallas, TX, 75205
Huston, Valerie, 1020 Jasmine St, Denver, CO, 80220
Hutchins, Carleen, 112 Essex Ave, Montclair, NJ, 07042
Ivins, Janet, 704 Powderhouse Rd, Vestal, NY, 13850
Ihas, Diana, c/o Laura Kruennen 6255 Honolulu Ave #6, Tujunga, CA, 91042
Ims, Christine, 740 W 187 St Apt. 3D, New York, NY, 10033
Inouye, Mei, PO 867, Gunnison, UT, 84634
Ionson, Kristine, 1365 Worcester, Grand Rapids, MI, 49505
Irvine, Jeffrey, 24070 Hermitage Rd, Beachwood, OH, 44122
Iversen, Peter, 220 8th St NE, Wavely, IA, 50677
Ives, Lori, 264 East Green St, Claremont, CA, 91711
Jaakkola, Leo, 3824 North Shore Dr, West Palm Beach, FL, 33407
Jackle, Ben D., 624 Henderson House, 5514 S. University, Chicago, IL, 60637
Jackson, Jennifer, 2975 N Iroquois Dr, Provo, UT, 84604
Jacobs, Veronica, 1111 Park Ave, New York, NY, 10128
Jacobs, Idalynn, 3103-A Woodlawn Ave, Nashville, TN, 37215
Jacobson, Les, 2202 Lincolnwood Dr, Evanston, IL, 60201
Jacobson, Thomas, 1196 Magnolia Ave, Carlsbad, CA, 92008
Jaffe, Elizabeth, 328 S 17 St, San Jose, CA, 95112
Jagoe, Kevin, 10991 Mandarin Sta. Dr W., Jacksonville, FL, 32257
Jalicki, Michael, 727 Joyce Ln, Florence, SC, 29501
James, Kevin, 505-455 Lisgar St, Ottawa, Ontario, K1R 5G9, CANADA
James, Mary Elliott, PO Box 1085, Cambria, CA, 93428
Janda, Susan, 1189 Churchill St, St Paul, MN, 55103-1009
Janzen, Henry, R.R. #2, Guelph, Ontario, N1H 6H8, CANADA
Jeanneret, Marc, 61 Babcock St, Brookline, MA, 02146
Jensen, Janet, 1 Langdon St, Madison, WI, 53703
Jensen, Kristine, 2211 Plymouth St, Midland, MI, 48642
Jesaitis, Anna, 27 Annette Park Dr, Bozeman, MT, 59715
Jim, Kevin, 255 Bright St, San Francisco, CA, 94132
Johnson, Andrew, 341 S Lafayette St, Macomb, IL, 61455
Johnson, Leslie, 1115 36th Ave, Seattle, WA, 98122
Johnson-Rancier, Christine, 13704 Crested Butte NE, Albuquerque, NM, 87112
Joiner, Anna, 8 Split Oak Ct, Taylors, SC, 29687
Jones, Liz, 10232 Dodge Ln, Louisville, KY, 40272
Jones, Lisa, 1011 Palm Ave #212, West Hollywood, CA, 90069
Kalal, Gladys, 111 Marinette Trail, Madison, WI, 53705
Kalbach, Shane, 7616 Alexandria Pl, Stockton, CA, 95207
Kalisch Kraber, Joan, 511 Texas Ave, Austin, TX, 78705
Kallevig, Brooke, 403 E Oxford St, Duluth, MN, 55803
Kamberger, Sheridan, 222 W McMillan Apt. No. 1, Cincinnati, OH, 45219
Kanter, Ann, 1131 Laurel Ave, Deerfield, IL, 60015
Kaplan, David, 1819 Old Maple Ln, Savoy, IL, 61874
Kaplan, Elizabeth, 1610 Croton Lake Rd, Yorktown Heights, NY, 10598
Karp, Hilary Jo, 835 Island Meadow Ct, Houston, TX, 77062
Kass, Philip, 209 Park Rd, Havertown, PA, 19083
Katims, Milton, 8001 Sand Pt. Way NE, Seattle, WA, 98115
Kato, Roland, 4325 Cedarhurst Cir, Los Angeles, CA, 90027-2106
Katz, Leah, 403 S Highland Ave, Los Angeles, CA, 90036
Kearney-Looman, Anne, 305 W Sixth St, Houghton, MI, 49931
Kelch, Carleton, 37 Fairfield Drive, Dix Hills, NY, 11746
Keller, Julie, 1521 S Corona St, Denver, CO, 80210
Kelly, Lucy, 5401 North Shoreland Ave, Whitefish Bay, WI, 53217
Kelly, Mary, 3509 Werner Ave, Austin, TX, 78722
Kelts, David, 170 Shawnee Ln, Florissant, MO, 63033
Kerr, David, 105 Pine Shadows, Conroe, TX, 77301
Keung, Bonnie, 1407 Pershing Ave, Wheaton, IL, 60187
Kilman, Sherrie, 2443 Barcelona Dr, Sandy, UT, 84093
Kim, Seon, 4009 15th Ave Apt. 126, Seattle, WA, 98105
Kimber, Michael, 105 Tumbleweed Dr, Lawrence, KS, 66049
King, Jill, 6 Bryn Mawr Ln, Carmel, IN, 46032
King, Catherine, 555 E 10th Ave, Denver, CO, 80203
Kingsley, Chiara, 1555 N Markdale, Mesa, AZ, 85201
Kingston, Elizabeth, 177 Little Park Rd, Grand Junction, CO, 81503
Kircher, Alicia, 2424 138th Ave SE, Bellevue, WA, 98005
Kirkwood, Linda, 3847 Avon Rd, Geneseo, NY, 14454-1106
Kjemtrup, Inge, 16060 Skyline Blvd, Woodside, CA, 94062
Klatz, Harold, 1024 Maple Ave, Evanston, IL, 60202
Klein, Janet, 746 Bamboo Dr, Sunnyvale, CA, 94086
Kline, Linda, 95 Hannibal Cove #248, Memphis, TN, 38103
Knechtel, Baird, 103 North Dr, Islington, Ont, M9A 4R5, CANADA
Knudsen, Vance, 1202 Lincoln Ave, San Jose, CA, 95125
Koblick, Daniel, 5436 S East View Park, Chicago, IL, 60615
Kocak, Bige Bediz, 4 icadde No. 5/11, 06510 Emek-Ankara, TURKEY
Kolpitck, John, 1970 Friendship Dr, New Concord, OH, 43762
Korda, Marion, 3111 Talisman Rd, Louisville, KY, 40220
Korwin, Jamie, 1919 E. Washington St, Joliet, IL, 60433
Kosmala, Jerzy, 882 Wylie Dr, Baton Rouge, LA, 70808
Koster, Melinda, PO Box 33081, Amarillo, TX, 79120
Koven, Renita, 7659 Boeing Ave, Los Angeles, CA, 90045
Kramer, Karen, 3641 Beech, Flossmoor, IL, 60422

Krenek, Jennifer, 17702 Hidden Forest Dr, Spring, TX, 77399
 Kresha, Jonathan, 7119 Westboro, San Antonio, TX, 78229
 Kreuziger, Amy, 1219 Market Pl., Waukesha, WI, 53186
 Krohn, Eileen, 21820 NE 56th, Redmond, WA, 98053
 Kronman, Craig, 55 Asilomar Cir., Oakland, CA, 94611
 Krovoza, Rosemarie, 3875 Landfair Rd, Pasadena, CA, 91107
 Krstolich, Jeanette, 4607 N Magnolia, Chicago, IL, 60640
 Kruger, Anna, 140 Claremont Ave, New York, NY, 10027
 Kruse, Steven, 6568 W 51st, Mission, KS, 66202-1734
 Kuennen-Poper, Laura, 6255 Honolulu Ave #6, Jujunga, CA, 91042
 Kundert-Clements, Gabrielle, 19644 Islander St, Olney, MD, 20832
 Kurr, Steven M., "2630 High Ridge Trl., #102", Fitchburg, WI, 53713
 Kurtz, Carrie, 9815 Holiday Dr, Louisville, KY, 40272
 Kwan, Elizabeth, 1723 Rollin St, SO. Pasadena, CA, 91030
 Kwan, Margaret, 1723 Rollin St, SO. Pasadena, CA, 91030
 Kwok, Daniel, 317 W. 23rd Pl., Chicago, IL, 60616
 La Fayette, Sheryl, 12677 Memorial Dr, Houston, TX, 77024,
 LaCourse, Michelle, 32 North Elm St, Northampton, MA, 01060
 Lakatos, Janet, 1329 Raymond Ave, Glendale, CA, 91201
 Lane, Lee, 1570 Ashland, Evanston, IL, 60201
 Lara, Joel, 1411 Kingsgate Rd, Oklahoma City, OK, 73159
 Larsen, Aimee, 2430 N 1400 E, Layton, UT, 84040
 Larsen, Grace, 5997 Burrell St, Salt Lake City, UT, 84118
 Larsen, Denitza, 3259 Harrison Blvd, Ogden, UT, 84403
 Larson, Steve, 5201-412 Farmington Ave, Hartford, CT, 06105
 Lawrence, Virginia, 3615 Campus NE, Albuquerque, NM, 87106
 Lee, Allan, 1724 Wilson Ave, Arcadia, CA, 91006
 Lee, Duke, 12147 Huntington Venture, Houston, TX, 77099
 Lee, Jieun, 200 W 70th St, New York, NY, 10023
 Lee, Joong-Oh, 7388 S.W 80th St Apt. #252, Miami, FL, 33143
 Leger, Mark, 2407 Davis Ln, Austin, TX, 78745
 Leland, Jane V., 2016 Schiller Ave, Wilmette, IL, 60091
 Lemieux, Erin, 328 E. Main St Apt. 310, Rochester, NY, 14604
 Lenkewitz, Uta von, Ahornweg 9, Rheinbach, D-53359, GERMANY
 Lerdaahl, Unni, Margrethes Fryd 13 B, 6500 Kristiansund NORWAY
 Levenberg, Jeffrey, 365 Cottonwood Dr, Longhorne, PA, 19047
 Levin, Andrew, 322 Pendleton Rd, Clemson, SC, 29631
 Levin, Harold, 73 Sussex St, Jersey City, NJ, 07302
 Levin, Leonard M., 7318 Pershing Ave Apt. #2W, St Louis, MO, 63130
 Levine, Jesse, Homer Clark Ln, Sandy Hook, CT, 06482
 Levinson, Mikhail, Michoacan 26-7 Col. Condesa, Mexico City, 6100,
 MEXICO
 Levy, Jane, 689 Cornell Rd, Pasadena, CA, 91106
 Lewis, Arthur, R.R. 1 Box 148, Bloomington, IL, 61704-9774
 Lewis, Chris, 1155 W 400 N, Salt Lake City, UT, 84116
 Lewis, Peggy, 944 Michigan, Evanston, IL, 60202
 Lewis, Margaret, 944 Michigan Ave, Evanston, IL, 60202
 Lewis, Courtney, 3424 Sugar Leo Rd, St George, UT, 84790
 Leyvand, Alex, 1818 Park North Way, Indianapolis, IN, 46260
 Lichten, Catie, 58 Washington Blvd, Oak Park, IL, 60302
 Lim, Soon-Lee, 58 Toh Tuck Crescent, Singapore 596959,
 REPUBLIC OF SINGAPORE
 Lin, Jessica, 541 Lanecrest, Houston, TX, 77024
 Lind, Anjali, 2925 Eden Ave #2, Cincinnati, OH, 45219
 Lind, Dan, 1622 Cambridge Cir, Charlottesville, VA, 22903
 Lindemann, H, 4 Moyes, St Marrickville, N.S.W., 2204, AUSTRALIA
 Ling, Corri, 6231 Greeley Blvd, Springfield, VA, 22152
 Lipchak, Susan, 15 Brookfield Rd, Willowdale, Ontario, M2P 1B1, CANADA
 Lish, Joel, 18244 Jovan St, Reseda, CA, 91335
 Little, Carrie, 1424 N Chester Ave, Pasadena, CA, 91104
 Liu, Brenda, 16140 SW Lindsay Ct, Lake Oswego, OR, 97035
 Liu, Shiou-Huei, 1615 Hoyt Tower Dr, Bloomfield Hills, MI, 48302
 Liu, Hui, 441 E. Erie St Apt. 4111, Chicago, IL, 60611
 Liu, Jessica, 541 Lanecrest, Houston, TX, 77024
 Lively, Emma, 28 West 73rd St, New York, NY, 10023
 Lobaugh, Charlotte, 7918 Meridith Ave, Omaha, NE, 68134
 Locketz, Seymour, 2613 Inglewood Ave S, Minneapolis, MN, 55416-3927
 Loeffler, Alfred, 308 Mission Serra Terrace, Chico, CA, 95926
 Logan, Jane, 45D Alexander St, Ottawa, Ontario, K1M 1N1, CANADA
 Loo, Michael, 370 Ocean Ave Apt. 502, Revere, MA, 02151
 Lorenzo, Donna, 235 Palmdale Dr Apt. 7, Williamsville, NY, 14221
 Loucks, Jennifer, 1629 W 1170 N, Provo, UT, 84604
 Loughran, Hugh, Hiragishi 1-Jo, Toyohira-Ku, Sapporo 062, JAPAN
 Lovelace, Kimberley, 5 Beauregard, Little Rock, AR, 72206
 Lugovier, Busya, 719 1/2 West Ave S, LaCrosse, WI, 54601
 Lukaszewiki, Lisa, 33W025 Rochefort Ln, PO Box 725, Wayne, IL, 60184
 Lund, Tessya, 3557 S 100 E, Bountiful, UT, 84010,
 Lundy, Shari, 18 Bromley Cres, Etobicoke, Ont, M9A 3X3, CANADA
 Lydon, Wanda, PO Box 6151, San Antonio, TX, 78209
 Lynch, Sylvia, 121 N 2nd St, Olean, NY, 14760
 Lynch, Corrian, 1737 N. 72nd St, Wauwatosa, WI, 53213-8351
 Ma, Shaw-Ming, 244 Gabilan Ave, Sunnyvale, CA, 94086
 MacGibbon, Judy, 4880 County Rd 6, Maple Plain, MN, 55359
 MacLaine-Oldcroft, Margot, 5903 Gleam Ct, Agoura, CA, 91301
 MacLean, John, 146 Woodhaven St, Spartanburg, SC, 29307
 Macomber, Glenda, PO Box 5055, Galt, CA, 95632
 Madsen, Kathryn, 2820 N Indian Hills Dr, Provo, UT, 84604
 Magers, William, 5305 S Palm Dr, Tempe, AZ, 85283-1918
 Major, Ann Marie, 1512 Woodledge Circle, State College, PA, 16803-1855
 Malstrom, Michael, 1139 W 650 N, Provo, UT, 84601
 Mann, Shawn, 3709 3/4 Brunswick Ave, Los Angeles, CA, 90039
 Manning, Irving, 665 Via Santa Ynez, Pacific Palisades, CA, 90272
 Maril, Andrea, 3514 S. Husband St, Stillwater, OK, 74074
 Marquette, Marjorie, 729 8th St, Wilmette, IL, 60091
 Marriott, Kate, 2023 Lincoln Cir, Salt Lake City, UT, 84124
 Marriott, Hollis, 655 N. Cedar, Laramie, WY, 82072
 Marschall, David, 315 Cutler St, Raleigh, NC, 27603
 Marsh, Susan, 111 Emerson St Apt. #844, Denver, CO, 80218-3788
 Marsh, Peter, 33 S. Craig Ave #3, Pasadena, CA, 91107
 Martin, Jennifer, 1656 Rutledge Way, Stockton, CA, 95207
 Martin, Joanne, 266 Waterloo St, Winnipeg, MB, R3N 0S5, CANADA
 Martin, Spencer, 247 North Volutsia, Wichita, KS, 67214
 Martinez, David, 9323 Elgin Dr, El Paso, TX, 79907
 Martinez, Katherine, 372 W 800 N, Sunset, UT, 84015
 Martinez, Debra, 3518 Forest Lawn Ave, Omaha, NE, 68112
 Martinson, Kenneth A., 118 Leroy St, # M5, Potsdam, NY, 13676
 Martz, Dee, 2108 Ellis St, Stevens Point, WI, 54481
 Maslowski, Henryka, 3002 Lansbury, Claremont, CA, 91711
 Mason, Katherine, 9285 Wexford Rd, Boulder, CO, 80303
 Mathews, Louise, 2240 W 3800 S, West Valley City, UT, 84119
 Matson, Kimberly, 2222 W Roscoe St, Chicago, IL, 60618
 Mattered, Vincent, 702 Orleans Ct, Warwick, RI, 02886
 Mattis, Kathleen, 127 Jefferson Rd, St Louis, MO, 63119
 Maurice, Donald, Conservatorium of Music, Box 756, Wellington,
 NEW ZEALAND
 Mawhinney, Malcolm, 76 Namata Rd, Onehunga, NEW ZEALAND
 Mayost, S A, 674 Hillcrest Ave, Ottawa, Ont, K2A 2N3, CANADA
 McCain, Corrina, 725 3rd St, Helena, MT, 59601
 McCall, Patricia, 4614 Glenwood Dr, Macon, GA, 31210
 McCann, Darrin, 2204 Pullman Ln, Redondo Beach, CA, 90278
 McCarty, Patricia, 25 Carruth St, Boston, MA, 02124
 McCay, Kerry, 909 Elmwood #H3, Evanston, IL, 60202
 McClelland, Michael, 4561 NW 67 Terrace, Lauderhill, FL, 33319
 McConnell, Pamela, 5113 SW 71st Pl, Miami, FL, 33155
 McCrary, Laura, 732 Newport Ave, Long Beach, CA, 90804
 McCurdy, Nicole, 303 Gail Ct, Prospect Heights, IL, 60070
 McDermott, Helen, 3373 W. 29th Ave, Denver, CO, 80211
 McDonald, Marjorie, 35 Potter Pond, Lexington, MA, 2173

McFall, Felicia, 419 30th Ave E, Seattle, WA, 98112
 McFarland, Karen, 923 Canterbury Dr, Logan, UT, 84321
 McGuan, Patrick, 912 Lexington, Wheaton, IL, 60187
 McHenry, Wendy J., 11600-B Argonne Forest Trail, Austin, TX, 78759
 McInnes, Donald, 10985 Bluffsides Dr Suite 5204, Studio City, CA, 91604
 McMillan, Bill, 489 St Germain Ave, Toronto, ONT, M5M 1W9, CANADA
 Meinsen, Danielle, 2605 17th St, Sacramento, CA, 95818
 Merritt, Dale, 1138 W. Townley Ave, Phoenix, AZ, 85021
 Metzger, Nancy, 3934 E. Elm Street, Wichita, KS, 67208
 Metzler, Thomas, 604 S. Central Ave, Glendale, CA, 91604
 Meyer, Katie, 3368 S Lucille Ln, Lafayette, CA, 94549
 Meyer, Shauna K., 3233 East View Drive, Shingle Springs, CA, 95682
 Meyer, Adam P., 1820 Sheridan Rd Jones Arts Room 204, Evanston, IL, 60201
 Michaels, Mel, 11206 Canton Dr, Studio City, CA, 91604
 Michelic, Matthew, 835 E Winnebago St, Appleton, WI, 54911
 Michels, Maureen, 2210 S. Main St, Winston-Salem, NC, 27127
 Miller, Catherine, 30951 Lakeshore Blvd, Willowick, OH, 44095
 Miller, George, 22700 Cass Ave, Woodland Hills, CA, 91364
 Miller, Margaret, 17995 Bakers Farm Rd, Colorado Springs, CO, 80908
 Millett, Maxanne, 5222 N Cliffside Dr, Phoenix, AZ, 85018
 Milley, Barbara, 145 Pearl St, Newton, MA, 02158
 Miner, Elizabeth, 1127 E. 135 S., Lindon, UT, 84042
 Miskolczy, Victoria, 465 S Madison Ave #316, Pasadena, CA, 91101
 Moellmann, Alexandra, 1573 Harris Rd, Penfield, NY, 14526
 Moll, Elizabeth, 77 Marlboro Rd, Delmar, NY, 12054
 Moody, Lisa, 284 Balfour Ave, Winnipeg, MB, R3L 1N6, CANADA
 Moraga, Jorge, 1311 Lodgewood Way, Oxnard, CA, 93030
 Moravec, Andreanna, 175 North Harbor Dr, Suite 510, Chicago, IL, 60601
 Moree, Debra, 738 Five Mile Dr, Ithaca, NY, 14850
 Morgan, Nancy E., 3240 Rosie Cr Rd, Fairbanks, AK, 99709
 Morgan, LeeAnn, 4306 156th Ave NE, Redmond, WA, 98052
 Morgan, George, 65 Ave D, Atlantic Highlands, NJ, 07716
 Morrow, Ruth, 1405 Jeff Davis Dr, Tyler, TX, 75703
 Morrow, Cynthia, 8135 Redlands No. 102, Playa Del Rey, CA, 90293
 Morton, Victoria, 1510 Chiri Ct, San Martin, CA, 95046
 Mount, Liana, 460 W 57 St, New York, NY, 10019
 Mukogawa, Carole, PO Box 27819, Los Angeles, CA, 90027
 Mutchler, KC, 2440 Trossock, St Louis, MO, 63122
 Muzzy, Carissa, 28 W. Geneva Rd, West Chicago, IL, 60185
 Myers, Roger, 10430 Morado Circle #2335, Austin, TX, 78759
 Myers, Joanna H., 4450 Curran Rd, Buchanan, MI, 49107
 Nagle, Laura, 59 Old Oxford Rd, Chester, NY, 10918
 Nehring, Nancy, 1039 -7th St E., Saskatoon, SK, S7H 0Y7, CANADA
 Neidhold, Caryn Wiegand, 835 Cliff View Dr, Reno, NV, 89523
 Nelson, Suzanne, 5 Ivy Trail, Greenville, SC, 29615
 Nelson, John, 3700 Monarch Cir., Naperville, IL, 60564
 Nelson, Leah, 2507 Northland Dr, Austin, TX, 78756
 Neubauer, Paul, c/o Chamber Music Society of Lincoln Center, 70 Lincoln Center Plaza, NY, NY, 10023-6582
 Neubert, Peter, 218 Pleasant St, Oak Park, IL, 60302
 Neufeld, Dan, 11750 Sunset Blvd, Los Angeles, CA, 90049
 Neumann, Daniel, PO Box 1384, Santa Rosa, CA, 95404
 Neumann, Susan, 1428 Imperial Dr, Bismark, ND, 58504,
 Neville, Mike, 1089 West Ridgetop Cove, South Jordan, UT, 84095
 Newman, Maria, 7834 Rim Caynon Rd, Sunland, CA, 91040
 Newton, John, RR #2, Desboro, Ont., N0H 1K0, CANADA
 Nicholson, Christina, 3569 S Meadowlark, Springfield, MO, 65807
 Nickolaus, Melanie, 1931 N Howe St, Chicago, IL, 60614
 Nieland, Michael, 1400 Inverness Ave, Pittsburgh, PA, 15217
 Nielsen, Chris, 725 Bentley Ct, Tyler, TX, 75703
 Nielson, Carol, 2542-35th Street, Los Alamos, NM, 87544
 Nilsson, Eva, Skidsparet 11, Umea, S-90338 SWEDEN
 Nisbet, Meredith, 116 Evonshire Dr, Arkadelphia, AR, 71923
 Nordstrom, Harry, 611 E 5th St, Northfield, MN, 55057
 Norris, Scott, 2011 Royal Downs Dr, Katy, TX, 77450
 Norwitz, Sherrie, 3403 Clifftmont Ave, Baltimore, MD, 21213
 Novog, Novi, 16696 Haynes St, Van Nuys, CA, 91406
 Nowak, Michael, PO Box 6929, Los Osos, CA, 93412
 Nuccio, Judy, 1540 Long Valley Rd, Glenview, IL, 60025
 O'Neill, Richard, 200 Waughtown, Winston-Salem, NC, 27117
 O'Brien, James, 4711 W. Metaline, Kennewick, WA, 99336
 O'Daniel, Karen, 1208 Wright Rd, Murray, KY, 42071
 O'Fallon, David, 211 N Pierce Ave, Wheaton, IL, 60187
 Oddo, Vincent, 1230 Heatherfield, Glenview, IL, 60025
 Offman, Judy, 3814 Linkview Dr, Houston, TX, 77025
 Oh, Yun-Jin, 1101 N Calvert St #1208, Baltimore, MD, 21202
 Ohlsen, Linnea, 1169 E Alameda, Santa Fe, NM, 87501
 Ohlsen, Linnea D., 1169 E. Alameda, Santa Fe, NM, 87501
 Ojstersek, Gunter, Im Nonnengartenl, D-67127 Rodersheim-Gronau, GERMANY
 Ollis, Asya, 2504 Whisper Ridge Ln, Arlington, TX, 76006
 Olson, Karen, 48 Edward St, Demorest, NJ, 07627
 Olson, Victoria, 6410 Hillside St, Shawnee, KS, 66218
 Oppelt, Robert, 988 Madison, Birmingham, MI, 48009
 Oquist, Kjersten, 8442 SE 23rd Ave, Portland, OR, 97202
 Ortiz, Mario, 1080 N 470 W, Orem, UT, 84057
 Orynawka, Leo, 2278 Long Rd, Grand Island, NY, 14072-1330
 Ostrander, Joanna, 4660 S Wolff St, Denver, CO, 80236
 Ostrander, Rachel, 4660 S Wolff St, Denver, CO, 80236
 Ostroff, Barbara, 401 Conard Dr, Springfield, PA, 19064,
 Oswell, Simon, PO Box 1384, Pacific Palisades, CA, 90272
 Ouzounian, Michael, 170 West End Ave, New York, NY, 10023
 Ovington, Geoffrey, Staton Rd R.R. 1 Box 10, Shushan, NY, 12873
 Ozipko, Marnie, 11704-136 St, Edmonton, Alb, T5M 1M8, CANADA
 Palmer, Mary, 956 Copley LN, Joliet, IL, 60436
 Palumbo, Michael, 5463 S 125 E, Ogden, UT, 84405
 Papich, George, 714 Kiowa Dr West, Lake Kiowa, TX, 76240
 Parente, Leilani, 11831 S Willow Cir, Houston, TX, 77071
 Park, Hyun-Shin, Songpa-Ku Jasmil-Dong 86 Asia, Seoul, 2-1803, KOREA
 Park, Soung-Hee, 60 West 66th, New York, NY, 10023
 Parotti, Sergio, Av. Federico Lacroze 2560, 11 H, Buenos Aires, 1426, ARGENTINA
 Pascal, Peggy, 1215 Spruce St, Winnetka, IL, 60093
 Paskaruk, Greg, 11-604 Edward Ave, Richmond Hill, Ontario, L4C 9Y5, CANADA
 Patten, Jeffrey, 1375 Meyer Rd, Hoffman Estates, IL, 60194
 Patterson, Ann, 311 Ashmount Ln, Arlington, TX, 76017
 Pattison, Warren, 425 Bernard St, Denton, TX, 76201
 Pellett, Jill, 8 Homer Clark Ln, Sandy Hook, CT, 06482
 Perdakis, Petula, 6 Withers Ln, Hockessin, DE, 19707
 Perkins, Jane, 108 Sudden Valley, Bellingham, WA, 98226
 Perna, Leslie, 2221 Concordia Dr, Columbia, MO, 65203
 Pervan, Mary, 13544 S. 88th Ave, Orlandpark, IL., 60462
 Pescor, James, 5011 Waw Ban See, Clarkston, MI, 48348
 Petersen, Jane, 1345 Wilton Way, Salt Lake City, UT, 84108
 Peterson, Erik, 26 W. Vermont, Villa Park, IL, 60181
 Pettengill, Edward, 3639 Saddlemire Rd, Binghamton, NY, 13903
 Pettit, Rachel, BYU Deseret Towers T-420, Provo, UT, 84604
 Phelan, Jean, 3750 Rosemeade Pkwy, Dallas, TX, 75287,
 Phelps, Sylvia, 15303 Friends St, Pacific Palisades, CA, 90272
 Phelps-Grenlee, Barbara, PO Box 2079, Cheyenne, WY, 82003
 Phillips, Heather, 3965 Whispering Trails Dr, Hoffman Estates, IL, 60165
 Picken, Andrew, 13550 Foothill Blvd No. 10, Sylmar, CA, 91342
 Pieters, Joanna, 7 St John's Rd, Harrow, Middlesex, HA1 2EE, UK
 Pikler, Charles, 1255 Fairfield Rd, Glencoe, IL, 60022
 Piltz, Hans -Karl, 4523 W. First Ave, Vancouver, BC, V6R 1H7, CANADA
 Pimentel-Cedre, H, PO Box 40674, Philadelphia, PA, 19107

Pinkerton, Jennifer, 3712 N Riverside Dr, Bethany, OK, 73008
 Pinks, Mark, 13715 SW 66 St, Miami, FL, 33183
 Pinner, Jay Martin, 11 Tassel Trail, Greenville, SC, 29609
 Pitelka, Kazi, 2027 N. Mar Vista Ave, Altadena, CA, 91001-3129
 Pittman, Meme, 2264 Sweetbrier Rd, Schenectady, NY, 12309
 Plexico, Byron, 6449 Park Central Dr W, Indianapolis, IN, 46260
 Plummer, Kathryn, 3416 Benham Ave, Nashville, TN, 37215
 Polick, Laura D., 961 Wild Ginger Trl, West Chicago, IL, 60185
 Pollett, Patricia, U. of Queensland Music Dept, Brisbane, Qld, 4072,
 AUSTRALIA
 Pollsen, Cindy, R.R. 1 Box 262D, Chester, NY, 10918
 Poorbaugh, Kara, 5817 Old Forge Cir, Raleigh, NC, 27609
 Popke, Gloria, N3299 Ebert Rd, New London, WI, 54961
 Posset, John R., 2604 Steffin Hill, Beaver Falls, PA, 15010
 Potter, Clark, 5300 30th, Lincoln, NE, 68516
 Poularikas, Barbara, 208 Bel-Air Rd, Huntsville, AL, 35802
 Pounds, Dwight, 1713 Karen St, Bowling Green, KY, 42104
 Power, Elizabeth, 320 W 84th St, New York, NY, 10024
 Powers, Pamela, 7962 Cedar Mt Rd, Divide, CO, 80814
 Prentice, Cynthia, 77 Dogwood Ln, Trumbull, CT, 06611
 Prentice, David, Box 69, Flesherton, Ontario, N0C 1E0, CANADA
 Prescott, Karie, 9038 1/2 Hubbard St, Culver City, CA, 90232
 Preucil, William, 317 Windsor Dr, Iowa City, IA, 52245
 Preves, Milton, 721 Raleigh Rd, Glenview, IL, 60025
 Primrose, Hiroko, 1339 KoKo Head Ave, Honolulu, HI, 96816
 Przygocki, James, University of Wyoming, Laramie, WY, 82071
 Puchhammer-Sidillot, Jutta, 7595 Sartre, Brossard, Quibec, J4X 1S3,
 CANADA
 Puskar, Janet K., 1300 Prairie Ln, Montgomery, AL, 36117
 Quiroz, Janet, 1712 W Roma Ave, Phoenix, AZ, 85015
 Radmer, Robert, 5620 Abilene Trail, Austin, TX, 78749
 Raileanu, Eufrosian, 235 President St, Brooklyn, NY, 11231
 Raimi, Max, 419 8th St, Wilmette, IL, 60091
 Ramiez, Edmundo, 60 Lincoln Center Box 678, New York, NY, 10023
 Ramos, Miguel, 2066 Violet Ave, Boulder, CO, 80304-0608
 Rasmussen, Judy, 700 Sherman Rd, Glenview, IL, 60025
 Ravnan, Ellen, 10339 B E Peakview Ave, Englewood, CO, 80111
 Rawls, Scott, 1722 Claredon Cir, Greensboro, NC, 27410
 Ray, Linda, 885 20th, Beaumont, TX, 77706
 Rayne, Melinda, 362 Elwood St, Redwood City, CA, 94062
 Reagen, Rhona, 5127 Lee St, Skokie, IL, 60077
 Reichenbach, Reto, 606 St Paul St, Baltimore, MD, 21202
 Reiher, Stephanie, 6519 Greenfield Ct, Lanham/Seabrook, MD, 20706
 Rekas, Linda, 433 Talbert Ct, Baldwin, MO, 63021
 Rensberger, Lisa, 104 Dupee Pl, Wilmette, IL, 60091
 Renz, Laura, 906 Elizabeth Ct, Mt. Pleasant, MI, 48858
 Requejo, Alberto, 1921 Willow Creek Dr, Austin, TX, 78741
 Rhodes, Dianna, 10575 N 6000 W, Highland, UT, 84003
 Rhodes, Samuel, 89 Booth Ave, Englewood, NJ, 07631
 Ricci, Leslie, 81 Meredith Dr, Cranston, RI, 02920
 Richards, Melanie, 1059 Briar Ave, Provo, UT, 84604
 Richardson, Tiffany Elena, 5952 Innisvale Dr, Fairfax Station, VA, 22039
 Richman, Sue, 420 Ashwood Pl, Boca Raton, FL, 33431-8217
 Richter, Claude, PO Box 6822, Malibu, CA, 90264
 Ridge, Amanda, 865 N 160 W, Provo, UT, 84604
 Ridolfi, Robert, 5561 S Stockwell Rd, Tucson, AZ, 85746
 Riley, John, 37 Tanglewood Dr, Henderson, NV, 89012
 Riley, Carolyn, 2027 Bermuda St #3, Long Beach, CA, 90814
 Riley, Leila, 512 Roosevelt, Ypsilanti, MI, 48197
 Ritscher, Karen, 241 W 97th St Apt. 13M, New York, NY, 10025
 Robbins, Sandra, 6 Quaker Hill Court East, Croton-on-Hudson, NY, 10520
 Roberts, Claudia, 13100 S. 2200 West, Riverton, UT, 84065
 Rockney, Karen, 1231 Dori Lane, Indianapolis, IN, 46260
 Rodgers, Oliver, 179 Kendal Dr, Kennett Square, PA, 19348
 Rodland, Carol, 57 Chris Terrace, Ringwood, NJ, 07456
 Rodman, Becky, 1079 Glenhaven Dr, Pacific Palisades, CA, 90272
 Rogers, Amber, 1419 N 7th Ave E, Duluth, MN, 55805
 Rogers, Sara, 13207 H. Dr N, Battle Creek, MI, 49014-8924
 Roggen, Ann, 11 W 69th St, New York, NY, 10023
 Rolih, Christine, 1388 Potmac Ct, Carol Stream, IL, 60188
 Rooks, Naomi Graf, 137 Larch Rd, Briarcliff Manor, NY, 10510
 Rose, Phillip, PO Box 27-430, Wellington, NEW ZEALAND
 Rose, Ellen, 2807 Lawtherwood Pl., Dallas, TX, 75214
 Rosen, David, 800 W. 1st Street No. 1503, Los Angeles, CA, 90012
 Rosen, Alice, "25/ F, Flat C, Block 3155 Connaught Rd W", HONG KONG
 Rosenbaum, George, 2222 Ella Ct, Grand Junction, CO, 81505
 Rosenberg, Joel, 1950 E Browning Ave, Salt Lake City, UT, 84108
 Rosenblum, Myron, 39-23 47th St, Sunnyside, NY, 11104
 Rosenthal, Thomas, 46 Rustic Gate Ln, Dix Hills, NY, 11746
 Rosky, Jacqueline, 2304 Speed Ave, Louisville, KY, 40205
 Ruan, Sandlyn, 4441 S Meridian, Puyallup, WA, 98373
 Rubin, Sarah, 13 Hollowglen, Irvine, CA, 92714,
 Rudoy, Leslie, 3150 Lake Shore Dr, Chicago, IL, 60657
 Ruosso, Suzanne, 1360A Ephesus Church Rd, Chapel Hill, NC, 27514
 Rush, Tracey, 2872 Illinois Ave, Dubuque, IA, 52001-5409
 Rush, Philip, 459 Alta Mesa Dr, Riverside, CA, 92507
 Rushton, Angela, 98 Rogers Hall, Provo, UT, 84604
 Russell, Mark, 10682 Sherborne Rd, Fishers, IN, 46038-2669
 Russell, Christine, 3800 Venard Rd, Downers Grove, IL, 60515
 Rutledge, Christine, "U. of Iowa, School of Music", Iowa City, IA, 52242
 Ryan, Pamela, 2130 Atchena Nene, Tallahassee, FL, 32312
 Ryberg, Sonja, 3343 Kinkaid Dr, Dallas, TX, 75220
 Rynearson, Paul, PO Box 4009, Malibu, CA, 90264
 Sacchi, Carolyn, 3768 Rice Blvd, Houston, TX, 77005
 Sagos, John S, 1410 W Argyle Apt.2, Chicago, IL, 60640
 Sah, Analee, 14 Silver Beech Ct, Pouquott, NY, 11733
 Salil, Sheth, 1912 Springtree Dr, Maryland Heights, MO, 63043
 Samuels, Rachel, 123 Bay Path Drive, Oak Ridge, TN, 37830
 Sanchez, Cynthia, 7610 Cameron Rd, Austin, TX, 78752
 Sandford, Donald, 205 Alco Ave, Maryville, MO, 64468
 Sandler, Myron, 3756 Hayvenhurst Ave, Encino, CA, 91436
 Sandoz, Helen, 6606 N Williams, Portland, OR, 97217
 Satina, Albert, 912 West Verde Ln, Phoenix, AZ, 85013
 Saul, Thomas, 207 Parklands Dr, Rochester, NY, 14616
 Sawodny, Wolfgang, Foehrenweg 27, Eichingen 2, D-89275, GERMANY
 Scanlon, John, 385 Flint Ave, Long Beach, CA, 90814
 Schade, Terry, 1727 W Stroud, Caruthers, CA, 93609
 Schicker, Kathleen, 24 Oak Hill Manor, Glen Carbon, IL, 62034
 Schmidt, Stan, 112 Evergreen, Elmhurst, IL, 60126
 Schmitz, Margery, 3612 Kerry Ct, Denver, CA, 95316
 Schmitz, Patricia, 5972 E Eli St, Tucson, AZ, 85711
 Schnaidt, Ann, 618 E Plum, Fort Collins, CO, 80524
 Schneider, Virginia, 1800 S 2nd St, Louisville, KY, 40208
 Schoen, William, 3180 N Lakeshore Dr, Chicago, IL, 60657
 Schoer, Norman, 2825 West 99th Place, Evergreen Park, IL, 60805
 Schotten, Yizhak, 3970 Ridgmaar Sq Dr, Ann Arbor, MI, 48105
 Schroeter, Sally, 2214 Grantland Ave, Nashville, TN, 37204
 Schwandt, Jacquelyn, 12301 N MacArthur, Oklahoma City, OK, 73142
 Schwartz, David, 12230 Iredell St, Studio City, CA, 91604
 Scoggins, Michael, 302 E 900 S, Salt Lake City, UT, 84111
 Scoggins, Amanda, 3833 Donna Lynn Lane, Orlando, FL, 32817
 Sego, David, 808 E June St, Mesa, AZ, 85203
 Seidenberg, Daniel, 10915 Rose Ave #6, Los Angeles, CA, 90034
 Seidman, Jeanann, 202 Vanderpool, Houston, TX, 77024
 Seitz, Ted, 22103 Main St, Hayward, CA, 94541
 Selden, William, 5 Riverfield Dr, Westport, CT, 06880
 Sentamans, Susy, 46610 Guadassuar, Valencia, SPAIN
 Serban, Marinela, Jahnstr 7, Goerlitz, D-02828, GERMANY

Servoss, Yvette, 2589 E 2750 N, Layton, UT, 84040
 Shallenberger, Jennifer, 17 Easton St, Allston, MA, 02134
 Shanks, Marion, 4110 SW Charming Way, Portland, OR, 97225
 Shapiro, Elizabeth, 1909 Deercreech Ln, Northbrook, IL, 60062
 Shaughnessy, Christopher, PO Box 14, Sagaponack, NY, 11962
 Shaw, Kenneth, 1810 Amos Dr, Conway, AR, 72032
 Shehan, Gale, 109 Doane St, Ottawa, Ont, K2B 6G8, CANADA
 Shimizu, Margaret, 207 N. Cove St, Sierra Madre, CA, 91024
 Showell, Jeffrey, U. of Arizona Music, Tucson, AZ, 85721
 Shufelt, Debra, 200 Prospect St, Herkimer, NY, 13350
 Shumway, Sally, 27 Pershing Ave, Yonkers, NY, 10705
 Sieh, Tyler, "R.R. 1, Box 33", Courtland, MN, 56021
 Sihler, Kathleen, 812 Kingsley Ave, Waterloo, IA, 50701
 Silberman, Daryl, 10915 Rose Ave, Los Angeles, CA, 90034
 Sills, David, 1909 W Harvard Ave, Muncie, IN, 47304
 Silver, Eva, 250 S Canyon View Dr, Los Angeles, CA, 90049
 Simon, Benjamin, 882 Chimalus Dr, Palo Alto, CA, 94306
 Simon, Melissa, 6541 N Mozart, Chicago, IL, 60645
 Sims, Janet, 10190 N Foothill Blvd, Cupertino, CA, 95014
 Singer, Josh, 6501 E Ida Ave, Englewood, CO, 80111
 Sirota, Jonah, 2825 Bellefontaine, Houston, TX, 77025
 Siviero, Juan, 2222 W Roscoe St, Chicago, IL, 60618,
 Skelley, Chrissie, 1512 Oswego Rd, Naperville, IL, 60540
 Sklar, Arnold, 7135 Keystone, Lincolnwood, IL, 60646
 Skupen, Hannah, 123 Orange Grove Ave, Placentia, CA, 92870
 Slaughter, Robert, 1184 N. Maine St #60, Fort Bragg, CA, 95437
 Slosser, Ann, 4602 Browndale Ave S, Edina, MN, 55424
 Slowik, Peter, 3968 W. Oak Ave, Northbrook, IL, 60062
 Smith, Alissa, 115 Central Park West, New York, NY, 10023
 Smith, Chalmers, 2020 Byron St, Palo Alto, CA, 94301
 Smith, David W., 1411 Silva St, Long Beach, CA, 90807
 Smith, Dean, 3220 Magnolia, Denver, CO, 80207
 Smith, Jennifer, 1612 5th Ave N, Great Falls, MT, 59401
 Smith, Matthew, 7901 Henry Ave #F407, Philadelphia, PA, 19128
 Smolaga, Borys B., 226 Boulevard St, Shreveport, LA, 71104-2420
 Smolensky, Marcus, 278 Market St, Milliflinburg, PA, 17844
 Snyder, Kathryn, 6820-27 Whispering Falls, Raleigh, NC, 27613
 Sobin, Linda, 7105 North 15 Ln, McAllen, TX, 78504
 Solomon, Stanley, 290 Berkeley St, Toronto, Ontario, M5A 2X5, CANADA
 Solomonow, Rami, 9442 Springfield Ave, Evanston, IL, 60203
 Somerville, Shawn, 17126 Little Cypress, Cypress, TX, 77429
 Sonnenberg, Susanna L., 8251 Ravenel Drive, Colorado Springs, CO, 80920
 Sons, Tracy, 2443 S Race St, Denver, CO, 80210
 Speaker, Edwin, 417 Red Sail Way, Satellite Beach, FL, 32937
 Speed, Angela, 1116 S Slate Canyon Dr, Provo, UT, 84606
 Spencer, Nora, 26 Valley Hill Dr, Worcester, MA, 01602
 Spenlove, Lisa, 135 S Mtn Rd, Fruit Heights, UT, 84037
 Spicknall, Sharilyn, 640 W Krislynn Woods Ave, West Terre Haute, IN, 47885
 Spikham, Somkiat, 118/302 Soi10/7 Bangrapattana, Bangouthong, Non-thabur, 111, THAILAND
 Spittel, Richard, 5506 Rockleigh, Arbutus, MD, 21227
 Stains, Betsy, 4642 Strayer Dr, Hilliard, OH, 43026
 Stamon, Nick, 4380 Middlesex Drive, San Diego, CA, 92116
 Stanbury, Jean, 43 Circuit Rd, Chestnut Hill, MA, 02167
 Stanick, Mary and Gerald, 8531 Bairdmore Cres., Richmond, BC, V7C 1M8, CANADA
 Starkman, Jane, 106 Gibbs Street, Newton Centre, MA, 02159
 Statlard, Leanne, 3128 Haddenpton Dr, Los Angeles, CA, 90064
 Steely, Kathryn, 950 North Countryside Dr Apt#217, Palatine, IL, 60067
 Steffy, Renee, 467 Fruitville Pike, Manheim, PA, 17545
 Stein, Kenneth, 1320 Sherman Ave, Evanston, IL, 60201
 Stein, Rebecca, 6329 East Beal City Rd, Mt Pleasant, MI, 48858
 Steinkraus, William, PO Box 3038, Norton, CT, 06820
 Steltenpohl, Lisa, 124 Stone Marsh Lane, N. Barrington, IL, 60010
 Stenzen, Adrian, 3102 Diablo View Rd, Lafayette, CA, 94549
 Stephenson, Angela, 8520 Etta Dr, Springfiled, VA, 22152
 Stepniak, Michael, 7641 Carroll Ave, Takoma Park, MD, 20912
 Sterba, Steven, 740 69th St, Willowbrook, IL, 60521
 Stevens, Lora, 3010 S Cherry Wy, Denver, CO, 80222
 Stevenson, Bertha, 3258 Austin Dr, Colorado Springs, CO, 80909
 Stewart, Danny, 5 Flint Ct, Rohnert Park, CA, 94928
 Stierhof, Karl, Linzerstr 352/IV/1, Vienna, A-1140, AUSTRIA
 Stohs, Joanne, 3422 Sunleaf Way, Richmond, CA, 94806
 Stoicescu, Ciprian, c/o Sagunto 160, Valencia, B35, 46009, SPAIN
 Stoll, Barrett, 999 310th St, Atalissa, IA, 52720
 Stone, Susan, 2445 21st Ave, Rock Island, IL, 61201
 Stone, Shawne, 775 Maryhurst Cir. , West Linn, OR, 97068
 Stoskopf, Robert, 3478 B. Pleasantbrook Village Ln, Atlanta, GA, 30340-5661
 Straka, Leslie, 3870 Yorkshire Ave, Eugene, OR, 97405
 Strauss, Michael, 7042 Steven Ln, Indianapolis, IN, 46260
 Strong, Leticia, 1260 Meadowbrook Rd, Altadena, CA, 91001
 Stuen-Walker, Elizabeth, 4123 Susan Ct, Bellingham, WA, 98226
 Subotnick, Linn, 11750 Moorpark St, Studio City, CA, 91604
 Sunderman Jr., Dr F. William, 270 Barnes Rd PO Box 54, Whiting, VT, 05778
 Swanson, Marissa, 16140 Jamacia Ave W., Lakeville, MN, 55044
 Szlubowski, Tomasz, 4261 Whitehaven St, Baton Rouge, LA, 70808
 Szoke, Heidi, 3124 S 2800 E, Salt Lake City, UT, 84109
 Tachau, Paula K. and Frank, 200 Lee St #2-A, Evanston, IL, 60202
 Taft, Bradford, 306 E Seven Oaks, Greenville, SC, 29605
 Takarabe, Tamae Clara, 2859 West Roscoe St, Chicago, IL, 60618
 Takeuchi, Gary, 1310 Grand Vista Way, Monterey Park, CA, 91754
 Tatton, Thomas, 7511 Parkwoods Dr, Stockton, CA, 95207
 Taylor, Charletta, 630 Emerson Apt. 24, Evanston, IL, 60201
 Taylor, Rebecca, 1605 E. Forest Ave, Wheaton, IL, 60187
 Temple, Suzanne, 1812 Essex Dr, Ft Collins, CO, 80526
 Tetenbaum, Marvin, 849 S. Adams St, Hinsdale, IL, 60521
 Thayer, Delores, 18 Kosior Dr, Hadley, MA, 1035
 Thieci, Ian, 128 Kings Rd, Harrow, HA2 9JH, ENGLAND
 Thomas, Teresa, 2335 Dearborn, Missoula, MT, 59801
 Thomas, Kelly, 924 N. Main Street, Fortville, IN, 46040
 Thomason, Daniel, 10917 Pickford Way, Culver City, CA, 90230
 Thompson, Marcus A., 11 Waverley Ave, Newton, MA, 02158-2103
 Thompson, John, "205 Sierra Morena Circle, S.W.", Calgary, AB, T3H 2W8, CANADA
 Thompson, Beth Ann, 482 W. Center, Snowflake, AZ, 85937
 Thorberg, Mildreth, 2475 Virginia Ave NW, Washington, D.C., 20037
 Thornblade, Gwendoline, 27 Central Terrace, Auburndale, MA, 02166
 Thornton, Douglas, 6588 Lancaster Dr, Warrenton, VA, 22186
 Thurnheer, Werner, Rainstrasse 38, Thalwil, CH-8800, SWITZERLAND
 Tietze, Philip, 1431 Saratoga Ave, Morgantown, WV, 26505
 Timblin, William, 1303 First Ave, Sterling, IL, 61081
 Tischer, Raymond, 3313 Communtiy Ave, La Crescenta, CA, 91214
 Tischer, Ann, 224 Loyola Dr, Santa Barbara, CA, 93109
 Tobey, Marta, 1510 Sonoma Ave, Albany, CA, 94706
 Tolberg, Adelaide, 84 Kingston Rd, Berkeley, CA, 94707
 Tolia, Linda, 32267 Auburn Dr, Beverly Hills, MI , 48025
 Toney, Angela, 122 B N Walnut Cr, Greensboro, NC, 27409
 Tree, Michael, PO Box 193, Marlboro, VT, 05344
 Treffinger, Sally, 12240 W. Oklahoma Ave, West Allis, WI, 53227
 Treter, Christine, 5791 Fern Ct, Greendale, WI, 53129
 Truchon, Effie, 1001 South 96th, West Allis, WI, 53214
 Turner, Nils, PO Box 48, Mount Wilson, CA, 91023
 Turner, Dawn, PO Box 26796, Indianapolis, IN, 46226
 Tuttle, Karen, 2132 Pine St, Philadelphia, PA, 19103

Ulfeng, David, 7817 Van Buren NE, Minneapolis, MN, 55432
 Undercofler, Katherine, 95 Stuyvesant Rd, Pittsford, NY, 14534
 Updegraff, Erin, 704 Sherwood Ct, Naperville, IL, 60565
 Urrasio, Nancy, 231 N 3rd St, Philadelphia, PA, 19106-1233
 Vacher, Mary, 30 Clinton St, Waltham, MA, 02154
 Vamos, Roland, 58 East College St, Oberlin, OH, 44074
 Van Hamel, Diederik, 6 Lower Byrdcliffe Rd, Woodstock, NY, 12498
 VanBecker, Leslie, 539 Paris St, SE, Grand Rapids, MI, 49503
 Vandenberg, Mary, 1100 Slayton Ave, Grand Haven, MI, 49417
 Vann, Judith, 707 Roantree Dr, Brentwood, TN, 37027
 VanValkinburgh, Terri, 908 Reba Pl. Apt. 3N, Evanston, IL, 60202
 Vela, Glori, 4314 Fairmont Dr, Grand Prairie, TX, 75052
 Venczel-Dimitrov, Vladimir, 333 Orange Ave #28, Coronado, CA, 92118
 Vendryes, Basil, 6647 S Heritage Place W, Englewood, CO, 80111
 Venstrom, Kristine, 1240 Stanyan St Apt. A, San Francisco, CA, 94117
 Verebes, Robert, 505-6875 Norwalk, Montréal, Québec, H4W 3G2,
 CANADA
 Vernon, Robert, 32340 Burlwood Dr, Solon, OH, 44139
 Vick, Laura, 915 N Linden St, Northfield, MN, 55057
 Vidulich, Michael L., PO Box 47-126, Ponsonby, Auckland 1,
 NEW ZEALAND
 Vo, Brian-Trung, 13871 Shady Ln, Santa Ana, CA, 92706
 Volocyk, Jenny, 1043 Glandish Ln, Glenview, IL, 60025
 Vullmahn, Francis, 0435 S. 700 E., Knox, IN, 46534
 Waddle, John, 2032 St Clair Ave, St Paul, MN, 55105
 Wadley, Erica, 2401 E. Glen St #55, Tucson, AZ, 85719
 Walker, Emily, 205 S 30th, Laramie, WY, 82070
 Walker, Jennifer, PO Box 6103, Flagstaff, AZ, 86011
 Wallace, Randall, 43 W 13th St, New York, NY, 10011
 Wallace, David, 410 W 53rd St, New York, NY, 10019
 Walters, Barbara, 1707 East Willow Ave, Wheaton, IL, 60187
 Walther, David, 93 Coolidge Rd, Concord, MA, 01742
 Wang, Qiang, 29043 Spruce Grove Dr, Rancho Palos Verdes, CA, 90275
 Warner, Jason, 1403 Dean St, Peoria, IL, 61615
 Warrington, Martha, 7310 SW Westgate Way, Portland, OR, 97225
 Warshaw, Marvin, 177 Howard Ave, New Haven, CT, 06519
 Warwick, Jennifer, 29 Bryan St, Havertown, PA, 19083
 Washell, Arthur, 450 Chrysler Rd, Endwell, NY, 13760
 Watson, Michael, 6201 15th NW, Seattle, WA, 98107
 Watten, Ralph, 1209 Weeks Ave, Superior, WI, 54880
 Weaver, Michael, 1214 Sidney Dr, Wilmington, NC, 28405
 Weaver, Shirley, 5257 Mt. Alifan Dr, San Diego, CA, 92111
 Weber, Marie C., Box 358 118 W Main St, Campbelltown, PA, 17010
 Wedge, Benton, 6523 N. Newgard #2H, Chicago, IL, 60626
 Weik, Amanda, 1222 Shelter Cove, Winston-Salem, NC, 27106
 Weisberg, Diane, 17832 Boniello Dr, Boca Raton, FL, 33496
 Weiss, David, 4604 W Virginia Ave, Bethesda, MD, 20874
 Wells, John, PO Box 113, Los Altos, CA, 94023
 Wels, Walter, 146-35 59th Ave, Flushing, NY, 11355-5422
 Werne, Patricia, 10 North St Box 214, Norfolk, CT, 06058
 Westman, Aaron, 2601 Fir Park Way, Santa Rosa, CA, 95404
 Wetzel, Minor, 4904 Carmel Rd, La Canada, CA, 91011
 Wheeler, Margaret, 4716 Wrightwind Dr SE, Kentwood, MI, 49546
 Wheeler, Lawrence, 5818 Picasso Pl, Houston, TX, 77096
 White, John, 36 Seeleys, Harlow, Essex, CM17 OAD, UK
 White, Isaac, 1225 12th Ave, Greeley, CO, 80631
 White-Smith, Juliet, 3618 Platte Drive, Fort Collins, CO, 80526
 Whiting, Kasparowitz, PO Box 12925, San Luis Obispo, CA, 93406
 Whitlow, Phyllis, 1305 Brookgreen Dr, Cary, NC, 27511
 Whitman, Daniel, One Moringstar LN, Cleavland, OH, 44106
 Whitson, Bruce, Dallnstr 35, Kreuztal-Ferndorf, D-57223, GERMANY
 Whittaker, Charles, 550 Twin Springs Rd, Atlanta, GA, 30327
 Whittaker, Amber, 2535 E Isabella Ave, Mesa, AZ, 85204
 Wicker, Ruth, 926 W. Main Street #4, Kalamazoo, MI, 49006
 Wieder, Jamie, 8038 Hwy 762, Philpot, KY, 42366
 Wiggan, Jennifer, 10350 Almayo Ave #9, Los Angeles, CA, 90064
 Wilcox, Fred, 53C Crescent Rd, Greenbelt, MD, 20770
 Wilcox, Laura, 54 Gloucester Gr., Toronto, Ontario, M6C 2A3, CANADA
 Willcox, Scott, 206 Ira St, Urbana, IL, 61802-2260
 Williams, A. Daryl, 300 Colledge Hill Rd, Clinton, NY, 13323
 Williams, Lawrence, 1714 Endriss Dr, Martinez, CA, 94553
 Williams, Emily, 156 Asbury Apt. 5, Evanston, IL, 60202
 Williams, Ryan, 15 Ingham Dr, Stevens, PA, 17578
 Willis, William, 3114 Muensterman Ave, Evansville, IN, 47720
 Wilson, Evan, 104 N. Orange Dr, Los Angeles, CA, 90036
 Winget, Marie, 135 W Forrest Hill, Peoria, IL, 61604
 Winrich, Christina, 5265 N Shoreland Ave, Milwaukee, WI, 53217
 Winship, Marissa, 1218 2nd. St, Manhattan Beach, CA, 90266
 Winslow, Barbara, 10225 Kensington Pkwy, Kensington, MD, 20895
 Wolf, Annalee, 21 Vauxhall Pl, Chapel Hill, NC, 27514
 Wolf, Aaron S., 28 Balsam Ct, Holland, PA, 18966
 Wong, Nick, 6209 Crooked Stick Cir, Stockton, CA, 95219
 Woodruff, Lucia, 3204 Cherry Ln, Austin, TX, 78703
 Woods, Sherry, 911 Mimosa Dr, Florence, SC, 29501
 Woodside, Laura, 7531 SW 137 St, Miami, FL, 33158
 Woodward, Ann, 3700 Stoney Creek Rd, Chapel Hill, NC, 27514
 Woolf, Stephanie, 3615 Hoods Hill Rd, Nashville, TN, 37215
 Wreede, Katrina, 2884 Carmel St, Oakland, CA, 94602
 Wright, Carla, 302 Normandy, San Antonio, TX, 78209
 Wright, Donald, 3411 Mount Baker Dr, Austin, TX, 78731
 Yates, Stacy, 3516 Foxglove Ln, Louisville, KY, 40241
 Yelton, Erin, 8491 Kilkeny Dr, Cincinnati, OH, 45244
 Ying, Phillip, 145 W 67th St, New York, NY, 10023
 Yn, Teresa, 1180 St Charles Ct, Los Altos, CA, 94024
 Yorgason, Jen, 9638 S 2720 E, Sandy, UT, 84092
 Young, Roslyn L., 270 Riveside Dr, New York, NY, 10025
 Zaslav, Bernard, 25608 Creekview Circle, Salinas, CA, 93908
 Zeigler, Cheryl, 2009 Rucker Ave, Everett, WA, 98201
 Zeyringer, Franz, Musik Hochschule, Poellau, A-8225, AUSTRIA
 Ziabrikova, Olga, USM Box 9048, Hattiesburg, MS, 39402
 Zinoviyev, Mihail, 16103 Bryant St, N. Hills, CA, 91343

Listing of Member Organizations & Institutions

- Anderson Music Library, 2301 S Third St, Louisville, KY, 40292
- Bayerische Staatsbibliothek, DFG/ZS Biblio, München, D-80539, Germany
- Baylor Library-Serials, PO Box 97151, Waco, TX, 76798-7151
- Bein-Fushi Violins, 410 S Michigan Ave, Chicago, IL, 60605
- Bob Jones University, J S Mack Libr-Periodicals, Greenville, SC, 29614
- Bowling Green State University, Jerome Library, Serials Department
1168587, Bowling Green, OH, 43403
- Chapman University, Library, 333 N. Glassell, Orange, CA, 92866
- Chicago Public Library Music Section, 400 S. State St, Chicago, IL, 60605
- Chris Newport University, Capt. J Smith Library, 1 University Place,
Newport News, VA, 23606-2949
- Cincinnati Library, Library Sq 800 Vine St, Cincinnati, OH, 45202-2071
- Cleveland Institute Music Library, 11021 East Blvd, Cleveland, OH, 44106
- Dartmouth College, Baker Library-Serials, Hanover, NH, 03755
- DePaul University, Technical Services, 2350 N. Kenmore Ave, Chicago, IL,
60614
- Duke University-Music Libr, PO Box 90661, Durham, NC, 27708
- Eastman School, Sibley Music Library, 27 Gibbs St, Rochester, NY, 14604
- Florida State University, Ser Acq Unit/Lib Tech Ser, 620 S Woodward St,
Tallahassee, FL, 32306
- Free Library of Philadelphia, Serials Section, 2000 Hamilton St LL,
Philadelphia, PA, 19130-3814
- Fritz Reuter & Sons, Inc, 3917 W Touhy, Lincolnwood, IL, 60645
- Harid Conservatory Music Library, 2285 Potomac Rd, Boca Raton, FL,
33431
- Harmonie Park Press, 23630 Pinewood, Warren, MI, 48091
- Indiana University, Library Serials Department, 1320 E. 10th Street,
Bloomington, IN, 47405-3907
- Joseph Patelson Music House Ltd., Music Dealers-Publishers, 160 West
56th Street, NY, NY, 10019
- KC Strings Violin Shop, 5826 Merriam Dr, Merriam, KS, 66203
- Lawrence University, Periodicals, Seeley G. Mudd Library, Appleton, WI,
54912
- Library of Congress, Gift Sect/Exchange & Gift Div, Washington, D.C.,
20549
- Max Aronoff Viola Institute, 6302 54th Ave Ct West, Tacoma, WA, 98467
- Music Article Guide, PO Box 27066, Philadelphia, PA, 19118
- Natiman University Library, PO Box 830657, Birmingham, AL, 35283
- National Kaoshung Normal University. Lib, FOS-(9453140), PO Box 956,
Oregon, IL, 61061
- National Taiwan University, Air Fr (03966) , Westwood, MA, 02090
- New England Conservatory, Spaulding Library, 33 Gainsborough St,
Boston, MA, 02115
- Nicholas Frirsz Violins, PO Box 146 Rt 22, Schuyler Lake, NY, 13457
- North Texas State University, Library 1233956 Technical Services,
Box 305190, Denton, TX, 76203-5190
- Northwestern Univesity, Library-Serials Dept., Evanston, IL, 60208
- Oberlin College, Main Library Mudd Center, Oberlin, OH, 44074-1532
- Peabody Institute, Friedheim Library, 1 E Mt Vernon Pl, Baltimore, MD,
21202-2397
- Periodicals Department, University Libraries, 1 Murray St, Murray, KY,
42071-3300
- Rapkievian Fine Violins, 418 Undercliff Ave, Edgewater, NJ, 07020
- Rarities for Strings Publ, 50 Bellevue Ave, Bristol, CT, 06010
- RBP Music Publishers, 2507 Montrose Blvd #41, Houston, TX, 77006
- Rice University, Fondren Library MS 235, PO Box 1892, Houston, TX,
77251-1892
- Robertson Violin Shop, 3201 Carlisle Blvd NE, Albuquerque, NM, 87110
- Rutgers University, Laurie Music Library, 8 Chapel Dr, New Brunswick, NJ,
08901-8527
- San Francisco Conservatory of Music-Library, 1201 Ortega St,
San Francisco, CA, 94122-4498
- School of Instrumental Music, Education Dept of WA, Librarian,
PO Box 232, North Perth, WA, 6006
- SMU CUL HAM Periodicals, PO Box 750135, Dallas, TX, 75275-0135
- State University of New York-Buffalo, Lockwood Library Bldg.,
Serials Dept., Buffalo, NY, 14260
- Syracuse University Library, Serials Division, Syracuse, NY, 13244
- Thompson & Seman Inc, 4504 Oakton, Skokie, IL, 60076
- University of Alberta Library, Bibliographic Services-Serials, 5th Floor
Cameron, Edmonton, AB, T6G 2J8, CANADA
- University of Cincinnati, Serials Records, Central Library, Cincinnati, OH,
45221
- University of Colorado Libraries, Serials Department, Campus Box 184,
Boulder, CO, 80309-0184
- University of Connecticut, Library, 369 Fairfield Rd, Storrs, CT, 6269
- University of Illinois-Music Bldg, Music Library-E, 1114 West Nevada St,
Urbana, IL, 61801-3859
- University of Iowa Library, Serials Dept, Iowa City, IA, 52242
- University of Kansas Libraries, Serials/ Retrieval Svcs, 210 Watson,
Lawrence, KS, 66045-0001
- University of Kentucky, Fine Arts Library, Music, 500 S. Limestone,
Lexington, KY, 40506-0001
- University of Memphis, McWherter Lib Periodicals Dept,
Campus Box 526500, Memphis, TN, 38152-0001
- University of Michigan, Music Library, 3239 Moore Bldg, Ann Arbor, MI,
48109
- Univ of Nevada-Las Vegas, Library Periodicals, 4505 S. Maryland Pkwy,
PO Box 457009, Las Vegas, NV, 89154-7009
- University of Newcastle, Auchmuty Library, Serials Section, Callaghan,
New South Wales, 2308, AUSTRALIA
- University of North Carolina, Serials Department, CB #3938 Davis Library,
Chapel Hill, NC, 27514
- University of Northern Colorado, Michener Library Serials Record Div ESS,
501-20th Street, Greeley, CO, 80639-0001
- University of Oregon, Knight Libr-Serials, 1299 Univ of Oregon, Eugene,
OR, 97403
- University of Southern Mississippi, Cook Library-Serials, S. Station Box
5053, Hattiesburg, MS, 39406-1000
- University of Wisconsin, Mills Music Library, 728 State St, Madison, WI,
53706-1418
- VUL Periodicals Rec 001AHC9873, Ste 700 Baker Bldg, 110 21st Ave S,
Nashville, TN, 37203-2408
- West Virginia University, Music Library/ Creative Arts, PO Box 6111,
Morgantown, WV, 26506-6111
- William Bartruff & Company, 3249 First Ave S, Minneapolis, MN, 55408
- William Harris Lee & Co., Inc, 410 S. Michigan Ave, Chicago, IL, 60605

28th Year!

INTERNATIONAL STRING WORKSHOP

Gerald Fischbach, Director

join

DONALD MCINNES & EDWARD ADELSON

Glasgow

in

Scotland!

at the Royal Scottish Academy of Music & Drama

July 20-August 2, 1999

with additional world-class faculty:

Louis Bergonzi

Gerald Fischbach

Abram Loft

Randy Sabien

Robert Culver

Simon Fischer

Eduard Melkus

William Westne

Catherine Elliott

Iain Fraser

Yfrah Neaman

Phyllis Young

Evelyn Elsing

William L. Jones

Marvin Rabin

... & Special Guests!



- All Levels of Pedagogy & Repertoire • Master Classes • International String Orchestra
- Power of Process • Melkus Ensemble • Chamber Music • Jazz Improvisation • Scottish Fiddling
- International Festival of Concerts • Optional trips to Edinburgh, Loch Lomond, Scottish Isles!

Also: curricula for Orchestral Conducting, Piano, Choral Conducting, General Music, Watercolor

Want more info?

Dept VSA, 187 Aqua View Drive, Cedarburg, WI 53012 USA

tel: 414-377-7062; fax: 414-377-7096; e-mail: thintz@execpc.com

Check out our Website! www.internationalworkshops.org



SANDRA ROBBINS

Fine Stringed Instruments and Bows

Specializing in Violas and Viola Bows

VIOLAS

**Bruno Barbieri
G.B. Ceruti
Mario Contin
Joseph Curtin
Otto Erdesz
Celeste Farotto**

**Francois Fent
Juan Guillami
Robert Isley
Brian Newman
Jean Petitcolas
John Wilkinson**

BOWS

**Pascal Audinot
Charles Bazin
Arthur Bultitude
Albert Caressa
Chanot Chardon
Dupuy a Paris
Joseph Fonclause
Nicolas Eury
J.S. Finkel**

**Jean Grunberger a Paris
W.E. Hill and Sons
Lamy pere
Feret-Marcotte
E.A. Ouchard
Douglas Raguse
Benoit Rolland
Adolph Schuster**

by appointment only

**6 Quaker Hill Court East, Croton-on-Hudson, New York 10520
(914) 271-5564 telephone; (914) 271-9763 fax
e-mail: eo-sr@worldnet.att.net**

Linda Ghidossi-deLuca plays:



Photographer: Keith Silva

"I can't tell you how many times I've been asked if the viola I play is an old Italian instrument? Ease of playability, a tremendously rich sound, projection, the ability to blend, and personality all combine to give me the viola I never thought I'd own, old or new: a 1995 Anthony Lane."

Linda Ghidossi-de Luca
1977 Masters Juilliard

Principal: New Century Chamber Orchestra,
Berkeley, Santa Rosa, and Vallejo Symphonies.

*recorded Shostakovich Symphony for Strings Opus 110a,
New Albion Records C.D. Written with the Heart's Blood,
1996 Grammy Nominee

*recently recorded Ginastera Concerto for Strings, d'Note
Records, not yet released.

Anthony Lane

Maker of Violins, Violas, Cellos

276 Liberty Road, Petaluma, CA 94952, USA. Tel/Fax 707-795-5929

ProViola Classics



To order, please send a check for \$12.00 plus \$2.50
shipping to:

ProViola Classics
400 Crestover Circle
Richardson, TX 75080
or call:

(972) 480-9571

and we will send a CD out with an invoice.

You can also FAX an order to us at:

(972) 480-8023

and we will send the CD out with an invoice.

The Viola Sonatas of William Flackton

recorded on CD

by violist

Ronald Houston

**including all four of the
Flackton Sonatas plus the
Eccles Sonata in g minor
and short pieces by Bach
and Handel**

"Beautiful tone, excellent instrumental level, and most of all, an unusually
clear understanding of the stylistic needs of the music."—Donald McInnes,
Prof. of Viola, USC

"Superlative....clarity and insight....Bravo"—David Brown, AVS Journal

"Lovely performance"—Tully Potter, The Strad



The American Viola Society (AVS) is an association for the promotion of viola performance and research. Your personal and financial support is appreciated. As an AVS member, you receive three issues of the Society's journal (*JAVS*) each year and *The Viola* as it is published by the International Viola Society. Membership also brings you the satisfaction of knowing you belong to a collegial group dedicated to the furtherance of our instrument and its literature.

Please enroll me/my group in the American Viola Society (AVS) for one year and begin my subscriptions to JAVS and The Viola. My check for one year's dues, payable to the American Viola Society, is enclosed in the amount indicated here:

- | | |
|--|---|
| <input type="checkbox"/> \$30 Renewal Membership | <input type="checkbox"/> \$35 International Membership
(Residing outside the U.S.) |
| <input type="checkbox"/> \$30 New Membership | <input type="checkbox"/> \$20 International Student Membership
(Residing outside the U.S.) |
| <input type="checkbox"/> \$15 Student Membership | <input type="checkbox"/> \$100 or more AVS Benefactor |
| <input type="checkbox"/> \$15 Emeritus Membership* | <input type="checkbox"/> \$50 to \$100 AVS Contributor |
| <input type="checkbox"/> \$40 AVS/Canadian Membership
(includes both CVS newsletter and <i>JAVS</i>) | |
- I wish to contribute to the Primrose Memorial Scholarship Fund for \$_____.
- I wish to make a tax-deductible contribution to the AVS Endowment for \$_____.

TOTAL ENCLOSED: \$ _____

Please indicate your appropriate membership category:

- Professional
- Amateur
- Educational Organization
- Music Business
- Library
- Other _____

Please send AVS your biographical material, photographs (clearly labeled), brochures, concert programs, posters, press releases, clippings, and other related material on a regular basis. Such items will become part of our important resource files and may be considered for publication. We serve as a clearinghouse for many viola-related requests.

Name _____

Telephone _____

Address _____

Fax _____

City / State / Zip _____

E-mail _____

check if this is a new address

(Please list permanent address above rather than school address.)

If you are a student, in which school are you enrolled? _____

*Send this form with check to Ellen Rose, AVS Treasurer, 2807
Lawtherwood Place Dallas, TX 75214*

* persons who have been regular members for at least eight years, who have passed their 65th birthday, and who choose to be classified as emeritus members

For membership inquiries and address changes, contact Catherine Forbes, AVS Secretary, 1128 Woodland Dr., Arlington, TX 76012 (e-mail: CFORBES@UTARLG.UTA.EDU)

INDEX TO ADVERTISERS

Alf Studios, Concert Violas	68	Anthony Lane	94
George Andrix, CD	8	Latham Music Enterprises	62
Avera Music Press	67	William Harris Lee, Co.	78
Bearden Violin Shop	37	Henry Mancini Institute	80
Bein & Fushi	4	Steven McCann	57
Boston University	38	Miller & Fein	76
California Summer Music	74	William Moennig & Son	18
Eric Chapman	65	Moes & Moes	8
Clarion Instrument Insurance	14	Music City Strings	47
Cleveland Institute	16	Ernest Nussbaum, Practice Violas	68
Coda Bow	6	Orford Arts Centre	13
John M. Connolly & Co.	9	Geoffrey Ovington Violin	58
Joseph Conrad	13	Theodore Presser Co.	68
Joseph Curtin Studios	48	Peter Paul Prier	96
D'Addario	56	ProViola Classics, CD	94
Dampit	30	RBP Music Publishers	47
Encore School for Strings	27	Maurice W. Riley	40
Four Seasons Orchestra	60	Sandra Robbins	93
Claire Givens Violin	40	Robertson & Sons	35
Todd Goldenberg, Violin Maker	58	Roosevelt University	10
Harid Conservatory	69	San Francisco Conservatory	22
Heritage Insurance Services	74	William Robert Scott	38
Mark Anton Hollinger	62	Shar Products Company	8
Carleen Hutchins	40	Shawnee Press	32
Ideal Musical Merchandise	66	Stamell Stringed Instruments	58
International String Workshop	92	Kenneth Stein Violin	64
John-Brasil	30	University of Southern California	36
Ira B. Kraemer & Co	47	University of Washington	58

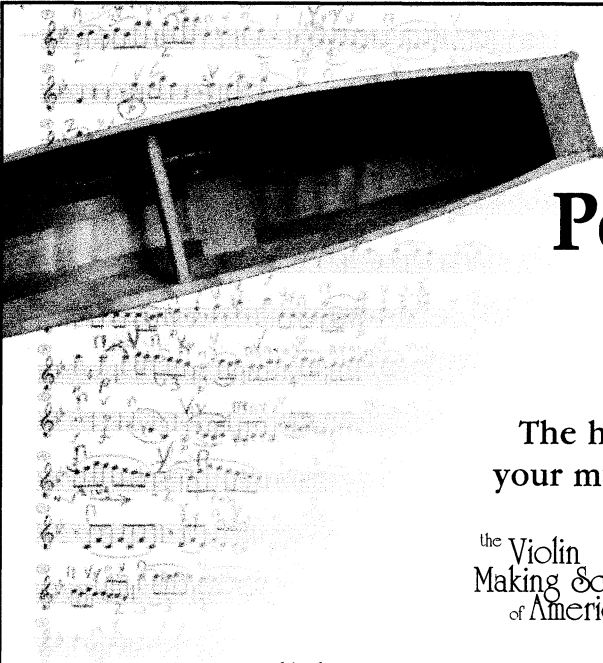

Peter Prier & Sons Violin

The harmonic center of
your musical community.

the Violin
Making School
of America



Tel: (801) 364-3651 / 308 East 200 South, Salt Lake City, UT 84111
Fax: (801) 364-3652 / www.prierviols.com