

audison



prima

PRODUCT INFORMATION

Elettromedia September 2015



bit Drive
YOUR SOUND

Full DA



ideato,
progettato,
ingegnerizzato
in Italia



Product Information

Elettromedia - September 2015

Audison Prima: the OEM Integrator	3
Sound Packs, Plug&Sound!	3
APSP G6 Prima Sound Pack for VW Golf 6	5
Audison Prima technologies	7
Audison Prima amplifiers	8
Audison Prima speaker	10
New AP bit software features	14
Technical Sheet	15
About us	47
Press kit	48

audison

For more information visit www.audison.eu



Audison Prima, the OEM Integrator!

SOUND PACK, Plug&Sound!

With the "Prima Sound Pack", Audison offers a **complete solution for your car**: the R&D team analyzed in detail the problems of **OEM Integration** and through intensive research and listening tests was able to reach a level of performance once only reserved for complex and intrusive systems.

This was possible with new solutions like the **built-in DSP processor** in the AP bit amplifiers and a significant reduction in the size of all the components, preserving the most precious requirement of OEM Integration: **Space**.

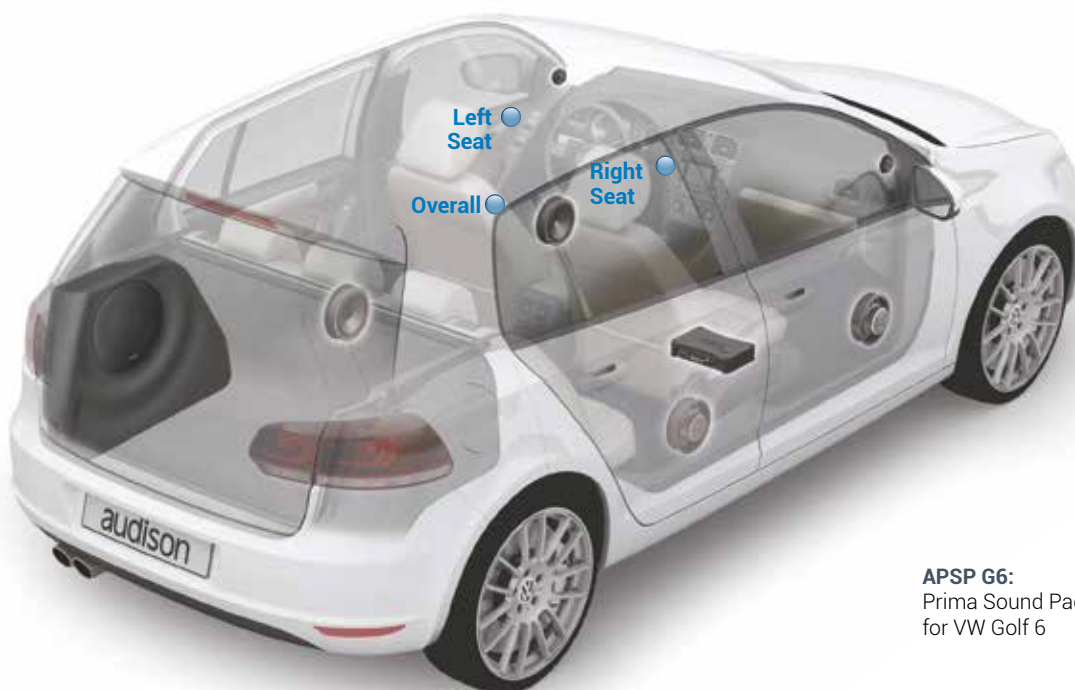

APSP G6:
Prima Sound Pack
for VW Golf 6

DCC - Direct Cockpit Current

To respond to the need of connecting the amplifier **direct in the cockpit without connect the battery**, the Audison R&D team equipped the Prima amplifiers with an innovative management circuit which constantly monitors in real-time the power supply current consumption. If a high amount of current is requested for a long duration, which may heat up the cables, the circuit immediately limits only the power peaks, letting the amplifier continue to play. **This solution provides higher safety and reliability in OEM upgrade applications.**

Golf® is a trademark of Volkswagen®



Thanks to the use of the Audison bit Drive technology, the Prima Sound Packs are "Plug&Sound", providing **7 specific DSP "Drive presets"** to satisfy the demand of several car audio enthusiasts matching their music tastes for different listening positions (Left seat, Right Seat, Overall).

Each preset is conceived with an extensive in-car measurement and listening sessions performed by the Audison R&D Team which combines equalization, fine time-alignment and level adjustments.



bit Drive technology is incorporated in all of its products featuring sound digital processing functions (DSP); with these products today, thanks to the bit Tune, you can implement with automatic procedure the ideal audio system.

Audison R&D is always driven by **Istinto Innovativo**: to fully take advantage **of the AP bit features of storing setup files**, they created a dedicated section on the **Audison bit Drive Portal** where a collection of alternative set-up files are available for download, **increasing the end users level of customization achieving "Your Sound"**.



Thanks to **AP8.9 bit optical digital input** (24 bit /48 kHz) selectable via the DRC, Sound Packs are fully compatible with the **Audison Full DA** technology, providing pure digital signal transfer without the limitations and signal alterations of a traditional analog system.



Full Digital Audio tecnology provides pure digital signal transfer from the source, through the processor into the amplifiers.

APSP G6 Prima Sound Pack for VW Golf 6



A "Sound Pack" developed specifically for the VW Golf 6: the system's pulsing heart is the Audison AP8.9 bit amplifier featuring **bit Drive technology**, combined with **a dedicated Prima speaker system and accessories** for **real OEM integration!**

Subwoofer: APBX G6

The Plug&Sound sealed passive subwoofer system integrates perfectly into the car's interior. The subwoofer itself has been engineered to mate perfectly with the available enclosure volume, exploiting all the power the AP8.9 bit delivers.



TECHNICAL SPECIFICATIONS

Component		APBX G6 SUBWOOFER
Size	mm (in.)	250 (10)
Power Handling	W (peak)	900
	W (continuos)	300
Impedance	Ω	4

Accessories: Heavyduty metal grill featuring Aluminum Audison Logo, Wiring kit, Fixing kit

Front Speakers: AP 6.5 G6 - AP 1 SP

2 way system featuring the AP 6.5 G6 woofer, AP 1 SP tweeter and a specific crossover. The system is packaged with composite OEM speaker baffles, harnesses and seals to retrofit the woofer and tweeter into speaker factory locations to an OEM standard.



TECHNICAL SPECIFICATIONS

Component		AP 6.5 G6 - AP 1 SP
Size	mm (in.)	Woofer 165 (6.5) Tweeter 26 (1)
Power Handling	W (peak)	300
	W (continuos)	100
Impedance	Ω	4
Frequency Response	Hz	60 ÷ 20k
Crossover type		2-Way passive



Golf® is a trademark of Volkswagen®

APSP G6 Prima Sound Pack for VW Golf 6



Amplifier: AP8.9 bit

The Audison AP8.9 bit is the foundation which the Sound Pack is built upon. The 8 channels in this flexible "all-in-one" amplifier have been configured to power the complete speaker system including the APBX G6 subwoofer system.



AP8.9 bit OUTPUT CHANNEL MAP

Channel	Mode	Speaker	Power
1-2 3-4	Bridge	AP 6.5 G6 - AP 1SP	2 x 130W RMS @ 4 Ω
5-6	Stereo	OEM Speakers	2 x 35W RMS @ 4Ω
7-8	Bridge	APBX G6 - Subwoofer	1 x 130W RMS @ 4 Ω



DCC - Direct Cockpit Current: Wiring kit

Wiring and routing the power supply and speaker connections for an amplifier has never been so easy! Using **DCC Technology**, the Prima Sound Pack APSP G6 is packaged with a specific harness which derives the power supply for the AP8.9 bit from directly behind the OEM headunit.

This avoids the time-consuming operation of routing the power supply cable from the battery.

The AP8.9 bit input/output connections to the OEM headunit and OEM speaker wiring are simplified with a single customized wiring kit, easy to route in the vehicle interior. This drastically decreases the installation time and avoids the possibility for improper wiring.

Both wiring kits ensure the quickest, safest and most reliable installation, with the added benefit of being able to revert to the original OEM system without costly replacement parts and time.

Bit Drive Set-up: Further use of the Audison bit Drive technology, the Prima Sound Packs are **"Plug&Sound"**, providing 7 specific DSP **"Drive presets"** developed to achieve the optimal performance in the VW Golf 6.

The 7 DSP ensure listening pleasure for a wide range of music enthusiasts, thanks to the combination of equalization, fine time-alignment and level adjustments programmed by the Audison R&D team through extensive in-car measurements and listening sessions.



Bit Drive Portal: A collection of alternative set-up files will also be available for download on the **Audison bit Drive Portal**, increasing the users level of customization.

AP8.9 bit PRESETS

Preset n°	Listening Position	Your Sound
1	LHD	Acoustic
2	LHD	Live
3	LHD	Rhythm
4	RHD	Acoustic
5	RHD	Live
6	RHD	Rhythm
7	OVERALL	Acoustic

LHD: Left Hand Drive
RHD: Right Hand Drive

Golf® is a trademark of Volkswagen®

AUDISON PRIMA TECHNOLOGIES

95% of vehicles manufactured today come to market with OEM infotainment systems with great usability and connectivity, but suffer with second-rate sound due to the poor quality of the components themselves. It is generally difficult to improve on the sound quality of these systems without major interventions; the source units are fully integrated into the dashboard, operated through touch screens and steering wheel controls. Also, the speakers are mounted in less than ideal positions with limited space. The Audison R&D team has focused their work on OEM Integration, achieving fantastic results with the renowned bit processors. The father was the bit One, a real reference within its own category, followed by other DSPs, until the latest ingredient was added; the bit Tune. This revolutionary instrument provides the ability to verify and adjust all the systems main parameters, achieving unimaginable results.

With the introduction of the APM (Acoustic Performance Measurement) measurement system, the R&D team has calculated that in general, most OEM systems have elevate distortion. After further analysis of these measurements, the main cause of this distortion is due to the relatively small power coming from the source/amplifier driving the speakers. Therefore, in order to achieve higher performance, it is advisable to increase the power of the system by adding an amplifier, instead of the traditional route of replacing the factory speakers.

An additional problem in OEM systems is that in order to mask the speakers physical limits, the acoustic response is equalized according to the speakers typology and the amplifiers used, nullifying the positive effects of replacing the audio components installed after the source unit.

For this reason, the Audison R&D team has introduced an amplifier range with built-in DSP; neutralizing the original OEM equalization and adding one more suitable to the new components, rectifying the overall acoustic response. The DSP also provides the ability to manage time delays, reducing the acoustic asymmetries caused by the speakers' improper placement to a minimum, which has always been the main issue with quality Car Audio systems.

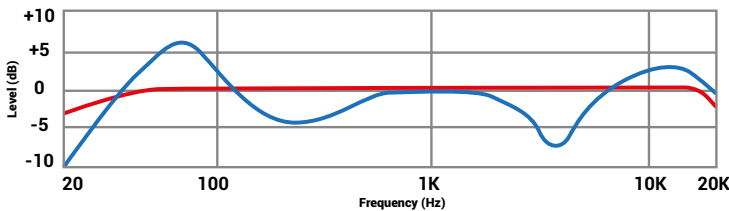

Typical OEM head unit frequency response (Factory EQ)

Optimal frequency response to be provided to an aftermarket system

The new Prima line, designed for OEM Integration, is made up of key components. The line starts with a range of powerful, extremely compact amplifiers featuring built-in DSP. All of the speakers boast high efficiency, offering a wide array of accessories developed to minimize the fitment time. In designing the speakers, the R&D team faced electro-acoustic issues due to the OEM placement. Using the very powerful Klippel software and performing extensive listening sessions, the performance has been refined to the smallest detail. The result is a range of efficient speakers that can perfectly integrate to the vehicle, significantly enhancing the performance.



EISA, European Imaging and Sound Association, has nominated Audison AP8.9 built-in processor amplifier for the title EUROPEAN IN-CAR INTEGRATION 2014-2015, with the following motivation:

This powerful integration processor blends perfectly into the OEM system of virtually any car, compensating for their OEM sound system settings and providing all kinds of necessary correction for the nine independent channels. Eight channels of built-in amplification can be internally routed and bridged to be grouped and adjusted according to the user's needs or the system layout. The AP8.9 bit is supplied with proven pre-sets for typical speaker set-ups but the parameters are fully customizable to suit individual tastes, and users can share their own personalized settings with others online. This is a compact and extremely flexible device that can make a world of difference to the quality of sound produced by almost any in-car system.



AUDISON PRIMA AMPLIFIERS

The Audison Prima amplifiers are characterized by extremely compact dimensions and elegant look.

For the first time, Audison has made an amplifier equipped with a built-in processor. This feature opens a new era: the incredible power of our DSP is now put at the service of OEM Integration. The presence of the processor ensures full compatibility of Prima amplifiers with the bit Drive technology: the amplifiers feature seven Drive presets corresponding to different system setups, selectable according to your own preference via a rotary dial. This solution reduces the setup time to a minimum, also eliminating any possibility of error.

It is also possible to create your own preset through the PC software supplied with the product, giving you finger-tip control of all the DSP's parameters. Additionally, thanks to the bit Drive Portal, more presets can be downloaded and shared with the other users in the community.

The built-in DSP functions are similar to those found on bit Ten and bit One, but there is something new and important on the equalizer output. Unlike a 31-band graphic equalizer, the AP bit equalizer features 10 parametric "poles" to draw the target curve via the PC software. This solution preserves a noticeable amount of resources for the DSP, with the plus of providing better acoustic response, thanks to the drastic reduction of phase variations found in graphic equalizers.

The R&D team succeeded in the difficult task of condensing traditional Audison power and quality into the palm of your hand. The reduction in dimension was achieved with the use of a special power supply, never employed in Car Audio, along with the most advanced electronic components available in the market. All of this together, provides the ability to achieve high power delivery, ensuring, at the same time, unheard of thermal stability.

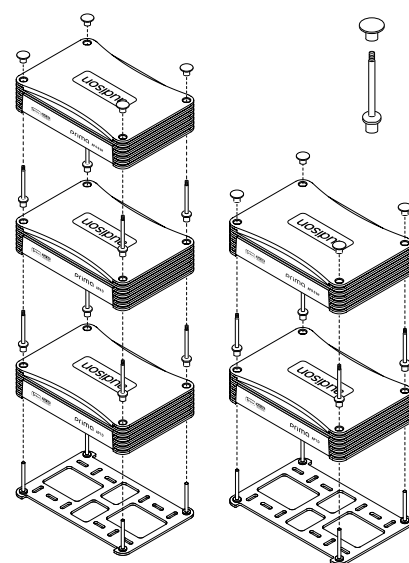

With the APTK 3 (Audison Prima Tower Kit 3) staking system it's possible to stack up to 3 AP amps to save space without any problem of overheating (screws are supplied).



To respond to the need of connecting the amplifier to the OEM amplifiers power supply cables, often with reduced gauge, the Audison R&D team equipped the Prima amplifiers with an innovative management circuit which constantly monitors in real-time the power supply current consumption. If a high amount of current is requested for a long duration, which may heat up the cables, the circuit immediately limits only the power peaks, letting the amplifier continue to play. This solution provides higher safety and reliability in OEM upgrade applications.

The innovative power supply stage ensures very high efficiency and stability for the amplifiers, capable of short term operation with as little as 7 Volts! This eliminates the numerous problems and disadvantages integrating aftermarket systems with vehicles featuring Start&Stop technology.

In order to solve the problem associated with OEM amplifiers that feature signal interruption, shutting down when a proper speaker "load" is not present as often found in aftermarket Integration, the Prima amplifiers feature ASP (Automatic Speaker Presence). Available as an optional plug-in accessory, this circuit provides the ability to simulate the OEM speakers' presence during the short time frame the head unit performs the check after being turned on, thus avoiding any interruption of the signal being sent to the amplifier.

The Prima amplifier line is made up of three models featuring a nine channel DSP, all channels independently adjustable via PC software. The difference is found in the powered amplifier channels;

AP8.9 bit: 35 W x 8 @ 4 Ω

AP5.9 bit: 20 W x 2; 50 W x 2; 150 W x 1 @ 4 Ω

AP4.9 bit: 70 W x 4 @ 4 Ω.

In addition to the bit models, there are two non-DSP models, working as extensions of power;

AP4 D: 70 W x 4 @ 4 Ω

AP1 D: 540 W x 1 @ 2 Ω

Thanks to the nine-channel DSP, the only one available within the Car Audio industry, the combinations are virtually unlimited: for instance, you can choose to connect an AP5.9 bit with the supplied link cables to an AP4 D amplifier, creating a very powerful system with minimum space.

All the bit models feature six analog input channels, four for the Front/Rear and two ore selectable channels, all equipped with sensitivity adjustment manageable via software.

The two auxiliary channels provide the ability to connect two more channels into the front channel mix, or used to create a stereo analog

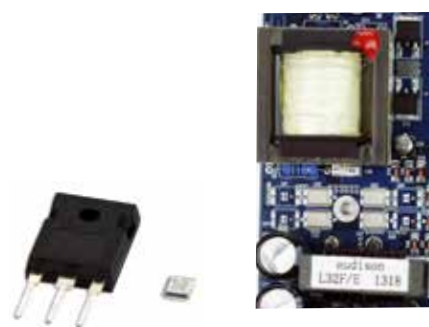

The size reduction was achieved through the use of last generation electronic components: the picture show the miniaturization of a power device and their use in the Prima amplifiers.



AP bit amplifiers have 7 Drive preset for 7 different system configuration selectable by a switch in the front panel without PC software.



AUX input, selectable via the DRC. Another interesting possibility the six input channels offer is to use the fifth channel as a center channel input, with the sixth for a subwoofer input; passing the Dolby Digital system signals should the OEM head unit be equipped with it. The bit amplifiers also feature an optical digital input (96 kHz/24 bit) selectable via the DRC, making them fully compatible with the Audison Full DA technology.

The Prima amplifiers feature functions recently fine-tuned by the R&D team: ART (Automatic Remote Turn On/Off), automatically turning on and off via the connection of the source unit speaker outputs;

AST (Automatic Signal Turn On/Off), when connected via the PRE input, automatically turning on when signal is detected and turning off when signal is not available for a specified time.

To improve OEM Integration, the Audison Prima amplifiers are equipped with quick release connectors for quick, fail-safe Plug&Play installations. Using the optional "rack mounting" kit, you can stack Audison Prima amplifiers without cooling issues, preserving the most precious requirement of OEM Integration: SPACE!

AUDISON PRIMA SPEAKER

With the Prima speaker range, different solutions have been introduced to simplify, to the maximum extent, OEM Integration and achieve a result capable of satisfying the Audison quality criteria.

The electro-acoustic designers focused their attention on those drivers dedicated in reproducing the whole audio range the coaxial, as these are those most critical in reconstructing the sound stage and so in recreating the "live" effect in a Car Audio system. By using advanced technologies such as Finite Element Method (FEM) modelling, as well as a prolonged "Voicing" phase, consisting of in-car listening sessions, it has been decided to adopt a concentric tweeter within the woofer, providing one single point of emission. This typology of speaker ensures that the musical signal is reproduced with high linearity of acoustic phase; therefore the listener perceives it as being disarmingly natural.



In order to control dispersion of the high frequency range, the concentric tweeter features an acoustic lens specifically designed to ensure an extremely linear frequency response when installed in the door, thus entirely off-axis. The combination of such build choices offer the possibility to achieve performance and sound quality comparable to a two-way system for those vehicles prohibiting this type of speaker installation.



Full Digital Audio technology provides pure digital signal transfer from the source, through the processor into the amplifiers.



The AP bit amplifiers built-in processor provides the ability to set new performance standards for OEM Integration, ensuring full compatibility with the bit Drive technology. Through the management software, the powerful 32 bit DSP ensures all the functionalities which made the Audison bit One and bit Ten renowned worldwide.



A long development time was dedicated to the coaxial drivers, resulting in a totally new concentric tweeter.

On top of this, a believable acoustic sound stage is projected towards the listener.

The concentric tweeter also provides the ability to mount the speakers in extreme locations. As an example, in installations where the tweeter of a typical coaxial driver protrudes and may come in contact with the OEM door panel/grille, the Prima line makes the installation simple and reliable.

It was during the aforementioned "Voicing" phase that the Audison designers decided to employ a 32 mm pure copper voice coil for the coax woofers; an unusual choice from a technical and cost standpoint for this market range where most competitive product employs a 25 mm coil. The reasons behind that choice can be found in the will to respect the two main goals of this project: high power handling and maximum efficiency. In fact, combined with an amplifier, the 32mm coil ensures musical reproduction void of compression, especially during musical peaks where the motor assembly has to withstand mechanical and thermal stress.

The efficiency has been maximised by eliminating low pass crossover components for the woofer: even just a simple filter inductor in series with the woofer, due to the resistance of its winding, introduces a loss which in turn lowers efficiency and sound pressure level.

By not employing any type of filter, our designers had to optimize the cone profile in each model using the Klippel R&D Scan Vibrometer to obtain a calibrated "mechanical" low-pass cut-off frequency, therefore achieving a frequency response close to that of a filtered woofer!

The result of this exhausting work of research gave life to a series of speakers capable of handling noticeable power combined with high efficiency and a balanced timbre.

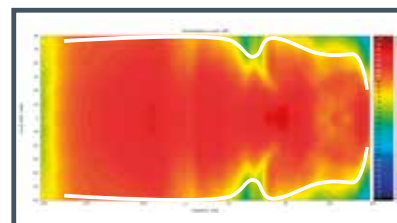

Prima coax 3D dispersion graph shows an almost constant envelope within the audio bandwidth (see the white curve profile).

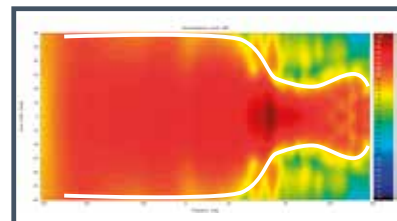

In comparison a conventional coax envelope shows a deep dispersion roll-off starting from 2 kHz (see the white curve profile).

Prima vs. conventional coax 45° Off-axis frequency response

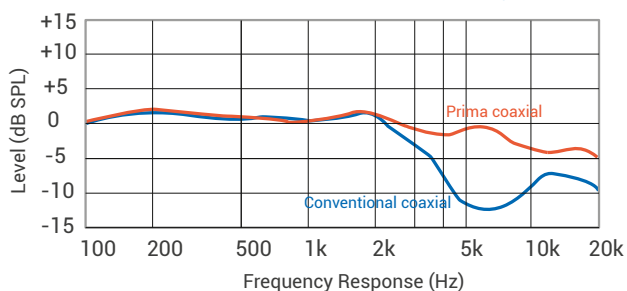

The APX 690 coax, specifically designed for a rear deck mount, boasts a 40 mm tweeter with horn loading, ensuring efficiency close to 96 dB! Besides, an acoustic lens is applied to the tweeter, improving the horizontal dispersion to maximize its performance in the less than ideal rear deck mount. To compensate for the natural loss of energy occurring beyond 10 kHz, the APX 690 also features a PEI (polyethylene injected) supertweeter, which boosts the response of the very high frequency ranges. For all of the models, deep attention has been put in the installation ergonomics with the target of easing OEM Integration as much as possible. In order to achieve this goal, the Audison designers developed a low profile basket with a very acoustically transparent design featuring straight spokes coated with abrasion-resistant and scratch-proof material. The fast-on terminals differ as the OEM standards require, in order to prevent any polarity inversion in the connection, with their 4,8 mm positive pole and 2,8 mm negative poles. They also feature a protective cover, avoiding short circuits with the metal car parts and resistance to high temperatures. AP 6.5, AP 5 and AP 8 also feature dual connection terminals: this solution provides the ability to connect the OEM source wire to the one set of terminals on the woofer in the door, with the second set providing the signal to the tweeter crossover, again easing installation.



For the vehicles equipped with an 8 in. woofer as standard OEM component, the Audison Technical Department developed the AP 8 which, also thanks to the wide emission surface, provides higher energy in the low frequency range, ensuring excellent performance when the use of a subwoofer is prohibited due to space limitations. The woofer and coaxial surrounds feature shallow TPU (Thermoplastic Polyurethane) and exclusive "Triple Wave" profile, directly inherited from accredited Audison Voce series, ensuring maximum excursion and high reliability.



The 40 mm horn loading dome tweeter contributing to maximize efficiency to increase it up to 96 dB SPL. The acoustics lens is specifically designed and applied to the tweeter to increase dispersion in high frequency range.



The AP 1 tweeter is a very sophisticated component from a design standpoint. The 26 mm diaphragm, combined with a wide external suspension, actively contribute to the overall emission, providing the ability to increase sound pressure while lowering the resonance frequency, all with extremely low moving mass. The powerful motor is characterized by a large Neodymium magnet.

Further to an in-depth analysis of the most common Integration situations of aftermarket tweeters in OEM systems, the AP 1 features a special acoustic lens with the purpose of strengthening the frequency range between 10kHz and 13kHz, to compensate for the loss of level caused by fitment behind OEM grilles. The AP1 is supplied with a dedicated crossover and also includes all the "tricks" especially designed for OEM Integration: miniature sized case, damping tape to place between the case and the mounting surface to prevent vibrations, and connection cables to significantly ease the installation.

The AP 1 crossover features a two-position level selector providing the ability to adapt its response to its two main applications: +2dB if installed behind the OEM grille, 0dB for an A-pillar installation without additional grilles between the tweeter and the listener.

The three-way APK 163 system deserves special attention; the Audison designers developed a separate crossover dedicated to each speaker, simplifying OEM speaker replacement operation, negating the routing of additional cables through the door, which could void the car warranty. AP 4 is the system midbass: it inherits the triple wave suspension from the larger diameter components, and is capable of providing excellent response on bass frequencies down to the 80Hz range. During listening sessions of this component, it has been decided to employ a 25 mm coil, as it ensures more balance in the mid-high range and most of all, provides the ability to extend the frequency response up to 7,5 kHz with a remarkable 93dB efficiency. With Prima speaker, the Audison R&D team had a difficult target: combine the strict requirements of OEM Integration with the Audison audio quality.



The target was centered through an exhaustive research combined with long listening sessions that brought the speakers to a level of performance that was thought impossible to obtain in OEM Integration.



The AP 1 tweeter's 26 mm diameter emission diaphragm, combined with its wide roll surround, maximize efficiency and reduce resonance frequency.



The AP 1 tweeter is provided with an extremely small sized dedicated passive crossover featuring an attenuation switch (0 dB, +2 dB) to correct the response in the car compartment according to the different installation conditions.

AP bit Software New features.

CONTROLLED BASS-BOOST

Through this function, if enabled, you can operate on the equalization of sub channel and woofers. You can choose the parametric equalizer pole where you can operate and vary the "Q" factor by acting on the wheel of the mouse, if it features that function. When heavy equalization is set, the software will activate through soft clipping, eliminating the subsequent distortions. This feature can also be enabled and disabled through DRC.

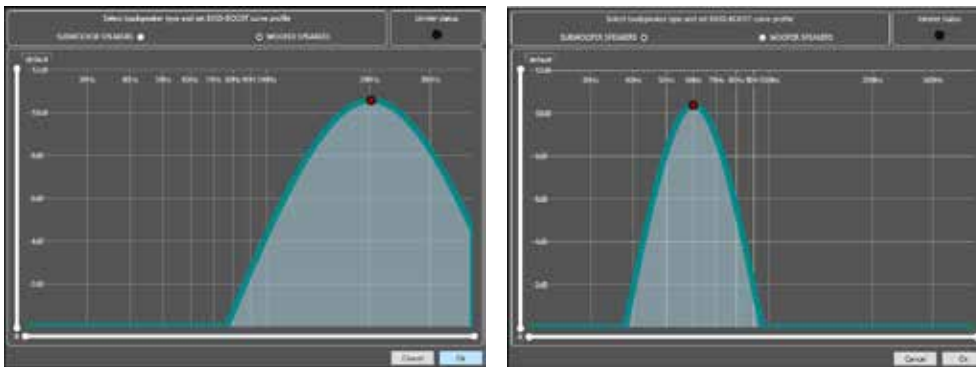

MUTED HEAD SIGNAL

In presence of gongs signals while playing the AUX or Optical input, the device automatically takes the input back to the Master by setting the volume selected by the user for this function. When the signal generated by the vehicle ends, playback moves back to the previously selected source and at its original volume.

NEW INPUT CONFIGURATIONS

New input configurations have been introduced, for a total of nine possible options; the software reconstructs the subwoofer signal from the front, rear or both channels if an input configuration that does not include the subwoofer has been selected.

1) F + R + AUX	Front stereo + Rear stereo + ingresso AUX stereo.
2) 2 WAY F + R	Front stereo 2 vie attivo + Rear stereo.
3) F + R + SUB L/R	Front stereo + Rear stereo + SUB stereo
4) F + R + SUB	Front stereo + Rear stereo + SUB mono
5) F + R + C + SUB	Front stereo + Rear stereo + Center + SUB mono
6) F + AUX	Front stereo + un ingresso AUX stereo
7) 2 WAY F + AUX	Front stereo 2 vie attivo + un ingresso AUX stereo
8) 2 WAY F + SUB L/R	Front stereo 2 vie attivo + SUB stereo
9) 2 WAY F + SUB L/R	Front stereo 2 vie attivo + SUB mono

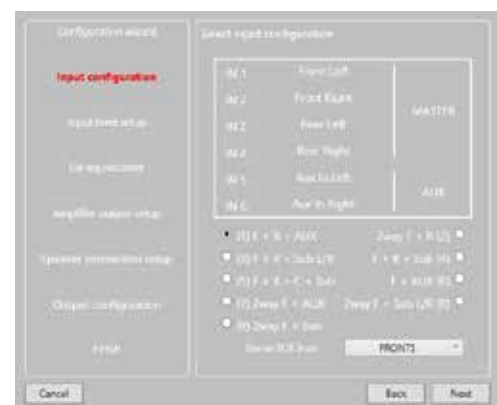



ideato,
progettato,
ingegnerizzato
in Italia



AP8.9 bit

8 channel amplifier featuring
9 channel built-in processor.

The AP8.9 bit amplifier was designed by Audison R&D Department to achieve maximum sound quality in OEM Integration applications. The powerful management software proves the ability to acquire the bit Drive presets which the Audison team fine-tuned specifically for your car. Thanks to the innovative power supply stage, a power of 520 W total can be achieved in an extremely compact case. The non-amplifiable ninth channel can be used to drive a subwoofer via the mono AP1 D amplifier.

POWER SUPPLY

Voltage:	7.5 ÷ 15 VDC
Idling current:	1.5 A
Switched off:	<0.04 mA
Consumption @ 14.4 VDC 2Ω Max Musical Power (without CPL):	30 A
Remote IN	7 ÷ 15 VDC (1 mA)
Remote OUT	11 ÷ 15 VDC (200 mA)
Fuse	30 A
ART (Automatic Remote Turn on/off)	Speakers to input - selectable
AST (Automatic Signal Turn on/off)	Pre-In to input - selectable
CPL (Continuous Power Limiting)	Max continuous power - selectable

AMPLIFIER STAGE

Distortion - THD (1kHz @ 4Ω, 90% Power):	0.05 %
Bandwidth (-3 dB, 2 V RMS, 4Ω):	10 ÷ 22k Hz
S/N ratio @ A weighted, 1V, Max Power:	95 dBA
Damping factor @ 1 kHz, 2 V RMS, 4Ω:	>70
Input sensitivity:	2 ÷ 15 V RMS
Input impedance:	15k Ω
LOAD IMPEDANCE (MIN):	
• 8 Ch:	2Ω
• 4 Ch - Bridge (1-2) (3-4) (5-6) (7-8):	4Ω
OUTPUT POWER (RMS) @ 12.0 ÷ 14.4 VDC, 1% THD:	
• 8 Ch @ 4Ω:	35 W x 8
• 8 Ch @ 2Ω:	65 W x 8
• 4 Ch - (Bridge 1/2; 3/4; 5/6; 7/8) @ 4Ω:	130 W x 4
OUTPUT POWER (RMS) @ 14.4 VDC, 10% THD:	
• 8 Ch @ 4Ω:	45 W x 8
• 8 Ch @ 2Ω:	85 W x 8
• 4 Ch - (Bridge 1/2; 3/4; 5/6; 7/8) @ 4Ω:	170 W x 4

CEA SPECIFICATIONS



Output power @ 4Ω, ≤1% THD+N, 14.4 V:	35 W x 8 Ch
SN ratio (ref. 1 W output):	85 dBA

SIGNAL CONNECTIONS

Sub Out (RCA Pre-Out)	0 ÷ 4 V RMS Max
Input Stage:	
• Config 1	Hi / Lo level FL-FR-RL-RR + N.2 customizable
• Config 2	Hi/Lo level FL-FR-RL-RR+Stereo Aux In (DRC select.)
• Optical IN (max 96 kHz/24 bit)	S/P-DIF PCM 96 kHz/24 bit max

DIGITAL SIGNAL PROCESSOR

(32 bit Cirrus Logic; Clock speed: 147 MHz)

Crossover:	Full / Hi Pass / Lo Pass / Band Pass
Crossover type and slope:	Linkwitz @ 12/24 dB - Butterworth @ 6/12/18/24 dB
Crossover Frequency:	68 steps @ 20 ÷ 20k Hz
Phase inversion:	0° / 180°
Analog Input Equalizer:	Automatic De-Equalization
Output Equalizer	N.9 Parametrics Equalizers: ±12 dB;10 pole; 20 ÷ 20k Hz
Time Alignment Distance	0 ÷ 510 cm / 0 ÷ 200.8 in.
Time Alignment Delay	0 ÷ 15 ms
Time Alignment Step	0,08 ms; 2,8 cm / 1.1 in.
Time Alignment Fine Set	0,02 ms; 0,7 cm / 0.27 in.
SYSTEM SET:	
Preset (Drive Preset)	Rotary switch for 7 installation Presets
Acoustic Preset	N.2 DSP Memory, DRC selectable

CONTROL CONNECTIONS

From / to personal computer	1 x micro USB-B
To Audison Electronics	DRC controls
ASP	Automatic Speaker Presence
Optical / AUX select	12V control for Optical In / AUX enable
Master enable	12V control for Master In enable

GENERAL REQUIREMENTS

PC connections	Micro USB (1.1 / 2.0 / 3.0)
Software/PC requirements:	Microsoft Windows (32/64 bit): XP, Vista, Windows 7, Windows 8
Graphic card min. resolution:	800 x 600
Ambient operating temperature range:	0 °C to 55 °C (32°F to 131°F)

SIZE / WEIGHT

Max size (mm/in.):	198x45,50 x 134/7.8x1.8x5.27
Weight (kg/lb):	1.5 / 3.3



ideato,
progettato,
ingegnerizzato
in Italia

AP5.9 bit

5 channel amplifier featuring
9 channel built-in processor.

AP5.9 bit amplifier is ideal to realize a two way front full active plus subwoofer system using the fifth mono channel with 270 W @ 2 Ω. The built-in processor, that this amplifier shares with the AP8.9 bit, provides the ability to assign the pre-outs to the AP4 D amplifier, creating a very powerful system in a small space thanks to the "rack mounting" system.



POWER SUPPLY

Voltage:	7.5 ÷ 15 VDC
Idling current:	1.5 A
Switched off:	<1.4 mA
Consumption @ 14.4 VDC 2Ω Max Musical Power (without CPL):	30 A
Remote IN	7 ÷ 15 VDC (1 mA)
Remote OUT	11 ÷ 15 VDC (200 mA)
Fuse	30 A
ART (Automatic Remote Turn on/off)	Speakers to input - selectable
AST (Automatic Signal Turn on/off)	Pre-In to input - selectable
CPL (Continuous Power Limiting)	Max continuous power - selectable

AMPLIFIER STAGE

Distortion - THD @ 1 kHz, 4 Ω, 90% Output Power (Ch 1-2-3-4):	0.08 %
Distortion - THD @ 1 kHz, 4 Ω, 90% Output Power (Ch 5):	0.1 %
Bandwidth (-3 dB, 2 V RMS, 4Ω):	10 ÷ 20k Hz / 10 ÷ 500Hz SUB
S/N ratio @ A weighted, 1V, Max Power:	95 dBA
Damping factor @ 1 kHz, 2 V RMS, 4Ω:	>70
Input sensitivity:	2 ÷ 15 V RMS
Input impedance:	15k Ω
LOAD IMPEDANCE (MIN):	
• Ch: 1-2-3-4-5	2Ω
MAX POWER	530 W
OUTPUT POWER (RMS) @ 12.0 ÷ 14.4 VDC, 1% THD:	
• 5 Ch @ 4Ω:	20 W x 2 + 50 W x 2 + 150 W x 1
• 5 Ch @ 2Ω:	40 W x 2 + 90 W x 2 + 270 W x 1
OUTPUT POWER (RMS) @ 14.4 VDC, 10% THD:	
• 5 Ch @ 4Ω:	25 W x 2 + 60 W x 2 + 190 W x 1
• 5 Ch @ 2Ω:	50 W x 2 + 115 W x 2 + 350 W x 1

CEA SPECIFICATIONS



Output power @ 4Ω, <1% THD+N, 14.4 V:	20 W x 2 + 50 W x 2 + 150 W x 1
SN ratio (ref. 1 W output):	80 dBA

SIGNAL CONNECTIONS

Input Stage:	
• Config 1	Hi / Lo level FL-FR-RL-RR + N.2 customizable
• Config 2	Hi / Lo level FL-FR-RL-RR + Stereo Aux In (Selectable: DRC/select.)
• Optical IN (max 96kHz/24bit) S/P-DIF PCM 96 kHz/24 bit max (Selectable: DRC/select.)	

DIGITAL SIGNAL PROCESSOR

(32 bit Cirrus Logic; Clock speed: 147 MHz)

Crossover:	Full / Hi Pass / Lo Pass / Band Pass
Crossover type and slope:	Linkwitz @ 12/24 dB - Butterworth @ 6/12/18/24 dB
Crossover Frequency:	68 steps @ 20 ÷ 20k Hz
Phase inversion:	0° / 180°
Analog Input Equalizer:	Automatic De-Equalization
Output Equalizer	N.9 Parametrics Equalizers: ±12 dB; 10 pole; 20 ÷ 20k Hz
Time Alignment Distance	0 ÷ 510 cm / 0 ÷ 200.8 in.
Time Alignment Delay	0 ÷ 15 ms
Time Alignment Step	0,08 ms; 2,8 cm / 1.1 in.
Time Alignment Fine Set	0,02 ms; 0,7 cm / 0.27 in.
SYSTEM SET:	
Preset (Drive Preset)	Rotary switch for 7 installation Presets
Acoustic Preset	N.2 DSP Memory, DRC selectable

CONTROL CONNECTIONS

From / to personal computer	1 x micro USB-B
To Audison Electronics	DRC controls
ASP	For module: Automatic Speaker Presence
Optical / AUX select	12V control for Optical In / AUX enable
Master enable	12V control for Master In enable

GENERAL REQUIREMENTS

PC connections	Micro USB (1.1 / 2.0 / 3.0)
Software/PC requirements:	Microsoft Windows (32/64 bit): XP, Vista, Windows 7, Windows 8
Graphic card min. resolution:	800 x 600
Ambient operating temperature range:	0 °C to 55 °C (32°F to 131°F)

SIZE / WEIGHT

Max size (mm/in.):	198x45,50 x 134/7.8x1.8x5.27
Weight (kg/lb):	1.5 / 3.3



ideato,
progettato,
ingegnerizzato
in Italia



AP4.9 bit

4 channel amplifier featuring
9 channel built-in processor.

AP4.9 bit amplifier was designed for the Integration into OEM front/rear systems where a lot of power is required. The built-in processor, that this amplifier shares with the AP8.9 bit, provides the ability to assign the pre-outs to the AP1 D amplifier to drive a subwoofer, to the AP4 D amplifier to have 4 additional amplified channels exceeding 1080 W @ 4 - 2 Ω total power.

POWER SUPPLY

Voltage:	7.5 ÷ 15 VDC
Idling current:	1.32 A
Switched off:	<2 mA
Consumption @ 14.4 VDC 2Ω Max Musical Power (without CPL):	30 A
Remote IN	7 ÷ 15 VDC (1 mA)
Remote OUT	11 ÷ 15 VDC (200 mA)
Fuse	30 A
ART (Automatic Remote Turn on/off)	Speakers to input - selectable
AST (Automatic Signal Turn on/off)	Pre-In to input - selectable
CPL (Continuous Power Limiting)	Max continuous power - selectable

AMPLIFIER STAGE

Distortion - THD @ 1 kHz, 4 Ω, 90% Output Power:	0.10 %
Bandwidth @ -3 dB, 2 V RMS, 4Ω:	10 ÷ 20k Hz
S/N ratio @ A weighted, 2V, Output Power:	95 dBA
Damping factor @ 1 kHz, 2 V RMS, 4Ω:	>170
Input sensitivity:	2 ÷ 15 V RMS
Input impedance:	15k Ω
LOAD IMPEDANCE (MIN):	
• 4 Ch: 1-2-3-4	2Ω
• 2 Ch: Bridge (1-2) (3-4)	4Ω
MAX POWER	520 W
OUTPUT POWER (RMS) @ 14.4 VDC, 1% THD:	
• 4 Ch @ 4Ω:	70 W x 4
• 4 Ch @ 2Ω:	130 W x 4
• 2 Ch - (Bridge 1/2; 3/4) @ 4 W	260 W x 2
OUTPUT POWER (RMS) @ 14.4 VDC, 10% THD:	
• 4 Ch @ 4Ω:	90 W x 4
• 4 Ch @ 2Ω:	180 W x 4
• 2 Ch - (Bridge 1/2; 3/4) @ 4 W	360 W x 2

CEA SPECIFICATIONS



Output power @ 4Ω, <1% THD+N, 14.4 V:	70 W x 4
SN ratio (ref. 1 W output):	75 dBA

SIGNAL CONNECTIONS

Input Stage:	
• Config 1	Hi / Lo level FL-FR-RL-RR + N.2 customizable
• Config 2	Hi / Lo level FL-FR-RL-RR + Stereo Aux In (Selectable: DRC/wire)
• Optical IN (S/P-DIF PCM)	96 kHz/24 bit max (Selectable: DRC/wire)

DIGITAL SIGNAL PROCESSOR

(32 bit Cirrus Logic; Clock speed: 147 MHz)

Crossover:	Full / Hi Pass / Lo Pass / Band Pass
Crossover type and slope:	Linkwitz @ 12/24 dB - Butterworth @ 6/12/18/24 dB
Crossover Frequency:	68 steps @ 20 ÷ 20k Hz
Phase inversion:	0° / 180°
Analog Input Equalizer:	Automatic De-Equalization
Output Equalizer	N.9 Parametrics Equalizers: ±12 dB; 10 pole; 20 ÷ 20k Hz
Time Alignment Distance	0 ÷ 510 cm / 0 ÷ 200.8 in.
Time Alignment Delay	0 ÷ 15 ms
Time Alignment Step	0,08 ms; 2,8 cm / 1.1 in.
Time Alignment Fine Set	0,02 ms; 0,7 cm / 0.27 in.
SYSTEM SET:	
Preset (Drive Preset)	Rotary switch for 7 installation Presets
Acoustic Preset	N.2 DSP Memory, DRC selectable/customizable

CONTROL CONNECTIONS

From / to personal computer	1 x micro USB-B
To Audison Electronics	DRC controls
ASP	For module: Automatic Speaker Presence
Optical / AUX select	12V control for Optical In / AUX enable
Master enable	12V control for Master In enable

GENERAL REQUIREMENTS

PC connections	Micro USB (1.1 / 2.0 / 3.0)
Software/PC requirements:	Microsoft Windows (32/64 bit): XP, Vista, Windows 7, Windows 8
Graphic card min. resolution:	800 x 600
Ambient operating temperature range:	0 °C to 55 °C (32°F to 131°F)

SIZE / WEIGHT

Max size (mm/in.):	198x45,50 x 134/7.8x1.8x5.27
Weight (kg/lb):	1,36 / 2.99



ideato,
progettato,
ingegnerizzato
in Italia

AP4 D

4 channel amplifier.

AP4 D amplifier was designed as an extension for the AP4.9 bit and AP5.9 bit amplifiers, offering 4 additional 70 W @ 4 Ω amplified channels.



POWER SUPPLY

Voltage:	7.5 ÷ 15 VDC
Idling current:	1 A
Switched off:	<0.05 mA
Consumption @ 14.4 VDC 2Ω Max Musical Power (without CPL):	27 A
Remote IN	7 ÷ 15 VDC (1 mA)
Fuse	30 A

AMPLIFIER STAGE

Distortion - THD @ 1 kHz, 4 Ω, 90% Output Power:	0.1 %
Bandwidth @ -3 dB, 2 V RMS, 4Ω:	10 ÷ 30k Hz
S/N ratio @ A weighted, 1,5V, Max Power:	100 dBA
Damping factor @ 1 kHz, 2 VRMS, 4 Ω	170
Input sensitivity PRE IN:	Selectable: 1,5 - 3 - 4,5 V RMS
Input sensitivity SPEAKER IN:	Selectable: 3 - 6 - 9 V RMS
Input impedance:	15k Ω
LOAD IMPEDANCE (MIN):	
• 4 Ch: 1-2-3-4	2Ω
• 2 Ch: Bridge (1-2) (3-4)	4Ω
MAX POWER	520 W
OUTPUT POWER (RMS) @ 14.4 VDC, 1% THD:	
• 4 Ch @ 4Ω:	70 W x 4
• 4 Ch @ 2Ω:	130 W x 4
• 2 Ch - (Bridge 1/2; 3/4) @ 4 W	260 W x 2
OUTPUT POWER (RMS) @ 14.4 VDC, 10% THD:	
• 4 Ch @ 4Ω:	90 W x 4
• 4 Ch @ 2Ω:	180 W x 4
• 2 Ch - (Bridge 1/2; 3/4) @ 4 W	360 W x 2

CEA SPECIFICATIONS



Output power @ 4Ω, <1% THD+N, 14.4 V:	70 W x 4
SN ratio (ref. 1 W output):	85 dBA

SIGNAL CONNECTIONS

PRE IN	RCA
SPEAKER IN	wired
MUTE (Energy Saving Control)	wired from AP4.9 bit / AP5.9 bit

GENERAL REQUIREMENTS

Ambient operating temperature range:	0 °C to 55 °C (32°F to 131°F)
--------------------------------------	-------------------------------

SIZE / WEIGHT

Max size (mm/in.):	198x45,50 x 134 / 7.8x1.8x5.27
Weight (kg/lb):	1.33 / 2.93



ideato,
progettato,
ingegnerizzato
in Italia

AP1 D

Mono amplifier.

The AP1 D amplifier was designed to drive a subwoofer and is the ideal extension of the AP8.9 bit and AP4.9 bit. At 2 Ohms it is stable and can supply 540 W power with extremely compact dimension. With the APTK 3 (Audison Prima Tower Kit 3) staking system it's possible to stack the AP1 D and save space without any problem of overheating.



POWER SUPPLY

Voltage:	7.5 ÷ 15 VDC
Idling current:	1 A
Switched off:	<0.05 mA
Consumption @ 14.4 VDC 2Ω Max Musical Power:	30 A
Remote IN	7 ÷ 15 VDC (1 mA)
Fuse	30 A

AMPLIFIER STAGE

Distortion - THD @ 1 kHz, 4 Ω, 90% Output Power:	0.2 %
Distortion - THD @ 100 Hz, 4 Ω, 90% Output Power:	0.3 %
Bandwidth (-3 dB, 2 V RMS, 4Ω):	16 ÷ 40k Hz
S/N ratio @ A weighted, 1,5V, Output Power:	100 dBA
Damping factor @ 100 Hz, 2 VRMS, 4 Ω:	150
Damping factor @ 1 kHz, 2 VRMS, 4 Ω:	160
Input sensitivity PRE IN:	Selectable: 1,5 - 3,0 - 4,5 V RMS
Input sensitivity SPEAKER IN:	Selectable: 3,0 - 6,0 - 9,0 V RMS
Input impedance:	15k Ω
LOAD IMPEDANCE (MIN):	
• Ch: 1	2Ω
MAX POWER	540 W
OUTPUT POWER (RMS) @ 14.4 VDC, 1% THD:	
• 1 Ch @ 4Ω:	310 W x 1
• 1 Ch @ 2Ω:	540 W x 1
OUTPUT POWER (RMS) @ 14.4 VDC, 10% THD:	
• 1 Ch @ 4Ω:	380 W x 1
• 1 Ch @ 2Ω:	680 W x 1

CEA SPECIFICATIONS



Output power @ 4Ω, <1% THD+N, 14.4 V:	310 W x 1
SN ratio (ref. 1 W output):	79 dBA

SIGNAL CONNECTIONS

PRE IN	RCA
SPEAKER IN	wired
MUTE (Energy Saving Control)	wired from AP4.9 bit / AP5.9 bit

GENERAL REQUIREMENTS

Ambient operating temperature range:	0 °C to 55 °C (32°F to 131°F)
--------------------------------------	-------------------------------

SIZE / WEIGHT

Max size (mm/in.):	198x45,50 x 134/7.8x1.8x5.27
Weight (kg/lb):	1.32 / 2.91



**AP8.9 bit
+ AP1 D**

PRESET 5:
3 WAY ACTIVE FRONT
+ REAR + EXTERNAL
AMPLIFIED SUB

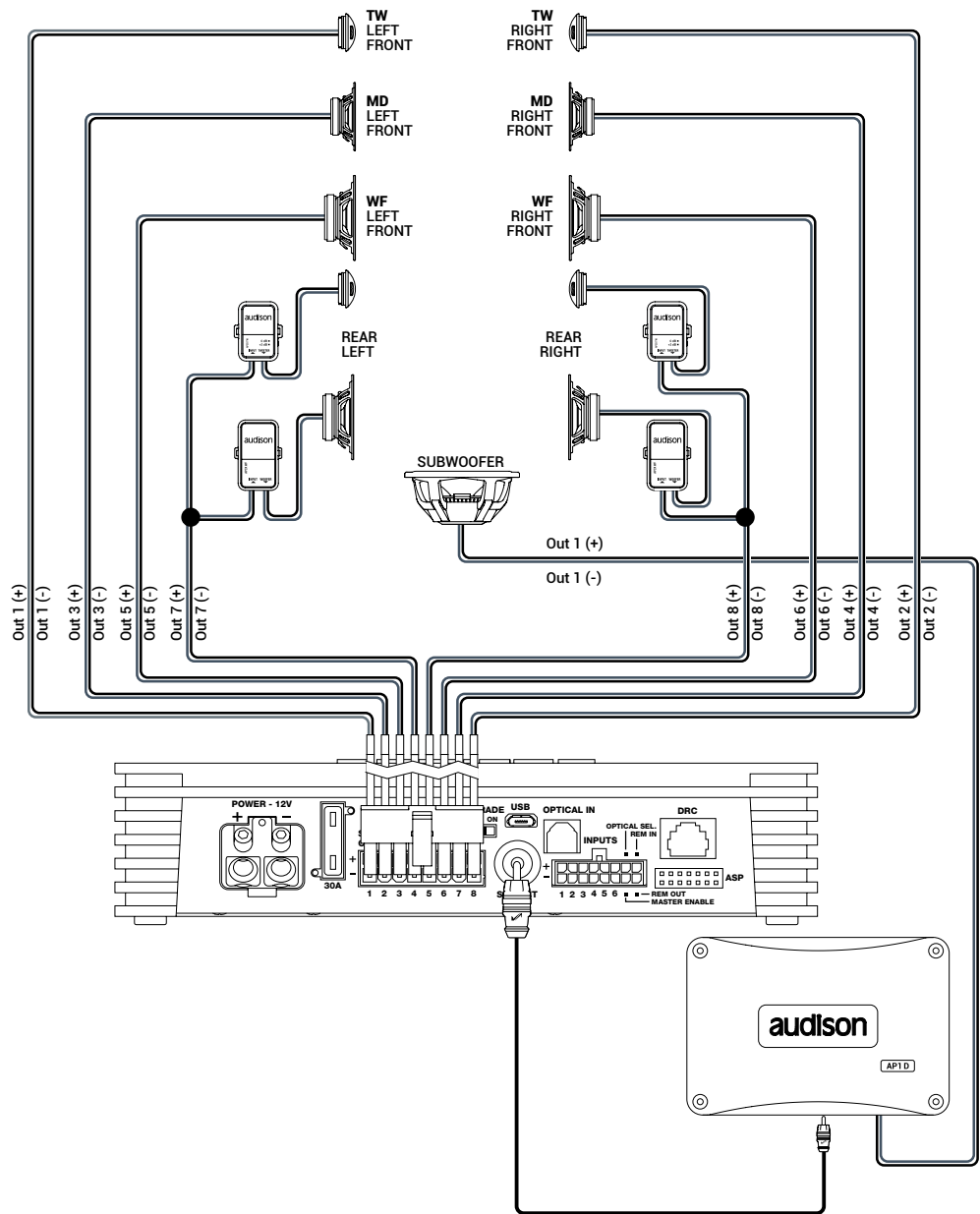

OUTPUT CONFIGURATION:

AP TYPE	OUTPUT	TYPE	CUT FILTER	FILTER TYPE	CUT FREQUENCY	TIME ALIGNMENT*	POWER @ 4Ω	POWER @ 2Ω
8.9 bit	OUT 1	FRONT TW LEFT	HI PASS	Linkwitz	3000Hz @12 dB	82,2 cm	35 W	65 W
8.9 bit	OUT 2	FRONT TW RIGHT	HI PASS	Linkwitz	3000 Hz @12 dB	116,2 cm	35 W	65 W
8.9 bit	OUT 3	FRONT MD LEFT	BAND PASS	Linkwitz	500 Hz @12 dB 3000 Hz @ 12 dB	82,2 cm	35 W	65 W
8.9 bit	OUT 4	FRONT MD RIGHT	BAND PASS	Linkwitz	500 Hz @12 dB 3000 Hz @ 12 dB	116,2 cm	35 W	65 W
8.9 bit	OUT 5	FRONT WF LEFT	BAND PASS	Linkwitz	80 Hz @12 dB 500 Hz @ 12 dB	82,2 cm	35 W	65 W
8.9 bit	OUT 6	FRONT WF RIGHT	BAND PASS	Linkwitz	80 Hz @12 dB 500 Hz @ 12 dB	116,2 cm	35 W	65 W
8.9 bit	OUT 7	REAR LEFT	HI PASS	Linkwitz	80 Hz @12 dB	62,3 cm	35 W	65 W
8.9 bit	OUT 8	REAR RIGHT	HI PASS	Linkwitz	80 Hz @12 dB	116,2 cm	35 W	65 W
AP1 D	PRE OUT	SUB WOOFER	LO PASS	Linkwitz	80 Hz @12 dB	121,8 cm	310 W	540 W

■ = Max power suggested Loads: 820 W

INPUT CONFIGURATION:

Master input: Front + Rear
Aux input: In1 + In 2
Optical: S/P-DIF PCM 96kHz/24 bit max

MEMORY CONFIGURATION:

Memory A: Acoustic
Memory B: Rhythm

*Listening Point: Driver

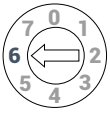

**AP8.9 bit
+ AP1 D**

PRESET 6:
2 WAY ACTIVE FRONT
+ REAR + EXTERNAL
AMPLIFIED SUB

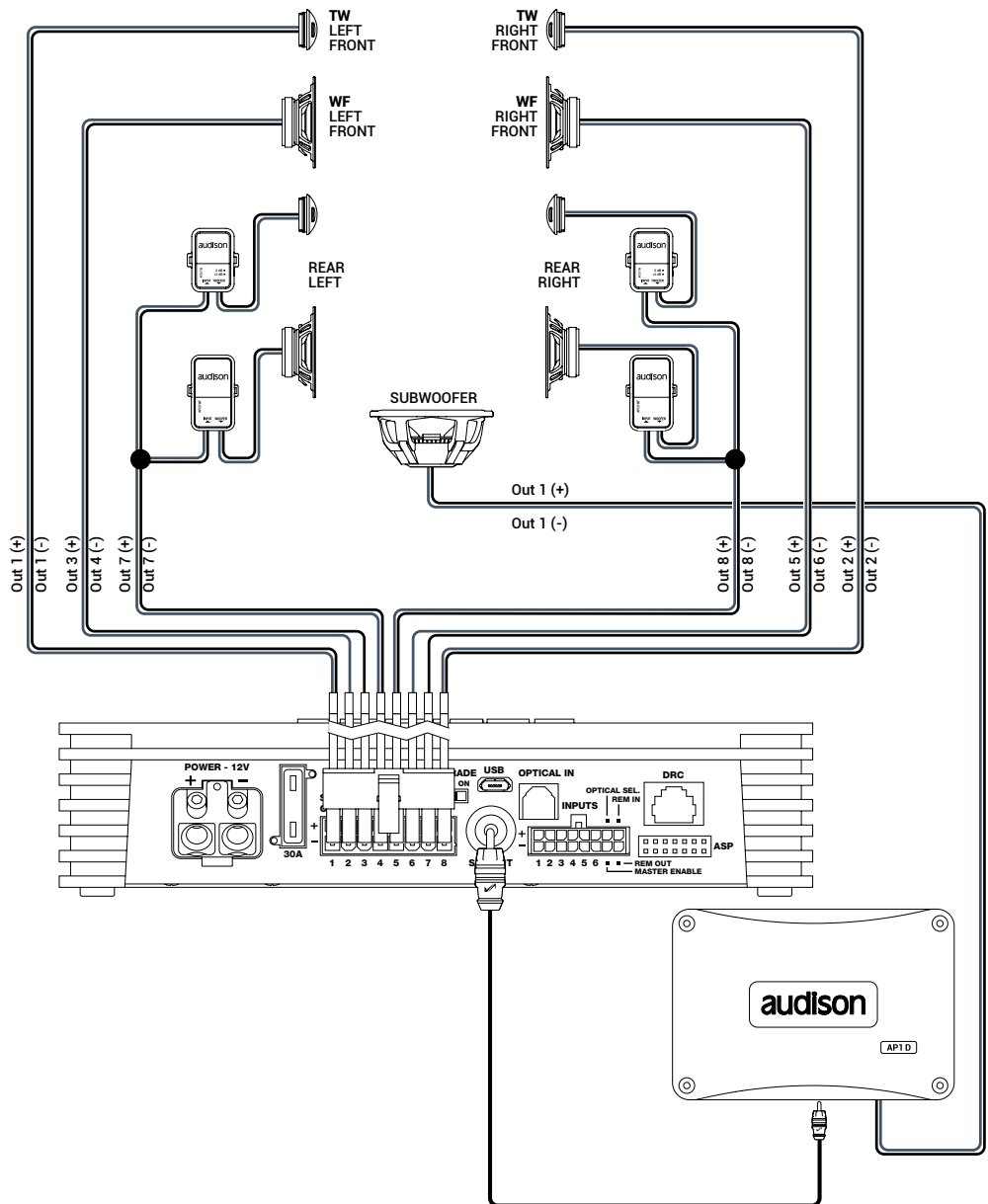

OUTPUT CONFIGURATION:

AP TYPE	OUTPUT	TYPE	CUT FILTER	FILTER TYPE	CUT FREQUENCY	TIME ALIGNMENT*	POWER @ 4Ω	POWER @ 2Ω
8.9 bit	OUT 1	FRONT TW LEFT	HI PASS	Linkwitz	3000Hz @12 dB	82,2 cm	35 W	65 W
8.9 bit	OUT 2	FRONT TW RIGHT	HI PASS	Linkwitz	3000 Hz @12 dB	116,2 cm	35 W	65 W
8.9 bit	OUT 3+ 4-	FRONT WF LEFT	BAND PASS	Linkwitz	80 Hz @12 dB 3000 HZ @ 12 dB	82,2 cm	130 W	N. A.
8.9 bit	OUT 5+ 6-	FRONT WF RIGHT	BAND PASS	Linkwitz	80 Hz @12 dB 3000 HZ @ 12 dB	116,2 cm	130 W	N. A.
8.9 bit	OUT 7	REAR LEFT	HI PASS	Linkwitz	80 Hz @12 dB	62,3 cm	35 W	65 W
8.9 bit	OUT 8	REAR RIGHT	HI PASS	Linkwitz	80 Hz @12 dB	116,2 cm	35 W	65 W
AP1 D	SUB OUT	SUB WOOFER	LO PASS	Linkwitz	80 Hz @12 dB	121,8 cm	310 W	540 W

■ = Max power suggested Loads: 940 W

MEMORY CONFIGURATION:

Memory A: Acoustic
Memory B: Rhythm

*Listening Point: Driver



**AP8.9 bit
+ AP1 D**

PRESET 7:
2 WAY ACTIVE FRONT
+ REAR
+ 2 WAY CENTER CHANNEL
+ EXTERNAL AMPLIFIED SUB

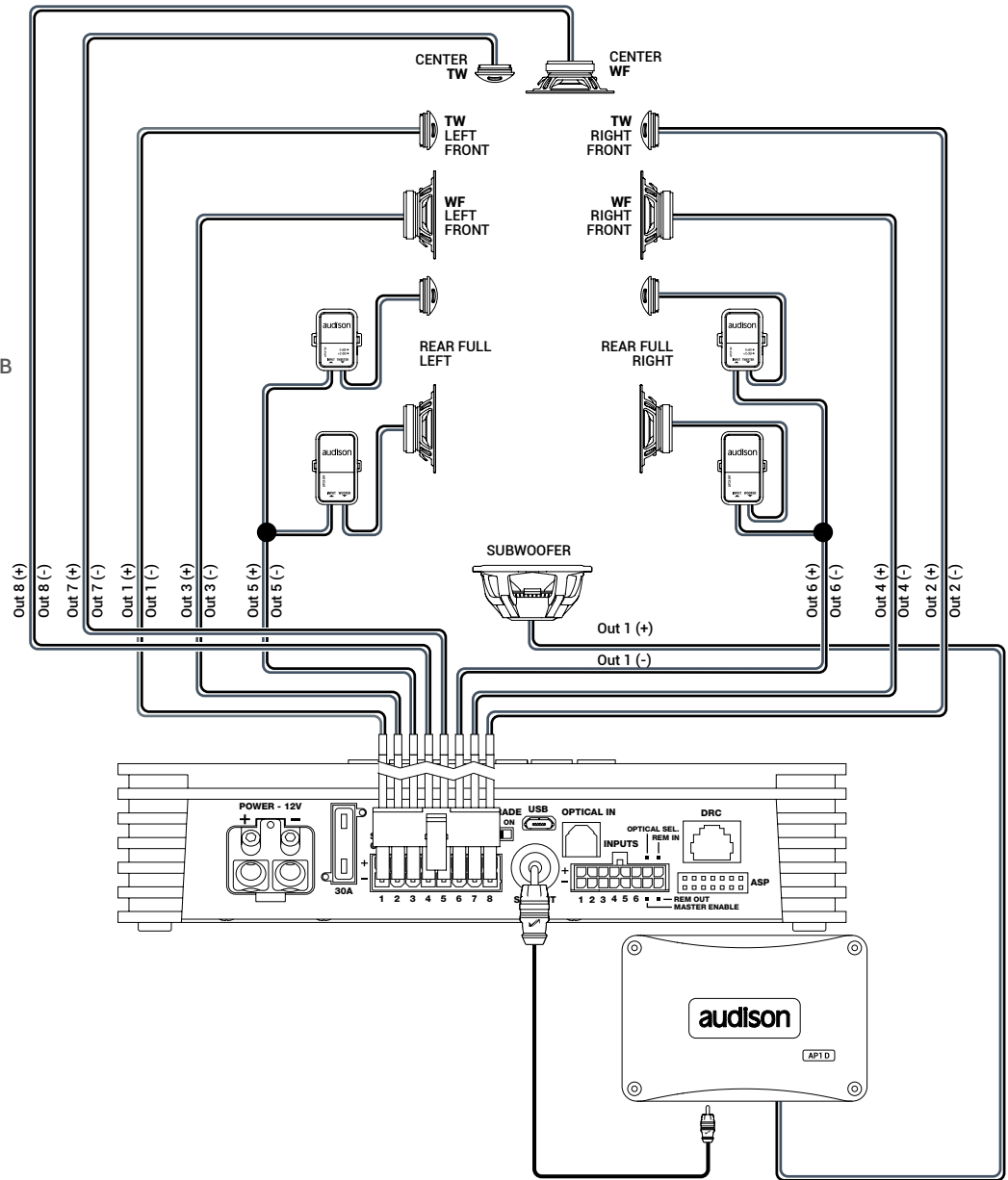

OUTPUT CONFIGURATION:

AP TYPE	OUTPUT	TYPE	CUT FILTER	FILTER TYPE	CUT FREQUENCY	TIME ALIGNMENT*	POWER @ 4Ω	POWER @ 2Ω
8.9 bit	OUT 1	FRONT TW LEFT	HI PASS	Linkwitz	3000Hz @12 dB	82,2 cm	35 W	65 W
8.9 bit	OUT 2	FRONT TW RIGHT	HI PASS	Linkwitz	3000 Hz @12 dB	116,2 cm	35 W	65 W
8.9 bit	OUT 3	FRONT WF LEFT	BAND PASS	Linkwitz	80 Hz @12 dB 3000 HZ @ 12 dB	82,2 cm	35 W	65 W
8.9 bit	OUT 4	FRONT WF RIGHT	BAND PASS	Linkwitz	80 Hz @12 dB 3000 HZ @ 12 dB	116,2 cm	35 W	65 W
8.9 bit	OUT 5	REAR LEFT	HI PASS	Linkwitz	80 Hz @12 dB	62,3 cm	35 W	65 W
8.9 bit	OUT 6	REAR RIGHT	HI PASS	Linkwitz	80 Hz @12 dB	116,2 cm	35 W	65 W
8.9 bit	OUT 7	CENTER TW	HI PASS	Linkwitz	3000 Hz @12 dB	79,3 cm	35 W	65 W
8.9 bit	OUT 8	CENTER WF	BAND PASS	Linkwitz	300 Hz @12 dB 3000 HZ @ 12 dB	79,3 cm	35 W	65 W
AP1 D	SUB OUT	SUB WOOFER	LO PASS	Linkwitz	80 Hz @12 dB	121,8 cm	310 W	540 W

■ = Max power suggested Loads: 820 W

INPUT CONFIGURATION:

Master input: Front + Rear
Aux input: In1 + In 2
Optical: S/P-DIF PCM 96kHz/24 bit max

MEMORY CONFIGURATION:

Memory A: Acoustic
Memory B: Rhythm

*Listening Point: Driver

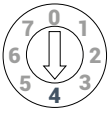

**AP5.9 bit
+ AP4.9 bit**

**PRESET 4:
3 WAY ACTIVE FRONT
+ SUBWOOFER**

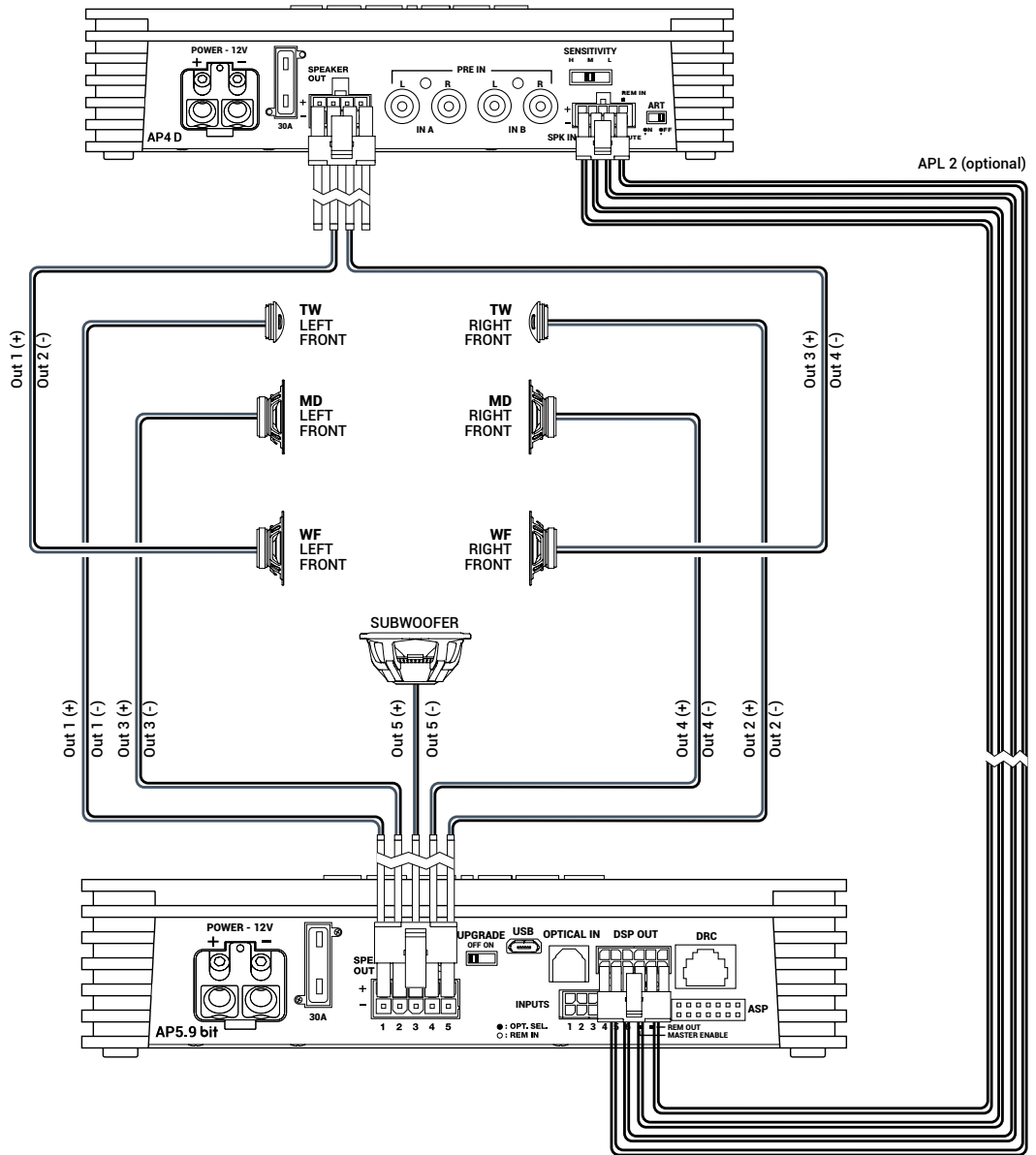

OUTPUT CONFIGURATION:

AP TYPE	OUTPUT	TYPE	CUT FILTER	FILTER TYPE	CUT FREQUENCY	TIME ALIGNMENT*	POWER @ 4Ω	POWER @ 2Ω
5.9 bit	OUT 1	FRONT TW LEFT	HI PASS	Linkwitz	500 Hz @12 dB	82,2 cm	20 W	35 W
5.9 bit	OUT 2	FRONT TW RIGHT	HI PASS	Linkwitz	500 Hz @12 dB	116,2 cm	20 W	35 W
5.9 bit	OUT 3	FRONT MD LEFT	BAND PASS	Linkwitz	500 Hz @12 dB 3000 HZ @ 12 dB	82,2 cm	50 W	85 W
5.9 bit	OUT 4	FRONT MD RIGHT	BAND PASS	Linkwitz	500 Hz @12 dB 3000 HZ @ 12 dB	116,2 cm	50 W	85 W
4 D	OUT 1+2-	FRONT WF LEFT	BAND PASS	Linkwitz	80 Hz @12 dB 500 HZ @ 12 dB	82,2 cm	260 W	N. A.
4 D	OUT 3+4-	FRONT WF RIGHT	BAND PASS	Linkwitz	80 Hz @12 dB 500 HZ @ 12 dB	116,2 cm	260 W	N. A.
5.9 bit	OUT 5	SUBWOOFER	LO PASS	Linkwitz	80 Hz @12 dB	121,8 cm	140 W	280 W

■ = Max power suggested Loads: 940 W

INPUT CONFIGURATION:

Master input: Front + AUX
Aux input: In1 + In 2
Optical: S/P-DIF PCM 96kHz/24 bit max

MEMORY CONFIGURATION:

Memory A: Acoustic
Memory B: Rhythm

**Listening Point:* Driver





**AP5.9 bit
+ AP4 D**

**PRESET 5:
3 WAY ACTIVE FRONT
+ REAR + SUBWOOFER**

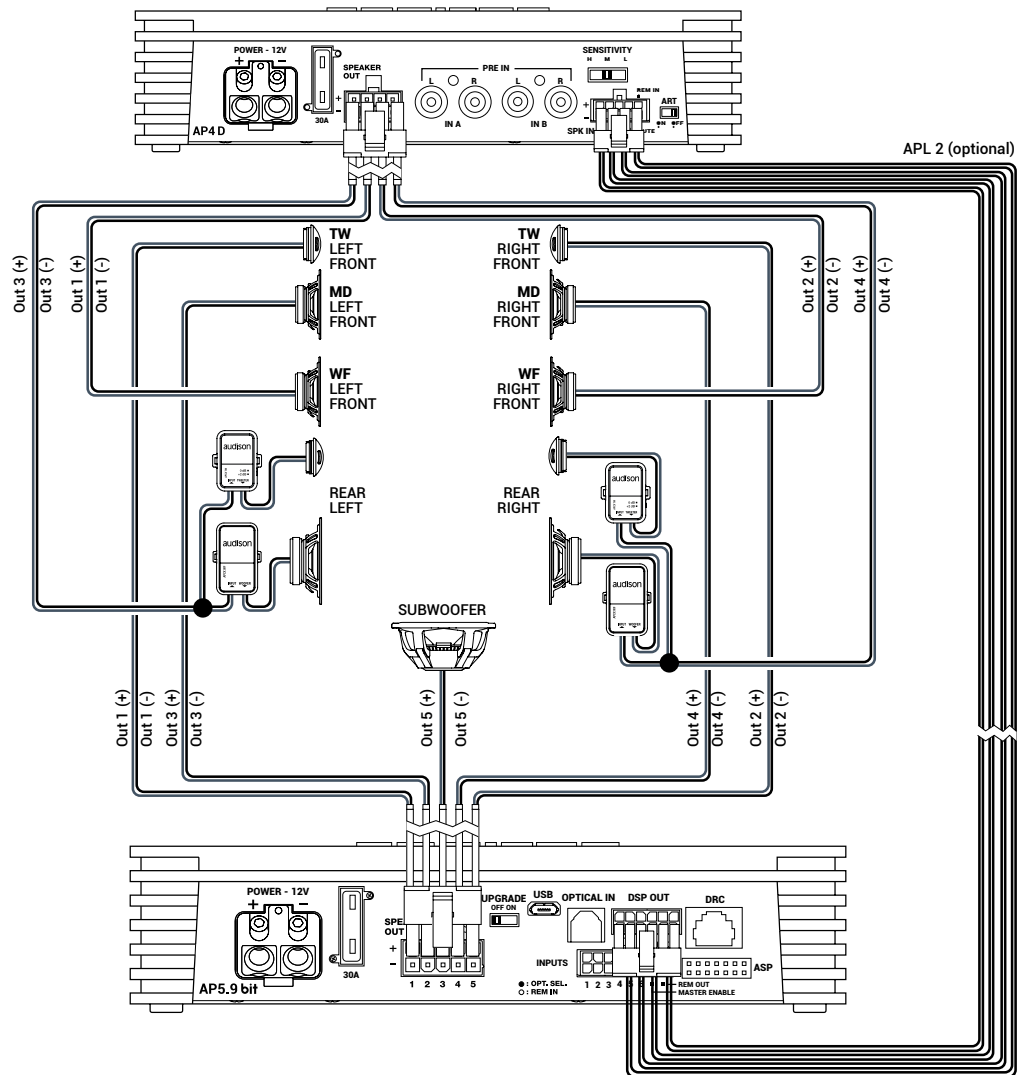

OUTPUT CONFIGURATION:

AP TYPE	OUTPUT	TYPE	CUT FILTER	FILTER TYPE	CUT FREQUENCY	TIME ALIGNMENT*	POWER @ 4Ω	POWER @ 2Ω
5.9 bit	OUT 1	FRONT TW LEFT	HI PASS	Linkwitz	3000 Hz @12 dB	82,2 cm	20 W	35 W
5.9 bit	OUT 2	FRONT TW RIGHT	HI PASS	Linkwitz	3000 Hz @12 dB	116,2 cm	20 W	35 W
5.9 bit	OUT 3	FRONT MD LEFT	BAND PASS	Linkwitz	500 Hz @12 dB 3000 Hz @ 12 dB	82,2 cm	50 W	85 W
5.9 bit	OUT 4	FRONT MD RIGHT	BAND PASS	Linkwitz	500 Hz @12 dB 3000 Hz @ 12 dB	116,2 cm	50 W	85 W
4 D	OUT 1	FRONT WF LEFT	BAND PASS	Linkwitz	80 Hz @12 dB 500 Hz @ 12 dB	82,2 cm	70 W	140 W
4 D	OUT 2	FRONT WF RIGHT	BAND PASS	Linkwitz	80 Hz @12 dB 500 Hz @ 12 dB	116,2 cm	70 W	140 W
4 D	OUT 3	REAR LEFT	HI PASS	Linkwitz	80 Hz @12 dB	62,3 cm	70 W	140 W
4 D	OUT 4	REAR RIGHT	HI PASS	Linkwitz	80 Hz @12 dB	116,2 cm	70 W	140 W
5.9 bit	OUT 5	SUBWOOFER	LO PASS	Linkwitz	80 Hz @12 dB	121,8 cm	140 W	280 W

■ = Max power suggested Loads: 700 W

INPUT CONFIGURATION:

Master input: Front + Rear
Aux input: In1 + In 2
Optical: S/P-DIF PCM 96kHz/24 bit max

MEMORY CONFIGURATION:

Memory A: Acoustic
Memory B: Rhythm

**Listening Point:* Driver

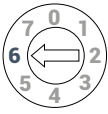

**AP5.9 bit
+ AP4 D**

**PRESET 6:
2 WAY ACTIVE FRONT
+ REAR + SUBWOOFER**

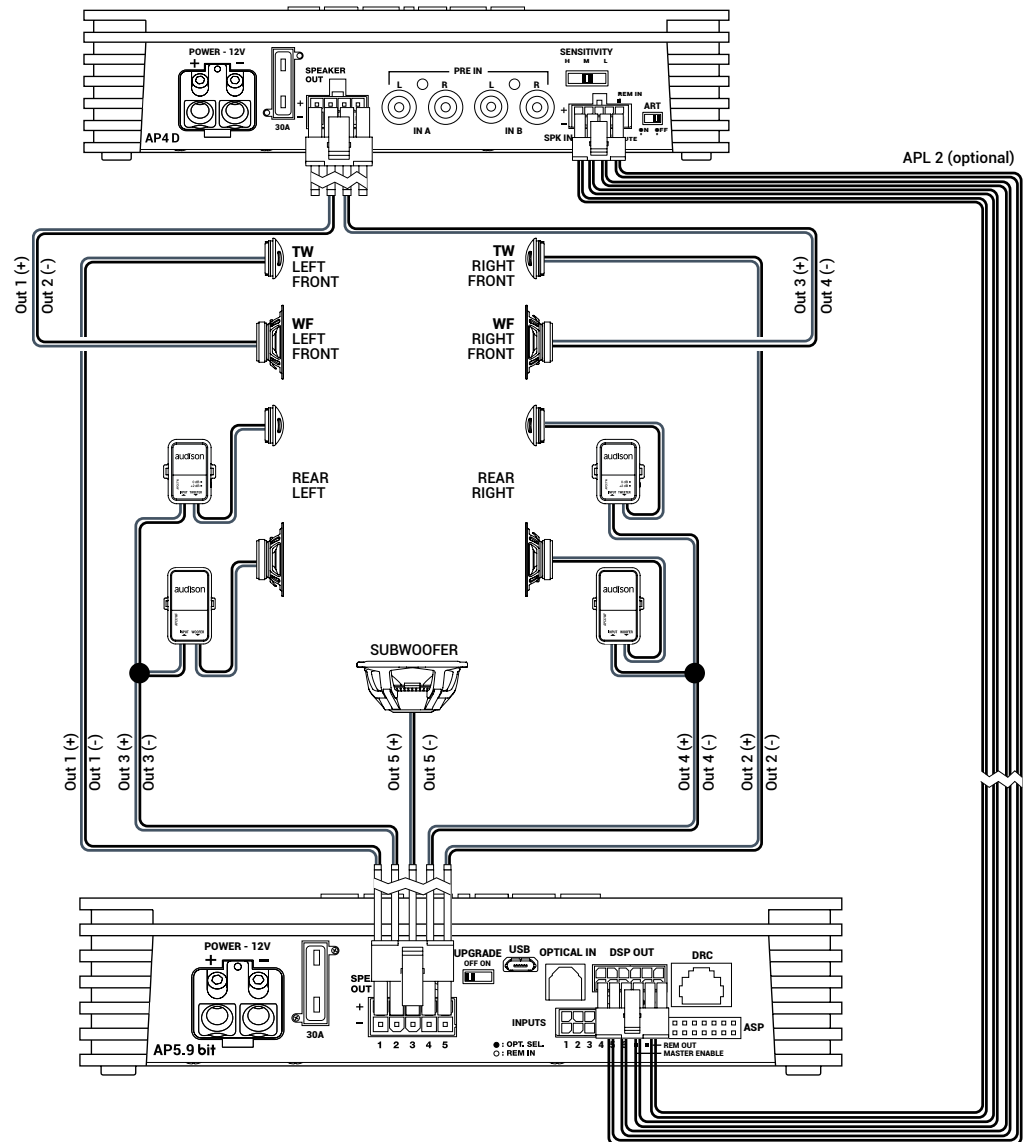

OUTPUT CONFIGURATION:

AP TYPE	OUTPUT	TYPE	CUT FILTER	FILTER TYPE	CUT FREQUENCY	TIME ALIGNMENT*	POWER @ 4Ω	POWER @ 2Ω
5.9 bit	OUT 1	FRONT TW LEFT	HI PASS	Linkwitz	3000 Hz @12 dB	82,2 cm	20 W	35 W
5.9 bit	OUT 2	FRONT TW RIGHT	HI PASS	Linkwitz	3000 Hz @12 dB	116,2 cm	20 W	35 W
4 D	OUT 1+2-	FRONT WF LEFT	BAND PASS	Linkwitz	80 Hz @12 dB 3000 HZ @ 12 dB	82,2 cm	260 W	N. A.
4 D	OUT 3+ 4-	FRONT WF RIGHT	BAND PASS	Linkwitz	80 Hz @12 dB 3000 HZ @ 12 dB	116,2 cm	260 W	N. A.
5.9 bit	OUT 3	REAR LEFT	HI PASS	Linkwitz	80 Hz @12 dB	62,3 cm	50 W	85 W
5.9 bit	OUT 4	REAR RIGHT	HI PASS	Linkwitz	80 Hz @12 dB	116,2 cm	50 W	85 W
5.9 bit	OUT 5	SUBWOOFER	LO PASS	Linkwitz	80 Hz @12 dB	121,8 cm	140 W	280 W

■ = Max power suggested Loads: 940 W

INPUT CONFIGURATION:

Master input: Front + Rear
Aux input: In1 + In 2
Optical: S/P-DIF PCM 96kHz/24 bit max

MEMORY CONFIGURATION:

Memory A: Acoustic
Memory B: Rhythm

**Listening Point:* Driver

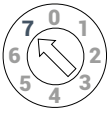

**AP5.9 bit
+ AP4 D**

PRESET 7:
2 WAY ACTIVE FRONT
+ REAR + 2 WAY
CENTER CHANNEL
+ SUBWOOFER

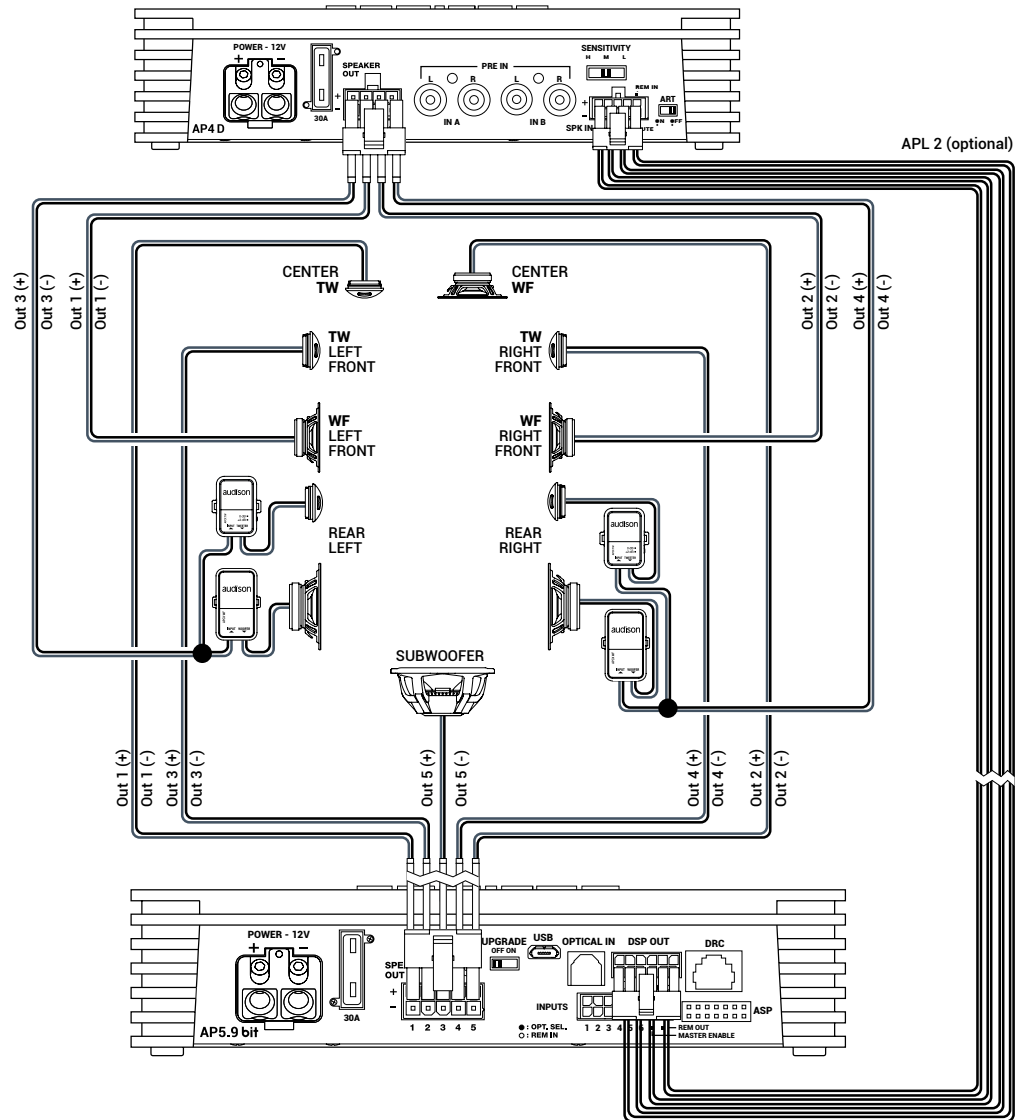

OUTPUT CONFIGURATION:

AP TYPE	OUTPUT	TYPE	CUT FILTER	FILTER TYPE	CUT FREQUENCY	TIME ALIGNMENT*	POWER @ 4Ω	POWER @ 2Ω
5.9 bit	OUT 1	CENTRE TW	HI PASS	Linkwitz	3000 Hz @12 dB	82,2 cm	20 W	35 W
5.9 bit	OUT 2	CENTRE WF	BAND PASS	Linkwitz	300 Hz @12 dB 3000 HZ @ 12 dB	79,3 cm	20 W	35 W
5.9 bit	OUT 3	FRONT TW LEFT	HI PASS	Linkwitz	3000 Hz @12 dB	82,2 cm	50 W	85 W
5.9 bit	OUT 4	FRONT TW LEFT	HI PASS	Linkwitz	3000 Hz @12 dB	116,2 cm	50 W	85 W
4 D	OUT 1	FRONT WF LEFT	BAND PASS	Linkwitz	80 Hz @12 dB 3000 HZ @ 12 dB	82,2 cm	70 W	140 W
4 D	OUT 2	FRONT WF RIGHT	BAND PASS	Linkwitz	80 Hz @12 dB 3000 HZ @ 12 dB	116,2 cm	70 W	140 W
4 D	OUT 3	REAR LEFT	HI PASS	Linkwitz	80 Hz @12 dB	62,3 cm	70 W	140 W
4 D	OUT 4	REAR RIGHT	HI PASS	Linkwitz	80 Hz @12 dB	116,2 cm	70 W	140 W
5.9 bit	OUT 5	SUBWOOFER	LO PASS	Linkwitz	80 Hz @12 dB	121,8 cm	140 W	280 W

■ = Max power suggested Loads: 700 W

INPUT CONFIGURATION:

Master input: Front + Rear
Aux input: In1 + In 2
Optical: S/P-DIF PCM 96kHz/24 bit max

MEMORY CONFIGURATION:

Memory A: Acoustic
Memory B: Rhythm

**Listening Point:* Driver

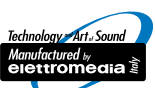



**AP4.9 bit
+ AP1 D**

PRESET 1:
FRONT + REAR
+ EXTERNAL SUBWOOFER

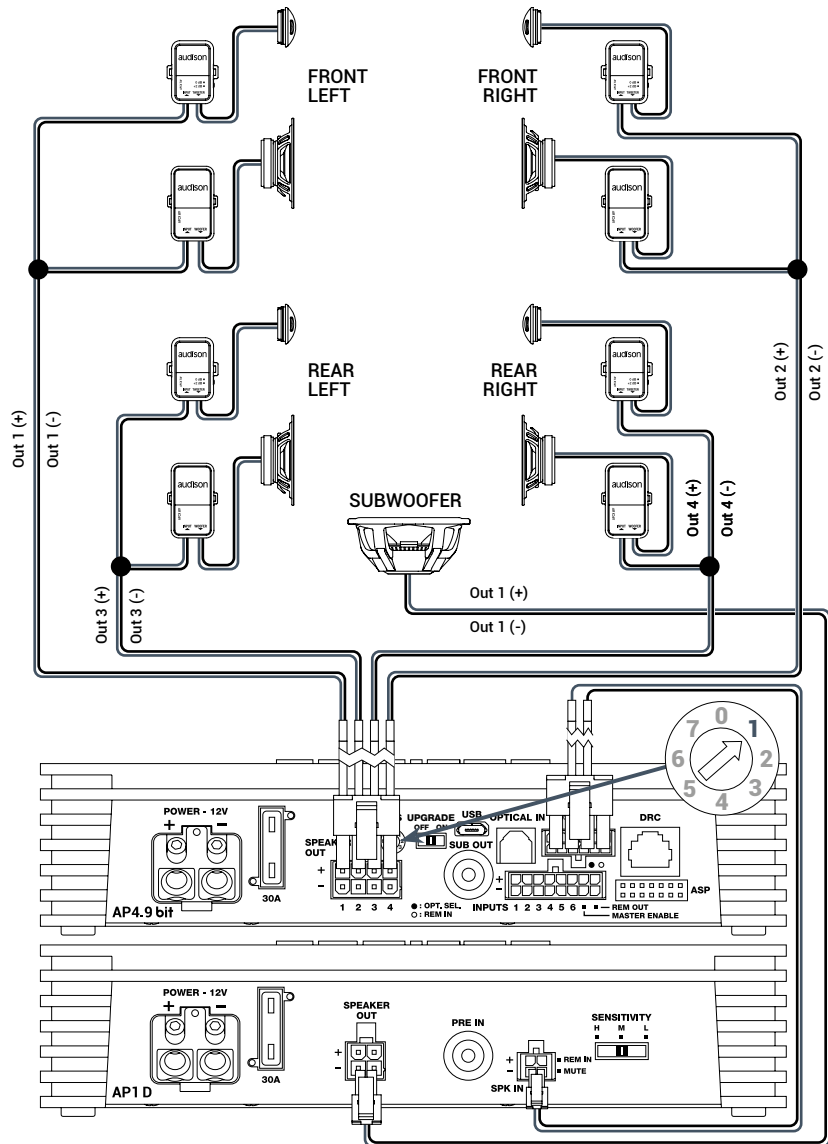

OUTPUT CONFIGURATION:

AP TYPE	OUTPUT	TYPE	CUT FILTER	FILTER TYPE	CUT FREQUENCY	TIME ALIGNMENT*	POWER @ 4Ω	POWER @ 2Ω
4.9 bit	OUT 1	FRONT FULL LEFT	HI PASS	Linkwitz	80 Hz @12 dB	82,2 cm	70 W	130 W
4.9 bit	OUT 2	FRONT FULL RIGHT	HI PASS	Linkwitz	80 Hz @12 dB	116,2 cm	70 W	130 W
4.9 bit	OUT 3	REAR FULL LEFT	HI PASS	Linkwitz	80 Hz @12 dB	82,2 cm	70 W	130 W
4.9 bit	OUT 4	REAR FULL RIGHT	HI PASS	Linkwitz	80 Hz @12 dB	116,2 cm	70 W	130 W
1 D	OUT 1	SUB WOOFER	LO PASS	Linkwitz	80 Hz @12 dB	121,8 cm	280 W	520 W

■ = Max power at suggested loads: 800 W

INPUT CONFIGURATION:

Master input: Front + Rear
Aux input: In1 + In 2
Optical: S/P-DIF PCM 96kHz/24 bit max

MEMORY CONFIGURATION:

Memory A: Acoustic
Memory B: Rhythm

**Listening Point:* Driver

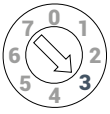

**AP4.9 bit
+ AP1 D**

PRESET 3:
HI POWER FRONT
+ EXTERNAL SUBWOOFER

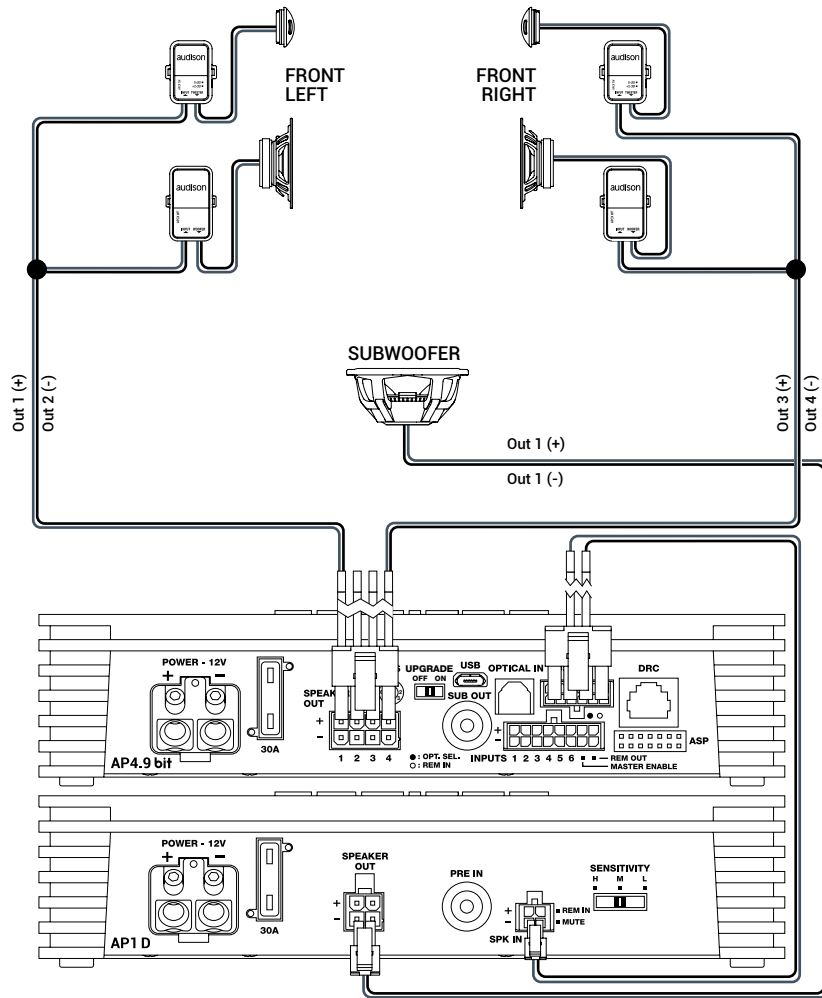

OUTPUT CONFIGURATION:

AP TYPE	OUTPUT	TYPE	CUT FILTER	FILTER TYPE	CUT FREQUENCY	TIME ALIGNMENT*	POWER @ 40	POWER @ 20
4.9 bit	OUT 1+ 2-	FRONT LEFT	HI PASS	Linkwitz	80 Hz @12 dB	82,2 cm	260 W	N. A.
4.9 bit	OUT 3+ 4-	FRONT RIGHT	HI PASS	Linkwitz	80 Hz @12 dB	116,2 cm	260 W	N. A.
1 D	OUT 1	SUBWOOFER	LO PASS	Linkwitz	80 Hz @12 dB	121,8 cm	260 W	520 W

☐ = Max power at suggested loads: 1040 W

INPUT CONFIGURATION:

Master input: Front + AUX
Aux input: In1 + In 2
Optical: S/P-DIF PCM 96kHz/24 bit max

MEMORY CONFIGURATION:

Memory A: Acoustic
Memory B: Rhythm

**Listening Point:* Driver



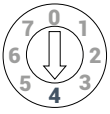

AP4.9 bit
+ AP4 D
+ AP1 D

PRESET 4:
3 WAY ACTIVE FRONT
+ SUBWOOFER

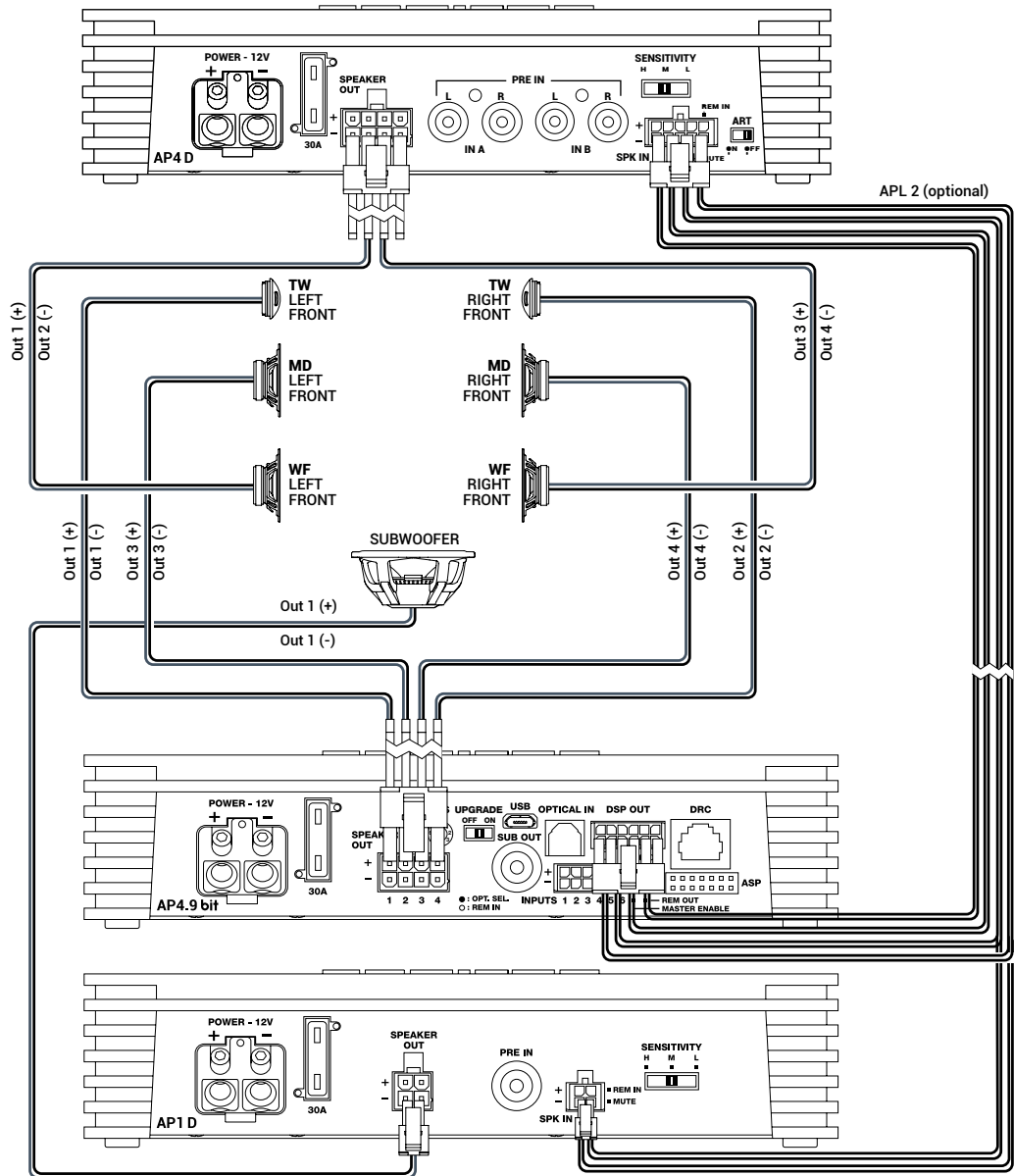

OUTPUT CONFIGURATION:

AP TYPE	OUTPUT	TYPE	CUT FILTER	FILTER TYPE	CUT FREQUENCY	TIME ALIGNMENT*	POWER @ 4Ω	POWER @ 2Ω
4.9 bit	OUT 1	FRONT TW LEFT	HI PASS	Linkwitz	3000 Hz @12 dB	82,2 cm	70 W	130 W
4.9 bit	OUT 2	FRONT TW RIGHT	HI PASS	Linkwitz	3000 Hz @12 dB	116,2 cm	70 W	130 W
4.9 bit	OUT 3	FRONT MD LEFT	BAND PASS	Linkwitz	500 Hz @12 dB 3000 HZ @ 12 dB	82,2 cm	70 W	130 W
4.9 bit	OUT 4	FRONT MD RIGHT	BAND PASS	Linkwitz	500 Hz @12 dB 3000 HZ @ 12 dB	116,2 cm	70 W	130 W
4D	OUT 1+ 2-	FRONT WF LEFT	BAND PASS	Linkwitz	80 Hz @12 dB 500 HZ @ 12 dB	82,2 cm	140 W	N. A.
4D	OUT 3+ 4-	FRONT WF RIGHT	BAND PASS	Linkwitz	80 Hz @12 dB 500 HZ @ 12 dB	116,2 cm	140 W	N. A.
1D	OUT 1	SUBWOOFER	LO PASS	Linkwitz	80 Hz @12 dB	121,8 cm	280 W	520 W

* = Max power suggested Loads: 1080 W

INPUT CONFIGURATION:

Master input: Front + AUX
Aux input: In1 + In 2
Optical: S/P-DIF PCM 96kHz/24 bit max

MEMORY CONFIGURATION:

Memory A: Acoustic
Memory B: Rhythm

*Listening Point: Driver





**AP4.9 bit
+ AP4 D
+ AP1 D**

**PRESET 5:
3 WAY ACTIVE FRONT
+ REAR
+ SUBWOOFER**

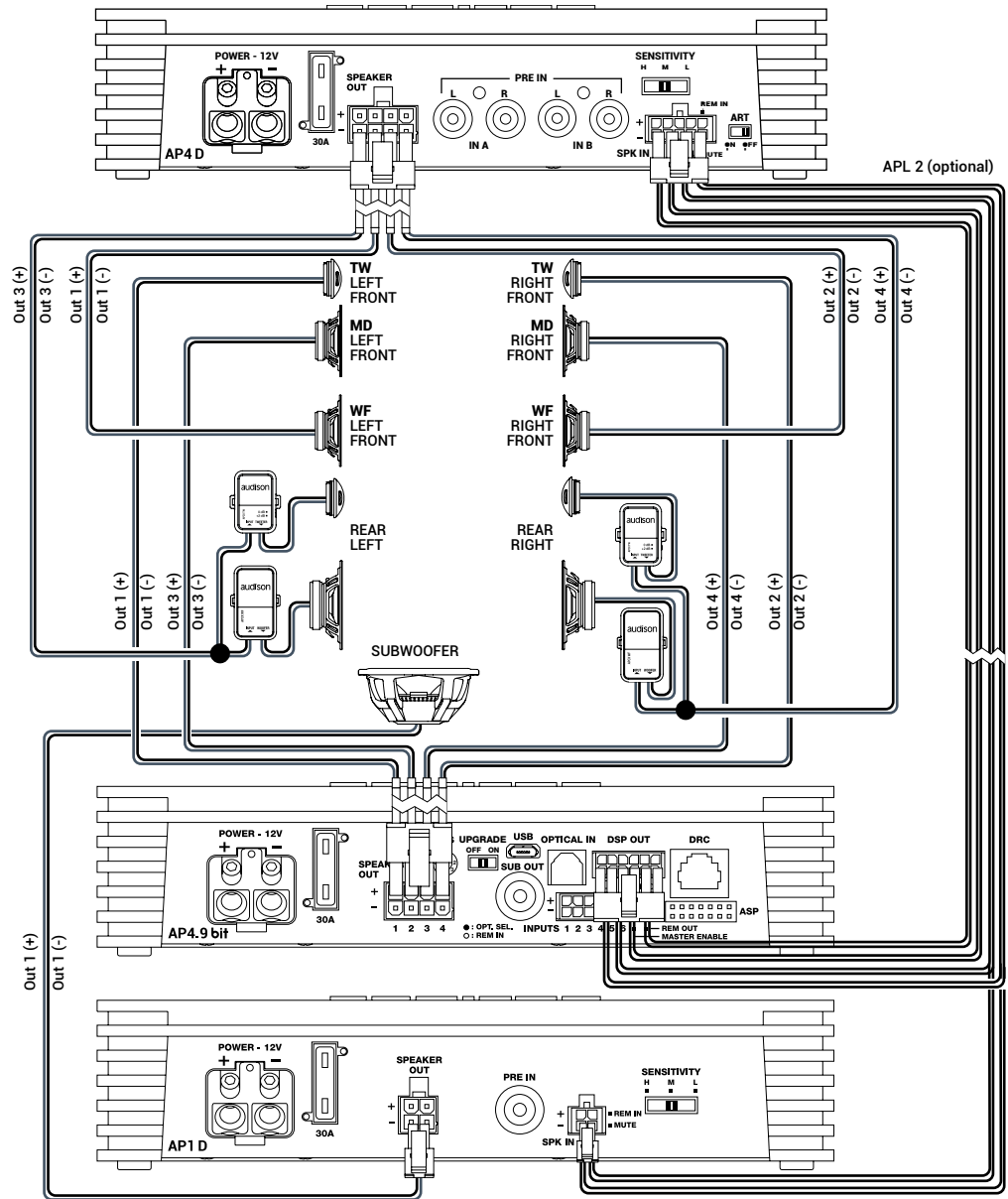

OUTPUT CONFIGURATION:

AP TYPE	OUTPUT	TYPE	CUT FILTER	FILTER TYPE	CUT FREQUENCY	TIME ALIGNMENT*	POWER @ 4Ω	POWER @ 2Ω
4.9 bit	OUT 1	FRONT TW LEFT	HI PASS	Linkwitz	3000 Hz @12 dB	82,2 cm	70 W	130 W
4.9 bit	OUT 2	FRONT TW RIGHT	HI PASS	Linkwitz	3000 Hz @12 dB	116,2 cm	70 W	130 W
4.9 bit	OUT 3	FRONT MD LEFT	BAND PASS	Linkwitz	500 Hz @12 dB 3000 Hz @ 12 dB	82,2 cm	70 W	130 W
4.9 bit	OUT 4	FRONT MD RIGHT	BAND PASS	Linkwitz	500 Hz @12 dB 3000 Hz @ 12 dB	116,2 cm	70 W	130 W
4 D	OUT 1	FRONT WF LEFT	BAND PASS	Linkwitz	80 Hz @12 dB 500 Hz @ 12 dB	82,2 cm	70 W	140 W
4 D	OUT 2	FRONT WF RIGHT	BAND PASS	Linkwitz	80 Hz @12 dB 500 Hz @ 12 dB	116,2 cm	70 W	140 W
4 D	OUT 3	REAR LEFT	HI PASS	Linkwitz	80 Hz @12 dB	62,3 cm	70 W	140 W
4 D	OUT 4	REAR RIGHT	HI PASS	Linkwitz	80 Hz @12 dB	116,2 cm	70 W	140 W
1 D	OUT 1	SUBWOOFER	LO PASS	Linkwitz	80 Hz @12 dB	121,8 cm	280 W	520 W

* = Max power suggested Loads: 1080 W

INPUT CONFIGURATION:

Master input: Front + Rear
Aux input: In1 + In 2
Optical: S/P-DIF PCM 96kHz/24 bit max

MEMORY CONFIGURATION:

Memory A: Acoustic
Memory B: Rhythm

*Listening Point: Driver

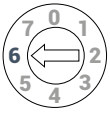

**AP4.9 bit
+ AP4 D
+ AP1 D**

**PRESET 6:
2 WAY ACTIVE FRONT
+ REAR
+ SUBWOOFER**

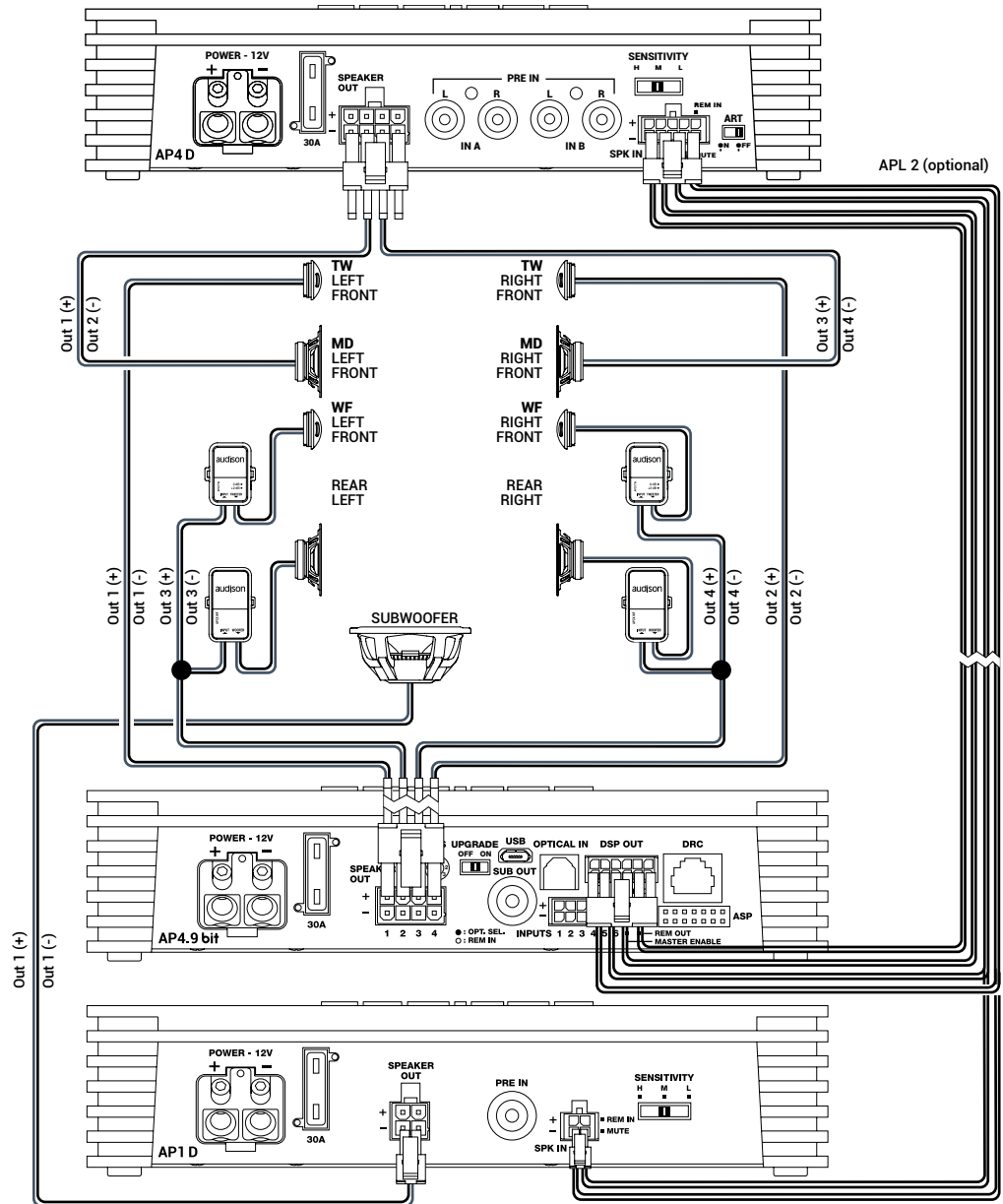

OUTPUT CONFIGURATION:

AP TYPE	OUTPUT	TYPE	CUT FILTER	FILTER TYPE	CUT FREQUENCY	TIME ALIGNMENT*	POWER @ 4Ω	POWER @ 2Ω
4.9 bit	OUT 1	FRONT TW LEFT	HI PASS	Linkwitz	3000 Hz @12 dB	82,2 cm	70 W	130 W
4.9 bit	OUT 2	FRONT TW RIGHT	HI PASS	Linkwitz	3000 Hz @12 dB	116,2 cm	70 W	130 W
4 D	OUT 1+ 2-	FRONT WF LEFT	BAND PASS	Linkwitz	80 Hz @12 dB 3000 Hz @ 12 dB	82,2 cm	260 W	N. A.
4 D	OUT 3+ 4-	FRONT WF RIGHT	BAND PASS	Linkwitz	80 Hz @12 dB 3000 Hz @ 12 dB	116,2 cm	260 W	N. A.
4.9 bit	OUT 3	REAR LEFT	HI PASS	Linkwitz	80 Hz @12 dB	62,3 cm	70 W	130 W
4.9 bit	OUT 4	REAR RIGHT	HI PASS	Linkwitz	80 Hz @12 dB	116,2 cm	70 W	130 W
1 D	OUT 1	SUBWOOFER	LO PASS	Linkwitz	80 Hz @12 dB	121,8 cm	280 W	520 W

* = Max power suggested Loads: 1320 W

INPUT CONFIGURATION:

Master input: Front + Rear
Aux input: In1 + In 2
Optical: S/P-DIF PCM 96kHz/24 bit max

MEMORY CONFIGURATION:

Memory A: Acoustic
Memory B: Rhythm

**Listening Point:* Driver



**AP4.9 bit
+ AP4 D
+ AP1 D**

PRESET 7:
2 WAY ACTIVE FRONT
+ 2 WAY ACTIVE CENTER
+ REAR + SUBWOOFER

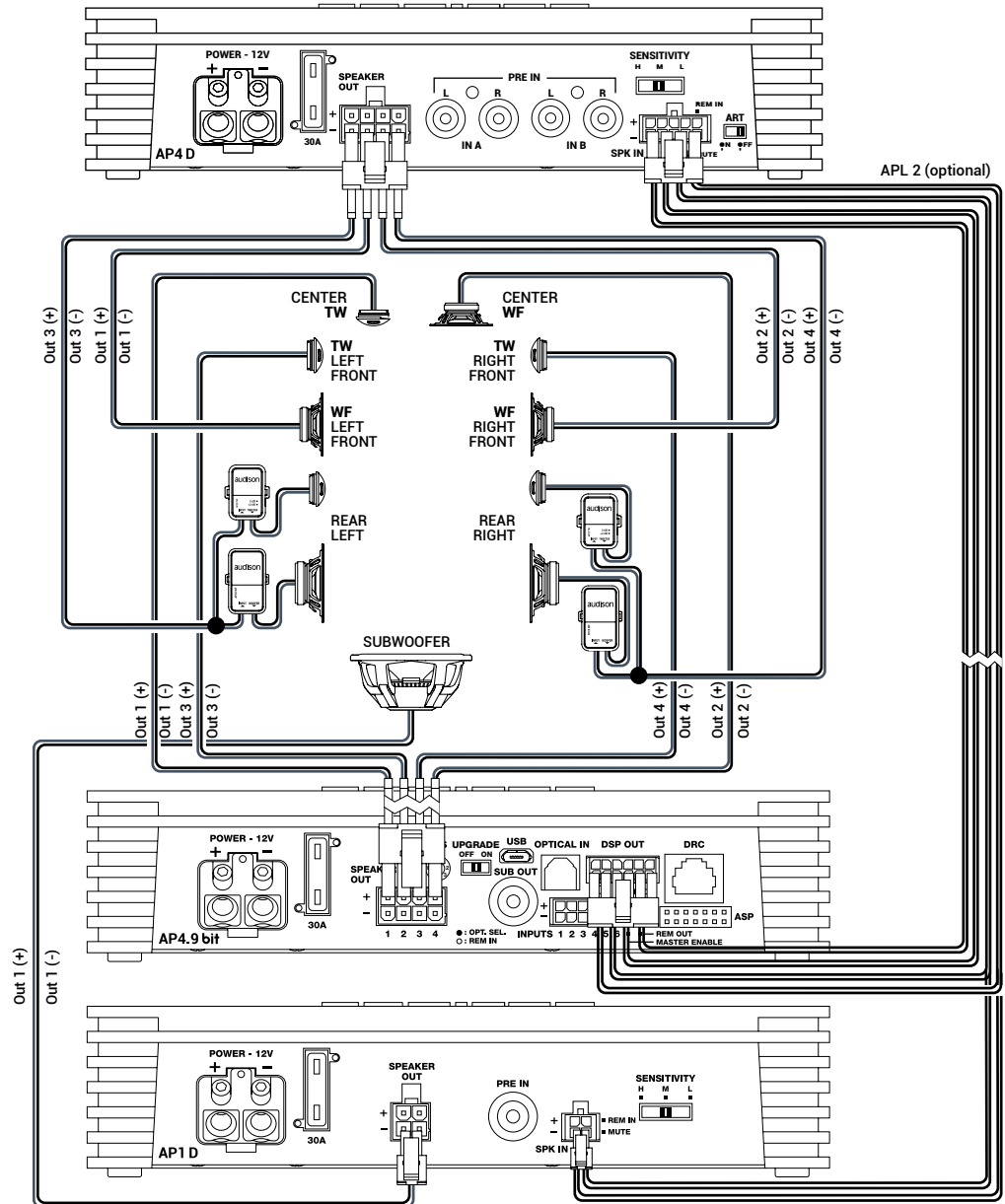

OUTPUT CONFIGURATION:

AP TYPE	OUTPUT	TYPE	CUT FILTER	FILTER TYPE	CUT FREQUENCY	TIME ALIGNMENT*	POWER @ 4Ω	POWER @ 2Ω
4.9 bit	OUT 1	CENTRE TW	HI PASS	Linkwitz	3000 Hz @12 dB	79,3 cm	70 W	130 W
4.9 bit	OUT 2	CENTRE WF	BAND PASS	Linkwitz	300 Hz @12 dB 3000 HZ @ 12 dB	79,3 cm	70 W	130 W
4.9 bit	OUT 3	FRONT TW LEFT	HI PASS	Linkwitz	3000 Hz @12 dB	82,2 cm	70 W	130 W
4.9 bit	OUT 4	FRONT TW RIGHT	HI PASS	Linkwitz	3000 Hz @12 dB	116,2 cm	70 W	130 W
4 D	OUT 1	FRONT WF LEFT	BAND PASS	Linkwitz	80 Hz @12 dB 3000 HZ @ 12 dB	82,2 cm	70 W	140 W
4 D	OUT 2	FRONT WF RIGHT	BAND PASS	Linkwitz	80 Hz @12 dB 3000 HZ @ 12 dB	116,2 cm	70 W	140 W
4 D	OUT 3	REAR LEFT	HI PASS	Linkwitz	80 Hz @12 dB	62,3 cm	70 W	140 W
4 D	OUT 4	REAR RIGHT	HI PASS	Linkwitz	80 Hz @12 dB	116,2 cm	70 W	140 W
1 D	OUT 1	SUBWOOFER	LO PASS	Linkwitz	80 Hz @12 dB	121,8 cm	280 W	520 W

* = Max power suggested Loads: 1080 W

INPUT CONFIGURATION:

Master input: Front + Rear
Aux input: In1 + In 2
Optical: S/P-DIF PCM 96kHz/24 bit max

MEMORY CONFIGURATION:

Memory A: Acoustic
Memory B: Rhythm
**Listening Point: Driver*

AP 1 TWEETER

- 1 26 mm diameter diaphragm combined with a wide-roll surround provides maximum efficiency and reduced resonance frequency.
- 2 Neodymium magnet with low carbon content plates, provides reduced size and more linear sound reproduction, even during the most demanding audio passages.
- 3 Acoustic lens designed to compensate for and fine tune the in-car frequency response anomalies in the 10 kHz - 13 kHz bandwidth caused by restrictive OEM grilles in critical OEM placements.
- 4 Extremely compact dedicated passive crossover APCX TW supplied with the product, optimised for OEM Integration, featuring an attenuation switch (0 dB, +2 dB) to tune the in-car response according to different installation conditions.
- 5 Passive crossovers are supplied with "OEM Integration compliant" fast-on connectors. The ends, different in each of the two poles, eliminate any possible connection errors and speed up the required installation time.
- 6 Wide array of mounting accessories supplied with the product, for high fitment flexibility in OEM Integration.
- 7 CCAW (Copper Clad Aluminium Wire) ultra-light ferrofluid cooled voice coil is wound on a Kapton former, for better heat dissipation.
- 8 Dome profile and motor are optimised with FEM (Finite Element Method) simulation technology.
- 9 Developed with the KLIPPEL suite.

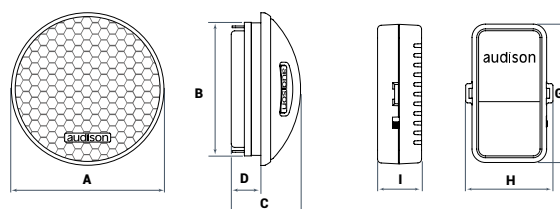
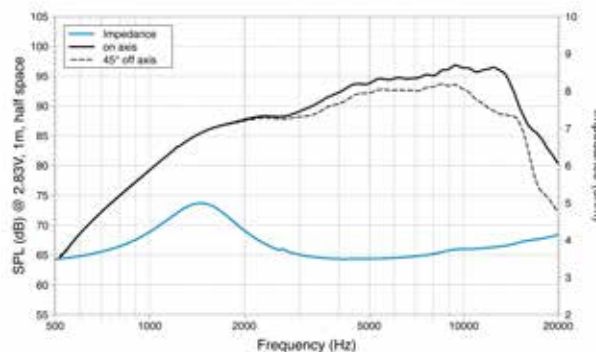

A	B	C	D	mm	in.
44	38.5	20	8.5		
1.7	1.5	0.78	0.33		

G	H	I	mm	in.
46.5	37.5	20.1		
1.83	1.47	0.8		

TECHNICAL SPECIFICATIONS

Component	Tweeter	
Size	mm (in.)	26 (1)
Power Handling	W peak	150
	Hi-pass filtered @ 3,5 kHz - 12 dB Oct	
Impedance	Ω	4
Frequency Response	Hz	2k ÷ 20k
Magnet size	mm	19 x 3
D x h	(in.)	(0.75 x 0.12)
Weight of one speaker	kg (lb)	0,04 (0.09)
Weight of one crossover	kg (lb)	0,04 (0.09)
Voice Coil Ø	mm (in.)	20 (0.8)

ELECTRO-ACOUSTIC PARAMETERS

D	mm	27.5
Xmax	mm	-
Re	Ω	3,5
Fs	Hz	1500
Le	mH	0,02
Vas	l	-
Mms	g	0,16
Cms	mm/N	0,09
BL	T·m	1,3
Qts		0,98
Qes		2,78
Qms		1,5
Spl	dB	93

AP 4 MIDBASS

- 1 Very extended frequency response, in both high and low frequencies, combined with high efficiency.
- 2 No passive crossover required to maximize efficiency: the cone is optimised with the Klippel R&D Scan Vibrometer to obtain a calibrated mechanical low-pass cut-off frequency.
- 3 Water-repellent treated paper cone, featuring a profile developed with FEM (Finite Element Method) simulation technology and optimized with the Klippel R&D Scan Vibrometer.
- 4 Reduced mounting depth, providing ease of installation in OEM placements.
- 5 TPU (Thermoplastic Polyurethane) surround, featuring the exclusive shallow "Triple Wave" profile, for maximum excursion linearity.
- 6 25 mm pure copper voice coil; ensuring precise balance in the mid-high frequency range.
- 7 Compact basket, protected by abrasion-resistant and scratch-proof coating.
- 8 Developed with the KLIPPEL suite.

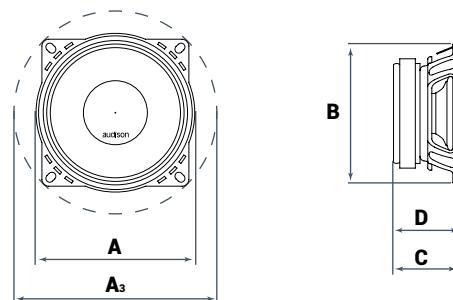
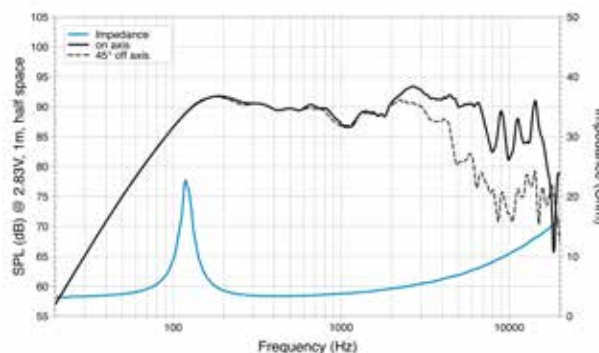

A	A ₃	B	C	D	
103	130	93	43	41	mm
4	5.12	3.66	1.7	1.62	in.

TECHNICAL SPECIFICATIONS

Component		Midbas
Size	mm (in.)	100 (4)
Power Handling	W peak	120
	W continuous	40
Impedance	Ω	4
Frequency Response	Hz	80 ÷ 7,5k
Magnet size	mm	70 x 32 x 10
	(in.)	(2.75 x 1.26 x 0.39)
Weight of one speaker	kg (lb)	0,4 (0.88)
Voice Coil Ø	mm (in.)	25 (1)

ELECTRO-ACOUSTIC PARAMETERS

D	mm	85
Xmax	mm	±1,8
Re	Ω	3,2
Fs	Hz	125
Le	mH	0,16
Vas	l	1,5
Mms	g	5
Cms	mm/N	0,3
BL	T·m	3,4
Qts		1
Qes		1,2
Qms		7,6
Spl	dB	91

AP 5 WOOFER

- 32 mm pure copper mobile voice coil, for high power handling and outstanding low frequency control.
- Water-repellent treated paper cone, featuring a profile developed with FEM (Finite Element Method) simulation technology and optimized with the Klippel R&D Scan Vibrometer.
- No passive crossover required to maximize efficiency: the cone is optimised with the Klippel R&D Scan Vibrometer to obtain a calibrated mechanical low-pass cut-off frequency.
- Reduced mounting depth, providing ease of installation in OEM placements.
- TPU (Thermoplastic Polyurethane) surround, featuring the exclusive shallow "Triple Wave" profile, for maximum excursion linearity.
- Compact basket, protected by abrasion-resistant and scratch-proof coating, the motor affixed with damping epoxy adhesive.
- High current fast-on terminal with double contact on positive and negative poles for installation flexibility and quick connection. The terminal features a temperature resistant plastic cover, protecting it against accidental short circuits.
- Developed with the KLIPPEL suite.

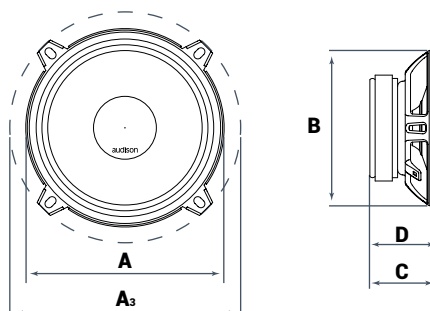
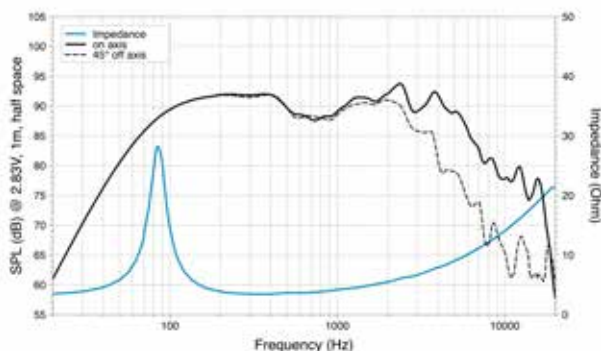

A	A ₃	B	C	D	
130	150	119	51,5	48,5	mm
5.12	5.9	4.68	2.03	1.9	in.

TECHNICAL SPECIFICATIONS

Component		Woofer
Size	mm (in.)	130 (5)
Power Handling	W peak	150
	W continuous	50
Impedance	Ω	4
Frequency Response	Hz	70 ÷ 5k
Magnet size	mm	85 x 40 x 13
	(in.)	(3.35 x 1.57 x 0.51)
Weight of one speaker	kg (lb)	0,65 (1.43)
Voice Coil Ø	mm (in.)	32 (1.26)

ELECTRO-ACOUSTIC PARAMETERS

D	mm	107
Xmax	mm	±2
Re	Ω	3,1
Fs	Hz	90
Le	mH	0,25
Vas	l	4
Mms	g	9
Cms	mm/N	0,34
BL	T·m	4,6
Qts		0,68
Qes		0,74
Qms		8
Spl	dB	93

AP 6.5 WOOFER

- 1 32 mm pure copper mobile voice coil, for high power handling and outstanding low frequency control.
- 2 Water-repellent treated paper cone, featuring a profile developed with FEM (Finite Element Method) simulation technology and optimized with the Klippel R&D Scan Vibrometer.
- 3 No passive crossover required to maximize efficiency: the cone is optimised with the Klippel R&D Scan Vibrometer to obtain a calibrated mechanical low-pass cut-off frequency.
- 4 Reduced mounting depth, providing ease of installation in OEM placements.
- 5 TPU (Thermoplastic Polyurethane) surround, featuring the exclusive shallow "Triple Wave" profile, for maximum excursion linearity.
- 6 Compact basket, protected by abrasion-resistant and scratch-proof coating, the motor affixed with damping epoxy adhesive.
- 7 High current fast-on terminal with double contact on positive and negative poles for high flexibility and quick connection. The terminal features a temperature resistant plastic cover, protecting it against accidental short circuits.
- 8 Developed with the KLIPPEL suite.

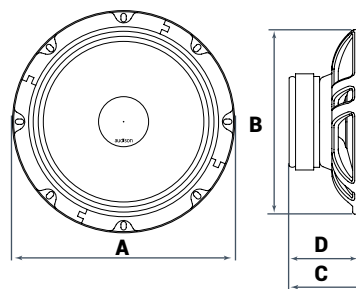
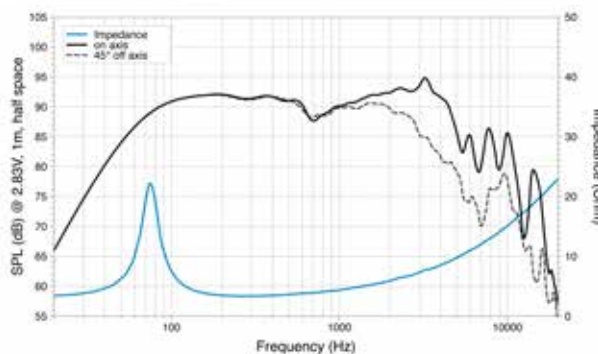

A	A _s	B	C	D	
165	-	141	60	56	mm
8.23	-	6.85	2.75	2.6	in.

TECHNICAL SPECIFICATIONS

Component		Woofer
Size	mm (in.)	165 (6.5)
Power Handling	W peak	210
	W continuous	70
Impedance	Ω	4
Frequency Response	Hz	60 ÷ 5k
Magnet size	mm	85 x 40 x 15
D x h	(in.)	(3.35 x 1.57 x 0.59)
Weight of one speaker	kg (lb)	0,78 (1.72)
Voice Coil Ø	mm (in.)	32 (1.26)

ELECTRO-ACOUSTIC PARAMETERS

D	mm	129
X _{max}	mm	±2,5
R _e	Ω	3,1
F _s	Hz	80
L _e	mH	0,23
V _{as}	l	7,6
M _{ms}	g	12
C _{ms}	mm/N	0,31
BL	T·m	4,7
Q _{ts}		0,7
Q _{es}		0,8
Q _{ms}		4,7
Spl	dB	93,5



AP 8 WOOFER



- 1 Water-repellent treated paper cone, featuring a profile developed with FEM (Finite Element Method) simulation technology and optimized with the Klippel Scan Vibrometer.
- 2 No passive crossover required to maximize efficiency: dome profile optimised with Klippel R&D Scan Vibrometer to obtain a calibrated mechanical low-pass cut-off frequency.
- 3 Reduced mounting depth, providing ease of installation in OEM placements.
- 4 TPU (Thermoplastic Polyurethane) surround, featuring the exclusive shallow "Triple Wave" profile, for maximum excursion linearity.
- 5 Compact basket, protected by abrasion-resistant and scratch-proof coating, the motor affixed with damping epoxy adhesive.
- 6 High current fast-on terminal with double contact on positive and negative poles for high flexibility and quick connection. The terminal features a temperature resistant plastic cover, protecting it against accidental short circuits.
- 7 Developed with the KLIPPEL suite.

*Grille included

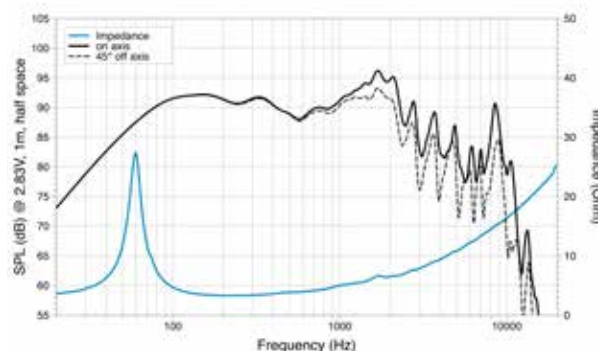
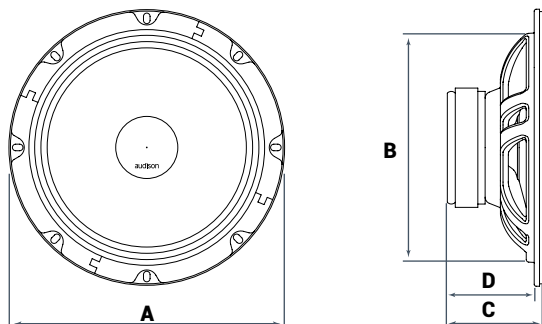

A	A ₃	B	C	D	
209	-	174	70	66	mm
8.23	-	6.85	2.75	2.6	in.

TECHNICAL SPECIFICATIONS

Component		Woofer
Size	mm (in.)	200 (8)
Power Handling	W peak	300
	W continuous	100
Impedance	Ω	4
Frequency Response	Hz	35 ÷ 3k
Magnet size	mm	90 x 40 x 17
D x h	(in.)	(3.54 x 1.57 x 0.67)
Weight of one speaker	kg (lb)	1,2 (2.64)
Voice Coil Ø	mm (in.)	25 (1)

ELECTRO-ACOUSTIC PARAMETERS

D	mm	159
Xmax	mm	±3,3
Re	Ω	3,1
Fs	Hz	60
Le	mH	0,3
Vas	l	20
Mms	g	19
Cms	mm/N	0,35
BL	T·m	5,4
Qts		0,7
Qes		0,8
Qms		5
Spl	dB	93,5

APX 4 COAXIAL

- 1 Concentric Coaxial Tweeter: tweeter is mounted within the woofer with one single point of emission providing consistent phase response, with an accurate recreation of the sound stage comparable to that of a component system.
- 2 Tweeter features an acoustic lens specifically designed to ensure an extremely linear frequency response, even in off-axis placements, typical of in-door installations.
- 3 32 mm pure copper voice coil, for high power handling and outstanding low frequency control
- 4 Overall mounting depth optimized for OEM Integration thanks to the concentric tweeter and the low profile basket
- 5 Water-repellent treated paper cone, featuring a profile developed with FEM (Finite Element Method) simulation technology and optimized with the Klippel Scan Vibrometer.
- 6 TPU (Thermoplastic Polyurethane) surround, featuring the exclusive shallow "Triple Wave" profile, for maximum excursion linearity.
- 7 Compact basket, protected by abrasion-resistant and scratch-proof coating, the motor affixed with damping epoxy adhesive.
- 8 High current fast-on terminal with double contact on positive and negative poles for high flexibility and quick connection. The terminal features a temperature resistant plastic cover, protecting it against accidental short circuits.
- 9 Developed with the KLIPPEL suite.

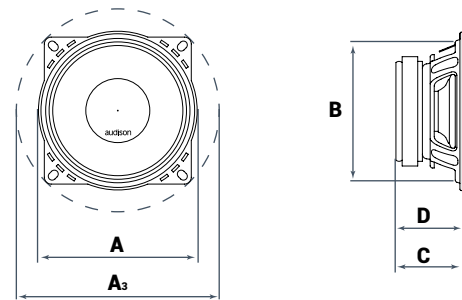
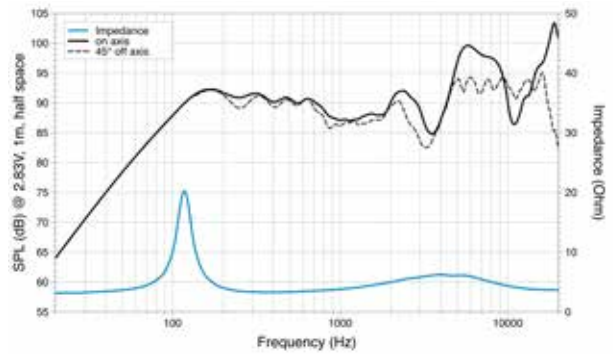

A	A ₃	B	C	D	
102	130	93	43	41	mm
4	5.12	3.66	1.7	1.62	in.

TECHNICAL SPECIFICATIONS

Component		2-way Coaxial
Size	mm (in.)	Woofer 100 (4) Tweeter 24 (0.9)
Power Handling	W peak	120
	W continuous	40
Impedance	Ω	4
Frequency Response	Hz	80 ÷ 23k
Magnet size	mm	75 x 40 x 10
D x h	(in.)	(2.95 x 1.57 x 0.4)
Weight of one speaker	kg (lb)	0,49 (1.08)
Woofer Voice Coil Ø	mm (in.)	32 (1.26)
Tweeter Voice Coil Ø	mm (in.)	15 (0.6)

ELECTRO-ACOUSTIC PARAMETERS

D	mm	85
Xmax	mm	±1,3
Re	Ω	3,1
Fs	Hz	125
Le	mH	0,04
Vas	l	1,5
Mms	g	5,3
Cms	mm/N	0,3
BL	T·m	3,2
Qts		1
Qes		1,2
Qms		8
Spl	dB	91

APX 5 COAXIAL

- 1 Concentric Coaxial Tweeter: tweeter is mounted within the woofer with one single point of emission providing consistent phase response, with an accurate recreation of the sound stage comparable to that of a component system.
- 2 Tweeter features an acoustic lens specifically designed to ensure an extremely linear frequency response, even in off-axis placement, typical of in-door installations.
- 3 32 mm pure copper voice coil, for high power handling and outstanding low frequency control
- 4 Overall mounting depth optimized for OEM Integration thanks to the concentric tweeter and the low profile basket.
- 5 Water-repellent treated paper cone, featuring a profile developed with FEM (Finite Element Method) simulation technology and optimized with the Klippel Scan Vibrometer.
- 6 TPU (Thermoplastic Polyurethane) surround, featuring the exclusive shallow "Triple Wave" profile, for maximum excursion linearity.
- 7 Compact basket, protected by abrasion-resistant and scratch-proof coating, the motor affixed with damping epoxy adhesive.
- 8 High current fast-on terminal with double contact on positive and negative poles for high flexibility and quick connection. The terminal features a temperature resistant plastic cover, protecting it against accidental short circuits.
- 9 Developed with the KLIPPEL suite.



From R&D to final product
KLIPPEL
since 2005

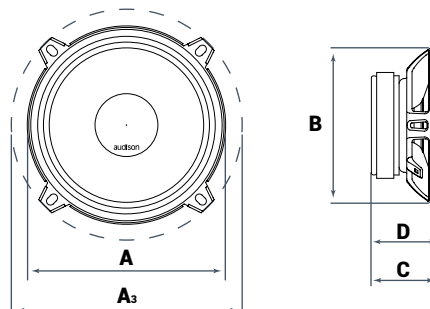
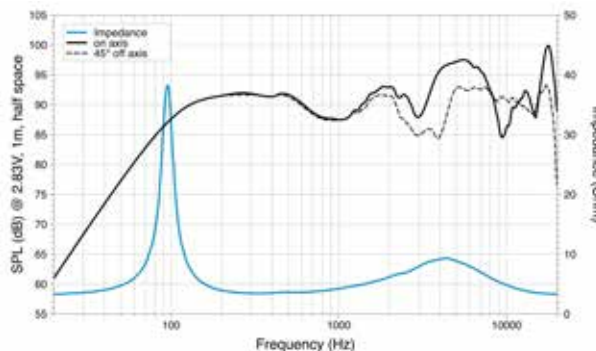

A	A ₃	B	C	D	
130	150	119	51	48	mm
5.12	5.9	4.68	2	1.89	in.

TECHNICAL SPECIFICATIONS

Component		2-way Coaxial
Size	mm (in.)	Woofer 130 (5) Tweeter 24 (0.9)
Power Handling	W peak	150
	W continuous	50
Impedance	Ω	4
Frequency Response	Hz	70 ÷ 23k
Magnet size	mm	85 x 40 x 13
D x h	(in.)	(3.35 x 1.57 x 0.51)
Weight of one speaker	kg (lb)	0,74 (1.63)
Woofer Voice Coil Ø	mm (in.)	32 (1.26)
Tweeter Voice Coil Ø	mm (in.)	15 (0.6)

ELECTRO-ACOUSTIC PARAMETERS

D	mm	107
Xmax	mm	±2
Re	Ω	3,1
Fs	Hz	90
Le	mH	0,07
Vas	l	3,8
Mms	g	8,2
Cms	mm/N	0,33
BL	T·m	4,6
Qts		0,7
Qes		0,75
Qms		10,6
Spl	dB	93

APX 6.5 COAXIAL

- 1 Concentric Coaxial Tweeter: tweeter is mounted within the woofer with one single point of emission providing consistent phase response, with an accurate recreation of the sound stage comparable to that of a component system.
- 2 Tweeter features an acoustic lens specifically designed to ensure an extremely linear frequency response, even in off-axis placement, typical of in-door installations.
- 3 32 mm pure copper voice coil, for high power handling and outstanding low frequency control.
- 4 Overall mounting depth optimized for OEM Integration thanks to the concentric tweeter and the low profile basket.
- 5 Water-repellent treated paper cone, featuring a profile developed with FEM (Finite Element Method) simulation technology and optimized with the Klippel Scan Vibrometer.
- 6 TPU (Thermoplastic Polyurethane) surround, featuring the exclusive shallow "Triple Wave" profile, for maximum excursion linearity.
- 7 Compact basket, protected by abrasion-resistant and scratch-proof coating, the motor affixed with damping epoxy adhesive.
- 8 High current fast-on terminal with double contact on positive and negative poles for high flexibility and quick connection. The terminal features a temperature resistant plastic cover, protecting it against accidental short circuits.
- 9 Developed with the KLIPPEL suite.

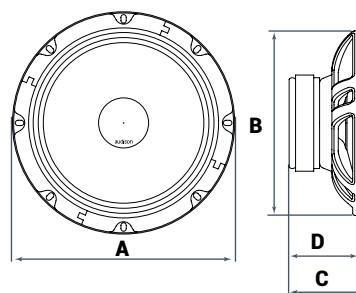
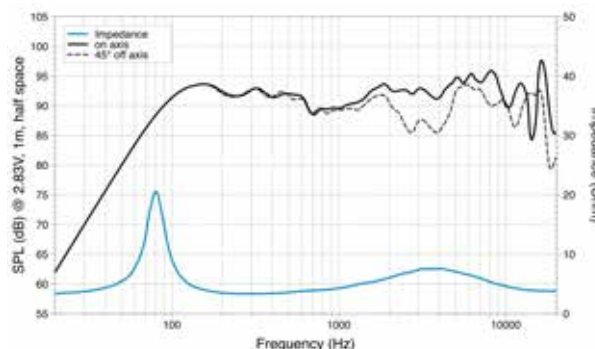

A	A _s	B	C	D	
165	-	141	60	57	mm
6.5	-	5.55	2.36	2.24	in.

TECHNICAL SPECIFICATIONS

Component	2-way Coaxial	
Size	mm (in.)	Woofer 165 (6.5) Tweeter 24 (0.9)
Power Handling	W peak	210
	W continuous	70
Impedance	Ω	4
Frequency Response	Hz	60 ÷ 23k
Magnet size	mm	85 x 40 x 15
D x h	(in.)	(3.35 x 1.57 x 0.59)
Weight of one speaker	kg (lb)	0,87 (1.92)
Woofer Voice Coil Ø	mm (in.)	32 (1.26)
Tweeter Voice Coil Ø	mm (in.)	15 (0.6)

ELECTRO-ACOUSTIC PARAMETERS

D	mm	129
Xmax	mm	±2
Re	Ω	3,1
Fs	Hz	80
Le	mH	0,1
Vas	l	8,1
Mms	g	11,5
Cms	mm/N	0,33
BL	T·m	4,6
Qts		0,73
Qes		0,84
Qms		5,4
Spl	dB	94



APX 570 COAXIAL

- 1 Concentric Coaxial Tweeter: tweeter is mounted within the woofer with one single point of emission providing consistent phase response, with an accurate recreation of the sound stage comparable to that of a component system.
- 2 Tweeter features an acoustic lens specifically designed to ensure an extremely linear frequency response, even in off-axis placement, typical of in-door installations.
- 3 32 mm pure copper voice coil, for high power handling and outstanding low frequency control
- 4 Overall mounting depth optimized for OEM Integration thanks to the concentric tweeter and the low profile basket.
- 5 Water-repellent treated paper cone, featuring a profile developed with FEM (Finite Element Method) simulation technology and optimized with the Klippel Scan Vibrometer.
- 6 TPU (Thermoplastic Polyurethane) surround, featuring the exclusive shallow "Triple Wave" profile, for maximum excursion linearity.
- 7 Compact basket, protected by abrasion-resistant and scratch-proof coating, the motor affixed with damping epoxy adhesive.
- 8 High current fast-on terminal with double contact on positive and negative poles for high flexibility and quick connection. The terminal features a temperature resistant plastic cover, protecting it against accidental short circuits.
- 9 Developed with the KLIPPEL suite.

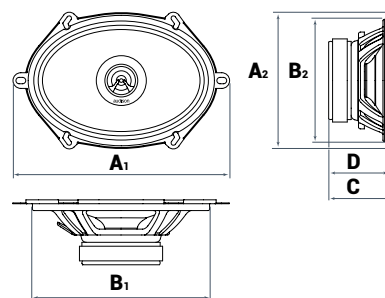
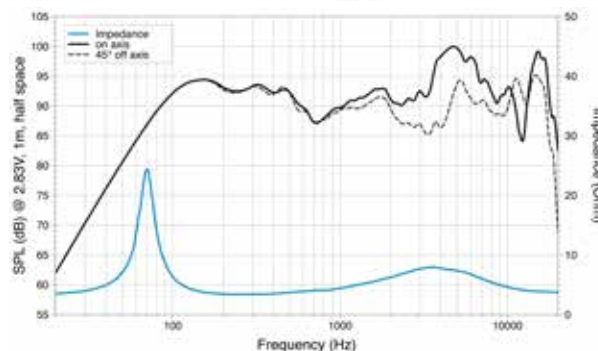

A ₁	A ₂	B ₁	B ₂	C	D	
221	140	182	126	67	63	mm
8.7	5.5	7.17	4.96	2.64	2.48	in.

TECHNICAL SPECIFICATIONS

Component		2-way Coaxial
Size	mm (in.)	Woofer (5 x 7) Tweeter 24 (0.9)
Power Handling	W peak	210
	W continuous	70
Impedance	Ω	4
Frequency Response	Hz	60 ÷ 23k
Magnet size	mm	85 x 40 x 15
D x h	(in.)	(3.35 x 1.57 x 0.59)
Weight of one speaker	kg (lb)	0,885 (1.95)
Woofer Voice Coil Ø	mm (in.)	32 (1.26)
Tweeter Voice Coil Ø	mm (in.)	15 (0.6)

ELECTRO-ACOUSTIC PARAMETERS

D	mm	139
Xmax	mm	±2
Re	Ω	3,1
Fs	Hz	70
Le	mH	0,12
Vas	l	12,5
Mms	g	12
Cms	mm/N	0,4
BL	T·m	4,2
Qts		0,8
Qes		0,9
Qms		8,4
Spl	dB	93



APX 690 COAXIAL



- 1 Horn Loaded Tweeter: 40 mm horn loaded dome tweeter contributing to its incredible efficiency of up to 96dB SPL.
- 2 Acoustics lens applied to the tweeter, specifically designed to increase dispersion in the high frequency range.
- 3 PEI (Polyethylene injected) supertweeter employed to strengthen emission of very high frequency ranges otherwise affected by off-axis positioning common to rear deck installations.
- 4 Water-repellent treated paper cone, featuring a profile developed with FEM (Finite Element Method) simulation technology and optimized with the Klippel Scan Vibrometer.
- 5 Pure copper mobile voice coil, wound on Kapton former, for better thermal and mechanical capacity.
- 6 TPU (Thermoplastic Polyurethane) surround, featuring the exclusive shallow "Triple Wave" profile, for maximum excursion linearity.
- 7 Polycotton spider material ensuring reliable performance and linear response to musical transients.
- 8 Large motor assembly, optimised with FEM (Finite Element Method) technology, for stable control and linear excursion.
- 9 Low carbon content plates for maximum magnetic permeability and high heat dissipation.
- 10 Compact basket, protected by abrasion-resistant and scratch-proof coating, the motor affixed with damping epoxy adhesive.
- 11 High current fast-on terminal with temperature resistant plastic cover, protecting it against accidental short circuits.
- 12 Developed with the KLIPPEL suite.

* Grille included

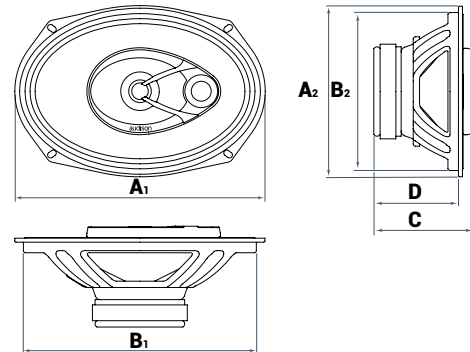
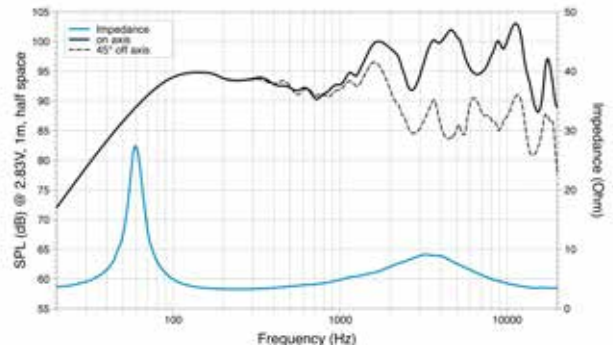

A ₁	A ₂	B ₁	B ₂	C	D	E ₁	E ₂	F	
238	162	222	151	96	81	276	202	25	mm
9.37	6.38	8.74	5.95	3.78	3.19	10.86	7.95	0.98	in.

TECHNICAL SPECIFICATIONS

Component		3-way Coaxial
Size	mm (in.)	Woofer (6 x 9) Tweeter 40 (1.58) SuperTweeter 15 (0.6)
Power Handling	W peak	300
	W continuous	100
Impedance	Ω	4
Frequency Response	Hz	40 ÷ 23k
Magnet size	mm	90 x 32 x 15
D x h	(in.)	(3.54 x 1.26 x 0.59)
Weight of one speaker	kg (lb)	1,225 (2.7)
Woofer Voice Coil Ø	mm (in.)	25 (1)
Tweeter Voice Coil Ø	mm (in.)	20 (0.78)

ELECTRO-ACOUSTIC PARAMETERS

D	mm	171
Xmax	mm	±3,5
Re	Ω	3,2
Fs	Hz	60
Le	mH	0,2
Vas	l	36
Mms	g	16,6
Cms	mm/N	0,5
BL	T·m	5,3
Qts		0,6
Qes		0,7
Qms		6,7
Spl	dB	96

APK 130 2 WAY SYSTEM

From R&D to final product
KLIPPEL
since 2005

- 1 AP1 tweeter with 26 mm diameter diaphragm combined with a wide-roll surround provides maximum efficiency and reduced resonance frequency.
- 2 AP 1 tweeter with acoustic lens designed to compensate for and fine tune the in-car frequency response anomalies in the 10kHz-13kHz bandwidth caused by restrictive OEM grilles in critical OEM placements.
- 3 APCX TW very compact tweeter passive crossover optimised for OEM Integration featuring an attenuation switch (0 dB, +2dB) to tune the in-car response according to different installation conditions.
- 4 Passive crossovers are supplied with "OEM Integration compliant" fast-on connectors. The ends, different in each of the two poles, eliminate any possible connection errors and speed up the required installation time.
- 5 AP 5 woofer with 32 mm pure copper voice coil, for high power handling and outstanding low frequency control.
- 6 AP 5 woofer with water-repellent treated paper cone, featuring a profile developed with FEM (Finite Element Method) simulation technology and optimized with the Klippel R&D Scan Vibrometer.
- 7 AP5 woofer with reduced mounting depth, providing ease of installation in OEM placements.
- 8 AP5 woofer with TPU (Thermoplastic Polyurethane) surround, featuring the exclusive shallow "Triple Wave" profile, for maximum excursion linearity.
- 9 AP 5 woofer with compact basket, protected by abrasion-resistant and scratch-proof coating, the motor affixed with damping epoxy adhesive.
- 10 AP 5 woofer with high current fast-on terminal with double contact on positive and negative poles for high flexibility and quick connection. The terminal features a temperature resistant plastic cover, protecting it against accidental short circuits.
- 11 Developed with the KLIPPEL suite.

* Grille included



TECHNICAL SPECIFICATIONS

Component		2-way System
Size	mm (in.)	Woofer 130 (5) Tweeter 26 (1)
Power Handling	W peak	225
	W continuos	75
Impedance	Ω	4
Frequency Response	Hz	70 ÷ 20k
Crossover type		HP @ 3,5 kHz - 6 dB Oct
Component adjustment	dB	+2; 0
Woofer Magnet size	mm	85 x 40 x 13
D x d x h	(in.)	(3.35 x 1.57 x 0.51)
Tweeter Magnet size	mm	19 x 13
D x d x h	(in.)	(0.75 x 0.12)
Weight of one speaker	kg (lb)	Woofer 0,65 (1.43)
		Tweeter 0,04 (0.09)
Voice Coil Ø	mm (in.)	Woofer 32 (1.26) Tweeter 20 (0.8)

ELECTRO-ACOUSTIC PARAMETERS

D	mm	107
Xmax	mm	±2
Re	Ω	3,1
Fs	Hz	90
Le	mH	0,25
Vas	l	4
Mms	g	9
Cms	mm/N	0,34
BL	T•m	4,6
Qts		0,68
Qes		0,74
Qms		8
Spl	dB	93

APK 165

2 WAY SYSTEM



- 1 AP 1 tweeter with 26 mm diameter diaphragm combined with a wide-roll surround provides maximum efficiency and reduced resonance frequency.
- 2 AP 1 tweeter with acoustic lens designed to compensate for and fine tune the in-car frequency response anomalies in the 10kHz - 13kHz bandwidth caused by restrictive OEM grilles in critical OEM placements.
- 3 APCX TW very compact tweeter passive crossover optimised for OEM Integration featuring an attenuation switch (0 dB, +2dB) to tune the in-car response according to different installation conditions.
- 4 Passive crossovers are supplied with "OEM Integration compliant" fast-on connectors. The ends, different in each of the two poles, eliminate any possible connection errors and speed up the required installation time.
- 5 AP 6.5 woofer with 32 mm pure copper voice coil, for high power handling and outstanding low frequency control.
- 6 AP 6.5 woofer with water-repellent treated paper cone, featuring a profile developed with FEM (Finite Element Method) simulation technology and optimized with the Klippel R&D Scan Vibrometer.
- 7 AP 6.5 woofer with reduced mounting depth, providing ease of installation in OEM placements.
- 8 AP 6.5 woofer with TPU (Thermoplastic Polyurethane) surround, featuring the exclusive shallow "Triple Wave" profile, for maximum excursion linearity.
- 9 AP 6.5 woofer with compact basket, protected by abrasion-resistant and scratch-proof coating, the motor affixed with damping epoxy adhesive.
- 10 AP 6.5 woofer with high current fast-on terminal with double contact on positive and negative poles for high flexibility and quick connection. The terminal features a temperature resistant plastic cover, protecting it against accidental short circuits.
- 11 Developed with the KLIPPEL suite.

* Grille included

TECHNICAL SPECIFICATIONS

Component	2-way System	
Size	mm (in.)	Woofer 165 (6.5) Tweeter 26 (1)
Power Handling	W peak	300
	W continuous	100
Impedance	Ω	4
Frequency Response	Hz	60 ÷ 20k
Crossover type		HP @ 3,5 kHz - 6 dB Oct
Component adjustment	dB	+2; 0
Woofer Magnet size	mm	85 x 40 x 15
D x d x h	(in.)	(3.35 x 1.57 x 0.59)
Tweeter Magnet size	mm	19 x 3
D x d x h	(in.)	(0.75 x 0.12)
Weight of one speaker	kg (lb)	Woofer 0,78 (1.72) Tweeter 0,04 (0.09)
Voice Coil Ø	mm (in.)	Woofer 32 (1.26) Tweeter 20 (0.8)

ELECTRO-ACOUSTIC PARAMETERS

D	mm	129
Xmax	mm	±2,5
Re	Ω	3,1
Fs	Hz	80
Le	mH	0,23
Vas	l	7,6
Mms	g	12
Cms	mm/N	0,31
BL	T·m	4,7
Qts		0,7
Qes		0,8
Qms		4,7
Spl	dB	93,5

APK 163 3 WAY SYSTEM

- 1 AP 1 tweeter with 26 mm diameter diaphragm combined with a wide-roll surround provides maximum efficiency and reduced resonance frequency.
- 2 AP 1 tweeter with acoustic lens designed to compensate for and fine tune the in-car frequency response anomalies in the 10kHz - 13kHz bandwidth caused by restrictive OEM grilles in critical OEM placements.
- 3 Dedicated crossovers for each component: APCX TW compact tweeter passive crossover optimised for OEM Integration featuring an attenuation switch (0 dB, +2dB) to tune the in-car response according to different installation conditions; APCX MD midbass crossover and APCX WF woofer crossover. The passive crossovers boast very reduced dimensions and are optimised for OEM Integration.
- 4 AP4 midbass with extended frequency response, combined with high efficiency.
- 5 AP 6.5 woofer with 32 mm pure copper voice coil, for high power handling and outstanding low frequency control.
- 6 AP 6.5 woofer and AP 4 midbass with water-repellent treated paper cone, featuring a profile developed with FEM (Finite Element Method) simulation technology and optimized with the Klippel R&D Scan Vibrometer.
- 7 AP 6.5 woofer and AP 4 midbass with reduced mounting depth, providing ease of installation in OEM placements.
- 8 AP 6.5 woofer and AP 4 midbass with TPU (Thermoplastic Polyurethane) surround, featuring the exclusive shallow "Triple Wave" profile, for maximum excursion linearity.
- 9 AP 6.5 woofer and AP 4 midbass with compact basket, protected by abrasion-resistant and scratch-proof coating, the motor affixed with damping epoxy adhesive.
- 10 AP 6.5 woofer with high current fast-on terminal with double contact on positive and negative poles for high flexibility and quick connection. The terminal features temperature resistant plastic cover, protecting it against accidental short circuits.
- 11 Developed with the KLIPPEL suite.

* Grille included

ELECTRO-ACOUSTIC PARAMETERS

D	mm	129
Xmax	mm	±2,5
Re	Ω	3,1
Fs	Hz	80
Le	mH	0,23
Vas	l	7,6
Mms	g	12
Cms	mm/N	0,31
BL	T•m	4,7
Qts		0,7
Qes		0,8
Qms		4,7
Spl	dB	93,5

From R&D to final product
KLIPPEL
since 2005



TECHNICAL SPECIFICATIONS

Component	3-way System	
Size	mm (in.)	Woofer 165 (6.5) Midbass 100 (4) Tweeter 26 (1)
Power Handling	W peak	375
	W continuous	125
Impedance	Ω	4
Frequency Response	Hz	50 ÷ 20k
Crossover type		LP @ 600 Hz - 6 dB Oct HP @ 600/3,5 kHz - 6/6 dB Oct HP @ 3,5 kHz - 6 dB Oct
Component adjustment	dB	+2; 0
Woofer Magnet size	mm	85 x 40 x 15
D x h	(in.)	(3.35 x 1.57 x 0.59)
Midrange Magnet size	mm	70 x 32 x 10
D x h	(in.)	(2.75 x 1.26 x 0.39)
Tweeter Magnet size	mm	19 x 13
D x h	(in.)	(0.75 x 0.12)
Weight of one speaker	kg (lb)	Woofer 0,78 (1.72) Midbass 0,4 (0.88) Tweeter 0,04 (0.09)
Voice Coil Ø	mm (in.)	Woofer 32 (1.26) Midbass 25 (1) Tweeter 20 (0.8)

APSP G6

Prima Sound Pack for VW Golf 6



1. Developed specifically for VW Golf 6
2. 7 presets designed for VW Golf 6 by the Audison R&D Team for a "Plug&Sound" performance.
3. Easy installation (< 2h).
4. APBX G6 sealed passive subwoofer, perfectly integrating into the car's trunk.
5. Two way system, packaged with composite OEM speaker baffles, harnesses and seals, for perfect integration into the A-pillars.
6. Dedicated hi-quality wiring kit, easy to route through the vehicle.
7. Specific T-Harness; it takes the power to supply the AP8.9 bit from directly behind the OEM head unit.



TECHNICAL SPECIFICATIONS

Component		AP 6.5 G6 - AP 1 SP 2 WAY SYSTEM	APBX G6 SUBWOOFER
Size	mm (in.)	Woofer 165 (6,5) Tweeter 26 (1)	250 (10)
Power Handling	W (peak)	300	900
	W (continuous)	100	300
Impedance	Ω	4	4
Frequency Response	Hz	60 ÷ 20k	-
Crossover type		2-Way passive	Digital

AP8.9 bit OUTPUT CHANNEL MAP

Channel	Mode	Speaker	Power
1-2 3-4	Bridge	AP 6.5 G6 - AP 1 SP	2 x 130W RMS @ 4Ω
5-6	Stereo	OEM Speakers	2 x 35W RMS @ 4Ω
7-8	Bridge	APBX G6 - Subwoofer	1 x 130W RMS @ 4Ω

AP8.9 bit PRESETS

Preset n°	Listening Position	Your Sound
1	LHD	Acoustic
2	LHD	Live
3	LHD	Rhythm
4	RHD	Acoustic
5	RHD	Live
6	RHD	Rhythm
7	OVERALL	Acoustic

LHD: Left Hand Drive
RHD: Right Hand Drive

Golf® is a trademark of Volkswagen®

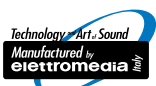



ABOUT US

Elettromedia, an Italian company, is a leader within the world-wide car Hi-Fi market. Born in 1987 in Potenza Picena by a group of friends who shared the same passion for in-car high fidelity, throughout the past years Elettromedia has been walking the path of excellence: its products are distributed in more than 50 countries; the company has received many awards and acknowledgements from the most authoritative leaders within the car audio industry; it also can boast reviews of more than 3000 pages published in 30 different languages (visit: www.elettromedia.it/press_area.asp). The Elettromedia brands are Audison, Hertz, Connection and AZaudiocomp. Through a co-branding strategy, the company offers all of the components required for a complete, top-level car audio system.

CONTACTS:

**Elettromedia s.r.l. Strada Regina km 3,500 - 62018 Potenza Picena (Mc) - Italy
T +39 0733 870 870 - F +39 0733 870 880 - www.elettromedia.it**

AWARDS

This section displays a grid of various award logos. The top three rows feature EISA Awards (European International Sound Awards) for 'Best Product' in different categories and years. The middle row includes 'THE PROMISED IN YEAR' and 'BEST OF car audio 2007' logos. The bottom row shows 'Auto Sound Web GRAND PRIX' logos for 2011, 2008, and 2006, along with 'Innovations International CES' logos for 2009, 2007, 2006, and 2005. At the bottom right, there are three more EISA Awards logos for specific product categories.

All specifications subject to change without notice. 1.5.D

Press Kit

Prima Product Information (PDF version, 150 dpi resolution)

LOGOS: Audison, Prima, Plug&Sound, bit Drive, Full DA, Klippel.
(Adobe Illustrator version, 300 dpi resolution)

PHOTO (JPEG version, 300 dpi resolution)



AP 1 AP 4 AP 5 AP 6.5 AP 8



APX 4 APX 5 APX 6.5 APX 570



APX 690 APK 130 APK 165



APK 163



APSP G6



AP5.9 bit AP4.9 bit



AP4 D AP1 D AP8.9 bit

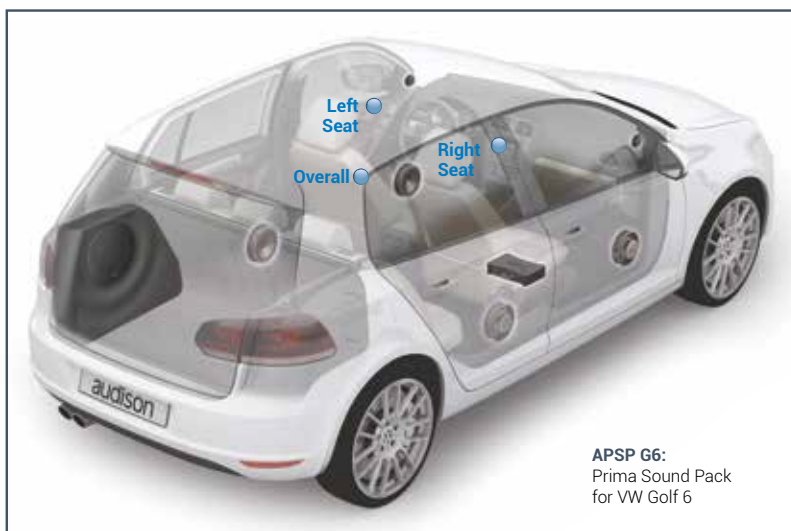

APSP G6:
Prima Sound Pack
for VW Golf 6

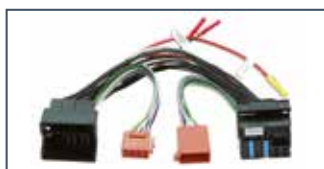

DCC_T-harness



Wiring kit

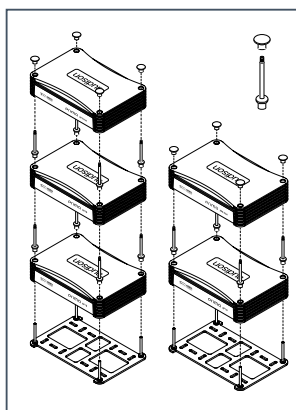

Technologies



Elettromedia_Headquarter



All Specifications Subject to Change Without Notice

www.audison.eu

audison
ISTINTO
INNOVATIVO

PART OF ELETTROMEDIA
62018 Potenza Picena (MC) Italy
T +39 0733 870 870 - F +39 0733 870 880
www.elettromedia.it