



# User Manual

## TARGET 550 IRS

Official Distributor:



**ASP Group s.r.o.**

Adresa: Staroplzenecka 290, 326 00, Letkov  
Czech Republic

Tel.: +420 378 21 21 21

E-mail: [info@aspgroup.cz](mailto:info@aspgroup.cz)

Web: [www.aspgroup.eu](http://www.aspgroup.eu)

### DEAR CUSTOMER :

Our ATV is manufactured under strict quality control systems. The warranty document sent to dealers guarantees all written items. Given that you follow the maintenance procedure by using original parts and riding normally, we readily assent to repair or change them.

This warranty excludes:

- 1.Using unspecified Engine Oil.
  - 2.Improper maintenance or repairs.
  - 3.Using non-original or modified accessories and parts.
  - 4.Operating inaptly, lack of conformity to manual.
  - 5.Parts subject to normal wear such as tear Seat, Spark Plug, Bulbs, Wire, Filters, Battery, Brakes, Belt, Chain, Sprockets, Tyres etc.
- This manual is a simple introduction of operation and basic maintenance checking. In case of further questions, contact your dealer for assistance.

## GENERAL SAFETY

### CARBON MONOXIDE

When running your engine, ensure the place is well ventilated. Never run your engine in a closed area. (Run your engine in an open area.) If you have to run your engine in a closed area, be sure to use an extractor

#### ▲ Caution

Exhaust contains toxic gas which may cause one to lose consciousness and even result in death.

### GASOLINE

Gasoline is a low ignition point and explosive material. Work in a well-ventilated place, no flame or spark should be allowed in the work place or where gasoline is being stored.

#### ▲ Caution

Gasoline is highly flammable, and may explode under some conditions, keep it away from children.

### USED ENGINE OIL

#### ▲ Caution

Prolonged contact with used engine oil (or transmission oil) may cause skin cancer although it might not be verified. We recommend that you wash your hands with soap and water right after contacting. Keep the used oil beyond reach of children.

### HOT COMPONENTS

#### ▲ Caution

Components of the engine and exhaust system can become extremely hot after engine running. They remain very hot even after the engine has been stopped for some time. When performing service work on these parts, wear insulated gloves and wait until cooling off.

### BATTERY

#### ▲ Caution

- Battery emits explosive gases; flame is strictly prohibited. Keeps the place well ventilated when charging the battery.
- Battery contains sulfuric acid (electrolyte) which can cause serious burns so be careful do not be spray on your eyes or skin. If you get battery acid on your skin, flush it off immediately with water. If you get battery acid in your eyes, flush it out immediately with water and then go to hospital to see an ophthalmologist.
- If you swallow it by mistake, drink a lot of water or milk, and take some laxative such as castor oil or vegetable oil and then go to see a doctor.
- Keep electrolyte beyond reach of children.

### BRAKE SHOE

Do not use an air hose or a dry brush to clean components of the brake system; use a vacuum cleaner or the equivalent to avoid dust flying.

#### ▲ Caution

Inhaling brake shoe or pad dust may cause disorders and cancer of the breathing system.

### BRAKE FLUID

#### ▲ Caution

Spilling brake fluid on painted, plastic, or rubber parts may cause damage to the parts. Place a clean towel on the above-mentioned parts for protection when servicing the brake system. Keep the brake fluid beyond reach of children.

## OWNER MEMO

**NAME:**  
**PURCHASING DATE:**  
**TYPE:**  
**FRAME NO.:**  
**KEY NO.:**  
**SPECIAL NOTE:**

## KEY NUMBER

Your key's identification number is engraved on the steel plate beside your key as shown in the above illustration. Record this number and store carefully to provide for reference if you need a new key.

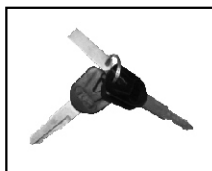

## PRE-OPERATION CHECKS

Before you set-off on a journey:	
Fuel:	Check you have sufficient petrol for your journey.
Brakes:	Check the brakes are working properly.
Tyres:	Check tyres are adequately inflated. Check tyres for physical damage.
Lighting System:	Check lights and signalling devices are working.
Mirrors:	Check mirrors are clean and correctly adjusted.
Engine Oil:	Check oil level.

## CONTENTS

Specifications.....	5
Important Identification Numbers.....	14
General Illustration.....	16
Operation Indications.....	16
Periodical Maintenance Schedule.....	32
Basic safety rules.....	37

## SPECIFICATIONS

ITEM		VSE 400C.C.				
Dimension	Overall Length	2080 mm	Suspension System	Front	Double Arm	
	Overall Width	1240 mm		Rear	Unit Swing	
	Overall Height	1320 mm	Tire Specifications	Front	AT 23x7-10	
	Wheel Base	1290 mm		Rear	AT 22x11-10	
	Wheel Tread	Front	1050 mm	Brake System	Front	Disk (∅ 180mm)
		Rear	975 mm		Rear	Disk (∅ 180mm)
	Curb Weight	Front	154 kg	Performance	Max. Speed	Above 92 km/hr
		Rear	161 kg			
		Total	315 kg			
	Weight	Passengers/ Weight	Two / 150 kg	Transmission devices	Transfer	Shaft drive
Total Weight		Front	197 kg		Shift lever	L, H, N, R
		Rear	293 kg		Shift	Manual lever
		Total	490 kg		Clutch type	Wet multi-plate
Type		S.O.H.C.	Transmission		Continuously variable Centrifugal type	
Engine	Fuel Used	Petrol	Speedometer	0 ~ 300 km/hr		
	Cycle/cooling	4-Stroke/Water Cooled	Horn	93 ~ 112dB/A		
	Cylinder	Bore	∅86 mm	Lubrication System	Pump forced circulation	
		Stroke	69.4 mm	Engine lubrication system	SAE 10W/40 SG/CC	
	Number/ Arrangement	Single Cylinder	Engine oil capacity	3.5L		
				Gear lubrication	Differential / Final Reduction device	Spec.
	Displacement	403.1 cc	Exhaust Concentration	Capacity	350 c.c.	
	Compression Ratio	9.2		Solid Particulate		
	Max. HP	14.9kw / 6500rpm		CO	Below 7.0g/ km	
	Max. Torque	25.5Nm / 4000rpm	HC	Below 1.5g/ km		
Ignition	C.D.I.	Nox	Below 0.4g/ Km			
Starting System	Electrical / Recoil starter	Fuel Capacity	15±0.3L			
Air Filtration	Sponge	Spark Plug	NGK CR7E			
LAMPS	FRONT LAMPS (HI / LO)	12V 55WX2 55WX2	BRAKE LAMPS	12V 21WX1		
	REAR LAMPS	12V 5WX1	TURN LAMPS	12V 10WX4		

This list is only for reference; the parts are according to real vehicle.  
 Any modification may be done without prior notice.

## SPECIFICATIONS

ITEM		VSE-D (IRS) 400 C.C.				
Dimension	Overall Length	2030 mm	Suspension System	Front	Double Arm	
	Overall Width	1250 mm		Rear	Double Arm	
	Overall Height	1300 mm	Tire Specifications	Front	AT25x8-12	
	Wheel Base	1280 mm		Rear	AT25x10-12	
	Wheel Tread	Front	1050 mm	Brake System	Front	Disk (∅200mm)x2
		Rear	975 mm		Rear	Disk (∅180mm)
	Curb Weight	Front	180 kg	Performance	Max. Speed	Above 92 km/hr
		Rear	184 kg			
		Total	364 kg			
	Passengers/ Weight	Two / 150 kg	Transmission devices	Transfer	Shaft drive	
Total Weight	Front	220 kg		Shift lever	L, H, N, R	
	Rear	319 kg		Shift	Manual lever	
	Total	539 kg		Clutch type	Wet multi-plate	
Type	S.O.H.C.	Transmission	Continuously variable Centrifugal type			
Fuel Used	Petrol	Speedometer	0 ~ 300 km/hr			
Cycle/cooling	4-Stroke/Water Cooled	Horn	93 ~ 112dB/A			
Engine	Cylinder	Bore	∅86 mm	Lubrication System	Pump forced circulation	
		Stroke	69.4 mm	Engine lubrication system	SAE 10W/40 SG/CC	
	Number/ Arrangement	Single Cylinder	Engine oil capacity		3.5L	
			Gear lubrication	Differential / Final Reduction device	Spec.	SAE 90#
	Capacity	450 c.c.				
	Displacement	403.1 cc	Exhaust Concentration	Solid Particulate		
	Compression Ratio	9.2		CO	Below 7.0g/ km	
	Max. HP	14.9kw / 6500rpm		HC	Below 1.5g/ km	
	Max. Torque	25.5Nm / 4000rpm		Nox	Below 0.4g/ Km	
	Ignition	C.D.I.	Fuel Capacity	15±0.3L		
Starting System	Electrical / Recoil starter	Spark Plug	NGK CR7E			
Air Filtration	Sponge	Battery	12V 18AH			
LAMPS	FRONT LAMPS (HI / LO)	12V 55WX2 55WX2	BRAKE LAMPS	12V 21WX1		
	REAR LAMPS	12V 5WX1	TURN LAMPS	12V 10WX4		

This list is only for reference; the parts are according to real vehicle.  
Any modification may be done without prior notice.

## SPECIFICATIONS

ITEM		VSF460 C.C.				
Dimension	Overall Length	2080 mm	Suspension System	Front	Double Arm	
	Overall Width	1240 mm		Rear	Unit Swing	
	Overall Height	1320 mm	Tire Specifications	Front	AT 23 x 7 -10	
	Wheel Base	1290 mm		Rear	At 22x 11 -10	
	Wheel Tread	Front	1050 mm	Brake System	Front	Disk (∅180mm)x2
		Rear	975 mm		Rear	Disk (∅220mm)
	Curb Weight	Front	194 kg	Performance	Max. Speed	Above 92 km/hr
		Rear	167 kg			
		Total	361 kg			
	Passengers/ Weight	Two / 150 kg	Transmission devices	Transfer	Shaft drive	
Total Weight	Front	245 kg		Shift lever	L, H, N, R	
	Rear	366 kg		Shift	Manual lever	
	Total	611 kg		Clutch type	Wet multi-plate	
Type	S.O.H.C.	Transmission	Continuously variable Centrifugal type			
Fuel Used	Petrol	Speedometer	0 ~ 300 km/hr			
Cycle/cooling	4-Stroke/Water Cooled	Horn	93 ~ 112dB/A			
Engine	Cylinder	Bore	∅92 mm	Lubrication System	Pump forced circulation	
		Stroke	69.4 mm	Engine lubrication system	SAE 10W/40 SG/CC	
	Number/ Arrangement	Single Cylinder	Engine oil capacity		3.75L	
			Gear lubrication	Differential / Final Reduction device	Spec.	SAE 90#
	Capacity	350 c.c.				
	Displacement	461.3 cc	Exhaust Concentration	Solid Particulate		
	Compression Ratio	10.1:1		CO	Below 7.0g/ km	
	Max. HP	14.7w / 6000rpm		HC	Below 1.5g/ km	
	Max. Torque	27.5Nm / 3500rpm		Nox	Below 0.4g/ Km	
	Ignition	C.D.I.	Fuel Capacity	15±0.3L		
Starting System	Electrical / Recoil starter	Spark Plug	NGK CR7E			
Air Filtration	Sponge	Battery	12V 18AH			
LAMPS	FRONT LAMPS (HI / LO)	12V 55WX2 55WX2	BRAKE LAMPS	12V 21WX1		
	REAR LAMPS	12V 5WX1	TURN LAMPS	12V 10WX4		

This list is only for reference; the parts are according to real vehicle.  
Any modification may be done without prior notice.

## SPECIFICATIONS

ITEM		VSF-D (IRS) 460 C.C.					
Dimension	Overall Length	2030 mm		Suspension System	Front Double Arm		
	Overall Width	1250 mm		Suspension System	Rear Double A-Arm		
	Overall Height	1300 mm		Tire Specifications	Front AT 25 x 8 -12		
	Wheel Base	1280 mm			Rear At 25x 10 -12		
	Wheel Tread	Front	1050 mm		Brake System	Front Disk (∅200mm)x2	
		Rear	975 mm			Rear Disk (∅180mm)	
	Curb Weight	Front	201 kg		Performance	Max. Speed Above 92 km/hr	
		Rear	182 kg				
		Total	383 kg				
	Passengers/ Weight	Two / 150 kg		Transmission devices	Transfer	Shaft drive	
Total Weight	Front	253 kg			Shift lever	L, H, N, R	
	Rear	380 kg			Shift	Manual lever	
	Total	633 kg			Clutch type	Wet multi-plate	
Engine	Type	S.O.H.C.		Transmission	Continuously variable Centrifugal type		
	Fuel Used	Petrol		Speedometer	0 ~ 300 km/hr		
	Cycle/cooling	4-Stroke/Water Cooled		Horn	93 ~ 112dB/A		
	Cylinder	Bore	∅92 mm		Lubrication System	Pump forced circulation	
		Stroke	69.4 mm		Engine lubrication system	SAE 10W/40 SG/CC	
		Number/ Arrangement	Single Cylinder		Engine oil capacity		3.75L
					Gear lubrication	Differential / Final Reduction device	Spec. Capacity
	Displacement	461.3 cc		Exhaust Concentration	Solid Particulate		
	Compression Ratio	10.1:1			CO	Below 7.0g/ km	
	Max. HP	14.7w / 6000rpm			HC	Below 1.5g/ km	
	Max. Torque	27.5Nm / 3500rpm			Nox	Below 0.4g/ Km	
	Ignition	C.D.I.		Fuel Capacity		15±0.3L	
	Starting System	Electrical / Recoil starter		Spark Plug		NGK CR7E	
	Air Filtration	Sponge		Battery		12V 18AH	
	LAMPS	FRONT LAMPS (HI / LO)	12V 55WX2 55WX2		BRAKE LAMPS 12V 21WX1		
REAR LAMPS		12V 5WX1		TURN LAMPS 12V 10WX4			

This list is only for reference; the parts are according to real vehicle.  
Any modification may be done without prior notice.

## SPECIFICATIONS

ITEM		VSG 500C.C.				
Dimension	Overall Length	2080 mm		Suspension System	Front Double Arm	
	Overall Width	1240 mm		Suspension System	Rear Unit Swing	
	Overall Height	1320 mm		Tire Specifications	Front AT 23x7-10	
	Wheel Base	1290 mm			Rear AT 22x11-10	
	Wheel Tread	Front	1050 mm		Brake System	Front Disk (∅180mm)
		Rear	975 mm			Rear Disk (∅180mm)
	Curb Weight	Front	154 kg		Performance	Max. Speed Above 92 km/hr
		Rear	161 kg			
		Total	315 kg			
	Passengers/ Weight	Two / 150 kg		Transmission devices	Transfer	Shaft drive
Total Weight	Front	197 kg			Shift lever	L, H, N, R
	Rear	293 kg			Shift	Manual lever
	Total	490 kg			Clutch type	Wet multi-plate
Type	S.O.H.C.		Transmission	Continuously variable Centrifugal type		
Fuel Used	Petrol		Speedometer	0 ~ 300 km/hr		
Cycle/cooling	4-Stroke/Water Cooled		Horn	93 ~ 112dB/A		
Cylinder	Bore	∅92 mm		Lubrication System	Pump forced circulation	
	Stroke	75.6 mm		Engine lubrication system	SAE 10W/40 SG/CC	
	Number/ Arrangement	Single Cylinder		Engine oil capacity		3.5L
				Gear lubrication	Differential / Final Reduction device	Spec. Capacity
Displacement	502.56 cc		Exhaust Concentration	Solid Particulate		
Compression Ratio	9.9:1			CO	Below 7.0g/ km	
Max. HP	14.8kw / 7000rpm			HC	Below 1.5g/ km	
Max. Torque	33.3Nm / 5000rpm			Nox	Below 0.4g/ Km	
Ignition	C.D.I.		Fuel Capacity		15±0.3L	
Starting System	Electrical / Recoil starter		Spark Plug		NGK CR7E	
Air Filtration	Sponge		Battery		12V 18AH	
LAMPS	FRONT LAMPS (HI / LO)	12V 55WX2 55WX2		BRAKE LAMPS 12V 21WX1		
	REAR LAMPS	12V 5WX1		TURN LAMPS 12V 10WX4		

This list is only for reference; the parts are according to real vehicle.  
Any modification may be done without prior notice.

## SPECIFICATIONS

ITEM		VSG-D (IRS) 500 C.C.					
Dimension	Overall Length	2030 mm	Suspension System	Front	Double Arm		
	Overall Width	1250 mm		Rear	Double Arm		
	Overall Height	1300 mm	Tire Specifications	Front	AT 25X8-12		
	Wheel Base	1280 mm		Rear	AT 25X10-12		
	Wheel Tread	Front	1050 mm	Brake System	Front	Disk (∅200mm)X2	
		Rear	975 mm		Rear	Disk (∅180mm)	
	Curb Weight	Front	180 kg	Performance	Max. Speed	Above 92 km/hr	
		Rear	184 kg				
		Total	264 kg				
	Passengers/ Weight	Two / 150 kg	Transmission devices	Transfer	Shaft drive		
Total Weight	Front	220 kg		Shift lever	L, H, N, R		
	Rear	319 kg		Shift	Manual lever		
	Total	539 kg		Clutch type	Wet multi-plate		
Type	S.O.H.C.	Transmission	Continuously variable	Centrifugal type			
Fuel Used	Petrol	Speedometer	0 ~ 300 km/hr				
Cycle/cooling	4-Stroke/Water Cooled	Horn	93 ~ 112dB/A				
Engine	Cylinder	Bore	∅92 mm	Lubrication System		Pump forced circulation	
		Stroke	75.6 mm	Engine lubrication system		SAE 10W/40 SG/CC	
		Number/ Arrangement	Single Cylinder	Engine oil capacity		3.75L	
				Gear lubrication	Differential / Final Reduction device	Spec.	SAE 90#
	Capacity	450 c.c.					
	Displacement	502.56 cc	Exhaust Concentration	Solid Particulate			
	Compression Ratio	9.9:1		CO	Below 7.0g/ km		
	Max. HP	14.8kw / 7000rpm		HC	Below 1.5g/ km		
	Max. Torque	33.3Nm / 5000rpm		Nox	Below 0.4g/ Km		
	Ignition	C.D.I.	Fuel Capacity		15±0.3L		
Starting System	Electrical / Recoil starter	Spark Plug		NGK CR7E			
Air Filtration	Sponge	Battery		12V 18AH			
LAMPS	FRONT LAMPS (HI / LO)	12V 55WX2 55WX2	BRAKE LAMPS		12V 21WX1		
	REAR LAMPS	12V 5WX1	TURN LAMPS		12V 10WX4		

This list is only for reference; the parts are according to real vehicle.  
Any modification may be done without prior notice.

## SPECIFICATIONS

ITEM		VSG-D (IRS-EFI) 500 C.C.					
Dimension	Overall Length	2030 mm	Suspension System	Front	Double Arm		
	Overall Width	1250 mm		Rear	Double Arm		
	Overall Height	1300 mm	Tire Specifications	Front	AT 25X8-12		
	Wheel Base	1280 mm		Rear	AT 25X10-12		
	Wheel Tread	Front	1050 mm	Brake System	Front	Disk (∅200mm)X2	
		Rear	975 mm		Rear	Disk (∅180mm)	
	Curb Weight	Front	180 kg	Performance	Max. Speed	Above 70 km/hr	
		Rear	184 kg				
		Total	264 kg				
	Passengers/ Weight	Two / 150 kg	Transmission devices	Transfer	Shaft drive		
Total Weight	Front	220 kg		Shift lever	L, H, N, R		
	Rear	319 kg		Shift	Manual lever		
	Total	539 kg		Clutch type	Wet multi-plate		
Type	S.O.H.C.	Transmission	Continuously variable	Centrifugal type			
Fuel Used	Petrol	Speedometer	0 ~ 300 km/hr				
Cycle/cooling	4-Stroke/Water Cooled	Horn	93 ~ 112dB/A				
Engine	Cylinder	Bore	∅92 mm	Lubrication System		Pump forced circulation	
		Stroke	75.6 mm	Engine lubrication system		SAE 10W/40 SG/CC	
		Number/ Arrangement	Single Cylinder	Engine oil capacity		3.75L	
				Gear lubrication	Differential / Final Reduction device	Spec.	SAE 90#
	Capacity	450 c.c.					
	Displacement	502.56 cc	Exhaust Concentration	Solid Particulate			
	Compression Ratio	9.9:1		CO	Below 7.0g/ km		
	Max. HP	14.4kw / 5500rpm		HC	Below 1.5g/ km		
	Max. Torque	31.2Nm / 3600rpm		Nox	Below 0.4g/ Km		
	Ignition	Transistorized Ignition	Fuel Capacity		15±0.3L		
Starting System	Electrical / Recoil starter	Spark Plug		NGK CR7E			
Air Filtration	Sponge	Battery		12V 18AH			
LAMPS	FRONT LAMPS (HI / LO)	12V 55WX2 55WX2	BRAKE LAMPS		12V 21WX1		
	REAR LAMPS	12V 5WX1	TURN LAMPS		12V 10WX4		

This list is only for reference; the parts are according to real vehicle.  
Any modification may be done without prior notice.

## SPECIFICATIONS

ITEM		VSG-C 500C.C.				
Dimension	Overall Length	2060 mm	Suspension System	Front	Double Arm	
	Overall Width	1330 mm		Rear	Double Arm	
	Overall Height	1245 mm	Tire Specifications	Front	195/55 R15 85V/6.5×15	
	Wheel Base	1320 mm		Rear	205/55 R15 88V/6.5×15	
	Wheel Tread	Front	1862 mm	Brake System	Front	Disk (∅200mm)X2
		Rear	1903 mm		Rear	Disk (∅220mm)
	Curb Weight	Front	162 kg	Performance	Max. Speed	Above 92 km/hr
		Rear	168 kg			
		Total	330 kg			
	Passengers/ Weight	Two / 150 kg	Transmission devices	Transfer	Shaft drive	
Total Weight	Front	205kg		Shift lever	L, H, N, R	
	Rear	300kg		Shift	Manual lever	
	Total	505 kg		Clutch type	Wet multi-plate	
Type	S.O.H.C.	Transmission	Continuously variable	Centrifugal type		
Fuel Used	Petrol	Speedometer	0 ~ 300 km/hr			
Cycle/cooling	4-Stroke/Water Cooled	Horn	93 ~ 112dB/A			
Engine	Bore	∅92 mm	Lubrication System		Pump forced circulation	
		Stroke	75.6 mm	Engine lubrication system		SAE 10W/40 SG/CC
	Number/ Arrangement	Single Cylinder	Engine oil capacity		3.8L	
			Gear lubrication	Differential / Final Reduction device	Spec.	SAE 90#
	Capacity	450 c.c.				
	Displacement	502.56 cc	Exhaust Concentration	Solid Particulate		
	Compression Ratio	9.9:1		CO	Below 7.0g/ km	
	Max. HP	14.8kw / 7000rpm		HC	Below 1.5g/ km	
	Max. Torque	33.3Nm / 5000rpm		Nox	Below 0.4g/ Km	
	Ignition	C.D.I.	Fuel Capacity		15±0.3L	
Starting System	Electrical / Recoil starter	Spark Plug		NGK CR7E		
Air Filtration	Sponge	Battery		12V 18AH		
LAMPS	FRONT LAMPS (HI / LO)	12V 55WX2 55WX2	BRAKE LAMPS		12V 21WX1	
	REAR LAMPS	12V 5WX1	TURN LAMPS		12V 10WX4	

This list is only for reference; the parts are according to real vehicle.  
Any modification may be done without prior notice.

## SPECIFICATIONS

ITEM		VSG-C (EFI) 500 C.C.				
Dimension	Overall Length	2060 mm	Suspension System	Front	Double Arm	
	Overall Width	1330 mm		Rear	Double Arm	
	Overall Height	1245 mm	Tire Specifications	Front	195/55 R15 85V/6.5×15	
	Wheel Base	1320 mm		Rear	205/55 R15 88V/6.5×15	
	Wheel Tread	Front	1862 mm	Brake System	Front	Disk (∅200mm)X2
		Rear	1903 mm		Rear	Disk (∅220mm)
	Curb Weight	Front	162 kg	Performance	Max. Speed	Above 70 km/hr
		Rear	168 kg			
		Total	330 kg			
	Passengers/ Weight	Two / 150 kg	Transmission devices	Transfer	Shaft drive	
Total Weight	Front	205kg		Shift lever	L, H, N, R	
	Rear	300kg		Shift	Manual lever	
	Total	505 kg		Clutch type	Wet multi-plate	
Type	S.O.H.C.	Transmission	Continuously variable	Centrifugal type		
Fuel Used	Petrol	Speedometer	0 ~ 300 km/hr			
Cycle/cooling	4-Stroke/Water Cooled	Horn	93 ~ 112dB/A			
Engine	Bore	∅92 mm	Lubrication System		Pump forced circulation	
		Stroke	75.6 mm	Engine lubrication system		SAE 10W/40 SG/CC
	Number/ Arrangement	Single Cylinder	Engine oil capacity		3.8L	
			Gear lubrication	Differential / Final Reduction device	Spec.	SAE 90#
	Capacity	450 c.c.				
	Displacement	502.56 cc	Exhaust Concentration	Solid Particulate		
	Compression Ratio	9.9:1		CO	Below 7.0g/ km	
	Max. HP	14.4kw / 5500rpm		HC	Below 1.5g/ km	
	Max. Torque	31.2Nm / 3600rpm		Nox	Below 0.4g/ Km	
	Ignition	Transistorized Ignition	Fuel Capacity		15±0.3L	
Starting System	Electrical / Recoil starter	Spark Plug		NGK CR7E		
Air Filtration	Sponge	Battery		12V 18AH		
LAMPS	FRONT LAMPS (HI / LO)	12V 55WX2 55WX2	BRAKE LAMPS		12V 21WX1	
	REAR LAMPS	12V 5WX1	TURN LAMPS		12V 10WX4	

This list is only for reference; the parts are according to real vehicle.  
Any modification may be done without prior notice.

# IMPORTANT IDENTIFICATION NUMBERS

## 1. Chassis Number:

Record chassis and engine number for future reference.

Number is located front right hand side of chassis as shown in (1).

## 2. Engine number is located front of the engine as shown in (2).

## 3. Manufacturer's DATA PLATE

The manufacturer's data plate is located front right hand side of chassis as shown in (3)

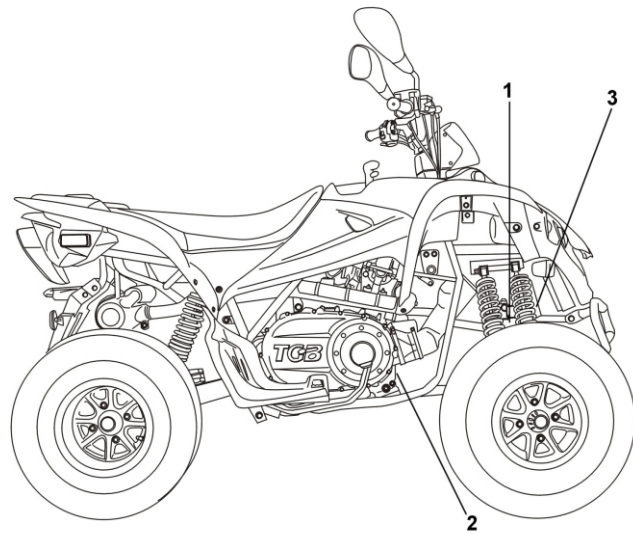

# WARNING LABELS:

- Before riding thoroughly read these labels of essential safety operation instructions.
- Do not tear off stickers. In case of wear or damage contact your dealer for replacements.

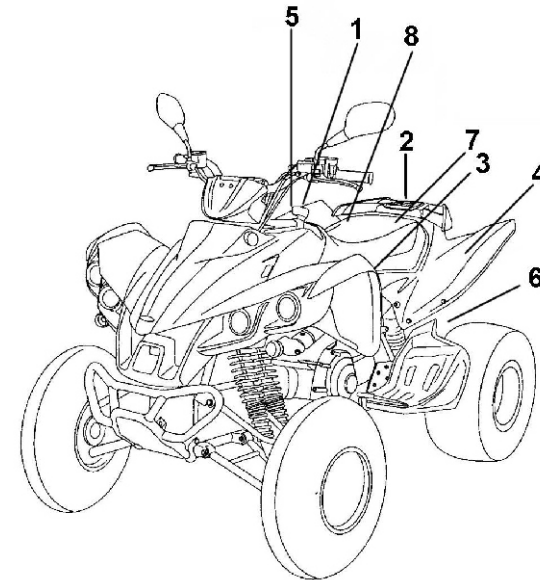

**1**

**WARNING**

**10**

Operating this ATV if you are under the age of 16 increases your chance of serious injury or death.

**NEVER** operate this ATV if you are under age 16.

**5**

**WARNING**

Failure to check vehicle capability before being towed could result in your being thrown from the ATV.

**TO engage reverse range:**

- Stop vehicle completely.
- Do not revolve in reverse.
- Fully set the hand or foot brake.
- Shift to gear lever fully to R position.

**TO engage 10-4th range:**

- Do not shift vehicle.
- Do not revolve in 10-4th playing terrain.

Handling, Forward Riding, Turnings, Slowing, and Combining. Refer to Owner's Guide for more information.

**2**

**WARNING**

**MAXIMUM LOAD: 50kg (110lbs)**

**6**

**WARNING**

An accident might occur while exceeding vehicle towing limit. Read owner's guide for details.

Towing weight should be within 10% of the rated trailer weight limit and should not be over 20kg (44 lbs).

**MAXIMUM TOWING CAPACITY: 20kg (44 lbs)**

**3**

**WARNING**

Improper ATV use can result in SEVERE INJURY or DEATH.

**DO NOT OPERATE THIS ATV IN THE FOLLOWING SITUATIONS:**

- When a user is using a motor vehicle to tow the ATV.
- Do not operate the vehicle on uneven or rough terrain.
- Do not operate the vehicle on steep slopes or open areas where it may fall.

**ALWAYS:**

- Use proper riding techniques in use of vehicle dependent on size and roughness of terrain.
- Do not operate the vehicle on steep slopes or open areas where it may fall.

**READ OWNER'S MANUAL, FOLDING AND UNFOLDING AND WARNING.**

**7**

The owner's manual contains important safety information and instructions which should be read carefully before operating the vehicle. If the vehicle has been repaired, consult the owner's manual from the previous owner or contact your local TSB dealer for assistance.

**4**

**WARNING**

Failure to properly use the vehicle could result in SEVERE INJURY or DEATH.

**NEVER** operate the vehicle on steep slopes or open areas where it may fall.

**NEVER** operate the vehicle on steep slopes or open areas where it may fall.

**NEVER** operate the vehicle on steep slopes or open areas where it may fall.

**8**

Failure to properly use the vehicle could result in SEVERE INJURY or DEATH.

**NEVER** operate the vehicle on steep slopes or open areas where it may fall.

**NEVER** operate the vehicle on steep slopes or open areas where it may fall.



## GENERAL ILLUSTRATION

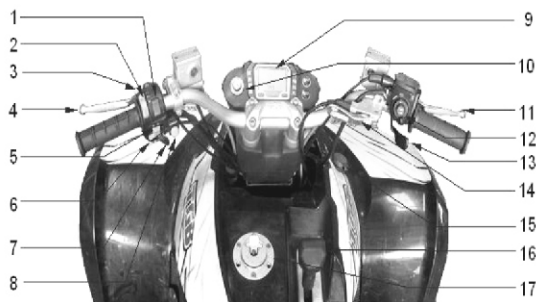

- |   |                          |
|---|--------------------------|
| 1. Hazard Lights                              | 9. Speedometer & Display |
| 2. High/Low Beam Switch                       | 10. Ignition Switch      |
| 3. Starter Switch                             | 11. Front Brake Lever    |
| 4. Rear Brake Lever                           | 12. 2D/4D/LOCK Switch    |
| 5. Winker Switch                              | 13. Throttle             |
| 6. Horn                                       | 14. Parking Brake        |
| 7. Choke Lever<br>(For Carburetor model only) | 15. Power Source         |
| 8. Over-ride                                  | 16. L/H/N/R Lever        |
|   | 17. Fuel Tank            |

## OPERATION INDICATIONS

### 1. Ignition Switch Function / Position

Position	Function	Key Out
	Position Lamp	NO
ON	All electrical systems operational	NO
OFF	While parking	YES



### 2. Signs and Functions

Position	Name	Function
	Starter Switch	Start engine
	Dimmer Switch	Hi-Beam/Lo-Beam Switch
	Hazard Warning	Continues flash
	Turn Signal Switch	Right/Left-hand direction
	Horn	Sounded by pushing
	Choke Lever	Use in low temperature



※ This vehicle is equipped with a safety protection system, to start the engine must be brake applied.

## REMOVE THE FUNCTION OF OVER-RIDE

1. Set the shift gear at "R", then press over-ride button (keep press the button)
2. As you move your finger away from over-ride button, the speed will be limited again when reverse.



function of over-ride

## 3. BRAKE LEVER

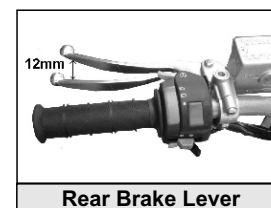

Rear Brake Lever

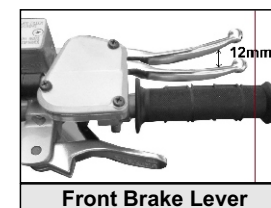

Front Brake Lever

**Attention:** Before each journey check whether the accustomed resistance exists with activity of the brake at the brake lever. Also check there is sufficient quantity of brake fluid in the reservoir.

**Attention:** Before each trip check the brake actuating system. The gap of the brake lever end should be 12 mm approximately. Inform your local dealer of possible deviations.

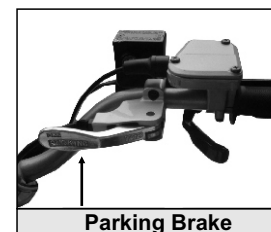

Parking Brake



Brake Fluid Level

**Attention:** Irregularities of brakes such as leaks and poor performance should only be dealt with by an authorised dealer.

The brake fluid level must be above the MIN mark. If the level keeps going down have an authorised dealer check it.

Always use DOT #4 brake fluid.

#### 4. REAR BRAKE PEDAL



By pressing the rear brake pedal will activate the rear brakes.

**NOTE:** By squeezing the rear brake lever may also activate the rear brake pedal.

#### 5. SHIFT LEVER

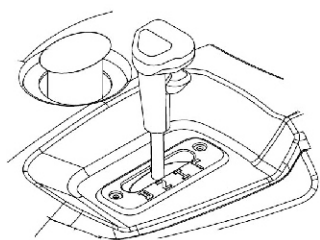

L:High torque use (advance gear)  
H:Normal use (driving gear)  
N:Parking use (Neutral)  
R:Reverse use

##### Shift lever instructions:

1. Engine starts only in Neutral (N) position
2. Engage a brake and push the knob in and move the shift lever from N to H, L or R (L Shift is used for rough surfaces)  
**※Shifting H to L and any gear/direction the vehicle must be at a complete stand still**
3. For reverse, with the brake on, push the knob in and move the shift lever from N to R

**Notice:Operating the shift lever when vehicle is moving can be hazardous. This is strictly prohibited.**  
**Always wait till the vehicle stops completely, do not operate the ATV at high speed in reverse under any circumstances**

#### 6. 2WD/4WD/LOCK SELECT BUTTON

The 2WD/4WD/LOCK SELECT BUTTON is for the use of changing the engine power engages on the wheels.

You can select 2WD, 4WD or LOCK for different road conditions.



Picture 1



Picture 2

2WD : Engage the engine power on the rear wheels only.

This is mainly use for normal riding.

4WD : Engage the engine power on both front and rear wheels with differential function.

There is a slip limited gear assy. inside the front differential can engage the right and left front wheels at different speeds. This provides much more traction than 2WD and should be used when riding on wet and slippery surfaces.

LOCK : Engage the engine power on both front and rear wheels without differential function. This provides all traction to four wheels and should be used when two or more wheels skid.

Shifting the 2WD/4WD/LOCK button :

1. Stop the vehicle completely.
2. Without Lock system: Shift the transfer lever to the preferred position (refer to picture 1).
3. With Lock system: (refer to picture 2)

##### 3-1. 4WD Mode:

Press the button to change mode from 2WD to 4WD and the indicator lamp will ON at dashboard in 4WD mode.



##### 3-2. Lock Mode:

Always follow the sequence 2WD→4WD→Lock to operate the button. When engage the lock functions, it should press the button to 4WD mode then shift the lock lever to the "LOCK" position and the indicator lamp will ON at dashboard in LOCK mode.



Note: During 2WD mode, lock button without function.

3-3. Release lock function:

To unengaged the lock function, always backward the sequence of 3-2 from LOCK→4WD→2WD.

### WARNING

Press the button when ATV is moving can be extremely dangerous can lose control while riding with a hand removed from the handlebar. The gear box mechanism can be damaged if pressing the shifting button when the ATV is in motion.

Always stop the ATV completely before shifting between 2WD, 4WD and LOCK.

## 7. RECOIL STARTER ( For Carburetor model only)



In case the vehicle does not start with the electric starter, the emergency recoil starter can be used to start the engine. To use the recoil starter, shift to neutral (N) and grip the starter rope-handle, which is on the engine magneto cover. Pull the rope until you feel the starter engage. Pull the rope forcefully to start the engine.

At the moment the engine starts, be sure to return the starter rope to its prior normal position.

### NOTE:

Switch off the headlights when starting the engine with the recoil starter.

## 8. TIRE



**Attention:** The vehicle is equipped with tubeless tyres. Tubeless tyres should never be repaired. Damaged tyres have to be renewed immediately.

**Attention:** Your authorised dealer should only renew tubeless tyres. Since the tyre pressure influences the driving ability, the mandatory tyre pressure should always be maintained. You should determine outer damages of tyres. The suggested minimum profile depth is 3mm; change the tyre immediately if below 3mm.

※ Tire pressure: 7 psi/26 psi for VSG-C

## 9. CHECK COOLANT RESERVE TANK



Check the coolant level in the front left side mudguard.

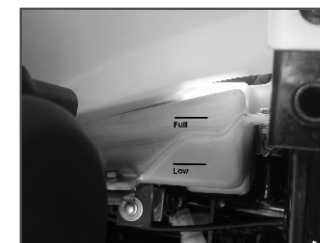

Add coolant to proper level if too low.

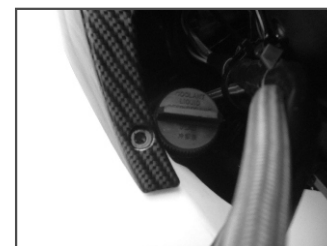

- Remove the front reserve tank cover, and then remove reserve tank filler cap.
- Reinstall the reserve tank filler cap.

### ▲ Caution

The reserve coolant tank level should not be over filled to avoid expansion when hot.

## 10. STEERING LOCK



The steering lock in principle should be used for theft protection. The handle bar is to be turned to the left and the key in the steering lock pressed and turned simultaneously (see illustration).

## 11. SPEEDOMETER AND DISPLAY DIGITAL TYPE

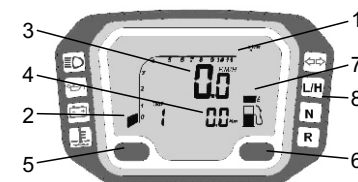

### PANEL DESCRIPTIONS

- |  |                              |
|--|------------------------------|
| 1. Tachometer Scale                                  | 5. RESET Button              |
| 2. Bar Tachometer                                    | 6. MODE Button               |
| 3. 1st row display: Speedometer and MAX speedometer. | 7. Fuel Meter Bar (Optional) |
| 4. 2nd row display: Other functions                  | 8. LED Indicator symbols     |

	Main-Beam Headlamp/Blue		Left-Direction Indicator/Green
			Right-Direction Indicator/Green
	Engine oil indicator	L/H	Drive Gear/Green
	Battery charge indicator	N	Neutral Gear/Green
	Engine Coolant Temperature/Red	R	Reverse Gear/Red

1. Engine oil indicator (Red): if this light turns on, please check if is enough engine oil, otherwise, please contact with your local dealer for inspection.
  2. Temperature indicator (Red): if lights turn on with engine running, implies cooling system problem. Please contact with your local dealer for inspection
  3. Battery charge warning light: if the light turns on while engine running, implies malfunction of battery system. Please contact with your local dealer for inspection
- ※When turn on ignition switch, engine oil indicator/ temperature indicator/ battery indicator will self-diagnostic, if this process is not found, could be some malfunction. Please contact with your local dealer for inspection
4. Turn signal light (green): on use of turn signal, lights will flash and audible warning  
Hazard warning: left/right light will flash and audible warning

#### Warning :

1. Engine oil warning light will light up when low on oil. Please proceed to fill with TGB special oil, after filling up, warning light will turn-off. Please always ride the vehicle with the engine oil warning light off, otherwise, it will cause damage to the engine.
2. If will cause severe damage to the engine if engine keep running under overheating circumstances

## FUNCTIONS

### BAR RPM: Bar Graphic Tachometer

1. The bar graphic tachometer reading is always displayed at the bar graph.
2. Tachometer bar graphic displays up to 11,000 RPM.

### RPM: Digital Tachometer

1. RPM is displayed in 2nd row.
2. Digital tachometer displays up to 19,900 RPM.
3. Tachometer signal picked up from either CDI or Ignition coil.

### Shift Warning RPM

1. Function enables you to set up an RPM shift warning.
2. Bar-graphic tachometer flashes when RPM reaches pre-set value, and stops flashing after you shift gear.

### MAX RPM: Maximum Tachometer

1. MAX RPM is displayed on 2nd row.
2. Displays highest tachometer reading achieved after last RESET operation.

### SPD: Speed Meter

1. Speed meter display is on 1st row of the screen.
2. Displays speedometer reading up to 300.0 Km/H or 187.5 mph.

### MAX: Maximum Speed Meter

1. MAX is displayed on 1st row.
2. Displays highest speed achieved after last RESET operation.

### AVG: Average Speed Meter

1. AVG is displayed on 2nd row.
2. Calculates average speed from last RESET.

### TRIP 1 & 2: Trip Meter 1 & 2

1. TRIP function registers cumulative trip distance from last RESET while bike is being ridden.
2. Display is on 2nd row of screen.

### ODO: Odometer

1. ODO registers cumulative distance traveled during motorbike operation.
2. ODO data is stored in memory, even when power is off.

### RT: Riding Timer

1. Calculates total operation time from last RESET.
2. Count automatically begins with vehicle movement.

### TT: Total Riding Timer

1. Calculates total operation time from the beginning of bike use.
2. Count automatically begins with vehicle movement.
3. TT data is stored in memory, even when power is off.

### 12/24 hour Clock

It displays 12- or 24-hour current time.

### Fuel Meter (Only for models with the function)

1. Has 7 bargraphic indicator of fuel status.
2. Last bar flashes to indicate low fuel level.

## BUTTON OPERATIONS

### MODE BUTTON

1. Press the MODE button to move all functions in loop sequence from one function screen to another when the speed sensor does not detect any signal input.

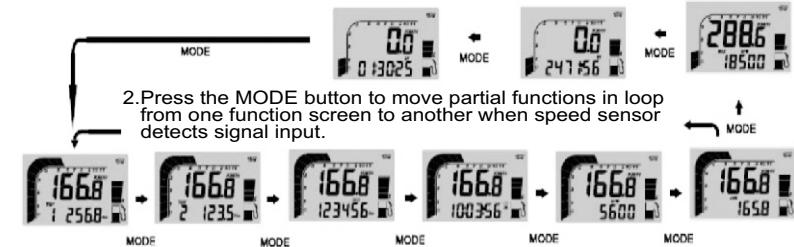

### RESET BUTTON

1. Press MODE button to the desired screen then press RESET button for 2 seconds to reset TRIP 2, MAX, and MAX RPM data from stored values to zero individually.
2. The data of Trip 1, AVG & RT is reset at the same time when one of the 3 data functions is being reset.
3. ODO, clock and TT data cannot be reset.



### SHIFT RPM WARNING OPERATION

1. Press MODE button to the RPM screen; pull on the throttle until the desired shift RPM warning displayed.
2. Press RESET button to confirm and set up the shift warning RPM.
3. Bar-graphic tachometer will flash to warning you shift gear.
4. Operate items 1 & 2 to readjust the shift warning RPM.

## UNIT & WHEEL CIRCUMFERENCE SETTING

1. Setup operations include 12/24hour clock, shift warning RPM, numbers of engine rotation per signal, wheel circumference and units. These must be set up step by step. The computer will automatically revert to main screen if no button operation for 75 seconds at any setting screen.
2. Press both MODE & RESET buttons to go into setting screen. In setting screens, press RESET button to add the flashing digit by 1 or convert units, press MODE button to confirm the digit setting and jump to next digit or next setting screen to be set. Press MODE button for 2 seconds at any setting screen to finish the setting and go to main screen.
3. It displays "12 or 24H and XX:XX-XX" symbols and AM/PM in case you select 12H.
4. Press RESET button converts 12/24H, press MODE button to complete the setting and jump to clock digit setting.
5. Press RESET button to increase flashing digit by one; press MODE button to confirm digit setting and jump to next digit.

6. Press MODE button to go to shift warning RPM setting screen after set clock.
  7. It displays " RPM rXXX00 ". Press RESET button to increase flashing digit by one; press MODE button to confirm digit setting and jump to next digit.
  8. Press MODE button to go to numbers of engine rotation per signal setting screen after completed shift warning RPM setting.
  9. It displays "SPC-X.X RPM", the default value is 1.0; there are 4 options: 1.0, 2.0, 3.0 and 0.5. It means the numbers of engine rotation per signal.
- For example the value 2.0 means the engine rotate 2 turns to output a signal.
10. Press RESET button to move in loop sequence from one to another value of the 4 values. Press MODE button to confirm the setting and go to wheel circumference setting screen.
  11. In "cXXXX" display, "c" means "Circumference", following 4 default digits; flashing digit is digit to be set.
  12. Press RESET button to increase flashing digit by one; press MODE button for 2 seconds to confirm digit setting and jump to main screen.

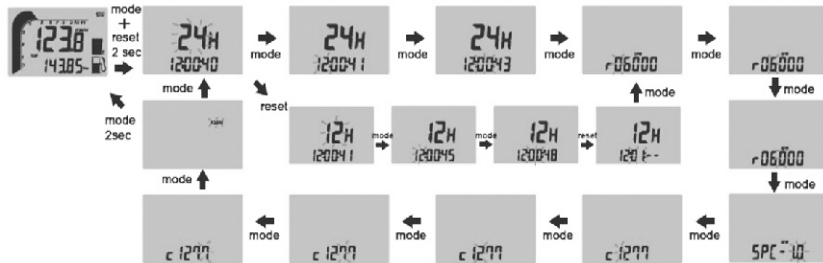

## SPEEDOMETER FOR EFI MODEL



### PANEL DESCRIPTIONS

- |  |                          |
|--|--------------------------|
| 1. 1 <sup>st</sup> row display: Speedometer and MAX speedometer. | 4. LED Indicator symbols |
| 2. 2 <sup>nd</sup> row display: Other functions.                 | 5. MODE Button           |
| 3. Fuel Meter bar (Optional).                                    | 6. SET Button.           |

	Main-Bean Headlamp/Blue		Turn single indicator/ Green
	Engine oil indicator/Red		Drive Gear/ Green
	Battery charge indicator		Neutral Gear/ Green
	Engine coolant Temperature/ Red		Reverse Gear/ Green
	Engine check / Yellow (EFI model)		

1. Engine oil indicator (Red): if this light turns on, please check if it is enough engine oil, otherwise, please contact with your local dealer for inspection.
  2. Temperature indicator (Red): if light turn on with engine running, implies cooling system problem. Please contact with your local dealer for inspection.
  3. Battery charge warning light: if the light turns on while engine running, implies malfunction of battery system. Please contact with your local dealer for inspection.
- ※When turn on ignition switch, engine oil indicator/temperature indicator/battery indicator will self-diagnostic, if this process is not found, could be some malfunction. Please contact with your local dealer for inspection.
4. Turn signal light (Green): on use of turn signal, lights will flash and audible warning.  
Hazard warning: left/right light will flash and audible warning.
  5. Engine check light (Yellow): if this light turns on, please contact with your local dealer for inspection.

#### Warning:

1. Engine oil warning light will light up when low on oil. Please proceed to fill with TGB special oil, after filling up, warning light will turn-off. Please always ride the vehicle with the engine oil warning light off, otherwise, it will cause damage to the engine.
2. If will cause severe damage to the engine if engine keep running under overheating circumstances.

## FONCTIONS

### MAX RPM: Maximum Tachometer

1. MAX RPM is displayed on 2nd row.
2. Displays highest tachometer reading achieved after last RESET operation.

### SPEED: Speed Meter

1. Speed meter display is on 1st row of the screen.
2. Displays speedometer reading up to 300.0 Km/H or 187.5 MPH.

### MAX SPEED: Maximum Speed Meter

1. MAX is displayed on 1st row.
2. Displays highest speed achieved after last RESET operation.

### SPEED AVG: Average Speed Meter

1. AVG is displayed on 2nd row.
2. Calculates average speed from last RESET.

### TRIP A & TRIP B: Trip Meter A & B

1. TRIP function registers cumulative trip distance from last RESET while bike is being ridden.
2. Display is on 2nd row of screen.

### ODO: Odometer

1. ODO registers cumulative distance traveled during motorbike operation.
2. ODO data is stored in memory even when power is off.

### RT: Riding Timer

1. Calculates total operation time from last RESET.
2. Count automatically begins with vehicle movement.

### TT: Total Riding Timer

1. Calculates total operation time from the beginning of bike use.
2. Count automatically begins with vehicle movement.
3. TT data is stored in memory even when power is off.

### Fuel Meter (Only for models with the function)

1. Have 7 bar graphic indicator of fuel status.
2. Last bar flashes to indicate low fuel level.

## BUTTON OPERATIONS

### MODE BUTTON

1. Press the MODE button to move all functions in loop sequence from one function screen to another.

ODO → RPM → TRIP A → TRIP B → MAX SPEED → SPEED AVG → RT → TT → MAX RPM → TIME → ODO

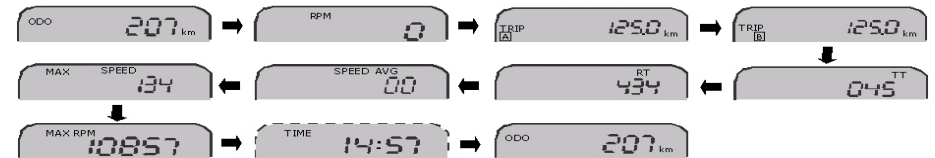

2. Press MODE for 10 seconds to change the display for KMH or MPH.

### RESET FUNCTION

1. Press MODE to the desired screen then press MODE and SET button simultaneously for 6 seconds to reset the data from stored values to zero. Each reset are individually, including TRIP A, TRIP B, RT, AVG SPEED, MAX SPEED and MAX RPM.
2. ODO, Clock and TT data cannot be reset.



### TIME FUNCTION

1. Press MODE to the (ODO screen for TYPE I or TIME screen for TYPE II) then presses MODE and SET button simultaneously for 3 seconds to set up the time.
2. When the digit is blinking, press SET button to desire digit then press MODE button to set up and jump to next digit.
3. After the time setting, press MODE and SET button simultaneously for save and back to ODO screen.
4. During setting, if the digit did not change over 10 seconds, the setting will auto save and back to time screen.
5. When speed over 10km/hr, the setting will save automatically.

10:25

## WHEEL CIRCUMFERENCE

1. Key OFF.
2. Press MODE button and permanently.
3. Key ON and press SET button to wheel circumference screen.
4. In "cXXXX" display, "c" means "Circumference", following 4 default digits; flashing digit is digit to be set



5. When the digit is blinking, press SET button to desire digit then press MODE button to set up and jump to next digit.
6. Press MODE for 3 seconds for saving the set up.
7. During setting, if the digit did not change over 10 seconds, the setting will auto save and back to ODO screen.

## SPEEDOMETER AND DISPLAY MECHANICAL TYPE

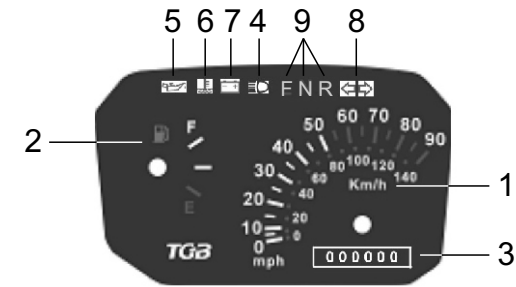

1. Speedometer
2. Fuel meter
3. Odometer
4. Hi-beam signal light (Blue): will turn on when use Hi-beam light
5. Engine oil indicator (Red): if this light turns on, please check if is enough engine oil, otherwise, please contact with your local dealer for inspection.
6. Temperature indicator (Red): if lights turn on with engine running, implies cooling system problem. Please contact with your local dealer for inspection
7. Battery charge warning light: if the light turns on while engine running, implies malfunction of battery system. Please contact with your local dealer for inspection
- ※When turn on ignition switch, engine oil indicator/ temperature indicator/ battery indicator will self-diagnostic, if this process is not found, could be of some malfunction. Please contact with your local dealer for inspection
8. Turn signal light (green): on use of turn signal, lights will turn on and audible warning Hazard warning: left/right light will flash and audible warning
9. Shifting instruction light

### WARNING :

1. Engine oil warning light will light up when low on oil. Please proceed to fill with TGB special oil, after filling up, warning light will turn-off. Please ride the vehicle with the engine oil warning light off, otherwise, it will cause damage to the engine.
2. If will cause severe damage to the engine if engine keep running under overheating circumstances



## 12. MAINTENANCE SCHEDULE

- ⊙ The below maintenance schedule is established by months, Kilometers and Miles and are dependent on which ever comes first.
- ⊙ Have your vehicle checked, adjusted, and recorded maintenance data by TGB dealer to maintain the ATV at the optimum condition.
- ⊙ Use the chart below for necessary service work to keep the vehicle operating at peak performance and economy. **Periodical Maintenance Schedule**

### PERIODICAL MAINTENANCE SCHEDULE

INTERVAL ITEM	MONTHS	1	3	6	12
	Kms	INITIAL 200	EVERY 1000	EVERY 2000	EVERY 4000
	MILES	INITIAL 120	EVERY 600	EVERY 1200	EVERY 2400
Muffler Bolts and Exhaust Pipe Nuts		T	T	T	T
Valve Clearance		I	-	I	I
Air Cleaner		-	C	C	R
Engine Idle RPM		I	I	I	I
Spark Plus		-	-	I	I
		Replace Every 6000KM (4000 MILES)			
Engine Oi		R	-	R	R
Oil Filter		R	-	R	R
Front Differential Set Oil		R	-	R	R
		Replace Every 6000KM (4000 MILES)			
Final Gear Oil		R	-	R	R
		Replace Every 6000KM (4000 MILES)			
C.V.T Belt		-	-	I	I
Fuel Tube		-	-	I	I
		Replace Every 4 Years			
Throttle Cable Play		I	I	I	I
Brakes		I	I	I	I
Brake Hose		-	-	I	I
		Replace Every 4 Years			
Brake Fluid		-	I	I	I
		Replace Every 2 Years			
Tires		-	I	I	I
Suspensions		-	-	I	I
Steering System		I	I	I	I
Chassis Bolts and Nuts		T	T	T	T
General Lubrications		-	L	L	L
Grease nipple(Universal Joint Assy)		-	-	L	L

※ Fuel Filter (EFI Model)

Replace Every 2 Years

L: Lubricate C:Clean R: Replace T: Tighten I: Inspection, cleaning and adjustment

Have your ATV serviced and checked by an Authorised TGB Dealer. Ensure the service book is stamped and signed. Failure to do so could invalidate your warranty.

The maintenance schedule is established by taking the monthly 1000 kilometers as a reference which ever comes first.

#### REMARKS:

- 1.Clean or replace the air cleaner element more often when the ATV is operated in dusty conditions or in a heavily polluted environment.
- 2.Maintenance should be performed more often if the ATV is frequently operated in high speed and after the ATV has accumulated a higher mileage.
- 3.Preventive maintenance
  - a.Ignition system - perform maintenance and check when continuous abnormal misfire, after-burn, and overheating occurs.
  - b.Carbon deposit removal – remove carbon deposits in cylinder head, piston and exhaust system when power is obviously lower than normal.

## 13. SPARK PLUG

Recommended spark plug: CR7E. Remove spark plug cap. Clean dirt around the spark plug hole. Remove spark plug. Measure spark plug gap.

**Spark plug gap:0.7~0.8 mm**

Carefully bend ground electrode of the plug to adjust the gap if necessary.

Hold spark plug washer and install the spark plug by screwing it.

Tighten the plug by turning 1/2 turn more with plug socket after installed.

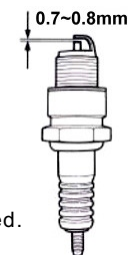

## 14. AIR CLEANER

Remove seat.

Loosen 4 hooks from the air cleaner cover and then remove the cover.

Loosen the clamp strip and 1 screw of air cleaner element, and then remove the air cleaner element. Clean the element with non-flammable or high-flash point solvent and then squeeze it completely dry.

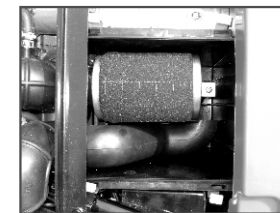
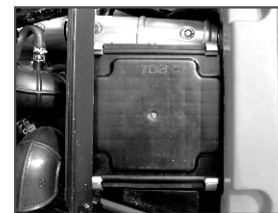

## 15. CARBURETTOR IDLE SPEED ADJUSTMENT (For Carburetor model only)

Set the parking brake.

Shift the transmission to neutral.

Warm up engine.

Connect tachometer (the wire clamp of tachometer is connected to the high tension cable).

Turn the throttle valve stopper screw to specified idle speed.

Specified idle speed: ATV400:1700±100 rpm/ATV500:1500±100rpm

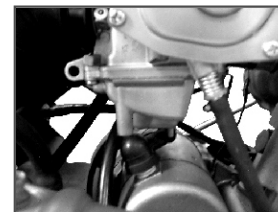

※ For EFI Model, Please contact your local dealer for idle adjustment.

## 16. ENGINE OIL

Turn off engine, and park the ATV in flat surface with parking brake.

Check oil level with oil dipstick.

Do not screw the dipstick into engine when checking. If oil level is low level, fill with recommended oil to upper level.

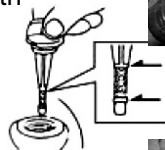

## OIL CHANGE

Place an oil pan under the ATV and remove oil drain plug.

After drained, make sure washer can be re-used. Install oil drain plug to a satisfactory torque.



## ENGINE OIL FILTER CHANGE

Drain engine oil out.

Install oil Filter to a satisfactory torque.

Add oil to crankcase (oil viscosity SAE 10W-40)

**Engine oil capacity: 3500 / 3750c.c. when replacing**

Install dipstick, start the engine for several minutes.

Turn off engine and check oil level again.

Check for any engine oil leaks.



## 17. GEAR OIL

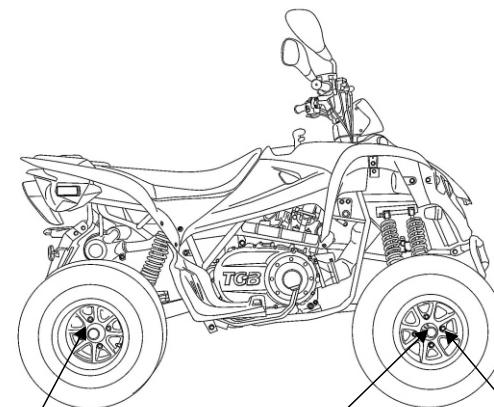

Rear Differential



Front Differential

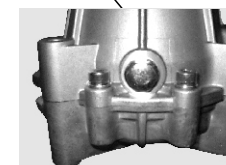

## Gear Oil Change

Remove oil filler bolt.

Remove drain plug and drain gear oil out.

Install the drain plug to a satisfactory torque.

Make sure that the drain bolt washer can be re-used or re-place.

Add oil to specified quantity.

## Gear Oil Quantity: 300~350 ml. (IRS 450ml) When replacing

Make sure that the filler bolt washer can be re-used or re-place and install the bolt to a satisfactory torque.

(oil viscosity SAE 90#)

Start engine and run engine for 2-3 minutes.

Turn off engine and make sure that oil level is correct.

Check for any leaks.

## 18. SEAT-LOCK



Removal of seat: After opening the lock by turning the key the seat can be removed by pressing the seat-lock and lifting the seat at the rear.

Assembly of seat: Put the seat into the front guide and press the rear down until it latches.

Take care with assembly of the seat that you don't squash or damage the electric cables.