

and control available in the area was inadequate; furthermore, the studies were of a general reconnaissance nature. After considering these factors it was decided to determine the vertical scale of the oblique photographs by measuring the bluff height on the vertical photographs with a stereometer. As the face of the bluff or cut was not always parallel to the flight direction of the plane, at least two measurements of the bluff height were made within the field of each oblique (Figure 10). This general procedure worked well in this particular project as the project was large enough to justify the use of specially equipped aircraft. For smaller projects, however, and for projects requiring a higher degree of precision, other procedures must be developed. The most promising involves terrestrial photogrammetry. There is a definite need for a light portable camera having stable metric characteristics. This camera should be designed to permit attachment to a very light theodolite or telescopic alidade or to be used independently.

Geology is an earth science. Its very nature precludes its being divorced wholly from field investigation. However, some geologic problems, such as structure contouring in well-exposed areas, lend themselves in large part to solution by photogrammetric and photointerpretation methods. The photogrammetric instruments now available are adequate for solution of such problems. Other geologic studies such as those associated with intensive geologic investigation of mineralized areas must be performed, in large part, by field methods. Parts of such investigations, however, may be expedited by the use of photogrammetry. The use of photogrammetry under such conditions can be increased by designing equipment which can be used under field conditions and which can be successfully operated by men with little photogrammetric training. Such instruments will hasten the full acceptance of photogrammetry as a valuable tool in the study of geology.

## NEW ASPECTS OF MONO-PHOTOGRAMMETRY\*

*Heinz Gruner, Scientific Bureau, Bausch & Lomb Optical Co.,  
Rochester, New York*

### INTRODUCTION

HAVING chosen the subject Mono-Photogrammetry for today's discussion I do not wish to give the impression that I am discussing something basically new. If we look through the early photogrammetric literature before the first World War, we find that several authors have concerned themselves with the theory and some practical applications of Mono-Photogrammetry. The Austrian Professor Zaar has given the theory in one of the volumes of the *International Archives of Photogrammetry*. Since then little has been heard of this subject which in the quoted literature was named "Mirror photogrammetry." In more recent text books<sup>1</sup> we find remarks on the possibility of using mirror images for photogrammetric measurements.

In view of the advancement of our science during the last 40 years, and particularly in view of the achievements in the optical and mechanical fields, it seems appropriate that we review the subject of Mono-Photogrammetry and try to visualize what the advanced technology has to offer to this field of endeavor.

\* Presented at Semi-Annual Meeting of the Society, in Philadelphia, Pa., Sept. 16, 1954.

<sup>1</sup> O. Lacmann: Die Photogrammetrie in ihrer Anwendung auf nichttopographischen Gebieten.

or. There are two optical components now at our disposal which are capable of changing the aspects of Mono-Photogrammetry very greatly: 1) The wide-angle lens covering a field of 90 degrees and recently being practically free from radial distortion; it has almost completely replaced the old time photogrammetric lenses which covered at the best 60 degrees. 2) The photogrammetric projector which was unknown 40 years ago and is now available in a variety of forms and optical properties for the evaluation of pairs of photograms. In addition we have comparators and stereocomparators for sizes of pictures and measuring ranges much larger than 3-4 decades ago. We now have better and faster working computing equipment for the analytical treatment of the data extracted from the photograms. And finally we have entirely new working materials which may be employed for the physical reconstruction of the objects under test. All these improvements present a challenge to us to reconsider and to re-investigate the potentialities of Mono-Photogrammetry. The prospects are that we may discover new and unlimited fields of application in arts and sciences, in research laboratories, in the industry and in organizations concerned with investigations.

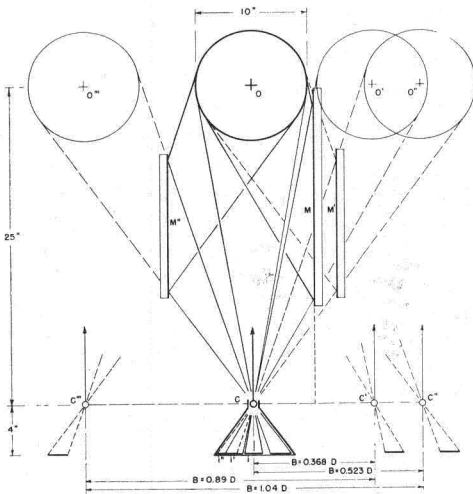

FIG. 1.—Geometrical relationships between real and apparent photostation and object using mirrors parallel with the exposure axis.

stereoscopy. At first thought this statement may seem to be contradictory, as we know that for the three-dimensional perception of a photographed object two exposure stations separated by a certain distance are necessary. In the familiar field of aerial photogrammetry the two aerial exposure stations are separated by the aerial base, from which the object, the earth's surface, is being photographed. If it were possible to transfer this stereoscopic base into the object space, to place the object at one end, and an identical replica of it at the other end of the base, then one single exposure station would suffice to produce a photographic record which can be investigated three-dimensionally. The practical realization of this problem is achieved by placing a reflecting surface into the object space in close proximity to the object itself. This naturally limits the matter of investigation to small dimensions and places it within finite distance of the recording camera. Consequently Mono-Photogrammetry belongs in the province of terrestrial photogrammetry, and more specifically in the region of short range photogrammetry.

#### BASIC GEOMETRY

Figure 1 is a presentation in plan of the relationship between object space and camera station. The circle of 10 inches diameter denotes the base of a cylindrical space above it. Into this space the matter of investigation may be placed. The object of investigation may be alive or dead. It may have a solid shape or may

be in a transitory state. It may be permanent or existent only for the duration of a millisecond. It may be self-luminous or require artificial illumination. It may require a time or an instantaneous exposure, or multiple exposures. In other words it may be any matter or phenomenon of which the shape or trace of movement can be recorded through a lens and by a photographic emulsion.

At a distance of approximately 30 inches = 750 mm. the photogrammetric camera is placed with its axis horizontal and pointing towards the center of the cylindrical space. The camera is equipped with a wide angle lens of 4 inches focal length. It is focused upon the center of the cylindrical space, and its variable iris diaphragm is stopped down to about  $f/11$ . This results in a usable depth zone of from 600 to 1200 mm. distance. The reflecting surface is set up to one side of the exposure axis. It consists of a high quality first surface mirror of about 18 inches length and 15 inches height. It is arranged to be vertical and parallel with the exposure axis. By the law of reflection this mirror surface produces a faithful replica of the matter contained in the cylindrical space. This apparent object is recorded by the photogrammetric camera as a left-right reversed image. The camera station also is imaged by this reflecting surface, and the apparent second photostation is located at a distance equal to twice the perpendicular distance of the original photostation from the reflecting surface. This distance establishes an artificial photogrammetric base which in this case is equal to the distance between the centers of the actual and the apparent cylindrical space into which the object is placed. The two images recorded as the real and as the apparent object are, therefore, two different central perspectives, and can be subjected to stereoscopic examination.

The length of the artificial stereoscopic base and the base-distance-ratio is controlled by the position of the mirror. The base length increases twice as fast as the displacement of the mirror surface from the axis of photography. The freedom of placing the mirror is limited by the field angle of the photographic lens. If, as suggested here, a wide angle lens of 90 degree field is used, a base-distance ratio as high as .523 may be obtained. This is almost equal to the conventional base-height ratio of vertical aerial photography. It follows that a strong depth perception due to the parallax differences of the corresponding images can be obtained. The lower limit of this base-distance ratio in our example would be about .368 which is conditioned by the fact that vignetting would take place if the mirror is placed still closer to the photographic axis. To make full use of the camera field a second mirror may be placed in symmetry with the first one. The object and camera station duplication is repeated and the possibilities of a more complete and more accurate reconstruction of the object are greatly enhanced. Thereby not only are there established two stereobases of equal lengths but also a third one which comprises the left and right apparent photostation, and which creates a base length that might be as much as 1.04 of the object distance.

The relations shown here and established in a horizontal plane apply of course unaltered in a vertical or any inclined plane. Figure 1 when rotated 90 degrees would show these relationships in a vertical plane. Significant in these examples is the fact that the exposure axis and the apparent photographic base are perpendicular to each other. This establishes what is known in terrestrial photogrammetry as the "Normal Case." It is a case very simple to treat, particularly if we employ the analytical method of evaluation.

In aerial photogrammetry we have recently become conscious of the advantages of convergent photography. As this category of photography increases the base-height ratio and improves the intersection of corresponding image rays at the object point, the precision of the evaluation of convergent photograms is substantially increased. Figure 2 shows the convergent case of Mono-Photo-

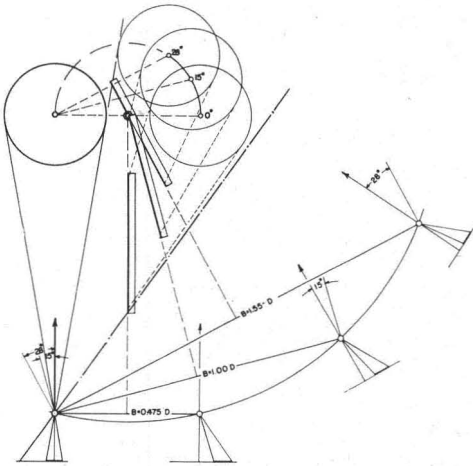

FIG. 2.—Mirror rotation and movement of the apparent object and camera station establish the "convergent case" of Mono-Photogrammetry.

distance ratio and with it the obtainable precision of measurement. Both the apparent object and the apparent camera station travel on circles. Their common center coincides with the axis of the mirror rotation. There is a limit beyond which the rotation of the mirror ceases to yield advantages. This limit is reached when the apparent object begins to be vignetted by the real object. This takes place in our case at an angle of 28 degrees of convergency. Convergency angles considerably in excess of 20 degrees, however, seem to be undesirable since the parallactic differences of corresponding image points become so great that the model surface seems to deteriorate as soon as the measuring mark of the stereo-comparator or projection plotter loses contact with the surface.

THE EVALUATION OF THE PHOTOGRAMS

Two methods of evaluation are at hand: first, the analytical method based on linear coordinate measurements from the photograms; second, the projective evaluation using photogrammetric projectors such as the Multiplex, ER 55, etc. The first method will be preferred if the nature of the investigation matter is such that only a limited number of prominent points are to be determined by their three space coordinates. The second method, which distinguishes itself by the absence of any computational requirements will be preferred if the subject matter is of such nature that it might be represented by contouring or by the development of profiles in one or a series of given planes.

Figure 3 shows the surprising sim-

grammetry. It is produced by establishing an axis in the plane of reflection about which the mirror is rotated. In the initial zero position of the mirror we again have the normal case with a base distance ratio of .475. As we rotate the mirror, for example 15 degrees, we notice that the apparent object travels from the zero to the 15 degree position, and that by the same law of reflection the photogrammetric base also rotates 15 degrees. Its length increases to a distance now approximately equal to the object distance. At the real and the apparent photostation the camera axis is averted 15 degrees from normality. We have thereby a truly symmetrical case of 15 degree convergent photography. The rotation of the mirror is, therefore, a simple means of controlling the base

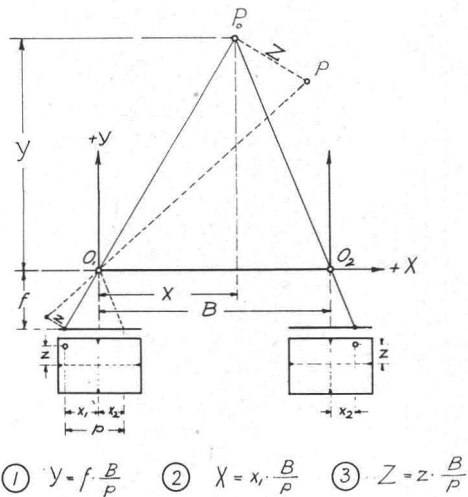

FIG. 3.—The normal case establishes simple geometrical relations and formulae for evaluation by computation of space coordinates.

plicity of the analytical treatment of the normal case of photogrammetry which results from a mirror arrangement parallel with the photographic axis.  $O_1$  and  $O_2$  are the real and the apparent centers of perspective,  $P_0$  is the planimetric position of a chosen object point.  $P$  is the spatial position shown here in plan by rotating the vertical plane containing  $O_1P_0$  and  $P$  into the plane of the drawing. A spatial XYZ-coordinate system is established with its origin in  $O_1$  and with its positive axis containing the base. Known quantities are  $B$  the base,  $f$  the principal distance of the camera,  $x_1$  and  $x_2$  are the abscissae of the conjugate image points in the image plane measured in a rectangular coordinate system established by the fiducial marks of the camera itself.  $z$  is the ordinate of the two corresponding images, which of course, is of equal magnitude for both. These quantities are measured on a comparator or better still on a Stereo-Comparator where  $x_1$  and  $(x_1+x_2) = p$  are measured. The space coordinates  $Y, Y, Z$  are then computed by the three simple formulae shown in Figure 3.

The case of symmetrical convergency is presented in Figure 4. The measurement of plate coordinates is the same as in the normal case. Because of the rotation of the plane through the angle  $\Phi$  with respect to the base line  $O_1O_2$ , the formulae from which the space location of a surface point in the X-Y-Z-coordinate system shall be evolved are somewhat more involved than in the normal case. They can, however, be reduced to a reasonably convenient form if we substitute the directional angles  $\alpha_1$  and  $\alpha_2$  for the measured quantities  $x_1$  and  $x_2$ . The resulting four formulae are given in Figure 4. If great quantities of measurements and subsequent computations have to be made, as would be the case in high speed photography used to capture the behavior of a matter in transitory condition, these formulae could be transformed so as to be accessible to electronic computing systems.

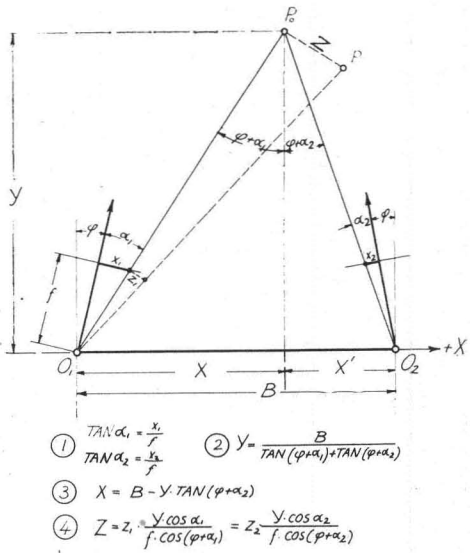

FIG. 4.—The case of symmetrical convergency provides increased precision of evaluation, requires a larger volume of computational work if analytical method of evaluation is used.

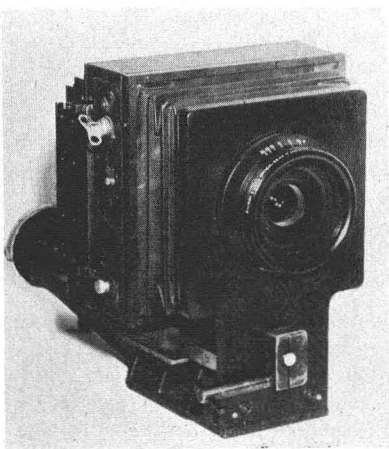

FIG. 5.—Experimental model of wide-angle photogrammetric camera, designed for cranio-graphic studies, B&L H63 Planigon lens, focal plane shutter, micro-setting of principal distance, attachments for controlling exterior orientation data.

The projective evaluation of the photograms is fairly simple and can be dealt with in very few words. The interior orientation of photogrammetric projectors is determined by well known methods of calibration. The exterior orientation of the projectors is readily determinable, i.e. the base length and

the angle of convergency. By the nature of the process there is no differential tilt, no differential convergency, and no differential swing. Projectors will, therefore, be set up by given orientation data. An attempt to establish the exterior orientation by the well known method of parallax elimination in the resulting model would fail because of the relatively small areas occupied by corresponding imagery. Essential aids in establishing and checking this orientation are the nadir points location and a reference target in the object space.

#### INSTRUMENTATION

An experimental model of the camera is shown in Figure 5. This camera is equipped with the wide-angle Bausch & Lomb Planigon lens of 4 inches focal length and a focal plane shutter. The negative format is 5×7 inches. The camera is focusable by a micrometer screw and has all the necessary attachments to determine its principal distance, principal point, and essential data of exterior orientation. The lens (for schematic diagram see June 1954 issue of this journal, page 508, Figure 1) is the Bausch & Lomb Planigon lens of 4 inches focal length, which was developed from the well known Metrogon formula by adding the

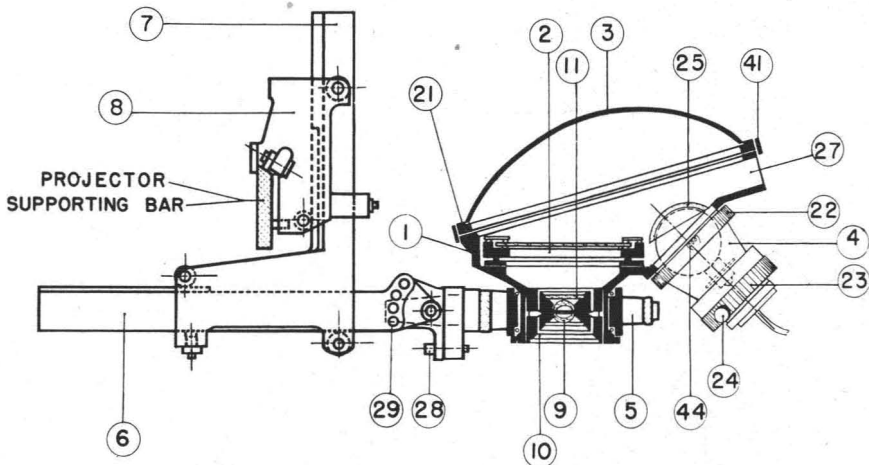

FIG. 6.—Schematic cross-section of the B&L version of the ER55 projectors, trade-named "Balplex" projector, dispositive size 110×110 mm., principal distance 55 mm., optimal projection distance 525 mm.

fifth element, a plano parallel plate. The air space between the spherical elements and the plano part is permitted to vary. The lens can, therefore, be used in a focusable camera where the *E*-element is rigidly built into the focal plane frame where it may serve to support the emulsion on the film base. In front of the lens is a radially gradient filter which moderates the illumination difference between the center and the marginal portions of the field. The lens formula has been developed for focal lengths of 1½, 3, 4 and 6 inches. Maximum aperture in each case is  $f/6.3$ .

First surface mirrors are readily available in sizes up to 14 inches by 18 inches. They are thick glass plates with the reflecting surface polished to a planeity of a few fringes, coated with aluminum and protected by a thin layer of silicon monoxide.

Comparators and stereocomparators are well known and available in different designs. They need no further description at this time.

Photogrammetric projectors such as the Multiplex projectors and the USGS

ER 55 Projector are fairly well known. But may I be permitted to call special attention to a few features of the Bausch & Lomb version of the ER 55 Projector which make this projector particularly suitable for its mono-photogrammetric applications? The schematic diagram, Figure 6, shows the general arrangements of the lamp, the ellipsoidal reflector, the diapositive plane, and the projection lens. The lens is pivotably built into the projector chamber. The pivot axis

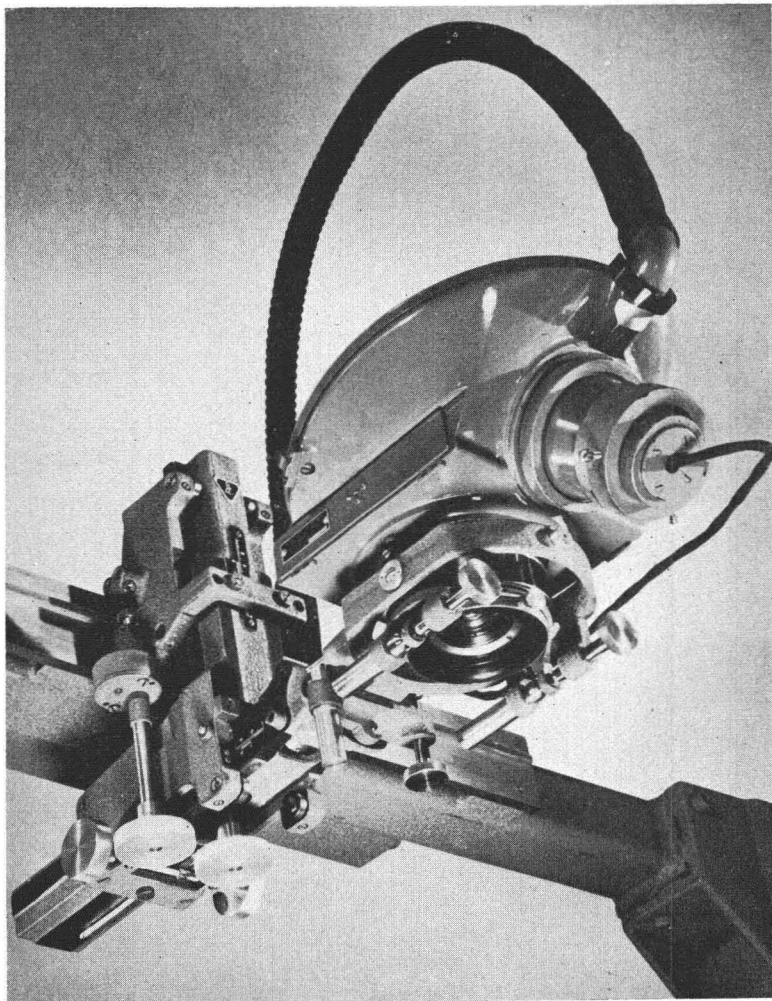

FIG. 7.—The principles of Multiplex design are maintained in the bracket, showing the X-, Y-Z setting motions, the yoke incorporating the three rotary setting motions, longitudinal, transverse tilt and swing. Scheimpflug ring for tilting the lens visible inside the lens cone.

passes through the internal center of perspective. The lens is held in position by an adjustable ring accessible from below. It is called the Scheimpflug ring because of its function to establish the condition in which the plane of critical focus is tilted into a plane parallel with the mapping surface. The projector can, therefore, be used in any exterior orientation for the production of a photographic copy of fair quality of the image projected onto the mapping plane.

Figure 7 shows the physical appearance of this projector and also the

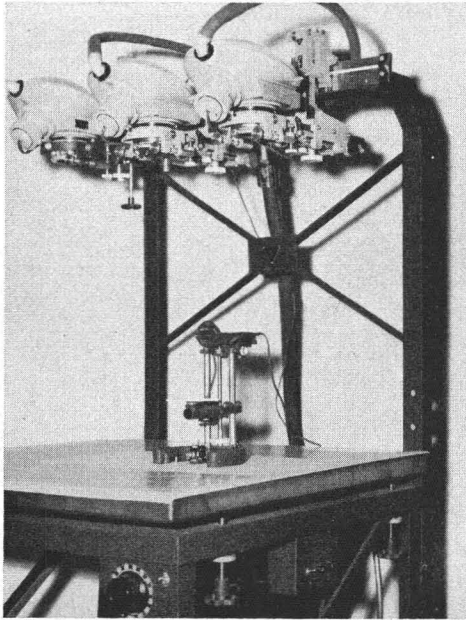

FIG. 8.—B&L Supporting Unit with extended projection range, universal tracing tables and cooling unit.

shown here corresponds to the normal case in which two mirrors had been set up to the left and right of the exposure camera, in such a manner that the base-distance ratio is about 0.4.

#### EXAMPLES OF APPLICATION

As an example of this type of photography I have chosen the fascimile of a human head. This is shown as a contact copy from the negative in Figure 9. The photographic result is a full front picture in the center which is flanked by two mirror images showing two distinctly different perspectives of the head. The fact that the left and right satellite images are left-to-right reversed is clearly expressed by the directions in which the eyes point in the three pictures.

Three diapositives are made from the original negative, first a projection print at approximately one half times reduction with the emulsion of the negative facing the lens. This diapositive will be inserted in the central projector. Two more diapositives are made after turning the negative upside down in the printer. These two diapositives are inserted respectively in the left and right projectors. It is obvious that a spatial model can be perceived from corresponding image rays projected from the left and the central projector as well as from image rays emitted from the central and the right projector. If corresponding image rays originating in the left and the right projector are used to form the model surface, the double base length greatly en-

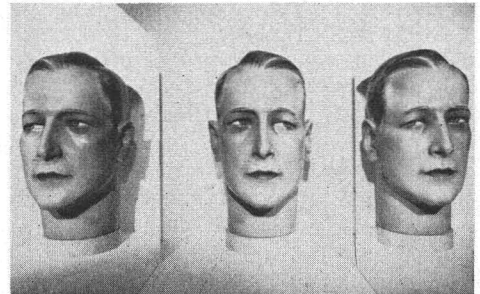

FIG. 9.—Contact print of mono-photogram produced with two mirrors set parallel with the camera axis.

Scheimpflug ring. The standard mounting bracket provides a tilt range in the transverse direction of plus minus 60 degrees of the projector axis from its initial vertical direction. The same range has been added experimentally to the longitudinal tilt of the projection axis. Extreme angles of avertence may, therefore, be handled by this projector as they may occur with unusual orientations of the base line within the  $X$ - $Y$ - $Z$  coordinate system.

The well known Bausch & Lomb supporting unit originally developed for use with Multiplex projectors serves as a plotting stand. It is shown in Figure 8 with three of the new projectors demanding a projection distance between 400 and 650 mm. On the working surface is the well known universal tracing table and beneath it a cooling unit which is required to keep the temperature inside the projectors within reasonable limits. The orientation in which these projectors are



hances the depth impression and the precision of setting the measuring mark. To illustrate the stereo effect thus obtainable Figure 10 presents the stereotriplet resulting from the described printing process. Direct vision or a small lens stereoscope may be used to perceive the (exaggerated) depth from the neighboring pairs of pictures. In each case the model surface can be scanned with the tracing table and the measuring mark, and the desired information plotted on the map sheet underneath. In the chosen example of a human head, this is an invitation to carve the observed stereo surface directly into a suitable material, such as foamed plaster of Paris, and to produce a photo sculpture in precise geometry.

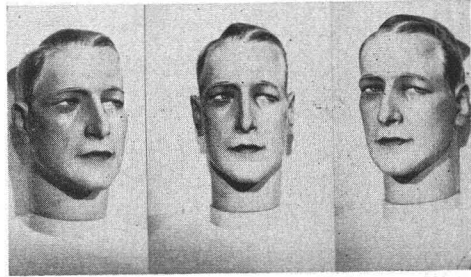

FIG. 10.—Stereotriplet. The center image is a contact print on the center portion of the negative. The satellite images are printed through the back of the negative to present the object in correct geometrical orientation.

As a second example of practical application of Mono-Photogrammetry reference is made to a special case of convergent photography. This is shown in Figure 11. Of particular interest are two vertical planes in the object space which are normal upon another. In plan view their traces are given by the two diameters  $AB$  and  $CD$  of the base circle. They make an angle of 45 degrees with the photographic axis. The two symmetrically located mirrors are rotated from parallelism through an angle  $\alpha$ , which is chosen so that the diameter  $AB$  of the apparent object on the right will be pointed at the camera station, and so will the apparent object diameter  $CD$  on the left side of the diagram. The angle at which this condition is obtained can be determined quite easily once the location of the apparent station is known. We know that upon rotating the mirror

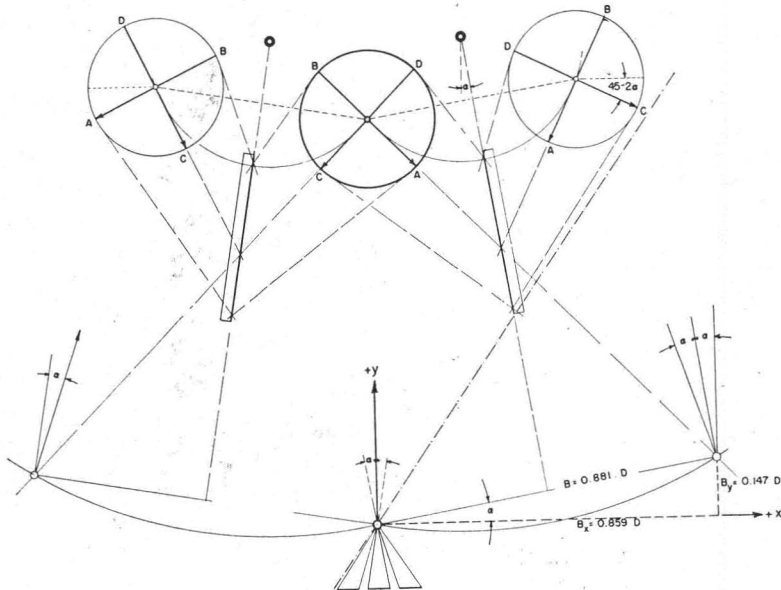

FIG. 11.—A special case of symmetrical convergence. Two planes in the object space normal upon another furnish critical profiles of the object, for direct evaluation of dimensions from paper prints.

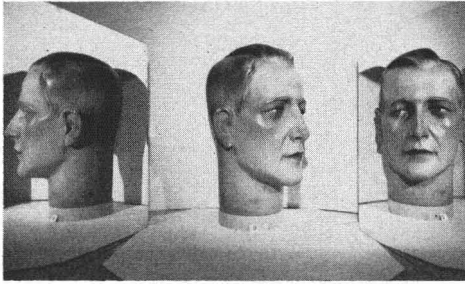

FIG. 12.—Contact copy of mono-photogram showing characteristic profiles as mirror images.

mirror. The photographic results are two satellite images which furnish two complete profiles contained in planes normal upon each other. It will furthermore be noted, that the two diameters are rotated in the satellite images to such position that they make an angle of 45 degrees minus Two Alpha with the line perpendicular upon the exposure axis in the conventional  $X$ - $Y$ -coordinate system, and that the apparent photo base is rotated through the angle Alpha. The base can be resolved in two components  $B_x$  and  $B_y$  which will be used as data of the exterior orientation, when setting up projectors for the evaluation of the photogram.

A significant application of this case is that of photography of the human head, which next to the skin pattern obtained in fingerprinting shows the most distinguishable characteristics of the human body. It is, therefore, best qualified to serve for identification purposes.

The two important planes indicated by the diameters  $AB$  and  $CD$  are in this case 1) the plane of symmetry which divides the skull in two equal halves, and 2) the vertical plane normal upon the former which passes through the widest part of the skull. If we, therefore, orient in our object space the human head with its plane of symmetry turned 45 degrees away from the camera axis, the two satellite images will furnish the two most characteristic profiles.

Using once more the facsimile head, Figure 12 exemplifies the photographic results obtainable with a single exposure. The two satellite images reveal the two significant profiles. They contain the most important information and provide a complete description leading to positive identification of an individual. They display the minute characteristics and asymmetries which often escape notice in the conventional type of photography. They record measurably the several diameters of

the apparent photostation travels on a circle passing through the real photostation and having its center in the center of rotation of the mirror. The second geometrical locus for the apparent station is simply the extension of the diameter  $BA$ . The perpendicular dropped from the center upon the apparent base determines the angle through which the mirror should be rotated from its initial position of parallelism with the photo axis. This setting will also be applied to the left

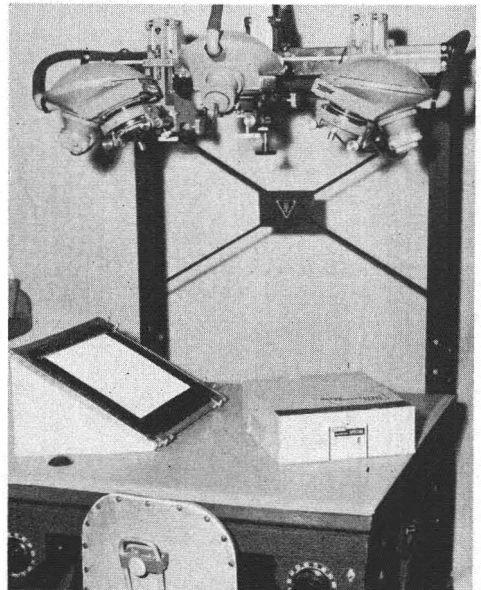

FIG. 13.—Stereo triplet of symmetrical convergence set up on B&L Supporting Unit for dimensional evaluation using the slate surface as common reference plane. Copying easel exemplifies method of obtaining profile prints of satellite images from central projector.

the human skull which from the medical view point are most important for the identification of a person alive or dead, even though his face may have become disfigured by facial surgery, accident, death, or other causes. Criteria and dimensions outside of the planes of the two profile planes may easily be derived by the projective method and measurement on the resulting model surface.

Figure 13 shows the practical setup of this stereo triplet in the projectors on the Bausch & Lomb supporting unit. Here the two stereo bases are installed by their  $B_x$  and  $B_y$  components. This results in the vertical orientation of the central projector, and a convergent orientation by the angle of two Alpha of the lateral projectors. The plane of projection to which all measurements with the tracing table are referred is normal to the central projection axis. All spatial dimensions can be derived from the planimetric position and the elevation differences read from the tracing table counter.

In many cases, photographic copies presenting the two main profiles will suffice to reconstruct or identify the matter of investigation by two dimensional measurements. These copies can be directly obtained on the supporting unit by placing a copying easel inclined to the angle of Two Alpha on the working table (Figure 13) and exposing photographic paper to the profile image, projected from the central projector. In this application the Scheimpflug ring is adjusted to cant the lens to that position which will result in the best photographic focus over the tilted emulsion plane. This application of Mono-Photogrammetry is capable of supplying unambiguous records to all organizations, which are concerned with the identification of human beings whose record may be famous or humble, honorable or criminal.

#### ACCURACY CONSIDERATIONS

From experiences in aerial topographic mapping in which we deal with the base-height ratios of from 0.6 to 1.2, we can justly extrapolate the accuracy which we may obtain by the procedures described. The setting accuracy of the measuring mark on the model surface will of course greatly depend upon the surface properties of the object of investigation. These properties may range from excellent to poor. The relative distance error under average conditions can be expected to be in the vicinity of .1 mm or better. Since the reconstruction of the spatial object takes place at a scale of two-thirds to three-quarters of the natural size, we can expect that the standard error of spatial dimensions will also be of that order of magnitude. It will not be necessary here to dwell on the error theory of this procedure. The interested reader is referred to Dr. B. Hallert's paper on the theory of errors in terrestrial photogrammetry; this may be logically applied to Mono-Photogrammetry.

### SOME ASPECTS OF "NON-TOPOGRAPHIC PHOTOGRAMMETRY\*"

*Gomer T. McNeil, Executive Director, Photogrammetry, Inc.,  
Silver Spring, Maryland*

**E**VEN although the term Photogrammetry has been defined by its most logical spokesman, the American Society of Photogrammetry, as being "the art or science of obtaining reliable measurements by means of photography," it has

\* Presented at Semi Annual Meeting of the Society, Philadelphia, Pa., Sept. 16, 1954.