

OCTOBER 1991

HOROLOGICAL TIMES™

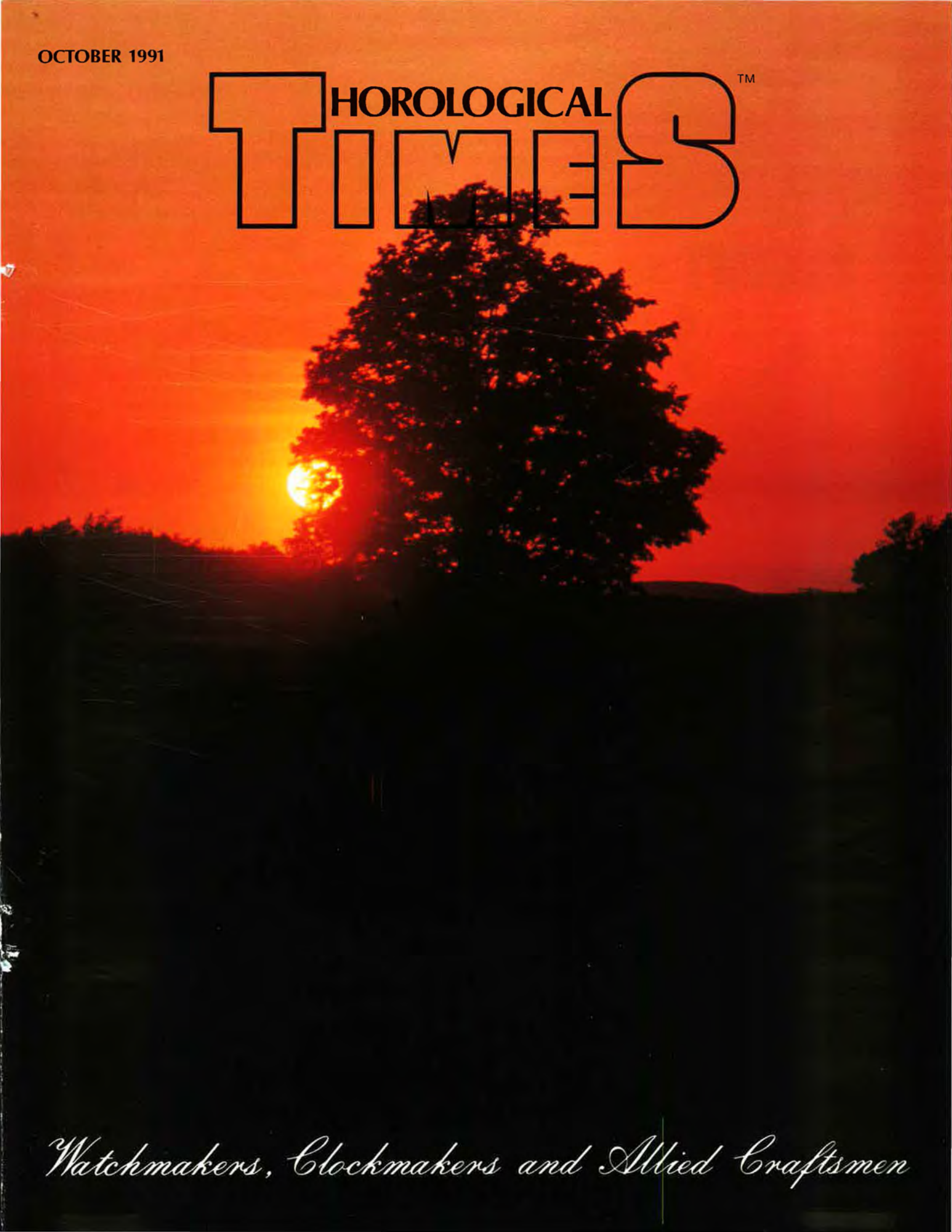

Watchmakers, Clockmakers and Allied Craftsmen

NEW CRYSTAL PRESS

*Finally! A High-Quality,
Low-Priced Crystal Press!*

NEW!

\$41.50



Our new press puts the "squeeze" on other economy presses, with superior quality and more features:

- Solid Metal Construction
- Polished Plunger and Handle
- Painted Finish
- Plunger Lock For Hands-Off Pressure
- Smooth Lever Action
- Mounting Holes
- Durable Nylon Dies - 6 Flat, 6 Tapered
- Knurled Handle For a Sure Grip

MINERAL GLASS CRYSTALS

*Quality Swiss Made - Specially
Priced Assortments*



*Refills
Available
On All Sizes*

36 pc. Assortment \$45.00

Clear Styrene Storage Box
Contains 1 Each of Most Popular Sizes
From 19.0 to 32.0

72 pc. Assortment \$90.00

Clear Styrene Storage Box
Contains 1 Each of Most Popular Sizes
From 14.0 to 35.0

FREE - Special Offer With Either Assortment

Ultraviolet Glass Adhesive In Needle Point Tube

Perfect for Mineral Glass Crystals - Cures in seconds
in sun or ultraviolet light. Same clarity as glass.

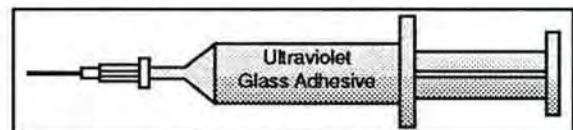

Regular \$3.95 Value



Esslinger & Co.

National Wats: 800-328-0205 Minnesota Wats: 800-392-0334
FAX: 612-452-4298; Toll Free FAX: 1-800-548-9304; Inquiries -Info: 612-452-7180

1165 Medallion Drive, St. Paul, Minnesota 55120; P.O. Box 64561, St. Paul, Minnesota 55164

HOROLOGICAL TIMES™



Official Publication of the American Watchmakers Institute

<i>Alice B. Carpenter</i>	2	PRESIDENT'S MESSAGE
<i>Henry B. Fried</i>	6	QUESTIONS & ANSWERS <i>Schild Freres Hebdomas Watch</i>
<i>Joe Crooks</i>	10	BENCH TIPS <i>Honda Part Repairs Portescap VC-10</i>
<i>Archie B. Perkins</i>	14	TECHNICALLY WATCHES <i>Antique Watch Restoration, Part LXX</i>
<i>David A. Christianson</i>	20	TIMELOCKS <i>The Yale #1 Timelock</i>
<i>Tom Dorman</i>	27	CLOCK TIMERS <i>Getting Started, Part II</i>
<i>J.M. Huckabee</i>	30	LATHE WORK, Part II <i>Construction of the Center Locator Tool</i>
<i>Fred S. Burckhardt</i>	33	ROCK QUARRY <i>Give Me a Real Live Person</i>
<i>Marshall F. Richmond</i>	35	PICKLE BARREL <i>Jewelry Crafting and Repair</i>
<i>Henry B. Fried</i>	37	PENDULUMS <i>Temperature Effects, Part 4</i>
<i>Henry B. Fried</i>	41	BOOK REVIEW <i>Complete Price Guide to Watches, No. 11</i>
<i>Charles Cleves</i>	42	OLD WATCHES <i>Plique-a-jour & Silver Soldering Techniques</i>
<i>Wes Door</i>	44	SHOP TALK <i>How to Start & Manage a Business, Part 2</i>
<i>Joseph L. Cerullo</i>	46	AFFILIATE CHAPTER COLUMN <i>How Proposals are Made to the AWI Board of Directors</i>

USING A PIVOT POLISHER

14

LOOKING INSIDE A YALE #1 TIMELOCK

20



42

DEPARTMENTS

Up Front/4
Ask Huck/19
Material Search Network/43
AWI Project Extend/45
Association News/47
Bulletin Board/48
New Products/News in the Trade/50
Classified Ads/52
Dates to Remember/56
Advertisers' Index/56

HOROLOGICAL TIMES (ISSN0145-9546) is published monthly and copyrighted by the American Watchmakers Institute, 3700 Harrison Avenue, Cincinnati, Ohio 45211, for \$40.00 per year (\$4.50 per copy in the United States and \$50.00 per year; \$5.50 per copy outside the U.S.). Second class postage paid at Cincinnati, Ohio. POSTMASTER: Send address changes to HOROLOGICAL TIMES, P.O. Box 11011, Cincinnati, Ohio 45211.

OFFICE HOURS: Monday through Friday 8:00 AM to 4:00 PM (Eastern Standard Time). Closed on all national holidays. AWI HOTLINE: (513) 661-4636 (24-hour recording), FAX: (513) 661-3131.

HOROLOGICAL TIMES™

EXECUTIVE AND EDITORIAL OFFICES

AWI Central
P.O. Box 11011
3700 Harrison Avenue
Cincinnati, OH 45211
Telephone: (513) 661-3838
Fax: (513) 661-3131

Milton C. Stevens: *Co-Editor*
Michael P. Danner: *Co-Editor*
Regina Stenger: *Associate Editor*
Harold J. Herman: *Senior Technical Editor*
Donna Baas: *Production Director*

James Lubic: *Technical & Educational Services Manager*
Margie M. Brater: *Circulation Manager*
Nancy Wellmann: *Business Manager*
Mary Sansalone: *Seminar Coordinator*

TECHNICAL EDITORS:

James Adams	Wes Door
Robert F. Bishop	Henry B. Fried
James H. Broughton	Ewell D. Hartman
Fred S. Burckhardt	Robert A. Nelson
Charles Cleves	Archie B. Perkins
Steven G. Conover	Marshall F. Richmond
Joe Crooks	Marvin E. Whitney

AWI OFFICERS:

Alice B. Carpenter, CMW, CMEW: *President*
Wes Door, CMW: *First Vice President*
James Adams, CMW: *Second Vice President*
Fred S. Burckhardt: *Secretary*
Marvin E. Whitney, CMW, CMC, FAWI: *Treasurer*

AWI DIRECTORS:

William Biederman, CMW
James H. Broughton, CMEW
Buddy Carpenter, CMC, CMEW
Henry Frystak, CMW
Ewell D. Hartman, CMW, FAWI
Gerhard Hutter, CMW
Gerald G. Jaeger, CMW, CMEW, FAWI
Robert L. Macomber, CMC
Benjamin Matz, CMW
Robert A. Nelson, CMW, CMEW

Joseph L. Cerullo, CMW, CMC: *Affiliate Chapter Director*
Wit Jarochofski: *Research & Education Council Director*
Robert F. Bishop, CMEW: *Immediate Past President*

Milton C. Stevens, FAWI: *Executive Secretary*
Michael P. Danner: *Administrative Director*
Henry B. Fried, CMW, CMC, FAWI: *Technical Director*

Reprinting and reproduction is prohibited without permission from the American Watchmakers Institute.
Copyright ©1991 by the American Watchmakers Institute.

★ FELLOWS ★ OF THE AMERICAN WATCHMAKERS INSTITUTE

George Daniels
Henry B. Fried
Josephine F. Hagans
* Orville R. Hagans
Ewell D. Hartman
Harold J. Herman

Gerald G. Jaeger
Robert A. Nelson
* Hamilton E. Pease
Milton C. Stevens
Marvin E. Whitney
* Deceased

President's Message

Those of you who attended the Affiliate Chapter Meeting and also the general business meeting may remember that one of the resolutions brought by the North Carolina delegate was a request for AWI to print information in *Horological Times* as to how the general membership could obtain a copy of the Constitution & Bylaws.

Maybe everyone is not aware that in the meeting packets given to delegates, directors, and guests each year is a copy of the AWI Constitution & Bylaws. It is anticipated that delegates will turn these copies over to their chapter's office so that each chapter always had a current copy on file. Obviously, this isn't being done.

In years past, we used to enclose a copy of the Constitution & Bylaws in every member's annual renewal packet. When we began to feel the financial pinch, we discontinued this practice. It was questionable how many of the 7000+ copies sent each year were ever read. Members who are interested can receive a copy merely by contacting AWI Central and asking for it.

This document could be called our "bible." It governs everything we do. We always try to run our meetings by it.

Sometimes it can be frustrating. Ask anyone who has had a proposal to bring before the Board which requires changes to either the Constitution or the Bylaws. Such proposals must go to the Constitution & Bylaws Committee and they must indicate all portions of the Constitution or Bylaws that their proposal will affect. The Committee makes sure that none of proposed changes conflict with other sections of these documents. If there are conflicts, the proposal is returned to its originator to be resolved and resubmitted.

While at times this process seems to be going in circles and asking for a lot of work, it is a good thing. It insures that when changes are made, all sections of these documents are in agreement. It insures that we never slight anyone or what they are trying to do. It insures that by following the Constitution & Bylaws everyone has the same availability to the rules. And, if we fail to follow our Constitution, well . . . that's what our Parliamentarian is for: to bring us back to following both Robert's Rules of Order, and also to the fuller framework of our Constitution & Bylaws.

The Constitution and Bylaws Committee has a great responsibility. They must be a "watch-dog" to see that we do not drift from our original intent as stated in our Constitution & Bylaws. You may be interested in learning more about:

- (1) What the purpose of AWI is;
- (2) The classes of membership;
- (3) The three categories of committees and their duties;
- (4) The make-up of the Affiliate Chapters, the Industry Advisory Board, the Research & Education Council, the ELM Trust.
- (5) What it says about the AWI Fellow Award, the James M. Dodson Perpetuation Fund, dues, and the duties of the elected officers.
- (6) How to make a Constitutional or Bylaws amendment.

As a member, you can obtain this knowledge by reading our Constitution & Bylaws. And you can obtain a copy by writing to AWI Central. They will mail you a copy, no postage required, just for the asking.

Alice B. Carpenter

ON THE FRONT: *Sunset by Gary Williams of Manlius, NY.*

**Buy 200
Maxell
Batteries
and get
a little
something
off.**



Free case-back
openers from Maxell.

A little something off. Like the backs of most watches made today. Because when you buy 200 Maxell batteries, not only will you be getting the finest and most reliable batteries available, but you'll also receive a free case-back opener of your choice of either a European style or Japanese style watch. So see your Maxell distributor today and pick up some batteries. And we'll get off your back. Offer subject to availability.

maxell

UP FRONT

ADDITIONAL VIDEOS RECENTLY ADDED TO THE AWI VIDEO LIBRARY

We have recently added the video tapes described here to the AWI Video Lending Library. There is no charge for the use or any of these programs. All can be used for individual study; some are suitable for viewing by small groups.

Setting Instructions For Citizen Calibres 6800, 6820, and 6850--This series of Citizen watches are analog multi-function movements which have eight modes which can be set with the push button. The tape details: *Calendar*--The hand type calendar featuring the recognition of leap year. The month and date can be set quickly, except the recognition of leap year. No need of adjustment at the end of month in leap year. *Alarm 1*--(quick set alarm) has a maximum range of up to 23 hours, 59 minutes, by 1 minute after the next minute at current time. *Alarm 2*--(daily alarm). *Stopwatch*--Minute, second, 1/20 second (maximum measuring range: 60 minutes), measurement of split time, featuring split memo/stop memo function and memo calling function. *Timer*--Maximum setting range: 60 minutes by 1 minute. *Local Time*--Hour and minute (set by 30 minutes second cannot be adjusted). *Other Functions*--Calendar monitor; Daily alarm set time monitor; Zero second return function. In the VHS format; viewing time 50 minutes. Ideal for individual viewing, small group program, or training session.

Setting Instructions For Citizen Calibres C020, C050, C070, and C080--This is a combination watch that uses both liquid crystal and analog display. The film discusses the following features: *Analog Section*--Deals with hours, minutes, and seconds. *Digital Section*--Time/Calendar, either time or calendar is displayed. Time: AM/PM, hour/minutes/seconds. Set to 12/24 hour system. Calendar: month/date/day. *Alarm 1*--AM/PM, hours/minutes; time length up to alarm is indicated graphically. *Alarm 2*--AM/PM, hours/minutes, snooze time; can be set 0 to 10 minutes. *Stopwatch*--24-hour system, minutes/seconds, 1/100 seconds with 60 minutes maximum. Hours/minutes/seconds, longer than 60 minutes illustrated graphically. *Racing Timer*--60-minute watch: Either automatically repeating function and automatic chronograph function can be used. The rest of set time and automatic chronograph are indicated graphically. *Timer*--Minutes/

seconds, from 60 minutes to 1 minute. The rest of set time is indicated graphically. Produced in the VHS format; viewing time 40 minutes. Ideal for individual study, small groups or training sessions.

Setting and Handling Instructions For Citizen Calibres 6700, 6720, and 6750--This series features analog multi-hand quartz watches which indicate year, month, day and date in addition to hour, minute, and second in 24-hour system. This series is a perpetual calendar which does not need to be adjusted at the end of each month and leap year. They show the calendar from March 1, 1900 to February 28, 2100 by operating its buttons. Produced in the VHS format. Ideal for individual study, small groups, or training sessions. Viewing time 30 minutes.

Setting and Handling Instructions For Citizen Calibres 3530, 6810, and 6840--This is a multi-function analog watch with alarm and chronographic functions. It was developed from the 34** series with an alarm mechanism by adding chronographic and timer functions and was designed to increase marketability of the sports products and to reinforce the product group of moderate prices. Produced in the VHS format. Ideal for individual study, small groups, or training sessions. Viewing time 50 minutes.

Jewel Bearings--This is a comprehensive program presenting all of the details of producing jewel bearings for watches. It has been put on video tape in the VHS format from an old Elgin Watch Company film. In black and white, the viewing time is approximately 1 hour, 15 minutes. Because of its length, it probably would not be suitable for large group viewing. Excellent information for anyone interested in the production of watch jewels.

The 19th Basel Fair, 1991--This is a nontechnical presentation featuring a vast variety of new designs, materials, styles, trends, functions, and features of watches on display at the Basel Fair in 1991. Prepared in the VHS format, viewing time is approximately 30 minutes. Ideal for the individual or small groups who wish to be apprised of the newest trends in watches, material, and designs.

Girard Perregaux: A Presentation at the 1991 Basel Fair--This is the story of the Girard Perregaux Company detailing its history and various watch features. Produced in the VHS format, the viewing time is approximately 15 minutes.

Unique Features of Seiko Intelligent Quartz Calibres K362 and 6M13--This video, produced in the VHS format, discusses the many unique features of these upscale multi-function watches marketed by the Seiko Watch Company. The viewing time is approximately 20 minutes. The tape is useful for anyone who is involved in servicing or selling watches. It can be used for individual study or small group viewing. Excellent for a guild meeting or store training session.

The 18th Basel Fair, 1990--This is a nontechnical presentation dealing with the features of a variety of upscale Swiss watches. It covers both mechanical and quartz watches, each having the industry's most advanced technical features. Also discussed are new materials presently used in the production of watch cases and bracelets. A brief discussion of Swiss jewelry also is featured in a brief segment of the presentation. Filmed in VHS format, viewing time is approximately 25 minutes. Ideal for individual viewing, a small group program or store training session.

A CAREER WITH A FUTURE

ENGRAVING

PLACEMENT
FOR
GRADUATES



JEWELRY

FINANCIAL
AID
AVAILABLE

WATCHMAKING

CLOCK REPAIR

Call or Write

GEM CITY COLLEGE

700 STATE • QUINCY, IL 62301

217-222-0391

SAVINGS

FOR THE WATCHMAKER



YIGOR® WATERPROOF TESTER #5555 from Bergeon®

Test water-resistance under normal conditions of wear.

List \$562.00

NOW \$495.00

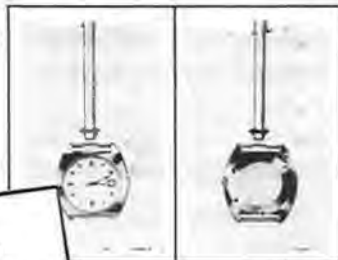

YIGOR® MESH BRACELET CUTTER AND TRIMMER #6496 from Bergeon®

Unique linkage design increases the pressure for a clean cut with one closing action.

List \$101.50

NOW \$79.50



YIGOR® "TRIPLE-DUTY" REPAIR ENVELOPES EV-110

Box of 1000
List \$41.50

NOW \$38.75



YIGOR® CASE CLOSING PLIERS PL-91

List \$15.75

NOW \$14.25



YIGOR® KEY SET #5537 from Bergeon®

List \$140.00

Opens Oyster Cases
made by Rolex.

NOW \$125.00

RODICO "ONE TOUCH" DRY CLEANER #6033

The Genuine Original

List \$8.25

NOW \$7.50



FREE!
Ask for Our New
Findings, Tool and
Dason
Ring Catalog.

DRS

Inc.
JEWELER'S DEPARTMENT STORE

DISCOUNTERS OF TOOLS & SUPPLIES for the Jeweler & Watchmaker

56 West 47th Street, New York, NY 10036
212-819-0470 • FAX: 212-354-2270
Toll Free: 800-223-8960 • FAX: 800-526-8682

WE ACCEPT MASTERCARD AND VISA



Questions & Answers

Henry B. Fried, CMW, CMC, FAWI, FBHI, ★ FNAWCC



Schild Freres Hebdomas Watch

Q I have enclosed some drawings of a watch that I'd like some information about. The watch was made about 1910.

Armin Dahle
Morristown, MN

A Your drawings reveal a watch that is quite familiar to me, having worked on these as well as somewhat connected with their resurgence and popularity.

Your watch is a Hebdomas (Hebdo is Greek for 'seven', and domas means 'days'), although the watch will run for eight days on that long mainspring. The factory that produced these is Schild Freres, in Grenchen, Switzerland. Some of the earliest advertisements for WWI watches feature the same make in 12 and 13 lignes for wristwatch use by the military. The pocket watches appeared still earlier in open face and hunting styles. The hunting models had an elliptical dial with the 12 and 6 perpendicular to the pendant position.

About 15 years ago, Mr. Arnold Fuchs, president of the Arnex Time Corp., engaged me as a consultant and we re-introduced this exact watch with beautifully decorated, real hard-fired porcelain dials. It became a best seller and it is still available from them.

The mainspring, it must be emphasized, cannot be fully wound on purpose. Rather, it has a knuckle end which fits into recesses in the barrel's inside edge. When almost fully wound, the spring will slip until it rests comforta-

bly in the next recess. If it were possible to wind fully, the leverage on such a large diameter barrel would cause the teeth to strip.

I am enclosing a photocopy from that 1972 catalog showing the watch and the (then) selling price.

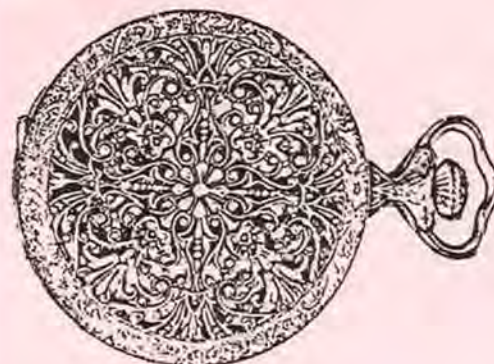
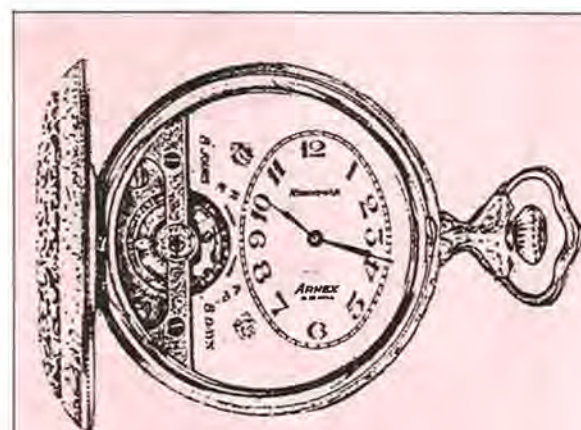
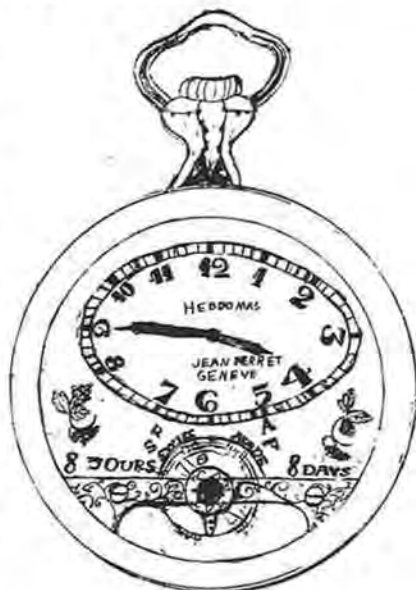

Borel Quartz Crown Assortment

Borel has assembled the 45 most common dustproof and waterproof types used on today's quartz watches, which require smaller sizes and taps. Includes diameters:

2.50, 2.75, 3.00, 3.25, 3.50, 3.75 and Taps 10, 11, 12 & 13

This new updated assortment includes tap 13 sizes, more WP sizes and more tap 12 crowns than previous assortment. 1 each yellow and white of 40 numbers, plus 5 Blue Stone Crowns, yellow only. Total of 85 Crowns, in 60 bottle cabinet.

**Newly updated
75 1/2 Asst. \$90**



















60 bottle cabinet.

**SWISS
MADE**



No other replacement crown approaches Borel Crown in quality, looks or effectiveness. Borel Crowns are made by the top Swiss producer of crowns for new-watch production. Borel stocks the complete range of sizes, styles, types, tap sizes, post lengths, and tube openings. You'll find exactly the crown you need.

Dustproof Type	Diameter	Design	Tap 10	Tap 11	Tap 12	Tap 13
	2.75mm	 ●	652/10	652/11	652/12	
	3.00mm	 ●	656/10	656/11	656/12	
	3.25mm	 ●	660/10	660/11	660/12	660/13
	3.50mm	 ●	664/10	664/11	664/12	
	3.50mm	 ●	666/10	666/11		

Waterproof Type	Diameter	Tube	Post	Design	Tap 10	Tap 11	Tap 12	Tap 13
	2.50mm	1.50mm	Flush	 ●	752/10	752/11	752/12	752/13
	2.75mm	1.60mm	Flush	 ●	754/10		754/12	
	3.00mm	1.60mm	Flush	 ●	756/10	756/11	756/12	
	3.00mm	1.80mm	Flush	 ●	758/10			
	3.25mm	1.80mm	Flush	 ●	760/10	760/11		
	3.25mm	1.60mm	Flush	 ●	762/10	762/11		
	3.50mm	1.80mm	Flush	 ●	764/10	764/11		
	3.50mm	1.60mm	Flush	 ●	766/11	766/11	766/12	766/13
	3.50mm	2.00mm	Flush	 ●	768/10	768/11	768/12	
	3.75mm	1.60mm	Flush	 ●	770/10	770/11		

Assortment, now, includes 5 Blue Stone Crowns DP 3.00, 3.50, 4.00 and WP 3.00, 3.50.

**Japanese
Style Crown
Asst.**

95 1/2 Asst. \$99



Borel has put together this unique assortment of crowns styled as those used on the popular Japanese brand watches: Seiko, Pulsar, Lorus and Citizen. Includes 48 numbers, most of which are the waterproof type with gasket, diameters from 2.5mm to 5.5mm. Total 96 crowns, 1 each of yellow and white of 48 numbers. Refills available. 60 bottle cabinets.

Some of the numbers in the assortment are: J-32M29

J-506-2254 J-25N02 J-35E09 J-30E02 J-35M10 J-40M17
J-506-2614 J-40M32 J-45M30 J-50D05 J-35D03 J-35N57
J-506-2847 J-40M24 J-45D01 J-45W29 J-35M82 J-35M68



Jules Borel & Company, 1110 Grand Avenue, Kansas City, MO 64106
National Order Desk — 1-800-333-4646; FAX Order 1-800-333-4083

Borel & Frei, 712 South Olive, Los Angeles, CA 90014
National Order Desk — 1-800-654-9591

Otto Frei — Jules Borel, P.O. Box 796, Oakland, CA 94604
National Order Desk — 1-800-772-3456



Q Recently a friend brought this military-looking chronograph to my shop for repair. As I still consider myself a trainee watchmaker, I felt it would be responsible to identify the watch and obtain necessary technical information from AWI before tearing into this watch.

This watch is approximately 15-1/2 lignes, two-button chronograph, brass case, nickel-plated, with "Wassergeschützt, Uhrenfabrik A.G., Glashutte (SA)" on the inside back cover. The movement and outside back cover are marked 204067. My friend's father claimed to have acquired the watch from a German soldier during WWII.

If you could help me identify this watch and its history or significance, we would be greatly thankful.

Jon Horton
Kihei, Hawaii

A I have searched through my many references, catalogs, and three volumes of Glashutte-made watches by A. Lange Sohmes) without identifying your chronograph. I also was in Glashutte this

Spring and spent some time there but saw nothing like your watch while there.

Glashutte, a small village about 15 miles southwest of Dresden, was the site of the A. Lange Watch Factory, the "Patek Philippe" of Germany where the very highest grade of watches were made.

It is quite possible, in my opinion, that this was a hurriedly designed and made chronograph by that company for WWII use on demand from the German military government. The reason, I surmise, for not having a name put on the watch was that it was made as a expedient item not at all reflecting the reputation of the local maker, and so to at least put some identification on it, they put the name of the locality. One other maker, named Assman, was also located nearby, but I doubt if they were still in business at that time.

As it is, the Russians, when they overran Germany, removed all the machinery, equipment, and supplies and moved it into Russia. Today, there is a museum that used to be the Grossman School of Horology, some buildings, and also talk of re-instituting the name (Lange). This recently was announced by the company



that bought out the I.W.C. Company of Schaffhausen in Switzerland. They estimate that it will take at least two years before any timepieces will come out of Glashutte.

Incidentally again, searches through German material catalogs fail to reveal this movement as well. It is quite easy to believe that it came from some German officer's body.

Wish I could do more, but I have really made some searches. By the way, Wassergeschützt means sealed from water, and "Uhrenfabrik" means watch factory, "A.G." means Inc., and "SA" stands for Sachen, the area. It's a nice collector's item.

Henry B. Fried

The Best CENTER CATCHES

ARE NOW AVAILABLE!

LESS THAN
\$2.95 EACH
BY THE DOZEN!



These are French-made center clasps of the highest quality. The plating is **5 Microns**. The bottom portion has 2 adjustments for catching. They are available in the following mm increments:

2.3mm, 3.0mm, 4.0mm, 5.0mm, 6.0mm, 8.0mm, 9.0mm, **10.0mm, 12.0mm, 14.0mm, and 16.0mm.** YELLOW & WHITE.

Don't forget: We're still your **GRUEN & ROLEX** Headquarters.

MAKE YOUR MOVE
AND
Guenther SONS

404 W. 7th St
Rm. 408
Los Angeles, CA
90014



800-462-1962

INFO (213) 892-8033 Fax: (213) 892-8035

WOODWORKING MACHINERY



- POWERMATIC
- SAKURA
- JET
- ARTISAN
- MINI MAX
- We also have woodworking books!

(304) 562-3538
CATALOG \$1.00

P.O. Box 536-HT • Hurricane WV • 25526

Twin City Special Savings

X TIC

Popular Watch Movements

FE 6320 - Swiss Quartz Movement

Ligne: 6-3/4 x 8
Height: 3.50mm
Interchange: Ronda 672, FF60, ST 69,
ESA 961.001

FE 6320 \$6.50

Timex #23 Movement \$5.25

Timex #160-3 Movement . . . \$10.50

X Toc

Neycraft Fiber Furnace with Manual Control

Rapid heating - 1000° F in just 10 minutes.
Uses 25% less energy than conventional
ovens. Large 9" x 9" x 6-1/2" firing
chamber handles flasks up to 5-1/2". One
year warranty.



Reg. \$457.00

CA 2001 . . . now only \$395.00

X DOUGH

Embossed Jewelers Foil

Quality foil in rolls 7-1/2" wide x 150' long.
Reg. \$15.50 per roll.

PA 900 - Gold Satin . . . \$12.50 / roll

PA 902 - Silver Nugget . . . 12.50 / roll

Bags-In-A-Box SAVE 25%!

Handy bench top dispenser prevents clutter.
Bags measure 2" x 3" Price per 1000

EV 232 reg. \$16.00
now only \$12.00

EV 232WB (white block) . . . reg. \$20.00
now only \$16.00

Jeweler's Secret Polishing Cloth

Treated cloth removes tarnish and adds luster
to gold, silver and platinum. Unique formula
leaves no messy rouge on your fingers.

Sugg. retail - \$3.00 each

Your cost only \$1.25 each!

CL 360 . . . \$30.00 per carton of 24

Jewel Safe Jewelry Cleaner

Economical jewelry cleaner restores beauty to
fine jewelry, precious stones, gold and silver.
6 oz. jar includes ring tray and brush.

Sugg. retail - \$2.50 each

Your cost only 99¢ each!

CL 380 . . . \$35.64 per carton of 36

Butcher Block Jewelers Bench

SPECIAL PURCHASE SAVE \$100!

The working surface of this sturdy bench has
butcher block construction, not the pressed
wood or particle board found on most jewelers
benches today.

Features three spacious drawers, sliding arm-
rests, bench pin and mandrel holders, tool slide
rack, and a large metal bench pan to recover
precious metals.

Can be shipped UPS.

BN 041 . . . only \$285.00!

PP 500 - Ultrathin (1.3mm) Spring Bar Assortment

500 stainless steel spring bars in a plastic
case. 10 sizes from 1/4" to 7/8" Ideal replace-
ments for Seiko, Pulsar and Lorus. Reg. \$49.95

PP 500 . . . special \$39.95

Seiko Style Replacement Guard Chains



Reg. \$17.40 dz

#1015/1Y (YGF) . . . now \$13.40 dz

#1015/1W (WGF) . . . now \$13.40 dz



HIGH QUALITY!
VALUE PRICED!

Beveled Mineral Glass Crystals

Beautifully beveled and polished, these are
ideal replacement crystals for Seiko, Pulsar
and Lorus.

Sizes available from 12.0mm to 40mm.

BMG Crystals . . . only \$15.00 dz

Custom assortments available,
3 dozen minimum.

14KY Lobster Claw Clasp

8.5mm x 3.93mm reg. \$4.95

LBC 009 . . . only \$3.95

Blank Job Envelopes

All purpose envelopes. 5-1/2" x 3-18"

Heavy Duty Brown Kraft

EV 207 . . . ~~\$14.95~~ now \$12.00 per 500

White Concord

EV 208 . . . ~~\$14.95~~ now \$12.00 per 500

Triple Duty Repair Envelopes

Strong, buff paper envelopes have 2 detach-
able claim checks, for fool-proof filing system.
Groups of 1000 in series of 1 to 10,000.

EV 110 . . . ~~\$41.50~~ now \$38.50 per 1000

Specify Group, numbered 1 through 10.

PC 11 - Solid Link Clasp & Screw Assortment

11 Clasps and corresponding screws, in yellow.
11 popular link sizes, from 1.8mm to 13.3mm.

PC 11 . . . \$29.95

PC 12 - Clasp Assortment

12 clasps, designed to fit Seiko, Pulsar and
Citizen watch band, in a plastic organizer case.
Includes 1 yellow and 1 white in the following
sizes: 5mm, 6mm, 7mm, 8mm, 10mm, 15mm.

PC 12 . . . only \$29.95

Purchase any 3 items from this page and receive a FREE

RM 123 Spring Bar Tool!



Prices good until
October 31, 1991



TWIN CITY SUPPLY

612/545-2725

USA: 800/328-6009 FAX: 612/545-4715

6150 Wayzata Blvd., Minneapolis, MN 55416-1239

Bench Tips

Joe Crooks



Honda Part Repairs Portescap VC-10

This month's tip is from William Miller of Mansfield, Ohio.

I have a repair tidbit for those out there who have Bulova/Portescap VC-10 cleaning machines. After 15 years of use, the main drive belt broke on my machine. I bought a suitable replacement from my local Honda motorcycle dealer, part #91351-937-000. My cost was only \$3.55.

Thanks for the tip, Bill. When I first read your letter I thought, ah heck, another tip for a watch lathe.

We have flogged that horse to death.

The price of the Honda belt is nice, but how did you come up with a motorcycle belt to repair a cleaning machine? Do you own a Honda bike? It is very unlikely that Portescap has quit supplying parts for the VC-10.

Next thing you know someone will come up with a model airplane prop to replace the fan on a cleaning machine dryer . . .

Send your tips to: **Jingle Joe Crooks,**
Horological Times
P.O. Box 11011, Cincinnati, OH 45211

COMPLETE O-RING GASKET ASSORTMENT

Fits Most Watches, Including Seiko and Citizen

**SPECIAL
INTRODUCTORY
OFFER
NOW ONLY \$129.⁹⁵
REGULARLY \$149.⁹⁵**

**NOW AVAILABLE
FROM YOUR
LOCAL MATERIAL
DISTRIBUTOR**



- 720 Gaskets
180 Sizes, 4 Sizes
- 14.5 MM Inside Diameter
to 32 mm Inside Diameter
- Refills Always Available

**TAKE ADVANTAGE OF
THIS TREMENDOUS
VALUE TODAY.**



NEWALL MANUFACTURING • CHICAGO, IL
SERVING THE WATCH INDUSTRY SINCE 1909



QUARTZ WATCH MOVEMENT SPECIALS

MORE THAN 500 DIFFERENT MOVEMENT MODELS IN STOCK. LARGEST INVENTORY & STOCK AVAILABILITY

LOW PRICE



ISA 369
6 3/4 x 8
3-HANDS

only \$5.95 ea

SAVE MORE! ~~6-PAK 5.75~~ ~~12-PAK 5.50~~ ~~24-PAK 5.25~~



OUR FAMOUS
Quartz WATCH MOVEMENT
GUIDE & SUPPLEMENT

NEWLY UPDATED SEPTEMBER, 1991. OVER 100 PAGES LISTING 3,000+ MOVEMENTS PLUS CROSS REFERENCES, FREE LIGNE SIZE GUIDE INCLUDED.

FREE! SALE \$9.95 REG \$19.95
BONUS... BUY NOW & RECEIVE MECHANICAL GUIDE FREE

WE DON'T DABBLE -- WE DEAL IN WATCH MOVEMENTS. CALL FOR VOLUME PURCHASES.

ORIGINAL



Y482
6 3/4 x 8
2-HANDS

only \$6.75 ea

SAVE MORE! ~~6-PAK 6.50~~ ~~12-PAK 6.25~~ ~~24-PAK 6.00~~

LOW PRICE



ESA 561.001
6 3/4 x 8
2-HANDS

only \$6.85 ea

SAVE MORE! ~~6-PAK 6.75~~ ~~12-PAK 6.50~~ ~~24-PAK 6.25~~

**FANTASTIC LOW
WATCH BATTERY PRICES TOO!**

ORIGINAL



ESA 578.004
5 1/2 x 6 3/4
2-HANDS

only \$8.95 ea

SAVE MORE! ~~6-PAK 8.75~~ ~~12-PAK 8.50~~ ~~24-PAK 8.25~~

HOT!



MIYOTA 2020 (2025)
6 3/4 x 8
2-HANDS

only \$7.50 ea

SAVE MORE! ~~6-PAK 7.25~~ ~~12-PAK 7.10~~ ~~24-PAK 6.95~~

HOT!



FE 6820
5 1/2 x 6 3/4
2-HANDS

only \$9.85 ea

SAVE MORE! ~~6-PAK 9.75~~ ~~12-PAK 9.50~~ ~~24-PAK 9.25~~

AMAZING!



MIYOTA 2030 (2035)
6 3/4 x 8
3-HANDS

only \$7.50 ea

SAVE MORE! ~~6-PAK 7.25~~ ~~12-PAK 7.10~~ ~~24-PAK 6.95~~

HOT!



Y481
6 3/4 x 8
3-HANDS

only \$6.75 ea

SAVE MORE! ~~6-PAK 6.50~~ ~~12-PAK 6.25~~ ~~24-PAK 6.00~~



Y588
replaces Y590
5 1/2 x 6 3/4
2-HANDS

only \$9.95 ea

SAVE MORE! ~~6-PAK 9.75~~ ~~12-PAK 9.50~~ ~~24-PAK 9.00~~

POPULAR!



ESA 561.101
6 3/4 x 8
3-HANDS

only \$7.95 ea

SAVE MORE! ~~6-PAK 7.50~~ ~~12-PAK 7.25~~ ~~24-PAK 7.00~~

BRAND NEW!



MIYOTA 5Y20
replaces 3220
5 1/2 x 6 3/4
2-HANDS

only \$9.85 ea

SAVE MORE! ~~6-PAK 9.50~~ ~~12-PAK 9.25~~ ~~24-PAK 9.10~~

BRAND NEW!



VX10
replaces V237
5 1/2 x 6 3/4
2-HANDS

only \$7.95 ea

SAVE MORE! ~~6-PAK 7.75~~ ~~12-PAK 7.50~~ ~~24-PAK 7.25~~

ORIGINAL



Y149
11 1/2
3-HANDS DATE

only \$14.95 ea

SAVE MORE! ~~6-PAK 14.50~~ ~~12-PAK 14.25~~ ~~24-PAK 13.90~~

ORIGINAL



EBOSA 701.111
8 3/4
3-HANDS DATE

only \$11.95 ea

SAVE MORE! ~~6-PAK 11.50~~ ~~12-PAK 11.25~~ ~~24-PAK 10.95~~

BRAND NEW!



VX11
replaces V238
5 1/2 x 6 3/4
3-HANDS

only \$7.95 ea

SAVE MORE! ~~6-PAK 7.75~~ ~~12-PAK 7.50~~ ~~24-PAK 7.25~~

OCEANSIDE
TIME
Worldwide Importers and Distributors

HARD TO GET!



ESA 280.001
3 3/4 x 6 3/4
2-HANDS

only \$29.95 ea

SAVE MORE! ~~6-PAK 29.50~~ ~~12-PAK 28.00~~ ~~24-PAK 27.00~~

24 HOUR ORDER LINES TOLL FREE 800-292-5522
FAX (714) 279-5671

SEEKING PROSPECTIVE CANDIDATES FOR THE AWI BOARD OF DIRECTORS

The committee involved with securing candidates to run for the AWI Board of Directors is seeking recommendations from the membership. If you plan to suggest a possible candidate, please send that individual's name and background to: Mr. James H. Broughton, Chairman; Nominations for Board of Directors Committee; AWI Central; 3700 Harrison Avenue; Cincinnati, OH 45211.

Each recommendation will be carefully considered by the committee. Candidates will be selected on the basis of their past local association or AWI experience, geographical location, present job status, horological experience, and willingness to serve.

Mr. Broughton must receive all recommendations before December 31, 1991 to be considered for the 1992 election.

WITSCHI Announces THE WATCH EXPERT



*A State-of-the-Art
Mechanical Watch Analyzer
With a Recession-Fighting
Price of \$1,680.00*

It's clean looking, user friendly, very portable, and look what it can do:

- Automatic gain control.
- Four selectable measuring times.
- Printer-connection for the printout of the numerical or graphical measuring protocol.*
- Built-in speaker to hear the watch, switchable ON and OFF.
- * Printer pictured in background is an option.
- Graph recording of the watch-beats on a LCD graphic display.
- Selectable resolution (magnification) of the diagram recording.
- Numerical display of; **rate**, **beat error** and **amplitude**.
- Automatic selection of the number of beats for all current watch types. Manual selection for any special number of beats.
- Automatic search of the beat number corresponding to the rate zero of the watch.

WITSCHI ELECTRONICS USA, Ltd.

P.O. Box 2, Palmyra, NJ 08065-0002
Tel.: 1-800-882-7977 Fax: 1-609-829-2266

We Salute These New Members!

ABARABAR, Sergio L., Jr.--San Diego, CA
 ANDERSON, Ronald E.--Barnhart, MO
 APPEL, Martha--New York, NY
 CARBOY, Michael--New York, NY
 CHERRY, Michael A.--Telford, PA
 CHON, Yong Kwan--Baltimore, MD
 CLAASSEN, Stephen R.--Ft. Lauderdale, FL
 COMPTON, June B.--Tyler, TX
 CORRELL, Robert K.--Big Flats, NY
 DUQUE, Alberto--San Diego, CA
 DUNCAN, Donald D.--Norco, CA
 ELLENBURG, Timothy--Ft. Walton Beach, FL

GILUN, Anna--St. Catherines, Ontario
 GLASSER, Estelle--Brooklyn, NY
 HAUGSTEN, Chris--Santa Rosa, CA
 HICKOK, James M.--Social Circle, GA
 HITE, George--Chestnut Hill, MA
 Sponsor: James Broughton
 JOHN, Julius A.--Ft. Walton Beach, FL
 KAPLAN, Edward--Enfield, CT
 KOTAPSKI, Matthew--Aberdeen, MD
 KOTAPSKI, Stanley--Aberdeen, MD
 LEE, Marshall--Nortonville, KY
 LEVINE, Lawrence--Las Vegas, NV
 LEVINGSTON, Gideon Rory--Sevenoaks, England

Sponsor: Mark Heist
 LIVINGSTON, David E.--Laconia, NH
 LLOYD, Lewis T.--Chelmsford, MA
 LOCKE, Vernon C.--Riverside, CA
 Sponsor: Remy Battain
 LOWRY, Robert D.--Lake Mary, FL
 Sponsor: Steve Callihan
 MADDOX, Edward--Apply Valley, CA
 Sponsor: Ivan W. Godwin
 MARICONDA, Joe--Newmarket, Ontario

MC CLAIN, Richard A.--Colorado Springs, CO
 MENDOZA, Francisco--Royal Oak, MI
 MERCHANT, Keith--White Rock, Canada
 MIGLIAZZO, Vincent--Los Angeles, CA
 MURRAY, R.E.--Santa Ana, CA
 PAPCUN, George E.--Longwood, FL
 PEMBERTON, David F.--Flagstaff, AZ
 RHODES, William L.--Huntingdon Valley, PA
 RICE, Allen W.--Mt. Ranier, MD
 SEESE, Adrian--Boswell, PA

SHAW, Arthur A.--Thousand Oaks, CA
 STOEHR, Gaylan L.--Chattanooga, TN
 SZCODRONSKI, Kevin R.--Ankeny, IA
 TIMCIK, Richard J.--Wyoming, PA
 UHRIG, Edward O.--Catonsville, MD
 WANG, Shih Hwa--Rancho Cordova, CA
 WHITE, Stanley--Thomasboro, IL
 Sponsor: Robert M. Leach
 WRIGHT, Arthur W.--Hatfield, MA
 YADEVIA, Louis K.--Upper Darby, PA
 YORK, Gary--Graham, WA

Germanow-Simon Slashes Prices on all G-S Mineral Glass Round Crystal Sets

These are the same high quality Mineral Glass Crystals you have come to expect from G-S.

Don't buy assortments in makeshift containers. G-S assortments are placed in durable drawers (at no additional charge) with numbered and spaced index cards. The professional, proven, handiest system for over 70 years.

All crystals in sets—\$1.25 each

Buy the Full Range for Super Thin Watches

240 sizes - 12.0 mm to 36.0 mm in 1/10 mm graduations 1 mm thin (.040")

SET MG-18: ~~\$600~~ \$300

20 dozen MG MINERAL GLASS crystals
 12.0 mm to 36.0 mm (Complete Set)
 in FREE cabinet

SET MG-5: ~~\$146~~ \$75

5 dozen MG MINERAL GLASS crystals
 26.5 mm to 32.5 mm (Starter Set) in FREE
 drawer

SET MG-10: ~~\$386~~ \$180

12 dozen MG MINERAL GLASS crystals
 12.0 mm to 26.4 mm in FREE drawer

SET MG-3: ~~\$78~~ \$37⁵⁰

2½ dozen MG MINERAL GLASS crystals
 12.0 mm to 14.9 mm in FREE drawer

SET MG-8: ~~\$324~~ \$120

8 dozen MG MINERAL GLASS crystals
 26.5 mm to 36.0 mm in FREE drawer

Compare our new set prices and then
 order from your Material Distributor.
 You make more profit when you fit
 G-S crystals in your store.

**Why Not Drop Us
 A Note?**



EXPRESS YOURSELF!

What you do like . . . what you
 don't like . . . about the
Horological Times.



Germanow-Simon Corporation

Dept. 420, P.O. Box 1091 • Rochester, NY 14603
 1-800-252-5335

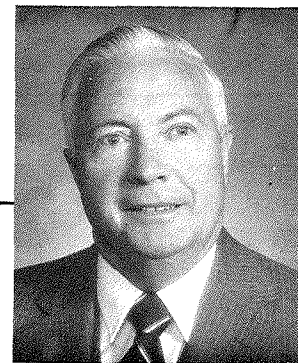

Archie B. Perkins, CMW, FNAWCC, CMBHI
(All rights reserved by the author)

Antique Watch Restoration © 1991

PART LXX

GRINDING AND LAPPING PIVOTS WITH A PIVOT POLISHER

Another method that was used by the American watch factories for finishing pivots was using the pivot polisher. The pivot polisher was also used almost exclusively by American chronometer makers. This method of finishing pivots is a machine lapping method.

The pivot polisher has been made by several companies. Some of these companies are Derbyshire, Harding, Levin, Moseley, and Rivett.

Figure 1 shows a Moseley pivot polisher being used to polish a square shouldered pivot on a pinion. The index finger of the left hand is being used on the rocking bar to rock the lap back and forth on the shoulder of the pivot when polishing the shoulder. The thumb and index finger of the right hand are shown holding the knob on the spindle to move the spindle and lap back and forth endwise while polishing the diameter of the pivot.

The spindle of the Moseley pivot polisher can be raised or lowered by turning a large micrometer nut which moves the spindle and its base either upward or downward. The spindle base can be locked into position with a locking screw. The spindle can be turned to any angle and locked into position for grinding and polishing angles.

The Moseley pivot polisher fits on a shoe on the lathe bed. This prevents the tool from twisting out of alignment on the lathe bed.

DRIVING THE PIVOT POLISHER

Figure 2 shows the Moseley pivot polisher fitted to the lathe bed. Also shown is the driving arrangement for the pivot polisher. To drive the pivot polisher, a countershaft and an idler stand are used. The drive wheel on the countershaft for driving the pivot polisher is a large speed wheel which is 4 to 5 inches in diameter. This drives the small pulley on the spindle of the pivot polisher. This driving arrangement gives several turns of the pivot polisher spindle to one of the speed wheel. This makes it

Figure 1

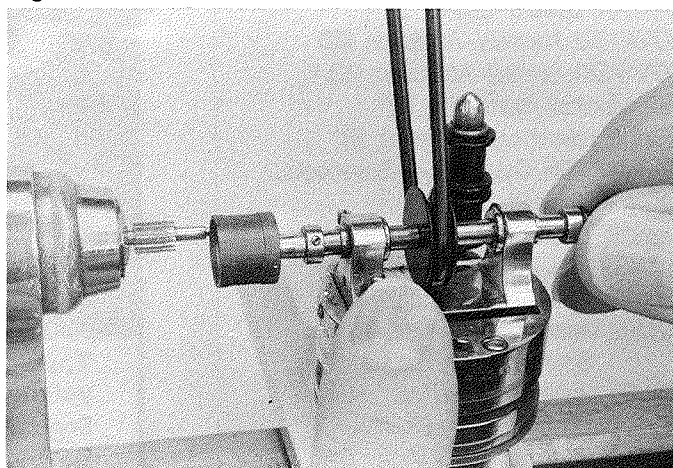

Figure 2

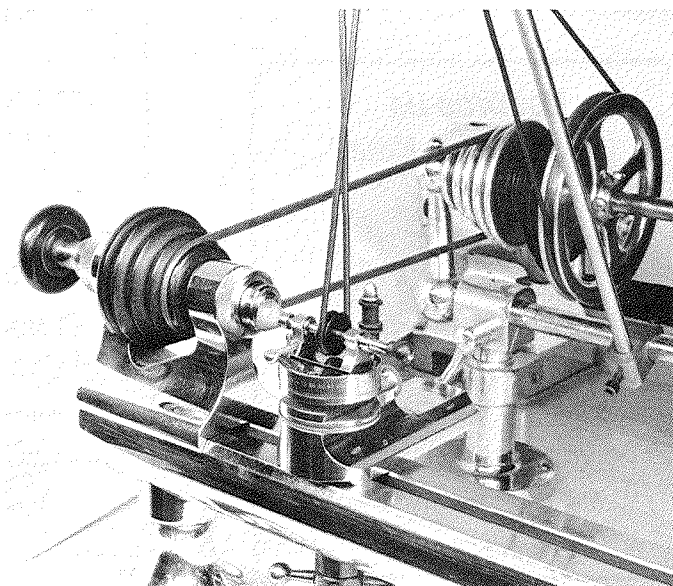
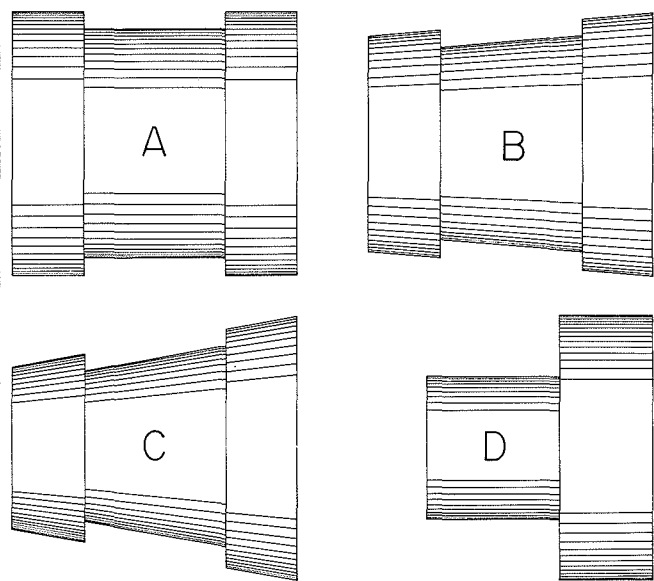

Figure 3



possible to turn the spindle of the pivot polisher at high speeds. This is important when lapping pivots.

The belt for driving the pivot polisher should be a thin endless belt. The belt can be a piece of 3/32" fusible plastic belting. The belting should be joined leaving a smooth joint. The belt goes from the speed wheel on the countershaft, over the idler pulleys (not shown) to the pulley on the spindle of the pivot polisher.

THE PIVOT POLISHER LAPS

Figure 3 shows some of the most used lap shapes. View A shows a regular shaped lap. This shape of lap is mainly used for straight short surfaces such as pivots and beveled corners. This style of lap is also used for conical shouldered pivots on balance staffs and pallet arbors after the corner of the lap has been rounded for the cone of the pivot.

The lap shown in View B, Figure 3 is used for surfaces where there is less than 90 degrees between two adjoining surfaces being polished. When polishing back tapers such as the oil grooves on balance staffs, the lap shown in View C, Figure 3 is used.

The lap shown at D, Figure 3 is used for straight surfaces. The grinding and polishing surface on the lap can be left longer for lapping longer surfaces. The lap's shape can be varied for different surfaces.

Figure 4, View A shows how the laps fit the spindle of the pivot polisher. The end of the spindle is slightly tapered and the hole in the lap has a matching taper to fit the spindle snugly. The taper is 2 degrees.

View B, Figure 4 shows the tapered reamer used to ream the hole in a lap to fit the tapered spindle of the pivot polisher. This reamer is also necessary when new laps are made by the watchmaker. The taper on the reamer must match the taper on the spindle of the pivot polisher

Livesay's

Inc.

Wholesale Jeweler & Watchmaker Supplies
456 West Columbus Drive
Tampa, Florida 33602

BRACELET SCREW ASSORTMENT

A 55 piece assortment contains 5 each of 11 sizes of screws for repairing watch bracelets and clasps. Refills \$.40 each.

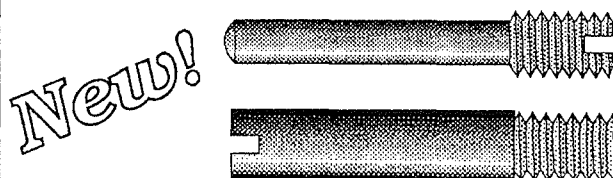

#MM-BSA55

\$19.95

WATCH TISSUE PAPER

Lint free, anti-tarnish, 4 1/4" square tissues for wrapping and cleaning watch parts, jewelry, etc. Box contains 1,000 sheets.

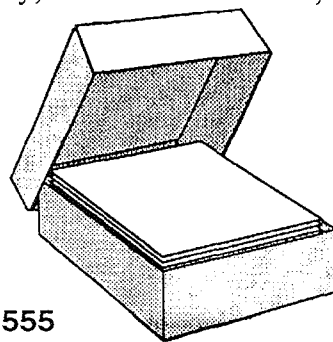

#23.555

\$5.80

Call or FAX for Free Tool, Findings, and Watch Catalogs!



Phone Orders

(800) 476-2715*

Toll Free 24 Hour FAX Orders

(800) 476-8016*



Tampa (813)229-2715 Local Fax (813)221-8016

*All States Toll Free including Alaska, Hawaii, Puerto Rico, and the Virgin Islands

1091

Figure 4

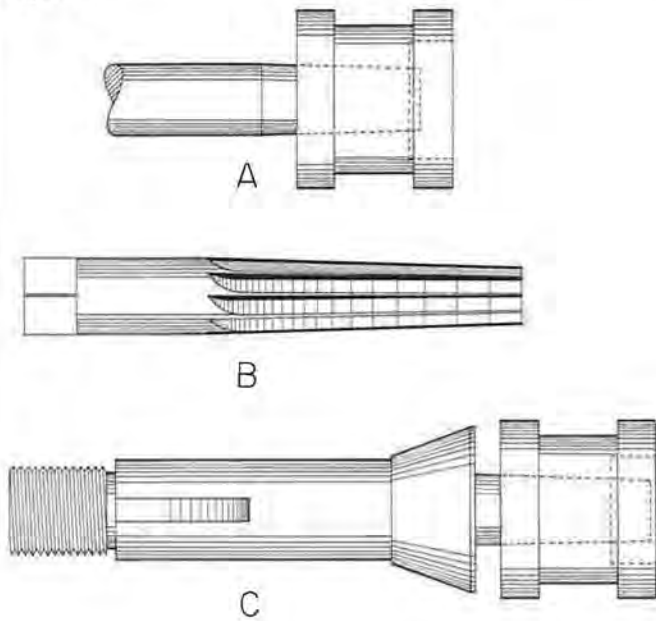

exactly; otherwise, the laps will worm themselves off of the spindle when they are being used.

Another necessary item needed for the laps is a taper chuck. This is to hold a lap when shaping it or when redressing its surfaces. The taper chuck is shown in View C, Figure 4. The taper on the chuck must also match the taper reamer and the tapered holes in the laps. Note: The

Figure 5

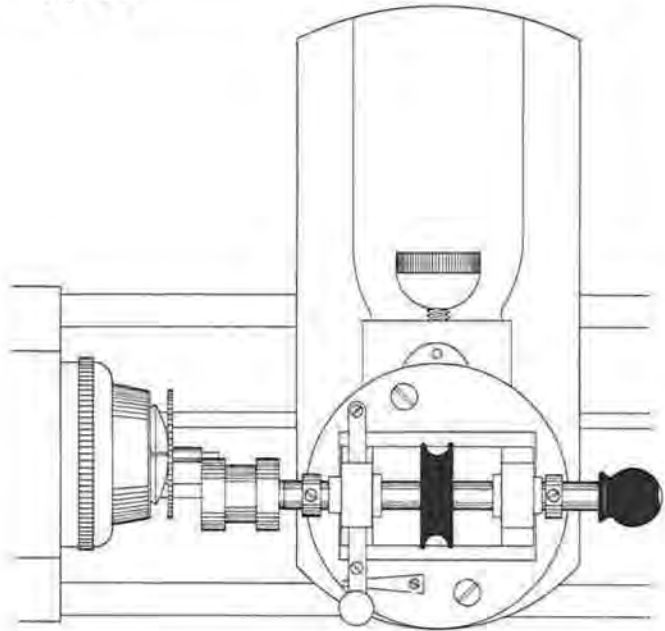

materials that laps are made of are: cast iron, steel, copper, and bellmetal for grinding. For polishing, softer materials are used such as lead, tin, ivory, and boxwood.

SETTING THE PIVOT POLISHER FOR POLISHING A SQUARE SHOULDERED PIVOT

Figure 5 shows how the pivot polisher is set for polishing a square shouldered pivot. For this operation, the spindle is set parallel to the lathe bed as shown. This places the index scale of the base on zero. Then the height of the spindle is adjusted so it is on the exact center with the lathe center.

When tightening the pivot polisher to the lathe bed, the lap should be set very closely to the pivot. Further adjustment is made by turning the screws in the rocking bar. The lap should contact the pivot with very little pressure. This is controlled by the screws in the rocking bar. The axial motion of the spindle is set by adjusting the two collars on the spindle of the attachment. Note: The laps used for lapping pivots are usually bellmetal for smoothing the pivot, and boxwood for the final finish.

LAPPING A SQUARE SHOULDERED PIVOT

Figure 6, View A shows the lap set for lapping a square shouldered pivot. A bellmetal lap is used first if the pivot is scored. The grinding material used on the bellmetal lap depends on how deep the pivot is scored. For a lightly scored pivot, Number 1 or 2 diamantine can be used. If the scores are very deep, one may need to use 600 grit alumina (aluminum oxide) powder or a coarser material like Linde C™. Another compound which works nicely is Clover™ 1000 or 1200 grit lapping compounds (silicon carbide). This is already mixed in grease, whereas the diamantine and alumina need to be mixed in oil before being used.

When grinding or lapping a pivot, it is most

Figure 6

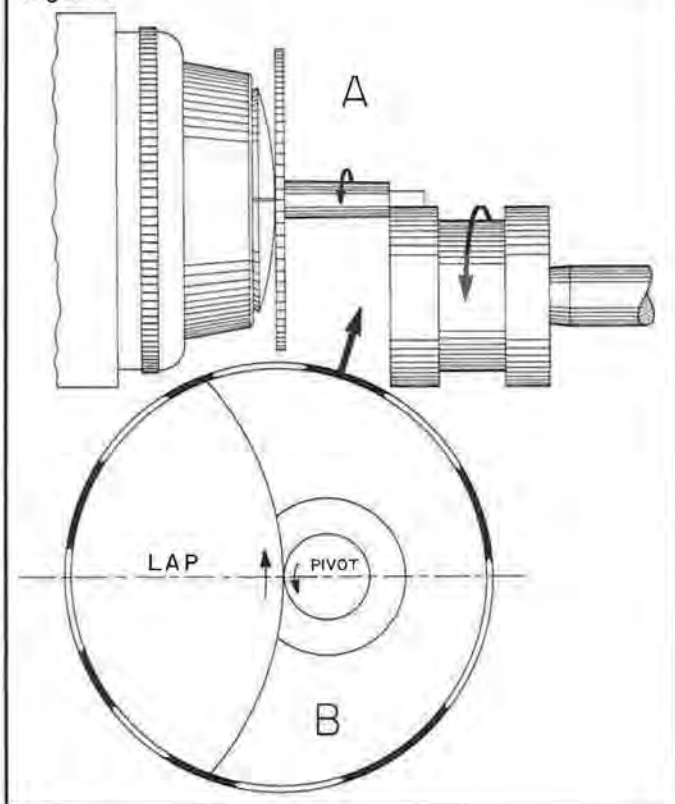

important that the pivot and lap run absolutely true. It is also very important to have the lap turn in the proper direction in relationship to the direction that the pivot turns. This relationship is shown by the arrows in View A, Figure 6. The arrows show that both the pivot and lap are turning in the same direction. This causes the two surfaces in contact to oppose each other. View B, Figure 6 shows an end view of the lap and the pivot. Note that the lap is set on the same center as the pivot. The arrows show the proper direction of travel for the lap and pivot. Always keep in mind that the surface of the lap should oppose the surface of the pivot when they are turning. The ratio between the speed of the lap and the speed of the pivot should be approximately 6:1. The lap should turn 6 turns to one of the pivot. The lapping compound is applied to the acting surfaces of the lap sparingly. To lap the pivot, as the lap and pivot are turning at the proper speed, the lap is moved back and forth axially on the pivot to lap the diameter of the pivot. Then the end of the lap is rocked back and forth on the shoulder of the pivot by moving the rocking bar with the finger. One should check the diameter and finish of the pivot quite often in order to avoid reducing the pivot too much. Do not disturb the pinion in the chuck. Remove the headstock from the lathe bed if necessary to inspect the work. The pivot can be cleaned with pithwood so it can be inspected.

(Please turn to the next page)

YOUNG-NEAL COMPANY, INC.

1838 Elm Hill Pike, #116
Nashville, TN 37210

INFORMATION ORDERS: \$10 Minimum
(615) 889-0060 (800) 251-8580

We accept MasterCard & Visa

Selling only
EVEREADY WATCH CELLS
at competitive prices!

**Our Crystal Fitting Services
Are the Very Best.**
**Offering in Most Cases Same Day
Service. If You Haven't
Tried Us, You Should.**

FOUNTAIN PENS WANTED

I WISH TO PURCHASE PENS BY PARKER & WATERMAN WITH FILIGREE METAL OVERLAY & MOTHER OF PEARL INLAY MADE BETWEEN 1900-1930 ALONG WITH OTHER HIGH-GRADE UNUSUAL OLDER PENS. PENS MUST BE IN EXCELLENT CONDITION FREE OF CRACKS & DENTS FOR THESE PRICES. DAMAGED PENS ALSO WANTED ALONG WITH PARTIAL PENS AT LOWER PRICES.



PAYING \$7,000 + UP FOR PARKER OR L.E. WATERMAN SNAKE PEN



PAYING \$1,000 + UP FOR PARKER #31 OR #41 LARGE SIZE FILIGREE OVERLAY PEN



PAYING \$4,000 FOR PARKER #47 ALTERNATING BLACK & WHITE MOTHER OF PEARL.

Charles Cleves

CLEVES & LONNEMANN JEWELERS
319 FAIRFIELD AVE., BELLEVUE, KY 41073

STORE: (606) 261-3636
HOME: (606) 491-0354

Figure 7

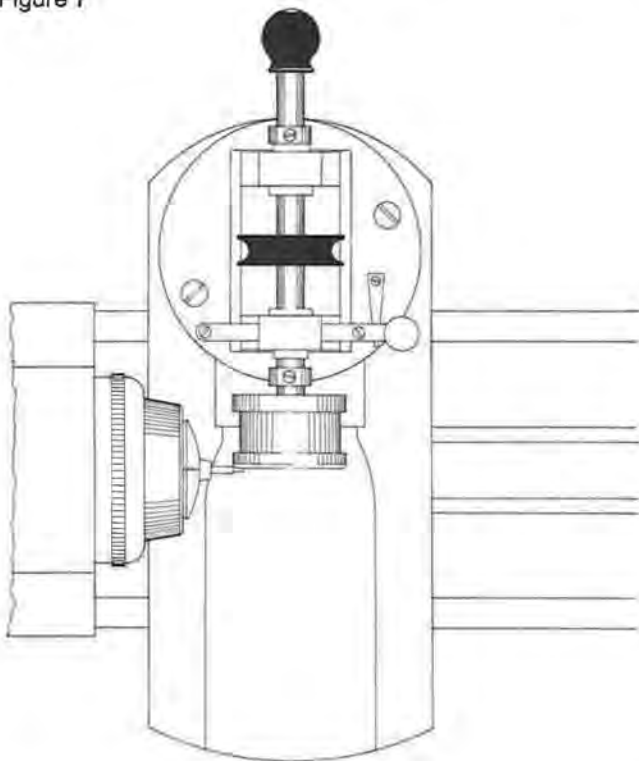
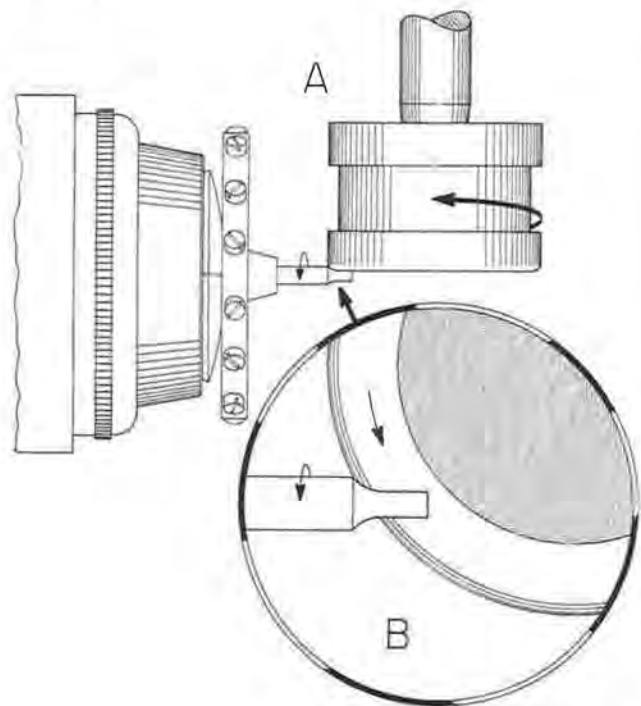

Figure 8



After the pivot has been lapped smooth, it is thoroughly cleaned with pithwood dipped in a good solvent without disturbing the pinion in the chuck. Then the bellmetal lap is replaced with a boxwood lap for giving the pivot its final finish. The material used on the boxwood lap is Number 3 diamantine or Linde A™. This should be mixed with oil, or alcohol can even be used. When alcohol is used, it will soon evaporate leaving the material dry which will produce a high polish on the pivot. This makes the pivot easy to clean for viewing.

SETTING THE LAP FOR LAPPING CONICAL SHOULDERS PIVOTS

Figure 7 shows how the pivot polisher is set for lapping conical shouldered pivots. In this case, the pivot polisher is placed on the lathe bed from the backside of the bed. The spindle of the pivot polisher is swiveled around 90 degrees so the spindle is at right angles to the lathe bed as shown in Figure 7. The lap is set above center with the lathe center when lapping conical shouldered pivots. The amount that the lap is set above center depends somewhat on how much roundness the corner of the lap has and the amount of curvature on the cone of the pivot. If the curve on the corner of the lap matches exactly the curve on the cone of the pivot, then it would not be necessary to set the lap above center. Since it is nearly impossible to have the curve of the lap match the curve of the pivot cone, one must raise the lap until the two curves do match. This is easier than trying to shape the lap each time to match the pivot exactly.

LAPPING CONICAL SHOULDERS PIVOTS

Figure 8 shows how a conical shouldered pivot is lapped. View A shows the lap set into position on the pivot. The arrows show the direction that the pivot and lap turn. View B shows an end view of the lap against the pivot. Note that the lap is above center with the pivot. The arrows show the direction that the pivot and lap turn. The lap and pivot must turn absolutely true. The lap should contact the pivot lightly to avoid breaking the pivot during the lapping operation. The lap used for smoothing is bellmetal, and a boxwood lap is used for polishing the pivot. The same lapping and polishing materials are used on conical pivots as are used for square shouldered pivots. When lapping and polishing conical shouldered pivots, the lap is moved back and forth on the pivot by moving the rocking bar of the pivot polisher.

For additional information on the use of the pivot polisher, consult the following references:

Goodrich, Ward L. *The Watchmakers Lathe*, North American Watch Tool and Supply Co., Chicago, IL, 1952, pp. 187-208.

Levin, Louis and Samuel. *Practical Benchwork for Horologists*, Los Angeles, CA, 1950, pp. 46-52.

Perkins, Archie B. "Technically Watches" *Horological Times*, American Watchmakers Institute, Cincinnati, OH, October 1983, pp. 10-12, 14.

"Antique Watch Restoration" will continue next month.

□

Ask Huck

CLOCKMAKING BITS

By J.M. Huckabee
CMC, FBHI

About...

CHANGING A MOVEMENT BEAT RATE and ESCAPEMENT CONSTRUCTION

Q. I have a number of old American clock movements. Is it feasible to lengthen the pendulum rods and use them in schoolhouse clock cases?

A. The technical answer to your question is yes. The practical aspect may be yes or no, depending on your clockmaking ability.

Pendulum length is a function of the gear train and escapement design, which precludes an arbitrary change in pendulum rod length. We also have physical problems with case, dial, hands, etc.

Let's assume we have a movement with a dynamic pendulum length of seven inches and an escape wheel of 35 teeth. This is somewhat like the old American kitchen clock. Looking in a recent catalog, I find verge and escape wheel sets in a range of 26-52 teeth. We can change the escapement and change the pendulum length, but this is not a linear change to pendulum length.

Imagine our seven-inch pendulum and 35-tooth wheel being changed to a 26-tooth escapement. Each pendulum beat must occupy about 1.35 times the time of the original rate. This says our new pendulum dynamic length will be about 1.81 times the original seven inches, or about 12.68 inches. We could extend this value further by changing the escape wheel pinion by one additional count--say from six to seven. A pinion change would require the relocation of at least one wheel in the gear train.

So we find the answer to be yes, technically speaking, but with far-reaching practical problems.

If you would like to test the issue, I suggest you study some pendulum length tables and train calculations. Many books on clockmaking present this subject. It is indeed interesting to study gear trains because the combination of trains and pendulum lengths are in endless combinations.

The old American movements have adequate power to swing most any length pendulum. By example, as an apprentice, I built a 15-tooth escapement for one of these movements which used a two-pound pendulum ball at 58-1/2 beats per minute. That beat rate has a pendulum dynamic length of about 41 inches.

Q. I'm gathering skills and materials to build my first clock. What type of escapement would you recommend? Why do you make the recommendation?



A. For a firm recommendation, I would like to know the type and size clock you have in mind, as well as the case type. There is no "best type" of escapement suitable for all clocks.

Let's explore some circumstances. Your skills and tools are an important factor, as well as the application.

The strap-type recoil escapement is no doubt one of the most successful escapements ever devised for short pendulum mantel clocks. A look at the antique clocks in existence is vivid evidence of this success story. The wheels are robust, verge easy to form, easy to adjust, and they are moderately good timekeepers. You can't go too far wrong with this escapement in a short pendulum clock.

The Brocot escapement is another type that's easy to construct. It's not as robust as the previous escapement, but the brass anchor frame makes adjustment easy and the pins are very easy to construct from dead-hard steel. This is probably a little better timekeeper, and with weight drive can be an excellent timekeeper. I would use this with shorter pendulum clocks--say in the order of 120 beats per minute and faster.

For a free-standing clock that beats seconds, I would use a solid anchor recoil escapement. This is very durable and not bad as a timekeeper at seconds beat rate. The wheel is strong and quite suitable for a free-standing case.

For a seconds beat wall hanging regulator, by all means use a Graham deadbeat escapement. The wheel is delicate and anchor difficult to construct in true form. With a good pendulum it will give a fine degree of accuracy.

Unless you are an experienced clock builder, I do not recommend a gravity escapement. Here are the reasons: It's a very busy mechanism, lots of parts in motion. It is intolerant to vibration, requires a very long gear train and a critical speed governor on the escape wheel shaft. It is less suitable for short pendulum movements. I've only built three gravity escapements in my clockmaking tenure. I'm convinced it's an interesting and excellent escapement, but not the place to begin.

If you feel comfortable in making repair parts for the recoil, Brocot, and deadbeat escapements, by all means select one and build it. There is no satisfaction equal to building your own clock.

Got a question? Send it to: "Ask Huck," c/o Horological Times, P.O. Box 11011, Cincinnati, OH 45211.

TIMELOCKS

David A. Christianson, CMW, CMBHI
Copyright ©1991



THE YALE #1 TIMELOCK ... and its E. Howard Movements Part II

The clock movements that control the Yale #1 timelock were manufactured by the prestigious E. Howard and Company of Boston. These are robust but finely finished, top quality movements, using state-of-the-art design and technology of the latter 19th century (Figure 1).

Although these movements are pretty basic in function, they do possess some interesting features that deserve comment:

- 1) The fourth wheel is jewelled on the lower plate but is brass on the upper.
- 2) The barrel arbor through the third wheel has brass pivot holes on top and bottom.
- 3) The main hour dials are mounted on a large toothed wheel driven directly from the main wheel but are not within the main train of wheels (Figure 2).
- 4) The "hours-of-run-time" dials are nothing more than winding indicators geared from the main wheel



Figure 1. The two E. Howard clock movements that control the Yale #1 timelock.

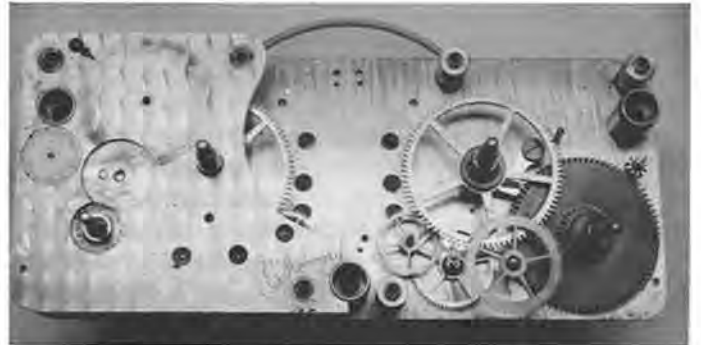
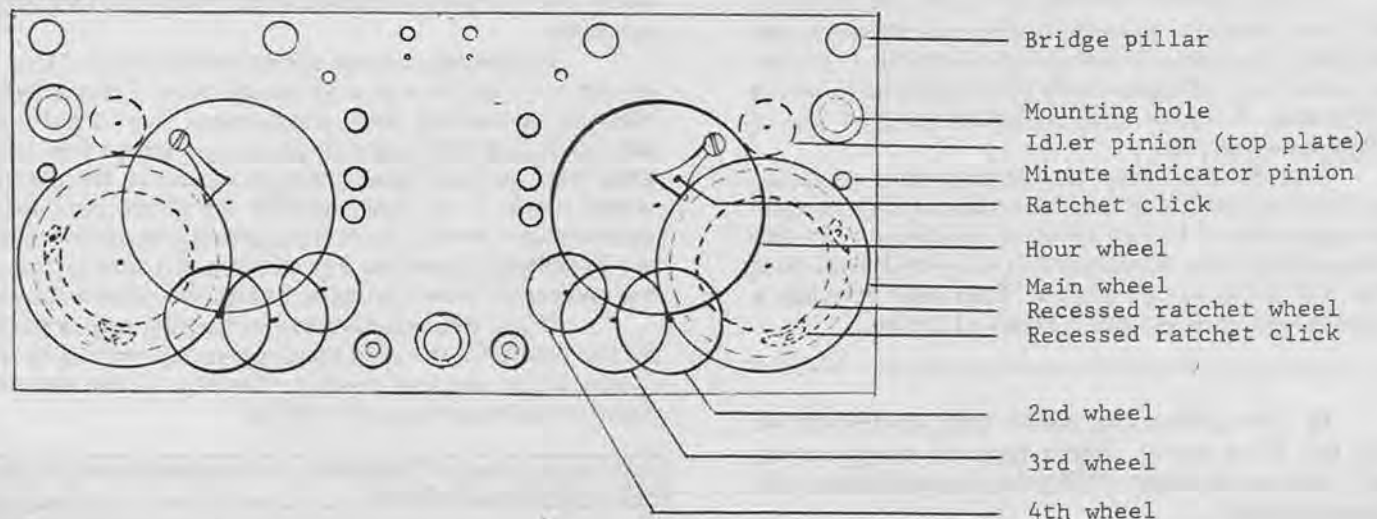

Figure 2. Train of one movement exposed. Note that the large hour wheel is turned by the main wheel via an idler pinion not shown (see Figure 17).

Figure 2b



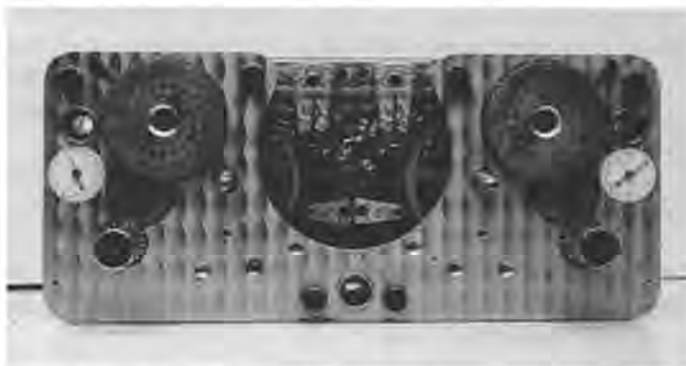

Figure 3. Hour dials removed showing "hour-to-run-time" dials (winding indicators) geared from the main wheel arbors.

arbor (Figure 3).

5) The small, white porcelain dials indicate fractions of an hour (minutes) and are used for indicating the fractions of the hour when setting the main dials to the correct time. These dials each have a moveable indicator hand slip-fitted to a pinion arbor that is driven from the main wheel (Figure 2). Remember, these are indicators only, showing the passage of minutes for convenience.

6) The stop-works are located on the outside bottom of each barrel and prevent the mainsprings from running completely down to zero, thus preserving a reserve power force on each main wheel (Figure 4).

7) The movements are "handed"; i.e., one movement propels its escape wheel (and its main dial) clockwise and the other movement counterclockwise. Consequently, the barrels turn in opposite directions. The trains turn in opposite directions and the platform escapements are themselves "handed" left and right.

REPAIR NOTES

A. Because the movements are "handed" left and right, the mainsprings turn in opposite directions and therefore the barrel hooks are attached in an opposite manner. Consequently, the barrels are not interchangeable.

B. In theory, the train wheels are interchangeable but in practice it is advisable not to interchange them from one train to the other. These parts have "worn-in" over the years and, even with new bushings, pivots, and/or jewels, the wear on pinion leaves and teeth, along with

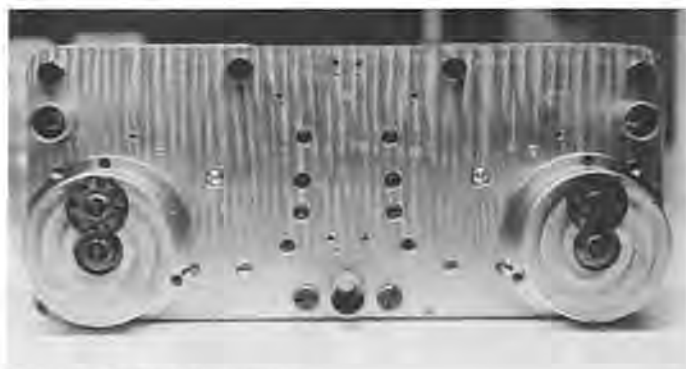
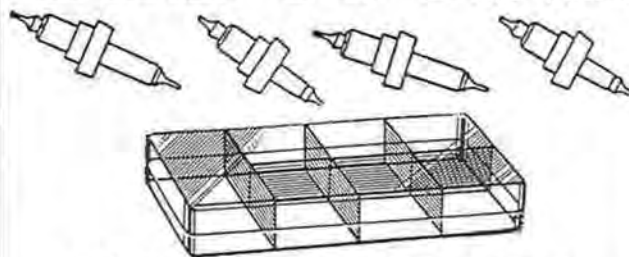

Figure 4. Barrel arbor stopworks.

HARD-TO-FIND!



AMERICAN POCKET WATCH STAFF ASSORTMENT

American pocket watches have become **THE THING** to own and repairs on them are at an all time high! Presenting a brand new staff assortment featuring the most complete and popular sizes of Elgin and Waltham. There are 18 different Elgin numbers from 0 Size to 18 Size and 18 Waltham in the same size range. Assortment comes with one of each staff in numbered bottles in a 36 partition plastic box. Refills are always available. **SPECIAL PRICE - ONLY \$37.50.**

039262 \$37.50 asst.

This is the first in a series of American balance staff assortments. Others will follow in the near future.

WHILE THEY LAST!



MOVEMENT HOLDER

SWISS-MADE movement holder for LCD, quartz, or mechanical wrist watch movements from 12 to 35mm. Fully adjustable arms can be set in any combination of positions for movement inspection and testing. Widely spaced legs assure a steady work area. There's plenty of room for a mirror under holder for top and bottom inspection at the same time. Very limited quantities.

WHILE THEY LAST - ONLY \$24.50!

069292 \$24.50 each

S. LaRose, Inc.
Worldwide Distributors to Horologists

234 Commerce Place, P.O. Box 21208
 Greensboro, N.C., 27420, U.S.A.
 Phone (919) 275-0462
 FAX Number 1-800-537-4513

slight differences in pivot hole locations, could and would cause unnecessary problems.

C. Since the movements are left- and right-handed, the escape wheels turn in opposite directions. The pallet forks are oriented in opposite fashion, the pallet jewels also, and the escape wheels themselves have teeth angled in opposite directions (Figures 5 and 6).

D. Slight differences in pivot hole locations make interchanging parts from the left platform to the right virtually impossible without major reworking of the components. Apparently these movements, although mass produced, were hand-fitted and hand-adjusted.

E. Because of their age, these movements will definitely require thorough cleaning and rebushing of pivot holes along with the possible replacement of cracked pivot jewels. *But*, because these magnificent timelocks were in service during the time of regular, periodic and professionally applied service, and were taken out of

service before more sporadic servicing was practiced, most of these movements will probably require little else to restore them to their former state of excellence. See the *Horological Times* September 1989 and August 1991 issues for past and present servicing techniques.

F. RESERVE POWER. This is the partially prewound mainspring that stores potential energy to insure instant starting and avoid a more rapid time loss as the spring relaxes to a full state of rest with no stored energy. See the following section--"Reassembly Procedures," paragraphs #11 and #12.

DISASSEMBLY PROCEDURES

1. Remove the dials by removing the thumb nuts located in the center of each main dial (Figure 7).

2. Remove the winding arbor guards (friction fit) by pulling off from the arbor (Figure 8).

3. Block the wheel train with pegwood at the 4th wheel and remove the platform escapement (Figure 9).

4. With your finger braking the 4th wheel, remove the pegwood block and let the train run down slowly until it stops. Reserve power will still remain on the mainspring.

5. To remove the reserve power:

a) Remove the screws retaining the two stopwork gears (Figure 10).

b) With a let-down key on the winding arbor, put pressure on the mainspring until the stopwork gears separate slightly.



Figure 5. Right-hand escapement platform.

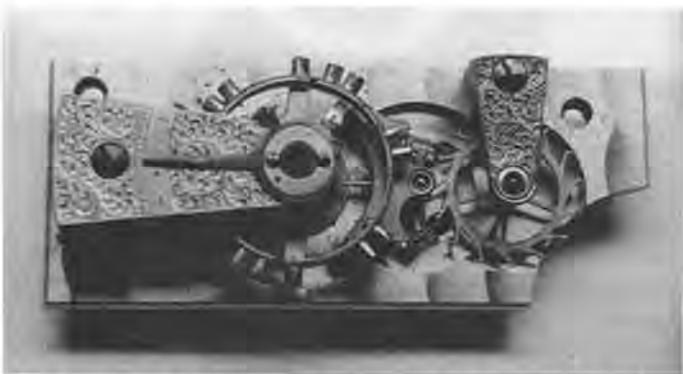

Figure 6. Left-hand escapement platform. Note the differences in orientation of components with Figure 4.



Figure 7. Movement with one hour dial removed.



Figure 8. Removing the friction tight winding guides and winding pinion. Note the minute recording pinion and its white porcelain dial.

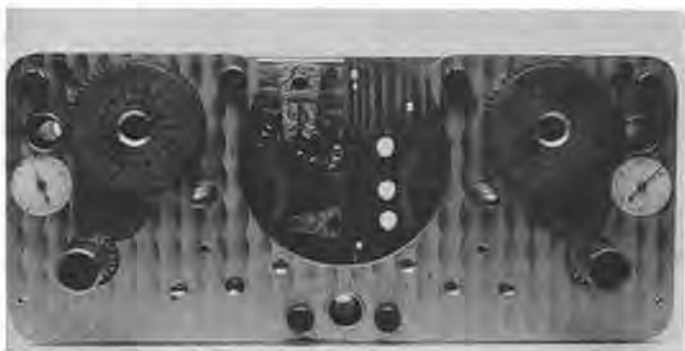

Figure 9. Platform escapement removed, after blocking 4th wheel.



Figure 10. Removing the stopworks screws.

c) Pull off the stopwork gears (Figure 11).
 d) Slowly let down the remainder of the mainspring power by controlling the speed of the train with the let-down key.

6. Remove the three barrel retaining screws and pull the barrel (with mainspring enclosed) from the arbor, twisting the arbor clockwise to release the inner terminal hook (Figure 12).

7. Remove the "hours-of-run-time" (wind indicator) dials and intermediate gears (one each screw) (Figure 13).

8. Remove the indicator hand (friction fit) (Figure 13).

9. Remove the top plate screws and lift off each train bridge (Figure 14).



Figure 11. After putting slight pressure on the mainspring arbor in the direction of wind, the stopworks can be removed.

The new QTM 901 is the most complete diagnostic test meter on the market. It is designed by a watchmaker, for a watchmaker, and is watchmaker affordable.

The QTM 901 tests:

- 1) Magnetic pickup of coil.
- 2) Battery and circuit output voltages.
- 3) Current consumption.
- 4) Coil resistance.
- 5) Watch mechanically.

It has a variable voltage power supply, is easy to use (one 7-position switch), and video tapes are available for demonstrations. **Available from most material supply houses.**

THE BEST PART!
All this for only \$395.00!

For information,
 call or write:

**FINN TIME
 PRODUCTS, INC.**
 200 Lake Avenue
 Suite 202
 Lake Worth, FL 33460
 (407) 533-1103



**P
 CC Precision
 Crystal Cutting Co.**

"For All Your Watch Crystal Needs"

**SAME DAY
 SERVICE**

SATISFACTION GUARANTEED ON ALL WORK

Suppliers of All Major Crystals Expert Crystal Cutter
 With 10 Years Experience

**LOWEST
 Prices in the Country**

SHIP TO:
Precision Crystal Cutting
23940 Eureka
Taylor, MI 48180

Reference &
 Price List
 On Request

(313) 287-3480
FAX (313) 374-2927 (24 hrs.)

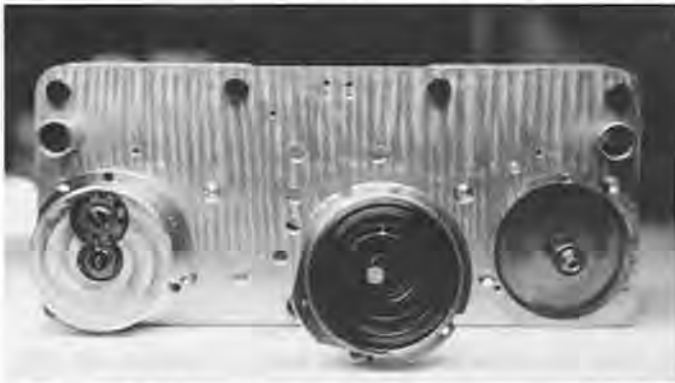

Figure 12. Barrel with mainspring removed.



Figure 14. Both movement trains exposed.



Figure 13. "Hour-to-run-time" wheel removed along with idler pinion and minute recording hand.

10. Remember to keep ALL parts from each train side separated, mark major pieces, and put each train's wheels into separate baskets.

CLEANING PROCEDURE

1. Pre-clean this movement completely disassembled, keeping parts from each movement separated. Pre-cleaning can be accomplished using either ultrasonics or by hand using a presoak in a good metal degreasing solvent, followed by a thorough scrubbing in a recognized clock cleaning solution. Rinse completely and dry.

2. Movement inspection and repairs are done at this point (Figure 15), followed by the checking of train side shake, end shake, and freedom.

3. Re-clean the entire disassembled movement using any acceptable clock cleaning method. Rinse with a commercial clock rinse solution and dry using heated, moving air to prevent any residue from forming on the movement plates and components.

4. Peg each pivot hole and jewel hole completely, using frequently resharpened pegwood to provide thoroughly clean pivot hole surfaces.

5. Clean each pivot in pithwood and inspect and clean all wheel and pinion teeth by passing through pithwood if needed.

6. Completely disassemble the balance hole/cap jewel assemblies. Clean in "One Dip" hairspring cleaner, blow dry, and scrape and peg hole and cap jewels with pegwood.

7. Clean the balance wheel and hairspring as



Figure 15. Extreme pivot hole wear in the train bridge. Note the two previous repairs using a prick punch in an effort to move metal into the severely worn holes and thereby trying to upright their respective train wheels. Note, also, a previously installed bushing. It showed almost no wear even after many years of service.

sembly in "One Dip" hairspring cleaner and dry in clean, sifted "jewelers" sawdust.

8. Remove mainsprings from the barrels using a mainspring winder. Wipe with a solvent-soaked cloth and dry by pulling the springs through a clean, dry, lint-free cloth, being sure to use a clean section with each pull.

REASSEMBLY PROCEDURE

1. Lubricate the mainsprings by wiping with a quality mainspring grease (by hand) and reinsert in their respective barrels using your mainspring winder.

2. Lubricate the main wheel ratchet teeth and install in the lower plate (Figure 16).

3. Assemble the train wheels, winding indicator pinions, and the three spacer sleeves. Check each wheel for its proper side shake.

4. Lubricate the idler gear mounted on the inside of each top plate with a quality clock oil (Figure 17).

5. Replace the top plate being sure to mesh the idler gear with the dial drive wheel before securing the plate into position. Check each wheel for proper end shake and the train for freedom.

6. Install the lubricated mainspring barrels onto the lower plate, being sure that the inner terminal of each spring curves snugly around their respective arbors



Figure 16. Main wheel winding ratchet and clock recessed on the underside of the main wheel (barrel side).

and the hook on each is hooked into the inner terminal holes.

7. Put the escapement into "perfect" beat.

8. Lubricate the platform escapement pivots and balance pivots using a high-grade watch oil. Remember to put a light touch of oil on the pallet fork pivots along with a small drop of oil on each pallet stone face and three teeth



Figure 17. Idler gear on top plate connecting the main wheel with the hour wheel.

of each escape wheel.

9. Install the two escapement platforms, gently sliding them into place so as not to damage the escape wheel pinion and the 4th wheel as they mesh together (Figure 18).

10. Lubricate the train wheel pivots with a light clock oil, including the winding indicator pinion pivots, the pivots of the two dial arbors, and the upper and lower barrel arbor pivots.

11. Prewind the two mainsprings two full turns of the winding arbor. If the repairs are done correctly, both movements will start running.

12. Install the stopwork gears on each barrel so that the large tooth prevents the springs from unwinding

GLASS STARTER SYSTEM



● CRYSTAL GRINDER		\$237.50
● F-BLK-50 ASS'T —	1 GROSS FLAT UNFINISHED TEMPERED BLANKS (1 mm. flat in variety of shapes)	\$171.50
● RG-1 ASS'T —	1 GROSS REGULAR BLANKS (inside height with no walls)	\$205.00
● VIDEO TAPE —	FITTING GLASS WATCH CRYSTALS	\$29.50
		\$643.50
	SPECIAL PRICE TO INCLUDE ALL OF THE ABOVE	\$550.00

In addition, each system includes a Vernier Gauge, Crystal Cement, practice crystals/bezels, and finished and blank crystal catalogues.

ORDER FROM YOUR WATCH MATERIAL WHOLESALER

AMERICAN PERFIT CRYSTAL CORP.

653 Eleventh Ave.

New York, NY 10036

further (Figure 19).

13. Wind each movement four more full winds and adjust the timing rates on the rate recorder with the movement in a vertical (normal operating) position.



Figure 18. Installing the platform escapements by gently sliding into position.

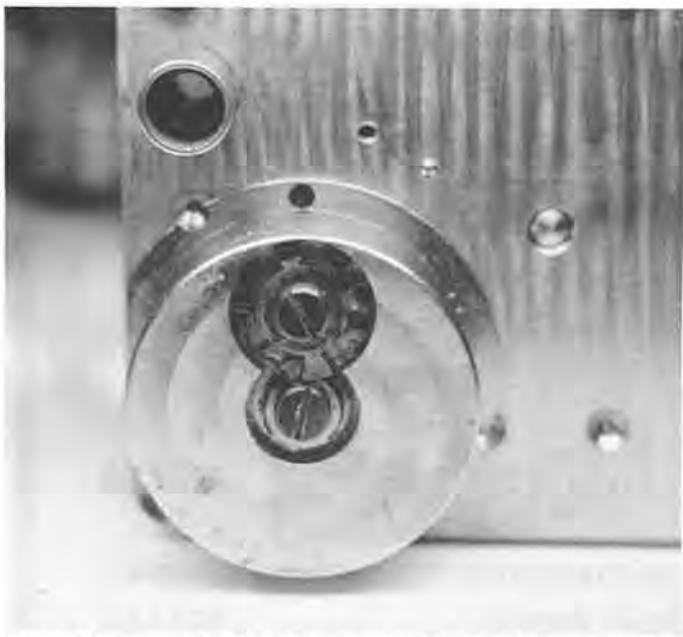

Figure 19. Stop works installed after putting two full winds on the main spring so that the large tooth can prevent further unwinding of the main spring.

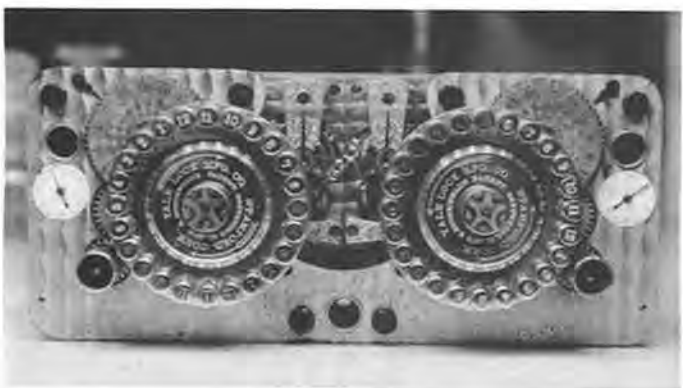

Figure 20. Dials and indicator hands replaced on the movements.

14. Wind each movement fully and recheck the timing rate.

15. The dials and indicator hands are now placed on the movements and set to indicate the current time at the top of each dial (Figure 20).

16. Allow the movements to run for 24 hours, periodically checking the time indicated by the dials to assure proper functioning.

17. Dry clean the timelock case, levers, pivots, and block.

18. *DO NOT* lubricate the levers, pivots, and block of the timelock mechanism.

19. Install the movement into its case (Figure 21).

20. Wind the movements fully, set the dials to an opening and closing time, and allow the movements to run, checking to see that the entrance hole in the side of the timelock case is properly unblocked at the preset opening time and then becomes blocked again at closing (and remains so until opening time the next day). □

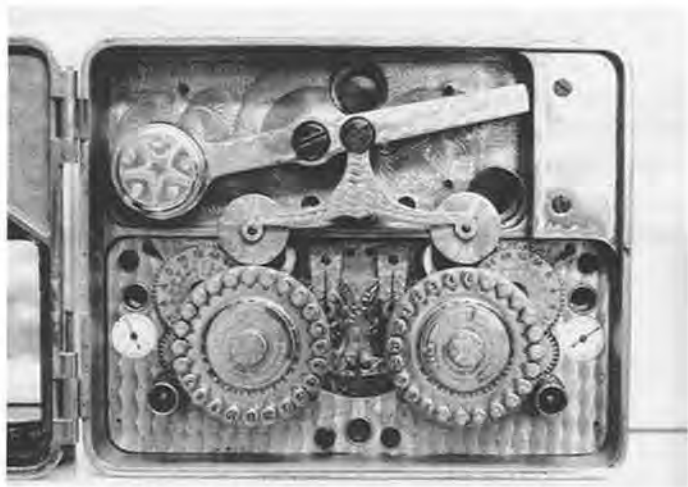

Figure 21. E. Howard movement re-installed in its timelock case.

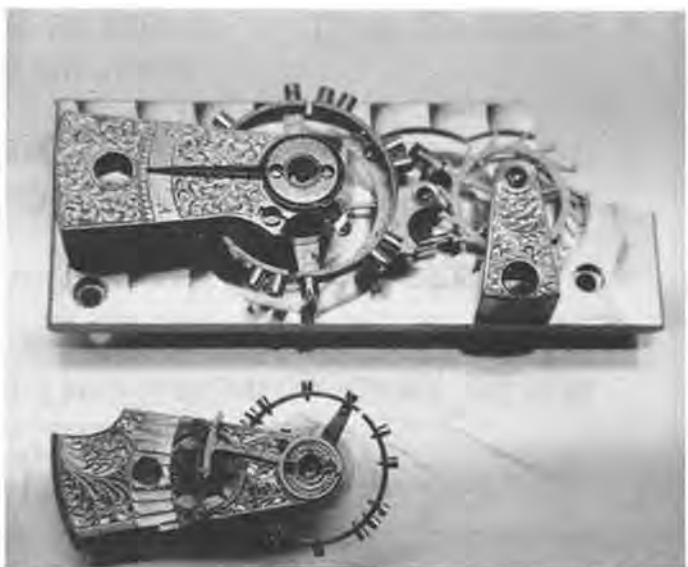

Figure 22. Size comparison between the E. Howard balance and platform with an 18 size Elgin balance assembly and bridge.

Clock Timers

Getting Started

Part II

by

Tom Dorman, CC

Last month we discussed how to get a valid reading of a clock's rate using a timer. If a standard was provided for the clock, or if one has been calculated by counting the train, then the clock rate can be set.

If no standard is available, a practical test can be set up so that an error correction can be calculated. By noting the error over a measured interval a correction factor can be applied to the measured current rate so that a new rate is determined. This method is also useful when the published standard does not result in a clock running at a good rate. It should be noted that the method is not original, but has been published elsewhere, and in any case is just basic error correction math.

A key to getting a useful correction factor is to take care setting the hands to the correct time of day. Some clocks have slack at the minute arbor which allows some free play in the minute hand. If the hand

is to the right side it may fall downward, to the left side of the dial it may fall downward, but this time it would show a time that is one or two minutes different from the time it showed on the right side of the dial. To remove this factor it is recommended that in all cases the minute hand should be gently moved counterclockwise to take out this slack before reading the time.

Write down the time of day when the clock is set to the correct time. Let the clock run at least 16 hours. Taking the above precaution with the minute hand, determine how many minutes fast or slow the clock has run. Divide the *minutes* elapsed into the minutes in error. This is the Error Fraction (EF).

Take a fresh reading of the current average rate. The clock should be disturbed as little as possible before taking this new reading, as it probably provides a more stable reading than that taken before the beginning of the test.

Eccentric Escape Wheel

(Four Pallet-to-Wheel Positions)

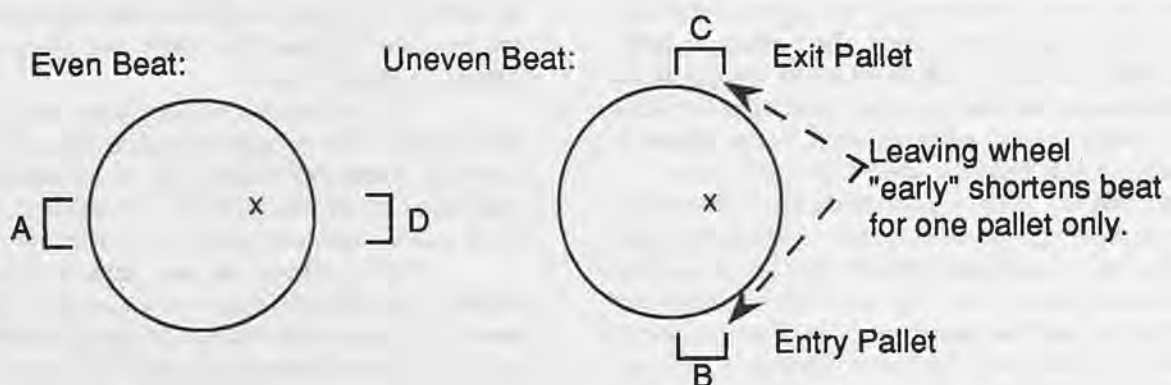

To **increase** the value of the current reading:

$$(EF + 1) \times \text{Current Rate} = \text{New Rate}$$

Add "1" to EF, then multiply times current rate.

To **decrease** the value of the current reading:

$$(EF - 1) \times \text{Current Rate} = \text{New Rate}$$

Subtract "1" from EF, then multiply times current rate.

The above calculations dodge a fundamental difference between timers that will be mentioned briefly. Some timers measure the time between ticks, or milliseconds (MS). Others measure beats-per-hour ("Train"), or beats-per-minute (BPM). It is left to the reader to think through the relationship between "faster" and less time between ticks (MS), or "faster" and more beats-per-interval, as it applies to their timer. Having done this, the reader will know whether they need to increase or decrease the value of the current reading to adjust the rate appropriately.

The accuracy of the new rate will depend on how carefully the following factors were handled during the test period:

- (1) Setting the minute hand carefully, dealing with slack.
- (2) Observing time at the end of the test, dealing with slack in exactly the same way as in (1), and correct time of day to the same reference.
- (3) Accurate estimate of any fractions of minutes gained/lost in addition to whole minutes gained/lost.
- (4) Knowing exact length of test, in minutes.
- (5) Consistency of the clock rate over the test period, and during the new run period after adjusting the rate.
- (6) Accuracy of the stable readings taken during the adjustment actions.

Point (5) above calls attention to a special strategy which must be followed if the clock is mainspring-driven. Some escapements, like dead-beat, are fairly insensitive to mainspring power. They run about the same rate when the spring is fully wound as they do on the eighth day, although wear or adjustments in the escapement can interfere. On the other hand, recoil escapements often show a serious lack of isochronism over the eight days.

To produce a rate that deals with this variable, all mainspring clocks should be regulated with the spring a little over half-wound. The clock should be wound about one turn after each day of the test period to try to use the same section of spring each day. After the standard and/or apparent rate is established, the clock might be expected to run fast when fully wound and slow by the eighth day, being

about right over the whole week.

The standards derived by counting train may not result in a clock that keeps good time. Strike and chime unlocking, normal wear patterns, manufacturing tolerances, lubrication and undetected corrosion may contribute to small differences between clocks. While a correct repair may call for isolation of these causes, in many cases the above correction routine may be applied to achieve a satisfactory rate. Therefore, it is a good idea to write down the time of day when time is set on every clock. If it runs fast or slow, but at the correct standard, then a correction factor can be calculated if desired. Such clocks require more test time to make sure the rate will be correct week after week.

SETTING BEAT

Timers that provide for an odd number to be put into the beat counter can be used to set the beat. With a "1" in the counter (or a "3" for short pendulums), the value from tick-to-tock will be nearly the same as tock-to-tick when the clock is in beat. If a "3" is put in the counter, we are finding a weighted average beat, more heavily influenced by two left-going beats than one right-going beat in the first number, followed by two right-going beats plus one left-going beat in the second number that comes up. While not quite as accurate, it serves well when the pendulum or balance is fast.

We have a chance to view, in numbers, an error that is inherent in all escape wheel clocks. The tips of the escape teeth never fall on a circle that is exactly concentric with the escape arbor pivots. Not all teeth exactly reach a best-fit circle, either. This means that each tooth will be released for escapement at a different point in the swing of the pendulum than the previous tooth. As we march around the escape wheel and observe the readings given in the timer when the pendulum goes to the left (ignoring those when the pendulum goes to the right), we will see that the values increase around one half of the wheel as we proceed to the high point and then decrease as we proceed to the low point of the eccentricity.

If we look at the values only when the pendulum is going to the right, the same thing will be observed. If we try to watch both sets of values, right vs. left, we will see that they are marching around opposite each other.

All this means is that if we set the beat of a clock when the escape wheel is exactly at the high point or at the low point of the eccentricity, the clock will have an optimum beat. At all other points, the beat will be affected by the eccentricity.

With a timer, we can look for the minimum value when the pendulum is going to the left, and then the minimum when it is going to the right, and set the beat so these values are the same. In this way, we can be sure the pendulum goes as far past the point of escapement to the right as it does to the left.

This is a more optimum beat than the usual method of listening to two adjacent beats and setting the crutch so they are equal. With the timer we can see that unless the audible method was used at the high or low points, the beat would be wrong on one side of the swing or the other.

This method also gives us information about when an escape wheel should be topped. If the range of values when the pendulum is going left, for instance, varies by more than 5% of the average left-going value (approximately), topping will improve the eccentricity of the escape wheel significantly. What this means to the clock is that it will run longer in the face of contamination, low lubrication, and non-vertical placement. As the excursion of the pendulum decreases, it will reach the point of escapement failure sooner if the escape wheel is eccentric.

Topping an escape wheel is relatively simple with a lathe. Assume the escape pivots are concentric with the arbor, and chuck the arbor in the lathe. Set the tool rest well away from the escape wheel and make sure it is solid so it can't slip toward the wheel in any way. Put a fine or medium India stone flat against the rest, and turning the escape wheel the direction it takes in the clock, slowly move the stone toward the wheel teeth. Not turning too fast, allow the stone to touch the high area of the escape wheel without following its eccentricity. At first, a 'runk-runk' sound will be heard as the stone touches only the high teeth. Gradually, there will be a sound all around the wheel, indicating that all teeth are the same height. Finish the back side of all teeth with a fine stone to remove the kerf raised and to restore the tip width, but do not remove any metal from the tip as this will negate the concentricity achieved. Any teeth that were bent or broken should have been fixed before this operation so now the wheel should produce much more uniform ranges of values on one side of the pendulum swing, and of course on the other, but not with the same exact values. It is now much easier to set the beat as above, or even by the audible method.

This concludes the two-part series on use of the timer. Feedback on this article and use of timers in general is welcomed, and can be sent to the author via the *Times*.

If you have any ideas to share with the *Horological Times* staff, send you letters to:



**AWI CENTRAL
3700 Harrison Avenue
Cincinnati, OH 45211**



**OK,
WE ADMIT IT:**

**YOU'D
PROBABLY RATHER
BE THINKING
ABOUT SOME WILD
TROPICAL PARADISE
THAN ABOUT
WHERE YOU'RE
GOING TO PLACE
YOUR NEXT
WATCH MATERIAL
OR TOOL ORDER.**

**BUT, WHEN YOU DO GET AROUND TO IT...
WE HOPE YOU'LL THINK ABOUT
GIVING US A TRY!**

DAVIS SUPPLY

**333 W. CHURCH AVE., S.W.
P.O. BOX 1140
ROANOKE, VA 24006
(703) 345-8040**

**ORDER: (800) 533-6293 IN VA: (800) 533-1523
FAX: (703) 344-5153**

THE WATCH BAND COMPANY

**702 Overlook Avenue
Cincinnati, OH 45238
Local Phone: (513) 621-4199
Fax Line: (513) 651-5624
(800) 927-7832**

This Month's Specials



Q240

18MM BLK	PCS X \$2.50 =
20MM BLK	PCS X \$2.50 =
18MM BRN	PCS X \$2.50 =
20MM BRN	PCS X \$2.50 =



8000

16MM BRN	PCS X \$1.75 =
18MM BRN	PCS X \$1.75 =
20MM BRN	PCS X \$1.75 =
16MM BLK	PCS X \$1.75 =
18MM BLK	PCS X \$1.75 =
20MM BLK	PCS X \$1.75 =



L8000 LONG

18MM BLK	PCS X \$2.00 =
20MM BLK	PCS X \$2.50 =



S622

18MM BLK	PCS X \$3.00 =
18MM BRN	PCS X \$3.00 =



7000

16MM BLK	PCS X \$1.75 =
18MM BLK	PCS X \$1.75 =
16MM BRN	PCS X \$1.75 =
18MM BRN	PCS X \$1.75 =

0130

08MM BLK	PCS X \$2.50 =
10MM BLK	PCS X \$2.50 =
14MM BLK	PCS X \$2.50 =
10MM BRN	PCS X \$2.50 =
12MM BRN	PCS X \$2.50 =
18MM BRN	PCS X \$2.50 =

***SATISFACTION GUARANTEED
**WE PAY SHIPPING ON PRE-PAID ORDERS
SUGGESTED RETAIL \$10.00 to \$15.00**

TOTAL: _____

LATHE WORK

Part II

Construction of the Center Locator Tool

By J.M. Huckabee, CMC, FBHI

Let's construct a center locator tool. This is one of the most important tools in miniature lathe work. It is easy to build and will serve as an excellent exercise for the student and craftsman alike.

It is of utmost importance that our center drill and locator fit with essentially zero clearance. This requires making the center drill and the locator drill from the same piece of raw material. Further, the locator drill should be made inordinately long in order to assess alignment during drilling. Observe the length of this bit in Figure 10.

Raw material for the bits is best in a pre-hardened form and cutting edges ground to shape. My choice is a piece of music wire from the local hobby store. A diameter of 1 mm is suitable for mid-

size clock work. A 36-inch length of this wire is less than a half dollar in my area. While there, pick up a 1-foot length of 5/32 inch brass rod and a 1/2 inch wood dowel. The entire cost is on the order of \$2.00.

Music wire is too hard to saw or file. The best cut-off method is the edge of a grinding wheel. Be cautious not to permit the material to become heated, as that will spoil the ultimate cutting edge.

Looking again to Figure 10, examine the tip of our long spade drill. Grind the tip as you would a watchmakers screwdriver. Make the tapered area about 4 diameters long. Our objective is to maintain as much rigidity as possible, even at the expense of chip-space. When the shape has been completed, finish the tip angle and cutting edges with a small hand-held oil stone. Be sure the respective edges are

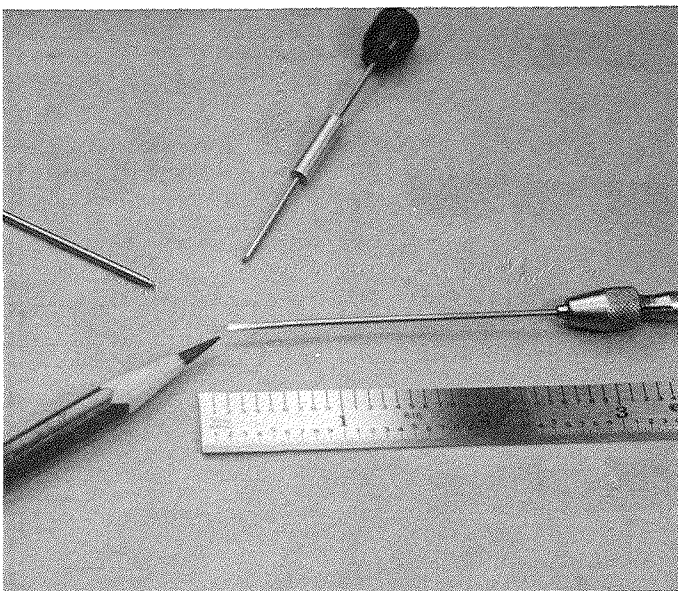

Figure 10. We need a long spade bit to drill the deep locator hole.

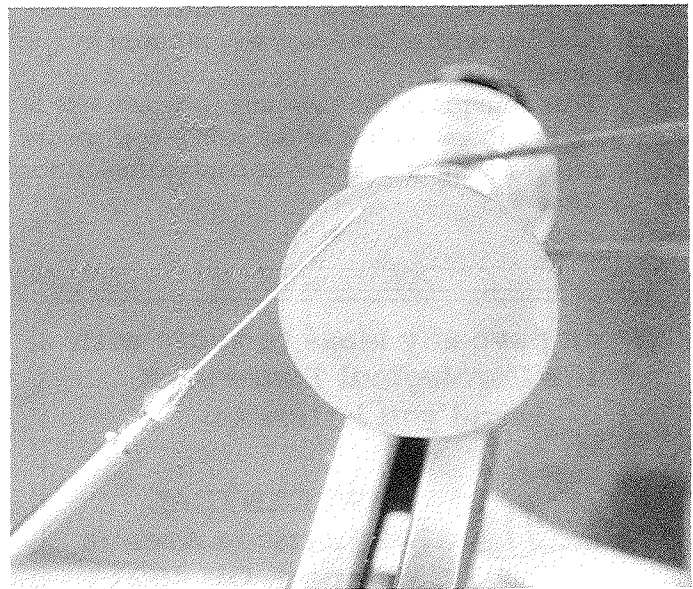

Figure 11. Making the spade drill bit on a grinding disc.

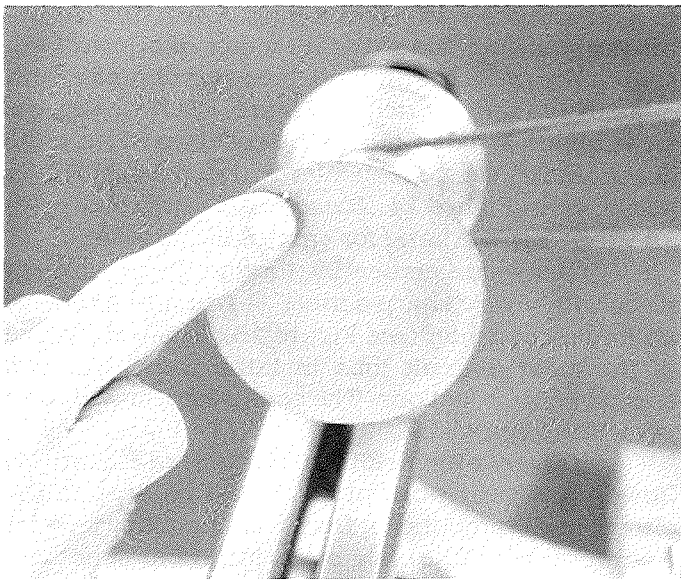

Figure 12. Hold a finger on the drill bit to detect heat.

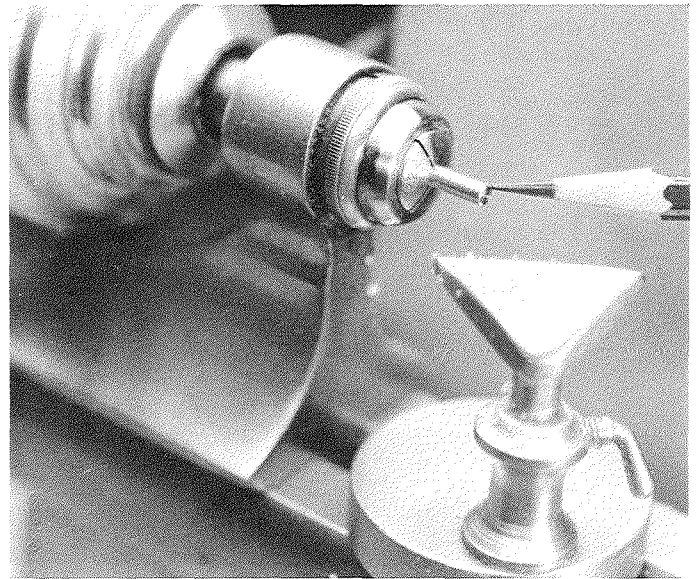

Figure 13. Face and chamfer the locator stock.

symmetrical and sharp.

Turn your attention to Figure 11. Our grinding disc is a piece of 240 grit aluminum oxide abrasive paper cemented onto a small wood backing. Drive the disc at high speed and touch the surfaces alternately, frequently inspecting symmetry of the

progress. My method of doing this is shown in Figure 12. Rest a fingertip onto the work piece. This reduces bounce and gives an assessment of the heat generated.

With our drill bit finished we prepare the raw material for our locator. Cut a piece of brass rod

AMERICAN WATCHMAKERS INSTITUTE
1991

JOHN A. DOE
000 SMITH ST.
NOWHERE, OH 12345

MEMBER

00000
1/82
0000
CMW

Membership Number Month Billed Certification Number Type of Certification Year Joined

Alice S. Carpenter President *Paul H. Smith* Secretary

Your AWI membership card signifies that you are entitled to the many services offered by your association. However, we must have the correct information from your card to be able to serve you most efficiently.

This illustration points out the important, coded information on the right side of your membership card. Always use your AWI membership number when corresponding or ordering from AWI.

1992 HOROLOGICAL TOUR WITH HENRY FRIED

On May 4, 1992 the 18th annual AWI Horological Tour will be highlighted with attendance at the World Expo in Spain's Seville. Auspiciously, we start in Paris with its historical and dramatic sights and entertainments which include attendance at the Follies Bergere. Horologically, we will visit the French industry headquarters and a factory. For the collector, the Museum of et Metiers is one of the world's best and most interesting. A planned meeting with officers and members of France's ANCAHA, the equivalent of America's NAWCC collector group, will be included. Other Parisian attractions such as the Louvre, famous Marche de Pouce (flea market) beckon as well.

With our Parisian headquarters of three days we also visit the Chateau country nearby, a must even for those who've been to Paris before. We also visit Blois, the origin of enameling on watches in the 1600s. The Chartres Cathedral, whose beauty of construction, stained windows, original engineering construction and architecture (and probably one of the most photogenic sundials) which attracts scholars, art historians, and architects, will be on our list of visits.

A French "Bullet Train" ride to Geneva will provide an opportunity to visit the Patek Philippe factory and museum to which we have been invited as well as other famous watch factories, time permitting. The Geneva horological museum also contains many rare examples of the horologists' art. In nearby Anemasse, a name familiar to watchmakers, is a factory producing for this industry. On a clear day from Lake Geneva, one can see the peaks of Mont Blanc, highest in Europe. However, not only can we see it from Geneva, but we will visit it at hand. From interesting and attractive Chamonix, we ascend this great mountain to its 12,610-foot level by cable car, where it is possible to see into three countries.

We leave Geneva for Spain's capitol, Madrid. The Prado museum is one of the world's finest. Madrid itself has a clock and watch museum as well as the famous Royal Palace collection of clocks acquired by Charles III, a rabid clock buff in 1770. From Madrid, we travel to Seville via their latest high-speed train. Seville, famed in history, opera legend and drama will in 1992 be the site of the World's Expo '92. We will visit the Fair for a full-day visit with meals. Going into southern Spain, we visit the clock and watch museum in Jerez de Frontenac, owned and operated by the owner of one of the most known bodegas. In our visit many years ago, the tour director, horologists, and guides were most gracious hosts.

With our headquarters in Marabella, we will radiate daily to memorable Malaga, Granada, Costa Del Sol, Fuengirola, the Generalife and other places en route. On this tour, all meals will be provided. Write for the detailed brochure and join us for a memorable experience and good fellowship.

Horologically and touringly yours,

Henry B. Fried

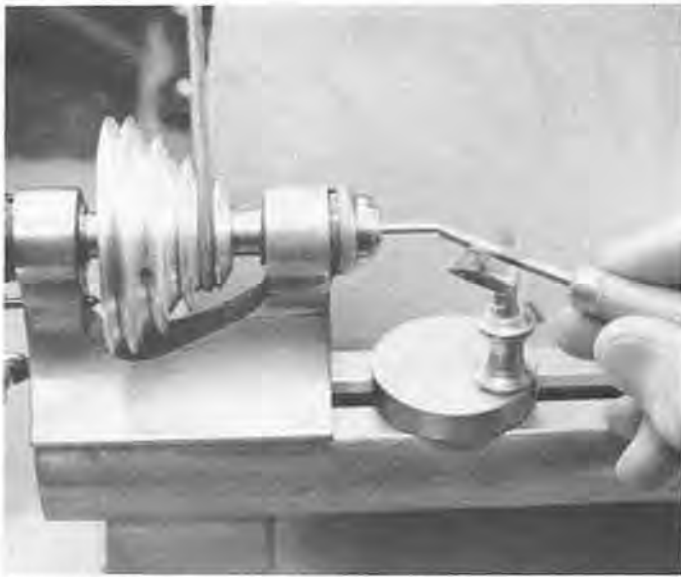

Figure 14. Locate exact center with a pointed graver.



Figure 15. Test truth of running center with a very sharp scribe.

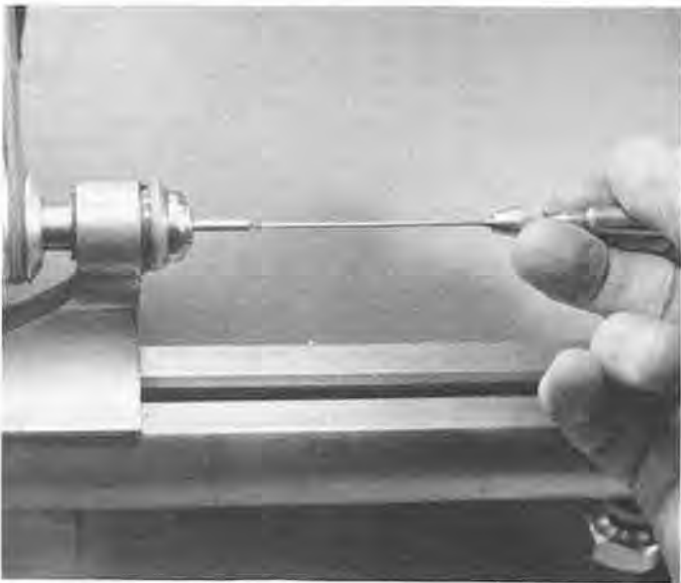

Figure 16. Drilling the locator with a long spade bit.

to approximately 16-18 mm long. A suitable diameter is about four times the diameter of our drill bit. Chuck the piece to run true, face and chamfer both ends. This is illustrated in Figure 13. Now slip the piece about 3/4 depth into the collet and locate the exact center. We locate center with a pointed graver as shown in Figure 14. These views were made with an excessive overhang for ease of illustration.

Test your center by touching the running piece with a very sharp scriber. A trimmer indicates an imperfect center (see Figure 15). This step is one of the most difficult jobs in lathe work, but this should be your last one. The center locator will solve your future problems.

Observe the drilling operation in Figure 16. Remember, your work piece should be deep in the chuck; and watch the bit from front and top views for a straight entry. The bit has very little chip-space and will need to be withdrawn frequently. Use a generous amount of lubricant.

With the hole completed, cut the cup-center before the piece is removed from the lathe. This assures concentricity of the hole and cup. Exchange ends with the piece and see if the hole runs true. If the hole runs true, cut a cup in this end also; otherwise, just deburr the hole exit.

Next we will prepare the center drill. The material should be from the adjacent piece of stock that the previous drill was made from. Cut to length, chamfer the ends, and drive into a piece of the wood dowel about 15 mm long. A pre-drilled hole of smaller size will serve as a guide and a little white glue helps lock things in place. Chuck this up by the wire section and hold the outside end with a point center. The dowel should be held very close to the chuck. Cut to suitable shape and mark a dot in three equally spaced positions of the knob. The dot is on the knob small end of Figure 17.

(Please turn to page 34)



Figure 17. Grinding the center drill bit.



Fred S. Burckhardt

Give Me a Real Live Person

Usually smile when people talk about the "good old days." I can remember when some of those "good old days" weren't so good. There are some things I surely do miss. One is talking with a person on the phone.

Answering machines are good--for what I don't know. Have you ever heard this before?: "This is Ding-Dong. I can't come to the phone right now, but if you would like to leave your name and number, I'll get back to you as soon as possible." Then the voice hurriedly says, "Wait for the bee---."

That's the message you usually hear when you try to call a customer to tell them their watch or clock is ready. Six months later they call back and say, "Is my watch (or clock) ready yet? You told me you would call."

My favorite is when you call another business. This is when you get the business from the business.

"Thank you for calling 777-9644. If you listen carefully to the directions, your call will be directed to the proper department. If you have a touch tone phone, press 1. If you have a rotary dial phone, forget it; you'll never do business with us . . .

"Thank you for pressing 1. It doesn't do anything, but we wanted you to get some practice. If you want watch material, press 2. If you want clock material, press 3. If you want watch *and* clock material, press 4. If you want the jewelry department, press 5. If you want to order watch and clock material *and* jewelry, press 6. If you want the findings department, press 7. If you want watch material and findings, press 8. If you want clock material and findings, press 9. If you want jewelry and findings, press 10. If you want watch and clock material, jewelry *and* findings, press 11."

. . . This goes on for two hours or until they reach 123, whichever comes first. The other day I got up to 94. This was: "If you have been in the business over 40 years, don't want to order anything, but would like to enter our contest to win the Grand Prize, two fun-filled weeks with members of the Russian coup, you'll have to hang up and dial 777-9645." So you hang up, dial the number, and go through the same thing.

There was one time when a *real live person* came on the line. It was someone who worked there and was trying to get an outside line but pressed the wrong button. When I told her who I was, there was a moan and the phone went blank. I had to dial again and go through the numbers. I must admit, there were a few brief shining seconds. Even the moan sounded good.

Not all companies have systems like that. A few even let you talk to a person. It's debatable if they *are* real or not, though. One time I asked for the material department, and this is what I got: "Hello, this is Angela. I'll be taking your order today. First tell me your name, address, zip code, phone number, and account number. Please don't go too fast; my pencil has lead in it . . . heh, heh, heh."

I felt like throwing up, but I gave her the information. Then she said, "Please give me the manufacturer's name, the model, the part name, and our stock number. Everything must be in that exact order."

I said, "I don't know what your stock number is. Can't you look it up?" I realize I should never had said that. I sensed she was getting flustered and was starting to panic.

"I'm not trained to look up stock numbers. You're getting me all confused."

I said, "Relax. Isn't there someone who can look up the numbers for you?"

"I don't know," she answered. "I've never had a request like this before. Hold on till I check." I could hear her whimpering.

In a few minutes, a stern voice came on the line asking, "What is it you need?"

When I told him, he said, "If you don't have our stock number, we can't help you."

I then said, "How can I find your stock number if you can't tell me?"

"We don't have time to look up stock numbers," he replied. "We used to years ago, but business slowed down and we had to get rid of some help and cut down

(Continued on next page)



Figure 18. Backside of the grinding disc.

Examine Figure 17 for the relationship of the center drill and grinding disc. This illustration is to develop the idea; it's really a two-hand operation. I hold the locator and rotate the knob to produce a conical tip, and then grind the three sides. A single knob-marker is in view in Figure 17. I hold the position such that two markers are in view, touch down, then turn until the next two are in view, etc. It is best that each facet is visited several times. Touch down lightly as the delicate tip is easily annealed by over zealous grinding. Inspect frequently by looking directly into the point. It is necessary for the point to be on center. In use, this center drill has the same problem as any tool having an extremely fine edge. Be sure to use lube and go easy on the pressure.

A word about the grinding disc: This is a piece of 1/8 inch brass rod about 2-1/2 inches long pressed into an undersized hole of a piece of 3/4 inch long dowel of about an inch in diameter. All surfaces are turned true. The wood disc is a piece of 1/8 inch plywood about 2-1/2 inches in diameter. This disc is attached with white glue and four small nails. Turn the disc true in round. Abrasive papers are affixed with rubber cement and then cut to disc diameter. In use, the disc may not run true in flat. If so, just flex the shaft a little until it runs essentially true. In operation, the disc flexes and does not present the problem associated with an untrue stone. Use this to sharpen gravers, to rework screwdrivers, tweezers, etc. It's a real joy to use! See the backside in Figure 18.

A word of caution – keep your lathe bearings flooded with oil during and after grinding.

As our center locator tool shows, most difficult work can be made easy with a simple tool. Don't expect to find all of them in a catalog; most must come from your own creative thinking.

□

ROCK QUARRY

(Continued from previous page)

on the service. Things still aren't looking too good."

"Gee, that's hard to understand," I said. "Thanks for your time."

I called another supply house on their WATS line. There was no problem, except after taking the order, the clerk said, "Is that all?"

I said, "Yes."

She said, "We have a minimum charge for orders taken on the WATS line."

"Fine, whatever it is, I can understand," I said.

"You know this line costs us money, so we have to have a minimum charge."

"I know, I know. Charge me whatever it is," I said.

Then she came with the blockbuster. "You know we are having a new phone system installed. When you call, all you have to do is follow the instructions and you will be directed to the proper department."

"Sounds like a good idea to me," I replied. "Be sure to let me know when it's in operation. I can hardly wait!"

□

KEY TEST FOR QUARTZ WATCHES

The "KEY TEST FOR QUARTZ WATCHES" by Ewell Hartman, CMW is a quick and simple method of locating the problem in a quartz analog movement. The only tool required is a meter.

Material and instructions for learning this test are supplied by the AWI-ELM Trust as part of their educational work. There is no charge to any group wishing to learn this test. There are great benefits to learning this in a group setting. However, for individuals who may not be able to participate in a group, it is available to them also.

For more information call or write to the AWI office for an information sheet and application form.

□



Marshall F. Richmond, CMW

JEWELRY CRAFTING AND REPAIR MORE PROBLEM JEWELRY REPAIRS

Previously we have discussed problems in ring repair which were mostly directed at gold and silver (hard soldering), and possible solutions for some of them. In this article we will try and broaden out into other problems that arise with other articles of jewelry, even them being often corrected using hard solder.

METALS BANDS

A problem that was recently brought to my attention pertains to catches on watch bands. These often result in being a jewelry repair rather than a watch repair. There are many types of watch bands and bracelets with catches, sliding buckles, ratchets, and other types of fastenings, and it would be impossible to cover all of them (especially in one article), so I'll start with the ladies' metal bands. Some are detachable from the watch, so it is possible to replace them. Others are welded to the case and are not replaceable as a band; so if a buckle, catch, or part is broken or lost, sometimes they can be ordered from the material house and the part replaced. However, the material house often cannot identify it, or even if they *could* the watch manufacturer can't or won't supply it to their approved material distributor. Therefore, the answer you get is to send the watch to the manufacturer and maybe they will replace or repair it.

There are several good assortments available in watch bracelet buckles, and with these probably most jobs can be repaired by replacing the buckle from one of these assortments. Being a jewelry craftsman I can usually find a way to repair catches, buckles, broken links, or replace missing hinge pins, screws, or rivets by making and installing them, so it is very few of these jobs that have to be returned to the customer not repaired. Many of these ladies' bands on new watches are brought in to have the band shortened, and most of them have a tolerance of maybe one half inch that it can be shortened, but if the shortening is done with one side of the buckle then it doesn't want to let the buckle center under the wrist when the watch is centered on the top of the wrist. As the opposite side is welded or gold-soldered to the band to

move, it will require heating until the solder flows to remove it in order to cut some off the band. But if it is electric spot-welded, it will have to be cut off, and the piece of end remaining in the end of the buckle filed or ground out, then gold-soldered back in place.

As most watches today are plated, heat will have a tendency to discolor the metal where heated. Much of this discoloration can be eliminated if the article is dipped in a solution of boric acid and alcohol, then set afire and let burn off, which will leave a coating of boric acid. This coating will keep the metal from oxidizing when heat is applied, as the discoloration is caused by oxidation. Before making repairs on these types of bands, you should explain to the customer what the risks are; they might not be willing to take the risk for the repair.

Most buckles found on men's watches today are the fold-over type with an adjustment made by removing a spring bar that is in a pair of holes that are in a series of holes. The band end can be moved to about a maximum of five eighths of an inch and a minimum of one eighth inch, as there are six holes an eighth of an inch apart. As these spring bars are replaceable, lost or broken ones create no problem. However, the hinges are usually connected with a pin that is riveted on each end, and when these are broken or lost, it is no large project to find a piece of rivet wire the correct diameter, rivet one end while holding in a pin vise, inserting it, cutting it off leaving enough to rivet the other end, and then rivet it with a ball end of the chasers hammer. Most of these are stainless steel, so if any breaks must be repaired they can be done with gold or silver hard solder using Aircasil flux. This will work on ferrous metals where the regular flux for nonferrous metals will not. The soldering process is the same.

CRACKS OR CHECKS IN KARAT GOLD

One of the outstanding problems that I have encountered in working with karat gold rings is the porous metal often found where the shank widens out to form the top of stone-set or signet rings. This is usually found in cast rings and rarely found in die-struck ring mountings. Although

when the ring is left for sizing or repair it may show no signs of cracks or checks, after it has had the size changed and the ring rounded out on the ring mandrel, these checks begin to show up. If the ring has been made smaller, these checks will show up on the outside of the shank; if larger, they are more apt to show up on the inside of the ring. There can be several theoretical causes for this, and trying to explain this will neither keep the checks from forming nor will it correct the problem, so I will explain how I usually cover them up.

First, if the ring has stones that will stand boiling, I boil it in sulphuric acid pickling solution which will loosen any dirt down deep in these crevices--if not remove them. Next, it is cycled through the ultrasonic tank using a strong jewelry cleaning solution. Then it is boiled in clear water that removes any residues of the cleaning solution. Steam is even better, but most small shops do not have steam cleaners, so boiling in water is next best.

Solder flux is next applied, then small flakes of gold solder (the same karat as the metal in the ring), spacing them in different areas over the checks, and then applying heat with the torch. It is important to flow the solder over the surface, then apply heat on the other side of the metal which will draw the solder into the crevices. It is equally important not to use too much heat to boil the solder, for when polished, pits may show in the surface. This defeats the purpose of trying to cover up flaws in the metal so it can be polished smooth. Sometimes these cracks can be burnished closed with a burnishing tool, and when polished they are hardly noticeable.

MISSING OR BROKEN PRONGS

Another especially pesky problem that every so often arises is a missing or broken prong on a ring with some stones that will not take heat, such as opals, emeralds, amethyst, or pearls in multi-stone rings. Even putting a solder tip on a broken prong is almost impossible without removing stone(s), regardless of how it is shielded or whatever shielding compound may be used. If one prong is broken off, then there is a pretty good chance that others are weak and will not stand the removal and resetting of stones. Also, if the prongs on other stones are badly worn, it needs replacing prongs and/or settings to be able to make a satisfactory repair. Yet with the cost of replacing prongs and mountings, if there are very many to replace, the cost can easily surpass the value of the ring when completed.

Mothers' rings with several synthetic stones can usually have prongs re-tipped or replaced without removing the stones. However, even the synthetic stones in May or August (greens) will sometimes break when heated and must be replaced. Since these are not very expensive, the risk can be taken if the estimated cost of repair is adequate to absorb the extra cost. On many of these rings which have four-prong settings and only the tip of the prong is worn, a solder tip can be put on the tip over the edge of the stone, and when finished after polishing looks like the original prong before wear.

An old master jeweler once told me a good rule to follow on the choice of re-tipping and replacing a prong:

If the metal is still over the edge of the stone, a solder tip is usually sufficient. But if the tip does not go over the edge of the stone, the prong should be replaced. One observation that I've made is that if a prong is worn off, the metal is not porous; but if it is broken off when magnified, the end where it is broken off will be rough and porous. Therefore, you would probably be correct in assuming that the other prongs would also be porous. So if the stone needs to be removed and reset, probably all prongs should be replaced.

PRONG REPLACEMENT

Replacing prongs is a very complicated repair. In learning to do this, the start should be made using rings with a four-prong setting and a stone that will take heat without damage. After becoming proficient and comfortable doing these simple prong jobs, the next step is six-prong solitaires using the same type of stone that will stand heat.

Next, after mastering this, you can advance to doing rings with two or more stones in a straight line single row. Multi-row or multi-level settings can be attempted, especially if the prongs to be replaced are on the outside edge or ends.

Getting the experience is best done on multi-stone diamond rings because the chance of damage to the stones is minimal if all precleaning and preparations have been correctly made. The outside prongs can be either replaced or re-tipped as the wear indicates. Replacing inner prongs can be nearly impossible because getting the heat into the base where the solder needs to be flowed is difficult. Where the prong is broken off down at the base of the setting between two rows of stones, I sometimes use a small drill (.8 mm or smaller). I'll drill a domed seat in the spot where the prong is broken off. Then taking a piece of gold wire with a small amount of gold solder flowed on the end, seat this in the domed seat while the heat is being applied. I usually have steady enough hands to hold the wire in a pair of locking tweezers in place while heating until the solder flows. If I do not feel that my hands are steady enough for a particular job, then the use of the third hand tool will allow it to be held in place while being soldered.

There is no end to the problems that prongs can cause as there are so many different types of settings and requests to repair them.

BEAD REPLACEMENT

Bead replacements on bead-set (flat settings) can also create special problems. One way that I have used to replace worn or missing beads is to use a solder ball with a karat gold center and apply it with a solder pick.

Preparation of the work is very important, for the ring must be absolutely clean in order to control the flow of solder. I often drill a domed seat where the bead has been first, then flux. A small chip of karat gold is snipped from a piece of gold wire with side or end cutters placed on the heat pad and fluxed. When heat is applied, it will form a small, almost perfect sphere. A small chip of solder can be clipped from a thin strip the same way using the end or side cutters, fluxed, and placed on top of the karat (Please turn to page 38)

PENDULUMS

PART 4 TEMPERATURE EFFECTS

By Henry B. Fried,
CMW, CMC, FAWI, FBHI, ★FNAWCC



Our definition of a simple pendulum is one using a weightless string connected to a bob. Actually such a pendulum is impossible in a clock because the pendulum rod itself will weigh much more than any string. Therefore, any other than the scientist's simple pendulum is called a compound pendulum. All clock pendulums are of this compound variety.

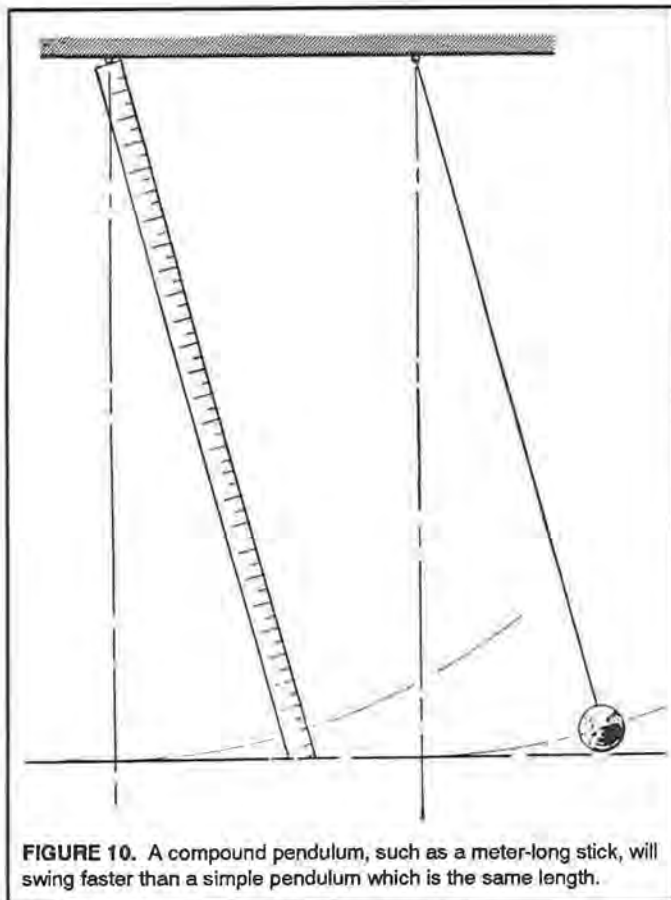

FIGURE 10. A compound pendulum, such as a meter-long stick, will swing faster than a simple pendulum which is the same length.

We measure compound pendulums from the point of suspension to the center of the weight, as demonstrated earlier in *Figure 3* (*Horological Times*, July 1991). With a simple pendulum the balancing point is just above the center of the bob. Should we make the rod heavier or bulkier as in a compound pendulum, it would swing faster. The balancing point, or center of gravity, would be higher up on the bob, or maybe even shift to a point on the rod itself.

Examine *Figure 10* in which a simple pendulum is compared to a meter-long stick with an overall length near that of a second pendulum, 39+ inches. Should we suspend the stick and start it swinging, we discover that it makes 72 oscillations to the minute. Its effective length is $2/3$ of its overall length, or about 26 inches. The point at the 26th inch is called the center of oscillation. This is, theoretically, where all the mass would be if it was concentrated at one point.

Thus we see that a compound pendulum, such as in *Figure 11*, measuring about 55 inches overall, will swing in unison with a simple pendulum which is much shorter. In this case, the gridiron section above the massive bob adds so much weight to the section above the rod that the overall length has to be extended.

COMPENSATING FOR TEMPERATURE

When Huyghens first used pendulums in clocks over 300 years ago, timekeeping accuracy improved from a matter of hours to a matter of seconds! Precise timekeeping, however, was out of reach as long as the pendulum elongated in heat causing it to swing more slowly, and contracted in the cold, hastening its beat.

Chart A lists the expansion rates of different metals and materials. Actually, the resulting expansion or contraction is minute, affecting each pendu-

CHART A:

Material	(Coefficient of Expansion) Expansion for 1°C in 1 million cm length	Change in rate for 20°C in seconds per day
Aluminum	25.5	22
Antimony	12.	10½
Brass	18.9	16½
Bronze	16.8(0-85°)	15
Copper	14.48(0-38°)	13
Glass	8.33(0-100°)	7
Gold	15.52(0-100°)	14
Iron	12.10	10½
Invar	.5	0.4
Lead	25.08(0-100°)	22.
Nickel	12.79(40°)	11
Silver	18.8	16½
Wood		
Beech	2.57(2-34°)	2¼
Mahogany	3.61(2-34°)	3½
Oak	4.92(2-34°)	4½
Pine	5.41(2-34°)	5
Ash	9.51(0-100°)	8½
Steel	11.00	9½
Zinc	26.28	23

0° Centigrade = 32° Fahrenheit; 100° Centigrade = 212° F.

$$F = \frac{C \times 9}{5} + 32 \quad \text{example:} \quad \frac{20^\circ C \times 9}{5} + 32 = \frac{180}{5} + 32 = 36 + 32 = 68^\circ F$$

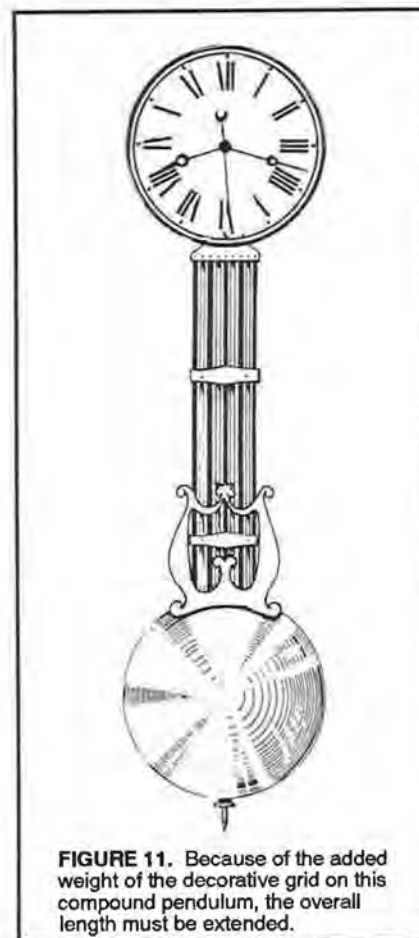

FIGURE 11. Because of the added weight of the decorative grid on this compound pendulum, the overall length must be extended.

lum swing in micro-seconds or less. Yet each tiny variation of a second pendulum added 86,400 times a day, which amounts to considerable error due to temperature changes alone! In order to understand the changes in recognizable figures, the length standards of the materials are purposely listed long.

We see that a pendulum rod made of aluminum would expand or contract so greatly in heat or cold that it could cause a change of about 22 seconds in the daily rate of a clock, comparing summer and winter extremes.

A brass rod pendulum acts only slightly better. Invar, an alloy of iron and nickel, from which good balance wheels and hairsprings are sometimes made, makes the best pendulum rod. An invar rod remains practically the same length in both heat and cold. However, it is too expensive for almost all but the most precise and expensive clocks.

One of the cheapest commodities and one of the best for our use is wood. It is usually highly varnished to prevent moisture absorption. The rod is profiled to a lens shape, streamlining it against air currents.

It would seem from the chart that beech would be the best wood for a pendulum rod. Most wooden rods are made of pine, highly shellacked; some are made of mahogany.

In 1726, George Graham, a famous English watch and clockmaker, invented a pendulum which compensated for the expansion and contraction of

PICKLE BARREL

(Continued from page 36)

gold sphere. When heated, this will flow over the sphere, making a sphere larger, which is in fact a karat gold sphere with a gold solder coating. With the solder pick, this can be set in the drilled dome, and heat applied. The solder will flow down to the setting, leaving the karat gold bead in place ready to finish, which can be done with a beading tool or a cup bur.

It seems that the biggest problem we have is people. It has always seemed to me that over 95% of the people that were customers were good people, easy to get along with and please. The other 5% can cause enough trouble to make a person want to give up . . . But much of the problem we have with people is a lack of communication. So, it might be a worthwhile project to make up an information sheet that is given to each customer explaining policies, warranties, risks that can be involved and who should assume what risks, *whenever* taking in a repair. A delicate stone is one example of a risk, and should be the risk of the customer. A high enough charge should be quoted to cover any stone replacements that might be needed.

In next month's article we will discuss repairs of pins, bracelets, jewelry catches, and the use of findings such as jump rings, spring rings, and chain repair.

□

the rod during temperature changes. About the same time, John Harrison introduced another variation. Both types are still in use and are known by their inventors' names.

USING MERCURY

The Graham pendulum uses a simple mercury thermometer as its principle. This is illustrated in *Figure 12*. We all know that mercury will rise and fall in a tube as the temperature changes. In *Figure 12*, the long steel rod expands as the air grows warmer causing slower swings. But the mercury rises in the tube about 15 times as much as the steel rod lengthens. Assuring correct dimensions, the corresponding rise in the mercury offsets the lengthening of the steel rod. Thus the center of gravity of the pendulum remains at the same length.

Some mercury pendulums use twin iron jars instead of the showy single glass jar. Of course, the iron is less breakable and it does conduct temperature changes more rapidly than thin glass.

Many short fancy mantle clocks feature twin glass jars of mercury, but these are more a sales point than a step toward precision. The exact proportions of mercury to the other measurements of the pendulum are seldom obeyed. Some cheaper varieties show silvered dowels encased in glass tubes to simulate a mercury pendulum.

BRASS COUNTERACTS STEEL

The Harrison pendulum uses the difference in ex-

pansion rates of two metals--brass and steel--to compensate for temperature changes. Under heat, brass expands about twice as much as steel does.

Study the diagram in *Figure 13*. Steel rod *A* rests in stirrup *B*. Two brass rods *C* connect *B* with a scaffold *D*. Steel rods *E* are riveted to *D* and joined below to the plate *F*. Rod *G* is suspended from the center of this plate. A lens-shaped iron or lead bob rests on this rod.

When the long steel rod *A* expands downward, the shorter brass rods *D* expand upward, slightly more in proportion than *A*. However, the connecting steel rods *E* stretch downward, with the result that the overall length of the pendulum remains the same.

Exposed to cold, the Harrison pendulum reacts in the opposite manner. It is commonly called a gridiron pendulum; a typical one appears in *Figure 14*. It usually has nine rods--five of them in tension. The steel rods are pulled upon by the weight of the other parts of the pendulum, while the brass rods act like pillars under compression from the parts which they support.

Many decorative clocks have fake gridiron pendulums of alternating polished steel and brass rods, all riveted together to cross-bars above and below. These do not compensate for temperature changes at all. Such a clock is shown in *Figure 11*.

Other fine pendulums compensate for temperature with telescoped tubes rather than rods of different metals. This method provides a more com-

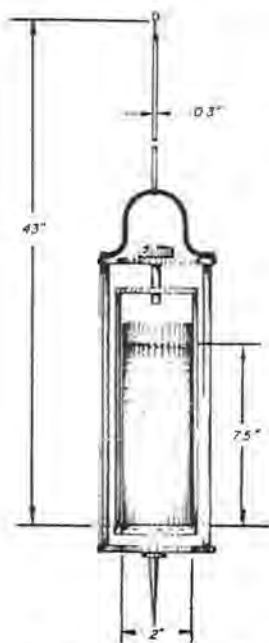

FIGURE 12. The Graham pendulum suspends a jar of mercury within its framework. As the steel rod lengthens in heat, mercury rises, maintaining the center of gravity.

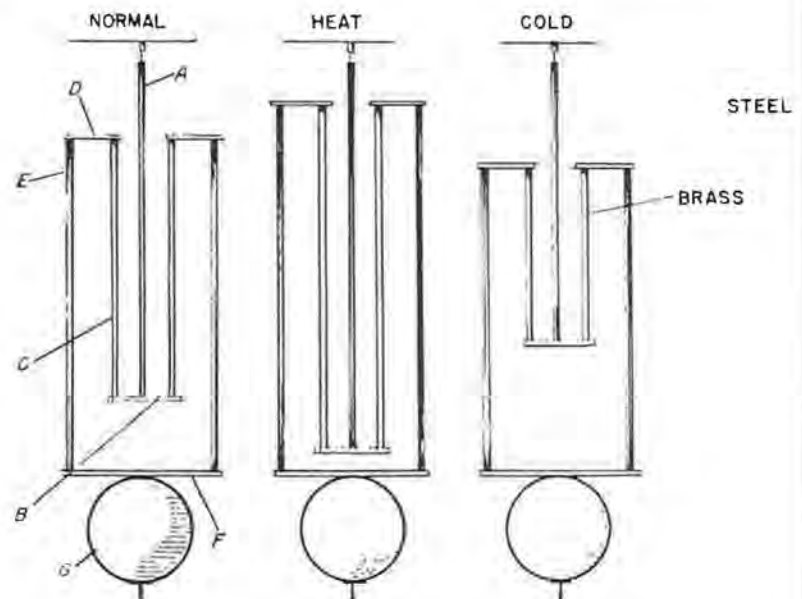

FIGURE 13. The Harrison pendulum uses the different expansion rates of steel and brass to compensate for temperature change. As steel rod *A* stretches downward under heat, brass rod *C* pushes upward and steel rod *E* down. The length of the pendulum remains the same.

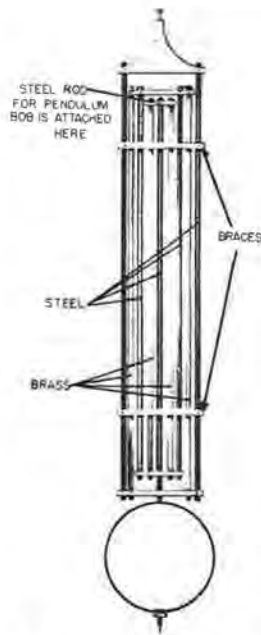

FIGURE 14. During temperature compensation, steel rods are pulled down while brass rods act as pillars under compression.



FIGURE 15. An inverted pendulum concentrates its mass in the clock movement. Adjusting the height of the ball regulates the beat.



FIGURE 16. Rear view of the inverted pendulum clock shows the point of suspension where the pendulum pivots on a stud in the wall or often from a statue's hand.

pact pendulum rod, lighter and quicker to react to temperature changes. The most notable example of this type is the great clock at the Houses of Parliament in London, sometimes called "Big Ben" ("Big Ben" is actually the name of the great bell, not the clock).

THE METRONOME

An entirely different device and a variation of the pendulum is the metronome, used to count rhythm in music. It was invented in the early 19th century by Leonhard Malzel. Beethoven marked the second movement of his Eighth Symphony 88 beats per minute--an impossible formula before the metronome was invented.

This device uses an upside-down pendulum with an adjustable bob. Sliding the weight up the rod slows the beat; moving it closer to the pivot point hastens the beat.

The principle of the metronome is used in the clock shown in *Figure 15*. The movement is contained in a ball above the point of suspension which is also the pivot point. The movement serves as a counterweight to slow the motion of the pendulum. It is regulated by raising the bob for a slower beat or lowering for faster timekeeping. It is possible with this clock to make the pendulum beat seconds or slower.

□

Saving Your Horological Times?

Well, if you are . . .

. . . we have the answer to protecting and organizing your magazines. Our leather-look binder holds 12 issues (one volume). End the frustration of searching for back issues or trying to remember technical details that you just *know* you've read. If you are interested in organization, send a check or money order in the amount of **\$8.95** to **HT Binders, P.O. Box 11011, Cincinnati, OH 45211.**

Allow 3 weeks for handling and delivery.

BOOK REVIEW

COMPLETE PRICE GUIDE TO WATCHES, No. 11 by Cooksey Shugart and Tom Engle. 5-1/4" x 8", 630 pages, fully illustrated. Published by Cooksey Shugart, 1991 @ \$20.00.

Of this new edition's 630 pages (50 more than the previous edition), 245 are devoted to wristwatches. Of the 50 new pages, 40 also are of wristwatches, mainly those in the high-end price range and more desirable to collectors and dealers.

Most of the editing and changes appear to have been concentrated on wristwatches. Those in the upper range also show some price changes. An Agassiz World Time, for example, listed in the 1990 edition estimated at \$16,000 is revalued at \$4000 less, currently. Chronograph watches show modest appreciation while wristwatches in the lower price end have depreciated much, some even being omitted from this new edition.

Waltham wristwatches show some models declining in value while others of the same brand just holding onto last year's estimates.

Audemars Piguet, although becoming better known, has received much attention by the editors, yet show depreciations in values at the auctions. There are 70 Audemars Piguet wristwatch models represented here. One, a cushion-shaped minute repeater, appraised in last year's guide at \$120,000, has lost \$20,000 in estimate in this current issue. The wrist Audemars with self-winding and visible tourbillon at its upper left has also shrunk in estimate from \$18,000 to \$10,000.

Watches with mundane name labels also show a depreciation in this current guide. The Cartier name and products, however, have held their ground value-wise. Auto-grille-form also have held steady price attractiveness.

The American names such as Elgin and Gruen show little change as have some Hamiltons, but the previously much-desired Hamilton Ventura, the pioneer, odd-shaped electric watch, has decreased. Hamilton incidentally is represented by more movement photos as are Elgin and Waltham in this newest book.

The LeCoultre label as well as Longines in the medium price range show little if any changes but their higher priced watches show some decline from 1990 values. The Mido "Mystery" watch, priced last year at \$350, has jumped to a \$1000 ticket in this current volume.

Of the 250 Patek Philippe wristwatches in the 1991 publication (compared to 237 Pateks in 1990), most indicate a decline. Rolex watches suffer but a negligible

change. This new edition illustrates 200 Rolex models compared to the 133 pictured last year.

Universal, Vacheron & Constantin also show some decreases although a previously pictured minute repeater with a \$80,000 label has jumped to a new high of \$110,000.

Pocket watches strangely have shown a strong comeback according to the authors and their team of appraisers. For the most part, these have increased in value. The new edition also shows a good representation of additional pocket watches.

The authors also have endeavored to remove some of the errors and ambiguity and virtually all in the 11-page Watch Terminology with some improvement in the general text.

While the 1990 edition with its 574 pages appears thicker (1-3/8") than the new 630-page 1991 edition (1"), the editor-publisher states that the paper quality of the new, though thinner, is superior in quality and durability.

The Table of Contents in this new publication has its page edges printed with black tabs adjacent to the subject. This continues on each page at the same height for each topic. Thus, viewed edgewise, while not indented, it appears as in some dictionaries. This is designed to permit quick and easy location. The Table of Contents also lists the beginning and last page of each topic in this table.

In all, the 1991 (No. 11) edition is a more complete volume than its predecessors, containing illustrations of movements, individual names, and history of the various American and European watches shown within its covers. It also contains methods of arriving at values, tips on buying at auctions, and many other instructional facets helpful to the collector or dealer as well as serving as a very good identification and age guide.

Henry B. Fried

□

Are You Using Your
AWI Identification Mark?
If Not, You Should Be!



Plique-a-jour and Silver Soldering Techniques

I recently took a course in plique-a-jour enameling, taught by Valeri Timofeev from Moscow, Russia. It was held at the Thompson Enamel Company in Bellevue, Kentucky. The Thompson Company went to great expense to bring several top artists in different enameling techniques over from Russia. This was just another small step among many others that this company has undertaken to preserve the art of enameling. Thompson Enamel is the only remaining manufacturer of glass powder for enameling in all of North and South America. And we think watchmaking is a dying art.

Valeri is one of the top enamellers of plique-a-jour in the world. He has been in numerous exhibits in the United States, Europe, and Russia. His works are exhibited in museums in Russia.

Plique-a-jour is like cloissone in that colors are separated by thin strips of silver, gold, or copper wire. The difference is that cloissone is done against a background, and plique-a-jour is not backed by any metal. It looks like a stained-glass effect: small glass windows held in place only by thin strips of metal

around the edges.

The reason I took the course was to get a better understanding of the process involved, since plique-a-jour was used in jewelry and timepieces for many years. What I got was the basics in jewelry making. For the course we were going to construct a 1-inch by 1-inch square with a hexagon pattern inside, similar to a honeycomb. Then once the metal frame was constructed, we were to fill the holes in with glass. See Figure 1 for a diagram of the individual pieces before they were soldered together. But the first problem was that we had to fire the whole piece in the kiln at 1450 degrees F. This required the solder to have an extremely high melting point in order to fire it in the kiln. On the other hand, the solder had to be easy flowing enough to solder fine silver wires together without melting or distorting them.

I asked Valeri where he purchased his solder, and his answer was that he made it. He used 72% fine silver and 28% copper. These were mixed together in a crucible and the ball was then ground up into small particles using a coarse file. Now we had a solder that could be applied with a small paintbrush in very small amounts--one that would flow easily before fine wires burn up or get distorted.

Figure 1

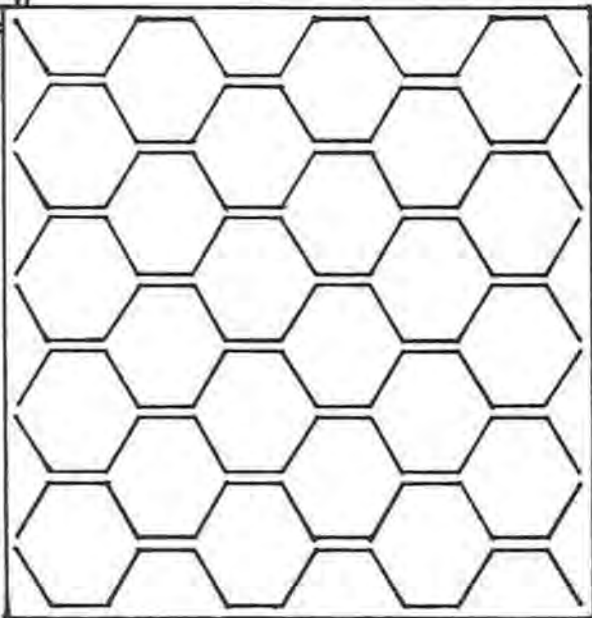

Figure 2

Another problem was that no alloy could come in contact with the glass. Once you heat an alloy in the kiln at 1450 degrees, there are gases released that affect the glass adherence. The second step of the process solved this. We removed the copper from all of the soldered parts without disturbing the rest of the piece. This was a five-step process of heating the piece in the kiln at 1440 degrees for 1-1/2 minutes, and then placing the piece in a 5% sulfuric acid solution for five minutes. The furnace causes the copper to rise to the surface while the mild sulfuric acid eats up the copper and doesn't disturb the silver. Once this process is completed five times, all of the copper is removed, and all you have left is fine bright silver. This process can also be used on silver jewelry you are repairing if you don't want the yellowish solder to show. Another by-product of this process solves the problem which was making the solder harder so it would not break down under repeated firings for longer and longer periods of time. By removing the copper from the solder, the joints become much harder and resistant to melting.

Now back to steps involved in making the framework.

First, we constructed a square wire frame with 1-inch sides and soldered a jump ring across the open corner. The frame was constructed of a single piece of silver wire by filing notches every inch and bending at these spots. One of the most unusual things we did was glue the pieces of silver onto a piece of titanium with "Best Test Paper Cement." The cement holds the wires in place until they are all assembled into the square framework. The piece of titanium had small notches around the edges approximately 5 mm apart so that iron binding wire could be wound around the entire piece before soldering. This way the wires wouldn't move as the glue evaporated away. This whole piece was then dipped into borax and the small filings of silver solder were painted onto the joints with a small paintbrush.

Next diffused heat was applied so that the whole piece would heat up at once and all of the small particles of solder were sucked into the cracks. We then cleaned off the piece, inspected all of the joints, and soldered all of the spots that needed it.

Once all of the connections were checked, we could bend this square honeycomb to give it some style. I chose to bend mine around a dowel stick approximately 3/4 inch in diameter. Making the framework was the easiest part of the whole piece.



Figure 3

Applying the colored glass powder by mixing it with 20% solution of Klyr-fir and getting it to hold into the holes while firing it was the hardest part. After five or six firings and adding more glass powder each time a hole opens up, the piece is almost finished. It must then be stoned down and fired one last time. While it took me approximately 1 hour to form each of my honeycomb squares and assemble them, it took me 10 hours to fill in all of the holes with glass powder. It is a very time-consuming art and jewelry making procedure.

Figures 2 and 3 show samples of Valeri's work. The bases of the goblets unscrew and fit inside the egg formed by pressing the two cups together . . . Maybe some day I'll be able to make fine pieces like this. □

AWI Material Search Network

EDITOR'S NOTE: This column is designed to work in conjunction with the AWI Movement Bank. If you can supply any of the items listed here, please send details to the Material Search Network. **Do not send the items.** Members requesting these items will be advised of their availability and will contact you direct.

V4 Seiko crown - Case #6105-8000, Crown #65W01NS.

W7 Replacement movement for one shown here in good or repairable condition.



Setting
Parts



X6 Waltham 16s, 23 jewel, Vanguard Model 1623 or Model A, lever set, double roller, pallet complete, C/C pivots part #4839.

If you can supply any of these items, please contact: **AWI Material Search Network, AWI Central, P.O. Box 11011, Cincinnati, OH 45211; Fax (513) 661-3131.** □



HOW TO START AND MANAGE A BUSINESS PART 2

Selecting a business location can be one of the most important business decisions one will make. If we guess wrong, it could be quite costly to relocate at a later date.

HOME TOWN VS. ANOTHER TOWN

If we are locating in our own home town, part of our battle is won. We certainly know a lot more about our own home town area than we do about some other town. We still must consider all of the following factors--or should I say, we should ask ourselves the same questions--whether we decide to locate in our home town or in another town. Of course, we should know more of the answers about our own stomping grounds.

WHAT INDUSTRIES ARE IN THE AREA?

Does the town depend on one principal industry, and is that industry "governmentally controlled"--such as an atomic plant which may depend on political decisions for its survival? If it is an automotive plant, is it subject to closing due to relocation or foreign competition? How vital is this one industry in providing the work force for the area? Are there enough other industries around to indicate that a one-plant shutdown would not wreak havoc with the business community?

FARM AREA

Is this a farm area, and if so, to what extent do the successes of the crops affect the business community? Possibly there is a combination of farm and industry, and if so, we need to weigh the values of each based on our best judgement.

RETIREMENT COMMUNITY

If a retirement area is to be considered, we should establish whether it is considered a high income or low income community. There is good news and bad news here. Many retired people do not want to spend "big bucks" even if they have it to spend. They were born in an era of learning to save, and also they remember when

the prices were reasonable. Besides, they are saving some of their money for their "old age." If it's mostly repairs we want, old folks do have some old "turnips" (old pocket watches) to repair. Also, they will buy new watches for their kids--or we should say their grandchildren. They will have plenty of time to visit with us while we are doing a small repair job for them or selling them a new watch or other items. They will have enough time to explain how things were in the "good ole days," if we have time to listen.

WHAT'S THE ATMOSPHERE?

The paragraph above is a good example of a certain kind of atmosphere. If we have lots of patience and time to spend, then retirement community life may be a good business climate for us. If not, we may want to ride in the "fast lane" and consider a more lively community.

TYPE OF CLIENTELE

What type of clientele do we want? What type lives in the community that we're checking out? For some reason all areas are not filled with Pateks, and there is a need for repairs and sales on less expensive watches.

COMPETITION

How many jewelry stores (or watch repair shops) are in the town already? Will the town support another store? Will the addition of our store "divide the pie in too many pieces," or did someone retire and close a store so our new store will not increase the number of competitors? How close will we be to our nearest competitor?

Do we feel a need to be close to our competition, as people are used to dealing within a certain area, and we want to be a part of it? Or is the town growing and we want to move with it, and if so, in which direction?

IN THE TOWN--OR IN MALLS

Nowadays, just about every town has a mall in addition to their older downtown shopping areas. The choice is ours to locate our business in either of these areas. The

Figure 1

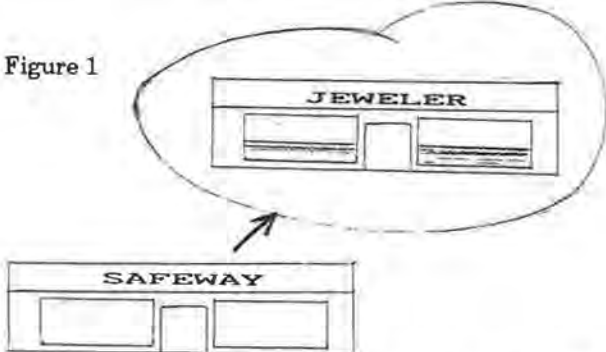

The older downtown stores have a better track record, or we should say history. This can be traced from "good sales for a number of years" to "good sales but falling off" to "everybody's moving out." With a mild amount of research, we can check on this before making our business location selection.

If we decide on the mall, we may even have a choice of an inside mall or a generally smaller outside shopping mall. The renters won't hesitate to charge the appropriate high-enough price. This will be explained in the contract which probably has two important points that we will want to carefully consider: 1) In addition to a rental fee, many malls like to collect a percentage of our monies from our business, and 2) Most of them will also insist that *our* business hours coincide with theirs (none of this 9 to 5 stuff).

Of course, if we don't mind the longer hours, we will learn an interesting thing about malls with their long hours. This fact is that with these long hours come more sales, and this is the stuff that malls are made of.

This is one of the major trade-offs: longer hours equal more sales.

On the other hand, if our overhead (including extra help) is not profitable because the extra sales do not pay for the additional overhead, we may be sorry. Let's read the fine print in our contract.

If we decide to locate in a downtown area, we will not have the same problems as in a mall. First, if we set up a store or a shop for ourselves, we are the boss and we set the 9 to 5 (or whatever) hours. We will not make those evening sales, but who cares? We do not need that extra help to man the showcases into the wee hours.

Another option is to buy a store or rent a building that was previously another type of business. For instance, I worked (served a four-year apprenticeship) for a jeweler who rented and had a downtown location. After these four years I went into the Navy during World War II (yes, I'm older than I look). Anyway, after the war, I returned home and found that the jeweler had moved. I thought at first he just wanted to hide from me, but this wasn't the case. A Safeway grocery store moved and sold the building to my boss. He remodeled this old store (Figure 1), changing it into a beautiful jewelry store. And yes, he hired me back. It wasn't until later I decided to open my own store. That's another story.

We will continue this subject next month. Get a good night's sleep, unless you work in a mall. If you do, you have no choice. □

PROJECT EXTEND

PROJECT EXTEND PROVIDES SELF-HELP EDUCATIONAL OPPORTUNITIES FOR: 1) *The newly trained individual seeking to gain speed and profitability.* 2) *The marginal or self-trained individual seeking to fill gaps in their training.* 3) *The experienced craftsman seeking to extend skills in certain specialties.*

In order to provide access to a maximum number of AWI members, there will be no tuition for the programs offered at the AWI Extension Development Center. Attendees will be responsible for their transportation and room and board. Motel rooms are available for approximately \$50 per day; most courses last five days. A limited number of grants will be available for those who need help with room and board.

PROJECT EXTEND'S TENTATIVE SCHEDULE

The course schedule presented here is **TENTATIVE**. However, those interested in specific programs are encouraged to register now. Class sizes are limited and registrations will be accepted by earliest postmark or fax date. Each class requires a registration fee of **\$50** which will be refunded when you attend the class. For specific course and registration details, please contact: **AWI CENTRAL, 3700 HARRISON AVE., CINCINNATI, OH 45211; (513) 661-3838; FAX (513) 661-3131.**

1991

Sept. 16-20	Jewelry Repair	Marshall Richmond
Sept. 23-27	Clock Repair III (restoration)	David Christianson
Sept. 30-Oct. 4	Clock Repair I (beginners)	James Lubic
Oct. 7-11	Clock Repair II (advanced)	Roland Iverson
Oct. 14-18	Clock Repair VI (striking & chiming clocks)	John Nagle
Oct. 21-25	Quartz I (beginners)	Gerald Jaeger
Oct. 28-Nov. 1	Quartz II (advanced)	Robert Bishop
Nov. 4-8	Watch Repair I (staffing, poising, and timing)	James Lubic
Nov. 11-15	Watch Repair II (hairspring vibrating and finishing)	Harold Herman

1992

Jan. 13-17	Clock Repair V (prep. and completion of CMC exam)	James Lubic
Jan. 20-24	Watch Repair VII (prep. and completion of CMW exam)	James Lubic
Feb. 10-14	Quartz III (prep. and completion of CMEW exam)	Alice Carpenter
Feb. 17-21	Watch Repair III (complicated)	James Lubic
March 2-6	Lathe I (beginners)	James Lubic
March 9-13	Lathe II (advanced)	Archie Perkins
March 16-20	Watch Case Repair	Marshall Richmond
March 23-27	Clock Case Repair	James Williams

Affiliate Chapter Column



Joseph L. Cerullo, CMW, CMC

How Proposals are Made to the AWI Board of Directors

This month I would like to recap the events of the Affiliate Chapter Meeting for those who could not attend this past June.

Our meeting begins on Friday morning at 9:00 AM and continues until our agenda is met. This is usually around 3:00 to 4:00 PM on Friday. During this time we personally introduce each delegate and his or her alternate present. We then have a Keynote Speaker from the industry to address us. This year we had Scott Chou from Seiko Time Corporation. Scott spoke to us about the importance AWI and the Affiliate Chapters have on the average bench watchmaker. They provide education and assistance in our daily work. Scott also spoke about the direction that his company and others are heading for in the near future. This direction includes both research, technology and after-sales service. It is more important than ever in these times of change to keep in touch with the industry, for sometimes it seems like the pace of change is increasing.

After our business is taken care of, each delegate present is given a chance to address the group and elaborate on the prepared report which was already submitted by each chapter delegate. During this time we review the delegates' reports and make notes of items which might prove to be helpful in running our guild. At the same time, an awards committee which has been appointed by the Chairman reviews each report for merit and consideration in selecting the Affiliate Chapter which has done the most for its members. This guild will receive an award for its efforts at Saturday night's banquet. This year's winner was the Horological Association of Virginia, and was accepted by their delegate, C.E. Hardy.

After considering any old business and new business, we continue with the reading of proposals from the delegates for consideration by the chapter delegates. These proposals would not require AWI Board approval and would only affect the running or function of the Affiliate Chapters. I've noticed in the past few years that there haven't been any proposals filed for our consideration. I'm not sure if this is good or bad. On one hand, it appears that we are doing everything right and that we don't require any change. On the other hand, that notion scares me! This is because I've never been part of a group which never had room for improvement. I believe that as a delegate you should take some time and think it over carefully when you draft

your annual reports.

Our next order of business is to begin hearing proposals for consideration by the AWI Board. Each delegate is given a chance to submit a formal written proposal for consideration. Each proposal raised requires a second from the chapter delegates; after a second is given, discussion begins to explore its merit and intent. After discussion, the Chairman calls for a vote from the delegates present. A majority vote will either carry or defeat the proposal. If the proposal is passed by the delegates, it is then presented to the AWI Board on Sunday before the conclusion of the Board Meeting.

The AWI Board hears the proposals from the Chapter Chairman, they also discuss them, and then they too vote on the proposal's merit. A majority vote will either pass or reject a proposal from the chapters. During the AWI Board vote, the Affiliate Chapter Chairman has a voting right as an AWI Director.

These proposals are an important part of our work. It is through these proposals that we can direct the AWI. This is the process that allows the average member to be heard and to effect a change in the system.

I believe that more effort should be made throughout the year to compile these proposals. This means that each delegate should petition his or her guild throughout the year for their suggestions. This will give the delegate more time to research the proposals or suggestions and decide whether they have merit and will benefit not only their group but the AWI membership in general.

One final thing you should remember as delegates preparing these proposals is that if they *are* approved by the AWI Board, they have to be acted upon. Therefore, if your proposal is a good one, but if its cost to AWI to implement it is excessive, you should give suggestions on covering the costs. Otherwise, the proposal might be voted down for financial reasons only.

Remember: Make your proposals specific in nature. And make them good for everyone concerned.

The following are those proposals submitted to the AWI from the Affiliate Chapters, and the results of the Board's voting.

**RESULTS FROM THE AWI BOARD MEETING
SUNDAY, JUNE 30th, 1991**

- (1) ARIZONA--The State of Arizona would like to request AWI to make contact with NAWCC in regard to trying to hold their yearly meetings on a different time schedule permitting members belonging to both organizations free to attend if desired. *Voting: In Favor*
- (2) ARIZONA--That AWI would be willing to work with or finance the Library Committee to study or produce a plan to convert some of our educational books on horological subjects to cassette tapes. *Voting: In Favor*
- (3) MASSACHUSETTS--To change the requirements for AWI delegates' travel to Affiliate Chapter Meeting funding. If an Affiliate Chapter meets the minimum number of 15 AWI members but not the 60% requirement, AWI will fund the delegates' travel in the ratio that that chapter has of the 60% rule. *Voting: In Favor*
- (4) NORTH CAROLINA--We request that AWI appoint a committee to look into the possibility of a credit union for members. *Voting: In Favor*
- (5) NORTH CAROLINA--We request that AWI print in the *Horological Times* the availability of the Constitution and Bylaws to the general membership and how they may be obtained. *Voting: In Favor*
- (6) NORTH CAROLINA--We propose that AWI provide their address and phone number on all membership cards. *Voting: In Favor*
- (7) NEW YORK--AWI compose a letter to all companies not providing material and/or technical information expressing the dissatisfaction of the watch repair trade. *Voting: Not In Favor*

*Total: 6 passed
1 failed*



UPCOMING CONVENTIONS

**New York State Watchmakers
Annual Convention
October 4-6, 1991
Waterloo, NY**

**Illinois Watchmakers Association
Annual Convention
October 18-20, 1991
Thelma Keller Ramada Inn -- Effingham, IL**

**Florida State Watchmakers Association
Annual Convention
October 25-27, 1991**

Association News

OPEN HOUSE

**WATCHMAKERS ASSOCIATION OF NEW JERSEY
EXTENDS AN INVITATION TO ALL**

**WATCHMAKERS, CLOCKMAKERS
HOBBYISTS & COLLECTORS**

**TO ATTEND OUR MONTHLY MEETING
NOVEMBER 12, 1991**

Our monthly technical programs and discussions will keep you abreast of the latest advances and servicing techniques. Have your questions answered by experts in all phases of horology.

We meet in the First Presbyterian Church on the corner of Springfield and North Union Avenues in Cranford, New Jersey. For further details, call Paul Richter (201) 797-1620.

NEW YORK



Pictured above are the recently elected officers of the Horological Society of New York. Front row (left to right): Frank Carpathia, executive committee and editor of *The Loupe*, Howard Fass, president; Ted Fishkow, vice president and financial secretary. Second row (left to right): Walter Pangretica, executive committee; Jack Schecter, executive committee; Ben Matz, recording secretary; Frank Loynaz, executive committee. Back row: Dan Richter, sgt. at arms; Howard Levy, trustee; Henry Loeser, executive committee; and Al Rudnick, executive committee. □

BULLETIN BOARD

A. NEW REQUESTS

TIME BARREL DIMENSIONS FOR SETH THOMAS 124

Martin Lepley, Meadville, PA, is servicing a Seth Thomas 124 chime clock and has reason to believe someone has substituted an incorrect mainspring barrel. We have a number of references on this clock, but none give the dimensions of the mainspring barrel. We would appreciate hearing from anyone who can provide this information.

H & R SUPERIOR CAPILLARY OILERS

Harold Neill, Houston Technical College, is seeking the person or firm who makes H & R Superior extra fine capillary oilers, stock #42130/1. Mr. Neill is aware that H & R is a trademark of Grobet USA-Hammel-Dixon (formerly Hammel Riglander) but this firm cannot supply these oilers and cannot or will not provide the name of the manufacturer. AWI had the same lack of success in obtaining the name from Grobet USA-Hammel-Dixon. Mr. Neill is of the opinion that a firm by the name of C.N. or C.R. Price is the manufacturer.

ETERNA-MATIC WATCH MOVEMENTS

This may not exactly be a "Bulletin Board" item, but Jim Lubic is in need of a variety of Eterna-Matic watch movements for use in Project Extend. We can offer you a tax credit for any you care to donate to our training program.

B. RESPONSES

UNITED METAL GOODS MFG. CO.

Trond Skullestad, Cupertino, CA, has offered to provide what James Campbell needs to service the United Metal Goods Mfg. Co. electric clock he has for repair.

SONCEBOZ CHART DRIVE TIMEPIECE

Robert Hoffman, Buffalo, NY, whose firm Buffalo Watch & Clock Repair services these clocks, was able to provide the address and phone numbers in answer to David Brown, Sr.'s request.

C. ITEMS STILL NEEDED

WATERBURY TIME & STRIKE MOVEMENT

Howard Wiseman, Norfolk, VA, has a Waterbury Clock Company Time and Strike movement which is 3-3/4 inches round and 1-1/16 inches thick (wide). He

describes his problem as follows:

The gathering pallet has two pins to pick up the rack, and this gathering pallet is attached to the two-pin strike wheel arbor. The problem lies in the fact that the gathering pallet will stop between the teeth of the rack regardless of the position or adjustments made.

Needless to say, the clock will not strike properly for at least one or two hours, then it will stick again as the time train moves it forward. This movement has a groove on the side of the hour pipe for the hour hand to be attached. There are no markings or numbers on the plates or wheels to identify the correct way to reassemble the movement properly.

If you are familiar with this movement and can offer suggestions for solving this problem, we would like to hear from you.

MISSIONARY'S CLOCK

Robert Trainer, Waverly, OH, has a customer who has been a missionary in India for many years and purchased the clock pictured here in India. Can anyone identify the manufacturer of the clock and give its approximate age?



On the back plate of the clock is engraved the name SOLDANO just below the hands setting stem. In the extreme lower left hand corner is engraved the number 1118. The strike select lever provides for silent, grand strike, strike.



LENZKIRCH A.U.G. CLOCK

Arnold McCloud, Newton, KS, has the clock pictured here for repair. If anyone has experience with this clock, Mr. McCloud would like details on setting up the strike and chime mechanism.

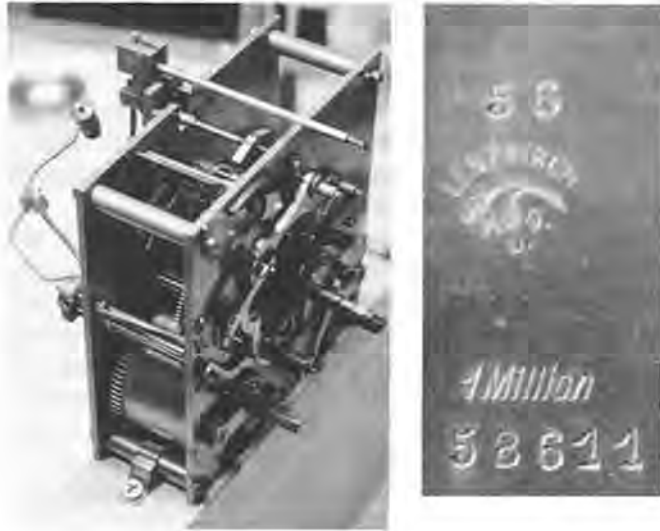

LORCH LATHE

Murray Falk, Calgary, Alberta, Canada, has a very old "Lorch" 6 mm lathe set with many accessories and attachments, but to complete the set he still needs cone chucks set and collets #13 to 17. If collets larger than 41 were made for this instrument, he needs them too. Donald de Carle's book *The Watchmaker's Lathe and How to Use It*, 1st Edition, 1952, describes this tool (pages 131-134). Falk would like to correspond with anyone who has parts, accessories, or attachments. Mr. Falk has tried for several years on this. Several times references have been made that Lorch has disappeared, but surely not all its products have also. If anyone has or can name a source for these items, we would like to hear from you.

PIERRE BIDAUX WATCH

Jim Stanley, Ft. Wayne, IN, seeks the name and address of the distributor for Pierre Bidaux watches.

CUCKOO CLOCKS

R.W. Dietzel, Albuquerque, NM, has two questions both relating to cuckoo clocks.

1. *Is there a parts source (new or used) for outdated cuckoo clocks? Quite often only a chain wheel is terminally worn and the remainder of the clock is in excellent condition. It seems a shame to let these old beauties die because a single part is no longer available. The suppliers that we usually depend on no longer support many of these cuckoos. Those companies are: S. LaRose, Timesavers, and Cuckoo Clock Mfg. Co., New York, NY.*

2. *Is there a publication for identifying cuckoo clocks from the layout pattern of their rear plates as one finds in the 400-Day Clock Repair Guide by C. Terwilliger? To illustrate this problem, here is a tracing of a cuckoo rear plate. There are no other marks whatsoever on the clock plates, front or rear. How does one identify?*

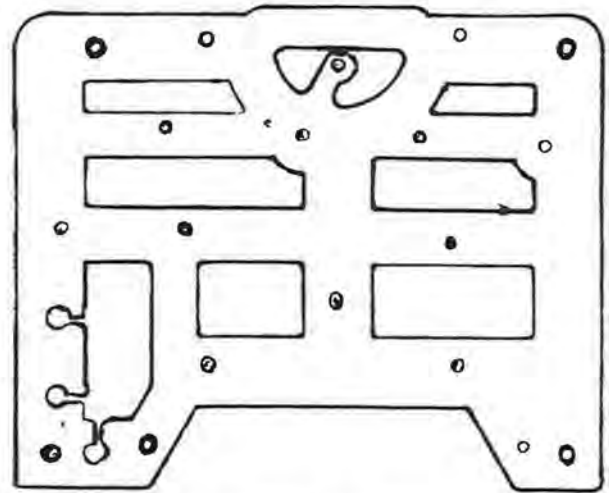

The 7-point star wheel is located between plates.

Do you have information regarding this month's requests?

Do you need information about one of this month's responses?

If so, send a self-addressed, stamped business-size envelope and your request to: "Bulletin Board," c/o AWI Central, 3700 Harrison Avenue, Cincinnati, OH 45211.

□

New Products/News in the Trade

AMERICAN PERFIT'S NEW WATCH CRYSTAL CATALOG

The American Perfit Crystal corporation has announced their new, 52-page, up-to-date, complete glass watch crystal replacement catalog (No. 42). It includes the full line of finished and unfinished glass watch crystals currently being supplied. Catalog No. 42 is available from your watch material supplier or directly from the **American Perfit Crystal Corporation at 653 Eleventh Ave., New York, NY 10036**. All direct requests should include a check for \$3.50 to cover the cost of postage and handling.

LOW-COST, HIGH-QUALITY CRYSTAL PRESS FROM ESSLINGER

New from Esslinger & Company is this inexpensive, high-quality crystal press with solid metal construction. The press has smooth lever action, plunger lock for hands-off pressure, durable nylon dies (6 flat, 6 tapered), and knurled handle for a sure grip.

To order, call or write **Esslinger & Co., 1165 Medallion Drive, St. Paul, MN 55120; (800) 328-0205; in MN (800) 392-0334 and (612) 452-7180**.

Esslinger's crystal press



BATT-TRONIC'S "BANNER" OFFER

As a service to retailers throughout the industry, Batt-Tronic is offering a series of colorful banners to help sell more products. As the leading distributor of watch batteries in America, Batt-Tronic is in constant

contact with many jewelers across the nation," said Harry Hillson, President. "We know that consumers trust retail jewelers to provide professional service and quality products. These banners will not only demonstrate this to the consumer, but will also provide the retailer with increased sales and store traffic," Hillson continued.

The banners currently available are the Watch Battery Center, Lobster Claw Clasp, and Replacement Watchbands. The newest banner features a reminder to the consumer to adjust watches for the end of Daylight Savings Time in October. Retailers may display these banners on windows, walls, or in-counter displays.

Batt-Tronic customers receive their banners with their monthly informational mailing. Others may obtain them by writing to **Batt-Tronic Corp., P.O. Box 10, Orangeburg, NY 10962-0010**.



Batt-Tronic

INTRODUCING A WATCH WHOSE TIME HAS COME-- AGAIN

Bulova Corporation has announced the launch of Accutron, a line of American-designed, Swiss-crafted timepieces that are aimed at the luxury watch market. The Accutron line consists of 26 styles in five distinctive families. All watches are crafted in Switzerland and feature the finest Swiss movements, sapphire crystals, 18 karat gold plating, and leather straps made of royal and teju lizard, crocodile, and emu. All watches are water resistant to 3 atmospheres, or 100 feet. The Ac-

cutron collection is priced from \$395 to \$1,095 retail.

The new Accutron was inspired by architectural designs and centers around a three-tiered pattern. This design feature is carried through in each of the five families: 1) The "Empire" collection, featuring a square, three-tiered case with round bezel. 2) The "Reflection" collection, which has round cases with an integrated bezel that carries through to the strap or bracelet. 3) The "Boulevard" collection, the group that draws on the "classic" Accutron watches that were popular from the 1960s and 1970s. These four models include one chronograph. 4) The "Millennia" collection, with timeless designs from yesteryear characterizing this group. Two of the four models feature curved cases and a curved bombay sapphire crystal. 5) The "Whisper" collection, featuring six models that are ultra-thin in design. The styles are traditional, yet carry the three-tiered design on the case.



Said Herbert C. Hofmann, President and CEO of Bulova, "Accutron is the most dramatic design and quality statement in the industry today. It draws off of the strong heritage of Accutron, yet offers a new and innovative product for consumers."

The Bulova Accutron revolutionized timekeeping accuracy with its tuning fork movement. Today's Accutron utilizes a quartz movement, offering the greatest accuracy in timekeeping.

"What we recognized was

that the Accutron name continued to have tremendous equity. It not only symbolized technological achievement but design innovation as well. After years in development, we felt we had a collection of watches that was strong enough to live up to the Accutron name," said Paul Sayegh, Executive Vice President of Bulova.

The innovation in the watch design carries through the complete program. For example, the watches come with a limited 25-year warranty. "We wanted to make sure consumers and customers knew how serious we were about the quality of the program, and to say that 'Bulova stands squarely behind the new Accutron' with a no-gimmick warranty," said Hofmann. The Accutron three-tiered design is also seen on the display, which utilizes the Accutron symbol, a stylized tuning fork, to display the watches. The whole display is cast in brass and plated in gold.

ITALIAN-DESIGN FRANCHI-MENOTTI WATCHES INTRODUCED IN U.S.

At the Jewelers of America Fall Show held in New York recently, one of Italy's fastest growing watch companies introduced its line to the United States market. Franchi-Menotti, based in Milan, Italy, is unveiling a collection of professional sport watches designed and priced for better and high-end jewelry and department stores.

"The philosophy behind Franchi-Menotti is to make sports watches that match technical excellence with the special aesthetics of Italian design and style," stated Boaz Hirshberg, President of Empire Watches, the exclusive distributor for Franchi-Menotti in North America. "Introduced to the Italian marketplace only 18 months ago, Franchi-Menotti has already made a strong impact, particularly with active 18- to 45-year-old sports enthusiasts."

Designed and produced

in Italy, Franchi-Menotti watches feature Swiss-made parts and utilize the newest technologies in their manufacture. Suggested retail prices begin at \$300 and range up to \$1,200. The flagship line is the *Italian Navy Collection*, or *Collezione Marina Militare Italiana*, which derives directly from the company's beginnings.

Under the banner of professional watches, a group of three lines—*Quartz Collection*, *Automatic Collection*, and *Ladies' Collection*—rounds out the high-performance sports watches from Franchi-Menotti. Selected styles from these include Bluesymbol, a PVD-treated stainless steel watch with leather band, which also comes as a compass watch.

For more information, contact: **Empire Watches, 580 Fifth Ave., Suite 521, New York, NY 10036; (212) 719-2329.**



From the Italian Navy Collection, Franchi-Menotti.

LECTURE ON AMERICAN POCKET WATCHES AT THE TIME MUSEUM

The Time Museum in Rockford, Illinois is issuing invitations to an upcoming lecture to introduce a ground-breaking new book, *The Time Museum Historical Catalog of American Pocket Watches*. With 133 black & white and 419 full-color photographs, the 330-page book contains two historical essays by Donald Hoke and a well-illustrated catalog of watches.

"I have read the proofs of this book," says Henry Fried, "and Dr. Don Hoke's excellent essays and descriptions of the very select and representative watches in the collection. It appears to me that virtually every American maker is ideally represented. This book should enrich the most knowledgeable collector of such watches and provide a well-recommended basis for all others."

Roy Erhardt commented, "This beautifully produced and authoritatively written book is a 'must-have' for American watch collectors and every major library. The full-color catalog illustrates the world's greatest collection of American watches on exhibit to the public."

On Sunday, October 20, 1991 at 2:00 PM, the author will present a lecture entitled "Industrial Innovation: the Story of American Pocket Watches in the 1900s." Admission is complimentary, but seating is limited. For tickets, call Karon Anderson or Dorothy Mastrocola at the **Time Museum** at (815) 398-6000, ext. 2943 (closed Mondays). The Time Museum is located at the **Clock Tower Resort and Conference Center** at the intersection of I-90 and Business 20 in Rockford, Illinois.

The new book is now available from **The Time Museum Bookshop, Dept. 134, 7801 East State St., P.O. Box 5285, Rockford, IL 61125-0285; (815) 398-6000.**



SPECIAL EXHIBIT TO FEATURE MILITARY TIMEPIECES

An exhibit of military timepieces is scheduled to open at the Watch & Clock Museum of the NAWCC in November 1991 and continue through April 1992. The Watch & Clock Museum is located at **514 Poplar Street, Columbia, PA**. Exhibit chairman is William R. Bricker, a retired senior naval commander and instructor at the United States Naval War College. Bricker recently helped to organize a similar exhibit of naval timepieces for the War College in Rhode Island.

The exhibit at the Watch & Clock Museum will depict the evolution of various military timepieces. Particular timepieces to be included are military wristwatches, naval deck watches, navigation watches, and aircraft instrument panel clocks and chronometers. An exhibit highlight will be an 18K gold-cased pocket chronometer which was recently donated to the Museum. The inscribed pocket chronometer was presented to Com. Oliver H. Perry by the United States Government in honor of Perry's defense of the American flag on Lake Erie in 1813.

During World War II, Hamilton Watch Company, located in Lancaster, PA, was the only United States watch company able to produce a chronometer which met the specifications of the US Navy. The first company to mass produce the chronometer, Hamilton yielded more chronometers in one month than were manufactured worldwide in one year prior to WWII. The greatest turnout in one month was during October of 1944, when Hamilton delivered 546 chronometers to the Naval Observatory in Washington, DC.

The design of the Hamilton ship's chronometer was similar to its Swiss predecessor; however, changes were made to accommodate mass production and to create a timepiece which performed beyond expectations. After meeting the commitment of their contract, Hamilton used the remaining inventory to assemble chronometers to sell to the public for \$250 each.

After producing 750 pieces for resale, the inventory was exhausted. Hamilton sold the remaining unused parts and equipment bringing an end to a distinguished generation of the Hamilton Watch Company.

The museum is open Tuesdays through Saturdays, 9:00 AM to 4:00 PM; closed major holidays. Admission is charged. Group tours are available by appointment. For further information, call the museum at (717) 684-8261.

PAUL McNICHOL NAMED L&R DIRECTOR OF INTERNATIONAL SALES

Paul J. McNichol, National Sales Manager for L&R Manufacturing Co., has been appointed Director of International Sales. L&R is a leading producer of ultrasonic cleaning systems and solutions. President of L&R, James Lazarus, stated, "Paul has led the company in its sales efforts for some time. He has been integrating our world-wide business into his domain for some time now. We felt that the same leadership he has applied domestically could be utilized in all the markets throughout the world."

L&R is located at **577 Elm St., Kearny, NJ 07032.**

CYRIL C. GSELL TO HEAD BULOVA SPORTSTIME DIVISION

Cyril C. Gsell has joined Bulova Corporation as Vice President/Sportstime Products Division, it was recently announced by Herbert C. Hofmann, Bulova's President and CEO.

In his new position, Mr. Gsell will be responsible for coordinating the marketing, merchandising, and sales programs of Bulova's Sportstime product lines, which include watches and clocks licensed by the National Football League, National Basketball Association, Major League Baseball, and National Hockey League.

Mr. Gsell was formerly Vice President, Sports Watches and Clocks for Elgin Clock and Home Products.

Classified Ads

REGULATIONS AND RATES

Ads are payable in advance \$.60 per word, \$.70 per word in **bold type**. Classified display ads are \$25.00 per column inch, 2-1/4" wide. Ads are not commissionable or discountable. The publisher reserves the right to edit all copy. Price lists of services will not be accepted. Confidential ads are \$4.00 additional for postage and handling. The first of the month is issue date. Copy must be received 30 days in advance (e.g. June issue closes for copy on May 1st).

HOROLOGICAL TIMES, P.O. Box 11011, Cincinnati, OH 45211
Phone (513) 661-3838 Fax (513) 661-3131

TRADESMAN

37 Years experience in restoring and making parts for French and English Carriage Clocks and Platform Escapements, Balance Staffs, Cylinders, Repivoting, Hairsprings, Pinions, etc. **JOHN BARRS**, 8442 N.E. 140th St., Bothell, WA 98011; (206) 820-8288.

THE MORTICIAN NO COMEBACKS

We correct past mistakes & bury them. Specializing in wheel work, repivoting & making of parts. Repeaters, Audemars Piguet, Piaget, Rolex & Quartz Conversions. All work guaranteed 2 years and done by Jal Small, CMW & Associates; (713) 561-5147.

DIAL REFINISHING

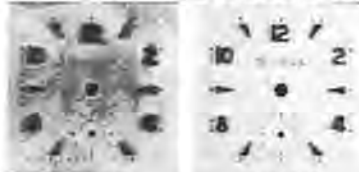

BEFORE

AFTER

Quartz Conversions
Diamond Dial Conversions
Emblem & Name Personalization

Write for Brochures
INTERNATIONAL DIAL CO., INC.
58 W. SUGARTREE
P.O. BOX 970
WILMINGTON, OH 45177

GIDEON LEVINGSTON CASEMAKER

Complete cases or parts made, from early pocket to modern wristwatch. All aspects including springing and engine turning. 2 Pond Cottage, Godden Green, Sevenoaks, Kent TN15 0JN, England. Telephone or Fax 0732 62400.

SHIP'S CHRONOMETERS OVERHAULED. Also **HAMILTON 21 PARTS** for sale: Staffs or escape pinions \$60; escape wheels \$110; detent springs \$175; locking jewels \$40; keys, box hardware, etc. I buy chronometers and partial movements. **1 year guarantee on repairs.** **DEWEY CLARK**, (301) 592-3617.

WATCH RESTORATION and repair work. Custom staffs, pivoting, and regilding. Ron DeCorte, Box 6126, Toledo, OH 43614; (419) 381-1081.

CUSTOM BALANCE STAFFS cut and fitted. Platforms repaired. James Bourne, CMW, P.O. Box 215, Ladysmith, WI 54848. Phone (715) 532-3166.

CLOCK and MUSIC BOX parts, mainsprings, material and tools. Custom made to order or repair of gears, pinions, and parts. Catalog \$2.00. **TANI ENGINEERING**, Box 338, Atwater, OH 44201; (216) 947-2268.

PRECISION TIME-TECH

Service and restoration of Rolex, Piaget, Patek Philippe, Vacheron-Constantin. Antique pocket watches a specialty. Swiss trained master watchmaker. Rolex certified. Custom part manufacture. Expedient service and professional quality. All work fully guaranteed.

PRECISION TIME-TECH
1125 Laurel Street, San Carlos, CA 94070
(415) 595-9334

WE'VE MOVED!!

Larger Shop, More Technicians to Serve You Better
ELECTRONIC EQUIPMENT SERVICE
We are Factory Authorized Service for:
* VIBROGRAF & PORTESCAP
* TICK-O-PRINT & L&R

We service all makes of ultrasonics, all makes of watch rate recorders, and related equipment. 25 years experience.
JACK PHILLIPS - ELECTRONIC INSTRUMENT SERVICE
757 Lincoln Ave., #26 San Rafael, CA 94901
For Information, Call (415) 453-9288

CLOCK WHEEL AND PINION CUTTING, RETOOTHING, AND OTHER CUSTOM WORK. Movements overhauled with **2-year guarantee.** All work done by a CMC or a CC. Send SASE for price list. **HUGH'S CLOCK SHOP**, 125 Ganttown Rd., Turnersville, NJ 08012; (609) 228-1539.

HAND ENGRAVING, CLOCK & WATCH REPAIR. For price list write to: Steven Kaminsky, P.O. Box 66, McComb, OH 45858.

Have your watches serviced by the pros! Quality Watch Repair will expertly service your quartz or mechanical watches. We service most makes and brands from Rolex to Lorus. Send work to Q.W.R., Box 670932, Marietta, GA 30066, or call 1-800-783-9711 or (404) 423-9558.

CUTTERS cycloidal for clock wheels and pinions. Module 0.2 to 1.0. Constant profile producing traditional square bottomed teeth, 104 sizes. Escape cutters: recoil (set of seven sizes), dead beat (set of four sizes). Ratchets 60° and 70°. All cutters made in 8% cobalt M42 High Speed Steel and heat treated under vacuum. Also cutter grinding wheels, Grit and CBN. Send for Information Sheet, prices, and order forms to: P.P. Thornton (Successors), Ltd., Horological Cutter Makers, The Old Bakehouse, Upper Tysoe, Warwickshire, CV35 0TR, England.

VIBROGRAF WATCHMASTER SERVICE

The Factory service for Vibrograf timers and cleaners in the U.S.A.

- New and Factory reconditioned watch repair equipment available.
- Vibrograf timers, Watchmaster timers, cleaners purchased — traded.
- Products for the jeweler — soldering, engraving, ultrasonic tanks, polishers, and microscopes in stock.

For information call:
Mr. Joseph D. Presti
or

Mr. John J. Hager

**VIBROGRAF
U.S.A. CORP.**
504 Cherry Lane
Floral Park, N.Y. 11001
(516) 437-8700

Serving the industry with quality products for over 50 years.

POCKET WATCH CASE REPAIR -- Bezels, hinges, springs, dents, etc. **HARRY MAZAR**, Tick-Tock Specialties, 308 N. McLeansboro St., Benton, IL 62812. Phone (618) 439-6995.

CLOCKS: gearcutting, repivoting, jeweling, rebushing. **REPAIRING:** timers, aircraft clocks, pocket watches. **ROY H. NIEGEL**, CMC, CMW, 101 E. Saint Joe Drive, Spirit Lake, Idaho 83869. SASE or CALL (208) 623-4330.

MURPHY'S CRYSTAL SERVICE

FAST -- QUALITY WORK

- * 24-hour turnaround on most jobs
- * Complete crystal fitting service
- * Specializing in custom cut flat mineral glass crystals

CALL OR WRITE FOR PRICE LIST
PHONE (209) 576-8865
2324 WESTMINSTER DR.
MODESTO, CA 95355

QUARTZ CONVERSIONS

WATCH RUSTED? DISCONTINUED?
NO PARTS? SENTIMENTAL? GOLD CASE?
SEND IT TO AL ZAMORA

FOR A NEW SWISS QUALITY MOVEMENT
AND FIRST QUALITY JOB CONVERSION.
95% SIZES POSSIBLE, POCKETS ALSO.
SAFE REGISTERED MAIL.

ALFONSO ZAMORA
280 PRESIDIO PLACE
BUFFALO, NY 14221
(716) 633-6138

TIMING MACHINES -- NEW AND REFURBISHED. Quality Service and Repair. **DON HOLDEN**, Box 56, Penna. Furnace, PA 16865. Call (814) 692-2285

DIAL REFINISHING CO. FAST SERVICE, FINEST QUALITY, quantity works welcome. Specialize on changing dial feet positions to fit the quartz movement. Send your works to: **KIRK DIAL OF SEATTLE**, 4th & Pike Bldg., Suite 625, Seattle, WA 98101; (206) 623-2452.

Hairsprings Vibrated

Hair Springing, Ltd.

280 Constitution Circle • P.O. Box 166
No. Brunswick, NJ 08902-0166 • (201) 247-3021

DON'T GIVE UP HOPE, GIVE US A TRY!

Dependable repair of all types of high-grade watches--Patek Philippe, Rolex, Omega, etc. We repair all types of Accutrons by Bulova, Omega, Movado, Longines, etc. and Hamilton electric calibres 500-505. Rolex double springs and most other watch parts made. Watch crystals custom made. If you need a watch repaired--high-grade, antique, complicated, etc.--and want fast, dependable service with high quality **GUARANTEED**, give us a try; so don't worry, be happy! Over 30 years experience in all phases of watch repair and watch parts manufacturing. J. Park, CMW, Time Zone, 3578-F Memorial Drive, Decatur, GA 30032; (404) 289-4464; Mon.-Sat. 10 am - 9 pm.

CLOCK WHEEL AND PINION CUTTING

Fast service -- Write for free Brochure and price list. **Fendleys**, 2535 Himes St., Irving, TX 75060. (214) 986-7698.

ARTICLES FOR SALE

OVERSTOCKED LAST CHANCE: Useable 17J mechanical movements, \$4.50 ea. (new). 5-1/2 - 11-1/2 some day/daters Japanese-Swiss quartz movements, \$9.50 ea. Watchmaker tools and equipment, 1/2 price off regular price. Crystals - plastic, mineral, glass, \$11.50 per dozen. **No Collect Calls.** Lot orders 1 dozen only C.O.D. Kurt W. Kelpo, (915) 949-3524.

WATCHES, ETC. Having trouble finding that staff, stem, or wheel? **CALL US!** We have a large selection of hard-to-find mechanical wristwatch and pocket watch parts. Also many used watch repair tools, equipment, and lathes. Send SASE for equipment list. Include detailed request for specific parts needed. **OCTOBER CLEARANCE:** L&R 3 jar cleaners: \$75.00. GS 4 or 7 drawer stackable crystal cabinets with drawers: \$30.00. GS 18 drawer crystal cabinets only: \$60.00 (drawers available). Marshall parts cabinet (2 drawer): \$25.00. 100 loose assorted glass and plastic crystals: \$25.00. **WATCHES, ETC.**, 5934 NW 39th, Oklahoma City, OK 73122; (405) 789-2824.

BE ALL THE CLOCKMAKER YOU CAN BE! Thornton Cutters in stock. **KEN LAW, CMC**, H.C. 30, Box 825, Prescott, Arizona 86301.

NEW Electronic Timing Machines



* **TIMETRAX 600 Wrist & Pocket Watch Timer:** Measures & displays watch trains in vibrations per hour. Calculates gain or loss in Sec/day. Over 40 preprogrammed trains: 7200-36000/hr. Highly stable TCXO timebase. Complete w/watch holder & pickups\$595

* **TIMETRAX 400 Clock Timer:** Measures & displays clock trains in vibrations per hour. Extended timing range for 400 day & Atmos clocks. Balance mode aids in setting movement in beat. Complete w/pickup\$395

* **TICK TECH 195 Clock Timer:** Measures Timing interval between ticks in milliseconds and Beats/Minute. Portable, battery powered, complete w/pickup\$225

All units made in USA, 1 yr. warranty, complete with instructions & reference tables. Send 3 stamps for info & our new 1990 Catalog of Horological Literature.

 **Adams Brown Co., Box 357,**
Cranbury, NJ 08512 (609) 655-8269

Classified Ads

ARTICLES FOR SALE

H. ABE

USED WATCH MOVEMENTS

2 Florida Way Lonaconing, MD 21539

Mr. Watchmaker -- If you have a problem finding parts for older watches, badly rusted or damaged beyond repair, we may be able to help you. We have lots of movements for parts at reasonable prices. Some suitable for replacement. If not satisfactory you may return.

Phone (301) 463-6595

USED WATCHMAKERS TOOLS, EQUIPMENT, MATERIAL, SUPPLIES, WATCHES, MOVEMENTS, AND RELATED ITEMS. Write or call for our latest list. Tom Mister, Dashto Jewelers, 983 Providence Square Shopping Center, Virginia Beach, VA 23464; (804) 495-2471.

HERMLE MOVEMENTS: Lowest prices in U.S. Factory fresh, 2-year warranty. Butterworth Clock Repair, 1715 Pearlview, Muscatine, IA 52761; 1-800-258-5418.

MINI QUARTZ MOVEMENTS. Guaranteed lowest prices--as low as \$2.30. Two-year guarantee. Large selection of hands and numerals. Free delivery. SASE or call (704) 333-0221. HALL CLOCK SHOP, 1512 Central Ave., Charlotte, NC 28205.

QUALITY TRADITIONAL CLOCKMAKING TOOLS & SUPPLIES

Depth Tools -- Mainspring Winders
Lathe File Rests -- Finger Plate Clamps
Milling Spindles

From J.M. Wild, England
Michael M. Ambrosino, agent
33-67 165th Street Flushing, NY 11358
Catalogues \$5.00

CUCKOO CLOCK AND BIRD CAGE BELLOWS MATERIAL

Save time, money, and work re-covering bellows. Easier than replacing. For information, send business-size SASE to:

JANDI GOGGIN
Box 175H, Huntington, NY 11743-0175

BUSINESSES FOR SALE

RETIRING - Complete watch repair shop \$4,000.00. Call for details Mon., Tues. & Wed. Cecil Thomas, 503 Minor St., Huntsville, AL 35801; (205) 536-4671.

If you are a competent watchmaker with \$50,000 to invest in a wholesale trade shop, I will finance \$50,000. Your investment will be returned to you in net profit within two years. Please write: Box BS1091, c/o *Horological Times*, P.O. Box 11011, Cincinnati, OH 45211.

LEADING RETAIL CLOCK SALES AND SERVICE BUSINESS established 1978. Owners retiring. Solid sales and profits record. Tremendous growth opportunity in affluent, suburban area of Twin Cities. Asking \$45M plus inventory. Good terms to right party. (612) 475-1489.

HELP WANTED

WATCHMAKERS NEEDED UP TO \$1,000 WEEKLY PLUS BENEFITS

Qualified in Bulova Accutrons, Mechanical, Quartz, and Short Jobs. All Skill Levels.
(313) 559-5329

SITUATIONS WANTED

Seeking a career-oriented position involving the purchase, sale & repair of antique & vintage timepieces. Prefer relocation to Atlanta or other south Atlantic location. Write or call Michael H. Katz, 14 Berkley St., Watertown, MA 02172; (617) 924-9287.

SAN DIEGO JEWELERS: Need capable watchmaker? Box 979, Santa Maria, CA 93454.

WORK WANTED: Recent graduate of Houston Tech College of Watch Repair wishes to relocate to Washington/Oregon area. Needs entry level position in watch and/or clock repair. Will pay own interview/relocation expenses. David Emery, 9900 Richmond Ave. #904, Houston, TX 77042.

SCHOOLS

ATTENTION STUDENTS: New course catalog available free for Laurie Penman's correspondence course in clock repair. Send your request to USA course agent Steven G. Conover, 203 John Glenn Ave., Reading, PA 19607.

JOSEPH BULOVA SCHOOL

40-24 62nd St. Woodside, NY 11377
Phone (718) 424-2929

Quality Instruction Since 1945 

WATCHMAKING

(17 months)

WATCH REPAIR

(9 and 13 months)

JEWELRY REPAIR

BASIC ELECTRONICS

Ideal Housing, Dining, Recreation
NATTS approved, BEOG available



TEXAS INSTITUTE OF
JEWELRY TECHNOLOGY

A Division of Paris Junior College

Comprehensive Training

- * Jewelry Repair
- * Watch Repair
- * Casting
- * Watch Making
- * Stone Setting
- * Gemology

ASSOCIATE DEGREE OR CERTIFICATE

Paris Junior College

2400 Clarksville St. • Paris, TX 75460-6298
TEXAS-1-800-441-1398
OUTSIDE-1-800-232-5804

BOOKS

Clockmakers Newsletter is edited by Steven G. Conover and is in its fifth year. *CN's* monthly issues give you clock repair information, articles, repair tips, and Q & A. With your payment of \$34 for a new one year subscription, mention this ad and choose one of these bonus issues free: *Making Cutters for the Bushing Tool*, *400-Day Clock Repair*, or *Making Large Bushings on the Unimat Lathe*. Don't forget to order your copy of the 210-page hardcover book, *Chime Clock Repair*, by Steven G. Conover, \$28.50 postpaid. PA residents add 6% sales tax on book only. *Clockmakers Newsletter*, 203 John Glenn Ave., Reading, PA 19607.

**The Time Museum
Historical Catalogue of
American
Pocket Watches**

by Donald Robert Hoke \$79.95*



"...virtually every American maker is ideally represented." *Henry Fried*

"The full color catalogue illustrates the world's greatest collection of American watches on exhibit to the public."
Roy Erhardt, Jr.

"The book brings together and illustrates almost the whole of American watchmaking history..."
Theodore R. Crom

"For all interested in horology it will prove a ready reference work and valuable library addition."
D.J. Blackwell

**The Time Museum Catalogue of
Chronometers**

by Anthony G. Randall (Dec. 91)

Other Time Museum Catalogues available
(both by Anthony J. Turner): *Astrolabes* \$115*
Water-Clocks, Fire-Clocks, Sand-Glasses \$95*

From your bookseller
or directly from the publisher.

Just FAX your credit card order (815) 398-4700
or tel: (815) 398-6000 ext. 2943. (closed Monday).
The Time Museum, Dept. 126, 7801 E. State St.,
P.O. 5285, Rockford, Illinois 61125-0285, U.S.A.

*Plus postage and handling.

Unusual Pocket Watches & Wristwatches Wanted.
Especially Patek Philippe, Howard, Illinois, Waltham, Chronometers, Strikers, Moonphase, Tourbillons, Virgules, Karrusel, Musicales, Historical, and Solld Golde. Early American watches a specialty. Need not run. Call TOLL FREE 1-800-23J-BUNN or 913-383-2880. Maundy International, P.O. Box 13028H, Overland Park, Kansas 66212.

We buy watchmakers tools, equipment, material, and related items as well as jewelers and clockmakers tools and watch collections, etc. Specialize in estate purchases. Call or write Tom Mister, Dashto Jewelers, 983 Providence Square Shopping Center, Virginia Beach, VA 23464; (804) 495-2471.

We pay 97% of market for karat gold scrap (any amount)! Also, buy filings, gold fill, sweeps, silver, platinum! Immediate 24-hour payment return mail! Ship insured/registered mail to: AMERICAN METALS COMPANY, 253 King St., Dept. HT, Charleston, SC 29401. Established 1960. Phone (803) 722-2073.

WANTED: Complete watch parts supply house. Will buy any amount of wrist and pocket material and parts for both ladies and gents, including cases, dials, crystals, movements, etc. Also buying complete watches in any condition. S. Medlock Watches. Call (813) 923-5762 afternoons or evening or write P.O. Box 21027, Sarasota, FL 34276.

SWATCH WATCHES - Wanted to buy new old stock. Call Michael at Timepieces, 656 Beacon St., Boston, MA 02215; (617) 536-3883; Fax (617) 536-5453.

HAMILTON ELECTRIC REPAIRMAN
seeks parts! Movements, balances, etc. desperately needed. Want anything related to Hamilton Electrics. Rene Rondeau, 120 Harbor Drive, Corte Madera, CA 94925; (415) 924-6534.

WANTED: Unusual American pocket watches/movements. I buy entire collections, estates, watchmakers' inventories. Over 30 years experience of honest and reliable confidential transactions. JON HANSON, Box 5499, Beverly Hills, CA 90210; (213) 826-7778.

Watches Wanted



We desperately need for our retail customers fine watches by:

Rolex, Patek Philippe, Audemars Piguet, Vacheron & Constantin, Movado, Gubelin, etc.

We are paying top prices for any high quality, unusual or complicated
Wrist or Pocket Watches

When You're Ready to Sell a Fine Watch
Call us Toll Free 1-800-842-8625
In Texas 1-214-902-0664

Always prompt immediate payment!

Wingate's Quality Watches

P.O. Box 59760 • Dallas, TX 75229-1760

WANTED TO BUY

ATTENTION WATCHMAKERS! Small ad, higher prices! We need your vintage watches for our European customers. Top prices paid for Patek, Vacheron, Rolex, Cartier, Movado, chronographs, and others. Buying all brands, new old stock. Buying mint boxed comic characters. Buying preowned modern Rolex and Cartier. Buying ladies enamels. National Watch Exchange, 107 S. 8th St., Philadelphia, PA 19106. 1-800-43-ROLEX. 1-800-562-6788.

WANTED ASAP

10,000 NEW MEN'S & WOMEN'S YELLOW GOLD-FILLED TOP/SS BACK SCISSOR STYLE WATCHBANDS. ALL BRANDS ACCEPTED.
GF SPECIALTIES, LTD.
P.O. Box 17216 Milwaukee, WI 53217
(414) 351-6926

WANTED

- Diamonds - all sizes, qualities: even chipped, old mine, single cut
- Scrap watch bands - paying \$12-\$27 lb.
- Dead watch batteries (unsorted accepted)
- Gold filled & gold scrap - filings, 10, 14, 18K, buffing waste, etc.
- Sterling & plated flatware
- China, old watches - Rolex, etc.

CALL TOLL FREE **1-800-426-2344**



Ron Fried
President

**SPECIALTY METALS
REFINING COMPANY**
10 Bay Street
Westport, CT 06880

Members
Jewelers Board of Trade
Our 70th Consecutive Ad

**BUY • SELL
HIRE • RELOCATE
LEARN • FIND**

**Classifieds in
Horological Times
help you do what you
want to do!**

Dates to Remember

OCTOBER 1991

4-6--New York State Watchmakers Annual Convention; Waterloo, NY.

4-6--Advanced Lathe Bench Course (AWI); Roy Hovey, instructor; Atlanta, GA.*

5-6--Advanced Quartz Watch Repair Bench Course (AWI); Robert Bishop, instructor; Boston, MA.*

5-6--400-Day Clock Repair Bench Course (AWI); John A. Nagle, instructor; Richmond, VA.*

6--Introduction to Quartz Watch Repair Bench Course (AWI); Buddy Carpenter, instructor; Kansas City, MO.*

18-20--Illinois Watchmakers Association Annual Convention; Thelma Keller Ramada Inn Convention Center; Effingham, IL. For more information: Duane Laramée, 101 N. Water, Decatur, IL 62523.

18-20--Introduction to Clock Repair Bench Course (AWI); James Lubic, instructor; Marquett, MI.*

20--Useful Techniques: Mechanical Watch Repair Bench Course (AWI); James Adams, instructor; Boston, MA.*

25-27--Florida State Watchmakers Association Annual Convention; Ramada Hotel; Fort Myers, FL.

27--Servicing ETA Quartz Chronographs Bench Course (AWI); James Broughton, instructor; Minneapolis, MN.*

NOVEMBER 1991

9-10--400-Day Clock Repair Bench Course (AWI); John A. Nagle, instructor; Charlotte, NC.*

9-10--Repair of the Atmos Clock Bench Course (AWI); Gerald Jaeger, instructor; Houston, TX.*

10--Servicing ETA Quartz Chronographs Bench Course (AWI); James Broughton, instructor; Atlanta, GA.*

10--Introduction to Quartz Watch Repair Bench Course (AWI); Buddy Carpenter, instructor; Oklahoma City, OK.*

16-17--Cuckoo Clock Repair Bench Course (AWI); James Williams, instructor; Albuquerque, NM.*

16-17--Introduction to the Watchmakers Lathe Bench Course (AWI); James Lubic, instructor; Kansas City, MO.*

30-Dec. 1--400-Day Clock Repair Bench Course (AWI); John A. Nagle, instructor; Savannah, GA.*

JANUARY 1992

17-19--Advanced Clock Repair Bench Course (AWI); Roland Iverson, instructor; Alexandria, VA.*

19--Introduction to Quartz Watch Repair Bench Course (AWI); Buddy Carpenter, instructor; Atlanta, GA.*

19--Useful Techniques: Mechanical Watch Repair Bench Course (AWI); James Adams, instructor; Albuquerque, NM.*

25-26--Cuckoo Clock Repair Bench Course (AWI); James Williams, instructor; Phoenix, AZ.*

25-26--400-Day Clock Repair Bench Course (AWI); John Nagle, instructor; Austin, TX.*

26--Servicing ETA Quartz Chronographs Bench Course (AWI); James Broughton, instructor; San Diego, CA.*

FEBRUARY 1992

16--Introduction to Quartz Watch Repair Bench Course (AWI); Buddy Carpenter, instructor; Albuquerque, NM.*

22-23--400-Day Clock Repair Bench Course (AWI); John A. Nagle, instructor; Albuquerque, NM.*

22-23--Cuckoo Clock Repair Bench Course (AWI); James Williams, instructor; Orlando, FL.*

23--Useful Techniques: Mechanical Watch Repair Bench Course (AWI); James Adams, instructor; Ellisville, MS.*

23--Servicing ETA Quartz Chronographs Bench Course (AWI); James Broughton, instructor; Phoenix, AZ.*

MARCH 1992

29--Servicing ETA Quartz Chronographs Bench Course (AWI); James Broughton, instructor; Bay Area, CA.*

***For more information on AWI Bench Courses and Regional Seminars, contact AWI Central, P.O. Box 11011, 3700 Harrison Avenue, Cincinnati, OH 45211; (513) 661-3838; fax (513) 661-3131.**

Ad Index

American Perfit Crystal Corp.	25
Blue Ridge Machinery & Tools	8
Borel Co.	7
Cas-Ker Co.	inside back cover
Charles Cleves	17
Davis Supply	29
DRS, Inc.	5
Esslinger & Co.	inside front cover
Finn Time Products	23
Gem City College	4
Germanow-Simon	13
Guenther & Sons	8
S. LaRose, Inc.	21
Livesay's, Inc.	15
Maxell Corp.	3
Newall Manufacturing	10
Oceanside Time	11
Precision Crystal Cutting Co.	23
Twin City Supply Co.	9
Watch Band Co.	29
Witschi Electronics	12
Young-Neal Co., Inc.	17

Stereo Jewelscope

Specifically designed for gemstone use.

- Quality wide-field lenses provide high resolution and clear optics.
- 10X and 30X stereo magnification with turret style quick change and precision rack and pinion focusing.
- Upper and lower illumination can be used independently or together.
- Extra long focusing range.
- 360° swivel allows clerk or customer counter use.

No.290.999 Stereo Jewelscope

\$625⁰⁰



- Gem Clamp included.
 - Optional Darkfield Attachment displays minor flaws in diamonds.
- No.290.999DF \$110.00

Special Terms Available

Cas-Ker Co.

2121 SPRING GROVE AVENUE PO BOX 14069 CINCINNATI OH 45250-0069
Instant credit to accounts well rated in Jewelers Board of Trade and Dun & Bradstreet.

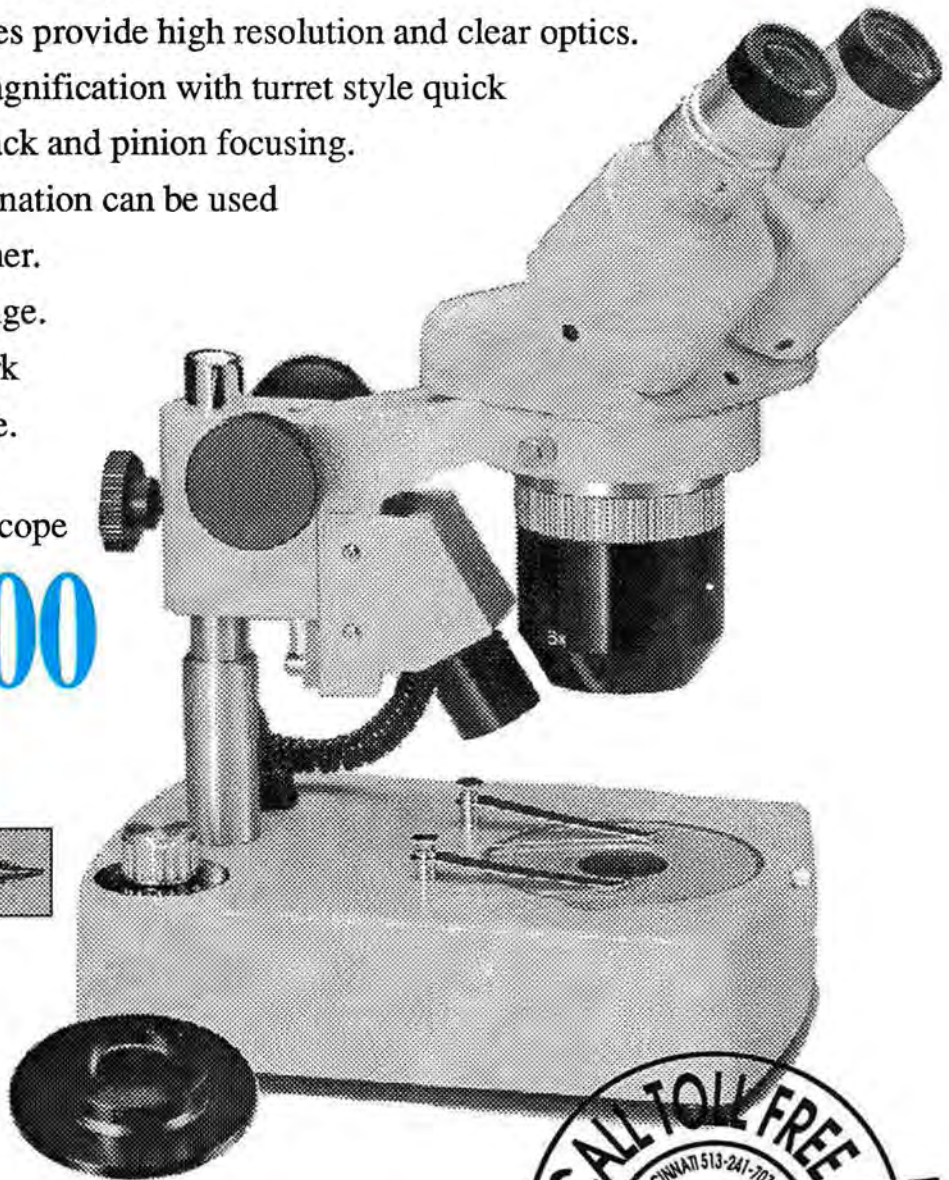

AWI BENCH COURSES

Fiscal 1991-1992

To register for these courses, please send along with your request a registration fee of **\$25 per instruction day** (for AWI members) to: **AWI Central, P.O. Box 11011, Cincinnati, OH 45211.**
PLEASE NOTE: Registrations are limited and will be

selected by the earliest postmarks. You may register by Fax if you wish; if so, please include your Visa or MasterCard number, card expiration date, and signature. FAX: (513) 661-3131; INFORMATION: (513) 661-3838.

OCTOBER 1991

- 4-6--Advanced Lathe--Atlanta, GA
- 5-6--Advanced Quartz Watch Repair--Boston, MA
- 5-6--400-Day Clock Repair--Richmond, VA
- 6--Introduction to Quartz Watch Repair--Kansas City, MO
- 18-20--Introduction to Clock Repair--Marquett, MI
- 20--Useful Techniques: Mechanical Watch Repair--Boston, MA
- 27--Servicing ETA Quartz Chronographs--Minneapolis, MN

NOVEMBER 1991

- 9-10--400-Day Clock Repair--Charlotte, NC
- 9-10--Repair of the Atmos Clock--Houston, TX
- 10--Servicing ETA Quartz Chronographs--Atlanta, GA
- 10--Introduction to Quartz Watch Repair--Oklahoma City, OK
- 16-17--Cuckoo Clock Repair--Albuquerque, NM
- 16-17--Introduction to the Watchmaker's Lathe--Kansas City, MO
- 30-Dec. 1--400-Day Clock Repair--Savannah, GA

JANUARY 1992

- 17-19--Advanced Clock Repair--Alexandria, VA
- 19--Introduction to Quartz Watch Repair--Atlanta, GA
- 19--Useful Techniques: Mechanical Watch Repair--Albuquerque, NM
- 25-26--Cuckoo Clock Repair--Phoenix, AZ
- 25-26--400-Day Clock Repair--Austin, TX

FEBRUARY 1992

- 16--Introduction to Quartz Watch Repair--Albuquerque, NM
- 22-23--400-Day Clock Repair--Albuquerque, NM
- 22-23--Cuckoo Clock Repair--Orlando, FL
- 23--Useful Techniques: Mechanical Watch Repair--Ellisville, MS
- 23--Servicing ETA Quartz Chronographs--Phoenix, AZ

MARCH 1992

- 29--Servicing ETA Quartz Chronographs--Bay Area, CA

COURSES AND INSTRUCTORS

- Introduction to Quartz Watch Repair
Buddy Carpenter, CMC, CMEW
- Advanced Quartz Watch Repair
Robert Bishop, CMEW
- Retrofitting, Casing & Coil Repair
James Broughton, CMEW
- Introduction to Clock Repair
James Lubic
- Advanced Clock Repair
Roland Iverson, CMC
- Repair of the Atmos Clock
Gerald Jaeger, CMW, CMEW, FAWI
- Useful Techniques: Mechanical Watch Repair
James Adams, CMW, FBHI
- Introduction to the Watchmaker's Lathe
James Lubic
- Cuckoo Clock Repair
James Williams
- 400-Day Clock Repair
John A. Nagle
- Servicing ETA Quartz Chronographs
James Broughton, CMEW
- Advanced Lathe
Roy Hovey