

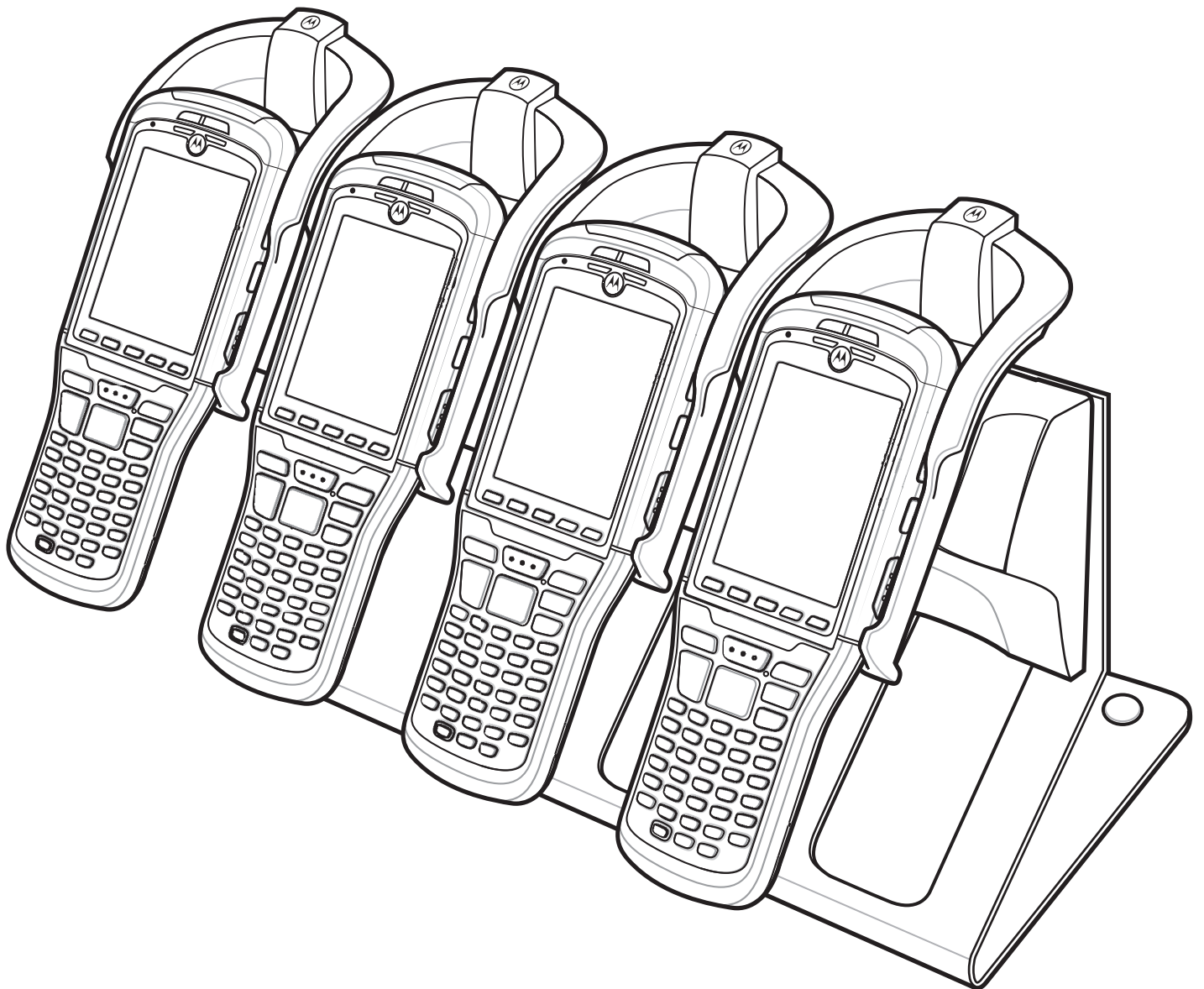

MC9500-K Mobile Computer

Integrator Guide



***MC9500-K Mobile Computer
Integrator Guide***

72E-118503-01

Rev. A

September 2009

© 2009 by Motorola, Inc. All rights reserved.

No part of this publication may be reproduced or used in any form, or by any electrical or mechanical means, without permission in writing from Motorola. This includes electronic or mechanical means, such as photocopying, recording, or information storage and retrieval systems. The material in this manual is subject to change without notice.

The software is provided strictly on an “as is” basis. All software, including firmware, furnished to the user is on a licensed basis. Motorola grants to the user a non-transferable and non-exclusive license to use each software or firmware program delivered hereunder (licensed program). Except as noted below, such license may not be assigned, sublicensed, or otherwise transferred by the user without prior written consent of Motorola. No right to copy a licensed program in whole or in part is granted, except as permitted under copyright law. The user shall not modify, merge, or incorporate any form or portion of a licensed program with other program material, create a derivative work from a licensed program, or use a licensed program in a network without written permission from Motorola. The user agrees to maintain Motorola’s copyright notice on the licensed programs delivered hereunder, and to include the same on any authorized copies it makes, in whole or in part. The user agrees not to decompile, disassemble, decode, or reverse engineer any licensed program delivered to the user or any portion thereof.

Motorola reserves the right to make changes to any software or product to improve reliability, function, or design.

Motorola does not assume any product liability arising out of, or in connection with, the application or use of any product, circuit, or application described herein.

No license is granted, either expressly or by implication, estoppel, or otherwise under any Motorola, Inc., intellectual property rights. An implied license only exists for equipment, circuits, and subsystems contained in Motorola products.

MOTOROLA and the Stylized M Logo and Symbol and the Symbol logo are registered in the US Patent & Trademark Office. Bluetooth is a registered trademark of Bluetooth SIG. Microsoft, Windows and ActiveSync are either registered trademarks or trademarks of Microsoft Corporation. All other product or service names are the property of their respective owners.

Motorola, Inc.
One Motorola Plaza
Holtsville, New York 11742-1300
<http://www.motorola.com/enterprisemobility>

Patents

This product is covered by one or more of the patents listed on the website: <http://www.motorola.com/enterprisemobility/patents>.

Revision History

Changes to the original manual are listed below:

Change	Date	Description
-01 Rev. A	09/13/09	Initial release.

Table of Contents

Patents.....	ii
Revision History.....	iii

Table of Contents

About This Guide

Introduction.....	xi
Documentation Set.....	xi
Configurations.....	xii
Keypads.....	xii
Software Versions.....	xii
Chapter Descriptions.....	xiv
Notational Conventions.....	xv
Related Documents.....	xv
Service Information.....	xvi

Chapter 1: Getting Started

Introduction.....	1-1
Unpacking the MC9500-K.....	1-1
Getting Started.....	1-2
Installing a microSD Card.....	1-2
Installing the SIM Card.....	1-3
Installing the Battery.....	1-5
Charging the Battery.....	1-5
Charging Temperature.....	1-6
Powering On the MC9500-K.....	1-7
Calibrating the Screen.....	1-7
Resetting the MC9500-K.....	1-7
Performing a Warm Boot.....	1-7
Performing a Cold Boot.....	1-7
Performing a Clean Boot.....	1-7
Keypad Replacement.....	1-8

Handstrap Replacement	1-10
-----------------------------	------

Chapter 2: Accessories

Introduction	2-1
Guide Cup Installation	2-3
Universal Wall Mounting Bracket	2-5
Mounting Multiple Brackets	2-7
Four Bay Ethernet Cradle Wall Mounting	2-10
Daisy chaining Ethernet Cradles	2-11
Ethernet Cradle Drivers	2-12
LED Indicators	2-13
Speed LED	2-13
Link LED	2-13
Four Bay Charge Only Cradle Wall Mounting	2-14
Four Slot Battery Charger Wall Mounting	2-15
Universal Desk Mounting Bracket	2-17
Four Bay Ethernet Cradle Desktop Mounting	2-17
Four Bay Charge Only Cradle Desktop Mounting	2-19
Four Slot Battery Charger Desk Mount Setup	2-21
Single Bay USB Cradle	2-22
Setup	2-22
Single Slot Battery Charger	2-24
Setup	2-24
Single Bay USB Cradle/Single Slot Battery Charger	2-24
Magnetic Stripe Reader	2-27
Attaching and Removing the MSR	2-27
Using the MSR	2-27
USB/Charge Cable	2-28
Auto Charge Cable	2-29
Headset Adapter Cable	2-31
Modem Dongle	2-32
Connecting to the MC9500-K	2-33
Using the Correct Telephone Line Type	2-34
Configuring the MC9500-K for the Modem	2-34
Connecting the Modem	2-36

Chapter 3: ActiveSync

Introduction	3-1
Installing ActiveSync	3-1
Mobile Computer Setup	3-2
Setting Up an ActiveSync Connection on the Host Computer	3-2
Synchronization with a Windows Mobile 6 Device	3-3

Chapter 4: Application Deployment for Mobile 6

Introduction	4-1
Security	4-1
Application Security	4-1

Digital Signatures	4-1
Locking Down a Mobile Computer	4-2
Installing Certificates	4-3
Device Management Security	4-3
Remote API Security	4-3
Packaging	4-4
Deployment	4-4
Installation Using ActiveSync	4-4
Installation Using Storage Card	4-4
Installation Using AirBEAM	4-5
MSP 3.X	4-5
Image Update	4-5
Creating a Splash Screen	4-6
XML Provisioning	4-6
Creating an XML Provisioning File	4-7
XML Provisioning vs. RegMerge and Copy File	4-7
RegMerge	4-7
CopyFiles	4-8
Storage	4-8
Random Access Memory	4-9
Volatile File Storage (Cache Disk)	4-9
Persistent Storage	4-9
Application Folder	4-9
Enterprise Mobility Developer Kits	4-9

Chapter 5: MC9596 - GSM HSDPA Configuration

Introduction	5-1
Quick Startup Steps	5-1
MC9596-K Service Verification	5-2
Ensuring Network Coverage	5-2
Configuring a Data Connection	5-3
MC9596-K Settings	5-5
Phone	5-5
Sounds	5-5
Security	5-6
Services	5-7
Call Barring (Call Blocking)	5-7
Caller ID	5-8
Call Forwarding	5-8
Call Waiting	5-9
Voice Mail and Text Messages	5-9
Fixed Dialing	5-10
Network	5-11
Changing Networks Manually	5-11
Viewing Available Networks	5-11
Setting Preferred Networks	5-12
Phone Info	5-13
Network Time Synchronization	5-14
Enhanced Operator Name String	5-14

Service Provider Name Display	5-15
WWAN Band Selection	5-15
PAP CHAP GPRS Authentication	5-16

Chapter 6: MC9598 - CDMA EvDO Configuration

Introduction	6-1
Quick Startup Steps	6-1
CDMA Phone Activation	6-2
Verizon Wireless Activation	6-2
Automatic Activation	6-2
Manual Activation	6-3
Sprint Activation	6-5
Automatic Activation	6-5
Manual Activation	6-6
Other Carriers Manual Activation	6-8
Activation Test	6-10
Establishing a Data Connection	6-10
CDMA Settings	6-12
Phone	6-12
Location Settings	6-13
Data Settings	6-13
Sprint Data Settings	6-13
Verizon Wireless Data Settings	6-14
Additional Service provider Data Settings	6-15
System Settings	6-16
Sprint System	6-16
Verizon System	6-17
Additional Service Provider System	6-17
Version Information	6-18
Services	6-18
Call Barring (Call Blocking)	6-18
Caller ID	6-19
Call Forwarding	6-19
Call Waiting	6-19
Voice Mail and Short Message Service (SMS)	6-19
Network Time Synchronization	6-19

Chapter 7: Interactive Sensor Technology Configuration

Introduction	7-1
IST Menu	7-1
General Tab	7-2
Power Management Tab	7-3
Keep Alive On Motion	7-3
On Face Down	7-3
Wake Up on Motion	7-4
Setting Sensitivity	7-4
Display Tab	7-4
Event Log Tab	7-5

Motion Event Details	7-5
Chapter 8: Wireless Applications	
Introduction	8-1
Signal Strength Icon	8-2
Turning the WLAN Radio On and Off	8-4
Chapter 9: Maintenance and Troubleshooting	
Introduction	9-1
Maintaining the MC9500-K	9-1
Removing the Screen Protector	9-2
Battery Safety Guidelines	9-2
Storage	9-3
Cleaning	9-4
Materials Required	9-4
Cleaning the MC9500-K	9-4
Housing	9-4
Display	9-4
Scanner Exit Window	9-4
Interface Connector	9-4
Battery Contacts	9-5
Cleaning Cradle Connectors	9-5
Cleaning Frequency	9-6
Troubleshooting	9-7
MC9500-K	9-7
Bluetooth Connection	9-9
Single Bay USB Cradle	9-10
Single Slot Battery Charger	9-11
Four Bay Ethernet Cradle	9-11
Four Bay Charge Only Cradle	9-12
Four Slot Battery Charger	9-13
Cables	9-13
Magnetic Stripe Reader	9-14
Appendix A: Technical Specifications	
MC9500-K Technical Specifications	A-1
MC9500-K	A-1
MC9500-K Accessory Specifications	A-7
Single Bay USB Cradle	A-7
Single Slot Battery Charger	A-7
Four Bay Ethernet Cradle	A-8
Four Bay Charge Only Cradle	A-9
Four Slot Battery Charger	A-9
Magnetic Stripe Reader	A-10

Appendix B: Special Software Configurations

Battery Usage Threshold Setting	B-1
Registry Setting	B-1
Bluetooth Configuration Setting	B-2

Glossary

Index

About This Guide

Introduction

This guide provides information about using the MC9500-K Series mobile computers and accessories.

✓ **NOTE** Screens and windows pictured in this guide are samples and can differ from actual screens.

Documentation Set

The documentation set for the MC9500-K provides information for specific user needs, and includes:

- **MC9500-K Series Quick Start Guide** - describes how to get the MC9500-K mobile computer up and running.
- **MC9500-K Series Mobile Computer User Guide** - describes how to use the MC9500-K mobile computer.
- **MC9500-K Series Mobile Computer Integrator Guide** - describes how to set up the MC9500-K mobile computer and accessories.
- **Microsoft® Applications for Windows Mobile 6 User Guide** - describes how to use Microsoft developed applications.
- **Enterprise Mobility Application Guide** - describes how to use Enterprise Mobility developed sample applications.
- **Enterprise Mobility Developer Kit (EMDK) Help File** - provides API information for writing applications.

Configurations

This guide covers the following configurations:

Configuration	Radios	Display	Memory	Data Capture Options	Operating System	Keypads
MC9590-K	WLAN: 802.11 a/b/g WPAN: Bluetooth v2.0 EDR GPS: SiRF Star III	3.7" VGA Color	128 MB RAM/ 512 MB Flash	1D laser scanner, 2D imager, 1D laser scanner and camera or 2D imager and camera	Windows Mobile 6.1 Classic	See Keypads below.
MC9596-K	WLAN: 802.11a/b/g WPAN: Bluetooth v2.0 EDR WWAN: HSDPA GPS: SiRF Star III	3.7" VGA Color	128 MB RAM/ 512 MB Flash	1D laser scanner, 2D imager, 1D laser scanner and camera or 2D imager and camera	Windows Mobile 6.1 Professional	See Keypads below.
MC9598-K	WLAN: 802.11a/b/g WPAN: Bluetooth v2.0 EDR WWAN: EvDO GPS: SiRF Star III	3.7" VGA Color	128 MB RAM/ 512 MB Flash	1D laser scanner, 2D imager, 1D laser scanner and camera or 2D imager and camera	Windows Mobile 6.1 Professional	See Keypads below.

Keypads

The following keypads are available:

- Alpha Primary
- Telephony Numeric
- Calculator Numeric
- Alpha Numeric.

See *MC9500-K Series User Guide* for specific keypad information.

Software Versions

This guide covers various software configurations and references are made to operating system or software versions for:

- Adaptation Kit Update (AKU) version
- OEM version
- BTEplorer version
- Fusion version
- Phone version.

AKU Version

To determine the Adaptation Kit Update (AKU) version:

Tap **Start > Settings > System tab > About icon > Version tab.**

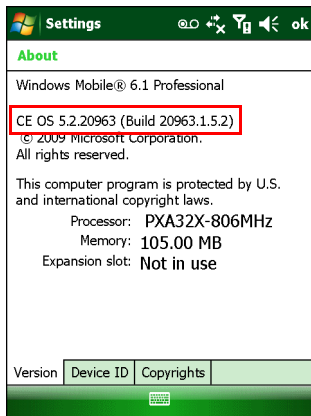

The second line lists the operating system version and the build number. The last part of the build number represents the AKU number. For example, *Build 20963.1.5.2* indicates that the device is running AKU version 1.5.2.

OEM Version

To determine the OEM software version:

Tap **Start > Settings > System tab > System Info icon > System tab.**

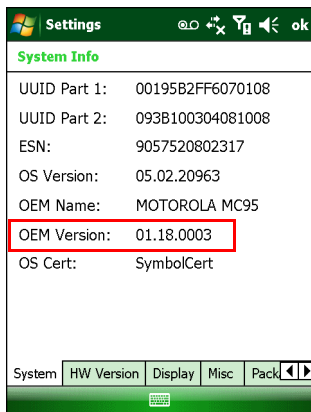

Fusion Software

To determine the Fusion software version:

Tap **Wireless Strength icon > Wireless Status > Versions.**

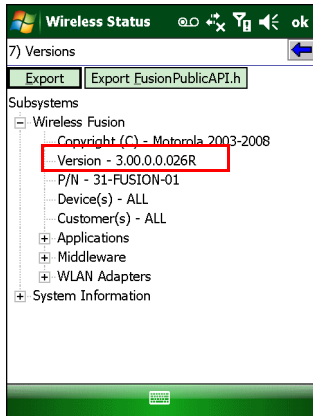

Phone Software

To determine the Phone software version:

On the MC9596-K, tap **Start > Phone > Menu > Options > PhoneInfo** tab. On the MC9598-K, tap **Start > Phone > Menu > Options > Version Information** tab.

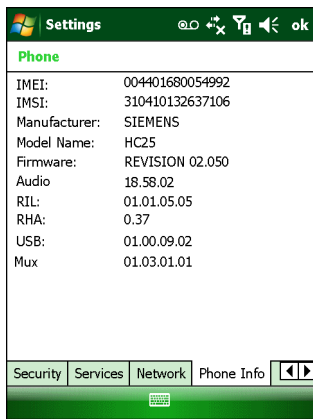

MC9596

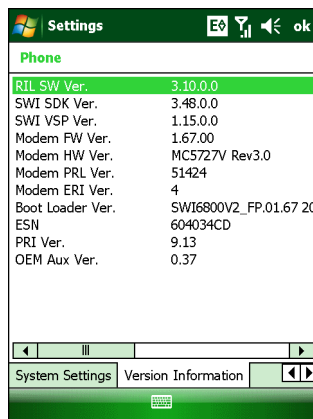

MC9598

Chapter Descriptions

Topics covered in this guide are as follows:

- [Chapter 1, Getting Started](#) provides information on getting the MC9500-K up and running for the first time.
- [Chapter 2, Accessories](#) describes the accessories available for the MC9500-K series and how to set up power connections and mounting information.
- [Chapter 3, ActiveSync](#) provides instructions on installing ActiveSync and setting up a partnership between the MC9500-K and a host computer.
- [Chapter 4, Application Deployment for Mobile 6](#) provides information for provisioning and deploying applications on the MC9500-K.
- [Chapter 5, MC9596 - GSM HSDPA Configuration](#) explains how to configure the MC9596-K service on an HSDPA network and establish settings.

- *Chapter 6, MC9598 - CDMA EvDO Configuration* explains how to configure the MC9598-K service on a CDMA wireless network.
- *Chapter 7, Interactive Sensor Technology Configuration* describes how to configure interactive sensing technology of the MC9500-K.
- *Chapter 8, Wireless Applications* describes how to configure Fusion wireless application.
- *Chapter 9, Maintenance and Troubleshooting* includes instructions on cleaning and storing the MC9500-K, and provides troubleshooting solutions for potential problems during MC9500-K operation.
- *Appendix A, Technical Specifications* provides the technical specifications for the MC9500-K.
- *Appendix B, Voice Quality Manager* provides information on Voice Quality Manager software.
- *Appendix C, Keypads* provides keypad layouts and operation.

Notational Conventions

The following conventions are used in this document:

- “Mobile computer” refers to the Motorola MC9500-K series of hand-held computers.
- *Italics* are used to highlight the following:
 - Chapters and sections in this and related documents
 - Icons on a screen.
- **Bold** text is used to highlight the following:
 - Dialog box, window, and screen names
 - Drop-down list and list box names
 - Check box and radio button names
 - Key names on a keypad
 - Button names on a screen.
- Bullets (•) indicate:
 - Action items
 - Lists of alternatives
 - Lists of required steps that are not necessarily sequential
- Sequential lists (e.g., those that describe step-by-step procedures) appear as numbered lists.

Related Documents

- *MC9500-K Quick Start Guide*, p/n 72-118504-xx.
- *MC9500-K Windows Mobile 6.1 Regulatory Guide*, p/n 72-118502-xx.
- *MC9500-K Mobile Computer User Guide*, p/n 72E-118504-xx.
- *Mobility Services Platform User Guide*, p/n 72E-100158-xx.
- *Microsoft® Applications for Windows Mobile 6 User Guide*, p/n 72E-108299-xx.
- *Wireless Fusion Enterprise Mobility Suite User Guide for Version 3.0*, p/n 72E-122495-xx.

- *Enterprise Mobility Application Guide*, p/n 72E-68901-xx.
- *Enterprise Mobility Developer Kits (EMDKs)*, available at: <http://www.motorola.com/enterprisemobility/support>.
- Latest ActiveSync software, available at: <http://www.microsoft.com>.

For the latest version of this guide and all guides, go to: <http://www.motorola.com/enterprisemobility/manuals>.

Service Information

If you have a problem with your equipment, contact Motorola Enterprise Mobility support for your region. Contact information is available at: <http://www.motorola.com/enterprisemobility/contactsupport>.

When contacting Enterprise Mobility support, please have the following information available:

- Serial number of the unit (found on manufacturing label)
- Model number or product name (found on manufacturing label)
- Software type and version number.

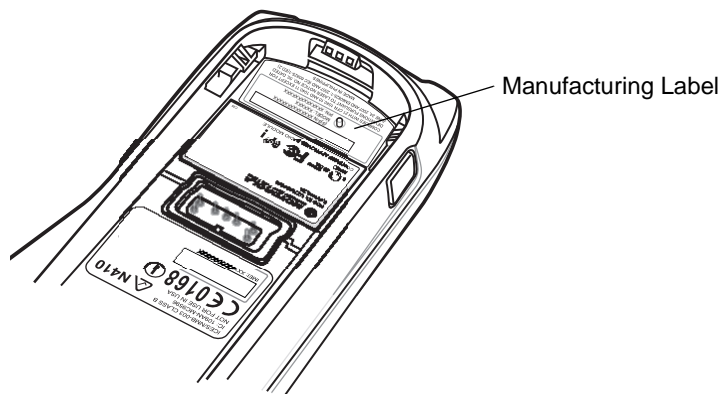

Motorola responds to calls by email, telephone or fax within the time limits set forth in support agreements.

If your problem cannot be solved by Motorola Enterprise Mobility Support, you may need to return your equipment for servicing and will be given specific directions. Motorola is not responsible for any damages incurred during shipment if the approved shipping container is not used. Shipping the units improperly can possibly void the warranty.

If you purchased your Enterprise Mobility business product from a Motorola business partner, contact that business partner for support.

Chapter 1 Getting Started

Introduction

This chapter provides information about the MC9500-K, accessories, charging the MC9500-K, and resetting the MC9500-K.

Unpacking the MC9500-K

Carefully remove all protective material from the MC9500-K and save the shipping container for later storage and shipping. Verify that you received the following equipment:

- MC9500-K
- Lithium-ion battery
- Regulatory Guide
- Quick Start Guide.

Inspect the equipment. If any equipment is missing or damaged, contact the Motorola Enterprise Mobility support immediately. See [Service Information on page xvi](#) for contact information.

Getting Started

To start using the MC9500-K for the first time:

- Install a microSD card (optional)
- Install the SIM card (MC9596-K only)
- Install the battery.
- Charge the MC9500-K.

Installing a microSD Card

The microSD card slot provides secondary non-volatile storage. The slot is located under the battery pack. Refer to the documentation provided with the card for more information, and follow the manufacturer's recommendations for use.



CAUTION Follow proper ESD precautions to avoid damaging the microSD card. Proper ESD precautions include, but are not limited to, working on an ESD mat and ensuring that the operator is properly grounded.

To install the microSD card:

1. Remove the SD card cover using flathead screwdriver.

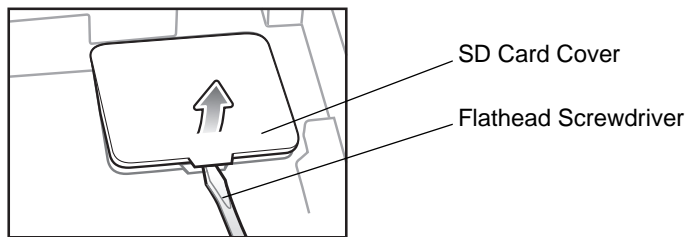

Figure 1-1 SD Card Cover Removal

2. Slide the microSD card holder door to the left to open.
3. Lift microSD card holder door.

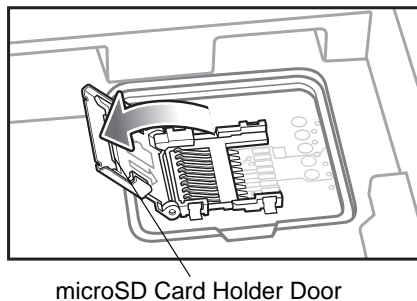

Figure 1-2 Lift SD Card Holder Door

4. Insert the microSD card into card holder door ensuring that the card slides into the holding tabs on each side of the door.

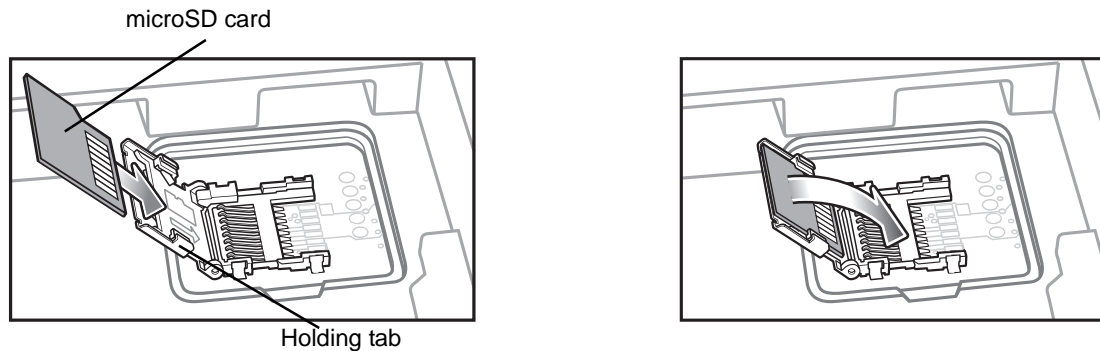

Figure 1-3 Insert microSD Card in Holder

5. Close the card holder door and slide to the right to lock into place.
6. Align the SD card cover over the access hole and press down until it snaps into place.

Installing the SIM Card

- ✓ **NOTE** MC9596-K configuration only.

GSM phone service requires a Subscriber Identification Module (SIM) card, or smart card. Obtain the card from the your service provider. The card fits into the MC9596-K and can contain the following information:

- Mobile phone service provider account details.
- Information regarding service access and preferences.
- Contact information, which can be moved to Contacts on the MC9596-K.
- Any additional services to which you have subscribed.

- ✓ **NOTE** For more information about SIM cards, refer to the service provider's documentation.

To install the SIM card:

1. Remove SIM card cover using flathead screwdriver.

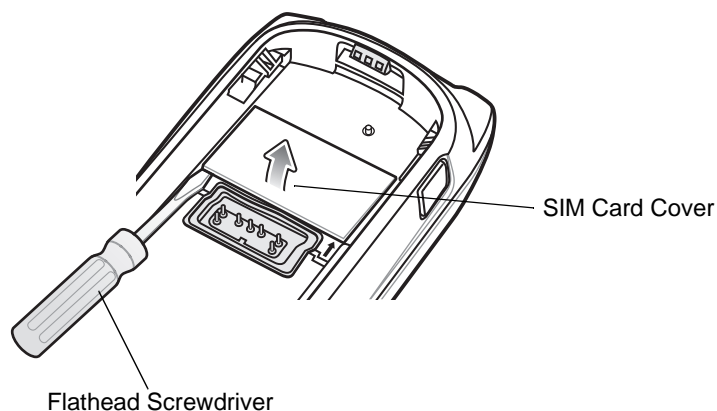

Figure 1-4 SIM Card Cover Removal

2. Slide the SIM card holder door to the left to unlock.
3. Lift the SIM card holder door.

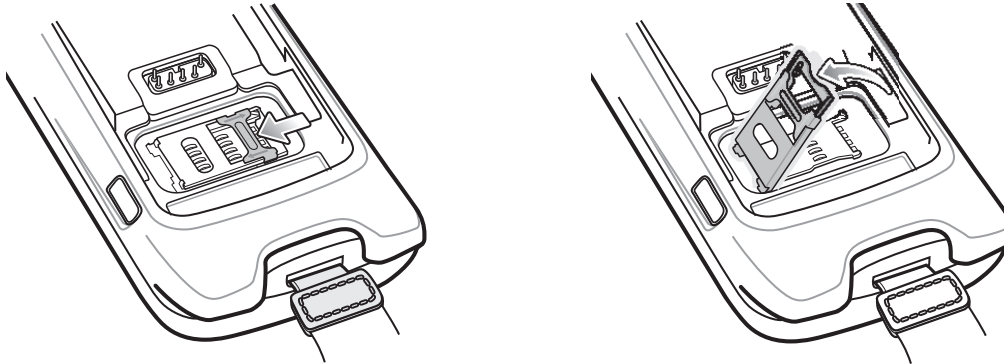

Figure 1-5 *Lifting the SIM Cover*

4. Insert the SIM card, as shown in [Figure 1-6](#) into the holder door with the contacts facing down and the card notch facing up.

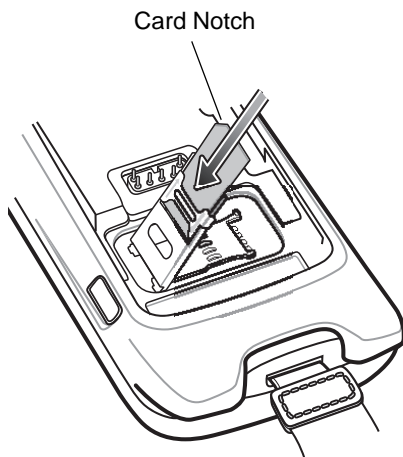

Figure 1-6 *Inserting the SIM Card*

5. Close SIM card holder door and slide to the right to lock into place.
6. Align the SIM card cover over the access hole and press down until it snaps into place.
7. Install the battery.
8. After completing initial MC9596 setup or after replacing a SIM card:
 - a. Press the red **Power** button.
 - b. On the Today screen, tap **Wireless Manager**.
 - c. Ensure Phone is on.
 - d. Press the red **Power** button to suspend the MC9596.
 - e. Perform a warm boot. See [Resetting the MC9500-K on page 1-7](#).
 - f. Make a call to verify cellular connection.

✓ **NOTE** For detailed information about WWAN activation and settings, refer to [Chapter 5, MC9596 - GSM HSDPA Configuration](#) and [Chapter 6, MC9598 - CDMA EvDO Configuration](#).

Installing the Battery

To install the battery:

1. Insert the battery, top first, into the battery compartment.
2. Press the battery down into the battery compartment until the battery release latches snap into place.

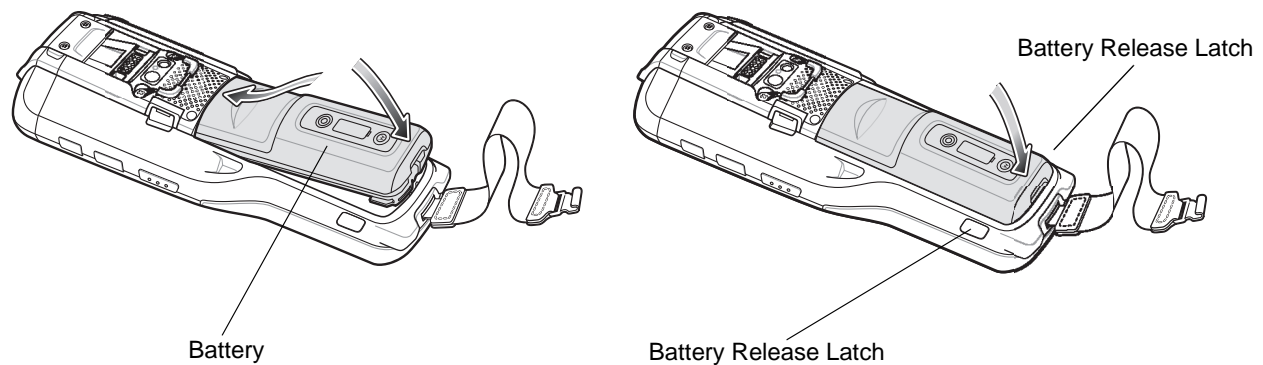

Figure 1-7 *Inserting the Battery*

3. The MC95XX powers up automatically after inserting the battery, if the battery has been charged previously.

Charging the Battery



CAUTION Ensure that you follow the guidelines for battery safety described in *Battery Safety Guidelines* on page 9-2.

Before using the MC9500-K for the first time, charge the battery.

To charge the battery, use either a charging cable or a cradle:



NOTE For cable and cradle setup and charging procedures see [Chapter 2, Accessories](#).

- Cables:
 - USB Charging Cable
 - Charge Only Cable
- Cradles:
 - Single Bay USB Cradle
 - Four Bay Charge Only Cradle
 - Four Bay Ethernet Cradle.

Align and hook the MC9500-K interface pocket onto the cradle's or cable's cleat. The battery automatically begins charging. See [Table 1-1](#) for charging indications. The 4800 mAh battery fully charges in less than six hours.

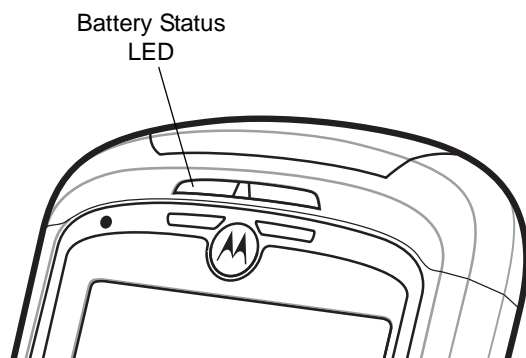

Battery Status LED

Table 1-1 LED Charge Indicators

Charging/Battery Status LED	Indication
Off	Indicates that the: <ul style="list-style-type: none"> • battery is not charging • MC9500-K is not connected correctly to the cradle or not connected to a power source. • cradle is not powered.
Slow Blinking Amber (1 blink every 2 seconds)	Indicates that a healthy battery is charging.
Slow Blinking Red (1 blink every 2 seconds)	Indicates that an unhealthy battery is charging.
Solid Green	Indicates that a healthy battery is fully charged.
Solid Red	Indicates that an unhealthy battery is fully charged.
Fast Blinking Amber (2 blinks/second)	Indicates a charging error, e.g.: <ul style="list-style-type: none"> • temperature is too low or too high. • charging has gone on too long without completion (typically eight hours).
Single Blink Amber (when Power button pressed)	Battery depleted.

The MC9500-K is equipped with a memory backup battery which automatically charges from the fully-charged main battery. When using the MC9500-K for the first time, the backup battery requires approximately 36 hours to fully charge. This is also true any time the backup battery is discharged, which occurs when the main battery is removed for several hours. The backup battery retains RAM data in memory for at least 15 minutes (at room temperature) when the MC9500-K's main battery is removed. When the MC9500-K reaches a very low battery state, the combination of main battery and backup battery retains RAM data in memory for at least 48 hours.

Charging Temperature

Charge batteries in temperatures from 0°C to 40°C (32°F to 104°F). Note that charging is intelligently controlled by the MC9500-K.

To accomplish this, for small periods of time, the MC9500-K or accessory alternately enables and disables battery charging to keep the battery at acceptable temperatures. The MC9500-K or accessory indicates when charging is disabled due to abnormal temperatures via its LED. See [Table 1-1](#).

Powering On the MC9500-K

✓ **NOTE** The boot up time is for 512 MB configurations.

After the MC9500-K is connected to power the splash screen displays for about 2.5 minutes (during a clean boot) or 30 seconds (during a cold boot) as the MC9500-K initializes its flash file system, then the calibration window appears.

Calibrating the Screen

✓ **NOTE** The Calibration screen can be accessed by tapping **Start > Settings > Screen > Align Screen** button or by pressing the CTRL button followed by the BKSP button.

To calibrate the screen so the cursor on the touch screen aligns with the tip of the stylus:

1. Remove the stylus from its holder on the side of the MC9500-K.
2. Carefully press and briefly hold the tip of stylus on the center of each target that appears on the screen.
3. Repeat as the target moves around the screen, then tap the screen to continue.

Resetting the MC9500-K

There are three reset functions, warm boot, cold boot and clean boot. A warm boot restarts the MC9500-K by closing all running programs. A cold boot also restarts the MC9500-K, and also resets the clock. Data saved in flash memory or a memory card is not lost. A clean boot resets the MC9500-K to factory defaults.

Perform a warm boot first. If the MC9500-K still does not respond, perform a cold boot.

Performing a Warm Boot

Hold down the **Power** button for approximately five seconds. As soon as the MC9500-K starts to perform a warm boot release the **Power** button.

Performing a Cold Boot

To perform a cold boot:

1. Simultaneously press the **Power** button and the 1 and 9 keys.
2. The MC9500-K initializes.

Performing a Clean Boot



CAUTION A clean boot should only be performed by an authorized system administrator. You must connect the MC9500-K to AC power during a clean boot.

Removing AC power from the MC9500-K during a clean boot may render the MC9500-K inoperable.

A clean boot resets the MC9500-K to the factory default settings. All data in the **Application** folder is retained. You must download the Clean Boot Package file from the Support Central web site (<http://www.motorola.com/enterprisemobility/support>) and install on the MC9500-K.

To perform a clean boot:

1. Download the Clean Boot Package from the Support Central web site. Follow the instructions included in the package for installing the package onto the MC9500-K.
2. Simultaneously press the **Power** button and the **1** and **9** keys.
3. Immediately, as soon as the device starts to boot and before the splash screen is visible, press and hold the left scan button.
4. Insert the MC9500-K into a powered cradle or cable.
5. The MC9500-K updates and then re-boots.
6. After successful clean boot, the calibration screen appears.

Keypad Replacement

The MC9500-K has interchangeable modular keypads. The modular keypads can be changed in the field as necessary to support specialized applications.



CAUTION Do not remove the keypad while the MC9500-K is on. Follow proper Electro-Static Discharge (ESD) precautions to avoid damage to the device. Proper ESD precautions include, but are not limited to, working on an ESD mat and ensuring that the operator is properly grounded.

1. If the MC9500-K is in suspend mode, press the Power button to wake the device. Wait for the MC9500-K to fully awake from suspend mode.
2. Press the Power button to suspend the MC9500-K.
3. Wait for red Decode LED to turn on and then turn off.
4. Un-hook the handstrap.
5. Remove the battery.
6. Remove and discard two screws securing the keypad to the housing.

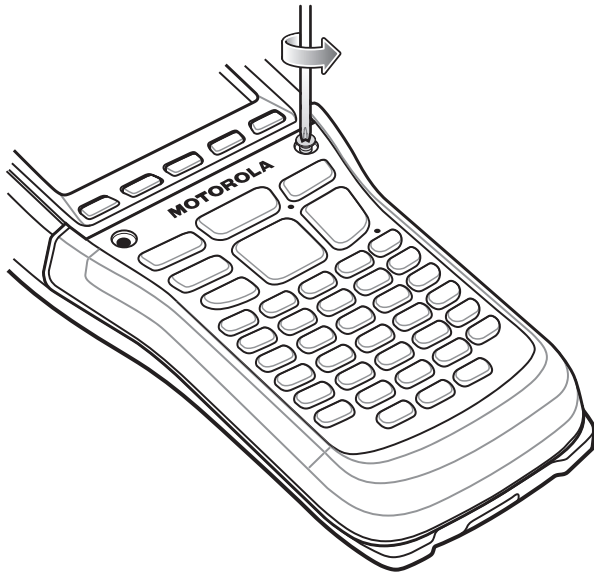

Figure 1-8 *Remove Screws*

7. Slide the keypad down toward the bottom of the device and then lift.

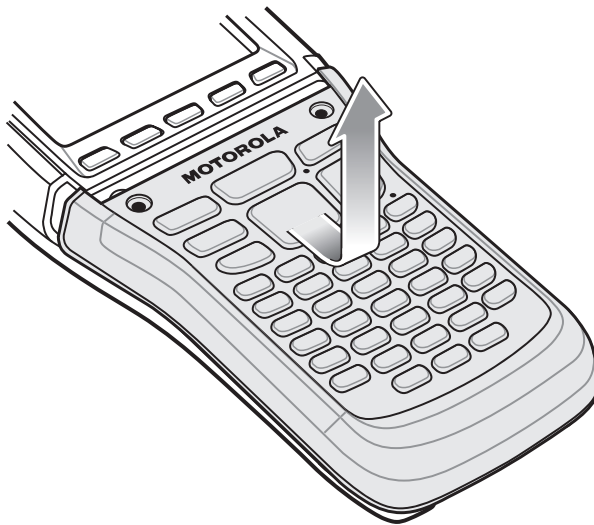

Figure 1-9 *Remove Keypad*

8. Align the new keypad with the housing.
9. Press the keypad down and then slide the keypad up.

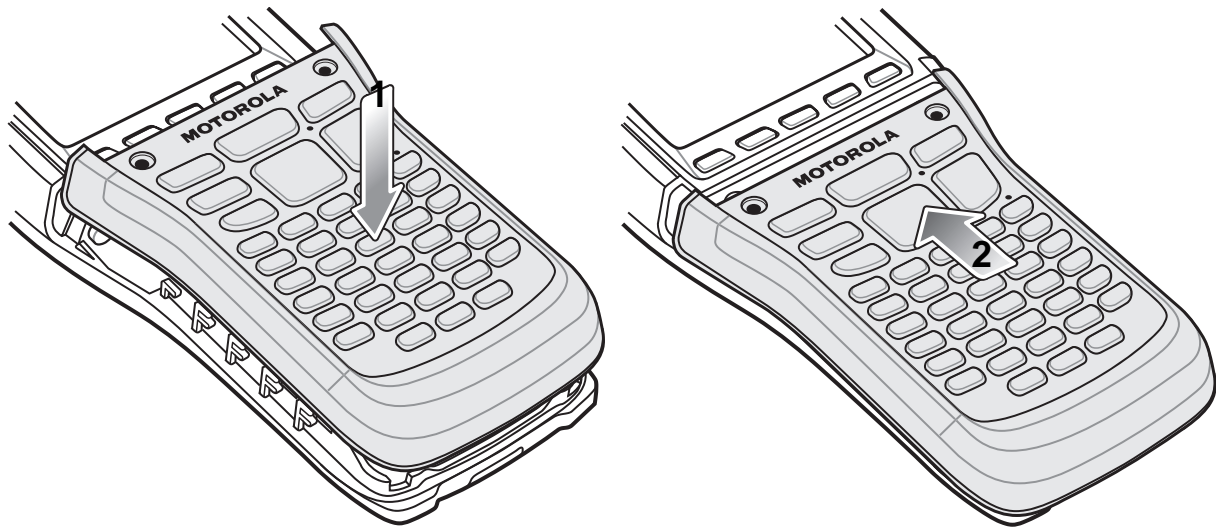

Figure 1-10 *Replace Keypad*

10. Secure the keypad with two new screws provided with the keypad. Torque the screws to 2.5 kg-cm (0.18 ft-lbs.)

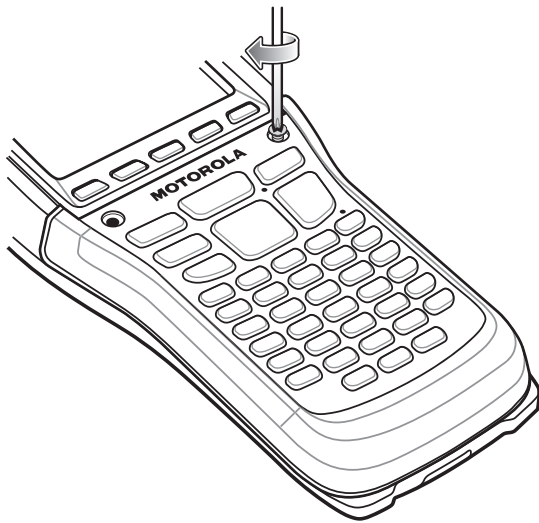

Figure 1-11 *Replace New Screws*

11. Replace the battery.
12. Press the power button for five seconds to perform a warm boot.

Handstrap Replacement

To remove the handstrap:

1. Press the Power button to place the MC9500-K in suspend mode.
2. Wait for the Decode LED to light red and then turn off.
3. Unhook the handstrap from the handstrap bar.
4. Remove the two screws securing the handstrap bar to the housing.

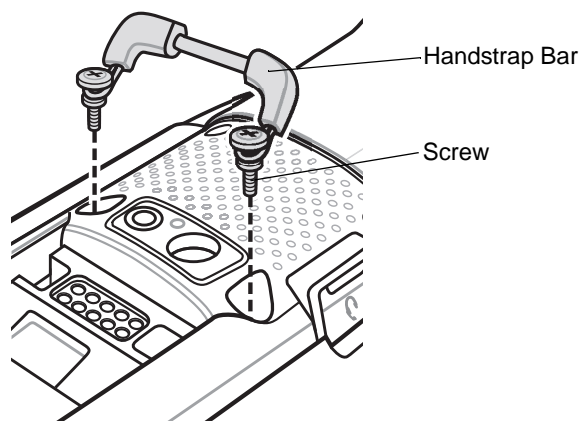

Figure 1-12 Remove Screws Securing Handstrap Bar

5. Remove the battery.

✓ **NOTE** A pin holds the loop end of the handstrap in the housing slot.

6. With the handstrap slot pointing upward, push the handstrap into the slot of the housing slightly to provide slack.

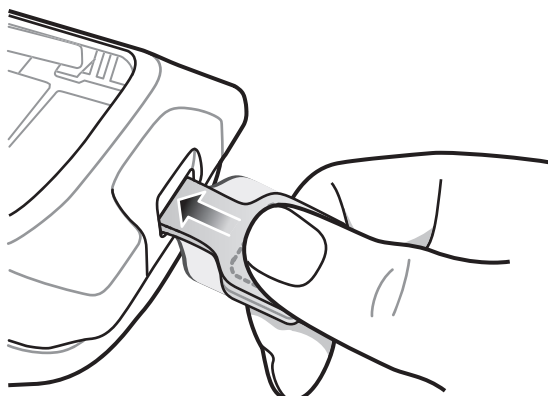

Figure 1-13 Push Handstrap Loop into Slot

7. Grasp the end of the handstrap and turn it sharply/tug to dislodge the pin and remove the handstrap.

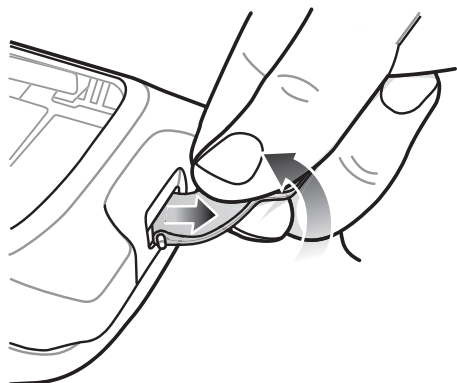

Figure 1-14 Turn Pin and Loop

8. Remove the loop end of the handstrap and pin from the housing slot.

To replace a new handstrap:

1. Pinch the loop end of the new handstrap and insert the loop into the housing slot. Ensure that the loop is completely inserted into the housing slot.

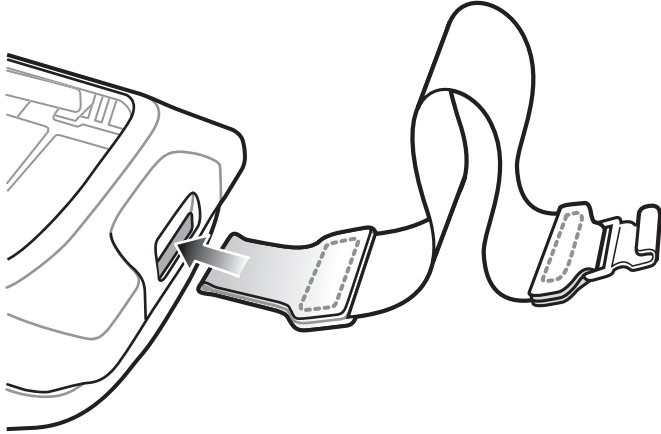

Figure 1-15 *Insert Strap and Pin into Slot*

2. In the battery compartment area, insert the pin into the loop of the handstrap.

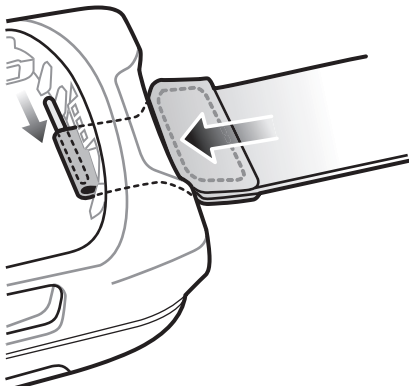

Figure 1-16 *Insert Pin into Loop*

3. Ensure that the pin is centered in the loop.
4. Pull the handstrap so that the pin locks into the slot.

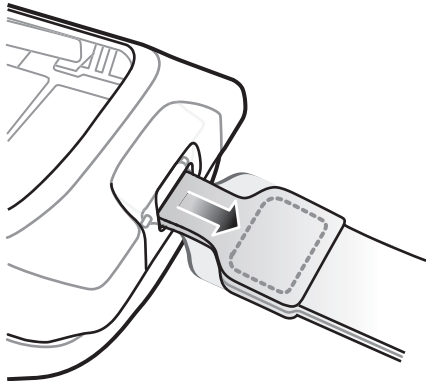

Figure 1-17 *Pull Handstrap to Lock Pin*

5. Secure the new handstrap bar and screws into the housing.
6. Insert the battery.
7. Re-hook the handstrap clip onto the handstrap bar.

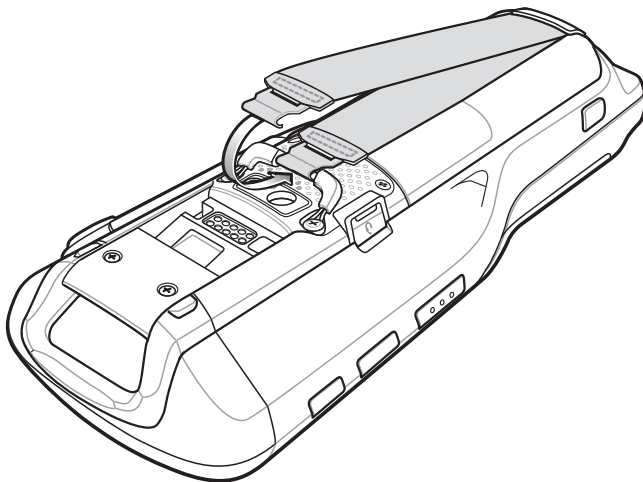

Figure 1-18 *Re-hook Handstrap onto Handstrap Bar*

Chapter 2 Accessories

Introduction

MC9500-K accessories, listed below, provide a variety of product support capabilities.

Table 2-1 MC9500-K Series Accessories

Accessory	Part Number	Description
Cradles		
Single Bay USB Cradle	CRD9500-1000UR	Charges the MC9500-K main battery. Synchronizes the MC9500-K with a host computer through a USB connection.
Four Bay Charge Only Cradle	CRD9500-4000CR	Charges up to four MC9500-K devices.
Four Bay Ethernet Cradle	CRD9500-4000ER	Charges up to four MC9500-K devices and connects the MC9500-K devices to an Ethernet network.
Vehicle Cradle	VCD9500-1000R	Installs in a vehicle and charges the MC9500-K main battery.
Chargers		
Single Slot Battery Charger	SAC9500-1000CR	Charges an MC9500-K battery.
Four Slot Battery Charger	SAC9500-4000CR	Charges up to four MC9500-K batteries.
Vehicle Battery Charger	VBC9500-1000R	Charges an MC9500-K battery in a vehicle.
Cables		
USB/Charge Cable	25-116365-01R	Provides power to the MC9500-K and USB communication with a host computer.
Auto Charge Cable	VCA9500-01R	Charges the MC9500-K using a vehicle's cigarette lighter and provides power to a Vehicle Battery Charger.
DEX Cable	25-116366-01R	Connects the MC9500-K to a vendor machine.

Table 2-1 MC9500-K Series Accessories (Continued)

Accessory	Part Number	Description
4-way DC cable	25-85992-01R	Used to power up to four Four Slot Battery Chargers with one power supply (50-14000-241R).
USB Sync Cable	25-124330-01R	Connects Single Bay USB Cradle to the host system. USB A to USB micro-B.
DC "Y" Cable	25-122026-01R	Connects the Single Bay USB cradle and a Single Slot Battery Charger to a single power supply or two Single Slot battery Chargers to a single power supply.
Modem Adapter Cable	25-116367-01R	Connects the MC9500-K to the Modem Dongle.
Headset Adapter Cable	21-116368-01R	Connects a VXI headset (50-11300-050R) to the MC9500-K.
AC Line Cord	23844-00-00R	Connects a power supply to an outlet (US only).
DC Cable	50-16002-029R	Connects from the four bay cradle to a power supply.
Jumper Cable	25-122028-01R	Connects the Vehicle Battery Charger to the Vehicle Cradle.
Miscellaneous		
Modem Dongle	MDM9000-100R	Provides modem connectivity.
Magnetic Stripe Reader	MSR9500-100R	Snaps onto the MC9500-K and adds magstripe read capabilities.
Spare 4800 mAh lithium-ion battery	BTRY-MC95IABA0 BTRY-MC95IABA0-10	Replacement 4800 mAh battery. Replacement 4800 mAh battery (10-pack).
Belt Mounted Rigid Holster	SG-MC9511110-01R	Clips onto belt to hold the MC9500-K when not in use.
Fabric Holster	SG-MC9521110-01R	Soft holder for added protection.
Handstrap	SG-MC9523043-01R	Replacement handstrap (5-pack).
Desk Mounting Bracket	KT-116363-01R	Use for mounting a four bay cradle or two four slot battery chargers on a desk.
Universal Wall Mounting Bracket	KT-116362-01R	Use for mounting a four bay cradle or two four slot battery chargers on a wall.
Vehicle Mounting Bracket	KT-122012-01R	Used for mounting the vehicle cradle and vehicle battery charger in a vehicle.
Guide Cups	KT-122014-01R	Provides assistance for placing an MC9500-K onto a four bay cradle (4-pack).
Screen Protector	KT-122010-01R	Package of 3 screen protectors.
Spare Stylus, 3 Pack	KT-122016-03R	Replacement spring loaded stylus (3-pack).
Spare Stylus, 50 Pack	KT-122018-50R	Replacement spring loaded stylus (50-pack).

Table 2-1 MC9500-K Series Accessories (Continued)

Accessory	Part Number	Description
Power Supply	KT-14000-148R	Supports the Single Bay USB Cradle, Single Slot Battery Charger and Four Slot Battery Charger.
Power Supply	50-14000-241R	Supports one Four Bay cradle or up to four (4) Four Slot Battery Chargers.

Guide Cup Installation

Optional guide cups can be used with the four bay cradles to assist the user when hooking the MC9500-K onto the cradle.

To install the guide cups:

1. Align the tabs on the guide cup with the guide slots on the universal cleat.
2. Slide the guide cup into the guide slots.

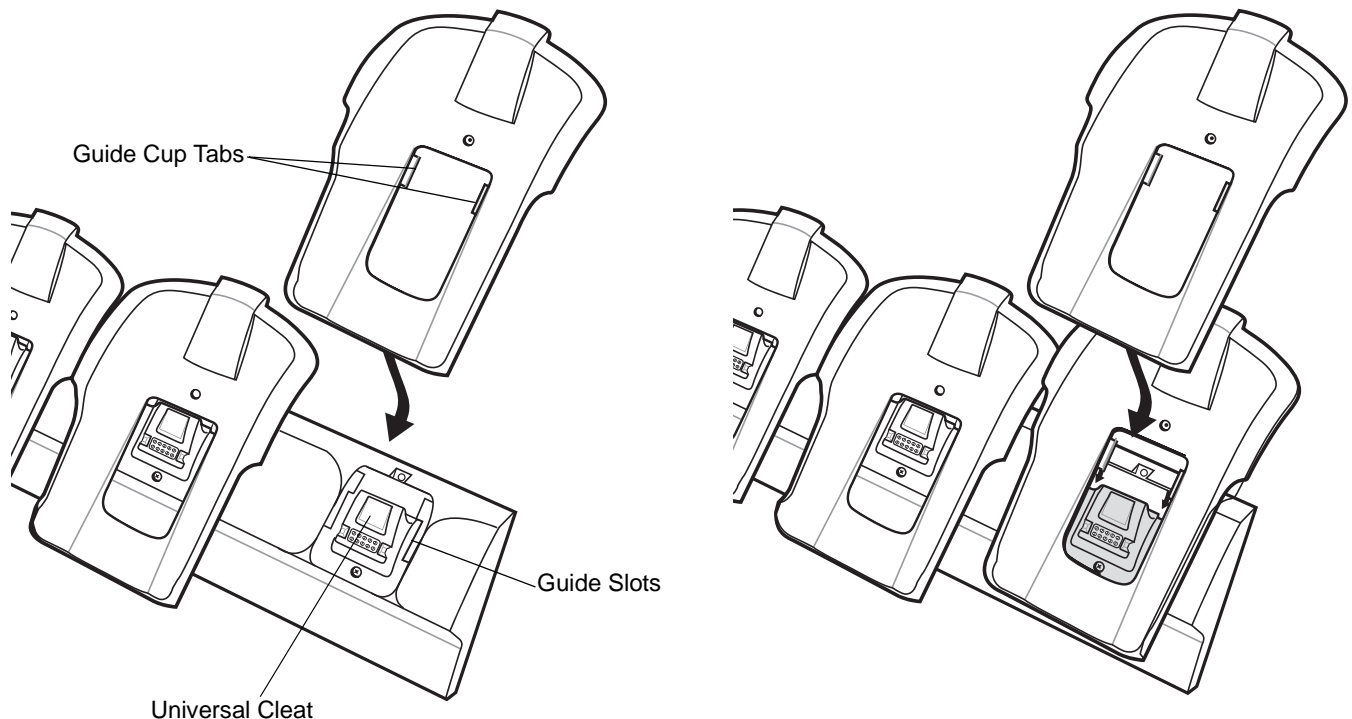

Figure 2-1 Align Guide Cup with Universal Cleat

3. Ensure that the guide cup is seated properly.
4. Using the provided screw, secure the guide cup to the cradle. Torque the screw to 2.0 kgf-cm (1.73 in-lbs.)

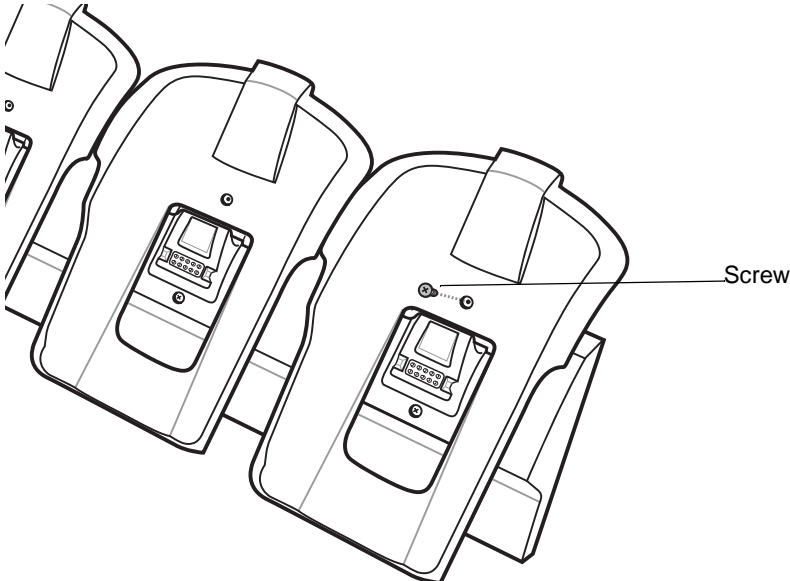

Figure 2-2 Secure Guide Cup to Cradle

Universal Wall Mounting Bracket

Use the Universal Wall Mounting Bracket to mount a Four Bay Ethernet cradle, Four Bay Charge Only cradle or two Four Slot Battery Chargers on a wall.

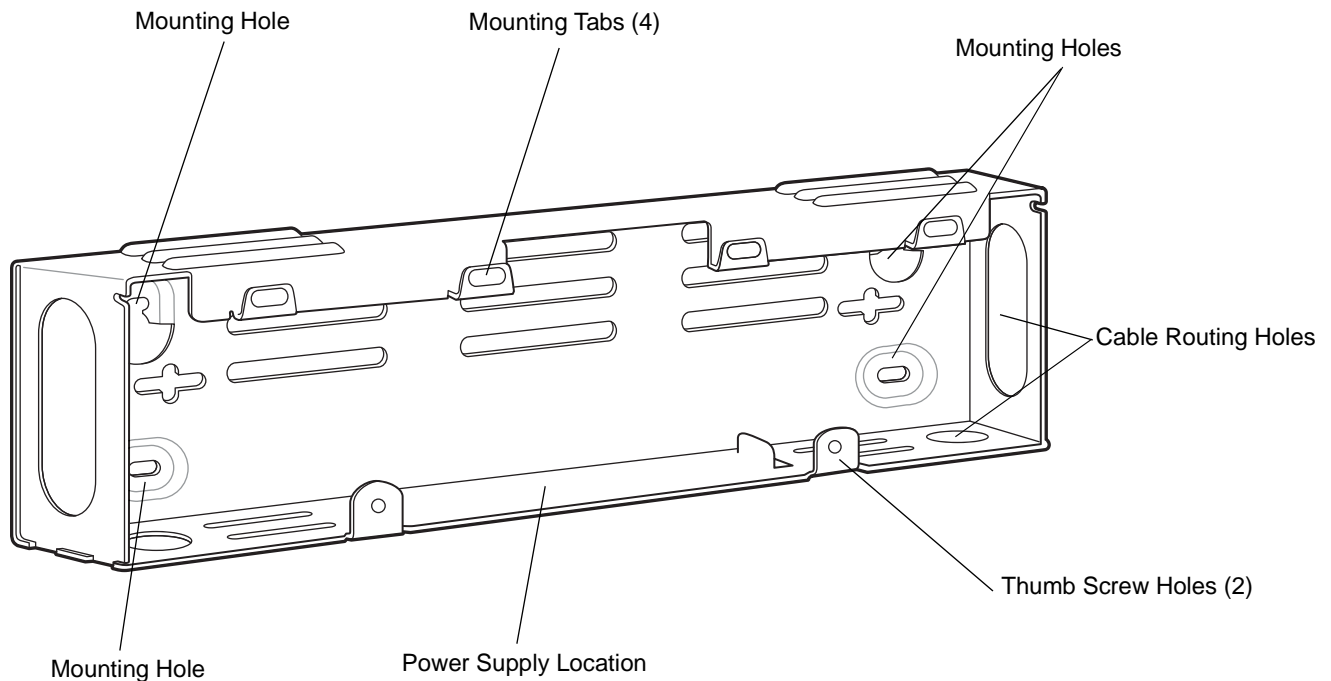

Figure 2-3 Universal Wall Mounting Bracket

✓ **NOTE** Use fasteners appropriate for the type of wall and the Universal Wall Mount Bracket mounting slots.

For mounting on metal surfaces, it is recommended to use 4 mm or #8 pan head machine screws with a minimum thread engagement of the screw size (diameter).

For mounting on non-metal surfaces, it is recommended to use 4.8 mm or #10 pan head self-tapping screws with suitable length and wall plug.

To attach the Universal Wall Mounting Bracket to the wall:

1. Place the template (supplied with the Universal Wall Mounting Bracket) onto the wall, level and mark the four screw hole locations and drill holes.
2. If the template is not available, use the dimensions in [Figure 2-4 on page 2-6](#).

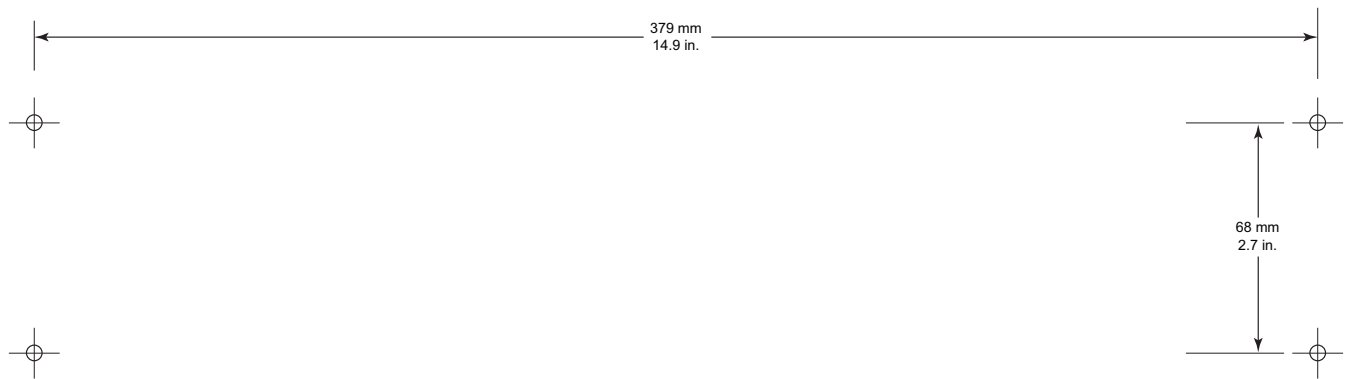

Figure 2-4 *Mounting Hole Dimensions*

3. Install top two screws into the wall.

The screw heads should protrude 12.7 mm (0.5") from the wall.

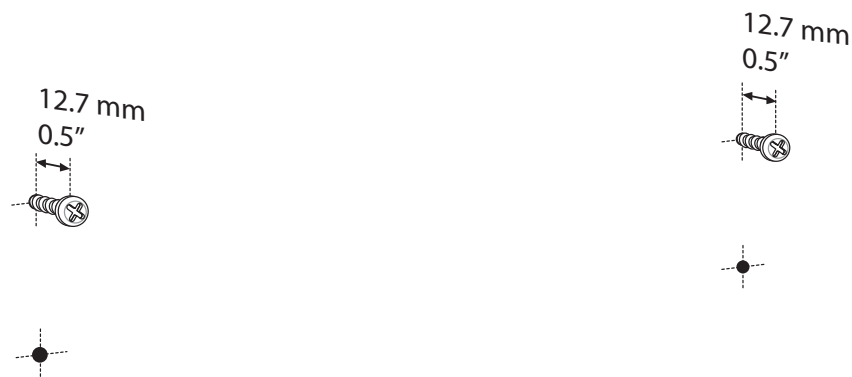

Figure 2-5 *Install top Two Screws*

4. Align the mounting bracket's top two mounting holes with the screws. Place mounting bracket on screws.

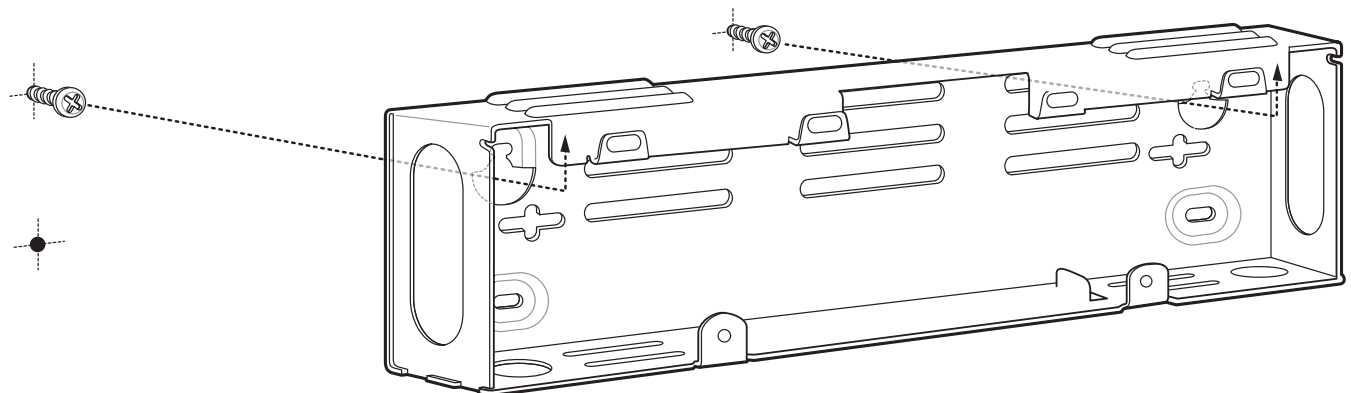

Figure 2-6 *Install Bracket on Screws*

5. Tighten the two screws to the wall securing the bracket.
6. Install and secure two screws at the bottom of the bracket.

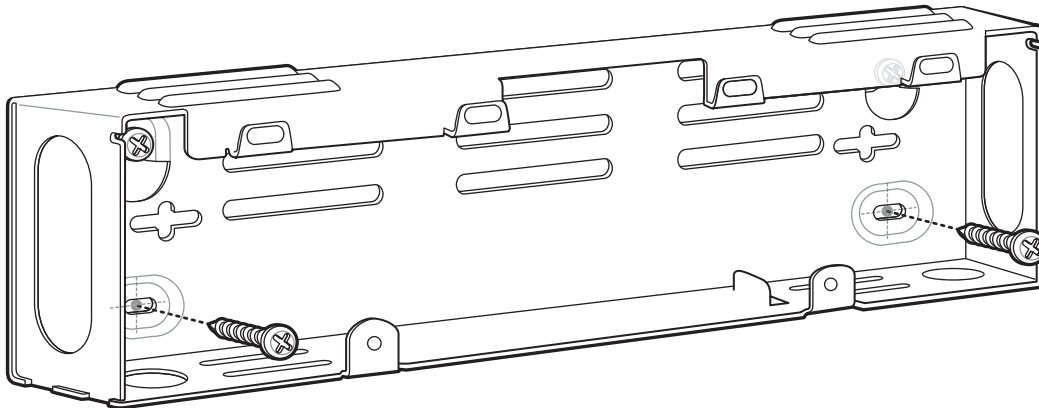

Figure 2-7 *Install Bottom Two Screws*

Mounting Multiple Brackets

When mounting multiple brackets on a wall:

- Place brackets next to each other so that the brackets touch.
- Distance from top mounting hole of one bracket to top mounting hole of next bracket should be 254 mm (10 in.) minimum.
- Vertical space between brackets should be 131 mm (5.2 in.) minimum.
- Lowest bracket should not be less 610 mm (18 in.) from the floor.
- Top bracket should not be higher than 1.8 m (6 ft.) from the floor.

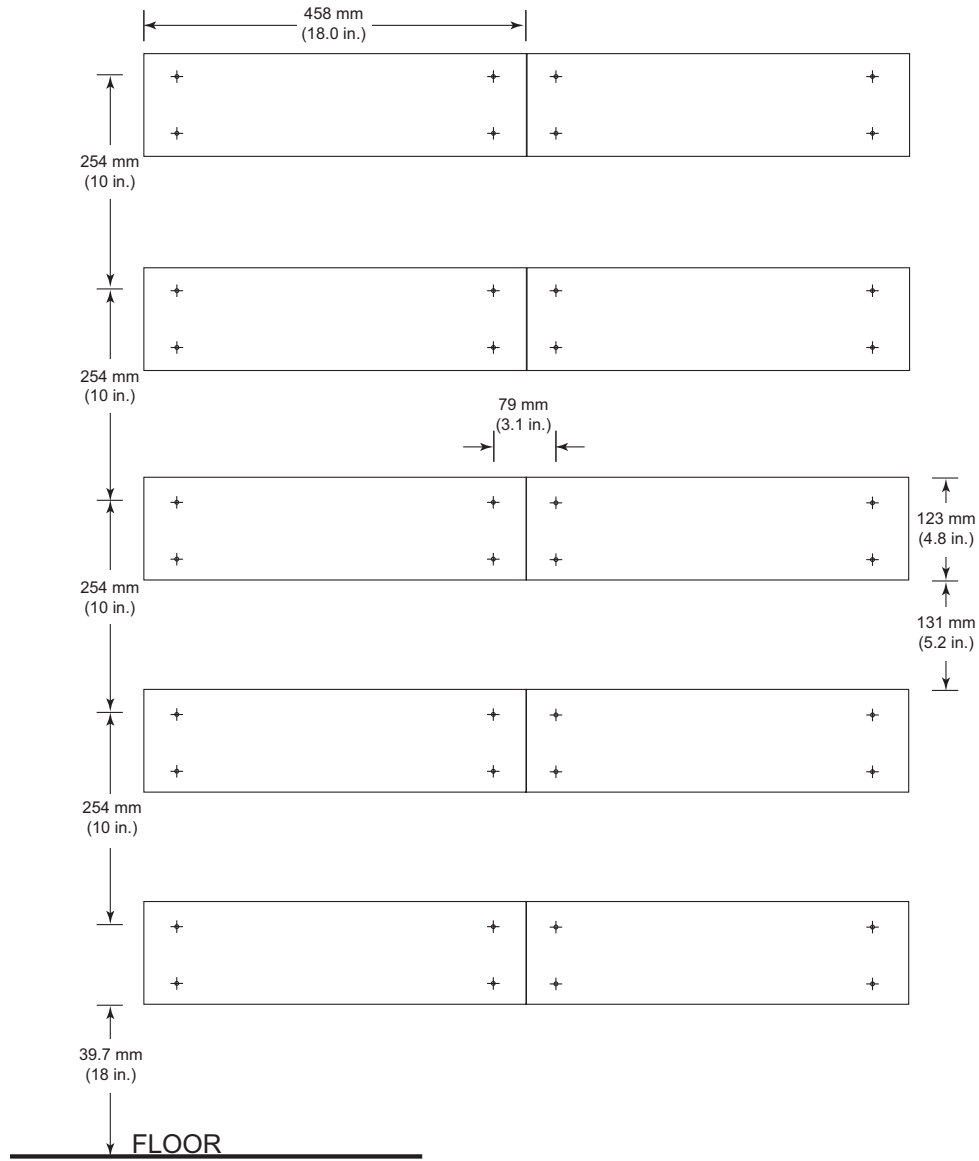

Figure 2-8 Multiple Mount Bracket Layout

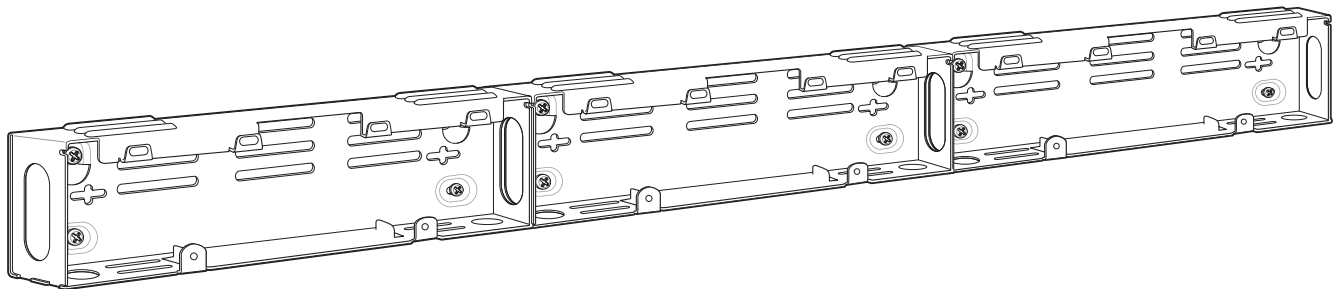

Figure 2-9 Mounting Multiple Brackets Horizontally

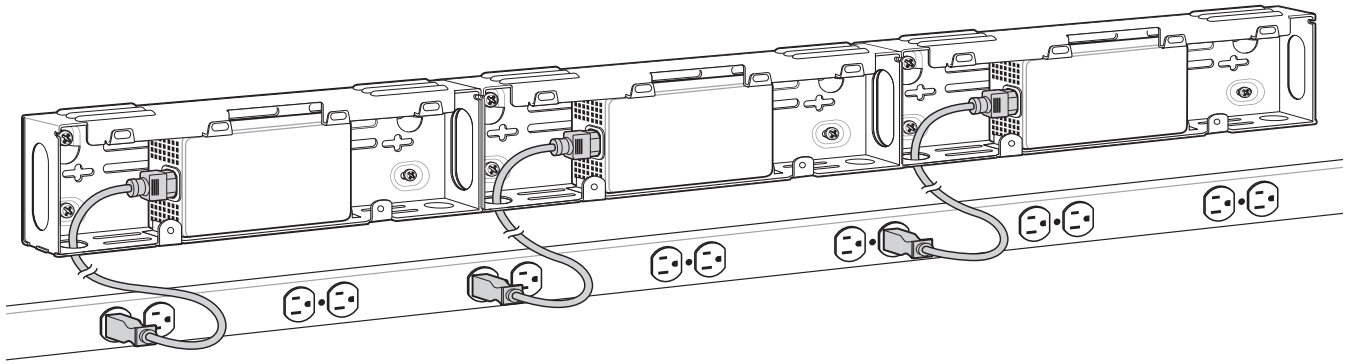

Figure 2-10 *Mounting Brackets with Power Strip under Brackets*

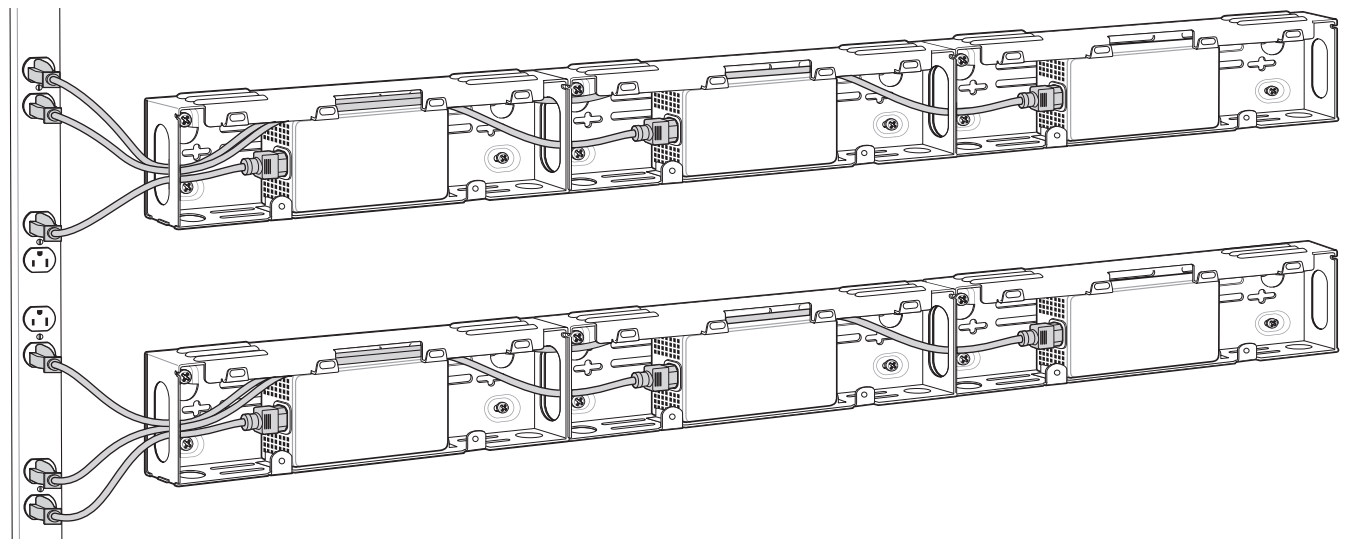

Figure 2-11 *Mounting Brackets with Power Strip Adjacent to Brackets*

Four Bay Ethernet Cradle Wall Mounting

To mount the Four Bay Ethernet Cradle on a Universal Wall Mount bracket:

1. Connect the AC line cord to the power supply.
2. Route the AC line cord through the bracket.
3. Connect the DC cable to the power supply. Coil the DC cable so that it fits into the bracket.

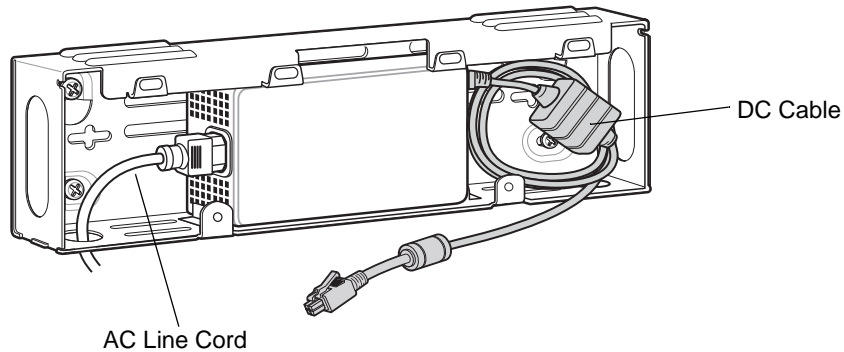

Figure 2-12 Power Connections

4. Repeat for each cradle.
5. While holding the cradle close to the bracket, connect the DC Cable to the power port on the cradle.
6. Connect a Ethernet cable to the Ethernet Port 1 connector on the back of the cradle.

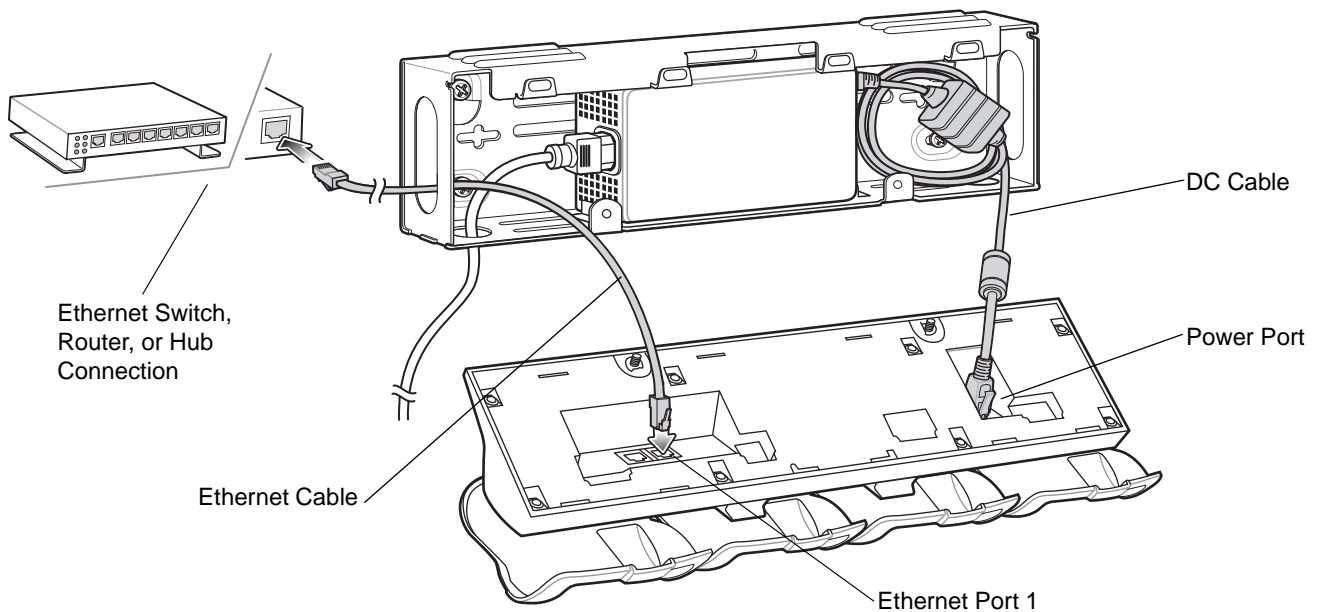

Figure 2-13 Four Bay Ethernet Cradle Connection

7. Route the Ethernet cable through the bracket to an ethernet hub.
8. Place cables neatly in the bracket and secure with tie wraps as required. Ensure that all cables are within the bracket to avoid pinching wires.

9. Align the four mounting slots on the back of the cradle with the four mounting tabs on the bracket.

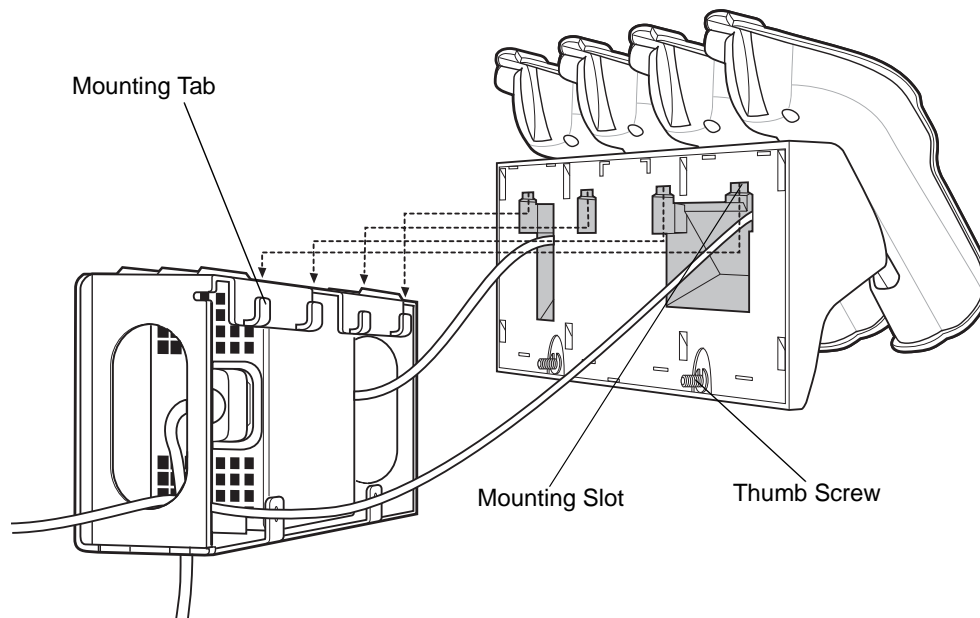

Figure 2-14 Mount Four Bay Cradle onto Mount Bracket

10. Hang the cradle on the bracket ensuring that the cradle is aligned properly.
11. Secure the two thumb screws to hold the cradle to the bracket.
12. Plug the AC line cord into an AC outlet.

Daisy chaining Ethernet Cradles

Daisychain up to four Ethernet cradles to connect several cradles to an Ethernet network. Use either a straight or crossover cable. Daisy-chaining should not be attempted when the main Ethernet connection to the first cradle is 10 Mbps as throughput issues will almost certainly result.

To daisychain more than one Ethernet cradle:

1. Connect power to each Ethernet cradle to daisychain.
2. Connect an Ethernet cable to Port 1 of the first cradle as shown in [Figure 2-13](#).
3. Connect a second Ethernet cable between Port 2 of the first cradle, and Port 1 of the second cradle.
4. Connect additional cradles as described in Step 3.

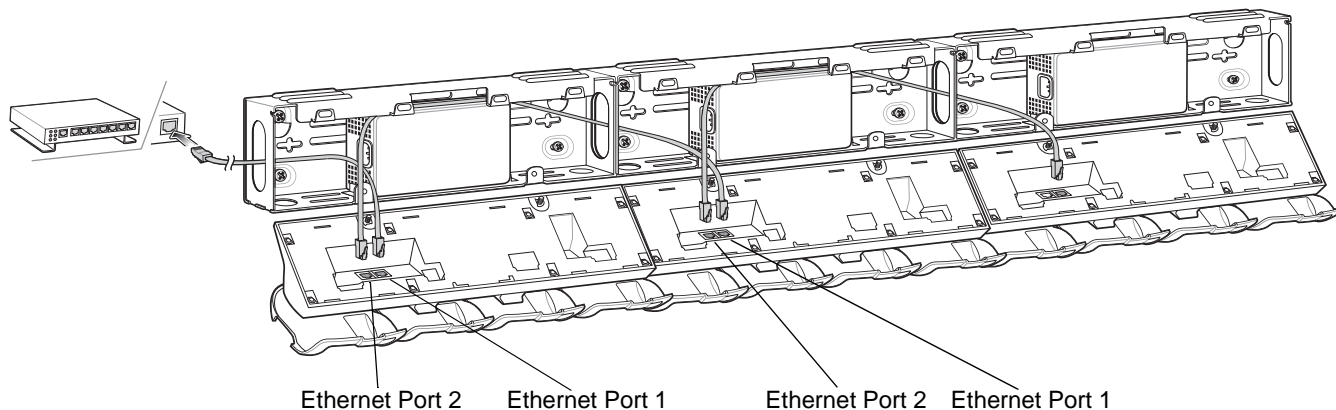

Figure 2-15 *Daisy-chaining Four Bay Ethernet Cradles*

Ethernet Cradle Drivers

The MC9500-K includes Ethernet cradle drivers that initiate automatically when you place the MC9500-K in a properly connected Four Bay Ethernet cradle. After inserting the MC9500-K, configure the Ethernet connection:

1. Tap **Start > Settings > Connections tab > WiFi icon**. The **Configure Network Adapters** window appears.

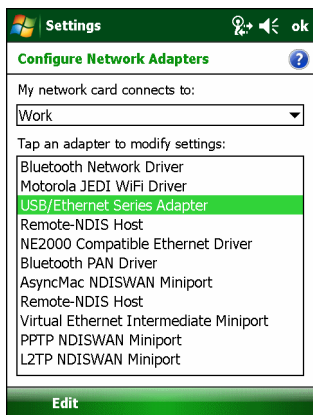

Figure 2-16 *Configure Network Adapters Window*

2. In the **My network card connects to:** drop-down list, select the appropriate connection.
3. In the **Tap an adapter to modify settings:** list, select **USB/Ethernet Series Adapter**.

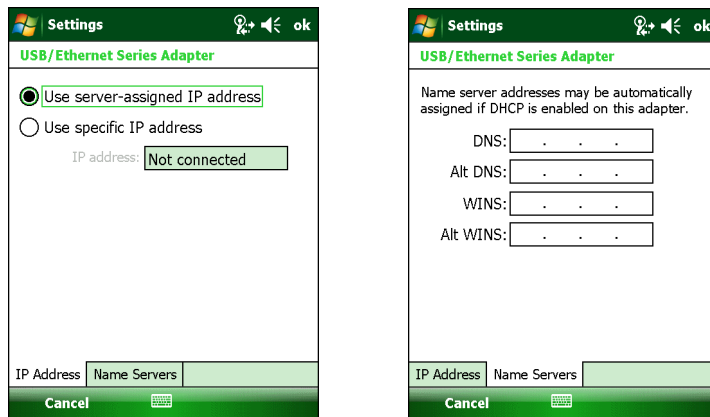

Figure 2-17 *IP Address Tab*

4. In the **IP address** window, select the appropriate radio button:
 - **Use server-assigned IP address**
or
 - **Use specific IP address.** Enter the IP address, Subnet mask, and Default gateway, as needed.
5. Tap the **Name Servers** tab.
6. Enter the appropriate DNS, Alt DNS, WINS, and Alt WINS server addresses.
7. Tap **ok**.
8. Tap **ok** to confirm the setup.
9. Tap **ok** to exit.

LED Indicators

Speed LED

The cradle's green Speed LED lights to indicate that the transfer rate is 100 Mbps. When it is not lit it indicates that the transfer rate is 10Mbps.

Link LED

The cradle's yellow Link LED blinks to indicate activity, or stays lit to indicate that a link is established. When it is not lit it indicates there is no link.

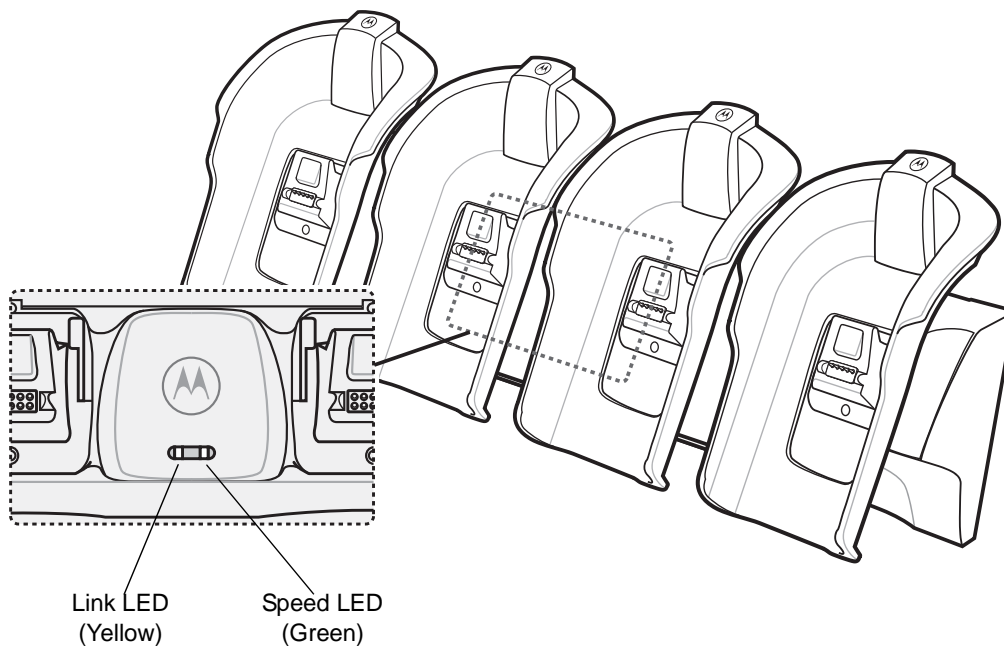

Figure 2-18 Four Bay Ethernet Cradle LED Indicators

Four Bay Charge Only Cradle Wall Mounting

1. Connect the AC line cord to the power supply.
2. Route the AC Line Cord through the bracket.
3. Connect the DC line cord to the power supply. Coil the DC cable so that it fits into the bracket.

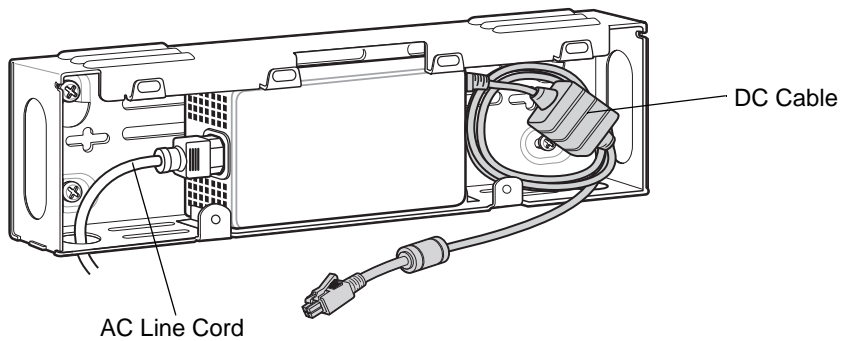

Figure 2-19 Power Connections

4. Repeat for each cradle.
5. While holding the cradle close to the bracket, connect the DC line cord to the power port on the cradle.

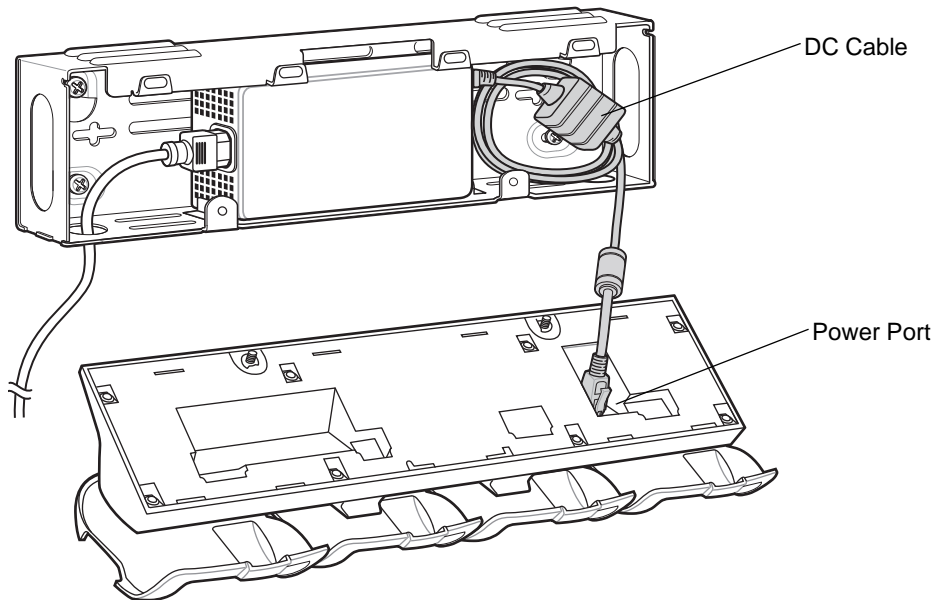

Figure 2-20 Connect DC Power Cable to Cradle

6. Place cables neatly in the bracket and secure with tie wraps as required. Ensure that all cables are within the bracket to avoid pinching wires.
7. Align the four mounting slots on the back of the cradle with the four mounting tabs on the bracket.

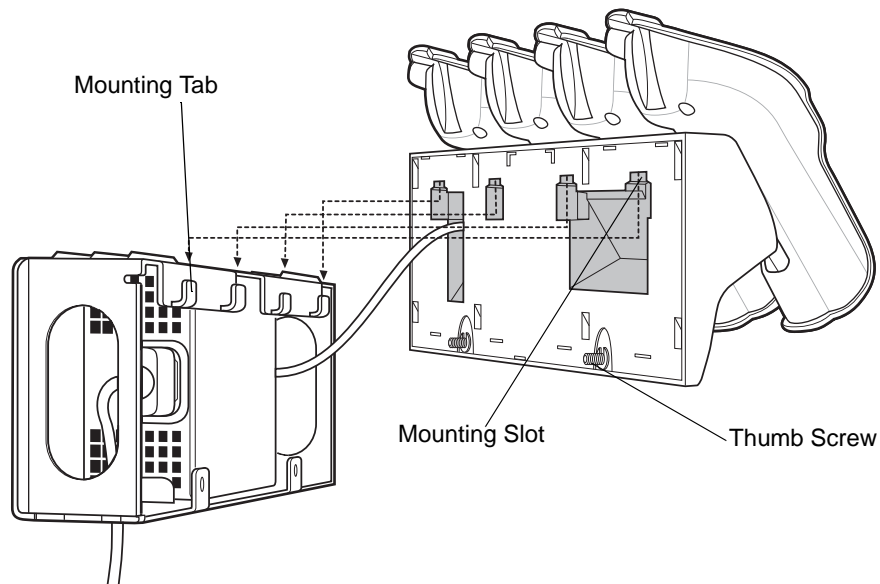

Figure 2-21 Four Bay Charge Only Cradle Mounting on Bracket

8. Hang the cradle on the bracket ensuring that the cradle is aligned properly.
9. Secures the two thumb screws to hold the cradle to the bracket.

Four Slot Battery Charger Wall Mounting

Two Four Slot Battery Chargers can be mounted on a Universal Wall Mounting Bracket.

1. Connect the AC line cord to the power supply.
2. Route the AC line cord through the bracket to an outlet.
3. Connect the 4-way DC cable to the power supply.

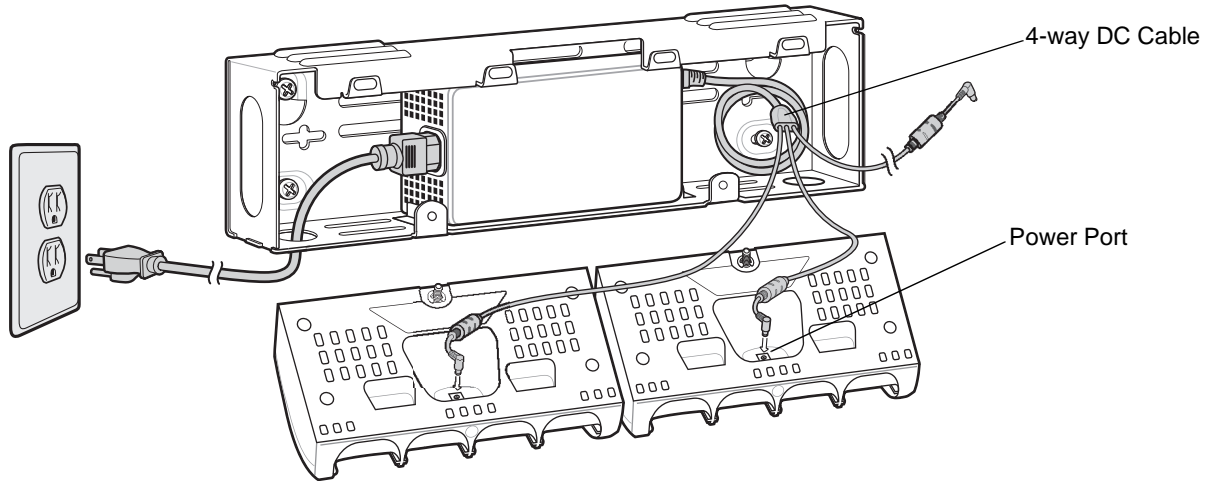

Figure 2-22 Four Slot Battery Charger Connection

4. Place cables neatly in the bracket and secure with tie wraps as required. Ensure that all cables are within the bracket to avoid pinching wires.
5. While holding the charger close to the bracket, connect one end of the 3-way DC cable to the power port on the charger.
6. Align the four mounting slots on the back of the cradle with the four mounting tabs on the bracket.

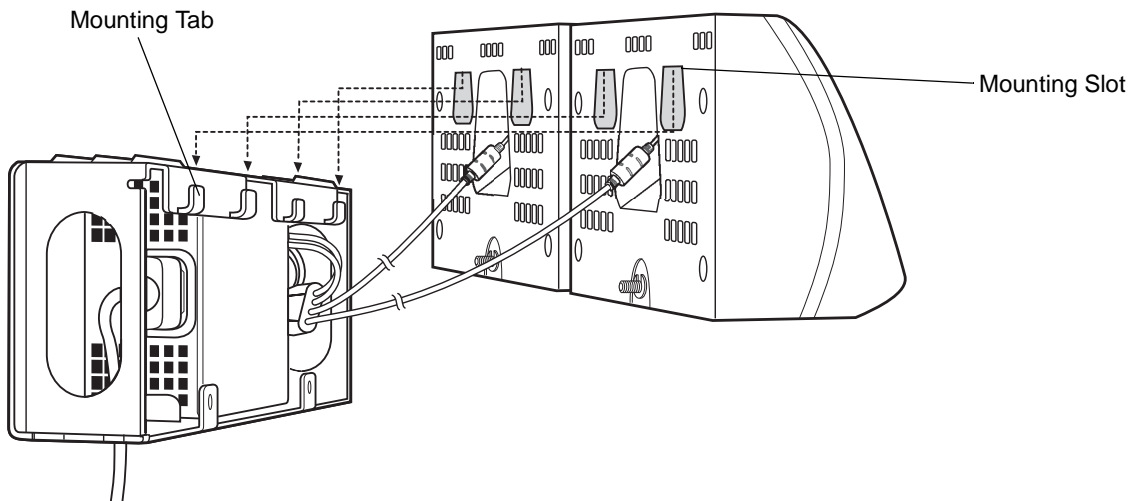

Figure 2-23 Four Slot Battery Charger Connection

7. Hang the charger on the bracket ensuring that the charger is aligned properly.
8. Secures the two thumb screws to hold the charger to the bracket.
9. Repeat steps 5 through 8 for the second charger.

When mounting four Four Slot Battery Chargers on two mounting brackets, only one power supply is required. Connect the 4-way cable to the power supply. Each cable connects to four Four Slot Battery Chargers.

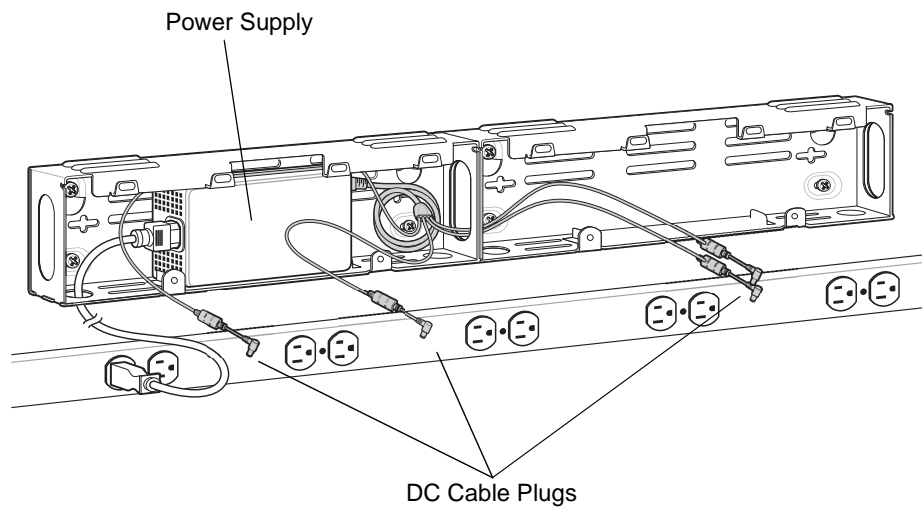

Figure 2-24 Mount Four Four Slot Battery Chargers

Universal Desk Mounting Bracket

Use the Universal Desk Mounting Bracket to mount a Four Bay Ethernet cradle or a Four Bay Charge Only cradle.

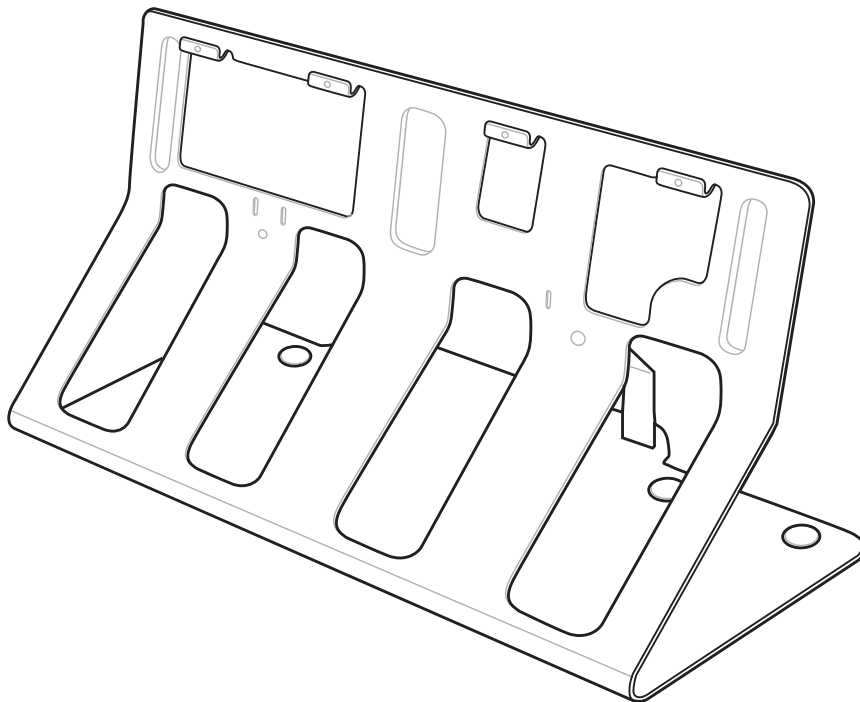

Figure 2-25 Desk Mounting Bracket

Four Bay Ethernet Cradle Desktop Mounting

1. Align the four slots on the back of the cradle with the four cleats on the bracket.

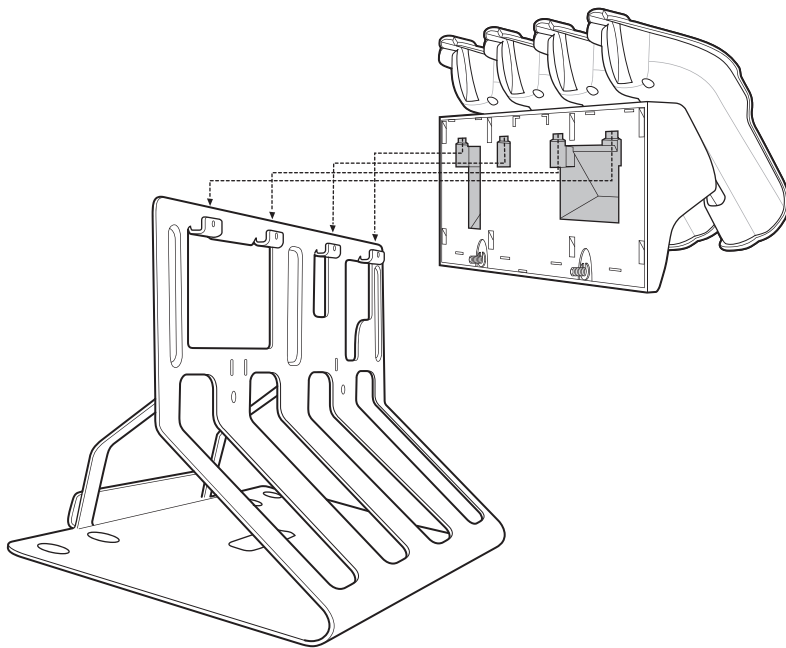

Figure 2-26 *Place Cradle onto Universal Desk Mount Bracket*

2. Hang the cradle on the bracket ensuring that the cradle is aligned properly.
3. Secures the two thumb screws to hold the cradle to the bracket.
4. Place the power supply on to the bracket.
5. Connect the AC line cord to the power supply.
6. Route the AC line cord to an outlet.
7. Connect the DC line cord to the power supply.
8. Connect the DC line cord to the power port on the cradle.

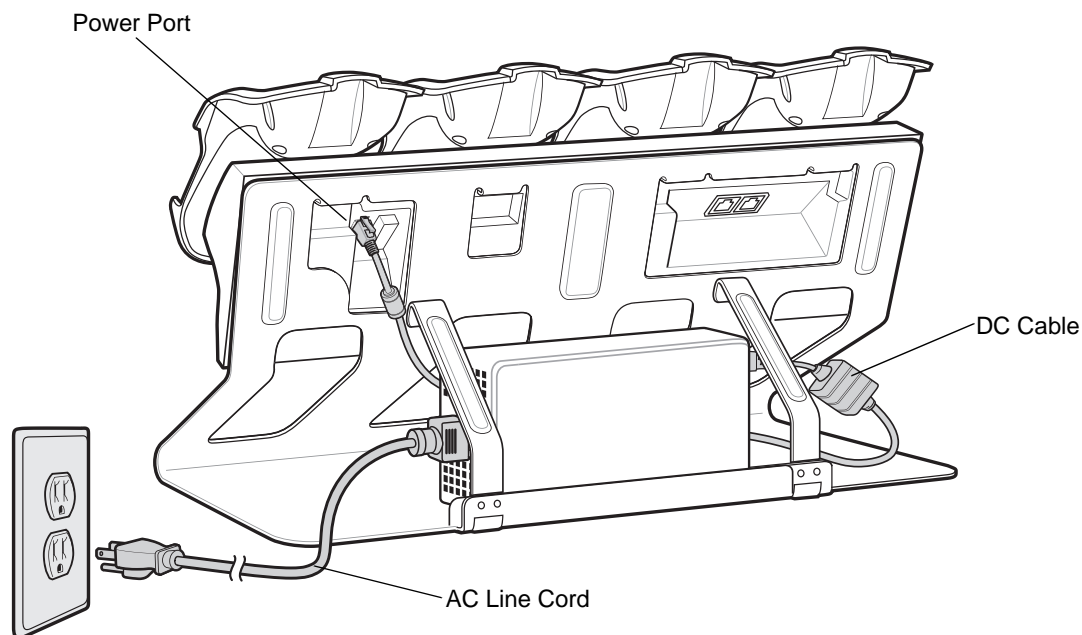

Figure 2-27 Power Connection

9. Connect a Ethernet cable to the Ethernet Port 1 connector on the back of the cradle.
10. Route the network cable to a network hub.

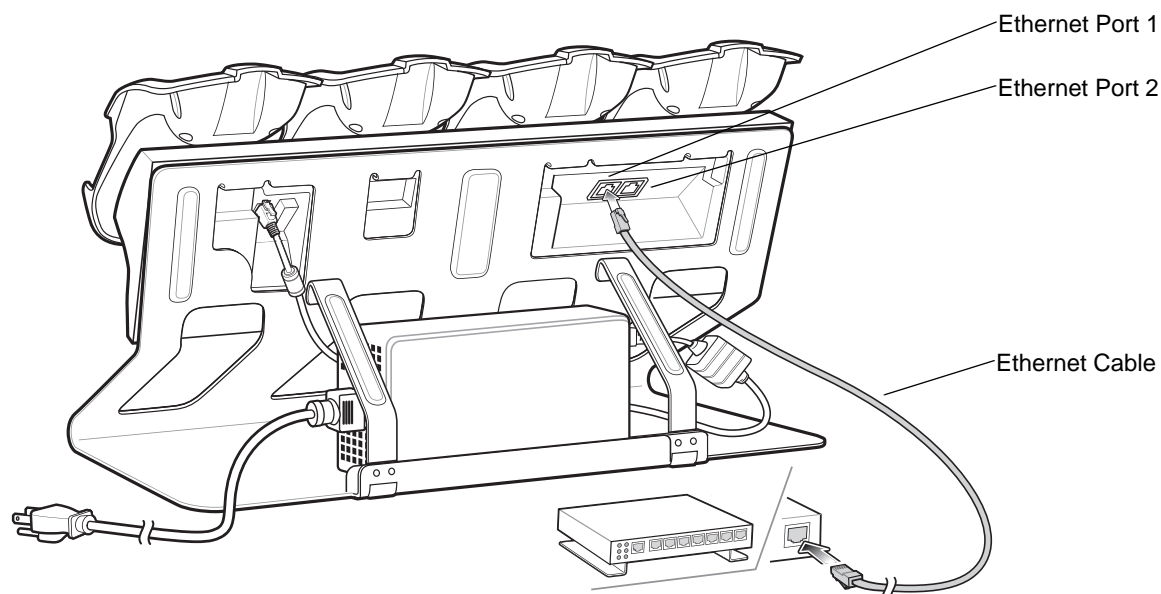

Figure 2-28 Ethernet Connection

11. Place cables neatly in the bracket and secure with tie wraps as required.

Four Bay Charge Only Cradle Desktop Mounting

1. Align the four slots on the back of the cradle with the four cleats on the bracket.
2. Hang the cradle on the bracket ensuring that the cradle is aligned properly.

3. Secures the two thumb screws to hold the cradle to the bracket.
4. Place the power supply on to the bracket.
5. Connect the AC line cord to the power supply.
6. Route the AC line cord to an outlet.
7. Connect the DC line cord to the power supply.
8. Connect the DC line cord to the power port on the cradle.

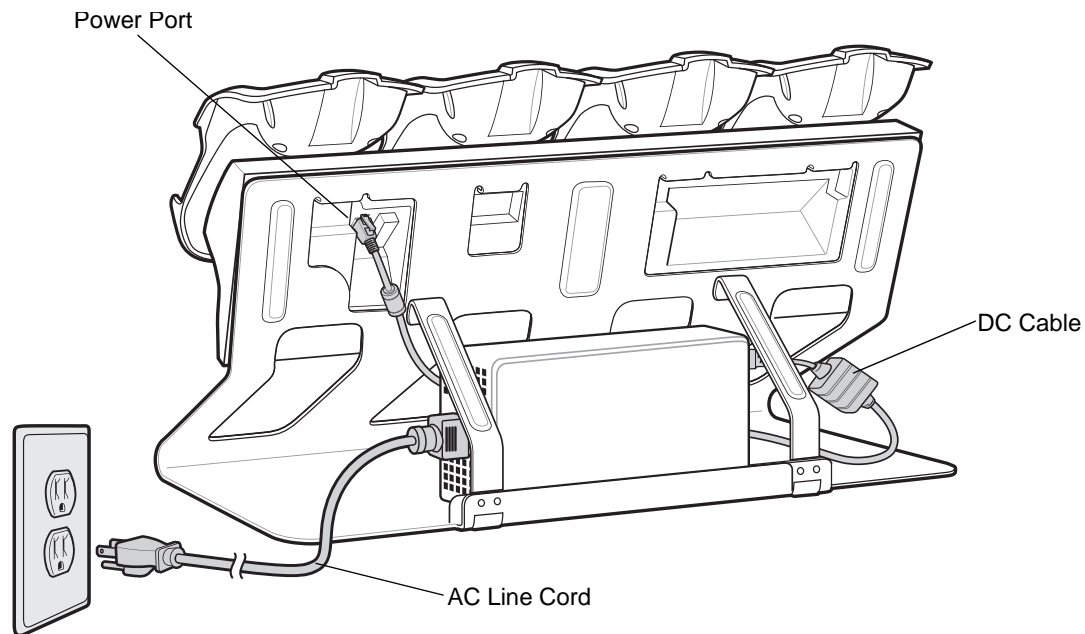

Figure 2-29 *Power Connection*

9. Place cables neatly in the bracket and secure with tie wraps as required.

Four Slot Battery Charger Desk Mount Setup

This section describes how to set up the Four Slot Battery Charger with a desk mount bracket.

1. Align the thumb screw on the charger with the screw hole in the desk mount bracket.

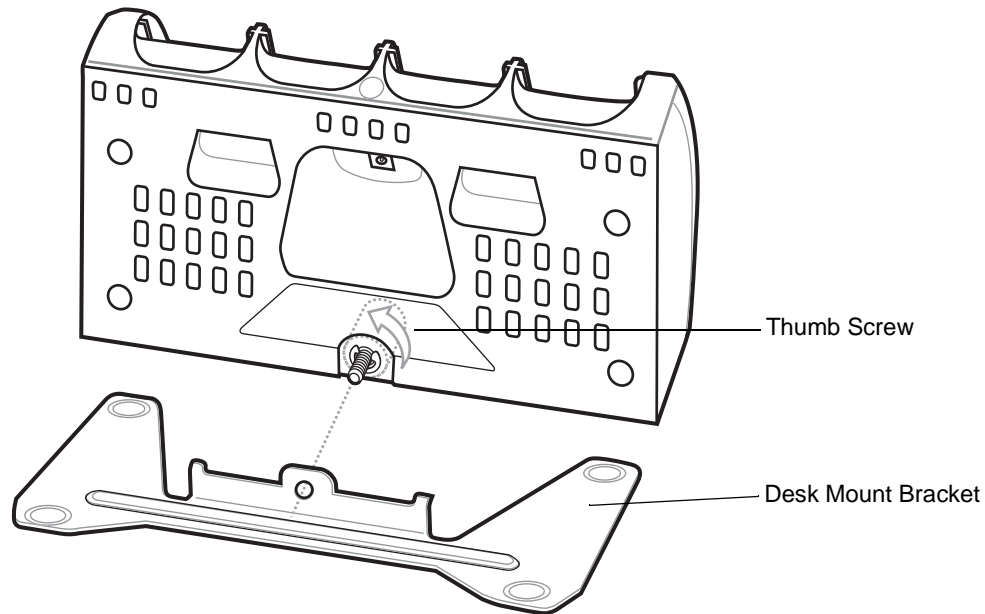

Figure 2-30 Connect Charger to Desk Mount Bracket

2. Connect the power supply DC line cord to the power port on the back of the charger.
3. Plug the AC line cord into the power supply.
4. Plug the AC line cord into an outlet.

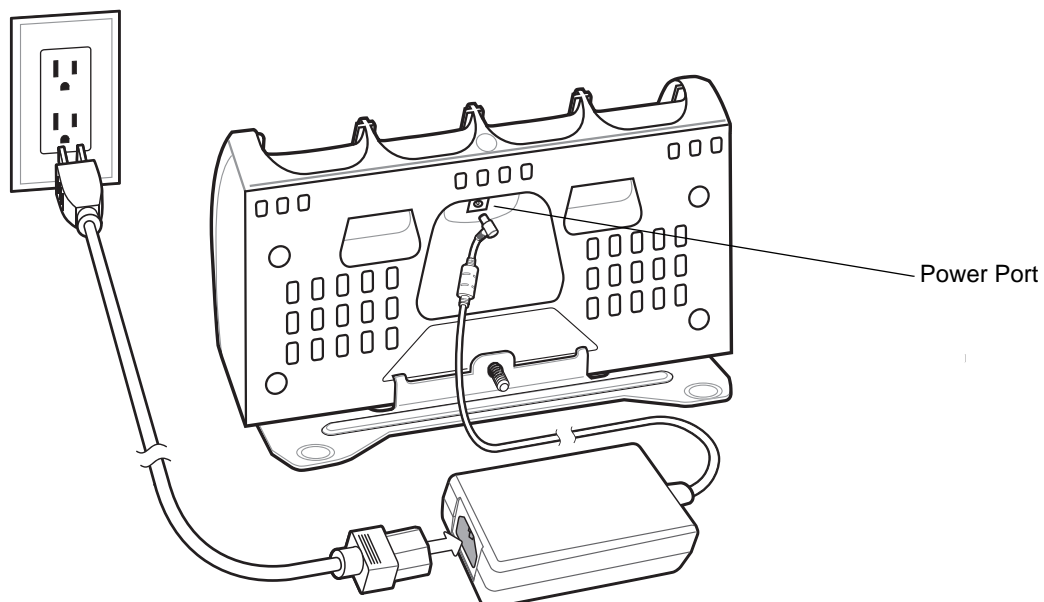

Figure 2-31 Four Slot Battery Charger Power Connection

Single Bay USB Cradle

This section describes how to set up a Single Bay USB cradle. For USB communication setup procedures see [Chapter 3, ActiveSync](#).

The Single Bay USB Cradle:

- Provides 5.4 VDC power for operating the MC9500-K.
- Synchronizes information between the MC9500-K and a host computer. See [Chapter 3, ActiveSync](#) for information on setting up a partnership between the MC9500-K and a host computer.
- Charges the MC9500-K's battery.

Setup

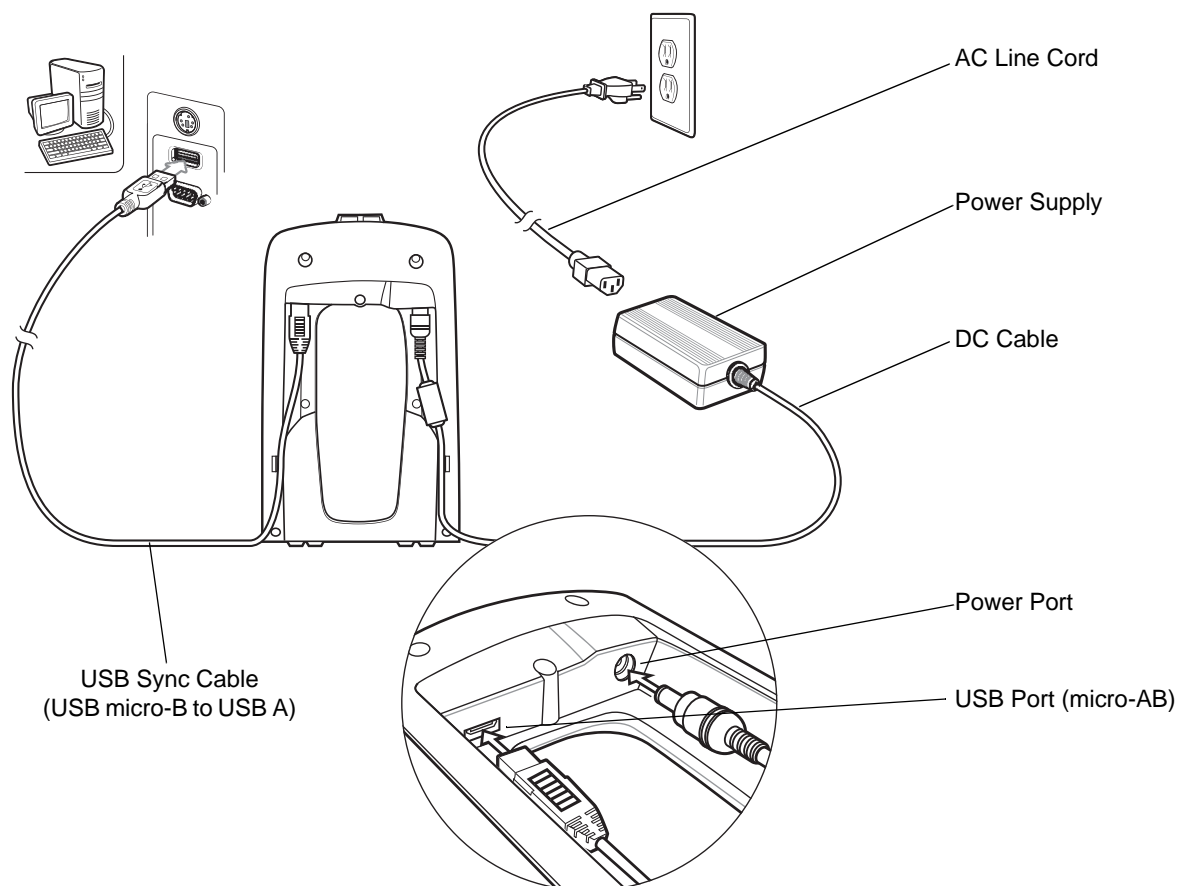

Figure 2-32 Single Bay USB Cradle Power and USB Connections

1. Connect the power supply DC line cord to the power port on the back of the cradle.
2. Plug the AC line cord into the power supply.
3. Plug the AC line cord into an AC outlet.

✓ **NOTE** Ensure that the correct USB Sync cable is used. The cable must have a USB micro-B connector.

4. Connect the USB Sync cable to the USB port on the back of the cradle.
5. Connect the other end of the USB Sync cable to the USB port on the host computer.

Single Slot Battery Charger

This section describes how to set up the Single Slot Battery Charger.

Setup

1. Connect the power supply DC cable to the power port on the back of the charger.
2. Plug the AC line cord into the power supply.
3. Plug the AC line cord into an outlet.

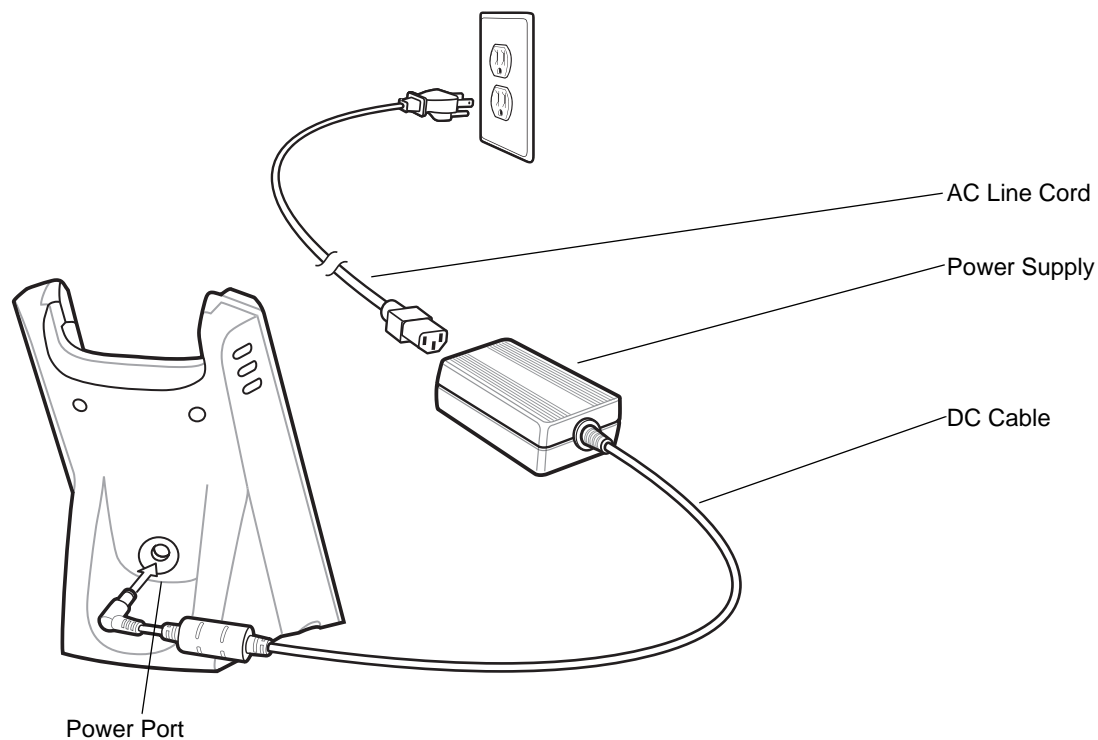

Figure 2-33 Single Slot Battery Charger Setup

Single Bay USB Cradle/Single Slot Battery Charger

The Single Slot Battery Charging Charger and the Single Bay USB Cradle can be connected together using the supplied clip.

1. Snap the clip onto the bottom of the Single Slot Battery Charger.

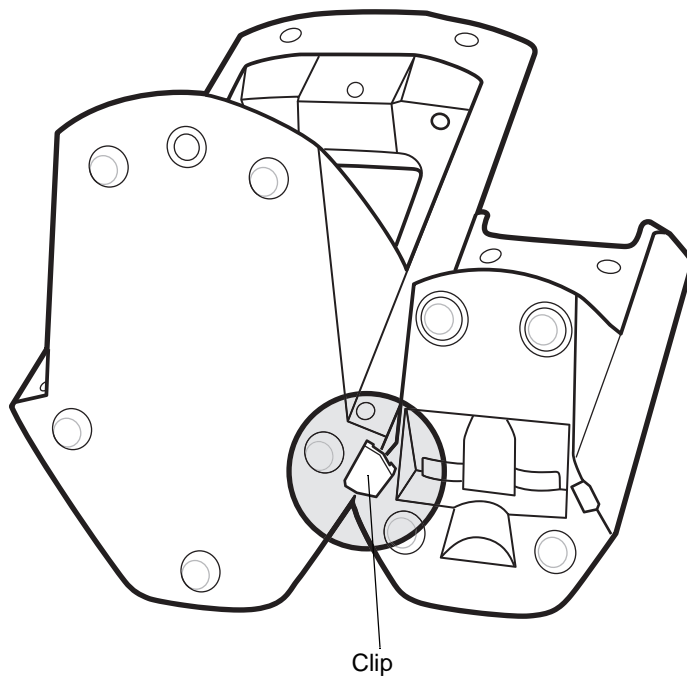

Figure 2-34 Single Bay USB Cradle with Clip

2. Align the Single Bay USB Cradle with the clip.
3. Snap the Single Bay USB Cradle onto the clip.

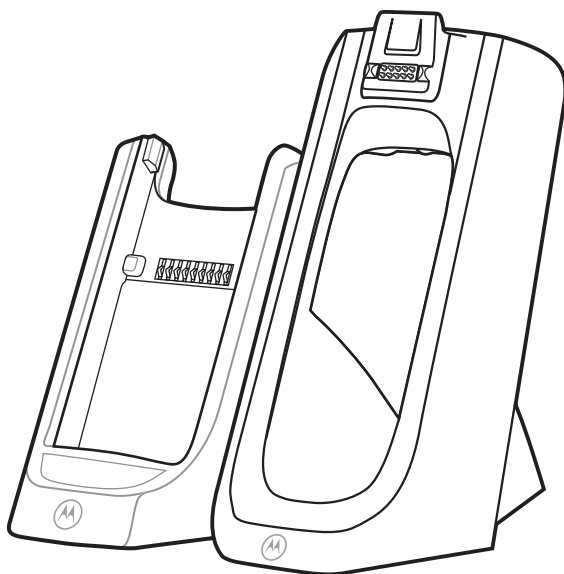

Figure 2-35 Single Bay USB Cradle and Battery Charger

Use the DC “Y” Cable to power both cradles.

1. Connect the power supply DC line cord to the female jack of the DC “Y” cable.
2. Connect one power plug of the DC “Y” cable to the power port on the Single Bay USB cradle and the other power plug to the power port of the Single Slot Battery Charger.

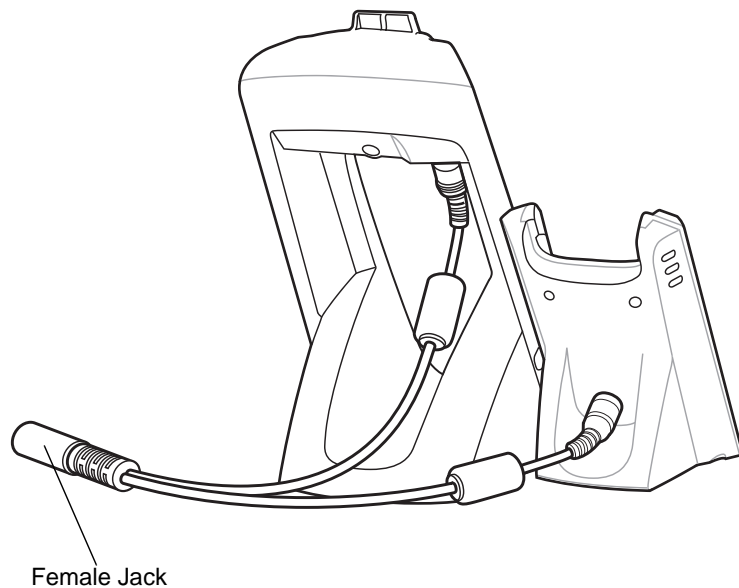

Figure 2-36 DC "Y" Cable Connected to Single Bay USB Cradle and Single Slot Battery Charger

3. Plug the AC line cord into the power supply.
4. Plug the AC line cord into an outlet.

Use the DC "Y" Cable to power two Single Slot Battery Chargers.

1. Connect the power supply DC line cord to the female jack of the DC "Y" cable.
2. Connect each power plug of the DC "Y" cable to the power ports on the Single Slot Battery Charger.

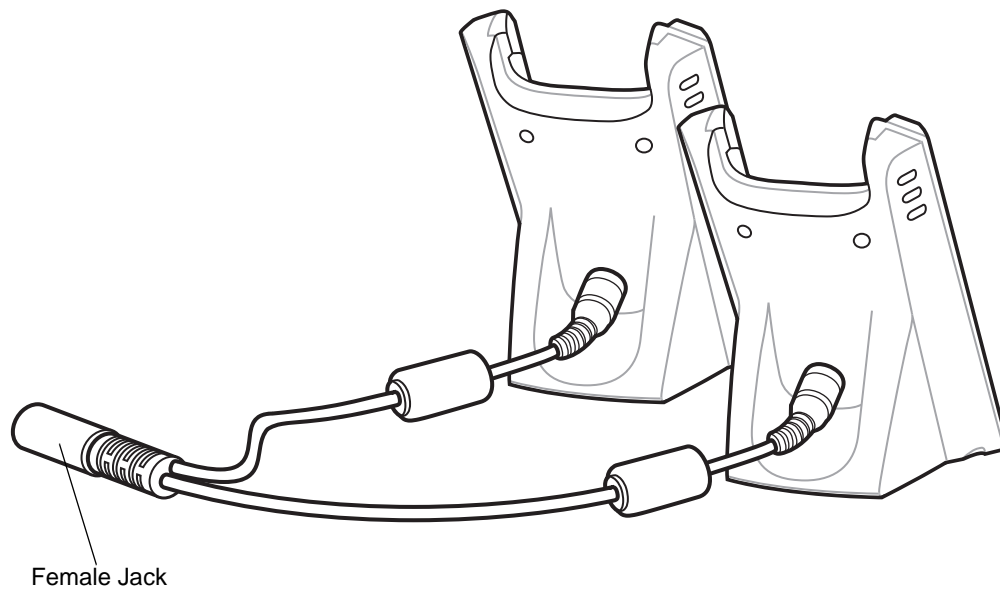

Figure 2-37 DC "Y" Cable Connected to Two Single Slot Battery Chargers

3. Plug the AC line cord into the power supply.
4. Plug the AC line cord into an outlet.

Magnetic Stripe Reader

This section describes how to set up and use the snap-on Magnetic Stripe Reader (MSR) with the MC9500-K. The MSR snaps on to the back of the MC9500-K and removes easily when not in use.

When attached to the MC9500-K, the MSR allows the MC9500-K to capture data from magnetic stripe cards. To download sample MSR data capture software, visit <http://www.motorola.com/enterprisemobility/support>.

- ✓ **NOTE** The MSR provides pass-through charging so that the MC9500-K can be charged while MSR is attached and connected to a cradle or cable.

While charging, the MSR functionality is disabled.

When hooking the MC9500-K with MSR onto a four bay cradle, remove the guide cup before using.

Attaching and Removing the MSR

Align and hook the MC9500-K interface pocket onto the MSR's cleat.

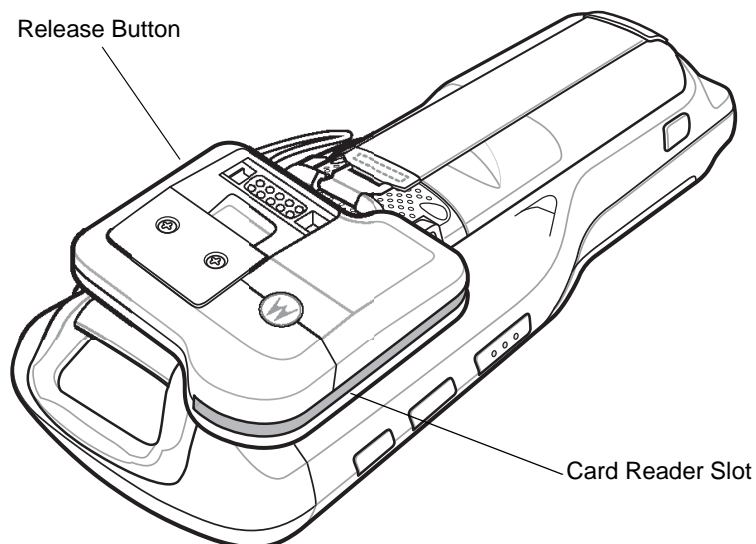

Figure 2-38 MSR Installation

To remove the MSR press the release button and remove the MSR from the MC9500-K.

Using the MSR

The *MSR3000* sample application illustrates how an application handles MSR inputs (refer to *Motorola Enterprise Mobility Applications User's Guide*).

To use the MSR:

1. Attach the MSR to the MC9500-K.
2. Power on the MC9500-K.
3. Tap **Start** > **Samples.C** > **MSR** to start the sample application.

4. Swipe the magnetic stripe card through the MSR, with the magnetic stripe on the card away from you. Swipe the card in either direction, up and down or down and up. For best results, gently press on the card while swiping to ensure contact with the bottom of the MSR slot.

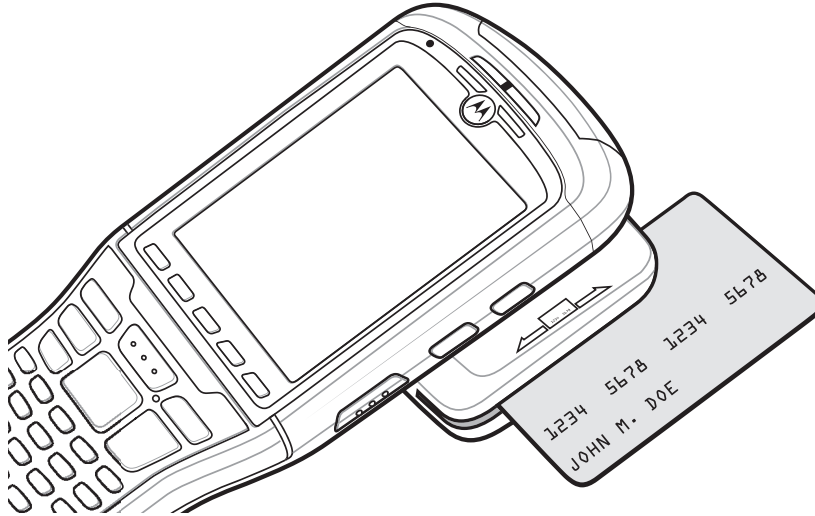

Figure 2-39 *Magnetic Stripe Card Swiping*

USB/Charge Cable

Provide the MC9500-K with operating and charging power when used with the Motorola approved power supply.

Synchronize information between the MC9500-K and a host computer. With customized or third party software, it can also synchronize the MC9500-K with corporate databases.

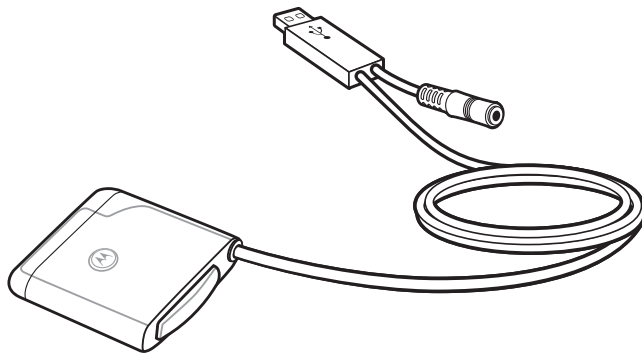

Figure 2-40 *USB/Charge Cable*

To connect the MC9500-K:

1. Align and hook the cleat of the cable onto the interface pocket of the MC9500-K.
2. Press the square down until it attached to the matching mechanism.

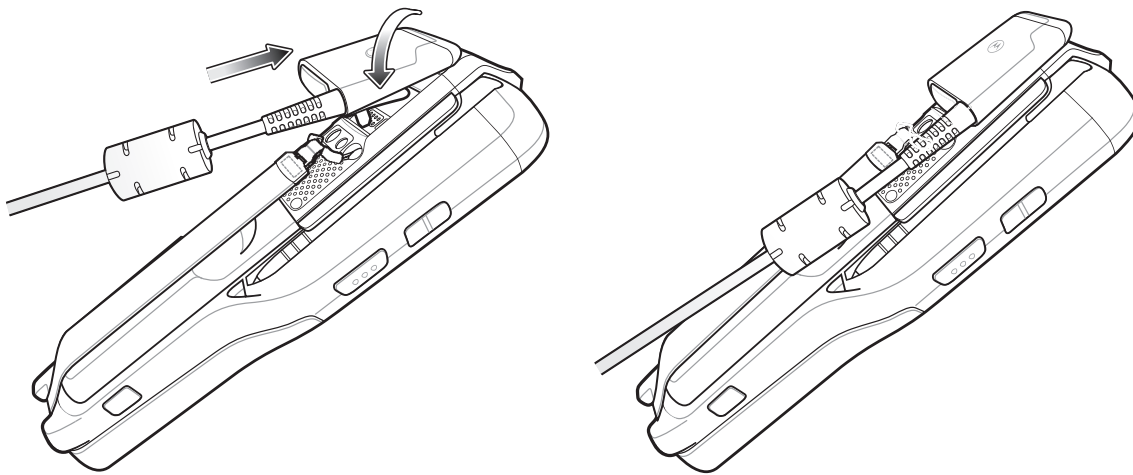

Figure 2-41 Connecting Cable to MC9500-K

3. Connect the DC cable from the power supply to the barrel jack.
4. Connect the USB connector to the host computer.

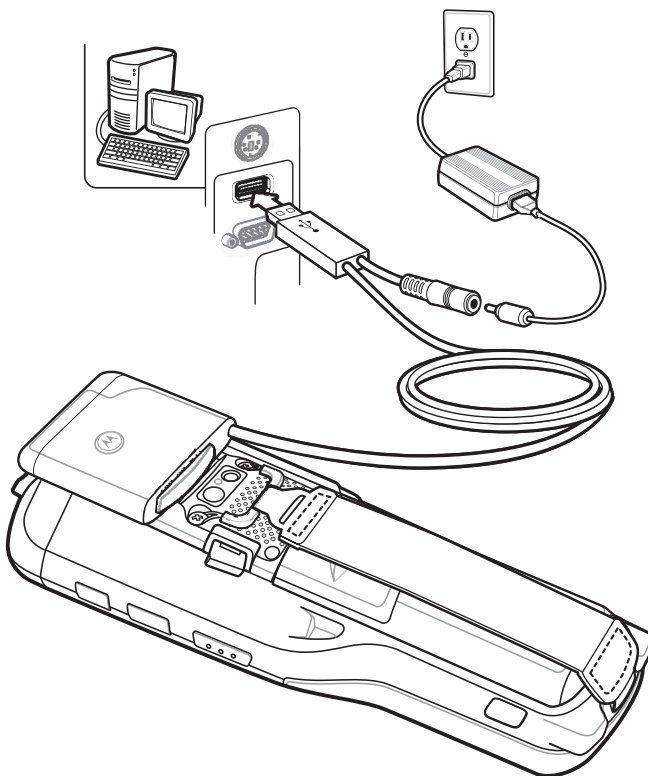

Figure 2-42 Connection to Host Computer and Power Supply

Auto Charge Cable

Provide the MC9500-K with operating and charging power when used with a vehicle cigarette lighter.

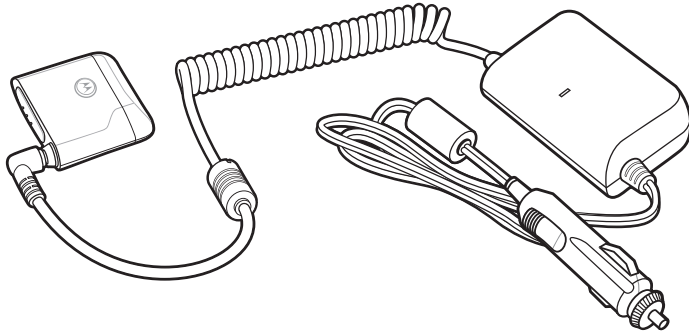

Figure 2-43 Auto Charge Cable

1. Align and hook the Vehicle Adapter Module onto the MC9500-K.
2. Press the Vehicle Adapter Module down until it snaps into position.

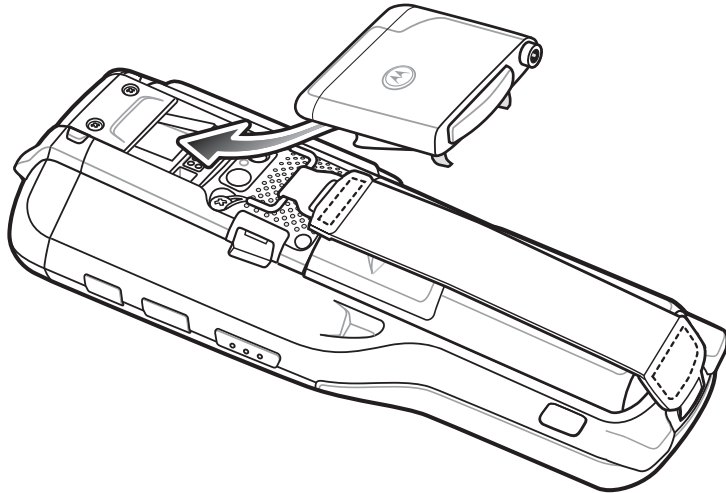

Figure 2-44 Connect Vehicle Adapter Module

3. Connect the power plug of the cable into the power port on the Vehicle Adapter Module.

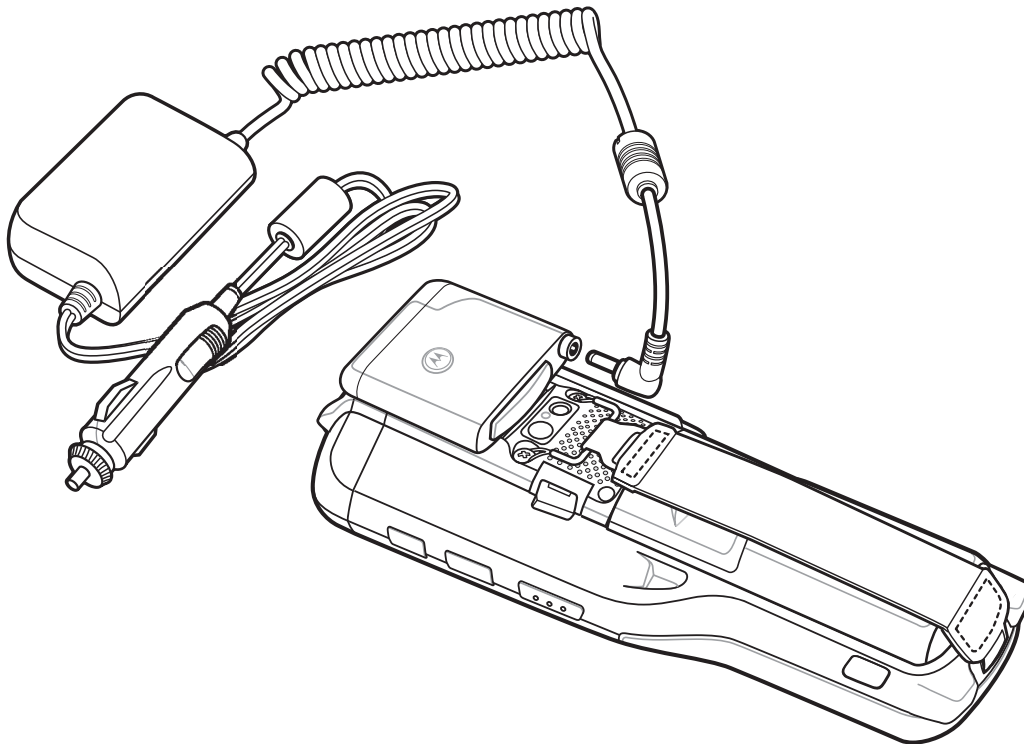

Figure 2-45 *Connect Vehicle Power to Vehicle Adapter Module*

4. Plug the power plug into the cigarette lighter.

Headset Adapter Cable

Use the Headset Adapter Cable to connects a headset to the MC9500-K.

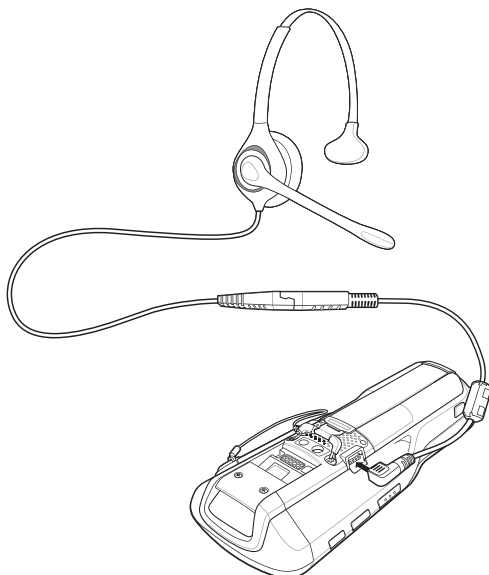

Figure 2-46 *Headset Connection*

Modem Dongle

This section describes how to setup and use the MDM9000 Modem Dongle with the MC9500-K.

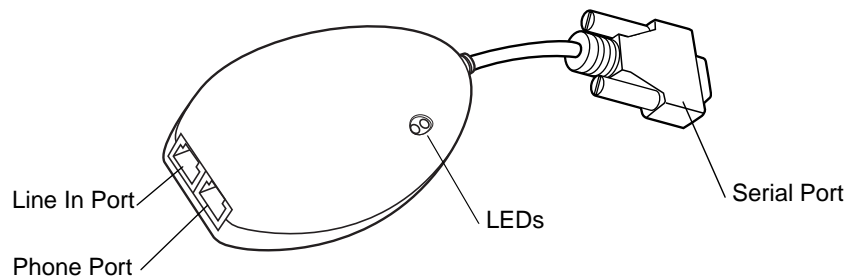

Figure 2-47 Modem Dongle

The Modem Dongle enables data communication between the MC9500-K and a host computer, remotely through a telephone line, and synchronizes information between the MC9500-K and a host computer.

The following items are required for a modem connection:

- Telephone number, IP address and DNS/WINS address information from the dial-in server administrator
- Dial-in account on the host system, including a user ID and password
- RJ11 or RJ12 modem cable
- Functioning telephone jack that supports plug-in modems connected to the local telephone system
Setup of Country Codes to use the modem with the appropriate country's telephone network.

The following items are required for communication:

- MC9500-K
- Modem dongle
- Module adapter cable
- Microsoft ActiveSync
Setup of host computer and mobile computer.

Connecting to the MC9500-K

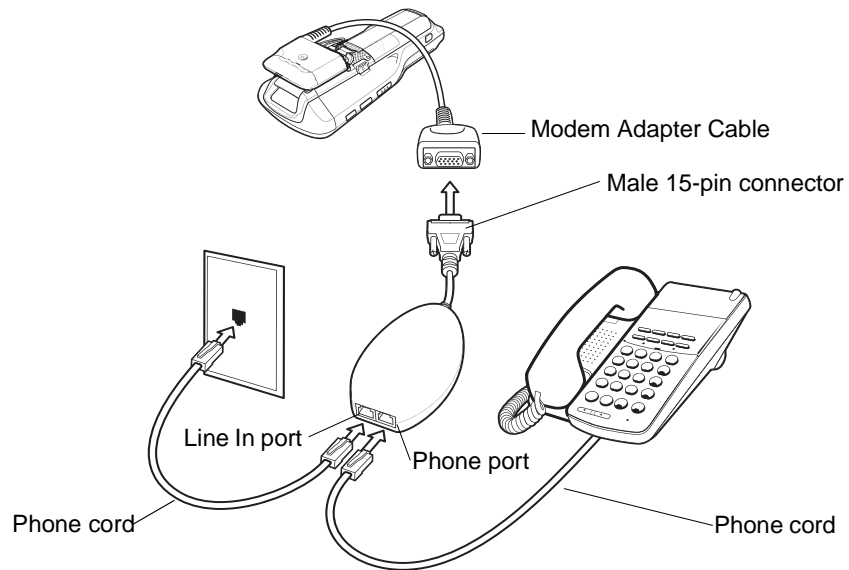

Figure 2-48 Modem Dongle Connection - MC9500-K



CAUTION Do not connect the modem's 15-pin connector into a VGA port of a host computer.

Using the Correct Telephone Line Type

Use a standard analog telephone line, as in most households. In an office, use a line connected to a fax machine or modem. In a hotel, request a room with a standard telephone line or data port. If necessary, check with the local phone company or administrator to make sure you are using the right type of line before sending data.

✓ **NOTE** If using a phone, connect the cord from the phone to the Phone port on the modem.

Table 2-2 Modem Indicators

LED	Indication
Off	Modem is not properly connected to the MC9500-K; modem is not receiving power.
Green	Modem is connected to the MC9500-K and is receiving power.
Solid Amber	MC9500-K is communicating with the host computer.

Configuring the MC9500-K for the Modem

To create a new modem connection:

1. Connect the modem to the MC9500-K as shown in [Figure 2-48 on page 2-33](#).
2. Tap **Start > Settings > Connections** tab > **Connections** icon.

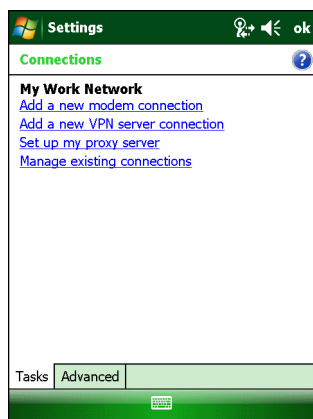

Figure 2-49 Connections Window

3. In the **Connections** window, select **Add a new modem connection** to create a connection.

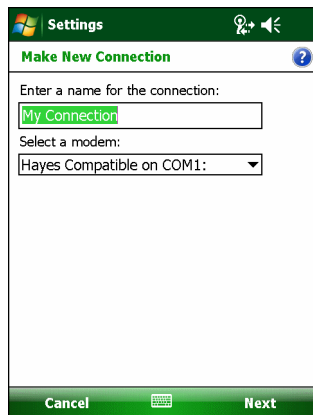

Figure 2-50 *New Connection Window*

4. Enter a name for the connection. In the drop-down menu, select **Hayes Compatible on COM1**, then tap **Next**.

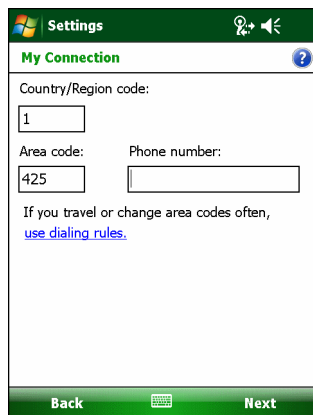

Figure 2-51 *My Connection Window - Phone Number*

5. Enter the country region code, area code and access phone number in the **My Connection** window and tap **Next**.

✓ **NOTE** Depending on the location when dialing, additional numbers may need to be dialed (e.g., a 9 prefix is often required if dialing from work; a country code is needed if dialing internationally). To avoid creating new modem connections for each situation, tap **use dialing rules** to define frequently used dialing locations.

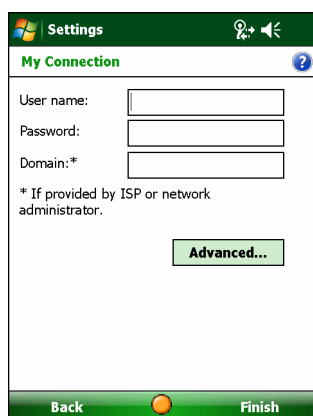

Figure 2-52 *My Connection Window - User Information Settings*

6. If necessary, enter the user name, password and domain.
7. Tap **Finish**.

Connecting the Modem

To start the connection:

1. Tap **Start > Settings > Connections tab > Connections**.
2. In the **Connections** window, tap **Manage existing connections**.
3. Tap and hold the connection name, then select **Connect** from the menu that appears. The modem attempts to connect.

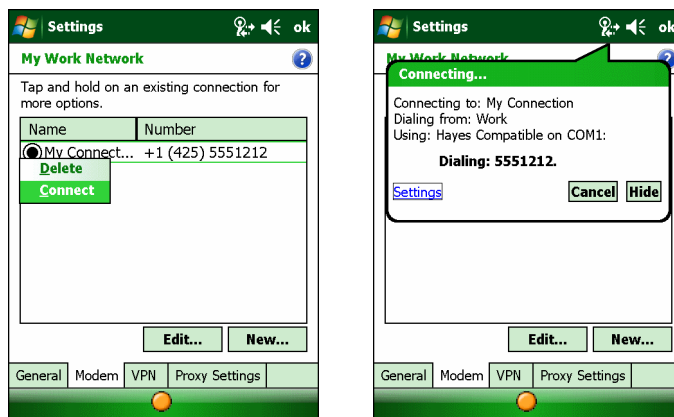

Figure 2-53 *Creating a Connection*

Chapter 3 ActiveSync

Introduction

To communicate with various host devices, install Microsoft ActiveSync (version 4.5 or higher) on the host computer. Use ActiveSync to synchronize information on the mobile computer with information on the host computer. Changes made on the mobile computer or host computer appear in both places after synchronization.

- ✓ **NOTE** When a mobile computer with Windows Mobile 6 is connected to a host computer and an ActiveSync connection is made, the WLAN radio is disabled. This is a Microsoft security feature to prevent connection to two networks at the same time.

ActiveSync software:

- Allows working with mobile computer-compatible host applications on the host computer. ActiveSync replicates data from the mobile computer so the host application can view, enter, and modify data on the mobile computer.
- Synchronizes files between the mobile computer and host computer, converting the files to the correct format.
- Backs up the data stored on the mobile computer. Synchronization is a one-step procedure that ensures the data is always safe and up-to-date.
- Copies (rather than synchronizes) files between the mobile computer and host computer.
- Controls when synchronization occurs by selecting a synchronization mode, e.g., set to synchronize continually while the mobile computer is connected to the host computer, or set to only synchronize on command.
- Selects the types of information to synchronize and control how much data is synchronized.

Installing ActiveSync

To install ActiveSync on the host computer, download version 4.5 or higher from the Microsoft web site at <http://www.microsoft.com>. Refer to the installation procedures included with the ActiveSync software.

Mobile Computer Setup

✓ **NOTE** Microsoft recommends installing ActiveSync on the host computer before connecting the mobile computer.

The mobile computer can be set up to communicate with a USB connection. [Chapter 2, Accessories](#) provides the accessory setup and cable connection information for use with the mobile computer. The mobile computer communication settings must be set to match the communication settings used with ActiveSync.

1. On the mobile computer tap **Start > Programs > ActiveSync** icon. The **ActiveSync** window appears.

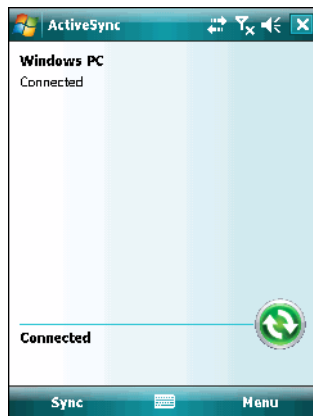

Figure 3-1 ActiveSync Window

2. Tap **Menu > Connections**.
3. Select the connection type from the drop-down list.
4. Tap **OK** to exit the **Connections** window and tap **OK** to exit the **ActiveSync** window.
5. Proceed with installing ActiveSync on the host computer and setting up a partnership.

Setting Up an ActiveSync Connection on the Host Computer

To start ActiveSync:

1. Select **Start > Programs > Microsoft ActiveSync** on the host computer. The **ActiveSync** Window displays.

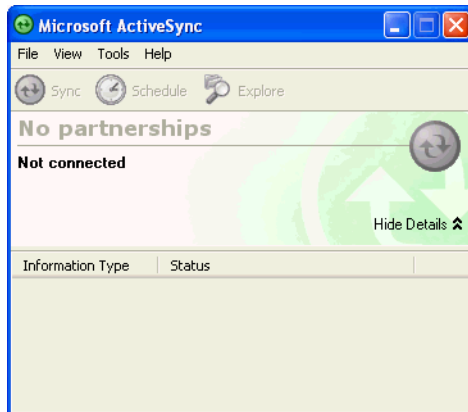

Figure 3-2 ActiveSync Window

- ✓ **NOTE** Assign each mobile computer a unique device name. Do not try to synchronize more than one mobile computer to the same name.

2. In the **ActiveSync** window, select **File > Connection Settings**. The **Connection Settings** window appears.



Figure 3-3 Connection Settings Window

3. Select the appropriate check box for the type of connection used.
4. Select the **Show status icon in Taskbar** check box.
5. Select **OK** to save any changes made.

Synchronization with a Windows Mobile 6 Device

- ✓ **NOTE** When a mobile computer with Windows Mobile 6 is connected to a host computer and an ActiveSync connection is made, the WLAN radio (if applicable) is disabled. This is a Microsoft security feature to prevent connection to two networks at the same time.

To synchronize with a Windows Mobile 6 device:

1. If the **Get Connected** window does not appear on the host computer, select **Start > All Programs > Microsoft ActiveSync**.

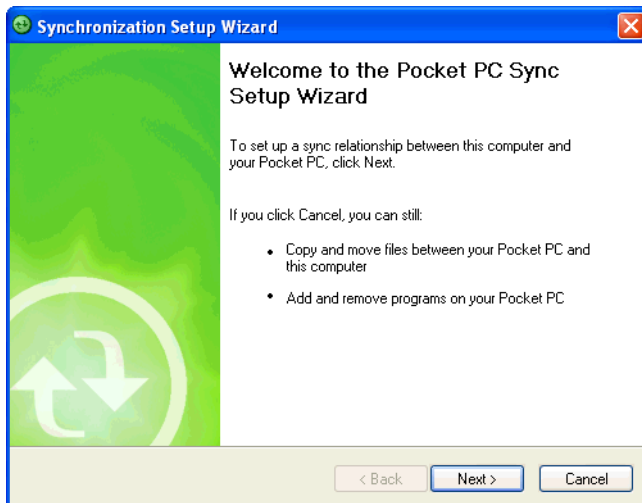

Figure 3-4 *Synchronization Setup Wizard Window*

2. Click **Next**.

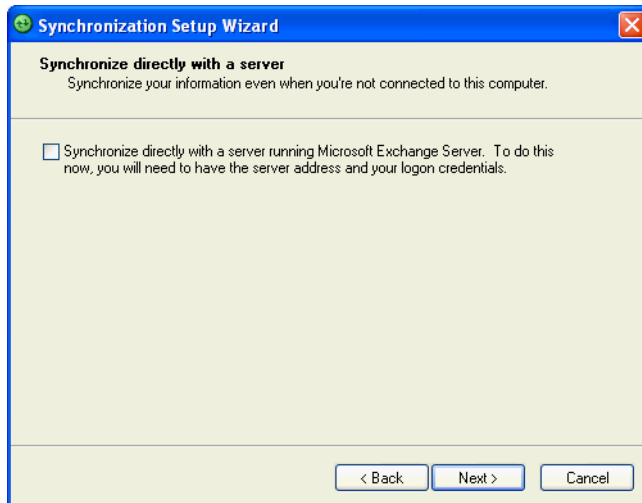

Figure 3-5 *Synchronization Directly With a Server Window*

3. Select the check box to synchronize with a server running Microsoft Exchange if applicable.

4. Click **Next**.

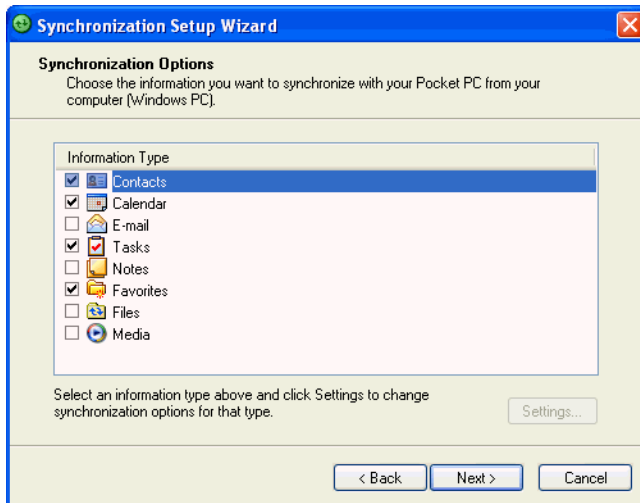

Figure 3-6 *Synchronization Option Window*

5. Select the appropriate settings and click **Next**.

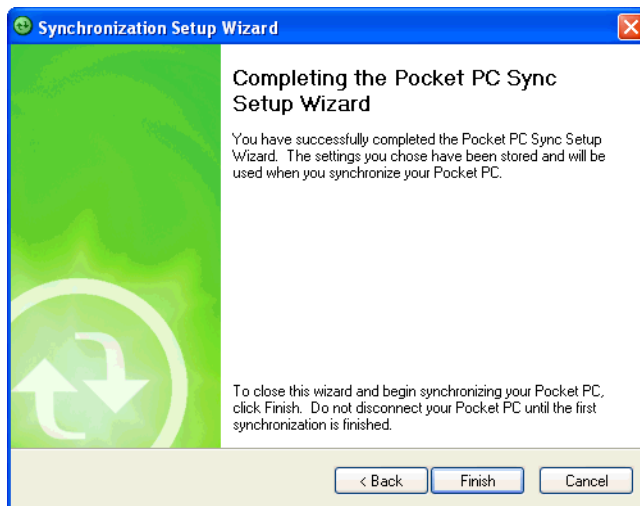

Figure 3-7 *Wizard Complete Window*

6. Click **Finish**.

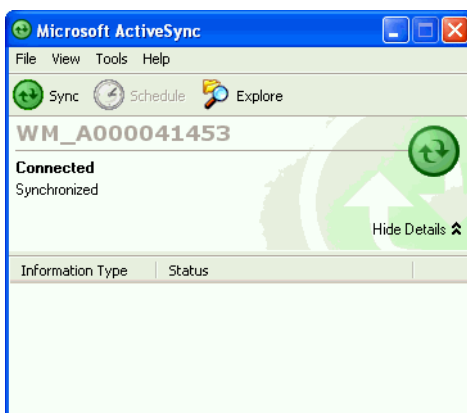

Figure 3-8 *ActiveSync Connected Window*

During the first synchronization, information stored on the mobile computer is copied to the host computer. When the copy is complete and all data is synchronized, the mobile computer can be disconnect from the host computer.

✓ **NOTE** The first ActiveSync operation must be performed with a local, direct connection. Windows Mobile retains partnerships information after a cold boot.

For more information about using ActiveSync, start ActiveSync on the host computer, then see ActiveSync Help.

Chapter 4 Application Deployment for Mobile 6

Introduction

This chapter describes new features in Windows Mobile 6 including new security features, how to package applications, and procedures for deploying applications onto the MC9500-K.

Security

The MC9500-K implement a set of security policies that determine whether an application is allowed to run and, if allowed, with what level of trust. To develop an application, you must know the security configuration of the device, and how to sign an application with the appropriate certificate to allow the application to run (and to run with the needed level of trust).

Application Security

Application security controls the applications that can run on the MC9500-K.

- Trusted - All applications must be digitally signed by a certificate on the MC9500-K.
- Prompted - User is prompted to allow unsigned applications to run.
- Open - All applications run.

Developers can include their own certificates and provision the device to “trusted.”

Digital Signatures

Digital signatures provide a way to authenticate the author of EXEs, DLLs, and packages. Digitally signed applications give users confidence that an application comes from where they think it comes from. For example, if an end-user downloads an update package from the internet that is digitally signed with Motorola's software certificate, they are assured that the package is authentic and that it was created by Motorola. By enforcing the use of digital signatures, users can also prevent malicious applications from executing on the MC9500-K. For example, users can provision the MC9500-K to only execute “trusted” applications (digitally signed).

Motorola ships all Windows Mobile 6 based products in an “open” state, which means all signed and unsigned applications should work. However, customers can still reconfigure their MC9500-Ks to operate in the “trusted”

mode. This means that only applications signed with a certificate from the Privileged Execution Trust Certificate Store can run.

To support the broadest number of deployments, third-party software developers should perform the following when releasing software for a Windows Mobile 6 devices:

- Sign all their EXEs & DLLs with their private key
- Provide the corresponding public certificate to end-users so that it can be installed into Privileged Execution Trust Certificate Store.

If the software is installed via a .CAB file, developer should also:

- Sign the .CAB file with their private key
- Provide the corresponding public certificate to end-users so that it can be installed into SPC Certificate Store.

Locking Down a Mobile Computer

Like most configuration options in Windows Mobile 6, security settings are set via XML provisioning. For example, to enforce the “trusted” model and only allow applications signed with a privileged certificate to run, use the following provisioning document:

```
<wap-provisioningdoc>
  <characteristic type="SecurityPolicy">
    <!-- Disallow unsigned apps -->
    <parm name= "4102" value= "0"/>

    <!-- No Prompt -->
    <parm name= "4122" value= "1"/>
  </characteristic>
</wap-provisioningdoc>
```

For more information on various security options, refer to the Security Policy Settings topic in the latest Windows Mobile documentation.

Installing Certificates

Use XML provisioning to query and delete certificates from certificate stores. To add a new certificate the Privileged Execution Trust Certificate Store, use the following sample provisioning document:

```
<wap-provisioningdoc>
  <characteristic type= "CertificateStore">
  <characteristic type= "Privileged Execution Trust Authorities">
  <characteristic type= "657141E12FA45786F6A57CA6464032D4B3A55475">
    <parm name= "EncodedCertificate" value= "
      This is sample text. This is sample text. This is sample text. This is sample text.
      This is sample text. This is sample text. This is sample text. This is sample text.
      This is sample text. This is sample text. This is sample text. This is sample text. = "/>
  </characteristic>
  </characteristic>
  </characteristic>
</wap-provisioningdoc>
```

To create your own provisioning document with real certificate information:

1. Obtain a certificate from a security provider such as VeriSign.
2. Double-click on the certificate file (.CER) to open it.
3. Click on the *Details* tab and locate the *Thumbprint* field.
4. Copy the contents of the *Thumbprint* field and replace the value in the XML example above.
5. Click the **Copy to File...** button.
6. Click **Next** to start the Certificate Export Wizard.
7. Select *Base-64 encoded X.509 (.CER)* and then click **Next**.
8. Set the File Name to CertOutput.xml and click **Next**.
9. Click **Finish** to export the certificate.
10. Open the exported file, CertOutput.xml, in a text editor (i.e., NotePad).
11. Copy the contents of the file (excluding the first line, last line, and CR/LF) and replace the value of the *"EncodedCertificate"* parameter in the xml example above.

Device Management Security

You can control access to certain device settings and security levels, such as installing applications and changing security settings. Refer to the *Windows Mobile Version 6 Help* file for information on device management security.

Remote API Security

The Remote API (RAPI) enables applications that run on a desktop to perform actions on a remote device. RAPI provides the ability to manipulate the file system on the remote device, including the creation and deletion of files and directories. By default, Motorola ships with RAPI in the restricted mode. Certain tools, such as RAPIConfig,

may not work properly. Refer to the *Windows Mobile Version 6 Help* file for finding information on Remote API security policies.

Packaging

✓ **NOTE** Applications compiled for Windows Mobile 6 are not backward-compatible with previous versions.

Packaging combines an application's executable files into a single file, called a package. This makes it easier to deploy and install an application to the MC9500-K. Package new applications and updates, such as new DLL files, as CAB files, then deploy them to Mobile 6 devices. Refer to the *Microsoft Windows Mobile 6 Help* file for information on CAB files.

Deployment

To install applications onto the MC9500-K, developers package the application and all required files into a CAB file, then load the file onto the MC9500-K using one of the following options:

- Microsoft ActiveSync 4.5 or higher
- Storage Card
- MSP 3.X
- AirBEAM
- Image Update (for updating the operating system).

Refer to the *Microsoft Windows Mobile 6 Help* file for information on CAB files.

Installation Using ActiveSync

To install an application package:

1. Connect the MC9500-K to a host computer using ActiveSync. See [Chapter 3, ActiveSync](#) for more information.
2. Locate the package file on the host computer.
3. In ActiveSync on the host computer, open **Explorer** for the MC9500-K.
4. Copy the CAB file from the host computer to the \temp directory on the MC9500-K.
5. On the MC9500-K, navigate to the \temp directory.
6. Tap on the application CAB file. The application installs on the MC9500-K.

Installation Using Storage Card

To install an application package:

1. Copy the package CAB file to a storage card using an appropriate storage card reader.
2. Install the storage card into the MC9500-K.
3. On the MC9500-K, open **File Explorer**.

4. Open the **Storage Card** directory.
5. Tap the package CAB file. The application installs on the MC9500-K.

Installation Using AirBEAM

The AirBEAM Smart Client provides backward-compatible legacy AirBEAM functionality and backward-compatible legacy MSP 2.x Level 2 Agent functionality.

Refer to the *AirBEAM Smart Windows CE Client Product Reference Guide*, p/n 72-63060-xx, for instructions for AirBEAM Smart client.

MSP 3.X

The MSP 3 Client Software is a set of software components that come pre-installed on the MC55. The MSP 3 Client software consists of the following components:

The RD Client provides support for MSP 3 Staging functionality, provides support for the MSP 3 Legacy Staging process, and provides support for backward-compatible legacy MSP 2.x Legacy Staging functionality.

The MSP 3 Agent provides MSP 3 Provisioning functionality and Control functionality when used with MSP 3.2 Control Edition.

Refer to the *Mobility Services Platform 3.2 User's Guide*, p/n 72E-100158-xx, for instructions for using the Rapid Deployment and MSP3 Agent clients.

Image Update

Windows Mobile 6 contains an Image Update feature that updates all operating system components. All updates are distributed as update packages. Update packages can contain either partial or complete updates for the operating system. Motorola distributes the update packages on the Support Central Web Site, <http://www.motorola.com/enterprisemobility/support>.

To update an operating system component, copy the update package to the MC9500-K using one of a variety of transports, including ActiveSync, an microSD card, or MSP. Then, initiate the update using one of the following methods:

- Double-tap the package file in **File Explorer** (similar to extracting a CAB file)
- Perform a special boot sequence that initiates the update.

✓ **NOTE** The MC9500-K must have at least 5 MB of free space to perform an OS update.

To initiate an update:

1. Go to the Support Central web site, <http://www.motorola.com/enterprisemobility/support>.
2. Download the appropriate update package.
3. Copy the update package to either the \temp directory on the MC9500-K, or to a microSD card.
4. Connect the MC9500-K to AC power. See [Chapter 2, Accessories](#).
5. Simultaneously press the **Power** button and the **1** and **9** keys.
6. Immediately, as soon as the device starts to boot and before the splash screen is visible, press and hold the left scan button. The BootLoader screen appears.

7. Release the left scan button.
8. The Update Loader application first looks for a file on a microSD card. If it does not find it, it looks in the \temp directory.
When it finds the appropriate file, it loads the package onto the MC9500-K. A progress bar displays until the update completes.
9. The MC9500-K re-boots.
10. The calibration screen appears.

✓ **NOTE** When initiating an update via a boot sequence, the update loader looks for updates first on the root of an installed microSD card and then in the \temp folder on the MC9500-K's persistent storage volume. A response file, pkgs.lst, indicates which files to update. In most cases, Motorola provides this pkgs.lst file with the update and you should only modify it when updating a splash screen partition. See [Creating a Splash Screen](#) for more information.

Creating a Splash Screen

Use a bitmap file to create a customized splash screens for the MC9500-K. Use Image Update with a bitmap file, rather than a package file, to update the splash screen.

To create a custom splash screen:

1. Create a .bmp file using a graphic program with the following specifications:
 - Size: 592 x 480.
 - Colors: 16 bits per pixel (65536 colors) for color displays.

2. Modify the bitmap file and save.

To load the splash screen on the MC9500-K:

1. Create a text file named pkgs.lst which contains the name of the bmp file. For example, *mysplash.bmp*.
2. Copy the bmp file and the pkgs.lst file to one of the following:
 - SD card root directory
 - MC9500-K's \temp directory.
3. If using an SD card, insert the SD card into the MC9500-K.
4. Perform a cold boot.
5. Press the left side scan button for 5 seconds while booting to invoke the Update Loader and install the splash screen.

XML Provisioning

To configure the settings on an MC9500-K, use XML provisioning. To install an XML provisioning file on the MC9500-K, create a Cabinet Provisioning File (CPF). A CPF file is similar to a CAB file and contains just one file: _setup.xml. Like a CAB file, the CPF extension is associated with WCELoad.EXE. Opening a CPF extracts the XML code and uses it to provision and configure the MC9500-K. The user receives an e-mail notification indicating success or failure.

XML provisioning provides the ability to configure various features of the MC9500-K (i.e., registry and file system). However, some settings require security privileges. To change registry settings via a CPF file, you must have certain privileges (roles). Some registry keys require you to simply be an *Authenticated User*, while other registry keys require you to be a *Manager*. Refer to the *Microsoft Windows Mobile 6 Help* file, *Metabase Settings for Registry Configuration Service Provider* section, for the default role settings in Windows Mobile 6.

For those registry settings that require the *Manager* role, the CPF file must be signed with a privileged certificate installed on the device. Refer to the *Microsoft Windows Mobile 6 Help* file and the *Windows Mobile 6 SDK* for instructions and sample test certificates.

Creating an XML Provisioning File

To create a .cpf file:

1. Create a valid provisioning XML file named `_setup.xml` using an XML editor or the tools supplied with Visual Studio 2005. (For example, use the `SampleReg.xml` sample created in the [RegMerge](#) section and rename it `_setup.xml`.) Ensure the file contains the required parameters for the operation. Refer to the *Microsoft Windows Mobile 6 Help* file for information.
2. In the Windows Mobile 6 tools directory on the desktop computer (typically `\Program Files\Windows CE Tools\wce500\Windows Mobile 6 Pocket PC SDK\Tools`), run the `Makecab.exe` utility, using the following syntax to create a .cpf file from the `_setup.xml` file:

```
MakeCab.exe /D COMPRESS=OFF _setup.xml myOutCpf
```

✓ **NOTE** COMPRESS=OFF is required for backward compatibility with Pocket PC.

3. Optionally, use the `Authenticode` tools to sign the .cpf file.
4. Tap the filename to install.
5. Certain applications and settings require a cold boot to take affect. In these cases, cold boot the MC9500-K. Refer to the *Windows Mobile Version 6 Help* file for more information.

XML Provisioning vs. RegMerge and Copy File

Prior to Windows Mobile 6, Motorola used two drivers (`RegMerge` and `CopyFiles`) to update the registry and to copy files during a cold boot. With Mobile 6, Motorola recommends using XML provisioning instead. `RegMerge` and `CopyFiles` are supported for backward compatibility but Motorola may eliminate support in the future. The following sections provide examples of how `RegMerge` and `CopyFiles` were used, and how to perform the same function using XML provisioning.

RegMerge

`RegMerge.dll` is a built-in driver that allows updating the registry during a clean boot. `RegMerge` runs very early in the boot process and looks for registry files (.reg files) in certain Flash File System folders (i.e., `\Application`) during a clean boot. It then merges the registry changes into the system registry located in RAM.

The following example uses `RegMerge` to set a registry key:

SampleReg.reg

```
[HKEY_LOCAL_MACHINE\Hardware\DeviceMap\Backlight]
"BacklightIntensity"=dword:00000036
```

The following example uses XML provisioning to perform the same task:

SampleReg.xml

```
<wap-provisioningdoc>
  <characteristic type= "Registry">
    <characteristic type= "HKLM\Hardware\DeviceMap\Backlight">
      <parm name= "BacklightIntensity" value= "54" datatype= "integer" />
    </characteristic>
  </characteristic>
</wap-provisioningdoc>
```

CopyFiles

CopyFiles copies files from one folder to another on a clean boot. During a clean boot CopyFiles looks for files with a .CPY extension in the root of the Application FFS partition. These files are text files containing the source and destination for the desired files to copy, separated by ">".

The following example uses CopyFiles to copy a file from the \Application folder to the \Windows folder:

SampleCpy.cpy

```
\Application\example.txt > \Windows\example.txt
```

The following example uses XML provisioning to perform the same task:

SampleCpy.xml

```
<wap-provisioningdoc>
  <characteristic type= "FileOperation">
    <characteristic type= "\Windows" translation= "filesystem">
      <characteristic type= "MakeDir"/>
      <characteristic type= "example.txt" translation= "filesystem">
        <characteristic type= "Copy">
          <parm name= "Source" value= "\Application\example.txt" translation= "filesystem"/>
        </characteristic>
      </characteristic>
    </characteristic>
  </characteristic>
</wap-provisioningdoc>
```

Storage

Mobile 6 contains three types of file storage:

- Random Access Memory (RAM)
- Persistent Storage
- Application folder.

Random Access Memory

Executing programs use RAM to store data. Data stored in RAM is lost upon a warm boot. RAM also included a volatile file storage area called *Cache Disk*.

Volatile File Storage (Cache Disk)

Windows Mobile 6 memory architecture uses persistent storage for all files, registry settings, and database objects to ensure data is retained even after a power failure. Persistent storage is implemented using Flash memory technology which is generally slower than volatile RAM memory. In certain situations the speed of the operation is more important than the integrity of the data. For these situations, Motorola has provided a small volatile File Storage volume, accessed as the *Cache Disk* folder. Disk operations to the *Cache Disk* folder are much faster than to any of the persistent storage volumes, but data is lost across warm boots and power interruptions. Note that a backup battery powers RAM memory, including the *Cache Disk*, when you remove the main battery for a short period of time.

The MC9500-K uses the *Cache Disk* for temporary data that can be restored from other sources, for example, for temporarily “caching” HTML web pages by a browser or generating formatted files to send to a printer. Both situations benefit from the increased speed of the cache disk, but you can restore the data if needed.

DO NOT use the *Cache Disk* as a method to improve application performance. Analyze applications that perform slower in persistent storage to optimize disk access. Common areas for optimization include minimizing the number of reads and writes to a file, removing unneeded debug logging, and minimizing file flushing or closing files.

Persistent Storage

Windows Mobile 6 protects all data and applications from power-related loss. Because Windows Mobile 6 mounts the entire file system and registry in persistent storage (rather than using RAM), MC9500-K devices provide a reliable storage platform even in the absence of battery power.

Persistent storage provides application developers with a reliable storage system available through the standard file system and registry APIs. Persistent storage is optimized for large reads and writes; therefore, applications reading and writing data in large chunks tend to outperform those applications reading and writing small blocks of data. Data in persistent storage is lost upon a clean boot.

Persistent storage contains all the directories under the root directory except for Application, Cache Disk, and Storage Card (if a storage card is installed). Persistent storage is approximately 60 MB (formatted).

Application Folder

The Application folder is a super-persistent storage that is persistent even after a clean boot. Accessing data in the Application folder is slower than accessing persistent storage. The Application folder is used for deployment and device-unique data. For example, network profiles can be stored in the Application folder so that connection to the network is available after a cold boot. The Application folder is approximately 20 MB (formatted).

Enterprise Mobility Developer Kits

The Motorola Enterprise Mobility Developer Kit (EMDK) family of products allows you to write applications that take advantage of the capture, move and manage capabilities of the MC9500-K. Go to the Support Central (<http://support.symbol.com>) to download the appropriate developer kit.

Chapter 5 MC9596 - GSM HSDPA Configuration

Introduction

This chapter explains how to verify MC9596-K service on an Global System for Mobile communications (GSM) wireless network and establish settings.

GSM networks deliver mobile voice and data services, such as Short Message Service (SMS)/Text Messaging, with full roaming capabilities across the world. High-speed Downlink Packet Access (HSDPA) enabled networks offer Internet-based content and packet-based data services. This enables services such as internet browsing, e-mail on the move, powerful visual communications, multimedia messages, and location-based services.

When using the MC9596-K as a phone, services can include speed dialing, call tracking, voice mail, call forwarding, conference calling, and caller ID, depending on the type of service.

Also use the integrated phone as a modem to connect the MC9596-K to an ISP or work network. The GSM enabled MC9596-K can connect to the Internet or work network using Cellular Line, or using the modem specified by the mobile phone service provider.

- ✓ **NOTE** Before using an MC9596-K on a wireless network, first select a provider, establish a voice and data-enabled service plan, and configure the MC9596-K (where applicable). Refer to the *MC9500-K Mobile Computer User Guide* for information on how to use the phone and services.

Quick Startup Steps

To use the MC9596-K for phone and data connections:

1. Install an activated SIM card. See [Installing the SIM Card on page 1-3](#).
2. Ensure network coverage. See [Ensuring Network Coverage on page 5-2](#).
3. Configure a data connection. See [Configuring a Data Connection on page 5-3](#).

- ✓ **NOTE** Data connection configuration is pre-packaged with T-Mobile service. Other service providers may require data connection configuration.

4. Configure phone settings. See [MC9596-K Settings on page 5-5](#).

MC9596-K Service Verification

MC9596-K phone and data services require a live SIM card, obtained from a service provider, installed in the MC9596-K phone. The SIM card has embedded circuitry on one side of its surface which, when inserted into an MC9596-K phone, provides phone service. The SIM card provides a phone number, determines the features or services available to the subscriber, and identifies the subscriber to the network.

In addition to SIM card installation, the MC9596-K may require various settings to operate as a phone with data connection features.

Ensuring Network Coverage

1. Ensure an activated SIM card, from the phone service provider, is installed in the MC9596-K.

✓ **NOTE** The SIM card must be enabled to connect to the network.

2. Verify active phone and data services by tapping  to display the **Phone** dialog. The Carrier name appears in the dialog box.



Figure 5-1 Connectivity Dialog

3. Verify SIM card functionality:
 - a. Tap **Start > Settings > Personal tab > Phone icon > Network tab**.

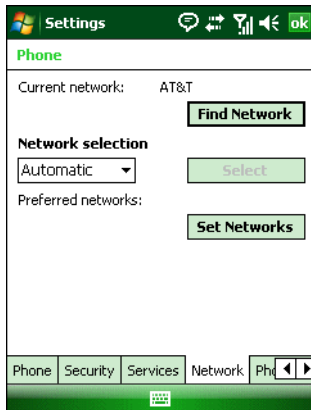

Figure 5-2 Phone Settings Window - Network Tab

- b. Ensure the service provider's network appears in the **Current network:** field.
- c. If the network does not appear, tap **Find Network**. If the network still does not appear, verify that the SIM card was installed correctly. If it was, and no network appears, contact the service provider.

Configuring a Data Connection

A data connection allows Internet access across a wireless network.

To set up a new data connection:

1. Acquire an Access Point Name (APN) from the service provider.
2. Tap **Start > Settings > Connections tab > Connections icon > Tasks** tab.

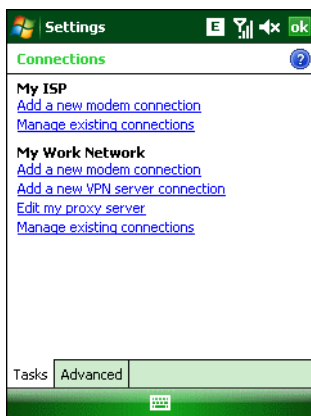

Figure 5-3 Connections Window

3. Under **My ISP** select **Add a new modem connection**.

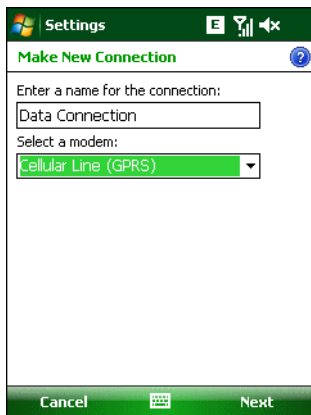

Figure 5-4 Connections Window - Make New Connection

4. Enter a connection name in the *Enter a name for the connection:* text box.
5. Select **Cellular Line (GPRS)** from the **Select a modem:** drop-down list.
6. Tap **Next**.

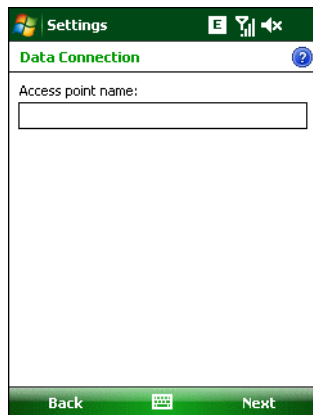

Figure 5-5 Connections Window - Access Point Name

7. Enter the APN from the service provider in the **Access point name:** text box.
8. Tap **Next**.

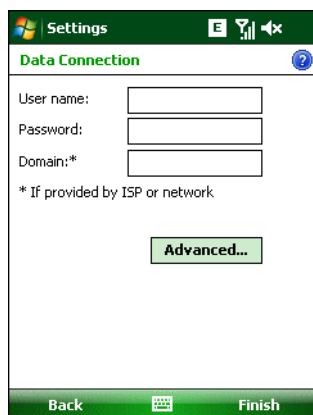

Figure 5-6 Connections Window - User Name & Password

9. Enter a username in the User name text box, if required by the service provider.
10. Enter a password in the Password text box, if required by the service provider.
11. Enter a domain name in the Domain text box, if required by the service provider.
12. Tap **Finish**.
13. Tap **ok** to exit **Connections**.

MC9596-K Settings

Use the **Phone Settings** window to customize settings, such as the ring type and ring tone for incoming calls, security options, and other options depending on the type of service.

Phone

Use the **Phone** tab to customize ring type, ring tone, keypad tone.

Tap **Start > Settings > Personal tab > Phone icon > Phone tab**

or

Start > Phone > Menu > Options > Phone tab.

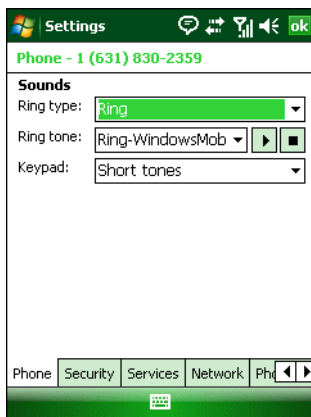



Figure 5-7 MC9596-K Phone Window - Phone Tab

Sounds

1. **Phone Number** automatically displays on the **Phone** tab when a live SIM card is installed.
2. Select a ring type from the **Ring type:** drop-down list. The ring type changes the way the MC9596-K rings when you receive an incoming call. Regardless of the ring type selected, a dialog box appears on the MC9596-K's display for incoming calls.
3. Select a ring tone for incoming calls from the **Ring tone:** drop-down list. To hear a sample of the selected ring tone, tap . Tap  to end the ring tone.

✓ **NOTE** To use custom .wav, .mid, or .wma files as ring tones, use ActiveSync on the host computer to copy the file to the /Windows/Rings folder on the MC9596-K. Then select the sound from the ring tone list.

4. Select a keypad tone from the **Keypad:** drop-down list. This selection determines the tone that sounds when entering a phone number on the keypad.
Select **Short tones** or **Long tones** to specify the duration of the sound when you press a number on the keypad. Select **Off** to disable tones.

✓ **NOTE** Turning off sounds saves power and prolongs battery life.

Security

Enabling a PIN



NOTE Place emergency calls at any time, without requiring a PIN or a SIM card.

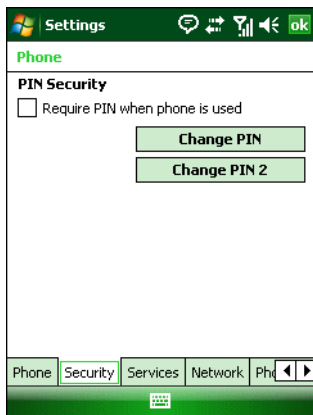

Figure 5-8 Security Tab

To require a PIN when using the phone:

1. From the **Security** tab ([Figure 5-8](#)), select the **Require PIN when phone is used** check box under **Security**.

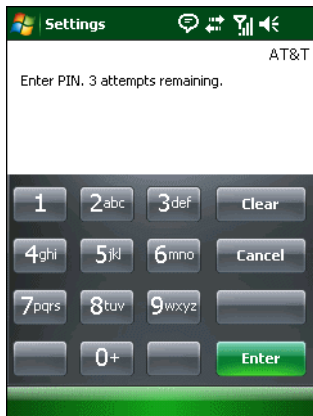

Figure 5-9 Enter PIN

2. Use the touch keypad to enter a four to eight digit PIN.
3. Tap **Enter** to enable the PIN and return to the **Phone** tab.

Changing a PIN



CAUTION If you enter an incorrect PIN, the message “SIM PIN incorrect: Try again” appears. After three consecutive incorrect attempts, the SIM card is blocked. The phone does not allow you to attempt to enter your PIN again and you must obtain a PIN Unblock Key from your service provider.

1. From the **Security** tab ([Figure 5-8](#)), tap **Change PIN**.
2. Use the touch keypad to enter the current PIN.

3. Tap **Enter**.
4. Use the touch keypad to enter a new four to eight digit PIN.
5. Tap **Enter**.
6. Reenter the new PIN for confirmation and tap **Enter**.
7. Tap **ok** to confirm the change.

Disabling a PIN

1. From the **Security** tab ([Figure 5-8](#)), deselect the **Require PIN when phone is used** check box.
2. Use the touch keypad to enter the current PIN.
3. Tap **Enter**.
4. Tap **ok** to confirm the change and exit settings.

Services

Use the *Services* tab to configure settings for subscribed phone services. For example, block certain types of incoming and/or outgoing calls ([page 5-7](#)), disclose the caller's identity when making outgoing calls ([page 5-8](#)), forward incoming calls to a different phone number ([page 5-8](#)), receive notification of incoming calls when a phone session is in use ([page 5-9](#)), and set up voice mail and short message service ([page 5-9](#)).

1. Tap **Start > Settings > Personal tab > Phone icon > Services** tab.

or

Start > Phone > Menu > Options > Services tab.

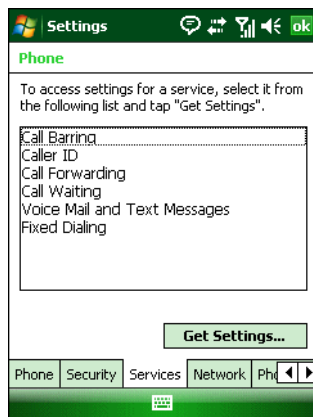

Figure 5-10 MC9596-K Phone Window - Services Tab

2. Select a service from the list and tap **Get Settings...**
3. Change services settings as follows.

Call Barring (Call Blocking)

Use call barring to block certain types of incoming and/or outgoing calls. Select the type of incoming and/or outgoing calls to block.

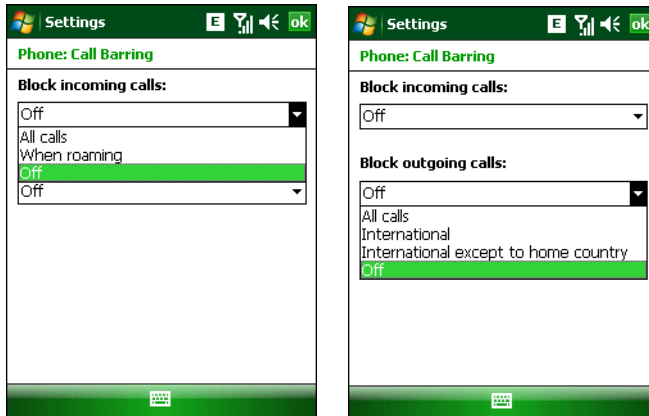

Figure 5-11 Call Barring/Call Blocking

Caller ID

Enable caller ID to reveal the identity of the person making an outgoing call. Select the **Everyone** radio button to always display the caller ID. Select the **No one** radio button to prevent the caller's identity from appearing to others.

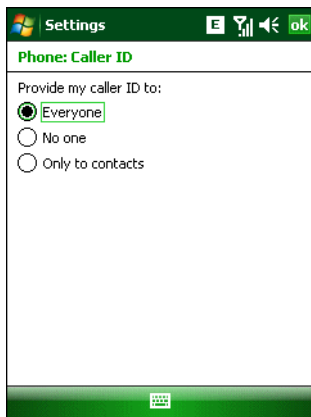

Figure 5-12 Caller ID

Call Forwarding

✓ **NOTE** Call Forwarding may not be available on all networks. Check with your service provider for availability.

Use call forwarding to forward incoming calls to a different phone number.

- To forward all calls to a different phone number:
 - select the **Forward all incoming phone calls** check box.
 - enter the phone number to receive forwarded calls in the **To:** text box.

- To forward incoming calls to a different phone number based on a specific situation, select one or more of the check boxes under **Forward phone calls only if:**
 - **No answer:** enter the phone number to receive forwarded calls only when the phone cannot be answered. Then select a time period from the **Forward after:** drop-down list. Options are 5, 10, 15, 20, 25, and 30 seconds.
 - **Unavailable:** enter the phone number to receive forwarded calls only when the phone is turned off or the user is unreachable.
 - **Busy:** enter the phone number to receive forwarded calls only when the line is busy.

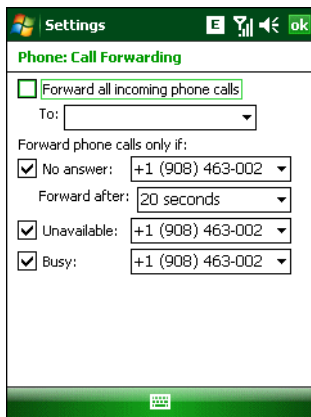

Figure 5-13 Call Forwarding

Call Waiting

✓ **NOTE** Call Waiting may not be available on all networks. Check with your service provider for availability.

Call waiting notifies you of an incoming call when the phone is in a phone session. Select the **Notify me** radio button to enable call waiting. Select the **Do not notify me** radio button to disable call waiting.

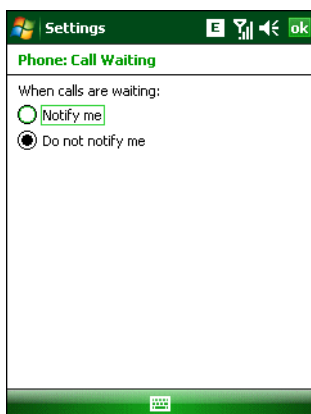

Figure 5-14 Call Waiting

Voice Mail and Text Messages

To use voice mail and send short messages, enter the voice mail and/or text message phone number in the appropriate text boxes.

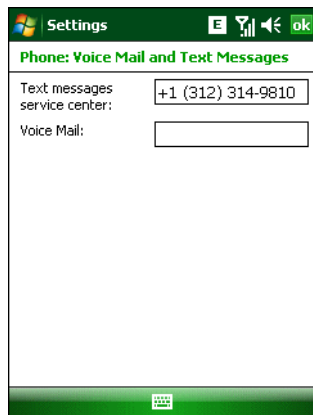

Figure 5-15 Voice Mail and Text Messages

Fixed Dialing

Use Fixed Dialing to restrict the phone to dial only the phone number(s) or area code(s) specified in a Fixed Dialing list.

1. Select **Fixed Dialing** and tap **Get Settings**.

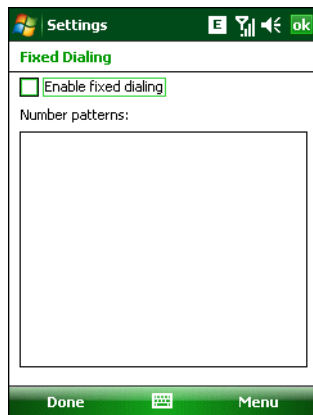

Figure 5-16 Fixed Dialing Window

2. Select the **Enable fixed dialing** check box.
3. To add a number to the list, tap **Menu > Add**.
4. Enter the phone number or area code to restrict and tap **Done**.
5. Repeat steps 3 and 4 to add more numbers, and tap **Done** twice when complete.
6. Enter **PIN2** and tap **Done**.

✓ **NOTE** PIN2 is buffered in the MC9596 indefinitely after entry and will not be requested again until a warm boot of the MC9596 has been performed. Should PIN2 be required, then the user must perform a warm boot of the MC9596.

Network

Use the **Network** tab to view available networks, determine the order in which the phone accesses another network if the current network is unavailable, and specify whether to change networks manually or automatically. The current network remains active until it's changed, the signal is lost, or the SIM card is changed.

The network the MC9596-K currently uses appears in the **Current network:** field at the top of the window.

Changing Networks Manually

1. Tap **Start > Settings > Personal tab > Phone icon > Network tab**

or

Start > Phone > Menu > Options > Network tab.

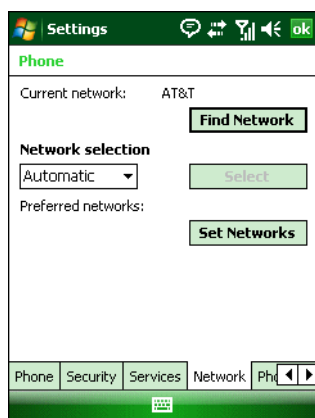

Figure 5-17 MC9596-K Phone Window - Network Tab

2. From the **Network selection** drop-down list, select **Manual**.

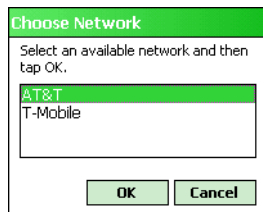

Figure 5-18 Choose Network

3. From the **Choose Network** window, select the network to use.
4. Tap **OK**.

Viewing Available Networks

To view all wireless networks available:

1. Tap **Start > Settings > Personal tab > Phone icon > Network tab**.

or

Start > Phone > Options > Network tab.

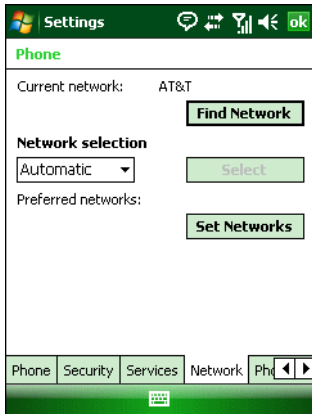

Figure 5-19 MC9596-K Phone Window - Network Tab

2. Tap Find Network.

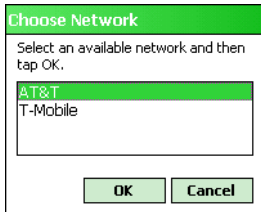

Figure 5-20 Choose Network

3. From the Choose Network window, select the network to use.

4. Tap OK.

Setting Preferred Networks

Set networks in a preferred order of access. Setting preferred networks allows the MC9596-K to access a second preferred network if the first is unavailable.

1. Tap Start > Settings > Personal tab > Phone icon > Network tab

or

Start > Phone > Menu > Options > Network tab.

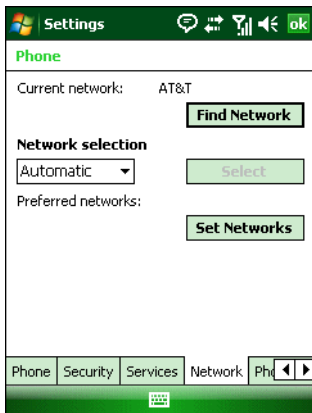

Figure 5-21 MC9596-K Phone Window - Network Tab

2. Tap **Set Networks** to view all available networks.

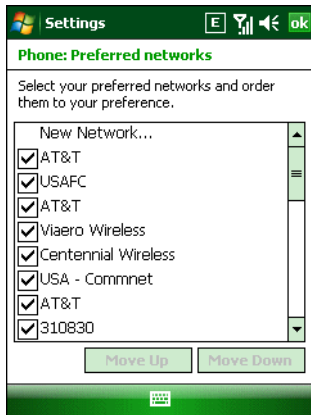

Figure 5-22 Preferred Networks

3. Select the preferred networks by tapping one or more check boxes.
4. Tap **Move Up** and **Move Down**, as necessary, to place the selected networks in the preferred order.
5. Tap **ok** to send the new settings to the network.
6. From the **Network** tab, select **Automatic** from the **Network selection** drop-down list.
7. Tap **ok** to exit settings.

Phone Info

Use the *Phone Info* tab to view hardware and software information about the phone.

1. Tap **Start > Settings > Personal tab > Phone icon > Phone Info** tab

or

Start > Phone > Menu > Options > Phone Info tab.

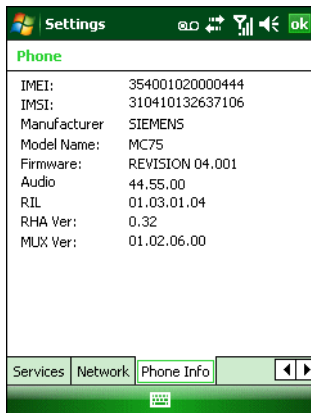

Figure 5-23 MC9596-K Phone Window - Phone Info Tab

2. Tap **ok** to exit settings.

Network Time Synchronization

The MC9596-K is configured to synchronize the clock with the time from the carrier network. Use a registry key on the MC9596-K to disable this feature.

✓ **NOTE** Network Time Synchronization can interfere with Fusion AutoTime Configuration. Determine if Network Time Synchronization or Fusion AutoTime Configuration is the preferred method for synchronizing the clock on the MC9500-K.

Not all cellular carriers support Network Time Synchronization. Contact your service provider for more information.

Using a registry editor, navigate to the following:

[HKEY_LOCAL_MACHINE\SOFTWARE\Symbol\RIL\PHA\HC25]

Create the following key:

"SyncSystemTime"=dword:00000001

where:

dword:0 = disabled

dword:1 = enabled

After setting the registry key, warm boot the MC9596-K.

Enhanced Operator Name String

The MC9596-K is enabled to download and display the name of the GSM network currently logged in to. Four registry keys on the MC9596-K have to be edited to disable this feature.

Using a registry editor, navigate to each of the following:

[HKEY_LOCAL_MACHINE\Software\Microsoft\RIL]

[HKEY_LOCAL_MACHINE\Software\Microsoft\RIL\Configurations\GSM_HC25]

Edit the following key:

"EonsEnable"=dword:1

where:

dword:0 = disabled

dword:1 = enabled (default)

Using a registry editor, navigate to each of the following:

[HKEY_LOCAL_MACHINE\Comm\Cellular\Ril]

[HKEY_LOCAL_MACHINE\Comm\Cellular\Ril\Configurations\GSM_HC25]

Edit the following key:

"EonsEnabled"=dword:1

where:

dword:0 = disabled

dword:1 = enabled (default)

After setting the registry key, warm boot the MC9596-K.

Service Provider Name Display

The MC9596-K displays the provider name in the Phone dialer by default. A registry key can be set to change what displays on the Phone dialer.

Using a registry editor, navigate to the following:

[HKEY_LOCAL_MACHINE\Software\Microsoft\RIL]

Create the following key:

“UseServiceProviderName”=dword: 0

where:

dword:0 = Display provider name (default)

dword:1 = Display service provider name

dword:2 = Display both provider and service provider name

After setting the registry key, warm boot the MC9596-K.

WWAN Band Selection

By default MC9500-K connects automatic to a 2G or 3G network if found upon registering. A registry setting can be used to configure the MC9500-K to connect only to a 2G or 3G network.

Using a registry editor, navigate to the following:

[HKEY_LOCAL_MACHINE\Software\Microsoft\RIL]

Create the following key:

“Selection2G3G”=dword: 1

where:

dword:1 = automatic (default)

dword:2 = GSM only (2G)

dword:3 = HSPDPA only (3G)

After setting the registry key, warm boot the MC9596-K.

PAP CHAP GPRS Authentication

The GPRS authentication is set to use CHAP and then PAP. The authentication can be set to use only CHAP or only PAP.

Using a registry editor, navigate to the following:

[HKEY_LOCAL_MACHINE\SOFTWARE\Microsoft\RIL]

Create the following key:

“SetGPRSAuthentication”=dword: 0

where:

dword:1 = PAP only.

dword:2 = CHAP only.

dword:3 = CHAP first, then PAP (default)

If this registry key is not set, the CHAP first, then PAP setting will be used.

Chapter 6 MC9598 - CDMA EvDO Configuration

Introduction

This chapter explains how to activate an MCMC9598-K on a Code Division Multiple Access (CDMA) wireless network and establish settings.

CDMA is a form of wireless multiplexing in which data (e.g., Short Message Service) can be sent over multiple frequencies simultaneously, optimizing the use of available bandwidth. In an CDMA system data is broken into packets, each of which are given a unique identifier, so that they can be sent out over multiple frequencies and then re-built in the correct order by the receiver.

When using the MC9598-K as a phone, services can include speed dialing, call tracking, voice mail, call forwarding, conference calling and caller ID, depending on the type of service.

The integrated phone in the MC9598-K can also be used as a modem to connect the MC9598-K to an ISP or work network. The MC9598-K can connect to the Internet or work network using Cellular Line, or using the modem specified by the mobile phone service provider.

- ✓ **NOTE** Before the MC9598-K can be used on a CDMA wireless network, a provider must be selected, a voice and data-enabled service plan must be established and the MC9598-K must be properly configured (where applicable).

Refer to the *MC9598-K User Guide* for information on how to use the phone and services.

Quick Startup Steps

To start using the MC9598-K for phone and data connections:

1. Install the battery. See [Installing the Battery on page 1-5](#).
2. Activate the phone. See [CDMA Phone Activation on page 6-2](#).
3. Configure phone settings. See [CDMA Settings on page 6-12](#).
4. Use the phone.

CDMA Phone Activation

CDMA phone service is available from a number of service providers including Sprint®, Verizon Wireless®, Alltel, Bell Mobility and Telus. In addition to service activation for each provider, various settings may be required for the MC9598-K to operate as a phone. There can be different Activation Wizards depending upon the carrier. Verizon Wireless and Sprint use an automatic activation processes. All other carriers use the manual activation process.

Verizon Wireless Activation

Automatic Activation

The **Activation Wizard** allows automatic activation. To activate the MC9598-K using the automated service, the MC9598-K attempts to call the network on a special number that automatically downloads the phone number and identification codes from the network.

Verizon Wireless automatically downloads the provisioning data. This process is invisible to the user and occurs once, after account activation, during the first data connection attempt.

- ✓ **NOTE** After an MC9598-K is provisioned for Verizon Wireless service, it is strongly recommended that no other service provider loads are downloaded to the MC9598-K and no changes are made to any of the provisioning information.

To activate the phone using the Verizon Wireless automated service:

1. Ensure the MC9598-K is in a strong signal area.
2. The Activation Wizard automatically starts whenever the phone is turned on. If the wizard does not appear, tap **Start > Phone > Menu > Activation Wizard...**

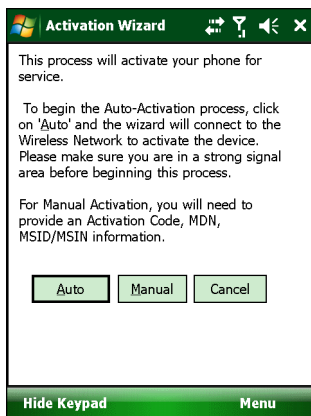

Figure 6-1 Verizon Activation Wizard

3. Tap **Auto** to connect to the Verizon Wireless Network to automate activation. Automated activation provides all required codes and identification numbers over the network. No additional activation setup is required.
4. If activation is successful the **Congratulations** window appears.

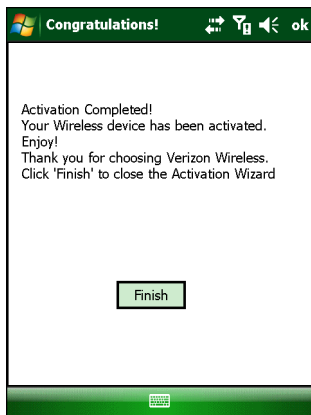

Figure 6-2 *Congratulations! Window*

5. Tap **Finish** to close the **Activation Wizard**.
6. If activation fails, an error message appears.

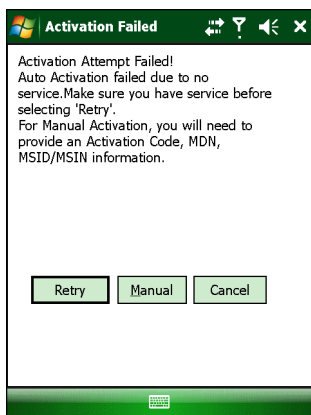

Figure 6-3 *Activation Failure Error Message*

7. Tap **Retry** to try automatic activation again or tap **Manual** to activate manually.

✓ **NOTE** If activation was not successful, contact the service provider.

Manual Activation

To manually activate the phone:

1. Ensure the MC9598-K is in a strong signal area.
2. Tap **Start > Phone > Menu > Activation Wizard...**
3. Tap **Manual**.

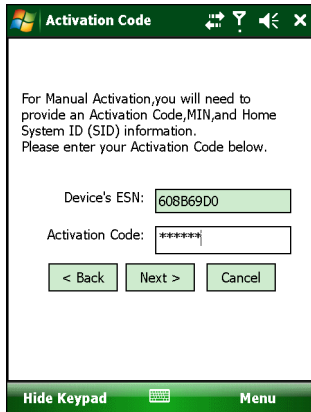

Figure 6-4 Activation Wizard - Activation Code

4. In the **Activation Code** text box, enter the activation code.
5. Tap **Next >**. If the activation code is incorrect, an error dialog box appears.

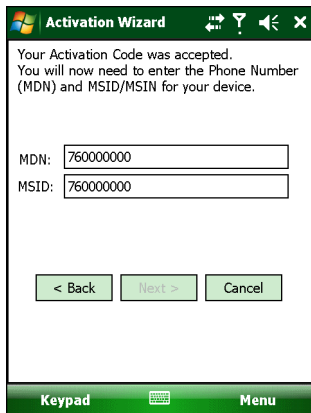

Figure 6-5 Activation Wizard - MDN and MSID

6. Enter the MDN and MSID. The MDN and MSID are the area code and phone number received from the service provider.
7. Tap **Next >**. A confirmation dialog box appears.

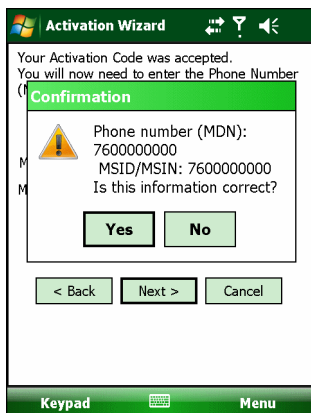

Figure 6-6 Activation Wizard - Confirmation

8. Verify that the MDN and MSIN numbers entered are correct, tap **Yes** to confirm.
9. Tap **Finish**.

✓ **NOTE** If activation was not successful, contact the service provider.

Sprint Activation

Automatic Activation

To activate the phone using Sprint service:

1. Ensure the MC9598-K is in a strong signal area.
2. The Activation Wizard automatically starts whenever the phone is turned on.

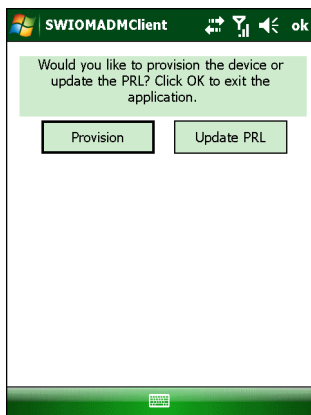

Figure 6-7 Activation Wizard

3. Tap **Provision**. If communication with the network is successful, a confirmation window appears.

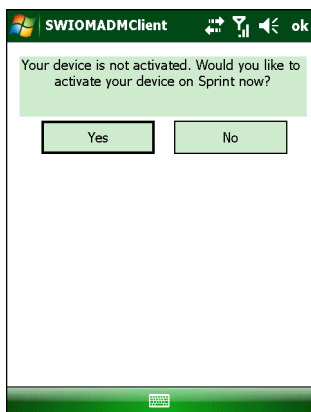

Figure 6-8 Activation Wizard Confirmation Window

4. Tap **Yes**.
5. Automatic provisioning begins. Upon successful activation, a confirmation window appears.

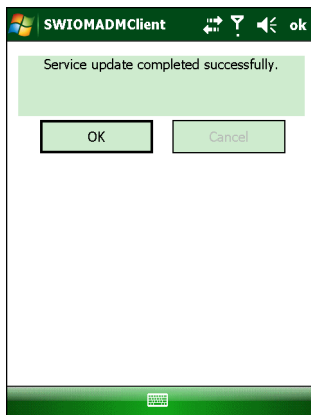

Figure 6-9 Provisioning Complete

If activation is unsuccessful, a window appears to re-try the activation process. Tap **Yes** to try again.

6. Tap **OK** to close the application.

✓ **NOTE** If activation was not successful, contact the service provider.

Manual Activation

To manually activate the phone:

1. Ensure the MC9598-K is in a strong signal area.
2. Tap **Start > Phone > Menu > Activation Wizard...**

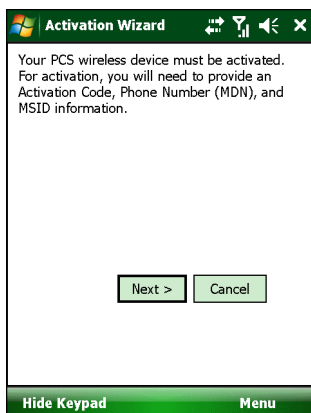

Figure 6-10 Activation Wizard

3. Tap **Next >**.

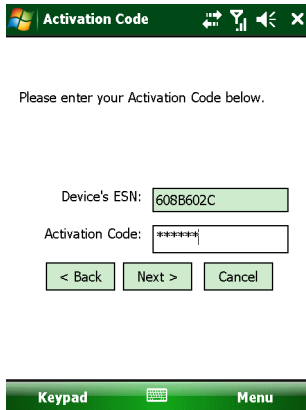

Figure 6-11 Activation Wizard - Enter Activation Code

4. Enter the 6-digit activation code from your service provider.
5. Tap **Next >**. If the activation code is incorrect, an error dialog box appears.

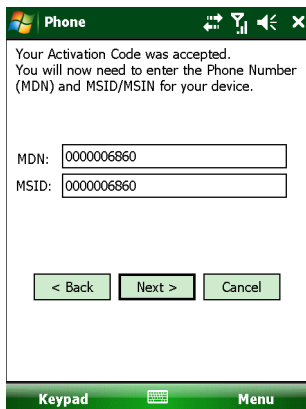

Figure 6-12 Activation Wizard - MDN and MSID

6. Enter the MDN and MSID. The MDN and MSID are the area code and phone number received from the service provider.
7. Tap **Next >**. A confirmation dialog box appears.

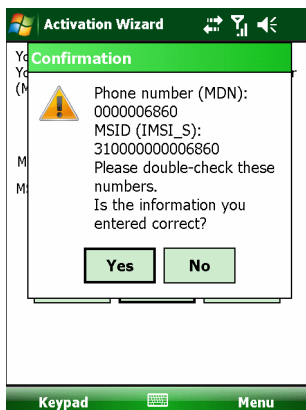

Figure 6-13 Activation Wizard - Confirmation

- Verify that the MDN and MSIN numbers entered are correct, tap **Yes** to confirm. The **Congratulations!** window appears.

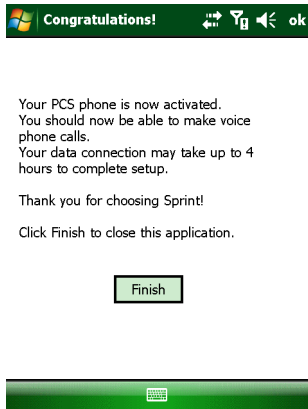

Figure 6-14 Activation Wizard - Activation Complete

- Tap **Finish** to complete activation.

✓ **NOTE** If activation was not successful, contact the service provider.

Other Carriers Manual Activation

To activate the phone:

- Ensure the MC9598-K is in a strong signal area.
- The Activation Wizard automatically starts whenever the phone is turned on. If the wizard does not appear, tap **Start > Phone > Menu > Activation Wizard...**

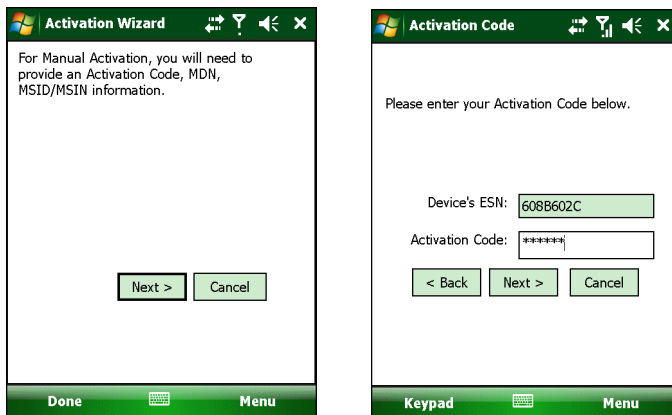

Figure 6-15

- Tap **Next >**.
- In the **Activation Code** text box, enter the 6-digit activation code from your service provider.
- Tap **Next >**. If the activation code is incorrect, an error dialog box appears.

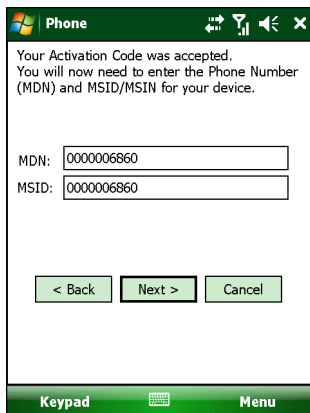

Figure 6-16 Activation Wizard - MDN and MSID

6. Enter the MDN and MSID. The MDN and MSID are the area code and phone number received from the service provider.
7. Tap **Next >**.

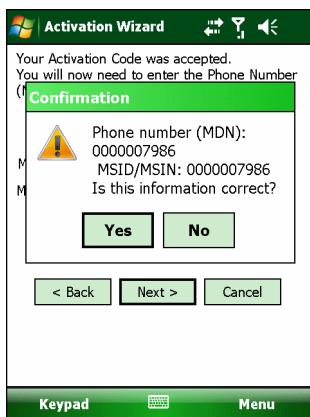

Figure 6-17 Activation Wizard - Confirmation

8. Verify that the MDN and MSIN numbers entered are correct, tap **Yes** to confirm.

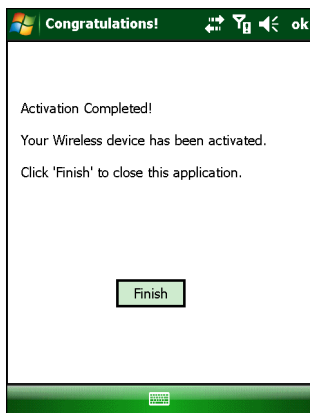

Figure 6-18 Activation Wizard - Activation Complete

9. Tap **Finish** to complete activation. The phone can be used in approximately four hours.

✓ **NOTE** If activation was not successful, contact the service provider.

Activation Test

Approximately four hours after activation is completed, test the service.

1. Tap **Start > Phone**.

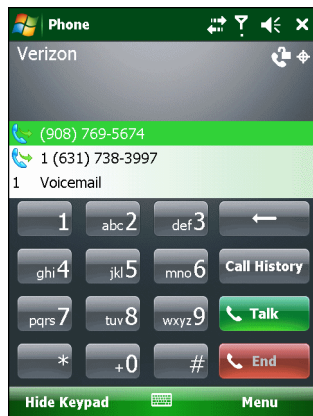

Figure 6-19 Phone Window - Example

2. Ensure the carrier name displays on the window.
3. Make a voice call to ensure activation was successful.

✓ **NOTE** If activation was not successful, contact the service provider.

Establishing a Data Connection

✓ **NOTE** Ensure that you have data service activated with your service provider.

A data connection allows Internet access across a wireless network. Data connection is pre-packaged with service accounts.

To verify active data service:

1. Tap **Start > Internet Explorer**.
2. In the address bar, enter a URL for a web site.
3. Tap **E** to display the **Connectivity** dialog. The dialog box displays the data connection information.

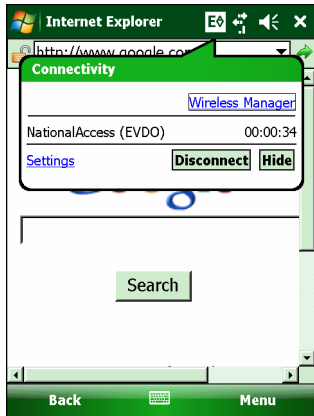

Figure 6-20 *Data Connection*

CDMA Settings

Use the **Phone Settings** window to customize CDMA phone settings, such as the ring type and ring tone for incoming calls and other options depending on the type of service.

Phone

Use the **Phone** tab to customize ring type, ring tone and keypad tone when entering phone numbers.

1. Tap **Start > Settings > Personal** tab > **Phone** icon > **Phone** tab.

or

Start > Phone > Menu > Options > Phone tab.

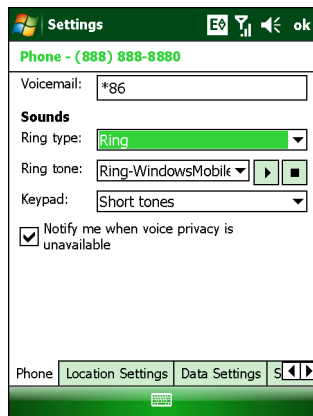

Figure 6-21 Phone Window - Phone Tab

2. Phone and voicemail phone numbers automatically display when phone service is activated.
3. Select a ring type from the **Ring type:** drop-down list. The ring type changes the way the MC9598-K rings to notify the user of an incoming call. Regardless of the ring type selected, a dialog box appears on the display for incoming calls.
4. Select a ring tone for incoming calls from the **Ring tone:** drop-down list. To hear a sample of the selected ring tone, tap . Tap to end the ring tone.

✓ **NOTE** To use custom .wav, .mid or .wma files as ring tones, use ActiveSync on the host PC to copy the file to the /Windows/Rings folder on the MC9598-K. Then, select the sound from the ring tone list.
5. Select a keypad tone from the **Keypad:** drop-down list. This selection determines the tone that sounds when entering a phone number on the keypad.
 - a. Select **Short Tones** for a tone that sounds only for one or two seconds.
 - b. Select **Long Tones** for a continuous sound for as long as the number on the keypad is pressed.
 - c. Select **Off** to disable tones.
6. Tap **Other Settings...** to set additional sounds and notifications for the MC9598-K.
7. Select the **Notify me when voice privacy is unavailable** check box to receive a message when dialing.

8. Tap **ok** to exit settings.

✓ **NOTE** Turning off sounds saves power and prolongs battery life.

Location Settings

Use the **Location** tab to allow the network to detect the position of the MC9598-K's radio.

1. Tap **Start > Settings > Personal tab > Phone icon > Location Settings** tab.

or

Start > Phone > Menu > Options > Location Settings tab.

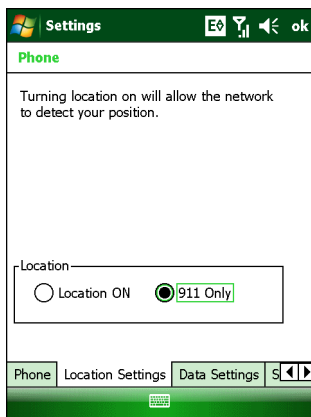

Figure 6-22 Phone Window - Location Tab (Typical)

2. Select the **Location ON** radio button to allow the network to detect the position of the MC9598-K's radio.

or

Select the **911 Only** button to turn off location detection, hiding the location of the radio from all but 911 emergency service.

3. Tap **ok** to confirm **Location ON** or **911 Only**.
4. Tap **ok** again to exit settings.

Data Settings

Sprint Data Settings

Use the **Data Settings** tab to reset connection settings for PCS Vision and update the Vision profile, and to start IP-based Over-The-Air (IOTA) provisioning.

1. Tap **Start > Settings > Personal tab > Phone icon > Data Settings** tab.

or

Start > Phone > Menu > Options > Data Settings tab.

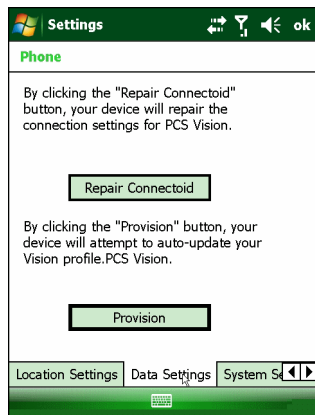

Figure 6-23 Phone Window - Sprint Data Tab

2. Tap **Repair Connectoid** to reset PCS Vision connection settings.

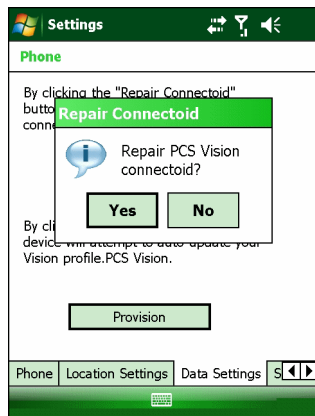

Figure 6-24 Reset Connection Settings Dialog

3. Tap **Yes**.
4. Tap **ok**.
5. Tap **Provision** to manually start provisioning.
6. Tap **ok** to exit.

Verizon Wireless Data Settings

Use the **Data** tab to reset connection settings for national access.

1. Tap **Start > Settings > Personal tab > Phone icon > Data Settings** tab.
or
Start > Phone > Menu > Options > Data Settings tab.

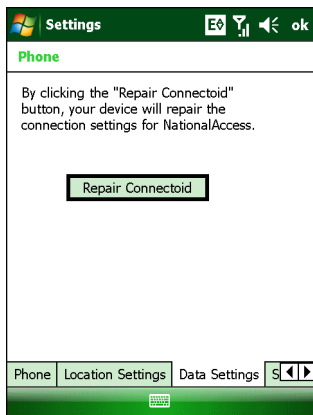

Figure 6-25 Phone Window - Verizon Data Tab

2. Tap **Repair Connectoid** to reset connection settings for National Access.
3. Tap **Yes**.
4. Tap **ok**.
5. Tap **ok** to exit settings.

Additional Service provider Data Settings

Use the *Data* tab to reset connection settings for the 3G connection.

1. Tap **Start > Settings > Personal tab > Phone icon > Data Settings** tab.

or

Start > Phone > Menu > Options > Data Settings tab.

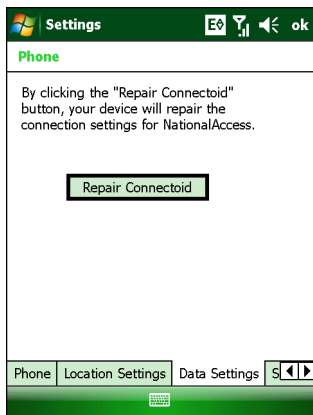

Figure 6-26 Phone Window - Data Tab

2. Tap **Reset Connection** to reset connection settings for the 3G connection.
3. Tap **Yes**.
4. Tap **ok**.
5. Tap **ok** to exit settings.

System Settings

Use the **System Settings** tab to select roaming options.

Tap **Start > Settings > Personal tab > Phone icon > System Settings tab**.

or

Tap **Start > Phone > Menu > Options > System tab**.

Sprint System

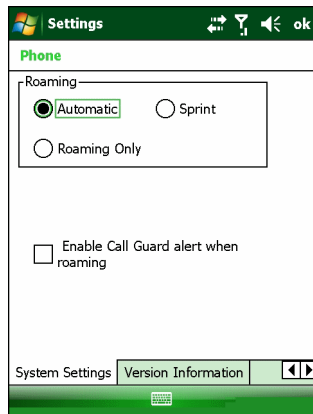

Figure 6-27 Phone Window - System Settings Tab - Sprint

1. Roaming:

- Select the **Automatic** radio button to allow the phone to automatically seek a roaming network where the Sprint Nationwide PCS Network is not available. Automatic roaming is available where Sprint implemented roaming with other wireless carriers.
- Select the **Sprint** radio button to allow the phone to automatically seek a roaming network within the Sprint Nationwide PCS Network only.
- Select **Roaming Only** radio button to allow the phone to automatically seek a roaming network.

2. Select the **Enable Call Guard alert when roaming** check box to control roaming charges by receiving a reminder when a roaming call is made or received. When a roaming call is made or received, **Roaming rate applies for this call. Press OK to dial.** appears on the MC9598-K display screen.

3. Tap **ok** to exit settings.

Verizon System

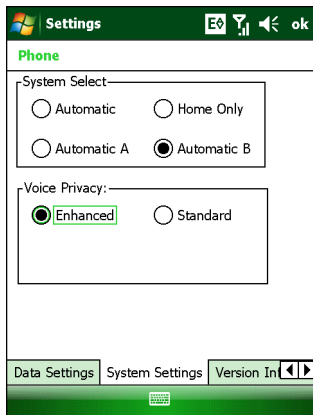

Figure 6-28 Phone Window - System Settings Tab - Verizon

1. System Select allows the user to change the system roaming preference of the radio in order to control the type of network the radio can lock onto for service.
 - Select the **Automatic** radio button to allow the radio to lock onto networks based on the provisioning of the radio.
 - Select the **Automatic A** or **Automatic B** radio button to allow the radio to lock onto an A or B network carrier, respectively, if no other network can be found that matches the radio's provisioning.
 - Select the **Home Only** radio button to prevent the radio from locking on any network that is considered a roaming network.
2. Voice Privacy allows the user to enable or disable voice privacy.
 - Select the **Enhanced** radio button to trigger the network to use voice privacy whenever the current network supports it. When in a call, if network privacy is being used, a voice privacy icon is displayed in the user interface.
 - Select the **Standard** radio button to prevent voice privacy from being used when in a call.
3. Tap **ok** to exit settings.

Additional Service Provider System

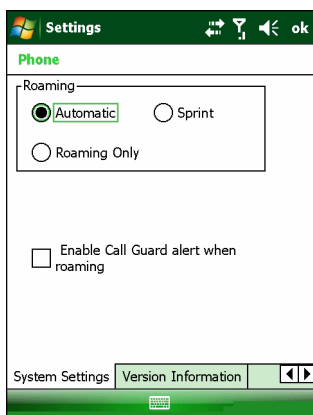

Figure 6-29 Phone Window - System Settings Tab - Additional

1. System Select allows the user to change the system roaming preference of the radio in order to control the type of network the radio can lock onto for service.
 - Select the **Automatic** radio button to allow the radio to lock onto networks based on the provisioning of the radio.
 - Select the **Home Only** radio button to prevent the radio from locking on any network that is considered a roaming network.
2. Voice Privacy allows the user to enable or disable voice privacy.
 - Select the **Enhanced** radio button to trigger the network to use voice privacy whenever the current network supports it. When in a call, if network privacy is being used, a voice privacy icon is displayed in the user interface.
 - Select the **Standard** radio button to prevent voice privacy from being used when in a call.
3. Tap **ok** to exit settings.

Version Information

Use the **Version Information** tab to view phone number and version information.

1. Tap **Start > Settings > Personal tab > Phone icon > Version Information** tab.

or

Start > Phone > Menu > Options > Version Information tab.

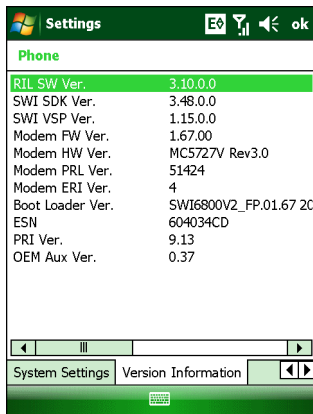

Figure 6-30 Phone Window - (Typical)

2. Tap **ok** to exit settings.

Services

Depending on the type of subscribed phone services, the following services may be available: call barring, caller ID, call forwarding, call waiting, voice mail and Short Message Service (SMS).

Call Barring (Call Blocking)

Call barring blocks certain types of incoming and/or outgoing calls. This service is setup when an account is opened with the service provider.

Caller ID

Caller ID provides a way for people to know the identity of the person making an outgoing call. To disable caller ID and block the outgoing phone number:

1. Enter *67 on the phone keypad.
2. Enter the phone number to call.

✓ **NOTE** *67, followed by the phone number, must be entered on a call-by-call basis to block the outgoing phone number.

Call Forwarding

✓ **NOTE** Call Forwarding may not be available on all networks. Check with your service provider for availability.

Use call forwarding to forward incoming calls to a different phone number. To enable call forwarding and send calls to another phone number:

1. Enter *72 on the phone keypad.
2. Enter the area code and phone number of the phone to accept the forwarded calls.
3. Tap **Talk**.
4. A beep sounds indicating activation.
5. Tap **End**.

To disable call forwarding:

1. Enter *73 (Verizon Wireless) on the phone keypad.
2. Tap **Talk**.
3. A beep sounds indicating deactivation.
4. Tap **End**.

Call Waiting

✓ **NOTE** Call Waiting may not be available on all networks. Check with your service provider for availability.

Call waiting notifies the user of an incoming call when the phone is in a phone session. This service is setup when an account is opened with the service provider.

Voice Mail and Short Message Service (SMS)

This service is setup when an account is opened with the service provider.

Network Time Synchronization

The MC9598-K can be configured to synchronize the clock with the time from the carrier network. A registry key on the MC9598-K has to be created to enable this feature.

Using a registry editor, navigate to the following:

[HKEY_LOCAL_MACHINE\SOFTWARE\Symbol\RL\RHAMC5725]

Create the following key:

"SyncSystemTime"=dword:00000001

where:

dword:0 = disabled

dword:1 = enabled

After setting the registry key, warm boot the MC9598-K.

Chapter 7 Interactive Sensor Technology Configuration

Introduction

This chapter provides information for configuring the Interactive Sensor Technology (IST) settings. IST settings can be accessed:

- Tap **Start > Settings > System > IST Settings** icon.
- Tap the **IST Settings** icon in the Command bar.



Figure 7-1 *IST Settings Icon*

IST Menu

Tap the **IST Settings** icon to open the menu. This menu lists IST configuration settings.

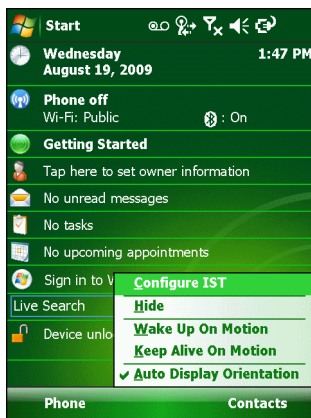

Figure 7-2 *IST Settings Icon Menu*

Use this menu to access the configuration settings listed in [Table 7-1](#). An enabled options is indicated with a check mark next to the option.

Table 7-1 IST Tray Icon Menu Items

Menu Item	Description
Configure IST	Opens the IST Settings window.
Hide	Removes IST Settings icon from the Command bar.
Wake Up On Motion	Wakes the MC9500-K from suspend mode if it was placed in suspend mode due to inactivity.
Keep Alive On Motion	Prevents going into suspend mode motion is detected. See Keep Alive On Motion on page 7-3 for more information.
Auto Display Orientation	Enables auto display orientation. See Display Tab on page 7-4 for more information.

General Tab

Use the **General** tab to view IST software information and control the display of the **IST Setting** icon.

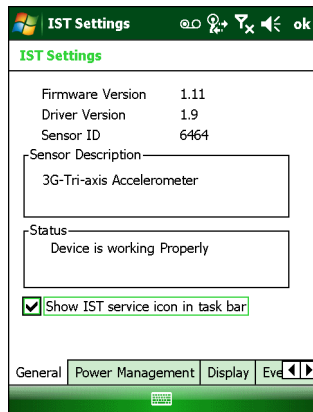
**Figure 7-3** General Tab**Table 7-2** IST General Tab Information

Item	Description
Firmware Version	Displays the version information of IST device firmware.
Driver Version	Displays the version information of IST driver.
Sensor ID	Displays identification tag of the sensor.
Sensor Description	Displays a description of the sensor.

Table 7-2 IST General Tab Information

Item	Description
Status	<p>Displays status information of the IST device. If the IST is not working properly it displays the error message.</p> <hr/> <p>Device working Properly - Normal state.</p> <p>IST Hardware not present - When there is no response from IST hardware. Please contact service department.</p> <p>Need calibration - Device is not calibrated. Contact your system administrator.</p>
Show IST service icon in task bar	Enables the IST Setting icon to display in the Command bar.

Power Management Tab

Use the **Power Management** tab to configure power management settings.

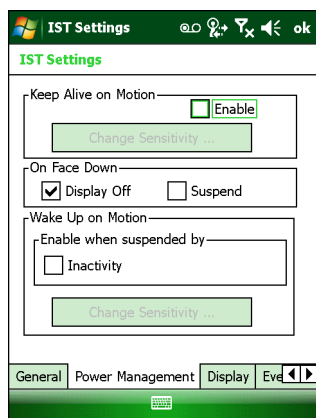
**Figure 7-4** Power Management Tab

Keep Alive On Motion

Select the **Enabled** checkbox to prevent the MC9500-K from going into suspend mode while it is in motion. The motion sensitivity is configurable. To set the sensitivity, tap the **Change Sensitivity...** button.

- ✓ **NOTE** There is no time out defined for suspend due to IST inactivity. To aggressively manage power, while there is no motion, set the MC9500-K suspend time out to a very short time using system power settings. This setting suspends the MC9500-K when there is no motion activity or any other activity within this set time out.

On Face Down

The **On Face Down** section provides configurable options to control what happens when the MC9500-K is placed with the display face down.

Select the **Display Off** checkbox to turn off the backlight when the MC9500-K is placed face-down. The backlight automatically powers on when the MC9500-K is tuned face-up.

Select the **Suspend** checkbox to suspend the MC9500-K when it placed face-down. To wake the MC9500-K use the controls listed in the **Wake Up on Motion** section below.

Wake Up on Motion

The **Wake Up on Motion** section provides configurable options for waking the MC9500-K from suspend mode by shaking the MC9500-K.

Select **Inactivity** checkbox to allow IST to wake the MC9500-K when it was suspended due to inactivity.

Use the **Change Sensitivity...** button to configure the sensitivity settings.

Setting Sensitivity

Use the slider to set the sensitivity. A low setting indicates that a harder shake (faster movement) is required for the IST to initiate a wake up action. The sensitivity can be set from “0” to “10” and when the sensitivity is set to lower values a simple shake/motion can be detected by IST. A high setting allows IST to issue a wake up action when an easier movement to the MC9500-K is detected. Shake the MC9500-K to test the set sensitivity. An audio sound is heard and a message is displayed on screen when the shaking level reaches the set sensitivity level.

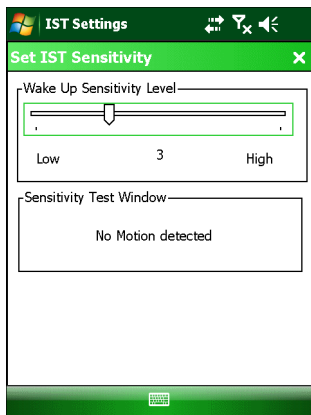

Figure 7-5 Set IST Sensitivity Window

Display Tab

Use the **Display** tab configure display interaction settings.

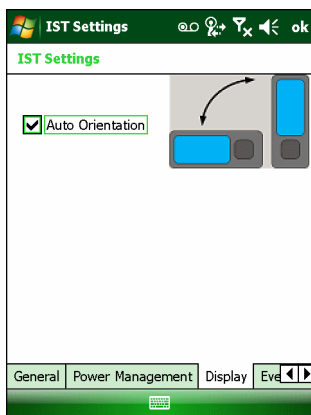

Figure 7-6 Display Tab

The Auto Orientation parameter controls the display rotation according to the MC9500-K orientation. Select the **Auto Orientation** checkbox to enable this feature. Auto orientation is disabled by default.

Event Log Tab

Use the **Event Log** tab to display the event details. This feature in IST mainly focuses on abuse by dropping the device.

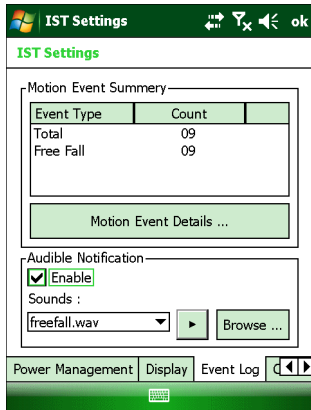

Figure 7-7 Event Log Tab

The **Motion Event Summary** list displays a summary of the event report. To view the full report tap the **Motion Event Details...** button.

Use the Audible Notification panel to enable playing of a wave file when the MC9500-K is dropped. Select a desired .wav file from the Sounds: drop-down list.

Motion Event Details

The **Motion Event Detail** list displays the date and time, duration and the type of the drop event. This event list can display up to last 32 motion events. A drop event is registered when the MC9500-K drops 1.07 m (42 in.) in normal operation and 1.27 m (50 in.) in suspend mode.

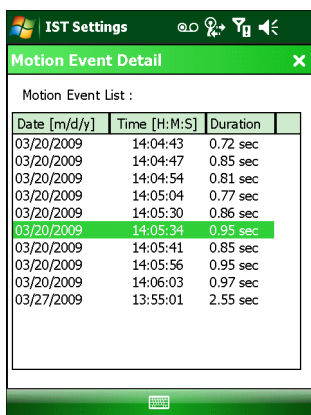

Figure 7-8 Motion Event Detail Window

Chapter 8 Wireless Applications

Introduction

Wireless Local Area Networks (LANs) allow mobile computers to communicate wirelessly and send captured data to a host device in real time. Before using the MC9500 on a WLAN, the facility must be set up with the required hardware to run the wireless LAN and the MC9500 must be configured. Refer to the documentation provided with the access points (APs) for instructions on setting up the hardware.

- ✓ **NOTE** 802.11d is enabled by default. When enabled, the AP must be configured the same in order to connect.

To configure the MC9500-K, a set of wireless applications provide the tools to configure and test the wireless radio in the MC9500-K. Refer to the *Wireless Fusion Enterprise Mobility Suite User Guide for Version 3.00* for information on configuring wireless profiles. Go to <http://www.motorola.com/enterprisemobility/manuals> for the latest version of this guide. See *Software Versions on page xii* to determine the Fusion version on the MC9500-K.

- ✓ **NOTE** Select the Country for the MC9500-K's country of operation. The access point prompts for the correct country code on the first login. A warning message also displays stating an incorrect country setting may result in illegal radio operation. Selecting the correct country is central to legally operating the access point. Each country has its own regulatory restrictions concerning electromagnetic emissions and the maximum RF signal that can be transmitted. To ensure compliance with national and local laws, set the country accurately. MC9500-K users cannot configure their access point until a two character country code (for example, United States - us) is set. The Country setting drop-down list in the US version of the MC9500-K only contains "US" in the list. The Country setting drop-down list in the WW version does not contain "US" in the list.

The **Wireless Application** menu on the task tray provides the following wireless applications:

- Find WLANs
- Manage Profiles
- Manage Certs
- Manage PACs
- Options
- Wireless Status

- Wireless Diagnostics
- Log On/Off
- Enable/Disable Radio
- Hide Menu
- Exit.

Tap the **Signal Strength** icon to display the **Wireless Applications** menu.

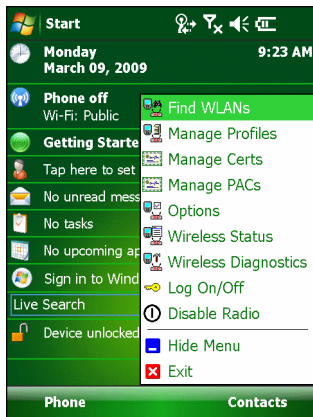

Figure 8-1 *Wireless Applications Menu*



Signal Strength Icon

The **Signal Strength** icon in the task tray indicates the MC9500's wireless signal strength as follows:

Table 8-1 *Signal Strength Icons Descriptions*

Icon	Status	Action
	Excellent signal strength	Wireless LAN network is ready to use.
	Very good signal strength	Wireless LAN network is ready to use.
	Good signal strength	Wireless LAN network is ready to use.
	Fair signal strength	Wireless LAN network is ready to use. Notify the network administrator that the signal strength is only "Fair".
	Poor signal strength	Wireless LAN network is ready to use. Performance may not be optimum. Notify the network administrator that the signal strength is "Poor".

Table 8-1 *Signal Strength Icons Descriptions (Continued)*

Icon	Status	Action
	Out-of-network range (not associated)	No WLAN network connection. Notify the network administrator.
	The WLAN radio is disabled.	WLAN is disabled. To enable, choose Enable Radio from the Wireless Applications menu.
None	The Wireless Launcher application was exited.	The Wireless Launcher application has been closed.

Turning the WLAN Radio On and Off

To turn the WLAN radio off tap the **Signal Strength** icon and select **Disable Radio**.

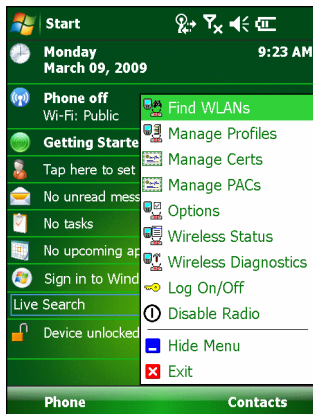

Figure 8-2 *Disable Radio*

To turn the WLAN radio on tap the **Signal Strength** icon and select **Enable Radio**.

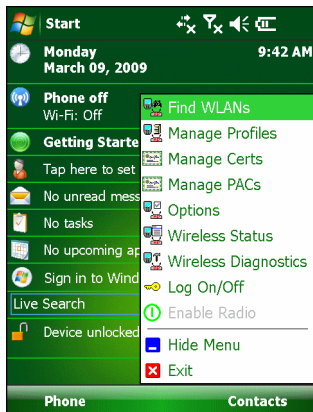

Figure 8-3 *Enable Radio*

Chapter 9 Maintenance and Troubleshooting

Introduction

This chapter includes instructions on cleaning and storing the MC9500-K, and provides troubleshooting solutions for potential problems during MC9500-K operation.

Maintaining the MC9500-K

For trouble-free service, observe the following tips when using the MC9500-K:

- Do not scratch the screen of the MC9500-K. When working with the MC9500-K, use the supplied stylus or plastic-tipped pens intended for use with a touch-sensitive screen. Never use an actual pen or pencil or other sharp object on the surface of the MC9500-K screen.

Motorola recommends using a screen protector, p/n KT-122010-01R.

- The touch-sensitive screen of the MC9500-K is poly-carbonate. Do not drop the MC9500-K or subject it to strong impact.
- Protect the MC9500-K from temperature extremes. Do not leave it on the dashboard of a car on a hot day, and keep it away from heat sources.
- Do not store the MC9500-K in any location that is dusty, damp or wet.
- Use a soft lens cloth to clean the MC9500-K. If the surface of the MC9500-K screen becomes soiled, clean it with a soft cloth moistened with a diluted window-cleaning solution.
- Periodically replace the rechargeable battery to ensure maximum battery life and product performance. Battery life depends on individual usage patterns. The battery provides health status to assist in determining useful battery life. See [Chapter 2, Battery Management](#) for more information.

- A screen protector is applied to the MC9500-K. Motorola recommends using this to minimize wear and tear. Screen protectors enhance the usability and durability of touch screen displays. Benefits include:
 - Protection from scratches and gouges
 - Durable writing
 - Abrasion and chemical resistance
 - Glare reduction
 - Keeping the device's screen looking new
 - Quick and easy installation.

Removing the Screen Protector

A screen protector is applied to the MC9500-K. Motorola recommends using this to minimize wear and tear. Screen protectors enhance the usability and durability of touch screen displays.

To remove the screen protector, lift the corner using a thin plastic card, such as a credit card, then carefully lift it off the display.



Figure 9-1 *Removing the Screen Protector*



CAUTION Do not use a sharp object to remove the protector. Doing so can damage the display.



NOTE Not using a screen protector can affect warranty coverage. To purchase replacement protectors, contact your local account manager or Motorola, Inc. These include screen protector installation instructions. Part number: KT-122010-01R Screen Protector 3/pk.

Battery Safety Guidelines

- The area in which the units are charged should be clear of debris and combustible materials or chemicals. Particular care should be taken where the device is charged in a non commercial environment.
- Follow battery usage, storage, and charging guidelines found in the user's guide.
- Improper battery use may result in a fire, explosion, or other hazard.

- To charge the mobile device battery, the battery and charger temperatures must be between +32 °F and +104 °F (0 °C and +40 °C)
- Do not use incompatible batteries and chargers. Use of an incompatible battery or charger may present a risk of fire, explosion, leakage, or other hazard. If you have any questions about the compatibility of a battery or a charger, contact Motorola Enterprise Mobility support.
- For devices that utilize a USB port as a charging source, the device shall only be connected to products that bear the USB-IF logo or have completed the USB-IF compliance program.
- To enable authentication of an approved battery, as required by IEEE1725 clause 10.2.1, all batteries will carry a Motorola hologram. Do not fit any battery without checking it has the Motorola authentication hologram.
- Do not disassemble or open, crush, bend or deform, puncture, or shred.
- Severe impact from dropping any battery-operated device on a hard surface could cause the battery to overheat.
- Do not short circuit a battery or allow metallic or conductive objects to contact the battery terminals.
- Do not modify or remanufacture, attempt to insert foreign objects into the battery, immerse or expose to water or other liquids, or expose to fire, explosion, or other hazard.
- Do not leave or store the equipment in or near areas that might get very hot, such as in a parked vehicle or near a radiator or other heat source. Do not place battery into a microwave oven or dryer.
- Battery usage by children should be supervised.
- Please follow local regulations to properly dispose of used re-chargeable batteries.
- Do not dispose of batteries in fire.
- In the event of a battery leak, do not allow the liquid to come in contact with the skin or eyes. If contact has been made, wash the affected area with large amounts of water and seek medical advice.
- If you suspect damage to your equipment or battery, contact Motorola Enterprise Mobility support to arrange for inspection.

Storage

When storing the MC9500-K for long periods it is recommended to remove the main battery and place the device in storage mode. This disconnects the backup battery preventing it from completely discharging while being stored.

1. Ensure that the backup battery is fully charged.
2. Remove the main battery.
3. Simultaneously press the 1, 9 and Power keys for three seconds.

The backup battery charge level should be verified at least once a year and charged to full charge.

Cleaning



CAUTION Always wear eye protection.

Read warning label on compressed air and alcohol product before using.

If you have to use any other solution for medical reasons please contact Motorola for more information.



WARNING! Avoid exposing this product to contact with hot oil or other flammable liquids. If such exposure occurs, unplug the device and clean the product immediately in accordance with these guidelines.

Materials Required

- Alcohol wipes
- Lens tissue
- Cotton tipped applicators
- Isopropyl alcohol
- Can of compressed air with a tube.

Cleaning the MC9500-K

Housing

Using the alcohol wipes, wipe the housing including keys and in-between keys.

Display

The display can be wiped down with the alcohol wipes, but care should be taken not to allow any pooling of liquid around the edges of the display. Immediately dry the display with a soft, non-abrasive cloth to prevent streaking.

Scanner Exit Window

Wipe the scanner exit window periodically with a lens tissue or other material suitable for cleaning optical material such as eyeglasses.

Interface Connector

1. Remove the battery from MC9500-K. See *Replacing the Battery* on page 1-8.
2. Dip the cotton portion of the cotton tipped applicator in isopropyl alcohol.
3. Rub the cotton portion of the cotton tipped applicator back-and-forth across the interface connector on the back of the MC9500-K. Do not leave any cotton residue on the connector.
4. Repeat at least three times.
5. Use the cotton tipped applicator dipped in alcohol to remove any grease and dirt near the connector area.
6. Use a dry cotton tipped applicator and repeat steps 3 through 5.

7. Spray compressed air on the connector area by pointing the tube/nozzle about ½ inch away from the surface. CAUTION: Do not point nozzle at yourself and others, ensure the nozzle or tube is away from your face.
8. Inspect the area for any grease or dirt, repeat if required.
9. Replace the battery.

Battery Contacts

1. Remove the battery from MC9500-K. See *Replacing the Battery on page 1-8*.
2. Dip the cotton portion of the cotton tipped applicator in isopropyl alcohol.
3. Rub the cotton portion of the cotton tipped applicator back-and-forth across the battery contacts on the back of the battery. Do not leave any cotton residue on the contacts.
4. Repeat at least three times.
5. Use the cotton tipped applicator dipped in alcohol to remove any grease and dirt near the contact area.
6. Use a dry cotton tipped applicator and repeat steps 3 through 5.
7. Spray compressed air on the contact area by pointing the tube/nozzle about ½ inch away from the surface. CAUTION: Do not point nozzle at yourself and others, ensure the nozzle or tube is away from your face.
8. Inspect the area for any grease or dirt, repeat if required.
9. Replace the battery in the MC9500-K.

Cleaning Cradle Connectors

To clean the connectors on a cradle:

1. Remove the DC power cable from the cradle.
2. Dip the cotton portion of the cotton tipped applicator in isopropyl alcohol.
3. Rub the cotton portion of the cotton tipped applicator along the pins of the connector(s). Slowly move the applicator back-and-forth from one side of the connector to the other. Do not let any cotton residue on the connector.
4. All sides of the connector should also be rubbed with the cotton tipped applicator.
5. Spray compressed air in the connector area by pointing the tube/nozzle about ½ inch away from the surface. CAUTION: do not point nozzle at yourself and others, ensure the nozzle or tube is pointed away from your face.
6. Ensure that there is no lint left by the cotton tipped applicator, remove lint if found.
7. If grease and other dirt can be found on other areas of the cradle, use lint free cloth and alcohol to remove.
8. Allow at least 10 to 30 minutes (depending on ambient temperature and humidity) for the alcohol to air dry before applying power to cradle.

If the temperature is low and humidity is high, longer drying time is required. Warm temperature and dry humidity requires less drying time.

Cleaning Frequency

The cleaning frequency is up to the customer's discretion due to the varied environments in which the mobile devices are used. They may be cleaned as frequently as required. However when used in dirty environments it may be advisable to periodically clean the scanner exit window to ensure optimum scanning performance.

Troubleshooting

MC9500-K

Table 9-1 Troubleshooting the MC9500-K

Problem	Cause	Solution
MC9500-K does not turn on.	Battery not charged.	Charge or replace the battery in the MC9500-K.
	Battery not installed properly.	Install the battery properly. See <i>Installing the Battery</i> on page 1-6.
	System crash.	Perform a warm boot. If the MC9500-K still does not turn on, perform a cold boot. See <i>Resetting the MC9500-K</i> on page 3-3.
Battery did not charge.	Battery failed.	Replace battery. If the MC9500-K still does not operate, perform a warm boot, then a cold boot. See <i>Resetting the MC9500-K</i> on page 3-3.
	No power to cradle or cable.	Ensure that power is applied to the cradle or cable. The Battery Status LED flashes amber to indicate that the MC9500-K is charging.
	MC9500-K removed from cradle while battery was charging.	Place the MC9500-K onto the cradle. The 4800 mAh battery fully charges in less than six hours.
	Extreme battery temperature.	Battery does not charge if ambient temperature is below 0°C (32°F) or above 40°C (104°F).
	MC9500-K not functioning.	Perform a warm boot. If the MC9500-K still does not turn on, perform a cold boot. See <i>Resetting the MC9500-K</i> on page 3-3.
Cannot see characters on display.	MC9500-K not powered on.	Press the Power button.
During data communication, no data transmitted, or transmitted data was incomplete.	MC9500-K removed from cradle or disconnected from host computer during communication.	Replace the MC9500-K onto the cradle, or reattach the communication cable and re-transmit.
	Incorrect cable configuration.	See the system administrator.
	Communication software was incorrectly installed or configured.	Perform setup. Chapter 2, Accessories for details.
No sound.	Volume setting is low or turned off.	Adjust the volume. See <i>Adjusting Volume</i> on page 3-20.

Table 9-1 Troubleshooting the MC9500-K (Continued)

Problem	Cause	Solution
MC9500-K shuts off.	MC9500-K is inactive.	The MC9500-K turns off after a period of inactivity. If the MC9500-K is running on battery power, set this period from 1 to 5 minutes, in one-minute intervals. If the MC9500-K is running on external power, set this period to 1, 2, 5, 10, 15, or 30 minutes. Check the Power window by selecting Start > Settings > System tab and tapping the Power icon. Select the Advanced tab and change the setting for a longer delay before the automatic shutoff feature activates.
	Battery is depleted.	Replace the battery.
	Battery is not inserted properly.	Insert the battery properly. See <i>Installing the Battery on page 1-6</i> .
After the MC9500-K suspends due to inactivity, the device wakes upon movement.	IST is set to wake the device when motion is detected.	Disable Wake on Motion feature in IST. See Chapter 7, Interactive Sensor Technology Configuration for more information.
The MC9500-K does not go into suspend mode upon inactivity.	IST is set to keep the device from going into suspend mode if motion is detected.	Disable Keep Alive on Motion feature in IST. See Chapter 7, Interactive Sensor Technology Configuration for more information.
Tapping the window buttons or icons does not activate the corresponding feature.	Screen is not calibrated correctly.	Re-calibrate the screen. Press the CTRL key then the BKSP key to open the calibration screen.
	The MC9500-K is not responding.	Warm boot the MC9500-K. See <i>Resetting the MC9500-K on page 3-3</i> .
A message appears stating that the MC9500-K memory is full.	Too many files stored on the MC9500-K.	Delete unused memos and records. If necessary, save these records on the host computer (or use an microSD card for additional memory).
	Too many applications installed on the MC9500-K.	Remove user-installed applications on the MC9500-K to recover memory. Select Start > Settings > System tab and tap the Remove Programs icon. Select the unused program and tap Remove .
The Battery Status LED flashes with the Power button is pressed and the MC9500-K does not turn on.	The MC9500-K's battery is low.	Recharge the battery.
The red Decode LED turns on and then off when the Power button is pressed.	Indicates that it is safe to remove the battery.	Normal operation.

Table 9-1 Troubleshooting the MC9500-K (Continued)

Problem	Cause	Solution
Camera application does not launch.	DataWedge application running.	Stop DataWedge application. Tap Start > Settings > System > Task Manager . Select DataWedge application and tap End Task .
The MC9500-K does not decode with reading bar code.	Scanning application is not loaded.	Load a scanning application on the MC9500-K. See your system administrator.
	Unreadable bar code.	Ensure the symbol is not defaced.
	Distance between exit window and bar code is incorrect.	Place the MC9500-K within proper scanning range.
	MC9500-K is not programmed for the bar code.	Program the MC9500-K to accept the type of bar code being scanned. Refer to the EMDK or Control Panel application.
	MC9500-K is not programmed to generate a beep.	If the MC9500-K does not beep on a good decode, set the application to generate a beep on good decode.
	Battery is low.	If the scanner stops emitting a laser beam upon a trigger press, check the battery level. When the battery is low, the scanner shuts off before the MC9500-K low battery condition notification. Note: If the scanner is still not reading symbols, contact the distributor or Motorola.

Bluetooth Connection

Table 9-2 Troubleshooting Bluetooth Connection

Problem	Cause	Solution
MC9500-K cannot find any Bluetooth devices nearby.	Too far from other Bluetooth devices.	Move closer to the other Bluetooth device(s), within a range of 10 meters.
	The Bluetooth device(s) nearby are not turned on.	Turn on the Bluetooth device(s) to find.
	The Bluetooth device(s) are not in discoverable mode.	Set the Bluetooth device(s) to discoverable mode. If needed, refer to the device's user documentation for help.
When trying to connect a Bluetooth phone and MC9500-K, the phone thinks a previously paired MC9500-K is used.	The phone remembers the name and address of the MC9500-K it last paired with via the Bluetooth radio.	Manually delete the pairing device and name from the phone. Refer to the phone's user documentation for instructions.

Single Bay USB Cradle

Table 9-3 Troubleshooting the Single Bay USB Cradle

Symptom	Possible Cause	Action
MC9500-K battery is not charging.	MC9500-K was removed from cradle or cradle was unplugged from AC power too soon.	Ensure cradle is receiving power. Ensure MC9500-K is seated correctly. Confirm main battery is charging under Start > Settings > System > Power . The 4800 mAh battery fully charges in less than six hours.
	Battery is faulty.	Verify that other batteries charge properly. If so, replace the faulty battery.
	No power to cradle.	Ensure that power is applied to the cradle. The Battery Status LED flashes amber to indicate that the MC9500-K is charging.
	The MC9500-K is not fully seated in the cradle.	Remove and re-insert the MC9500-K onto the cradle properly.
	Extreme battery temperature.	Battery does not charge if ambient temperature is below 0°C (32°F) or above 40°C (104°F).
	Single Bay USB Cradle is not functioning properly.	Replace the Single Bay USB Cradle.
During data communication, no data transmits, or transmitted data was incomplete.	MC9500-K removed from cradle during communications.	Replace MC9500-K in cradle and retransmit.
	Communication software is not installed or configured properly.	Perform setup as described in Chapter 2, Accessories .
	Incorrect USB Sync cable.	Ensure that the correct USB Sync cable is used. See Chapter 2, Accessories for more information.

Single Slot Battery Charger

Table 9-4 *Single Slot Battery Charger*

Symptom	Possible Cause	Action
Spare battery is not charging.	Battery not fully seated in charging slot.	Remove and re-insert the spare battery in the cradle, ensuring it is properly seated.
	Battery inserted incorrectly.	Re-insert the battery so the charging contacts on the battery align with the contacts on the cradle.
	Battery is faulty.	Verify that other batteries charge properly. If so, replace the faulty battery.
	No power to charger.	Ensure that power is applied to the charger. The Battery Status LED flashes amber to indicate that the battery is charging.
	Single Slot Battery Charger is not functioning properly.	Replace the Single Slot Battery Charger.

Four Bay Ethernet Cradle

Table 9-5 *Troubleshooting the Four Bay Ethernet Cradle*

Symptom	Cause	Solution
During communication, no data transmits, or transmitted data was incomplete.	MC9500-K removed from cradle during communications.	Replace MC9500-K in cradle and retransmit.
	MC9500-K has no active connection.	The Link LED flashes yellow if there is an active connection. See <i>Four Bay Ethernet Cradle</i> on page 8-9.

Table 9-5 *Troubleshooting the Four Bay Ethernet Cradle (Continued)*

Symptom	Cause	Solution
Battery is not charging.	MC9500-K removed from the cradle too soon.	Replace the MC9500-K in the cradle. The 4800 mAh battery fully charges in less than six hours. Tap Start > Settings > System > Power to view battery status.
	Battery is faulty.	Verify that other batteries charge properly. If so, replace the faulty battery.
	No power to cradle.	Ensure that power is applied to the cradle. The Battery Status LED flashes amber to indicate that the MC9500-K is charging.
	MC9500-K is not inserted correctly in the cradle.	Remove the MC9500-K and reinsert it correctly. Verify charging is active. Tap Start > Settings > System > Power to view battery status.
	Ambient temperature of the cradle is too warm.	Move the cradle to an area where the ambient temperature is between 0°C (32°F) and 35°C (95°F).
	Single Four Bay Ethernet Cradle is not functioning properly.	Replace the Four Bay Ethernet Cradle.

Four Bay Charge Only Cradle

Table 9-6 *Troubleshooting the Four Bay Ethernet Cradle*

Symptom	Cause	Solution
Battery is not charging.	MC9500-K removed from the cradle too soon.	Replace the MC9500-K in the cradle. The 4800 mAh battery fully charges in less than six hours. Tap Start > Settings > System > Power to view battery status.
	Battery is faulty.	Verify that other batteries charge properly. If so, replace the faulty battery.
	No power to cradle.	Ensure that power is applied to the cradle. The Battery Status LED flashes amber to indicate that the MC9500-K is charging.
	MC9500-K is not inserted correctly in the cradle.	Remove the MC9500-K and reinsert it correctly. Verify charging is active. Tap Start > Settings > System > Power to view battery status.
	Ambient temperature of the cradle is too warm.	Move the cradle to an area where the ambient temperature is between 0°C (32°F) and 35°C (95°F).
	Four Bay Charge Only Cradle is not functioning properly.	Replace the Four Bay Charge Only Cradle.

Four Slot Battery Charger

Table 9-7 Troubleshooting The Four Slot Battery Charger

Symptom	Possible Cause	Action
Battery not charging.	Battery was removed from the charger or charger was unplugged from AC power too soon.	Re-insert the battery in the charger or re-connect the charger's power supply. The 4800 mAh battery fully charges in less than six hours.
	Battery is faulty.	Verify that other batteries charge properly. If so, replace the faulty battery.
	No power to charger.	Ensure that power is applied to the charger. The Battery Status LED flashes amber to indicate that the battery is charging.
	Battery contacts not connected to charger.	Verify that the battery is seated in the battery well correctly with the contacts facing down.
	Four Slot Battery Charger is not functioning properly.	Replace the Four Slot Battery Charger.

Cables

Table 9-8 Troubleshooting the Cables

Symptom	Possible Cause	Action
MC9500-K battery is not charging.	MC9500-K was disconnected from AC power too soon.	Connect the power cable correctly. Confirm main battery is charging under Start > Settings > System > Power . The 4800 mAh battery fully charges in less than six hours.
	Battery is faulty.	Verify that other batteries charge properly. If so, replace the faulty battery.
	No power to cable.	Ensure that power is applied to the cable. The Battery Status LED flashes amber to indicate that the battery is charging.
	The MC9500-K is not fully attached to power.	Detach and re-attach the power cable to the MC9500-K, ensuring it is firmly connected.
	Cable is not functioning properly.	Replace the cable.

Table 9-8 *Troubleshooting the Cables (Continued)*

Symptom	Possible Cause	Action
During data communication, no data transmits, or transmitted data was incomplete.	Cable was disconnected from MC9500-K during communications.	Re-attach the cable and retransmit.
	Incorrect cable configuration.	See the system administrator.
	Communication software is not installed or configured properly.	Perform setup as described in Chapter 2, Accessories .

Magnetic Stripe Reader

Table 9-9 *Troubleshooting the Magnetic Stripe Reader*

Symptom	Possible Cause	Action
MSR cannot read card.	MSR removed from MC9500-K during card swipe.	Reattach MSR to MC9500-K and reswipe the card.
	Faulty magnetic stripe on card.	See the system administrator.
	MSR application is not installed or configured properly.	Ensure the MSR application is installed on the MC9500-K. Ensure the MSR application is configured correctly.
MC9500-K battery is not charging.	MC9500-K was removed from MSR or MSR was unplugged from AC power too soon.	Ensure the MSR is attached correctly.
	Battery is faulty.	Verify that other batteries charge properly. If so, replace the faulty battery.
	The MC9500-K is not fully attached to the MSR.	Detach and re-attach the MSR to the MC9500-K, ensuring it is firmly connected.
	MSR is faulty.	Replace MSR.
During data communication, no data transmits, or transmitted data was incomplete.	MC9500-K detached from MSR during communications.	Reattach MC9500-K to MSR and retransmit.
	Communication software is not installed or configured properly.	Perform setup as described in Chapter 2, Accessories .

Appendix A Technical Specifications

MC9500-K Technical Specifications

The following tables summarize the mobile computer's intended operating environment and technical hardware specifications.

MC9500-K

Table A-1 MC9500-K Technical Specifications

Item	Description
Physical Characteristics	
Dimensions	Height: 23.36 cm (9.2 in.) Depth: 5.08 cm (2.0 in.) Width: 8.89 cm (3.5 in.)
Weight	623.7 g (22 oz.)
Display	Transflective color 3.7" VGA with backlight, TFT-LCD, 65K colors, 480 pixels W x 640 pixels L
Touch Panel	Polycarbonate analog resistive touch
Backlight	LED backlight
Battery	Rechargeable Lithium Ion 3.7V, 4800 mAh Smart battery
Expansion Slot	User accessible microSD slot. Supports up to 16 GB cards.
Network Connections	High-speed USB client, full-speed USB host
Notification	Programmable LED, audio notifications and vibrator alerts.
Keypad Options	Alpha Primary Alpha Numeric Calculator Numeric Telephony Numeric

Table A-1 MC9500-K Technical Specifications (Continued)

Item	Description
Audio	VoWWAN; VoWLAN; TEAM Express compliant, rugged audio connector; high-quality speakerphone; headset (wired or Bluetooth) and handset and speaker phone modes.
Performance Characteristics	
CPU	Marvell PXA320 processor at 806 MHz
Operating System	MC9590: Microsoft® Windows Mobile™ 6.1 Classic MC9596 and MC9598: Microsoft® Windows Mobile™ 6.1 Professional
Memory	128 MB RAM/512MB Flash
Interface	USB 2.0 Client/USB 1.1 Host
Output Power	USB: 5 VDC @ 200 mA max.
User Environment	
Operating Temperature	-20°C to 50°C (-4°F to 122°F)
Storage Temperature	-40°C to 70°C (-40°F to 158°F)
Charging Temperature	32°F to 104°F / 0° C to 40° C
Humidity	5 - 95% non-condensing
Drop Specification	1.8 m (6 ft.) drop to concrete across the operating temperature range; meets and exceeds applicable MIL-STD-810G drop specifications.
Tumble	2000 1 m (3.2 ft.) tumbles (4,000 hits) at room temperature; meets and exceeds applicable IEC tumble specifications.
Electrostatic Discharge (ESD)	+/-15kVdc air discharge, +/-8kVdc direct discharge, +/-8kVdc indirect discharge
Sealing	IP67 sealing; meets and exceeds applicable IEC sealing specifications.
Wireless WAN Data and Voice Communications	
Wireless Wide Area Network (WWAN) radios	MC9596: GSM: GPRS/HSDPA (850, 900, 1800, 1900 and 2100 MHz) MC9598: CDMA: EvDO Rev. A (850 and 1900MHz)
Wireless LAN Data and Voice Communications	
Wireless Local Area Network (WLAN) radio	Tri-mode IEEE® 802.11a/b/g
Data Rates Supported	1, 2, 5.5, 6, 9, 11, 12, 18, 24, 36, 48, and 54 Mbps
Operating Channels	Chan 1-13 (2412-2472 MHz), Chan 14 (2484 MHz) Japan only; actual operating channels/frequencies depend on regulatory rules and certification agency

Table A-1 MC9500-K Technical Specifications (Continued)

Item	Description
WLAN Security	TKIP, AES, WPA (Personal or Enterprise), WPA2 (Personal or Enterprise), 802.1x, EAP-TLS, TTLS (CHAP, MS-CHAP, MS-CHAPv2, PAP or MD5), PEAP (TLS, MSCHAPv2, EAP-GTC), LEAP, EAP-FAST (TLS, MS-CHAPv2, EAP-GTC), CCXv4 certified, support for IPv6, FIPS140-2 certified
Spreading Technique	Direct Sequence Spread Spectrum (DSSS) and Orthogonal Frequency Division Multiplexing (OFDM)
Antenna	Internal with diversity
Voice Communication	Voice-over-IP ready (with P2P, PBX, PTT clients), Wi-Fi™-certified, IEEE 802.11 a/b/g direct sequence wireless LAN, Wi-Fi Multimedia (WMM), Motorola Voice Quality manager (VQM)
Wireless PAN Data and Voice Communications	
Bluetooth	Class II, v 2.1 with EDR; internal antenna.
Regulatory	
Electrical Safety	IEC/UL/CSA/EN 60950-1
Environmental	RoHS-compliant
WLAN and Bluetooth (PAN)	USA: FCC Part 15.247, 15.407 Canada: RSS-210 EU: EN 300 328, EN 301 893 Japan: ARIB STD-T33, T66, T70, T71 Australia: AS/NZS 4268s
Wireless Wide Area Network	GSM-HSDPA Global: 3GPP TS 51.010, 3GPP TS 34.121, 3GPP TS 34.123, GCF approved module USA: FCC Part 22, Part 24 Canada: RSS-132, RSS-133 EU: EN 301 511, EN 301 908 Australia: AS/ACIF S 024 CDMA-EvDO Rev A USA: FCC Part 22, Part 24 Canada: RSS-129, RSS-133 HAC compliant
RF Exposure	USA: FCC Part 2, FCC OET Bulletin 65 Supplement C Canada: RSS-102 EU: EN 50360 Japan: ARIB STD T56 Australia: Radio communications Standard 2003

Table A-1 MC9500-K Technical Specifications (Continued)

Item	Description
EMI/RFI	USA: FCC Part 15, Class B Canada: ICES 003 Class B EU: EN55022 Class B, EN55024, EN 301 489-1, EN 301 489-7, EN 301 489-17, EN 301 489-19, EN 301 489-24, EN 60601-1-2, EN 50121-3-2, EN 50121-4 Australia: AS/NZS CISPR-22
Laser Safety	IEC/Class 2/FDA Class II in accordance with IEC60825-1/EN60825-1
Data Capture Specifications	
Options	1D laser scanner 2D imager 1D laser scanner and color camera 2D imager and color camera
Linear 1D Scanner (SE950) Specifications	
Optical Resolution	4mil minimum element width
Roll	+/- 35° from vertical
Pitch Angle	+/- 65° from normal
Skew Tolerance	+/- 50° from normal
Ambient Light	10,000 ft. candles (107,640 Lux)
Shock	2,000 +/- 5% G
Scan Rate	104 (+/- 12) scans/sec (bidirectional)
Scan Angle	47° +/- 5° (typical); 35° +/- 3° reduced
2D Imager Engine (SE4500) Specifications	
Field of View	Horizontal - 40° Vertical - 25°
Optical Resolution	752 H x 480 V pixels (gray scale)
Roll	360°
Pitch Angle	+/- 60° from normal
Skew Tolerance	+/- 60° from normal
Ambient Light	9,000 ft. candles (96,900 Lux)
Shock	2,000 +/- 5% G
Focal Distance from Front of Engine	Near: 5 inches Far: 9 inches
Aiming Element (VLD)	655 nm +/- 10 nm

Table A-1 MC9500-K Technical Specifications (Continued)

Item	Description
Illumination Element (LED)	625 nm +/- 5 nm LEDs (2x)
Camera Specifications	
Resolution	2 Mega pixel with flash and auto focus.

Table A-2 Data Capture Options

Item	Description		
Laser Decode Capability	Code 39 Codabar Interleaved 2 of 5 MSI UPC/EAN supplementals Webcode GS1 DataBar Truncated GS1 DataBar Expanded GS1 DataBar Stacked Omni	Code 128 Code 11 EAN-8 UPCA Coupon Code Chinese 2 of 5 GS1 DataBar Limited GS1 DataBar Expanded Stacked	Code 93 Discrete 2 of 5 EAN-13 UPCE Trioptic 39 GS1 DataBar GS1 DataBar Stacked

Table A-2 *Data Capture Options (Continued)*

Item	Description		
Imaging Decode Capability	Code 39 Codabar Discrete 2 of 5 EAN-13 UPC/EAN supplementals Webcode Composite C Macro PDF-417 Data Matrix US Planet Canadian 4-state Chinese 2 of 5 microQR GS1 DataBar Truncated GS1 DataBar Expanded GS1 DataBar Stacked Omni	Code 128 Code 11 MSI UPCA Coupon Code TLC39 Micro PDF-417 (Macro) Micro PDF-417 Maxi Code UK 4-state Japanese 4-state USPS 4-state (US4CB) GS1 DataBar GS1 DataBar Limited GS1 DataBar Expanded Stacked	Code 93 Interleaved 2 of 5 EAN-8 UPCE Trioptic 39 Composite AB PDF-417 QR Code US Postnet Australian 4-state Dutch Kix Aztec GS1 DataBar Stacked
Camera Decode Capability	Code 39 Codabar Discrete 2 of 5 EAN-13 UPC/EAN supplementals Webcode Composite C Macro PDF-417 Data Matrix US Planet Canadian 4-state GS1 DataBar GS1 DataBar Truncated GS1 DataBar Expanded GS1 DataBar Stacked Omni	Code 128 Code 11 MSI UPCA Coupon Code TLC39 Micro PDF-417 (Macro) Micro PDF-417 Maxi Code UK 4-state Japanese 4-state GS1 DataBar Limited GS1 DataBar Expanded Stacked	Code 93 Interleaved 2 of 5 EAN-8 UPCE Trioptic 39 Composite AB PDF-417 QR Code US Postnet Australian 4-state Dutch Kix GS1 DataBar Stacked

MC9500-K Accessory Specifications

Single Bay USB Cradle

Table A-3 Single Bay USB Cradle Technical Specifications

Feature	Description
Dimensions	Height: 15.45 cm (6.08 in.) Width: 12.00 cm (4.72 in.) Depth: 18.90 cm (7.44 in.)
Weight	430 g (15.2 oz)
Input Power	12 VDC
Power Consumption	22 watts
Interface	USB
Operating Temperature	0°C to 50°C (32°F to 122°F)
Storage Temperature	-40°C to 70°C (-40°F to 158°F)
Charging Temperature	0°C to 40°C (32°F to 104°F)
Humidity	5% to 95% non-condensing
Drop	76.2 cm (30.0 in.) drops to vinyl tiled concrete at room temperature
Electrostatic Discharge (ESD)	+/- 15 kV air +/- 8 kV contact

Single Slot Battery Charger

Table A-4 Single Slot Battery Charger Technical Specifications

Feature	Description
Dimensions	Height: 11.15 cm (4.39 in.) Width: 7.70 cm (3.03 in.) Depth: 9.95 cm (3.92 in.)
Weight	105 g (3.7 oz)
Input Power	12 VDC
Power Consumption	4.7 watts
Interface	USB
Operating Temperature	0°C to 40°C (32°F to 104°F)
Storage Temperature	-40°C to 70°C (-40°F to 158°F)

Table A-4 Single Slot Battery Charger Technical Specifications (Continued)

Feature	Description
Charging Temperature	0°C to 40°C (32°F to 104°F)
Humidity	5% to 95% non-condensing
Drop	76.2 cm (30.0 in.) drops to vinyl tiled concrete at room temperature
Electrostatic Discharge (ESD)	+/- 15 kV air +/- 8 kV contact

Four Bay Ethernet Cradle

Table A-5 Four Bay Ethernet Cradle Technical Specifications

Feature	Description
Dimensions	Height: 11.3 cm (4.45 in.) Width: 45.7 cm (18.00 in.) Depth: 5.6 cm (2.20 in.)
Weight	735 g (1.47 lb)
Input Power	12 VDC
Power Consumption	88 watts
Interface	Ethernet
Operating Temperature	0°C to 50°C (32°F to 122°F)
Storage Temperature	-40°C to 70°C (-40°F to 158°F)
Charging Temperature	0°C to 40°C (32°F to 104°F)
Humidity	5% to 95% non-condensing
Drop	76.2 cm (30.0 in.) drops to vinyl tiled concrete at room temperature
Electrostatic Discharge (ESD)	+/- 15 kV air +/- 8 kV contact

Four Bay Charge Only Cradle

Table A-6 *Four Bay Charge Only Cradle Technical Specifications*

Feature	Description
Dimensions	Height: 11.3 cm (4.45 in.) Width: 45.7 cm (18.00 in.) Depth: 5.6 cm (2.20 in.)
Weight	705 g (1.41 lb)
Input Power	12 VDC
Power Consumption	88 watts
Operating Temperature	0°C to 50°C (32°F to 122°F)
Storage Temperature	-40°C to 70°C (-40°F to 158°F)
Charging Temperature	0°C to 40°C (32°F to 104°F)
Humidity	5% to 95% non-condensing
Drop	76.2 cm (30.0 in.) drops to vinyl tiled concrete at room temperature
Electrostatic Discharge (ESD)	+/- 15 kV air +/- 8 kV contact

Four Slot Battery Charger

Table A-7 *Four Slot Battery Charger Technical Specifications*

Feature	Description
Dimensions	Height: 3.47 cm (1.37 in.) Width: 15.50 cm (6.10 in.) Depth: 21.00 cm (8.27 in.)
Weight	386 g (13.6 oz)
Input Power	12 VDC
Power Consumption	19 watts
Operating Temperature	0°C to 40°C (32°F to 104°F)
Storage Temperature	-40°C to 70°C (-40°F to 158°F)
Charging Temperature	0°C to 40°C (32°F to 104°F)

Table A-7 Four Slot Battery Charger Technical Specifications (Continued)

Feature	Description
Humidity	5% to 95% non-condensing
Drop	76.2 cm (30.0 in.) drops to vinyl tiled concrete at room temperature
Electrostatic Discharge (ESD)	+/- 15 kV air +/- 8 kV contact

Magnetic Stripe Reader

Table A-8 Magnetic Stripe Reader (MSR) Technical Specifications

Feature	Description
Dimensions	Height: 3.56 cm (1.4 in.) Width: 8.38 cm (3.3 in.) Depth: 7.87 cm (3.1 in.)
Weight	48 g (1.7 oz)
Interface	Serial with baud rate up to 19,200
Format	ANSI, ISO, AAMVA, CA DMV, user-configurable generic format
Swipe Speed	5 to 50 in. (127 to 1270 mm) /sec, bi-directional
Decoders	Generic, Raw Data
Mode	Buffered, unbuffered
Track Reading Capabilities	Tracks 1 and 3: 210 bpi Track 2: 75 and 210 bpi, autodetect
Operating Temperature	0°C to 50°C (32°F to 122°F)
Storage Temperature	-40°C to 70°C (-40°F to 158°F)
Humidity	5% to 95% non-condensing
Drop	1.22 m (4 ft.) drops to concrete
Electrostatic Discharge (ESD)	+/- 15 kV air +/- 8 kV contact

Appendix B Special Software Configurations

Battery Usage Threshold Setting

By default the Battery Usage Threshold value is set to a pre-defined value (400 by default). To change the threshold value, a registry key must be created to allow changing this value.

A battery becomes unhealthy when the *Battery Usage Indication* reach a predefined threshold (end of usable life).



NOTE The point at which a battery becomes unhealthy may vary depending upon the environment and charging conditions

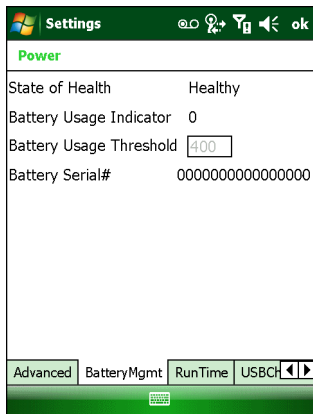

Figure B-1 Power BatteryMgmt Tab

Registry Setting

Create the following registry key:

```
[HKEY_LOCAL_MACHINE\ControlPanel\Power]
```

```
    "EnableCycleCntThresholdEdit"=DWORD:0
```

where:

dword:0 = Enable threshold change

Warm boot the MC9500-K to have the registry setting take effect.

1. Tap **Start > Settings > Power > BatteryMgmt** tab.

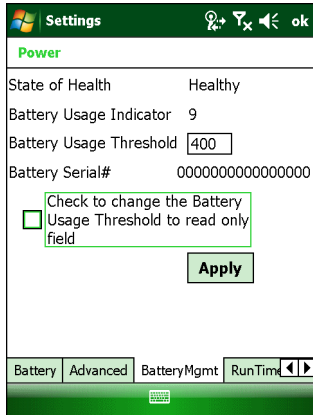

Figure B-2 BatteryMgmt Tab with Threshold Change Checkbox

2. In the **Battery Usage Threshold** text box, enter a new value.
3. Select the **Check to change the Battery Age Threshold to read only field** checkbox.
4. Tap **Apply**.
5. Tap **ok**. The new value is set and then the registry key is deleted.

Bluetooth Configuration Setting

The MC9500-K supports both the Microsoft Bluetooth stack and the StoneStreet One Bluetooth stack. Only one Bluetooth stack can be used at a time. By default, the Microsoft Bluetooth stack is enabled. A registry key on the MC9500-K can be modified to disable the Microsoft stack and enable the StoneStreet One stack.

Using a registry editor, navigate to the following:

```
[HKEY_LOCAL_MACHINE\Software\SymbolBluetooth
```

Edit the following key:

```
"SSStack"=dword:1
```

where:

- 0 = enable Microsoft stack and disable StoneStreet One stack (default)
- 1 = enable StoneStreet One stack and disable Microsoft stack

After setting the registry key, warm boot the MC9500-K.

Glossary

A

API. An interface by means of which one software component communicates with or controls another. Usually used to refer to services provided by one software component to another, usually via software interrupts or function calls

Aperture. The opening in an optical system defined by a lens or baffle that establishes the field of view.

Application Programming Interface. See **API**.

ANSI Terminal. A display terminal that follows commands in the ANSI standard terminal language. For example, it uses escape sequences to control the cursor, clear the screen and set colors. Communications programs support the ANSI terminal mode and often default to this terminal emulation for dial-up connections to online services.

ASCII. American Standard Code for Information Interchange. A 7 bit-plus-parity code representing 128 letters, numerals, punctuation marks and control characters. It is a standard data transmission code in the U.S.

Autodiscrimination. The ability of an interface controller to determine the code type of a scanned bar code. After this determination is made, the information content is decoded.

B

Bar. The dark element in a printed bar code symbol.

Bar Code. A pattern of variable-width bars and spaces which represents numeric or alphanumeric data in machine-readable form. The general format of a bar code symbol consists of a leading margin, start character, data or message character, check character (if any), stop character, and trailing margin. Within this framework, each recognizable symbology uses its own unique format. See **Symbology**.

Bar Code Density. The number of characters represented per unit of measurement (e.g., characters per inch).

Bar Height. The dimension of a bar measured perpendicular to the bar width.

Bar Width. Thickness of a bar measured from the edge closest to the symbol start character to the trailing edge of the same bar.

BIOS. Basic Input Output System. A collection of ROM-based code with a standard API used to interface with standard PC hardware.

Bit. Binary digit. One bit is the basic unit of binary information. Generally, eight consecutive bits compose one byte of data. The pattern of 0 and 1 values within the byte determines its meaning.

Bits per Second (bps). Bits transmitted or received.

BOOTP. A protocol for remote booting of diskless devices. Assigns an IP address to a machine and may specify a boot file. The client sends a bootp request as a broadcast to the bootp server port (67) and the bootp server responds using the bootp client port (68). The bootp server must have a table of all devices, associated MAC addresses and IP addresses.

boot or boot-up. The process a computer goes through when it starts. During boot-up, the computer can run self-diagnostic tests and configure hardware and software.

bps. See **Bits Per Second**.

Byte. On an addressable boundary, eight adjacent binary digits (0 and 1) combined in a pattern to represent a specific character or numeric value. Bits are numbered from the right, 0 through 7, with bit 0 the low-order bit. One byte in memory is used to store one ASCII character.

C

CDRH. Center for Devices and Radiological Health. A federal agency responsible for regulating laser product safety. This agency specifies various laser operation classes based on power output during operation.

CDRH Class 1. This is the lowest power CDRH laser classification. This class is considered intrinsically safe, even if all laser output were directed into the eye's pupil. There are no special operating procedures for this class.

CDRH Class 2. No additional software mechanisms are needed to conform to this limit. Laser operation in this class poses no danger for unintentional direct human exposure.

Character. A pattern of bars and spaces which either directly represents data or indicates a control function, such as a number, letter, punctuation mark, or communications control contained in a message.

Character Set. Those characters available for encoding in a particular bar code symbology.

Check Digit. A digit used to verify a correct symbol decode. The scanner inserts the decoded data into an arithmetic formula and checks that the resulting number matches the encoded check digit. Check digits are required for UPC but are optional for other symbologies. Using check digits decreases the chance of substitution errors when a symbol is decoded.

Codabar. A discrete self-checking code with a character set consisting of digits 0 to 9 and six additional characters: ("-", "\$", ".", "/", ",", "+").

Code 128. A high density symbology which allows the controller to encode all 128 ASCII characters without adding extra symbol elements.

Code 3 of 9 (Code 39). A versatile and widely used alphanumeric bar code symbology with a set of 43 character types, including all uppercase letters, numerals from 0 to 9 and 7 special characters (“-”, “.”, “/”, “+”, “%”, “\$” and space). The code name is derived from the fact that 3 of 9 elements representing a character are wide, while the remaining 6 are narrow.

Code 93. An industrial symbology compatible with Code 39 but offering a full character ASCII set and a higher coding density than Code 39.

Code Length. Number of data characters in a bar code between the start and stop characters, not including those characters.

Cold Boot. A cold boot restarts the mobile computer and erases all user stored records and entries.

COM port. Communication port; ports are identified by number, e.g., COM1, COM2.

Continuous Code. A bar code or symbol in which all spaces within the symbol are parts of characters. There are no intercharacter gaps in a continuous code. The absence of gaps allows for greater information density.

Cradle. A cradle is used for charging the terminal battery and for communicating with a host computer, and provides a storage place for the terminal when not in use.

D

Data Communications Equipment (DCE). A device (such as a modem) which is designed to attach directly to a DTE (Data Terminal Equipment) device.

DCE. See **Data Communications Equipment**.

DCP. See **Device Configuration Package**.

Dead Zone. An area within a scanner's field of view, in which specular reflection may prevent a successful decode.

Decode. To recognize a bar code symbology (e.g., UPC/EAN) and then analyze the content of the specific bar code scanned.

Decode Algorithm. A decoding scheme that converts pulse widths into data representation of the letters or numbers encoded within a bar code symbol.

Decryption. Decryption is the decoding and unscrambling of received encrypted data. Also see, **Encryption** and **Key**.

Depth of Field. The range between minimum and maximum distances at which a scanner can read a symbol with a certain minimum element width.

Device Configuration Package. The Symbol Device Configuration Package provides the Product Reference Guide (PRG), flash partitions, Terminal Configuration Manager (TCM) and the associated TCM scripts. With this package hex images that represent flash partitions can be created and downloaded to the mobile computer.

Discrete Code. A bar code or symbol in which the spaces between characters (intercharacter gaps) are not part of the code.

Discrete 2 of 5. A binary bar code symbology representing each character by a group of five bars, two of which are wide. The location of wide bars in the group determines which character is encoded; spaces are insignificant. Only numeric characters (0 to 9) and START/STOP characters may be encoded.

DRAM. Dynamic random access memory.

DTE. See **Data Terminal Equipment**.

E

EAN. European Article Number. This European/International version of the UPC provides its own coding format and symbology standards. Element dimensions are specified metrically. EAN is used primarily in retail.

Element. Generic term for a bar or space.

Encoded Area. Total linear dimension occupied by all characters of a code pattern, including start/stop characters and data.

ENQ (RS-232). ENQ software handshaking is also supported for the data sent to the host.

ESD. Electro-Static Discharge

F

File Transfer Protocol (FTP). A TCP/IP application protocol governing file transfer via network or telephone lines. See **TCP/IP**.

Flash Disk. An additional megabyte of non-volatile memory for storing application and configuration files.

Flash Memory. Flash memory is nonvolatile, semi-permanent storage that can be electronically erased in the circuit and reprogrammed. Series 9000 mobile computers use Flash memory to store the operating system (ROM-DOS), the terminal emulators, and the Citrix ICA Client for DOS.

FTP. See **File Transfer Protocol**.

H

Hard Reset. See **Cold Boot**.

Hz. Hertz; A unit of frequency equal to one cycle per second.

Host Computer. A computer that serves other terminals in a network, providing such services as computation, database access, supervisory programs and network control.

I

IDE. Intelligent drive electronics. Refers to the solid-state hard drive type.

IEC. International Electrotechnical Commission. This international agency regulates laser safety by specifying various laser operation classes based on power output during operation.

IEC (825) Class 1. This is the lowest power IEC laser classification. Conformity is ensured through a software restriction of 120 seconds of laser operation within any 1000 second window and an automatic laser shutdown if the scanner's oscillating mirror fails.

IEEE Address. See **MAC Address**.

Input/Output Ports. I/O ports are primarily dedicated to passing information into or out of the terminal's memory. Series 9500 mobile computers includes a USB ports.

Interleaved 2 of 5. A binary bar code symbology representing character pairs in groups of five bars and five interleaved spaces. Interleaving provides for greater information density. The location of wide elements (bar/spaces) within each group determines which characters are encoded. This continuous code type uses no intercharacter spaces. Only numeric (0 to 9) and START/STOP characters may be encoded.

Intercharacter Gap. The space between two adjacent bar code characters in a discrete code.

Interleaved Bar Code. A bar code in which characters are paired together, using bars to represent the first character and the intervening spaces to represent the second.

Internet Protocol Address. See **IP**.

IOCTL. Input/Output Control.

I/O Ports. interface The connection between two devices, defined by common physical characteristics, signal characteristics, and signal meanings. Types of interfaces include RS-232 and PCMCIA.

IP. Internet Protocol. The IP part of the TCP/IP communications protocol. IP implements the network layer (layer 3) of the protocol, which contains a network address and is used to route a message to a different network or subnetwork. IP accepts "packets" from the layer 4 transport protocol (TCP or UDP), adds its own header to it and delivers a "datagram" to the layer 2 data link protocol. It may also break the packet into fragments to support the maximum transmission unit (MTU) of the network.

IP Address. (Internet Protocol address) The address of a computer attached to an IP network. Every client and server station must have a unique IP address. A 32-bit address used by a computer on a IP network. Client workstations have either a permanent address or one that is dynamically assigned to them each session. IP addresses are written as four sets of numbers separated by periods; for example, 204.171.64.2.

IPX/SPX. Internet Package Exchange/Sequential Packet Exchange. A communications protocol for Novell. IPX is Novell's Layer 3 protocol, similar to XNS and IP, and used in NetWare networks. SPX is Novell's version of the Xerox SPP protocol.

IS-95. Interim Standard 95. The EIA/TIA standard that governs the operation of CDMA cellular service. Versions include IS-95A and IS-95B. See CDMA.

K

Key. A key is the specific code used by the algorithm to encrypt or decrypt the data. Also see, **Encryption** and **Decrypting**.

L

LASER. Light Amplification by Stimulated Emission of Radiation. The laser is an intense light source. Light from a laser is all the same frequency, unlike the output of an incandescent bulb. Laser light is typically coherent and has a high energy density.

Laser Diode. A semiconductor type of laser connected to a power source to generate a laser beam. This laser type is a compact source of coherent light.

laser scanner. A type of bar code reader that uses a beam of laser light.

LCD. See **Liquid Crystal Display**.

LED Indicator. A semiconductor diode (LED - Light Emitting Diode) used as an indicator, often in digital displays. The semiconductor uses applied voltage to produce light of a certain frequency determined by the semiconductor's particular chemical composition.

Light Emitting Diode. See **LED**.

Liquid Crystal Display (LCD). A display that uses liquid crystal sealed between two glass plates. The crystals are excited by precise electrical charges, causing them to reflect light outside according to their bias. They use little electricity and react relatively quickly. They require external light to reflect their information to the user.

M

MC. Mobile Computer.

MDN. Mobile Directory Number. The directory listing telephone number that is dialed (generally using POTS) to reach a mobile unit. The MDN is usually associated with a MIN in a cellular telephone -- in the US and Canada, the MDN and MIN are the same value for voice cellular users. International roaming considerations often result in the MDN being different from the MIN.

MIL. 1 mil = 1 thousandth of an inch.

MIN. Mobile Identification Number. The unique account number associated with a cellular device. It is broadcast by the cellular device when accessing the cellular system.

Misread (Misdecode). A condition which occurs when the data output of a reader or interface controller does not agree with the data encoded within a bar code symbol.

Mobile Computer. In this text, *mobile computer* refers to the Symbol Series 9000 wireless portable computer. It can be set up to run as a stand-alone device, or it can be set up to communicate with a network, using wireless radio technology.

N

Nominal. The exact (or ideal) intended value for a specified parameter. Tolerances are specified as positive and negative deviations from this value.

Nominal Size. Standard size for a bar code symbol. Most UPC/EAN codes are used over a range of magnifications (e.g., from 0.80 to 2.00 of nominal).

NVM. Non-Volatile Memory.

O

ODI. See **Open Data-Link Interface**.

Open Data-Link Interface (ODI). Novell's driver specification for an interface between network hardware and higher-level protocols. It supports multiple protocols on a single NIC (Network Interface Controller). It is capable of understanding and translating any network information or request sent by any other ODI-compatible protocol into something a NetWare client can understand and process.

Open System Authentication. Open System authentication is a null authentication algorithm.

P

PAN . Personal area network. Using Bluetooth wireless technology, PANs enable devices to communicate wirelessly. Generally, a wireless PAN consists of a dynamic group of less than 255 devices that communicate within about a 33-foot range. Only devices within this limited area typically participate in the network.

Parameter. A variable that can have different values assigned to it.

PC Card. A plug-in expansion card for laptop computers and other devices, also called a PCMCIA card. PC Cards are 85.6mm long x 54 mm wide, and have a 68 pin connector. There are several different kinds:

Type I; 3.3 mm high; use - RAM or Flash RAM

Type II; 5 mm high; use - modems, LAN adaptors

Type III; 10.5 high; use - Hard Disks

PCMCIA. Personal Computer Memory Card Interface Association. See **PC Card**.

Percent Decode. The average probability that a single scan of a bar code would result in a successful decode. In a well-designed bar code scanning system, that probability should approach near 100%.

PING. (Packet Internet Groper) An Internet utility used to determine whether a particular IP address is online. It is used to test and debug a network by sending out a packet and waiting for a response.

Print Contrast Signal (PCS). Measurement of the contrast (brightness difference) between the bars and spaces of a symbol. A minimum PCS value is needed for a bar code symbol to be scannable. $PCS = (RL - RD) / RL$, where RL is the reflectance factor of the background and RD the reflectance factor of the dark bars.

Programming Mode. The state in which a scanner is configured for parameter values. See **Scanning Mode**.

Q

Quiet Zone. A clear space, containing no dark marks, which precedes the start character of a bar code symbol and follows the stop character.

QWERTY. A standard keyboard commonly used on North American and some European PC keyboards. "QWERTY" refers to the arrangement of keys on the left side of the third row of keys.

R

RAM. Random Access Memory. Data in RAM can be accessed in random order, and quickly written and read.

Reflectance. Amount of light returned from an illuminated surface.

Resolution. The narrowest element dimension which is distinguished by a particular reading device or printed with a particular device or method.

RF. Radio Frequency.

ROM. Read-Only Memory. Data stored in ROM cannot be changed or removed.

Router. A device that connects networks and supports the required protocols for packet filtering. Routers are typically used to extend the range of cabling and to organize the topology of a network into subnets. See **Subnet**.

RS-232. An Electronic Industries Association (EIA) standard that defines the connector, connector pins, and signals used to transfer data serially from one device to another.

S

Scan Area. Area intended to contain a symbol.

Scanner. An electronic device used to scan bar code symbols and produce a digitized pattern that corresponds to the bars and spaces of the symbol. Its three main components are: 1) Light source (laser or photoelectric cell) - illuminates a bar code; 2) Photodetector - registers the difference in reflected light (more light reflected from spaces); 3) Signal conditioning circuit - transforms optical detector output into a digitized bar pattern.

Scanning Mode. The scanner is energized, programmed and ready to read a bar code.

Scanning Sequence. A method of programming or configuring parameters for a bar code reading system by scanning bar code menus.

SDK. Software Development Kit

Self-Checking Code. A symbology that uses a checking algorithm to detect encoding errors within the characters of a bar code symbol.

Shared Key. Shared Key authentication is an algorithm where both the AP and the MU share an authentication key.

SHIP. Symbol Host Interface Program.

SID. System Identification code. An identifier issued by the FCC for each market. It is also broadcast by the cellular carriers to allow cellular devices to distinguish between the home and roaming service.

SMDK. Symbol Mobility Developer's Kit.

Soft Reset. See **Warm Boot**.

Space. The lighter element of a bar code formed by the background between bars.

Specular Reflection. The mirror-like direct reflection of light from a surface, which can cause difficulty decoding a bar code.

Start/Stop Character. A pattern of bars and spaces that provides the scanner with start and stop reading instructions and scanning direction. The start and stop characters are normally to the left and right margins of a horizontal code.

STEP. Symbol Terminal Enabler Program.

Subnet. A subset of nodes on a network that are serviced by the same router. See **Router**.

Subnet Mask. A 32-bit number used to separate the network and host sections of an IP address. A custom subnet mask subdivides an IP network into smaller subsections. The mask is a binary pattern that is matched up with the IP address to turn part of the host ID address field into a field for subnets. Default is often 255.255.255.0.

Substrate. A foundation material on which a substance or image is placed.

SVTP. Symbol Virtual Terminal Program.

Symbol. A scannable unit that encodes data within the conventions of a certain symbology, usually including start/stop characters, quiet zones, data characters and check characters.

Symbol Aspect Ratio. The ratio of symbol height to symbol width.

Symbol Height. The distance between the outside edges of the quiet zones of the first row and the last row.

Symbol Length. Length of symbol measured from the beginning of the quiet zone (margin) adjacent to the start character to the end of the quiet zone (margin) adjacent to a stop character.

Symbology. The structural rules and conventions for representing data within a particular bar code type (e.g. UPC/EAN, Code 39, PDF417, etc.).

T

TCP/IP. (Transmission Control Protocol/Internet Protocol) A communications protocol used to internetwork dissimilar systems. This standard is the protocol of the Internet and has become the global standard for communications. TCP provides transport functions, which ensures that the total amount of bytes sent is received correctly at the other end. UDP is an alternate transport that does not guarantee delivery. It is widely used for real-time voice and video transmissions where erroneous packets are not retransmitted. IP provides the routing mechanism. TCP/IP is a routable protocol, which means that all messages contain not only the address of the destination station, but the address of a destination network. This allows TCP/IP messages to be sent to multiple networks within an organization or around the world, hence its use in the worldwide Internet. Every client and server in a TCP/IP network requires an IP address, which is either permanently assigned or dynamically assigned at startup.

Telnet. A terminal emulation protocol commonly used on the Internet and TCP/IP-based networks. It allows a user at a terminal or computer to log onto a remote device and run a program.

Terminal. See **Mobile Computer**.

Terminal Emulation. A "terminal emulation" emulates a character-based mainframe session on a remote non-mainframe terminal, including all display features, commands and function keys. The VC5000 Series supports Terminal Emulations in 3270, 5250 and VT220.

Terminate and Stay Resident (TSR). A program under DOS that ends its foreground execution to remain resident in memory to service hardware/software interrupts, providing background operation. It remains in memory and may provide services on behalf of other DOS programs.

TFTP. (Trivial File Transfer Protocol) A version of the TCP/IP FTP (File Transfer Protocol) protocol that has no directory or password capability. It is the protocol used for upgrading firmware, downloading software and remote booting of diskless devices.

Tolerance. Allowable deviation from the nominal bar or space width.

Transmission Control Protocol/Internet Protocol. See **TCP/IP**.

Trivial File Transfer Protocol. See **TFTP**.

TSR. See **Terminate and Stay Resident**.

U

UDP. User Datagram Protocol. A protocol within the IP protocol suite that is used in place of TCP when a reliable delivery is not required. For example, UDP is used for real-time audio and video traffic where lost packets are simply ignored, because there is no time to retransmit. If UDP is used and a reliable delivery is required, packet sequence checking and error notification must be written into the applications.

UPC. Universal Product Code. A relatively complex numeric symbology. Each character consists of two bars and two spaces, each of which is any of four widths. The standard symbology for retail food packages in the United States.

V

Visible Laser Diode (VLD). A solid state device which produces visible laser light.

W

Warm Boot. A warm boot restarts the mobile computer by closing all running programs. All data that is not saved to flash memory is lost.

Index

Numerics

4-way DC cable2-2, 2-16

A

accessories

4-way DC cable 2-2
auto charge cable 2-1
DC "Y" cable 2-2
desk mounting bracket 2-2
DEX cable 2-1
four bay charge only cradle 2-1
four bay Ethernet cradle 2-1
four slot battery charger 2-1
four slot Ethernet cradle 2-22
guide cups 2-2
handstrap 2-2
headset adapter cable 2-2
holster 2-2
magnetic stripe reader 2-2
MMC 1-2
modem adapter cable 2-2
MSR 2-27
 installation 2-27
 magnetic stripe reading 2-27
screen protector 2-2
SIM card 1-3
single bay USB cradle 2-1, 2-22
single slot battery charger 2-1
spare battery 2-2
specifications A-7
universal mounting bracket 2-5
universal wall mounting bracket 2-2
USB sync cable 2-2
USB/charge cable 2-1
vehicle battery charger 2-1

vehicle cradle 2-1
vehicle mounting bracket 2-2
activation
 CDMA 6-10
 Sprint CDMA 6-5
 Verizon CDMA 6-2, 6-3
ActiveSync 3-1
 deploying CAB files 4-4
 installing 3-1
 setting up a connection 3-2
AirBEAM
 deploying CAB files 4-5
APN 5-3
application deployment 4-1, 4-4
 CAB files 4-4
application folder 4-9
application packaging 4-4
application security 4-1
auto charge cable 2-1, 2-29

B

battery
 charging 1-5
 installing 1-5
battery charging 1-5
boot
 clean 1-8
 cold 1-7
 warm 1-7
bullets xv

C

CAB files 4-4, 4-7
 deployment via ActiveSync 4-4
 deployment via AirBEAM 4-5

- deployment via image update 4-5
- deployment via storage card 4-4
- cables
 - 4-way DC cable 2-2
 - auto charge cable 2-1
 - DC "Y" cable 2-2
 - DEX cable 2-1
 - headset adapter cable 2-2
 - modem adapter cable 2-2
 - USB sync cable 2-2
- cache disk 4-9
- calibrating the screen 1-7
- call barring 6-18
- call blocking See call barring 5-7
- call forwarding 5-8, 6-19
- call waiting 5-9, 6-19
- caller id 5-8, 6-19
- CDMA
 - activate Sprint 6-5
 - activate Verizon 6-2
 - activate Verizon automated 6-2, 6-3
 - data connection 6-10
 - settings
 - data, Sprint 6-13
 - data, Verizon 6-14
 - location 6-13
 - phone 6-12
 - phone info 6-18
 - provisioning 6-14
 - services 6-18, 6-19
 - system, Sprint 6-16
 - system, Verizon 6-17
 - test activation 6-10
- certificates 4-3
- changing a PIN for phone use 5-6
- charge only cradle 2-1
- charging temperature 1-6
- clean boot 1-8
- cleaning 9-1
- cold boot 1-7
- configuration xii
- conventions
 - notational xv
- copyfile 4-8
- cpf file 4-7
- cradles
 - daisy chaining 2-11
 - Ethernet drivers 2-12
 - four bay charge only
 - setup 2-14
 - four bay Ethernet
 - setup 2-10
 - four slot Ethernet 2-22
 - single bay USB 2-22

- setup 2-22
- universal mounting bracket 2-5
- creating cpf file 4-7
- creating splash screen 4-6

D

- data capture xii
- data connection 5-3, 6-10
- DC "Y" cable 2-2
- deployment 4-1, 4-4
 - CAB files 4-4
- desk mounting bracket 2-2
- DEX cable 2-1
- digital signatures 4-1
- disabling PIN for phone use 5-7
- display xii

E

- EMDK 4-9
- enabling PIN for phone use 5-6
- enhanced operator name string 5-14
- Enterprise Mobility Developer Kit 4-9
- EONS 5-14
- ESD 1-2
- Ethernet cradle 2-1, 2-22

F

- fabric holster 2-2
- flash file system
 - copyfile 4-8
 - regmerge 4-7
- four bay charge only cradle
 - setup 2-14
- four bay Ethernet cradle
 - daisy chaining 2-11
 - setup 2-10
- four slot battery charger 2-1
 - setup 2-15
- four slot Ethernet cradle
 - daisy chaining 2-11
 - drivers 2-12
 - link indicator 2-13
 - speed indicator 2-13

G

- GPRS
 - data connection 5-1, 5-3
 - registry file 5-3
 - settings
 - services 6-18

WAN configuration 5-3

GSM

- access point name 5-3
- configure GPRS data connection 5-1, 5-3
- ensuring network coverage 5-1, 5-2
- settings
 - networks 5-11
 - phone 5-5
 - phone info 5-13
 - PIN 5-6, 5-7
 - security 5-6
 - services 5-7, 5-8, 5-9
 - sound 5-5
- guide cups 2-2, 2-3

H

- handstrap 2-2
- hard reset 1-7, 1-8
- headset adapter cable 2-2
- holster 2-2

I

- image update
 - deploying CAB files 4-5
- information, service xvi
- installing battery 1-5
- internet
 - wireless connection 5-3, 6-10

K

- keypads xii

L

- lithium-ion battery 1-1
- locking EDA 4-2

M

- magnetic stripe reader 2-2, 2-27
 - installation 2-27
 - magnetic stripe reading 2-27
- main battery
 - charging 1-2
 - installing 1-2, 6-1
- maintenance 9-1
- memory xii
- MMC 1-2
- modem adapter cable 2-2
- MSR 2-27
 - installation 2-27

- magnetic stripe reading 2-27
- multi media card 1-2

N

- network
 - configuring GPRS WAN 5-3
 - GSM 5-11
- network coverage, GSM 5-1, 5-2
- notational conventions xv

O

- operating environment A-1
- operating system xii

P

- packaging 4-4
- persistent storage 4-9
- phone
 - activation 6-2, 6-3, 6-5
 - phone activation 6-10
 - phone security 5-6, 5-7
 - phone settings 5-5
 - PIN, changing for phone 5-6
 - PIN, disabling for phone use 5-7
 - PIN, enabling for phone use 5-6
 - provisioning 6-14

R

- radios xii
- RAM 4-9
- random access memory 4-9
- RAPI 4-3
- regmerge 4-7
- remote API 4-3
- reset
 - hard 1-7, 1-8
 - soft 1-7
- rigid holster 2-2

S

- screen
 - calibration 1-7
- screen protector 2-2
- security 4-1
 - application 4-1
 - certificates 4-3
 - device management 4-3
 - digital signatures 4-1
 - locking device 4-2

- remote API 4-3
- service informationxvi
- service provider name display 5-15
- services, CDMA
 - call barring 6-18
 - call forwarding 6-19
 - call waiting 6-19
 - caller id 6-19
 - SMS 6-19
 - voice mail 6-19
- services, GSM
 - call barring 5-7
 - call forwarding 5-8
 - call waiting 5-9
 - caller id 5-8
 - text messages 5-9
 - voice mail 5-9
- settings
 - CDMA 6-1, 6-12
 - GSM 5-1
 - GSM/GPRS 5-5
- short message service 6-19
- SIM card
 - accessories 1-3
 - activation 5-2
 - install 1-3
 - network access 5-11
- single bay USB cradle 2-1, 2-22
- SMS 6-19
- soft reset 1-7
- spare battery 2-2
- splash screen
 - creating 4-6
- Sprint phone activation 6-5
- starting the EDA 1-2, 1-7
- storage 4-8
 - application folder 4-9
 - cache disk 4-9
 - persistent 4-9
 - volatile 4-9
- storage card
 - deploying CAB files 4-4
- stylus 2-2
- subscriber identification module 1-3

T

- technical specifications A-1
 - accessories A-7
- temperature A-2
 - charging 1-6
- text messages 5-9
- troubleshooting 9-7

U

- universal wall mounting bracket 2-2
- unpacking 1-1
- USB charge cable 2-1
- USB sync cable 2-2
- USB/charge cable 2-28

V

- vehicle battery charger 2-1
- vehicle cradle 2-1
- vehicle mounting bracket 2-2
- Verizon phone activation 6-2, 6-3
- voice mail 5-9, 6-19
- volatile storage 4-9

W

- warm boot 1-7
- wireless
 - internet 5-3, 6-10
- WLAN 802.11 a/b/g xii
- WPAN Bluetooth xii
- WWAN
 - configuring GPRS 5-3

X

- XML provisioning 4-6, 4-7
 - certificates 4-3



MOTOROLA

Motorola, Inc.
One Motorola Plaza
Holtsville, New York 11742, USA
1-800-927-9626
<http://www.motorola.com>

MOTOROLA and the Stylized M Logo and Symbol and the Symbol logo are registered in the U.S. Patent and Trademark Office.
All other product or service names are the property of their registered owners.
© Motorola, Inc. 2009