

ALCT 6/24-2

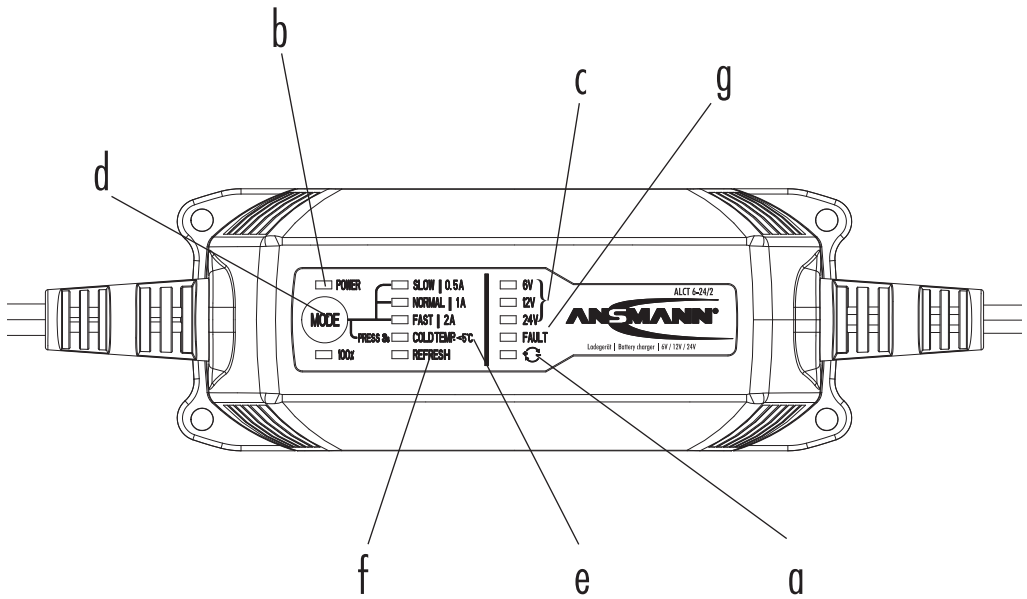

D GB F CZ DK E EST GR H I
LV NL P PL RO RUS S SK SLO UA

[1]



[2]

	0,5A	1A	2A	❄️
6V	✓	✗	✗	✓
12V	✓	✓	✓	✓
24V	✓	✓	✗	✓

GB Instruction Manual ALCT 6/24-2

PREFACE

Dear Customer,

Thank you for purchasing the ANSMANN charger ALCT 6-24/2. These operating instructions will help you to use all features of your ALCT 6-24/2. We hope you will be happy with your new charger.

Your Team ANSMANN

SAFETY INSTRUCTIONS

- > Keep your charger in a dry place (indoor use only). There must be adequate ventilation – a window partly open for example.
- > Do not use the device if there are signs of any damage to the housing, mains plug or cables. Please contact an authorized dealer!
- > The charger should not be covered during use.
- > Use the device only as intended (according to the charger specifications and instructions).
- > In order to avoid the risk of fire and / or electrical shock, the charger must be protected against high humidity and water.
- > Do not use this charger near flammable gases or liquids at any time.
- > Never attempt to open the charger.
- > Never charge a frozen or damaged battery.
- > When the charger is not in use - disconnect it from the mains supply.
- > Improper use of the battery charger may result in danger to the user.
- > Keep away from children! Children should be supervised to ensure that they do not play with the charger.
- > This device is not to be used by children or persons with reduced physical, sensory or mental capabilities, or lack of experience and knowledge, unless they are given adequate supervision and specific instructions!
- > If the safety instructions are not followed, this may cause damage to the device or serious injury to the user.
- > For non-maintenance free batteries, please check the acid level and top-up if necessary.

WARNING

- > Charging lead acid batteries can generate explosive gases. Please ensure sufficient ventilation and avoid fire or naked flames and smoking. Due to emerging explosive gases it is important to ensure that the battery terminals are connected or disconnected when the charger is disconnected from the mains to avoid sparks.
- > Battery acid is corrosive. If battery acid gets in your eyes or on your skin, wash immediately with plenty of water and seek urgent medical attention.
- > Make sure that the battery terminals are contacted with the correct polarity (red to the positive pole terminal, black to the negative pole terminal).
- > A Spark can arise if the charger is connected to the battery whilst connected to the mains. Please ensure it is disconnected from the mains before connecting or disconnecting the red and black charging leads to or from the battery.

CARE & MAINTENANCE

- > Carry out repairs only through authorized dealers.
- > Carry out cleaning and maintenance work to be done only when the mains plug is disconnected.
- > Cleaning only with a dry cloth.

OVERVIEW FUNCTIONS

- > Automatic lead acid charger for 6V/12V/24V batteries.
- > Adjustable charging current (0,5A/1A/2A) dependent on battery nominal voltage.
- > Overcharge protection.
- > Protection against short-circuit and wrong polarity.
- > Automatic start of recharge.
- > Automatic „REFRESH“ mode.
- > Selectable „COLD TEMP.“ mode.

COMMISSIONING

1. Connect charger to the battery with the correct polarity

First connect the charger to the battery to be charged. Connect the red pole terminal to the positive pole (+) of the battery, then the black pole terminal to the negative (-) pole of the battery. Make sure that the battery terminals are connected correctly. If the battery is installed in the vehicle and the battery terminals are not accessible, please consult the vehicle manual for advice.

If the clamps are accidentally attached to the poles the wrong way around, the LED lights red (see fig.1a). Reconnect the terminals with the correct polarity immediately.

2. Connect the device to the mains supply

Insert the mains plug of the charger into the socket. The „POWER“ LED (see fig.1b) will light red.

3. Automatic Voltage Identification/Autosensing

The LEDs 6V/12V/24V (see fig.1c) flash for a few seconds until the device has detected the battery voltage. The corresponding LED lights up permanently. The selected battery will now be charged with the default charging current of 0,5A. Please check that the detected voltage matches with the voltage of the battery to be charged. If this is not the case, the battery is probably defective. We therefore recommend that the battery should be checked and replaced if necessary.

4. Setting the charge current using the „Mode“ button

Depending on the battery voltage, various charging currents (see fig.2) can be chosen using the MODE button (see fig.1d). If you make no manual adjustment it will charge with the default setting of 0,5A. We recommend smaller batteries whose capacity is below 2Ah to be charged with 0,5A. Batteries with more than 2Ah, but less than 6Ah capacity, should be charged with 1A and above 6Ah with 2A.

5. At temperatures below 5 °C (41 °F) we recommend the “COLD TEMPERATURE” mode. To activate, press the „MODE“ button for about 3 seconds.

Due to cold temperatures the voltage level of the battery will change, so the battery connected for normal charging process cannot be fully charged to 100%. Therefore, we recommend the „COLD TEMP.“ Mode (see fig.1e), through this, the battery will be fully charged to 100% despite the cold.

6. „REFRESH“ will automatically start when the battery is fully exhausted.

If the battery is completely discharged, i.e. the voltage is much lower than the nominal battery voltage such as: below 5V for a 6V battery, below 10V for 12V battery and below 20V for a 24V battery, the charger automatically switches to refresh mode (see fig.1f) and charges the battery by pulse charging until a sufficient voltage for the normal charging process has been reached. The charging current for further charging after the completion of the refresh mode can be further selected.

7. „FAULT“ will be displayed when the battery is deemed defective

In the case of a defective battery the „FAULT“ LED (see fig.1g) is on. The charging stops. Unplug the power cord and disconnect the battery. We recommend that you check the battery and replace as required.

8. Battery fully charged

Once the battery is fully charged, unplug the mains cord and afterwards remove the battery terminals of the battery, first the black terminal (-) and then the red (+) terminal.

9. Trickle charge

Alternatively, the battery can be left connected for an extended period (e.g. for the winter). The charger detects any loss of capacity and recharges automatically.

SPECIFICATIONS

Input Voltage:	230V AC / 50Hz
Protection class:	II
Protection:	IP65
Charge voltage:	6V: 7,25V / 12V: 14,5V / 24V: 29,0V
Charge voltage COLD TEMP.:	6V: 7,45V / 12V: 14,9V / 24V: 29,8V
Adjustable charging currents:	0,5A / 1A / 2A
Battery capacity:	1,2Ah - 80Ah

DISCLAIMERS

The information in this manual may be amended without notice. ANSMANN assumes no liability for any direct, indirect, incidental or consequential damages or any other damages caused by improper handling or disregard of the information contained in this manual.

WARRANTY INFORMATION

ANSMANN offers a 3 year warranty on this device. No guarantee will be given on damage to the charger due to non-compliance with these instructions.

Information subject to change without prior notice. ANSMANN assumes no liability for printing errors. 06/2014