



Impressora Zebra MZ220

As impressoras móveis Zebra MZ220 são uma combinação perfeita de recursos, preço e design. Uma impressora de ciclo de trabalho médio para impressão de recibos, faturas e etiquetas.





Zebra®
MZ™ Series
Mobile Printers
User Guide



Table of Contents

Proprietary Statements	5
Document Conventions	7
Introduction to the MZ Series	8
Unpacking and Inspection	8
Reporting Damage	8
Getting Ready to Print	10
Battery	10
Installing and Removing the Battery	10
MZ Series Quad Power Station	14
Battery Safety	15
Charger Safety	15
Loading the Media (All models)	16
Using Pre-Printed Receipt Media	17
Operator Controls	19
Verify the Printer Is Working	21
Printing a Configuration Label	21
Connecting the Printer	21
Cable Communication	22
IR Communications	23
Wireless Communications with Bluetooth™	24
Bluetooth Networking Overview	24
WLAN Overview	25
Setting Up the Software	25
Wearing the Printer	26
Belt Clip	26
Adjustable Shoulder Strap	27
Preventive Maintenance	28
Extending Battery Life	28
General Cleaning Instructions	29
Troubleshooting	31
Interpreting Indicators	31
Troubleshooting Topics	31
Resetting an MZ Series Printer	33
Determining Your Printer Version	33
Troubleshooting Tests	34
Printing a Configuration Label	34
Communications Diagnostics	34
Calling Technical Support	35
Specifications	39
Printing Specifications	39
Memory and Communications Specifications, MZ series	39
Media Specifications	39
Font and Bar Code Specifications for MZ Series	40
USB Communications Port	41
Physical, Environmental and Electrical Specifications	41
MZ Series Accessories	43
Appendix A	48
Interface Cables	48
USB Cable	48

continued

More Interface Cables	48
Appendix B.....	49
Media Supplies.....	49
MZ Series Media	49
Appendix C	49
Maintenance Supplies.....	49
Appendix D.....	50
Battery Disposal	50
Product Disposal	50
Appendix E.....	51
Product Support.....	51
Product Support Contacts	52
Appendix F.....	53
Using zebra.com.....	53
Index.....	55
Patent Numbers	56

Proprietary Statements

This manual contains proprietary information of Zebra Technologies Corporation. It is intended solely for the information and use of parties operating and maintaining the equipment described herein. Such proprietary information may not be used, reproduced, or disclosed to any other parties for any other purpose without the expressed written permission of Zebra Technologies Corporation.

Product Improvements

Since continuous product improvement is a policy of Zebra Technologies Corporation, all specifications and signs are subject to change without notice.

FCC Compliance Statement

NOTE: This equipment has been tested and found to comply with the limits of a Class B digital device, pursuant to Part 15 of the FCC Rules. These limits are designed to provide reasonable protection against harmful interference in a residential installation. This equipment generates, uses and can radiate radio frequency energy and, if not installed and used in accordance with the instructions, may cause harmful interference to radio communications. However, there is no guarantee that interference will not occur in a particular installation. If this equipment does cause harmful interference to radio or television reception, which can be determined by turning the equipment off and on, the user is encouraged to try to correct the interference by one or more of the following measures:

- Reorient or relocate the receiving antenna.
- Increase the separation between the equipment and receiver.
- Connect the equipment into an outlet or circuit different from that to which the receiver is connected.
- Consult the dealer or an experienced radio/TV technician for help.

WARNING: Exposure to Radio Frequency radiation. To conform to FCC RF exposure requirements this device shall be used in accordance with the operating conditions and instructions listed in this manual. Note that there are several radio options available with this printer. Additional regulatory information is contained in later sections devoted to each radio individually.

NOTE: This unit was tested with shielded cables on the peripheral devices. Shielded cables must be used with the unit to insure compliance.

Changes or modifications to this unit not expressly approved by Zebra Technologies Corporation could void the user's authority to operate this equipment.

Canadian Compliance Statement

This Class B digital apparatus complies with Canadian ICES-003.

Cet appareil numérique de la classe B est conforme à la norme NMB-003 du Canada.

"IC:" before the equipment certification number signifies that the Industry Canada technical specifications were met. It does not guarantee that the certified product will operate to the user's satisfaction.

Agency Approvals and Regulatory Information

- Design certified by TUV
- Canadian STD RSS-210
- EN60950: 2000 Safety Standard
- C-Tick (Australia)
- FCC part 15
- EN55024:1998 European Immunity Standard
- NOM/NYCE (Mexico)
- EN55022:1998 Class B European Electromagnetic Radiation Standard

Liability Disclaimer

Inasmuch as every effort has been made to supply accurate information in this manual, Zebra Technologies Corporation is not liable for any erroneous information or omissions. Zebra Technologies Corporation reserves the right to correct any such errors and disclaims liability resulting therefrom.

No Liability for Consequential Damage

In no event shall Zebra Technologies Corporation or anyone else involved in the creation, production, or delivery of the accompanying product (including hardware and software) be liable for any damages whatsoever (including, without limitation, damages for loss of business profits, business interruption, loss of business information, or other pecuniary loss) arising out of the use of or the results of use of or inability to use such product, even if Zebra Technologies Corporation has been advised of the possibility of such damages. Because some states do not allow the exclusion of liability for consequential or incidental damages, the above limitation may not apply to you.

continued

Copyrights

The copyrights in this manual and the label print engine described therein are owned by Zebra Technologies Corporation. Unauthorized reproduction of this manual or the software in the label print engine may result in imprisonment of up to one year and fines of up to \$10,000 (17 U.S.C.506). Copyright violators may be subject to civil liability.

This product may contain ZPL[®], ZPL II[®], and ZebraLink[™] programs; Element Energy Equalizer[®] Circuit; E3[®]; and AGFA fonts. Software © ZIH Corp. All rights reserved worldwide. ZebraLink and all product names and numbers are trademarks, and Zebra, the Zebra logo, ZPL, ZPL II, Element Energy Equalizer Circuit, and E3 Circuit are registered trademarks of ZIH Corp. All rights reserved worldwide.

Monotype[®], Intellifont[®] and UFST[®] are trademarks of Monotype Imaging, Inc. registered in the United States Patent and Trademark Office and may be registered in certain jurisdictions.

Andy[™], CG Palacio[™], CG Century Schoolbook[™], CG Triumvirate[™], CG Times[™], Monotype Kai[™], Monotype Mincho[™] and Monotype Sung[™] are trademarks of Monotype Imaging, Inc. and may be registered in some jurisdictions.

HY Gothic Hangul[™] is a trademark of Hanyang Systems, Inc.

Angsana[™] is a trademark of Unity Progress Company (UPC) Limited.

Andale[®], Arial[®], Book Antiqua[®], Corsiva[®], Gill Sans[®], Sorts[®] and Times New Roman[®] are trademarks of The Monotype Corporation registered in the United States Patent and Trademark Office and may be registered in certain jurisdictions.

Century Gothic[™], Bookman Old Style[™] and Century Schoolbook[™] are trademarks of The Monotype Corporation and may be registered in certain jurisdictions.

HGPGothicB is a trademark of the Ricoh company, Ltd. and may be registered in some jurisdictions.

Univers[™] is a trademark of Heidelberger Druckmaschinen AG, which may be registered in certain jurisdictions, exclusively licensed through Linotype Library GmbH, a wholly owned subsidiary of Heidelberger Druckmaschinen AG.

Futura[®] is a trademark of Bauer Types SA registered in the United States Patent and Trademark Office and may be registered in some jurisdictions.

TrueType[®] is a trademark of Apple Computer, Inc. registered in the United States Patent and Trademark Office and may be registered in certain jurisdictions.

All other product names are the property of their respective owners.

All other brand names, product names, or trademarks belong to their respective holders.

©2013 ZIH Corp.

Document Conventions

The following conventions are used throughout this document to convey certain information:

If you are viewing this guide online, click the underlined text to jump to a related Web site. Click on *italic text* (not underlined) to jump to that location in this manual.

Cautions, Important, and Note



Caution • Warns you of the potential for electrostatic discharge.



Caution • Warns you of a potential electric shock situation.



Caution • Warns you of a situation where excessive heat could cause a burn



Caution • Advises you that failure to take or avoid a specific action could result in physical harm to you.

Caution • Advises you that failure to take or avoid a specific action could result in physical harm to the hardware.



Important • Advises you of information that is essential to complete a task.



Note • Indicates neutral or positive information that emphasizes or supplements important points of the main text.

Introduction to the MZ Series

Thank you for choosing one of our Zebra® MZ™ series Mobile Printers. These rugged printers are sure to become productive and efficient additions to your workplace thanks to their innovative design. Because they are made by Zebra Technologies, you're assured of world-class support for all of your bar code printers, software, and supplies.

- This user's guide gives you the information you will need to operate any MZ series printer.
- The MZ series uses the CPCL programming language. To create and print labels using the CPCL language, refer to the Mobile Printing Systems CPCL Programming Guide and our Label Vista™ label creation program which are both available on either the MZ series product CD or at www.zebra.com.

Unpacking and Inspection

Inspect the printer for possible shipping damage:

- Check all exterior surfaces for damage.
- Open the media cover (refer to "Loading the Media" in the Getting Ready to Print section) and inspect the media compartment for damage.

In case shipping is required, save the carton and all packing material.

Reporting Damage

If you discover shipping damage:

- Immediately notify and file a damage report with the shipping company. Zebra Technologies Corporation is not responsible for any damage incurred during shipment of the printer and will not cover the repair of this damage under its warranty policy.
- Keep the carton and all packing material for inspection.
- Notify your authorized Zebra re-seller.

Figure 1: MZ Series Overview (MZ 220 Illustrated)

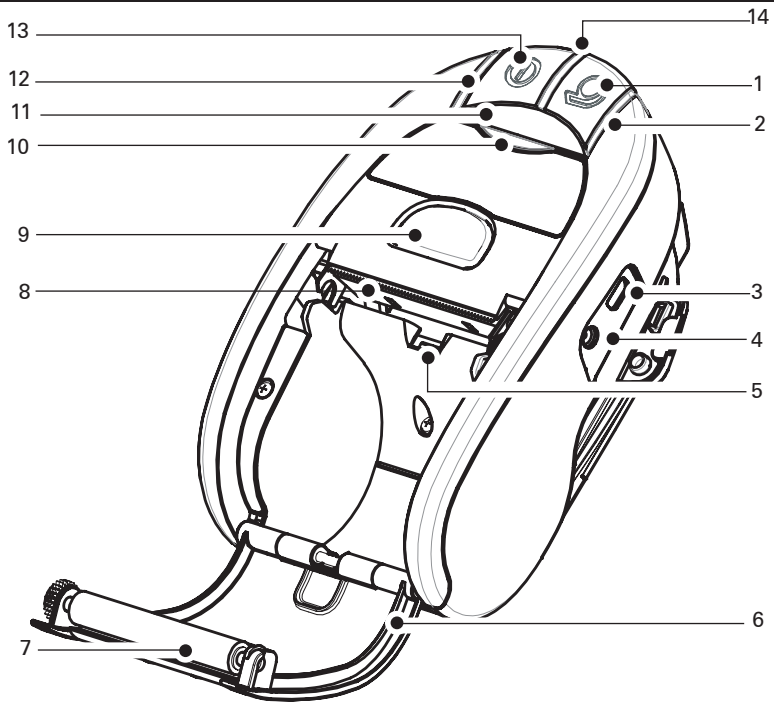

1. Feed Switch
2. Media Status Light
3. USB Port
4. Battery Charging Receptacle
5. Media/Black Bar Sensor
6. Media Cover
7. Platen
8. Printhead
9. Latch Release Button
10. Communications Status Indicator
11. IR window
12. Charge Status Indicator
13. Power Switch
14. Power Indicator
15. Belt Clip
16. Battery Door Latch
17. Battery Compartment Cover
18. Battery Pack
19. External Charge Contacts

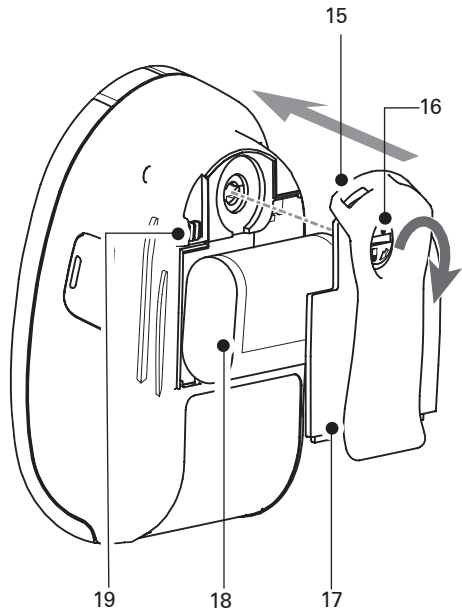

Getting Ready to Print

Battery

Installing and Removing the Battery

! Important • Batteries are shipped partially charged. Remove any protective packaging from new battery packs prior to use.

Figure 2.1: Installing the Battery

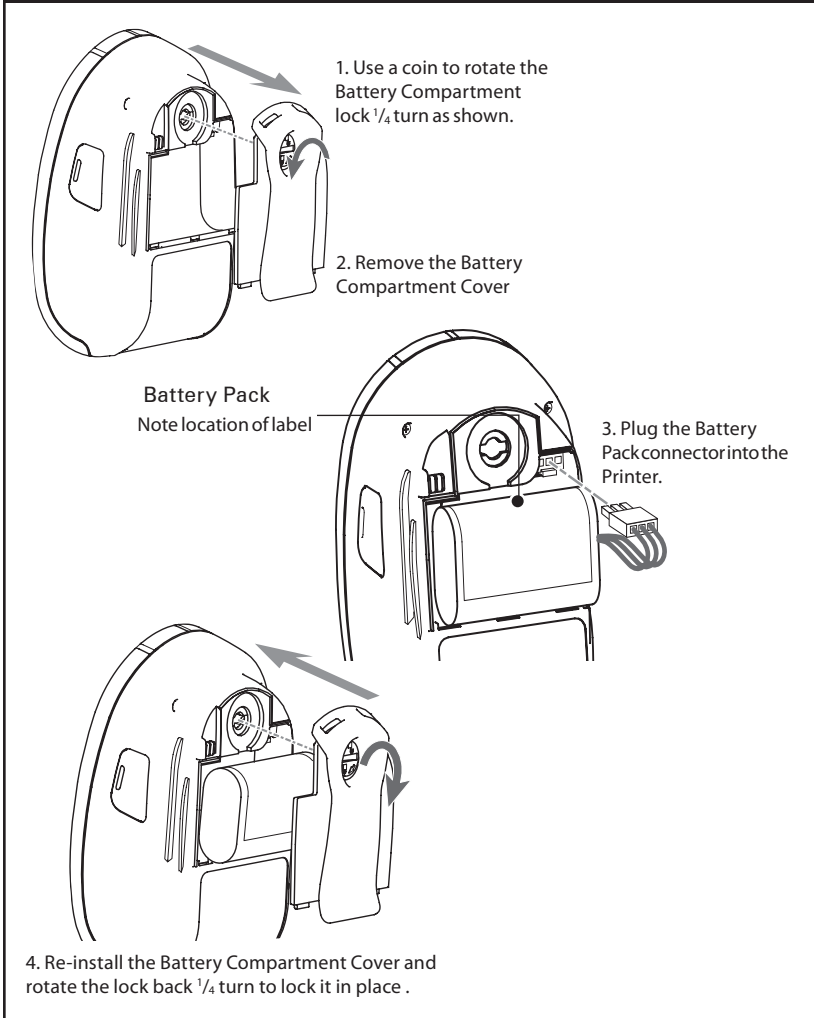

! Ensure the battery leads are not pinched prior to replacing the battery cover.

Figure 2.2: Removing the Battery

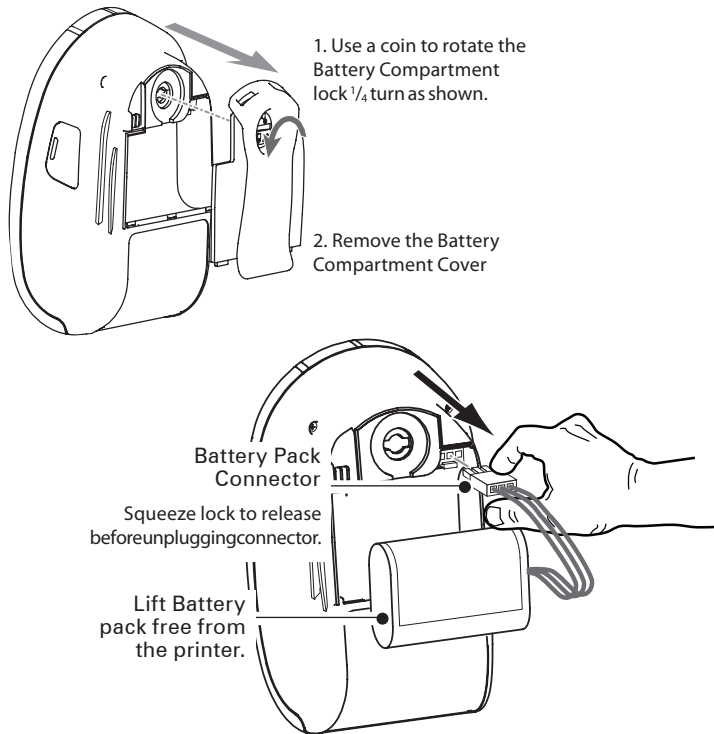

Always release the locking bar before unplugging the battery connector. Do not attempt to remove the connector by force, or by using pliers, etc. as this could cause damage to the printer's CPU assembly.

4. Install a replacement battery by following the procedure described in Figure 2.1

When the battery is first installed, the printer power and charge indicators should indicate the battery is not fully charged (see “Charging the Battery” below and “Operator Controls”).

! You must charge the battery fully before using the printer for the first time.

Charging the Battery

Preparing the Charger Power Supply

Before charging the battery for the first time, you must prepare the Charger Power Supply. Refer to Figure 3 below:

Figure 3: Preparing the Charger Power Supply

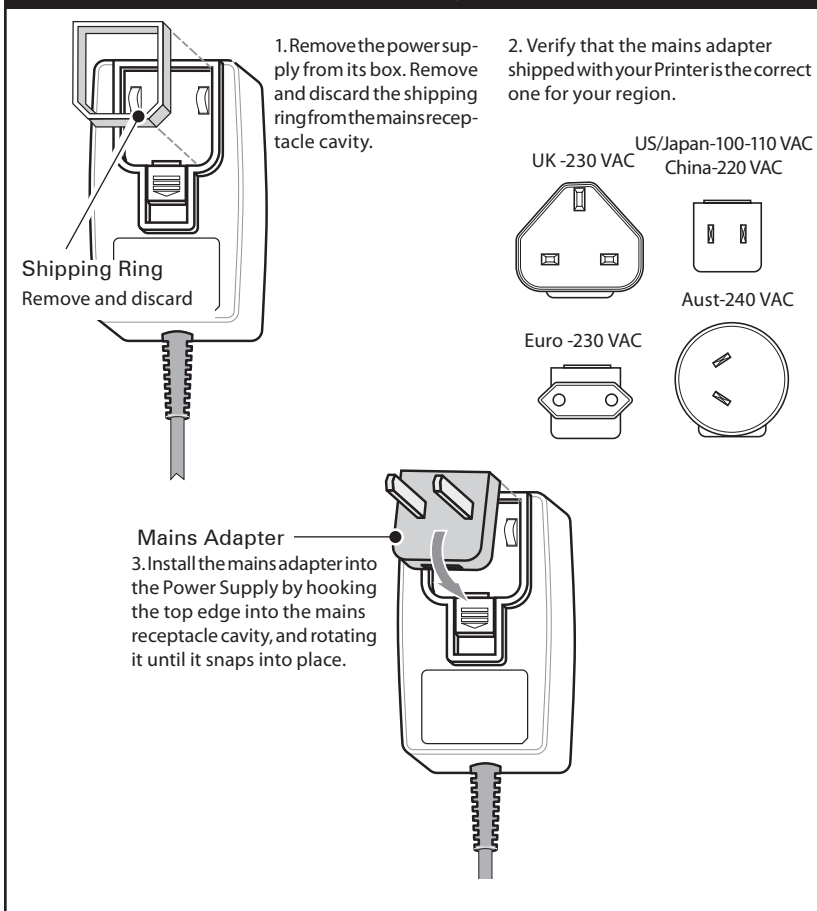

continued

Figure 4: Charging the Battery

MZ Series Charger Power Supply p/n AT17947-1
110-240 VAC 50-60 Hz 0.6A Input; 12 VDC 1.25 A output
Plug into AC receptacle

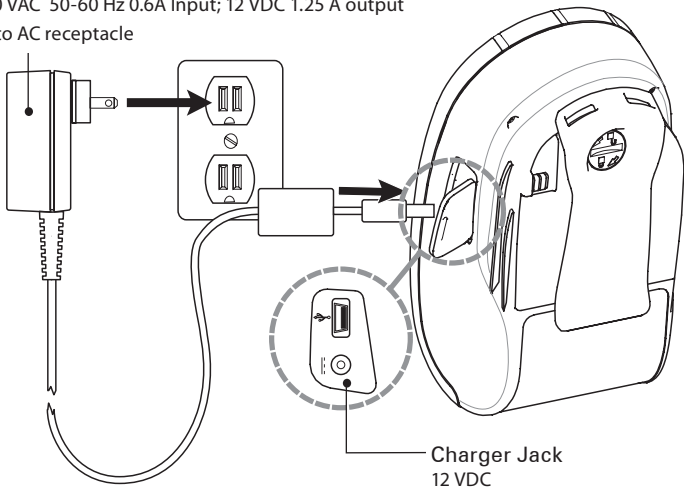

Charging the battery

Refer to Figure 4.

1. Plug the Charger Power Supply into the appropriate A.C. wall receptacle. Then insert the charge cable into the printer's charger jack.
2. The printer's charger indicator will indicate the status of the charger as follows:
 - An amber light indicates the battery is charging, and that the battery is less than 90% charged.
 - A green light indicates the battery is fully charged. The battery is ready for use.

Approximate Charge Times :

Batteries are fully charged after 2.5 hours from the low-battery shut-off state. Partially discharged batteries will take less time to charge.



NOTES: Use of the printer while charging will increase charge times. Charge times are for completely discharged batteries. As a safety feature the battery will stop charging after 4.5 hours regardless of the battery's charge state.

MZ Series Quad Power Station

The MZ series Quad Power Station is designed to dock and charge up to four MZ series printers of either type simultaneously.

1. Ensure that the Power Station has been installed properly per its instruction manual. Ensure that the power supply is properly connected and its power indicator light is on.
2. Slide a printer into any one of the four docking bays as shown in Figure 5.



NOTES: If you are using a shoulder strap, ensure it is pulled away from the printer when installing in the Power Station.
Do not use the printer when it is installed in the Power Station

The printer's charge status indicator will turn amber if the printer is properly inserted and the battery is less than 90% charged.

The printer's charge indicators will allow you to monitor the

Figure 5: MZ Series Quad Power Station

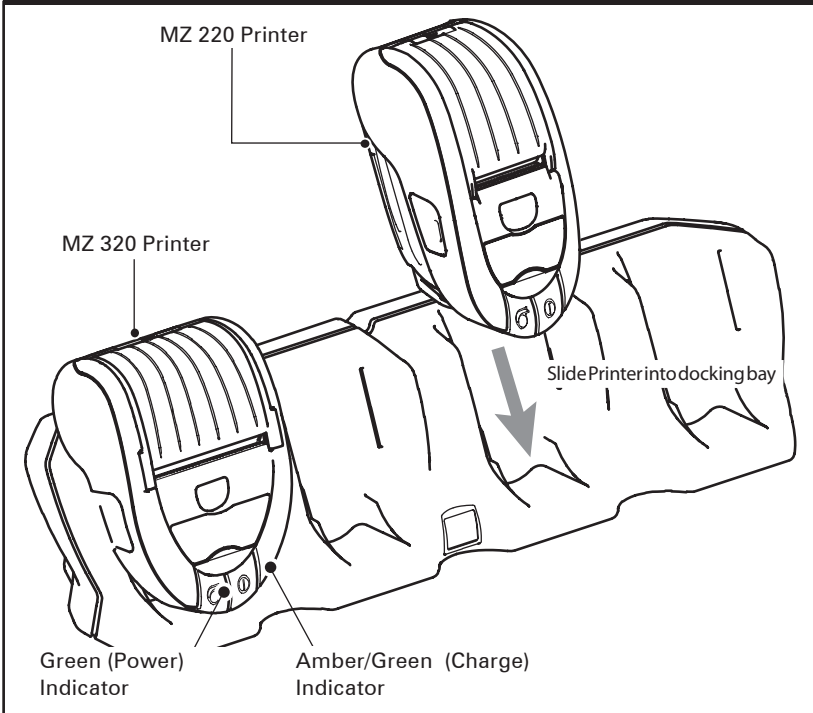

charging process. Refer to the Controls section of this manual for more information.

Battery Safety



Caution • Avoid accidental short circuiting of any battery. Allowing battery terminals to contact conductive material will create a short circuit which could cause burns and other injuries or could start a fire.



Important • Always dispose of used batteries properly. Refer to Appendix D for more battery recycling information.

Caution • Use of any charger not approved specifically by Zebra for use with its batteries could cause damage to the battery pack or the printer and will void the warranty.



Read carefully and always observe the safety guidelines for Li-Ion batteries provided with each Battery Pack.

Charger Safety



Do not place the Power Station in locations where liquids or metallic objects may be dropped into the charging bays.



Use care when installing either the Charger Power Supply shipped with the printer or the power supply supplied with the MZ series Power Station. Do not block the ventilating slots on the top and bottom covers of either power supply.

Ensure that the Charger Power Supply is plugged into a power source which will not accidentally be turned off if you will be charging batteries overnight.

Loading the Media (All models)

1. Open the printer: Refer to Figure 6.
 - Press the latch release button on the top of the printer as shown at “1” below. The media cover will flip open automatically revealing the media compartment.
2. Load the media: Refer to Figure 7
 - Insert the roll of media into the media compartment. Ensure that the media pulls off the core in the direction shown in Figure 6.
3. Close the Media Cover: Refer to Figure 8.
 - Pull a short length of media out of the printer
 - Close the Media Cover firmly and ensure it is securely latched on both sides..
 - Turn on the printer and press the Feed button. The printer will advance media until the Feed button is released. Verify the media is feeding properly and without binding or skewing sideways.

Figure 6: Opening the MZ Printer (MZ 220 shown)

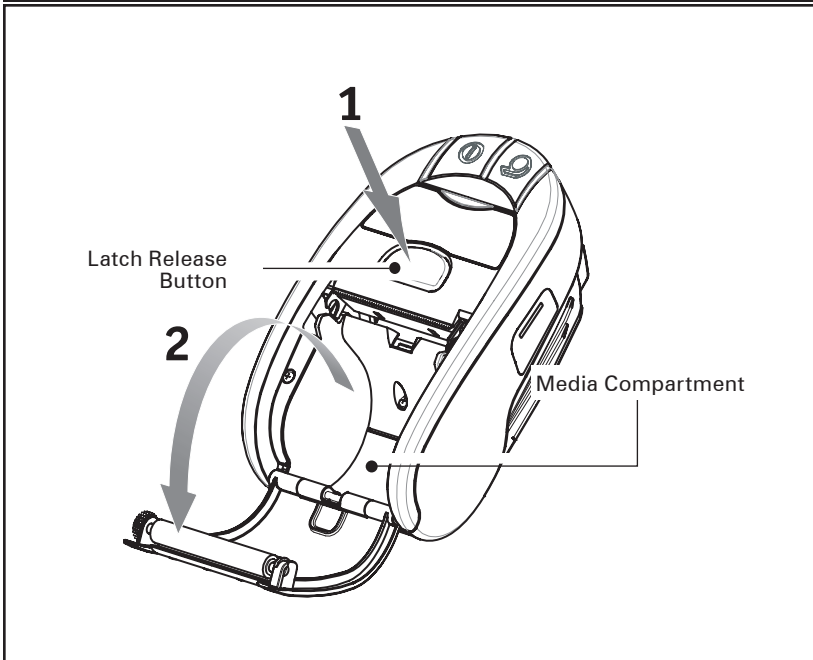

continued

Using Pre-Printed Receipt Media

MZ series printers built after 6/16/2008 support alignment of pre-printed receipts by using a sensor in the printhead. (Refer to “Determining Your Printer’s Version” in the Troubleshooting section of this manual for more information) Please be aware of the following factors:

- 1) Note the black bar location and dimensions as detailed in the Specifications section of this manual.
- 2) Complete information on using pre-printed media can be found in the FORM command topic in the CPCL Programming Manual. The CPCL manual is available on the MZ Product CD or on the Zebra Web site at <http://www.zebra.com/manuals>.

Figure 7: Installing Media

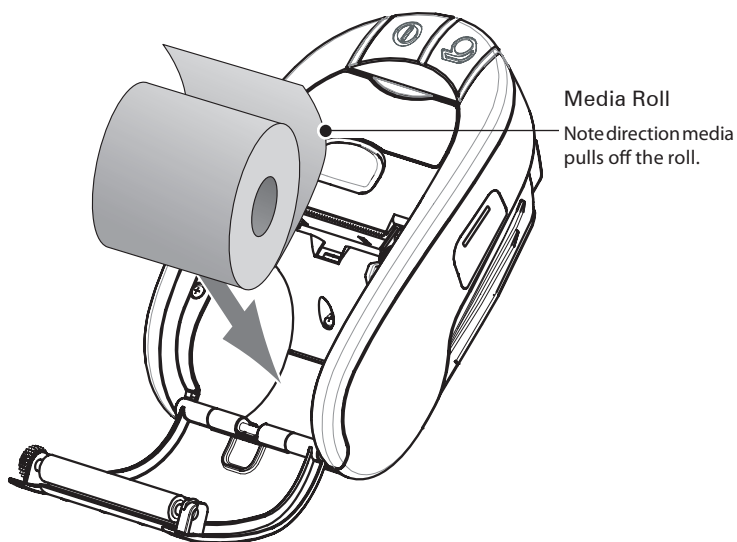
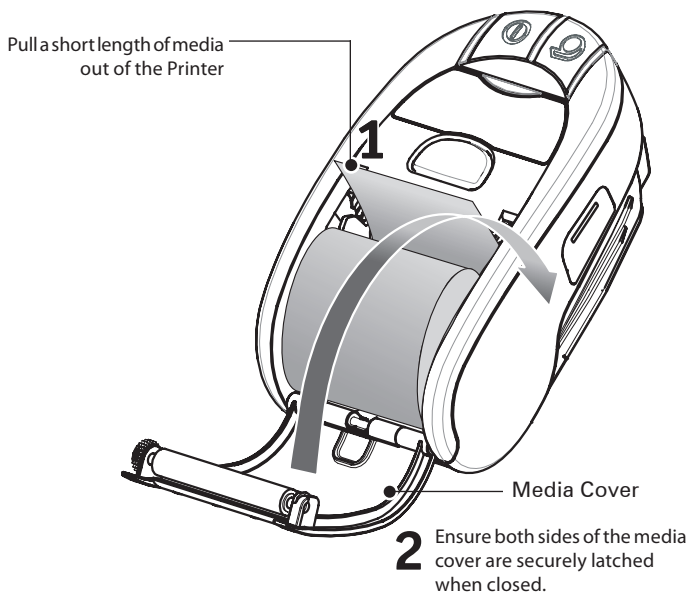

Figure 8: Closing the Media Cover



Operator Controls

MZ series printer controls are detailed below and in Figure 9.

The printer has two control buttons and four multipurpose indicators.

The Power Button turns the printer on and off.

The Feed Button advances a length of media until it is released.

The Green/Amber indicator to the left of the Power Button indicates the status of the printer's built-in charger:

- The indicator is off indicates the battery is not being charged.
- If the indicator is amber the battery is being charged.
- If the indicator is green, the battery is fully charged.

The Green Indicator between the Power and Feed buttons has two states:

- A rapidly blinking light indicates a low battery condition.
- A steadily lit indicator means that power is on and the battery charge level is sufficient for use

The Amber Indicator to the right of the Feed button is an error indicator.

- An un-lit indicator means there is no error condition and the printer can be used.
- A blinking indicator could mean one of two conditions exist, which will inhibit printer operation:
 1. There is no media loaded.
 2. The media cover is open.
 3. If both the above conditions are met and the error light is still flashing, there could be no application loaded in the printer, or the application could have become corrupted.

The Blue Indicator just above the product I.D. label is a communications indicator. Its functions vary depending on the wireless communications option installed in the printer.

- If the printer uses only standard IrDA[®] wireless communication:
 - A blinking light indicates data is being received from a linked IrDA device.
- If the printer has a Bluetooth[™] radio option:
 1. A steady light indicates the printer has paired with an-

- other Bluetooth device.
2. A blinking light indicates that the printer is receiving data via Bluetooth communications.
- If the printer has an 802.11b/g radio installed:
 1. A steady light indicates the printer has associated with a wireless Local Area Network (WLAN).
 2. A blinking light indicates that the printer is attempting to associate with a WLAN.

Figure 9: Printer Controls

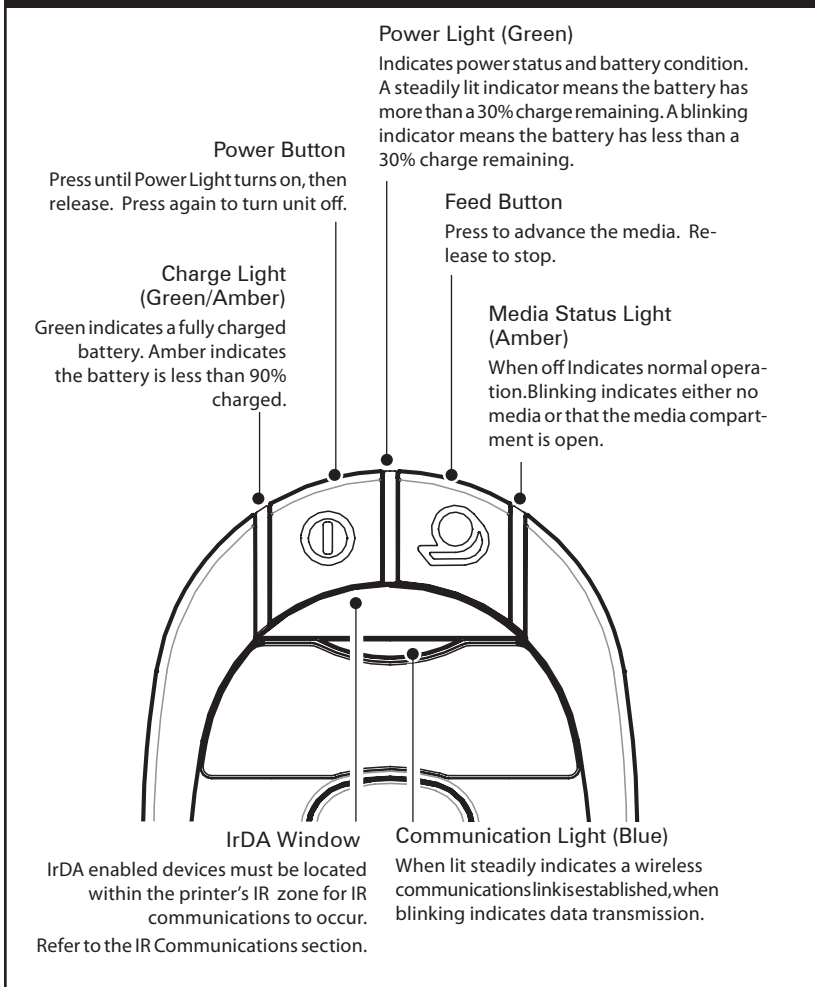

Verify the Printer Is Working

Before you connect the printer to your computer, portable data terminal or wireless LAN, make sure that the printer is in proper working order. You can do this by printing a configuration label using the “two key reset” method. If you can’t get this label to print, refer to “Troubleshooting”.

Printing a Configuration Label

1. Turn the printer off. Load the media compartment with journal media (media with no black bars printed on the back)
2. Press and hold the Feed Button.
3. Press and release the Power button and keep the Feed button pressed. When printing starts, release the Feed button.

The unit will print a line of interlocking “x” characters to ensure all elements of the print head are working, print out the version of software loaded in the printer and then print two reports.

The first report indicates model, ROM version, serial number, etc. The second report prints out more detailed information on the printer’s configuration and parameter settings. If no second report appears, there is no application loaded. (See the Troubleshooting Section for sample printouts and a further discussion on how to use the configuration label as a diagnostic tool.)

Connecting the Printer

The printer must establish communications with a host terminal which sends the data to be printed. Communications occur in four basic ways:

- Via a cable using the USB 2.0 protocol. USB drivers are included in the Zebra Universal Driver which can be downloaded from www.zebra.com.
- Via the industry standard IrDA protocol. IR capability is standard with MZ series printers.
- By means of an optional Bluetooth short range radio link.
- By means of a wireless LAN (Local Area Network) using an optional radio per 802.11b/g specifications.

Cable Communication

Caution • The printer should be turned off before connecting or disconnecting the communications cable.

The small connector on the USB cable plugs into the printer. The connectors are keyed to assure correct alignment; do not try to force the cable if it does not plug in. The other end of the cable must be plugged into the host terminal as shown in Figure 10, or the USB port on a computer as shown in Figure 11. The MZ series utilizes the USB Open HCI interface driver allowing it to communicate with Windows® based devices.

USB drivers are included in the Zebra Universal Driver which can be downloaded from the Zebra Web site. Other terminals or communications devices may require the installation of special drivers to use the USB connection. Consult the factory for further details.

Figure 10: Cable Communications

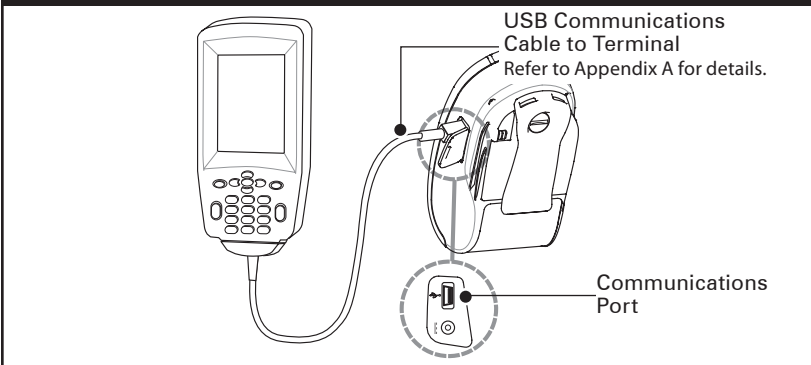
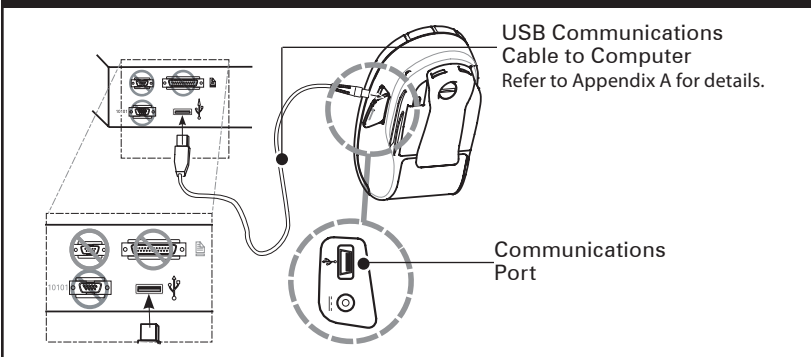

Figure 11: Communications with a P.C.



IR Communications

Ensure that the terminal sending and receiving data is within the shaded zone depicted in Figure 12. The IR window on the front of the printer must face the corresponding window on the terminal to properly send and receive signals. The maximum distance IrDA signals can be transmitted reliably is 1M (39") (39").

Figure 12: IR Communication Zone

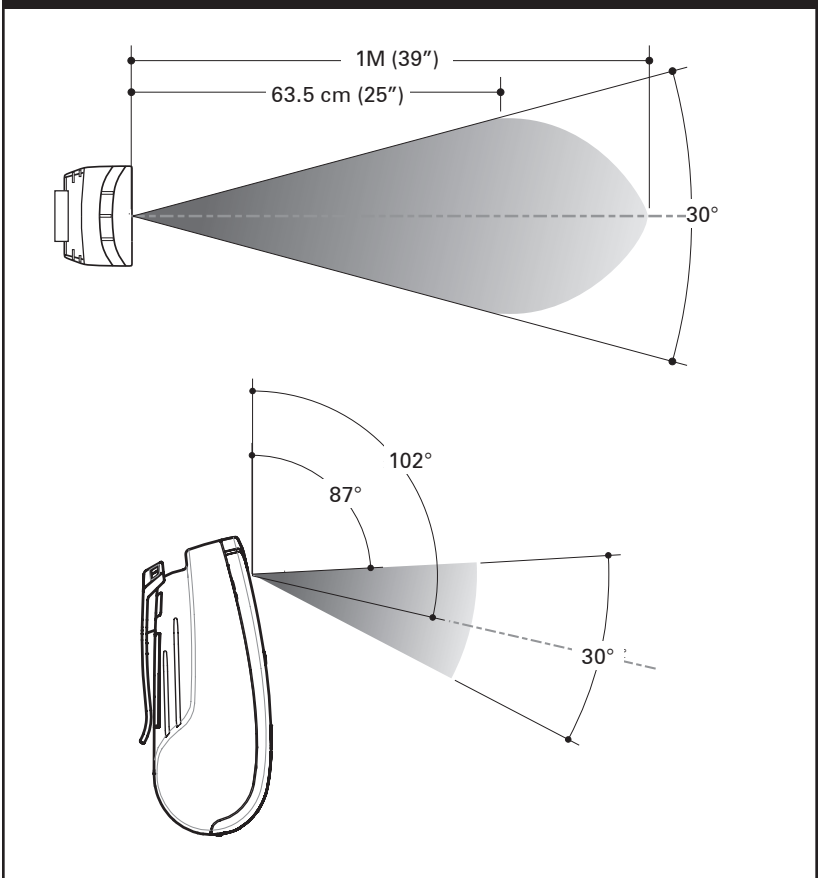

Wireless Communications with Bluetooth™

Bluetooth is a worldwide standard for the exchange of data between two devices via radio frequencies. Bluetooth radios are relatively low powered to help prevent interference with other devices running at similar radio frequencies. This limits the range of a Bluetooth device to about 10 meters (32 feet). Both the printer and the device it communicates with must follow the Bluetooth standard. Only one of the radio options can be installed in the printer at one time and the antenna used for these transmitters must not be co-located or must not operate in conjunction with any other antenna.

Bluetooth Networking Overview

Each Bluetooth enabled MZ series printer is identified by a unique Bluetooth Device Address (BDA) loaded into the printer when manufactured. In order to exchange data, two Bluetooth enabled devices must establish a connection.

Bluetooth software is always running in the background, ready to respond to connection requests. One device (known as the master) must request a connection with another. The second device (the slave) then accepts or rejects the connection. A Bluetooth enabled MZ series printer will normally act as a slave creating a miniature network with the terminal sometimes referred to as a "piconet."

For the most part, communications using the Bluetooth protocol are initiated and processed without any operator intervention.

WLAN Overview

All MZ series printers can be equipped with radios using the industry standard 802.11b/g protocol. MZ series printers will have the FCC I.D. number of the radio on the serial number label on the back of the unit.

MZ series printers with the Zebra 802.11b/g WLAN radio option can be identified by the FCC ID: I28MD-CXLAN11G on the serial number label on the back of the printer.

Methods of establishing communications to MZ series printers will vary with each LAN application. General information on establishing WLAN communications can be found in either the "CPCL Programmers Manual" or the "Zebra Mobile Printer Wireless Configuration Guide" both available on-line at www.zebra.com.

More information and LAN configuration utilities are included in Zebra's Label Vista™ program (version 2.8 and later). Label Vista may be downloaded from the Zebra Web site.

Setting Up the Software

MZ series printers use Zebra's CPCL Programming language which was designed for mobile printing applications. CPCL is fully described in the "CPCL Programmers Manual", available on-line from the Zebra Web site.

You can also use Label Vista™, Zebra's Windows® based label creation program which uses a graphical interface to create and edit labels in the CPCL language.

Refer to Appendix F for tips on downloading the Label Vista application from Zebra's Web site.

Wearing the Printer

Belt Clip

Refer to Figure 13. All MZ series printers are have a belt clip installed as a standard feature. To use: hook the clip over your belt, and ensure that the clip is securely attached to the belt. The belt clip will pivot slightly to allow you to move freely while wearing the printer.

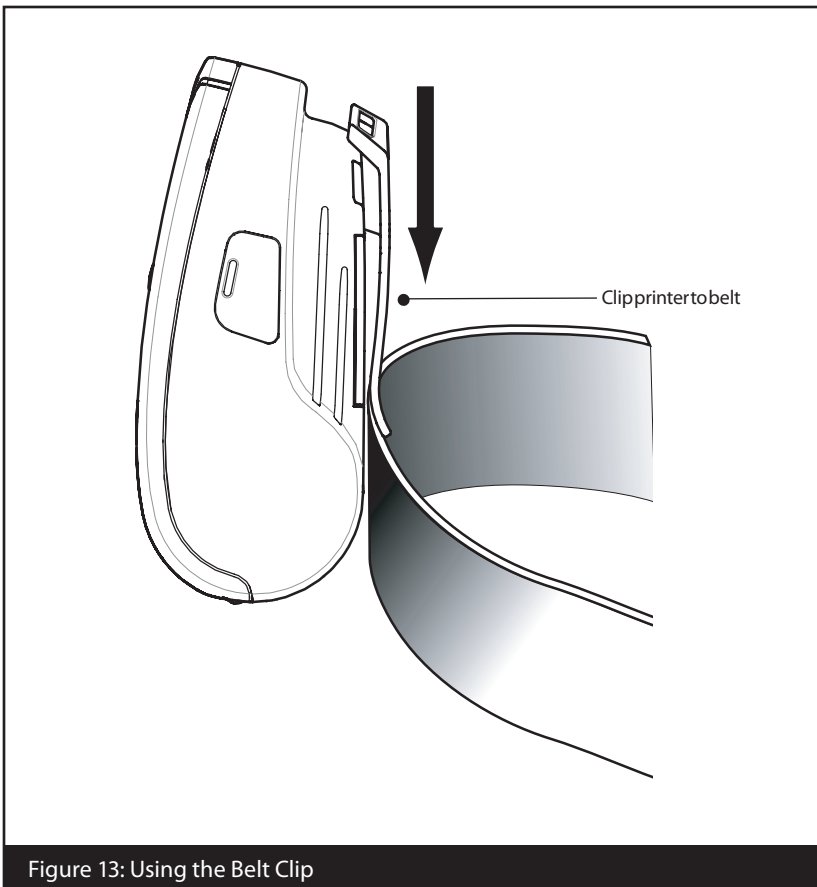

Figure 13: Using the Belt Clip

continued

Adjustable Shoulder Strap

Refer to Figure 14 if you have ordered the shoulder strap option for your printer. Secure each end of the shoulder strap as shown below. Use the main buckle on the shoulder strap to adjust to the desired length.



NOTE: If you are using a shoulder strap, ensure it is pulled away from the printer when installing in the Power Station. See page 13.

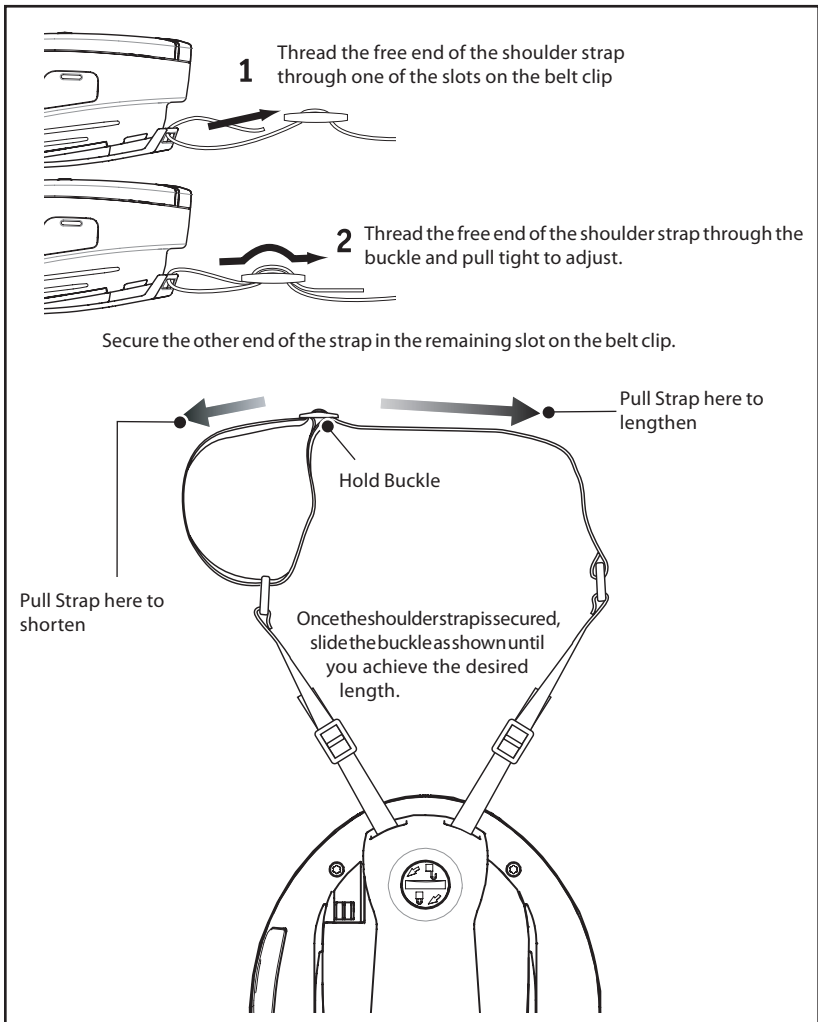

Figure 14: Using the Optional Shoulder Strap

Preventive Maintenance

Extending Battery Life

- Always observe the safety precautions in the Lithium-Ion Battery Technical Bulletin included with each Battery Pack.
- Never expose the battery to direct sunlight or temperatures over 104° F (40° C).
- Do not charge the battery when the temperature exceeds 113° F (45° C).
- Always use a Zebra power supply designed specifically for the MZ series printers. Use of any other kind of power supply may damage the battery.
- Use the correct media for your printing requirements. An authorized Zebra re-seller can help you determine the optimum media for your application.
- If you print the same text or graphic on every label, consider using a pre-printed label.
- Choose the correct print darkness, and print speed for your media.



NOTE: Use of label media in an MZ series printer requires a “Tone” setting of 50 for best results. The Tone setting can be modified by connecting the printer to a PC and using the Label Vista application. Refer to the Cable Communications section of “Connecting the Printer” in this manual.

- Use software handshaking (XON/XOFF) whenever possible.
- Remember that any rechargeable battery will lose its ability to maintain a charge over time. It can only be recharged a finite number of times before it must be replaced. Always dispose of batteries properly. Refer to Appendix D for more information on battery disposal.
- If you print while charging the battery, charge times will be prolonged. Extensive printing while charging could deplete the battery enough to cause the low battery warning indicator to turn on. You should suspend printing at that time and allow the battery to re-charge completely.

continued

General Cleaning Instructions



Caution • To avoid possible personal injury or damage to the printer, never insert any pointed or sharp objects into the printer.

Always turn the printer off before performing any cleaning procedures.

Use care when working near the tear bar. The edges are very sharp.



Caution • The printhead can be very hot after prolonged printing. Allow it to cool off before attempting any cleaning procedures.



Only use a Zebra cleaning pen or a cotton swab saturated with alcohol for cleaning the printhead.

Caution • Use only cleaning agents specified in the following tables. Zebra Technologies Corporation will not be responsible for damage caused by any other cleaning materials used on this printer.

MZ Series Cleaning Instructions		
Area	Method	Interval
Printhead	Use a Zebra cleaning pen or a 70% isopropyl alcohol solution on a cotton swab to clean the print elements from end to end (the print elements are located in the thin gray line on the printhead).	After every five rolls of media (or more often, if needed)
Platen	Rotate the platen roller and clean it thoroughly with a Zebra cleaning pen or a 70% isopropyl alcohol solution and a cotton swab.	
Tear bar	Clean thoroughly with a Zebra cleaning pen or a 70% isopropyl alcohol solution and a cotton swab.	
Exterior	Water dampened cloth	As needed
Media Compartment Interior	Brush/air blow.	After every five rolls of media (or more often, if needed)
Media/Black Bar Sensor		

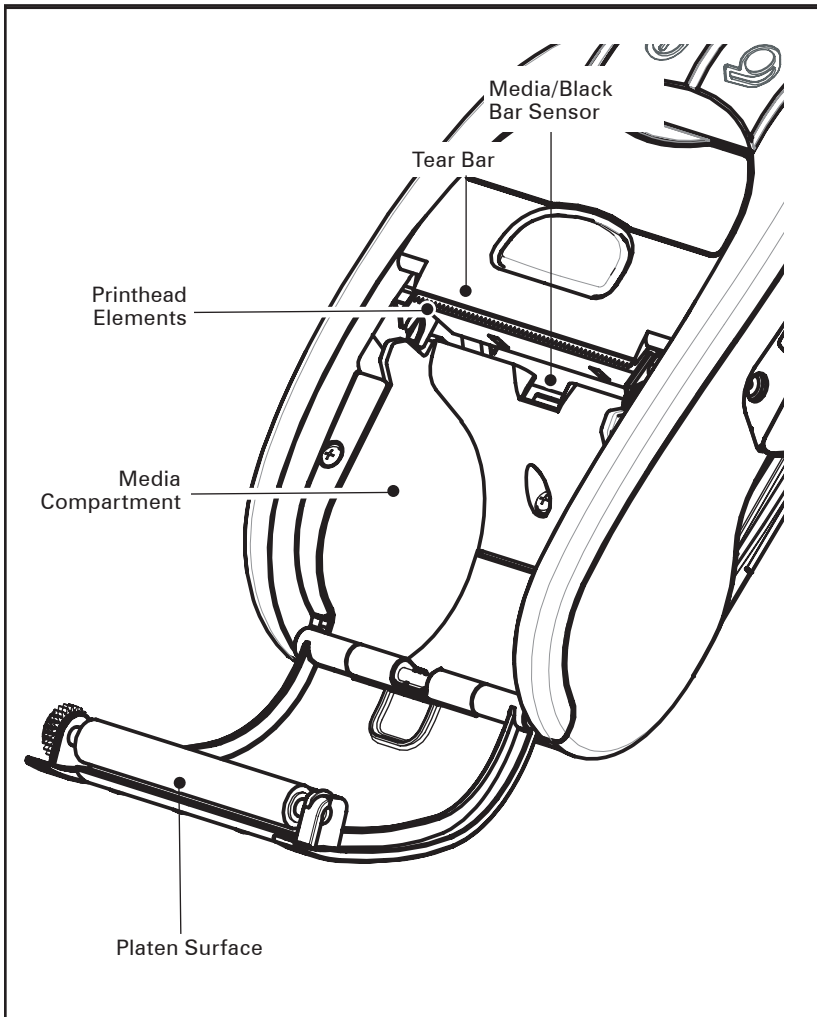

Figure 15: MZ Series Cleaning



Note • Twelve packs of approved cleaning pens are available from Zebra as p/n 105950-035.



Caution • To avoid possible personal injury or damage to the Printer, never insert any pointed or sharp objects into the Printer.

Troubleshooting

Interpreting Indicators

The printer's indicators display various printer functions and their status. Check the indicator status, then refer to the Troubleshooting topic referenced in the chart.

Function	Indicator Color	Indicator Status: Steady	Indicator Status: Blinking	Troubleshooting Topic
Power	Green	Indicates printer is on and battery condition is OK to use.	Blinking signifies Low Battery	3
Charger	Amber/ Green	Off indicates battery is not charging. Amber indicates battery is charging. Green indicates battery is charged.	N/A	1,6,10
Error	Amber	Off indicates no error condition	No media or media door is open. Application may be missing or corrupted	2,4,7,9
Commu- nications	Blue	Cable/IrDA: N/A	Data is being re- ceived	5,8
		Bluetooth: Printer has paired with another Bluetooth device.	Data is being re- ceived	5,8
		802.11b/g: Radio is associated with a WLAN	Radio is trying to as- sociate with a WLAN.	5,8

Troubleshooting Topics

1. No power:

- Ensure you press and hold the Power switch until the Power light comes on.
- Check that battery is installed properly.
- Recharge or replace battery as necessary.

2. Media does not feed:

- Be sure Media Cover is closed and latched.
- Check media compartment. Ensure media is not binding on the sides of the compartment.

3. Poor or faded print

- Clean printhead.
- Check battery for possible damage. Recharge or replace as necessary.

-
- Check quality of media.
 - If using label media, ensure the “Tone” setting is set to 50.
4. Partial or missing print:
- Check media alignment.
 - Clean printhead.
 - Ensure Media Cover is properly closed and latched.
5. No print:
- Replace battery.
 - Check cable to terminal.
 - (Wireless units only) Restore wireless connection.
6. Reduced battery life:
- Check battery date code — if battery is one to two years old, short life may be due to normal aging.
 - Recharge or replace battery.
7. Flashing Amber indicator:
- Check that media is loaded and that printhead is closed and securely latched.
 - If media is present and latch is closed, indicates that no application is present or application is corrupted. Program must be re-loaded.
8. Communication Error:
- (Wireless units only) Check that media is loaded, head is closed and blue communication link light is on.
 - (USB) Replace cable to terminal.
9. Label Jam:
- Open media cover.
 - Generously apply alcohol to Printer in area of jammed label.
10. Battery Pack Is Hard to Install
- Do not force the battery into place. Verify you have not pinched any wires between the battery and the printer.
 - Verify you are plugging the battery connector into the printer correctly.

Resetting an MZ Series Printer



If the printer has locked up and is not responding to any operator inputs or external commands, either from a connected terminal or from a linked LAN, you can perform a forced reset as follows:

Units built before June 18, 2008 (see Figure 16- Determining Your Printer Version, below):

Units with a S/N having a Year Built and Week Built code earlier than "08-25" are reset using the following procedure:

1. Open the media compartment and remove any media.
2. Press the Feed button and hold it approximately ten seconds until the Power, Communications and Error indicators turn off and stay off.
3. After the three indicators turn off, reload the media and close the media compartment cover.
4. Wait at least ten more seconds and press the Power button. The Printer will restart and normal operation can resume.

Units built after June 18, 2008 (see Figure 16- Determining Your Printer Version, below):

Units with a S/N having a Year Built and Week Built code of "08-25" or later are reset using the following procedure:

1. Press and hold the power button for 5 seconds and then release. The printer will power down.
2. Re-start the Printer as usual. Any pending data in the printer will have been deleted and must be re-sent.

Determining Your Printer Version

The printer build date is identified by the Year and Week codes of the printer serial number label located on the bottom of the unit. (See Figure 16 below).

Figure 16: Determining Your Printer Version (MZ 320 illustrated)

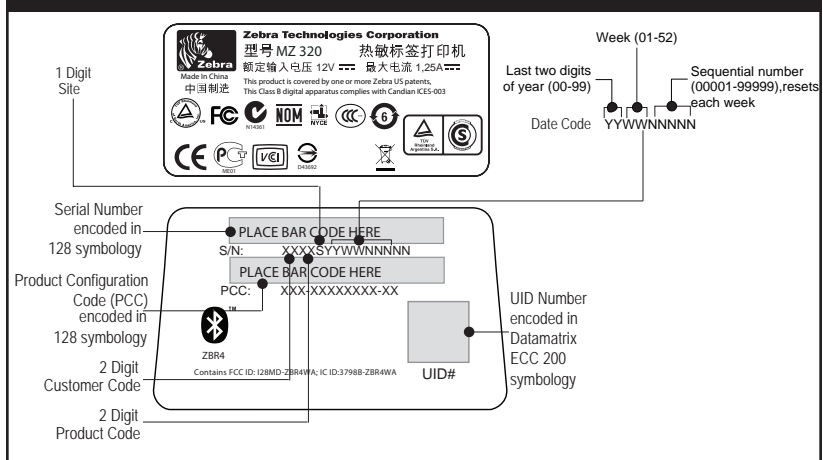

Troubleshooting Tests

Printing a Configuration Label

To print out a listing of the printer's current configuration follow these steps:

1. Turn the printer off. Load the media compartment with journal media (media with no black bars printed on the back)
2. Press and hold the Feed Button.
3. Press and release the Power button and keep the Feed button pressed. When printing starts, release the Feed button.

Refer to Figures 16 and 16a for a sample configuration print-out.

Communications Diagnostics

If there is a problem transferring data between the computer and the printer, try putting the printer in the Communications Diagnostics Mode (also referred to as the "DUMP" mode). The printer will print the ASCII characters and their text representation (or the period '.', if not a printable character) for any data received from the host computer

To enter Communications Diagnostics Mode:

1. Print a configuration label as described above.
2. At the end of 2nd diagnostics report, the printer will print: "Press FEED key to enter DUMP mode".
3. Press the FEED key. The printer will print: "Entering DUMP mode".



Note • If the FEED key is not pressed within 3 seconds, the printer will print "DUMP mode not entered" and will resume normal operation.

4. At this point, the printer is in DUMP mode and will print the ASCII hex codes of any data sent to it, and their text representation (or "." if not a printable character).

Additionally, a file with a ".dmp" extension containing the ASCII information will be created and stored in the printer's memory. It can be viewed, "cloned" or deleted using the Label Vista application. (Refer the Label Vista documentation for more information.)

To terminate the Communications Diagnostics Mode and return the printer to normal operations:

1. Turn the printer OFF.
2. Wait 5 seconds.
3. Turn the printer ON.

Calling Technical Support

If the printer fails to print the configuration label, or you encounter problems not covered in the Troubleshooting Guide, contact Zebra Technical Support. Technical Support addresses and phone numbers for your area can be found in Appendix D of this manual. You will need to supply the following information:

- Model number and type (e.g. MZ 220)
- Unit serial number (Found on the large label on the back of the printer, also found in the configuration label print-out. Refer to Figure17.)
- Product Configuration Code (PCC) (15 digit number found on the label on the back of the unit)

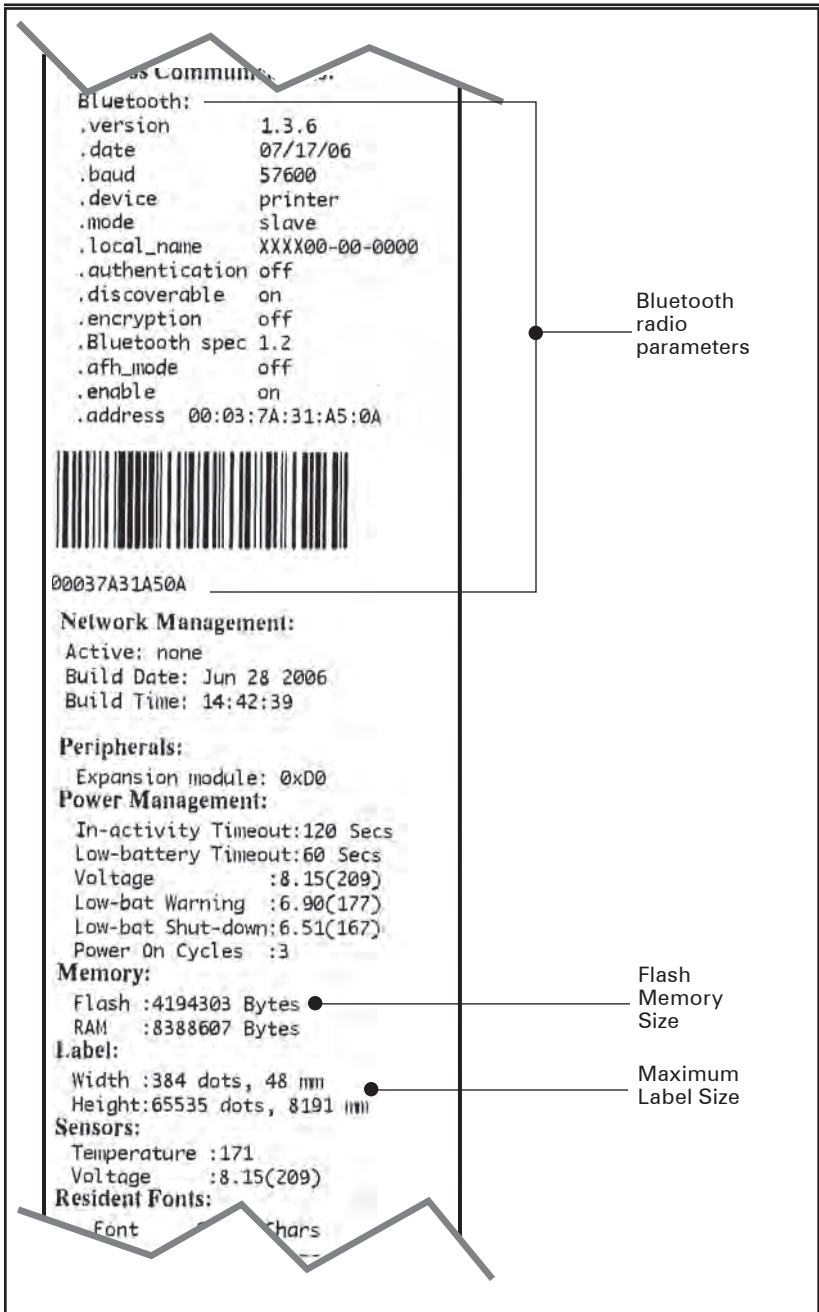

Figure17a: Configuration Label Example (continued)

continued

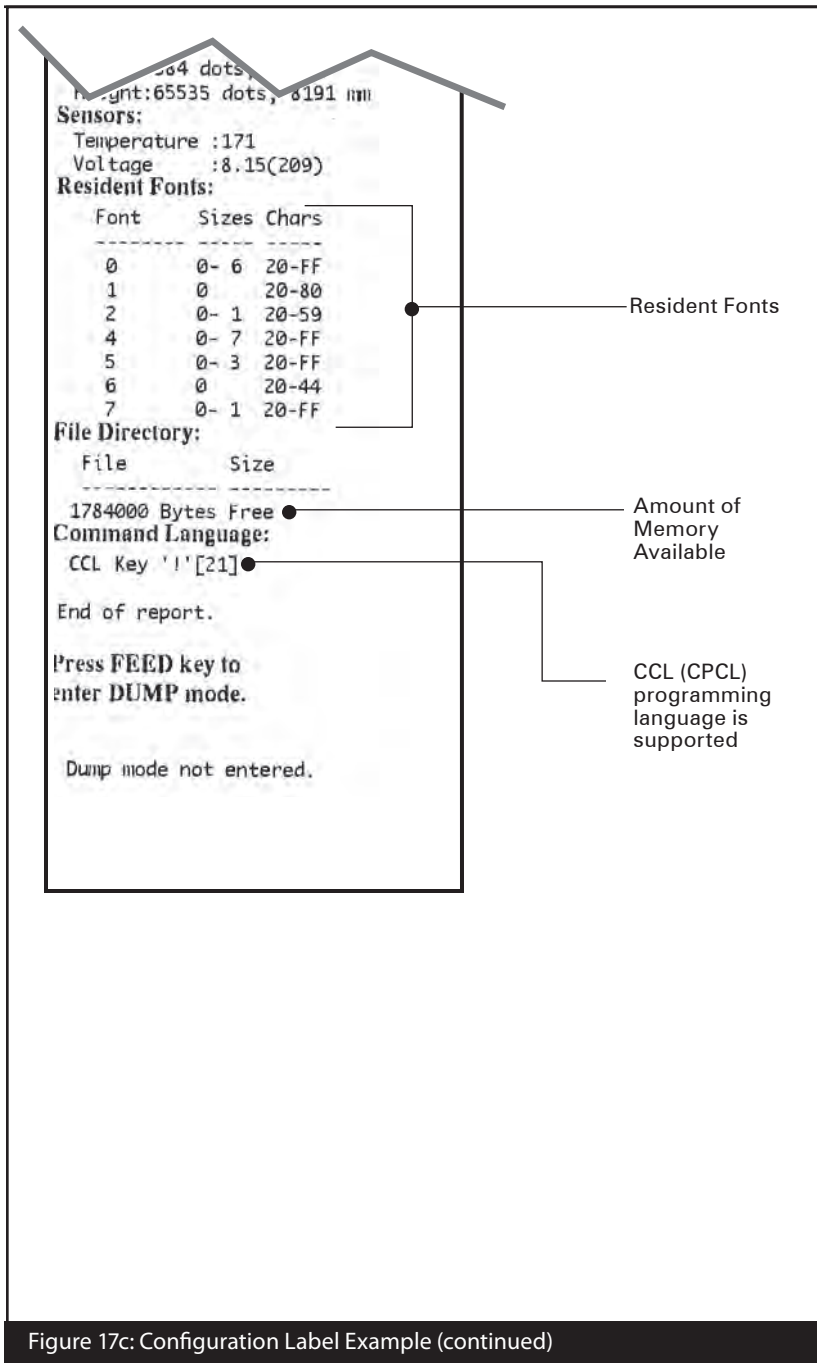

Figure 17c: Configuration Label Example (continued)

Specifications



Note.- Printer specifications are subject to change without notice.

Printing Specifications

Parameter	MZ 220	MZ 320
Print Width	Up to 1.89 in. (48,0 mm)	Up to 2.9 in. (71,2 mm)
Print Speed (max)	3" per second (76,2 mm/second)	
Print Speed (normal)	2" per second (5,0 mm/second)	
Print Head Life, calculated	1 x 10 ⁶ in. (25,4 Km) nominal	
Print Density	203 dots/inch (8 dots/mm)	
Printhead Burn Line to Tear Edge	0.2 in. (5,08 mm)	

Memory and Communications Specifications, MZ series

Flash Memory	8 MB
SRAM	16 MB
Standard Communications	USB 2.0 Full Speed Interface (12 Mbps) & Infrared wireless link (meets IrDA 1.1 communications specifications)
Optional Wireless Communications	Optional Bluetooth compatible module Optional 802.11b/g SRRF module Only one wireless option may be installed in a printer.

Media Specifications

Parameter	MZ 220	MZ 320
Width	2.0 ± .03 in. (50,8 ± 0,8 mm)	3.0 ± .03 in. (76,2 mm ± 0,8 mm)
Max. Width Printable Area	1.9" (48,3 mm)	2.9" (73,7 mm)
Length	Maximum length will vary with the size of loaded applications. Refer to the configuration label for actual maximum label size.	
Label Thickness	.002 in to .004 in (0,050 mm to 0,102 mm)	
Max. Media Roll dia.	1.88 in. (47,8 mm) O.D.	
Label Inner Core Diameter	0.40 to 0.75 in.. (10,2 to 19,0 mm)	
Black Mark Dimensions	The reflective media black marks should extend past the centerline of the roll on the front side of the media. Minimum mark width: 0.59 in. (15 mm) perpendicular to edge of media, centered within the width of the roll. Mark length: 0.19 - 0.24 in. (3,0-6,0 mm) parallel to edge of media	

Use Zebra brand direct thermal or UV resistant coated media that is outside wound. Refer to Appendix "B" for more details.

Font and Bar Code Specifications for MZ Series

Linear & 2-D Bar Bar Codes Available	Codabar (NW-7)
	UCC/EAN 128
	Code 39
	Code 93
	EAN 8/JAN 8, 2 and 5 digit extensions
	EAN 13/JAN 13, 2 and 5 digit extensions
	EAN 14/JAN 14, 2 and 5 digit extensions
	Interleaved 2 of 5
	MSI/Plessey
	FIM/POSTNET
	UPC-A, 2 and 5 digit extensions
	UPC-E, 2 and 5 digit extensions
	QR Code
	MaxiCode
	PDF 417
RSS (Reduced Space Symbology®)	
Composite Symbology®	
Rotation Angles	0°, 90°, 180°, and 270°
Fonts Available	<p>Standard Fonts: 25 bit-mapped fonts; 1 scalable (CG Trimvirate Bold Condensed*)</p> <p>Downloadable optional bit-mapped & scalable fonts via Label Vista software</p> <p>International character sets: Chinese 16 x 16 (trad.), 16 x 16 (simplified), 24 x 24 (simplified); Japanese 16 x 16, 24 x 24 Korean Myang 16 x 16 Greek Hebrew/Arabic</p>

*Contains UFST from Agfa Monotype Corporation

USB Communications Port

Pin#	Signal Name	Type	Description
1	VBUS	-	USB Bus Power
2	USB -	bi-directional	I/O signals
3	USB +	bi-directional	I/O signals
4	USB_ID	-	Identifies A/B connector
5	Return	-	Ground

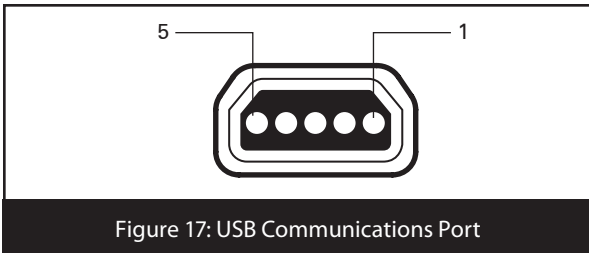

Figure 17: USB Communications Port

Physical, Environmental and Electrical Specifications

Parameter	MZ 220	MZ 320
Weight w/ battery, excluding media	.70 lbs. (317,5 g.)	.75 lbs. (340,2 kg.)
Temperature	Operating : 14° to 122° F (-10° to 50° C)	
	Charging: 32° to 104° F (-0° to 40° C)	
	Storage w/o battery: -4° to 140° F (-25° to 60° C)	
	Storage w/ battery: -4° to 113° F (-25° to 45° C)	
Relative Humidity	Operating: 10% to 90% (non-condensing)	
	Storage: 10% to 90% (non-condensing)	
Battery	Lithium-Ion, 7.4 VDC (nominal); 1500 mAHr.	
Printer Input Power	12.0 VDC; 1.25A	
Ingression Protection (IP) Rating	42	

continued

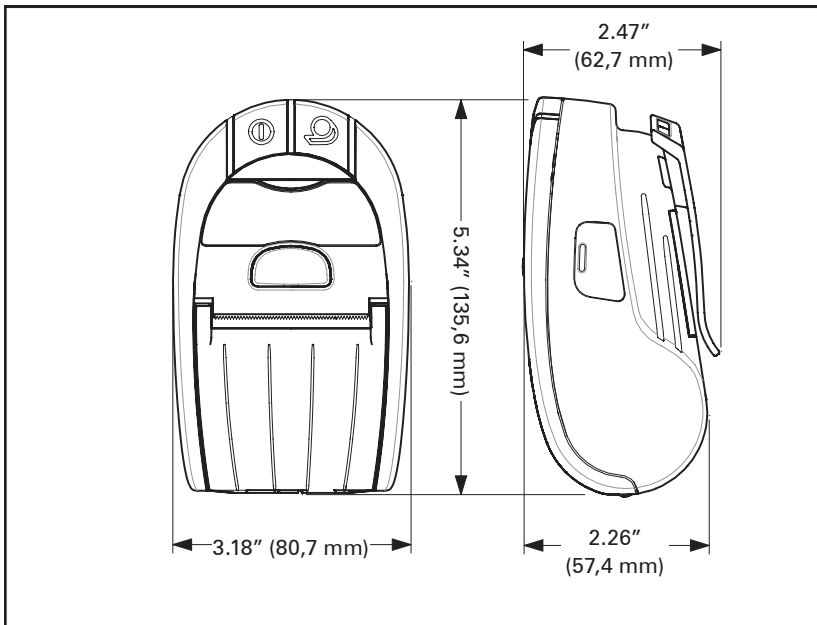

Figure 18: MZ 220 Overall Dimensions

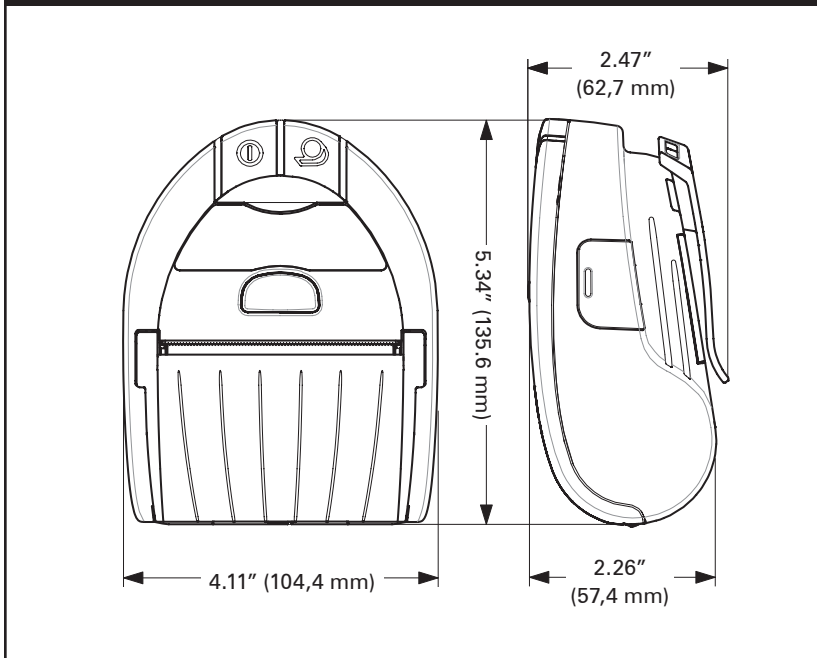

Figure 19: MZ 320 Overall Dimensions

MZ Series Accessories

Description	MZ 220	MZ 320
Adjustable shoulder strap	•	•
Protective soft case	•	•
Vehicle Adapter Cable	•	•
Extra battery packs	•	•
MZ Series Quad Power Station 100-240 VAC	•	•



Refer to Appendix A for information on Data I/O Cables
For more details on available accessories, contact your authorized
Zebra re-seller.

Appendix A

Interface Cables

USB Cable

Part Number AT17010-1; USB A to USB Mini B Cable

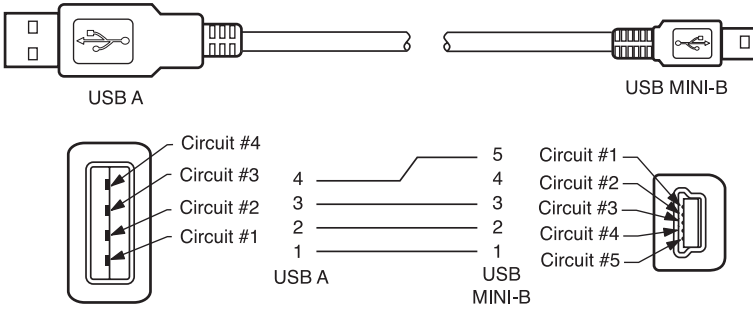

MORE INTERFACE CABLES



Contact the Factory or your Zebra Sales Representative for more information on interface cables to most major manufacturer's data terminals.

You may also visit the Zebra Web site at <http://www.zebra.com> for a listing of interface cables for all series of Zebra mobile printers

Appendix B

Media Supplies

To insure maximum printer life and consistent print quality and performance for your individual application, it is recommended that only media produced by Zebra be used.

Advantages include:

- Consistent quality and reliability of media products.
- Large range of stocked and standard formats.
- In-house custom format design service.
- Large production capacity which services the needs of many large and small media consumers including major retail chains world wide.
- Media products that meet or exceed industry standards.

MZ Series Media

Z-Select 4000D 3.2 mil Receipt				
Width x Length	Part #	Length	Rolls/Carton	Wt/Carton
2.00" (50,8 mm) x Cont.	10011043	55' (16,76 M)	36	9 lbs.
3.00" (76,2 mm) x Cont.	10011044	55' (16,76 M)	36	13 lbs.
Z-Select 1000D 2.4 mil Receipt				
Width x Length	Part #	Length	Rolls/Carton	Wt/Carton
2.00" (50,8 mm) x Cont.	10011041	80' (24,39 M)	36	9 lbs.
3.00" (76,2 mm) x Cont.	10011042	80' (24,39 M)	36	13 lbs.

For more information call Zebra Technologies Corporation at +1.866.230.9495 (U.S., Canada and Mexico) and ask to speak to a Media Sales Representative.

Appendix C

Maintenance Supplies

In addition to using quality media provided by Zebra, it is recommended that the printer be cleaned as prescribed in the maintenance section. The following items are available for this purpose:

- Cleaning Pen (12 pack), Reorder No. 105950-035

Appendix D

Battery Disposal



The EPA certified RBRC® Battery Recycling Seal on the Lithium-Ion (Li-ion) battery supplied with your printer indicates Zebra Technologies Corporation is voluntarily participating in an industry program to collect and recycle these batteries at the end of their useful life, when taken out of service in the United States or Canada. The RBRC program provides a convenient alternative to placing used Li-ion batteries into the trash or the municipal waste stream, which may be illegal in your area.



Important • When the battery is worn out, insulate the terminals with tape before disposal

Please call 1-800-8-BATTERY for information on Li-ion battery recycling and disposal bans/restrictions in your area. Zebra Technologies Corporation’s involvement in this program is part of our commitment to preserving our environment and conserving our natural resources.

Outside North America, please follow local battery recycling guidelines.

Product Disposal



Do not dispose of this product in unsorted municipal waste. This product is recyclable. Please recycle according to your local standards. For more information, please see our web site at: <http://www.zebra.com/recycle>.



Appendix E

Product Support

When calling with a specific problem regarding your printer, please have the following information on hand:

- Model number/type (e.g. MZ 220)
- Unit serial number
- Product Configuration Code (PCC)

For Product Support Contacts, see the table on the next page or contact your local re-seller.

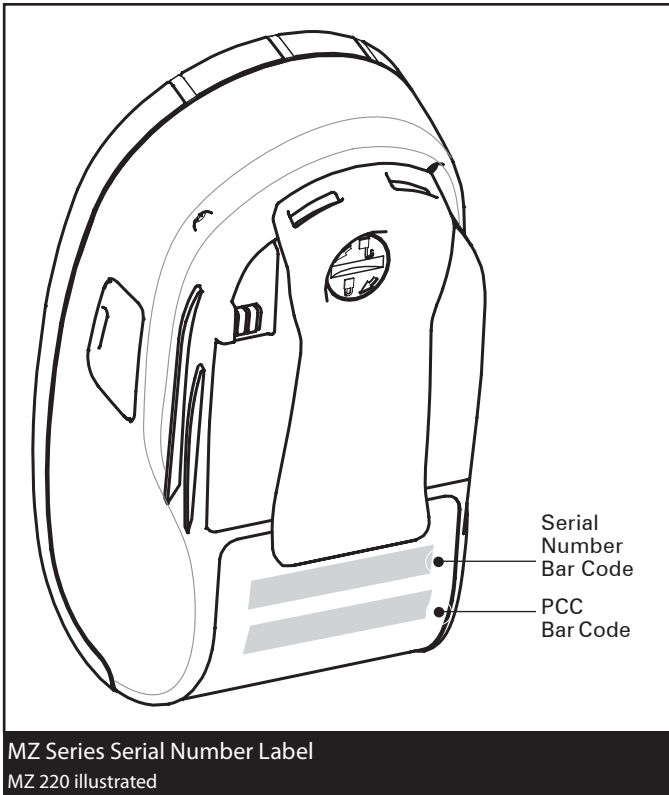

Product Support Contacts

In the Americas contact

Regional Headquarters	Technical Support	Customer Service Dept.
Zebra Technologies Corporation 475 Half Day Road, Suite 500 Lincolnshire, Illinois 60069 U.S.A T: +1 847 634 6700 Toll-free +1 800 423 0422	T: +1 847 913 2259 F: +1 847 913 2578 Hardware: hwtsamerica@zebra.com Software: swtsamerica@zebra.com	For printers, parts, media, and ribbon, please call your distributor, or contact us. T: +1 866 230 9494 F: +1 847 913 8766 E: VHCustServ@zebra.com

In Europe, Africa, the Middle East, and India contact

Regional Headquarters	Technical Support	Internal Sales Dept.
Zebra Technologies Europe Limited Dukes Meadow Millboard Road Bourne End Buckinghamshire SL8 5XF, UK T: +44 (0) 1628 556000 F: +44 (0) 1628 556001	Self Service Knowledgebase: www.zebra.com/knowledgebase Email Back Technical Library: Send email to: emb@zebra.com Subject: Emallist On-Line case registration: www.zebra.com/techrequest	For printers, parts, media, and ribbon, please call your distributor, or contact us. T: +44 (0) 1494 768316 F: +44 (0) 1494 768244 E: mseurope@zebra.com

In the Asia Pacific region contact

Regional Headquarters	Technical Support	Customer Service
Zebra Technologies Asia Pacific, LLC 71 Robinson Road #05-02/03 Singapore 068895 T: +65 6858 0722 F: +65 6885 0838	T: +65 6858 0722 F: +65 6885 0838 E: tsasiapacific@zebra.com com	For printers, parts, media, and ribbon, please call your distributor, or contact us. T: +65 6858 0722 F: +65 6885 0837

Appendix F

Using zebra.com

The following details using the search functions on Zebra's Web site www.zebra.com for finding specific documents .

Go to <http://www.zebra.com/us/en/support-downloads.html>
Select the appropriate printer in the Printer Support dropdown menu.

ZEBRA TECHNOLOGIES Solutions Products & Services Support & Downloads How To Buy Partners

Home > Support & Downloads

SUPPORT & DOWNLOADS

Zebra offers high quality customer care and downloads that support compatibility improvements. Reach out for immediate support today.

Printer Support

Select Printer

- LP 2844-Z Desktop Printer
- Mediatech Software Formats
- MZ 220 Mobile Printer
- MZ 320 Mobile Printer**
- P1001 Card Printer
- P1101 Card Printer
- P110m Card Printer
- P1201 Card Printer
- P205 Card Printer

Accessories

Software

Locations Solutions Support

LE CUSTOMER SUPPORT PORTAL

Repair Center

Learn how to send your Zebra products to our repair center near you.

Submit a Repair Order »

Locate a Repair Center »

Support Questions

Hardware »

Software »

Select printer model (e.g. MZ 320)

allows end-users to address their needs, reduce the soft costs associated with down printers and increase up-time, and realize a comprehensive offering of service options.

Learn More »

HP145 Fax88 »

Click on the Manuals tab and select the desired language from the dropdown menu.

SUPPORT FOR THE MZ 320 MOBILE PRINTER

Simplify transactions and print three inch-wide receipts quickly and easily from the palm of your hand with Zebra's compact and easy-to-carry mobile printer.

ONLINE TECH SUPPORT

Technical Support Links

- Submit a Repair Order »
- Contact Technical Support »
- Check Warranty or Service Agreement Status »

Related Product Information

- Product Details »
- Software »
- Service Contracts »
- Register Your Product »
- Regional Information »

Drivers Firmware & Service Packs Software & Utilities **Manuals**

English

Select language

Model (en)

Series User Guide (EN)- LMAN-MZ3-006 rev A

At the resulting screen, select "MZ Series User Guide (en)" or Download to view.

Go to <http://www.zebra.com/us/en/support-downloads/mobile/mz-320.html>
 Click on Software & Utilities tab to download Label Vista.

SUPPORT FOR THE MZ 320 MOBILE PRINTER

Simplify transactions and print three-inch-wide receipts quickly and easily from the palm of your hand with Zebra's compact and easy-to-carry mobile printer.

ONLINE TECH SUPPORT

Technical Support Links

- Submit a Repair Order »
- Contact Technical Support »
- Check Warranty or Service Agreement Status »

Related Product Information

- Product Details »
- Software »
- Service Contracts »
- Register Your Product »
- Warranty Information »

Drivers **Firmware & Service Packs** **Software & Utilities** **Manuals**

Recommended	Version	Operating System	Download
Zebra Setup Utilities (Learn More)	v1.19.1000	Windows>P Windows Vista, Windows 2008, Windows 2003, Windows 7, Windows 8	Download (6 MB)

SUPPORT FOR THE MZ 320 MOBILE PRINTER

Simplify transactions and print three-inch-wide receipts quickly and easily from the palm of your hand with Zebra's compact and easy-to-carry mobile printer.

ONLINE TECH SUPPORT

Technical Support Links

- Submit a Repair Order »
- Contact Technical Support »
- Check Warranty or Service Agreement Status »

Related Product Information

- Product Details »
- Software »
- Service Contracts »
- Register Your Product »
- Warranty Information »

Drivers **Firmware & Service Packs** **Software & Utilities** **Manuals**

Utilities	Description	Operating System	System Requirements	Download
Label Vista	Label Vista™ is free software for designing labels for CPCL-compatible Zebra mobile or Combar mobile printers.	Windows XP		Download (4 MB) »

Click on "Download" to download Label Vista to your local drive

Index

A

Accessories

- Belt clip 26
- list of 43
- Shoulder Strap 27

B

Battery, charging 12

- MZ Series Charger Power Supply 13
- using Quad Power Station 14

Battery, installing 10

Battery life, tips for extending 28

Battery, removing 11

Bluetooth Device Address (BDA) 24

Bluetooth™ Networking Overview 24

C

Cleaning

- general instructions 29

Communications

- infrared (IR) 23
- USB
 - Connector signals 41
 - with a cable 22

Communications diagnostics 34

Configuration Label

- printing 34
- to determine maximum label size 37,?39

D

Damage, shipping 8

L

Label Vista 25

- use in troubleshooting 34

M

Manual

- CPCL Programming 8,?25

Media

- loading 16
- pre-printed 17

O

Operator Controls 19

P

Programming language

- CPCL 8

R

Radio options.?See Wireless communications

S

Safety Precautions

- placement of charger 15
- while charging batteries 15

Software 25

Specifications

- Font/bar Code 40
- Memory/communications 39
- Physical 41
- printing 39

T

Technical Support, contacting 35

Troubleshooting

- Communications Diagnostics Mode 34
- control panel indicators 31

Troubleshooting tests 34

- printing a configuration label 21,?34
- QL configuration label example 33,?36

Troubleshooting Topics 31

W

Wireless communications

- Bluetooth™ radio 24
- Infrared (IrDA) 23
- WLAN Overview 25

Patent Numbers

This product and/or its use may be covered by one or more of the following US patents and corresponding international patents worldwide

D 275,286	5,029,183	5,367,151	5,552,592	6,068,415
D 347,021	5,047,617	5,372,439	5,570,123	6,068,415
D 389,178	5,103,461	5,373,148	5,578,810	6,095,704
D 430,199	5,113,445	5,378,882	5,589,680	6,109,801
D 433,702	5,140,144	5,396,053	5,612,531	6,123,471
D 549,768	5,132,709	5,396,055	5,642,666	6,147,767
3,964,673	5,142,550	5,399,846	5,657,066	6,151,037
4,019,676	5,149,950	5,408,081	5,768,991	6,201,255 B1
4,044,946	5,157,687	5,410,139	5,790,162	6,231,253 B1
4,360,798	5,168,148	5,410,140	5,791,796	6,261,009
4,369,361	5,168,149	5,412,198	5,806,993	6,261,013
4,387,297	5,180,904	5,415,482	5,813,343	6,267,521
4,460,120	5,229,591	5,418,812	5,816,718	6,270,072 B1
4,496,831	5,230,088	5,420,411	5,820,279	6,285,845 B1
4,593,186	5,235,167	5,436,440	5,848,848	6,292,595
4,607,156	5,243,655	5,444,231	5,860,753	6,296,032
4,673,805	5,247,162	5,449,891	5,872,585	6,364,550
4,736,095	5,250,791	5,449,893	5,874,980	6,379,058 B1
4,758,717	5,250,792	5,468,949	5,909,233	6,409,401 B1
4,816,660	5,262,627	5,479,000	5,976,720	6,411,397 B1
4,845,350	5,267,800	5,479,002	5,978,004	6,428,227 B2
4,896,026	5,280,163	5,479,441	5,995,128	6,530,705
4,897,532	5,280,164	5,486,057	5,997,193	6,540,122
4,923,281	5,280,498	5,503,483	6,004,053	6,607,316
4,933,538	5,304,786	5,504,322	6,010,257	6,609,844
4,992,717	5,304,788	5,528,621	6,020,906	6,874,958
5,015,833	5,321,246	5,532,469	6,034,708	6,899,477
5,017,765	5,335,170	5,543,610	6,036,383	
5,021,641	5,364,133	5,545,889	6,057,870	



www.zebra.com

Zebra Technologies Corporation

475 Half Day Road, Suite 500

Lincolnshire, IL 60069 USA

T: +1 847.634.6700 or +1 800.423.0442