

VnM SignMaker, Safety Signs & Labels

User Manual

Version 2.2D

Updated: 1/2017



VnM 8 SignMaker





TABLE OF CONTENTS

Introduction	2
Quick Start	3
Overview	4
Loading Ink Roll	5
Loading Media	6
Power Up	7
Print and Font Settings	8
Keypad Navigation	9
VnM®8 Templates	
a) 1 to 5 Line Horizontal	10
b) 1 Line Vertical	11
c) 2 Line Horizontal	12
d) Multi Line Header	13
e) ANSI Header	14
f) Die Cut	15
g) Arc Flash	16
h) Custom 1 Line	17
i) Hazardous Waste	18
j) VnM8 Apps	19
OSHA and ANSI Safety Identification	20
Fonts and Symbols	21-22
Connecting to a PC	23
Maintenance/Troubleshooting	24
Accessories	25
Frequently Asked Questions	25
Technical Support/Service and Repair	26

Introduction

Thank you for purchasing the VnM®8 SignMaker by Cobra Systems, Inc.

Throughout this manual you will find User Tips, Troubleshooting, and step-by-step instructions that will show you how to create signs and labels that are perfect for all of your safety and identification requirements.

Specifications

Dimensions:	17.32" (W) x 13.23" (H) x 20.24" (D)
Operating Conditions:	41°-104° F (5°-40° C)
Storage Conditions:	-40°-140° F (-40°-60° C)
Resolution:	300 DPI
AC Input:	100-240V, 3.0a, 50-60Hz
DC Output:	24V, 8.33A, 200W
Print Speed:	4" per second
Connections:	VnM® Keypad, USB, LPT, Ethernet 10/100

Warranty

VnM®8 SignMaker comes with a Limited Lifetime Warranty, 1-Year Print-head Warranty, 6-Month Cutter Warranty, and 1-Year Keypad Warranty.

Out of the Box

The VnM®8 SignMaker System includes:

1. VnM®8 SignMaker Printer (1)
2. VnM®8 SignMaker Keypad (1)
3. Printer Power Cord (1)
4. Printer USB Cable (1)
5. Take-Up Core for VnM® Ink (1)
6. Cleaning Pen (1)

①



②



③



⑤



④



⑥



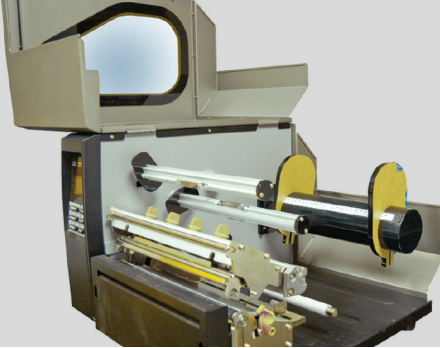

PRINTER MUST BE TURNED OFF!

1. Open the VnM8 SignMaker.

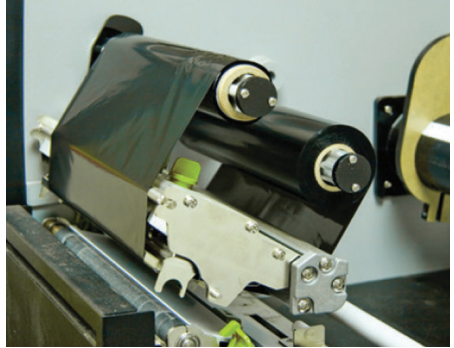

2. Load VnM Ink Roll and attach to take up core.

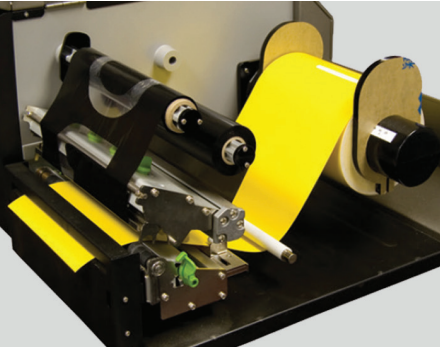

3. Load VnM Media and feed through VnM8 Cutter.



4. Be sure to use both hands when closing down the print head.

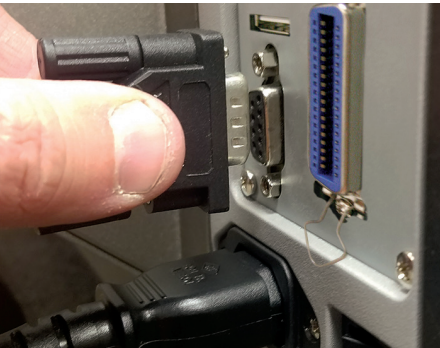

5. Plug in VnM8 Keypad.



6. Connect power cord to the VnM8 SignMaker and outlet. Turn ON VnM8 SignMaker.

NOTE: Always have the VnM printer cover closed when powering on.



VnM8 SignMaker Front View

- 1. LED indicators
- 2. Touchscreen
- 3. Operation buttons
- 4. Media exit chute
- 5. Printer cover opener

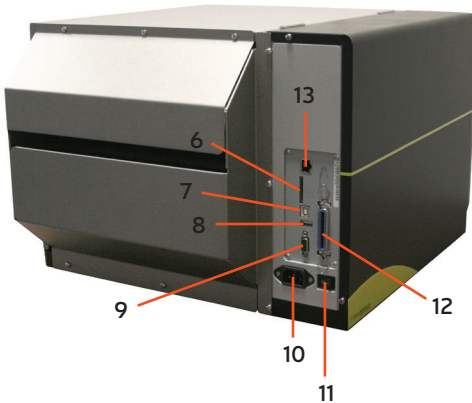

VnM8 SignMaker Rear View

- 6. SD card socket
- 7. USB interface
- 8. USB host
- 9. GPIO interface
- 10. Power cord socket
- 11. Power switch
- 12. Centronics interface
- 13. Ethernet interface

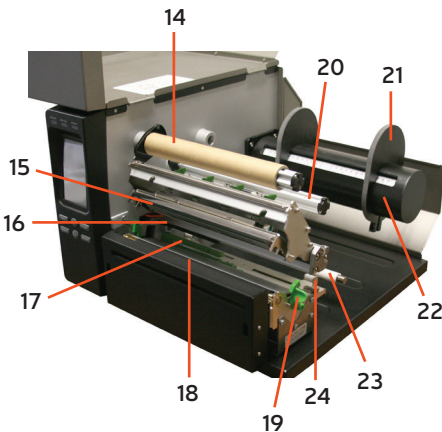

VnM8 SignMaker Interior View

- 14. Ribbon rewind spindle
- 15. Print head
- 16. Ribbon sensor
- 17. Media sensor
- 18. Platen roller
- 19. Print head release lever
- 20. Ribbon supply spindle
- 21. Label roll guard
- 22. Label supply spindle
- 23. Media guide bar
- 24. Label guide

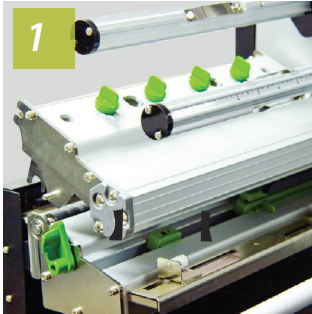

1 With printer turned off, open the cover, press down on the printhead and push back the green lever to raise the printhead.



2 Use the cleaning pen to gently clean the surface of the print head before each ribbon installation.

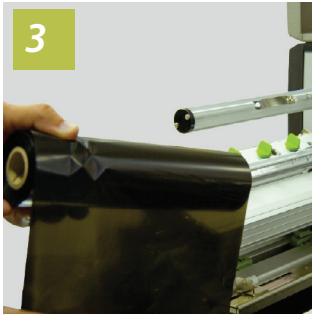

3 Slide VnM8 ink roll onto rear spindle.



4 Center ink roll on spindle and feed above black plastic sensor under printhead.

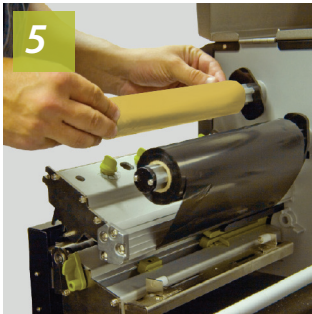

5 Attach empty take-up core to the front ink spindle.

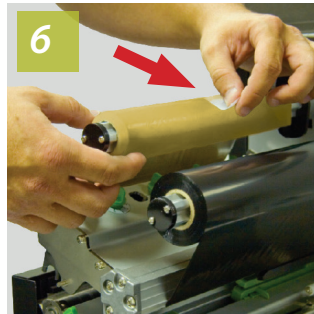

6 Pull ink through and up to the take-up core and securely attach with tape.

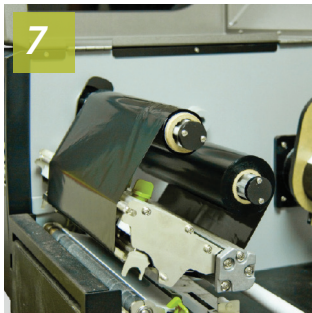

7 Hand wind the ink to remove any slack.



8 With hands on both sides, push down on the printhead until the green latch clicks.

NOTE: Always have the VnM printer cover closed when powering on.

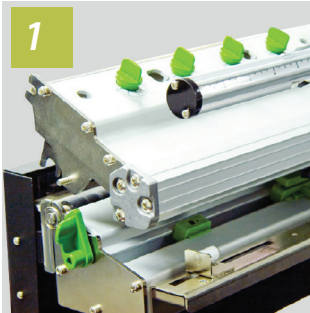

1

With printer turned off, open the cover, press down on the printhead and push back the green lever to raise the printhead.



2

Slide the VnM8 vinyl media onto rear spindle and center.



3

Secure the media spindle with end guides, keeping everything centered.

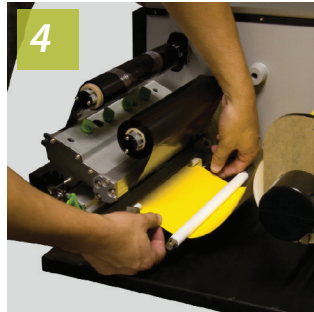

4

Feed media under the white bar and through the white media guides.



5

Now feed the media under the green sensor bar.



6

Pull the media from under the printhead and between the cutter gap.

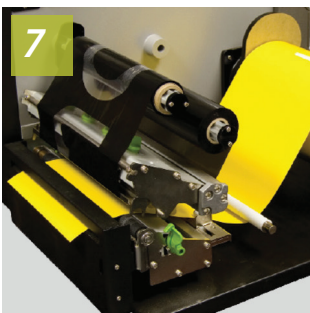

7

Make sure media and ribbon are properly installed.



8

With hands on both sides, push down on the printhead until the green latch clicks.

IMPORTANT: To prevent smudges and fingerprints, handle media on the ends of the roll.

Connecting VnM®8 Keypad and Power Up

1. Make sure power switch is OFF.
2. After connecting the key pad, connect the power supply into the printer.
3. Plug the printer into your power source, **preferably using a surge protector**.
4. Turn on the VnM8.

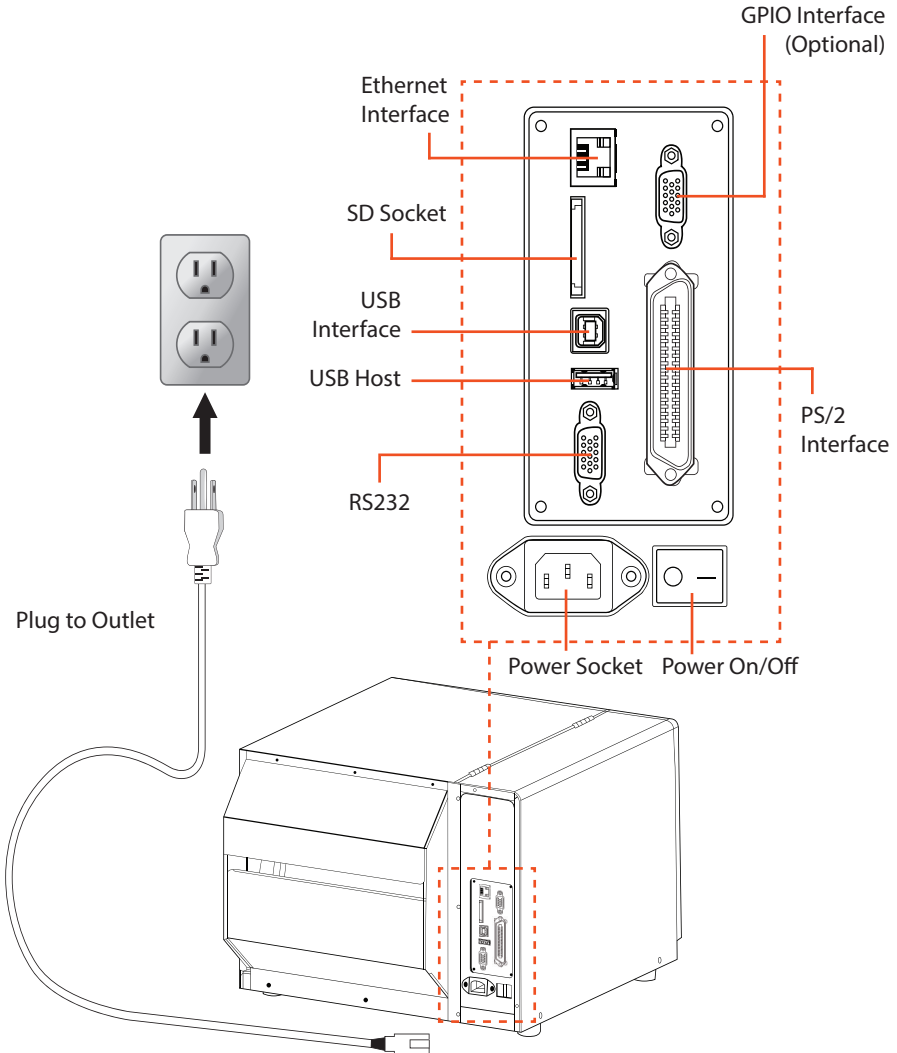

IMPORTANT: Keep all magnetic devices away from the VnM8 printer.

To change print settings for certain VnM inks and media, including font, make sure you are on the main menu; press and hold the ALT + EXIT keys at the same time.

A) To Change Print Settings

1. This should be the first screen you see.

SELECT MEDIA WIDTH:
Press 4,5,6,7, or 8

2. Press the DOWN arrow key until you see VNM PRINT SETTINGS and press ENTER.

VNM PRINT SETTINGS
Press ENTER

3. Using the up and down arrows on the keyboard, locate your desired ink and media and press ENTER.

VNM BLACK INK 1
PRESS ENTER

Standard settings for
VnM Black ink

VNM BLACK INK 2
PRESS ENTER

High Density settings for
VnM Black ink

VNM WHITE INK 1
PRESS ENTER

Standard settings for
VnM White ink

VNM WHITE INK 2
PRESS ENTER

High Density settings for
VnM White ink

LOOK AT VNM MANUAL
TURN CUTTER ON

Turns the cutter on

LOOK AT VNM MANUAL
TURN CUTTER OFF

Turns the cutter off

LOOK AT VNM MANUAL
TURN PARTIAL CUT ON

Turns the partial cut on

LOOK AT VNM MANUAL
BLANK CUT

Turns the blank cut on

4. To manually change the print speed, print density, and /or cutter settings, press ENTER or VNM MANUAL SETTINGS.

VNM MANUAL SETTINGS
Press ENTER

5. Enter the Printer speed and press ENTER. Recommended at 2.

ENTER SPEED:
2

6. Enter the print density and press ENTER. Recommended density based on the ink color being used:

Black: 6-9, White: 10-13

Blue: 2-4, Green: 2-4, Red: 2-4

ENTER DENSITY:
5

B) To Change Font Settings

1. This should be the first screen you see.

SELECT MEDIA WIDTH:
Press 4,5,6,7, or 8

2. Press the UP arrow key until you see SELECT FONT/SYMBOLS and press ENTER.

SELECT FONT/SYMBOLS
Press ENTER

3. Using the up and down arrows on the keyboard, locate your desired font and press ENTER. To get back to the main menu after you have selected your font, hold down ALT and EXIT.

CHOOSE FONT/SYMBOLS:
BOLD

CHOOSE FONT/SYMBOLS:
NORMAL

CHOOSE FONT/SYMBOLS:
SYMBOLS3

CHOOSE FONT/SYMBOLS:
SYMBOLS2

CHOOSE FONT/SYMBOLS:
SYMBOLS1

CHOOSE FONT/SYMBOLS:
PIPE MAKER

CHOOSE FONT/SYMBOLS:
UTILITY

CHOOSE FONT/SYMBOLS:
ITALIC

NOTE: See pages 21-22 for fonts and symbols.

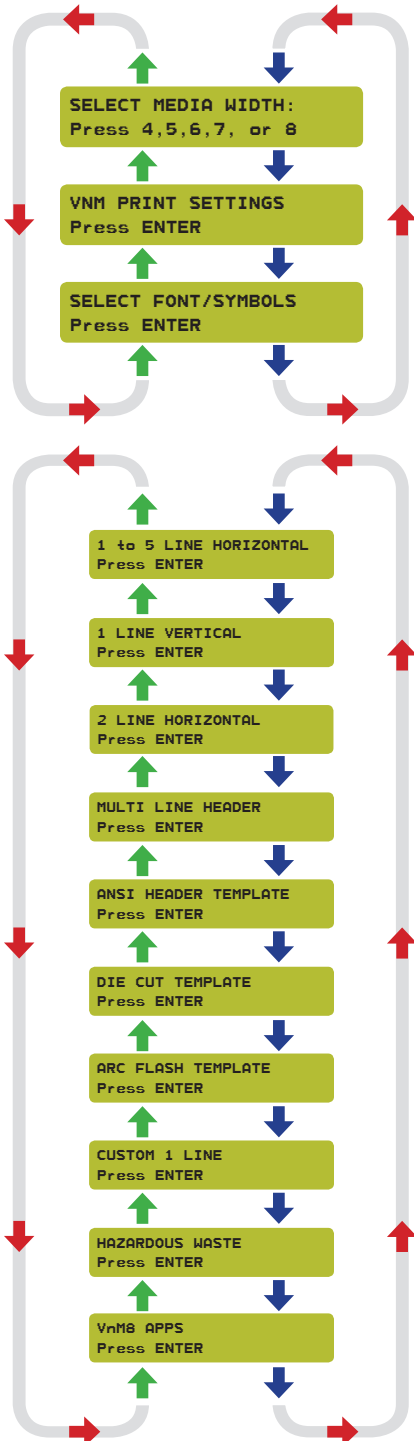

The VnM®8 keypad navigation tree on the left displays the flow and order of all the available options/templates.

Detailed information about each template starts on page 10.

VnM®8 SignMaker Prompt: MAIN MENU

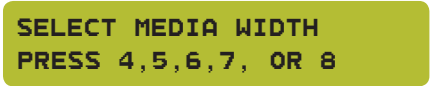

“SELECT MEDIA WIDTH” is the Main Menu when powering on the VnM 8 SignMaker, and when pressing the ALT + EXIT keys.



To begin printing, select the size of media that is loaded in the printer.

Use the UP and DOWN arrow keys on the VnM®8 Keypad to navigate through the templates. Press the ENTER key to select your template.



If an entry error has been made, press the EXIT key and re-enter the information.

VnM8 Tips
HOW TO PRINT QUOTATIONS

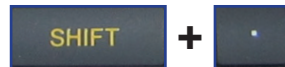

In order to print quotations (") or inch and foot marks, press the SHIFT key + PERIOD key (on the numeric keypad). Do not use the keypad QUOTATION key, you will have blank text.

The 1 to 5 Line Horizontal template is the most versatile template for the VnM®8 SignMaker. Create anything from 1 to 5 lines of text and your font size will adjust automatically to your selected media size.

The CAUTION sign below was created by selecting the SYMBOLS1 font (explained on page 8). Select the 1 to 5 LINE HORIZONTAL template and choose 1 for the number of lines to be printed. For this CAUTION sign, you will enter: /CAUTION (The / mark represents the CAUTION symbol.) To use any other symbols, use the reference chart on pages 21-22.



a) 1 Line Template sign, no (N) reverse text printing, using SYMBOLS1 font

1 to 5 LINE HORIZONTAL
Press ENTER

X INCH - HOW MANY LINES?
Press 1,2,3,4, or 5

ENTER LINE 1:
/CAUTION

ENTER QUANTITY TO PRINT:
1

RESERVE TEXT?
1. (Y)ES or 2. (N)O

1. Select the 1 to 5 LINE HORIZONTAL template by pressing the ENTER key on the keyboard.
2. Select how many lines of text to print by pressing the numbers 1, 2, 3, 4, or 5. DO NOT PRESS ENTER.
3. Enter the text/symbols for your sign and press ENTER when finished.
4. Enter the quantity of signs to print and press ENTER.
5. Select if you would like REVERSE TEXT. Press Y or 1 for Yes, Press N or 2 for No.



b) 1 Line Template, (Y) reverse text

VnM8 Tips

TO GET BACK TO THE MAIN MENU PRESS AND HOLD THE ALT AND EXIT BUTTONS AT THE SAME TIME.

The 1 Line Vertical template allows you to easily create instant vertical signs and labels. The samples below were created with our 1 Line Vertical template.



a) No (N) reverse text



b) Reverse (Y) text



c) SYMBOLS1 font

1 LINE VERTICAL
Press **ENTER**

ENTER TEXT:
EXIT

ENTER QUANTITY TO PRINT:
1

REVERSE TEXT?
1.(Y)ES or 2.(N)O

1. Select the 1 LINE VERTICAL template by pressing the ENTER key.
2. Enter the text/symbols for your vertical sign and press ENTER.
3. Enter the quantity of signs to print and press ENTER.
4. Select if you would like reverse text. Press Y or 1 for Yes, Press N or 2 for No.

VnM8 Tips

**IF YOU ARE USING A
8 INCH MEDIA, TRY USING
A 6 INCH TEMPLATE TO GET
A SMALLER FONT**

The 2 Line Horizontal template allows you to create signs with two different sizes of type, samples a) and b). The samples below were created with the 2 Line Horizontal template.

**BOILER WATER
TO BOILER #5**

a) 2 Line Horizontal

**LABORATORY
ROOM 602**

b) 2 Line Horizontal

**2 LINE HORIZONTAL
PRESS ENTER**

**Enter LINE 1:
BOILER WATER**

**Enter LINE 2:
TO BOILER #5**

**ENTER QUANTITY TO PRINT:
1**

1. Select the 2 Line Horizontal template by pressing the ENTER key.
2. Enter the text/symbols for your first line of your sign and press ENTER.
3. Enter the text/symbols for your second line of your sign and press ENTER.
4. Enter the quantity to print and press ENTER.

VnM8 Tips

**MAKE SURE YOU ARE USING
THE RIGHT PRINT SETTING
WITH THE PROPER INK
AND MEDIA**

The Multi Line Header template is perfect for creating custom header signs with any necessary text. The samples below were created with our Multi Line Header template.

SYMBOLS1 font is selected first then choose the Header template and press ENTER. For the Header line, "/CAUTION" is shown on the keypad, press ENTER. Then enter the information for the 1st, 2nd, 3rd and 4th line. The "/" seen on the keypad (after SYMBOLS1 font is chosen) translates to the yield symbol.



a) SYMBOLS1 font, 3 Line Header



b) 2 Line Header

NOTE: Keep in mind the 4 lines below the header are always standard BOLD font even if you change the symbol. You do not have to print 4 extra lines when using the Multi Line Header template.

**MULTI LINE HEADER
PRESS ENTER**

**X INCH-HOW MANY LINES?
PRESS 1,2,3, OR 4**

**ENTER HEADER :
/CAUTION**

**ENTER LINE 1 :
DO NOT STAND**

**ENTER LINE 2 :
WITHIN 25 FEET**

**ENTER LINE 3 :
OF MACHINERY**

**ENTER QUANTITY TO PRINT :
1**

1. Select the Multi Line Header template by pressing the ENTER key.
2. Enter the media width by pressing the number 1, 2, 3, or 4. DO NOT PRESS ENTER.
3. Enter the text/symbols for the header and press ENTER.
4. Enter the text/symbols for your first line of text and press ENTER.
5. Enter the text/symbols for your second line of text and press ENTER.
6. Enter the text/symbols for your third line of text and press ENTER.
7. Enter the quantity to print and press ENTER.

The ANSI header template is perfect for creating Caution, Danger, Warning, Notice, and Safety signs. 1 to 4 lines of additional text can be added to customize your sign. The samples below were created with our ANSI templates.



a) ANSI, DANGER, 2 lines



b) ANSI, NOTICE, 3 lines



c) ANSI, WARNING, 4 lines

NOTE: ANSI signs offer two sizes only: 5" x 7" and 7" x 10", utilizing the 5" or 7" width vinyl. Based on the sign's content, text will automatically adjust to the signs width.

ANSI HEADER TEMPLATE
Press ENTER

DANGER HEADER?
Press ENTER

X INCH - HOW MANY LINES?
Press 1, 2, 3, or 4

ENTER LINE 1:
HIGH

ENTER LINE 2:
VOLTAGE

ENTER QUANTITY TO PRINT:
1

1. Select the ANSI Header template by pressing the ENTER key.
2. Select a header option. Choose from: CAUTION, DANGER, NOTICE, SAFETY, WARNING, or BLANK HEADER and press ENTER.
3. Select how many lines of text to print by pressing the numbers 1, 2, 3, or 4. DO NOT PRESS ENTER.
4. Enter the text/symbols for your first line and press ENTER.
5. Enter the text/symbols for your second line and press ENTER.
6. Enter the quantity of signs to print and press ENTER.

The Die Cut Template is perfect for creating Caution, Danger, Warning, Notice, and Safety signs. This template only works with 7"x10" VnM pre-printed Die Cut labels. The samples below were created with our Die Cut Template.



a) Die Cut, WARNING



b) Die Cut, DANGER



c) Die Cut, DANGER2



d) Die Cut, CAUTION



e) Die Cut, NOTICE

DIE CUT TEMPLATE
Press ENTER

X INCH - HOW MANY LINES?
Press 1,2,3, or 4

ENTER LINE 1:
HOT

ENTER LINE 2:
SURFACE

ENTER QUANTITY TO PRINT:
1

1. Select DIE CUT TEMPLATES by pressing the ENTER key.
2. Select how many lines of text to print by pressing the numbers 1, 2, 3, or 4. DO NOT PRESS ENTER.
3. Enter the text/symbols for your first line and press ENTER.
4. Enter the text/symbols for your second line and press ENTER.
5. Enter the quantity of signs to print and press ENTER.

The Arc Flash Templates meets the NEC electrical code for “Arc flash hazard warnings” which are required to reduce the occurrences of serious injury, or death, due to arcing faults to individuals working on or near energized electrical equipment. The samples below were created with our Arc Flash Template.



a) 7 X 10 INCHES



a) 4 X 7 INCHES

**SELECT MEDIA WIDTH:
PRESS 4, 5, 6, 7, OR 8**

1. Select media width 4" or 7" only by pressing the number. DO NOT PRESS ENTER.

**ARC FLASH TEMPLATE
PRESS ENTER**

2. Select ARC FLASH TEMPLATE and press ENTER.

**ENTER QUANTITY TO PRINT:
1**

3. Enter the quantity to print and press ENTER.

NOTE: Must use 4" or 7" Orange VnM8 Premium Vinyl or Engineer Grade Reflective media for the arc flash template.

VnM8 Tips

**TO GET BACK TO THE
MAIN MENU PRESS AND
HOLD DOWN THE ALT KEY
AND EXIT BUTTON**

The Custom 1 Line template is a great way to label parts bins, 5S and Tool applications. The samples below were created with our Custom 1 Line template.



a) 4 x 1 inches (actual size)

CUSTOM 1 LINE
Press **ENTER**

X X ?
Press **1** or **2**

ENTER LINE 1:
140 VOLTS

ENTER QUANTITY TO PRINT:
1

1. Select the CUSTOM 1 LINE template by pressing the ENTER key.
2. Enter the second dimension which represents the HEIGHT of the label: Press 1 for 1" and 2 for 2".
3. Enter text and/or symbols for the line of text and press ENTER.
4. Enter quantity of labels to print and press ENTER.

NOTE: Text copy will be condensed or expanded to accommodate the width & height of the media and size selection.



b) 4 x 2 inches (actual size)

Print the California Hazardous Waste Labels using the VnM8 SignMaker.

**Hazardous Waste
PRESS ENTER**

1. Select the Hazardous Waste template by pressing ENTER. From here you can print the hazardous waste label, set the company contact info and set the date/time settings.

Print Label

ENTER EPA ID#:	ENTER CA WASTE #:
ENTER MANIFEST DOC #:	ENTER CONTENTS COMP L1:
ENTER EPA WASTE #:	ENTER CONTENTS COMP L2:

ADMINISTRATION

Enter Company ABC COMPANY	Enter State: CA
Enter Street Address 123 MAIN ST.	Enter Zip Code: 92001
Enter City: LOS ANGELES	Enter Phone Number: 555 874 4569

DATE/TIME SETUP

FOUR Digit Year 2016	Enter Hour (0-23): 11
Enter Month (1-12): 9	Enter Minute (0-59): 5
Enter Day (1-31): 21	

**SELECT PHYSICAL STATE
SOLID**



2. Select Print Label to begin filling out the Hazardous Waste Label form.

2a-f. Enter the information prompted to complete the label.

3. Select Administration to enter the contact information.

3a-f. Enter the information prompted to complete the company information to be printed on all Hazardous Warning Labels.

4. Select Date/Time Setup to synchronize the VnM8 Keypad to a real time clock.

4a-e. Enter the date and time information as prompted on the screen.

5. To Select the Physical State and Hazardous Properties, use the UP & Down arrows to navigate to Solid or Liquid and Flammable, Toxic, Corrosive, Reactivity, or other.

Fire Template

1. Scroll to VnM8 APPS and press ENTER.
2. Select FIRE EXTINGUISHER and press ENTER.
3. Enter the quantity to print and press ENTER.



a) Ext. 4x18

Eye Wash Template

1. Scroll to VnM8 APPS and press ENTER.
2. Select EYE WASH and press ENTER.
3. Enter the quantity to print and press ENTER.



b) Eye Wash Template 5x7

Safety signs are an important element to safety and hazard identification. Identifying hazards cuts down on employee injuries and can save lives. Examples of standards when indicating certain situations or hazards:

DANGER

Indicates an immediate hazard that has a high probability of severe injury or death.



ANSI Danger for Arc Flash Labels

WARNING

Indicates a potentially hazardous situation that if not avoided may result in serious injury or death.



ANSI Warning for Arc Flash Labels

CAUTION

Indicates a potentially hazardous situation that may result in minor or moderate injury, but not death.



ANSI Caution for Arc Flash Labels

NOTICE

Indicates general information necessary to avoid any confusion.



ANSI and OSHA header templates are for the VnM4 and VnM8 SignMaker's, in addition to header die cut media.

SAFETY

Indicates general information necessary to avoid any confusion.





























Create your sign in seconds and save money and time.

VnM® 8 Fonts and Symbols

The SELECT FONT/SYMBOLS template includes 5 different fonts and 3 different symbol options using the legend below. Choose the appropriate symbol(s) for your sign.

Keypad	1	2	3	4	5	6	7	8	9	-	+	!	@	#	\$	%	^	&	*	()	€	=	;	/	?
Normal	1	2	3	4	5	6	7	8	9	-	+	!	@	#	\$	%	^	&	*	()	€	=	;	/	?
Italic	1	2	3	4	5	6	7	8	9	-	+	!	@	#	\$	%	^	&	*	()	€	=	;	/	?
Bold	1	2	3	4	5	6	7	8	9	-	+	!	@	#	\$	%	^	&	*	()	€	=	;	/	?
Pipe Marker	1	2	3	4	5	6	7	8	9	-	+	!	@	#	\$	%	^	&	*	()	€	=	;	/	?
Utility	1	2	3	4	5	6	7	8	9	-	+	!	@	#	\$	%	^	&	*	()	€	=	;	/	?
Symbols 1	1	2	3	4	5	6	7	8	9	-	+	!	@	#	\$	%	^	&	*	()	€	=	;	/	?
Symbols 2	1	2	3	4	5	6	7	8	9	-	+	!	@	#	\$	%	^	&	*	()	€	=	;	/	?
Symbols 3	1	2	3	4	5	6	7	8	9	-	+	!	@	#	\$	%	^	&	*	()	€	=	;	/	?

Keypad	a	b	c	d	e	f	g	h	i	j	k	l	m	n	o	p	q	r	s	t	u	v	w	x	y	z
Normal	a	b	c	d	e	f	g	h	i	j	k	l	m	n	o	p	q	r	s	t	u	v	w	x	y	z
Italic	a	b	c	d	e	f	g	h	i	j	k	l	m	n	o	p	q	r	s	t	u	v	w	x	y	z
Bold	a	b	c	d	e	f	g	h	i	j	k	l	m	n	o	p	q	r	s	t	u	v	w	x	y	z
Pipe Marker	a	b	c	d	e	f	g	h	i	j	k	l	m	n	o	p	q	r	s	t	u	v	w	x	y	z
Utility	a	b	c	d	e	f	g	h	i	j	k	l	m	n	o	p	q	r	s	t	u	v	w	x	y	z
Symbols 1	a	b	c	d	e	f	g	h	i	j	k	l	m	n	o	p	q	r	s	t	u	v	w	x	y	z
Symbols 2	a	b	c	d	e	f	g	h	i	j	k	l	m	n	o	p	q	r	s	t	u	v	w	x	y	z
Symbols 3	a	b	c	d	e	f	g	h	i	j	k	l	m	n	o	p	q	r	s	t	u	v	w	x	y	z

Keypad	A	B	C	D	E	F	G	H	I	J	K	L	M	N	O	P	Q	R	S	T	U	V	W	X	Y	Z	
Normal	A	B	C	D	E	F	G	H	I	J	K	L	M	N	O	P	Q	R	S	T	U	V	W	X	Y	Z	
Italic	A	<i>B</i>	<i>C</i>	<i>D</i>	<i>E</i>	<i>F</i>	<i>G</i>	<i>H</i>	<i>I</i>	<i>J</i>	<i>K</i>	<i>L</i>	<i>M</i>	<i>N</i>	<i>O</i>	<i>P</i>	<i>Q</i>	<i>R</i>	<i>S</i>	<i>T</i>	<i>U</i>	<i>V</i>	<i>W</i>	<i>X</i>	<i>Y</i>	<i>Z</i>	
Bold	A	B	C	D	E	F	G	H	I	J	K	L	M	N	O	P	Q	R	S	T	U	V	W	X	Y	Z	
Pipe Marker	A	B	C	D	E	F	G	H	I	J	K	L	M	N	O	P	Q	R	S	T	U	V	W	X	Y	Z	
Utility	A	B	C	D	E	F	G	H	I	J	K	L	M	N	O	P	Q	R	S	T	U	V	W	X	Y	Z	
Symbols 1	A	B	C	D	E	F	G	H	I	J	K	L	M	N	O	P	Q	R	S	T	U	V	W	X	Y	Z	
Symbols 2	A	B	C	D	E	F	G	H	I	J	K	L	M	N	O	P	Q	R	S	T	U	V	W	X	Y	Z	
Symbols 3																											

Review the Fonts and Symbols legend, then select your option from the keyboard column, e.g.: SYMBOLS 1 to print the Skull and Crossbones; hold the shift key and press the ! key. The ! will appear in the keyboard's display, but will print the Skull and Crossbones.

PC Connection for additional template and printing options

1. Download & install the PC VnM SignMaker Print Driver from: vnmsignmaker.com
2. Once the Driver has been installed, go to:
Start > Control Panel > Printers and Faxes
Right mouse click on the VnM SignMaker Printer icon and click on "Properties".
3. Click on Printing Preferences, then click on the "Stock" Tab.

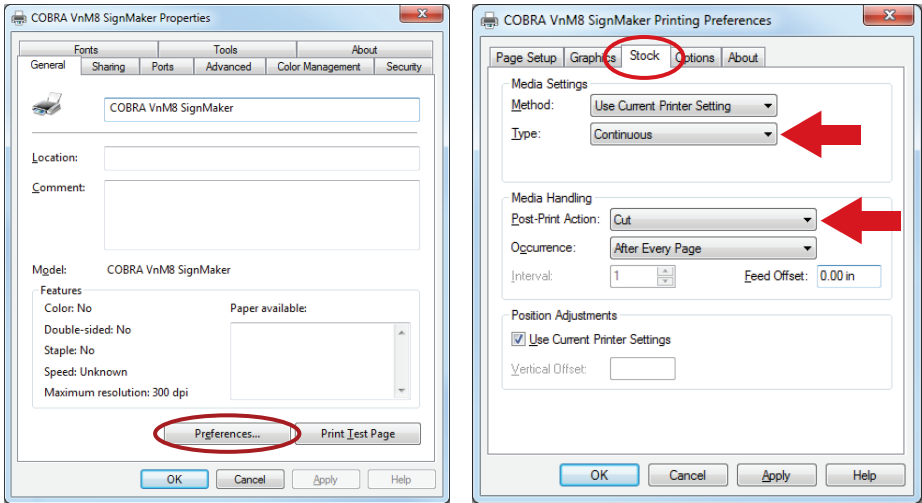

4. Set Stock Type to "Continuous".
5. Set the Post-Print Action to "Cut" and the Occurrence to "After Every Page".
6. Connect USB cable to the PC's USB port.
7. Plug power cord into AC Power Receptacle at the rear of the printer, then plug the power cord into a grounded AC outlet.
8. Print signs and labels on the VnM SignMaker using programs such as Microsoft Word, Adobe Illustrator, and other popular label design software applications such as VnM® LabelDirect.*

*Please note that Cobra Systems does not support custom label design software applications or programs. For technical support on software applications please contact the respective software developer.

Print Head Cleaning

The VnM SignMaker comes with a cleaning pen for the print head. Use the cleaning pen to gently clean the surface of the print head before each ribbon installation. Proper cleaning of the print head will ensure a longer life span of the print head and provide you with a superior print quality.

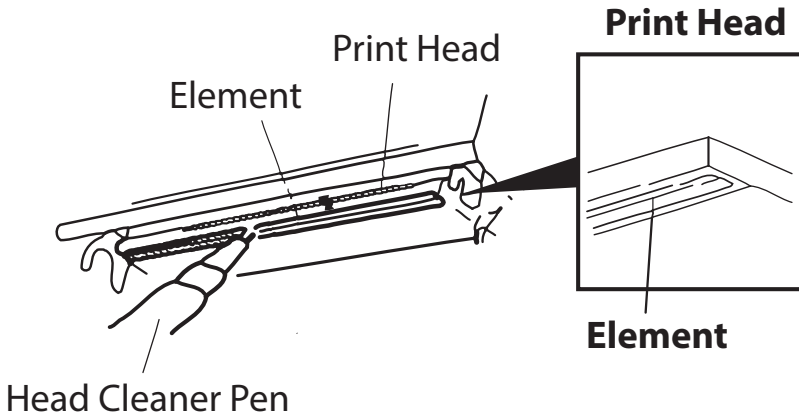

Opening Printer Covers

Do not open printer covers when the unit is powered on as this will cause an error. If done accidentally, turn printer off and close covers completely, then power back on.

VnM SignMaker Troubleshooting

ISSUE: The Ink Ribbon comes out through the cutter after loading a new roll.

Remedy: The Ink Roll was changed while the printer was powered on. Turn the printer off, re-tape the Ink Roll to the take-up core and close the printer cover. Turn the power back on and the ink roll sensor will reset.

ISSUE: The red light on the printer is flashing.

Remedy: Turn the printer off and then on.

ISSUE: Print quality is inconsistent and blotchy after loading new media.

Remedy: Check the test print section on the VnM keyboard for the correct print setting. For optimal print quality, and to keep the media and ribbon fingerprint-free, minimize direct contact with the media.

VnM®8 SignMaker accessories sold separately, include:

VnM® Label Direct Sign Software



Frequently Asked Questions

- Q: How do I get out of a VnM® template? A: To return to the main menu, or if you made an entry error, press the ALT + EXIT keys.
- Q: How do I correct a spelling or entry error? A: To correct the word you just typed, use the larger arrow, bottom right on the key pad. To correct the line you just typed, hit CLEAR. If the error is on a previous line, you will have to retype your sign. Press the ALT + EXIT keys and start over.
- Q: How do I create quotation marks on a sign? A: While holding down the SHIFT key, press the PERIOD key twice in rapid succession.
- Q: How do I prevent the ink ribbon from coming out with the vinyl and being cut? A: Secure the ink ribbon to the take-up core with a piece of tape; wind ribbon on core to remove slack. Turn the printer off and wait two seconds, then turn it back on. Print a label.
- Q: How do I correct poor print quality? A: Make sure you are using the correct print setting for the vinyl and ink ribbon you're printing with. (Refer to page 8 for correct print settings.) Also, make sure the print head is clean. (Recommend cleaning the print head each time vinyl media and/or ink ribbon is installed.) Keep skin contact to a minimum when working with vinyl media.



Toll Free: 1.855.485.9343

**VnM SignMaker by Cobra Systems, Inc.
3521 E. Enterprise Dr.
Anaheim, CA 92807**

www.vnmsignmaker.com