

C10J

PRODUCTION OF PRODUCER GAS, WATER-GAS, SYNTHESIS GAS FROM SOLID CARBONACEOUS MATERIAL, OR MIXTURES CONTAINING THESE GASES (synthesis gas from liquid or gaseous hydrocarbons [C01B](#); underground gasification of minerals [E21B 43/295](#)); **CARBURETTING AIR OR OTHER GASES**

Definition statement

This place covers:

Processes or apparatus for production of fuel gases by carburetting air or other gases without pyrolysis, including controlling supply of air or liquid, temperature, humidity and other parameters.

Processes or apparatus for production of combustible gases containing carbon monoxide (including producer gas, wood gas, town gas, synthesis gas (syngas), manufactured gas and water gas) from solid carbonaceous materials. This includes fixed-bed gasification of lump fuel, gasification of granular or pulverulent fuels in suspension, gasification using molten salts or metals, carburetting by pyrolysis of carbonaceous material in the fuel bed and carburetting by pyrolysis of carbonaceous material in a carburettor.

Relationships with other classification places

Production of synthesis gas from liquid or gaseous hydrocarbons, and the synthesis gas per se, are covered by group [C01B 3/00](#).

Destructive distillation processes, e.g. carbonisation or coking, and excluding gasification processes (see Glossary), are covered by subclass [C10B](#). Combinations of gasification and destructive distillation are covered by group [C10J 3/58](#).

Other gaseous fuels, including natural gas, substitute natural gas or synthetic natural gas (SNG) and liquefied petroleum gas (LPG), are covered by group [C10L 3/00](#).

Purifying or modifying the chemical composition of combustible gases containing carbon monoxide is covered by subclass [C10K](#).

References

Limiting references

This place does not cover:

Destructive distillation processes	C10B
Underground gasification of minerals	E21B 43/295

Application-oriented references

Examples of places where the subject matter of this place is covered when specially adapted, used for a particular purpose, or incorporated in a larger system:

Plants with an integrated combined cycle, having more than one engine delivering power externally to the plant	F01K 23/06
Plant characterised by the engines using gaseous fuel generated in the plant from solid fuel	F02B 43/08
Gas turbine plant with separate fuel gasifiers	F02C 3/28
Carburettors for supplying combustible mixtures to internal combustion engines	F02M

Incineration of waste with pyrolysis or gasification as pre-treatment	F23G 5/027
Combination of fuel cell with means for gasification of solid fuel	H01M 8/0643

References out of a residual place

Examples of places in relation to which this place is residual:

Separation of gases or vapour by diffusion	B01D 53/22
Multi-step process for production of hydrogen or of gaseous mixtures containing a substantial proportion of hydrogen	C01B 3/02
Multi-step process for preparation of ammonia	C01C 1/0405
Multi-step process for preparation of hydrocarbons from carbon monoxide with hydrogen	C07C 1/04
Multi-step process for preparation of compounds having hydroxy or O-metal groups bound to a carbon atom not belonging to a six-membered aromatic ring by reduction of oxides of carbon exclusively with hydrogen or hydrogen-containing gases, one step being the formation of initial mixture of carbon oxides and hydrogen for synthesis	C07C 29/1518
Preparation of urea	C07C 273/02
Multi-step process for production of liquid hydrocarbon mixtures of undefined composition from oxides of carbon	C10G 2/00
Production of synthetic natural gas	C10L 3/08
Plants with an integrated combined cycle, having more than one engine delivering power externally to the plant	F01K 23/06
Plant characterised by the engines using gaseous fuel generated in the plant from solid fuel	F02B 43/08
Gas turbine plant with separate fuel gasifiers	F02C 3/28
Incineration of waste with pyrolysis or gasification as pre-treatment	F23G 5/027
Combination of fuel cell with means for gasification of solid fuel	H01M 8/0643

Informative references

Attention is drawn to the following places, which may be of interest for search:

Apparatus for generating gases	B01J 7/00
Apparatus for chemical or physical process conducted in the presence of fluids and solid particles	B01J 8/00
Coupling of an air fractionation unit (ASU) to an oxygen-consuming unit	F25J 3/04521
Processes or apparatus for separating of H ₂ /CO mixtures, i.e. synthesis gas, involving the use of liquefaction or solidification	F25J 3/0625

Special rules of classification

In the absence of an indication to the contrary, classification is made in the last appropriate place ("last place rule").

Multiple classification symbols may be allocated to cover the disclosed subject-matter.

Details of gasification apparatus are mandatory classified with Indexing codes of [C10J 2200/00](#) subgroups.

Details of gasification processes are mandatory classified with Indexing codes of [C10J 2300/00](#) subgroups.

Glossary of terms

In this place, the following terms or expressions are used with the meaning indicated:

Carburettng	Carburettng air or gas generally comprises passing it in contact with liquid fuel and thereby mixing the air/gas and fuel. This often involves lowering the air pressure e.g. in a venturi.
Destructive distillation	The process of pyrolysis conducted in a distillation apparatus to allow the volatile products to be collected. An example is tar making from pinewood slices (which are rich in terpenes), which are heated in an airless container causing the material to decompose, leaving charcoal and turpentine as by-products.
Gasification	Gasification is somewhat similar to pyrolysis and confusion between these terms is common. Gasification is a partial oxidation process that converts materials such as coal, biomass or plastic waste into a gaseous mixture of carbon monoxide and hydrogen (also known as synthesis gas) by reacting the raw material at high temperatures with controlled amounts of oxygen and/or steam. See also the entry for pyrolysis.
Producer gas	A gas mixture containing carbon monoxide (CO), hydrogen (H ₂), carbon dioxide (CO ₂) and nitrogen (N ₂). In the USA, producer gas is a generic term referring to wood gas, town gas, synthesis gas, syngas or raw gas. In the UK, producer gas, also known as suction gas, means a fuel gas made from coke or other carbonaceous material. Air is passed over the red-hot fuel and carbon monoxide is produced in an exothermic reaction which reads $2C + O_2 \rightarrow 2CO$. The nitrogen in the air remains unchanged and dilutes the gas, so it has a low calorific value. The gas may be used to power gas turbines which are suited to fuels of low calorific value.
Pyrolysis	The chemical decomposition of organic materials by heating in the absence of oxygen or any other reagents, except possibly steam. Pyrolysis is somewhat endothermic and the products can be gases, liquids (e.g. light crude oil from depolymerisation of organic waste) and/or solids (e.g. coke and volatiles produced by coking coal). See also the entry for gasification.
Synthesis gas (syngas)	A gas mixture that contains varying amounts of carbon monoxide (CO) and hydrogen (H ₂) generated by the gasification of a carbon-containing material to a gaseous product with a heating value (but less than half the energy density of natural gas). When used as a fuel, it is produced by gasification of coal or municipal waste by the following reactions: $C + O_2 \rightarrow CO_2$; $CO_2 + C \rightarrow 2CO$; $C + H_2O \rightarrow CO + H_2$. The name comes from the gas's use as an intermediate in creating synthetic natural gas (SNG) and in producing ammonia or methanol.
Town gas	Also known as coal gas, and contains hydrogen (H ₂), carbon monoxide (CO), carbon dioxide (CO ₂), methane (CH ₄), nitrogen (N ₂) and volatile hydrocarbons. It is made by blowing air and steam over an incandescent fuel bed, usually of coke or coal. The words "coal gas" could also be used to mean gas made by the destructive distillation of coal. The gas was used inter alia for lighting before the advent of electric lighting, and for heating and cooking before natural gas became widely available.

Water-gas	A mixture of carbon monoxide (CO) and hydrogen (H ₂) produced by passing steam over red-hot coke using the endothermic reaction $C + H_2O \rightarrow CO + H_2$. This product had a lower calorific value than coal gas so the gas was often passed through a heated retort into which oil was sprayed; the resulting mixed gas was called carburetted water gas.
Wood gas	The product of thermal gasification of biomass (e.g. coal, wood chips, sawdust, charcoal) in a gasifier or wood gas generator. It is the result of a high temperature reaction (> 700 degrees C) where carbon reacts with steam or a limited amount of air producing carbon monoxide (CO), carbon dioxide (CO ₂), hydrogen (H ₂) and methane (CH ₄). It can be filtered, purified or scrubbed and used to power internal combustion engines, gas turbines, Stirling engines or fuel cells.

Synonyms and Keywords

In patent documents the following synonyms are often used:

Producer gas	Wood gas, town gas, syngas, synthesis gas, raw gas (in USA)
Producer gas	Suction gas (in UK)
Wood gas	Holzgas, air gas, blue gas
Coal gas	Town gas

C10J 1/00

Production of fuel gases by carburetting air or other gases without pyrolysis (for internal-combustion engines [F02](#))

Definition statement

This place covers:

Fuel gases produced by carburetting air or other gases without pyrolysis

References

Application-oriented references

Examples of places where the subject matter of this place is covered when specially adapted, used for a particular purpose, or incorporated in a larger system:

Carburettors for supplying combustible mixtures to internal combustion engines	F02M
--	----------------------

C10J 3/00

Production of combustible gases containing carbon monoxide from solid carbonaceous fuels (destructive distillation processes [C10B](#))

Definition statement

This place covers:

Production of combustible gases containing carbon monoxide from solid carbonaceous fuels as well as a slurry of solid carbonaceous, such as a coal water slurry.

C10J 3/02

Fixed-bed gasification of lump fuel

Definition statement

This place covers:

All beds undergoing reaction of gasification of solid fuel, e.g. fixed-bed, moving bed gasification, such as a Lurgi gasifier, rotary drum gasification.

C10J 3/30

Fuel charging devices

References

Informative references

Attention is drawn to the following places, which may be of interest for search:

Feeding of the particles in the reactor	B01J 8/0015
Feeding or discharging devices	B65G 53/40
Feeding or distributing of lump or pulverulent fuel to combustion apparatus	F23K 3/00
Charging; Discharging; Manipulation of charge	F27D 3/00

C10J 3/34

Grates; Mechanical ash-removing devices

References

Informative references

Attention is drawn to the following places, which may be of interest for search:

Feeding or discharging devices	B65G 53/40
Grates; Cleaning or raking grates	F23H
Removing ash, clinker, or slag from combustion chamber	F23J 1/00
Charging; Discharging; Manipulation of charge	F27D 3/00

C10J 3/44

adapted for use on vehicles

Definition statement

This place covers:

Apparatus for fixed bed gasification of lump fuel adapted for use on vehicles, e.g. portable gasification apparatus, gasification occurring on a vehicle burning the produced gas in the engine

References

Informative references

Attention is drawn to the following places, which may be of interest for search:

Arrangement concerning gas-producing plants in connection with fuel supply of combustion engines	B60K 15/10
--	----------------------------

C10J 3/463

{in stationary fluidised beds}

Definition statement

This place covers:

Gasification in stationary fluidised bed

References

Limiting references

This place does not cover:

Gasification in circulating fluidised bed	C10J 3/54
---	---------------------------

C10J 3/466

{Entrained flow processes}

Definition statement

This place covers:

Gasification of granular or pulverulent fuels in entrained bed, such as GE-*Texaco* gasifier, *E-gas* gasifier, *Shell* gasifier, *Prenflo* gasifier or *TPRI* gasifier, such as shown in following figures:

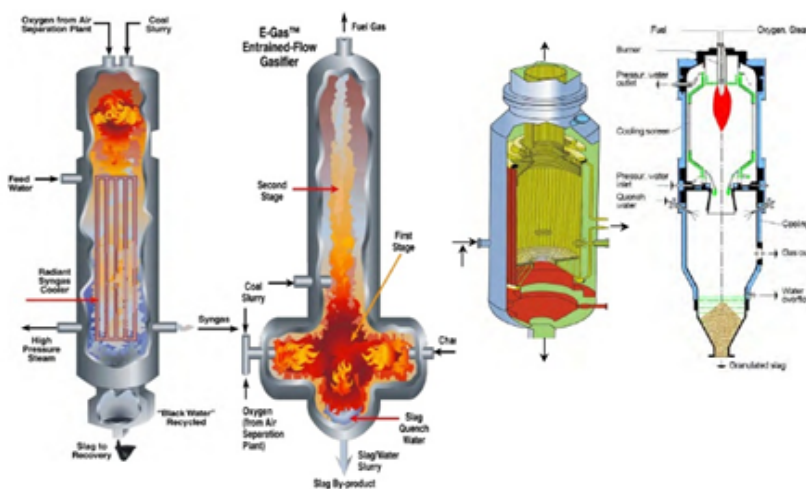

Special rules of classification

Fluidised bed processes are classified in [C10J 3/466](#)

Reactors for fluidised bed processes are classified in [C10J 3/485](#)

Fluidized bed processes and reactors by the Winkler technique are classified in [C10J 3/54](#) and [C10J 3/56](#)

Dense cloud gasification, e.g. dense fluidized bed, is classified in [C10J 3/463](#)

C10J 3/482

{Gasifiers with stationary fluidised bed}

Definition statement

This place covers:

Gasifiers with stationary fluidised bed

References

Limiting references

This place does not cover:

Gasifiers with circulating fluidised bed	C10J 3/56
--	---------------------------

C10J 3/50

Fuel charging devices

Definition statement

This place covers:

Gasifiers with nozzles, gasifiers with screw feeders, feed pressurisation using lock hoppers, or preparation, such as milling and drying, of fuel for gasification process

References

Informative references

Attention is drawn to the following places, which may be of interest for search:

Feed or outlet devices; Feed or outletcontrolling devices	B01J 4/00
Feeding or discharging devices	B65G 53/40
Fuel feeders specially adapted for fluidised bed combustion apparatus	F23C 10/22
Burners for combustion of pulverulent fuel	F23D 1/00
Preparation of lump or pulverulent fuel in readiness for delivery to combustion apparatus	F23K 1/00
Feeding or distributing of lump or pulverulent fuel to combustion apparatus	F23K 3/00

C10J 3/52

Ash-removing devices

References

Informative references

Attention is drawn to the following places, which may be of interest for search:

Feeding or discharging devices	B65G 53/40
Removing ash, clinker, or slag from combustion chamber	F23J 1/00

C10J 3/54

Gasification of granular or pulverulent fuels by the Winkler technique, i.e. by fluidisation

Definition statement

This place covers:

Gasification in a circulating fluidised bed or expanded bed, such as shown in following figure:

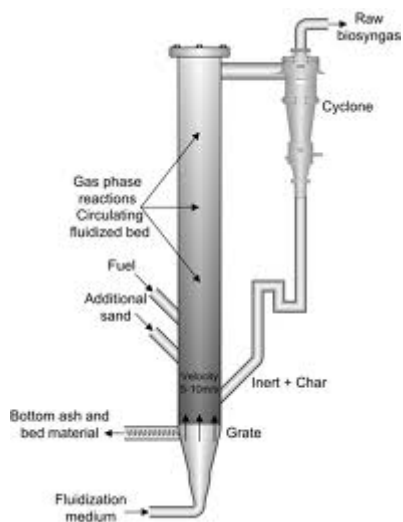

C10J 3/57

Gasification using molten salts or metals ([C10J 3/02](#), [C10J 3/46](#) take precedence)

Special rules of classification

[C10J 3/02](#), [C10J 3/46](#) takes precedence

C10J 3/58

combined with pre-distillation of the fuel

Definition statement

This place covers:

Gasification including a pre-distillation before gasification, such as a pyrolysis step prior to gasification step.

References

Limiting references

This place does not cover:

Pre-distillation, such as a pyrolysis, followed by gasification of pyrolysis gas and/or pyrolysis liquids, such as pyrolysis tar cracking or reforming, without gasification step of solid charge

[C10K](#), [C10G 9/00](#),
[C01B 3/24](#), [C01B 3/34](#)

C10J 3/62

with separate withdrawal of the distillation products

Definition statement

This place covers:

Gasification including a pre-distillation before gasification whereby the distillation products such as pyrolysis gas (pyrogas) are withdrawn separately from the syngas. Examples are shown in the following figures:

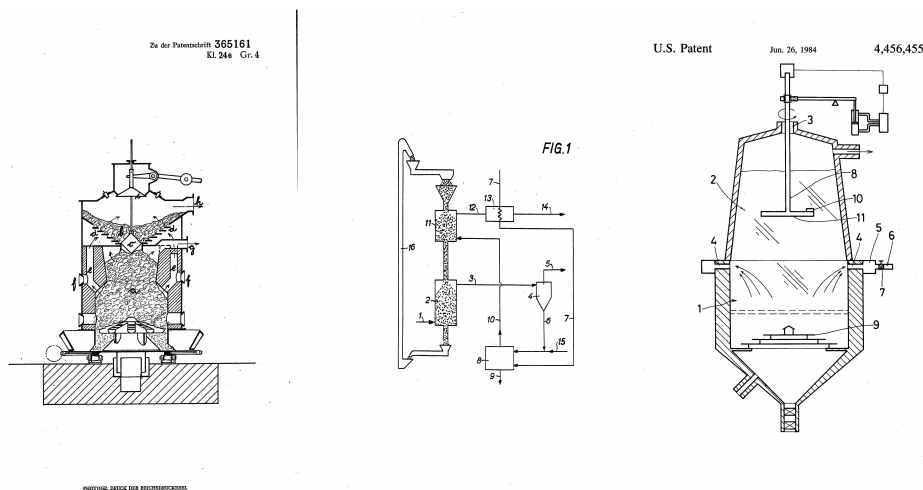

Glossary of terms

In this place, the following terms or expressions are used with the meaning indicated:

Distillation products	Volatile products released from solid charge during pre-distillation or pyrolysis pre-step.
-----------------------	---

C10J 3/64

with decomposition of the distillation products

Definition statement

This place covers:

Gasification including the decomposition of the distillation products, such as pyrolysis gas (pyrogas) and/or pyrolysis liquids (pyroliquids). The decomposition may occur in a reforming zone separate from the gasification zone, such as partial combustion of pyrolysis gas or cracking of pyrolysis tar. Examples are shown in the following figures:

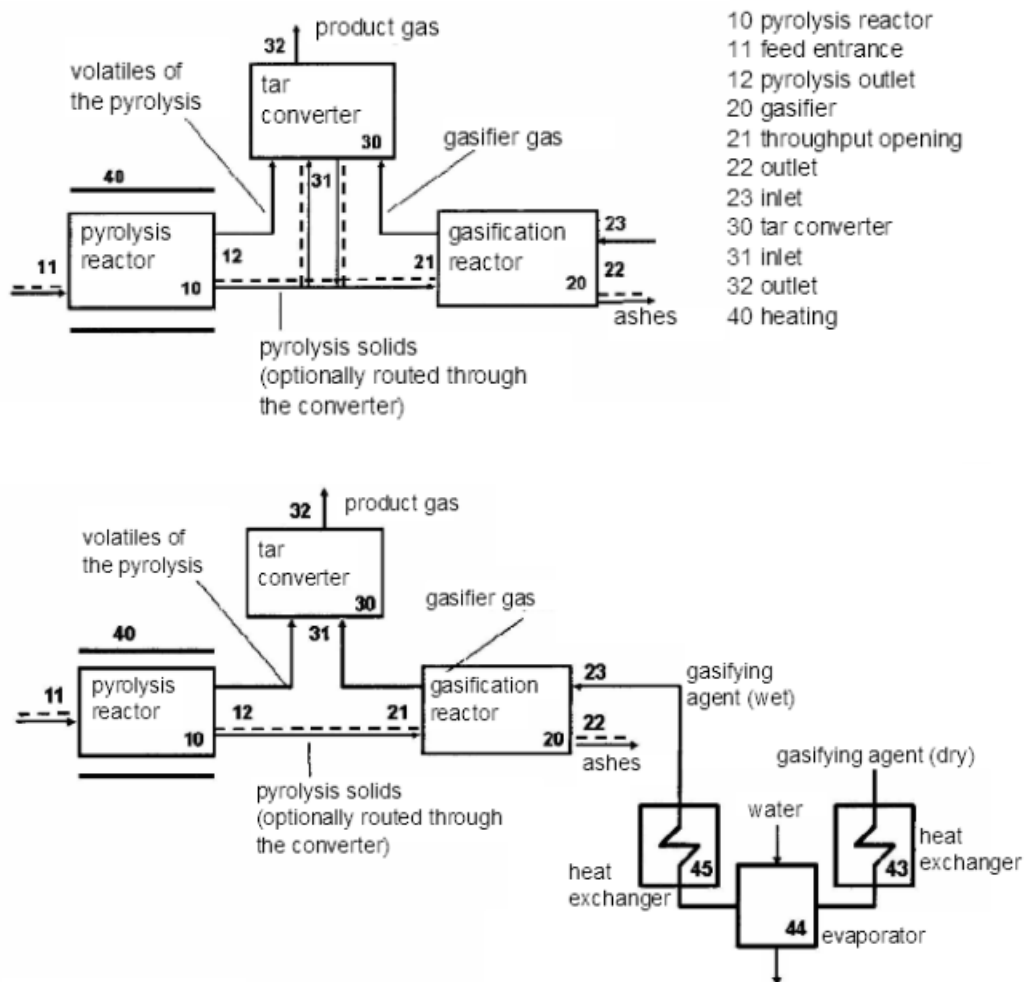

Glossary of terms

In this place, the following terms or expressions are used with the meaning indicated:

Distillation products	Volatile products released from solid charge during pre-distillation or pyrolysis pre-step.
-----------------------	---

C10J 3/66

by introducing them into the gasification zone

Definition statement

This place covers:

Gasification including the decomposition of the distillation products, such as pyrolysis gas (pyrogas) and/or pyrolysis liquids (pyroliquids).

Examples are shown in the following figures:

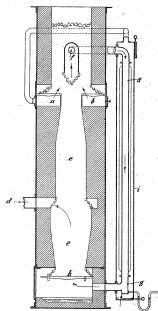

Zu der Patentschrift
№ 202375.

PHOTOUR. BUREAU DER HOCHSCHULE

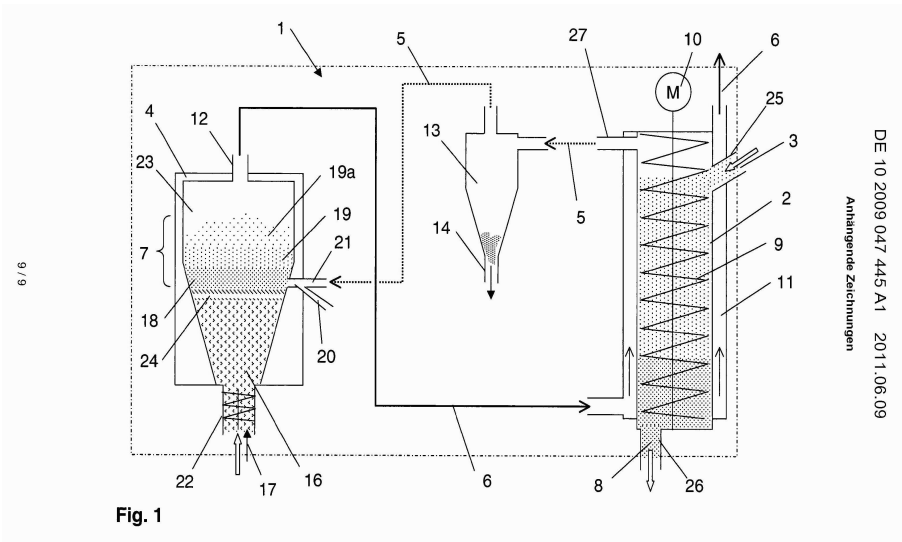
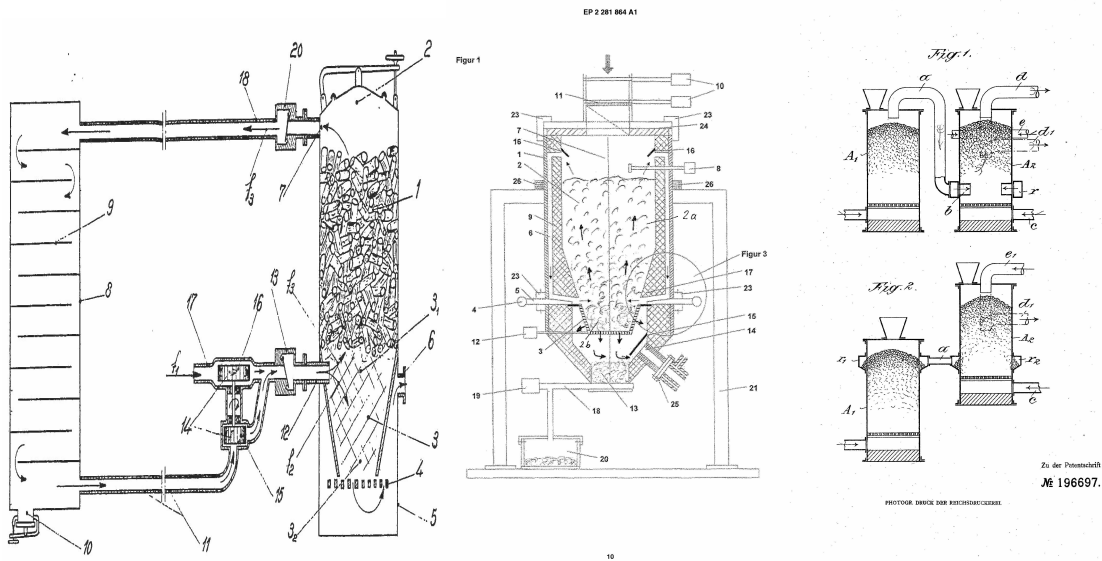

Fig. 1

9 / 9



Glossary of terms

In this place, the following terms or expressions are used with the meaning indicated:

Gasification zone	Zone where solids are converted by gasification, such as by partial combustion or steam reforming
-------------------	---

C10J 3/76

Water jackets; Steam boiler-jackets

Definition statement

This place covers:

Gasifiers having cooling means inside or on the outside of the gasification chamber itself, i.e. same vessel, such as shown in the following figures:

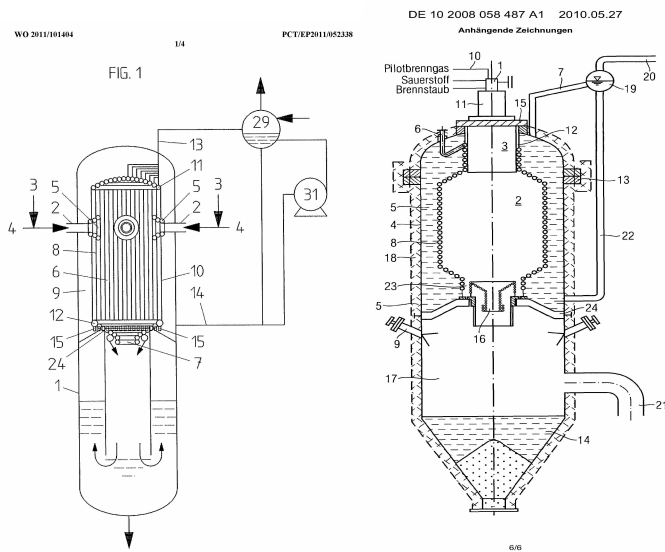

References

Limiting references

This place does not cover:

Gasification with separate waste heat boilers	C10J 3/86
---	---------------------------

Informative references

Attention is drawn to the following places, which may be of interest for search:

Heat-exchange apparatus, not provided for in another subclass, in which the heat-exchange media do not come into direct contact	F28D
---	----------------------

C10J 3/78

High-pressure apparatus

Definition statement

This place covers:

Supercritical gasification

C10J 3/84

with means for removing dust or tar from the gas

Definition statement

This place covers:

Gasifiers having a gas filter, cyclone, water spray or a quench, e.g. such as shown in the following figures:

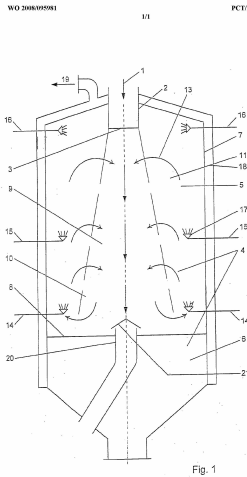

ERSATZBLATT (REGEL 26)
EP 2 017 002 A1

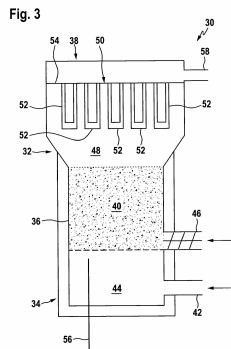
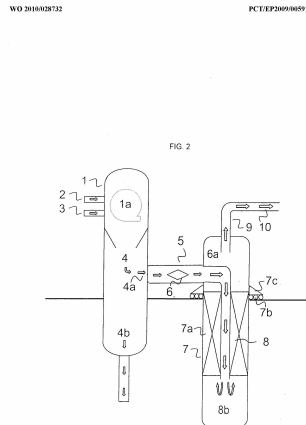
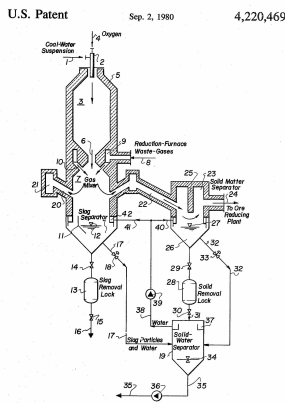

Tar cracking, e.g. reforming, partial oxidation

References

Informative references

Attention is drawn to the following places, which may be of interest for search:

Filters, i.e. particle separators, or filtering processes specially modified for separating dispersed particles from gases or vapours	B01D 46/00
Separating dispersed particles from gases, air or vapours by liquid as separating agent	B01D 47/00
Apparatus using free vortex flow, e.g. cyclones	B04C

Purifying combustible gases containing carbon monoxide	C10K 1/00
--	---------------------------

Synonyms and Keywords

In patent documents, the following words/expressions are often used as synonyms:

- "nozzle scrubber", "orifice scrubber" and "venturi scrubber"

C10J 3/86

combined with waste-heat boilers

Definition statement

This place covers:

Gasifiers connected with a separate heat exchanger, such as shown in following figures:

Patent Application Publication Oct. 21, 2010 Sheet 2 of 5 US 2010/0263841 A1

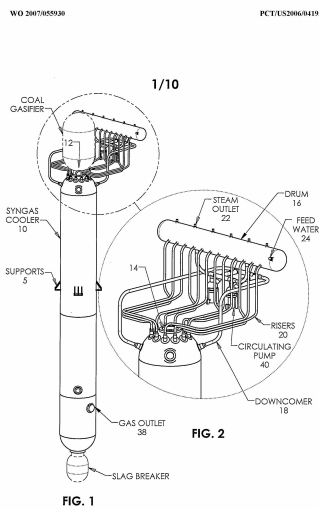
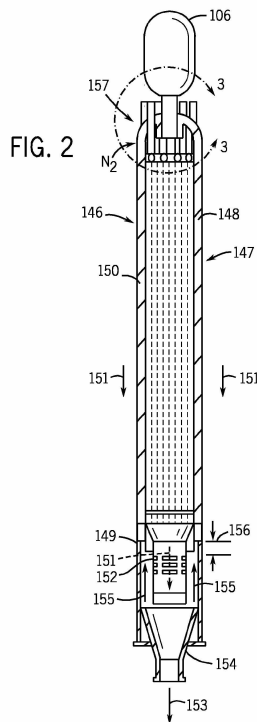

DE 10 2006 040 833 A1 2008.03.06

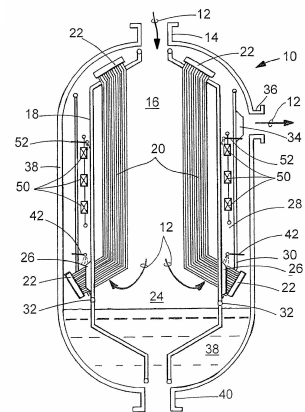

References

Informative references

Attention is drawn to the following places, which may be of interest for search:

Methods of steam generation characterised by form of heating method by exploitation of the heat content of hot gas being loaded with particles, e.g. waste heat boilers after a coal gasification plant	F22B 1/1846
Heat-exchange apparatus, not provided for in another subclass, in which the heat-exchange media do not come into direct contact	F28D