

# Stacker De-Stacker



## and SDS Line Amplifier



global **invacom**  
completing the picture



- 2 LNB inputs into one cable
- Both LNB inputs independently selectable by voltage/tone or DiSEqC 1.2 controls
- DiSEqC loop through to LNB/Multiswitch
- Independently Powered
- Covers cable lengths up to 60 metres\*
- May be used in a Non DiSEqC installation

\*Requires use of an SDS Line Amplifier.

### Product Overview

DiSEqC Stacker De-Stacker(SDS) allows two satellite bands (0.95-2.15GHz) to be transmitted via a single common coaxial cable, between the LNB/multi-switch feeds and the satellite receivers (STB).

Combining of the bands is implemented in "Stacker" with frequency UP conversion of one of the satellite signals (SAT) and combining it with the other (SATTV). The second signal, SATTV is not converted and can carry terrestrial signals (15-860MHz) in addition to the satellite band.

The combined signal from the "Stacker" is distributed via the common cable and split into the original two signals in "De-Stacker", which also DOWN converts one of the bands (SAT) to the original frequencies. Terrestrial is made available on one of the "De-Stacker" ports.

Automatic Slope Compensation allows the unit to cover cable lengths of up to 30 metres. Extendable to cover cable lengths up to 60 metres with the addition of an SDS Line Amplifier.

Powering of the system is provided from a separate 20V power supply connected to "De-Stacker" to avoid any switching problems from the Set-top box (STB).

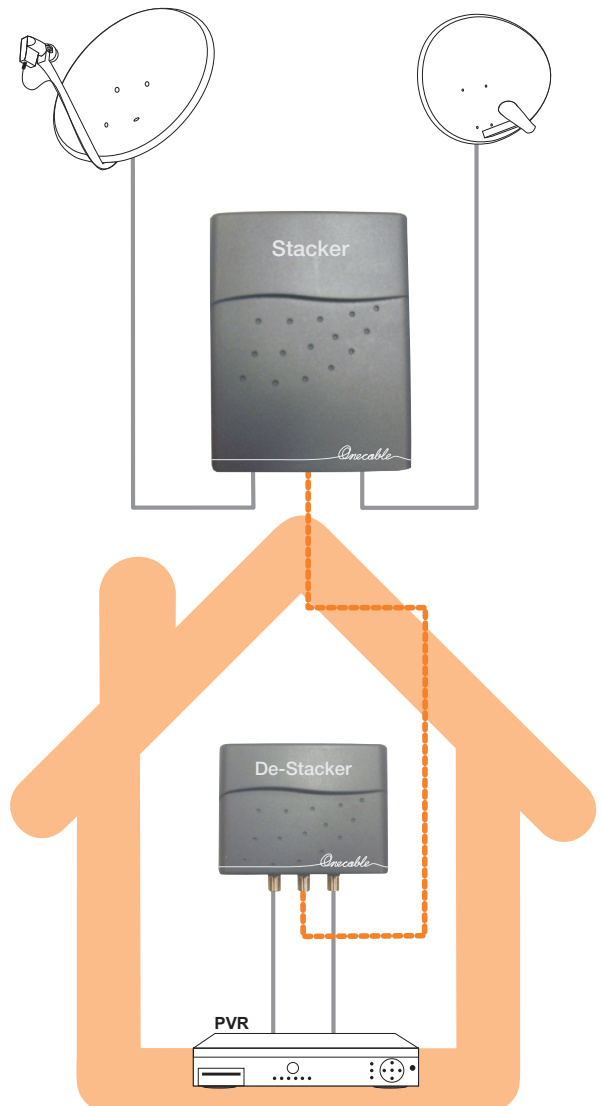

Typical DTH Installation Diagram

# Stacker De-Stacker and SDS Line Amp

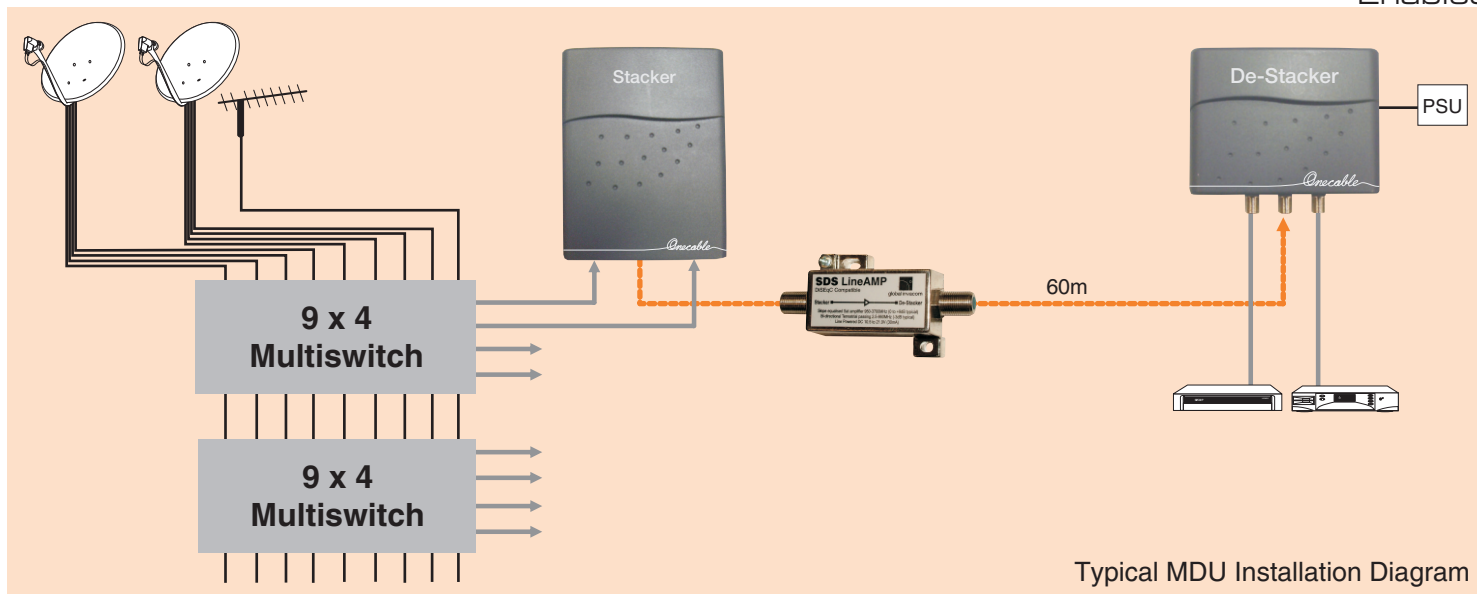

## Applications

The SDS has been designed to allow two satellite signals to be fed down one coaxial cable before being returned to its original configuration to feed two STB's or a twin tuner satellite STB. Signals can be supplied by either a universal multi-port LNB or more typically from a multiswitch. By allowing DiSEqC commands to pass through the "Stacker" it is possible to connect the unit to a DiSEqC multiswitch for operation on a 9 wire system.

Whilst the DiSEqC SDS can be used in DiSEqC applications, it can also be used in situations where DiSEqC is not present.

The SDS can be used for coaxial cable lengths up to 30 metres, however from 30 to 60 metres the SDS Line Amplifier must be fitted. Reliable operation is determined by the position of the amplifier, quality of coaxial cable fitted and signal strength from LNB or multiswitch.

## Specification

### Stacker

RF I/P SAT	950 – 2150MHz
RF I/P SATTV	15 – 2150MHz
COM (Common Output) Port	15-3700MHz
Min RF I/P Signal Level's	-41dBm (+68dBμV) *30m -39dBm (+70dBμV) with *60m and line amplifier installed in the common cable
MAX RF I/P Signal Level's	-14dBm (+95dBμV) total power
Noise Figure	18dB
Return Loss	10dB min at SAT, SATTV and COM
Isolation Port to Port	40dB min
Output DC power for LNB (multi-switch)	400mA Max
Power Consumption	100mA

\*Using Professional 'Twin Screened' 75 Ohm Coaxial Cable.

### DeStacker

RF O/P SAT	949-2149MHz
RF O/P SATTV	15-2150MHz
COM (Common Output) Port	15-3700MHz
Noise Figure	19dB
Return Loss	10dB min at port A, B and COM for specified frequency ranges.
Isolation Port to Port	40dB min
Power Supply	External +20V/1.2A Switch Mode Power Supply.
Power Consumption	100mA
Communication Protocols Accepted	Voltage, Tone, DiSEqC 1.2

### SDS Line Amplifier

Frequency Range	2.5MHz – 860MHz & 950MHz - 3700MHz
Insertion Gain	Terrestrial: -6 dB min Satellite: 950MHz -1dB ± 1 dB 2150MHz +5dB ± 1dB 2500MHz +6dB ± 1dB 3700MHz +9dB ± 1 dB
Noise Figure	Satellite: 950MHz 6dB max 2150MHz 5dB max 2500MHz 4.5dB max 3700MHz 4.3dB max
Supply Voltage	10.5V to 21V
Current Passed	Max 650mA including the SDS current draw.