

Automation Product Overview
2006/2007

Future-Proof Automation with **xSystem**

With
xSystem
Micro Innovation
offers you a perfectly
matched product
range for control
and visualization
solutions.

xSystemy



xSystemN

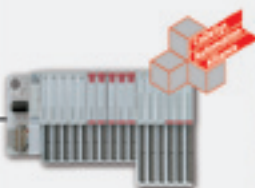

Published: Micro Innovation AG
Spinnereistrasse 8-14
9008 St. Gallen
Switzerland

© 2006 by Micro Innovation AG





M001754-01

The information provided in this brochure may not always apply in the described form in actual applications or may change slightly as a result of further developments of the products.
An obligation to provide the respective characteristics shall only exist if expressly agreed in the terms of contract.

Subject to availability and technical modifications.

Table of Contents

 HMI, HMI-PLC
 XI/ON, WINbloc
 Software
 Service, sales, support

Topics	Pages																
	<table> <tr> <td>The company – your partner</td> <td>4</td> </tr> <tr> <td>Micro Innovation – Moeller</td> <td>5</td> </tr> <tr> <td>Two partners – one team</td> <td>6</td> </tr> </table>	The company – your partner	4	Micro Innovation – Moeller	5	Two partners – one team	6										
The company – your partner	4																
Micro Innovation – Moeller	5																
Two partners – one team	6																
	<table> <tr> <td>Innovative visualization solutions</td> <td>8</td> </tr> <tr> <td>XV200</td> <td>10</td> </tr> <tr> <td>XV400</td> <td>12</td> </tr> <tr> <td>XVS400</td> <td>14</td> </tr> <tr> <td>XVH300</td> <td>16</td> </tr> <tr> <td>Device overview</td> <td>18</td> </tr> <tr> <td>XVC100</td> <td>22</td> </tr> <tr> <td>XVC600</td> <td>24</td> </tr> </table>	Innovative visualization solutions	8	XV200	10	XV400	12	XVS400	14	XVH300	16	Device overview	18	XVC100	22	XVC600	24
Innovative visualization solutions	8																
XV200	10																
XV400	12																
XVS400	14																
XVH300	16																
Device overview	18																
XVC100	22																
XVC600	24																
	<table> <tr> <td>Modular I/O systems</td> <td>26</td> </tr> <tr> <td>XI/ON</td> <td>28</td> </tr> <tr> <td>XI/ON system configuration</td> <td>30</td> </tr> <tr> <td>XI/ON gateways</td> <td>32</td> </tr> <tr> <td>XI/ON SmartWire</td> <td>33</td> </tr> <tr> <td>XI/ON tailor-made</td> <td>34</td> </tr> <tr> <td>XI/ON everything at a glance</td> <td>36</td> </tr> <tr> <td>WINbloc</td> <td>38</td> </tr> </table>	Modular I/O systems	26	XI/ON	28	XI/ON system configuration	30	XI/ON gateways	32	XI/ON SmartWire	33	XI/ON tailor-made	34	XI/ON everything at a glance	36	WINbloc	38
Modular I/O systems	26																
XI/ON	28																
XI/ON system configuration	30																
XI/ON gateways	32																
XI/ON SmartWire	33																
XI/ON tailor-made	34																
XI/ON everything at a glance	36																
WINbloc	38																
	<table> <tr> <td>GALILEO</td> <td>40</td> </tr> <tr> <td>MXpro</td> <td>44</td> </tr> <tr> <td>Application libraries</td> <td>46</td> </tr> <tr> <td>Communication libraries</td> <td>48</td> </tr> <tr> <td>I/Oassistant</td> <td>49</td> </tr> <tr> <td>EPAM</td> <td>50</td> </tr> </table>	GALILEO	40	MXpro	44	Application libraries	46	Communication libraries	48	I/Oassistant	49	EPAM	50				
GALILEO	40																
MXpro	44																
Application libraries	46																
Communication libraries	48																
I/Oassistant	49																
EPAM	50																
	<table> <tr> <td>Services</td> <td>52</td> </tr> <tr> <td>Suppliers worldwide</td> <td>54</td> </tr> </table>	Services	52	Suppliers worldwide	54												
Services	52																
Suppliers worldwide	54																

The company – your partner

For innovations in automation

Thinking globally, looking ahead, shaping the future, realizing visions, supplying solutions – this is our aim.

Embodying the almost indefinable in our name, thus securing the lead, finding different ways.

Innovation in automation, in building systems engineering or in the industrial environment – this is our commitment.



Micro Innovation, with its headquarter in St. Gallen Switzerland, is one of the leading manufacturers of innovative solutions in the field of industrial and building automation as well as machine and system building.

Our products are manufactured in Switzerland and Germany in order to ensure the highest standards in quality.

Micro Innovation was founded in 1990, inspired by the vision of making complex control systems easy to operate. At that time the company had already closed a gap in the market with its innovative devices and had thus revolutionized machine operation.

Micro Innovation started out as one of the first companies to supply rugged **infra-red touch technology**.

The company has now successfully established itself in the automation sector with the development and sale of touch-sensitive HMI equipment and is a leading supplier of infra-red touch displays.

The existing range of tried and tested flat-screen display solutions has now been extended to include powerful onboard PLC functionality in compliance with IEC 61131-3.

This enables the implementation of seamless system solutions via all network levels with integrated operator systems.

The company has enjoyed a successful collaboration with Moeller for over fifteen years.

The international sales channels of the Moeller Group have made visualization systems accessible to all important markets worldwide.

These powerful devices are thus in operation round the clock, successfully performing their tasks all over the world.

Continuous growth and the additional focus on system solutions are now leading to the next logical step:

- Expansion of our support and sales network in Germany with headquarters in Bonn
- Acquisition and further development of the recognized brand name xSystem

xSystem

Micro Innovation – Moeller

Outlooks for the future

For many years Micro Innovation has provided the expertise for Moeller visualization systems with infra-red touch technology. From the VTP and MV4 device series up to the current XV device generation, these innovative visualization solutions always came with the know-how of Moeller's Swiss subsidiary built in. Regardless of whether hardware or software, everything comes from a single source.

To achieve greater customer proximity, all essential parts of the xSystem products have now been combined in one operative unit and under the management of Micro Innovation. This now enables Micro Innovation to offer future-proof system solutions that are highly attractive and which are based on a seamless and cost-effective design using HMIs, HMI-PLCs and the XI/ON remote I/O system.

Products that go together can now grow together.

At the same time collaboration between Moeller and Micro Innovation will be further expanded both in sales and in technical aspects – to your advantage.

Micro Innovation and Moeller two specialists that form a team working hand in hand with one goal in mind: Innovative solutions for you.

We believe that as a mobile unit we can meet your requirements quickly and effectively. Short decision routes and direct contact shortens the development process and form the basis for economical solutions.

We are proud to be your partners.



mi micro innovation
A MOELLER  Company

Yang-Soo Kang
Chief executive officer
Micro Innovation Holding AG

MOELLER



Dr. Martin U. Scheffter
Chief executive officer
Moeller Holding GmbH

The Right Partner for Your Application.



Micro Innovation – give your machine a face.

Since 1990 we have been operating in a rapidly changing market with continuously growing success. Since then we have integrated your requirements and experience into our products with the aim of making everything as easy as possible for you. The personal contact provided by our support and sales departments will give you the surety of having a competent advisor on your side. Regardless of whether standard products or custom developments are required, we will find the right solutions and provide optimum support.

Machine and system visualization, the business card of your system solution is the interface to the operator.

A number of communication options ensure that your system can be integrated in existing installations. Whether Profibus DP, CAN, Device Net, Modbus-IP, everything is possible.

The XI/ON modular remote I/O system with its unique ability to combine high density low-cost I/O with high granularity slice modules is the ideal partner for our powerful touch panels with brilliant infra-red technology and safety glass displays.

xSystem enables the creation of an intuitive dialog between man and machine. The machine now has a face.

We look forward to helping you with it.

Micro Innovation two partners,

 **micro innovation**
A MOELLER Company

**and Moeller –
one team.**

MOELLER 

We keep power under control.

Moeller – quality and efficiency.

For over a hundred years the Moeller Group has always been concerned with creative ways of handling energy and giving it direction, form and purpose to thus make it available where it is needed. This is achieved through the use of quality products and technical innovations, with products and solutions for industry and buildings. As leading specialists in electrical engineering, Moeller is always the right address when it comes to energy distribution, switching, protecting, operating, visualization and control.

Moeller is always present where there are growing markets: as an advisor close to hand with its own branches and production sites – your strong local partner with global expertise. You benefit from short routes and a global sales network of the company's own subsidiaries and distributors in over 90 countries.

Moeller is always ready for new challenges and shapes the future of electrical engineering with new ideas, helping you in the creation of efficient and future-oriented solutions. We bring passion and focus to our core area of expertise – energy distribution and automation.

Innovative Visualization Solution with Integrated PLC



xSystemV

xV200

xV400

xVS400

xVH300

Whether for machine/system building or for single projects, there is hardly an application in which a HMI cannot simplify operation and support the operator.

Modern touch displays ensure clear, flexible menu guidance in any language required and enable the machine manufacturer to sell machines worldwide with only one hardware and software solution. From 5.7" to 15" HMI-PLC touch displays, the ideal solution can be found for any machine. Solutions for open-loop, closed-loop, positioning and communication tasks can now be implemented with MXpro in accordance with IEC 61131-3.

The visualization system can be created easily using Galileo.

HMI or HMI-PLC

The removable Compact-Flash™ determines the device function and the project design tool required. Using the devices as a HMI provides you with a user-friendly and inexpensive touch operator panel. Devices can be connected to virtually any programmable controller thanks to the open interfaces and wide range of communication options provided by the Galileo visualization software. The same level of flexibility is provided with the HMI-PLC function – the visualization combined with the MXpro PLC software. MXpro is an IEC 61131-3 compliant programming system based on CoDeSys from 3S. As well as ensuring considerable cost savings for the PLC, use of the panel as a HMI-PLC provides a flexible automation platform that allows a wide range of network options including the most advanced IT technology.

Portrait format

The panels can be used in portrait format (rotated 90°) if required.



Programming device

Both the visualization system and the PLC functionality can be developed on a standard PC and then transferred quickly and network-enabled to the panel via a LAN.

Control level

OPC client/servers or DXS services provide limitless opportunities for the integration of panels in the control level and the IT world.

Teleservice/remote diagnostics

Standard modems/routers can be used to provide you with unrestricted remote access to the entire system. Thanks to the integrated web server functions in the panel, you can view its latest service data simply via a browser.

Alarms

Increase production, send SMS messages or emails in the event of faults.

Infra-red light matrix touch

Thanks to its optical light matrix touch system and the safety glass operating surface, the panel can match the most demanding mechanical requirements.

Resistive touch

A front design with an absolutely flat (seamless) polyester seal on resistive touch panels meets the highest standards in terms of cleanliness, resistance to greases, oils and cracking.



Over 100 communication protocols provide connection to the entire automation world.



XV200

The XV200 touch display series offers a fully graphical 5.7" monochrome or color display with 256 greyscales/ colors, resistive touch technology as well as a wide range of communication and networking options



XV400

Micro Innovation's XV400 touch display series is a scalable future-proof device generation. Its ability to be expanded with specific communication options ensures optimum flexibility.



XVS400

Thanks to the wide range of interfaces available onboard, the XVS400 compact devices can be adapted precisely to the world's leading automation systems.



XVH300

The XVH300 HMI displays with 5.7" infra-red or resistive touch are specially developed and powerful visualization and data management systems with Ethernet and communication interfaces such as Sucom A, Suconet K or CAN onboard.

HMI or HMI-PLC XV200 Future-Proof Machine Operation at an Excellent Price



CANopen

Ethernet

RS232



xSystemV

5.7"

color or mono

Ethernet

CANopen

MPI and Profibus

RS232

PLC (optional)

The new XV200 touch display device series offers either a fully graphical 5.7" FSTN monochrome display with 256 greyscales or a fully graphical 5.7" color display with 256 colors, industrial resistive touch technology as well as a wide range of communication and network options. The touch-sensitive display ensures intuitive operation and visualization. Language-neutral and self-explanatory touch switches can be created to provide clearly designed operating screens. PLC functionality can be implemented on the XV200 devices if required. All devices come with an Ethernet and USB Device interface. Depending on the device type, CAN, Profibus (MPI/PPI/DP) or RS232 can be provided as additional interfaces.

Flexible communication

Thanks to the large selection of protocols available and the RS232 interface, visualization systems can be provided for the latest PLCs – in particular the following: Moeller easy control relays, the tried and tested Moeller PS4 programmable controllers. Others can also be connected via DF1 or Modbus RTU.

The CAN interface enables data exchange implementation between the various CANopen controller components such as: Moeller XC100/200 or the XN-PLC-CANopen programmable XI/ON gateway and many motion systems. With integrated PLC functionality the complete range of CAN-based I/O and motion systems are available.

The Profibus interface, which is connected to controllers via MPI or PPI, offers additional communication options. Alternatively it can be used as a DP master at up to 1.5 Mbaud.

The onboard Ethernet interface ensures fast program downloads as well as supporting networking with other xSystem controllers via UDP or TCP/IP and the CoDeSys-based SymARTI driver. Other industrial Ethernet protocols such as Industrial Ethernet or EtherNet/IP are available.

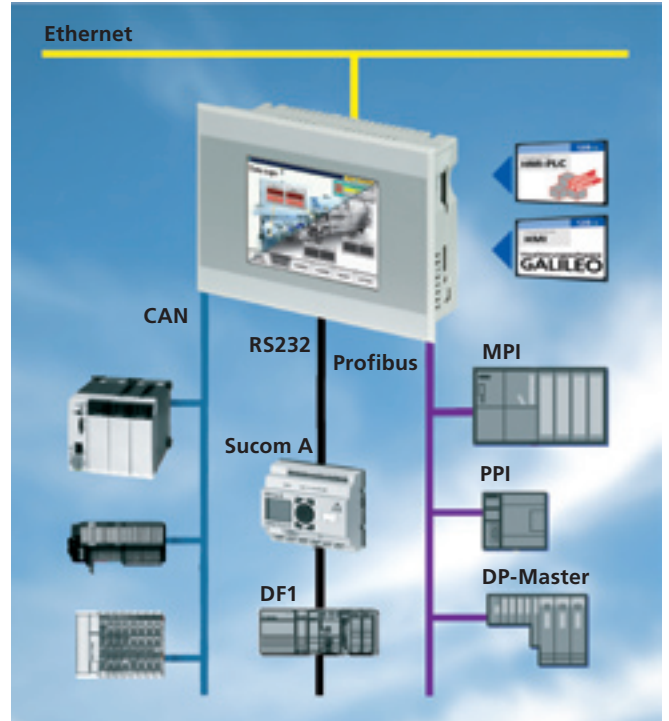

HMI or HMI-PLC

If required the XV200 can also provide the PLC functionality for small automation tasks. Programming in compliance with IEC 61131-3 is carried out in the CoDeSys-based *MXpro* software.

The Galileo visualization tool offers a number of features such as UNICODE support, password management (200 levels, 500 users), online project simulation on the PC, alarm and history functions, recipe management and printer functions.

The UL/CS approved devices are suitable for use worldwide. XV200 devices are designed for operation in dust-laden environments in accordance with the ATEX Directive 94/9/EC Group 22 Cat. 3 D.



The XV200 can be used alternatively in portrait format (rotated 90°). The small mounting depth and the rugged front (IP65) of XV200 series devices means that they are ideally suited for operation close to the machine.



- 1 Ethernet
- 2 CAN or Profibus (optional)
- 3 RS232 (optional)
- 4 24 V DC
- 5 CompactFlash
- 6 USB Device

HMI or HMI-PLC XV400

The Right Solution for Every Task

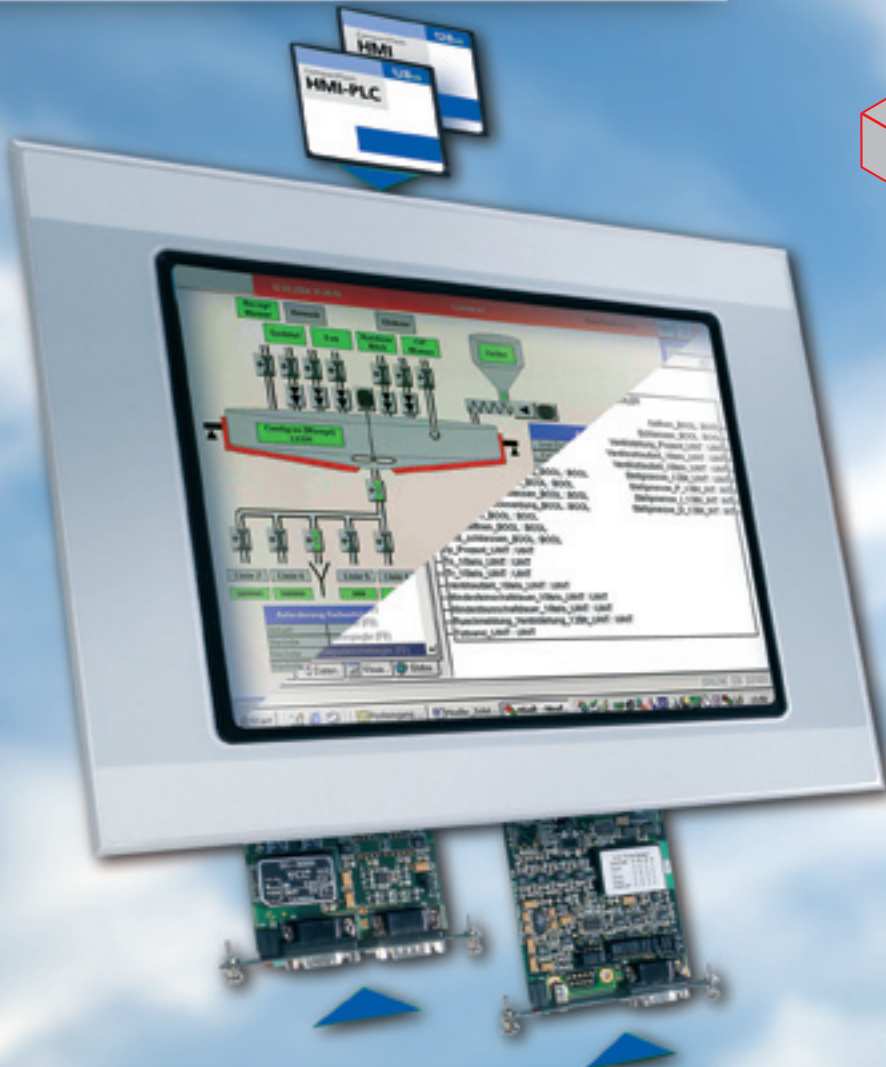
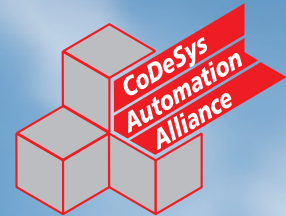

CANopen

Ethernet

RS232



xSystemv

5.7" to 12.1"

Infra-red or resistive

Ethernet

USB

RS232

CANopen

Communication cards

PLC (optional)

Micro Innovation's XV400 touch display series is a scalable future-proof device generation. The powerful computer architecture with a processing speed of 400 MHz provides sufficient performance for complex HMI or combined HMI-PLC applications.

XV400 devices are available in different touch technologies for use in a wide range of environmental conditions.

The highly rugged infra-red light matrix touch or the industrial resistive touch with an absolutely flat laminated polyester foil are protected against cracking.

The scalable display sizes from 5.7" to 12.1", over 100 communication protocols as well as CAN and optional Profibus DP (12 Mbaud) enable the XV400 series to master any task.



Communication onboard

- 1 CANopen
- 2 USB
- 3 Ethernet
- 4 RS232
- 5 24 V DC

The communication professional:

Over 100 communication protocols to all popular PLC systems.

The devices of the XV400 series offer a wide range of communication options. One or two communication slots, CAN, Ethernet 10/100Mbit, USB Host, USB Device, RS232 directly onboard ensure maximum flexibility, whether as HMI, HMI-PLC, panel with gateway function or as a connection via Ethernet TCP/IP to the control level. Onboard functions such as WEB browser, FTP server, remote client/ server or OPC client/server offer not only new networking options and programming options, they also provide customers and users with a considerable innovation edge for their automation solution.

List of some available protocols:

A. BRADLEY	DF1 / EtherNet/IP
BECKHOFF	TwinCAT ADS
EIB	EIB-ETS2
MITSUBISHI	A Series
MOELLER	easy / Sucom A / Suconet K / CANopen / CoDeSys
OMRON	C H K Series
SAIA	S-Bus / MPI
SIEMENS	PPI / MPI / DP Slave / Industrial Ethernet
TELEMECHANIQUE	Unitelway new
Others	OPC / Modbus RTU / Modbus TCP/IP / CoDeSys (SymArti) / CANopen (SDO/PDO) / 3964R



Developed for the harshest environment

Thanks to the optical light matrix touch system and the safety glass operating surface the infra-red touch devices can match even the most demanding mechanical requirements.

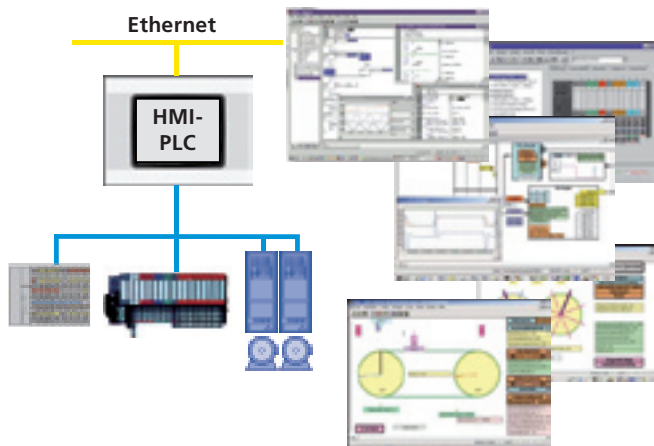

Powerful PLC

As well as ensuring considerable cost savings for the PLC, usage of the XV400 as a HMI-PLC provides a powerful and flexible automation platform that allows a wide range of network options including the most advanced IT technology. The Galileo and MXpro project design tools, together with closed-loop control toolboxes enable you to implement inexpensive and compact solutions in one device for even complex control tasks. The MXpro PLC programming tool is based on CoDeSys from 3S and is IEC 61131-3 compliant.

HMI or HMI-PLC XVS400 Compact System for Worldwide Use

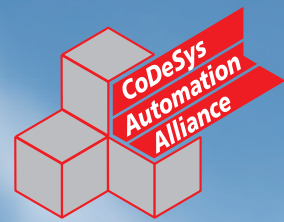

Ethernet

RS232



xSystemV

5.7" to 12.1"

Infra-red or resistive

Ethernet

USB

RS232

MPI and Profibus

PLC (optional)

Thanks to the extensive range of interfaces available onboard, the XVS400 compact devices can be adapted to the world's leading automation systems. With versatile Ethernet and USB interfaces as well, these products offer the most advanced networking options. Devices with color screens and a screen diagonal of 5.7" to 12.1" are available. The integral IEC 61131-3 compliant PLC supports all the programming languages of the standard including structured text and sequential function chart for the optimum implementation of the control task. The Profibus Master interface provided makes the XVS devices highly flexible alternatives for the visualization and automation world.

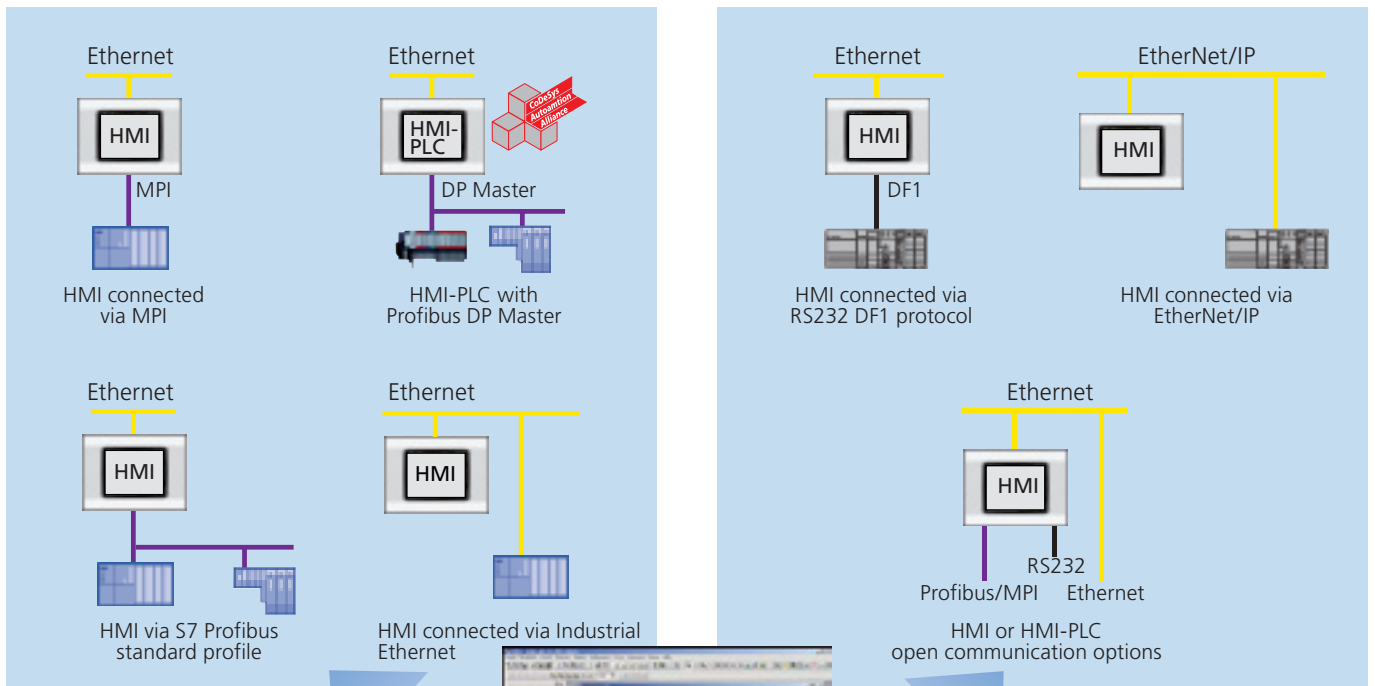

Application examples

- MPI
- PPI
- Industrial Ethernet
- Profibus DP (1.5 MBaud)
- S7 Profibus standard profile

Application examples

- DF1
- EtherNet/IP

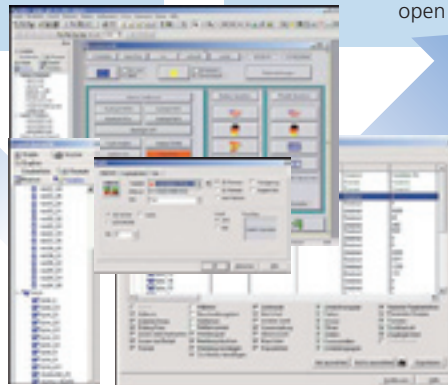

A visualization project for controllers "worldwide".

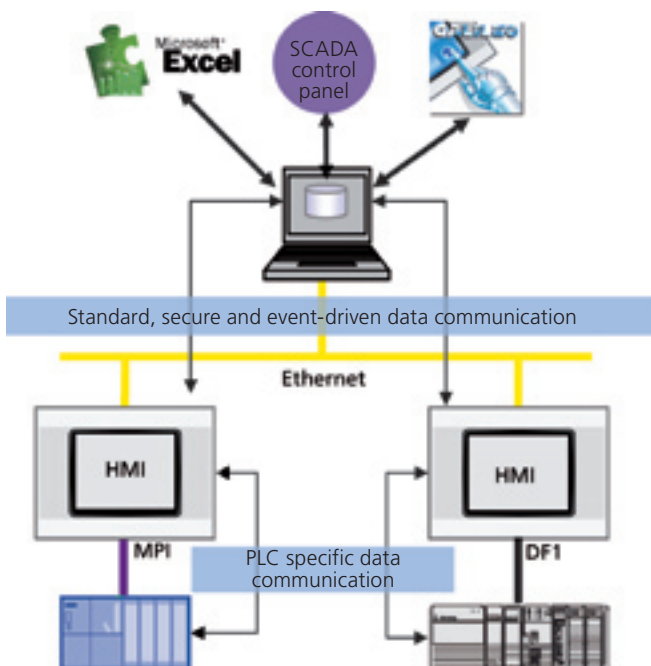

DXS server tool

The universal Micro Innovation panel allows a wide range of PLC systems to be combined homogeneously and integrated in the control level via the DXS service (Data Exchange Service). Communication with the higher-level network is implemented via a rugged, event-driven and transaction-oriented protocol and via Ethernet.

This open networking facility enables data from all data sources to be processed uniformly and efficiently, both in control desks, secure data servers and in ERP systems. Process evaluations can also be created in Excel.

HMI XVH300

Visualization and Data Management System

CANopen

Ethernet

RS232

Suconet K



xSystemV

5.7"

Infra-red or resistive

Ethernet

CANopen

Suconet K

RS232

The XVH-340 (infra-red touch) and XVH-330 (resistive touch) are specially developed, powerful visualization and data management systems. With its small mounting depth, the rugged metallized design is very compact and offers fan-free operation, i.e. no rotating parts and maintenance-free. A removable memory medium for application and operating system ensures optimum user convenience. For users of the Moeller PLC products the XVH300 devices can offer either a CAN or the combination of Sucom A and Suconet K as a fieldbus interface. Together with the Ethernet interface the device combines the tried and tested PLC technology with the latest requirements in graphically driven operation and flexible networking.

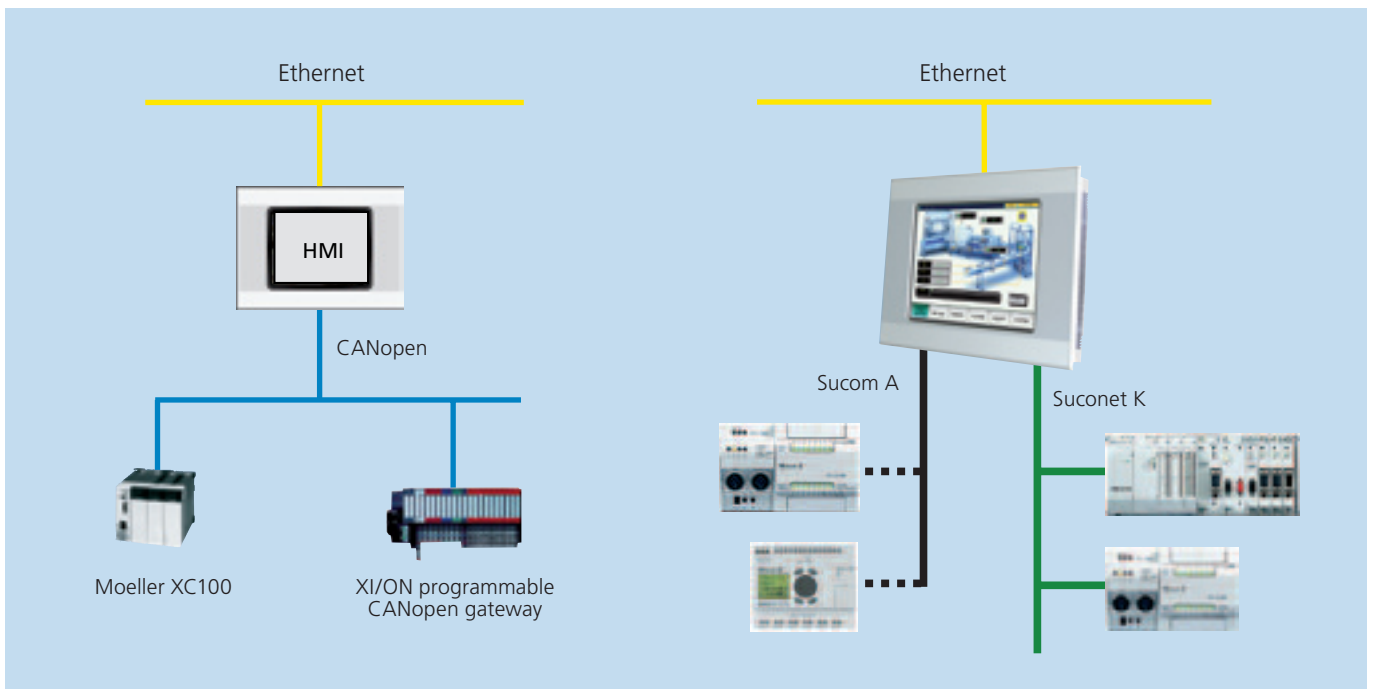

XVH300 application examples

CAN Monitor tool

The CAN Monitor tool enables the monitoring and tracing of CAN telegrams with a related time stamp, COB-ID and data directly on the Micro Innovation panel. Error frames are not detected. XV200, XV400 and XVH300 devices with onboard CAN interface support the CAN monitor function.

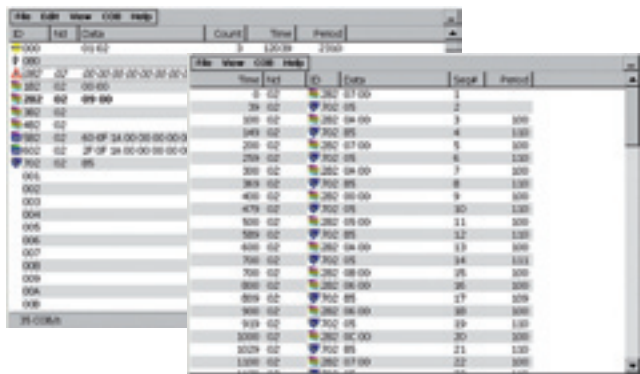

CE Telediag tool

This tool enables user-friendly teleservice via a modem connection with a dialup assistant and device callback. XV200 / XVS400 / XV400 and XVH300 devices with onboard System Port (RS232) interface support the CE Telediag function.

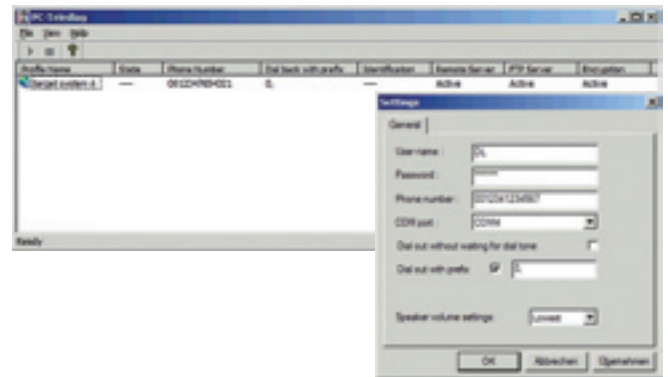

S7-PG Router tool

This tool enables the programming of S7 programmable controllers connected to the Micro Innovation panel via its Ethernet interface. XV200 and XVS400 devices with onboard Profibus and Ethernet interface support the S7 PG Routing function.





XV200, XV400, XVS400, XVH300

5.7"

Technical Data

5.7"

	XV200	XV200
	eco mono	eco color
		
	Resistive, FSTN mono	Resistive, CSTN Color
Function	HMI with optional PLC	HMI with optional PLC
Display / touch		
Display	FSTN-LCD (monochrome display)	CSTN-LCD (color display)
Active display area	5.7" (approx. 115 x 86 mm)	5.7" (approx. 115 x 86 mm)
Resolution (pixels)	QVGA 320 x 240 (240 x 320 portrait)	QVGA 320 x 240 (240 x 320 portrait)
Number of useable colors	256 grayscales	256 colors
Backlight	1 CCFL, dimmable via software	1 CCFL, dimmable via software
Half-life of backlight	50 000 h	50 000 h
Touch	resistive	resistive
Protective panel: Safety glass, non-reflective	–	–
Protective panel: Glass, non-reflective	●	●
Controller		
Processor	RISC, 32-bit, 200 MHz	RISC, 32-bit, 200 MHz
Memory	32 MB	32 MB
Retain memory/ internal Flash memory	100 Byte / 1.5MB linear	100 Byte / 1.5MB linear
CompactFlash slot (number)	1	1
Real-time clock	Yes	Yes
Operating system	WinCE	WinCE
Interfaces		
Onboard	Ethernet, USB Device	Ethernet, USB Device, RS232
Onboard for selection	Profibus (MPI/PPI/DP) up to 1.5Mbit/s, CAN, RS232	Profibus (MPI/PPI/DP) up to 1.5Mbit/s, CAN
Slots for communication modules	–	–
Power supply		
Rated value	24 VDC protected against reverse polarity, 0.35 A maximum	24 VDC protected against reverse polarity, 0.35 A maximum
Permissible voltage range	20.4 .. 28.8 VDC RMS value	20.4 .. 28.8 VDC RMS value
General data		
Ambient conditions, operation	0...50°C, 10...95% rel. air humidity, non-condensing	0...50°C, 10...95% rel. air humidity, non-condensing
Ambient conditions, storage/transport Standard	-20...60°C, 10...95% rel. air humidity, non-condensing CE, UL/CSA, CCC, EX22	-20...60°C, 10...95% rel. air humidity, non-condensing CE, UL/CSA, CCC, EX22
Protection type	IP 65 front, IP 20 rear	IP 65 front, IP 20 rear
Dimensions		
Device (WxHxD)	212 x 156 x 55 mm	212 x 156 x 55 mm
Mounting cutout (WxH)	198 x 142 mm	198 x 142 mm
Weight	approx. 0.7 kg	approx. 0.7 kg

5.7"

XV400

modular

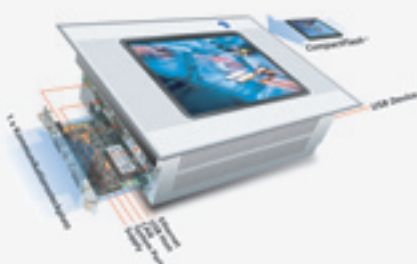

Resistive

Infra-red

HMI with optional PLC

5.7"

XVS400

compact

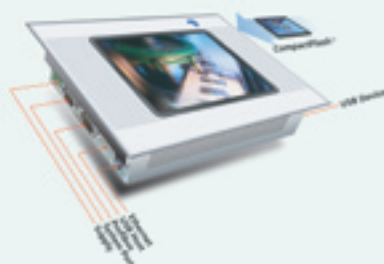

Resistive

Infra-red

HMI with optional PLC

5.7"

XVH300

compact



Resistive

Infra-red

HMI

XV400, XVS400

10.4" and 12.1"

Technical Data



10.4"

XV400

modular

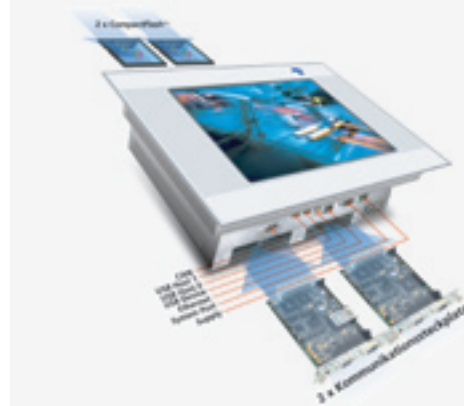

Resistive

Infra-red

HMI with optional PLC

Function

Display / touch

Display

Active display area

Resolution (pixels)

Number of useable colors

Backlight

Half-life of backlight (normal)

Touch

Protective panel: Safety glass, non-reflective

Protective panel: Glass, non-reflective

Controller

Processor

Memory

Retain memory/internal Flash memory

CompactFlash slot (number)

Real-time clock

Operating system

Interfaces

Onboard

Onboard for selection

Slot for communication modules

Power supply

Rated value

Permissible voltage range

General data

Ambient conditions, operation

Ambient conditions storage/transport

Standard

Protection type

Dimensions

Device (WxHxD)

Mounting cutout (WxH)

Weight

TFT-LCD (color display)

10.4" (approx. 211 x 158 mm)

VGA 640 x 480 (480 x 640 portrait)

65536 colors

2 CCFL, dimmable via software

50 000 h

resistive | infra-red

– | ●

fully laminated | –

RISC, 32-bit, 400 MHz

64 MB

32 KB / 1.5MB linear

2

Yes

WinCE

Ethernet, RS232, 2xUSB Host, USB Device, CAN

–

2 x slots

24 VDC protected against reverse polarity,
1.3 A maximum

20.4 .. 28.8 VDC RMS value

0...50°C, 10...95% rel. air humidity, non-condensing

-20...60°C, 10...95% rel. air humidity, non-condensing

CE, UL/CSA, CCC, EX22

IP 65 front, IP 20 rear

345 x 260 x 93 mm

329 x 238 mm

approx. 4.1 kg

10.4"

XVS400
compact

12.1"

XV400
modular

12.1"

XVS400
compact

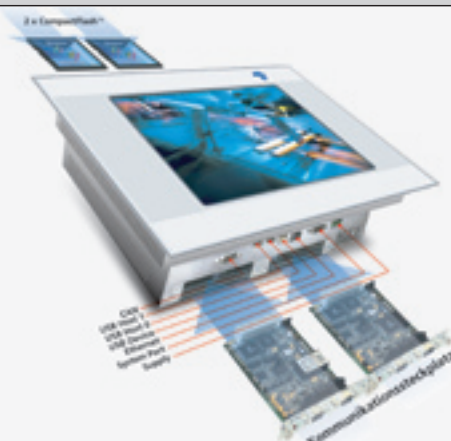

Resistive | **Infra-red**

Resistive | **Infra-red**

Resistive | **Infra-red**

HMI with optional PLC

HMI with optional PLC

HMI with optional PLC

TFT-LCD (color display) 10.4" (approx. 211 x 158 mm) VGA 640 x 480 (480 x 640 portrait) 65536 colors 2 CCFL, dimmable via software 50 000 h	TFT-LCD (color display) 12.1" (approx. 246 x 185 mm) SVGA 800 x 600 (600 x 800 portrait) 65536 colors 2 CCFL, dimmable via software 50 000 h	TFT-LCD (color display) 12.1" (approx. 246 x 185 mm) SVGA 800 x 600 (600 x 800 portrait) 65536 colors 2 CCFL, dimmable via software 50 000 h
resistive infra-red - ●	resistive infra-red - ●	resistive infra-red - ●
fully laminated -	fully laminated -	fully laminated -
RISC, 32-bit, 400 MHz 64 MB 32 KB / 1.5MB linear 2 Yes WinCE	RISC, 32-bit, 400 MHz 64 MB 32 KB / 1.5MB linear 2 Yes WinCE	RISC, 32-bit, 400 MHz 64 MB 32 KB / 1.5MB linear 2 Yes WinCE
Ethernet, RS232, 2xUSB Host, USB Device, Profibus - -	Ethernet, RS232, 2xUSB Host, USB Device, CAN - 2 x slots	Ethernet, RS232, 2xUSB Host, USB Device, Profibus - -
24 VDC protected against reverse polarity, 1.0 A maximum 20.4 .. 28.8 VDC RMS value	24 VDC protected against reverse polarity, 1.3 A maximum 20.4 .. 28.8 VDC RMS value	24 VDC protected against reverse polarity, 1.0 A maximum 20.4 .. 28.8 VDC RMS value
0...50°C, 10...95% rel. air humidity, non-condensing -20...60°C, 10...95% rel. air humidity, non-condensing CE, UL/CSA, CCC, EX22 IP 65 front, IP 20 rear	0...50°C, 10...95% rel. air humidity, non-condensing -20...60°C, 10...95% rel. air humidity, non-condensing CE, UL/CSA, CCC, EX22 IP 65 front, IP 20 rear	0...50°C, 10...95% rel. air humidity, non-condensing -20...60°C, 10...95% rel. air humidity, non-condensing CE, UL/CSA, CCC, EX22 IP 65 front, IP 20 rear
345 x 260 x 67 mm 329 x 238 mm approx. 3.7 kg	361 x 279 x 93 mm 344 x 262 mm approx. 4.5 kg	361 x 279 x 67 mm 344 x 262 mm approx. 4.1 kg

XVC100

Text Display HMI-PLC



xSystem

8 x 20 characters

incl. PLC

Inputs and outputs

CANopen

RS232

CompactFlash

The XVC100 compact display PLC integrates an operator panel with text display and a powerful compact PLC in one device. This future-oriented device concept offers a wide range of automation and networking options. A fully-fledged compact PLC with digital and analog inputs and outputs is integrated behind the membrane keyboard with an 8 x 20 character display. The integrated CAN bus allows the connection of remote peripheral devices. All connectors can be accessed from the rear. The PLC is programmed in compliance with the IEC 61131-3 industrial standard, thus turning the XVC100 display PLC into a universal device for automation applications. A user-friendly PLC function library is available for the simple and efficient programming of visualization functions.

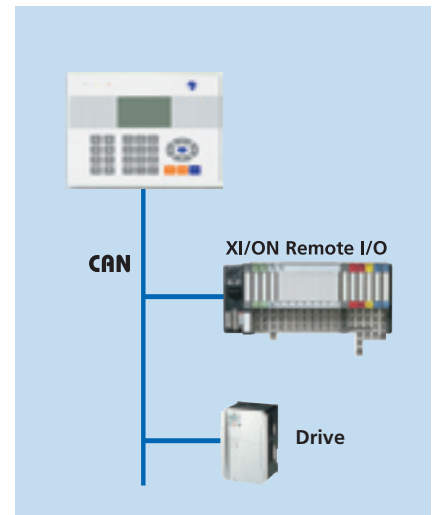
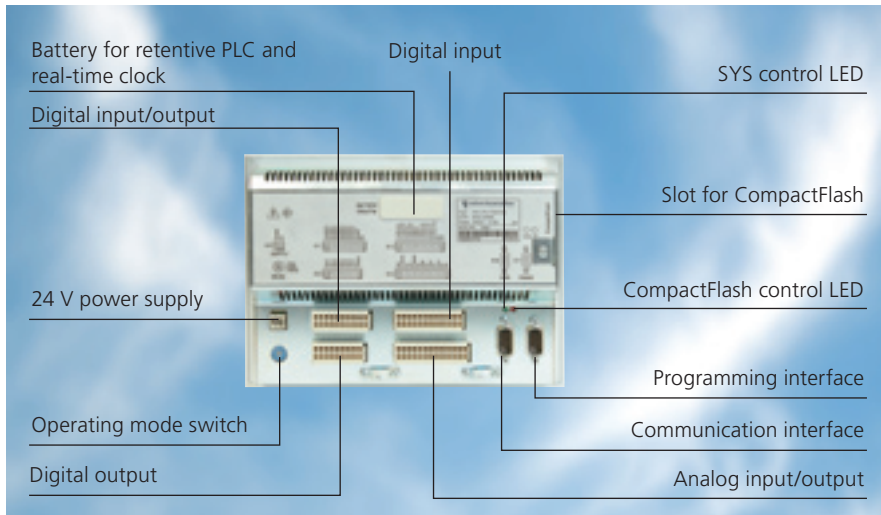

Processor

c166

Retain memory

8 KByte

Data/programm memory

56 KB/384 kB

Compact Flash™ slot

1

Display

8 x 20 characters

Display type

LCD, mono

Number of usable colors

2

Backlight

LED backlight

Active display area

65 x 33 mm

Keyboard type

Membrane keyboard

Number of keys

28 keys

Communication onboard

CAN, RS232

Onboard I/O

Inputs: digital / analog

10* / 2

*of which counter / interrupt / encoder

2 / 2 / 1

Outputs: digital / analog

8 / 2

Selectable digital inputs/outputs

8

Project design

PLC: MXpro

Visualization: Function blocks

Power supply

Rated value

24 VDC, 0.2 A maximum

Permissible range

18.5...30.2 VDC

Ambient conditions, operation (°C)

0...60, 10...90% rel. air humidity,

non-condensing

Ambient conditions, storage (°C)

-20...60, 10...90% rel. air humidity,

non-condensing

Standards

CE, CCC, EX22

Protection type

IP65 front, IP20 rear

Dimensions

212 x 156 x 50 mm

Cutout (WxH)

198 x 142 mm

Weight

approx. 0.9 kg

The XVC100 provides the machine and system builder with a low-cost device for a wide range of tasks whilst still offering the tried and tested features of the xSystem and the user-friendly project design features. The rugged and compact design enables applications that were previously impossible due to space or price restrictions.

HMI-PLC XVC600

The Open Platform for Your Automation



xSystem

10.4", 15"

Infra-red

Open platform

Ethernet, USB

CANopen, RS232

Communication cards

incl. PLC + EPAM

Machines and systems in particular are increasingly being implemented with modular designs. Every unit must be integrated into the product range which is suited to the product.

Micro Innovation's XVC600 automation system allows the system supplier to optimally adapt the automation technology to the process conditions at hand, an invaluable benefit in terms of seamless system design and flexibility for visualization, operation and control systems. The XVC600 series brings premium power to the compact class of automation. Micro Innovation has added essential features such as scalability and flexibility to the well-established features of a combination device consisting of a graphical operator panel with a touch screen and a powerful fan-free PLC without any moving parts.

XVC-601



Type:

Color TFT
Number of colors: 256 K
Backlight:
dimnable via software

Resolution:

640x480, 1024x768

Touch:

Type: Infra-red touch
(resistive touch in preparation)

Processor:

Pentium 200MHz to 650 MHz

Memory:

32 - 512MB DRAM
Retain memory: 32KB

Data/Programm memory:

Removable CompactFlash
32 to 512MB

Interfaces:

CAN, Ethernet
seriell, mouse/keyboard, USB
optional Profibus DP-Master

Programming:

PLC: MX_{pro} IEC61131-3
Visualization: EPAM

Power supply:

Nominal value 24 V DC, from 15 W
Permissible range 18.5...30.2 V DC

General Data:

0..50°C
10...90% rel. air humidity

Protection type:

IP65 front,
EMC class:
EN61000-6-2, EN50081-2

Dimensions (WxHxD):

10.4": 345 x 260 x 100 mm
15": 427 x 332 x 100 mm

The tried and tested touch display HMI-PLCs of the XVC600 series offer with their integrated fieldbus and Ethernet interfaces a wide range of communication and networking options for industrial applications. The devices can be run completely fan-free and without any moving parts.

A removable CompactFlash is used as a mass storage memory.

This memory makes the device at home even in harsh environments! The CPU performance is scalable thanks to the ETX standard used.

New technologies and powerful processors compliant with the ETX standard can be used directly.

In this way, the devices are able to meet future requirements and ensure long-term availability.

An infra-red touch system can be used as an input unit.

The infra-red touch technology enables absolute soft touch operation. The scratchproof safety glass for the front protects the TFT display and ensures a clear picture.

For further information on additional products such as:

- Infra-red touch DVI panel
 - Display-free compact devices
- please contact your Micro Innovation agent.

One Step Ahead with Modular I/O Systems

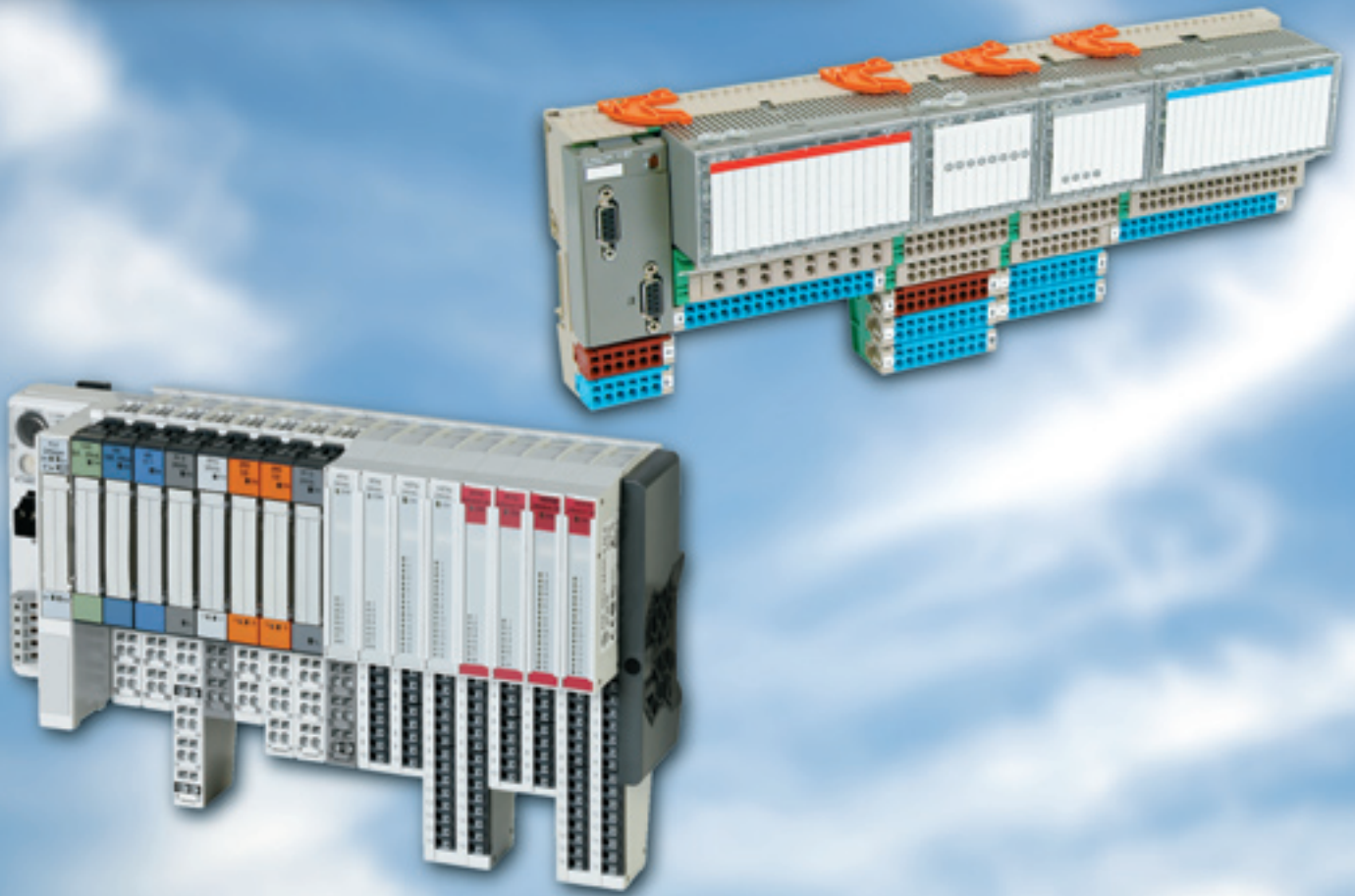

xSystemN

XI/ON

WINbloc - compact

The application ranges of remote I/Os are as varied as the different applications themselves – whether in motion control, temperature or speed measurement, current and voltage data acquisition.

They are used wherever remote signal processing is an essential element of the automation concept.

Micro Innovation offers the right I/O system for every application, from the highly granular XI/ON system to the compact WINbloc system, and of course, combined operation on the same bus line. The result: an easy-to-handle modular concept – adaptable to any application, intelligent and ready for future developments.



Conventional automation solutions often cannot provide highly responsive and flexible intelligence directly in the field. In machine building, for example, where signals have to be processed directly at the machine or when system sections have to continue to be accessible even when the bus has failed. In cases like these, small autonomous units are used that are integrated via the network with maximum transparency. Remote I/O systems from Micro Innovation allow you to keep one step ahead, since decentralized structures increase the manageability of the system and reduce wiring costs.



The benefits of decentralized intelligence are obvious: Wherever extensive processes or systems can be divided into independent subprocesses, decentralized automation offers a flexible solution. Programming, commissioning and service become more manageable and are therefore subject to fewer errors and are less costly. Last but not least, the availability of the system is also increased since the subsystems function autonomously.



XI/ON

As much as necessary, as little as possible. This is the principle on which the XI/ON modular I/O system is based. The highly granular modularity of the system allows you to buy only the I/Os you actually need. A comprehensive range of digital and analog I/Os and technology modules are available for this purpose. On the field level, the wiring is implemented using base modules that are also available in different versions to match the requirements at hand: 2, 3 or 4-wire terminal designs are available, with screw or spring-loaded terminals to meet the needs of the application exactly.

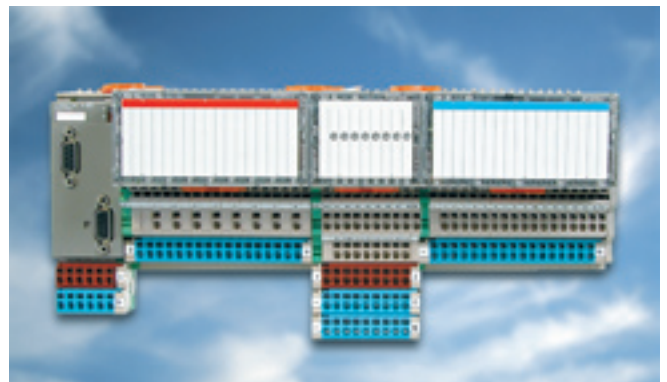

WINbloc

WINbloc and WINbloc Eco offer the compact and cost-efficient solutions in block designs for Profibus-DP and CANopen. The plug-in electronics module allows implementation of flexible solutions with a high level of availability. A wide range of electronics and base modules are available. I/O combination modules are offered for the most commonly used combinations. For fast and simple installation base modules come with spring-loaded terminals for 2, 3, and 4-wire connections. In this way any application required can be easily implemented.

XI/ON Modular I/O System

Intelligent, Flexible, Economical

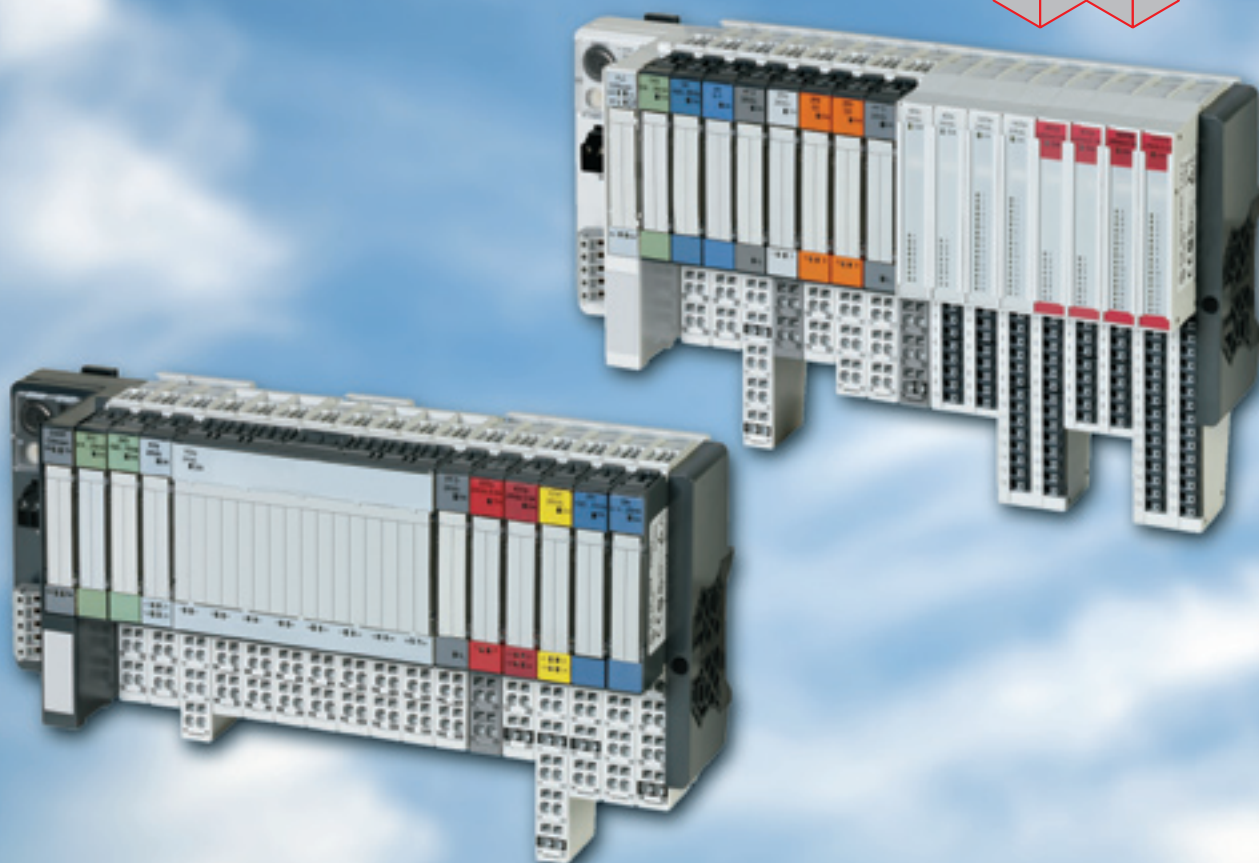

xSystemN

High modularity

Standard and
ECO modules

CANopen

Profibus

DeviceNet

Ethernet

SmartWire

The right solution for every requirement

In an automation world in which technologies are growing even closer together, solutions are required that can sustainably improve productivity and thus economy.

The XI/ON remote I/O system – our open and flexible communication platform – allows you to implement economical automation solutions quickly and simply. All components offer outstandingly user-friendly handling as well as standard interfaces for Profibus DP, CANopen, DeviceNet and Ethernet and comply with all international standards. A high level of modularity, low wiring requirements, a wide range of functions and accurate diagnostics routines are the benefits of this system.

Decentralized peripheral devices

The decentralized structure of automation systems is an essential element of state-of-the-art automation concepts. The modular design of the application is also becoming increasingly important in addition to the distribution of digital and analog I/O points. Decentralized preprocessing via intelligent gateways relieves the processing requirements of the central controller. Distributed intelligence makes automation systems faster, more reliable and more affordable.

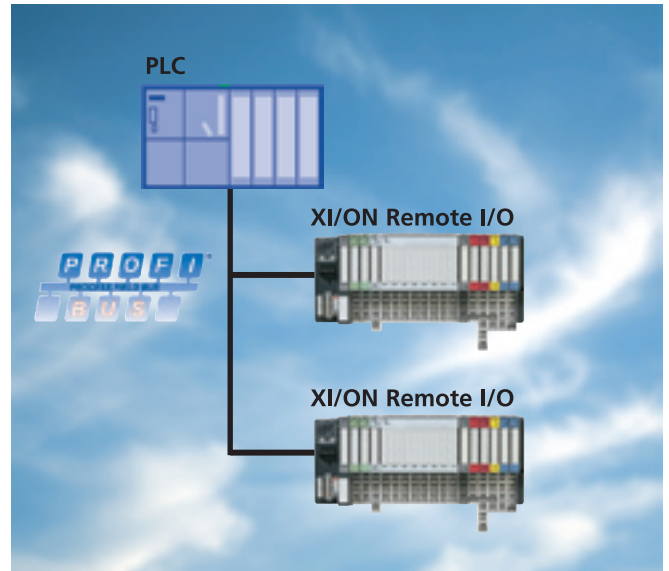

Conventional solution with remote I/O

XI/ON can be connected to a wide range of controllers as a highly granular decentralized I/O system.

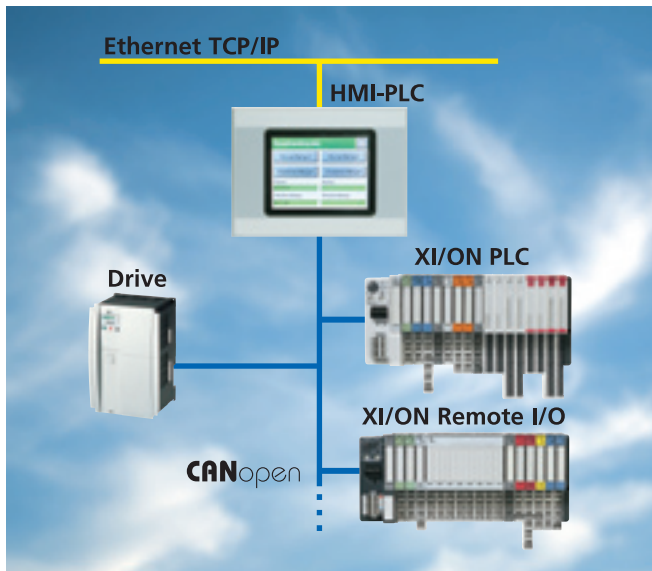

Distributed intelligence with XI/ON PLC

The programmable CANopen gateway now brings PLC performance directly to the fieldbus terminal. The device is ideal for decentralized automation concepts and for relieving the processing load on the higher-level PLC.

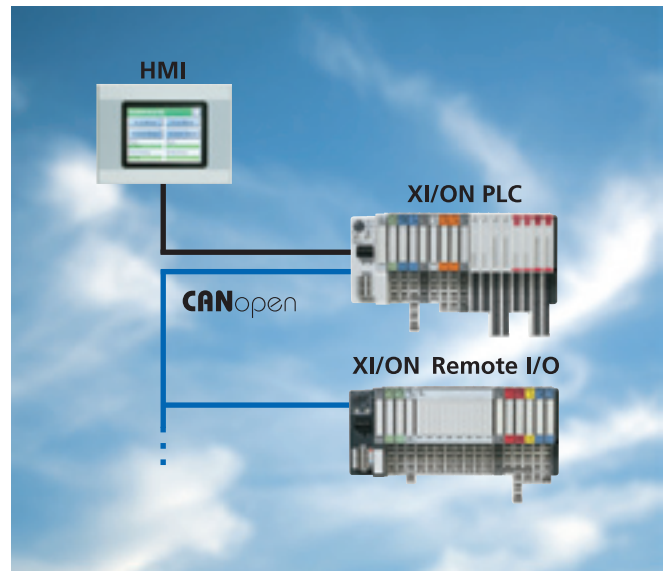

XI/ON PLC as a flexible compact controller

The intelligent gateway can also be used as a stand-alone space-optimized PLC and connected to remote stations.

XI/ON Remote I/O – More Flexibility in the Application

Openness

- The gateway product range supports the CANopen, Profibus-DP, DeviceNet and Ethernet fieldbus systems
- The modules can be used for any bus

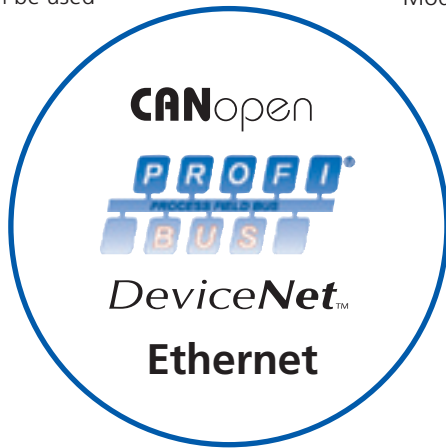

XI/ON standard modules

- Pluggable modules
- Fast modules change (hot swappable)
- Wiring on base module
- Screw or tension clamp terminal
- Mechanical coding of Module

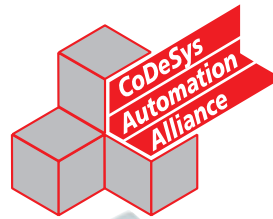
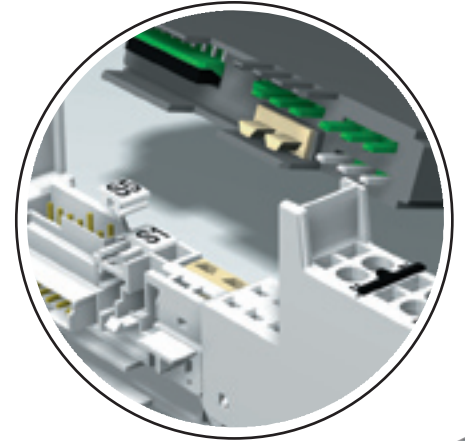

Service interface

- Commissioning of station also without head-end controller
- Station diagnostics
- Programming interface

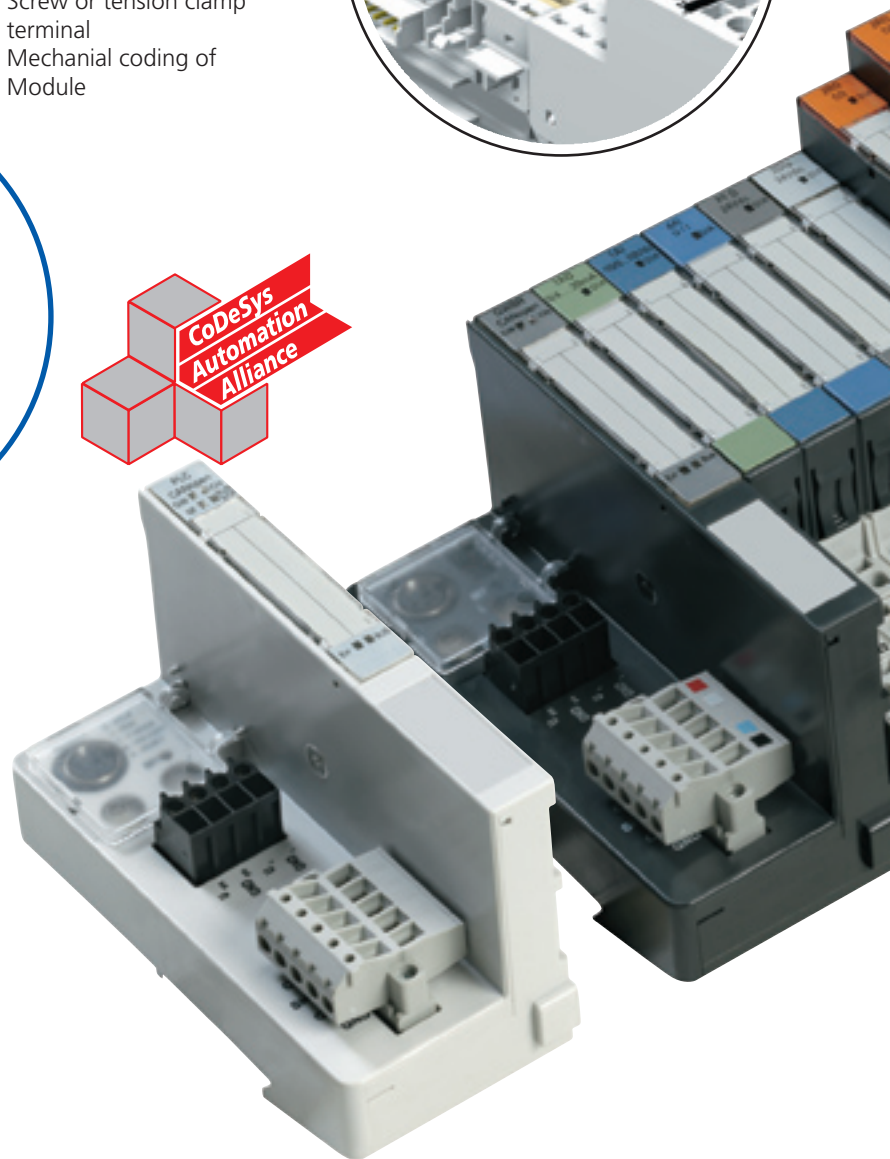

Gateways

- Fieldbus gateway
- Programmable gateway

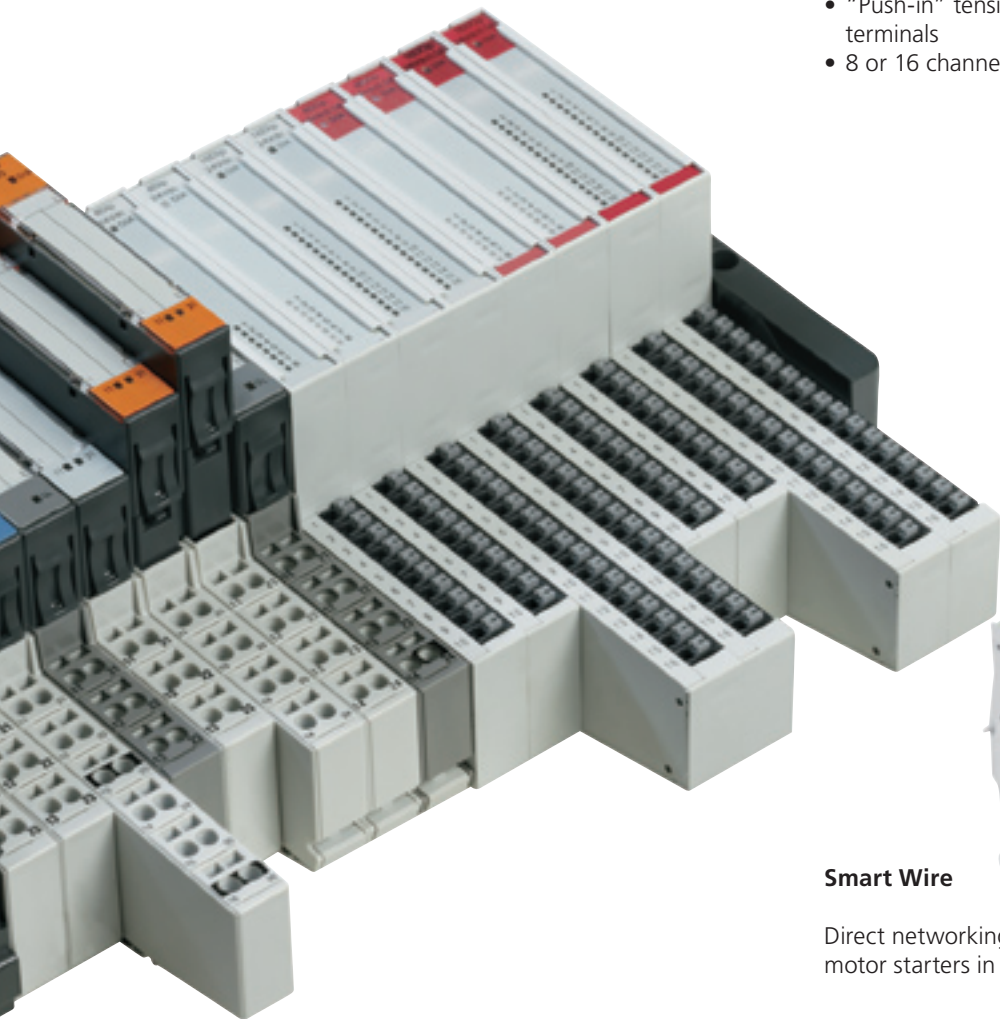

Power feeding modules

- Field supply of XI/ON modules with 24 V DC and 120/230 V AC
- Forming of potential groups
- Diagnostics functions:
Monitoring of the field voltage

XI/ON ECO modules

- High channel density (up to 16 DI/DO on 12.5 mm)
- "Push-in" tension clamp terminals
- 8 or 16 channels per module



Smart Wire

Direct networking of Moeller motor starters in XI/ON

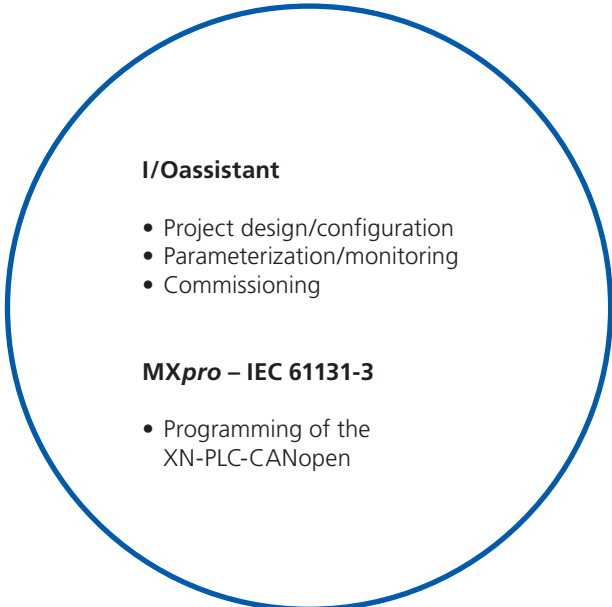
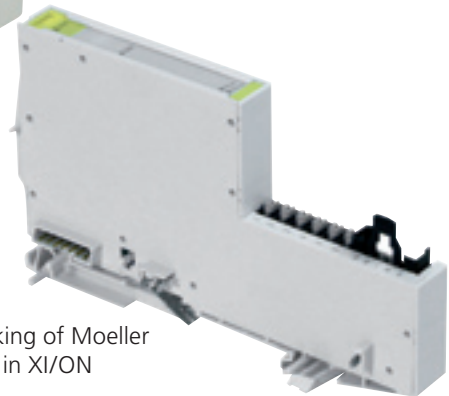

I/Oassistant

- Project design/configuration
- Parameterization/monitoring
- Commissioning

MXpro – IEC 61131-3

- Programming of the XN-PLC-CANopen

The Right Gateway for Every Application

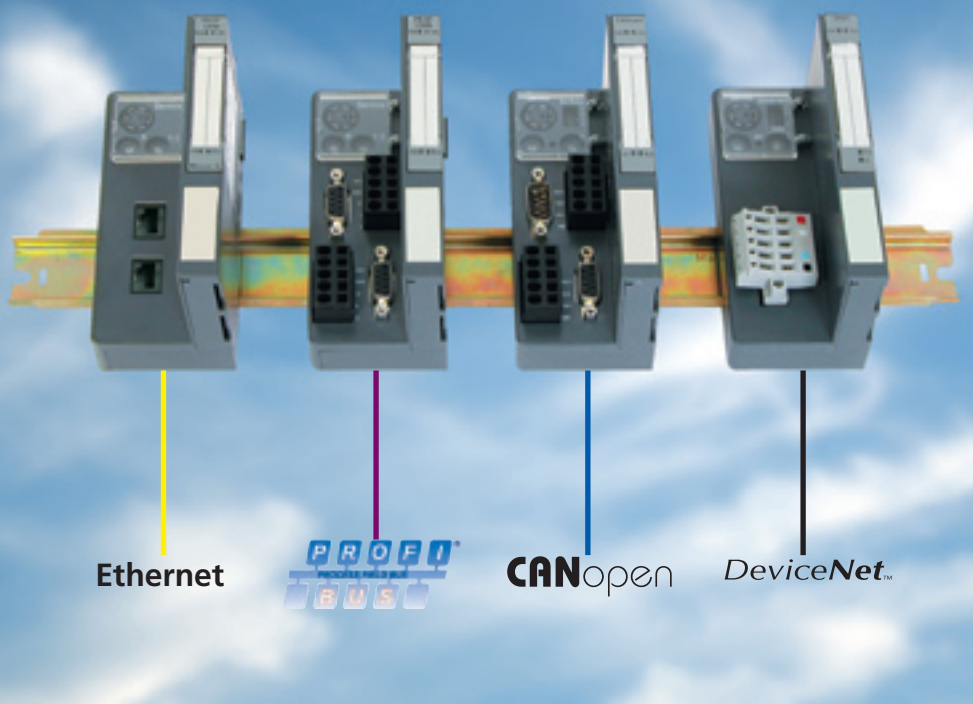

The XI/ON system can be used on all standard bus systems. You can choose between Profibus DP, CANopen, DeviceNet or Ethernet for the required gateway. Many gateways have the advantage of a feeder module already integrated, which saves costs and space. The integrated service interface is an outstanding feature. This enables the function of the station to be tested completely via the I/Oassistant diagnostics and commissioning software without the need for the high-level fieldbus master. In this way faults can be detected and rectified simply before the system is commissioned.

Programmable CANopen gateway

The programmable CANopen gateway brings PLC performance directly to the fieldbus terminal. The device is ideal for decentralized automation concepts and for relieving the processing load on the higher-level PLC. Programming or online commissioning can be carried out via the integrated service interface or with networked systems via the CANopen fieldbus. The device can also be used as a stand-alone space-optimized PLC and connected to remote XI/ON stations.

XI/ON Interface for easyConnect SmartWire from Moeller

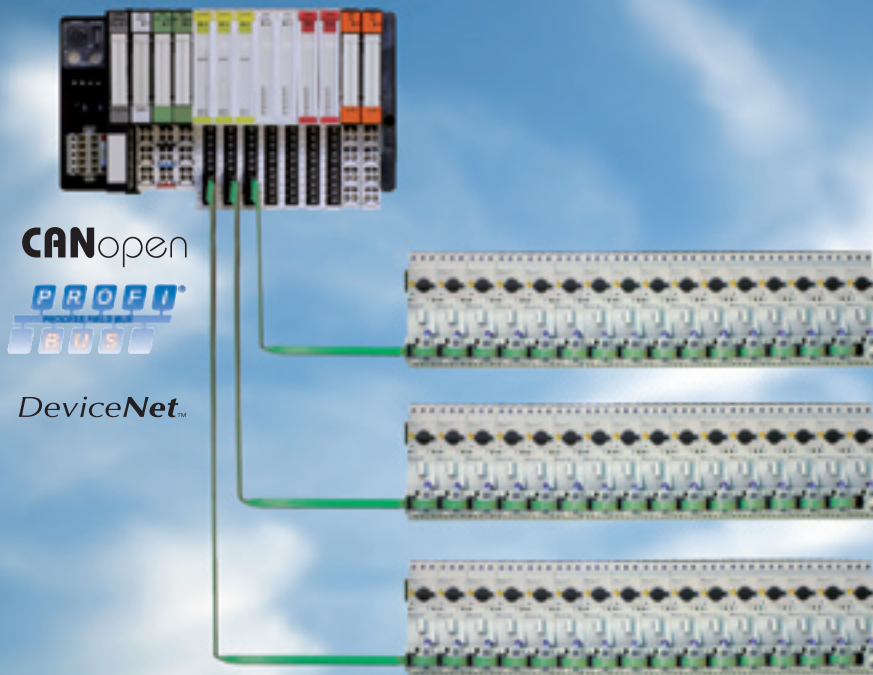

The tried and tested XI/ON system has now been expanded with the SmartWire interface slice module. In addition to a number of different inputs and outputs, this also allows standard Moeller motor starters and contactors to be connected directly to XI/ON.



- 3 SmartWire lines pro XI/ON station
- 16 nodes per line
- Simple configuration by means of pushbutton
- Autodetect function

MOELLER



SmartWire allows connection of switching devices to the PLC without any complex control wiring required. The control wiring between the PLC and the switching devices is replaced by pluggable pre-assembled connection cables.

The wiring requirement is drastically reduced and wiring faults become a thing of the past.

This achieves savings in mounting, commissioning and troubleshooting during operation.

The inputs/outputs of the PLC are replaced by the SmartWire modules. This considerably simplifies engineering and documentation since the terminal points of the control circuit are unnecessary.

SmartWire is an addition to the tried and tested Moeller switching devices and is designed as an accessory for the standard devices.

The flexibility of the switching devices is fully retained since the well-established system accessories can still be used.

The use of standard devices reduces inventory costs and ensures the worldwide availability of the spare parts. Gateways or interface modules are used to connect a wide range of fieldbus systems.

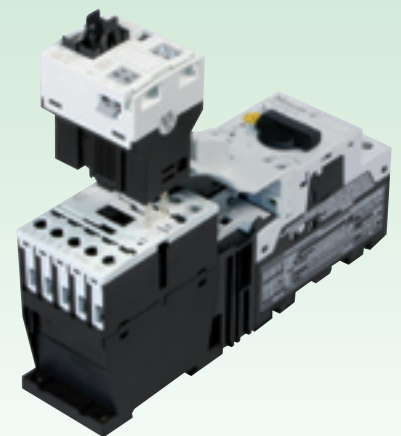

www.moeller.net

XI/ON Tailor-Made for Your Application – Pluggable, Coded, Variable

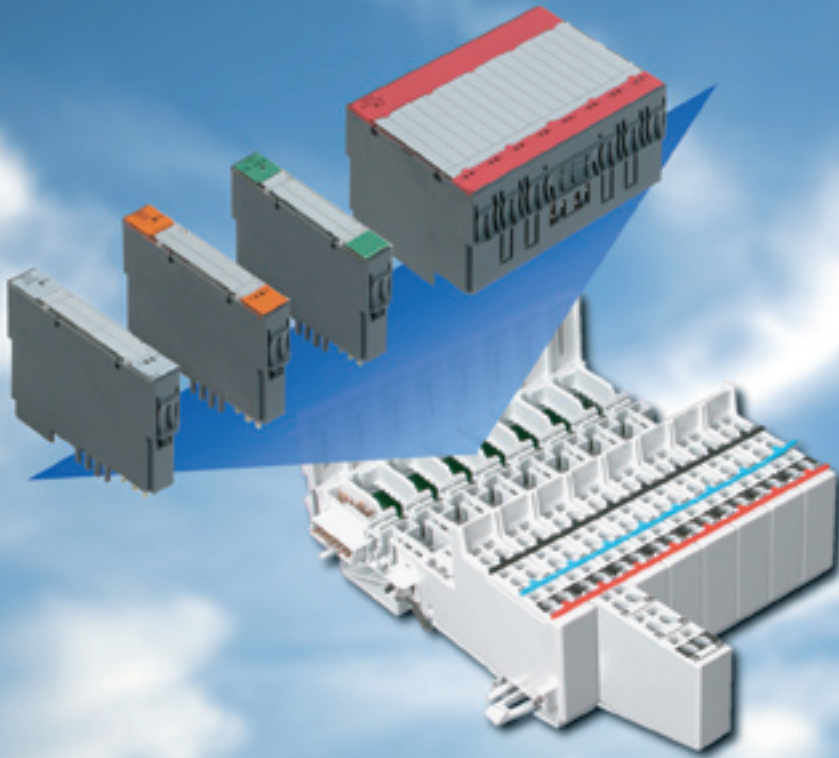

Safety through coding

The pluggable design of the modules enable them to be exchanged quickly and without tools, even under live conditions (hot swappable). The mechanical coding prevents modules from being plugged incorrectly.

The XI/ON standard modules are pluggable and consist of an electronic module and a base module implemented as a strip terminal. The different modules allow you to build up your station to your exact requirements.

Slice and block modules with 1, 2, 4, 16 or 32 channels per module are available. These consist of a wide range of analog and digital I/O modules to meet your requirements exactly.

Digital inputs: 24 V DC, 120/230 V AC
 Digital outputs: 24 V DC, 120/230 V AC, relay
 Analog inputs: 0/4..20 mA, +/- 10 V, U/I configurable, PT/Ni, Thermo
 Analog outputs: 0/4..20 mA; +/- 10 V

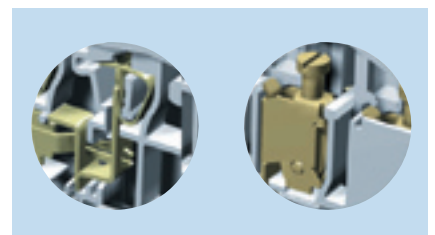
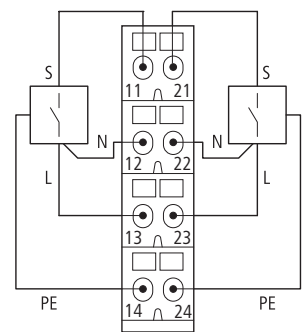

The base modules of the XI/ON standard systems are available with 2, 3 or 4-wire circuits and tension clamp or screw terminals. An additional terminal strip is unnecessary.

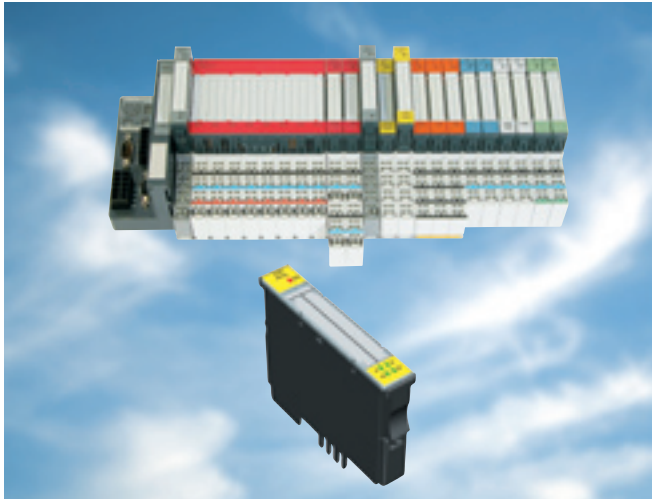

**XI/ON technology modules:
Interfaces and counters**

The serial interface modules of the XI/ON range enable them to transfer serial data streams via the XI/ON system. This enables the connection of different devices such as printers, scanners or barcode readers with a serial RS232, RS485 or RS422 interface.

The XN-1SSI module allows the connection of encoders with an SSI interface, a supply voltage of 24 V DC (500 mA), a word length of up to 32 bits and a transmission rate of max. 1 MHz.

The XN-1CNT counter module detects normalized signals up to 200 kHz.

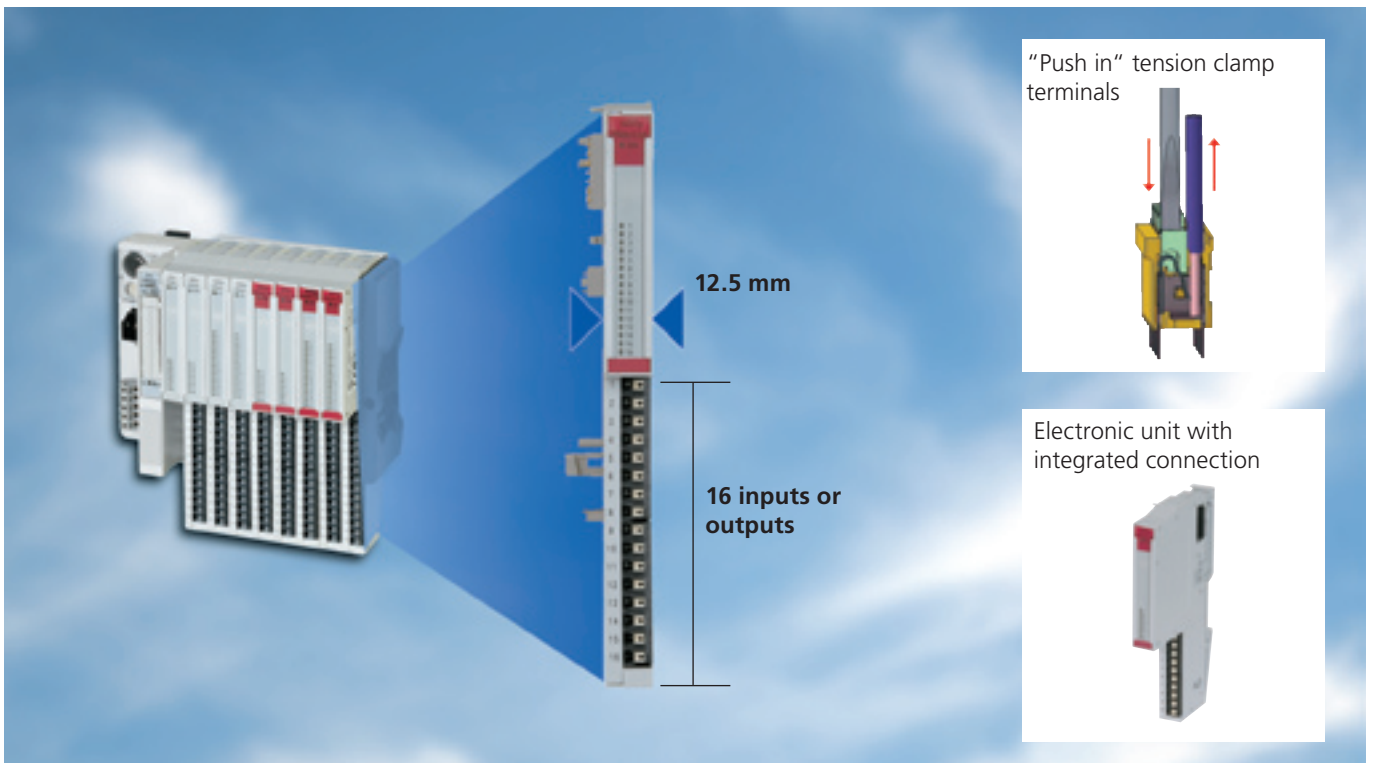

**XI/ON ECO modules:
More information where space is at a premium**

Save space and costs with XI/ON ECO I/O modules. The Moeller XI/ON remote I/O system has been expanded with the new price and space optimized XI/ON ECO I/O modules. Depending on type, 8 or 16 inputs and outputs can be connected over a width of only 12.5 mm.

The high connection density reduces the mounting width for typical applications. All modules are implemented with an integrated connection level.



Key benefits of the XI/ON ECO modules at a glance:

- Space saving with 16 channels on 12.5 mm width
- Cost saving with electronic unit with integrated connection level
- Connection via "Push in" tension clamp terminal saves time required for mounting
- Can be combined with existing XI/ON modules

XI/ON Modular I/O System Everything at a Glance

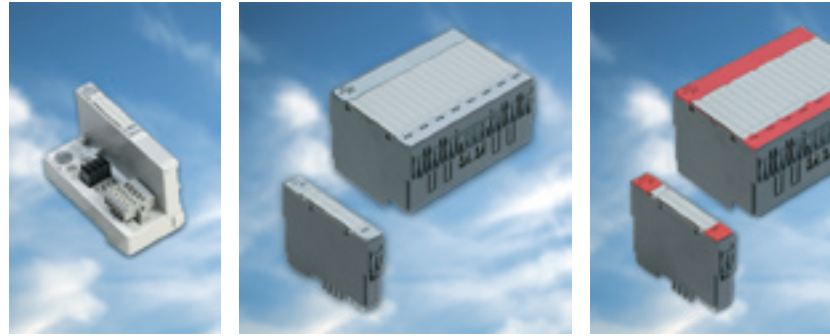
As much as necessary, as few as possible. This is the principle on which the XI/ON modular I/O system is based. The highly granular design of the system allows you to buy only the I/Os you actually need. A comprehensive range of digital and analog I/Os and technology modules are provided for this purpose.



Base modules		Gateways				Digital input						Digital output						Relay mod
		XI-GWBR-PBDP	XI-GWBR-CANOPEN	XI-GWBR-DNET	XI-PLC-CANOPEN	XI-2DI-24VDC-P	XI-2DI-24VDC-N	XI-2DI-120/230VAC-P	XI-4DI-24VDC-P	XI-16DI-24VDC-N	XI-32DI-24VDC-P	XI-2DO-24VDC-2A-P	XI-2DO-24VDC-0,5A-P	XI-2DO-120/230VAC-0,5A-P	XI-4DO-24VDC-0,5A-P	XI-16DO-24VDC-0,5A-N	XI-32DO-24VDC-0,5A-P	XI-
	XN-S3x-SBB					•	•	•										
	XN-S3x-SBC										•	•	•	•				
	XN-S4x-SBBC					•	•	•										
	XN-S4x-SBBS								•	•								•
	XN-S4x-SBCS											•	•	•	•			•
	XN-S6x-SBBSBB								•	•								
	XN-S4x-SBBS-CJ																	
XN-S6x-SBCSBC													•					
	XN-B3x-SBB										•							
	XN-B3x-SBC													•				
	XN-B4x-SBBC										•							
	XN-B6x-SBBSBB																	•
	XN-B6x-SBCSBC														•			
	XN-P3x-SBB																	
	XN-P3x-SBB-B																	
	XN-P4x-SBBC																	
	XN-P4x-SBBC-B																	

WINbloc

Bridges



The bridge connects the expandable I/O modules with Profibus-DP or CANopen, in which each I/O module represents a passive network station on the fieldbus.

The bus address setting is carried out with rotary coding switches on the I/O modules.

- A maximum of 10 I/O modules can be connected per bridge
- Bus connection either via SUB-D or tension clamp terminals
- Fieldbus electrically isolated
- Operating voltage: 24 V DC

DP Bridge

Transmission speed: up to 1.5 Mbit/s

DP Bridge/12 Mbaud

Transmission speed: up to 12 Mbit/s

CAN Bridge

Transmission speed: up to 1 Mbit/s

Digital I/O modules for CANopen

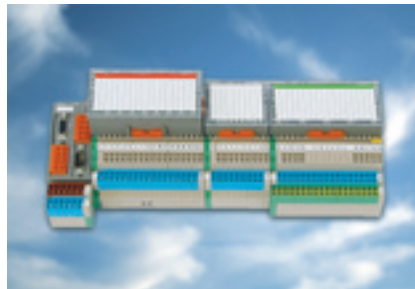

Input modules 8/16/32-channel

CAN-8-(16)DI/P
CAN-16-(32)DI/P-2x8 (2x16)

Output modules 4/8/16/32-channel

Either 0.5 A or 2 A
Short-circuit proof design -PK
With short-circuit monitoring LED
CAN-4DO/2.0A-PK
CAN-8-(16)DO/0.5A-PK
CAN-16-(32)DO/0.5A-P-2x8 (2x16)

Combi modules 8/32-channel

Optimum combination of input/output modules
Either 0.5 A or 2 A outputs
Short-circuit proof design -PK
With short-circuit monitoring LED
CAN-4DI/4DO/0.5A-PK
CAN-24DI/8DO/0.5A-PK

Relay modules 8/16-channel

Make contact
CAN-8(16)DO-R-NO

Analog I/O modules for CANopen

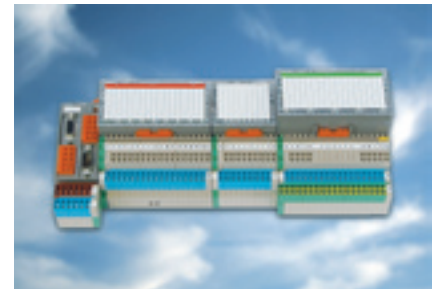

Input modules 4-channel

Input ranges:
10/0..+10 V, 0/4..20 mA
Resolution 16-bit
Reverse polarity protection
CAN-4AI/UI

Analog input PT100

Resolution 0.1 K, 0.1 W
CAN-4AI/PT100

Analog input

Thermo K, J, R, S, T, N, E, B
Resolution 1K
CAN-4AI/Thermo

Output modules 4-channel

output range:
10/0..+10 V, 0/4..20 mA
Reverse polarity protection
Resolution 16-bit
CAN-4AO/UI

Combi modules 4-channel

Input/output ranges:
10/0..+10 V, 0/4..20 mA
Reverse polarity protection
CAN-3AI/1AO/UI

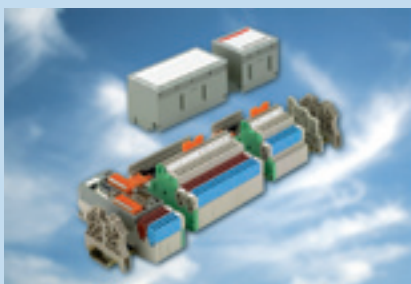

Wide selection of I/O functions

The basic structure of the WINbloc system consists of a bridge, an electronic and a base module. The wide selection of I/O modules means that any possible combination can be implemented. Simply fit up to 10 I/O modules in a row and create the station exactly to the requirements of the application. It couldn't be simpler.

Fast and economical wiring

Different base modules with either 2, 3 or 4-wire connection are available for the connection. Modularity on the entire line!
The I/O points can be connected with tension clamp terminals allowing easier access.

Digital I/O modules for Profibus-DP

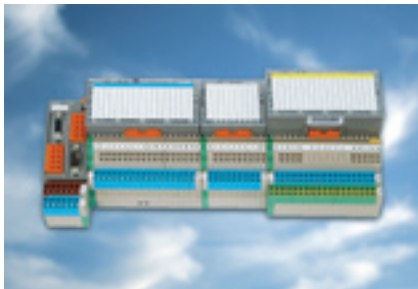

Input modules 8/16/32-channel

Either 24 V DC, 120 V AC or 230 V AC either positive/negative switching
DP-8-(16)DI/P, **DP-16-(32)DI/P-2x8 (2x16)**
DP-8-DI/N, **DP-8-DI/115VAC (230VAC)**

Output modules 4/8/16/32-channel

Either 0.5 A or 2 A
 Short-circuit proof design -PK
 With short-circuit monitoring LED
DP-4DO/2.0A-PK
DP-8-(16)DO/0.5A-PK
DP-16-(32)DO/0.5A-P-2x8 (2x16)

Combi modules 8/12/16/32-channel

Optimum combination of input/output modules
 Either 0.5 A or 2 A outputs
 Short-circuit proof design -PK
 With short-circuit monitoring LED
DP-4DI/4DO/0.5A-PK
DP-8DI/4DO/0.5A-PK
DP-8DI/4DO/2.0A-PK
DP-8DI/8DO/0.5A-PK
DP-24DI/8DO/0.5A-PK

Relay modules 8/16-channel

Either make contact or potential-free changeover contact
DP-8(16)DO-R-NO, **DP-8DO-R-CO**

Analog I/O modules and counter for Profibus-DP

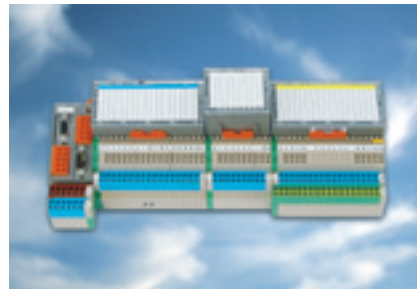

Input modules 4-channel

Input ranges: 10/0..+10 V, 0/4..20 mA
 Resolution 16-bit, reverse polarity protection
DP-4AI/UI
 Analog input PT100
 Resolution 0.5 K, 0.1 W/0.25 K, 0.025 W
DP-4AI/PT100
 Analog input
 Thermo K, J, R, S, T, N, E, B
 Resolution 1 K, 0.25 K
DP-4AI/Thermo

Output modules 4-channel

Output ranges: 10/0..+10 V, 0/4..20 mA
 Reverse polarity protection, resolution 12-bit
DP-4AO/UI

Combi modules 4-channel

Input/output ranges:
 10/0..+10 V, 0/4..20 mA
 Reverse polarity protection
DP-3AI/1AO/UI

Counter module 1-channel, 25kHz

Forwards/backward positioning
 Counter range 0..65535
 Limit preset via Profibus-DP
DP-1CNT/24VDC

WINbloc Eco for Profibus-DP

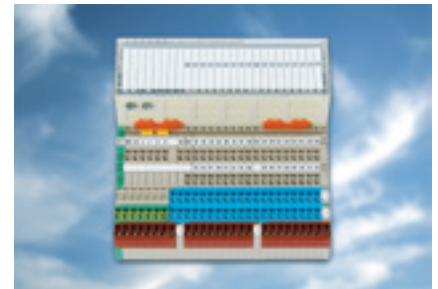

Digital input modules

Positive switching
DP-16DI/P-ECO
DP-32DI/P-ECO

Digital output modules

Positive switching
 Short-circuit proof
DP-16DO/0.5A-PK-ECO
DP-32DO/0.5A-PK-ECO

Combi modules

Positive switching
 Short-circuit proof
DP-16DI-P/16DO/0,5A-PK-ECO

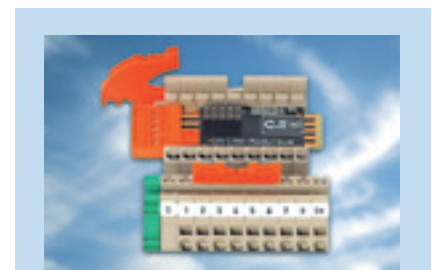

Modular plug adapter – Reliable connection

The electronics of the base elements are contacted reliably by using the sliding module bus link. A clip is used to ensure reliable mechanical connection. The electronic unit is then simply plugged onto the base modules and locked – that's it!

WINbloc Eco

The economical and compact alternative for connecting to Profibus-DP. The system consists only of a base and electronic module. A bridge is not required. The fieldbus connection is implemented by direct wiring on the base module. Each WINbloc Eco module is a passive station on the Profibus-DP network. In addition to the extensive diagnostics LEDs, the signals are also indicated directly and clearly at the terminals.

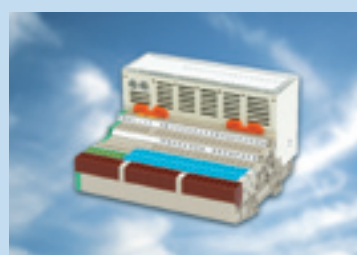

Galileo – Interactive Visualization Tool

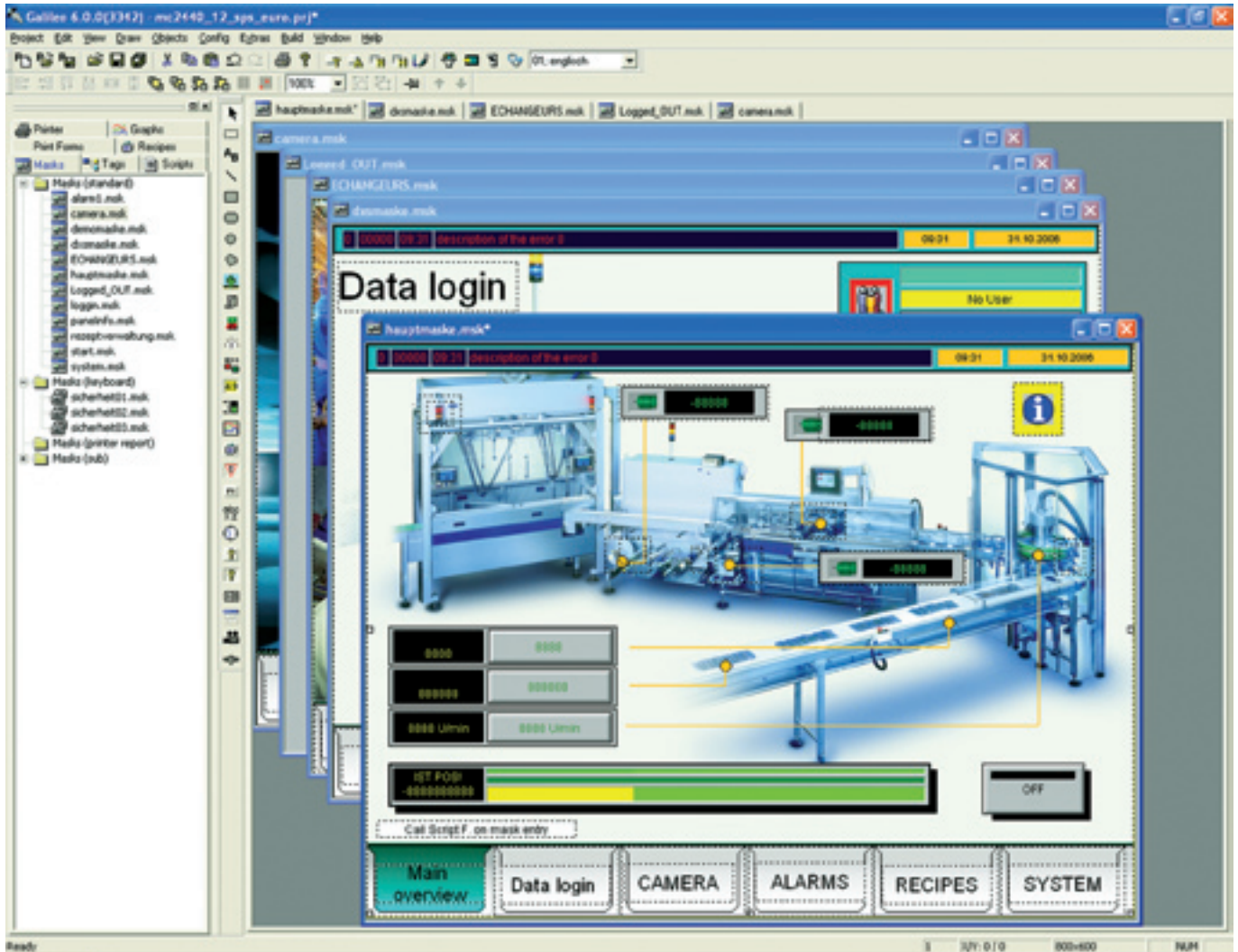

Galileo is an easy to learn and yet powerful and extensive project design environment that can be used ideally in all system and machine building applications close to the machine and process.

Galileo is designed for use in all sectors and offers comprehensive project design for all graphical operating devices from the Micro Innovation HMI product range as well as for stand-alone PC solutions. Galileo provides the project designer with a full range of functions without any graduated restrictions on tags or screens, and takes into account the performance level of the panel used.



Reliable and simple connection to the control level and office world.

Comprehensive project design of all graphical panels up to and with the PC control station.

Up to 8 communication options at the same time, with data bridge.

Some of over 100 protocols to all standard PLCs

A. BRADLEY	DF1 / EtherNet/IP
BECKHOFF	TwinCAT ADS
EIB	EIB-ETS2
MITSUBISHI	A Series
MOELLER	easy / SucomA / Suconet K / CANopen / CoDeSys
OMRON	C H K Series
SAIA	S-Bus / MPI
SIEMENS	PPI / MPI / DP Slave / Industrial Ethernet
TELEMECH.	Unitelway new
Various	OPC / Modbus RTU / Modbus TCP/IP / CoDeSys (SymArti) / CANopen (SDO/PDO) / 3964R

GALILEO Highlights

- Fast project design with project simulation on the design PC
- Easy to learn and intuitive graphical user interface with project overview window
- Drag & drop positioning of objects WYSIWYG (what you see is what you get)
- Simple parameter definition of objects
- Enhanced password handling with complex password and aging
- Extensiv recipe handling
- Alarm handling with time stamp, history and diagnostics support with picture display
- User-friendly multiple definitions of texts and pictures to variables
- Many graphical objects such as bargraph, slide adjuster, graph plot, camera
- Object parameter list, any number of data objects on one screen
- Dynamic measuring unit change (e .g. °C ↔ °F, inch ↔ mm)
- Many specific objects and functions
- Direct printing on the panel (reports, forms)
- Brilliant picture display with up to 65536 colors
- Import of 15 different picture formats
- Simple import of PLC variables
- Online language change
- Unicode support (also Asian character sets)
- Text import/export in XML format, e. g. Excel
- Always full functionality available, no graduated performance

Galileo – Fast, Simple Project Design

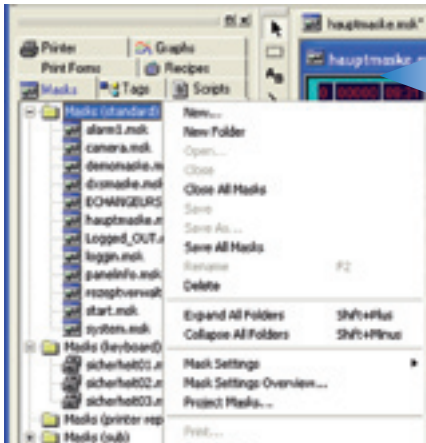

Fast project design

The required project data and information is shown in clearly visible groups in the project overview for simple selection. Other useful functions are available in every individual group via the context menu.

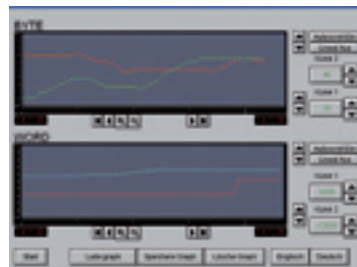

Simple configuration of objects

Double-clicking the object concerned will activate the object configuration: Tag selection, object style, BMP/Text/ colors, object-related settings, view and operability.

A number of ready-to-use objects for fast project design



- Picture import
- Screen change
- Buttons
- Selector switch
- Status display
- Value entry display
- Bargraph
- Graph
- Recipe
- Alarm window
- Special functions
- Text entry
- Time/date
- Help buttons
- Help window
- Parameter list
- Sub screen
- Camera
- Slide adjuster

Online language change, Text export/import with Unicode support.

An export and import interface allows you to extract texts in XML format from the project and translate them with external tools (e.g. Excel). Unicode support means that Asian picture characters can also be implemented. Different languages can also be selected on the panel.

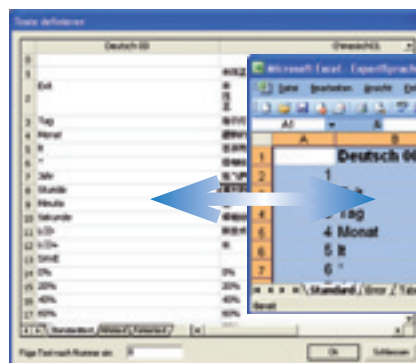
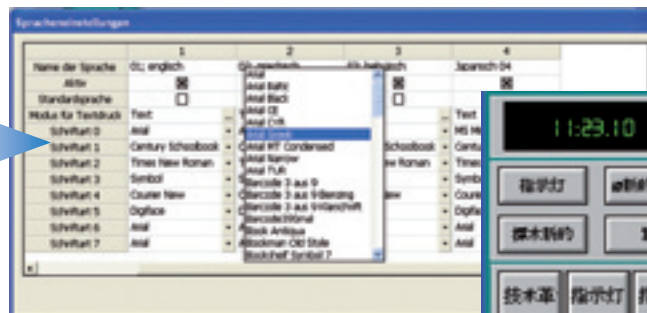

Project ready in a few steps

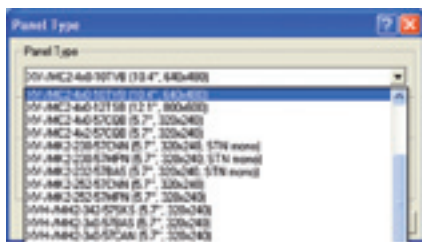

1 Open the project and select the panel type.

The project will automatically allow all the features of the selected panel.

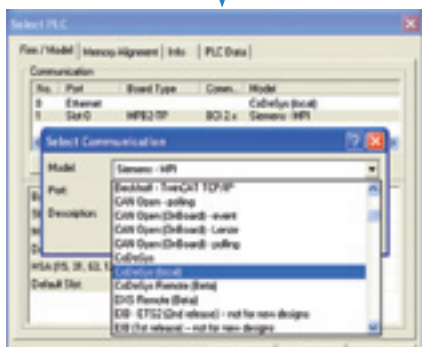

2 Select communication.

Up to 8 communication protocols can be operated simultaneously from a selection of over 100. Data can thus be transferred via the panel from PLC to PLC.

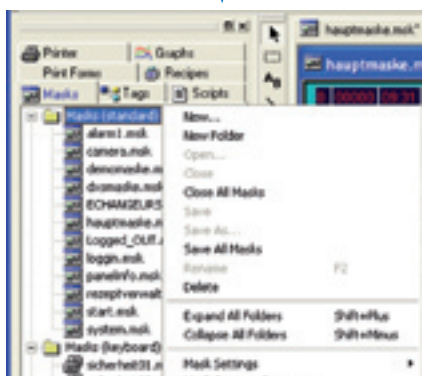

3 Create screens.

Full screens, sub screens, dialog screens and user-defined entry screens can be designed. Several ready-to-use standard screens for efficient project design are also available.



4 Create variables or import from MXpro (CoDeSys).

A specific entry dialog is provided for tag definition according to the communication protocol selected. Data from MXpro or other CoDeSys-based PLCs can be imported easily and synchronized when the PLC project is changed.

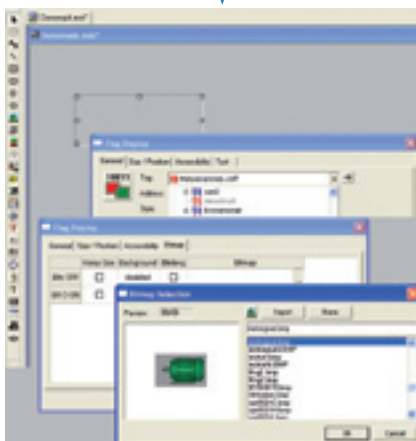

5 Position the object on screen.

Drag & drop functionality allows all visualization objects to be positioned on the screens and their wide range of properties to then be adapted to the application at hand.



6 Simulation of the project on the design PC.

Your project can be compiled and simulated directly on the design PC at any time. Detailed error messages and warnings notify you of any inconsistencies in the project. The simulation tool enables your project to be tested easily and developed efficiently.

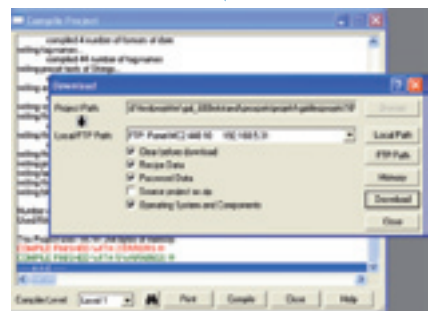

7 Download to the panel.

Once the compilation has been successfully completed, the project can be transferred during operation by clicking "Online" on the panel.



MXpro: Programming Compliant with International Standards

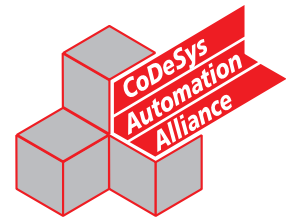

All xSystem controllers of Micro Innovation are programmed with MXpro. MXpro is based on standard CoDeSys software from 3S. Fully developed technical features, simple handling and a widespread use of this software in automation components for different manufacturers guarantee successful programming with this software.

User-friendly PLC configuration

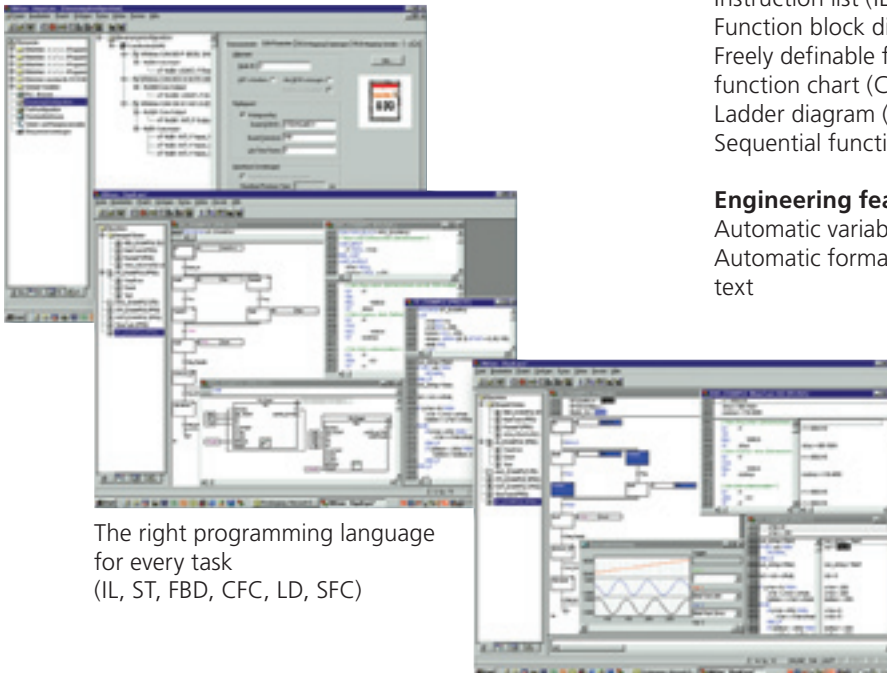

The right programming language for every task (IL, ST, FBD, CFC, LD, SFC)

Programming languages

- Instruction list (IL) and structured text (ST)
- Function block diagram (FBD)
- Freely definable function block chart/continuous function chart (CFC)
- Ladder diagram (LD)
- Sequential function chart (SFC)

Engineering feature

- Automatic variable declaration
- Automatic formatting and coloring of code/declaration text

Extensive debugging and commissioning tools save time and money

Debugging and commissioning

MXpro offers you a number of important functions for debugging, testing and commissioning your PLC applications quickly and efficiently. All these features are available as soon as you log onto the PLC (online mode)

Simulation

You can also test your application program when the PLC is not connected. This is possible thanks to the integrated online simulation. You don't need to forgo the regular operator interface either, and handling is not any different to online mode with the PLC connected.

A number of features simplify application creation and support one aim: cost savings by reducing engineering times. Here is a selection of other features: Global search and replace, generation and use of libraries, context-sensitive help, output of a cross-reference list, checking of unused tags, etc.

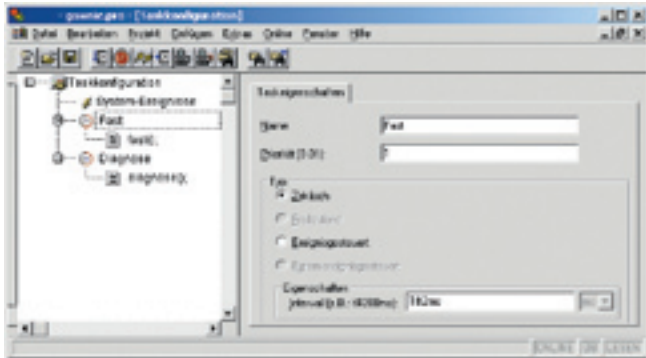

Multitasking

The structuring of the application into several independent runtime programs (multitasking) optimizes the resources of your PLC and simplifies the implementation of time-critical tasks. Give priority to high-speed processes and provide slower processes with only as much processing time as required.

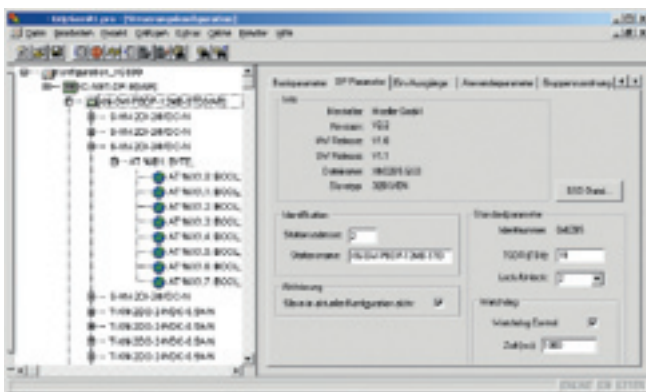

Fieldbus configurator included

The hardware configurator shows all the local I/Os and the remote periphery (Profibus or CANopen) on one user interface. You can configure and parameterize the inputs and outputs directly, and assign them with a symbolic name. This prevents the occurrence of any assignment errors between the peripheral devices and the PLC program. You can also test variables in online mode.

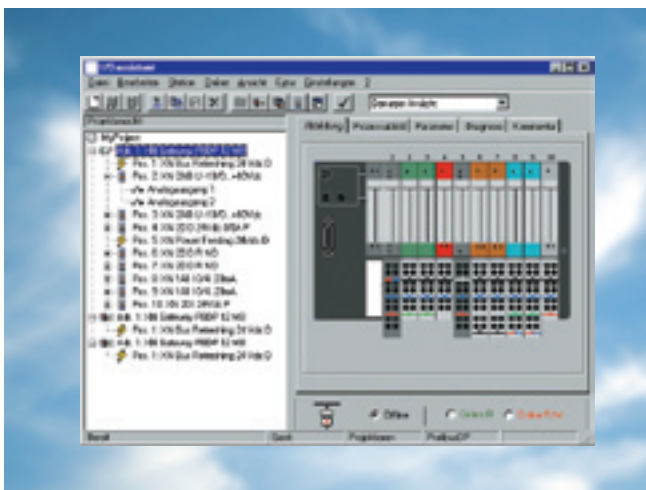

Multitasking

Up to 16 time and/or event driven tasks

Visualization

Integrated tool for diagnostics and commissioning support

Configuration

Configurator for local I/Os as well as CANopen and Profibus-DP stations

Communication

RS232, Ethernet, in distributed networks via CANopen, OPC server, UDP, TCP/IP, FTP client/server, Modbus Master/Slave, email, SMS

Password protection

8 levels

Languages

D, GB

Libraries

IEC, CompactFlash access, closed-loop control, motion control, etc.

Special features

Network variables for cross traffic via CAN and Ethernet

I/Oassistant

Instantly online, instantly viewed, instantly tested

The I/Oassistant integrated in MXpro provides you with a specifically designed tool for configuring XI/ON from MXpro. Without leaving MXpro, all the functions of the I/Oassistant are available for interactively planning and implementing your remote XI/ON station.

For this you select gateways, electronic and base modules as well as the corresponding accessories.

The tool automatically checks that the structure is correct.

The individual stations are then configured offline or online.

Once everything is set to your satisfaction, you can put the system into operation.

Application Libraries for Additional PLC Functions



Micro Innovation provides ready-to-use libraries for programming the controllers with MXpro for several applications.

The libraries can be incorporated simply via the MXpro Library Manager.

The additional function blocks of the libraries are then available like all other standard function blocks. The function block interfaces are kept as simple as possible and are normally easy to understand without requiring any extensive study in manuals.

The user is therefore provided with ready-to-use solutions for automation tasks in many situations involving closed-loop and motion control.

Closed-loop control toolbox

The closed-loop control toolbox contains around 120 function blocks. This firstly enables the implemented closed-loop control know-how to be utilized with the standard function blocks and secondly allows function blocks to be combined and cascaded in order to create special application solutions.

PID controller: The right controller can be selected for every control problem. The split range PID controller thus provides solutions for typical heating / cooling temperature controllers. The autotuning controller is used for the automatic setting of the parameters at the start of the control phase.

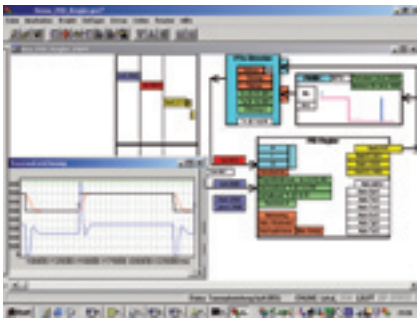

Three step controller:

In addition to standard PID three step controllers, other robust and easy to set variants are available that are suitable for any valve opening time. The scan times of differential and integral components are optimized automatically.

Pulse width modulation (PWM):

If the control system does not have an analog actuator, pulse width modulation outputs are connected behind the PID or fuzzy controllers. Conventional PWM algorithms are available and the noise-shape process with a highly dynamic switching frequency.

Fuzzy control: The fuzzy function blocks enable even inexperienced users to integrate fuzzy systems/controllers in a control concept. Even the gain factor or setpoint of a PID controller can be

programmed effortlessly with fuzzy logic.

Signal processing and simulations:

Ramp delay function blocks and PT1 filters can be used to improve signal quality. First to tenth order PTn control systems can be simulated with the toolbox function blocks without an additional software package.

Motion control toolbox

The motion control toolbox contains approximately 40 function blocks that can be individually integrated and adapted to the automation solution in question.

Positioning

The toolbox contains basic positioning function blocks for elementary tasks and also more powerful function blocks with the following features:

- Asynchronous point-to-point positioning
- Master-slave positioning (e.g. interpolation)
- Incremental dimension positioning
- Rotary axis positioning (bending, turning) with optimized paths over the zero point
- Automatic referencing
- Manual mode with step width limitation
- Contouring error, wire break and positioning range monitoring
- Crawl speed zone at the end of positioning
- Compensation of the zero point coverage of hydraulic axes

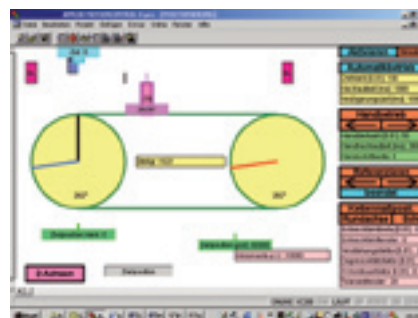

Possible applications include handling tasks in the automobile supplier industry (manufacture of cup springs and spiral springs), winding of spiral springs, cable winding machines, pipe bending, positioning and synchronization of stages or curtains in theaters.

Electronic gears

An electronic gear system can be implemented with the synchronization function blocks.

Different speeds can be synchronized with any transmission ratio.

Angle synchronization with online configurable offset between master and slave axes is also possible.

Three master axis variants are provided. The internal master is controlled in the same program. The external master is used by an external device to control the master. An incremental encoder records the motion of the master axis. With the virtual master, the slave axes follow a simulated axis.

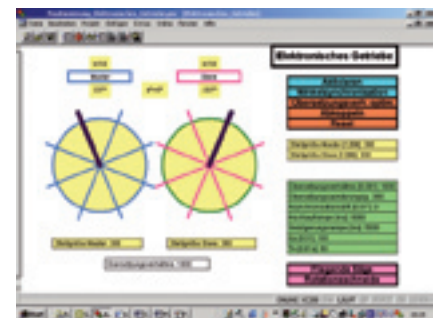

Applications include: Press synchronization control with virtual master; angle and speed synchronization of belts; drawing of weaving materials with 5 slave axes and increasing transmission ratio per axis.

Flying saw

The "flying saw" function is a combination positioning and electronic gears. Positioning operations are carried out relative to the synchronized motion.

Communication Libraries

Flexible, Versatile and Efficient

Communication functions are increasingly becoming a central element in automation solutions. In addition to the conventional remote connections for peripheral devices via fieldbus systems such as CANopen or Profibus, data communication between PLCs or higher-level systems are of major importance. OPC, FTP, TCP/IP, email, web are just some of the technologies here that can be used for data communication or for transferring files.

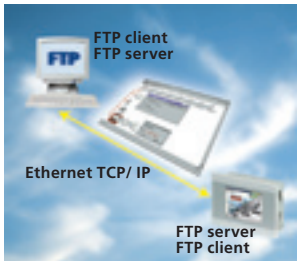

FTP server: Updating recipe data

Micro Innovation controller uses a standard file system for internal program storage. This also applies to the pluggable external memory cards or a memory stick connected via the USB interface. Recipe data can be created really easily as a "normal" file, transferred to the PLC and read from there. Recipe data can now thus be updated easily via any PC.

FTP client: Sending data archives automatically

The FTP client function blocks enable files that were created by the PLC to also be stored on any drives that can be accessed via the network. If, for example, the target drive is not accessible due to problems on the network, an alternative drive can be accessed. Daily or weekly logs can thus be stored locally and archived at any time. With a few function block calls, files can be saved from the PLC onto a network drive.

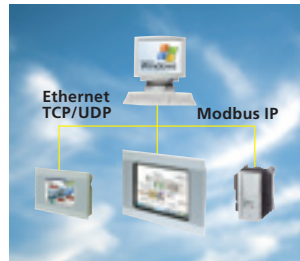

UDP and TCP/IP

UDP and TCP/IP are protocols used on very many operating system platforms, which enable a simple and standard data exchange between the PLC and external systems. This can be other controllers or even PC-based applications.

Modbus / TCP

Modbus is a communication protocol that is widely used with different communication media. Modbus can be implemented as a serial connection (RS232/485) or as a Modbus IP Ethernet version.

Ready-to-use libraries for the masters and also the slave function are also available.

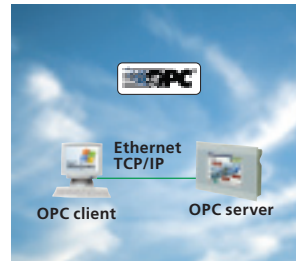

OPC server

Virtually all SCADA, visualization and control systems support the OPC client/server interface. The OPC server is used by the controllers to present the process data to the OPC clients. The OPC server supports data access via the serial interface and via the Ethernet, and each OPC server is able to process requests from several clients. If data is to be used several times, for example by a visualization system or a database, different software packages can access the data of the OPC server without the need for any manufacturer specific conventions or additional implementations.

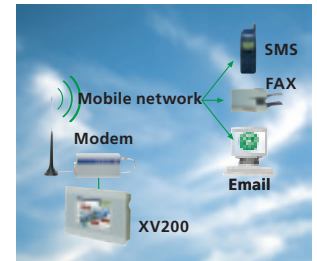

SMS messaging or email

System states or alarm messages can be sent simply by SMS or email – whether for logging or for direct communication with the service technician. The ready-made user modules provide you with all the options you need to be always notified in time about the operating state of the machine or plant.

**Further information and downloads are
can be obtained at:
<http://www.microinnovation.com>**

I/Oassistant: Configuration Software for XI/ON and WINbloc I/O System

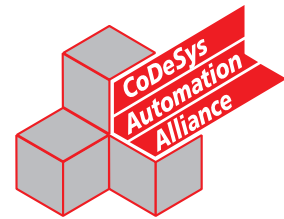

Instantly online, instantly viewed, instantly tested!

The I/Oassistant provides you with a universal tool that supports you interactively throughout the planning and implementation stage of your XI/ON system. First of all, you need to create and structure a project on screen. To do this, you select gateways, electronics/base modules and the appropriate accessories. Then you configure the individual stations either offline or online. Once everything is set to your satisfaction, you can put the complete system into operation.

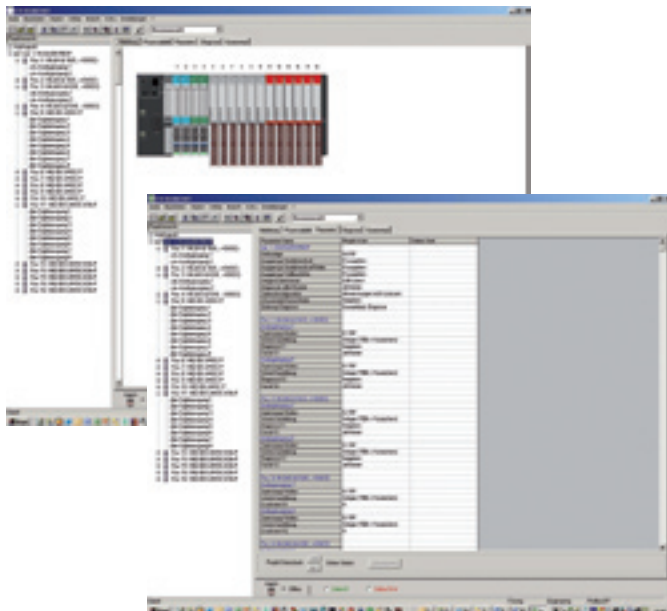

Commissioning without a fieldbus master

The I/Oassistant checks the station, reads in process data, outputs values and visualizes the diagnostics data of the channels. In this way you can commission your station without a higher-level controller and ensure that sections of the system are operating correctly.

You set the outputs and modify values directly from the PC. By forcing the values you can instantly view the behavior of your application. You can thus check the field wiring, for example, without having a fully installed control system.

Integration in MXpro

The I/Oassistant integrated MXpro is the special configuration tool for XI/ON and can also be accessed from within MXpro. You can therefore make full use of all I/Oassistant functions for interactive planning and implementation of your remote XI/ON station without having to exit MXpro.

Design plan and parts list generation

Once the planning has been completed, the software can generate a detailed project documentation that includes overview picture and parts lists.

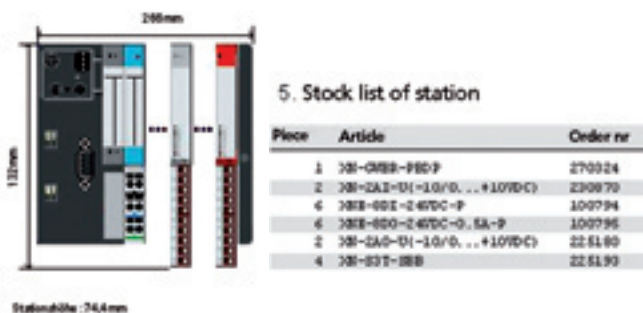

EPLAN support

EPLAN macros are available for the XI/ON modular I/O system. This saves the time required for configuring and helps to prevent configuration errors.

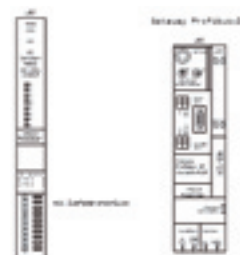

EPAM: Visualization Tool under Microsoft-Office

EPAM is designed as an open visualization system for OEM machine builders and can be extended at any time with the customer's own functions using Visual Basic macros.



Simple and efficient project design with EXCEL

Import of variables from MXpro

Easy positioning

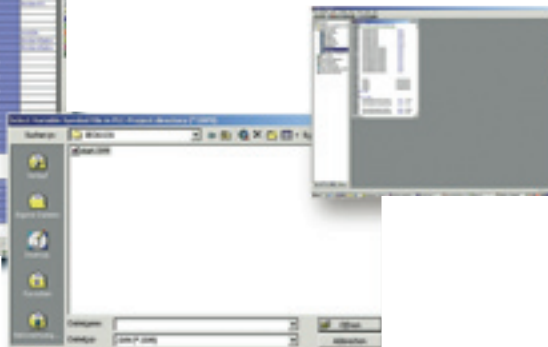

... and it's ready

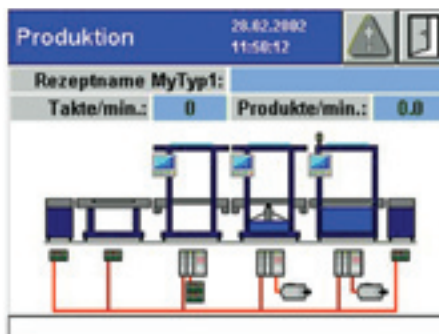

Project design with MS Excel

The visualization project is designed in Microsoft Excel. Once EPAM is installed and an add-in is installed in Microsoft-Excel, all the necessary commands and objects are available for designing a visualization system. Button, switch, alphanumeric variable, bargraph, message element, bitmaps etc.

The PLC variables can be imported simply from MXpro. The project is designed in a tabular description of the visualization system. The tables are then later interpreted on the target system by the EPAM runtime.

An interpreter is also provided within Excel.

This enables functions and the screens to be tested beforehand on the design PC. This test also enables the visualization of process values from the PLC. All the features of Excel are available during the project design phase.

Already existing screens or objects can be reused simply with Copy & Paste.

A program expansion with custom Visual Basic macros enables the system to be linked to external data sources.

WEB-EPAM enables both new and existing EPAM applications to be turned into remote HMI systems via the Intranet/Internet.

EPAM application



Intranet/internet

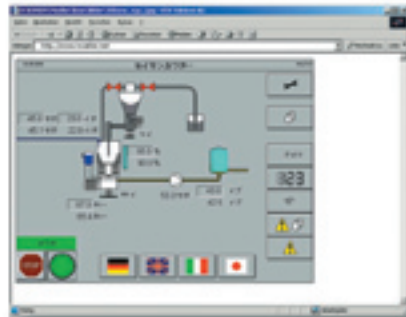
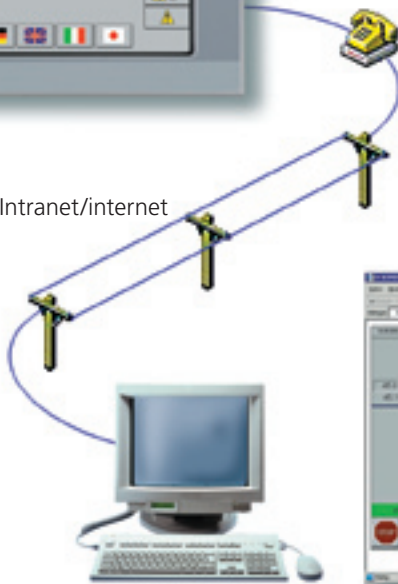

Java-enabled standard browser

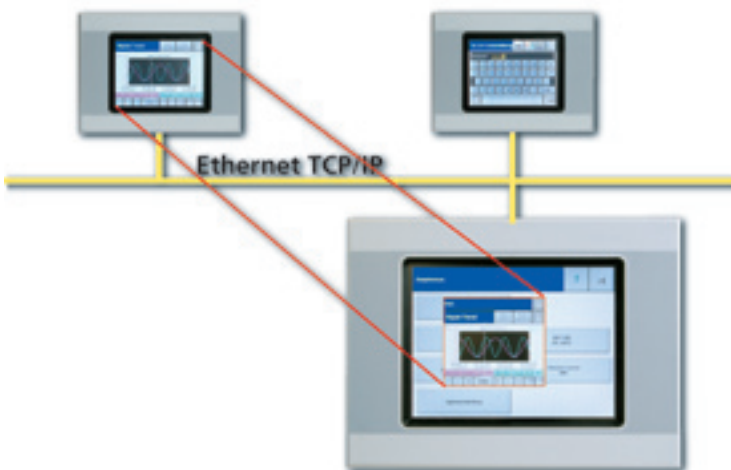

WEB-EPAM

Each visualization system created with EPAM is web-enabled automatically. A Java applet is simply loaded on the target system via the integrated web server and generates a 1:1 image of the visualization in any standard Java-compatible browser, enabling the system to be operated remotely with any standard PC without the need to install additional software.

Identification is implemented with user passwords so that only authorized persons are allowed access.

Picture in picture display with EPAM remote control

EPAM's remote control object enables the screen pages of other touch screens to be displayed. The operating states of individual system sections can thus be diagnosed and controlled remotely. A 1:1 copy of the actual image of a XV400 with a 5.7" display is shown on the visualization page of a XV400 with a 10.4" display. All touch functions can be carried out locally or remotely via the screen shown in the remote XV400. All this is possible at no extra cost and without any additional engineering requirements or software packages.

Services – With Special Customer Proximity

Consulting

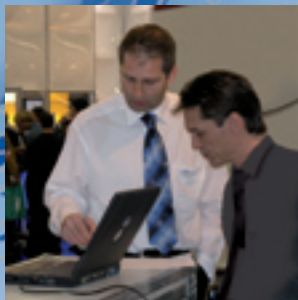

Training



Field Service

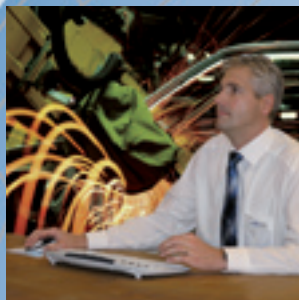

**Partner
Support**



Consulting / Support

Our commercial hotline is available for any inquiries concerning orders, shipments and prices.

+49 (0) 228 602 2020

Our support specialists are available for technical questions about our products and their programming.

+49 (0) 228 602 2002

Field Service

The Field Service offers fast and competent support in the event of emergencies such as machine or system outages. The Field Service offers tailor-made service and maintenance contracts. For this Micro Innovation uses the Field Service of Moeller GmbH which has been tried and tested for many years.

+49 (0) 228 602 3666

(available 24h / 365 days)

Training

Micro Innovation can offer training courses and workshops specially tailored to your requirements.

Solution Provider

Micro Innovation works closely with competent partners that support or implement your software projects as required.

Information at

info@microinnovation.com

Micro Innovation GmbH
Nideggerstrasse 6-10
53115 Bonn
Germany

Micro Innovation AG
Spinnereistrasse 8-14
9008 St. Gallen
Switzerland

We would like you to visit our company.

Please send us information material:

Automation product overview 2006/2007

Automation catalogue 2006/2007

Company: _____

Name: _____

First name: _____

Department/Function: _____

Street: _____

Zip code/Town: _____

Country: _____

Telephone: _____

Email: _____

Please add my name to the distribution list for your electronic newsletter.

<http://www.microinnovation.com>

Suppliers of Micro Innovation Products "Worldwide"

Argentina

Moeller Electric S.A.
Habana 3336/46
C1419GPZ Buenos Aires
Tel.: +54 (0 11) 45 74-04 11
Fax: +54 (0 11) 45 74-48 17
Email: webmaster@moellerarg.com.ar

Armenia

Mshak JSC
3 Hakop Hakopian Str.
375033 Yerevan, Republic of Armenia
Tel.: +374 1 276 991
Fax: +374 1 276 991
Email: msh@mshak.am

INSTA Ltd.

8 Zakariadzhe Str.
0177 Tbilisi - Georgia
Tel.: +995 32 202020
Fax: +995 32 202022
Email: sales@insta.ge

Australia

Moeller Electric Pty. Ltd.
4 Caribbean Drive
Scoresby, Victoria, 3179
Tel.: +61 (03) 98 39 11 00
Fax: +61 (03) 98 39 11 77
Email: marketing@moeller.com.au

Austria

Moeller Gebäudeautomation KG
Hauptverwaltung Vertrieb
Schedygasse 42
A-1215 Wien
Tel.: +43 (01) 2 77 45-0
Fax: +43 (01) 2 77 45-33 00
Email: info.aut@moeller.net

Azerbaijan

Mikhail Ali-Zade
Aga-Neymatulla Str. 47A, apt. 6
AZ1052 Baku, Azerbaijan
Tel.: +994 12 98 77 19
Fax: +994 12 98 77 19
Email: ims.imc@azdata.net

INSTA Ltd.

8 Zakariadzhe Str.
0177 Tbilisi - Georgia
Tel.: +995 32 20 20 20
Fax: +995 32 20 20 22
Email: sales@insta.ge

Bahrain

Najat Construction & Trading Est
Post Box: 5774, Sitra,
Bahrain (Arabian Gulf)
Building no. 3077, Road No. 447
Al-Qarya 604
Sitra, Bahrain (Arabian Gulf)
Tel.: +973 () 73 17 31, 73 05 25
Fax: +973 () 73 05 45
Email: najatbn@batelco.com.bh

Bangladesh

Tarn Associates
House No. 87 (1st floor), Road No. 9A
Dhanmondi, Residential Area
Dhaka 1209
Tel.: +88 (02) 9 11 75 36
Fax: +88 (02) 9 11 28 44
Email: tarn@bdcom.com

Belgium

Moeller Electric N.V.-S.A.
Ikaroslaan 24
BE-1930 Zaventem
Tel.: +32 (0)2 7 19 88 11
Fax: +32 (0)2 7 25 00 72
Email: info.be@moeller.net

Belarus

UP Elektroplan
2-8 Chebotareva Str.
220009 Minsk
Tel.: +375 17 174 709
Fax: +375 17 174 732
Email: eplan@bip.by

Bolivia

Hiller Electric S.A.
Av. El Trompillo esq. Chaco
Casilla 370
Santa Cruz
Tel.: +591 (03) 3 52 25 20
Fax: +591 (03) 3 52 64 04
Email: mail@hillerelectric.com.bo

Bosnia/Herzegovina

Elektrosystem d.o.o.
ul. Pilanska 3
BiH-78000 Banja Luka
Tel.: +387 (0 51) 31 75 00
Fax: +387 (0 51) 31 75 00
Email: elsist@inecco.net

Botswana

Sharps Electrical (Pty) Ltd.
P.O. Box 603, Gaborone
Plot 1236, Haile Selassie Road
Old Industrial Site
Gaborone
Tel.: 09267 395 23 41
Fax: 09267 395 14 16
Email: clauder@sharps.co.bw

Brazil

Moeller Electric Ltda.
Rua Wallace Barnes, 45B - Distrito Industrial
13054-701 Campinas - SP
Tel.: +55 (0 19) 37 65 55 01
Fax: +55 (0 19) 32 25 55 01
Email: moeller@moeller.com.br

Bulgaria

Moeller Elektrotechnika s.r.o.
Balsha Str. 1, r.d. Ivan Vazov
1408 Sofia
Tel.: +359 2 952 18 34
+359 2 952 16 30
Fax: +359 2 952 15 98
Email: office@moeller.bg

Canada

Moeller Electric Ltd.
7275 Rapistan Court
Mississauga, Ontario L5N 5Z4
Tel.: +1 (09 05) 5 42-23 23
Fax: +1 (09 05) 5 42-23 21
Email: info@moeller.ca

Chile

Induelectro S.A.
P.O. Box 72- 3
Zenteno 842
Santiago de Chile
Tel.: +56 (02) 6 95 43 29
Fax: +56 (02) 6 95 57 20
Email: Induelectro@Induelectro.cl

Felipe Bahamondes S.A.
Maria Luisa Santander 0475
Providencia - Casilla 3425
664 0814 Santiago
Tel.: +56 (02) 3 41 12 71
Fax: +56 (02) 3 41 12 75
Email: felipe@mailblocks.com

China

Moeller Electric Co., Ltd.
Shanghai East Ocean Centre
11 / Floor, No 618, Yan An Road (E.)
Shanghai 200001
Tel.: +86 (0 21) 63 52 72 56
Fax: +86 (0 21) 63 52 73 49
Email: info@moeller-china.com

China (Hongkong)

Moeller Electric Limited
Room 1303 Bonham Trade Centre
No. 50 Bonham Strand East
Sheung Wan, Hong Kong
Tel.: +852 () 25 23 06 24
Fax: +852 () 25 23 00 97
Email: fghk@netvigator.com

Peter, Charles & Co.

China Aerospace Centre 2nd Floor,
143 Hoi Bun Road, Kwun Tong,
Kowloon, Hong Kong
Tel.: +852 () 23 69 40 50
Fax: +852 () 27 22 40 80
Email: pcc@pcc.com.hk

Columbia

Hanseatica Compañia Limitada
P.O. Box A. A. 14467
Calle 17 # 69B-06
Bogota - Colombia
Tel.: +57 (01) 412 2814, 412 6715
Fax: +57 (01) 92 6614, 411 8863
Email: electricos@hanseatica.com

Dem. Rep. Congo (Zaire)

ELMAS S.P.R.L.
Commune de Limete
14 rue No. 5.885
Kinshasa
Tel.: +243 89 12 59
Fax: +243 8 84 38 16
Email: moeller20032002@yahoo.fr

Croatia

Unikomerc elektro d.d.
Sektor Elektrooprema
Amruseva 10
41000 Zagreb
Tel.: +385 (01) 4817- 651
Fax: +385 (01) 4817- 652
Email: uni-elektro@zg.htnet.hr

Gromel d.o.o.

Zagrebacka 9
10450 Jastrebarsko
Tel.: +385 (01) 62 83 825
Fax: +385 (01) 62 83 825
Email: gromel-elektrotehnika@zg.tel.net

Czech Republic

Moeller Elektrotechnika s.r.o.
Komárovská 2406
CZ - 193 00 Praha 9
Tel.: +420 (2) 67 99 04 11
Fax: +420 (2) 67 99 04 19
Email: office.praha@moeller-cz.com

Denmark

Gycom Danmark A/S
Valløerækken 26
DK 4600 Køge
Tel.: +45 56 26 66 35
Fax: +45 56 26 77 78
Email: admin@gycom.dk

Dominican Republic

Cogesis
Controles Germanicos de sistemas industriales S.A.
P.O. Box 738, Antonio Maceo #114
Centro de los Héroses
Santo Domingo / Rep. Dom.
Tel.: +1 (08 09) 5 35 56 29
Fax: +1 (08 09) 5 32 04 74, 5 08 28 85
Email: cogesis@codetel.net.do

Ecuador

Oficina Técnica Chanage
Apartado Postal 17-08-8090
Centro Comercial „LA Y“, Local 1E
Avda. América N39-334 y Vozandes Quito
Tel.: +593 (0)2-226 2585,
+593 (0)2-292 1800
Fax: +593 (0)2-320 1171,
+593 (0)2-226 2163
Email: info@chanage-ec.com

Oficina Tecnica Chanage

Casilla 09-01-8423
Avda. J. Tanca Marengo Km. 2,5
Centro Comercial Sepropisa,
Locales 12 y 13
Guayaquil
Tel.: +593 (04) 23 21 91, 38 10 03,
38 12 50

El Salvador

Prestegard Electro, S.A. de C.V.
Apartado Postal 2195
11 Avenida Norte 240
San Salvador, El Salvador
Tel.: +503 () 2 71 16 90, 2 22 12 12
Fax: +503 () 2 21 38 51
Email: prestegard@navegante.com.sv

Estonia

Moeller Elektrotechnika s.r.o.
Pärnu road 160 A
EE-11317 Tallin, Estonia
Tel.: +372 6 58 89 00
Fax: +372 6 58 89 01
Email: office@moeller.ee

Sakala Tööstusautomaatika AS

Keskuse 9
76901 Tabasalu
Tel.: +372 6 03 22 48
Fax: +372 6 03 22 51
Email: sakt@sakt.ee

Ethiopia

Beta Electrical Control & Service Eng.
PLC
P.O. Box 18134
Keskuse 9
Addis Ababa
Tel.: +251 (1) 15 03 82
Fax: +251 (1) 52 89 00
Email: route@telecom.net.et

Finland

Gycom Finland Oy
Työpaikankatu 10 A
FI-05800 Helsinki
Tel.: +358 96 84 17 44
Fax: +359 68 41 74 33
Email: admin@Gycom.fi

France

Moeller Electric S.A.S.
346, rue de la Belle Etoile
Paris Nord II - B.P. 51060
95947 Roissy C.D.G. Cedex
Tel.: +33 (01) 41 84 50 50
Fax: +33 (01) 41 84 50 52
Email: info@moeller-fr.com

Georgia

INSTA Ltd.
8, Zakariadzhe Str.,
0177 Tbilisi, Georgia
Tel.: +995 32 20 20 20
Fax: +995 32 20 20 22
Email: sales@insta.ge

Germany

Micro Innovation GmbH
Nideggerstrasse 6-10
53115 Bonn
Tel.: +49 (0) 228 602 2020
Fax: +49 (0) 228 602 1713
Email: info@microinnovation.com

Ghana

Atlantic Climate Control Ltd.
C131/3 Farrar Ave.
P. O. Box 9116 KIA
Accra
Tel.: +233 (21) 22 82 14
Fax: +233 (21) 22 31 75
Email: patrick.ata@atlantic.com.gh

Greece

Pilux & Danpex
20, G. Katehaki Str.
54627 Thessaloniki
Tel.: +30 (2310) 5 22 67 02
Fax: +30 (2310) 52 40 77
Email: pilux-1@otenet.gr

Guatemala

Prestelectro
Apartado Postal 219-A,
6 Avenida 1-65 Zona 9
01009 Guatemala
Tel.: +502 (03) 32 09 41, 32 78 09
Fax: +502 (03) 32 09 97
Email: oveprestegard@intelnet.net.gt

Haiti

Elmecen SA
P.O. Box 13183 Port-au-Prince
26, Route de l'Aéroport, Etage Sogecom
Port-au-Prince
Haiti W.I.
Tel.: +509 () 2 49-37 77, 5 10 37 77
Fax: +509 () 2 46-45 40, 2 46 08 37
Email: elmecen@haitelonline.com

Hungary

Moeller Electric Kft.
Röppentyű u. 57.
1139 Budapest
Tel.: +36 (01) 3 50-56 90
Fax: +36 (01) 3 50-56 91
Email: moeller@moeller.hu

Iceland

Reykjafell GmbH
Skipholtí 35
125 Reykjavik
Tel.: +354 () 5 88 60 10
Fax: +354 () 5 88 60 88
Email: reykjafell@reykjafell.is

India

Moeller Vertrieb International - India Branch
409, Barton Centre, 84 MG Road
Bangalore - 560 001
Tel.: +91 (0 80) 5 32 15 98
Fax: +91 (0 80) 5 32 13 43
Email: moeller@bgl.vsnl.net.in

Indonesia

PT. KM Niaga
Taman Palembang Lestari
Ruko Pelangi Blok C No. 7
Cengkareng, Jakarta 11370
Tel.: +62-21-559 575 84
Fax: +62-21-559 575 47
Email: kmniaga@cbn.net.id

Iran

Rahat Co.
No. 172/1, West Taleghani Ave.
Between Vesal and Ghods
14178 Tehran
Tel.: +98 (0 21) 6 40 33 21-6 40 33 52
Fax: +98 (0 21) 6 46 54 96
Email: rahat@mail.dci.co.ir

Ireland

Moeller Electric Ireland Ltd.
94 Lagan Road,
Dublin Industrial Estate,
Dublin 11
Tel.: +353 (01) 8 30 04 00
Fax: +353 (01) 8 30 05 37
Email: kloekner@indigo.ie

Process & Energy Equipment Ltd.

Portgate Business Park
Ringaskiddy
Cork
Tel.: +353 (0) 2 14 37 02 80
Fax: +353 (0) 2 14 37 02 88
Email: info@peel.ie

Charles Nolan & Co. Ltd.

„Techna House“
Terenure Road East
Dublin 6
Tel.: +353 (1) 4 90 66 11
Fax: +353 (1) 4 90 12 74
Email: rnolan@cnolan.ie

Israel

Katzenstein, Adler & Co. Ltd.
P.O. Box 2416
2 Hasadna St.
Ra Anana 43106
Tel.: +972 (09) 7 47 57 77
Fax: +972 (09) 7 44 03 60
Email: k-a@k-a.co.il

Italy

Moeller Electric S.r.l.
Via Giovanni XXIII, 43
20090 Rodano MI
Tel.: +39 () 02 95 95 01
Fax: +39 () 02 95 95 04 00
Email: info@moeller.it

Japan

Moeller Electric Ltd.
Head Office, Katokichi Bldg. 5F
5-14-10, Nishinakajima, Yodogawa-ku
Osaka, 532-0011
Tel.: +81 (6) 6 6306 1613
Fax: +81 (6) 6 6306 1619
Email: info@jpn-moeller.co.jp

Jordan

PHOTON Import & Export Co.
P.O. Box 438
11821 Amman
Tel.: +962 (06) 4 64 34 61
Fax: +962 (06) 4 64 34 60
Email: photon@wanadoo.jo

Kazakhstan

TOO PF Elektroservice
200, Aiteke bi.
480096 Almaty
Tel.: +7 (0 32 72) 68 28 60
Fax: +7 (0 32 72) 68 28 65
Email: kazservice@yahoo.com

Kenya

Moeller Controls Ltd.
P.O. Box 30747
Nairobi
Tel.: +254 20 861 756
Fax: +254 20 861 798
Email: moeller@nbi.ispkenya.com

Korea

Delta Corporation
Moeller Building
403-1, Daebang-Dong
Dongjak-Ku
Seoul
Tel.: +82 (02) 8 13 00 33
Fax: +82 (02) 8 15 94 37
Email: moeller@ideltasystem.co.kr

Kuwait

Dakheel Aljassar Electrical Industries
PO Box 145
Safat 13002
Kuwait
Tel.: +965 4 81 17 22
Fax: +965 4 84 32 60

Latvia

Moeller Elektrotehnika s.r.o., Latvijas Parstavnieciba
Zemitana iela 2b
LV - 1012 Riga, Lettland
Tel.: +371 (7) 84 44 35
Fax: +371 (7) 84 44 36
Email: office@moeller.lv

AS Energofirma JAUDA

Krustpils iela 119
1057 Riga
Tel.: +371 7 12 57 55
Fax: +371 7 12 57 40
Email: komerc@jauda.com

Lebanon

Progress, Engineering & Trading Enterprises
P.O. Box 11-1111
Pharaon Bldg, Opp. Electricité du Liban
Chafaca Str. Al-Nahr
Beirut
Tel.: +961 (01) 44 46 64, 44 31 75
Fax: +961 (01) 56 18 80
Email: progress@inco.com.lb

Lituania

Moeller Elektrotechnika s.r.o., Atstovybe
Seimyniskiu g. 3a/Sluckio g.2
LT - 2600 Vilnius
Tel.: +370 (52) 79 05 53
Fax: +370 (52) 79 05 63
Email: office@moeller.net

UAB Elstila

Jonavos 62A
3000 Kaunas
Tel.: +370 52 20 58 02
Fax: +370 52 20 12 80
Email: centras@elstila.lt

Luxembourg

Moeller Electric S.A.
Boîte Postale 1823, 1018 Luxembourg
65, rue des Bruyères
1274 Luxembourg-Howald
Tel.: +352 () 48 10 81-1
Fax: +352 () 49 07 82
Email: info.lux@moeller.net

Malaysia

Fullban Sdn Bhd
3 Jalan 4/89B, Kawasan Perindustrian Trisegei
Batu 3 1/2, Jalan Sungai Besi
Kuala Lumpur 57100
Tel.: +60-3-79842389, +60-3-79842309
Fax: +60-3-79842368
Email: fullban@po.jaring.my

Macedonia

ES-MIK Elektrosystem d.o.o.
bl. III Makedonska Brigada bb.
MK - 91000 Skopje
Tel.: +389 (0 2) 46 02 95
Fax: +389 (0 2) 46 02 98
Email: elektrosistem-mk@mt.net.mk

Mexico

Moeller Electric, S.A. de C.V.
Calle Ingenieros Civiles No. 204
Chachapa, Puebla
C.P. 72990 Puebla
Tel.: +52 (02 22) 2 86 60 00
Fax: +52 (02 22) 2 86 60 02
Email: ocastell@moeller.com.mx

Namibia

ICE Industrial Controls & Engineering
P. O. Box 5076
Marconi Street 45
Windhoek, Namibia
Tel.: +264 (0 61) 23 83 47, 23 83 48
Fax: +264 (0 61) 23 45 95
Email: alexfrech@ice.com.na

Netherlands

Moeller Electric N.V.
Postbus 2022, 5300 CA Zaltbommel
Ambacht 6
5301 KW Zaltbommel
Tel.: +31 (04 18) 57 02 00
Fax: +31 (04 18) 51 52 84
Email: info@moeller.nl

New Zealand

Bremca Industries Ltd
PO Box 7169
10 Kennedy Place Opawa
Christchurch
Tel.: +64 (03) 3 32 63 70
Fax: +64 (03) 3 32 63 77
Email: ken@bremca.co.nz

Nigeria

Etco (Nigeria) Ltd.
P.O. Box 337
14 Creek Road
Apapa-Lagos
Tel.: +234 (01) 80 40 70, 80 40 71
Fax: +234 (01) 5 87 78 26, 2 61 21 94

Norway

Moeller Electric AS
Prost Stabels vei 22
2019 Skedsmokorset
Postboks 244
2021 Skedsmokorset
Tel.: +47 () 63 87 02 00
Fax: +47 () 63 87 02 01
Email: firmapost.nor@moeller.net

Pakistan

Home & Foreign Traders
P.O. Box No: 7775
73/III - Dilkusha Chambers
Marston Road
Karachi 74400
Tel.: +92 (0 21) 7 72-15 25 - 7 72-40 98
Fax: +92 (0 21) 7 72-40 98
Email: hftnoor1@multi.net.pk

Paraguay

TECNOUNION S.A.
Avda. España No. 2221
2401 Asunción
Tel.: +595 (0 21) 20 15 50
Fax: +595 (0 21) 20 15 50
Email: mail@tecnounion.com

SAIMCO S.A.

Av. Eusebio Ayala esq./San Carlos Km 9
San Lorenzo
Tel.: +595 (0 21) 50 09 25
Fax: +595 (0 21) 50 09 25
Email: saimco@highway.com.py

Peru

EPLI S.A.C.
Jr. Tarapoto 1175
Brena Lima 05
Tel.: +51 (1) 3 30-15 95
Fax: +51 (1) 4 24-86 29
Email: import@epli.com.pe

Philippines

Moeller Electric Pte. Ltd.
3 Toh Tuck Link
German District Centre, 03-05
Singapore 596228
Tel.: +65 64 68 02 88
Fax: +65 64 68 17 11
Email: moeller.sgp@moeller.com.sg

EGO Electrical Supply Co Inc

2nd Floor Gotesco Tower A,
1129 Concepcion Street
Ermita, Manila
Tel.: +63 2 5 27 14 83
Fax: +63 2 5 27 14 83

Poland

Moeller Electric Sp. z o.o.
Ul. Galaktyczna 30
80-299 Gdansk
Tel.: +48 (0 58) 5 54 79 00
Fax: +48 (0 58) 5 54 79 09
Email: office@moeller.pl

Portugual

Moeller Electric, S.A., Sucursal em Portugal
Edifício Atlas I
Av. José Gomes Ferreira
9 sala 31 Miraflores
1495-139 Alges
Tel.: +351 (21) 4 12 12 04
Fax: +351 (21) 4 12 12 03

Rumania

Moeller Electric SRL
Iride Business Park, No. 9 Building
No. 9-9A, Dimitrie Pompei Blvd.
020335 Bucuresti, District 2
Tel.: +40 (0) 21-2 43 38 32, 21-2 43 37 36
Fax: +40 (0) 21-2 43 38 60, 21-2 43 38 61
Email: info@moeller.ro

Russia

OOO Moeller Electric
Kronshtadtsky bul., 7
125212 Moscow
Tel.: +7 (0 95) 7 30 60 60
Fax: +7 (0 95) 7 30 60 59
Email: info@moeller.ru

Saudi Arabia

A. M. Al-Ghamdi Industrial, Control Systems Est.
P.O. Box: 42456
5th Floor, 3rd Tower,
New Al-Akharia Building, Siten Street
Riyadh
Tel.: +966 (01) 4 78 57 98
Fax: +966 (01) 4 76 25 61
Email: gics@nooralshomoe.com

Serbia and Montenegro

Beobars d.o.o.
Avtoput 5
11077 Novi Beograd
Tel.: +381 (0 11) 3 19 41 53
Fax: +381 (0 11) 3 19 49 78
Email: beobars@eunet.yu

ESYU-Elektrosystem d.o.o.
Pariske komune br. 41
11070 Novi Beograd
Tel.: +381 (0 11) 269 36 08
Fax: +381 (0 11) 269 72 12
Email: esyu@infosky.net

Singapore

Moeller Electric Pte. Ltd.
3 Toh Tuck Link
03-05 German District
Singapore 596228
Tel.: +65 64 68 02 88
Fax: +65 64 68 17 11

Slowakia

Moeller Electric s.r.o.
Kopcianska 22
SK - 851 01 Bratislava
Tel.: +421 (02) 63 81 01 15
Fax: +421 (02) 63 83 82 33
Email: moeller@moeller.sk

Slovenia

Elektronabava d.o.o.
Cesta 24 Junija 3
1231 Ljubljana
Tel.: +386 (0)1 58 99 300
Fax: +386 (0)1 58 99 490
Email: info@elektronabava.si

Synatec d.o.o.

Vojkova 8b, p.p. 50
SLO - 5280 Idrija
Tel.: +386 (05) 3 72 06 50
Fax: +386 (05) 3 72 06 60
Email: info@synatec.si

Republic of South Africa

Moeller Electric (Pty) Limited
P.O. Box 100, Kempton Park, 1620
9 Derrick Road, Spartan
Kempton Park, 1620
Tel.: +27 (0 11) 9 75 39 37, 9 75 39 38
Fax: +27 (0 11) 3 94 25 23, 9 75 92 97
Email: moeller@usconet.com

Spain

Moeller Electric, S.A.
Acer, 16-18 1a planta
08038 Barcelona
Tel.: +34 () 93 2 23 23 66
Fax: +34 () 93 2 23 29 33
Email: marketing@moeller.es

Sri Lanka

Richardson Projects Pvt Ltd
342, Galle Road, 3rd Floor
Colombo 3
Tel.: +94 1 56 44 54
Fax: +94 1 56 44 56
Email: naz@eureka.lk

Sudan

Sudana Electromechanical Co Ltd.
P.O. Box 3443
Khartoum
Tel.: +249 (011) 77 80 91
Fax: +249 (011) 77 23 81, 78 22 95
Email: sudana@sudanet.net

Surinam

N. V. Elgawa
P.O. Box 1120
Verl. Gemenelandsweg no. 76
Paramaribo
Tel.: +597 () 49 94 47
Fax: +597 () 46 57 41

Sweden

Moeller Electric AB
Box 1171, Kista
Skalholtsgatan 6
SE 16426 Kista
Tel.: +46 (08) 6 32 30 00
Fax: +46 (08) 6 32 32 99
Email: info.swe@moeller.net

Switzerland

Micro Innovation AG
Spinnereistrasse 8-14
9008 St. Gallen
Tel.: +41 (0) 71 243 24 24
Fax: +41 (0) 71 243 24 90
Email: info@microinnovation.com

Syria

Hovaguimian Bros.
P.O. Box 5093
Marrge, Rammy str.
Damascus
Tel.: +963 (011) 2 21 84 05
Fax: +963 (011) 2 24 48 69
Email: hb.hovag@mail.sy

Taiwan

San Shin Corporation
Room 705 Bank Tower
205 Tun Hwa North Road
Taipei
Tel.: +886-2-2 27 15 32 87
Fax: +886-2-2 27 16 97 94
Email: sanshinco@gcn.net.tw

Sergeant Co. Ltd

Floor 9-7, No. 290 Sec 2 Nan Tun Road
Taichong
Tel.: +886 (04) 4 71 08 96
Fax: +886 (04) 4 72 63 76

Tajikistan

TOO PF Elektroservice
200 Aiteke bi Str.
480096, Almaty, Kazakhstan
Tel.: +007 3272 68 28 60
Fax: +007 3272 25 25 18
Email: kazservice@yahoo.com

Tanzania

EM Consultants Ltd.
Plot 1160/17
Jamhuri Street
P.O. Box 5579
Dar Es Salaam
Tel.: +255 (22) 212 2250
Fax: +255 (22) 212 2251
Email: moeller@africaonline.co.tz

Thailand

Moeller Electric Limited
99/167 Moo 2
Chaengwattana Road, Thungsohong
Laksi
Bangkok 10210
Tel.: +66 (02) 5 75 05 30
Fax: +66 (02) 5 75 05 25
Email: enquiry@moeller.co.th

Trinidad

ANANDs Electrical Ltd.
#4 Aranguez Main Road
San Juan, Trinidad, West Indies
Tel.: +1 (08 68) 6 75-11 63, 6 38-93 59,
6 38-94 30
Fax: +1 (08 68) 6 75-61 20
Email: anands@carib-link.net

Tunisia

Rafik Hamouda
17, rue du Maroc
7000 Bizerte
Tel.: +216 (02) 42 30 50
Fax: +216 (02) 42 32 22
Email: moeller.hamouda@planet.tn

Turkey

Moeller Elektrik Ticaret
Limited Sirketi
Degirmenyolu Sok. Kutay Is Merkezi
D. Blok Kat 1 No. 4-5
81110 Üstbostanci Istanbul
Tel.: +90 (02 16) 5 75 58 04
Fax: +90 (02 16) 5 75 44 64
Email: canerbilgin@superonline.com

Uganda

Avo Machinery Ltd.
Plot 69 Nasser Rd
PO Box 545
Kampala
Tel.: +256 (0 41) 23 45 11
Fax: +256 (0 41) 25 44 47
Email: avo@starcom.co.ug

Ukraine

DP Moeller Electric
Bereznyakovskaja 29, 6 floor
02098 Kiev
Tel.: +38 (0 44) 4 96 09 58
Fax: +38 (0 44) 4 96 09 54
Email: office@moeller.kiev.ua

United Arab Emirates

Juma Al Majid Est,
For Electro Mechanical Works
P.O. Box 60204
Dubai
Tel.: +971 (04) 2 85 42 23, 2 85 42 25
Fax: +971 (04) 2 85 46 78
Email: jmemkms@emirates.net.ae

United Kingdom

Moeller Electric Ltd.
P.O. Box 35
Gatehouse Close
Aylesbury, Bucks, HP19 8DH
Tel.: +44 (0 12 96) 39 33 22
Fax: +44 (0 12 96) 42 18 54
Email: marketing@moeller.co.uk

USA

Moeller Electric Inc.
4140 World Houston Parkway, #100
Houston, Texas 77032
Tel.: 713.933.0999
Fax: 832.613.6255
Email: info@moellerusa.net

Venezuela

Somerinca, C.A.
Edificio Esteban piso 2
Calle Vargas - Boleita Norte
Apartado 76051
Caracas 1070 - A
Tel.: +58 (212) 2 35 10 81
Fax: +58 (212) 2 38 56 25
Email: hcastrog@somerincayv.com

Vietnam

Thien Nghi Trading & Services Co., Ltd.
I41-I42, D11 Tay Thanh Street,
Tan Binh Industrial Park
Ward 15, Tan Binh District
Ho Chi Minh City
Tel.: +84 (08) 8 15 01 38
Fax: +84 (08) 8 15 01 37
Email: thiennghi@hcm.vnn.vn

Zambia

Electrical Maintenance Lusaka Ltd
P.O. Box 31189
Lusaka
Tel.: +9260 (1) 22 78 24
Email: ceo@eml-eis.com

Electrical & Instrumentation Services Ltd.

(E.I.S.)
P.O. Box 22612
Eshowe Road
Kitwe
Tel.: +9260 (2) 22 80 77
Fax: +9260 (2) 22 07 97
Email: kitwe@eml-eis.com

Zimbabwe

Ames Electrical
P.O. Box 8002
8 Josiah Chinamano Road
Belmont, Bulawayo
Tel.: +263 (09) 88 10 21
Fax: +263 (09) 88 10 30
Email: ames@mweb.co.zw

Holding

Micro Innovation Holding AG
Spinnereistrasse 8-14
9008 St. Gallen
Switzerland
Tel.: +41 (0) 71 243 24 00
Fax: +41 (0) 71 243 24 90
www.microinnovation.com

Product Company

Micro Innovation AG
Spinnereistrasse 8-14
9008 St. Gallen
Switzerland
Tel.: +41 (0) 71 243 24 24
Fax: +41 (0) 71 243 24 90
www.microinnovation.com

Sales Company

Micro Innovation GmbH
Nideggerstrasse 6-10
53115 Bonn
Germany
Tel.: +49 (0) 228 602 2020
Fax: +49 (0) 228 602 1713
Email: info@microinnovation.com

Service/Repair Center

Micro Innovation GmbH
Carl-Benz-Strasse 19
78224 Singen
Germany
Tel.: +49 (0) 7731 7896 110
Fax: +49 (0) 7731 7896 101
servicecenter@microinnovation.com