

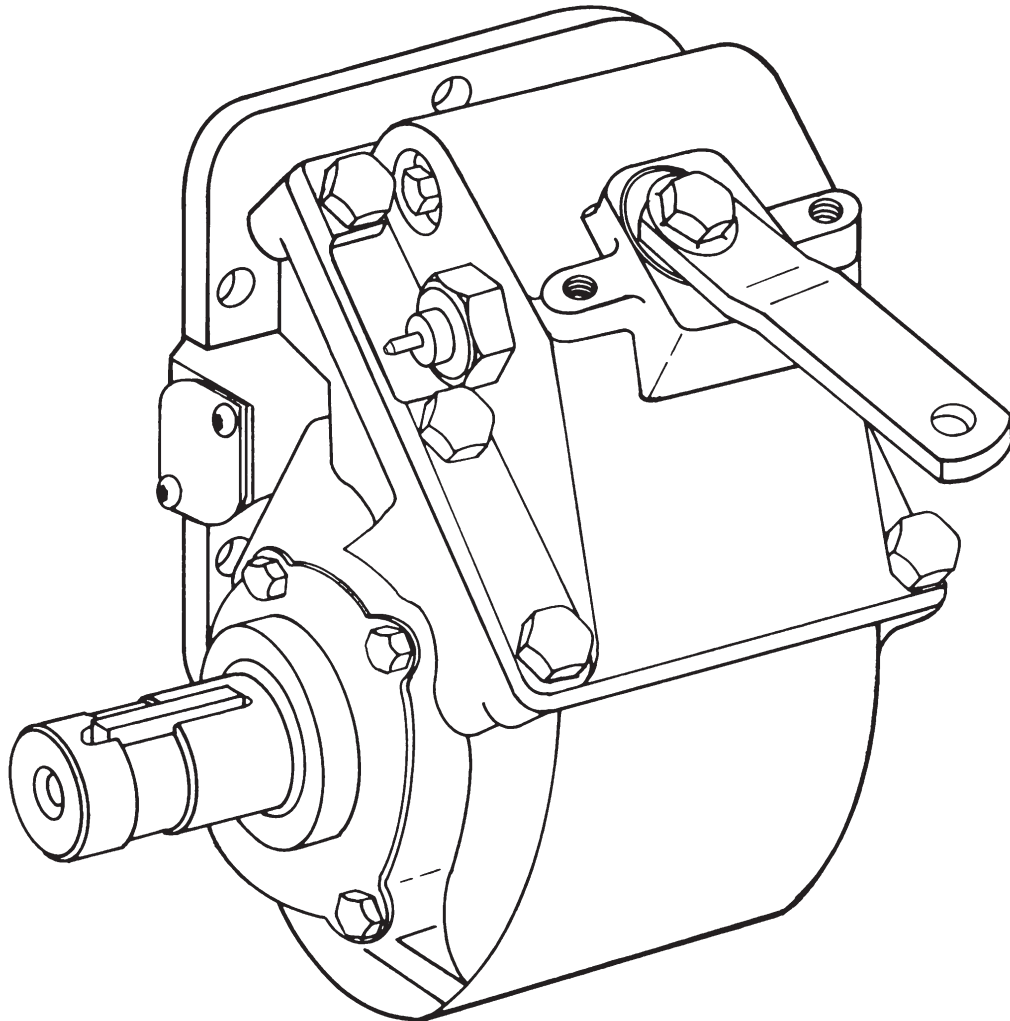

TG SERIES PTO

PARTS LIST AND SERVICE MANUAL



TG SERIES PTO

EXPLODED VIEW

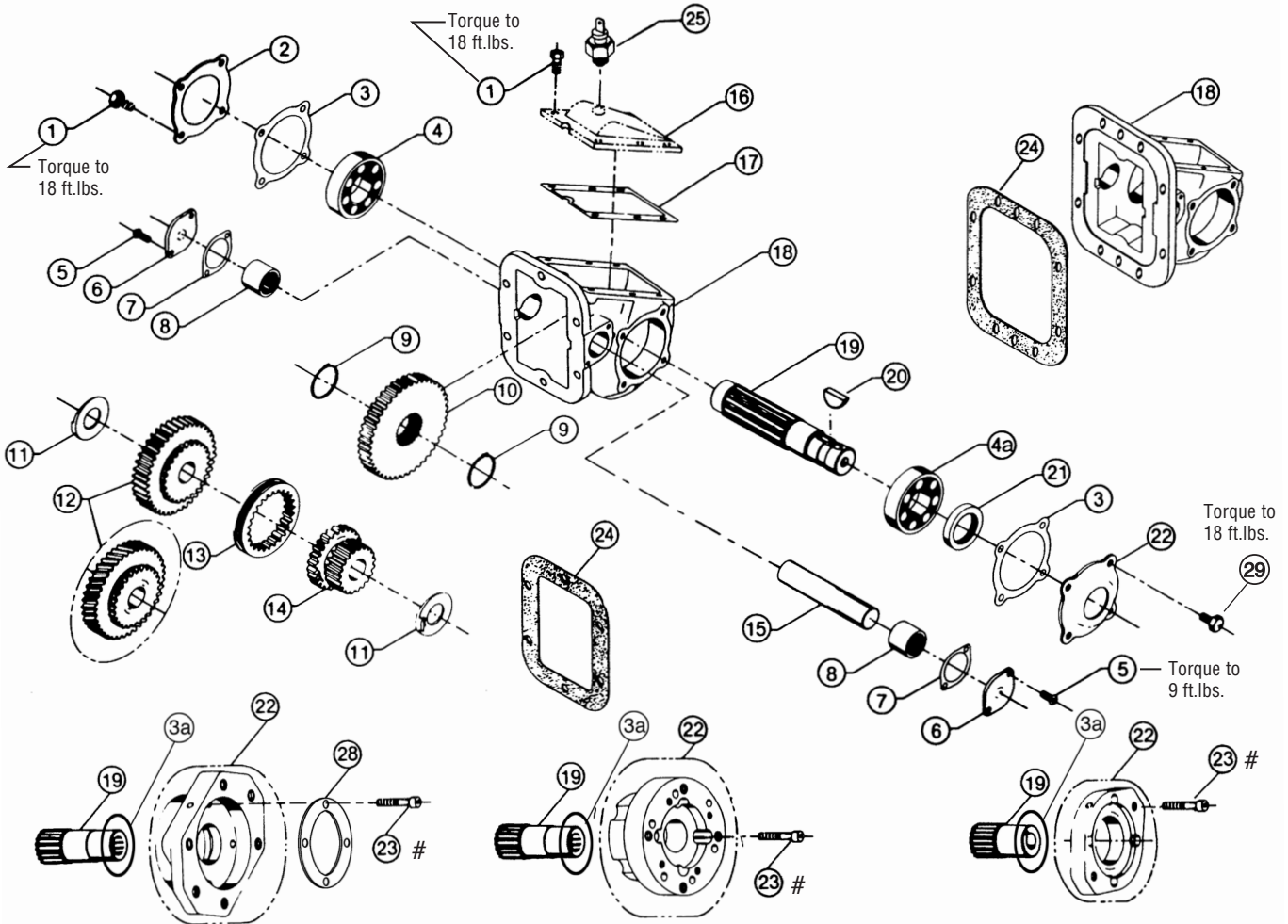

"L", "K", "P" & "V" HYD. FLANGE

"M" & "N" HYD. FLANGE

"F", "Q", "R" & "T" HYD. FLANGE

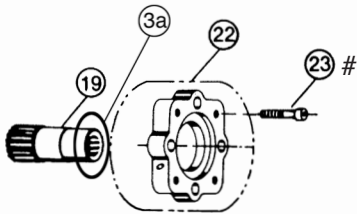

"G" HYD. FLANGE

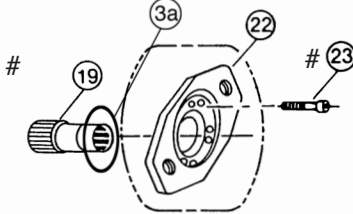

"S" HYD. FLANGE

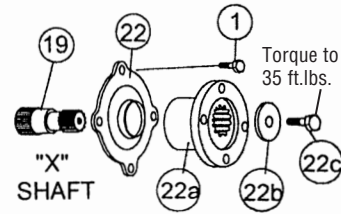

"X" SHAFT

"C" & "2" COMP. FLANGE

Torque to 25 ft.lbs. Note: For "I" and "Z" options, and "KG" and "PG" options, see page 14.

ASSEMBLY ARRANGEMENTS

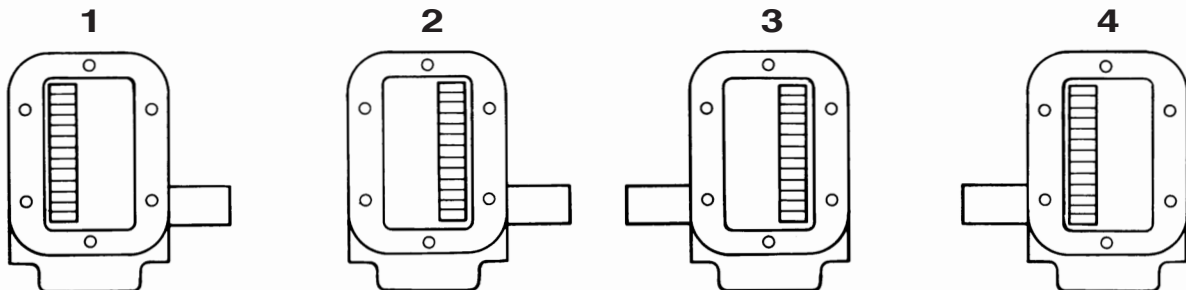

PARTS LIST AND DESCRIPTION

ITEM	QTY	PART NUMBER	DESCRIPTION	ITEM	QTY	PART NUMBER	DESCRIPTION
1	10	19T33233	Capscrew		4	19T96512	Capscrew (Hyd. "I", "Z" Only)
2	1	15T34323	Closed Bearing Cap	N.S.	1	19MK4717	Bolt Kit "G" Flange (Option)
	1	15T34576	Bearing Cap "KG" & PG Shaft	N.S.	1	13M51717	Tube, Gasket Eliminator (For W80 Only)
3	1	13T38542	Gasket		24	13M35091	.010 6-Bolt Gasket
3a	1	12T36751	O-Ring (Output)		1	13M35092	.020 6-Bolt Gasket
4	1	10T21017	Output Bearing		1	13M13541	Allison Gasket (U60, A69)
4a	1	10T38248	Output Bearing "I", "Z"		1	13M35151	.010 8-Bolt Gasket
	4	19T34530	Buttonhead Capscrew (Std.)		2	13M35152	.020 8-Bolt Gasket
	1	19M2562S	Flat Capscrew (I85, G85)		1	13T35198	.010 Gasket (TG6N-I85)
	1	19T34530	Buttonhead Capscrew (I85)		1	13T35199	.020 Gasket (TG6N-I85)
	2	19T31664	Socket Capscrew (I85)	25			Positive Indicator Switch (includes O-Ring)
	4	19T31664	Socket Capscrew (S71)		1	30T38111	For 1 & 4 Assy. (White) N.O.
	3	19T34530	Buttonhead Capscrew (G85)		1	30T38110	For 2 & 3 Assy. (Black) N.C.
6	2	15T33977	Idler Shaft Cap	N.S.	1	25T35724	Cap Plug F, G, K, M, N, Q, S
	2	15T35351	Idler Shaft Cap (TG6N-I85)			25T35725	Cap Plug L, P
	2	15T35612	Idler Shaft Cap (TG6N-S71) (See page 21 for installation)			25T38309	Cap Plug I
						25T35520	Cap Plug R
7	2	13T38286	Gasket			25T37387	Cap Plug T
8	2	10T24175	Input Bearing			25T35936	Cap Plug Z
9	2	24T23937	Snap Ring (as required)	27	1	43T37236	Zerk ("KG" or "PG")
10	1	See Page 4	Output Gear	28	1	58T38789	Installation Ring (Output Flg. "K", "L", "P", "KG", "PG", "Z", "6", "6G")
11	2	21T34281	Thrust Washer	29	4	19T41756	Capscrew ("B", "C", "2", "X" Output)
	2	21T38375	Coated Washer (A) Gears	N.S.	2	26T37992	Dowel Pins (TG6F)
12	1	See Page 4	Input Gear	N.S.	1	30M91113	Two Terminal Switch N.O. (I option)
13	1	49T33959	Clutch			30M92247	Two Terminal Switch N.C. (I option)
		49T38158	Clutch (A69)	N.S.	1	30TK4123	Switch w/booted contr N.C.
14	1	See Page 4	Ratio Gear			30TK4124	Switch w/booted contr N.O.
15	1	07T33974	Idler Shaft	N.S.	1	36M111NP	Nameplate
16	1	See Pg 6-10	Shift Cover Assembly	N.S.	1	36MK3841	Label Packet
17	1	13T38541	Gasket	N.S.	1	TG-GSK-A1	Gasket & Seal Kit – Air Shift Items 3, 3a, 7, 17, 21, (1)12T36526 (See Air Cover Pg 6, Items 10 & 4)
18			Housings				
	1	01T37765	6-Bolt (6F) Housing	N.S.	1	TG-GSK-C	Gasket & Seal Kit – Cable Shift Items 3, 3a, 7, 17, 21, (1)12T36526 (See Cable Cov Pg 7, Items 1,5,6,9)
	1	01T33958	6-Bolt Housing Std				
	1	01T34461	8-Bolt Housing Std	N.S.	1	TG-GSK-S	Gasket & Seal Kit – Lectra Shift Items 3, 3a, 7, 17, 21, (1)12T36526 (See Lectra Shift Pg 7, Items 10 & 4)
	1	01T35032	8-Bolt 'M' Housing				
	1	01T35342	6-Bolt (TG6N) Housing	N.S.	1	TG-GSK-T	Gasket & Seal Kit – E-Hydra (before 12/07) Items 3,3a, 7, 17, 21, (1) 12T36526 See E-Hydra page 8 (8, 14, 12T35345)
19			Output Shafts				
	1	06T41757	"X", "C", "2" Shaft	N.S.	1	TG-GSK-T1	Gasket & Seal Kit – E-Hydra (12/07 & later) Items 3,3a, 7, 17, 21, (1) 12T36526 See E-Hydra page 8 (2, 11)
	1	06T36857	"B" Shaft				
	1	06T35048	"Q", "S" Shaft	N.S.	1	TG-RBK-A1	Rebuild Kit – Air Shift Items 3, 3a, 4, 7, 8, 9, 11*, 17, 20, 21, (1)12T36526 (See Air Cover Pg 6, Items 10 & 4)
	1	06T35082	"R" Shaft				
	1	06T39143	"M", "K", "6" Hyd. Shaft	N.S.	1	TG-RBK-C	Rebuild Kit – Cable Shift Items 3, 3a, 4, 7, 8, 9, 11*, 17, 20, 21, (1)12T36526 (See Cable Cover Pg 7, Items 1,5,6,9)
	1	06T38373	"KG" Hyd. Shaft				
	1	06T39140	"F", "N" Hyd. Shaft	N.S.	1	TG-RBK-S	Rebuild Kit – Lectra Shift Items 3, 4, 7, 8, 9, 11*, 17, 20, 21, (1)12T36526 (See Lectra Shift Pg 7, Items 10 & 4)
	1	06T39136	"G" Hyd. Shaft				
	1	06T39139	"L" Hyd. Shaft	N.S.	1	TG-RBK-T	Rebuild Kit – E-Hydra (before 12/07) Items 3, 3a, 4, 7, 8, 9, 11*, 17, 20, 21 (1) 12T36526 (See E-Hydra page 8 (8, 14, 12T35343))
	1	06T36136	"P" Hyd. Shaft				
	1	06T38374	"PG" Hyd. Shaft				
	1	06T38261	"I" Hyd. Shaft				
	1	06T37335	"T" Hyd. Shaft				
	1	06T38242	"Z" Hyd. Shaft				
20	1	26T01627	Woodruff Key (Std. Shaft)				
	1	26T35254	Key ("F" Shaft Only)				
21	1	11T37790	Shaft Seal (2 Req. for "KG" or "PG" Output)				
22			Bearing Caps				
	1	15T41683	"B", "C", "2", "X" Output***	N.S.	1	TG-RBK-T	Rebuild Kit – E-Hydra (before 12/07) Items 3, 3a, 4, 7, 8, 9, 11*, 17, 20, 21 (1) 12T36526 (See E-Hydra page 8 (8, 14, 12T35343))
	1	14T39166	"T", "F", "Q", "R" Hyd. Flange				
	1	14T39165	"G" Hyd. Flange				
	1	14T39163	"K", "KG, L, P, PG" Hyd. Flange	N.S.	1	TG-RBK-T	Rebuild Kit – E-Hydra (before 12/07) Items 3, 3a, 4, 7, 8, 9, 11*, 17, 20, 21 (1) 12T36526 (See E-Hydra page 8 (8, 14, 12T35343))
	1	14T39167	"M" Hyd. Flange				
	1	14T39164	"N" Hyd. Flange				
	1	14T39162	"S" Hyd. Flange				
	1	14T38259	"I" Hyd. Flange				
	1	14T38244	"Z" Hyd. Flange				
	1	14T39528	"6, 6G" Hyd. Flange				
22a	1	18T38246	Pilot Ring "I", "Z" Hyd. (see pg 15)				
	1	14T37357	"C" Companion Flange				
	1	14T37378	"2" Companion Flange	N.S.	1	TG-RBK-T	Rebuild Kit – E-Hydra (before 12/07) Items 3, 3a, 4, 7, 8, 9, 11*, 17, 20, 21 (1) 12T36526 (See E-Hydra page 8 (8, 14, 12T35343))
22b	1	21T20092	Flat Washer ("2", "C", "X" Only)				
22c	1	19T38266	Capscrew ("2", "C", "X" Only)				
23	4	19T34462	Capscrew (Hyd. L, K, P, "KG", "PG" Assy. Only)	N.S.	1	TG-RBK-T1	Rebuild Kit – E-Hydra (12/07 & later) Items 3, 3a, 4, 7, 8, 9, 11*, 17, 20, 21 (1) 12T36526 (See E-Hydra page 8 (2, 11, 12T35343))
	4	19T38249	"M" Hyd. Flange Assy. Only				
	4	19M84478	"N" Hyd. Flange Assy. Only				
	4	19T39257	"F", "G", "Q", "R", "S" & "T" Hyd. Assy. Only				

In assembly and disassembly the recommended torque value of all Hex Head Capscrews is 18 ft.lbs. and the recommended torque value on the Button Head Capscrews is 9 ft.lbs. Should any capscrew loosen over time, the capscrew should be discarded and threads examined for damage. Use new capscrews with lock patch.**

Note: Hydraulic Flange Capscrews are 25 ft.lbs. * It is recommended to use Loctite #640 on outside of seal when replacing the shaft seal.

GEAR SET SELECTION CHART

TRANSMISSION & RATIO DESIGNATOR

U60 04

ITEM 12 INPUT GEAR	TEETH	TRANS	NOTE
03T38783	(30T)	A69	9
03T34810	(18T)	C57	
03T34452	(23T)	C60	
03T34454	(20T)	C61	
03T34453	(24T)	C70	
03T34455	(28T)	C76	
03T40079	(37T)	D94	
03T94192	(42T)	F10	
03T35189	(42T)	F11	
03T35031	(21T)	F61	
03T35613	(25T)	F62	
03T35024	(24T)	F63	
03T35025	(25T)	F65	
03T38140	(24T)	F66	
03T37658	(23T)	F67	
03T37657	(26T)	F70	
03T96626	(29T)	F75	
03T37740	(28T)	F84	7
03T39458	(28T)	F86	
03T42592	(40T)	F97	
03T96624	(26T)	G70	
03T34325	(27T)	G73	
03T37766A	(28T)	G79	16
03T35180	(30T)	G85	
03T37787A	(29T)	G92	16
03T34456	(24T)	H65	
03T35194	(23T)	I80	
03T37328	(34T)	I84	
03T35350	(38T)	I85	2
03T34597	(26T)	M65	
03T38530	(31T)	M80	10
03T38531	(30T)	M83	
03T37219	(32T)	M89	
03T42337	(26T)	M90	
03T37655A	(35T)	N10	11,16
03T35730	(16T)	N56	14
03T34449	(23T)	N60	11
03T39158	(24T)	N70	12
03T34458	(24T)	N71	
03T93851	(24T)	N72	12
03T37024	(27T)	N78	
03T35489A	(30T)	N79	15,16
03T35488A	(28T)	N80	15,16
03T34457	(28T)	N81	
03T36591	(27T)	N92	
03T35360	(24T)	R68	
03T35361	(29T)	R85	
03T36083	(24T)	S58	
03T34286	(21T)	S60	
03T96746	(22T)	S61	
03T36421	(21T)	S62	
03T38184	(22T)	S63	

ITEM 12 INPUT GEAR	TEETH	TRANS	NOTE
03T38233	(21T)	S64	
03T94243	(26T)	S68	
03T34287	(24T)	S70	
03T35540	(29T)	S71	
03T37918	(28T)	S73	
03T37016	(32T)	S80	
03T37015	(36T)	S89	
03T36552	(21T)	T61	
03T38546	(29T)	T81	
03T35650	(28T)	T82	
03T34451	(20T)	U57	
03T34285	(24T)	U60	5
03T34732	(24T)	U6004	8
03T39495	(24T)	U62	
03T34450	(24T)	U67	
03T34284	(24T)	U68	
03T35399	(30T)	U79	
03T35107	(25T)	U80	
03T34326	(31T)	W80	13
03T35033A	(36T)	W96	6,16
03T36823A	(35T)	W97	16
03T96773	(24T)	X68	
03T17306A	(38T)	Z10	16
03T39491A	(32T)	Z90	16
03T39492A	(32T)	Z91	16
03T37260A	(32T)	Z92	16
03T37784A	(32T)	Z93	16
03T35935A	(37T)	Z98	16
03T17307A	(31T)	Z99	16

RATIO	ITEM 14 RATIO GEAR	TEETH	ITEM 10 OUTPT GEAR	TEETH
04	04T34277	(13T)	02T34278	(36T)
05	04T34275	(16T)	02T34276	(34T)
06	04T34441	(19T)	02T34440	(31T)
07	04T34271	(21T)	02T34272	(29T)
08	04T35186	(23T)	02T35185	(26T)
09	04T34399	(24T)	02T34398	(26T)
12**	04T34443	(27T)	02T34442	(23T)
13**	04T34308	(28T)	02T39373	(21T)
15**	04T34445	(30T)	02T34444	(20T)
18**	04T34605	(31T)	02T34606	(18T)
12H	04T35155	(26T)	02T35162	(23T)
13H	04T35363	(27T)	02T35362	(21T)
15H	04T34598	(29T)	02T39172	(20T)
18H	04T34605	(31T)	02T34601	(18T)

** These ratios have been obsoleted and are replaced by the "H" option ratios. Contact Muncie for parts availability.

NOTE: Input Ratio Gear & Output Gear Must Be Used In Pairs As Shown Above.

The TG Series PTO is designed to allow easy change from one model transmission to another by changing only one gear and to allow changing speeds by changing two gears.

The chart shows gear part numbers for each transmission designator (Ex:U60) and each speed ratio available (Ex: 04).

- When using this gear substitute stud kit 20MKM602 (metric) for the one in the PTO kit.
- With this gear a special housing (01T35342) and a stud kit 20MKM104 (metric) is used. Refer to service manual for special idler caps required.
- With this gear substitute stud kit 20mkm104 (metric)-R68 or 20mkm105 (metric)-R85 for the one in PTO kit.
- With this gear a special housing (01T35342) is used and 15T35612 idler caps, (4) 19T31664 cap screws.
- When using this gear, replace the gasket pack with 52MK1002 or add 13M13541 gasket/shim when used with 04 or 05 ration on Allison Transmissions. Note that the TG04 ratios kits from Muncie Power include this gasket (kit), but the TG 05 ratio kits do not.
- This gear requires the use of a special shift cover which is supplied when ordered with this kit number. Also, add 36M3566TC visor instruction.
- With this gear a special housing (01T37765 w/(2) 26T37992 pins), a stud kit 20TK4049 (metric), and 52TK4113 packet is used. Use of any other housing is not approved.

- Input gear includes the ratio gear, for constant engage only.
- The TG Series PTO always uses a special shifter cover when this input gear is used. Requires 20MKM604 stud kit and 23M60270 spacer and 52TK4470 kit to be used with the installation of the PTO & shift collar (49T38158.)
- Used only with special housing 01T35342 (N) and metric stud kit 20MKM602.
- Install 15MK33977 clearance kit on closed end PTO. Sell this kit when selling this gear.
- When selling this gear include the visor seal decal, 36M3566TC, with the boxed gear. When assembling a unit mount this decal on the visor label included with the PTO before applying to vehicle visor.
- 13M51717 tube, gasket eliminator, is to be included with the boxed gear or when assembled into a unit.
- Requires adapter plate kit 29TK3863.
- Include special lube sheet MC94-02
- Gears with "A" include (2) coated thrust washers 21T38375 (item 11)

AIR COVER OPTION "A" OR "E"

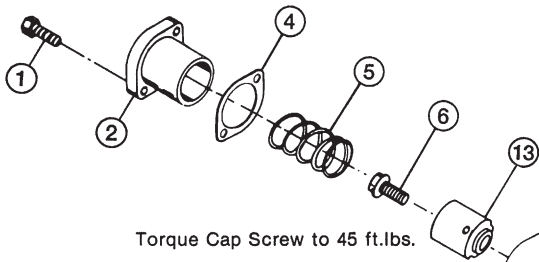

ASSEMBLY PART NUMBERS:
16TA3803 For Assemblies 1 & 4 (Assembly Shown)
16TA3804 For Assemblies 2 & 3

Lubricate piston before installing in cover cup.



V-Ring Installation

Torque Cap Screw to 45 ft.lbs.

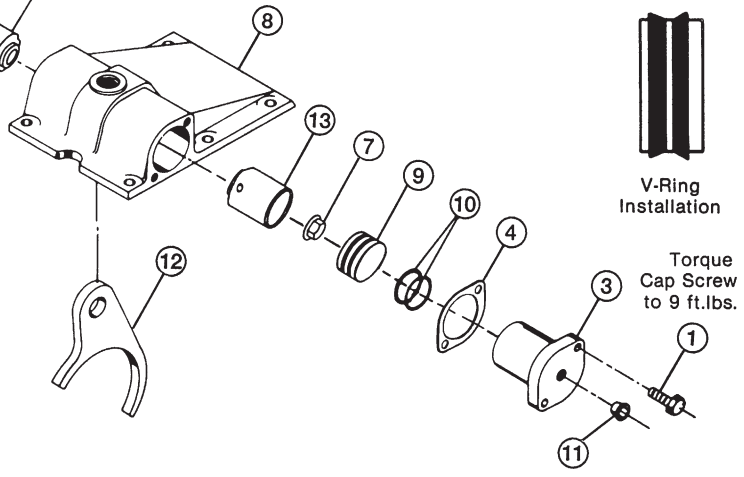

AIR COVER PARTS LIST AND DESCRIPTION			
ITEM	QTY	PART NUMBER	DESCRIPTION
1	4	19T34494	Capscrew
2	1	28T35675	Cover Cup (Closed End)
3	1	28T34480	Cover Cup
4	2	13T38286	Gasket*
5	1	27T35073	Spring
6	1	19T35681	Capscrew
7	1	22T35682	Nut
8	1	16T35377	Cover Housing
9	1	49T35204	Piston
10	2	28T35205	V-Ring
11	1	25T34029	Cap Plug
12	1	28T34481	Yoke
13	2	28T35695	Guide

CONSTANT MESH "M" SHIFT OPTION

For Assemblies 1 & 4 use: 16TA3804 Air Cover and: Replace (1)28T34480 with (1)28T35675; Remove (1)49T35204 piston and (2)28T35205 v-rings; Install (1)25T32143 plug w/12T36526 o-ring into indicator switch hole.

For Assemblies 2 & 3 use: 16TA3803 Air Cover and change as indicated above.

When using the U6004 (03T34732) input gear use: (1)16T35377 cover housing; Install (2)15T33977 shaft caps with (2)13T38286 gasket & (4)19T34530 cap-screws; Install (1)25T32143 plug w/12T36526 o-ring into indicator switch hole.

TG-ASSK-1
 Air Cover Seal Kit – Items 4, 10 & (2)12T35343 [From Page 3 – Item 17, (1)12T36526]

RBK-3838
 Air Cover Rebuild Kit – Items 1, 2, 3, 4, 5, 10, 12, (2)12T35343 [From Page 3 – Item 17, (1)12T36526]

*When repairing cover with O-ring seals (4) use RTV with supplied gaskets.

DOUBLE ACTING AIR SHIFT OPTION 16TA3955

Add to Standard Air Cover Parts List:

(1) 28T34480,
 (1) 49T35204,
 (2) 28T35205

Delete: (1) 27T35073,
 (1) 28T35675

REVERSED COVER INSTALLATION

ASSEMBLED SHIFTER PART NUMBERS:
 (Includes Adapter Plate and Hardware)

16TK3835 (Reversed Air Cover For Assys. 1 & 4)
16TK3836 (Reversed Air Cover For Assys. 2 & 3)
16TK3837 CONVERSION KIT (Requires Standard Cover – Used with Air or Lectra Shift Covers Only)

CONVERSION KIT INCLUDES:

ITEM	QTY	PART NUMBER	DESCRIPTION
12	1	28T35581	Yoke
14	1	28T35184	Adapter Plate
15	4	19T35237	Socket Capscrew
16	2	19T35236	Hex Capscrew
17	4	19T33233	Hex Capscrew
N.S.	1	13T38541	Gasket

** Items are included with the standard cover and are reused in this assembly.

NOTE: Change Indicator Switch from the original item 25 shown on page 3, Switch not included in Kit.

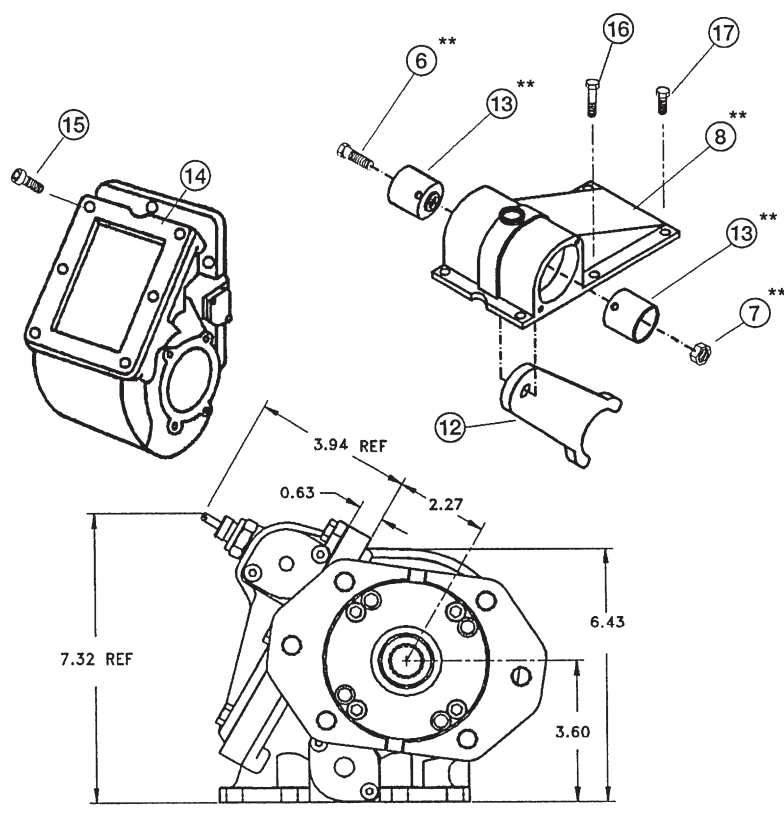

CABLE COVER OPTION "C"

CABLE COVER PARTS LIST AND DESCRIPTION			
ITEM	QTY	PART NUMBER	DESCRIPTION
1	1	12T36878	O-Ring
2	1	17T34495	Shifter Rail
3	2	19T34259	Capscrew
4	1	17T34254	Shifter Lever
5	1	28T35061	Retainer Washer
6	1	12T36871	O-Ring
7	1	16T34473	Cable Cover Housing
8	1	28T34476	Yoke
9	1	21T35071	Copper Washer
10	1	27T34253	Spring
11	1	28T34252	Poppet
12	1	28T34474	Yoke Plate
13	1	28T34261	Trigger

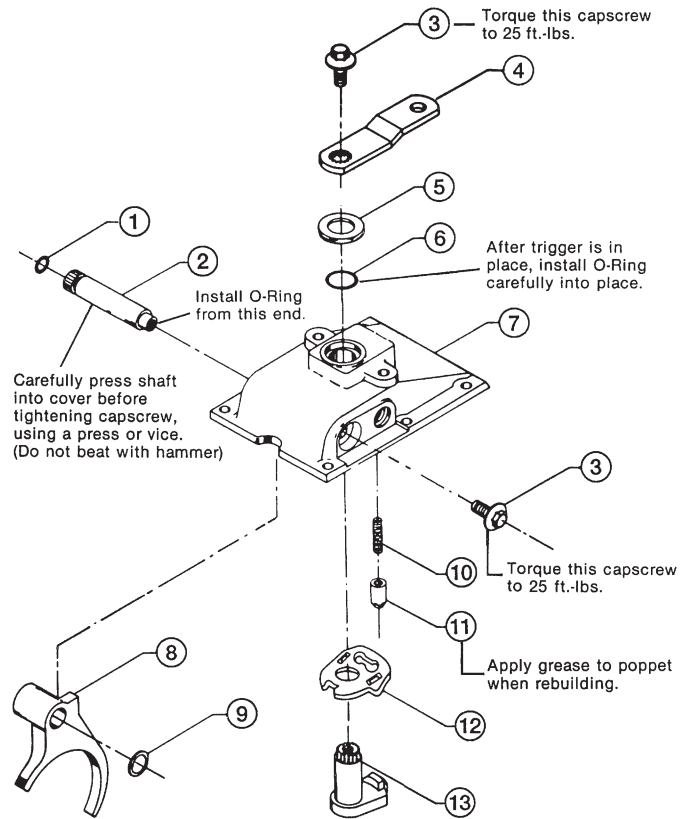

ASSY PART NUMBER: 16TA3735 ALL ASSEMBLIES

Indicator switch sold separately

TG-CSRK Cable Cover Rebuild Kit – Items 1, 2, 5, 6, 9, 10, 11
[From Page 3 – Item 17, (1)12T36526]

TG-CSSK Cable Cover Seal Kit – Items 1, 5, 6, 9
[From Page 3 – Item 17, (1)12T36526]

16TA3793 Cable Cover with Breather Port (W96)
(Item 7 – 16T35166)

NOTE: When rebuilding cover lubricate all O-Rings before installation.

Cable Shift Option "C" Includes 28MCC120 Cable, 28MK0155 Knob, and 36MK1210A Light Kit

LECTRA SHIFT OPTION "S"

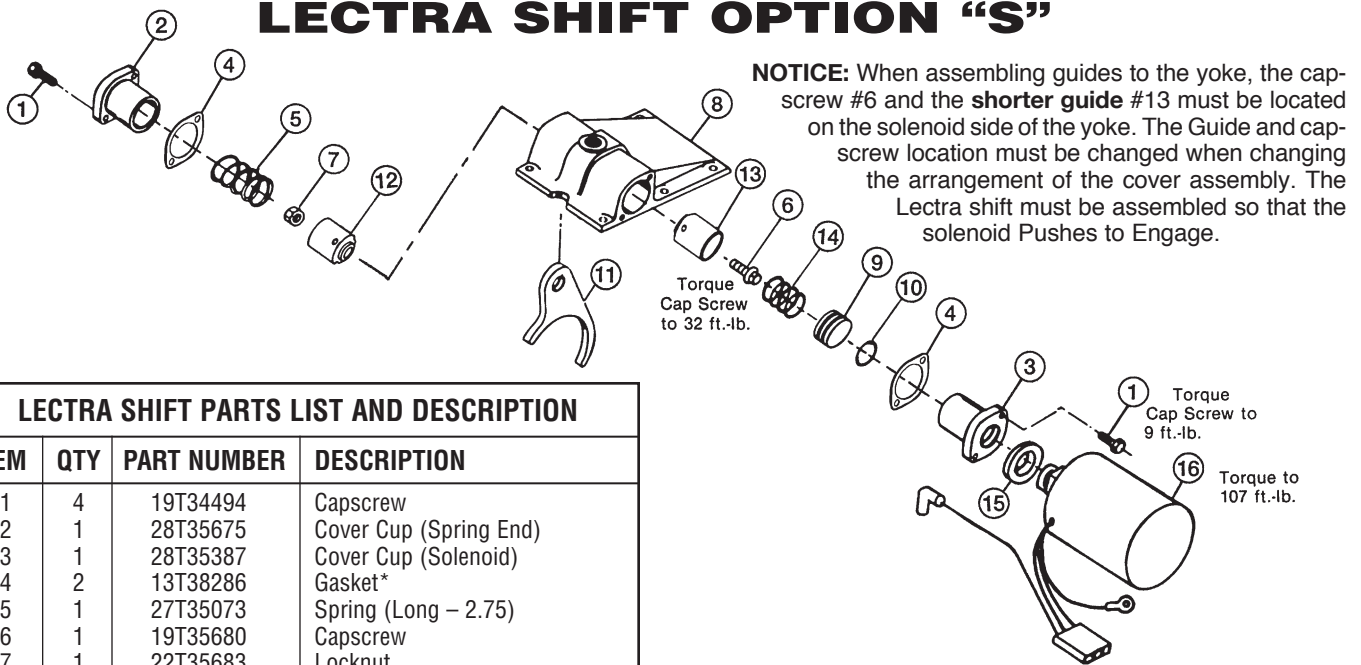

LECTRA SHIFT PARTS LIST AND DESCRIPTION			
ITEM	QTY	PART NUMBER	DESCRIPTION
1	4	19T34494	Capscrew
2	1	28T35675	Cover Cup (Spring End)
3	1	28T35387	Cover Cup (Solenoid)
4	2	13T38286	Gasket*
5	1	27T35073	Spring (Long – 2.75)
6	1	19T35680	Capscrew
7	1	22T35683	Locknut
8	1	16T35377	Cover Housing
9	1	49T35389	Piston
10	1	12T35304	O-Ring
11	1	28T34481	Yoke
12	1	28T35695	Guide (Long)
13	1	28T35390	Guide (Short)
14	1	27T35391	Spring (Short – 1.09)
15	1	28T35392	Spacer
16	1	28TK4587	Solenoid (w/grd wire kit)

ASSEMBLY PART NUMBERS:

16TA3822-A For Assemblies 1 & 4 (Assembly Shown)

16TA3823-A For Assemblies 2 & 3

TG-SSSK Lectra Shift Seal Kit – Items 4, 10 & (2)12T35343
[From Page 3 – Item 17, (1)12T36526]

*When repairing cover with O-ring seals (4) use RTV with supplied gaskets.

E-HYDRA SHIFT TG P.T.O.

SHIFT COVER ASSEMBLY

U.S. PATENT NO
CANADIAN PAT. NO: 2,348,315

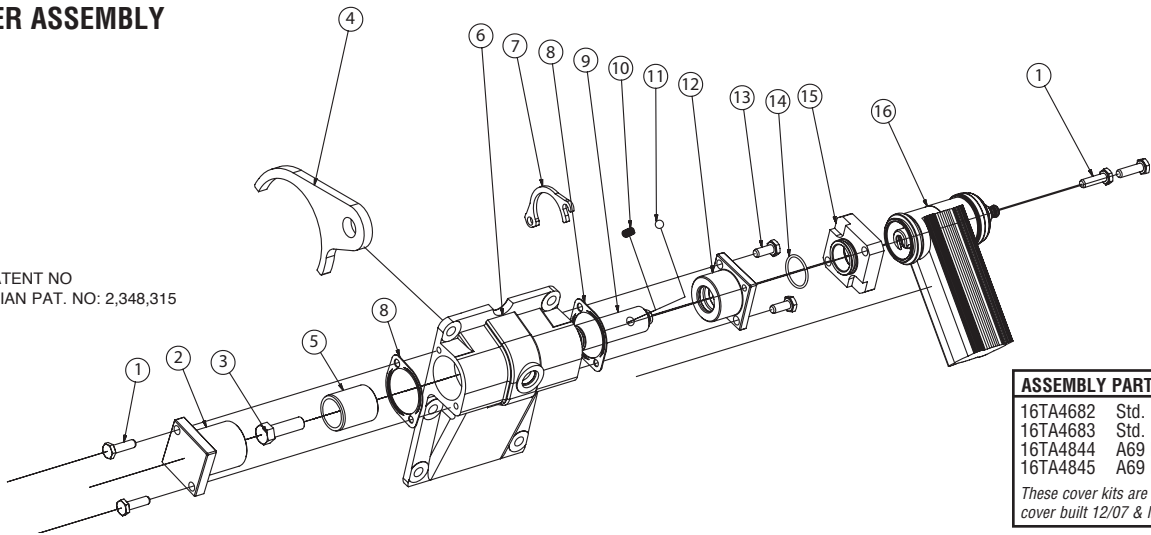

ASSEMBLY PART NUMBERS

16TA4682 Std. Kit 1 & 4
16TA4683 Std. Kit 2 & 3
16TA4844 A69 Kit 1 & 4
16TA4845 A69 Kit 2 & 3

These cover kits are replaced by cover built 12/07 & later.

SHIFT COVER ASSEMBLY PARTS LIST AND DESCRIPTION — E HYDRA BUILT BEFORE 12/07

ITEM	QTY	PART NUMBER	DESCRIPTION	ITEM	QTY	PART NUMBER	DESCRIPTION
1	4	19T34494	Capscrew	10	1	27T39813	Spring
2	1	28T40052	Cup, Spring	11	1	28T39814	Ball
3	1	19T35681	Capscrew	12	1	28T40051	Adapter – STD 16TA4682 & 16TA4683
4	1	28T38167	Yoke – 1 or 4 Assembly			28T40215	Adapter – Allison 1000/2000
		28T34481	– 2 or 3 Assembly				(16TA4844 & 16TA4845)
5	1	28T40053	Guide	13	2	19T34028	Capscrew
6	1	16T40050	Cover, Housing	14	1	12T36280	O-Ring
7	1	1214KES5C00	Retainer – Included with 28TA4685	15	1	28T39175	Adapter
8	2	13T40303	Gasket	16	1	28TA4685	Cylinder Assembly-(REF# 194KES5E212) 12V
9	1	28T39592	Shift Shaft – STD 16TA4682 & 16TA4683	N.S.	1	12T35343	O-Ring – Included with 28TA4685
		28T40214	Shift Shaft – Allison 1000/2000				
			(16TA4844 & 16TA4845)				

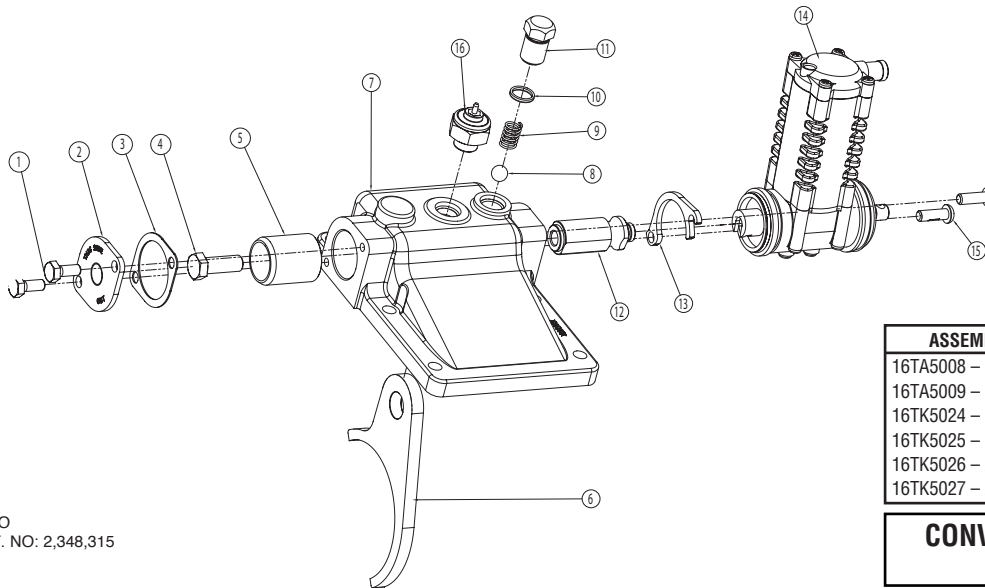

U.S. PATENT NO
CANADIAN PAT. NO: 2,348,315

ASSEMBLY PART NUMBERS

16TA5008 – Standard Assemblies 1 & 4
16TA5009 – Standard Assemblies 2 & 3
16TK5024 – Standard Assemblies 1 & 4
16TK5025 – Standard Assemblies 2 & 3
16TK5026 – A69 Assemblies 1 & 4
16TK5027 – A69 Assemblies 2 & 3

CONVERSION KITS

See Page 14

SHIFT COVER ASSEMBLY PARTS LIST AND DESCRIPTION — E HYDRA BUILT 04/10 AND CURRENT

ITEM	QTY	PART NUMBER	DESCRIPTION	ITEM	QTY	PART NUMBER	DESCRIPTION
1	2	19T34028	Capscrew, Hex Head 1/4-20 X 5/8	9	1	27T41384	Spring
2	1	15T33977	Cap, Shaft	10	1	12T41760	O-Ring, Poppet
3	1	13T38286	Gasket	11	1	28T41383	Poppet
4	1	19T40289	Capscrew, Hex Head 3/8-24 UNF X 1.00	12	1	28T41694	Shifter Rod
5	1	28T40053	Guide	13	1	194KES5E212	Retainer
6	1	28T34481	Yoke	14	1	28TA4685	Cylinder Assembly
7	1	16T41696	Cover, Housing	15	2	19T34512	Capscrew, Hexagon Socket Button Head
8	1	28T41391	3/8 Steel Ball	16	1	30T38110	Indicator Switch

* Indicator switch is included with the PTO and not in any kit.

TG PTO CLUTCH RING INSTALLATION FOR ALLISON 1000/2000 TRANSMISSION

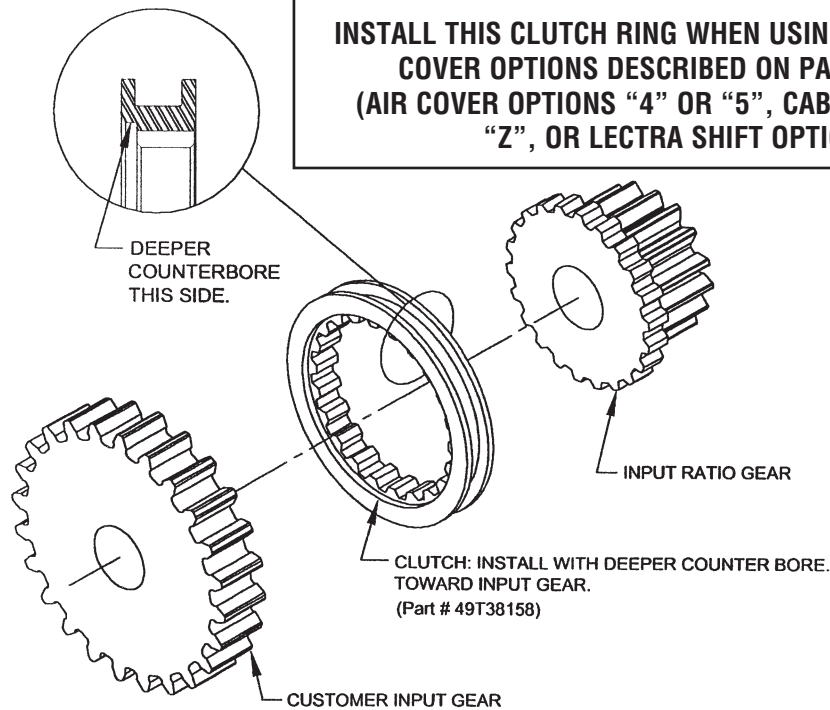

INSTALL THIS CLUTCH RING WHEN USING WITH ANY OF THE COVER OPTIONS DESCRIBED ON PAGES 9 AND 10. (AIR COVER OPTIONS "4" OR "5", CABLE COVER OPTION "Z", OR LECTRA SHIFT OPTION "6")

AIR COVER OPTION "4" OR "5"

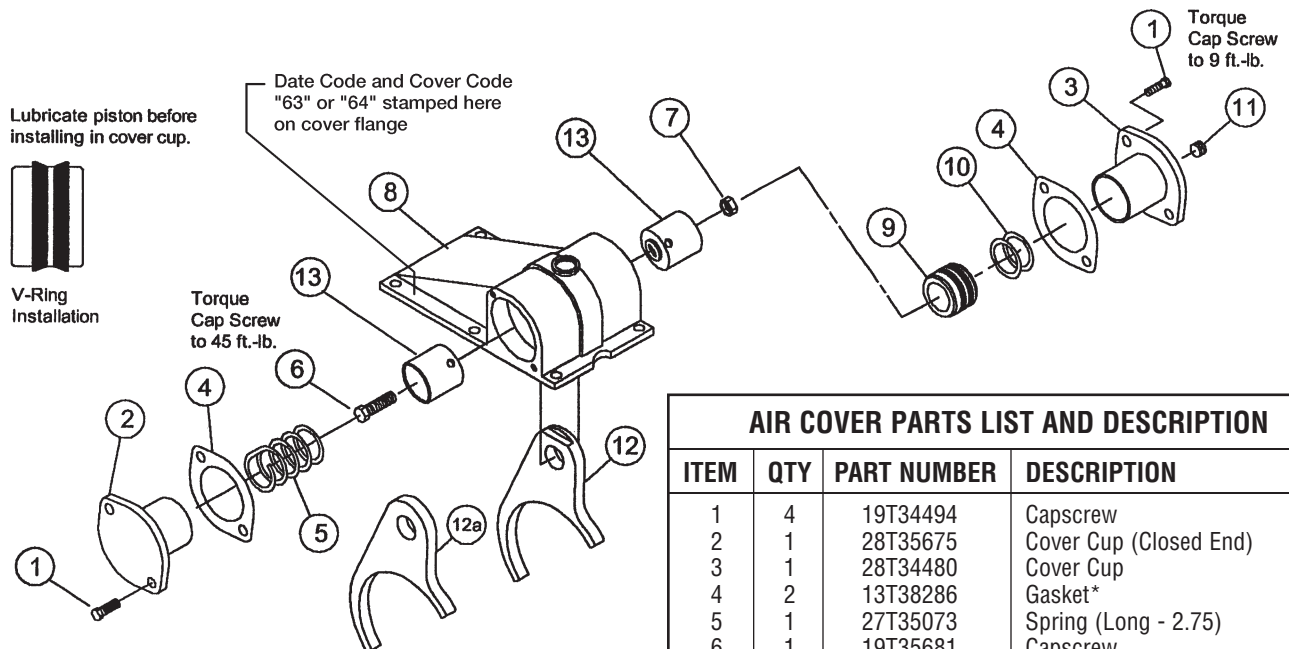

AIR COVER PARTS LIST AND DESCRIPTION

ITEM	QTY	PART NUMBER	DESCRIPTION
1	4	19T34494	Capscrew
2	1	28T35675	Cover Cup (Closed End)
3	1	28T34480	Cover Cup
4	2	13T38286	Gasket*
5	1	27T35073	Spring (Long - 2.75)
6	1	19T35681	Capscrew
7	1	22T35683	Nut
8	1	16T35377	Cover Housing
9	1	49T38168	Piston
10	2	28T35205	V-Ring
11	1	25T34029	Cap Plug
12	1	28T38167	Yoke (1 or 4 ass'y w/notch)
12a	1	28T34481	Yoke (2 or 3 ass'y)
13	2	28T35695	Guide

ASSEMBLY PART NUMBERS:

16TA4063 For Assemblies 1 & 4 (Assembly Shown)

16TA4064 For Assemblies 2 & 3

TG-ASSK-1 Air Cover Seal Kit - Items 4, 10
[From Page 3 - Item 17, (1)12T36526]

*When repairing cover with O-ring seals (4) use RTV with supplied gaskets.

CABLE COVER OPTION "Z"

CABLE COVER PARTS LIST AND DESCRIPTION			
ITEM	QTY	PART NUMBER	DESCRIPTION
1	1	12T36878	O-Ring
2	1	17T34495	Shifter Rail
3	2	19T34259	Capscrew
4	1	17T34254	Shift Lever
5	1	28T35061	Retainer Washer
6	1	12T36871	O-Ring
7	1	16T34473	Cable Cover Housing
8	1	28T34476	Yoke
9	1	21T35071	Copper Washer
10	1	27T34253	Spring
11	1	28T34252	Poppet
12	1	28T38164	Yoke Plate (Ass'y 1 & 4)
12a	1	28T38165	Yoke Plate (Ass'y 2 & 3)
13	1	28T34261	Trigger
14	1	18T38166	Spacer

ASSEMBLY PART NUMBERS:
16TA4060 For Assemblies 1 & 4
16TA4061 For Assemblies 2 & 3

Cable Shift Option "Z" Includes 28MCC120 Cable, 28MK0155 Knob, and 36MK1210A Light Kit

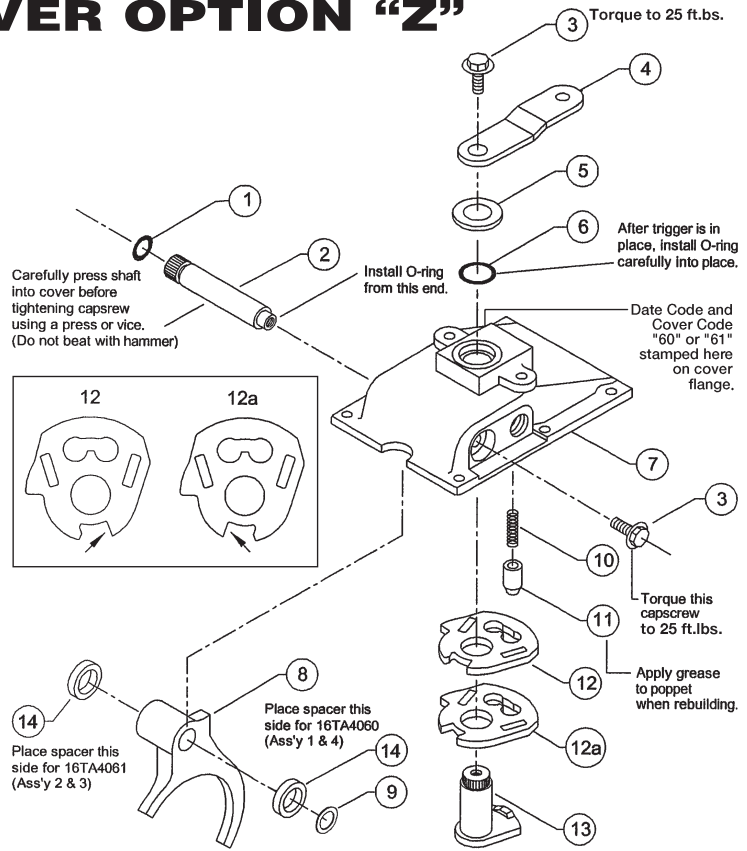

LECTRA SHIFT OPTION "6"

NOTICE: When assembling guides to the yoke, the cap screw #6 and the **shorter guide** #13 must be located on the solenoid side of the yoke. The Guide and cap screw location must be changed when changing the arrangement of the cover assembly.

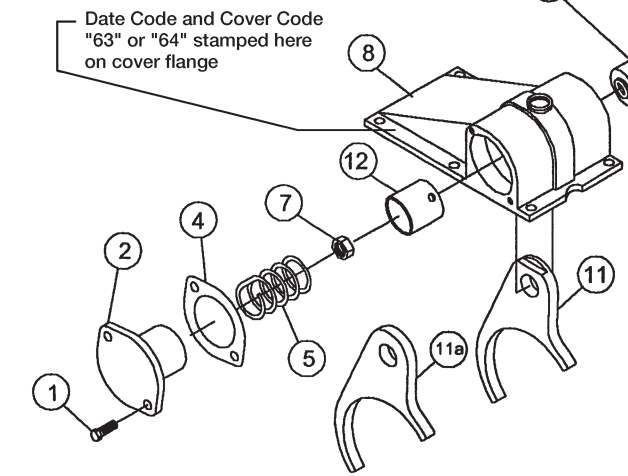

ASSEMBLY PART NUMBERS:
16TA4066 For Assemblies 1 & 4 (Assembly Shown)
16TA4067 For Assemblies 2 & 3
TG-SSSK Lectra Shift Seal Kit – Items 4, 10
 [From Page 3 – Item 17, (1)12T36526]
 *When repairing cover with O-ring seals (4) use RTV with supplied gaskets.

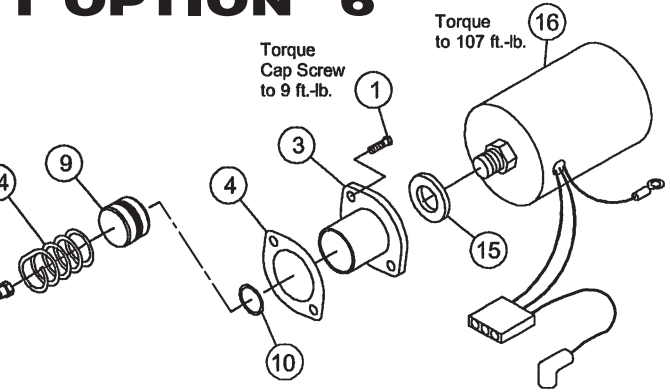

LECTRA SHIFT PARTS LIST AND DESCRIPTION			
ITEM	QTY	PART NUMBER	DESCRIPTION
1	4	19T34494	Cap screw
2	1	28T35675	Cover Cup (Spring End)
3	1	28T35387	Cover Cup (Solenoid)
4	2	13T38286	Gasket*
5	1	27T35073	Spring (Long – 2.75)
6	1	19T35680	Cap screw
7	1	22T35683	Locknut
8	1	16T35377	Cover Housing
9	1	49T38169	Piston
10	1	12T35304	O-Ring
11	1	28T38167	Yoke (1 & 4 Ass'y w/notch)
11a	1	28T34481	Yoke (2 & 3 Ass'y)
12	1	28T35695	Guide (Long)
13	1	28T35390	Guide (Short)
14	1	27T35391	Spring (Short – 1.09)
15	1	28T35392	Spacer
16	1	28TK4587	Solenoid (w/grd wire kit)

TG SERIES ELECTRIC-AIR SHIFT SYSTEM

PARTS LIST AND DESCRIPTION

Do not use the electric-air shift with any overspeed protection device.

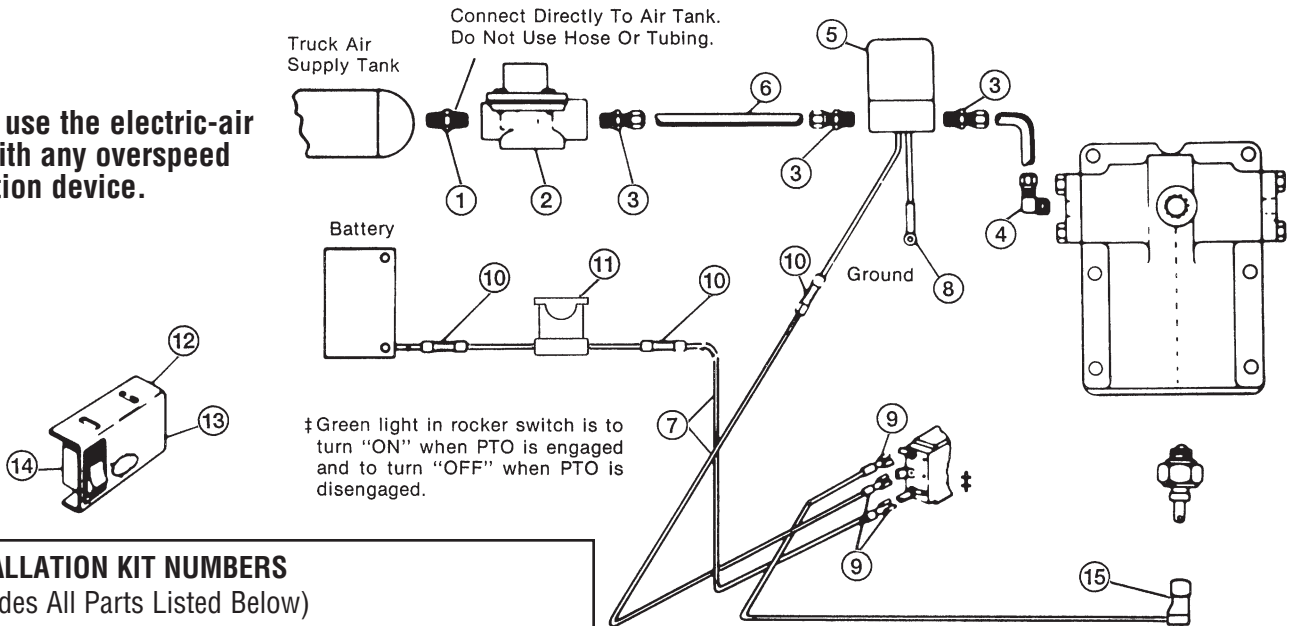

INSTALLATION KIT NUMBERS

(Includes All Parts Listed Below)

48M61200-A (12 Volt Solenoid and Switch)

48M62400-A (24 Volt Solenoid and Switch)

ITEM	QTY	PART NUMBER	DESCRIPTION
1	1	44MB2164	Pipe Nipple
2	1	31M15759	Pressure Protection Valve
3	3	44MB6844	Tube Fitting
4	1	44MB6942	Tube Fitting (Elbow)
5	1	35M30692	12V Solenoid Valve
		35M31692	24V Solenoid Valve
6	1	45M44430	Air Tubing – 30 ft
7	30	37M18000	Electric Wire – 30 ft
8	1	34M18009	Eyelet Terminal
9	3	34M18250	Spade Terminal
10	3	34M18002	Butt Splice
11	1	33T36299	Fuse Assembly
12	1	36MA1005	Dash Bracket
13	1	36M01007	Face Plate
14	1	30T35687	Switch 12VDC
		30T35712	Switch 24VDC
15	1	34T38163	Booted Connector
N.S.	1	36MK1007	Bolt Kit (Includes: 6 Bolts, 6 Nuts, 6 Flat Washers, 6 Lock Washers)

Indicator switch sold separately – Not included in kit.

CONVERSION KIT NUMBERS – WIRE TO ELECTRIC AIR

(12 Volt Only Listed)

16MK0200-A (For Assys. 1 & 4)

16MK1200-A (For Assys. 2 & 3)

Air System Users Only...You will not receive any air through the pressure protection valve to the PTO system until your main tank pressure exceeds 65 PSI. Some chassis have dual air systems; be sure to connect to the air supply at the location recommended by the vehicle manufacturer.

NOTE: Solenoid Valve (Item 5) should be mounted on firewall to protect it from corrosive environment.

EATON FULLER CEEMAT TRANSMISSIONS

48MK1435-14 (1 OR 4 ASSY); **48MK1435-23** (2 OR 3 ASSY)

(Used in addition to the kit above)



Eaton Fuller Transmission Electrical Connector

PTO Harness W1A W5
Supplied by Eaton

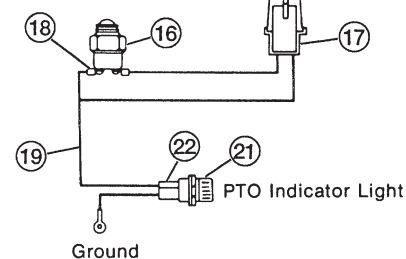

ITEM	QTY	PART NUMBER	DESCRIPTION
13	1	36T35431	Face Plate
16	1	30M91113	Indicator Switch 1 or 4
		30M92247	Indicator Switch 2 or 3
17	1	34MA1420	Wiring Harness
18	2	34M18009	Ring Terminal
19	15	37M18000	Electric Wire
21	1	32MSR12V	Light 12VDC
22	2	34M18187	Spade Terminal

Eaton is requiring the installation of their wiring harness through a special connection from their harness to a special PTO indicator switch.

TG SERIES STANDARD AIR SHIFT SYSTEM

PARTS LIST AND DESCRIPTION

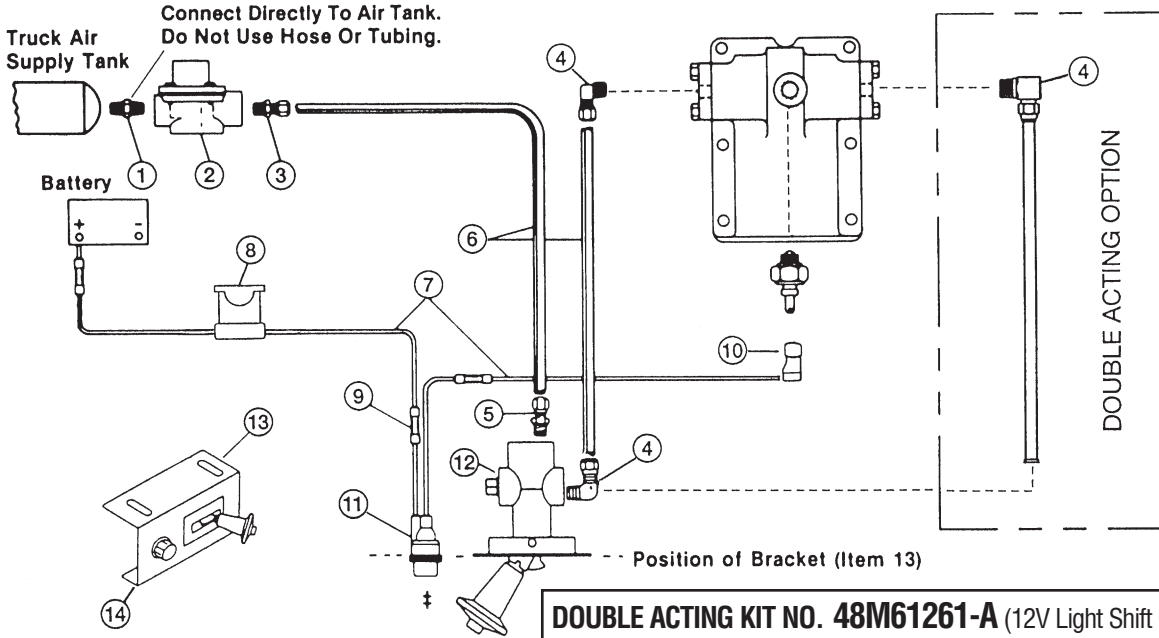

‡ Red indicator light is to turn "ON" when PTO is engaged, and is to turn "OFF" when PTO is disengaged.

INSTALLATION KIT NUMBERS

(Includes All Parts Listed Below)

48M61250-A (12 Volt Light)

48M62450-A (24 Volt Light)

ITEM	QTY	PART NUMBER	DESCRIPTION
1	1	44MB2164	Pipe Nipple
2	1	31M15759	Pressure Protection Valve
3	1	44MB6844	Tube Fitting
4	2	44MB6942	Tube Fitting (Elbow)
5	1	44MB6842	Tube Fitting
6	1	45M44430	Air Tubing – 30 ft
7	12	37M18000	Electric Wire – 12 ft
8	1	33T36299	Fuse Assembly
9	3	34M18002	Butt Splice
10	1	34T38163	Booted Connector
11	1	32M12001	12V Light
	1	32M24001	24V Light
12	1	35M18653	Air Valve
13	1	36MA1004	Dash Bracket
14	1	36M01005	Face Plate
N.S.	1	36MK1007	Bolt Kit (Includes: 6 Bolts, 6 Nuts, 6 Flat Washers, 6 Lock Washers)

Indicator switch sold separately – Not included in kit.

48T38317-A (12 Volt Light)

Same as **48M61250-A** less Item 12 (35M18653 Air Valve).

CONVERSION KIT NUMBERS – WIRE TO STANDARD AIR

(12 Volt Only Listed)

16MK3803-A (For Assys. 1 & 4)

16MK3804-A (For Assys. 2 & 3)

DOUBLE ACTING KIT NO. 48M61261-A (12V Light Shift Option "D")

Includes parts listed in 48M61250-A with the exception of item no.'s listed below.

ITEM	QTY	PART NUMBER	DESCRIPTION
4	3	44MB6942	Tube Fitting (Elbow)
12	1	35T37955	Air Valve
13	1	36T38049	Dash Bracket
14	1	36T38016	Face Plate
N.S.	4	22MX2520	.25-20 Hex Nut
N.S.	4	19T34530	.25-20 x .5 Button Hd
N.S.	1	36MK1011	Bolt Kit

EATON FULLER CEMAT TRANSMISSIONS

48MK1434-14 (1 OR 4 ASSY); **48MK1434-23** (2 OR 3 ASSY)

(Used in addition to the kit above)

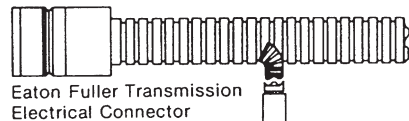

PTO Harness
Supplied by Eaton

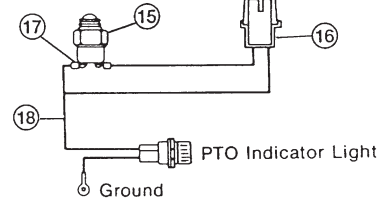

ITEM	QTY	PART NUMBER	DESCRIPTION
15	1	30M91113	Indicator Switch 1 or 4
	1	30M92247	Indicator Switch 2 or 3
16	1	34MA1420	Wiring Harness
17	2	34M18009	Ring Terminal
18	1	37M18180	Electric Wire

Eaton is requiring the installation of their wiring harness through a special connection from their harness to a special PTO indicator switch.

TG SERIES AIR SHIFT SYSTEM FOR NISSAN MLS-61A OR B

BASE KIT 48TK4518 "N" SHIFT OPTION			
ITEM	QTY	PART NUMBER	DESCRIPTION
9	1	23T35796	Solenoid Bracket
10	2	44MB6844	Compression Fitting
12	2	19T35800	Machine Screw
15	2	21T35901	Lock Washer
16	1	19T20522	Hex Head Cap Screw
17	1	22T35145	Hex Nut
19	1	44MB6842	Compression Fitting
20	1	44MB6942	Compression Fitting
21	1	45M44430	Tubing - 30 Ft.
22	2	34T35436	.250" Male Spade Terminal
23	2	34T35908	.250" Female Spade Terminal
24	1	35M30692	Solenoid 12 VDC
25	1	37T42512	Wire 12.5 ft.
26	4	34M18002	Butt Splice

Activation Kit Model Year 1999-2002
48TK4517 (Sold Separately)
 Same as 48TK4516 except relay 30T37926
 in place of 30T38973

ACTIVATION KIT 48TK4516 FOR NISSAN 2003-2004			
ITEM	QTY	PART NUMBER	DESCRIPTION
1	1	30T36232	Clutch Switch
2	1	30T38973	Relay (2003)
3	2	44T35790	Sleeve
4	1	44T35791	Pipe Coupling
5	2	44T35792	Nut
6	1	44T35793	Tee
7	1	23T36291	Switch Bracket
8	1	23T36264	Push Plate
11	1	30T36235	Switch
13	2	22T36293	Hexnut
14	1	22T36297	Hexnut
18	2	19T36292	Hex Head Cap Screw

ACTIVATION KIT 48TK4693 FOR NISSAN 2005-2006			
ITEM	QTY	PART NUMBER	DESCRIPTION
1	1	30T36232	Clutch Switch
2	1	30T38973	Relay (2003)
7	1	23T36291	Switch Bracket
8	1	23T36264	Push Plate
11	1	30T36235	Switch
13	2	22T36293	Hexnut
14	1	22T36297	Hexnut
18	2	19T36292	Hex Head Cap Screw
27	1	44TK4607	Plastic Airline Kit

INSIDE CAB

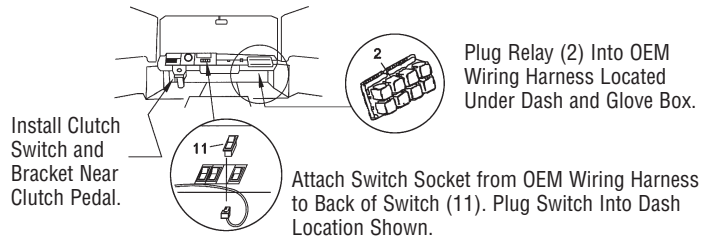

CLUTCH SWITCH INSTALLATION

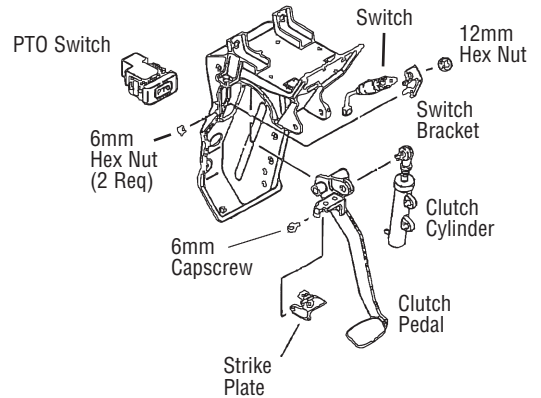

CHASSIS CONNECTIONS

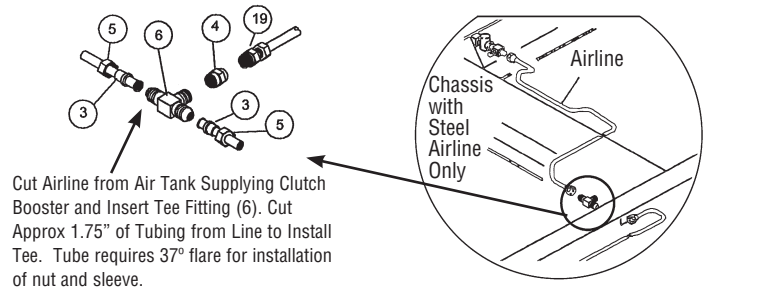

For chassis with 6mm plastic airline: DO NOT CUT AIRLINE.

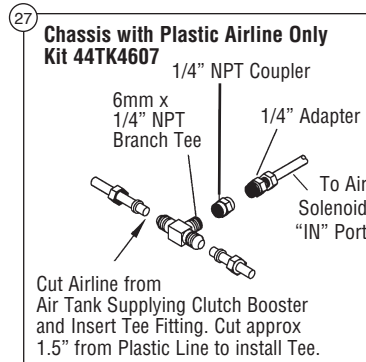

Install pressure protection valve at air tank and install PTO using Standard installation.

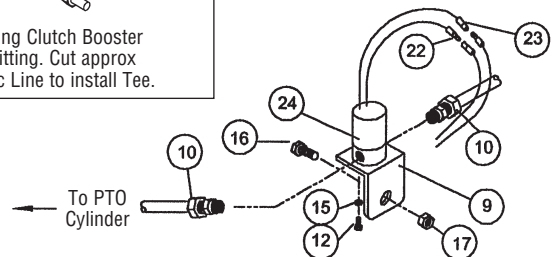

TG SERIES LECTRA SHIFT SYSTEM

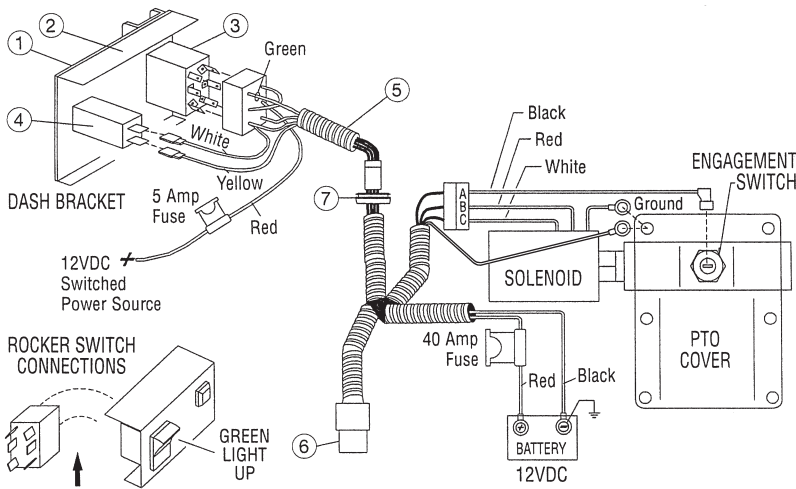

INSTALLATION KIT NUMBER 48TK3981

(Includes All Parts Listed Below)

ITEM	QTY	PART NUMBER	DESCRIPTION
1	1	36T35431	Face Plate
2	1	36MA1005	Dash Bracket
3	1	30T37620	Switch
4	1	32MSR12V	Light 12VDC
5	1	34T37751	Wire Harness
6*	1	37T37621	Relay
7	1	37T35674	Grommet
8	1	19T35439	Sheet Metal Screw
N.S.	5	28T35442	Wire Tie
N.S.	1	36MK1007	Bolt Kit
N.S.	1	36T35710	Dash Label (MC92-01)

Indicator switch sold separately – Not incl. in above kit.

* Relay is supplied in the wire harness.

CONVERSION KIT NUMBERS – WIRE TO LECTRA SHIFT

(12 Volt Only Listed) **16MK3848-A** (For Assys. 1 & 4)

16MK3849-A (For Assys. 2 & 3)

Service Kit: 48TK3976 Includes wire harness relay, rocker switch & Indicator Light

REPLACEMENT PARTS *Repl. fuses sold as service items*

ITEM	QTY	PART NUMBER	DESCRIPTION
N.S.	1	33T37923	5 Amp Fuse
N.S.	1	33T36951	40 Amp Fuse
N.S.	1	37T38559	Relay Cover

TG SERIES E-HYDRA SHIFT SYSTEM

WIRING DIAGRAM FOR ACTIVATION KIT 48TK4686

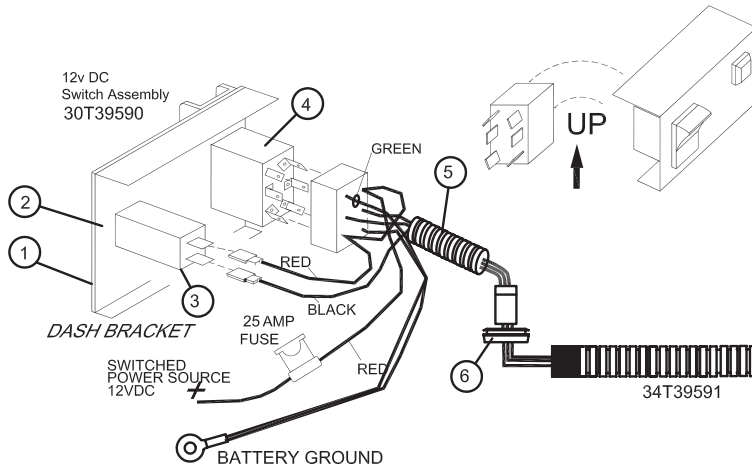

48TK4686 ACTIVATION KIT

ITEM	QTY	PART NUMBER	DESCRIPTION
1	1	36T35431	Faceplate
2	1	36MA1005	Bracket, Dash
3	1	32MSR12V	12V Light
4	1	30T39590	Rocker Switch
5	1	34T39591	Wire Harness
6	1	37T39628	Grommet
N.S.	1	36MK1007	Bolt Kit
N.S.	1	36T39187	Dash Label
N.S.	1	36T40209	Caution Label
N.S.	1	IN05-04	Instruction Sheet

IMPORTANT:

Follow PTO installation instructions IN84-03

1. The rocker switch and dash bracket (if used) is to be mounted in the cab within easy reach of the operator.
2. PTO engagement is made by pushing the rocker switch fully to the engage position and releasing the switch immediately upon engagement. (indicator light will light)
3. Drill .750 dia. hole in firewall, install black plastic grommet (p/n 37T39628) in hole and run the three wire connector through the grommet and plug into cab harness portion of harness. Note the orientation of the connector to insure proper assembly.
4. Plug the rocker switch receptacle onto the switch so that the green wire is up as noted in diagram.

E-HYDRA SHIFTER KITS*

16TK5024 Standard 1 or 4 ass'y
16TK5025 Standard 2 or 3 ass'y

16TK5026 Allison 1000/2000 1 or 4 ass'y
16TK5027 Allison 1000/2000 2 or 3 ass'y

* includes shifter, indicator switch, and activation kit.

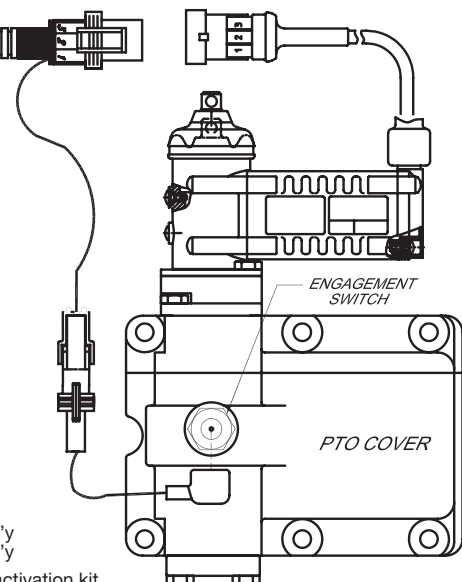

SPECIAL OUTPUT SHAFT OPTIONS

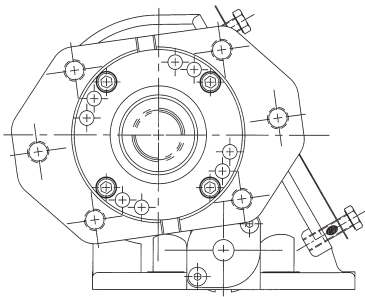

“Z” OPTION

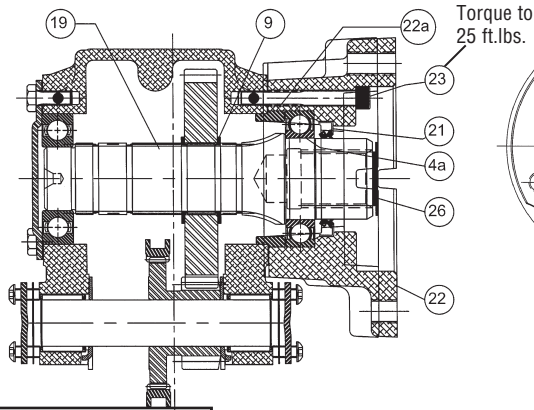

“I” OPTION

“Z” OPTION • KIT 14TA4423			
SAE “B” FLANGE – SAE “C” 1-1/4”-14T SPLINE			
ITEM	QTY	PART NUMBER	DESCRIPTION
4a	1	10T38248	Bearing
9	2	24T23937	Snap Ring
19	1	06T38242	Shaft, Output
21	1	11T38247	Shaft Seal
22	1	14T38244	Hydraulic Flange
22a	1	18T38246	Pilot Ring
23	4	19T96512	Capscrew
26	1	25T35936	Caplug

“I” OPTION • KIT 14TA4422 DIN 5462			
ITEM	QTY	PART NUMBER	DESCRIPTION
4a	1	10T38248	Bearing
9	2	24T23937	Snap Ring
19	1	06T38261	Shaft, Output
21	1	11T38247	Shaft Seal
22	1	14T38259	Hydraulic Flange
22a	1	18T38246	Pilot Ring
23	4	19T96512	Capscrew
26	1	25T37767	Caplug

SPECIAL GREASE OPTION HYDRAULIC KITS

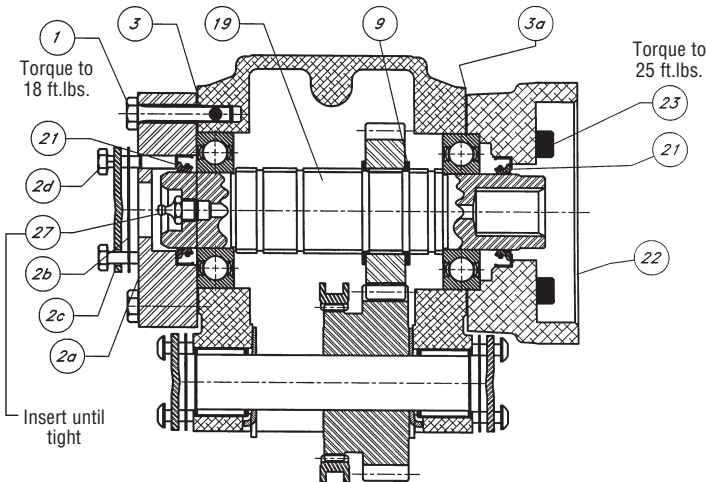

GREASE BEARING CAP KIT • KIT 15TK4471			
ITEM	QTY	PART NUMBER	DESCRIPTION
1	4	19T38772	Capscrew
2a	1	15TA4491	Bearing Cap Includes Seal 11T37790 + Cover 15T38771
2b	2	13T38286	Gasket
2c	2	15T33977	Cap
2d	2	19T34028	Capscrew
3	1	13T38542	Gasket

TG HYDRAULIC FLANGE CONVERSION KIT: FOR “KG” TG SHAFT • KIT 14TA4551			
ITEM	QTY	PART NUMBER	DESCRIPTION
Kit	1	15TK4471	Grease Bearing Cap Kit
3a	1	12T36751	O-Ring
9	2	24T23937	Snap Ring
19	1	06T38373	Shaft
22	1	14TA4535	Flange
23	4	19T34462	Capscrew
27	1	43T37236	Grease Fitting (Zerk)
CONVERSION KIT WITHOUT FLANGE: KIT 06TK4441			
Same as Kit 14TA4551 less Item 22 (14TA4535 Flange).			

TG HYDRAULIC FLANGE CONVERSION KIT: FOR “PG” TG SHAFT • KIT 14TA4552			
ITEM	QTY	PART NUMBER	DESCRIPTION
Kit	1	15TK4471	Grease Bearing Cap Kit
3a	1	12T36751	O-Ring
9	2	24T23937	Snap Ring
19	1	06T38374	Shaft
22	1	14TA4535	Flange
23	4	19T34462	Capscrew
27	1	43T37236	Grease Fitting (Zerk)
CONVERSION KIT WITHOUT FLANGE: KIT 06TK4442			
Same as Kit 14TA4552 less Item 22 (14TA4535 Flange).			

OUTPUT GEAR INSTALLATION

**OUTPUT RATIO 04-13
REMOTE TYPE SHAFT**

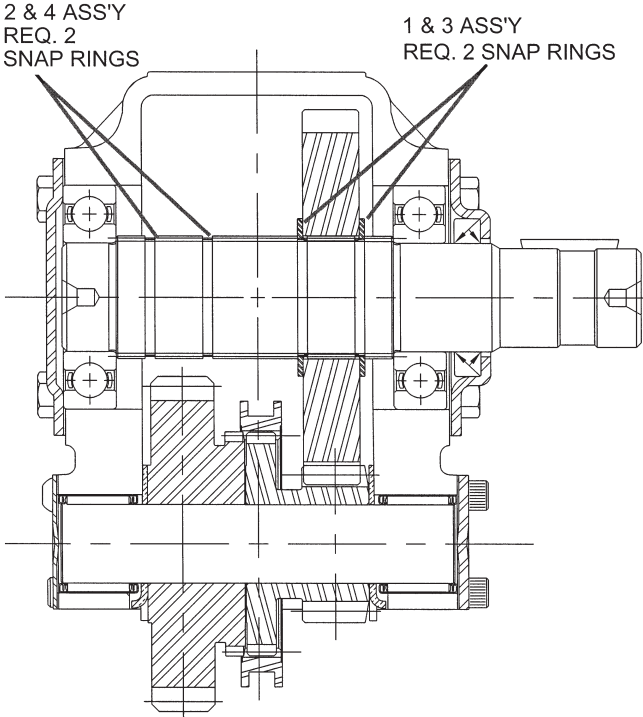

**OUTPUT RATIO 15 & 18
REMOTE TYPE SHAFT**

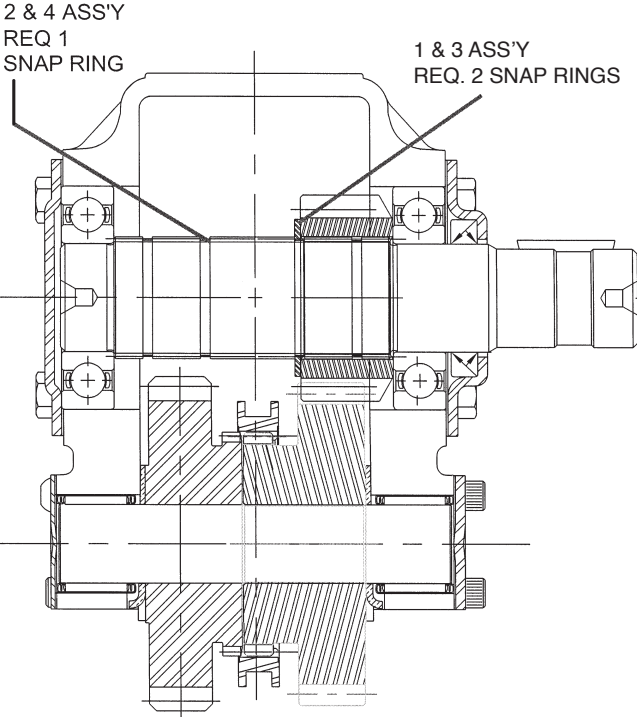

**OUTPUT RATIO 04-13
HYDRAULIC TYPE SHAFT**

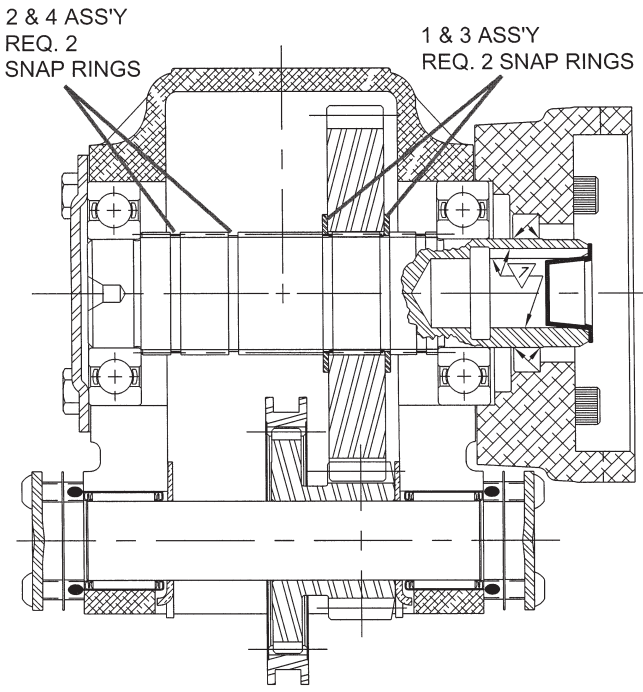

**OUTPUT RATIO 15 & 18
HYDRAULIC TYPE SHAFT**

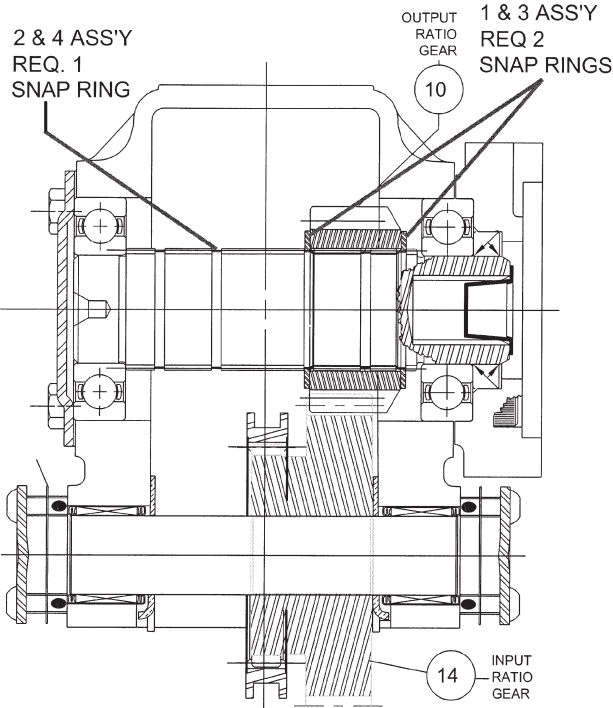

HYDRAULIC ASSEMBLIES

Conversion kits include Output Shaft, Hydraulic Flange, Capscrews, Gasket, Shaft Seal, and Snap Ring.

CONVERSION KIT NUMBER 14TA3974 ("C" ASSEMBLY) 1410 OUTPUT ASSEMBLY

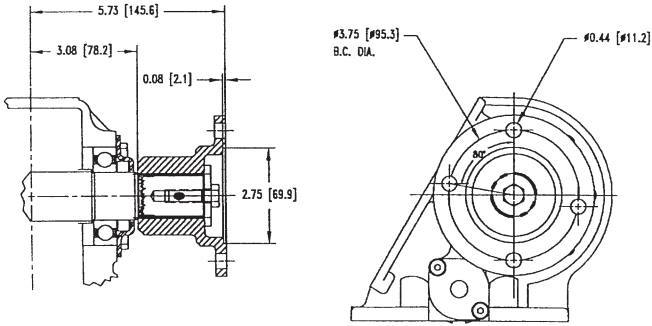

CONVERSION KIT NUMBER 14TA4527 ("F" ASSEMBLY)

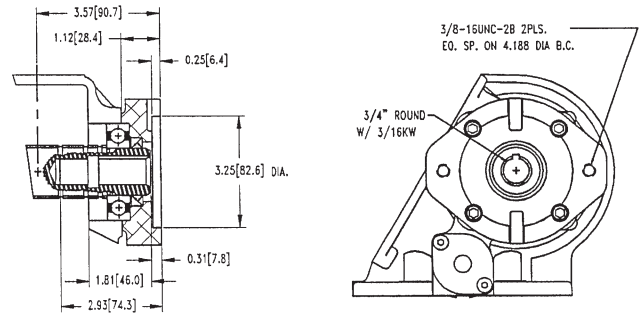

Supplied with .188 Key 1" Long for Long Shafted Pumps

CONVERSION KIT NUMBER 14TA4528 ("G" ASSEMBLY)

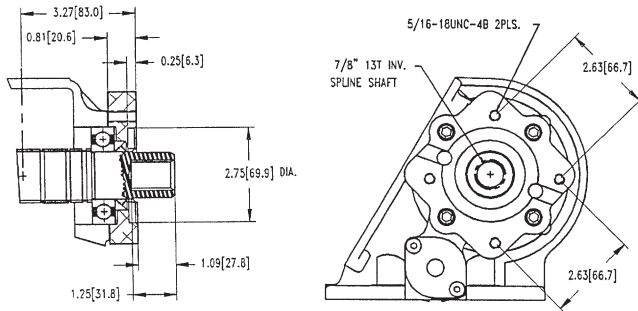

Pump Bolt Kit 19MK4717

CONVERSION KIT NUMBER 14TA4422 ("I" ASSEMBLY)

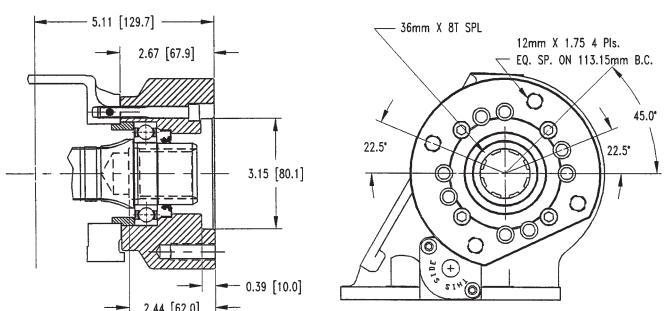

Flange and Seal - 14TA4424

CONVERSION KIT NUMBER 14TA4531 ("K" ASSEMBLY)

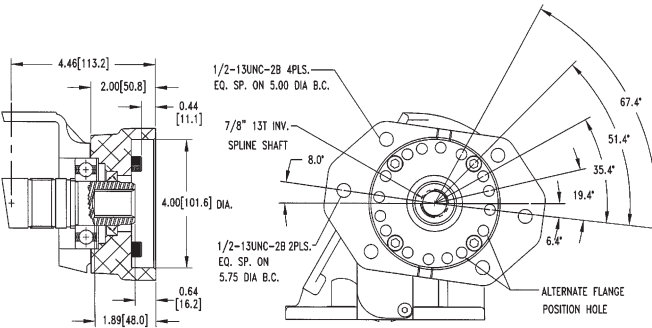

CONVERSION KIT NUMBER 14TA4550 ("L" ASSEMBLY)

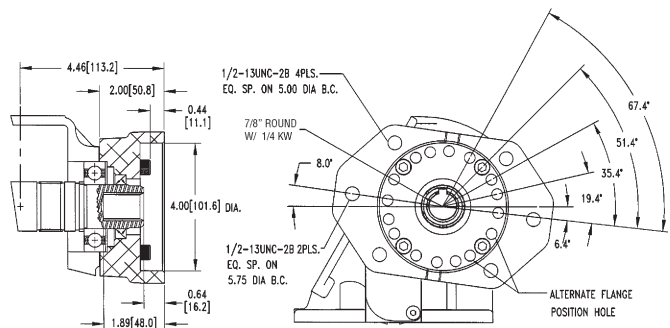

CONVERSION KIT NUMBER 14TA4553 ("M" ASSEMBLY)

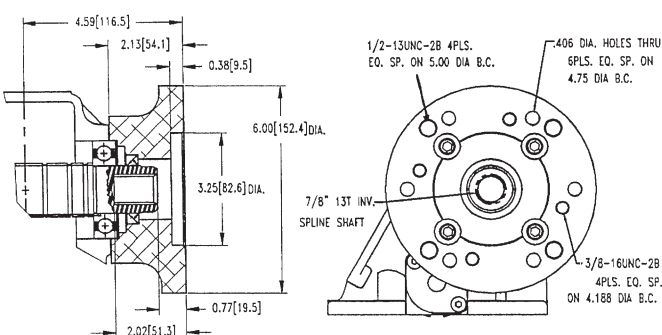

CONVERSION KIT NUMBER 14TA4554 ("N" ASSEMBLY)

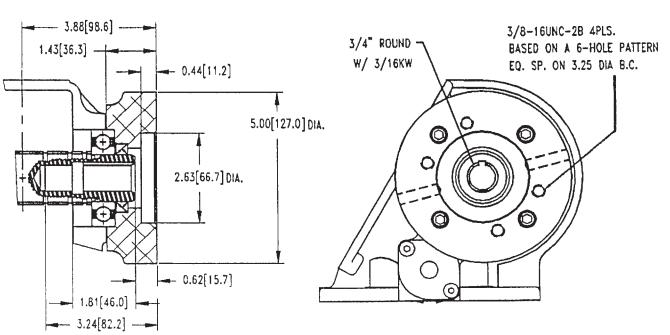

CONVERSION KIT NUMBER 14TA4532 ("P" ASSEMBLY)

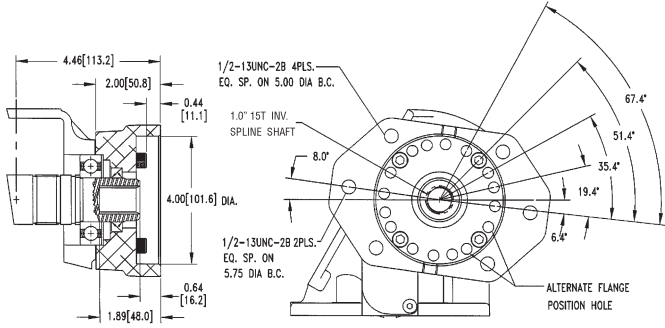

CONVERSION KIT NUMBER 14TA4529 ("Q" ASSEMBLY)

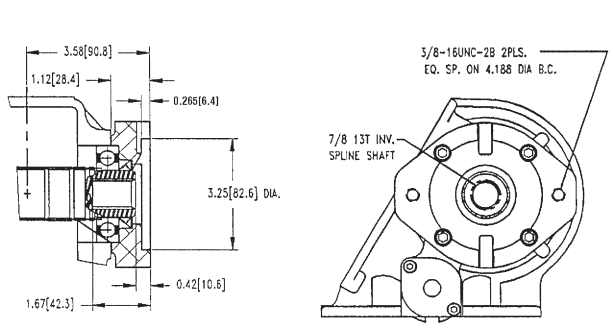

CONVERSION KIT NUMBER 14TA4541 ("R" ASSEMBLY)

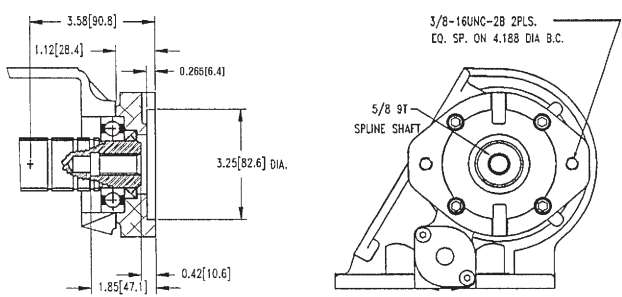

CONVERSION KIT NUMBER 14TA4530 ("S" ASSEMBLY)

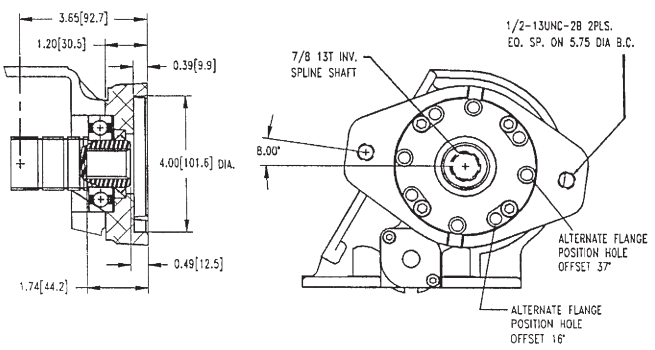

CONVERSION KIT NUMBER 14TA4533 ("T" ASSEMBLY)

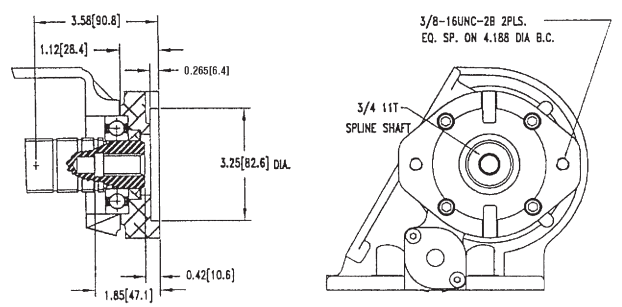

CONVERSION KIT NUMBER 14TA4915 ("6" ASSEMBLY)

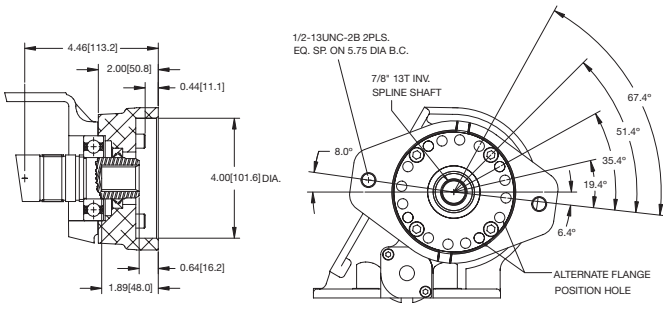

**"X" BASE OUTPUT ASSEMBLY
USED IN "C" & "2" OUTPUTS**

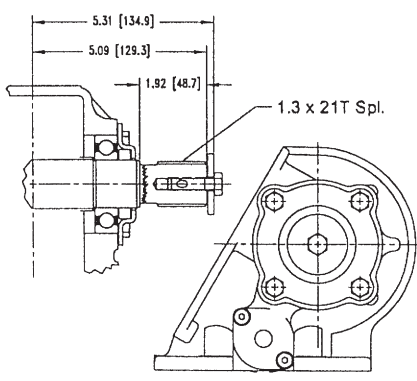

**CONVERSION KIT NUMBER
14TA4423 ("Z" ASSEMBLY)**

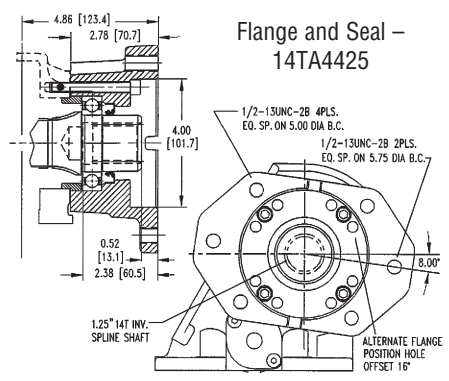

**CONVERSION KIT NUMBER
14TA3975 ("2" ASSEMBLY)
DIN OUTPUT ASSEMBLY**

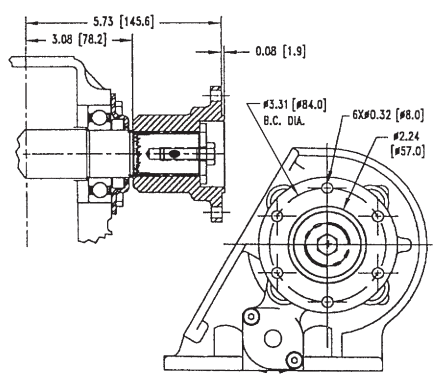

Note: Output shafts are supplied with a pure copper anti-seize compound installed in the shaft cavity. PTO applications under severe duty cycles and/or high torque requirements may require servicing this shaft connection by periodically cleaning and re-greasing the shafts.

TG SERIES HYDRAULIC FLANGE CONVERSION KITS

The following charts show the part numbers for the TG Series hydraulic mount output flanges. These flanges have the oring groove as shown in the photo for the 12T36751 o-ring. Previous versions of the TG flanges did not have the oring groove and were sealed with a gasket 13T38542. The CS6/8 flange shown are the previous versions of the TG flange without the groove. These flanges are still currently used in the CS6/8 line.

DESCRIPTION	TG FLANGE	CS6/8 FLANGE
F,Q,R,T Flg	14T39166	14T39141
G Flg	14T39165	14T39137
K,KG,L,P,PG Flg	14T39163	14T37779
M Flg	14T39167	14M39159
N Flg	14T39164	14M39130
S Flg	14T39162	14T35464
V Flg	Obsolete	Obsolete
I Flg	14T38259**	14T38259
Z Flg	14T38244**	14T38244
6 Flg	14T39528	14T38981

** These flanges still require the 13T38542 gasket and do not have the O-ring groove.



TG SERIES Flange

TG SERIES SHAFT AND FLANGE KITS

SHAFT & FLG. KIT	TG KIT	FLG. W/SEAL QTY (1)	SHAFT QTY (1)	RING QTY (1)	CAPSCREW QTY (4)	O'RING QTY (1)	CAPPLUG QTY (1)	SNAP RING QTY (2)	GASKET QTY (1)
6	14TA4915	14TA4914	06T39143	58T38789	19T34462	12T36751	25T35724	24T23937	13T38542
F	14TA4527	14TA4536	06T39140	KEY 26T35254	19T39257	12T36751	25T35724	24T23937	13T38542
G	14TA4528	14TA4537	06T39136	NA	19T39257	12T36751	25T35724	24T23937	13T38542
K	14TA4531	14TA4535	06T39143	58T38789	19T34462	12T36751	25T35724	24T23937	13T38542
L	14TA4550	14TA4535	06T39139	58T38789	19T34462	12T36751	25T35725	24T23937	13T38542
M	14TA4553	14TA4555	06T39143	NA	19M31200	12T36751	25T35724	24T23937	13T38542
N	14TA4554	14TA4556	06T39140	NA	19M84478	12T36751	25T35724	24T23937	13T38542
P	14TA4532	14TA4535	06T39136	58T38789	19T34462	12T36751	25T35725	24T23937	13T38542
Q	14TA4529	14TA4536	06T35048	NA	19T39257	12T36751	25T35724	24T23937	13T38542
R	14TA4541	14TA4536	06T35082	NA	19T39257	12T36751	25T35520	24T23937	13T38542
S	14TA4530	14TA4538	06T35048	NA	19T39257	12T36751	25T35724	24T23937	13T38542
T	14TA4533	14TA4536	06T37335	NA	19T39257	12T36751	25T37387	24T23937	13T38542
V	Obsolete								

GREASEABLE SHAFT

KG	14TA4551	14TA4535	06T38373	58T38789	19T34462	12T36751	25T35724	24T23937	13T38542
PG	14TA4552	14T39163	06T38374	58T38789	19T34462	12T36751	25T35724	24T23937	13T38542

LRG OD SHAFT	TG KIT	FLG. W/SEAL QTY (1)	SHAFT QTY (1)	RING QTY (1)	CAPSCREW QTY (4)	O'RING QTY (1)	CAPPLUG QTY (1)	SNAP RING QTY (2)	GASKET QTY (1)
I **	14TA4422	14TA4424	06T38261	18T38246	19T96512	NA	25T38309	24T23937	13T38542
Z **	14TA4423	14TA4425	06T38242	18T38246	19T96512	NA	25T35936	24T23937	13T38542

LRG OD SHAFT	TG KIT	FLG. W/SEAL QTY (1)	SHAFT QTY (1)	COMP. FLG. QTY (1)	CAPSCREW QTY (4)	KEY/WASHER QTY (1)	FLG. CAP SCREW QTY (1)	SNAP RING QTY (2)	GASKET QTY (1)
B **	NA	15TA5220	06T36857	NA	19T41756	26T01627	NA	24T23937	13T38542
C **	14TA3974	15TA5220	06T41757	14T37357	19T41756	21T20092	19T38266	24T23937	13T38542
2 **	14TA3975	15TA5220	06T41757	14T37378	19T41756	21T20092	19T38266	24T23937	13T38542
X **	NA	15TA5220	06T41757	NA	19T41756	21T20092	19T38266	24T23937	13T38542

Flange Only w/Seal	TG SERIES	FLG. ONLY	SEAL
K, L, P Flg W/Seal	14TA4535	14T39163	11T37790
F,Q,R Flg W/Seal	14TA4536	14T39166	11T37790
G Flg W/Seal	14TA4537	14T39165	11T37790
S Flg W/Seal	14TA4538	14T39162	11T37790
V Flg W/Seal	Obsolete.		
M Flg W/Seal	14TA4555	14T39167	11T37790
N Flg W/Seal	14TA4556	14T39164	11T37790
6 Flg W/Seal	NA	14T39528	11T37790
I Flg W/Seal	14TA4424	14T38259	11T38247
Z Flg W/Seal	14TA4425	14T38244	11T38247
B, C, 2, X W/Seal	15TA5220	15T41683	11T37790

** These flanges still require the 13T38542 gasket and do not have the O-ring groove.

TG SERIES SEAL KIT OR REBUILD KIT

FOR UNITS WITH DIRECT MOUNT PUMP FLANGE

Examine the under side of the hydraulic mounting flange. If there is an o-ring groove as shown then use the o-ring 12T36751 provided in the kit. If groove is not present, then use the 2nd gasket provided (13T38542).

Lubricate seals and o-rings prior to installation. Place the o-ring around the output shaft bearing which protrudes from the housing before installing the output flange.

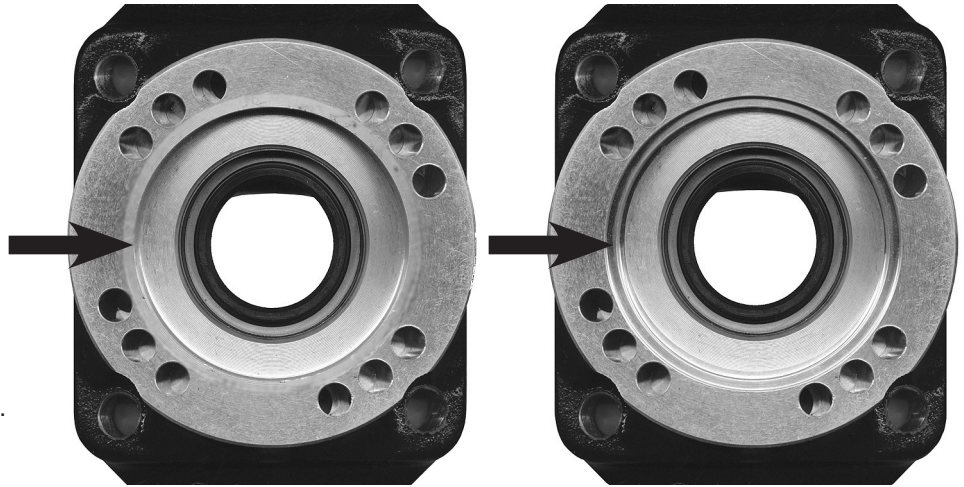

NO GROOVE IN FLANGE
(USE 13T38542 GASKET)

GROOVE FOR O-RING
(USE 12T36751 O-RING)

TG SERIES CLEARANCE IDLER CAP

1. The “Clearance Idler Cap” is to be installed on the TG series in the location where interference occurs (typically on the side opposite of the output shaft).
2. If an idler cap already exists, remove the cap and gasket.
3. On the side with the “Standard Cap” mount with two gaskets.
4. Use RTV # 598 Black recommended (not provided). Place gasket material in a small bead around the surface close to the bearing leaving a gap to prevent RTV from getting into the Bearing.
5. Install “Clearance Cap” with flat head capscrew closest to mounting pad and button-head capscrew in upper position. Torque the flathead screw to 6 ft-lbs and the button head to 8 ft-lbs.

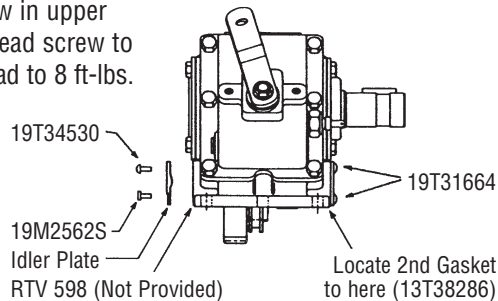

MOUNTING DIMENSIONS

IN INCHES (MM)

Shift covers (cable, air, lever, and Lectra Shift) are interchangeable with 6-Bolt or 8-Bolt housings as shown.

6-BOLT	DESIGNATOR	A	B
	TG6S	.895 (22.73)	.38 (9.6)
	TG6N	.826 (20.98)	.31 (7.9)

8-BOLT	DESIGNATOR	A	B
	TG8S	1.168 (29.67)	.66 (16.8)
	TG8M	1.068 (27.13)	.56 (14.2)

CABLE SHIFT

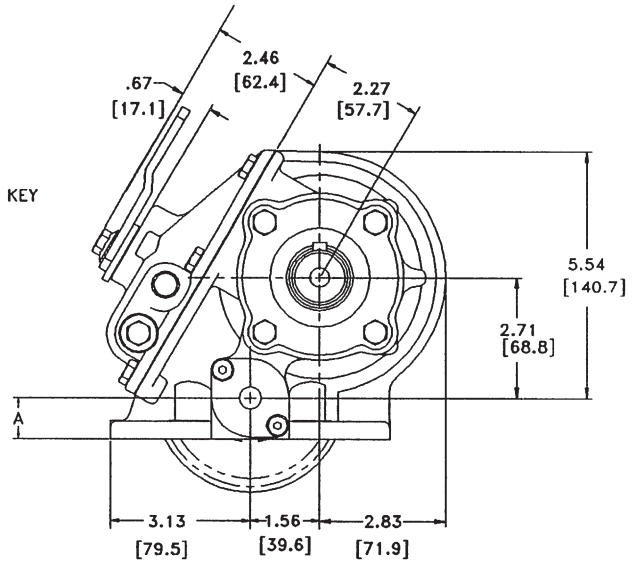
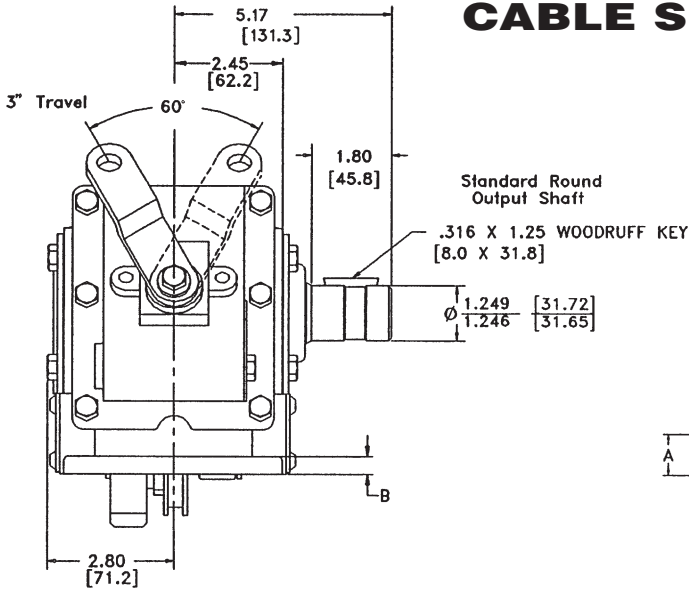

AIR SHIFT

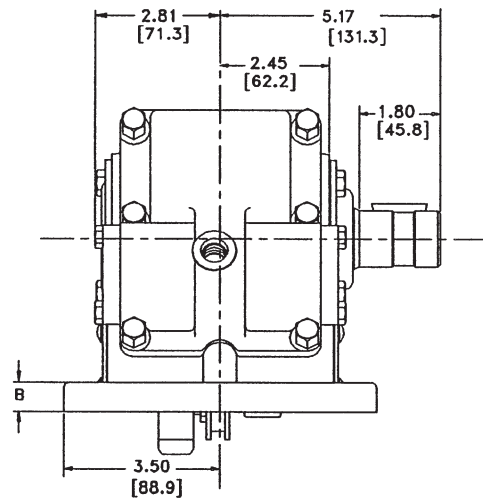
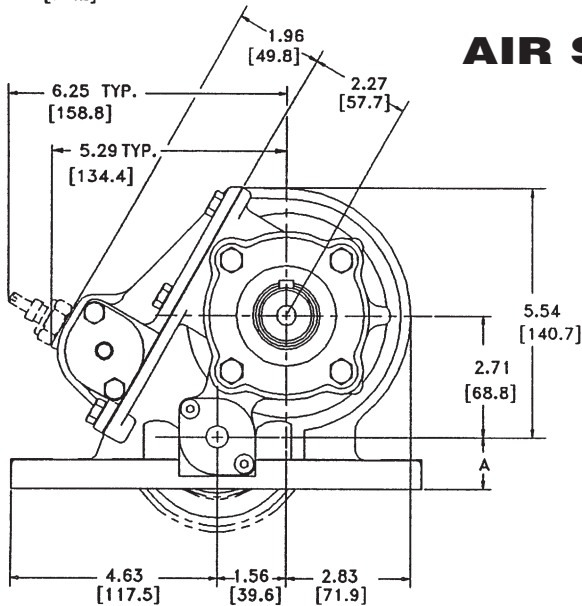

SPECIAL IDLER PLATE INSTALLATION

CONVERSION KIT	IDLER PLATE	CODE	CAPSCREW
15MK33977	15T35074	M, Q, E, V	(3) 19T34530 / (1) 19M2562S
15MK35351	15T35351	F, TG6N-I85	See Illustration
N.A.	15T35612	TG6N-S71	(4) 19T31664

Locate onto appropriate side with interference at PTO mounting pad.

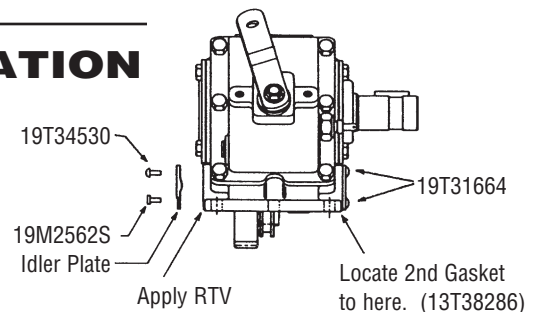

MOUNTING DIMENSIONS

IN INCHES (MM)

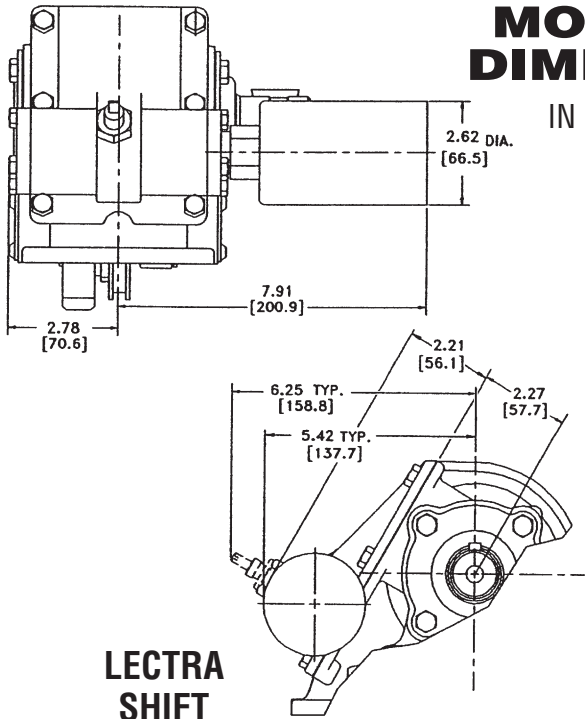

**LECTRA
SHIFT**

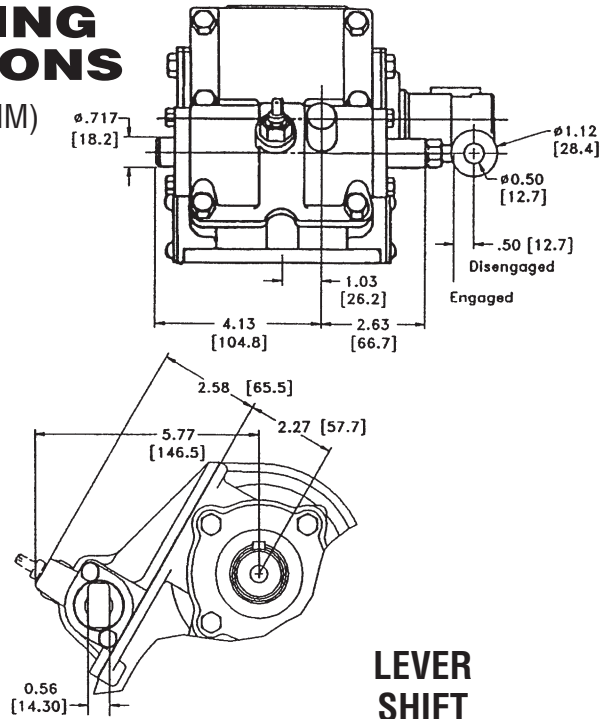

**LEVER
SHIFT**

MOUNTING KITS AND GASKET PACKS

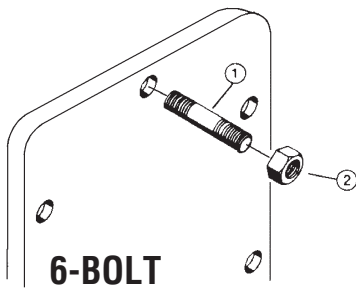

6-BOLT

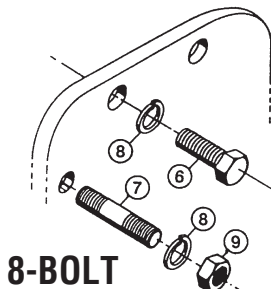

8-BOLT

6-BOLT MOUNTING KITS

Item	Qty	Part No.	Description
20MK6700 TG6S, TG6D, TG6N-S71, TG6N-S73			
1	6	20M38150	Stud
2	6	22T39282	Hex Nut
20MKM602 TG6B, TG6C			
1	6	20M39040	40mm Stud
2	6	22T39282	Hex Nut
20MKM104 TG6N-185			
1	4	20M39040	40mm Stud
1	2	20M39045	45mm Stud
2	6	22T39282	Hex Nut
20TK4049A TG6F-F84, F86			
1	6	20M39040	40mm Stud
2	6	22T39282	Hex Nut
N.S.	1	13T38145	Loctite Gasket Elim.
N.S.	1	MC99-06	Instruction Sheet
20TK4074 TG6B-184			
1	6	20T37990	Stud, 1.5"
2	6	22T39282	Hex Nut
N.S.	1	IN99-06	Instruction Sheet

8-BOLT MOUNTING KITS

Item	Qty	Part No.	Description
20MK8801 TG8S, TG8D, TG8M			
6	6	19M44138	Capscrew
7	2	20M44200	Stud
8	8	21ML4375	Lockwasher
9	2	22MX4420	Nut
20MKM801 TG8B, TG8C			
7	8	20M47050	50mm Stud
8	8	21ML4375	Lockwasher
9	8	22MX4420	Nut

GASKET PACKS

Qty	Part No.	Description
52TK4443 TG6S, TG6D, TG6B, TG6C (w/Std Input Gears), TG6N-S71, TG6N-S73		
1	IN8403	PTO Manual
1	13M35091	.010" Gasket
1	13M35092	.020" Gasket
1	13T38541	Shifter Gasket
1	36M111NP	Nameplate
52TK4444 TG6S-U60, TG6B-A68		
1	IN8403	PTO Manual
1	13M13541	.030" Gasket
1	13T38541	Shifter Gasket
1	36M111NP	Nameplate
52TK4447 TG6N-185		
1	IN8403	PTO Manual
2	13T35198	.010" Gasket
1	13T35199	.020" Gasket
1	13T38541	Shifter Gasket
52TK4448 TG6F-F84		
1	IN8403	PTO Manual
1	13T38541	Shifter Gasket
1	36M111NP	Nameplate
52TK4445 TG8S, TG8D, TG8B, TG8C (w/Std Input Gears)		
1	IN8403	PTO Manual
1	13M35151	.010" Gasket
2	13M35152	.020" Gasket
1	13T38541	Shifter Gasket
1	36M111NP	Nameplate
52TK4470 TG6B-A69		
1	IN8403	PTO Manual
2	13M35091	.010" Gasket
5	13M35092	.020" Gasket
1	13T38541	Shifter Gasket
1	36M111NP	Nameplate

CABLE MOUNTING KIT 47M13802

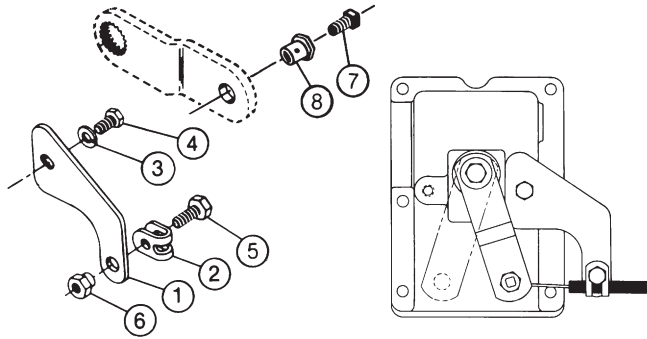

ITEM	QTY	PART NUMBER	DESCRIPTION
1	1	28MZ5017	Flat Bracket
2	1	28MZ5019	Swivel Bracket
3	1	21M10000	Lockwasher
4	1	19M10001	Capscrew
5	1	19M10000	Capscrew
6	1	28MZ5018	Shoulder Nut
7	1	28M15020	Sq. Hd. Set Screw
8	1	22MZ8019	Pivot Pin
*	1	28MCC120	10' Cable
*	1	28MK0155	Knob

* Not included in Kit. Included with PTO with Cable Shift option.

PRESSURE LUBE KIT 43MK3734

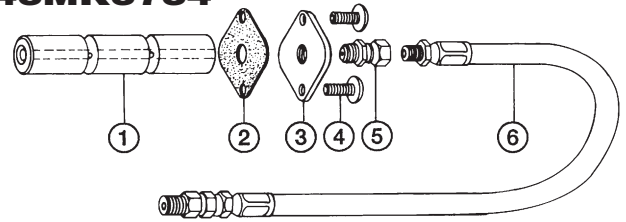

ITEM	QTY	PART NUMBER	DESCRIPTION
1	1	07T34511	Idler Shaft
2	2	13T38286	Gasket
3	1	15T34475	Cover Cap
4	2	19T37907	Capscrew
5	1	43T37385	Orifice Fitting
6	1	45M4R536	Hose

DASH LIGHT KIT 36MK1210-A

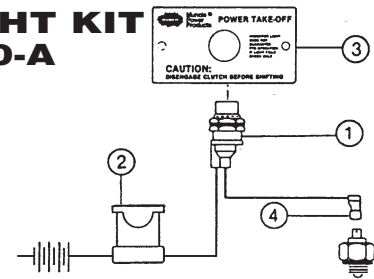

ITEM	QTY	PART NUMBER	DESCRIPTION
1	1	32M12001	Indicator Light
2	1	33T36299	Fuse Holder
3	1	36M16818	Dash Face Plate
4	1	34T38163	Booted Connector

OPTIONAL ACCESSORIES

AWS-CT-12V Audible warning to indicate PTO engagement. Chime tone has various loudness (Db) adjustment. Attaches to standard PTO switch, not included.

47MGM165-3, 47MGM85-3, 47MGM55-3 Heavy duty cable shift bracket kits for push-pull type shift cables.

43MK8205 Lubrication Pump/Cooler System includes 12VDC lube pump, oil cooler, temperature switch, hoses, connectors. For continuous duty applications on manual transmissions or transfer cases. 43TK6065P Same as above without oil cooler.

TG-RPS-A Air Pressure Switch Kit for indicator light when standard switch interferes with vehicle frame. Replaces mech. switch on air shifted TG PTO with a pneumatic switch.

LABEL PACKETS

LABEL PACKET (STD) 36MK3841

- 2 36M35644 FRAME LABEL
- 1 36T38634 VISOR LABEL
- 1 36M35652 DASH LABEL

LABEL PACKET (I84, I85, A69, U60) 36TK4667

- 2 36M35644 FRAME LABEL
- 1 36T38634 VISOR LABEL
- 1 36M35652 DASH LABEL
- 2 36T39562 SAFETY LABEL
- 1 IN91-05 INSTRUCTIONS



**Muncie[®]
Power
Products**

SP94-03 (Rev. 7-13) Printed in the U.S.A.
© Muncie Power Products, Inc. 2013

Muncie Power Products, Inc. *Member of the Interpump Hydraulics Group*
General Offices and Distribution Center • P.O. Box 548 • Muncie, IN 47308-0548
(765) 284-7721 • FAX (765) 284-6991 • E-mail info@munciepower.com
Web site <http://www.munciepower.com>

Drive Products, Exclusive Agents for Canada, *ISO Certified by an Accredited Registrar*

