

# Pressure Booster System

## Installation/Operating Manual

### Hydro-Unit Single Line

Hydro-Unit Single Line SVP



CE

## Legal information/Copyright

Original operating manual Hydro-Unit Single Line

All rights reserved. The contents provided herein must neither be distributed, copied, reproduced, edited or processed for any other purpose, nor otherwise transmitted, published or made available to a third party without the manufacturer's express written consent.

Subject to technical modification without prior notice.

© Duijvelaar Pompen B.V., Alphen aan den Rijn, Netherlands 2023-05-29

# Contents

	<b>Glossary.....</b>	<b>6</b>
<b>1</b>	<b>General.....</b>	<b>7</b>
	1.1 Principles .....	7
	1.2 Software changes .....	7
	1.3 Installation of partly completed machinery.....	7
	1.4 Target group .....	7
	1.5 Other applicable documents .....	7
	1.6 Symbols .....	7
	1.7 Key to safety symbols/markings .....	8
<b>2</b>	<b>Safety .....</b>	<b>9</b>
	2.1 General .....	9
	2.2 Intended use .....	9
	2.3 Personnel qualification and personnel training .....	10
	2.4 Consequences and risks caused by non-compliance with this manual .....	10
	2.5 Safety awareness .....	10
	2.6 Safety information for the operator/user .....	10
	2.7 Safety information for maintenance, inspection and installation .....	11
	2.8 Unauthorised modes of operation.....	11
	2.9 Electromagnetic compatibility (EMC).....	11
	2.9.1 Interference emission requirements .....	11
	2.9.2 Line harmonics requirements .....	12
	2.9.3 Interference immunity requirements.....	12
<b>3</b>	<b>Transport/Storage/Disposal.....</b>	<b>14</b>
	3.1 Checking the condition upon delivery .....	14
	3.2 Transport.....	14
	3.3 Storage/preservation .....	14
	3.4 Return to supplier .....	15
	3.5 Disposal .....	15
<b>4</b>	<b>Description .....</b>	<b>17</b>
	4.1 General description.....	17
	4.2 Product information as per Regulation No. 1907/2006 (REACH).....	17
	4.3 Designation .....	17
	4.4 Name plate .....	17
	4.5 Design details .....	18
	4.6 Configuration and function .....	19
	4.7 Noise characteristics.....	20
	4.8 Scope of supply .....	20
	4.8.1 Inlet conditions, version M.....	21
	4.8.2 Inlet conditions, version F.....	22
	4.8.3 Inlet conditions, version L.....	23
	4.9 Dimensions and weights.....	24
<b>5</b>	<b>Installation at Site .....</b>	<b>25</b>
	5.1 Checks to be carried out prior to installation.....	25
	5.2 Installing the pressure booster system .....	26
	5.3 Mounting the accumulator .....	26
	5.4 Connecting the piping .....	26
	5.4.1 Fitting an expansion joint (optional).....	27

5.4.2	Fitting the pressure reducer (optional)	27
5.5	Electrical connection	28
5.5.1	Sizing the power cable	29
5.5.2	Connecting the pressure booster system	29
5.5.3	Fitting the dry running protection device	29
5.5.4	Removing the housing cover	30
5.5.5	Overview of terminal strips	32
5.5.6	Connection to mains power supply and motor	32
5.5.7	Establishing an earth connection	37
<b>6</b>	<b>Commissioning/Start-up/Shutdown</b>	<b>38</b>
6.1	Commissioning/Start-up	38
6.1.1	Prerequisites for commissioning/start-up	38
6.1.2	Commissioning/start-up of pressure booster system	38
6.1.3	Dry running protection	39
6.1.4	Start-up	39
6.1.5	Checklist for commissioning/start-up	40
6.2	Operating limits	41
6.2.1	Frequency of starts	41
6.2.2	Ambient conditions	41
6.2.3	Maximum operating pressure	41
6.2.4	Fluid handled	41
6.2.5	Minimum flow rate	42
6.3	Shutdown	42
6.3.1	Shutdown	42
6.3.2	Measures to be taken for shutdown	43
<b>7</b>	<b>Operation</b>	<b>44</b>
7.1	Standard control panel	44
7.1.1	Display	45
7.1.2	Main screen	47
7.1.3	Settings menu	49
7.1.4	Service interface and LED traffic light function	52
<b>8</b>	<b>Servicing/Maintenance</b>	<b>53</b>
8.1	General information/Safety regulations	53
8.1.1	Inspection contract	54
8.2	Servicing/inspection	54
8.2.1	Supervision of operation	54
8.2.2	Maintenance schedule	54
8.2.3	Setting the pre-charge pressure	55
8.2.4	Replacing the non-return valve	56
<b>9</b>	<b>Trouble-shooting</b>	<b>59</b>
9.1	Faults/malfunctions: Trouble-shooting	60
9.2	Alerts	61
9.3	Warnings	64
9.4	Information messages	65
<b>10</b>	<b>Related Documents</b>	<b>66</b>
10.1	General assembly drawings/exploded views with list of components	66
10.1.1	Hydro-Unit Single Line SVP with DPV 2B, 4B, 6B, 10B, 15C	66
10.1.2	Hydro Unit Single Line SVP with DPV 25B, 40B, 60B, 90B, 125B	67
<b>11</b>	<b>EU Declaration of Conformity</b>	<b>68</b>
<b>12</b>	<b>Certificate of Decontamination</b>	<b>69</b>
<b>13</b>	<b>Commissioning Report</b>	<b>70</b>



# Glossary

## **Accumulator**

---

Pressure losses may occur in the piping downstream of the pressure booster system as a result of losses due to leakage. The accumulator serves to compensate for pressure losses and minimises the frequency of starts of the pressure booster system.

## **Braking resistor**

---

Takes up the braking power produced during generator operation.

## **Certificate of decontamination**

---

A certificate of decontamination is enclosed by the customer when returning the product to the manufacturer to certify that the product has been properly drained to eliminate any environmental and health hazards arising from components in contact with the fluid handled.

## **Dry running protection**

---

Dry running protection devices prevent the pump from being operated without the fluid to be handled, which would result in pump damage.

## **IE4**

---

Efficiency class to  
IEC TS 60034-30-2:2016 = Super Premium  
Efficiency (IE = International Efficiency)

## **IE5**

---

Efficiency class to  
IEC TS 60034-30-2:2016 = Ultra Premium  
Efficiency (IE = International Efficiency)

## **Manual mode**

---

Direct operation on the power supply network, independently of the control unit.

## **Switchgear and controlgear assembly**

---

Control cabinet with one or several control units / switchgears and electrical equipment.

# 1 General

## 1.1 Principles

This operating manual is valid for the type series and variants indicated on the front cover.

The operating manual describes the proper and safe use of this equipment in all phases of operation.

The name plate indicates the type series, the main operating data and the serial number. The serial number uniquely describes the product and is used as identification in all further business processes.

In the event of damage, immediately contact your nearest DP service facility to maintain the right to claim under warranty.

## 1.2 Software changes

The software has been specially created for this product and thoroughly tested. Making changes or additions to the software or parts of the software is prohibited. This does not, however, apply to software updates by DP .

## 1.3 Installation of partly completed machinery

To install partly completed machinery supplied by DP refer to the sub-sections under Servicing/Maintenance.

## 1.4 Target group

This operating manual is aimed at the target group of trained and qualified specialist technical personnel. [⇒ Section 2.3, Page 10]

## 1.5 Other applicable documents

Table 1: Overview of other applicable documents

Document	Contents
Sub-supplier product literature	Operating manuals, circuit diagram and other product literature describing accessories and integrated machinery components







## 1.6 Symbols

Table 2: Symbols used in this manual

Symbol	Description
✓	Conditions which need to be fulfilled before proceeding with the step-by-step instructions
▷	Safety instructions
⇒	Result of an action
⇔	Cross-references
1. 2.	Step-by-step instructions
	Note Recommendations and important information on how to handle the product

## 1.7 Key to safety symbols/markings

Table 3: Definition of safety symbols/markings

Symbol	Description
 <b>DANGER</b>	<b>DANGER</b> This signal word indicates a high-risk hazard which, if not avoided, will result in death or serious injury.
 <b>WARNING</b>	<b>WARNING</b> This signal word indicates a medium-risk hazard which, if not avoided, could result in death or serious injury.
 <b>CAUTION</b>	<b>CAUTION</b> This signal word indicates a hazard which, if not avoided, could result in damage to the machine and its functions.
	<b>General hazard</b> In conjunction with one of the signal words this symbol indicates a hazard which will or could result in death or serious injury.
	<b>Electrical hazard</b> In conjunction with one of the signal words this symbol indicates a hazard involving electrical voltage and identifies information about protection against electrical voltage.
	<b>Machine damage</b> In conjunction with the signal word CAUTION this symbol indicates a hazard for the machine and its functions.



## 2 Safety



**DANGER**

All the information contained in this section refers to hazardous situations.

In addition to the present general safety information the action-related safety information given in the other sections must be observed.

### 2.1 General

- This operating manual contains general installation, operating and maintenance instructions that must be observed to ensure safe operation of the system and prevent personal injury and damage to property.
- Comply with all the safety instructions given in the individual sections of this operating manual.
- The operating manual must be read and understood by the responsible specialist personnel/operators prior to installation and commissioning.
- The contents of this operating manual must be available to the specialist personnel at the site at all times.
- Information and markings attached directly to the product must always be complied with and kept in a perfectly legible condition at all times. This applies to, for example:
  - Arrow indicating the direction of rotation
  - Markings for connections
  - Name plate
- The operator is responsible for ensuring compliance with all local regulations not taken into account.

### 2.2 Intended use

- The pressure booster system must only be operated within the operating limits described in the other applicable documents.
- Only operate pressure booster systems which are in perfect technical condition.
- Do not operate partially assembled pressure booster systems.
- The pressure booster system must only handle the fluids described in the product literature of the respective design variant.
- Never operate the pressure booster system without the fluid to be handled.
- Observe the information on minimum flow rates specified in the product literature (to prevent overheating, bearing damage, etc).
- Observe the maximum flow rates indicated in the data sheet or product literature (to prevent overheating, cavitation damage, bearing damage, etc).
- Do not throttle the flow rate on the suction side of the pressure booster system (to prevent cavitation damage).
- Consult the manufacturer about any other modes of operation not described in the product literature.

## 2.3 Personnel qualification and personnel training

- All personnel involved must be fully qualified to install, operate, maintain and inspect the product this manual refers to.
- The responsibilities, competence and supervision of all personnel involved in transport, installation, operation, maintenance and inspection must be clearly defined by the operator.
- Deficits in knowledge must be rectified by means of training and instruction provided by sufficiently trained specialist personnel. If required, the operator can commission the manufacturer/supplier to train the personnel.
- Training on the pressure booster system must always be supervised by specialist technical personnel.

## 2.4 Consequences and risks caused by non-compliance with this manual

- Non-compliance with these operating instructions will lead to forfeiture of warranty cover and of any and all rights to claims for damages.
- Non-compliance can, for example, have the following consequences:
  - Hazards to persons due to electrical, thermal, mechanical and chemical effects and explosions
  - Failure of important product functions
  - Failure of prescribed maintenance and servicing practices
  - Hazard to the environment due to leakage of hazardous substances

## 2.5 Safety awareness

In addition to the safety information contained in this operating manual and the intended use, the following safety regulations shall be complied with:

- Accident prevention, health regulations and safety regulations
- Explosion protection regulations
- Safety regulations for handling hazardous substances
- Applicable standards, directives and laws

## 2.6 Safety information for the operator/user

- Fit protective equipment (e.g. contact guards) supplied by the operator for hot, cold or moving parts, and check that the equipment functions properly.
- Do not remove any protective equipment (e.g. contact guards) during operation.
- Eliminate all electrical hazards. (In this respect refer to the applicable national safety regulations and/or regulations issued by the local energy supply companies.)
- If stopping the pump does not increase potential risk, fit an emergency-stop control device in the immediate vicinity of the pump (set) during pump set installation.

## 2.7 Safety information for maintenance, inspection and installation

- Modifications or alterations of the pressure booster system are only permitted with the manufacturer's prior consent.
- Use only original spare parts or parts authorised by the manufacturer. The use of other parts can invalidate any liability of the manufacturer for resulting damage.
- The operator ensures that maintenance, inspection and installation are performed by authorised, qualified specialist personnel who are thoroughly familiar with the manual.
- Carry out work on the pressure booster system during standstill only.
- The pump casing must have cooled down to ambient temperature.
- Pump pressure must have been released and the pump must have been drained.
- When taking the pressure booster system out of service always adhere to the procedure described in the manual.
- Decontaminate pressure booster systems which handle fluids posing a health hazard.
- As soon as the work has been completed, re-install and/or re-activate any safety-relevant and protective devices. Before returning the product to service, observe all instructions on commissioning.
- Make sure the pressure booster system cannot be accessed by unauthorised persons (e.g. children).
- Prior to opening the device, pull the mains plug and wait for at least 10 minutes.

## 2.8 Unauthorised modes of operation

Always observe the limits stated in the product literature.

The warranty relating to the operating reliability and safety of the pressure booster system supplied is only valid if the equipment is used in accordance with its intended use.

[⇒ Section 2.2, Page 9]

## 2.9 Electromagnetic compatibility (EMC)

### 2.9.1 Interference emission requirements

The EN 61800-3 EMC product standard is relevant for electric variable speed drives/control systems. It specifies all pertinent requirements and refers to the relevant generic standards for complying with the EMC Directive.

Frequency inverters are commonly used by operators as a part of a system, plant or machine assembly. It should be noted that the operator bears all responsibility for the final EMC properties of the equipment, plant or installation.

A prerequisite or requirement for complying with the relevant standards or the limit values and inspection/test levels referenced by them is that all information and descriptions regarding EMC-compliant installation be observed and followed.

In accordance with the EMC product standard, the EMC requirements to be met depend on the purpose or intended use of the frequency inverter. Four categories are defined in the EMC product standard:

Table 4: Categories of intended use

Category	Definition	Limits to EN 55011
C1	Frequency inverters with a supply voltage under 1000 V installed in the first environment (residential and office areas).	Class B
C2	Frequency inverters with a supply voltage under 1000 V installed in the first environment (residential and office areas) that are neither ready to be plugged in/ connected nor are mobile and must be installed and commissioned by specialist personnel.	Class A, Group 1
C3	Frequency inverters with a supply voltage under 1000 V installed in the second environment (industrial environments).	Class A, Group 2
C4	Frequency inverters with a supply voltage over 1000 V and a nominal current over 400 A installed in the second environment (industrial environments) or that are envisaged for use in complex systems.	No borderline/ boundary <sup>1)</sup>

The following limit values and inspection/test levels must be complied with if the generic standard on interference emissions applies:

Table 5: Classification of installation environment

Environment	Generic standard	Limits to EN 55011
First environment (residential and office areas)	EN/IEC 61000-6-3 for private, business and commercial environments	Class B
Second environment (industrial environments)	EN/IEC 61000-6-4 for industrial environments	Class A, Group 1

The frequency inverter meets the following requirements:

Table 6: EMC properties of the frequency inverter

Power [kW]	Cable length [m]	Category to EN 61800-3	Limits to EN 55011
≤ 11	≤ 5	C1	Class B

The EN 61800-3 standard requires that the following warning be provided for drive systems that do not comply with category C1 specifications:

This product can produce high-frequency interference emissions that may necessitate targeted interference suppression measures in a residential or office environment.

## 2.9.2 Line harmonics requirements

The product is a device for professional applications as defined by EN 61000-3-2. The following generic standards apply when establishing a connection to the public power grid:

- EN 61000-3-2 for symmetric, three-phase devices (professional devices with a total power of up to 1 kW)
- EN 61000-3-12 for devices with a phase current of between 16 A and 75 A and professional devices from 1 kW up to a phase current of 16 A.

12 / 74

## 2.9.3 Interference immunity requirements

In general, the interference immunity requirements for a frequency inverter hinge on the specific environment in which the inverter is installed.

The requirements for industrial environments are therefore higher than those for residential and office environments.

The frequency inverter is designed such that the immunity requirements for industrial environments and, thus, the lower-level requirements for residential and office environments, are met and fulfilled.

<sup>1</sup> An EMC plan must be devised.

The following relevant generic standards are used for the interference immunity test:

- EN 61000-4-2: Electromagnetic compatibility (EMC)
  - Part 4-2: Testing and measurement techniques – Electrostatic discharge immunity test
- EN 61000-4-3: Electromagnetic compatibility (EMC)
  - Part 4-3: Testing and measurement techniques – Radiated, radio-frequency, electromagnetic field immunity test
- EN 61000-4-4: Electromagnetic compatibility (EMC)
  - Part 4-4: Testing and measurement techniques – Electrical fast transient/burst immunity test
- EN 61000-4-5: Electromagnetic compatibility (EMC)
  - Part 4-5: Testing and measurement techniques – Surge immunity test
- EN 61000-4-6: Electromagnetic compatibility (EMC)
  - Part 4-6: Testing and measurement techniques – Immunity to conducted disturbances, induced by radio-frequency fields



# 3 Transport/Storage/Disposal

## 3.1 Checking the condition upon delivery

1. On transfer of goods, check each packaging unit for damage.
2. In the event of in-transit damage, assess the exact damage, document it and notify DP or the supplying dealer and the insurer about the damage in writing immediately.

## 3.2 Transport

	<p><b>⚠ DANGER</b> <b>Pressure booster system tipping over</b> Danger to life from falling pressure booster system!</p> <ul style="list-style-type: none"><li>▷ Never suspend the pressure booster system by its power cable.</li><li>▷ Do not lift the pressure booster system by its manifold.</li><li>▷ Observe the applicable local accident prevention regulations.</li><li>▷ Observe the information on weights, centre of gravity and fastening points.</li><li>▷ Use suitable and permitted transport equipment, e.g. crane, forklift or pallet jack.</li></ul>
---	---

- ✓ Transport equipment / lifting equipment suitable for the corresponding weight has been selected and is on hand.
1. Remove the packaging. Remove the caps from the connection openings.
  2. Check for any in-transit damage.
  3. Transport the pressure booster system to the place of installation.
  4. Detach the pressure booster system from the pallet using a suitable tool.
  5. Separate the pressure booster system from the wooden skids with a suitable tool. Lift the pressure booster system off. Dispose of the wooden skids.
  6. Carefully place down the pressure booster system at the site of installation.

## 3.3 Storage/preservation

	<p><b>CAUTION</b> <b>Damage during storage due to frost, moisture, dirt, UV radiation or vermin</b> Corrosion/contamination of pressure booster system!</p> <ul style="list-style-type: none"><li>▷ Store the pressure booster system in a frost-proof room. Do not store outdoors.</li></ul>
---	---

	<p><b>CAUTION</b> <b>Wet, contaminated or damaged openings and connections</b> Leakage or damage of the pressure booster system!</p> <ul style="list-style-type: none"><li>▷ Only open the openings of the pressure booster system at the time of installation.</li></ul>
---	---

	<p><b>NOTE</b> Rotate the shaft by hand every three months, e.g. via the motor fan.</p>
---	---

If commissioning is to take place some time after delivery, the following measures are recommended when storing the pressure booster system:

Store the pressure booster system in a dry, protected room where the atmospheric humidity is as constant as possible.

Table 7: Ambient conditions for storage

Ambient condition	Value
Relative humidity	50 % maximum
Ambient temperature	0 °C to +40 °C

- Frost-free
- Well-ventilated

### 3.4 Return to supplier

1. Drain the pressure booster system as per operating instructions.
2. Always flush and clean the pressure booster system, particularly if it has been used for handling noxious, explosive, hot or other hazardous fluids.
3. If the pressure booster system has handled fluids whose residues could lead to corrosion damage in the presence of atmospheric humidity or could ignite upon contact with oxygen, the pressure booster system must also be neutralised, and anhydrous inert gas must be blown through the pressure booster system to ensure drying.
4. Always complete and enclose a certificate of decontamination when returning the pressure booster system. [⇒ Section 12, Page 69]  
Always indicate any safety and decontamination measures taken.



#### NOTE

If required, a blank certificate of decontamination can be downloaded from the following web site: [www.dp.nl/certificates-of-decontamination](http://www.dp.nl/certificates-of-decontamination)

### 3.5 Disposal



#### ⚠ WARNING

**Fluids handled, consumables and supplies which are hot and/or pose a health hazard**

Hazard to persons and the environment!

- Collect and properly dispose of flushing fluid and any fluid residues.
- Wear safety clothing and a protective mask if required.
- Observe all legal regulations on the disposal of fluids posing a health hazard.

1. Dismantle the pressure booster system.  
Collect greases and other lubricants during dismantling.
2. Separate and sort the pump materials, e.g. by:
  - Metals
  - Plastics
  - Electronic waste
  - Greases and other lubricants
3. Dispose of materials in accordance with local regulations or in another controlled manner.

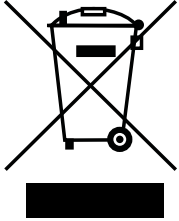

Electrical or electronic equipment marked with the adjacent symbol must not be disposed of in household waste at the end of its service life.

Contact your local waste disposal partner for returns.

If the used electrical or electronic equipment contains personal data, the operator is responsible for deleting it before the equipment is returned.



# 4 Description

## 4.1 General description

- Pressure booster system

## 4.2 Product information as per Regulation No. 1907/2006 (REACH)

For information as per chemicals Regulation (EC) No. 1907/2006 (REACH), see <http://www.dp.nl/reach>.

## 4.3 Designation

**Example: HU1 Single Line DPV 15/8 C SVP**

Table 8: Designation key

Code	Description
HU	Hydro-Unit
1	Number of pumps
Single Line	Type series
DPV 15	Size
	DPV 15
8 C	Number of stages
SVP	Design
	SVP
	Pressure booster system with variable speed system and SuPremE motor

## 4.4 Name plate

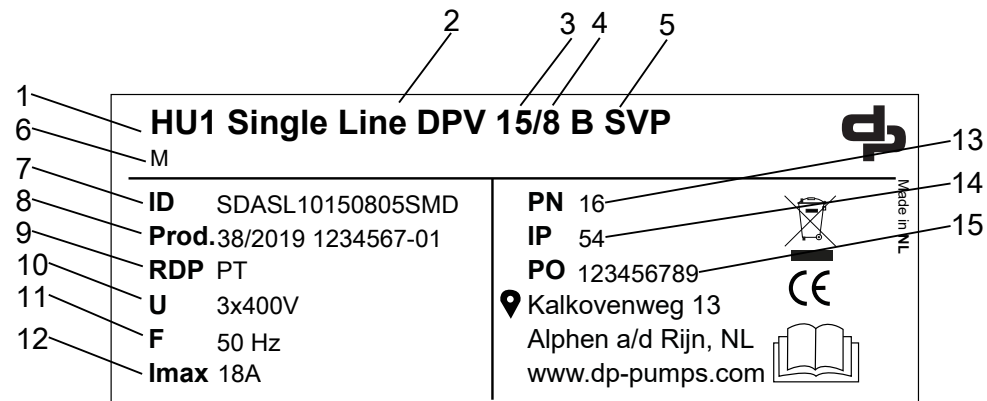

Fig. 1: Name plate (example)

1	Number of pumps	9	Dry running protection
2	Type series	10	Power supply voltage
3	Size	11	Power supply frequency
4	Number of stages	12	Maximum current input
5	Design	13	Max. operating pressure

6	Inlet conditions <sup>2)</sup>	14	Enclosure
7	Serial number	15	Order number
8	Month of production / year of production, consecutive number		

## 4.5 Design details

### Design

- Fully automatic pressure booster package system
- Variable speed operation
- Baseplate-mounted
- Hydraulic components made of stainless steel / brass
- Check valve per pump
- Shut-off valve for each pump
- Discharge-side, direct-flow membrane-type accumulator, approved for drinking water
- Pressure gauge
- Integrated dry running protection
- Pressure transmitter on the discharge side
- Anti-vibration pads per pump

### Installation

- Stationary dry installation

### Drive

- Electric motor
- Efficiency class IE4 / IE5 to IEC TS 60034-30-2:2016
- IP54 enclosure

### Automation

- Frequency inverter
- Control panel (display, keys, LEDs, service interface)
- Motor protection switch
- Control unit (IP54 enclosure)
- Fault message signalling contact
- Operation signalling contact

---

<sup>2)</sup> M = Inlet side of pressure booster system connected to the municipal water supply, suction head operation F = Pressure booster system with break tank arranged on same level as pump, suction head operation L= Pressure booster system with break tank arranged at a lower level, suction lift operation

## 4.6 Configuration and function



Fig. 2: Configuration

1	Control system	3	Membrane-type accumulator
2	Pump	4	Baseplate

**Design** The fully automatic pressure booster system pumps the fluid to the consumer installations in the set pressure range with a vertical high-pressure pump (2) (variable speed version).

**Function** The pump (2) is controlled and monitored by a motor-mounted frequency inverter. As the demand increases or decreases, the pump is started and stopped automatically. The standard setting is for the pressure booster system to start automatically as a function of pressure; the actual pressure is measured by an analog pressure measuring device (pressure transmitter). As long as the pressure booster system is in operation, the pump is started and stopped as a function of demand (standard setting). In this way it is ensured that the pump operates only in line with actual demand. The use of this variable speed pump reduces wear as well as the frequency of pump starts. A fault is output, which can be reported via volt-free contacts (e.g. to the control station). If the demand drops towards 0, the pressure booster system slowly runs down to the stop point. The pressure booster system is designed with integrated electronic dry running protection. A digital lack-of-water display can be connected at the corresponding contacts. During commissioning and after every power failure, the pressure booster system fills the piping system slowly to prevent any damage to the piping by surge pressure. If the pump has not been in operation for 24 hours, a test run is initiated.

## 4.7 Noise characteristics

The pressure booster system is available with different numbers and sizes of pumps. For the noise characteristics refer to the operating manual of the pump set. To calculate the expected total sound pressure level, add a defined value to the individual pump set's expected sound pressure level.

Table 9: Values for calculating the total expected sound pressure level

Number of pump sets	Value
	dB(A)
2	+ 3
3	+ 4,5
4	+ 6
5	+ 7
6	+ 7,5

**Example** Pressure booster system with 4 pump sets (value: + 6 dB(A))

Single pump = 48 dB(A)

$48 \text{ dB(A)} + 6 \text{ dB(A)} = 54 \text{ dB(A)}$

The expected total sound pressure level of 54 dB(A) may develop when all 4 pump sets are running under full-load conditions.

## 4.8 Scope of supply

Depending on the model, the following items are included in the scope of supply:

### Pressure booster system

- 1 vertical high-pressure centrifugal pump with oval flange or round flange
- Powder-coated / epoxy resin-coated steel baseplate
- Check valve
- Pressure transmitter on the discharge side
- Pressure gauge
- Pressure transmitter on the inlet side for dry running protection
- Discharge-side, direct-flow membrane-type accumulator, approved for drinking water

### Control unit

- IP54 enclosure
- Control panel (display, keys, LEDs, service interface)
- Three LEDs signalling the operating status
- Lockable master switch (repair switch)
- Frequency inverter

#### 4.8.1 Inlet conditions, version M

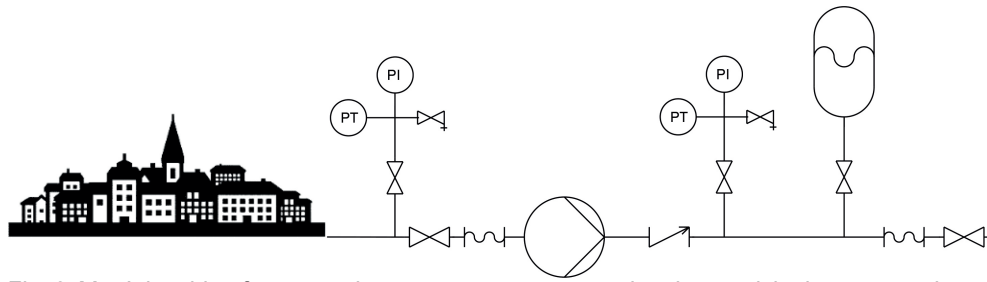

Fig. 3: M = Inlet side of pressure booster system connected to the municipal water supply, suction head operation

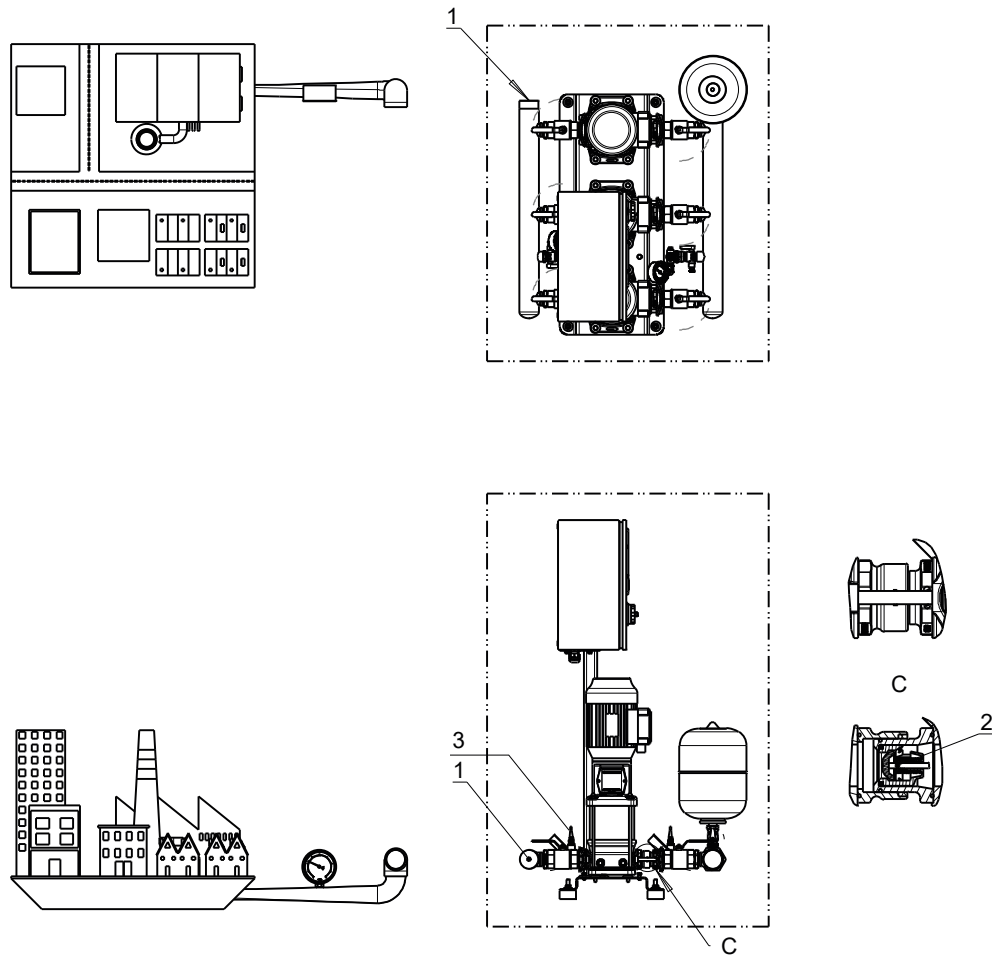

Fig. 4: Scope of supply for version M

1	Suction line (included in DP's scope of supply)
2	Lift check valve (included in DP's scope of supply)
3	Dry running protection (included in DP's scope of supply)

#### 4.8.2 Inlet conditions, version F

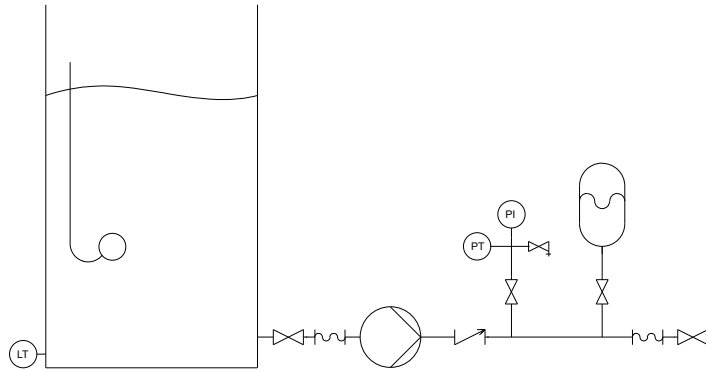

Fig. 5: F = Pressure booster system with break tank arranged on same level as pump, suction head operation

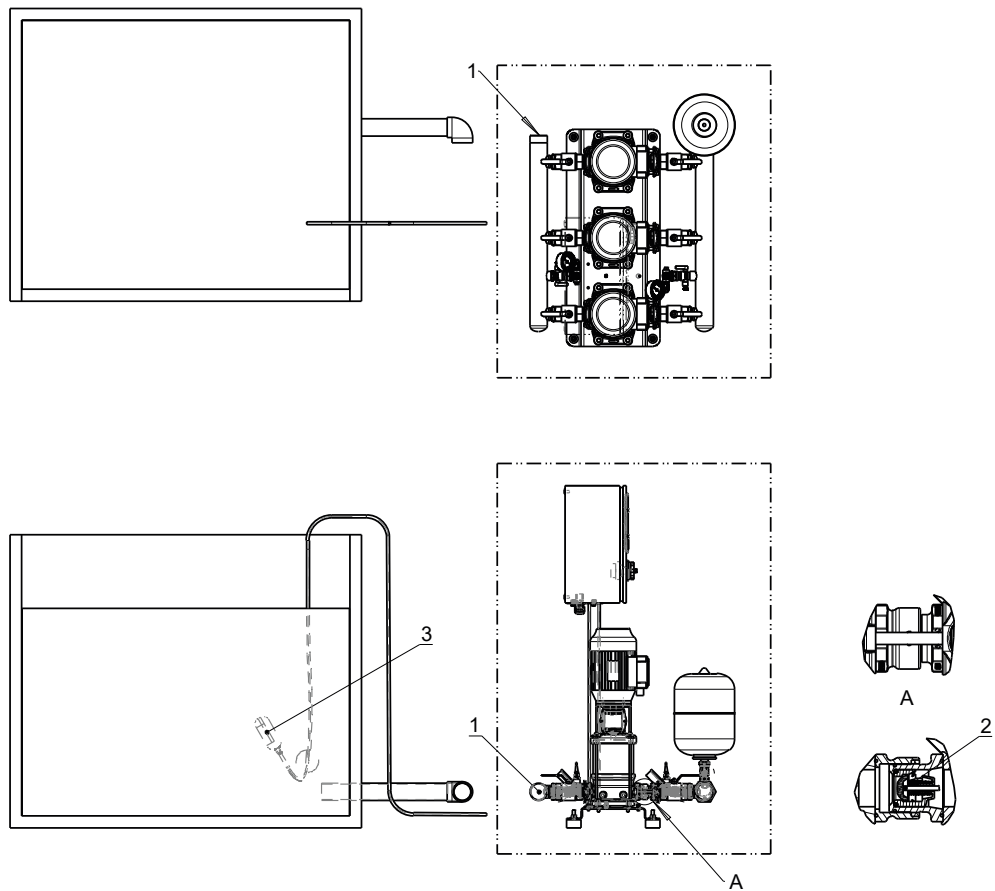
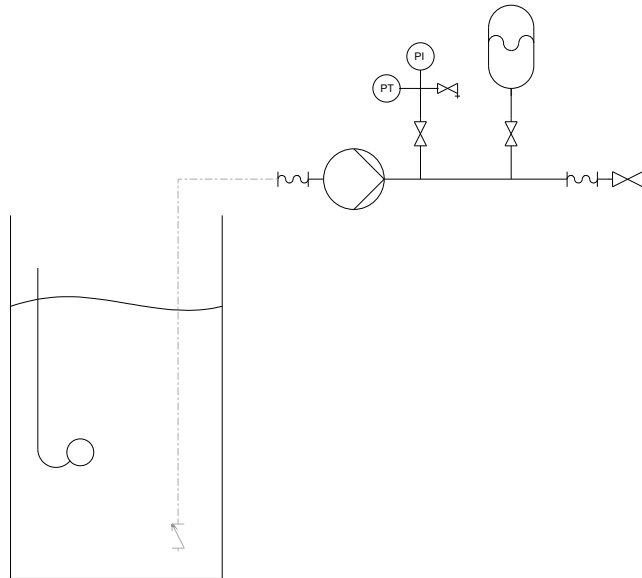

Fig. 6: Scope of supply, version F

1	Suction line (included in DP's scope of supply)
2	Lift check valve (included in DP's scope of supply)
3	Dry running protection (not included in DP's scope of supply)

### 4.8.3 Inlet conditions, version L



*Fig. 7:* L = Pressure booster system with break tank arranged at a lower level, suction lift operation

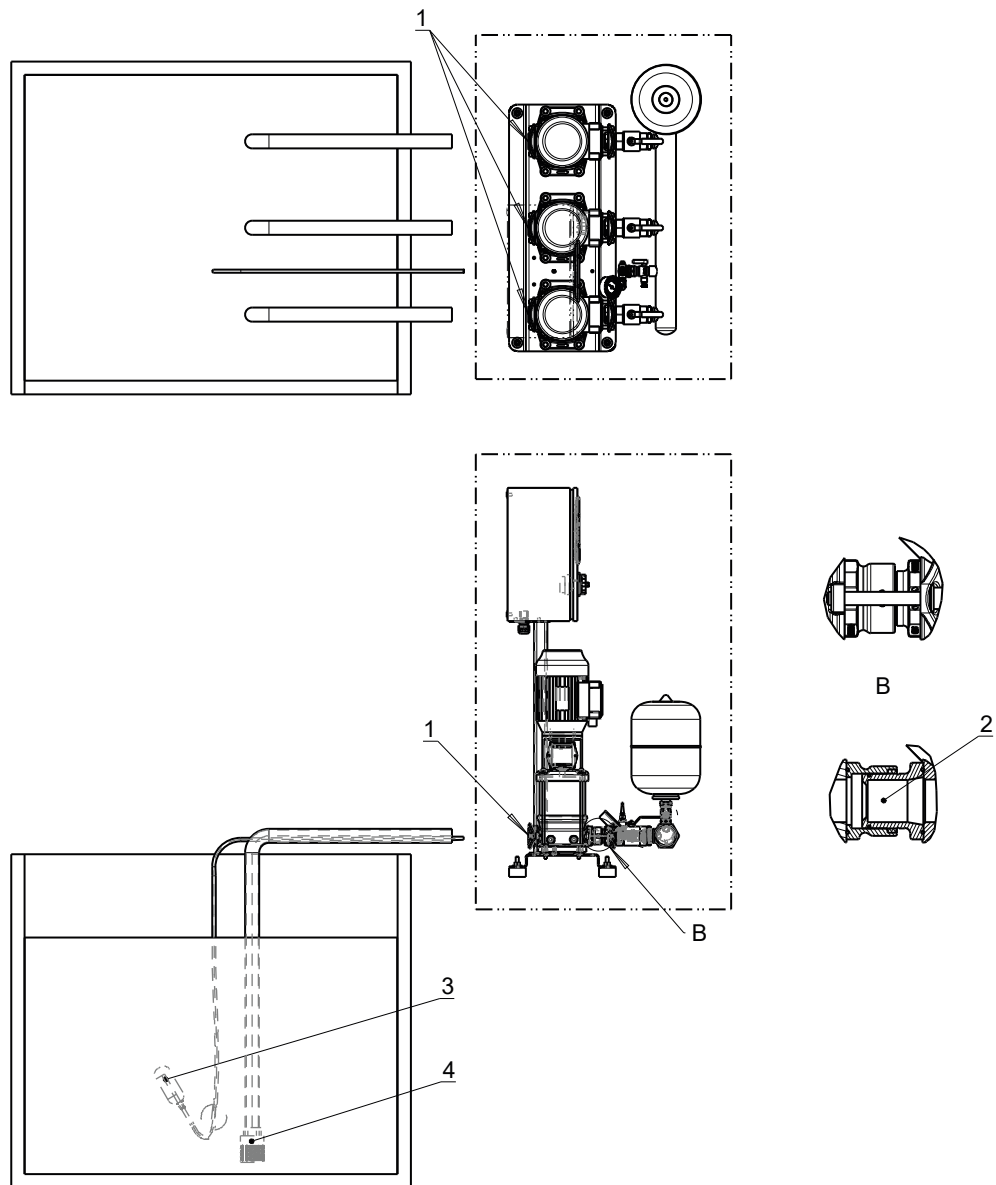

Fig. 8: Scope of supply, version L

1	Suction line (not included in DP's scope of supply)
2	Lift check valve (not included in DP's scope of supply)
3	Dry running protection (not included in DP's scope of supply)
4	Foot valve (not included in DP's scope of supply)

## 4.9 Dimensions and weights

For dimensions and weights refer to the outline drawing.



# 5 Installation at Site

## 5.1 Checks to be carried out prior to installation



### **WARNING**

**Installation on a mounting surface which is unsecured and cannot support the load**

Personal injury and damage to property!

- ▷ Use a concrete of compressive strength class C12/15 which meets the requirements of exposure class X0 to EN 206 .
- ▷ The mounting surface must be set, even, and level.
- ▷ Observe the weights indicated.



### **NOTE**

The anti-vibration mounts of the pressure booster system provide adequate insulation against solid-borne noise.

Thanks to level-adjustable feet (KSB accessory) the pressure booster system can also be installed in a horizontal position on uneven floors.

For pressure booster systems with DPV 2, 4, 6, 10, 15, level-adjustable feet are available as accessories.



### **NOTE**

Do not install pressure booster systems next to sleeping or living quarters.



### **NOTE**

The installation room must provide for suitable drainage.

Before beginning with the installation check the following:

- All structural work required has been checked and prepared in accordance with the dimensions in the outline drawing.
- The data on the name plate of the pressure booster system has been checked. The pressure booster system must be suitable for operation on the available power supply network.
- The place of installation is frost-free.
- The place of installation can be locked.
- The place of installation is well-ventilated.
- A suitably dimensioned drain connection (e.g. leading to a sewer) is available.
- If expansion joints are used, take note of their creep resistance. Expansion joints must be easily replaceable.

The pressure booster system is designed for a maximum ambient temperature of 0 °C to +40 °C at a relative humidity of 60 %.

## 5.2 Installing the pressure booster system



### **WARNING**

#### **Top-heavy pressure booster system**

Risk of personal injury by pressure booster system tipping over!

- ▷ Pressure booster systems awaiting final installation must be secured against tipping over.
- ▷ Firmly anchor the pressure booster system.



### **NOTE**

To prevent the transmission of piping forces and solid-borne noise, installing expansion joints with length-limiters is recommended.

- ✓ The pressure booster system's packaging has been removed.
  - ✓ A suitable installation site has been selected that meets the requirements.
  - ✓ Sufficient clearance in all directions is provided for servicing work.
1. Mark out the anchoring holes on the floor as shown in the outline drawing.
  2. Drill the holes (max. diameter: 12 mm).
  3. Insert plug fixings of appropriate size.
  4. Place the pressure booster system in its correct installation position.
  5. Use suitable bolts to firmly anchor the pressure booster system.

## 5.3 Mounting the accumulator



### **CAUTION**

#### **Dirt in the pressure booster system**

Damage to the pump sets!

- ▷ Clean the accumulator before filling it.

- ✓ The original operating manual of the pressure booster system is on hand.
1. Mechanically and electrically connect the accumulator in accordance with the original operating manual supplied.

## 5.4 Connecting the piping



### **CAUTION**

#### **Air pockets in suction line**

Pressure booster system cannot prime!

- ▷ Lay the pipe with a continuously rising slope.

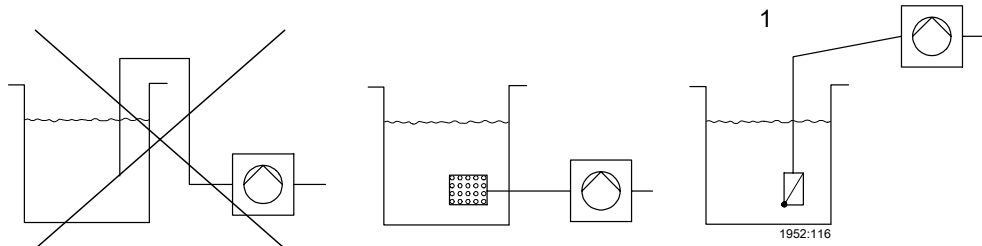

Fig. 9: Correct piping connection

1 Suction lift operation

1. Mechanically support the suction head line on site to provide for absorption of mechanical forces.
2. Install the piping without transmitting any stresses and strains.
3. Connect the piping to the distribution lines on the inlet side and discharge side.



#### NOTE

For single-pump systems, the shut-off valves must be fitted directly at the system's suction-side connection and discharge-side connection, respectively. This will enable straightforward replacement and servicing.

### 5.4.1 Fitting an expansion joint (optional)



#### **⚠ DANGER**

**Sparks and radiant heat**

Fire hazard!

- Take suitable precautions to protect the expansion joint if any welding work is carried out.



#### **CAUTION**

**Leaking expansion joint**

Flooding of installation room!

- Never use the expansion joint to compensate for misalignment or mismatch of the piping.
- Do not apply any paint to the expansion joint.
- Keep the expansion joint clean.
- Regularly check for cracks or blisters, exposed fabric or other defects.

- ✓ Sufficient clearance in all directions is provided for checking the expansion joint.
  - ✓ The expansion joint is not insulated along with the pipeline insulation.
1. Sufficient clearance in all directions is provided for checking the expansion joint.
  2. Install the expansion joint in the piping free of twist or distortion.
  3. Evenly tighten the bolts crosswise. The ends of the bolts must not protrude from the flange.

### 5.4.2 Fitting the pressure reducer (optional)



#### NOTE

A pipe length of approximately 600 mm must be provided on the inlet side to accommodate a pressure reducer, if necessary.



#### NOTE

A pressure reducer must be installed if the inlet pressure fluctuation is too high for the pressure booster system to operate as intended or if the total pressure (inlet pressure and shut-off head) exceeds the design pressure.

The inlet pressure ( $p_{inl}$ ) varies between 4 and 8 bar. A minimum pressure gradient of 5 m is required for the pressure reducer to function properly. This means that the pressure reducer must be mounted 5 m higher than the pressure booster system. The pressure drops by about 0.1 bar per metre of height difference. Alternatively, the pressure reducer can be subjected to a pressure of 0.5 bar.

**Example**  $p_{inl} = 4$  bar

Minimum pressure gradient = 5 m  $\pm$  0.5 bar

Downstream pressure: 4 bar - 0.5 bar = 3.5 bar.

✓ A minimum pressure gradient of 5 m is available.

1. Install the pressure reducer in the pipe on the inlet side.

## 5.5 Electrical connection



#### ⚠ DANGER

**Electrical connection work by unqualified personnel**

Danger of death from electric shock!

- ▷ Always have the electrical connections installed by a trained and qualified electrician.
- ▷ Observe regulations IEC 60364 .



#### ⚠ WARNING

**Incorrect connection to the mains**

Damage to the power supply network, short circuit!

- ▷ Observe the technical specifications of the local energy supply companies.



#### NOTE

Installing a motor protection device is recommended.



#### NOTE

If a residual current device is installed, observe the operating manual for the frequency inverter.

### Lightning protection

- Electrical installations must be protected against overvoltage (binding since 14 December 2018) (see DIN VDE 0100-443 (IEC 60364-4-44:2007/A1:2015, modified) and DIN VDE 0100-534 (IEC 60364-5-53:2001/A2:2015, modified)). Whenever modifications are made to existing installations, retrofitting a surge protective device (SPD) in accordance with VDE is mandatory.
- A maximum cable length of 10 metres should not be exceeded between the surge protective device (usually type 1, internal lightning protection) installed at the service entrance and the equipment to be protected. For longer cables, additional surge protective devices (type 2) must be provided in the sub-distribution board upstream of the equipment to be protected or directly in the equipment itself.
- The associated lightning protection concept must be provided by the operator or by a suitable provider commissioned by the operator. Surge protective devices can be offered for the control units on request.

## Wiring diagram

The wiring diagrams are located in the control cabinet, which is where they must be stored. The product literature of the switchgear and controlgear assembly supplied with the system includes a list of the electrical components installed. When ordering spare parts for electrical components, always indicate the number of the wiring diagram.

## Terminal assignment

For the terminal assignment refer to the wiring diagram.

### 5.5.1 Sizing the power cable

Determine the cross-section of the power cable based on the total rated power required.

### 5.5.2 Connecting the pressure booster system

- ✓ The pressure booster system can be operated on the power supply network in accordance with the data on the name plate.
  - ✓ The wiring diagram is available.
1. Connect terminals L1, L2, L3, PE and N in accordance with the wiring plan.
  2. Connect the potential equalisation conductor on the baseplate to the terminal with the earthing symbol.

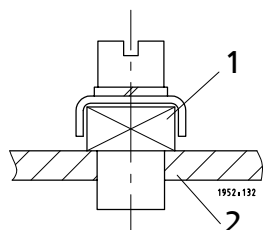

Fig. 10: Connecting the potential equalisation conductor

1	Earthing terminal	2	Baseplate
---	-------------------	---	-----------

3. Connect the remote ON/OFF input.
4. Connect the dry running protection device.
5. Connect the fire alert.
6. Ambient temperature monitoring device (optional) and/or connecting the digital inputs.

### 5.5.3 Fitting the dry running protection device

Install the dry running protection device supplied together with the pressure booster system as a separate, non-fitted accessory, or supplied at a later date for retrofitting, in accordance with its operating instructions and connect it to the switchgear and controlgear assembly. The switchgear and controlgear assembly is provided with the requisite inputs.

1. Remove the front cover to access the terminal strip.

400 V/ 3~ variant with 2 relays

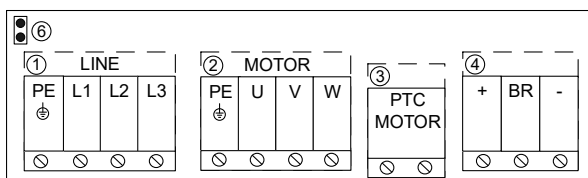

Fig. 11: Overview of terminal strips for 400 V/ 3~ variant with 1 relay

1	Connection to power supply network and motor	2	Control cables
---	--	---	----------------

**In the case of direct connection (direct connection of the pump system to the drinking water supply line of the public water supply system):**

1. Use a wire jumper to connect DI1 (B4) and +24 V (B3).
  - ⇒ When this connection type is used, monitoring by the suction-side pressure sensor protects the pump system against lack of water.

**In the case of indirect connection (connection to an unpressurised drinking water reservoir (water tank)):**

1. Remove the wire jumper between DI1 (B4) and +24 V (B3). Connect an external dry running protection device (e.g. a float switch) in its place.
  - ⇒ When this connection type is used, the lack-of-water function must be adjusted.

**Adjusting the lack-of-water function:**



**NOTE**

On PumpDrive 2 Eco the lack-of-water function cannot be adjusted via the control panel. Contact DP Service.  
To find out whether it is a PumpDrive 2 or PumpDrive 2 Eco refer to the name plate of the frequency inverter.

1. Log in at the frequency inverter using the customer login (standard: 0000). Open parameter 3 "Settings".
2. Open parameter 3-9-11 "Lack-of-water function". Adjust parameters 3-9-11-5 and 3-9-11-6 .
3. If a single-pump pressure booster system is operated with an indirect connection (e.g. water tank), set parameter 3-9-11-4 to "OFF".

**5.5.4 Removing the housing cover**



**⚠ DANGER**

**Contact with live components**

Risk of fatal injury due to electric shock!

- ▷ Any work on the product shall only be performed when it has been disconnected from the power supply (de-energised).
- ▷ Never remove the centre housing part from the heat sink.
- ▷ Mind the capacitor discharge time.  
After switching off the frequency inverter, wait 10 minutes until dangerous voltages have discharged.

The terminal wiring compartment is covered by a screwed-on housing cover. The terminals of the power and motor connection cables are fitted with an additional protective cover as a contact guard.

## Housing cover

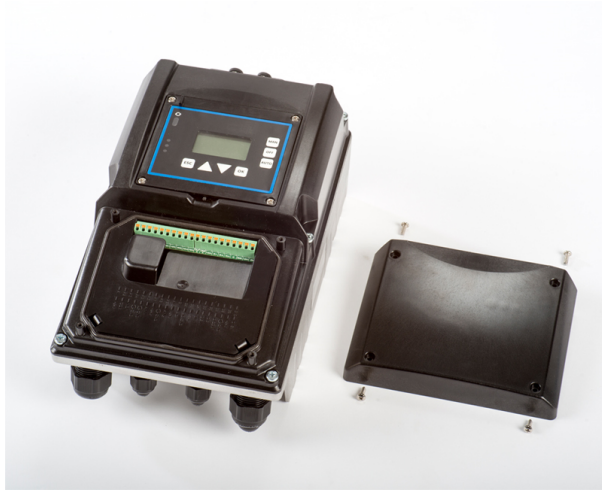

Fig. 12: Housing cover

1. Remove the cross recessed head screws at the cover.
2. Remove the cover.

## Protective cover

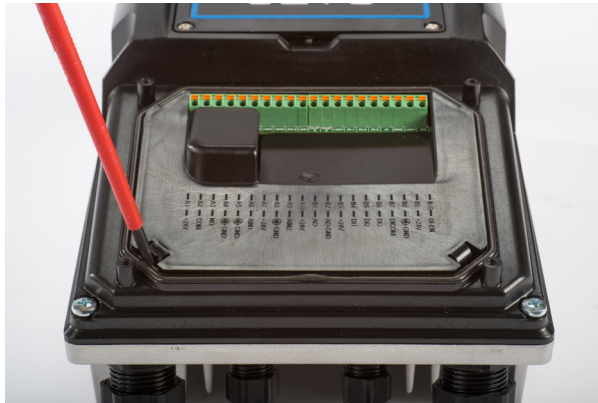

Fig. 13: Prying open the protective cover

1. The protective cover of the power and motor connection cables is push fit. Before connecting the power and motor connection cables, carefully pry open the protective cover using a wide screwdriver.



Fig. 14: Removing the protective cover

2. Remove the protective cover.

### 5.5.5 Overview of terminal strips

Variant with 1 relay

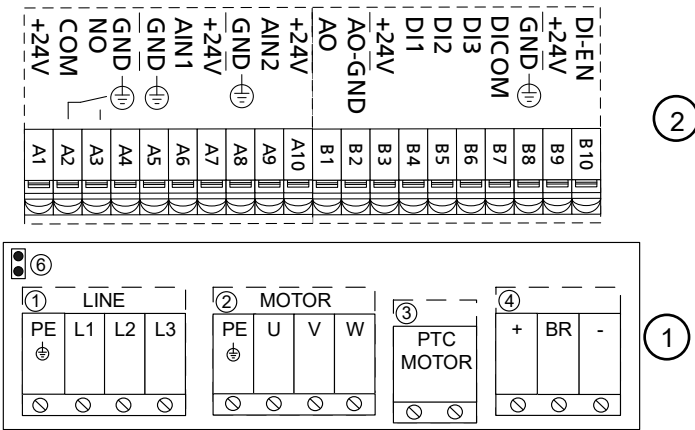

Fig. 15: Overview of terminal strips for variant with 1 relay

1	Connection to power supply network and motor	2	Control cables
---	--	---	----------------



#### NOTE

The new frequency inverter generation is equipped with a second relay.

Variant with 2 relays

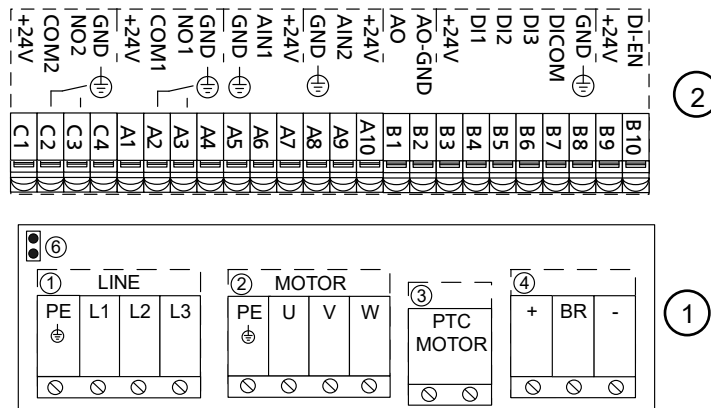

Fig. 16: Overview of terminal strips for variant with 2 relays

1	Connection to power supply network and motor	2	Control cables
---	--	---	----------------

### 5.5.6 Connection to mains power supply and motor



#### ⚠ DANGER

Touching or removing the terminals and connectors of the braking resistor

Risk of fatal injury due to electric shock!

- ▶ Never open or touch the terminals and connectors of the braking resistor as long as the frequency inverter is energised.





### CAUTION

#### Incorrect electrical installation

Damage to the frequency inverter!

- ▷ Never fit a contactor (in the motor connection cable) between the motor and the frequency inverter.

1. Route the power cable for the mains power supply and/or the motor connection cable through the cable glands and connect the cable(s) to the specified terminals.
2. Connect the line for a PTC connection/PTC thermistor to the PTC terminal strip (3).

Connecting motor monitoring devices (PTC thermistor)

If no PTC connection is available on the motor side, parameter 3-2-3-1 (PTC Analysis) must be deactivated.



### NOTE

IP55 enclosure protection as specified in the technical data is only provided if the cover has been fitted properly.

Size A

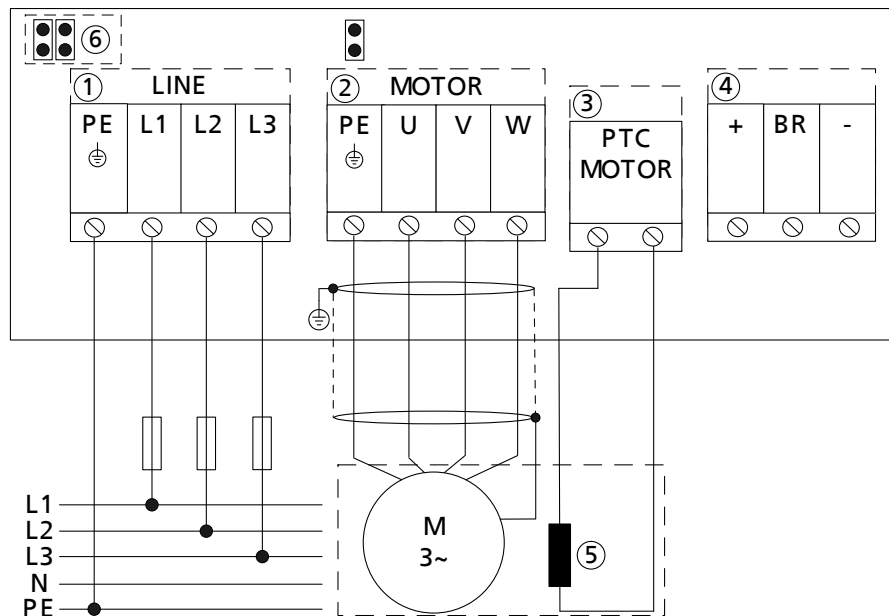

Fig. 17: Establishing the power supply network and motor connections, size A

①	Connection to the power supply network	②	Motor connection
③	PTC connection	④	Braking resistor
⑤	Motor PTC	⑥	Jumper for IT mains

Size B

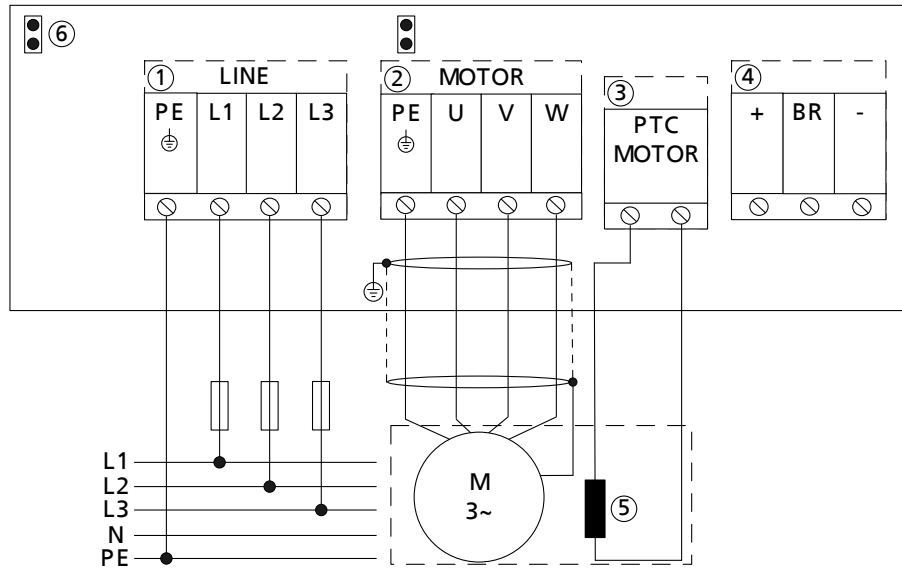

Fig. 18: Establishing the mains power supply and motor connections, size B

①	Mains connection	②	Motor connection
③	PTC connection	④	Braking resistor
⑤	Motor PTC	⑥	Jumper for IT mains

Size C

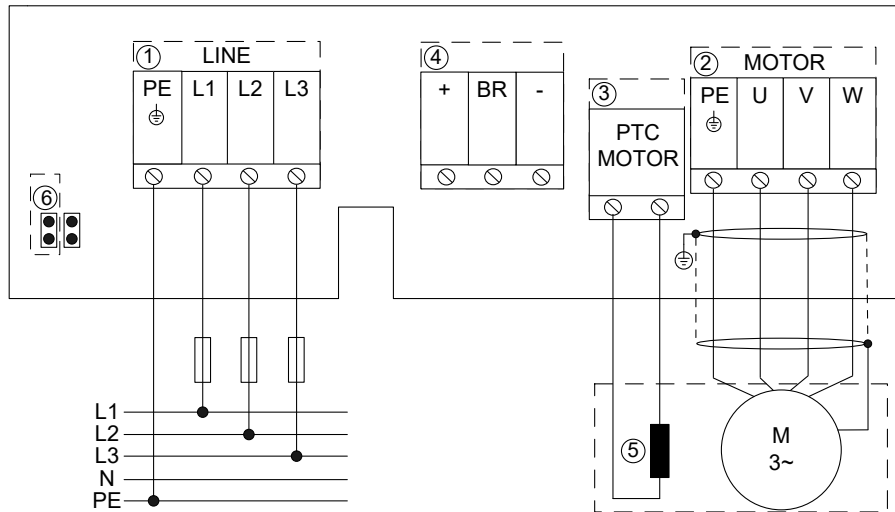

Fig. 19: Establishing the mains power supply and motor connections, size C

①	Mains connection	②	Motor connection
③	PTC connection	④	Braking resistor
⑤	Motor PTC	⑥	Jumper for IT mains

IT mains



**⚠ DANGER**

**Contact with live components**

Risk of fatal injury due to electric shock!

- Any work on the product shall only be performed when it has been disconnected from the power supply (de-energised).
- Never remove the centre housing part from the heat sink.
- Mind the capacitor discharge time.  
After switching off the frequency inverter, wait 10 minutes until dangerous voltages have discharged.

**Jumper in IT mains** If the frequency inverter is to be used in an IT mains, the relevant IT mains jumpers must be removed.

**5.5.6.1 Directly connecting the motor cable without motor connector (for sizes A and B only)**



**⚠ DANGER**

**Improper electrical connection**

Risk of fatal injury due to electric shock!

- Never simultaneously use the motor connector with a motor cable that is directly connected to the motor terminals.
- Never touch terminals and plug-type connections of the motor connector.

When directly connecting a motor cable to the designated motor terminals (U, V, W), the motor connector fitted at the factory must first be removed.

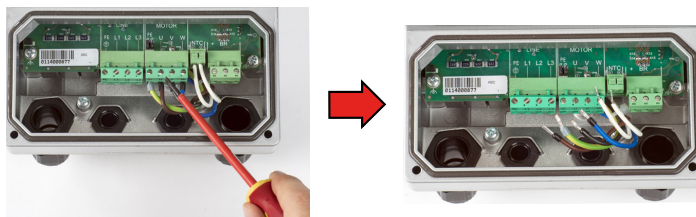

Fig. 20: Disconnecting the cores of the motor connector

1. Disconnect the cores of the motor connector at terminals U, V and W.

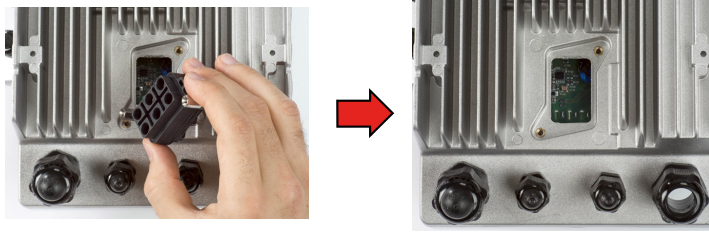

Fig. 21: Removing the motor connector

2. Remove the motor connector from the heat sink.

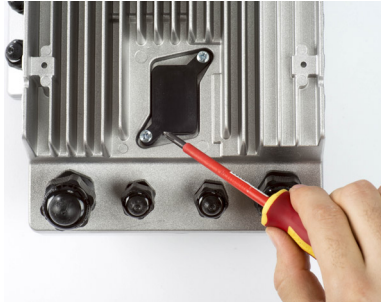

Fig. 22: Inserting and fastening the cover

3. Close the opening in the heat sink using the kit accompanying the frequency inverter (comprising a cover, gasket and bolts/screws).



**NOTE**

IP55 enclosure protection as specified in the technical data is only provided if the cover has been fitted properly.

**5.5.6.2 Retrofitting a frequency inverter for a SuPremE B2 motor (for sizes C only)**



Fig. 23: Plug

The heat sink is closed with a plug. The following steps must be carried out to retrofit a SuPremE B2 motor.

1. Remove the screwed-in plug.



Fig. 24: Removing the plug

2. Remove the nut of the plug inside the frequency inverter.



**NOTE**

IP55 enclosure protection as specified in the technical data is only provided if the O-ring has been fitted properly.

3. Place the O-ring onto the adapter.



Fig. 25: Inserting the O-ring



**⚠ DANGER**

**Pinching of power and motor connection cables**

Danger of death from electric shock!

- Never damage the insulation of the power and motor connection cables when inserting them into the opening of the frequency inverter.



Fig. 26: Inserting motor cables



Fig. 27: Connecting the motor cables

4. Place the frequency inverter onto the motor adapter of the SuPremE B2 motor and insert the motor cables of the SuPremE B2 motor into the opening of the frequency inverter.

5. Connect the motor cables as described.

6. Connect the PTC cables that are supplied as standard with the SuPremE B2 motor.

7. Close the frequency inverter with the protective cover and the housing cover.

### 5.5.7 Establishing an earth connection

The frequency inverter must be earthed.

Observe the following when establishing the earth connection:

- Ensure that the cable lengths are as short as possible.
- Use different earth bus bars for the control and power/motor connection cables.
- The earth bus bar of the control cable must not be affected by currents from the power/motor connection cables since this could be a source of interference.

Connect the following to the earth bus bar of the power/motor connection cable:

- Motor earthing connections
- Housing of the frequency inverter
- Shielding of the power/motor connection cable

Connect the following to the earth bus bar of the control cable:

- Shielding of the analog control connections
- Shielding of the sensor cables
- Shielding of the field bus connection cable

#### Installing multiple frequency inverters

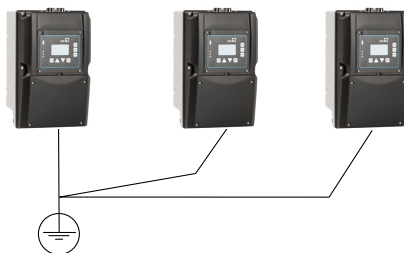

Fig. 28: Establishing an earth connection

If you are installing more than one frequency inverter, the star configuration is recommended.

# 6 Commissioning/Start-up/Shutdown

## 6.1 Commissioning/Start-up

### 6.1.1 Prerequisites for commissioning/start-up



#### CAUTION

##### Pump set running dry

Damage to the pump set/pressure booster system!

- Use dry running protection. If the dry running protection terminal is disabled by means of a bridge, the operator shall assume responsibility for any dry running that might occur.

Ensure that the following requirements are met prior to commissioning/start-up :

- The pressure booster system has been flushed and disinfected in accordance with local requirements.
- The pressure booster system has been properly connected to the electric power supply and is equipped with all protection devices.
- All relevant VDE standards and/or regulations applicable in the country of use are complied with.
- The dry running protection device has been installed. [⇒ Section 5.5.3, Page 29]

### 6.1.2 Commissioning/start-up of pressure booster system



#### NOTE

Prior to its delivery, the pressure booster system will be tested hydraulically with water and then drained again. For technical reasons the presence of some residual water is unavoidable.

Prior to commissioning/start-up observe EN 806. After prolonged standstill periods, flushing or professional disinfection is recommended. For extensive or branched piping systems, flushing the pressure booster system can be restricted to a limited area.

Commissioning should be carried out by specialist staff.



#### CAUTION

##### Foreign matter in the piping

Damage to the pump / pressure booster system!

- Before commissioning/starting up or functional check running the pressure booster system, make sure that there is no foreign matter in the pressure booster system or piping.



#### NOTE

Commissioning of the pressure booster system - even test running - shall only be carried out in full compliance with all pertinent VDE (German Association of Electrical Engineers) regulations.



#### CAUTION

##### Operation without the fluid to be handled

Damage to the pump sets!

- Prime the pressure booster system with the fluid to be handled.

- ✓ The pipe unions between the pump and the piping have been re-tightened.
  - ✓ The flange bolting has been checked for firm seating.
  - ✓ The cooling air inlet and outlet openings on the motor are unobstructed.
  - ✓ All shut-off valves of the pressure booster system are open.
  - ✓ The pre-charge pressure of the membrane-type accumulator has been checked.  
[⇒ Section 8.2.3, Page 55]
1. Set the master switch to "0"; unlock all motor protection switches (if applicable).
  2. Provide connection to power supply.
  3. Open/loosen the vent plugs on the pumps (refer to the pump's installation/operating manual).
  4. Slowly open the inlet-side shut-off element and prime the pressure booster system until the fluid to be handled escapes through all vent holes.
  5. Close and slightly tighten the pump vent plugs.
  6. Switch on all motor protection switches.
  7. Set the manual-0-automatic selector switches (if any) to Automatic.
  8. Switch on the master switch.
  9. Open the discharge-side shut-off element.
  10. When all pumps are running, loosen the vent plugs again to let any remaining air escape.
  11. Tighten the vent plug firmly.
  12. Check that the pumps are running smoothly.
  13. Close the discharge-side shut-off element for a short period and verify that the pumps reach the shut-off head.
  14. Close the discharge-side shut-off element, causing all pumps to stop.



#### NOTE

Minor leakage of the mechanical seals during commissioning is normal and will cease after a short period of operation.

### 6.1.3 Dry running protection

Pressure booster systems are fitted with a dry running protection device.

A float switch whose volt-free contact closes the circuit in upper float position can be connected to the control system as dry running protection. Follow the float switch manufacturer's instructions on how to set the float switch levels.

### 6.1.4 Start-up



#### NOTE

The pressure booster system is factory-set to the data indicated on the name plate.

#### Standard design

- ✓ The pressure booster system has been primed and vented.
1. Switch on the master switch.
- ⇒ The green LED lights up and signals the system's readiness for operation.

#### Additional instruments

- ✓ The pressure booster system has been primed and vented.
1. Set the manual-0-automatic selector switch to automatic.

⇒ The green LED lights up and signals the system's readiness for operation.

### 6.1.5 Checklist for commissioning/start-up

Table 10: Checklist

Steps to be carried out	Action	Done
1	Read the operating manual.	
2	Compare the power supply data against the name plate data.	
3	Check the earthing system/take measurements.	
4	Check the mechanical connection to the water mains. Re-tighten the flange and pipe unions.	
5	Prime and vent the pressure booster system from the inlet side.	
6	Check the inlet pressure.	
7	Check whether all cables are firmly connected to the terminals inside the control unit.	
8	Compare the settings of the motor protection switches with the name plate data and re-adjust if necessary.	
9	Check the start-up pressure and the stop pressure; re-adjust if necessary.	
10	Test the proper function of the dry running protection equipment. If not fitted, make a relevant note in the commissioning report.	
11	After the pump sets have been running for 5 to 10 minutes, vent them again.	
12	Set all switches to automatic.	
13	Check the pre-charge pressure.	
14	Enter any deviations from the name plate or order documentation in the commissioning report.	
15	Complete the commissioning report together with the operator/user and instruct the operator/user as to the function of the unit.	



## 6.2 Operating limits



### **⚠ DANGER**

#### **Non-compliance with operating limits**

Damage to the pump set!

- Comply with the operating data indicated in the data sheet.
- Avoid operation against a closed shut-off element.
- Never operate the pump set outside the limits specified below.



### **⚠ DANGER**

#### **Non-compliance with operating limits for the fluid handled**

Explosion hazard!

- Never use the pump to handle different fluids which might react chemically with each other.
- Never use the pump to handle a flammable fluid with a fluid temperature above the ignition temperature.

### 6.2.1 Frequency of starts

To prevent high temperature increases in the motor and impermissible loads on the pump, motor, seals and bearings, do not exceed a certain number of starts per hour. See original operating manual of the pump sets.

### 6.2.2 Ambient conditions

Observe the following parameters and values during operation:

Table 11: Permissible ambient conditions

Ambient condition	Value
Ambient temperature	0 °C to +40 °C <sup>3)</sup>
Relative humidity	50 % maximum

### 6.2.3 Maximum operating pressure



### **CAUTION**

#### **Permissible operating pressure exceeded**

Damage to connections and seals!

- Never exceed the operating pressure specified in the data sheet.

The maximum operating pressure equals 16, 25 or 40 bar, depending on the design variant. See name plate.

### 6.2.4 Fluid handled

#### 6.2.4.1 Permissible fluids to be handled

- Clean fluids not chemically or mechanically aggressive to the pump materials
- Drinking water
- Service water
- Cooling water

<sup>3</sup> VC: Maximum ambient temperature 30°C

## 6.2.4.2 Fluid temperature

Table 12: Temperature limits of the fluid handled

Permissible fluid temperature	Value
Maximum	+60 °C +25 °C to DIN 1988 (DVGW) <sup>4</sup>
Minimum	0 °C

## 6.2.5 Minimum flow rate

Table 13: Minimum flow rate per pump in manual mode

Size	Minimum flow rate per pump
	[l/h]
DPV 2	200
DPV 4	400
DPV 6	600
DPV 10	1100
DPV 15	1900
DPV 25	2800
DPV 40	4600
DPV 60	6100
DPV 85	8500
DPV 125	12500

## 6.3 Shutdown

### 6.3.1 Shutdown

#### Standard design

1. Set the master switch to 0.

#### Additional instruments

1. Set manual-0-automatic selector switch to 0.

---

<sup>4</sup> Applies to the handling of drinking water (Germany and the Netherlands only)

### 6.3.2 Measures to be taken for shutdown

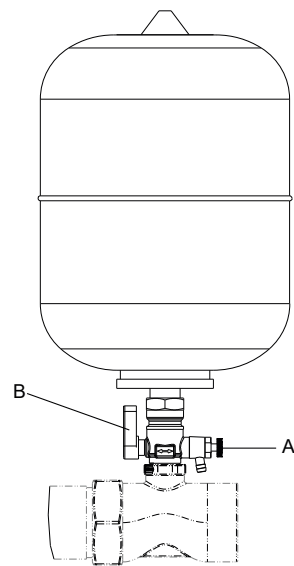

Fig. 29: Venting and draining the accumulator

A	Vent plug
B	Ball valve lever

- ✓ The pressure booster system has been switched off. [⇒ Section 6.3.1, Page 42]
- 1. Turn the ball valve lever B by 45 degrees.
- 2. Open vent plug A at the accumulator.
  - ⇒ The pressure booster system is being vented and drained.
- 3. Close vent plug A at the accumulator.
- 4. Turn the ball valve lever B back into open position (upwards).

# 7 Operation

## 7.1 Standard control panel

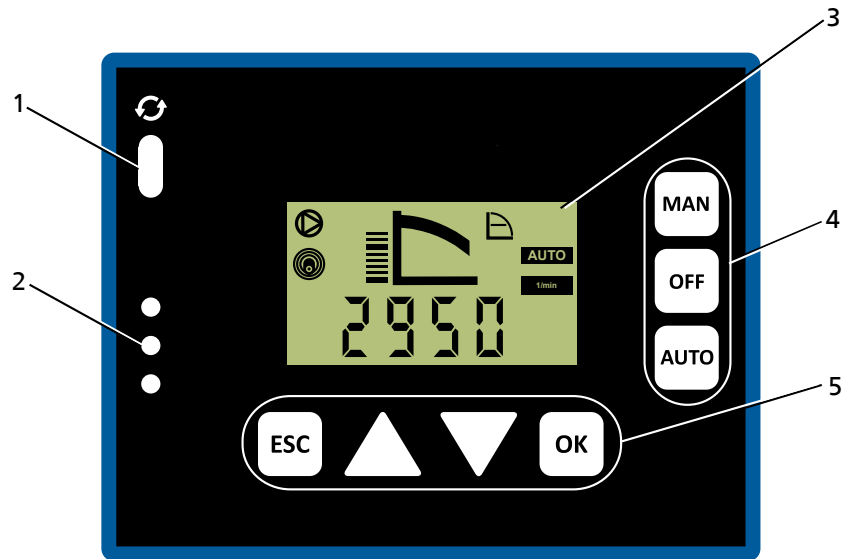

Fig. 30: Standard control panel

Table 14: Description of standard control panel

Position	Description	Function
1	Service interface	Optical interface
2	LED traffic light function	The traffic light function provides information about the system's operating status.
3	Display	Displays information on frequency inverter operation
4	Operating keys	Toggling operating modes
5	Navigation keys	Navigation and setting of parameters

### 7.1.1 Display

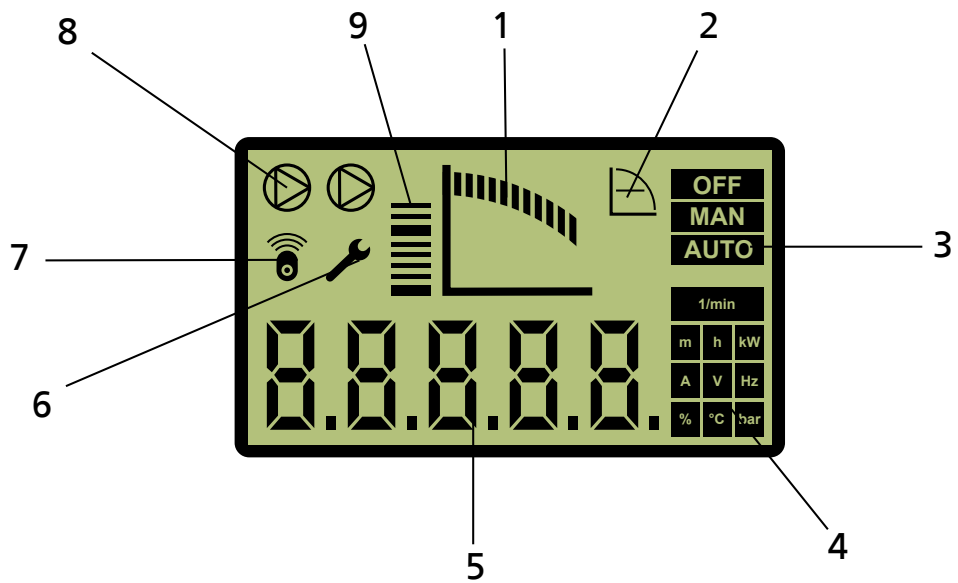

Fig. 31: Main screen (example)

1	Operating point display
2	Type of control
3	Display of the current operating mode
4	Units
5	Menu, parameter number, parameter values
6	Log in as customer
7	Active wireless connection The wireless icon illuminates when the Bluetooth module is inserted. The wireless icon flashes when communication takes place.
8	Single/dual pump
9	Rotational speed 0 - 100 %

Table 15: Menu, parameter number, parameter values, messages







Display	Function
 <p>Menu example: Open-loop Control</p>	<p>Menu example: Open-loop Control (1-3):</p> <ul style="list-style-type: none"> <li>- The letter S is used as the first character to identify a menu.</li> <li>- The second character identifies the first menu level, i.e. Operation S1-x-x-x, Diagnosis S2-x-x-x, Settings S3-x-x-x and Information S4-x-x-x.</li> <li>- The wrench icon shows that you have logged in as a customer.</li> </ul>
 <p>Parameter number example: Setpoint (Closed-loop Control)</p>	<p>Parameter number example: Setpoint (Closed-loop Control) (1-3-2):</p> <ul style="list-style-type: none"> <li>- The letter P is used as the first character to identify a parameter number.</li> <li>- The following characters show the parameter number.</li> <li>- The wrench icon shows that you have logged in as a customer.</li> </ul>
 <p>Parameter value example: Setpoint (Closed-loop Control)</p>	<p>Parameter value example: Setpoint (Closed-loop Control) (1-3-2) set to 4 bar:</p> <ul style="list-style-type: none"> <li>- If a parameter value can be edited, the digit flashes.</li> <li>- The wrench icon shows that you have logged in as a customer.</li> </ul>
 <p>Message example: Dry running</p>	<p>Message example: Dry running (E13):</p> <ul style="list-style-type: none"> <li>- A message is identified by the letter E (Error) and a unique number.</li> </ul>

Table 16: Assignment of keys

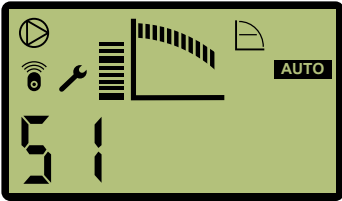
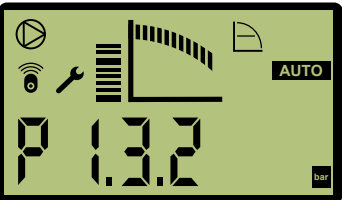
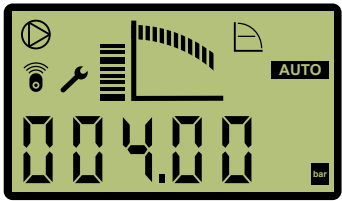
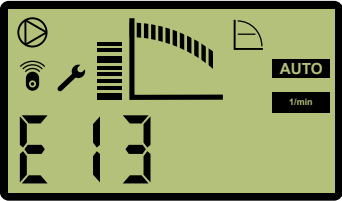
Key	Function
	<p><b>Arrow keys:</b></p> <ul style="list-style-type: none"> <li>- Move up/down in the menu options.</li> <li>- Increase/decrease a numerical value. (When an arrow key is pressed and held down, the response repeats in ever shorter intervals.)</li> </ul>
	<p><b>Escape key:</b></p> <ul style="list-style-type: none"> <li>- Delete/reset entry (the entry is not saved).</li> <li>- Move up one menu level.</li> </ul>
	<p><b>OK key:</b></p> <ul style="list-style-type: none"> <li>- Confirm settings.</li> <li>- Confirm menu selection.</li> <li>- Move to the next digit when entering numerals.</li> <li>- Message display: Acknowledge alert.</li> <li>- Measured value display: Go to Favourites menu.</li> </ul>

Key	Function
	MAN operating key: <ul style="list-style-type: none"> <li>– Starts the frequency inverter in manual operating mode.</li> </ul>
	OFF operating key: <ul style="list-style-type: none"> <li>– Stops the frequency inverter.</li> </ul>
	AUTO operating key: <ul style="list-style-type: none"> <li>– Switches to automatic operating mode.</li> </ul>





### Manual mode via control panel



#### NOTE

After a power failure, the frequency inverter reverts to the OFF operating mode. Manual mode must be restarted.

Table 17: Assignment of keys for manual mode

Key	Function
	MAN operating key: <ul style="list-style-type: none"> <li>– When switching the operating mode from AUTO to MAN, the current operating speed is used as control value (Manual) 1-3-4 and is displayed accordingly. The control point 1-3-10 must be set to Local.</li> <li>– When switching the operating mode from OFF to MAN, the frequency inverter operates at minimum speed. The control point 1-3-10 must be set to Local.</li> <li>– If the control value (Manual) 1-3-4 is defined via an analog input, the analog input speed is accepted.</li> </ul>
	<b>Arrow keys:</b> <ul style="list-style-type: none"> <li>– Pressing the arrow keys changes and immediately accepts the control value (Manual) 1-3-5. Making a change using the arrow key has a direct effect even when not confirmed with OK. The speed can only be changed between the set minimum speed and the maximum speed.</li> </ul>
 	<b>ESC/OK key:</b> <ul style="list-style-type: none"> <li>– Press the OK or ESC key to go from digit to digit. Press the ESC key to go back. Changes are rejected. Pressing the OK key for the right-hand digit takes you back to the main screen.</li> </ul>

### 7.1.2 Main screen

The main screen shows factory default operating values.

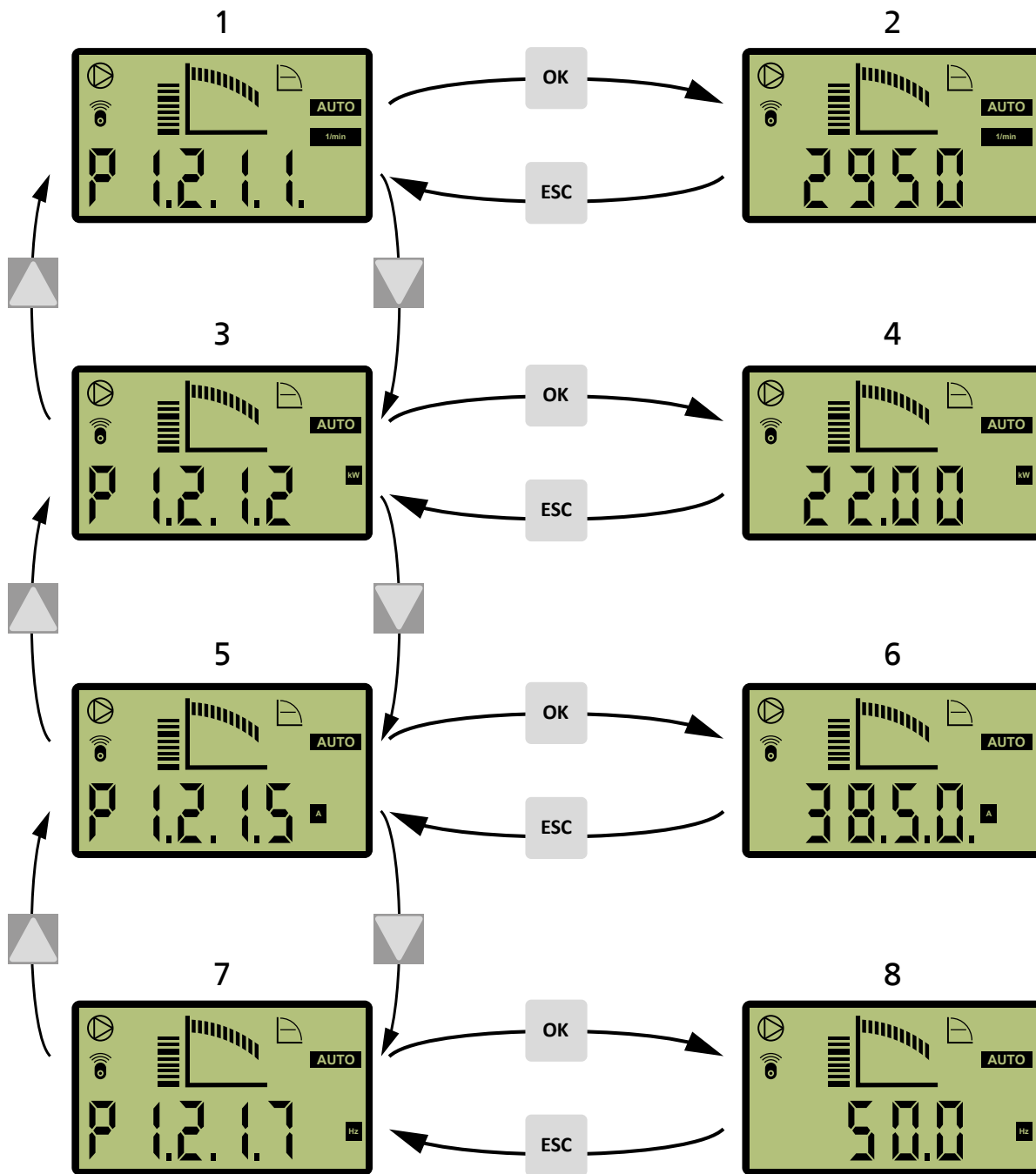

48 / 74 Fig. 32: Selecting and displaying operating values on the main screen

1	Parameter number for speed (1-2-1-1)
2	Current speed [rpm]
3	Parameter number for motor input power (1-2-1-2)
4	Current power input of motor in kW
5	Parameter number for motor current (1-2-1-5)
6	Current motor current in A
7	Parameter number for output frequency (1-2-1-7)
8	Current output frequency in Hz

If a message (alert, warning or information) is currently active, it will be displayed on the main screen.



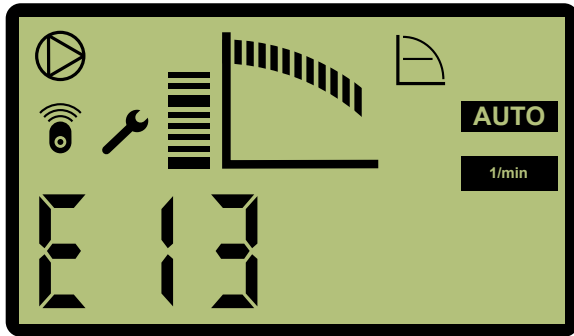

Fig. 33: Message display

A message is identified by the letter E (Error) and a unique number (see list of all messages in the Annex). The traffic light function shows whether the message is an alert (red LED), a warning (amber LED) or just information (green LED).

Messages are acknowledged by pressing OK. Acknowledged and gone messages are listed in the message history in Menu 2 – Diagnosis.



**NOTE**

If the motor standstill heater has been switched on, the display alternates between the measured value and the letter H.

**7.1.3 Settings menu**



**NOTE**

The standard control panel is designed to be used for simple settings only (e.g. setting the setpoint). We recommend using the Servicetool for more extensive configuration tasks.

**Opening the Settings menu:** Press and hold the ESC key and press OK.

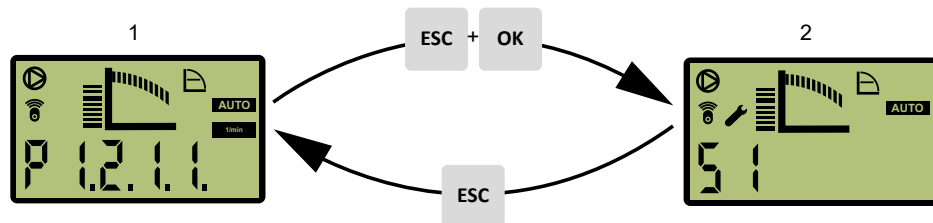

Fig. 34: Switching to the settings menu

1	Main screen	2	Settings menu
---	-------------	---	---------------

The wrench symbol indicates that the Settings menu has been opened and a value can be changed.

The parameter numbers identify the navigation path, which helps you find a particular parameter quickly and easily. The first digit of the parameter number indicates the first menu level, which is called up directly via the four menu keys.

**7.1.3.1 Menu: Operation**

The Operation section contains all information required for operating the machine and the process. This includes:

- Login to device with password
- Operating and measured values for motor, frequency inverter, pump and system
- Setpoints and control values
- Energy meter and operating hours



### 7.1.3.1.1 Access levels

Three access levels have been defined to prevent unintentional or unauthorised access to frequency inverter parameters:

Table 18: Access levels

Access level	Description
Standard (No Login)	Access without password entry.
Customer	Access level for the expert user with access to all parameters required for commissioning
Customer service	Access level for service personnel.

If a parameter's access level is not explicitly specified, the parameter is always assigned the *Customer* access level.

Table 19: Access level parameters

Parameter	Description	Possible settings	Factory setting
1-1-1	<i>Customer Login</i> Log in as customer	0000...9999	0000

Customer service parameters can only be accessed using the Servicetool and the appropriate dongle.



#### NOTE

If no keys are pressed for five minutes, the system will automatically return to the *Standard* access level..

The password can be changed after entering the factory default password.

Table 20: Parameter for changing the password (requires use of the Servicetool)

Parameter	Description	Possible settings	Factory setting
1-1-5	<i>Customer Access ID</i> Changing the customer access ID	0000...9999	-

### 7.1.3.2 Menu: Diagnosis

In the Diagnosis section, the user is provided with information about faults and warning messages that pertain to the pump set or process. The frequency inverter can be in fault (standstill) or warning (operational) status. The user can also find previous messages in the history.

#### Messages

All monitoring and protective functions trigger warnings or alerts. These are signalled via the amber or red LED of the LED traffic light function.

A corresponding message is output on the control panel display. If more than one message is output, the last one is displayed. Alerts have priority over warnings.

50 / 74

#### Pending messages

If a message has occurred and been acknowledged but has not gone, this message will be listed in the Pending Messages menu. All current messages can be displayed in the Diagnosis menu under Pending Messages (2-1). Active warnings and alerts can also be connected to the relay outputs.

#### Message history

Only messages that have come, been acknowledged, and gone are listed in the message history. The message history can be viewed by selecting the Message History parameter 2-2. The last 100 messages are listed here. You can use the arrow keys and the OK key to select an entry from the list.

## Acknowledging and resetting messages



### NOTE

Depending on the combination of settings, the frequency inverter could conceivably restart automatically after acknowledgement/reset or when the cause of the malfunction or fault has been eliminated.

**Acknowledgement** Messages can be acknowledged once the cause has been rectified. Messages can be acknowledged individually in the Diagnosis menu. A message can also be acknowledged via a digital input. Digital input 2 is defaulted for this purpose.

Overview of warnings and alerts [⇒ Section 9, Page 59]

Messages can be acknowledged as follows:

Table 21: Acknowledgement types for messages

Property of message	Type of acknowledgement
Self-acknowledging	Message is automatically acknowledged if condition for message no longer applies.
Automatic acknowledgement (configurable)	Users can choose between automatic acknowledgement and manual acknowledgement.
Partially automatic acknowledgement	Alerts that are partially acknowledged automatically carry out automatic acknowledgement in increasingly large intervals after the alert condition no longer applies. If the alert occurs repeatedly within a specific time window, automatic acknowledgement is suspended. As soon as the alarm condition of a pending alert no longer exists, the time interval is started. When this interval expires, automatic acknowledgement takes place. If the alert occurs again within 30 seconds after the time interval has started, the interval is extended by one increment. Should this not be the case, the previous (shorter) time interval is reverted to and corresponding action is taken again in 30 seconds. The time intervals are 1 second, 5 seconds, 20 seconds, and endless (i.e. manual acknowledgement is required). When the 20-second interval is extended, automatic acknowledgement no longer takes place.
No automatic acknowledgement	Must be acknowledged manually.

**Time stamp** If a message is not acknowledged and its condition comes and goes several times in this time window, the first occurrence of the message is always used for the Message Come time stamp. The Message Condition Gone time stamp, however, always shows the last time the message condition was no longer active.

### 7.1.3.3 Menu: Settings

General settings can be made or the settings for the process optimised in the Settings section.

#### Locking operating keys

Table 22: Parameters for setting the control panel

Parameter	Description	Possible settings	Factory setting
3-1-2-2	Control Keys Require Login <i>The MAN, OFF, AUTO and FUNC keys are locked without a valid login (customer).</i>	- 0 = OFF - 1 = ON	0 = OFF

**Locking operating keys** The operating keys of the control panel can be locked via the 3-1-2-2 parameter to prevent unauthorised operation or unauthorised acknowledgement of alerts.

### 7.1.3.4 Menu: Information

All direct information about the frequency inverter is provided in the Information section. Important details regarding the firmware version are listed here.

## 7.1.4 Service interface and LED traffic light function

**Service interface** The service interface allows a PC/notebook to be connected via a special cable (USB – optical).

The following action can be taken:

- Configuring and parameterising the frequency inverter with the service software
- Software update
- Saving and documenting set parameters







**LED traffic light function** The LED traffic light function provides information about the current operating status of the frequency inverter.

Table 23: LED description

LED	Description
● Red	One or more than one alert is active
● Amber	One or more than one warning is active
● Green	Steady light: Trouble-free operation

# 8 Servicing/Maintenance

## 8.1 General information/Safety regulations

	<p><b>⚠ DANGER</b> <b>Unintentional start-up of pressure booster system</b> Danger to life!</p> <ul style="list-style-type: none"><li>▶ De-energise the pressure booster system for any repair work or servicing work.</li><li>▶ Ensure that the pressure booster system cannot be re-energised unintentionally.</li></ul>
	<p><b>⚠ DANGER</b> <b>Voltage at the pressure booster system</b> Danger to life!</p> <ul style="list-style-type: none"><li>▶ Prior to opening the device, wait at least 10 minutes for any residual voltage to dissipate.</li></ul>
	<p><b>⚠ WARNING</b> <b>Improper lifting/moving of heavy assemblies or components</b> Personal injury and damage to property!</p> <ul style="list-style-type: none"><li>▶ Use suitable transport devices, lifting equipment and lifting tackle to move heavy assemblies or components.</li></ul>
	<p><b>⚠ WARNING</b> <b>Unintentional start-up of pressure booster system</b> Risk of injury by moving parts!</p> <ul style="list-style-type: none"><li>▶ Make sure the pressure booster system has been de-energised before commencing work on the pressure booster system.</li><li>▶ Make sure that the pressure booster system cannot be started up unintentionally.</li></ul>
	<p><b>⚠ WARNING</b> <b>Unqualified personnel performing work on the pressure booster system</b> Risk of personal injury!</p> <ul style="list-style-type: none"><li>▶ Always have repair and maintenance work performed by specially trained, qualified personnel.</li></ul>
	<p><b>CAUTION</b> <b>Incorrectly serviced pressure booster system</b> Function of pressure booster system not guaranteed!</p> <ul style="list-style-type: none"><li>▶ Regularly service the pressure booster system.</li><li>▶ Prepare a maintenance schedule for the pressure booster system, with special emphasis on lubricants, shaft seals and pump couplings.</li></ul>

The operator ensures that maintenance, inspection and installation are performed by authorised, qualified specialist personnel who are thoroughly familiar with the manual.

- Observe the safety instructions and information.
- For any work on the pump (set) observe the operating manual of the pump (set).
- In the event of damage you can always contact DP Service.
- A regular maintenance schedule will help avoid expensive repairs and contribute to trouble-free, reliable operation with a minimum of maintenance expenditure and work.
- Never use force when dismantling and reassembling the equipment.

### 8.1.1 Inspection contract

For all inspection and servicing work to be carried out at regular intervals we recommend taking out the maintenance contract offered. Get in touch with your service partner for details.

Checklist for commissioning/start-up, checklist for inspection

## 8.2 Servicing/inspection

### 8.2.1 Supervision of operation



#### CAUTION

##### Increased wear due to dry running

Damage to the pump set!

- ▷ Never operate the pump set without liquid fill.
- ▷ Never close the shut-off element in the suction line and/or supply line during pump operation.



#### CAUTION

##### Impermissibly high temperature of fluid handled

Damage to the pump!

- ▷ Prolonged operation against a closed shut-off element is not permitted (heating up of the fluid).
- ▷ Observe the temperature limits in the data sheet and in the section on operating limits.

While the pump is in operation, observe and check the following:

- If activated, check the functional check run.
- Measure the actual start-up pressure and stop pressure of the pump sets with a pressure gauge. Compare the values with the specifications on the name plate.
- Compare the pre-charge pressure of the accumulator with the recommended data. [⇒ Section 8.2.3, Page 55]
- Check the rolling element bearings for running noises. Vibrations, noise and an increase in current input occurring during unchanged operating conditions indicate wear.
- Monitor the functions of auxiliary connections, if any.

### 8.2.2 Maintenance schedule

Table 24: Overview of maintenance work

Maintenance interval	Servicing/maintenance work
At least once a year	Check the pump sets for smooth running and the mechanical seal for integrity.

Maintenance interval	Servicing/maintenance work
	Check the shut-off elements, drain valves and check valves for proper functioning and tightness.
	If fitted, clean the strainer in the pressure reducer.
	If fitted, check the expansion joints for any wear.
	Verify the pre-charge pressure. Check the accumulator for integrity. [⇒ Section 8.2.3, Page 55]
	Check the automatic switching functionality.
	Check the cut-in levels and cut-out levels.
	Check the inflow, inlet pressure, dry running protection, flow monitoring and pressure reducer.

### 8.2.3 Setting the pre-charge pressure



#### **WARNING**

##### **Wrong gas**

Danger of poisoning!

- ▷ Use only nitrogen as cushion gas of the membrane-type accumulator.



#### **CAUTION**

##### **Pre-charge pressure too high**

Damage to the accumulator!

- ▷ Observe the manufacturer's product literature (see name plate or operating manual of the accumulator).

The accumulator's pre-charge pressure ( $p$ ) must be lower than the set start-up pressure ( $p_E$ ) of the pressure booster system.

The best storage volumes are achieved with the following settings (mean value):

- Value 0.9 at start-up pressure  $> 3$  bar
- Value 0.8 at start-up pressure  $< 3$  bar

**Example 1**  $p_E = 5$  bar

$$5 \text{ bar} \times 0.9 = 4.5 \text{ bar}$$

With a start-up pressure of 5 bar the pre-charge pressure of the accumulator must be 4.5 bar.

**Example 2**  $p_E = 2$  bar

$$2 \text{ bar} \times 0.8 = 1.6 \text{ bar}$$

With a start-up pressure of 2 bar the pre-charge pressure of the accumulator must be 1.6 bar.

#### **Checking the pre-charge pressure**

1. Close the shut-off elements fitted underneath the membrane-type accumulator.
2. Drain the membrane-type accumulator via the drain valve.
3. Remove and store the protective cap of the membrane-type accumulator valve.
4. Check the pre-charge pressure using suitable equipment (e.g. tyre pressure gauge).
5. Fit the protective cap of the membrane-type accumulator valve.

#### **Filling the membrane-type accumulator**

1. Remove and store the protective cap of the membrane-type accumulator valve.
2. Add nitrogen through the valve.
3. Fit the protective cap of the membrane-type accumulator valve.

## 8.2.4 Replacing the non-return valve



### **⚠ DANGER**

#### **Voltage at the pressure booster system**

Danger to life!

- Prior to opening the device, wait at least 10 minutes for any residual voltage to dissipate.

1. De-energise the pump set and secure it against unintentional start-up. Comply with the local regulations.
2. Close the shut-off valve of the pump.
3. Place a suitable container under the drain connection.
4. Open the drain connections. To do so, observe the pump's operating manual.

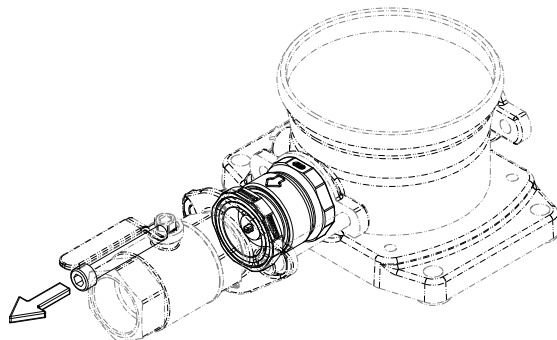

*Fig. 35: Removing the screw*

5. Remove the screw.

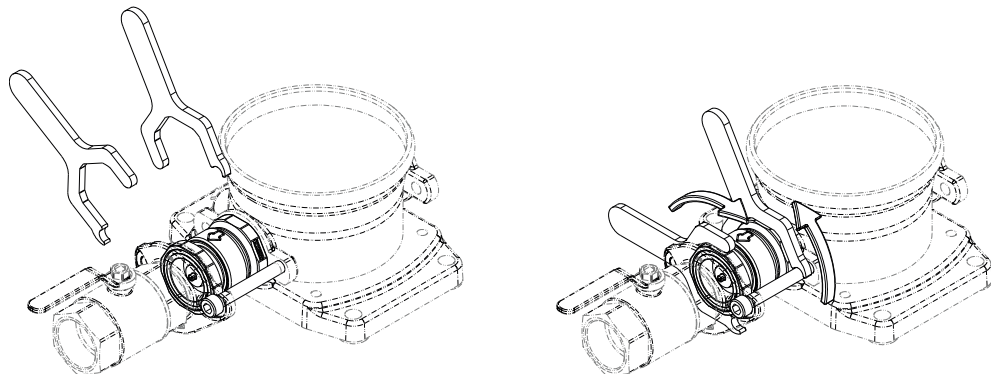

*Fig. 36: Screwing the valve's body parts into each other*

6. Use a suitable tool to screw the body parts of the non-return valve into each other to shorten the length of the body.

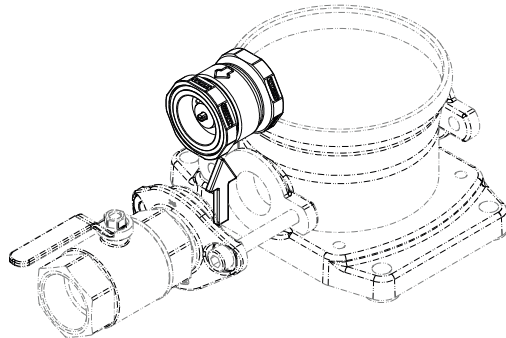

*Fig. 37: Removing the body*

7. Remove the body of the non-return valve.
8. Remove the insert check valve including O-rings.



9. Remove excessive contamination or deposits with a clean cloth.
10. Re-insert the insert check valve into the body. Apply lubricant to new O-rings. See table below.

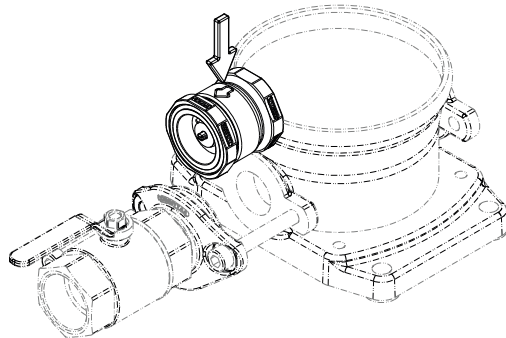

Fig. 38: Mounting the body

11. Mount the body of the non-return valve.

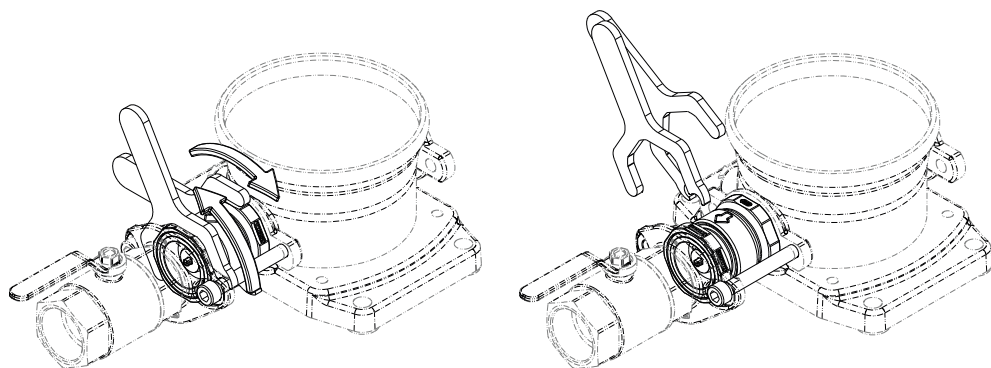

Fig. 39: Loosening the screwed connection of the body parts

12. Use a suitable tool to loosen the screwed connection of the body parts of the non-return valve to extend the body length.



Fig. 40: Verifying the alignment

13. Verify the correct alignment.

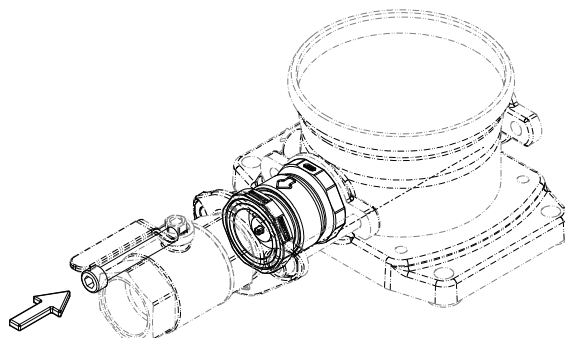

Fig. 41: Fitting the screw

14. Fit and tighten the screw.
15. Close the drain plugs of the pump. Properly dispose of the fluid collected.
16. Slowly open the shut-off valve and check for any leakage.

Table 25: Spare parts for servicing non-return valves, per pump

Material number	Description	Non-return valve	O-rings	O-ring lubricant (non-water soluble)
71630405	ER non-return valve DN 32	Watts Industries IN 032 DN 32	1x Eriks 12711456	Molykote ® G-5511 <sup>5)</sup>
			2x Eriks 12711457	
71630410	ER non-return valve DN 50	Watts Industries IN 050 DN 50	1x Eriks 12192264	
			2x Eriks 12711459	

---

<sup>5)</sup> Sealant for taps

## 9 Trouble-shooting



### **⚠ DANGER**

#### **Unintentional start-up**

Risk of fatal injury due to electric shock!

- ▷ Disconnect the frequency inverter from the mains before carrying out any maintenance and installation work.
- ▷ Prevent the frequency inverter from being re-started unintentionally when carrying out any maintenance and installation work.



### **⚠ DANGER**

#### **Contact with live components**

Risk of fatal injury due to electric shock!

- ▷ Any work on the product shall only be performed when it has been disconnected from the power supply (de-energised).
- ▷ Never remove the centre housing part from the heat sink.
- ▷ Mind the capacitor discharge time.  
After switching off the frequency inverter, wait 10 minutes until dangerous voltages have discharged.



### **NOTE**

Depending on the combination of settings, the frequency inverter could conceivably restart automatically after acknowledgement/reset or when the cause of the malfunction or fault has been eliminated.

The operator ensures that trouble-shooting is performed by authorised, qualified specialist personnel who are thoroughly familiar with the operating manual.

Reset the frequency inverter to the default factory settings before engaging in any fault rectification measures.

## 9.1 Faults/malfunctions: Trouble-shooting



### **! WARNING** Improper work to remedy faults

Risk of injury!

- ▷ For any work performed to remedy faults, observe the relevant information given in this operating manual and/or in the product literature provided by the accessories manufacturer.

If problems occur that are not described in the following table, consultation with the DP service is required.

- A Mains fuse rating too small for the nominal mains current.
- B Motor does not start.
- C Motor running unevenly.
- D Max. speed not reached.
- E Motor running at maximum speed only.
- F Motor running at minimum speed only.
- G No/faulty 24 V supply.
- H Wrong direction of rotation of the motor.
- I Fault message/protective tripping.

Table 26: Trouble-shooting

A	B	C	D	E	F	G	H	I	Possible cause	Remedy
-	X	-	-	-	-	X	-	-	No voltage applied	Check the mains voltage. Check the mains fuses.
-	X	-	-	-	-	-	-	-	No enable	Check enable via DIGIN-EN and system start.
X	-	-	-	-	-	-	-	-	Mains fuse rating too low for frequency inverter input current	Check configuration/selection of mains fuse.
-	-	-	X	-	-	-	-	-	No setpoint signal or setpoint set too low / drive overloaded and in i <sup>2</sup> t control mode	Check setpoint signal and operating point.
-	-	-	-	X	-	-	-	-	Process-related persistent control deviation (actual value smaller than setpoint) / no actual value (e.g. due to broken wire)	Check setpoint/actual value signal; check operating point; check controller setting.
-	X	-	-	-	-	-	-	X	Permissible voltage range undershot/exceeded	Check mains voltage; supply frequency inverter with required voltage.
-	-	-	-	-	-	-	-	X	Wrong direction of rotation setting.	Change the direction of rotation.
-	-	X	X	-	-	-	-	X	Frequency inverter overloaded	Reduce the power input by lowering the speed; check the motor/pump for blockages.
-	X	-	-	-	-	-	-	X	Short circuit in control cable/pump blocked	Check/replace control cable connections. Remove the pump blockage manually.
-	-	X	X	-	-	-	-	X	Temperature of power electronics or motor winding too high	<ul style="list-style-type: none"> <li>- Reduce the ambient temperature by improving ventilation.</li> <li>- Improve cooling by cleaning the cooling fins.</li> <li>- Ensure that the intake opening for the fans is not blocked.</li> <li>- Ensure that the fans are working properly.</li> <li>- Reduce the power input by changing the operating point (system-specific).</li> <li>- Check the permissible load and, if necessary, use external cooling.</li> </ul>
-	-	-	-	-	-	X	-	X	24 V voltage supply overloaded	Disconnect frequency inverter from the power supply and eliminate the cause of the overload.

A	B	C	D	E	F	G	H	I	Possible cause	Remedy
-	-	-	-	-	-	-	-	X	Dry running of pump	Check the hydraulic system and rectify the fault on the frequency inverter.
-	-	-	X	-	X	-	-	X	Sensor signal error (e.g. broken wire)	Check sensor and sensor cable.
-	X	X	-	-	-	-	-	X	Phase failure (drive)	Check motor connection and motor winding.

## 9.2 Alerts

Table 27: Alerts

Message code	Message	Description	Behaviour
E1	Thermal motor protection	PTC has tripped	Self-acknowledging (configurable)
E2	Overvoltage	Impermissible overvoltage (mains)	Partially self-acknowledging
E3	Undervoltage	Impermissible undervoltage (mains)	Partially self-acknowledging
E4	Phase failure (motor)	Phase failure (motor)	Non-self-acknowledging
E5	Short circuit	Motor short-circuited (defective motor winding)	Partially self-acknowledging
E6	Hardware error	Hardware defective	Non-self-acknowledging
E7	Heat sink temperature high	Power electronics overtemperature	Non-self-acknowledging
E8	PCB temperature high	Control electronics overtemperature	Non-self-acknowledging
E9	Overcurrent	Impermissible overcurrent	Partially self-acknowledging
E10	Braking resistor	Internal overcurrent (for example, if the ramp is too steep)	Non-self-acknowledging
E11	Dynamic overload protection	Impermissible overcurrent	Partially self-acknowledging
E12	Firmware update required	Firmware update required	Non-self-acknowledging
E13	Dry running	Dry running of pump	Non-self-acknowledging
E14	Dry running (external)	Dry running of pump	Self-acknowledging (configurable)
E15	Hydraulic blockage	Pumping against closed piping	Non-self-acknowledging
E16	No master control	Failure of actual value sensor/ Broken wire/ Local/ No redundancy	Self-acknowledging
E17	Lack of Water	Lack of Water	Self-acknowledging (configurable)
E18	No matching motor data available	The extended KSB SuPremE motor data could not be determined.	Self-acknowledging
E19	No motor data available	The motor data is not set	Self-acknowledging
E20	AMA fault	The extended motor data could not be determined.	Self-acknowledging
E76	24 V overload	Internal 24 V power supply unit overloaded	Self-acknowledging
E77	PumpMeter communication	Incorrect PumpMeter communication	Self-acknowledging
E83	Overflow	-	Non-self-acknowledging

Message code	Message	Description	Behaviour
E84	Setpoint/control value failure	-	Self-acknowledging
E98	HMI hardware test not passed.	Control panel is defective.	Non-self-acknowledging
E99	IO hardware test not passed.	Control electronics or M12 module defective.	Non-self-acknowledging

Table 28: Alerts

Alert	Possible causes	Remedy <sup>6/7)</sup>
Short circuit	Motor short-circuited (defective motor winding)	Check motor winding, perform dielectric test. Check motor for blockage.
	Power supply connected incorrectly	Check the cabling; connect the mains power supply to L1, L2, L3, PE.
	Parallel operation of motors	Impermissible operating range
	Motor terminal board wired incorrectly (delta/star)	Wire motor terminal board correctly.
	Motor power cable short circuit	Check motor power cable.
	Sensor cable shielding connected incorrectly	Connect sensor cable shielding to PE on one end only.
	24 V DC cabling short circuit	Check cabling.
Thermal motor protection	PTC thermistor connected incorrectly	Check PTC sensor connection.
	Incorrect motor data set	Match motor data settings to motor used.
	Wrong direction of rotation of the pump	Adjust the direction of rotation of the motor via the phase sequence.
	Hydraulic overload	Reduce the hydraulic load.
	Pump blocked mechanically/runs sluggishly	Check pump.
	Motor terminal board wired incorrectly (delta/star)	Wire motor terminal board correctly.
	Frequency inverter power < motor power and/or output current < motor current	Wrong device ordered, mount larger frequency inverter.
	Carrier frequency of frequency inverter set too high	Set carrier frequency to permissible range.
	Fluctuating DC link voltage when pump is not running	Check mains voltage quality.
	Fluctuating DC link voltage when pump operates at nominal values	Check mains voltage quality.
	Incorrect motor current measurement	Measure current using suitable snap-on ammeter and compare with the information displayed on the control panel. <b>NOTE!</b> Approx. 10 % tolerance is permissible.
	Pump runs in reverse when motor is not supplied with current.	Check swing check valve.
Motor voltage output is too low at nominal load, < 380 V at nominal load	Check line input voltage; enter motor current at 380 V mains voltage; fit larger-sized motor.	
Heat sink temperature high / PCB temperature high	Ambient temperature of frequency inverter > 50 °C	Impermissible operating range; mind power derating.
	Dirt in external fans	Clean fans.
	Heat sink/cooling fins dirty	Clean heat sink/cooling fins.
	Carrier frequency of frequency inverter set too high	Set carrier frequency to permissible range.
	Frequency inverter power < motor power and/or output current < motor current	Wrong device ordered, mount larger frequency inverter.

62 / 74

<sup>6</sup> Disconnect the frequency inverter from the power supply to rectify faults on current-carrying components. Observe the safety information!

<sup>7</sup> Restore the frequency inverter's default settings.

Alert	Possible causes	Remedy <sup>6)7)</sup>
	Frequency inverter mounted incorrectly	External fans must point upwards; on the wall-mounted model, the back of the heat sink must be closed.
Undervoltage	Line input voltage too low	Check the mains voltage.
	Fluctuating DC link voltage when pump is not running	Check mains voltage quality.
	Mains fuse has tripped	Fit new mains fuse.
	Brief interruption of mains voltage	Check the mains voltage.
Overvoltage	Line input voltage too high	Check the mains voltage.
	Fluctuating DC link voltage when pump is not running	Check mains voltage quality.
	Ramp times too short	Select longer ramp times.
	Pump runs in reverse when motor is not supplied with current.	Check swing check valve.
Overcurrent/ dynamic overload protection	Mains power supply connected incorrectly	Connect mains power supply to L1, L2, L3, PE.
	Motor terminal board wired incorrectly (delta/star)	Wire motor terminal board correctly.
	Incorrect motor data set (3-3-2)	Match motor data settings to motor used.
	Parallel operation of motors	This mode of operation is not permissible.
	Sensor cable shielding connected incorrectly	Connect sensor cable shielding to PE on one end only.
	Frequency inverter power < motor power and/or output current < motor current	Wrong device ordered, mount larger frequency inverter.
	Ramp times too short	Select longer ramp times.
	Wrong direction of rotation of the pump	Adjust the direction of rotation of the motor via the phase sequence.
	Pump blocked mechanically/runs sluggishly	Check pump.
	Carrier frequency of frequency inverter set too high	Set carrier frequency to permissible range.
	Incorrect motor current measurement	Measure current using suitable snap-on ammeter and compare with the information displayed on the control panel. Please note: Approx. 10 % tolerance is permissible.
	Pump runs in reverse when motor is not supplied with current.	Check swing check valve.
No master control	Device bus wired incorrectly (interruption, short circuit)	Re-wire properly.
	Sensor connected incorrectly (actual value failure)	Connect sensor correctly.
	No main pump recognised in system	Define role in multiple pump system.
Braking resistor	Stop ramp time too short	Increase ramp time.
	Pump runs in reverse when motor is not supplied with current.	Check swing check valve.
	Generator operation of pump	Impermissible operating range
Dry running / dry running (external)	Dry running of pump	Check piping. Check the pump valves.
	Hydraulic blockage	Check piping. Check the pump valves.

## 9.3 Warnings

Table 29: Warnings

Message code	Message	Description	Behaviour
E30	External message	External message present.	Self-acknowledging (configurable)
E50	Dynamic overload protection	Impermissible overcurrent	Self-acknowledging
E51	Overvoltage	Overvoltage	Self-acknowledging
E52	Undervoltage	Undervoltage	Self-acknowledging
E53	Resonance range	Resonance range	Self-acknowledging
E54	Broken wire	Broken wire	Self-acknowledging
E55	Actual value failure	Failure of actual value	Self-acknowledging
E56	Hydraulic blockage	Pumping against closed piping	Self-acknowledging
E56	Hydraulic blockage	Pumping against closed piping	Self-acknowledging
E57	Low flow	Low flow	Self-acknowledging
E58	Hydraulic overload	Hydraulic overload	Self-acknowledging
E59	Heat sink temperature high	Power electronics overtemperature	Self-acknowledging
E60	PCB temperature high	Control electronics overtemperature	Self-acknowledging
E61	Current high	Motor current high	Self-acknowledging
E62	Current low	Motor current low	Self-acknowledging
E63	Speed monitoring	Limit value violation, speed	Self-acknowledging
E64	Setpoint monitoring	Limit value violation, setpoint	Self-acknowledging
E65	Actual value monitoring	Limit value violation, actual value	Self-acknowledging
E66	Flow rate monitoring	Limit value violation, flow rate	Self-acknowledging
E67	Suction pressure monitoring	Limit value violation, suction pressure	Self-acknowledging
E68	Discharge pressure monitoring	Limit value violation, discharge pressure	Self-acknowledging
E69	Differential pressure monitoring	Limit value violation, differential pressure	Self-acknowledging
E70	Temperature monitoring	Limit value violation, temperature	Self-acknowledging
E71	Frequency high	Frequency high	Self-acknowledging
E72	Frequency low	Frequency low	Self-acknowledging
E73	Power high	Power high	Self-acknowledging
E74	Power low	Power low	Self-acknowledging
E75	Limited stop ramp	Set stop ramp time exceeded	Self-acknowledging
E76	24 V overload	Internal 24 V power supply unit overloaded	Self-acknowledging
E77	PumpMeter communication	Incorrect PumpMeter communication	Self-acknowledging
E78	Firmware update for field bus required	Module incompatible with main module	Self-acknowledging
E79	Firmware update for HMI required	Module incompatible with main module	Self-acknowledging
E83	Overflow	-	Non-self-acknowledging
E84	Setpoint/control value failure	-	Self-acknowledging
E99	General settings loaded	General settings loaded	Self-acknowledging

64 / 74

Table 30: Warnings

Warning	Possible causes	Remedy
Dynamic overload protection	Incorrect motor data set	Match motor data to motor used.
	Wrong direction of rotation of the pump	Adjust the direction of rotation of the motor via the phase sequence
	Hydraulic overload	Reduce the hydraulic load.
	Pump blocked mechanically/runs sluggishly	Check pump.
	Motor terminal board wired incorrectly (delta/star)	Wire motor terminal board correctly.



Warning	Possible causes	Remedy
	Frequency inverter power < motor power and/or output current < motor current	Wrong device ordered, mount larger frequency inverter.
	Frequency inverter carrier frequency set too high	Set carrier frequency to permissible range.
	Ambient temperature of frequency inverter > 50 °C	Impermissible operating range; mind power derating.
	Fluctuating DC link voltage when pump is not running	Check mains voltage quality.
	Incorrect motor current measurement	Measure current using suitable snap-on ammeter and compare with the information displayed on the control panel. <b>NOTE!</b> Approx. 10 % tolerance is permissible.
	Pump runs in reverse when motor is not supplied with current	Check swing check valve.
	Motor voltage output is too low at nominal load, < 380 V at nominal load	Check line input voltage; enter motor current at 380 V mains voltage; fit larger-sized motor.
Broken wire	Cable integrity monitoring	Replace defective sensor with new one.
Low flow/overload	The driven pump is operated under low flow/ overload conditions.	Impermissible operating range; operate the pump within the permissible range.
24 V overload	24 V DC voltage supply overload	Reduce current draw on 24 V DC supply; compare the number of electrical connections with the maximum permissible current load of the 24 V DC supply.
	Short circuit of consumers connected to 24 V DC voltage supply	Disconnect defective 24 V DC consumers.
	Control terminal wiring errors (DigIn, AnIn)	Re-wire properly.

## 9.4 Information messages

Table 31: Information messages

Message code	Message	Description	Behaviour
E100	Pump maintenance/service interval	Service interval set for pump expired.	Self-acknowledging
E101	Drive disabled	<ul style="list-style-type: none"> <li>– The motor is disabled while AMA is being carried out.</li> <li>– If the Overcurrent alert is output that causes the drive to be stopped, the drive remains disabled as long as this event is active.</li> <li>– In the event of a stop via the DI-EN digital input, the motor is not stopped by the stop ramp, but coasts to a standstill. The amount of time this process takes depends on the mass moment of inertia of the system. The drive remains disabled during coasting.</li> </ul>	Self-acknowledging
E102	Pipe flushing mode active	Performing the pipe flushing function	Self-acknowledging
E103	Pipe filling mode active	Performing the pipe filling function	Self-acknowledging
E104	Maintenance interval, motor bearings	Maintenance interval set for motor expired.	Self-acknowledging
E105	Factory-set defaults loaded	Factory-set defaults are being loaded.	Self-acknowledging
E106	User settings 1 loaded	User settings 1 were loaded.	Non-self-acknowledging
E107	User settings 2 loaded	User settings 2 were loaded.	Non-self-acknowledging

# 10 Related Documents

## 10.1 General assembly drawings/exploded views with list of components

### 10.1.1 Hydro-Unit Single Line SVP with DPV 2B, 4B, 6B, 10B, 15C

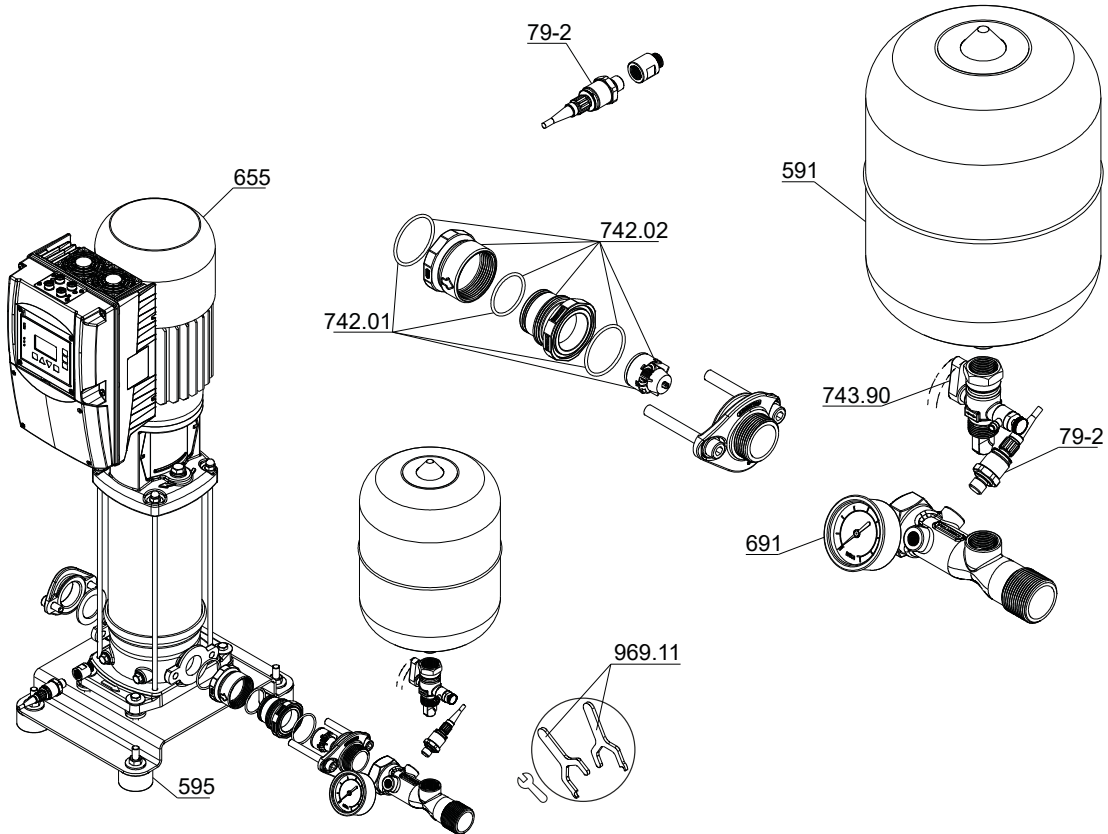

Fig. 42: Single Line SVP with DPV 2, 4, 6, 10, 15

Table 32: List of components

Part No.	Description	Part No.	Description
79-2	Measuring transducer	691	Pressure gauge
591	Membrane-type accumulator	742.01/02	Lift check valve
595	Anti-vibration pad	743.90	Ball valve
655	Pump	969.11	Tool

### 10.1.2 Hydro Unit Single Line SVP with DPV 25B, 40B, 60B, 90B, 125B

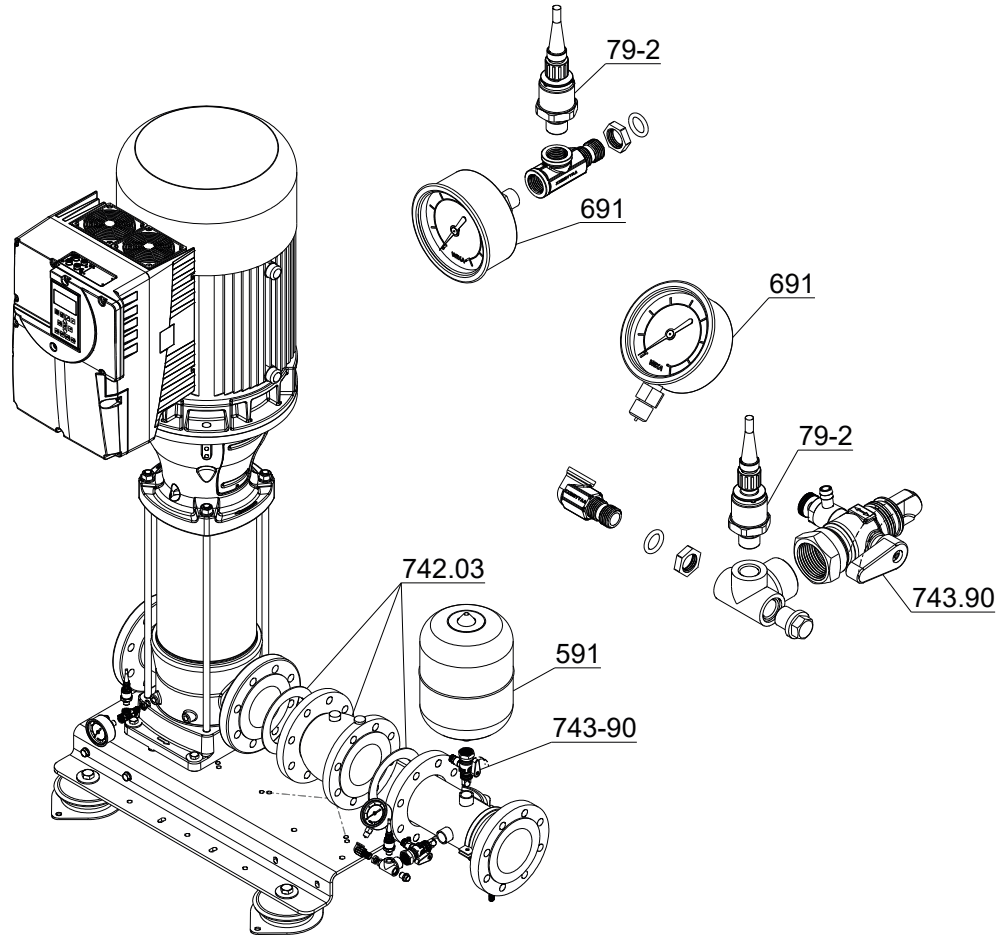

Fig. 43: Single Line SVP with DPV 25, DPV 40, DPV 60, DPV 85 and DPV 125

Table 33: List of components

Part No.	Description	Part No.	Description
79-2	Measuring transducer	742.03	Lift check valve
591	Membrane-type accumulator	743.90	Ball valve
691	Pressure gauge		

The individual parts of the pump set are shown in the product literature of the pump set.

# 11 EU Declaration of Conformity

Manufacturer:

**Duijvelaar Pompen  
DP Pumps  
Kalkovenweg 13  
2401 LJ Alphen aan den Rijn (The Netherlands)**

This EU Declaration of Conformity is issued under the sole responsibility of the manufacturer.

The manufacturer herewith declares that **the product**:

## Hydro-Unit Single Line SVP

**Type code: 38/2019 0000000-0001 - 52/2020 9999999-9999**

- is in conformity with the provisions of the following directives / regulations as amended from time to time:
  - Pump set: 2006/42/EC Machinery Directive
  - Electrical components<sup>8)</sup>: 2011/65/EU Restriction of the use of certain hazardous substances in electrical and electronic equipment (RoHS)
  - 2014/30/EU: Electromagnetic Compatibility (EMC)

The manufacturer also declares that

- the following harmonised international standards have been applied:
  - ISO 12100
  - EN 809
  - EN 60204-1
  - EN 806-2

Person authorised to compile the technical file:

Ron Bijman  
Manager Competence Centre Products  
Duijvelaar Pompen B.V.  
Kalkovenweg 13  
2401 LJ Alphen aan den Rijn (The Netherlands)

The EU Declaration of Conformity was issued in/on:

Alphen aan den Rijn, 1 July 2022



Ron Bijman  
Manager Competence Centre Products  
Duijvelaar Pompen B.V.  
Kalkovenweg 13  
2401 LJ Alphen aan den Rijn (The Netherlands)

---

<sup>8</sup> Where applicable

# 12 Certificate of Decontamination

Type: .....

Order number /  
Order item number<sup>9)</sup>: .....

Delivery date: .....

Application: .....

Fluid handled<sup>9)</sup>: .....

Please tick where applicable<sup>9)</sup>:



Corrosive



Oxidising



Flammable



Explosive



Hazardous to health



Seriously hazardous to health



Toxic



Radioactive



Bio-hazardous



Safe

Reason for return<sup>9)</sup>: .....

Comments: .....

The product / accessories have been carefully drained, cleaned and decontaminated inside and outside prior to dispatch / placing at your disposal.

We herewith declare that this product is free from hazardous chemicals and biological and radioactive substances.

For mag-drive pumps, the inner rotor unit (impeller, casing cover, bearing ring carrier, plain bearing, inner rotor) has been removed from the pump and cleaned. In cases of containment shroud leakage, the outer rotor, bearing bracket lantern, leakage barrier and bearing bracket or intermediate piece have also been cleaned.

For canned motor pumps, the rotor and plain bearing have been removed from the pump for cleaning. In cases of leakage at the stator can, the stator space has been examined for fluid leakage; if fluid handled has penetrated the stator space, it has been removed.

- No special safety precautions are required for further handling.
- The following safety precautions are required for flushing fluids, fluid residues and disposal:

.....  
.....

We confirm that the above data and information are correct and complete and that dispatch is effected in accordance with the relevant legal provisions.

.....  
Place, date and signature

.....  
Address

.....  
Company stamp

<sup>9)</sup> Required field



# 13 Commissioning Report

The pressure booster system specified below has been commissioned today by the undersigned, authorised DP Service who created this report.

## Pressure booster system details

Type series .....  
Size .....  
Serial number .....  
Order No. ....

## Purchaser/place of installation

Purchaser	Place of installation
Name .....	.....
Address .....	.....
.....	.....

## Operating data

For further data refer to the wiring diagram.

Start-up pressure  $p_E$  bar .....  
Inlet pressure monitoring  $p_{inl} - x$  .....  
(setting of inlet pressure switch)  
Stop pressure  $p_A$  bar .....  
Inlet pressure  $p_{inl}$  [bar] .....  
Pre-charge pressure .....  
of accumulator  $p_{pre-charge}$  .....  
[bar]

The operator or operator's representative herewith confirms to have received instructions on how to operate and service the pressure booster system. The relevant circuit diagrams and operating instructions have been handed over.

Non-conformities found during commissioning	Deadline for remedial action
Non-conformity 1.....	.....
.....	.....
.....	.....
.....	.....

Name of DP representative .....	Name of purchaser or representative .....
.....	.....
Place .....	Date .....
.....	.....

# Index

## A

Access levels	50
Alerts	61
Analog input	29, 32
Arrow keys	46, 47
Automation	18

## C

Certificate of Decontamination	69
Commissioning/start-up	38
Connection cables	
Control cable	30
Connection to mains power supply	33
Connection to the power supply network and motor	
Size A	33
Control cable	
Connecting	30
Earthing	37
Cover	
C-shaped	31
Protective cover	31

## D

Design	18
Designation	17
Disposal	15
Drive	18
Dry running protection	29, 38

## E

Earthing	
Connect	37
EMC Directive	11
Escape key	46
Event of damage	7

## F

Faults	
Causes and remedies	60

## I

Installation	18
Installation at site	25
Intended use	9
Interference emissions	11
IT mains	35

## J

Jumper	35
--------	----

## K

Key to safety symbols/markings	8
--------------------------------	---

## L

LED display	52
-------------	----

## M

Main screen	45
Mains and motor connection	
Size B	34
Size C	34
Maintenance work	54
Motor connection	33
Motor power cable	
Connecting	30

## O

OK key	46, 47
Operating limits	9
Other applicable documents	7

## P

Partly completed machinery	7
Personnel	10
Power/connection cables	
Control cable	37
Routing cables	33
PTC	
Size B	34
Size C	34
PTC thermistor	33
Size A	33

## Q

Qualification	10
---------------	----

## R

Return to supplier	15
--------------------	----

## S

Safety	9
Safety awareness	10
Scope of supply	20
Sensor	
Size A	33
Size B	34
Size C	34
Service interface	52
Shielding	37
Standard control panel	44

---

## T

Terminal strip	29, 32
Thermal motor protection	
Size A	33, 34
Size C	34
Traffic light	52

## W

Warnings	8, 64
Graphical control panel	52
Warranty claims	7





---

**duijvelaar** pompen  
**dp** pumps

Kalkovenweg 13  
2401 LJ Alphen aan den Rijn (NL)

☎ +31 72 48 83 88

[www.dp.nl](http://www.dp.nl)

2023-05-29

BE00001142 (1983.846/05-EN)

