

Fisher™ ET, EAT, and ETR Sliding-Stem Control Valves

Fisher ET, EAT, and ETR general-purpose control valves (figures 2, 3, and 4) are used for throttling or on-off control of a wide variety of liquids and gases. All three valve designs have single ports, balanced valve plugs, and cage guiding. Metal-to-PTFE seating for stringent shutoff requirements is standard in all valves except those with Cavitrol™ III cages. Metal-to-metal seating for higher temperatures is standard for valves with Cavitrol III cages and optional for all other valves.

The temperature limits of ET valves can be extended above 232°C (450°F) by using PEEK (PolyEtherEtherKetone) anti-extrusion rings in combination with a spring-loaded PTFE seal. The PEEK anti-extrusion rings expand to close off the clearance gap between the plug and the cage where the PTFE seal may extrude at high temperatures and pressures. The temperature limits are extended to 316°C (600°F) for non-oxidizing service and to 260°C (500°F) for oxidizing service.

The ET product line is available for a wide range of applications, including sulfide and chloride stress-cracking environments common to the oil and gas production industries. To discuss available constructions, contact your [Emerson sales office](#) and include the applicable codes and standards required for these environments.

The easy-e™ Valve Family

ET, EAT, and ETR control valves are part of the versatile easy-e family of Fisher industrial control valves. easy-e valves share the following characteristics:

- Multiple trim material choices
- Interchangeable, restricted-capacity trims and full-sized trims to match variable process flow demands



X1968

**FISHER ET VALVE WITH 667 ACTUATOR
AND FISHER FIELDVUE™ DVC7K**

- Different cage/plug styles that provide particular flow characteristics for highly-specialized applications. The standard cage comes in three different flow characteristics: quick-opening, linear, or equal percentage.
- Whisper Trim™ I, Whisper Trim III (figure 7), and Whisper NXG Trim, and WhisperFlo™ cages (figures 5 and 6) attenuate aerodynamic noise in gaseous service.
- To help eliminate cavitation damage in a properly-sized valve, a standard-travel, Cavitrol III, one-stage cage (figure 9) and a long-travel, Cavitrol III, two-stage cage are available in the NPS 1 through NPS 8 ET control valve.

Features

- **Compliance with the Clean Air Act—ENVIRO-SEAL™** packing systems (figures 10 and 11) that provide an improved stem seal to help prevent the loss of process fluid are available. These packing systems feature PTFE or Graphite ULF packing with live-loading for reduced packing maintenance.
- **PTFE Seating for Long-Lasting Shutoff Capability—**Controlled compression of standard seat construction protects PTFE disk between metal disk seat and disk retainer (figure 2). Only the edge of the PTFE disk is contacted by the flowstream during normal operation. Excellent shutoff is maintained by a backup ring or spring-loading that forces the valve plug seal ring against the cage (figure 2).
- **Valve Plug Stability—**Rugged cage guiding provides high valve plug stability, which reduces vibration and mechanical noise.
- **Cost-Effective Operation and Maintenance Economy—**Increased wear resistance of hardened stainless steel trim means longer-lasting service. When inspection or maintenance is necessary, the body can stay in the pipeline during removal of trim parts. Balanced valve plug construction permits use of smaller, lower-cost Fisher actuators. The ETR valve also permits easy body interior access without having to remove the bonnet or actuator (figure 4). And, trim inventory costs are cut because dimensional standardization permits use of most standard easy-e trim parts.
- **Compliance with European Standards—**Valves are available with dimensions specified by EN/DIN standards. See figure 15.
- **Sour Service Capability—**Unless otherwise noted, references are to NACE MR0175-2002. Optional materials are available to meet NACE MR0103 and NACE MR0175 / ISO 15156. Material requirements under these standards vary by edition and year of issue; the specific standard must be specified.

Table of Contents

Features	2	Trim Materials	11
Specifications	3	Materials and Temperature Limits for	
ENVIRO-SEAL Packing System		Other Parts	21
Specifications	4	Valve Body/Trim Temperature	
Trim Cartridge	6	Capabilities	23
ENVIRO-SEAL and HIGH-SEAL		Bonnet Selection Guidelines	24
Packing Systems	7	Maximum Flow Coefficients	24
ANSI/FCI Class VI Shutoff		Port Diameters, Valve Plug Travel,	
Capabilities	7	Stem and Yoke Boss Diameters	25
Tables		Metal Trim Parts	28
Available Constructions	5	Bolting Materials and Temperature Limits	28
Shutoff Classifications	5	Dimensions	29
Class VI Shutoff Availability	7	Ordering Information	32
Class VI Trim Materials	7		

Specifications

Available Configurations

ET: Single-port, globe-style control valve with cage guiding, balanced valve plug, and push-down-to-close valve plug action (figure 2)

EAT: Angle version of ET control valve, used to facilitate piping or in applications where a self-draining valve is desired (figure 3)

ETR: Same as ET control valve except with push-down-to-open valve plug action (figure 4)

Valve Sizes and End Connection Styles

Flanged raised-face per EN 1092-1/B and see table 1

Maximum Inlet Pressures and Temperatures^(1,2)

As listed below, unless limited by maximum pressure drop or material temperature capabilities

Valves with Cast Iron Bodies

Flanged: Consistent with CL125B or 250B per ASME B16.1

Valves with Steel and Stainless Steel Bodies

Flanged: Consistent with CL150, 300, and 600⁽³⁾ per ASME B16.34

Screwed or Welding: Consistent with flanged CL600 per ASME B16.34

Maximum Pressure Drops⁽²⁾

Same as maximum inlet pressure for specific construction defined above, except where further limited as follows:

All Valves Except Those with Cavitrol III, Whisper Trim III, Whisper NXG Trim, and WhisperFlo Cages: See figure 12.

Valves with Cavitrol III Cages: See figure 13.

Valves with Whisper Trim III and Whisper NXG Trim Cages: 0.999 $\Delta P/P_1$ maximum for levels A1 through D3

Valves for NACE MR0175 / ISO 15156 and MR0103: See figure 14

Shutoff Classifications Per ANSI/FCI 70-2 and IEC 60534-4

Class IV, V, or VI. See tables 2, 4, or 5

Construction Materials

Body, Bonnet, and Bonnet Spacer or Bottom Flange, if used: ■ Cast iron, ■ WCC carbon steel, or ■ LCC carbon steel, ■ WC9 chrome moly steel, ■ CF8M

(cast 316 stainless steel), ■ CF3M (cast 316L stainless steel) or ■ other materials upon request

Valve Plug, Cage, and Metal Seating Parts:

All Valves Except Those with Cavitrol III, Whisper NXG Trim, or Whisper Trim III Cages: See table 6

Valves with Cavitrol III Cages: See table 7

Valves with Whisper Trim III and Whisper NXG Trim Cages: See table 10

Valves with WhisperFlo Cages: See table 9

Bellows Seal Assembly: ■ 316L stainless steel or ■ N04400

All Other Parts: See table 12

Material Temperature Capabilities⁽²⁾

Body/Trim Combinations:

All Valves Except Those with Cavitrol III, Whisper NXG Trim, or Whisper Trim III Cages: See figure 12

Valves with Cavitrol III Cages: See table 7

Valves with Whisper Trim III and Whisper NXG Trim Cages: See table 10

Valves with WhisperFlo Cages: See table 9

Bolting For NACE MR0175 / ISO 15156 and MR0103: See table 22

Bonnets: See table 14

All Other Parts: See table 12

Flow Characteristics

Standard Cages: ■ Quick-opening, ■ linear, or ■ equal percentage

Whisper Trim, WhisperFlo, and Cavitrol Cages: Linear

Flow Directions

ET

Standard Cage: Normally down

Whisper Trim and WhisperFlo Cages: Always up

Cavitrol Cage: Always down

EAT

Standard Cage with Liner for Metal Seat: Normally down

Standard Cage without Liner: Flow up or down

Whisper Trim and WhisperFlo Cages: Always up

ETR

Standard Cage: Normally up

Whisper Trim Cage: Always down

Flow Coefficients and Noise Level Prediction

See table 15 and Catalog 12

- continued -

Specifications (continued)

Port Diameters and Maximum Valve Plug Travels

See tables 16, 18, and 16

Yoke Boss and Stem Diameters

See table 17

Typical Bonnet Styles

See table 14

Packing Arrangements

Standard Material: Single PTFE V-ring

Optional Materials: See table 12

ENVIRO-SEAL Packing Systems: See figures 10 and 11
ENVIRO-SEAL Packing Systems in vacuum service:
Standard ENVIRO-SEAL packing systems can be used in vacuum service with packing rings in standard orientation. Do not reverse the ENVIRO-SEAL PTFE packing rings. Also, see Bulletin 59.1:061, ENVIRO-SEAL Packing Systems for Sliding-Stem Valves ([D101633X012](#)).

Approximate Weights

- NPS 1: 14 kg (30 lb)
- NPS 1-1/2: 20 kg (45 lb)
- NPS 2: 39 kg (85 lb)
- NPS 2-1/2: 45 kg (100 lb)
- NPS 3: 57 kg (125 lb)
- NPS 4: 77 kg (170 lb)
- NPS 6: 159 kg (350 lb)
- NPS 8: 408 kg (900 lb)

Optional Safety Instrumented System Classification

SIL3 capable — certified by exida Consulting LLC

Additional Options

- Lubricator, ■ lubricator/isolating valve, ■ drilled and tapped connection in extension bonnet for leak-off service, ■ body drain plug, ■ style 3 fabricated extension bonnet made on order to a specific length for cryogenic service, ■ style NS bonnet for seismic service requirements, ■ packings suitable for nuclear service, ■ Class V shutoff for ET above 232°C (450°F) using PEEK anti-extrusion rings, ■ Trim Cartridge

1. EN (or other) ratings and end connections can usually be supplied; consult your [Emerson sales office](#).
2. The pressure or temperature limits in this bulletin, and any applicable code limitations, should not be exceeded.
3. Certain bonnet bolting material selections may require a CL600 easy-e valve assembly to be derated. Contact your Emerson Automation Solutions sales office for more information.
4. Limitation based on excessive noise increase if max ΔP/P₁ ratio for a given cage level is exceeded.

ENVIRO-SEAL Packing System Specifications

Applicable Stem Diameters

- 9.5 mm (3/8 inches), ■ 12.7 mm (1/2 inches), ■ 19.1 mm (3/4 inches), ■ 25.4 mm (1 inch), and ■ 31.8 mm (1-1/4 inches) diameter valve stems

Maximum Pressure/Temperature Limits⁽¹⁾

To Meet the EPA Fugitive Emission Standard of 100 PPM⁽²⁾
For ENVIRO-SEAL PTFE and ENVIRO-SEAL Duplex packing systems: full CL300 up to 232°C (450°F)
For ENVIRO-SEAL Graphite ULF packing: 104 bar (1500 psig) at 316°C (600°F)

Construction Materials

PTFE Packing Systems
Packing Ring and Lower Wiper: PTFE V-ring⁽³⁾
Male and Female Adaptor Rings: Carbon-filled PTFE V-ring

Graphite ULF Packing Systems: Graphite rings
Duplex Packing Systems:
Male and Female Adaptor Rings: Carbon-filled PTFE V-ring
Guide Bushings: Carbon graphite
Packing Rings: Graphite composite
Packing Washer: PTFE
Anti-Extrusion Washer: Filled PTFE (not required for Graphite ULF or duplex packing)
Lantern Ring: S31600 (316 stainless steel) (not required for Graphite ULF packing)
Packing Box Flange: S31600
Spring: ■ 17-7PH stainless steel or ■ N06600
Packing Follower: S31600 lined with carbon-filled PTFE
Packing Box Studs: Strain-hardened 316 stainless steel
Packing Box Nuts: 316 stainless steel SA194 Grade 8M

1. Refer to the valve specifications in this bulletin for pressure/temperature limits of valve parts. Do not exceed the pressure/temperature rating of the valve. Do not exceed any applicable code or standard limitation.
2. The Environmental Protection Agency (EPA) has set a limit of 100 parts per million (ppm) for fugitive emissions from a valve in selected VOC (Volatile Organic Compound) services.
3. In vacuum service, it is not necessary to reverse the ENVIRO-SEAL PTFE packing rings.

Table 1. Available Constructions

VALVE	VALVE SIZE, NPS	VALVE BODY MATERIAL AND END CONNECTION STYLE ⁽¹⁾							
		Cast Iron Valve Body		Carbon Steel, Alloy Steel, or Stainless Steel Valve Body					
		CL125 FF Flanged	CL250 RF Flanged	Screwed	RF or RTJ Flanged			Butt Weld	Socket Weld
			CL150	CL300	CL600				
ET	1, 1-1/2, or 2 2-1/2, 3, 4, 6, or 8	X	X	X	X	X	X	X	X
EAT	1 or 2 3, 4, or 6	---	---	---	X	X	X	X	X
ETR	1, 1-1/2, or 2 2-1/2, 3, or 4	---	---	X	X	X	X	X	X
		---	---	---	---	---	---	---	---
VALVE	VALVE SIZE, DN	STEEL VALVE BODY MATERIAL AND RAISED-FACE END CONNECTION STYLE ⁽²⁾							
		PN16	PN25	PN40	PN63	PN100			
ET	25, 40, 50, 65, 80, 100, 150, or 200	X	X	X	X	X			
EAT	25, 50, 80, 100, or 150	X	X	X	X	X			
ETR	25, 40, 50, 65, 80, or 100	X	X	X	X	X			

X = Available Construction.
1. End connection style abbreviations: FF - Flat Faced, RF - Raised Face, RTJ - Ring Type Joint.
2. End connection EN1092-1/B.

Table 2. Shutoff Classifications Per ANSI/FCI 70-2 and IEC 60534-4

Valve Design	Seating	Shutoff Class
All except those with Cavitrol III cages	PTFE	V Air Test
		V (optional)
		VI (optional) ⁽³⁾
	Metal	IV (standard)
		V (optional) ⁽¹⁾
		VI (optional) ⁽³⁾
ET with Cavitrol III one-stage cage	Metal	IV (standard)
ET with Cavitrol III two-stage cages	Metal	V (optional)
ET and EAT w/ TSO (Tight Shutoff) trim (CL125 through 600)	Replaceable, protected soft seat	TSO ⁽²⁾ TSO is not an ANSI/FCI leakage class.
ET w/ TSO (Tight Shutoff) trim (CL125 through 600)	Std or Cavitrol III trim. Replaceable, protected soft seat.	Valves with TSO trim are factory tested to a more stringent Emerson test requirement of no leakage at time of shipment. Test medium is water. Specify service ΔP when ordering. Shutoff class V.

1. Class V shutoff requires spring-loaded seal ring, radius-seat plug, and wide-bevel seat ring (not available with 8-inch port, quick-opening cage). Not available with trims 4, 29, and 85.
2. For additional information, contact your [Emerson sales office](#).
3. Refer to table 4.

Trim Cartridge

In addition to traditional trim selections outlined in this product bulletin, some configurations of Fisher ET control valves are also available with Trim Cartridge. Trim Cartridge combines all valve trim components plus the bonnet in a single, serialized cartridge. Trim Cartridge simplifies valve repair by streamlining valve repair procurement, inventory, and execution and is available as both a trim option in new valve assemblies or as a repair solution.

In new valve assemblies, Trim Cartridge simplifies repair parts procurement, inventory, and budgeting. Trim Cartridge provides complete trim and bonnet repair in a single part number reducing the amount of part numbers to order and a single box to inventory. It also increases maintenance budgeting accuracy as Trim Cartridge provides a more consistent trim repair cost due to its streamlined installation and complete trim repair design.

As a repair part, Trim Cartridge reduces a more than 20 part repair process to a single pre-assembled repair cartridge, seat ring gasket, and body to bonnet gasket. Each Trim Cartridge comes seat leak tested to CL V shut off and has pre-set ENVIRO-SEAL packing. Its factory assembled and tested design greatly reduces complexity and allows for streamlined installation and decreased repair time. Trim Cartridge can be utilized as a complete trim and bonnet repair solution for control valves with existing traditional trim or Trim Cartridge.

Figure 1. Fisher Trim Cartridge



Trim Cartridge contains ENVIRO-SEAL PTFE packing as the standard packing offering. Other available packing options are ENVIRO-SEAL Graphite ULF and ENVIRO-SEAL duplex. PEEK high temperature anti-extrusion rings are also available.

Trim Cartridge is fully backward compatible and has the same flow characteristics as comparable traditional trim.

Table 3. Trim Cartridge Table⁽¹⁾

VALVE	BONNET MATERIAL	SIZES	CHARACTERISTIC	STEM SIZES, INCHES	TRIM NUMBER	PLUG MATERIAL	ET CAGE MATERIAL	SEAT MATERIAL	STEM MATERIAL
ET	WCC, LCC, CF8M	NPS 1-4 Full and Reduced Ports	Equal Percent, Linear	3/8 and 1/2 (NPS 1 and 1.5)	1TC	416 SST	316 Chrome Plate	17-4 SST	316 SST
					27TC	316 SST HF Seat and Guide		316 SST w/ CoCr-A HF	
					29TC	316 SST		316 SST	
				1/2 (NPS 2, 3 and 4)	85TC (NACE)	316 SST		316 SST w/ CoCr-A HF	S20910
					87TC (NACE)	316 SST HF Seat and Guide			

1. If ordering a butt-weld or socket weld end valve that requires post-weld heat treatment after installation, Trim Cartridge should not be selected.

ENVIRO-SEAL, HIGH-SEAL Packing Systems

ENVIRO-SEAL and HIGH-SEAL packing systems offer exceptional sealing capabilities. These systems easily install in existing valves or can be purchased with new valves. These systems help seal the process to conserve valuable process fluid. The long-life and reliability of these systems also reduce maintenance costs and downtime.

For applications requiring compliance with environmental protection regulations, the unique ENVIRO-SEAL packing system (figure 11) and a unique ENVIRO-SEAL bellows seal system (figure 10) are offered. The emission control packing system keeps emission concentrations below the EPA 100 ppm requirement.

For an excellent stem seal in applications that are not environmentally-sensitive, the HIGH-SEAL Graphite

ULF packing system (figure 11) is offered. The HIGH-SEAL packing system provides improved sealing at pressure/temperature ratings beyond ENVIRO-SEAL limits.

ENVIRO-SEAL packing systems, available with PTFE, Graphite ULF, or duplex packing, and the HIGH-SEAL Graphite ULF packing system feature live-loading and unique packing-ring arrangements for long-term, consistent sealing performance.

ANSI/FCI Class VI Shutoff Capabilities

ET valves with soft seat and metal seat constructions can provide ANSI/FCI Class VI shut-off capabilities. See tables 4 and 5.

Table 4. Class VI Shutoff Availability^(1, 2)

Valve	Port Size, Inches	Seat	Minimum Seat Load
ET	$\geq 3.4375 \leq 7$	Soft	See Catalog 14
ET	$\geq 3.4375 \leq 7$	Metal	300 lbs/lineal inch

1. Limited retrofit capability. Consult your [Emerson sales office](#).
2. Not for use with NPS 8.

Table 5. Class VI Trim Materials

VALVE	CAGE/SEAT RING RETAINER	VALVE PLUG	SEAT RING	SEAL RING	TRIM TEMPERATURE LIMIT	
					°C	°F
ET	316 SST / ENC	S31600 w/ standard beveled seat	S31600/PTFE	UHMWPE ⁽¹⁾ R30003	-198 to 66	-325 to 150
	316 SST / ENC	S31600/CoCr-A seat w/ radiused seat (special design)	S31600 w/ wide beveled seat (special design)	UHMWPE R30003	-198 to 66	-325 to 150
	17-4 SST (17-4PH SST)	S41600 w/ standard beveled seat	S31600/PTFE	UHMWPE R30003	-29 to 66	-20 to 150
	17-4 SST	S41600 w/ radiused seat (special design)	S31600 w/ wide beveled seat (special design)	UHMWPE R30003	-29 to 66	-20 to 150

1. UHMWPE (Ultra High Molecular Weight Polyethylene)

Figure 2. Fisher ET Sectional with Standard Cages

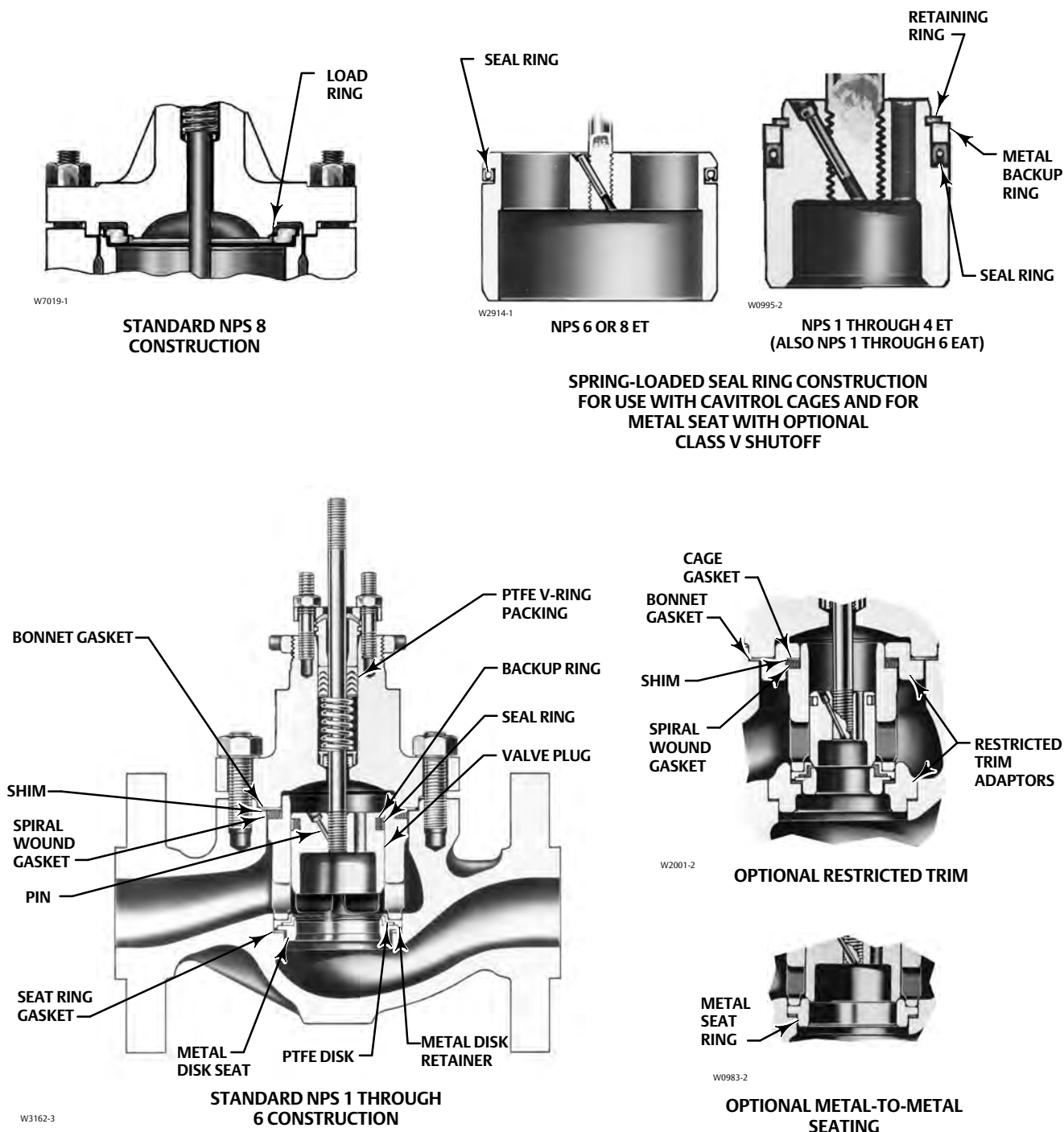
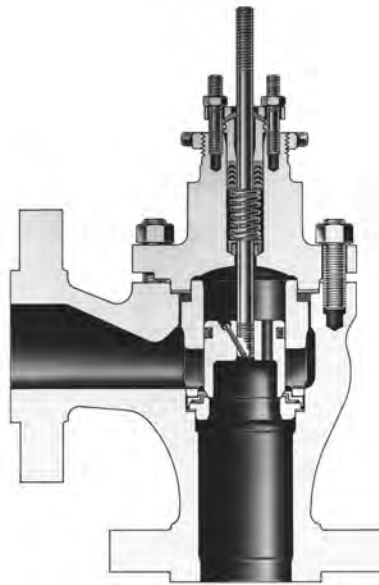
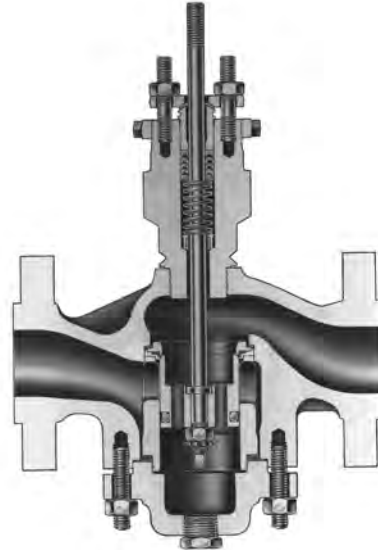

Figure 3. Fisher EAT Sectional



W0972-3

Figure 4. Fisher ETR Sectional



W1557-4

Figure 5. Typical Valve with WhisperFlo Aerodynamic or Whisper NXG Trim



W6980

WhisperFlo TRIM

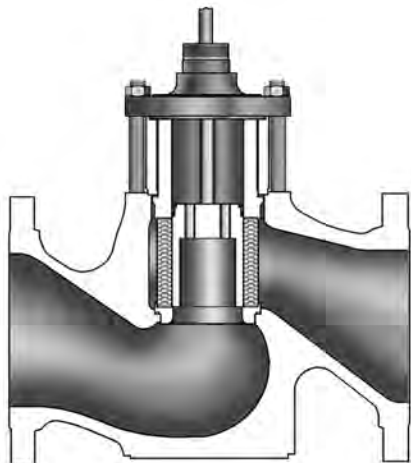

W6851-1

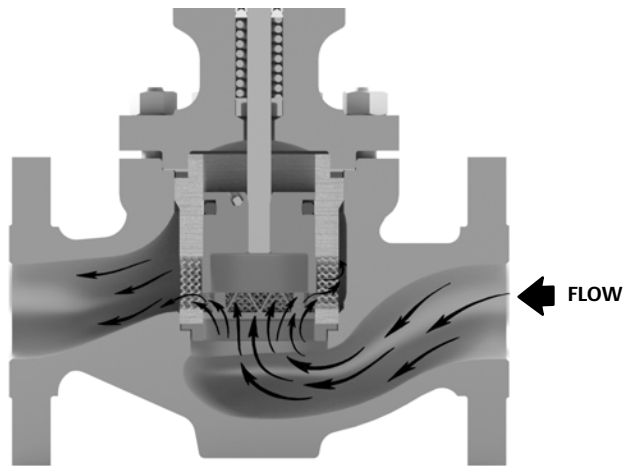

Whisper NXG TRIM

Figure 6. Typical WhisperFlo Cage

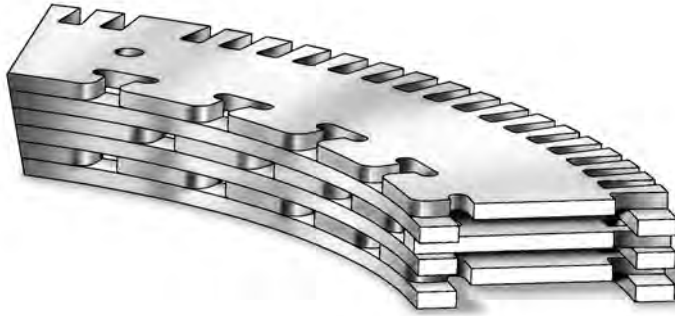

W7065

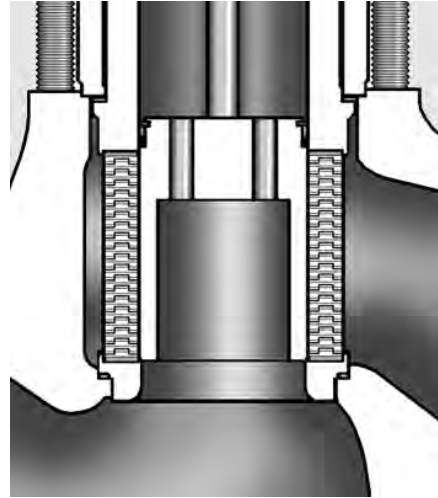

W6851-1

Table 6. Typical Combinations of Metal Trim Parts for All Valves Except Those for NACE MR0175 / ISO 15156 and MR0103 Specifications⁽¹⁾, Cavitrol III⁽²⁾, Whisper NXG Trim, Whisper Trim III⁽³⁾, and 4, 6, and 8-Inch WhisperFlo Cages⁽⁶⁾

Trim Designation	Valve Plug	Cage	Disk Seat and Retainer for Standard PTFE-Seat Construction	Seat Ring or Liner for Optional Metal-Seat Construction	Optional Liner (Metal Seat EAT Valve Only)
1 (typically used with optional metal-seat constructions in all designs and body materials except CF8M)	S41600 HT	17-4 SST HT	---	S41600 HT or CA15 HT ⁽⁴⁾	S41600 HT
	17-4 SST HT HT ⁽⁵⁾	17-4 SST HT ⁽⁵⁾			
3	S31600 with seat and guide hard faced with CoCr-A hardfacing alloy	R30006 or R30016 (alloy 6)	---	R30006 (alloy 6)	---
4 ⁽⁷⁾	S31600	17-4 SST HT	S31600	S31600	S31600
5 ⁽⁵⁾	S31600 with seat and guide hard faced with CoCr-A hardfacing alloy	R31233	R30006 Disk Seat & retainer	R30006 (alloy 6)	---
6 ⁽⁵⁾	S31600 with seat and guide hard faced with CoCr-A hardfacing alloy	S31603 CRPL	R30006 Disk Seat & retainer	R30006 (alloy 6)	---
27	S31600 with seat and guide hard faced with CoCr-A hardfacing alloy	316 SST with electroless nickel coating (ENC)	S31600 disk retainer with CoCr-A disk seat	R30006 (alloy 6)	---
28 ⁽⁸⁾	S31600 with seat hard faced with CoCr-A hardfacing alloy	316 SST with electroless nickel coating (ENC)	S31600 disk retainer with CoCr-A disk seat	R30006 (alloy 6)	---
29 (standard for CF8M bodies in all designs regardless of seat construction) ⁽⁸⁾	S31600	316 SST with electroless nickel coating (ENC)	S31600	S31600	S31600
37 and 37H (trim 37H has clearances for high-temperature service above 210°C [410°F])	S31600 with seat and guide hard faced with CoCr-A	17-4 SST HT	S31600 disk retainer with CoCr-A disk seat	Seat Ring: R30006 (alloy 6)	---
57 (standard for standard PTFE-seat ET, EAT, ETR in all body materials except CF8M)	S41600 HT	17-4 SST HT ⁽⁵⁾	S31600	---	---
	17-4 SST HT ⁽⁵⁾				
316L	S31603	316L SST with electroless nickel coating (ENC)	S31603	S31603	---
316L HF	S31603 with seat and guide hard faced with CoCr-A hardfacing alloy	316L SST with electroless nickel coating (ENC)	S31603 disk retainer with CoCr-A disk seat	R30006 (alloy 6)	---

1. For NACE MR0175 / ISO 15156 and MR0103 specification trims, see table 21
2. For Cavitrol III trims, see table 7.
3. For Whisper Trim III and Whisper NXG trims, see table 10
4. CA15 is used for NPS 6 and 8 full-sized and restricted-trim valves.
5. For 8-inch Whisper Trim I.
6. For 4, 6, and 8-Inch WhisperFlo trims, see table 9.
7. Not for use with Whisper Trim I.
8. Not for use with Whisper Trim I with 136 mm (5.375 inch) and larger ports.

Table 7. Cavitrol III⁽¹⁾ Metal Trim Part Materials and Body/Trim Temperature Capabilities

TRIM DESIGNATION	VALVE PLUG	CAGE	CAGE RETAINER	SEAT RING	BODY & BONNET	MATERIAL TEMPERATURE CAPABILITY				
						°C		°F		
						Min	Max	Min	Max	
76	Heat-treated S42000	17-4 SST H900 for Cavitrol III 1-stage or 17-4 SST H1075 for Cavitrol III 2-stage	S31600	S17400 with H900 heat-treat condition	WCC carbon steel, WC9 chrome moly steel, or LCC carbon steel	-29	These materials not limiting factors	-20	These materials not limiting factors	
					CF8M	NPS 1, 1-1/2, or 2 valve body size	-29	These materials and sizes not limiting factors	-20	These materials and sizes not limiting factors
						NPS 2-1/2 or 3 valve body size	-29	216	-20	420
						NPS 4, 6, or 8 valve body size	-29	177	-20	350

1. Available only in NPS 1 through 8 ET valves.

Table 8. DST⁽¹⁾ Metal Trim Part Materials and Body/Trim Temperature Capabilities

TRIM DESIGNATION	VALVE PLUG	CAGE	SEAT RING	BODY & BONNET	MATERIAL TEMPERATURE CAPABILITY ⁽²⁾				
					°C		°F		
					Min	Max	Min	Max	
581	R31233 Alloy	R31233	R31233	WCC	-29	316	-20	600	
				LCC	-46	316	-50	600	
				CF8M	NPS 3 NPS 4 Angle NPS 4 Globe (2-stage) NPS 6 Angle (2-stage) NPS 6 Globe (2-stage)	-73	316	-100	600
					NPS 4 Globe (3-stage) NPS 6 Angle (3-stage)	-73	204	-100	400
					NPS 6 Globe (3-Stage)	-73	260	-100	500
					NPS 8 Globe (3-Stage)	-73	149	-100	300

1. Available only in NPS 3 through 8 ET valves and NPS 4 through 6 EAT valves. For other materials and custom designs, see Bulletin 80.2:021 Dirty Service Trim ([D102310X012](#)).
2. PTFE/carbon seal ring with PEEK anti-extrusion rings may be used in temperatures up to 316°C (600°F) for non-oxidizing service or up to 260°C (500°F) for oxidizing service.

Table 9. WhisperFlo Metal Trim Part Materials and Valve Body/Trim Temperature Capabilities (NPS 4, 6, and 8 Fisher ET only)

TRIM DESIGNATION	VALVE BODY	VALVE PLUG	CAGE	CAGE RETAINER	SEAT	MATERIAL TEMPERATURE CAPABILITY ⁽¹⁾			
						°C		°F	
						Min	Max	Min	Max
901	WCC	S41600	410 SST	WCC ENC	S41600	-29	316	-20	600
902	WCC	S31600/CoCrA Seat and Guide	410 SST	WCC ENC	S31600/CoCrA	-29	316	-20	600
926	WCC	S31600/CoCrA Seat and Guide	410 SST NACE	WCC/NACE/ENC	S31600/CoCrA	-29	316	-20	600
936	316 CF8M	S31600/CoCrA Seat and Guide	316 SST/R31233	S31600/ENC	S31600/CoCrA	-198	316	-325	600
901C	WCC	S41000	410 SST	WCC ENC	S31600/PTFE	-29	232	-20	450
904C	WCC	S31600	410 SST	WCC ENC	S31600/PTFE	-29	149	-20	300
984C	WCC	S31600	410 SST NACE	WCC/NACE/ENC	S31600/PTFE	-29	149	-20	300
985C	CF8M	S31600	316 SST/R31233	S31600/ENC	S31600/PTFE	-73	149	-100	300
990	CD3MN	S31803/CoCrA Seat and Guide	2205 Duplex ⁽²⁾ /R31233	S31800/Cr Plate	S31803/CoCrA Seat	-51	316	-60	600
	LCC					-46	316	-51	600
	WCC					-29	316	-20	600
990C	CD3MN	S31803/CoCrA Seat and Guide	2205 Duplex ⁽²⁾ /R31233	S31800/Cr Plate	S31803/PTFE	-51	232	-60	450
	LCC					-46	232	-51	450
	WCC					-29	232	-20	450

1. Temperatures above 232°C (450°F) require PEEK anti-extrusion rings and spring-loaded seal ring. This option allows ET construction to be used up to 316°C (600°F) for non-oxidizing service and 260°C (500°F) for oxidizing service.
2. 22 Cr-5Ni duplex stainless steel

Table 10. Whisper Trim III and Whisper NXG Trim Metal Trim Part Materials and Body/Trim Temperature Capabilities

TRIM DESIGNATION	VALVE PLUG	CAGE	CAGE RETAINER	BAFFLE (FOR LEVEL D3 CAGE ONLY)	SEAT RING FOR METAL SEAT CONSTRUCTION	DISK SEAT AND RETAINER FOR PTFE SEAT CONSTRUCTION	STEM	BODY, BONNET & BONNET SPACER	MATERIAL TEMPERATURE CAPABILITY			
									°C		°F	
									Min	Max	Min	Max
19.1 through 111.1, 177.8 and 203.2 mm (0.75 through 4.375, 7 and 8 Inch) Port Sizes with Whisper Trim III Cage												
301G	S41600	17-4 SST	---	Steel	S41600	---	S31600	WCC, WC9	-29	316 ⁽²⁾	-20	600 ⁽²⁾
								CF8M ⁽⁵⁾	-29	176	-20	350
301GC	S41600	17-4 SST	---	Steel	---	S31600	S31600	WCC, WC9	-29	204	-20	400
								CF8M	-29	176	-20	350
312G ⁽¹⁾	S31600/ CoCr-A Seat & Guide	316 SST/ENC Electroless Nickel Coated	---	S31600	R30006	---	S20910	WCC, WC9	-29	316 ⁽²⁾	-20	600 ⁽²⁾
								CF8M	-198	316 ⁽²⁾	-325	600 ⁽²⁾
312GC ⁽¹⁾	S31600/ CoCr-A Seat & Guide	316 SST/ENC Electroless Nickel Coated	---	S31600	---	R30006/ S31600 ⁽⁶⁾	S20910	WCC, WC9	-29	204	-20	400
								CF8M	-73	204	-100	400
315G ⁽¹⁾	S31600/ CoCr-A Seat & Guide	316 SST Chrome Plate	---	S31600	R30006	---	S20910	WCC, WC9	-29	316 ⁽²⁾	-20	600 ⁽²⁾
								CF8M	-198	316 ⁽²⁾	-325	600 ⁽²⁾
315GC ⁽¹⁾	S31600/ CoCr-A Seat & Guide	316 SST Chrome Plate	---	S31600	---	R30006/ S31600 ⁽⁶⁾	S20910	WCC, WC9	-29	204	-20	400
								CF8M	-73	204	-100	400
306	S31803/ CoCr-A Seat & Guide (< 3"Port), S31803/ Ultimet Seat & Guide (≥ 3"Port)	2205 Duplex ⁽⁴⁾ Chrome Plate	---	S31803	S31803/ CoCr-A (< 3"Port), S31803/ Ultimet (≥ 3"Port)	---	S31803	WCC, WC9, CF8M	-29	316 ⁽²⁾	-20	600 ⁽²⁾
307G	S31600/ CoCr-A Seat & Guide	S17400	---	Steel	R30006	---	S31600	WCC, WC9	-29	210	-20	410
307GH ⁽³⁾	S31600/ CoCr-A Seat & Guide	S17400	---	Steel	R30006	---	S31600	WCC, WC9	210	316	410	600
19.1 through 111.1, 177.8 and 203.2 mm (0.75 through 4.375, 7 and 8 Inch) Port Sizes with Whisper NXG Trim Cage												
301GNXG	S41600	17-4 H1075	---	---	S41600	---	S31600	WCC, WC9	-29	316 ⁽²⁾	-20	600 ⁽²⁾
								CF8M ⁽⁵⁾	-29	176	-20	350
312G ⁽¹⁾ NXG	S31600/ CoCr-A Seat & Guide	S31603/ENC	---	---	R30006	---	S20910	WCC, WC9	-29	316 ⁽²⁾	-20	600 ⁽²⁾
								CF8M	-198	316 ⁽²⁾	-325	600 ⁽²⁾
307GNXG	S31600/ CoCr-A Seat & Guide	17-4 H1075	---	---	R30006	---	S31600	WCC, WC9	-29	210	-20	410
307GH ⁽³⁾ NXG	S31600/ CoCr-A Seat & Guide	17-4 H1075	---	---	R30006	---	S31600	WCC, WC9	210	316	410	600
306NXG	S31803/ Ultimet Seat & Guide	R31233 (Ultimet)	---	---	S31803/ Ultimet	---	S31803	WCC, WC9, CF8M or CD3MN	-29	316 ⁽²⁾	-20	600

-continued-

Table 10. Whisper Trim III and Whisper NXG Trim Metal Trim Part Materials and Body/Trim Temperature Capabilities (cont.)

TRIM DESIGNATION	VALVE PLUG	CAGE	CAGE RETAINER	BAFFLE (FOR LEVEL D3 CAGE ONLY)	SEAT RING FOR METAL-SEAT CONSTRUCTION	DISK SEAT AND RETAINER FOR PTFE-SEAT CONSTRUCTION	STEM	BODY, BONNET & BONNET SPACER	MATERIAL TEMPERATURE CAPABILITY			
									°C		°F	
136.5 mm (5.375 Inch) Port												
301	S17400	416 SST	WCC/ENC	Steel	S41600	---	S31600	WCC, WC9	-29	316 ⁽²⁾	-20	600 ⁽²⁾
								CF8M	-29	163	-20	325
301C	S17400	416 SST	WCC/ENC	Steel	---	S31600	S31600	WCC, WC9	-29	204	-20	400
								CF8M	-29	163	-20	325
304	S31600/ CoCr-A Seat & Guide	416 SST	WCC/ENC	Steel	S31600/ CoCr-A Seat	---	S31600	WCC, WC9	-29	316 ⁽²⁾	-20	600 ⁽²⁾
								CF8M	-29	177	-20	350
312 ⁽¹⁾	S31600/ CoCr-A Seat & Guide	316 SST/ENC Electroless Nickel Coated	316/ENC Electroless Nickel Coated	S31600	R30006	---	S20910	WCC, WC9	-29	260	-20	500
								CF8M	-198	316 ⁽²⁾	-325	600 ⁽²⁾
312C ⁽¹⁾	S31600/ CoCr-A Seat & Guide	316 SST/ENC Electroless Nickel Coated	316/ENC Electroless Nickel Coated	S31600	---	R30006/ S31600	S20910	WCC, WC9	-29	204	-20	400
								CF8M	-198	204	-325	400
306	S31803/ Ultimet Seat & Guide	2205 Duplex ⁽⁴⁾ Chrome Plate	---	S31803	S31803/ Ultimet	---	S31803	WCC, WC9, CF8M or CD3MN	-29	316 ⁽²⁾	-20	600 ⁽²⁾
<p>1. NACE compatible trims meets NACE MR0175 2002, MR0175/ISO15156, MR0103. 2. Temperatures above 202°C (450°F) require PEEK anti-extrusion rings and spring loaded. This option allows ET construction to be used up to 316°C (600°F) for non-oxidizing service and 260°C (500°F) for oxidizing service. 3. For high temperature service. 4. 22 Cr-5Ni duplex stainless steel. 5. Trim 301G and 301GNXG can be used up to 216°C (420°F) with NPS 3 CF8M body, can be used up to 288°C (550°F) with NPS 2 CF8M body. 6. For 8 inch port size, both disk seat and retainer use R30006.</p>												

Table 11. Materials and Temperature Limits for R31233 DST Body-to-bonnet Bolting Material Combinations⁽¹⁾

MATERIAL			BODY TYPE, SIZE, AND DESIGN	MATERIAL TEMPERATURE CAPABILITY			
Body	Bolting			°C		°F	
				Min	Max	Min	Max
WCC	Studs Nuts	SA193-B7/NCF2 SA194-2H/NCF2	All	-29	316	-20	600
LCC	Studs Nuts	SA193-B7/NCF2 SA194-2H/NCF2	All	-46	316	-50	600
CF8M	Studs Nuts	SA193-B7/NCF2 SA194-2H/NCF2	NPS 3 (Globe Long Neck) 3-Stage NPS 4 (Globe Long Neck) 2-Stage	-46	316	-50	600
			NPS 6 (Globe Short Neck) 2-Stage	-46	191	-50	375
			NPS 4 (Globe Long Neck) 3-Stage NPS 6 (Globe Short Neck) 3-Stage NPS 8 (Globe Short Neck) 3-Stage	-46	177	-50	350
			NPS 3 (Globe Short Neck) 2-Stage & 3-Stage NPS 4 (Globe Short Neck) 2-Stage & 3-Stage NPS 4 (Angle) 2-Stage & 3-Stage NPS 6 (Angle) 2-Stage & 3-Stage	-46	149	-50	300
	Studs Nuts	SA-193-B8M Class 2 (strain-hardened) SA-194-8M	NPS 3 (Globe Long Neck) 3-Stage NPS 4 (Globe Long Neck) 2-Stage	-73	316	-100	600
			NPS 4 (Globe Long Neck) 3-Stage	-73	177	-100	350
			NPS 3 (Globe Short Neck) 2-Stage NPS 4 (Globe Short Neck) 2-Stage & 3-Stage NPS 4 (Angle) 2-Stage NPS 6 (Angle) 2-Stage & 3-Stage	-73	149	-100	300
			NPS 3 (Globe Short Neck) 3-Stage NPS 4 (Angle) 3-Stage NPS 6 (Globe Short Neck) 2-Stage & 3-Stage	-73	121	-100	250
			NPS 8 (Globe Short Neck) 3-Stage	-73	93	-100	200
	Studs Nuts	S20910 SA194-7	NPS 3 (Globe Long Neck) 3-Stage NPS 4 (Globe Long Neck) 2-Stage	-73	316	-100	600
			NPS 6 (Globe Short Neck) 2-Stage	-73	218	-100	425
			NPS 4 (Globe Long Neck) 3-Stage	-73	204	-100	400
			NPS 6 (Globe Short Neck) 3-Stage	-73	191	-100	375
			NPS 3 (Globe Short Neck) 2-Stage NPS 4 (Globe Short Neck) 2-Stage NPS 4 (Angle) 2-Stage NPS 6 (Angle) 2-Stage	-73	177	-100	350
			NPS 3 (Globe Short Neck) 3-Stage NPS 4 (Globe Short Neck) 3-Stage NPS 4 (Angle) 3-Stage NPS 6 (Angle) 3-Stage	-73	149	-100	300

1. For the body/trim material combination temperature limits, please reference table 8.

Figure 7. Metal Seat and Whisper Trim III Cage in Fisher ET Valve

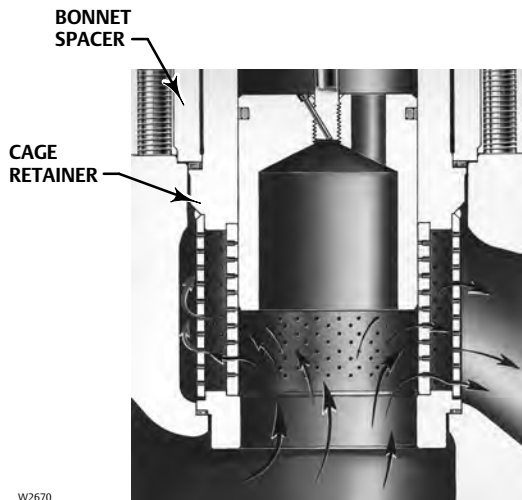

W2670

Figure 9. Cavitrol III One-Stage Cage

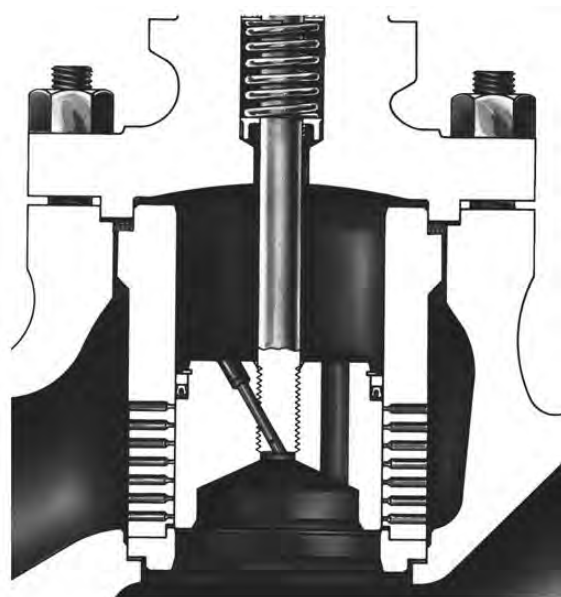

W3746A-4

Figure 8. Typical Balanced TSO Trim

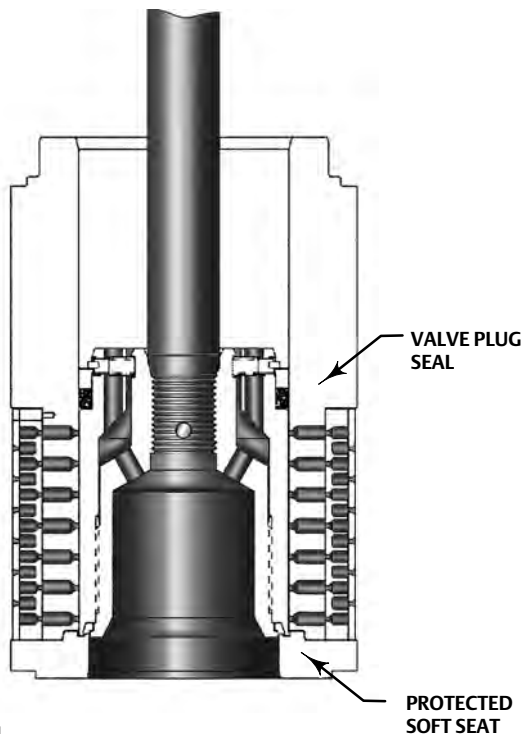

W7020-1

Figure 10. Typical ENVIRO-SEAL Bellows Seal Bonnet and Bellows Seal Assembly

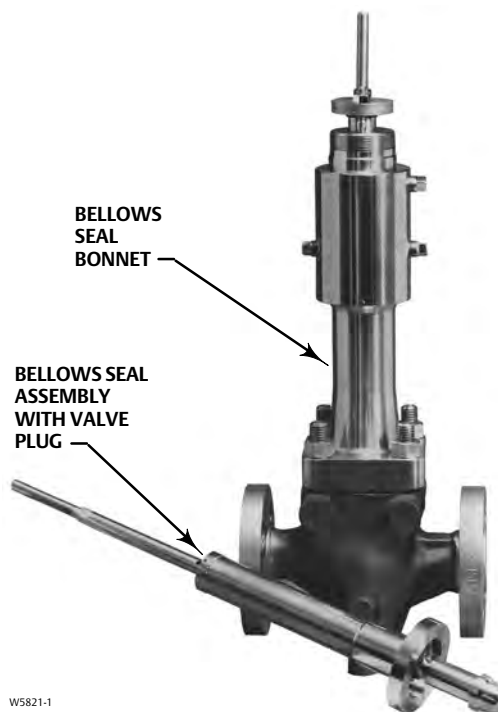

W5821-1

Figure 11. ENVIRO-SEAL and HIGH-SEAL Packing Systems

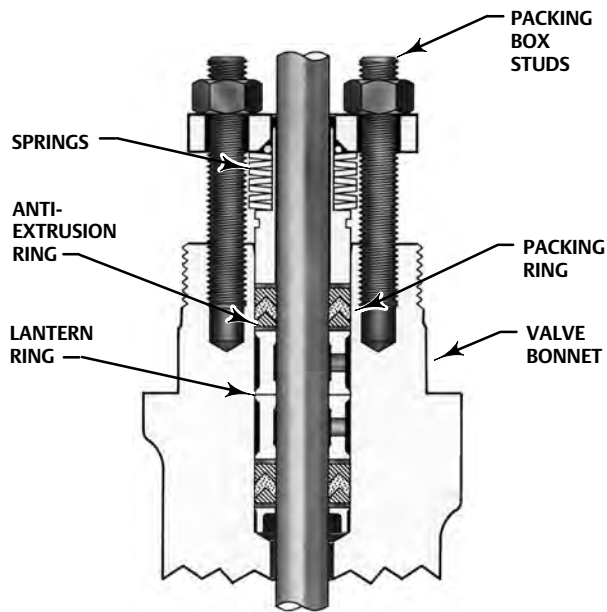

W5803-3

TYPICAL ENVIRO-SEAL PACKING SYSTEM WITH PTFE PACKING

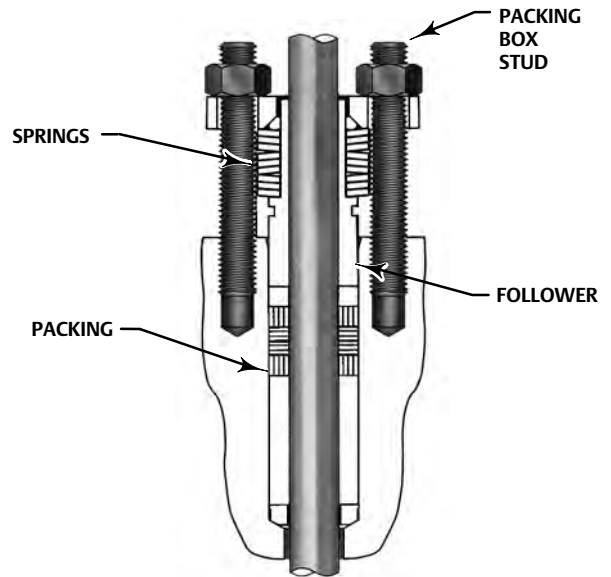

W8532-1

TYPICAL ENVIRO-SEAL PACKING SYSTEM WITH GRAPHITE ULF PACKING

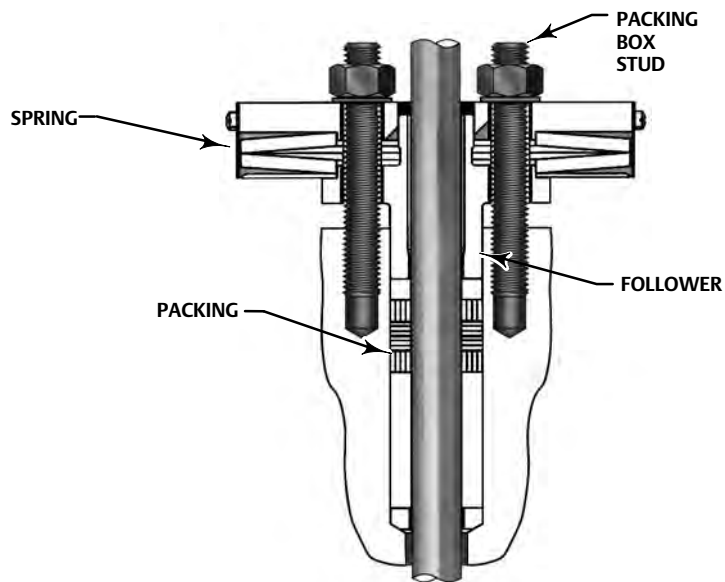

W8533-1

TYPICAL HIGH-SEAL PACKING SYSTEM WITH GRAPHITE ULF PACKING

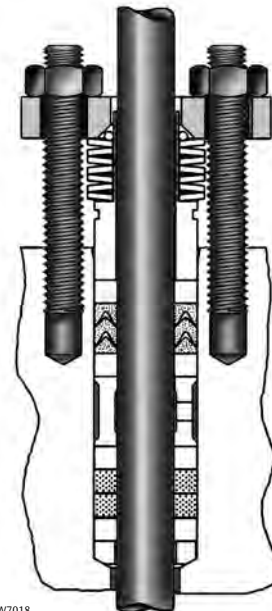

W7018

TYPICAL ENVIRO-SEAL PACKING SYSTEM WITH DUPLEX PACKING

Figure 12. Typical Trim for All Valves Except Those with Cavitrol III, Whisper Trim III, Whisper NXG Trim, or WhisperFlo Cages

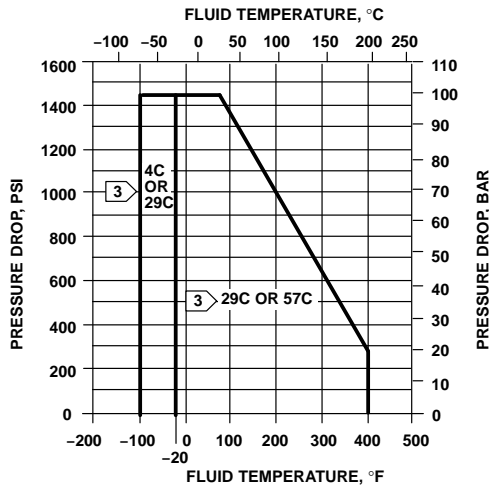

2 TRIM CAPABILITIES FOR PTFE SEATING

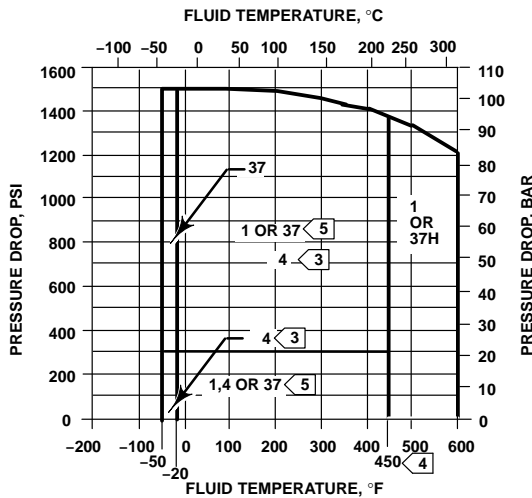

FOR OPTIONAL METAL SEATING WITH CL600 LCC STEEL BODY

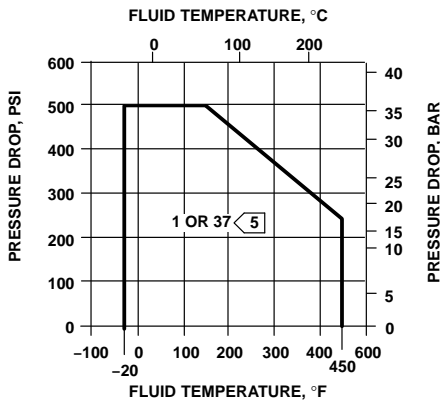

FOR OPTIONAL METAL SEATING WITH CL250B CAST IRON BODY

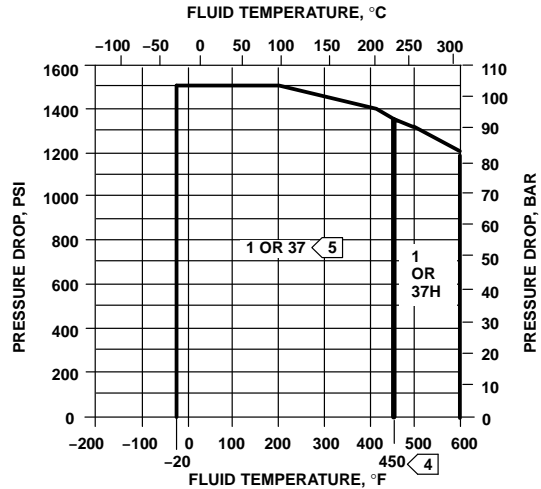

2 FOR OPTIONAL METAL SEATING WITH CL600 WCC STEEL, OR WC9 CHROME MOLY STEEL, BODY

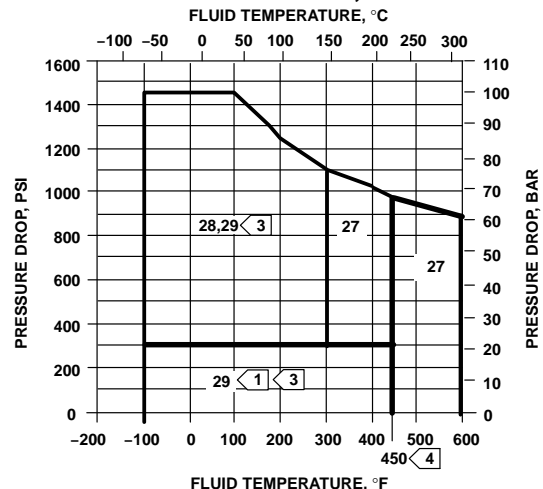

FOR OPTIONAL METAL SEATING WITH CL600 CF8M(316 SST) BODY

NOTES:

- 1 Use trim 27 instead of trim 29 for nonlubricating fluids such as superheated steam or dry gases between 149°C (300°F) and 232°C (450°F).
- 2 Do not exceed the maximum pressure and temperature for the pressure rating of the body material used, even though the trims shown may have higher capabilities.
- 3 Trims 4 and 29 may be used up to 99 bar (1440 psi) with clean dry gas. For process fluids other than clean dry gas, use trims 4 and 29 only up to 21 bar (300 psi).
- 4 Trims 1, 27, and 37H temperature limits can be extended to 316°C (600°F) for non-oxidizing service or 260°C (500°F) oxidizing service if PEEK anti-extrusion rings are used with spring-loaded seal rings.
- 5 Use trim 37H instead of trim 37 for temperatures above 210°C (410°F). Requires anti-extrusion rings and spring-loaded seal rings for temperatures above 232°C (450°F).

Figure 13. Typical Trim for Cavitrol III Cage Constructions

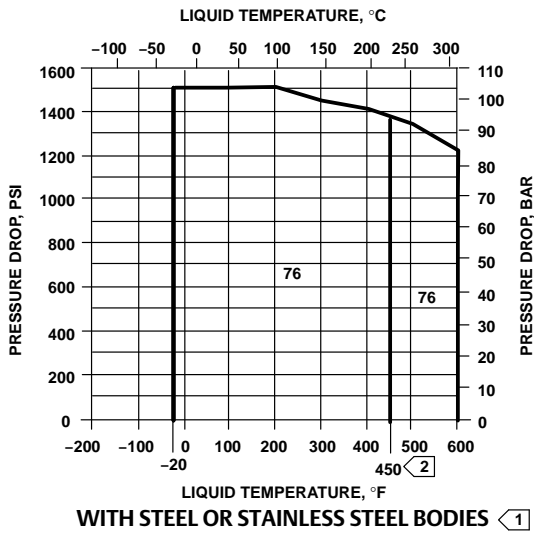

Notes:

- 1 Do not exceed the maximum pressure and temperature for the pressure rating of the body material used, even though the trim shown may have higher capabilities.
- 2 Trim 76 temperature limits can be extended to 316°C (600°F) for non-oxidizing service or 260°C (500°F) for oxidizing service if IF PEEK anti-extrusion rings are used with spring-loaded seal rings.

A6737

Table 12. Materials and Temperature Limits for Other Parts

PART			MATERIAL	TEMPERATURE CAPABILITIES			
				°C		°F	
				Min	Max	Min	Max
Body-to-bonnet bolting. See table 22 for NACE bolting materials and temperature limits	Cast iron body	Cap screws	Steel SAE Grade 5	-29	232	-20	450
	WCC body	Studs	Steel SA-193-B7	-29	..(5)	-20	..(5)
		Nuts	Steel SA-194-2H				
	LCC body	Studs	Steel SA-193-B7	-46	..(5)	-50	..(5)
		Nuts	Steel SA-194-2H				
	CF3M or CF8M (316 stainless steel) body	Studs	Steel SA-193-B7 (std) (NACE [non-exposed bolting])	-48	..(5)	-55	..(5)
		Nuts	Steel SA-194-2H (std) (NACE [non-exposed bolting])	-46	..(5)	-50	..(5)
		Studs	S30400 stainless steel SA-320-B8	..(5)	38	...(5)	100
Nuts		S30400 stainless steel SA-194-8					
Studs		S31600 stainless steel SA-193-B8M (strain-hardened) or S31600 stainless steel SA-193-B8M	..(5)	..(5)	..(5)	..(5)	
Nuts	S31600 stainless steel SA-194-8M						
Disk			PTFE	-73	204	-100	400
2-piece valve plug seal (standard for NPS 1 thru 6 valves except those with Cavitol III cage)	Backup ring	Fluorocarbon ⁽¹⁾		-18	204	0	400
		Ethylene-propylene ⁽²⁾		-40	232	-40	450
		Nitrile ⁽³⁾	For use with air and hydrocarbons	-40	71	-40	160
			For use with other compatible fluids	-40	82	-40	180
	Seal ring	Carbon-filled PTFE		-73	232	-100	450
Spring-loaded valve plug seal ⁽⁷⁾	Backup ring ⁽⁴⁾	S41600 stainless steel		-29	..(5)	-20	..(5)
		S31600 stainless steel		..(5)	..(5)	..(5)	..(5)
	Retaining ring ⁽⁴⁾	S30200 stainless steel (N07750, NACE Std)		..(5)	..(5)	..(5)	..(5)
	Seal ring	PTFE with N10276 spring		-73	232	-100	450
For applications using PEEK Anti-Extrusion Rings: Spring-loaded valve plug seal	Backup ring ⁽⁴⁾	S41600 stainless steel		-29	..(5)	-20	..(5)
		S31600 stainless steel		..(5)	..(5)	..(5)	..(5)
	Retaining ring ⁽⁴⁾	S30200 stainless steel		..(5)	..(5)	..(5)	..(5)
	Seal ring	PTFE/graphite with R30003spring		-73	316 ⁽⁶⁾	-100	600 ⁽⁶⁾
	Anti-extrusion rings	PEEK (PolyEtherEtherKetone)		..(5)		..(5)	
Valve plug stem			S31600 (S20910, NACE Std.) or S31603	..(5)	..(5)	..(5)	..(5)
Load ring (NPS 8 ET valve only)			S17400 or optional N06600 or N05500	..(5)	..(5)	..(5)	..(5)
Restricted trim adaptors	Cast iron		-73	232	-100	450	
	WCC steel		-29	..(5)	-20	..(5)	
	S31600 stainless steel		..(5)		..(5)		
Seat ring, bonnet and cage gaskets	FGM (standard)		..(5)		..(5)		
	PTFE-coated N04400		..(5)	149	..(5)	300	
Spiral wound gasket	N06600/graphite (FGM-standard)		..(5)		..(5)		
	N04400/PTFE		-73	149	-100	300	
Shim	S31600 stainless steel		..(5)	..(5)	..(5)	..(5)	
	N04400		..(5)	..(5)	..(5)	..(5)	
Packing	(temperatures shown are material temperature capabilities)	See table 14 for proper bonnet selection	PTFE V-ring	-40	232	-40	450
			PTFE/composition	-73	232	-100	450
			Graphite ribbon/filament	..(5)		..(5)	

-continued-

Table 12. Materials and Temperature Limits for Other Parts (continued)

PART		MATERIAL	TEMPERATURE CAPABILITIES			
			°C		°F	
			Min	Max	Min	Max
Packing flange, studs, and nuts when used with standard bonnet		S31600 stainless steel	...(5)		...(5)	
Metal packing box parts		S31600 or S17400 stainless steel depending on part	...(5)		...(5)	
Extension bonnet bushing	Trims 1 & 4	S41600 stainless steel	-29	...(5)	-20	...(5)
	Other trims	S31600 stainless steel	...(5)		...(5)	
1. For high-temperature air, hydrocarbons, and certain other chemicals and solvents. Not for use with steam or ammonia. Not recommended for water above 82°C (180°F). 2. Has excellent moisture resistance to hot water and steam and may be used with most fire-resistant hydraulic oils, but cannot be used with petroleum-based fluids and other hydrocarbons. 3. Cannot be used with fire-resistant hydraulic oils. 4. These parts not used with 137 mm (7 inch) ports or larger. 5. These materials not limiting factors. 6. This material may be used in temperatures up to 260°C (500°F) for oxidizing service. 7. Standard for NPS 8 valve regardless of cage and all NPS 1 thru 6 valves with Cavitrol III cages, optional in NPS 1 thru 6 valves with other than Cavitrol III cages.						

Table 13. Fisher ET Valve Body/Trim Temperature Capabilities For All Valves Except Cavitrol III, Whisper NXG Trim, Whisper Trim III Cage, and NPS 4, 6, and 8 ET with WhisperFlo Cage

BODY/BONNET ⁽³⁾ MATERIALS	TRIM DESIGNATION	VALVE SIZE, NPS	MATERIAL TEMPERATURE CAPABILITY			
			°C		°F	
			Min	Max	Min	Max
Cast Iron	1,3,27, 29 or 57	All	-29	232	-20	450
	5 ⁽⁵⁾	8	-29	232	-20	450
	6 ⁽⁵⁾		-29	232	-20	450
	37	All	-29	210	-20	410
	37H		210	232	410	450
CF3M (316L stainless steel)	316L	All	-198 ⁽⁴⁾	149 ⁽²⁾	-325 ⁽⁴⁾	300 ⁽²⁾
	316L HF		-198 ⁽⁴⁾	316 ⁽¹⁾	-325 ⁽⁴⁾	600 ⁽¹⁾
CF8M (316 stainless steel)	5 ⁽⁵⁾	8	-198 ⁽⁴⁾	316 ⁽¹⁾	-325 ⁽⁴⁾	600 ⁽¹⁾
	6 ⁽⁵⁾		-198 ⁽⁴⁾	316 ⁽¹⁾	-325 ⁽⁴⁾	600 ⁽¹⁾
	27	All	-198 ⁽⁴⁾	316 ⁽¹⁾	-325 ⁽⁴⁾	600 ⁽¹⁾
	28		-198 ⁽⁴⁾	149 ⁽²⁾	-325 ⁽⁴⁾	300 ⁽²⁾
	29		-198 ⁽⁴⁾	149 ⁽²⁾	-325 ⁽⁴⁾	300 ⁽²⁾
LCC steel	1	All	-29	316 ⁽¹⁾	-20	600 ⁽¹⁾
	4		-46	210	-50	410
	5 ⁽⁵⁾	8	-46	316 ⁽¹⁾	-50	600 ⁽¹⁾
	6 ⁽⁵⁾		-46	316 ⁽¹⁾	-50	600 ⁽¹⁾
	27	All	-46	316 ⁽¹⁾	-50	600 ⁽¹⁾
	29		-46	149 ⁽²⁾	-50	300 ⁽²⁾
	37		-46	210	-50	410
	37H		210	316 ⁽¹⁾	410	600 ⁽¹⁾
57	-29		232	-20	450	
WCC steel	1	All	-29	316 ⁽¹⁾	-20	600 ⁽¹⁾
	5 ⁽⁵⁾	8	-29	316 ⁽¹⁾	-20	600 ⁽¹⁾
	6 ⁽⁵⁾		-29	316 ⁽¹⁾	-20	600 ⁽¹⁾
	27	All	-29	316 ⁽¹⁾	-20	600 ⁽¹⁾
	29		-29	149 ⁽²⁾	-20	300 ⁽²⁾
	37		-29	210	-20	410
	37H		210	316 ⁽¹⁾	410	600 ⁽¹⁾
57	-29		232	-20	450	
WC9 Chrome moly steel	1 or 3	All	-29	316 ⁽¹⁾	-20	600 ⁽¹⁾
	5 ⁽⁵⁾	8	-29	316 ⁽¹⁾	-20	600 ⁽¹⁾
	6 ⁽⁵⁾		-29	316 ⁽¹⁾	-20	600 ⁽¹⁾
	27	All	-29	316 ⁽¹⁾	-20	600 ⁽¹⁾
	29		-29	149 ⁽²⁾	-20	300 ⁽²⁾
	37		-29	210	-20	410
	37H		210	316 ⁽¹⁾	410	600 ⁽¹⁾
57	-29		232	-20	450	

1. Temperatures above 232°C (450°F) require PEEK anti-extrusion rings and spring-loaded seal ring. This option allows ET construction to be used up to 316°C (600°F) for non-oxidizing service and 260°C (500°F) for oxidizing service.
2. Lubricating service allows usage to 232°C (450°F)
3. Same material also used for bottom flange, if required. Restricted trim and full-sized limits are the same.
4. May be used down to -254°C (-425°F) if manufacturing process includes Charpy impact test.
5. Only available for Whisper Trim I cages.

Table 14. Bonnet Selection Guidelines

BONNET STYLE	PACKING MATERIAL	IN-BODY PROCESS TEMPERATURE LIMITS ⁽¹⁾	
		°C	°F
Plain: ■ Standard for all valve sizes through NPS 6 with 2-13/16 yoke boss diameter ■ Standard for NPS 6 and 8 valves in cast iron and WCC steel bonnet material with 3-9/16 yoke boss diameter	PTFE V-ring	-18 to 232	0 to 450
	PTFE/Composition	-18 to 232	0 to 450
	Graphite ribbon/filament	-18 to 316 ⁽²⁾	0 to 600 ⁽²⁾
Style 1 Cast Extension: ■ Standard for NPS 8 valves in S31600 bonnet material with 3-9/16 yoke boss diameter	PTFE V-ring	-46 to 316 ⁽²⁾	-50 to 600 ⁽²⁾
	PTFE/Composition		
	Graphite ribbon/filament		
Style 2 Cast Extension: ■ Optional for NPS 2 through 4 valve sizes with 2-13/16 inch yoke boss diameter ■ Optional for NPS 6 and 8 valves with 3-9/16 yoke boss diameter.	PTFE V-ring	-101 to 316 ⁽²⁾	-150 to 600 ⁽²⁾
	PTFE/Composition		
	Graphite ribbon/filament		
ENVIRO-SEAL bellows seal bonnet	PTFE	For exceptional stem sealing capabilities. See Bulletin 59.1:070, ENVIRO-SEAL Bellows Seal Bonnets (D101641X012), for pressure/temperature ratings.	
	Graphite ULF	For exceptional stem sealing capabilities. See Bulletin 59.1:070, ENVIRO-SEAL Bellows Seal Bonnets (D101641X012), for pressure/temperature ratings.	

1. These in-body process temperatures assume an outside, ambient temperature of 21°C (70°F) and no insulation on the bonnet. When using any packing at low process temperatures, a cast extension bonnet may have to be used to prevent packing damage which could result from the formation of valve stem frost. Material selection for trim and other components will also be limiting factors.
2. Temperatures above 232°C (450°F) require PEEK anti-extrusion rings and spring-loaded seal ring.

Table 15. Maximum Flow Coefficients for Full-Sized Trim with Equal Percentage Cage and Normal Flow Direction

Valve		Valve Size, NPS	Cv at Max. Valve Plug Travel
ET		1	17.2
		1-1/2	35.8
		2	59.7
		2-1/2	99.4
		3	136
		4	224
		6	394
		8 ⁽¹⁾	567
		8 ⁽²⁾	819
EAT	with liner	1	18.5
		2	48.1
		3	149
		4	152
		6	336
	without liner	1	19.0
		2	47.2
		3	148
		4	156
		6	328
ETR		1	17.2
		1-1/2	35.8
		2	59.7
		2-1/2	99.4
		3	136
		4	224

1. With 51 mm (2 inch) travel.
2. With 76 mm (3 inch) travel.

Table 16. Port Diameters and Valve Plug Travel

VALVE SIZE, NPS				PORT DIAMETER ⁽¹⁾		MAXIMUM VALVE PLUG TRAVEL ⁽¹⁾	
ET or ETR		EAT		mm	Inch	mm	Inch
Full-Sized Trim	Restricted-Capacity Trim	Full-Sized Trim	Restricted-Capacity Trim				
1	1-1/2	1	2	33.3	1.3125	19.1	0.75
---	2	---	---	33.3	1.3125	19.1	0.75
1-1/2	---	2	---	46.7	1.875	19.1	0.75
---	2-1/2	---	---	46.7	1.875	19.1	0.75
2	3	---	4	58.7	2.3125	29	1.125
2-1/2	4	3	6	73.0	2.875	38	1.5
3	---	4	---	87.3	3.4375	38	1.5
4	---	6	---	111.1	4.375	51	2
6 ⁽²⁾	---	---	---	177.8 ⁽³⁾	7 ⁽³⁾	51 ⁽³⁾	2 ⁽³⁾
				---	---	---	---
8 ⁽²⁾	---	---	---	203.2	8	51	2
						76	3

1. For Cavitrol III trim, see table 18.
2. Not available in ETR valves.
3. Standard-travel cages.

Table 17. Stem and Yoke Boss Diameters

VALVE SIZE, NPS				STEM AND YOKE BOSS DIAMETERS							
ET or ETR		EAT		Standard				Optional			
Full-Sized Trim	Restricted-Capacity Trim	Full-Sized Trim	Restricted-Capacity Trim	Stem		Yoke Boss		Stem		Yoke Boss	
				mm	Inch	mm	Inch	mm	Inch	mm	Inch
1	1-1/2	1	2	9.5	3/8	54	2-1/8	12.7	1/2	71	2-13/16
---	2	---	---	12.7	1/2	71	2-13/16	---	---	---	---
1-1/2	---	2	---	9.5	3/8	54	2-1/8	12.7	1/2	71	2-13/16
---	2-1/2	---	---	12.7	1/2	71	2-13/16	---	---	---	---
2	3	---	4	12.7	1/2	71	2-13/16	19.1	3/4	90	3-9/16
2-1/2	4	3	6	12.7	1/2	71	2-13/16	19.1	3/4	90	3-9/16
3	---	4	---	12.7	1/2	71	2-13/16	19.1	3/4	90	3-9/16
4	---	6	---	12.7	1/2	71	2-13/16	19.1	3/4	90	3-9/16
								25.4	1	127	5
6 ⁽¹⁾	---	---	---	19.1	3/4	90	3-9/16	25.4 or 31.8	1 or 1-1/4	127	5
8 ⁽¹⁾	---	---	---								

1. Not available in ETR valves.

Table 18. Port Diameters and Valve Plug Travel for Cavitrol III Cage

ET VALVE SIZE, NPS	ONE-STAGE CAGE		TWO-STAGE CAGE	
	Port Diameters	Valve Plug Travel ⁽¹⁾	Port Diameters	Valve Plug Travel
mm				
1	33.3	25	25.4	25
1-1/2	47.6	22	33.3	38
2	58.7	29	47.6	51
2-1/2	73.0	38	58.7	64
3	87.3	41	73.0	76
4	111.1	54	73.0	102
6	177.8	57	136.5	102
8	203.2	86	177.8	152
Inch				
1	1.3125	1	1	1
1-1/2	1.875	0.875	1.3125	1.5
2	2.3125	1.125	1.875	2
2-1/2	2.875	1.5	2.3125	2.5
3	3.4375	1.625	2.875	3
4	4.375	2.125	2.875	4
6	7	2.25	5.375	4
8	8	3.375	7	6

1. The travel listed is the maximum travel that can be obtained for the given size. In situations where increased valve capacity is not needed, standard ET valve travels should be utilized in selecting the actuator.

Table 19. Port Diameter, Valve Plug Travel, and Stem and Yoke Boss Diameters for Whisper NXG Trim and Whisper III Trims⁽¹⁾

VALVE SIZE, NPS		PORT DIAMETER		MAX VALVE PLUG TRAVEL		STEM AND YOKE BOSS DIAMETERS								PERFORMANCE LEVEL
						Standard				Optional				
ET	EAT	mm	Inch	mm	Inch	Stem		Yoke Boss		Stem		Yoke Boss		
						mm	Inch	mm	Inch	mm	Inch	mm	Inch	
1	1	33.3	1 5/16	19	3/4	9.5	3/8	54	2 1/8	12.7	1/2	71	2 13/16	A1
1 1/2	2	47.6	1 7/8	19	3/4	9.5	3/8	54	2 1/8	12.7	1/2	71	2 13/16	A1
		33.3	1 5/16	19	3/4									A3, B1, B3
2	--	58.7	2 5/16	35	1 3/8	12.7	1/2	71	2 13/16	19.1	3/4	90	3 9/16	A1
2	--	33.3	1 5/16	29	1 1/8	12.7	1/2	71	2 13/16	19.1	3/4	90	3 9/16	A3, B1, B3, C1, C3, D1, D3
		73	2 7/8	38	1 1/2	12.7	1/2	71	2 13/16	19.1	3/4	90	3 9/16	A1
2 1/2	3	47.6	1 7/8	38	1 1/2	12.7	1/2	71	2 13/16	19.1	3/4	90	3 9/16	A3, B1, B3, C1, C3, D1, D3
		87.3	3 7/16											A1
3	4	58.7	2 5/16	38	1 1/2	12.7	1/2	71	2 13/16	19.1	3/4	90	3 9/16	A3, B1, B3, C1, C3, D1, D3
		111.1	4 3/8											51
4	6	87.3	3 7/16	51	2	12.7	1/2	71	2 13/16	25.4	1	127	5	A3, B1, B3, C1, C3, D1, D3
		177.8	7							51	2	19.1	3/4	90
6	--	136.5	5 3/8	76	3	19.1	3/4	90	3.5625	25.4 or 31.8	1 or 1 1/4	127	5	A3, B1, B3, C1, C3, D1, D3
		76	3	A1										
8	--	203.2	8	76	3	19.1	3/4	90	3.5625	25.4 or 31.8	1 or 1 1/4	127	5	A1
				102	4									A3, B1, B3, C1, C3

1. Refer Fisher Bulletin 80.1:010 Whisper Trim III (D100191X012) for more information.

Table 20. Port Diameters, Valve Plug Travel, Yoke Boss Diameters for TSO (Tight Shutoff) Trim

VALVE	TRIM	MAX TRAVEL		YOKE BOSS SIZE		PORT DIAMETER				C _v REDUCTION AT 100% TRAVEL ⁽¹⁾	UNBALANCE AREA
		mm	Inch	mm	Inch	Nominal		Actual TSO			
						mm	Inch	mm	Inch		mm
ET NPS 3	CAV III 2-Stage	76.2	3	90 127	3-9/16 5	73.0	2.875	68.3	2.6875	0%	0.098
ET NPS 4	CAV III 2-Stage	102	4	90 127	3-9/16 5	73.0	2.875	68.3	2.6875	5%	0.098
EAT NPS 4	Std	38.1	1.5	71.4 90	2-13/16 3-9/16	87.3	3.4375	82.6	3.25	6% 4%	0.118
EAT NPS 6	Std	50.8	2	90	3-9/16	111	4.375	106	4.1875	4% (linear) 3% (equal percent)	0.154

1. This column lists the percent reduction of published maximum C_v of the trim listed in the TRIM column.

Figure 14. Typical Trim for NACE MR0175 / ISO 15156 and MR0103 (Sour Service)

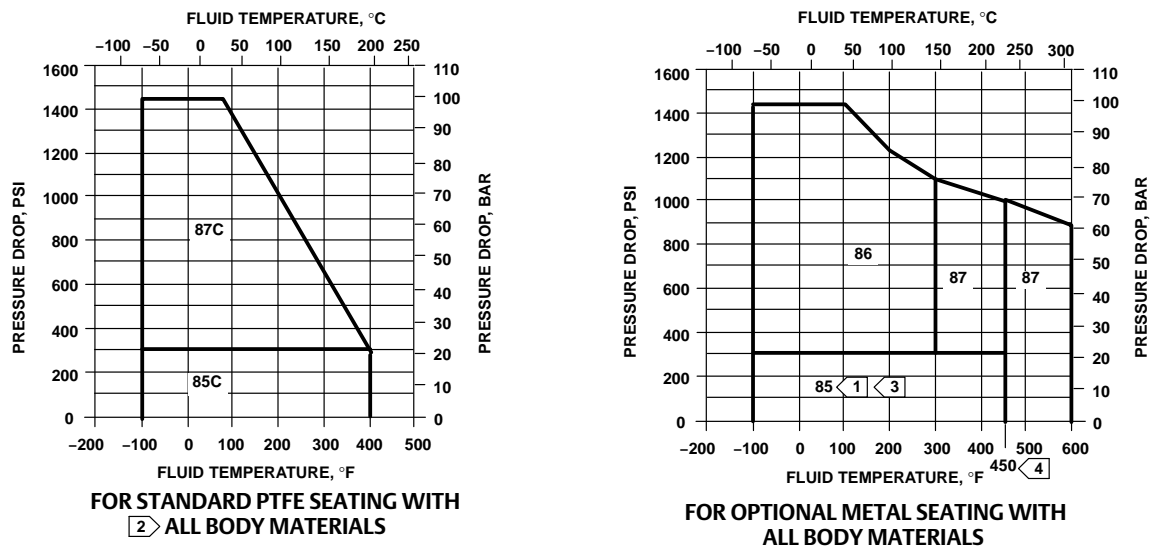

A6739-1

Notes:

- 1 Use trim 87 instead of trim 85 for nonlubricating fluids such as super-heated steam or dry gases between 149°C (300°F) and 232°C (450°F).
- 2 Do not exceed the maximum pressure and temperature for the pressure rating of the body material used, even though the trims shown may have higher capabilities.
- 3 Trim 85 may be used up to 99 bar (1440 psi) with clean dry gas. For process fluids other than clean dry gas, use trim 85 only up to 21 bar (300 psi).
- 4 Trim 87 temperature limits can be extended to 316°C (600°F) for non-oxidizing service or 260°C (500°F) for oxidizing service if PEEK anti-extrusion rings are used with spring-loaded seal rings.

Table 21. Metal Trim Part Materials for Compatibility with NACE MR0175 / ISO 15156 and MR0103 (Sour Service) Specifications. Environmental Restrictions Apply, Refer to Standard.

Trim Designation ⁽⁴⁾	Valve Plug	Cage	Seat Ring for Standard Metal Seat Construction	Optional Liner for Metal Seat (EAT only)	Disk Seat and Retainer for Optional PTFE-Seat Construction	Valve Stem, Packing Follower, Lantern Ring, Packing Box Ring, and Pin	Load Ring ⁽¹⁾
85 ⁽⁵⁾	S31600	316 SST with electroless nickel coating (ENC)	S31600	S31600	---	S20910 (Valve Stem) S31600 (All Other Parts)	N05500
85C ^(2, 5)	S31600	316 SST with electroless nickel coating (ENC)	---	---	S31600		
86 ⁽⁵⁾	S31600 with seat hard faced with CoCr-A hardfacing alloy	316 SST with electroless nickel coating (ENC)	R30006 (alloy 6)	---	---		
87 (Also used for 8-inch Whisper Trim I)	S31600 with seat and guide hard faced with CoCr-A hardfacing alloy	316 SST with electroless nickel coating (ENC) ⁽³⁾	R30006 (alloy 6)	---	---		
87C ⁽²⁾ (Also used for 8-inch Whisper Trim I)	S31600 with seat and guide hard faced with CoCr-A hardfacing alloy	316 SST with electroless nickel coating (ENC) ⁽³⁾	---	---	S31600		

1. NPS 8 valve body only.
 2. 85C and 87C are trims for PTFE-seat construction.
 3. 8-inch Whisper Trim I cage is 17-4 SST, double H1150 (NACE) / ENC.
 4. N07750 retaining ring is standard for spring-loaded seal ring construction.
 5. Not for use with Whisper Trim I with 136 mm (5.375 inch) and larger ports.

Table 22. Bolting Materials and Temperature Limits for Bolting Compliance with NACE MR0175-2002, NACE MR0175/ISO 15156, and NACE MR0103. Environmental restrictions may apply

VALVE BODY MATERIAL		BOLTING MATERIAL		TEMPERATURE CAPABILITIES			
				°C		°F	
				Min	Max	Min	Max
Non-exposed bolting (Standard)							
WCC and CF8M (316 SST)	Studs	Steel SA-193-B7		-48 ⁽²⁾	427	-55 ⁽²⁾	800
	Nuts	Steel SA-194-2H					
Exposed bolting (Optional) May require derating of valve⁽¹⁾ when these body-to-bonnet bolting materials are used							
WCC and CF8M	Studs	Steel SA-193-B7M		-48 ⁽²⁾	427	-55 ⁽²⁾	800
	Nuts	Steel SA-194-2HM					

1. Derating is not required for CL150 and 300 valves. Derating may be required for valves rated at CL600. Contact your [Emerson sales office](#) for assistance in determining the derating of valves when these body-to-bonnet bolting materials are used.
 2. -29°C (-20°F) with WCC body material.

Table 23. Fisher ET and ETR Dimensions

VALVE SIZE, NPS	A									G (MAX)	
	Pressure Rating, End Connection Style (1)									ET	ETR
	Scrd or SW	CL125 FF or CL150 RF	CL150 RTJ	CL250 RF or CL300 RF	CL300 RTJ	BW or CL600 RF	CL600 RTJ	PN16-40 (2)	PN63-100 (2)		
mm											
1	210	184	197	197	210	210	210	160	230	60	119
1-1/2	251	222	235	235	248	251	251	200	260	71	116
2	286	254	267	267	282	286	289	230	300	78	133
2-1/2	---	276	292	292	308	311	314	290	340	90	159
3	---	298	311	317	333	337	340	310	380	97	168
4	---	353	365	368	384	394	397	350	430	129	192
6	---	451	464	473	489	508	511	480	550	140	---
8	---	543	556	568	584	610	613	600	650	191	---
Inch											
1	8.25	7.25	7.75	7.75	8.25	8.25	8.25	See mm above	See mm above	2.38	4.69
1-1/2	9.88	8.75	9.25	9.25	9.75	9.88	9.88			2.81	4.56
2	11.25	10.00	10.50	10.50	11.12	11.25	11.38			3.06	5.25
2-1/2	---	10.88	11.38	11.50	12.12	12.25	12.38	See mm above	See mm above	3.56	6.25
3	---	11.75	12.25	12.50	13.12	13.25	13.38			3.81	6.62
4	---	13.88	14.38	14.50	15.12	15.50	15.62			5.06	7.56
6	---	17.75	18.25	18.62	19.25	20.00	20.12			5.51	---
8	---	21.38	21.88	22.38	23.00	24.00	24.12			7.50	---

1. End connection style abbreviations: BW - Butt-welding, FF - Flat Faced, Scrd - Screwed, SW - Socket-weld, RF - Raised Face, RTJ - Ring Type Joint
 2. Valves which meet EN 1092 flange standards and have EN face-to-face dimensions are available only from Europe (EN 558-1). Valves which meet EN 1092 flange standards but not EN face-to-face standards are available in the US. Consult your [Emerson sales office](#).

Figure 15. Fisher ET and ETR Dimensions (also see tables 23, 24, and 25)

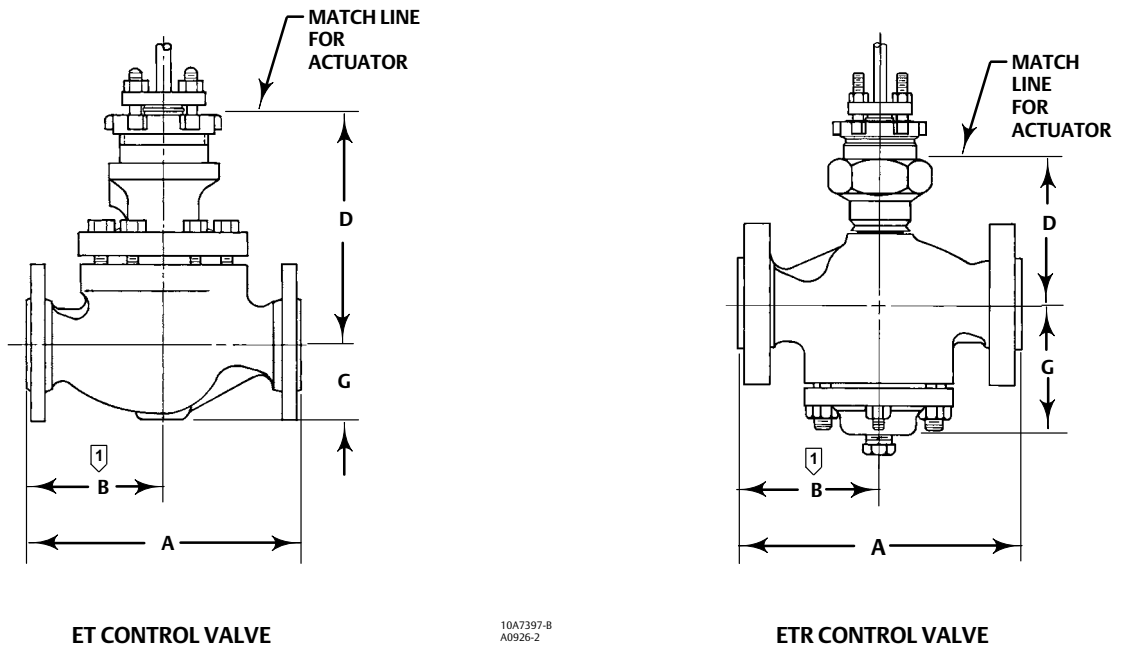

Notes:

1. $B = \frac{A}{2}$

2. For dimensions of valves with other end connections, consult your Emerson sales office.

Table 24. Fisher ET and ETR Dimensions

VALVE SIZE, NPS	D FOR PLAIN BONNET										
	ET Except with Cavtrol III Two-Stage Cage				ET with Cavtrol III Two-Stage Cage				ETR		
	Stem Diameter, mm				Stem Diameter, mm				Stem Diameter, mm		
	9.5	12.7	19.1	25.4 or 31.8	9.5	12.7	19.1	25.4 or 31.8	9.5	12.7	19.1
1	127	149	---	---	---	184	---	---	113	124	---
1-1/2	124	146	---	---	155	177	---	---	122	133	---
2	---	165	162	---	---	201	198	---	---	148	140
2-1/2	---	187	184	---	---	229	226	---	---	157	152
3	---	191	187	---	---	260	256	---	---	167	159
4	---	221	217	264	---	311	308	354	---	198	191
6 ⁽¹⁾	---	---	251	270	---	---	336	380	---	---	---
6 ⁽²⁾	---	---	312	330	---	---	---	---	---	---	---
8	---	---	375 ⁽³⁾	426	---	---	511	560	---	---	---
	Stem Diameter, Inch				Stem Diameter, Inch				Stem Diameter, Inch		
	3/8	1/2	3/4	1 or 1-1/4	3/8	1/2	3/4	1 or 1-1/4	3/8	1/2	3/4
1	5.00	5.88	---	---	---	7.25	---	---	4.44	4.88	---
1-1/2	4.88	5.75	---	---	6.09	6.97	---	---	4.81	5.25	---
2	---	6.50	6.38	---	---	7.91	7.78	---	---	5.81	5.50
2-1/2	---	7.38	7.25	---	---	9.03	8.91	---	---	6.31	6.00
3	---	7.50	7.38	---	---	10.22	10.09	---	---	6.56	6.25
4	---	8.69	8.56	10.38	---	12.25	12.12	13.94	---	7.81	7.50
6 ⁽¹⁾	---	---	9.88	10.62	---	---	13.22	14.97	---	---	---
6 ⁽²⁾	---	---	12.26	13.00	---	---	---	---	---	---	---
8	---	---	14.75 ⁽³⁾	16.75	---	---	20.12	22.06	---	---	---

1. For all NPS 6 valves except with Whisper III, Whisper NXG trims, and WhisperFlo cages.
 2. For NPS 6 valves with Whisper III, Whisper NXG trims, and WhisperFlo cages.
 3. Available only in cast iron or WCC steel for the stem diameter with plain bonnet.

Table 25. Fisher ET and ETR Dimensions

VALVE SIZE, NPS	D FOR EXTENSION AND ENVIRO-SEAL BELLOWS SEAL BONNETS (ET ONLY, EXCEPT WITH CAVITROL III CAGE)										
	Style 1 Ext. Bonnet				Style 2 Ext. Bonnet			ENVIRO-SEAL Bellows Seal Bonnet			
	Stem Diameter				Stem Diameter			Stem diameter			
	mm										
	9.5	12.7	19.1	25.4 or 31.8	9.5	12.7	19.1	9.5	12.7	19.1	
1	213	251	---	---	303	319	---	320	---	---	
1-1/2	210	248	---	---	300	316	---	317	---	---	
2	---	267	272	---	---	465	---	---	384	---	
2-1/2	---	289	294	---	---	492	---	---	---	---	
3	---	292	297	---	---	495	487	---	517	517	
4	---	322	327	370	---	526	518	---	541	---	
6 ⁽¹⁾	---	---	357	402	---	---	543	---	---	573	
6 ⁽²⁾	---	---	418	462	---	---	604	---	---	---	
8	---	---	421	450	---	---	621	---	---	703	
	Inch										
	3/8	1/2	3/4	1 or 1-1/4	3/8	1/2	3/4	3/8	1/2	3/4	
1	8.38	9.88	---	---	11.94	12.56	---	12.62	---	---	
1-1/2	8.25	9.75	---	---	11.81	12.44	---	12.50	---	---	
2	---	10.50	10.69	---	---	18.31	---	---	15.12	---	
2-1/2	---	11.38	11.56	---	---	19.38	---	---	---	---	
3	---	11.50	11.69	---	---	19.50	19.19	---	20.38	20.38	
4	---	12.69	12.88	14.56	---	20.69	20.38	---	21.31	---	
6 ⁽¹⁾	---	---	14.06	15.81	---	---	21.38	---	---	22.56	
6 ⁽²⁾	---	---	16.44	18.19	---	---	23.76	---	---	---	
8	---	---	16.56	17.75	---	---	24.44	---	---	27.69	

1. Standard-travel cages.
 2. For NPS 6 valves with Whisper III, Whisper NXG trims, and WhisperFlo cages.

Table 26. Fisher EAT Dimensions⁽¹⁾

VALVE SIZE, NPS	AA					
	CL150		CL300		CL600	
	RF	RTJ	RF	RTJ	BW, SW or RF	RTJ
	mm					
1	92	98	98	105	105	105
2	127	133	133	141	143	144
3	149	156	159	167	168	170
4	176	183	184	197	197	198
6	225	232	237	244	254	256
	Inch					
1	3.62	3.88	3.88	4.12	4.12	4.12
2	5.00	5.25	5.25	5.56	5.62	5.69
3	5.88	6.12	6.25	6.56	6.62	6.69
4	6.94	7.19	7.25	7.56	7.75	7.81
6	8.88	9.12	9.31	9.62	10.00	10.06

1. End connection style abbreviations: BW - Butt welding, FF - Flat Faced, Scrd - Screwed, SW - Socket weld, RF - Raised Face, RTJ - Ring Type Joint.

Table 27. Fisher EAT Dimensions

VALVE SIZE, NPS	DD						
	Plain Bonnet				Style 1 Extension Bonnet		
	Stem Diameter, mm				Stem Diameter, mm		
	9.5	12.7	19.1	25.4 or 38.1	9.5	12.7	19.1
1	111	133	---	---	197	253	---
2	98	121	---	---	184	223	---
3	---	149	146	---	---	251	256
4	---	140	137	---	---	241	246
6	---	144	141	187	---	246	251
	Stem Diameter, In.				Stem Diameter, In.		
	3/8	1/2	3/4	1 or 1-1/4	3/8	1/2	3/4
1	4.38	5.25	---	---	7.75	9.95	---
2	3.88	4.75	---	---	7.25	8.75	---
3	---	5.88	5.75	---	---	9.88	10.06
4	---	5.50	5.38	---	---	9.50	9.69
6	---	5.69	5.56	7.38	---	9.69	9.88

Figure 16. Fisher EAT Dimensions (also see tables 26, 27, and 28)

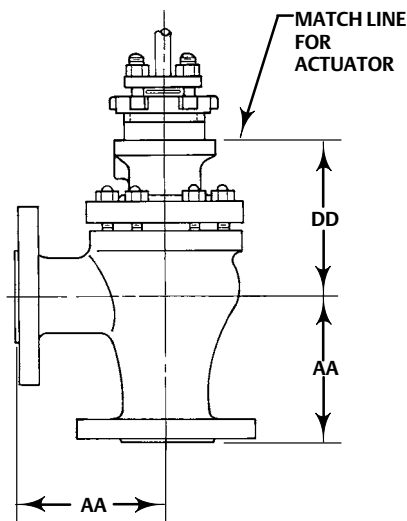

A0927-2

Note:
For dimensions of valves with PN (or other) end connections, consult your [Emerson sales office](#).

Table 28. Fisher EAT Dimensions

VALVE SIZE, NPS	DD					
	Style 2 Extension Bonnet			ENVIRO-SEAL Bellows Seal Bonnet		
	Stem Diameter, mm			Stem Diameter, mm		
	9.5	12.7	19.1	9.5	12.7	19.1
1	291	305	---	305	---	---
2	278	291	---	292	---	---
3	---	454	---	---	---	---
4	---	445	437	---	467	---
6	---	449	441	---	465	---
	Stem Diameter, In.			Stem Diameter, In.		
	3/8	1/2	3/4	3/8	1/2	3/4
1	11.44	12.00	---	12.00	---	---
2	10.94	11.44	---	11.50	---	---
3	---	17.88	---	---	---	---
4	---	17.50	17.19	---	18.38	---
6	---	17.69	17.38	---	18.31	---

Ordering Information

Inlet pressure and temperature must always be limited by the applicable ASME pressure/temperature rating. Pressure drop information for various trim material combinations is provided in figures 12, 13, and 14. The maximum allowable pressure drop for the application must not exceed the lowest value indicated for the combination of materials selected.

When ordering, specify:

Application Information

1. Type of application:
 - a. Throttling or on-off
 - b. Reducing or relief
2. Controlled fluid (include chemical analysis of fluid if possible)
3. Specific gravity of controlled fluid
4. Fluid temperature
5. Inlet pressures:
 - a. Minimum
 - b. Normal
 - c. Maximum
6. Pressure drops:
 - a. Minimum flowing drop

- b. Normal flowing drop
 - c. Maximum flowing drop
 - d. Maximum at shutoff
7. Flow rates:
 - a. Minimum controlled flow
 - b. Normal flow
 - c. Maximum flow
8. Maximum permissible noise level, if critical
9. Shutoff classification required
10. Valve stem diameter and bonnet type (plain, extension, or ENVIRO-SEAL bellows seal bonnet)
11. Line size and schedule

Valve Information

To determine what valve ordering information is needed, refer to the specifications. Review the description for each specification and in the referenced tables; write down your choice whenever there is a selection to be made. Always specify the valve design letter designation.

Actuator and Accessory Information

Refer to the specific actuator and accessory bulletins for required ordering information.

Product Bulletin

51.1:ET
October 2023

ET Valve
D100022X012

Neither Emerson, nor any of their affiliated entities assumes responsibility for the selection, use or maintenance of any product. Responsibility for proper selection, use, and maintenance of any product remains solely with the purchaser and end user.

Fisher, Cavitrol, easy-e, ENVIRO-SEAL, FIEDLVUE, Whisper Trim, and WhisperFlo are marks owned by one of the companies in the Emerson business unit of Emerson Electric Co. Emerson, and the Emerson logo are trademarks and service marks of Emerson Electric Co. All other marks are the property of their respective owners.

The contents of this publication are presented for informational purposes only, and while every effort has been made to ensure their accuracy, they are not to be construed as warranties or guarantees, express or implied, regarding the products or services described herein or their use or applicability. All sales are governed by our terms and conditions, which are available upon request. We reserve the right to modify or improve the designs or specifications of such products at any time without notice.

Emerson

Marshalltown, Iowa 50158 USA
Sorocaba, 18087 Brazil
Cernay, 68700 France
Dubai, United Arab Emirates
Singapore 128461 Singapore

www.Fisher.com

