

Spring Balancers

ENDO Series

Distributed by Ergonomic Partners
Sales@ErgonomicPartners.com
www.ErgonomicPartners.com
Tel: (314) 884-8884



CONDUCTIX
wampfler

© DELACHAUX GROUP

Contents

ENDO Balancers - Features and Benefits	3
Specification Data Sheet	4
Balancer Summary Chart	5
Spring Balancer Safety Features	6
Application Guidelines and Spring Tension Adjustment Systems	7
Retractor, Series ERP and ER Torque Reels	8
Balancer, Series EK, EW, and EWF-C	9
Balancer, Series EWF	10
Balancer, Series ELF Long Stroke Balancers	11
"ECO" Balancer, Series EW-X	12
"ECO" Balancer, Series EW-Y	13
Balancer, EWS Safety Balancers and ETP High Capacity Balancers	14
Balancer, Series EWA, With Snap-Back Prevention System	15
Balancer, Series EKN, for Electrostatic Discharge	15
Series SBC Clean Room Balancer	16
Air Tool Balancers, Series ATB and THB	17
Twin Hose Balancer, Series ST-30	18
Air Tool Reel, Series ATR	18
Series PRF Manual Trolleys	19
Spare Parts and Accessories	20-21
Dimensional Drawings	22-27
Balancer Warranty	28
General Warranty	29
Industrial Assembly Solutions	30
Field Service and Other Conductix-Wampfler Products	31
Conductix-Wampfler Contact Information	32

The people at Conductix-Wampfler (formerly IER/Insul-8) build quality spring-driven cable reels in Omaha, Nebraska, and have since 1946, in hundreds of configurations to suit the unique needs of demanding industrial users. We know spring motors and their capabilities! Now with the merger of Conductix and Wampfler, we proudly offer **ENDO** spring-driven tool balancers. Prior to the merger and since 1979, Wampfler USA was the exclusive USA distributor of quality ENDO products in the USA.

ENDO products are built at their ISO 9001:2000 certified factory in Niigata, Japan. Their stringent quality systems assure that you will get the right balancer . . . every time!

Conductix-Wampfler is the world leader in the design and manufacture of high-performance spring-driven devices for industrial applications and proud representative of ENDO balancers.



EK Series



EW Series



EWA Series



EWF/ELF Series



ETP Series



ENDO Balancers - Features and Benefits

ENDO Spring Balancers by Conductix-Wampfler are a valuable addition to your assembly line. They support heavy tools with cable tension equal to the weight of the suspended tools, which makes them seem virtually "weightless". As the tool is repositioned the balancer extends or retracts the support cable to follow the tool's movements. Constant tension on the cable is accomplished with a spring motor and a tapered drum. The assembler has the flexibility to reposition the tool, while experiencing comfortable operation and less fatigue. Similar to a Balancer is the **Retractor**, which does not have a tapered drum. The tension on the cable increases as the cable is extended.

All ENDO Retractors and Balancers Have an Exclusive 18 Month Warranty - See Pg. 28!

Typical Balancer Features - Depending on Model

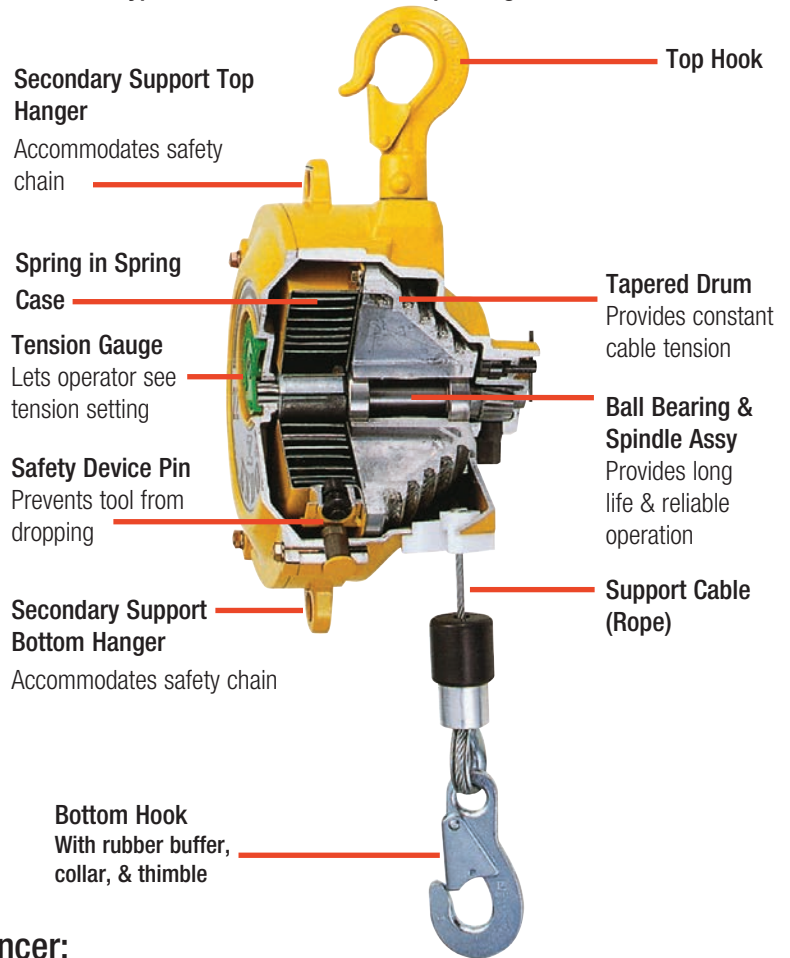

Advantages of Using an ENDO Spring Balancer:

- Suspend tools in assembly lines or other work areas
- Help the assembler with repetitive tasks such as installing fasteners: screws, nuts, bolts, etc.
- Hold fixtures, tools, welding guns, and similar equipment
- Improves efficiency and diminishes worker fatigue
- Stabilizes tool positioning and contributes to work accuracy
- Contributes to a safer working environment
- Keeps fixtures, tools, and welding guns off of the floor and clean.
- Eliminates the need to separately power the balancer

Balancers for Many Special Applications!



Food Prep - Pgs. 12-13



Clean Rooms - Pg. 16



Static Discharge - Pg. 15



Air Tools - Pgs. 17-18



I-Beam Trolleys - Pg. 19

Specification Data Sheet

To choose the balancer that will perform properly, please fill in the following information to obtain a quote.

Request Date: _____	Sales Person: _____
Company: _____	Contact: _____
_____	Title: _____
_____	Telephone: _____
_____	Fax: _____
_____	E-Mail: _____

General Operating Conditions

Environment: Indoor Outdoor Temperature range (°F) _____ Min _____ Max

Humidity (%) _____

Corrosives? (List) _____

Clean Room? _____

Food Prep Area? _____

Balancer Specifications

General Application _____

Type of Item to be suspended _____

Total Weight of Item to be suspended
(including any accessories) _____

Require Travel distance ("stroke") _____

Average Cycles (per day) _____

Balancer Feature Key - Referring to Chart on Pg. 5

These are the features available based on the model chosen - see listing in the table on Pg. 5 - far right column. See detailed model descriptions within the catalog and see pgs. 6 and 7 for further information.

Code	Feature	Code	Feature
A	Tension Gauge	G	Snap-Back Protection
B	Plug Type Cable Set	H	Handle System Torque Adjustment
C	Cartridge Spring Assembly	I	Cushion Cover Available
D	Drum Locking Device	J	Worm Gear Torque Adjustment
E	Ratchet Device (drum lock to keep wire rope extended)	K	Ratchet System Spring Tension Adjustment
F	Fall Arrest Device	L	Plastic Drum



Balancer Summary Chart

	Model	Pg.	Capacity lb (kg)	Stroke ft (m)	Feature Set (See Pg. 4)
LIGHT CAPACITY	EK-00 / EKN-00	9	1.1-3.3 (0.5-1.5)	1.64 (0.5)	K
	EK-0 / EKN-0 / SBC-15	9	1.1-3.3 (0.5-1.5)	3.28 (1.0)	K
	ERP-06 (retractor)	8	0.7-1.3 (0.3-0.6)	4.92 (1.5)	H
	ERP-1 (retractor)	8	1.1-2.2 (0.5-1.0)	4.92 (1.5)	H
	ERP-2 (retractor)	8	2.2-4.4 (1.0-2.0)	4.92 (1.5)	H
	ER-3A / 3B (torque reel)	8	3.9 (1.8) max	9.84 (3.0)	E, K
	ER-5A / 5B (torque reel)	8	5.5 (2.5) max	9.84 (3.0)	E, K
	ER-10A / 10B (torque reel)	8	11.9 (5.0) max	13.12 (4.0)	E,K
STANDARD	EW-3, EW-3X, EW-3Y	9,12, 13	2.2-6.6 (1.0-3.0)	4.27 (1.3)	B, K
	EW-4	9	4.4-8.8 (2.0-4.0)	4.27 (1.3)	B, K
	EW-5, EW-5X, EW-5Y	9, 12, 13	5.5-11.0 (2.5-5.0)	4.27 (1.3)	B, K
	EFW-3C	9	3.3-6.6 (1.5-3.0)	4.27 (1.3)	B, F, L, Riveted Spring
	EFW-5C	9	6.6-11.0 (3.0-5.0)	4.27 (1.3)	B, F, L, Riveted Spring
	EFW-7C	9	11.0-15.4 (5.0-7.0)	4.27 (1.3)	B, F, L, Riveted Spring
	EWS-3, EWS-3X, EWS-3Y	14, 12, 13	3.3-6.6 (1.5-3.0)	4.27 (1.3)	B, D, F, J
	EWS-5, EWS-5X, EWS-5Y	14, 12, 13	6.6-11.0 (3.0-5.0)	4.27 (1.3)	B, D, F, J
	EWS-7, EWS-7X, EWS-7Y	14, 12, 13	11.0-15.4 (5.0-7.0)	4.27 (1.3)	B, D, F, J
	EFW-9, EFW-9X, EFW-9Y	10, 12, 13	9.9-19.8 (4.5-9.0)	4.27 (1.3)	A, B, C, D, F, J
	EFW-15, EFW-15X, EFW-15Y	10, 12, 13	19.8-33.1 (9.0-15)	4.93 (1.5)	A, B, C, D, F, J
	EFW-22, EFW-22X, EFW-22Y, EWA-22	10, 12, 13, 15	33.1-48.5 (15.0-22.0)	4.93 (1.5)	A, B, C, D, F, I, J (+ K, G, EWA)
	EFW-30, EFW-30X, EFW-30Y, EWA-30	10, 12, 13, 15	48.5-66.1 (22.0-30.0)	4.93 (1.5)	A, B, C, D, F, I, J (+ K, G, EWA)
	EFW-40, EFW-40X, EFW-40Y, EWA-40	10, 12, 13, 15	66.1-88.2 (30.0-40.0)	4.93 (1.5)	A, B, C, D, F, I, J (+ K, G, EWA)
	EFW-50, EFW-50X, EFW-50Y, EWA-50	10, 12, 13, 15	88.2-110.2 (40.0-50.0)	4.93 (1.5)	A, B, C, D, F, I, J (+ K, G, EWA)
	EFW-60, EFW-60X, EFW-60Y, EWA-60	10, 12, 13, 15	110.2-132.2 (50.0-60.0)	4.93 (1.5)	A, B, C, D, F, I, J (+ K, G, EWA)
	EFW-70, EFW-70X, EFW-70Y, EWA-70	10, 12, 13, 15	132.2-154.3 (60.0-70.0)	4.93 (1.5)	A, B, C, D, F, I, J (+ K, G, EWA)
	EFW-90, EFW-90X, EFW-90Y	10	154.3-198.4 (70.0-90.0)	6.56 (2.0)	A, B, C, D, F, I, J
	EFW-105, EFW-105X, EFW-105Y	10	198.4-231.5 (85.0-105.0)	6.56 (2.0)	A, B, C, D, F, I, J
	EFW-120, EFW-120X, EFW-120Y	10	231.5-264.5 (100.0-120.0)	6.56 (2.0)	A, B, C, D, F, I, J
HIGH CAPACITY	ETP-15	14	264.6-308.6 (120.0-140.0)	3.94 (1.2)	F, J
	ETP-15	14	308.6-374.8 (140.0-170.0)	3.94 (1.2)	F, J
	ETP-16	14	374.8-440.9 (170.0-200.0)	3.94 (1.2)	F, J
	ELF-3	11	3.3-6.6 (1.5-3.0)	8.20 (2.5)	B, D, F
LONG STROKE	ELF-5	11	5.5-11.0 (3.0-5.0)	8.20 (2.5)	B, D, F
	ELF-9	11	11.0-19.8 (5.0-9.0)	8.20 (2.5)	B, D, F
	ELF-15	11	19.8-33.1 (9.0-15.0)	8.20 (2.5)	A, B, C, D, F, J
	ELF-22	11	33.1-48.5 (15.0-22.0)	8.20 (2.5)	A, B, C, D, F, J
	ELF-30	11	48.5-66.1 (22.0-30.0)	8.20 (2.5)	A, B, C, D, F, J
	ELF-40	11	66.1-88.2 (30.0-40.0)	8.20 (2.5)	A, B, C, D, F, J
	ELF-50	11	88.2-110.2 (40.0-50.0)	8.20 (2.5)	A, B, C, D, F, J
	ELF-60	11	110.2-132.2 (50.0-60.0)	8.20 (2.5)	A, B, C, D, F, J
	ELF-70	11	132.3 154.3 (60.0-70.0)	8.20 (2.5)	A, B, C, D, F, J

Balancer Safety Features

Check Out These Great Safety Features! (Some balancer models don't have all features shown - See Pg. 5)

Fall Arrest System



Prevents tool from dropping in the unlikely event that a spring breaks

Secondary Support Hangers



On top and bottom to accommodate safety chain

Snap-Back Protection

Works similar to the Fall Arrest system, except this is designed to stop the spool if the cable is ever cut

Drum Lock System



Available to lock the spool while replacing a tool

Plug-in Cable Set

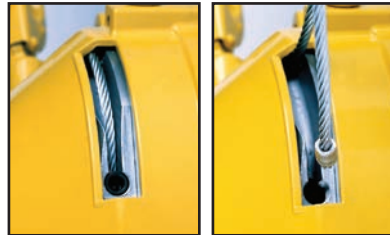

For easy cable replacement

Tension Gauge



Lets operator see tension setting

Safety Spring Canister



For safe spring replacement

All ENDO balancers have an exclusive 18 month warranty - see page 28 for details.

Application Guidelines

Spring Balancer Usage Guidelines

- Size the balancer to carry the total weight to be balanced - tool plus all accessories - and stroke (maximum to minimum height) required.
- Size to the upper end of the capacity range of the balancer when possible. For example, if the total tool weight is 10.5 pounds the EW-5 (5.5-11.0 pounds) would be a better choice than the EWF-9 (9.9-19.8 pounds).
- Always attach secondary support cable(s) to the eyelet provided for additional safety.
- Balancers are normally hung vertically and the rope is pulled out vertically. To prevent the rope from wearing on the guide, the rope should not be pulled out at an angle to the balancer body. The balancer can also be mounted horizontally, however a pulley system must be employed to guide the rope straight out of the balancer then down to the tool. Again, care must be taken to prevent the rope from wearing on the guide. A trolley and rail system can be used to help the balancer adjust to changing angles. Please refer to page 19 in this catalog and to the Conductix-Wampfler Tasksaver Workstation Equipment Catalog # 401.
- If multiple balancers are used in close together, install them at staggered heights to keep them from hitting each other
- The spring tension is factory preset to the mid-range of the rated capacity. To adjust the tension turn the worm gear or spindle clockwise to increase the tension and counterclockwise to decrease the tension. See below for more information.

BALANCER SAFETY WARNINGS - PLEASE READ

- Do not lift or transport personnel with any of the equipment shown or described in this catalog.
- Check all applicable industry, trade association, federal, state and local regulations.
- Be sure that supporting structure and load-attaching devices used in conjunction with this equipment are adequate to handle the rated load plus the weight of the equipment.
- Read all operating instructions and warnings carefully.

Spring Tensioning Systems

Depending on the model, the retractor or balancer will have one of three different spring tension adjustment systems: the Handle System, the Worm Gear System, or the Ratchet System.



Handle System

Turn clockwise to increase tension, counter-clockwise to decrease tension

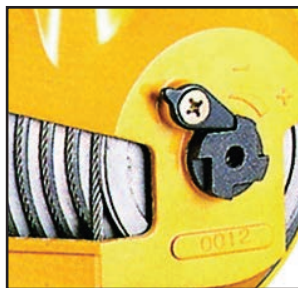

Ratchet System Spring Adjust

Insert Allen wrench and turn clockwise to increase tension and counter-clockwise to decrease tension



Worm Gear System

Turn clockwise to increase tension, counter-clockwise to decrease tension

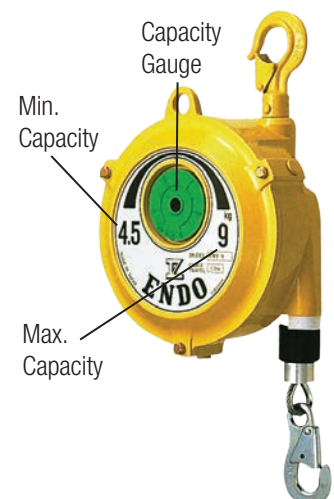

Spring Retractors and Torque Reels

ERP Series Retractor



ENDO ERP Series Spring Retractors are an economical choice for the suspension of tools when "zero gravity" is not required. Tension adjustment is easily performed without tools using the integrated handle system; clockwise increases tension; counterclockwise decreases tension. Unit includes an adjustable stopper to that can be positioned to limit the stroke.

- 0.05 inch (1.20 mm) diameter nylon-coated cable for clean operation - no greasy mess
- High impact ABS case
- Forged steel swivel eyelet

ERP Series Retractors WITHOUT Ratchet				
Capacity Range lb (kg)	Cable Travel ft (m)	Part No.	Wt lb (kg)	
0.7 to 1.3 (0.3 to 0.6)	4.92 (1.5)	ERP-06E	0.80 (0.36)	
1.1 to 2.2 (0.5 to 1.0)	4.92 (1.5)	ERP-1E	0.80 (0.36)	
2.2 to 4.4 (1.0 to 2.0)	4.92 (1.5)	ERP-2E	0.80 (0.36)	

For dimensional drawing, see Pg. 22

ER Series Torque Reel

ENDO ER Series Torque Reels are light-weight and compact. The long cable travel makes them suitable for hanging push button pendant stations and similar devices. Cylindrical drum prevents cable jamming. For dimensional drawings, see Pg. 22.

- Cable diameter: 0.09 in. (2.38 mm)
- Cast aluminum case
- Available with ratchet lock mechanism (ER-A), or without (ER-B)



ER-3A

ER Series Torque Reel - WITH Ratchet				
Max. Cap. lb (kg)	Active Cable Travel ft (m)	Spring Turns	Part No.	Wt lb (kg)
3.9 (1.8)	9.84 (3.0)	16	ER-3A	3.09 (1.40)
5.5 (2.5)	9.84 (3.0)	13	ER-5A	3.31 (1.50)
11.9 (5.0)	13.12 (4.0)	13	ER-10A	9.92 (4.50)



ER-10A

ER Series Torque Reel - WITHOUT Ratchet				
Max. Cap. lb (kg)	Active Cable Travel ft (m)	Spring Turns	Part No.	Wt lb (kg)
3.9 (1.8)	9.84 (3.0)	16	ER-3B	2.87 (1.30)
5.5 (2.5)	9.84 (3.0)	13	ER-5B	3.09 (1.40)
11.9 (5.0)	13.12 (4.0)	13	ER-10B	8.38 (3.80)

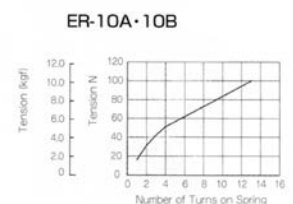
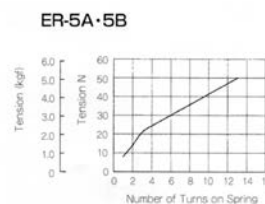
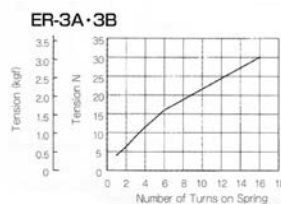

EK, EW, and EWF-C Series Balancers

EK Series

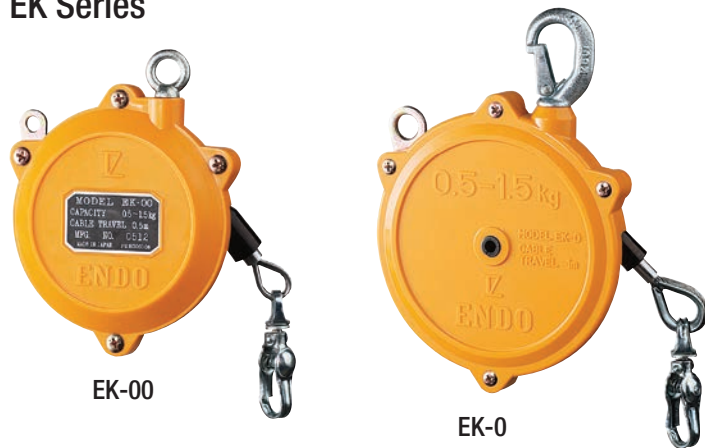

EK Series Balancers provide true "zero gravity" tool holding with no drifting or strain. The units have high impact cast ABS housings and the handle system for spring adjustment - See Pg. 7 for details. The tapered drums, quality springs, and ball bearings provide smooth cable travel throughout the stroke. Tension adjustment is easy and precise.

See Pg. 5 for details on choosing the correct balancer for the application. CE Mark available.

Both "EK" models have a capacity range of 1.1 to 3.3 lb (0.5 to 1.5 kg).

Cable Travel ft (m)	Part No.	Cable Dia in. (mm)	Wt lb (kg)
1.64 (0.50)	EK-00	0.08 (2.00)	0.40 (0.20)
3.28 (1.00)	EK-0	0.12 (0.50)	1.10 (0.50)

For dimensional drawing, see Pg. 22.

EW Series



EW Series Balancers have cast aluminum case and the ratchet system spring adjustment - see Pg. 7 for details. The cable is affixed with the "Plug-Type" cable set - See Pg. 6 for details.

EW Series Balancers are available in an **unpainted version**. To order, add "NP" at the end of the standard "EW" part number.

Max. Capacity lb (kg)	Cable Travel ft (m)	Part No.	Cable Dia in. (mm)	Wt lb (kg)
2.2 to 6.6 (1.0 to 3.0)	4.27 (1.30)	EW-3	0.12 (3)	3.10 (1.40)
4.4 to 8.8 (2.0 to 4.0)	4.27 (1.30)	EW-4	0.12 (3)	3.20 (1.40)
5.5 to 11.0 (2.5 to 5.0)	4.27 (1.30)	EW-5	0.12 (3)	3.30 (1.50)

For dimensional drawings, see Pg. 22.

EWF-C Series



EWF-C Series Balancers have aluminum die-cast housing and non-painted surface. These are are light capacity, but full of features such as:

- Plastic drum, which reduced the powder from rope abrasion; replaceable wire rope
- Fall arrest device to keep tools from falling if the spring breaks
- Riveted spring to enhance the safety of spring replacement
- Fully enclosed housing

Max. Capacity lb (kg)	Cable Travel ft (m)	Part No.	Cable Dia in. (mm)	Wt lb (kg)
3.3 to 6.6 (1.5 to 3.0)	4.27 (1.30)	EWF-3C	0.12 (3)	3.75 (1.7)
6.6 to 11.0 (3.0 to 5.0)	4.27 (1.30)	EWF-5C	0.12 (3)	4.19 (1.9)
11.0 to 15.4 (5.0 to 7.0)	4.27 (1.30)	EWF-7C	0.12 (3)	4.19 (1.9)

For dimensional drawings, see Pg. 22.

EWF Series Standard Stroke Balancers



EWF-9

The EWF Series features fully enclosed housing, fall-arrest device (auto-brake), and manual drum locks. If a spring breaks, the brake automatically locks to prevent tool damage. The manual drum lock keeps the drum from rotating to allow easy change out and maintenance of tools. Springs are enclosed in a replaceable cartridge for safe and easy repair.

Note: EWF Series Balancers are also available in an **unpainted version**. To order, add "-NP" at the end of the standard "EWF" part number.

Note: EWF Series Balancers are also available without the adjustable stopper. To order, add "-NS" at the end of the standard "EWF" part number.

Max. Capacity lb (kg)	Cable Travel ft (m)	Part No.	Cable Dia in. (mm)	Wt lb (kg)
9.9 to 19.8 (4.5 to 9.0)	4.27 (1.3)	EWF-9	0.16 (4.0)	7.5 (3.4)
19.8 to 33.1 (9.5 to 15.0)	4.93 (1.5)	EWF-15	0.16 (4.0)	8.4 (3.8)
33.1 to 48.5 (15 to 22)	4.93 (1.5)	EWF-22	0.19 (4.8)	16.1 (7.3)
48.5 to 66.1 (22 to 30)	4.93 (1.5)	EWF-30	0.19 (4.8)	17.0 (7.7)
66.1 to 88.2 (30 to 40)	4.93 (1.5)	EWF-40	0.19 (4.8)	21.4 (9.7)
88.2 to 110.2 (40 to 50)	4.93 (1.5)	EWF-50	0.19 (4.8)	22.2 (10.1)
110.2 to 132.3 (50 to 60)	4.93 (1.5)	EWF-60	0.19 (4.8)	24.5 (11.1)
132.3 to 154.3 (60 to 70)	4.93 (1.5)	EWF-70	0.19 (4.8)	25.1 (11.4)
154.3 to 198.4 (70 to 90)	6.56 (2.0)	EWF-90	0.19 (4.8)	48.5 (22.0)
198.4 to 231.5 (90 to 105)	6.56 (2.0)	EWF-105	0.19 (4.8)	53.0 (24.0)
231.5 to 264.5 (105 to 120)	6.56 (2.0)	EWF-120	0.19 (4.8)	61.7 (28.0)

For dimensional drawings, see Pg. 22



EWF-30



EWF-40



EWF-90

ELF Series Long Stroke Balancers



ELF-3

ENDO Long Stroke Spring Balancers are designed for high ceiling applications. They provide true "zero gravity" tool holding with no drifting or strain. The tapered drums and quality springs and bearings provides smooth cable travel throughout the stroke. Tension adjustment is easy and precise. The ELF models offer both the automatic brake and the manual drum safety lock. In the event that a spring breaks, an automatic centrifugal brake engages and locks, preventing damage to the tool. With the manual lock engaged, the drum will not rotate. This allows for easy change out or maintenance of tools.

Choose the correct balancer based on the total weight to be balanced (tool and all accessories) and stroke requirements. Try to utilize the upper range of the balancer capacity ratings.

All ENDO balancers have an exclusive 18 month warranty - see page 28 for details.

ELF Series Balancers Feature

- Cast aluminum case and a forged swivel hook.
- Automatic Safety Brake
- Manual Drum Safety Lock
- Exclusive 18 month warranty.



ELF-15

Capacity Range lb (kg)	Cable Travel ft (m)	Part No.	Cable Dia in. (mm)	Wt lb (kg)
3.3 to 6.6 (1.5 to 3.0)	8.20 (2.5)	ELF-3	0.16 (4.00)	10.1 (4.6)
6.6 to 11.0 (3.0 to 5.0)	8.20 (2.5)	ELF-5	0.16 (4.00)	10.6 (4.8)
11.0 to 19.8 (5 to 9)	8.20 (2.5)	ELF-9	0.16 (4.00)	11.9 (5.4)
19.8 to 33.1 (9 to 15)	8.20 (2.5)	ELF-15	0.19 (4.76)	22.0 (10.0)
33.1 to 48.5 (15 to 22)	8.20 (2.5)	ELF-22	0.19 (4.76)	22.5 (10.2)
48.5 to 66.1 (22 to 30)	8.20 (2.5)	ELF-30	0.19 (4.76)	24.3 (11.0)
66.1 to 88.2 (30 to 40)	8.20 (2.5)	ELF-40	0.19 (4.76)	30.9 (14.0)
88.2 to 110.2 (40 to 50)	8.20 (2.5)	ELF-50	0.19 (4.76)	32.0 (14.5)
110.2 to 132.3 (50 to 60)	8.20 (2.5)	ELF-60	0.19 (4.76)	37.6 (17.1)
132.3 to 154.3 (60 to 70)	8.20 (2.5)	ELF-70	0.19 (4.76)	39.7 (18.0)

For Dimensional Drawings, see Pg. 23.



ELF-22



ELF-50



ELF-70

EW-X Series "ECO" Balancers



EWS-5X

The Series "X" balancers are the "eco-friendly" balancers. They are the ultimate solution when particulates from the standard exterior balancer finish might contaminate food or sensitive assemblies. The basic features of the EW style are on Pg. 9; the EWS on Pg. 14; the EWF on Pg. 10. The specific features of the "X" version are as follows:

- Buffed and barrel-polished casing and cover
- Synthetic food-grade grease (H1 grade) on the spring
- Stainless steel lower hook, plug, rivet, bolts, and screws
- Zinc plated upper hook and pins

Rope Types:

- EW-3 to EWS-7: White Nylon, 3 mm diameter. EWF-9 to EWF-15: Black Nylon, 4 mm diameter
- EWF-22 to EWF-120: Stainless Steel, 4.8 mm diameter



EWF-22X

Max. Capacity lb (kg)	Cable Travel ft (m)	Part No.	Wt lb (kg)
2.2 to 6.6 (1.0 to 3.0)	4.27 (1.3)	EW-3X	3.1 (1.4)
3.3 to 6.6 (1.5 to 3.0)	4.27 (1.3)	EWS-3X	4.2 (1.9)
5.5 to 11.0 (2.5 to 5.0)	4.27 (1.3)	EW-5X	3.3 (1.5)
6.6 to 11.0 (3.0 to 5.0)	4.27 (1.3)	EWS-5X	4.6 (2.1)
11.0 to 15.4 (5.0 to 7.0)	4.27 (1.3)	EWS-7X	4.6 (2.1)
9.9 to 19.8 (4.5 to 9.0)	4.27 (1.3)	EWF-9X	7.5 (3.4)
19.8 to 33.1 (9.5 to 15.0)	4.93 (1.5)	EWF-15X	8.4 (3.8)
33.1 to 48.5 (15 to 22)	4.93 (1.5)	EWF-22X	16.1 (7.3)
48.5 to 66.1 (22 to 30)	4.93 (1.5)	EWF-30X	17.0 (7.7)
66.1 to 88.2 (30 to 40)	4.93 (1.5)	EWF-40X	21.4 (9.7)
88.2 to 110.2 (40 to 50)	4.93 (1.5)	EWF-50X	11.7 (10.1)
110.2 to 132.3 (50 to 60)	4.93 (1.5)	EWF-60X	24.5 (11.1)
132.3 to 154.3 (60 to 70)	4.93 (1.5)	EWF-70X	25.1 (11.4)
154.3 to 198.4 (70 to 90)	6.56 (2.0)	EWF-90X	48.5 (22.0)
198.4 to 231.5 (90 to 105)	6.56 (2.0)	EWF-105X	53.0 (24.0)
231.5 to 264.5 (105 to 120)	6.56 (2.0)	EWF-120X	61.7 (28.0)

For dimensional drawings, see Pg. 22

Page Intentionally
Left Blank

EWS / ETP Series Specialty Balancers

EWS Series Safety Balancers

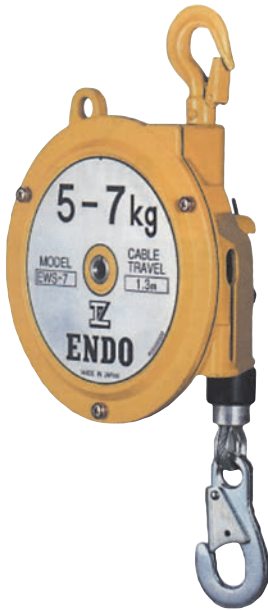

The EWS Series Balancers offer true zero gravity, with no drifting or strain. Tapered drum, quality springs and bearings provides smooth cable travel throughout the stroke. This model combines the smaller capacity EW series balancers with the safety features of the larger EWF series balancers. The EWS series has a manual drum lock which allows for easy change out of tools and fall arrest device. Tension adjustment is performed easily with a wrench. Additionally, the casing is fully enclosed, eliminating any potential pinch points around the drum. Other features:

- Tension Adjustment is Easy and Precise
- Cast aluminum case
- Forged steel swivel hook.
- Exclusive 18 month warranty, see Pg. 28

Choose an EWS balancer based upon the total weight to be balanced (tool and all accessories) and stroke requirements. Try to utilize the upper range of the EWS capacity ratings.

Capacity Range lb (kg)	Cable Travel ft (m)	Part No.	Cable Dia in. (mm)	Wt lb (kg)
3.3 to 6.6 (1.5 to 3.0)	4.27 (1.3)	EWS-3	0.12 (3.0)	4.2 (1.9)
6.6 to 11.0 (3.0 to 5.0)	4.27 (1.3)	EWS-5	0.12 (3.0)	4.6 (2.1)
11.0 to 15.4 (5.0 to 7.0)	4.27 (1.3)	EWS-7	0.12 (3.0)	4.6 (2.1)

For dimensional drawings, see Pg. 25.

ETP Series High Capacity



The ETP high capacity balancers offer true zero gravity, with no drifting or strain. Tapered drum, quality springs and bearings provides smooth cable travel throughout the stroke. The ETP Series is used for welding guns, large impact wrenches, and other heavy tools. All high capacity ETP balancers include the fall arrest device (auto-brake).

When choosing a balancer, selection is based upon the total weight to be balanced (tool and all accessories) and stroke requirements. Try to utilize the upper range of the capacity ratings.

- Tension adjustment is easy and precise.
- Cast aluminum case
- Forged Steel Swivel Hook.
- Exclusive 18 month warranty.

Capacity Range lb (kg)	Cable Travel ft (m)	Part No.	Cable Dia in. (mm)	Wt lb (kg)
264.6 to 308.6 (120.0 to 140.0)	3.94 (1.2)	ETP-14	0.24 (6.0)	53.1 (24.1)
308.6 to 374.8 (140.0 to 170.0)	3.94 (1.2)	ETP-15	0.24 (6.0)	63.3 (28.7)
374.8 to 440.9 (170.0 to 200.0)	3.94 (1.2)	ETP-16	0.24 (6.0)	65.5 (29.7)

For dimensional drawings, see Pg. 25.

EWA / EKN Series Specialty Balancers

EWA Series "Snap-Back Prevention" Balancer



The EWA Series safety balancers offer true zero gravity, with no drifting or strain. Tapered drum, quality springs and bearings provides smooth cable travel throughout the stroke. The EWA Series is used in conjunction with heaviest tools and welding machines. They are very similar to the standard ENDO balancers, but incorporate an additional safety mechanisms to prevent injury to the user.

If the suspension cable is cut, a centrifugal brake engages and the drum locks. This prevents the cable from snapping back and injuring operators or damaging equipment. The distance the severed cable will travel before the centrifugal brake engages is 3.9 inches (100 mm) or less. Used by several automotive manufacturers, the EWA sets the new standard for employee safety and ergonomics.

- Easy and Precise Tension Adjustment
- Cast Aluminum Case
- Forged Steel Swivel Hook
- Tension gauge
- Fall Arrest Device
- Spring Cartridge
- Drum Lock
- Plug-in Cable Set

Capacity Range lb (kg)	Cable Travel ft (m)	Part No.	Cable Dia in. (mm)	Wt lb (kg)
33.1 to 48.5 (15.0 to 22.0)	4.93 (1.5)	EWA-22	0.19 (4.76)	19.4 (8.8)
48.5 to 66.1 (22.0 to 30.0)	4.93 (1.5)	EWA-30	0.19 (4.76)	20.3 (9.2)
66.1 to 88.2 (30.0 to 40.0)	4.93 (1.5)	EWA-40	0.19 (4.76)	26.5 (12.0)
88.2 to 110.2 (40.0 to 50.0)	4.93 (1.5)	EWA-50	0.19 (4.76)	27.8 (12.6)
110.2 to 132.3 (50.0 to 60.0)	4.93 (1.5)	EWA-60	0.19 (4.76)	29.1 (13.2)
132.3 to 154.3 (60.0 to 70.0)	4.93 (1.5)	EWA-70	0.19 (4.76)	32.6 (14.8)

For dimensional drawings, see Pg. 25.

EKN Series Electrostatic Discharge Balancer



The EKN series balancers offer true zero gravity, with no drifting or strain. Tapered drum and quality springs and bearings provides smooth cable travel throughout the stroke. The EKN Series is used where electrostatic discharge can damage electronics or other sensitive assemblies, but where a "clean room" balancer is not needed. The EKN is fitted with a grounding wire, which attaches from the balancer to the secondary support hook. The grounding wire safely dissipates any static electricity charge generated by the friction of the cable while the balancer is in use.

When choosing a balancer, selection is based upon the total weight to be balanced (tool and all accessories) and stroke requirements. Try to utilize the upper range of the balancer capacity ratings.

- 0 spring tool balancers Tension adjustment is easy and precise.
- High impact plastic case
- Forged Steel Swivel Hook.
- Exclusive 18 month warranty.

Capacity Range lb (kg)	Cable Travel ft (m)	Part No.	Cable Dia in. (mm)	Wt lb (kg)
1.1 to 3.3 (0.5 to 1.5)	1.64 (0.5)	EKN-00	0.08 (2.0)	0.4 (0.2)
1.1 to 3.3 (0.5 to 1.5)	3.28 (1.0)	EKN-0	0.12 (3.0)	1.0 (0.5)

For dimensional drawings, see Pg. 24.

SBC Series Clean Room Balancer



The SBC-15 is a "clean room" tool balancer used in production of electronics, pharmaceuticals, and other environmentally sensitive components. Its specially sealed aluminum case provides a Class 10 protection rating which meets most clean room requirements. The cable is sheathed in nylon to prevent metal flaking and contamination of the clean environment. It can be used with a multitude of tools including torque drivers and vacuum pin setters. Like the EKN series, these balancers can be fitted with a grounding wire to dissipate static electricity.

Exclusive 18 Month Warranty

Capacity Range lb (kg)	Cable Travel ft (m)	Part No.	Cable Dia in. (mm)	Wt lb (kg)
1.1 to 3.3 (0.5 to 1.5)	3.28 (1.0)	SBC-15	0.12 (3.0)	2.6 (1.2)

For dimensional drawings, see Pg. 26.

ATB / THB Series Air Tool Balancers

Air tool balancers provide a safer and more organized workplace by eliminating the need for an air supply hose and a separate cable balancer. Air Tool Balancers are available with either 1/4" ID (Model ATB) or 3/8" ID (Model THB) both with braided urethane hose. Casings are made of durable, lightweight, high impact ABS resin.

Conductix-Wampfler offers a special kit* for the THB and ATB series balancers that allows air tools with bottom air inlets to hang right-side up. The kit has a fixture, a cable, and air line joint, plus an additional 13 inches of hose travel. The Air Tool Balancers feature:

- Easy and Precise Balancer Tension Adjustment
- High impact ABS case
- Forged Steel Swivel hook.
- Pressure Rating: 145 psi
- Exclusive 18 month warranty - See Pg. 36

ATB Series - 1/4" ID Hose



ATB with cover- See Pg. 19



A410-09-A001



ATB-1 fitted with horizontal tool hanger

Capacity Range lb (kg)	Hose Travel ft (m)	Part No.	Air Inlet	Wt lb (kg)
1.1 to 3.3 (0.5 to 1.5)	4.27 (1.3)	ATB-0	1/4" NPT	3.5 (1.58)
3.3 to 6.6 (1.5 to 3.0)	4.27 (1.3)	ATB-1	1/4" NPT	3.7 (1.66)
6.6 to 11.0 (3.0 to 5.0)	4.27 (1.3)	ATB-2	1/4" NPT	3.8 (1.73)
* Kit to Hang Tool Right-side Up		A410-09-A001		0.75 (0.34)

For dimensional drawings, see Pg. 23

THB Series - 3/8" ID Hose



Capacity Range lb (kg)	Hose Travel ft (m)	Part No.	Air Inlet	Wt lb (kg)
1.1 to 3.3 (0.5 to 1.5)	4.27 (1.3)	THB-15	3/8" NPT	4.2 (1.9)
3.3 to 5.5 (1.5 to 2.5)	4.27 (1.3)	THB-25	3/8" NPT	4.4 (2.0)
5.5 to 7.7 (2.5 to 3.5)	4.27 (1.3)	THB-35	3/8" NPT	4.6 (2.1)
7.7 to 11.0 (3.5 to 5.0)	4.27 (1.3)	THB-50	3/8" NPT	4.6 (2.1)
11.0 to 14.3 (5.0 to 6.5)	4.27 (1.3)	THB-65	3/8" NPT	4.9 (2.2)
* Kit to Hang Tool Right-side Up		A410-09-A001		0.75 (0.34)

For dimensional drawings, see Pg. 23

ST / ATR Series Air Tool Balancers

ST-30 Series Twin-Hose Balancer



The ST-30 Air Tool Balancer is to be used with feed-back air tools. The air is supplied through the outer hose to the tool, the inner hose provides the controller with the feed-back signal.

- Unique solution for feed-back tools.
- Easy and reliable operation.
- Eliminates problems with coiled hose.
- Exclusive 18 month warranty - See Pg. 28.

Main air inlet: R 3/8" NPT with 3/8" hose barb
Main air outlet: R 1/4" with adaptor for 1/4" FPT
Signal Air inlet and Outlet: Quick release coupling for 4 mm OD hose.

Capacity Range lb (kg)	Hose Travel ft (m)	Part No.	Outer Hose ID	Inner Hose ID	Wt lb (kg)
2.2 to 6.6 (1 to 3)	4.27 (1.3)	ST-30	3/8"	1/8"	6.2 (2.8)

For dimensional drawing - See Pg. 26.

ATR Series Air Tool Reel



The Air Tool Reel provides an air hose and ratchet mechanism that allows a tool to stay suspended. To disengage the ratchet and enable the hose to retract, simply pull lightly on the hose. The reel comes with a standard 6.5 foot (2.0 m) 3/8" hose. Additional hose can be added in 3.28, 6.56, and 9.84 foot (1, 2, and 3 meter) lengths. The reel also is made with a fall prevention device. In the case the spring breaks, the device prevents the tool from falling and becoming damaged. Available as both a hood mount (ATR-5) and as a wall mount (ATR-5-1).

- Hook, wall, or ceiling mount.
- Tension adjustment is easy and precise.
- High impact ABS case and a forged swivel hook.

Maximum Tension N	Maximum Pressure foot lbs	Maximum Pressure		Hose Travel ft (m)	Part No.	Wt lb (kg)
		Bar	PSI			
49	36	10	142	6.5 (2.0)	ATR-5	8.4 (3.8)
49	36	10	142	6.5 (2.0)	ATR-5-1	9.3 (4.2)

For dimensional drawing - See Pg. 26.

Air Tool Reel Accessories



Description	Length ft (m)	Part No.
Adjustable Rubber Hose Ball Stop	-	LBP007933
Special hose for extended length, with swivel joint	3.28 (1.0)	LBP000663
Special hose for extended length, with swivel joint	6.56 (2.0)	LBP000664
Special hose for extended length, with swivel joint	9.84 (3.0)	LBP000665

Accessories

Series PTF Manual Trolleys for I-Beams

The Series PTF manual trolleys are used for suspending all types of ENDO tool balancers from I-beams, railways, or jib booms. Model PTF-125 and PTF-250 are easily adjustable for different size beams. In addition, the frame is manufactured to protect the wheels from collisions with other trolleys. These trolleys can also be fitted with rubber bumpers for further protection.



Series PTF-60

Capacity lb (kg)	Min Curve Radius in (mm)	Part No.	Beam Width in (mm)	Wt lb (kg)
132 (60)	-- --	PTF-60	2.95 (75)	1.80 (0.80)
276 (125)	24 (600)	PTF-125	2.0 / 2.95 (50 / 75)	3.50 (1.60)
551 (250)	35 (900)	PTF-250	2.95 / 3.93 / 4.92 (75 / 100 / 125)	9.25 (4.20)

For dimensional drawings, see Pg. 27.



Series PTF-125



Series PTF-250

Spare Springs, Cables, and Hoses

Encapsulated Spring



Non-Encapsulated Spring



Cable



Hose



Balancer Model	Spring			Cable Part No.	Hose Part No.
	Part No.	Qty Req'd	Encapsulated?		
ELF-15	LPB000607	1	YES	LBP000223a	-
ELF-22	LPB000608	1	YES	LBP000223a	-
ELF-30	LPB000609	1	YES	LBP000223a	-
ELF-40	LPB000610	1	YES	LBP000223a	-
ELF-50	LPB000611	1	YES	LBP000223a	-
ELF-60	LPB000612	1	YES	LBP000223a	-
ELF-70	LPB000613	1	YES	LBP000223a	-
ER-3A	P2B300089	1	NO	LBP000095	-
ER-3B	P2B300089	1	NO	LBP000095	-
ER-5A	P2B300090	1	NO	LBP000095	-
ER-5B	P2B300090	1	NO	LBP000095	-
ER-10A	P2B300037a	1	NO	LBP000026	-
ER-10B	P2B300037a	1	NO	LBP000026	-
ELF-1	P2B300255	1	NO	LBP000298	-
ELF-2	P2B300256	1	NO	LBP000298	-
ELF-3	P2B300257	1	NO	LBP000298	-
ETP-14	P2B300264	2	NO	LBP000324	-
ETP-15	P2B300265	3	NO	LBP000324	-
ETP-16	P2B300267	3	NO	LBP000324	-
EW-3	P2B300074	1	NO	LBP000133	-
EW-5	P2B300075	1	NO	LBP000133	-
EW-9	LBP000596a	1	YES	LBP000136	-
EW-15	LBP000597a	1	YES	LBP000136	-
EW-22	LBP000598	1	YES	LBP000139	-
EW-30	LBP000599	1	YES	LBP000139	-
EW-40	LBP000600	1	YES	LBP000139	-
EW-50	LBP000601	1	YES	LBP000139	-
EW-60	LBP000602	1	YES	LBP000139	-
EW-70	LBP000603	1	YES	LBP000139	-
EW-90	LBP001137	1	YES	LBP001147	-
EW-105	LBP001138	1	YES	LBP001147	-
EW-120	LBP001139	1	YES	LBP001147	-
EWS-3	P2B300089a	1	NO	LBP000748	-
EWS-5	P2B300507	1	NO	LBP000748	-
EWS-7	P2B300508	1	NO	LBP000748	-
ATB-0	P2B300216	1	NO	-	LBP000164
ATB-1	P2B300217	1	NO	-	LBP000164
ATB-2	P2B300218	1	NO	-	LBP000164
ATR-5	P2B300428	1	NO	-	LBP000657
ATR-5-1	P2B300428	1	NO	-	LBP000657
THB-15	P2B300633	1	NO	-	LBP000768
THB-25	P2B300534a	1	NO	-	LBP000768
THB-35	P2B300535a	1	NO	-	LBP000768
THB-50	P2B300549	1	NO	-	LBP000768
THB-65	P2B300613a	1	NO	-	LBP000768
ST-30	P2B300535a	1	NO	-	LBP001070

Extended Cables, Hooks, and Spiral Hoses

Cable



Cable includes Crosby Golden Gate Hook, insulated, or not insulated and includes two-piece Crosby U-bolts and thimble to install Golden Gate Hook. Extended cables with Golden Gate Hooks are used when applications require extended cable size. The load rating of the hook is 1000 lbs. Maximum Voltage Capacity of the insulated hook is 50 Volts/DC.

Note: Extended cable does not increase the active travel.

Accessories WITHOUT Golden Gate Hook			
to be used with	Part No.	Cable Dia in. (mm)	Cable Lg ft (m)
EWF-9 to EWF-15	A410-09-C001	0.16 (4)	13.12 (4)
ETL-1 To ETL-3	A410-09-C002	0.16 (4)	13.12 (4)
EWF-22 to EWF-120 ELB-22 to ELB-70 EWA-22 to EWA-70	A410-09-C003	0.19 (4.76)	13.12 (4)

Accessories WITH Golden Gate Hook			
to be used with	Part No.	Cable Dia in. (mm)	Cable Lgth ft (m)
EWF-9 to EWF-15	A410-09-C005	0.32 (4)	13.12 (4)
EK-1 to EK-13	A410-09-C006	0.16 (4)	13.12 (4)
EWF-22 to EWF-120 ELB-22 to ELB-70 EWA-22 to EWA-70	A410-09-C007	0.18 (4.76)	13.12 (4)

Spiral Hose



Spiral hoses are clear blue polyurethane and have a tail and male NPT rigid fitting on the port side, and a male NPT swivel fitting on the tool side.

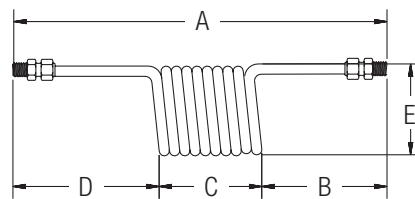

Part No.	Hose ID in. (mm)	Hose OD in. (mm)	Working Lgth ft (m)	A ft (mm)	B ft (mm)	C ft (mm)	D ft (mm)	E ft (mm)
424-14-06	0.250 (6.35)	0.375 (9.52)	8.0 (2.44)	2.592 (791)	1.700 (508)	0.592 (181)	0.333 (102)	0.167 (51)
424-14-12	0.250 (6.35)	0.375 (9.52)	12.00 (3.66)	2.969 (905)	1.700 (508)	0.969 (295)	0.333 (102)	0.167 (51)
424-14-18	0.250 (6.35)	0.375 (9.52)	16.00 (4.88)	3.313 (1010)	1.700 (508)	1.313 (400)	0.333 (102)	0.167 (51)
424-38-08	0.375 (9.52)	0.562 (14.27)	8.00 (2.44)	2.584 (787)	1.700 (508)	0.584 (178)	0.333 (102)	0.3313 (95)
424-38-12	0.375 (9.52)	0.562 (14.27)	12.00 (3.66)	3.000 (914)	1.700 (508)	1.000 (305)	0.333 (102)	0.313 (95)
424-38-16	0.375 (9.52)	0.562 (14.27)	16.00 (4.88)	3.333 (1016)	1.700 (508)	1.333 (406)	0.333 (102)	0.313 (95)
424-12-12	0.500 (12.70)	0.750 (14.27)	12.00 (3.66)	2.813 (857)	1.700 (508)	0.813 (248)	0.333 (102)	0.376 (114)
424-12-16	0.500 (12.70)	0.750 (14.27)	16.00 (4.88)	2.813 (914)	1.700 (508)	1.000 (305)	0.333 (102)	0.376 (114)
424-12-20	0.500 (12.70)	0.750 (14.27)	20.00 (6.10)	3.500 (1067)	1.700 (508)	1.500 (457)	0.333 (102)	0.376 (114)

Dimensional Drawings - Series ERP, ER, EK, EW, EWF

Series ERP

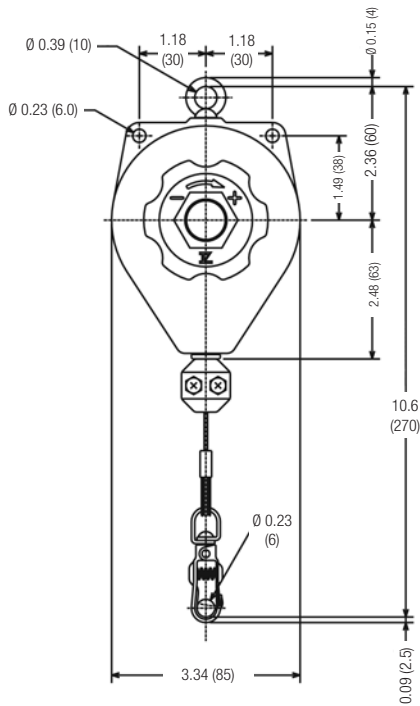

Series ER

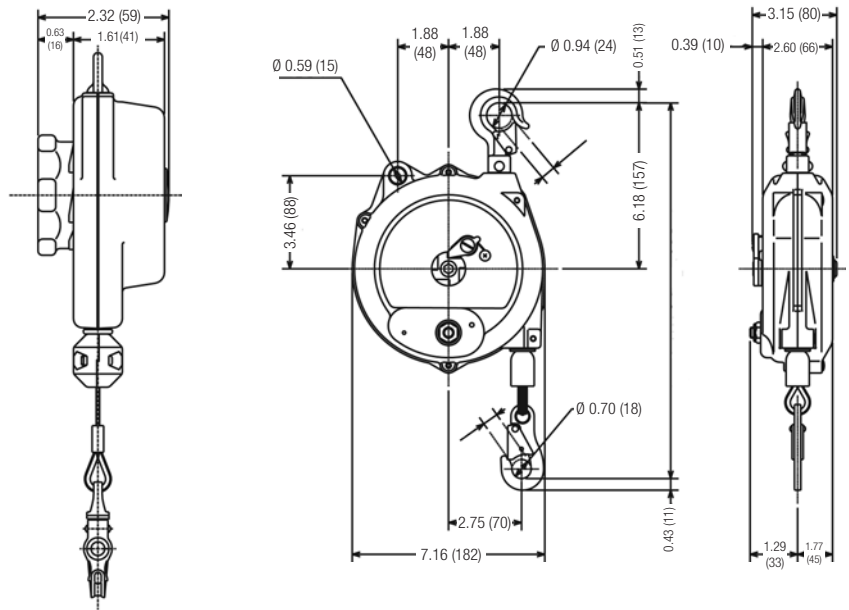

Series EK

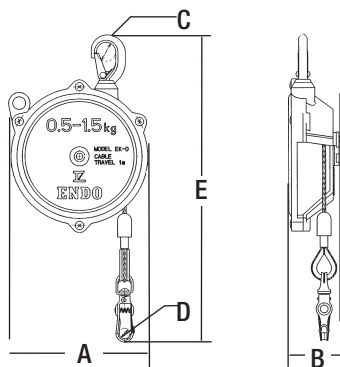

Series EW/EWF

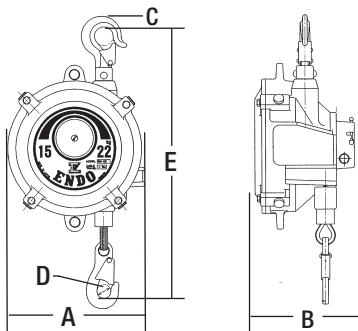

Part No.	Dimensions				
	A in. (mm)	B in. (mm)	C in. (mm)	D in. (mm)	E in. (mm)
EK-00	3.70 (93.9)	1.30 (33.0)	0.38 (9.65)	0.24 (6.09)	6.20 to 25.9 (157.4 to 657)
EK-0	5.00 (127)	1.90 (48.2)	0.71 (18)	0.35 (8.88)	9.30 to 48.7 (236 to 123)
EW-3	5.80 (147)	2.70 (68.5)	0.79 (20)	0.55 (13.9)	11.4 to 62.6 (289 to 159)
EW-4	5.80 (147)	2.70 (68.5)	0.79 (20)	0.55 (13.9)	11.4 to 62.6 (289 to 159)
EW-5	5.80 (147)	2.70 (68.5)	0.79 (20)	0.55 (13.9)	11.4 to 62.6 (289 to 159)
EWF-3C	6.30 (160)	3.50 (89)	0.43 (11)	0.43 (11)	
EWF-5C	6.30 (160)	3.50 (89)	0.43 (11)	0.71 (18)	
EWF-7C	6.30 (160)	3.50 (89)	0.43 (11)	0.71 (18)	
EWF-9	6.90 (175)	5.40 (137)	0.95 (24.1)	0.70 (17.7)	13.4 to 64.6 (340 to 164)
EWF-15	6.90 (175)	5.40 (137)	0.95 (24.1)	0.70 (17.7)	13.4 to 64.6 (340 to 164)
EWF-22	8.60 (218)	6.20 (157)	1.18 (29.9)	0.86 (21.8)	16.9 to 76.0 (429 to 193)
EWF-30	8.60 (218)	6.20 (157)	1.18 (29.9)	0.86 (21.8)	16.9 to 76.0 (429 to 193)
EWF-40	8.70 (220)	7.40 (187)	1.18 (29.9)	0.86 (21.8)	16.9 to 76.0 (429 to 193)
EWF-50	8.70 (220)	7.40 (187)	1.18 (29.9)	0.86 (21.8)	16.9 to 76.0 (429 to 193)
EWF-60	8.70 (220)	7.40 (187)	1.18 (29.9)	0.86 (21.8)	16.9 to 76.0 (429 to 193)
EWF-70	8.70 (220)	7.40 (187)	1.18 (29.9)	0.86 (21.8)	16.9 to 76.0 (429 to 193)
EWF-90	10.5 (266)	10.2 (259)	1.25 (31.7)	0.86 (21.8)	19.4 to 98.1 (492 to 249)
EWF-105	10.5 (266)	10.9 (276)	1.25 (31.7)	0.86 (21.8)	19.4 to 98.1 (492 to 249)
EWF-120	10.5 (266)	11.8 (299)	1.25 (31.7)	0.86 (21.8)	19.4 to 98.1 (492 to 249)

Dimensional Drawings - Series ELF, ATB, THB

Series ELF

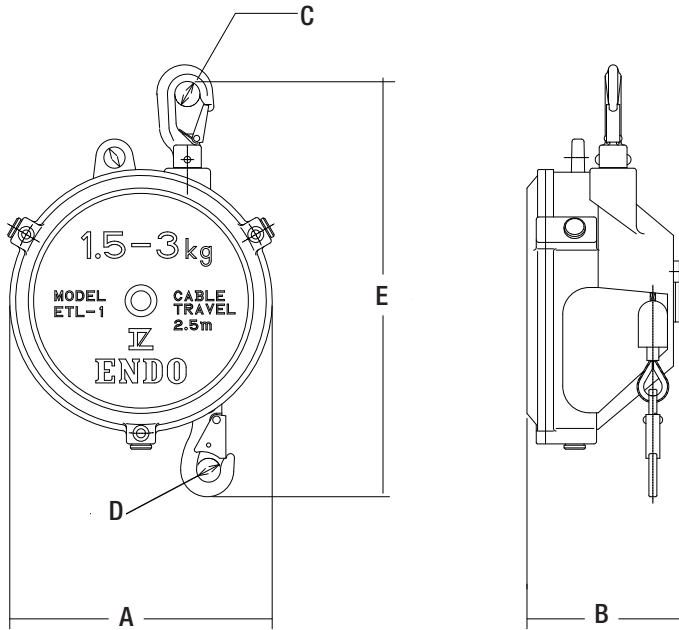

Dimensions					
Part No.	A in. (mm)	B in. (mm)	C in. (mm)	D in. (mm)	E in. (mm)
ELF-3	7.8 (198)	4.7 (119)	0.75 (19)	0.59 (14.9)	13.7 to 112.1 (347 to 284)
ELF-5	7.8 (198)	4.7 (119)	0.75 (19)	0.59 (14.9)	13.7 to 112.1 (347 to 284)
ELF-9	7.8 (198)	4.7 (119)	0.75 (19)	0.59 (14.9)	13.7 to 112.1 (347 to 284)
ELF-15	9.1 (231)	8.4 (213)	1.18 (29.9)	0.87 (22)	17.3 to 115.7 (439 to 293)
ELF-22	9.1 (231)	8.4 (213)	1.18 (29.9)	0.87 (22)	17.3 to 115.7 (439 to 293)
ELF-30	9.1 (231)	8.4 (213)	1.18 (29.9)	0.87 (22)	17.3 to 115.7 (439 to 293)
ELF-40	9.9 (251)	9.0 (228)	1.18 (29.9)	0.87 (22)	17.7 to 116.1 (449 to 294)
ELF-50	9.9 (251)	9.0 (228)	1.18 (29.9)	0.87 (22)	17.7 to 116.1 (449 to 294)
ELF-60	9.9 (251)	10.2 (259)	1.18 (29.9)	0.87 (22)	17.7 to 116.1 (449 to 294)
ELF-70	9.9 (251)	10.2 (259)	1.18 (29.9)	0.87 (22)	17.7 to 116.1 (449 to 294)

Series ATB and THB

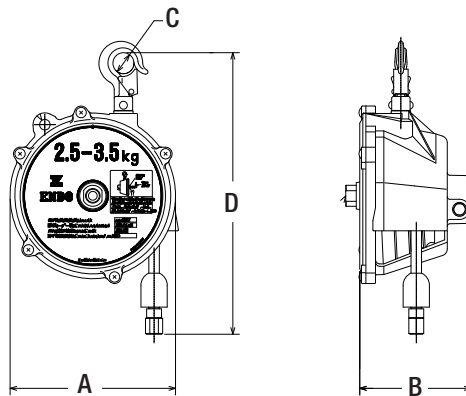

Part No.	A in. (mm)	B in. (mm)	C in. (mm)	D in. (mm)
ATB	7.5 (190)	3.3 (83.8)	0.75 (19)	10.0 to 61.3 (254 to 1557)
THB	7.5 (190)	5.0 (127)	0.95 (24.1)	10.7 to 61.9 (271 to 1572)

Dimensional Drawings - Series EKN

Series EKN-00

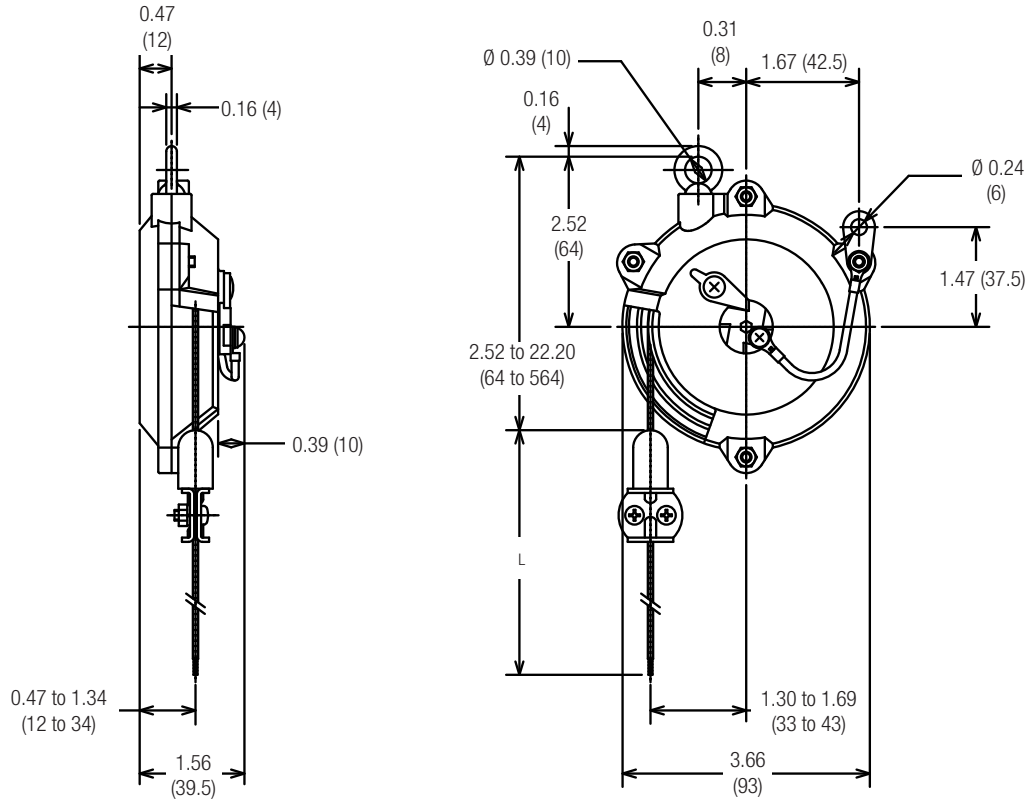

Series EKN-0

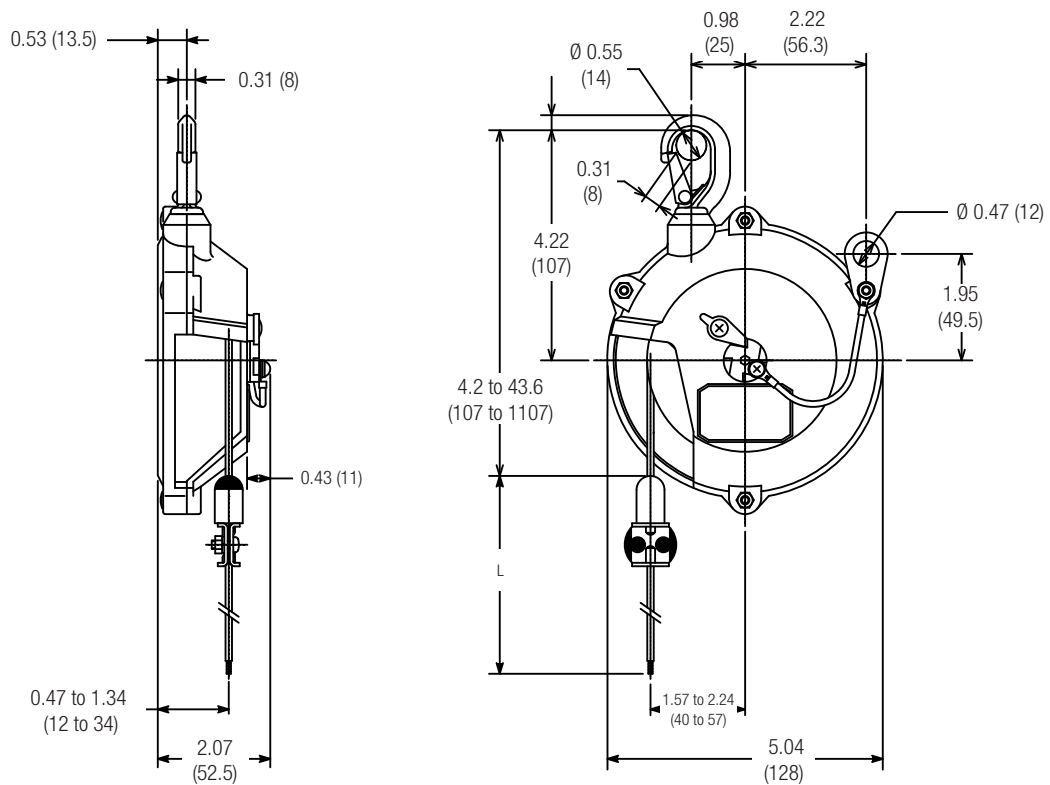

Dimensional Drawings - Series ETP, EWS, EWA

Series ETP

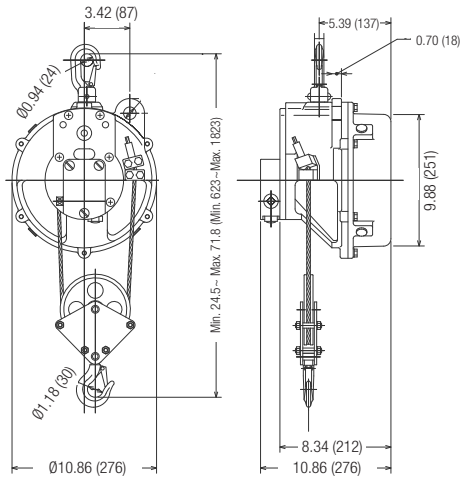

Series EWS

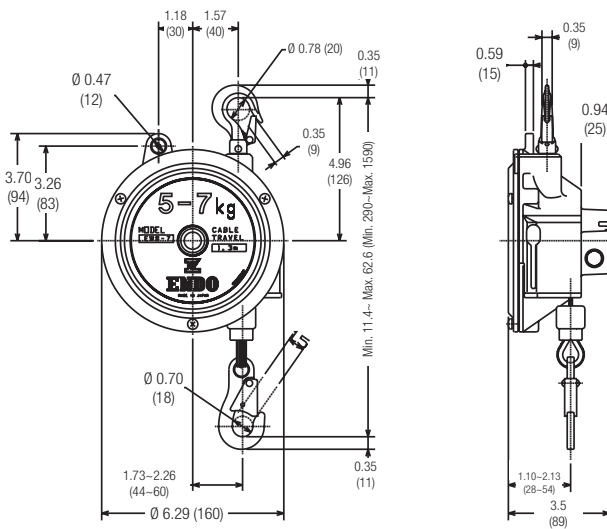

Series EWA

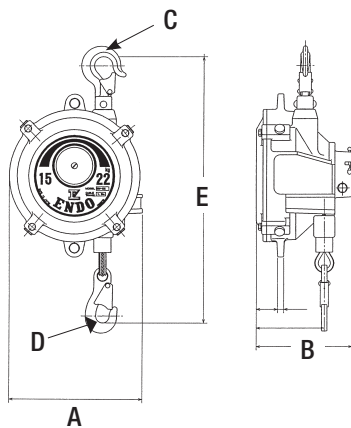

Dimensions

Model	A in. (mm)	B in. (mm)	C in. (mm)	D in. (mm)	E in. (mm)
EWA-22	8.6 (218)	6.2 (157)	1.18 (29.9)	0.86 (21.8)	1.69 to 76.0 (42.9 to 1930)
EWA-30	8.6 (218)	6.2 (157)	1.18 (29.9)	0.86 (21.8)	1.69 to 76.0 (42.9 to 1930)
EWA-40	8.7 (220)	7.4 (187)	1.8 (29.9)	0.86 (21.8)	1.69 to 76.0 (42.9 to 1930)
EWA-50	8.7 (220)	7.4 (187)	1.8 (29.9)	0.86 (21.8)	1.69 to 76.0 (42.9 to 1930)
EWA-60	8.7 (220)	7.4 (187)	1.8 (29.9)	0.86 (21.8)	1.69 to 76.0 (42.9 to 1930)
EWA-70	8.7 (220)	7.4 (187)	1.8 (29.9)	0.86 (21.8)	1.69 to 76.0 (42.9 to 1930)

Dimensional Drawings - Series ST, ATR, SBC

Series ST-30

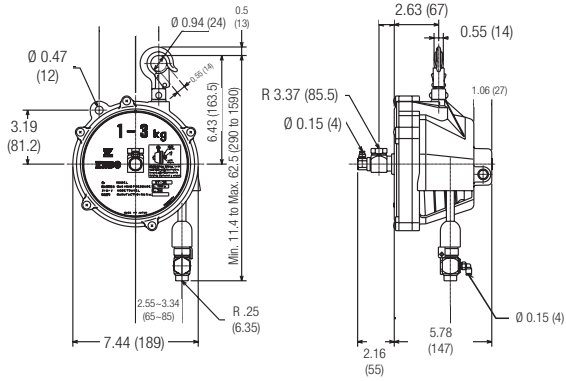

Series ATR-5

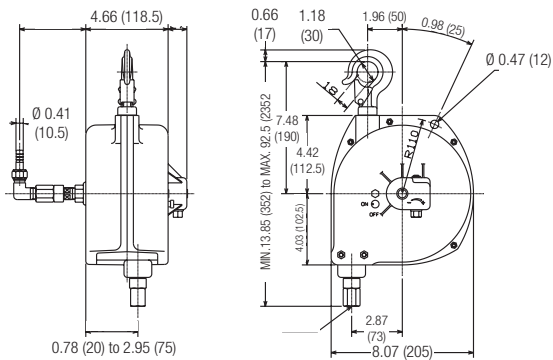

Series ATR-5-1

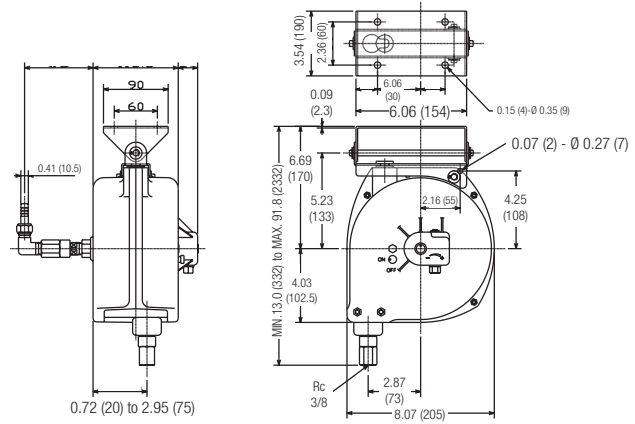

Series SBC

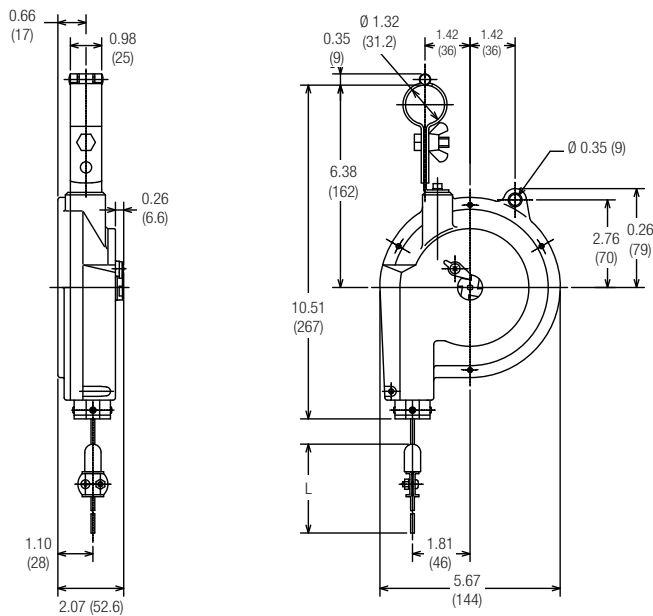

Dimensional Drawings - I-Beam Trolleys

Series PTF-125

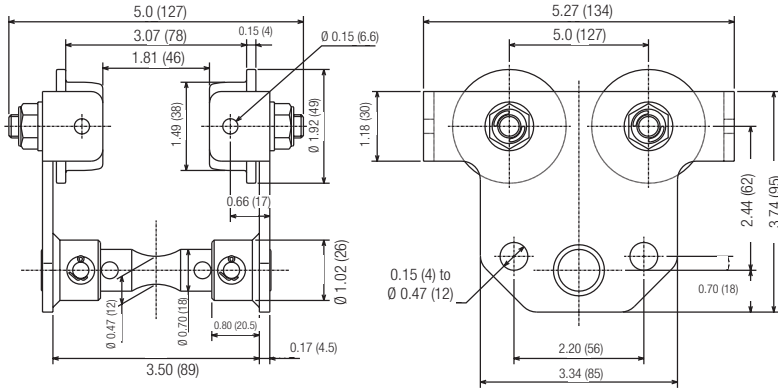

Series PTF-250

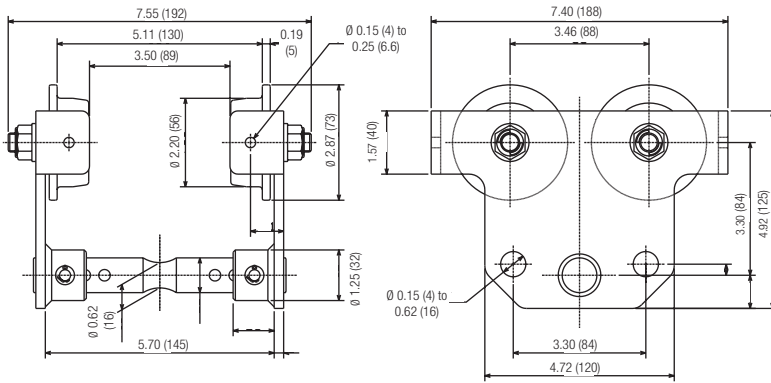

Series PTF-60

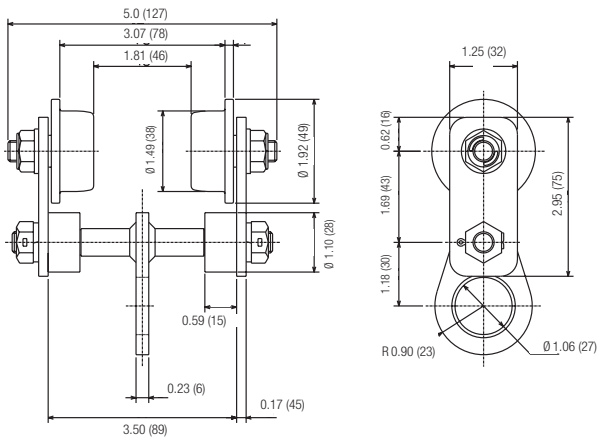

Part No.	Dimensions			
	EW	EK	ELB	ETP
PTF-60	3-60	--	15-60	--
PTF-125	3-70	11-13	15-60	--
PTF-250	3-70	11-13	15-70	14-16

ENDO Spring Balancer Warranty

For ENDO Balancers Distributed by Conductix-Wampfler

If an ENDO Spring Balancer as distributed by Conductix-Wampfler and shown on the list below, fails to perform within 18 months of the customer purchase date or within the stated "working cycles" ¹, whichever comes first, Conductix-Wampfler will supply part(s) to replace the failed parts free of charge and freight prepaid. If the Spring Balancer itself is returned to Conductix-Wampfler for repair, the freight cost and the repair labor cost shall be charged to the customer.

This warranty is valid only if the balancer has not been physically altered and has been operated and maintained in accordance with the instruction manual provided. The actual working cycles claimed by our customer will be accepted by Conductix-Wampfler based on the application offered by our customer.

Part No.	Max. Load lb (kg)	Stroke ft (m)	Working Cycles ¹
EK-00	3.3 (1.5)	1.64 (0.5)	500,000
EK-0	3.3 (1.5)	3.28 (1.0)	500,000
EW-3	6.6 (3.0)	4.26 (1.3)	500,000
EW-5	11.0 (5.0)	2.95 (0.9)	500,000
EW-9	19.8 (9.0)	2.95 (0.9)	150,000
EW-15	33.0 (15.0)	2.95 (0.9)	200,000
EW-22	48.5 (22.0)	4.26 (1.3)	130,000
EW-30	66.1 (30.0)	4.26 (1.3)	90,000
EW-40	88.1 (40.0)	4.26 (1.3)	120,000
EW-50	110.2 (50.0)	4.26 (1.3)	90,000
EW-60	132.2 (60.0)	4.26 (1.3)	90,000
EW-70	154.3 (70.0)	4.26 (1.3)	70,000
EW-90	198.4 (90.0)	4.92 (1.5)	120,000
EW-105	231.4 (105.0)	4.92 (1.5)	120,000
EW-120	264.5 (120.0)	4.92 (1.5)	120,000
ELF-3	6.6 (3.0)	6.56 (2.0)	300,000
ELF-5	11.0 (5.0)	6.56 (2.0)	300,000
ELF-9	19.8 (9.0)	6.56 (2.0)	200,000
ELF-15	33.0 (15.0)	6.56 (2.0)	50,000
ELF-22	48.5 (22.0)	7.87 (2.4)	40,000

Part No.	Max. Load lb (kg)	Stroke ft (m)	Working Cycles ¹
ELF-30	66.1 (30.0)	7.87 (2.4)	40,000
ELF-40	88.1 (40.0)	7.87 (2.4)	40,000
ELF-50	110.2 (50.0)	7.87 (2.4)	40,000
ELF-60	132.2 (60.0)	7.87 (2.4)	40,000
ELF-70	154.3 (70.0)	7.87 (2.4)	40,000
EWS-3	6.6 (3.0)	3.93 (1.2)	500,000
EWS-5	11.0 (5.0)	3.93 (1.2)	500,000
EWS-7	15.4 (7.0)	3.93 (1.2)	500,000
ETP-14	308.6 (140.0)	3.28 (1.0)	40,000
ETP-15	374.7 (170.0)	3.28 (1.0)	50,000
ETP-16	440.9 (200.0)	3.28 (1.0)	40,000
ATB-0	3.3 (1.5)	4.26 (1.3)	200,000
ATB-1	6.6 (3.0)	4.26 (1.3)	200,000
ATB-2	11.0 (5.0)	4.26 (1.3)	200,000
THB-25	5.51 (2.5)	4.26 (1.3)	200,000
THB-35	7.71 (3.5)	4.26 (1.3)	200,000
THB-50	11.02 (5.0)	4.26 (1.3)	200,000
ERP-06	1.32 (0.6)	4.92 (1.5)	200,000
ERP-1	2.20 (1.0)	4.92 (1.5)	200,000
ERP-2	4.40 (2.0)	4.92 (1.5)	200,000

¹ **Working Cycle:** Means that the full maximum rated load is carried by the balancer one full "stroke" (i.e.: starting at the bottom minimum height, then traveling all the way up, then back down to the minimum height)

Terms, Conditions, and General Warranty

The technical data and images which appear in this catalog are for informational purposes only. NO WARRANTIES, EXPRESSED OR IMPLIED, INCLUDING WARRANTIES OF MERCHANTABILITY OR FITNESS FOR A PARTICULAR PURPOSE, ARE CREATED BY THE DESCRIPTIONS AND DEPICTIONS OF THE PRODUCTS SHOWN IN THIS CATALOG. Conductix-Wampfler (“seller”) makes no warranty and assumes no liability as to the function of equipment or the operation of systems built according to customer design or of the ability of any of its products to interface, operate or function with any portions of customer systems not provided by Conductix-Wampfler.

Seller agrees to repair or exchange the goods sold hereunder necessitated by reason of defective workmanship, and material discovered and reported to Seller within one year after shipment of such goods to Buyer. Except where the nature of the defect is such that it is appropriate in Seller’s judgement to effect repairs on site, the seller’s obligation hereunder to remedy defects shall be limited to repairing or replacing (at Seller’s option), FOB point of original shipment by Seller, any part returned to Seller at the risk and cost of Buyer. Defective parts replaced by Seller shall become the property of Seller.

Seller shall only be obligated to make such repair or replacement of the goods which have been used by Buyer in service recommended by Seller and altered only as authorized by Seller. Seller is not responsible for defects which arise from improper installation, neglect, or improper use or from normal wear and tear.

Additionally, Seller’s obligation shall be limited by the manufacturer’s warranty (and shall not be further warranted by Seller) for all parts procured from others according to published data, specifications, or performance information not designed by or for Seller.

Seller further agrees to replace, or at Seller’s option to provide a refund of the sales price of any goods that did not conform to applicable specifications or which differ from that agreed to be supplied which non-conformity is discovered and forthwith reported to Seller within thirty (30) days after shipment to Buyer. Seller’s obligation to replace or refund the purchase price for non-conforming goods shall arise once Buyer returns such good FOB point of original shipment by Seller at the risk and cost of Buyer. Goods replaced by Seller shall be come property of Seller.

There is no guarantee or warranty as to anything made or sold by Seller, or any service performed, except as to title and freedom from encumbrances, and except as herein expressly stated and particularly without limiting the foregoing. There is no guarantee or warranty, express or implied, of merchantability or of fitness for any particular purpose or against claim of infringement or the like.

Seller makes no warranty (and assumes no liability) as to function of equipment or operation of systems built to Buyer’s design or of the ability of any goods to interface, operate or function with any portions of Buyer’s system not provided by Seller.

Seller’s liability on any claim; whether in contract (including negligence) or otherwise, for any loss or damage arising out of, connected with, or resulting from the manufacture, sale, delivery, resale, repair, replacement or use of any products or, services shall in no case exceed the price paid for the product or services or any part thereof which give rise to the claim. In no event shall Seller be liable for consequential, special, incidental or other damages, nor shall Seller be liable in respect to personal injury or damage to property on the subject matter hereof unless attributable to gross misconduct of Seller, which shall mean an act of omission by Seller demonstrating reckless disregard of the foreseeable consequences thereof.

Seller is not responsible for incorrect choice of models or where products are used in excess of their rated and recommended capacities and design functions or under abnormal conditions. Seller assumes no liability for loss of time, damage or injuries to property or persons resulting from the use of Seller’s products. Buyer shall hold Seller harmless from all liability, claims, suits and expenses in connection with loss or damage resulting from operation of products or utilization of services, respectively, of Seller and shall defend any suit or action which might arise there from Buyer’s name - provided that Seller shall have the right to elect to defend any such suit or action for the account of Buyer. The foregoing shall be the exclusive remedies of the buyer and all persons and entitles claiming through the Buyer.



Conductix-Wampfler Industrial Assembly Solutions!

Tasksaver: Workstation Equipment



Catalog Number: KAT04001-001-USA

- C-Rail System
- Air Festoon System
- Cable Festoon System
- Swivel Arms
- Tool Transporters
- Tool Carriers
- Jib Booms
- **Turn Tables**

ManAir: Electric and Air Supply System for Retrofit



Catalog Number: TDB0400-0010-USA

- Highly efficient compressed air supply
- No hose or cable loops
- No storage area
- No pull back forces
- Modular components for easy installation
- Simple design for low maintenance

WAKAIR-II: Tool Rail with high load capacity



Catalog Number: TDB0400-0006-USA

- Large load capacity at large spans
- Highly efficient compressed air supply
- No hose or cable loops
- No storage area; no pull-back force
- Modular components for easy installation
- Simple design for low maintenance

W5-traxX: Electric and Air Supply Systems



Catalog Number:

- Optimal compressed air supply, even for users with high air consumption
- High load capacity at light weight
- Maximum flexibility and adaptability
- Flexible and adaptable
- Safe, low-friction guiding

Other Products from Conductix-Wampfler

Spring Driven Cable Reels from Conductix-Wampfler represent only one product line from the broad spectrum of Conductix-Wampfler components for the transfer of energy, data, gases, and fluids. The solutions we deliver for your applications are based on your specific requirements. In many cases, a combination of several different Conductix-Wampfler products are needed to fill the application. You can count on all of Conductix-Wampfler's business units for hands-on engineering support - coupled with the perfect solution to meet your energy management and control needs.



Motor driven cable reels

Motor driven reels by Conductix-Wampfler are the perfect solution for managing long lengths of heavy cable and hoses in very demanding industrial applications. Monospiral, level wind, and random wind spools.

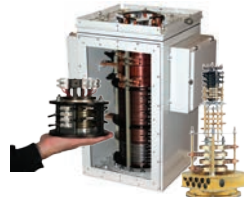

Slip ring assemblies

Whenever powered machinery needs to rotate 360°, field proven slip ring assemblies by Conductix-Wampfler can flawlessly transfer energy and data. Here, everything revolves around flexibility and reliability.



Energy guiding chains

The "Jack of all Trades" when it comes to managing energy and data cables and air and fluid hoses. A wide range of energy guiding chains are available for many industrial applications.



Inductive Power Transfer IPT®

The contact-less system for transferring energy and data. For all tasks that depend on high speeds and absolute resistance to wear.



Conductor bar

Whether they are enclosed conductor rails or expandable single-pole bar systems, Conductix-Wampfler's conductor bar is the proven solution to reliably move people and material.



Cable Festoon systems

It's hard to imagine Conductix-Wampfler cable trolleys not being used in virtually every industrial application. They are reliable and robust and available in an enormous variety of sizes and models.



Push Button Pendants

Our ergonomic pendants are ideally suited for industrial control applications. They are available in a wide range of configurations for overhead cranes and other machinery.



Radio remote controls

Safe, secure, and reliable radios use the latest in microprocessor technology. Available in several models for overhead crane control and other types of machinery.



Workstation equipment

Complete with tool transporters, reels, or an entire air and electric supply system. Workstation equipment provides safety and flexibility for difficult tasks.



Air hoists and balancers

ENDO Air hoists accurately place delicate loads and continuously vary the speed for precise positioning. They run cool in **continuous operations**.



Bumpers

Conductix-Wampfler offers a complete range of bumpers for the auto industry, cranes, and heavy machinery. These include rubber, rubber/metal, and cellular types.



Welded Cap Conductor Rail

Our patented Welded Cap Rail gives you the conductivity and light weight of aluminum plus the wearability of stainless steel.

www.ergonomicpartners.com

USA / LATIN AMERICA

10102 F Street
Omaha, NE 68127

CANADA

175 Blvd JF Kennedy
St. Jerome, QC J7Y 4B5

Distributed by Ergonomic Partners

Sales@ErgonomicPartners.com

www.ErgonomicPartners.com

Tel: (314) 884-8884

