



Cube[®] 3D Printer

2nd generation



User Guide

See inside for use and safety information.

Table of Contents

Introduction	2
Important safety information	
EN	3
DE	4
ES	5
FR	6
IT	7
DU	8
DA	9
JP	10
Cube 3D Printer features	11
At a glance	12
Requirements for your Cube	13
Unpacking and setting up your Cube	14
Link your Cube to your Cubify account	15
Unlock your Cube	16
Download and install Cube Software for Windows	16
Download and install Cube Software for Mac OSX	17
Download your free creations	17
Cubify Software overview	18
WI-FI set-up	20
Non-wireless computer set-up (without WI-FI options)	20
Update Cube firmware	20
Setting Print Jet gap	21
Material Cartridge installation	22
Printing preparation	23
Printing your first creation	24-25
Replacing Material Cartridge	26
Cloud printing from Cubify.com	27
Finishing your creation	27
Maintaining your Cube	28
Print Pad leveling instructions	29

1 INTRODUCTION

Thank you for purchasing the “Cube®” 3D Printer. This printer is portable with a plug and print design that enables everybody in the family to express their creativity like never before. With ten different material colors to choose from, enjoy the freedom to print in your true colors or to mix it up. Cube 3D Printers ready-to-print technology provides a new dimension to your imagination and helps you share your creations with others in the Cubify community at Cubify.com.

At Cubify.com you can:

- Upload your creations for sale
- Purchase creations from others
- Get your creations 3D printed and shipped to you
- Buy the Cube 3D Printer and Cube Cartridges
- Engage with other creative partners

COPYRIGHT INFORMATION

© 2013 by 3D Systems, Inc. All rights reserved. This document is subject to change without notice. This document is copyrighted and contains proprietary information that is the property of 3D Systems, Inc. Cubify, Cube, and the 3D Systems logo are registered trademarks of 3D Systems, Inc. Use of the Cubify.com website constitutes acceptance of its Terms of Service and Privacy Policy.

FCC NOTICE

This equipment has been tested and found to comply with the limits for a class “B” digital device, pursuant to Part 15 of the FCC Rules. These limits are designed to provide reasonable protection against harmful interference. This equipment generates, uses, and can radiate radio frequency energy and, if not installed and used in accordance with the instruction manual, may cause harmful interference to radio communications. Operation of this equipment in a residential area is likely to cause harmful interference in which case the user will be required to correct the interference at their expense.

WARRANTY

3D Systems warrants that the Cube 3D Printer will be free from defects in materials and workmanship, during the applicable warranty period, when used under the normal conditions described in the documentation provided to you, including this user’s guide. 3D Systems will promptly repair or replace the Cube 3D Printer, if required, to make it free of defects during the warranty period. This warranty excludes (i) normal consumable or expendable parts (such as Material Cartridges, Print Pads, and CubeStick), (ii) repairs required during the warranty period because of abnormal use or conditions (such as riots, floods, misuse, neglect or improper service by anyone except 3D Systems or its authorized service provider), and (iii) repairs required during the warranty period because of the use of non-integrated, non-approved or non-licensed materials in the Cube 3D Printer. The warranty period for the Cube 3D Printer is ninety (90) days and shall start on the date your Cube 3D printer is activated. For consumers who are covered by consumer protection laws or regulations in their country of residence, the benefits conferred by our ninety (90) day warranty are in addition to, and operate concurrently with, all rights and remedies conveyed by such consumers protection laws and regulations, including but not limited to these additional rights.

THIS WARRANTY IS THE ONLY WARRANTY PROVIDED FOR THE CUBE 3D PRINTER. TO THE MAXIMUM EXTENT PERMITTED BY LAW, 3D SYSTEMS EXPRESSLY DISCLAIMS ALL OTHER WARRANTIES FOR THE CUBE 3D PRINTER AND EACH OF ITS COMPONENTS, WHETHER THOSE WARRANTIES ARE EXPRESS, IMPLIED OR STATUTORY INCLUDING WARRANTIES OF MERCHANTABILITY AND FITNESS FOR INTENDED OR PARTICULAR PURPOSES.

LIMITATION OF LIABILITY

3D SYSTEMS WILL NOT BE RESPONSIBLE FOR CONSEQUENTIAL, EXEMPLARY OR INCIDENTAL DAMAGES (SUCH AS LOSS OF PROFIT OR EMPLOYEE’S TIME) REGARDLESS OF THE REASON. IN NO EVENT SHALL THE LIABILITY AND/OR OBLIGATIONS OF 3D SYSTEMS ARISING OUT OF THE PURCHASE, LEASE, LICENSE AND/OR USE OF THE EQUIPMENT BY YOU OR OTHERS EXCEED THE PURCHASE PRICE OF THE CUBE 3D PRINTER.

2 IMPORTANT SAFETY INFORMATION (EN)

SAFETY SYMBOLS AND DEFINITIONS



Hot Surface Hazard: A hot surface is accessible in the vicinity of this sign or at the Print Jet; avoid contact. Hot surfaces can cause severe burns.



Caution: Indicates something may happen that could cause loss of data, damage to equipment, or could cause personal injury.



Caution: Indicates a pinch point hazard that could cause person injury.

SAFETY GUIDELINES

- Follow all safety rules in this section and observe all cautions and warnings in this guide.
- Do not modify any safety features or make modifications to the Cube. Doing so is prohibited and voids warranty.
- Use of print materials, or 3D prints other than 3D Systems print materials and genuine 3D Systems components may void warranty.
- Adult supervision is required; observe children closely and intervene as necessary to prevent potential safety problems and ensure the Cube's appropriate use. Ensure small 3D prints are not accessible to young children. These 3D prints are potential choking hazards for young children.
- When the Cube is operating, the print tip on the Print Jet becomes hot; avoid touching this area until it has cooled down.
- Do not change color of material during printing; doing so may damage the Cube.

SICHERHEITSSYMBOLS UND DEFINITIONEN



Gefahr durch heiße Oberflächen: Eine heiße Oberfläche ist in der Nähe dieses Zeichens oder am Print Jet zugänglich; vermeiden Sie jeglichen Kontakt. Heiße Oberflächen können schwere Verbrennungen verursachen.



Achtung: Weist darauf hin, dass etwas passieren kann, was zum Verlust von Daten, zu Schäden an den Geräten oder zu Körperverletzungen führen könnte.



Achtung: Weist auf eine Einklemmgefahr hin, die zu Körperverletzungen führen könnte.

SICHERHEITSHINWEISE

- Befolgen Sie alle Sicherheitsvorschriften in diesem Abschnitt und beachten Sie alle Vorsichtsmaßnahmen und Warnhinweise in diesem Handbuch.
- Modifizieren Sie keine Sicherheitsmerkmale und nehmen Sie keine Änderungen am Cube-Drucker vor. Dies ist verboten und kann zum Erlöschen der Gewährleistung führen.
- Die Verwendung von Druckmaterialien oder 3D-Drucken, die keine Originalteile von 3D Systems sind, kann zum Erlöschen der Gewährleistung führen.
- Die Beaufsichtigung durch Erwachsene ist erforderlich; beobachten Sie Kinder genau und greifen Sie gegebenenfalls ein, um mögliche Sicherheitsprobleme zu vermeiden und um sicherzustellen, dass der Cube-Drucker ordnungsgemäß verwendet wird. Stellen Sie sicher, dass kleine 3D-Drucke für kleine Kinder nicht zugänglich sind. Diese 3D-Drucke bergen eine mögliche Erstickengefahr für kleine Kinder.
- Wenn der Cube-Drucker in Betrieb ist, wird die Druckdüse am Print Jet heiß; vermeiden Sie es, diesen Bereich zu berühren, bis er abgekühlt ist.
- Verändern Sie während des Druckens nicht die Farbe des Materials; dadurch kann der Cube-Drucker beschädigt werden.

2B INFORMACIÓN IMPORTANTE SOBRE SEGURIDAD (ES)

SÍMBOLOS Y DEFINICIONES DE SEGURIDAD



Peligro de superficie caliente: Una superficie caliente se encuentra cerca de esta señal o en la impresora; evite el contacto con esta. Las superficies calientes pueden causar quemaduras graves.



Precaución: Indica que algo puede ocurrir y causar una pérdida de datos, daños al equipo o lesiones.



Precaución: Indica un peligro de punto de pellizco que podría causar lesiones a una persona.

PAUTAS DE SEGURIDAD

- Siga todas las normas de seguridad de esta sección y esté atento a todas las precauciones y advertencias en esta guía.
- No modifique ninguna medida de seguridad ni realice modificaciones a la impresora Cube. Hacerlo está prohibido y anula la garantía.
- El uso de materiales de impresión o de piezas impresas en 3D que no sean componentes auténticos de 3D Systems puede anular la garantía.
- Se requiere la supervisión de un adulto; observe a los niños de cerca e intervenga cada vez que sea necesario para prevenir cualquier posible problema de seguridad y asegurar el uso adecuado de la impresora Cube. Asegúrese de que las piezas pequeñas impresas en 3D no estén al alcance de niños pequeños. Estas piezas impresas en 3D representan un posible peligro de asfixia para los niños pequeños.
- Cuando la impresora Cube está funcionando, la punta de impresión se calienta; evite tocar esta área hasta que se haya enfriado.
- No cambie el color de los materiales durante la impresión; esto puede dañar la impresora Cube.

2c INFORMATIONS IMPORTANTES RELATIVES À LA SÉCURITÉ (FR)

SYMBOLES DE SÉCURITÉ ET DÉFINITIONS



Surface chaude: Une surface chaude est présente à proximité de ce symbole ou sur l'imprimante ; évitez de la toucher. Les surfaces chaudes peuvent causer de graves brûlures.



Attention: Indique que quelque chose pourrait occasionner une perte des données, des dommages sur l'équipement ou des blessures.



Attention: Indique un risque de pincement qui pourrait occasionner une blessure.

CONSIGNES DE SÉCURITÉ

- Suivez toutes les consignes de sécurité de cette section et respectez tous les messages d'avertissement du présent manuel.
- Ne pas modifier les dispositifs de sécurité ou apporter des modifications au Cube. Cela est interdit et annule la garantie.
- L'utilisation de matériaux d'impression ou d'imprimés en 3D autres que les composants 3D Systems d'origine peut entraîner l'annulation de la garantie.
- La supervision d'un adulte est requise ; surveillez les enfants en restant à proximité et intervenez si nécessaire pour éviter tout problème de sécurité potentiel et garantir la bonne utilisation du Cube. Assurez-vous que les petits imprimés en 3D restent hors de portée des jeunes enfants. Ces imprimés en 3D présentent un risque d'étouffement pour les jeunes enfants.
- Lorsque le Cube fonctionne, l'extrémité de l'imprimante peut chauffer ; évitez de toucher cette zone jusqu'à ce qu'elle est refroidie.
- Ne pas modifier la couleur du matériau pendant l'impression ; cela peut endommager le Cube.

2D INFORMAZIONI IMPORTANTI SULLA SICUREZZA (IT)

SIMBOLI E DEFINIZIONI DI SICUREZZA



Pericolo di superficie calda: In prossimità di questo simbolo o del getto d'inchiostro è presente una superficie calda; evitare il contatto. Le superfici calde possono causare ustioni gravi.



Attenzione: Segnala che un determinato evento potrebbe causare la perdita di dati, danni all'impianto o lesioni personali.



Attenzione: Segnala la presenza di una zona ad alto rischio che potrebbe causare lesioni personali.

LINEE GUIDA DI SICUREZZA

- Attenersi a tutte le norme di sicurezza contenute in questa sezione e rispettare le avvertenze e le precauzioni indicate nella guida.
- Non alterare le caratteristiche di sicurezza né apportare modifiche a Cube. Queste operazioni sono vietate e determinano l'annullamento della garanzia.
- L'utilizzo di materiali di stampa o di componenti di stampa 3D non originali di 3D Systems può comportare l'annullamento della garanzia.
- È richiesta la supervisione di un adulto; tenere sotto stretta sorveglianza i bambini e, in caso di necessità, intervenire per evitare eventuali problemi di sicurezza e per garantire l'uso appropriato di Cube. Assicurarsi che i bambini non possano raggiungere i componenti più piccoli delle stampe 3D, poiché questi potrebbero costituire un pericolo di soffocamento.
- Durante l'attività di Cube, la puntina di stampa del getto d'inchiostro si riscalda; evitare il contatto con quest'area fino al completo raffreddamento.
- Non modificare il colore del materiale durante la stampa; quest'operazione potrebbe causare danni a Cube.

2E BELANGRIJKE VEILIGHEIDSINFORMATIE (DU)

VEILIGHEIDSSYMBOLEN EN DEFINITIES



Gevaar voor hete oppervlakken: Er is een toegankelijk heet oppervlak in de nabijheid van dit waarschuwingsteken of bij de Print Jet. Niet aanraken. Hete oppervlakken kunnen ernstige brandwonden veroorzaken.



Let op: Duidt op iets wat kan gebeuren dat verlies van gegevens, beschadiging van de apparatuur of lichamelijk letsel kan veroorzaken.



Let op: Duidt op een gevaarlijk knelpunt dat lichamelijk letsel kan veroorzaken.

VEILIGHEIDSVOORSCHRIFTEN

- Volg alle veiligheidsvoorschriften in dit gedeelte en neem alle opmerkingen en waarschuwingen in deze handleiding in acht.
- Breng geen wijzigingen aan de veiligheidsvoorzieningen of de Cube aan. Dit is verboden en de garantie komt hierdoor te vervallen.
- Door gebruik van printmaterialen of 3D-prints anders dan originele 3D Systems-onderdelen kan de garantie komen te vervallen.
- Oezicht door een volwassene is vereist; houd kinderen nauwlettend in het oog en grijp zo nodig in om mogelijke veiligheidsproblemen te voorkomen en het juiste gebruik van de Cube te verzekeren. Zorg dat jonge kinderen niet bij kleine 3D-prints kunnen komen. Deze 3D-prints houden potentieel verstikkingsgevaar in voor jonge kinderen.
- Wanneer de Cube in werking is, wordt de printtip op de Print Jet heet. Raak dit oppervlak niet aan totdat het is afgekoeld.
- Wijzig de kleur van het materiaal niet tijdens het printen, anders kan de Cube worden beschadigd.

SIKKERHEDSSYMBOLER OG -DEFINITIONER



Fare for varm overflade: Der findes en varm overflade i nærheden af dette skilt eller ved printaggregatet; undgå kontakt. Varme overflader kan forårsage alvorlige forbrændinger.



Forsigtig: Viser at der kunne ske noget som kan resultere i datatab, beskadigelse af udstyr eller personskade.



Forsigtig: Viser at der findes en knusefare, som kan forårsage personskade.

SIKKERHEDSRETNINGSLINIER

- Følg alle sikkerhedsreglerne i denne sektion og overhold forsigtighedsregler og advarsler i denne vejledning.
- Sikkerhedsfeatures må ikke modificeres og der må ikke foretages andre modifikationer til Cube. Det er forbudt at gøre det og det vil ugyldiggøre garantien.
- Brugen af andre printmaterialer eller 3D prints end de ægte 3D Systems komponenter kan ugyldiggøre garantien.
- Det er påkrævet at en voksen holder opsyn; hold nøje øje med børn og trød ind hvis det er nødvendigt for at undgå potentielle sikkerhedsproblemer og at sikre at Cube bruges rigtigt. Sørg for at små børn ikke har adgang til små 3D prints. Disse 3D prints kan udgøre en kvælningfare for små børn.
- Når Cube er i drift bliver spidsen på printaggregatet varm, så dette område må ikke røres før det er kølet af.
- Materialets farve må ikke ændres under trykning; det kan beskadige Cube.

2G 安全に関する重要情報 (JP)

安全関連シンボルと定義



高熱面の危険: このシンボルサインの近くまたはプリントジェット部には表面が高熱となっている部分があります。触れないように注意してください。高熱面で火傷することになります。



要注意: データの喪失、機器の損傷、または人身傷害を引き起こすような何かが起こる場合もあることを示します。



要注意: 人身傷害を引き起こす可能性のある危険個所を示します。

SIK 安全ガイドライン

- 本項の安全ルールのすべてに従い、また本書のすべての要注意および警告事項を守ってください。
- 安全機能を修正したり、Cube に改変を加えたりしないでください。そうすることは禁じられており、保証は無効になります。
- 純正 3D Systems コンポーネント以外のプリント材料や 3D プリントの使用は、保証を無効にする場合があります。
- 大人の監視が必要です。子供が使用している時には身近で見守り、安全上の問題を未然に防ぎ、Cube が適切に使用されるよう、必要に応じて介入するようにしてください。小型の 3D プリントが幼児の手に届くことのないようにしてください。これらの 3D プリントは幼児にとっては、のどを詰まらせる危険物となります。
- Cube が動作中は、プリントジェット上のプリントチップが熱くなります。その部分が冷めるまでは、触れないようにしてください。
- プリント中に材料の色を変更しないでください。そうすると Cube を損傷させることがあります。

3 CUBE 3D PRINTER FEATURES

The Print Jet print tip heats the material and produces a thin flowing material of plastic creating layers that adhere to the Print Pad. After each layer is produced, the Print Pad lowers so that a new layer can be drawn on top of the last. This process continues until the last layer on the top of the creation is jetted.

CUBE 3D PRINTER FEATURES

- Material Cartridge
- Durable, ABS & PLA Plastic
- 25 free 3D print creations
- USB & WI-FI connectivity

CUBE 3D PRINTER PROPERTIES

Technology:	Plastic Jet Printing (PJP)
Print Jets:	Single jet
Max. Creation Size:	5.5" x 5.5" x 5.5" (140 x 140 x 140 mm)
Material:	Tough recyclable plastic
Layer Thickness:	10 mil 0.01 inches 250 microns 0.25 mm
Supports:	Fully automated; easy to peel off
Cartridge:	1 Cartridge prints 13 to 14 mid-sized creations
Material Colors:	See Cubify.com for color choices

4 AT A GLANCE

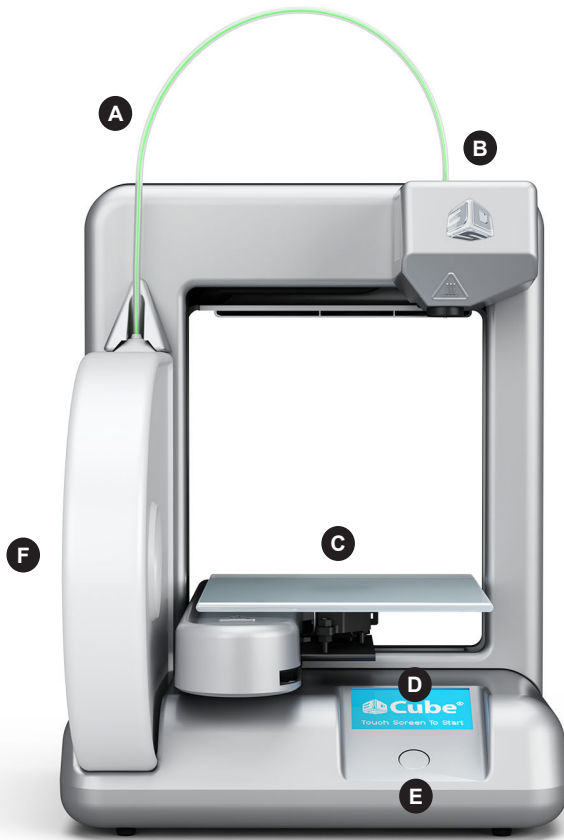

- A Cube Tube
- B Print Jet
- C Print Pad
- D Operator's Touchscreen
- E ON/OFF Push-Button Power Switch & Menu Function
- F Material Cartridge
- G Fuse
- H Power Cord Connection
- I USB Port*
- J USB Connection**

*For firmware update only.

**For loading Cube build files only.

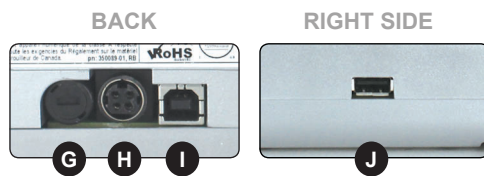

5 REQUIREMENTS FOR YOUR CUBE

WEIGHT & DIMENSIONS

- Weight (without cartridge): 4.3 kg (9.5 lbs.)

SOFTWARE

- Complimentary software for Windows and Mac OSX. This application converts your 3D model into layered slices (G-code), ready for printing on your machine.

MINIMUM HARDWARE REQUIREMENTS

- A PC with these minimum requirements will be required to run the Cubify Software
- Processor: Multi-core processor - 2 GHz or faster per core
- System RAM: 2 GB
- Screen Resolution: 1024x768

WINDOWS REQUIREMENTS

- Cubify Software runs on 32 and 64-bit Operating Systems
- Windows XP Professional or Home Edition with Service Pack 3
- Windows 7
- Windows is required for ad-hoc WiFi Print Job submission. **NOTE: Ad-Hoc WI-FI connection will not connect to Windows XP operating systems**
- If not already installed, the Cubify Software installer will automatically install the Microsoft .NET 4.0 Framework

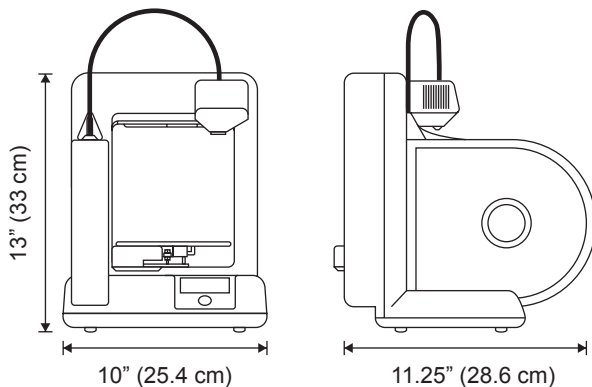

WIRELESS OPTIONS

- 802.11b/g with: WLAN Infrastructure or Ad hoc Mode.

NON-WIRELESS OPTION

- USB Memory Stick, to transfer print files (supplied with the Cube)

MAC OSX REQUIREMENTS

- Cubify Software runs on Mac OSX 10.8

ELECTRICAL REQUIREMENTS

- Outlet requirements: 100-240 Volts, at 50/60 Hz.
- Cube electrical rating: 24V DC, 3.75 amp.

MATERIAL STORAGE

- All polymers degrade with time. The following conditions ensure the material remains high quality:
- Do not unpack until material is needed.
- Store at room temperature: 16-29° C (60 - 85° F)

OPERATING ENVIRONMENT

- Room Temperature: 16-29° C (60 - 85° F)
- Nozzle- 280°C (536°F)
- Print Pad- 66-77° C (150-170°F)

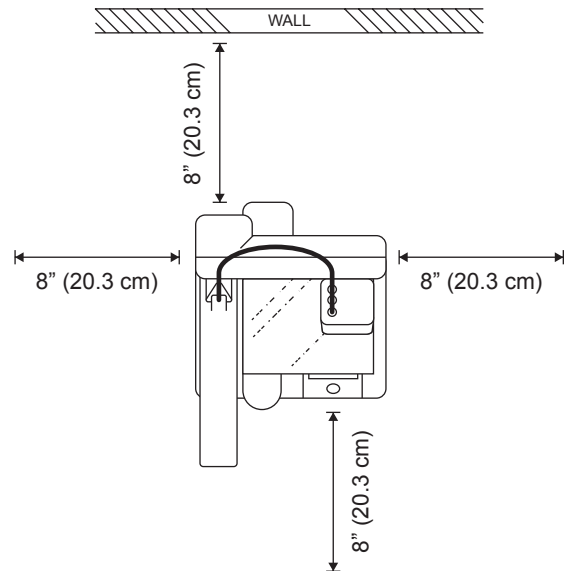

6 UNPACKING AND SETTING UP YOUR CUBE

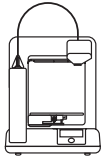

The Cube

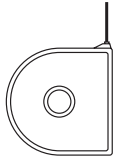

Material Cartridge*

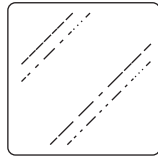

Print Pad



CubeStick™

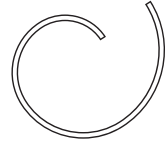

Cube Tube



Power Supply



Power Cord



USB Cable**

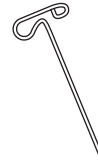

Unclog Tool***



USB Stick

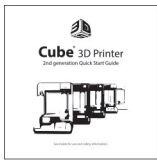

Quick Start Guide

*Neon green included **For downloading firmware ***For unclogging filament in Print Jet

SETTING UP YOUR CUBE

1. Remove the white plastic inserts from each side of the box by pinching the tabs in and bending the inserts out. Pull to remove both from the box. Lift top of carton up and remove.
2. Lift foam from the top of Cube. Remove foam from the midsection and below the plate by gently pulling out from the front. Remove Cube from box.
3. Lift foam that Cube was sitting on to access power supply and other accessories.
4. Remove the Print Pad from the foam under the Cube and set it aside.
5. Plug round connector of power supply into the back of the Cube.
6. Plug power cord into power supply, then into outlet or power strip.

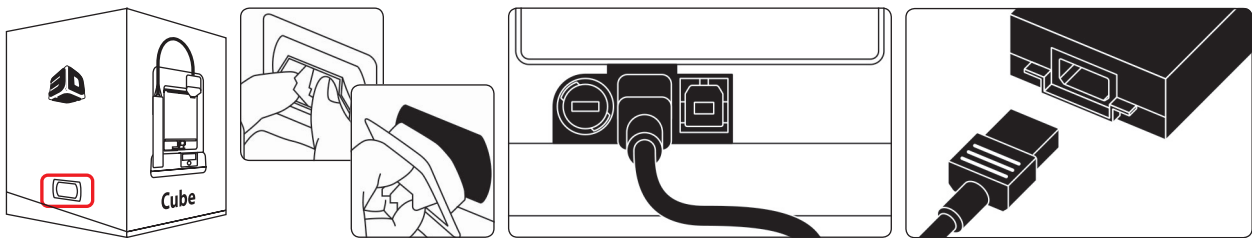

7 LINK YOUR CUBE TO YOUR CUBIFY ACCOUNT

Creating an account on Cubify.com is easy and gives you access to all of the great designs and collections that will drive and inspire your creativity. Once you have set up an account you will be able to activate your Cube by entering your Cube's individual serial number in the designated bar under the [Activate My Cube](#) tab. An activation code will then be sent to the email account you used to register. This code will be used to unlock your Cube so that you can get your 3D printing underway.

NOTE: If you do not receive an activation code email, please check your spam filter settings.

1. Go to Cubify.com and log in to your account or click [Sign Up](#) to create an account.
2. Click on [Activate My Cube](#) from [My Cubify](#) drop down menu.

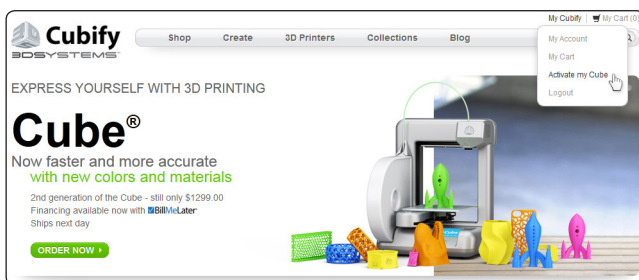

3. Enter your 12-character serial number (digits and letters found on the back of your Cube), then click [Activate](#).



4. Your Cube's serial number is now activated on Cubify.com and your Cube will be assigned to your Cubify account. Your activation code will be displayed, and also sent to you in an e-mail along with links to help you get started creating. Make sure the email doesn't get caught in your spam filter!
5. Using the links from your activation code email, or the [My Cubes](#) section in your account, you can download:
 - The Cube Software, which turns your 3D models into a file that the Cube can print. **The software must be installed on your computer. Your Cube won't print without it!**
 - 25 free, ready-to-print 3D files created by top artists and designers (also on your USB stick)
 - Cube 3D Printer User Guide (also on your USB stick)
 - Material Safety Data Sheets
6. Now it is time to unlock your Cube so you can begin creating.

NOTE: If you use a PC, you need Microsoft® Windows® 7 or XP (SP3+). If you use a Mac, you need Mac OSX 10.8+

8 UNLOCK YOUR CUBE

Once you've linked your Cube to your Cubify account, you can activate your Cube to start printing!

1. Your activation code to unlock your Cube will appear on the "Congratulations" screen after you activate your Cube in your Cubify account. A copy of the code should also be sent to your email.
2. Make sure your Cube is plugged in. Press the button on the front panel to turn it on. It may take a few seconds for it to warm up.
3. Tap on the touchscreen to view the **Unlock Cube** screen.
4. Enter your activation code and then tap on the check box to unlock your Cube. Your Cube will automatically transition to the main menu touchscreen and is now unlocked and ready to create!

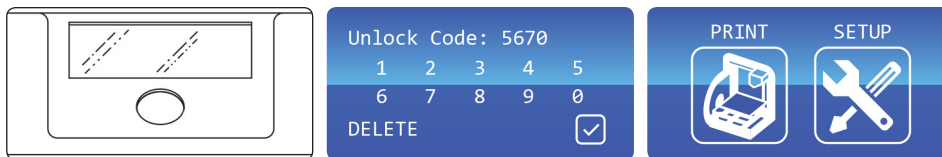

9 DOWNLOAD AND INSTALL CUBE SOFTWARE FOR WINDOWS

Download the Cube Software and experiment with it to create your own designs.

1. To download Cube Software, go to [My Cubify](#) and click on [My Accounts](#). Click on [My Downloads](#) and select Cube software on the menu page.
 2. Click on Setup.exe in the Cube Client.zip. The next screen will ask you if you would like to open this file. Click **Yes**.
 3. The Cubify Setup Wizard will guide you through the steps to install the software on your computer. Click **Next** to launch the Setup Wizard.
- It is necessary to download the Cube software in order to be able to import .stl or .creation files and convert them to .cube files.
 - The .cube file is a machine-specific file type that is coded for the Cube to read and print.

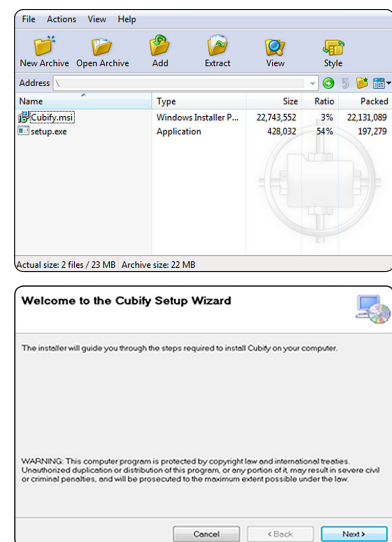

10 DOWNLOAD AND INSTALL CUBE SOFTWARE FOR MAC OSX

Download the Cube Software and experiment with it to create your own designs.

1. In the menu, Click on [Download Cube Software](#). Double click on the zip file and the [Cubify Mac installer.dmg](#) will appear.
2. Double click [Cubify Mac Installer.dmg](#), to make a new window open. Drag to install into the [Applications](#) folder.
3. If the “Drag to install” window did not open, locate the [Cubify](#) driver in your device panel. Click on [Cubify](#) to download software.

NOTE: Safari users will not have to unzip the dmg; it unzips as it downloads.

- It is necessary to download the Cube software in order to be able to import .stl or .creation files and convert them to .cube files.
- The .cube file is a machine-specific file type that is coded for the Cube to read and print.

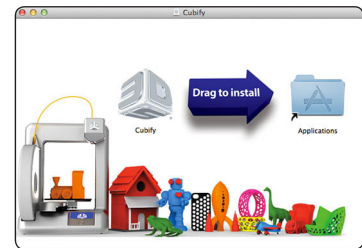
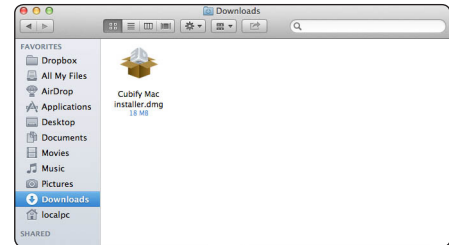

11 DOWNLOAD YOUR FREE CREATIONS

Follow these simple steps to access your 25 free creations:

1. Click on [Download Free Creations](#) to start your immediate download.
2. Click [Extract](#) in the Creation zip file and extract it to your computer.

There are a couple of file types involved in 3D printing with your Cube:

- **.stl** file: A 3-dimensional solid computer-aided design (CAD) file that defines the geometry to be printed. This is the typical file type output of a 3D design program or software tool.
- **.creation** file: These files represent the pre-made 3D models that are optimized for your Cube and available on Cubify for download. Simply import your .creation file into the Cube software and click [Build](#) to prepare your creation for print.
- **.cube** file: This is the machine code read by the Cube 3D Printer that enables it to build your print.

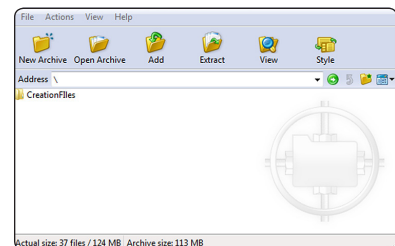
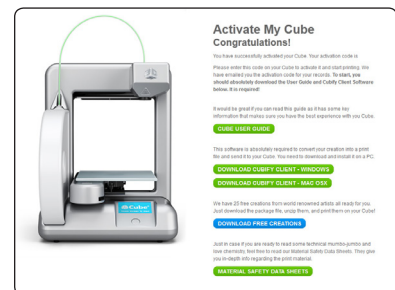

12 CUBIFY SOFTWARE OVERVIEW

Cubify Software allows you manipulate your design before sending it to the Cube for printing. It simulates the Cube's Print Pad so you can orient, scale, re-size and rotate the 3D print to get the best result when printing. Become familiar with the software and understand the functions before starting your first print.



IMPORT

Select your creation file.



HEAL

Fix your creation.



ORIENT & SCALE

Rotate the X, Y, Z axis; move creation back & forth or side to side; increase or decrease your creation.



CENTER

Center your creation on the Print Pad; multiple items are auto-positioned.



BUILD

Creates the Cube file by adding support structures; the slicing process will prepare your creation.



PRINT

Transfers your creation to the Cube.

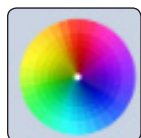

COLOR*

Select your background and model color.

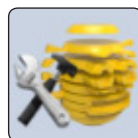

SETTINGS

Choose your print size; turn rafts & supports ON or OFF.



MODEL INFO

Displays your creation information.



SAVE

Saves your creation without printing.



UNLOAD

Deletes your creation from the Cube software.



CONFIGURE

Connect your computer and the Cube via WI-FI using the USB cable. Also, download firmware upgrades.

These icons permit you to view your creation in various view points. After selecting a particular view, place your cursor on the part and hold the mouse button down; rotate the Print Pad to view different angles of the part.

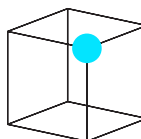

Isometric

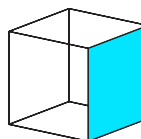

Right

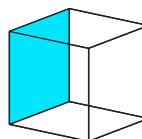

Left

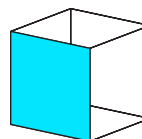

Front

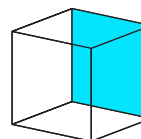

Back

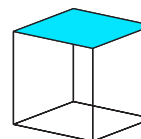

Top

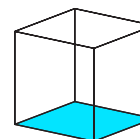

Bottom

* The color you select will not affect the color of your printed creation

13 WI-FI SETUP

SET UP A COMPUTER (AD HOC) NETWORK

An ad hoc network is a temporary connection to your Cube through your computer or wireless smart phone.

Ad hoc networks can only be wireless, so you must have a wireless network adapter installed in your computer to setup or join an ad hoc network.

NOTE: Ad hoc will not connect to operating systems running Windows XP.

1. Tap on **Setup** in the main menu and scroll until you come to the **WI-FI Setup** screen.
2. Tap **WI-FI Setup**.
3. Tap on **Ad Hoc** in the menu screen. The next screen will show **Ad Hoc mode enabled** meaning it is ready to connect to your computer.
4. Open your **Internet Access** located in your Network Settings.
NOTE: Always select your Cube from your network settings before opening Cube Software.
5. Select your Cube on the menu. Click on **Connect**. This may take a few minutes.
7. Open your Cube software and click on “Configure” and select your Cube from the menu. Click on “Connect;” once connected, you may begin to print your creation.

SET UP A COMPUTER (WLAN) NETWORK

WLAN (wireless local area network) allow easy establishment of a secure wireless network.

WLAN connection will allow you to connect to your printer through the Cube Software.

1. Tap on **Setup** in the main menu and scroll until you come to the **WI-FI Setup**.
2. Tap on **WI-FI Setup**.
3. Tap on **WLAN** in the menu screen. “Acquiring networks” screen appears, meaning it is searching for available networks to connect to the printer.
4. Tap the on the touch screen to select your network. If your network is password protected, enter your password and tap on “OK.”
5. After your **WI-FI** is set up, if needed, the **WI-FI** firmware may update to the latest version if the latest firmware is not installed. **NOTE: This will only occur when you are connecting to the network for the first time and if the WI-FI firmware needs updating.** Once it is updated, the network will be successfully connected.
6. If the **WI-FI** firmware update was necessary, you may get one of two responses: (1) Network connected update successful; (2) Network connected... Update not successful. **NOTE: If WiFi firmware update reported unsuccessful, the WLAN WiFi connection should still work. The WiFi firmware will try again with next connection attempt.**
7. Click the function button to take you back to the main menu before printing
8. Open your Cube software and click on “Configure” and select your Cube from the menu. Click on “Connect;” once connected, you may begin to print your creation.
9. Open your **Internet Access** located on your computer’s taskbar.
10. Scroll and select the network on the menu. Click on **Connect**. This may take a few minutes.

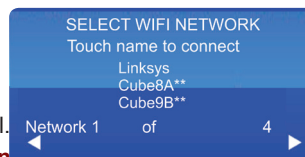
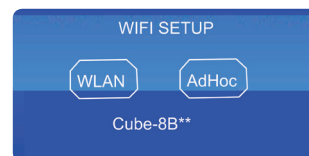
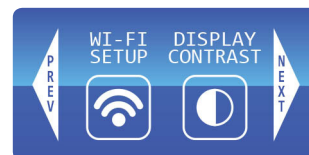
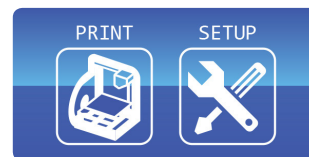

SWITCHING FROM AD-HOC TO WLAN CONNECTION (OR VICE VERSA)

1. Close out Cube Software.
2. Disconnect the Cube's wireless connection through the Internet Access menu on your operating system.
3. Now follow steps for WLAN / ad-hoc set up.
4. Re-open your software after your Cube successfully connects to WLAN / ad-hoc.

14 NON-WIRELESS COMPUTER SETUP

If you are not connected to a network, you can download your creations from your computer and save them to your USB Memory Stick for printing.

- When printing with the USB Memory Stick, the file must be in the main folder located on the memory stick. If it is put into another folder it cannot be accessed from Cube screen.
- Install your USB Memory Stick into your computer's USB connection and save your creation to your USB Memory Stick.
- When you are ready to print your creation, install your memory stick into the Cube's USB connection and print your creations.

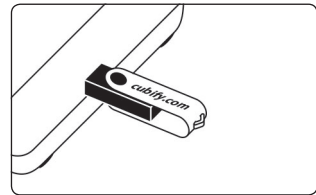

15 UPDATE CUBE FIRMWARE

1. Tap on **Setup** on the Cube touch screen and scroll to **Update Firmware**.
2. If your USB Memory Stick is connected to the Cube, please remove the memory stick, (the screen will display the directions to do this). Tap the **NEXT** arrow on the display; locate the USB cable and connect the cable to the Cube USB port located on the back of the Cube (again, these instructions will be displayed on the screen). Connect the other end of cable to your computer's USB port.

NOTE: Never leave the USB cable connected except when upgrading the firmware.

3. Tap the **NEXT** arrow. **SETTINGS SAVED** will be displayed at the top of the screen. You will have 6 seconds to press and hold the control button until firmware loader appears on the screen. If the button is released before the firmware screen appears, the screen will go blank. Repeat Step 1 to restart the update firmware process.
4. Continue to hold button until **Settings Saved** and then **Cube Firmware Loader** appears on the touch screen. You are now in the correct mode to update your firmware. **NOTE: Even though the update is unsuccessful, WLAN WI-FI should still work, To try again, simply reconnect to the network,**
5. Open Cubify Software and click the **Configure** icon; click on **Load New Cube Firmware**. Once you see the pop-up message **Firmware Updated Successfully**, click **OK**.
6. Disconnect the USB cable from your Cube and computer; unplug the Cube power cord. Plug power cord back in and press the Cube power button; a message will display on the touchscreen "Setting restored," click on the check mark to save settings. This does not change your previous settings that you have made. Your new firmware is now installed.

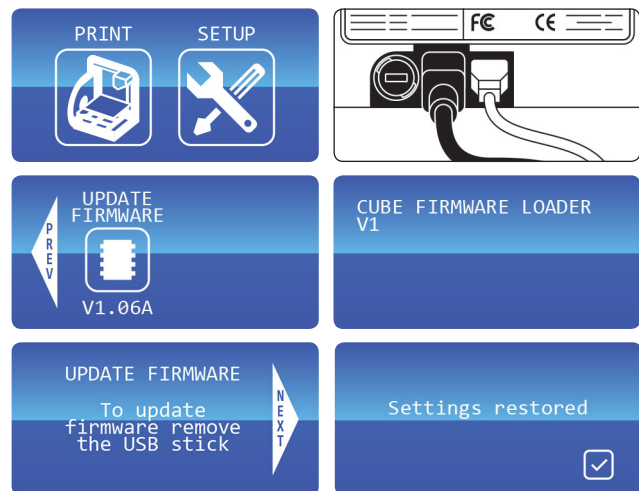

16 SETTING PRINT JET GAP

There must be an appropriate distance between the print tip and the Print Pad to make sure the first printed layer sticks properly.



When the Cube is operating, the print tip on the Print Jet nozzle becomes hot; avoid touching this area until it has cooled down.

1. Make sure the textured side of the Print Pad is facing upwards. Place the magnetic side of the print pad onto the magnetic print plate.
2. Press **Set Up** on your Cube's touchscreen and tap **Next** until **Set Gap** appears.
3. Select **Set Gap**. The Print Jet and Print Pad will move into position to set the gap. Place a standard piece of paper between the print tip and Print Pad. If the paper cannot slide between the tip and pad, tap the **down** arrow on the touchscreen until you can slide the paper between the tip and pad.

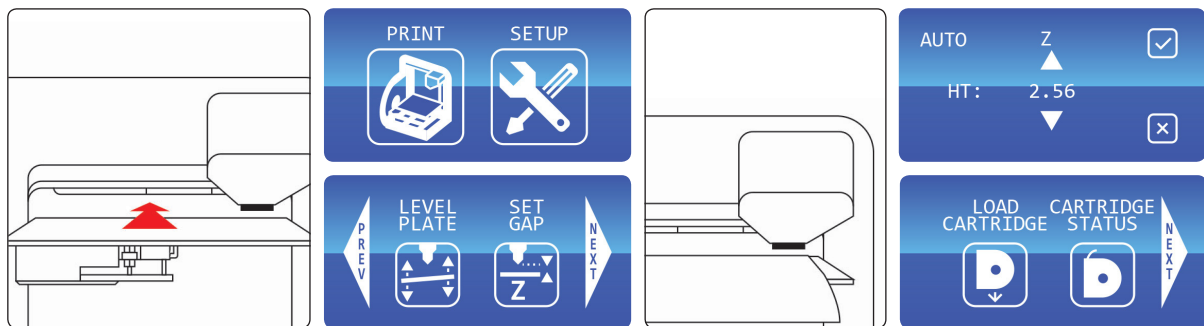

4. Press the **Z** up key to move the Print Pad toward the print tip until the paper is tight between the Print Pad and print tip. Tap the down key until the paper slides back and forth with no resistance.
5. Tap the check mark to save this setting to the printer's memory. If the setting is saved, the "Gap" value will be applied for each subsequent print. If you wish to cancel this setting, tap the **X** box.
6. If you have any trouble printing after the gap setting has been saved, you can use this procedure at any time to change the gap.
7. Once the gap has been set, tap **PREV** to start the **Load Cartridge** process.

17 MATERIAL CARTRIDGE INSTALLATION

1. Use scissors to remove the cartridge from its packaging.
2. Tap **Setup** on your Cube's touchscreen, select **Load Cartridge**, and press **Next**.
3. Remove the thumbscrew from the side of the Material Cartridge and remove the blue tape from the material. Save the screw to reinstall into cartridge if material was not fully used during printing. This will prevent filament from unravelling during storage. Press **Next** to begin cartridge installation.



Do not pull out plastic until the thumbscrew is removed from the cartridge. Failure to remove the thumbscrew will damage the cartridge.

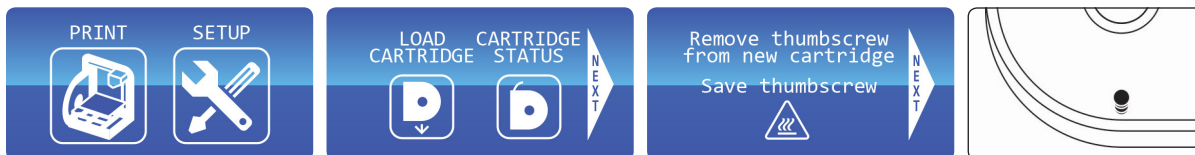

4. Tilt cartridge so that bottom of cartridge is resting on cartridge holder.
5. Slide cartridge in the holder ensuring that top of cartridge feeder is seated into the Cube feeder. Do not slide cartridge without tilting, doing so can cause damage to the Cube Feeder.
6. Insert the filament coming from the tube into the hole at the top of the Print Jet. Press **Next**, and continue to push filament into the Print Jet until it feeds through on its own.

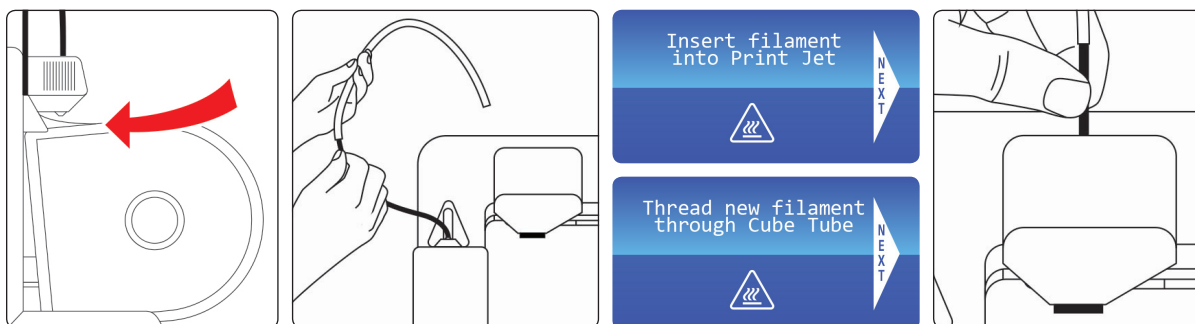

7. Filament will then be drawn into the Print Jet until a small amount comes out of the heated tip at the bottom. Carefully dispose of the filament without touching the hot print tip. Press **Next**.
(If nothing comes out of the print tip, remove the plastic from the top of the Print Jet and repeat these installation steps.)



WARNING: PRINT TIP BECOMES EXTREMELY HOT DURING SET-UP AND OPERATION. DO NOT TOUCH PRINT TIP.

8. Insert Cube Tube (the clear tube that's already around the filament at the top) into the Print Jet. Press **Next** and your cartridge is loaded and ready to go!

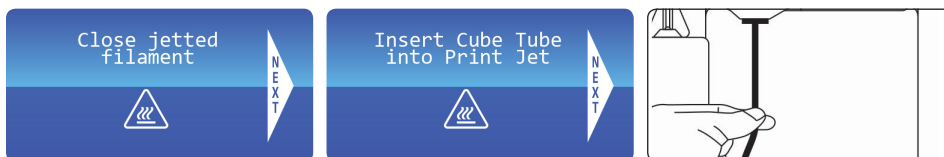

18 PRINTING PREPARATION

NOTE: CubeStick must be applied to the Print Pad every time you start a new creation.



CAUTION: Do not use any adhesive other than the CubeStick. Doing so can damage your print tip and the Print Pad. Make sure you use the 2nd generation CubeStick for your 2nd generation Cube.



WARNING: APPLY ADHESIVE JUST PRIOR TO STARTING A PRINT. ADHESIVE WILL DRY IF YOU WAIT TO START A PRINT AFTER APPLICATION. ADHESIVE SHOULD STILL BE WET AT START OF PRINT.

1. Find the CubeStick in the original packaging.
2. Remove Print Pad from the Cube. Apply a thin, even coat of adhesive on the entire top surface of the Print Pad. (Don't over-apply!) Check the Print Pad after applying the adhesive to make sure there aren't any gaps where the adhesive was not applied. If you find any gaps, apply adhesive to those areas. Never put glue on side with magnet.
3. Replace CubeStick cap after use.
4. Place Print Pad on the Print Pad platform.

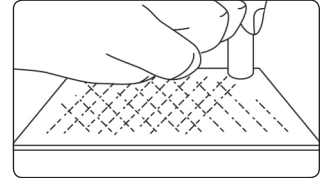

19 PRINTING YOUR FIRST CREATION

NOTE: Your Cube will have printed test creations before leaving the factory. These test creations may have been printed in a different material color than you are using. Therefore, a small amount of material may be remaining in the Print Jet. The start of your first creation may have some of this material color until it transitions over to your material color.



WARNING: PRINT JET NOZZLE TIP BECOMES EXTREMELY HOT DURING SET-UP AND OPERATION. DO NOT TOUCH NOZZLE.

Do not change color of material or cartridge during printing; doing so may damage the Cube.

To get started printing your first creation; the creation files that were downloaded when you activated your account or a .stl file will need to be converted to a .Cube file. This is the machine code file that the Cube printer will read to build your creation.

WI-FI CONNECTION

if you wished to connect to WI-FI via Ad hoc or WLAN connection, please refer to Section 14: WI-FI Set-Up and follow the step by step instructions. Then resume these instructions and follow the steps below to connect to your Cube. These steps apply to both Ad Hoc and WLAN connections.

1. Open Cube Software and click on **Configure**. Click on your Cube model in the dialog box and click on **Connect**. Your computer is now connected to your Cube.
2. Click on **Import** and select a file from the creation files that you downloaded from Cubify.com or a .stl file. The creation that you selected will appear on Print Pad. The software's Print Pad is a simulation of your Cube Print Pad.
3. In the software you can orient, scale, and manipulate your creation to ensure that you obtain the optimum printing results. Refer to Section 13: Cubify Software Overview to understand the different functions your software provides.
4. To prepare your creation file for printing, click on **Build** and save your creation as a .cube file.

PRINTING WITH WI-FI CONNECTION

1. If have a WI-FI connection, click on **Print** and select the Cube file saved from your creation file; click on **Open** to send your file to the Cube.
2. On the Cube touchscreen, finger tap check box to start the build file or tap the **X** box to cancel.
3. The Cube will begin the heating process; this will take a few minutes. During the heating process, the print tip and the Print Pad will reach the temperatures that have been preset by the manufacturer. Once these temperatures are reached, your creation will begin to print.

NOTE: During printing operation, please do not place a cover over your Cube. The Cube generates heat during printing and if covered, it can cause damage to the Cube.

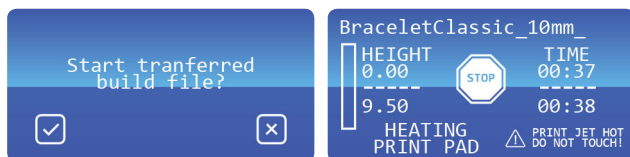

PRINTING YOUR FIRST CREATION *(continued)*

PRINTING FROM THE USB MEMORY STICK

1. If you are using your USB Memory Stick to download your Cube file, please install the USB Memory Stick into the USB port on your computer. Open the file folder where your Cube file is located and save it on the USB Memory Stick. Remove memory stick and install it into the Cube's USB port.
2. Tap **Print** on the touchscreen and use left or right arrows until you see your Cube file displayed.
3. Tap on your .cube file; the print touchscreen will appear showing the total time it will take to print your creation and the time left to complete it during printing. It also shows the maximum height of your creation and the current height while printing.
4. The Cube will begin the heating process that will take a few minutes. During the heating process, the print tip and the Print Pad will reach the temperatures that have been preset by the manufacturer. Once these temperatures are reached, your creation will begin to print. Once the creation is finished printing, your touch screen will display **Print Finished**, press the check box to confirm. Wait until the Print Pad is completely cool before removing your print.

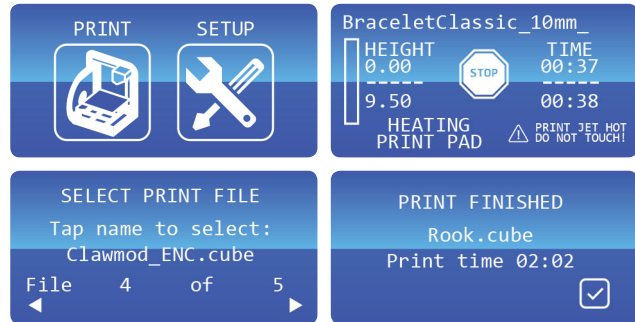

WARNING: PRINT JET NOZZLE TIP BECOMES EXTREMELY HOT DURING SET-UP AND OPERATION. DO NOT TOUCH NOZZLE.

Do not change color of material or cartridge during printing; doing so may damage the Cube.

ABORTING YOUR PRINT

To abort your creation during warm up or printing, finger tap the **STOP** button on touchscreen. The next screen will read **Are you sure you want to abort the print?** Finger tap the check box to abort or tap the X box to cancel. Wait until the print tip completely cools before touching.

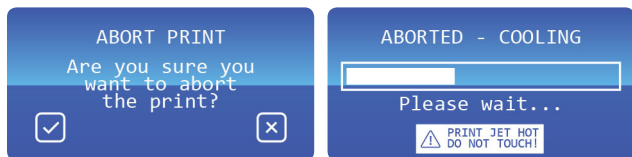

20 REPLACING MATERIAL CARTRIDGE



Do not change color of material or cartridge during printing; doing so may damage the Cube.

1. After being instructed by the touchscreen, pull Cube Tube away from top of Print Jet. Do not pull the material out until the touch screen instructs you to do so.
2. Pull material out of Print Jet and press **Next**.

NOTE: After the material is pulled out from the print jet, material debris may be visible at the print tip that could clog the tip. Using the unclog tool, insert the tool's point into the Print Jet; if debris is present, it will protrude from the print tip.

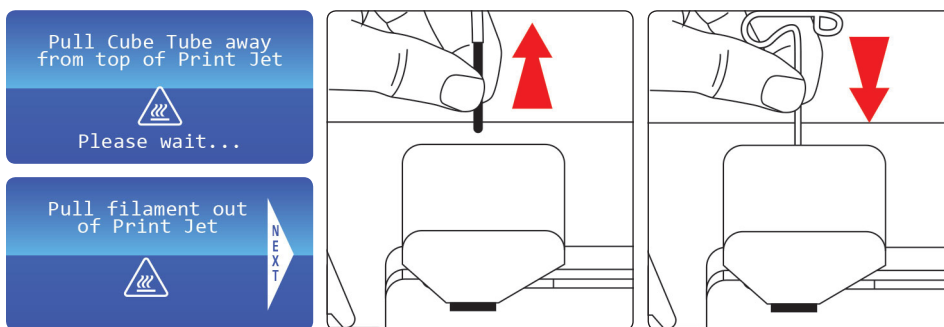

3. Tilt cartridge down to clear Cube feeder and remove cartridge from cube; remove the Cube Tube from material. Replace thumb screw into cartridge to hold the unused material in place. Refer to Step 18: Material Cartridge Installation for instructions on how to install your new cartridge.

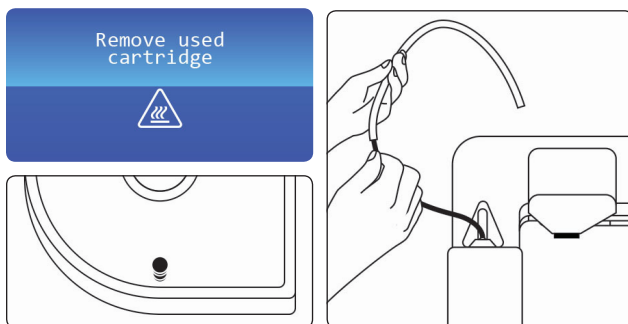

21 CLOUD PRINTING FROM CUBIFY.COM

1. Click on **My Cubify** and select **My Account**.
2. Click on **My Downloads**.

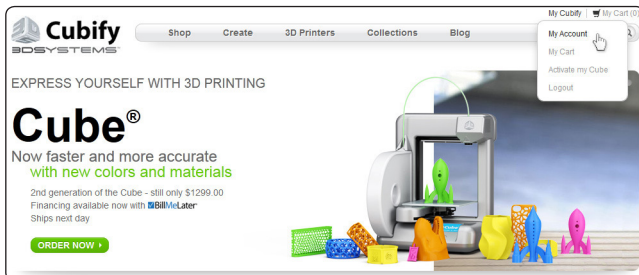

3. If you would like to download a file to save on your computer or print using Cube software, click on **DOWNLOAD**. The file will download to the Cube software on your computer to save your creation.
4. Your file can download directly to your Cube by clicking on **PRINT ON MY CUBE**; the Select Cube Printer screen will appear and will search for available Cube printers on your network.
5. If a Cube was not discovered in your network, you can either save the .cube file to your computer or connect through an ad hoc network (refer to PRINTING WITH WI-FI CONNECTION, page 25).
6. If a Cube is discovered in your network, you have a choice of printing now or decline printing. If you select print now, your print will start printing on the Cube you selected in the network.

22 FINISHING FIRST CREATION

REMOVING YOUR CREATION FROM THE PRINT PAD

- Place the Print Pad with your creation in a container (not supplied) filled with regular warm tap water and let it soak approximately five minutes or until your creation eases free from the Print Pad. Clean and dry the Print Pad before reuse.
- To clean your Print Pad, rinse under tap water and dry with a lint-free wipe.

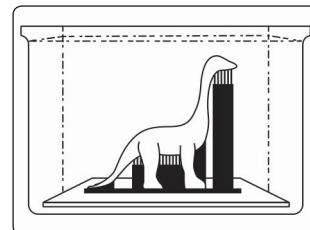

REMOVING RAFTS AND SUPPORTS (IF REQUIRED)

- Use small pliers to remove supports and rafts. In places where the supports are inside your creation and are hard to get to, use small wire snips (not provided) to remove the supports.

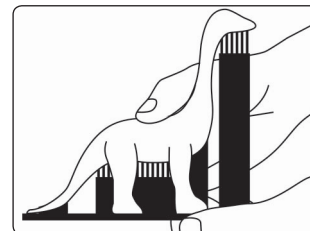

23 MAINTAINING YOUR CUBE

CLEANING THE EXTERIOR

- Clean the Cube's exterior with a lint free cloth and water. Dampen the cloth with water and wipe the outer surfaces of any debris that is visible.

CLEANING THE PRINT PAD

- Submerge the Print Pad in a container filled with warm tap water. Please do not use well water; it contains certain minerals that may make your creation difficult to remove from the Print Pad.
- Rinse pad under tap water and dry using a lint free wipe.

CLEANING THE PRINT TIP

- Using the small pliers, pull away any plastic debris away from the Print Jet tip (if the debris is stubborn, the Print Jet may need to be heated to make the debris soft enough to remove).

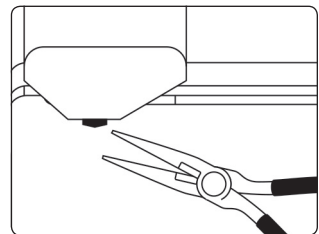

CLEANING THE TOUCHSCREEN



WARNING: PRINT JET NOZZLE TIP BECOMES EXTREMELY HOT DURING SET-UP AND OPERATION. DO NOT TOUCH NOZZLE.

- Wipe the touchscreen with the soft, lint-free cloth. Do not spray cleaners on the touchscreen.

4 AMP FUSE REPLACEMENT



CAUTION: Before replacing the fuse, switch Cube's power off and unplug power cord.

1. 4 Amp, 250 V fast blow fuse is located on the back left side of your Cube.
2. Using a flat screwdriver, turn screwdriver counterclockwise to remove fuse from the fuse holder.
3. Using a flat screwdriver, turn screwdriver clockwise to install new fuse into the fuse holder. After new fuse is installed, plug power cord into outlet and switch power on.

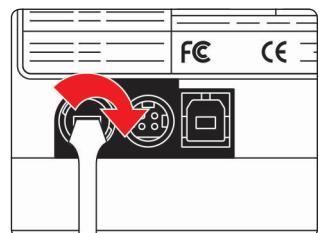
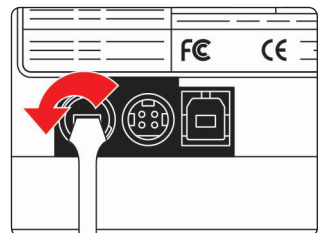

24 PRINT PAD LEVELING INSTRUCTIONS

Your Print Pad may become un-leveled when transporting your Cube. If this occurs, please follow these instructions to level your Print Pad for optimum creation experience. The Print Pad pad can be leveled with the two adjusting bolts located underneath the front and back of the pad.

1. Press the power button on the Cube control panel.
2. Ensure Print Pad is properly installed on print plate.
3. Finger tap **SETUP** on the touchscreen and scroll through the menu until **LEVEL PLATE** appears. Press **LEVEL PLATE**; the Print Pad will move up to Print Jet tip.
4. Using the **Up** arrow, raise the Print Pad to the Print Jet tip until the tip is near the Print Pad but not touching it.
5. Touch the “clockwise” and “counter-clockwise” buttons to automatically move the Print Jet around the four corners of the Print Pad. During each movement along the sides of the Print Pad, observe any gaps between the pad and the Print Jet. If there are gaps on one side of Print Pad and the Print Jet tip is barely touching the Print Pad on the other side, the Print Pad pad is not level.

NOTE: Please refer to the FRONT TO BACK or SIDE TO SIDE instructions on how to turn the adjusting knob bolts to level the pad properly.

6. Place a standard sheet of paper between the Print Jet tip and the Print Pad where the adjustment needs to be made. If the paper cannot slide between the Print Jet tip and Print Pad, tap the **down** arrow key on touchscreen.

ROLL SIDE TO SIDE

If the gap between the Print Pad and Print Jet tip is at the right or left side, adjust the pad using the rear adjusting knob bolt (B). If the gap is too low, the pad is too low and will need to be moved up.

1. If the pad needs to be moved up, turn the front adjusting knob bolt (A) clockwise to loosen and then turn the rear adjusting knob bolt (B) clockwise. To move the pad down, turn the rear adjusting knob bolt (B) counterclockwise.
2. While adjusting, slide the paper between the Print Jet tip and Print Pad where the adjustment was needed; the paper should slide back and forth with no resistance. If resistance is felt, the pad is too high. Please repeat the adjustment.
3. Once adjustments are made, tighten the adjusting knob bolts.

TILT FRONT TO BACK

If the gap between the Print Pad and Print Jet tip is at the front or back of pad, adjust the pad using the rear adjusting knob bolt (B). If the gap appears on the side, the pad is too low and will need to be moved up.

1. If the pad needs to be moved up, turn the front adjusting knob bolt (A) clockwise to loosen and then turn the back adjusting knob bolt (B) clockwise. To move the pad down, turn the rear adjusting knob bolt (B) counterclockwise.
2. While adjusting, slide the paper between the Print Jet tip and Print Pad where the adjustment was needed; the paper should slide back and forth with no resistance. If resistance is felt, the pad is too high. Please repeat the adjustment.
3. Once adjustments are made, tighten the adjusting knob bolts.

NOTE: After the print jet is adjusted, you will need to reset the print jet gap; please refer to Section 16: Setting Print Jet Gap.

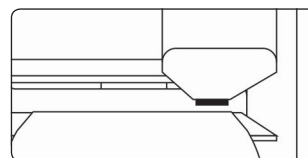
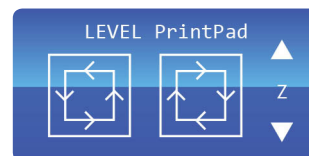
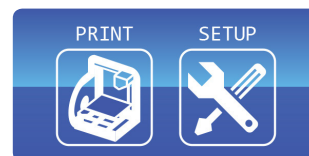
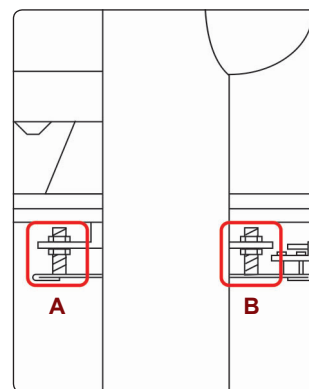

3D Systems, Inc.
333 Three D Systems Circle | Rock Hill, SC | 29730
Cubify.com

©2013 3D Systems, Inc. All rights reserved.
The 3D Systems logo, Cube and Cubify are
registered trademarks of 3D Systems, Inc.

pn 350341-01, Rev. C