

# Forgotten Books

— [www.forgottenbooks.com](http://www.forgottenbooks.com) —

Copyright © 2016 FB &c Ltd.

All rights reserved. No part of this publication may be reproduced, distributed, or transmitted in any form or by any means, including photocopying, recording, or other electronic or mechanical methods, without the prior written permission of the publisher, except in the case of brief quotations embodied in critical reviews and certain other noncommercial uses permitted by copyright law.

**Stefan Marinov**

# **THE THORNY WAY OF TRUTH**

**Part I**

**Documents on the process of restoration  
of the absolute space-time conceptions**

**EST-OVEST**  
**Editrice Internazionale**





**Stefan Marinov**

# **THE THORNY WAY OF TRUTH**

**Part I**

**Comments on the process of restoration  
of the absolute space-time conceptions**

**EST-OVEST**  
Editrice Internazionale

**Published in Austria  
by  
International Publishers »East-West«**

**© International Publishers »East-West«  
Marinov**

**First published in 1982  
Second edition, 1987  
Third edition, 1988**

- Addresses of the International Publishers »East-West« Affiliates:  
AUSTRIA — Morrellenfeldgasse 16, 8010 Graz.  
BULGARIA — ul. Elin Pelin 22, 1421 Sofia. Tel. (02) 66.73.78.  
ITALY — via Puggia 47, 16131 Genova. Tel. (010) 31.59.78.**

**DRUCK: RM-DRUCK GRAZ, AUSTRIA**

ЛУКА АКО НЕ ГО ТЪПЧЕШ,  
ТОЙ ГЛАВА НЕ ПРАВИ.

Градинарско правило\*

---

\* If the onion is not trampled down, it does not make a head.  
Garden rule (Bulgarian).

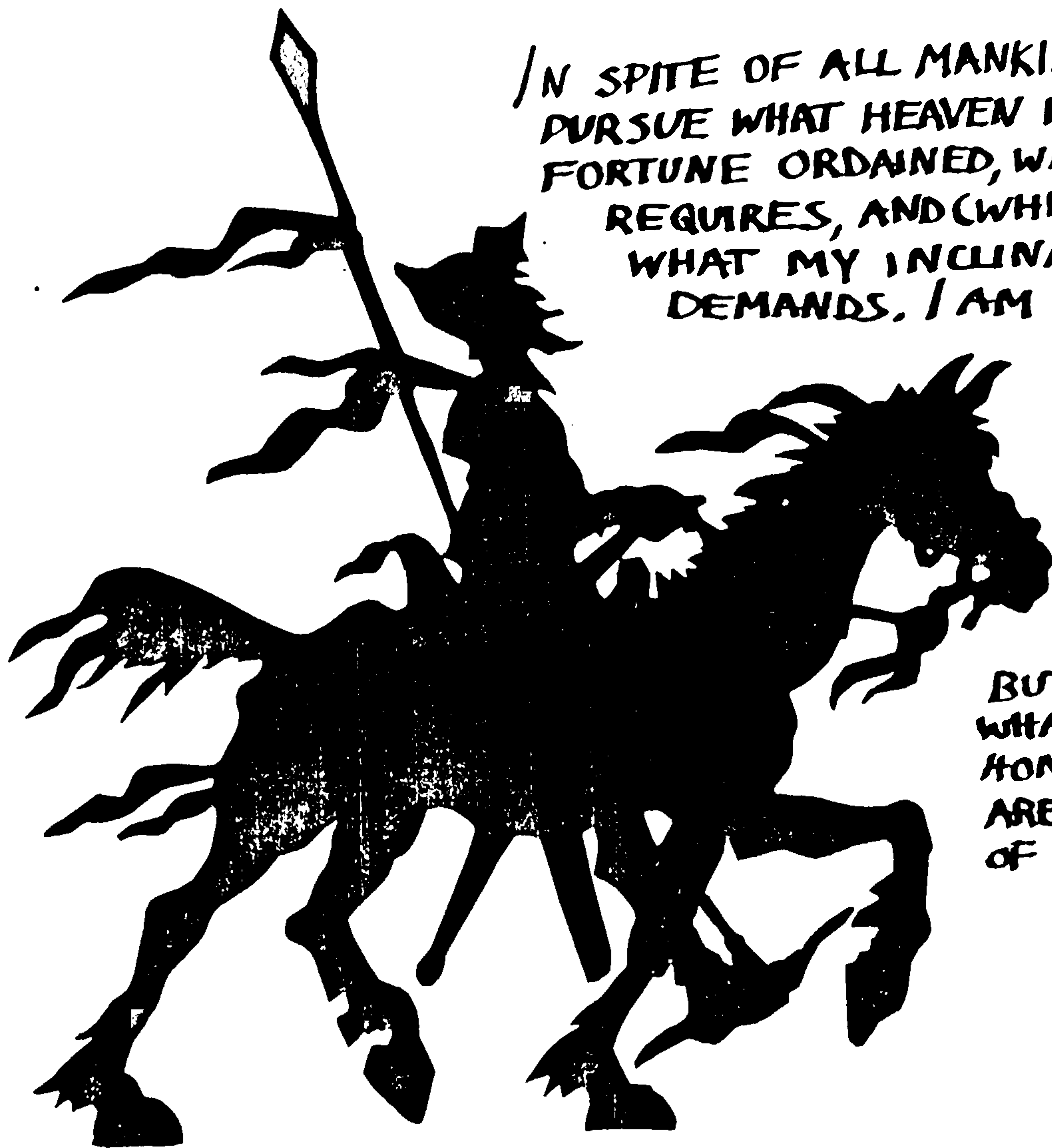

IN SPITE OF ALL MANKIND, I WILL  
PURSUE WHAT HEAVEN HAS FATED,  
FORTUNE ORDAINED, WHAT REASON  
REQUIRES, AND (WHICH IS MORE)  
WHAT MY INCLINATION  
DEMANDS, I AM SENSIBLE

OF THE MANY  
TROUBLES  
AND DANGERS  
THAT ATTEND  
THE  
PROSECUTION  
OF KNIGHT-  
ERRANTRY,

BUT I ALSO KNOW  
WHAT INFINITE  
HONOURS AND REWARDS  
ARE THE CONSEQUENCES  
OF THE PERFORMANCE

- DON QUIXOTE  
CHAPTER VI

## PREFACE TO THE FIRST EDITION

In the present book I gathered a small part of my correspondence with editors of physical journals, their referees, with certain physicists and political persons referring to my fight of long standing for scientific truth in the domain of space-time physics.

The correspondence before September 1977 (when I crossed the iron curtain) remained in my Sofia archives and partly was confiscated during the perquisition in April 1977 when I was detained in a psychiatric clinic. The whole correspondence, literary and scientific production (including all copy-books on quantum mechanics) which the police was able to seize in November 1966 when I was imprisoned for a first time was burnt, as the public prosecutor said me after the liberation in 1967.

The correspondence after September 1977 was periodically destroyed by me, as I often am expelled from one country to another and I change my home frequently, so that I must always be able to transfer the whole goods and chattels on my own back.

Nevertheless, I hope, I succeeded to make an enough systematic, characteristic and representative choice of my correspondence, so that the "landscape after the battle" presented on 200 pages only can restore in the reader's eyes the whole battle without the necessity of appending additional explanations and comments.

I give always the originals of the income correspondence. The outcome correspondence is retyped, as I have only the copies of the letters which are bad for a xerox reproduction. The outcome correspondence from Graz (where I lived from July 1981 until March 1982 and where I am living now) is given with the photocopies of the original letters which are good for reproduction.

As a rule, I present only one letter from a scientific journal which has rejected a paper of me, but many journals which have rejected papers are not presented. Such is, for example, Prof. A. Klemm (ZEITSCHRIFT FÜR NATURFORSCHUNG) with whom I exchanged at least 20 letters and whom I visited personally in Mainz in April 1978, trying to persuade him and his referee, Prof. Friedrich, to accept a paper. I could not succeed but Prof. Klemm was always very kind with me, whilst Prof. Friedrich offered me a delightful pizza and a very nice conversation, so that I use the occasion to thank them both and to present my excuses that their correspondence is not presented in the book.

More than one letter are presented from certain journals (as PHYS. REV., IL NUOVO CIMENTO, NATURE) and to certain of the rejection letters the referee's comments and my answers are attached. I chose such comments and such answers which are clear for a direct reading, but I give always references to the sections of CLASSICAL PHYSICS where the matter under discussion can be found, so that the interested reader can make contact with the discussed article if it has not later appeared in another journal.

I hope that these discussions with anonymous (and non-anonymous) referees and supervisors can help the scientific community in the more speedy restoration of the absolute space-time conceptions. On the other hand, with this art of publication I show that the referees of the scientific journals must in the future think and rethink before writing stupid comments, as one can always strip down their trousers.

After this introduction (see p. 9) there are given a couple of articles from political journals and magazines which can serve as a biographical sketch.

A list of all my scientific publications in space-time physics is given on p. 42.

When reading this book and my CLASSICAL PHYSICS (or EPPUR SI MUOVE, or at least my published papers), the reader may pose the question: Why was it so difficult for Marinov to restore the absolute space-time conceptions, having: (i) crucial experiments with positive outcome, (ii) clear, simple and logic theory, (iii) enough publications in articles and books where both the experiments and the theory are duely presented?



First I think that the restoration of the absolute conceptions was not terribly difficult, as it took me only a dozen of years. Then the reader must take into account that my scientific work was disturbed considerably by the harassments and persecutions to which I am exposed not only in the totalitarian but also in the "parliament" countries, because of my christian communism and unconditional pacifism\* and by the fact that since January 1974 I have not a possibility to work in a scientific institution, remaining all those years without a firm job: in Bulgaria I received a monthly pension of \$ 80 as a paranoic without the right to take any job, while in the West I worked serving in hotels, washing dishes, picking up apples and cleaning stalls (work which I am doing since a year).\*\* On the other hand, I dedicate a great deal of my time to literary, social and political activity, travels, sport and enjoying the life in an everyday contact with Nature\*\*\*.

Thus, according to me, the restoration of the absolute space-time conceptions was a relatively easy task and I am wondering, indeed, why humanity has erred 3/4 of a century in the relativistic quagmire. Here many explanations may be given:

One of the answers is: Noone could execute an experiment rejecting the principle of relativity.

Another answer is: The 4-dimensional formalism offers a perfect mathematical tool for calculating the motion and the radiation of particles moving with high velocities.

Those are the scientific answers. But there are people who support non-scientific alternatives, as, for example, the alternative that the "international Jewry" resists feverishly against the destruction of the "Einstein myth", and since the Jews have leading positions in science in all countries of the world (in the West and in the East), they suppress any anti-Einsteinian activity.\*\*\*\*

I think that the present book can give the right answer. Undoubtedly the inability of mankind in carrying out so many years the crucial experiment was an important factor. But I performed such an experiment 9 years ago and the physicists and astronomers still live embracing the "relativistic prejudices". It is true that the "scientific community" is suspicious about the veracity of my experiments, but, as this book shows, from their part there is no interest to see the experiments and a fear to discuss them.

Certain scientists (as Held, Cavalleri, Sexl) are persuaded that the principle of relativity is true; they have not the desire to see and discuss anti-relativity experiments as people rejecting parapsychology are not interested in observing medianic manifestations. I consider such scientists as horned but honest persons. However, scientists as Bergmann, Finkelstein, Petiau, Wheeler (as I concluded from conversations and correspondence with them) have understood that the principle of relativity is a failure. They make any effort to cover my experiments with silence, because they know that the demonstration of these experiments and their discussion will destroy the present theory on which they have built their scientific careers.

---

\* I type these lines on the 27 September 1982 (the fifth anniversary of my transfer to the West). As the reader can check (see p. 256) tomorrow the Austrian police must come to arrest and expel me from Austria.

\*\* When I said to my friend Prof. Borsellino that I am earning my bread and the possibility to continue the scientific research by cleaning in a stall, he made the following witty remark: "E' piú piacevole pulire la merda dei cavalli che quella degli uomini."

\*\*\* It is not meant the journal NATURE, although with that damned vehicle since 10 years I am also in an almost every-day nightmarish Kafkian contact.

\*\*\*\* It is interesting to note the opinion of a German physicist with whom I had long conversations (he bought 10 copies of EPPUR SI MUOVE immediately after its publication). He is an expert in history of science. According to him I shall be killed neither by the KGB nor by the CIA since as "anticommunist" for the KGB and as a "communist" for the CIA I am not dangerous at all. But I shall be killed by the Jews. My friend spoke to me so in 1979. Since I am still sane and safe, obviously, until the present day his theoretical prediction is not experimentally confirmed.

Of course, I cannot say which scientist to which extent has recognized the failure of relativity. Even any single scientist cannot give an answer to himself how firm is his own persuasion, as the blinding shine of the 4-dimensional formalism does not give a possibility to many of them to accept the absolute physical reality. I am sure that the prevailing majority of the space-time specialists has not understood hitherto the difference between the Lorentz and Marinov invariances. Meanwhile this difference is very simple and clear. The Lorentz invariance is available for an observer at rest in absolute space who describes the motion of a particle moving first with a velocity  $v$  with respect to absolute space and then with another velocity  $v'$  (which normally is much higher than  $v$ ). The Marinov invariance is available when there is a particle moving with a certain velocity  $v$  in absolute space and an observer who first is at rest with respect to absolute space and then moves with a velocity  $V$ . Thus, for the Lorentz invariance there is one observer and a particle which moves with two different velocities with respect to distant matter, whilst for the Marinov invariance there is one particle and an observer who moves with two different velocities with respect to distant matter. Or to put it differently: When applying a Lorentz invariance the observed particle changes its character of motion with respect to distant matter, while when applying the Marinov invariance the character of motion of the observed particle remains the same and only the observer changes his character of motion with respect to distant matter. Obviously, for relativity these two alternatives do not exist.

Such scientists who are blinded by the efficiency of the 4-dimensional formalism (as my good friend Prof. Froissart) consider the failure of the principle of relativity as a real catastrophe. So Prof. Froissart sent me once in Sofia many and many years ago the following signed by him declaration:

If Marinov's "coupled-mirrors" experiment is true, then whole modern physics will crumble to pieces and any effort is to be done to rebuild it again in a logical body of knowledge.

Prof. Cavalleri was more laconic. He wrote in a referee's comments on an article submitted from Sofia many and many years ago the following:

If Marinov's "coupled-mirrors" experiment is true, he must receive the Nobel prize.

Of course, it is exciting to blow up the whole body of modern physics, but, as I show in CLASSICAL PHYSICS, the failure of the principle of relativity does not lead to such disastrous results as Prof. Froissart and Prof. Cavalleri expect.

A predominant part of the editors of the physical journals (who, normally, are not space-time specialists) and their referees are of the type of Prof. Froissart and Prof. Cavalleri (the first one is my "chief inquisitor" in JOURNAL DE PHYSIQUE, the second one in IL NUOVO CIMENTO). But many of my friends, absolutists, support the opinion, that the majority is of the type of Prof. Bergmann and Prof. Finkelstein. Thus my friends defend the conception that there is an "international conspiracy" against the "absolutists". Although many facts may be considered in favour of this conception, I do not share it. Dr. Staruszkiewicz wrote me in a letter of the 15 September 1979 that I wrongly consider the characters of the political and scientific establishments as similar. Indeed, I sustain the opinion that these two, and any other "establishment", have a similar character. Politicians make mafias and conspire, scientists make mafias and conspire. But as the politicians, so the scientists, recognize too late the danger of the revolutionary movements and they make a "conspiracy" when it is too late. If it were not so, any progress in human social and scientific activity would be impossible. Thus I think that, at the present time, there is no "conspiracy" against me. If my papers have been systematically rejected by the scientific journals in the last 10 years, this is due predominantly to the inertia of the scientific thinking.

As a proof of a "conspiracy" against me many people consider the article of Ms. Vera Rich in NATURE (see p. 16). In this article (which, according to me is written very well) Ms. Rich puts in the mouth of Sakharov the accusation that I am a mad man, but that he is only against the compulsory treatment to which I was subjected in Bulgaria.

Accusing me in madness and covering this accusation with the name of Sakharov, NATURE published only a small part of my letter (see p.17) written after my immediate visit to Sakharov, who was terrified seeing himself in one line with the Bulgarian spiritual sadists. Then NATURE closed its pages for my papers and correspondence, as with a one-page paper one cannot show that Einstein is wrong, but one can certainly show that one is not mad.

Any unexperienced person may see here a "conspiracy", but as I know the poor Vera Rich very well, I should like to assure the reader that it is not so. Ms. Vera Rich wrote the sentence:

Andrei Dmitrievich says: "The man's a nut-case (*psikh*), but I wouldn't want to condemn anyone to a mental hospital!"

only because of her naivety. Indeed, Sakharov said me the following, after showing him the alleged "accusation in madness":

Может, в бытовом разговоре я сказал что-то в этом духе, но как же можно это писать в газете, как же можно!? Что это за идиот, который это печатал?

I give Sakharov's words in Russian and I consider them as a "бытовой разговор" which must be not printed, as Dr. Maddox can then with the whole right become offended and institute legal proceedings for calomny against Sakharov and me.

And another weighty proof. The conspirators pay the executors of the "dirty work" well. Ms. Vera Rich was not paid. Indeed, if she was paid, she had not to steel from me £ 165 (see pp.154,176,182) in the most brutal manner, forgetting наказ Великого Комбинатора: "Верочка, надо чтить уголовный кодекс!" I must confess that until now it remains an enigma for me WHY Vera Rich committed such an act - had Ms. Thatcher's government reduced the living level of the Albions so disastrously? As the revealing of this low-style robbery may become pernicious for Vera Rich's journalistic career, with the present lines I declare that I grant the sum to her, so that she can buy her a new type-writer and I forbid to anybody to use my "private dealings" with Vera Rich to make damaging remarks about her.

I know that even if now Ms. Rich will be not fired from NATURE, the reading of these lines will be a bitter pill for her. It must be bitter, Верочка! Understand me well. I am not against robbery. But rob the totalitarian state, rob the capitalists, not the poor people. Or using Lenin's words: "Экспроприруй экспроприатора, но, ради Бога, не воруй у ограбленного!" And think seven times before raising the finger to point to somebody saying: "He is mad." In Bulgaria I was accused in madness by academicians, professors and policemen and I know how difficult is to defend the integrity of one's mind if the accusators bind one's mouth and imprison one in an isolator, depriving him of any possibility of contact with thinking human beings. And for my big surprise, coming to the Nest, the first words which I heard were: "Marinov is a rabid dog." And my mouth was bound again, as I show with the present book.

As the reader sees, my introduction has left its scientific path and undertaken the moral one. I am glad with this, as the scientific introduction may become very long because the strange human mental creation called "relativity", the story of its rise and the story of its fall, in which I took an active part, may be commented and analysed on many and many pages. However, according to me, in our terrible century we have to dedicate much more attention and time to "morality" than to "science". Our scientific progress is too big, but in morality mankind is there where it was at the time of Jesus Christ, if not on a more lower level (Pilatus technically was unable to kill millions of human beings and Irodus had some grounds to kill the innocent children - a fear for his throne - meanwhile the massacre in West-Beirut was unmotivated).

The incredibly rapid progress of science in the XXth century makes indispensable a radical change in our moral behaviour. Either mankind will find forces to introduce this radical change or it will perish. There is no another alternative. And I think

that the people who have understood this have to put aside any other activity and dedicate their life in promoting the moral rebirth of mankind.

The first important task which mankind has to solve (and can solve) is the pacification of Europe. A *conditione sine qua non* for the pacification of Europe is the democratization of the Eastern countries, which inevitably will be followed by a more radical and speedy socialization of the Western countries. Since 20 years my political efforts are dedicated to this scope.

From the political articles (see pp. 28 - 35), the reader can obtain an information on my action in Paris to free my Russian colleague Orlov (whom personally I do not know). The action failed as the French police, under the pressure of the American Embassy, escorted me during a week day and night impeding me to burn myself and then expelled me from France.

After the failure of that first tentative, I work on the realization of its repetition. However, now I wish to enhance its level and to gain a higher support of the public opinion which will impel the French government to respect my noble act and to leave me freedom of choice. Now I shall not address American Presidents - even Carter declared recently that Reagan does not defend the human rights. The ultimatum for the liberation of Orlov will be addressed to the President of the Soviet Supreme of USSR. Either he will free Orlov, or I shall burn myself in front of the Soviet Embassy in Paris.

I shall present the ultimatum after the recognition of my scientific achievements. This recognition will give me a moral weight and a high tribune. The action will be enormously effective if in 1983 a Nobel prize for physics will be discerned to me (in such a case the burning date will be the 16 January 1984). However, if I shall see that the action must be undertaken earlier, I shall not expect for a Nobel prize.

I beg all those who will read these lines to help me. Put aside your own little problems, go out from your bureaucratic shells, forget for a while your every-day efforts for the benefit of your own careers. We all have to solve one big task; without its solution all our endeavour for personal prosperity is senseless.

Help my fight to free Orlov. Helping Orlov and helping me, you help yourself.

Graz, 27 September 1982

Stefan MARINOV

#### PREFACE TO THE SECOND EDITION

The second edition of this book, The Thorny Way of Truth, Part I (TWT-I), represents an authentic reprint of the first edition where only the misprints are corrected which I could perceive.

On the new pages, certain documents and three papers are reproduced which came to light after the publication of the third edition of TNT-II. They concern not only the space-time aspects of my research but also the perpetuum-mobile aspects, as space-time physics, electromagnetism and the violation of the fundamental laws of conservation are tightly interrelated.

I wrote in the preface to the second edition of TWT-II:

In the TWT-I there were many actors playing the same role. To spare my time and the time of the reader, I concentrated all world "relativists" to a single person: Dr. Maddox, and I should say, the TWT-II became a two-actors drama.

The documents which came to light after June 1986 and are reproduced <sup>in the</sup> present second edition of TWT-I tend further to this trend: my TWT remains predominantly a two-actors drama. This drama had a very pleasant denouement. In the first days of March I visited Dr. Maddox in London with the aim to bring finally my submitted materials to print. I

had long and very nice conversations with Dr. Maddox and he did all what was necessary, spending much time in correcting my English and the scientific presentation, so that my letters to Gorbachev can appear on the 12 March and my paper on the violation of the principles of relativity, equivalence and energy conservation on the 26 March. I was extremely pleased by meeting Dr. Maddox and I saw that he already is feeling that "something is rotten in the realm of relativity". Of course, when publishing the paper, he will attach a note of doubt, but one must be aware that as Gorbachev cannot manifest publicly all his thoughts neither Dr. Maddox can do. His Secretary, Miss Mary, was always very kind to me and I beg the reader to take the Russian text on p. 302 only as a jocular literary story (and, as a matter of fact, it was such a one). (See it now in TWT-II)

This year, 1987, will lead to big quakes in physics. As my TWT-books show, I awaited for the fall of relativity much earlier, as I firmly believe in the maxima: "when the experiments speak, the gods keep silent". My books show that the "gods" have done some efforts to cover my experiments with silence and to postpone the official announcement of the death of Mr. R. E. Tivity (see my Ten Jena Commandments), but the result was the same as of the efforts of the physicians in Liubliana to save Tito's life.

Relativity is dead. Now the big problem with the violation of the laws of conservation, first of all of the energy conservation, explodes. A big problem. A tremendous problem. Its understanding and solution are in the future.

Graz, 7 March 1987

Stefan MARINOV

#### PREFACE TO THE THIRD EDITION

The third edition of this book is a REPRINT from the first and second editions. The changes which were made are the following: The correspondence of the years 1986-1987 which was included to the second edition is now transferred to the second edition of TWT-III. Thus now the correspondence of the years 1974-1982 is in the present book, TWT-I, of the years 1982-1986 in TWT-II and of the years 1986-1988 in TWT-III. In the first edition of TWT-I there were no scientific papers, in the second edition there were three papers and now, in the third edition, there are nine papers, all of them dealing with space-time problems.

Graz, 10 September 1988

Stefan MARINOV

CLIPPINGS FROM JOURNALS

## *Business Brief*

### **Einstein challenged**

Just months after the Viking spaceship brought empirical proof of his theories, a scattered minority of the world's scientists are saying Einstein got his theory of relativity wrong. They are planning a conference in Bulgaria this spring ("The International Conference on Space-Time Absoluteness", no less) to prove their point. Were they to succeed in denting the hitherto sacred relativity theory, the repercussions on modern science and technology would be large. Modern astronomy, electronics, nuclear physics and nuclear energy, for example, rely implicitly on much of Einstein's thought.

Few physicists have bothered to question or test the general theory of relativity since it became established as one of the landmarks of scientific thought. True, in 1905 when the junior patents officer in Zurich first published its precursor, the special theory of relativity, it was ignored. But since an eclipse of the sun in 1919 proved one of that junior patent officer's predictions right, Einstein has been unimpeachable. Thus a book published in 1971 by Britain's leading atomic clock expert which argued that Einstein's concept of time was impossible has lain apparently unread on the London Science Museum's shelves ever since. And when the Bulgarian conference was advertised in *New Scientist* in September, learned readers thought it was a joke—which it is not.

The world of Newtonian physics which Einstein took by storm already had cracks in it. Newton postulated rest and motion in relation to an immovable, absolute and featureless space, a concept which he later refined to that of the luminiferous ether. But the famous Michelson-Morley experiment in 1887, though designed to establish the velocity of the earth with respect to this ether, failed to find any velocity.

Such problems were the concern of a small band of outstanding physicists at the turn of this century. Poincaré and Lorentz both postulated theories of relativity, but Einstein's was

the most revolutionary. Also, it was based on the minimum of both experimental evidence and mathematics (Einstein knew little maths at the time he brought out his special theory).

#### **Time and space swap**

Einstein began with two assumptions for his special theory. One was that absolute motion and absolute rest could not be detected by any experiment. The other was that light travelled in a vacuum at a constant velocity, regardless of the motion of its source. He then showed that the position and time of an event could only be established relative to an arbitrarily chosen frame of reference. Thus, from the earth, the moon appears to be moving and the earth at rest, but to the man in the moon it appears that the moon is static and the earth moving. So far, so innocuous. But Einstein drew some surprising conclusions.

One is that, as the speed of an object increases, relative to the observer, its length decreases and it gains mass: if you propel a one-foot ruler and a one-pound weight at 163,000 miles a second, the ruler will measure six inches and the weight will have a mass of two pounds. If that sounds nutty, wait for more. As the speed increases, time slows down. This so-called time dilation can be illustrated by a tale of twins. One stays on earth, while the other hurtles into space at extraordinary speed: the stay-at-home brother gets older faster. Furthermore, in Einstein's relativist universe, space and time are interchangeable. The farther an astronomer looks out into space, the farther back is he looking in time. He is a Wellsian time-traveller, or, as T. S. Eliot put it, "All time is eternally present".

The general theory of relativity, which Einstein published in 1915, proved no less sensational. It is about the gravitational effect of the huge objects that make up the universe. According to Einstein, gravity curves space, which he says is finite but unbounded. The traveller heading off into space would describe a gigantic circle

and slower than each other. The theory must be wrong. QED. Mathematicians reply that it is Dingle who got his sums wrong, not Einstein: that Dingle used a linear transformation to derive two different values for the same quantity, which is impossible.

Dingle retorts that Einstein getting his equations right does not necessarily mean that his theory reflects the empirical world accurately. Unfortunately for Dingle, however, the empirical evidence—from high-energy physics through to the Viking space-shot—has been piling up on Einstein's side.

High-energy physicists accelerate sub-nuclear particles to near the speed of light. It turns out, as Einstein predicted, that as the particles gain speed they gain mass, too. Particle physics also appears to confirm Einstein's extraordinary contention that time would go slower for the space-traveller twin than for his brother at rest on earth (his brother is, of course, only relatively at rest, because the earth is moving).

The sub-nuclear particles are observed by the tracks they leave as they pass through various measuring devices at rapid speeds. Some kinds of particle leave tracks of only a few inches before they decay into other kinds of particle. But, speed them up even faster, and they can "live" for several yards. This increase in life is out of proportion to the increase in speed, so the physicists say the clock paradox is supported by experimental evidence. Some of them say, however, that, whereas Einstein's relativity says it is the velocity that causes the

apparent slowing down of time, in the experiment it is the acceleration that does this. It has also been argued that the slower ageing could be accounted for by Lorentzian relativity.

So much for experiments on special relativity. The general theory is about gravity, which has practically no impact on particles (nobody yet having found the so-called graviton particles alleged by some physicists to exist). So, to compare Newtonian and Einsteinian relativity, one has to turn to the cosmos. Black holes, apparently imploding under their own gravitational pull, could tell something about relativity, but for the moment nobody knows enough about them really to be sure they conform to Einstein's general relativity. The general theory has gained credibility from the growing consensus among astronomers in favour of the idea of an expanding universe. Furthermore, there is the 1919 experiment which first rocketed relativity into the limelight. This was an explanation of why each time the planet Mercury revolves round the sun, it gets a bit closer to the sun at the nearest point (its perihelion). This could not be accounted for by Newtonian gravitation, but it could be explained by the gravitational effect of relativity. In the past decade an American astronomer has produced an alternative explanation, that the advance of Mercury's perihelion is caused by a bulge in the sun. Viking refuted.

### Why it matters

If relativity only breaks down (if at all) in the most extreme cosmic conditions, does it matter? After all, if the sun became a black hole, there is nothing anyone could do about it.

One reason why it may matter which version of relativity is correct can be illustrated with reference to Newton. Einstein did not replace Newton, but refined him. A sceptic could have said 70 years ago that it matters not whether Newton is right, if all it affects is the explanation of why Mercury's perihelion is advancing. Newtonian physics is still in everyday use by scientists, while Einstein's is inherent in nuclear and electronics technologies.

Just as Einstein did not appreciate in 1905 the practical significance, for better or worse, of  $E=Mc^2$ , so we do not know today the significance any substantial refinements of

Einstein's theories will have.

Although astronomers are open-minded about general relativity, the special theory is almost universally accepted. Evidence against it is at present tenuous. It tends to concentrate on disproving one or other of Einstein's grandiose assumptions: the impossibility of determining absolute motion; and the constant velocity of light.

A possible candidate for an absolute frame of reference, against which events could be measured absolutely rather relatively, is the background radiation, constant throughout the cosmos in any direction you look, which astronomers claim is the afterbirth of the primeval big bang from which the universe was created.

Scientists tend to be horrified at the possibility of an ether being discovered. Though discrediting relativity might make understanding science easier for the layman, it could shake astronomy and particle physics to the roots. This is where the ideas to be discussed at the Bulgarian conference are interesting. They could explain a lot of the phenomena of relativity, without using relativity.

The organiser is Mr Stefan Marinov of the Sofia Laboratory for Fundamental Physical Problems. His physical ideas are on the verge between originality and crankiness but are plausible enough to have attracted interest among just a few more orthodox physicists. He claims that absolute motion can be measured, using calculations of the velocity of light.

How to measure the one-way velocity of light has been a problem for centuries. You need synchronised clocks at both ends, but at the same time you have to make assumptions about the velocity of light in order to synchronise them. An old approach to the problem is the so-called coupled-mirrors experiment. Take two cogwheels with two teeth. Light will only pass through one tooth and then the other if it is passing at a certain velocity. It should be possible to deduce the velocity from the number of revolutions at which the light goes through both wheels. Marinov's experiment also involves reflecting the light back, and demonstrates that its velocity is different in one direction to the other direction (although the average velocity equates with Einstein). This would mean the earth is moving relative to an absolute reference frame.

### Einstein's relativity of time

If you can't swallow this, join the anti-Einsteins, for it is the key idea that rocked the Newtonian view of the universe. Bloggs and Jones are travelling in their spaceships, but Bloggs is going much faster in the same direction. Each craft has two synchronised clocks, one at either end, like this:



Bloggs checks his two clocks,  $b_1$  and  $b_2$ , by measuring the passage of light between them. He finds, not surprisingly, that light travels equal distances back and forward, like this:

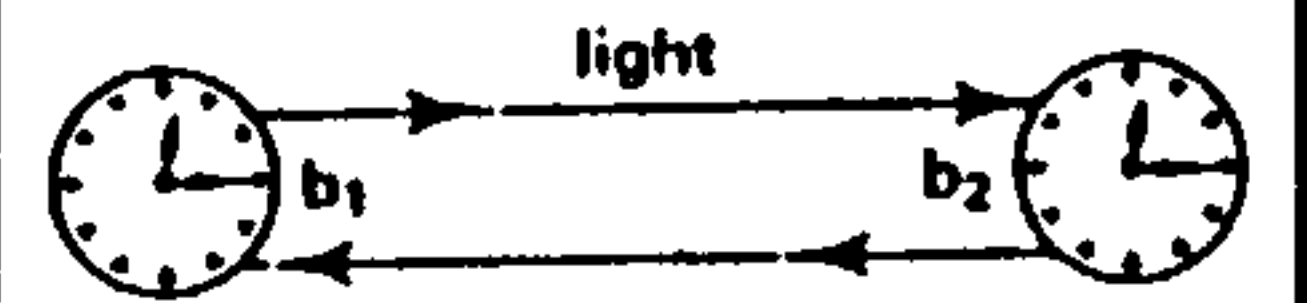

But remember that Bloggs is travelling much faster than Jones. Jones sees Bloggs's clocks quite differently; because relative to him, Bloggs is streaking to the left, the passage of light is like this:

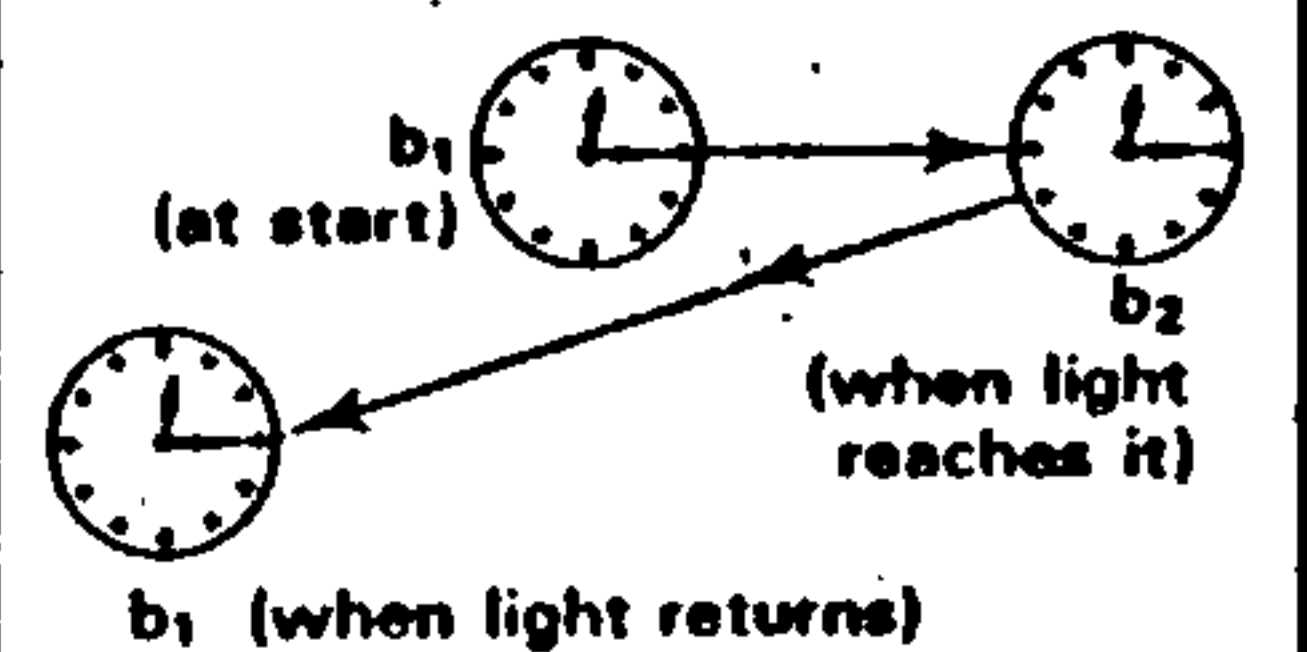

Jones concludes Bloggs hasn't synchronised his clocks properly. Yet, when Bloggs does a similar test of Jones's synchronised clocks, the traveller thinks the other's clocks are not synchronised. According to Einstein, both are right.

If Marinov is right, he will have demolished one of the foundations of the special theory. But he claims he can still explain many of the strange predictions of relativity, such as time dilation. This means his ideas are less of a threat to particle physics and astronomy than those that simply purport to show Einstein was wrong. Marinov claims he has in fact demonstrated absolute motion. But there must be some doubts about how good his Bulgarian equipment is, and he would like his experiments to be repeated by other scientists on more sophisticated equipment. Any takers?



Isaac Newton: overtaken



EXCLUSIF

## LE SAVANT QUI VIENT DU FROID

### ● Quel cynisme !

A la conférence de Belgrade, les pays signataires de l'acte final d'Helsinki, et parmi eux les pays de l'Est, jurent leurs grands dieux que chez eux les droits de l'homme sont respectés, dorlotés, mais au même moment à Prague, quatre intellectuels sont condamnés à des peines sévères pour délit d'opinion. Au terme d'un procès quasiment à huis clos, sans témoins, sans observateurs étrangers. Dont l'acte d'accusation semble sorti du magasin des accessoires staliniens : « Conspiration contre la République », « liens avec des diplomates et des agents de liaison chargés de payer les traîtres avec des tablettes de chocolat ».

En fait, le seul crime de ces Tchécoslovaques — trois sont signataires de la charte 77 — c'est d'avoir fait connaître en Occident des textes mis à l'index dans leur pays. Et qui peuvent difficilement être considérés comme subversifs. Est-ce un hasard si cette parodie de justice a été organisée au moment où, à Belgrade, les « Trente-cinq » examinaient l'application des obligations internationales relatives à la libre circulation des hommes et des idées ? Sûrement pas. Voilà longtemps que le hasard a été extirpé du paysage marxiste. Moscou et ses satellites ont voulu mesurer l'importance que les pays occidentaux continuaient à accorder au respect des droits de l'homme. Ils en ont été pour leurs frais. Car la dénonciation du procès de Prague a été générale à l'Ouest. Même le parti communiste français a refusé de cautionner ce « déni de justice ». Et l'Humanité n'hésitait pas à s'en prendre au régime de M. Gustav Husak. Et à écrire :

« Ce qui porte atteinte au crédit de l'Etat tchécoslovaque c'est moins la diffusion à l'étranger de manifestes d'intellectuels mécontents, que la manière dont on les traite dans leur propre patrie. Il n'est pas tolérable qu'un écrivain, un journaliste, un homme de théâtre, même quand il déclare ne pas mettre en cause la légalité socialiste, perde son emploi ou soit mis au ban de la société quand il n'est pas traduit devant les tribunaux pour délit d'opinion. »

La conférence de Belgrade aura été une tribune, non un tribunal. Les délégués occidentaux auront protesté, mais non condamné. Le sort des dissidents de l'Est en sera-t-il pour autant changé ? Sans doute. Car désormais, comme le constatait un éditorialiste français, aucun Etat ne peut plus compter sur le silence des autres pour emprisonner, mettre aux travaux forcés, bannir de force ou interner dans des prisons psychiatriques, des êtres humains dont le seul crime est d'avoir des opinions différentes de celles du régime en place.

● Le silence, nous allons encore le rompre. Et cette fois en faveur d'un savant qui vient du froid. Il s'appelle Stefan Marinov. Il a 46 ans, un teint d'ambre sombre qui évoque davantage les courses en montagne que les longues veilles dans un la-

boratoire, les séjours en prison ou en salle psychiatrique.

Stefan Marinov est le premier dissident bulgare à connaître le bannissement en Europe occidentale. Plus précisément en Belgique.

Depuis plus de dix ans il s'oppose aux autorités de son pays mais sans jamais quitter les chemins de la légalité.

Est-ce son combat politique pour un socialisme à visage humain qu'il faut cerner, appréhender ou ses découvertes scientifiques ? Est-ce sur le communiste qu'il demeure malgré les vilenies commises au nom de Marx, sur « l'ermite solitaire resté fidèle au Dieu vrai », comme il dit, qu'il faut s'attarder ou sur le savant dont les travaux vont peut-être ébranler un des dogmes de la physique contemporaine : la théorie d'Einstein sur la relativité ?

Personnage attachant, personnalité exceptionnellement riche, Stefan Marinov est un alliage de Pliouchtch et de Sakharov.

Ses racines se sont développées dans le terreau d'une famille bourgeoise convertie au marxisme, très proche du secrétaire du P.C.B. Kostov. Il a étudié à Prague, à Sofia, à Varna. Il a boulingué, comme navigateur au long cours, sur la plupart des mers du globe. Il a visité l'Occident, mais aussi la Chine et le Sud-Est asiatique.

Il explique :

— Avant le XX<sup>e</sup> congrès du parti communiste d'Union soviétique, tout était simple pour un fervent communiste. Après, il a fallu se poser des questions. Quand Roger Garaudy a lu le rapport secret de Nikita Khrouchtchev sur le stalinisme, il s'est écrié : « C'est le jour le plus noir de ma vie ». Personnellement j'ai aussi subi un grand choc mais je me suis plutôt demandé : « Comment les dirigeants peuvent-ils prétendre n'avoir pas soupçonné les excès staliniens alors que le petit peuple les connaissait ? ».

Stefan Marinov se lance alors sur le sentier abrupt de la contestation.

Pendant le congrès mondial des étudiants à Sofia, au début des années 60, il distribue des tracts prônant un « désarmement par la base ».

— Mon idée était assez naïve, avoue-t-il. Je conseillais aux jeunes de l'Est de trouver des amis



**THIS PAGE IS LOCKED TO FREE MEMBERS**

Purchase full membership to immediately unlock this page

**SAVE \$3,999,994**

Did you know we sell  
paperback books too?

To buy our entire catalog  
in paperback would cost  
over \$4,000,000

Access it all now for  
\$8.99/month

\*Fair usage policy applies

**Continue**

Monde

continuer à écrire. Il termine un ouvrage de 1.500 pages, « Physique classique », et fait circuler des textes à coloration politique. A ses amis, à ses collègues, il répète :

— Nous sommes un pays démocratique. Nous avons une Constitution. Il faut que le pouvoir s'y conforme.

On a beau lui faire remarquer que ces lois ne sont jamais respectées, que la Constitution est seu-

lement une œuvre décorative, Stefan Marinov s'entête à en réclamer l'application.

En mars 1974, il est chassé de l'institut. On lui accorde, pour vivre, une pension de malade mental. Quatre-vingts leva par mois. Un salaire de femme de ménage...

Il installe chez lui — une des plus belles maisons de Sofia — un laboratoire de physique fondamentale avec l'aide d'amis, de parents.

LETTRE A ENRICO BERLINGUER

● Cette lettre souvent poignante a été écrite il y a un an. Mais son destinataire, Enrico Berlinguer, chef du parti communiste Italien, ne l'a jamais reçue. Malgré les persécutions, les souffrances subies sous un régime communiste, Stefan Marinov se réclame encore du communisme et souhaite devenir membre du P.C.I.

Honorable camarade Berlinguer,

Par la présente, je souhaite adhérer et vous demande d'être admis au parti communiste Italien. Je me dois, étant citoyen de la République populaire bulgare, d'expliquer ma requête : nos maîtres nous enseignent que les prolétaires sont les citoyens du monde, et pourtant, les frontières, les passeports, les barbelés et les prisons sont toujours là, instruments des exploités, dans les mains des riches contre les pauvres, contraignant ces derniers au travail abrutissant en temps de paix, à une marche résignée en temps de guerre.

J'ai grandi dans une famille d'intellectuels communistes. Peut-être ai-je pris conscience des idées marxistes au temps où l'on perçoit le monde par le cœur et non par la raison, quand l'âme humaine se laisse influencer plus facilement par la brume religieuse. Mais à 45 ans, j'ai parcouru beaucoup de pays de par le monde, même au-delà de l'obscur et morose muraille de Chine ; j'ai expérimenté, j'ai appris d'autrui toute la profondeur des vilenies commises par des gens qui laissent flotter dans leurs mains des drapeaux aux couleurs et effigies de Marx. Pourtant, tout ce que j'ai lu et vu n'est pas parvenu à amoindrir ni ébranler ma foi et ma conviction en l'équité de ces normes de conduite sociale que nous appelons communistes. Pourtant, ce n'est pas simple de vivre le communisme dans les pays où le socialisme « a vaincu ».

Vous devez savoir que les portes qui conduisent aux palais des partis communistes dirigeants sont fermées aux libres penseurs, à tous ceux pour qui la démagogie, le mensonge, la dénonciation, le reniement, la trahison, le fratricide sont totalement étrangers. Or, dans notre pays, ceux qui parlent du communisme et le défendent hors des cadres officiels sont persécutés et punis de manière plus rigoureuse et atroce que ceux qui défendent n'importe quelle autre idéologie, culte ou hérésie. Chez nous, la machine qui guette les gens, soit en raison de leur intérêt pour une autre littérature, soit de leur opinion exprimée devant un verre de vin ou dans le secret de l'alcôve, est basée sur la meilleure technique moderne et sur un vaste réseau formé par une population qu'on a forcée et entraînée. Les méthodes policières ont été perfectionnées à un tel point que les machines fascistes qui les ont précédées n'en sont que le pâle reflet. Ce ne devrait pas être mon rôle de vous expliquer comment cela nous est arrivé. L'histoire du mouvement ouvrier international au long du XX<sup>e</sup> siècle est suffisamment embrouillée, compliquée, contradictoire, d'autant plus que peu d'efforts ont été consacrés à en restaurer l'authenticité.

Et pourtant, il est indispensable que l'humanité, et en premier lieu les communistes (à l'Est et à l'Ouest) sachent ce qu'en U.R.S.S., Chine, Bulgarie et Cambodge,

par le passé et actuellement, on a fait, construit et détruit. On a fait pas mal de choses : on a construit des villes, des usines, des immeubles d'habitation en béton à étages multiples, des universités, des casernes, des croiseurs, des fusées ; mais on a beaucoup détruit, et la principale responsable en est l'industrie de la guerre, pillant les trésors de la terre, dilapidant les matières premières, mutilant les villes et les villages, les polluant par la fumée, la suie et les gaz empoisonnés et aussi par le bruit qui tue le calme auquel on a droit. Mais surtout, on a dilapidé les valeurs morales que le peuple avait maintenues, à travers les siècles de guerre, de calamités et de famine, au temps où le monde était gouverné par des assassins.

Je proviens d'une famille aisée d'intellectuels. Mes parents, famille et amis ont tous recherché le communisme, en temps de guerre comme aux premières années de l'après-guerre, pour sa richesse spirituelle, avec les gens purs, courageux, fiers et bons, luttant pour la sainte vérité. Le parti de l'époque réunissait la meilleure part de la société. Les périls de la lutte avaient constitué un filtre excellent puisque, à part la purification spirituelle, le parti ne pouvait offrir que privations, supplices et souffrances. Aujourd'hui, les partis vainqueurs réservent des carrières, de l'aisance et des richesses, mais il faut les demander à travers un nouveau filtrage, il faut tendre la main aux arrivistes, aux koulaks et, en se dépersonnalisant, se condamner à un esclavage spirituel.

Je ne veux pas que mon point de vue vous apparaisse partial — même en temps de guerre, des éléments mauvais s'étaient introduits dans le parti, et le parti d'aujourd'hui compte beaucoup de gens de valeur — je veux simplement rappeler la règle.

Ceux qui veulent penser librement refusent de se mettre du côté des exploités, ces derniers pourchassent les libres penseurs comme les diables pourchassent les justes et, d'année en année, le parti est filtré, les gens honnêtes se renferment sur eux-mêmes, et s'ils ouvrent la bouche, ils sont incarcérés. Notre société devient un désert spirituel dans lequel, ici et là, on peut découvrir un ermite solitaire, resté fidèle au Dieu vrai.

Avec l'espoir de trouver des amis, des adeptes, avec l'espoir de sortir du désert spirituel, avec l'envie ardente de lutter pour l'achèvement de normes de cohabitation communiste dans notre société, je cherche une voie vers le P.C.I. Vous devez savoir ce que telle lettre va me valoir de souffrances et de supplices alors que je ne dis rien de plus que ce qu'il est, que nous autres, les marxistes de l'Est, nous ne pouvons nous appeler des communistes, qu'il n'y a pas, chez nous, un parti où nous pourrions nous intégrer, où on nous accepterait.

Mais j'ai assez souffert pour mon amour de la liberté et je supporterai et endurerai ces souffrances supplémentaires. Ce que je crains, ce n'est pas la souffrance physique, mais celle de ne pas être compris, que vous ne preniez pas la main que je vous tends, que vous laissiez s'éteindre sans l'entendre mon cri déchirant.

Stefan MARINOV ◊

Monde

## LE SAVANT QUI VIENT DU FROID

(suite)

— Personne n'a pris de risques pour moi, dit-il. Tout le monde a épouvantablement peur. Mais cette peur n'annihile pas la gentillesse et la compréhension naturelles des Bulgares.

Dans son laboratoire de fortune, Stefan Marinov poursuit ses recherches sur l'espace-temps, échafaude une théorie sur l'existence de l'espace absolu et par l'expérience des « miroirs couplés » remet en cause le principe général de la relativité énoncé par Einstein.

Ses découvertes méprisées en Bulgarie — « Gallée a été victime des jésuites, moi j'ai été persécuté par les jésuites modernes de mon pays », dit Marinov — le physicien bulgare veut les faire connaître à l'étranger. Il se rend aux ambassades américaine et française. Là il supplie des diplomates occidentaux de faire parvenir à l'Ouest certains de ses écrits. Les Français refusent de l'aider. Les Américains appellent la police bulgare. Qui rosse copieusement Stefan Marinov, lui déboîte un bras et lui abime un œil.

Et le voilà enfermé dans un asile psychiatrique. Où il peut méditer à loisir sur ce qu'il appelle « la coalition des droites ».

— Brejnev et Nixon s'entendaient, malgré les différences idéologiques, pour assujettir le peuple.

Une de ses lettres parvient jusqu'à un professeur polonais. Dans cette missive, Marinov lance un appel, un cri plutôt :

— Sauvez mon âme.

Après un séjour de trois mois dans une prison psychiatrique, Stefan Marinov entreprend de réunir une conférence internationale à Varna, consacrée aux problèmes « Espace-Temps ». Andreï Sakharov, Prix Nobel et dissident soviétique, accepte de présider cette réunion scientifique, du 5 au 15 mai 77.

Le chef du service culturel du ministère bulgare des Affaires étrangères a donné son accord oral. Marinov lance les premières invitations. The Economist et le Daily Telegraph annoncent la conférence. Le New Scientist expose succinctement les théories de Marinov.

Mais le 15 avril, le physicien bulgare est arrêté. Les membres de la police politique le pressent d'expédier des télégrammes annulant la conférence sous prétexte d'une jambe cassée.

— A l'étranger, on ne prendra jamais au sérieux une telle excuse, leur explique Marinov. Il faut affirmer que la conférence est décommandée parce que l'on craint un tremblement de terre.

Après 20 jours de prison, après 2 lettres adressées au ministre de l'Intérieur, Stefan Marinov a obtenu un visa de sortie. Il se trouve actuellement en Belgique où sera édité dans quelques semaines son livre « Et pourtant elle tourne ». Avec une préface d'Andréï Sakharov.

Sur ses années d'opposition légale au gouvernement bulgare, sur ses séjours en prison et en asile psychiatrique, il admet :

— Je me demande souvent comment je suis sorti sain de ce « carnaval ». Ma chance, finalement, aura été d'avoir à faire à des Bulgares et non à des Soviétiques. Chez nous, il n'y a pas de psychiatres

K.G.Bistes et dans les cliniques où j'ai été enfermé, j'ai toujours trouvé aide et compréhension discrètes.

Les souffrances endurées sous un régime communiste n'ont pas ébranlé la foi de Stefan Marinov dans le marxisme. Il vient de demander son admission au parti communiste italien.

Pliouchtch, rescapé des goulags de l'insuline, banni de force de la Russie soviétique, se tournait, lui aussi, vers l'eurocommunisme. ♦

### EINSTEIN REMIS EN QUESTION ?



● Voici ce qu'écrit Andréï Sakharov à propos de la théorie Espace-Temps absolu élaborée par Stefan Marinov.

Tant d'écrits, tant d'expériences ont été, ces cent dernières années, consacrés à la recherche d'un hypothétique Espace-Temps absolu qu'il semble insensé de poursuivre la discussion et de dépenser temps et argent à s'efforcer de réfuter le principe de la relativité.

Ce principe qu'en premier lieu et de manière on ne peut plus explicite formule Galilée, s'est vu confirmé par tant d'expériences que tout chercheur du quatrième quart du XX<sup>e</sup> siècle s'essayant à le réfuter apparaîtrait vouloir découvrir le « mouvement perpétuel ».

En ouvrant le livre de Stefan Marinov, le lecteur est profondément choqué. La partie théorique le laisse incrédule et le surprend d'autant que les textes entrent en contradiction flagrante avec les théories les mieux établies et les plus généralement acceptées. La partie expérimentale, il la parcourt avec la même défiance, recherchant les erreurs d'expériences qui apparaissent contredire de telles théories.

Cependant, en lisant le livre de bout en bout, il se prend à réaliser que la base expérimentale du principe général de la relativité (Einstein) est loin d'être aussi solide et indiscutable qu'il n'est généralement admis. Je voudrais en premier lieu faire ressortir que l'expérience appelée « disque tournant » a été réalisée pour la première fois il y a quelque soixante ans, et les effets V/C en premier ordre y ont été aisément mesurés.

On pourrait douter de l'authenticité des expériences « miroirs couplés » de Marinov, et que les effets qu'il dit avoir enregistrés ne soient provoqués par quelque cause extérieure. Cependant, le lien entre l'expérience « disque tournant » et son expérience « miroirs couplés » (ou « interrupteurs couplés ») est si clair qu'on en est amené à accepter en toute logique les résultats. Les différentes variantes des expériences « disque tournant » et « plate-forme mouvante » que Marinov a réalisées nous amènent à accepter d'autant plus la réalité physique de l'Espace-Temps absolu tel qu'il le conçoit. Si les résultats expérimentaux repris par Marinov devaient être confirmés par d'autres expérimentateurs, la théorie spéciale de la relativité serait définitivement rejetée. Cependant, comme on peut le voir dans la partie théorique de ce livre, les changements qui devraient être introduits dans la physique à grande vitesse ne seraient pas aussi radicaux que certains adversaires d'Einstein l'ont proclamé et continuent à le faire. La transformation de Lorentz (pour autant qu'elle soit traitée d'un point de vue absolu) et le formalisme quadridimensionnel de Minkowski continueraient à être un instrument mathématique important entre les mains des théoriciens. ♦

## Anti-relativist draws others into the whirlpool

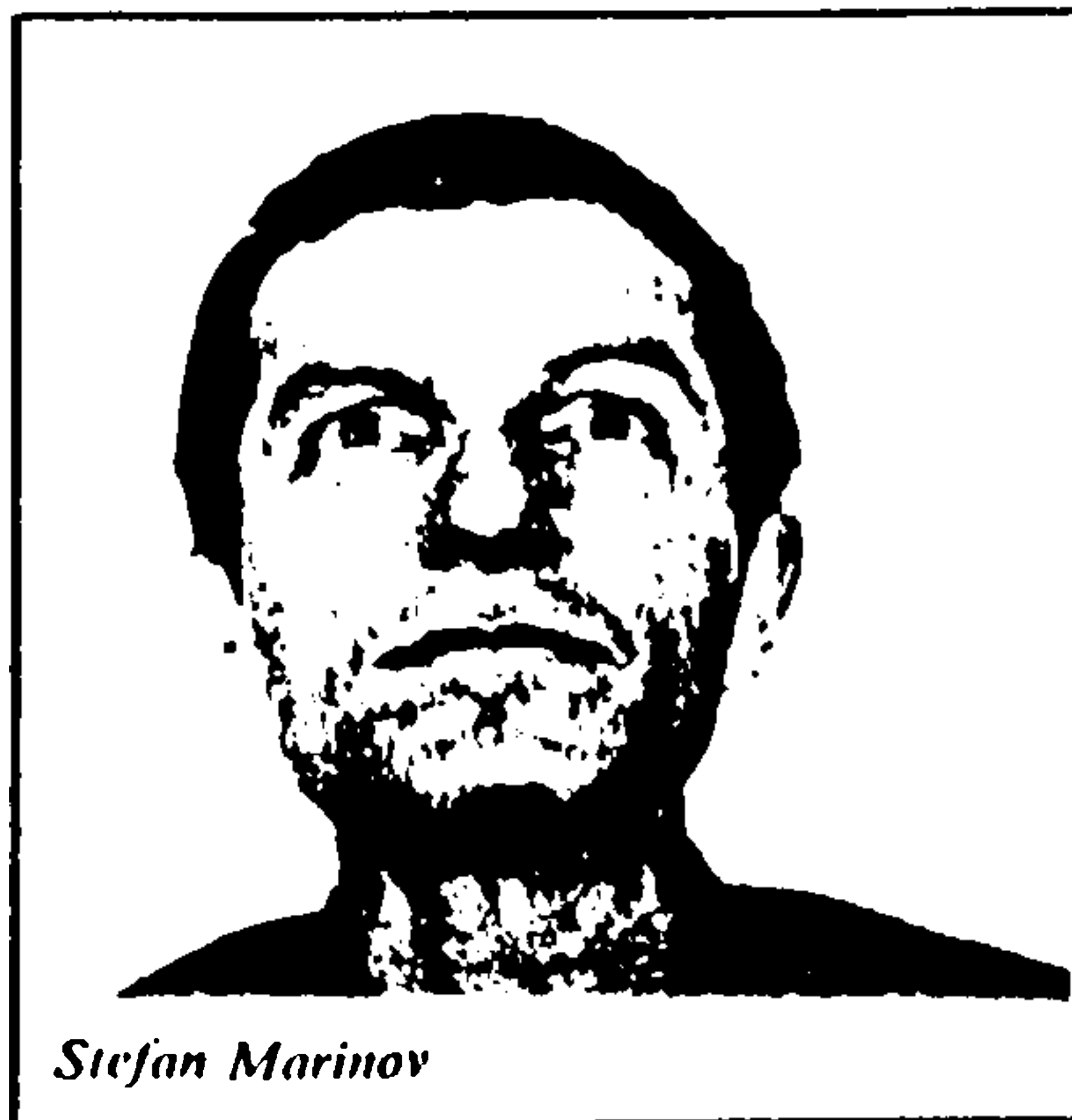

Stefan Marinov

*O father Galileo, cunning one and wise,  
Thy trial persisteth still even from age to age;  
Moralist and philosopher try thee, the fool eke tries,  
And everyone who counts himself a learned sage.*

*So wast thou then a coward, valourless, without honour,  
Thyself knowing the truth, to spit on truth, deride,  
Saving thy mortal frame, to fraud to sing "hosanna",  
Before all men to trample thine honour and thy pride.*

*Holy lord of the spirit, my teacher wise and dear,  
Is the common herd worth our torments and our blood.  
Shout yourself hoarse—no sound will reach its blunted ears;  
Throw your heart at its feet—onward it still doth plod.*

*So, doctors, I bow and swear: "There is no absolute space!  
All I affirmed is lunacy—bring on your drugs apace!"*

RESTRICTIONS on scientific correspondence in the Soviet Union and its satellites have, over recent years, become familiar—the classic study of the problem being *The Medvedev Papers*. One of the most curious by-products of the system is the recent appearance, in Belgium, of an anti-relativistic tract with the lofty title *Eppur si Muove* and a preface signed by no less a person than A. D. Sakharov—presumably the dissident academician of that name. In fact, as the author of the book, Stefan Marinov, himself admits, Sakharov never wrote such a preface; Marinov claims, however, that Sakharov gave him permission to append his name to a preface written by Marinov on his behalf.

Although this may appear at first glance somewhat a trivial matter—that of a 'fringe scientist' trying to gain the backing of an eminent member of the orthodox community—the appearance of the preface could have considerable implications for Academician Sakharov. The various campaigns launched against him within the Soviet Union regularly imply that he has 'abandoned' or 'betrayed' science for 'so-called dissidence', and his apparent endorsement of a scientific theory which he himself does not hold, simply because its author was himself in trouble with the authorities in his own country, could add valuable fuel to this debate. The history of this curious preface is therefore worth looking into.

Stefan Marinov first made his appearance in the western media in the autumn of 1976, when large advertisements began to appear for a conference on 'Space and Time Absoluteness' the following May, on his initiative. A certain 'A. D. Sacharov' of Moscow was listed, variously, as Chairman or Patron of the conference. This surprising announcement led to considerable speculation, and a general consensus of opinion that it could not be Academician Sakharov who was meant. Even the difference in spelling

was cited to support this idea, by those who did not realise that the Russian name САХАРОВ would, in certain transliteration systems, be rendered as 'Sacharov'. In fact at the time of the announcement, Marinov and his western supporters were still trying to contact Academician Sakharov by telephone, to ask for his consent, and were approaching anyone (the present author included) whom they felt might be able to make such a contact.

Marinov's next attempt to contact Sakharov came the following spring. His *magnum opus*, refuting the theory of relativity and all associated physics, was ready for publication, and he wished Sakharov to provide a preface. Having still failed to contact Sakharov over the Varna Conference, Marinov wrote the preface himself, distributed copies to possible contacts with the request that they forward them to Sakharov, and added a covering letter which, in the manner of a student applying for an *exeat*, said that unless he heard to the contrary, he would assume that he had Sakharov's permission to proceed. In one version of the covering letter, he added a brief self-portrait. "As far as I know, I am the unique 'dissident' in my country (once in a prison, twice in a loony bin). I descend from an old family of intellectual communists, and I am a Marxist (I have even written a book on mathematical political economy—in Russian—and I have a translation in Serbo-Croatian). My opinions are most close to those of Roy Medvedev."

Marinov was soon to be back in the mental hospital for a third time. At the end of April 1977, telegrams signed 'Marinov' were sent to journalists and others who had any connection with the Varna conference, cancelling it on the grounds that an earthquake was expected. The immediate assumption, that Marinov had taken this means of cancelling an event which had no supporters, proved false. Marinov had been removed to hospital by the authorities,

who had then notified in his name all those on his address list. News of this reached the West in May, but journalists were earnestly requested by his friends not to publish, since this would endanger his life. In all events, once the critical dates of the planned conference were over, Marinov was released, and in late summer he was allowed to emigrate. He settled in Belgium.

In October, 1977, the news-magazine *Pourquoi Pas?* carried a massive article on Marinov, 'The Scientist who came in from the cold', with a reprint of the 'Sacharov' preface. This, allowing for translation and editorial omission, was identical with Marinov's own draft. Although it seemed highly unlikely that Sakharov would have lent his name, I decided to seek confirmation on this point. It is virtually impossible to get a letter through to Sakharov, and direct telephone contact is likewise a random matter with minute probability of success. Nevertheless, the message reached Sakharov by two channels, and two answers were received. One, via a physicist, ran 'Academician Sakharov knows of the book, but did not wish to be associated with it, as he does not agree with the theory!' The other, less formal message, was transmitted as 'Andrei Dmitrievich says: "The man's a nut-case (*psikh*), but I wouldn't want to condemn anyone to a mental hospital!"'

At the end of November, Marinov turned up, uninvited, at the Science Session of the Venice Biennale. Asked about the preface, he maintained that a 'courier', described as 'an eminent physicist' and a 'young girl', had taken the book to Sakharov who received the courier, expressed sympathy for Marinov's plight, and agreed to 'think about' the matter of the preface. Sakharov is well known for his kindness and compassionate interest in all those in trouble; and he probably meant simply to give an expression of personal sympathy coupled with a polite refusal

to involve himself with Marinov's theories. Unfortunately, Marinov construed this as consent to have his signature added to the preface. Although a number of people entreated Marinov to withdraw it, he refused, saying that as it had appeared in *Pourquoi Pas?*, it was now too late to do so. Moreover, he needed Sakharov's name to sell the book; unless he could sell 5,000 copies at \$20 each he could not get the money he needed to carry out the experiments described in it. (One presumes he meant 'replicate'.) A long and hysterical telex was dis-

patched to Sakharov c/o the Soviet Academy, and copies circulated among the Biennale journalists. Sakharov at that time was not even in Moscow; he and his wife were staging a sit-in in a Siberian labour camp where her nephew Edvard Kuznetsov, the dissident writer, had been refused his regular visit from the Sakharovs. At the time of writing, Marinov is still trying to get a message through to Sakharov.

Marinov's experiences in defence of his theories have undoubtedly made him only the more adamant in maintaining them. His poems imply that

his incarceration in the mental hospital was on account of his theories (see sonnet opposite). Clearly he is willing to take any means to promulgate them, even resorting to 'short cuts' when no answer is forthcoming. This is almost certainly not the first such occurrence in the long history of East European censorship—a number of very curious documents have reached the West from time to time. The whole episode is yet another illustration of the curious situations which can arise when governments restrict the freedom of scientific contact and correspondence.

Vera Rich

*Nature* Vol. 272 16 March 1978

## Marinov recants

STEFAN Marinov, the Bulgarian anti-relativist, caused a considerable stir earlier this year when his book *Eppur si Muove* came out with a preface signed by Academician Andrei D. Sakharov.

According to verbal messages relayed by friends, Sakharov repudiated the preface (see *Nature* 271, 296-297; 1978). Marinov, however, was unwilling to accept these reports, and, leaving his Belgian exile, flew to Moscow as a week-end tourist. He reports the outcome in a letter to *Nature's* correspondent on Soviet affairs:

"Dr Sakharov told me that he had never given any oral message which could be understood as a consent that the foreword written by me and sent about a year ago to him could appear

signed with his name. He had expressed only a general sympathy towards me. He wishes to be no more involved in my fight for the restoration of absolute space-time. I begged him to publish clearly in the press his opinion of my theory; however he refused to do this, because he is dedicating his time to other problems. 'Our ways have crossed once' he said 'and I should prefer that they do not cross another time'.

"I presented to Dr Sakharov my excuses for the highly unpleasant incident of this foreword, and I do this publicly with the present declaration.

"Sakharov's foreword has appeared only in the 1000 copies already published. The foreword will be removed from the 3000 copies which will be printed as 'second edition'." — 1'

# Monde Pourquoi Pas? n° 3106 du

DISSIDENCE

8.6.78

## LA CROISADE DE MARINOV

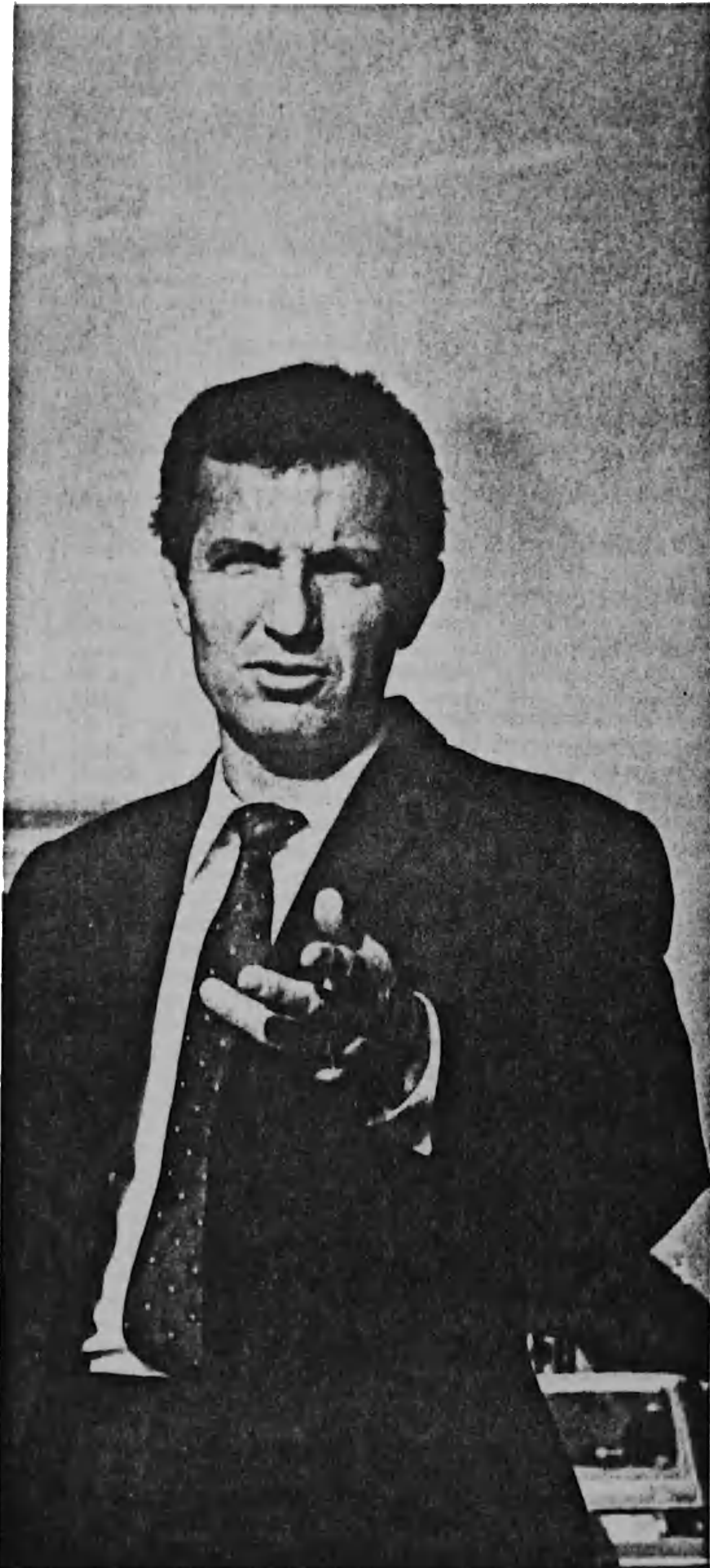

● Dissident bulgare, savant révolutionnaire — Il réfute Einstein — chassé de son pays, Stefan Marinov, 47 ans, est d'une trempe résistante et rare, de celle qui ne plie ni sous la menace, ni sous la violence. Convaincu que le socialisme à visage humain n'est pas une vaine figure de rhétorique, mais une réalité à conquérir, il refuse l'apathie, le renoncement et l'hypocrisie dans un combat qui devrait nous intéresser tous, car il concerne aussi bien ceux qui vivent dans des pays où la liberté et la dignité de l'individu sont bafouées que dans d'autres, privilégiés, mais non à l'abri d'une telle menace.

Les autorités bulgares n'ont guère apprécié les opinions contestataires de Stefan Marinov. Aussi, après l'avoir condamné et emprisonné, l'ont-elles exilé, faisant de lui le premier Bulgare banni en Occident (voir « P. P. ? » du 27-10-77). Pour qu'il se tienne tranquille et qu'on finisse par l'oublier? C'est la raison habituelle dans les pays de l'Est. En l'occurrence, c'était mal connaître Stefan Marinov. Au moment où l'U.R.S.S. sonde les réactions occidentales en durcissant ses mesures répressives, toute initiative relevant le défi prend de l'importance.

**M.** Stefan Marinov, qui vit en Belgique depuis 1977, pourrait se contenter d'oublier ses mésaventures passées — rappelons qu'il a aussi connu l'hôpital psychiatrique — et se consacrer exclusivement à un travail scientifique jugé suffisamment important pour avoir attiré l'attention des Américains. Au moment où ces lignes paraissent, c'est aux Etats-Unis qu'il expose ses idées. Mais M. Marinov ne croit pas que l'exil doit l'empêcher de militer en faveur des droits de l'homme. Il ne croit pas davantage que ce combat doit être compartimenté selon les nationalités. Partisan d'une dissidence internationale, il est prêt à payer de sa personne pour défendre les droits fondamentaux, tels qu'ils figurent dans la Charte des Nations unies ou dans l'Acte final d'Helsinki.

C'est dans cet état d'esprit que Stefan Marinov s'est rendu à Prague pour prendre contact avec des citoyens tchécoslovaques poursuivant le même objectif humanitaire, c'est-à-dire les signataires de la Charte 77. Il rencontra notamment Jiri Hajek, un des

Stefan Marinov, le refus de plier.

promoteurs de la Charte et principal porte-parole des signataires.

### Appréhendé place Venceslas

Le 29 avril, Marinov a manifesté sur la place Venceslas, brandissant une pancarte avec ces mots : « Votre Charte est la nôtre, Marinov, Bulgarie ».

Jusqu'alors, les dissidents bulgares s'étaient tenus cois. Il s'agissait de montrer que le combat pour le respect des droits fondamentaux est le combat de tous.

La manifestation fut de courte durée. En fait, la police était avertie, probablement par un journaliste auquel Marinov avait confié son projet. Une quarantaine de policiers l'attendaient sur place. Aussi fut-il emmené pour interrogatoire, frappé et brutalisé, puis, le soir même, embarqué dans une voiture et conduit par des agents de la Sécurité vers la frontière de la République fédérale allemande, à Eisenstein (Bavière).

Dans la traversée d'une forêt, il eut l'impression que ses derniers moments étaient venus, car on aurait pu le déposer là et l'abattre. Compte tenu des procédés de terreur qui règnent actuellement en Tchécoslovaquie et que vient de dénoncer Rudolf Slansky, fils de l'ancien secrétaire du P.C. (pendu en 1952 puis réhabilité), il eût été possible que Marinov disparaisse, car c'est le processus en cours actuellement, l'exemple chilien et argentin étant jugé efficace par la Sécurité d'Etat tchécoslovaque.

On se tromperait en imaginant qu'un dissident va automatiquement bénéficier de quelque considération à l'Ouest. Arrivé dans la République fédérale allemande, Stefan Marinov se heurta à des difficultés administratives. La « sensibilité » particulière des fonctionnaires allemands résultait des mesures de prudence prises à l'occasion du voyage de M. Leonid Brejnev en République fédérale.

Mais qu'est-ce qui a pu sensibiliser l'ambassade des Etats-Unis à Sofia contre Stefan Marinov ? C'est une autre histoire, mais qui mérite d'être contée. Ce que Marinov a fait dans une lettre, datée du 1<sup>er</sup> novembre 1977, adressée au président Jimmy Carter. Nous la reproduisons ici quasi in extenso :

### Lettre à Jimmy Carter

M. le Président,

En mars 1974, je fus emprisonné à la Clinique psychiatrique de l'Ecole médicale supérieure de Sofia, où j'avais déjà passé 7 mois en 66/67. Je fus à nouveau détenu contre ma volonté pour être soigné et libéré de mes idées « injustes » du domaine de la physique (je démontre par la théorie et les expériences que la théorie de la relativité d'Einstein ne correspond pas à la réalité) et de mes conceptions « fausses » en matière de politique (j'affirme que le socialisme à visage bestial ne peut nullement être appelé socialisme).

Pendant cette période, je n'étais pas isolé en cellule fermée et gardé par un policier, comme en 66/67, et je parvins à m'échapper le 3 avril.

Après avoir changé de vêtements au domicile d'un ami, je me rendis à l'ambassade américaine à Sofia et je m'adressai à M. Snow dans le but de faire transmettre à la presse mes protestations contre cette scandaleuse et honteuse détention. M.



Vladimir Slepak quelques jours avant son arrestation.

Snow me connaissait bien, m'ayant mis en rapport quelques mois auparavant avec le professeur Goudsmit, l'éditeur de la « Physical Review », parce qu'à l'époque, mon courrier était intercepté.

Au lieu de m'apporter de l'aide, on appela la police bulgare, et je fus frappé brutalement dans le vestibule (donc en territoire américain) sous les yeux d'une vingtaine de personnes américaines qui ne firent pas le moindre mouvement pour mettre fin à cette barbarie, malgré mes cris désespérés et le fait que je ne puisse me défendre (j'avais été jeté au sol, les mains liées).

On m'a reconduit et enfermé dans la même cellule que sept ans auparavant. Au procès, l'accusateur public défendit la thèse que je représentais, non seulement aux yeux des autorités bulgares, mais aussi à ceux des Américains, un élément socialement dangereux. Ce qui aggrava ma situation et je fus condamné au traitement forcé (on soigna ma folie par Trisedil).

A l'hôpital psychiatrique, j'écrivis une lettre à





Zinaida Grigorenko attendant le retour de son mari, pseudo-aliéné.

l'ambassadeur américain, protestant contre le honteux traitement ordonné par les employés d'ambassade et lui enjoignant de venir me présenter personnellement ses excuses à la clinique. Ce qu'il ne fit pas. Je ne puis savoir si ma lettre atteignit jamais l'ambassade.

A votre entrée à la Maison-Blanche, j'écrivis une lettre au nouvel ambassadeur, lui présentant une requête pour injure. Ce qui fut transmis au Département d'Etat d'où me revint une réponse négative communiquée oralement par le consul, M. Thibaut.

Maintenant, je m'adresse à vous directement. Je vous prie, M. le Président, d'étudier ce cas attentivement. J'ai vécu 46 ans en Bulgarie. Comme marin, j'ai visité différents pays d'Europe, d'Afrique et d'Asie. J'ai été à plusieurs reprises incarcéré en raison de mes activités scientifiques et politiques. Mais aucune fois dans ma vie, je ne fus battu. Jamais mon père ni ma mère ne m'ont giflé. Je n'ai passé, le 3 avril 1974, que quelque 30 ou 40 minutes sur le territoire américain, et je fus couvert de sang. Lorsque je fus relâché de l'aile, certains de mes amis se moquèrent de moi : « Tu es en effet tout à fait fou. Est-ce qu'un homme normal irait chercher protection et compréhension chez les Américains ? Ils sont pires que les cannibales stalinien ».

Stefan Malinov ne mâche pas ses mots. Plus loin, il écrit :

« ...en pleine Conférence de Belgrade, les néostalinien paranoïaques de Prague ont organisé une parodie de procès, mais le gouvernement américain n'est pas intervenu. Je connais la réponse : c'est une affaire interne de la Tchécoslovaquie, et le gouvernement américain n'a aucun droit d'intervention. D'accord. Mais je fus frappé sur le sol américain, où la police bulgare ne pouvait pas entrer sans l'accord de l'ambassadeur. Présentez-moi les excuses du gouvernement américain. La répercussion de votre lettre dans nos pays sera énorme ».

Jusqu'à présent, cette lettre est restée sans réponse.

### L'Irrespect des lois

Revenons à la manifestation du 29 avril.

L'objectif était de prouver aux citoyens de Prague qu'ils sont aussi soutenus dans leurs revendications par des citoyens d'autres pays. Stefan Marinov a voulu que la Bulgarie soit présente. Il suffit d'un seul homme pour défendre l'honneur d'un pays. Bien entendu, la police de Prague n'a pas compris les choses de cette manière. Arrêté, c'est à coups de poing et de fouet que Marinov a été traité. On a confisqué son passeport bulgare, sa carte d'identité belge, deux copies de son livre scientifique « Eppur si muove », des manuscrits d'articles, un livre de poésie de Marie Valachova (édité à Prague), un livre russe sur l'histoire du stalinisme, son agenda et son argent. Pour ces faits aussi — accompagnés de brutalités et de menaces de mort — Marinov a écrit directement au président de la République tchécoslovaque, réclamant son passeport et carte d'identité, ses livres et son argent, et une indemnité pour les dommages subis. Une autre lettre, adressée au président du Conseil bulgare, insiste pour que les autorités bulgares donnent l'ordre à leur ambassade en Belgique pour qu'un nouveau passeport lui soit délivré. En attendant, il a pu s'expliquer à cette ambassade où il fut bien reçu.

La thèse principale de Marinov se trouve contenue dans la lettre au président de la République socialiste tchécoslovaque, lorsque, après avoir résumé les faits, il écrit : « Tous ces actes de la police tchécoslovaque allaient à l'encontre des lois de votre pays ».

Il aborde là le nœud du problème qui a suscité ce qu'on appelle des dissidents. Ce sont rarement des ennemis idéologiques en ce sens qu'ils ne sont pas, a priori, anticommunistes ou ennemis de leur pays. Ils exigent simplement que les actes soient conformes aux lois. C'est de l'irrespect des lois pour ceux qui ont la charge de les défendre que naît la contestation. Marinov fait remarquer que dans certains pays occidentaux — l'Italie et la R.F.A. — des opposants ont recouru au rapt et à l'assassinat. Ils agissent contre la loi. Le paradoxe est de voir dans des pays de l'Europe de l'Est se développer le même processus, non pas par des opposants qui, lorsqu'ils manifestent, le font paisiblement, mais pas les représentants du régime.

### Plusieurs tests pour un défi

Une des aberrations du marxisme est d'avoir accouché de l'Etat répressif sous le masque de l'Etat socialiste. Et c'est le propre de l'Etat répres-

**THIS PAGE IS LOCKED TO FREE MEMBERS**  
Purchase full membership to immediately unlock this page

**FORGOTTEN BOOKS**

# **FULL MEMBERSHIP**

**797,885 Books!**  
**All you can read**  
**for only**  
**\$8.99/month**

**Continue**

\*Fair usage policy applies





Stefan Marinov et ses miroirs couplés.

### L'ANNÉE EINSTEIN

## Une foi qui dérange : la dissidence de Marinov

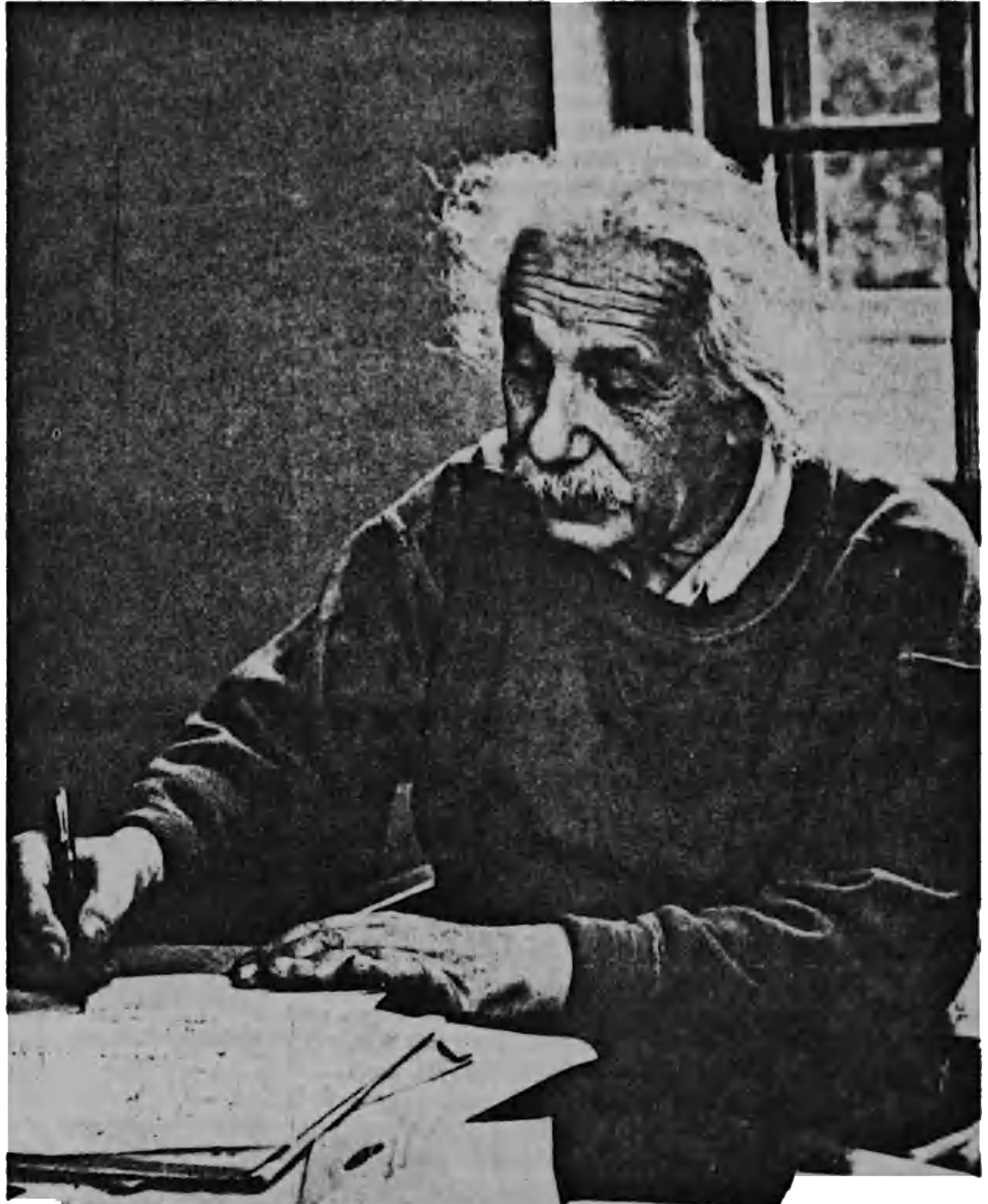

Einstein à Princeton, sept ans avant sa mort (1955).

● Lorsque la gloire d'un homme est bien établie, lorsque ses théories, d'abord contestées, ont fini par convaincre tout le monde, il paraît bien hasardeux, voire incongru, d'élever la voix pour les contester. C'est pourtant ce que fait le physicien Stefan Marinov en s'attaquant à Einstein. Et il a beaucoup de mal à se faire entendre. Nous n'avons pas à prendre parti dans une question aussi complexe. Seuls des scientifiques peuvent éclairer le débat — pour autant qu'ils en acceptent le principe. Notre propos se borne à laisser entendre la voix d'un dissident. Doublement dissident. Et d'enregistrer ses tribulations.

**C**HAQUE jour, des milliers d'hommes célèbrent leur anniversaire. Cela n'a pas beaucoup d'importance, si ce n'est pour les intéressés. Mais comme si cela ne suffisait pas, on commémore aussi la naissance ou la mort de quelques privilégiés dont le nom mérite d'être retenu. A ce titre, le 14 mars marque cette année l'anniversaire le plus important des temps modernes puisqu'il y a cent ans que naissait à Ulm l'homme qui allait avan-

cer des idées nouvelles particulièrement fertiles, susceptibles de transformer fondamentalement les conceptions de l'univers et de réorienter les recherches scientifiques.

Tout le monde reconnaît aujourd'hui le génie et l'importance capitale d'Albert Einstein, ce génie que, dans sa hargne antisémite de mégalomane criminel, Adolf Hitler a voulu écraser en mettant sa tête à prix.

Einstein n'eut pas qu'à affronter la persécution des nazis. Lorsqu'en 1905, obscur employé du Bureau des brevets en Suisse, il publia sa première théorie de la relativité, on eut du mal à le suivre. Donc, on le combattit. La physique se fiait encore à des absolus que ce jeune chercheur de 26 ans rejetait.

En 1887, l'Américain Michelson s'était livré à une expérience ingénieuse en vue de mettre en évidence le mouvement de la Terre à travers l'éther. On la considéra comme un échec. Einstein comme une réussite, parce qu'elle le renforçait dans l'idée que l'éther n'existait pas. A partir de quoi, immobilité et mouvement ne signifie rien, à moins de considérer un objet par rapport à un autre. Les notions

## Monde

fondamentales d'espace et de temps sont relatives au système de référence de chaque observateur.

Dans la théorie de la relativité généralisée, qu'il mettra au point en 1915, la gravitation selon Einstein s'écarte sensiblement de la théorie sacro-sainte de Newton. C'est une conception du monde qui est bouleversée, et qui, malgré les réticences, voire l'hostilité la plus dénigrante envers la théorie nouvelle, devra céder, pan par pan, sous les coups que lui infligent les chercheurs dont les expériences confirment la pensée et les calculs d'Einstein.

### Quelque chose de pourri...

Partout, hommage est rendu à cet esprit génial dont les théories, extraordinairement fécondes, ont dominé la science du XX<sup>e</sup> siècle. Nous allons dire : désormais sans conteste. Mais la science ne progresserait pas s'il ne se trouvait des hommes suffisamment imaginatifs et audacieux pour remettre en cause ce qui paraît le mieux établi. N'est-ce pas ce qu'Einstein lui-même avait fait ? Il serait étonnant qu'il ne puisse pas, à son tour, être contesté, ne serait-ce que sur certains aspects de sa recherche. C'est pourquoi, plutôt que de refaire, après tant d'autres, le bilan de ses découvertes, nous avons préféré commémorer ce centenaire en écoutant ce que nous dit le jeune physicien bulgare Stefan Marinov, retour d'un séjour aux Etats-Unis, et à la veille de son départ pour Berne où il participait à l'hommage rendu à la mémoire d'Einstein. Car il s'en réclame tout en combattant certaines de ses théories.

Et on verra que, comme Einstein, mais dans un autre contexte, Stefan Marinov se voit obligé de prendre des options politiques. Mais commençons par les recherches et les expériences scientifiques. Quel est leur but principal ?

— Quelque chose est pourri dans le royaume de la relativité, nous dit M. Marinov avec un charmant sourire. Et pas seulement quelque chose, mais le dogme fondamental, c'est-à-dire le principe de la relativité de Lorentz-Poincaré-Einstein. J'en suis arrivé là après une analyse approfondie de la littérature contemporaine comme de celle de la fin du XIX<sup>e</sup> et du début du XX<sup>e</sup> siècle. Et par mes travaux théoriques et expérimentaux, j'en démontre l'inconsistance. Aujourd'hui, le principe de la relativité est accepté comme une loi inébranlable de la nature et on y croit comme on croit dans la véracité du principe de la conservation de l'énergie. Ces deux principes ne représentent pourtant rien de plus que des conclusions logiques issues de nombreuses expériences effectuées sur notre Terre et parce que, jusqu'à aujourd'hui, personne n'a réussi à construire un « *perpetuum mobile* » ou un tachymètre absolu. Mais rien, rien, rien n'exclut la possibilité de construire de tels appareils. Si l'Académie des Sciences de Paris considère comme anormal n'importe quel projet de mouvement perpétuel, moi, comme physicien, je tiens pour anormale la position de l'Académie. Ce n'est pas une attitude scientifique, c'est une attitude dogmatique. Mais jamais les dogmes n'ont rendu service à qui que ce soit. Un million d'expériences effectuées ne sont pas suffisantes, parce que la million et unième peut s'avérer positive.

— Considérez-vous la vôtre, avec les « miroirs couplés », comme la million et unième ?

— Certainement. Le principe de la relativité n'est pas quelque chose de moderne. Galilée l'a formulé pour la première fois assez exactement. Newton aussi l'a défendu.

### L'absolu retrouvé

— Qu'est-ce qui vous a amené à l'expérience des miroirs couplés ?

— L'analyse des expériences accomplies auparavant m'a convaincu qu'une expérience optico-mécanique devait aboutir à un résultat positif. Comme partie mécanique, j'ai choisi l'axe tournant. En 1958, Briscoe avait proposé l'utilisation de signaux à ultrasons.

— Quelles expériences vous ont convaincu que le principe de la relativité peut être renversé ?

— En premier lieu, celles de Harress (Allemagne, 1912) et de Sagnac (France, 1913) avec le disque tournant, répétée par Michelson-Gale-Pearson (U.S.A., 1925). Ces expériences — de même que les laser-gyroscopes dans les fusées soviétiques et américaines — ont montré, avec une certitude irréprochable, que, par rapport à un objet qui tourne dans l'espace absolu, la vitesse de la lumière est anisotrope, c'est-à-dire que cette vitesse est différente dans les différentes directions.

Notant qu'un laboratoire installé sur la surface de la Terre exécute diverses rotations (autour de l'axe de la Terre avec, pour la largeur de Bruxelles, une vitesse de 0,3 km/s ; autour du Soleil à une vitesse de 30 km/s ; autour du centre de notre galaxie à une vitesse de 250 km/s pour une durée de rotation de 220.000.000 ans ; autour du centre de notre groupe de galaxies à une vitesse de 500 km/s), M. Marinov a mesuré, à l'aide de son appareil aux miroirs couplés, la résultante, c'est-à-dire la somme géométrique de toutes ces vitesses rotatives, qu'il appelle vitesse absolue de laboratoire. L'expérience l'amène à présumer que le centre de notre groupe de galaxies est au repos dans l'espace absolu.

En tenant compte de la radiation du fond (découverte pour laquelle Penzias et Wilson ont obtenu le Prix Nobel de physique), deux chercheurs américains, Wilkinson et Corey, de Princeton, ont obtenu pour la vitesse de la Terre des chiffres qui ont permis à Stefan Marinov de conclure qu'ils arrivaient à la même mesure que lui. Seule la méthode était différente. Mais alors, pourquoi s'obstine-t-on à ne pas reconnaître ses résultats ? Il répond :

— Parce que mes expériences montrent directement que le principe de la relativité n'est pas tenable. Imaginez combien de livres devraient être corrigés et combien de milliers de professeurs devraient changer le contenu de leurs leçons. D'une part, mes résultats représentent une catastrophe pour la carrière scientifique d'une armée de savants. D'autre part, mon appareil est, en effet, un tachymètre absolu et donne un repère absolu dans l'espace. Cet appareil représente donc quelque chose d'extrêmement important pour les fusées balistiques et cosmiques. Je suis sûr que dans les laboratoires militaires américains, et peut-être soviétiques, on travaille avec cet appareil. Evidemment, on ne veut pas que cela se sache.

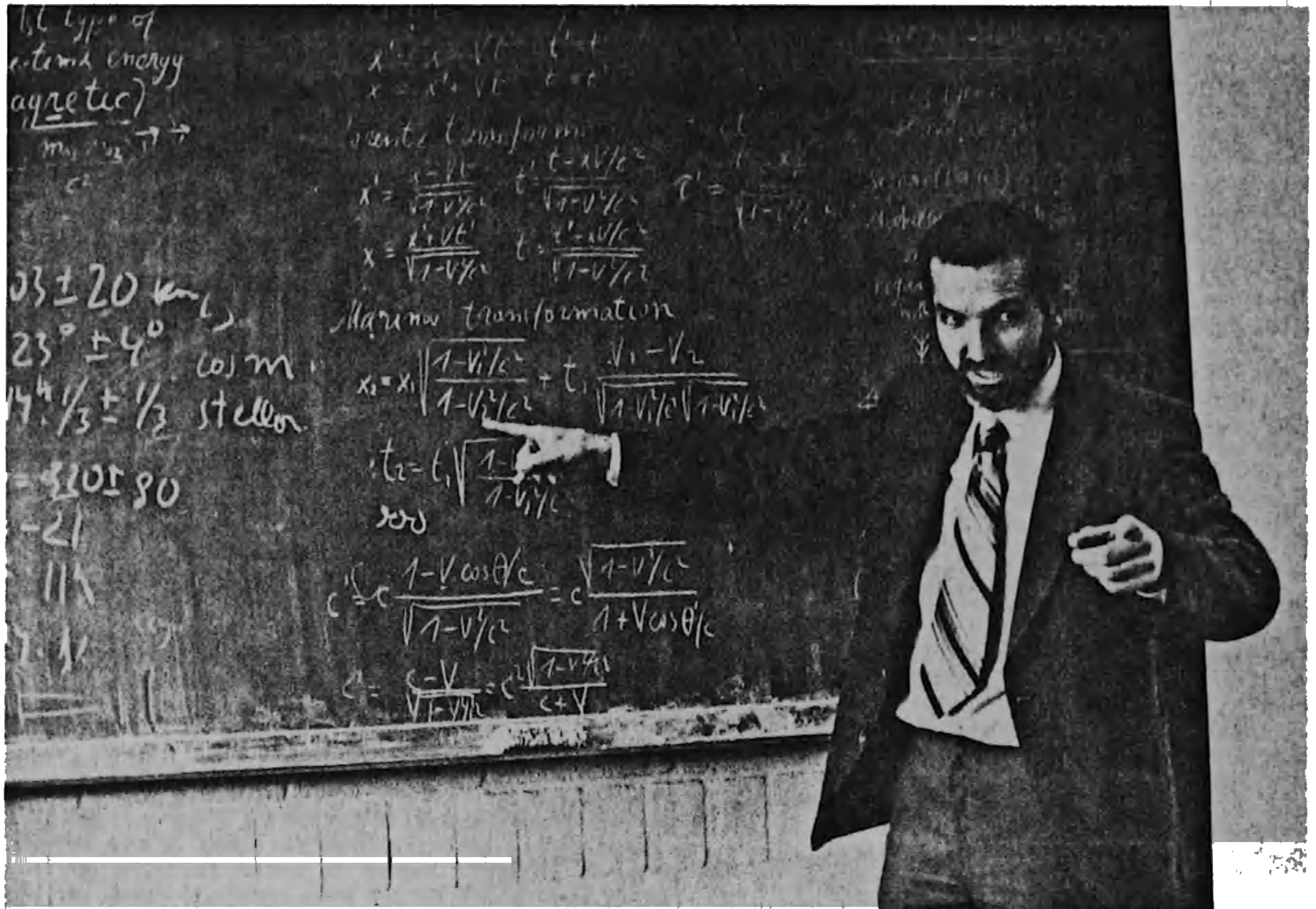

Adversaire résolu de la relativité.

### Un refus généralisé

Quel a pu être l'apport d'Einstein sur un homme qui rejette une part de sa création scientifique ?

— Enorme, répond Marinov. Marx disait souvent : « Je ne suis pas un marxiste ». En lisant attentivement Einstein, on peut trouver l'équivalent de cette déclaration : « Je ne suis pas un relativiste ». Einstein nous a laissé de formidables constructions mathématiques et des résultats physiques importants. Mon reproche, c'est qu'il n'ait pas bien analysé les expériences du disque tournant. Je me considère comme un élève d'Einstein. Sans la lecture de ses œuvres, je ne pourrais pas réussir à le combattre en rejetant le principe de la relativité. Les articles originaux d'Einstein sont dispersés et difficiles à trouver, surtout en Amérique. Il faut pouvoir lire le russe, ce que je fais, pour prendre connaissance de l'ensemble de ses écrits. L'ignorance de l'histoire de la physique qu'on découvre chez les savants américains est stupéfiante. Selon moi, le meilleur monument que l'on puisse ériger à la gloire d'un savant, d'un philosophe ou d'un écrivain, c'est de publier son œuvre. Au lieu de quoi l'Académie américaine des Sciences érige à Washington un monument monstrueux qui va coûter 1.600.000 dollars. Les épigones sont les pires ennemis des maîtres parce qu'ils les transforment en idoles muettes et érigent des monuments accablants. Le pire coup contre

Lénine et les idées de la Révolution a été l'érection de son mausolée à Moscou. Les constructeurs de mausolées s'efforcent par tous les moyens de cacher la vérité sur l'essence de l'espace-temps que nous révèlent les expériences.

— Ce sont des accusations qui mériteraient d'être étayées par des faits.

— Votre hebdomadaire ne pourrait pas m'accorder assez de pages. Mais je puis vous dire ceci : à une trentaine de savants renommés et de critiques de journaux scientifiques qui déclaraient fausse ma théorie et prétendaient que mes expériences ne peuvent pas donner les résultats positifs que j'affirme avoir obtenus, j'ai proposé 1.000, 2.000 ou 3.000 dollars s'ils daignaient publier leur opinion dans la presse. Personne n'a bougé. J'ai envoyé mon livre « Eppur si muove » à tous les journaux scientifiques qui donnent un compte rendu des livres de physique. Aucun n'a réagi. J'ai alors proposé d'offrir 1.000 dollars pour un compte rendu négatif. Rien.

Quant à l'expérience avec son appareil, M. Marinov l'a proposée aux quatre conférences consacrées au centenaire d'Einstein : Princeton, Jérusalem, Berlin et Berne. De Berne vint l'unique réponse, déclarant que ce n'était pas le moment approprié pour se livrer à cette démonstration. En Belgique, l'année dernière, Stefan Marinov se vit infliger un autre refus lorsqu'il proposa, à l'U.L.B., sa thèse de doctorat : « Mesure de vitesse absolue de la Terre et

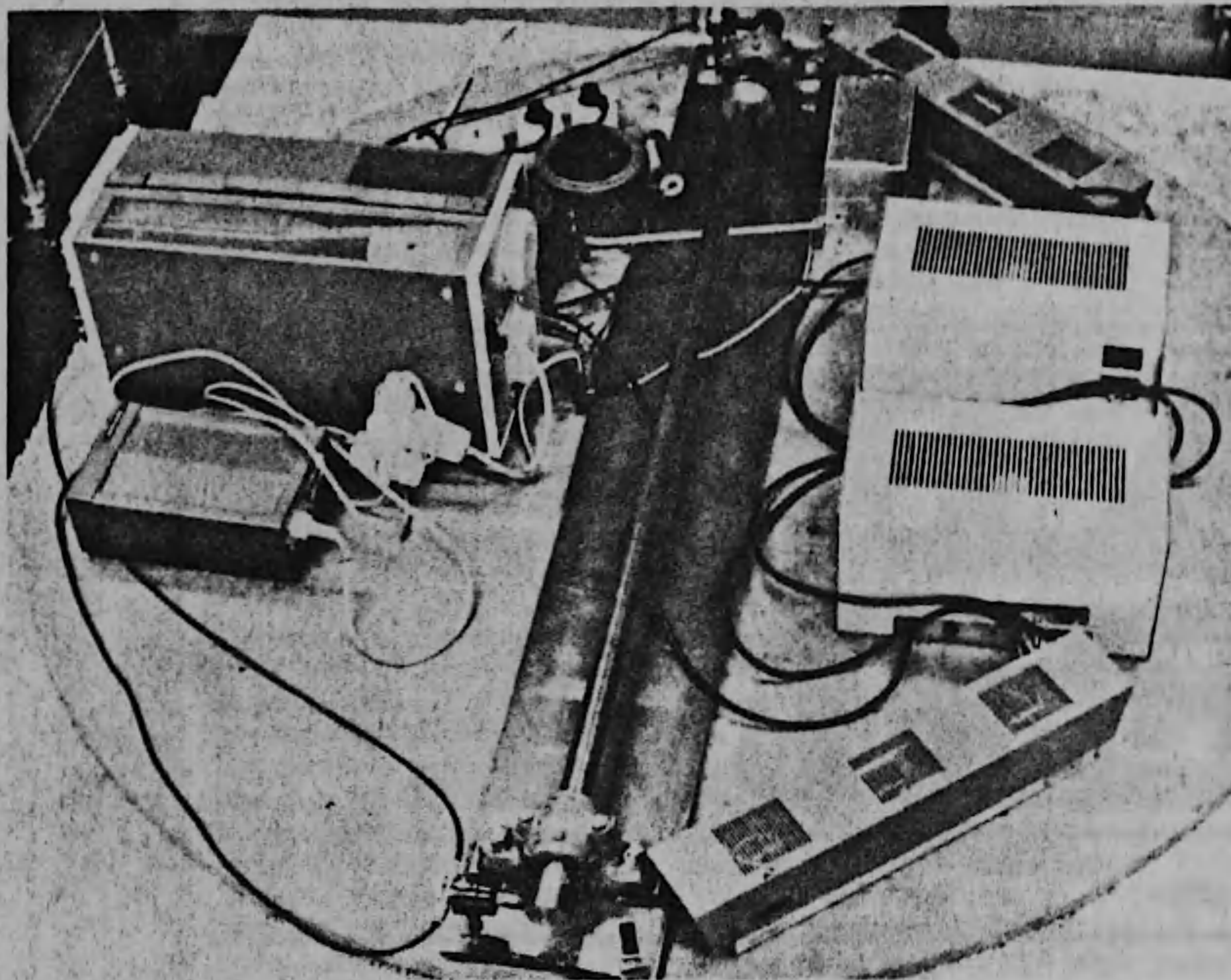

Moins d'argent pour la recherche que pour un monument.

son importance pour la théorie ». Le prof. Rasmont, président de la Faculté des Sciences, lui fit savoir que la Section de Physique considérait comme « anormal d'accepter qu'une telle thèse soit déposée ».

M. Marinov ne subit pas d'emblée l'opposition de préjugés. Un membre du Congrès américain, M. Robert K. Dornan, dans sa recommandation au directeur de Grants National Science Foundation, fait valoir que l'expérience est intéressante à tenter, même si c'est pour confirmer, une fois de plus, la théorie de la relativité d'Einstein. Spécialisé dans les questions scientifiques et technologiques, M. Dornan a fait son enquête avant de conclure qu'il n'y a pas lieu de fermer la porte au nez de M. Marinov. Néanmoins, une lettre de la Foundation devait informer le physicien bulgare que « malgré leurs mérites intrinsèques, bien des propositions intéressantes ne peuvent être soutenues ». Parmi diverses raisons, le manque de fonds disponibles, écrit le directeur, Marcel Bardon, tandis que son assistant, J.A. Krumhansl, suggère deux mois plus tard, après une réanalyse de la proposition, que les « frais et le peu de chance de succès de l'expérience ne justifient pas » une attitude de refus.

C'est un fait reconnu que l'on trouve de moins en moins d'argent aux Etats-Unis pour la recherche théorique si l'on n'en entrevoit pas des applications rapides dans le domaine pratique — ce qui fait dire qu'Einstein, aujourd'hui, serait mal pris.

Finalement, Stephan Marinov a tout de même pu réaliser son expérience à la V.U.B., grâce à divers appuis dont ceux des prof. Van Geen et Ronsmans. Elle n'a pas donné l'exactitude des expériences de Sofia mais, dit Marinov, elle a clairement montré quels paramètres doivent être améliorés pour pouvoir enregistrer l'effet absolu — effet absolu qui, selon ses adversaires, n'existe pas et que la technique, à supposer qu'il existât, ne pourrait pas capter.

## Une foi qui dérange

Une particularité de Stephan Marinov, c'est qu'il ne dérange pas seulement les milieux scientifiques. Ses démêlés avec les autorités de son propre pays, mais aussi avec les Tchécoslovaques et les Américains (1).

Marinov observe que si Galilée était persécuté par l'Eglise, lui, c'est le contraire. Sans l'appui du Rév. van Stapel, du Foyer catholique européen, il n'aurait pu se rendre aux Etats-Unis ; et sans l'intervention du Rév. Steinbruck, de Washington, il aurait eu l'ennui de se voir arrêter et déporter...

Pourquoi, puisqu'il était invité ?

Il ne trouve qu'une réponse : le désintérêt du gouvernement américain pour les dissidents de l'Est et l'aspect démagogique de la campagne de Carter pour les droits de l'homme. Il a écrit au président mais n'a pas reçu de réponse.

Désormais, Marinov est nanti d'un passeport délivré par le « Gouvernement mondial des citoyens du monde » — un document symbolique avec lequel on ne va pas loin. Lancé dans un combat apparemment sans fin, il compte retourner en Bulgarie, après un passage par l'Espagne où il veut s'inscrire au P.C. Car — et c'est peut-être la clé d'une méfiance qu'il a rencontrée aux Etats-Unis — il est resté communiste, mais non sans nuance puisqu'il ne croit pas en n'importe quel communisme. Sans déstalinisation, dit-il, il n'y a pas de différence entre socialisme et fascisme. C'est dans cette perspective que Stefan Marinov poursuit un combat idéologique sans fin, qu'il écrit à Brejnev comme à Berlinguer.

Et ceci nous porte au-delà de la relativité vers un nouvel absolu, car ce sont des actes de foi. ♦

(1) « Pourquoi Pas ? » n° 3074 et n° 3106.

# PAESE SERA

Mercoledì 27 Giugno 1979

CURIOSITA'

## «Einstein? Solo un visionario»

Al primo Congresso mondiale di scienza e di religione fioriscono «rivoluzionarie» e cervelotiche teorie per spiegare i segreti della vita

The text of the article see on the next page.

ABBIAMO preso nota dell'ora, perché potrebbe risultare storica: diciassette e tredici del 26 giugno 1979, sala Zeffiro del Midas Hotel: Stefan Marinov, fisico, navigatore di lungo corso, ingegnere, poeta, bulgaro di nazionalità ma ora trasferitosi in Italia dopo essere stato passato per il solito manicomio, annuncia che entro sei mesi la teoria della relatività risulterà spacciata. Con un esperimento di laboratorio egli ha infatti dimostrato che la Terra si muove in uno spazio assoluto in un tempo assoluto perfettamente misurabile «in sé», che dunque lo spazio-tempo di Einstein è una favola, torniamo ai meno inquietanti parametri di Galileo, per favore. E scommette dieci milioni, di lire ma convertibili eventualmente anche in dollari, che nessuno potrà smentirlo.

Marinov è un tipo piuttosto simpatico, con sorrisi sarcastici nella barba grigia; è forse un tantino confuso (non nel senso preteso dagli psichiatri bulgari) ma indubbiamente seducente con uno charme provocatorio vagamente radicale, non a caso definisce «ammucchiata» l'unanimità dei fisici alle teorie di Einstein; lui nel giro di un quarto d'ora restaura non solo i vecchi canoni meccanicistici ma rimette anche sul trono il buon Dio, ovvero il Bene autonomo rispetto alla scienza che dovrebbe occuparsi solo del Vero ma intima a papa Wojtyła di scomunicare o qualcosa del genere Carter, Breznev e Deng Xiaoping con le loro atomiche diaboliche.

Al Midas da domenica scorsa a domenica prossima si svolge un «Primo congresso mondiale di scienza e di religione» con sottotitolo esplicativo «Parapsicologia, psicotronica e teologie a confronto»; di scienziati ce ne sono pochini e di teologi apostoloci-romani ancora meno, pare che i vari Palazzi delle ideologie dominanti abbiano sabotato l'importante convegno, il gesuita padre Arupe ha spedito fulmineamente a Belgrado due preti che avevano accettato di fare i relatori e la burocrazia sovietica ha accampato ogni pretesto per negare il visto alla parapsicologa, anche se di professione interprete, Barbara Ivanova.

Quest'ultimo impedimento è stato sciolto, pare, dal genovese conte Lelio Gallateri di Genola, psicobiofisico, psicotronico ed accademico di Maeternach (Lussemburgo) che si è seduto a tavolino, ha scritto una lettera a Breznev, sicché quella Barbara Ivanova ha potuto finalmente venire a Roma a dire dalla tribuna del congresso quelle

che a noi sono sembrate disarmanti banalità: ovvero che i parapsicologi devono aiutare il prossimo perché altrimenti un «effetto boomerang» li fa ammalare e che è comunque bene restaurare, al di là di questa «epoca pragmatica» antiche ideologie che onorino la Sfera Cosmica, l'Inconscio Collettivo, la Noosfera o qualcosa del genere.

Va subito detto peraltro che il tono di questo congresso è tutt'altro che aggressivo, i cultori di discipline come l'ufologia, la conversazione con i morti, la misteriosofia dei costruttori di cattedrali o la precognizione (che peraltro hanno ignorato il convegno, ridotto a poche decine di persone) si sentirebbero umiliati nel notare come la Scienza, anziché tacciata di totalitarismo e manipolazione, venga blandita da questi profeti delle nuove religioni; la sola accusa che le rivolgono è di essere insufficiente e di pretendere di spiegare con la chimica e la fisica i pensieri i sentimenti o i segreti della vita: «Quale molecola sarebbe responsabile dell'Amleto?», l'ha sfidata a rispondere il dottor Singh, teorico della reincarnazione.

Alla Scienza insomma si chiede di starsene nei suoi laboratori a studiare «la materia» lasciando ai teologi e ai teosperimentatori la «energia» intesa come qualcosa di psichico e divino. Quell'esegeta indiano ha spiegato il tutto coi testi Veda, coltivando il divino afflato dell'atma che è in noi, anziché rinascere in corpi di animali inferiori potremmo «cambiarci d'abito» rinascendo come uomini o meglio ancora come puri spiriti. Un professore iraniano, anche se residente a Parigi, molto bello nel caffetano e turbante bianchi dei teologi musulmani ha argomentato che la scienza è incoerente perché supera continuamente le proprie stesse teorie senza mai arrivare a verità assolute (quasi che mai l'avesse preteso) sicché dovrebbe cedere il passo a qualche religione.

Non è che tutti i congressisti se ne restino su queste somme vette: dopo che un relatore aveva riassunto l'universo in un triangolo, sistemando ai vertici Spirito, Mente e Corpo, uno dalla sala si è alzato a chiedere: «Non ho capito dove mette l'Anima»; il problema era indubbiamente peregrino ma lo spirito ecumenico ha impedito che venisse dibattuto, «Non siamo qui per discutere dei triangoli», ha ricordato Lelio Gallateri di Genola, che di questo convegno è un po' l'anima e il factotum, «ma per trovare un minimo di accordo, l'umanità è in pericolo

ecc. ecc.». Invero anche nella sua relazione non tutto era stato chiaro: per corroborare straordinarie entità come gli Eoni (elementi intelligenti viaggianti nello spazio), il Pensiero Radiante, il Bioplasma, venivano citate bagattelle come le seguenti, garantite quali «progressi scientifici in parapsicologia»: un giapponese ha costruito l'aurometro, macchinetta per misurare l'energia emessa da ogni individuo; il famoso Bakster scopritore della coscienza delle piante ha rivelato anche col suo poligrafo che se versate della benzina in un vasetto di yogurt, gli enzimi di yogurt di un vasetto vicino svengono dal dispiacere; in Cecoslovacchia qualcuno ha distribuito agli scolari piramidi di plastica invitandoli ad usarle per riaffilare le lamette per barba — il che confermerebbe che, se anche gli antichi egiziani non usavano le lamette, tuttavia con le piramidi avevano realizzato una fonte di straordinaria energia.

Gli spiriti di Piero Angela (autore di una stroncatura televisiva a puntate dell'occultismo contemporaneo) e del professor Zichichi (che in «Acquario» sogghignava di fronte ai cultori di queste mistiche eterodosse) aleggiano nel congresso: i convenuti sono invitati ad esprimere per cartolina-scheda il loro giudizio su quella stroncatura, che sarebbe poi come fare un referendum tra i romanisti a proposito di un rigore della Lazio in un derby. Zichichi è citato con ironia; la lusingata scienza, insomma, è nemica. Sui banchi dell'ingresso vengono offerti peraltro marchingegni meccanici come misuratori della «tensione» individuale, fotoapparati Kirlian, Esp tester; dalle pareti occhieggiano foto di miracoli ovvero di violazioni delle leggi fisiche: ectoplasmi che sorvolano facce umane, «pensieri» ripresi con la Polaroid, nuvole bianche che escono dalle bare, esseri «extra» in foto di famiglia. A dire il vero qualcuno dei più illustri autori di «foto con la mente» fu a suo tempo smascherato come truffatore e dovette salvarsi con la fuga; ma che importa, forse che anche Einstein non è stato un bidone?

ENZO RAVA



**DROITS DE L'HOMME**

# Interview d'un futur suicidé



Stefan Marinov : « Malgré les apparences, nous sommes vraiment dangereux ».

● Même formulée sur un ton tranquille par un homme serein, elle vous atteint comme un coup de poing, une déclaration de ce genre :

— Je m'immolerai par le feu le 14 janvier devant l'ambassade soviétique à Paris.

Le candidat au suicide s'appelle Stefan Marinov. Vous le connaissez à travers les articles que nous lui avons consacrés à plusieurs reprises. Vous savez les mauvais traitements qu'il a subis dans le goulag de l'insuline en Bulgarie, ses démêlés avec les diplomates de l'ambassade américaine à Sofia, les coups de fouet que lui ont infligés les flics tchécoslovaques, l'incrédulité avec laquelle ses travaux de physicien sur l'espace-temps absolu (remettant en cause la théorie de la relativité d'Einstein) ont été accueillis.

Après tant de mésaventures, Stefan Marinov n'aspire toujours pas au repos. Au contraire. Pour obtenir la libération du physicien et dissident soviétique Youri Orlov, pour forcer le président Jimmy Carter à relancer sa croisade en faveur des droits de l'homme dans les pays de l'Est, voilà qu'il menace de se transformer en bonze incandescent dans une rue de Paris. Et précisément le 14 janvier, date anniversaire du suicide par le feu de Jan Palach à Prague.

Pourquoi tenir pour responsable de la détention abusive de Youri Orlov aussi bien le président des Etats-Unis que les dirigeants soviétiques ? N'est-il pas choquant d'acheter la liberté d'un homme au prix de la vie d'un autre ? Comment réagissent les dissidents vis-à-vis de ce type d'action ? Autant de questions que nous avons posées à Stefan Marinov.

● En menaçant de vous immoler par le feu, vous voulez mettre en évidence et condamner le soutien que M. Carter et le gouvernement américain offrent au pouvoir soviétique pour étouffer la voix des dissidents, défenseurs des droits civiques. Vous reprochez donc au président des Etats-Unis les atteintes aux droits de l'homme dans les pays de l'Est.

— Je tiens en effet Carter pour responsable des cochonneries se trouvant dans la cour de son voisin. Comme je considère Pie XII responsable de Dachau et d'Oswiecim. Dachau ne se trouvait pas dans la cité du Vatican aux pelouses nettes et aux parterres fleuris. Le pape était pourtant coupable des massacres dans les camps et les chambres à gaz des nazis. Sa responsabilité était morale. Celle de Carter, actuellement, est juridique. Les Etats-Unis n'ont-ils pas signé les accords d'Helsinki ? Ces accords représentent un contrat. Si les clauses de ce contrat ne sont pas respectées par l'une des parties contractantes, il faut le rompre. Par son silence complice, Carter tend à montrer que les accords d'Helsinki ne sont qu'un bout de papier démagogique, de la poudre jetée aux yeux de l'opinion internationale.

● Les Etats-Unis et l'Union soviétique entretiennent des contacts à différents niveaux (équilibre nucléaire, partage du monde). Pensez-vous que le président Carter va chicaner M. Brejnev sur la question des droits de l'homme quand ce dernier peut lui causer des problèmes, par représailles, dans des domaines vitaux ?

— Dans le monde, domine l'opinion que Carter, même s'il ne défend pas les droits de l'homme dans les pays totalitaires de droite (Chili, Argentine), voudrait ardemment les défendre dans les pays totalitaires de gauche (U.R.S.S., Vietnam). Quelle erreur ! Par mon action, j'entends mettre Carter au pied du mur. Je veux qu'il s'engage formellement, par écrit, à lutter pour les droits civiques dans les pays de l'Est. Sinon je me ferai brûler à Paris. Ce scandale nuira certainement à sa carrière politique. Et s'il croit en Dieu, comme il le dit souvent, il aura avec sa conscience de graves problèmes, proportionnels à la profondeur de sa dévotion. D'autre part, un refus de Carter prouverait à l'opinion publique, de façon nette, que les dissidents des pays de l'Est ne sont pas considérés par le gouvernement américain comme des amis, que l'Ouest a peur de ces gens.

● Ne surestimez-vous pas la force des dissidents ? Pour quelles raisons les craindrait-on en Occident alors qu'ils apparaissent déjà si faibles en face de leurs propres gouvernements ?

— Malgré les apparences, nous sommes vraiment dangereux pour tous les gens au pouvoir. Les régimes policiers de l'Est semblent forts, font semblant d'être forts. En fait, ils sont à la veille de l'écroulement. Certains pensent qu'on ne recourt pas à un stalinisme authentique à l'Est parce que le pouvoir est assez sûr de lui et qu'il n'a pas besoin d'une terreur sangulnaire. C'est faux. Il est impossible de recommencer avec le stalinisme. Ce serait une débâcle pour le régime. Le stalinisme, l'hitlérisme, n'importe quelle dictature sanglante de ce type peuvent s'exercer uniquement si l'on a réussi à duper idéologiquement une part importante de la population. A l'Est, ce n'est plus possible désormais. Ce n'est donc pas la bonté de Brejnev ou d'Andropov qui a mis un masque humain au néostalinisme mais leur impuissance. Et les gouverne-

**THIS PAGE IS LOCKED TO FREE MEMBERS**

Purchase full membership to immediately unlock this page

**SAVE \$3,999,994**

Did you know we sell  
paperback books too?

To buy our entire catalog  
in paperback would cost  
over \$4,000,000

Access it all now for  
\$8.99/month

\*Fair usage policy applies

**Continue**

# **LIBERTE POUR ORLOV**

## **CONFERENCE**

dédiée à la décision du dissident bulgare, Stefan Marinov, de s'immoler par le feu, si le Président Carter n'interviendrait par écrit en faveur de la libération du prisonnier de conscience russe, Youri Orlov.

## **PROGRAMME**

Présentation avec le film « Stefan Marinov, le dissident dissident ».

**PART I - DISSIDENCE POLITIQUE :** La situation en Bulgarie. Sources et caractère de la dissidence bulgare. Le goulag de l'insuline bulgare. Les dissidents vis-à-vis de la « droite » et la « gauche » occidentale. Le communisme qui suit la parole du Christ.

**PART II - DISSIDENCE SCIENTIFIQUE :** Présentation de la théorie de l'espace-temps absolu. Explication et discussion de l'expérience des « miroirs couplés » avec laquelle pour la première fois dans l'histoire Marinov a réussi à mesurer la vitesse absolue de laboratoire, c'est-à-dire de la Terre, dans l'espace absolu. Cette expérience démontre l'invalidité du principe de la relativité et restaure l'éther lumineux.

Intervention de Stefan Marinov.

Intervention des représentants de l'opinion publique.

Discussion avec la salle.

Sont invités d'envoyer un message ou de participer à la Conférence (personnellement ou par l'intermédiaire d'un représentant) :

Jean-Paul II  
Giscard d'Estaing  
Raymond Barre  
Jacque Chirac  
François Mitterand  
George Marchais  
Roger Garaudy  
Alain Krivine  
Lorant Schwartz  
Alessandro Pertini  
Enrico Berlinguer  
Marco Panella  
Santiago Carillo  
Helmut Schmidt  
Franz-Josef Strauss  
Margaret Thatcher  
Harold Wilson  
Leo Tindemans  
André Cools

Jan Vergeer  
Robert Kennedy  
Robert Dornan  
Leonid Brejnev  
Andrei Sakharov  
Vladimir Maximov  
Leonid Plioutch  
Alexander Zinoviev  
Todor Jivkov  
Nicola Tendjerkov  
Gustav Husak  
Jiri Hajek  
Jiri Pelikan  
Pavel Tigrid  
Erick Honnecker  
Wolf Biermann  
Josip-Broz Tito  
Michajlo Michajlov  
Paul Goma

**Palais des Congrès, Salle bleue,  
12 janvier 1980 (samedi), 20 h 30.  
Métro : Porte Maillot  
Entrée libre**

**M. Jimmy Carter  
Président des EU  
La Maison Blanche  
Washington**

**Stefan Marinov  
rue Stéphanie 83  
B-1020 Bruxelles  
9 septembre 1979**

**M. le Président,**

**Ma troisième lettre à vous (de 29 novembre 1978) n'a pas été répondu personnellement par vous, mais complètement formellement (ainsi que ma deuxième lettre) par un employé dans la Maison Blanche.**

**Ça me contraint de vous écrire pour la quatrième fois. Le ton dur et ultimatif de ma présente lettre est provoqué seulement par votre silence.**

**La politique de « détente sans liberté » est arrivée à un fiasco complet. Maintenant les deux alternatives suivantes sont restées devant le monde : a) détente avec liberté ou b) guerre froide qui inévitablement peut être suivie d'une chaude. Dans les quelques mois prochains le monde doit se décider laquelle de ces deux voies à suivre. Dans une mesure considérable le choix est dans vos mains.**

**Quand vous êtes entré à la Maison Blanche, vous avez hautement arboré le drapeau des droits de l'homme et de la souveraineté nationale. Mais nous ne voyons pas une réalisation de votre programme solennellement proclamé. Est-ce que c'est le résultat d'une incapacité et impossibilité objective d'accomplir ce programme, ou le résultat d'un manque de bonne volonté ? Je crains, les faits et les fruits regrettables de nos contacts mutuels parlent en faveur de la seconde présupposition.**

**Je veux que vous montriez clairement devant le monde la face vraie de votre politique : Etes-vous pour l'implication des Accords d'Helsinki avec des actions ou avec des paroles ; êtes-vous pour la liberté et pour le respect des droits de l'homme ou pour la connivence à la violence et la tyrannie ? Pour ce but je vous présente l'ultimatum suivant :**

**Insistez auprès du gouvernement soviétique pour la libération de mon collègue, le docteur ès sciences physiques et membre correspondant de l'Académie des Sciences de l'URSS, Youri Orlov, le représentant du groupe moteur pour l'accomplissement des Accords d'Helsinki dans l'Union Soviétique, condamné sans évidence de crime.**

**Dans le cas que vous ne pourriez pas avoir de succès et vous ne m'informiez pas avec une lettre personnelle sur les efforts que vous avez entrepris pour la libération d'Orlov, en janvier (le jour où Jan Palach se brûla sur la place de Saint Venceslas à Prague) je m'immolerai par le feu en face de l'ambassade soviétique à Paris.**

**Je vous en prie de comprendre que l'honorable libération d'Orlov (laquelle ne doit pas être suivie par une expulsion de l'Union Soviétique) ne marquera pas une faiblesse et défaite de l'Etat Soviétique. Ce sera une de ses plus grandes victoires sur sa voie épineuse vers la restauration de la légalité et de la liberté spirituelle, laquelle il a entrepris il y a 20 ans. L'honorable libération d'Orlov va montrer devant tous le monde que la détente avec liberté n'est pas une utopie, et seulement une telle espèce de relations peut être nommé « détente ». Cette libération va montrer que les différents pays dans le monde peuvent vivre en paix, confiance mutuelle et solidarité honnête.**

**Si vous ne faites aucun effort et gardez le silence, avec l'extinction des flammes de mon immolation tous les espoirs de l'humanité pour la paix et pour le sauvetage de l'holocauste nucléaire s'éteindront.**

**Stefan. Marinov**

**Citoyen de la République Populaire de Bulgarie,  
Membre du gouvernement mondial**

## **AU PEUPLE DE PARIS**

**Amis et camarades Inconnus,**

**Je m'adresse à vous tous avec qui nous nous bousculons dans les rues, voyageons dans le métro, cherchons du pain et de la joie dans la grande ville, s'étouffant de la hâte et des gaz des voitures ; à vous tous qui voyez l'enfer vers lequel nous emporte impétieusement le sort implacable, mais qui croyez encore que l'humanité peut trouver des forces pour arrêter la folie nucléaire et totalitaire.**

**Le 9 septembre je m'adressais au Président Carter avec un ultimatum, la traduction duquel est imprimée sur ce tract. Comme m'a averti récemment la première secrétaire de l'ambassade américaine à Bruxelles, Mme Eltz, la possibilité d'une réponse de la part de Carter à mon ultimatum est presque exclue. Devant moi est restée seulement une voie, la voie de l'immolation. Avant d'entreprendre ce pas décisif, je voudrais t'expliquer, peuple de Paris, pourquoi je l'avais choisi. Pour ça le 12 janvier, à la veille de mon immolation (qui aura lieu le 14 janvier 1980 à une heure de l'après-midi en face de l'ambassade soviétique à Paris) je t'appelle au Palais des Congrès. Viens pour m'écouter.**

**Je ne voudrais pas qu'après mon départ les amis de lutte me reprochent une faiblesse momentanée, les journalistes avec une plume légère un aventurisme maniacal et les enragés, qui poussent des millions de gens vers le suicide, une folie.**

**Je suis un représentant de la dissidence est-européenne. On nous appelle avec un nom étrange — des pensants différemment (inacomisliashchie). L'histoire nous a donné, ou mieux dire, nous avons choisi, seulement une arme — de penser différemment. Contre nous on lutte avec tous les moyens possibles : le mensonge, la calomnie, la corruption, le chantage, le fouet, les chaînes, le parapluie empoisonné. Et quand à nous — nous avons seulement un moyen de résister: de penser et parler obéissant à la voix de notre conscience. Nous ne nous permettons pas de poser des machines infernales, de tirer de derrière le coin, de voler de l'argent, de mentir au peuple et même d'avoir une activité clandestine, de mentir à la police, simplement de s'organiser. Et quand V. Maximov se permit de dire quelques paroles plus dures dans la presse, beaucoup ont levé les mains : « Même à ça, frère, tu n'a pas le droit ». Je suis convaincu qu'exactement cette auto-limitation, qui nous a légué Jésus, donne un espoir que, peut-être, nous pourrions arrêter la folie.**

**On se demande si nous avons le droit au suicide comme forme de protestation et revendication. Ou même ce droit doit être rejeté. Le premier vers lequel je m'adressais pour une aide dans mon action était L. Plioutch, l'homme qui est le plus proche de mon cœur. Plioutch a dit : « Je suis contre. Tu n'a pas le droit ». Et se détourna. Même Plioutch, le « saint » Plioutch me laissa seul.**

**Mais j'ai décidé de continuer à marcher sur la route, sur laquelle une voix m'appelle. Le problème n'est pas de montrer que Carter ne s'intéresse pas à la liberté d'un certain Russe et à la vie d'un certain Bulgare. Avec mon acte je veux crier la douleur des millions de gens dans les pays totalitaires et leur aspiration vers la liberté.**

**Je ne veux pas quitter ce monde. Je suis le premier qui a mesuré la vitesse absolue de la Terre et deviné l'énigme du sphynx de l'espace-temps. Je voudrais être un témoin du triomphe de la simplicité, de la clarté et de l'élégance dans la physique. Et quelle richesse est la beauté éternelle de la nature, l'amour et l'amitié de nos proches... Mais une voix ne me donne pas la paix.**

Youra, je ne te connais pas. Toi moi non plus. Tu n'a pas réclamé mon aide. Mais ton malheur est mon malheur, notre malheur. Ta liberté est ma liberté, notre liberté. Quand les Bulgares se sont levés à la lutte contre les envahisseurs turques, ils ont écrit sur leur drapeau deux paroles « Liberté ou la mort », c'est-à-dire il est mieux d'être mort mais pas esclave. Maintenant l'époque est différente. L'alternative est la même « Liberté ou mort », mais le sens est différent : Ou nous serons capables de reconquérir la liberté, ou nous tous mourrons sans savoir pourquoi dans la plus terrible des guerres de l'histoire humaine. Devant cette mort apocalyptique ma mort n'est pas une mort.

Ma décision n'est plus dans mes mains. L'unique chose que je peux dire, c'est de répéter les paroles éternelles : « Mon Dieu, si tu peux, enlève le calice amer de ma bouche ; si non, que ta volonté soit exécutée » .

Peuple de Paris, sans notre liberté tu ne peux pas préserver ta liberté. Si tu peux, aide-moi, comme je veux donner une aide à Orlov et à toi.

1 Janvier 1980

Stefan Marinov

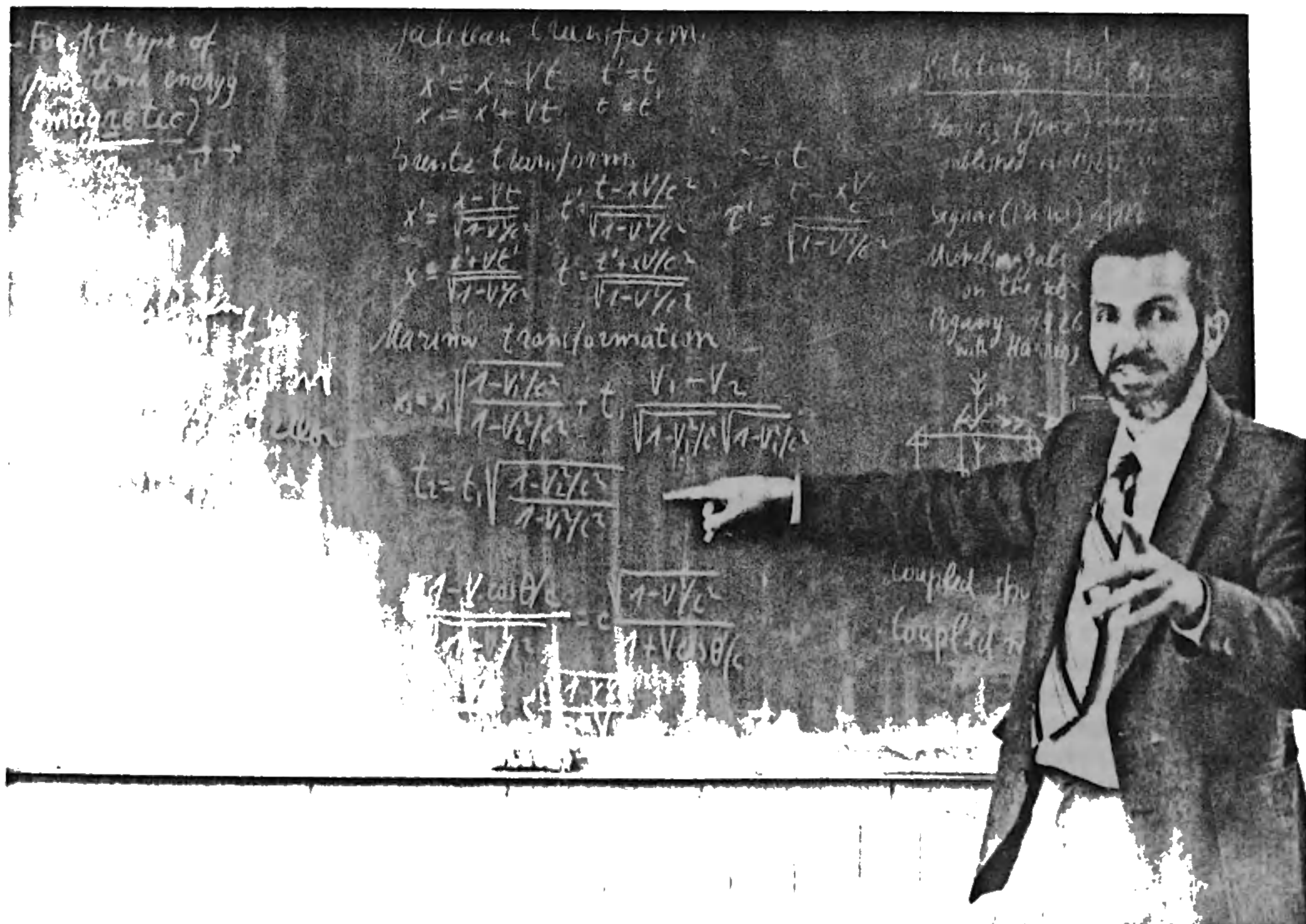

"POURQUOI PAS?" - Bruxelles, 31 janvier 1980

EUROPE DE L'EST

## Marinov, le « dissident dissident »

● Nos lecteurs connaissent l'intellectuel dissident bulgare Stefan Marinov, physicien et écrivain qui vivait en Belgique. Parmi les contestataires de l'Est, il occupe une place à part : son passeport bulgare ne lui a pas été retiré.

Comme nous l'avons annoncé (voir le « Pourquoi Pas ? » du 20-12-79), Stefan Marinov s'est rendu récemment à Paris en annonçant son intention de s'immoler par le feu le 14 janvier devant l'ambassade d'U.R.S.S. pour obtenir la libération du prisonnier de conscience russe Youri Orlov.

**A**LORS qu'il placardait sans autorisation officielle des affiches pour annoncer son geste, et la réunion publique organisée par lui la veille pour expliquer son action, Stefan Marinov a été arrêté courtoisement, relâché, puis conduit dans un asile psychiatrique où il a passé une journée.



Stefan Marinov, un contestataire pas comme les autres.



De célèbres dissidents soviétiques : de gauche à droite, Vladimir Plioutch, Marek Halter, Vladimir Boukovski, Edouard Kouznetzov et Alexandre Guinzbourg.

Libéré; il a pu organiser la réunion prévue dans une salle du Palais des Congrès, Porte Maillot, et se déplacer dans Paris. Des policiers suivaient ses mouvements pour l'empêcher de se suicider. Après trois jours, Marinov a estimé plus commode pour chacun de ne plus jouer à cache-cache. Il a donc achevé son séjour parisien en cordiale compagnie avec ceux qui avaient pour mission de veiller sur lui, partageant avec eux les taxis et même un repas chez des amis. Pour fêter sans doute son non-suicide...

Le plus intéressant dans cet épisode est, outre le geste symbolique, le caractère personnel de la position que Stefan Marinov a expliquée à ses interlocuteurs parisiens.

Apparenté par certains aspects à la pensée de Nicolas Berdiaeff, attentif aux sources chrétiennes d'un certain marxisme, il se définit comme « dissident dissident ». Une cause pour laquelle il se sent tout feu, tout flamme...

Il considère que les coupables du retour à la guerre froide sont « non seulement les dinosaures sclérosés qui, épris d'une peur paranoïaque, se cachent de leur peuple derrière les murs ténébreux du Kremlin. Coupable est aussi, dit-il, le gouvernement des Etats-Unis. Au lieu d'aider les forces de la paix dans l'Union soviétique et ses satellites, l'Amérique poursuit, et sa marine donne une aide aux forces de la guerre dans les pays qui les encerclent et renforce son propre potentiel destructif. C'est ça exactement que cherchaient les dinosaures avec l'installation des fusées SS 20 et avec l'intervention en Afghanistan — créer la psychose guerrière, gonfler dans les yeux de la population le mythe de la « peste jaune armée par les capitalistes judéo-américains », et étouffer la voix des meilleurs fils du peuple qui réclament la liberté et la fraternité

avec tous les peuples du monde. On ne doit, ajoute-t-il, jamais oublier les paroles prophétiques de Trotsky prononcées pendant les grandes purges : « Le stalinisme, déchiré par ses contradictions internes, inévitablement va s'écrouler. Il y a seulement un facteur qui peut le sauver — la guerre ».

Avant son expérience parisienne, Stefan Marinov avait été invité par un membre du Congrès des Etats-Unis, le républicain Robert K. Dornan, par une lettre datée du 10 octobre 1979, pour venir discuter aux U.S.A. avec lui des droits de l'homme dans les pays de l'Est. Mais le visa pour les Etats-Unis ne lui a pas été accordé par le consulat U.S. à Bruxelles parce que « sa demande n'établissait pas suffisamment ses moyens de couvrir les frais de son séjour ». « De plus, lui écrivait le vice-consul le 28 décembre 1979, vous n'avez pas démontré que les buts de votre voyage sont en accord avec un visa B2, délivré pour des visites temporaires aux U.S.A. pour le plaisir ». « Si vous avez d'autres questions concernant le visa, je vous prie de me contacter », concluait le vice-consul.

On sait que M. Marinov est resté citoyen bulgare, d'un pays qui n'a pas de prisonniers politiques selon son n° 1, M. Todor Jivkov, que le dissident contredit sur ce point. Il a l'intention de se rendre prochainement dans son pays pour quelques jours et s'attend à y être admis. Voilà qui s'appelle jouer avec le feu. Mais il espère aussi que le chaud succédant dans une certaine mesure au froid, l'U.R.S.S. envisage d'autoriser l'émigration de Youri Orlov.

Comme le séjour éventuel de Stefan Marinov en Bulgarie, le sort de Youri Orlov — et de bien d'autres dissidents soviétiques — nous apprendra jusqu'où va la « ligne dure » actuellement adoptée à Moscou et ses répercussions dans les pays d'Europe centrale. ♦



# Aspira al Nobel lo scienziato che contesta Einstein

## Fuggito dal suo paese, la Bulgaria, dove era stato chiuso in manicomio, Stefan Marinov abita nella nostra città

Si dice comunista, ma crede fermamente nelle forze del bene coordinate da Dio. Si dichiara dissidente a sinistra del sistema socialista applicato nel suo paese, la Bulgaria, ma vive in una villa neogotica di San Martino con un conte amante della parapsicologia. Come scienziati medioevali, rappresentati nell'antica iconografia tra alambicchi e fiamme diaboliche, accosta la fisica moderna anche al mondo del paranormale. E come i suoi colleghi vissuti prima di Galileo Galilei è convinto che lo spazio sia assoluto e che Einstein abbia parecchi torti nella sua descrizione della legge della relatività.

Si tratta di Stefan Morinov costretto a starsene lontano dalla sua patria d'origine pena l'essere rinchiuso in manicomio e approdato nella nostra città dove ha trovato buona ospitalità presso il parapsicologo Lelio Calateri, ormai completamente votato a due somme cause: farsi pubblicità in azioni clamorose contro il regime del suo paese e difendere il primato della sua grande scoperta scientifica, ovvero l'erroreità delle idee einsteiniane.

*-In Bulgaria dicevano che sono matto e per questo sono stato rinchiuso per diverso tempo in manicomio - spiega Marinov nella sua villa rifugio avvolta dalle magiche luci del sole rifranto - La mia pazzia consiste solo nel non condividere il pensiero politico dei dirigenti bulgari e le idee di altri fisici. Tutto lì. Eppure anche ai tempi di Galileo Galilei nessuno credeva alle grandi scoperte dello scienziato pisano. Contro di lui hanno addirittura fatto un processo. Nella stessa maniera si è mossa contro di me la scienza ufficiale, quasi fosse un delitto non esser d'accordo con lei.*

Marinov parla scioltamente l'italiano e dalla stringata logica dei suoi ragionamenti non sembra proprio matto. *«Nonostante quello che gli altri fisici e filosofi affermano - continua - nonostante ciò che Einstein stesso ha sostenuto, io dico che la terra si muove nello spazio assoluto e che il suo moto è registrabile in laboratorio. Prova che io posso testimoniare».*

La cosa lo interessa enormemente e ammiccando spiega subito il perché. *«La mia è una*

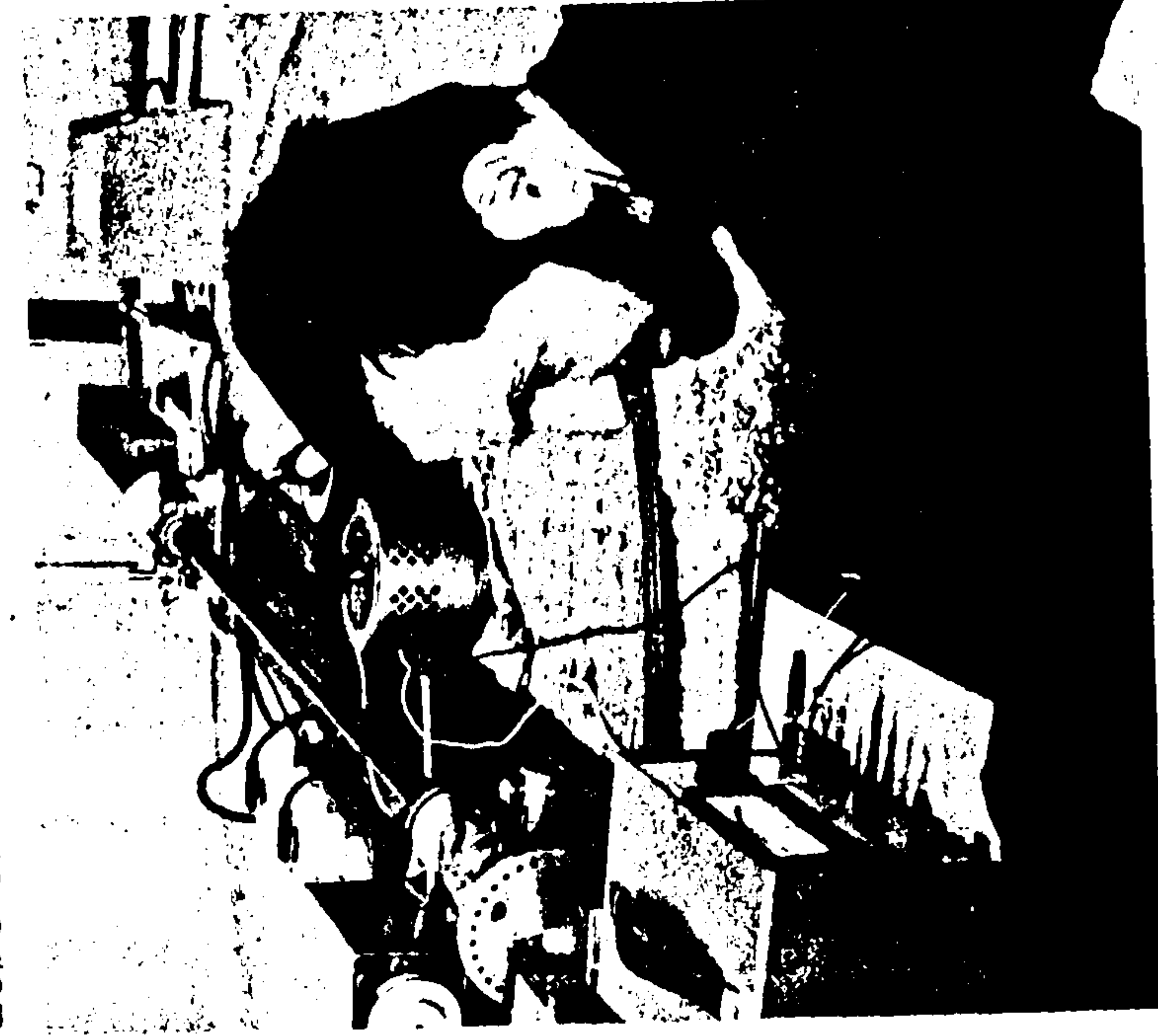

Lo scienziato Stefan Marinov compie un esperimento

grande scoperta. E non vorrei che qualcun altro se ne appropriasse. C'è un fisico italiano che vive in Brasile, Lattes, che ha fatto recentemente esperimenti simili ai miei. Non vorrei, visto l'ampia pubblicità data alle sue teorie, passare in secondo ordine e perdere la battaglia sul Nobel». Premio che gli sta incredibilmente a cuore «non solo per il riconoscimento scientifico - come dice - ma anche perché così le mie azioni di protesta contro il regime bulgaro sarebbero sicuramente amplificate».

Pol, rapidamente spiega in che cosa consiste la sua grande scoperta. *«Il principio della relatività è strettamente legato alla propagazione della luce, che si diffonde nel vuoto alla velocità "c" di 300 mila chilometri per secondo. Il vuoto non può essere attaccato ad un oggetto, perché il vuoto non si può trascinare. Quindi in un laboratorio che si muove nello spazio assoluto con una velocità "v" la velocità della luce dev'essere "c-v" nell'andata e "c più v" nella direzione opposta».*

E' proprio questa differenza tra l'andata e il ritorno della

luce che appassiona Marinov. *«Finora tutti i fisici hanno misurato la velocità della luce nel suo andare e ritorno. Mai nessuno l'ha misurata lateralmente nel suo procedere avanti».*

*«Io invece - continua Marinov - l'ho fatto col mio esperimento degli specchi accoppiati. Proprio per tali osservazioni mi sento di sostenere le ragioni del filosofo rinascimentale Nicola Cusano che dice che il mondo è una sfera il centro è dappertutto e la superficie non si può mai trovare».*

Pertanto la teoria dell'universo che si espande è sicuramente discutibile. Ho misurato la velocità del sole che trecento chilometri al secondo. Se la mia osservazione è allora la terra è quasi attorno all'universo, pratica dove avvenne quello che noi scienziati chiamiamo bang, lo scoppio che ha origine a tutto».

Sarà vero? Marinov ne è certo. *«Soprattutto perché gli scienziati dopo tante insistenze ne stanno ancora discutendo».*

**THIS PAGE IS LOCKED TO FREE MEMBERS**  
Purchase full membership to immediately unlock this page

**FORGOTTEN BOOKS**

# **FULL MEMBERSHIP**

**797,885 Books!**  
**All you can read**  
**for only**  
**\$8.99/month**

**Continue**

\*Fair usage policy applies



Martedì 6 luglio 1982

## I lavori del convegno di Genova

# La scienza rifiuta di incontrare la parapsicologia

### Perché il fisico Borsellino declina l'invito

Il Congresso di parapsicologia alla Fiera di Genova prosegue.

«Difficilmente — dice il professor Antonio Borsellino, direttore dell'Istituto di fisica all'Università di Genova — parteciperò a questo congresso, come difficilmente penso interverrà Piero Angela e altri studiosi poichè tutto quanto avevamo da vedere, da sentire e da sperimentare è già stato fatto e le conclusioni da noi tratte le conosce bene, per cui non vedo la ragione di tentare l'ennesima prova. Ormai la parapsicologia è stata smascherata in tutti i sensi, sia nel senso di quelli che si servivano di questa con frode, magari per guadagnarci sopra, sia dalla parte degli animi ingenui e fiduciosi. Mi creda, la parapsicologia è una scienza fondata sul niente, tant'è vero che esperimenti che sono stati ripetuti sotto il nostro controllo non hanno dato alcun risultato e persino Uri Geller, il più grande piegatore di cucchini e posateria d'ogni genere, è ormai scomparso dalla scena da quando sono stati scoperti alcuni trucchi clamorosi. Quanto poi alla 'fotografia Kirlian' che dimostrerebbe come gli esseri viventi abbiano intorno a sé, e le persone dotate di poteri paranormali in misura maggiore, un alone di energia resa visibile in fotografia, questo è stato da noi confutato dimostrando che l' 'effetto corona' è ritrovabile anche intorno a una semplice foglia di plastica inumidita e ciò è dovuto alle leggi dei campi magnetici. Come vede, ad ogni spiegazione paranormale c'è una spiegazione razionale che spazza via qualsiasi eventuale dubbio. Piero Angela, me stesso e altri scien-

ziati, in tutto una ventina in Italia, avevamo costituito un comitato a difesa della razionalità. Abbiamo effettuato accurati controlli per dimostrare come gran parte dei fenomeni paranormali siano semplicemente spiegabili con leggi fisiche o chimiche o ancora più semplicemente con trucchi da prestigiatore. Purtroppo, però, ben difficilmente riusciamo, con le nostre spiegazioni logiche, a convincere gli assertori di questa scienza, perchè non c'è più sordo di chi non vuol sentire e in questo caso, questi sono così fermamente convinti delle loro tesi che non vogliono vedere neanche la più semplice evidenza».

— Che cosa ne pensa, in qualità di fisico, degli esperimenti sullo spazio-tempo assoluto, effettuati da Stefan Marinov che si svolgeranno dall'8 all'11 luglio? Sarà veramente la fine delle teorie di Einstein sulla relatività?

«Dubito che Stefano Marinov possa demolire con i suoi esperimenti postulati così fondamentali come quelli di Einstein, tanto più che i suoi esperimenti sono scarsamente affidabili.» Stefan Marinov afferma invece di aver avuto sempre quasi tutti gli studiosi fisici contro, persino il Comitato Nobel che non vole dare peso ai suoi esperimenti. «Le assicuro invece che se il Comitato avesse ritrovato nelle teorie di Marinov qualcosa di veramente importante, non avrebbe esitato a buttarla all'aria, in quattro e quattr'otto tutta la relatività e l'equivalenza einsteiniana; se ci fosse stato qualcosa di veramente importante negli esperimenti di Marinov, non ci sarebbe sfuggito.»

c.mar.

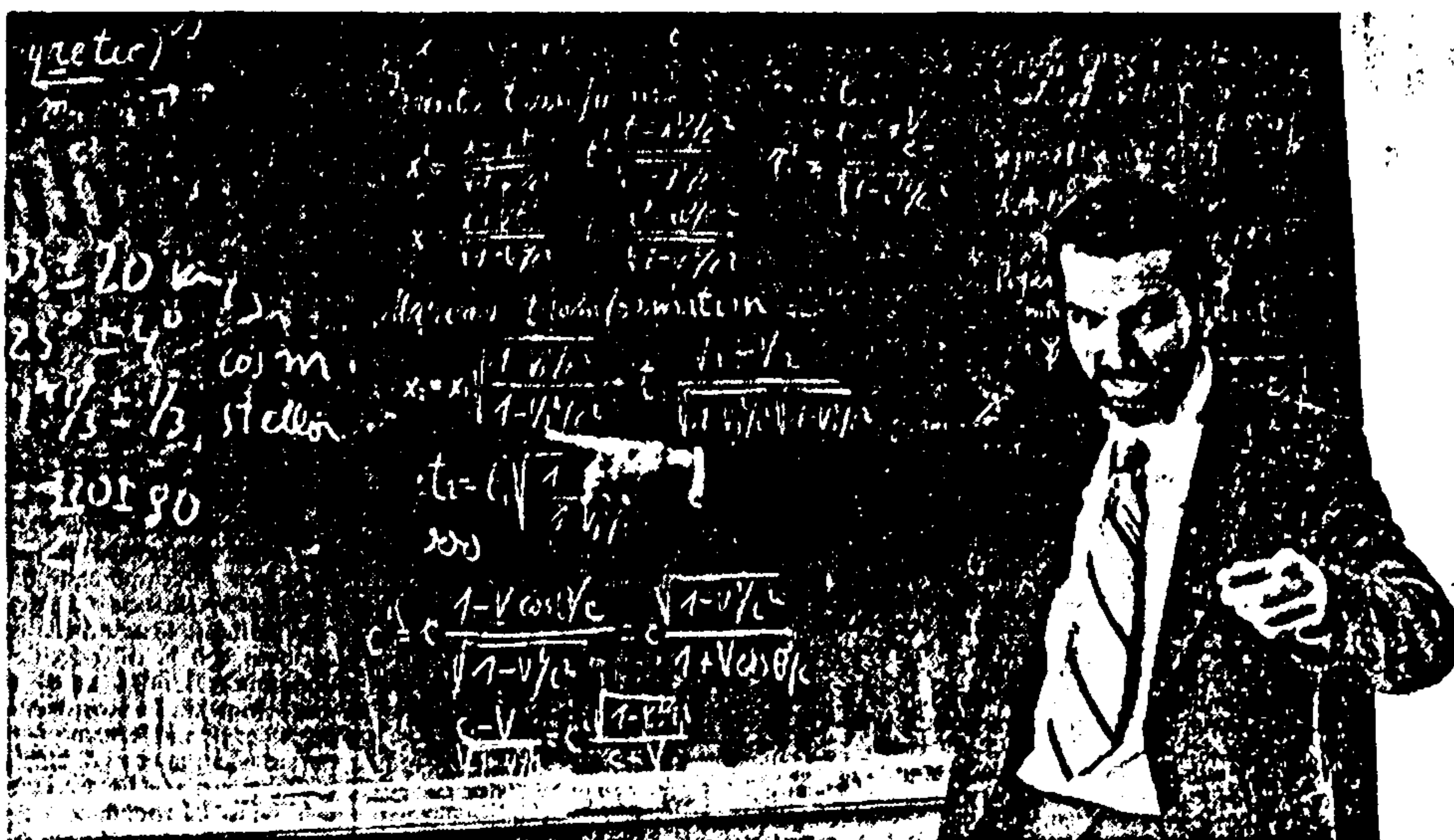

**S**i chiama Stefan Marinov, ha 51 anni, un diploma di capitano di lungo corso e una laurea in fisica. In Belgio, per lui, hanno inventato una definizione: «il dissidente dissidente». Significa che Marinov, bulgaro, contestatore nei confronti dei regimi a «socialismo reale», non ha deciso di appiattirsi — come tanti altri esuli — sul modello occidentale: continua a dichiararsi comunista e fedele alla carta costituzionale del proprio Paese («Noi abbiamo una costituzione democratica. E' il potere a non rispettarla») e denuncia l'accordo sostanziale che — dice — regna tra Usa e Urss nella spartizione del mondo.

Queste denunce, che poi sono un'accusa agli Stati Uniti di far solo della demagogia con i diritti dell'uomo, non hanno, in realtà, avuto grande diffusione: Marinov è un dissidente scomodo. E' difficile sventolarlo come bandiera «anti», perché la sua filosofia finisce per essere contraria a qualsiasi forma di potere. Scomodo doppiamente perché, se politicamente non è «affidabile» come strumento di propaganda, scientificamente il fisico Marinov da anni «rompe le scatole» con le sue tesi che, per sintetizzare al massimo, possono definirsi anti-einsteiniane, opposte, cioè, al principio della relatività.

Stefan Marinov nasce a Sofia da una famiglia di intellettuali borghesi, comunisti e legati al segretario del PC Kostov. Suo padre, quando il comunismo sale al potere, diventa diplomatico e, con la famiglia, gira varie città. Per questo Stefan studia un po' a Sofia, un po' a Praga, un po' a Varna. Sono studi apparentemente confusi: Marinov lascia l'università, dove sta specializzandosi in fisica, per diplomarsi capitano di lungo corso. Gira il mondo per qualche anno. Quando torna, consegue la laurea in fisica e trova lavoro nell'Istituto di ricerche universitarie di Sofia.

Una vita normale. Se non arrivasse il XX congresso del Pcus a mettere in discussione tutto quello che — dice Marinov — era dato per assodato: a mettere in gioco la credibilità dei regimi comunisti nei Paesi satelliti. Marinov

diventa «scomodo». Comincia a frequentare circoli di intellettuali critici e a diffondere giornalini (una sorta di lettere fatte in più copie e mandate ad amici, conoscenti, personalità) satirici.

La sua prima azione pubblica si svolge durante il congresso degli studenti a Sofia nel '60. Marinov distribuisce volantini proponendo il «disarmo di base», un'idea apparentemente ingenua, costruita però su una forte provocazione: ogni aderente all'iniziativa si impegna a trovare un altro studente in un Paese della Nato e, insieme a lui, a rifiutare il servizio militare. «Uno in meno per parte», spiega Marinov ironicamente. E aggiunge: «Del resto Marx aveva scritto che gli esercizi devono essere fatti da volontari».

Tenuto d'occhio dalla polizia politica, Marinov prosegue i suoi studi finché, nel 1966, dopo due lettere inviate al ministero degli Interni con la pressante richiesta di ottenere il visto per la Cecoslovacchia, viene arrestato. Dieci giorni di prigione, e, poi, internamento in un manicomio. «Dopo tre mesi di osservazione — sempre in isolamento — una commissione di cinque medici mi definì paranoico. Su questa base mi sottoposero per quattro mesi ad un trattamento a dosi di Mageptil: mi sembrava di impazzire a

prendere quella roba. Ma peggio fu quando finalmente mi lasciarono libero. Fuori mi sentivo assalire dalla depressione, mi prendevano manie suicide. Fu quello, più ancora che i sette mesi nel manicomio, il periodo più brutto».

Tornato a casa con l'invito a non farsi più notare, Marinov riprende i suoi esperimenti per confermare la teoria dello spazio-tempo assoluto («Sia teoricamente, sia con le prove di laboratorio ho dimostrato l'infondatezza della teoria della relatività di Einstein: questo non significa che neghi l'enorme importanza dello scienziato, solo dico che, considerandomi suo allievo, sono andato più avanti»).

Per qualche anno Marinov sta tranquillo nel suo laboratorio; ma torna in prigione nel settembre del '73: Breznev è in visita a Sofia e, per tutto il periodo della sua permanenza, i dissidenti sono messi «al sicuro».

Dall'arresto passa nuovamente al manicomio. Ma questa volta non è in isolamento e non viene guardato a vista. «Per questo riuscii a scappare e, dopo essermi fatto prestare degli abiti da un amico, raggiunsi l'ambasciata americana. Cercai il console, mister Snow, che conoscevo perché aveva fatto da tramite per i miei rapporti con scienziati del suo Paese.

Ma dall'ambasciata telefonarono alla polizia. Vennero gli agenti, mi legarono le mani e — nel vestibolo di quello che doveva essere territorio americano — mi picchiarono, rompendomi un braccio. Poi mi portarono via, nuovamente nella clinica. Capii allora che Nixon e Breznev dicevano parole diverse ma volevano la stessa cosa: assoggettare i popoli spartendosi il governo del mondo».

Pochi mesi dopo, nel marzo 1974, torna libero, Marinov è privato del lavoro e si vede assegnata una pensione di 80 leva al mese come «malato di mente». Con l'aiuto di qualche amico riesce a continuare i suoi esperimenti in un laboratorio che installa dentro casa.

Quando pensa di aver approfondito sufficientemente la propria teoria fisica e convinto di non dare più «fastidio» decide di organizzare un convegno. Ottiene un placet orale dal capo dei servizi culturali del ministero degli Esteri bulgaro e invia lettere di convocazione in tutto il mondo. Il congresso scientifico — il dissidente sovietico Andrei Sakharov ha assicurato la sua partecipazione come presidente — si dovrà tenere a Varna dal 5 al 15 maggio 1977. «Il 15 aprile vengo convocato dalla polizia: il tuo convegno non si può fare, mi dicono. Mi ordinano di mandare a tutti tele-

grammi adducendo la scusa di una gamba rotta. Ma come volete che ci credano? chiedo. Suggestisco una scusa, scientificamente ancor più ridicola, ma loro non se ne rendono conto: diciamo che è previsto un terremoto per quei giorni. Prima di accettare le loro condizioni, però, contratto e ottengo un visto per l'Occidente».

Così, nel '77, Marinov approda in Belgio dove prosegue sul doppio binario — politico e scientifico — la propria attività. Da Bruxelles invia anche una lunga lettera a Enrico Berlinguer chiedendogli la tessera del Pci: «Io sono comunista, credo nei principi di eguaglianza e di libertà garantiti dalla nostra costituzione. Chi non crede a quei principi sono i dirigenti dei nostri Paesi», spiega Marinov. Ma non riceve risposta (in seguito, quando si trasferirà in Italia, otterrà la tessera del Psi).

Dal Belgio si muove speso. Riesce con una comitiva di turisti ad andare anche a Mosca e a parlare con Sakharov («Sulla mia teoria non prese posizione: per me non è né sì, né no, disse»), il 29 aprile 1978 va in piazza Venceslao a Praga per manifestare — da solo — a favore dei firmatari della Carta '77 con un cartello: «La vostra carta è la nostra. Marinov, Bulgaria». Ma qualcuno lo tradisce

e in piazza trova una quarantina di poliziotti. «Mi riempiono di botte e mi caricarono su un'auto portandomi alla frontiera con la Germania federale. Però si tennero il mio passaporto bulgaro, la mia carta d'identità belga, tutti i miei documenti, i libri e i soldi».

Nello stesso anno viene invitato negli Stati Uniti dove illustra la propria teoria (esperimenti su quella base saranno poi eseguiti e sono ancora in corso, da Torr e Kolen per conto della Nasa), ma non ottiene grandi simpatie: continua a dichiararsi comunista e a pretendere le scuse da Carter per il brutto episodio dell'ambasciata americana a Sofia di quattro anni prima.

Partecipa a convegni, scrive libri: ha pubblicato, tra l'altro, il trattato «Fisica classica», testi di economia politica, e una raccolta di poesie: queste ultime saranno, tra breve, edite anche in Italia da un editore genovese. Nel 1980 si trasferisce in Italia, a Genova. Quasi nessuno sembra accorgersi della sua presenza anche perché, in questo periodo, Marinov si dedica solo alla ricerca e al tentativo di propagandare i propri studi. Tentativo che incontra grosse resistenze, in verità: «Le riviste scientifiche si rifiutano di pubblicare il risultato dei miei studi che, pure, sono stati presentati in convegni in varie parti del mondo, comprese tutte le manifestazioni celebrative dei cento anni della nascita di Einstein nel 1979. E si rifiutano anche di pubblicare critiche alla mia teoria. In pratica hanno deciso che, opponendomi alla teoria della relatività che è finora accettata, non faccio discorsi scientifici. La risposta quasi generale è il rifiuto del dogmatismo, cioè l'atteggiamento antiscientifico: noi mi dicono che sbaglio, ma mi dicono che non posso avere ragione. Ancora un dogma insomma».

Ora Marinov ha lasciato l'Italia. E' in Austria dove con alcuni scienziati, sta conducendo i suoi esperimenti. Ma ha anche un altro impegno: ottenere il visto per uno dei più noti dissidenti sovietici, il fisico Yuri Orlov. Sorride tranquillo: «Quando tornerò in Italia porterò con me la dimostrazione della mia teoria e Orlov libero».

Mario Bottan

## Un dissidente troppo dissenziente ignoriamolo

# Behörde weist Dissidenten aus

Stefan Marinov, ein bulgarischer Dissident und Physiker, lebt seit einigen Monaten in Niederschöckel bei Graz. Jetzt wird er aus Österreich ausgewiesen. Die Begründung: „...da ein weiterer Aufenthalt in Österreich öffentlichen Interessen zuwiderläuft und die öffentliche Ruhe, Ordnung und Sicherheit gefährdet, hat die Behörde von ihrem Recht Gebrauch gemacht, das gegenständliche Aufenthaltsverbot zu erlassen.“ Wenn Stefan Marinov diese Entscheidung der Bezirkshauptmannschaft Graz-Umgebung nicht befolgt, wird er mit Polizeigewalt außer Landes gebracht.

Wer ist dieser Stefan Marinov? Ist er wirklich so gefährlich?

Geboren wurde Stefan Marinov 1931 als Sohn einer reichen Familie in Sofia, die sich aber noch während des Ersten Weltkrieges zum Kommunismus bekannt hat. Er war Assistent an der Physikalischen Fakultät in Sofia und Mitarbeiter der Bulgarischen Akademie der Wissenschaften. Er wandte sich zunehmend gegen das kommunistische Regime. Er verlangte, daß die Rechte der bulgarischen Staatsbürger nicht nur auf dem Papier anerkannt würden, sondern in der Praxis auch ausgeübt werden dürften. Von diesen seinen „falschen Gedanken“ wurde er das erste Mal 1966/67 im Kerker und in der Psychiatrie „geheilt“.

Neben seiner politischen Tätigkeit trat Stefan Marinov auf wissenschaftlicher Ebene mit der These auf, die heutige Raum-Zeit-Physik, die sich auf die Relativitätstheorie stützt, sei falsch. In wissenschaftlichen Abhandlungen versuchte er zu beweisen, daß die absolute Geschwindigkeit der Erde meßbar sei. Eine revolutionierende These. Dies war für die bulgarischen Behörden der Grund, ihn 1974 von der

Akademie der Wissenschaften zu pensionieren, noch zweimal für längere Zeit in psychiatrische Kliniken zu stecken (1974, 1977), für verrückt zu erklären, und 1977 diesen unbequemen Wissenschaftler in den Westen ausreisen zu lassen. 1982 wurde er schließlich ausgebürgert und sein Haus konfisziert.

In Graz widmete er sich nur noch seinen wissenschaftlichen Tätigkeiten. Er hielt einen Vortrag an der TU und bewarb sich ebenda um eine Professorenstelle. Er veröffentlichte sein fünfbändiges Lebenswerk „Classical Physics“, in dem er seine Theorie der Raum-Zeit-Physik wissenschaftlich darlegt. Ein Student an der Technischen Universität in Graz führt ein Experiment durch, das die Theorie von Stefan Marinov bestätigen soll.

Jetzt machen ihm die Behörden einen Strich durch die Rechnung — wenn es bei ihrem Beschluß bleibt. Österreich ist bekannt für seine Bereitschaft, Flüchtlinge und Dissidenten aufzunehmen. Warum nicht diesen bulgarischen Physiker, diesen Stefan Marinov? **Peter Rudlof**



Stefan Marinov: Seine Berufung gegen das Aufenthaltsverbot verhindert nicht eine zwangsweise Ausweisung aus Österreich

## Welche Drahtzieher?

(Zum Artikel „Behörde weist Dissidenten aus“ vom 29. September)

Mit Interesse las ich Ihre Reportage über das von der BH verhängte Aufenthaltsverbot gegenüber dem bulgarischen Physiker Stefan Marinov. Ich möchte Sie auffordern, Nachforschungen zu betreiben, welche einflußreichen Drahtzieher wir diese paternalistische Sorge um die Aufrechterhaltung der „öffentlichen Ruhe, Ordnung und Sicherheit“, wie es in der amtlichen Begründung heißt, zu verdanken haben.

Mag. Adolf Sawoff, Graz

LIST OF PUBLICATIONS

MARINOV'S PUBLICATIONS  
IN THE DOMAIN OF SPACE-TIME PHYSICS

- 1970, Phys. Lett., 32A, 183.  
 1972a, Phys. Lett., 40A, 73.  
 1972b, Phys. Lett., 41A, 433.  
 1973, Phys. Lett., 44A, 21.  
 1974a, Int. J. Theor. Phys., 9, 139.  
 1974b, Czechosl. J. Phys., B24, 965.  
 1975a, Int. J. Theor. Phys., 13, 189.  
 1975b, Phys. Lett., 54A, 19.  
 1976a, Found. Phys., 6, 571.  
 1976b, Int. J. Theor. Phys., 15, 829.  
 1977a, Found. Phys., 7, 947.  
 1977b, Phys. Lett., 62A, 293.  
 1977c, Abstracts GR8 (Waterloo, Canada), 244.  
 1978a, Found. Phys., 8, 137.  
 1978b, Found. Phys., 8, 637.  
 1978c, Spec. Sc. Techn., 1, 231.  
 1978d, Spec. Sc. Techn. 1, 235.  
 1978e, Spec. Sc. Techn., 1, 239.  
 1978f, Spec. Sc. Techn., 1, 520.  
 1978g, Found. Phys., 8, 801.  
 1979a, Found. Phys., 9, 445.  
 1979b, J. Phys. A, 12, L99.  
 1980a, Gen. Rel. Grav., 12, 57.  
 1980b, Spec. Sc. Techn., 3, 57.  
 1980c, Ind. J. Theor. Phys., 28, 329.  
 1980d, Abstracts GR9 (Jena, DDR), 658.  
 1981a, Found. Phys., 11, 115.  
 1981b, Ind. J. Phys., 55B, 403.  
 1981c, Phys. Lett., 81A, 252.  
 1982a, Found. Phys., 12, 543.  
 1982b, Found. Phys., 12, 551.

EPPUR SI MUOVE (First edition: C.B.D.S., Bruxelles, 1977),  
 (Second edition: East-Nest, Graz, 1981).

CLASSICAL PHYSICS (East-Nest, Graz, 1981).

THE THORNY WAY OF TRUTH (East-Nest, Graz, 1982).

PROCEEDINGS OF ICSTA, Genoa 8-11 July 1982, edited together  
 with J. P. Wesley (East-Nest, Graz, 1982).

CORRESPONDENCE



ВМИ - СОФИЯ  
МЕДИЦИНСКИ ФАКУЛТЕТ  
КАТЕДРА ПО ПСИХИАТРИЯ

Изм. № 238  
София 28.11.19... М

### УДОСТОВЕРЕНИЕ

Психиатричната клиника при ВМИ - София удостоверява, че *Стефан*  
*Марин* години, от гр. (с.) *София*  
 " *Марин* *Марин* е бил на лечение в клиниката от *29. III* 196 *74*  
 " *Врл. Белман* до *М. VII* 196 *74* диагноза: *мрлу 1956 от 18. XI 1964*  
*Паномия*

Настоящото се дава да послужи пред *М. во Мароули*  
*Зориче*

За директор на клиниката,  
 гл. асистент: *Т. Занков*  
 (доц. д-р К. Занков)

This is an official certificate stating that Stefan Marinov was treated at the Psychiatric Clinic of the High Medical Institute, Sofia, in the years 1966 (wrongly written 1956), 1967, and 1974 with a diagnosis

P A R A N O I A .

**THIS PAGE IS LOCKED TO FREE MEMBERS**

Purchase full membership to immediately unlock this page

**SAVE \$3,999,994**

Did you know we sell  
paperback books too?

To buy our entire catalog  
in paperback would cost  
over \$4,000,000

Access it all now for  
\$8.99/month

\*Fair usage policy applies

**Continue**



BULGARIAN ACADEMY OF SCIENCES

Sofia, "7 Naevri" Str. No. 1  
Tel. 87-77-31  
Telex 22424

N=316

May 18th, 1977.

Professor S. Prokhevnik  
University of New South Wales  
P.O.Box 1  
Kensington NSW 2033  
Australia

Dear Professor Prokhevnik,

I have been asked to express our President's surprise on the receipt of the cable of May 10th signed by you and your colleagues. With reference to that I would like to make you familiar with some facts that might be of interest to you.

In 1973 Mr. Stephan Marinov was pensioned off due to illness and since he has not worked in any of the Academy's Institutes. Recently we have learned from the inquiries made by foreign scientists and scientific institutions that acting on his absolutely private initiative Mr. Marinov had decided to organize an International Conference and later on he had given up the idea. He probably did not manage to inform in time all the persons and scientific institutions who knew about Marinov's conference and an unfortunate consequence of this was that Mr. P.T. Pappas from Queen Mary College in London came to Bulgaria. On the latter's request we have arranged for him a visit to the Institute of Physics and the rest of his time he spent as a personal guest of Marinov and he visited also the town of Varna.

As far as our information goes no restrictions whatsoever, have been imposed on the activity of Marinov.

Please, inform all the colleagues of yours concerned about with the contents of this letter. I hope that this misunderstanding would not infringe on the friendly relations of scientific co-operation we have with all foreign scientists and scientific institutions.

With best regards,

Sincerely yours,  
*M. Popov*  
Eng. M. Popov

Head of the International  
Relations Department

Saint Gery 23  
000 Bruxelles

November 1977

President of the US  
The White House  
Washington, D.C.

Mr. President,

In March 1974 I was imprisoned in the psychiatric clinic of the High Medical School Sofia, where I spent seven months in 1966/1967. Again I was detained against my will be cured from "unjust" physical ideas (I am showing by theory and experiments that Einstein's theory of relativity is not adequate to physical reality) and "false" conceptions (I assert that a socialism with a bestial face is not socialism at all).

This time I was not locked in an isolator and guarded by a policeman as in 1966/67, and on the 3 April I could escape. After having changed my clothes in the house of a friend, I went to the American Embassy in Sofia and addressed Mr. Snow with the plea to forward to the mass media my protest against this scandalous and shameful detention. Mr. Snow knew me very well, since some months ago he has restored my connection with Prof. Sudsmit, the editor of PHYSICAL REVIEW, because at that time my post was intercepted. Instead of help, the Bulgarian police was called, and I was bestially beaten in the lobby (i.e., on American territory) before the eyes of at least 20 Americans who did nothing to stop this barbarism, despite my desperate cries and the fact that I could not defend myself (I was knocked down on the floor and my hands were tied).

I was brought again to the loony bin and locked in the same isolator as seven years ago. In the process the public prosecutor defended the thesis that not only in the eyes of the Bulgarian authorities but also in the eyes of the Americans I am a socially dangerous element. This aggravated my situation terribly and I was sentenced to compulsory-treatment (my "foolness" was cured this time by triseditl).

In the psychiatry I wrote a letter to the American Ambassador, protesting against the shameful beating which was ordered by the Embassy's employees, and begged him to come personally to the clinic to present his excuses. This was not done. Neither I know whether my letter has reached the Embassy.

When you entered the White House, I wrote again a letter to the new Ambassador presenting a claim for injury. The case was sent to the State Department, from where a negative answer has come, communicated to me orally by the Consul, Mr. Thibaut.

Now I am addressing you directly. I beg you, Mr. President, to study carefully this case. I live 46 years in Bulgaria. As a seaman I visited different European, African and Asian countries. Many times I was detained in prisons and clinics because of my scientific and social activity. But no single time in my life was I beaten. Never my father or mother have slapped me. On the 3 April 1974 I spent on American territory not more than 30 or 40 minutes and my body was covered with blood. After being released from the asylum, certain of my friends laughed on me: "You are a fool, indeed. Will a normal man go to search protection and understanding to Americans. They are worse than the Stalin cannibals!"

I think that from your high post you have to defend the honour of America. Of course, you are not responsible for the errors and the crimes (the Viet-nam war) of the Nixon-Ford administration, but you, as a President of the United State, have to defend the honour of your big nation.

Concerning the human rights you follow a radically new politics. But many of my friends and many leftly thinking people (to whom I appertain) assert that your defence is a pure demagoguery and, as a matter of fact, you do nothing in reality. Now, exactly during the time of the Belgrade conference, the paranoid neo-stalinist in Prague have organized a farce process, but no protest has come from the part of the American government. I know the answer: those are internal affairs of Czechoslovakia and the American government has not the right to intervene. O.K. - but I was beaten on American territory, where Bulgarian police cannot enter without the consent of the Embassy. Present me the excuses of the American government. Show that you factually defend the human rights. The reverberation of your letter in our countries will be enormous.

Mr. President, from your speeches and actions it is clear that you have recognized the most simple truth that now the conflicts in the world cannot more be solved by violence. In these terrible years of the XXth century when every minute the planetary suicide can begin, the words have the unique power to save us from the nuclear cauchemare. Show your firmness and readiness to defend the honour, the freedom and the rights of anyone who has knocked on your door.

Sincerely yours,      Stefan Marinov

8.11, 1977

Dear Dr. Marinov,

I am very pleased to know that you are safe at last in the West. I look forward to seeing you in London later this month. I am afraid that I cannot afford either time or money to come to Brussels just at this moment, much as I should like to.

I shall send you a copy of the Pimeniad within the next few days, as soon as I can get it xeroxed. But there is no need to worry about the quality of the translation. I have been a translator of poetry from the Slavonic languages for 21 years and my work is very well thought of by those in a position to know. I have a good working knowledge of Church Slavonic, since it is the language which we use in our church. I have sung in the choir for more than half my life, so I can certainly appreciate the Church Slavonic "flavour" of your poem. This I have rendered into English by the type of archaic English used in the Church of England prayerbook and the Authorized Version of the Bible. I understood from Dr. Prokhorovnik that you had especially asked for me to translate your works. I assumed that you knew of my ability and competence to deal with a difficult poem of this kind. So, please, set your mind at rest!

I could not, of course, send you the text to Bulgaria. Politically, it would have been most dangerous for you to receive a letter from me - and there was no one going on a visit whom I could trust with so dangerous a mission. Dr. Prokhorovnik went back to Australia without leaving me an address, so I could not contact him. Under the circumstances, there was only one person whom I cared to consult on this matter - Victor Swoboda, who is Senior Lecturer in Russian and Ukrainian, at the School of Slavonic and East European Studies, University of London. I have

a very longstanding working relationship with him as regards ~~next~~ Slavonic linguistics and poetry. We once collaborated on a collection of ~~xxx~~ the works of Taras Shevchenko - that was some 16 years ago. He has gone over my version of the Pimeniad thoroughly, and made several interesting suggestions about it, which I duly took into account in preparing my version.

The Pimeniad has not yet been published, but is under consideration by an Editor. Do you wish me to tell him to stop considering it? If so, I fear that you will lose all chance of its publication. Once an author withdraws a piece of work from an Editor, it is very difficult to get him to ~~xxxx~~ accept it later. The Sonnets are not with any Editor yet. I had an idea to show them to Viktor Fainberg of the Campaign Against Psychiatric Abuse (He knows your brother, I think), but I have not yet had a chance to do so as Mr. Fainberg has been very busy recently. It is very difficult to get anyone to take any interest in the Russian text - the emigres would not have been interested unless they could have published your story, while you were still in Bulgaria - and this you did not wish done. But if you come to London, there are one or two possibilities we can discuss.

By the way, I must tell you that I can do absolutely nothing towards getting your scientific work published in NATURE. I have nothing whatever to do with that side of the magazine, I am simply a journalist. It would be contrary to all professional etiquette for me to interfere in this matter. Please try to understand this! When you have been in the West a little longer, you will probably understand better how things are done here. Until then, please believe me that I cannot help you in that side of your activity!

It won't help, either, if you talk about expecting to receive a Nobel Prize for your work. Even if you feel sure you are going to get one, it is not something that is even spoken of in advance! There is a tradition of "modesty" in these matters. I can't say anything about your chances - your work is right outside my own field, but it certainly won't help you in your scientific career to boast in advance of the awards you hope to receive. Since your work is so contrary to the present scientific tradition, it is very important that you should appear to be a sound and respectable scientist, in the tradition that people accept here. Your long and excited Telex messages to NATURE, for example, did not make a very good impression!

I have very little time at the moment. I have been extremely busy with the Russian Revolution Anniversary - there was a lot of extra work for me to do, as you can imagine. And I do not like writing letters very much. But I felt that I must reassure you as soon as possible that the Priz PIMENIAD has not been published, and will not be published without your consent. As soon as I can get a xerox copy made (which will be in a day or so), I will mail it to you. But I must ask you to assure me that you will not send it to any other Editor until we have a definite refusal from the Editor who is considering it at present. This is very very important. To submit the same piece of work to two publications simultaneously is contrary to all prakt professional practice. No reputable journal will deal with a writer who behaves in such a way. If you do this, then I fear that no one will take any notice of your work, and you could even find yourself involved in serious difficulties, if two editors should accept the same poem simultaneously. In view of all that has happened to you, I feel it is very important that you should make a good impression in your business affairs in the West,

If you want to deal with serious Journals, who pay good fees, and who have a sound reputation, it is wise to follow the established practices. Of course, there are publishers and Journals who are less particular, but no one takes them at all seriously, and it is better not to deal with them.

I hope that all is going well with you. Please let me know when you are coming to London, and where I can contact you. It would be better to write in advance, as I am not in London every day.

Sincerely,

A handwritten signature in cursive script that reads "Vera Rich".

Vera Rich



DOCTEUR JACQUES FLAMENT  
PROFESSEUR À L'UNIVERSITÉ DE BRUXELLES  
CHEF DE SERVICE  
À L'INSTITUT DE PSYCHIATRIE  
HÔPITAL UNIVERSITAIRE BRUGMANN

BRUXELLES, LE 21 novembre 1977  
20, AVENUE BRILLAT-SAVARIN - 1050 B.  
CONSULTATIONS: *rue de Florence*  
~~14, AVENUE BRILLAT-SAVARIN - 1050 B.~~  
TÉL. ~~539.00.91~~ *539.00.91*

Monsieur Stefan MARINOV  
rue St.Géry, 23  
1000 Bruxelles.

Je soussigné certifie avoir examiné cliniquement à deux reprises, les 7 et 21 novembre 1977, Monsieur Stefan MARINOV, âgé de 46 ans.

Au cours des deux entretiens prolongés que j'ai eus avec lui, destinés à évaluer son état de santé psychologique, je l'ai interrogé sur les différents domaines de son histoire personnelle et de ses antécédents médicaux.

Je certifie qu'au cours de ces deux entretiens cliniques, je n'ai observé chez Monsieur Stefan MARINOV aucun symptôme de troubles psychopathologiques.

J'estime en conséquence que son état de santé psychologique peut actuellement être considéré comme normal.

En l'absence de données anamnestiques provenant d'une autre source que les déclarations de Monsieur MARINOV lui-même, il n'est pas possible de porter un jugement clinique certain sur ce qu'il a pu en être dans le passé.

Par ailleurs, n'ayant aucune compétence personnelle dans le domaine d'activités scientifiques de Monsieur MARINOV, il ne m'est pas possible d'exprimer un avis clinique sur la nature et la qualité de son jugement critique à l'égard de sa propre oeuvre scientifique.



**THIS PAGE IS LOCKED TO FREE MEMBERS**  
Purchase full membership to immediately unlock this page

**FORGOTTEN BOOKS**

# **FULL MEMBERSHIP**

**797,885 Books!**  
**All you can read**  
**for only**  
**\$8.99/month**

**Continue**

\*Fair usage policy applies





UNIVERSITÉ CATHOLIQUE DE LOUVAIN  
INSTITUT DE PHYSIQUE THÉORIQUE

CHEMIN DU CYCLOTRON, 9

B - 1348 LOUVAIN-LA-NEUVE  
BELGIQUE

TÉLÉPHONE 010-41.81.81  
TÉLEX 59065

D.SPEISER/NR

Louvain-la-Neuve, le 26 avril 1978.

Monsieur S. MARINOV  
rue St. Géry, 23  
1000 BRUXELLES

Cher Monsieur Marinov,

Je vous remercie vivement de votre lettre ainsi que des envois que vous ajoutez.

Je suis bien conscient de votre situation; cependant, Mr. Finkelstein ne m'a pas invité à donner un second avis mais je lui enverrai une copie de votre lettre et de la mienne. Par ailleurs, ne craignez rien à ce propos : Mr. Finkelstein possède une perspicacité pénétrante, il connaît la relativité bien mieux que moi et, ayant eu lui-même quelques fois des difficultés avec des referees, il n'hésitera pas à mettre mon avis de côté si cela lui semble indiqué.

Cependant, je dois réitérer mon opinion que vous ne vous rendez pas un service en publiant cette réplique sous la forme actuelle.

Je me contente de répéter quelques points concernant vos remarques :

Rem. II : vous écrivez : "I give which had to be Newton's statement ..." et après, "this juxtaposition representing a contemporaneous retrospection ...". Une telle attitude, qui d'ailleurs n'est pas formellement déclarée dans le papier lui-même, ne peut que confondre le lecteur et ce n'est certainement ni bonne histoire, ni bonne argumentation.

Rem. IV : Je n'ai pas suggéré de discuter la théorie de Maxwell et QED, mais de confronter vos prédictions avec les prédictions de ses théories.

Rem. V : (p. 3, 1re ligne et 4e ligne du bas) vous écrivez : "Newtonian World aether theory ...". L'optique de Newton, je le réaffirme, était corpusculaire (voir ci-dessous).

1.9 du bas : vous écrivez "one can say the principle of relativity only introducing ...". Il existe évidemment une autre façon, celle qui consiste à modifier les lois de la mécanique qui fut choisie par Einstein et acceptée par presque la totalité des physiciens. Elle est certainement sans contradiction interne et ne peut être rejetée que sur base d'une expérience.

Rem. VI : 1) Il est exact que Newton parlait d'éther mais ceci dans le contexte de la gravitation.

2) Son optique était principalement une optique corpusculaire. S'il y pensait à un éther, c'est à vous de donner des citations exactes. D'après l'espace absolu "éther" peut être totalement trompeur.

Rem. VII : Vous écrivez : "for the mechanic phenomena... While for the electromagnetic phenomena...the principle of relativity is not valid". Où alors se situe la limite exacte entre phénomène mécanique et phénomène électromagnétique pour la discussion d'une expérience combinant les deux aspects? Cette question semble fondamentale.

Rem. VIII : Mon point n'est pas qu'en réalité nous ne trouvons que des corps imparfaitement rigides, mais que, selon les principes de la théorie d'Einstein, de tels corps ne peuvent exister puisqu'un signal ne peut se propager instantanément.

Rem. IX : Je ne suis pas d'accord avec votre interprétation d'Alvaeger et al., mais comme je vous l'ai dit lors de notre entrevue, je suis d'accord avec vous qu'une nouvelle expérience peut être très intéressante.

Rem. X : Evidemment, si vous voulez, tout est un "phénomène quantique" mais l'interférence n'est pas un phénomène quantique spécifique, c'est-à-dire qu'on peut déjà l'expliquer par l'Optique Ondulatoire Classique. Je ne comprends toujours pas la phrase : "the frequency...is an individual property...", à moins que vous fassiez allusions à la relation de Planck 
$$\nu = \frac{E}{h} .$$

Comme je l'ai dit, j'envoie cette lettre avec la vôtre à Mr. Finkelstein qui prendra sa décision, mais je me permets de répéter mes doutes sur l'opportunité de publier le travail sous cette forme.

Je vous prie, Cher Monsieur Marinov, de bien vouloir également transmettre mes compliments à Madame Marinov.

# SYRACUSE UNIVERSITY

DEPARTMENT OF PHYSICS

201 PHYSICS BUILDING | SYRACUSE, NEW YORK 13210

April 27, 1978

Professor Stefan Marinov  
rue Stephanie 83  
B-1020 Bruxelles  
Belgique

Dear Professor Marinov:

I have just received your note of 16 April, during the last week of our academic year. I am about to leave for the summer, and for a leave of absence, so that I shall be absent from Syracuse University for the remainder of the year.

I am reasonably familiar with your work, and in particular with the coupled-mirrors experiment. In my opinion this experiment is fundamentally flawed, in that it is based on the assumption that there is such a thing as a perfectly rigid body, in this case the rotating shaft on which the two mirrors are mounted.

Already in the twenties an engineer in Germany proposed to refute (special) relativity by using for the transmission of signals an "inextendible" string which would be pulled suddenly at one end. Such experiments do not work, at the conceptual level, against a theory that denies the existence of such rigid bodies, as does the theory of relativity. In practice, the upper limit for the signal speed through the use of "rigid bodies", "inextensible strings", and the like, is the speed of elastic waves in such materials, at least five powers of ten below the speed of light. Thus your coupled-mirrors experiment would not be accepted as a valid experiment bearing on relativity, regardless of the results obtained.

At the macroscopic level at least a major portion of the postulate of special relativity is confirmed by the working of particle accelerators, which are designed on the assumption of relativistic speed-mass relationships, etc., and could not possibly work if Galilean-Newtonian space-time were correct. At the microscopic level all relationships between relativistic elementary particles confirm the validity of relativistic mass and momentum formulas. If the theory is to be attacked in its foundations, one would have to come to terms with this large body of experimental evidence available, in my opinion long before attempting difficult new experiments, whose interpretation is likely to be controversial.

Sincerely yours,



Peter G. Bergmann

III/3 - 003

D u l d u n g  
=====

Der Aufenthalt des Herrn M A R I N O V , Vorname Stefan, geb. 01.02.1931 in Sofia, verh. Diplom-Physiker, bulgarischer Staatsangehöriger, wohnhaft in 1020 Brüssel, Rue Stephanie 83, z.Zt. wohnhaft in Regen, Frauenmühle (Person Taubeneder) wird vorläufig gem. § 17 AuslG geduldet unter folgenden Bedingungen:

- 1.) Der Aufenthalt wird auf den Landkreis Regen beschränkt.
- 2.) Der Ausländer hat sich täglich 2 x um 10.00 Uhr und 18.00 Uhr, persönlich bei der Polizeiinspektion Regen zu melden.



Regen, den 02. Mai 1978

Landratsamt

I.A.

!

Patzelt

Regierungsrat

Stefan Marinov  
rue Stephanie 83  
B-1020 Bruxelles

Le 7 mai 1978

Au President de la  
Republique Socialiste  
Tchecoslovaque

P r a g u e

M. le President!

Le 29 avril a 11.00 j'ai fait une demonstration devant le monument de Saint Venceslas pour montrer aux citoyens de Prague qu'il y a un Bulgare qui soutiens ouvertement et sans aucune peur les revendications de la Charte 77. Comme vous le savez bien, dans la Charte 77 on exige que le gouvernement tchecoslovaque respecte les lois de pays. Rien de plus!

Ma demonstration paisible etait violament interrompue par la police. J'etais reconduit dans un bureau policier, ou j'etais brutalement maltraite par de coup de poings et de fouet. On m'a confisque le passeport bulgare, la carte d'identite belge, deux copies de mon livre scientifique EPPUR SI MUOVE, les manuscripts de quelques articles scientifiques, le livre de Marie Valachova edite a Prague quelques annees apres que vous etiez au pouvoir, un livre russe sur l'histoire de stalinisme, mon agenda et tous l'argent.

Premierement les agents qui m'ont brutalise disaient qu'on va m'assassiner, apres ils disaient qu'on va me mettre dans une prison pour deux ans, apres dans un hopital psychiatrique, mais finalement ils deciderent de m'expulser illegalement a travers la "frontiere verte" sur le territoire de la R.F.A.

Tous ces acts de la police tchecoslovaque etaient contre les lois de votre pays. J'insiste que les documents d'identite delivres a moi par les gouvernements bulgare et belge me soient immediatement renvoyes, de meme que tous les livres et argent confisques. Pour les dommages corporels causes par le vandalisme des votres agents je revendique la somme de \$ 1000 (je dois souligner que pour les dommages corporels beaucoup plus graves causes par la battue dans l'ambassade americaine de Sofia en avril 1974 je revendique devant le gouvernement americain la somme de \$ 5000).

M. le President! Vous voyez aux quelles graves crises sociales sont livres les pays (comme Italie et la R.F.A.) ou les opposants qui ne sont pas contents des gouvernements agissent sans respecter la loi, enlevant et tuant des hommes innocents. Mais, je pense, il est beaucoup plus dangereux quand les gouvernement qui ne sont pas contents des ses opposant agissent sans respecter la loi. Si vous considerez qu'avec ma demonstration j'ai viole quelque loi tchecoslovaque, je suis pret de me rendre immediatement a Prague pour apparaitre devant le tribunal. Je ne suis pas un Lenine d'avoir peur de repondre pour mes actes devant n'importe quel tribunal legitime. Mais si vous ne pouvez inventer une accusation contre moi, j'insiste que vous vous excusez par une forme ecrite pour la barbarie des agents de votre police secrete et que vous satisfaisiez les revendications ci-dessus mentionnees.

Si vous laissez cette lettre sans reponse, je ne vois pas une autre alternative que de maltraiter et defigurer votre ambassadeur ici a Bruxelles de la meme façon. Mais ne pensez vous pas, M. le President, que sur cette voie tres vite nous allions remplacer tous notre lois d'une societe civilisee par les lois barbares de la jungle?

Stefan Marinov

Stefan Marinov  
rue Stephanie 83  
B-1020 Bruxelles

13 May 1978

Prof. Peter G. Bergmann  
Syracuse University  
Deptm. of Physics  
201 Physics Building  
Syracuse  
N.Y. 13210

Dear Prof. Bergmann:

Thank you very much for your letter of the April 27.

If you are acquainted with the scheme of my "coupled-mirrors" experiment, then I am unpleasantly shocked to read your objections. During the last 10 years I sent to different journals at least 40 papers (any paper sent to 5-6 different journals). Thus I received about 200 negative referees' opinions. And all of them have been written exactly in the same style as your objections. Only about 2-3 referees have understood the essence of the "coupled-mirrors" experiment and of my absolute space-time theory, although, I must recognize, the essence of this experiment, as well as of my theory, is extremely simple.

Having not a possibility to write you a longer letter, I shall emphasize only the following: In the "coupled-mirrors" experiment there is no transmission of signals. A rotating axle (of any material, if you like, of rubber) represents a clock with large space extension.

You did not wish to see my book EPPUR SI MUOVE. I do not know how much of my papers do you have read. Have you read my last paper in FOUND. PHYS. 8, 137 (1978)? Have you compared the results for the Sun's absolute velocity obtained with my interferometric "coupled-mirrors" experiment in 1975,  $v = 303 \pm 20$  km/sec, R.A. = 14h 17m  $\pm$  20m,  $D = -23^\circ \pm 4^\circ$  with the results obtained by the Princeton group (Wilkinson and Corey) later when measuring the slight anisotropy of the cosmic background radiation:  $v = 320 \pm 80$  km/sec, R.A. = 12  $\pm$  1 hr,  $D = -21^\circ \pm 21^\circ$ ? Why you do not publish your opinion in the press? To anyone of those 200 referees who have criticized my experiment and theory I say: Criticize them in the press. We have no time, was the answer. All right, I said, for your paper I shall pay you \$ 500. No one has written a paper for \$ 500. Neither you shall write it. I am sure. Tell me, then, Prof. Bergmann, is this a science? I have been criticized by small scientists as Horedt, Grøn, Vrcelj, who cannot understand that opening a discussion on my experiments and theory they kill relativity. More clever relativists prefer to keep silence. You are a very clever relativist and you will not open a fire against me. The world will not know that you are afraid to open a fire, but I know this.

Now I am preparing the edition of my CLASSICAL PHYSICS (1500 pages). All high-velocity effects in electromagnetism (synchrotrons etc.) are explained in the frame of my theory. Assurance that I can explain all effects of modern physics can be found after reading EPPUR SI MUOVE. Excuse me for the rather harsh tone. But I am tired. Three years I cannot find a journal to publish the detailed account on my interferometric "coupled-mirrors" experiment. You are in the editorial boards of many journals. Recommend a paper of me. No - you will not. You are feeling that something cracks.

Yours,

Stefan Marinov





EMBASSY OF THE  
UNITED STATES OF AMERICA

May 23, 1978

Mr. Stefan Marinov  
Rue Stephanie 83  
1020 Bruxelles

Dear Mr. Marinov:

The Department of State has alerted both NASA and National Bureau of Standards to the possibility of your visit. NBS is prepared to arrange a program for you. You should contact Dr. H. Steffen Peiser, Office of International Relations, Room A-511, Administration Building, National Bureau of Standards, Washington, D.C. 20234. You should be as specific as possible about your interests.

If you wish to make direct contact with NASA to indicate subjects which you might wish to discuss beyond the scope of your book, you may contact Dr. Phillip A. Thibideau (who is not a scientist), International Programs, Room 7077, 400 Maryland Avenue, S.W., Washington, D.C. 20546.

Sincerely yours,

A handwritten signature in cursive script that reads "Andre J. Navez".

Andre J. Navez  
First Secretary

*Dear Mr. Marinov:*

*This will be our last contact as I am leaving Brussels at the end of this month. I extend to you all my very best personal wishes and am sure I will hear of you in the future. Good luck!*

A handwritten signature in cursive script that reads "Andre Navez".

**THIS PAGE IS LOCKED TO FREE MEMBERS**

Purchase full membership to immediately unlock this page

**SAVE \$3,999,994**

Did you know we sell  
paperback books too?

To buy our entire catalog  
in paperback would cost  
over \$4,000,000

Access it all now for  
\$8.99/month

\*Fair usage policy applies

**Continue**

HAROLD C. HOLLENBECK  
9TH DISTRICT, NEW JERSEY

COMMITTEES:

BANKING, FINANCE AND  
URBAN AFFAIRS

SUBCOMMITTEES:

DOMESTIC MONETARY POLICY  
INTERNATIONAL DEVELOPMENT  
INTERNATIONAL TRADE

SCIENCE AND TECHNOLOGY

SUBCOMMITTEES:

SPACE SCIENCE AND APPLICATIONS  
SCIENCE, RESEARCH AND TECHNOLOGY  
FOSSIL AND NUCLEAR ENERGY

**Congress of the United States**  
**House of Representatives**  
**Washington, D.C. 20515**

WASHINGTON OFFICE:  
1221 LONGWORTH HOUSE OFFICE BUILDING  
WASHINGTON, D.C. 20515  
(202) 223-5061

DISTRICT OFFICES:

1550 LEMOINE AVENUE  
FORT LEE, NEW JERSEY 07024  
947-8868

47 ORIENT WAY  
RUTHERFORD, NEW JERSEY 07070

30TH STREET POST OFFICE  
UNION CITY, NEW JERSEY 07087

July 18, 1978

Dr. Stefan Marinov  
Allen Lee Hotel  
2224 F Street, N.W.  
Washington, D.C. 20037

Dear Dr. Marinov:

I have read with interest the copies of your letters to President Brezhnev and President Carter regarding the Orlov and Shcharansky trial. I regret that we were unable to hear from you at the informal briefing sponsored by Mr. Harkin and myself, but you can appreciate the schedule was packed tight.

In light of Mr. Scheuer's announcements that his subcommittee will hold hearings on the subject of science and human rights, I believe that the hearings, when held, would be a more appropriate forum for publication of these letters than the transcript of the meeting held today. I would urge you to contact his office (2402 Rayburn House Office Building) to keep abreast of his plans.

Once again, thank you for providing me with copies of your letters. I hope that the efforts to free Dr. Shcharansky will eventually succeed.

Sincerely,

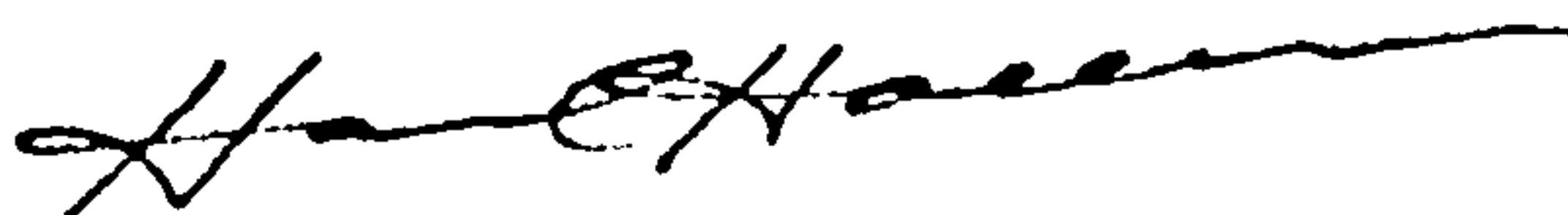

HAROLD C. HOLLENBECK  
Member of Congress

ROBERT K. DORNAN  
27TH DISTRICT, CALIFORNIA

SCIENCE AND TECHNOLOGY

SUBCOMMITTEES:

FOSSIL AND NUCLEAR ENERGY  
RESEARCH, DEVELOPMENT AND  
DEMONSTRATION

ADVANCED ENERGY TECHNOLOGY  
AND ENERGY CONSERVATION  
SCIENCE, RESEARCH AND TECHNOLOGY

MERCHANT MARINE AND  
FISHERIES

SUBCOMMITTEES:

FISHERIES AND WILDLIFE CONSERVATION  
AND THE ENVIRONMENT  
PANAMA CANAL



Congress of the United States  
House of Representatives  
Washington, D.C. 20515

WASHINGTON OFFICE:  
419 CANNON HOUSE OFFICE BUILDING  
WASHINGTON, D.C. 20515  
(202) 225-6451

DISTRICT OFFICE:  
14223 FEDERAL BUILDING  
11000 WILSHIRE BOULEVARD  
LOS ANGELES, CALIFORNIA 90024  
(213) 824-7222

August 18, 1978

Mr. Kenneth B. Foster  
Director for Grants  
National Science Foundation  
1800 G Street, N.W.  
Room 248  
Washington, D.C. 20550

Dear Mr. Foster:

I am writing to ask that you give serious consideration to a scientific proposal authored by Dr. Stefan Marinov, on June 27, 1978, for measuring the Earth's absolute velocity with the help of an interferometric "coupled mirrors" experiment.

It is my understanding that Dr. Marinov's proposed experimentation, if successful, would challenge the prevailing Einstein theory of special relativity. This, in itself, makes the Marinov proposal profoundly interesting. Although such an assessment does not, in itself, constitute an endorsement of Dr. Marinov's theoretical position, his claims or his results, I gather, from independent inquiries I have made among members of the scientific community, that he is, indeed, a sound physicist. None of the gentlemen I have contacted, subscribe to the view that the scientific community should close the door, so to speak, on Dr. Marinov's theoretical position. In the realm of theoretical physics, there is always room for surprises.

It is my further understanding that Dr. Marinov's particular experiment has never been replicated. In that case, I believe, there is ample justification to pursue this avenue of scientific inquiry. Nothing could be lost. According to Dr. Huseyin Yilmaz of the Perception Technology Corporation of Winchester, Massachusetts: "This experiment should be done if for no other reason than to once more confirm Einstein's theory of special relativity."

I would ask that your office give positive consideration to this worthwhile proposal.

Sincerely,

Robert K. Dornan  
Member of Congress



UNITED STATES DEPARTMENT OF COMMERCE  
National Bureau of Standards  
Washington, D.C. 20234

September 8, 1978

Dr. Stefan Marinov  
Allen Lee Hotel  
2224 F Street, N.W.  
Washington, DC 20037

Dear Dr. Marinov:

Thank you for your communication which we received and which at your request I return enclosed.

I regret very much that my colleagues and I have no interest in collaborating with you along the lines of your proposal as written. Under these conditions, laboratory space cannot be placed at your disposal.

With good wishes to you personally.

Sincerely,

*H. Steffen Peiser*  
H. STEFFEN PEISER  
Chief  
Office of International Relations

Enclosure



National Aeronautics and  
Space Administration

Washington, D.C.  
20546

REF: 1

y to Attn of. **LIB-15**

Mr. Stefan Marinov  
Allen Lee Hotel  
2224 F Street, N.W.  
Washington, DC 20037

Dear Mr. Marinov:

Thank you for your August 15, 1978 letter inquiring about the possibilities for conducting your gravitational physics experiment. As Dr. Jeffrey Rosendhal explained when he met with you on June 16, your proposed experiment is not directly relevant to NASA's mission, particularly since the proposed work is completely ground-based and does not require the use of space techniques or the space environment. There is, therefore, no programmatic interest here at NASA in your proposed work.

Sincerely,

  
Philip A. Thibideau  
International Program Policy Office  
International Affairs Division

THE WHITE HOUSE

WASHINGTON

September 21, 1978

Dear Mr. Marinov:

This is to acknowledge your letter of July 17 to President Carter concerning your desire to pursue your scientific work. I regret the delay in replying.

As you can understand, it is simply not possible for the President to give personal attention to each one of the great number of problems and appeals which are sent to him each day. Hence, he has asked officials of the various departments and agencies to do so on his behalf in instances where they have special authority under the law or special expertise.

I have taken the liberty of forwarding a copy of your letter for review by officials of the National Science Foundation. I am certain they will provide answers to your questions and inform you of the proper procedures in handling your concerns. You should be hearing from them soon.

We welcome your warm words of support and send you the President's best wishes.

Sincerely,



Landon Kite  
Staff Assistant

Mr. Stefan Marinov  
The Allen Lee Hotel  
2224 F Street, N.W.  
Washington, D.C. 20037

NATIONAL SCIENCE FOUNDATION  
WASHINGTON, D.C. 20550

Dr. Stefan Marinov  
The Allen Lee Hotel  
2224 F Street, N.W.  
Washington, D.C. 20037

Dear Dr. Marinov:

We regret to inform you that the National Science Foundation is unable to support your proposal entitled, "Measurement of the Earth's Absolute Velocity with the Help of the Interferometric 'Coupled-Mirrors' Experiment," PHY78-22985.

In evaluating each proposal submitted to the Foundation, a number of factors are considered. They include the following: the scientific merit of the proposal and its merit in relation to other proposals received by the Foundation in the same general field of science; the relation of the proposal to contemporary research in the field; the distribution among fields of science within the program of the Foundation; the geographical distribution of research support by the Foundation; and, finally, the funds available for research support. Thus, many excellent proposals cannot be supported for reasons aside from intrinsic merit, although this is an important consideration.

Sincerely yours,



Marcel Bardon  
Director, Division of Physics



NATIONAL SCIENCE FOUNDATION  
WASHINGTON, D.C. 20550

October 2, 1978

Dr. Stefan Marinov  
The Allen Lee Hotel  
2224 F Street, N.W.  
Washington, D.C. 20037

Dear Dr. Marinov:

I have enclosed verbatim copies of the reviews of your proposal as I promised to do during our meeting this morning. I have also enclosed a copy of the document (NSF Circular 127) which you requested covering the procedure for reconsideration of your proposal.

Sincerely yours,



Richard A. Isaacson  
Program Director for  
Gravitational Physics

Enclosures

FIRST REFEREE

I have examined the proposed experiment to measure a possible variation in the speed of light with direction. I could not understand the apparatus drawn in the proposal (p. 2). However, the similar experiment discussed in the attached Sec. 19.2 of Mr. Marinov's book is clearer. Mr. Marinov's claim seems to be that his proposed experiment is sensitive at first-order in  $(v/c)$  to a variation in the speed of light with direction. I do not believe this is the case; despite the addition of the rotating mirrors, the experiment is essentially a Michelson-Morley experiment and is sensitive only at second-order in  $(v/c)$ .

I recommend that the proposal not be supported.

OVERALL RATING

EXCELLENT

VERY GOOD

GOOD

FAIR

POOR

**THIS PAGE IS LOCKED TO FREE MEMBERS**  
Purchase full membership to immediately unlock this page

**FORGOTTEN BOOKS**

**FULL**

**MEMBERSHIP**

**797,885 Books!**

**All you can read  
for only**

**\$8.99/month**

**Continue**

\*Fair usage policy applies



More to the point, though, is that if this is what the experiment is about; it has changed from being a one-way to a two-way Michelson-Morley experiment, since the interference is between fringes formed from the single source s. On this interpretation of the author's plan the rotating axle does nothing for the experiment except create trouble. To do a one-way Michelson-Morley experiment of this kind one would need two independent coherent sources of light sufficiently stable to interfere.

I have to confess that I cannot understand the claimed relationship between the time delay and the rotational velocities of the mirrors (Equation (1)). It seems to be just mistaken. I am also quite puzzled by the discrepancies between the experiment as described in the proposal and in the appendix. The appendix shows a shutter in front of the source, coupled to the axle. This is missing in the proposal, but so far as I can see it does not get round any other objections stated above.

As proposed the experiment is not at all viable and it is far from clear that the author knows what he is doing.

OVERALL RATING

- EXCELLENT
- VERY GOOD
- GOOD
- FAIR
- POOR

THIRD REFEREE

Dr. Marinov has constructed a cleverly conceived experiment to measure the "one-way" velocity of light, has detected an absolute velocity of 300 km s<sup>-1</sup> for the earth, and has interpreted his experimental results in terms of his own theory of absolute space time. He requests funding for further development of his experiment.

This proposal should not be funded by the National Science Foundation. First, current experimental results by numerous other investigators contradict the claimed experimental result of the author. Although I neither have sufficient details nor am competent to locate his experimental error, the author's experiment must either have a systematic error or be measuring some quantity other than the velocity of light. Second, since Einstein's special relativistic theory of space time has been shown to be viable by countless high energy experiments and by exhaustive theoretical development, there seems to be little motivation for alternative, especially absolute, spacetime theories.

OVERALL RATING

- EXCELLENT
- VERY GOOD
- GOOD
- FAIR
- POOR

FOURTH REFEREE

Dr. Marinov claims to have observed the absolute velocity of the earth in an experiment which leads to an effect which is first order in the velocity. The Michelson Morley experiment searched for an effect second order in the expected velocity.

Marinov appears to be unaware of the fact that first order experiments have been done in recent years, with very considerable care. These have led to null results in contradiction with Marinov. A good guide to the recent experiments is pages 491 and 492 of the book Relativity by C. Møller, second edition.

It is recommended that Marinov's proposal be rejected, for a number of reasons. His estimate that a competent job could be done in a month indicates a lack of realism and a lack of understanding of the time required to carefully explore all of the problems which arise in such experiments. Marinov has not given evidence, in his proposal, that he has studied the available literature to understand why other recent carefully done experiments are in contradiction with his work. It is most likely that his work is incorrect.

I will now make a few comments concerning a possible career for Dr. Marinov in the United States. We should be friendly and hospitable to refugees seeking asylum here. After careful study I believe that funding this proposal will unnecessarily delay Marinov in pursuit of a successful career in the United States. He is obviously skilled in experimental optics, but his knowledge and background in physics do not meet the current standards for senior academic/research positions in the United States. There are many opportunities available in industry in consequence of recent developments in quantum optics. There are a number of laser corporations, and companies developing spectroscopic equipment. Dr. Marinov would be qualified for an excellent position where his skills could be properly employed and well rewarded. Many organizations would permit him to do this kind of experiment "out of hours". Most experimental physicists do work considerably more than a 40 hour week. If Marinov pursues such a career he will in my opinion, discover the errors in his experiment at the same time that he is advancing to a position commensurate with his obvious talents.

OVERALL RATING

- EXCELLENT
- VERY GOOD
- GOOD
- FAIR
- POOR

Stefan Marinov  
The Allen Lee Hotel  
2224 F Street, N.W.  
Washington, D.C. 20037

October 8, 1978

Dr. Marcel Bardon  
Dr. Richard Isaacson  
Division of Physics  
National Science Foundation  
Washington, D.C. 20550

---

Ref. Bardon's letter of Sept. 28,  
Isaacson's letter of Oct. 2.

Dear Sirs:

I received your information concerning the rejection of my proposal entitled "Measurement of the Earth's Absolute Velocity with the Help of the Interferometric 'Coupled-Mirrors' Experiment" and I thank you for the attention.

I consider the referees' opinions as highly incompetent.

According to the NSF CIRCULAR NO. 127 of the 27th April 1977, point 5b, I am addressing you for a reconsideration of my proposal.

I am attaching apart my objections.

Hoping to hear soon from you,

Sincerely yours,  
Stefan Marinov

Enclosures:

- 1) My paper "Measurement of the Laboratory's Absolute Velocity", submitted to SCIENCE.
- 2) Two referees' opinions to this paper.
- 3) My answers to these two referees' opinions.
- 4) My paper LET NEWTON BE!
- 5) My book EPPUR SI MUOVE.
- 6) The letters of Dr. H. E. Puthoff and of Dr. J. P. Wesley.

OBJECTIONS OF THE AUTHOR, STEFAN MARINOV, TO THE REFEREES' OPINIONS ON THE PROPOSAL ENTITLED "MEASUREMENT OF THE EARTH'S ABSOLUTE VELOCITY WITH THE HELP OF THE INTERFEROMETRIC COUPLED-MIRRORS EXPERIMENT". - PHY 78 - 22985

I consider the criticisms of all referees as extremely poor and absolutely incompetent. I insist for a reconsideration of my proposal by a competent space-time specialist who is a good theoretician and a good experimenter (however, where to find such a bird!?). As a rule, the space-time theoreticians (those who can manipulate with the tensor apparatus) are very scholastic and have no feeling and understanding for experiments (because they have never entered an experimental laboratory, except, may be, as students), while the experimenters have a mystic fear before the authorities and always think that the experiments serve to prove well established theories but never to reject them.

Since the referees defend almost the same viewpoints and their comments are pretty short (except that of the second referee which is the best), I shall give a common answer, dividing it, for clarity, in items.

Remark I. The first and second referees assert that in my "coupled-mirrors" experiment eventual first-order in  $v/c$  effects cannot be measured but only second-order effects, and it represents simply a variation of the Michelson-Morley experiment where

both reflecting mirrors are put on a rotating axle which "does nothing for the experiment except create trouble" (the second referee); or, as the first referee writes "despite the addition of the rotating mirrors, the experiment is essentially a Michelson-Morley experiment and is sensitive only at second order in  $v/c$ ." My answer is the following: I shall pay immediately \$ 2000 to any of the referees who will publish and sign this opinion in the press. However I am absolutely sure that no one of the referees will dare to defend such a stupidity in the press (for an anonymous opinion no one can be derided, but for a signed and published...). Thus, if no one of the referees will appear during a three-months term with such an opinion in the press (the best is to send a letter to SCIENCE, where in one of the next issues the account on my Bulgarian "coupled-mirrors" experiment will be published) and no one of the referees will withdraw his opinion as incompetent and wrong, then the unique conclusion to be drawn is that such referees are not honest scientists and, according to me, the NSF must never collaborate with them in the future.

Note: Interesting is the attitude of the fourth referee. He writes:

Dr. Marinov claims to have observed the absolute velocity of the earth in an experiment which leads to an effect which is of first order in the velocity. The Michelson Morley experiment searched for an effect second order in the expected velocity.

Marinov appears to be unaware of the fact that first order experiments have been done in recent years, with very considerable care. These have led to null results in contradiction with Marinov.

Thus, according to this referee, the "coupled-mirrors" experiment is of first order in  $v/c$  (N.B. It is not good to write "first order in the velocity"! ). The objection which he makes is that it has to give (as all "first order experiments done in recent years") a null result. On this topic see remark II.

Remark II. Since 15 years I work in theoretical and experimental space-time physics. In my papers and book I show that until now no first-order in  $v/c$  experiment has been done because in all experiments where first-order effects have been searched for there is a mutual annihilation of the first-order effects in the final result. The unique experiment where the first order effects have been not annihilated is the Harress-Sagnac "rotating disk" experiment. 60 years ago this very simple experiment has patently shown the availability of first-order in  $v/c$  effects. As I point out in my answer to the referees of SCIENCE (which is enclosed), with the help of my interferometric "coupled-mirrors" experiment I measured the resultant "Sagnac" first-order in  $v/c$  effect on a rotating disk representing: 1) the laboratory rotating about the Earth's axis, 2) the laboratory rotating about the Sun, 3) the laboratory rotating about the center of our Galaxy, 4) the laboratory rotating about the center of the Meta-galaxy. In my papers and book, I analyse all important first-order experiments and show why they have remained insensitive to these effects. Thus the suggestion of the fourth referee "A good guide to the recent experiments is pages 491 and 492 of the book Relativity by C. Møller, second edition" can be considered only as a grotesque lack of tact.

Note: It is commonly accepted to consider the Einstein dogma for the light velocity constancy valid only for inertially moving systems. It must become clear once for ever that "inertially" moving systems do not exist. Any uniform motion is rotation as any straight line is a curve.

Remark III. The referees are very categorical rejecting the proposal as unsound. However, to affirm that something is unsound and "poor", one must first understand it. I give the word to every of the referees:

First referee: "I have examined the proposed experiment to measure a possible variation in the speed of light with direction. I could not understand the apparatus drawn in the proposal."

Second referee: "I have to confess that I cannot understand the claimed relationship between the time delay and the rotational velocities of the mirrors (Equation (1))."

Third referee: "Although I neither have sufficient details nor am competent to locate his experimental error, the author's experiment must either have a systematic error or be measuring some quantity other than the velocity of light."

Fourth referee: "Marinov has not given evidence, in his proposal, that he has studied the available literature to understand why other recent carefully done experiments are in contradiction with his work. It is most likely that his work is incorrect."

Remark IV. I showed that the referees' opinion are incompetent in general. Thus, it is not necessary to object the scarce critical remarks on certain details. However, since certain person think that "in general" they may be wrong, but, occasionally, certain of their particular remarks or simple doubts may be right, I shall give my objections also to these scarce particular remarks:

a) The second referee writes: "One might comment on the horrid technical difficulties in making such a measurement in the presence of the vibrations from the rotating axle." - Let me note with respect to this remark that François Remy, AJP, 46(7), 763 (1978), has observed interference picture in a Michelson interferometer where only one of the mirrors is moving. Thus the frequencies of both interfering light beams are different in Remy's experiment and he observed the beating of these two beams. Thus the "horrid" technical difficulties are not so horrid.

b) The second referee continues: "More to the point, though, is that if this is what the experiment is about, it has changed from being a one-way to a two-way Michelson-Morley experiment, since the interference is between fringes formed from the single source S. On this interpretation of the author's plan the rotating axle does nothing for the experiment except create trouble. To do a one-way Michelson-Morley experiment of this kind one would need two independent coherent sources of light sufficiently stable to interfere." - I repeat once more, this is exactly the rotating axle which makes the experiment sensitive to first order in  $v/c$  effects. I enclose my paper LET NEWTON BE!, where all is explained with pictures and allegories, so that even the small children can understand the essence of my experiment. If the rotating axle is not used (i.e., if a Newtonian time synchronization - see EPPUR SI MUOVE - is not realized), then with a single light source one, indeed, cannot set up a first-order in  $v/c$  experiment. With two coherent light sources one can set up a first order in  $v/c$  experiment. However, as I show in EPPUR SI MUOVE, with such a "coherent lasers" experiment (term introduced by me) only a change in the velocity can be measured but not the absolute velocity (by rotating the apparatus about an axis perpendicular to its absolute velocity) because of the appearing time dilation for the lasers. This problem was considered by M. F. Podlaha and T. Sjodin, LETT. NUOVO CIMENTO, 20, 593 (1977). Let me note that I sent to Dr. Podlaha the manuscript of EPPUR SI MUOVE two years ago. Thus the paper of Dr. Podlaha is a plagiarism of my explanation of the null effect in the "coherent lasers" experiment. In the mentioned paper my name is not mentioned. My paper dedicated to the "coherent lasers" experiment was rejected by 7 leading physical journals, including IL NUOVO CIMENTO. The reason is that I firmly defend the existence of absolute space-time, affirming that the light velocity constancy is a lie, while Dr. Podlaha and the others who publish without difficulties speak only about "a possible Newtonian explanation". If I have presented the proposal for a repetition of my "coupled-mirrors" experiment as an experiment which aims to confirm the Einstein light velocity constancy dogma within effects of first order in  $v/c$ , to my proposal, surely, a grant would be awarded. However, how can I do this, when with my proper eyes I have seen the positive effects in my Sofia apparatus and their existence is out of any doubt.

c) The second referee writes: "The appendix shows a shutter in front of the source, coupled to the axle. This is missing in the proposal, but so far as I can see it does not get round any other objections stated above." - In EPPUR SI MUOVE it is written (p. 105): "...let us put in action the shutters  $Sh_1$  and  $Sh_2$  which should allow light to pass through them only when the rotating mirrors  $RM_1$  and  $RM_2$  are perpendicular to the incident beams. This synchronization is performed by making the opening of the shutters ( $\approx 10^{-6}$  sec) to be governed by the rotating shaft itself. Instead of shutters, we also used simple slits placed along the light paths to the rotating mirrors." When

performing the experiment, I realized that the shutters are not necessary, and that only slits (which produce light pulses of a duration about  $10^{-5}$  sec) can perfectly serve.

d) The fourth referee writes: "Marinov's knowledge and background in physics do not meet the current standards for senior academic/research positions in the United States." - I beg the referee to show proofs to this accusation in my papers and book. If he can not do this, I beg him to retract his accusation because accusations without proofs are called a calomny.

e) The fourth referee writes: "It is recommended that Marinov's proposal be rejected, for a number of reasons. His estimate that a competent job could be done in a month indicates a lack of realism and a lack of understanding of the time required to carefully explore all of the problems which arise in such experiments." - I have already done this experiment and I know better than the referee during which time and how it is to be repeated. I repeat: If a good axle will be given to me and I have access to a currently equipped optical laboratory, I can demonstrate the positive effect in less than a month. If I cannot succeed to do this, I shall pay \$ 3000 to the referee. I am a foreigner in the States. It is possible that a search of the axle will continue a couple of months. However, I perfectly know the possibilities of this country and I know that the axle can be found in a week.

Final Remark. If the NSF will agree, I shall deposite the sum of \$ 7000 (\$ 3000 for the fourth referee and \$ 2000 for any of the first two referees) in the Physics Division.

Stefan Marinov

- Editorial note. I. The paper "Measurement of the laboratory's absolute velocity" is published in GENERAL RELATIVITY AND GRAVITATION, 12, 57 (1980), (CLASSICAL PHYSICS, vol. III, §52B).
2. The paper "Let Newton be!" is accepted for publication by the RENAISSANCE UNIVERSAL JOURNAL (CLASSICAL PHYSICS, vol. III, §52A).
3. The paper on the "coherent lasers" experiment under the title "Decisive experiments for the proof of the light velocity's direction dependence" is published in INDIAN JOURNAL OF THEORETICAL PHYSICS, 28, 329 (1980), (CLASSICAL PHYSICS, vol. III, §67).



EXECUTIVE OFFICE OF THE PRESIDENT  
OFFICE OF SCIENCE AND TECHNOLOGY POLICY

WASHINGTON, D.C. 20500

October 19, 1978

Dear Dr. Marinov,

I have your letter of October 12 and the enclosed materials. As you know the National Science Foundation relies on a peer review process to assess the scientific merit of proposals it receives. Over the years we have learned that reliance on this system, including its associated appeals process, is the best way to protect the interest of the taxpayer in the support of scientific research and to guarantee that meritorious projects are funded.

I am aware that you have applied to the NSF for support of your research and that following external review of your proposal, you were denied support. I am also aware that you have appealed this decision of NSF.

I am assured by NSF that your appeal will be given careful consideration. In your case, as in others, I consider reliance on the outcome of the peer review process to be essential to sound management of the NSF research program.

Sincerely,



Ted Greenwood  
Senior Policy Analyst

Stefan Marinov  
Allen Lee Hotel  
2224 F Street, N.W.  
Washington, D.C. 20037

**THIS PAGE IS LOCKED TO FREE MEMBERS**

Purchase full membership to immediately unlock this page

**SAVE \$3,999,994**

Did you know we sell  
paperback books too?

To buy our entire catalog  
in paperback would cost  
over \$4,000,000

Access it all now for  
\$8.99/month

\*Fair usage policy applies

**Continue**

NATIONAL SCIENCE FOUNDATION

WASHINGTON, D.C. 20550

November 14, 1978

**nsf**

OFFICE OF THE  
ASSISTANT DIRECTOR  
FOR MATHEMATICAL AND  
PHYSICAL SCIENCES,  
AND ENGINEERING

Dr. Stefan Marinov  
2224 F Street, N. W.  
Washington, D. C. 20037

Dear Dr. Marinov:

This letter is in reply to your request of October 8, that we reconsider the declination of your proposal No. PHY 78-22985, "Measurement of the Earth's Absolute Velocity With the Help of the Interferometric 'Coupled-Mirrors' Experiment".

I have had a careful reanalysis of the original actions on your proposal made by my Special Assistant, Dr. William S. Butcher, and by Dr. John R. Pasta, Director of the Division of Mathematical and Computer Sciences. Neither one was connected in any way with the original handling of your proposal. They have reached the conclusion that the declination of your proposal was proper and should be allowed to stand. I have examined the file myself, and I agree with their recommendation.

Your proposal was sent for review to six reviewers chosen by the Program Director within the Division of Physics. Two of these failed to respond, and you have copies of the reviews of the four who did. I think you will agree on reading these reviews that your proposal has had careful consideration. It is my conclusion that experiments of this kind could be important, but in the opinion of the reviewers, the probability of success is small. Taking these two factors into account, it is our judgment that the likelihood of success of the measurements which you propose does not justify support within our available funds, given the pressure of other worthy proposals.

It is my decision that your proposal has been carefully reconsidered and that the declination should be allowed to stand. I should also remind you that the National Science Foundation provides you an opportunity for reconsideration by the Deputy Director, as described in NSF Important Notice No. 61, should you care to pursue this matter further.

Sincerely yours,



J. A. Krumhansl  
Assistant Director

Enclosure - NSF Important Notice No. 61

**IL NUOVO CIMENTO**

*REDAZIONE*  
Dr. S. Marinov  
83, rue Stephanie  
1020 BRUXELLES  
(Belgio)

li 30 November 19 78

Via L. degli Andalò, 2 - 40124 BOLOGNA (Italy)  
Tel. ~~37.00.41~~ 33.15.54

Dear Doctor Marinov,

With reference to your book "Eppur si muove" we like to inform you that we have sent it for a review in "Il Nuovo Cimento", but we still haven't received back the answer.

As soon as possible we will send you the review, after receiving it from the author.

Kind regards,

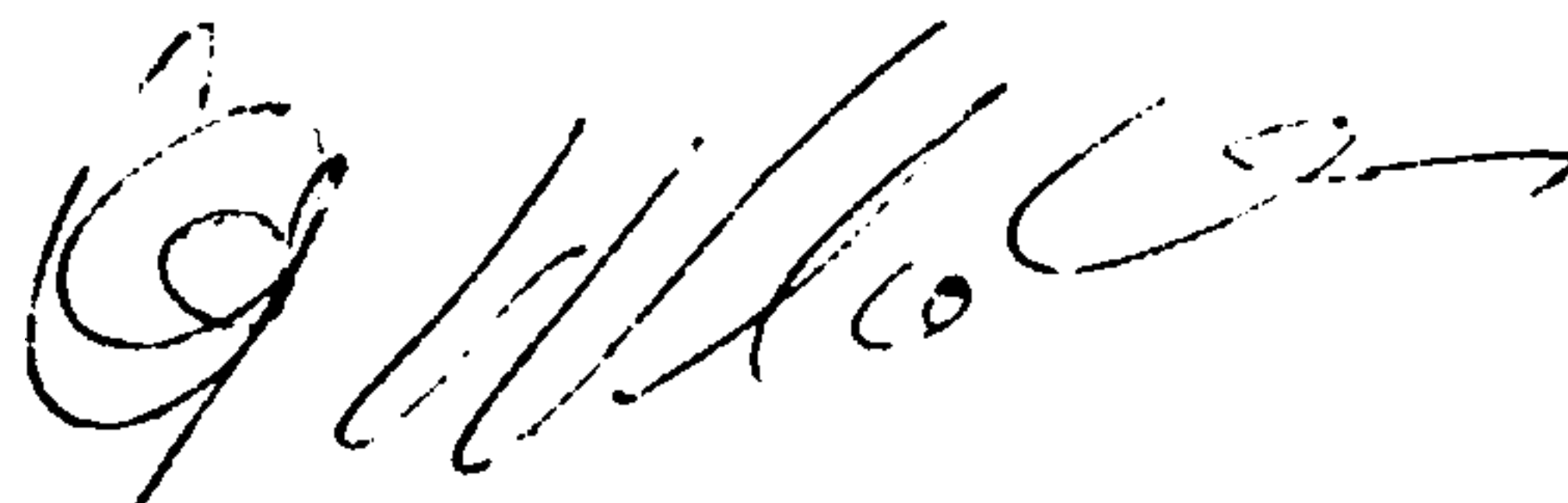
  
Monique van Vloten  
secretary

Best wishes from  
all of us,

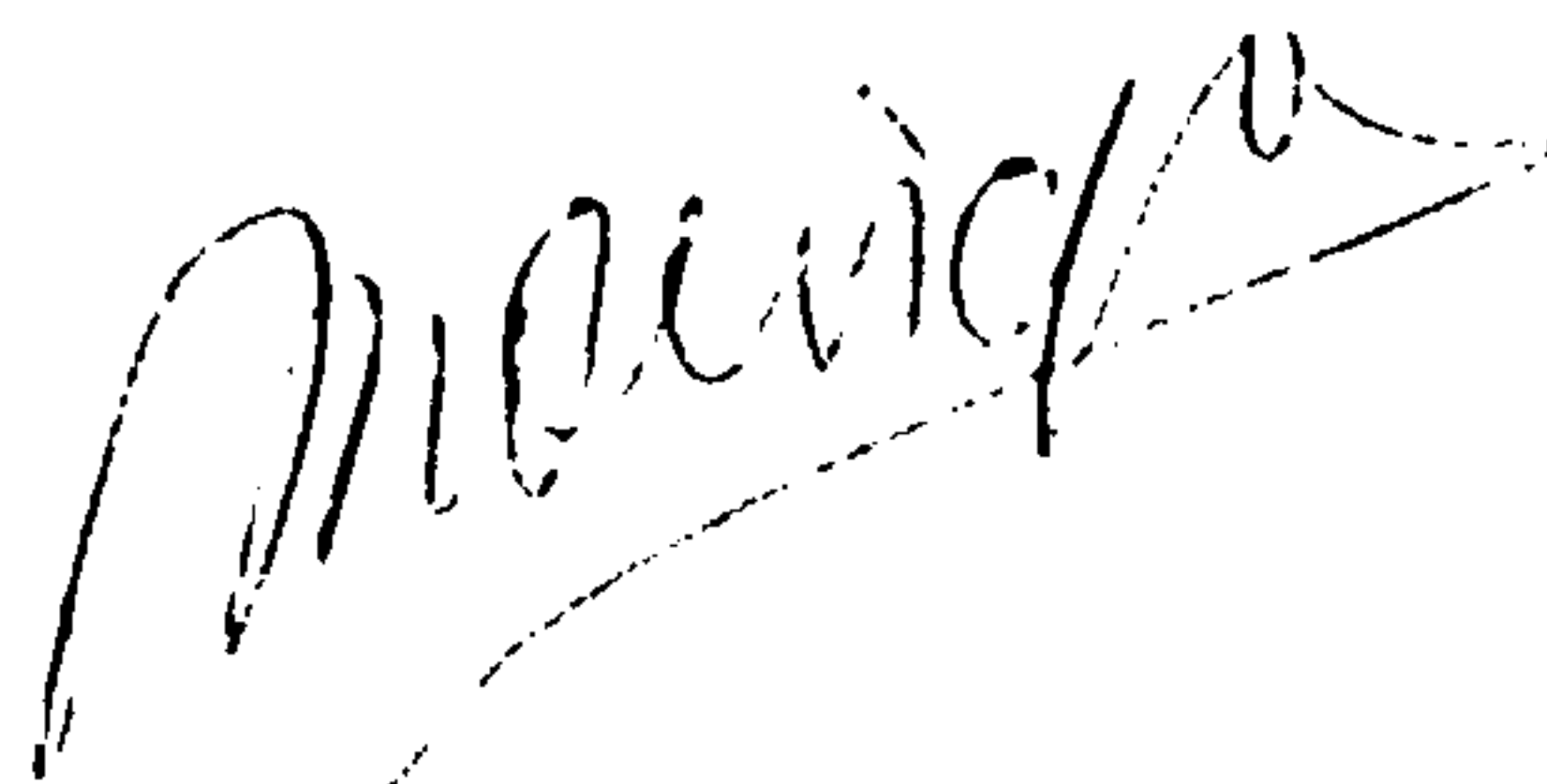

EXECUTIVE OFFICE OF THE PRESIDENT  
OFFICE OF SCIENCE AND TECHNOLOGY POLICY  
WASHINGTON, D.C. 20500

December 7, 1978

Mr. Stefan Marinov  
Allen Lee Hotel  
2224 F Street, N.W.  
Washington, D.C. 20037

Dear Mr. Marinov:

I have your letter of November 29 and the accompanying materials. I assume Mr. Kite is giving appropriate attention to your letter to President Carter. On the scientific aspects of the issues you raise, I can only repeat my view as expressed in my letter of October 19, that NSF's process of review of scientific research proposals must be relied on in your case as in others. I am sure your appeal will be given careful consideration.

Sincerely,

*Ted Greenwood*  
ra

Ted Greenwood  
Senior Policy Analyst



THE  
GEORGE  
WASHINGTON  
UNIVERSITY

*Washington, D.C. 20052 / The Graduate School of Arts and Sciences*

December 7, 1978

Stefan Marinov  
Allen Lee Hotel  
2224 F St., NW  
Washington, D.C. 20037

Dear Mr. Marinov:

The Admissions Committee has made a careful review of your application, letters of recommendation and the transcripts of your past academic experience and has found that it cannot recommend acceptance. I, therefore, must inform you that we are unable to offer you admission to the Graduate School of Arts and Sciences.

Thank you for considering the George Washington University.

Sincerely,

Henry Solomon  
Dean

Office of  
Admissions



THE  
GEORGE  
WASHINGTON  
UNIVERSITY

December 8, 1978

Washington, D.C.  
20052

Telephone  
(202) 676-6040

Mr. Stefan Marinov  
Allen Lee Hotel  
2224 "F" Street, N. W.  
Washington, D. C. 20037

Dear Mr. Marinov:

I very much regret to advise you that you are not eligible for admission to the Division of University Students.

An applicant who has been denied admission to any degree-granting branch of the University will not be considered for admission to the Division of University Students.

I am sorry that we cannot serve you in working toward your educational goals.

Sincerely,

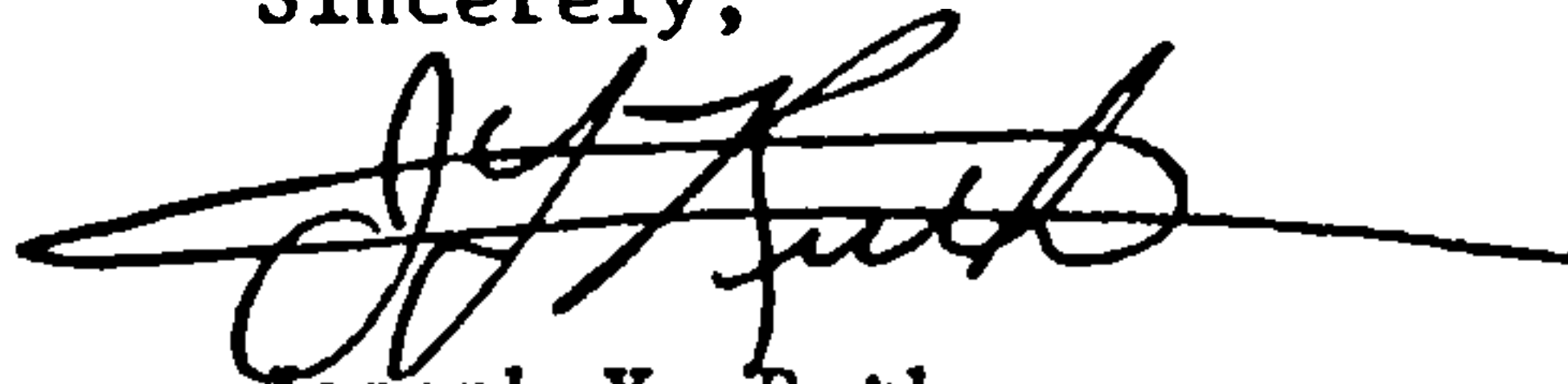

Joseph Y. Ruth  
Director of Admissions

JYR:dmg

# World Government of World Citizens

Our Ref. No. WC/14128/III .....

Your Ref. No. ....

Washington, D.C., December 14, 1978

Mr. Jimmy Carter  
President of the United States  
The White House  
1600 Pennsylvania Avenue  
Washington, D.C.

Mr. President:

It has come to our attention that Mr. Stefan Marinov, a registered citizen of our Government, has received notice from the U.S. Immigration and Naturalization Service to the effect that he would be deported if he did not leave the United States within a prescribed period.

A distinguished physicist and dissident from Bulgaria, Mr. Marinov, with whom, we are informed, your administration has been in correspondence recently, has requested that we intercede on his behalf vis-a-vis the U.S. Government.

We respectfully request, Mr. President, that this situation be reviewed in the light of your administration's stated policy - reaffirmed on December 6th last - that human rights be rigorously respected and implemented both here and abroad.

We should be glad to receive notice from your office that this inappropriate and undoubtedly low-level policy decision in Mr. Marinov's regard be rescinded.

Please accept, Mr. President, the assurances of our most high esteem.

  
Garry Davis  
World Coordinator

Copy: Mr. Stefan Marinov



December 19, 1978



1226 VERMONT AVENUE, N.W.  
WASHINGTON, D.C. 20005  
202 / 667-1377

President Jimmy Carter  
The White House  
Washington, DC 20500

Dear President Carter:

The Immigration Office has threatened arrest and deportation of one of my parishioners at Luther Place Memorial Church.

I speak of Mr. Stefan Marinov, a Bulgarian dissident, who has suffered imprisonment, torture and forced exile because he is an open, honest, and faithful idealist. He deserves better from the nation that places the Statue of Liberty at its port of entry.

In fact, as your records will reveal, he was even severely beaten by Bulgarian police-guards in the hallway of our American Embassy in Sofia... on American "soil". We should make amends for allowing that reprehensible act by accepting, at the very least, Mr. Marinov as a permanent resident. He was, after all, invited by the First Secretary of the American Embassy in Brussels, Belgium to come to the U.S.A. to establish scientific contacts with the National Bureau of Standards and N.A.S.A. Though young, he is a thoroughly accomplished physicist.

At present, it is my understanding that he has no papers of any nation. He is a deeply believing, non-violent citizen of God's world. For the United States literally to force Stefan Marinov over our borders is to belie your entire human rights advocacy as well as to fail utterly in the Christmas season to observe the most basic human virtue, hospitality to the "stranger".

I want you to know, Mr. President, that he has a home at Luther Place, this tiny part of our common world community, along with many urban refugees from our capital streets, to which you referred in your letter to me of September 21, 1978. We intend that he shall continue to enjoy safety, security and shelter under God's roof in our churchly asylum, protected by the common world law of benevolence and peace.

In a word, appropriate for this or any other season, there will be "room at the inn", the U.S. State Department, and Immigration Offices notwithstanding.

The Christmas gift of welcome to the holy family that wanders homeless on earth from the South China seas to Djibouti, through the homeless waifs of Sao Paulo and South Chicago, in squalid refugee camps and dank prisons, while alas but a prayer for millions of our fellow citizens, can for a few be a reality. It is thus that we at Luther Place cannot but respond as Christians to Stefan Marinov's appeal. We are confident that you will do likewise.

Peace and joy,

John F. Steinbruck  
Pastor, Luther Place Memorial Church

**THIS PAGE IS LOCKED TO FREE MEMBERS**  
Purchase full membership to immediately unlock this page

**FORGOTTEN BOOKS**

# **FULL MEMBERSHIP**

**797,885 Books!**  
**All you can read**  
**for only**  
**\$8.99/month**

**Continue**

\*Fair usage policy applies



R2 PRL

THE PHYSICAL REVIEW  
— AND —  
PHYSICAL REVIEW LETTERS

BROOKHAVEN NATIONAL LABORATORY, UPTON, NEW YORK 11973

Telephone (516) 924-5533 (FTS) 664-2540

Telex: C/o BNL, 96-7703 Cable Address: BROOKLAB

December 21, 1978

Dr. Stefan Marinov  
rue Stephanie 83  
1020 Bruxelles, Belgium

Re: Manuscript No. LZ1055

Dear Dr. Marinov:

The manuscript by Stefan Marinov  
entitled "Disrupted 'rotating disk' experiment"

has been reviewed by our referee(s). On the basis of the  
resulting report(s), it is our judgment that the paper is  
unacceptable for publication in Physical Review Letters.  
We are therefore returning the manuscript herewith, together  
with a copy of the criticism that led to our decision.

Yours sincerely,

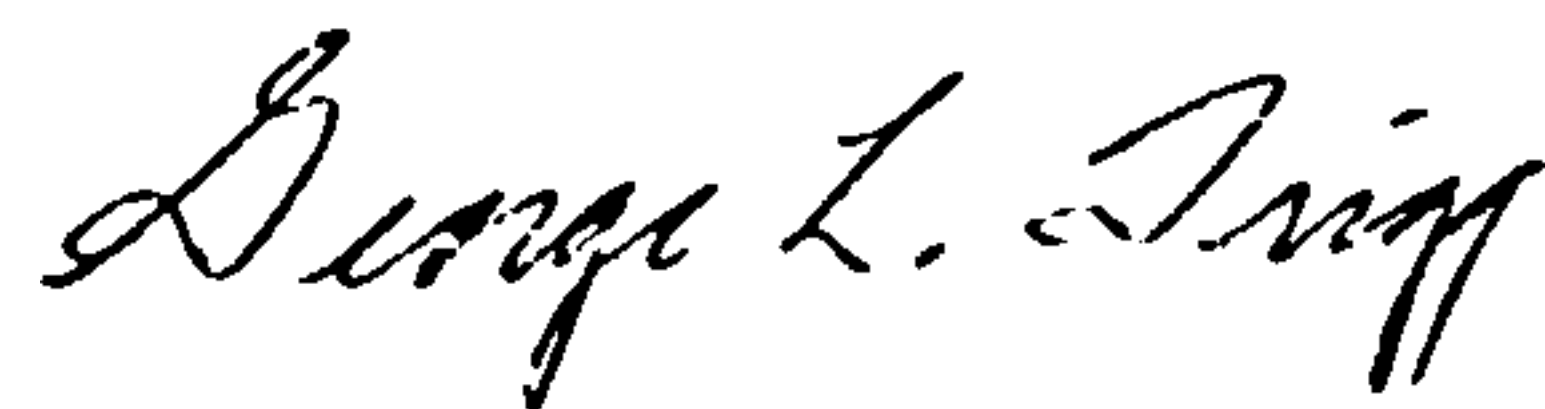

George L. Trigg  
Editor

Enc.

GLT/jw

REFEREE REPORT

Disrupted "rotating disk" experiment

by

Stefan Marinov

This paper is unsuitable for publication – and for much the same sort of reasons as applied to another paper by the same title about two and half years ago. The author simply has not done what he thinks he has.

The author is the exponent of a theory that differs from accepted concepts. On the basis of his theory, he deduces that with his experimental setup, a certain Wheatstone bridge, is balance when the disk is at rest, will become unbalanced as the speed of the disk is increased, and return to balance when a particular rotational speed, deducible from his Eq. (5), is reached. It is not at all clear from his account whether or not this happened. He has given us some numbers, and come up with a figure – not very precise – for the speed of light. We do not even know why the value for N is what it is.

As I said two years ago, the program that is required almost certainly cannot be accomplished in a Letter. Again, it certainly has not been accomplished here.

Incidentally, it is worth noting that the time differences the author predicts are, for his apparatus, of order  $10^{-15}$  sec. This is much smaller than the stability of rotational speed ( $\sim 10^{-5}$  sec) and even than the response time of his photoresistors (say  $10^{-10}$  sec). I doubt that he can see the effect he predicts.

AUTHOR'S ANSWER TO THE REFEREE'S COMMENTS ON THE  
PAPER "DISRUPTED ROTATING DISK EXPERIMENT"  
BY STEFAN MARINOV

I reject the referee's comments as entirely inconsistent. My objections are the following:

Remark I - Theoretical. According to my absolute space-time theory, the disrupted "rotating disk" experiment must give a positive effect of the size which I measured with my set-up and which is described by formula (5) in my Letter. Certain relativists (in conversation, correspondence, or in referee's comments on my papers) assert that the effect must be null, other that the effect must be positive, as predicted and measured by me. The most eloquent paper on this topic is Grøn's paper: "Relativistic Description of Marinov's Modification of the Harress Experiment", Phys. Lett., 56A, 73 (1976). From the referee's comments one cannot draw a conclusion which is the opinion defended by the referee (I presume that the referee is a relativist because it is hardly to believe that Phys. Rev. Lett. will have an absolutist in its referees' staff). Thus: (i) According to the referee, must the effect in the disrupted "rotating disk" experiment be positive (as observed by me) or null? (ii) According to the referee, is the velocity of light along a straight line on a rotating disk direction dependent or not? - I insist that the referee gives clear answers to these two questions using the words "yes" and "not".

However, without expecting for the referee's answers, I shall assume that they will be positive because otherwise the referee will demonstrate a total incompetence in the experimental background of high-velocity light kinematics and, more specifically, in the interpretation and understanding of the historical Harress-Sagnac "rotating disk" experiment.

In the light of this remark, I shall accept that the referee has no objections to the theoretical part of my paper, i.e., to the theoretical validity of formula (5), but only to its experimental part.

Remark II - Experimental. Here my objections are the following:

a) The referee asserts that from my account it is not clear whether I, indeed, have measured the effect described by formula (5). The referee writes:

It is not at all clear from his account whether or not this happened. He has given us some numbers, and come up with a figure - not very precise - for the speed of light. We do not even know why the value for N is what it is.

Let me cite the last paragraph of my paper:

"We experimentally checked formula (5), putting there  $\Delta = \lambda = 633$  nm,  $\theta = 60^{\circ}0 \pm 0^{\circ}3$ ,  $R = 40.0 \pm 0.2$  cm. The number of revolutions per second  $N = \Omega/2\pi$  was measured by a light stroboscopic cyclometer and maintained automatically with a precision  $\delta N/N = \pm 2 \times 10^{-4}$ . We registered  $N = 92.90 \pm 0.02$  rev/sec. Putting the figures into formula (5), we obtain, supposing that the velocity of light is an unknown quantity,  $c = (2.98 \pm 0.07) \times 10^8$  m/sec, where for  $\delta c$  we take the maximum absolute measuring error."

Thus at the mentioned value of N the bridge comes again into equilibrium and, thus, the optical path  $\Delta$  changes with one wavelength. I cannot see how can one better answer such a stupid question: "We do not even know why the value of N is what it is."

Amazing is the assertion of the referee that I come to a "not very precise figure" for the speed of light. I know perfectly well that the speed of light has been measured with a better precision. My aim is not to measure the speed of light. My aim is to es-

establish the direction dependence of light velocity along a straight line on a rotating disk. The figure for the light velocity which I established experimentally shows that I established the light velocity direction dependence with  $(0.07:2.98) \times 100 = 2.3\%$  certainty. I could write formula (5) in the form

$$k\Delta = \frac{\Omega R^2}{c} (2 \tan \frac{\theta}{2} + \sin \theta)$$

and say that according to certain relativists the factor  $k$  must be zero, while according to my absolute space-time theory and to other relativists this factor must be unity, and to show then that I established with 2.3% certainty that this factor must be unity. I think that all this will unnecessarily increase the volume of the paper. My paper is entirely clear. It is clear also for the referee. He only searches certain motivations to support his suggestion for rejection, because he feels that my paper is DANGEROUS (the positive result in my disrupted "rotating disk" experiment logically leads to the acceptance of the positive result in my "coupled-mirrors" experiment and then whole relativity crumbles to pieces - the referee has understood this perfectly well). However when one searches to find objections against a clear and consistent paper, the objections, inevitably, must be unclear and inconsistent.

b) The referee asserts that my program cannot be accomplished in a Letter. I already have published more than 20 papers and a book dedicated to high-velocity light kinematics and I performed many decisive experiments. Now I am working on a publication of the five volumes of my CLASSICAL PHYSICS. The Letter under question gives only the account on the performance of the disrupted "rotating disk" experiment. This experimental account is extremely important because, I repeat, many relativists think that the effect must be null. My experiment is easily performable and any relativist who has certain doubts concerning its positive result can repeat it (however how many relativists perform experiments and how many relativists analyse experiments!).

c) The final ("experimental") remarks show that the referee has never done or analysed light kinematic experiments. My set-up represents only a modification of the historical Harress-Sagnac "rotating disk" experiment which in the last 60 years has been performed thousands and thousands of times (all laser gyroscopes represent, as a matter of fact, "rotating disk" experiments). Which is this "stability" of rotational speed that the referee has estimated of being  $10^{-5}$  sec? Thus this "stability" is  $10^{10}$  times lower than the effect in the experiment (which is about  $10^{-15}$  sec). If in an experiment there is a fluctuation factor which is of the order of the effect to be measured, then the error is 100%. Thus, according to the referee, my random error must be  $10^{12}\%$ . Is this the conclusion of the referee?

Then the referee notes that the response time of the photoresistor is of the order of  $10^{-10}$  sec (let me note that at the present time one cannot construct photoresistors with such a short response time!!!). Since the effect is  $10^{-15}$  sec, may be, the referee again sees here a source for a random error of  $10^7\%$ . Incredible incompetence! The photoresistors represent "eyes". They register the change in the illumination. And the illumination changes only with the change in the velocity. Instead of a photoresistor one can put a piece of paper and see how the illumination changes with the velocity. May be, the referee knows that the "response time" of our eyes is about  $10^{-1}$  sec, thus  $10^9$  times lower than the response time attributed by the referee to the photoresistors. And the experiment can perfectly be performed using as registering instrument our eyes.

Conclusions. I consider this referee's report as highly incompetent and I am surprised that such incompetent opinions can come from a referee of PHYS. REV. LETT. I think, I have the right to insist for a reconsideration of the Letter by another, more competent, referee. I should be very glad if the first referee will answer my objections, however I am sure that he will not do this, because he difficultly can find ground for defence of his opinions (if one assumes that in his criticism a certain "point of view" is defended). I think that the unique estimable move for the referee is the withdrawal of his critical remarks.

Stefan Marinov

Referee's Second Report  
Disrupted Rotating Disk Experiment  
by  
Stefan Marinov

The author has completely misunderstood the intent of my remarks. I will try to make myself clearer. Let me first say that I would probably be classified as a "relativist," since I have yet to see a convincing account of an experiment which contradicts the theory of relativity. Nevertheless, my answers to his questions (i) and (ii) cannot be unqualified "yes" or "no" but only "I would expect null" and "I believe not." I am prepared to accept firm, sound experimental evidence that my beliefs and expectations are unjustified. The author has not provided this.

The author has a theory which produces a formula Eq. (5), for an optical path difference. He measures this by means of optical interference effects on a pair of photoresistors. I maintain, as did the referee of his earlier paper by the same title, that he must do the following: Measure the "disequilibrium" of the bridge - say, the extra emf that must be inserted into one arm to bring it back into balance - as a function of rotational speed  $\Omega$ . Present a plot of the resulting curve, including error bars (and discuss carefully how the errors were

arrived at). On the same axes, show the curve that his theory would predict (this entails relating his path difference  $\Delta$  to a difference in intensity – a standard problem) and the curve that the standard theory of relativity would predict. It will then be possible to judge whether his experiment really refutes the standard theory. It may be that he can do this in a Letter; my expectation is that an adequate discussion of errors – essential in such an undertaking – will preclude that. Until he does that, however, no one will take his claim seriously and there is no point in wasting space publishing it.

As for the experimental remarks, they were provided by an experimentalist colleague and I am not prepared to defend them. I interpret them to mean that, indeed, the author does have random errors of the order of magnitude that he infers, and that it will be incumbent on him to convince readers that he does not.



AUTHOR'S ANSWER TO THE SECOND REFEREE'S COMMENTS .  
ON THE PAPER "DISRUPTED ROTATING DISK EXPERIMENT"  
BY STEFAN MARINOV

I am really amazed that the referee has found pertinacity to defend his incompetent and inconsistent criticism, having in his hands my competent and consistent rebuttal.

I reject his second report as extremely poor and I insist for a reconsideration of my paper by a competent (theoretically and experimentally) arbitrator, to whom my whole correspondence with the referee will be forwarded.

Now I shall show how poor the second referee's report is.

Remark I - Theoretical. The referee (against all my expectations!!!) affirms that the effect in the disrupted "rotating disk" experiment must be null and that the velocity of light along a straight line on a rotating disk is not direction dependent. I repeat (see my first answer) that there are many relativists (I think such must be any honest relativist) who affirm exactly the opposite. Let me cite here certain of them:

1. E. J. Post, REV. MOD. PHYS., 39, 475 (1967).
2. Ø. Grøn, AM. J. PHYS., 43, 869 (1975).
3. V. L. Telegdi, PHYSICS TODAY, 27/11, 11 (1974).
4. P. F. Browne, J. PHYS. A, 10, 727 (1977).

Now I shall show with the help of very simple calculations that the effects in the "rotating disk" experiments measured hundreds of thousands of times show that the velocity of light along a straight line on a rotating disk is direction dependent. (N.B. As a matter of fact, only the velocity of light along a straight line on a rotating disk has been until now measured; it is impossible to measure the velocity of light along a curved line.)

Take the most simple scheme of the "rotating disk" experiment (fig. 1): SM is a semitransparent mirror and  $M_1, M_2, M_3$  are mirrors. If all these mirrors together with the source S and the observer O are first at rest and then rotate with angular velocity  $\Omega$ , the difference in the interference pictures corresponds to a time delay between the "direct" and "opposite" photons

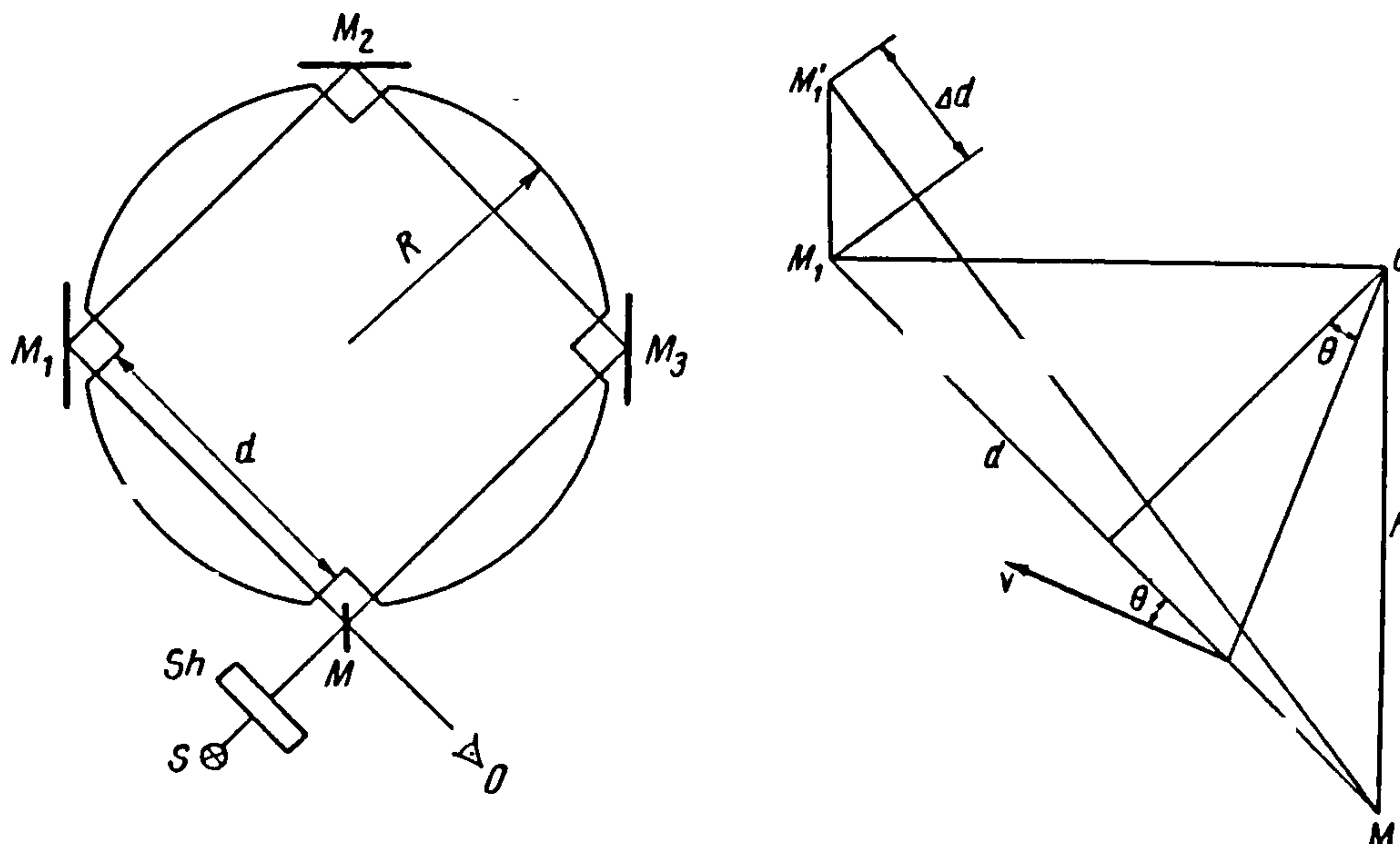

Fig. 1

**THIS PAGE IS LOCKED TO FREE MEMBERS**

Purchase full membership to immediately unlock this page

**SAVE \$3,999,994**

Did you know we sell  
paperback books too?

To buy our entire catalog  
in paperback would cost  
over \$4,000,000

Access it all now for  
\$8.99/month

\*Fair usage policy applies

**Continue**

false Einstein dogma: "The velocity of light is not direction dependent." All these scientists don't think about experiments, don't analyse experiments and when other people do experiments they use their administrative power (as referees, editors, leading professors) to conceal the experimental truth from the world's scientific opinion.

Remark II - Experimental. Nevertheless, even being persuaded that the disrupted "rotating disk" experiment must give a null result, the referee writes:

I am prepared to accept firm, sound experimental evidence that my beliefs and expectations are unjustified. The author has not provided this.

Any experimenter has his style of measurement and of presentation of the results in the press. If I had to follow the referee's suggestions, I had to calibrate my bridge, as this is done for my "coupled-mirrors" experiment where no change with one  $\lambda$  in the light paths can be achieved. However in all my other "interferometric" experiments (the repetition of Fizeau's "water tube" experiment, the different variations of the non-disrupted "rotating disk" experiment, the different variations of the "moving platform" experiment) I succeeded to obtain a change with one  $\lambda$  and thus no calibration is needed; at the same time I obtain a very accurate and firm result. When changing the velocity of rotation the bridge comes into a very sensibly registrable disequilibrium (shown by the diagonal galvanometer), reaches a maximum disequilibrium and then, when the difference in the light paths becomes equal to  $\lambda$ , returns again into equilibrium. I register only this velocity when the bridge comes again into equilibrium and I know that at this moment the difference in the light paths of the "direct" and "opposite" photons is equal to one  $\lambda$ . If I plot the readings of the galvanometer versus the rotational velocity, the curve in fig. 2 will be obtained, where the bars are the fluctuations of the galvanometer. According to the referee and to certain incompetent relativists, the bridge must remain the whole time into equilibrium. Thus the "theoretical" line plotted by the referee must be parallel to the x-axis. Poor theory!

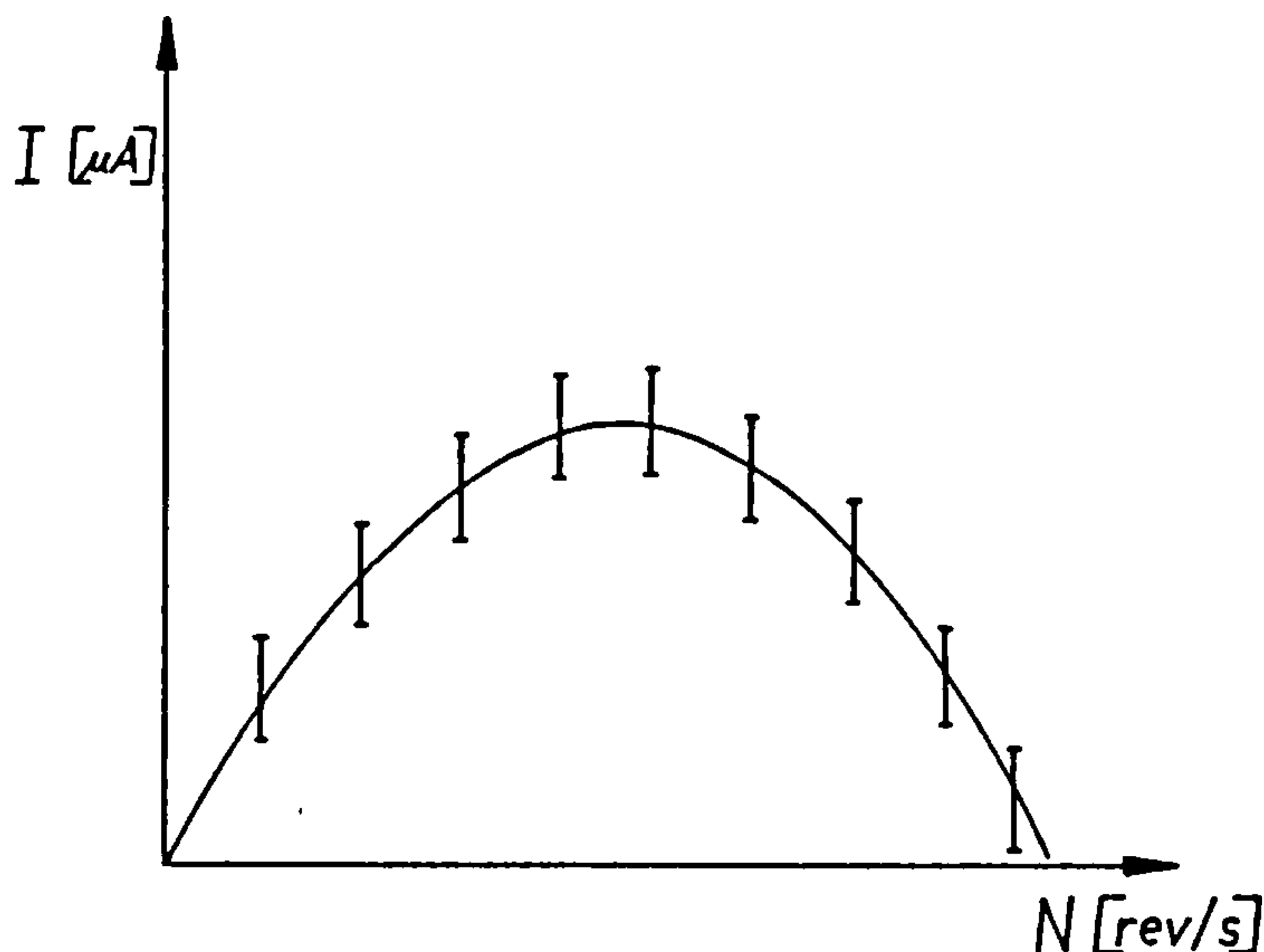

Fig. 2

My experiment was performed about three years ago in Sofia. It is difficult for me to restore the readings of the bridge's galvanometer which corresponded to the different rotational velocities. As far as I remember, the current at maximum disequilibrium was about 500 times bigger than the fluctuations of the galvanometer.

My bridge's method is an excellent method where extremely exact results can be obtained without making calibration. This exactitude permitted me to show experimentally that the dispersive term in the Fizeau-Lorentz formula for the convection of light is not such one as predicted theoretically by Lorentz and Einstein. My account on this exact repetition of the "water tube" experiment was sent to half a dozen of physical magazines and rejected by all of them (any of my papers appears after about 15 rejections!!!).

Instead to teach me how to measure (being absolutely unacquainted with experimental work!!!), it is better for the referee to study my method and to advise his friends experimenters to use it because for me it is difficult to tell this through the press. In this method the unique sources of errors are the fluctuations of the galvanometer and the inaccuracies in the different quantities appearing in the formula, however no calibration errors appear, i.e., it is not necessary, as the referee writes, "to relate path difference  $\Delta$  to difference in intensity".

To show that the referee is not an experimenter, it is sufficient to cite the fact that he attributes to a photoresistor a response time of  $10^{-10}$  sec and when I turned his attention to this and to other experimental stupidities in his first report, the following answer was given:

As for the experimental remarks, they were provided by an experimentalist colleague and I am not prepared to defend them.

I think that the referee of PHYS. REV. LETT. must be able to defend any of his assertions which he has signed with his name. If he has no experimental knowledges, he has to keep silent on the experimental details of the submitted paper and leave this work to another competent referee. However, even as a theoretician I do not see much competence in my referee, if he solemnly asserts that the velocity of light along a straight line on a rotating disk is not direction dependent. I repeat once more that if he will accept the direction dependence, then automatically he has to accept the positive effect in my "coupled-mirrors" experiment and the invalidity of the principle of relativity. It is for this reason that my paper LZ1055 must be published.

Conclusion. I insist for an arbitration. It will be a shameful fact if my paper will remain rejected on the grounds of such incompetent referee's opinions.

Stefan Marinov

- Editorial note. 1. The paper "Disrupted rotating disk experiment" is still not published in a journal (CLASSICAL PHYSICS, vol III, §61).  
2. The final rejection of the paper LZ1055 by PHYSICAL REVIEW LETTERS is given in the letter of 26 Febr. 1979 (see p.100).

Editorial note  
to the second  
edition.

The above discussed paper under the title "The interrupted 'rotating disk' experiment" was published in J. PHYS. A, 16, 1885 (1983).

# Applied Optics

A publication of the Optical Society of America

JOHN N. HOWARD  
EDITOR

7 Norman Road  
Newton Highlands, Massachusetts 02161  
(617) 332-1743

Air Force Geophysics Laboratory  
Hanscom AFB, Massachusetts 01731

10 January 1979

Dr. Stefan Marinov  
rue Stephanie 83  
1020 Bruxelles,  
Belgium

Dear Dr. Marinov:

I regret to say that the reader of your manuscript has not recommended publication of this material in Applied Optics. I enclose his comments. I am, therefore, returning the manuscript to you.

Sincerely,

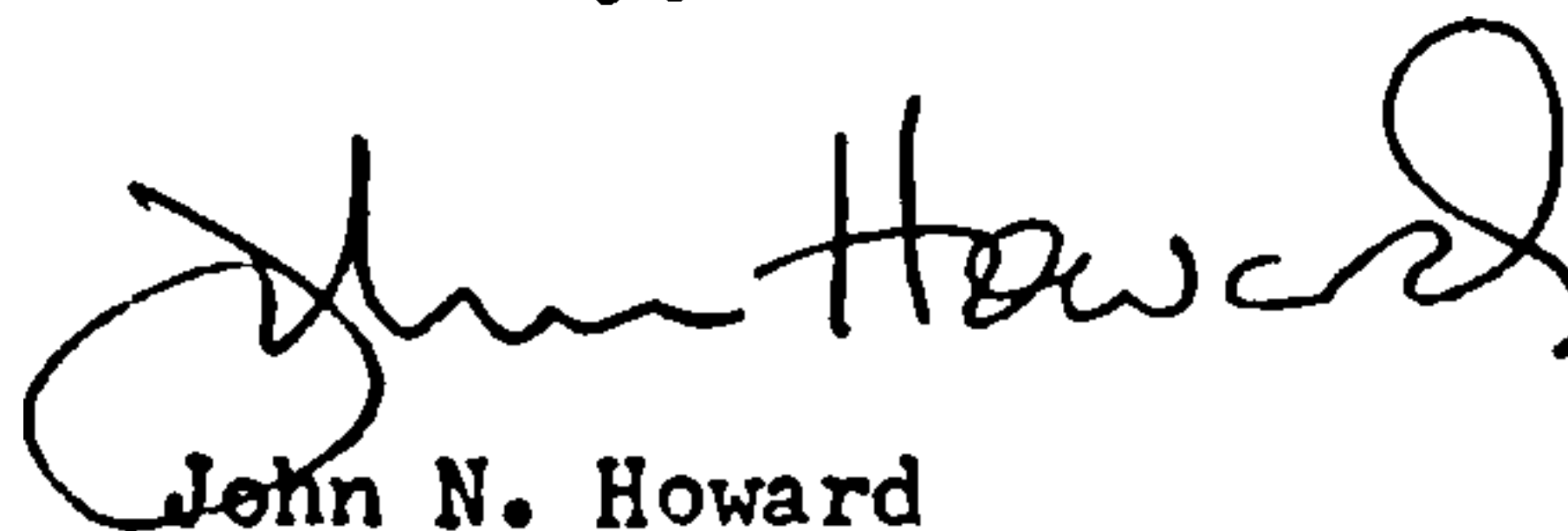

John N. Howard  
Editor, Applied Optics  
Chief Scientist, AFGL

**THIS PAGE IS LOCKED TO FREE MEMBERS**  
Purchase full membership to immediately unlock this page

**FORGOTTEN BOOKS**

# **FULL MEMBERSHIP**

**797,885 Books!**  
**All you can read**  
**for only**  
**\$8.99/month**

**Continue**

\*Fair usage policy applies



# physics today

335 East 45 Street / New York, N.Y. 10017 / 212 661 9404

Harold L. Davis / Editor

18 January 1979

Dr. Stefan Marinov  
2224 F Street, N.W.  
Washington, D.C. 20037

Dear Dr. Marinov:

We have reviewed your letter "Experimental Refutation of the Principle of Equivalence" and your manuscript "Let Newton Be!" and have decided against publication. Our policy is to avoid publishing reports of original work. Such manuscripts should be directed to an appropriate specialized journal whose referees are in a position to judge the significance of the work.

Sincerely,



Harold L. Davis  
Editor

HLD:sh  
Enc.

# THE PHYSICAL REVIEW

AND

# PHYSICAL REVIEW LETTERS

Physical Review D

BROOKHAVEN NATIONAL LABORATORY, UPTON, NEW YORK 11973

Editor

Telephone (516) 924-5533

(FTS) 664-2540

D. NORDSTROM

Telex: 9/oBNL, 96-7703

Cable Address: BROOKLAB

Associate Editor:

STANLEY G. BROWN

January 18, 1979

Dr. S. Marinov  
Allen Lee Hotel  
2224 F. Street, N.W.  
Washington, D. C. 20037

Dear Dr. Marinov:

We regret to inform you that we cannot accept your paper "Measurement of the laboratory's absolute velocity" for publication in Physical Review D. As we cited as the basis of rejection for your two earlier papers "Fundamentals of electromagnetism according to absolute space-time theory" and "Fundamentals of gravimagnetism and the mercury problem according to absolute space-time theory", we cannot consider for publication manuscripts whose main results consist of material that has been published elsewhere (or that has been accepted or is under active consideration elsewhere). As with your earlier work it is our information that the results of and discussion of your interferometric "coupled-mirrors" experiment of 1975 are contained in your book "Eppur Si Muove". Therefore we cannot accept your paper for publication.

We wish to advise you that we will not consider for possible publication any manuscripts whose main points are already contained in previous publications of yours such as your book. We will only consider papers containing new, previously unpublished results.

We are therefore returning your manuscript herewith.

Yours sincerely



D. Nordstrom  
Editor

DN/kw  
enc.



# THE PHYSICAL REVIEW

AND

# PHYSICAL REVIEW LETTERS

BROOKHAVEN NATIONAL LABORATORY, UPTON, NEW YORK 11973

Telephone (516) 924-5533 (FTS) 664-2540

Telex: 9/0BNL, 96-7703 Cable Address: BROOKLAB

PHYSICAL REVIEW LETTERS

Editor

ROBERT K. ADAIR  
Department of Physics  
Yale University  
New Haven, Conn. 06520  
Tel. 203-436-1582

HOME: 50 Deepwood Dr.  
Hamden, Conn. 06430  
Tel. 203-777-2955

February 26, 1979

Dr. Stefan Marinov  
rue Stephanie 83  
1020 Bruxelles, Belgium

Re: Manuscript No. LZ1055

Dear Dr. Marinov:

As you may know, Physical Review Letters is a selective journal published by the American Physical Society. The editors are enjoined by the Society, through the Publications Committee of the Council of the Society, to follow procedures which result in the selection of but 45% of the submitted papers for publication. We are directed to require that the papers are especially important, timely and clearly and completely presented. We consider that it is the responsibility of the author to demonstrate that his paper is important, complete and correct. The 55% of the submitted papers which we do not accept for publication (about 1300 papers a year) are, for the most part, substantial contributions to physics. The authors of these papers have not, however, convinced the referees, chosen by the editors as representative of the informed readership which the authors address, that the paper is sufficiently important for our consideration and sufficiently clearly presented so that the probity of the result can be considered by a critical reader.

Often papers which present important results are rejected on the basis that it is not possible to present the results in a sufficiently complete form within the brief format required by our length constraints. In particular, we find that we are then able to publish few papers which attack areas of physics which are broadly held to be valid inasmuch as it is seldom

**THIS PAGE IS LOCKED TO FREE MEMBERS**

Purchase full membership to immediately unlock this page

**SAVE \$3,999,994**

Did you know we sell  
paperback books too?

To buy our entire catalog  
in paperback would cost  
over \$4,000,000

Access it all now for  
\$8.99/month

\*Fair usage policy applies

**Continue**

DANTE B. FASCELL  
CHAIRMAN

CLAIBORNE PELL  
CO-CHAIRMAN

COMMISSIONERS  
DICK CLARK  
PATRICK J. LEAHY  
RICHARD STONE  
CLIFFORD P. CASE  
ROBERT DOLE  
JONATHAN B. BINGHAM  
PAUL SIMON  
SIDNEY R. YATES  
JOHN BUCHANAN  
MILLICENT FENWICK

COMMISSION ON  
SECURITY AND COOPERATION IN EUROPE  
CONGRESS OF THE UNITED STATES  
WASHINGTON, D.C. 20515

March 10, 1979

EXECUTIVE BRANCH  
COMMISSIONERS  
PATRICIA M. DERIAN  
DAVID E. MCGIFFERT  
FRANK A. WEIL

R. SPENCER OLIVER  
STAFF DIRECTOR

ALFRED FRIENDLY, JR.  
DEPUTY STAFF DIRECTOR

3257 HOUSE OFFICE BUILDING, ANNEX 2

(202) 225-1901

Stefan Marinov  
rue Stephanie 83  
1020 Bruxelles  
Belgium

Dear Mr. Marinov:

On behalf of the Commission, I would like to thank you for your wonderful collection of poems. It will I'm sure make a fine addition to our growing library.

I recall our telephone call shortly before you left the United States, during which you informed me that because of your lack of the proper residence status, you were being forced to leave the country. I take it from the return address on your letter that you are currently residing in Brussels. Perhaps, if you were to contact directly, relevant scientific institutions in this country asking for their sponsorship, as well as our embassy in Brussels for the proper immigration documents, your problems with remaining in the U.S. could be solved.

Thank you again for sending us your collection of poems.

Sincerely,

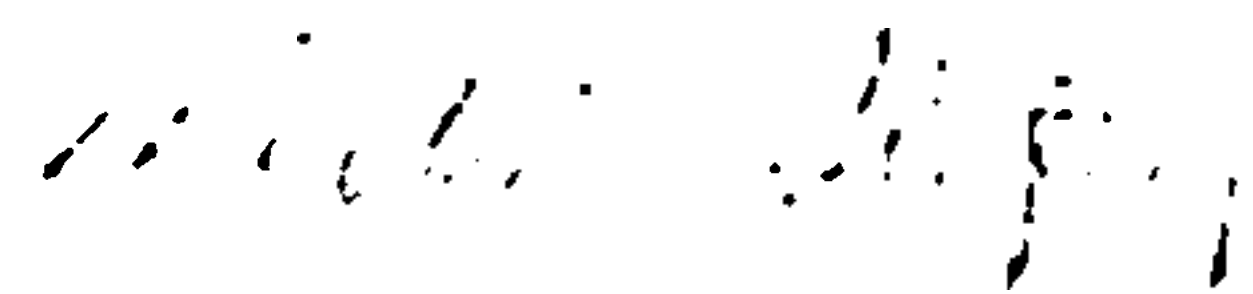

Martin C. Sletzinger  
Staff Assistant

MCS/ams



PECOLA VATICANA  
- 00120 CITTA DEL VATICANO

TEL. (06) 698/3411

Castel Gandolfo, 18 April 1979

Dr. Stefan Marinov

Via Puggia 47/1  
16131 GENOVA

Dear Dr. Marinov,

I found your letter and book in the mail, which arrived during my absence from the Specola and have already answered Mr. Vanistendael. I deferred my answer to yourself somewhat because I was hoping to get some advice from somebody more qualified than I am in your field of physics, to whom I have given your work "Eppur si muove". So far I got a "prima facie" answer, which confirms my own opinion that the questions you move are certainly worth the most careful consideration and investigation. Whether your results and conclusions can really be compelling to change the axiomatics of relativity is something he could not affirm without a more detailed study of the question, for which at the moment time is lacking. He promised me to look into it as soon as he finds the opportunity, which may take some time. If I get further news, I will let you know.

I want you to know however that, contrary to the information, received by Mr Vanistendael, I am not the director of the Vatican Observatory, but only a scientist working at that institute (which moreover is not engaged in your field), and have in no way the authority or the influence which could help you from an institutional point of view.

My personal view is that the Church should be, and I think I can affirm is indeed very strongly interested that humanity in general tries to acquire the right insight in such fundamental questions of nature, but that in themselves these questions have no theological or religious impact. That therefore Christians, especially when they are scientists, should find in their religion a strong motive of interest in such questions, but should refrain in trying to answer them from their religious principles or letting their religious convictions be influenced by any, provisional or so called "final" answers to them. Likewise should the Church encourage research and scientific activity as a fundamental component of the human vocation (often this encouragement will appear only "moral", but will nevertheless be real and important and effective), but should not even try to give an answer or to take a position "in merito". That such things unfortunately happened in the past, is no reason why they should happen again, and I should be inclined to speak in the same way of other "ideologies" or religions.

- 104 -

For this reason I am rather disappointed to find your name on the list of speakers at the Congress of Science and Religion, which, judging from the list of participants and their related competences and subjects, is rather all set up to commit exactly the error which I indicated. And this I say as a christian, as a priest and as a scientist as well. If your theories should break through, and as a fellow scientist I wish you all luck, it has to start I think on the pure scientific level. I know that this may be very hard and I agree that Einstein himself might have a tough time if he were to start now (he did not have it easy in his time either), but it is the only right way to go.

Yours sincerely,

E. De Graeve SJ

**THIS PAGE IS LOCKED TO FREE MEMBERS**

Purchase full membership to immediately unlock this page

**FORGOTTEN BOOKS**

**FULL**

**MEMBERSHIP**

**797,885 Books!**

**All you can read**

**for only**

**\$8.99/month**

**Continue**

\*Fair usage policy applies



THE EPOCH OF GALILEO AND THE EPOCH OF JOHN PAUL II

Address delivered by Stefan Marinov at the First World Congress  
of Science and Religions, Rome 24 June - 1 July, 1979

Before I begin with my disquisition I would like to explain what I mean by the notion "God".

I am a materialist, and for me the notion "God" is a moral but not a physical one. God does not exist outside the human spirit, but is a product of that spirit. Science is also a product of human spirit. However, science represents a response to a reality, which exists independently of the spirit, while religion is a response to the spirit itself.

If we wish to define the notions "science" and "religion" in the most simple and concise way, I think we have to give the following definitions. Science explains what is true and what is false; religion explains what is good and what is bad. In science there is always a reality, which can give an answer to a question raised by man. This answer is objective and absolute. Admittedly, the answer can come too late, an answer which for a long time has been accepted as true may be rejected as false some day. Thus the image of reality, its model (a very modern word) in a man's head can be subjective, but the reality itself is absolute. For religion such a material reality does not exist. The answers given by religion are subjective and relative.

The most important aspect of science is that there is the experiment as an absolute judge. And when the experiment speaks, gods keep silent. Of course, the experiment can be done in an erroneous manner, can be interpreted erroneously, not all factors may have been taken into consideration, but the fundamental point is that the possibility of an experiment does exist. In religion there is no experiment. There is no apparatus in the whole world, no electronic calculator however much sophisticated that can answer a question such as the following one: If one slaps me on the right cheek, do I have to offer him my left cheek, or not?

However, if we open the book of the centuries old human history, we can establish that all religions (including the atheistic ones, as, for instance, communism) define the good and the evil in the same manner. Thus, if all religions give the same answers to the questions of good and evil, we must conclude that the good and the evil, God and Devil, must also be absolute categories. Many gods have been created on our earth: one puts his god on the Olympus, another in the seventh heaven, a third one in his head. For the one God is male, for another female or hermaphrodite, for a third something defined by the void word "force" or only a conception. Hence the models (a very modern word!) are different, but the substance of God and Devil, the substance of the good and the evil, which all men create subjectively is the same. Thus all of us, believers and non-believers, theists and atheists, we must accept: God exists.

Dostoevski, one of the most important prophets in human history, said through his hero Ivan Karamasov: "If God does not exist - all is permitted." No, all is not permitted to man, because God does exist. A God for all of us - good, wise and loving.

This is, in a few words, my concept of the notion "God".

.....

I am a scientist. A representative of the science that is in a most solid way attached to material reality: physics. To explain in a most lucid and clear manner what the essence of science is, I shall tell you in a few words my own experiences, which provide an eloquent example. My theory, i.e., my subjective model of material reality, and my experiments, i.e., the objective proofs of this model, are concerned with the most important physical notions: the space, the time, the mathematical construction of our world. Hence they are of general interest and, surely, are interesting for the present competent audience.

And another remarkable fact: I speak to you only three months after the solemnities dedicated to the memory of one of the greatest physicists in human history - Albert

Einstein. Everybody has heard on the radio, seen on television, read in the newspapers about these events. The most important mathematical creation of Einstein is his theory of relativity. Proposing a model of this world and proceeding from age old human experience, Einstein concluded that the principle of relativity is a fundamental law in physics and must be accepted axiomatically as true because until today no experiment has refuted it.

The principle of relativity can in the most simple and concrete way be defined as follows: No experiment exists and can exist with the help of which one could measure the absolute velocity of a laboratory, i.e., its velocity with respect to the masses of the whole universe. The principle of relativity is very similar to the principle of conservation of energy which asserts: No experiment exists or can exist, in which the initial energy of an isolated system will be more or less than its final energy. The principle of relativity was introduced already in ancient Chinese science. In the Western culture, this principle was formulated for the first time with a sufficient clarity by the immortal Galileo. Einstein presented the principle of relativity in the perfect language of mathematical equations. And now, I beg your attention: I have carried out an experiment (for the first time in 1973, and a second more accurate variation in 1975) with the help of which I succeeded in measuring the absolute velocity of the earth. Thus, I have demonstrated with an objective experiment that the principle of relativity is not true. Therefore the whole of this impressive mathematical construction which is called "the theory of relativity" is not adequate to reality. Everybody of you will now raise his hand: "Why then do all say and write that this principle is right?" All of you I can answer as follows: Wait six months, maybe a year, and all will begin to say and write exactly the opposite. Well! That is science! That is the absolute and objective force of reality which exists outside the spirit. Those in the establishment can slam the doors of the journals, of the institutes, of the congresses, because in science, as in politics, everybody is afraid to lose his power, but all these efforts are efforts of dwarves. The experiment is that which decides - not the President, the Director, the Genius. One can insist that there are not spots on the Sun, one can insist a year, two, three, but the spots are there, and one must accept them, because otherwise one becomes ridiculous, ri-di-cu-lous.

Now in five minutes I should like to explain the essence of my experiment. In Bulgaria I performed the experiment with coupled mirrors - in 1973 the deviative variant and in 1975 the interferometric variant. In a photograph I show the experiment with the coupled shutters, which I carried out three months ago in Brussels. This last variation is much easier for understanding the essence of the method, and its construction is much more simple and clear.

My experiments are the first in human history with the help of which I measured the unidirectional light velocity. Why is the velocity of light so important?

Because the principle of relativity is closely connected with the propagation of light. Light propagates in a vacuum with the velocity "c", equal to three hundred thousands kilometers per second. The vacuum is at rest with respect to absolute space. The vacuum cannot be attached to some object, since a vacuum cannot be dragged. One can drag something, but "nothing" cannot be dragged. Thus in a laboratory which moves in absolute space at a speed "v", the speed of light must be "c - v" along the direction of motion and "c + v" along the opposite direction.

In all experiments which have been carried out until today, scientists have always measured the speed "there-and-back". People measure this speed tens of thousands of times every day. Every pilot, every captain on a ship, every policeman on a highway using a radar apparatus measures the speed of light to and fro. But nobody before me has measured the speed only to. As the speed "there" is "c - v" and "back" "c + v", the speed "there-and-back" is always "c".

Here is the "coupled-shutters" experiment (see photo). An axle rotates at 10,000 rpm. The shutters which are disks with holes are fastened to the axle. A laser emits



light in one direction, another one in the opposite direction. Two photodiodes register the intensity of light which illuminates them. If the rotational speed of the axle increases, the intensity of the light on the photodiodes increases or decreases depending on the positions of the holes and the light spots when the axle is at rest. A formula unifies this change with the parameters of the apparatus and the unidirectional speed of light. With this apparatus I achieved an accuracy of 10% , i.e., I measured the unidirectional speed of light with an error of 30,000 km/sec. With the help of the experiment in Sofia I have established that the absolute velocity of the earth is about 300 km/sec, i.e., 100 times lower than the accuracy of my Brussel's experiment. This extremely simple experiment shows clearly which parameters must be improved so that one can reach the precision of my Sofia experiment.

I must tell you that in Washington I visited the National Bureau of Standards, where my colleague Dr. Luther has measured the "there-and-back" speed of light with an accuracy of 30 cm/sec, i.e., to an exactitude 100 millions of times higher than my exactitude. However I have measured the speed only "there", while the Americans, as all other people before them, have measured the speed "there-and-back".

Everyone of you will exclaim: But this experiment is so simple! Why was it not carried out until now? - I also cannot understand why, as I could not understand, when being a boy, why only Columbus has succeeded in making the egg stand on its end.

The speed of light to and fro was measured for the first time in a laboratory by Fizeau in 1849 with a basis of 8 kilometers. A couple of years later Foucault succeeded in measuring this speed with a basis of 4 meters. My basis is 1.5 m. Thus my experiment could have been carried out 130 years ago, and the theory of relativity would not have been created.

When I say that this is the first experiment where one measures the velocity of light in one direction, I do not "cast words on the wind". Excuse me, I am not an Italian. If

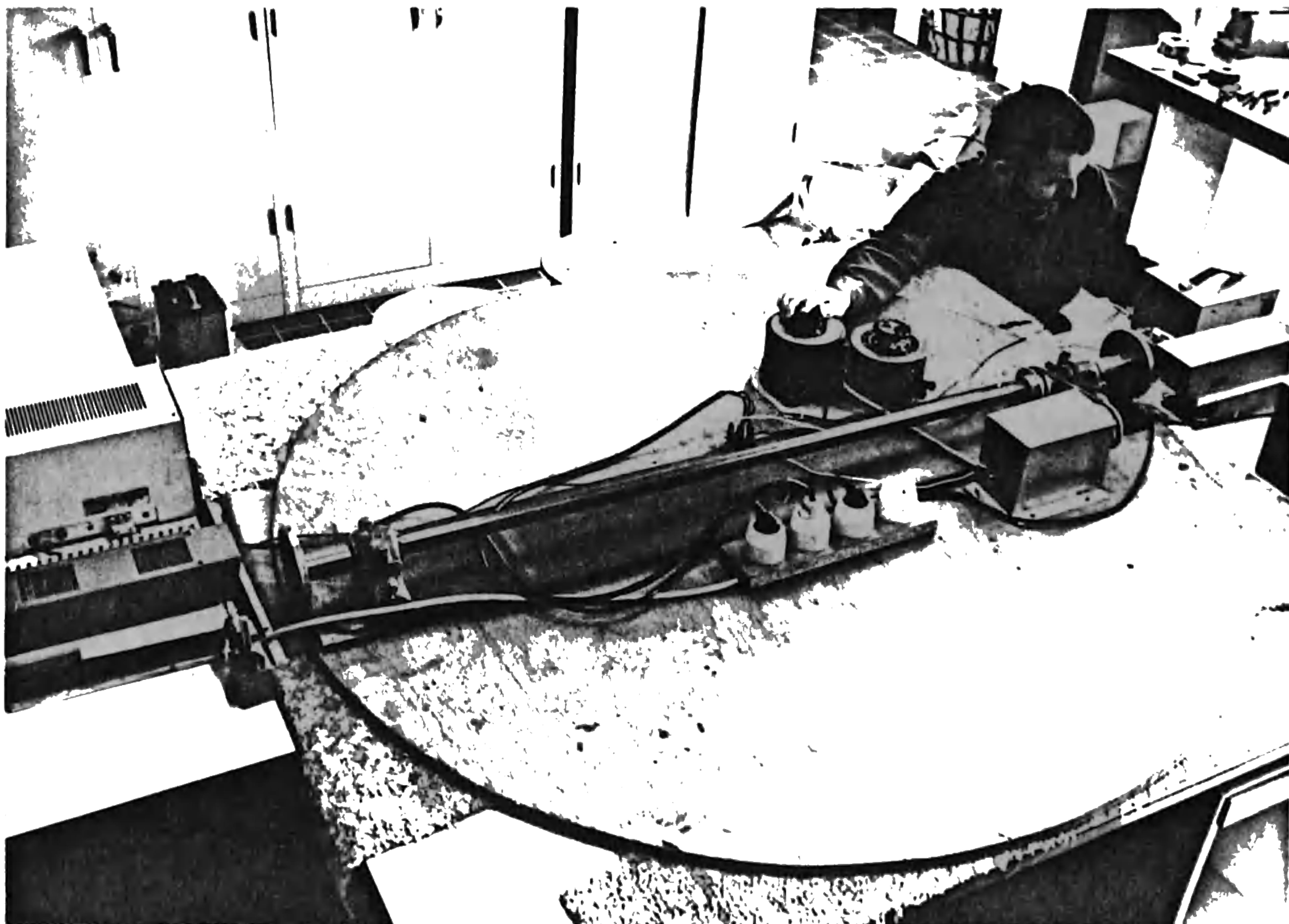

**THIS PAGE IS LOCKED TO FREE MEMBERS**

Purchase full membership to immediately unlock this page

**SAVE \$3,999,994**

Did you know we sell  
paperback books too?

To buy our entire catalog  
in paperback would cost  
over \$4,000,000

Access it all now for  
\$8.99/month

\*Fair usage policy applies

**Continue**

laboratory and I have registered it. The absolute velocity of the Sun is  $300 \pm 20$  km/sec; the equatorial coordinates of its apex are: right ascension 13h 23m  $\pm$  20m, declination  $-23^\circ \pm 4^\circ$ . Again our world is stable, space is space and time is time. And all of you, you can go to sleep calmly this evening - the galaxies do not escape from us, as if our galaxy were mad. The Creator, indeed, has made a simple, clear and lucid world. The Creator has constructed a whole multiform universe with three elements only: space, time and energy. With three bricks, with three bricks only - the whole of this marvelous and astonishing building, including the normal, paranormal and archi-para-meta-ortho-normal phenomena, the existence of which is denied by the major part of my colleagues, the physicists, such as the illustrious and fascinating Prof. Zichicchi. But the paranormal phenomena do exist, they are real, they can be measured. Otherwise all these people, who came from so many countries in the world, would not lose time and money to meet here in Rome. Prof. Zichicchi says: If I can measure an effect with an apparatus, the phenomenon does exist, if I cannot - sorry - no. The problem is that the substance of the paranormal phenomena is such that the apparatus which can register and detect them is man himself. And if Zichicchi says that the phenomena do not exist, I can conclude only the following: Dear Antonio, your apparatus is not sensitive enough. Do you measure a current of pico-amperes with a micro-amperemeter? I must confess that I was the same as Zichicchi. I registered the paranormal phenomena for the first time at the age of 48. And I am enormously thankful for this to Signora Rita Ramella, the head of the Press-Office of our Congress. We have among us an exceptional quack, pranotherapist and woman. Make the acquaintance with Rita, speak with her, enter into contact with her spirit. On our Earth there is not only Sai Baba.

Here I finish with the epoch of Galileo, i.e., with the problems of the true and the false, with the problems of science, and I approach the epoch of John Paul II, i.e., the problems of good and evil, the problems of religion.

Science has made an astonishing progress, has discovered many things, gigantic energies, enormous possibilities to change the world and man himself. But what of all this is good and what evil? - Science, Galileo cannot give the answer. Here religion has to speak, Wojtyla has to speak.

Never, never, never in human history has man had such a need for religion as today. Man can change the desert into paradise, and man can poison all the oceans; man can understand the language of the dolphins, and kill all the whales; man can change the genes, perfect himself, and man can create people artificially, people without a mother; man can change man's mentality, kill with medicines the pains, the sadness, but also the doubt, the nostalgia, the love; man can make the music of Beethoven enter into every house, but also the cacophony, the most idiotic. Finally, man can destroy all that has existed on our earth for billions of years. What can be done and what not? What is permitted and what is not permitted? You, John Paul, are the one who must give the answers.

I shall permit myself to illustrate the role and the importance of faith and of religion with the example of my people. For 500 years the Bulgarians were under the Ottoman yoke. For 500 years the Bulgarian Orthodox church, the priests, the monks defended the unfortunate people in its sufferings. And the Bulgarian church saved the people. The Bulgarians were not exterminated or assimilated, they did not betray their culture, they did not forget or renounce their customs, their traditions, as many other peoples whose faith was feeble and who today cannot be found on the geographic map.

Dark forces hold our earth in their hands. Only religion, faith, the devotion to God and to the Good can save man. First defining the good and the evil; then defending the good against the evil. Defining and defending.

Man on our planet wishes to know what is the way of God that he must follow, man searches to save himself from the suicide to which mad politicians and generals precipitate him: Wojtyla has defended human rights, the liberty of the spirit, the liberty of choice. But is this sufficient? Millions are in prisons, in camps, in mental hospitals - in Chile, in Argentina, in the empire of Bocassa, in the happy motherland of the workers and the peasants. All these people await your help, John Paul.

At this congress many religions are represented. But two of the more powerful religions, followed by numerous masses of people are not represented: the christian-orthodox religion and the communist religion. I was baptized in a Bulgarian orthodox church and my parents are communists. Thus I have the right in the name of these two religions to address all present here with the words: God for all men is unique, the good and the evil are absolute categories. Let us unify to save our poor earth from the hands of the Devil who has acquired an enormous power, as never in human history. Brezhnev, Carter and Den Xiaoping hold atomic bombs in their hands. I, poor man, I think that the Devil has entered into the souls of these people. A son of God cannot hold in his hand an atomic bomb, only a Devil. John Paul, answer whether my judgement is just! Answer! Your sacred duty is to give an answer. And if the Devil has entered into the souls of our poor brothers, what do we have to do to chase him away and to save their souls from eternal hell? Answer, John Paul; answer clearly what we have to do. The people with the name of God in their hearts expect your word.

I have two sons. The one is a Bulgarian citizen, the other is a Belgian citizen. The one finished his military service in the Bulgarian army a year ago, the other will begin his service in the Belgian army in three years. The one is in the contingent of the armies of the Warsaw pact, the other is in the contingent of the NATO armies. Tell me, John Paul, why the generals Jacobowski and Haig have the force to put knives in the hands of my sons and to push them one against the other, and why I, their father, do not have the force to take the knives from their hands. Tell me, John Paul, what I have to do, seeing that my blind sons may become fratricides. Tell me, I expect your word.

If you are my father, do not leave me alone and without help, as I search for a way not to lose my two poor sons.

Editorial note. This speech of Marinov was published in the BULLETIN OF THE TYCHONIAN SOCIETY (Canada) 28, 14 (1980). It was commented in the Italian journal PAESE SERA (see p. 26 ).

INTERNATIONAL JOURNAL OF THEORETICAL PHYSICS  
GEORGIA INSTITUTE OF TECHNOLOGY

ATLANTA, GEORGIA 30332  
(404) 894-5201

PROF. DAVID FINKELSTEIN, EDITOR

28 June 1979

REF: 79-25

Professor S. Marinov  
Laboratory for Fundamental Physical Problems  
ul. Elin Pelin 22  
Sofia 1421  
BULGARIA

Dear Professor Marinov:

Thank you for your manuscript "Measurement of the Laboratory's Absolute Velocity". We regret that we cannot accept it for publication, and return it herewith, together with a referee's review for your information.

Sincerely yours,

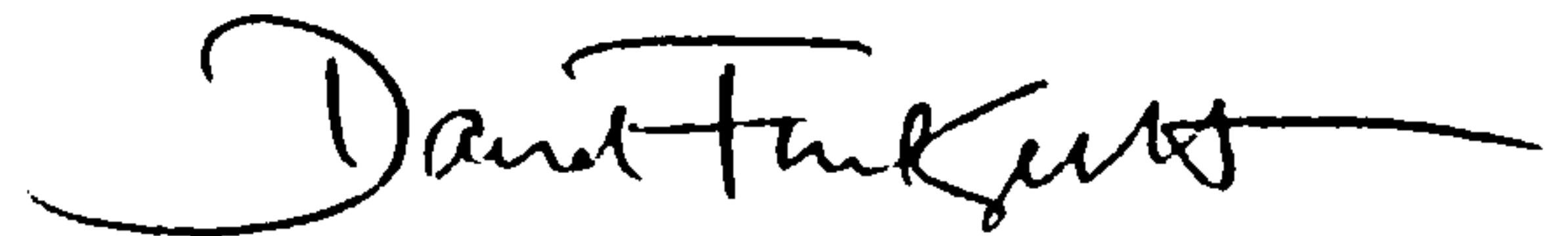

David Finkelstein, Editor  
Helen Heard, Secretary

DF:hh

**THIS PAGE IS LOCKED TO FREE MEMBERS**  
Purchase full membership to immediately unlock this page

**FORGOTTEN BOOKS**

# **FULL MEMBERSHIP**

**797,885 Books!**  
**All you can read**  
**for only**  
**\$8.99/month**

**Continue**

\*Fair usage policy applies



# JOURNAL OF THE OPTICAL SOCIETY OF AMERICA

570 UNIVERSITY TERRACE • LOS ALTOS, CA 94022



July 17, 1979

JOSEPH W. GOODMAN, *EDITOR*  
HONMAI GOODMAN, *ASST. TO THE EDITOR*  
TELEPHONE (415) 941-9089

Dr. Stefan Marinov  
Organizzazione Internazionale Congressi  
Via Puggia 47-1  
16131 Genova  
ITALY

Dear Dr. Marinov:

It has been a long-standing policy of the Journal of the Optical Society of America that we do not publish papers that are concerned with the validity of, or the interpretation of, the special theory of relativity. This policy was followed by Dr. Sinclair before me and by Dr. MacAdam before him. It is a policy that I wish to continue while the journal is under my editorship.

There are many reasons for this policy. Primarily, there are many other more appropriate journals for publication of such material. One, for example, is Physical Review D, edited by Dr. D. L. Nordstrom, whose address is below:

Dr. D. L. Nordstrom, Editor  
Physical Review D  
Brookhaven National Laboratories  
Upton, NY 11973

There are a multitude of other journals devoted to the foundations of physics for which such a paper would be appropriate.

After reading your manuscript "Drag-of-light experiments", it is my opinion that this paper is really concerned with a test and interpretation of the special theory of relativity. For this reason I am returning your manuscript with the suggestion that you submit it to another journal that covers this subject area, such as the journal mentioned above.

We appreciate your interest in JOSA, and we regret that we can not consider the paper that you have submitted.

Sincerely yours,

*Joseph W. Goodman*

Monsieur S. MARINOV  
ORGANIZZAZIONE INTERNAZIONALE CONGRESSI  
Via Puggia 47 - 1  
16131 GENOVA

Italie

Cher Monsieur,

Les mémoires que vous avez soumis successivement pour publication aux Annales de l'Institut H. Poincaré :

"The Interferometric "coupled-mirrors" experiment"

"The quasi-Roemer and quasi-Bradley experiments according to absolute space-time theory"

"The quasi-Doppler experiment according to absolute space-time theory"

"Kinematic time dilation"

ont été examinés par le Comité d'édition.

Les rapporteurs ont conclu à la non-publication de ces travaux par les Annales de l'Institut Henri Poincaré.

Vous présentez avec raison la nécessité de reprendre avec toute la précision possible des mesures actuelles les expériences ~~des~~ très anciennes qui ont motivé en partie les recherches théoriques qui ont conduit aux théories mathématiques de la Relativité restreinte et généralisée actuelles.

Toutefois ces recherches doivent être d'abord expérimentales et ne doivent pas prendre pour guide des bases théoriques déduites des théories relativistes qu'elles ont pour but de justifier, d'améliorer ou de réfuter.

Vos travaux doivent donc d'abord être soumis à des recherches expérimentales pour en analyser la possibilité de réalisation et les précisions à rechercher.

Suivant votre demande je vous retourne les textes de vos derniers articles

1 - The quasi-Roemer and quasi-bradley experiments according to absolute space-time theory

2 - The quasi-Doppler experiment according to absolute space-time theory.

Veillez agréer, Cher Monsieur, l'expression de mes sentiments les meilleurs.

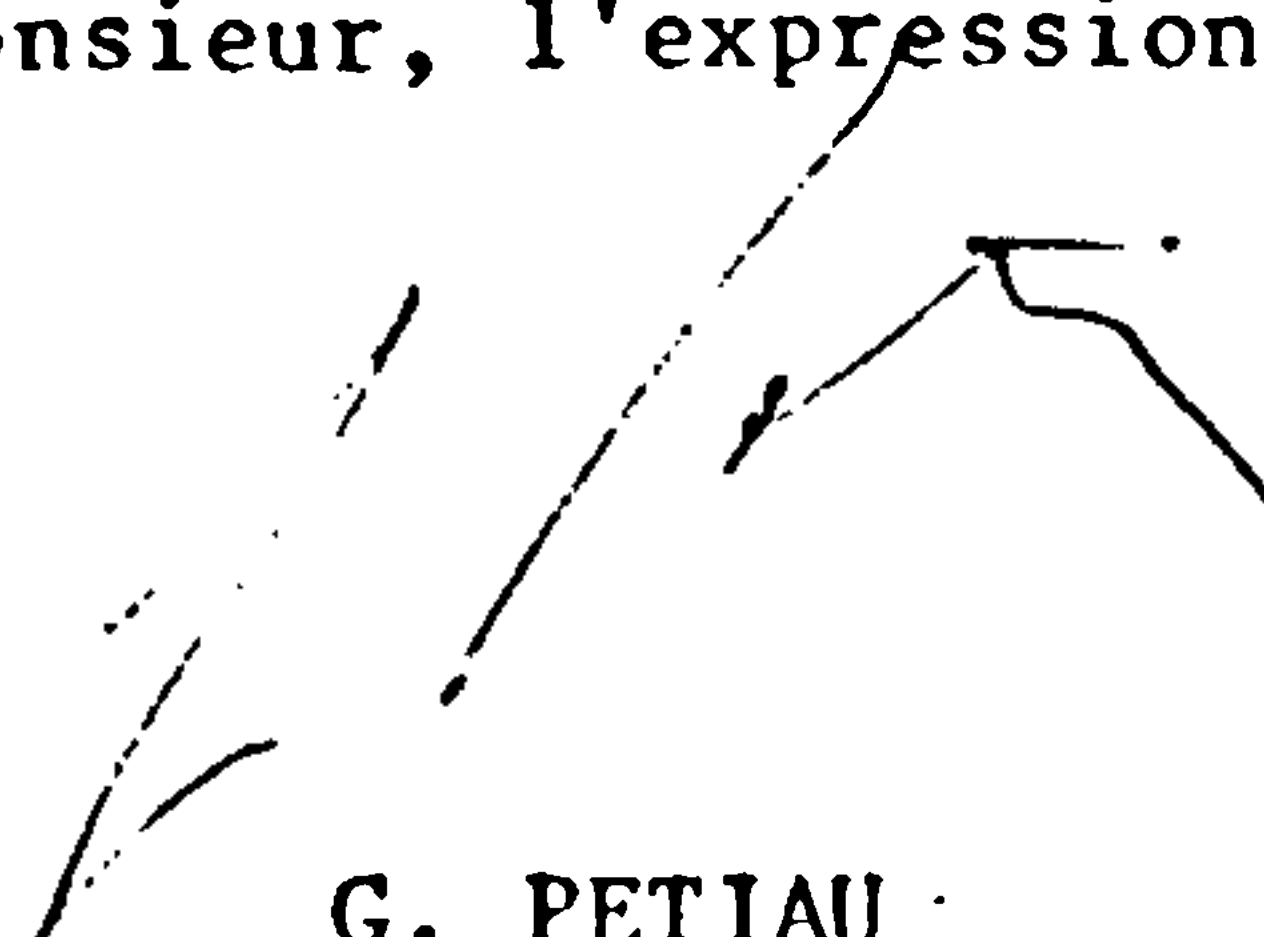

G. PETIAU



# ANNALEN DER PHYSIK

REDAKTION

PROF. DR. G. RICHTER, BERLIN

Akademie der Wissenschaften der DDR  
DDR-1199 Berlin-Adlershof, Rudower Chaussee 5

PROF. DR. W. WALCHER, MARBURG/L.

Philippe-Universität, D-3560 Marburg/L., Physikalisches Institut

JOHANN AMBROSIUS BARTH · VERLAG · DDR-701 LEIPZIG

Prof. Dr. G. Richter, DDR-1199 Berlin-Adlershof, Rudower Chaussee 5

## Einschreiben!

Herrn  
Stefan Marinov

Allen Lee Hotel  
2224 F Street, N.W.

Washington, D.C. 20037

USA

Ihre Zeichen

Ihre Nachricht vom

Meine Zeichen

Datum

Prof. Ri/K1

14. 8. 1979

Betrifft:

Sehr geehrter Herr Marinov,

Ihre an die ANNALEN eingereichte Arbeit

"Cosmological Aspects of absolute Space-Time Theory"

behandelt die Frage, ob die kosmologische Rotverschiebung linear oder quadratisch mit der Entfernung  $r$  anwächst. Sie behaupten, daß die quadratische Abhängigkeit von  $r$  die empirischen Fakten besser wiedergibt als die lineare - entgegen der Meinung der Astronomen. Da diese Frage eine empirisch-astronomische ist, schlagen wir vor, die Arbeit einer astronomischen Zeitschrift einzusenden.

Gleichzeitig senden wir Ihnen zu unserer Entlastung Ihr Manuskript wieder zu.

Mit freundlichen Grüßen

  
Prof. Dr. G. Richter

**THIS PAGE IS LOCKED TO FREE MEMBERS**

Purchase full membership to immediately unlock this page

**SAVE \$3,999,994**

Did you know we sell  
paperback books too?

To buy our entire catalog  
in paperback would cost  
over \$4,000,000

Access it all now for  
\$8.99/month

\*Fair usage policy applies

**Continue**

Stefan Marinov  
rue Stephanie 83  
B-1020 Bruxelles  
phone 02/427.64.66  
17 August 1979

Dr. Davies  
Editor in Chief  
NATURE  
4 Little Essex Street  
London WC2R 3LF

Dear Dr. Davies:

My last two efforts: the sending of the paper "Measurement of the One-Way Velocity of Light and the Earth's Absolute Velocity" and the sending of the advertisement on the International Conference on Space-Time Absoluteness (ICSTA) again brought no positive results. - Both these publications have been rejected by NATURE. In Sofia I received only the telex-information about the rejection and in Genoa the letter of Richard Webb of the 9th July for the rejection of the advertisement. A letter with explanation for the rejection of the paper has still not reached me and, obviously, will reach me no any more.

With this letter, I am addressing you, Dr. Davies, with the request: Please, write me openly and clearly why so many years NATURE refuses to publish the accounts on my experiments which are decisive for the sound evolution of physics and astronomy? I tried to receive this answer from you personally when you have visited Washington last autumn, but you refused to see me. With my scientific and social activity I have shown that I have the right to ask from you such an open and clear answer. Please, give it!

About a year and a half ago the book review office of NATURE asked me politely for my book EPPUR SI MUOVE, even before its appearance. Immediately after the publication of the book (in December 1977) I sent this book to London. Until now I have not received information whether my book has been received in NATURE, although I wrote at least five letters on this topic. In my letters I asked for the return of the book, if there will be no intention for writing a review. I stated also in one or two of these letters that for a NEGATIVE review I shall pay \$ 1000 to NATURE. Why NATURE does not send back to me the book which costs \$ 20 and which was sent following the request of NATURE? Please, give me an open and clear answer.

NATURE tries to show a concern about the dissident scientists. I am a dissident not only in the East, I am a dissident also in the West. In 1978 I was two times expelled: in April from Czechoslovakia in Western direction because I were "Anti-communist" and in December from the States into Eastern direction because I am "Communist". I am also a dissident in science. I am about two years in the West and I did not find a working place or a support by some scientific institution from this or that side of the ocean. I pay all my experimental, theoretical and publication activity (three books in a year and a half) with my own money. If I make all these sacrifices, it signifies that I have to say something to the world. I beg you for an open and clear answer: will NATURE inform the scientific community about my experimental achievements or not, and if not WHY?

Sincerely yours,

Stefan Marinov

Editorial note. This letter remained without answer, or as an answer to this letter may be considered the letter of Dr. John Maddox of the 22 Sept. 1980 (see p.176).

The paper "Measurement of the one-way velocity of light and the Earth's absolute velocity" has appeared under the title "The experimental measurement of the one-way light velocity and its possibilities for absolute velocity measurement" in SPEC. SC. TECHN., 3, 57 (1980). (CLASSICAL PHYSICS, vol. III, §50C,D).

# newscientist

King's Reach Tower, Stamford Street, London SE1 9LS  
Telegrams: Verditure SEI Telex: 9157 48 MAGDIV G  
Switchboard: 01-261 5000

20th September 1979

Stefan Marinov,  
rue Stephanie 83,  
B.- 1020,  
Bruxelles.

Dear Mr Marinov,

Thank you for your letter of 15th September. I am afraid we reserve the right to publish or reject "letters to the editor" and it is not our policy to enter into any correspondence on our choice of letters for publication.

Yours sincerely,

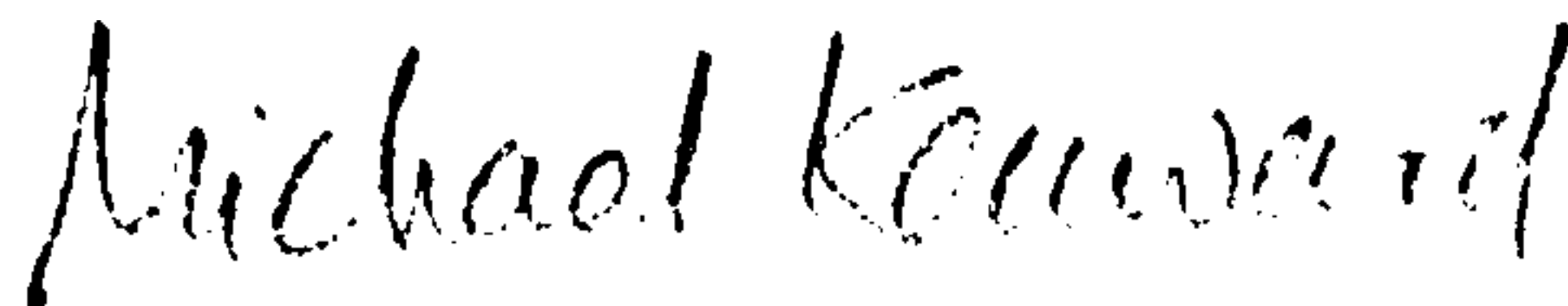

Michael Kenward  
Editor



DEPARTMENT OF STATE

Washington, D.C. 20520

Mr. Stefan Marinov  
Rue Stephanie 83  
B-1020 Brussels, Belgium

Dear Mr. Marinov:

I have been asked to thank you for and to respond to your letter of September 9 to President Carter.

You have asked basic questions about the human rights policy followed by the United States. I can assure you that our policy is sincerely directed toward achieving greater respect for human rights and fundamental freedoms in all countries of the world, including the Soviet Union, and that we shall not relax in our efforts to reach this goal.

We take all appropriate opportunities to express our human rights concerns to the Soviet authorities. President Carter himself discussed this subject when he met with President Brezhnev in Vienna in June. It was a major aspect of the 1977-1978 Belgrade meeting to follow-up the Helsinki Final Act, and it will also be a major part of the Madrid follow-up meeting in 1980.

With regard to the specific case you raise, both the President and the Secretary of State expressed publicly the outrage of the United States when Yuriy Orlov was convicted in 1978, and this government took a number of concrete steps to emphasize its position. We shall continue to do everything we can to encourage the Soviets to permit Mr. Orlov and others to exercise the basic human rights to which the Soviet Government committed itself in the Helsinki Final Act and other international documents.

The moral support of concerned individuals like you is appreciated and contributes to the weight of world public opinion which we hope will convince the Soviet authorities to fulfill their international

**THIS PAGE IS LOCKED TO FREE MEMBERS**

Purchase full membership to immediately unlock this page

**FORGOTTEN BOOKS**

**FULL**

**MEMBERSHIP**

**797,885 Books!**

**All you can read  
for only**

**\$8.99/month**

**Continue**

\*Fair usage policy applies



DANTE B. FASCELL  
CHAIRMAN

CLAIBORNE PELL  
CO-CHAIRMAN

COMMISSIONERS  
GEORGE McGOVERN  
PATRICK J. LEAHY  
RICHARD STONE  
JACOB K. JAVITS  
ROBERT DOLE  
SIDNEY R. YATES  
JONATHAN B. BINGHAM  
PAUL SIMON  
JOHN BUCHANAN  
MILLICENT FENWICK

COMMISSION ON  
SECURITY AND COOPERATION IN EUROPE

CONGRESS OF THE UNITED STATES

WASHINGTON, D.C. 20515

September 26, 1979

EXECUTIVE BRANCH  
COMMISSIONERS  
PATRICIA M. DERIAN  
DAVID E. McGIFFERT  
FRANK A. WEIL

R. SPENCER OLIVER  
STAFF DIRECTOR

GUY E. CORIDEN  
DEPUTY STAFF DIRECTOR

3281 HOUSE OFFICE BUILDING, ANNEX 2

(202) 225-1991

Mr. Stefan Marinov  
rue Stephanie 83  
B-1020 Bruxelles

Dear Mr. Marinov:

I have just received your letter of September 17 with the enclosure of your letter to President Carter. Your proposed plan of action as set forth in those letters is shocking to say the least.

I must tell you that the Commission is in no position to have your letter published in any American journal. We will, however look into the matter of your visa denial in the hope of ascertaining the motivations behind it. In the event that we are successful I will be sure to contact you.

Best of luck in your endeavors.

Sincerely,

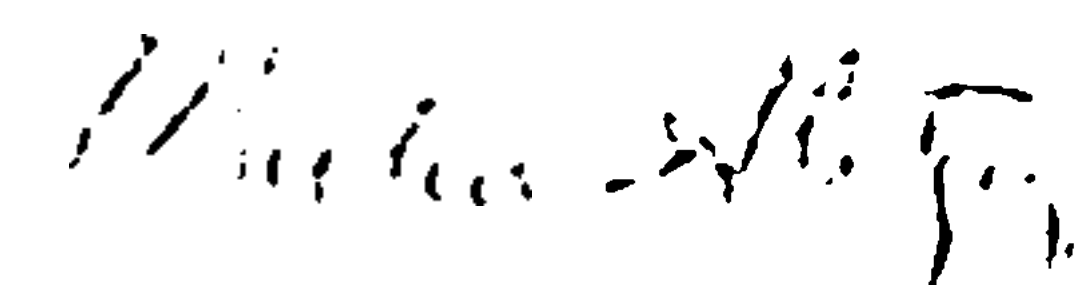

Martin Sletzinger

Université Libre de Bruxelles

1050 BRUXELLES, le 9 octobre 1979  
Avenue F.-D. Roosevelt, 50



LE RECTEUR

R. 3593/79 J.M./SC

Cher Monsieur,

J'ai bien reçu votre lettre du 14 septembre 1979 et ses annexes que j'ai soumises à l'examen de la Faculté des Sciences.

Celle-ci estime que le point de vue que vous défendez présente un intérêt dans la mesure où les résultats d'expériences qui mettraient en évidence le mouvement absolu de la terre, seraient établis avec certitude.

Il faudrait donc pouvoir les vérifier de façon indépendante et de manière très soignée. Or, les services de physique expérimentale de l'Université ne sont pas spécialement équipés pour ce faire et sont engagés dans des recherches de nature très différente. En conséquence, il apparaît difficile de mobiliser les moyens nécessaires en hommes et en matériel pour la réalisation d'une entreprise délicate dans sa réalisation et aléatoire quant à ses résultats.

Je le regrette vivement et vous renvoie sous pli séparé les publications que vous nous aviez adressées.

Je vous prie de croire, cher Monsieur, à l'expression de mes sentiments distingués.

LE RECTEUR,

J. MICHOT

A Monsieur S. MARINOV,  
Rue Stéphanie, 83  
1020 BRUXELLES



**ROBERT K. DORNAN**  
27TH DISTRICT, CALIFORNIA

**SCIENCE AND TECHNOLOGY**

**SUBCOMMITTEES:**

**FOSSIL AND NUCLEAR ENERGY  
RESEARCH, DEVELOPMENT AND  
DEMONSTRATION**

**ADVANCED ENERGY TECHNOLOGY  
AND ENERGY CONSERVATION  
SCIENCE, RESEARCH AND TECHNOLOGY**

**MERCHANT MARINE AND  
FISHERIES**

**SUBCOMMITTEES:**

**FISHERIES AND WILDLIFE CONSERVATION  
AND THE ENVIRONMENT  
PANAMA CANAL**



**Congress of the United States**  
**House of Representatives**  
**Washington, D.C. 20515**

**WASHINGTON OFFICE:**  
419 CANNON HOUSE OFFICE BUILDING  
WASHINGTON, D.C. 20515  
(202) 225-8491

**DISTRICT OFFICE:**  
1423 FEDERAL BUILDING  
11000 WILSHIRE BOULEVARD  
LOS ANGELES, CALIFORNIA 90024  
(213) 824-7222

October 10, 1979

Mr. Stefan Marinov  
rue Stephanie 83  
1020 Bruxelles  
Belgium

Dear Mr. Marinov:

This is to acknowledge your letter of September 17, 1979.

I have received your books and the attached informational material.

I would be very pleased if you could come to the United States and discuss with me issues of current concern, in particular, the status and publicity concerning human rights violations in the Communist regimes of Eastern Europe. I am also interested in discussing with you the current status of your scientific investigations.

Please notify me of the possibility of your arrival.

Sincerely,

A handwritten signature in dark ink, appearing to read "Robert K. Dornan", written over a faint circular stamp or watermark.

Robert K. Dornan  
Member of Congress

RKD/iw

**THIS PAGE IS LOCKED TO FREE MEMBERS**

Purchase full membership to immediately unlock this page

**SAVE \$3,999,994**

Did you know we sell  
paperback books too?

To buy our entire catalog  
in paperback would cost  
over \$4,000,000

Access it all now for  
\$8.99/month

\*Fair usage policy applies

**Continue**

**Fonds National  
de la  
Recherche Scientifique**

---

Rue d'Egmont 5 • B - 1050 Bruxelles • Téléphone (02) 512.58.15

Extension

227

Référence à rappeler

CB - 20.986

le 16 novembre 1979.

Monsieur,

En réponse à votre lettre du 14 septembre 1979 dont nous avons pris connaissance avec une grande attention, nous sommes au regret de devoir vous informer que, par suite de la limitation des moyens financiers dont dispose notre Institution, il ne nous est pas possible de réserver une suite favorable à votre demande d'intervention.

Veillez agréer, Monsieur, l'expression de nos sentiments distingués.



Paul LEVAUX  
Secrétaire général

Monsieur Stefan MARINOV

rue Stéphanie 83

1020 BRUXELLES

Société Française de Physique/Centre National de la Recherche Scientifique

*Commission des Publications Françaises de Physique*

Secrétariat : Bâtiment 510, Université Paris-Sud, F 91405 Orsay Cedex

Tél. 941.82.50 (poste 33-63) et 928.71.69

Décember 7, 1979

Dr. S. Marinov  
Rue Stéphanie 83  
B-1020 Bruxelles  
Belgique

n/réf. 9-1198

We are sorry that we cannot accept your manuscript entitled

Relativistic effects in the radiation from macroscopic light sources

for publication in the

*Journal de Physique*/~~Revue~~

We return it herewith, together with a copy of the referee's report.

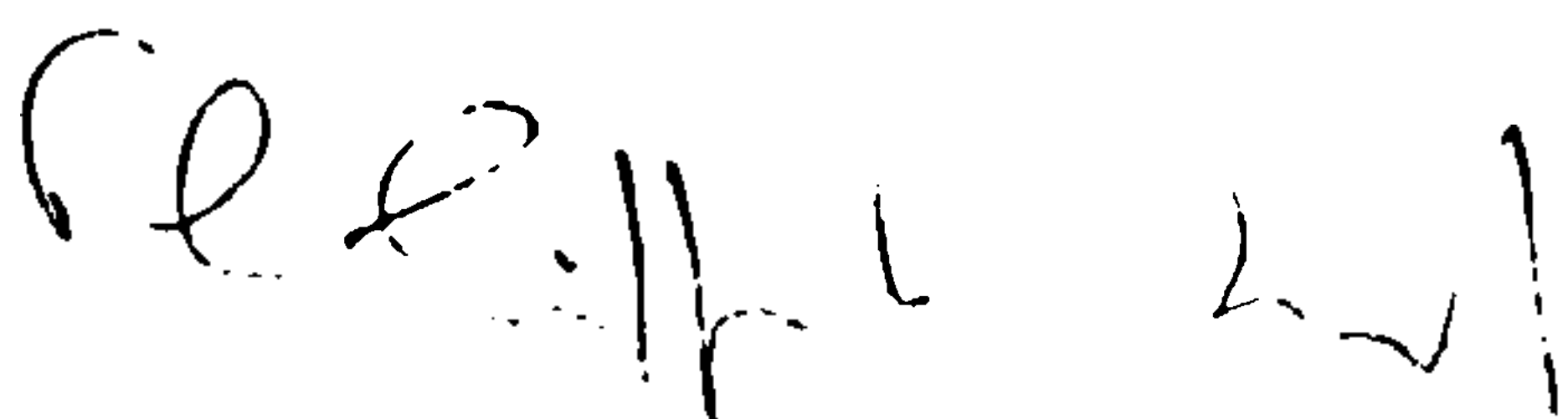

Philippe Monod

# Secrétariat de la Commission des Publications Françaises de Physique

Bâtiment 510, Université Paris-Sud, F 91405 Orsay Cedex

Manuscript submitted for publication in *Journal de Physique*

our ref. 9.1198

Author (s) S. Marinov

Title Relativistic effects in the radiation from macroscopic light sources

## REFEREE'S REPORT

The paper "Relativistic effects..." submitted by S. MARINOV suffers from many defects, some of which may be easily corrected, some perhaps less easily, but in any case should be corrected before publication. The order in which they are indicated below is no prejudice of the difficulty of their correction.

- As it is stated, the experiment is not a test of an absolute motion of anything with respect to a hypothetical aether : the only parameter versus which the results are plotted is a relative velocity.

- There are some calculational mistakes in the accessible part of chapter 4 : for example eq. 4.5 with  $V = 0$  is incompatible with 4.1.

- By the form of the equations of chapter 4, it seems that  $r$  is treated as a constant. The author, seemingly, computes some instantaneous energy flux. The description of the experiment does not involve this concept at all : the energy flux is apparently integrated along the motion of the light source and/or the photocells, with an ill-defined boundary, which strongly depends upon the geometry of the source and of the cells. This is confirmed by the fact that the author states that by pulsing the source, he is able to suppress the effect. There is thus a substantial discrepancy between the "theory" and the actual handling of the experiment.

- Given these imprecise experimental integration conditions, with varying acceptance, it is impossible for the reader to compute the result which would be predicted by the standard theory of relativity. The author should give a "standard relativistic" estimate of the effect as well as a "Marinov relativistic" estimate, taking into account the time dependence of the acceptance of his device.

- The sensitivity claimed for the experiment depends very strongly on a number of geometrical conditions which should be fulfilled with a high accuracy. All calculations are made on the basis of an underlying symmetry, but obviously this symmetry has to be achieved by a number of adjustments, some of which are alluded to in the text. Presumably these adjustments are done with the apparatus at rest, where numerous dissymmetry effects

**THIS PAGE IS LOCKED TO FREE MEMBERS**  
Purchase full membership to immediately unlock this page

**FORGOTTEN BOOKS**

# **FULL MEMBERSHIP**

**797,885 Books!**

**All you can read  
for only  
\$8.99/month**

**Continue**

\*Fair usage policy applies



AUTHOR'S ANSWER TO THE REFEREE'S COMMENTS ON THE  
PAPER "RELATIVISTIC EFFECTS IN THE RADIATION FROM  
MACROSCOPIC LIGHT SOURCES" BY STEFAN MARINOV

I cannot accept the referee's report since it is totally inconsistent. Now I shall show that any of the referee's accusations is deprived of ground (the items in my answer correspond to the items of the referee's comments).

- With the "wired photocells" experiment one cannot measure the absolute velocity of the laboratory, as it is done with my "coupled-mirrors" experiment. This is stated clearly in my paper and the referee also notes this clear theoretical and experimental affirmation in my paper. Then he "attacks" my experiment with the motivation that the effects are produced only by the relative velocity of source and observer. Thus his first attack must be considered either as deprived of sense and irrelevant or as a dishonesty.

- The referee shows a mathematical discrepancy between my formulas (4.1) and (4.5). Indeed, there is a typing. If the referee is a dignified physicist and a colleague, he will carry out the extremely simple integration in formula (4.5) and will correct himself the typing. I consider the rejection of a paper on the grounds of such an obvious typing not only as a lack of colleague feelings but as a dishonesty.

- Yes, in the cases a and b of the experiment the distance  $r$  is not constant. Only in the case c it is constant. Nevertheless the calculation can be made in the manner presented in the paper and the experimental results show that the measured effect is exactly the same as my "theory" predicts it\*. If the referee thinks that according to his theory this experiment must give different results, he must calculate which must be these results and then he has to carry out the experiment and show that the experimental evidence confirms his predictions. It is the scientific community which will then decide who is right. The referee notes that "the energy flux is apparently integrated along the motion of the source and /or the photocells, with an ill-defined boundary, which strongly depends upon the geometry of the source and of the cells". Yes, the energy flux depends strongly on the geometry but what is the "illness"? As I show in my paper, all possible side effects which enter in the fluctuations are much less than the effect to be measured. The fact that, according to my predictions, by pulsing the source one can suppress the effect (this variation was not performed by me, as clearly stated in the paper!!!) does not speak about certain "illness". This "pulsing variation" only shows in an extremely clear way that the propagation of light energy is such as predicted by the aether model. There is no discrepancy between my theory and the actual handling of the experiment. If there is, it must be shown by the referee. (Calomniez, calomniez, il en restera quelque chose!).

- The theoretical essence of the experiment is so simple. If the reader (i.e., the referee) is unable to compute the result which would be predicted by the standard theory of relativity, this signifies that: 1) either the referee is not acquainted with the theory of relativity, or 2) the theory of relativity is a bad theory and does not give a possibility for such a calculation. I pay credibility to my referee, since I pay credibility to JOURNAL DE PHYSIQUE, and I exclude item 1). Thus only item 2) remains valid. But if a theory which is crowned as a top of geniality cannot calculate

---

\* Putting the word theory in quotation marks the referee tries to show that my "theory" is not a theory. This must be done by mathematical and physical motivations but not using punctuation marks, because in such a case I shall further write not the referee but the "referee".

e effect in such a simple experiment, this theory must be immediately thrown overboard. I am not a "relativist" and I am not obliged to give a "standard relativistic" estimate of the effect. I have given the "Marinov" estimate and I have confirmed my calculations by the experiment. I can say here only the following: In the whole literature one analyses the relativistic (i.e., high-velocity) distribution in the radiation only for the case of a moving source. I have not met even a theoretical article where one analyses the distribution caused by the motion of the observer. If the referee knows such an article, I beg him to quote it and he will immediately receive from 500 Dollars. His wife will be very glad to have \$ 500 before Christmas. Helas, the referee is unable to help his wife. As I show in my paper, the "relativistic distribution" in the radiation can be analysed for the case of a moving observer only proceeding from the aether model. The referee can make the objection that for the theory of relativity the cases a) source moving, cells at rest and b) cells moving, source at rest must give the same result, because, for the theory of relativity, these two cases are identical. Yes, for the theory of relativity these two cases must be identical\*. But they are not, as the experimental results show this. The difficulties for the rear-relativist (i.e., for the referee) are not in the "ill-defined boundary". They are his inability to calculate the effect in such a simple experiment. If the referee is able to calculate (with sane-defined boundary) the effect (without using the aether model!!!), I shall pay him \$ 1000. Helas, his wife, etc. However, if he cannot calculate the effect for a moving observer and he is an honest physicist, he must immediately withdraw his criticism. Since until now I have received about 100 negative opinions from different referees and no one has withdrawn his opinion after receiving my objections, the probability that the referee of the JOURNAL DE PHYSIQUE will do this is only . This is a tragic situation in our beloved science.

- The referee writes 7 lines which express his misbelief concerning the reliability of my experiment. Yes, in any experiment are many geometrical and other conditions. The strong side of all my experiments (see EPPUR SI MUOVE, C.B.D.S., Bruxelles, 1977) is the fact that I use always a differential method where all geometrical and other differences which are incalculable are automatically eliminated. As it is mentioned in the paper (p.15), the zero current is established at low rotational rate ( $N = 5$  rev/sec) by corresponding shift of the cells (case a) or of the lamp (case b). I simply measure the appearing difference in current when increasing the rotational velocity. At this increase all remains symmetric. There is an asymmetry only in the "relativistic" distribution in the radiation which is registered by the galvanometer.

#### Referee's conclusions:

a) The referee suggests I must show that the theory of relativity contradicts my experimental results. I repeat, according to me, relativity cannot calculate the effect for the case of a moving observer. I am unable to calculate something, when a theory does not give me possibility to calculate this. Can one calculate the atomic spectra with the mathematical apparatus of classical electrodynamics?

b) My theory explains the results observed and I show this enough clearly in my paper.

c) If the referee knows how one calculates the radiation in the accelerators and if he throws a glance at the formulas in my paper, he must immediately understand that I can calculate the synchrotron radiation and I must obtain exactly those results which he has observed. This is done not in EPPUR SI MUOVE but in my manuscript CLASSICAL PHYSICS (5 volumes). Prospects of EPPUR SI MUOVE have been sent to 1000 leading scientific public libraries in the whole world. Until now 200 copies are bought (granted,

---

\* Common language interpretation of the theory of relativity: Put your nose in my posterior. You have a nose in posterior and I have a nose in posterior. The difference is only relative.



borrowed, ordered but not paid etc.), many from private persons. The reason that my book is not a "standard library book" is that the libraries' advisors are persons of the same kind as my referee.

Ending I am asking the referee: Has he understood that I have, for the first time in history, observed two effects:

- a) relativistic distribution in the radiation from a macroscopic light source,
- b) relativistic distribution in the radiation caused by the motion of the observer (motion relatively to the walls of the laboratory).

If he has understood this, he had to mention this and not to search for a stupid typing. I consider this not only as a sign of dishonesty, but also as a sign of scientific incompetence.

#### Concerning the paper "DRAG-OF-LIGHT" EXPERIMENTS.

- If my estimation of  $dn/d\lambda$  is bad, the referee has to note which is the error.
- The referee accuses me that when plotting the "Marinov" and "Lorentz" curves I select the best points for the "Marinov" curve and the worse points for the "Lorentz" curve. I beg the referee to plot the curves according to his choice (i.e., to choose the best points for the "Lorentz" curve and the worse ones for the "Marinov" curve). Then an arbitrator will decide which curve fits better. I must repeat (see the paper) that the densities reached by Michels are not sufficient to take an absolutely firm decision which curve is the best. For this reason I point at the theoretical absurdity of the Lorentz formula. Is the Lorentz formula theoretically absurd or not? I am sure that the referee will have not the courage to answer this question. For an answer I shall pay him \$ 50 (fifty).

Stefan Marinov

- Editorial note.
1. The paper "Relativistic effects in the radiation from macroscopic light sources" is still not published in a journal (CLASSICAL PHYSICS, vol. III, §68).
  2. The paper "Drag-of-light experiments" is still not published in a journal (CLASSICAL PHYSICS, vol. III, §57).

**THIS PAGE IS LOCKED TO FREE MEMBERS**

Purchase full membership to immediately unlock this page

**SAVE \$3,999,994**

Did you know we sell  
paperback books too?

To buy our entire catalog  
in paperback would cost  
over \$4,000,000

Access it all now for  
\$8.99/month

\*Fair usage policy applies

**Continue**

- As regards the credibility of the experiment, there is no check either given by the author or available to the referee to put this very delicate experiment on a credible footing. People who claim an accuracy of a few  $10^{-7}$  should make sure, and convince the readers, that they are not just raising an amount of dust proportional to the speed.

Now, since MARINOV expresses so deep concerns about the "tragic situation of our beloved Science", and since he is ready to cough up \$ 1000 to get this situation straightened, let me have a hand at it.

The flux of photons emitted by a stationary source can be represented by a flux vector  $\phi^\mu$ , such that

$dN = \phi^\mu dS_\mu$  is the number of photons going through a 3-dimensional surface <sup>element</sup> in space-time.

If  $u^\mu$  is the 4-velocity of the source, at rest, it is (1,0,0,0).

In this case, we have :

$$\phi^0 = \frac{K}{\lambda^2}, \quad \vec{\phi} = K \frac{\vec{x}}{\lambda^3} \quad (\lambda^2 = x^2)$$

This we can express in a covariant form with  $x^\mu$  and  $u^\mu$  as :

$$\phi^\mu = \frac{K}{\lambda^3} \left\{ \lambda u^\mu + (x^\mu - x \cdot u u^\mu) \right\} = \frac{K}{\lambda^3} \left[ (\lambda - x \cdot u) u^\mu + x^\mu \right]$$

The invariant expression for  $\lambda$  is of course given by  $\lambda^2 = (u \cdot x)^2 - x^2$

This is enough to analyze MARINOV's experiments. We shall do that in lowest order in  $v$ , assuming straight line motion.

Case a) Source moving, cells at rest.

To 1st order in  $v/c$  (we take  $c = 1$ ), we have  $u^\mu = (1, 0, 0, v)$

Since we do not know exactly what the configuration of the slit and cells is, but we do know that it is static, we assume that the number of photons on one ~~cell~~ is the total number falling on the ~~slit~~ <sup>cell slit</sup> times some function (acceptance of the cell), which only depends upon the point of emission of the photons.

Hence the integrated number is (we assume the position of the slit to be  $z$ )

$$N = \int \phi^3(z) f(\xi) dS dt = K \int \left\{ [r - (t - \tau) + v(z - \xi)] v + z - \xi \right\} \times$$

with  $t - \tau = z - \xi$  and  $r = (t - \tau) - v(z - \xi)$   $\times \frac{f(\xi)}{r^3} dS dt$

$$N = S \int \frac{K f(\xi) d\xi}{(z - \xi)^2 (1 - v)^3} = \frac{A}{(1 - v)^3}$$

The number of photons received by the other cell is obtained by changing the sign of  $v$ .

Hence  $\frac{\Delta N}{N} = 6v$

which agrees perfectly with "MARINOV's theory".

Case b) Source at rest, cell moving.

Here, we just have a cell crossing at a small angle a thin beam of light. The integrated number of photons is this time :

$$N = \int \phi^v dS_\nu$$

The coordinates of the cell are ( $T$  is time at the cell)

$$Z = vT + z_1$$

$$X = -\frac{v z_1}{R} T$$

We have  $\phi^\mu = \left( \frac{k}{z^2}, 0, 0, \frac{k}{z^2} \right)$

$$dS^\mu = \left( dx dy \frac{dz}{v}, 0, 0, dx dy dz \right)$$

$\int dx dy = f(z)$  is the area of the cross section of the cell within the beam.

$$N = \int k f(z) \left( \frac{1}{v} - 1 \right) dz$$

To get the signal of the other cell, reverse the sign of  $v$  and of  $dz$ , and you get

$$\boxed{\frac{\Delta N}{N} = -2v}$$

again in agreement with MARINOV's result.

(His minus sign is concealed behind the different conventions he takes immediately before Eqs. 5.1 and 5.2).

Case b') "Pulsed variant": If the limits of integration are not set by the contours of the moving cell, but by some time modulation of the light source (dependent on  $\tau$ ), then all photons going through the slit are caught by the cell and that independently of the cell's speed, or distance, and  $\Delta N = 0$

Case c) Both source and cell in motion:

As in a) i)  $\phi^0 \sim \phi^3 \sim \frac{k}{(z-\zeta)^2 (1-v)^3}$

ii)  $\zeta = v\tau$  (position of the source)

iii)  $z = vT + z_1$  (position of the cell.  $z_1$  is the lamp-cell distance)

**THIS PAGE IS LOCKED TO FREE MEMBERS**  
Purchase full membership to immediately unlock this page

**FORGOTTEN BOOKS**

# **FULL MEMBERSHIP**

**797,885 Books!**  
**All you can read**  
**for only**  
**\$8.99/month**

**Continue**

\*Fair usage policy applies



The integral being bounded by

$$X - \frac{z_1}{R} v T = \alpha \quad |\alpha| < \delta$$

$$\frac{X \left( \gamma - v T + \frac{v z_1}{1-v} \right)}{\left| \frac{z_1}{1-v} \right|} = \beta \quad |\beta| < \varepsilon$$

The second line should be taken in the neighbourhood of small X and T (cell crossing the nearly stationary beam).

Thus  $\int dX dT \approx \frac{D(X,T)}{D(\alpha,\beta)} \Big|_{X,T=0} \approx \left[ \frac{z_1, v}{R} \quad \frac{\gamma(1-v) + v z_1}{z_1} \right]^{-1}$

Hence  $N \approx (\gamma + v(z_1 - \gamma))^{-1}$

and  $\frac{\Delta N}{N} = -2v \frac{z_1 - \gamma}{\gamma}$

This quantity may be small if the cell goes around quite close behind the slit :

$z_1 - \gamma \ll \gamma$  . Since MARINOV does not condescend to tell where the slits are (he does not even specify which distance of the cells is 98 cm : distance from center, from each other, from the lamp ?), I am right in writing that I am not able to carry the calculation through, even with the most drastic assumption for no fault of mine nor of the Relativity. But, anyway, MARINOV does not give any results to compare with. He only casually says that he could not see a visib

signal, which means that  $\frac{z_1 - \gamma}{\gamma} \approx .1$  .

To conclude, I take the Secrétaire de la Commission des Publications Françaises de Physique as a witness that I have

- 1°/ Saved "our beloved Science" from "its tragic situation".
- 2°/ Honestly earned \$ 1000 from M. MARINOV, having been "able to calculate (With <sup>sane</sup> ~~some~~ - defined boundary) the effect (Without using the aether model!!!)".
- 3°/ Stood my ground on my criticisms on MARINOV's paper.

SECOND AUTHOR'S ANSWER TO THE REFEREE'S COMMENTS  
ON THE PAPER "RELATIVISTIC EFFECTS IN THE RADIATION  
FROM MACROSCOPIC LIGHT SOURCES" BY STEFAN MARINOV

I am very surprised seeing that the referee has answered my criticism, and I am asking myself why our science is in such a situation that only by provocative statements, such as those presented by me, one can impel the referee to defend his untenable accusations.

I give my comments to all referee's statements. I am not proceeding as the referee who gives no answer to my short and clear questions a) and b) on p. 3 of my first comments.

Introductory paragraph. Writing my previous answer, I thought that the referee is still my old friend Prof. Marcel Froissart (College de France). However, visiting Prof. Froissart at the end of April, he said me, that the referee of my paper under discussion must be another person. This new referee states that I am an "old pal" of him, and I am very curious, indeed, to know who may be this "old friend" of me who states in a written form that I "have gone mad".

Indeed, during years I was compulsorily treated in Bulgarian psychiatric clinics. On the 10 and 11 January 1980 I was imprisoned in one of the psychiatric clinics of Paris (see the attached materials concerning this imprisonment). Well. Since two and a half years I am in the "free world". I came here after 12 years of harassment in Bulgarian prisons and psychiatries. I came here to defend the integrity of my soul as a human being and as a scientist. In these two and a half years I published three books and I circulated, with a very low efficiency, 25 papers between the different physical journals. I addressed a dozen of European and American Universities for a presentation of a Ph.D. thesis, however everywhere my applications have been rejected. The current motivation was that my thesis is "unnormal" (see the attached article from PORQUOI PAS? of the 15.III.79).

Why these accusations in madness? Why? To a man who seven years ago, for the first time in history, has measured the Earth's absolute velocity. Why? Is this the way to defend the scientific truth?

If the referee affirms that I am a mad man, he is indebted to present proofs. If he is unable to present such proofs, I cannot find words to qualify his attitude. I beg him only to understand that fighting for our mental survival in the East, we defend also human soul in the West. However people in the West still cannot realize the danger of totalitarianism and think that this danger is very far from them. So to our "quixotic and desperate efforts" to save humanity from a spiritual degradation, we receive neither support nor scornful silence, but further accusations in madness and imprisonment in psychiatric clinics. Quelle horreur!

I shall conclude my comments to the first referee's paragraph with the words of Kirkegaard: "The ability to avoid definitions is a proof of tact."

First remark. The referee writes: "If you cannot measure an absolute velocity, how can you tell you have proved that there is such a thing? (first sentence of his conclusion)." I cannot understand what does mean the referee with this statement. Thus I repeat for a hundredth time: By the help of the "wired photocells" experiment one cannot measure the Earth's absolute velocity. I have measured this velocity two times - in 1973 with the deviative "coupled-mirrors" experiment and in 1975 with the interferometric "coupled-mirrors" experiment. As I recently wrote to the Nobel committee in Stockholm, I am ready at any moment to go to Stockholm and demonstrate to a commission the positive results in my experiments. I make the same declaration before the "Commission des Publications Françaises de Physique" in these comments. The experiment is not difficult. I shall perform it in the variation described in SPEC. SC. TECHN.



(the paper is attached) which is much more simple.

Second remark. I do not require that the referee rewrites or retypes my papers. I only stated that a paper cannot be rejected because of an obvious typing error.

Third remark. I have shown categorically that relativity is a wrong theory by my "coupled-mirrors" experiment, measuring the Earth's absolute velocity in a closed laboratory. The experiment reported in the paper under discussion does not represent such a categorical disproof. But it hurts relativity in a very vulnerable point. According to the relativity theory, the effect caused by the relative motion of two objects must depend only on their relative velocity, but not on the velocities of these objects with respect to distant matter. For example, if the distance between a light source and an observer changes, a Doppler effect appears. According to relativity, it is of no importance whether the source changes its velocity with respect to distant matter or the observer. Relativity analyses the phenomenon either in a frame attached to the source or in a frame attached to the observer and for relativity these two analyses are absolutely identical. (N.B. My treatment of the light Doppler effect can be seen in FOUND. PHYS., 8, 637, 1978.) According to Einstein this "relativity" is valid for any physical phenomenon. I showed (theoretically and experimentally!!!) to a phenomenon where this "relativity" does not take place (I showed this in many other phenomena - see EPPUR SI MUOVE). The referee has accepted the "non-relativity" in the "wired photocells" experiment as something normal. May be, tomorrow when the world will recognize the positive effects in my "rotating axle" experiments, he will accept also them as normal and will explain them by mathematical formulas. But doing all this, he accuses me in madness. Quelle horreur!

I do not measure the geometry of the cells. Thus I cannot introduce an error in something which I even do not measure.

The referee writes that the result which I predict for the "pulsing variation" is a "dream". No, this is no dream. This is a prediction of the result in a strictly defined experiment. All experiments which I have proposed in the last 12 years have given, after performance, exactly these effects which I have predicted before their performance. Thus I have the right to be sure in my predictions. The most strange thing is that the referee predicts exactly the same results as me (see his page 4, case b'). The referee accuses me in madness, but he agrees with any physical statement which I make. Strange coincidence!

Fourth remark. The referee asserts: "By the way, cases a) and b) are not identical for Relativity, since the slits are at rest in both cases." Here we are!!!! Do the experiment with a source emitting a parallel light beam (say, a laser), throw away the slits! I affirm that the effect which one will observe will be exactly the same as this which I observed with the slits. If the referee will assert the effect must be identical for the cases a) and b), I am ready to come to Paris, to set up the experiment and to demonstrate two different effects. The referee, may be, will make the objection: "This is a dream; your experiment was performed with slits." Well, let us make the dream a reality. Let us lay a bet: I shall do the experiment in Paris. A commission of 10 scientists (set by the referee) will perform measurements. If the majority will affirm (in a written form) that I am right, the referee will pay me \$ 10,000. If the commission will affirm that the referee is right, I shall pay him the sum.

Fifth remark. The referee does not believe in the results of my experiments. Indeed, I measure very small changes in certain quantities. Such are all my high-velocity light experiments, described in EPPUR SI MUOVE. In all these experiments I use the very effective differential method. With relatively very simple experimental arrangements, I measure very subtle effects. I attach a photograph of the "wired photocells" experiment. It can be set up in any optical laboratory in a couple of hours. Do this experiment, see its sensitivity and stop to cackle: "We do not believe, we do not believe."

The report on my interferometric "coupled-mirrors" experiment finally has appeared (in GEN. REL. GRAV.), after five years of submission to different physical journals

**THIS PAGE IS LOCKED TO FREE MEMBERS**

Purchase full membership to immediately unlock this page

**SAVE \$3,999,994**

Did you know we sell  
paperback books too?

To buy our entire catalog  
in paperback would cost  
over \$4,000,000

Access it all now for  
\$8.99/month

\*Fair usage policy applies

**Continue**

time and the absoluteness of time is attached to light velocity; thus if one wishes that all should be O.K., one has to use the introduced by me Marinov transformation where it is exactly vice versa.

c) In his mathematical formulas the referee nowhere takes into account the slits and the fact that they are at rest in both cases a), b). Thus, obviously, the referee will calculate the same effect if the experiment will be performed with lasers and without slits (see the fourth remark).

And now I shall show that the referee uses the aether model. On p. 4 the referee write the following formula (I write  $c = c$  and not  $c = 1$ ; I give the advice to the referee always to write the velocity of light by  $c$  and not by unity - so many things will OPTICALLY become clear for him):

$$N = \int K f(Z) \left( \frac{c - v}{v} \right) dZ. \quad (2)$$

Let us assume (since this is not stated clearly by the referee) that

$$N = \int K f(Z) c dt \quad (3)$$

is the number of photons collected by the area (1) during a time  $dt$  when the cell is at rest with respect to the source. If now the cell moves with a velocity  $v$  from the source then during time  $dt$  it covers distance  $dZ$  and one can write formula (3) in the form

$$N = \int K f(Z) c \frac{dZ}{v}. \quad (4)$$

However, the referee works not with this formula (which must be written by Einstein) but with formula (2). Why? Why when the velocity of the cell changes with respect to the source the referee changes  $c$  in (4) by  $c - v$  in (2)? According to Einstein's theory, the photons move always with a velocity  $c$ , independently of the motion of the observer. (Please, do not confound the Lorentz theory of relativity based on the aether model and the Einstein theory of relativity based on the light velocity constancy in any inertial frame; Lorentz and Einstein both defend the principle of relativity. I reject this principle theoretically and EXPERIMENTALLY). Thus, according to Einstein, if a cell at rest with respect to a homogeneous parallel light beam collects a certain number of photons, it will collect the same number when moving with respect to the beam. If one asserts that the number of the photons collected in a unit of time changes, one has used the aether model, as one assumes that with respect to the cell the photons move with velocity  $c - v$ . Take into account that in the whole his analysis the referee has not taken into account the relativity in time synchronization. Indeed, a rotating disk assures a Newtonian time synchronization, as at any velocity of the rotating disk both cells are always the same time illuminated. Thus during equal time intervals two identical cells in identical situations collect different number of photons. Why? Think, my dear referee, think, and try to become as soon as possible "mad" as me, because otherwise inevitably you will remain between the fools.

Let me note that here we come to an amusing conclusion. According to the principle of relativity, the effects in the cases a) and b) must be identical. However, according to the dogma of the light velocity constancy in any inertial frame, for the case b) source at rest, cells moving, the effect must be null. Oh, the theory of relativity is so bad, that I cannot understand, indeed, how so many clever men have not realized this. I remember the lawyer Henry Dart from New Orleans who exclaimed once in SPECTR. LETT.: "If there is no aether, a Doppler effect cannot exist." Poor lawyer! At this moment he became "mad". Anyway, I prefer to be arranged between the madmen, but NOT between the fools!

Conclusion: I am sorry, very sorry, indeed, but the referee cannot earn the \$ 1000!

However, seeing that the referee needs money, I can still find a possibility to help him: On p. 2 of my previous answer I stated that if the referee will find an experimental or even a theoretical article where one analyses the distribution in the

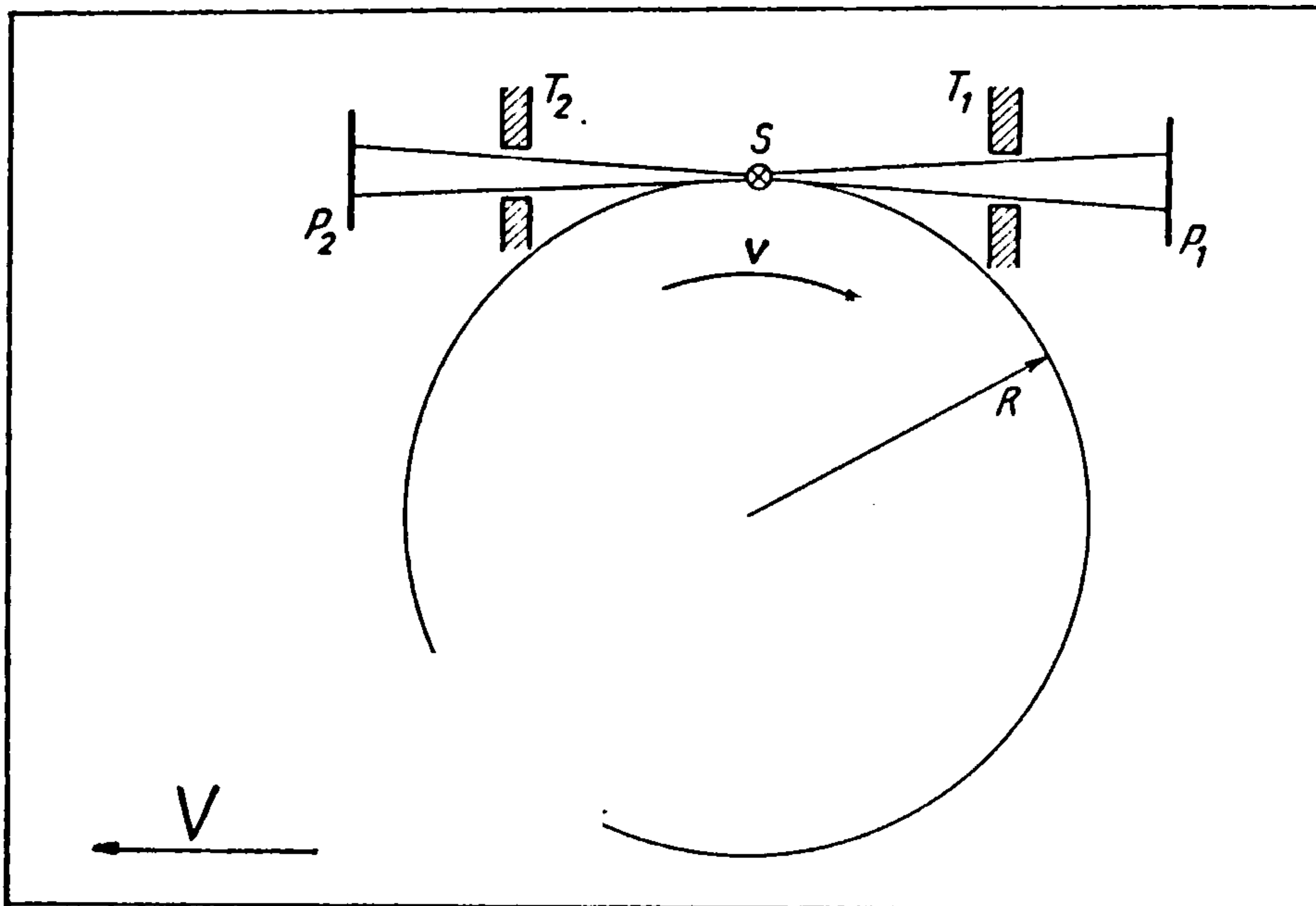

Fig. 2

light radiation caused by the motion of the observer, I shall pay him \$ 500. The term "analyses" is too vague. May be, the referee will present the article of Ancin, quoted by me, and will require the \$ 500. To free myself and the referee of any MISUNDERSTANDING, I send him the promised on p. 3 of my previous answer \$ 50 = Fr Fr 200. Here all is very simple. I asked the referee to answer whether the formula of Lorentz-Lorenz

$$n = \left( \frac{1 + 2K_L \mu}{1 - K_L \mu} \right)^{1/2} \quad (5)$$

is, according to him, logically sound or not. Nothing more. Only to GIVE AN ANSWER. Which will be the answer is of no importance. I beg the Secretary of the "Commission..." to pay attention: If the referee will affirm in a written form that, according to him, formula (5) is theoretically sound, he receives the 200 francs which are enclosed. If the referee will affirm that the formula is unsound (because for a certain fucked density  $\mu = 1/K_L$  we have  $n = \infty$ ) he again receives the 200 francs. He cannot receive the sum only if he will keep silent. More for the referee I cannot do, and in the last case I beg the Secretary to send back to me the money. I beg the Secretary to take into account that I am a poor Bulgarian dissident and 200 francs for me have more value than 2000 francs for any person who has a job. But sacrificing the 200 francs I do not consider me as a mad man. In this way I try to find a possibility to say on the pages of JOURNAL DE PHYSIQUE what have I measured and why the effects are such.

ADDENDUM. I am curious to hear which will be, according to the referee, the effect in the following variation of the "wired photocells on a rotating disk" experiment (see fig. 2). Here the rotating disk is mounted on a platform. When changing the velocity of the rotating source with  $v$ , the platform changes its velocity with  $V = v$ , as shown in the figure. Now, according to me, the effect will be  $2v/c$  and not  $6v/c$ , as in the case when the platform were at rest. One can also rotate the cells and move the platform in the opposite direction. Homework for the referee: Which will be the effect in such a case.

P.S. The distance of 98 cm is from the center of the cells to the center of the disk. Of importance is only the component of the cell's velocity along the direction of light!!!

# Acta Physica Austriaca

Edited in cooperation with the  
Austrian Academy of Sciences

Herausgegeben unter Mitwirkung der  
Österreichischen Akademie der Wissenschaften

by/von Paul Urban, Graz, and/und

Heinrich Mitter, Graz  
(Managing Editor)

EUROPHYSICS JOURNAL

Springer-Verlag Wien New York

Prof. Dr. Heinrich Mitter

Institut für Theoretische Physik  
Universität Graz  
Universitätsplatz 5  
A-8010 Graz

Dr. Stefan Marinov  
rue Stéphanie 83  
B-1020 Bruxelles  
Belgien

Dear Dr. Marinov,

unfortunately I have to inform you, that we cannot publish your paper in Acta Physica Austriaca. The reason is the negative judgement of our referee, which I include (it is written in German; since you indicated in your letter, that you can read this language, I have not translated the statement). According to the general policy of our journal (and all other scientific journals) the name of the referee must be kept confidential. Let me, however, tell you, that the referee is an experienced experimentalist and has read your paper very carefully. For your own work you should take his objections into account and try to make an error analysis of your experiment (i.e. look for the accuracy, with which you measure as critical as possible). Any good experimental paper must contain such an analysis. Otherwise nobody will trust the results.

Let me add some personal comments, which are not directly connected with your paper (and which are therefore also in no relation to the question of its rejection by our journal). It seems to me that you want to use your results for a theory, which contradicts special

Editorial Advisory Board  
Fachbeirat

G. Alepa, Zagreb  
M. Baldo-Ceolin, Padova  
K. Baumann, Graz  
P. Budini, Trieste  
F. Cap, Innsbruck  
T. Erber, Chicago, Ill.  
H. Felsner, Aachen  
J. Fischer, Praha  
O. Hittmair, Wien  
H. Jooa, Hamburg  
H. Kirchmayr, Wien  
E. Lednegg, Graz  
K. Lintner, Wien  
G. Marx, Budapest  
J. Pišút, Bratislava  
F. Rohrich, Syracuse, N. Y.  
H. Rollnik, Bonn  
H. Schopper, Hamburg  
K. H. Seeger, Wien  
L. Streit, Bielefeld  
W. Thiring, Wien  
I. Todorov, Sofia  
A. Trautman, Warszawa  
H. Überall, Washington, D. C.  
H. Vonech, Wien  
E. P. Wigner, Princeton, N. J.

**THIS PAGE IS LOCKED TO FREE MEMBERS**  
Purchase full membership to immediately unlock this page

**FORGOTTEN BOOKS**

# **FULL MEMBERSHIP**

**797,885 Books!**  
**All you can read**  
**for only**  
**\$8.99/month**

**Continue**

\*Fair usage policy applies



N/Réf : MH/AD n° 79/2352

Paris, le 13 décembre 1979

Monsieur S. Marinov  
rue Stéphanie 83  
1020 Bruxelles

Belgique

Monsieur,

L'article que vous avez eu l'obligeance de nous envoyer ne correspond pas aux normes de notre revue ; il s'agit de travaux originaux s'adressant à des spécialistes.

En vous remerciant de l'intérêt que vous portez à notre revue, je vous prie d'agréer, Monsieur, l'expression de mes sentiments distingués.

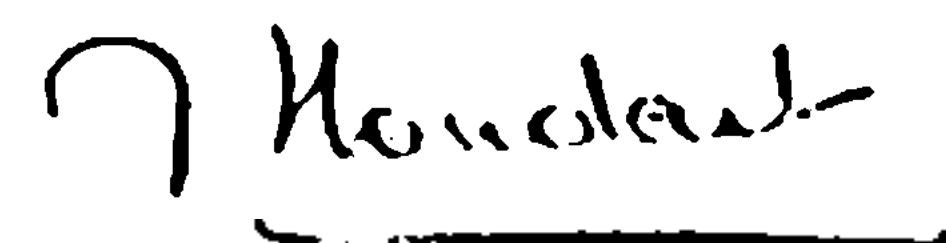

M. Houdart

P.J. : Vous trouverez ci-joint votre manuscrit.



EMBASSY OF THE  
UNITED STATES OF AMERICA

Paris, France

January 11, 1980

Mr. Stefan Marinov  
c/o Francois Delage  
17, rue de Sevres  
75006 Paris

Dear Mr. Marinov:

Ambassador Hartman has asked me to reply to your letter of January 6, 1980, informing us of your previous correspondence with U.S. officials and your plans in Paris.

As Mr. Stephen Cohen, Deputy Assistant Secretary of State for Human Rights and Humanitarian Affairs, has written to you, the policy of the United States is sincerely directed toward achieving greater respect for human rights and fundamental freedoms in all countries of the world, including the Soviet Union. The record is clear in this respect, and there is every intention to continue our efforts in this direction. Mr. Cohen has also explained to you the position of the U.S. Administration with regard to the case of Mr. Yuriy Orlov.

I can only reiterate what Mr. Cohen said with respect to your own plans. We hope you will see the wisdom in his suggestion that you continue your work on behalf of human rights, rather than to attempt more dramatic actions which will have less real effect on improving the situation.

Sincerely,

  
John J. Maresca  
First Secretary



**CZECHOSLOVAK JOURNAL OF PHYSICS**

Editorial Office

~~Journal of Physics~~ Czechosl. Acad. Sci.  
~~Subvencová 19, Praha 8~~ Czechoslovakia

Institute of Physics  
Na Slovance 2, 180 40 Praha 8

Dr.S.Marinov  
rue Stéphanie 83  
1020 Bruxelles  
Belgium

5.2.1980

Vážený pane doktore,

vracíme Vám článek "The quasi-Roemer and quasi-Bradley experiments according to absolute space-time theory", protože nebyl přijat k publikaci v našem časopise. Recensní posudek přikládáme.

Dále Vám zasíláme odpověď recenzenta na Vaši odpověď na recensní posudek článku "Moving platform experiments".

S pozdravem

*E. Vlachá*  
E.Vlachá  
sekret.redakce

Č.J. 44/1980

**THIS PAGE IS LOCKED TO FREE MEMBERS**

Purchase full membership to immediately unlock this page

**SAVE \$3,999,994**

Did you know we sell  
paperback books too?

To buy our entire catalog  
in paperback would cost  
over \$4,000,000

Access it all now for  
\$8.99/month

\*Fair usage policy applies

**Continue**



DEPARTMENT OF STATE

Washington, D.C. 20520

February 26, 1980

Dear Mr. Dornan:

I am replying to your letter of February 6 regarding the nonimmigrant visa case of Mr. Stefan Marinov.

Our Embassy at Brussels reported that Mr. Marinov is ineligible for a nonimmigrant visa under Section 214(b) and Section 212(a)(28) of the Immigration and Nationality Act. The provisions of Section 212(a)(28) are quoted in the enclosure.

Section 214(b) of the Act provides that "every alien shall be presumed to be an immigrant until he establishes to the satisfaction of the consular officer at the time of application for a visa...that he is entitled to a nonimmigrant status under Section 101(a)(15)." To qualify for a nonimmigrant status, an applicant must show that he has a residence abroad which he has no intention of abandoning, and that he will depart the United States upon the completion of his legally authorized sojourn.

A permanent residence abroad is generally established through presentation of evidence that an applicant has compelling economic, social, or family ties in his homeland which would cause him to leave the United States after the completion of his visit. The Act, in Section 291, places the burden of proof on the applicant to establish clear intention to depart after a temporary stay in this country. The consular officer must objectively evaluate the facts and circumstances surrounding every application and make a judgment whether an applicant has sustained the burden of proof required by law. In administering the law as written by Congress, consular officers must deny a visa in any case in which they do not find the evidence convincing.

Mr. Marinov's ineligibility under Section 212(a)(28) may be waived under Section 212(d)(3)(A) with the concurrence of the Attorney General upon a recommendation by the Secretary of State. However, waiver procedures may not be instituted until Mr. Marinov has satisfied the provisions of Section 214(b) of the Act.

Sincerely,

J. Brian Atwood  
Assistant Secretary  
for Congressional Relations

The Honorable  
Robert K. Dornan,  
House of Representatives.

UNIVERSITÀ DI GENOVA  
ISTITUTO DI SCIENZE FISICHE



5 Marzo 1980

GENOVA, .....  
VIALE BENEDETTO XV, 5  
C. A. P. 16132 - ITALY  
Tel. 515.055-6-7-8

Dott. S. Marinov  
GENOVA

Prot. N° ISF 174  
SV/soc

Caro Dott. Marinov,

sono spiacente di dover dire che la Sua proposta non è sufficientemente precisa e dettagliata per poter essere inoltrata come progetto di esperimento ad un Ente di ricerca con prospettive di finanziamento.

Per quanto riguarda poi la possibilità di una sistemazione personale, Le preciso nuovamente che presso gli Istituti universitari in Italia oggi non esistono possibilità legali in tale senso.

Con i migliori saluti.

(prof. S. Vitale)  
DIRETTORE ISF

ROYAL ACADEMY OF SCIENCES  
NOBEL COMMITTEE FOR PHYSICS  
STUREGATAN 14  
S-114 36 STOCKHOLM

March 15, 1980.

Mr Stefan Marinov  
Organizzazione Internazionale Congressi  
Via Puggia 47 - 1

I-16131 GENOVA - Italy

Dear Sir,

This is to acknowledge receipt of your communication dated 2 March 79 (!)  
I regret to have to tell you the Nobel Committees (or the Nobel  
Foundation) do not have any means or possibilities to spend  
money on the type of purpose you are asking for. The sole task  
of the Nobel Organization is on the decision of the different  
prizes.

Yours sincerely,

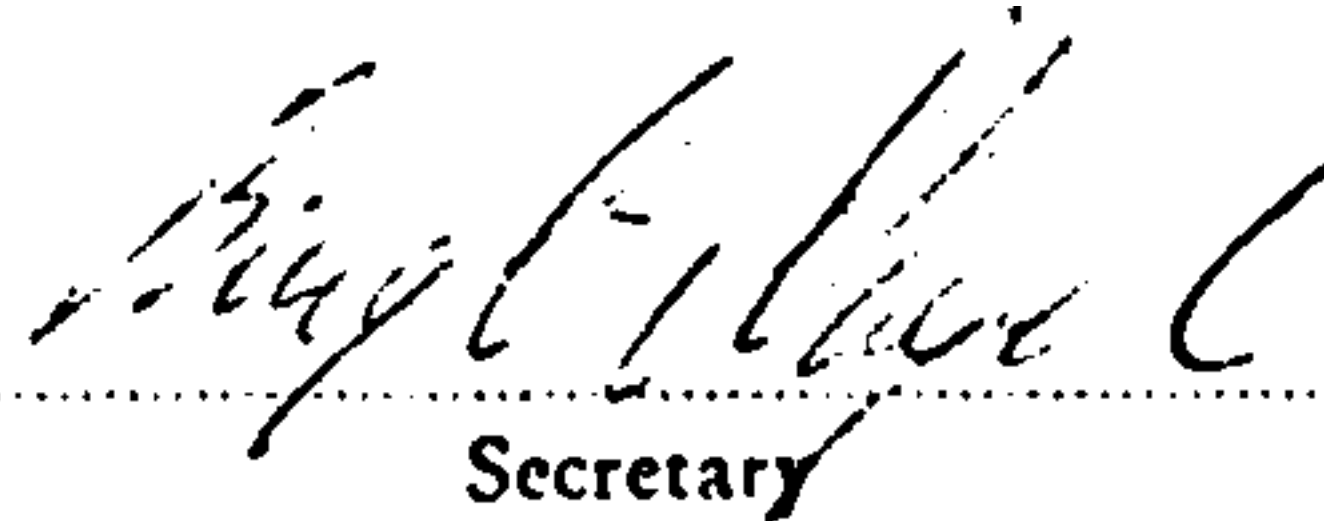

.....  
Secretary

Bengt Nagel

**THIS PAGE IS LOCKED TO FREE MEMBERS**  
Purchase full membership to immediately unlock this page

**FORGOTTEN BOOKS**

# **FULL MEMBERSHIP**

**797,885 Books!**

**All you can read  
for only  
\$8.99/month**

**Continue**

\*Fair usage policy applies



Stefan Marinov  
via Puggia 47  
I-16131 Genova  
2 April 1980

Dr. Peter Newmark  
Acting Editor  
NATURE  
4 Little Essex Street  
London WC2R 3LF

Dear Dr. Newmark,

I send you in two copies my paper

DIFFERENT METHODS FOR MEASUREMENT OF THE EARTH'S ABSOLUTE VELOCITY,  
submitting it for publication to NATURE.

The Physics Abstracts classification number is 03.30.

All charges will be paid by myself.

Herewith I transfer the copyright for this paper to NATURE.

To the several letters which I wrote in the last months to your predecessor Mr. Davies, to your collaborator Mrs. Rich and to your book's review office, I received no answer. I should like to bring to your knowledge the following:

1) In December 1977 your books' review office asked for my book EPPUR SI MUOVE which I sent in January 1978. To all letters (at least 5) which I wrote to your office asking whether the book will be reviewed in NATURE no answer came. Then I wrote (at least 5 letters) to the same office and to Mr. Davies begging NATURE to retribute my book, since it was sent on the request of NATURE. No answer came. Please, be so kind to inform me whether under your leadership NATURE will give a review of this book and if not, whether NATURE will retribute this book, or, in the case of lost, pay it - price £ 25.

2) Your collaborator Very Rich offered me in 1976 to translate certain Russian poetries of me, asking for the translation, as far as I remember, £ 165. The money was paid to her through my friend Prof. Prokhovnik in three payments in 1976 and 1977. Until now I have not received the translations although sending to Mrs. Rich at least 10 letters.

I hope, you are informed about the contacts between me and your scientific advisers Mr. Sharrock and Woodham and about the systematic rejection of my papers by NATURE. The paper attached which will appear in GEN. REL. GRAV. was sent to NATURE in 1975. This decisive paper appears with a delay of 5 years which represents a big harm to physics.

Hoping to receive your answer soon and hoping that finally NATURE will accept a paper of me,

Sincerely yours,

Stefan Marinov

PS. Certain materials for your information are enclosed.

Editorial note. The paper "Different methods for the measurement of the Earth's absolute velocity" is a short review article.

As an answer to this letter may be considered the letter of Dr. John Maddox of the 22 Sept. 1980 (see p.176).

Stefan Marinov  
Via Puggia 47  
-16131 Genova  
1 April 1980

Prof. de Schutter  
Rector of the VUB  
(to the attention  
of Mrs. Trieste)  
Blvd. Gen. Jacques  
Bruxelles

Dear Prof. de Schutter,

Almost half a year has passed since you have taken the decision to give attention to my request to defend a Ph. D. in physics in the Free University of Brussels (VUB). As it was said to me by Mrs. Trieste in the first days of February, the decision has to be taken in a week.

I should like to know finally which is the decision, since soon the academic year will finish, and one will be constrained to await the autumn. I cannot understand why the Free University of Brussels (French and Flemish) has such a fear to give me the right to defend a Ph. D. If my future opponents think that my theory is not adequate to physical reality and my experiments wrong, they have to show this in a public debate before an academic forum. Let me note that my procedure for a defence of a Ph. D. in totalitarian Bulgaria is since 10 years open, because the Academy cannot find a quorum to close the procedure and at the same time there was a tremendous fear to let me defend the thesis (in Bulgaria the fear was not only scientific but for 80% political). Since, I hope, in Brussels there is no political fear, I think that the time for taking a decision must be reduced to two years. Since I have asked the ULB to defend a thesis in April 1978, the two years are over and a decision must be taken.

Hoping to hear from you in a due time,

Sincerely yours,  
Stefan Marinov

PS. Write to my address in Italy.

I will be in Brussels, probably, in the first days of May.

Editorial note. This letter remained unanswered.



# »RUĐER BOŠKOVIĆ« INSTITUTE

Bijenička 54, 41001 Zagreb, Croatia Yugoslavia

---

Professor Stefan Marinov  
Laboratory for Fundamental Physical Problems  
ul. Blin Tolin 22  
SOFIA 1421, Bulgaria

P. O. Box: 1016  
Phone: (041) 424-355  
Telex: 21383 yu lrb 70  
Cable: INSTRUBO, Zagreb

---

Our ref.

Your ref.

Date 17 April, 1980

Dear Professor Stefanov,

Enclosed please find the referees' reports on your paper "The Quasi-Wiener Experiment according to Absolute Space-Time Theory". Unfortunately, on the basis of these reports, we are unable to accept your paper for publication in Fizika.

We are sorry for being so late with our answer. There have been some changes in the Editorial Board of Fizika and therefore we were not able to send you our answer earlier.

Yours sincerely,

Vladimir Šips  
Publishing Editor

Enclosures: 3

**THIS PAGE IS LOCKED TO FREE MEMBERS**

Purchase full membership to immediately unlock this page

**SAVE \$3,999,994**

Did you know we sell  
paperback books too?

To buy our entire catalog  
in paperback would cost  
over \$4,000,000

Access it all now for  
\$8.99/month

\*Fair usage policy applies

**Continue**

Société Française de Physique/Centre National de la Recherche Scientifique

*Commission des Publications Françaises de Physique*

Secrétariat : Bâtiment 510, Université Paris-Sud, F 91405 Orsay Cedex

Tél. 941.82.50 (poste 33-63) et 928.71.69

May 28, 1980

Dr. S. Marinov  
Via Puggia 47  
16131 Genova  
Italia

n/réf. 9-1198

Dear Dr. Marinov,

You will find enclosed the hidden "enveloppe" put in your last package. We cannot accept to play a role of go-between in a personal controversy, and henceforth, we shall not transmit anymore your personal letters to the referee.

From a more scientific point of view, we consider that our information is now sufficient to reject definitively your articles 9-1198 and 9-1148.

Sincerely yours,



S. Feneuille  
Président de la Société  
Française de Physique.

Editorial note. This is the answer of JOURNAL DE PHYSIQUE to the second answer of Marinov on the referee's comments on paper 9-1198 (see p.139 and especially p.143). Whether the referee himself has refused to accept the 200 francs put in the hidden "enveloppe" saving himself to say one of the fateful words "yes" or "not" or the decision of depriving the referee of the money has been taken by Prof. Feneuille himself remains a secret of history. Ces sont les valets de Gascogne!

# Optics Letters

R.W. Terhune, *Editor*  
Research Laboratories, S-2076  
Ford Motor Company  
P.O. Box 2053  
Dearborn, Michigan 48121

June 12, 1980  
Ms. 733

Dr. Stefan Marinov  
via Puggia 47  
16131 Genova, Italy

Re: Ms. 733, "The Relation Between Proper Mass and Absolute Mass  
Deduced from the Compton Effect"

Dear Dr. Marinov:

Enclosed along with your manuscript, is the report of our reviewer. In view of his recommendations, both as to suitability and scientific quality, we feel that we cannot accept your paper for publication in Optics Letters.

We regret that we are not able to send you a more favorable report.

Sincerely yours,



W. H. Weber  
Associate Editor

mmd  
Enclosures

UNIVERSITY OF CALIFORNIA, SANTA BARBARA

BERKELEY • DAVIS • IRVINE • LOS ANGELES • RIVERSIDE • SAN DIEGO • SAN FRANCISCO



SANTA BARBARA • SANTA CRUZ

DEPARTMENT OF PHYSICS

SANTA BARBARA, CALIFORNIA 93106

July 14, 1980

MAIL RECEIVED

JUL 18 1980

PHYS. REV.-P.R.L.

Dr. D. Nordstrom, Editor  
The Physical Review  
1 Research Road  
Box 1000  
Ridge, New York 11961

Dear Dr. Nordstrom:

I have reviewed the paper "Kinematic Time Dilation" by S. Marinov and the correspondence of the previous referee and the author. I have focused attention exclusively on Sections I and II of the paper which are at the heart of the dispute with the previous referee and which contain the significant claim that the special theory of relativity is logically inconsistent.

The author attempts to demonstrate the logical inconsistency of special relativity by means of a simple example related to the standard twin paradox. The example itself is not without interest from a pedagogical point of view. The author attempts to demonstrate the inconsistency by showing that the special theory of relativity would imply two mutually contradictory relationships (his eqs. (2) and (3)) for appropriately defined time measurements of the two twins in his example. In fact, his relation (3) is not a consequence of special relativity and his demonstration of it and arguments for it are simply incorrect in the framework of that theory. In particular the following steps in the argument are incorrect: The author asserts at the top of page 6, that when twin 3 is moving with a velocity  $2v$  in an inertial frame where twin 4 is moving with velocity  $v$  then in an inertial frame where twin 4 is at rest twin 3 will have speed  $v$ . This is not the prediction of the special relativistic law for the transformation of velocities although it would be the result if the Galilean transformation were applied. Special relativity predicts  $v/(1 - 2v^2/c^2)$  for the velocity of twin 3 on the second half of the journey in the frame where twin 4 is at rest. The speed of twin 3 is thus different on the outward and the return journey and the proper times to accomplish these parts of the journey are not equal. As a consequence, eq. (4) is not the correct relation between times  $t_3$  and  $t_4$  as defined by the author. For the same reason, the relation  $t_3 = 2t'$  is incorrect as can also be seen fr

**THIS PAGE IS LOCKED TO FREE MEMBERS**  
Purchase full membership to immediately unlock this page

**FORGOTTEN BOOKS**

# **FULL MEMBERSHIP**

**797,885 Books!**  
**All you can read**  
**for only**  
**\$8.99/month**

**Continue**

\*Fair usage policy applies



# JOURNAL OF MATHEMATICAL PHYSICS

PUBLISHED BY THE AMERICAN INSTITUTE OF PHYSICS

JOHN R. KLAUDER  
Editor

201-582-4016

Office of the Editor  
BELL LABORATORIES  
600 MOUNTAIN AVENUE  
MURRAY HILL, NEW JERSEY 07971

June 24, 1980

Prof. S. Marinov  
via Puggia 47  
16131 Genova, ITALY

Dear Prof. Marinov:

Your manuscripts entitled "The Fundamentals of Electromagnetism According to Absolute Space-Time Theory" and "The Fundamentals of Gravimagnetism and the Mercury Problem According to Absolute Space-Time Theory" are being returned under separate cover. We regret that these papers are unsuitable for the Journal of Mathematical Physics.

Sincerely yours,

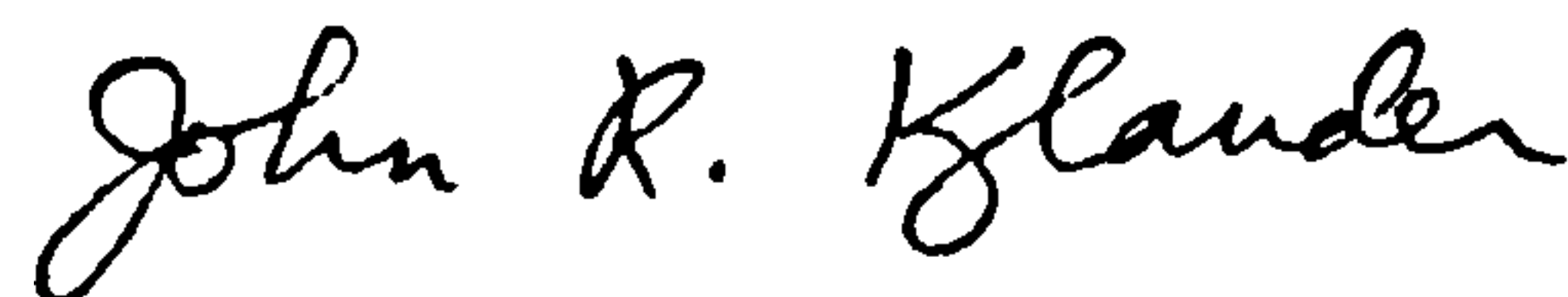

John R. Klauder

JRK:bvc

U.S.C. One copy of each manuscript

P.S. We suggest that you send your manuscripts to Foundations of Physics or Physical Review D.

. (010)315978

Dr. John Maddox  
NATURE  
4 Little Essex Street  
London WC2R 3LF

---

your ref. JM/MS/M-041616

te

THE TEN JENA COMMANDMENTS,  
publication in NATURE (in the social informal part). In the case of  
u very much to make no changes in the text, except for certain gram-  
corrections if necessary, and to print both pictures.

in the GR9 Conference and my dadzi-bao have played a decisive role  
of the absolute space-time conceptions. However, of an extreme im-  
rating this process is the publication of the present note in NA-  
t the publication of this note in NATURE will accelerate the award  
r the absolute velocity's measurement with a year. Thus in the case  
he note I am ready to pay the necessary sum to publish it as an ad-  
asked many times for this your predecessors but always the answer  
h to hope that finally you will understand that this favour can be  
political dissident who during 12 years lingered in the Bulgarian

on to inform you that I still have not received your answer to my  
ne. I still do not know whether my paper NEWTONIAN AND EINSTEINIAN  
NS will be accepted or rejected. I still do not know whether my  
has been received by your review office (following the request of  
ears ago). I still have not received an explanation from Mrs. Vera  
ll send back to me the money for the translation of my poetries  
ade (or at least I do not know whether she has them translated).

e now a speedy decision. In the case of a negative decision I should  
present note in another journal. I think it can be clear for you  
lication of this note is of an extreme importance. I beg you very  
bout your decision by phone (at any time during day and night) for

Sincerely yours,  
Stefan Marinov

The information "The ten Jena commandments" was published in the  
L. TYCH. SOC., 30, 8 (1981), (CLASSICAL PHYSICS, vol I, p. vi).

The paper "Newtonian and Einsteinian time synchronizations" will be  
lished in the PROCEEDINGS OF ICSTA (CLASSICAL PHYSICS, vol. III, §9).

As an answer to this letter may be considered the letter of Dr. John  
dox of the 22 Sept. 1980 (see p.176).



SOCIETÀ ITALIANA DI FISICA

# IL NUOVO CIMENTO

REDAZIONE

li 30 Luglio 1980

Via L. degli Andalò, 2 - 40124 BOLOGNA (Italy)  
Tel. ~~051~~ 33.15.54

Gent.mo Dr.  
S. Marinov  
EST-OVEST Editrice Internazionale  
Via Puggia, 47/1  
16131 GENOVA

---

Caro Dottor Marinov,

dopo aver nuovamente consultato il prof. Arecchi ed il prof. De Sabbata, Le confermo che i Suoi articoli non sono accettabili; in particolare, il prof. De Sabbata mi ha confermato di averLe ripetuto a Jena le sue opinioni in proposito.

Stando così le cose, Le restituisco accluso i manoscritti dei Suoi articoli.

In accordo con la Vice-Direzione La informo che d'ora in poi i Suoi articoli Le saranno restituiti senza neppure essere esaminati.

Con questo consideriamo chiusa ogni polemica in proposito perchè non intendiamo discutere più oltre la questione.

Distinti saluti,

  
Paolino Papali  
Segretario di Redazione

**THIS PAGE IS LOCKED TO FREE MEMBERS**

Purchase full membership to immediately unlock this page

**SAVE \$3,999,994**

Did you know we sell  
paperback books too?

To buy our entire catalog  
in paperback would cost  
over \$4,000,000

Access it all now for  
\$8.99/month

\*Fair usage policy applies

**Continue**

Stefan Marinov  
via Puggia 47  
I-16131 Genova

Prof. V. de Sabbata  
Istituto di Fisica  
Bologna

2 agosto 1980

Caro Vincenzo,

Ho letto la lettera del Dott. Papali con tristezza. Ti amo, Vincenzo, e non voglio perderti. E' per questo che ti scrivo questa lettera. Non per pregarti di cambiare il tuo compartimento, affinche io potrei stampare articoli nel N.C. Questi ultimi due articoli respinti sono cosi importanti che certo troveranno la loro pubblicazione. Vi saranno editori nel mondo interessati a stampare qualche importante novita...

Tu hai visto chiaramente la situazione a Jena, hai visto come tutti coloro che hanno il potere nel campo della fisica dello spazio-tempo hanno paura di affrontare il problema dei concetti e delle prove dell'assoluta. Li capisco bene i poveri Bergmann, Wheeler e compagnia bella, ma loro sforzi sono sforzi inutili. Quando gli esperimenti parlano, non solo i Bergmann e i Wheeler, ma persino gli dei tacciono. Non si rifiutano esperimenti con il silenzio, chiudendo le pagine dei giornali, strappando manifesti e cercando l'aiuto della polizia (e quale! - quella tedesca orientale!!!). Ma non si puo, ma non si puo. Bergmann, Wheeler ed altri agendo cosi mi rendono chiaro: Hanno capito l'importanza degli esperimenti da me eseguiti e sperano salvare la situazione con metodi banali e spesso vigliacchi, metodi utilizzati dal potere per difendere posizioni contro la verita.\*

Ma tu, Vincenzo! - Non posso ammettere che anche tu hai capito l'importanza dei miei esperimenti e teoria, non posso ammettere che anche tu sei entrato nel gioco degli "uomini al potere". Non posso, non posso, non posso. - Sei un musicista, sei un comunista, hai il naso di Cyrano...

Nel campo "relativista" non tutti hanno capito l'importanza delle mie ricerche. Prendi Held. E' un uomo onesto. Lui e convinto che io abbia fatto errori tecnici e non abbia misurato la velocita assoluta della terra.\*\* Cio nonostante ha stampato il rapporto sul esperimento interferenziale degli specchi accoppiati. Held non ha paura di questo esperimento. Ritengo che sei nelle condizioni di Held - non hai approfondito gli esperimenti e certamente non hai letto EPPUR SI MUOVE. Siamo tutti uomini soggetti ad errori. Errare humanum est. Sei un teorico (come Held), sei un musicista.

Ma se hai capito l'importanza dei miei esperimenti, come Bergmann e Wheeler, e hai chiuso le porte del N.C. per paura, ne resto profondamente adolorato. Caro Vincenzo, ho 50 anni. Sono stato tradito da tanti amici e i tradimenti non mi commuovono piu. Ma piango ogni volta vedendo un amico metterci sulle sue spalle la terribile croce di Juda. Se piango, piango per l'amico, non per me.

Nel caso che questa lettera rimarra senza risposta, sara grande la mia tristezza. Piangero perche ti amo, perche non voglio vederti con quella croce sulle spalle, nazione.

---

\* Fra l'altro nel campo dei fisici sassoni circolano voci che "Marinov e un pericoloso comunista italiano!?" Me lo hanno detto due sassoni.

\*\* Come io adesso (dopo aver ricevuto la documentazione) sono convinto che Lattes ha fatto errori tecnici ed ha misurato effetti-fantasma; nel esperimento di Lattes una sincronizzazione newtonian non e stata realizzata e dunque, secondo la mia teoria e ricchissima esperienza, la velocita assoluta non si puo misurare.

Salutami la tua gentile moglie. Se mi inviti ad un tuo concerto, verro a Bologna con un grande bouquet.

Accludo il mio libro di poesia. Come vedi, cerco anche rifugio nell'arte. La poesia sulla pagine 128 e stata musicata (mia moglie tedesca era cantante). Te la suonero. E' buona.

Unisco di nuovo i due articoli respinti dal N.C. affinche sia certo che e una decisione da te maturata. Per me non sono due articoli - sono due canzoni, sono poesia. Vincenzo, legendole non senti la musica, la chiarezza, la mano del Dio? - Una canzone di Schubert non e scritta da Schubert, - e soltanto trascritta perche nasce di ispirazione divina. Anche questi due articoli (compiuti in due giorni) sono stati solo trascritti dalla mia mano - ne sono convinto.

Finalmente accludo alcuni materiali politici. Ti prego leggere la lettera a Berlinguer. La mia domanda d'iscrivermi al vostro Pci e stata esaminata tre mesi nella federazione di Genova e quattro mesi alle Botteghe Oscure. E poi hanno preso una decisione oscurantissima: "Non ti prenderemo, Marinov, i tuoi piedi puzzano." Perche non volete ascoltare le nostre voci? - Sono voci che vengono dal vostro futuro.

Amicus verus:

Stefan Marinov

**A.R.** **AVVISO DI RICEVIMENTO O DI RISCOSSIONE**

della: del: N. 7365 di L. ....  
 Raccomandata  Vaglia spedito il 1-9-80  
 Assicurata  Pacco dall'Ufficio di GE - C

indirizzata a V. de Sabbata  
via Repubblica 11 50122 Firenze

Dichiaro di aver ricevuto quanto spedito il .....  
ricevuto riscosso

Firma dell'incaricato della distribuzione o del pagamento [Signature]

Firma V. De Sabbata

Bollo dell'Ufficio di distribuzione o di pagamento

ISTITUTO POLIGRAFICO DELLO STATO

Editorial note. The mentioned in the letter two articles are:

1. "How to measure the Earth's absolute velocity with neutron interferometry" (CLASSICAL PHYSICS, vol. III, §44A,B, §52D).
2. "The Michelson experiment with neutrons treated by the absolute space-time theory" (CLASSICAL PHYSICS, vol III, §44C,G).

Laboratorium voor  
Kern- en Stralingsfysika

- 168 -

Katholieke  
Universiteit  
Leuven

Departement  
Natuurkunde



Monsieur S. MARINOV

Via Puggia, 47

16131 GENOVA

ITALY.

Uw kenmerk

Ons kenmerk

80/610/PM/MD.

3030 Leuven, le 5 Août 1980.

Monsieur Marinov,

Comme je vous ai écrit dans la lettre du 5 juin, j'ai soumis votre livre et vos publications à un collègue, qui est compétent en matière de relativité. Entretiens j'ai aussi rencontré Mr. Van Istendael.

Mon collègue trouve votre travail intéressant, et il vous conseille de vous mettre en rapport avec:

C.M. WILL

Department of Physics

Stanford University

Stanford, California 94305

U.S.A.

Pour faire les expériences il faut du temps, de la place, de l'aide technique et de l'argent. Il est certain que la faculté des sciences de K.U.Leuven ne peut pas vous procurer cela.

Pour présenter un doctorat, il faut trouver un promoteur, qui se porte garant de la valeur scientifique de votre étude; à Leuven mon collègue ne voit personne.

Par le même courrier j'envoie tout ce que j'ai reçu.

Agréez, Monsieur Marinov, l'expression de mes sentiments les meilleurs.

**THIS PAGE IS LOCKED TO FREE MEMBERS**  
Purchase full membership to immediately unlock this page

**FORGOTTEN BOOKS**

**FULL**

**MEMBERSHIP**

**797,885 Books!**

**All you can read  
for only**

**\$8.99/month**

**Continue**

\*Fair usage policy applies



# GENERAL RELATIVITY AND GRAVITATION

A Journal of Studies in General Relativity and Related Topics

Published under the Auspices of the International Committee on General Relativity and Gravitation (GRG)

Members: L. Bel (Paris), B. Bertotti (Pavia), V. B. Braginsky (Moscow), R. Debever (Brussels), M. Demianski (Warsaw), J. Ehlers (Munich), W. Israel (Edmonton), E. D. Lifschitz (Moscow), M. Magnusson (Reykjavik), S. Mavrides (Paris), E. T. Newman (Pittsburgh), M. Novello (Rio de Janeiro), J. D. Novikov (Moscow), A. Papapetrou (Paris), R. Penrose (Oxford), Y. Plebanski (Mexico City), A. K. Raychaudhuri (Calcutta), R. K. Sachs (Berkeley), E. Schmutzer (Jena), D. V. Sclama (Oxford), R. Sexl (Vienna), H. Takeno (Hiroshima), K. S. Thorne (Pasadena), J. Weber (College Park, Maryland)

Editor: A. Held  
Institute of Theoretical Physics  
Sidlerstrasse 5  
CH - 3012 Berne  
Switzerland

Honorary Editor: A. Mercier, Berne

Berne, 20th August 1980

Dr. Stefan Marinov  
Via Puggia 47/1  
16 131 Genova

Italia

Dear Dr. Marinov,

We had an agreement that I would publish one article explaining your experiment and that it would contain no theory or polemic.

You inserted a note added in proof which broke that agreement.

I suggest that in the future you no longer submit articles to this journal.

Yours sincerely,

A handwritten signature in black ink, appearing to read 'A. Held', written in a cursive style.

A. Held

*General Relativity and Gravitation, Vol. 12, No. 9, 1980*

## Editorial

One of the problems that people connected with organized research often encounter is the accusation, made by those who operate on the fringe of science and who generate what one euphemistically might call unusual ideas, that organized science represents a form of "establishment" which closes rank in the face of new ideas and refuses to consider them or give their authors a hearing.

This problem is especially acute in the field of relativity where the theory leads to concepts which sometimes go against common sense and intuition. One merely has to think of the twin paradox, and the literature that it has spawned. This journal is, of course, especially vulnerable to such accusations, and we are often hard put to know how to handle them. S. Marinov has, for some years, been propounding a theory based on results that he claims to have obtained in an experiment. The journal has rejected a number of his articles, all of which tended to be polemic and self-serving.

Following discussions with him in which I listened to his complaints about his inability to obtain a forum for his ideas and experiments, I made an agreement with him that the journal would publish one article describing his experiment. The article was to contain no theory and would be nothing other than a straightforward report of what he had done.

He submitted such an article and it was accepted. However, when he returned his proofs to the printer, he returned them with a "note added in proof." This note broke the agreement and obviously should never have been published.

As the privilege of adding a "note in proof" without the delay of recycling it through the editing-referecing procedure is a valuable one and to the best of my knowledge has never been abused, we have—until now—had no built-in control, and the typesetter has been in the habit of setting the note and appending it to the article without question.

I apologize for this oversight and also for the fact that that portion of Marinov's article which had no right to appear in a scientific journal did appear in *GRG*.

A. Held  
*Editor*

---

Editorial note. The paper mentioned here and in the preceding letter of Dr. Held is "Laboratory measurement of the Earth's absolute velocity" published in *GEN. REL. GRAV.* 12, 57 (1980), (CLASSICAL PHYSICS, vol. III, §52B).



MARCH OF THE FIFTH ANTIMILITARIST MARCH  
(La Spezia - Livorno, August 1980)

Composed by  
S. Marinov

Dedicated to  
Rita



My bro-ther, po - or bro-ther, so pale is yo - ur face, -



no one in this world bo-tthers a - bout the fu - ture days.

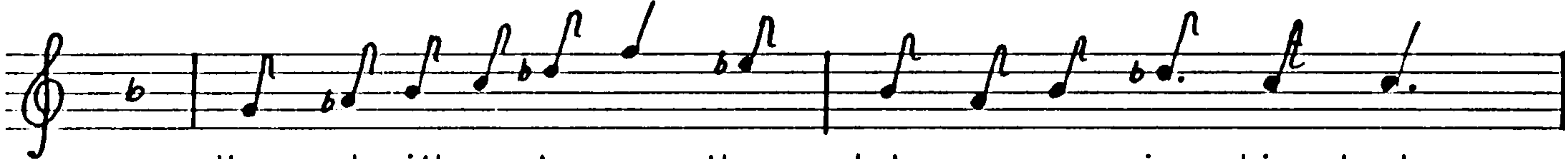

We march with you to - ge - ther but no one gives his hand,



nor do we know whe - e - ther we shall march to the end.

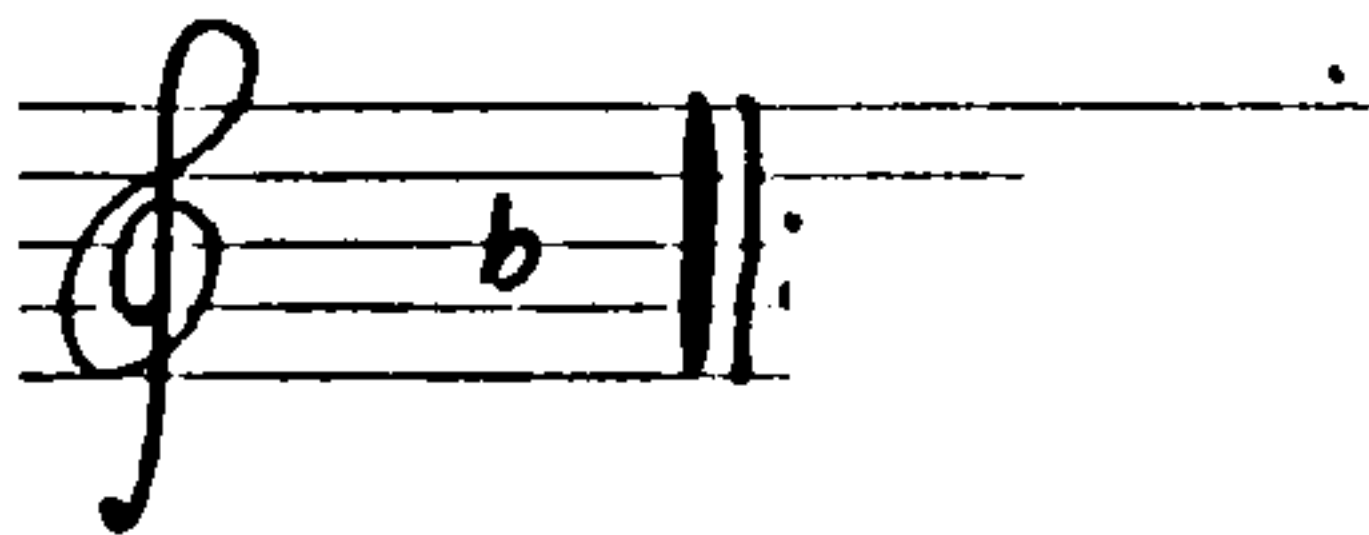

it is no time for dy - ing.

My brother, poor brother,  
so pale is your face, -  
noone in this world bothers  
about the future days.  
We march with you together  
but noone gives his hand,  
nor do we know whether  
we shall march to the end.

It is no time, it is no time,  
it is no time for dying.

We are so weak and feeble  
against the coming war, -  
dumb and deaf are the people,  
and we have hope no more.  
Where shall we find affection,  
when shall we dance and play? -  
From every dark direction  
missiles await their pray.

It is the time, it is the time,  
it is the time for dying.

**THIS PAGE IS LOCKED TO FREE MEMBERS**

Purchase full membership to immediately unlock this page

**SAVE \$3,999,994**

Did you know we sell  
paperback books too?

To buy our entire catalog  
in paperback would cost  
over \$4,000,000

Access it all now for  
\$8.99/month

\*Fair usage policy applies

**Continue**

MINISTERE  
DE L'INTERIEUR

REPUBLIQUE FRANCAISE

DIRECTION GENERALE  
de la  
POLICE NATIONALE

POLICE DE L'AIR ET DES  
FRONTIERES

MOTIVATION D'UN ACTE ADMINISTRATIF

En application de la circulaire du 11 janvier 1980  
M. *PARINOV... STEFAN* de nationalité *Bulgare*  
né le *1.2.1931* à *SOFIA*

est informé qu'une décision de non-admission en France a été prise à son encontre le *17.9.1980* au poste frontière de *NOY-DONN* pour le motif suivant :

Voyageur démuné de passeport ou de titre de voyage.

Voyageur démuné de carte d'identité nationale.

Présence sur le territoire français susceptible de porter atteinte à l'ordre public

Autres motifs (à préciser) *a proféré des insultes et menaces envers les fonctionnaires du service de l'immigration et des visas de fait et rebellior moti l'emploi de la force pour le ramener à raison.*

Fait à *NOY-DONN*, le *17.9.80*.

/-o Chef du poste frontière

(Signature et cachet du poste)

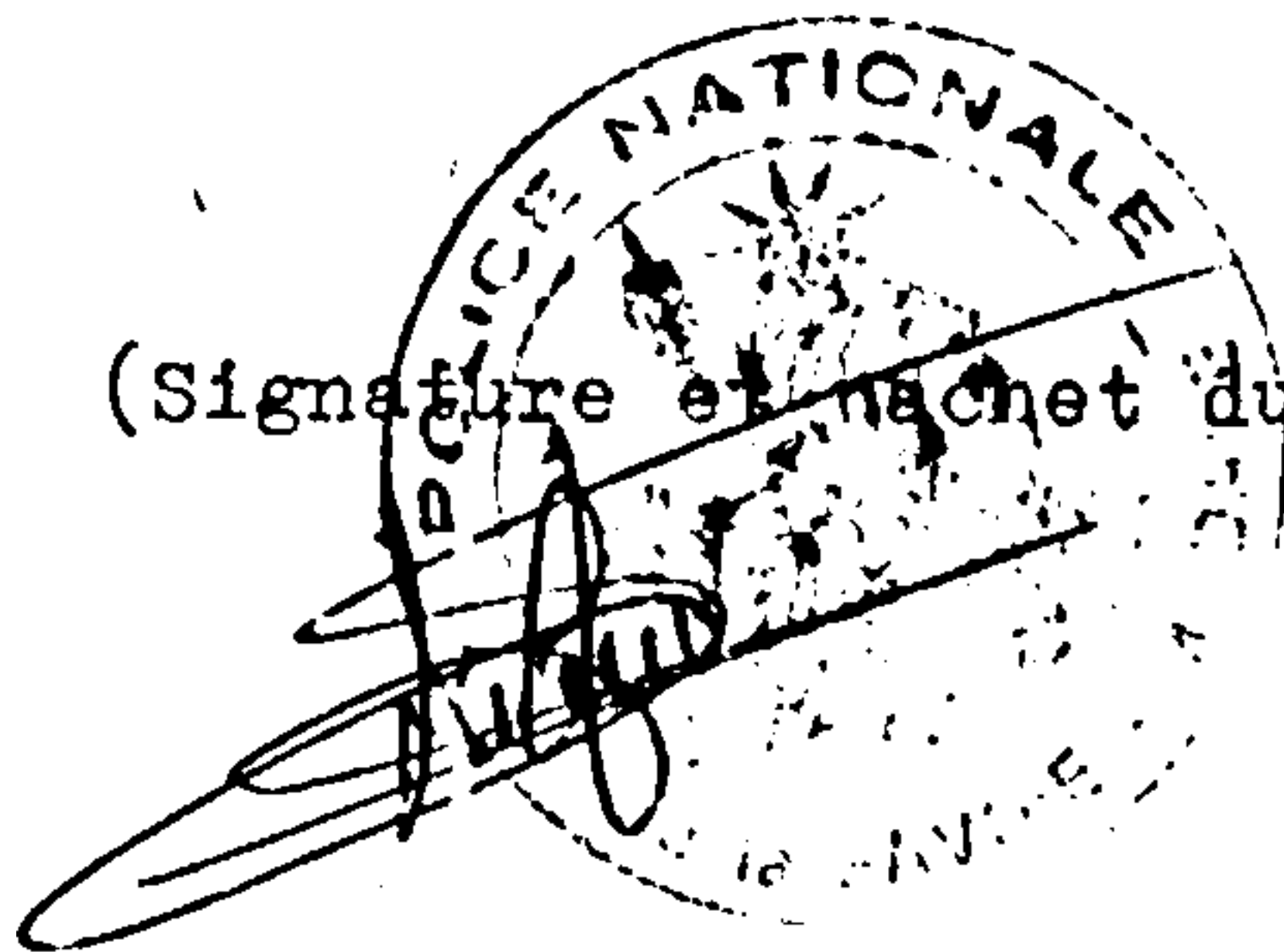

Editorial note. Document for the second re-expulsion from France on the 17.IX.80 with a remark, included after the categorical insistence of Marinov, that he was beaten by the French policemen.

Dr S. MARINOV  
Via Puggia 47  
16131 Genova  
Italia

September 19, 1980

Dear Dr Marinov,

I am returning to you your manuscript entitled "Moving Platform" experiments. I can find no one who will take seriously your basic theme, - that you have "disproven" the special theory of relativity by one experiment. As I have said to you before, the evidence against the "aether" (absolute motion) hypothesis is so overwhelming that, if experiments performed by one person appear to contradict it, one naturally suspects those experiments (or their interpretation). The suspicion is strongly reinforced by such statements as that which you make on p. 8 : "To register an effect disproving the principle of relativity is such a rare happiness, as to see the flowering of an agave in the desert". This bald evidence of an emotional commitment to certain conclusions, which is clearly contradictory to the whole spirit of scientific enquiry, reinforces the scepticism which is inevitable in the circumstances. One is further put off by statements like that further down on p. 8 that "on a rotating disk the velocity of light is direction dependent and the principle of relativity break down" which seems to indicate a lack of understanding of the nature of the special theory of relativity and an ignorance of the general theory.

Finally, your conclusions seem to give the game away completely. First, you admit that "four different variants of the 'moving platform' experiment are the same as those predicted by the relativity theory"; then you fall back on the "rotating disk" experiment, which, in the light of my previous remark, carries little conviction. Finally, it seems that your conclusion is only that "the principle of relativity breaks down also for inertial motion, at least conceptually". Such a conclusion has the status only of one man's opinion.

A final comment on lines 14-15 of p. 17, your "firm conclusion" is ambiguous. The velocity of light at (not along) the rim of rotating disk is direction dependent as measured by observer on the disk, and not by an inertial observer (as any undergraduate knows). Where does that leave your "firm conclusion"?

I am in the process of turning over the editorship of this journal to another. Were I not, I would advise you not to bother sending us any more papers as unconvincing as this latest one. I think that my successor may agree, but I will leave it for him to say.

Sincerely,

P.R. Wallace  
Editor

# ature

Macmillan Journals Ltd  
4 Little Essex Street  
London WC2R 3LF  
Telephone 01-836 6633  
Telex 262024  
Advertising 01-240 2044

JM/MS  
22 September 1980

Dr Stefan Marinov  
Est-Ovest  
Via Puggia 47/1  
16131 Genova  
ITALY

Dear Dr Marinov:

I hope that I may be able to deal with all the points you have raised in your recent correspondence.

In many ways the most important of these is your accusation of fraud against Mrs Vera Rich, to whom I have talked and who has written to you separately. I do very much hope that her explanation will have satisfied you. Perhaps you will now kindly confirm in writing that that is the case. You will appreciate my concern that those who work for Nature should be accused in this way, albeit in private correspondence.

Second, I fear that Nature cannot publish the Jena Commandments.

Third, I am returning the copy of your book by separate post.

Fourth, and on the general question of why Nature has consistently declined to publish an account of your research, I must explain that to my knowledge we have never received an account of your work which was sufficiently specific for it to survive the scrutiny of the expert advisers to whom we would have to send it. Please do not misunderstand me. I am not saying that your work is not authentic - merely that it cannot be authenticated from the accounts which you have given, or sent to Nature. Do you not think that, now that you are in the West, you ought to find some way of repeating the experiment which, ingenious though it is, should not require vast resources? There must be many laboratories in European universities willing to provide the house-room you would need.

I do earnestly suggest that you read my answers carefully, and that you communicate with us again only when you have some detailed account of a novel experiment to communicate to our readers.

Yours sincerely,



**THIS PAGE IS LOCKED TO FREE MEMBERS**  
Purchase full membership to immediately unlock this page

**FORGOTTEN BOOKS**

**FULL**

**MEMBERSHIP**

**797,885 Books!**

**All you can read  
for only**

**\$8.99/month**

**Continue**

\*Fair usage policy applies



АКАДЕМИЯ НАУК СССР

**ЖУРНАЛ ЭКСПЕРИМЕНТАЛЬНОЙ И ТЕОРЕТИЧЕСКОЙ ФИЗИКИ**

Москва, В-334, Воробьевское шоссе, 2

Тел. 137-56-22

д-р С. Маринову  
Генуя, Италия

25 сентября 1980.

Глубокоуважаемый д-р Маринов!

Редакция ЖЭТФ рассмотрела присланную Вами статью "Кинетическое удлинение времени".

К сожалению, редакция была вынуждена признать, что содержание этой статьи не находится на современном теоретическом уровне и не может представить научного интереса для публикации в ЖЭТФ.

Зам. Главного редактора

*Е.М. Лифшиц* /Е.М. Лифшиц/

Acta Physica Slovaca

1980, 31, 1-2

FYZIKÁLNY ÚSTAV Slovenskej akadémie vied  
ФИЗИЧЕСКИЙ ИНСТИТУТ Словацкой академии наук  
INSTITUTE OF PHYSICS Slovak academy of sciences

Dúbravská cesta, CS — 899 30 Bratislava

Dr. S. M a r i n o v

Via Fuggia 47/1

16131 G E N O V A

Italia

Bratislava 6.10.1980.

Vážený doktor Marinov,

priložene Vám zasielam recenzný posudok na Váš  
článok "The disrupted "rotating disk" experiment". Redakčná  
rada časopisu rozhodla článok neuverejniť, nakoľko nie je dos-  
tatočne jasne zdôvodnená nutnosť publikovať ho v časopise  
Acta Physica Slovaca.

Nemáme námietky proti publikovaniu článku  
v inom časopise.

Nevyžiadané rukopisy nevraciam.

S pozdravom

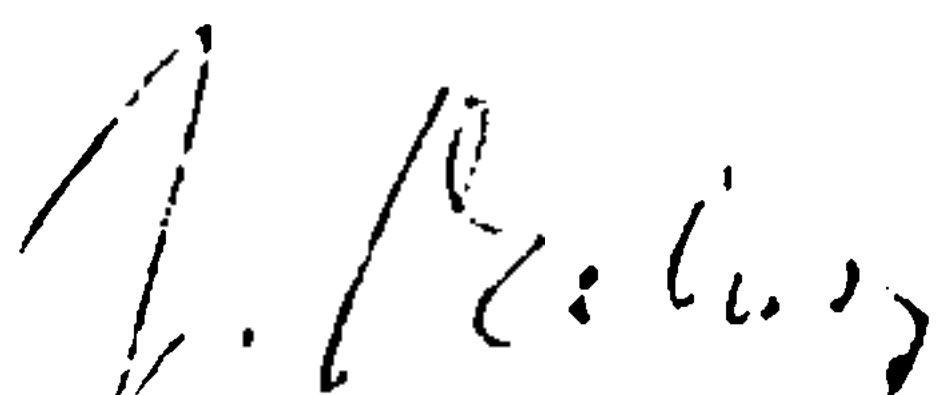
  
RNDr. J. Kalužný CSc.,  
výkonný redaktor



# AMERICAN JOURNAL of PHYSICS

---

A Journal of the American Association of Physics Teachers

John S. Rigden, Editor  
Philip B. James, Assistant Editor

Room 240 Benton Hall  
University of Missouri - St. Louis  
St. Louis, Missouri 63121 U.S.A.

October 27, 1980

Dr. Stefan Marinov  
Via Puggia 47  
16131 Genova, ITALY

Dear Dr. Marinov:

The American Journal of Physics will not, unfortunately, be able to publish your article "Let Newton Be!". References to the editorial in the July 1980 issue of AJP will immediately indicate that your paper is in violation of our editorial policy concerning the exclusion of papers which deal with research as defined there. It is clear that the interpretation of the results of your experiments is quite controversial; therefore, this paper is a perfect example of a paper which should be published in a research literature rather than a pedagogical journal.

I wish you success in obtaining the eventual publication of your work.

Sincerely,



Philip B. James  
Assistant Editor

PBJ/gls

**THIS PAGE IS LOCKED TO FREE MEMBERS**

Purchase full membership to immediately unlock this page

**SAVE \$3,999,994**

Did you know we sell  
paperback books too?

To buy our entire catalog  
in paperback would cost  
over \$4,000,000

Access it all now for  
\$8.99/month

\*Fair usage policy applies

**Continue**

# nature

Macmillan Journals Ltd  
4 Little Essex Street  
London WC2R 3LF  
Telephone 01-836 8633  
Telex 282024  
Advertising 01-240 2044

JM/MS  
29 October 1980

Dr Stefan Marinov  
Est-Ovest  
Via Puggia 47/1  
16131 Genova  
ITALY

Dear Dr Marinov:

Thank you for your further letter. You will appreciate that I cannot become involved in your personal dealings with Vera Rich. In that respect my concern is merely that you should not make damaging remarks about her.

I am however returning the printed copy of your book. I had thought that the manuscript would have been the document about which you were most anxious.

As to your scientific work, I am sorry that you found my advice unhelpful - even patronising. It was however well intended, and I am afraid that on the basis of the documents which you have exchanged with members of the Nature staff in recent years it would not be possible for us further to advertise the kind of experiments you have already completed. If, of course, there are unpublished results which you wish to see published, and if your account of these could survive the rigours of our refereeing system, we would be happy to consider that account for publication.

On the broader question of your Jena declaration and so on, I must say that I would be prepared to publish in our Correspondence column any interesting and original observations you may have to make about the condition of the scientific community, but it is only fair that I should say that much of what you have written under this heading would mystify rather than enlighten our readers.

Yours sincerely,



John Maddox  
Editor

Stefan Marinov  
via Puggia 47  
I-16131 Genova  
30 октября 1980 г.

Проф. Е. М. Лифшиц  
Ж Э Т Ф  
Воробьевское шоссе 2  
Москва, В-334

Глубокоуважаемый "Егор Макарьч",

Очень очень Вам благодарен за письмо с 25-го сентября, с которым Вы отклонили мою статью "Кинетическое удлинение времени", посланную Вам 21-го августа. Быстрый ответ редакторов всегда считаю за ЛИЧНОЕ КО МНЕ УВАЖЕНИЕ. Увы, мало уже осталось таких редакторов, которые меня уважают. К примеру Финкельштейн /с которым Вы делили комнату в Триесте/ посылает мне свои письма о непринятии после года, притом без какой бы то ни было критики.

Теперь посылаю Вам следующие две статьи:

1. Как измерить абсолютную скорость Земли с помощью нейтронной интерферометрии,
2. Эксперимент Майкельсона с нейтронами в свете абсолютной пространственно-временной теории.

Номер классификации по ФИЗИКС АБСТРАКТС - 03.30.

Настоящим письмом передаю "копирайт" журналу ЖЭТФ.

Все расходы по опубликованию будут за мой счет.

Эти две статьи были посланы в ФИЗИКС ЛЕТТЕРЗ, но мой добрый друг Проф. тер Хаар отверг их. Прошу Вас, не влияйтесь мнением тер Хаара. Статьи эти исключительной важности. Без всякой ложной скромности их могу назвать историческими. Но если, все таки, и Вы отвергнете их /прошу быть самому рецензентом/, то, ради Бога, не пишите в письме, что статьи не находятся на "современном теоретическом уровне", а то через пару месяцев Вам будет стыдно читать свое письмо. Качество статьи определяется только его адекватностью ФИЗИЧЕСКОЙ РЕАЛЬНОСТИ, а не избытком напыщенных математических формул и витиеватых умозаключений, которые уму человеческому ничего не говорят. Простите, Егор Макарьч. Мне стыдно поучать моего учителя, но что ж поделать - приходится иногда и в писаниях учителей ошибочки находить, а то и в писаниях учителей наших учителей.

Сердечное поздравление, что в конце концов ЖЭТФ решился отпечатать статьи Андрея Дмитрича.

В ожидании ответа,

Искренне Ваш:  
Стефан Маринов

- Заметка издателя.
1. Во время Второй конференции имени Марселя Гроссмана /Триест, июль 1979 г./ Маринов называл Евгения Михайловича Лифшица в шутку Егором Макарьчем, ибо бреет себе голову Лифшиц как председатель колхоза на Кубани.
  2. Статья "Как измерить абсолютную скорость Земли с помощью нейтронной интерферометрии" представлена в CLASSICAL PHYSICS, vol. III, §52D.
  3. Статья "Эксперимент Майкельсона с нейтронами в свете абсолютной пространственно-временной теории" представлена в CLASSICAL PHYSICS, vol. III, §44G.



EMBASSY OF THE  
UNITED STATES OF AMERICA

Consular Section  
25 Boulevard du Regent  
1000 Brussels, Belgium

October 31, 1980

Mr. Stefan Marinov  
via Puggia 47  
16131 Genova, Italy

Dear Mr. Marinov:

I refer to your visit to my office and our conversation on October 22, 1980 concerning your application for a temporary visitor visa for business submitted in January of this year.

In confirmation of what I told you at the time of your visit, a review of your file indicates that you have been found ineligible for a non-immigrant visa under Section 214(b) and Section 212(a)(28) of the U.S. Immigration and Nationality Act. The Department of State in Washington, D.C. has concurred in this finding.

Section 214(b) of the Act provides that "every alien shall be presumed to be an immigrant until he establishes to the satisfaction of the consular officer at the time of application for a visa...that he is entitled to a nonimmigrant status under Section 101(a)(15)." To qualify for a nonimmigrant status, an applicant must show that he has a residence abroad which he has no intention of abandoning, and that he will depart the United States upon the completion of his legally authorized sojourn. Additionally, the alien must satisfy the consular officer that he qualifies for a nonimmigrant visa under one of the sub-sections contained in Section 101(a)(15).

Section 212(a)(28) of the Act provides that "aliens who are, or at any time have been, members of any of the following classes...(D) aliens not within any of the other provisions of this paragraph who advocate the economic, international, and governmental doctrines of world communism..."

Your ineligibility under Section 212(a)(28), determined at the time of your application here in Brussels in 1978, may be waived under Section 212(d)(3)(A) of the Act with the concurrence of the U.S. Attorney General upon a recommendation by the Secretary of State. However, waiver procedures may not be instituted until the provisions of Section 214(b) have been satisfied.

Sincerely,

Robert J. Bel  
Consul of the  
United States of America

**THIS PAGE IS LOCKED TO FREE MEMBERS**  
Purchase full membership to immediately unlock this page

**FORGOTTEN BOOKS**

# **FULL MEMBERSHIP**

**797,885 Books!**  
**All you can read**  
**for only**  
**\$8.99/month**

**Continue**

\*Fair usage policy applies



Thus your assertion that "equation (4) is not the correct relation between times  $t_3$  and  $t_4$ , as defined by the author" is not correct.

From here it follows that all your objections are untenable.

If you shall recognize your error and if you shall write to Dr. Nordstrom, suggesting that my paper should be published, you will do a big favour to our beloved science. Otherwise the restoration of the absolute space-time conceptions and of the aether (aether-Marinov, not aether-Newtonian) model of light propagation will be delayed by months and, may be, by years. Your decision is of a great importance for physics. I wish to hope in your scientific honesty.

I should like to add that I am a Bulgarian dissident and I lingered in Bulgarian prisons and psychiatric clinics in the period 1966-1977 (with long interruptions during which I continued my scientific and experimental work). I hope to receive the Nobel prize for my measurement of the Earth's absolute velocity (see the attached article from the Italian journal IL LAVORO). My contributions to the process of liberalization of the Eastern countries as a Nobel prize winner will be enormous. Thus your decision has not only an importance for physics but also for freedom. If you are concerned with the destiny of our planet, you have to look at the recognition of your STUPID error with a due attention. In Bulgaria I was accused as a mad man on political reasons but during the processes in 1974 the proof of my madness and the necessity for a compulsory treatment was based on the ground that I sustain completely mad scientific ideas and perform experiments which are similar to PERPETUUM MOBILE experiments, as anybody knows that the Earth's absolute velocity cannot be measured. I wish to defend before the scientific community the integrity of my soul. If you shall not recognize your error you shall help in the most direct way the Bulgarian spiritual sadists.

Help me in the name of God.

Sincerely yours,

Stefan Marinov

. Copy to Dr. Nordstrom (PHYS. REV.).

Editorial note. 1. This is the answer of Marinov to the comments of Dr. Hartle of the 14 July 1980 (see p.160). Marinov has not received an answer from Dr. Hartle. As an answer to the present letter (and to whole file of Marinov's papers and rebuttals submitted to PHYS. REV. and PHYS. REV. LETT.) may be considered the letter of Dr. David Lazarus of the 19 November 1980 (see p.189).

2. The paper "Kinematic time dilation" is presented in CLASSICAL PHYSICS, vol. III, §8).

Stefan Marinov  
via Puggia 47  
I-16131 Genova  
2 November 1980

Dr. John Maddox  
NATURE  
4 Little Essex Street  
London WC2R 3LF

Dear Dr. Maddox,

Thank you very much for your letter of the 29 October. I was extremely pleased to receive your answer so quickly.

I think that my dealings with Mrs. Vera Rich are not personal as she asked writtenly money for the performance of the translation of my poems in 1976 acting as the NATURE-writer on science in the communist countries. Reading her articles where she expresses concern with the tragedy of the free scientists in the Eastern countries, I, of course, had confidence in her honesty. About the fraud of Mrs. Rich I wrote only to you and to NOBODY ELSE IN THE WORLD. I think that the repute of NATURE and of Mrs. Rich are not to be blamed for some stupid £ 165 and I shall not do this. Permit me only a small parallel which I made reading your "In that respect my concern is merely that you should not make damaging remarks about her." - After being beaten in a Bulgarian prison one has always to sign a declaration that one will never speak or write on the beating. If you have nothing to add to the "Mrs. Rich case", consider it from my side as CLOSED.

Thank you very much for having finally sent my book. If you should see the files in your Book's review office, you shall find AT LEAST 5 letters with which I asked for sending back to me the book. Thanks once more.

Following your suggestion, I submit to NATURE my article HOW TO MEASURE THE EARTH'S ABSOLUTE VELOCITY BY THE HELP OF NEUTRON INTERFEROMETRY, where I present unpublished results. I should like to hope that this article will survive the rigours of your refereeing system. As the Werner's experiment is now reviewed in the SCIENTIFIC AMERICAN, I think that this experiment has suscitated a large interest between the scientific community.

I prepared a very short correspondence on the TEN JENA COMMANDMENTS. I am sure that even if you would accept it, you shall not publish the picture, stating that "we do not publish pictures in our correspondence columns". Then you shall cut Held's letter, stating that this is a private affair. Do all what you find as necessary, but publish at least a single sentence from this correspondence. I state again for a publication of the picture I am ready to pay to NATURE \$ 500. Dear Dr. Maddox, be not so afraid, science will not explode if you publish this picture. The unique thing which will succeed is that the restoration of absolute space-time will be anticipated with 6 months.

Hoping to hear soon from you,

Sincerely yours,  
Stefan Marinov

PS. A copy of Held's letter is enclosed.

- Editorial note.
1. The paper "How to measure the Earth's absolute velocity with the help of neutron interferometry" is presented in CLASSICAL PHYSICS, vol. III, §44B and §52D.
  2. The information "The ten Jena commandments" is published in the BULL. TYCH. SOC., 30, 8 (1981), (CLASSICAL PHYSICS, vol. I, p. vi.)
  3. The mentioned letter of A. Held, the editor of GEN. REL. GRAV., is of 20 August 1980 (see p.170).



PARLEMENT EUROPEEN

            
GROUPE DEMOCRATE-CHRETIEN  
(Groupe du parti populaire européen)

BRUXELLES, le 14 novembre 1980

3, Boulevard de l'Empereur  
Tél. 513.40.70 - Telex: EURPAR 24541

Monsieur S. MARINOV  
Est-Ouest  
Via Puggia 47/1

Réf.: G D C /WV/km

I - 16131 GENOVA

Cher Monsieur Marinov,

J'ai bien reçu votre lettre du 30 octobre dernier et j'ai pris connaissance du contenu.

Je regrette de devoir vous dire qu'en effet toutes les démarches qu'ont fait auprès de la Fondation Konrad Adenauer, sont jusqu'à présent restées sans résultat, et que de notre part nous ne voyons plus d'autres possibilités pour vous appuyer.

Tout en étant convaincu d'avoir fait tout notre possible et en regrettant de ne pas avoir abouti à un résultat favorable, je vous prie d'agréer, cher Monsieur Marinov, l'expression de mes sentiments distingués,

W. VERGEER

**THIS PAGE IS LOCKED TO FREE MEMBERS**

Purchase full membership to immediately unlock this page

**SAVE \$3,999,994**

Did you know we sell  
paperback books too?

To buy our entire catalog  
in paperback would cost  
over \$4,000,000

Access it all now for  
\$8.99/month

\*Fair usage policy applies

**Continue**

# NUCLEAR PHYSICS

JOURNAL DEVOTED TO THE EXPERIMENTAL AND THEORETICAL STUDY OF  
THE FUNDAMENTAL CONSTITUENTS OF MATTER AND THEIR INTERACTIONS

Dr. S. Marinov  
Laboratory for Fundamental  
Physical Problems  
Via Puggia, 47  
16131 Genova  
Italy

Editorial Office of  
"NUCLEAR PHYSICS"  
c/o Nordita  
Blegdamsvej 17  
2100 COPENHAGEN Ø  
DENMARK

19th November, 1980

*How to measure the Earth's absolute velocity....*

*The Michelson experiment with neutrons....*

Dear Dr. Marinov,

Thank you for your letter of 24 October submitting the above papers for publication in Nuclear Physics B. Your earlier letter and enclosures did not reach us.

We very much regret that as the subject matter of the papers lies outside the normal scope of this journal, the papers cannot be considered for publication.

The manuscripts are being returned to you under separate cover in order that they may be submitted elsewhere without further delay.

Yours sincerely,

*K. Jones*  
for The Editors

## The Institute of Physics

LMR/DS/A444L & 443L

24 November 1980

Dr S Marinov  
Via Puggia 47  
16131 Genova  
Italy

Publishing Division  
Techno House  
Redcliffe Way  
Bristol BS1 6NX  
England

Telex 449149  
Telephone 0272 297481

Dear Dr Marinov,

Letter: How to measure the Earth's absolute ...

Letter: The Michelson experiment with neutrons ...

Author: Marinov

You may be wondering why you have not yet received a decision on these Letters, which you submitted in September.

Unfortunately, we have had difficulty in finding suitable referees. However, we do hope to receive the reports shortly.

We will of course inform you of the referees' decision as soon as we hear from them.

With apologies for the delay.

Yours sincerely,



Linda M Richardson  
Staff Editor  
for The Institute of Physics

PP

**Sira Institute Limited**

Telephone 01-467 2636

Telex 896649

Registered Office

Registered in England No 150576

SOUTH HILL CHISLEHURST KENT BR7 5EH ENGLAND

**Sira**

OPTICA ACTA

Dr S. Marinov,  
via Fuggia 47,  
16131 Genova,  
Italy.

November 29th 1980.

Dear Dr Marinov,

Thank you for your letter of 5th September 1980.

Your paper has been studied by two referees and their reports sent to the Board for final decision.

The Board have now studied the paper, the referees' reports and your replies and regret that they have decided against publication.

Your paper is returned in case you wish to submit it elsewhere.

Yours sincerely

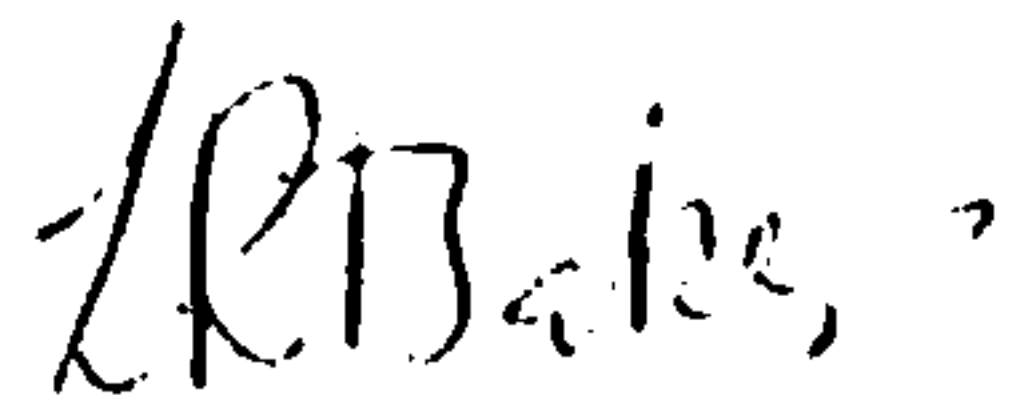

L.R. Baker.

**THIS PAGE IS LOCKED TO FREE MEMBERS**  
Purchase full membership to immediately unlock this page

**FORGOTTEN BOOKS**

# **FULL MEMBERSHIP**

**797,885 Books!**  
**All you can read**  
**for only**  
**\$8.99/month**

**Continue**

\*Fair usage policy applies



АКАДЕМИЯ НАУК СССР

**ЖУРНАЛ ЭКСПЕРИМЕНТАЛЬНОЙ И ТЕОРЕТИЧЕСКОЙ ФИЗИКИ**

Москва, В-334, Воробьевское шоссе, 2

Тел. 137-56-22

Италия, Генуя  
д-ру С. Маринову

II декабря 1980.

Глубокоуважаемый д-р Маринов!

Должен сообщить Вам, что редакция ЖЭТФ не находит возможным опубликовать Ваши статьи "Как измерить абсолютную скорость Земли с помощью нейтронной интерферометрии" и "Эксперимент Майкельсона с нейтронами в свете абсолютной пространственно-временной теории" - так же, как она не нашла возможным опубликовать Ваши предыдущие статьи.

В связи с этим я могу лишь добавить, что указанная позиция редакции относится ко всем вообще статьям, посвященным в том или ином виде опровержению специальной теории относительности.

Зам. Главного редактора  
Академик

/Е.М. Лифшиц/

# PHYSICS LETTERS A

R HAAR  
Department of Theoretical Physics  
Huygensplein 1  
1061 XZ Amsterdam  
The Netherlands

7.ii.81

Dear Dr Marinov,

Thank you for your letter and the return of your manuscript. For the absolutely last time I have sent it to the referee. However, you should realize that your manuscripts take up a disproportionate amount of the referee's time and of mine. As you know, both the referee and I have been a great deal more sympathetic to your efforts to restore absolute frames than others. You should, however, ~~fa~~ accept the situation: the absolute space-time theory is not accepted at this moment and most physicists feel that all the available experimental evidence points to the correctness of Einstein's theory. I am not going to argue one way or the other, but only want to point out that this situation will not be changed by the publication of more short notes. The overwhelming majority of people will not read your papers, and you are not helping yourself at all by trying to get more of these theoretical papers published. The only way this can be changed is by producing irrefutable experimental evidence that you are right and Einstein is wrong - as I have stressed several times.

If the referee agrees with my attitude, I shall return your papers to you and in future return all manuscripts you send me, unless there is an experimental paper where the experiments are of the necessary accuracy. This may sound harsh to you, but I am sure that in the long run it will be much more helpful to you than the publication of small snippets. Moreover, Physics Letters is a letter journal and is not the place to publish a serial story developing further details of a theory. Of course, if the referee disagrees with me, and agrees with you, I shall follow the referee's advice.

I am sorry that I have to be so uncompromising, because I appreciate your position. However, you might consider the possibility that the great majority of the physicists are right and you wrong.

With best regards,

Yours sincerely,





IMPERIAL COLLEGE OF SCIENCE AND TECHNOLOGY



The Blackett Laboratory,  
Prince Consort Road, London SW7 2BZ  
Telephone: 01-589 5111. Telex: 261503

12th. February, 1981.

Dear Dr. Marinov,

- PAPERS:
- 1) The Michelson Experiment with neutrons treated by the absolute space-time theory.
  - 2) How to measure the Earth's absolute velocity by the help of neutron interferometry.
  - 3) The motion of any particle is attached to absolute space.

I thank you for sending us the above papers for publication in Journal of Physics A. A comment that frequently appears in the referee's reports on your papers is that they are either based directly on, or are theoretical developments coming from, your experimental results on absolute spacetime. However your measurements have not been repeated by other experimentalists and I think that it is fair to say that your results have not yet been accepted by the international scientific community. Under these circumstances the referees ask whether or not such papers should be published.

We thought that this question was sufficiently important to be raised and discussed at length at a recent Editorial Board Meeting. The conclusion reached by the Board was that it was not appropriate to accept papers of this type until such time as the crucial experimental results have been verified by other workers. I regret therefore that we cannot accept the three papers listed above and we will feel obliged to apply the same criteria to any future material that you send us.

I would like to emphasise that these papers are not being rejected simply because they deal with a subject that stands in contradiction to the special theory of relativity. Over the years quite a few papers have been published in Journal of Physics A containing speculative and controversial material. In my opinion this is a valid and valuable part of scientific publishing and we intend to continue in this way. However, I and the Editorial Board, do feel that radically new experimental results do need to be properly verified before building a labyrinth of theoretical ideas on them.

**THIS PAGE IS LOCKED TO FREE MEMBERS**

Purchase full membership to immediately unlock this page

**SAVE \$3,999,994**

Did you know we sell  
paperback books too?

To buy our entire catalog  
in paperback would cost  
over \$4,000,000

Access it all now for  
\$8.99/month

\*Fair usage policy applies

**Continue**

# THE PHYSICAL REVIEW

AND

# PHYSICAL REVIEW LETTERS

EDITORIAL OFFICES - 1 RESEARCH ROAD

BOX 1000 - RIDGE, NEW YORK 11961

Telephone (516) 924-5533

February 23, 1981

Dr. S. Marinov  
EST-OVEST  
Editrice Internazionale  
via Puggia 47  
16131 Genova, Italy

Re: Manuscript No. LY1403

Dear Dr. Marinov:

Since it has come to our attention that your manuscript "How to measure the earth's absolute velocity by the help of neutron interferometry" has already been submitted to the Journal of Physics A, we return it as ineligible for ever again being considered by Physical Review Letters.

Sincerely yours,

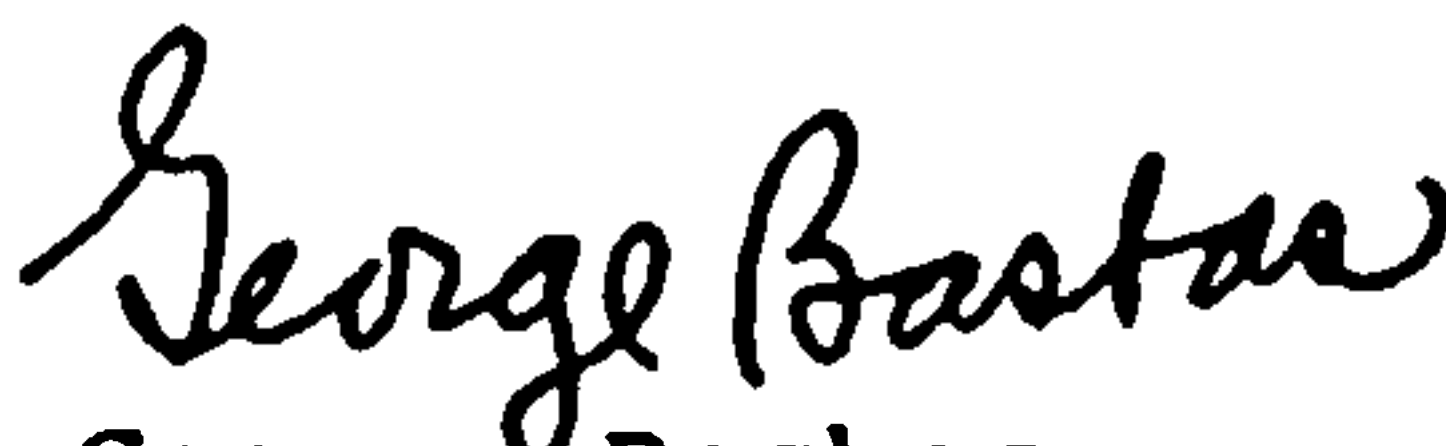

George Basbas  
Associate Editor

Enc.  
GB/jaw

Stefan Marinov  
via Puggia 47  
I-16131 Genova

27 февраля 1981 г.

Проф Е. М. Лифшиц  
Ж Э Т Ф  
Воробьевское шоссе 2  
Москва, В-334

Дорогой "Егор Макарьч",

Большое спасибо за письмо с 11-го декабря 1980-го года, хотя отклонение моих статей "Как измерить абсолютную скорость Земли с помощью нейтронной интерферометрии" и "Эксперимент Майкельсона с нейтронами в свете абсолютной пространственно-временной теории" не было, конечно, приятным сюрпризом для меня.

Вы пишете, что ЖЭТФ отклоняет все статьи, посвященные опровержению специальной теории относительности. Думаю, что ЖЭТФу пора от этой прокрустовой практики отказаться. Писал же Владим Владимьч: "Юноши, взгляд на эксперимент, на эксперимент вострите уши". А то что к юношам относится, тоже и мужчин в соку касается. Пора бы, Егор Макарьч, к экспериментам приглядеться. Знаю, что неприятненько это для Вас, но как говорил не раз тов. Сталин: "Эксперименты вещь упрямая. Не надо глаза на эксперименты закрывать." Это один из важнейших заветов Виссаронича. /Слово "важнейших" читается так "ва-а-ажнейших"/.

Так вот, посылаю Вам новую статью, больно уж ЭКСПЕРИМЕНТАЛЬНУЮ. Знаю, что к прокрустову ложу ЖЭТФа она не подходит, но Вы все-таки почитайте-ка ее перед тем как топором замахнуть, чтобы ей ноги отрезать. А что ножки торчат, этого не отрицаю. Все-же, надеюсь, что и с такими торчащими ножками пройдет статейка в печать. Увидим-с.

Искренне Вас почитающий  
и читающий,

Стефан Маринов

Приложение: Статья "Движение всякой частицы связано с абсолютным пространством".

И еще и еще раз говорю и вторю: Собственное время нужно всегда сводить к универсальному. ЦК партии должен быть один. Что получится, если ЦК-ов на Руси будет тьща? - Неразбериха полнейшая, как и в физике, простите, Адальберта Цвейшгейна, где каждая инерциально летающая ласточка на своих часах время мерит. А когда одно время - порядок. Как и когда ЦК один - тоже порядок. Какой порядок - второй вопрос, важно что порядок. Покупайте универсальные часы марки СтеМар. Недорого берем, самым Господом-Богом заводятся.

IMPERIAL COLLEGE OF SCIENCE AND TECHNOLOGY



The Blackett Laboratory,  
Prince Consort Road, London SW7 2BZ  
Telephone: 01-589 5111. Telex: 261503

CJI/MM.

5th. March, 1981.

Dr. S. Marinov,  
Est-Ovest Editrice Internazionale  
Via Puggia 4711  
16131 Genova,  
ITALY.

Dear Dr. Marinov,

Thank you for your letter concerning the papers which you submitted to Journal of Physics A. I would like to re-emphasise that we are not rejecting them because they oppose special relativity and we are certainly not part of an international conspiracy "to suppress your work". However, the fact still remains that many of your papers rely on experiments that you have performed which have not been independently verified.

Your proposal to come to London is hardly practicable because the Institute of Physics does not have the type of facilities that you require. You would need to visit an English University for that. But in any event, this is not really relevant. I am not an experimental physicist and neither are the members of my Board. It is not us that you have to convince but our experimental colleagues who, over many decades, have formulated criteria by which experimental techniques and results can be assessed for reliability. I and the Board are responsible only for the publishing of papers and in the case of work involving experimental results we must rely upon our colleagues for advice.

I realise the situation is very irritating for you and with all honesty I really do hope that you manage to persuade other experimentalists to take up your work. Until that time, however, I am afraid that our Board's decision must remain.

Yours sincerely,

A handwritten signature in cursive script, appearing to read 'C.J. Isham'.

C.J. Isham  
Hon. Editor - Journal of Physics A.

**THIS PAGE IS LOCKED TO FREE MEMBERS**  
Purchase full membership to immediately unlock this page

**FORGOTTEN BOOKS**

# **FULL MEMBERSHIP**

**797,885 Books!**  
**All you can read**  
**for only**  
**\$8.99/month**

**Continue**

\*Fair usage policy applies



You are, I assume, primarily a theoretician, and if so it was a remarkable achievement on your part to get such an experiment working at all. But the most important skill of an experimental physicist is to be able to detect and guard against the many subtle and unexpected effects which can arise in an experiment with real apparatus (as opposed to a Gedanken experiment), and to convince his colleagues that he has done so; otherwise they will pay little attention to his results. This becomes absolutely imperative when he claims to have obtained a result which contradicts all accepted theory. And this, I am afraid, you have not done.

Let me list some of the criticisms that an experimentalist would have of your experiment, as reported. First, the measured angle  $\alpha$  (fig.1 of your GRG paper) was extremely small - about  $3.5 \times 10^{-9}$  radian, I think - corresponding to a distance  $\alpha R$  of about  $14\text{\AA}$  around the rim of the disc. You ran the experiment in air: it would only need a tiny amount of air resistance to twist the drive shaft by this amount. Even if the experiment were run in vacuo, one would need to make sure that friction in the bearings was small enough not to produce this amount of twist.

Again, the temperature was not controlled. You may be right in claiming that the resultant fluctuations in effective path length would not be large enough to matter (though I find this surprising, with your long path-length), but how about differential changes with temperature in the sensitivities of your two detectors? One certainly can't trust them to be perfectly matched, in this sort of experiment.

There are a great many experimental checks that one would want to see made, and reported, before accepting the results. First, was the balance point stable or did it drift with time, when the shaft was not rotating? If so, by how much, and how was this allowed for? Was the experiment tried with the shaft rotating first clockwise and then anticlockwise, and with the shaft driven first from one end and then from the other? These tests would show up twisting of the shaft due to air resistance, or due to bearing friction.

Was the variation of signal with angle, when the apparatus was rotated, of the expected form and magnitude? Likewise for the variation of signal with time over 24 hours, at constant angle? In both cases, how reproducible were the results, and how much scatter did they show? How did the signal vary between July and January, and was the variation of the expected form? (For example, is the change from 279 km/sec in July to 327 km/sec in January what one would expect from the earth's motion?).

On the face of it, one would expect this experiment to be very difficult to perform, and open to several serious systematic errors, as discussed above; and there is no evidence that any steps have been taken to guard against these. An experimentalist would therefore incline to believe that the agreement with the background radiation result is no more than a remarkable coincidence; certainly not a firm enough piece of evidence to overturn a theory which - inelegant though you may find it - does fit all other known observations.

I would certainly not take the dogmatic view that your result "must be wrong", and like Dr. Isham I would very much like to see it repeated by an independent group, with all the precautions necessary to make the result reasonably convincing. If, when that is done, the results

- 203 -

confirm your findings, then I am sure that your name will be remembered by future physicists. There really is no international conspiracy to suppress your results: it is simply that the evidence at present is very much less convincing than you suppose. And until there is more convincing experimental evidence, I'm afraid that I have to confirm the decision of Dr. Isham and his Editorial Board.

Since the paper which you sent to me is essentially a unified version of the papers already considered by the Board, I am afraid that this paper too must await experimental confirmation of your coupled-mirrors result, and I am asking the Institute's publishing division to return it to you.

Yours sincerely,

*A. S. Chamberlain*



Stefan Marinov  
via Puggia 47  
I-16131 Genova  
11 April 1981

Prof. R. G. Chambers  
University of Bristol  
H. H. Wills Physics Lab.  
Royal Fort  
Tyndall Avenue  
Bristol BS8 ITL

Dear Prof. Chambers,

Thank you very much for your letter of the 30 March 1981.

I shall try to answer your questions and objections concerning my interferometric "coupled-mirrors" experiment, although my hopes that you would accept the positive results of this experiment are feeble. The reason for this is the character of your letter: it is written not with the desire and the intention to receive more information on my experiment but with the aim to present some "motivations" which have to justify the rejection of my paper "Elastic collisions of particles in absolute space". Indeed, in that paper I give an exciting view-point to high-velocity physics against which no single word of objection can be raised, but from your letter one cannot see that my lucid and elegant analysis has excited you. In that paper I present for a first time a report on my observations over a violation of the energy conservation law, but again your curiosity remains frozen - no single exclamation, no single question - only the proverbial English imperturbability. Congratulations!

Well. Let us look at your comments on the "coupled-mirrors" experiment. The report in GEN. REL. GRAV. has been published after 5 years of submission to almost all physical journals in the world (surely also to the J. PHYS. - my archives before 1977 remained in Sofia; on the other hand, in the last 10 years I published about 30 papers but the number of the submitted papers is about 100 and as any of these 100 papers was sent at least to 5 journals, obviously the memory of a normal man cannot memorize which paper where has been submitted). The report on the interferometric "coupled-mirrors" experiment was submitted in a letter-form, as a short paper, as a longer paper, with less or more theoretical details, with less or more experimental details, the editor of the journal X suggested shortening of this, the editor of the journal Y suggested shortening of that etc. etc. (as an example take the manuscript of my paper published in J. PHYS. A, 12, L99 (1979) and see how had I to mutilate the paper following the suggestions of the referee; and when I saw that the paper has appeared with a page almost blank, I cried). Thus, if you do not find enough experimental details, the guilt is not mine. However, I think that even in this form the paper gives enough indications, so that a reader interested into the problem reading attentively my paper can give answer almost to all of the questions posed by you.

1. You note that the resistance of the air or the friction in the bearing can produce a twist in the shaft larger than  $3.5 \times 10^{-9}$  radians which will lead to a change in the difference in the optical paths of the "transmitted" and "reflected" photons larger than  $14 \text{ \AA}$ . Yes, the angle proportional to the effect is very small and the doubts of the reader must be inversely proportional to this angle. However, you have to take into account that the experiment is performed at a steady rotational speed. The resistance of air, the friction in the bearing have done their work: the shaft rotates and now I begin to measure rotating the platform. In the paper is written (p. 61):

During a whole day we search for the moment when the Wheatstone bridge is in equilibrium if the axis of the apparatus points east-west. At this moment the Earth's absolute velocity lies in the plane of the laboratory's meridian. Thus turning the axis of the apparatus north-south, we can measure  $v$  in the horizontal plane of the laboratory.

The most clear indication that  $v$  lies in the meridian is the following: the rate of disequilibrium of the bridge for a unit angle of rotation of the platform is the biggest when the axis points east-west and less when it points north-south.

**THIS PAGE IS LOCKED TO FREE MEMBERS**

Purchase full membership to immediately unlock this page

**SAVE \$3,999,994**

Did you know we sell  
paperback books too?

To buy our entire catalog  
in paperback would cost  
over \$4,000,000

Access it all now for  
\$8.99/month

\*Fair usage policy applies

**Continue**

6. I have rotated the axle only in one direction because for this direction was projected the form of the rotating disks with the mirrors on them, with the aim to diminish the turbulence of the air. The axle was driven from the middle point, thus the twists of the disks were the same. If you have understood well the method, you have not to pose such stupid questions whether I have driven the axle from one side and whether I have established which will be the twist. In such a case the twist will correspond not to parts of wavelength but to tens and, may be, hundreds of wavelengths.

7. I established that the disks do not get twisted differentially at different velocities of the shaft when finding the average illumination (see p. 60 of the paper). I registered that the illumination over the photoresistors changes from minimum to maximum (that corresponds to a change in the difference in the optical paths of the "transmitted" and "reflected" photons equal to  $\lambda/2$ ) when the rotational rate changes with (take formula (1) from the paper for  $\alpha = 0$ ,  $v = 0$ , multiplying it by R and setting  $\delta R = \lambda/4$ )

$$\Delta N = \frac{c(\lambda/4)}{2\pi dR} = 13 \text{ rev/sec.} \quad (3)$$

If the change in the rotational rate has led to a differential twist of the disks, the change of the illumination over the photoresistors from minimum to maximum had to appear for another change  $\Delta N$ . Let me emphasize once more that when I change the velocity of rotation the illumination over both photoresistors changes in the same direction, while when rotating the platform at a fixed rate of rotation of the shaft the illuminations change in opposite directions. In the first case the bridge does not come into disequilibrium, however in the second case it does. Dear Prof. Chambers, I have made too many experiments with rotating axles and rotating disks using my superb differential method. Why you do not give me a possibility to contact the scientific community and to explain how one has to do all these experiments. They are not as difficult as you suppose, although the accuracy achieved is relatively very high.

8. I cannot understand the question: "Was the variation of signal with angle, when the apparatus was rotated, of the expected form and magnitude?" - When I performed the measurements I did not know the Earth's absolute velocity,  $v$ , thus I could not "expect" a certain value (as, for example, I expect the value  $\Delta N$  in formula (3) of the present letter, since I know the value of  $c$ ). The variation of the signal between July and January was between those given in the paper. The values remained in my Sofia archives.

9. The question: "Is the change from 279 km/sec in July to 327 km/sec in January what one would expect from the Earth's motion" can be answered easily by yourself if you would perform certain simple calculations. I give in the paper the values of my observations with a time difference of 6 months just to facilitate the calculations of the reader.

10. You consider me as a theoretician. I am both a theoretician and experimentalist. I think that the scientific community has to recognize the experimental abilities of a man who in the second half of the XXth century has measured the Earth's absolute velocity in a closed laboratory by an optical experiment. Read my papers, read my book EPPUR SI MUOVE (price \$ 25); I think, I deserve a recognition and I think that it is not more possible to cover my experimental and theoretical achievements by silence.

Conclusion. My answer to your questions and objections shows that you could not find a single systematic error in my method. I cannot accept your criticism as a motivation for the rejection of my papers submitted to J. PHYS.

.Dear Prof. Chambers, you consider the theory of relativity as an elegant theory. If a scientist makes this declaration after having read my paper ELASTIC COLLISION OF PARTICLES IN ABSOLUTE SPACE, one can only sigh: "God, help him." If you have not made a xerox copy of my paper, write me, and I shall send you again the copy; one writes such pers only a few in a century.

You write: "... I would very much like to see it (my experiment) repeated by an independent group..." Now I submit to the J. PHYS. A two papers (they can be published in letters):

1. IMPROVED VARIATION OF THE INTERFEROMETRIC "COUPLED-MIRRORS" EXPERIMENT,
2. THE DISRUPTED "ROTATING DISK" EXPERIMENT.

I do not like loquacious theories, I like short and clear experiments. The acceptance or the rejection of these two papers will show whether your wish to see my experiment repeated is real or imaginary.

Hoping to receive your answer soon,

Sincerely yours,  
Stefan Marinov

PS. I send you my book ECONOMIA POLITICA TEORICA. On pp. 123-130 you can find certain documents about my contacts with the National Science Foundation and about my expulsion from the US.

- Editorial note.
1. The paper "Elastic collisions of particles in absolute space" is presented in CLASSICAL PHYSICS, vol. III, §44.
  2. The paper discussed in the above letter of Marinov and in the preceding letter of Prof. Chambers is published in GEN. REL. GRAV. 12, 57 (1980), (CLASSICAL PHYSICS, vol. III, §52B).
  3. The paper "Improved variation of the interferometric 'coupled-mirrors' experiment" is presented in CLASSICAL PHYSICS, vol. III, §52C.
  4. The paper "The disrupted 'rotating disk' experiment" is presented in CLASSICAL PHYSICS, vol. III, §61.

Editorial note to the second edition. The paper "The disrupted 'rotating disk' experiment" was published under the title "The interrupted 'rotating disk' experiment" in JOURNAL OF PHYSICS A, 16, 1885 (1983).

**PROGRESS OF THEORETICAL PHYSICS**

*Publication Office*  
Yukawa Hall, Kyoto University  
Kyoto, Japan

Our Ref. E-42-81-et  
Your Ref.

Dr. Stefan Marinov  
Via Puggia 47  
16131, Genova  
Italy

April 20, 1981

Dear Sir :

We received your manuscript entitled " The Motion of Any Particle is attached to Absolute Space " and discussed publication of this paper at today's editorial meeting. We considered the content of the manuscript unsuitable for publication in the Progress of Theoretical Physics. We are therefore returning your manuscript herewith.

Yours sincerely,

Editorial Office  
Prog. Theor. Phys.

et  
encl. manuscript

**THIS PAGE IS LOCKED TO FREE MEMBERS**  
Purchase full membership to immediately unlock this page

**FORGOTTEN BOOKS**

# **FULL MEMBERSHIP**

**797,885 Books!**  
**All you can read**  
**for only**  
**\$8.99/month**

**Continue**

\*Fair usage policy applies



# Konrad -Adenauer- Stiftung

Konrad-Adenauer-Stiftung e. V. · Postfach 1260 · 5205 Sankt Augustin bei Bonn

 Der Vorsitzende

Herrn  
Stefan Marinov  
Via Puggia 47/1  
16131 Genova  
Italia

25. Mai 1981

Durchwahl

Sehr geehrter Herr Marinov,

Herr Dr. Rühle hat mir Ihren Brief vom 25. April zur Kenntnis gebracht und mich über Ihr Problem eingehend informiert. Leider sieht sich die Konrad-Adenauer-Stiftung außerstande, Ihnen zu helfen. Die Mittel der Stiftung sind durch Gesetz für bestimmte Ausgabenbereiche vorgesehen, von denen keiner die Thematik Ihrer Arbeit abdeckt.

Ich bitte daher um Verständnis, wenn ich Ihnen diese unangenehme Mitteilung machen muß. Dieses bedaure ich um so mehr, als ich durch einen Forscher in meinem früheren Wahlkreis, der ähnliche Gedanken wie Sie geäußert hat, an Ihrem Problem persönlich interessiert bin.

In der Hoffnung, daß Sie einen Geldgeber finden mögen und damit auch die Bewältigung Ihres politischen Anliegens möglich wird, verbleibe ich

mit freundlichen Grüßen

4

(Dr. Bruno Heck)  
Bundesminister a. D.

THE FRANKLIN INSTITUTE • PHILADELPHIA, PA. 19103 • (215) 448-1000

JOURNAL OF THE FRANKLIN INSTITUTE

May 27, 1981

Professor Dr. Stéfan Marinov  
EST-OVEST  
Via Puggia 47/1  
16131 Genova, Italy

Dear Professor Marinov:

We are indeed sorry, but we must once again return your new paper, entitled "The Fundamental Equations in Electromagnetism and Gravimagnetism", because the topic is outside the editorial scope of this journal. This holds true for the other papers as well. They are more suited for publication in physics journals devoted to gravitational problems where they would find a wider, more interested audience than in this journal.

The readership of the Journal of The Franklin Institute is primarily made up of engineers who are interested in electrical and mechanical engineering theory and practice.

Problems such as you address in this as well as the other papers you have previously sent us are not within the editorial realm of the JFI. There are numerous physics journals where this topic would find a larger, interested readership.

Thus we regret again to return your paper, but we are obliged to adhere to our current stated editorial policy.

Thank you however for allowing us to consider your paper.

Sincerely yours,

  
Martin A. Pomerantz  
editor

MAP/1h  
enclosures



UNIVERSITY OF BRISTOL

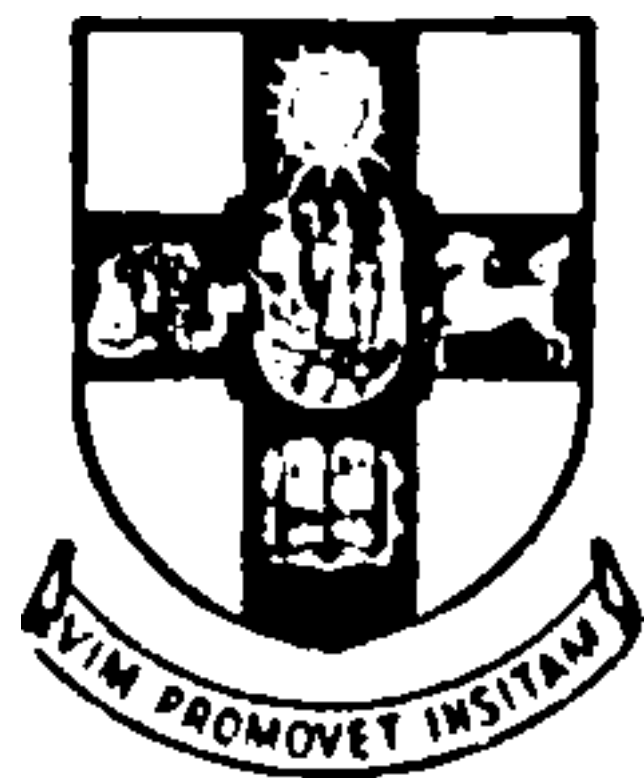

H. H. WILLS PHYSICS LABORATORY  
ROYAL FORT  
TYNDALL AVENUE  
BRISTOL  
BS8 1TL

Telephone Bristol 24161 ext: 49  
Professor R.G.Chambers M.A., Ph.D.

29th May 1981

Dr.S.Marinov  
Est-Ovest Editrice Internazionale  
Via Puggia, 47/1  
16131 Genova  
Italy.

Dear Dr.Marinov,

Thank you for your letter of 11th April, and apologies for this delayed reply. I am afraid I remain unconvinced, for the reasons I gave before. In particular I expressed surprise before that temperature fluctuations did not produce substantial variations in the effective path length, though I didn't bother to work out what temperature stability was implied. You yourself now point out that this implies a temperature stability of better than  $10^{-5}$  °C, over a distance of 100 cm or so: the average temperature along one arm must remain equal to that along the other to this accuracy. Or if they differ, the difference must remain constant to this accuracy when the whole apparatus (including two large and rapidly rotating discs) is rotated through 90°. I can only say that I find this extremely surprising, and that it confirms my belief that an independent confirmation of the result is needed. The Michelson-Morley experiment was considerably less difficult than yours, but they took considerable care to avoid temperature fluctuations, and Miller's apparent positive result when he repeated their experiment was due to temperature effects, as shown in Rev.Mod.Phys., 1955. It is really quite unconvincing to dismiss temperature effects in this way without careful discussion.

I return herewith the two papers you enclosed. I don't see the relevance of the "disrupted disc" experiment. The other one could be relevant, but you must be well aware that scientific journals do not publish papers written in this autobiographical style. In any case, the appropriate journal to submit it to would surely be GRG, which published your account of the previous experiment.

Yours sincerely,

*R.G. Chambers*

**THIS PAGE IS LOCKED TO FREE MEMBERS**

Purchase full membership to immediately unlock this page

**SAVE \$3,999,994**

Did you know we sell  
paperback books too?

To buy our entire catalog  
in paperback would cost  
over \$4,000,000

Access it all now for  
\$8.99/month

\*Fair usage policy applies

**Continue**

# ANNALS OF PHYSICS

*Editor-in-Chief:*

HERMAN FESHBACH  
Department of Physics  
Massachusetts Institute of Technology  
Cambridge, Massachusetts 02139

M.I.T. Rm. 6-214

*Publishers:*

ACADEMIC PRESS, Inc.  
111 Fifth Avenue  
New York, New York 10003

*Assistant Editors:*

BERNARD T. FELD  
ROMAN W. JACKIW  
ARTHUR M. JAFFE  
RICHARD WILSON

*Consulting Editor:*

P.M. MORSE

June 8, 1981

Dr. S. Marinov  
via Puggia 47/1.  
16131 Genova  
ITALY

Dear Dr. Marinov:

We are returning your paper "Relativistic Effects in the Radiation from Macroscopic Light Sources" under separate cover. This manuscript is not suitable for publication in Annals. As you must surely realize, the theory of special relativity has been verified in an enormous number of different experimental situations. Any attempt to modify it must therefore not only demonstrate some deviation from experimental work but also must show how the large body of supporting evidence can be reinterpreted or shown to be incorrect. This is, I well recognize, an enormous task. But the reinterpretation of the work of the last century need not be expected to be of minor importance.

I personally do not believe it will be profitable for you to continue to send manuscripts of this kind to this journal.

Yours sincerely,



Herman Feshbach  
Editor

- 215 -

Stefan Marinov  
Via Puggia 47  
I-16131 Genova

June 1981

Dr. Harold Davis  
PHYSICS TODAY  
335 East 45th Street  
New York  
NY 10017

Dear Dr. Davis,

I send you for publication in PHYSICS TODAY my correspondence  
SCIENTISTS IN DEVIL'S WORK.

I use the occasion to inform you that on the 24 January 1981 I sent you my correspondence MANIPULATED RELATIVITY, however until today I have received neither an acknowledgment for reception nor any other information. In July 1980 I sent you my information for certain curious events on the 9th GR Conference entitled THE TEN JENA COMMANDMENTS, but that letter also remained without answer. Finally on the 24 May 1981 I sent to your Advertisement Division my advertisement entitled INTERNATIONAL CONFERENCE ON SPACE-TIME ABSOLUTENESS, but until today neither to this letter came an answer.

I beg you very much to look at the archives and to inform me whether all those materials have reached you and to give me an answer about your decision on their eventual publication. I should like to hope that our 10-years correspondence will not end in such manner.

I beg you very much to pay a due attention to the correspondence sent with the present letter. If you would insist certain "hard" words can be substituted with more "soft".

Hoping to receive your answer soon,

Sincerely yours,

Stefan Marinov

### SCIENTISTS IN DEVIL'S WORK

I read Dr. Stumpff's letter (PHYSICS TODAY, May 1981, p. 102) with a stupefaction. Can the moral of a scientist fall so low?! I trembled of indignation, loathing, and horror, when reading Dr. Stumpff's words: "The work (in war industry - S.M.) is just as challenging, interesting and (possibly more) worth-while as anything McNeill and the rest of the 'ivory tower league' is working on." --- The production of any device on a less or more higher technological level may be challenging and interesting, still more if it is paid well. However the production of devices whose destination is the murdering of people, the mastering of nuclear, bacteriological or particle beams weapons for extermination of thousands, millions, and billions of human beings is a crime against humanity. Such a work can be only a damnation.

Dr. Stumpff motivates his entrance in the laboratories of the Black Devil with the fact that on the other side of the iron curtain thousands of his Soviet colleagues work in the labs of the Red Devil, producing the same horrible weapons under the slogan: "We don't want to live under America's domination!" --- Poor Dr. Stumpff! Have you read ever the Bible? Have you not heard Solomon's parable about the two mothers?

Although being persuaded that the work in the Devil's workshops is "for a defence", Dr. Stumpff feels that such a work is not very "clean". So he attacks the first Russian Nobel peace prize winner with the words: "Sakharov is not exactly a saint!", alluding to Sakharov's work in "defence industry" 20 years ago. Yes! Sakharov also <sup>was</sup> a serve of the Devil. If nuclear bombs will destroy to-morrow America, a part of the responsibility will fall on Sakharov's conscience. However this noble spirit and courageous man heard the voice of God, found moral forces, deserted the caves of the Devil and today he is a banner and a hope for whole mankind. Taking the decision to stop his sinister service under the Devil's orders, Sakharov knew well that he will face the death. Dr. Stumpff has not to face such a tragic alternative. If Dr. Stumpff will be unable to join the "ivory tower league", he simply will remain unemployed, as he affirms with an impudent frankness: "Without the defence industry, jobs for scientists would be significantly harder to find."

Recently it came to my knowledge that in NASA one works over the use of my cosmic speedometer (light velocity's direction dependence) for supplying intercontinental rockets with an absolute direction indicator. With the present note I should like to diffuse the declaration: "I do not permit my discovery to be used for military purposes!" We, the scientists from the "ivory tower", have no means to defend our inventions and discoveries from the ominous hand of the Devil. But we, at least, can take the following collective decision: To not speak on scientific matters with those from the Devil's labs, to not send them preprints, and to pray God to have mercy and save the souls of our blind brothers as He saved the soul of Sakharov.

Stefan Marinov

Citizen of the World, born Bulgarian  
via Puggia 47, I-16131 Genova

Editorial note. This letter to the Editor (see the preceding page) beside to PHYSICS TODAY (see also p.247) was sent also to a couple of journals as NATURE, SCIENCE, NEW SCIENTIST, PHYSICS BULLETIN, etc, but noone had the courage to print it.

**THIS PAGE IS LOCKED TO FREE MEMBERS**  
Purchase full membership to immediately unlock this page

**FORGOTTEN BOOKS**

# **FULL MEMBERSHIP**

**797,885 Books!**  
**All you can read**  
**for only**  
**\$8.99/month**

**Continue**

\*Fair usage policy applies



Princeton University

DEPARTMENT OF PHYSICS: JOSEPH HENRY LABORATORIES

JADWIN HALL

POST OFFICE BOX 708

PRINCETON, NEW JERSEY 08544

June 27, 1981

Dear Dr. Marinova:

Thank you for your letter of June 15 and the implied invitation to the next conference on the absoluteness of space-time. Unfortunately, it is not clear from your letter whether the conference will be held this year July 8-11 or next year at an as not yet determined date. If it is this year, I am surely unable to come but I would like to try to go next year -depending on the date. Please let me know.

May I also suggest that you invite also Dr. Dirac to the conference. His theory of the changing gravitational constant is in harmony with your ideas.

Sincerely yours

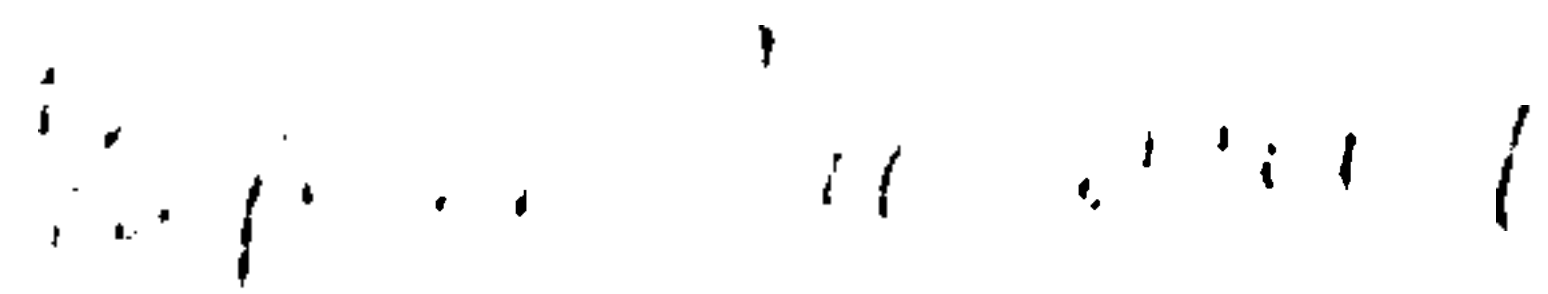

Eugene P. Wigner

INTERNATIONAL ATOMIC ENERGY AGENCY  
UNITED NATIONS EDUCATIONAL, SCIENTIFIC AND CULTURAL ORGANIZATION



INTERNATIONAL CENTRE FOR THEORETICAL PHYSICS  
100 TRIESTE (ITALY) - P. O. B. 588 - MIRAMARE - STRADA COSTIERA 11 - TELEPHONES: 224281/2/3/4/5/6  
CABLE: CENTRATOM - TELEX 400802 ICTP

DIRECTOR  
ABDUS SALAM

29 June 1981

Dear Dr. Marinov,

Thank you for your letter of 18 June.

As you know, I have never given critical thought to your work. My present views are of the "establishment" and I believe in Einstein's work. However, it is important for science that you should have an occasion to have your views aired and that those for the "establishment" should participate. Could you somehow make certain of this by offering funds and facilities to such people? If I can come, I shall attend, but as you are aware, the sort of life I lead, I am liable at the last moment to be summoned to a meeting of UNESCO or UNDP which I cannot refuse since we get funds from them.

With kindest regards,

Yours sincerely,

A handwritten signature in dark ink, appearing to read "Abdus Salam".

Abdus Salam

Dr. S. Marinov  
Via Puggia 47  
16131 Genova



345 Whitney Avenue  
New Haven, Connecticut 06511  
203 624-2566

# American Scientist

9 July 1981

*Board of Editors* Caryl P. Haskins, *Chairman*  
Sidney Altman  
D. Allan Bromley  
W.J. Cunningham  
Richard G. Harrison  
William Kessen  
George D. Mostow  
Irving Rouse  
Brian J. Skinner  
Peter P. Wegener

*Editor* Michelle Press

Dr. Stefan Marinov  
Organizzazione Internazionale  
Congressi  
Via Puggia 47-1  
16131 Genova, Italy

Dear Dr. Marinov:

In October 1978, you submitted your manuscript "Let Newton Be" to American Scientist for publication. At that time we outlined to you the kind of article we publish: review papers which report on a corpus of research findings that have already achieved general acceptance in the particular field involved. As a secondary medium, we must leave presentation of experimental results that are highly specialized in nature to primary journals, where they will reach an audience fully qualified to evaluate them.

The editorial mandate of our journal is to publish papers that bring readers up to date on the "state of the art" in fields of research other than their own. This eliminates from consideration papers that present "new" concepts or theories before they have been generally accepted among the scientists working in that area of research.

I am afraid that we must also decline to publish an announcement of the International Conference on Space-Time Absoluteness, as we do not have a section devoted to news releases, calendars of events, etc.

We hope you will find a suitable publication to make your work better known, and we are sorry American Scientist cannot help you out.

Sincerely,

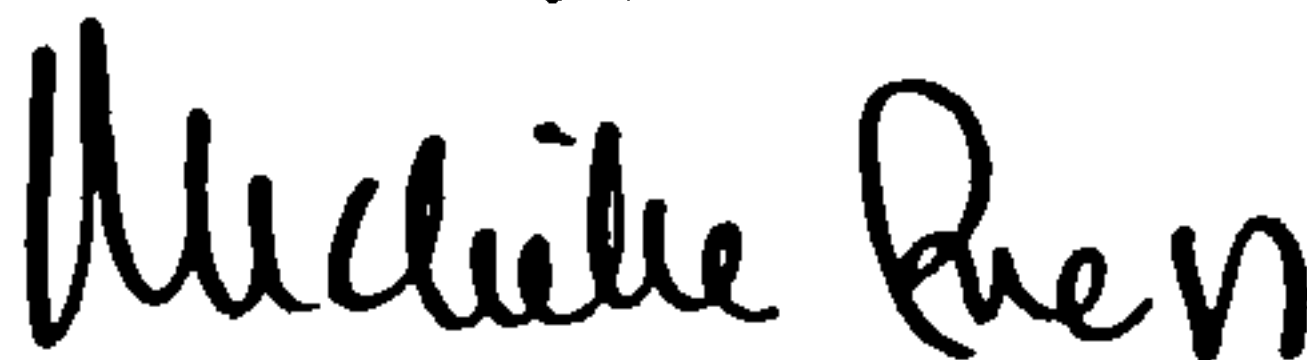

Michelle Press  
Editor

MP/caw

**THIS PAGE IS LOCKED TO FREE MEMBERS**

Purchase full membership to immediately unlock this page

**SAVE \$3,999,994**

Did you know we sell  
paperback books too?

To buy our entire catalog  
in paperback would cost  
over \$4,000,000

Access it all now for  
\$8.99/month

\*Fair usage policy applies

**Continue**



UNIVERSITY OF BRISTOL

Professor J. M. Ziman, F.R.S.  
Telephone Bristol 24161 Ext. 116

H. H. WILLS PHYSICS LABORATORY  
ROYAL FORT  
TYNDALL AVENUE  
BRISTOL  
BS8 1TL

20th July 1981

Dr. Stefan Marinov  
Est-Ovest Editrice Internazionale  
Via Puggia 47/1  
16131 Genova  
ITALY

Dear r. Marinov,

I am afraid that I am not willing to submit  
your papers for publication by the Royal Society.

Yours sincerely,

A handwritten signature in cursive script, appearing to read 'J. M. Ziman'.

pp Prof Ziman

# IL NUOVO CIMENTO

VICE DIREZIONE «BT»

referee report on the paper no.

author S. Marinov

title Elastic collisions of particles in absolute space

(to be typewritten in English)

"Errare humanum est, perseverare diabolicum".

I have already written that when Marinov arrived at the Tangherlini transformations (after many wrong and self contradictory attempts) he arrived at special relativity. Indeed the very clear papers by Mansouri and Sexl (General Rel. and Grav. 8, 497, 515, 809 (1977) have shown that the connection between  $t$  and  $x$  is via an arbitrary parameter  $\epsilon$  of synchronization. If  $\epsilon = -\beta x/c$  we have the Lorentz transformations, if  $\epsilon = 0$  the Tangherlini transformations (absolute synchronization). But the physics is the same. Consequently, the pretended positive result of the coupled-mirrors experiment is in contrast with the theory of Marinov himself. All the other experiments mentioned in Marinov's paper are correctly explained in any standard text of relativity.

Unless Marinov is able to criticize in a correct way the fundamental, clear, right papers of Mansouri and Sexl, any other paper claiming some difference with special relativity is useless.

I will send Marinov a preprint of a paper with Spinelli mainly written as a criticism to Marinov's ideas and submitted to Foundation of Physics.

This in the hope that Marinov can understand these connections.

Editorial note. These referee's comments were sent to Marinov by Prof. Arecchi without any accompanying letter. The date of reception in Graz was the 26 July 1981. These comments are written by Prof. Cavalleri. Marinov's comments are given on the next page.

Stefan Marinov  
c/o Karl Mocnik  
Radegunderstr. 38  
A-8045 Graz

Prof. F.T. Arecchi  
IL NUOVO CIMENTO  
Istituto di Ottica  
Largo Enrico Fermi, 6  
I-50125 Firenze

26 July 1981

Dear Prof. Arecchi,

Thank you very much for the *express letter* with the referee's comments of Prof. Cavalleri on my paper "Elastic collisions..." which was resent to me here in Graz from Genoa. As I did not find your letter in the envelope, I have to conclude that my paper is still under examination. I shall be very thankful to you, if you will take the decision as soon as possible. I repeat, a rejection will be a disaster for me, as I shall lose another half a year submitting it to another journal and in July 1982 I organize in Genoa the Int. Conf. on Space-Time Absoluteness. The appearance of the paper many months before the conference will be decisive for its success. I hope that you will have understanding for my preoccupations. I have already paid 430 English pounds for a whole-page announcement in NATURE of ICSTA. Please, do not forget that I am a poor Bulgarian political dissident.

Cavalleri's criticism is irrelevant and very poor. The problem about the Galilei, Lorentz and Marinov transformations is important when discussing the effects of second order in  $v/c$ . For effects of first order in  $v/c$  the Galilei transformation is sufficient. My paper, in its predominant part, is dedicated to these effects. However, Prof. Cavalleri does not write a single word on these effects.

I agree that the physics for the Lorentz and Marinov transformations is the same, but *only if the Lorentz transformation is considered from an absolute point of view*, i.e., if one assumes that the principle of relativity is *not* true and that the velocity of light (and of any massive particle) is direction dependent in frames moving in absolute space. The positive result of my "coupled-mirrors" experiment is not in contrast with my theory but with the relativistic treatment (in the sense of Einstein and Lorentz-Poincaré) of the Lorentz-Voigt transformation.

Tangherlini (with whom I had lengthy discussions in Jena) has proposed the same formulas for the coordinates as me. However, he has *not* presented the transformation formulas for the *velocities*. If he had done this, absolute space-time could be restored *20 years ago* (Tangherlini's paper was published in 1961), and the scientific community should have labeled the transformation with his name.

Cavalleri writes that all experiments considered in my paper are correctly explained in any standard text of relativity. I am really *amazed*. Can he cite a *single paper* in the world where one explains the Michelson experiment with neutrons? Can he find a single paper where one explains the "coupled-mirrors" experiment with photons and neutrons? Can he find a single paper where one has written the formula for the one-way velocity of any particle

$$v = c/n - V\cos\theta/n^2?$$

Can he find a single paper where one has formulated the theorem on the rotating disk? Can he find a single paper where one has written the Newton-Lorentz equation in a moving frame? Can he find a single paper where one presents an experimental verification of this equation? --- In my paper there are so many *discoveries*, but Prof. Cavalleri has not seen a single of them.

**THIS PAGE IS LOCKED TO FREE MEMBERS**  
Purchase full membership to immediately unlock this page

**FORGOTTEN BOOKS**

# **FULL MEMBERSHIP**

**797,885 Books!**  
**All you can read**  
**for only**  
**\$8.99/month**

**Continue**

\*Fair usage policy applies





PHYSICAL SOCIETY OF JAPAN

Kikai-Shinko Building, 3-5-8 Shiba-Koen, Minato-ku  
Tokyo 105, Japan

August 11, 1981

Dr. Stefan Marinov  
via Puggia 47,  
16131 Genova,  
Italy

Dear Dr. Marinov:

Your manuscript #6129 entitled "The Quasi-Roemer and Quasi-Bradley Experiments according to Absolute Space-Time Theory" was examined by another referee. His comments are given in the attached sheet.

We regret to inform you that the Editorial Committee, on examining the two referees' comments, has concluded that your manuscript is not appropriate for publication in our Journal. Your manuscript is enclosed herewith.

Sincerely yours,

Sadao Hoshino  
Editor  
Journal of the Physical  
Society of Japan

# FOUNDATIONS OF PHYSICS

An International Journal Devoted to the Conceptual Bases and Fundamental Theories of  
Modern Physics, Biophysics, and Cosmology

Editors

WOLFGANG YOURGRAU

~~University of Denver~~  
2329 South High Street  
Denver, Colorado 80210

USA

ALWYN VAN DER MERWE

University of Denver  
~~2329 South High Street~~  
Denver, Colorado 80210

418 Mary Reed Bldg.

August 13, 1981

Dear Dr. Marinov:

We should appreciate it very much indeed if you would be kind enough to act as a referee for the enclosed paper, by Cavalleri & Spinelli.

*+ J. WILCZYŃSKI*

Should you recommend the paper, for publication without any modification, there is no need to state your reasons for doing so. However, should you reject the paper, in toto, then it would be desirable that you specify, in any way you choose, your grounds upon which you based your verdict. Finally, in case you recommend publication subject to certain changes, etc., please be so kind and be very explicit so that the author may profit from your counsel.

Of course, we realize that you will be inundated with your own work. Nevertheless, we hope that you will find the time to give us an opinion on ~~this~~ <sup>the</sup> paper.

Yours most sincerely,

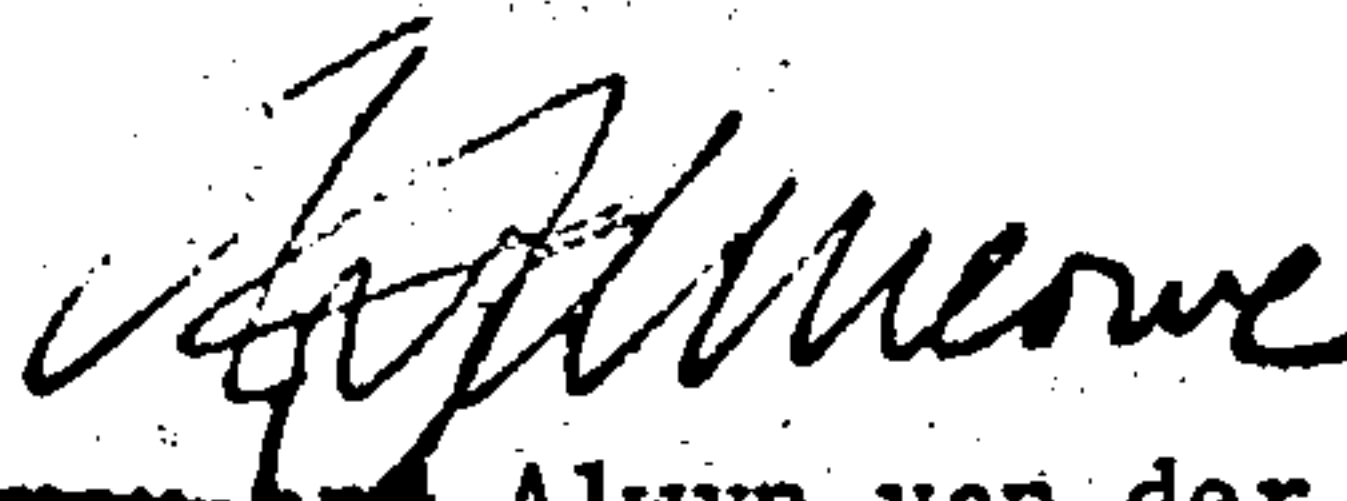

~~Wolfgang Yourgrau and~~ Alwyn van der Merwe  
Editors

AvdM/bg

Enc. Cavalleri & Spinelli Ms

*WILCZYŃSKI MS*



Stefan Marinov  
c/o Karl Mocnik  
Radegunderstr. 38  
A-8045 Graz  
Austria

15 September 1981

Prof. A. van der Merwe  
FOUNDATIONS OF PHYSICS  
University of Denver  
418 Mary Reed Bldg.  
Denver  
CO 80210

Re: Cavalleri+Spinelli's paper

Dear Prof. van der Merwe:

I enclose my letter of the 26 July 1981 to Prof. Arecchi, the editor of IL NUOVO CIMENTO (for your information I enclose also the referee's opinion of Prof. Cavalleri on my paper "Elastic collision ..."). As you can see reading this letter, I have already taken the obligation to recommend Cavalleri+Spinelli's paper for publication. I do this with the present letter.

XXXXX

As a rule, the referee is an well-intended person who has to help the author and the editor, so that the readers can obtain certain valuable and true information which can be profitable for deepening their knowledge in the secrets of Nature. In the case of Cavalleri+Spinelli's paper, I am interested that they present in the press as much as possible of negative criticism on the absolute space-time conceptions and that they present this criticism in the most vulnerable and obviously wrong manner. In this way the process of restoration of the absolute conceptions will be considerably accelerated what will be highly profitable for physics. Thus, I am not interested in correcting the errors of Cavalleri and Spinelli. On the other hand, as a referee to whom you have paid trust, I must help authors and editor, so that FOUND. PHYS. does not print rubbish. What to do, I really don't know. Here I should like to cite the opinion which I gave to my very good friend Prof. Prokhovnik, when he sent me his paper "The empty ghost of Michelson-Morley: A criticism to Marinov's coupled-mirrors experiment" for opinion:

"As a friend I give you the advice not to publish the paper because your ad hoc hypothesis about a mechanical twist of a rotating shaft (the so-called by me "Lorentz twist") is wrong (as is wrong the ad hoc conception about the famous "Lorentz contraction"). However, as a scientist-competitor, I should like very much that you publish your paper because when after a couple of repetitions of my experiment the scientific community will become persuaded that a "Lorentz twist" does not exist, then only my theory will remain valid and yours, which is also an absolute theory and thus highly competitive to mine, will be rejected."

Prof. Cavalleri and Prof. Spinelli are not my close friends but I know both of them personally (with Prof. Cavalleri I maintained a long-years correspondence not only on scientific but also on moral problems, as he is a deeply believing Christian) and I like them very much. However, they are (or at least have been until a very recent time!) convinced relativists. Thus for me and for the scientific community it is of big importance that they print as much rubbish as possible. But you, Prof. van der Merwe, are also my friend and I do not wish that your journal publishes rubbish. What to do? How can I transfer a wolf, a goat, and a cabbage through the river?

I think that the right thing to do is to give a honest criticism to Cavalleri+Spinelli's paper as it is written in the Bible:

Tell the truth and do your best,  
and God will send you peace and rest.

Thus, I have the following remarks.

**THIS PAGE IS LOCKED TO FREE MEMBERS**

Purchase full membership to immediately unlock this page

**SAVE \$3,999,994**

Did you know we sell  
paperback books too?

To buy our entire catalog  
in paperback would cost  
over \$4,000,000

Access it all now for  
\$8.99/month

\*Fair usage policy applies

**Continue**

on the distance between A and B and on the absolute velocity of the frame in which A and B are at rest. So many years I submit a paper on this simple problem, but it is rejected, rejected, rejected, and people think that if the velocity of transfer is low the desynchronization disappears. Fortunately, Cavalleri+Spinelli admit a desynchronization also at a low velocity. Second: Cavalleri+Spinelli think that only the synchronization by the help of light signals is a noble one and worth to be treated and analysed in theoretical papers. They consider the synchronization by the help of rusty rotating axes as childish and primitive. Well. In my paper published in PHYS. LETT. 81A, 252 (1981), I proposed an absolute time synchronization by the help of light signals (this is the first proposal of this kind ever published in the literature). Read this paper, Cavalleri and Spinelli. Say your opinion in the press (it will be fine to say your judgement in the criticized paper). Is the synchronization parameter  $\epsilon$  in this experiment equal to zero? If it is equal to zero, is relativity dead? Or it can further survive? I know that my PHYS. LETT. paper is very uncomfortable for the relativists and they will prefer keep silence on it and continue the speculations over the parameter  $\epsilon$ , as if this paper had not been published. Third. If the international network of atomic clocks (p. 6) has not registered discrepancies in the clocks' readings from which the absolute velocity of the Earth can be calculated, this is due just to the absolute time dilation of these clocks. However, for a circular motion there was a discrepancy (Hafele and Keating). After a rotation along a circular path the discrepancies due to the absolute velocity of the Earth annihilate mutually, because along the half of the circular path the velocity of the Hafele+Keating's plane was along the absolute velocity of the Earth but along the other half of the circular path it was against. Childish problems!

Remark IV. Cavalleri+Spinelli write:

"A modern aether is no longer the naive (my italics - S.M.) fluid conceived in the past century. It would consist of fields, mainly the electromagnetic field radiated by all atoms in the universe."

Firstly: A fluid cannot be naive. Naive can be a writer who invents "fluids" and "fields". Secondly: Fluid is something which can flow. The scientists in the last century imagined the aether as a medium at rest. Thirdly: I showed that the aether is this frame of reference in which the mass of the whole universe is at rest. The aether is defined not only by the motion of the mass-less particles (photons, electromagnetic radiation) but also by the motion of any massive particle (neutrons, electrons, phonons, birds, tanks). Any particle is attached to absolute space through its proper mass. The experiment of Werner et al. on the Sagnac effect for neutrons has shown this clearly for the massive particles called "neutrons". In any circular accelerator the particles revolve with different velocities along their trajectories. The historical paper on this extremely important for physics problem ("Elastic collision of particles in absolute space") is since half a year in the hands of Cavalleri-Spinelli and they write such poor and inconsistent criticisms that one asks oneself "Have they read the paper? Can they be so blind?" I write this because I have the feeling (the submission of their paper to FOUND. PHYS. is a proof) that Cavalleri+Spinelli have still not understood that I am right. The other big relativists (Bergmann, Wheeler, Weber, Schmutzer, de Sabbata, Bohm, Finkelstein, Petiau, etc.) have since long time understood that I am right and for this reason they keep a strict and total silence.

Remark V. I am very interested to read Cavalleri's paper which will be published in PHYS. REV. LETT., as I am highly interested in the deduction of quantum results in a classical way. The Sagnac effect with neutrons is considered by the persons who proposed the experiment (Anandan etc.) and by the people who carried out the experiment (Werner etc.) as a quantum effect. I showed that this is a purely classical effect.

Remark VI. Prof. Cavalleri cites my book EPPUR SI MUOVE. However he has not read it. I sent him this book three years ago and he returned it (without any letter) back after such a short time that it was physically impossible for him to read it. It is good when one gives references to read these references.

Remark VII. Cavalleri+Spinelli declare (p. 4) that my "rotating axle" experiments are wrong conceptually, i.e., that theoretically they must give a null result. I am extremely glad to see published this statement. For such a declaration published in the press I promised three years ago \$ 500 to Prof. Bergmann who made this statement in a letter to me. A year ago I announced the offer in the press (GEN. REL. GRAV., 2, 57 (1980)). However, Prof. Bergmann is enough clever not to make this declaration. Seeing that Cavalleri+Spinelli make such a declaration without any material losses for me, I can only be glad and I shall only beg Prof. van der Merwe to publish their paper.

Remark VIII. Cavalleri+Spinelli show doubts whether my experiment was technically enough good. I made many declarations (in letters and in the press) that I am ready to visit any scientific institution in any country and demonstrate the positive effects in my experiments. Such a declaration I sent to the Nobel Committee (see the ICSTA-1982 announcement which will be published on the 24 September 1981 in NATURE).

Remark IX. Cavalleri+Spinelli affirm (p.5) - and agree with this affirmation - that Duffy has shown that the positive effect in my "coupled-mirrors" experiment is in contrast with my own theory. I think that I know better my theory than Duffy and Cavalleri+Spinelli. To make such declaration is the same thing as to say that two and two are five. The positive result in the "coupled-mirrors" experiment contradicts neither the Mariovič transformation (where the anisotropy of light velocity appears explicitly) nor the Lorentz transformation (where the anisotropy of light velocity appears implicitly through the relativity of the time coordinates). Duffy (a prospective visitor of ICSTA-1977) simply sustains (as Prokhovnik) the opinion that there must be a "Lorentz twist". Cavalleri+Spinelli have, obviously, not read Duffy's paper (or read in a hate) and surely they have not read Prokhovnik's paper "The empty ghost..." published in FOUND. PHYS. and the discussion on this paper of Prokhovnik and Wesley. I think that if one writes on a topic which was largely discussed in the journal where the paper is submitted, one has to read the papers published on the topic in this journal. Otherwise the readers have the right to feel themselves offended.

Remark X. Some five years ago Prof. Cavalleri wrote me in a letter that if I really have measured the Earth's absolute velocity with my "coupled-mirrors" experiment, I shall receive the Nobel prize. The awardness of a Nobel prize is a delicate scientific and political problem. Let us leave this decision to the Nobel committee. However, I am very curious to hear which will be the sort of the theory of relativity if the effect in my experiment is indeed positive. And what changes must Cavalleri+Spinelli introduce in their conceptions if the experiment undoubtedly shows that I am right? If they should enumerate the changes which are to be introduced in space-time physics if the positive effect in my experiments will be accepted by the scientific community (over half a page) and include this text in their paper, I shall send to both of them \$ 500. Especially they have to say which will be the sort of the Lorentz transformation, of the Lorentz equation and of the Maxwell equations. I already gave answer to all these questions, but I should like to know the opinion of Cavalleri+Spinelli. Let me mention that when I asked Prof. Bergmann on the GR9 Conference to confirm before the auditory whether he sustains his opinion written in a letter to me that the "coupled-mirrors" experiment must give a null result, he spoke 10 minutes and said neither "yes" nor "no". When I insisted once more that he pronounces only one of the two words "yes" or "no", he spoke again five minutes without saying "yes" or "no". Then Prof. Schmutzer took the word and stated that my experiment for the measurement of the inertial velocity in a closed laboratory and my accelerated "coupled-mirrors" experiment (Eppur si muove) with which I made local distinction between a gravitational and kinematic acceleration (disproof of the principle of equivalence) are predictable and explainable by the theory of relativity.

Remark XI. Cavalleri+Spinelli mention only the names of Marinov, Vargas, Chang (p. 4) as people who have made experimental or theoretical attempts for a laboratory measurement of the absolute motion. I shall cite other authors who have written the following:

"If it were possible to measure with sufficient accuracy the velocity of light without returning the ray to its starting point, the problem of measuring the first power of the relative velocity of the Earth with respect to the aether would be solved. This may not be as hopeless as might appear at first sight, since the difficulties are entirely mechanical and may possibly be surmounted in the course of time."

The names of these authors are Michelson and Morley, the year of publication is 1887. This is the paper in which Michelson+Morley give their account on the historical experiment for measurement of the two-way light velocity where effects of second order in  $v/c$  will be registrable if  $v$  is of the order of 30 km/sec. The paper is published in two journals: THE PHILOSOPHICAL MAGAZINE and AMERICAN JOURNAL OF SCIENCE. After giving this general opinion, Michelson+Morley present the proposition of an experiment which is almost the same as my deviative "coupled-mirrors" experiment (Czech. J. Phys.). They use a bridge method with two selenium cells where the null instrument is a telephone (remember this method from the students' laboratories). If Prof. Cavalleri will send me a signed declaration that he has ever read the original communication of Michelson and Morley, I shall send him \$ 50. I must recognize that when I mastered my deviative "coupled-mirrors" experiment, I have not read this communication (both mentioned journals are not available in the Bulgarian libraries). For this reason I wrote in my paper in Czech. J. Phys. (1974):

"Thus we are surprised, indeed, that Michelson, the king of the exactitude, has not performed the "coupled-mirrors" experiment and has overseen its magnificent first-order in  $v/c$  possibilities" (p. 969).

As one sees, Michelson has not overseen these magnificent first-order in  $v/c$  possibilities, but Cavalleri+Spinelli don't see them even after the performance of the experiment. Scientists are very strange creatures, says the layman. May be, he is right. It remains, however, an enigma for me, why Michelson has not measured the one-way light velocity. The Michelson-Gale-Pearson experiment (1925) on the Sagnac effect over the Earth was one of the most costly experiments in the whole history of physics before WWII. We know that Michelson has lost the interest to this experiment, because it had not to give something important for science. Why then he has not used a fraction of the expended money to build the "coupled-mirrors" experiment! - When the American Academy of Sciences assigned \$ 1,500,000 for the erection of the Einstein monument in front of the Academy's building in Washington (a horrible sculpture against which was the predominant part of Washington's public opinion), I wrote to the President of the Academy (at that time I was in Washington) that if he will give me 1/100 part of the money, then before the monument should be erected, I shall demonstrate to him and to the Academy's staff the absolute motion of the Earth. To my very polite letter I received no answer.

Remark XII. Tangherlini has written the transformation only for the space and time coordinates (p. 5). He has not written the transformation formulas for the velocities. I did this and I show by experiments that these transformation formulas are adequate to physical reality. For this reason these transformations will enter in the history of physics under the name "Marinov transformations". (Read on this topic THE TEN JENA COMMANDMENTS - information where to find them is given in the ICSTA-1982 announcement).

Remark XIII. Cavalleri+Spinelli note as my merit the establishment of the fact that a light clock moving with a velocity  $v$  in a direction perpendicular to its "arm" has a time unit  $T = \gamma T_0$ , where  $T_0$  is the time unit when the clock is at rest in absolute space (p. 6). This is not my merit, as any school teacher explains this to the children and one could see this explanation even in a TV program in Switzerland dedicated to Einstein's 100 anniversary. My merit is that I showed this (INT. J. THEOR. PHYS. 1975) for any angle between the velocity of the clock and its "arm".

Remark XIV. §3 of the paper is dedicated to the problem of showing that if time is considered as relative, then light velocity must be considered as absolute. This problem is so elementary that must not be treated in FOUND. PHYS. Thus when one reads: "These simple considerations seem not yet been understood by Marinov and Var-

**THIS PAGE IS LOCKED TO FREE MEMBERS**  
Purchase full membership to immediately unlock this page

**FORGOTTEN BOOKS**

**FULL**

**MEMBERSHIP**

**797,885 Books!**

**All you can read**

**for only**

**\$8.99/month**

**Continue**

\*Fair usage policy applies



Stefan Marinov  
c/o Karl Mocnik  
Radegunderstr. 38  
A-8045 Graz

2 October 1981

Prof. F. T. Arecchi  
IL NUOVO CIMENTO  
Istituto Nazionale di Ottica  
Largo Enrico Fermi  
Firenze

Dear Prof. Arecchi,

In his letters of the 21 and 22 September, Prof. Cavalleri confirmed his firm decision against the publication of my paper "Elastic collisions of particles in absolute space" (submitted to you on the 13 March 1981) and of the paper "The laboratory motion of a charge in a uniform magnetic field" (submitted to Prof. Cavalleri on the 15 September 1981). The objections of Prof. Cavalleri are again completely irrelevant and he does not criticize a single topic of the matter presented in the submitted papers (as he has done in his first criticism). As a matter of fact, his letters again repeat for a hundredth time the (wrong!!!) assertion that the Marinov transformation is equivalent to special relativity. Prof. Cavalleri gives me only the following aut aut:

Consequently, you have to clearly choose: if you maintain the Tangherlini transformation, you have to accept S.R. and reject your experiment. (N.B. How an experiment can be rejected?! Even the Lord cannot do this. One can reject only theories. - S.M.) If you support the latter which, if true, should upset all the present physics (my italics - S.M.), you must reject the coordinate transformations you are using. (Why reject the transformation predicting the effect? - S.M.)

Concluding his letter of the 22 September, Prof. Cavalleri writes:

I think that Bergmann, Wheeler, Weber, Schmutzer, Bohm, Finkelstein, and others keep a strict and total silence not because they think that you are right but because they consider you as stubborn (stubborn are my experiments, not me - S.M.) and the dialogue with you is completely useless. Indeed, it is a question of simple logic and of pure mathematical derivation to show the equivalence of S.R. with the Tangherlini transformation. Any other long paper (those are the unique words dedicated to my paper which is under examination and for which one writes all these letters and loses precious time - S.M.) trying to confuse the matter and deceptively avoiding this basic problem is useless (this "deceptively" is exactly in the style of the writers in PRAVDA and LITERATURNIAIA GAZETA when they attack us, the dissidents, without giving us any possibility to expose our points of view - S.M.).

Dear Prof. Arecchi, I lost half a year with the submission of my paper in IL NUOVO CIMENTO. I begged you many times (even I came in March personally to you in Firenze, Prof. Borsellino phoned you a couple of times) to give me a final decision in May, later in the first days of June, so that in a case of a negative decision I can submit the paper to another journal. Now it is too late for submission to another journal and expose myself to the same ordeal. Thus I present the enclosed QUESTIONNAIRE. If my papers (both) will be not accepted for publication or if, in the case of rejection, this questionnaire will be not answered thoroughly by Prof. Cavalleri and signed, then on the 20 October I shall come to Florence and begin a hunger strike in front of the doors of your institute.

I must present this questionnaire to Prof. Cavalleri because in his "criticism" on the submitted papers he avoids any criticism as, obviously, he is unable (or afraid) to present a single critical remark. In the columns "yes", "no", and "I don't know" must be at least one cross to every question and not more than one cross.

Sincerely yours,

Stefan Marinov  
*S. Marinov.*

QUESTIONNAIRE

YES	NO	I DON'T KNOW
-----	----	--------------

1. If  $v$  is the velocity of a particle in absolute space measured in absolute time,  $v'$  its velocity in a frame moving with a velocity  $V$  in absolute space, both measured also in absolute time, then the relation between  $v$  and  $v'$  is the following (this is the Marinov velocity transformation)

$$\vec{v}' = \vec{v} + \left[ \left( (1 - v^2/c^2)^{-1/2} - 1 \right) \frac{\vec{v} \cdot \vec{V}}{V^2} - (1 - v^2/c^2)^{-1/2} \right] \vec{V}. \quad (1)$$

For a one-dimensional case one has

$$v' = \frac{v - V}{(1 - v^2/c^2)^{1/2}}. \quad (2)$$

Are these formulas good (yes) or bad (no)?.....

2. If  $v = c$ , one obtains from formula (1) for the light velocity in the moving frame,  $v' = c'$ , the following expression

$$c' = c \frac{1 - V \cos \theta / c}{(1 - v^2/c^2)^{1/2}} = c \frac{(1 - v^2/c^2)^{1/2}}{1 + V \cos \theta' / c}, \quad (3)$$

where  $\theta$  is the angle between  $\vec{v}$  and  $\vec{V}$  and  $\theta'$  is the angle between  $\vec{v}'$  and  $\vec{V}$ . For a one-dimensional case one has

$$c' = c \left( \frac{1 - V/c}{1 + V/c} \right)^{1/2}. \quad (4)$$

Are these formulas good (yes) or bad (no)?.....

3. Prof. Cavalleri writes that to perform a differentiation in order to obtain the velocity transformation is a simple exercise for students. I beg him to write his formulas corresponding to my formulas (1) - (4), if he considers them as bad, i.e. I beg him to write the "Tangherlini velocity transformation", as I have never seen it:  $x' = \gamma(x - Vt)$  ;  $t' = \gamma^{-1}t$  ;

$$v' = \frac{dx'}{dt'} = \frac{\gamma(dx - V dt)}{\gamma^{-1} dt} = \gamma^2 \left( \frac{dx}{dt} - V \right) = \frac{v - V}{1 - v^2/c^2} \quad (1')$$

$$\text{your eq. (2) } \gamma \text{ appears instead of } \gamma^2. \quad (2')$$

4. The velocity transformation formulas following from the Lorentz coordinate transformation (one calls them, strangely enough, Einstein transformation formulas for velocities, although it is a simple exercise for students, etc) are the following (for simplicity's sake I give only the one-dimensional case)

$$v' = \frac{v - V}{1 - vV/c^2}. \quad (3')$$

If  $v = c$ , one obtains for the light velocity in the moving frame,  $v' = c'$ , the following expression

$$c' = c. \quad (4')$$

Are these formulas good (yes) or bad (no)?..... X





**THIS PAGE IS LOCKED TO FREE MEMBERS**

Purchase full membership to immediately unlock this page

**SAVE \$3,999,994**

Did you know we sell  
paperback books too?

To buy our entire catalog  
in paperback would cost  
over \$4,000,000

Access it all now for  
\$8.99/month

\*Fair usage policy applies

**Continue**

YES NO I DON'T KNOW

22. Can we consider the laboratory in its diurnal rotation as a rotating disk? Michelson, Gale, Pearson (1925) and Werner et al. have shown that we can and we must, but I wish that Prof. Cavalleris gives a clear answer to this question.....

X *the Earth h  
not a <sup>rotation</sup> period  
equal to one  
year but one  
day*

23. If question 22 is answered positively, can we consider the laboratory in its yearly revolution about the Sun as a rotating disk?..

X

24. If question 23 is answered positively, can we consider the laboratory in its revolution about the center of the galaxy (one rotation in 200,000,000 years) as a rotating disk?.....

X *For meassur  
the Sagnac  
effect due  
to the  
revolution  
around the  
sun or the  
centre of the Galax*

25. If question 24 is answered positively, can and must one affirm that the velocity of any particle (photon, neutron) in the laboratory is direction dependent and depends on the resulting velocity of all rotations in which the laboratory takes part?.....

X *we should need a  
rigid disk of the  
size with mirrors  
it*

26. I call this resultant velocity "absolute velocity" of the laboratory. According to Prof. Cavalleri is this term good (yes) or bad (no)?.....

27. I showed that the Michelson experiment with neutrons must give a null result. Is my demonstration good (yes) or bad (no)?.....

28. The velocity of light in a medium moving with a velocity V measured by an observer at rest is given by the formula (so-called Fresnel's or Fizeau's formula)

$$v = \frac{c}{n} + V(1 - \frac{1}{n^2})\cos\theta, \quad (11)$$

where  $\theta$  is the angle between the velocity of light propagation and the velocity of the medium. Is this formula good (yes) or bad (no)?..

X *they  
to two  
synchroni*

29. I showed that the velocity of light in a medium at rest measured by a moving observer is

$$v^0 = \frac{c}{n} - V\cos\theta, \quad (12)$$

where  $\theta$  is the angle between the velocity of the observer and the velocity of light propagation. Is this formula good (yes) or bad (no)?.....

X *they must be di  
since this correspo  
to different  
synchronizations*

30. If question 29 is answered negatively, please write the right formula for the case considered:  
.....

31. If question 29 is answered positively, is there an asymmetry between formulas (11) and (12)?.....

32. Is the theorem on the rotating disk (p. 15 of "Elastic collisions....") logically resolved?.....

33. I show that if there is a charge q, an electric field E', and a magnetic field B', as measured in a laboratory moving with a velocity V in absolute space, then the equation of motion of the charge (the so-called relative Lorentz equation) is

$$\frac{d}{dt} \frac{m(\vec{v}' + \vec{V})}{\{1 - (\vec{v}' + \vec{V})^2/c^2\}^{1/2}} = \frac{q}{c} \left\{ \left(1 - \frac{\vec{v}' \cdot \vec{V}}{c^2}\right) c\vec{E}' + \vec{v}' \times \vec{B}' \right\}. \quad (13)$$

Is this formula good (yes) or bad (no)?.....

X *with  $\epsilon = 0$   
(absolute  
synchronizations*

	YES	NO	I DON'T KNOW
34. If question 33 is answered negatively, please, write the right formula for the case considered: .....			
35. If question 33 is answered positively, have I presented in §13 of "Elastic collisions..." an experimental confirmation of formula (13)?.....			
36. Have I rightly explained the motion of a charge in a uniform magnetic field in a laboratory moving in absolute space (in the paper "The laboratory motion...")?.....		X	
37. I affirm that the particles revolving in circular accelerators have different velocities along different points of their orbits, because of the absolute motion of the laboratory. Does Prof. Cavalleri agree with this conclusion, following from the relative Lorentz equation?.....	$\Sigma=0$ ↓ X	$\Sigma \neq 0$ ↓ X	
38. Prof. Cavalleri wrote to me (see his letter of the 21 Sept.): About knowledge and research truth is the fundamental value and we cannot accept papers which are (the word deleted -S.M.) to be wrong by us and which should <u>irremediably</u> damage (my italics - S.M.) the reputation of <u>Nuovo Cimento</u> .  When Mr. Al. Haig was in Berlin and saw the indignant masses of young Germans who demonstrated outrageously against the new arms race started by Washington, he said: These poor young men do not realize that with their demonstrations they help the covered Soviet imperialism. Their demonstrations damage heavily the defence potential of the free countries. But I am for democracy and I can only repeat the words of Voltaire: "I strongly disagree with your opinion, this is a dangerous and nuisible opinion. But I shall stand to death for your right to say this opinion freely."  Does Prof. Cavalleri considers Haig's (and Voltaire's) standpoint as a good one (yes) or as a bad one (no)?.....			<p>Because in a laboratory you have intrinsically + Einstein synchronization</p> <p>For political opinions Yes</p> <p>For scientific truth No</p>

Date:

Signature:

Prof. G. Cavalleri

- Editorial note. 1. The paper "Elastic collisions of particles in absolute space" is presented in CLASSICAL PHYSICS, vol. III, §44.  
2. The paper "The laboratory motion of a charge in a uniform magnetic field" is presented in CLASSICAL PHYSICS, vol. V, §36C.

Editorial note to the second edition. The paper "The laboratory motion of a charge in a uniform magnetic field" was published in THE TOTH-MAATIAN REVIEW (Lubbock, Texas), 3, 1033 (1984).

Stefan Marinov  
c/o Karl Mocnik  
Radegunderstr. 38  
A-8045 Graz

Prof. G. Cavalleri  
CISE  
Casella postale 12081  
I-20100 Milano

2 October 1981

My dear Giancarlo,

Thank you very much for your letters of the 21 and 22 September. My friend Karl Mocnik found them in an envelope addressed to him and he assumes that you have forgotten to write my name as the addressee. Thus he still awaits an answer from you on his last letter and the decision of the editor concerning the acceptance or rejection of his paper.

See attached my letter to Prof. Arecchi and the original of the QUESTIONNAIRE which is for you (the copy which is not so good is sent to Prof. Arecchi, as I hope that after answering the questionnaire you will send a photocopy of it to Prof. Arecchi).

As my questionnaire is very long, here only a short answer to your letters.

The letter of the 21 September.

1. I am very glad that you declare yourself and Spinelli absolute absolutists. I hope that you both will take part in ICSTA. I attach the announcement which has already appeared in NATURE.

2. You say that you, Spinelli, Duffy, Sjödin, Mansouri, and Sexl know better the connection between my experiments and the Marinov transformation (the connection with the experiments must be made with the formulas for velocities transformation which, unfortunately, Tangherlini has not written). I prefer to hear the opinion of the experiments and not the opinions of men. The experiment shows better who knows better the connection between theory and experiments, because, obviously, this one who gives the right prediction understands the theory better.

3. After my visit to you in 1977, we had no more contact (until your criticism on the "Elastic collisions..."). As the paper of Mansouri and Sexl appeared (or came to our knowledge) after our meeting, you physically could not give me a suggestion to present a criticism to this paper.

4. The paper of Mansouri and Sexl is bad. Nevertheless, I repeat that it is much better than many other papers written by relative and absolute relativists. I shall criticize it only if you will promise me to suggest the publication in N.C. Otherwise I have no time to lose. I cannot submit this criticism to GEN. REL. GRAV. as Dr. Held wrote me a year ago: "After the publication of your NOTE ADDED IN PROOF to your paper in vol 12, p. 57 (1980), please, do not submit more papers to this journal." As you know well in the NOTE ADDED IN PROOF I tried to open Bergmann's mouth with \$ 500.

5. I have systematically not what to eat since 4 years, as 4 years I am without a firm job. Nevertheless during this time I published 3 books, many papers, I carried out costly experiments (costly for my pocket), visited all important space-time conferences and performed many trips in East, West Europe and USA. Now, absolutely alone, I am organizing an international conference. I am systematically hungry, but I do the job. If I have paid more than \$ 1000 for one page in NATURE, I can pay \$ 70 for 10 pages in N.C. (The last page tax of N.C. about which I have information was \$ 7 for a page). However, let me mention that Prof. Borsellino promised me to intervene, so that my paper should be published without payment. At any rate the Physical Institute in Genoa will pay the tax, as already it has paid two of my very costly papers. Thus, be not concerned about the money which I shall pay for a paper. If it is necessary, I shall steel, but the paper will be paid. I promised to pay you \$ 500 if you will appear with a strongly negative paper against my paper "Elastic collisions..." in N.C. If you have doubts in my financial possibilities, I can prepay the sum. But you will not appear with a negative criticism. You are afraid to do this. Let me mention that when I sent

**THIS PAGE IS LOCKED TO FREE MEMBERS**  
Purchase full membership to immediately unlock this page

**FORGOTTEN BOOKS**

**FULL**

**MEMBERSHIP**

**797,885 Books!**

**All you can read  
for only**

**\$8.99/month**

**Continue**

\*Fair usage policy applies



Stefan Marinov  
c/o Bruno Sperl  
Niederschöcklstr. 62  
A-8044 Weinitzen

Prof. G. Cavalleri  
CISE  
Casella postale 12081  
I-20100 Milano

18 November 1981

My dear Giancarlo,

Thank you very much for your preprints which have been resent to me from Genoa. I received also the QUESTIONNAIRE and I thank you indeed for all "crosses". I was delighted to read it. Now I do not give you more than 6 months until you will accept the failure of relativity. Believe me, Bergmann, Wheeler, Schmutzer, de Sabbata have already accepted this failure. You are one of the last mohicans.

Only a couple of words to your answers, as neither I nor you have time for long discussions. Now the lengthy discussions only in the press. Die Zeit für Liebesbriefe ist schon längst vorbei.

1, 2, 3. I write the velocity transformation formulas in absolute time, you write them in proper time. Thus I write the formulas which correspond to formula (29) in S. Marinov, Found. Phys., 9, 445 (1979), while you write the formulas corresponding to formula (30) in that paper. But in my question 1 I write clearly: "If  $v$  is the velocity of a particle in absolute space measured in ABSOLUTE TIME,  $v'$  its velocity in a frame moving with a velocity  $V$  in absolute space, both measured also in ABSOLUTE TIME." Dear Giancarlo, one must read before criticizing. When I write, I am extremely clear and exact, because I manipulate with simple and CHILDISH conceptions, so that I can always give the necessary exact and full information.

5. If you agree that there is a difference between the Marinov and Einstein velocity addition formulas, then which is the true one? They cannot be true together. Leave all these "synchronization procederes, epsylons, and similar rubbish". When a particle moves in a certain frame, it moves with a certain velocity and does not care a damn fuck about "synchronizations". Understand this, Giancarlo, I beg you in the name of our Lord.

6. Why my deduction (to divide by absolute, i.e., universal, time) is bad, if I obtain the right formulas which explain all phenomena. The student Einstein had once divided by the relative time, and now 100 years we have to repeat his student's error. During 100 years no single professor has corrected the error of a student. Why one is not permitted to divide by absolute time? Why? Why? May be Stalin has ordered to divide always by relative time?

7.8. You must answer by cross, not by words. I agree that one can make synchronization sending snails from one space point to another, but I ask whether one is able to synchronize two events at a single moment (this is the very synchronization), and you have to put a cross, nothing more than a cross - yes or no.

9. You say that one cannot synchronize with a rotating axle. But I have done it. Excuse me. "Herr Professor, sagte jemand zu Hegel. Die Fakten, aber, widersprechen Ihre Theorie." "Desto schlimmer für die Fakten, antwortete Hegel."

10. I shall be extremely glad if you would be able to show by calculations, that one is unable to make a Newtonian time synchronization by the help of light signals as proposed by me in Phys. Lett., 81A, 252 (1981). One is on the rotating disk, velocity of light is direction dependent. Please, show that the synchronization is not Newtonian. You can't, dear Giancarlo. You can't. There is no axle, there are no Lorentz contractions, twists (please, note that the term is introduced by me, not by the relativists, but the whole this company has embraced this MARINOV'S TERM. Is it not funny? And you assert that even if there is no axle, still there is a twist, i.e., the vacuum has a twist. Excuse me, but this stupidity is not introduced by me, this is yours.)

13. As I see you are not curious to see my experiments. May be you are right. Certain people treat curiosity as a sign of bad education.

18.

16. 17. My formula  $v' = \frac{c}{n} - \frac{V}{n^2} \cos \theta$  is not good, affirm you, but it explains well Harress-Sagnac, Werner's,  $n^2$  etc. experiments, affirm you, too. Das ist die grosse Kunst - with wrong formulas to make right explanations. But, please, explain Werner's experiment with your "naive" formula  $v' = c/n$ . If you should be able, not \$ 1000, but \$ 10,000 shall I pay you. It is strange, indeed, that the right formula cannot give the right explanation. With your formula, Giancarlo, there will be no Sagnac effect for neutrons, no, but the effect is there. "Desto schlimmer für den Effekt" will you say, may be.

19. Formulas (8) and (9) are valid not only when the center of rotation is encircled by the path of the particles. The center may be outside, the importance is that  $V$  must be the linear velocity of the disk's points with respect to absolute space. When Michelson and Gale (or Werner) made their experiments, the center of rotation was at the pole, but the effect was there and could be calculated both with formulas (8) and (9).

20. Very good answer.

21. Also another very good answer.

22. A perfect answer. Go on, go on.

23. My dear, Giancarlo, why you do not continue? If the Earth is connected with long steel bars with the Sun, it will be a rotating disk, and a Sagnac effect will be there. Put out the bars; you assert, there is no Sagnac effect. How the existence of rigid connection can influence the Sagnac effect? Please, consider the Earth, as the Moon, always having the same face to the Sun. Will be or will be not a Sagnac effect? Michelson, not better Werner, has measured the Earth's daily rotational velocity over an area of  $9 \text{ cm}^2$ , nine square centimeters, no more. Why have I to make an interferometer of the size of the Earth's orbit if I wish to measure the rotation about the Sun?

28. 29. I pose simple questions, and you always insert these different types of synchronization. "If you wish to be learned and wise, synchronize, synchronize."

33. I am curious to see that you accept my "relative Lorentz equation". All right, you attach again your tiny epsilon, but you agree that this equation is good.

35. H-m-m-m. The formula was good, but the explanation is not accepted by you. I understand, for you it is difficult to accept that the photons move with different velocities in the laboratory, and now this terrible Marinov asserts that also the electrons in an accelerator move with different velocities along different point of their orbit. I agree, it is too much for you to accept that also the electrons have direction dependent velocities. Now in a paper which will soon appear in FOUND. PHYS. I show that even the propagation of sound is direction dependent. It's too much for you, I understand. But take into account that even when you play ball with your child, then the ball has a different velocity from you to the child and from the child to you, because you both move in absolute space. Terrible Marinov, terrible.

38. People create political and religious ideas, people create scientific ideas. People are erroneous. The religious and scientific ideas which they propose may be good or bad. Only the free discussion can reveal the good ideas in religion and the true ideas in science. Read on this topic my speech on the First world congress on science and religion (Rome, June 1979), entitled "The epoch of Galileo and the epoch of John Paul the Second". If you are interested, I shall send you a copy.

Conclusion. Earn now the \$ 1000 with a strongly negative article. Such a strongly negative article is extremely important for the success of my congress, and may be for my Nobel prize. Thus I beg you, take the money, take the money Giancarlo. If you wish, I shall bring them personally to your wife.

Yours: *Stefan* S. Marinov



Stefan Marinov  
c/o Bruno Sperl  
Niederschöcklstr. 62  
A-8044 Graz  
18 November 1981

Prof. F. T. Arecchi  
IL NUOVO CIMENTO  
Istituto Nazionale di Ottica  
Largo E. Fermi, 6  
I-50125 Firenze

Dear Prof. Arecchi:

I received the QUESTIONNAIRE sent to you and to Prof. Cavalleri on the 2 October. Although the questionnaire is not signed and not all questions are answered with one and only one cross, it satisfies me completely. I send you a copy, so that you can also have the pleasure to read it. Thus, I shall not come to make hunger strike in front of your institute.

I am awaiting now for your decision about the acceptance or rejection of both submitted papers:

1. Elastic collisions of particles in absolute space (submitted to you on the 13 March).
2. The laboratory motion of a charge in a uniform magnetic field (submitted to Prof. Cavalleri on the 15 September).

My friend Karl Mocnik awaits also for the decision on his paper "Measurement of the Earth's absolute velocity with a rotating Mach-Zehnder interferometer".

I think that after such a long time, a decision finally must be made. The publication of my papers many months before the meeting of the INT. CONF. SP.-TIME ABS.(ICSTA) - see the attached announcement, is extremely important and to a certain extent decisive for the success of the conference. If the papers will be not accepted now by your journal, I am afraid there is no time to submit them to another journal, so that they can appear before ICSTA. Thus the long examination of my paper will directly undermine my conference. I hope that you will have understanding for my preoccupations.

As Prof. Cavalleri still rejects thoroughly my theory, formulas, and experimental results, I declare solemnly before your authority: I am ready to pay \$ 1000, if Prof. Cavalleri will appear with a strongly negative paper in the next issue of IL NUOVO CIMENTO, after the issue in which my two papers will be published and so that his paper will be published no later than in March 1982. I am ready to deposit the money on your bank account immediately. You must be the arbitrator, deciding that Cavalleri's paper is, indeed, strongly negative. If my papers will be rejected, I must confess, dear Prof. Arecchi, that you will blame the motto of N.C. "provare e riprovare". If after the appearance of my papers, Prof. Cavalleri will not dare to criticize them, this signifies that he accepts an unconditional capitulation.

I hope that you will pay a due attention to this letter.

Please, write me on the address in this letter.

I attach the announcement of ICSTA.

Sincerely yours,

*S. Marinov*  
Stefan Marinov

**THIS PAGE IS LOCKED TO FREE MEMBERS**

Purchase full membership to immediately unlock this page

**SAVE \$3,999,994**

Did you know we sell  
paperback books too?

To buy our entire catalog  
in paperback would cost  
over \$4,000,000

Access it all now for  
\$8.99/month

\*Fair usage policy applies

**Continue**

# FOUNDATIONS OF PHYSICS

An International Journal Devoted to the Conceptual Bases and Fundamental Theories of  
Modern Physics, Biophysics, and Cosmology

---

Published by Plenum Publishing Corporation, 233 Spring Street, New York, N.Y. 10013

---

Editor: ALWYN VAN DER MERWE  
Department of Physics  
University of Denver  
Denver, Colorado 80208  
United States of America

## TO WHOM IT MAY CONCERN

I feel the Marinov experiment should be repeated because:

First, Marinov's reported result in which he "measured the absolute velocity of the closed laboratory" appears to make the special theory of relativity untenable. The special theory of relativity has been regarded by most physicists as a corner stone of modern physics; so that one needs to examine very carefully any such reported experimental evidence that would negate special relativity. Because of the importance of the matter, a repetition of the Marinov experiment is to be strongly recommended. It makes no difference whether the results turn out positive or null, the outcome will still be of value.

Second, quite apart from special relativity, it is important to know whether or not the velocity of light is actually fixed in an "absolute space." This information would appear to be very significant when attempting to locate the precise positions of missiles or satellites in space.

Third, if a positive result were to be obtained to the accuracy hoped for in the Wesley proposal, it would, in fact, provide an interesting and important astronomical observation. The velocity of the solar system with respect to the 3°K thermal cosmic background is only roughly known.

Although I have not examined all of the details of the Wesley proposal; it appears that he has expended considerable effort in the matter. From his resume, as well as his proposal, I would judge him to be thoroughly competent to repeat the Marinov experiment. I hope that his experimental setup will be made available to others who can carry out observations in order to remove any further question in the matter.

While the Appendix of the Wesley proposal and his past contributions to the pages of Foundations of Physics testify to the breadth of his knowledge in space-time physics and the originality of his thinking, I do not necessarily share his view. However, the important point is to have the Marinov experiment repeated quite independent of what one's individual beliefs might be. From the standpoint of an editor such as myself, who regularly receives papers arguing for and against Marinov's theory, a definitive experiment such as Dr. Wesley's, settling the matter one way or another, is devoutly to be hoped for.

Alwyn van der Merwe  
Professor of Physics

March 25, 1982

Dr. Harold Davis  
PHYSICS TODAY  
335 East 45th Street  
New York  
NY 10017

s,

LETTER TO THE EDITOR entitled

IS OUR SPACE-TIME NEWTONIAN,

publish it as soon as possible. I attach a copy of the letter of Mr. June 1981 and I hope that this letter will be published.

the acknowledgement for reception of my LETTER TO THE EDITOR entitled 'IL' WORK. Will you publish this letter? Such a brilliantly written you declined it? Why? In the meantime you published another letter of you give place in PHYSICS TODAY to scientists who must be judged by courts as criminals against mankind and you do not give space to scientists fight against the demon of totalitarianism for freedom and peace?

In his letter (the last) Dr. Stumpff writes: "I am not stupid." --- Dear does not write in a paper "I am not stupid", one shows in a paper that I really do not understand your editorial policy: To reject my letter to print such low philological stuff.

ears you rejected to give space to my contributions to PHYSICS TODAY. I hope that the present letter will be published. And I insist for the publication of SCIENTISTS IN DEVIL'S WORK. If you will not publish SCIENTISTS IN DEVIL'S WORK, in the name of God, I beg you to write me: WHY?

our Conference Schedule will announce the meeting of ICSTA.

Sincerely yours,  
Stefan Marinov

In his letter of the 9 June 1981 Mr. Greely, the Advertising Editor of PHYSICS TODAY suggested that Marinov presents the matter of the advertisement INTERNATIONAL CONFERENCE ON SPACE-TIME ABSOLUTENESS as a LETTER TO THE EDITOR.

JM/MS  
27 May 1982

Dr Stefan Marinov  
Est-Ovest  
Via Puggia 47/1  
16131 Genova

Dear Dr Marinov:

Thank you for your letter and for sending us a set of your monumental work, Classical Physics. I am afraid I cannot, however, agree to join with you in the fight for the restoration of absolute space-time because I think your cause is wrong. Indeed, I am sorry to see that the five volumes that you have sent, which are full of good sensible physics and mathematics, are marr~~y~~ed by your advocacy of this lost cause.

If you wish, I will ask somebody to review your books, but I should explain that it may be difficult to find somebody willing to take on the job. Perhaps you would let me know what you would like me to do. If you wish I will return the volumes.

Yours sincerely,



John Maddox  
Editor

**THIS PAGE IS LOCKED TO FREE MEMBERS**  
Purchase full membership to immediately unlock this page

**FORGOTTEN BOOKS**

# **FULL MEMBERSHIP**

**797,885 Books!**  
**All you can read**  
**for only**  
**\$8.99/month**

**Continue**

\*Fair usage policy applies



**IL NUOVO CIMENTO**

REDAZIONE

li 30 June 1982

Via L. degli Andalò, 9 - 40124 BOLOGNA (Italy)  
Tel. ~~051~~ 83.15.54

Dr. Stefan Marinov  
 Est-Ovest Editrice Internazionale  
 Via Puggia, 47/1  
 16131 GENOVA GE

---

Dear Doctor Marinov.

herewith we are returning your papers "How to measure the earth's absolute velocity ....." and "The Michelson experiment with neutrons ....." . This decision has been taken in full agreement with Prof. Bertotti.

As stated in my letter of July 30, 1980, we will return without examination any paper you will submit to our journal.

This is because we don't recognize any scientific value to your papers. Moreover, your appreciations about the correctness and the competence of our vice-Directors and referees are completely out of place.

Sincerely yours,

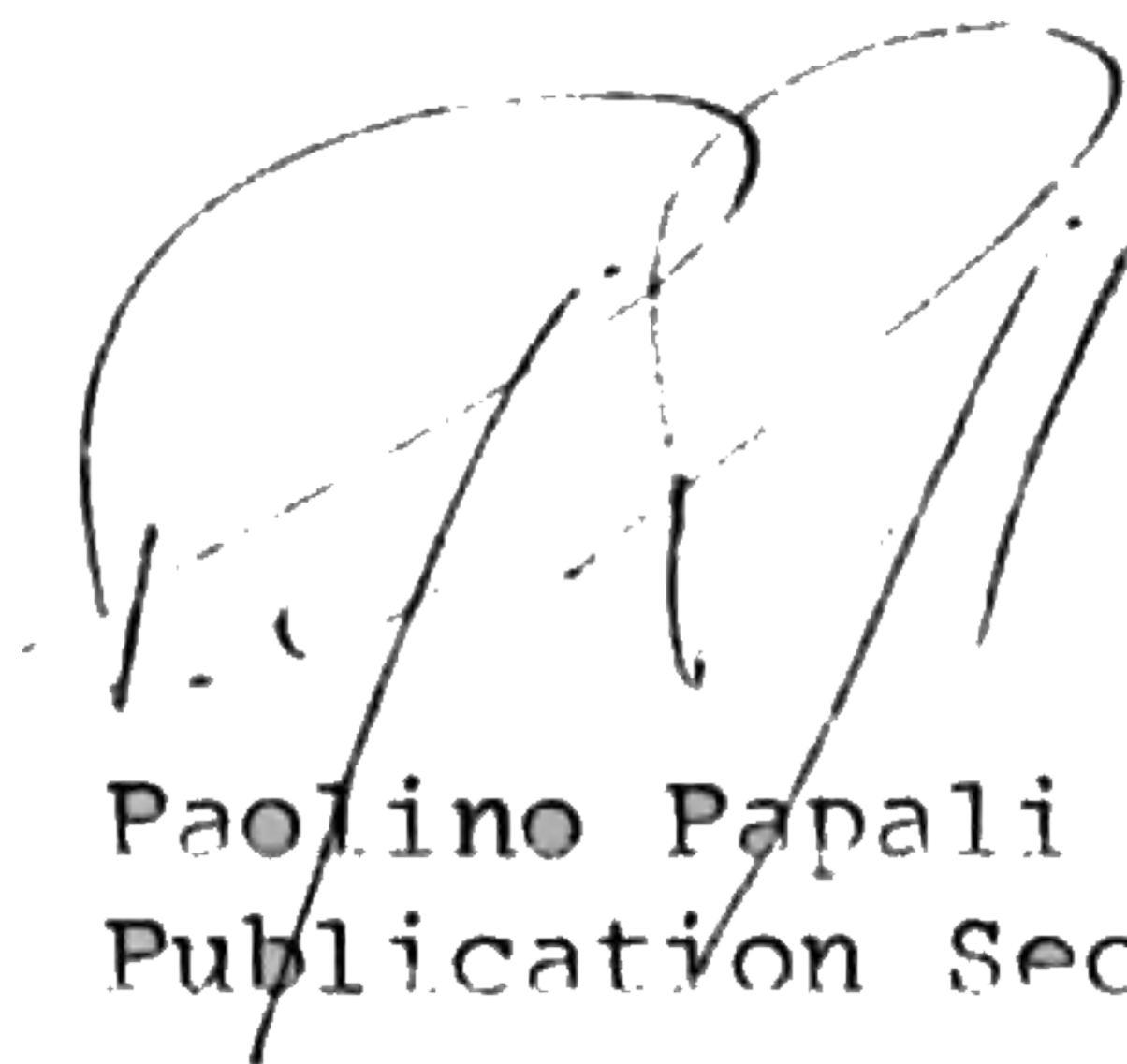

Paolino Papali  
 Publication Secretary

Editorial note. The titles of the rejected papers are written by Dr. Papali wrongly. The papers "How to measure the Earth's absolute velocity..." and "The Michelson experiment with neutrons..." were rejected by the general letter of IL NUOVO CIMENTO of 30 July 1980 (see p.164). With the present letter IL NUOVO CIMENTO has rejected the papers "Elastic collisions of particles in absolute space (CLASSICAL PHYSICS, vol. III, §44) and "The laboratory motion of a charge in a uniform magnetic field (CLASSICAL PHYSICS, vol. V, §36C). The lengthy correspondence on these two papers see on pp. 223-225 and 234-244.

# ature

Macmillan Journals Ltd  
4 Little Essex Street  
London WC2R 3LF  
Telephone 01-836 6633  
Telex 262024  
Advertising 01-240 2044

Dr Stefan Marinov  
Est-Ovest  
Via Puggia 47/1  
16131 Genova  
Italy

6th July 1982

Dear Dr Marinov

Thank you for sending the five volumes of your work, Classical Physics, to Nature for consideration for review.

Mr Maddox and I have discussed the books, and he made a number of suggestions of potential reviewers that I might approach. However I am sorry to say that after spending a considerable amount of time in trying to find an appropriate person I have been unable to persuade anyone to take on the job.

As you requested I am therefore returning the books. I hope they receive a critical appraisal in some other journal.

Yours sincerely

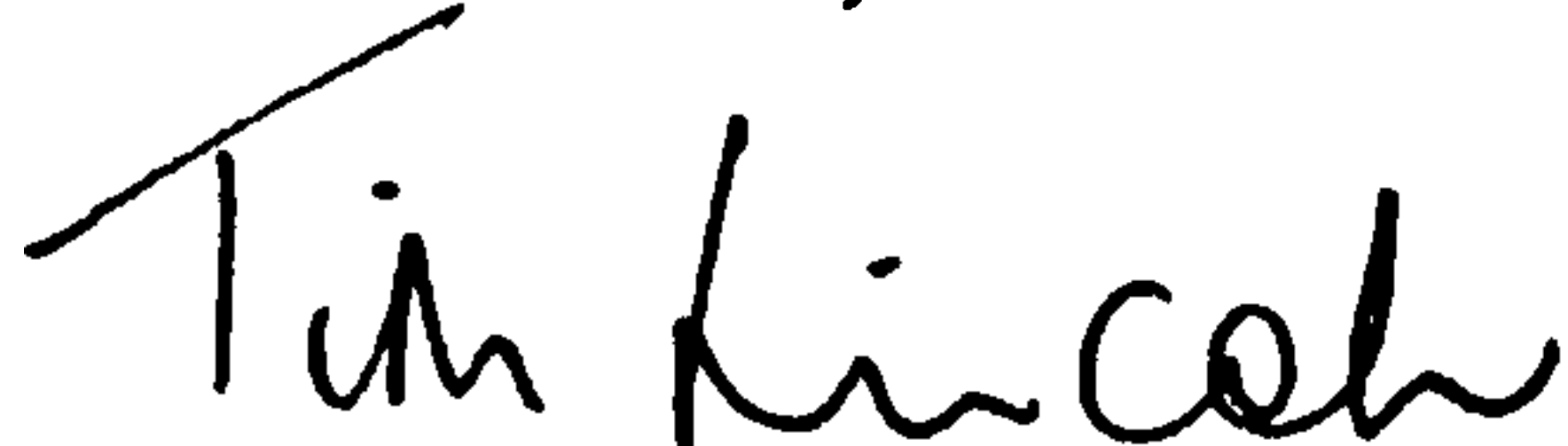

Tim Lincoln  
Book Review Editor



Stefan Marinov  
Niederschöcklstr. 62  
A-8044 Graz

23 July 1982  
(the letter is sent  
from Genoa)

3rd Marcel Grossmann Meeting  
Int. Center for Theor. Phys.  
P.O.B. 586  
Miramare  
I-34100 Trieste

Dear Sirs,

I send you the copy of the letter which I sent you on the 8 June. Until now I have not your answer whether my participation is accepted and I have not received detailed information about the organization of my trip. As there is only a month until the opening of the conference, I beg you to inform me by an express letter whether my participation is accepted and to send me all necessary information. I shall fly from Vienna and after the conference I shall make a visit to my brother in Sydney.

If my participation is not accepted, I beg you for a written information.

Looking forward for your express answer,

Sincerely yours,  
Stefan Marinov

Editorial note. With his letter of the 8 June 1982 Marinov applied for taking part at the 3rd Marcel Grossmann Meeting in Shanghai. Both letters of Marinov remained unanswered.

Marinov has taken part in the 2nd Marcel Grossmann Meeting (Trieste, July 1979), giving a speech. The contribution of Marinov to the Proceedings of the Meeting were accepted personally by Prof. Ruffini in Trieste, but to the at least 8 letters which Marinov wrote to Prof. Ruffini he received neither a single answer whether his contribution will be included in the Proceedings.

Editorial note to the second edition. Marinov's contribution to the 2nd Marcel Grossman Meeting was published in the PROCEEDINGS OF THE SECOND MARCEL GROSSMANN MEETING ON GENERAL LATIVITY (North-Holland Publ. Co., 1982), p. 547.

**THIS PAGE IS LOCKED TO FREE MEMBERS**

Purchase full membership to immediately unlock this page

**SAVE \$3,999,994**

Did you know we sell  
paperback books too?

To buy our entire catalog  
in paperback would cost  
over \$4,000,000

Access it all now for  
\$8.99/month

\*Fair usage policy applies

**Continue**

# newscientist

Commonwealth House, 1-19 New Oxford Street, London WC1 ING  
Telex: 9157 48 MAGDIV G  
Switchboard: 01-404 0700

16th August 1982

Stefan Marinov,  
Niederschöcklstr. 62,  
A-8044 Graz.

Dear Mr Marinov,

It is not, I'm afraid, possible to return books sent to us for review.

Yours sincerely,



Michael Kenward  
Editor

ACTA PHYSICA HUNGARICA  
DEPARTMENT OF ATOMIC PHYSICS  
BUDAPEST POLYTECHNICAL UNIVERSITY  
BUDAPEST  
BUDAFOKI ÚT 8. HUNGARY  
H-1521

*Budapest, 7th September, 1982.*

Stefan Marinov  
Via Puggia 47,  
16131 Genova, Italy

Dear Dr Marinov,

I am returning herewith your paper on "Kinematic Time Dilation", which, according to our Referee's opinion, is not acceptable for Acta Physica. Regarding the future, please note that we cannot consider articles of this type for publication.

Yours sincerely

*I. Kovács*

I. Kovács

Editor

Encl. 21 pages

3 figures

Bezirkshauptmannschaft Graz-Umgebung

Graz, am 21.9.1982.....

Zahl: 2/I M 172 - 1982

B E S C H E I D

über die Erlassung eines Aufenthaltsverbotes

Die Bezirkshauptmannschaft Graz-Umgebung erläßt gegen Herrn -  
Frau (Name, Geburtsdatum, Anschrift) MARINOV Stefan, geb. 1.2.1931 in Sofia  
bulgar. Staatsangehöriger, wh. in 8044 Weinitzen, Niederschöcklstr. 62.

gem. § 3(1) (2) lit. (a) u. (e) in Verbindung mit § 4 des  
Bundesgesetzes vom 17. März 1954, BGBl. 75/1954 (Fremdenpolizeigesetz)  
ein unbefristetes \*

~~bis/zum~~ //////////////////// ~~befristetes\*~~  
das Bundesgebiet Österreich\*

} Aufenthaltsverbot für

Das Aufenthaltsverbot wird gem. § 3 Abs. 3 des Fremdenpolizeige-  
setzes auch auf den (die)\* Ehegatten(in) //////  
//// und die minderjährigen Kinder ////

////  
///  
///

ausgedehnt.

Gem. § 6 (1) des Fremdenpolizeigesetzes ist das Gebiet, für das  
das Aufenthaltsverbot erlassen wurde, innerhalb einer Frist  
von einer Woche nach Rechtskraft des Bescheides bei sonstiger An-  
wendung von Zwangsmaßnahmen gem. § 5 (1) des Fremdenpolizeigesetzes zu  
verlassen.\*

Einer allfälligen Berufung wird gem. § 64 Abs. 2 AVG. 1950 die auf-  
schiebende Wirkung aberkannt.\*

Gem. § 12 des Fremdenpolizeigesetzes sind die Kosten, die bei der  
Durchführung des Aufenthaltsverbotes entstehen, von den Genannten zu  
tragen.

B e g r ü n d u n g:

M A R I N O V Stefan, geb. am 1.2.1931 in Sofia, ist F r e m d  
im Sinne des § 1 Fremdenpolizeigesetzes, da er die österr. Staatsbür-  
gerschaft nicht besitzt.

Gemäß § 3 (1) u. (2) a u. e des Fremdenpolizeigesetzes BGBl. Nr.  
75/1954 kann gegen Fremde deren Aufenthalt im Bundesgebiet die öffent-  
liche Ruhe, Ordnung oder Sicherheit gefährdet oder anderen öffentlichen In-  
teressen zuwiderläuft, bzw. die den Besitz oder redlichen Erwerb ihrer  
Unterhaltungsmittel nicht nachzuweisen vermögen, ein Aufenthaltsverbot  
erlassen werden.

Genannter ist nicht in der Lage den Besitz oder redlichen Er-  
werb seiner Unterhaltungsmittel nachzuweisen. Er ist weder kranken- noch  
sozialversichert und als völlig mittellos zu betrachten. Des weiteren  
wurde G. n. wegen Übertretung des Faß u. Fremdenpolizeigesetzes zu je  
1000.- S rechtskräftig bestraft.  
\* Nichtzutreffendes streichen.

**THIS PAGE IS LOCKED TO FREE MEMBERS**  
Purchase full membership to immediately unlock this page

**FORGOTTEN BOOKS**

# **FULL MEMBERSHIP**

**797,885 Books!**  
**All you can read**  
**for only**  
**\$8.99/month**

**Continue**

\*Fair usage policy applies



**ПИСЬМО СТЕФАНА МАРИНОВА  
ПРЕДСЕДАТЕЛЮ ГОСУДАРСТВЕННОГО СОВЕТА  
НАРОДНОЙ РЕСПУБЛИКИ БОЛГАРИИ  
ТОДОРУ ЖИВКОВУ**

Господин Председатель,

Сегодня, 19-го апреля 1982 г., неофициальным путем я узнал, что указом №3039 от 28 декабря 1981 г., подписанным Вами, я лишен болгарского гражданства и вся моя движимая и недвижимая собственность подлежит конфискации. Санкция мотивирована тем, что моя деятельность наносит вред интересам Народной Республики Болгарии.

Желаю довести до Вашего сведения, что Болгария конституционное государство, управляемое законами, а не прихотями и капризами административных лиц. Ваше мнение относительно того, вредит ли моя деятельность интересам НРБ, совсем недостаточно, чтобы я был лишен болгарского гражданства. Эту санкцию может дать только суд, где прокурор предъявляет обвинение и где я могу защититься.

Готов в любой момент прибыть в Софию и показать перед судом, что моя деятельность физика, социалиста и пацифиста не только что не вредит интересам НРБ, но исключительно необходима, чтобы провести процесс демократизации и демилитаризации Болгарии как можно более быстро и более радикально и чтобы имя болгарской науки было поднято высоко перед миром. Я не Ленин, чтобы бояться предстать перед государственным судом и пытаться укрываться тут или там. Уважаю суд НРБ и приму с полным удовлетворением любой его приговор, будь он и несправедливый, твердо зная, что несправедливый приговор тяготеет не над осужденным, а над тем, кто его произносит. Но если Вы лишите меня возможности предстать перед законным судом в Софии, значит, суд боится меня.

С уважением

*Стефан Маринов*

LETTER OF STEFAN MARINOV TO THE PRESIDENT OF THE PEOPLE'S REPUBLIC OF BULGARIA

Mr. President,

Today, on the 19 April 1982, it came to my knowledge on an inofficial way that with the ukase of the 28 December 1981, signed by you, I am deprived of a Bulgarian citizenship and all my movable and immovable property is to be confiscated. The motivation is that my activity is against the interests of the People's Republic of Bulgaria.

I wish to bring to your knowledge that Bulgaria is a constitutional country ruled by laws and not by the whims and fancies of the public administrators. Your opinion whether or not my activity is against the interests of Bulgaria is not sufficient to deprive me of a Bulgarian citizenship. This sanction can be taken only by the Court, where the public prosecutor presents an accusation and I have the right and the possibility of defence.

I am ready to come at any time in Sofia and to show to the Court that my activity of a physicist, socialist, and pacifist is not noxious to the interests of the PRB, but, exactly on the contrary, it is indispensable for the process of democratisation and demilitarisation of Bulgaria, and for enhancing the name of the Bulgarian science before the world. I am not Lenin to be afraid to appear before a State Court and to seek to hide myself here and there. I esteem the Court of the PRB and will accept with satisfaction any its sentence, knowing firmly that an unjust sentence weighs not on the condemned but on those who pronounce it. If you will deprive me of the possibility to appear before the Court, it follows that the Court is afraid of me.

With respect, Stefan Marinov

S C I E N T I F I C P A P E R S



THE MAXWELL-MICHELSON PUZZLE AND THE BLINDNESS OF MANKIND

Stefan Marinov

Institute for Fundamental Physics

Morellenfeldgasse 16

A-8010 Graz, Austria

It is shown that, according to the aether concepts of light propagation, the travel times of the photons split in the Michelson interferometer are equal for almost all directions which the axis of the apparatus concludes with its absolute velocity.

Fritzchen is my neighbour's kid. He is 15 years old but enough clever and sly for his age. His teacher in physics talked in the class-room about light velocity, Einstein and the Michelson-Morley experiment on the occasion of the 100-th anniversary of its performance. Always when Fritzchen meets with problems which seem unclear from his point of view, he comes to me to talk about.

I explained to Fritzchen how Abraham Michelson has constructed his interferometer which is the theory of the experiment suggested by James Clerk Maxwell, and which were the experimental results. Let me repeat what I narrated to Fritzchen.

Light emitted by the source  $S$  (fig. 1) is split into two beams by the semitransparent mirror  $SM$ . The transmitted beam goes to the mirror  $M_1$  and returning back reflects on  $SM$ , while the reflected beam goes to the mirror  $M_2$ , returns back, goes through  $SM$  and interfering with the former beam reaches the observer  $O$ . If the distances  $L_1$  and  $L_2$  from the point of separation at  $SM$  to the mirrors  $M_1$  and  $M_2$  are equal to the same length  $L$ , then the photons in both beams will meet at  $SM$  again with the same time delays if their velocity in the aether is  $c$ .

Maxwell posed the question what will occur if the apparatus moves in the aether (i.e., in absolute space) with a velocity  $V$  in parallel to the line  $S - SM - M_1$ .

In fig. 2 the picture in absolute space is presented. The photons in both beams separate when the mirrors are at the positions  $SM, M_1, M_2$ . The "parallel" beam re

**THIS PAGE IS LOCKED TO FREE MEMBERS**

Purchase full membership to immediately unlock this page

**SAVE \$3,999,994**

Did you know we sell  
paperback books too?

To buy our entire catalog  
in paperback would cost  
over \$4,000,000

Access it all now for  
\$8.99/month

\*Fair usage policy applies

**Continue**

$$\Delta t_1 = \Delta t_1' + \Delta t_1'' = 2L/c(1 - v^2/c^2). \quad (6)$$

And the open-minded boy said: "Thus if neither of the split beams concludes with the perpendicular to the absolute velocity an angle smaller than  $V/c$ , no difference in their to and fro times can appear. How could uncle James Clerk oversee this simple thing?"

I looked at his beautiful blue eyes and said: "Fritzchen, bitte, sein ein kluges Kind, schrei nur nicht laut, was du wirklich siehst. Die Schneider des Königs sind sehr böse Leute und die werden dir die Augen ausstechen!"

#### FIGURE CAPTIONS

Fig. 1. The Michelson interferometer.

Fig. 2. The Michelson experiment in absolute space according to Maxwell.

Fig. 3. The Michelson experiment in absolute space according to Fritzchen.

The figures are attached to the following article!!!

## THE MICHELSON-MORLEY EXPERIMENT AND THE BLINDNESS OF MANKIND

Stefan Marinov

Institute for Fundamental Physics

Morellenfeldgasse 16

A-8010 Graz, Austria

Abstract. I show that if one takes into account the neglected until today mirror-Bradley effect (which is an analogue to the aberration effect discovered by Bradley in the case when a light ray reflects on a mirror moving with a velocity parallel to its surface), then the classical aether concepts lead to a null effect in the historical Michelson-Morley experiment. Proceeding from the classical formulas for the light velocity in a laboratory moving with respect to the aether, I obtain the formulas for the wavelengths and the formulas for the one-way light velocities expressed through the two-way light velocity in the moving laboratory. All these formulas were splendidly confirmed by my "rotating axle" experiments. Then I introduce the classical notion for time dilation which is an absolute effect depending on the absolute velocity of the "clock". Finally I show that my extremely simple, clear and understandable formulas give the basis for whole high-velocity physics.

### 1. THE MICHELSON-MORLEY EXPERIMENT IN MAXWELL'S TREATMENT

What I should like to narrate in this article seems to appear rather an Agatha Christie detective story where the reader supposes all the time that X is the murderer, as all facts speak against him, but at the end when the author points to a small detail which was under the reader's eyes during the whole action, it turns out that the unsuspected Y the perpetrator is and (what is more exciting!) that the killed person lives.

My detective story lasts 100 years. It began in 1887 when Michelson and Morley established that there is no positive effect in their interference experiment, although the aether theory of light propagation ostensibly such an effect does predict.

What else has not been done in order to explain theoretically this null effect!

- First Fitzgerald and Lorentz put forward the length contraction hypothesis.

Then came Einstein turning on the head the old good on its feet staying Newtonian physics and proposed theories where time is space, space time, yesterday is tomorrow and tomorrow yesterday. And 100 years humanity discusses and analyses the damned Michelson-Morley experiment, and in a search to explain its null effect one brings water from wells lying behind seven mountains and seven seas.

Thus 100 years humanity believes that this one who has killed the good old physics was the Michelson-Morley experiment. Now, after the celebration of the 100th anniversary of this "historical" experiment (recently *Physics Today* dedicated a whole issue to this anniversary), I shall show that this experiment is absolutely innocent. I shall point at a small detail which during those 100 years *none* has seen, although every child who has two eyes could see it.

First I shall describe the Michelson-Morley experiment (Fig. 1). Light emitted by the source S is split by the semitransparent mirror SM into two beams. The transmitted beam goes to mirror  $M_1$ , comes back and reflects on SM, while the reflected beam goes to mirror  $M_2$ , comes back, goes through SM and then both interfering beams reach the observer O. When the lengths  $L_1$  and  $L_2$  from the separation point at SM to the mirrors  $M_1$  and  $M_2$  are equal,  $L_1 = L_2 = L$ , and the light velocity in all directions is  $c$ , then the photons who separated at SM will meet again at SM after *the same time*.

Maxwell posed the question what will occur if the apparatus moves in the aether (i.e., in absolute space) with a velocity  $v$  in parallel to the line S - SM -  $M_1$ .

I show in Fig. 2 this case from the viewpoint of an observer attached to the aether. The photons separate at SM when the mirrors have the positions SM,  $M_1$ ,  $M_2$ . The "parallel" photons reflect on  $M_1$  when it is at the position  $M_1'$ , the "perpendicular" photons reflect on  $M_2$  when it is at the position  $M_2'$ , and the photons meet at SM when the positions of the mirrors are SM'',  $M_1''$ ,  $M_2''$ . We can write the following equalities

$$c\Delta t_1' = L + v\Delta t_1', \quad c\Delta t_1'' = L - v\Delta t_1'', \quad (1)$$

$$c\Delta t_2' = (L^2 + v^2\Delta t_2'^2)^{1/2}, \quad c\Delta t_2'' = (L^2 + v^2\Delta t_2''^2)^{1/2}, \quad (2)$$

**THIS PAGE IS LOCKED TO FREE MEMBERS**  
Purchase full membership to immediately unlock this page

**FORGOTTEN BOOKS**

# **FULL MEMBERSHIP**

**797,885 Books!**  
**All you can read**  
**for only**  
**\$8.99/month**

**Continue**

\*Fair usage policy applies



the incident angle and  $\phi' = \arccos(\mathbf{n}', \mathbf{m})$  the reflection angle. The wavelengths of the reflected photons will be equal to the wavelengths of the incident photons:

Let us now suppose that the mirror moves with a velocity  $v$  in absolute space. The impact between the light beam and the mirror will lead to two new phenomena:

1) The wavelengths of the reflected photons will be no more equal to the wavelengths of the incident photons. I call this effect the *mirror-Doppler effect*, in order to discern it from the classical Doppler effect caused by the motion of the source in absolute space (I must emphasize that the motion of the observer leads to *no change* of the light wavelength). If the mirror is a microscopic body which changes its velocity during the elastic collision with the *single* photons, we come to the Compton effect. I have shown<sup>1</sup> that the mirror-Doppler effect and the Compton effect are two *different names* of the *same phenomenon* and that any clever child can understand the corresponding mathematics and "physics" very easily.

2) The reflection angle will be no more equal to the incident angle. This effect was noticed and analysed by nobody and I call it the *mirror-Bradley effect*, as it relates to the light aberration discovered by Bradley (classical Bradley effect) in the same way as the mirror-Doppler effect relates to the classical Doppler effect. It must be only noted that a classical Bradley effect is caused only by the motion of the observer but not by the motion of the source.

The relation between the wavelengths of the incident photons,  $\lambda$ , and the wavelengths of the reflected photons is the following<sup>1</sup>

$$\lambda' = \lambda \frac{1 + v \cos(\mathbf{v}, \mathbf{n})/c}{1 + v \cos(\mathbf{v}, \mathbf{n}')/c}, \quad \text{i.e.,} \quad \lambda' = \lambda \frac{1 + v \cos \theta / c}{1 - v \cos(2\phi \pm \theta) / c}, \quad (5)$$

where  $\theta = (\mathbf{v}, \mathbf{n})$  and the sign "+" ("-") relates to the case where the vector  $\mathbf{v}$  divides (does not divide) the angle between the vectors  $\mathbf{n}$  and  $\mathbf{n}'$ .

The relation between the incident and reflection angles is the following

$$\phi' = \phi + (v/c) \sin(\mathbf{v}, \mathbf{n}) \{ \cos(\mathbf{n}', \mathbf{m}) - \cos(\mathbf{n}, \mathbf{m}) \}, \quad \text{i.e.,} \quad \phi' = \phi + 2(v/c) \sin \theta \cos \phi. \quad (6)$$

The reader can persuade himself in the veracity of the last two formulas by

considering reflection of light beams at different angles  $\theta$  and  $\phi$ . The mirror-Doppler effect will evoke no difficulties, as this effect has been many times verified. The mirror-Bradley effect, however, was until today observed by nobody (I show below that as a matter of fact this effect was observed but not understood in the Michelson-Morley experiment). One can produce a physical analogue to the mirror-Doppler effect by throwing a rubber ball on the surface of a rotating disk. One can then easily establish that the deflection angle from the perpendicular to the disk's surface (the vertical) will be proportional to the factor  $v/c$ , where  $v$  is the linear rotational velocity of the disk (quicker rotation leads to a bigger deflection angle) and  $c$  is the velocity of the ball (bigger ball's velocity during the collision, i.e., bigger height of fall, leads to a smaller deflection angle).

It is well known that the classical Doppler effect is tightly connected with the classical Bradley effect: when the Doppler effect is maximal the Bradley effect is minimal and vice versa. At the mirror-Doppler and mirror-Bradley effects there are two angles,  $\theta$  and  $\phi$ , but again at a maximal mirror-Doppler effect the mirror-Bradley effect is minimal and vice versa.

The last formula shows that the light paths in the Michelson-Morley experiment will be not as in Fig. 2 but as in Fig. 3. Indeed, we have for the reflected on SM beam  $\theta = 0$ ,  $\phi = \pi/4$  and we obtain according to formula (6)  $\phi' = \phi = \pi/4$ , as it is drawn in Fig. 3 and not  $\phi' = \pi/4 + v/c$ , as it is drawn in Fig. 2.

Let us calculate as an exercise the wavelength of the reflected photons. If  $\lambda$  is the wavelength of the radiated light in the case that the source rests in absolute space, the wavelength of the photons emitted from the moving in Figs. 2 and 3 will be, on the ground of the classical Doppler effect (see formula (17) below),  $\lambda' = \lambda/(1 + v/c)$ . Consequently we obtain according to formula (5) for the wavelength of the photons along the direction  $SM-M_2$   $\lambda'' = \lambda'(1 + v/c) = \lambda$ .

Let us find now the direction of the beam which is reflected from mirror  $M_2$ . Proceeding again from formula (6) we obtain for  $\theta = \pi/2$ ,  $\phi = 0$  a reflection angle  $\phi' = 2v/c$ .



### 3. THE MICHELSON-MORLEY EXPERIMENT IN THE AUTHOR'S TREATMENT

Let us calculate, according to Fig. 3, the time in which the reflected on SM photons will return back to SM. It is clear that now the formulas (2) must be replaced by the following formulas

$$c\Delta t_2' = L, \quad c\Delta t_2'' = (L^2 + v^2\Delta t_2^2)^{1/2}, \quad (7)$$

and the formula (4) must be replaced by the following formula

$$\Delta t_2 = \Delta t_2' + \Delta t_2'' = 2L/c(1 - v^2/c^2). \quad (8)$$

Comparing formulas (3) and (8) we come to the conclusion that the "parallel" and "perpendicular" photons will meet on SM *exactly after the same time*.

And Michelson and Morley rotated and rotated day and night their on mercury swimming apparatus *en attendant Godo*. Later A. Miller repeated this experiment during whole his life on the surface of the Earth, under the surface, on mountains, on balloons, he made the frame of iron, of wood, he measured in air, in vacuum, in summer and in winter. Then came Kennady and Thorndike with their interferometer with different arms ( $L_1 \neq L_2$ ), then other and other indefatigable researchers, culminating with the masterpiece of Brillet and Hall who used laser light and increased fantastically its sensitivity. And all these people rotated the apparatus like crack-brained. And all looked for a drift in the interference picture which, as I showed, can *never* according to the *good old physics* appear. And none has done the path from Fig. 2 to Fig. 3 during all those 100 years. Is it comical? - No. It is *tragic!* And will this story teach us that humanity can be during centuries blind? - Hardly. Again false dogmas and wrong prejudices will be erected and again mankind will march behind these dogmas as blind behind an one-eyed.

### 4. THE FORMULAS FOR THE ONE-WAY LIGHT VELOCITIES AND WAVELENGTHS

I call the angle between a light ray and the absolute velocity of the laboratory the *absolute* angle and denote it by  $\theta$ , if it will be considered with respect to absolute space. When this angle will be considered with respect to the labora

**THIS PAGE IS LOCKED TO FREE MEMBERS**

Purchase full membership to immediately unlock this page

**SAVE \$3,999,994**

Did you know we sell  
paperback books too?

To buy our entire catalog  
in paperback would cost  
over \$4,000,000

Access it all now for  
\$8.99/month

\*Fair usage policy applies

**Continue**

with the absolute laboratory's velocity  $v$ . On the grounds of formulas (1) we can write

$$L/\Delta t' = c' = c - v \cos \theta' = \nu \lambda', \quad (12)$$

$$L/\Delta t'' = c'' = c + v \cos \theta' = \nu \lambda'', \quad (13)$$

where  $\lambda'$  is the wavelength for the light ray to  $M_1$  and  $\lambda''$  is the wavelength for the light ray from  $M_1$ ,  $\Delta t'$  and  $\Delta t''$  are the respective times of flight and  $\nu$  is the light frequency. I wrote formulas (12) and (13) for the *general case* where the light track  $L$  concludes an *arbitrary* relative angle with its velocity. The angle between the light beam and the absolute velocity for the flights to and fro is  $(v, n') = \theta'$ ,  $(v, n'') = \pi - \theta'$ , and I used the general formula  $c^i = c - v \cos(v, n^i)$ .

Let us further suppose that the mirrors  $SM$  and  $M_2$  are in such positions so that the ray  $SM - M_2$  is at right angles with the absolute velocity. We can write in this case

$$2L/\Delta t = c_M = \nu \lambda, \quad (14)$$

where  $\lambda$  is the wavelength of the *standing waves* along the track  $SM - M_2$ . I must emphasize that only this wavelength can be *directly* measured as Wiener did in 1890. I should like to emphasize further that in the Michelson-Morley experiment there is no energy transfer to the mirrors  $M_1$  and  $M_2$  because along both light tracks there are only standing waves. And the experiment shows only that at every position of the apparatus on the tracks  $SM - M_1$  and  $SM - M_2$  always the *same* numbers of standing waves are built up, as I show in Ref. 1 proceeding from formula (17), and as anybody can easily calculate (see also the article on p. 104).

From the equality  $\Delta t = \Delta t' + \Delta t''$ , which follows from the formulas (3) and (8), and from the last three formulas we obtain

$$1/\lambda' + 1/\lambda'' = 2/\lambda. \quad (15)$$

On the other side, by dividing equation (12) by the equation (13), we find

$$\lambda'/\lambda'' = (1 - v \cos \theta'/c)/(1 + v \cos \theta'), \quad (16)$$

and we see that (15) and (16) are two equations with two unknowns and their solu-

tion yields

$$\lambda' = \lambda/(1 + v\cos\theta'/c), \quad \lambda'' = \lambda/(1 - v\cos\theta'/c). \quad (17)$$

Now we obtain from formulas (11), (12) and (13)

$$c' = c(1 - v\cos\theta'/c) = c_M(1 - v\cos\theta'/c)/(1 - v^2/c^2), \quad (18)$$

$$c'' = c(1 + v\cos\theta'/c) = c_M(1 + v\cos\theta'/c)/(1 - v^2/c^2). \quad (19)$$

Here I turn over the last page of the Agatha Christie's story "Who killed Mr. Aether". I showed that not Michelson and Morley were the murderers as mankind thinks led on the nose by miserable detectives almost 100 years. The Michelson-Morley experiment gives a splendid support to the aether concepts and offers an experimental proof of the mirror-Bradley effect. The perpetrators who committed the act were Einstein and his company. However, as the reader sees the aether was not killed at all. The aether is living, more sane and more magnificent than ever. I showed the existence of the aether with my "rotating axle" experiments<sup>1-4</sup> with which I measured the Earth's absolute velocity. The "coupled shutters" experiment<sup>4</sup> gave in February 1984 for its magnitude and for the equatorial coordinates of its apex the following figures:  $v = 360 \pm 40$  km/sec,  $\delta = -24^\circ \pm 7^\circ$ ,  $\alpha = 12.5^h \pm 1^h$ .

The deduction of formulas (17) from formulas (12) - (16) was given first by R. Monti (Bologna)<sup>6</sup>.

## 5. THE TIME DILATION

Formulas (3), (4) and (8) show that a moving light clock (an apparatus where a light pulse is sent to a mirror which after its return generates immediately a new light pulse covering the same path) makes less tick-tacks than a light clock at rest in absolute space and this dilation depends on the *absolute* velocity of the moving clock.

Let us take now two such light clocks A and <sup>B</sup>(Fig. 4). When both clocks have the same "arms" and are at rest one to another, they will have the same rate.

When, however, the one clock (A) rests in absolute space and the other (B) performs a rotational motion (with a radius much bigger than the "arm" of the clock), its light pulse will come always a little bit later to the starting point than the pulse in the clock A. Formula (4) shows that if the period of the clock at rest is  $T = 2L/c$ , the period of the moving clock will be

$$T_0 = 2L/c(1 - v^2/c^2)^{1/2} = T/(1 - v^2/c^2)^{1/2} \cong T + v^2T/2c^2. \quad (20)$$

I call the time which is measured on clock A *universal time*, and the time measured on clock B *proper time*. When, say, for one revolution of clock B  $\Delta t$  universal seconds have elapsed, then on clock B will elapse, according to formula (20)

$$\Delta t_0 = \Delta t(1 - v^2/c^2)^{1/2} \cong \Delta t - v^2\Delta t/2c^2 \quad (21)$$

*proper second*. This is the *absolute time dilation effect*. I show<sup>1</sup> that every periodical physical system dilates its period according to formula (20). The question is to be posed, why according to formula (20) and not according to the formula  $T_0 = T/(1 - v^2/c^2)$ .

This is a *big* problem and in Ref. 1 I show the toilsome way on which I solved it and the essence of which is the following: As the quantities  $c$  and  $c_M$  must be expressed by the *same numbers* if measured on light clocks attached, respectively, to the absolute and relative laboratories, we *have to accept* the relation between their periods in the form (20) and thus we *must come* to the following fundamental relations; in which *inevitably* some discrepancies will appear with the previous formulas (it is impossible to eliminate logically these discrepancies

When we measure the light velocity in absolute space on a universal clock (i.e., a clock which is at rest in absolute space), we become the number

$$c, \quad (22)$$

which I call *universal absolute light velocity*.

When we measure the light velocity in absolute space on a proper clock (i.e., on a clock which moves in absolute space with the velocity  $v$ ), we become

$$c_0 = c/(1 - v^2/c^2)^{1/2}, \quad (23)$$

which I call *proper absolute light velocity*.

When we measure the light velocity in a moving frame (i.e., in a relative la-

**THIS PAGE IS LOCKED TO FREE MEMBERS**  
Purchase full membership to immediately unlock this page

**FORGOTTEN BOOKS**

# **FULL MEMBERSHIP**

**797,885 Books!**  
**All you can read**  
**for only**  
**\$8.99/month**

**Continue**

\*Fair usage policy applies



locity time energy of a mass m

$$e_0 = - mc^2(1 - v^2/c^2)^{1/2}, \quad e_0 = mc^2/(1 - v^2/c^2)^{1/2}, \quad e_{00} = mc^2/2(1 - v^2/c^2). \quad (29)$$

The second basic formula is the high-velocity form of the *space* and *space-time energies* of two electric charges or masses. For brevity I shall consider the respective space (electric) and space-time (magnetic) potentials of a charge q

$$\phi = \frac{q}{r} = \frac{q}{r' + \mathbf{v}' \cdot \mathbf{r}'/c}, \quad A = \frac{q\mathbf{v}}{cr} = \frac{q(\mathbf{v}' + \mathbf{r}'\mathbf{u}'/c)}{c(r' + \mathbf{v}' \cdot \mathbf{r}'/c)}, \quad (30)$$

where  $r$  is the distance from the observer to the charge and  $\mathbf{v}$  <sup>is</sup> the velocity of the charge at the moment of observation  $t$ ;  $\mathbf{r}'$  is the same oriented distance and  $\mathbf{v}'$  and  $\mathbf{u}'$  are the velocity and the acceleration of the charge at the *advanced moment*  $t' = t - r'/c$ . Contemporary physics calls this moment unjustly retarded moment and considers the potentials (30), which are called the Lienard-Wiechert potentials, completely upside down in the light of the *nonsensical* "propagation of interaction".

The connection between the left and right parts of formulas (30) is given by the equations

$$r = c(t - t'), \quad r' = c'_0(t - t'), \quad (31)$$

by substituting here the second formula (25) and writing  $\mathbf{v}' \cdot \mathbf{r}'/v'r' = \cos\theta'$ .

Proceeding from formulas (29) and (30) and the law of energy conservation, I deduce only by the help of mathematical logic *all* formulas of high-velocity physics of particles<sup>1</sup>, so that any clever child can understand the whole mathematics and "physics". By obtaining the Lorentz frictional forces at the radiation of electromagnetic waves, I do not meet the logical difficulties which convention physics meets working with the concept of "propagation of interaction"

and taking the second

formula (30) in the *wrong* form

$$A = \frac{q \mathbf{v}'}{c(r' + \mathbf{v}' \cdot \mathbf{r}'/c)}. \quad (32)$$

#### REFERENCES

1. S. Marinov, *Classical Physics* (East-West, Graz, 1981).
2. S. Marinov, Czech. J. Phys. **B24**, 965 (1974).
3. S. Marinov, Gen. Rel. Grav. **12**, 57 (1980).
4. S. Marinov, *The Thorny Way of Truth, Part II* (East-West, Graz, third ed. 1986)
5. S. Marinov, *The Thorny Way of Truth, Part I* (East-West, Graz, sec. ed. 1987).
6. R. Monti, private communication.

#### FIGURE CAPTIONS

- Fig. 1. The Michelson-Morley experiment.
- Fig. 2. The Michelson-Morley experiment in Maxwell's treatment.
- Fig. 3. The Michelson-Morley experiment in the author's treatment.
- Fig. 4. A rest light clock (A) and a moving light clock (B).



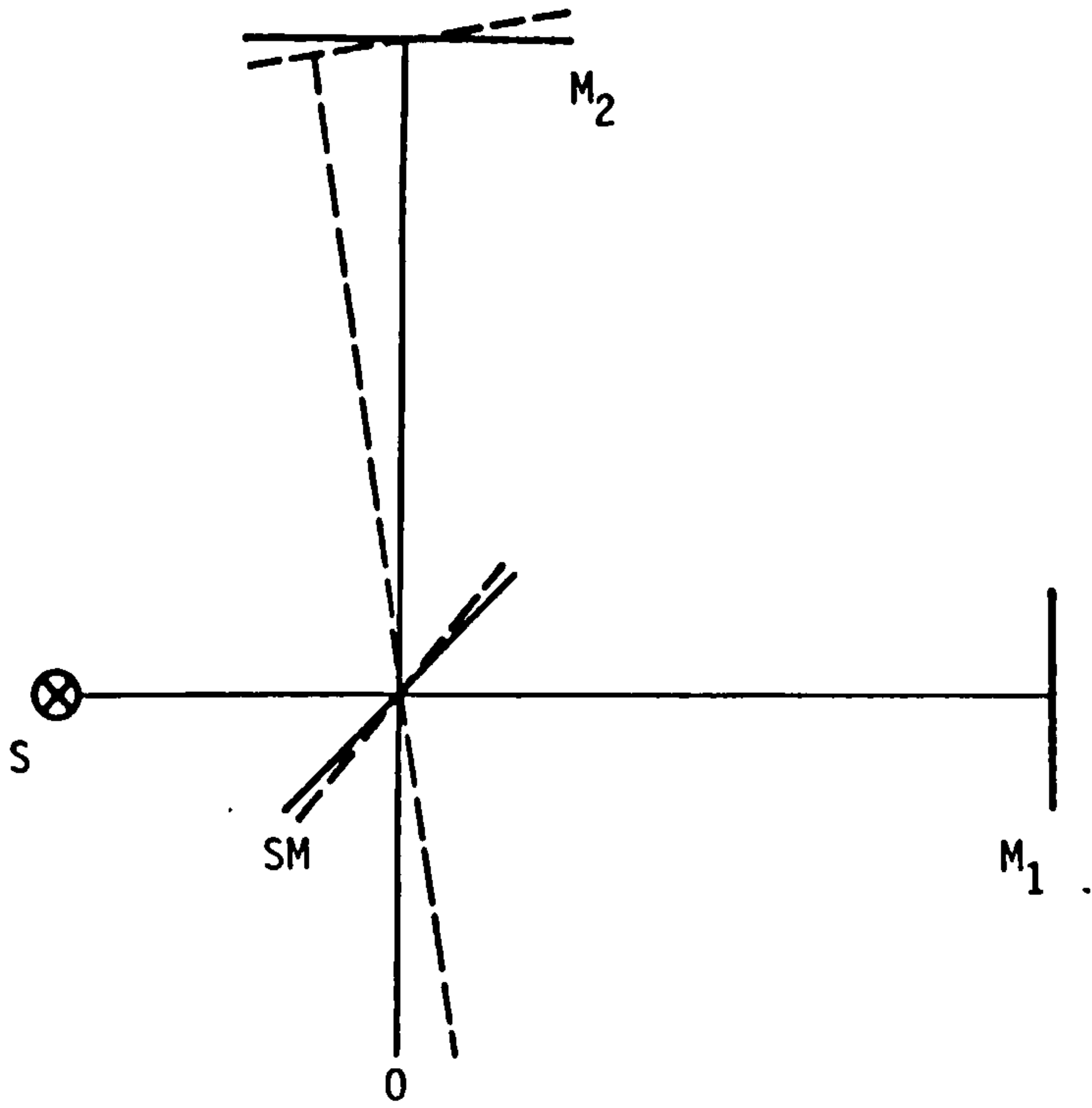

Fig. 1

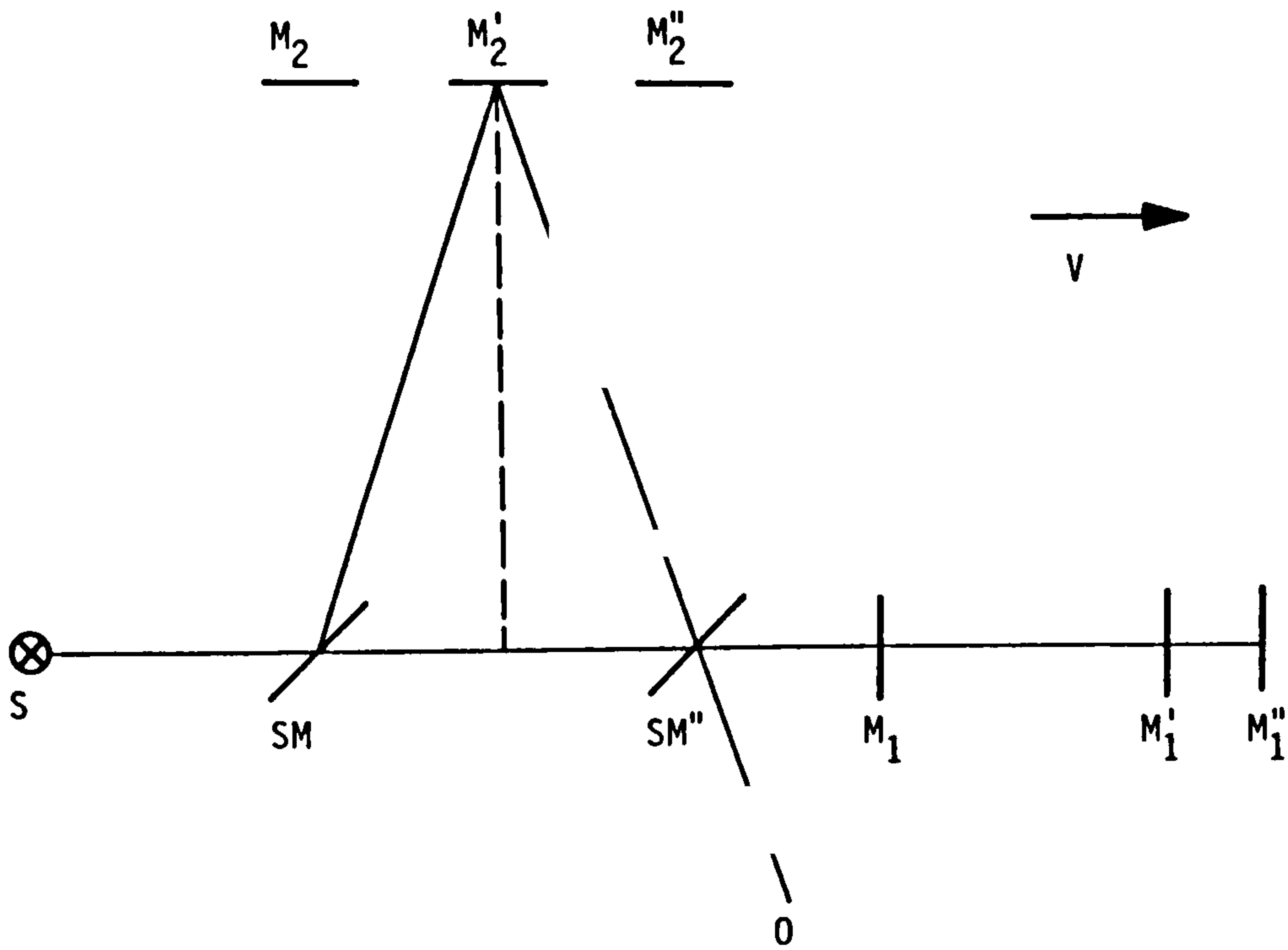

Fig. 2

**THIS PAGE IS LOCKED TO FREE MEMBERS**

Purchase full membership to immediately unlock this page

**SAVE \$3,999,994**

Did you know we sell  
paperback books too?

To buy our entire catalog  
in paperback would cost  
over \$4,000,000

Access it all now for  
\$8.99/month

\*Fair usage policy applies

**Continue**

THE ABSOLUTE CHARACTER OF LIGHT PROPAGATION

Stefan Marinov

Institute for Fundamental Physical Problems

Morellenfeldgasse 16,  
A-8010 Graz, Austria

I show that the historical Michelson, Sagnac and Wiener experiments give enough experimental evidence for accepting that the velocity of light in a laboratory moving with a velocity  $v$  in absolute space is  $c' = c^2/(c + v\cos\theta)$ , where  $\theta$  is the angle between  $\vec{c}$  and  $\vec{v}$ , as it is predicted by my absolute space-time theory.

A measurement of the Earth's absolute velocity by the help of an optical experiment in the *closed* laboratory was carried out for the first time by me /1/ in 1973. Then, in 1975/76 and in 1984, I increased the accuracy of the measurements with two other set-ups /2,3/. In all these apparatus I realized a "Newtonian" time synchronization by the help of a rotating axle and measured the *one-way light velocities* in two opposite directions, obtaining the Earth's absolute velocity as their difference. Carrying out measurements during half a year in 1975/76, I found by the help of the interferometric "coupled mirrors" experiment /2/ the following figures for the Sun's absolute velocity and for the equatorial coordinates of its apex:  $v = 303 \pm 20$  km/sec,  $\delta = -23^\circ \pm 4^\circ$ ,  $\alpha = 13^h 23^m \pm 20^m$ . My "coupled shutters" experiment gave /3/ for the Earth's absolute velocity in February 1984 the figures:  $v = 360 \pm 40$  km/sec,  $\delta = -24^\circ \pm 7^\circ$ ,  $\alpha = 12.5^h \pm 1^h$ . Similar figures have been obtained by measuring the slight anisotropy of the cosmic background radiation (see, for example, Ref. /4/).

Despite of this impressive experimental evidence, the scientific community still believes that the velocity of light in a moving laboratory is *not* direction dependent. This *nonsense* introduced into physics by the *mathematically contradictory* relativity theory continues to be taught in schools and universities and by idolizing the *wrong* Lorentz-Poincare-Einstein *principle of relativity* one hampers the sound evolution of electromagnetism, as I showed /3,5,7/ that the electromagnetic effects are determined not by the *relative* but by the *absolute* velocities of the interacting particles. So the *motional-transformer* induced electric intensity  $\vec{E} = (\vec{v} \cdot \text{grad}) \vec{A}$ , where  $\vec{A}$  is the magnetic potential originated at the reference point by a magnet moving with a velocity  $\vec{v}$ , discovered recently by me /3,5,8,9/, is still not accepted by the scientific community and one continues to make calculations in the considered case with the *wrong* formula  $\vec{E} = -\vec{v} \times \text{rot} \vec{A}$ , which (with an opposite sign) is valid only for the case when the wire moves with a velocity  $\vec{v}$  and the magnet is at rest and which I (and conventional physics) call *motional* induction.

When my experiments will finally be discussed by the scientific community? Why is this *graveyard silence* all over the world? Are there so many influential persons who profit by hiding the truth and by preaching lies? Is this not a proof that the leading world's space-time specialists have recognized the failure of relativity (by the help of my *accelerated "coupled mirrors" experiment* I demonstrated /6,7,10/ also the *invalidity* of the *principle of equivalence!*) and try to evade any discussion, as they realized that then soon the whole "magnificent" building of Einstein's theories will collapse as a play-cards house? Once more I should like to cite the beloved words of the great thinker Karl Marx: "L'ignorance n'a jamais rendu service a qui que se soit (Bruxelles, 1845)".

In this paper I shall show that even if one does not take into account my experiments where the Earth's absolute velocity has been directly

measured, and one analyses *properly* only the firmly accepted experiments of Michelson (i.e., Michelson-Morley), of Wiener (on the direct measurement of the light wavelength), and of Sagnac (on the measurement of the phase difference between two light signals propagating along a closed path in a laboratory rotating in absolute space), one comes *inevitably* to the result that the velocity of light in a moving laboratory *must be* direction dependent. Moreover, the combined analysis of these experiments gives a formula for the direction dependent light velocity with an accuracy of second order in  $v/c$ . Finally these experiments present a clear demonstration of the *absolute time dilation* predicted by my theory, namely that if the period of a clock which rests in absolute space is  $T$ , then at motion of the clock with an absolute velocity  $v$ , its period becomes  $T' = T(1 - v^2/c^2)^{1/2}$ .

Although the Michelson experiment, whose 100-th anniversary we celebrate this year ("Physics Today" has dedicated a whole issue to it) is known even to every college student, the scientific community has still not recognized the enormous reachness of information which it offers. In this experiment (fig. 1) light emitted from the source  $S$  is split by the semi-transparent mirror  $SM$ . Half of the light goes to mirror  $m$  covering the path  $r$  there and back in parallel to the absolute laboratory's velocity  $v$  and the other half goes to mirror  $M$  covering the path  $R$  there and back. Then both light beams interfere on the surface of the semi-transparent mirror  $SM$  and the interference picture is observed on the screen  $P$ . Along the paths  $r$  and  $R$  standing waves are built and we can denote their lengths by  $\lambda_{\perp}$  (along the path  $R$ ) and by  $\lambda_{\parallel}$  (along the path  $r$ ). As by rotating of the apparatus no change in the interference picture can be observed, the first conclusion which we must immediately draw is  $\lambda_{\perp} = \lambda_{\parallel} = \lambda$ . As  $v$  is exactly perpendicular to  $R$ , it is logical to assume that the light wavelength along the distance  $R$  there is equal to the light wavelength along the distance  $R$  back and equal to  $\lambda$ . However, the light wavelengths along the distance  $r$  there and back may be not equal and I shall denote them respectively by  $\lambda_1$  and  $\lambda_2$ . If  $R = r$ , we can denote this common distance by  $L$  and then write

$$2L/\lambda = L/\lambda_1 + L/\lambda_2, \quad (1)$$

as the phase difference between both beams at rest and at motion of the apparatus remains the *same*.

Let us now look at the Sagnac experiment (fig. 2) where by  $S$  and  $O$  are denoted sources and observers (*or vice versa!*). Let first  $O_A$  and  $O_B$  be two lasers emitting *coherent* light. The light emitted by  $O_A$  ( $O_B$ ) passes through the semi-transparent mirror  $SM_A$  ( $SM_B$ ) and then reflects on the semi-transparent mirrors  $SM''_A$ ,  $SM''_B$ ,  $SM_B$  ( $SM''_B$ ,  $SM''_A$ ,  $SM_A$ ). At the point  $S$  both beams interfere. Let us denote by  $C$  the point where both beams intersect and let us assume that points  $C$  and  $S$  are very near one to another. The whole apparatus is considered first at rest in absolute space and

**THIS PAGE IS LOCKED TO FREE MEMBERS**  
Purchase full membership to immediately unlock this page

**FORGOTTEN BOOKS**

# **FULL MEMBERSHIP**

**797,885 Books!**  
**All you can read**  
**for only**  
**\$8.99/month**

**Continue**

\*Fair usage policy applies



electromotor EM with the cog-wheels  $C_A$  and  $C_B$  at its ends which chop the light emitted by the source S (S') and observe the *twice-chopped* light at  $O_A$  and  $O_B$  ( $O'_A$  and  $O'_B$ ). Now the "effective" distance is  $d$  between the cog-wheels. If at rest of the rotating disk both observers see middle light illumination, then at rotation the one will see bigger and the other smaller illumination. The respective formulas /3/ give the velocity of rotation.

But the "coupled shutters" experiment gives <sup>an</sup> effect also when, at a constant velocity  $v$ , one rotates the axle (together with the source S', the mirrors  $SM'_A$ ,  $SM'_B$ ,  $SM''_A$ ,  $SM''_B$ , and the observers  $O'_A$ ,  $O'_B$ ) over  $90^\circ$ . Let at axle perpendicular to the absolute velocity of the laboratory both observers see middle light illumination. Then when making the axle parallel to the absolute velocity, the one observer will see bigger illumination and the other smaller. As both cog-wheels represent *rigidly connected clocks* they cannot suffer *different* time dilations as is the case with *independent* clocks. This is the whole "trick" with my "rotating axle" experiments which the relativists either cannot or (I think) *do not wish* to understand.

If  $\theta$  is the angle between the absolute velocity of the laboratory and the direction of light propagation, my theory predicts for the light velocity the following formula /6,7/

$$c' = c^2 / (c + v \cos \theta), \quad (4)$$

where  $c$  is the two-way velocity. If  $\nu$  is the light frequency, we shall have  $c = \nu \lambda$ ,  $c' = \nu \lambda'$ , and for the light wavelength we obtain

$$\lambda' = \lambda / (1 + v \cos \theta / c). \quad (5)$$

We see that this formula satisfies equations (3).

I show /6,7/ that formulas (4) and (5) are true within an accuracy of *any order* in  $v/c$ . It is clear that the second order in  $v/c$  effects cannot be observed in the Sagnac experiment, as they cancel one another. But second order in  $v/c$  effects can be observed in the Michelson experiment. Obviously only formula (5) satisfies the requirement of the Michelson experiment that the number of the standing light waves in both arms must be equal within an accuracy of *second order* in  $v/c$ . General relativity predicts *third order* in  $v/c$  effects in the Sagnac experiment (see above). My theory affirms that such effects *do not exist*. I hope that with precise ring laser (better, fibre) gyroscopes one will be able to show experimentally that within effects of third order in  $v/c$  my formula is the right one and not the general relativity formula.

Let us now consider another very interesting aspect of the Michelson experiment which has remained until now unnoticed. Let us look only at the standing waves pattern along the path R in fig. 1. If we shall measure the length of these standing waves, this will be the Wiener experiment. Now I pose the question: Is there

a difference in the number of the standing waves at rest and at motion of the apparatus? - If there is such a difference, this will be an *effective* quasi-Wiener experiment by the help of which one would be able to measure a *change* in the absolute velocity of the apparatus. According to my theory, however, there is *no* such a difference. At rest and at motion of the apparatus, exactly the same number of standing light waves can be counted along the distance  $R$ . This is due to the *absolute time dilation*, as if at rest of the light source the period of the emitted light is  $T$ , then, at motion, this period becomes  $T(1 - v^2/c^2)^{1/2}$ , which leads to a *lengthening* of the <sup>wavelengths</sup> of light propagating in *absolute space* from  $\lambda$  to  $\lambda/(1 - v^2/c^2)^{1/2}$ , so that their *projections* along the path  $R$  remain equal to  $\lambda$ .

All these aspects of my theory become entirely clear when analysing the "coherent lasers" experiment /13/, a scheme of which is given in fig. 3, where  $D_A$  and  $D_B$  are two detectors detecting the interference of the light emitted by the coherent lasers  $L_A$  and  $L_B$ . As I show in Ref. 13, due to the absolute time dilation of the emitting lasers, one cannot measure the laboratory's absolute velocity by rotating the apparatus over  $90^\circ$  (as this can be done with the "rotating axle" experiments where the "clocks" (the cog-wheels) rotate always *synchronously*). However, with the "coherent lasers" experiment one can measure a *change* in the absolute velocity, as in this case the absolute time dilations of both lasers are *equal* (for more detail see Ref. 13).

#### REFERENCES

- /1/. S. Marinov, Czech. J. Phys. B24 (1974) 965.
- /2/. S. Marinov, Gen. Rel. Grav. 12 (1980) 57.
- /3/. S. Marinov, The Thorny Way of Truth, Part II (East-West, Graz, first ed. 1984, third ed. 1986).
- /4/. E.S. Cheng et al., Astrophys. J. 232 (1979) L139.
- /5/. S. Marinov, The Thorny Way of Truth, Part I (East-West, Graz, sec. ed. 1987).
- /6/. S. Marinov, Eppur si muove (C.B.D.S., Bruxelles, 1977, third ed. East-West, Graz, 1987).
- /7/. S. Marinov, Classical Physics (East-West, Graz, 1981).
- /8/. S. Marinov, Nature 322 (21 August 1986) p. x.
- /9/. S. Marinov, New Scientist 112 (1986) 48.
- /10/. S. Marinov, Ind. J. Theor. Phys. 31 (1983) 93.
- /11/. L. D. Landau and E. M. Lifshitz, The Classical Theory of Fields (Pergamon Press, 1959).
- /12/. S. Marinov, Found. Phys. 8 (1978) 801.
- /13/. S. Marinov, Ind. J. Theor. Phys. 28 (1980) 329.



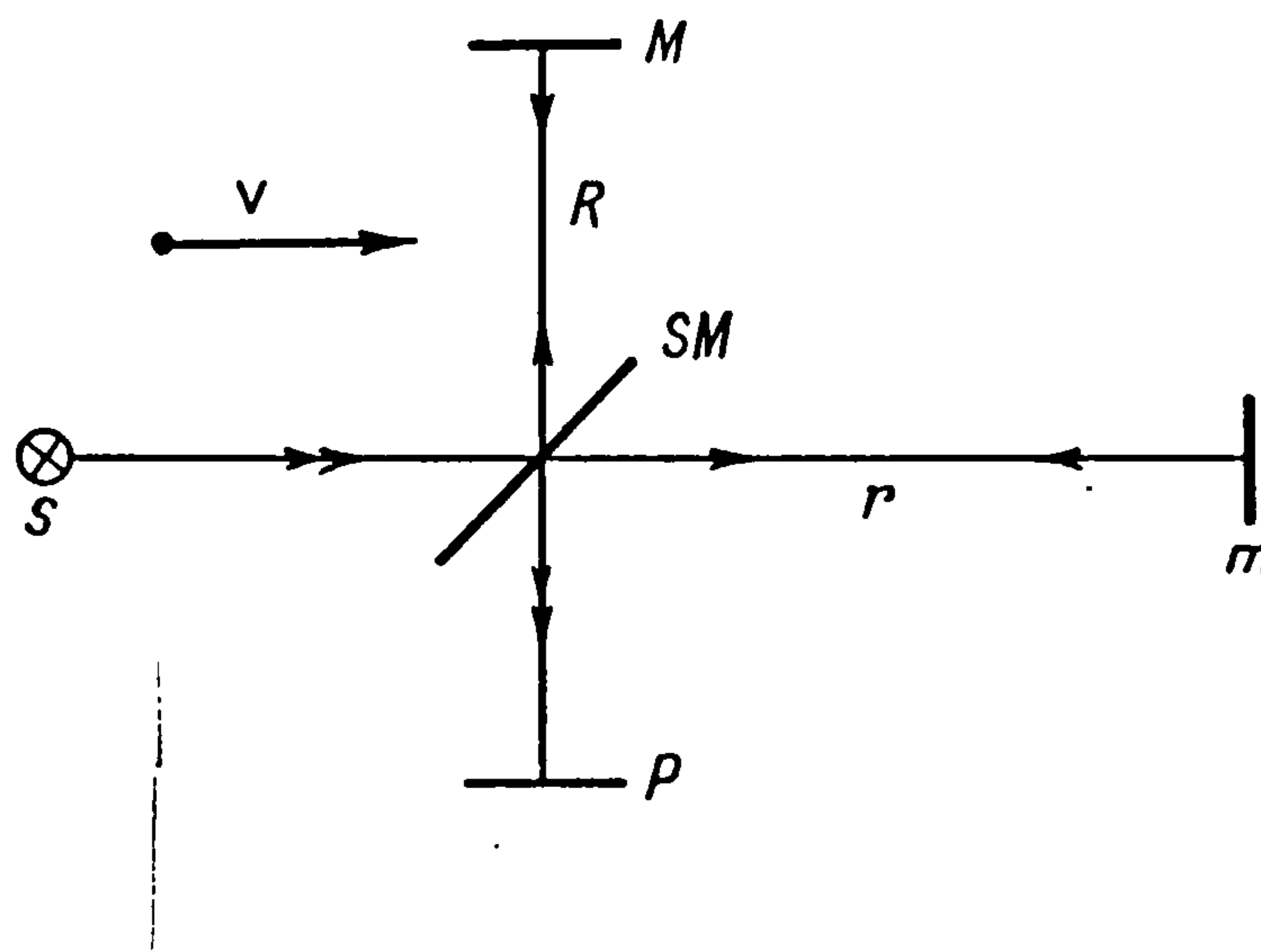

Fig. 1. - The Michelson experiment

**THIS PAGE IS LOCKED TO FREE MEMBERS**

Purchase full membership to immediately unlock this page

**SAVE \$3,999,994**

Did you know we sell  
paperback books too?

To buy our entire catalog  
in paperback would cost  
over \$4,000,000

Access it all now for  
\$8.99/month

\*Fair usage policy applies

**Continue**

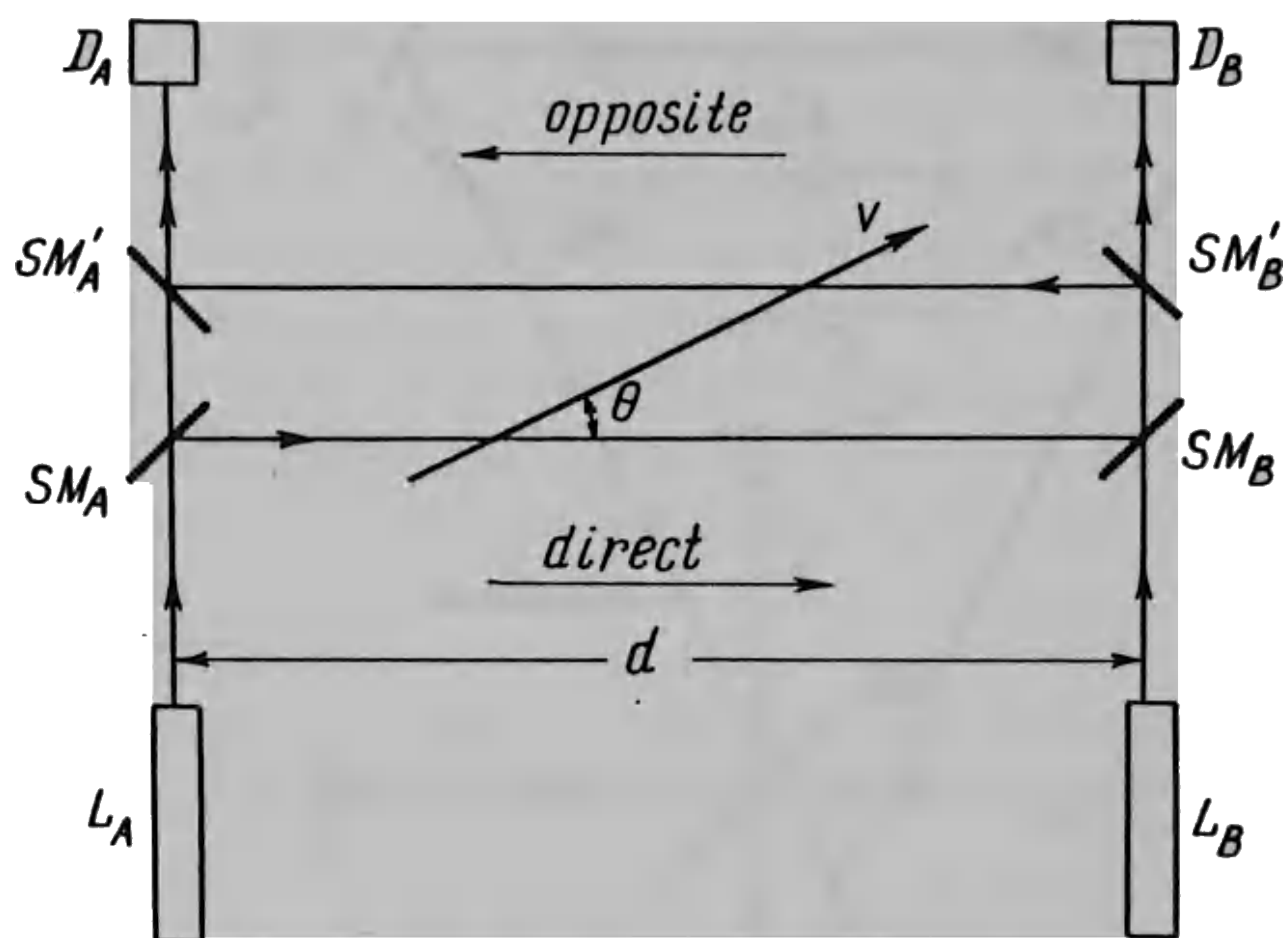

Fig. 3. - The "coherent lasers" experiment

SILVERTOOTH'S EXPERIMENT FOR MEASURING THE AETHER DRIFT  
IS INCONCLUSIVE

Stefan Marinov  
Institute for Fundamental Physics  
Morellengasse 16  
A-8010 Graz, Austria

Silvertooth has announced of having measured the Earth's absolute velocity by an optical laboratory experiment which can be considered as a variation of the quasi-Wiener experiment. I show that in the frame of my absolute space-time theory neither the quasi-Wiener nor Silvertooth's experiment can give a positive effect depending on the absolute velocity,  $v$ , of the laboratory, as those are standing waves experiments where all absolute effects of first and second order in  $v/c$  are mutually annihilated.

Recently Silvertooth<sup>1</sup> carrying out a variation of the quasi-Wiener experiment (the name "quasi-Wiener experiment" and the relevant theory are given by me<sup>2,3</sup>) succeeded, as he asserts, to measure the laboratory's absolute velocity with a very high accuracy. Let me note that Wiener<sup>4</sup> measured the light wavelength for the first time directly by producing light standing waves and letting them act on a photographic film. If a similar method should be used for measurement of the Earth's absolute velocity, I called it the quasi-Wiener experiment. Although a light source moving in absolute space (the aether) contracts the waves emitted in the direction of motion and delates those emitted against the direction of motion, the standing waves pattern remains without change (of first as well as of second order in  $v/c$ ). Thus I concluded that one cannot measure the Earth's absolute velocity by the help of the quasi-Wiener experiment.

This can be shown by the help of the most simple calculations. Let a light source and an ideal mirror be placed on the x-axis of a frame K. If this frame is at rest in absolute space (or the absolute velocity is perpendicular to the x-axis), the electric intensities of the light waves incident and reflected by the mirror will be

$$E_1 = E_{\max} \sin(\omega t + kx), \quad E_2 = E_{\max} \sin(\omega t - kx), \quad (1)$$

where  $E_{\max}$  is the amplitude of the electric intensity,  $\omega$  is the angular frequency and  $k$  is the angular wave-number. The time  $t$  is registered on a clock attached to frame  $K$  and  $x$  is the distance from the frame's origin to the point of observation of the electric intensity. The mirror has a larger abscissa than the source.

The incident and reflected light waves will interfere. For the electric intensity of the produced standing waves we obtain

$$E = E_1 + E_2 = 2E_{\max} \sin(\omega t) \cos(kx). \quad (2)$$

Suppose now that frame  $K$  is set into motion in absolute space with a velocity  $v$  in the  $x$ -direction (or that we rotate the moving frame  $K$ , so that its velocity  $v$  becomes parallel to the  $x$ -axis). Instead of  $\omega$  and  $k$  in equations (1), we have now to write the quantities

$$\omega_{1,2} = \omega, \quad k_{1,2} = 2\pi/\lambda_{1,2} = (2\pi/\lambda)(1 \pm v/c) = k(1 \pm v/c), \quad (3)$$

where  $\lambda$  is the light wavelength for the case where  $K$  is at rest in absolute space (or the velocity of  $K$  is perpendicular to the  $x$ -axis) and  $\lambda_{1,2}$  are the light wavelengths to and fro for the case where  $K$  moves with a velocity  $v$  in a direction parallel to the positive direction of the  $x$ -axis. Formulas (3) are deduced in Refs. 2 and 3, and I show there that they are exact within an accuracy of any order in  $v/c$ . Instead of formulas (3) the classical wave theory predicts  $\omega_{1,2} = \omega$ ,  $\lambda_{1,2} = \lambda(1 \mp v/c)$  while the theory of special relativity predicts  $\omega_{1,2} = \omega$ ,  $\lambda_{1,2} = \lambda$ .

Thus according to my theory, the electric intensity of the standing light waves instead by formula (2) will be given by the following formula

$$E = E_1 + E_2 = 2E_{\max} \sin\{\omega(t + vx/c^2)\} \cos(kx). \quad (4)$$

Hence the distances between the nodes of the standing waves when the Wiener experiment is performed in a frame at rest and in motion with respect to absolute space will be exactly the same, and no even second-order differences in the pattern will be registered. The only difference is the following: When the laboratory is at rest in absolute space (or its velocity is perpendicular to the direction of light propagation),  $E$  obtains its maximum at all aninodes (i.e., for  $x = n\pi/k$ , where  $n$  is an

**THIS PAGE IS LOCKED TO FREE MEMBERS**  
Purchase full membership to immediately unlock this page

**FORGOTTEN BOOKS**

# **FULL MEMBERSHIP**

**797,885 Books!**  
**All you can read**  
**for only**  
**\$8.99/month**

**Continue**

\*Fair usage policy applies



quasi-Michelson experiment, as it represents, as the reader will see, a certain variation of the historic Michelson-Morley experiment. One must spend months to construct Silvertooth's quasi-Wiener experiment, while my quasi-Michelson experiment can be mounted in a day in any well-equipped optical laboratory. I carried out such an experiment in January 1987 (on the 2, 3 and 4 January) and remained with the impression that there was an effect. However, the more careful analysis later, <sup>(see the article's end)</sup> brought me to the firm conclusion that in this experiment there is definitely no effect. I shall show beneath that the analysis of Silvertooth's experiment in the frame of my absolute space-time theory leads to a null result as in almost all high-velocity optical experiments where a Newtonian time synchronization is not realized<sup>2,3</sup>.

Nevertheless I consider Silvertooth's experiment as deserving attention. Maybe I have not well understood Silverthooth's method and my repetition is not physically adequate variation of his experiment. I shall be extremely happy if he indeed has measured the Earth's absolute velocity with his set-up and if other people will confirm his results. At the present time Silvertooth is the only man who, after me, has announced of having measured the Earth's absolute velocity in a closed laboratory. Thus, his experiment, if being effective, will present a big experimental support to my absolute space-time theory. I am, however, firmly persuaded that his method is uneffective and thus only by realizing a Newtonian time synchronization by the help of a rotating axle one can measure the Earth's absolute velocity by an optic experiment in a closed laboratory, as I did a couple of times<sup>5,8,9</sup>.

I shall describe Silvertooth's experiment as I understand it and then I shall present my quasi-Michelson experiment.

Fig. 1 shows Silvertooth's set-up. Light coming from a He-Ne laser ( $\lambda = 6328 \text{ \AA}$ ) is split by a semitransparent mirror  $M_1$  in two beams which after being reflected by mirrors  $M_2, M_3, M_5$ , respectively,  $M_4, M_6$ , cross the detector  $D_1$  representing a thin transparent photoelectric sensitive surface (about  $50 \text{ \AA}$ ) deposited on a glass plate<sup>10</sup>. The two oppositely propagating light beams interfere and produce standing waves. When the laser with mirrors  $M_1$  and  $M_2$  is mounted on a platform which is moved over a distance  $\Delta$  to the right, the standing waves pattern will be shifted

around the ring accordingly. I show in Fig. 2a what will occur in absolute space, i.e., when the laboratory's absolute velocity is zero. If the point of separation M (i.e., mirrors  $M_1$  and  $M_2$  in Fig. 1) is at the initial position and the relation between the light wavelength and the geometry of the ring is as shown in Fig. 2a, there will be an antinode at the detector D (i.e., the detector  $D_1$ ), thus maximum illumination and consequently maximum photoelectric current. When displacing the point of separation M to the position  $M'$  over a distance  $\Delta = \lambda/4$ , points  $m'$  and  $n'$  (which correspond to points  $m$  and  $n$ ) will "come" to the detector and there will be a node (minimum illumination). In Fig. 2b I show what will occur when the laboratory moves with a velocity  $v = c/2$  to the right. According to my theory<sup>2,3</sup>, the light velocity along and against the direction of motion of the laboratory is given by a formula similar to formula (3) for the wavelength, namely  $c_{1,2} = c/(1 \pm v/c)$ , which is also valid within an accuracy of any order in  $v/c$ . Thus we shall have for the laboratory light velocity along and against the direction of motion  $c_1 = 2/3c$ ,  $c_2 = 2c$ , and for the respective wavelengths  $\lambda_1 = 2/3\lambda$ ,  $\lambda_2 = 2\lambda$ . By displacing the point of separation M over the same distance  $\Delta = \lambda/4$  points  $m'$  and  $n'$  (which correspond to points  $m$  and  $n$ ) will "come" to the detector D and Silvertooth supposes that there will be an illumination different from minimum, as he writes<sup>1</sup> (p. 5): "If the translating member (i.e., the point of separation of the light beams M - S.M.) moves towards  $M_3$  an amount  $\lambda$ , then the wave impinging on  $D_1$  by the route  $M_3$  will advance less than a wave ( $\lambda_2 > \lambda$ ), and the wave impinging on  $D_1$  by the route  $M_4$  will retard more than a wave ( $\lambda > \lambda_1$ ). Thus, the two waves will remain in the same relative phase, but the standing wave pattern will have shifted with respect to the photocathode of the detector  $D_1$  by a first order amount  $\delta = \lambda(v/c)$ ."

This assertion which represents the core of the experiment is not true. At the motion of M over a distance  $\Delta = \lambda$ , the standing waves pattern at  $D_1$  changes exactly with two antinodes. Indeed, when shifting M over a distance  $\Delta = \lambda/4$  in Fig. 2b, the vectors of the electric intensity of the two beams at D which had the same phases at the initial position, producing an antinode, obtain a diference of the phases  $\pi$ , and thus produce a node, exactly as in the case 2a. Fig. 3b shows this clearly.



Silvertooth, however, supposes that if there was an antinode at D and one wishes to have again a (third) antinode, one has to shift the moving platform over a distance  $\lambda \pm \lambda v/c$  (Silvertooth does not precise which sign, plus or minus, is to be taken). Then Silvertooth puts a second similar photodetector  $D_2$  between the mirrors  $M_7$  and  $M_8$  which is crossed by the to and fro going light beams and where the distance between the nodes of the standing waves pattern at rest and at motion of the apparatus is the same (this is true, as formula (4) clearly shows).

So Silvertooth supposes that if at the initial position of the platform there are antinodes at  $D_1$  and  $D_2$  and one moves the platform, then after a certain shift there will be a node at  $D_1$  and an antinode at  $D_2$ . From the equation  $2n(\lambda \pm \lambda v/c)/4 = (Zn \pm 1)\lambda/4$ , Silvertooth obtains  $n = c/2v$  and since  $n = \Delta/(\lambda/2)$ , he finds  $v = c\lambda/4\Delta$ , considering  $n$  as the number of the antinodes over the distance  $\Delta$ .

I modified Silvertooth's quasi-Wiener experiment to the experiment shown in Fig. 3 which I called the quasi-Michelson experiment. I let the laser be stationary in (this is not shown in the figure) the laboratory directing its light towards  $M_1$  by the help of a mirror mounted on the moving platform and I exchanged the transparent detectors by untransparent detectors (photodiodes). To this end I replaced mirror  $M_5$  by a semitransparent mirror having the same inclination as mirror  $M_3$  and beneath it I put an untransparent photodiode  $D_1$  whose photosensitive surface looked upwards (towards  $M_5$ ). Then I replaced mirror  $M_7$  by another semitransparent mirror and I put beneath it a mirror  $M_9$  solidly to the platform which reflected the incoming light upwards (towards  $M_7$ ) and to the left of  $M_7$  I put another untransparent photodiode  $D_2$  solidly to the laboratory whose photosensitive surface looked to the right (towards  $M_7$ ), so that  $M_7$ ,  $M_8$ ,  $M_9$  and  $D_2$  built a Michelson interferometer. Now the nodes and antinodes of the standing waves were produced on the semitransparent mirrors  $M_5$  and  $M_7$  and there was no need that the light beams cross the detectors. To have the same illuminations over the detectors  $D_1$  and  $D_2$  when shifting the movable platform, as it must be according to the present above theory, the light rays  $M_1M_4$ ,  $M_2M_3$  and  $M_7M_8$  must be exactly parallel to the motion of the platform. If this condition should be not realized, then by shifting the platform one can obtain non synchronous changes of the illuminations over  $D_1$  and  $D_2$

**THIS PAGE IS LOCKED TO FREE MEMBERS**

Purchase full membership to immediately unlock this page

**SAVE \$3,999,994**

Did you know we sell  
paperback books too?

To buy our entire catalog  
in paperback would cost  
over \$4,000,000

Access it all now for  
\$8.99/month

\*Fair usage policy applies

**Continue**

REFERENCES

1. E. W. Silvertooth, Spec. Sc. Techn. **10**, 3 (1987).
2. S. Marinov, Eppur si muove (C.B.D.S., Bruxelles, 1977, third ed. East-West, Graz, 1987).
3. S. Marinov, Classical Physics (East-West, Graz, 1981).
4. O. Wiener, Ann. der Phys. **40**, 203 (1890).
5. S. Marinov, The Thorny Way of Truth, Part II (East-West, Graz, 1984, third ed. 1986).
6. R. A. Muller, Scient. Am. **238**, 64 (1978).
7. E. S. Cheng et al., Astroph. J. **232**, 139 (1979).
8. S. Marinov, Czech. J. Phys. **B24**, 965 (1974).
9. S. Marinov, Gen. Rel. Grav. **12**, 57 (1980).
10. E. W. Silvertooth and S. F. Jacob, Appl. Opt. **22**, 1274 (1983).
11. E. M. Kelly, Optics Lett. **11**, 697 (1986).
12. S. J. Prokhovnik, Found. Phys. **9**, 883 (1979).
13. S. Marinov, Spec. Sc. Techn. **1**, 520 (1978).

FIGURE CAPTIONS

Fig. 1. Silvertooth's variation of the quasi-Wiener experiment.

Fig. 2. Physical explanation of Silvertooth's experiment.

Fig. 3. Marinov's variation of Silvertooth's experiment (a quasi-Michelson experiment

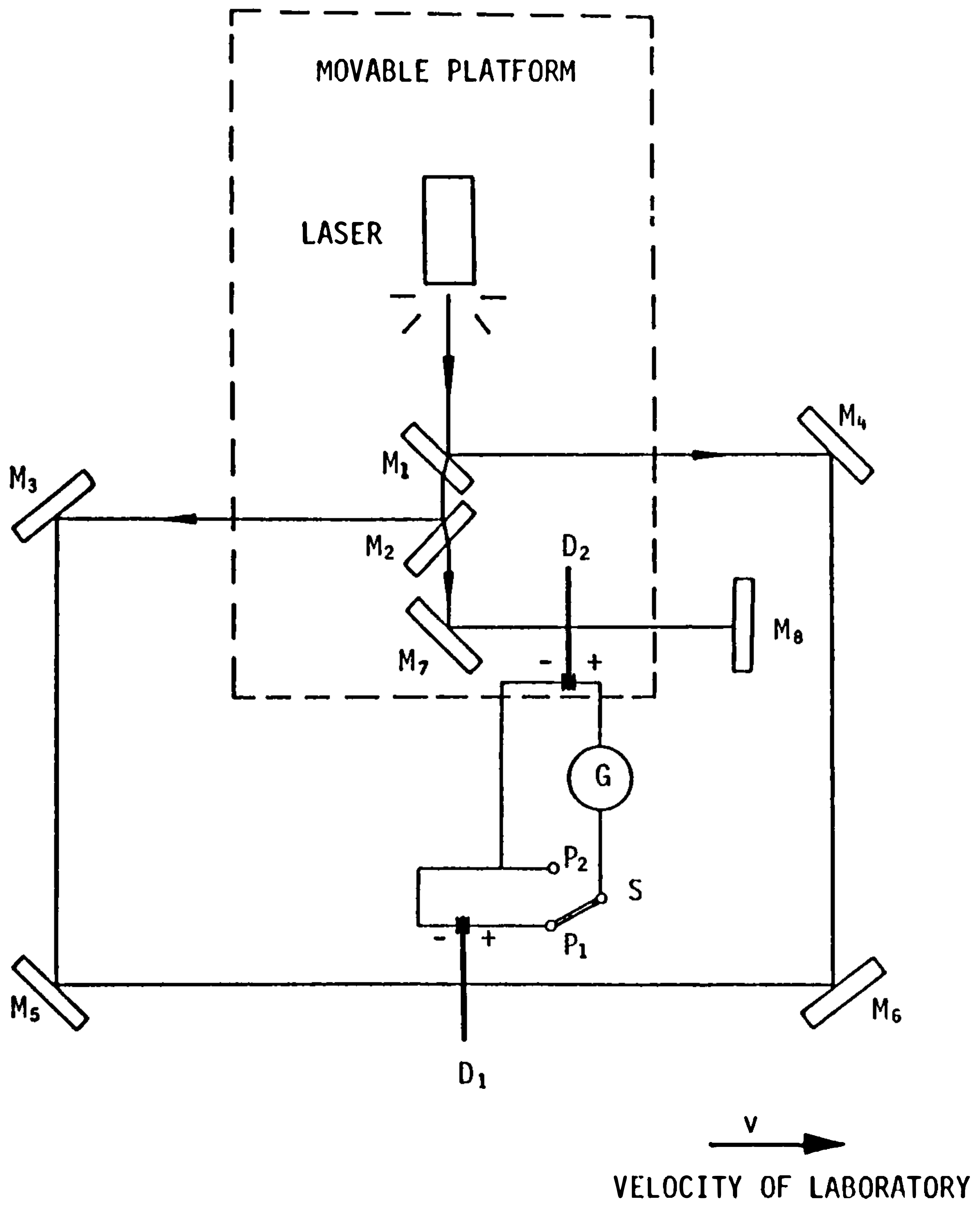

Fig. 1

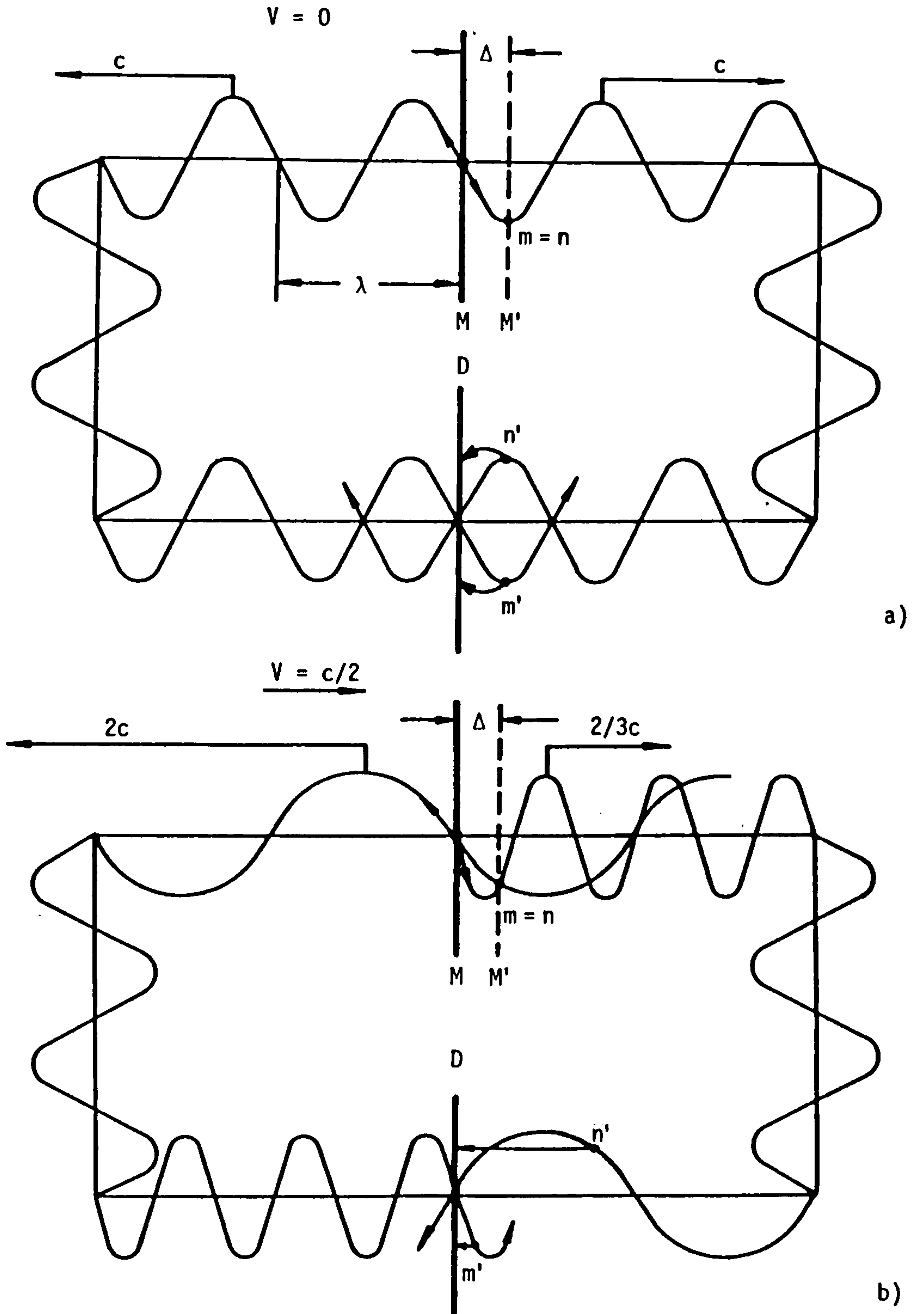

Fig. 2

**THIS PAGE IS LOCKED TO FREE MEMBERS**  
Purchase full membership to immediately unlock this page

**FORGOTTEN BOOKS**

# **FULL MEMBERSHIP**

**797,885 Books!**  
**All you can read**  
**for only**  
**\$8.99/month**

**Continue**

\*Fair usage policy applies



WHEN SHALL WE STOP TO DISCUSS RELATIVITY ?

(A comment on W. A. Scott Murray's article).

Stefan Marinov

Institute for Fundamental Physical Problems  
Morellenfeldgasse 16  
A-8010 Graz, Austria

The kinematic time dilation is an *absolute* effect and depends on the difference of the absolute velocities of the compared clocks. The gravitational time dilation is also an *absolute* effect and depends on the difference of the absolute gravitational potentials of the compared clocks. All "clock effects" observed until now give a firm and unequivocal confirmation of these two absolute phenomena. The gravitational and electromagnetic phenomena depend *not* on the *relative* velocities of the bodies but on their *absolute* velocities. The quantities which determine the gravitational and electromagnetic phenomena are the *potentials* and *not* the *intensities*. The latter are *derivatives* of the potentials and contain *less* analytical information. It may seem strange and unbelievable but the *motional-transformer induction*, appearing when a wire is at rest and a magnet moves (which is *not* reciprocal to the known *motional induction* appearing when a magnet is at rest and a wire moves), was discovered only recently by me. This discovery led me shortly to the discovery of the perpetuum mobile MAMIN COLIU.

All aspects of space-time physics, which must be considered only from an *absolute* point of view, are analysed in detail in my numerous papers, in the monograph<sup>1</sup> and in the encyclopaedic work<sup>2</sup>. I showed that the rate of any clock (i.e., the *duration* of its period, for example, the time in which a light pulse in a "light clock" goes to a mirror and returns back) depends on two factors:

- 1) on the absolute velocity of the clock,
- 2) on the absolute gravitational potential of the clock.

If the period of a "light clock" (or of a caesium clock, or of any other kind of "clock") is  $T$  when this clock is at rest in absolute space and when it is far from *local* concentration of matter, thus when its gravitational potential  $\phi$  is equal to the gravitational potential of the interstellar space, then its period for the case where the clock moves with the absolute velocity  $v \geq 0$  and the space domain in which it is located has a gravitational potential  $|\phi'| \geq |\phi|$  will be

$$T' = T \frac{1 + (\phi - \phi')/c^2}{(1 - v^2/c^2)^{1/2}}. \quad (1)$$

I call the interstellar gravitational potential  $\phi$  the *universal gravitational potential*. It is to be calculated according to the formula

$$\phi = -\gamma \int_V \frac{dm}{r}, \quad (2)$$

where  $V$  is the space of the whole universe (according to Nicolaus Cusanus, a sphere whose center is everywhere and the surface nowhere),  $\gamma$  is the gravitational constant,  $r$  is the distance from the arbitrarily chosen interstellar reference point to any

mass  $dm$  existing in the world, or *at least* to any body which can be observed and for which a more or less exact estimate of its mass and distance can be made. The calculation<sup>1,2</sup> of the integral (2) gives  $|\Phi| \leq c^2$ . It is *logical* to assume  $\Phi = -c^2$ . By the same formula (2) is to be calculated the local gravitational potential  $\Phi'$ , for which one must always obtain  $|\Phi| \geq c^2$ , as the distances to certain masses are substantially smaller of the distances when the reference point is taken in the interstellar space.

Formula (1) is *exact*<sup>1,2</sup>. Within an accuracy of second order in  $v/c$  it can be written in the form

$$T' = T(I + v^2/2c^2 + \Delta\Phi/c^2), \quad (3)$$

where I denote  $\Delta\Phi = \Phi - \Phi' \geq 0$ .

The experiment of Hafele and Keating<sup>3</sup> gave a splendid confirmation of formula (3), as it can be seen from their report, from my analysis<sup>1,2</sup> and from Dr. Murray's article<sup>4</sup>. Hafele and Keating are relativists. The theoretical explanation of their "clocks-around-the-world" experiment is given by Hafele in Ref. 5, where for predicting the effectshe uses the mathematical apparatus of "general relativity". Hafele's analysis is cumbersome (as *cumbersome* and *illégible* is any article all over the world where this apparatus is used). After the performance of the "clocks-around-the-world" experiment I tried to convince Dr. Hafele in a series of letters that his experiment is to be explained without any conceptual, mathematical and logical difficulties by the help of my simple and clear absolute space-time theory but my endeavours brought no success. Dr. Hafele remained a relativist and as such a one he left in the seventies the field of space-time physics and dedicated his time to more "earthly" matters in the Illinois Caterpillar Company. Then in 1978 I went to Washington, D.C., and tried to explain the same things to Dr. Keating personally but again my voice remained a voice in a desert.

Now Dr. Murray<sup>4</sup> points to the fact that the readings of atomic clocks placed at sea level at different latitudes give no differences in their readings. Dr. Murray asserts that "the gravitational potential at sea level is the same everywhere in the world" (p. 31), thus one has to put in (3)  $\Delta\Phi = 0$ . On the other hand, as the velocities of two points on the Earth's surface with different latitudes are different, two such clocks must have different rates, what has *not* been observed, and Dr. Murray becomes doubtful about the validity of formula (3).

Dr. Murray is simply wrong. The gravitational potentials at the points on sea level on different latitudes are *not* equal. Moreover, the following relation is valid

$$v^2 = -2\Delta\Phi, \quad (4)$$

so that it must be  $T' = T$  for two clocks placed at two different latitudes on sea level, where  $v$  is the difference in their absolute velocities and  $\Delta\Phi$  is the difference in their gravitational potentials.



Such is also the opinion of Hafele and Keating, and Dr. Murray cites it on p. 31 of his article.

Now I shall show all this analytically. On p. 31 Dr. Murray gives a cross-section of the Earth's rotational ellipsoid. The internal gravitational potential at any point  $(x,y,z)$  of such a *homogeneous, oblate, rotational* ellipsoid with major axis  $a$  and minor axis  $b$  (the axis of rotation) consisting of an incompressible fluid is given by the formula<sup>2</sup>

$$\phi = -\frac{\gamma\mu}{2}\{I_0 - I_a(x^2 + y^2) - I_b z^2\}, \quad (5)$$

where  $\mu$  is the mass density and

$$I_0 = \frac{4\pi}{3} \frac{a^2}{b^2} (4b^2 - a^2), \quad I_a = \frac{4\pi}{15} \frac{6b^2 - a^2}{b^2}, \quad I_b = \frac{4\pi}{15} \frac{3b^2 + 2a^2}{b^2}. \quad (6)$$

The potential on the equator ( $x^2 + y^2 = a^2, z = 0$ ) is

$$\phi_{\text{equ}} = -\frac{\gamma\mu}{2}(I_0 - I_a a^2), \quad (7)$$

and the potential at the pole ( $x^2 + y^2 = 0, z = b$ ) is

$$\phi_{\text{pole}} = -\frac{\gamma\mu}{2}(I_0 - I_b b^2), \quad (8)$$

so that for their difference we obtain

$$\phi_{\text{pole}} - \phi_{\text{equ}} = \frac{\gamma\mu}{2}(I_b b^2 - I_a a^2) = \frac{2\pi\gamma\mu}{15b^2}(a^4 - 4a^2 b^2 + 3b^4), \quad (9)$$

and putting here  $a = b + x$ , where  $x$  is a small positive quantity and its powers higher than the first can be neglected, we obtain

$$\phi_{\text{pole}} - \phi_{\text{equ}} \cong -\frac{2\pi\gamma\mu b}{15} x. \quad (10)$$

As this quantity is *negative*, we conclude that the gravitational potential of an oblate rotational ellipsoid at the pole is *stronger* (i.e., its *magnitude* is great than at the equator! Consequently, for a greater latitude it is always stronger than for a smaller latitude. This conclusion can be done immediately considering a *very oblate* (with  $b/a \rightarrow 0$ ) rotational ellipsoid. In such an ellipsoid the distances to the farthest from the equator masses are twice the distances to the farthest from the pole masses.

Now I shall show the validity of formula (4). The equation of a rotational ellipsoid is

$$(x^2 + y^2)/a^2 + z^2/b^2 = 1. \quad (1)$$

On the masses of this *rotating fluid* ellipsoid, besides the gravitational potential (5), also a "centrifugal potential"

$$\phi^* = -\frac{1}{2}\Omega^2(x^2 + y^2), \quad (1)$$

**THIS PAGE IS LOCKED TO FREE MEMBERS**

Purchase full membership to immediately unlock this page

**SAVE \$3,999,994**

Did you know we sell  
paperback books too?

To buy our entire catalog  
in paperback would cost  
over \$4,000,000

Access it all now for  
\$8.99/month

\*Fair usage policy applies

**Continue**

valid, and the inductions (16) and (17) are *analytically*<sup>and</sup> *physically* substantially different. The revelation of the character of the motional-transformer induction led me to the discovery of a machine which I called MAMIN COLIU (MARinov's Motional-transformer INductor COupled with a LIghtly rotating Unit) and which produces energy from nothing<sup>6,7</sup>. In this machine the rotor which is a permanent magnet induces current in a coil at rest but the magnetic field of the induced current does *not* brake the rotor's rotation.

The scientific community must change *as soon as possible* its space-time conceptions, otherwise it will continue to roam in the relativistic quagmire and, instead to come to see how MAMIN COLIU produces energy from nothing, it covers my theory and *experiments* with silence and *disdain*.

I came, however, to the conviction that the relativists are unable to change their conceptions. As relativity is already 80 years old, one can say that all living relativists were born *blind*. And it is impossible to explain to a blind man how beautiful is the world: he simply cannot understand your descriptions as a born blind has lived his whole life in darkness. Thus I think we have to leave all living relativists to die in peace and to stop the discussions with them. As now the whole energetic structure of the world must be transferred to "free energy", we have to solve many different technical and social problems which will appear. These problems we shall solve with the young people who are born now and whose eyes are still "seeing". I am addressing these young men and women.

### References

1. Marinov, S. *Eppur si muove*. C.B.D.S., Bruxelles, 1977; third ed. East-West, Graz, 1987.
2. Marinov, S. *Classical Physics*. East-West, Graz, 1981.
3. Hafele, J.C. and Keating, R.E. Around-the-world atomic clocks (two papers). *Science*, vol. 177, 1972, pp. 166, 168.
4. Murray, W.A.S. If you want to know the time... *Wireless World*, vol. , 1986, p. 28.
5. Hafele, J.C. . *Am. J. Phys.*, vol. 42, 1972, p. 81.
6. Marinov, S. *The Thorny Way of Truth, Part II*. East-West, Graz, 1984; third ed. 1986.
7. Marinov, S. Marinov to the world scientific conscience. *New Scientist*, vol. 112, 1986, p. 48.

LATE DISCOVERY OF THE MOTIONAL-TRANSFORMER INDUCTION

Stefan Marinov

Institute for Fundamental Physics

Morellenfeldgasse 16

A-8010 Graz, Austria

Abstract. Humanity knows only two kinds of induced electromagnetic intensity: the motional induction  $E_{\text{mot}} = \mathbf{v} \times \text{rot} \mathbf{A}$  and the transformer induction  $E_{\text{tr}} = - \partial \mathbf{A} / \partial t$ , where  $\mathbf{A}$  is the magnetic potential generated by the surrounding system and  $\mathbf{v}$  is the velocity of the test unit positive charge. If the surrounding system moves with a velocity  $\mathbf{v}$ , the induced electric intensity is not the topsy-turvy motional induction  $E_{\text{mot}} = - \mathbf{v} \times \text{rot} \mathbf{A}$ , as humanity thinks, but the motional-transformer induction  $E_{\text{mot-tr}} = (\mathbf{v} \cdot \text{grad}) \mathbf{A}$  which I have recently discovered.

In Ref. 1-6 I informed the scientific community that I have discovered a third type of electromagnetic induction which I called the motional-transformer induction. The motional-transformer induction had to be discovered in the XIXth century but, strangely enough, humanity failed to notice it. I see three reasons that this fundamental kind of induction remained undiscovered until the end of the XXth century:

1) The early victory of the wrong "intensity" and "flux" interaction concepts of Faraday-Maxwell (as opposed to the "potential" and "point-to-point" interaction concepts of Weber-Riemann).

2) The early victory of the wrong principle of relativity of Lorentz-Einstein (as opposed to the absolute (or aether) concepts of Newton-Ives).

3) The fact that for closed wires the motional and motional-transformer inductions lead to the same induced circular tension, as I showed in Ref. 5.

I say that I have "discovered" the motional-transformer induction. Meanwhile any logically thinking child acquainted with the basic rules of mathematics must come to it when contemplating the fundamental equation of motion in electromagnetism, called the Lorentz equation (I call it the Newton-Lorentz equation<sup>7,8</sup>)

$$\mathbf{E} = - \text{grad} \phi - \partial \mathbf{A} / \partial t + \mathbf{v} \times \text{rot} \mathbf{A}, \quad (1)$$

where  $\mathbf{E}$  is the electric intensity at the reference point, i.e., the force acting on a unit positive electric charge placed at the reference point and moving with a

velocity  $v$  in the used rest frame of reference, where the surrounding system of electric charges generates an electric potential  $\phi$  and a magnetic potential  $A$ .

Considering an electrically neutral system of charges where the electric action of the positive charges is neutralized by the electric action of the negative charges (such is a system of closed wires along which direct or alternating currents flow), we shall have  $\phi = 0$  and this assumption will be held throughout the whole paper. Let us assume that the surrounding system represents only one current loop. There are possible three fundamentally different cases:

1) The loop is at rest, the current is constant, the test charge is moving. Then equation (1) reduces to the following one

$$E_{\text{mot}} = \mathbf{v} \times \text{rot} A, \quad (2)$$

and I (as well as conventional physics) call this the motional induction.

2) The loop is at rest, the current is alternating, the test charge is at rest. Then equation (1) reduces to the following one

$$E_{\text{tr}} = - \partial A / \partial t, \quad (3)$$

and I (as well as conventional physics) call this the transformer induction.

3) The loop is moving, the current is constant, the test charge is at rest. Then equation (1) reduces to the following one, if taking into account that in this case  $A$  is an explicit function of the time  $t$  through the distances  $r_i$  of the  $n$  current elements of the loop to the reference point

$$E_{\text{mot-tr}} = - \frac{\partial A}{\partial t} = - \sum_{i=1}^n \frac{\partial A_i(r_i(t))}{\partial t} = - \sum_{i=1}^n \left( \frac{\partial A_i}{\partial r_i} \frac{\partial r_i}{\partial x_i} \frac{\partial x_i}{\partial t} + \frac{\partial A_i}{\partial r_i} \frac{\partial r_i}{\partial y_i} \frac{\partial y_i}{\partial t} + \frac{\partial A_i}{\partial r_i} \frac{\partial r_i}{\partial z_i} \frac{\partial z_i}{\partial t} \right) = \sum_{i=1}^n (\mathbf{v}_i \cdot \text{grad}) A_i, \quad (4)$$

where  $\mathbf{v}_i = - \partial \mathbf{r}_i / \partial t$  is the velocity of the  $i$ th current element of the loop, so that  $-\mathbf{v}_i$  is the velocity of the test charge in the moving inertial frame attached to  $i$ th current element of the loop. If the whole current loop moves with the velocity  $\mathbf{v}$  formula (4) reduces to the following one

$$E_{\text{mot-tr}} = (\mathbf{v} \cdot \text{grad}) A. \quad (5)$$

I call this kind of electromagnetic induction the motional-transformer induction

**THIS PAGE IS LOCKED TO FREE MEMBERS**  
Purchase full membership to immediately unlock this page

**FORGOTTEN BOOKS**

**FULL**

**MEMBERSHIP**

**797,885 Books!**

**All you can read**

**for only**

**\$8.99/month**

**Continue**

\*Fair usage policy applies



net in which tension is induced when disk and magnet rotate together but no tension is induced when only the magnet rotates) splendidly confirms<sup>4-6</sup> formula (5). The most direct confirmation of this formula and of the invalidity of formula (6) offers the today forgotten Kennard's experiment<sup>2,4-6,9</sup> which represents as a matter of fact a cemented Faraday disk where the current is "closed" through a condenser and where sliding contacts are used not at all. Müller<sup>5,6</sup> was the first physicist who developed a method to measure induced tensions not in a whole loop but only in parts of the loop and thus confirmed Kennard's measurements in closed wires.

The physical explanation of the motional-transformer induction can be given by every child. Indeed, let us again consider the test unit charge at rest and the current loop first at rest in which the current changes and then in motion preserving the current constant. The test charge will in both cases feel a change in  $A$ . And in both cases the test charge will begin to move with an acceleration  $u = - \partial A / \partial t$ , if its mass is also unit. Thus a charge at rest is accelerated always when  $A$  changes and its acceleration is opposite to  $dA$ . A moving charge is always accelerated when  $\text{rot}A \neq 0$  and its acceleration is perpendicular both to its velocity  $v$  and to  $\text{rot}A$ . This is the whole essence of magnetism. Nothing more is to be added. Thus I can only smile hearing that conventional physics sees a "physical" manifestation of the magnetic potential only in the Bohm-Aharónov effect.

I shall show the difference between formulas (5) and (6) on the example of a circular loop with a radius  $R$  along which a constant current  $I$  flows. Its magnetic potential at a reference point distant  $\rho$  ( $\rho > R$ ) from the center of the loop and lying in the loop's plane is given by the following formula, being parallel to the nearest current element,

$$A = \frac{\mu_0 I R}{2} \int_0^\pi \frac{\cos\phi \, d\phi}{(R^2 - 2R\rho\cos\phi + \rho^2)^{1/2}} = \frac{\mu_0 I R}{2(\rho^2 - R^2)^{1/2}}, \quad (7)$$

where  $\mu_0$  is the magnetic constant. Working in a cylindrical frame of reference whose  $z$ -axis is perpendicular to the loop's plane and the direction of the current is counter-clockwise if looked from the positive  $z$ -axis, we obtain for the rotation of the magnetic potential called magnetic intensity

$$\mathbf{B} = \text{rot}\mathbf{A} = \left(\frac{1}{\rho} \frac{\partial A_z}{\partial \phi} - \frac{\partial A_\phi}{\partial z}\right) \hat{\rho} + \left(\frac{\partial A_\rho}{\partial z} - \frac{\partial A_z}{\partial \rho}\right) \hat{\phi} + \left(\frac{1}{\rho} \frac{\partial(\rho A_\phi)}{\partial \rho} - \frac{1}{\rho} \frac{\partial A_\rho}{\partial \phi}\right) \hat{z} = \frac{1}{\rho} \frac{\partial(\rho A)}{\partial \rho} \hat{z} = - \frac{\mu_0 I R^3}{2\rho(\rho^2 - R^2)^{3/2}} \hat{z} \quad (8)$$

Thus when moving the test charge with a velocity  $\mathbf{v}$  away from the loop, we obtain according to formula (2) an induced electric intensity

$$\mathbf{E}_{\text{mot}} = \mathbf{v} \times \mathbf{B} = v \hat{\rho} \times B \hat{z} = -v B \hat{\phi} = \frac{\mu_0 v I R^3 \hat{\phi}}{2\rho(\rho^2 - R^2)^{3/2}} \cong \frac{\mu_0 v I R^3}{2\rho^4} \hat{\phi}, \quad (9)$$

where the result on the right side is written for  $\rho \gg R$ .

However when moving the loop away from the test charge with a velocity  $\mathbf{v}$ , we obtain according to formula (5) an induced electric intensity

$$\mathbf{E}_{\text{mot-tr}} = (\mathbf{v} \cdot \text{grad})\mathbf{A} = \left(v_\rho \frac{\partial}{\partial \rho} + \frac{v_\phi}{\rho} \frac{\partial}{\partial \phi} + v_z \frac{\partial}{\partial z}\right)(\mathbf{A}_\rho + \mathbf{A}_\phi + \mathbf{A}_z) = v \frac{\partial A}{\partial \rho} \hat{\phi} = \frac{\mu_0 v I R \hat{\phi}}{2(\rho^2 - R^2)^{3/2}} \cong \frac{\mu_0 v I R}{2\rho^2} \hat{\phi}, \quad (10)$$

where the result on the right side is written for  $\rho \gg R$ .

Formulas (9) and (10) are obviously different, while conventional physics asserts that in both these cases the induced intensity must be given by the same formula (9).

The difference between both inductions becomes drastic if we take a very long circular solenoid with radius  $R$ ,  $n$  windings on a unit of length and flowing current  $I$ , where the magnetic potential and the intensity at a reference point distant  $\rho$  ( $\rho > R$ ) from the axis of the solenoid are

$$A = \mu_0 n I R^2 / 2\rho, \quad B = 0, \quad (11)$$

so that when moving the test charge with velocity  $\mathbf{v}$  away from the solenoid or the solenoid with the same velocity away from the test charge, the motional and motional-transformer induced electric intensities will be, respectively,

$$\mathbf{E}_{\text{mot}} = \mathbf{v} \times \mathbf{B} = 0, \quad \mathbf{E}_{\text{mot-tr}} = (\mathbf{v} \cdot \text{grad})\mathbf{A} = v \frac{\partial A}{\partial \rho} \hat{\phi} = \frac{\mu_0 n I R^2}{2\rho^2} \hat{\phi} \neq 0. \quad (12)$$

Thus if such a long solenoid is encircled by a circular wire, then by moving the wire no tension in no part of the wire will be induced. However by moving the solenoid a clockwise tension will be induced in the wire's half to which the sole-



noid approaches and an equal counter-clockwise tension will be induced in the half from which the solenoid removes. Thus in the whole circular wire the tension will be null, as in the preceding case, but in parts of the wire there will be electric tensions.

One can easily understand that the motional and motional-transformer inductions can be not identical considering a magnet which can rotate about an axle perpendicular to the axis connecting its poles and a test charge in front of it at a distance  $\rho$  from the axle. When rotating the magnet about the axle a motional-transformer electric intensity will be induced. As conventional physics is unable to calculate the force acting on the test charge in this case, it is impelled to carry out the calculation by rotating the test charge around the magnet moving the charge along a circular path with radius  $\rho$ . It is obvious that those are two completely different non-inertial motions and they can in no way be considered as reciprocal even according to the principle of relativity which is valid only for two reciprocal inertial motions.

The discovery of the motional-transformer induction is of a tremendous importance for the energetic survival of mankind. The Lenz rule can be violated and energy can be created from nothing if one will succeed to induce motional-transformer electric tension in a wire lying thoroughly in space where  $B$  is zero. In such a case the magnetic ponderomotive interaction between the induced current and the magnets generating the magnetic potential will be zero and there will be no "counter action" braking the motion of the magnets, as this is the case in any conventional generator. Such a generator without magnetic braking moment is my machine MAMIN COLIU<sup>1-6</sup>.

**THIS PAGE IS LOCKED TO FREE MEMBERS**

Purchase full membership to immediately unlock this page

**SAVE \$3,999,994**

Did you know we sell  
paperback books too?

To buy our entire catalog  
in paperback would cost  
over \$4,000,000

Access it all now for  
\$8.99/month

\*Fair usage policy applies

**Continue**

THE ELECTROMAGNETIC EFFECTS ARE DETERMINED BY THE  
POTENTIALS AND NOT BY THE INTENSITIES

Stefan Marinov

Institute for Fundamental Physical Problems  
Morellenfeldgasse 16  
A-8010 Graz, Austria

I compare the magnetic fields of two infinitely long solenoids, one with a circular cross-section, the other with a rectangular cross-section, and I show that the electric intensity induced in a wire put in the solenoids depends on the magnetic potential and not on the magnetic intensity generated by the solenoids. I refer to experiments verifying my calculations.

In my books<sup>1-4</sup> and in a couple of advertisements<sup>5-7</sup> I showed that the physical and mathematical basis of conventional electromagnetism is *terribly far* from reality and in many aspects wrong. All my efforts to present my concepts, my formulas and the results of my experiments in long articles have been sapped by editors and referees in a non-gentleman way, as the collections of documents<sup>3,4</sup> clearly testify.

Let me note that in the seventies and early eighties I could publish about 40 papers dedicated predominantly to light kinematics where I showed that the principles of relativity and equivalence are wrong. I succeeded to publish the reports on two of my measurements<sup>8,9</sup> of the laboratory's absolute velocity and on my experimental disproof<sup>10</sup> of the principle of equivalence. Although the report on my last measurement of the Earth's absolute velocity by the help of the "coupled shutters" (or quasi-Fizeau) experiment, carried out in Graz in February 1984 and published only in my book<sup>4</sup> and in the collection<sup>11</sup> edited by Wesley, can by yet not find space in the journals of the "establishment", one can say that my achievements in space-time physics are sufficiently well known to the scientific community, taking also into account that I took part in all important conferences on space-time physics in the last decade and organized my own conference<sup>12</sup>. Nevertheless the scientific community ignores my *extremely important* contributions. If one would peruse the *Citation Index*, one will see that no more than 10 authors have referred to my works.

However my experimental and theoretical research after 1983, inspired by the excellent experiments of F. Müller (Miami, USA) revealing the "seat" of the electromagnetic induction (the reports on Müller's experiments can be seen only in Refs. 4 and 11), led me not only to the conclusion that the conventional Maxwell-Einstein concepts on electromagnetism are wrong but that even the fundamental laws of energy and angular momentum conservation can be violated in electromagnetism. I carried out a couple of experiments where such violations can easily be observed<sup>3-7</sup>. As these *fantastic* aspects of electromagnetism are of an extreme importance for the

energetic and ecological survival of mankind, I do not abandon the efforts to bring my discoveries to the judgement of the scientific community.

This article is dedicated to the big problem whether the electric and magnetic potentials,  $\phi$  and  $\vec{A}$ , or the electric and magnetic intensities,  $\vec{E}$  and  $\vec{B}$ , are the relevant *primordial* physical quantities which determine the motion of the charged particles. As  $\vec{E}$  and  $\vec{B}$  are defined as space and time derivatives of  $\phi$  and  $\vec{A}$ , there must be, evidently, a certain freedom in the "choice" of  $\phi$  and  $\vec{A}$  which is expressed in the so-called gauge transformation<sup>2</sup>. To be shorter, I shall explain what a gauge transformation is speaking with a "four-dimensional language", largely used in my theoretical approach<sup>2</sup>. If  $\vec{A}$  is the electromagnetic 4-potential by whose help the electromagnetic intensity 4-tensor  $\overset{\leftrightarrow}{F}$  can be calculated according to the formula<sup>2</sup>

$$\overset{\leftrightarrow}{F} = \nabla \times \vec{A}, \quad (1)$$

where by the sign  $\vec{\phantom{A}}$  I denote a 4-vector, by the sign  $\overset{\leftrightarrow}{\phantom{F}}$  a 4-tensor, and by the sign  $\nabla = (\partial/\partial x)\hat{x} + (\partial/\partial y)\hat{y} + (\partial/\partial z)\hat{z} - (\epsilon_0\mu_0)^{1/2}(\partial/\partial t)\hat{t}$  the Erma operator, then by the help of a new 4-potential

$$\vec{A}' = \vec{A} + \nabla f(x,y,z,t), \quad (2)$$

where  $f(x,y,z,t)$  is an arbitrary function of the space and time coordinates of the reference point, the same electromagnetic intensity 4-tensor will be obtained, as the following mathematical equality is identically valid  $\nabla \times \nabla f(x,y,z,t) = 0$ . This equality is the 4-dimensional analogue to the 3-dimensional identically valid equality  $\text{rot}\{\text{grad}f(x,y,z)\} = 0$ .

Thus for conventional physics  $\vec{A}$  and  $\vec{A}'$  are *physically* identical quantities, although *mathematically* they are different.

My theory and *experiments* lead to the undoubtful conclusion that the *primordial* physical quantities are the electric and magnetic potentials and thus the 4-potentials  $\vec{A}$  and  $\vec{A}'$  are *not* identical physically as they lead to *different* motions of the test charge.

Here I shall shortly note that conventional physics accepts that the magnetic potential can be "observed" only in quantum electromagnetism, namely in the so-called Bohm-Aharonov effect. In the whole domain of classical electromagnetism, according to the conventional theory, one can "observe" only  $\vec{E}$  and  $\vec{B}$ . According to me one can "observe" neither  $\phi$ ,  $\vec{A}$  nor  $\vec{E}$ ,  $\vec{B}$ ; one observes only relative displacements of material objects. These relative displacements are absolute and do not depend on the "observer". The relativistic concepts that the observer A sees this and the observer B sees that are totally nonsensical. The observers A and B always see the same things, namely that the object C has moved in a certain way with respect to the object D. How our formulas describe these displacements is a mental speculation.

Now I shall show that I am right and conventional electromagnetism wrong. I showed<sup>4</sup> that if we have a magnet and a wire, then the cases: 1) magnet at rest, wire

moving, and 2) wire at rest, magnet moving, lead to *different* intensities induced in the wire. I showed further<sup>4</sup> that for *closed* wires the induced electric tensions become equal but for *non-closed* wires they are, in general, different.

Let us have an infinitely long solenoid with a circular cross-section and an axis parallel to the z-axis of the reference frame which rests in absolute space. It is well-known that the magnetic intensity in the solenoid is constant pointing along the z-axis, i.e.,  $\vec{B} = B_z \hat{z}$ , where  $B_z = \text{Const}$ . For  $\vec{B}$  constant the following mathematical relation is valid

$$\text{rot}(\vec{B} \times \vec{r}) = -(\vec{B} \cdot \text{grad})\vec{r} + \vec{B} \text{div}\vec{r} = -\vec{B} + 3\vec{B} = 2\vec{B}. \quad (3)$$

Comparing this with the definition equality  $\vec{B} = \text{rot}\vec{A}$ , we can write

$$\vec{A} = (1/2)\vec{B} \times \vec{r} + \vec{A}_0, \quad (4)$$

where  $\vec{A}_0$  is an unknown vector whose rotation is equal to zero. If we choose  $\vec{A}_0 = 0$ , we can write the magnetic potential in components as follows

$$\vec{A} = (-yB_z/2, xB_z/2, 0). \quad (5)$$

Such is the magnetic potential in an infinitely long *cylindrical* solenoid. If, however, the infinitely long solenoid has a *rectangular* cross-section (see in fig. 1 the cross-section of the solenoid in the xy-plane), with  $b \ll d$ , where  $b$  is the side parallel to the y-axis and  $d$  is the side parallel to the x-axis, the undetermined vector  $\vec{A}_0$  in (4) is to be chosen as follows  $\vec{A}_0 = (-yB_z/2, -xB_z/2, 0)$ . Now the magnetic potential in (4) will have the following components

$$\vec{A} = (-yB_z, 0, 0). \quad (6)$$

One can easily find the potentials (5) and (6) by proceeding from the definition equality for the magnetic potential (which, I must emphasize, represents the assertion of the eighth axiom of my theory of classical physics<sup>1,2</sup>)

$$\vec{A} = \frac{\mu_0}{4\pi} \sum_{i=1}^n (I d\vec{r}_i) / r_i, \quad (7)$$

where  $\mu_0$  is the magnetic constant,  $I$  is the current flowing in the solenoid,  $d\vec{r}_i$  is the  $i$ -th current element, and  $n$  is the number of all current elements of the solenoid.

The *exact* mathematical calculation of  $\vec{A}$  and  $\vec{B}$  of an infinitely long circular solenoid can be found in a *very limited* number of publications<sup>13,14</sup>. If  $\vec{\rho}$  is the polar radius-vector of the reference point in a cylindrical frame of reference whose z-axis coincides with the solenoid's axis,  $R$  the radius of the circular cross-section,  $I$  the flowing current, and  $n$  the number of turns on a unit of length, we shall have (for a counter-clockwise direction of the current if looking from the positive end of the z-axis) ·

**THIS PAGE IS LOCKED TO FREE MEMBERS**  
Purchase full membership to immediately unlock this page

**FORGOTTEN BOOKS**

**FULL**

**MEMBERSHIP**

**797,885 Books!**

**All you can read**

**for only**

**\$8.99/month**

**Continue**

\*Fair usage policy applies



Thus we see that for  $|y| \ll b$  the formula (6) is verified taking into account that in the previous solenoid the current flows in the opposite direction.

Hence the magnetic intensity in two very long solenoids, respectively with a circular and rectangular cross-sections (the latter with  $b \ll d$ ) have the *same* constant value in the solenoid (see formulas (8) and (12)). Consequently, conventional physics will predict that the motion of a test charge in two such solenoids must have exactly the same character. However the magnetic potentials of these two solenoids have *different* values (see formulas (5) or (8) and (6) or (11)). And I affirm that the motion of a test charge in two such solenoids *must be different*.

The experiments which confirm my stand-point are the following: Let us put the wire  $b-b_0$  in the rectangular solenoid, first as it is shown in fig. 1, i.e., in parallel to the y-axis and then in parallel to the x-axis. If now we move the wire with a velocity  $v$ , respectively along the positive direction of the x-axis and along the positive direction of the y-axis, the induced electric intensity which I (and conventional physics, too) call *motional* electric intensity and <sup>which</sup> is to be calculated from the formula

$$\vec{E}_{\text{mot}} = \vec{v} \times \text{rot} \vec{A} \quad (13)$$

will be

$$E_y = -v_x B_z = \mu_0 n I v \quad (14)$$

in the first case, and

$$E_x = v_y B_z = -\mu_0 n I v \quad (15)$$

in the second case.

If, however, the wire will be kept at rest and the solenoid will be moved with the two mentioned velocities, the induced electric intensity which I have *discovered* and called *motional-transformer* electric intensity and which is to be calculated from the formula<sup>3-7</sup>

$$\vec{E}_{\text{mot-tr}} = (\vec{v} \cdot \text{grad}) \vec{A} \quad (16)$$

will give

$$E_y = v_x (\partial A_y / \partial x) = 0 \quad (17)$$

in the first case, and

$$E_x = v_y (\partial A_x / \partial y) = \mu_0 n I v \quad (18)$$

in the second case.

If we should move wire and solenoid *together*, then in the first case (when the wire is parallel to the y-axis and the motion is along the positive direction of the x-axis) the induced electric intensity will be given by formula (14), while in the second case (when the wire is parallel to the x-axis and the motion is along the positive direction of the y-axis) the induced electric intensity will be null. These results are obtained as *superposition* of the motional and motional-transformer inductions.

These predictions of my theory are *splendidly confirmed* by the induction effects which I observed in the *demonstrational Faraday-Barlow machine* constructed recently by me<sup>4,15</sup> and by the *historical Kennard's experiment*<sup>16</sup> which is almost totally forgotten by conventional electromagnetism. The explanation of the effects observed by Kennard is given by me in refs. 3, 4 and 7.

If one cannot understand what a motional-transformer induction is, one will be unable to understand how can I create energy out of nothing in my perpetuum mobile MAMIN COLIU<sup>3,4,6,7</sup>.

The dispute whether the electromagnetic intensities or the electromagnetic potentials determine the electromagnetic effects reminds me the story of a rabbi who had to decide the quarrel of two neighbours about a goat. After having heard both sides, the rabbi concluded that both disputants are right. Returning home, he told this to his son who exclaimed: "But how can both be right, if they defend different versions!" "And you, too, are right, my son" sighed the rabbi.

It is time for the scientific community to understand that the potentials and not the intensities determine the electromagnetic interactions. But I must emphasize that the scientific community will be able to do this, only after having thrown over board the relativistic nonsense.

#### REFERENCES

- <sup>1</sup> S. Marinov, *Eppur si muove* (C.B.D.S., 1977, third ed. East-West, Graz, 1987).
- <sup>2</sup> S. Marinov, *Classical Physics* (East-West, Graz, 1981).
- <sup>3</sup> S. Marinov, *The Thorny Way of Truth, Part I* (East-West, Graz, 1982, sec. ed. 1987).
- <sup>4</sup> S. Marinov, *The Thorny Way of Truth, Part II* (East-West, Graz, 1984, third ed. 1986).
- <sup>5</sup> S. Marinov, *Nature* 317, p. xii (26 Sept. 1985).
- <sup>6</sup> S. Marinov, *Nature* 322, p. x (21 August 1986).
- <sup>7</sup> S. Marinov, *New Scientist* 112, 48 (1986).
- <sup>8</sup> S. Marinov, *Czech. J. Phys.* B24, 965 (1974).
- <sup>9</sup> S. Marinov, *Gen.Rel. Grav.* 12, 57 (1980).
- <sup>10</sup> S. Marinov, *Ind. J. Theor. Phys.* 31, 93 (1983).
- <sup>11</sup> J. P. Wesley, *Progress in Space-Time Physics 1987* (Benjamin Wesley, Blumberg, West Germany, 1987).
- <sup>12</sup> S. Marinov and J. P. Wesley, *Proceedings Int. Conf. Space-Time Absoluteness* (East-West, Graz, 1982).
- <sup>13</sup> W. T. Scott, *The Physics of Electricity and Magnetism* (John Wiley, New York, 1966).  
B. B. Dasgupta, *Am. J. Phys.* 52, 258 (1984).  
S. Marinov, *Int. J. Gen. Systems* 13, 2 (1987).
- <sup>16</sup> E. H. Kennard, *Philosoph. Mag.* 33, 179 (1917).

#### FIGURE CAPTION

Fig. 1. - Cross-section of a rectangular solenoid.



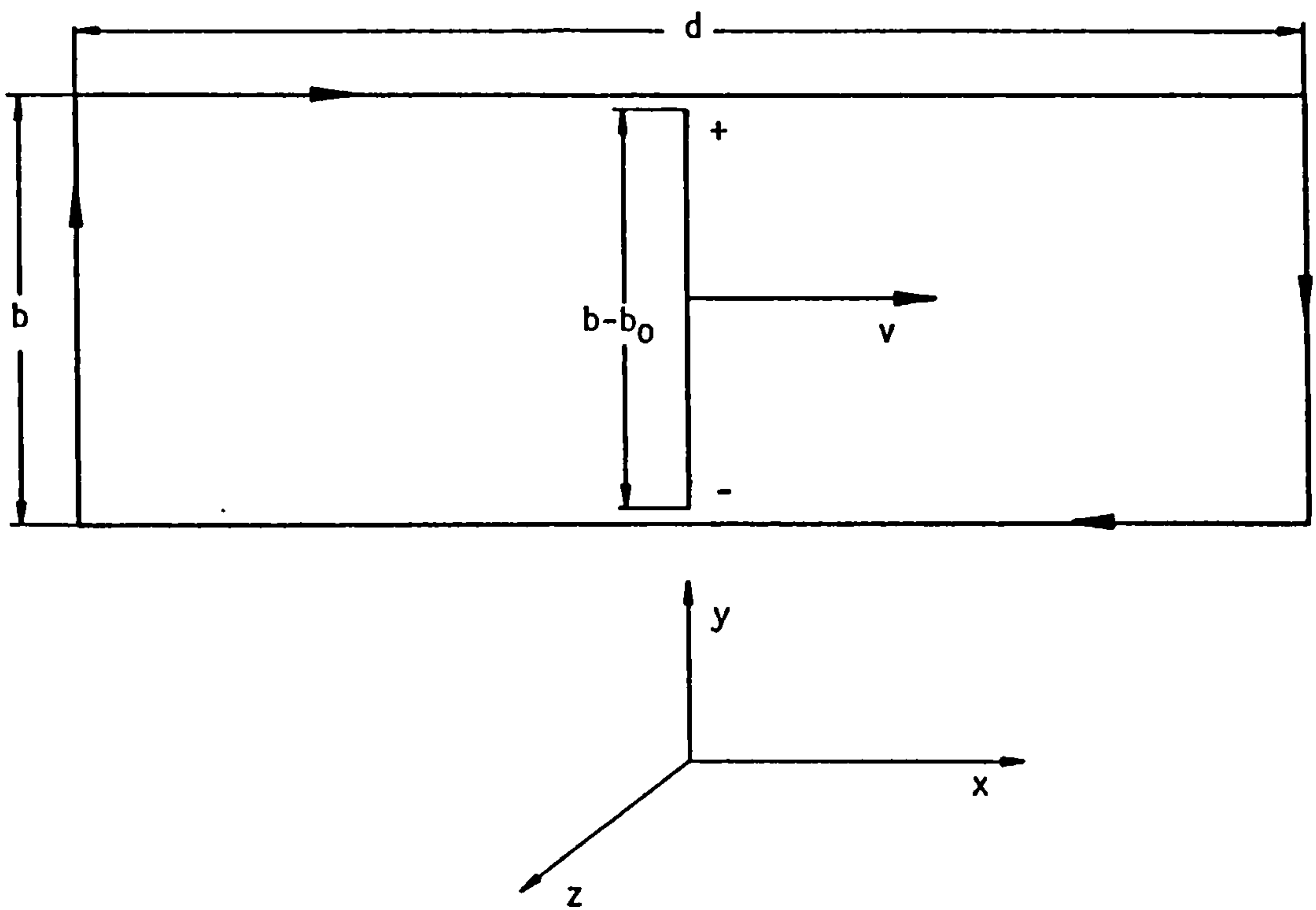

Fig. 1

**THIS PAGE IS LOCKED TO FREE MEMBERS**

Purchase full membership to immediately unlock this page

**SAVE \$3,999,994**

Did you know we sell  
paperback books too?

To buy our entire catalog  
in paperback would cost  
over \$4,000,000

Access it all now for  
\$8.99/month

\*Fair usage policy applies

**Continue**

plates has someone measured ponderomotive forces when putting the capacitor in an external magnetic intensity field.

The situation with respect to the first of the above characteristics is the following: Any author of textbooks on electromagnetism asserts that displacement current with density  $J_D = (1/4\pi)\partial E/\partial t$ , where  $E$  is the electric intensity at a reference point taken between the plates of a capacitor, generates the same magnetic intensity as conduction current with density  $J_C = J_D$ . However, strangely enough, there is only one article<sup>1</sup> where this magnetic intensity has been allegedly measured. Indeed, Bartlett and Corle (B+C) write<sup>1</sup> (p. 59): "To our knowledge, however, no one has as yet measured the displacement current in the apparently direct fashion by observing the magnetic field inside a capacitor that is being slowly charged." I can confirm that this is true according to my knowledge, too. But I must add that B+C have not measured the magnetic field of displacement current as they claim, as the displacement current does not generate magnetic field.

The apparatus and the measuring method of B+C are too complicated to be discussed here in detail. I shall only say the following: According to the prevailing opinion of the specialists in electromagnetism (and according to my opinion), the magnetic field of a current element (the density of the displacement current multiplied by the volume between the capacitor's plates is such a current element) cannot be measured, as one cannot isolate the magnetic field of the remaining part of the circuit. One is able only to measure the ponderomotive action on a current element by using sliding contacts, but, as I noted above, nobody until today has succeeded to measure forces acting on vacuum. Nevertheless, B+C, although understanding all those difficulties, claim of having resolved the problem for an element of alternating current. Meanwhile until today nobody all over the world has succeeded in measuring the magnetic field even of an element of direct current.

First I shall give some simple theory. Let us have a wire of length  $d$  and let us find the magnetic potential at a distance  $r$  from the middle of the wire if current  $I$  flows along it. According to the fundamental definition equality (the eighth axiom of my absolute space-time theory<sup>2</sup>), the magnetic potential generated by a current ele-

ment  $I dr$  ( $dr$  is a linear element directed along the electric current  $I$  flowing in a wire) at a distance  $r$  from it is  $\mathbf{A} = I dr / cr$ , where  $c$  is the velocity of light (in the system CGS). Thus for the magnetic potential of our straight wire we shall have, taking the  $x$ -axis parallel <sup>(the current flowing in the positive direction)</sup> to the wire, its origine at the middle of the wire, the  $y$ -axis pointing to the reference point, and considering the magnetic potential of the whole wire as twice the potential generated by its right half,

$$\mathbf{A}_d = (2I/c) \int_0^{d/2} (x^2 + y^2)^{-1/2} dx \hat{\mathbf{x}} = (2I/c) \text{Arsinh}(d/2y) \hat{\mathbf{x}}. \quad (1)$$

For the magnetic intensity, <sup>at a point on the positive  $y$ -axis,</sup> according to the definition equality, we shall have

$$\mathbf{B}_d = \text{rot} \mathbf{A}_d = (2Id/cy)(d^2 + 4y^2)^{-1/2} \hat{\mathbf{z}}. \quad (2)$$

Thus the magnetic intensity generated by an infinitely long wire at a distance  $y = r$  from it will be

$$\mathbf{B}_\infty = (2I/cy) \hat{\mathbf{z}}. \quad (3)$$

Let us now consider an infinitely long wire which is interrupted in the middle by a capacitor, the distance between whose <sup>circular</sup> plates is  $d$ . According to my concepts, the magnitude of the magnetic intensity at a point distant  $r$  from the central point of the axis of the capacitor will be

$$B = B_\infty - B_d = (2I/cr) \{1 - d(d^2 + 4r^2)^{-1/2}\} \cong 4Ir/cd^2, \quad (4)$$

where the result on the right side is written for  $d \gg r$ . Thus we see that if, at this condition, we measure the magnetic field at different distances,  $r$ , from the central point of the capacitor's axis, the magnetic intensity will be directly proportional to  $r$ .

Exactly these kind of measurements have been done by B+C. One can see this reading in the abstract of their paper which I give in toto: "We have measured the magnetic field directly inside a thin, circular, parallel-plate capacitor as it is being charged. We find that this field varies linearly with distance from the axis, as is to be expected if a uniform displacement current flows between the plates. The measured slope of  $B$  vs  $r$  agrees with predictions to within 5%."

B+C have found from the slope of their measuring graph  $dB/dr = 1.171 \pm 0.005$  mG/cm. This result says only one thing (supposing that the radius,  $R$ , of the capacitor's plates is substantially smaller than  $d$ ): That for their experiment

$$I/d^2 = (c/4)dB/dr = 8782 \text{ abampere/cm}^2 = 5 \times 10^{-9} \text{ A/cm}^2. \text{ Nothing else!}$$

B+C have established that at a certain distance  $r_0$  the magnetic field was maximum and then it began to decrease with the increase of  $r$ . This distance  $r_0$  can be found by differentiating the exact formula (4) with respect to  $r$ . This gives  $r_0 = 0.64d$ , for infinitely long conducting wires. If the length,  $D$ , of the conducting wires is comparable with the separation,  $d$ , between the capacitor's plates,  $r_0$  is obtained as a solution of an equation of power 4 with respect to  $r_0^2$ . In the experiment of B+C  $D \cong 10d$  and they found experimentally  $r_0 = 3.6d$  (at  $R/d = 3.1$ ).

To establish with an absolute surety that the displacement current does not generate magnetic field, I carried out the following experiment. The space of a cylindrical capacitor with a variable distance,  $d$ , between its plates, to which alternating current along long enough wires was conducted, was filled with barium titanat (whose electrical permittivity is about 10,000). In the circuit changeable inductive coils with thick wire and low Ohmic resistance were inserted and at any specific distance between the capacitor's plates, and respective specific capacitance, a respective induction was inserted, so that the circuit remained always at resonance at the used 50 Hz frequency of tension coming from a variable transformer. I measured the magnetic field produced only by the "positive" pulses of the current by the help of a Hall sond put at a constant distance  $r = 10$  cm from the central point of the capacitor's axis. The distance between the plates was changed from  $d = 0$  to  $d = 6$  cm and by changing the tension applied (and the inductance of the coils), the current was always maintained at  $I = 10$  A. The capacitor's plates were etched, by the help of what the surface and capacitance can be increased until 100 times. The radius of the plates was  $R = 4$  cm.

As the current flowing along the wires was maintained always at the same value, the displacement current "flowing" between the plates of the capacitor had always the same value and, according to Maxwell's concepts, the magnetic field at the

**THIS PAGE IS LOCKED TO FREE MEMBERS**  
Purchase full membership to immediately unlock this page

**FORGOTTEN BOOKS**

# **FULL MEMBERSHIP**

**797,885 Books!**  
**All you can read**  
**for only**  
**\$8.99/month**

**Continue**

\*Fair usage policy applies



derable lengths of displacement currents.

My Bul-Cub Machine without Stator<sup>5</sup> shows violation of the angular momentum conservation law as a body of about 2 kg comes into rotation only by the action of internal forces. First Graham and Lahoz<sup>6</sup> have observed such a violation but neither they nor the whole scientific community has understood the capital importance of their experiment.

Another apparatus constructed recently by me which violates the angular momentum conservation law using the fact that displacement current cannot absorb magnetic forces is my Rotating Ampere's Bridge<sup>5</sup>. An apparatus which is planned to be constructed and which will violate the momentum conservation law is my Flying Ampere's bridge. Both these apparatus are based on the self-propulsion<sup>5</sup> of a  $\Pi$ -form wire observed first by Ampere.

Let me note that Dr. Maddox<sup>7</sup> cheered the experimental success of B+C in a lengthy comments entitled "Measuring the unmeasurable". I think that Dr. Maddox has to entitle his comments on my above experiment by something like "Alas, the unmeasurable cannot be measured".

- 
1. D. F. Bartlett and T. R. Corle, Phys. Rev. Lett. **55**, 59 (1985).
  2. S. Marinov, Classical Physics (East-West Publ., Graz, 1981).
  3. S. Marinov, The Thorny Way of Truth, Part II (East-West<sup>Publ.</sup>, Graz, 1984, third ed. 1986).
  4. H. Grassmann, Pogg. Ann. **64**, 4 (1845).
  5. S. Marinov, The Thorny Way of Truth, Part III (East-West Publ., Graz, 1988).
  6. G. M. Graham and D. G. Lahoz, Nature **285**, 154 (1980).
  7. J. Maddox, Nature **316**, 101 (1985).

PHYSICAL ESSENCE OF THE MAXWELL-LORENTZ EQUATIONS

Stefan Marinov  
Institute for Fundamental Physics  
Morellenfeldgasse 16  
A-8010 Graz, Austria

I show that the whole body of electromagnetism can be deduced by mathematical speculations only from two axiomatic assertions, the laws of Coulomb and Neumann. The equation of motion to which these two laws lead is the fundamental Lorentz equation (which I call the Newton-Lorentz equation). The "Lorentz condition" giving the relation between the electric and magnetic potentials is a simple mathematical corollary from their definition equalities and I call it the equation of potential connection. The Maxwell-Lorentz equations are trivial mathematical corollaries from the Newton-Lorentz equation, the equation of potential connection, and the mathematical relations between electric and magnetic potentials, on the one side, and charge and current densities, on the other. Maxwell's displacement current, with respective magnetic properties, does not exist. This allows to violate the laws of momentum and angular momentum conservation as I recently did experimentally.

PACS numbers: 03.50.De, 41.10.Fs

My electromagnetic experiments<sup>1-5</sup> showed that the electromagnetic interactions:

- 1) Depend on the absolute and not on the relative velocities of the particles.
- 2) Are "point-to-point" and not "closed current" and "flux" interactions.
- 3) Are determined by the electric and magnetic potentials and not by the electric and magnetic intensities, the latter being simple mathematical functions of the former.
- 4) Are momentary and do not propagate with the velocity of light (with the velocity of light propagate only radiated energy and conduction current).
- 5) Violate the laws of momentum, angular momentum and energy conservation.



It is too early to present a rigorous logical theory explaining all known and newly observed electromagnetic phenomena. As contemporary physics is based exclusively on the laws of conservation, thousands of experiments are to be carried out and sufficient experimental evidence is to be scrutinized before being able to propose a satisfactory theory.

In this paper I shall only try to point out at certain erroneous concepts of conventional theory with the aim to make more easy the acceptance of the "strange" results of my experiments, noting that the latter, as a matter of fact, appear incorporated in the mathematical body of conventional electromagnetic theory if one looks at the formulas from a rigorous logical point of view.

I showed<sup>1,2</sup> that whole classical electromagnetism is mathematical corollary of the following two axiomatic assertions:

If there are two electric charges,  $q_1$ ,  $q_2$ , moving with the velocities  $v_1$ ,  $v_2$ , and the distance between them is  $r$ , then

1) their electric energy is (Coulomb's law)

$$U = q_1 q_2 / r, \quad (1)$$

2) their magnetic energy is (Neumann's law)

$$W = q_1 q_2 v_1 \cdot v_2 / c^2 r, \quad (2)$$

where  $c$  is the velocity of light (in the CGS-system).

Using the law of superposition (the electric and magnetic energies of a system of more than two charges is the sum of the energies of all its pairs) and putting (1) and (2) in the law of conservation of energy,  $dE_0 + dU + dW = 0$ , where  $E_0$  is the sum of the time energies (my term)  $e_0 = mc^2(1 - v^2/c^2)^{-1/2}$  of any of the particles of the system,  $m$  being the respective particle's mass and  $v$  its velocity, I showed<sup>1,2</sup> that one can by rigorous (and very simple) mathematical speculations obtain the Newton-Lorentz equation and from it all electromagnetic "laws" (thus, in electromagnetism there are, practically, only two "experimental" laws: those of Coulomb and Neumann).

I obtain the fundamental equation in electromagnetism (the equation of motion) which I call the Newton-Lorentz equation in the form

$$(d/dt)(p_0 + q\mathbf{A}/c) = -q \text{grad}(\phi - \mathbf{v} \cdot \mathbf{A}/c), \quad (3)$$

**THIS PAGE IS LOCKED TO FREE MEMBERS**

Purchase full membership to immediately unlock this page

**SAVE \$3,999,994**

Did you know we sell  
paperback books too?

To buy our entire catalog  
in paperback would cost  
over \$4,000,000

Access it all now for  
\$8.99/month

\*Fair usage policy applies

**Continue**

$$\text{rot} \mathbf{B} = \partial \mathbf{E} / c \partial t + (4\pi/c) \mathbf{J}, \quad (11)$$

$$\text{div} \mathbf{E} = 4\pi \mathbf{Q}. \quad (12)$$

The first pair of the Maxwell-Lorentz equations is a trivial mathematical corollary of the definition equations (7). Moreover, the first equation (7) offers much more information than eq. (8), as many aspects of the function  $\mathbf{E}$  disappear in the function  $\text{rot} \mathbf{E}$  which is a special space derivative (rotation) of  $\mathbf{E}$ . But Maxwell, by substituting  $\text{rot} \mathbf{A}$  in (8) by  $\mathbf{B}$ , tried to show that  $\mathbf{E}$  becomes to a certain degree a function of  $\mathbf{B}$  (and vice versa). This is a capital error.  $\mathbf{E}$  is a function only of  $\phi$  and  $\mathbf{A}$ , and  $\mathbf{B}$  is a function only of  $\mathbf{A}$ . If  $\mathbf{E}$  and  $\mathbf{B}$  are defined according to eq. (7), then, by necessity, they will be related by the relation (8), but this does not signify that they become functions of one another and the assertion that the "magnetic field" can generate "electric field" (and vice versa) is senseless.

Following the same trend, Maxwell supposed that according to equation (11)  $\mathbf{B}$  becomes to a certain degree a function of  $\mathbf{E}$ . This is again not true.  $\mathbf{B}$  is simply another mathematical presentation of  $\mathbf{A}$ , noting that  $\mathbf{A}$ , of course, contains much more information than  $\mathbf{B}$ , as  $\mathbf{B}$  is a special space derivative of  $\mathbf{A}$ .

Now I shall show why Maxwell's concepts are wrong. As a matter of fact only eq. (11) needs a critical examination, as eq. (8) and (9) are completely plain and do not need any discussion. It is even too lofty to call them "equations" and to attach to them the names of certain persons, as they are trivial mathematical corollaries of the definition equalities (7). Eq. (12) is not such a trivial consequence of eq. (7), as for its deduction one needs also eq. (10) and (5) but its physical treatment does not offer difficulties.

Thus critical remains only eq. (11). Maxwell supposed that if a conduction current becomes <sup>interrupted</sup> at the plates of a capacitor, between those plates a current with density  $\mathbf{J}_D = (1/4\pi) \partial \mathbf{E} / \partial t$  "flows" which he called "displacement current". Maxwell supposed that displacement current has the same "magnetic character" as conduction current with the same density  $\mathbf{J} = \mathbf{J}_D$ , i.e., that it generates magnetic forces and reacts with ponderomotive force to the magnetic forces of other conduction currents. I showed<sup>3-5</sup> that this is not true: the displacement current neither generates magne-

tic forces nor "absorbs" magnetic forces of other currents. Thus eq. (11) is not to be treated as Maxwell and conventional physics do.

To make its interpretation more clear, let us present eq. (11) in its integral form which can be obtained by integrating eq. (11) over a certain surface  $S$  bounded by the closed line  $L$  and using Stokes' theorem

$$\oint_L \mathbf{B} \cdot d\mathbf{l} = (1/c)(\partial/\partial t) \int_S \mathbf{E} \cdot d\mathbf{s} + (4\pi/c) \int_S \mathbf{J} \cdot d\mathbf{s}. \quad (13)$$

The magnetic intensity  $\mathbf{B}$  is generated by the currents in whole space. Meanwhile in (13) the linear integral of  $\mathbf{B}$  along the closed path  $L$  is related only to the conduction current crossing the surface  $S$ . If from both sides of  $S$  there are capacitor's plates on which conduction currents interrupt, those interrupted conduction currents generate such an electric intensity field  $\mathbf{E}$  between the capacitor's plates that  $\oint \mathbf{B} \cdot d\mathbf{l} = (\partial/c\partial t) \int \mathbf{E} \cdot d\mathbf{s}$ . Thus it is not the changing electric field  $\partial\mathbf{E}/\partial t$  which generates  $\mathbf{B}$ . The integral on the right side gives simply information about the quantity of conduction current interrupted by the surface  $S$ .  $\mathbf{B}$  is determined only by  $\mathbf{A}$ , i.e., only by flowing charges. But neither at the reference point (eq. (11)) nor at the surface  $S$  (eq. (13)) are there flowing charges. Nevertheless a magnetic field may exist between the capacitor's plates. Information about the conduction currents flowing in the neighbourhood of surface  $S$ , which determine  $\mathbf{B}$ , is given through the quantity  $\partial\mathbf{E}/\partial t$ .

This is the physical essence of the "displacement current" and of the third (and most discussed) Maxwell-Lorentz equation. Although the term "displacement current" is highly inappropriate, for historical reasons, I think, we have to call further the quantity  $(1/4\pi)\partial\mathbf{E}/\partial t$  density of the displacement current, knowing firmly that such a current, as physical quantity provided with adequate magnetic properties, does not exist.

Before considering eq. (11) and (13) at the availability of dielectrics, I should like to classify the different electromagnetic forces which act on a unit positive electric charge, as the concepts of conventional physics here are in many aspects wrong.

The fundamental Newton-Lorentz equation (6) - its left-hand side - shows that

these forces are three. The first force is electric, i.e., it is originated by the electric potential of the surrounding system, and the other two forces are magnetic, i.e., they are originated by the magnetic potential of the surrounding system: :

1) Coulomb electric intensity

$$E_{\text{coul}} = - \text{grad}\Phi. \quad (14)$$

2) Transformer electric intensity

$$E_{\text{tr}} = - (1/c)\partial A/\partial t. \quad (15)$$

3) Motional electric intensity

$$E_{\text{mot}} = (\mathbf{v}/c)\times\text{rot}\mathbf{A}. \quad (16)$$

The transformer electric intensity can have two substantially different aspects:

2a) Rest-transformer electric intensity (in case where the wires of the surrounding systems are at rest and only the flowing currents change)

$$E_{\text{rest-tr}} = - (1/c)\partial A(t)/\partial t. \quad (17)$$

2b) Motional-transformer electric intensity (in case where the currents flowing in the wires of the surrounding system are constant but the wires move, and the magnetic potential becomes a composite function of time through the radius-vectors,  $\mathbf{r}_i$ , of the different current elements whose total number is  $n$ )

$$E_{\text{mot-tr}} = -\frac{1}{c} \sum_{i=1}^n \frac{\partial A_i\{\mathbf{r}_i(t)\}}{\partial t} = -\frac{1}{c} \sum_{i=1}^n \left( \frac{\partial A_i}{\partial x_i} \frac{\partial x_i}{\partial t} + \frac{\partial A_i}{\partial y_i} \frac{\partial y_i}{\partial t} + \frac{\partial A_i}{\partial z_i} \frac{\partial z_i}{\partial t} \right) = \frac{1}{c} \sum_{i=1}^n (\mathbf{v}_i \cdot \text{grad}) A_i, \quad (18)$$

where  $\mathbf{v}_i = - \partial \mathbf{r}_i / \partial t$  is the velocity of the  $i$ th current element of the surrounding system which generates the magnetic potential  $A_i$  at the reference point.

Conventional physics does not know the motional-transformer electric intensity which I have recently discovered<sup>3</sup>.

The unification of  $E_{\text{coul}}$  and  $E_{\text{tr}}$  in one quantity  $E = E_{\text{coul}} + E_{\text{tr}}$ , according to the first formula (7), called electric intensity, has certain advantages when one works with the 4-dimensional mathematical apparatus, but leads to many inconveniences as one unifies in one quantity an electric and a magnetic force.

It is obvious that the Maxwell-Lorentz equation (8) must be written

$$\text{rot}E_{\text{tr}} = - (1/c)\partial B/\partial t, \quad (19)$$

**THIS PAGE IS LOCKED TO FREE MEMBERS**  
Purchase full membership to immediately unlock this page

**FORGOTTEN BOOKS**

**FULL**

**MEMBERSHIP**

**797,885 Books!**

**All you can read**

**for only**

**\$8.99/month**

**Continue**

\*Fair usage policy applies



than the cross-section of the capacitor, then  $\int_S \mathbf{D} \cdot d\mathbf{s} = 4\pi q$ , where  $q$  is the charge on the one of the plates. Consequently, for any distance between the plates, the integral  $\int_S (\partial \mathbf{D} / \partial t) \cdot d\mathbf{s}$  will have the same value, equal to the value when the plates will be infinitely near one to another, in which case  $\mathbf{E} = \mathbf{D}$ . Thus we see that if eq. (13) is to be written with  $\mathbf{D}$  instead with  $\mathbf{E}$ , then for different distances between the plates the same magnetic intensity  $\mathbf{B}$  will be calculated along the line  $L$ . My experiment<sup>4</sup>, however, showed that at  $\epsilon \approx 10,000$  which can be considered as high enough,  $\mathbf{B}$  is dependent on the distance between the plates and thus equation (13), as well as equation (21) are to be written not with  $\mathbf{D}$  but with  $\mathbf{E}$  also in the case of availability of dielectrics. This is easily understandable.  $\mathbf{B}$  is determined only by conduction currents.  $\partial \mathbf{E} / \partial t$  on the surface  $S$  gives information about the conduction currents which are by this surface interrupted. The dielectric only deforms the electric intensity lines, concentrating them to the space of location of the dielectric, but the dielectric changes nothing on the quantity of free charges  $q$ .

If in the space domain of the considered system there are magnetics with high permeability,  $\mu$ , the magnetic intensity will become  $\mathbf{B} = \mu \mathbf{H}$ , where  $\mathbf{H}$  is the magnetic intensity when there are no magnetics. Conventional physics calls in such a case  $\mathbf{B}$  "magnetic induction" and retains the term "magnetic intensity" for  $\mathbf{H}$ . In contradistinction to eq. (11) which is to be written with  $\mathbf{E}$  (not  $\mathbf{D}$ ) and  $\mathbf{H}$  (not  $\mathbf{B}$ ); equation (8) is to be written with  $\mathbf{B}$  (not  $\mathbf{H}$ ) and  $\mathbf{E}$  (not  $\mathbf{D}$ ). I should like to note that conventional physics writes equation (11) wrongly with  $\mathbf{D}$  (see, for example, ref. 6).

There is a substantial difference between dielectrics and magnetics. The dielectrics make only new distribution of the available electric intensity, while the magnetics generate new magnetic intensity. I shall give the following example which will clear this substantial difference. If there is an electric charge  $q$ , then the Coulomb electric intensity generated by it will be  $\mathbf{E} = -q \text{grad}(1/r) = qr/r^3$ . If putting this charge in a dielectric with high permittivity  $\epsilon$ , the electric displacement will remain exactly the same as the electric intensity  $\mathbf{D} = \mathbf{E} = qr/r^3$ . If, however, there is a long enough solenoid with  $nI$  ampere-windings on a unit of

length, the magnetic intensity will be  $H = nI$  in the solenoid and  $H = 0$  outside. If putting this solenoid in magnetic with high permeability,  $\mu$ , the magnetic intensity, i.e., induction, in the solenoid will become  $B = \mu nI = \mu H$  and will be  $\mu$  times higher. For this reason I evade, as far as possible, to use two different symbols and two different terms for  $B$  and  $H$ , as the magnetization of the magnetics is equal to the insertion of additional "ampere-windings". But I use two different symbols,  $E$  and  $D$ , and two different terms for the electric intensity and the electric displacement.

The most eloquent confirmation that Maxwell's displacement current is only a mathematical fiction offers my Bul-Cub machine without stator<sup>5</sup> and my Ampere's rotating bridge<sup>5</sup> which violate the angular momentum conservation law as the magnetic forces acting on displacement currents in these experiments do not lead to ponderomotive reaction and as the magnetic forces between current elements violate Newton's third law. This violation can be observed macroscopically for loops which remain unclosed because <sup>of</sup> the availability of capacitors which interrupt the conduction currents.

Grassmann<sup>7</sup> first established that the interaction between current elements violates Newton's third law. This result follows trivially from the Newton-Lorentz equation (6). Indeed, assuming that  $q$  is a charge moving stationary in a wire with a velocity  $\mathbf{v}$  and that  $q'$  is another charge moving also stationary in another (or the same) wire with velocity  $\mathbf{v}'$ , we obtain from (6) that the time change of  $\mathbf{p}_0$  (which I call kinetic force of the charge  $q$ ) appearing as a result of the electromagnetic interaction between  $q$  and  $q'$  will be (one must put in (6)  $\Phi = 0$ ,  $\partial A/\partial t = 0$ )

$$d\mathbf{p}_0/dt = (q/c)\mathbf{v}\times\text{rot}\mathbf{A} = (q/c)\mathbf{v}\times\text{rot}(q'\mathbf{v}'/cr) = (qq'/c^2r^3)\mathbf{v}\times(\mathbf{v}'\times\mathbf{r}), \quad (14)$$

while the kinetic force of the charge  $q'$  will be

$$d\mathbf{p}'_0/dt = (qq'/c^2r)\mathbf{v}'\times(\mathbf{v}\times\mathbf{r}'), \quad (15)$$

where  $\mathbf{r}$  is the vector distance from  $q'$  to  $q$  and  $\mathbf{r}'$  from  $q$  to  $q'$ , so that  $\mathbf{r} = -\mathbf{r}'$ . It is obvious that the kinetic forces of the interacting charges  $q$  and  $q'$  are not equal and oppositely directed, as it must be according to Newton's third law.

As the Newton-Lorentz equation written in the form (3) shows, equal and opposite-



ly directed are only the full kinetic forces (my term) of the charges

$$(d/dt)(p_0 + qA/c) = -(d/dt)(p'_0 + q'A'/c). \quad (16)$$

The motion of the electric charges in circuits when alternating currents at low frequency flow (in my experiments the frequency was 50 Hz) are quasi-stationary and I could demonstrate macroscopic violations of Newton's third law by replacing parts of the conduction currents in the circuits by displacement currents "flowing" between the plates of capacitors. A very simple trick which mankind failed to notice during a century. It is hard to predict the technical results of this "discovery", but it surely will change the whole "way of life" on our planet.

- 
1. S. Marinov, Eppur si muove (Centre Belge de la Documentation Scientifique, Brussels, 1977, third ed. East-West Publ., Graz, 1987).
  2. S. Marinov, Classical Physics (East-West Publ., Graz, 1981).
  3. S. Marinov, The Thorny Way of Truth, Part II (East-West Publ., Graz, 1984, third ed. 1986).
  4. S. Marinov, see the preceding paper: "Maxwell's displacement current does not generate magnetic field".
  5. S. Marinov, The Thorny Way of Truth, Part III (East-West Publ., Graz, 1988).
  6. W. T. Scott, The Physics of Electricity and Magnetism (John Wiley, New York, 1959)
  7. H. Grassmann, Pogg. Ann. **64**, 4 (1845).

**THIS PAGE IS LOCKED TO FREE MEMBERS**

Purchase full membership to immediately unlock this page

**SAVE \$3,999,994**

Did you know we sell  
paperback books too?

To buy our entire catalog  
in paperback would cost  
over \$4,000,000

Access it all now for  
\$8.99/month

\*Fair usage policy applies

**Continue**







**THE THORNY WAY OF TRUTH** represents a collection of documents of different kind which show the enormous difficulties which Stefan Marinov had to overcome on his way in restoring absolute space and time, in revealing the gravitational character of kinetic energy and the static character (in general) of our world. The »law of inertia« is valid for any collective creation of political, moral, artistic or scientific character. Traditions and conservatism are indispensable for the functioning of any society, science or religion. However, if one gives no freedom for the communication of new ideas and of the results of new experiences and experiments, the progress in human society and science is impossible. As this book shows, our society is rather the same as in the times of Jesus Christ and Galileo. Of course, the norms of behaviour have become more sophisticated but one is not sure whether this »sophistication« is a result of our enlightenment and humanisation or those who maintain the power have understood that the imprisonment in psychiatric clinics is more effective than a crucifixion and the covering with silence is more effective than a denial.

**Price: \$ 25**