

Architectural Drafting

PISCATAWAY TECH CADD PROGRAM



INTRODUCTION

Drawing is considered to be a universal language. Drafting is a technical drawing used by designers to graphically present ideas and represent objects necessary for a designed environment. A set of these drafted illustrations is called a **construction document or (CD)**. There are common rules and standards to ensure that all designers are able to understand what is in the drawing. These design drawings use a graphic language to communicate each and every piece of information necessary to convey an idea and ultimately create a design. The following section of this handbook will guide you through the common drafting standards.

ARCHITECTURAL DRAFTING

Architectural drafting is basically pictorial images of buildings, interiors, details, or other items that need to be built. These are different from other types of drawings as they are drawn to scale, include accurate measurements and detailed information, and other information necessary to build a structure. These documents are graphic representations to communicate how to do the construction, remodeling, or installation of a design project. These include drawings for floor plans, elevations, sections, details, ceiling plans, finish schedules, and mechanical information such as electrical, plumbing, air conditioning, and heating plans.

TYPES OF DESIGN DRAFTING

There are three categories of drawings in design: **process drawings** (*preliminary images, sketches, schematics, etc.*), **construction documents** (*drafted drawings, working drawings, plans, elevations, sections, details, etc.*), and **presentation drawings** (*illustrated sketches and three-dimensional views including perspectives, oblique, isometrics, etc.*). The main focus of this section is the drafted drawing of which there are also three different types: technical sketch, mechanical drafting, and **CAD** (computer-aided drafting). These all fall under the heading of architectural drafting as they each convey building detail in scale and use of a common graphic language.

TECHNICAL SKETCH

Like an artist may use sketches to develop ideas for a painting or sculpture; technical sketches are used during the development of ideas for initial or preliminary plans. The ability to make quick and accurate sketches is a valuable advantage that helps you convey design ideas to others. A sketch may be of an object, an idea of something you are thinking about, or a combination of both. Most of us think of a sketch as a freehand drawing, which is not always the case. You may sketch on graph paper to take advantage of the lined squares, or you may sketch on plain paper with or without the help of drawing instruments. Technical sketches are drawn without mechanical aid, like a T-square, compass, or straight edge, but, like other forms of architectural drafting, are drawn to scale and contain a variety of line weights and line styles (Figure 1). The pencil or pen is guided by the hand of the drafter alone and this is usually done on trace paper over a 1/4 grid paper. The grid paper becomes the guide helping to keep lines straight. A technical sketch gives an idea that the design is still being developed while a mechanically drafted or CAD drawing implies an advanced state of planning and gives the impression the design has been finalized.



Figure 1. Examples of technical sketch showing ideas and scale of design

Computer Aided Drafting

When drafted documents are prepared on a computer, they are referred to as computer-aided drafting (CAD). An advantage of CAD is the speed of revisions to a document. Instead of redrafting an entire page alterations can be made quickly and easily and the page reprinted or plotted. CAD

drawings can also be easily stored electronically and shipped to other designers who can make revisions or alterations. Some design and drafting work can be completed more quickly on CAD; however, you will still need to use technical or mechanical drafting for design development.

DRAFTING MEDIA

The papers and films used to draw on are drafting media. While sketching may be done on any size piece of paper or on a variety of types of paper, all forms of architectural drafting, from technical sketching to mechanical drafting, are done on standard sizes and types of paper. There are two main types of paper, tracing and vellum, and there are drafting films such as Mylar and acetate. Tracing paper and drafting vellum are the two most widely used types of drafting media.



TRACING PAPER

(Also called TRACE) is a medium-grade white (or slightly yellow tinted) transparent paper that takes pencil, ink and marker well. Trace is typically used for sketching and developing ideas, developing initial and preliminary layouts and developing space planning. It is an inexpensive paper and, since it is transparent, a new sheet can be placed over a preliminary drawing to refine it. It is easier and neater to do this than to erase and redraw lines on the original. Some designers use trace for presentations in the early phase of a design project, then, when the designs are approved and fully developed, they are transferred to vellum.

DRAFTING VELLUM

(Also called TRACING VELLUM) is a high-grade white (or slightly tinted) transparent paper that takes pencil well, and from which pencil lines can be easily erased. Reproductions can be made directly from pencil drawings on drafting vellum. Vellum also takes pen and ink well. On most papers, ink will bleed (that is spread and absorb into the paper). Ink lines on vellum are crisp and solid as it does not absorb the ink readily; however, caution must be taken to not unintentionally smear the ink before it dries.

GRID or GRAPH PAPER

Available in a variety of grid patterns, most grid media used in design has 4 squares per inch. This can represent 1/4 scale for drawing purposes. It is used for planning, drawing, rough design sketching, technical sketches, or simply under a sheet of trace as a guide.

Scales

Architect's Scale

Architect's scales are usually triangular and are used wherever dimensions are measured in feet and inches. Major divisions on the scale represent feet; those divisions are subdivided into 12ths or 16ths, depending on the individual scale. Figure 3-29 shows the triangular architect's scale and segments of each of the eleven scales found on this particular type of scale. Notice that all scales except the 16th scale are actually two scales read either from left to right or right to left. When reading a scale numbered from left to right, notice that the numerals are closer to the outside edge. On scales numbered from right to left, notice that the numerals are closer to the inside edge.

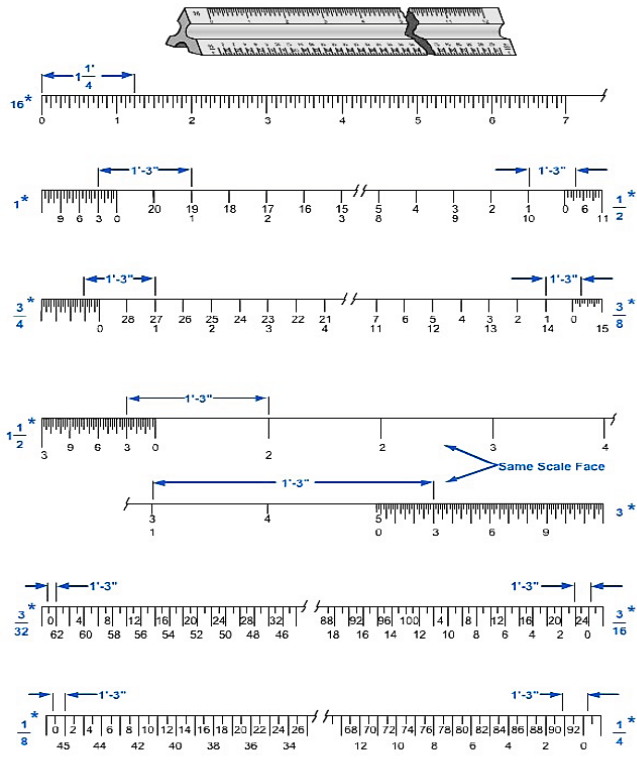

Note:
 16 scale is subdivided into sixteenths.
 All others are subdivided into twelfths.
 * scale designation numbers.

Figure 3-29 – Architect's scale.

3 inches = 1 foot
1 1/2 inches = 1 foot
1 inch = 1 foot
3/4 inch = 1 foot
1/2 inch = 1 foot
3/8 inch = 1 foot
1/4 inch = 1 foot
1/16 inch = 1 foot
1/8 inch = 1 foot
3/32 inch = 1 foot

DRAFTING SHEET SIZES

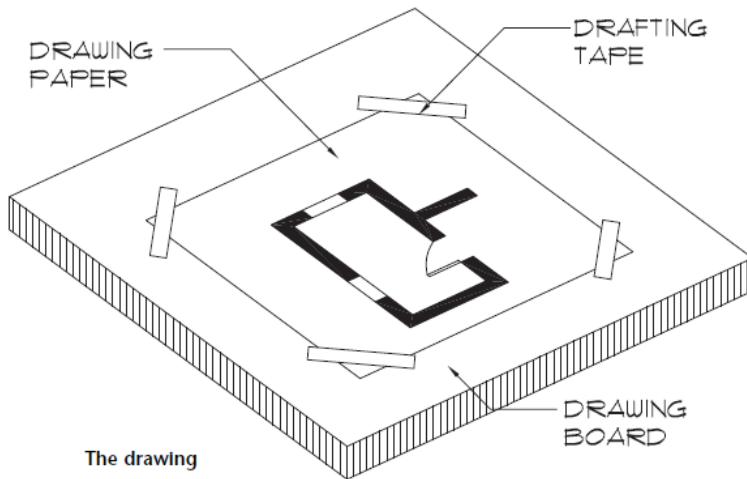

The drawing paper is held in place on the drawing surface with small pieces of drafting tape.

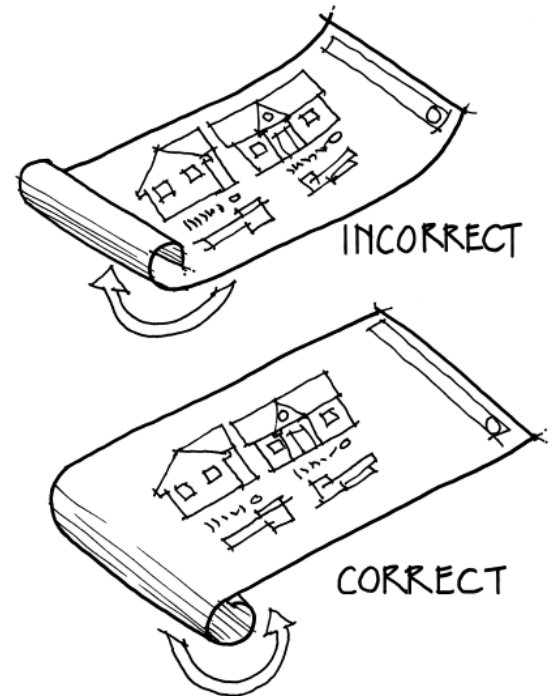

Most drafting media are available in three styles: rolls, plain sheets, and preprinted sheets with borders and title blocks. There are also sheets available with non-photo blue (a light blue color that does not reproduce when making blueprints) grids.

According to **ANSI (American National Standards Institute)** in the United States an 8.5 x 11 inch piece of paper is an architectural 'A' size sheet. This is typically referred to as letter size. The 'B' size sheets are 11 x 17 and are typically referred to as a "tabloid" size sheet of paper. The 'C' size sheets are 18 x 24 inches and the 'D' size sheets are 24 x 36 inches. Most drafting for design purposes is done on the B, C, and D size sheets. The decision for choosing a size should be based on project requirements, the scale of the drawings, and the scope and size of the final structure. Trace and vellum maybe purchased on rolls that require sizing the paper properly. Trace may be sized by measuring the length needed and using a straight edge, T-square, or parallel rule to rip the paper off of the roll. Trace rips easily and slightly rough edges are expected. Vellum from a roll should be measured to its proper length and then using a straight edge and an X-Acto knife on a proper cutting surfaces trim the paper to its proper length. Scissors should never be used in cutting trace or vellum.

PAPER SIZES

SIZE	ENGINEERING	ARCHITECTURAL
A	8.5" X 11"	9" X 12"
B	11" X 17"	12" X 18"
C	17" X 22"	18" X 24"
D	22" X 34"	24" X 36"
E	34" X 44"	36" X 48"

Key Terms to Remember

- ANSI (American National Standards Institute)
- Drafting media are available in three styles: rolls, plain sheets, and preprinted sheets
- TRACING VELLUM) is a high-grade white (or slightly tinted) transparent paper that takes pencil well
- There are two main types of paper, tracing and vellum, and there are drafting films such as Mylar and acetate.
- Technical sketches are used during the development of ideas for initial or preliminary plans.
- Three categories of drawings in design: **process drawings**, **construction documents**, and **presentation drawings**.
- A working drawing or a **construction document** is called (CDs).
- Most drafting for design purposes is done on the B, C, and D size sheets.
- Architect's scales are usually triangular and are used wherever dimensions are measured in feet and inches.



LINE WEIGHTS

Line weight and line quality are extremely important to a successful set of design drawings. Usually a set of design drawings will go to many different people including the client, other designers or architects, manufacturers, builders, and others within the profession. The lines used for design drawings must be crisp and dark so that they are easy to reproduce and clear copies can be made from them. The line weight is the light or darkness and width of a line. Manual pencil drafting, drafting in ink and computer-aided drafting documents must have a variety of line weights. Varied drawing line weights, typically three, should be used on every drawing. These include light, medium, and bold lines. Aside from these lines used to illustrate a drawing, there are also guidelines and border lines. Guidelines are used for page layout and borderlines are used for framing the page. These different weights technically help to create an easy to understand document and artistically add visual interest to the document. These documents must also have consistent line quality, which is the uniformity of lines throughout a drawing. These two elements give a sense of professionalism to the documents, provide visual interest, create a clear and easy to read document, and demonstrate the drafting skills and abilities of the designer. Pencil lines should be solid, uniform in width, and consistent in darkness throughout their length. If a line in a drawing needs to be changed, make sure to erase it cleanly and recreate the line in the appropriate line weight and quality. If only a part of the line needs to be modified, erase using the erasing shield and make sure the new segment and the existing segment match perfectly in width and darkness.

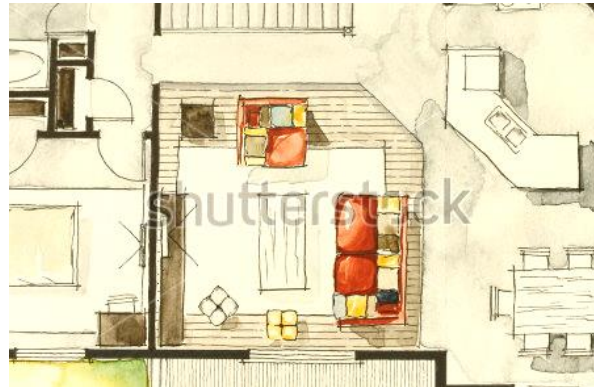

Being consistent also applies to pen and ink drawings and CAD drawings. A pen and ink drawing is usually created first with very light guidelines. When using ink technical or drafting pens, typically the light, medium, and dark weights are created in proportion to one another. For example, if light is a width of .05, then medium is .1 and dark is .2. The actual width of each line type should also be related to the size and scale of the drawing. A drawing in 1/4" scale, like a floor plan, may need smaller pen widths than a drawing in 1-1/2" scale, like a kitchen cabinet drawer detail. The best way to create consistent line weights and line quality is to keep your pencil or pen perpendicular to the drawing surface and drawing media. This keeps the width of the line consistent. Also, keep a constant pressure as you draw a line type from its start to finish. This takes practice and can be mastered if you focus on creating the line consistently and do not try to rush a drafted document. Keep in mind the hardness/softness and the diameter of the pencil lead only help control the line weight. You also need to use a consistent amount of pressure on the pencil as you draft to keep each weight of line uniform. If the line seems either too light or too dark try varying the amount of pressure you place on the pencil as you draft. Remember, these drawings are meant to be copied and distributed to a variety of design professionals so the lines need to be crisp and readable.

LINES AND LINE QUALITY

- **Guidelines or Construction Lines (4H to 6H pencil lead in a .3mm mechanical pencil)**

The initial lines that you will draw on your paper are guidelines or what some refer to as construction lines. These lines are temporary and used to lay out the page, create the initial shapes, and provide a guide for lettering heights. The line weight for guidelines is to be very light as they should be almost invisible on the finished drawing. They must be dark enough for you to see, light enough to erase lines easily, and barely visible when copies or other form of reproductions are made from the drawing. Using a harder 4H to 6H pencil lead in a .3mm mechanical pencil creates the best guidelines. You can also use a blue lead for guidelines as it will not photocopy.

- **Bold Lines (soft B to 2B pencil lead in a .5mm or .7mm mechanical pencil)**

Primary objects in a drawing should be created using a bold line. Bold lines are very dark and have a thick width. These are created with a .5mm or .7mm mechanical pencil and a soft B to 2B pencil lead. Walls in plan view and the outline around the perimeter of an elevation or three-dimensional object are examples where bold lines should be used.

- **Medium Lines (HB pencil lead in a .5mm mechanical pencil)**

Secondary objects such as doors, furnishings, counters, and cabinets should be drawn in a medium line weight. In elevation and 3D views, the perimeter of an object may be drawn in a bold line weight however the information inside the object should be drawn in a medium weight. Medium line weights are

best created using a .5 mm width pencil with HB pencil lead.

- **Light Lines (H to 2H pencil lead in a .3mm or .5mm)**

Action lines, information lines, and fill patterns should be drawn with light lines. Action lines show potential movement of an object and include door swings in plan view and hinge direction in elevation view. Information lines convey information about a drawing and include dimension lines, center lines, leader lines, sections lines, and so on. Fill patterns are specific symbols used to indicate a type of material being used. The light lines can be created with a .5 mm pencil or with a .3 mm pencil and H to 2H pencil leads. It is very important that all of these lines are visible, so do not confuse the term “light” with “hard to see,”

- **Border Lines (2B to 4B pencil lead in a .7mm or .9mm pencil)**

Border lines are used to create a margin on the drawing sheet and to create the lines around the title block. Border lines should be as dark and about twice as thick as bold lines. A .7 mm or .9 mm pencil with a 2B to 4B lead works well for creating borderlines.

Keep in mind that the softer the lead, B, 2B, etc., the easier it is to smudge the line once it is drawn. For this reason border lines should be the last line drawn on your drafted document.

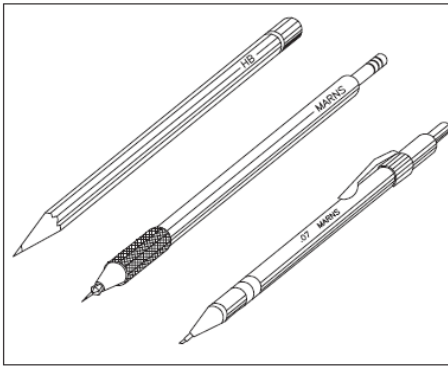

LINE WEIGHTS FOR LETTERING

The weight of the lines for lettering varies with the size and scale of the drawing and the visual importance of the lettering. Random notes on the drawing and information from leader lines and dimension lines may be a lightweight line to match the line style. Text within a title block may be medium to bold depending upon its importance. Likewise, lettering used to label a drawing such as **FLOOR PLAN** or **SOUTH ELEVATION**, may need to be medium or bold as well. Within the range of light, medium, and bold line weights, you may also vary the weights slightly as needed to emphasize a part of the drawing. Typical lettering heights are: 3/16" - 1/4" for main titles under drawings: 1/8" - 3/16" for subtitles and room names: 1/8" for notes and dimensions: and 1/2" for sheet number in the title block.

*Table 2-2 Pencil-lead Weights**

9H 8H 7H 6H 5H 4H	}	Hard pencil leads are used for drawings, light layouts, and drawings requiring a high degree of accuracy.
3H 2H H F HB B	}	These leads are used for sketching, architectural line work, lettering and general purposes.
2B 3B 4B 5B 6B	}	Soft leads are used for sketching, rendering, and graphical accents.

*The gradations can vary with different brands and types of drawing media.
When in doubt, try a sample or test first.

DRAFTING STANDARDS AND SYMBOLS

Architectural drawings are intended to communicate design intentions in a clear manner. This can be best presented with graphic symbols and written forms. Industry standards have been developed to provide a universal language of graphic symbols and written forms for different design companies and building professions. Typical drafting standards and symbols are described below.

LINE TYPES

Along with line weight and quality, there are standards for different types of lines. Each has a definite meaning and is recognized as a typical symbol or object within the building trades industry. Listed below are the standard types of lines that will typically be used in design drawings.

Solid Line

Solid Line

Solid lines are used to indicate visible objects that can be seen in plan, elevation or 3D views. Solid lines are also used for leader lines and dimension lines.

Dashed Line

Dashed Line

Hidden objects or edges are drawn with short dashed lines. These are used to show hidden parts of an object or objects below or behind another object. Dashed lines are also used to indicate shelving or cabinets above a counter. These lines should be in contact at corners and when perpendicular to another line.

Movement, Ghost or Phantom Line

Movement, Ghost or Phantom Line

These lines are a series of dashes and very short dashes and are used to show movement or imply direction. These typically are used instead of a dashed line to show an alternate position of an object that can be moved. One object would be drawn with a solid line and its alternate position would be dashed or a phantom line. This can include bi-swing doors, the space needed for drawer and cabinet door openings, sliding door opening direction, hinge points for doors and windows in elevation views, etc.

Leader Line

Leader Line

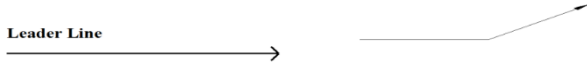

Leader lines are used to connect notes or references to objects or lines in a drawing. Leader lines start as a solid line and end in an arrow. Leader lines may be drawn at an angle or curved.

Break Lines

Break Lines

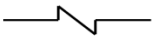

Break lines are used when the extents of a drawing cannot fit on the size of paper being used for the drawing. It can also be used when you only need to illustrate a portion of a design or a partial view.

Center Line

Center Line



Center lines are used to indicate the center of a plan, object, circle, arc, or any symmetrical object. Use a series of very long and short dashes to create a center line. If two center lines intersect use short dashes at the intersection.

Section Line

Section Line

The section line is used to show a cutaway view of a floor plan. A section cutting all the way through a floor plan is referred to as a full section. The direction of the arrows shows the direction of the section view.

The symbols on the end of the section line indicate the drawing number on top and the page number the section will be located on the bottom (Figure 3).

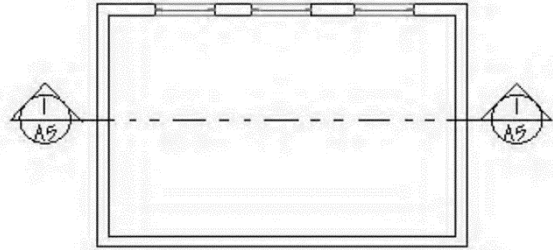

Figure 3. Section symbols and lines placed on a drawing

Dimension Line

The dimension line is used to show the measurement of an object. It can be used to indicate length, width, diameter, etc. The dimensions are listed in feet and inches on floor plans and elevations (Figure 4). Detail drawings of cabinetry or other custom pieces are dimensioned in inches.

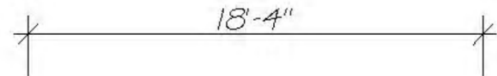

Figure 4. Use of dimension line

MATERIAL SYMBOLS

Material symbols represent the construction materials cut in section. Below is a list of materials and their symbols used on architectural drawings (Figures 5 & 6).

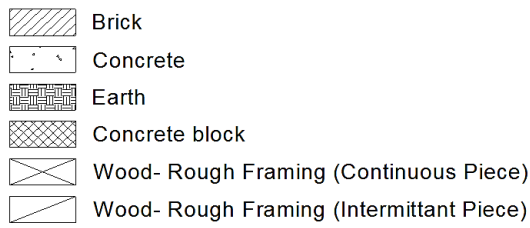

Figure 5. Examples of material symbols in section

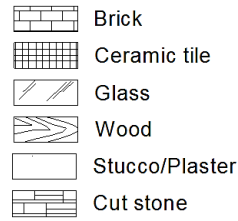

Figure 6. Examples of material symbols in elevation

ARCHITECTURAL GRAPHIC SYMBOLS

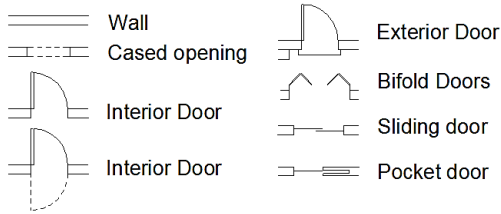

Figure 7, Walls & doors symbols in plan view

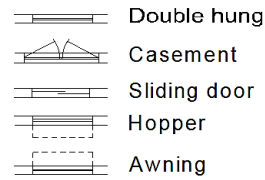

Figure 8. Window symbols in plan view

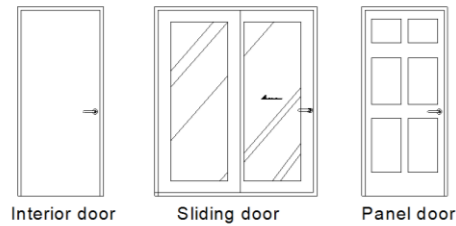

Figure 9. Examples of door symbols in plan view

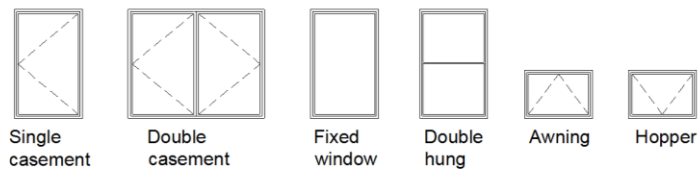

Figure 10. Examples of window symbols in elevation view

Drawing Numbering System

The following standards for sheet numbering comes from "[The Uniform Drawing System](#)" published by the Construction Specifications System Institute (CSI) in 1997 and incorporated into the National Institute of Building Sciences (NIBS) United States National CAD Standard, 2005.

1. All drawings must be assigned a sheet number. The sheet number should appear in the lower right corner of the drawing.
2. The first letter of a sheet number indicates the discipline name. Immediately after this is a three-digit number indicating the type of drawing and its sequence in the set. Thus, a typical drawing sheet number would look like this: A101. This would be the first architectural plan, usually the site plan or the basement floor plan. Sheets should be numbered consecutively within a series from 01 to 99.
3. Sheets are bound into "sets" and should be organized in the following sequence of disciplines:

C = Civil (earthworks, cut and fill, retaining walls, ponds, parking lots, streets, sidewalks, sewer and water outside of building, electrical power and lighting and telecommunications outside of building)
L = Landscape (topsoil, trees, shrubs, turf, ground cover, brick or stone paving benches, usually only outside of building)
A = Architectural
S = Structural
M = Mechanical (Heating, Ventilating and Air Conditioning)
P = Plumbing (inside building)
Q =Equipment (freezers, refrigerators, etc. – pre-manufactured items that are built-in and need to be connected to water, sewer, electricity or gas)
F = Fire Protection (fire sprinklers, standpipes, fire extinguishers)
E = Electrical (power and lighting)
T = Telecommunications (telephone, CCTV, cable TV, wired computer network, intercom, sound, security and other low-voltage equipment)
I = Interior Furnishings (furniture, sometimes carpet, and Built-in custom or standard millwork and cabinets)

Drawing Sets should include:

- Title Sheet
- Name and address of project
- General Notes
- Index of drawings
- Material symbols
- Legend of symbols
- Abbreviations

4. Drawings within a discipline are numbered sequentially with three-digit numbers according with the following system:

100 series: site plans, floor plans, and reflected ceiling plans, selective demolition plans – starting with A101, which is usually the site plan.
200 series: exterior elevations – starting with A201
300 series: building sections – starting with A301
400 series: large scale "blown up" plans, elevations and wall sections – starting with A401
500 series: details and interior elevations – starting with A501
600 series: schedules (such as room finish schedules, door schedules, window schedules) and diagrams (plumbing riser diagrams, single line electrical diagrams) - on small projects, schedules and diagrams can be included on the plan sheets - starting with A601

DRAWING SYMBOLS FOR CROSS- REFERENCE

Section Symbol

Section symbols are used to indicate where sections are cut. The **section mark consists of a 1/2" diameter circle**, an arrow that indicates the view direction of sight which is filled solid black, and two numbers (Figure 11). The upper number tells the section number on the sheet and the lower number indicates the sheet number where the section is drawn. Generally a section call-out is composed of two same section marks, one on each end of the cutting plane line, (Figure 12).

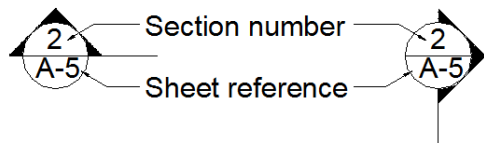

Figure11 Section symbol

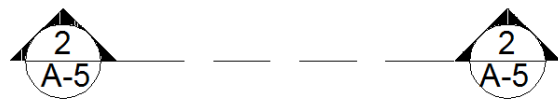

Figure 12. Simplified section symbol on one end

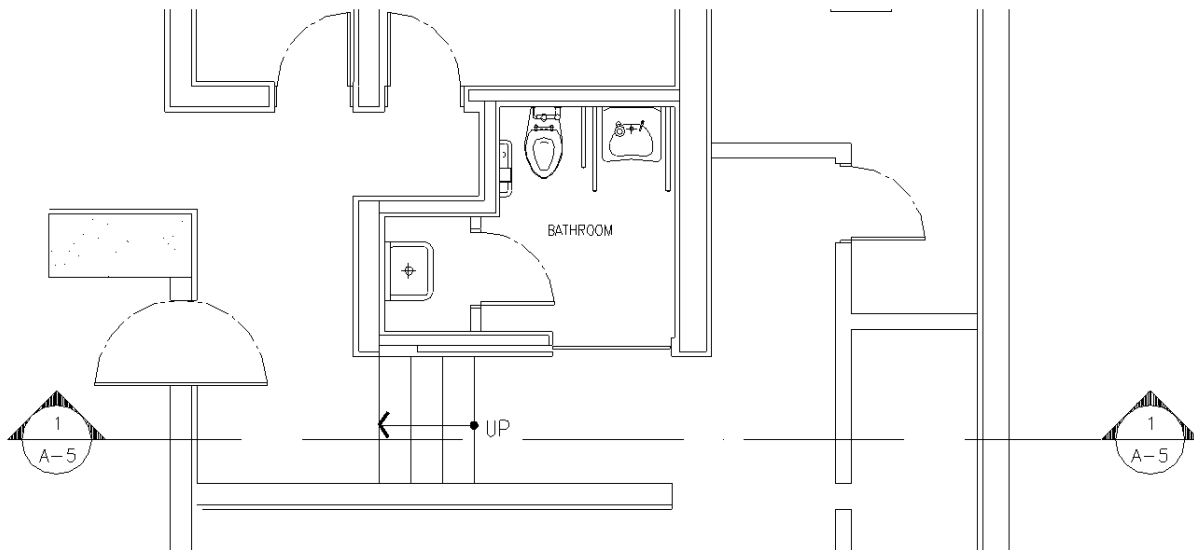

Figure 13. Section symbols used on the plan view

Elevation Symbol

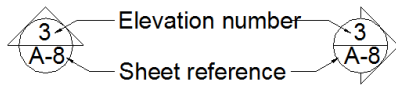

Figure 14. Elevation symbol

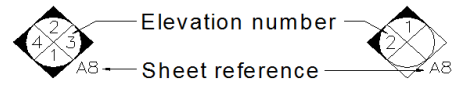

Figure 15. Multiple elevation symbol

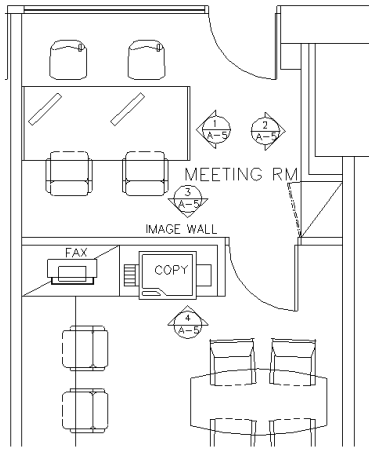

Figure 16. Elevation symbol used on the plan view

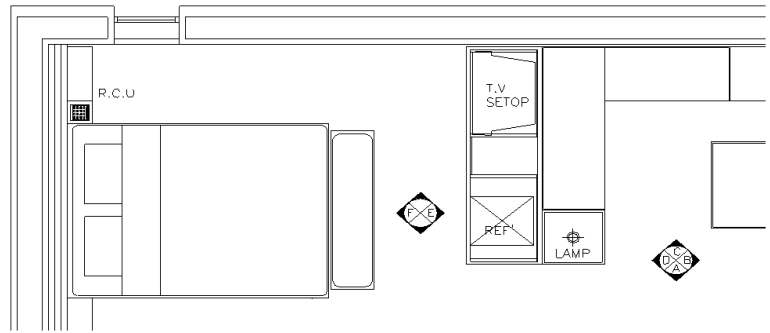

Figure 17. Multiple elevation symbol used on the plan view

Elevation marks are used to indicate which direction and from which point on the floor plan is drawn. The **elevation mark consists of a 1/2" diameter circle**, an arrow that indicates the direction of sight, and two numbers. The upper number tells the elevation number on the sheet and the lower number indicates the sheet where the elevation is drawn. Elevation marks can be placed at each spot for different elevation views, as shown Figure 14. Or multiple elevation symbols may be used for the elevation views that are drawn from one middle spot of the space (Figure 15).

Detail Symbol

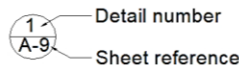

Figure 18. Detail symbol

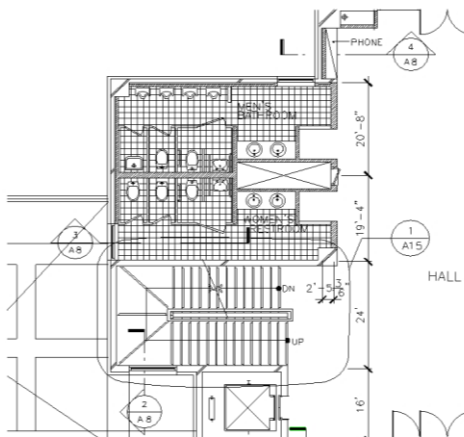

Figure 19. Detail symbol used on the plan view

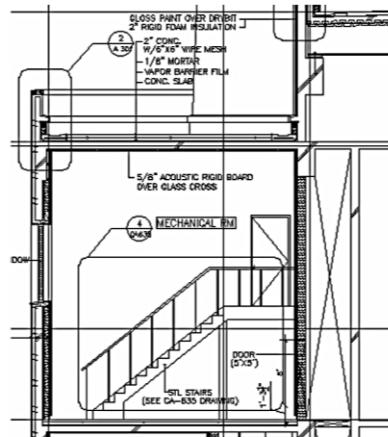

Figure 20. Detail symbol used on the section view

Detail drawings are identified by a detail mark composed of a 1/2" diameter circle and two numbers. The upper number tells the detail number on the sheet and the lower number indicates the sheet number where the detail is drawn (Figure 18). The feature that needs a detail drawing is enclosed in a large circle and connected to the circle of the detail mark with a leader (Figure 19). Detail symbols are used on not only floor plan but also elevation or section drawings (Figure 20).

Elevation Datum

Elevation data are used to indicate a level line control point. An elevation datum has three parts. Farthest from the drawing is a 1/4" diameter circle with two lines crossing inside horizontally and vertically, and the upper right part and lower left part are filled with solid black. Above the horizontal line stretched out from the middle of the circle is a description of a point where a level is measured such as ceiling line, grade, or finished floor plan. The actual elevation that is the height of the point is described below the horizontal line (Figure 21). An elevation datum is generally used for exterior elevations. A point is where a level is measured.

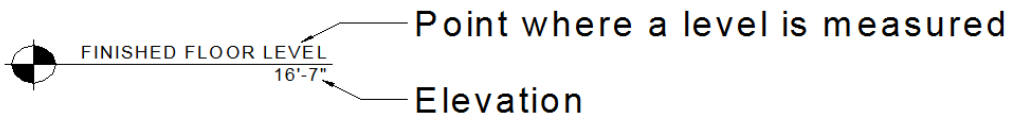

Figure 21. Elevation Datum

Door Number Symbol

Doors are identified by a door number symbol. A door number symbol has a 3/8" diameter circle and a number inside (Figure 22). The number indicates either door number or door type, depending on the project. The number is then referenced to the door schedule.



Figure 22. Door number symbol

Window Letter Symbol

Windows are identified by a window number symbol. A window letter symbol has a $\frac{3}{8}$ " diameter hexagon and a letter inside (Figure 23). The letter indicates either door number or door type, depending on the project. The letter is then referenced to the window schedule.



Figure 23. Window number symbol

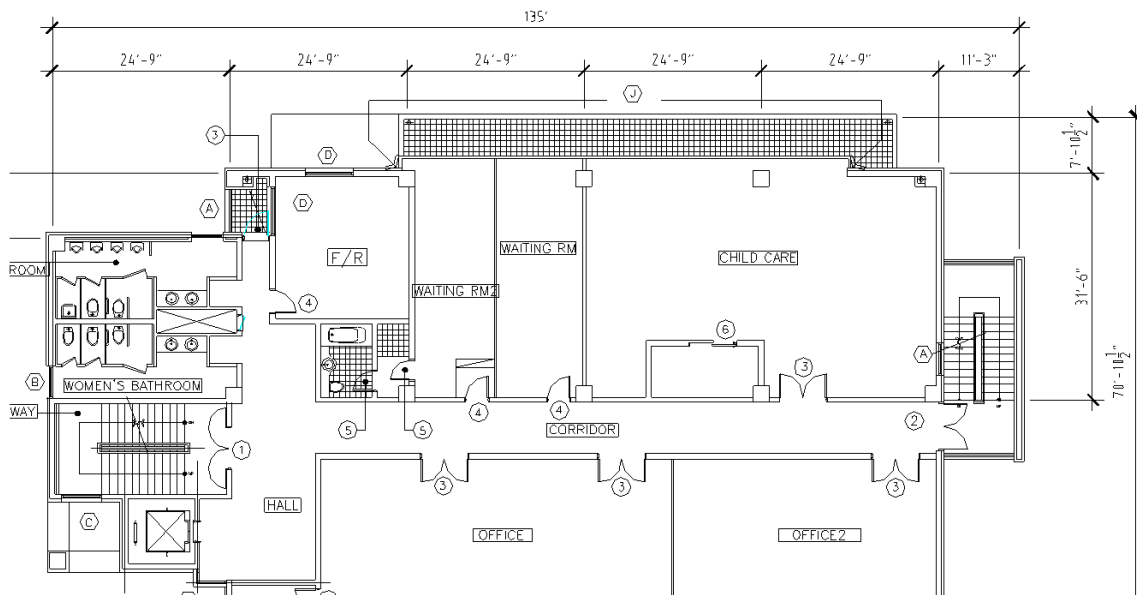
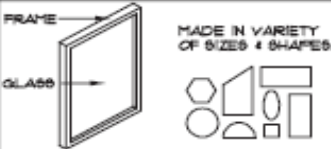
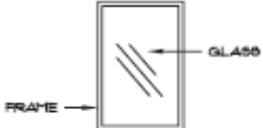

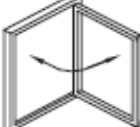
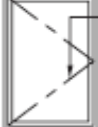

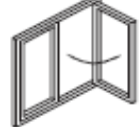



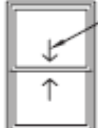

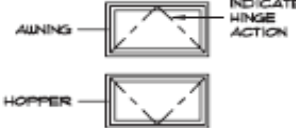
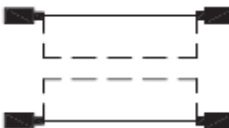
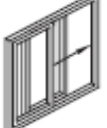

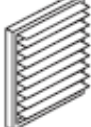

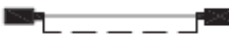
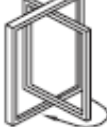
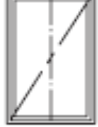
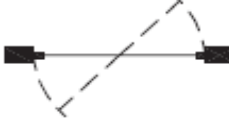

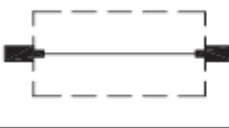

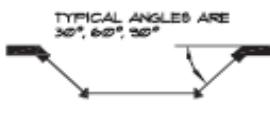



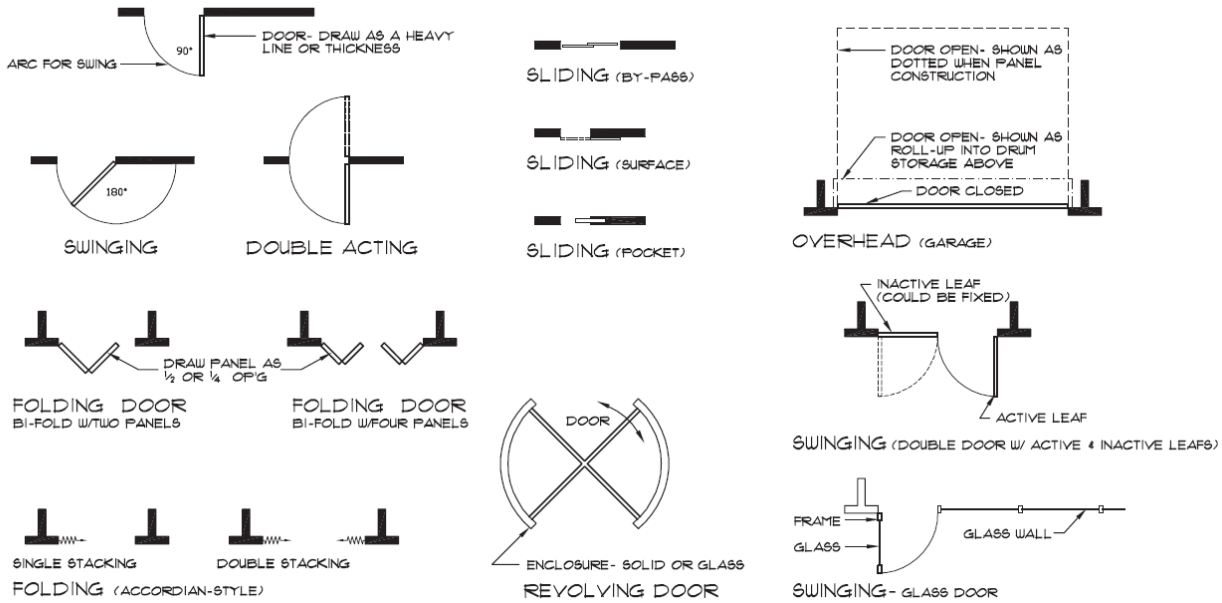

Figure 24. Door and window symbols used on the plan view

WINDOWS - TYPES AS DEFINED BY OPERATION

TYPE	SKETCH	ELEVATION	PLAN
FIXED	 <p>MADE IN VARIETY OF SIZES & SHAPES.</p>		
CASEMENT	 <p>HINGED AT SIDE AND SINGS OUTWARD.</p>	 <p>INDICATES HINGE ACTION</p>	
DOUBLE CASEMENT	 <p>HINGED AT SIDES AND SINGS OUTWARD.</p>	 <p>INDICATES HINGE ACTION</p>	
SINGLE AND DOUBLE HUNG	 <p>CONTAINS TWO SASH WHICH SLIDE. IF ONE IS FIXED, UNIT IS A 'SINGLE-HUNG'.</p>	 <p>INDICATES SLIDING SECTION</p>	
AWNING AND HOPPER	 <p>AWNINGS ARE HINGED AT TOP - OFTEN SINGS OUT TO KEEP RAIN OUT. HOPPERS ARE BOTTOM HINGED - OFTEN SING IN TO KEEP RAIN OUT.</p>	 <p>INDICATES HINGE ACTION</p>	
SLIDING	 <p>CAN BE MADE WITH ONE OR BOTH SASH AS SLIDING UNITS. ALSO MADE AS ONE CENTER FIXED UNIT AND SLIDING UNITS EACH SIDE.</p>	 <p>INDICATES SLIDING SECTION</p>	
JALOUSIE	 <p>SERIES OF SMALL, HINGED (AWNINGS) GLASS SECTIONS ALL OPERATED TOGETHER OR IN SECTIONS.</p>		
PIVOT	 <p>PIVOTS ON 2 POINTS AT CENTER OF TOP AND BOTTOM OF WINDOW USED FOR EASE OF CLEANING.</p>		
PROJECTED	 <p>SINGS OPEN AND SLIDES AT SAME TIME THROUGH SPECIAL LINKAGE. CAN BE TYPED AS HOPPER CASEMENT, OR AWNING.</p>		
BAY	 <p>ANGLE VARIES</p>		 <p>TYPICAL ANGLES ARE 30°, 45°, 60°</p>
BOW			



TITLE BLOCK

TITLE BLOCK - Borders, contents, (use title block handout for info), and sheet numbering.

THE TITLE BLOCK AND BORDER

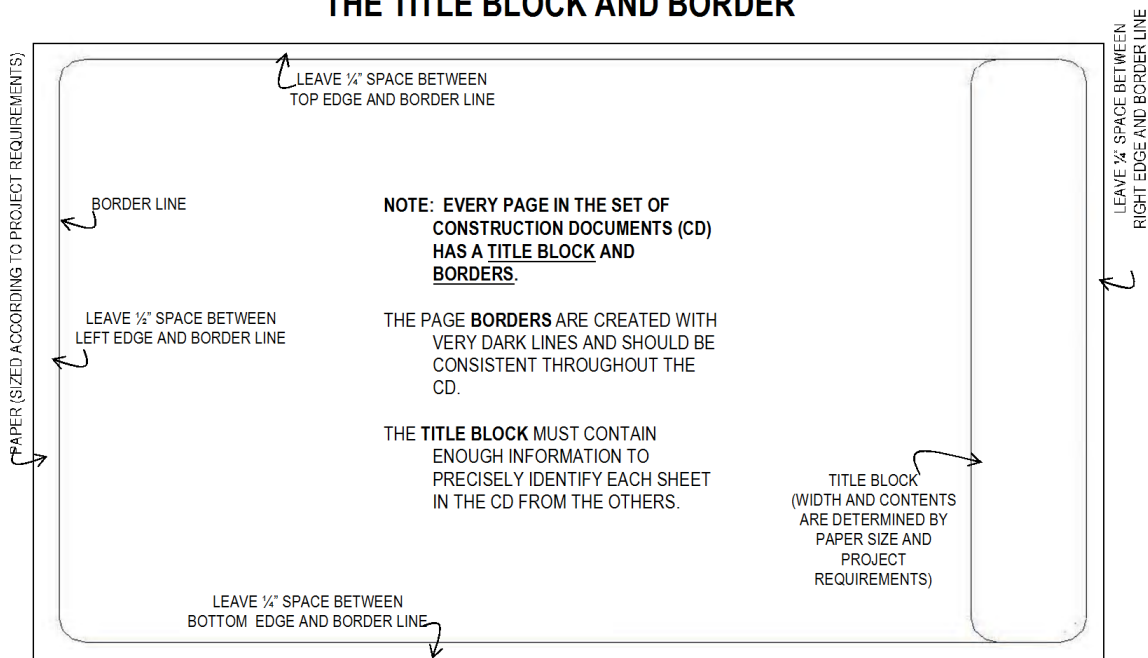

TYPICAL SCALES FOR DRAWINGS

FLOOR PLANS

A floor plan is an aerial plan view that is horizontally cut approximately 4 feet above the floor (Figure 25). It is considered the most important architectural drawing that presents a significant amount of information on the design and construction. It includes wall, door, window, stair, appliance, equipment, cabinetry, and built-in interior elements. A floor plan is drawn to a scale (see Typical Scales for Plans) with different line weights and line types to deliver different levels of information clearly. For instance, dotted/hidden lines are

	RESIDENTIAL DRAWINGS	COMMERCIAL DRAWINGS
SITE PLAN	1"20' OR 40'	1"20' OR 40'
FOUNDATION PLAN	1/4" =1'-0"	1/8"=1'-0"
FLOOR PLAN	1/4" =1'-0"	1/8"=1'-0"
ELEVATIONS	1/4" =1'-0"	1/8"=1'-0"
BUILDING SECTIONS	3/4" =1'-0"	1/4"=1'-0"
CONSTRUCTION DETAILS	3/4" =1'-0"	1/2"=1'-0"
INTERIOR DETAILS	3/8" =1'-0" TO 1/2"=1'-0"	1/2"=1'-0"
LIGHTING/ ELECTRICAL HVAC/ PLUMBING PLANS	1/4" =1'-0"	1/8"=1'-0"

used to indicate the items that are located above the cutting line such as upper cabinets, upper part of stairway, openings, soffits, or other important upper part of the wall or ceiling features. Ceiling changes can be denoted with dashed lines called out for notes in a small project. Cross referencing symbols are used to relate the information on the floor plan to other drawings such as elevation, section, and detail drawings.

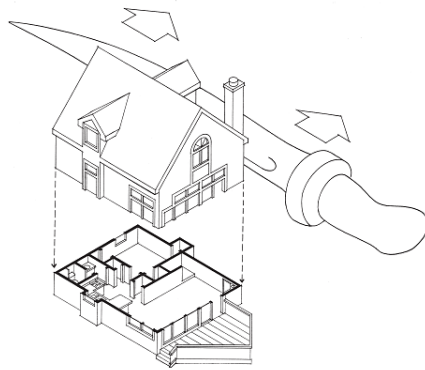

Figure 25. Concept of floor plan view

Dimension technique

The text of the dimension is always written on the top or left of the dimension line. Extension lines are used to bring the dimension line a distance from the object so it is easily read and not confused as part of the object. The extension line starts about $1/16''$ from the edge of the object, never touching it. And it extends about $1/8''$ past the dimension line. At the intersection of the extension line and the dimension line is a tick, The tick mark on a dimension line is an important detail and crosses at a 45 degree angle at the intersection of the dimension and extension lines. It is typically $1/8''$ long, however this may vary with the size and scale of a drawing. Use your best judgment, but typically a tick mark is the length of the overlap of the dimension and extension lines (for example if you overlap the lines by $1/8''$ then the tick mark will be $1/8''$ in length). The height of dimension text is typically between $3/16''$ to $1/8''$, but not below $3/32''$ when printed. This assures its readability. Dimension text doesn't touch the line. See Figure 28 for an example.

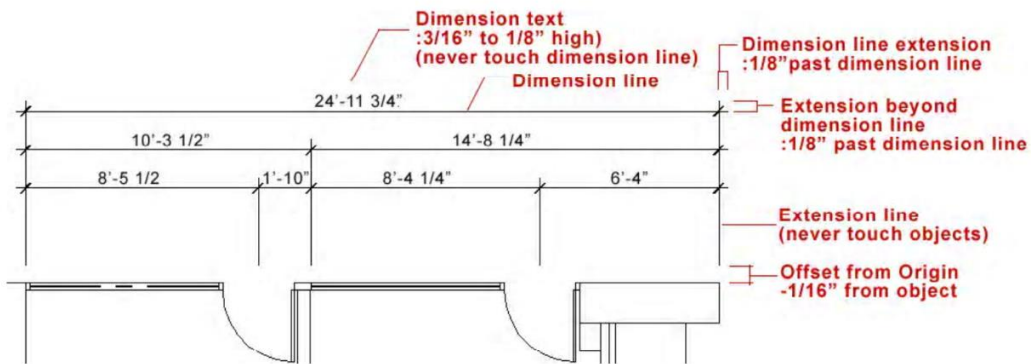

Figure 28. Dimension techniques for floor plans

Dimensioning angled objects

The location and angle of walls need to be shown with proper dimensioning techniques. To anchor the angled walls as a unique location, they should be measured along both an x and a y axis as in a grid (Figure 29). This way allows construction people to lay out angled walls easily. Perpendicular dimensions to the angled walls may be added to give better dimension information.

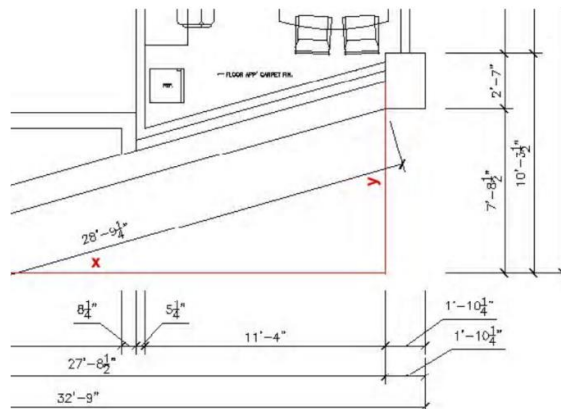

Figure 30. An example of dimensioning an angled wall along an x and a y axis.

Dimensioning curved objects

The important point in dimensioning a curve is that the builder must be able to replicate the curve from a drawing to the site. To do this, three components should be included: actual curvature, location of center point of the curve, and extent of the curve. The actual curvature is denoted as radius of the curve, which emanates from the center point for the curve. The center point of the curve should be also dimensioned by locating it along x and y axis to anchor the point. The extent of the curve which may be only part of a full circle or half circle should be measured by giving location information on the each end of the curve related to other objects on the drawing.

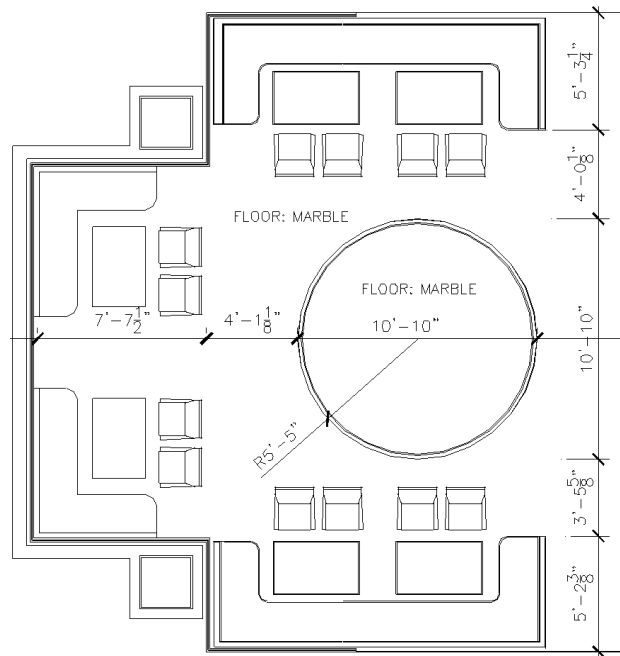

Figure 31 dimensioning a curve

Dimensioning wood/light-weight gauge steel frame buildings

1. For opening dimension, dimension window/exterior door opening/interior partition locations from the **outside face of studs to the center of the openings/interior partitions** (Figure 32).
2. For exterior wall dimension, dimension each wall location from the outside of stud face to the outside of stud face.
3. For interior wall dimension, dimension each wall location from the outside of stud face to the center of the wall, and from the center of the wall to the center of another interior wall.
4. For overall dimension, dimension overall wall locations from the outside of stud face to outside of stud face.
5. Dimension interior walls to structural elements including columns or existing walls.
6. Give angle or radius/diameter where necessary.
7. Dimension built-in furniture/cabinetry.
8. Dimension stairways.

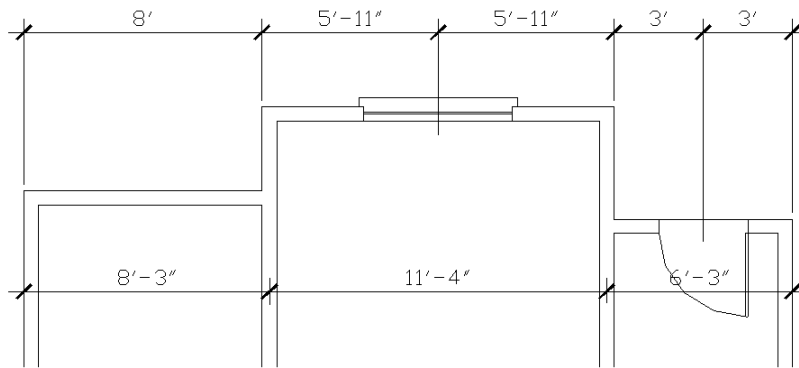

Figure 32. Dimensioning frame buildings

Dimensioning Concrete/ Masonry buildings

1. For opening dimension, dimension window/exterior door opening/interior partition locations from the **outside of the wall facing to the edge of the openings** (Figure 33).
2. For wall dimension, dimension each wall location to the outside of faces. But when pilasters or concrete columns are placed, dimension them to their centerline.
3. For overall dimension, dimension overall wall locations from the outside of faces.
4. Dimension interior walls to structural elements including columns or existing walls.
5. Give angle or radius/diameter where necessary.
6. Dimension built-in furniture/cabinetry.
7. Dimension stairways.

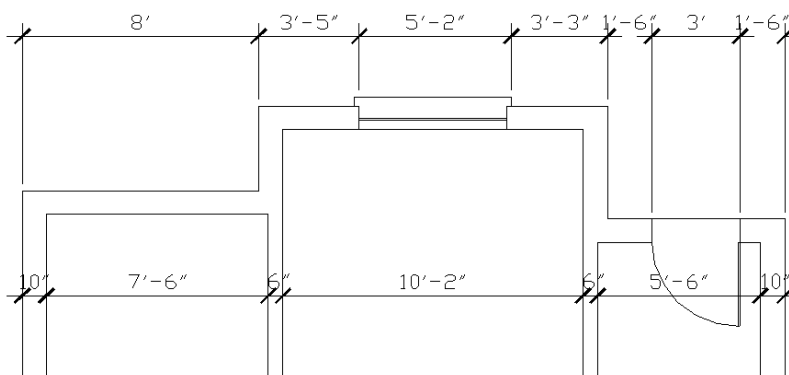
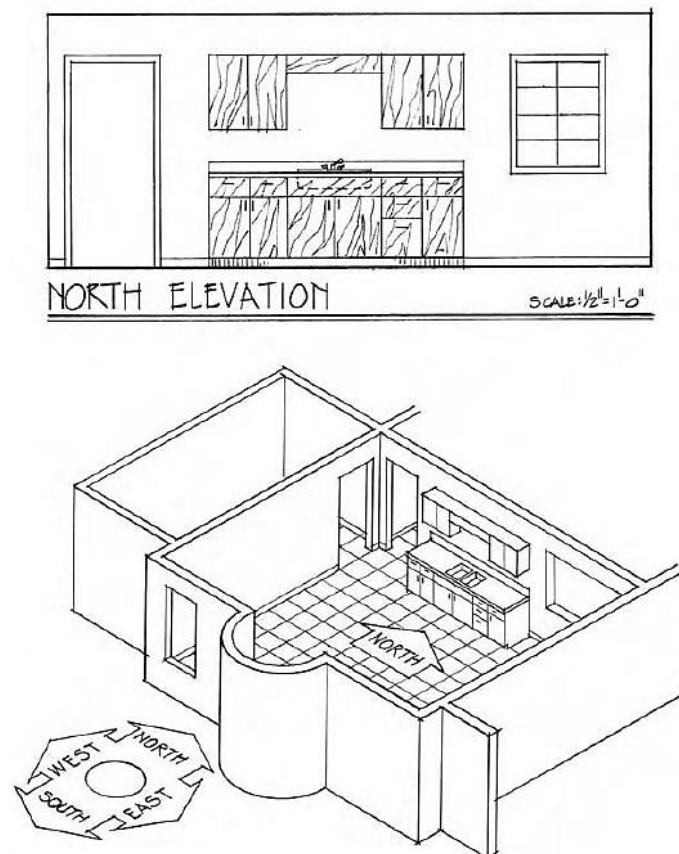

Figure 33. Dimensioning concrete/ masonry buildings

INTERIOR ELEVATION DRAWINGS

An interior elevation is a vertically projected surface inside a building. It provides complimentary information of vertical elements that a plan view cannot describe such as heights of interior elements; vertical materials; and other important vertical information that cannot be shown in other drawings. It is a vertical surface or plane seen perpendicular to the viewer's picture plane (Figure 34). Separate elevation drawings are required for all different walls since elevations drawn looking perpendicular to one side of the building will distort inclined walls of the other side of the building, when a floor plan or object has an irregular shape (Figures 35 & 36). If an entire building elevation is needed for an irregularly shaped building or object, a distortion on an elevation drawing is necessary (Figure 37). Typical interior elevations show vertical locations of doors, windows, and other openings; profiles of objects; connection to the floor, ceiling, and adjacent objects; material information; and vertical dimensions.



Referencing and Naming Interior Elevations

Figure 34 Concept of interior elevations

Decorative elements may be added on interior elevation drawings to indicate important interior

design features or to deliver the character of the space, based on the designer's judgment. Adding people can be an effective way to make the space more realistic and to give a relative sense for heights of objects in the space (Figures 38 & 39).

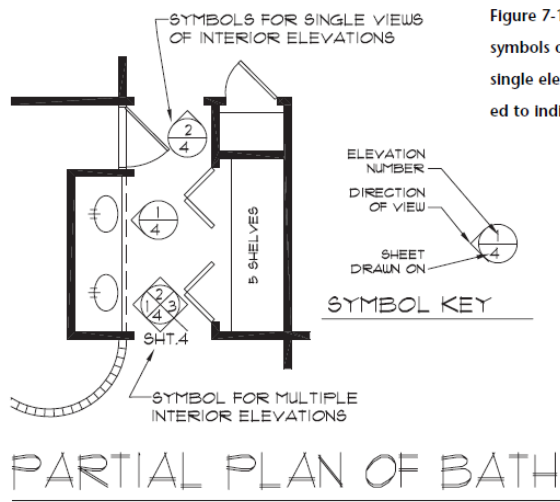

Figure 7-17 Elevation reference symbols on a plan can indicate a single elevation view or be divided to indicate multiple views.

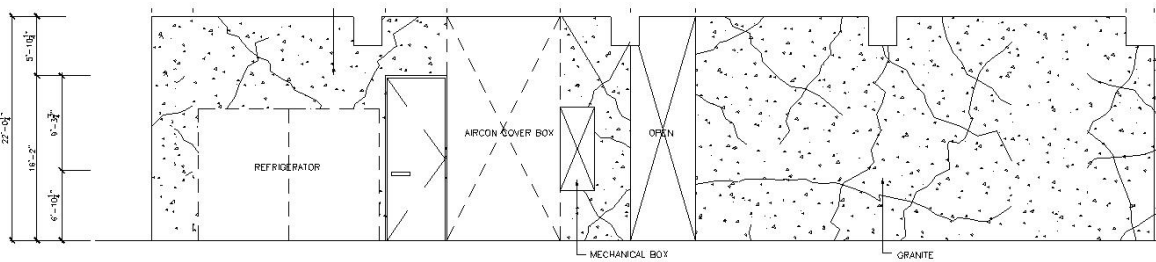
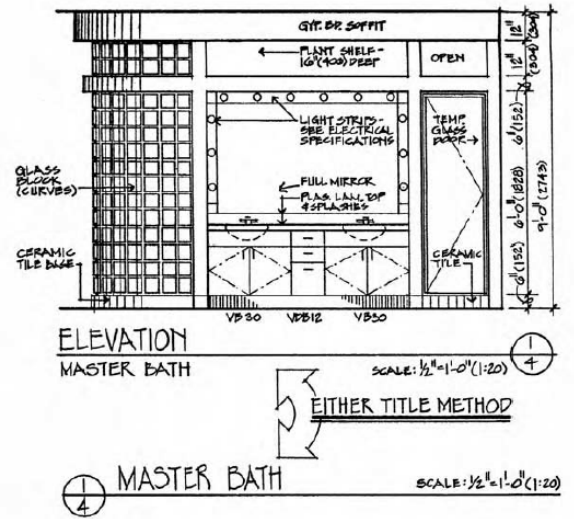

Figure 38 A typical interior elevation drawing with material representation



Figure 39 Adding people on interior elevation drawings gives a relative sense of object heights

Exterior ELEVATION DRAWINGS

Label the important levels including the bottom of the footing, grade, finished floor line, finished ceiling line, and roof line with the elevation datum symbol. There are two methods to label these vertical dimensions in exterior elevation drawings. One is using a vertical dimension line with horizontal lines that extend out from features lettered parallel to it. Each extension indicates what the feature is with a note on it such as top plate, finished floor, etc. (Figure 41). The other is giving the elevation height of each feature from the elevation established for the finished grade of the soil around the building. In this case, elevation datum symbol is associated with each extension line to indicate each elevation height (Figure 42). Vertical distances in exterior elevations typically start above the elevation of the bottom of the footing.

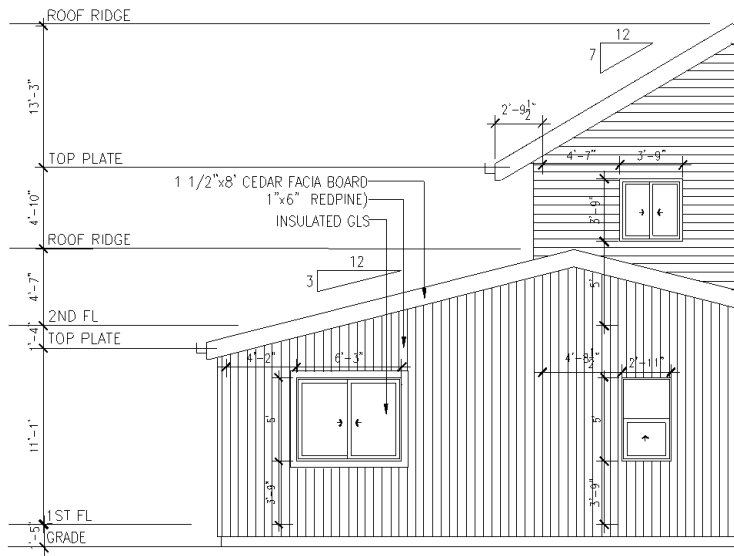

Figure 41. Dimensioning exterior elevations 1

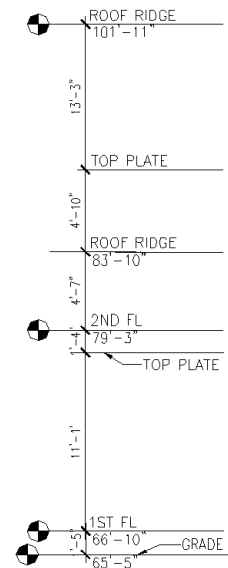

Figure 42. Dimensioning exterior elevations 2

SECTION DRAWINGS

A section drawing is a vertical- cut through of a space or objects (Figure 43). Typical section drawings can be drawn of an entire building, individual interior space, or object such as built-in cabinet (Figures 44 & 45). Sections of spaces in interior drawings are sometimes confused with interior elevations and details. Section drawings for spaces may illustrate similar items as elevation drawings. But section drawings are different from elevation drawings in that they are primarily intended to show the construction of the wall, floor, ceiling, or the object being cut through. Sections aim to show relationships of how different parts are constructed together in a space rather than the items attached to walls. So, a section drawing also presents the construction elements that create the boundaries of spaces, while an elevation drawing focuses on the characteristics of the surfaces of the boundaries represented as single lines on the drawing. When a cut-through line is very close to the objects, not inside the objects, it usually gets to illustrate vertical shapes as shown on elevation drawings, causing confusion between a section and elevation.

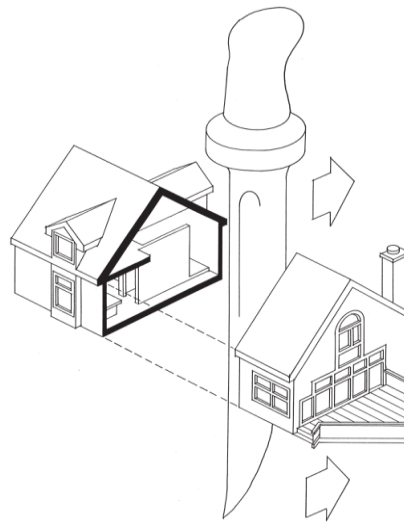

Figure 43 Concept of section drawings

When sections are cut through small portions of a space or object, they are often referred to as section details or details. However, a section drawing is different from these drawings in that a section drawing typically refers to a drawing that cuts through a single space, many spaces on a single floor, or an entire building. Detail drawings are not always drawn in section and may include an enlarged drawing of the floor plan or elevation.

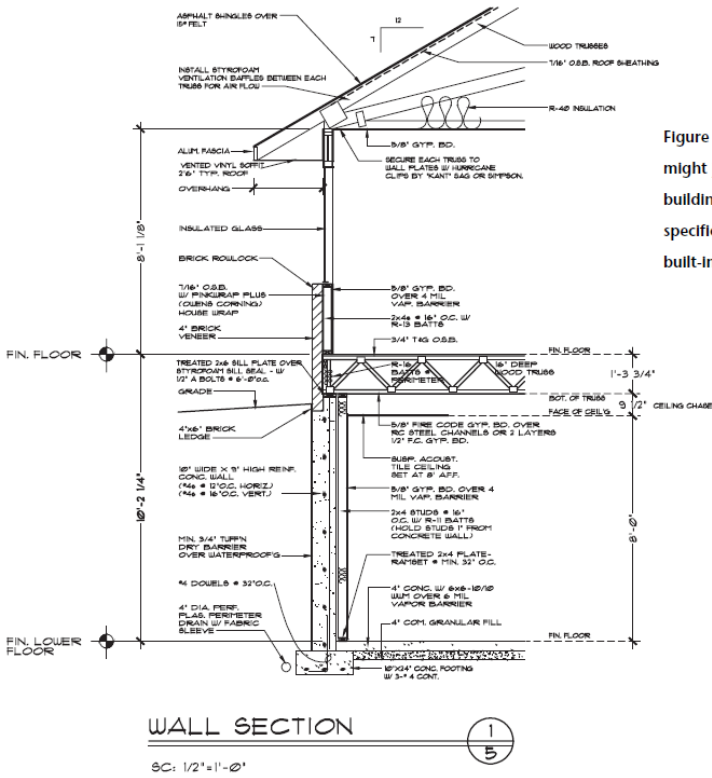
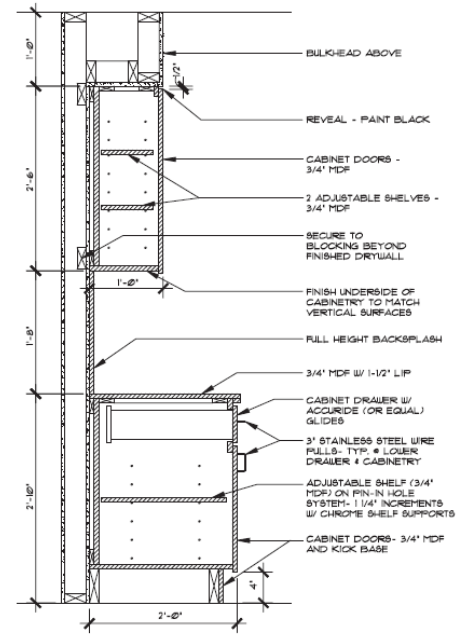

Figure 8-6 An enlarged section might just show part of a building assembly to depict specific details, such as this built-in cabinet construction.



Figures 44 & 45

INTERIOR DETAIL DRAWINGS

Interior detail drawings illustrate small portions of a space or object at a large scale. They are intended to accurately show materials and finish application. Detail drawings are not always drawn in section and may include an enlarged drawing of the floor plan or elevation (Figure 46). Section details provide information on the location and construction of different parts, the relationships of these parts to the surroundings, and the juncture of materials. Details are referenced from plan, elevation, and section drawings.

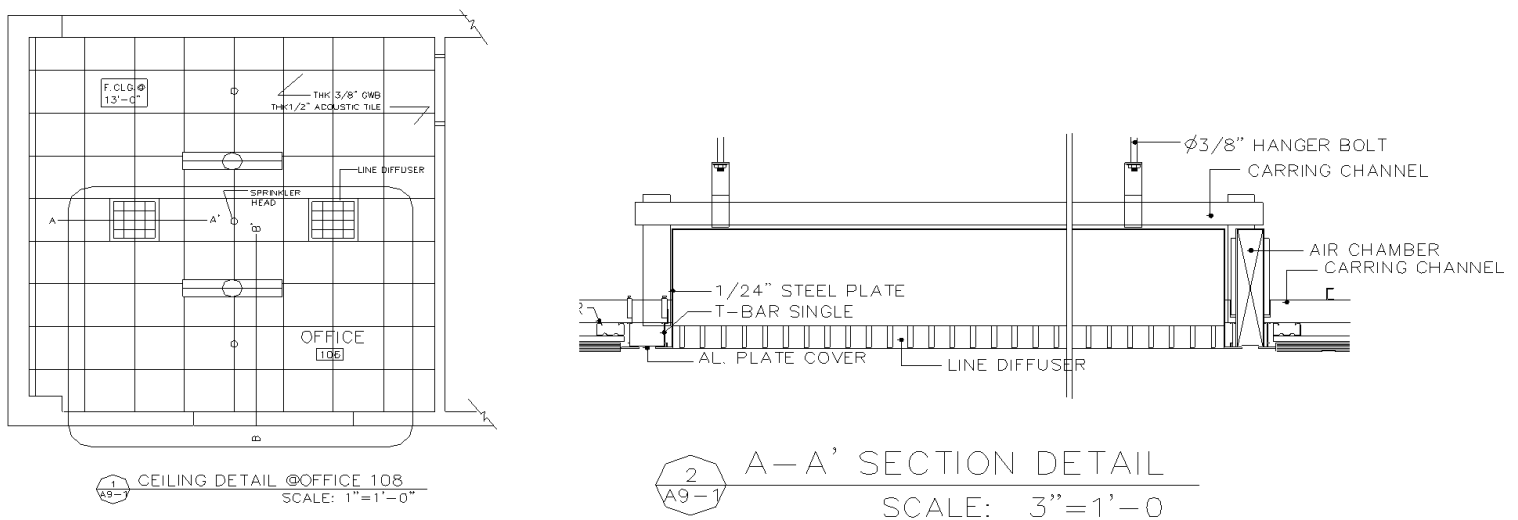

Figure 46. Detail drawings with an enlarged plan drawing of part of the ceiling

Design drawings contain huge amounts of information that is needed for other people involved in the project such as consultants, contractors, and builders. But all the information needed is hard to be illustrated effectively on the actual drawings. Some information is best communicated in the form of specifications, and other information in schedules.

A schedule refers to a tabular form with rows and columns of data to effectively organize information. Schedules deliver deeper information than can be shown on the actual drawings, but not as deep information as in specifications. Schedules must be clear and easy to read. Although the format of schedules may vary among design firms, typical schedules are drawn in grid lines spaced either $3/16$ or $1/4$ inch apart, but no less than $3/16$ inch for readability. The height of lettering is either $3/32$ or $1/8$ inch.

Common types of interior schedules include finish schedule, door schedule, window schedule, and FF+E schedule.

Door Schedule

Doors are identified by a number of other designations shown on the floor plan (Figure 47). These are referenced to a door schedule that contains more detailed information about each door. Door schedules consist of two parts. The first part is in a tabular form, and the second part is a graphic representation of each type of door. In a residential or small project, doors are marked with each number for the type of doors on the floor plan, not with door numbers defined by room numbers. For instance, a door marked with number 1 means the door type 1. Door schedules for residential or small projects or relatively contain less information than big projects or commercial projects. A typical residential door schedule in a table contains the mark, number (quantity), size (nominal size), and type of door, material, and remarks (Figure 48). It is commonly followed by a graphic representation of door types such as door elevations (Figure 49). Door elevations in a graphic representation form are drawn at a $1/4"=1'-0"$ scale in general and may include dimensions.

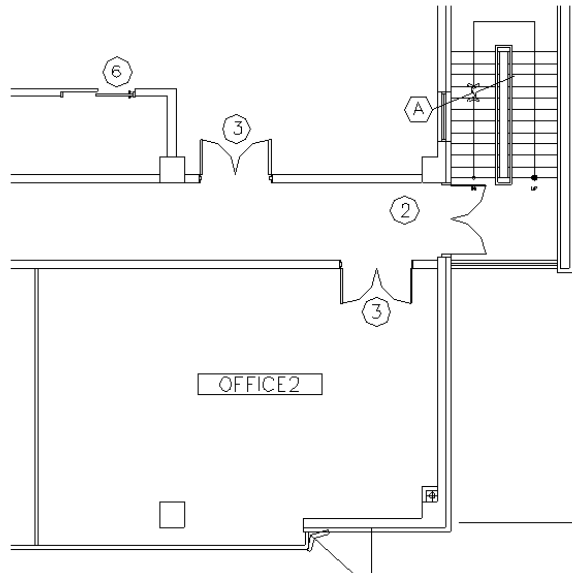

Figure 47 Door marks on floor plan

DOOR SCHEDULE					
MARK	NO	SIZE	TYPE	MATERIAL	REMARKS
1	2	6'-0" x 6'-8" x 1 3/4"	PANEL	W'D, BIRCH	NATURAL FINISH
2	5	3'-0" x 6'-8" x 1 3/4"	PANEL	W'D/FABRIC	INSULATED DOOR
3	2	3'-0" x 6'-8" x 1 3/4"	PANEL	W'D/GLS	1/4" TEMPERED GLS
4	2	3'-0" x 6'-8" x 1 3/4"	FLUSH	W'D	MT'L PT

Figure 48. A typical door schedule for a small or residential project.

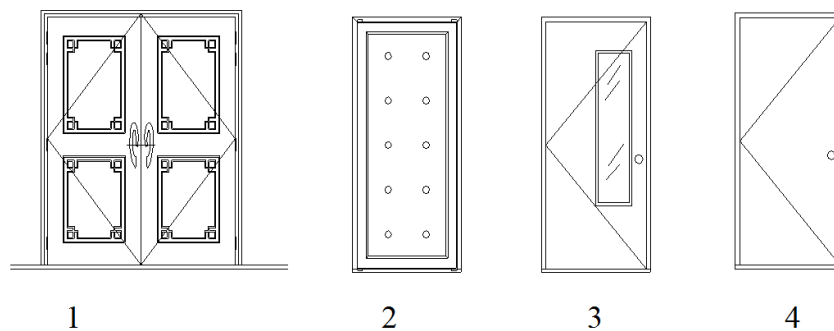

Figure 49. A typical graphic representation of door schedule below the table.

More complicated door schedules may contain the mark, number (quantity), door opening size (nominal), door type, door material, frame material, frame finish, and remarks (Figure 50).

DOOR SCHEDULE								
MARK	NO	DOOR OPENING			FRAME			REMARKS
		SIZE	TYPE	MATERIAL	MATERIAL	FINISH		
1	2	6'-0" x 6'-8" x 1 3/4"	PANEL	W'D, BIRCH	W'D	SS	NATURAL FINISH	
2	5	3'-0" x 6'-8" x 1 3/4"	PANEL	W'D/FABRIC	MT'L	PT	INSULATED DOOR	
3	2	3'-0" x 6'-8" x 1 3/4"	PANEL	W'D/GLS	MT'L	PT	1/4" TEMPERED GLS	
4	2	3'-0" x 6'-8" x 1 3/4"	FLUSH	W'D	MT'L	PT		

Figure 50. Another type of door schedule for a small or residential project.

In a commercial or big project, door numbers are defined by the room numbers. Typically the door numbers are the same as the room number, or marked with an additional number or letter for a more complicated project. For instance, 100-1 or 100-A can be used for the first door in a room with the room number 100, 100-2 or 100-B for the second door, and so forth. More detailed information is necessary including door number, door type number, door opening size, door type, door material, door finish, and frame type, frame material, frame finish, frame hardware, frame fire rating, and remarks (Figure 51).

DOOR SCHEDULE												
DOOR NO.	DOOR TYPE	DOOR OPENING				FRAME						REMARKS
		SIZE	TYPE	MATERIAL	FINISH	TYPE	MATERIAL	FINISH	HARDWARE	RATING		
①	2	3'-0" x 6'-8" x 1 3/4"	PANEL	W'D/FABRIC	ST	HM1	MT'L	PT1	SET #2	20 MINUTES	HARDWARE MUST MEET 20 MINUTE RATED DOORS	
②	1	6'-0" x 6'-8" x 1 3/4"	PANEL	W'D, BIRCH	ST	HM1	MT'L	PT1	SET #1	3/4" HOUR	HARDWARE MUST MEET 3/4 MINUTE RATED DOORS	
③	1	6'-0" x 6'-8" x 1 3/4"	PANEL	W'D, BIRCH	ST	HM1	MT'L	PT1	SET #1	3/4 HOUR	HARDWARE MUST MEET 3/4 MINUTE RATED DOORS	
④	4	3'-0" x 6'-8" x 1 3/4"	FLUSH	W'D	ST	HM2	MT'L	PT2	SET #3	NONE		
⑤												

Figure 51. A commercial door schedule

Besides a table and a graphic representation of the door type, a commercial door schedule also contains notations for general notes, each door type, door finish, frame type, frame finish, hardware, or detail drawings for different types of doors or frame constructions. An abbreviation key should be provided when abbreviations are used such as WD (wood), ST (Stain), or MTL (Metal) in door schedules.

Window Schedule

Window schedules are similar to door schedules in terms of organization and lay out. As doors, windows are identified by a number of other designations shown on the floor plan (Figure 52). These are referenced to a window schedule that contains more detailed information about each window. Window schedules also consist of two parts. The first part is in a tabular form, and the

second part is a graphic representation of each type of window. A graphic representation of window types is typically window elevations drawn at a 1/4" - 1'-0" scale. Windows are marked with each alphabetical letter for the type of windows on the floor plan. For instance, a window marked with letter **A** means the window type A. A typical door schedule table for a residential project has a briefer form than a commercial project, because residential windows are very standard and the information for installation may not be necessary. The items in a typical window schedule for a small or residential project include the mark, number (quantity), unit size, rough opening size, type of window, material, finish, glazing (type of glass) and remarks (Figure 53).

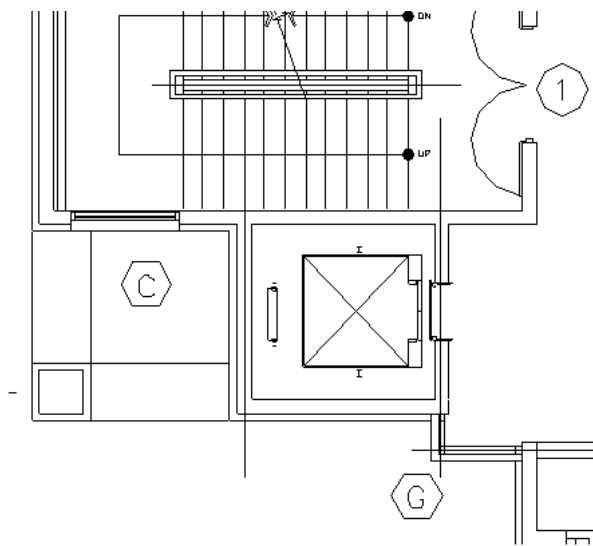

Figure52. Window marks on floor plan

WINDOW SCHEDULE								
MARK	NO	SIZE	ROUGH OPENING	TYPE	MATERIAL	FINISH	GLAZING	REMARKS
A	2	6'5" x 6'	6'5-1/2" x 6'0-1/2"	FIXED	ALUM	BRONZE	5/8" CLEAR TEMPERED	
B	5	5' x 1'2"	5'0-1/2" x 1'2-1/2"	FIXED	DO	DO	5/8" CLEAR TEMPERED	
C	2	8' x 11'	8'0-1/2" x 11'0-1/2"	FIXED	DO	DO	5/8" INSUL	ENGY EFF GL
D								
E								

Figure 53. A typical window schedule for a residential project.

Window schedules in a commercial project are more complicated than a residential project due to various types and materials of windows. The items include the mark, number (quantity),

manufacturer & style, model number, size of window, rough opening, window type, material, finish, glazing (type of glass) and remarks (Figure 54).

WINDOW SCHEDULE										
MARK	NO	MANF. STYLE	MODEL NO.	SIZE	ROUGH OPENING	TYPE	MATERIAL	FINISH	GLAZING	REMARKS
A	2	MARVIN/ ARCHITECT SERIES	WD354	6'5" x 6'	6'5-1/2" x 6'0-1/2"	FIXED	ALUM	BRONZE	5/8" CLEAR TEMPERED	
B	5	MARVIN/ ARCHITECT SERIES	WD342	5' x 1'2"	5'0-1/2" x 1'2-1/2"	FIXED	DO	DO	5/8" CLEAR TEMPERED	
C	2	MARVIN/ ARCHITECT SERIES	WD323	8' x 11'	8'0-1/2" x 11'0-1/2"	FIXED	DO	DO	5/8" INSUL	ENGY EFF GL
D										
E										

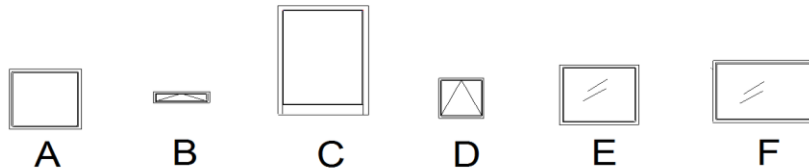

Figure 54. A typical window schedule for a commercial project including a table and window elevations

Interior Finish Schedule

An interior finish schedule provides information on the finish materials to be applied to each wall, ceiling, floor surface, and base in a tabular form. Interior finish schedules typically include a tabular form. In a big commercial project, the second part may be added, which is the legend or materials key, if separate finish plans are not provided. Residential finish schedules are briefer than commercial finish schedules since residential finishes are more likely to be common. Commercial projects usually use a much wider range of interior finish materials and need a more complex interior finish schedule. The items in a typical interior finish schedule for a

WINDOW SCHEDULE										
MARK	NO	MANF. STYLE	MODEL NO.	SIZE	ROUGH OPENING	TYPE	MATERIAL	FINISH	GLAZING	REMARKS
A	2	MARVIN/ ARCHITECT SERIES	WD354	6'5" x 6'	6'5-1/2" x 6'0-1/2"	FIXED	ALUM	BRONZE	5/8" CLEAR TEMPERED	
B	5	MARVIN/ ARCHITECT SERIES	WD342	5' x 1'2"	5'0-1/2" x 1'2-1/2"	FIXED	DO	DO	5/8" CLEAR TEMPERED	
C	2	MARVIN/ ARCHITECT SERIES	WD323	8' x 11'	8'0-1/2" x 11'0-1/2"	FIXED	DO	DO	5/8" INSUL	ENGY EFF GL
D										
E										

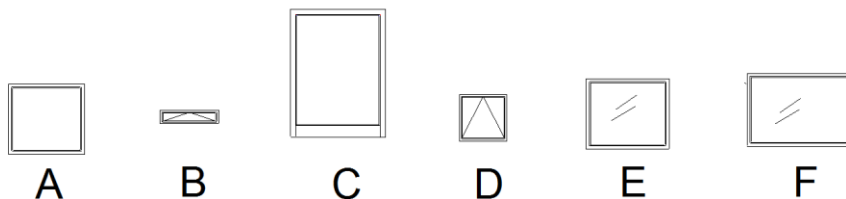

Figure 54. A typical window schedule for a commercial project including a table and window elevations

small or residential project include room name, floor material, base material, wall material, ceiling material, ceiling height, and remark (Figure 55). More sub- items can be added to each surface item when different materials are applied to one of the surfaces. For instance, the wall item may include sub items such as north wall, east wall, south wall, or north wall, when different wall finishes are applied to different walls.

ROOM FINISH SCHEDULE						
ROOM NAME	FLOOR	BASE	WALLS	CEILING	CEILING HEIGHT	REMARKS
FOYER	CERAMIC TILE	6" CERAMIC TILE	PAINT	PTD. GYP. BD	8'-8"	
LIVING ROOM	HARDWOOD	4" WOOD	WALLPAPER	PTD. GYP. BD	8'-8"	COFFERED CEILING
FAMILY ROOM	NATURAL CORK	4" RUBBER	WALLPAPER	PTD. GYP. BD	8'-8"	
DINING ROOM						

Figure 55. A typical interior finish schedule for a residential project

The items for a commercial project include mark (room number), room name, floor material, base material, wall material, ceiling material, ceiling height, and remarks. Each surface item lists all the specific finishes that are planned to be applied in the project. Among these materials, the material that will be used in a specific room is checked. For instance, the floor item may include materials such as carpet, carpet 2, vinyl tile, and vinyl tile 2 for the project, and the carpet may be marked as a floor material for the Room 101 (Figure 56).

ROOM FINISH SCHEDULE																			
MARK	ROOM NAME	FLOOR				BASE			WALLS			CEILING	CEILING HEIGHT	REMARKS					
		CARPET1	CARPET2	VINYL TILE1	VINYL TILE2	CERAMIC TILE	4" VINYL	WOOD	CERAMIC TILE	WALLPAPER	PAINT1	PAINT2	PAINT3	CERAMIC TILE	PTD. GYP. BD1	PTD. GYP. BD2	ACOUS. TILE		
101	OFFICE1	<input type="radio"/>				<input type="radio"/>					<input type="radio"/>							9'-0"	SEE COLOR SCHEDULE
102	OFFICE2	<input type="radio"/>				<input type="radio"/>					<input type="radio"/>							9'-0"	DO
103	OFFICE3		<input type="radio"/>			<input type="radio"/>					<input type="radio"/>							10'-0"	DO
104																			

Figure 56. A typical interior finish schedule for a commercial project

Furnishing, Furniture, and Equipment (FF+E) Schedule

Specifying, ordering, and placing FF+E is an integral part of interior designer's job. To inform installation which FF+E will be placed where correctly, a separate drawing called the FF+E plan

or FF+E installation plan may be created. In a small project, furniture selection may be noted in each place where furniture is shown on the FF+E furniture plan. But in a large commercial project, an organized schedule is necessary to show FF+E information in a clear way. Each furniture piece is identified by the keys shown on the furniture plan, which are referenced to the furniture schedule. A typical FF+E schedule contains information of mark, number (quantity), manufacturer and catalog number, description, fabric, finish, and remarks (Figure 57). The marks are in the form of codes that indicate generic types of furniture. For instance, C means chair, and T means table. In a more complicated project, the code may be a combination of letters and numbers to provide more detailed information such as T07/101. In this case, T indicates table, 07 refers to the 7th type of table for the project, and 101 after the slash means the room number where this table will be located.

Electrical Plans

Electrical plans can include electrical outlets, telephones, communication devices, and other items requiring electrical power. In small projects, these items can be shown together with the lighting. An example of this type of drawing is illustrated in Figure 14-18. On large commercial projects, the electrical plan, often referred to as a power or power/communication plan, shows the outlets and related electrical devices separately (Figure 14-19). In most cases, the plumbing fixtures and items such as cabinetry and other built-in items are shown in order to more closely coordinate the location of electrical power devices. In some instances, such as in open office situations, designers also prefer to show the furniture, as many times it relates directly to the electrical outlet locations (Figure 14-20). The interior designer prepares the power plan and then forwards it to the electrical engineer to detail the circuitry, wire sizes, panel boxes, and other electrical specifications. On small residential plans, the drawing is given directly to the electrical contractor to install the work according to accepted practices. The telephone and other communication systems are also generally shown on the electrical plan. Locations of telephones, public address systems, computer terminals, intercommunication devices, and security systems are the responsibility of the interior designer in consultation with specialists.

Scale of Electrical Plans

Electrical plans in commercial spaces are generally drawn at the same scale as the floor plans.

The most common scale for commercial projects is $1/8" = 1'-0"$ (1:100 metric). However, in

complex installations, the scale might be increased to 1/4" = 1'-0" (1:50 metric). The scale the plan is drawn at should be noted and placed either adjacent to or directly below the title.

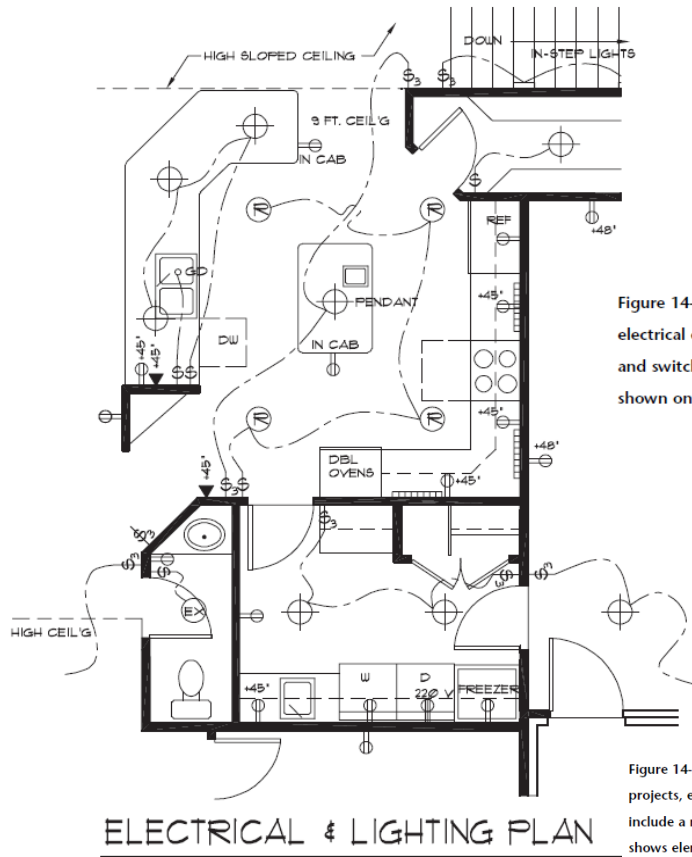
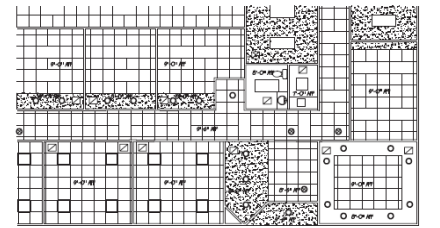

Figure 14-18 In small projects, electrical outlet, light fixtures, and switching patterns can be shown on the same floor plan.

ELECTRICAL & LIGHTING PLAN

SC: 1/4" = 1'-0"

Figure 14-2 In large commercial projects, electrical drawings often include a reflected ceiling plan that shows elements on the ceiling, a lighting plan for fixtures and switching, and a power plan for electrical supply devices



REFLECTED CEILING PLAN

SCALE: 1/4" = 1'-0"

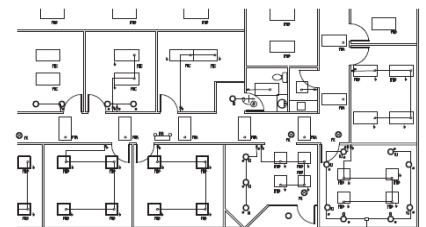





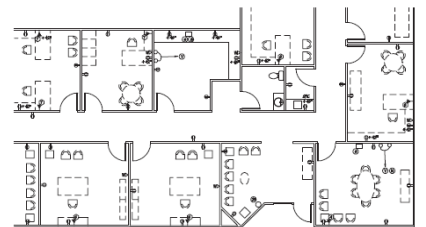

















LIGHTING PLAN

SCALE: 1/4" = 1'-0"



POWER & COMMUNICATION PLAN

SCALE: 1/4" = 1'-0"

COMMON ELECTRICAL SYMBOLS	
POWER RECEPTACLES	WIRING
 DUPLEX POWER RECEPTACLE  DUPLEX POWER RECEPTACLE W/ GROUND FAULT INTERRUPTER CIRCUIT (WP=WEATHERPROOF)  DUPLEX POWER RECEPTACLE W/ ISOLATED GROUND TERMINALS  DUPLEX POWER RECEPTACLE ON DEDICATED CIRCUIT  DUPLEX POWER RECEPTACLE W/ TOP HALF SWITCHED  QUADRAPLEX POWER RECEPTACLE  DUPLEX RECEPTACLE FLUSH FLOOR MOUNTED  QUADRAPLEX POWER RECEPTACLE FLUSH FLOOR MOUNTED	 JUNCTION BOX W/ WHIP  JUNCTION BOX FLUSH FLOOR MOUNTED W/ WHIP
	FIRE ALARM SYSTEM DEVICES
	 S/A SMOKE ALARM - WIRE DIRECT W/ BATTERY BACK-UP
	EMERGENCY / EXIT LIGHTING
	 EXIT LIGHT W/ STANDBY BATTERY  EMERGENCY LIGHTS PACK
COMMUNICATION / DATA	RESIDENTIAL
 TELEPHONE OUTLET  DATA OUTLET  COMBINATION TELE/DATA OUTLET (CAN SPECIFY # OF TELE VERSES DATA PORTS WITH SUBSCRIPT) OR  CABLE TV OUTLET  FLUSH FLOOR MOUNTED TELE/DATA COMBO. OUTLET (CAN SPECIFY # OF TELE VERSES DATA PORTS WITH SUBSCRIPT) OR  FLUSH FLOOR MOUNTED TV CABLE OUTLET	 DOORBELL - VERIFY LOCATION OF CHIMES (2 MIN.) W/ OWNER  G.D. GARBAGE DISPOSAL  ELECTRIC GARAGE DOOR OPENER
	MISCELLANEOUS
	 ESP ELECTRICAL SERVICE PANEL

Reflected Ceiling Plans

The lighting of interiors is important to our activities and our perception of the world. By creatively controlling natural and artificial light, the interior designer can create striking designs while providing for the visual needs of the user. Lighting design is a combination of art and applied science. It guides our vision, and can affect our attitudes and behavior. The designer can also ensure the conservation of energy by employing efficient luminaires. The switching of lighting controls and systematic maintenance programs can also affect energy conservation. The type of lighting system the interior designer selects determines the amount of detail the construction drawings need. Lighting systems can refer to the individual types of luminaires or to the total installation. They are described as direct, indirect, direct-indirect, diffuse, semi-direct and semi-indirect, as illustrated in Figure 14-5.

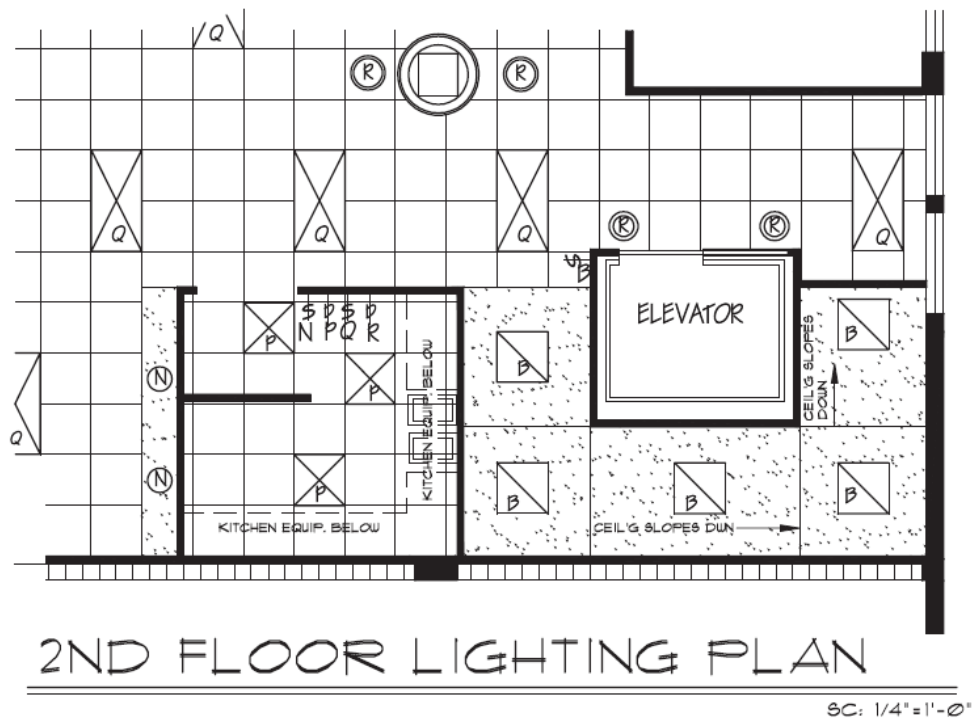

STANDARD SWITCHING SYMBOLS	
$\$$	SINGLE POLE SWITCH
$\$$ ₃	THREE-WAY SWITCH
$\$$ ₄	FOUR-WAY SWITCH
$\$$ _{DM}	DIMMER SWITCH
$\$$ _D	AUTOMATIC DOOR SWITCH
$\$$ _{TK}	KEY OPERATED SWITCH
$\$$ _{TRC}	REMOTE CONTROL SWITCH
$\$$ _{WP}	WEATHERPROOF SWITCH
$\$$ _{LV}	LOW VOLTAGE SWITCHING SYSTEM
$\$$ _T	TIME SWITCH
$\$$ _{FPB}	CEILING PULL SWITCH
NOTE: ANY SPECIAL TYPE OF SWITCH CAN BE DESIGNATED WITH AN 'S' WITH THE ADDITION OF A SUBSCRIPT TO DESIGNATE SOME SPECIAL VARIATION OF STANDARD SWITCHES. WHEN A SPECIAL SYMBOL IS	

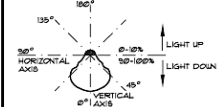
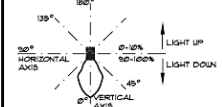
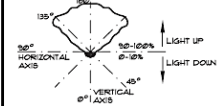
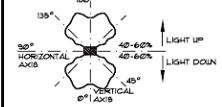
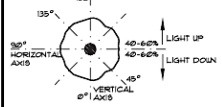
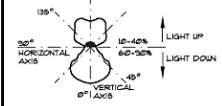
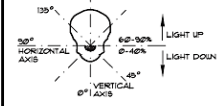
TYPE	LIGHT DISTRIBUTION	CHARACTERISTICS
DIRECT-WIDE BEAM		90-100% OF LIGHT OUTPUT IS DIRECTED DOWN. WIDE BEAM DIRECT LIGHTING CAN BE USED FOR EMPHASIS AND HIGHLIGHTING.
DIRECT-NARROW BEAM		90-100% OF LIGHT OUTPUT IS DIRECTED DOWN. NARROW BEAM DIRECT LIGHTING CAN BE USED FOR EMPHASIS AND HIGHLIGHTING.
INDIRECT		90-100% OF LIGHT OUTPUT IS DIRECTED UP TOWARD THE CEILING. CAN CREATE A FEELING OF HEIGHT AND PREVENT DARK CEILINGS.
DIRECT / INDIRECT		EQUAL AMOUNT OF LIGHT DIRECTED DOWN AS WELL AS UP WITH LITTLE PROVIDED TO THE SIDES. DIRECT GLARE IS REDUCED.
DIFFUSE		LIGHT OUTPUT IS DIRECTED IN ALL DIRECTIONS. DIRECT GLARE CAN BE PREVENTED BY DIFFUSE ENCLOSURES.
SEMI-DIRECT		10-40% OF LIGHT OUTPUT IS DIRECTED UPWARD, WHILE 60-90% OF LIGHT IS DIRECTED DOWN. SHADOWS ARE NOT AS HARSH.
SEMI-INDIRECT		60-90% OF LIGHT IS DIRECTED DOWN, WHICH SOFTENS HARSH SHADOWS.

Scale of Reflected Ceiling Plans

Reflected ceiling plans should be drawn at the same scale as the floor plans. Depending on the complexity of the project and ceiling treatment, the most common scale for residential and small commercial projects is $1/4" = 1'-0"$ (1:50 metric) and $1/8" = 1'-0"$ (1:100 metric) for large commercial projects.

COMMON LIGHT SYMBOLS



CEILING MOUNTED LIGHT FIXTURE



CEILING MOUNTED PENDANT LIGHT FIXTURE



RECESSED LIGHT FIXTURE



WALL MOUNTED LIGHT FIXTURE



CEILING OR WALL MOUNTED TRACK LIGHTING
- LENGTH & NO. OF FIXTURE ON PLAN



RECESSED WALL WASHER LIGHT FIXTURE



EXHAUST FAN / LIGHT COMBINATION (VENT TO
OUTDOORS)



2'x4' SURFACE MOUNTED FLUORESCENT LIGHT
FIXTURE



2'x4' RECESSED FLUORESCENT LIGHT FIXTURE



2'x2' RECESSED FLUORESCENT LIGHT FIXTURE



1'x4' SUSPENDED FLUORESCENT LIGHT
FIXTURE (CERTAIN FIXTURES MAY BE ABLE
TO CONNECT TO FORM CONTINUOUS ROW)

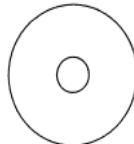

CEILING FAN W/ INTEGRAL LIGHT(S) -
PROVIDE SEPARATE SWITCHING FOR FAN &
LIGHT(S)



UNDERCABINET FLUORESCENT LIGHT FIXTURE
W/ INTEGRAL SWITCH (WIRE DIRECT)











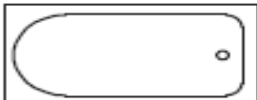

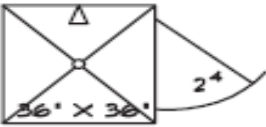

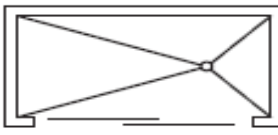



EXIT LIGHT W/ STANDBY
BATTERY













EMERGENCY LIGHTS PACK

















FIXTURES

 STANDARD TUB	 OVAL TUB	 36" X 36" SQUARE SHOWER	 SHOWER HEAD
 RECTANGULAR SHOWER	 D.F. DRINKING FOUNTAIN	 TANK TOILET	 WALL HUNG TOILET
 WALL HUNG LAVATORY	 PEDESTAL LAVATORY	 LAVATORY IN COUNTER TOP OR CURED MARBLE TOP	 CORNER LAVATORY
 FLOOR MOUNTED TOILET	 WALL HUNG URINAL	 FLOOR MOUNTED URINAL	 FLOOR DRAIN
 DOUBLE BOWL KITCHEN SINK			

OTHER SYMBOLS

CLEAN OUT ON FLOOR	
CLEAN OUT IN WALL	
GATE VALVE	
GLOBE VALVE	
CHECK VALVE	
STOP COCK	
FLOOR, ROOF, OR SHOWER DRAIN	
VENT THROUGH ROOF	
1/2" WASTE DOWN (UP)	
1/2" HOT WATER DOWN (UP)	
1/2" COLD WATER DOWN (UP)	

PLUMBING PIPE

SOIL, WASTE OR LEADER (ABOVE GROUND)	
SOIL, WASTE OR LEADER (UNDERGROUND)	
VENT	
COLD WATER	
HOT WATER	
HOT WATER RETURN	
FIRE LINE	
MAIN SUPPLY, SPRINKLER	
BRANCH & HEAD, SPRINKLER	
GAS, LOW PRESSURE	
GAS, MEDIUM PRESSURE	
GAS, HIGH PRESSURE	
CAST IRON PIPE	
CLAY TILE PIPE	
REINFORCED CONCRETE PIPE	
DRAIN TILE - OPEN OR AGRICULTURAL	

Scale of Plumbing Drawings

A variety of scales may be used to draw plumbing systems, depending whether the drawings are depicted in plan views, isometrics, or enlarged details. The most common scale is $1/4" = 1'-0"$ (1:50 metric) for residential and small commercial projects and $1/8" = 1'-0"$ (1:100 metric) for large commercial ones. Floor plans serve as the base drawing and are turned into plumbing plans by the addition of piping, controls, and other devices. Domestic water lines and sanitary sewer lines are drawn as an overlay on the floor plans.

Mechanical (HVAC) Plans

Engineers, architects, and mechanical contractors are the primary designers of HVAC plans (Figure 15-1). However, interior designers are often called on to coordinate the way the HVAC is installed and to monitor how it will affect the interiors of a building. A designer needs to be able to interpret the basic HVAC plans (particularly the reflected ceiling plan) for coordination of light fixtures, registers, grilles, thermostats, and other items that interface with the system (Figure 15-2).

Scale of HVAC Plans

HVAC plans are generally drawn at the same scale as the floor plans. The most common scale is $1/4" = 1'-0"$ (1:50 metric) for residential and small commercial projects and $1/8" = 1'-0"$ (1:100 metric) for large commercial ones. The scale the HVAC plan is drawn at should be noted either adjacent to or directly below the drawing title.

Figure 15-2 This ceiling plan shows the location of HVAC ducting and ceiling registers in relation to ceiling light fixtures and dropped soffits.

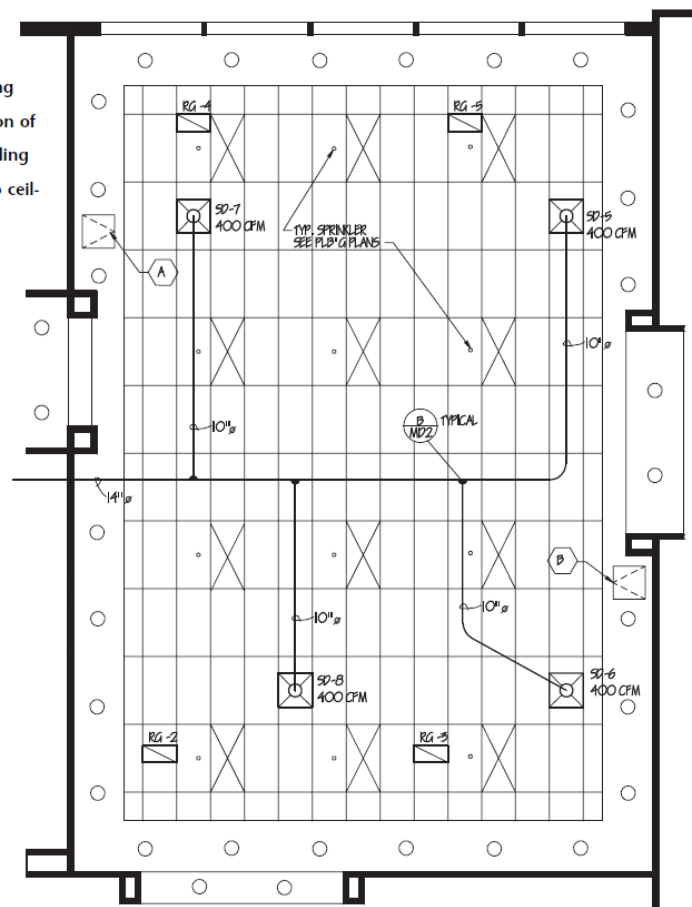

REFLECTED CEILING PLAN AT LOBBY

SCALE: $1/4" = 1'-0"$

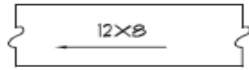

12' WIDE BY 8' DEEP DUCT
WITH DIRECTION OF AIR FLOW

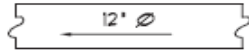

12' DIAMETER ROUND DUCT
WITH DIRECTION OF AIR FLOW

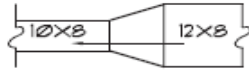

DUCT REDUCTION
SIZE CHANGE



AUTOMATIC OR MANUAL DAMPER
(CONTROLS VOLUME OF AIR FLOW)



AIR SUPPLY DUCT SEEN
IN SECTION VIEW

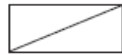

RETURN AIR DUCT SEEN
IN SECTION VIEW



FLOOR SUPPLY REGISTER



ROUND CEILING SUPPLY
DIFFUSER OUTLET

ARROWS INDICATE DIRECTION
OF AIR FLOW

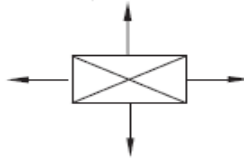

RECTANGULAR CEILING SUPPLY
DIFFUSER OUTLET

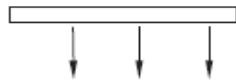

LINEAR AIR DIFFUSER

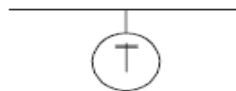

THERMOSTAT

HEATING AND AIR CONDITIONING SYMBOLS

FURNITURE INSTALLATION PLANS

The selection of furniture is an integral phase in the design of interior spaces, as it affects human functions and desires. Spaces can also be personalized by furniture, which reflects individual preferences, activities, and needs. This chapter will discuss furniture in both residential and commercial buildings. In commercial spaces, furniture generally reflects the concept, theme, or image an establishment wants to convey to the public or their clients. The selection of furniture in residential spaces often reflects the personal tastes and lifestyles of the individuals who occupy them. Furniture is often included in what interior designers call the furniture, furnishings, and equipment (FF&E) package.

Scale of Furniture Installation Plans

Furniture installation plans are drawn at as small a scale as possible to reduce the amount of space they take up on the sheet. The furniture drawn in plan view may be simplistic in form to prevent clutter. For example, a chair could be drawn as a rectangle, with no back or arms depicted.

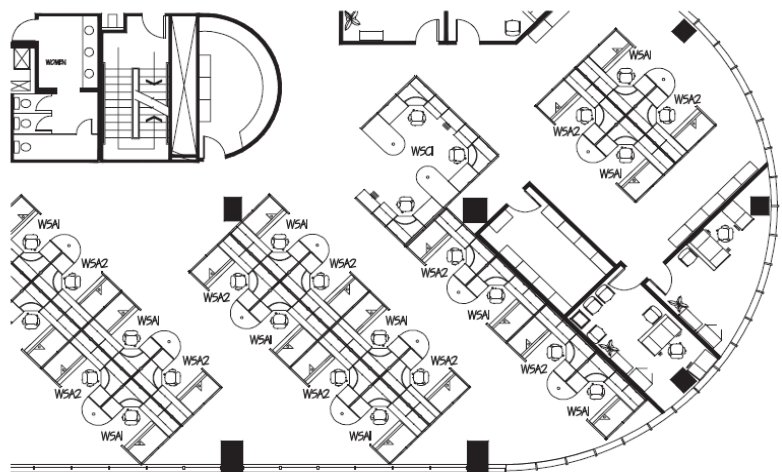
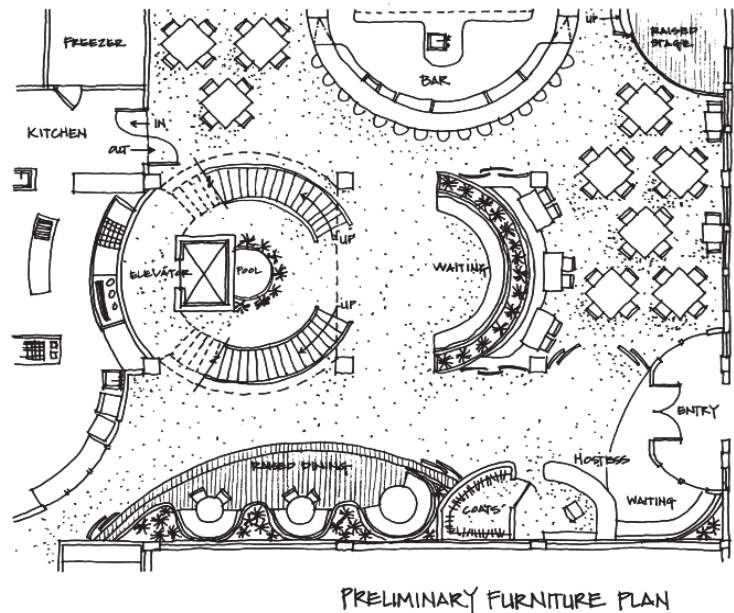
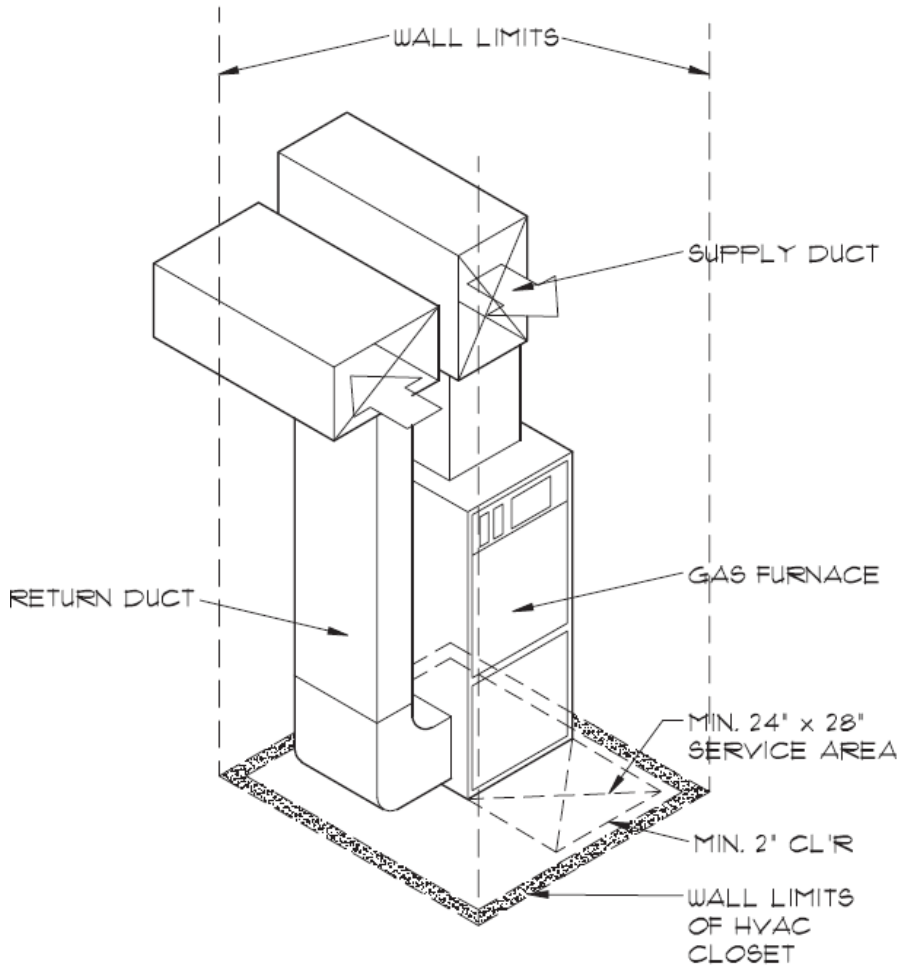
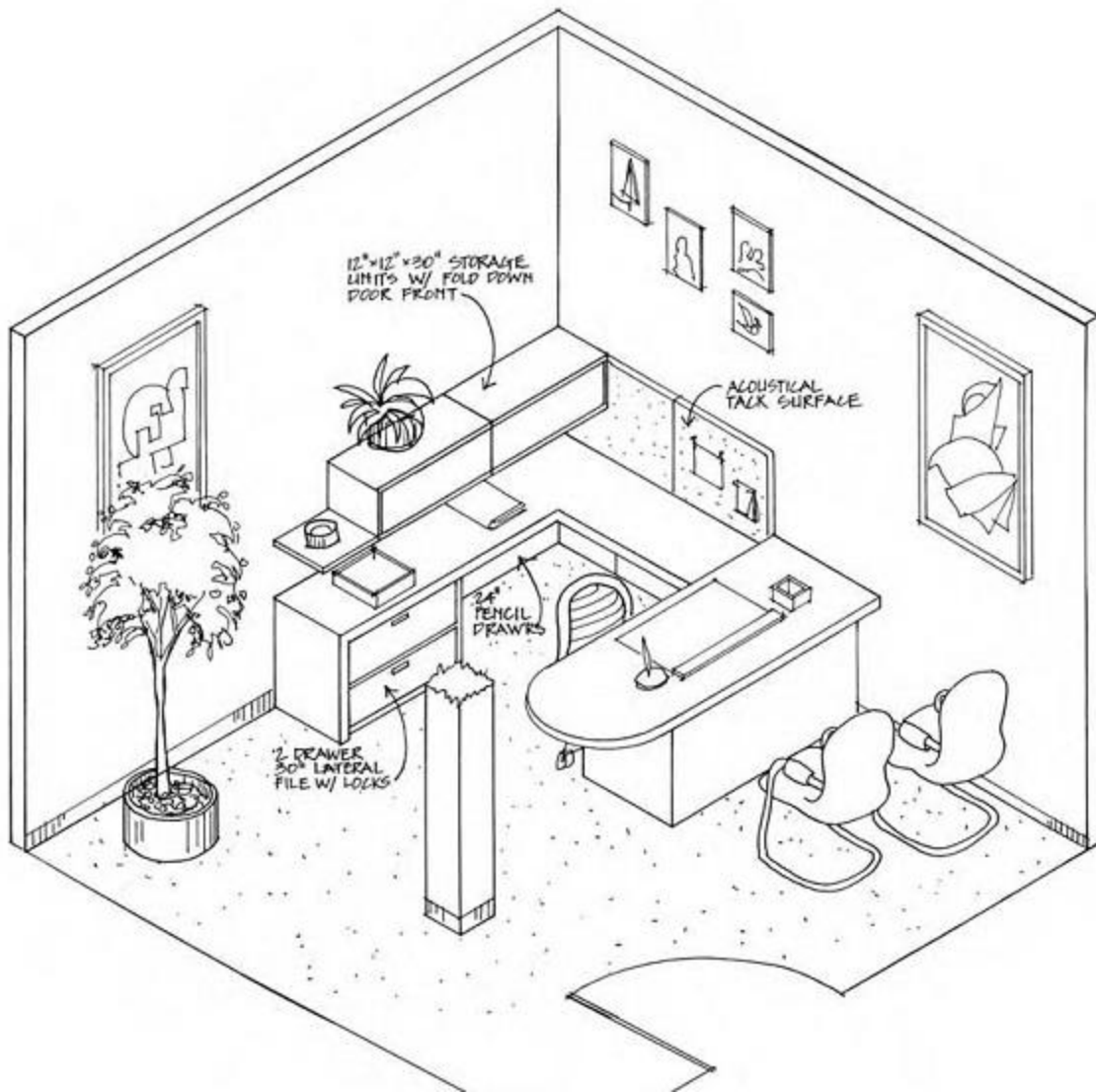

Figure 12-6 In this furniture plan, workstations are coded WSA1, WSC1, etc. — then specified in detail in the job book or schedule.



ISOMETRIC OF FURNACE
INSTALLATION

NO SCALE



GLOSSARY

Acoustical tile — Fiberboard, fiberglass, or similar material used to absorb sound rather than reflect it. Often used as a ceiling material.

Air exchanger — An HVAC unit designed to exhaust stale air and draw in fresh air. In cold climates, the units often capture latent heat in the air and redirect it to the heating system.

Acrylic paint — a water-based paint made with synthetic resins.

Ampere — the unit used to measure the rate of flow of electrical current.

Alcove — Recessed niche or space connected to the side of a larger space or room.

Alloy — A substance produced by the combination of two or more metals, or a nonmetal fused with a metal.

Ampere — The unit used to measure the rate of flow of electrical current.

Alcove — Recessed niche or space connected to the side of a larger space or room.

Anchor bolt — A threaded rod cast or shot into concrete (or masonry) and used for anchoring — e.g., securing a sill plate to the foundation.

Anodize — Use an electrolytic process and a combination of chemicals to place a protective oxide film on metal.

Architect — A professional who designs and draws up instruments such as construction drawings for buildings and other structures in the built environment.

Areaway — An open area below grade that allows light and ventilation toward a basement door or window.

Ashlar — Stone that is cut in rectangular shapes and fitted together.

Ash pit — A recessed pit below a fireplace hearth that is used to collect ashes.

Atrium — An open space or court within a building.

Awning — A covering made of canvas, metal, or another material. The term is also used to describe a window that is hinged at the top and swings outward.

Attic — A space between the ceiling and roof of a building.

Baffle — A device used to block the flow of sound, light, or wind.

Baluster — A row of posts that supports a rail, such as a handrail used on a stairway.

Banister — Another term for a handrail.

Baseboard — A finish and protective board (or other material) covering where a wall and floor meet.

Basement — Lowest story of a building, generally entirely or partially below ground.

Base plate — A steel plate used at the bottom of a column to spread vertical loads out and anchor the column to the floor.

Batt — A blanket of insulating material (such as fiberglass) manufactured in specific widths to be installed between framing members.

Batten — Narrow strip of material (usually wood) that conceals the spacing between larger boards — such as in board and batten siding.

Batter — A wall that slopes away from perpendicular and is seen mostly in concrete or masonry construction.

Bay window — A window element projecting from a building, which generally has three sides.

Beam — A horizontal structural member that supports loads.

Beam ceiling — A ceiling treatment that exposes ceiling beams to view.

Bearing wall — A wall that supports vertical loads.

Bib — A faucet with threads for the attachment of a water hose. Also called a hose bib.

Blocking — Wood framing pieces used to reinforce, secure, or provide backing for other members or materials.

Bookmatch — A wood veneer pattern produced by alternating sheets (flitches) similar to the leaves of a book.

Brick veneer — A facing of brick installed in front of a frame, concrete, or concrete block wall.

BTU — An abbreviation for “British Thermal Unit,” which is the standard measurement for heat loss and gain.

Building inspector — An official whose job is to inspect remodeling or new building construction for safety and compliance with the various building codes.

Built-up beam — A roofing type composed of several smaller beams, all secured together.

Built-up roof — Roofing type composed of layers of felt and asphalt, commonly top-coated with gravel.

C.O.M. — Customer’s own material. The customer purchases upholstery from another party rather than the furniture manufacturer.

CAD — Computer-aided design

CADD — Computer-aided design and drafting. However, this term is not used as much as the former designation.

Cant strip — A triangular strip of material used to support or eliminate sharp turns in roofing materials or flashings.

Cantilever — A projected structure that is supported only at one end.

Carriage — The supporting linear frame that holds the treads and risers in a stair.

Casement — A window that is hinged on the vertical side.

Casing — The frame around a window or door.

Caulking — A waterproof material used to seal small spaces between adjoining surfaces.

Cavity wall — A hollow wall made up by two layers of masonry walls constructed a few inches apart.

Cement — An adhesive masonry material.

Circuit breaker — A device that opens or closes an electrical circuit. It opens (breaks) a circuit automatically if an unusually high level of current passes through it.

Chamfer — Easing or angling of the edge of two adjoining planes, often at a 45-degree angle.

Channel — A standardized structural steel shape, which resembles a U.

Chase — A space within a building for routing pipes, ducts, wiring, or other utilities.

Checking — Cracks or splits in a board caused by drying or seasonal changes.

Chimney — A flue used to exhaust gases and smoke from a building. See also Flue.

Chord — The bottom, top, or diagonal member of a truss.

Cinder block — A concrete masonry unit made of cinders and cement.

Cleanout — Removable cover or insert in a sewer waste line for cleaning or inspection of the line.

Clerestory — High windows placed in an interior or exterior wall, used mostly for admitting light to a space.

Collar beam — A horizontal member used to connect opposing rafters in roof framing.

Column — A perpendicular load-carrying member.

Concrete — A mixture of cement, gravel, sand, and water that hardens to a strong solid state.

Concrete block — A precast hollow or solid masonry unit of concrete. See also Cinder block.

Concrete masonry unit (CMU) — A concrete block made of hardened concrete, with or without hollow core cells.

Conduit — An outer channel (primarily of metal) used to contain electrical wiring for protection and safety.

Control joint — A groove troweled or cut in concrete slabs that permits the regulation of cracks.

Corbel — The projecting of masonry construction by placing courses cantilevered beyond the lower ones.

Cornerbead — A metal molding used in plaster or drywall construction to protect and finish corners.

Cornice — The projecting element of a roof or wall.

Course — A continuous row of masonry laid with the same uniform height.

Court — A partial or full open space within a building.

Cripple — A vertical structural member in a door or window that is less than full-height.

Curtain wall — The exterior portion of a building that does not support loads.

Damper — The adjustable plate in a chimney or air duct that regulates the draft or air flow.

Duct — A rectangular- or circular-shaped material (metal, fiberboard, etc.) that is used to transfer air from one space to another.

Diffuser — A device that scatters (diffuses) air, light, or sound into a space.

Dormer — A housing projecting from a sloping roof that accommodates a window.

Double-hung — A window that has bottom and top sashes, either of which can be slid up and down.

Drip — A groove or projecting edge incorporated below a surface to carry water or cause it to drip away from a vertical surface below.

Dimension line — A line that shows the distance (in measured increments) between two points. It consists of a line and arrowheads, dots, or slash marks to mark the exact point of reference.

Drywall — Construction using premade gypsum board panels (versus lath and plaster, which is a wet system).

Eave — The section of a roof that projects over a wall below.

Edge band — Thin veneer of material (such as wood) applied to the edge of a panel, such as plywood.

Efflorescence — Powdery deposit on the surface face of masonry. It is a result of water leaching to the surface and transporting chemical salts from within the structure.

EIFS — Exterior insulation and finish system. Coating system of reinforced stucco applied to the surface of an insulated plastic foam board.

Elevation — A drawing of the front, side, or rear of an object.

Escutcheon — A cover plate on door hardware; or cover for the gap around piping where it enters a surface.

Fascia — A vertical band (wood or other material) secured to the cornice or roof overhang.

Fenestration — The placement of windows on a wall surface.

Finished lumber — Wood that has been dressed (milled or sanded) to be used for constructing cabinetwork and other building trim.

Firebrick — A brick that is hard and withstands great heat. It is used to line fireplaces, furnaces, etc.

Fire door — A door that resists fire and prevents it from spreading between spaces. Fire doors are rated as 20-minute, one-hour, two-hour, etc.

Fire resistant — Capable of slowing the spread of or providing a barrier to fire.

Firestopping — Fire-resistant material installed to close the opening through or around the edge of a floor, to prevent the spread of fire between levels.

Firewall — A wall assembly that prevents fire from spreading between adjacent spaces. Firewalls are rated as one-hour, two-hour, three-hour, and four-hour.

Fixed window — A sealed, no opening window or glass section.

Fixture — An item of plumbing or electric equipment. The term is also used to denote other specialty items such as medical, laboratory, and display elements (as used in retailing and commercial facilities).

Flagstone — A flat stone used for flooring, steps, walls, and walks.

Flange — The horizontal top and bottom sections of a steel beam.

Flashing — The sheet metalwork used to make a construction assembly weathertight.

Flitch beam — A structural beam utilizing a steel plate sandwiched and bolted between two wood members.

Float — To use a trowel (or tool called a float) to spread cement, stucco, plaster, gypsum joint compound, or other workable materials.

Floor joist — A horizontal structural member that supports and distributes floor loads.

Floor plan — A view from above in a building where an imaginary horizontal cut has been made about four feet above the floor plane.

Flue — A vertical shaft that exhausts smoke from a wood or gas fireplace; also, the piping used to exhaust gases from water heaters and furnaces.

Flush — Aligned, level, or even.

Footing — An enlarged base that supports a wall, pier, or column and distributes the weights of a structure onto the ground.

Framing — The wood or steel construction of a building's framework.

French door — Pair of glazed doors hinged at the door frame jambs, and swinging to meet in the center of the opening.

Frieze — A decorative board of cornice trim fastened to a structure.

Frost line — The depth at which frost penetrates the ground during the winter season.

Furred — Lined with a separate surface material, as on a wall, ceiling, or other assembly.

Furring — Narrow strips of wood or metal secured to a wall or ceiling for the purpose of providing a new ground (surface) to attach other finish materials.

Galvanized — Treated with zinc and lead to prevent rusting.

Gauge — Measure designating the diameter of a wire or thickness of a sheet of material, such as metal.

GFIC — Ground fault interrupter circuit. An electrical device in a circuit that quickly disconnects when current is leaked to the ground often used in moist spaces.

Glass block — Masonry unit made of glass, with a hollow center.

Glazing — Installing glass in windows or doors.

Glue-laminated beams — Structural beams composed of layers of wood glued together under pressure. Abbreviated as glulam.

Grain — Direction of longitudinal axes of wood grain fibers found in wood members.

Grout — A paste like mixture of cement, sand, and water used for laying and filing joints in masonry construction.

Gusset plate — A metal plate used to connect various portions (chords) of a truss.

Gypsum — Material made of hydrated sulfate of calcium, used to make sheets of wallboard.

Hardboard — A sheet material made by compressing and gluing fine fibers of wood.

Head — The top of a door or window.

Hearth — Noncombustible horizontal surface immediately outside of a fireplace opening.

Heartwood — Center region of cells in a tree trunk.

Heat pump — Mechanical unit that can heat or cool buildings using refrigeration cycles of air or liquid mediums.

Hollow-core door — Door made with face veneers separated by an inner core of gridded spacers, with solid material around the four edges.

Hose bib — An exterior mounted water faucet. It is frost-proofed in cold climates.

Insulation — Various materials used primarily for the reduction of heat gain or loss through floors, walls, and ceilings of buildings.

Jalousie — Horizontal windows composed of a number of long, hinged glass panels that are operated in unison.

Jamb — The vertical side of a door or window.

Joist — Structural members of wood, steel, or concrete used to support floors, ceilings, and roofs.

Kiln-dried — Refers primarily to lumber that has been dried in a kiln to reduce its moisture content.

Knee brace — Short diagonal brace joining a beam and column.

Lag screw — Large structural wood screw turned with a wrench. Has hexagonal or square head.

Landing — Platform at the beginning or end of a stair, or between runs.

Lath — A base material (often metal) that serves as a base for plaster or stucco.

Lattice — Open framework of wood or other material arranged in a grid-like pattern.

Lavatory — A washbasin in a bathroom. The term sink is often reserved for kitchens, laundry rooms and other spaces.

Lintel — The horizontal structural member that spans openings and supports loads from above, such as at a doorway or above a window.

Live Load — The no static weights of people, snow, furniture, and equipment on a floor, roof, or structural member.

Lockset — Hardware assembly for a door, which includes a deadbolt and latch.

Louver — An assembly used to admit or exhaust air, such as a gable vent or other device.

LVL — Laminated veneer lumber. Thin wood veneers glued together to make a larger structural member.

Mantel — Decorative trim piece or member around a fireplace opening.

Masonry — Materials of brick, stone, concrete block, and burned clay (such as ceramic tile).

Masonry veneer — A layer of masonry units such as brick, stone, or tile facing a frame or masonry wall.

MDF — Medium-density fiberboard.

Metal lath — Expanded metal mesh used as base for applying stucco or plaster.

Millwork — Wood building products used for finish work, such as cabinetry, moldings, and other trim.

Moisture barrier — Sheathing made of various materials that retards transfer of water vapor through walls, floors, and ceilings in buildings.

Mullion — Vertical divider placed between doors or windows.

Muntin — Thin divider trim that separates panes of glass in a window assembly.

Newel — Post that serves as termination for guardrails and handrails.

Nonbearing wall — Wall that has no load-bearing capacity to support other elements other than its own weight.

Nominal — Refers to common size terminology for standard items, rather than their actual size, such as a 2x4 stud, which is actually 1.5 inches by 3.5 inches.

Nosing — Portion of the stair tread that projects beyond the riser below. Also used to describe projection of front edge of a countertop.

Ogee — S-shaped curve mostly found in trim and roof gutters.

Oriented strand board (OSB) — Construction panel composed of adhesives and shreds /flakes of wood fiber oriented in specific directions.

Parapet — The portion of a building's exterior wall that extends above the roofline.

Pier — A concrete or masonry footing used to support a load from above, such as a column.

Pilaster — Vertical column like element in a wall that provides support or stiffening.

Pitch — The incline of a roof or other plane expressed as a ratio of the span to the height.

Plaster — cementitious material made of Portland cement or gypsum. Applied in paste form to a substrate of lath or masonry, and hardens to a finishable surface.

Plate — A horizontal bottom or top member in wall framing.

Plenum — Space used primarily for HVAC ducting. Usually found between ceiling of a space and floor above, or an elevated area constructed for HVAC purposes.

Plumb — Vertical.

Rafter — Structural member that supports the roof assembly and its finished roofing material.

Raze — Demolish existing construction.

Reinforced concrete — Concrete that has steel reinforcing added to increase its ability to handle various loading forces.

Register — Grille installed at the termination of a mechanical duct for supplying, returning, or exhausting air flow, usually in a directional manner.

Riser — The vertical part of a stair step.

Rough opening — The initial framing size of an opening used to accept a door, widow, or other assembly.

Rowlock — In masonry construction, a brick laid on its long edge, with the end exposed in the wall face.

Run — The horizontal distance of a stair.

R-value — Numerical measurement of a material's resistance to the flow of heat.

Sash — The frame that holds window glass in place.

Scribe — The process of fitting materials such as woodwork or counter backsplashes to irregular faces of a wall or floor surface.

Sealer — Coating that closes the porous surface of a material such as concrete.

Shim — Tapered piece of wood or other material used between two parts for filing voids and to aid in leveling.

Sill — The lowest part or bottom of a window or door. Also can refer to rough wood member that rests on a foundation wall.

Soffit — The horizontal exposed part of a building overhang, such as a roof or balcony.

Soldier — In masonry, a brick (or other masonry unit) laid on its end, with the narrow face to the outside or finished wall face.

Specifications — Written documents that accompany drawings and contain specific information that cannot be conveyed by the drawings alone. They address the materials and the workmanship needed to construct various parts of a building.

Spline — Thin material inserted in grooves cut in two joining pieces of material. Used to hold or align the mating materials.

Split jamb — Preassembled door frame that is made in two halves, installed and locked from opposite sides of an opening.

Sprinkler head — A wall or ceiling device that sprays water in a predetermined coverage pattern, primarily for extinguishing fire.

Stile — The vertical piece in a door panel.

Stringer — The sloped member of a stairway that supports the treads and risers.

Strip flooring — Finished wood flooring manufactured in narrow widths of tongue-and-groove boards.

Stucco — Mixture of portland cement base and sand, which is applied to the exterior of a building. A similar coat applied to the interior of a building is called plaster.

Stud — Vertical wood or steel framing member that is primarily used to build walls.

Sub floor — The under floor sheathing that provides the proper surface for the finished flooring.

Tempered glass — Heat-treated glass that resists breakage.

Terrazzo — Durable flooring made of small stone or other materials embedded in a strong cement-bonding agent and ground smooth.

Thermostat — Electrical or mechanical device that controls the HVAC system by maintaining a preset temperature or providing an override setting.

Threshold — Strip of material used under doors to cover the joint between the finished floor and sill.

Thru — Architectural slang and abbreviation for the word through.

Timber — Wood that is larger in cross-section than 4 x 6 in. (102 x 152 mm).

Top plate — The horizontal framing member on top of a stud wall.

Transom — Small window located directly above a door.

Tread — The horizontal plane of a stairway that one steps on.

Truss — A structural assembly of wood or steel used to span great distances with the minimum amount of material.

Type X gypsum board — A specialized type of gypsum board used for greater fire resistance.

Vapor barrier — Material, generally a sheeting, that prevents water vapor migration into unwanted areas of a building.

Varnish — A tough transparent coating made of a combination of resinous substances with alcohol or oil. Applied with a brush or sprayer.

Veneer — Thin sheets of wood or other material used in surface applications to other materials.

Vent — The vertical pipe in a plumbing system that exhausts sewer gas and provides pressure equalization.

Vestibule — The entry or open area dedicated to the entrance of a building.

Waferboard — Sheathing material or panel made by pressing and gluing flat flakes of wood.

Wainscot — Lower section of a wall finish, usually a different material than the upper section.

Water closet — Common name for a toilet that contains a bowl of water.

Water resistant gypsum board — Panel of gypsum board that is manufactured to resist dampness. Often used in bathrooms as a subsurface for ceramic tile.

Weep hole — A small aperture in masonry construction that allows the drainage of water to the exterior of the building.

Weld — To fuse together two pieces of metal using intense heat from an electrode or rod.

Welded-wire fabric (WWF) wires — A grid for concrete slab reinforcing, made of various diameters and strengths welded together.

Winder — The triangular tread found on a stairway.

Wood molding — Wood assemblies curved or angled in various convex or concave shapes used for trim.

Wrought iron — Soft, malleable iron that can be forged into different shapes.

Dyed yarn — Yarn that is colorized before knitting or weaving into a fabric.

Zero-clearance fireplace — A metal prefabricated fireplace designed to be placed directly against wood framing, without causing combustion of the wood.