

# MEMOIRS

OF THE

# QUEENSLAND MUSEUM

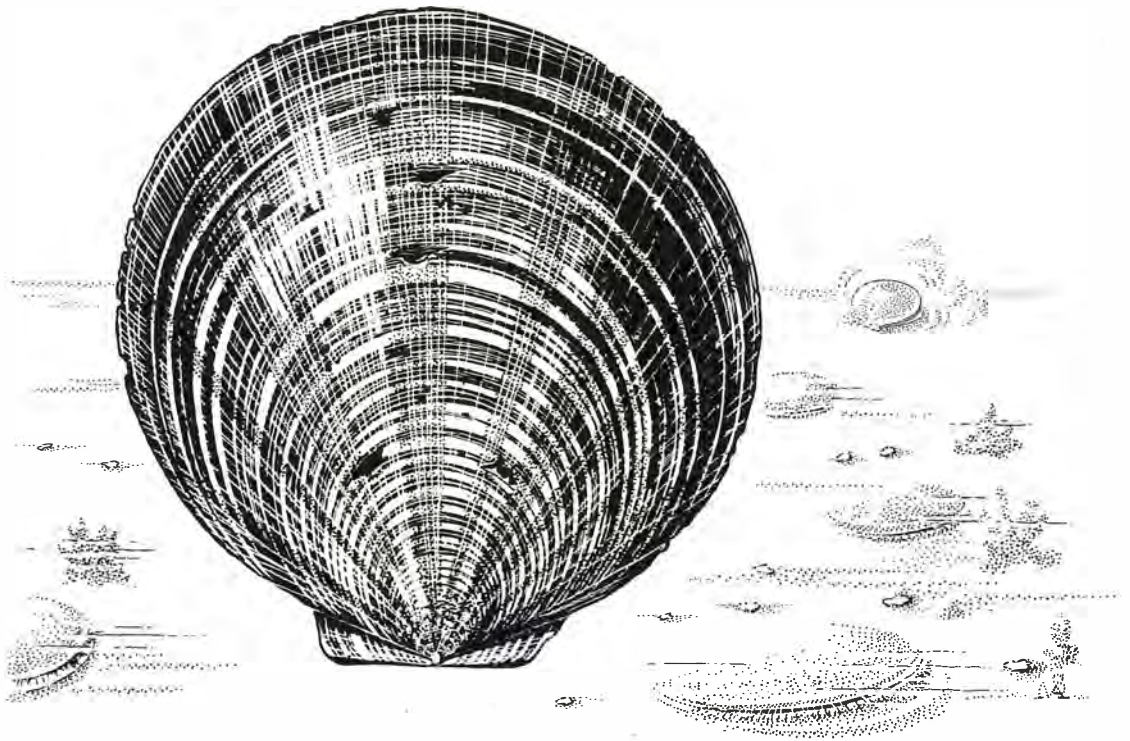

BRISBANE  
10 AUGUST, 1994

VOLUME 36  
PART 2

VOLUME 36  
PART 2

# MEMOIRS

OF THE

# QUEENSLAND MUSEUM

---

**Minister:** Hon. D. Wells, MA, LLB, MLA  
**Director:** A. Bartholomai, MSc, PhD  
**Editors:** M.C.L. Dredge, MSc, W. Zacharin, BSc, L.M. Joll, PhD,  
R.J. McLoughlin, MSc & P.A. Jell, PhD

© Queensland Museum,  
PO Box 3300, South Brisbane, Q. 4101, Australia.  
Phone (07) 840 7555.  
Fax (07) 846 1918

National Library of Australia card number  
ISSN 0079-8835

NOTE

Papers published in this volume and in all previous volumes of the *Memoirs of the Queensland Museum* may be reproduced for scientific research, individual study or other educational purposes. Properly acknowledged quotations may be made but queries regarding the republication of any papers should be addressed to the Director. Copies of the journal can be purchased from the Queensland Museum Bookshop.

**A Queensland Government Project**  
Typeset at the Queensland Museum.  
Printed by Merino Lithographics,  
18 Baldock Street, Moorooka, Queensland 4105.

## *Preface*

The First Australasian Scallop Workshop was held in Taroona, Tasmania in July 1988 and was attended by 51 participants from Australia, New Zealand and Japan.

It proved to be a very valuable forum for exchange of ideas on scallop biology, management and culture. The organisers of that workshop, Mike Dredge, Will Zacharin and Lindsay Joll, along with Richard McLoughlin must be thanked again for taking the initiative in organising the second Australasian Scallop Workshop at the East Coaster Resort, Triabunna, Tasmania, 23–25 March 1993.

Support for the second Australasian Workshop has been provided by the Fishing Industry Research and Development Corporation, the Commonwealth Department of Industry Technology Employment and Commerce, state departments responsible for fisheries in Queensland, Western Australia and Tasmania, and the CSIRO Division of Fisheries. Thanks for this support are extended to each of those bodies, in the context of both the workshop and publication of the proceedings.

Scallop resources are notoriously difficult to manage because of wide fluctuations in recruitment and problems with harvesting technology; this emphasises the need for workshops of this nature to obtain maximum benefit from dissemination of knowledge and experience in scallop biology and management.

Recently we have seen progress towards more rational management of scallop resources in this part of the world and for the first time in southeastern Australia there appears to be a cooperative and constructive approach to scallop fishery management. While scallop stocks in Victoria and Tasmania have been in decline in recent years, the saucer scallop fisheries in Western Australia and Queensland have stabilised or are expanding. The background to such variation, and of the associated problems of recruitment variability in scallops from W.A. to Tasmania are discussed in some detail.

It is pleasing to note also that an appropriate time allocation has been made towards considering the impact of our scallop harvesting technology, both on the scallops themselves and on the environment which sustains them. It is clear that the industry cannot afford to continue using inefficient and destructive fishing gear if better technology is available.

The workshop was perfectly placed in Triabunna to explore recent progress in scallop culture and reseeded. Free exchange of ideas on methodology and technology relating to these activities shows promise that scallop enhancement may achieve its full potential in the coming years. The enhancement project in Tasmania has been operating since 1987 and all types of difficulties from appropriate gear to aspects of marketing are still being researched by the company.

This workshop provided an opportunity for biologists, managers, marine farmers, fishers and others with an interest in scallops to expand their understanding of scallops and pass on some of their hard earned knowledge and experience to others.

The make-up of this workshop is unusual, to say the least, in that organisers have brought together so many facets of industry and have recognised the importance of marketing to the scallop fisheries.

Finally, some public health issues associated with scallop fisheries around the world have been brought to the workshop's attention. Such issues, largely associated with dinoflagellate-derived toxins, have not been a major issue in Australia to this time. Their significance in an international context, and their potential to affect scallop marketing and fisheries in Australia, is a major consideration for the future.

*Mike Dredge,  
Deception Bay, Queensland; June 1994.*

## SCALLOP FISHERIES IN SOUTHERN AUSTRALIA: MANAGING FOR STOCK RECOVERY

WILL ZACHARIN

Zacharin, W. 1994 08 10: Scallop fisheries in southern Australia: managing for stock recovery. *Memoirs of the Queensland Museum* 36(2): 241-246. Brisbane. ISSN 0079-8835.

Scallop fisheries in southern Australia are showing signs of stock recovery after a period of low abundance. The recovery has been sporadic and slow although large areas of the fishing grounds have been subject to little or no fishing for up to 5 years. New management strategies designed to encourage stock recovery and promote sustainable harvests in the future are in place. Management strategies and fishery monitoring programs are presented.

*Will Zacharin, Sea Fisheries Division, Department of Primary Industry and Fisheries, GPO Box 619F, Hobart, Tasmania 7001, Australia; 15 April, 1994*

There are 5 distinct commercial scallop fishing zones in southern Australia: Port Phillip Bay and Lakes Entrance in Victoria; the greater area of Bass Strait (known as the Central Zone), the 20 nautical mile zone around the north coast of Tasmania called the Tasmanian Zone, and the east coast of Tasmania (Fig.1). They are geographically distinct in terms of their historical catch and fleet dynamics. Management is under the control of 3 separate authorities; the Victorian and Tasmanian State Governments and the Commonwealth Government (Australian Fish Management Authority). Three different management strategies are operating.

The Bass Strait Scallop Consultative Committee (BSSCC) formed in 1991 to develop a rational management plan for scallop fisheries across Bass Strait. This was the second time in the fisheries' history that such a process had been attempted (Zacharin, 1990, 1991). An earlier plan developed by the Bass Strait Task Force which recommended that the fisheries' jurisdiction be split between Victoria and Tasmania was not effectively implemented (Zacharin, 1990). Fishermen and managers recognised that future harvesting strategies needed to be based on current biological knowledge of the species (in regard to reproductive maturity and growth rates), fleet dynamics and the need for economic efficiency. The committee drafted a management plan with 5 main objectives: 1, to control fishing effort to a level which is consistent with the current state of knowledge of scallop stocks; 2, to encourage investigation and modification of the most appropriate fishing equipment and fishing practices to improve catch efficiency and to minimise damage to the scallop beds; 3, to allow further scientific and other data to be collected so

that management decisions can be based on a sound understanding of biological and operational characteristics of the fishery; 4, to allow an effective level of recruitment to the fishery by prohibiting the taking of scallops of <80mm with a view to allowing adult stocks to complete at least two major spawnings before harvest; and 5, to allow participants to maximise their return from harvesting the scallop resource. (Bass Strait Scallop Management Plan 1992, Commonwealth Fisheries Act 1991).

The resultant management strategy combines input and output controls to restrict the number of fishers; to prohibit the taking of small scallops; to control scallop landings and to provide a level of profitability to the fleet.

### CONTROLS ON FISHING

In the past, both the States and the Commonwealth restricted fishing activities by imposing input controls, such as closed seasons, size limits and dredge restrictions. Over the past 4 years there has been a shift towards output controls as they are perceived to be more effective in managing catch and controlling quality, provided that the necessary level of monitoring and enforcement is present. A size limit of 80mm at widest diameter, however, still exists. The two main strategies of the new management plan for the Central Zone of Bass Strait are the '20% trashing rate' requirement and the 'two-spawnings' criterion. The 20% trashing rate was designed as a yield optimisation strategy, through limiting the capture of, and minimising incidental mortality to small (<80mm at widest diameter) scallops. The 'two spawning' criterion is a parallel management requirement designed to allow scallops two

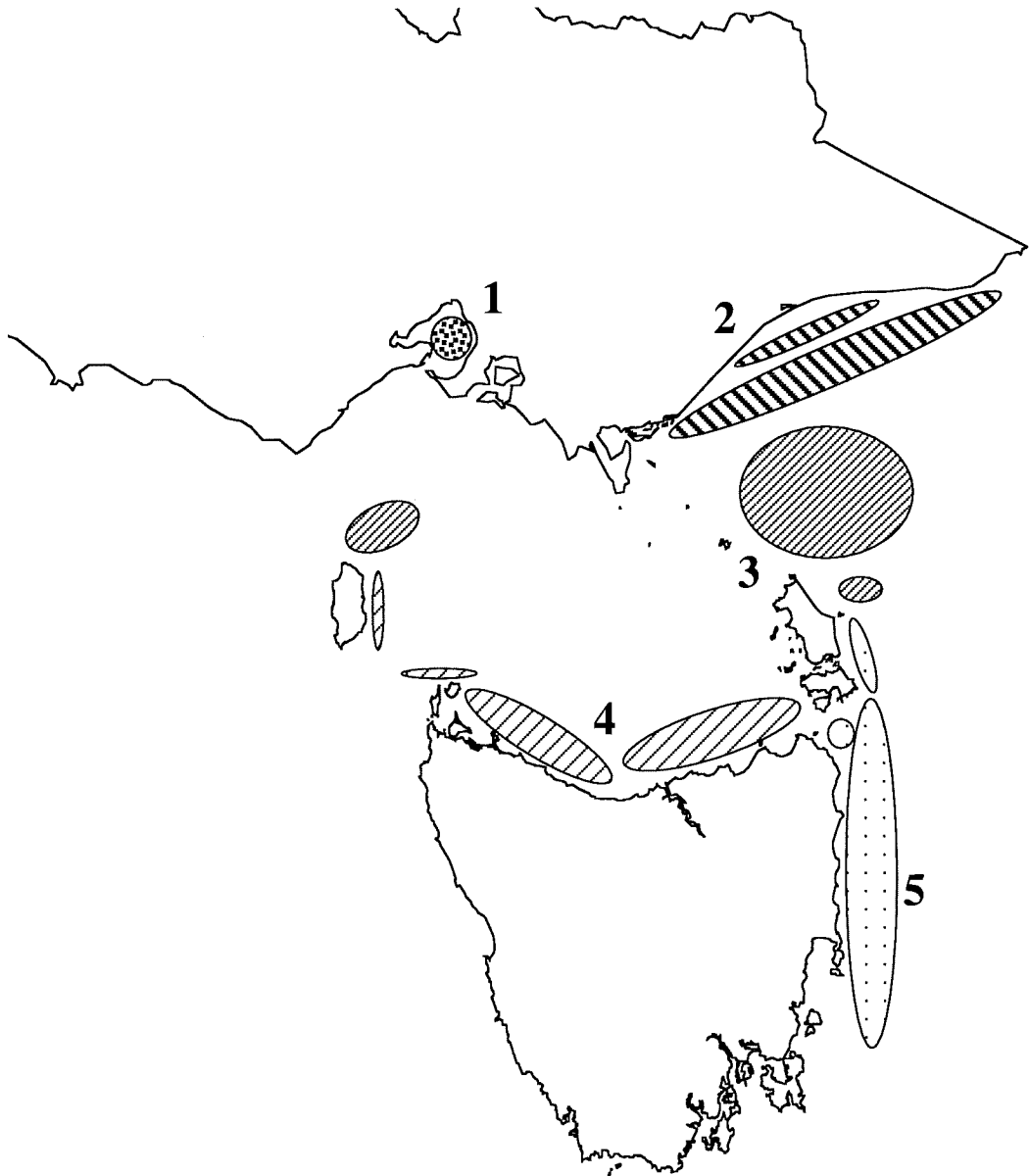

FIG.1. Southern Australian scallop fishery divided into 5 distinct zones. Port Phillip Bay (1), Lakes Entrance (2), Bass Strait (3), northern Tasmania (4), and eastern Tasmania (5).

major spawnings prior to their being fished, without regard to size. Thus scallops need both to have spawned twice and have less than 20% of the catch smaller than 80mm at widest diameter prior to their being fished.

The trashing rate is the proportion of small scallops discarded over a fishing ground during

commercial operations. If more than 20% of the catch landed on the sorting tray is being returned to the water, fishermen are required to cease fishing in the area until scallop size increases. This is not difficult for the majority of Bass Strait scallop beds as they are usually of the one size or age class. However, in the event of two age

classes being mixed in the one area, a 20% trashing rate is considered acceptable, having regard for increasing mortality in the older age class, and the potential of predators to significantly reduce the remaining scallops on a fished bed.

Failure of fishermen to leave the area can result in a 3 month closure to the whole fishery. This closure can be implemented by the management committee under a specific provision in the Bass Strait scallop management plan.

Application of trashing rates are not new in shellfish management. A trashing rate of not more than 30% of landed catch was introduced into the eastern U.S offshore clam fishery in 1983. The reason was to prevent wastage due to excessive discarding and to meet minimum size requirements (Murawski & Serchuk, 1989).

Two major spawnings from adults, prior to their being fished, are considered essential if sufficient reproductive output from the fishery is to occur. Commercial scallops in Bass Strait have their first major spawning in their second year (1+ age class). However, fecundity is relatively low at this age (R. McLouglin pers. comm.) and therefore delaying the fishing until the scallops' second major spawning is desirable to increase the probability of some recruitment from that particular age class of adult spawners. Restricting fishing operations even further until a third major spawning has occurred cannot be defended, as natural mortality is thought to be high in Bass Strait populations after scallops reach an age of four years. High levels of predation by starfish on commercial scallop beds have been observed on a number of occasions.

Delaying the time of first capture till after the second spawning has a number of other benefits. Scallops have another year's growth, which results in the majority of the population reaching a shell height 70mm (shell width 80mm). Individual yields increase c.30%, and the landed value of the fishery should rise. There is an assumption that there is no rapid increase in natural mortality. A yield optimisation model needs to be completed to support this assumption.

The crux of the management plan is, if the trashing rate is below 20%, then it can be assumed that the bed should be fished until it is no longer economically viable to continue. After fishing scallops will still remain in the area but at a low density.

#### CATCH RESTRICTIONS

The Bass Strait fishery opens on 1 April of each

year and closes in late December. This summer closure protects juveniles from dredge damage and stops scallops with poor meat condition being landed. In most years, post spawning meat and gonad condition does not improve until March. Scallop landings are subject to 'quota', set per trip or fortnightly. At present the quota is 150 units per fortnight; a unit being a black polypropylene onion bag measuring 900mm x 580mm and having a volume of 0.08 m<sup>3</sup>. This measure owes its derivation to the past availability and suitability of onion bags for landing scallops.

While the fortnightly quota does reduce fishing effort to some extent, this is not its primary purpose. It is a marketing tool which provides for the landing of quality scallops and prevents wastage due to time delays in landing and processing larger volumes. It prevents a 'gold rush' event, as occurs when there is a competitive total allowable catch. The catch quota was agreed through negotiation between Government, fishermen and the processing sector. If costs of fishing rise and landed price falls or even remains steady, it is possible for the industry to re-negotiate the catch quota at any time. Profitability of the fleet is a main objective of the management plan.

Catch is also controlled in the Victorian and Tasmanian Zones. In Victoria a weekly catch limit is currently operating, while in Tasmania, a 'per trip' limit will continue to operate when fishing recommences in the future.

#### QUOTA MONITORING AND CATCH DATA

Each unit or bag landed must have a plastic colour-coded tag attached. Tags are issued each month in advance by the Australian Fish Management Authority. Unused tags are returned as a cost saving measure and are re-issued the following year but in a different month. Numerical coding also changes each month and year to ensure unused tags will not be held over from year to year. The tag system allows efficient monitoring and enforcement of the quota, and in providing a validation system for scallop landings through the processing sector.

A new logbook introduced in 1992 is based on a 7 x 7 nautical mile grid. Returns are filled out for each trip and data entered on a central computer database in Hobart. The system will give a better assessment of fleet dynamics, exploitation rates and total landed catch from the Central Zone. In the past the fleet has provided catch returns without meaningful spatial data to the State authority in which the vessel was based.

Consequently, no comprehensive analysis of the fishery has been possible. Victorian and Tasmanian fishery managers continue to collate their own catch returns from the inshore 20 nautical mile zones.

### LICENSING

All 3 jurisdictional zones are limited entry fisheries and no new licences will be issued. There are 165 vessels licensed to fish in the Central Zone. Of these 73 are based in Tasmania and 92 in Victoria. Licences in Victoria are transferable and have been for the better part of the 30-year history of the fishery. In Tasmania, limited entry was not introduced until 1986 with transferability following in 1992 (Zacharin, 1990). Central Zone licences are still non-transferable pending the development of options for reducing the number of participants in the fishery. It is desirable that the issue of transferability be resolved, as Central Zone licences cannot be split from State scallop licences, which are transferable. It would be highly undesirable to create a 'third' scallop fleet in the Central Zone of Bass Strait. An important objective of the licensing policy is to have all the Central Zone licences held by the State scallop fleets, as the inshore scallop fishing grounds have historically provided the bulk of the scallop catch, with the Central Zone providing good catches intermittently.

### FISHING GEAR

The southern scallop fishery uses tooth-bar steel box dredges 2–4.5m wide. Protruding teeth on the bars range from 2.5–15cm, depending on the type of bottom sediment and the individual operator. These dredges can cause high levels of incidental damage and alternative designs are still being investigated. Evidence from dredge trials shows that up to 50% of scallops in the dredge's path may be damaged, depending on the type of bottom, length of toothbar, density of scallops and fishing practices. Dredge efficiency can be low, having been experimentally measured at 10% (McLouglin *et al.*, 1991). Gear technology improvements are important to this fishery as any reduction in incidental mortality and increases in efficiency will reduce costs and increase yields.

### EFFECTIVENESS OF MANAGEMENT STRATEGIES

The new plan for the Central Zone has yet to be

tested under rigorous fishing operations due to the low level of commercial fishing operations. Mechanisms such as at-sea monitoring and shore based market measurers will provide for a quick response to any problems that arise with regard to scallop size. The Victorian fishery has been operating under a tag system for two years and the scallop industry seems pleased with the progress of this system.

Any management plan for the southern scallop fishery should be complementary between Victorian and Tasmanian authorities. The new plan for the Central Zone goes a long way towards achieving this; however, further gains may be difficult because of the differences in fleet dynamics between the two States.

The Victorian scallop fishery has a single licensed fleet that is heavily depreciated and largely reliant on annual scallop fishing seasons. In Tasmania the multi-purpose fishing fleet has evolved with the majority of scallop licences being on vessels with rock lobster entitlements. Other Tasmanian scallop vessels are licensed to drop-line, trawl or take shark during a closed scallop season. These differences in dynamics between the Victorian and Tasmanian fleets have resulted in each having different economic constraints. The zoning of the Bass Strait scallop fishery needs to be retained to enable the subtle differences in management priorities to operate, as appropriate for each State's fishing industry.

### RESEARCH AND DEVELOPMENT REQUIREMENTS

Six future research needs, identified for the southern scallop fishery by the Bass Strait Management Committee, are listed in order of priority: 1, confirmation that Bass Strait scallops consist of a single stock; 2, development of an efficient and reliable recruitment monitoring technique to provide an index of annual spatfall; 3, development of statistically reliable survey techniques for assessing biomass on individual beds; 4, assessment of the overall impact of predation by starfish (*Coscinasterias* sp.) on scallop populations; 5, investigation of recruitment enhancement/sea ranching of scallops as per the New Zealand model; and 6, investigation of differences in growth rates and fecundity schedules for scallops in different regions of Bass Strait (Bass Strait Scallop Management Committee 1992, *mimeo*).

The second priority is important in providing a measure of success of the management plan,



specifically the two-spawning criterion. A recruitment index also provides early warning of recruitment failure or 'above-average' recruitment success.

The impact of predatory starfish was demonstrated to be of considerable importance in 1992. An identified scallop bed east of Deal Island in Bass Strait was decimated by starfish during a delay to fishing, in an attempt to conform to the two-spawning criterion and improve scallop yields. Further investigation of these predators is necessary to prevent such an occurrence happening again.

#### PROGNOSIS FOR 1993 AND BEYOND

There has been a significant recovery of scallop stock(s) in both Port Phillip Bay and off Lakes Entrance in Victoria. A large settlement occurred in the spring of 1990 with subsequent recruitment to the fisheries in 1992. Further settlement has been observed in each of the following years and the fisheries are showing good prospects for the next one to two years (Zacharin - pers. obs.). It is ironic that the beds off Lakes Entrance (which have been sporadically fished) have recovered before the scallop grounds in Tasmania (where the fishery has been closed for five years). In this instance, total closure of the fishery has not led to any earlier stock recovery than has been observed in Victorian waters, where fishing continued. However, there is no certainty that the factors affecting recruitment off Lakes Entrance apply over a much wider area, and no conclusions can be made in terms of management for stock recovery.

Recent exploratory excursions into the Central Zone and the northern Tasmanian Zone have shown that juvenile scallops are present over a wide area. If these juveniles successfully recruit into the fishery in 1993 and 1994, an economically viable fishery will again operate in the Tasmanian and Central Zones.

#### LESSONS TO BE LEARNT

The recovery of the Victorian scallop grounds, through what appears in Port Phillip Bay to be due to an enormous settlement event in 1991, is difficult to explain. The residual stock in the bay was apparently at an all time low at 19 million, but one of the largest recorded settlements has occurred. The estimated abundance is in excess of 800 million scallops (D. Molloy, pers. comm.). This is another example of the critical influence of

environmental variables on successful spawning events, settlement and subsequent recruitment. Stock/recruit relationships of *P. fumatus* in southern Australia appear to be extremely noisy if they exist at all. These observations support the new strategy of allowing two major spawnings before harvesting, particularly in the offshore fisheries where retention of spat over scallop grounds will be more variable than in the enclosed environs of Port Phillip Bay.

It is important to remember that the scallop fleets of Victoria and Tasmania are different in terms of their level of capital investment, vessel specifications, fishing patterns and reliance on the scallop resource for income. No hard and fast management plan across the three existing zones will be successful in meeting both States' administrative and economic requirements. Complementary management plans that take account of these differences are preferable to continued friction between the two State based fleets. One needs to be aware that the majority of the historical catch has come from the state 20 nautical mile zones, the Central Zone resource being one of sporadic opportunity.

Change for its own sake can be a destructive policy. The success or otherwise of the current management plan operating in the southern scallop fishery should be assessed before major changes are contemplated. Feedback on the effects of the trashing rate and two spawning strategy will not be evident for two to three years. With the new logbook providing better spatial information on catch, an integrated catch database system and progression towards developing a recruitment index or forecasting system, management of the scallop resources in southern Australia can only improve.

The Australian Fish Management Authority will probably relinquish responsibility for the Bass Strait scallop fishery in 1994 and leave joint management to the Victorian and Tasmanian agencies. A jurisdictional line would be drawn for the purpose of monitoring and enforcement responsibilities. The existence of remaining Bass Strait permits for the Central Zone which are not attached to state scallop licences may impede this process.

#### ACKNOWLEDGEMENTS

Thanks are due to the many members of the Bass Strait Scallop Consultative Committee for plugging away at a new management plan after ten years of meetings at all manner of manage-

ment committees and venues. I would also thank two anonymous referees for suggesting improvements to this manuscript.

#### LITERATURE CITED

- COMMONWEALTH FISHERIES ACT 1991: BASS STRAIT SCALLOP MANAGEMENT PLAN 1992.
- MCCLOUGHLIN, R.J, YOUNG, P.C., MARTIN, R.B. & PARSLOW, J. 1991. The Australian scallop dredge: estimates of catching efficiency and associated indirect fishing mortality. *Fishery Research* 11: 1-24.
- MURAWSKI, S.A. & SERCHUK, F.M. 1989. Mechanized shellfish harvesting and its management: the offshore clam fishery of the eastern United States. Pp. 479-506. In Caddy, J.F., (ed.), 'Marine invertebrate fisheries'.
- ZACHARIN, W.F 1990. Scallop fisheries management: the Tasmanian experience. Pp. 1-11. In Dredge, M.L.C., Zacharin, W.F. & Joll, L.M., (eds), 'Proceedings of the Australasian Scallop Workshop Hobart 1988'. (Tasmanian Government Printer: Hobart).
- ZACHARIN, W.F. 1991. Slow recovery for Bass Strait scallops. *Australian Fisheries* 50(1): 28-30.

# POPULATION AND BIOLOGY OF THE COMMERCIAL SCALLOP (*PECTEN FUMATUS*) IN JERVIS BAY, NSW

HECTOR R. FUENTES

Fuentes, H.R. 1994 08 10: Population and biology of the commercial scallop (*Pecten fumatus*) in Jervis Bay, NSW. *Memoirs of the Queensland Museum* 36(2): 247-259. Brisbane. ISSN 0079-8835.

Following a peak in 1981/82, the commercial scallop fishery in Jervis Bay declined to the point where the dredge fishery finished in 1984 and the dive fishery in 1989-90. Despite past economic importance, little information was available on the biology of *Pecten fumatus* in Jervis Bay. Two small, low density, scallop beds in the south and north of the bay had different densities. Most scallops were found at depths of 15-20m. Density increased from 1990 to 1992. Recruitment events occurred in November 1989, November 1990 and in March 1991. Three groups that may be age classes 0+, 1+ and 2+ years were identified in each year. Lower reproductive activity occurred from December to March and 3 or 4 periods of higher activity occurred between April and December, suggesting multiple spawning behaviour. There was poor correlation between water temperature and gonad index, but significant correlation was found between increasing numbers of parasitised scallops and period of increasing water temperature. Main settlement occurred from November to January. It appears that there are factors which prevent successful settlement in locations other than the two main beds. There was a greater settlement at depths of 8-14m.

*Hector R. Fuentes, NSW Fisheries, Fisheries Research Institute, P.O. Box 21, Cronulla, New South Wales 2230, Australia; Present address: Queensland Department of Primary Industries, Northern Fisheries Centre, P.O. Box 5396, Cairns, Queensland 4870; 23 May, 1994.*

In 1988 a study was initiated in Jervis Bay to provide baseline information on commercial molluscs for a management plan. Four species are of economic interest but this study deals only with the commercial scallop (*Pecten fumatus*), which has been the basis of an intermittent fishery since 1970.

Historical information (Hamer & Jacobs, 1987; Young & Martin, 1989) suggests that commercial scallop harvests in NSW were high in the early 1970's, but there is no indication of the total production in Jervis Bay. However, during the fiscal year 1981-1982 the fishery reported 2,822 tonnes (Stewart et al., 1991) for NSW with 1,329 tonnes coming from Jervis Bay. Anecdotal information suggests that up to 35 dredge boats and an unknown number of commercial scallop divers were operating in the bay during the 1981-1982 peak in the fishery. The dredge boats stopped operating in 1983-84 when the scallop fishery became uneconomic. The divers persisted until the end of 1990, although they have harvested <10 tonnes per annum in recent years. Recreational divers harvest scallops in Jervis Bay, but there are no catch estimates. Due to the low density of scallops, the NSW Department of Fisheries recommended a total closure of the

fishery from November, 1991 to June, 1994 to allow stock recovery.

The aims of population level work were to provide information on distribution, abundance, size composition and settlement. The aim of work at the individual level was to increase the knowledge of the reproductive cycle.

## MATERIALS AND METHODS

### POPULATION SURVEYS

The distribution and abundance of scallops (Fig. 1) were estimated during grid and transect dive surveys during 1989-1991 (Fuentes et al., 1992). Random transect surveys in February 1990 and 1991 (Fuentes et al., 1992) examined populations in areas identified during grid surveys as having high concentrations of scallops. In April 1992, 35 transects were allocated to each area. In the transect surveys, scallops were classified according to size: small (flat shell <30mm), medium (30-60mm) and large (>60mm). The length categories were chosen on basis of the length-age relationships (Hamer, 1987). Transects containing scallops were grouped into: high density transects (>0.1 scal/m<sup>2</sup>) and low density transects (<0.1 scal/m<sup>2</sup>).

Population size structure was based on length-

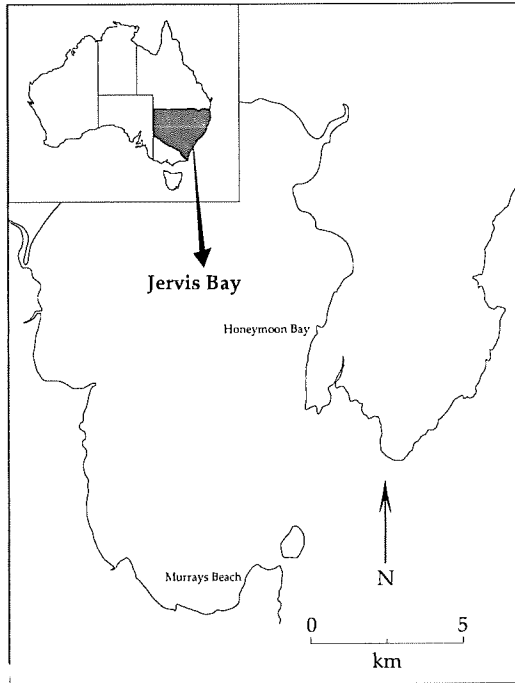

FIG.1. Location of Jervis Bay.

frequency surveys in the Murrays Beach bed (Fuentes et al., 1992). Only data from surveys between September, 1989 and August, 1991 are included herein. All samples were taken from the Murrays Beach bed by 2–3 divers who collected all scallops that they saw during 40–50 min dives in 17–20 m. The collections were assumed to estimate the actual length-frequency distribution of scallops in the bed.

#### REPRODUCTIVE BIOLOGY

Regular collections of 50 scallops of commercial size (>65 mm) were taken by SCUBA divers from the Murrays Beach bed. Monthly or fortnightly samples were taken according to the state of the gonads. Based on the assumption that the gonad weight of mature individuals changes in relation to total body weight during the breeding season, a gonosomatic index (GSI) was used as indicator of reproductive condition (Grant & Tyler, 1983; Barber & Blake, 1991). A GSI was calculated for each nonparasitised scallop:  $GSI = (GW/BW - GW) * 100$ , where GW is the gonad weight and BW is the body weight in grams. Mean GSI values and frequencies of parasitised scallops were correlated to weekly bottom temperatures from near the collecting site.

Macroscopic and microscopic examinations of gonads were conducted to investigate scallop reproductive behaviour and to implement an easy and rapid technique to assess the reproductive condition of scallops. In the macroscopic study, dissected gonads were classified into 7 stages: Immature, Developing 1, Developing 2, Ripe, Spawning 1, Spawning 2 and Parasitised. In the microscopic study, the female sections of the gonads were classified into 9 stages: Immature, Early development, Ripe, Partial spawning, Extensive spawning, Resorption, Resting and Parasitised.

#### SETTLEMENT

A longline system with collector bags acting as artificial substrata was used to study the spatial and temporal characteristics of scallop settlement. From August 1989 to February 1990 settlement was studied near the Murrays Beach and Honeymoon Bay scallop beds. From August 1990 to February 1991, Plantation Point, Huskisson and Green Point were added for settlement studies. For detailed descriptions of the sampling design and location of collectors see Fuentes et al. (1992).

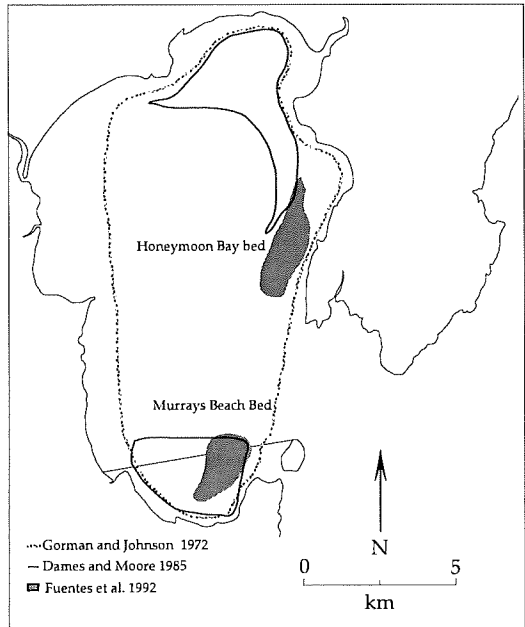

FIG.2. Distribution changes of the commercial scallop, *P. fumatus*, in Jervis Bay. The straight line is the boundary between State and Commonwealth waters.

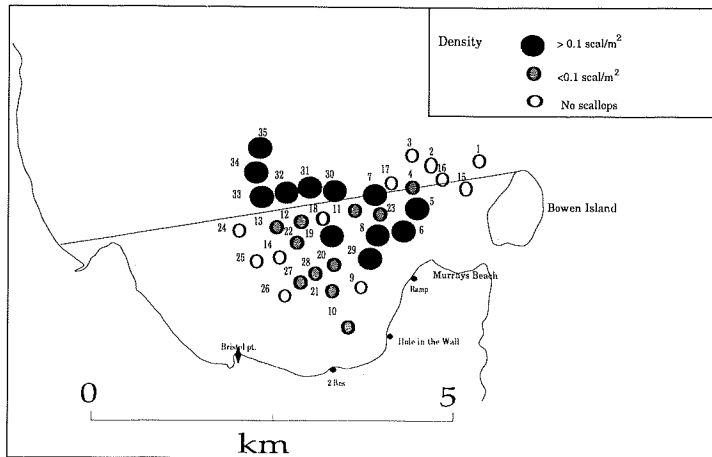

FIG.3. Location of transects at Murrays Beach Bed in April 1992. Figures on the circles are transect numbers.

## RESULTS AND DISCUSSION

### POPULATION SURVEYS

**DISTRIBUTION:** The first assessments of commercial scallop distribution including abundance were obtained from the dredge surveys conducted by FRV Kapala during the 1970 and 1971 peak in the scallop fishery (Gorman & Johnson, 1972). No further scallop investigations were conducted in Jervis Bay until the fishery boomed again in the early 1980's. At this time a dive survey

(Butcher et al., 1981) and a number of other studies (Jacobs, 1983; Hamer, 1987; Williams & Jacobs, 1987; Williams & Diver, 1988; Fuentes et al., 1992) indicated that *P. fumatus* occurred throughout the bay (Fuentes et al., 1990).

Commercial scallops were primarily confined to Murrays Beach and Honeymoon Bay (Fig. 2), with only few individuals observed elsewhere. More scallops were found between 15–20m than between 5–15m. What constrained the commercial scallop to this distribution is unknown, but natural environmental changes, fishing methods, overfishing or a combination of factors should be examined.

Dredging was the most common method of harvesting scallops in Jervis Bay during the years of intensive fishing. Although some studies have alleged that dredging has no adverse effect on scallops (Butcher et al., 1981), other authors have suggested that dredges both cause considerable damage to scallops that are left in the dredge track (Caddy, 1973; McLoughlin et al., 1991) or cause detrimental changes to the bottom (McLoughlin et al., 1991; Riemann and Hoffmann, 1991) which prevent or inhibit scallop settlement. However, it

TABLE 1. Sampling effort and abundance of scallops in the two main scallop beds in Jervis Bay during transect dives in February 1990, February 1991 and April 1992. <sup>a</sup> include only transects with scallops.

	Murrays Beach			Honeymoon Bay			TOTAL		
	1990	1991	1992	1990	1991	1992	1990	1991	1992
No. of transects	35	35	35	34	35	35	69	70	70
Area covered (m <sup>2</sup> )	2100	2100	2100	2040	2100	2100	4140	4200	4200
Mean dive time (min)	9.8	9.5	10.3	10.1	7.9	7.7			
Transects with scallops	19	20	23	14	12	20	33	32	44
Transects without scallops	16	15	12	20	23	15	36	38	26
Total scallops	149	150	1367	42	33	156	191	183	1523
Small scallops (<30mm)	21	76	9	3	5	8	24	81	17
Medium (31–60mm)	46	33	1109	11	13	88	57	46	1197
Large scallops (>60mm)	82	41	249	28	15	60	110	56	309
Mean scallops/transect <sup>a</sup>	7.8	7.5	59.43	3.0	2.7	7.42	5.8	5.7	34.66
Mean scallops/all transects	4.3	4.3	39.0	1.2	0.9	4.5	2.4	2.6	21.7
Density (per m <sup>2</sup> ) <sup>a</sup>	0.129	0.125	0.991	0.051	0.046	0.124	0.096	0.095	0.577
Total density (per m <sup>2</sup> )	0.071	0.071	0.650	0.021	0.016	0.087	0.046	0.043	0.073

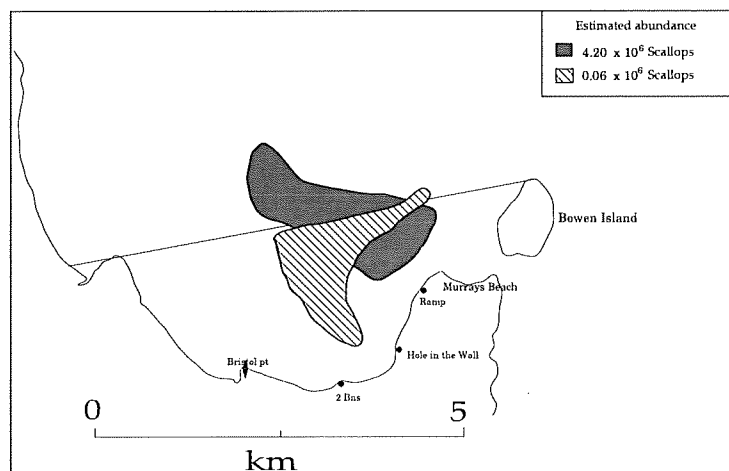

FIG.4. Survey areas showing the differential abundance of commercial scallops in the Murrays Beach Bed during the transect survey in April 1992.

is still not known if fishing technique was the only factor responsible for a decrease in these fisheries.

**ABUNDANCE:** Dredge surveys and dive surveys provide similar estimates of scallop distributions (McShane, 1982; McShane & O'Connor, 1982); however, dive surveys yield more precise estimates of abundance although the estimates typically are lower. There were no dredge vessels operating in Jervis Bay during the time of this study, therefore, only estimates from dive surveys were available.

The Murrays Beach bed typically contained a relatively low density of scallops, and the Honeymoon Bay bed was even more sparsely populated. However, a comparison of transect surveys in 1992 with previous surveys in 1990 and 1991 (Table 1) indicated differences in the abundance of the three size classes and an increase in the total number of scallops. At both locations, the number of medium size scallops were more abundant in 1992 than in previous years, which suggest improved recruitment to the fishery.

In the 1992 transect survey at the Murrays Beach bed, scallops were found in only 23 transects.

The average number of scallops in all transects was  $0.991 \text{ scal/m}^2$  ( $SE = \pm 0.264$ ). The location and scallop density for each transect (Fig. 3) identified the E-W boundaries of the bed, but it did not identify the northern limit of the bed which extends towards the middle of the bay. Within the bed, areas of high ( $>0.1 \text{ scal/m}^2$ ) and low ( $<0.1 \text{ scal/m}^2$ ) density were identified (Fig. 4). The high density area ( $2.3 \text{ km}^2$ ) contained  $4.20 \times 10^6$  scallops while the low density area ( $1.6 \text{ km}^2$ ) contained  $c.0.06 \times 10^6$  scallops (Table 2). The bed occupied  $3.7 \text{ km}^2$ , and interpolation among the most external

transects containing scallops indicated that the bed contained  $3.66 \times 10^6$  scallops.

This exercise was repeated at Honeymoon Bay where 20 transects contained scallops (Fig. 5). The average number of scallops per  $\text{m}^2$  in all transects with scallops was  $0.130$  ( $SE = \pm 0.039$ ). Plotting the location and density for each transect defined the boundaries of this bed (Fig. 6). The high density area ( $>0.1 \text{ scal/m}^2$ ) was almost completely surrounded by a low density area ( $<0.1 \text{ scal/m}^2$ ). The high density area ( $2.3 \text{ km}^2$ ) contained  $0.61 \times 10^6$  scallops (Table 2). The total area of  $6.0 \text{ km}^2$  contained approximately  $0.78 \times 10^6$  scallops.

TABLE 2. Mean of scallop density and estimation of abundance at 2 locations in Jervis Bay during April 1992. Abundance estimates were calculated using only those transects containing scallops.

	Av. Scal/m <sup>2</sup>	95% confidence limit		St. error	No. of Transects	Est. area (km <sup>2</sup> )	Abundance (x10 <sup>6</sup> )
		Upper	Lower				
Murrays Beach							
Density/transect	0.991	1.538	0.443	0.264	23	3.7	3.66
high density	1.865	2.633	1.097	0.349	12	2.3	4.20
low density	0.036	0.049	0.023	0.006	11	1.6	0.06
Honeymoon Bay							
Density/transect	0.130	0.223	0.037	0.039	20	6.0	0.78
high density	0.273	0.449	0.097	0.034	8	2.3	0.61
low density	0.035	0.047	0.022	0.006	12	6.0	0.78

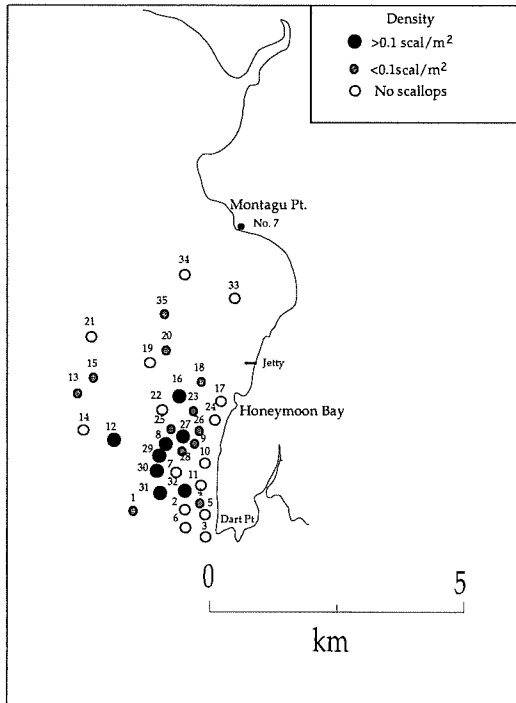

FIG.5. Location of all transects at Honeymoon Bay. Figures on the circles are the transect numbers in April 1992.

**SIZE STRUCTURE:**The population size composition and progression of the modal size classes (Fig.7) illustrate variations in size composition through time. At least two size classes were evident in most samples. The number of scallops increased in the last six samples and the highest numbers of small scallops were also taken near the end of the investigation.

The first recruitment observed during this study occurred in November 1989 when two cohorts were observed; one with a mode in the 28mm class-size and a second in the 63mm class-size. On the basis of Hamer's (1987) ageing criteria, the first cohort could represent a 0+ age group and the second a mixture of 1+ and 2+ age groups. The two cohort structure seen in November 1989 and January 1990 persist until May 1990. From July 1990 to September 1990, the population size distribution was unimodal with no cohort components.

A second recruitment pulse appeared in November 1990. A few individuals of 28mm (0+ year of age class) suggest a small recruitment, or less than that of the corresponding month in the

previous year (November 1989). The sample from January 1991 showed the 0+ age group seen in November 1990 at 43mm.

The sample from March 1991 showed 2 size groups similar to those observed in November, 1989. This suggests that the main recruitment in the second year of this study occurred 4 months later than in the previous season. From March to May 1991, the two cohorts were evident, but they merged again by July 1991.

Small scallops are hard to see, and only one sample (March, 1991) had any individuals <10mm in shell length. Scallops <20mm shell length were also found in few samples (November, 1989, January, 1990, March and May, 1991). The collection of small individuals coincided with estimated recruitment times. Small scallops were collected from around the bases of seaweed, arborescent polychaetes and sponges. Medium and large individuals were more conspicuous as they were only partly buried in the sandy sediment. They shared the substratum with polychaete hummocks but were not always near the base of emergent benthic organisms.

Differences in recruitment from one year to

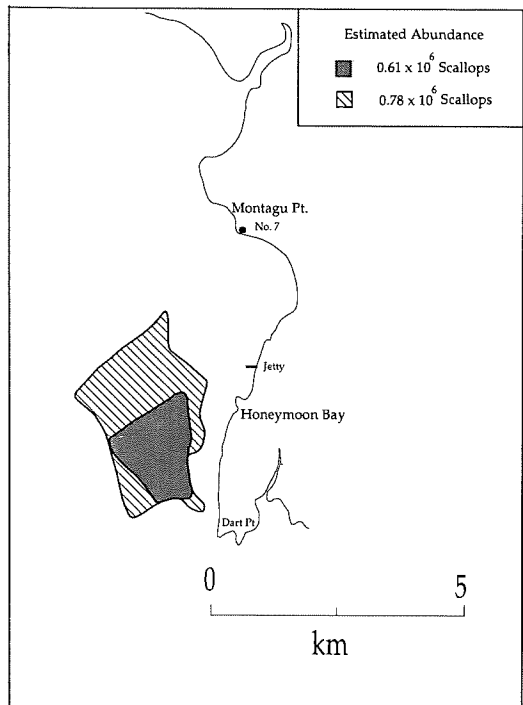

FIG.6. Areas of differential abundance of the commercial scallops at Honeymoon Bay in April 1992.

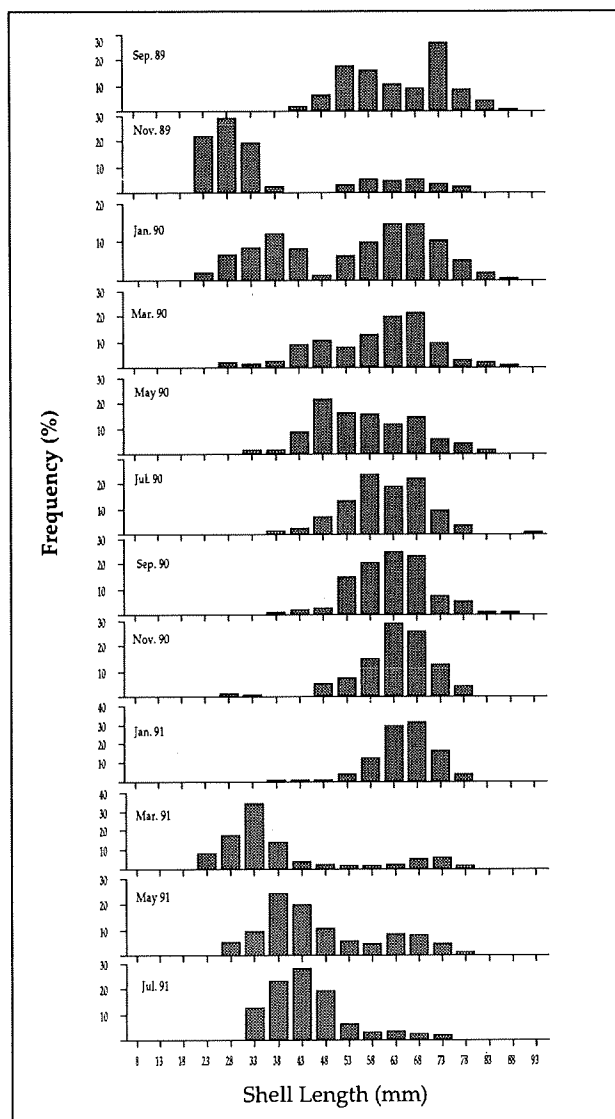

FIG.7. Length-frequency histograms for Jervis Bay commercial scallops from September 1989 to July 1991. Class-size interval = 5mm.

another like those observed for the commercial scallop in Jervis Bay (Table 3), are typical of scallop species and appear to be influenced by changes in oceanographic conditions such as temperature and nutrient availability. Settlement and post settlement conditions in 1989 may not have been the same as in 1990 or 1991.

## BIOLOGICAL STUDIES

### REPRODUCTIVE CYCLE:

**Gonosomatic index (GSI):** Two periods of low GSI were December 1989 to March 1990 and November 1990 to March 1991 (Fig.8). Four peaks occurred in the 1989/90 cycle (August to September, mid-November, mid-April to mid-May and after mid-July), and four during the 1990/91 cycle (mid-August, late October, late April and mid-May). In both years, each peak was followed by a decrease in GSI, which may correspond to a partial spawning event. Jacobs (1983) described a similar situation, with at least 3 spawning peaks in Jervis Bay: late winter to early spring, early summer and late autumn. The reproductive cycle of *P. fumatus* in Port Phillip Bay (Sause et al., 1987a,b) showed a similar pattern with some gamete release taking place in winter and a major release in late spring. Regional differences in spawning behaviour may exist among *P. fumatus* populations in South Australia, eastern Victoria, southern New South Wales and Tasmania.

Parasitised gonads were present in every sample (Fig. 9), although the frequency increased from January to June 1990 and from November 1990 to March 1991. There was no obvious temporal pattern in the occurrence of parasitised gonads, but the mean frequency of occurrence from August 1990 to July 1990 was higher than the similar period in the year 1989–1990. The degree of infestation may be indicated by the orange and red in the parasitised gonads. An orange gonad could be the early stage of infestation in which animals are still reproductive. A red gonad could be a final stage of infestation resulting in total loss of reproductive capacity.

Many exogenous factors influence reproduction in scallops, but temperature and food are most important (Macdonald & Thompson, 1986; Barber & Blake, 1991). The annual average bottom temperature (18.17°C from August 1989 to July 1990 and 19.02°C from August 1990 to July 1991) were significantly different when compared in an ANOVA (df=1, MSE=18.60, F=16.18, P>0.0001).

Temperature data were correlated with GSI and



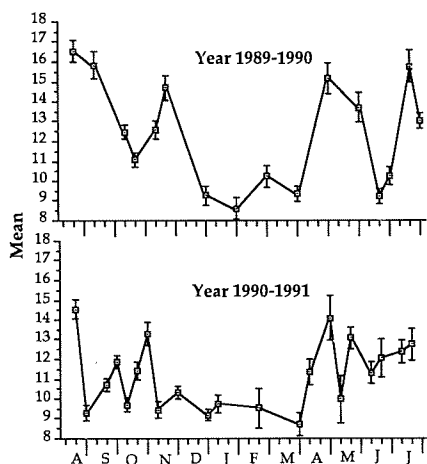

FIG.8. Commercial scallops gonadosomatic index (GSI) from August to July in two consecutive years in Jervis Bay.

frequency of parasitised scallops. Temperature has been positively correlated with GSI in other species (Paulet & Boucher,1991), but in this study such a correlation was not clear. During the first year, the correlation coefficients between bottom temperature and GSI have negative values and are not significantly different over lags of up to 3 previous weeks. In the second year, such correlations are not significant. The correlation coefficients between bottom temperature and the frequency of parasitised scallops are not significant in the first year, but in the second year, the correlation coefficients are significant over lags of up to 3 weeks.

Bottom temperature did not seem to have a direct influence on GSI, however, the positive correlation between temperature and frequency of parasitised scallops may be a factor that reduces the reproductive capacity of the scallop

TABLE 3. Comparison between settlement on collectors and recruitment of the commercial scallop in Jervis Bay.

	1989-1990		Recruitment 1991	1990-1991		Recruitment 1992
	Mean	SE		Mean	SE	
Oct-Dec	12.72	0.84		79.89	8.32	
Nov-Jan	7.22	0.93		22.33	20.6	
Dec-Feb	0.06	0.006		4.94	0.90	
Abundance (Scal/m <sup>2</sup> )			0.13			0.99

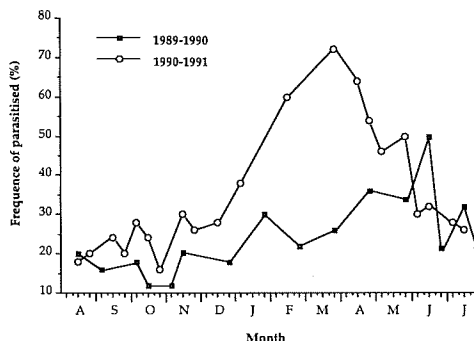

FIG.9. Percent frequency of parasitized scallops in Jervis Bay during the sampling period from August 1989 to July 1991.

population by increasing the number of infertile individuals. A year of low temperatures followed by one or more of high temperatures (such as the period August 1989 to July 1991) could reduce recruitment in subsequent years.

**Macroscopic staging:** The majority of gonads in all samples were in the Developing 2 or Spawning 1 stages (Fig.10). The Developing 2 stage made up >40% of the samples in October and May of both years and September and December of 1990. The second most common stage, Spawning 1, peaked between February and March, June, August and November of 1990 and in March 1991. The number of ripe gonads peaked in November 1989 and April 1991 but smaller peaks occurred throughout the year. Spawning 2 gonads peaked in late August of 1990, showed smaller peaks in the previous January and June, and showed no strong peaks in the second year of sampling. In the first year, there was a greater percentage of gonads in spawning condition (Spawning 1 and Spawning 2 stages) than in the second year. In the second year, there were more developing gonads (Developing 1 and Developing 2 stages) and ripe gonads.

Observer experience is needed to make correct classifications and determine macroscopic stages. For example, differences in gonad thickness between Developing 1 and Developing 2 stages, and differences in the turgor of Ripe and Spawning 1 gonads are determined subjectively. Presence of the alimentary loop and its visual characteristics are also subjectively determined. The colour and outline of the loop depends on the type and amount of food eaten and the position of the loop within the gonad. Sometimes the loop

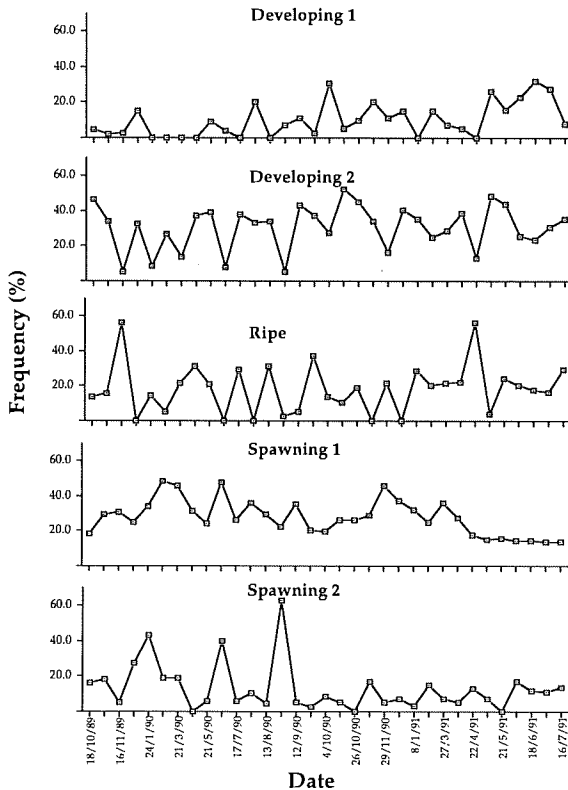

FIG.10. Percent frequency of macroscopic stages for commercial scallops from Jervis Bay during October 1989 to July 1991. Figures on the bottom are days of sampling.

may be pushed towards one wall of the gonad as the gonad ripens. After almost complete spawning (Spawning 2), some gonads retain fluid so the gut loop may be invisible.

**Microscopic staging:** No specimens were in the Immature or Early Development stages as the samples contained only adults. All other microscopic stages were present most of the year (Fig. 11). Developing, ripe and resorbing scallops occurred in 11 of 12 months with peaks in May, April and July, and April and May respectively. The Partial Spawning stage was present in all 12 months with a peak between February and March and the Extended Spawning stage was found in 9 of the 12 months. Resting gonads were present during summer (December, January, February) and winter (June, July, August). Resting gonads were most numerous in December and June.

The Partial Spawning stage occurred every month, the Resorption stage occurred in all

months except one, and the Extended Spawning stage was not numerous. Therefore, the commercial scallop in Jervis Bay spawns a number of times during the breeding season. It seems unlikely that complete spawning with an entire release of gametes occurred in Jervis Bay.

Histologic examination of gonads is important to confirm spawning, as a drop in the gonadosomatic index (GSI) may indicate resorption. If resorption is high, fecundity estimates are not related to the numbers of viable eggs released (Tremblay, 1988). The area of the gonad is also important in analysis because a previous test (Fuentes et al., 1992) showed that the fore region of the female part had significantly more oocytes per follicle than either the mid or tip regions. Furthermore, histological sections often showed an 'edge effect', i.e., the follicles had collapsed at the edges of the section and the oocytes were dislodged from the follicle walls. Consequently, gonads were only compared by taking sections from the same region of the gonads and making classification on the centres of the sections.

The finding that the Jervis Bay commercial scallops have extended dribble spawning is not unusual. In other species of scallops, mature gonads are present all year (Paulet et al., 1988) and partial spawning or more extensive spawning can occur in any month of the year (Coe, 1945). Paulet et al. (1988) suggested that dribble spawning could be an adaptation to an unpredictable environment.

The hypothesis is that at least some larvae will find favourable conditions and the chances of either very weak or very strong recruitment are minimised (Paulet et al., 1988).

**Comparison of macro- and microscopic staging schemes:** Classifications derived from macroscopic and microscopic staging were compared to determine whether a simpler technique would allow an accurate prediction of scallop reproductive behaviour. When the macroscopic and microscopic techniques were compared, the macroscopic stages Developing 1, Developing 2, Ripe, Spawning 1 and Spawning 2 were assumed to correspond with microscopic stages Early Development, Developing, Ripe, Partial Spawning and Extensive Spawning, respectively. The comparison gave a poor result, for example microscopic staging consistently overestimated the condition of developing scallops (Fig. 12). The accuracy of the macroscopic technique was

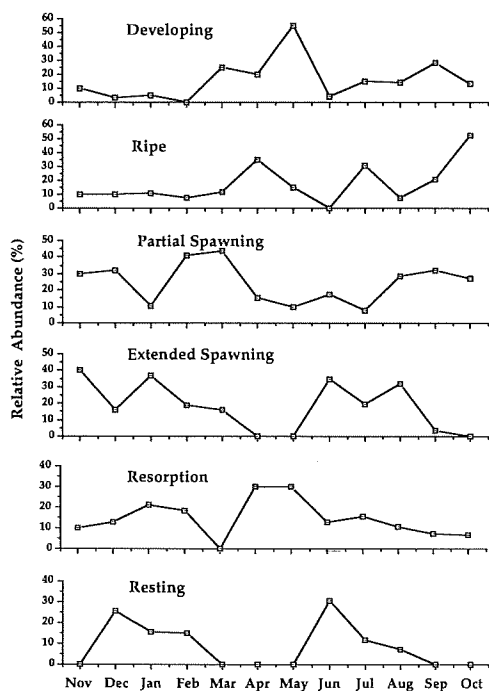

FIG.11. Relative abundance (%) of microscopic stages for commercial scallops from Jervis Bay. No specimens were in Immature or Early Development stages.

correct only c.50% of the time when classifying Ripe and Spawning scallops, with no consistency between the degree of over- or underestimation of gonad stage.

The lack of correspondence can only be partly explained. For example: some scallops gave the macroscopic appearance of being in Spawning 1 stage, but key histological features meant they were placed in the microscopic Resorption stage. It was not possible to macroscopically classify scallops as being in either the Resorption or Resting stage. For similar reasons, scallops appearing to be in the macroscopic Spawning 2 stage could have been in the Resorption or Resting stages. Another problem may have occurred when the loop of the alimentary canal was visible and the gonad was therefore classified in the Developing 2 stage, but the gonad would be classified as Ripe when viewed microscopically. When a gonad displayed orange spots it was allocated to Spawning 1 stage. However, if the section did not encompass the spotted area, the gonad would be

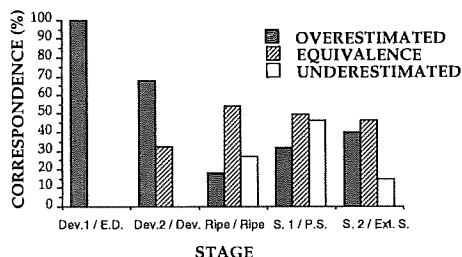

FIG.12. Correspondence between macro- and microscopic stages. DEV. 1=Developing 1; E.D.=Early Development; DEV.2=Developing 2; DEV.=Developing; S.1=Spawning 1; P.S.=Spawning 1; S.2=Spawning 2; EXT.S.=Extended Spawning.

classified as Ripe when viewed under the microscope. The first three of the scenarios above lead to an underestimation of gonad stage; the fourth leads to an overestimation.

Macroscopic and microscopic staging schemes have their own sets of advantages and disadvantages. Macroscopic staging is imperative where the animals cannot be sacrificed, and its relatively few stages are suitable for a rough classification of gonads while in the field or under hatchery conditions. However, the macroscopic scheme depends very much on the observer's ability to make correct classifications, e.g., scallops classified in Spawning 1 or Spawning 2 stages might really be in Resorption or Resting stages. The primary advantage of the microscopic scheme is that it provides a more accurate understanding of an individual animal's condition, but a lengthy period of time is required to prepare and process histological material. As Jervis Bay scallops do not appear to have a well defined reproductive cycle and they appear to dribble spawn, provision might need to be made for microscopic staging to follow their reproductive development during recovery of the population.

#### SETTLEMENT

Two studies were aimed at the spatial and temporal characteristics of scallop settlement in Jervis Bay. The first study, carried out on the two scallop beds assessed the magnitude, depth stratification and seasonality of settlement. The second study of 5 locations, initiated in September 1990 and finished in February 1991, ad-

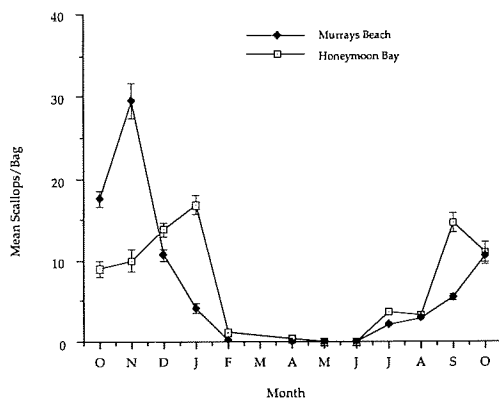

FIG.13. Mean and standard error of the number of commercial scallop spat settled by month at two locations in Jervis Bay (Oct 1989 – Oct 1990).

ressed the question of larval dispersion within the bay and allowed comparison of settlement between years.

In the first study, settlement data was analysed by time, location, zone and site according to the design described in Fuentes et al. (1992). Significant temporal variability was found in the

TABLE 4. Summary of analysis of variance (ANOVA) of scallop spat settlement at 2 locations, 2 zones and 3 sites over time at Jervis Bay. \*0.01- $p > 0.001$ ; \*\*0.001- $p > 0.0001$ ; \*\*\* $p = 0.0001$ ; ns=no significance.

Source of variation	df	SS	F value	Sgnif.
Location	1	11.714	5.32	ns
Zone	1	12.301	12.30	ns
Location*Zone	1	4.850	2.20	ns
Site (Location*Zone)	6	13.212	11.39	***
Time	8	979.800	107.83	***
Location*Time	8	133.110	14.65	***
Zone*Time	8	17.640	1.94	ns
Time*Site (Loc.*Zone)	34	38.619	5.88	***
Location*Zone*Time	8	12.257	1.35	ns
Depth	5	7.704	5.16	***
Location*Depth	5	6.875	4.61	**
Zone*Depth	4	4.323	3.62	*
Time*Depth	40	25.612	2.15	**
Time*Depth*Site (Location*Zone)	286	85.380	1.54	***
Residual	812	156.964		

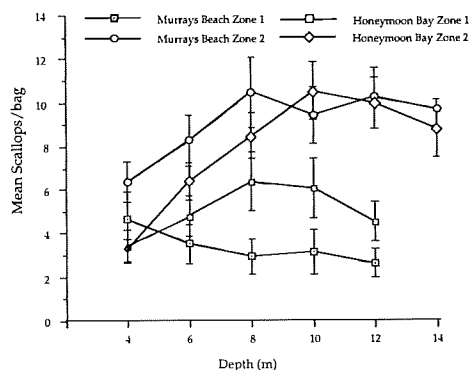

FIG.14. Mean and standard error of the number of scallop spat settled by depth stata, zone and site.

mean number of spat that settled on the experimental longlines (Table 4). Maximum settlement was recorded from November to January (Fig. 13). At both locations, settlement was minimal from February to June, but increased after July. Different temporal pattern in settlement were observed at Murrays Beach and Honeymoon Bay. It appeared that the duration of settlement was similar at both locations, but peak settlement seemed to occur two months earlier at Murrays Beach. The time of maximum larval abundance varies within *P. fumatus* (Young & Martin, 1989). In Tasmanian waters between King Island and Banks Strait, similar temporal differences in settlement were found from one location to another, within the same location (Young et al., 1988), and from one year to the next (Hortle & Cropp, 1987). Settlement begins in September (Young & Martin, 1989) and continues to December, but at decreasing intensities, in southern Tasmania (Hortle & Cropp, 1987). In eastern Bass Strait, settlement occurs November–December (Hortle, 1983; Young et al., 1988).

Differences in settlement at the first two spatial scales (location and zone) were not significant, but the differences among sites (within zone and location), were significant, suggesting small scale patchiness in settlement of *P. fumatus* in Jervis Bay. Spatial variability in settlement of *P. fumatus* has been documented in Port Phillip Bay; differences were observed in the number of settling spat at sites only 30km apart (Gwyther et al., 1985; Sause et al., 1987b; Coleman, 1988).

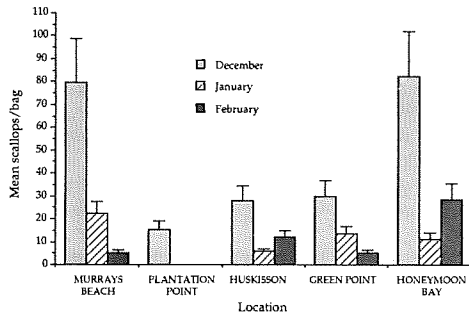

FIG. 15. Mean and standard error of the number of scallop spat settled from December 1990 to February 1991 by location and time.

Similar variability occurs in Bass Strait in areas separated by large distances (Young et al., 1992).

Mean numbers of spat that settled at different depth strata were significantly different. The highest settlement in Zone 1 (14m) was in the 8–12m Depth strata and in Zone 2 (18m) settlement was greatest at 8–14m (Fig. 14). The lowest settlement was at the 4m depth stratum. Hurtle & Cropp (1987) found that fewer spat settled near the surface and near the seabed (10–20m in a depth of 31m) in Mercury Passage on the east coast of Tasmania. Young et al. (1988, 1992) reported that larvae tended to settle on collectors placed near the bottom rather than on those higher in the water column off northern Tasmania. A combination of water temperature (thermal stratification), with factors such as larval behaviour, could also influence settlement in Jervis Bay. Jervis Bay has a strong thermal stratification most of the year (Holloway et al., 1989, 1990) and *P. fumatus* settlement, like that of other species (Mileikovsky, 1973; Mann & Wolf, 1983; Tremblay & Sinclair, 1988), may be influenced by such stratification.

In the second study (September, 1990 to February, 1991) settlement was observed in each of the five locations where longlines were placed (Fig. 15). Significant spatial and temporal variability was found in the mean number of spat that settled on collector bags with variation occurring among the five locations, among the three times and between the two sites within each location. Comparisons of settlement at different depths show similarities to results of the first study: settlement was lower on collector bags placed near the surface than on those placed near

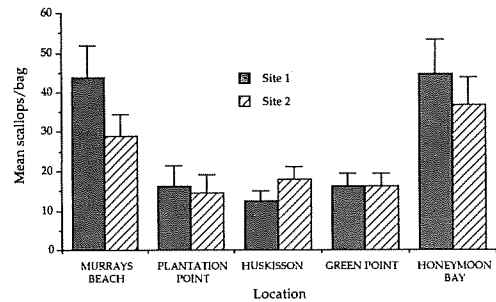

FIG. 16. Mean and standard error of the number of scallop spat settled from December 1990 to February 1991 by location and site.

the bottom. Comparisons indicated higher settlement at Murrays Beach and Honeymoon Bay (outer Bay) than at the other three locations (inner Bay). The temporal variations in this second study were similar to those in the first i.e. highest in December (Fig. 16). However, in this year there were no differences in the timing of settlement between Murrays Beach and Honeymoon Bay.

It has been postulated that the larvae of *P. fumatus* may not disperse widely from the adult population and that the number of larvae reaching the pediveliger stage may be related to the size of the nearby adult populations (Mason, 1983; Young et al., 1988). In Jervis Bay, there were differences between years in the mean number of spat that settled on collectors. More spat were observed in December 1990 than in December 1989 at both locations. The average number that settled per collector was higher at Murrays Beach probably because the abundance in the nearby population is higher than in Honeymoon Bay. Whether successful settlement in Jervis Bay is related to the proximity or size of the adult population is still to be demonstrated.

The low densities of the adult populations at Murrays Beach and Honeymoon Bay could be the reason for the low settlement during the study period. The settlement figures (average of 35 scallops/collector bag in November 1989 at Murrays Beach and 15 scallops/collector bag in January 1990 at Honeymoon Bay) are less than the average of 89 scallops/collector bag reported in 1982 off Huskisson (Jacobs, 1983). Furthermore, figures for Jervis Bay are much lower than figures reported for eastern Tasmania (516 scallops/collector bag in 1982/83, 425 scallops/col-

lector bag in 1984/85 and 325 scallops/collector bag in 1985/86, Hortle & Cropp, 1987) and for Port Phillip Bay (Sause et al., 1987b).

From these two studies, it is concluded that scallop larvae were distributed around the bay and that there were limitations on settlement at areas other than the two main beds. One implication of this conclusion is that changes which inhibit settlement may have occurred in the habitat at some sites. This might be the reason why commercial scallops disappeared from areas they were abundant in the previous decade. A second implication derived from this study is that the presence of larvae in the water column, the timing of spat settlement and the variation in settlement with depth are relevant factors in the design of systems for the collection of wild spat.

The magnitude, stratification and timing of larval settlement and dispersion are important management issues for commercial scallop fisheries. Attempts have been made to relate *P. fumatus* settlement in one year to recruitment in subsequent years (Sause et al., 1987b; Gwyther & Burgess, 1987; Coleman, 1988; Coleman & Gwyther, 1988). Coleman (1988) found that successful settlement may not necessarily mean good subsequent recruitment. However, in this study differences in settlement were evident and they coincide with a greater adult densities recruitment observed in the Murrays Beach and Honeymoon Bay beds in the transect surveys in 1992.

#### ACKNOWLEDGEMENTS

Thanks are due to L. Diver and A. Smith for their technical assistance during the study and to R. Williams for comment on the manuscript and constant encouragement. Thanks to E. Ortiz for assistance with the statistical analysis. Thanks are also due to an anonymous referee and to M. Dredge for critically reading the manuscript. I thank the CSIRO Jervis Bay Marine Station for providing the temperature data.

#### LITERATURE CITED

- ANON. 1981. The effects of scallop dredging on Port Phillip Bay. A summary. Marine Science Laboratory Victoria Technical Report 2: 1-12.
- BARBER, B.C. & BLAKE, N.J. 1991. Reproductive biology. In S. Shumway, (ed.), 'Scallop biology ecology and aquaculture. Developments in Aquaculture and Fisheries Sciences 21: 377-428. (Elsevier: New York).
- BUTCHER, T., MATTHEWS, J., GLAISTER, J. & HAMER, G. 1981. Study suggests scallop dredges causing few problems in Jervis Bay. Australian Fisheries 40(9): 9-12.
- CADDY, J.F. 1973. Underwater observations on tracts of dredges and trawls and some effects of dredging on a scallop ground. Journal of Fisheries Research Board Canada 30(2): 173-180.
- COE, W.R. 1945. Development of the reproductive system and variations in the sexuality in *Pecten* and other pelecypod mollusks. Transactions of the Connecticut Academy Arts and Sciences 36: 673-700.
- COLEMAN, N. 1988. Spat catches as an indication of recruitment to scallop populations in Victoria waters. Pp. 51-60. In Dredge, M.L.C., Zacharin, W.F. & Joll, L.M., (eds). 'Proceedings of the Australian Scallop Workshop, Hobart.' (Tasmanian Government Printer: Hobart).
- COLEMAN, N. & GWYTHYR, D. 1988. Abundance of scallops in Port Phillip Bay and predictions of yields for the 1988 season. Marine Science Laboratory Victoria, Technical Report 67: 1-12.
- DAMES & MOORE Pty. Ltd. 1985. Jervis Bay sediment and seagrass study for the Department of Housing. Report, Canberra, 36p.
- FUENTES, H.R., SMITH, A.K. & WILLIAMS, R.J. 1990. Survey results show few scallops in Jervis Bay. Australian Fisheries 49(8): 34-35.
- FUENTES, H.R., WILLIAMS, R.J., DIVER, L.P. & SMITH, A.K. 1992. Project 6: 'Commercial molluscs of Jervis Bay. Final Report to the Department of Defence in the Jervis Bay Marine Ecology Study'. (Fisheries Research Institute, NSW Agriculture & Fisheries: Cronulla). 193p.
- GORMAN, T.B. & JOHNSON, H.T. 1972. Cruise report for cruises 71-17, 71-18 and 71-19. F.R.V. Kapala cruise report 517: 1-16.
- GRANT, A. & TYLER, P.A. 1983. The analysis of data in studies of invertebrate reproduction. I. Introduction to statistic analysis of gonad indices and maturity indices. International Journal of Invertebrate Reproduction 6: 259-269.
- GWYTHYR, D., SAUSE, B. & BYRNE, J.L. 1985. Towards a longer term strategy for Port Phillip Bay scallop fishery management. Australian Fisheries 44(8): 4-7.
- GWYTHYR, D. & BURGESS, D.C. 1987. Abundance of scallops in Port Phillip Bay and predictions of yield for the 1987 season. Marine Science Laboratory Victoria, Technical Report 64: 1-17.
- HAMER, G. 1987. Scallop biology and management. NSW Agriculture and Fisheries Agfact F1.0.2: 1-8.
- HAMER, G. & JACOBS, N. 1987. The biology, fishery and management of the commercial scallop (*Pecten fumatus*) in Jervis Bay, New South Wales. Wetlands (Australia) 6(2): 39-47.
- HOLLOWAY, P.E., SYMONDS, G., NUNES VAS, R., JEFFREY, M. & MATHIAS, J. 1989. 'Oceanographic measurements in Jervis Bay. December, 1988 to January, 1989'. Working

- paper, 1989/2. Dept. of Geography and Oceanography. Univ. College, UNSW; Aust. Defence Force Academy. 44p.
- HOLLOWAY, P.E., SYMONDS, G., NUNES VAS, R. & JEFFREY, M. 1990. 'Oceanographic measurements in Jervis Bay: April, 1989 to April, 1990'. Working Paper, 1990/91. Dept. Geography and Oceanography. Univ. College, UNSW; Aust. Defence Force Academy. 45p.
- HORTLE, M.E. 1983. Scallop recruitment may be estimated. *FINTAS* 6(3): 37.
- HORTLE, M.E. & CROPP, D.A. 1987. Settlement of the commercial scallop, *Pecten fumatus* (Reeve) 1855, on artificial collectors in Eastern Tasmania. *Aquaculture*, Technical Paper 66: 79-95.
- JACOBS, N.E. 1983. The growth and the reproductive biology of the scallop *Pecten fumatus (alba)* in Jervis Bay NSW. Hons Thesis, Univ. NSW. (Unpubl.) 55p.
- MACDONALD, B.A. & THOMSON, R.J. 1986. Influence of temperature and food availability on ecological energetics of the giant scallop *Placopecten magellanicus*. III. Physiological ecology, the gametogenic cycle and scope for growth. *Marine Biology* 93: 37-48.
- MANN, R. & WOLF, C.C. 1983. Swimming behaviour of larvae of the ocean quahog *Antartica islandica* in response to pressure and temperature. *Marine Ecology Progress Series* 13: 211-218.
- MASON, J. 1983. 'Scallop and queen fisheries in the British Isles'. (Fishing News: England) 143p.
- McLOUGHLIN, R.J., YOUNG, P.C., MARTIN, R.B. & PARSLAW, J. 1991. The Australian scallop dredge: estimates of catching efficiency and associated indirect fishing mortality. *Fisheries Research* 11: 1-24.
- McSHANE, P.E. 1982. A comparison of dredge and dive surveys of scallop population in Port Phillip Bay, Victoria. *Marine Science Laboratory Victoria*, Technical Report 10: 1-12.
- McSHANE, P.E. & O'CONNOR, M.S. 1982. Dredge tow estimate of scallop distribution, abundance and size composition in Port Phillip Bay, Victoria, January, 1982. *Marine Science Laboratory Victoria*, Technical Report 9: 1-12.
- MILEIKOVSKY, S.A. 1973. Speed of active movement of pelagic larvae of marine invertebrates and their ability to regulate their vertical position. *Marine Biology* 23: 11-17.
- PAULET, Y.M., LUCAS, A. & GERARD, A. 1988. Reproduction and larval development in two *Pecten maximus* (L.) populations from Brittany. *Journal of Experimental Marine Biology and Ecology* 119: 145-156.
- PAULET, Y.M. & BOUCHER, J. 1991. Is reproduction mainly regulated by temperature or photoperiod in *Pecten maximus*? *Invertebrate Reproduction and Development* 19(1): 61-70.
- RIEMANN, B. & HOFFMANN, E. 1991. Ecological consequences of dredging and bottom trawling in the Limfjord, Denmark. *Marine Ecology Progress Series* 67: 171-178.
- SAUSE, B.L., GWYTHYER, D., HANNA, P.J. & O'CONNOR, N.A. 1987a. Evidence of winter-spring spawning of the scallop *Pecten alba* (Tate) in Port Phillip Bay, Victoria. *Australian Journal of Marine and Freshwater Research* 38: 329-337.
- SAUSE, B.L., GWYTHYER, D. & BURGESS, D. 1987b. Larval settlement, juvenile growth and the potential use of spatfall indices to predict recruitment of the scallop *Pecten alba* Tate in Port Phillip Bay, Victoria, Australia. *Fisheries Research* 6: 81-92.
- STEWART, P., KAILOLA, P.P. & RAMIREZ, C. 1991. Twenty-five years of Australian fisheries statistics. Bureau of Rural Resources, Canberra, Working Paper WP/14/91.
- TREMBLAY, M.J. 1988. A summary of the Proceedings of the Halifax sea scallop workshop, August 13-14, 1987. *Canadian Technical Report on Fisheries and Aquatic Science* 1605: 1-12.
- TREMBLAY, J.M. & SINCLAIR, M. 1988. The vertical and horizontal distribution of sea scallop (*Placopecten magellanicus*) larvae in the Bay of Fundy in 1984 and 1985. *Journal of Northwestern Atlantic Fisheries Science* 8: 43-53.
- WILLIAMS, R.J. & DIVER, L.P. 1988. Commercial molluscs of Jervis Bay. Pp. 163-197. In 'Jervis Bay Marine Ecological Studies. First Interim Report'. (Fisheries Research Institute, NSW Agriculture and Fisheries: Cronulla).
- YOUNG, P.C., MARTIN, R.B., McLOUGHLIN, R.J. & WEST, G. 1988. Variability in spatfall and recruitment of commercial scallops (*Pecten fumatus*) in Bass Strait. Pp. 80-81. In *Dredge*, M.L.C., Zacharin, W.F. & Joll, L.M., (eds), 'Proceedings of the Australian Scallop Workshop, Hobart'. (Tasmanian Government Printer: Hobart).
- YOUNG, P.C. & MARTIN, R. 1989. The scallop fisheries of Australia and their management. *Aquatic Science* 1(4): 615-638.
- YOUNG, P.C., McLOUGHLIN, R.J. & MARTIN, R.B. 1992. Scallop (*Pecten fumatus*) settlement in Bass Strait, Australia. *Journal of Shellfish Research* 11(2): 315-323.





## UNUSUALLY HIGH RECRUITMENT IN THE SHARK BAY SAUCER SCALLOP (*AMUSIUM BALLOTI*) FISHERY

L.M. JOLL

Joll, L.M. 1994 08 10: Unusually high recruitment in the Shark Bay saucer scallop (*Amusium balloti*) fishery. *Memoirs of the Queensland Museum* 36(2): 261-267. Brisbane. ISSN 0079-8835.

From 1983, when the Shark Bay scallop fishery reached full exploitation, to 1990, the largest annual catch had been 731 tonnes (meat weight) in 1988. In 1991 and 1992 catches of 2,532 and 4,144 tonnes, respectively, were taken. The increased catch in 1991 was attained despite total effort being the second lowest on record, while catch per unit effort (CPUE) was the highest on record. Total effort in 1992 increased considerably and was the highest on record, while CPUE was second only to that achieved in 1991. The very high catches and CPUEs were the result of a massive increase in the recruitment of juveniles derived from the 1990 breeding season. Annual stock surveys showed recruitment indices in some areas of Shark Bay up to six times higher than the previous record. Juveniles recruited in 1990 formed the bulk of the fishable stock in 1991, but the available effort in the fishery was unable to take all the fishable stock in 1991 and the 1992 catch was composed mostly of residual animals carried over from the 1991 season. High recruitment into the Shark Bay saucer scallop fishery is usually associated with low mean sea levels (= weak Leeuwin Current) over the winter (spawning) months. A chance association of spawning with an additional hydrological or other environmental event favourable to larval retention or survival may have multiplied the effect of a weak Leeuwin Current.

*L.M. Joll, Bernard Bowen Fisheries Research Institute, Western Australian Marine Research Laboratories, P.O. Box 20, North Beach, Western Australia 6020; 9 March 1994.*

The fishery for saucer scallops (*Amusium balloti* Bernardi, 1861) in Shark Bay has been fully exploited since 1983; its catch depends on recruitment from the breeding season of the previous year (Joll & Caputi, in press). Surveys of recruit (0+) and residual (1+ and older) scallops at the start of each season showed recruitment from the 1990 breeding season as the highest recorded. As a result of the very high recruitment, the 1991 catch was approximately three times higher than the previous record catch. However, despite the high catch in 1991, there were still large numbers of scallops at the end of the 1991 season. These formed the basis of the 1992 fishery, which took a catch over 50% greater than the record 1991 catch. Joll & Caputi (in press) have shown that these high levels of recruitment are associated with low mean sea levels, which reflect periods of a weak Leeuwin Current. This paper examines the background to the high 1990 recruitment and documents features of the event for use in population dynamics studies.

### MATERIALS AND METHODS

Scallops are caught by vessels which are licenced to fish only for scallops (using 25.6m [14fm] headrope length nets of 100mm mesh)

and vessels which fish for prawns and scallops (using 29.3m [16fm] nets of 50mm mesh) (Joll, 1987, 1989a). Catch and effort data are obtained from a voluntary logbook system completed by all vessels in both sectors of the fishery, and catch data are cross-checked with receipt records of wholesale buyers. Catch per unit effort (CPUE) data were derived from the catch and effort of the scallop fleet. Effort of prawn/scallop vessels may be directed at either prawns or scallops or a combination of the two. To determine a standardised effort value for the prawn/scallop fleet equivalent to the effort of the scallop fleet, the catch of the prawn/scallop fleet was divided by the CPUE of the scallop fleet. Total effort was calculated as the sum of the effort of the scallop fleet and the standardised effort of the prawn/scallop fleet.

Surveys of scallop abundance have been conducted in November each year since 1983, at the end of the scallop and prawn fishing seasons and near the end of the breeding season, using the 20m twin-rigged research vessel 'Flinders'. A standardised pattern of survey trawls is carried out, using twin 50mm mesh trawls of 22.0m (12fm) total head rope length, to determine the abundance of scallops in the areas of the bay where the fishery operates. Scallops caught in

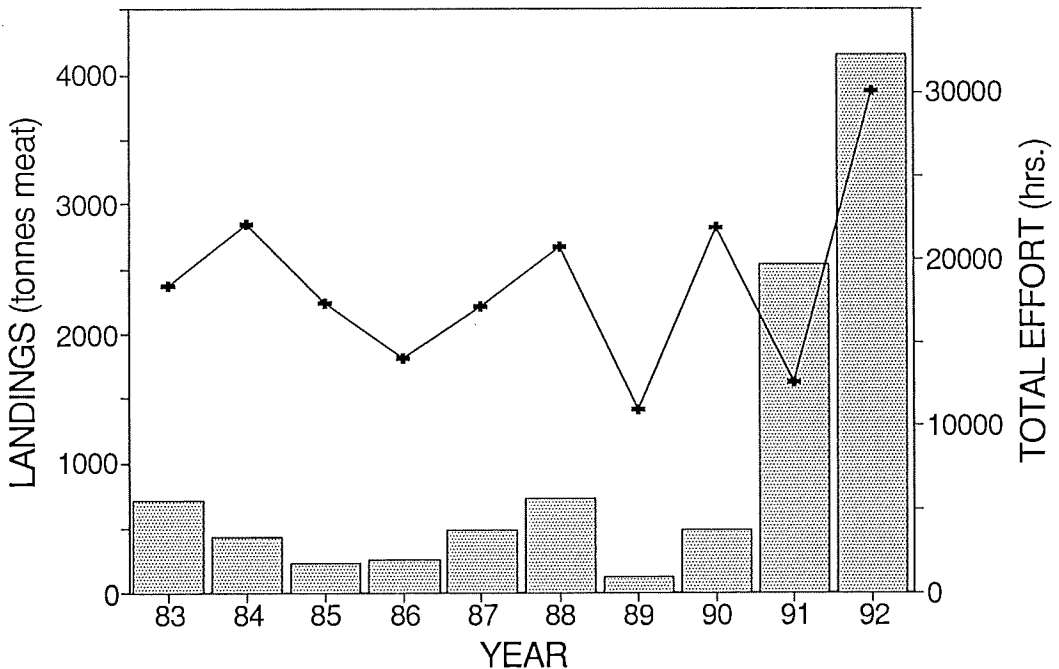

FIG. 1. Scallop catches (tonnes meat) from Shark Bay, 1983–1992 (stippled bars) and estimated total effort (+).

each survey trawl are separated, primarily on the basis of size, into recruits (0+ animals derived from the breeding season commenced in April that year (Joll, 1987)) and residuals (1+ and older animals) and the numbers of each category recorded. Most recruits are less than 75 mm in most years and most residuals are larger than 75 mm. However, when size overlaps occur, the recruits and residuals can still be separated on the pattern of the daily growth rings on the coloured left valve (Joll, 1988), with recruits showing widely spaced rings over the whole surface of the left valve while residuals have a zone of highly compacted rings near the valve margin.

Survey trawls are normally of 20 minutes duration and c.1 nautical mile long, although in areas of high abundance shorter trawl durations and distances are used. The distance covered by each survey trawl is determined either by radar fixes (1983–1989) or from global positioning system readings (1990 onwards) and, using the time taken for the trawl, the average speed of the trawl is determined. Catches of scallops are adjusted to catches per nautical mile, while the effect of speed on catchability is partially compensated for by applying factors determined by Penn (unpub.) for the catchability of adult (=residual-size) scallops relative to an arbitrary speed of 3.4kt. Survey

data for each trawl shot are ultimately expressed as the catch of scallops per nautical mile (spnm) at 3.4kt for 12fm of head rope. The adjustment for the effect of speed on catchability does not compensate for the differences in catchability of recruit and residual-sized scallops and the indices for these two categories cannot be compared directly. However, the data allow for year-to-year comparisons within the categories.

Abundance indices of scallops on the main grounds (Shark Bay N of 25° 30'S) and the smaller ground in Denham Sound are derived from survey data as the mean abundance of recruits and residuals in the survey shots. The main grounds are further sub-divided into northern (N of 25° 10'S) and southern (S of 25° 10'S) sub-areas. Because the main grounds have contributed the bulk of the catch in most years, previous work (Joll & Caputi, in press) has concentrated on the relationship between an environmental factor (Leeuwin Current strength) and the index of abundance of recruits on the main grounds. The survey data have also been used to examine the relationship between index of abundance of recruits and residuals on the main grounds and catch from these grounds in the following year. However, recruitment in 1990 also gave rise to a significant catch from the

TABLE 1. Abundance indices of scallops from various sub-areas in Shark Bay from surveys in November 1983–92 (data are spnm for 12 ftm of net towed at 3.4 kts). REC.=recruits; RES.=residuals.

	MAIN GROUNDS				DENHAM SD.	
	N. AREA		S. AREA		Rec.	Res.
	Rec.	Res.	Rec.	Res.		
1983	47	237	32	301	65	158
1984	54	73	81	7	33	0.1
1985	134	91	247	2	30	0.5
1986	277	47	75	0.3	51	0.7
1987	598	133	609	35	32	7
1988	18	132	58	49	12	2
1989	97	45	19	2	32	1
1990	608	77	3756	73	631	21
1991	169	2411	50	4253	100	683
1992	162	770	157	467	761	439

Denham Sound grounds and data relating Leeuwin Current strength to recruit abundance and catch on the Denham Sound grounds are also presented.

Strength of the Leeuwin Current, flowing S along the Western Australian coast during the austral winter, is reflected in coastal sea levels (Reid & Mantyla, 1976; Pearce & Phillips, 1988). The major spawning activity of *A. balloti* in Shark Bay occurs between April and July (Joll & Caputi, in press) and it is the strength of the current in these months which is most relevant. Unfortunately, sea level data are not available for the Shark Bay area for all of the relevant period, but the available data shows that changes in sea level at Carnarvon (25°S, 114°E) are reflected in sea level data from Fremantle (32°S, 116°E) one month later (Joll & Caputi, in press). As an index of Leeuwin Current strength in the Shark Bay area in April to July, the mean value of the sea level at Fremantle, lagged one month (i.e. May to August), was used.

## RESULTS

### CATCH AND EFFORT

Total scallop catch from Shark Bay by all vessels licenced ranged from 121 tonnes to 731 tonnes between 1983–1990, with a mean of 432 tonnes/year (Fig. 1). Catches for 1991 and 1992 were 2,532 and 4,144 tonnes respectively. The increase in catch in 1991 occurred despite total effort being the second lowest on record, while catch per unit effort (CPUE) of the scallop fleet was the highest on record at 200.2 kg h<sup>-1</sup>,

more than 5 times higher than the previous highest CPUE. The low effort figure for the 1991 season was a consequence of processing limitations on the fishing vessels, with vessels only fishing for a few hours each day and spending the remainder of the day processing the catch. The effort in the 1992 season was the highest on record, partly as a result of a large increase in effort by the prawn/scallop fleet, but the CPUE of the scallop fleet of 137.9 kg h<sup>-1</sup> was second only to the 1991 figure and nearly 4 times greater than the previous highest CPUE recorded.

### SURVEY DATA

There was a very high abundance of recruits in November 1990, with an exceptionally high abundance in the southern sub-area of the main grounds - over 6 times higher than any of the previous indices determined for any sub-area of Shark Bay (Table 1). Moreover, despite a high 1991 catch, residual scallops in November 1991 were exceptionally abundant in the southern sub-area and high in the other sub-areas. These high abundances of residual scallops came about because, unlike years in which recruitment was at a more normal level, the effort of the scallop and prawn/scallop fleets could not fully exploit the 1991 recruitment. Another very large catch was taken in 1992, based primarily on the residual scallops detected in the 1991 survey, which were derived from the 1990 recruitment. By November 1992 the abundance of residual scallops had decreased considerably, reflecting the impact of the fishing activities of the fleets in the 1992 season, when recruitment to the fishery was close to normal.

Recruitment levels for 1990, categorized into 3 abundance classes (Fig. 2A), show that recruitment was not uniform through the sub-areas. The principal area of recruitment was in the southern sub-area of the main grounds, with a core of very high abundance (5,000 spnm) surrounded by an area of relatively high abundance (1,000–4,999 spnm). Residual scallop abundance in the 1991 survey (Fig. 2B) reflected fairly closely the distribution of recruits in the 1990 survey, with the exception of a small area of high abundance of residual scallops in the northern area. The apparent emergence of this area of residual scallops in November 1992 may indicate that recruitment in the northern sub-area occurred slightly later and was not measured fully by the November 1991 survey.

The highest recorded catches (12fm net at 3.4kts) in the 1990 and 1991 surveys were 19,075

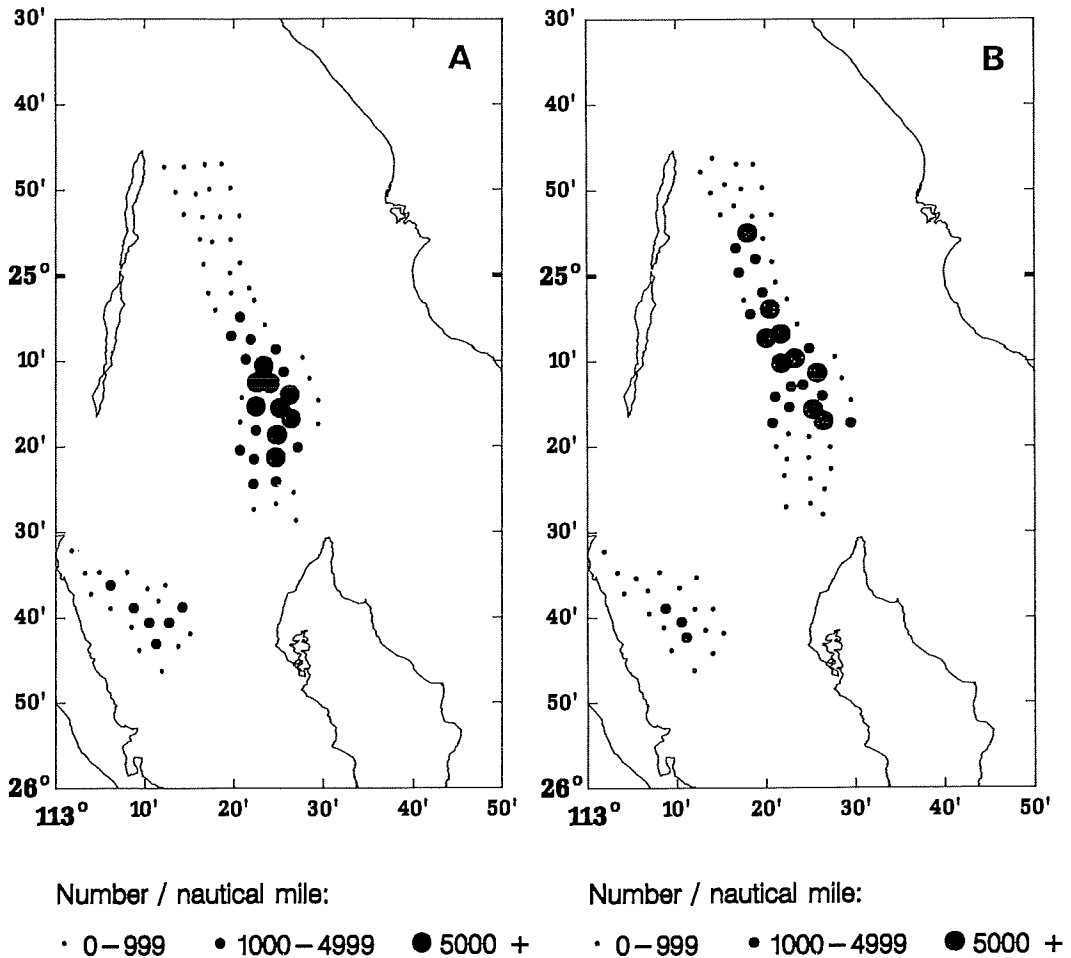

FIG. 2. Distribution of the abundance of scallops in Shark Bay recorded in surveys in November. A, Recruits, 1990. B, Residuals, 1991.

recruit spnm in 1990 and 59,242 residual spnm in 1991. Conversion of these catch rates to abundances requires application of catchability factors relevant to the various trawl speeds. Joll & Penn (1990) showed that the catchability of residual-size scallops at a speed of 2.5 kt is approximately 0.6, while the adjustment of this catchability factor to the higher trawl speed of 3.4kt at which the survey data are expressed is also 0.6 (Penn unpubl. data). Application of these catchability factors to the 1991 figure for the highest catch of residual scallops equates to an actual abundance of 164,561 spnm in the path of the trawl. Assuming a trawl path of 60% of the headrope length of

trawl used (Joll & Penn, 1990), the area swept in a 1 nautical mile trawl would be 24,446 m<sup>2</sup>. On this basis density of adult scallops in the shot with the highest abundance of residual scallops in the 1991 survey was estimated to be 6.7 scallops m<sup>-2</sup>. The catchability of recruit scallops has not yet been formally determined. However, based on the lower swimming capacities of smaller scallops and the increased latency of their response to a stimulus to swim (Joll 1989b), it could be expected that the catchability of recruit-sized (50-60mm) scallops would be about 30-40% of that of residual-size scallops. On the basis that the catchability of recruit-size scallops is 40% of that

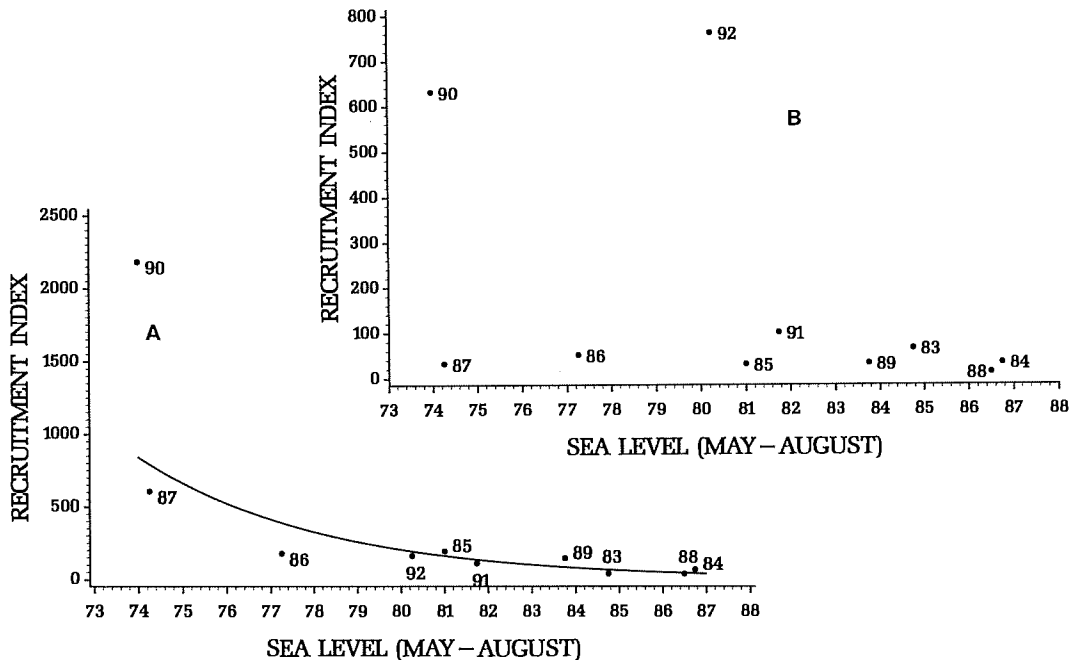

FIG. 3. Relationship between the index of recruit abundance (mean spnm) in Shark Bay and mean Fremantle sea level (cm) over the period May to August. A (bottom left), Main grounds. B, (upper right), Denham Sound.

of residual-size scallops, the density of recruit scallops in the path of the trawl with the highest catch of recruits in the 1991 survey was estimated at 5.4 scallops  $m^{-2}$ .

#### EFFECTS OF THE LEEUWIN CURRENT

The relationship between the recruitment index for the main grounds and mean Fremantle sea level over the period May to August in the period 1983 to 1992 (Fig. 3A) shows that the recruitment index was highest in years when the mean sea level was low. Recruitment data for Denham Sound (Fig. 3B) show a high recruitment index in 1990, when sea level was low. However, in 1987 when sea level was similarly low, there was no increase in recruitment and in 1992, when sea level was not particularly low, there was also a high recruitment.

In most years there is a high level of exploitation of the scallops recruiting to the fishery, which gives rise to a strong correlation between the abundance index of recruits in one year and catch on the main grounds in the following year and between sea-level in one year and catch on the main grounds the following year (Joll & Caputi, in press). However, because of the inability of the fleet to fully exploit the fishable stock available in 1991, there was a considerable

carry-over of scallops into 1992. This gave rise to a high catch in 1992 on both the main grounds and the Denham Sound grounds which was not related to the sea-level of the immediately previous year (Fig. 4A,B). Although survey data showing recruitment strengths are not available prior to 1983, the inclusion of data for the 1983 catch and the 1982 sea level provide additional confirmation of a relationship between sea level and catch in the following year (except 1992) on both the main grounds and in Denham Sound.

#### DISCUSSION

The high 1990 recruitment led to massive 1991 and 1992 scallop catches. On a live weight basis, the 1992 catch of scallops was over 20,000 tonnes, making it the second largest single species fishery in Australia in that year after greenback jack mackerel. The combined catch of scallops by the scallop and prawn/scallop fleets in 1991 and 1992 was a little less than twice the accumulated catch of the previous eight years. The mean CPUE in 1991 was approximately 18 times greater than the highest mean CPUE in the Queensland saucer scallop fishery 1976-1987 (Dredge, 1988). Using an estimated mean adduc-

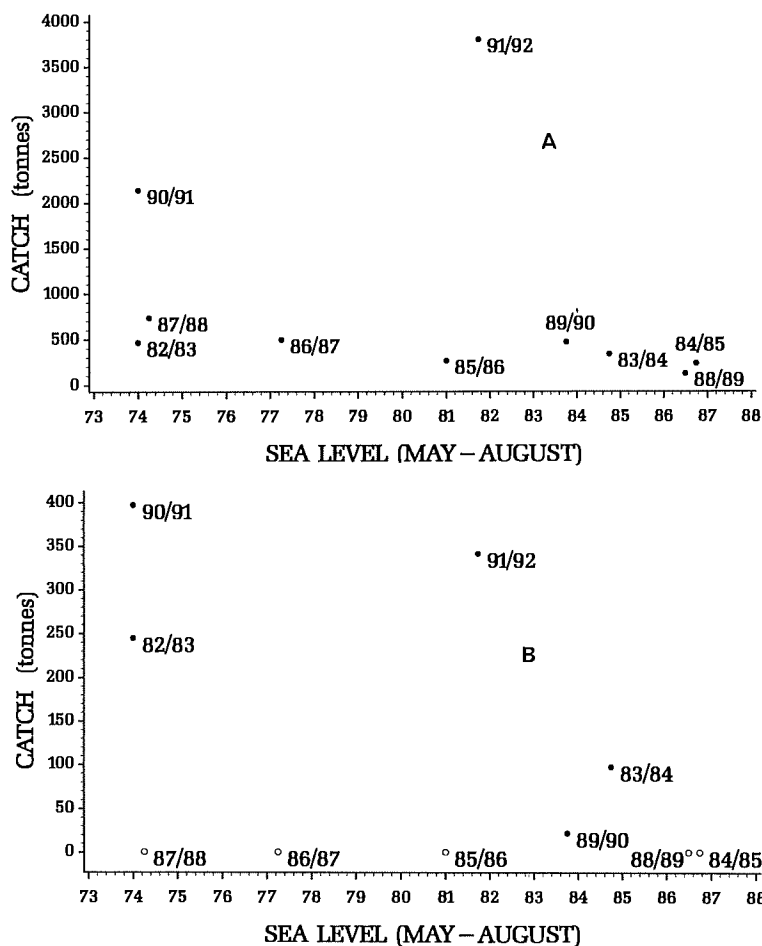

FIG. 4. Relationship between total catch (tonnes meat) and mean Fremantle sea level (cm) over the period May to August in the previous year. (86/87): (Year of sea level data/ Year of catch data). A (upper), Main grounds. B (lower), Denham Sound (open circles represent years of no effort in Denham Sound).

tor weight of 15g for scallops caught in 1991 and a mean of 20g for 1992, there were approximately 376 million scallops caught over 2 years. If most of these scallops had been caught in the year in which they recruited to the fishery, as is the case in years of more normal levels of recruitment (and without adjusting for the natural mortality of scallops from 1991 to 1992), an estimated catch of at least 5,500 tonnes would have been taken in 1991.

Estimated densities of scallops in the area of highest abundance in the 1990 and 1991 surveys were as high as 6.7 scallops  $m^{-2}$ . Higher densities of residual scallops than recruit scallops is probably a reflection of local variation in abundance, with slightly different areas trawled in

different years. Alternatively, differences in catchability between recruit and residual-size scallops may have been underestimated, which would reduce the estimated density of recruits.

Based on the minimum value of the upper category of abundances (Fig. 2), this figure equates (on the same basis as previous estimates) to densities of 0.57 residual scallops  $m^{-2}$  and 1.42 recruit scallops  $m^{-2}$ . Dredge (1988) noted maximum density of *Amusium balloti* in Queensland at around  $1m^{-2}$ , while Joll & Penn (1990) reported densities of scallops of 0.08-0.09  $m^{-2}$  in an area of Shark Bay in 1986. The area occupied by scallops at an estimated average minimum density of 1.42 recruits  $m^{-2}$  and 0.57 residuals  $m^{-2}$  in the 1990 and 1991 surveys (based on the area enclosed by shots of 5,000 spm or greater) was around 90  $km^2$  and 60  $km^2$  in the two years respectively. Scallops at very high local densities and generally high densities across a wide area over a two year period indicate a capacity of the environment to support large numbers of scallops without any apparent

depletion of the food resources.

The mechanism by which the Leeuwin Current affects recruitment success in Shark Bay is not fully understood. Satellite imagery shows that, when the Leeuwin Current is near the coast off Shark Bay, bodies of warm Leeuwin Current water sometimes move away from the main flow of the current and enter Shark Bay (Joll & Caputi, in press). This may flush larvae out of the bay or into the saline embayments along the mainland shore line. Hydrological flushing has been recognised as factor affecting recruitment in *Placopecten magellanicus* and *Pecten maximus* (Dickie, 1955; Caddy, 1979, 1989; Thouzeau &

Lehay, 1988). Alternatively, the higher temperature or lower nutrient levels of the Leeuwin Current water (Pearce, 1991) may provide an environment which is less suitable for larvae.

The abundance pattern of 1990 (Fig. 2A) had a core of very high abundance surrounded by an area of relatively high abundance, suggesting that larvae were contained within a well-defined eddy feature at settlement. Dredge (1988) suggested that a gyre in Hervey Bay in Queensland may act to trap larvae of *A. balloti* and Caddy (1979) hypothesized that recruitment to the Bay of Fundy scallop fishery was positively influenced by the degree of retention of larvae within a gyre. Greater retention of larvae within Shark Bay, perhaps inside clearly defined hydrographic features, appears to be the most likely cause of increased larval survival and juvenile recruitment in years when the Leeuwin Current is weak.

The reason for disproportionately high recruitment in 1990, compared with that occurring at similar average sea level values in 1982 and 1987 is not clear. There may have been some additional hydrological factor which led to an unusually high level of larval retention within the bay or some other environmental event which led to a high retention or survival rate of larvae. The action of an additional favourable factor or factors within a low sea level environment already basically conducive to good larval survival may have been greatly heightened by the synchronisation of that event with spawning activity. *Amusium balloti* is a multiple spawner (Joll, 1987, 1989a) with a larval life of c.22 days (Rose et al., 1988). With a relatively short larval life it may be that recruitment success can benefit from chance associations between spawning and short term environmental factors which are not reflected in the mean sea level. The very compact and unimodal size-frequency distribution of the 1990 recruits in the areas of very high abundance suggests that the bulk of the recruits in these areas were derived from one spawning. Synchronisation of an additional hydrological or other environmental event with a period of spawning may have led to the levels of recruitment success observed in 1990.

#### LITERATURE CITED

- CADDY, J.F. 1979. Long-term trends and evidence for production cycles in the Bay of Fundy scallop fishery. *Rapports et Procès-Verbaux des Réunions de Conseil International pour l'Exploration de la Mer* 175: 97-108.
- CADDY, J.F. 1989. Recent developments in research and management for wild stocks of bivalves and gastropods. Pp. 665-700. In J.F. Caddy, (ed.), 'Marine invertebrate fisheries: their assessment and management'. (John Wiley and Sons: New York).
- DICKIE, L.M. 1955. Fluctuations in abundance of the giant scallop, *Placopecten magellanicus* (Gmelin), in the Digby area of the Bay of Fundy. *Journal of Fisheries Research Board Canada* 12: 797-857.
- DREDGE, M.C.L. 1988. Recruitment overfishing in a tropical scallop fishery. *Journal of Shellfish Research* 7: 233-239.
- JOLL, L.M. 1987. The Shark Bay scallop fishery. Fisheries Department Western Australia, Fisheries Management Paper 11:1-123.
- JOLL, L.M. 1988. Daily growth rings in juvenile saucer scallops, *Amusium balloti* (Bernardi). *Journal of Shellfish Research* 7: 73-76.
- JOLL, L.M. 1989a. History, biology and management of Western Australian stocks of the saucer scallop *Amusium balloti*. Pp. 30-41. In M.L.C. Dredge, W.F. Zacharin & L.M. Joll, (eds), 'Proceedings of the Australasian Scallop Workshop, Hobart'. (Tasmanian Government Printer: Hobart).
- JOLL, L.M. 1989b. Swimming behaviour of the saucer scallop *Amusium balloti* (Mollusca: Pectinidae). *Marine Biology* 102: 299-305.
- JOLL, L.M. & CAPUTI, N. in press. Environmental influences on recruitment in the saucer scallop (*Amusium balloti*) fishery of Shark Bay. In 'Proceedings of the Shellfish life histories and shell fishery models Symposium'. ICES Marine Sciences Symposia.
- JOLL, L.M. & PENN, J.W. 1990. The application of high-resolution navigation systems to Leslie-DeLury depletion experiments for the measurement of trawl efficiency under open-sea conditions. *Fisheries Research* 9: 41-55.
- PEARCE, A.F. & PHILLIPS, B.F. 1988. ENSO events, the Leeuwin Current, and larval recruitment of the western rock lobster. *Journal du Conseil (International pour l'Exploration de la Mer)* 45:13-21.
- PEARCE, A.F. 1991. Eastern boundary currents of the southern hemisphere. *Journal of the Royal Society of Western Australia* 74: 35-45.
- REID, J.L. & MANTYLA, A.W. 1976. The effect of the geostrophic flow upon coastal sea elevations in the northern North Pacific Ocean. *Journal of Geophysical Research* 81:3100-3110.
- ROSE, R.A., CAMPBELL, G.R. & SANDERS, S.G. 1988. Larval development of the saucer scallop *Amusium balloti* (Bernardi) (Mollusca: Pectinidae). *Australian Journal of Marine and Freshwater Research* 39: 153-160.
- THOUZEAU, G. & LEHAY, D. 1988. Variabilité spatio-temporelle de la distribution, de la croissance et de la survie des juvéniles de *Pecten maximus* (L.) issus des pontes 1985, en baie de Saint-Brieuc. *Oceanologica Acta* 11: 267-283.





## HATCHERY PRODUCTION OF WESTERN AUSTRALIAN SCALLOPS

DEREK A. CROPP

Cropp, D.A. 1994 08 10. Hatchery production of Western Australian scallops. *Memoirs of the Queensland Museum* 36(2): 269-275. Brisbane. ISSN 0079-8835.

Adult scallops (*Amusium balloti*, *Chlamys australis* and *Chlamys scabricostata*) from Shark Bay, Western Australia were transported to 6,000l and 12,000l pools of raw seawater at a commercial hatchery. Adults were fed daily with cultured microalgae to improve gonad condition. Successful, induced spawnings were conducted for all species with *A. balloti* spawnings conducted in all months from April to December inclusive, over a 3 year period. Adults were induced to spawn by the addition of sperm and a water temperature increase. For the most successful batches, larvae were respectively reared to settlement in 12, 12 and 17 days at  $22.2 \pm 0.94^\circ\text{C}$ ,  $24.35 \pm 1.2^\circ\text{C}$  and  $20.2 \pm 0.8^\circ\text{C}$ . Up to 6.1 million pediveligers were placed into settling tanks from one spawning. Batches of settled spat regularly exceeded 0.5 million with the highest count attained of approximately 2.4 million spat at the completion of the metamorphosis/settlement stage. Large scale hatchery production techniques were developed and a potential for aquaculture has been shown, particularly for *C. australis*.

*Derek A. Cropp, Aquatech Australia Pty Ltd, 15 Wignall Street, North Hobart, Tasmania 7000; 9 March 1994.*

Ten species of scallops have been documented in W.A. waters (Wells & Bryce, 1985) but an accurate number or species is difficult to obtain due to species overlap and name changes.

Of commercially important W.A. species, only *Amusium pleuronectes australiae* (Habe, 1964) was omitted from Wells & Bryce's list; it was also omitted from a record of scallops in Shark Bay (Slack-Smith, 1990). It is occasionally part of the by-catch of the *Amusium balloti* (Bernardi, 1861) fishery and forms the basis of a small fishery in the Northern Territory (Young & Martin, 1989). Other commercial species are *Pecten modestus* (Reeve, 1852), *Chlamys australis* (Sowerby, 1842), *Chlamys (Mimachlamys) asperrimus* (Lamarck, 1819), *Annachlamys leopardus* (Reeve, 1853) and *Amusium balloti*. *Pecten fumatus* Reeve, 1852 may occur along the southern coast of W. A. (Joll, 1988) but hatchery production of it is documented (Cropp, 1988a; Cropp & Frankish, 1988; Dix & Sjardin, 1975). *A. balloti* and *A. pleuronectes australiae* belong to the Amusiidae; other species mentioned above belong to the Pectinidae.

Of recent studies on hatchery production of Australian scallops (Connolly, 1990; Cropp, 1988a, Cropp & Frankish, 1988; Dix & Sjardin, 1975; Rose et al., 1988; Rose & Dix, 1984) only one (Rose & Dix, 1984) dealt with *Chlamys* as its commercial importance in Australia has been minimal; two (Connolly, 1990; Rose et al., 1988) reviewed hatchery culture trials on *A. balloti*.

Rose & Dix (1984) provided information on larvae of the doughboy scallop, *Chlamys asper-*

*rimus*, which is similar to *C. australis* from W.A. They occupy similar ecological niches but the temperature regimes of their environs are 9–20°C for *C. asperrimus* and 17–25°C for *C. australis* (Cropp, 1993b)

*A. balloti*, the saucer or swimming scallop, is the target species for significant trawl fisheries in central Queensland (Williams & Dredge, 1981) and Shark Bay, W.A. (Joll, 1987). It is a tropical-subtropical species which appears to prefer 19–24°C water on medium to coarse sandy mud bottoms. Its natural spat settlement and recruitment have been studied (McDuff, 1975; Kettle, 1984; Dredge, 1981; Campbell, 1987; Sumpton et al., 1990) as has hatchery culturing (Rose et al., 1988; Connolly, 1990). These studies were hindered by the tendency of the metamorphosing larvae not to exude a strong byssal thread (Rose et al., 1988; Dredge, 1981). The attachment was also found to be for a short time period only (Rose et al., 1988), unlike *Pecten* or *Chlamys* (Dix & Sjardin, 1975; Rose & Dix, 1984; Sause et al., 1987; Hortle & Cropp, 1987; Cropp, 1993a). Improvements in broodstock conditioning and larval rearing techniques (Gwyther et al., 1991; Cropp, 1988a) have been implemented and further developed in the study reviewed herein.

In Shark Bay the scallop by-catch of the *A. balloti* fishery is c. 1–5% *C. australis*, *C. scabricostata* and *A. leopardus* (plus occasional rarer species). This by-catch is generally returned to the sea as processing is deemed difficult and markets have not been established. However, the meat and gonad from processed *C. australis* is

almost identical to that from the cooler water *C. asperrimus*, which is common in Tasmania and well received on the market. Hence a potential exists for marketing *C. australis*. *Chlamys scabricostata* does not grow to the same adult size that *C. australis* or *C. asperrimus* does (S. Slack-Smith pers. comm.). *C. australis* was deemed as having a better potential for aquaculture.

The most common spat production technique for overseas scallop culture is based around collection of natural spat at sea (Ito, 1988; Bull, 1988). From this perspective alone, it is necessary to be able to distinguish between larvae which are likely to be present in the water column at similar times. For this reason a small scale hatchery trial involving *C. scabricostata* was conducted prior to the culture of *C. australis*. Adults of this species were induced to spawn and the larvae reared under the same conditions as for *C. australis*. Larvae produced by *A. balloti* adults have been reared under similar conditions and are distinguishable from *C. australis* and *C. scabricostata*.

Various *Chlamys* species are cultured in hatcheries and in some areas grown-out in culture operations overseas (Broom & Mason, 1978; Mason, 1983; Cropp, 1988b). *Chlamys* generally attach firmly to substrates upon settlement and remain attached for several months. Interception of the natural settlement and spat attachment process (with artificial substrates) has been found to be viable (Hortle & Cropp, 1987) and economically feasible on a large scale (Rhodes & Widman, 1980; Maru, 1985; Cropp, 1987) for numerous different species overseas and within Australia (Bull, 1988; Cropp, 1988b). It has allowed industries to develop through the availability of large amounts of spat.

*Amusium*, however, exhibits a weak and temporary attachment (byssus) only (Dredge, 1981; Gwyther et al., 1991) and collection of significant quantities of spat at sea is therefore unlikely. This necessitates the hatchery production of spat. The small population of *C. australis* in Shark Bay, suggests that natural spatfall would probably be minimal and thus, if an aquaculture industry was to develop for this species, hatchery culture would also be necessary. Significant quantities of *C. scabricostata* would probably be obtainable from spat collectors deployed in Shark Bay, hence the hatchery trial simply examined larval development in this species.

An assessment of meat recovery (as % of live weight) from various species suggested that most market potential was in *A. balloti* and *C.*

*australis*. Larval development of these species was carefully examined in addition to a brief larval rearing trial with *C. scabricostata*. The southern species, *P. modestus* is acknowledged to have aquaculture potential also. The fact that it is similar to *P. fumatus*, which has been produced in commercial quantities in a hatchery, suggests that the larval rearing techniques for both species would probably be similar. Thus no special effort was made to rear the species in a hatchery. As an aquaculture species, *A. leopardus* was perceived to be inferior due to slow growth and relatively low meat recovery from live weight; consequently no hatchery work was conducted on this species.

## MATERIALS AND METHODS

Saucer scallops were collected from trawlers in Shark Bay, between April and October of each year from 1989 to 1991. Broodstock for the *C. scabricostata* spawning were collected in June 1990, and for the *C. australis* spawning in July 1991. The scallops were obtained from sorting trays, placed into either small portable tanks containing aerated water or into steel mesh baskets in the vessels' circulating tanks. Scallops held in the vessels tanks were placed into small portable tanks upon arrival in port. They were transported in the tanks, by road, to a hatchery at Carnarvon and placed in 6000l and 12000l above-ground swimming pools, at c.15–20°C, for 5 days prior to a spawning being attempted with some of the animals. In mid-winter, 2 kW electrical immersion heaters were used to maintain the water temperature.

Saltwater was pumped through cartridge filters in the series: 20µm, 10µm, 5µm, 2µm and 1µm. Broodstock pools were filled with 20µm filtered water, larvae tanks with 1–20µm filtered water, depending on the daily water quality (thorough filtering for dirty water), and 1µm filtered water was used for algal cultures.

During the broodstock holding period, 50% of the pool volume was changed at least every second day and on occasions daily. Initially, volumes of a non-axenic algal culture, *Tetraselmis suecica*, were added daily in sufficient quantity to establish a food cell density in the holding pool of 30000–40000 cells ml<sup>-1</sup>. After early gonad conditioning work exhibited poor results, the algae species was changed to another non-axenic alga, *Chaetoceros gracilis*. When available, this diet was supplemented (with approximately 5000 cells ml<sup>-1</sup>) by non-axenic

TABLE 1. Average annual results for each of the development stages per spawning batch of *A. balloti*.

Year	No. of Batches	No.Females	F	D	P	Pediveliger Size ( $\mu\text{m}$ )	Days to settlement
1989	19	13.26	27.4005	1.4298	68658	202.45	15.40
1990	11	12.91	21.9327	0.8896	496,667	212.82	14.30
1991	5	9.00	18.5000	2.7420	1,765,000	211.00	11.75

F= No. Fertilized eggs ( $\times 10^6$ ); D= No. 'D' veligers ( $\times 10^6$ ); P= No. Pediveligers (Cropp,1993a)

TABLE 2. Average annual size and growth rates of *A. balloti* larvae per batch. Only batches where an accurate Day 2 and pediveliger size were available are documented in this table, hence the batch and pediveliger difference to Table 1. Pediveliger size is taken as the larval size on settlement day (Cropp,1993a).

Year	No. of Batches	Size ( $\mu\text{m}$ )	Size of 'D' larvae, day 2( $\mu\text{m}$ )	Pediveliger size ( $\mu\text{m}$ )	Days to settlement	Daily growth of larvae, day 2 to settlement ( $\mu\text{m day}^{-1}$ )
1989	10	75	114.56	201.78	15.40	5.66
1990	5	75	119.70	214.38	14.30	6.62
1991	4	75	123.30	211.00	11.75	7.46

*Chaetoceros calcitrans*, *Pavlova lutheri* and Tahitian *Isochrysis* (*aff.*) *galbana*.

Gonad condition of live scallops was monitored visually on a regular basis. When well developed or mature gonads were apparent, selected animals were cleaned and a spawning was attempted. In most spawnings, 4–10 male and 10–20 female *A. balloti* were used. For the other spawnings, 3 male and 6 female *C. australis*, and 2 male with 4 female *C. scabricostata* were used. A combination of water temperature increases and addition of sperm extracted from spare broodstock were used as spawning stimuli.

## RESULTS

Thirtyfive successful spawnings of *A. balloti* were conducted over the 3 years (Cropp, 1993a)(Tables 1,2). A maximum of about 6 million and often in excess of 3 million eggs were obtained from *A. balloti* females, up to 4.5 million eggs from *C. australis* females and about 0.5 million eggs per *C. scabricostata* female resulted from induced spawnings (Cropp,1993b).

Larvae were reared in larvae tanks at a salinity of 35ppt and an average temperature of  $22.2 \pm 0.94^\circ\text{C}$  (mean  $\pm$  s.d.) for *A. balloti*,  $24.35 \pm 1.2^\circ\text{C}$  for *C. australis* and  $20.2 \pm 0.8^\circ\text{C}$  for *C. scabricostata*. The algal diet was composed of similar portions of *C. calcitrans*, *P. lutheri* and Tahitian *I. (aff.) galbana* at a density increasing from 10000 cells  $\text{ml}^{-1}$  on day 2 up to 15000 cells  $\text{ml}^{-1}$  at day 12 (settlement) and then to 25000 cells  $\text{ml}^{-1}$

for settled spat. The diet of one batch of *A. balloti* larvae reared in July-August 1991 (Fig.1) is representative of that fed to other larval batches. Larval water was changed totally on or about every two days. For the most successful batches, larvae were respectively reared to settlement in 12, 12 and 17 days (Cropp,1993a,b).

Larval development for *A. balloti* commenced with eggs of  $75.9 \pm 4.4 \mu\text{m}$  ( $n=40$ ), a first 'D' stage veliger (day 2) of  $123.3 \pm 2.06 \mu\text{m}$  and a pediveliger of  $211.0 \pm 1.41 \mu\text{m}$  (Fig.2). Larval development of *A. balloti* as documented (Rose et al.,1988) was verified in this work. For the batch being examined, 4.1 million pediveligers were put into settlement tanks with 30 mesh spat

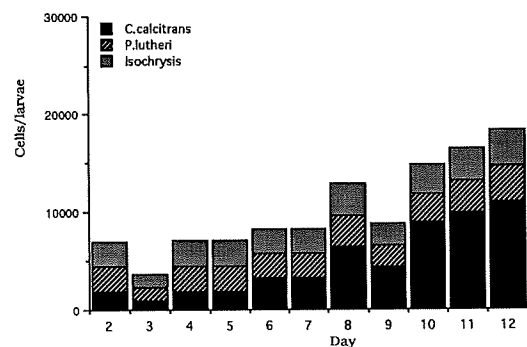

FIG. 1. Algal diet for *A. balloti* larvae during the culture phase, July-August 1991.

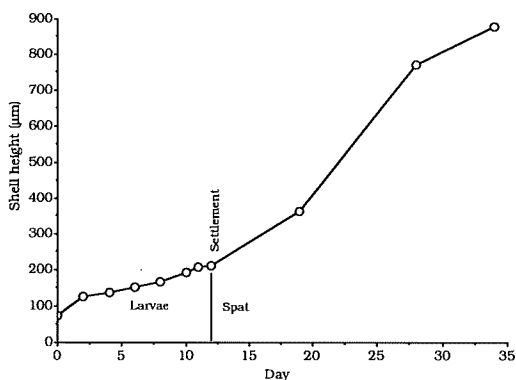

FIG. 2. Growth of *A. balloti* larvae and spat, July-August 1991 (Cropp, 1993a).

collectors. On day 19 spat were 362 µm in size, and by day 28, 1.4 million spat of 772 µm in size were present (41,333 ± 4,509 spat/collector plus 160,000 loose spat). The shell of spat gradually changed from opaque to white as they grew (>4mm), a feature which has not been documented previously. It is also an aspect to be considered when identifying naturally occurring spat collected in tropical and sub-tropical areas.

Mature eggs of *C. australis* were 62.2 ± 2.2 µm ( $n = 30$ ) and the first D-shaped larvae were 108.5 ± 4.1 µm long (Fig. 4). Total eggs produced from the 4 females was 12.55 million (Fig. 5). By day 4 the larvae measured 124.1 ± 5.0 µm long. The D-shaped larvae developed rapidly up to day 8 when a characteristic scallop larval shape was displayed.

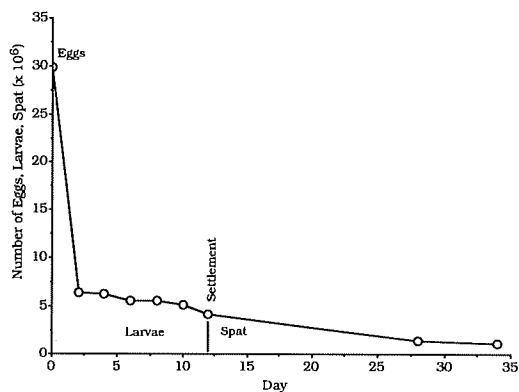

FIG. 3. Number of *A. balloti* eggs, larvae and spat surviving during the culture phase, July-August 1991 (Cropp, 1993a).

Precise size of fully developed pediveligers is difficult to ascertain; for *C. australis*, a sample of swimming pediveligers taken on day 12 had a mean length of 203.6 ± 12.1 µm. At that stage c.50% of the larvae had an motile foot. A sample of settled spat on day 15 had a length of 296.9 ± 48.3 µm. Thin new (dissoconch) shell was evident on the outer edge of spat. About 2.4 million spat (39.3%) settled from 6.1 million eyed larvae at day 12. The spat count included an estimation of those spat attached to the wall and bottom of the tank. A sample of 5 collectors was washed and spat counted on day 16. The mean count per collector was 37,800 ± 6,058; spat were approximately 300 µm.

Eggs produced by *C. scabricostata* females had a diameter of 60–63 µm (Fig. 6). Sufficient sperm

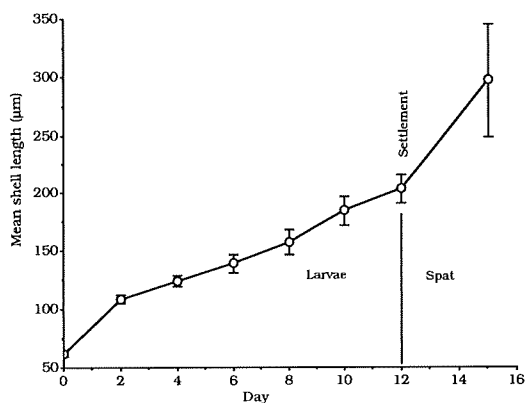

FIG. 4. Growth of *C. australis* larvae and spat: (shell length with s.d.); ( $n = 30$ ) (Cropp, 1993b).

solution was added to give a ratio of 4–5 sperm per egg (with a total of 1.54 million eggs, Fig. 7). After 46 hours (day 2) at 21.8°C, 800,000 larvae (51.95% of eggs) had developed into D-shaped veligers with a mean length of 103.4 µm (Figs 6,7) and 82.2 µm height. At day 13 the larvae were 197 µm long and exhibited a prominent eye-spot. By day 17 numerous pediveligers were evident. The 75,000 remaining larvae were 220 µm long and had grown at a rate of 8.33 µm day<sup>-1</sup> since becoming D-shaped larvae at day 2. Metamorphosis and settlement occurred over days 17–20. By day 21 settled spat were 250 µm long and exhibited new shell.

## DISCUSSION

Examination of the commonly assessed phases

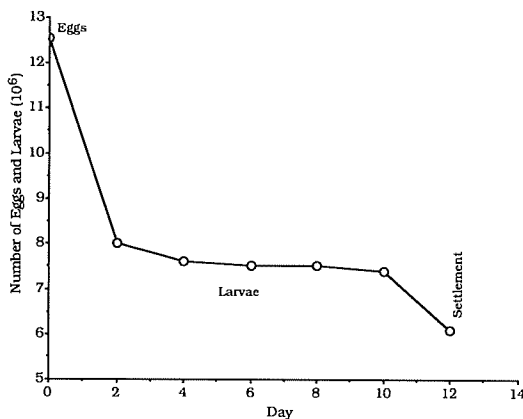

FIG. 5. Number of *C. australis* eggs and larvae surviving during the culture phase (Cropp, 1993b).

of the larval rearing stage for *A. balloti* indicated that culture in 1991 was markedly more successful than culture of larvae in 1990 and especially 1989. A combination of factors was responsible for this success. The major improvements were in broodstock conditioning, and thus quality of eggs, the effectiveness of the water filtration system (improved water quality) and variations in the larval culture conditions (Cropp, 1993a).

Use of high quality mature eggs produced benefits throughout the larval culture period. Less mortality occurred and larger veligers resulted. Subsequent use of water with a stable temperature and salinity further enhanced the growth and survival of larvae.

An average survival figure in 1991 of 14.8% from eggs to D-shaped larvae and 64.4% from

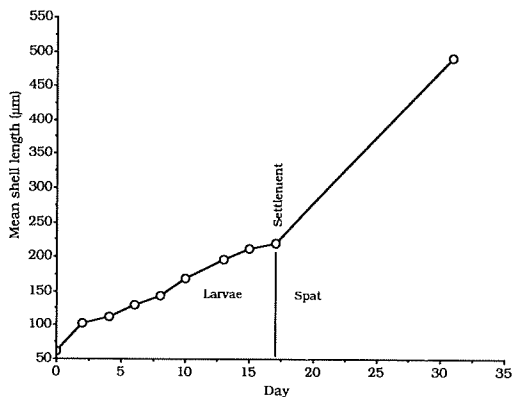

FIG. 6. Growth of *C. scabricostata* larvae and spat: (shell length).

D-shaped larvae to pediveligers compares favourably with data from Canadian research (Thompson et al., 1985) on the Japanese scallop *Patinopecten yessoensis*. Larval rearing of this species produced survival rates for corresponding phases of 10% and 10%. These figures may have resulted from the use of antibiotics and non-axenic algae in the culture process.

Rose et al. (1988) recorded a growth of 5.2 µm day<sup>-1</sup> for *A. balloti* larvae from the first D stage to the umbral veliger, then 6.3 µm day<sup>-1</sup> until the pediveliger stage. Larvae in our study attained an overall average (for 1991) of 7.5 µm day<sup>-1</sup> for the period from the first D-shaped larvae (day 2) to pediveliger. The batch spawned on 24 July 1991 gave an overall growth rate of 8.7 µm day<sup>-1</sup> for the same phase.

Rose & Dix (1984) found that the mean egg

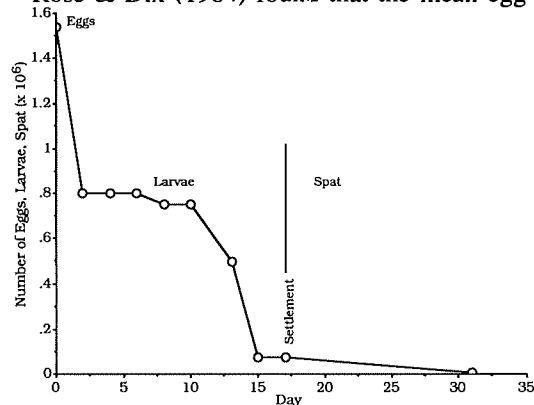

FIG. 7. Number of eggs, larvae and spat for *C. scabricostata* during the culture phase.

diameter for *C. asperimus* was 61.5 ± 0.4 µm, the first D-shaped larval stage with a prodissoconch I shell occurred after 2 days and was 108 µm long, and that fully developed pediveligers occurred on day 19, when larvae were 194 µm long. Corresponding data for *C. australis* were 62.2 ± 2.2 µm, 108.5 ± 4.1 µm and 203.6 ± 12.1 µm (day 12) respectively.

*C. australis* larvae were reared at 23–24°C in a subtropical area, whilst *C. asperimus* larvae (Rose & Dix, 1984) were reared at 17–18°C in a cool temperate area. The higher rearing temperature for *C. australis* is thought to be responsible for the comparatively short larval period.

Larval development appears to be very similar for *C. asperimus* and *C. australis* and the spat settle at a similar size. In the *C. australis* trial, 63.7% of eggs developed into D-shaped larvae,

76.3% developed from D-shaped larvae to metamorphosis and overall, 48.6% of eggs developed through to metamorphosis. These are extremely high survival rates and as far as known, they exceed those documented for hatchery culture of any other species of scallop world-wide.

Overall, these trials have established viable techniques for the production of commercial quantities of *A. balloti* and *C. australis*. For *A. balloti* this may mean that large quantities of spat could be used to enhance the wild fishery, although this is unlikely to be required at present due to the buoyant state of the fishery. Catches recorded recently in W.A. have been higher than previous peaks in the history of the fishery. Associated declines in market value, and a depressed world scallop market, have threatened the commercial viability of the scallop trawling industry and eliminated the possibility of a viable culture industry at present. For *C. australis*, hatchery produced spat may allow its aquaculture potential to be developed as it has been for *C. asperrimus* in Tasmania. However, the economic value of *C. australis* would be affected by the depressed market and commercial viability of a culture operation would need careful examination before proceeding.

#### ACKNOWLEDGEMENT

This research was funded by the Fishing Industry Research and Development Council.

#### LITERATURE CITED

- BROOM, M.J. & MASON, J. 1978. Growth and spawning in the Pectinid *Chlamys opercularis* in relation to temperature and phytoplankton concentration. *Marine Biology* 47: 277–285.
- BULL, M.F. 1988. A New Zealand scallop enhancement project—cost and benefits. Pp. 154–165. In M.C.L. Dredge, W.F. Zacharin & L.M. Joll (eds), 'Proceedings of the Australian Scallop Workshop, Hobart, Australia'. (Tasmanian Government Printer: Hobart).
- CAMPBELL, G.R. 1987. 'A final report to the Fishing Industry Research Committee on the recruitment into commercial stocks of the saucer scallop *Amusium japonicum balloti*.' 27p. (Queensland Department of Primary Industries: Deception Bay)
- CONNOLLY, N.M. 1990. Some aspects of the mariculture of the tropical/subtropical scallop, *Amusium balloti* (Bernardi). Hons Thesis, James Cook Univ. North Queensland. 93p.
- CROPP, D.A. 1988a. 'FIRTA 84/93 Hatchery production of scallop spat for large scale reseeding trials. Final Report'. (Fishing Industry Research Trust Account, Department of Primary Industry: Canberra).
- CROPP, D.A. 1988b. Scallop culture in the Pacific Region. Pp. 193–211. In Evans, L.H. & O'Sullivan, D.B., (eds), 'Proceedings of the First Australian Shellfish Aquaculture Conference Perth' (Curtin University of Technology: Perth).
- CROPP, D.A. 1992. 'Aquaculture of the saucer scallop *Amusium balloti*. Final Report' (Fisheries Research and Development Corporation, Department of Primary Industries: Canberra).
- CROPP, D.A. 1993a. Development of large scale hatchery production techniques for *Amusium balloti* (Bernardi, 1861) in Western Australia. *Aquaculture* 115: 285–296
- CROPP, D.A. 1993b. Hatchery culture potential of the scallop *Chlamys australis* in Western Australia. *Aquaculture* 115:31–40
- CROPP, D.A. & FRANKISH, K.R. 1988. Cost comparison of hatchery and naturally produced spat for the scallop *Pecten fumatus* Reeve. Pp. 196–225. In M.C.L. Dredge, W.F. Zacharin & L.M. Joll, (eds), 'Proceedings of the Australian Scallop Workshop, Hobart' (Tasmanian Government Printer: Hobart).
- CROPP, R.A. 1987. Feasibility of scallop culture in Tasmania. Tasmanian Department of Sea Fisheries Technical Report 15: 1–24.
- DIX, T.G. & SJARDIN, M.J. 1975. Larvae of the commercial scallop, *Pecten meridionalis* from Tasmania. *Australian Journal of Marine and Freshwater Research* 26: 109–112.
- DREDGE, M.C.L. 1981. Reproductive biology of the saucer scallop *Amusium japonicum balloti* (Bernardi) in central Queensland waters. *Australian Journal of Marine and Freshwater Research* 32: 775–787.
- GWYTHYER, D., CROPP, D.A., JOLL, L.M. & DREDGE, M.C.L. 1991. Australia. Developments in Aquaculture and Fisheries Science 21: 835–851.
- HORTLE, M.E. & CROPP, D.A. 1987. Settlement of the commercial scallop *Pecten fumatus* (Reeve) 1855, on artificial collectors in eastern Tasmanian waters. *Aquaculture* 66: 79–95.
- ITO, H. 1988. Sowing culture of scallop in Japan. Pp. 63–68. In Sparks, A.K. (ed.), 'New and innovative advances in biology/engineering with potential for use in aquaculture. (NOAA Technical Report NMFS 70).
- JOLL, L.M. 1987. The Shark Bay Scallop Fishery. Fisheries Management Paper 11: 1–123.
- JOLL, L.M. 1988. History, biology and management of Western Australian stocks of the saucer scallop *Amusium balloti*. Pp.30–41. In M.C.L. Dredge, W.F. Zacharin & L.M. Joll, (eds), 'Proceedings of the Australian Scallop Workshop, Hobart, Australia' (Tasmanian Government Printer: Hobart).
- KETTLE, B.T. 1984. Settlement and growth of the local scallops *Amusium pleuronectes* (Linné) and

- Amusium balloti* Habe. Hons. Thesis. James Cook Uni. North Queensland. 93p.
- MARU, K. 1985. Ecological studies on the seed production of scallop, *Patinopecten yessoensis*. Journal of the Hokkaido Institute of Fisheries 27: 1-53.
- MASON, J. 1983. 'Scallop and queen fisheries in the British Isles'. (Fishing News: Farnham, Surrey).
- MCDUFF, M.M. 1975. A study of some aspects of the population ecology and reproductive biology of *Amusium pleuronectes* (Linné) in coastal waters of Townsville. Hons. Thesis James Cook University. 85p.
- RHODES, E.W. & WIDMAN, J.C. 1980. Some aspects of the controlled production of the bay scallop (*Argopecten irradians*). Proceedings of the World Mariculture Society 11: 235-246.
- ROSE, R.A., CAMPBELL, G.R. & SANDERS, S.G. 1988. Larval development of the saucer scallop *Amusium balloti* (Bernardi) (Mollusca: Pectinidae). Australian Journal of Marine and Freshwater Research 39: 153-160.
- ROSE, R.A. & DIX, T.G. 1984. Larval and juvenile development of the doughboy scallop, *Chlamys (Chlamys) asperrimus* (Lamarck) (Mollusca: Pectinidae). Australian Journal of Marine and Freshwater Research 35: 315-23.
- SAUSE, B.L., GWYTHYER, D. & BURGESS, D. 1987. Larval settlement, juvenile growth and the potential use of spatfall indices to predict recruitment of the scallop *Pecten alba* Tate in Port Phillip Bay, Victoria, Australia. Fisheries Research 6: 81-92.
- SLACK-SMITH, S.M. 1990. The bivalves of Shark Bay, Western Australia. Pp. 129-158. In P.F. Berry, S.D. Bradshaw & B.R. Wilson, (eds), 'Research in Shark Bay. Report of the Franco-Australie Bicentenary Expedition Committee.' (Western Australian Museum: Perth).
- SUMPTON, W.D., BROWN, I.W. & DREDGE, M.C.L. 1990. Settlement of bivalve spat on artificial collectors in a subtropical embayment in Queensland, Australia. Journal of Shellfish Research 9: 227-231.
- THOMPSON, D., BOURNE, N. & MANSON, C. 1985. 'Scallop breeding studies'. (Pacific Biological Research Station: Nanaimo, British Columbia, Internal Report) 16p.
- WELLS, F. & BRYCE, C.W. 1985. 'Seashells of Western Australia'. (Western Australian Museum: Perth) 207p.
- WILLIAMS, M.J. & DREDGE, M.C.L. 1981. Growth of the saucer scallop, *Amusium japonicum balloti* Habe in central eastern Queensland. Australian Journal of Marine and Freshwater Research 32: 657-666.
- YOUNG, P.C. & MARTIN, R.B. 1989. The scallop fisheries of Australia and their management. Aquatic Sciences 1: 615-638.





## MODELLING MANAGEMENT MEASURES IN THE QUEENSLAND SCALLOP FISHERY

M.C.L. DREDGE

Dredge, M.C.L. 1994 08 10: Modelling management in the Queensland scallop fishery. *Memoirs of the Queensland Museum* 36(2): 277-282. Brisbane. ISSN 0079-8835.

The saucer scallop *Amusium japonicum balloti* is the basis of a trawl fishery with an average annual meat production of about 1,000 tonnes in Queensland. A variable size limit (90mm in summer and autumn, 95mm in winter and spring) and a ban on fishing during daylight are significant components of the management package imposed on the fishery.

Effects of alternative management regimes on yield per recruit, value per recruit and spawners per recruit have been evaluated using a modelling procedure. The effect of variation in growth parameters has been interpreted in the model.

Results indicate that increasing the size limit to 95mm throughout the year would increase spawners per recruit minimally while decreasing value per recruit 15-20%. A 95mm size limit for most of the year with 24 hour a day fishing, would decrease spawners per recruit by 15-35% in the ranges of F examined, while increasing relative value per recruit only at lower exploitation levels.

*M.C.L. Dredge, Queensland Department of Primary Industries, Southern Fisheries Centre, P.O. Box 76, Deception Bay 4508, Queensland; 15 April, 1994.*

Queensland's saucer scallop (*Amusium japonicum balloti*) fishery is a component of the state's multi-species trawl fishery. Some 900 trawlers (10-20m long), are licensed to fish for a number of species of penaeid prawns, slipper lobsters (Scyllaridae), crabs and scallops. Catch and effort data were monitored voluntarily in particular fisheries, but have been compulsory and comprehensive since 1988. The current return system calls for daily records of effort and catch within 30'x30' spatial grids, with some data being available at a finer spatial resolution (6'x6').

The trawl fishery annually takes c.10,000 tonnes of product, with variation in total production and species proportions between years. Scallops contribute an average of c.1000 tonnes of meat annually (Neil Trainor, pers. comm.).

All of the state's licensed trawlers are legally entitled to fish for scallops. Not all vessels do catch them, however. During 1988-1992, 270-360 vessels reported catches of scallops (Neil Trainor, pers. comm.). There appears to be excess fishing capacity in the state's trawl fleet in the context of taking the state's annual scallop catch.

Queensland's saucer scallop stock was first fished in the mid 1950's (Ruello, 1975), when prawn trawlers working out of Hervey Bay took appreciable quantities. The fishery remained an irregular 'off season' source of income for prawn trawl operators until the mid 1970's, when serious attempts to export saucer scallop meat to

the U.S. and south east Asia became profitable (Dredge, 1985). Effort directed towards scallop stocks increased rapidly (Fig.1), total catches increased then levelled off, while catch rates decreased by an order of magnitude during 1978-1985.

The scallop fishery has been managed through both input and output controls, largely since 1985 (Table 1). Management was initially directed towards maximising yield per recruit through the use of a size limit, initially set at 80mm shell height (SH), but later increased (Table 1). As effort directed at the scallop resource increased and catch rates fell, managers expressed concern about the state of the resource and directed management measures towards maintenance of spawning stock levels. These included introduction of a variable size limit (90mm SH in summer and autumn, 95mm in winter and spring) designed to reduce fishing effort during the species' winter spawning season, introduction of daylight trawl closures in order to reduce fishing effort, and the short-lived trialing of areas closed to fishing as spawning stock protection sites.

The industry has repeatedly expressed concern about the management package which has evolved over the past 10 years. Some fishermen regard the daylight trawl ban as discriminatory. Others would prefer to have a year-round size limit of 90 or 95mm SH. An alternative proposal involves 24 hour a day fishing while having a

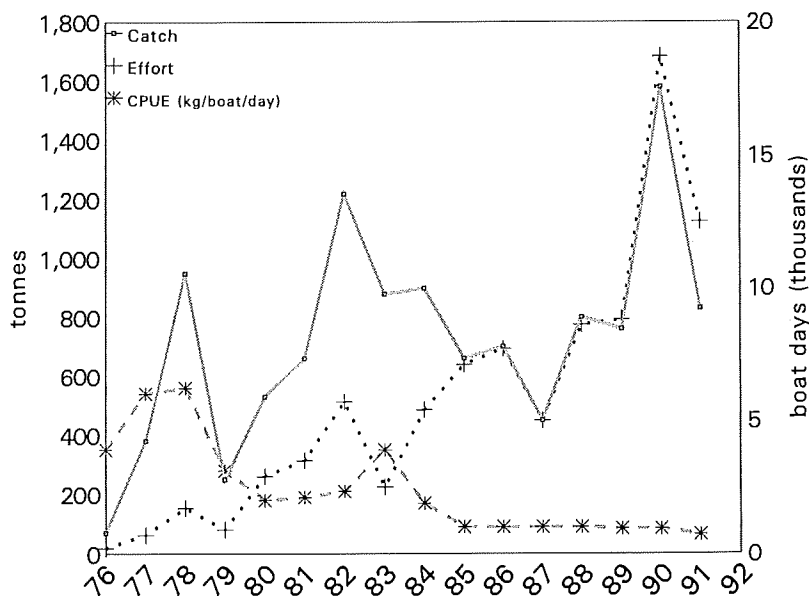

FIG. 1. Total landings and catch rates from the Queensland saucer scallop fishery.

95mm SH size limit for May-January, and a 90mm SH limit for February-April, inclusive.

These alternatives have been evaluated in terms of meat yield per recruit, value per recruit, and spawners per recruit, using outputs from a series

of computer based simulations. The results of this evaluation form the basis of this paper.

recruitment cohorts and the other defined time. The resultant matrix developed a series of cohorts linked to recruitment events over time. All simulations were based on two identical, normally distributed recruitment pulses being fed into

of computer based simulations. The results of this evaluation form the basis of this paper.

## MATERIALS AND METHODS

Theoretical yield per recruit outcomes from a range of management scenarios were modelled using QuickBasic programmes based on those described in Dredge (1992). The programmes were structured to create a series of overlaying two dimensional matrices.

### THE MODEL

In the initial matrix, one axis defined numbers in a series of

TABLE 1. Summary of management procedures in the scallop fishery (P. Pond, pers. comm.)

Date	Shell size	Gear size	Max. mesh size	Trawl closures	Designated shucking areas	Preservation zones
11/84	80 mm	Combined headrope and footrope <109m	82 mm			
7/84	85 mm		75 mm			
10/87	90 mm			Daylight trawl ban 1/10-31/1 each year		
12/87				Daylight trawl ban lifted		
11/88					Urangan, Gladstone & Rosslyn Bay	
2/89				Daylight trawl ban		Three 10-minute by 10-minute areas closed to fishing
3/89	95mm 4/89 - 10/89 90mm 11/90 - 3/91					
5/90	95mm 5/90 - 10/90 90mm 11/90 - 4/91					Closures deleted

the model over a 16 week time period, in order to simulate a four month, bi-modal spawning process commencing in early winter (Dredge,1981). The model was stepped through the 'time' axis, both to feed in recruits and to diminish the numbers of scallops in each cohort through a process equivalent to natural mortality, i.e. though the process  $N_{t+1} = N_t \cdot e^{-M}$ , where  $N_t$  represents numbers at time  $t$ ,  $N_{t+1}$  are numbers at time  $t+1$ , and  $M$  the coefficient of natural mortality.  $M$  was ascribed a value of  $0.02 \text{ week}^{-1}$  (Dredge,1985).

The second matrix was used to estimate size at age (shell height) in each cohort at each age. Growth rates of scallops are known to vary with location, apparently as a function of depth and tidal regime (Williams & Dredge,1981; Dredge & Robins-Troeger, unpubl. data). Three different growth scenarios were used in this model. Subsets of this matrix were used to ascribe size at age for scallops from areas where growth was rapid ( $L_t=105(1-e^{-(0.055*t)})$ ), intermediate ( $L_t=100(1-e^{-(0.051*t)})$ ), and slow ( $L_t=97(1-e^{-(0.049*t)})$ ), with  $t$  in weeks. Von Bertalanffy growth parameters were derived from Williams & Dredge (1981) and Dredge & Robins (unpubl. data). The model was based upon 55% of scallop being taken from 'fast growth' areas, 35% from 'intermediate growth' rate areas, and 10% from 'slow growth' areas. These figures are based on the average spatial distribution of catch for 1989-1991 inclusive (Trainer pers. comm.).

A third matrix was used to convert shell height to adductor weight for scallops in each cohort at each age. Monthly shell height to adductor weight conversions, based on those in Williams & Dredge (1981), were used for this procedure. A dollar value was ascribed to scallops in each cohort at each age by multiplying numbers of survivors by meat weight by unit value of meat in a fourth matrix. This required a correction factor based on the individual meat weights, as there is an appreciable difference in scallop prices based on individual meat sizes (Hart, this memoir).

Fishing was simulated through a process which involved identifying those cohorts in which scallops were larger than a given ('legal') size and increasing the mortality rate to include a component for fishing mortality ( $F$ ), ranging between light ( $F=0.005 \text{ week}^{-1}$ ) to very heavy ( $F=0.040 \text{ week}^{-1}$ ). The resultant 'catch' of both meat weight and value was accumulated as the model was stepped through time.

An index of the number of spawning scallops was developed by averaging the sum of the num-

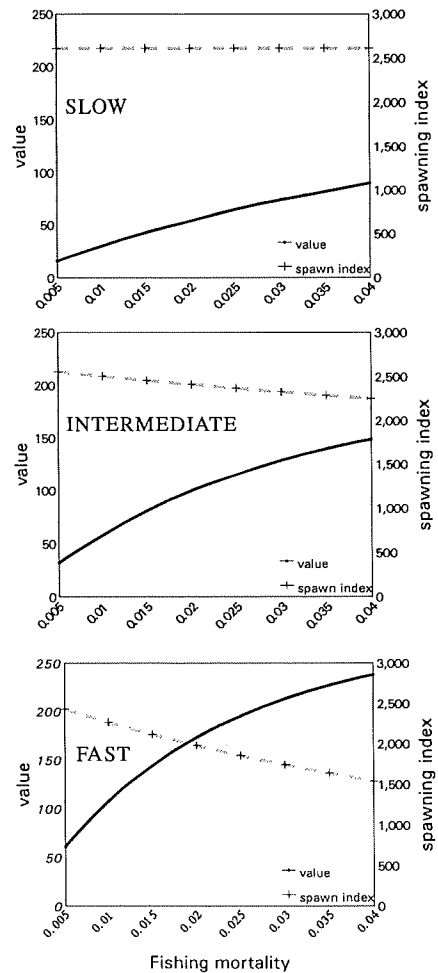

FIG.2. Value per recruit and spawners per recruit from scallops with differing growth parameters.

ber of one and two year old scallops which survived at the beginning and end of the winter spawning period. This index has been used as an index of spawners per recruit.

MANAGEMENT SCENARIOS

Yield per recruit in meat weight and dollar value, and spawners per recruit were estimated in the following management scenarios:

- 1) A 90mm SH size limit in summer and autumn and 95mm SH size limit in winter and spring, with no daylight fishing (the existing management situation).

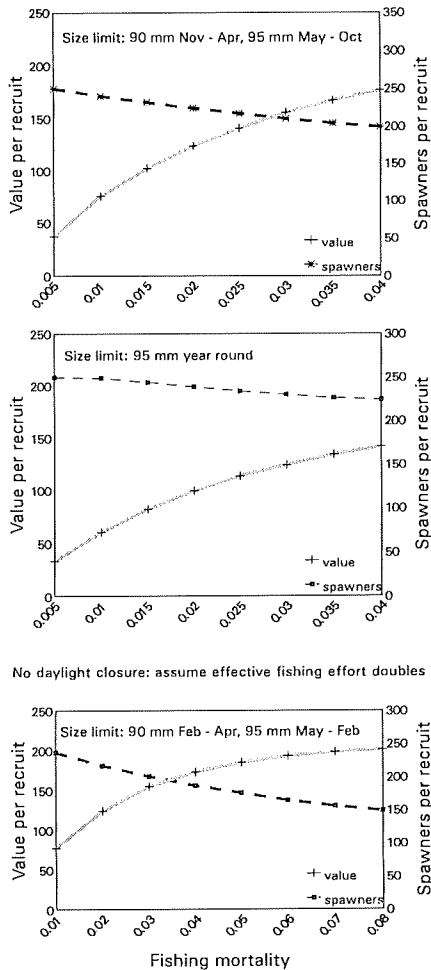

FIG.3. Variation in value per recruit and spawners per recruit as a consequence of varying management regimes.

2) A year round 95mm SH size limit, with no daylight fishing.

3) A 95mm SH size limit in May–January, and a 90mm SH limit in February–April (inclusive), with an increase in fishing mortality commensurate with 24 hour a day fishing throughout the year. This was achieved by assuming that the fishing mortality rate (F) doubled as a consequence of allowing 24 hour a day fishing.

Model runs were carried out over a 104 week time span, which approximates the effective maximum life span of the species (Heald & Caputi, 1981; Dredge, 1985). Yield per recruit and

spawners per recruit were estimated as a function of fishing mortality (F) between 0.005–0.040 week<sup>-1</sup>.

## RESULTS

Output from model runs is most readily interpreted in graphic form.

### EFFECT OF VARIATION ON GROWTH PARAMETERS

Spawners per recruit and catch value per recruit from equivalent recruitment processes were compared for populations with 3 sets of growth parameters. Variation in growth parameters had an appreciable effect in 'per recruit' output (Fig. 2). Value per recruit of slow growing scallops was 1/3–1/2 of that in fast growing scallops, with the differential increasing as exploitation rates increased. Conversely, spawners per recruit from slow growing scallops remained at near steady levels as the exploitation rate increased, indicating how few attained legal size before they commenced spawning. Spawner per recruit levels from fast growing scallops declined from about 90% to 60% of those seen in slow growing scallops as the rate of exploitation increased.

### EFFECT OF VARIATION ON MANAGEMENT SCENARIOS

Variations in 'per recruit' output as a consequence of varying management scenarios are depicted in Fig. 3. If the output derived by modelling the existing management situation is used as a reference point, altering size limits from 90mm SH (summer and autumn), 95mm SH (winter and spring) (management scenario 1) to 95mm SH all year round (management scenario 2) would result in a general decrease of 20–35% value per recruit (rising with increasing F) and a commensurate increase of 5–12% in terms of spawners per recruit. This is dependant upon the relative input of fast, intermediate and slow growing scallops to the fishery.

Results from the model suggest that consequences of changing the management regime from 90 mm SH (summer and autumn), 95 mm SH (winter and spring) (management scenario 1) to one in which effective fishing mortality was doubled (no daylight closure) and size limits were held at 90mm SH in February to May, and 95mm SH for the remainder of the year (scenario 2), value per recruit would increase substantially (40%) at low levels of exploitation, but change little at higher exploitation levels. Spawners per recruit would be reduced by about 10% at lower levels of ex-

ploitation, and up to 25% at the highest exploitation level examined.

## DISCUSSION

The model demonstrates that yield per recruit and spawners per recruit will be markedly influenced by growth parameters of scallops taken in the fishery. There is evidence that growth parameters of scallops may vary considerably over relatively small distances (Williams & Dredge, 1981; Ansell et al., 1991; Ciocco, 1991). Such variation in growth parameters can have a marked effect on optimum age or size at first capture for yield per recruit maximisation. Variation in growth parameters have been recognised and incorporated into the model described in this paper. There is, however, no reason why proportions of landings from slow, intermediate and fast growing areas should remain constant, and consequently the model's output should be treated as indicative. In years when a high proportion of landings come from areas where scallops grow quickly, yield per recruit may be maximised by having a larger size limit, and conversely, when scallop settlement occurs predominantly in 'slow growth' areas, yield would be increased with a smaller size limit. Given the lead-in time and information requirements for a management system using flexible size limits, implementation seems unlikely in the short term.

The output derived by modelling the fishery under alternative management scenarios indicated that variation in exploitation levels effected both trends and absolute values of yield per recruit.

Dredge (1992) suggested that a size limit of 90mm SH maintained throughout the year would have little effect on value per recruit by comparison with the existing 90mm SH (winter and spring), 95mm SH (summer and autumn) size limits. Output from the model used in this study suggested that increasing size limits to 95mm SH on a year round basis would induce a substantial loss to the fishery with a relatively minor increase in terms of spawners per recruit.

The management option involving size limits being set at 90mm SH in February to May, and 95mm SH for the remainder of the year, and increasing exploitation by allowing 24 hour a day trawling was examined. Results indicated that spawners per recruit would be reduced by 10-25%, and value per recruit would be increased only at low levels of exploitation. This scenario involved a fair degree of uncertainty, however, as

an arbitrary doubling of fishing mortality was used to simulate the effects of allowing 24 hour a day trawling. Verification of such an arbitrary procedure is not possible.

Given the current limitations in our understanding of spawning stock and subsequent recruitment levels, the model output indicates that the existing management package offers a reasonable compromise between obtaining maximum catch value from the resource while maintaining brood stock levels.

By comparison, the Western Australian agency which manages a fishery for the same species has a management philosophy based on limited entry, minimising capture costs, and minimising conflict between alternative fisheries in the main fishing ground (Shark Bay). Maintenance of a substantial breeding population is considered critical to management. This is achieved by having a summer closure, and a predominantly winter fishery, thus allowing the bulk of animals to spawn early in the (winter) spawning season. (Joll, 1987, 1989). Size limits are not used in the WA fishery, as scallop shucking in the fishery takes place at sea.

Queensland fisheries managers seek to maintain biological sustainability and long term economic viability of the (integrated east coast trawl) fishery while recognising social values in defining management actions (Glaister et al., 1993). The differences in management philosophy have resulted in fisheries which have markedly different seasonality, input costs and numbers of participants.

## ACKNOWLEDGEMENTS

Neil Trainor provided many of the catch and effort statistics from the Queensland commercial fisheries data base, SUNFISH. Julie Robins-Troeger prepared the graphics, and the editorial committee at Southern Fisheries Centre reviewed the manuscript. My thanks to all of these people for their efforts.

## LITERATURE CITED

- ANSELL, A.D., DAO, J.C. & MASON, J. 1991. Three scallop fisheries: *Pecten maximus*, *Chlamys* (*Aequipecten*) *opercularis* and *C. (Chlamys) varia*. In S.E. Shumway (ed.), 'Scallops: biology, ecology and aquaculture'. (Elsevier: Amsterdam).
- CIOCCO, N.F. 1991. Difference in individual growth rate among scallop (*Chlamys tehuelcha* (d'Orb)) populations from San Jose Gulf (Argentina). Fisheries Research 12: 31-42.

- DREDGE, M.C.L. 1981. Reproductive biology of the saucer scallop *Amusium japonicum balloti* (Bernardi) in central Queensland waters. Australian Journal of Marine and Freshwater Research 32: 775-787.
- DREDGE, M.C.L. 1985. Estimates of natural mortality and yield per recruit for *Amusium japonicum balloti* Bernardi (Pectinidae) based on tag recoveries. Journal of Shellfish Research 5(2): 103-109.
- DREDGE, M.C.L. 1992. Using size limits to maintain scallop stocks in Queensland. In D.A. Hancock (ed.), 'Legal sizes and their use in fisheries management'. Australian Society for Fish Biology Workshop, Lorne, 24 August 1990. Bureau of Rural Resources Proceedings No. 13. (Australian Government Publishing Service, Canberra).
- GLAISTER, J.G., POND, P.C & STOREY, J.G. 1993. 'Framework for management for the East Coast trawl fishery'. (Queensland Fish Management Authority: Brisbane).
- HART, B. this memoir. Dilemma of the boutique Queensland scallop.
- HEALD, D.I. & CAPUTI, N. 1981. Some aspects of growth, recruitment and reproduction in the southern saucer scallop, *Amusium balloti* (Bernardi, 1861) in Shark Bay, Western Australia. Fisheries Research Bulletin of Western Australia 25: 1-33.
- JOLL, L.M. 1987. The Shark Bay scallop fishery. Fisheries Department, Western Australia, Fisheries management Paper 11.
- JOLL, L.M. 1989. History, biology and management of Western Australian stocks of the saucer scallop *Amusium balloti*. In M.C.L. Dredge, W.F. Zacharin & L.M. Joll (eds), 'Proceedings of the Australasian scallop workshop'. (Tasmanian Government Printer: Hobart).
- RUELLO, N.V. 1975. An annotated bibliography of prawns and the prawning industry in Australia. In P.C. Young (ed.), 'First Australian prawn seminar'. (Australian Government Publishing Service: Canberra).
- WILLIAMS, M.J. & DREDGE, M.C.L. 1981. Growth of the saucer scallop *Amusium japonicum balloti* Bernardi in central eastern Queensland. Australian Journal of Marine and Freshwater Research 32: 657-666.

## SCALLOP FISHERIES, CULTURE AND ENHANCEMENT IN THE UNITED STATES

SANDRA E. SHUMWAY AND MICHAEL CASTAGNA

Shumway, S.E. & Castagna, M. 1994 08 10: Scallop fisheries, culture and enhancement in the United States. *Memoirs of the Queensland Museum* 36(2): 283–298. Brisbane. ISSN 0079-8835.

Information is provided on distribution, commercial landings and landed value of: sea scallop, *Placopecten magellanicus*, bay scallop, *Argopecten irradians*, calico scallop, *Argopecten gibbus*, pink scallop *Chlamys rubida*, spiny scallop, *Chlamys hastata* and weathervane scallop, *Patinopecten caurinus*. Where applicable, information is provided on fishing regulations and management plans. Aquaculture of scallop is limited to a few ventures utilizing the bay scallop, *A. irradians*. Enhancement programs are designed to reinstate populations of *A. irradians* to areas decimated by the 'brown tide' *Aureococcus anophagefferens* and regional efforts to provide some stability to local fishing efforts.

*Sandra E. Shumway, Bigelow Laboratory for Ocean Sciences, West Boothbay Harbor, Maine 04575, USA (present address: Natural Science Division, Southampton College LIU, Southampton, New York 11968, USA) & Michael Castagna, Virginia Institute of Marine Science, Wachapreague, Virginia 23480, USA; 20 June 1994.*

Scallops are commercially important shellfish worldwide (Table 1); US landings of all scallops were 40 million pounds of meat (18,000 tonnes) valued at \$US162.5 x 10<sup>6</sup> for 1991 (O'Bannon, 1991a). This represented a decrease of 1.6 million pounds (700 tonnes) (4%) but an increase of \$US4.4x10<sup>6</sup> (3%) compared with 1990. Four species (sea scallop, calico scallop, bay scallop, and weathervane scallop) contribute to the major wild fisheries in the US with minor fisheries for pink scallop and spiny scallop. In 1983 and 1987 Massachusetts reported 418,800 and 29,400 pounds (190 and 13 tonnes) respectively annual landings of the Icelandic scallop, *Chlamys islandica* and Rhode Island reported landing 2,800 pounds (1.2 tonnes) of this species in 1983. *C. islandica* is not regularly fished in US waters.

Aquaculture and enhancement efforts are limited activities in the US to the extent that scallop aquaculture is not even listed by FAO in their annual statistics reports (FAO, 1992); however, where these activities do occur they contribute to local economies. Further, production from domestic activities (fisheries, aquaculture and enhancement) does not totally meet supply requirements and scallops are regularly imported from other countries (Tables 2,3).

We present a brief overview of US scallop fisheries, aquaculture and enhancement efforts. It is not intended to be comprehensive.

### COMMERCIAL FISHERIES

#### SEA SCALLOP, *PLACOPECTEN MAGELLANICUS*

This large, long-lived species attains shell

heights of 8.5ins (20cm) and supports an intensive fishery throughout its range from Newfoundland to North Carolina. American commercial fishing efforts centre on Georges Bank, coastal New England and mid-Atlantic states (Naidu, 1990; Fig.1). The fishery is >100 years old and *P. magellanicus* is the most important pectinid in the world (Naidu, 1990). During 1976–1987 it accounted for 30% of mean annual global production of all scallop species combined (Table 1). In some years, *P. magellanicus* has contributed >0.5 of global scallop production. Enhancement of some species (particularly the Japanese scallop, *Patinopecten yessoensis*) and sporadic booms in natural production of calico scallops (*A. gibbus*) have relegated sea scallop landings to a seemingly secondary role. The adductor muscle (meat) is the only portion commonly marketed in the US, although there is steady interest in developing a 'roe-on' product.

Sea scallops comprise the bulk of scallops landed in the US (Table 2) with New Bedford, Massachusetts being the leading producer in 1991, landing of 21.9 million pounds (10,000 tonnes) of meats (56% of national total) (O'Bannon, 1992a). The average ex-vessel price per pound of meat increased from \$US3.85 (\$US1.75/kg) in 1990 to \$US4.04 (\$US1.84/kg) in 1991. Total catch and landed values are given (Figs 2,3; Table 4). Regional landings vary; the New England region consistently produces most scallops and more southerly regions the least (Fig.2).

The commercial fishery operates year-round using otter trawls and dredges. Recreational

TABLE 1. Nominal landings (MT, round weight) of scallop species. Figures in parentheses are % contribution to global production in any given year. Source: Yearbook of Fishery Statistics, FAO, Rome, Vol. 70.

SPECIES	1984	1985	1986	1987	1988	1989	1990
* <i>Argopecten gibbus</i> (Atlantic calico scallop)	395,710 (47.2)	125,609 (20.8)	16,916 (3.2)	85,363 (11.6)	121,720 (14.0)	67,330 (8.0)	11,220 (1.3)
* <i>Argopecten irradians</i> (bay scallop)	6,597 (0.8)	5,153 (0.8)	4,714 (0.9)	2904 (0.4)	2,329 (0.3)	1,360 (0.2)	2,596 (0.3)
<i>Argopecten purpuratus</i> (Chilean scallop)	23,190 (2.8)	51,578 (8.5)	16,563 (3.1)	5,602 (0.8)	7,878 (0.9)	4,062 (0.5)	7,467 (0.9)
<i>Chlamys islandica</i> (Iceland scallop)	15,583 (1.8)	17,068 (2.8)	16,429 (3.1)	13,385 (1.8)	10,059 (1.2)	10,772 (1.3)	12,117 (1.4)
<i>Chlamys opercularis</i> (queen scallop)	13,472 (1.6)	10,913 (1.8)	11,761 (2.2)	14,343 (1.9)	15,613 (1.8)	13,129 (1.6)	17,489 (2.0)
<i>Patinopecten yessoensis</i> (Japanese scallop)	214,569 (25.6)	238,236 (39.4)	276,596 (52.1)	344,519 (46.6)	466,530 (53.7)	502,136 (59.8)	571,003 (65.1)
* <i>Patinopecten caurinus</i> (weathervane scallop)	5,445 (0.6)	3,649 (0.6)	2,608 (0.5)	2,714 (0.4)	961 (0.1)	1,398 (0.2)	2,415 (0.3)
<i>Pecten maximus</i> (giant scallop)	22,253 (2.6)	20,128 (3.3)	17,353 (3.3)	15,357 (2.1)	15,812 (1.8)	15,852 (1.9)	14,433 (1.6)
<i>Pecten jacobaeus</i> (Pilgrim's scallop)	7 -	2 -	4 -	4 -	4 -	1 -	1 -
<i>Pecten novaezealandiae</i> (New Zealand scallop)	4660 (0.6)	3204 (0.5)	4,570 (3.3)	937 (0.1)	723 (0.1)	533 (0.1)	563 (0.1)
* <i>Placopecten magellanicus</i> (sea scallop)	103,113 (12.3)	104,946 (17.4)	130,281 (24.5)	193,519 (26.2)	193,700 (22.3)	206,262 (24.5)	216,865 (24.7)
other Pectinidae	33,468 (4.0)	23,729 (3.9)	32,944 (6.2)	59,959 (8.1)	32,766 (3.8)	15,963 (1.9)	20,467 (2.3)
World total	838,067	604,215	530,739	738,606	868,095	840,223	876,636

\*species fished commercially in the US.

fisheries are rare and occur predominantly in Maine where scallops are collected by divers.

Management of sea scallop resources has historically been a local issue. US scallop management efforts started when Maine imposed a summer closure sometime between 1901 and 1917. Many local management regulations are still in effect and many more have been implemented to conserve stocks and control gear conflicts. No regulation of the offshore fishery existed prior to 1983 other than what the industry imposed upon itself. In inshore waters, scallop management has existed for a long time (Shumway & Schick, 1987). Maine has had long-standing regulations for conservation of scallop stocks within its 3mile territorial limits; New Hampshire has had conservation regulations of a 3.25inch (8.25cm) minimum shell height and an April 15 through October 31 closed season since 1977. Massachusetts, with the largest offshore scallop fishery out of New Bedford, has had no regulations as it has no large inshore beds of sea scal-

lops. Each state has modified their regulations to at least comply with the US federal regulations for the Fisheries Conservation Zone (FCZ), but Maine's regulations remain even more restrictive, with specific area restrictions on season, gear type and gear size, a ban on nighttime fishing for scallops, drag size limits which vary with season and a requirement for a hand-fishing license for divers and a boat license for druggers.

Regulations in the US offshore scallop fishery, which includes Georges Bank, Gulf of Maine and mid-Atlantic Bight as far south as Cape Hatteras (Fig. 1) have been imposed by industry in the form of crew size, maximum allowable time at sea per trip, minimum time at the dock between trips and a maximum of two tows dumped on deck at one time prior to shucking. With advent of the 200 mile Fisheries Conservation Zone, New England and mid-Atlantic Fisheries Management Councils developed and implemented the Sea Scallop Fisheries Management Plan (FMP) to regulate the fishery. The



TABLE 2. U.S. supply of scallop meats 1972-89) (meat weight in million pounds) (after Dore,1991)

Year	U.S. commercial landings			Total Domestic	Imports	Total Supply	Percent Imports
	Bay	Calico	Sea				
1972	2.0	1.4	7.0	10.4	20.8	31.2	66.7
1973	1.0	0.6	6.4	8.0	19.8	27.8	71.2
1974	1.5	1.1	6.4	9.1	18.1	27.2	66.5
1975	1.6	2.0	10.1	13.7	19.7	33.4	59.0
1976	1.6	2.3	19.9	23.7	25.3	49.0	51.6
1977	1.7	1.1	25.0	27.8	29.8	57.6	52.3
1978	1.4	0.9	31.0	33.3	28.4	61.7	46.0
1979	1.8	0.9	31.5	34.1	25.2	59.3	42.5
1980	1.0	-	28.8	29.7	20.9	50.6	41.3
1981	0.7	14.6	30.3	45.6	26.2	71.8	36.5
1982	1.8	11.0	21.3	34.1	20.9	55.0	38.0
1983	2.3	9.6	20.5	32.4	34.3	66.7	51.4
1984	1.7	39.3	18.4	59.5	27.3	86.8	31.4
1985	1.3	12.5	15.8	29.7	42.0	71.7	58.6
1986	0.7	1.6	20.0	22.3	47.9	70.3	68.1
1987	0.6	8.2	32.0	40.8	39.9	80.7	49.4
1988	0.6	11.9	30.6	43.0	32.0	75.0	42.7
1989	0.3	6.6	33.8	40.6	40.9	81.5	50.2
1990	0.5	1.1	39.9	41.5	39.8	81.3	48.9
1991	0.4	0.3	39.3	40.0	29.5	69.5	42.5

basis for managing the Georges Bank, Gulf of Maine and mid-Atlantic scallop fisheries under the FMP has been to increase yield per recruit by controlling age/size of recruitment by imposing a maximum average meat count. The FMP was implemented in May,1983, and imposed a 30 meat count per pound maximum with an equivalent shell height of 3.5inches (8.9cm). The

TABLE 3. Domestic and imported scallop species on the U.S. market

DOMESTIC	
Sea scallop	<i>Placopecten magellanicus</i>
Calico scallop	<i>Argopecten gibbus</i>
Bay scallop	<i>Argopecten irradians</i>
Weathervane scallop	<i>Patinopecten caurinus</i>
Pink scallop	<i>Chlamys rubida</i>
Spiny scallop	<i>Chlamys hastata</i>
IMPORTED	
Japanese scallop	<i>Pecten yessoensis</i>
Queen scallop	<i>Chlamys opercularis</i>
Icelandic scallop	<i>Chlamys islandica</i>
Pacific calico scallop	<i>Argopecten circularis</i>
Bay scallop	<i>Argopecten irradians</i>
Peruvian scallop	<i>Argopecten purpuratus</i>

Regional Director of National Marine Fisheries Service (NMFS) immediately increased the count to 35/pound with a shell height minimum of 3.275inches (8.6cm) due to the unwillingness of Canada to go along with a 30 count maximum. This temporary change in the limits was to be in effect until January,1984, when the limits would go to 30 meats per pound and 3.5inch (8.9cm) shell height. The 30 count regulation was delayed until January 1986 due to industry and political pressures and the 35 meat count was retained. Under this scheme of an average meat count, small scallop meats may be mixed with large meats as long as the average meets the maximum count requirement.

In 1984, a large set of scallops in the Great South Channel of Georges Bank promised to sustain the scallop fishery for some time; however, most of this set was harvested at a small size and the meats were mixed with larger meats to achieve the 35 count maximum. Almost the entire set was harvested at well below its potential yield per recruit and before it was able to significantly contribute to reproduction. To prevent this from happening again, the Councils proposed Amendment 1 to the FMP that would institute a 40 count minimum meat size, which would create an

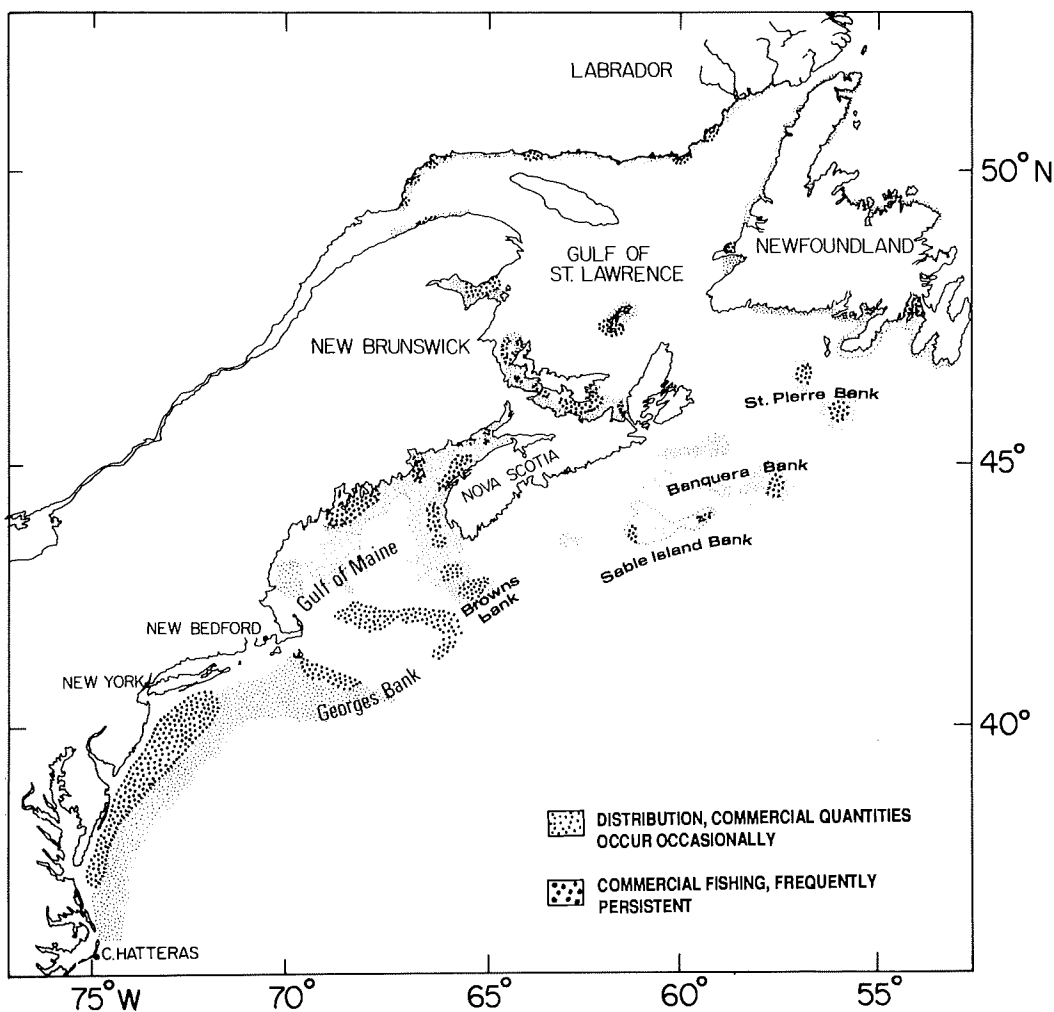

FIG.1. Distribution of the sea scallop, *Placopecten magellanicus*, and commercial fishing grounds.

average meat count of around 30, but would prohibit the mixing of scallops much smaller than the minimum size. This effort brought much criticism from the industry.

Amendment 1 to the FMP went into effect on January 1, 1986, but was delayed by the Regional Director of NMFS and was rescinded May 28, 1986. Scallop management then returned to the FMP and the 30 count average with a 10% tolerance (effectively a 33 count average) and 3.5 inch (8.9 cm) shell height was imposed. The shell height of 3.5 inches is based on an average shell height to meat weight regression showing the shell height for a 30 count scallop meat.

Industry criticism has been levied against the 3.5 inch (8.9 cm) shell size as well. The industry arguments centred on the fact that the shell height to meat weight relationship is highly variable from location to location and from season to season (Fig. 12; Serchuk, 1983; Serchuk & Rak, 1983; Schick et al., 1988). With scallop sets occurring at different locations in different years, or even in the same year, having one shell height to meat weight regression represent the whole fishery they claim is unreasonable. Currently shellstockers can harvest scallops in the mid-Atlantic Bight at 3.5 inch (8.9 cm) shell height that have meats too small for the at-sea shuckers to

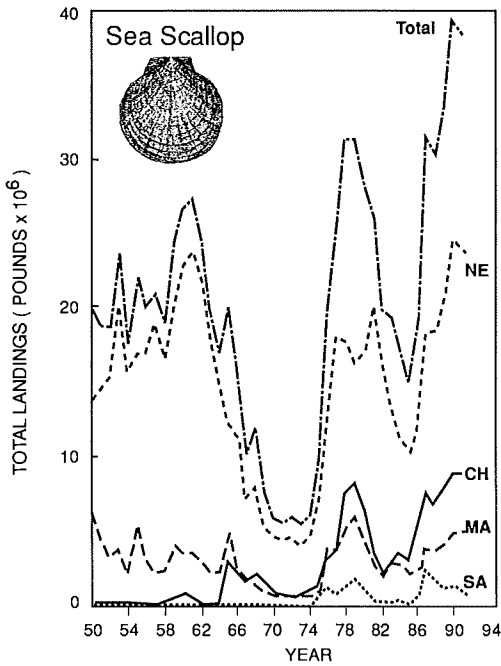

FIG.2. Landings of sea scallop, *Placopecten magellanicus*. Data from O'Bannon 1992b)

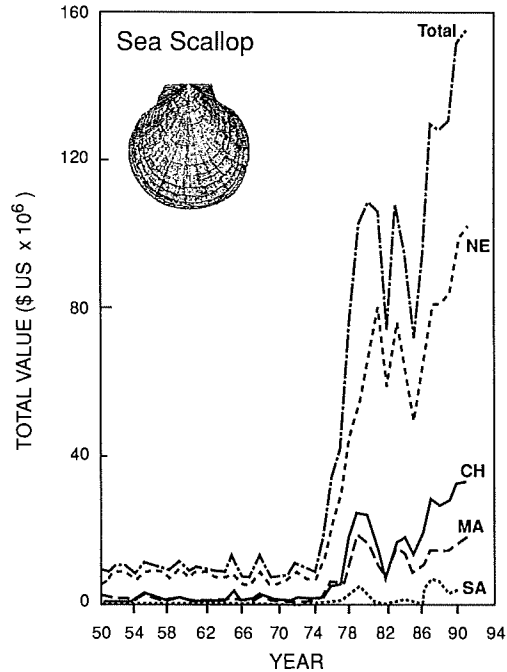

FIG.3. Landed value of sea scallops, *Placopecten magellanicus* (meats). Data from O'Bannon 1992b)

harvest even at 33 count. With the large recruitment of recent year classes producing a bonanza for the shellstockers and little for the at-sea shuckers, there is much asperity in the industry with cries of unfair management practices.

In response to industry criticism, the Councils put forth Amendment 2, which contains options for management of the scallop resource. During several hearings industry spokesmen made it clear that most options were untenable, or at least unpalatable to them. Current regulations require a 30 average meat count per pound standard for shucked scallops and a 3.5inch (8.9cm) minimum shell height standard for unshucked scallops. 'Fishing effort on Georges Bank is at record levels and far beyond what the resource can sustain in the long run' (Anonymous, 1992).

Discussions are now focussed on implementation of Amendment #4 (designed to replace the meat count system) which includes the following common elements (Commercial Fisheries News, Dec. 1992): a moratorium restricting entry into the fishery; maximum crew size of nine, including the captain; 3.25inch (8.3cm) ring size minimum that would increase to 3.5inches (8.9cm) the third year of the plan; 5.5inch (14.0cm) minimum mesh size for trawl gear; 30 foot (9.2m) limit on

the total width of all dredges and a 144 foot (44m) limit on the sweep of trawl gear; no onboard shucking and sorting machines on boats that land shucked scallops; continuation of the 12h landing windows and no at-sea transfer of scallops; continuation of the 3.5inch (8.9cm) minimum shell height standard for shellstockers (fishermen who land scallops in their shells); no chaffing gear, cookies or other devices which obstruct the top or sides of the scallop dredge and a 5.5inch (14.0cm) minimum twine top on top of all dredge gear; annual permits and mandatory data reporting for vessel owners, dealers, brokers and processors as well as licenses for vessel captains; continuation of the meat count as an alternative to the following gear restrictions: increased ring size, 5.5inch (14.0cm) trawl mesh, 5.5inch (14.0cm) twine top, and prohibitions on chaffing gear, cookies and other obstructing devices. In additions, there are four alternatives proposed: 1) (preferred) limited days at sea by vessel group (full-time fleet, part-time fleet, occasional fleet); 2) limits on days at sea; 3) adjustable trip limit with fixed layover; 4) fixed trip limit with adjustable layover.

Inasmuch as the goals of management are to optimize yield while at the same time stabilizing

TABLE 4. Historical catch statistics (total catch by regions) for sea scallops, (*Placopecten magellanicus*), for the period 1950—1991 (numbers in thousands). (O'Bannon, 1992b)

Year	New England		Middle Atlantic		Chesapeake		South Atlantic		Total	
	Pounds	Dollars	Pounds	Dollars,	Pounds	Dollars,	Pounds	Dollars	Pounds	Dollars
1950	13,753	6,384	6,135	2,781	92	39	—	—	19,980	9,204
1951	14,444	6,471	4,259	1,825	43	28	—	—	18,746	8,324
1952	15,392	9,093	3,205	1,721	32	18	—	—	18,629	10,832
1953	19,987	8,864	3,590	1,595	41	17	—	—	23,618	10,476
1954	15,594	7,028	2,037	948	—	—	—	—	17,631	7,976
1955	16,848	8,821	5,244	2,610	33	18	2	2	22,125	11,449
1956	16,881	9,109	3,164	1,700	21	13	—	—	20,066	10,822
1957	18,781	9,119	2,167	1,040	46	21	—	—	20,994	10,180
1958	16,410	7,941	2,324	1,097	243	102	—	—	18,977	9,140
1959	20,259	9,825	3,949	1,814	436	166	—	—	24,644	11,805
1960	22,462	7,823	3,356	1,153	781	290	—	—	26,599	9,266
1961	23,775	9,035	3,368	1,238	318	131	—	—	27,461	10,404
1962	21,724	8,857	2,815	1,134	95	33	—	—	24,634	10,024
1963	17,794	8,257	2,099	978	46	22	—	—	19,939	9,257
1964	14,536	7,955	2,184	1,194	194	95	—	—	16,914	9,244
1965	12,335	8,350	4,813	3,051	2,830	1,725	92	56	20,070	13,182
1966	11,147	5,520	2,528	1,186	2,300	919	—	—	15,975	7,625
1967	7,025	5,438	1,585	1,174	1,632	1,154	—	—	10,242	7,,766
1968	7,938	8,850	1,978	2,194	2,112	2,268	42	42	12,070	13,354
1969	5,107	5,636	912	982	1,378	1,474	13	13	7,410	8,105
1970	4,467	6,028	635	835	750	995	—	—	5,852	7,858
1971	4,346	6,418	514	771	546	802	—	—	5,406	7,991
1972	4,422	8,628	468	933	960	1,856	—	—	5,850	11,417
1973	3,949	7,072	569	1,067	773	1,347	—	—	5,291	9,486
1974	4,611	7,174	534	817	872	1,276	—	—	6,017	9,267
1975	7,081	13,382	981	1,780	1,270	2,330	421	421	9753	17,913
1976	11,970	22,247	3,633	6,029	2,878	4,865	1,107	1,432	19,588	34,573
1977	17,951	29,721	3,596	5,747	3,627	5,529	657	954	25,831	41,951
1978	17,688	44,876	5,040	12,185	7,456	18,029	984	1,828	31,168	76,918
1979	16,202	55,037	5,772	18,717	7,676	24,376	1,694	4,989	31,344	103,028
1980	17,018	65,571	4,143	16,274	6,140	23,776	861	2,979	28,162	108,600
1981	19,910	80,212	2,570	10,709	3,350	14,467	125	478	25,955	105,866
1982	15,822	58,995	1,920	7,244	2,194	8,370	2	1	19,936	74,590
1983	13,574	76,385	2,719	15,436	2,915	16,296	26	151	19,234	108,268
1984	11,124	62,652	2,,573	13,813	3,324	17,747	170	816	17,191	95,028
1985	10,223	50,078	1,849	8,532	2,873	13,380	13	56	14,958	72,046
1986	11,707	61,669	2,317	10,388	4,264	18,914	974	3,952	19,262	94,923
1987	18,280	81,038	3,558	13,979	7,352	28,345	2,213	6,889	31,403	130,251
1988	18,388	81,234	3,431	14,214	6,631	26,468	1,851	6,579	30,301	128,495
1989	20,576	84,034	4,024	15,000	7,719	28,470	1,013	3,638	33,332	131,142
1990	24,661	99,057	4,664	16,432	8,785	32,147	1,165	4,036	39,275	151,672
1991	24,031	101,932	4,845	18,119	8,851	32,,897	635	2,324	38,362	155,272

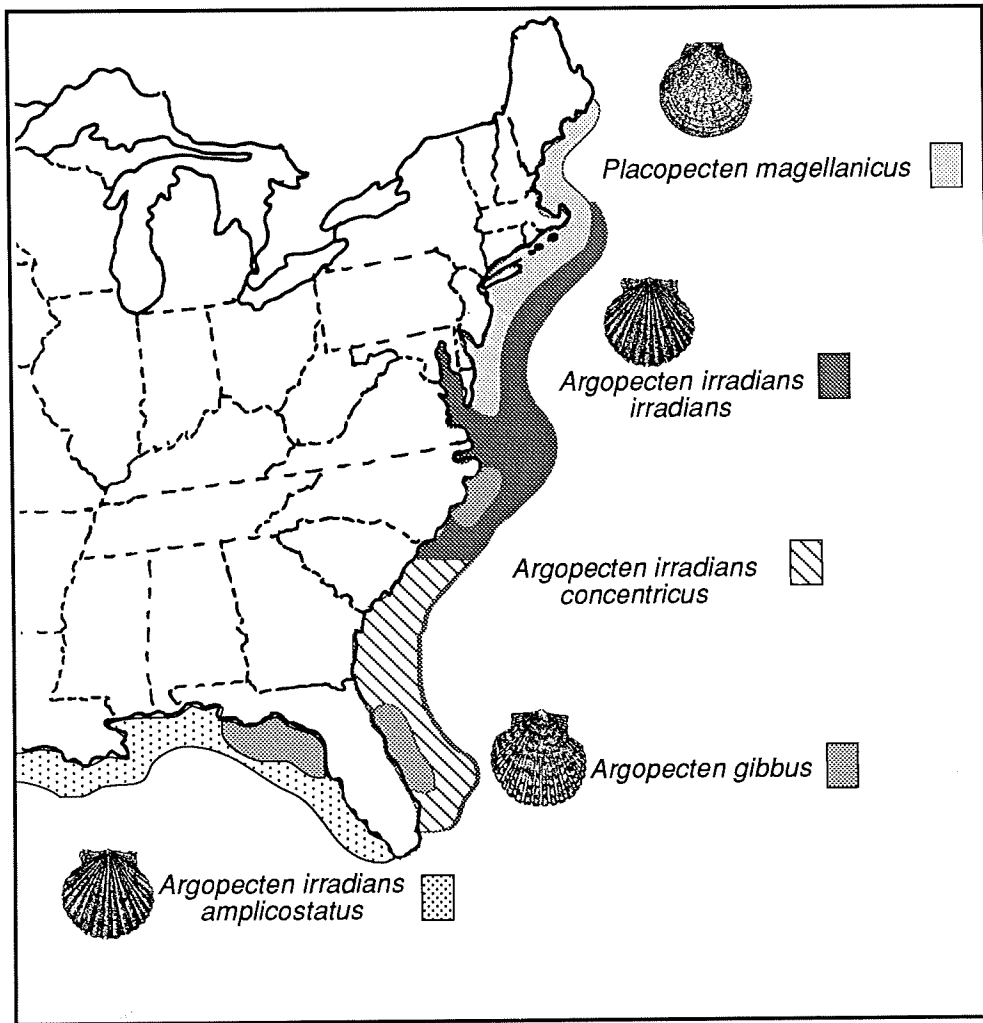

FIG.4. Distribution of bay scallops, *Argopecten irradians*.

the catches, it seems reasonable that considerable attention should be paid to the high level of variability that can occur in meat weight within a given fishing area. Since a single meat count is not going to be valid 'across the board', different meat count and/or shell height regulations are needed for separate fishing zones. It is further suggested that, since seasonal and yearly variation in meat weights have been demonstrated, meat count regulations should be based on yearly sampling and set on a seasonal and area-specific basis. While a constantly changing count/size limit will cause problems with regard to compliance and enforcement, it will strip away in-

equities between harvesting techniques and increase yield to the fishermen by effectively increasing yield-per-recruit and allowing management closer to the limits of the resource.

At a time when the scallop fishery is increasing, and for a species which experiences such drastic fluctuations, management cannot be too careful in the regulations it imposes.

#### BAY SCALLOP, *ARGOPECTEN IRRADIANS*

The species range is discontinuous along the Atlantic coast of North America between Nova Scotia and Colombia. *A. irradians irradians* occurs from Cape Cod to New Jersey where it is

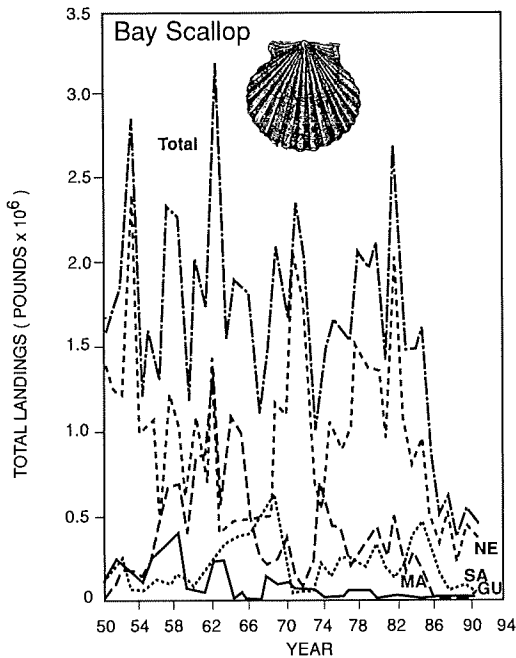

FIG.5. Landings of bay scallops, *Argopecten irradians*. Data from O'Bannon 1992b).

replaced by *A. irradians concentricus* which extends from New Jersey to Florida. *A. irradians ampliocostatus* is found in the western Gulf of Mexico to Colombia (Fig.4). While this species represents only a minor component of US commercial fisheries (Tables 1,2), it is extremely important to local economies.

Rhodes (1990) reviewed the biology and fishery of *A. irradians* which is a small, short-lived species, usually spawning only once; however, a second spawning by some individuals takes place in some regions. They occur in shallow water (<10m) in protected bays and estuaries, reaching a size of c.4inches (10cm) in 16 months. Meat counts are 50–100/pound (23–45/kg).

Landings vary between seasons (Table 5) and populations are dependent upon natural recruitment for continuation, although some enhancement efforts have been attempted. In 1985, bay scallop populations in the northeast were decimated by blooms of a previously unknown microalga, *Aureococcus anophagefferens* ('brown tide') (Tettelbach & Wenczel,1993; Fig.11). Three successive years of algal blooms resulted in virtually all native stock in the Peconic Bays and the New York fishery being eliminated. Eelgrass beds were also depleted, reducing the

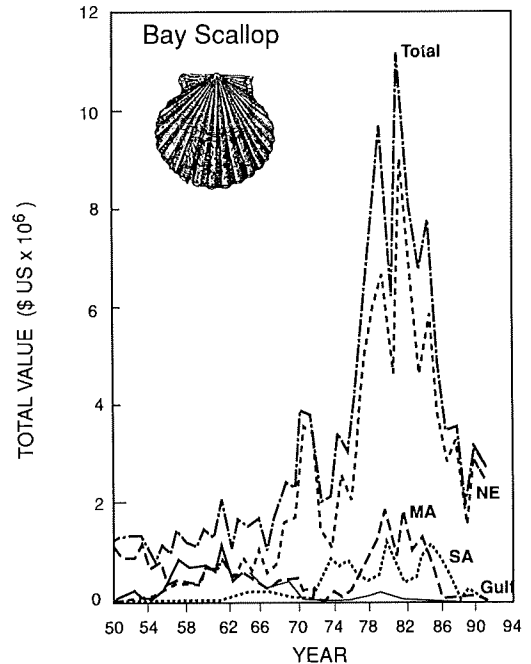

FIG.6. Landed value of bay scallops, *Argopecten irradians*. Data from O'Bannon 1992b)

total area of suitable habitat for scallop settlement. Landings for 1991 were 438,000pounds of meats (200tonnes) valued at \$US2.7 million. This is a decrease of 101,000 pounds (46tonnes) (19%) and \$US436,000 (14%) compared with 1990 (O'Bannon,1992a). Massachusetts was the leading state with 375,000 pounds (170tonnes) of meats, 86% of the national total. The average ex-vessel price was \$US6.09/pound (\$US2.77/kg) of meats compared with \$US5.76 (\$US2.62/kg) in 1990 (Figs 5,6; Table 5).

Commercial fishing records for *A. irradians* date back to 1858 (Ingersoll,1886) and the introduction of the dredge in 1874. Commercial fishing for *A. irradians* is strictly limited and there is a large recreational fishery. Harvest is usually limited to September–December. In most areas, the bay scallop fishery is a protected resource. Scallops are usually collected by diver, hand-picking or rake. Some fishermen use small boats equipped with outboard engines and one or two small dredges. Scallops are culled on board and only the meats are harvested. Catch limits are determined on a season-by-season basis by fisheries officials in accordance with population fluctuations (Rhodes,1990).

TABLE 5. Historical catch statistics (total catch by regions) for bay scallops (*Argopecten* sp.) for the period 1950–1991 (numbers in thousands). (O'Bannon, 1992b)

Year	New England		Middle Atlantic		South Atlantic		Gulf		Grand Total	
	Pounds	Dollars	Pounds	Dollars	Pounds	Dollars	Pounds	Dollars	Pounds	Dollars
1950	1,376	1,130	27	32	72	39	125	63	1,600	1,264
1951	1,253	959	101	121	183	96	252	161	1,789	1,337
1952	1,188	913	182	255	254	126	210	48	1,834	1,342
1953	2,397	1,222	162	102	65	33	229	53	2,853	1,410
1954	987	688	127	110	52	26	43	10	1,209	834
1955	1,070	837	226	210	78	39	223	53	1,597	1,139
1956	433	433	464	426	125	63	278	70	1,300	992
1957	1,230	880	674	447	109	37	315	91	2,328	1,455
1958	1,013	680	688	413	169	58	401	75	2,271	1,226
1959	591	700	385	386	128	51	82	19	1,186	1,156
1960	1,063	759	843	674	69	27	56	14	2,031	1,474
1961	704	671	862	621	106	42	36	14	1,708	1,348
1962	1,425	1,081	1,353	851	168	67	213	68	3,159	2,067
1963	391	492	577	404	321	122	228	59	1,517	1,077
1964	466	595	1,063	886	340	173	18	14	1,887	1,668
1965	459	562	982	766	379	196	39	24	1,859	1,548
1966	880	1,076	492	408	399	184	9	4	1,780	1,672
1967	455	579	248	258	387	211	7	5	1,097	1,053
1968	491	776	218	374	639	422	143	122	1,491	1,694
1969	1,172	1,592	249	377	613	383	80	61	2,114	2,413
1970	1,101	1,704	365	470	130	91	104	56	1,700	2,321
1971	2,063	3,531	144	234	60	42	48	39	2,315	3,846
1972	1,776	3,407	93	215	128	110	35	40	2,032	3,772
1973	694	1,462	230	467	37	33	53	63	1,014	2,025
1974	567	1,014	694	872	220	199	16	18	1,497	2,103
1975	1,054	2,568	444	713	135	105	14	16	1,647	3,402
1976	890	1,973	438	816	248	194	14	24	1,590	3,007
1977	1,044	3,085	199	489	257	509	46	58	1,546	4,141
1978	1,521	4,982	280	837	221	393	49	91	2,071	6,303
1979	1,382	5,967	346	1,243	193	514	62	137	1,983	7,861
1980	1,356	6,671	431	1,840	328	1,107	11	29	2,126	9,647
1981	964	4,630	244	891	189	656	22	62	1,419	6,239
1982	2,022	8,949	500	1,809	137	352	13	35	2,672	11,145
1983	1,083	6,491	167	992	205	509	22	75	1,477	8,067
1984	808	4,573	279	1,264	384	876	10	26	1,481	6,739
1985	958	5,812	174	828	456	1,072	4	10	1,592	7,722
1986	509	3,797	13	65	306	838	27	86	855	4,786
1987	341	2,813	2	3	155	501	19	80	515	3,397
1988	530	3,339	2	2	39	73	39	73	608	3,487
1989	215	1,494	2	22	84	214	57	162	358	1,892
1990	450	2,812	11	132	78	158	–	–	539	3,102
1991	375	2,438	15	117	45	100	3	11	438	2,666

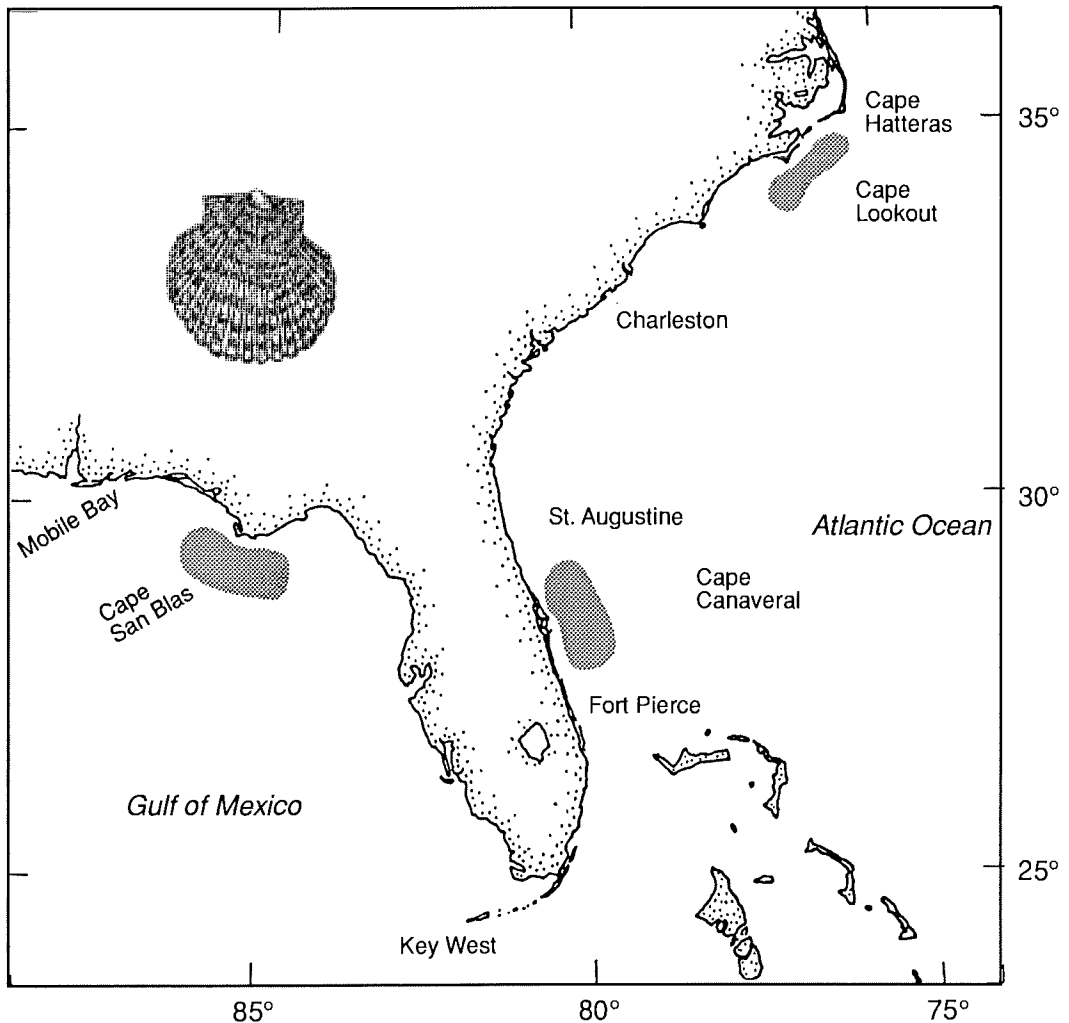

FIG.7. Commercial fishing grounds for the calico scallop, *Argopecten gibbus* (after Blake & Moyer, 1990)

#### CALICO SCALLOP, *ARGOPECTEN GIBBUS*

This species supports a variable fishery off Florida (Fig.7). Locations of commercial stocks vary from year to year; however, Cape Lookout, Cape Canaveral and Cape Sand Blas are key areas. The fishery and biology were reviewed by Blake & Moyer (1990). The scallops grow to <3inches (7.5cm) and the adductor muscle (meat) is small and brownish (meat count 100–300 per pound; normally 150–200). Hand-shucking is not economically feasible; thus, even though large stocks of calico scallops were known as early as 1949, the species was not harvested commercially prior to automation in the late 1970's.

During its peak (1984), landings exceeded 39 million pounds (17,700tonnes) and the fishery was almost non-existent in the late 1980's and early 1990's (Tables 1,2; Fig.8). Annual variations in production impact not only the total US catch, they also determine the position of the US among world scallop producers. Landings were 286,000 pounds (122tonnes) of meats valued at \$US858,000 in 1991. According to O'Bannon (1992a), this represented a decrease of 849,000 pounds (390tonnes) (75%) and \$US423,000 (33%) compared with 1990. All calico scallops were landed on the east coast of Florida in 1991. The average ex-vessel price was \$US3.00/pound



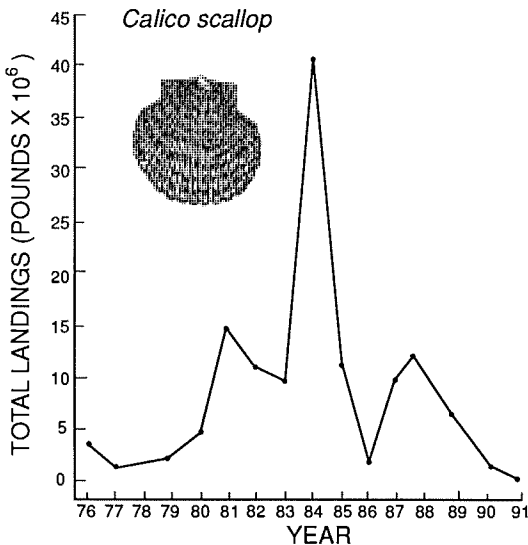

FIG.8. Landings of calico scallops, *Argopecten gibbus*. Data from Blake and Moyer 1990; O'Bannon 1992b).

(\$US1.36/kg) of meats compared to \$US1.13 (\$US0.51/kg) in 1990.

Since stocks of *A. gibbus* are annual, over-fishing is not considered a problem, thus there are no state or federal fishery management programs. The fishery is totally dependent upon the natural population and regulation of landings is governed by a self-regulating association of industry members. Fishing efforts are limited until at least 75% of the stock at a particular location reaches a shell height of at least 38mm, the point at which much of the population will have undergone their first spawning event. A second spawning is not guaranteed and only takes place when environmental conditions are optimal.

#### WEATHERVANE SCALLOP, *PATINOPECTEN CAURINUS*

This large, long-lived species reaching up to c.10inches (25cm) and 28 years of age (Hennick, 1973) occurs from Alaska to Oregon (Fig.9). It requires 5–6 years to attain a shell height of 4inches (10cm) and reaches sexual maturity at c.3inches (7cm) shell height. Scallop meats are large, similar in appearance to those of *P. magellanicus*, and average counts are 10–40/pound (5–18/kg). Bourne (1990) reported that minor landings of weathervane scallops occurred sporadically along the coast of Washington until the late 1950's with recorded landings for this period (1935–1952) averaging about 360t (320tonnes) (Cheney & Mumford,1986). A small

fishery was developed in Alaska in 1967 and landings have fluctuated widely (Fig.10; Table 6). Oregon landings for 1989–1992 were less than 500 pounds (200kg) per year; Washington landings for the same period ranged from 13,000 pounds (6tonnes) in 1989 to 6,700 pounds (3tonnes) in 1992. Alaska reported landings of 464,000 pounds (210tonnes) for 1989. These values do not include confidential data; however, landings of *P. caurinus* continue to fluctuate and represent a small % of the US scallop fishery (NMFS).

Gear utilized ranges from old shrimp trawls to typical east coast drag (Bourne,1990) and methods of management vary. Alaska has had a seasonal restriction (June 1–March 31) in some areas, area closures and gear regulations. Many regulations were designed to protect crab resources (Bourne,1990). Minimum ring size on drags must be 4inches (10cm) inside diameter (some areas permit use of a 3inch (7.5cm) ring) and trawls have been eliminated from the legal gear restrictions. Washington regulates its fishery by gear size and mesh or ring size; Oregon by limited entry, gear and mesh or ring size; and California management is by permits (Bourne,1990).

#### PINK SCALLOP, *CHLAMYS RUBIDA*

#### SPINY SCALLOP, *CHLAMYS HASTATA*

Pink and spiny scallops are small and co-exist in discontinuous populations along the US west coast from Alaska to California (Fig.9); they are often referred to as 'singing scallops'. They are slow-growing, rarely attaining shell heights greater than 3.5inches (8cm). These species support a small commercial fishery in Washington and landings are small (Fig.10). The small size of these scallops has encouraged a market for whole scallops, often consumed steamed as one would eat mussels or clams. This is a dangerous venture given the paralytic shellfish toxins in the region and ability of scallops to concentrate and retain these toxins for extended periods of time (Shumway & Cembella, this memoir).

Fishing is by small drags or diving (Bourne, 1990) and the fishery is regulated by gear and mesh size in Washington.

## AQUACULTURE AND ENHANCEMENT

During 1920–1926, William Firth Wells carried out some bivalve culture investigations which he reported in his annual reports to the New York State Conservation Commission. Besides propagating the eastern oyster, *Crassostrea virginica*, he cultured quahogs, *Mercenaria mer-*

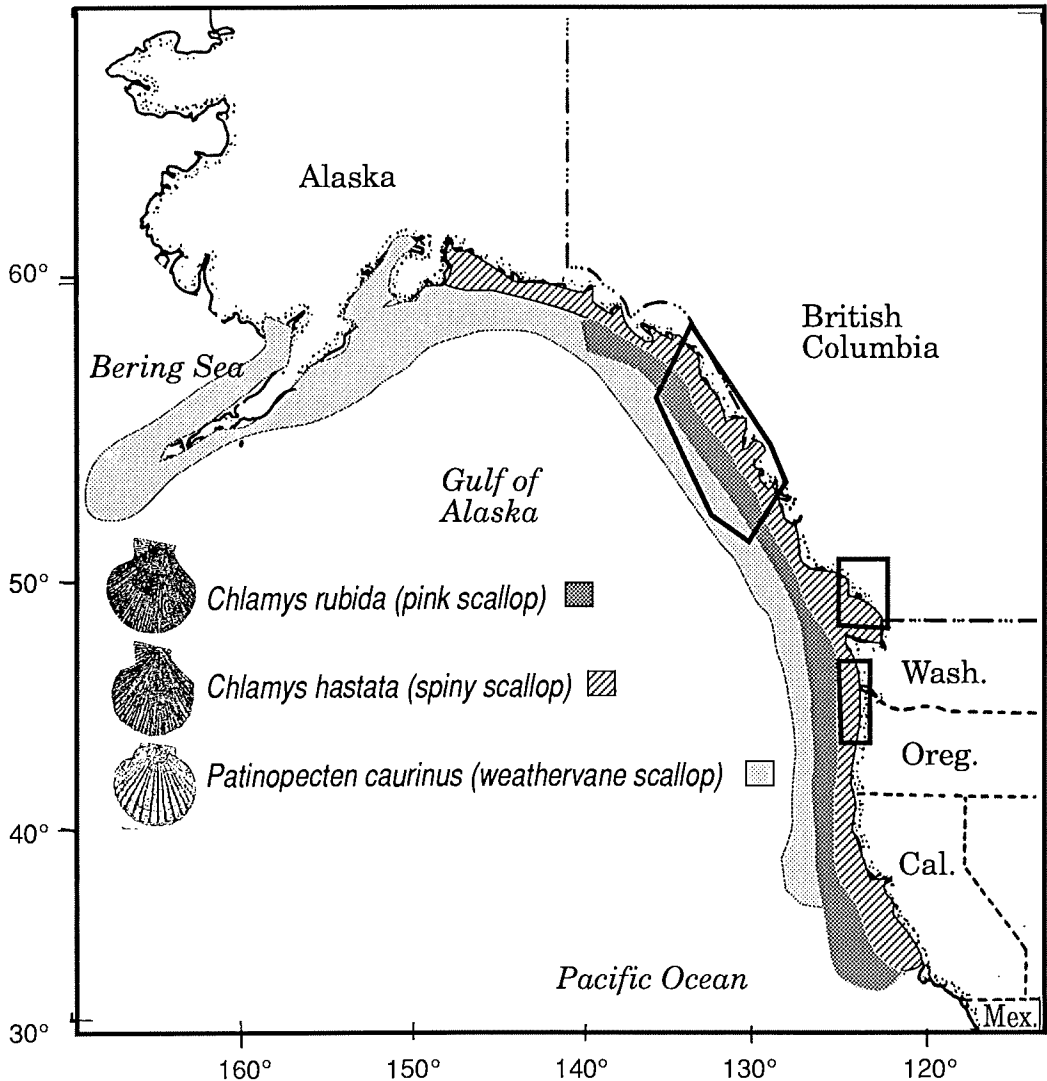

FIG.9. Distribution of Pacific coast scallop species: weathervane scallop, *Patinopecten caurinus*; pink scallop, *Chlamys rubida*; spiny scallop, *Chlamys hastata*. After Bourne 1990).

*cenaria*, soft clams, *Mya arenaria*, mussels, *Mytilus edulis* and bay scallops, *Argopecten irradians* (State of New York Conservation Department, 1969). Wells used a milk separator to clarify his culture water and to collect larvae from cultures for transfer. One of the earliest species he cultured was the bay scallop. It was perhaps the first bivalve cultured in the manner similar to what we think of today as aquaculture (late Joseph Glancy, pers. comm.).

Most scallop culture in the US now utilizes the

bay scallop, *A. irradians irradians* or *A. irradians concentricus*. The species is characterized by rapid growth, high fecundity and a high market value (Castagna, 1975; Castagna & Duggan, 1971, 1972). The hatchery technology is well known and successful manipulation of adult scallops in the hatchery can provide a sexually mature spawning stock throughout the year (Sastry & Blake, 1971; Barber & Blake, 1981). A number of companies have attempted to culture scallops but have not been economically successful and there

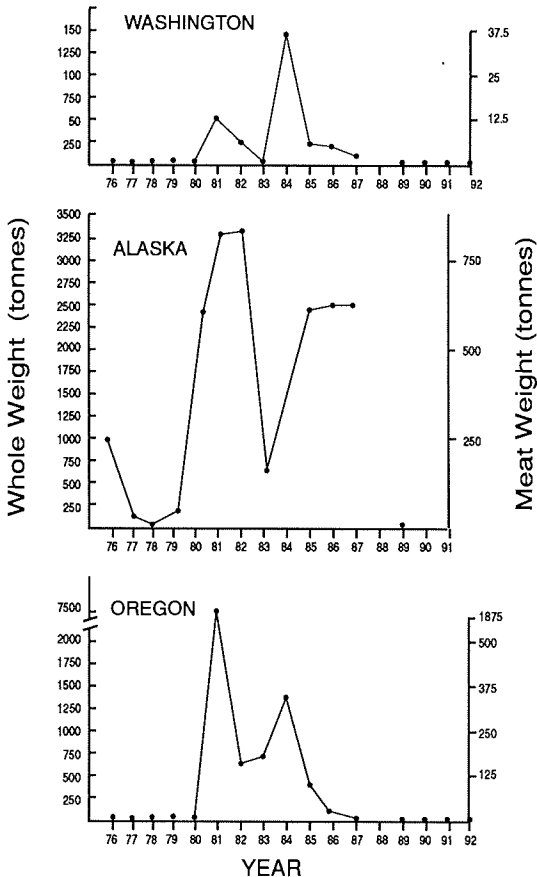

FIG.10. Landed value of weathervane scallops, *Patinopecten caurinus* (Bourne, 1990; NMFS, pers. comm.).

is no profitable, private aquaculture industry for bay scallops in the US (Rhodes, 1990; pers. obs.).

This species has been successfully cultured in China (F. Zhang, K. Chew, pers. comm.) and the product is being imported to the US. Recent unexplained mortalities have been attributed to insufficient genetic diversity and new broodstock has been supplied by Canadian sources (Atlantic Fish Farming, February 27, 1993).

A few companies have been involved in enhancement programs, also utilizing bay scallops. Perhaps the most successful is carried out by the Martha's Vineyard Shellfish Group which is a consortium of 5 towns (Chilmark, Gay Head, Oak Bluffs, Tisbury and West Tisbury) on Martha's Vineyard off the coast of Massachusetts. This group, using a number of federal and state grants, built a solar-assisted hatchery to produce *A. ir-*

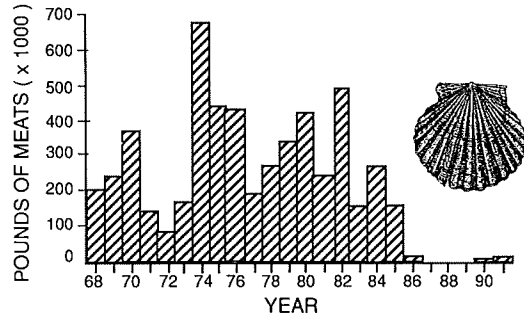

FIG.11. Commercial landings of bay scallops in New York (from Tettelbach & Wenczel, 1990).

*radians irradians* and clams, *Mercenaria mercenaria* (Karney, 1978). Their hatchery methods are standard except that the seawater is partially warmed in a passive solar system within the solarium-type building. The post-set scallops are held in an indoor, semi-closed nursery system supplemented with cultured algae until the juveniles are 3-5mm high, then moved out to a small embayment in burlap bags with a brick anchor and a plastic cola bottle inside the bag for a float. Several hundred to a few thousand seed are placed in each bag which is then anchored over the submerged vegetation in the bay. This allows the seed to grow to a size that offers sanctuary from some predators before the bag rots away allowing the juveniles to escape a few at a time and spread into the vegetation (R.C. Karney pers. comm.). Each township has legal jurisdiction over its own shellfish waters, sale of harvesting licenses and control of the harvest. Each township supporting the hatchery buys seed at about cost for replenishment or enhancement of an area. The effect of scallop enhancement has been to add a degree of stability to the harvest in the area that is seeded (Karney, 1978).

Another enhancement program was carried out in the Long Island Sound area after heavy mortalities of native scallops caused by a picoplankter, *Aureococcus anophagefferens*. Extensive reseeded of hatchery-reared scallops was initiated in the Peconic Bays by the Long Island Green Seal Committee in 1986 (Tettelbach & Wenczel, 1993). In the following two years, seed scallops (*A. irradians*) were purchased from a number of hatcheries and released in selected areas to enhance or replace the natural populations which were lost. The effects of this enhancement effort were not quantified in all areas, but

TABLE 6. Historic number of vessels, number of landings, landed weight of shucked meats, price per pound, exvessel value, landings per vessel, and exvessel value per vessel for the weathervane scallop fishery in Alaska during 1967-1991. All data for 1967-1968, and prices and exvessel values for 1967-1975 and 1979 were taken from Kaiser 1986); all other data were summarized from fish tickets. The 1991 data are preliminary. In years when only one or two vessels participated in a fishery, the harvest statistics are confidential. (from Kruse et al., 1992)

	No. of Vessels	No. of Landings	Landings Wt. (lbs)	Price (\$/lb)	Ex-vessel Value (\$)	Landings (lbs) per Vessel	Value (\$) per Vessel ,
1967	Confidential						
1968	19	125	1,677,268	0.85	1,425,678	88,277	75,036
1969	19	157	1,850,187	0.85	1,572,659	97,378	82,772
1970	7	137	1,440,338	1.00	1,440,338	205,763	205,763
1971	5	60	931,151	1.05	977,709	186,230	195,542
1972	5	65	61,167,034	1.15	1,342,089	233,407	268,418
1973	5	45	1,109,405	1.20	1,331,286	221,881	266,257
1974	3	29	504,438	1.30	655,769	168,146	218,590
1975	4	56	435,672	1.40	609,941	108,918	152,485
1976	Confidential						
1977	Confidential						
1978	0	0	0	-	0	0	0
1979	Confidential						
1980	8	56	632,535	4.32	2,732,551	79,067	341,569
1981	18	101	924,441	4.05	3,743,986	51,358	207,999
1982	13	120	913,996	3.77	3,445,765	70,307	265,059
1983	6	31	194,116	4.88	947,286	32,353	157,881
1984	10	61	389,817	4.47	1,742,482	38,982	174,248
1985	9	54	647,292	3.12	2,019,551	71,921	224,395
1986	9	86	682,622	3.66	2,498,397	75,847	277,600
1987	4	55	583,043	3.38	1,970,685	145,761	492,671
1988	4	47	341,070	3.49	1,190,334	85,268	297,584
1989	7	54	525,598	3.68	1,934,201	75,085	276,314
1990	9	144	1,448,642	3.37	5,016,724	165,405	557,414
1991	6	136	1,136,649	3.72	4,228,334	189,442	704,722
1992	7	120	1,546,231	3.91	6,045,763	220,890	863,680

a number of scientists involved in this experiment initially believed the effects of the seed planting were minimal (Bricelj et al., 1987; Tettelbach & Wenczel, 1993). Krause (1992), however, showed about 25% of the scallops in the area were survivors of those released. Subsequent reseeded efforts were further hampered by the shell-boring parasite, *Polydora* sp. and another 'brown tide'. While enhancement efforts are encouraging, the New York bay scallop fishery is precarious.

In the northeast there is some experimental culture of the sea scallop, *Placopecten magellanicus* at the hatchery on Beal Island, Maine. The technology for culturing this species has already been established in Canada; however aquaculture of this species has not been attempted in the US

(Culliney, 1974; Naidu & Cahill, 1986; Beninger, 1987; Mallet, 1988). The present study plans to test grow the scallops in near-bottom containers, either bags or cages. Some of these will be placed near salmon pens to see if the effluents will enhance growth rates. Initial studies by Belle (pers. comm.) indicate that increased growth rates can be realized in oysters and sea scallops grown in lantern nets suspended near salmon pens.

On the US Pacific coast, there has been some previous interest in culturing the rock scallop, *Crassadoma gigantea* (Jacobson, 1977; Leighton & Phleger, 1977, 1981; Leighton, 1979a,b; Monical, 1980; Cary et al., 1981, 1982) and there is an experimental culture program in Washington for this species (Chew, pers. comm.). A project was

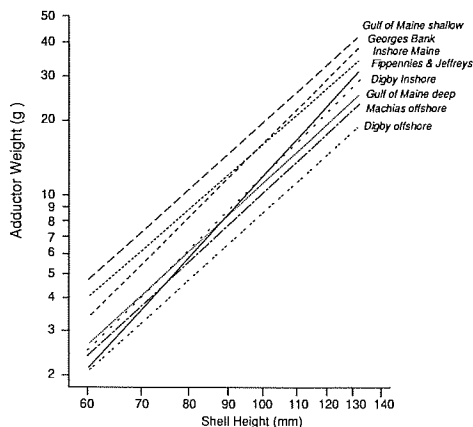

FIG.12. Regression analyses for adductor weight vs. shell height for *Placopecten magellanicus* from various geographic locations (Schick et al. 1987).

initiated in Alaska in 1987 to determine the feasibility of culturing weathervane scallops utilizing natural spat sets. In the Washington state hatchery, after preliminary culture experiments on *Pecten caurinus* and *C. gigantea* (Olsen, 1981, 1983), *C. gigantea* was grown and released in an attempted enhancement program (Olsen, 1984); however, the numbers released were insufficient to follow. Efforts have also been made to collect juvenile pink and spiny scallops from natural spat sets; however these species are too small and too slow growing to support an economical culture operation (Bourne, 1990).

Except for small, sporadic releases of *Argopecten* or *Crassadoma* over the years, there are no major scallop enhancement programs in the US. Scallop culture (mainly research) is underway in Maine, Massachusetts, New York and Virginia; however, it can hardly be considered a significant or economically feasible activity.

#### ACKNOWLEDGEMENTS

We are indebted to Barbara O'Bannon, Robert Morrill, and John Bishop of the National Marine Fisheries Service for landings data and helpful discussions. Thanks also to Gordon Kruse for making Table 6 available. Jan Barter prepared the tables and Jim Rollins drafted the figures.

#### LITERATURE CITED

ANONYMOUS 1992. Status of fishery resources off the northeastern United States for 1992. NOAA

Technical Memorandum NMFS-F/NEC-95: 1-133.

- BENINGER, P.G. 1987. A qualitative and quantitative study of the reproductive cycle of the giant scallop, *Placopecten magellanicus*, in the Bay of Fundy (New Brunswick, Canada). *Canadian Journal of Zoology* 65: 495-498.
- BARBER, B.J. & BLAKE, N.J. 1983. Energy storage and utilization in relation to gametogenesis in *A. irradians concentricus* (Say). *Journal of Experimental Marine Biology and Ecology* 52: 121-134.
- BLAKE, N.J. & MOYER, M.A. 1990. The calico scallop, *Argopecten gibbus*, fishery of Cape Canaveral, Florida. Pp. 00-00. In S.E. Shumway, (ed.), 'Scallops: biology, ecology and aquaculture'. (Elsevier: New York).
- BOURNE, N. 1990. West coast of North America. Pp.925-939. In S.E. Shumway, (ed.), 'Scallops: biology, ecology and aquaculture'. (Elsevier: New York).
- BRICELJ, M., EPP, J. & MALOUF, R. 1987. Interspecific variation in reproductive and somatic growth cycles of bay scallops *Argopecten irradians*. *Marine Ecology Progress Series* 36: 123-189.
- CARY, S.C., LEIGHTON, D.L. & PHLEGER, C.F. 1981. Food and feeding strategies in culture of larval and early juvenile purple-hinge rock scallops, *Hinnites multirugosis* (Gale). *Journal of the World Mariculture Society* 12: 156-169.
- CASTAGNA, M. 1975. Culture of the bay scallop, *Argopecten irradians* in Virginia. *Marine Fisheries Review* 37: 19-24.
- CASTAGNA, M. & DUGGAN, W.P. 1971. Rearing of the bay scallop, *Aequipecten irradians*. *Proceedings of the National Shellfisheries Association* 61: 80-85.
- CASTAGNA, M. & DUGGAN, W.P. 1972. Mariculture experiments with the bay scallop, *Argopecten irradians*, in waters of the seaside of Virginia. *Bulletin of the American Malacological Union* 37: 21.
- CHENEY, D.P. & MUMFORD, T.F. 1986. 'Shellfish and seaweed harvest of Puget Sound'. (University of Washington Press: Seattle).
- CULLINEY, L.L. 1974. Larval development of the giant scallop, *Placopecten magellanicus* (Gmelin). *Biological Bulletin* 147: 321-332.
- DORE, I. 1991. 'Shellfish'. (Van Nostrand Reinhold: New York). 240p.
- FAO 1992. Aquaculture production 1984-1990. Fishery Information, Data and Statistics Service, Fisheries Department. FAO Fisheries Circular 815: 1-206.
- HENNICK, D.P. 1973. Sea scallop, *Patinopecten caurinus*, investigations in Alaska. Final Report July 1, 1969-June 30, 1972. Commercial Fisheries Research and Development Act, Project 5-23-R.
- INGERSOLL, E. 1886. The scallop and its fishery. *American Naturalist* 20: 1001-1006.

- JACOBSEN, F.R. 1977. The reproductive cycle of the purple-hinge rock scallop *Hinnites multirugosus* Gale 1928 (Mollusca: Bivalvia). PhD Thesis, San Diego State University, San Diego, CA. 72p.
- KAISER, R.J. 1986. Characteristics of the Pacific wethervane scallop [*Pecten (Patinopecten) caurinus* Gould, 1850] fishery in Alaska. (Alaska Department of Fish and Game, Division of Commercial Fisheries: Kodiak) 100p.
- KARNEY, R.C. 1978. A program for the development of the shellfisheries of five towns on Martha's Vineyard. First Annual Report to the Economic Development Administration, U.S. Dept. Commerce Technical Assistance Grant 01-6-01519.
- KRAUSE, M.K. 1992. Use of genetic markers to evaluate the success of transplanted bay scallops. *Journal of Shellfish Research* 11: 199.
- KRUSE, G.H., LARSON, P.R. & MURPHY, M.C. 1992. Proposed interim management measures for commercial scallop fisheries in Alaska. Alaska Department of Fish and Game, Regional Information Report 5J92-08.
- LEIGHTON, D.L. 1979a. The rock scallop...a future in mariculture? *Sea Frontiers* 25: 18-19.
- LEIGHTON, D.L. 1979b. A growth profile for the rock scallop *Hinnites multirugosus* held at several depths off La Jolla, California. *Marine Biology* 51: 229-232.
- LEIGHTON, D.L. & PHLEGER, C.F. 1981. The suitability of the purple-hinge rock scallop to marine aquaculture. California Sea Grant College Program Technical Publication T-CSGCP-001: 1-85.
- MALLET, A.L. 1988. Larval growth, larval mortality, and metamorphosis success of the giant scallop, *Placopecten magellanicus*. Atelier sur l'élevage du pétoncle géant tenu à Gaspé (Québec) les 30 Novembre et 1 Décembre 1988: 49-51.
- MONICAL, J.B.Jr. 1980. Comparative studies on growth of the purple-hinge rock scallop *Hinnites multirugosus* (Gale) in the marine waters of southern California. Proceedings of the National Shellfisheries Association 70: 14-21.
- NAIDU, K.S. & CAHILL, F.M. 1986. Culturing giant scallops in Newfoundland waters. Canadian Fisheries and Aquatic Sciences, Manuscript Report 1876: 1-24.
- NAIDU, K.S. 1990. Sea Scallop, *Placopecten magellanicus*. Pp. 861-887. In S.E. Shumway, (ed.), 'Scallops: biology, ecology and aquaculture'. (Elsevier: New York).
- O'BANNON, B.K. (ed.) 1992a. Fisheries of the United States, 1991. NOAA/NMFS Current Fishery Statistics 9100: 1-113.
- O'BANNON, B.K. (ed.) 1992b. Historical Catch Statistics Atlantic and Gulf Coast States 1950-1991. NOAA/NMFS, Current Fishery Statistics 9210: 1-48.
- OLSEN, S.J. 1981. New Candidates with aquaculture potential in Washington state: Pinto abalone (*Haliotis kamtschatkana*), weathervane scallop (*Pecten caurinus*), and purple-hinge rock scallop (*Hinnites multirugosus*). *Journal of Shellfish Research* 1: 133.
- OLSEN, S.J. 1983. Abalone and scallop culture in Puget Sound. *Journal of Shellfish Research* 3: 113.
- OLSEN, S.J. 1984. 'Completion report on invertebrate aquaculture shellfish enhancement project 1978-1983'. (Shellfish enhancement project, final report, October 1, 1978-March 30, 1983. Washington Department of Fisheries: Olympia). 85p.
- RHODES, E.W. 1990. Fisheries and aquaculture of the Bay Scallop, *Argopecten irradians*, in eastern United States. In S.E. Shumway, (ed.), 'Scallops: biology, ecology and aquaculture'. (Elsevier: New York).
- SASTRY, A.N. & BLAKE, J. 1971. Regulation of gonad development in the bay scallop *Aequipecten irradians* Lamarck. *Biological Bulletin* 140: 274-283.
- SCHICK, D.F., SHUMWAY, S.E. & HUNTER, M. 1988. A comparison of growth rate between shallow water and deep water populations of scallops *Placopecten magellanicus* (Gmelin, 1791) in the Gulf of Maine. *American Malacological Bulletin* 6: 1-8.
- SERCHUK, F.M., 1983. Seasonality in sea scallop shell height-meat weight relationships: review and analysis of temporal and spatial variability and implications for management measures based on meat count. Woods Hole Laboratory Reference Document 83-85: 1-30.
- SERCHUK, F.M. & RAK, R.S. 1983. Biological characteristics of offshore Gulf of Maine sea scallop populations: size distributions, shell height-meat relationships and relative fecundity patterns. NMFS/Woods Hole Reference Document 83-07: 1-42.
- SHUMWAY, S.E. & SCHICK, D.F. 1987. Variability of growth, meat count and reproductive capacity in *Placopecten magellanicus*: are current management policies sufficiently flexible? ICES C.M. 1987/k.2 Shellfish Committee.
- SHUMWAY, S.E. & CEMBELLA, A.D. in press. The impact of toxic algal blooms on scallop culture and fisheries. *Reviews in Fisheries Science*.
- SHUMWAY, S.E. & CEMBELLA, A.D. this memoir. Toxic algal blooms: potential hazards to scallop culture and fisheries.
- STATE OF NEW YORK CONSERVATION DEPARTMENT 1969. Early oyster culture investigations by the New York State Conservation Commission 1920-1926.
- TETTELBACH, S.T. & WENCZEL, P. In press. Reseeding efforts and the status of bay scallop populations in New York following the occurrence of "brown tide" algal blooms. *Journal of Shellfish Research*.

# REPRODUCTION AND RECRUITMENT IN THE DOUGHBOY SCALLOP, *CHLAMYS ASPERRIMUS*, IN THE D'ENTRECASTEAUX CHANNEL, TASMANIA

WILL ZACHARIN

Zacharin, W. 1994 08 10: Reproduction and recruitment in the doughboy scallop, *Chlamys asperrimus*, in the D'Entrecasteaux Channel, Tasmania. *Memoirs of the Queensland Museum* 36(2): 299–306. Brisbane. ISSN 0079-8835.

Doughboy scallops in the D'Entrecasteaux Channel can grow to a shell height of 110mm. Reproductive output in this population displays both temporal and spatial changes. The highest gonosomatic index recorded was 45% for a doughboy of 105mm. The number of mature eggs released in the 90–95mm size class was significantly different between two annual peak spawnings and there is evidence for secondary or partial spawnings. Recruitment monitoring through the deployment of spat collectors and sampling of the populations suggests that hydrodynamic influences play an important role in recruitment success.

*Will Zacharin, Sea Fisheries Division, Department of Primary Industry and Fisheries, GPO Box 619F, Hobart 7001, Tasmania; 20 June 1994.*

The doughboy scallop, *Chlamys (Mimachlamys) asperrimus* (Lamarck, 1819), is an abundant benthic bivalve found throughout southern Australia. Large populations extend over wide areas in Bass Strait, and a commercial and recreational dredge fishery for the species has operated irregularly in the D'Entrecasteaux Channel in southeastern Tasmania since the 1930's (Perrin & Croome, 1988). An annual recreational dive fishery in the D'Entrecasteaux Channel is now the only remaining fishery.

For such a prominent member of the southern Australian benthic community, surprisingly little information exists in the scientific literature on the life history of the species. Larval and juvenile development of the doughboy were studied by Rose & Dix (1984); observations on epizoic sponge associations with the doughboy have been reported by Pitcher (1981) and Pitcher & Butler (1987), and some factors affecting mortality were described by Chernoff (1987). However, no studies have been conducted on growth, reproduction or population dynamics.

This study describes the reproduction and recruitment of the doughboy scallop in the D'Entrecasteaux Channel, a semi-enclosed inshore waterway in southern Tasmania (Fig. 1).

## MATERIALS AND METHODS

A sample of 10–50 doughboys was collected from the same population in Simpson's Bay at 14 day intervals over 28 months (1 July 1988–27 November 1990). In the laboratory the animals were measured (shell height to the nearest 0.1mm) and total somatic and gonad tissue were

weighted to the nearest 0.1g. Sex was determined according to colour of the gonad, males being white and females orange. Gonosomatic Index (GSI) was calculated as a ratio of gonad weight to somatic tissue weight. A significant decrease in the index was considered to be an indication of spawning (Dredge, 1981; Sause et al., 1987; West, 1990). The terminology of stages in the gonad reproductive cycle was based on that of *Pecten fumatus* (Sause et al., 1987), *Chlamys varia* (Shafee & Lucas, 1980) and *Amusium balloti* (Dredge, 1981).

A fecundity index was developed using an indirect method, in which the difference in gonad weight of mature female scallops immediately prior to spawning and after spawning was calculated. This weight loss on spawning can be used as an index of the number of ova released from the gonad. The underlying assumptions are that mature ova prior to spawning have the same mass from year to year, and ova mass is the same across all size classes.

Regular surveys of doughboy populations in the D'Entrecasteaux Channel have been conducted by the author since 1985 to monitor recruitment. Between 1985 and 1988, 110–119 random stations within each statistical area were sampled using a 2.5m wide toothed scallop dredge (Zacharin, 1986, 1987, 1988). Since 1989, scallop surveys have been conducted by diving, to more accurately sample doughboys in the size range 30–40mm (1+ animals) (Zacharin, 1991a,b; Zacharin et al., 1990).

As scallops are usually distributed at low densities over large areas and at high densities forming 'commercial beds' over small areas, sampling

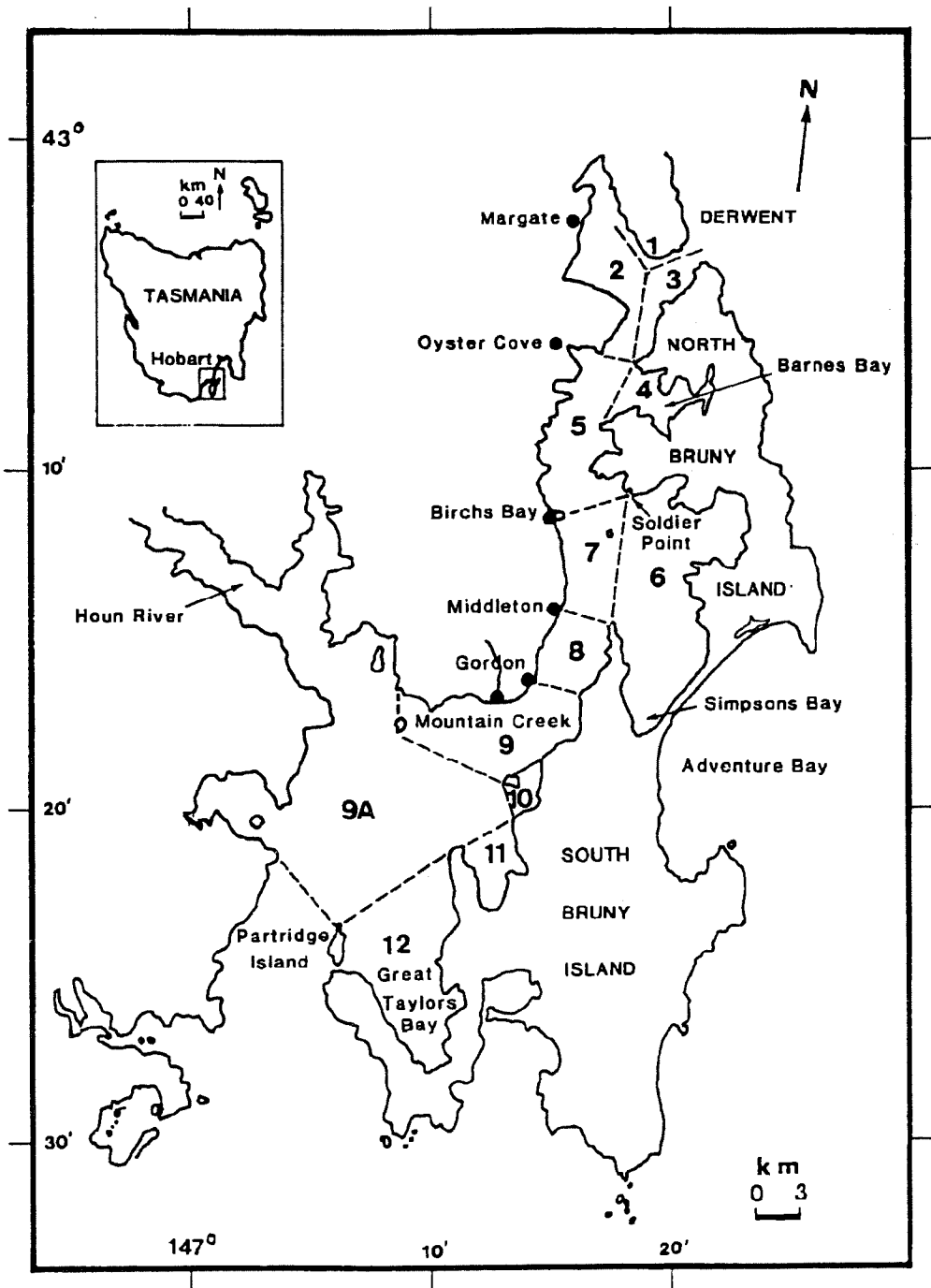

FIG.1. D'Entrecasteaux Channel as divided into statistical areas by Fairbridge (1953) for conducting scallop surveys. The same boundaries were used for the dredge and dive surveys between 1986 and 1992. (from Perrin & Croome, 1988)



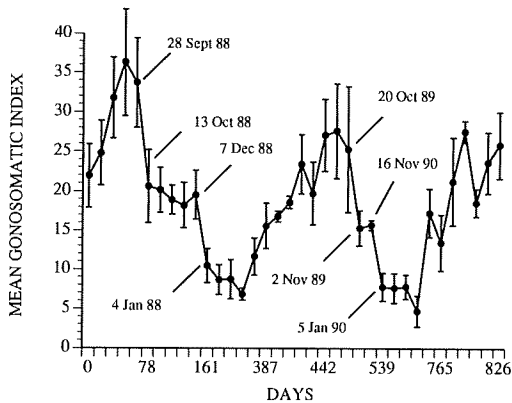

FIG. 2. Seasonal changes in mean gonosomatic index in the female doughboy scallop from the D'Entrecasteaux Channel. (Error bars =one standard deviation.).

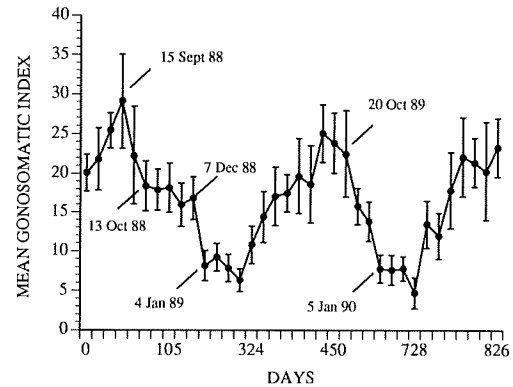

FIG. 3. Seasonal changes in mean gonosomatic index in the male doughboy scallop from D'Entrecasteaux Channel. (Error bars=one standard deviation.)

technique must compensate for this fact. To adjust for this pattern of distribution, diver surveys were conducted using the following procedure. A number of random sampling points were distributed over an area to give an indication of scallop distribution. Further non-random sampling points were chosen based on previous catch history of the area and from reported sightings by divers. At each site a 100m transect line weighted with lead and buoyed at each end was deployed parallel to the current. Two divers swam along the transect collecting all scallops within 1m of the weighted line. It is important to deploy the line

with the current and to swim with the current, as any scallops disturbed by the deployment of the line may move. As scallops tend to swim off the bottom and then free-fall to the substrate the majority are more likely to remain in the transect area if deployment is parallel to the current. The data were assembled as both total size frequencies for the whole of the channel area and as size frequencies of scallops in the various statistical areas.

Spat collection was conducted using small orange coloured onion bags with dark monofilament mesh filling as a settlement substrate. The

TABLE 1. Description of gonads and the histological condition of the various stages in the annual reproductive cycle of the scallop, *Chlamys asperimus* from the D'Entrecasteaux Channel, Tasmania.

Stage	Female	Male
(1) Resting	Gonad small, flat and yellow brown. Composed of loose connective tissue. Intestinal loop visible. Ciliated ducts present	
(2) Early development	Slight increase in gonad size. Follicles with primary oogonia or spermatogonia. Clear differentiation of male and female gonads. Intestinal loop not visible.	
(3) Late development	Gonad increased in volume, tip being tapered.	
	Gonad orange.	Gonad white.
(4) Mature	Gonad volume large with rounded tip. Little connective tissue.	
	Follicle packed with mature irregular polygonal oocytes.	Large number of spermatozoa. Follicles tightly packed.
(5) Spawning	Free space in the centre of the follicles as gametes are expelled. Appearance of more connective tissue. Loss of gonad colour.	
(6) Spent	Follicles nearly empty of all gametes. Increase in connective tissue. Phagocytes predominate.	

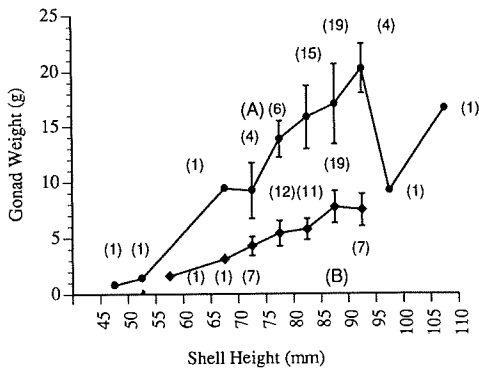

FIG.4. Fecundity index shown as a relationship between shell height (5mm intervals) and gonad weight for mature samples (A) collected on 15 and 28 September 1988 and immediate post-spawning samples (B) on 13 and 20 October 1988. Number of scallops shown in brackets.

first spat collectors were deployed on 18 September 1988 at various locations throughout the channel area. Sites were selected where tidal flow was greater around prominent headlands and islands. Collectors were observed each month to assess the intensity of spat settlement.

## RESULTS

### REPRODUCTION

Six distinct stages of development were recognised (Table 1). During late summer to autumn (January–March) gonads were completely spent and appeared to be in a ‘resting phase’. Accurate macroscopic identification of sex for the majority of individuals during the ‘resting phase’ proved to be impossible.

Fortnightly changes in mean GSI of females and males (Figs 2,3) are interpreted as increases

TABLE 2. Results from spat collectors deployed adjacent to Huon Island in the D'Entrecasteaux Channel (statistical area 9) during 1988/89.

Date	Number/Collector	Mean (mm)	Standard deviation
9/12/88	158-208	4.26	1.59
25/1/89	316	5.75	0.99
28/2/89	230	10.43	1.97
21/3/89	226-306	12.65	2.69
30/4/89	130-176	16.43	4.29

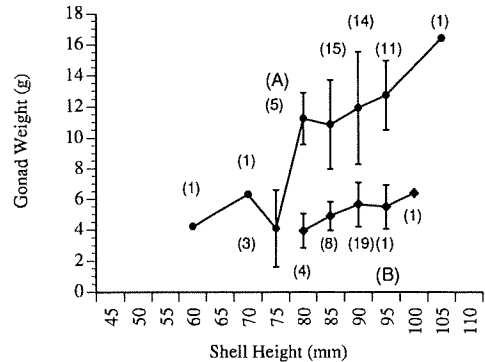

FIG.5. Fecundity index shown as a relationship between shell height (5mm intervals) and gonad weight from mature samples (A) collected on 4 and 12 October 1989 and immediate post-spawning samples (B) on 2 16 November 1989. Number of scallops shown in brackets.

in gonad weight due to follicular development and production of gametes; rapid decrease in gonad weight in September–October was indicative of spawning. The differences in gonad weights (being an index of ova number) for grouped samples (5mm) indicated a significant increase in ova number for the older and larger scallops (Figs 4,5). With the exception of rare large doughboys, gonad weight increased with size and peaked in the 90–95mm size class. Male GSI peaked earlier than female, and males appeared to commence releasing sperm earlier than females shed ova (Figs 2,3). GSI peaked earlier in 1988 (September) than in 1989 (October). The index of fecundity was significantly higher in 1988 with the average gonad weight of the 90–95mm size class being 38% higher than in 1989 (t-test,  $P < 0.02$ ). Gonad weight loss on spawning in 1988 for this size class was 63.12% of total gonad weight compared to 56.83% in 1989 (Figs 4,5). A significant decrease in gonad weight (suggestive of spawning) was observed between September and December in each year.

In both years there was a second rapid decline in gonad weight in late December–early January. This has been interpreted as being indicative of partial spawning. Data obtained from spat collectors supports this concept. It is not known what percentage of gametes released through earlier partial spawnings or late spawnings are competent; or their contribution to recruitment. However, collectors placed at a number of locations in

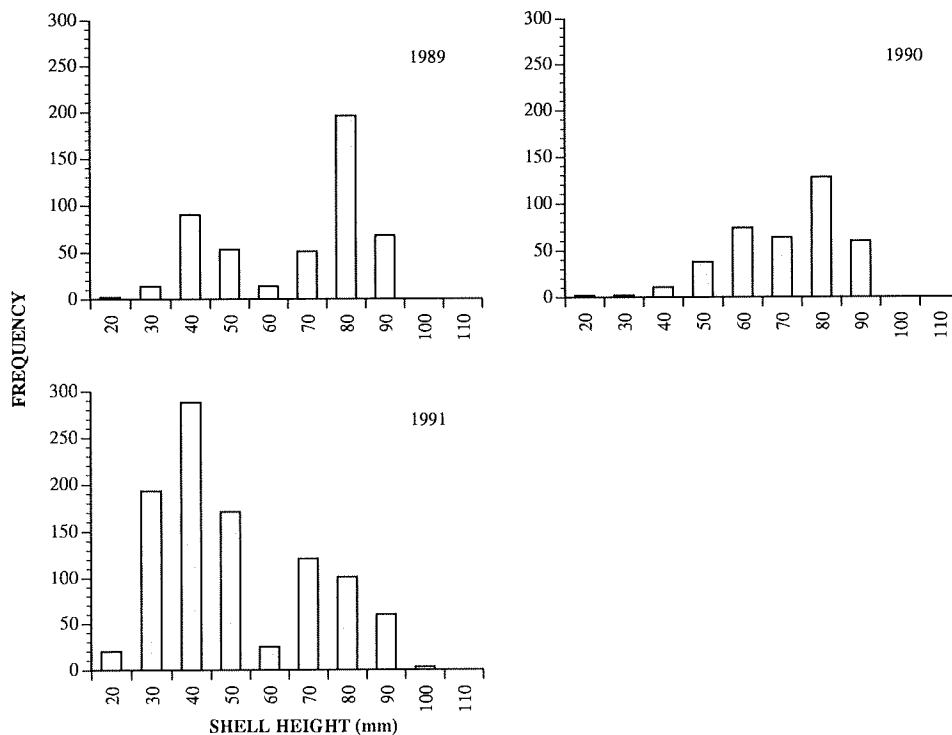

FIG.6. Frequency histograms of all doughboy scallops measured from all sites sampled during the 1989, 1990 and 1991 dive surveys.

the D'Entrecasteaux Channel between September and April suggest that minor settlement occurs over a number of months, but there is one major event (Table 2). The highest spat numbers (<5mm), in December, suggest the major September/October spawning contributes to greater spat settlement.

Sex ratio for all samples collected was 1:1. There was no change in sex ratio observed between different ages or shell height.

#### RECRUITMENT

Fig.6 shows the change in size frequency from 1989 to 1991. As the diver surveys were conducted between March and April each year, an index of potential recruitment was represented by numbers of the 1+ year class (30–40mm size range). Both survey results (Zacharin 1989, 1991, Zacharin *et al.* 1990) and observations of spat settlement indicate that there was strong settlement in 1988 and 1990. Size frequency histograms (Fig.7) demonstrate the spatial patchiness of scallop settlement and subsequent

recruitment by the relative abundance of 30–40mm scallops. In statistical areas 7, 8 and 9 such scallops were relatively abundant, particularly in 1991. In areas 6 and 10, 30–40mm scallops were rare except in the 1991 samples, whereas area 11 supported few recruits throughout the entire study period. The remaining seven statistical areas (Fig.1) were not sampled with sufficient regularity to give meaningful data.

#### DISCUSSION

Sustainable management of a scallop fishery is dependent in part on an understanding of the reproductive cycle and environmental influences that may change or alter the timing and frequency of spawning. An important objective of the fishery manager is to identify the minimum size and age at first maturity, to reduce the potential for recruitment overfishing. Knowledge of the reproductive cycle is also important in determining when, and to a lesser extent, where recruitment to the fishery may occur (Orensanz, 1986).

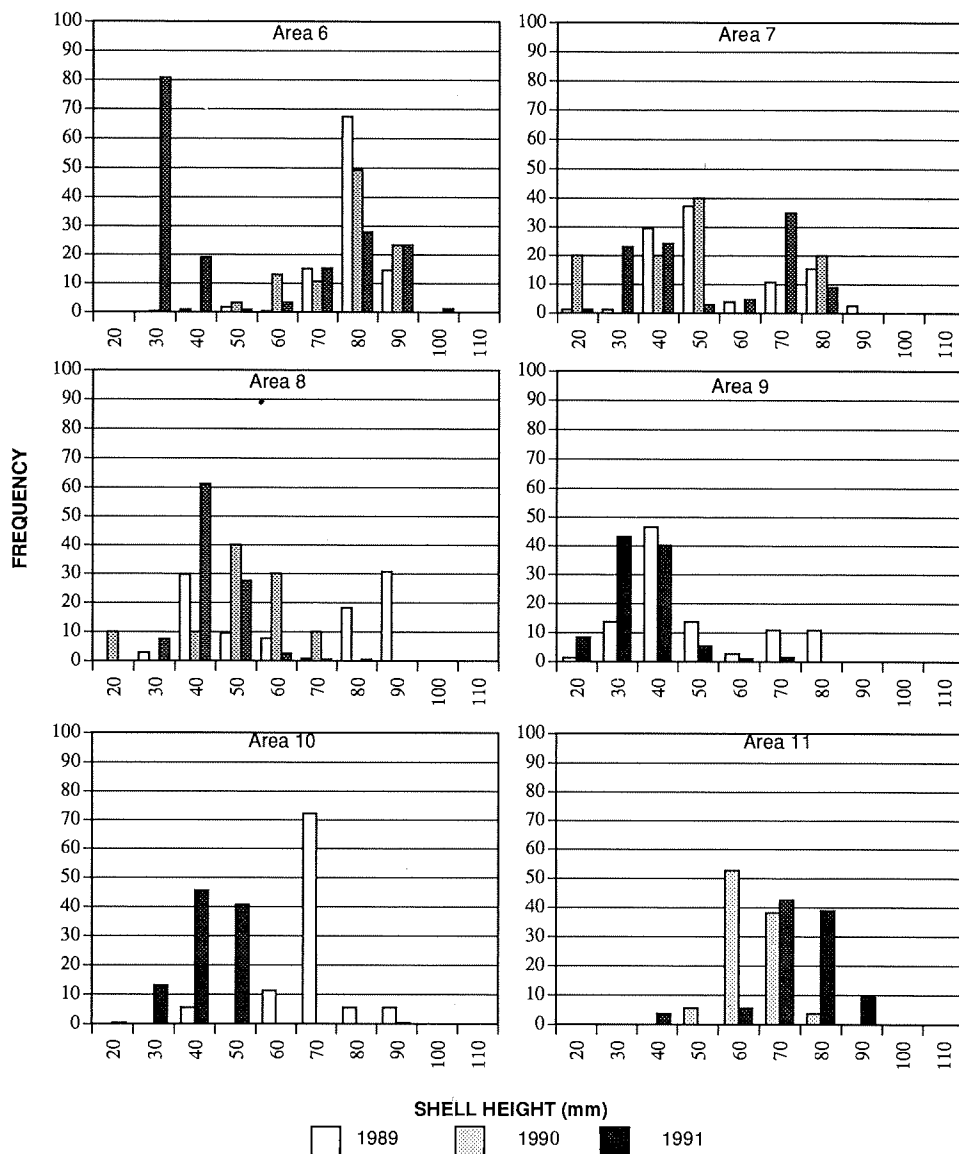

FIG. 7. Size frequency histograms by statistical area for doughboy scallop populations from dive surveys conducted in 1989, 1990 and 1991. Areas 10 and 11 have data from 1990 and 1991 only, while Area 9 has data from 1989 and 1991 only.

*C. asperimus* is a synchronous spawner, as is *P. fumatus* (Sause et al., 1987) and *E. bifrons* (Dix & Sjardin, 1975). However males matured and released sperm earlier than females. Gonads began early development in late March–early April. Maturation continued through the winter

months and a major spawning event occurred in late September–mid-October. A minor spawning event was observed in December; however, the significant decrease in GSI at this time may have been a consequence of oocyte lysis and reabsorption (Zacharin pers. obs.). Rose & Dix (1984)

collected zygotes from individuals in the D'-Entrecasteaux Channel during September/October in their study of the larvae of *C. asperrimus*, which is consistent with the results of this study.

Fecundity generally increased with shell height and age and peaked in the 90-95mm size class. Few doughboys larger than 95mm were found. Of the two located, one 101mm individual found in 1989 had the highest gonad weight recorded (16.4g).

The results illustrate the need to monitor populations over a number of seasons to establish the timing, frequency and level of ova release during spawning. The major spawning in 1988 occurred between 15 September and 20 October with the maximum mean GSI being 37.72% on 15 September. In 1989 the major spawning occurred four weeks later between 4 October and 16 November on the basis of GSI changes. Maximum gonad index is reached 2-3 weeks prior to spawning and some gamete 'leakage' occurs prior to the main spawning event. This was revealed by early spat settlement in the collectors.

Gonad weight loss was used as a measure of fecundity, as the number of ova released in any year may widely fluctuate. A count of total ova number, as is performed in many fecundity studies, may not have highlighted this difference. Total ova number released annually is preferable to the number of mature ova contained in the ovary. Research into stock/recruit relationships may be easier to interpret if the former and not the latter measure is more widely used.

Spat collection was an important process used to validate identification of both the peak spawning period and secondary or minor spawning events. During the two year period 1988/89-1989/90, highest spat numbers were recorded in December, with shell height frequency histograms indicating a further minor settlement in February. Spat <2mm shell height were observed in spat collectors during November-March, indicating some partial spawning or 'leakage' of gametes at a low level over a 5 month period. This gamete leakage has been reported for a number of other scallop species (Brand et al., 1980; Ciocco, 1991; Hortle & Cropp, 1987; Sause et al., 1987; Wolff, 1988).

Recruitment in the D'Entrecasteaux Channel region has been spatially and temporally erratic. Settlement of juveniles was high in both 1988 and 1990 with the highest number of recruits observed in 1990. Models of larval advection show that the strength and direction of wind at the time of spawning is an important determining factor in

the distribution of scallop larvae. (Butman, 1987; Orensanz et al., 1991; Young et al., 1992). This is well illustrated by the spatial changes in spat settlement and distribution of juvenile scallops in the D'Entrecasteaux Channel.

#### LITERATURE CITED

- BRAND, A.R., PAUL, J.D. & HOOGESTER, J.N. 1980. Spat settlement of scallops *Chlamys opercularis* (L.) and *Pecten maximus* (L.) on artificial collectors. *Journal of the Marine Biological Association of the United Kingdom* 60: 379-390.
- BUTMAN, C.A. 1987. Larval settlement of soft-sediment invertebrates: the spatial scales of pattern explained by active habitat selection and the emerging role of hydrodynamic processes. *Oceanography and Marine Biology Annual Review* 25: 113-165.
- CHERNOFF, H. 1987. Factors affecting mortality of the scallop *Chlamys asperrima* (Lamarck) and its epizoic sponges in South Australian waters. *Journal of Experimental Marine Biology and Ecology* 109: 155-171.
- CIOCCO, N.F. 1991. Differences in individual growth rate among scallop (*Chlamys techuelcha* (d'Orb)) populations from San Jose Gulf (Argentina). *Fisheries Research* 12: 31-42.
- DIX, T.G. & SJARDIN, M.J. 1975. Larvae of the commercial scallop (*Pecten meridionalis*) from Tasmania, Australia. *Australian Journal of Marine and Freshwater Research* 26: 109-112.
- DREDGE, M.C.L. 1981. Reproductive biology of the saucer scallop *Amusium japonicum balloti* (Bernardi) in central Queensland waters. *Australian Journal of Marine and Freshwater Research* 32: 775-787.
- HORTLE, M.E & CROPP, D.A. 1987. Settlement of the commercial scallop, *Pecten fumatus* (Reeve) 1855, on artificial collectors in eastern Tasmania. *Aquaculture* 66: 79-95.
- ORENSANZ, J.M. 1986. Size, environment and density: the regulation of a scallop stock and its management implications. *Canadian Special Publication on Fisheries and Aquatic Science* 92: 195-227.
- ORENSANZ, J.M., PARMA, A.N. & IRIBARNE, O.O. 1991. Population dynamics and management of natural stocks. Pp.625-714. In S.E. Shumway, (ed.), 'Scallops: biology, ecology and aquaculture'. (Elsevier: New York).
- PERRIN, R.A. & CROOME, R.L. 1988. The D'-Entrecasteaux Channel scallop fishery: Its past and possible future. *Papers and Proceedings of the Royal Society of Tasmania* 121: 179-197.
- PITCHER, C.R. 1981. Some mutualistic aspects of the ecology of the scallop *Chlamys asperrimus* (Lamarck) and its Epizoic sponges. BSc Hons Thesis, University of Adelaide.(Unpubl.).
- PITCHER, C.R. & BUTLER, A.J. 1987. Predation by

- asterioids, escape response, and morphometrics of scallops with epizoic sponges. *Journal of Experimental Marine Biology and Ecology* 112: 233–249.
- ROSE, R.A. & DIX, D.G. 1984. Larval and juvenile development of the doughboy scallop, *Chlamys (Chlamys) asperrimus* (Lamarck) (Mollusca:Pectinidae). *Australian Journal of Marine and Freshwater Research* 35: 315–323.
- SAUSE, B.L., GWYTHYER, D., HANNA, P.J. & O'CONNOR, N.A. 1987. Evidence for winter-spring spawning of the scallop *Pecten alba* (Tate) in Port Phillip Bay, Victoria. *Australian Journal of Marine and Freshwater Research* 38: 329–337.
- SHAFEE, M.S. & LUCAS, A. 1980. Quantitative studies of the reproduction of black scallop, *Chlamys varia* (L.) from Lanveoc area, Bay of Brest. *Journal of Experimental Marine Biology and Ecology* 42: 171–186.
- WEST, G. 1990. Methods of assessing ovarian development in fishes : a review. *Australian Journal of Marine and Freshwater Research* 41: 199–222.
- WOLFF, M. 1988. Spawning and recruitment in the Peruvian scallop *Argopecten purpuratus*. *Marine Ecology Program Series* 42: 213–217.
- YOUNG, P., MCLOUGHLIN, R.J. & MARTIN, R.B. 1992. Scallop (*Pecten fumatus*) settlement in Bass Strait, Australia. *Journal of Shellfish Research* 11: 315–323.
- ZACHARIN, W. 1986. D'Entrecasteaux Channel scallop survey, 1986. Tasmanian Department of Sea Fisheries Technical Report 9: 1–17.
- ZACHARIN, W. 1987. D'Entrecasteaux Channel scallop survey, 1987. Tasmanian Department of Sea Fisheries Technical Report 16: 1–17.
- ZACHARIN, W. 1988. D'Entrecasteaux Channel scallop survey, 1988. Tasmanian Department of Sea Fisheries Technical Report 27: 1–16.
- ZACHARIN, W. 1991a. Tasmanian Zone scallop survey, 1990. Tasmanian Department of Sea Fisheries Technical Report 42: 1–11.
- ZACHARIN, W. 1991b. D'Entrecasteaux Channel scallop survey, 1991. Tasmanian Department of Sea Fisheries Technical Report 45: 1–16.
- ZACHARIN, W., GREEN, R. & WATERWORTH, C. 1990. Estimated abundance of doughboy, queen and commercial scallop stocks in the D'-Entrecasteaux Channel, Tasmania 1989. Tasmanian Department of Sea Fisheries Technical Report 40: 1–17.

## SUSTAINABLE MANAGEMENT OF BASS STRAIT SCALLOPS

RICHARD J. MCLOUGHLIN

McLoughlin, R.J. 1994 08 10: Sustainable management of Bass Strait scallops. *Memoirs of the Queensland Museum* 36(2): 307-314. Brisbane. ISSN 0079-8835.

The history of scallop fishing in Bass Strait, its management and research is briefly reviewed. The extent of the known biology and ecology of the species is discussed in relation to the current management of the fishery, and an assessment of the current policy is presented. Growth and recruitment overfishing as it relates to this fishery is discussed in light of the 'two spawnings' criterion underpinning the current management plan.

*Richard McLoughlin, CSIRO Division of Fisheries, CSIRO Marine Laboratories, G.P.O. Box 1538, Hobart, Tasmania 7001; present address: Department of Primary Industry and Fisheries, G.P.O. Box 619F, Hobart, Tasmania 7001; 9 March, 1994.*

Large concentrations of the 'commercial' scallop, *Pecten fumatus*, were located off Lakes Entrance in Bass Strait in 1970. Research surveys sponsored by the Tasmanian Government between 1971 and 1973 located promising scallop beds along northern Tasmania. These were first exploited in 1973, a year that saw a resurgence of fishing activity in Port Phillip Bay. Discovery of major new beds off the Furneaux Island Group in eastern Bass Strait in the late 1970s sparked off a period of rapid expansion in the scallop industry. Fishing activity in the region increased dramatically, and total landings reached a record high in 1982-83 when the total catch (live weight) approached 12,000 tonnes and the number of vessels participating tripled in two years to 231 vessels (Young & Martin, 1989; Zacharin, 1990).

By 1985, the main beds in Bass Strait were depleted and the decline in landings was just as dramatic as the rise. Banks Strait, the last major scallop bed in Bass Strait, was fished out during 1986. The Tasmanian zone of southern Bass Strait was closed to scallop fishing following the 1987 season, and surveys have since shown that there has been little subsequent recruitment (Zacharin, 1987, 1989; McLoughlin et al., 1988; Martin et al., 1989; Martin, 1990).

Over this 20 year period, few, if any, commercially fished scallop beds have supported exploitation for more than 2 consecutive seasons. Few of these beds consisted of scallops comprising more than 1 or 2 year classes. The conclusion is that effort and capacity in this fishery has built up to the point that single recruitment events, resulting in discrete scallop beds of single year classes, are quickly fished out as the majority of the bed reaches a size at which they become commercially viable to land (McLoughlin et al., 1991). These beds do not, in general, appear to

regenerate or provide additional year classes of scallops in the time frame of the current fishery c. 20 years.

### MANAGEMENT AND RESEARCH

Zacharin (1990) and Gwyther (1990) described the management of Bass Strait scallops from both Tasmanian and Victorian perspectives. Present management resulted from concerns by State and Commonwealth Governments (and industry) following expansion during 1979-1983. The Bass Strait Interim Management Regime of November 1983 saw 97 Victorian and 134 Tasmanian based vessels gaining access to the whole Bass Strait fishery (i.e. their respective state waters and the Commonwealth controlled central zone greater than 20 nm from the coastline of the two states (Fig. 1)).

The Commonwealth Government then established the Bass Strait Scallop Task Force (BSSTF), consisting of government and industry representatives, whose brief was to develop a management plan that: 1. Effectively utilised the resource; 2. Was acceptable to all parties; and 3. Was legally enforceable. The Task Force was not able to develop a management plan agreeable to all parties, and the final recommendation presented to the 1985 meeting of the Australian Fisheries Council was to effect a high degree of separation between the Tasmanian and Victorian based fleets. Access to the Commonwealth controlled central zone was restricted to scallop vessels that qualified either for a Tasmanian or Victorian state license and that had an endorsement of their Commonwealth Fishing Boat Licence. The separation was finalised under Off-shore Constitutional Settlement agreements between the commonwealth and state governments

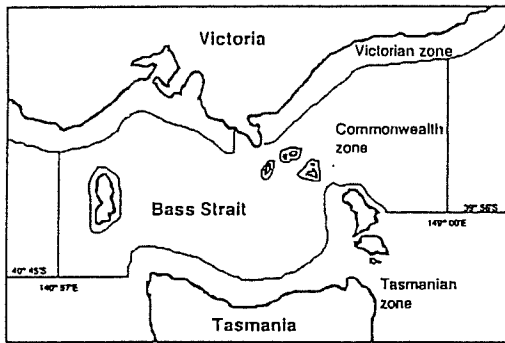

FIG. 1. Map of management zones for Bass Strait scallops. The boundaries for the two states lie 20 nautical miles offshore, with the islands belonging to Tasmania state waters.

in June 1986 (Zacharin, 1990). This management plan had no biological or objective fishery management principles as its basis.

Apart from limitations on entry into the central zone fishery, no other effort or catch control regulations were imposed until June 1990, when the then Commonwealth Minister for Primary Industries and Energy, Hon. John Kerin MP, announced closure of the Bass Strait central zone to all scallop fishing. In his media release the Minister stated that he had no option but to close the area until there was clear evidence that stocks had recovered to a level which would support a sustained and substantial commercial fishery. The Commonwealth decision was (apparently) prompted by two considerations: 1. The CSIRO recommendation in early 1989 that no fishing be allowed on any of the few remaining beds in Bass Strait until stocks recovered (Fishing Industry Research and Development Corporation grant no 1985/83 final report); and 2. Reports of limited fishing on beds of apparently immature scallops in the central zone by Victorian fishermen.

Only one major study of the biology, ecology and fishery for scallops in Bass Strait has been carried out (FIRDC 1985/83). It was the final report of this study to the funding body that included a recommendation for a 'two spawnings' criterion. Regional surveys during the CSIRO study indicated severe stock depletion and a lack of recruitment (McLoughlin et al., 1988; Martin et al., 1989). The research indicated that spawning age stocks had fallen to such a low level that failure to protect existing beds could preclude recovery of scallop stocks in Bass Strait for some years.

The CSIRO study also recommended that a

high priority should be to regular monitoring of the distribution and abundance of recruits and the size and condition of scallops on the few remaining beds. However this monitoring work was not carried out as it was not funded. The last survey of scallop stocks in the region was that carried out by CSIRO in May–June 1988. The decision by the Commonwealth to close the zone in 1990 was made in response to what appeared to be the imminent resumption of unregulated fishing following the collapse 3 years earlier, and concern as to the impact this might have on the recovery of scallop stocks. A bed of apparently immature scallops found near Deal Island in 1990 was surveyed in June of the same year and, despite some discussion based on interpretation of modes in the length frequency data, they were assessed by CSIRO and the Bureau of Rural Resources (BRR) as being predominately composed of 1+ year class scallops with a minor (6%) 2+ year class component (Martin 1990). It was this bed of scallops that was at risk of a resumption of unregulated fishing, and which prompted ministerial action.

In December 1990, the Commonwealth, Tasmanian and Victorian Primary Industry Ministers jointly announced a new management plan for the central zone scallop fishery; it represented a fundamental change in management philosophy (Anon. 1991). Two aspects of the new arrangements were: 1, that the Commonwealth wished to work towards handing over management to the two states, with an agreed jurisdiction line across the Strait for purposes of state fisheries administration; and 2, that opening of the central zone would be dependent upon the 'presence of commercial beds that have had the opportunity to spawn twice'.

#### OVERFISHING AND EXPLOITATION STRATEGIES

By the end of the 1987 season the fishery had collapsed. The total catch by Tasmanian vessels in 1987 was less than 500 tonnes, representing a 95% drop in annual landings in six years (Zacharin, 1990) with Victorian vessels landing 220 tonnes, a 90% drop in catches over the same period. CPUE for the same period dropped to 13% of 1982/83 levels; industry and managers accepted that overfishing was occurring.

Although generally applicable to all fish stocks, Sinclair et al. (1985) distinguished two types of overfishing of scallops; 'recruitment overfishing' and 'growth overfishing'. The first concept invol-



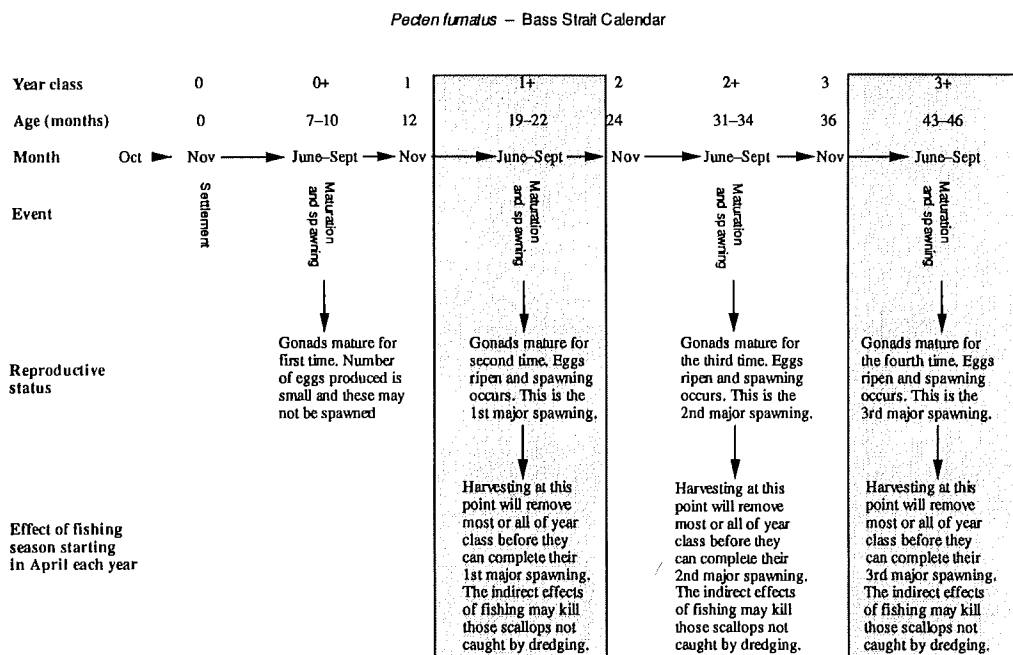

FIG.2. Biological calendar of scallop reproduction and fishing practice in Bass Strait scallops

ves the self-reproducing capacity of the population and describes a level of fishing that begins to limit the ability of the mature spawning population to effectively provide adequate future recruitment - in this case, adequate in terms of providing a commercial fishery. The second concept is relatively better understood, and describes fishing at a size or age at which the maximum yield in weight (or dollars if economic information is available) is not realized; that is, fishing the resource at a 'small' size when a larger size would provide better returns.

Having recognised the need for active management in Bass Strait, a number of strategies are worthy of consideration, including maximising yield from individual beds or populations. One approach to maximising yield from a population where annual recruitment to the same population can be ignored is to calculate the annual balance between growth of the scallops and removal from the population by death (Mohn,1986). This approach is relatively easy to evaluate given information about growth rates, mortality rates at age and the effective gear selectivity rates for each age. The problem lies in the assumptions of the 'yield-per-recruit' models used to derive this in-

formation, as they do not generally consider either environmental or fishery related variations in annual recruitment.

For example, the yield-per-recruit approach will generate the same advice on optimal fishing strategies whether or not recruitment overfishing is occurring, and yet it would be critical for a fishery manager to modify the strategies for management if such recruitment overfishing was occurring. Martin et al. (1990) examined the problems of simple yield-per-recruit management strategies for the Bass Strait scallop fishery, and concluded that they would generally provide poor results. These problems were further discussed by Young & Martin (1989).

It is still not certain whether recruitment of scallops in Bass Strait is dependent upon supply of larvae from nearby beds. However, regular spat monitoring over two years at six sites in Bass Strait, and advection modelling of larval trajectories with real wind and tide data using a verified circulation model (Fandry,1983), showed that larvae are conserved within Bass Strait in all but the windiest years (Young et al.,1992). A positive relationship between commercial catch rates and spatfall in the same 1° square in Bass Strait

also provides some evidence of a stock recruitment relationship (Young et al., 1990). Thus scallop stocks are probably self-sustaining in Bass Strait and a viable spawning stock should be maintained. Although a minimum stock level cannot be defined, a conservative approach to prevent recruitment overfishing should be incorporated into the management plan. Several authors have identified the possibility of recruitment overfishing in Bass Strait (McLoughlin et al., 1988; Martin et al., 1989; Zacharin, 1990; Young & Martin, 1989); the Bass Strait scallop management plan initiated in 1991 aims to avoid this problem.

#### AGE AND FECUNDITY

A biological 'calendar' of scallop reproduction and fishing (Fig. 2) shows that to achieve two major spawnings, scallops must be in their third year of growth. Fecundity of scallops of various ages and from various areas of Bass Strait was first determined by CSIRO during their 3 year research program (Martin et al., 1990). While fecundity was found to be variable, there appeared a relationship of size (age) and egg production, with 3+ year class scallops shedding 3-5 times as many eggs as 1+ scallops. These 3+ scallops were 75-85mm shell height. Although a linear age/fecundity schedule for Bass Strait scallops is drawn for simplicity (Fig. 2) it is probable that the relationship is non-linear, reaching an asymptote at some value approximate to maximum size of this species at around 140mm shell height.

#### STOCK MANAGEMENT

Despite the inherent problems with the assumptions underlying yield-per-recruit models, it is useful to consider an example of growth overfishing modelled for a hypothetical Bass Strait scallop bed. Typically, the model used is an analytical yield model developed for exploited fish populations (e.g., Beverton & Holt, 1957). Sinclair et al. (1985) for example, used such a model modified for use on scallops to estimate yield as a function of fishing effort and gear selectivity-at-age, where the annual catch from the population under a given fishing strategy equals the catch that can be taken from a single cohort throughout its life under the same strategy. The yield is maximised by maximising the following relationship for a single cohort,

$$Y = \int_{t-1}^t F_t \cdot N_t \cdot W_t \cdot dt \quad (1)$$

where Y is the annual yield,  $F_t$  is the instantaneous fishing mortality at time t,  $N_t$  is the abundance of the cohort at time t, and  $W_t$  is the meat weight in grams of the individual scallops at time t. The model assumes that fishing takes place on the same cohort over a number of years, and the management aim in this case is to target fishing on the age class (or time) when the yield is maximised. Sinclair et al. (1985) used this approach to examine the effect of varying management strategies in the Canadian fishery for the sea scallop *Placopecten magellanicus*, where up to 13 year classes may be present and fishing does not usually target on scallops until they are 5-6 years old. Their analysis showed clear overall yield benefits in targeting older year classes.

The same situation of multiple year classes and annual recruitment to beds does not occur in the Bass Strait fishery. Here, scallop beds are generally composed of a single dominant year class, are fished to 'extinction' in the same year as fishing commences, and very little survival occurs into the next year. The model does not then have to formally take into account fishing mortality in each year, since typically it is always in excess of the capacity of the bed to survive into the next year (McLoughlin et al., 1991). The model reduces to calculating the yield in each year from a given age/size structure, exploitation rate (E) and stock size (N), traded off against an annual natural mortality (M). An equation to calculate yield at time t thus reduces to:

$$Y_t = \sum E_t \cdot N_t \cdot W_t \quad (2),$$

while the number of scallops available for capture in each year is

$$N_{t+1} = N_t(1-M) \quad (3).$$

This has been modelled for three management strategies, using data from average meat weights at age for Bass Strait scallops and a 'hypothetical' scallop population, where:

$N_t$ : Although used only as an example, Zacharin (pers. comm. 1990) calculated the stock size available for capture at a bed near Deal Island as c.26 million scallops, assuming an overall 30% dredge efficiency during the survey of June 1990 (Martin, 1990; McLoughlin et al., 1991). Assum-

TABLE 1. Analytical (meat) yield model results for three management strategies, where (a) is scallops fished from age 1+ onwards, (b) is scallops fished from age 2+ onwards, (c) is scallops fished from age 3+ onwards, and (d) is scallops fished from age 1+ onwards with a selectivity factor of 50% for the 1+ scallops

	Age (Yrs)	Population (000,000)	Av. Wt (g)	Catch (tonnes)
(a)	1	23.5	7.7	180.9
	2	1.5	11.2	16.8
	3	1.0	14.0	14
	TOTAL			211.7
(b)	2	12.2	11.2	136.8
	3	0.7	14.0	10.9
	4	0.5	17.0	8.5
	TOTAL			156.2
(c)	3	6.3	14.0	88.9
	4	0.4	17.0	6.8
	5	0.3	18.0	4.6
	TOTAL			100.3
(d)	1	12.2	7.7	93.9
	2	1.5	11.2	16.8
	3	1.0	14.0	14
	TOTAL			124.7

(d) modified (50%) selectivity for year 1 cohort.

ing a realistic cohort age on this bed (from length frequency data), this has been converted to an age structured population of 23.5 million 1+ year scallops (90.3%), 1.5 million 2+ year scallops (5.7%) and 1 million 3+ year scallops (4%).

Wt: While average meat weights vary significantly in Bass Strait, particularly for the King Island beds, yields are given for average meat weights for age/size classes encountered in spawning condition.

M: a fixed annual natural mortality of 0.52 has been applied to individual cohorts. While this is the only published figure for this species (Gwyther & McShane, 1988), it is likely to be highly variable. This figure is used as an average value only.

The scenarios modelled under the assumptions above (Table 1) have the same population (a) fished after initial discovery as a combination of 1-, 2- and 3+ year old cohorts, (b) left for one year and fished at 2-, 3- and 4+ year old cohorts, and (c) left for two years and fished as 3-, 4- and 5+ year old cohorts. In this simple example substantial decreases in yield result from leaving the scallops until a majority are aged 2+ years and

older, and this trend is continued if they are not fished until the dominant cohort is 3 years old. However, it is worth considering this result more closely in relation to actual fishing practice in Bass Strait. Scallops in year 1 cohorts in July of each year typically range in size from 50–70mm shell height, but it is unlikely that many would either be landed or processed that were smaller than about 60mm shell height (ignoring the legal minimum size limit of 70mm), thus explaining the necessity for calculation of some effective exploitation rate, E. Assuming a normal size distribution of scallops in the cohort, only one half of the cohort would then be converted to 'yield'. This has been calculated in Table 1 (d), where it is clear that yield from this bed is substantially reduced if this strategy is used, rather than leaving the bed until the major cohort was 3 years old. This size selectivity can normally be accounted for, and adjusted at will in yield models, but is kept separate here for simplicity.

Regardless of the yield implications, the important result for a management strategy utilizing scenario (b) and (c) is in potential egg production as a measure of recruitment overfishing. Using (Fig. 3):

$$\text{Fecundity (millions of eggs)} = 1.086 (\text{years old}) + 0.148 \quad (5),$$

it is a simple matter to calculate the difference in age-based egg production from the three management strategies (Table 1). The differences

TABLE 2. Egg production for three management strategies, based on analytical yield model of Table 1 and age/fecundity schedule of Figure 3; where (a) is scallops fished from age 1+ onwards, (b) is scallops fished from age 2+ onwards, and (c) is scallops fished from age 3+ onwards

	Age	Pop. size (000,000)	Egg production ( $\times 10^{12}$ )	Cumulative egg production
(a)	1	23.5	29	
	2	1.5	3.5	
	3	1.0	3.4	
	TOTAL		35.9	35.9
(b)	2	12.2	28.3	
	3	0.8	2.6	
	4	0.5	2.2	
	TOTAL		33.2	69.1
(c)	3	6.3	21.6	
	4	0.4	1.8	
	5	0.3	1.4	
	TOTAL		24.8	93.9

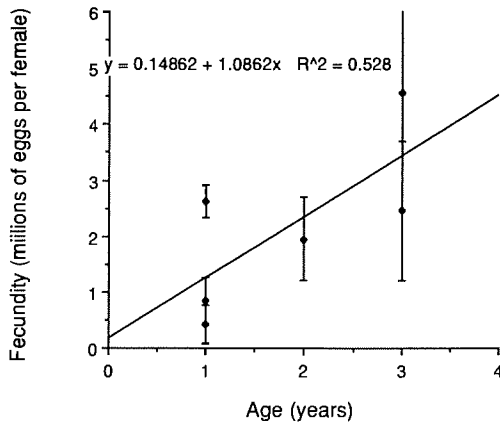

FIG. 3. Age (years) versus fecundity for six Bass Strait scallop beds.

in egg production from these strategies are evident from Table 2, where it is obvious that while most eggs are released when population size is at its highest, removing the population at this point will result in only a fraction of the total egg production that would have been realised if the population had been left until the major cohort was 3 years old, that is, the population spawns in each year of the three years until caught.

The difference in moving from management strategy (d) to strategy (c) will result in only a 20% drop in total yield, but a 260% increase in egg production. Over the medium to long term it is probable that this will be reflected in the recruitment strength of scallop stocks, as well as in higher overall prices from larger sized scallops.

## DISCUSSION

Given the high per-unit value and the relative ease of catching scallops when they are abundant, it is hardly surprising that continued consumer demand has had a significant impact on investment and effort in the Bass Strait fishery. Other complicating factors include 'diversified' fishing license policies in Tasmania, which maintains a large pool of potential effort, and conversely, the lack of diversified license policies in Victoria which forces effort into the fishery because of the inability of the licence holders to spread effort to other fish stocks. There is no easy management solution here, but is becoming evident that there is a need for bioeconomic modeling to determine not only effects of ecological and environmental variables on scallop stocks, but also the critical

problems of social and economic pressures on the scallop fishing industry and how these relate to stock management (Caddy, 1989).

A structural problem in the Bass Strait fishery is that these same social and economic pressures, and a lack of management foresight in the late 1970's and early 1980's, have resulted in a fleet capable of annual overfishing of available stocks. The management plan introduced in 1991 contains a mechanism for avoidance of the most serious long term problem, recruitment overfishing. The two spawnings criterion goes a long way to solving this chronic overfishing problem while also attempting to maximise the yield from existing recruits, but the economics of fishing will remain marginal while stocks remain low. This linking of 'yield-per-recruit' with 'eggs-per-recruit' is a valuable extension of the analytical yield model and was used by Mohn et al. (1984) to develop management strategies for Georges Bank scallops (Gabriel et al., 1989). The mechanism for achieving the two spawnings policy, that is, a trashing rate tied to a size limit, does not reduce its medium and long term validity and is also a valuable management tool for conservation of juvenile stocks. The trashing rate concept will also become increasingly important as (hopefully) stocks rebuild and new juvenile beds are discovered.

Similar policies for shifting fishing effort from younger age groups to older and larger age groups have resulted in substantial gains in long term yields and egg production in Canadian scallop fisheries (Caddy, 1989). Targeting of older age group scallops had a number of beneficial impacts on fishing strategies not characteristic of simple minimum size limits, which has been suggested as an alternative policy for the Bass Strait fishery. A minimum size limit without a viable system of protecting dense patches of new recruits by local area closures (particularly in multiple year class beds) would return the fishery to the destructive practice of fishing areas of predominately small shell in order to cull out the few large scallops, while inflicting high levels of incidental mortality on unlanded juveniles (McLoughlin et al., 1988; Caddy, 1989). The fact that this practice does occur at low stock levels in Bass Strait is evident from examination of the 1987 season (Martin et al., 1989).

The principle of the 'two spawnings' criteria is nothing more or less than one strategy for stock rebuilding. However, a stock rebuilding strategy, with the specific objective of increasing spawning stock abundance, is just one example of a

fishery management strategy (Sainsbury, 1992a). The management strategy may include the use of biological or fishery reference points and a specified way in which the reference points are to be used in the management of the fishery (e.g. no fishing on stocks until they have completed two spawnings). However, as Sainsbury (1992a) explained, the essential point is that the management strategy to be evaluated is but one aspect of a process that includes stock dynamics, economic dynamics, observations (of fleet and fishery performance), estimation procedures, management decisions and management implementation, all operating under a management policy with specific goals or objectives.

The exact causes and mechanisms of recruitment collapse are poorly known, although often a combination of high fishing mortality and environmental variability is indicated, and ecological interactions are suspected. The complexity of these interactions is such that there is little expectation that the population size at which recruitment collapse will happen can be accurately predicted (Sainsbury, 1992b). However, recruitment collapse has occurred in numerous marine resources, and it is strongly suspected in Bass Strait scallops from 1986-1990.

Ultimately, the reliability and success of any management strategy (for Bass Strait scallops) is seen to be dependent on the ability to forecast accurately (Mohn, 1986), although this may require a long time series of catch data to be reliable (Orensanz et al., 1991). However, with large interannual fluctuations in recruitment, growth and mortality typically occurring in Bass Strait scallops such a predictive capability is not yet possible. Management must therefore rely on maximising probability for both maximal annual yield and recruitment success in subsequent years, and these strategies must be maintained over a suitable time period to determine if they are successful.

In respect of Bass Strait scallops, the current management strategy is a stock rebuilding strategy based on output controls: two spawnings based on an average size at age, and catch restrictions, unrelated to stock size but implemented for orderly marketing and processing. However, there remains the risk that the underlying structural problems remain unattended. These are, critically, (1) overall fleet size, and (2) a lack of knowledge of stock size, resilience and productivity. The lack of a link between annual total catch and stock size is particularly worrisome as none of the usual stock management strategies

linking catch and stock, such as proportional escapement, constant escapement or proportional harvesting rate can be, or are, being applied. What is being applied is a constant quota which is generally recognised as a high risk strategy since it ignores interannual recruitment variability. For example, one possible scenario is that even with a two spawnings strategy, three adverse years of environmental conditions for recruitment will see all stocks (beds) available for fishing, and with the existing excess fishing capacity and with annual natural mortality, stock collapse would be once again a real possibility. Further, the existing management plan theoretically allows approximately 18,000 tonnes of scallops (live weight) to be landed in any year (ie., No. of vessels in fleet x monthly quota x no. of months available for fishing), despite the knowledge that in the history of the fishery no more than 12,000 tonnes has been landed in any one year.

What then might be a course of action for considering these problems? Initially, an assessment of the existing policy with regards to stock recovery will be necessary. Assuming that the stock does recover to some level consistent with a more constant level of annual recruitment, then in the medium term a linking of annual catch with stock size will become necessary for some level of sustainability (that is, an estimate of minimum spawning stock biomass-per-recruit). Of course, this is inextricably linked with profitability for the fleet, with the economics of fishing for the existing fleet only being viable at relatively high stock sizes - financial viability at lower stock sizes will rely on the reduced catch being shared among fewer operators. A policy objective in the medium term may well be an appropriate reduction in fleet size to a level at which economic viability is maintained at average annual catches.

#### ACKNOWLEDGEMENTS

This paper has grown out of discussions with many people, including people at all levels in the fishery - fishermen, managers and scientists. Particular thanks to AFMA, industry and state government members of the Bass Strait scallop Consultative Committee, Mr Will Zacharin and Drs. Peter Young, Tony Smith and Tony Koslow. Mr Richard Martin produced the biological calendar for scallops, and I thank him for permission to use it in this paper.

## LITERATURE CITED

- ANONYMOUS, 1991. 'Bass Strait scallop fishery preliminary management plan. No. BSS 1, Commonwealth Dept. Primary Industries and Energy'. (Australian Government Printer: Canberra). 10p.
- BEVERTON, R.J.H. & HOLT, S.J. 1957. On the dynamics of exploited fish populations. United Kingdom Ministry of Agriculture and Fisheries, Fisheries Investigation, Ser.2, 19: 1-533.
- CADDY, J.F. 1989. A perspective on the population dynamics and assessment of scallop fisheries, with special reference to the sea scallop, *Placopecten magellanicus* Gmelin. In J.F. Caddy, (ed.), 'Marine invertebrate fisheries. Their assessment and Management'. (John Wiley and Sons: New York).
- FANDRY, C. 1983. Model for the three dimensional structure of wind-driven and tidal circulation in Bass Strait. Australian Journal of Marine and Freshwater Research 34: 121-141.
- GABRIEL, W.L., SISSEWINE, M.P. & OVERHOLTZ, W.J. 1989. Analysis of spawning stock biomass per recruit: an example for Georges Bank Haddock. North American Journal of Fisheries Management 9: 383-391.
- GWYTHHER, D. 1990. History of management in the Victorian scallop industry. In Dredge, M.L.C., Zacharin, W.F. & Joll, L.M., (eds), 'Proceedings of the Australasian Scallop Workshop, Hobart'. (Tasmanian Government Printer: Hobart).
- GWYTHHER, D. & MCSHANE, P.E. 1988. Growth rate and natural mortality of the scallop *Pecten alba* in Port Phillip Bay, Australia, and evidence for changes in growth rate after a 20-year period. Fisheries Research 6: 347-361.
- MARTIN, R.B., YOUNG, P.C., MCLOUGHLIN, R.J. & WEST, G.J. 1989. Bad news in Bass Strait. Australian Fishing 48(3): 18-19.
- MARTIN, R.B., YOUNG, P.C. & MCLOUGHLIN, R.J. 1990. Problems with applying yield-per-recruit techniques to the management of the Bass Strait scallop fishery. In Dredge, M.L.C., Zacharin, W.F. & Joll, L.M., (eds), 'Proceedings of the Australasian Scallop Workshop, Hobart'. (Tasmanian Government Printer: Hobart).
- MARTIN, R.B. 1990. 'Bass Strait scallop survey, July 1990'. Unpublished report to Australian Fisheries Service. Canberra. 16p.
- MCLOUGHLIN, R.J., YOUNG, P.C. & MARTIN, R.B. 1988. CSIRO surveys show bleak outlook for Bass Strait scallops. Australian Fisheries 47: 43-46.
- MCLOUGHLIN, R.J., YOUNG, P.C., MARTIN, R.B. & PARSLow, J. 1991. The Australian scallop dredge: estimates of catching efficiency and associated indirect fishing mortality. Fisheries Research 11: 1-24.
- MOHN, R.K., ROBERT, G. & RODDICK, D.L. 1984. Status and harvest strategies for Georges Bank scallop stocks (NAFOSA 5Ze). ICES CM 1984/K: 15. 31p.
- MOHN, R.K. 1986. Generalizations and recent usages of yield per recruit analysis. Canadian Special Publication on Fisheries and Aquatic Science 92: 318-325.
- OREMSANZ, J.M., PARMA, A.M. & IRIBARNE, O.O. 1991. Population dynamics and management of natural stocks. Developments in Aquaculture and Fisheries Science 21: 1-1095.
- SAINSBURY, K. 1992a. 'The use of simulation to evaluate the performance of stock rebuilding strategies, including the use of reference points'. Unpublished manuscript, 18p.
- SAINSBURY, K. 1992b. 'Biological reference points for the spawning stock of Southern Bluefin Tuna. 1992 SBT Workshop, Port Lincoln'. (CSIRO Division of Fisheries: Hobart) 14p.
- SINCLAIR, M., MOHN, R.K., ROBERT, G. & RODDICK, D.L. 1985. Considerations for the effective management of Atlantic scallops. Canadian Technical Report on Fisheries and Aquatic Science 1382: 1-113.
- YOUNG, P.C. & MARTIN, R.B. 1989. The scallop fisheries of Australia and their management. Review of Aquatic Science 1: 615-638.
- YOUNG, P.C., MARTIN, R.B., MCLOUGHLIN, R.J. & WEST, G.J. 1990. Variability in spatfall and recruitment of commercial scallops (*Pecten fumatus*) in Bass Strait. In Dredge, M.L.C., Zacharin, W.F. & Joll, L.M., (eds), 'Proceedings of the Australasian Scallop Workshop, Hobart'. (Tasmanian Government Printer: Hobart).
- YOUNG, P.C., MCLOUGHLIN, R.J., MARTIN, R.B. 1992. Scallop (*Pecten fumatus*) settlement in Bass Strait, Australia. Journal of Shellfish Research 11:315-323.
- ZACHARIN, W.F. 1987. Tasmanian zone scallop survey. Department of Sea Fisheries Report 18: 1-19.
- ZACHARIN, W. F. 1989. Tasmanian zone scallop survey, 1989. Department of Sea Fisheries Report 41: 1-13.
- ZACHARIN, W.F. 1990. Scallop fisheries management: the Tasmanian experience. In Dredge, M.L.C., Zacharin, W.F. & Joll, L.M. (eds), 'Proceedings of the Australasian Scallop Workshop, Hobart'. (Tasmanian Government Printer: Hobart).

## THE IMPACT OF SCALLOP DREDGING ON A SOFT SEDIMENT COMMUNITY USING MULTIVARIATE TECHNIQUES

D.R. CURRIE AND G.D. PARRY

Currie, D.R. & Parry, G.D. 1994 08 10: The impact of scallop dredging on a soft sediment community using multivariate techniques. *Memoirs of the Queensland Museum* 36(2): 315-326. Brisbane. ISSN 0079-8835.

Changes to benthic infauna caused by scallop dredging in Port Phillip Bay were examined experimentally using a BACI (Before, After, Control, Impact) design. Analysis of 150x0.1 m<sup>2</sup> grab samples obtained from 2 pre-dredging and 3 post-dredging periods are described. A diverse fauna of 204 invertebrate species and 49,044 individuals were surveyed. Bray-Curtis community dissimilarities were used to assess changes to community structure following dredging. Pair-wise comparisons of community dissimilarity between the control and dredge plots through time enabled a test of the statistical significance of change following dredging. Multi-dimensional scaling (MDS) was used to describe patterns of change following dredging. Statistically significant ( $0.05 < p < 0.10$ ) changes to community structure were detected following dredging; ecological significance of these changes requires further analysis.

*D.R. Currie and G. D. Parry, Victorian Fisheries Research Institute, P.O. Box 114, Queenscliff 3225, Victoria; 15 April, 1994.*

The scallop industry in Port Phillip Bay is one of the most valuable commercial fisheries in Victoria and since its establishment in 1963 has produced up to 2000 tonnes, worth c.\$20 million, annually. Scallop dredging in Port Phillip Bay is also widely regarded in the Victorian community as environmentally damaging. Many changes to the ecology of Port Phillip Bay, noted by fishermen and others, have been attributed (rightly or wrongly) to scallop dredging. In response to these concerns, a series of linked physical (Black & Parry, this memoir) and biological studies were initiated in 1991 to provide information on the impacts of scallop dredging.

Shellfish dredging may cause a range of impacts (Messieh et al., 1991, Jones, 1992), but few are well-documented and biological impacts are particularly difficult to investigate because of the complexity of benthic communities and our limited knowledge of its natural variability (Messieh et al., 1991). Early studies (Caddy, 1973, Butcher et al., 1981) of the effect of dredging on benthic communities were qualitative. More recent quantitative studies involve experimental manipulations, but often lack the statistical power to detect a small impact (Petersen et al., 1987, McShane, 1981, Eleftheriou & Robertson, 1992) or involve an inappropriate scale of impact, i.e. the experimentally dredged site is much smaller than would be dredged during normal commercial activities (McShane, 1981, Eleftheriou & Robertson, 1992). Furthermore, the impacts of scallop dredging depend upon the type of gear,

amount of ground contact, type of seabed, depth, and strengths of currents (Jones, 1992). The extent of biological impacts must also depend on the vulnerability of the benthic communities.

Most of the world's scallop dredge fisheries use different gear, operate on a range of substrate types and harvest scallops from different biological communities. Consequently, even if the effects of scallop dredging had been investigated in several of the world's fisheries, it would not be surprising if the impacts differed.

The species most likely to be impacted by scallop dredging are those which live near scallops, on or just beneath the sediment surface, and which are not mobile enough to avoid dredges. Thus epifaunal and infaunal communities appear to be the most vulnerable to scallop dredging. This paper examines the effect of scallop dredging on infaunal communities.

Dredge-related changes to the abundance and diversity of infaunal animals were examined using a BACI (Before After Control Impact) design (Stewart-Oaten et al., 1986). This design involves simultaneous sampling of two plots (one control, and one dredge) on a number of occasions, both before and after experimentally dredging the 'dredge' plot. On each sampling occasion differences between plots were assessed using the Bray-Curtis dissimilarity measure and a t-test was used to determine whether changes to this dissimilarity measure following dredging were statistically significant.

Changes to community structure following

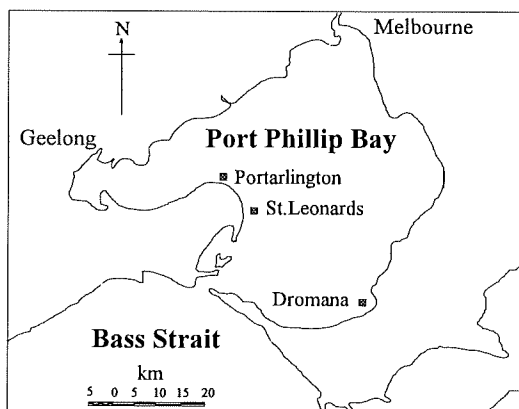

FIG.1. Map of Port Phillip Bay showing locations of main study areas used for scallop dredging trials.

dredging were also determined using multi-dimensional scaling (MDS). MDS provides a means of reducing large and complex data sets so that ecologically meaningful patterns and trends are more apparent and more readily interpreted (Gamito & Raffaelli, 1992). MDS is a powerful ordination procedure that attempts to place some measure of similarity between objects into 2 or more dimensional space, such that distances between objects correspond closely to the input similarities. While the computational algorithm for MDS is complex the graphical representation is conceptually simple and easily communicated (Clarke, 1993).

## METHODS

### STUDY DESIGN

This study is part of a much larger study examining dredging-related changes to the abundance of benthic animals in 3 areas of Port Phillip Bay (St Leonards, Dromana and Portarlington) during, 1991 (Parry & Currie, 1992). We describe only studies in an area near St Leonards closed to all scallop dredging during 1991 (Fig.1).

Two adjacent 600m x 600m experimental plots were located in 12–15m of water, c.2km offshore from St. Leonards. The more southerly was experimentally dredged by commercial vessels ('dredge' plot) and the other plot was left undredged ('control' plot).

The 'dredge' plot was commercially dredged over 3 days (16–18 July, 1991) by a fleet of 6 scallop vessels, using 3m wide 'Peninsula' dredges fitted with scraper/cutter bars that did not extend below the level of the skids (Hughes,

1973). Dredging was conducted for a maximum of 3 hours per day and coincided with periods in which there was a strong southerly tidal current that carried any dredging-related sediment away from the adjacent control site. The experimental plot was dredged with a moderately high fishing intensity compared to historical levels of fishing in Port Phillip Bay (Parry & Currie, 1992). A 2x dredging intensity (where 2x refers to the number of times a dredge would on average pass over any point within the plot) was chosen as this level of fishing was common in areas with high densities of scallops and because any lower intensity would have left too large a proportion of the 'dredged' plot undredged.

On the first morning of the experimental dredging the plot to be dredged was marked out with 4 equidistant large buoys along each side of the 600m x 600m plot using a Furuno GP 500 GPS Navigator connected to a colour video plotter. This GPS provides an accuracy of 15–25m in 95% of fixes. Where inaccuracy exceeded 25m due to intentional degradation of the system (selective availability) this was obvious on the plotter. The buoys marked out three 200m x 600m lane ways directed E–W. Scallop vessels dredged these lane ways sequentially and fishermen were encouraged to dredge the whole area as evenly as possible. On the second and third days of dredging the buoys marking out the lane way boundaries were moved 50m N and S of their initial positions to minimise any undredged 'shadows' resulting from vessels not dredging near the buoys.

Estimates of the distribution and abundance of animals living within the sediments at each plot were determined from replicate 0.1 m<sup>2</sup> Smith-McIntyre grab samples. 15 samples were taken from each plot on 2 sampling dates before (13/5/91, 02/7/91) and 3 after (18/7/91, 9/8/91 & 31/10/91) the experimental dredging. Each plot was sub-divided into 12 equal sectors to facilitate stratified random sampling; one grab was taken at random from within each sector and the remaining 3 grab samples were taken at random across the plot. Samples were drained, weighed and a 70ml subsample retained for sediment analysis. All animals retained on a 1mm sieve were sorted to an optimal taxonomic level (generally species) under a dissecting microscope, before being counted.

### DATA ANALYSIS

Differences between the control and dredge plots at each sampling period were examined



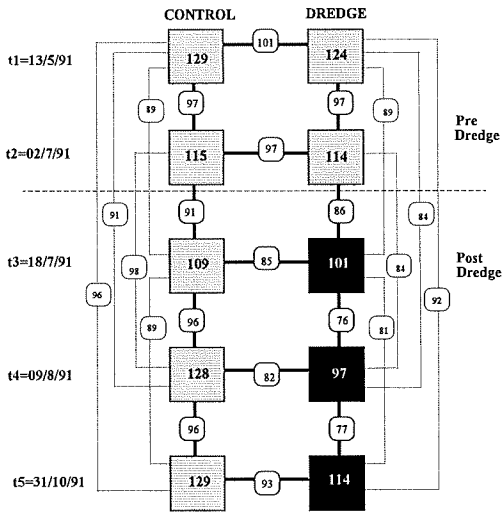

FIG.2. Schematic diagram showing differences between the number of species and number of shared species between different plots and sampling dates. Numbers in large squares are total number of species found on the control and dredge plot on each sampling date (t1-t5). Black squares show the number of species on the dredge site following the experimental dredging. Other numbers are the number of species shared between different plots and sampling times.

using Bray-Curtis (B-C) dissimilarity measures (Bray & Curtis, 1957).

The Bray Curtis dissimilarity measure is:

$$\delta_{jk} = \frac{\sum_{i=1}^s |Y_{ij} - Y_{ik}|}{\sum_{i=1}^s (Y_{ij} + Y_{ik})}$$

where  $Y_{ij}$  = the score for the  $i$ th species in the  $j$ th sample;  $Y_{ik}$  = the score for the  $i$ th species in the  $k$ th sample;  $\delta_{jk}$  = dissimilarity between the  $j$ th and  $k$ th samples summed over all  $s$  species. This particular measure was chosen because 1) it is not affected by joint absences 2) it gives more weighting to abundant species than rare ones, and 3) it has consistently performed well in preserving 'ecological distance' in a variety of simulations on different types of data (Faith et al., 1987).

On each sampling date the number of individuals of each species was calculated from the total number of individuals found on each plot. i.e. data from the 15 replicate grabs on each plot were pooled. Before calculating the B-C dissimilarity measures a double square root transfor-

mation was applied to the number of individuals of each species. This transformation prevents the abundant species from influencing the B-C dissimilarity excessively.

Five pairwise B-C dissimilarity measures comprising all control plot versus dredge plot comparisons for the 5 sampling periods (2 before and 3 after dredging) were used in the BACI analysis as proposed by Faith et al. (1991). The null hypothesis of no dredging effect is rejected if the mean of the B-C dissimilarity measures before dredging is lower than that after dredging, as judged by a  $t$  test.

Bray-Curtis dissimilarity measures calculated for all 10 plot\*date (2 plots x 5 dates) combinations, resulted in a triangular matrix of dissimilarities which were used to map the plot\*date inter-relationships in two dimensions. Hybrid multidimensional scaling (Belbin, 1990) was employed for the ordination. This technique is a hybrid between metric and non-metric multidimensional scaling that attempts to combine the best features of each of the two techniques (Faith et al., 1987). By specifying a 'cut-value' less than the lowest dissimilarity measure, monotonic regression was used. The final configuration presented is the best solution (i.e. it exhibited the lowest 'stress' value  $\approx$  least distortion) from 100 random starts.

## RESULTS

204 invertebrate species and 49,044 individuals were encountered at the 2 St Leonards plots during the course of this study (Appendix); 86 (42%) were crustaceans, 53 (26%) polychaetes, 38 (19%) molluscs, and 27 (13%) members of other phyla.

At St Leonards, as is common with most other ecological communities (Preston, 1948), there are a small number of abundant species and a large number of relatively rare species. The amphipod *Photis* sp.1 was the most abundant species and contributed 35% of the animals collected. Collectively the 20 most abundant species contributed 85% of the animals collected. By contrast, 105 species were represented in fewer than 10 of the 150 grab samples taken, and 38 species occurred in only one grab.

### CHANGES IN SPECIES NUMBERS

The difference between the total number of species sampled on the control and dredge plots was small before the dredging (5 at t1, 1 at t2; Figs 2,3) but increased following dredging (8 at t3, 31

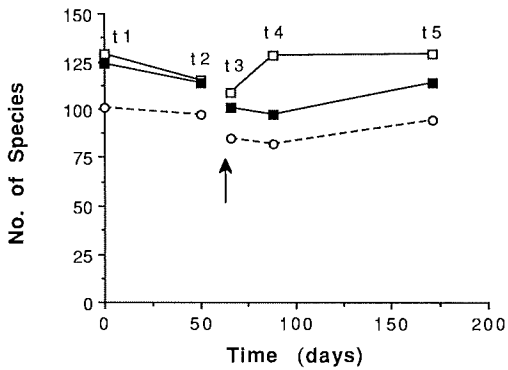

FIG.3. Total number of species recorded in 15 replicate grab samples taken from the control (□) and dredge (■) plots. The broken line indicates the number of species shared between the two plots. Arrow indicates when experimental dredging occurred.

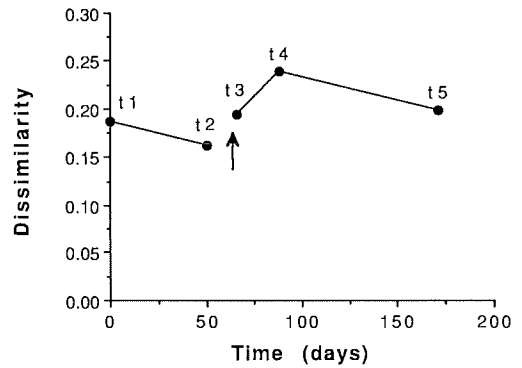

FIG.5. Bray-Curtis community dissimilarity between control and dredge plots before and after experimental dredging. Arrow indicates when experimental dredging occurred.

at t4, 15 at t5; Figs 2,3). The number of species shared between the control and dredge plots decreased from 101(t1) and 97(t2) before dredging to 85(t3), 82(t4) and 93(t5) following dredging (Figs 2,3). Other comparisons of the number of species shared between sampling times (Figs 2,3) also suggest that there was a reduction in the number of species following dredging. Over all 5 sampling times 72 species were always found on the control plot, but only 62 were always found on the dredge plot.

The mean difference in species number between both plots increased from 3 before dredging to 18 after dredging. A t-test of this increase in difference after dredging was significant at

$0.05 < p < 0.10$ . However the power of this test to detect a change of the observed magnitude was  $P < 0.30$  when  $\alpha = 0.05$ .

CHANGES IN NUMBERS OF INDIVIDUALS

The total number of individuals of all species sampled on the control plot and the dredge plot increased between t1 and t5, and particularly between t4 and t5 (Fig.4). This increase is the result of recruitment of juveniles, particularly of *Photis* sp.1, which accounts for approximately half of the overall increase during the study period (Currie & Parry, unpubl. data). However at each sampling time following dredging (t3–t5) the number of individuals on the dredge plot was

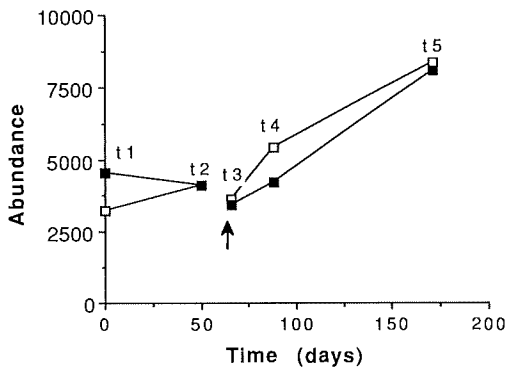

FIG.4. Total number of individuals in 15 replicate grab samples taken from the control (□) and dredge (■) plots. Arrow indicates when experimental dredging occurred.

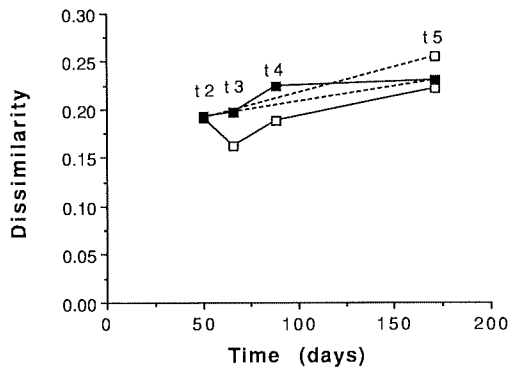

FIG.6. Bray-Curtis community dissimilarities between successive sampling dates (t1–t2, t2–t3, t3–t4, t4–t5, at control (□) and dredge (■) plots. Broken lines indicate t1–t5 comparisons for the control (□) and dredge (■) plots. t1 = 0 days.

lower than the number on the control plot, whereas before dredging there were either similar numbers on both plots (t2) or more on the dredge plot (t1, Fig.4).

#### COMMUNITY DISSIMILARITY

Bray-Curtis dissimilarity measures between the control and dredge plots on the 5 sampling dates (Fig.5) increased significantly (t-test,  $0.05 < p < 0.10$ ) from a mean of 0.175 before dredging to 0.211 after dredging, but the power of this test to detect a change of the observed magnitude was low ( $P < 0.32$  when  $\alpha = 0.05$ ). The first post-dredging sampling (t3) occurred on the last day of the experimental dredging and at this time there was minimal change in community dissimilarity, but the dissimilarity between the plots increased after 23 days (t4) before decreasing again after 88 days (t5). The increase in dissimilarity between t3 and t4 may have resulted from some moribund animals being collected on the dredge plot at t3, but these would not have been distinguishable from healthy animals in our analysis. Alternatively dredging may cause indirect ecological changes, such as increased vulnerability to predation, which take some time to have their maximum impact. The apparent increase in similarity of the plots between t4 and t5 is probably the result of recruitment of many additional species on both plots during this period. Recruitment of *Photis* sp.1 at this time makes only a small contribution to the B-C dissimilarity as a similar pattern of dissimilarity measures was obtained using only species presence-absence data (Currie & Parry, unpubl. data).

Comparison of Bray-Curtis dissimilarities between successive dates on the dredge and control plots (Fig.6) demonstrate that before dredging (t1-t2) there was little difference between successive samples. On the control plot following dredging there is a decrease in community dissimilarity in the periods t2-t3 and t3-t4, whereas on the dredge plot community dissimilarity increases in these same periods. On both the control and dredge plots there is an increase in dissimilarity in the period t4-t5 apparently due to recruitment of animals (particularly additional species) to both plots. Over the entire study period t1-t5 there was a larger increase in dissimilarity on the control plot than on the dredge plot. This appears to be the result of relatively lower recruitment of additional species on the dredge plot than on the control plot in the period

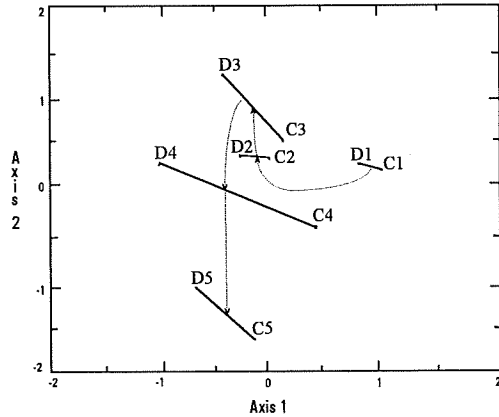

FIG.7. Two-dimensional scaling ordination mapping the relationships between benthic communities on the control (C) and dredge (D) sites before and after dredging. Numerals indicate the date of sampling (i.e. 1=13/5/91; 2=2/7/91; 3=18/7/91; 4=9/8/91; 5=31/10/91). Experimental dredging was conducted on 16, 17 and 18 July, 1991. The solid lines connect control and dredge plots sampled on the same date. The broken line connects the different sampling times in sequence from t1 to t5.

following dredging, and suggests that dredging may reduce larval settlement.

#### MULTIDIMENSIONAL SCALING (MDS)

The MDS ordination (Fig.7) maps the spatial and temporal changes in benthic community structure on the control and dredge plots before and after dredging. The stress coefficient of 0.153, indicates that the ordination is not unduly distorted (Clarke, 1993), and a fair representation of the input dissimilarities in 2-dimensions.

The MDS ordination summarises many of the changes on the control and dredge plots noted above. Length of the lines in Fig.7 provide a measure of the dissimilarity of the dredge and control plots through time. Short lines connect the control and dredge plots at the first and second sampling dates (C1-D1 and C2-D2), but immediately following dredging the length of the lines increase, indicating an increase in dissimilarity between the control and dredge plots. The line connecting C4-D4 is the longest which indicates that on the second sampling date after dredging (t4) the plots are at their most different. The subsequent decrease in the length of the line at t5 (C5-D5) indicates that the plots are becoming more similar.

The broken line in Fig. 7 suggests that both the control and dredge plots follow a similar temporal trajectory which probably represents seasonal changes on both plots. The greatest temporal change occurs between t4 and t5, and coincides with the high levels of recruitment observed on both plots. Consideration of changes on the control plot also suggest that temporal changes are small between t1 and t4 (C1, C2, C3 and C4 group together) but are greater between t4 and t5 (C5 is distant from C1, C2, C3 and C4). The three samples taken on the dredge plot following dredging (D3, D4, D5) are the most divergent.

### DISCUSSION

A statistically significant ( $0.05 < p < 0.10$ ) increase in the Bray-Curtis dissimilarity between the control and dredge plots occurs following the experimental dredging. This increase indicates that scallop dredging changes the benthic community structure at St Leonards. This change in community structure appears to be the result of a decrease in species number (Figs 2,3) and a decrease in abundance of particular species (Fig.4).

No previous studies have demonstrated a significant impact of shellfish dredging on benthic infauna, partly at least due to the low statistical power of the tests involved (McShane, 1981, Petersen et al., 1987). Low power results from the large spatial variability of benthic communities, the apparently small changes to the abundance of most species caused by dredging and from low intensity of sampling. The number of benthic samples already analysed in this study far exceeds the numbers analysed in previous studies, but still further pre-dredging and post-dredging samples must be analysed to confirm that our analysis is statistically robust. The usual statistical convention of  $p < 0.05$  has been relaxed in this study in an effort to more nearly balance type I and type II errors (Peterman, 1990). Analysis of the effects of dredging on individual species is in progress and should enable identification of any characteristics of these species that may cause them to be vulnerable to dredging. This will greatly reduce the risk that the changes observed are due to an impact coincident with dredging ('demonic intrusion', Hulbert, 1987), as will analysis of data collected at our other two study sites.

Assessment of the ecological significance of changes to community structure caused by dredging also remains to be determined. This assessment requires better estimates of the percentage

change in abundance of various species, the persistence of these changes, and information on the trophic and other ecological consequences of the changes to the infauna. Studies in progress will provide this additional information and clarify the ecological importance of changes to benthic communities caused by scallop dredging.

### ACKNOWLEDGEMENTS

We thank the technical staff at the Victorian Fisheries Research Institute, Queenscliff, for expert assistance. In particular we thank members of the Scallop Dredge Effects Program for their many hours of dedicated laboratory analysis; A. Bury, A. Jahnecke, R. Flint, M. Forsyth, S. Frlan & M. Miller. We would also like to thank the skipper D. Beyer, and crew R. Metcalf and M. Hoskins of the R.V. Sarda. Finally we thank the Victorian Scallop Industry for their co-operation in conducting the experimental dredging.

### LITERATURE CITED

- BELBIN, L. 1990. 'PATN Technical Reference Manual'. (CSIRO Division of Wildlife and Ecology: Canberra).
- BRAY, J.R. & CURTIS, J.T. 1957. An ordination of the upland forest communities of southern Wisconsin. *Ecological Monographs* 27: 325-349.
- BUTCHER, T., MATTHEWS, J., GLAISTER, J. & HAMER, G. 1981. Study suggests scallop dredges causing few problems in Jervis Bay. *Australian Fisheries* 40(9): 9-12.
- CADDY, J.F. 1973. Underwater observations on tracks of dredges and trawls and some effects of dredging on a scallop ground. *Journal of the Fisheries Research Board of Canada* 30: 173-180.
- CLARKE, K.R. 1993. Non-parametric multivariate analyses of changes in community structure. *Australian Journal of Ecology* 18: 117-143.
- ELEFThERIOU, A. & ROBERTSON, M.R. 1992. The effects of experimental scallop dredging on the fauna and physical environment of a shallow sandy community. *Netherlands Journal of Sea Research* 30: 289-299.
- FAITH, D.P., MINCHIN, P.R. & BELBIN, L. 1987. Compositional dissimilarity as a robust measure of ecological distance. *Vegetatio* 69: 57-68.
- FAITH, D.P., HUMPHREY, C.L. & DOSTINE, P.L. 1991. Statistical power and BACI designs in biological monitoring: comparative evaluation of measures of community dissimilarity based on benthic macro invertebrate communities in Rockhole Mine Creek, Northern Territory, Australia. *Australian Journal of Marine and Freshwater Research* 42: 589-602.
- GAMITO, S. & RAFFAELLI, D. 1992. The sensitivity of several ordination methods to sample replica-

- tion in benthic surveys. *Journal of Experimental Marine Biology and Ecology* 164: 221–232.
- HUGHES, W.D. 1973. Operational tests of Victorian scallop boats. *Australian Fisheries* 33(5): 14–16.
- HURLBERT, S.H. 1987. Pseudoreplication and the design of ecological field experiments. *Ecological Monographs* 54: 187–211.
- JONES, J.B. 1992. Environmental impact of trawling on the seabed: a review. *New Zealand Journal of Marine and Freshwater Research* 26: 59–67.
- McSHANE, P. 1981. The effect of scallop dredging on the macrobenthos of a muddy environment in Port Phillip Bay. Marine Science Laboratories, Queenscliff, Technical Report 4: 1–16.
- MESSIEH, S.N., ROWELL, T.W., PEER, D.L. & CRANFORD, P.J. 1991. The effects of trawling, dredging and ocean dumping on the eastern Canadian continental shelf seabed. *Continental Shelf Research* 11: 1237–1263.
- PARRY, G.D. & CURRIE, D.R. 1992. Interim report on the effects of scallop dredging on Port Phillip Bay. Marine Science Laboratories, Queenscliff, Internal report 193: 1–67.
- PETERMAN, R.M. 1990. Statistical power analysis can improve fisheries research and management. *Canadian Journal of Fisheries and Aquatic Science* 47: 2–15.
- PETERSON, C.H., SUMMERSON, H.C. & FEGLEY, S.R. 1987. Ecological consequences of mechanical harvesting of clams. *Fisheries Bulletin* 85: 281–298.
- PRESTON, F.W. 1948. The commonness and rarity of species. *Ecology* 29: 254–283.
- STEWART-OATEN, A., MURDOCH, W.M. & PARKER, K.R. 1986. Environmental impact assessment: 'pseudoreplication' in time? *Ecology* 67: 929–940.

## Appendix

Classification of the 204 benthic invertebrate species identified from 150 Smith–McIntyre grab samples taken at 'control' and 'dredge' plots off St. Leonards (38°10.06'S, 144°44.80'E. between the 13 May, 1991 and 31 October, 1991. Overall species rankings are given in ascending order of summed abundances. OBS = number of grab samples in which a species occurred.

**CRUSTACEA**

	SPECIES.	RANK	SUM	OBS.
<b>AMPHIPODA:</b>				
FAM: AMPELISCIDAE.	<i>Byblis mildura</i> Lowry & Poore, 1985	9	1409	143
	<i>Ampelisca euroa</i> Lowry & Poore, 1985	63	44	33
FAM: CAPRELLIDAE.	<i>Metaprotella cf. haswelliana</i> Haswell, 1884	151	3	3
FAM: COROPHIIDAE.	<i>Photis</i> sp.1	1	17004	146
	<i>Ericanthonius</i> sp.1	30	190	42
	<i>Aora mortoni</i> (Haswell, 1879)	141	4	1
FAM: CYPROIDEIDAE.	<i>Narapheonoides mullaya</i> Barnard, 1972	83	23	19
FAM: DEXAMINIDAE.	<i>Paradexamine lanacoura</i> Barnard, 1972	18	393	106
FAM: GAMMARIDAE.	<i>Melita</i> sp.1	68	36	27
	<i>Maera mastersi</i> (Haswell)	119	8	5
	<i>Ceradocus serratus</i> (Bate)	196	1	1
FAM: LEUCOTHOIDAE.	<i>Leucothoe assimilis</i> Barnard, 1974	101	16	14
	<i>Leucothoe</i> sp.1	167	2	1
	<i>Paraleucothoe novaehollandiae</i> Stebbing, 1899	166	2	2
FAM: LILJEBORGIIDAE.	<i>Liljeborgia</i> sp.1	32	176	70
	<i>Liljeborgia</i> sp.2	132	6	5
FAM: LYSIANASSIDAE.	<i>Endevoura mirabilis</i> Chilton, 1921	98	17	6
	<i>Hippomedon denticulatus</i> (Bate)	58	51	21
	<i>Amaryllis macrophthalmus</i> Haswell, 1879	85	22	15
	<i>Lysianassid</i> sp.1	122	8	6
	<i>Lysianassid</i> sp.2	144	4	3
	<i>Lysianassid</i> sp.3	191	1	1
	<i>Lysianassid</i> sp.4	74	29	1
FAM: MELPHIDIPPIDAE.	<i>Cheirocratus bassi</i> (Stebbing)	96	17	9
FAM: OEDICEROTIDAE.	<i>Oedicerotid</i> sp.1	13	720	102
	<i>Oedicerotid</i> sp.2	143	4	4
FAM: PHOXOCEPHALIDAE.	<i>Birubius babanekus</i> Barnard & Drummond, 1978	71	31	23
	<i>Phoxocephalus kukathus</i> Barnard & Drummond, 1978	73	30	22
	<i>Brolgus tattersalli</i> (Barnard)	72	30	22
	<i>Birubius panamuntus</i> Barnard & Drummond, 1976	84	22	18
	<i>Birubius cartoo</i> Barnard & Drummond, 1978	111	11	10
FAM: PODOCERIDAE.	<i>Dulichia</i> sp.1	57	52	24
<b>ISOPODA:</b>				
FAM: ANTHURIDAE.	<i>Amakusanthura pimelia</i> Poore & Lew Ton, 1985	134	6	6
	<i>Haliophasma cribense</i> Poore, 1975	76	27	8
	<i>Haliophasma canale</i> Poore, 1975	117	9	7
FAM: ASTACILLIDAE.	<i>Neastacilla deducta</i> (Hale)	203	1	1
FAM: EURYDICIDAE.	<i>Natatolana woodjonesi</i> (Hale)	61	50	28
	<i>Natatolana corpulenta</i> (Hale)	16	518	132
FAM: PARANTHURIDAE.	<i>Bulloganthura pambula</i> Poore, 1978	8	1871	148
	<i>Leptanthura diemenensis</i> (Haswell, 1884)	133	6	3
FAM: SEROLIDAE.	<i>Heteroserolis australiensis</i> (Beddard)	153	3	3
FAM: SPHAEROMIDAE.	<i>Exosphaeroma</i> sp. 1	131	6	4
<b>CUMACEA:</b>				
FAM: BODOTRIIDAE.	<i>Glyphocuma bakeri</i> (Hale)	202	1	1
FAM: DIASTYLIDAE.	<i>Gynodiastylis ambigua</i> Hale, 1946	42	91	35
	<i>Dimorphostylis cottoni</i> Hale, 1936	3	2324	143
	<i>Dicoides fletti</i> Hale, 1946	100	16	13
FAM: LEUCONIDAE.	<i>Hemileucon levis</i> Hale, 1945	44	90	28

*Crustacea cont.*

	SPECIES.	RANK	SUM	OBS.
<b>DECAPODA:</b>				
FAM: ALPHEIDAE.	<i>Alpheus euphrosyne</i> (de Man)	195	1	1
	<i>Athanopsis</i> sp.1	201	1	1
FAM: CALLIANASSIDAE.	<i>Callianassa arenosa</i> Poore, 1975	75	29	25
	<i>Upogebia dromana</i> Poore & Griffin, 1979	104	15	9
FAM: CRANGONIDAE.	<i>Pontophilus intermedius</i> (Bate)	121	8	7
FAM: DISCIADIDAE.	<i>Discias</i> sp.1	199	1	1
FAM: GALATHEIDAE.	<i>Galathea australiensis</i> (Stimpson)	165	2	2
	<i>Munida haswelli</i> (Henderson)	189	1	1
FAM: GONEPLACIDAE.	<i>Hexapus</i> sp.1	129	7	6
FAM: HIPPOLYTIDAE.	<i>Hippolyte tenuirostris</i> (Bate)	142	4	3
FAM: HYMENOSOMATIDAE.	<i>Halicarcinus rostratus</i> (Haswell)	35	130	70
	<i>Halicarcinus ovatus</i> (Stimpson)	79	26	17
FAM: LEUCOSIIDAE.	<i>Phylaxia intermedia</i> Miers, 1886	52	63	47
	<i>Philyra undecimspinosa</i> (Kinahan)	108	14	10
FAM: MAJIDAE.	<i>Majid</i> sp.1	193	1	1
	<i>Thacanophrys spatulifer</i> (Filhol)	188	1	1
FAM: PASIPHAEIDAE.	<i>Leptocheila</i> sp.1	200	1	1
FAM: PINNOTHERIDAE.	<i>Pinnotheres hickmani</i> (Baker)	194	1	1
FAM: PORCELLANIDAE.	<i>Polyonyx transversus</i> (Haswell)	113	10	9
FAM: PORTUNIDAE.	<i>Nectocarcinus integrifrons</i> (Latreille, 1825)	197	1	1
FAM: SERGESTIDAE.	<i>Leucifer</i> sp.1	97	17	12
FAM: XANTHIDAE.	<i>Heteropilumnus fimbriatus</i> (Milne Edwards)	190	1	1
<b>MYSIDACEA:</b>				
FAM: MYSIDAE.				
SF: GASTROSACCINAE.	<i>Paranchialina angusta</i> (Sars)	29	193	56
SF: SERIELLINAE.	<i>Siriella vincenti</i> (Tattersall)	45	85	14
SF: MYSINAE.	<i>Australomysis incisa</i> (Sars)	64	42	20
	<i>Tenagomysis</i> sp.1	27	213	54
<b>TANAIDACEA:</b>				
FAM: APSEUDIDAE.	<i>Apseudes</i> sp.1	92	18	14
FAM: KALLIAPSEUDIDAE.	<i>Kalliapseudes</i> sp.1	17	477	122
FAM: TANAIDAE.	<i>Tanaidae</i> sp.1	168	2	2
<b>OSTRACODA:</b>				
S/O: CYPRIDINIFORMES.				
FAM: CYPRIDINIDAE.	<i>Cypridinidae</i> sp.1	62	49	40
S/O: CYLINDROLEBERIDIDAE.	<i>Bathyleberis</i> sp.1	67	37	26
S/O: CYLINDROLEBERIDIDAE.	<i>Empoulsenia</i> sp.1	34	132	79
FAM: SARSIELLIDAE.	<i>Sarsiellid</i> sp.1	192	1	1
FAM: PHILOMEDIDAE.	<i>Philomedid</i> sp.1	198	1	1
<b>COPEPODA:</b>				
ORDER: CALANOID.	<i>Labidocera</i> sp.1	88	21	12
ORDER: CYCLOPOIDA.	<i>Cyclopoid</i> sp.1	152	3	2
<b>NEBALIACEA:</b>				
FAM: NEBALIIDAE.	<i>Nebalia</i> sp.1	120	8	7
LARVAE:	<i>Caridea larvae</i> sp.1	137	5	3
	<i>Brachyura zoea</i> sp.1	163	2	2

	SPECIES.	RANK	SUM	OBS.
<b>ECHINODERMATA</b>				
<b>CLASS: HOLOTHUROIDEA:</b>				
FAM: CHIRIDOTIDAE.	<i>Trochodota allani</i> (Joshua, 1912)	21	342	105
FAM: SYNAPTIDAE.	<i>Leptosynapta dolabrifera</i> (Stimpson, 1855)	116	9	5
<b>SUBCLASS: OPHIUROIDEA:</b>				
FAM: AMPHIURIDAE.	<i>Amphiura elandiformis</i> Clark, 1966	33	156	85
	<i>Ophiocentrus pilosus</i> (Lyman)	55	56	35
	<i>Amphipholis squamata</i> (D. Chiaje, 1828)	115	9	7
FAM: OPHIURIDAE.	<i>Ophiura kinbergi</i> Ljungman, 1866	51	63	46
<b>CLASS: ECHINOIDEA:</b>				
FAM: LOVENIIDAE.	<i>Echinocardium cordatum</i> (Pennant, 1777)	38	120	70
<b>CHORDATA</b>				
<b>ASCIDIACEA:</b>				
FAM: ASCIDIIDAE.	<i>Ascidia sydneyensis</i> Stimpson, 1885	109	13	9
	<i>Ascidella aspersa</i> (Müller)	123	8	5
FAM: STYELIDAE.	<i>Cnemidocarpa etheridgii</i> (Hardman)	170	2	2
FAM: PYURIDAE.	<i>Pyura stolonifera</i> (Heller, 1878)	171	2	2
<b>NEMERTINEA</b>				
	<i>Nemertean sp.1</i>	43	90	54
	<i>Nemertean sp.2</i>	50	65	36
	<i>Nemertean sp.3</i>	78	26	15
	<i>Nemertean sp.4</i>	180	1	1
	<i>Nemertean sp.5</i>	77	26	22
	<i>Nemertean sp.6</i>	66	37	22
	<i>Nemertean sp.7</i>	70	33	17
	<i>Nemertean sp.8</i>	127	7	4
	<i>Nemertean sp.9</i>	157	2	2
<b>PORIFERA</b>				
	<i>Demospongiae sp.1</i>	172	1	1
<b>PHORONIDA</b>				
	<i>Phoronis sp.1</i>	82	23	10
<b>PROTOZOA</b>				
<b>FORAMINIFERA:</b>				
FAM: MILIOTIDAE.	<i>Triloculina affinis</i> d'Orbigny, 1826	11	1262	129
	<i>Quinqueloculina sp.1</i>	90	19	13
	<i>Quinqueloculina sp.2</i>	118	8	7
FAM: POLYMORPHINIDAE.	<i>Guttulina sp.1</i>	164	2	2
<b>ECHIURA</b>				
	<i>Metabonellia haswelli</i> (Johnston & Tiegs)	169	2	2
	<i>Anelassorhynchus porcellus</i> (Fisher)	204	1	1



## ANNELIDA

	SPECIES.	RANK	SUM	OBS.
<b>POLYCHAETA:</b>				
FAM: AMPHERETIDAE.	<i>Ampharete</i> sp.1	14	672	105
FAM: CAPITELLIDAE.	<i>Capitellid</i> sp.1	39	106	20
	<i>Notomastus</i> sp.1	102	15	14
	<i>Notomastus</i> sp.2	145	3	3
FAM: CHAETOPTERIDAE.	<i>Chaetopterus variopedatus</i> (Renier, 1804)	110	11	11
FAM: CIRRATULIDAE.	<i>Chaetozone</i> sp.1	20	364	106
	<i>Tharyx</i> sp.1	106	14	14
FAM: DORVILLEIDAE.	<i>Dorvillea australiensis</i> (McIntosh, 1885)	59	50	29
FAM: EUNICIDAE.	<i>Marphysa</i> sp.1	40	105	51
FAM: FLABELLIGERIDAE.	<i>Diplocirrus</i> sp.1	47	74	52
FAM: GLYCERIDAE.	<i>Glycera cf. americana</i> Leidy, 1855	28	202	110
FAM: GONIADIDAE.	<i>Goniada emerita</i> Audouin & Milne Edwards, 1833	31	183	97
	<i>Ophioglycera</i> sp.1	174	1	1
FAM: HESIONIDAE.	<i>Nerimyra longicirrata</i> Knox & Cameron, 1971	60	50	39
	<i>Hesionid</i> sp.2	178	1	1
FAM: LUMBRINERIDAE.	<i>Lumbrineris latreilli</i> Audouin Milne Edwards, 1834	10	1353	145
FAM: MAGELONIDAE.	<i>Magelona cf. dakini</i> Jones, 1978	93	17	15
FAM: MALDANIDAE.	<i>Clymenella</i> sp.1	65	37	25
	<i>Asychis</i> sp.1	25	247	109
	<i>Maldanid</i> sp.1	125	7	7
FAM: NEPHTHYIDAE.	<i>Nephtys inornata</i> Rainer & Hutchings, 1977	6	2157	138
FAM: NEREIDAE.	<i>Simplisetia aequisetis</i> Hutchings & Turvey, 1982	80	25	22
	<i>Olganereis edmondsi</i> (Hartman)	86	21	18
	<i>Platynereis dumerilii antipoda</i> Hartman, 1954	89	19	9
	<i>Ceratonereis</i> sp.1	176	1	1
FAM: OPHELLIDAE.	<i>Armandia cf. intermedia</i> Fauvel, 1902	36	126	57
	<i>Polyophthalmus pictus</i> (Dujardin, 1839)	156	2	2
FAM: ORBINIIDAE.	<i>Leitoscoloplos bifurcatus</i> (Hartman, 1957)	15	585	118
FAM: PARAONIDAE.	<i>Aricidea</i> sp.1	5	2290	126
	<i>Paraonid</i> sp.1	19	378	74
	<i>Paraonis gracilis gracilis</i> (Tauber, 1879)	124	7	4
FAM: PECTINARIIDAE.	<i>Pectinaria cf. antipoda</i> Schmarda, 1861	126	7	7
FAM: PHYLLODOCIDAE.	<i>Phyllodoce</i> sp.1	37	121	78
	<i>Eulalia</i> sp.1	154	2	1
FAM: POLYNOIDAE.	<i>Paralepidonotus ampulliferus</i> (Grube, 1878)	114	9	8
	<i>Harmothoe</i> sp.1	23	307	118
	<i>Harmothoe spinosa</i> Kinberg, 1855	87	21	11
	<i>Malmgrenia microscala</i> (Kudenov)	130	6	6
FAM: SABELLIDAE.	<i>Jasmineira</i> sp.1	12	1062	102
	<i>Myxicola infundibulum</i> (Renier, 1804)	179	1	1
FAM: SERPULIDAE.	<i>Serpulid</i> sp.1	175	1	1
FAM: SIGALIONIDAE.	<i>Sigalion</i> sp.1	173	1	1
FAM: SPIONIDAE.	<i>Prionospio coorilla</i> Wilson, 1990	4	2316	108
	<i>Prionospio yuriel</i> Wilson, 1990	91	18	15
	<i>Polydora</i> sp.1	177	1	1
	<i>Laonice quadridentata</i> Blake & Kudenov, 1978	155	2	2
FAM: SYLLIDAE.	<i>Syllis</i> sp.1	146	3	3
FAM: TEREBEI.LID.Æ.	<i>Amaenna trilobata</i> Hutchings & Glasby, 1986	46	77	33
	<i>Terebellid</i> sp.1	112	10	8
	<i>Eupolyommia koorangia</i> Hutchings & Glasby, 1988	105	14	5
FAM: TRICHOBRANCHIDAE.	<i>Terebellides</i> sp.1	22	318	97
	<i>Artacamella dibranchiata</i> Knox & Cameron, 1971	2	3149	135

	SPECIES.	RANK.	SUM.	OBS.
<b>MOLLUSCA:</b>				
FAM: AGLAJIDAE.	<i>Aglaja taronga</i> Allan, 1933	95	17	14
FAM: ARCIDAE.	<i>Anadara trapezia</i> (Deshayes, 1840)	99	16	14
FAM: CARDIIDAE.	<i>Pratulium thetidus</i> (Lamarck, 1819)	107	14	11
	<i>Fulvia tenuicostata</i> (Lamarck, 1819)	160	2	2
FAM: CORBUI IDAE.	<i>Corbula cf. coxi</i> Pilsbury, 1897	7	1974	146
FAM: CYAMIIDAE.	<i>Cyamiomacra communis</i> Hedley, 1905	162	2	2
FAM: DORIDIDAE.	<i>Doris cameroni</i> (Allan, 1947)	187	1	1
FAM: EULIMIDAE.	<i>Strombiformis topaziaca</i> (Hedley, 1908)	158	2	1
FAM: GONIODORIDIDAE.	<i>Okenia sp. nov.</i>	181	1	1
FAM: HAMINEIDAE.	<i>Liloa brevis</i> (Quoy & Gaimard, 1834)	41	92	58
FAM: HIATELLIDAE.	<i>Hiatella australis</i> (Lamarck, 1818)	69	34	4
	<i>Hiatella subulata</i> (Gatliff & Gabriel, 1910)	159	2	2
FAM: KELLIIDAE.	<i>Melliteryx acupunctum</i> (Hedley, 1902)	94	17	11
FAM: MACTRIDAE.	<i>Macra jacksonensis</i> (Smith, 1885)	128	7	7
FAM: MONTACUTIDAE.	<i>Mysella donaciformis</i> Angas, 1878	136	5	5
FAM: MURICIDAE.	<i>Bedeve paivae</i> (Crosse, 1864)	140	4	2
FAM: MYTILIDAE.	<i>Amygdalum beddomi</i> Iredale, 1924	135	5	5
	<i>Musculus ulmus</i> Iredale, 1936	149	3	3
FAM: NASSARIDAE.	<i>Nassarius (Zeuxis) pyrrhus</i> (Menke, 1843)	53	62	40
FAM: NATICIDAE.	<i>Polinices sordidus</i> (Swainson, 1821)	139	4	3
	<i>Sinum zonale</i> (Quoy & Gaimard, 1833)	182	1	1
FAM: NUCULIDAE.	<i>Nucula pusilla</i> Angas, 1877	49	71	36
	<i>Nucula obliqua</i> (Lamarck, 1819)	3	15	14
FAM: OSTREIDAE.	<i>Ostrea angasi</i> Sowerby, 1871	184	1	1
FAM: PECTINIDAE.	<i>Pecten fumatus</i> Reeve, 1852	81	23	17
FAM: PERIPLOMATIDAE.	<i>Offadesma angasi</i> (Crosse & Fischer, 1864)	54	57	41
FAM: PHILINIDAE.	<i>Philine angasi</i> (Crosse & Fischer, 1865)	48	72	52
FAM: PTERIIDAE.	<i>Electroma georgiana</i> (Quoy & Gaimard, 1835)	150	3	3
FAM: PYRAMIDELLIDAE.	<i>Pyrgiscus fusca</i> (A Adams, 1853)	148	3	3
FAM: SEMELIDAE.	<i>Theora cf. lubrica</i> H & A Adams, 1866	24	269	78
FAM: SOLENIDAE.	<i>Solen vaginoides</i> (Lamarck, 1818)	183	1	1
FAM: TELLINIDAE.	<i>Tellina (Macomona) mariae</i> (Tenison Woods, 1875)	185	1	1
FAM: TROCHIDAE.	<i>Ethminolia vitilignea</i> (Menke, 1843)	147	3	3
FAM: VENERIDAE.	<i>Chioneryx cardioides</i> (Lamarck, 1818)	26	228	98
	<i>Callanaitis disjecta</i> (Perry, 1811)	138	4	4
	<i>Placamen placida</i> (Philippi, 1835)	186	1	1
	<i>Venerupis sp.</i> Lamarck, 1818	161	2	2

## SEDIMENT TRANSPORT RATES AND SEDIMENT DISTURBANCE DUE TO SCALLOP DREDGING IN PORT PHILLIP BAY

KERRY P. BLACK AND GREGORY D. PARRY

Black, K.P. & Parry, G.D. 1994 08 10: Sediment transport rates and sediment disturbance due to scallop dredging in Port Phillip Bay. *Memoirs of the Queensland Museum* 36(2): 327-341. Brisbane. ISSN 0079-8835.

The first direct measurements of turbidity caused by scallop dredging are presented. The physical effects of scallop dredging on the sediment dynamics of an enclosed, heavily-fished bay in southern Australia are indicated and data are provided to assess potential biological impact. Transport and deposition of sediments were measured within and beyond the sediment plume behind a scallop dredge. Natural suspended sediment concentrations were recorded with a bottom-mounted instrumented frame; sediment disturbance behind dredges was determined using the same instrumentation mounted on a towed sled. Concentrations in the sediment plume 2-16 seconds after dredging were 2-3 orders of magnitude higher than natural concentrations. Plume concentrations were similar to the natural levels after c. 9 minutes. Thus, for typical currents of approximately  $0.1\text{m}\cdot\text{s}^{-1}$ , suspended concentrations above natural levels were confined to a region within c. 54m of the dredge. However, the fine material remained in suspension longer, so dredging may be partially responsible for re-distribution of fine sediments in the bay.

*Kerry Black, Victorian Institute of Marine Sciences, 23 St Andrews Place, Melbourne, Victoria 3002; Greg Parry, Victorian Fisheries Research Institute, PO Box 114, Queenscliff, Victoria 3225; 15 April, 1994.*

Scallop dredging is the most valuable commercial fishery in Port Phillip Bay with annual harvests worth up to \$20 million. In a typical year dredges disturb approximately  $400\text{km}^2$  (20%) of the bed of Port Phillip Bay (Parry, unpubl. data). Thus, after a season of fishing, dredging represents a potential disturbance to sediment which may be equivalent to natural phenomena, particularly in deeper water where bottom wave energies are lower. By suspending the surface layer of sediment, dredging may be responsible for disturbance of previously buried material. Direct disturbance of fine sediments may result in the release of heavy metals, nutrients or toxic algal spores. Alternatively, dredging may simply break natural sediment bonds, allowing more suspension to occur during natural storms. Grain size and natural turbulence levels in the bay will determine where the sediments settle again.

This study tests whether dredging alters turbidity in the Bay and examines sedimentation patterns after a dredge passes through a region. To develop an appropriate quantitative comparison, both the natural and the dredge-related sediment concentrations were recorded. We are concerned with the physical sediment transport processes only; turbidity in the plumes, sedimentation, depth of disturbance and changes to the natural bonds in the sediments. Other factors such as incidental mortality of scallops and other

marine organisms, impact on habitat and short to medium-term impacts on biological communities were treated separately; the latter is presented elsewhere (Currie & Parry, this memoir).

Currents can be tidal, wind-driven, forced from Bass Strait or associated with internal density structure (Environmental Study of Port Phillip Bay, 1973; Black, 1993). Wave orbital motion which determines sediment transport rate is a function of water depth, wave height, wave period, wind strength and wind fetch. Grain sizes of suspended sediments during storms vary across the bay and decrease with distance above the bed. Sediment concentrations in suspension are also a function of the cohesiveness of the sediments, and cohesiveness may be reduced after dredging.

To cater for the wide range of natural conditions, measurements of natural sediment dynamics required simultaneous time series of forcing factors, including current strengths and wave activity, and the grain size distribution of bed sediments. Natural sediment concentrations and hydrodynamic variables were measured continuously with *in situ* bottom-mounted instruments, which were deployed for periods of several days to several weeks at three sites in the bay. These measurements complemented an existing numerical hydrodynamic model of the Bay (Black et al., 1993) and earlier sediment transport and wave studies (Black & Rosenberg, 1992).

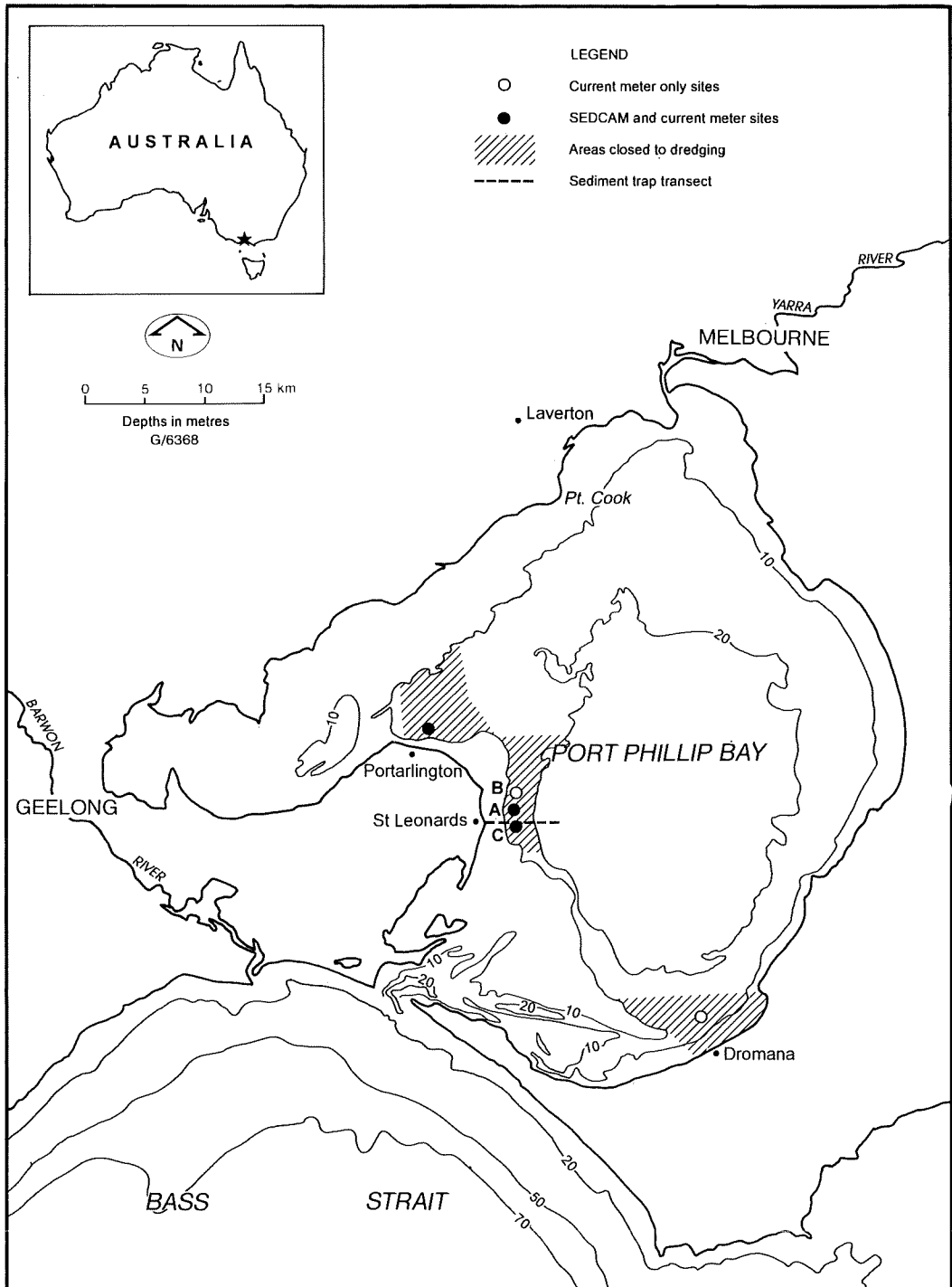

FIG.1. Study region where instruments were deployed. The experimental plots are shown at Dromana, Portarlington and St Leonards.

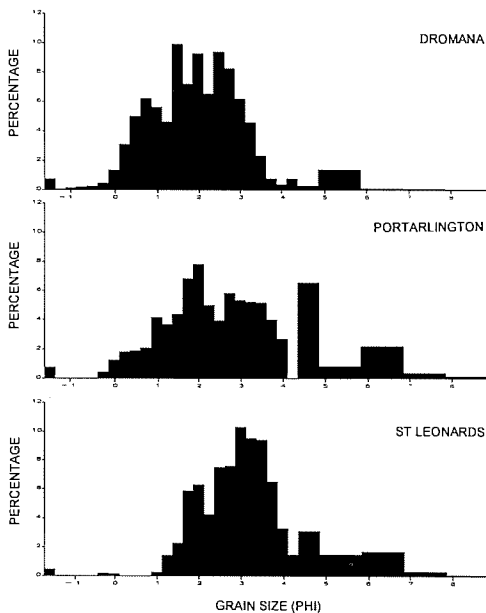

FIG.2. Representative bed sediment grain sizes at 3 study sites.

Measurements within the sediment plume of a scallop dredge required development of a towed monitoring sled. The sled was instrumented with turbidity monitors and pumps, the latter to sample for grain size and to calibrate turbidity monitors.

The overall study forms part of a series of linked biological and physical investigations, commenced in 1991 in response to a Victorian Government initiative (Parry & Currie, 1992; Currie & Parry, this memoir). The objectives were to: 1) compare quantities of sediment put into suspension by scallop dredging with natural sediment transport due to storms; 2) develop a sled-mounted monitoring system to be towed behind a scallop dredge to determine the amount of sediment disturbed by dredges of different design, the influence of vessel speed, cable length and sediment type on the amount of sediment

disturbed and catch efficiency of dredges of different designs, the optimal compromise between the catch efficiency and sediment disturbance; and 3) determine sedimentation patterns and areas of influence arising as a consequence of suspension of sediments by scallop dredging.

In this paper, we describe the scope of the overall study, and present results associated with the first objective and aspects of the second.

### STUDY REGION

Port Phillip Bay (PPB) is a large, semi-enclosed, predominantly tidal embayment linked to the ocean by a narrow, rocky entrance (Fig. 1). The surface area of the Bay is  $1.95 \times 10^9 \text{ m}^2$ , with a tidal prism of  $9.4 \times 10^8 \text{ m}^3$  and a mean depth of 12.8 m (Environmental Study of Port Phillip Bay, 1973).

The hydrodynamics are characterised by (i) an entrance region where fast ebb and flood jets (of the order  $3 \text{ m.s}^{-1}$ ) dominate the circulation, (ii) a flood-tidal delta, known as the Sands region, where strong currents occur in the major channels and (iii) a large 'inner' region, where tidal flows are weak (with an average of  $0.06 \text{ m.s}^{-1}$ ) (Black et al., 1993). These circulation patterns are broadly reflected by sandy bottoms in the faster flowing regions and fine muds deposited in the centre of the Bay. Sandy beds which predominate around the margins reflect local wave activity.

Three commercially-dredged sites at Dromana, Portarlington and St Leonards were selected for the study (Fig. 1). Each site was located at a similar depth (c.15m) in the 'inner' region, but sites had different bed sediments and were exposed to different current strengths and wave attack.

At Dromana, bed sediments were dominantly medium-fine sands with mean grain size (Table 1). A coarse fraction (0-1 phi; 0.5-1mm) was also present (Fig.2). At Portarlington, bed sediments were muddier (30.1%  $< 63 \mu\text{m}$ , Table 1) but the sediments also contained large numbers of shell fragments and the overall mean grain size was

TABLE 1. Mean grain sizes, percentage mud and sand, and spring tidal currents at the field sites. The standard deviations (SD) and the number of observations (N) are given.

Site	Mean grain size				Mud content			Spring tidal current (m/s)
	(mm)	(phi)	SD (phi)	N	(%)	SD	N	
Dromana	0.22	2.17	0.33	3	7.2	2.2	29	c.0.11
Portarlington	0.14	2.82	0.44	4	30.1	6.7	44	0.11
St Leonards	0.09	3.43	0.16	7	15.3	5.7	120	0.20

TABLE 2. Scope of field study and techniques applied at Dromana (Drom), Portarlington (Port) and St Leonards (StL). The symbols show: '+' technique applied; '-' not applied; 'P' planned.

Technique applied	Drom	Port	StL
Experimental dredging	+	+	+
Sediment traps			
-natural conditions	-	+	+
-during dredging	+	+	+
Depth rings	+	+	+
SEDCAM			
-natural conditions	-	+	+
-during dredging	-	+	+
Currents	+	+	+
Waves	+	+	+
Sea levels	—	+	-
Sediment monitoring sled	+	P	P
Sediment analyses			
-natural suspended	-	-	+
-bed sediment	+	+	+
-dredge plume	+	P	P
Comparison of dredges	-	-	P

0.14mm. St Leonards sediments were predominantly fine and very fine sand (Table 1). The coarse fraction noted at Dromana and Portarlington (<1phi; >0.5mm) was absent at St Leonards (Fig.2).

Spring tidal currents are slower at Dromana and Portarlington than at St Leonards (Table 1). Dromana is the most exposed to wave attack and Portarlington the most sheltered (Fig. 1).

#### FIELD MEASUREMENT TECHNIQUES

The investigations adopted a wide range of techniques (Table 2) including some novel approaches.

#### DREDGING OF EXPERIMENTAL PLOTS

Experimental plots were established within large areas (20–30km<sup>2</sup>, Fig.1) closed to all scallop dredging during 1991. Supervised dredging of these experimental plots by commercial scallop fishermen was undertaken as part of a series of controlled experiments designed to measure the effect of scallop dredging on biological communities (Currie & Parry, this memoir), bedform topography, sedimentation rates and turbidity.



FIG.3. *In situ* sediment transport unit (SEDCAM). The underwater video camera and the sediment sensor electronics are within the large housing. The smaller housing contains a battery power supply for the equipment and underwater lights. An acoustic pinger (foreground) is included to assist retrieval, if the frame was accidentally moved by a fishing boat.

TABLE 3A. The location and recording times for current meters and tide gauges deployed in Port Phillip Bay, 1991. All times are Australian Eastern Standard Time (AEST). Water depths are not corrected for tidal level at time of depth sounding. For recording intervals for S4 meters, SRB = special record blocks. For the measured parameters, V=current velocity (i.e. speed and direction and/or E/W and N/S components); T=temperature; C=conductivity; I=vertical tilt of instrument; P=pressure (a coarse value only); D=fine resolution pressure. The location of sites is shown in Fig. 1.

SITE	INSTRUMENT	MEASURED PARAMETERS	LAT./ LONG.	WATER DEPTH(m)	HEIGHT ABOVE BED (m)	DEPLOYMENT TIME		RECORDING TIME		RECORDING INTERVAL
						Mooring deployed	Mooring recovered	First record in water	Last record in water	
<b>CURRENT METERS</b>										
St L A	S4	V,C,T,P,I	38° 10.006'S	14.0	3.03	16:00 29/04/91	14:46 05/06/91	23:15 29/04/91	14:00 05/06/91	1 sec. av. for 1 min. every 45 min. SRB every 90 min.
			144° 44.74'E							
St L B	S4	V,C,T	38° 08.817'S	13.5	2.43	14:58 24/06/91	16:20 02/07/91	15:00 24/06/91	21:45 01/07/91	1 sec. av. for 1 min. every 15 min. SRB every 15 min.
			144° 44.926'E							
St L C	S4	V,C,T	38° 10.534'S	14.5	2.80	13:46 15/07/91	15:22 17/08/91	00:00 16/07/91	15:00 17/08/91	2 sec. av. for 1 min. every 60 min. SRB every 120 min.
			144° 44.883'E							
DROM	S4	V,C,T	38° 18.843'S	14.5	2.80	09:55 26/08/91	12:10 02/09/91	10:00 26/08/91	11:30 02/09/91	2 sec. av. for 1 min. every 30 min. SRB every 120 min.
			144° 56.410'E							
PORT	S4	V,C,T,P,I	38° 05.964'S	14.0	2.70	12:09 15/11/91	14:10 18/12/91	14:00 15/11/91	14:00 18/12/91	1 sec. av. for 2 min. every 120 min. SRB every 120 min.
			144° 40.910'E							
PORT NEIL BROWN		V,T,I	38° 05.964'S	14.0	6.10	12:09 15/11/91	14:10 18/12/91	12:20 15/11/91	14:10 18/12/91	Vector av. every 10 min.
			144° 40.910'E							
<b>TIDE GAUGE</b>										
PORT	AAND ERAA	D,T	38° 05.964'S	14.0	0.75	12:09 15/11/91	14:10 18/12/91	12:15 15/11/91	14:00 18/12/91	15 min.
			144° 40.910'E							

Experimental plots were 600x600m at Dromana and Portarlington and 600mx750m at St Leonards (Rosenberg et al.,1992). All plots were dredged with the same intensity and dredging was continued until the entire plot had, on average, been passed over twice by a scallop dredge. The Portarlington plot was dredged with this intensity on two occasions, three weeks apart. To achieve the desired intensity of dredging, 5-7 commercial scallop boats worked each plot over 2-3 days. Dredging was always restricted to approximately 3 hours per day when tidal currents were flowing strongly in the direction of down-

stream instrumentation. Relevant parameters were measured by locating turbidity sensors, a current meter and sediment traps downcurrent of the experimental plots.

CURRENTS AND TIDES

Currents and wave orbital motions were measured using an S4 electromagnetic current meter deployed on a mooring (Table 3A). These vector-averaging meters are suitable for combined wave and current environments. Sea levels were normally taken from permanent stations around the bay at Williamstown, Geelong and Pt

TABLE 3B. The location and recording times for video camera and sediment sensors deployed on SEDCAM in Port Phillip Bay, 1991. All times are AEST. Depths not corrected for tide at time of sounding. The location of sites is shown in Fig. 1.

VIDEO							
SITE	LAT./ LONG.	WATER DEPTH (m)	DEPLOYMENT TIME		RECORDING TIME		RECORDING INTERVAL
			Mooring deployed	Mooring recovered	First record in water	Last record in water	
St L A	38° 10.000'S 144° 44.737'E	14.0	15:30 29/04/91	14:30 05/06/91	23:00 29/04/91	07:00 05/06/91	1 min. burst every 8 hrs
St L C	38° 10.528'S 144° 44.883'E	14.5	13:30 15/07/91	15:10 17/08/91	16:00 15/07/91	08:00 17/08/91	1 min. burst every 8 hrs
PORT	38° 05.970'S 144° 40.910'E	14.0	12:20 15/11/91	14:04 18/12/91	16:00 15/11/91	08:00 18/12/91	1 min. burst every 8 hrs

SEDIMENT SENSORS								
SITE	LAT/LONG	WATER DEPTH (mm)	LEVEL ABOVE BED (m)	DEPLOYMENT TIME		RECORDING TIME		RECORDING INTERVAL
				Mooring deployed	Mooring recovered	First record in water	Last record in water	
St L A	38° 10.000'S 144° 44.737'E	14.0	0.11/ 0.41	15:30 29/04/91	14:30 05/06/91	00:02 30/04/91	14:14 05/06/91	3min. av. of 30sec. scans for 18 min. every hour
St L C	38° 10.528'S 144° 44.883'E	14.5	0.15/ 0.30	13:30 15/07/91	15:10 17/08/91	00:01 16/07/91	15:07 17/08/91	3min. av. of 30sec. scans for 18 min. every hour
PORT	38° 05.970'S 144° 40.910'E	14.0	0.15/ 0.35	12:20 15/11/91	14:04 18/12/91	00:04 16/11/91	14:04 18/12/91	4 min. av. of 1min scans for 20 min. every hour

Lonsdale. An Aanderaa WLR5 tide gauge was deployed at Portarlington where tidal constants and low frequency sea level measurements were needed (Table 3A).

Tidal analyses, using the procedure of Foreman (1977), were applied to each current meter and tide gauge time series. The tidal components could then be subtracted from the raw time series, leaving a residual current or sea level for separate analysis.

#### IN SITU SEDIMENT RECORDING INSTRUMENTATION (SEDCAM)

Sediment transport rates under natural conditions and during experimental dredging were measured with SEDCAM (Fig. 3), a free-standing aluminium frame upon which were mounted a Sony Video 8 camera, underwater lighting and 2 infra-red backscatter turbidity sensors (D&A Instruments; Downing et al., 1981). All instruments were mounted high enough to minimize any disturbance to the bed. The camera was placed c. 60cm above the bed. Filming was close enough to the bed to view the onset of sediment entrainment. Operating for 1 minute every 8 hours, up to

60 days of unattended operation was possible with a 3-hour film.

In conjunction with the adjacent current meter, SEDCAM enabled determination of the sediment threshold *in situ* (with undisturbed sediments) by inspection of the video film of the sea bed and current meter measurements. SEDCAM also records long-term variation in suspended sediment load. The equipment was originally developed for studies of sediment movement in wave/current environments in eastern Bass Strait (Black et al. in press).

The turbidity sensors were electronically controlled and powered from within an underwater housing so that no link to the surface was required. A bank of 6V rechargeable gel-cells powers the system for up to 6 weeks. Turbidity measurements were recorded at 30 or 60 sec intervals and averaged every 3–4 minutes (Table 3B) using a 4-channel 128K Wesdata 692 data logger.

The turbidity sensors were initially set 0.15–0.45m above the bed. Divers checked the exact elevations once the frame had settled into the sediments (Table 3B). Calibration of the sensors



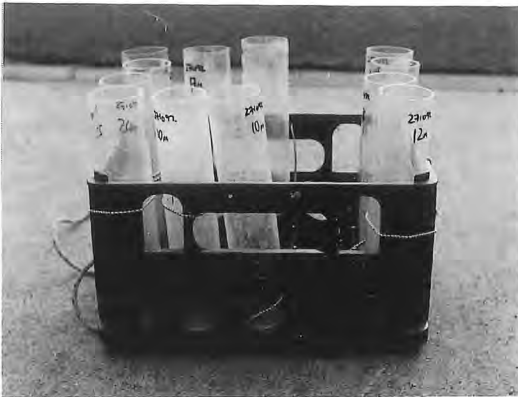

FIG.4. Bed sediment trap.

was essential (Appendix). SEDCAM and an adjacent current meter were deployed 80 and 60m downcurrent of the nearest boundary of the experimental plots at Portarlinton and St Leonards respectively. Equipment was deployed for 33 days at Portarlinton and twice at St Leonards for 38 and 33 days respectively (Table 3B).

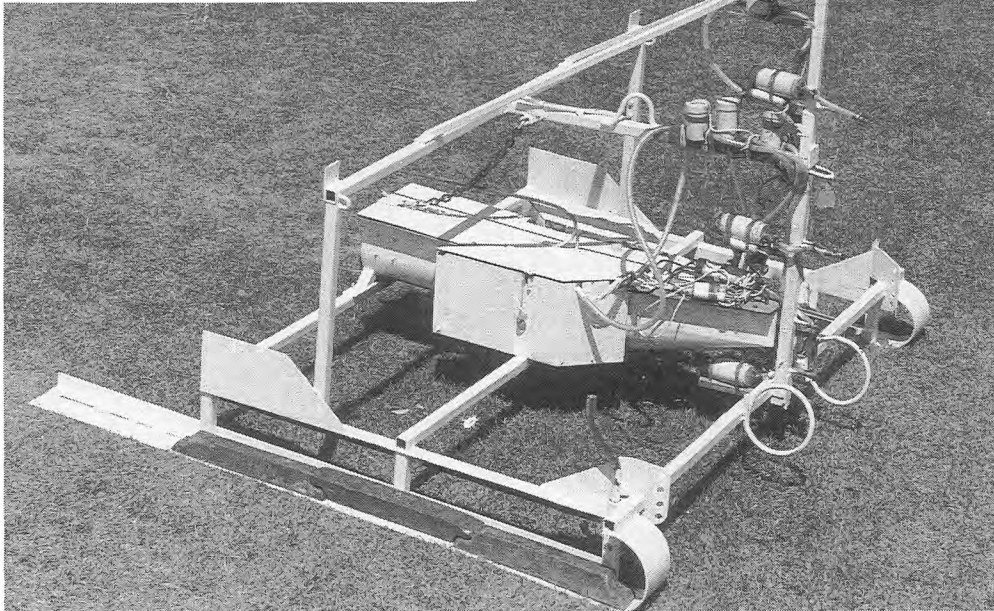

FIG.5. The sediment monitoring sled. Water pumps and turbidity sensors are placed on the upright at the front of the sled. The controlling electronics are located in an underwater housing within the metal protective container on the sled. Hoses terminate in metal housings where water samples are collected in plastic bags.

Turbidity sensors were regularly cleaned by divers to eliminate any marine fouling. However, the large amount of drifting seaweed and the activity of fish resulted in some interference with the sensors, particularly at St Leonards. Anomalous data were obvious from the exceptionally high readings and so these data could be detected in the final calibrated time series.

#### SEDIMENT TRAPS

Sediment traps were used in addition to the turbidity sensors to estimate time-integrated sedimentation rates in natural conditions and during dredging. Traps are particularly useful for examining relative deposition rates; any alterations to flow characteristics resulting from the



FIG.6. 'Depth rings' being placed in the bed to measure depth of sediment disturbance by scallop dredges.

traps themselves should affect all traps similarly. The traps record the total amount of sediment deposited during a storm or during dredging. Unlike the natural condition when sediment is continuously entrained and deposited, sediment entering a trap is not re-suspended. Accordingly, the actual net deposition during a storm will be less than that inferred from the trap results.

Each sediment trap consisted of twelve transparent acrylic tubes (70mm diameter x 350mm height) standing vertically in a plastic crate (Fig.4). The crate was normally placed on the bed by a diver (hence sampling occurred at 0.35m). Additional traps, sampling at elevations of 0.5, 1.0 and 2.0m, were placed on a supporting metal frame at the Portarlinton site to examine vertical variation in sediment concentration and grain size.

Sediment traps were placed 30, 60, 90, 200 and 400m downcurrent from the experimental plots, as well as at two 'control' sites located up-current. Traps were deployed just prior to the dredging, and removed as soon as possible after dredging was complete. To investigate the relationship between natural deposition and water depth, bed sediment traps were also placed along a transect perpendicular to the shoreline at St Leonards in depths of 10–23m (Fig.1).

#### SEDIMENT MONITORING SLED

Sediment disturbance due to scallop dredging was measured using a towed sled designed for the study (Fig. 5). Automated infra-red turbidity sensors and electric water pumps were attached at 0.25, 0.50, 1.14 and 2.00m above the bed and towed successively at 5, 20 and 50m behind the dredge. All instruments were electronically controlled on the sled so that no electrical link to the surface was required.

Turbidity sensors continuously-recorded the sediment concentrations during dredging operations. They provided a record of the sediment concentrations as a function of elevation above the bed and after different elapsed times, in accordance with the towing distance and boat speed. Thus the measured concentration decay rate (and the changing sediment grain characteristics) enable determination of contours showing sediment deposition behind the dredge.

Pumped samples of 2.5–3.5l of fluid were taken adjacent to each of the turbidity sensors for calibration. Pumps were controlled by a time-delay magnetic switch, triggered at the surface immediately before lowering the sled to the sea bed. Pumps operated for 30sec after a delay of 4mins. Water sample bags, placed inside metal housings on the sled, were replaced when the sled was brought to the surface after each calibration run.

Multiple boat speeds and depth to cable ratios were tested while catch efficiency was also monitored. The full range of calibration samples (from each level, at each distance behind the dredge, for each of the three measurement sites) are being collected. We present the results from trials at Dromana.

#### DEPTH OF DISTURBANCE

Colour-coded 'depth rings' were used to determine the depth of bed sediment disturbed by scallop dredges. Steel rings of 70mm diameter were placed on the sea bed (excluding St Leonards) and inserted 20, 40, 60 and 80mm below the surface using a special tool (Fig.6). 33–38 of these sets of rings were placed at 3–4m spacing diagonally across the dredge path before each experimental plot was dredged. The colour and number code allowed observers on each vessel to identify the rings caught by dredges.

#### POSITION FIXING AND WEATHER DATA

Instruments were deployed from the 20m research vessel 'Sarda' and located using a satellite Global Positioning System (GPS). This was a Furuno GP500 connected to a colour video plotter. Hourly winds were taken from an exposed anemometer on a low headland at Point Cook (Fig.1). Barometric pressure and rainfall (3hr intervals) were obtained from Laverton (Fig.1).

#### NATURE OF THE BED

Bed sediment samples were collected by divers using plastic corers, driven in by hand. In addition, replicate 0.1m<sup>2</sup> Smith-McIntyre grab

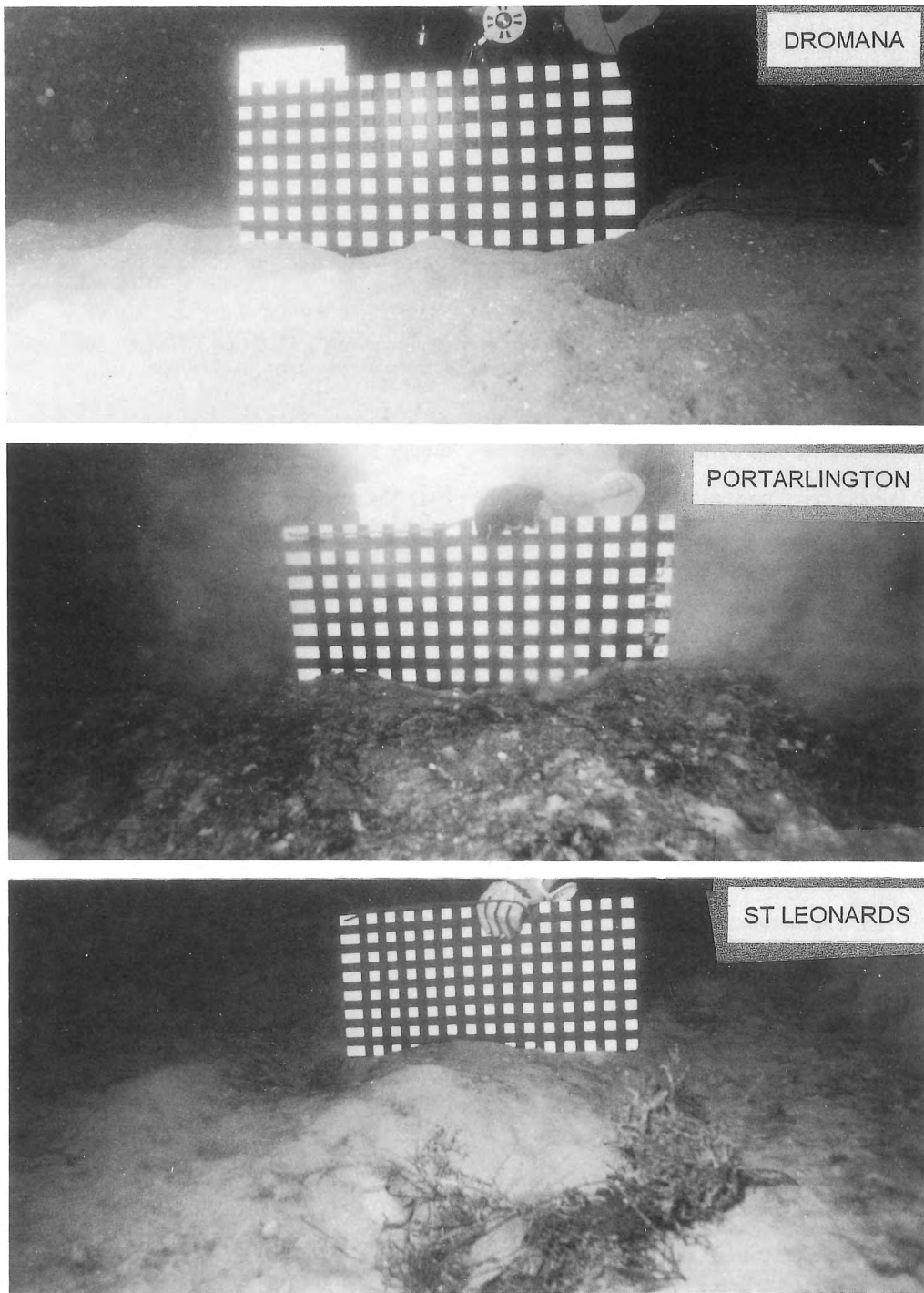

FIG.7. The sea bed at Dromana, Portarlington and St Leonards. The scale board is gridded at 2 cm intervals.

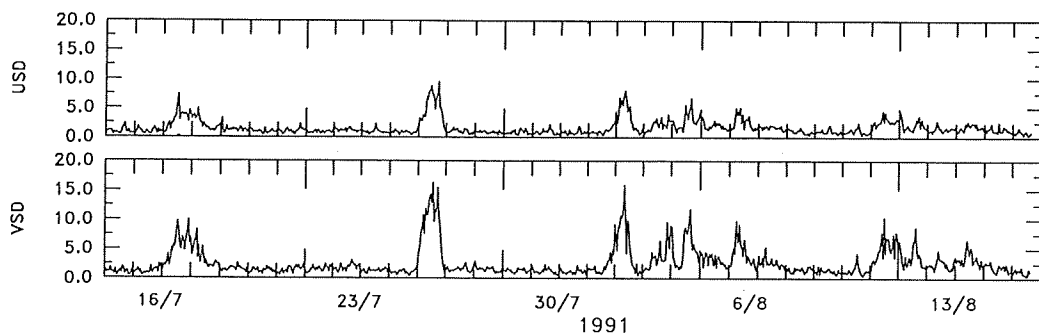

FIG.8. Wave orbital motion time series at St Leonards (Deployment C). USD and VSD are respectively the east/west and north/south components of the standard deviation of the wave orbital motion.

samples were taken at random within the experimental plots and 70ml subsamples taken for sediment analysis.

Diver-operated underwater video and underwater still (Fig.7) photography recorded appearance of the sites. The dredged and adjacent sites, plus a control site, were filmed before and

after dredging. (High turbidity prevented pre-dredge filming at Portarlington.)

FALL VELOCITY AND EQUIVALENT GRAIN SIZE

Bed sediment, sediment trap and dredge plume samples were analysed for fall velocities and equivalent grain sizes. Percentage sands and

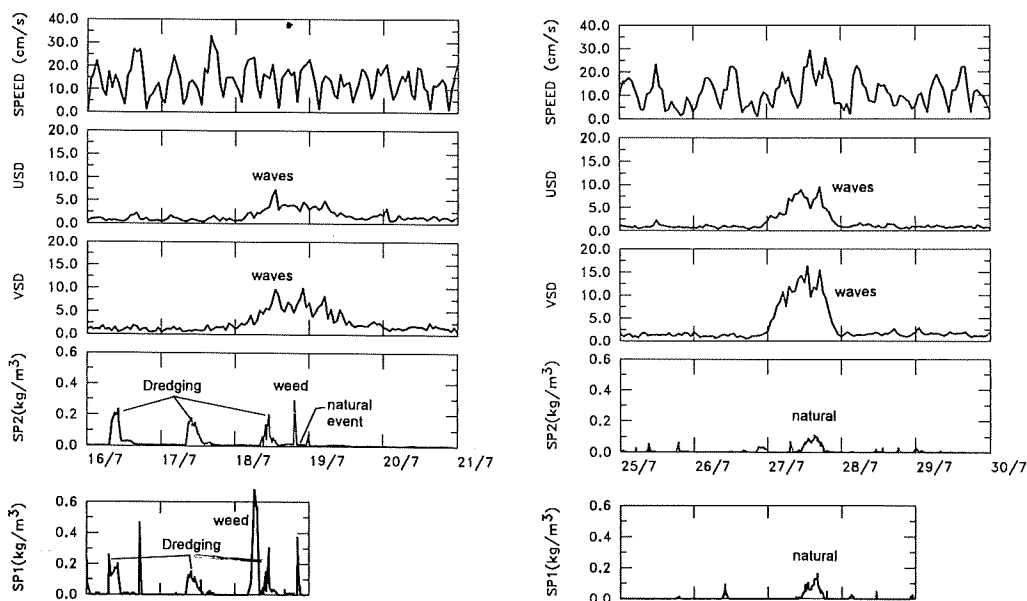

FIG.9. A, Measured currents (SPEED), bed orbital motion (USD and VSD), and suspended load (SP1 and SP2) at St Leonards C. The SPEED is the total current speed. USD and VSD are respectively the east/west and north/south components of the standard deviation of the wave orbital motion. SP1 and SP2 are the suspended sediment loads at 0.15 and 0.30 m above the bed respectively

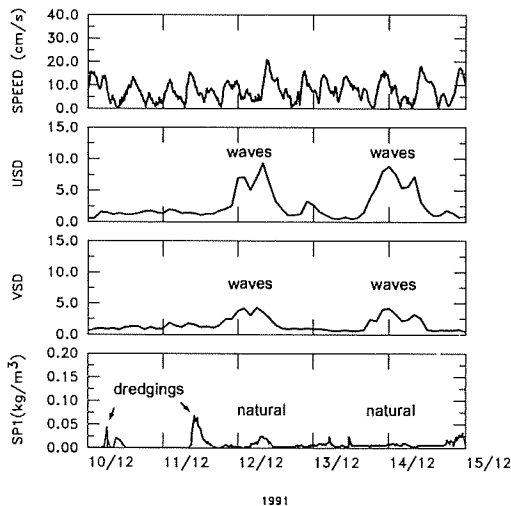

FIG. 9B. Measured currents (SPEED), bed orbital motion (USD and VSD), and suspended load (SP1) at Portarlinton (Deployment E). The SPEED is the total current speed. USD and VSD are respectively the east/west and north/south components of the standard deviation of the wave orbital motion. SP1 is the suspended sediment loads at 0.15 above the bed.

muds were obtained by collecting the mud fraction on a  $63\mu\text{m}$  filter. Fall velocities and equivalent grain sizes of the sand component were measured in an automated settling tube controlled by a Macintosh computer with software from the University of Waikato (de Lange, pers. comm.; Black & Rosenberg, 1991).

Pipette analysis was used for the muds (Tucker, 1988) and, to prevent destruction of the flocculated grains, all mud samples were kept and analysed in sea water. Using split sediment samples, fall velocities were much slower in fresh than in sea water.

## RESULTS

### CURRENTS AND WAVES

Tidal currents, disrupted by storms, dominated the circulation at the 3 sites. However, the tidal and wind-driven currents were usually insufficient to suspend sandy sediments at the sites on their own. Additional wave orbital currents were usually needed to initiate suspended sediment transport. Peaks in the wave orbital currents (Fig. 8) occur every 7–10 days in synchrony with the passage of high and low pressure systems at these latitudes. The magnitude of the peaks near the bed was determined by the water depth, wind

strength and wind direction. The latter determined the wind fetch and the resulting surface wave height.

### NATURAL CONCENTRATIONS

At St Leonards natural suspended sediment concentrations during the data collection period were up to  $c.0.1\text{kg.m}^{-3}$ , although concentrations of  $c.0.02\text{kg.m}^{-3}$  were more common (Fig. 9A). Similarly concentrations at Portarlinton were  $c.0.02\text{kg.m}^{-3}$  (Fig. 9B).

The wind strengths during the measurement periods were well above average (Fig. 10). One NNE wind exceeded  $17\text{m.s}^{-1}$  at Pt Cook which is above the 98 percentile of all measurements made over the period October 1987 to April 1989. Although this wind has one of the longest fetches in the bay for the St Leonards site, the measured suspended sediment load at St Leonards during this extreme event was  $<0.1\text{kg.m}^{-3}$ . Similarly the wind strengths at Portarlinton during the measurement period were commonly between 10–15  $\text{m.s}^{-1}$  and blowing across some of the longest fetches. Thus, the measured suspended loads are likely to be near the upper limit of the natural levels.

### CONCENTRATIONS DOWNCURRENT OF THE EXPERIMENTAL DREDGING PLOTS

Concentrations recorded downcurrent of the nearest boundary of experimental dredging plots were up to  $0.2\text{kg.m}^{-3}$  at 60m from the St Leonards plot and up to  $0.07\text{kg.m}^{-3}$  at 80m from the Portarlinton plot (Fig. 9A,B). Using the measured velocities and assuming 60 and 80m excursions of the plume, the dispersal times (between dredge disturbance and measurement of the plume concentrations downcurrent) range from 6 to 8 minutes at St Leonards and from 10 to 25 minutes at Portarlinton (Fig. 9A,B). After this time, the plume concentrations were about one order of magnitude greater than the common natural values of  $0.02\text{kg.m}^{-3}$ .

Measurements directly behind the dredge are available for Dromana only. There, concentrations reached nearly  $60\text{kg.m}^{-3}$  5m behind the dredge;  $c.20\text{kg.m}^{-3}$  at 20m; and  $12\text{kg.m}^{-3}$  at 50m (Fig. 11). For a boat speed of  $3\text{m.s}^{-1}$ , the distances represent elapsed times after disturbance by the dredge of 1.7, 6.7 and 16.7secs.

### COMPARISON OF DREDGE-RELATED AND NATURAL SUSPENDED SEDIMENT LOADS

Sediment concentrations 17secs after disturbance are 2–3 orders of magnitude higher than the

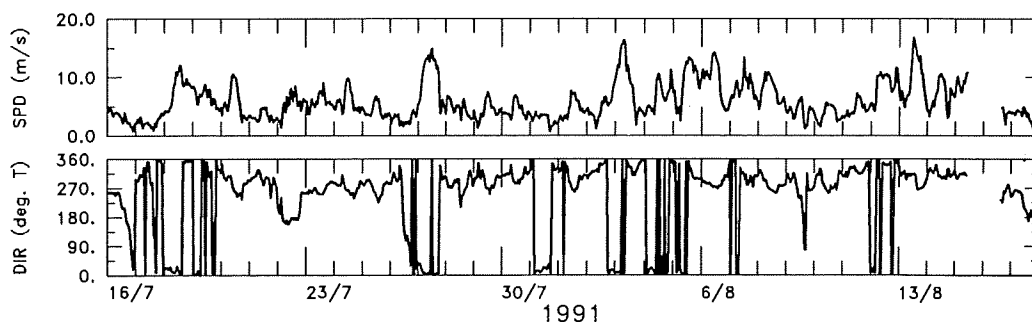

FIG.10. Wind speeds and directions measured at the Environment Protection Authority's Point Cook station during the St Leonards deployment.

natural levels. The dredging-related concentrations return to natural values recorded during large storms after about 9 minutes. However, they remain about an order of magnitude greater than the more commonly recorded storm levels. The elapsed time of 9 minutes is equivalent to 54m from the dredge for prevailing current strengths of  $0.1\text{ m}\cdot\text{s}^{-1}$ . Thus, elevated concentrations (equivalent to large storm events) and high sedimentation rates are restricted to within about 54m of the dredge.

#### DEPOSITION RATES

Fall velocities (calculated assuming quartz density in  $20^{\circ}\text{C}$  water) for the 30th, 50th and 70th percentiles of the bed sediment grain size distribution for Dromana are  $0.053$ ,  $0.039$  and  $0.027\text{ m}\cdot\text{s}^{-1}$  respectively. The measurements indicate a maximum plume elevation above the bed of about 2m. A simple calculation serves to explain the above results although more concise numerical modelling is being undertaken to treat the full grain size distribution. In the absence of any turbulence, the times for sediment to fall out of suspension from 2m above the bed would be 37,

51 and 74secs for the 3 fractions noted above. The turbulence behind a dredge would have the effect of increasing these times. However, the calculation demonstrates that most sediment would fall out of suspension within tens of metres behind the dredge in currents of order  $0.1\text{ m}\cdot\text{s}^{-1}$ , even though fine material may remain in suspension for much longer times.

#### DEPTH OF DISTURBANCE

The depth of disturbance by dredges at the 3 field sites was indicated by the number of rings captured from each depth within the sediment (Table 4). While the overall capture rate was low, highest numbers were collected from the surface and the rings indicated that the maximum depth of disturbance was 60mm at St Leonards and 40mm at Dromana and Portarlinton. The results suggest that the dredges dig further into the softer sediments at St Leonards than in the coarser sandier sediments at Dromana. The relatively low surface capture rates at Portarlinton remain unexplained.

The depth rings suggest that the 'Peninsula' dredge commonly-used in Port Phillip Bay typi-

TABLE 4. Number of depth rings recovered from each depth during experimental trials at each site.

<sup>a,b</sup> Individual rings from the same numbered set were collected in the same drag.

<sup>c</sup> The three rings collected on day 2 at Portarlinton (X 4) were from the same numbered set, but the 2cm ring was recovered by a different vessel from the other two.

Depth of rings (cm)	St. Leonards					Dromana					Portarlinton East X 2					Portarlinton East X 4				
	0	2	4	6	8	0	2	4	6	8	0	2	4	6	8	0	2	4	6	8
Day 1	-	0	0	0	0	7 <sup>a</sup>	1 <sup>a</sup>	1 <sup>a</sup>	0	0	0	0	0	0	0	0	0	0	0	0
Day 2	-	1 <sup>b</sup>	0	1 <sup>b</sup>	0	1	0	0	0	0	1	0	0	0	0	1 <sup>c</sup>	1 <sup>c</sup>	1 <sup>c</sup>	0	0
Day 3	-	5	2	0	0	-	-	-	-	-	-	-	-	-	-	-	-	-	-	
Total Recovered	-	6	2	1	0	8	1	1	0	0	1	0	0	0	0	1	1	1	0	0
Total Deployed	0	32	32	32	32	33	33	33	33	33	38	38	38	38	38	37	38	38	38	38

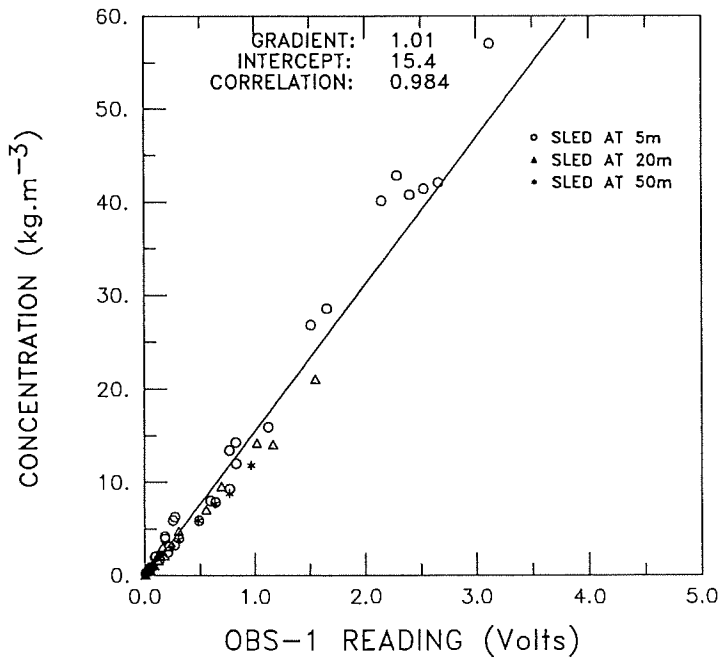

FIG.11. Sediment concentrations from water samples collected at 5, 20 and 50 m behind a Peninsula scallop dredge versus the turbidity sensor reading at Dromana.

cally disturbs the top 10–20mm of sediment, but that dredges sometimes disturb a layer up to 60mm thick. Predictions of sediment concentrations based on these estimates of the depth of sediment disturbance are similar to measured concentrations. Measurements at Dromana indicate that the plume extends about 1m above the bed immediately behind the dredge. Sediment concentration at the bed is c.1600 kg.m<sup>-3</sup>, after applying a pore volume correction factor of 0.6 to a density of 2650 kg.m<sup>-3</sup>. Thus, if a layer of sediment 1.5cm thick is disturbed and redistributed throughout a 1m height, then it will be 'diluted' 66 times, giving a sediment concentration of 24kg.m<sup>-3</sup>, i.e. 1600/66. This measurement is in accordance with that 5m behind the dredge, although measurements as high as 58kg.m<sup>-3</sup> were observed (Fig.11).

#### DISCUSSION AND CONCLUSIONS

Measurements of the sediment concentration behind the dredge define the characteristics of the plume and the depth of disturbance. This information can be used to assess the magnitude and

spatial extent of sediment disturbance by dredging and can be generalised to other sea bed types and grain size distributions. Thus, the measurements can be used to assess the potential environmental impact of scallop dredging. Impacts may be local physical changes that directly impact on biota (Currie & Parry, this memoir) or far-field changes, such as elevated turbidity that may impact on seagrass or reef communities.

Natural suspended sediment concentrations during storms were 2–3 orders of magnitude smaller than the concentration recorded immediately behind a scallop dredge. The dredging-related concentrations returned to natural storm levels after about 9 minutes at sites 60 and 80m downcurrent of the nearest boundary of experimental dredging plots, although the concentrations were still nearly an order of magnitude greater than those occurring during the more

common storm intensities. While a plume may be visually observed behind a dredge for longer than 9 minutes, the plume at these times will consist of fine sediments. Some of the finest sediments may take a considerable time to settle; the time would depend on the prevailing weather and the grain size. By disturbing the fine material, dredging may cause a significant redistribution of fine sediments within the Bay. In addition, the dredging may break natural sediment bonds (cohesiveness and biological bonding), causing increased likelihood of renewed suspension during natural storms.

Any direct environmental impact of the plume is likely to be small. However, the restricted spatial extent of the bulk of the deposition will result in localised high sedimentation. The measurements provide a quantitative estimate of the relative sediment concentrations during storms and dredging. However, a number of complexities in the natural system remain to be treated. For example, wave orbital motion is a strong function of water depth, and so more energy will be available at the bed for sediment

entrainment around the margins of the bay than in the deeper central regions. Indeed, quantities caught by sediment traps in this program along a transect with depths ranging from 10–23m were about 50g in 10m depths compared with <10g in water 15m or deeper, for the same time period.

We are now using the data to confirm wave prediction theory and have established an annual distribution of wave energies throughout the bay. In conjunction with a numerical hydrodynamic model of the tidal and wind-driven current speeds (Black et al., 1993), a summary of the hydrodynamic energy available at the sea bed for sediment suspension at all sites in the bay is being created. With the grain size data, this provides the basis for an estimate of natural annually-averaged suspended sediment loads for direct comparison with the dredging data.

#### ACKNOWLEDGEMENTS

We acknowledge support from David Hatton in data analysis. Thanks to Dave Byer (skipper), Bob Metcalf and Tom Budd (engineers) and Matt Hoskings and Mark Ferrier on the 'R.V. Sarda', and to Tony Sheehan skipper of 'R.V. Melita', plus all other crew members, for assistance with field work. Thanks also to the many Marine Science Laboratories staff members who deployed and retrieved sediment traps, including John Barry, Loren Brown, Anna Bury, Dave Currie, Rhonda Flint, David Forbes, Ross Haughton, Matt Hoskins, and Geoff Nicholson. Mike Forsyth undertook analyses for sediment samples. Andy Longmore collected water samples for field calibration of the turbidity sensors. Lastly, grateful acknowledgement to the skippers and crew of the following commercial scallop boats involved in experimental dredging trials: 'A.B. Hunter', 'A.B. Venture', 'Conquest', 'Grace', 'Jennann', 'Marie Lizette', 'Nephelle', 'Nimrod', 'Pegasus', 'Saint', 'Sandgroper', 'Tingara', and 'Trinity'.

#### LITERATURE CITED

- BLACK, K.P. & ROSENBERG, M.A. 1991. Hydrodynamics and sediment dynamics in wave driven environments. Volume 1. Field equipment and data. Victorian Institute of Marine Sciences, Technical Report 13: 1–229.
- BLACK, K.P. & ROSENBERG, M.A. 1992. Natural stability of beaches around a large bay. *Journal of Coastal Research* 8(2): 385–397.
- BLACK, K.P., HATTON, D.N., ROSENBERG, M.A. 1993. Dynamics of a large bay and ocean strait in Southern Australia. *Journal of Coastal Research* 9(2): 509–538.
- BLACK, K., ROSENBERG, M., SYMONDS, G., SIMONS, R. & PATTIARATCHI, N.P. IN PRESS. Measurements of wave, current and sea level dynamics of an exposed coastal site. International Biennial Conference on Physics of Estuaries and Coastal Seas.
- CURRIE, D.R. & PARRY, G.D. THIS MEMOIR. Preliminary analysis of the impact of scallop dredging on a soft sediment community using multivariate techniques.
- DOWNING, J.P., STERNBERG, R.N. & LISTER, C.R.B. 1981. New instrumentation for the investigation of sediment suspension processes in the shallow marine environment. In Nittrouer, C.A., (ed.), 'Sedimentary dynamics of continental shelves'. Special Issue of *Marine Geology* 42: 19–34.
- ENVIRONMENTAL STUDY OF PORT PHILLIP BAY, 1973. 'Report on Phase One 1968–1971'. (Melbourne Metropolitan Board of Works, and Fisheries and Wildlife Department of Victoria; Melbourne).
- FOREMAN, M.G.G. 1977. Manual for tidal heights analysis and prediction. Pacific Marine Science Report 77–10. (Institute of Ocean Sciences, Patricia Bay, Victoria, B.C.).
- PARRY, G.D. & CURRIE, D.R. 1992. 'Interim report on the effects of scallop dredging on Port Phillip Bay.' Marine Science Laboratories Internal Report 193.
- ROSENBERG, M., BLACK, K. & PARRY, G. 1992. Scallop dredging and sedimentation in Port Phillip Bay. Volume 1: Sediment and hydrodynamic measurements: Field data collection and analysis. Victorian Institute of Marine Sciences Working Paper 24: 1–78.
- TUCKER, M. 1988. 'Techniques in sedimentology.' (Blackwells: Oxford), 394p.



APPENDIX

CALIBRATION OF TURBIDITY SENSORS

Turbidity sensors were calibrated using the techniques applied by Black & Rosenberg (1991) using, for comparison, a bed sediment sample and sediment captured in a trap elevated 0.35m above the bed. Differences between the two calibrations were related to differences between grain sizes in the samples and so we adopted the calibration using suspended sediments rather than the bed sediments.

For validation, two sets of pumped suspended sediment samples were obtained using a 'March' 12V submersible electric pump attached to SED-CAM by divers. These were located 60 m downstream of experimentally-dredged plots. The concentrations derived from pumped samples and from sensors exhibit acceptable agreement (Fig.12), particularly at Portarlington. The larger deviation at St Leonards is probably a sample handling effect, related to pre-drying of samples, or a grain size effect. The grain size of sediments captured in sediment traps during storms used in the calibration will differ from that observed downstream of the experimental dredging.

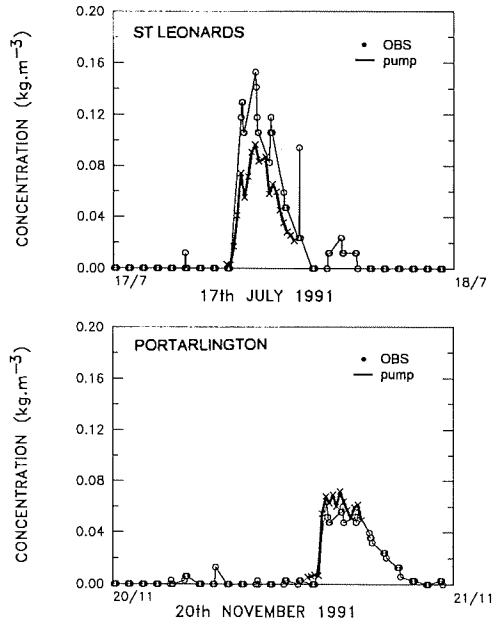

FIG.12. Comparison of sediment concentrations taken from pumped water samples and concentrations from the OBS turbidity sensors at 35 cm above the bed. The sites were downstream of experimental dredging plots at St Leonards and Portarlington.



## SCALLOP DREDGING: AN ENGINEERING APPROACH

P. COVER AND D. STERLING

Cover, P. & Sterling, D. 1994 08 10: Scallop dredging: an engineering approach. *Memoirs of the Queensland Museum* 36(2): 343-349. Brisbane. ISSN 0079-8835.

An appraisal of dredges used in the southeast Australian scallop fishery was undertaken and a comparison made with some scallop harvesting gear used elsewhere in the world.

Variations of the toothed mud dredge used in Australia were surveyed and described. Vertical forces on the toothed mud dredge consist of downward directed hydrodynamic lift, weight, and the upward component of the tow cable tension. These forces were analysed to show how the resultant contact pressure changed with tow speed. AMC flume tank and sea trial measurements were used to produce a mathematical model for the horizontal forces. Turning moments and dynamics during operation were analysed and modelled.

The toothed mud dredge was compared with the New Zealand dredge, Japanese Keta-ami, and Scottish mini dredge for downward contact pressures and drag forces per meter of swept width. The toothed mud dredge, keta-ami, and Scottish mini dredges exert high downward contact pressures with point loadings. The toothed mud dredge had the highest drag while the New Zealand dredge had the lowest drag especially at the lower tow speeds at which it is normally used.

*P. Cover and D. Sterling, Australian Maritime College, P.O. Box 21 Beaconsfield, Tasmania 7250; 20 May, 1994.*

Tasmanian, Victorian and Bass Strait scallop grounds have seen an extensive period of diminished returns and closures. The D'-Entrecasteaux Channel was closed from 1970 to 1981 and again in 1986 (Perrin, 1986), and the Bass Strait Tasmanian zone was closed in 1987 (Zacharin, 1991). This scallop fishery is suffering from low catch rates because of low stock levels and poor recruitment (D.P.I., Tas. Sea Fisheries data). The poor state of the fishery is partly attributed to inefficient and destructive fishing methods (McLoughlin et al, 1991).

Catching efficiency of the Australian scallop 'mud' dredge was found to be low: on average only 11.6% (McLoughlin et al., 1991), and incidental damage is high for the box type dredge. High incidental damage may be detrimental to the fishery's long term viability (Zacharin, 1988).

Scallop fishing gear used worldwide include box type dredges, the ring mesh bag type dredge, small multiple units and trawl gear. This gear has evolved; each in its own part of the world to suit a range of local conditions including scallop type, bottom terrain, and local technology. There is currently a drive to improve scallop harvesting gear both in efficiency (catching and engineering) and environmental impact.

To date there have been few studies of scallop dredges from an engineering viewpoint. That research includes work on: teeth and depressors

(Baird, 1959), drag measurements (Hughes, 1973) and the pressure drop behind a stalled foil (Vaccaro & Blott, 1987). Baird (1959) found that teeth improved catching efficiency and bottom contact was improved by a depressor (or diving) plate. Hughes (1973) measured typical bollard pulls and warp cable tensions for box dredges in Port Phillip Bay. Vaccaro & Blott (1987) suggested that a simple flat depressor plate at 60-75 with a gap to chord length ratio of 0.27 could improve efficiency of scallop harvesting gear.

The Australian Maritime College (AMC) is cooperating with CSIRO Division of Fisheries and the Tasmanian Fisheries Department to research better scallop harvesting gear; its role is to investigate the engineering aspects of the gear.

The work conducted to date by the AMC had its objectives to: 1, survey current box dredge designs; 2, assess the engineering performance of the box dredge; 3, compare the engineering aspects of the box dredge design to designs used elsewhere in the world.

## METHODS

### BOX DREDGE ENGINEERING PERFORMANCE

A standard box dredge (Fig.1), as used in Australia, was constructed and analysed in flume tank and sea trials. Tests in the flume tank involved suspending the dredge in the flow by load

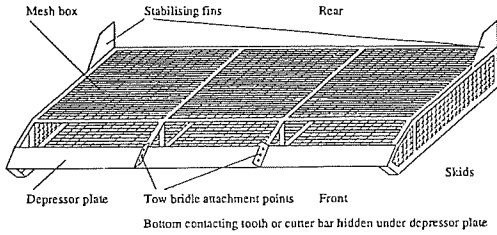

FIG.1. Schematic view of toothed mud dredge and descriptive terms

cells. This gave a measure of the downward and horizontal forces due to waterflow (hydrodynamic force). Sea trials allowed the total drag (including ground effect) to be measured and diver observations of the operational dynamics to be made. The turning moments and dynamics in operation were further analysed by mathematical modelling data from the tests. Modelling was based on equations of equilibrium applied to the system of forces acting on the box dredge.

For equilibrium or no rotation: 1, the sum of the moments about the teeth = 0 (moment arm dimensions in Fig.2). 2, the sum of the vertical forces = 0. 3, the ground reaction forces at the Front, Teeth, and Rear must always be greater than or equal to zero.

Sum of the moments = (Tow force – Hydrodynamic drag) x 0.285 – Weight x 0.413 – Upward Component of Tow Cable Tension x 0.360 + Hydrodynamic Downward Directed Lift x 0.318 – Ground Reaction at the Front x 0.200 + Ground Reaction at the Rear x 1.300

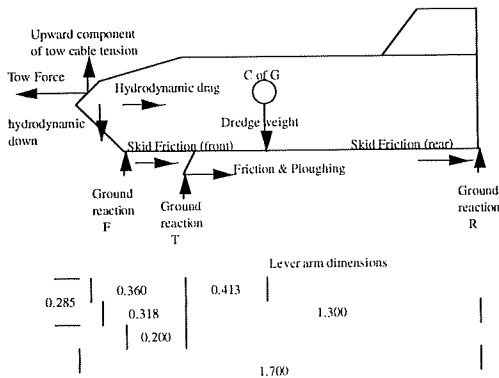

FIG.2. Diagram of forces and lever arms acting on toothed mud dredge.

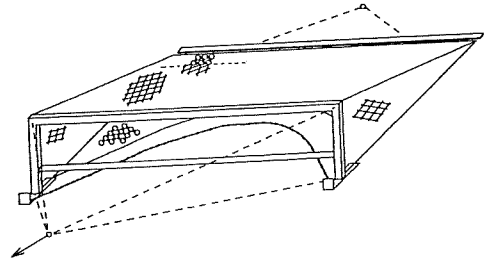

FIG.3. The New Zealand dredge.

Sum of the Vertical Forces = Weight + Hydrodynamic Downward Directed Lift – Upward Component of Tow Cable Tension – Ground Reaction at the Front – Ground Reaction at the Teeth – Ground Reaction at the Rear.

Dynamic equilibrium may exist with the ground reaction at front, teeth and rear varying dynamically in response to the terrain, sea conditions and other factors.

ENGINEERING COMPARISON OF BOX DREDGE WITH DREDGES USED ELSEWHERE

Three dredges used elsewhere in the world, obtained for comparison to the standard box dredge, were: 1, the New Zealand dredge (Fig.3) which comprises a flexible chain/ring mesh bag, tickler chain and towing frame. In New Zealand scallop fishing boats use a pair of ring bag dredges upto 2.5m wide with heavy tickler chains (Bull,1988); 2, the Japanese Keta-ami dredge (Fig.4) contains a flexible ring mesh bag with looped tickler chains mounted behind tines for use on hard mixed and rocky ground. It is designed to ride over rocky obstacles and not to

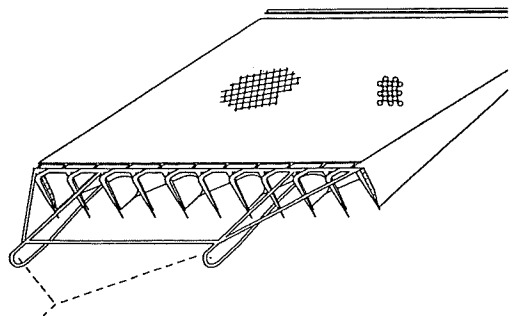

FIG.4. The Japanese Keta-ami dredge.

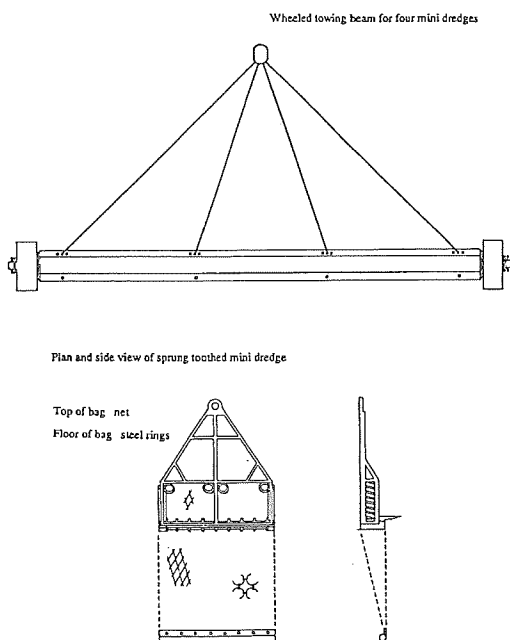

FIG.5. The Scottish mini dredges.

pick up rocks (Zacharin, pers. com.); and 3, the Scottish mini dredges (Fig.5) incorporate sprung teeth for use on hard and rocky grounds and are highly selective, not picking up rocks and other debris (Franklin, Pickett & Connor, 1980). The Scottish mini dredges are normally towed in gangs of three or more from a wheeled towing beam.

The downward contact pressures applied by the dredge components were calculated from measured downward forces or weights of objects divided by their sea bed contacting area. Downward contact pressures have been compared for the dredges analysed.

Total drag of each dredge was calculated from warp tension measurements using a load cell during sea trials. The catching width for each dredge was directly measured. Total drag for the four dredge types were compared on the basis of drag per meter of swept width.

## RESULTS

### SURVEY OF BOX DREDGE DESIGNS

In the SE Australian scallop fishery the local fishers exclusively use a box type dredge in conjunction with a dredge tipper. This is due to the systems ease of operation and safe handling char-

acteristics. The current dredge known as the toothed mud dredge (Gorman & Johnson, 1972; Hughes, 1972; Dix, 1982) is a heavy ( $300 \pm 150$ kg) steel structure composed of a steel mesh box on skids with a bottom contacting tooth bar or cutter bar and forward mounted depressor plate which also serves as the attachment point for the tow bridle.

The width of this dredge is about 3.3m but varies from 2.2–4.6m to suit boat size, width of the sorting tray and the vessel's towing capacity.

Fore to aft (length) dimensions vary only slightly between dredges irrespective of width. Typically the measurement from the back of the box to the tooth bar is about 1.2m. The box is 80–100mm above the skids. The skid length is 1.5m in a typical dredge, however forward extensions as in the Peninsula dredge modification can add up to 0.45m, while rear extensions of up to 0.3m are often used. The forward extension of the skids is a modification designed to reduce the tendency of the dredge to ride on its nose. The rearward extensions should similarly reduce the tendency for the dredge to ride on its rear.

A dredge height of 0.4m from bottom of skids to top of the box is generally adopted. Short stabilising fins are usually incorporated on each side at the rear and add an additional 0.25m to overall height.

The box type dredge generally referred to as the toothed mud dredge is often used with a device other than the tooth bar. In Port Phillip Bay it is more usual to fit a cutter bar which does not protrude below the depth of the skids. Alternatively a new device referred to as the 'mouth organ bar' can be fitted. In Bass Strait or Tasmanian waters the tooth bar normally has teeth protruding 20–60mm below the skids. The teeth are made from a hardened steel with the tips treated with hard face welding.

A variant of the box dredge known as the Bay dredge, has a long history of use in Port Phillip Bay. This dredge has the depressor plate set well forward of the box and low to the ground. The dredge is normally towed at a 5–8 knots. In one of the dredges observed, the cutter bar was angled aft in manner which would not function at all in digging up scallops from the sea bed. Intuitively the Bay dredge relies on the hydrodynamic action of the depressor to catch scallops.

On several dredges an old rubber tyre and length of chain are towed from the top rear of the box. This addition may hold the back of the dredge in ground contact or serve some dynamic purpose on rough or undulating terrain.

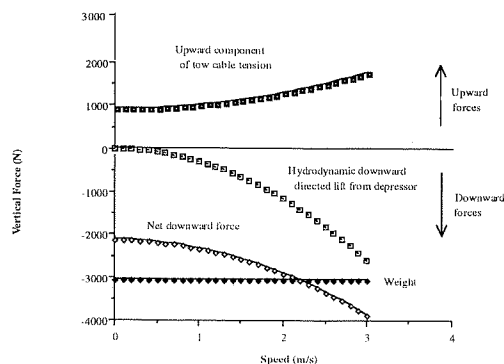

FIG.6. Vertical forces acting on toothed mud dredge modelled from lines of best fit of flume tank and sea trial data.

Dredges which have seen extensive use show high wear at the leading edges of the skids. In most cases this wear zone is patched or reinforced with hard facing weld. Dredges from Port Phillip Bay which have been extensively used exhibit thinning of the skids toward the rear. This may be due to the dredges riding harder on the rear of the skids when full or may be the result of using a short tow cable or from repeated wear during shooting away and haulback.

#### BOX DREDGE ENGINEERING PERFORMANCE

**Vertical forces.** Vertical forces acting on an operating dredge are: the weight, downward directed hydrodynamic lift from the depressor plate, and the upward component of the tow cable tension.

Weight of the dredge is partially reduced by buoyancy effects. The weight in water of the standard dredge was measured by suspending it in the flume tank by 'load cell' tension meters.

The hydrodynamic downward directed lift is the force exerted at right angles to the direction of flow by the deflecting action of the depressor plate. Hydrodynamic lift is generally proportional to velocity squared and was measured over a range of water speeds in the flume tank.

The upward component of the tow cable tension depends on the declination angle of the tow cable and the total drag acting on the dredge. For a completely rigorous treatment the weight and hydrodynamic drag of the tow cable should also be considered. Since the effect of cable weight and drag are relatively small they have been omitted for a more simplified view. The declination angle of the warp can be measured by an

inclinometer but for the shallow depths used in the sea trials, straight line geometry can be assumed. With this assumption the declination angle can be derived from the cable length to depth ratio used. The total drag was obtained from sea trials by measuring the tow cable tension over a range of tow speeds.

The net downward force is the sum of all the vertical forces and must be greater than 0 for the dredge to stay in bottom contact.

Mathematically these three components of the vertical forces can be summed and analysed with respect to speed as follows:

—The force due to weight ( $W$ ) is constant.

—The hydrodynamic force can be expressed as:  
 $L = \rho A C_L v^2$  where  $v$  = velocity,  $A$  = area of depressor,  $\rho$  = density of water,  $C_L$  = lift coefficient of depressor.

—The upward component of the tow cable tension can be expressed as:

$U = \text{Total Dredge Drag} \times \tan \Theta$  Where  $\Theta$  = declination angle of the tow cable or alternatively  
 $U = \text{Total Dredge Drag} \times \frac{1}{\text{cable length to depth ratio}}$

—The net downward force ( $N$ ) is the arithmetic sum of all the vertical forces.  $N = W + L - U$

Fig.6 shows how the vertical forces on the dredge change with speed.

**Horizontal forces:** The horizontal forces acting on the toothed mud dredge are the tow force (horizontal component of tow cable tension) which is equal and opposite to the drag forces. The total drag of the dredge is made up of: hydrodynamic drag, friction and ploughing forces.

The total drag was determined from sea trials

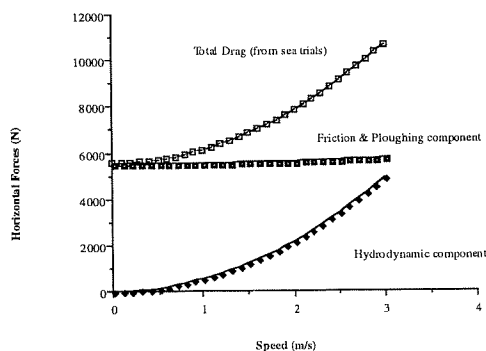

FIG.7. Horizontal forces acting on toothed mud dredge modelled from lines of best fit of flume tank and sea trial data.

TABLE 1. Estimated downward contact pressures for scallop dredges and their components. For comparison an 80kg man wearing size 8 shoes would exert a ground contact pressure of 26.1kPa.

Dredge type	Weight (in water)	Component	Contact pressure	Dynamic situation
Toothed mud	310kg (3050N)	Skids (in continuous contact) Skids (not in continuous contact) Toothed bar	12.7kPa extremely high extremely high	point loading; fore and aft rocking
New Zealand	90kg (880N)	Skids Tickler chain Chain and ring mesh belly	18.3kPa 2.2-3.2kPa 3.9kPa	some bouncing difuse loading difuse loading
Keta-ami	270kg (2645N)	Frame Tines Tickler chain Chain and ring mesh belly	10kPa extremely high 1.2-2.0kPa 2kPa	small contact area point loading; bounces over obstacles difuse loading difuse loading
Scottish	510kg (5000N)	Wheels Teeth Chain and ring mesh belly	80kPa extremely high 7.5kPa	point loading difuse loading

from measurements of tow cable tension over a range of tow speeds. The hydrodynamic drag component was measured in the flume tank by suspending the dredge in the flow without bottom contact. Friction and ploughing were calculated as the difference between the total drag and the hydrodynamic drag.

Hydrodynamic drag from the depressor plate and from the rest of the dredge can be expressed mathematically as:

$$D = 1/2 \rho A C_D v^2 \quad (\text{i.e. proportional to velocity squared})$$

Friction is a mechanical force and can be considered to be independent of speed. The normal expression for friction is:

$$F = \mu N \quad \mu = \text{coefficient of friction;}$$

N = the normal force (at right angles to the contacting surfaces).

In the case of an operational dredge the normal force is equivalent to the net downward force. Under the test conditions the net downward force increases with speed (Fig.6), therefore we would expect the friction force acting to also increase with speed.

In the ploughing force from the teeth could be a simple friction effect (i.e. independent of speed). However since the rate of ground shearing is determined by the speed of the dredge, this could lead to the ploughing force being speed sensitive.

From the trends observed in this sea trial and flume tank data with respect to speed, the horizontal force model (Fig.7) was developed.

**Resultant forces and turning (rocking) moments:** Configuration of all the forces acting on the toothed mud dredge (Fig.2) are such that a turning moment may exist causing the dredge to rock forward onto its nose or to rock back onto the rear of the skids. Dredge wear patterns indicate that this phenomenon commonly occurs.

The turning moments for two specific cases have been derived from the experimental data and the configuration of forces.

Modelling of all forces and resultant moments obtained by resolving ground reaction forces on skids and teeth show that where the cable length to depth ratio is greater than 7 the resultant effect suggests that the toothed mud dredge rocks forward onto its nose (Fig.8). Where a short cable length to depth ratio of 3 or less is used the dredge

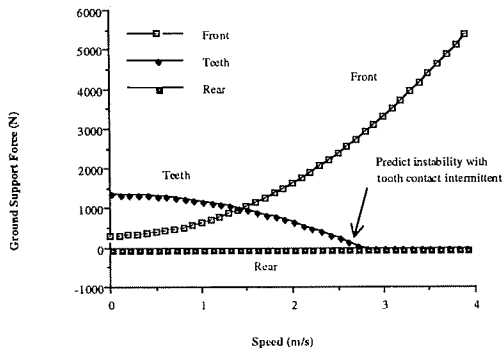

FIG.8. Ground support forces (Model 1) for toothed mud dredge at a length to depth ratio of 8 on hard ground..

would ride more heavily on the rear of the skids (Fig.9).

**Dynamic aspects:** An observed feature of toothed mud dredge performance on hard sand bottoms is a pronounced pulsing in warp tension. This feature is affected by altering the warp length and speed and is said to have some effect on catching performance depending on the terrain. Sea trial warp tension measurements using a chart recorder have yielded pulse periods of the order of two seconds with a variation in warp tension of up to  $\pm 30\%$ .

Approaching this phenomenon from a theoretical point of view, we can consider the dredge as having a moment of inertia ( $I$ ) about a fixed point (i.e. the teeth).

We can calculate  $I$  by:

$$I = \sum mr^2$$
 where  $m$  = mass of component,  
 $r$  = radius of gyration.

The forces operating are in the form of disturbing and restoring forces (or torques) (restoring torque =  $\tau$ ). The moment of inertia will be determined by the weight and shape of the dredge and will be constant for a particular dredge. The restoring torque will vary with the angle of the dredge ( $\Theta$ ) and therefore defining the restoring torque is difficult.

A natural period must exist and will depend on the restoring torque and the moment of inertia.

$$T = 2\pi \left(\frac{I}{\tau}\right)^{1/2}$$

#### ENGINEERING COMPARISON OF BOX WITH OTHER TYPES OF DREDGES

**Downward contact pressures:** The downward contact pressures for all four dredge types are compared in Table 1. The teeth of the toothed mud dredge and the skids if not in continuous contact will exert extremely high bottom contacting pressures. The New Zealand (Fig.3) dredge exhibits low contact pressures for all its bottom contacting elements. The Keta-ami (Fig.4) exerts extremely high bottom contact pressures at the tynes but low elsewhere. The Scottish mini dredges (Fig.5) also exert extremely high bottom contact pressures at the teeth but low elsewhere.

**Comparison of drag forces per m of swept width:** The toothed mud dredge has the highest drag per meter of swept width and the New Zealand dredge has the lowest drag (Fig.10).

The toothed mud dredge has the highest level of ground shear and friction type drag as well as the highest hydrodynamic drag. The ground shear and friction can be estimated by the y intercept

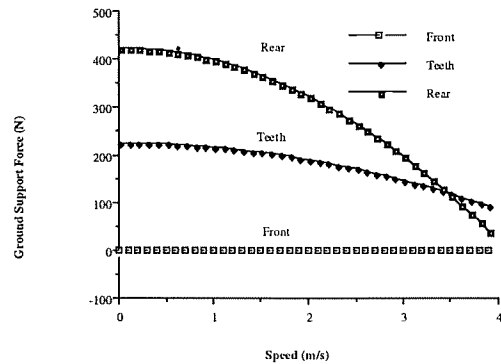

FIG.9. Ground support forces (Model 2) for toothed mud dredge at a length to depth ratio of 3 on hard ground.

on the drag curve (Fig.10). The hydrodynamic component is evident in the amount of increase in drag over the speed range.

The New Zealand dredge has significantly lower ground shear and friction than any of the other dredges. Its hydrodynamic drag component is however almost as high as that of the toothed mud dredge.

The low hydrodynamic drag of the Ket-ami and Scottish dredges reflect their low frontal area and absence of depressor plate devices.

#### DISCUSSION

The Bay dredge depressor plate approximates the criteria cited by Vaccaro & Blott (1987) for optimising the pressure drop behind a stalled horizontal wing in proximity with the ground. It is possible that this dredge is a hydrodynamic scallop catching device that has evolved over a period of time by trial and error.

The net downward force on the standard dredge is fairly high (greater than 2000N or 204kg) which should be more than adequate to maintain good bottom contact. Under normal operating conditions the net downward force will actually increase with speed and this should ensure better than necessary bottom contact.

At low speeds (up to 3 knots) the greatest source of drag on the toothed mud dredge is from friction and ploughing. At higher speeds (5–8 knots) the hydrodynamic component becomes dominant and is the component which will limit the towing speed. For the dredges using a cutter bar or mouthorgan bar (which does not protrude below



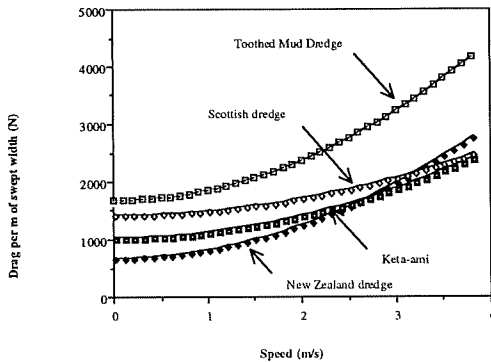

FIG.10. Comparison of dredge types with respect to their drag per m of swept width.

the skids) the friction and ploughing component of drag will be much reduced.

The box type dredges have a definite tendency to ride on the front or rear of the skids. This can be controlled by the warp length to depth and tow speed, or alleviated by the design modifications of skid extensions fore and aft. The tendency of the dredge to rock fore and aft may contribute advantageously or adversely to catching performance. It could be controlled to some extent by changes in warp length to depth, tow speed or the friction and ploughing forces (by altering tooth penetration). The addition of a rubber tyre and length of chain should help to reduce the tendency of the dredge to ride on its nose and could help to damp out fore and aft rocking.

Although the average downward contact pressure exerted by the toothed mud dredge is reasonably low, the point loading and dynamic action might mean that very high intermittent contact pressures will occur. The average downward contact pressure of the ring mesh bag and the other dredge types is very low and not likely to vary to any large degree.

The teeth and cutter bars of the toothed mud dredge, the tines of the Keta-ami and the sprung teeth of the Scottish dredge will exert a high point loading. Very high contact pressure is likely to contribute to damage of the catch and damage to the environment.

In terms of drag, the best performer was the New Zealand dredge. It had the lowest cost in terms of total drag at its operational speed of 3 knots. The toothed mud dredge performed poorly due to a much higher drag especially at 5–6 knots.

#### LITERATURE CITED

- BAIRD, R.H. 1959. Factors affecting the efficiency of dredge. In Kristjansson, H. (ed.), 'Modern fishing gear of the world 1'. (Fishing News Books: London).
- BULL, M.F. 1988. The New Zealand scallop fishery: a brief review of the fishery and its management. Pp.42–50. In Dredge, M.C.L., Zacharin, W.F. & Joll, L.M. (eds), 'Proceedings of the Australasian Scallop Workshop, Hobart'. (Tasmanian Government Printer: Hobart).
- DIX, T.G. 1982. 'Fishery situation report 8. Scallops'. (South Eastern Fisheries Committee, C.S.I.R.O. Marine Laboratories: Cronulla).
- FRANKLIN, A., PICKETT, G.D. & CONNOR, P.M. 1980. The scallop and its fishery in England and Wales. Ministry of Agriculture Fishing and Food, Laboratory Leaflet 51.
- GORMAN, T.B. & JOHNSON, H.T. 1972. 'F.R.V. Kapala cruise report no 5'. (Chief Secretaries Department, N.S.W. State Fisheries: Sydney).
- HUGHES, W.D. 1972. Scallop dredging gear and methods. Australian Fisheries July: 12–15.
- HUGHES, W.D. 1973. Operational tests on Victorian scallop boats. Australian Fisheries May: 14–16.
- MCLOUGHLIN, R.J. YOUNG, P.C. MARTIN, R.B. & PARSLOW, J. 1991. The Australian scallop dredge: estimates of catching efficiency and associated indirect fishing mortality. Journal of Fish Research 11: 1–24.
- PERRIN, R.A. 1986. The D'Entrecasteaux Channel scallop fishery: its past present and future. Master of Environmental Studies Thesis, University of Tasmania. (Unpubl.).
- VACCARO, M.J. & BLOTT, A.J. 1987. Scallop gear selectivity studies: hydrodynamic modifications. Narragansett Laboratory Reference Document 87–27. (National Marine Fisheries Service, Northeast Fisheries Centre, Fisheries Engineering Group, Narragansett, Rhode Island).
- ZACHARIN, W.F. 1988. Alternative dredge designs and their efficiency. In Dredge, M.C.L., Zacharin, W.F. & Joll, L.M. (eds), 'Proceedings of the Australasian Scallop Workshop, Hobart'. (Tasmanian Government Printer: Hobart).
- ZACHARIN, W.F. 1991. Slow recovery for Bass Strait scallops. Australian Fisheries, January 1991.



## IMPROVED HATCHERY AND NURSERY REARING TECHNIQUES FOR *PECTEN FUMATUS* REEVE

M.P. HEASMAN, W.A. O'CONNOR & A.W. FRAZER

Heasman, M.P., O'Connor, W.A. & Frazer, W.A. 1994 08 10: Improved hatchery and nursery rearing techniques for *Pecten fumatus* Reeve. *Memoirs of the Queensland Museum* 36(2): 351–356. Brisbane. ISSN 0079-8835.

Fortnightly sampling of a population of the hermaphroditic scallop *Pecten fumatus* in Jervis Bay was initiated in July 1991. Results over the first 18 months showed that wild stocks constitute a poor and unpredictable source of ripe ready-to-spawn broodstock for hatchery use. This prompted development of hatchery conditioning protocols. The most rapid development of gonads occurred when broodstock were held at 15°C and fed to satiation ( $6 \times 10^9$  cells scallop<sup>-1</sup> day<sup>-1</sup>) on a diet of approximately equal amounts of at least 3 of 4 microalgae, namely: *Chaetoceros calcitrans*, *Pavlova lutheri*, Tahitian *Isochrysis* and *Chroomonas salina*). Intra-gonadal injection of serotonin at 0.05 ml of a  $0.5 \times 10^{-4}$  N solution per scallop reliably induced sperm release within 5–25 min over a broad (12–24°C) temperature range. Survival from fertilisation to D-veliger stage was substantially improved by incubating eggs in suspension at up to 100 ml<sup>-1</sup> in aerated cylindro-conical vessels. Survival to metamorphosis on Day 16 ranged from 5–20%. Rates up to 70% were achieved with experimental scale cylindro-conical rearers when seawater was prefiltered to 1 m or when antibiotics were used. Post-settlement retention rates of 10–50% were achieved by transferring pediveligers onto cylindrical downweller screens fitted with 160 µm polyester mesh. Growth of 5–10 mm juvenile scallops maintained in an upweller nursery unit located at a site at the entrance to Port Stephens was found to increase with increasing seawater flow rates up to 40 ml g<sup>-1</sup> biomass min<sup>-1</sup> and to be suppressed when the surface area of scallops approached 100% that of the screens on which they were stocked. Mean growth rates of 2.8 mm week<sup>-1</sup> were exhibited over the size range 5–25 mm when maintained at low density in screens or lantern cages suspended from a long line at 20–24°C. Small spat in the hatchery grew faster with increasing temperature in the range 12–27°C but ceased growing at 1.5–3 mm.

M. P. Heasman, W. A. O'Connor, and A. W. Frazer, NSW Fisheries, Brackish Water Fish Culture Research Station, Salamander Bay, New South Wales 2301; 9 March 1994.

The NSW scallop fishery is spasmodic and confined to Jervis and Twofold Bays (Fig. 1). Peak annual catches of 1000–3000 tonnes live weight occur only once in 10 years with insignificant catches in intervening years (Fuentes et al., 1992). If higher and more consistent scallop yields are to be achieved in NSW, the central problem of low and variable annual recruitment of juveniles, must be addressed. Wild caught *Pecten fumatus* spat in Jervis Bay (and probably elsewhere in southern NSW) is likely to be low and unreliable in most years (Fuentes et al., 1992).

The importance of reliable, low-cost hatchery and nursery rearing techniques for *P. fumatus* and a successful pilot hatchery trial in May 1989 prompted a 3 year, Fishing Industry Research and Development Corporation (FRDC) funded, research project at the Brackish Water Fish Culture Research Station (BWFCRS) from July 1991.

The 1989 pilot study gave encouraging results using wild scallops from Jervis Bay as spawning stock and conventional hatchery rearing techni-

ques and equipment (Frankish et al., 1991). Approximately 6 million settled spat were being produced at estimated survival rates from spawning to D-veliger (1st feeding) stage of c.60% and from D-veliger to post-settlement, of c.70%. Several hundred thousand settled spat were retained and onreared to 10–20 mm shell height at a similar rate of survival (Frankish et al., 1990). These results contrasted with those previously attained by Tasmanian oyster hatcheries using comparable techniques and equipment. In attempting to meet Tasmanian government contracts for the supply of 4.2 million *P. fumatus* juveniles in the range 10–20 mm, the hatcheries were only able to supply 100000 and 280000 in 1987 and 1988 respectively. Up to this time, the largest spawning of *P. fumatus* had produced 125 million eggs but no hatchery had produced more than 500000 settled spat from one batch of larvae (Cropp & Frankish, 1989).

From the outset of this project, in 1991, it was considered that previous high variability in hatchery success with *P. fumatus* could have

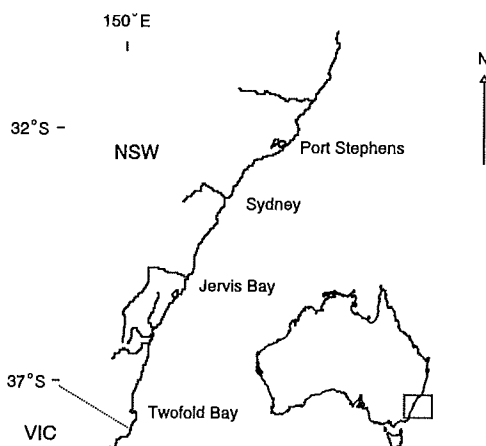

FIG. 1. Central and southern New South Wales.

arisen through one or a combination of several factors. These included: variability in the quality of eggs sourced from wild spawners; subtle, but critical differences in equipment and techniques employed, especially in relation to settlement and metamorphosis of pediveligers; disease(s) and larval nutrition factors.

## MATERIALS AND METHODS

### EVALUATION OF WILD STOCKS OF *P. FUMATUS* AS A SOURCE OF READY TO SPAWN BROODSTOCK

Fortnightly sampling of a Jervis Bay population of *P. fumatus* was initiated in July 1991. On each occasion 120–150 scallops in the range 55–90 mm shell length were collected by a professional diver. All collections made between 7–8am were road freighted (insulated from an underlying layer of ice which maintained them at 10–15°C) to BWFCRS within 8–10hrs. They were immediately stocked into a lantern cage suspended in a 1000l holding tank at ambient temperature (16–22°C). The following morning 40 randomly selected scallops was measured, subjected to a macro-visual staging of gonad condition (Fuentes et al., 1992) and then dissected to determine gonad somatic index (GSI)<sup>1</sup>.

$$GSI = \frac{\text{Weight of gonad}}{\text{Total shell free drained weight}} \times 100$$

Of the remaining 80–110 scallops, the 10 individuals exhibiting highest apparent gonad condition (degree of ripeness) were subjected to induction of spawning stimuli within 72h of capture. Induction of spawning stimuli comprised the exposure of scallops to 3 thermal cycles in which

temperature was raised 3–8°C above ambient over periods of 45–60 minutes.

Release of sperm and eggs was recorded for this hermaphroditic species with fecundity being determined in the case of egg releases.

### GONAD CONDITIONING PROTOCOLS FOR CAPTIVE BROODSTOCK

Attempts to condition broodstock in the hatchery were conducted between July and September, 1991. Wild scallops with medium to high gonadal development attained a ripe, 'ready to spawn', condition in 4–6 weeks during July and August at 16–19°C and fed to satiation. Gonad condition regressed as temperatures rose above 20°C in September and October.

These results prompted construction of a controlled temperature broodstock conditioning facility at the BWFCRS to develop techniques that would enable controlled ripening, stockpiling and induced spawning of captive broodstock throughout the year. This facility, commissioned in April 1992, comprised 4 water baths held at 12.0±0.5; 15.0±0.5; 18.0±0.5 and 21.0±0.5°C respectively, each accommodating 36 x 10 l plastic aerated aquaria to accommodate individual scallops. Experiments to identify appropriate microalgal diets and satiation feeding levels were initiated in June 1992. Subsequent trials to identify optimum combinations of holding temperature at 100, 50, 25 and 12% of satiation feeding levels were conducted in July 1992.

### SPAWNING INDUCTION AND INCUBATION PROTOCOLS

A series of trials was conducted to determine whether intergonadal injection of the neurotransmitter serotonin is more effective than temperature shocks in triggering spawning of ripe *P. fumatus*. To establish optimum dosage rates, 0.05ml serotonin was injected at concentrations of 10<sup>-6</sup> to 10<sup>-3</sup> N. Time to spawning of sperm and eggs was recorded as was fecundity in the case of released eggs. Fertilised eggs were stocked into 11 cylindrical vessels and incubated at densities of 1–100 eggs ml<sup>-1</sup> to gauge the effect of stocking density on survival to the 'D' veliger stage 48h after fertilisation.

### LARVAL REARING TECHNIQUES

Standard hatchery techniques and equipment for Sydney rock oysters (*Saccostrea commercialis*) larvae (Frankish et al., 1991) were used over the first 12 months. Consistently poor hatchery survival achieved by these means and lack of suitable facilities with which to conduct

replicated trials to evaluate alternative rearing techniques, prompted construction of a small scale bivalve larvae rearing system in August 1992. Ten standard 1000l flat-bottomed cylindrical oyster larval rearing vessels were utilised as controlled temperature baths, each accommodating 4x80l cylindrical rearers. As with the 1000l vessels, the smaller units were made of rotationally moulded polyethylene.

Experimental treatments comprised four types of seawater preparation ie. filtration to 0.2µm absolute; filtration to 1.0µm nominal; filtration to 1.0µm nominal plus 10mg l<sup>-1</sup> chloramphenicol and an unfiltered seawater control. These were combined factorially with two alternative diets, namely, a standard blend of 3 microalgal species (*C. calcitrans*, Tahitian *Isochrysis*, and *P. lutheri*) and the same blend of microalgae concentrated into a slurry by centrifugation and stored for 1–6 days prior to feeding. The chloramphenicol treatment was to evaluate the claim that a closely related European scallop *P. maximus*, cannot be hatchery reared with consistent success without use of such powerful broad spectrum antimicrobials (Samain et al., 1992) and hence whether microbial pathogens posed a significant constraint to hatchery success with this species.

Inclusion of chloramphenicol as an experimental treatment should not be construed as an endorsement of its use. To the contrary, identification of alternatives to use of broad spectrum antibiotics that will ensure consistently high survival of hatchery reared *P. fumatus* has become the most important single objective of this project.

#### LARVAL SETTLEMENT AND EARLY NURSERY REARING PROTOCOLS

Post settlement recovery of *P. fumatus* pediveligers using conventional plastic mesh catch (culch) materials and by transferring pediveligers directly onto downweller screens fitted with 160µm polyester mesh were compared. Subsequent growth and survival was monitored for post-larvae retained on downweller screens in the hatchery and for those transferred to upwellers screens and lantern cages at Tomaree Head, adjacent to the mouth of Port Stephens (32° 44'S; 152° 11'E; Fig. 1).

A trial to determine optimum stocking and water flow rates for small juvenile *P. fumatus* reared on upweller screens at Tomaree Head was initiated on Christmas Eve 1992. A total of about 20000 spat averaging 5.6mm and 30mg were stocked at 8 different densities (5 replicates per density) using 40 miniaturised upweller units

each consisting of vertically nested stacks of 8 interlocking screens.

The salinity tolerance of 1–2mm juvenile scallops was investigated in the laboratory as were interactive effects of salinity and temperature on growth and survival.

#### SPECIALIST HANDLING TECHNIQUES FOR EARLY JUVENILE AND ADULT SCALLOPS

Mechanical methods such as seawater jets and scrapers used to dislodge small (10mm) bysally attached *P. fumatus* from culch materials and nursery screens were found to cause injury and subsequent high mortality. To address this problem, the effectiveness of a number of irritant chemicals and physiological stress factors to induce detachment of 2–4mm juveniles was evaluated in fully replicated trials.

A comparable series of trials was also conducted to test the anaesthetic properties of a range of chemical compounds on mature *P. fumatus* of 55–75mm shell height. The aim was to identify quick and simple techniques of reducing stress and subsequent inadvertent spawning caused by routine handling and assessment of gonad status of hatchery conditioned scallops.

## RESULTS AND DISCUSSION

#### WILD STOCKS OF *P. FUMATUS* IN NSW AS A SOURCE OF RIPE BROOD STOCK

Fortnightly sampling of a Jervis Bay population of *P. fumatus* (July 1991–December 1992) revealed that this potential source of ripe 'ready to spawn' broodstock is nearly always unproductive and unpredictable. Even when breeding condition was highest, as indicated by peak in mean gonad-somatic index values of 18–21%, very few individual scallops, including those in a ripe condition (large, turgid, glossy and richly coloured gonads) responded positively and predictably to conventional spawning induction stimuli. Of 300 (10/collection) apparently ripe scallops subjected to spawning induction stimuli over the first 18 months of the project, less than 4% were successfully induced to spawn eggs. Moreover, seasonal peaks in breeding condition, were not consistent from year to year. For example, recorded mean GSI values were highest between December 1991 and March 1992 (Summer) but were continuously low during May–September 1992 (late Autumn–mid Spring). This pattern varied from that of chronically low mean GSI values recorded by Fuentes et al. (1992) through Summer and early Autumn of the two previous years and coin-

cided with unseasonally high winter sea temperatures and unseasonally low summer sea temperatures.

#### HATCHERY CONDITIONING PROTOCOLS

Experiments to identify appropriate microalgal diets, feeding rates and temperatures for gonadal growth were undertaken in June 1992. Results of microalgal clearance rate experiments indicated that *Pavlova lutheri*, Tahitian *Isochrysis* aff. *galbana*, *Chroomonas salina* and *Chaetoceros gracilis* are ingested by adult scallops at similar rates at 14, 18 and 21°C but more slowly at 11°C. Satiation feeding rate using diets containing approximately equal numbers of cells of these 4 species, was estimated as about  $6 \times 10^9$  cells per day for broodstock of 55–75mm shell height. Cell densities of *Tetraselmis suecica*, another microalga commonly used to feed bivalves, declined over the first 8h of the experiment but then fluctuated, indicating resuspension of undigested cells from the faeces.

In a subsequent 6 week conditioning experiment, egg production rate associated with inadvertent spawning, along with gonad size and condition factors, were found to be highest when broodstock were held at 15°C, lowest for scallops maintained at 21°C and of intermediate values at 12°C and 18°C. Across all these temperatures, feeding of individual scallops with twice daily algal rations of  $3 \times 10^9$  cells (100% satiation) and  $1.5 \times 10^9$  cells (50% satiation) produced higher gonad ratings and egg production rates than rations of  $0.75 \times 10^9$  cells (25% satiation) or  $0.375 \times 10^9$  cells (12.5% satiation).

Frequent inadvertent spawnings triggered by handling emphasised the need for conditioning equipment and protocols that minimise handling and other disturbance factors. No inadvertent spawning however, occurred at feeding rates of 25 or 12.5% of satiation at 12°C. Use of low temperatures combined with reduced feeding rates might therefore enable stockpiling of broodstock at prime reproductive condition.

Opportunistic use was made of near ideal water temperatures (14–16°C) in August and early September 1992 to condition 100 broodstock. Scallops were held in lantern cages suspended in 20,000l tanks in the bivalve hatchery at BWFCRS and fed to satiation on a diet comprising equal amounts of the previously cited 4 microalgal species. To reduce the incidence of inadvertent spawning, rations of microalgae were drip fed into the tanks. The impact of water changes was kept to a minimum and handling of stock was

totally avoided. No inadvertent spawnings were recorded over this period.

After 4 weeks of conditioning, 30 scallops were randomly selected and subjected to attempted thermal induction of spawning. Of these, 10 spawned as males and 12 as females, the latter yielding 25 million eggs and thence 13 million D-veliger larvae.

#### SPAWNING INDUCTION, FERTILIZATION AND INCUBATION PROTOCOLS

Attempts to induce spawnings in ripe *P. fumatus* sampled fortnightly from Jervis Bay, were almost always unsuccessful. This result was originally ascribed, at least in part, to inadequacy of a standard thermal spawning induction stimulus (exposure of scallops to successive temperature rise cycles of 3–8°C above ambient) to trigger spawning. This misconception was corrected when development of effective gonad conditioning protocols yielded broodstock that spawned viable eggs rapidly in response to the same thermal induction techniques.

A dose of 0.05ml intragonadal injection of a  $0.5 \times 10^{-4}$ N serotonin solution induced sperm release within 5–25 minutes over a broad range of temperature (14–22°C) in scallops with moderate to high gonad development. As with thermal shock technique however, induced spawning of eggs using serotonin was found to be effective only in suitably conditioned broodstock.

Injection of serotonin was nevertheless found to have a distinct advantage over the thermal induction of spawning. In being able to induce spawning of individual scallops held in isolation from one another. This in turn enables better control over the timing and extent (sperm to egg ratios) of fertilisation and the reduction of self fertilisation in hermaphroditic species such as *P. fumatus*. This attribute may prove particularly useful if applied to induced triploidy programs in the future. Use of serotonin induction of spawning has been extended to Sydney rock oysters at the BWFCRS in anticipation of this application.

Results of preliminary incubation trials conducted in November 1992 indicated that survival from fertilisation to D-veliger can be substantially improved by use of aerated cylindrical vessels in which eggs are kept in suspension rather than allowing them to settle in a monolayer on the floor of conventional flat bottom oyster larvae rearing vessels. Suspended incubation also enables eggs to be stocked at high densities (up to  $100 \text{ ml}^{-1}$ ) without apparent impairment to survival.

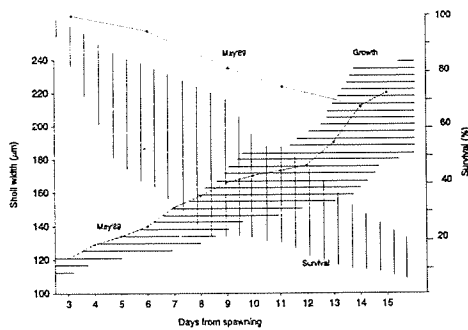

FIG. 2. Summary of the growth and survival of hatchery reared scallops (*Pecten fumatus*) at BWFCRS, Salamander Bay. Dotted lines represent the results of the May 89 larval batch. Shaded areas indicate the range of results obtained from 6 larval batches conducted since July 91.

#### LARVAL REARING TECHNIQUES

Larval rearing trials conducted over the first year of this project (Fig. 2) used standard 1000l flat-bottomed cylindrical tanks, used previously at the BWFCRS for the hatchery production of Sydney rock oysters (Frankish et al., 1991) and for the pilot hatchery production of *P. fumatus* in May 1989 (Frankish et al., 1990).

Survival to metamorphosis (Day 16–18) was 5–20% compared very poorly with the May '89 result but was in keeping with earlier results achieved by commercial hatcheries in Tasmania in 1987–1988 (Cropp & Frankish, 1989). Larval growth rate varied and was not correlated with survival. Metamorphosis was attained at shell height of 225–240µm 14–20 days after spawning.

The first trial to systematically address the problem of low hatchery survival was undertaken in October 1992. Survival rates from D-veliger stage to the onset of metamorphosis (Fig. 3) varied with method of seawater preparation, being highest (70–80%) with chloramphenicol treated seawater and lowest (less than 10%) for 0.2µm filtered and unfiltered seawater. Larval survival rates were reduced but growth rates enhanced by algal concentrate diets. Subsequent patterns of survival through metamorphosis were however different with highest retention rates of 30–40% with 1µm filtered seawater and lowest rates of less than 1% with both unfiltered and 0.2µm absolute filtered seawater treatments.

These results highlighted the importance of continued research to identify seawater preparation, management protocols and feeding/stocking

regimes that will enable consistent attainment of commercially acceptable hatchery survival rates. These are generally considered as nett yields of 0.2–1 of settled spat ml<sup>-1</sup> of rearer volume (L. Goard, pers. comm.). The major challenge faced by continuing research is achievement of satisfactory yields of settled spat without the use of antibiotics.

#### LARVAL SETTLEMENT AND EARLY NURSERY REARING PROTOCOLS

Of 7 larval rearing cycles completed during the first half of this project, 3 yielded significant numbers of spat. Approximately 15,000 spat were produced in November 1991; 30,000 in March 1992 and 200,000 in October/November 1992. Survival rates through settlement varied over the broad range 5–50%. Lowest survival was associated with the use of traditional plastic mesh culch materials deployed directly into larval rearing vessels. Much higher (10–50%) survival rates have however been consistently achieved by transferring pediveligers into downweller screens fitted with 160µm polyester mesh just prior to settlement.

Once settled onto downweller screens, subsequent mortality of spat was negligible. Growth of spat maintained in the hatchery is highly temperature dependent, increasing from c.15–150µm.day<sup>-1</sup> with rising temperature over the range 12–27°C. Growth abruptly stalled as hatchery held spat attained a size of 1.5–3mm.

*P. fumatus* spat transferred to a longline unit at

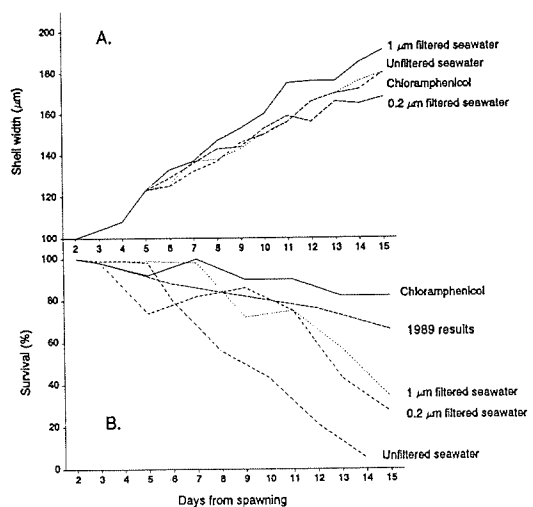

FIG. 3. Effect of water treatment on growth and survival of *Pecten fumatus* larvae.

Tomaree Head, grew at mean rates of 2.8mm week<sup>-1</sup> for sustained periods of up to 7 weeks at 20–23°C. This growth rate is higher than the previously highest summer rates of 1.7mm week<sup>-1</sup> (Cropp, 1985) for equivalent size *P. fumatus* glued to tapes suspended from midwater longlines in Tasmania.

A trial to determine optimum stocking rates of juvenile scallops reared in field upweller unit at Tomaree Head was initiated on Christmas Eve 1992. About 20,000 spat averaging 5.6mm and 30mg were stocked at 8 different densities (5 replicates per density) into 40 miniature upweller units, each of nested stacks of 8 interlocking screens.

Under prevailing conditions, including mean daily sea temperatures of 18–22°C and salinities of 34–35g.kg<sup>-1</sup>, growth rate of spat of 6–10mm shell height and 30–150mg live-weight, was constrained by flow rates of below about 40ml g biomass<sup>-1</sup> min<sup>-1</sup>. For scallops in this size range, suppression of growth due to crowding coincided with a stocking density of about 0.3 g.cm<sup>-2</sup> representing a surface area stocking rate approximating 100% of available screen area.

Salinity tolerance of 1–2mm juvenile *P. fumatus* was identified as a narrow range of 32–38mg ml<sup>-1</sup> outside of which significant mortality occurs within 72h. These results were consistent with salinity tolerances reported for adult *P. fumatus* (Nell & Gibbs, 1986).

#### SPECIALIST HANDLING TECHNIQUES

Hypersaline baths (45 g.kg<sup>-1</sup>) and exposure to air (emersion) for 2 hours were effective in inducing more than 95% of 1–3mm spat to detach from nursery screens. Hypersaline baths created by the addition of an artificial sea salt to seawater produced greater spat detachment after 2h than those created by equivalent additions of sodium chloride. The rate of detachment in hypersaline baths was unaffected by increasing temperature from 20–26°C, but was depressed at 11°C. Addition of magnesium chloride (27g.kg<sup>-1</sup>) to seawater and reduction of seawater pH to 2 were also effective in increasing spat detachment rate, but not as effective as hypersaline baths or air exposure. With the exception of spat exposed to seawater containing 115mg.kg<sup>-1</sup> available chlorine, no significant mortality and 95% reattachment occurred within 24h of all detachment methods tested.

Of 14 compounds tested, only chloral hydrate, Mg Cl<sub>2</sub> and Mg SO<sub>4</sub> induced anaesthesia in adult

scallops within 1h. Mg SO<sub>4</sub> was excluded from further testing due to high postanaesthesia mortality. Doses of 4g.l<sup>-1</sup> Chloral hydrate at 4g.l<sup>-1</sup> (0.024M) or MgCl<sub>2</sub> at 30g.l<sup>-1</sup> (0.31M) were most suitable on the basis of time to and recovery from anaesthesia. Neither anaesthetic caused mortality nor increased spawning activity. Mg Cl<sub>2</sub> reduced inadvertent spawning triggered by routine handling and maintenance activities. Time to anaesthesia for both agents was found to be affected (P<0.05) by water temperature.

#### ACKNOWLEDGEMENTS

We thank staff of the BWFCRS for assistance in manuscript preparation, Dr John Nell, Stephen Battaglione and John Holliday for editorial comments and Wayne Walker and John Kelly for collection and delivery of broodstock from Jervis Bay. This study was part of Fisheries Research and Development Corporation grant 91/53.

#### LITERATURE CITED

- CROPP, D.A. 1985. Scallops thrive in TFDA culture program. *Australian Fisheries* 44(1): 16-18.
- CROPP, D.A. & FRANKISH, K. 1989. Cost comparison of hatchery and natural scallop spat for the scallop *Pecten fumatus* Reeve. Pp. 196-225. In Dredge, M.L.C., Zacharine W.F. & Joll, L.M. (eds), 'Proceedings of the Australasian Scallop Workshop, Taroom, Tasmania, July 1988' (Tasmanian Government Printer: Hobart).
- FRANKISH, K., GOARD, L. & O'CONNOR, W. 1990. Hatchery scallop culture success in NSW. *Australasian Aquaculture Magazine* 4(9): 10-11.
- FRANKISH, K., GOARD, L. & O'CONNOR, W. 1991. 'The development of hatchery techniques for the production of Sydney rock Oysters (*Saccostrea commercialis*)'. Internal Report, NSW Fisheries, Brackish Water Fish Culture Research Station, 28p.
- FUENTES, H.R., WILLIAMS, R.J., DIVER, L.P. & SMITH, A.K. 1992. Commercial molluscs of Jervis Bay. Pp. 000-000. In 'Jervis Bay marine ecological study. Final Report'. (NSW Fisheries, Fisheries Research Institute: Cronulla).
- NELL, J.A. & GIBBS, P.J. 1986. Salinity tolerance and absorption of L- methionine by some Australian bivalve molluscs. *Australian Journal of Marine and Freshwater Research* 37: 721-727.
- SAMAIN, J.F., SEGUINEAU, C., COCHARD, J.C., DELAUNAY, F., NICHOLAS, J.L., MARTY, Y., GALOIS, R., MATHIEU, M. & MOAL, J. 1992. What about growth variability for *Pecten maximus* production? *Oceanis* 18: 49-66.



## HATCHERY REARING THE DOUGHBOY SCALLOP, *CHLAMYS (MIMACHLAMYS) ASPERRIMUS* (LAMARCK)

W.A. O'CONNOR, M.P. HEASMAN, A.W. FRAZER & J.J. TAYLOR

O'Connor, W.A., Heasman, M.P., Frazer, A.W. & Taylor, J.J. 1994 08 10: Hatchery rearing the doughboy scallop, *Chlamys (Mimachlamys) asperrimus* (Lamarck). *Memoirs of the Queensland Museum* 36(2): 357–360. Brisbane. ISSN 0079-8835.

Hatchery rearing and growout trials were conducted with the doughboy scallop, *Chlamys (Mimachlamys) asperrimus* (Lamarck) as a first step towards assessing their aquaculture potential. In 1992, broodstock, from Jervis Bay were in peak reproductive condition in June, August and September. Induced spawnings produced larvae that took 18–20 days to reach pediveliger stage and a further five days before all pediveligers had left the water column. An estimated 10 000 settled spat were deployed on a longline in Port Stephens, grew to an average 10mm and were transferred to lantern cages. Growth over the first year averaged c.1mm per week and reproductive maturity was reached at 30–35mm shell height. Initial observations suggest doughboy scallops have aquaculture potential and could be grown with *Pecten fumatus*.

W.A. O'Connor, M.P. Heasman, A.W. Frazer and J.J. Taylor, NSW Fisheries, Brackish Water Fish Culture Research Station, Salamander Bay, New South Wales 2301; 9 March, 1994.

The doughboy scallop or fan shell, *Chlamys (Mimachlamys) asperrimus* (Lamarck), is a subtidal bivalve of southern Australia, found from Shark Bay, Western Australia, to New South Wales (Wells & Bryce, 1988; Fig.1). Up to 100+ mm long (Zacharin et al., 1990), it is commonly byssally attached to solid objects in depths of 7–69m (Young & Martin, 1989). Unlike the commercial scallop *Pecten fumatus*, it is unisexual with the orange gonad of mature females clearly distinct from the off-white gonad of males.

In the Pacific region *Chlamys* have provided valuable fisheries but *C. asperrimus* has only been of minor commercial importance despite being dredged in Tasmania (Sanders, 1970). In southern Australia scallop fishing and aquacultural effort are largely directed toward *P. fumatus*, although increasing pressure on *P. fumatus* stocks could see a revival of the past practise of fishing *C. asperrimus* for sale as a 'roe on' product in the same market (Young & Martin, 1989). Alternatively *C. asperrimus* could potentially form a new culture industry (Cropp, 1989). However, only one report of its artificial propagation (Rose & Dix, 1984) has been made. More information on its biology is required to evaluate its potential for aquaculture and to allow management of wildstocks should fishing effort increase.

### METHODS

#### BROODSTOCK

Fortnightly throughout 1992 scallop broodstock were collected by divers from Jervis Bay

(Fig.1); reproductive condition was determined by macroscopic observations and through calculation of the gonado-somatic index (GSI). While stock capable of spawning were available most of the year, the population was in peak reproductive condition in June, August and September. This peak in condition is several months later than reported for stocks in the D'Entrecasteaux Channel, Tasmania (Grant, 1971).

#### SPAWNING

Spawning procedures were initially based on those of Gruffydd & Beaumont (1972). Brood stock were scrubbed clean of fouling organisms and maintained in the hatchery at the Brackish Water Fish Culture Research Station (BWFCRS), Port Stephens (Fig. 1). Scallops were

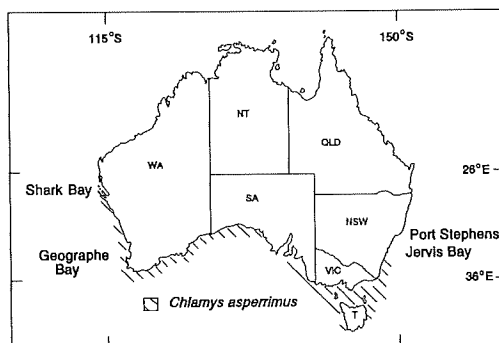

FIG.1. Distribution of the doughboy scallop around Australia.

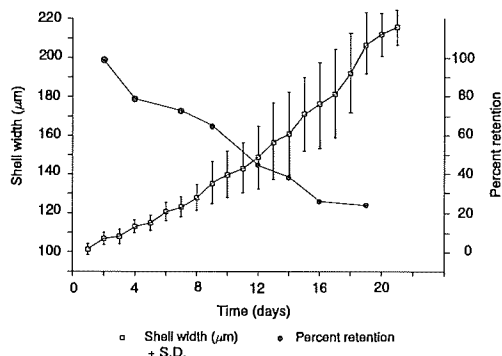

FIG.2. Growth and retention of hatchery reared *C. asperimus* larvae.

induced to spawn by placing broodstock in a bath of seawater (17.8°C, ambient to previous holding tank) for 1h and then increasing temperature 3–4°C over the following hour. Subsequent studies have shown that mature individuals can also be induced to spawn using intragonadal or intramuscular injections of serotonin, however, while a greater proportion of females can be induced to spawn with serotonin than with temperature induction the average fecundity is markedly reduced (O'Connor et al., unpubl. data).

## RESULTS

### LARVAL REARING

Larval rearing techniques and development followed those of Rose & Dix (1984). When scallops commenced spawning they were placed in separate 5l beakers of seawater. Spawning individuals released  $0.6 \times 10^6$  to  $5 \times 10^6$  eggs on many occasions exceeding the maximum fecundity reported by Rose & Dix (1984). As soon as possible following gamete release, sperm solution from several animals was mixed and added to the eggs. Fertilised eggs were then placed in a 1000l polyethylene tank at a density of 8 eggs ml<sup>-1</sup>.

Trochophores ( $78.8 \pm 5.1 \mu\text{m}$  width) were first observed 24h after fertilisation and the first D veligers ( $101 \pm 3.5 \mu\text{m}$  in shell width) were observed after 42h, 11% of the larvae sampled still being trochophores at this time. After 48h 'D' veliger larvae were collected on nylon mesh sieves and a 1000l tank stocked at 4 larvae/ml<sup>-1</sup>. Every 2–3 days larvae were sieved from the culture water and placed in a new tank of seawater. Water temperatures ranged 17.5–19.5°C during the larval rearing period. Mean larval size was

determined daily, while larval densities were determined at each water change (Fig.2). Larvae were fed algae (Tahitian *Isochrysis* aff. *galbana*, *Pavlova lutheri* and *Chaetoceros calcitrans*) twice daily on an equal dry weight basis. Feed rates were increased daily according to changes in larval size and density, ranging from the equivalent of 3500–20000 *T. Isochrysis* cells larva<sup>-1</sup> day<sup>-1</sup>.

The first pediveligers were observed on day 18 after fertilisation and settlement substrates were introduced on day 20. By day 25 larvae had left the water column with the majority choosing to settle on the base and lower wall of the tank.

### SETTLEMENT

Four types of settlement substrate were placed in the tank: PVC discs (140mm diameter); monofilament mesh; 15mm black nylon mesh and 5mm black nylon mesh bags. Four lines supporting PVC discs were hung in the tank. Each line supported 4 discs, equally spaced from the bottom of the tank to the water surface. Three bags each of the 3 types of mesh substrate were weighted and lowered into the tank. After 3 days the PVC discs were removed and settlement was evaluated on upper and lower surfaces of each disc. Settlement was poor (30–50 spat/disc) and most spat settled in the central recess on the underside of the disc. Mesh substrates were left in the tank for a week before being deployed in Port Stephens. Settlement on the mesh substrates was not assessed until spat were large enough to be retained by the surrounding bag if detachment from the substrate occurred as a result of handling. Following removal of all substrates, large numbers of larvae were found to have settled on the lower surfaces of the tank.

### SPAT

Settlement on the mesh substrates deployed in Port Stephens was assessed after 3 weeks. Spat numbers were greatest upon black nylon mesh collectors and spat were concentrated in regions where mesh was densely packed.

The lack of *C. asperimus* spat on other similar materials held on the longline showed no natural spat fall had occurred. Within twelve weeks spat had reached 10mm in size and were transferred to Japanese lantern cages. At this stage fewer than 6% of the number of the pediveligers put to set had been retained.

Growth in lantern cages in Port Stephens approximated 1mm a week throughout the first year (Fig.3) and sexual maturation occurred between

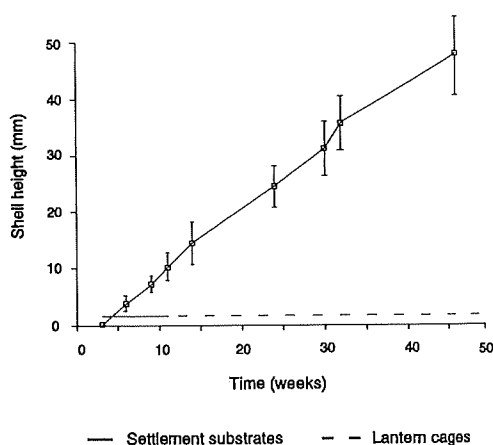

FIG.3. Growth of hatchery reared *C. asperrimus* in Port Stephens.

30–35mm shell height. Motile sperm was extracted from males of 26mm shell height, while oogenesis was evident in females as small as 28mm. This may indicate precocious maturity in the warmer northern extent of the species range and warrants further investigation.

### DISCUSSION

Experience in the hatchery production of mollusc species at the BWFCRS has indicated that *C. asperrimus* is well suited to mass production. Larval and spat survival have been good, but improved settlement techniques would be required. The recent success of nylon mesh screens in downwelling systems to settle *P. fumatus* (Heasman et al., this volume) larvae could be extended to *C. asperrimus* as a means to exert greater control of settlement. Similarly the potential for early maturation to retard growth needs to be addressed. The possibility of growth retardation associated with the early onset of functional maturity may be overcome in this species by induction of triploidy.

The incidence of either parasitic trematodes (*Bucephalis* sp.) or mudworm infestation (*Polydora* sp.) in mature *C. asperrimus*, collected from Jervis Bay, often exceeded 10 and 90% respectively per collection. While *Polydora* sp. has been a significant cause of mortality in *P. fumatus* held in lantern cages in Tasmania (Dix, 1981), neither *Polydora* or *Bucephalis* have been observed in *C. asperrimus* reared on longlines in Port Stephens. Potential problems associated

with sale of wildstock from Jervis Bay, notably mudworm, appear to have been eradicated with suspended culture, although mudworm may be a site specific problem.

Techniques used to rear *C. asperrimus* in these preliminary trials have been closely based upon those under development at the BWFCRS for the commercial scallop, *P. fumatus*, and may not be the most appropriate for this species. Adjustments to larval rearing techniques, such as feed rates and water temperatures, could improve larval growth and survival, while different growout techniques could benefit juvenile growth. Unlike other commercially exploited Australian scallop species, *C. asperrimus* retains the ability to form bysall attachments throughout its life which may permit the use of culture techniques developed for similarly attached bivalves such as mussels.

### ACKNOWLEDGEMENTS

We thank staff of the Brackish Water Fish Culture Research Station for assistance, in particular Drs John Nell and Geoff Allan for comment on the manuscript and Mr Lindsay Goard.

### LITERATURE CITED

- CROPP, D.A. 1989. Scallop culture in the Pacific region. Pp. 134–153. In Dredge, M.C.L., Zacharin, W.F. & Joll, L.M. (eds), 'Proceedings of the Australian Scallop Workshop, Hobart, Tasmania, 1988' (Tasmanian Government Printer: Hobart).
- DIX, T.G. 1981. Preliminary experiments in commercial scallop (*Pecten meridionalis*) culture in Tasmania. *Tasmanian Fisheries Research* 23: 18.
- GRANT, J.F. 1971. Scallop survey - D'Entrecasteaux Channel, Tasmania, 11-14 May 1971. *Tasmanian Fisheries Research* 5(2):21.
- GRUFFYDD, L.L.D. & BEAUMONT, A.R. 1972. A method of rearing *Pecten maximus* larvae in the laboratory. *Marine Biology* 15: 350-355.
- ROSE, R.A. & DIX, T.G. 1984. Larval and juvenile development of the doughboy scallop, *Chlamys (Chlamys) asperrimus* (Lamarck) (Mollusca: Pectinidae). *Australian Journal of Marine and Freshwater Research* 35: 315-323.
- SANDERS, M.J. 1970. The Australian scallop industry. *Australian Fishing* 29: 2-11.
- WELLS, F.E. & BRYCE, C.W. 1988. 'Seashells of Western Australia'. (Western Australian Museum: Perth).
- YOUNG, P.C. & MARTIN, R.B. 1989. The scallop fisheries of Australia and their management. *Reviews of Aquatic Science* 1(4): 615-638.
- ZACHARIN, W., GREEN, R. & WATERWORTH, C. 1990. Estimated abundance of Doughboy, Queen

and Commercial Scallop stocks in the D'-  
Entrecasteaux Channel, Tasmania 1989. Techni-

cal Report 40, Marine Laboratories, Division of  
Sea Fisheries, Hobart, Tasmania.

## TOXIC ALGAL BLOOMS: POTENTIAL HAZARDS TO SCALLOP CULTURE AND FISHERIES

SANDRA E. SHUMWAY AND ALLAN D. CEMBELLA

Shumway, S.E. & Cembella, A.D. 1994 08 10: Toxic algal blooms: potential hazards to scallop culture and fisheries. *Memoirs of the Queensland Museum* 36(2): 361–372. Brisbane. ISSN 0079-8835.

Phycotoxins from algal blooms are accumulated by filter-feeding bivalve molluscs. Since only the adductor muscle of scallops has been traditionally marketed, scallops are not usually included in routine monitoring programs but intensified aquaculture ventures in areas prone to toxic blooms have provoked public health concerns. Our focus on the sequestering and biotransformation of phycotoxins in scallops indicate that: 1) toxins are not distributed evenly; toxin is usually concentrated in the mantle and digestive gland; 2) some scallop tissues, e.g. digestive glands and mantles remain highly toxic throughout the year; 3) toxicity varies (43.5%) between individuals in the same area; 4) no correlations could be made between toxicity levels in gonadal and other tissues.

Scallop culture and commercial fisheries can thrive in areas prone to toxic algal blooms if only the adductor muscle is utilized. Safe marketing of "roe-on" scallops is feasible only under strict regulatory regimes. Marketing of mantles or whole scallops poses a high risk to public health and should only be undertaken after extensive monitoring. Scallop mariculturists should be aware of risks associated with phycotoxins. Further, public health guidelines with particular emphasis on toxin levels in individual tissues is necessary if scallops are to be marketed whole or in conjunction with tissues other than adductor muscles.

*Sandra E. Shumway, Bigelow Laboratory for Ocean Sciences, West Boothbay Harbour, Maine 04575, USA (present address: Natural Science Division, Southampton College LIU, Southampton, New York 11968, USA) & Allan D. Cembella, Institute for Marine Biosciences, National Research Council, 1411 Oxford Street, Halifax, Nova Scotia B3H 3Z1, Canada; 21 June 1994.*

The impact of toxic algal blooms on scallop culture and fisheries is often underestimated or even ignored since traditionally only the large adductor muscle is consumed. Adductor muscle tissue is usually free of accumulated toxins of algal origin (phycotoxins), although levels in excess of the regulatory limit may occur. Scallop species are, however, by no means exempt from the effects of toxic algal blooms (Table 1). Generally, scallops are not included in routine monitoring programs for paralytic shellfish toxins and they have only recently been covered by regulations of the Interstate Shellfish Sanitation Conference (ISSC) in the US. Areas prone to outbreaks of toxic algae overlap with areas where scallops are fished or cultured commercially (Fig.1). With expansion of scallop culture and increased interest in marketing non-traditional scallop tissues, as well as whole and 'roe-on' scallops, an understanding of the problems and hazards posed by toxic algae to the scallop industry is required.

Scallops are common inhabitants of nearly every coastal region worldwide and support major commercial fisheries and mariculture in-

dustries (Hardy,1991; Shumway,1991; Fig.1). Blooms of toxic and noxious algae are also regular cosmopolitan events (LoCicero,1975; Taylor & Seliger,1979; Anderson et al.,1985; Okaichi et al.,1989; Granéli et al.,1990; Hallegraeff,1993). Their impact on utilization of shellfish resources was reviewed by Shumway (1989, 1990) and Hallegraff (1993). Filter-feeding bivalves, such as scallops, accumulate toxic algae and associated toxins in their tissues rendering them vectors of various types of seafood poisoning, including paralytic shellfish poisoning (PSP), diarrhetic shellfish poisoning (DSP), amnesic shellfish poisoning (ASP). Such shellfish are unfit for human consumption.

While some groups of toxic algae have had devastating effects on scallop populations (Table 1), the primary threat to industry and public health is the potential for human illnesses such as DSP and PSP. Scallop culture and fisheries have been conducted in areas prone to blooms of highly toxic algae, e.g. Canada, Japan, United States, France (Shumway,1990,1991; Fig.1).

Since only the adductor muscle is generally consumed in North America, scallops are usually

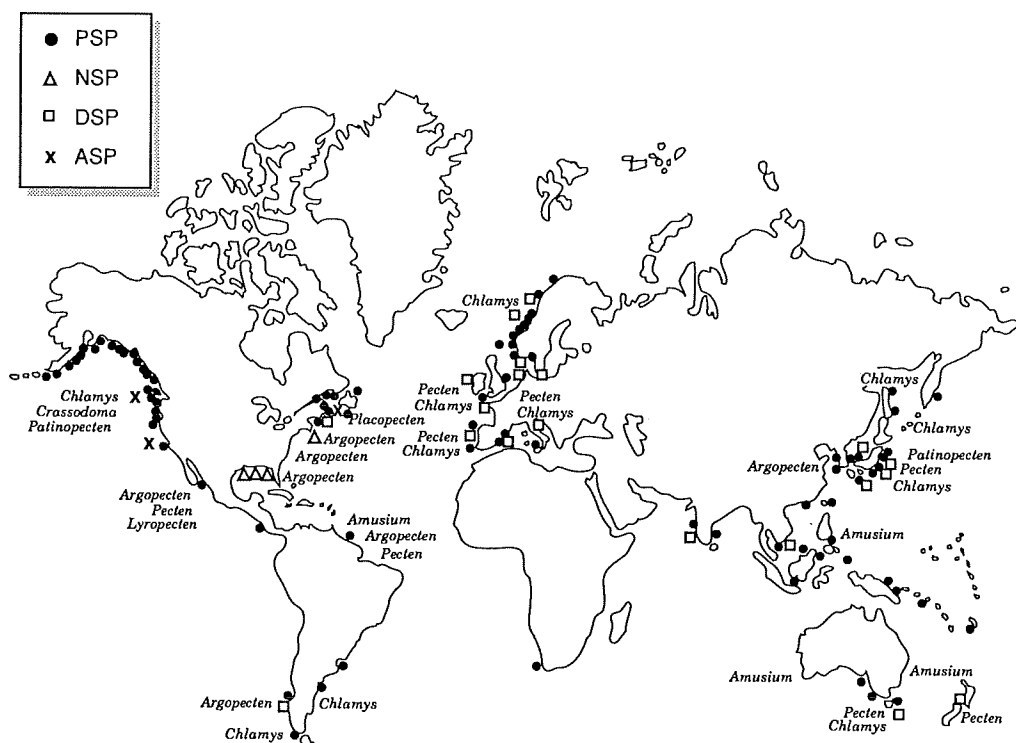

FIG.1. Geographical distribution of PSP, DSP, NSP and ASP toxins and their relationship to commercially utilised (fished and cultured) scallop genera.

shucked at sea where shells and unwanted tissues are discarded. These 'other' tissues include the mantle (rims or rings), gonad (roe), digestive gland (hepatopancreas, liver), and gills; together they comprise over 80% of the total weight of tissue (Schick et al., 1992; Fig.2). In some areas, e.g. Europe, Japan and southern Australia, scallops are sold with the gonad attached ('roe-on') and there has been a steady and continuing interest in fuller utilization of scallop tissues in other regions, particularly the US and Canada (Bourne & Read, 1965; Dewar et al., 1971). The idea that consumption of scallops is always safe should not be accepted unreservedly. While scallops are not the most common vectors of paralytic or diarrhetic shellfish poisonings, there have been several reported illnesses and even some deaths attributed to toxic scallops.

Prior to the occurrence of PSP toxins on Georges Banks, Bourne & Read (1965) advocated the marketing of scallop muscles with attached roes

and rims (mantles). Dewar et al. (1971) presented procedures and recipes for production of high-quality frozen and canned products and, based on results of Japanese taste panels, indicated consumer acceptance of these products. The sea scallop, *Placopecten magellanicus*, and Japanese scallop, *Patinopecten yessoensis*, support the two largest scallop fisheries worldwide; *P. magellanicus* is the focus of efforts to market roe-on product and whole animals, as is done with *Pt. yessoensis*. There is a renewed interest in marketing both whole and 'roe-on' scallops (*P. magellanicus*) from Canada and the northeastern US (Gillis et al., 1991; Merrill, 1992), and whole pink scallops (*Chlamys rubida*) from the Pacific northwest (Nishitani & Chew, 1988). However, the first reported incidence of PSP toxins on Georges Banks (Sharifzadeh et al., 1991; White et al., 1992a) and the persistent presence of these toxins in the Pacific northwest (Nishitani &

Chew, 1988; Shumway, 1990) has sparked new concerns with regard to consumer safety.

Scallops are opportunistic filter feeders which utilize both pelagic and benthic microorganisms as food sources (Shumway et al., 1987; Bricelj & Shumway, 1991). These organisms are consumed and concentrated in the digestive gland. Where toxic algal species are present, the shellfish become vectors of shellfish poisons including PSP and DSP. Poisonings due to PSP have been reported after consumption of both sea scallops (Medcof et al., 1947; Washington Office of Public Health Laboratories and Epidemiology, 1978), and pink and spiny scallops consumed whole (Canadian Department of Fisheries and Oceans, 1989). Seafood poisoning attributed to DSP following consumption of scallops has been known in Japan since 1977, and has resulted in several hundred illnesses (Nomata, pers. comm.). On September 23, 1983, a 5 year old boy died of PSP after eating scallops from Olotayan Island in the Philippines (Estudillo & Gonzales, 1984). One death was reported from consumption of *Chlamys nipponensis* in Iwate prefecture, Japan in 1962 (Nomata pers. comm.) and a death was also attributed to consumption of *Hinnites* in California (Sharpe, 1981).

Accumulation of PSP and DSP toxins has already had devastating effects on the scallop industry (both cultured and fished), especially in areas such as the Atlantic and Pacific coasts of North America and in Japan where toxic blooms are regular events (Ogata et al., 1982; Gillis et al., 1991; Nishihama, 1980). Japan has stopped supplying whole scallops to large markets such as France because of the presence of PSP toxins (Merrill, 1992). Careful monitoring of 'roe-on' scallops in Canadian waters resulted in closure of 'roe-on' fishing for most of the Canadian sector of Georges Bank during 1989 and 1990, when PSP toxin levels exceeded the tolerance limit ( $80\mu\text{g STXeq}/100\text{g}$ ) (Gillis et al., 1991). Efforts are currently underway by the National Marine Fisheries Service (NMFS) to develop a protocol for certification of 'roe-on' or whole scallops (*Placopecten* or *Argopecten*) harvested in US federal waters west of  $71^\circ\text{W}$  longitude.

Problems associated with scallop toxicity monitoring are exacerbated by high variability in toxicity between individual animals (Whitefleet-Smith et al., 1985; Gillis et al., 1991; White et al., 1992b). This variability can be considerable (Beitler, 1991; White et al., 1992b and references therein) and has been attributed to differences in season, geographical location, specific toxins in-

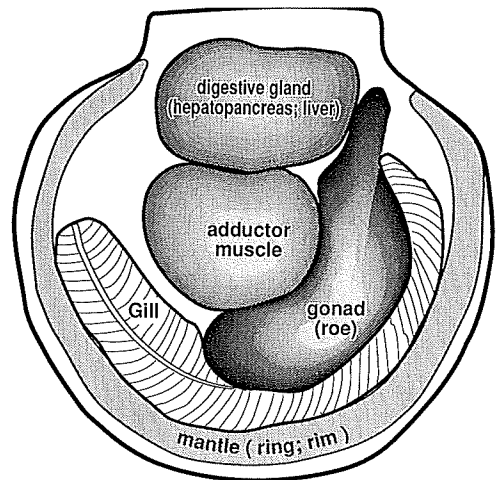

FIG. 2. Diagrammatic representation of scallop tissues.

involved and toxin concentrations. Finally, bioconversion of toxins between/within scallop tissues may also account for some of the variation in toxicity.

Total toxicity varies not only between locations and individuals, but also among tissues of individual scallops. Most available data on PSP toxin distribution among scallop tissues are for the sea scallop, *P. magellanicus* and Japanese scallop, *Pt. yessoensis* (Table 2). The digestive gland (hepatopancreas, liver) is usually the most toxic tissue; with levels in excess of  $45,000\mu\text{g STXeq}/100\text{g}$ , as determined by AOAC mouse bioassay, having been recorded in the Gulf of Maine (Watson-Wright et al., 1989). This is of particular importance for marketing of whole scallops and special care must be taken in any area where toxic algae are present to ensure regular testing for these toxins.

High levels of PSP toxicity have also been reported for gonadal tissue (roe). Watson-Wright et al. (1989) reported detectable PSP toxicity (i.e.  $40\mu\text{g STXeq}/100\text{g}$ ) in 69% of scallop gonadal samples analyzed ( $n=41$ ) from the Bay of Fundy, but found no correlation between the toxicity of gonadal tissue and other tissues. While these high toxicity levels (e.g.  $1300\mu\text{g STXeq}/100\text{g}$  tissue in *P. magellanicus* from Mascarene, New Brunswick; Microbiology Division, Food Research Laboratories: Health and Welfare, Canada; Black's Harbour, New Brunswick data reports), seem to be the exception rather than the rule, they again point to the need for strict monitoring prac-

TABLE 1. A summary of toxic and noxious algal blooms associated with scallops.

Algal species	Shellfish species affected	Notes	Location	Reference
<i>Dinophysis acuminata</i> <i>D. fortii</i>	<i>Chlamys nipponensis</i> <i>Patinopecten yessoensis</i> <i>Pecten albicans</i>	toxic	Japan	Anraku (1984)
<i>Alexandrium tamarense</i>	<i>Chlamys opercularis</i> <i>Pecten maximus</i>	highly toxic; not adversely affected	Northumberland U. K.	Ayres & Cullum (1978); Ingham et al. (1968); Wood & Mason (1968)
<i>A. tamarense</i>	<i>Placopecten magellanicus</i>	highly toxic	Gulf of Maine and eastern Canada; Bay of Fundy and St. Lawrence regions	Prakash (1963); Bourne (1965); Caddy & Chandler (1968); Prakash et al. (1971); Medcof (1972); Hurst (1975); Hartwell (1975); Hsu et al. (1978); Tufts (1979); Jamieson & Chandler (1983); Shumway et al. (1988); Gillis et al. (1991); Cembella & Shumway (1991)
<i>A. tamarense</i>	<i>Placopecten magellanicus</i>	highly toxic	Georges Bank, Gulf of Maine	White et al. (1992a,b)
<i>A. tamarense</i>	<i>Chlamys nipponensis</i> <i>Patinopecten yessoensis</i>	toxic	Japan	Oshima et al. (1982)
<i>A. tamarense</i>	<i>Argopecten irradians</i>	toxic	Massachusetts	Bicknell & Collins (1973)
<i>A. tamarense</i>	<i>Patinopecten yessoensis</i>	toxic	Japan	Sekiguchi et al. (1989)
<i>A. tamarense</i>	<i>Placopecten magellanicus</i>	violent swimming activity; production of mucus	laboratory	Shumway & Cucci (1987); Gainey & Shumway (1988a,b)
<i>A. tamarense</i>	<i>Pecten maximus</i>	toxic	laboratory	Lassus et al. (1989)
<i>A. tamarense</i>	<i>Patinopecten yessoensis</i>	toxic	Japan	Maruyama et al. (1983)
<i>A. tamarense</i>	<i>C. nipponensis</i> <i>C. nobilis</i>	toxic	Japan	Anraku (1984); Oshima et al. (1982)
<i>Alexandrium</i>	<i>Patinopecten yessoensis</i>	toxic	Japan	Nishihama (1980)
<i>A. catenella</i>	<i>Patinopecten yessoensis</i> <i>C. nipponensis akazara</i>	toxic	Japan	Noguchi et al. (1978, 1980a,b, 1984)
<i>A. catenella</i>	<i>Hinnites multirugosus</i> <i>Chlamys hastata</i>	toxic; human illness	British Columbia	DFO (1987; 1989)
<i>A. catenella</i>	<i>Hinnites multirugosus</i>	1 death from eating viscera	California	Sharpe (1981)
<i>A. catenella</i>	<i>Hinnites multirugosus</i> <i>Chlamys hastata</i> , <i>Pecten caurinus</i> , <i>Pecten</i> sp.	toxic	Pacific USA	Nishitani & Chew (1988)
<i>A. catenella</i>	<i>Chlamys patagonicus</i>	toxic	Chile	Avaria (1979); Guzman & Campodonico (1978)
<i>Gymnodinium catenatum</i>	<i>Equichlamys bifrons</i> , <i>Mimachlamys asperrimus</i> , <i>Pecten fumata</i>	toxic	Tasmania	Hallegraeff & Summer (1986); Hallegraeff et al. (1989); Oshima et al. (1982, 1987a,b)
<i>G. catenatum</i>	<i>Pecten albicans</i>	first report of toxicity by this species	Japan	Ikeda et al. (1989)
<i>G. breve</i>	<i>Argopecten irradians</i>	scallop deaths; recruitment failure	North Carolina	Barris (1988); Tester & Fowler (1990); Summerson & Peterson (1990)



TABLE 1 (continued)

Algal species	Shellfish species affected	Notes	Location	References
<i>G. veneficum</i>	<i>Pecten maximus</i>	scallop mortality	laboratory	Abbott & Ballantine (1957)
<i>Gyrodinium aureolum</i>	<i>Pecten maximus</i>	mortalities in young scallops	France	Lassus & Berthome (1988)
<i>Gy. aureolum</i>	<i>Pecten maximus</i>	numbers of larvae declining during bloom	Lough Hyne, Ireland	Minchin (1984)
<i>Gy. cf. aureolum</i>	<i>Pecten maximus</i>	high mortality in post-larvae and juveniles; reproduction and growth inhibited in adults	France	Erard-LeDenn et al. (1990)
<i>Ceratium tripos</i>	<i>Placopecten magellanicus</i>	nontoxic; mortalities due to O <sub>2</sub> depletion	New York Bight	Mahoney & Steimle (1979)
<i>Aureococcus anophagefferens</i>	<i>Argopecten irradians</i>	larval shell growth reduced and mortalities increased	laboratory	Gallagher et al. (1988)
<i>A. anophagefferens</i>	<i>Argopecten irradians</i>	mass mortalities	Long Is, NY; Narragansett Bay, RI; Barnegat Bay, NJ	Cosper et al. (1987); Tracey et al. (1988); Tracey (1985); Smayda & Fofonof (1989)
<i>A. anophagefferens</i>	<i>Argopecten irradians</i>	76% reduction in adductor weights; recruitment failure of year class	Long Island, NY	Bricelj et al. (1987)
<i>Rhizosolenia chunii</i>	<i>Pecten alba</i>	bitter taste rendered shellfish unmarketable for 7 months; digestive gland lesions and shellfish mortalities	Australia	Parry et al. (1989)
not specified, probably <i>Alexandrium</i>	<i>Patino. yessoensis</i> , <i>Chlamys farreri</i>	toxic	Korea	Jeon et al. (1988)
not specified	<i>Chlamys nobilis</i>	toxic	Japan	Nagashima et al. (1988)

*Alexandrium tamarense* (= *Gonyaulax tamarensis* = *Protogonyaulax tamarensis*); *A. catenella* (= *Gonyaulax catenella* = *Protogonyaulax catenella*); *Gymnodinium breve* (= *Ptychodiscus brevis*)

tices if scallop products other than adductor muscles are to be utilized.

#### ADDUCTOR MUSCLE TOXICITY

It had been generally accepted that scallop adductor muscle tissue tends to remain free of accumulated toxins (Medcof et al., 1947; Watson-Wright et al., 1989; Shumway, 1990); however, reports of adductor muscles with measurable toxicity, and even scores exceeding the regulatory limit of 80 µg STXeq/100g tissue have been reported for several scallop species (Table 1). It is impossible to estimate the toxicity of adductor muscles of scallops based on the toxicity of surrounding visceral tissue (Beitler, 1991; Watson-Wright et al., 1989) and no assumptions regarding the toxicity of individual scallop tissues should be made on any such correlations.

#### DETOXIFICATION

In addition to individual variations in toxin levels and among tissues within individuals, scallops exhibit slow and markedly variable rates of detoxification. All data available are for PSP toxins and are limited to *Pt. yessoensis*, *P. magellanicus*, *C. nipponensis akazara* and *Pecten maximus*. Once PSP toxins are accumulated by scallops, they are only slowly eliminated. Detectable PSP toxicity (40 µg STXeq/100g) by AOAC mouse bioassay has been reported to persist in *P. magellanicus* for extended periods ranging from several months to two years (Medcof et al., 1947; Jamieson & Chandler, 1983; Shumway et al., 1988; unpubl. data). Digestive glands of *Pt. yessoensis* (initial toxicity 34,000 µg STX eq/100g; i.e. 1700 MU/g tissue; MU = mouse units) were reported to contain 2,000 µg STX eq/100g (100 MU/g) even after being held in running

TABLE 2. Levels of paralytic shellfish toxins ( $\mu\text{g STXeq}/100\text{g}$  tissue) recorded in scallop species from various geographical locations. A conversion factor of 1 MU  $\approx$  0.20  $\mu\text{g STXeq}$  has been used to standardize data sets.

SPECIES	TISSUE	TOXIN LEVEL ( $\mu\text{g STXeq}/100\text{g}$ )	LOCATION	REFERENCE
<i>Chlamys nipponensis akazura</i>	Adductor	80	Ofunato Bay, Japan	Noguchi et al. (1978)
	Gonad(ovary)	640		
	Midgut gland	4000		
<i>Chlamys opercularis</i>	Whole	256	Flamborough Head, UK	Ingham et al. (1968)
<i>Chlamys rubida</i>	Adductor	56	Washington, USA	Anonymous (1987)
<i>Crassadoma gigantea*</i> (= <i>Hinnites multirogus</i> )	Adductor muscle	130	British Columbia	DFO (1989)
	Viscera+	2500		
	Whole body	1200		
	Adductor muscle	229	Washington, USA	
	Viscera+	2036		
	Whole body	295		
Adductor muscle	2000	California, USA	Anonymous (1980); Sharpe (1981)	
Viscera+	26000			
Whole body	13593			
<i>Patinopecten caurinus</i>	Adductor	58	Alaska, USA	Anonymous (1987)
<i>Patinopecten yessoensis</i>	Adductor	400	Ofunato Bay, Japan	Noguchi et al. (1978)
	Gonad(ovary)	900		
	Midgut gland	16000		
	Adductor	40	Funka Bay, Japan	Noguchi et al. (1980a,b)
Digestive gland	2040			
Other	220			
<i>Patinopecten yessoensis</i>	Digestive gland	20,000	Ofunato Bay, Japan	Sekiguchi et al. (1989)
	Digestive gland	8400	Ofunato Bay, Japan	Kodama et al. (1990)
	Digestive gland	6000	Kawauchi Bay, Japan	Ogata et al. (1982)
	Digestive gland	15000	Funka Bay, Japan	Nishihama (1980)
	Digestive gland	130,000-220,000	Japan	Noguchi et al. (1984)
	Adductor muscle	60-260		
	Hepatopancreas	34,000	Ofunato Bay, Japan	Oshima et al. (1982)
	Digestive gland	42,000-70,000	Ofunato Bay, Japan	Maruyama et al. (1983)
	Rectum	4200-12,400		
	Foot	3200-4600		
	Gonad	2200-3200		
	Mantle	1500-2200		
	Gill	1420-2200		
Adductor muscle	320-860 <sup>a</sup>			
Digestive gland	15,000			
		Funka Bay, Japan	Nishihama (1980)	
<i>Pecten maximus</i>	Whole	1568	Farne Bank, UK	Ingham et al. (1968)
<i>Pecten maximus</i>	Whole(?)	2700	laboratory	Lassus et al. (1989)
<i>Pecten grandis</i> (= <i>Placopecten magellanicus</i> )	Whole	1520	Lepreau Basin, New Brunswick	Medcof et al. (1947)
	Digestive gland	8000		
	Gill	560		
	Adductor muscle	<40		
	Gonad	190		
	Other	680		

TABLE 2. (continued)

SPECIES	TISSUE	TOXIN LEVEL ( $\mu\text{g STXeq}/100\text{g}$ )	LOCATION	REFERENCE
<i>Placopecten magellanicus</i>	Hepatopancreas	1440	Canadian Georges Bank	Gillis et al. (1991)
	Gonad	44		
	Adductor muscle	<40	Bay of Fundy, Canada	Hsu et al. (1979)
	Gonad	2400		
	Hepatopancreas	50,000		
Gill	570			
	Rims	4500		
<i>Placopecten magellanicus</i>	Adductor	<40*	Maine, USA	Shumway et al. (1988; unpubl. data)
	Gonad	420*		
	Digestive gland	4180*		
	Mantle	2830*		
<i>Placopecten magellanicus</i>	Whole <sup>+</sup>	3888	Georges Bank (Loran 1336543777)	White et al. (1992a,b); Shumway (unpubl.)
	Adductor	183*		
	Whole (- adductor)	14775*		
<i>Placopecten magellanicus</i>	Hepatopancreas	45,000*	Bay of Fundy, Canada	WatsonWright (1989)
	Gonad	1700*		
	Adductor muscle	undetectable		
	Gills	250*		
	Rims	4700*		
<i>Placopecten magellanicus</i>	Whole	2200*	Bay of Fundy, Digby, Canada	Jamieson & Chandler (1983)
	Digestive gland	150,000		
	Gonad	184-286*		
	Adductor	60		
	Gill	100-600		
	Digestive gland	140*	N Edge, Georges Bank	Jamieson & Chandler (1983)
	All other tissues	<32		
	Adductor	120*	Mascarene, Nova Scotia, Canada	Jamieson & Chandler (1983)
	Digestive gland	25,000		
<i>Placopecten magellanicus</i>	Liver <sup>b</sup>	36-66	N Edge, Georges Bank	Bourne (1965)
	Gonad	43*	Bay of Fundy, Canada	Bourne (1965)
	Liver	4000*		
	Mantle	1440*		
	Adductor	<32*		
	Gill	<32*		

\* maximum reported values

+ whole body minus adductor

<sup>a</sup> probably leached from other tissues; scallops were frozen whole for several months prior to dissection and analysis

<sup>b</sup> stomach and digestive diverticulum

seawater for five months in the laboratory (Oshima et al., 1982).

Cooking can reduce toxin levels considerably (Medcof et al., 1947; McFarren et al., 1960) and canning has been used to reduce toxicity of scallop tissue to acceptable levels (Noguchi et al., 1980a,b); however, as a means of reducing toxicity, canning is usually only effective when toxin levels are relatively low, although Noguchi

demonstrated that canning might be applicable for scallops with PSP toxicity at levels as high as  $8,000\mu\text{gSTXeq}/100\text{g}$  (400MU/g) tissue.

Freezing does not appreciably reduce toxin levels, although long-term storage at temperatures from 0 to  $-20^{\circ}\text{C}$  may lead to some degradation of specific toxins, often to more toxic derivatives. Moreover, freezing of whole scallops can result in migration of toxins from highly toxic

tissues, e.g. digestive gland, into adductor muscle, rendering the latter unsafe for human consumption (Noguchi et al., 1984; unpubl. data). Toxin can also leach from attached gonads to the adductor muscle during shipping (Bruce & Delaney, 1972).

### PRECAUTIONS

A market for roe-on scallops is feasible only under strict monitoring for algal toxins. Establishment of public health safety guidelines with particular emphasis on toxin levels in individual body parts is a necessity if scallops are to be marketed whole or in conjunction with any tissues other than adductor muscles.

Marketing of rims (mantles) or whole scallops can pose a high risk public health and should only be undertaken under the strictest of monitoring plans. The economic success of such an industry is questionable.

Mariculturists should be acutely aware of the potential risks and dangers associated with toxic algal blooms and the marketing of various scallop products.

Successful culture facilities and commercial fisheries can persist in areas prone to toxic algal blooms; however, only through careful site selection and monitoring can optimal utilization of scallop resources be realized and economic losses kept to a minimum.

### ACKNOWLEDGEMENTS

This project was funded by a grant cooperative agreement (#NA-90-AA-HSK030) from the National Oceanic and Atmospheric Administration (NOAA) awarded to the New England Fisheries Development Association. The views expressed are those of the authors and do not necessarily reflect the views of NOAA or any of its subagencies, nor those of any Australian fisheries administration agency.

### LITERATURE CITED

- ANONYMOUS, 1980. 'Fatal paralytic shellfish poisoning from scallops - a rarity'. California Morbidity 39. Infectious Disease Section, California Department of Health Services.
- ANONYMOUS, 1987. Virulent PSP kills 26 in Guatemala outbreak. Washington Dept. of Social & Health Services, Food Protection Report 3:1.
- ABBOTT, B.C. & BALLANTINE, D. 1957. The toxin from *Gymnodinium veneficum* Ballantine. Journal of the Marine Biological Association of the United Kingdom 36:169-189.
- ANDERSON, D.M., WHITE, A.W. & BADEN, D.G. (eds) 1985. 'Toxic dinoflagellates'. (Elsevier/North Holland: New York). 561p.
- ANRAKU, M. 1984. Shellfish poisoning in Japanese waters. Pp.105-109. In A.W. White, M. Anraku and K.-K. Hooi, (eds), 'Proceedings of a consultative meeting held in Singapore 11-14 September 1984'. (Southeast Asian Fisheries Development Center and the International Development Research Centre: Singapore).
- AVARIA, S.P. 1979. Red tides off the coast of Chile. Pp. 161-164. In D.L. Taylor & H.H. Seliger, (eds), 'Toxic dinoflagellate blooms'. (Elsevier/North Holland: New York).
- AYRES, P.A. & CULLUM, M.C. 1978. Paralytic shellfish poisoning. An account of investigations into mussel toxicity in England 1967-77. Fisheries Research Technical Report, MAFF Directorate of Fisheries Research, Lowestoft 40: 1-23.
- BEITLER, M.K. 1991. Toxicity of adductor muscles from the purple hinge rock scallop (*Crassadoma gigantea*) along the Pacific coast of North America. Toxicon 29: 889-893.
- BICKNELL, W.J. & COLLINS, J.C. 1973. 'The paralytic shellfish poisoning incident in Massachusetts'. (Atlantic City: American Public Health Association centennial meeting, 13 November 1972: Commonwealth).
- BOURNE, N. 1965. Paralytic shellfish poison in sea scallops (*Placopecten magellanicus*, Gmelin). Journal of the Fisheries Research Board of Canada 22: 1137-1149.
- BOURNE, N. & READ, F.C. 1965. Fuller utilization of sea scallops (*Placopecten magellanicus*, Gmelin). Fisheries Research Board of Canada. Manuscript Report Series 806: 1-24.
- BRICELJ, V.M., EPP, J. & MALOUF, R.E. 1987. Intraspecific variation in reproductive and somatic growth cycles of bay scallops *Argopecten irradians*. Marine Ecology Progress Series 35: 123-137.
- BRICELJ, V.M. & SHUMWAY, S.E. 1991. Physiology: energy acquisition and utilization. Pp. 305-346. In S.E. Shumway, (ed.), 'Scallops: biology, ecology and aquaculture'. (Elsevier: New York).
- BRUCE, W.R. & DELANEY, J.E. 1972. Report on the paralytic shellfish poisoning programme of Canada. (Unpubl.).
- CADDY, J.F. & CHANDLER, R.A. 1968. Accumulation of paralytic shellfish poison by the rough whelk (*Buccinum undatum* L.). Proceedings of the National Shellfisheries Association 58: 46-50.
- CEMBELLA, A.D. & SHUMWAY, S.E. 1991. 'Uptake, sequestering and biotransformation of paralytic shellfish toxins by the giant scallop *Placopecten magellanicus*: seasonal and spatial scales'. Fifth International Conference on Toxic

- Marine Phytoplankton, Newport, Rhode Island, USA. Abstract.
- COSPER, E.M., DENNISON, W.C., CARPENTER, E.J., BRICELJ, V.M., MITCHELL, J.G., KUENSTNER, S.H., COLFLESH, D. & DEWEY, M. 1987. Recurrent and persistent brown tide blooms perturb coastal marine ecosystem. *Estuaries* 10: 284–290.
- DEPARTMENT OF FISHERIES AND OCEANS 1987. 'Summary of paralytic shellfish toxicity records in the Pacific region'. (Dept. of Fisheries & Oceans: Burnaby, British Columbia). 41p.
- DEPARTMENT OF FISHERIES AND OCEANS 1989. 'Summary of paralytic shellfish toxicity records in the Pacific region'. (Dept. of Fisheries & Oceans: Burnaby, British Columbia). 20p.
- DEWAR, A.B., LIPTON, L. & MACK, G.E. 1971. The utilization of scallop rings and rocs. Nova Scotia Department of the Environment Technical Report 9: 1–27.
- ERARD-LEDENN, E., MORLAIX, M. & DAO, J.C. 1990. Effects of *Gyrodinium* cf. *aureolum* on *Pecten maximus* (post larvae, juveniles and adults). Pp. 132–136. In E. Granéli, B. Sundström, L. Edler & D.M. Anderson, (eds), 'Toxic marine phytoplankton'. (Elsevier: New York).
- ESTUDILLO, R.A. & GONZALES, C.L. 1984. Red tides and paralytic shellfish poisoning in the Philippines. Pp. 52–79. In A.W. White, M. Anraku & K.-K. Hooi, (eds), 'Toxic red tides and shellfish toxicity in southeast Asia'. (South east Asian Fisheries Development Center and the International Development Research Centre: Singapore).
- FIX-WICHMANN, C.F., BOYER, G.L., DIVAN, C.L., SCHANTZ, E.J. & SCHNOES, H.K. 1981. Neurotoxins of *Gonyaulax excavata* and Bay of Fundy scallops. *Tetrahedron Letters* 22: 1941–1944.
- GAINEY, L.F. Jr & SHUMWAY, S.E. 1988a. Physiological effects of *Protogonyaulax tamarensis* on cardiac activity in bivalve molluscs. *Comparative Biochemistry and Physiology* 91C: 159–164.
- GAINEY, L.F. Jr & SHUMWAY, S.E. 1988b. A compendium of the responses of bivalve molluscs to toxic dinoflagellates. *Journal of Shellfish Research* 7: 623–628.
- GALLAGHER, S.M., BRICELJ, V.M. & STOECKER, D.K. 1988. Effects of the brown tide alga on growth, feeding physiology and locomotory behavior of scallop larvae (*Argopecten irradians*). Pp. 511–542. In E.M. Cosper, V.M. Bricelj & E.J. Carpenter, (eds), 'Novel phytoplankton blooms: causes and impacts of recurrent brown tides and other unusual blooms'. (Springer-Verlag: New York). 799p.
- GILLIS, M., SURETTE, C., RICHARD, D. & WATSON-WRIGHT, W. 1991. Escalation of paralytic shellfish poison in viscera of Georges Bank scallops (*Placopecten magellanicus*) from 1988 to 1990. Proceedings of the Second Canadian Workshop on Harmful Marine Algae. Canadian Technical Report Series 1799: 9.
- GRANELI, E., SANDSTRÖM, B., EDLER, L. & ANDERSON, D.M. (eds) 1990. 'Toxic marine phytoplankton'. (Elsevier/North Holland: New York). 554p.
- GUZMAN, L. & CAMPODONICO, I. 1978. Red tides in Chile. *Interciencia* 3: 144–150.
- HALLEGRAEFF, G.M. 1993. A review of harmful algal blooms and their apparent global increase. *Phycologia* 32: 79–99.
- HALLEGRAEFF, G.M. & SUMMER, C.E. 1986. Toxic phytoplankton blooms affect shellfish farms. *Australian Fisheries* 45: 15–18.
- HALLEGRAEFF, G.M., STANLEY, S.O., BOLCH, C.J. & BLACKBURN, S.I. 1989. *Gymnodinium catenatum* blooms and shellfish toxicity in southern Tasmania, Australia. Pp. 77–80. In T. Okaichi, D.M. Anderson & T. Nemoto, (eds), 'Red tides: biology, environmental science, and toxicology'. (Elsevier/North Holland: New York).
- HARDY, D. 1991. 'Scallop farming'. (Blackwell Scientific: Cambridge, Mass.). 237p.
- HARTWELL, A.D. 1975. Hydrographic factors affecting the distribution and movement of toxic dinoflagellates in the western Gulf of Maine. Pp. 47–68. In V.R. LoCicero, (ed.), 'Proceedings of the First International Conference on Toxic Dinoflagellate Blooms'. (Massachusetts Science and Technology Foundation: Wakefield, Mass.). 541p.
- HSU, C.P., MARCHAND, A., SHIMIZU, Y. & SIMS, G.G. 1979. Paralytic shellfish toxins in the sea scallop, *Placopecten magellanicus*, in the Bay of Fundy. *Journal of the Fisheries Research Board of Canada* 36: 32–36.
- HURST, J.W. Jr 1975. The history of paralytic shellfish poisoning on the Maine Coast: 1958–1974. Pp. 525–528. In V.R. LoCicero, (ed.), 'Proceedings of the First International Conference on Toxic Dinoflagellate Blooms'. (Massachusetts Science and Technology Foundation: Wakefield, Mass.). 541p.
- IKEDA, T., MATSUNO, S., SATO, S., OGATA, T., KODAMA, M., FUKUYO, Y. & TAKAYAMA, H. 1989. First report on toxic shellfish poisoning caused by *Gymnodinium catenatum* Graham (Dinophyceae) in Japan. Pp. 411–414. In T. Okaichi, D.M. Anderson & T. Nemoto, (eds), 'Red tides: biology, environmental science, and toxicology'. (Elsevier/North Holland: New York). 489p.
- INGHAM, H.R., MASON, J. & WOOD, P.C. 1968. Distribution of toxin in molluscan shellfish following the occurrence of mussel toxicity in north-east England. *Nature* 220: 25–27.
- JAMIESON, G.S. & CHANDLER, R.A. 1983. Paralytic shellfish poison in sea scallops (*Placopecten magellanicus*) in the west Atlantic.

- Canadian Journal of Fisheries and Aquatic Sciences 40: 313–318.
- JEON, J.-K., YI, S.K. & HUH, H.T. 1988. Paralytic shellfish poison of bivalves in the Korean waters. *Journal of the Oceanological Society of Korea* 23: 123–127.
- KODAMA, M., OGATA, T., SATO, S. & SAKAMOTO, S. 1990. Possible association of marine bacteria with paralytic shellfish toxicity of bivalves. *Marine Ecology Progress Series* 61: 203–206.
- LASSUS, P. & BERTHOME, J.P. 1988. Status of 1987 algal blooms in IFREMER. ICES/annex III C.M. 1988/F:33A: 5–13.
- LASSUS, P., FREMY, J.M., LEDOUX, M., BARDOUIL, M. & BOHEC, M. 1989. Patterns of experimental contamination by *Protogonyaulax tamarensis* in some French commercial shellfish. *Toxicon* 27: 1313–1321.
- LOCICERO, V.R. (ed.) 1975. 'Proceedings of the First International Conference on Toxic Dinoflagellate Blooms'. (Massachusetts Science and Technology Foundation: Wakefield, Mass.). 541p.
- MAHONEY, J.B. & STEIMLE, F.W.Jr 1979. A mass mortality of marine animals associated with a bloom of *Ceratium tripos* in the New York Bight. Pp. 225–230. In D.L. Taylor & H.H. Seliger, (eds), 'Toxic dinoflagellate blooms'. (Elsevier/North Holland: New York).
- MCFARREN, E.F., SCHAFER, M.L., CAMPBELL, J.E., LEWIS, K.H., JENSEN, E.T. & SCHANTZ, E.J. 1960. Public health significance of paralytic shellfish poison. *Advances in Food Science* 1960: 135–179.
- MARUYAMA, J., NOGUCHI, T., ONOUE, Y., UEDA, Y., HASHIMOTO, K. & KAMIMURA, S. 1983. Anatomical distribution and profiles of the toxins in highly PSP-infested scallops from Ofunato Bay during 1980–1981. *Bulletin of the Japanese Society for Scientific Fisheries* 49: 233–235.
- MEDCOF, J.C., LEIM, A.H., NEEDLER, A.B., NEEDLER, A.W.H., GIBBARD, J. & NAUBERT, J. 1947. Paralytic shellfish poisoning on the Canadian Atlantic coast. *Bulletin of the Fisheries Research Board of Canada* 75: 1–32.
- MEDCOF, J.C. 1972. The St. Lawrence rough whelk fishery and its paralytic shellfish poisoning. Fisheries Research Board of Canada, Manuscript Report Series 1201: 1–26.
- MERRILL, A. 1992. Scallop farm doing well. *Atlantic Fish Farming* 1992: 8.
- MINCHIN, D. 1984. Aspects of the biology of young scallops, *Pecten maximus* (Linnaeus) (Pectinidea: Bivalvia) about the Irish coast. PhD Thesis, Trinity College, Dublin. Unpubl.
- NAGASHIMA, Y., SATO, Y., NOGUCHI, T., FUCHI, Y., HAYASHI, K. & HASHIMOTO, K. 1988. Paralytic shellfish poison in the "hiogi" scallop *Chlamys nobilis*. *Marine Biology* 98: 243–246.
- NISHIHAMA, Y. 1980. Seasonal abundance of *Protogonyaulax* sp. causing paralytic shellfish poisoning in Funka Bay, Hokkaido, Japan, 1978–1980. Pp.319–372. In Melteff, B.R. & Nevem, R.A., (eds), 'Proceedings of the North Pacific Aquaculture Symposium, Anchorage, Alaska'. (Alaska University, Alaska Seagrant Program: Fairbanks).
- NISHIHAMA, Y., TAKASUGI, S. & SATOH, N. 1980. Seasonal abundance of *Protogonyaulax* sp. (Dinophyceae) and the accumulation and elimination of the paralytic shellfish toxin by scallops in Funka Bay, Hokkaido, Japan. *Journal of the Hokkaido Fisheries Research Station* 37: 105–113.
- NISHITANI, L. & CHEW, K. 1988. PSP toxins in the Pacific coast states: monitoring programs and effects on bivalve industries. *Journal of Shellfish Research* 7: 653–669.
- NOGUCHI, T., ADACHI, R., IGUCHI, M., KAMIYA, H. & HASHIMOTO, K. 1978. Occurrence of toxic bivalves in association with *Gonyaulax* planktons in Ise, Owase and Ofunato Bays. *Bulletin of the Japanese Society for Scientific Fisheries* 44: 1245–1248.
- NOGUCHI, T., UEDA, Y., ONOUE, Y., KONO, M., KOYAMA, K., HASHIMOTO, K., SENO, Y. & MISHIMA, S. 1980a. Reduction in toxicity of PSP-infested scallops during canning process. *Bulletin of the Japanese Society for Scientific Fisheries* 46: 1273–1277.
- NOGUCHI, T., UEDA, Y., ONOUE, Y., KONO, M., KOYAMA, K., HASHIMOTO, K., TAKEUCHI, T., SENO, Y. & MISHIMA, S. 1980b. Reduction in toxicity of highly PSP-infested scallops during canning process and storage. *Bulletin of the Japanese Society for Scientific Fisheries* 46: 1339–1344.
- NOGUCHI, T., NAGASHIMA, Y., MARUYAMA, J., KAMIMURA, S., & HASHIMOTO, K. 1984. Toxicity of the adductor muscle of markedly PSP-infested scallop *Patinopecten yessoensis*. *Bulletin of the Japanese Society for Scientific Fisheries* 50: 517–520.
- OGATA, T., KODAMA, M., FUKUYO, Y., INOUE, T., KAMIYA, H., MATSUURA, F., SEKIGUCHI, K. & WATANABE, S. 1982. The occurrence of *Protogonyaulax* spp. in Ofunato Bay, in association with the toxification of the scallop *Patinopecten yessoensis*. *Bulletin of the Japanese Society for Scientific Fisheries* 48: 563–566.
- OKAICHI, T., ANDERSON, D.M. & NEMOTO, T. (eds) 1989. 'Red tides: biology, environmental science, and toxicology'. (Elsevier/North Holland: New York). 489p.
- OSHIMA, Y., YASUMOTO, T., KODAMA, M., OGATA, T., FUKUYO, Y. & MATSUURA, F. 1982. Features of paralytic shellfish poisoning in Tohoku district. *Bulletin of the Japanese Society for Scientific Fisheries* 48: 525–530.
- OSHIMA, Y., YASUMOTO, T., HALLEGRAEFF, G. & BLACKBURN, S. 1987a. Paralytic shellfish

- toxins and causative organisms in the tropical Pacific and Tasmanian waters. Pp. 423–428. In P. Gopalakrishnakone & C.K. Tan, (eds). 'Progress in venom and toxin research'. (Faculty of Medicine, National University of Singapore: Singapore).
- OSHIMA, Y., HASEGAWA, M., YASUMOTO, T., HALLEGRAEFF, G. & BLACKBURN, S. 1987b. Dinoflagellate *Gymnodinium catenatum* as the source of paralytic shellfish toxins in Tasmanian shellfish. *Toxicon* 25: 1105–1111.
- PARRY, G.D., LANGDON, J.S. & HUISMAN, J.M. 1989. Toxic effects of a bloom of the diatom *Rhizosolenia chunii* on shellfish in Port Phillip Bay, southeastern Australia. *Marine Biology* 102: 25–41.
- PRAKASH, A. 1963. Source of paralytic shellfish toxin in the Bay of Fundy. *Journal of the Fisheries Research Board of Canada* 20: 983–996.
- PRAKASH, A., MEDCOF, J.C. & TENNANT, A.D. 1971. Paralytic shellfish poisoning in eastern Canada. *Fisheries Research Board of Canada Bulletin* 177.
- SCHICK, D.F., SHUMWAY, S.E. & HUNTER, M. in press. Seasonal changes of allometric relationships in two populations of the scallop, *Placopecten magellanicus* (Gmelin) in the Gulf of Maine.
- SEKIGUCHI, S., INOGUCHI, N., SHIMIZU, M., SAITO, S., WATANABE, S., OGATA, T., KODAMA, M. & FUKUYO, Y. 1989. Occurrence of *Protogonyaulax tamarensis* and shellfish toxicity in Ofunato Bay from 1980–1986. Pp.399–402. In T. Okaichi, D.M. Anderson & T. Nemoto, (eds), 'Red tides: biology, environmental science, and toxicology'. (Elsevier/North Holland: New York).
- SHARIFZADEH, K., RIDLEY, N., WASKIEWICZ, R., LUONGO, P., GRADY, G.F., DEMARIA, A., TIMPERI, R.J., NASSIF, J., SUGITA, M., GEHMAN, V., PETERSON, P., ALEXANDER, A., BARRET, R., BALLENTINE, K., MIDDLEAUGH, J.P. & SOMERSET, I. 1991. Paralytic shellfish poisoning – Massachusetts and Alaska, 1990. *Morbidity and Mortality Weekly Report, Massachusetts Medical Society, New England Journal of Medicine* 40(10): pp.
- SHARPE, C.A. 1981. 'Paralytic shellfish poison, California-Summer 1980'. (State of California Dept. Health Services-Sanitary Engineering Section).
- SHIMIZU, Y. & YOSHIOKA, M. 1981. Transformation of paralytic shellfish toxins as demonstrated in scallop homogenates. *Science* 212: 547–549.
- SHUMWAY, S.E. 1989. Toxic Algae: A serious threat to shellfish aquaculture. *World Aquaculture* 20: 65–75.
- SHUMWAY, S.E. 1990. A review of the effects of algal blooms on shellfish and aquaculture. *Journal of the World Aquaculture Society* 21: 65–105.
- SHUMWAY, S.E. (ed.) 1991. 'Scallops: biology, ecology and aquaculture. Developments in Aquaculture and Fisheries Science, 21'. (Elsevier/North Holland: New York). 1095p.
- SHUMWAY, S.E. & CUCCI, T.L. 1987. The effects of the toxic dinoflagellate *Protogonyaulax tamarensis* on the feeding and behavior of the bivalve molluscs. *Aquatic Toxicology* 10: 9–27.
- SHUMWAY, S.E., SELVIN, R. & SCHICK, D.F. 1987. Food resources related to habitat in the scallop *Placopecten magellanicus* (Gmelin, 1791): A qualitative study. *Journal of Shellfish Research* 6: 89–95.
- SHUMWAY, S.E., SHERMAN-CASWELL, S. & HURST, J.W.Jr 1988. Paralytic shellfish poisoning in Maine: monitoring a monster. *Journal of Shellfish Research* 7: 643–652.
- SMAYDA, T.J. & FOFONOF, P. 1989. An extraordinary, noxious brown-tide in Narragansett Bay, II. Inimical effects. Pp. 133–137. In T. Okaichi, D.M. Anderson & T. Nemoto, (eds), 'Red tides: biology, environmental science, and toxicology'. (Elsevier/North Holland: New York).
- SUMMERSON, H.C. & PETERSON, C.H. 1990. Recruitment failure of the bay scallop *Argopecten irradians concentricus* during the first red tide, *Ptychodiscus brevis*, outbreak recorded in North Carolina. *Estuaries* 13: 322–331.
- TAYLOR, D.L. & SELIGER, H.H. (eds) 1979. 'Toxic dinoflagellate blooms'. (Elsevier-North Holland: New York). 505p.
- TESTER, P.A. & FOWLER, P.K. 1990. Brevetoxin contamination of *Mercenaria mercenaria* and *Crassostrea virginica*: a management issue. Pp. 499–503. In E. Granéli, L. Edler, B.G. Sundström & D.M. Anderson, (eds), 'Toxic marine phytoplankton'. (Elsevier/North Holland: New York).
- TRACEY, G.A. 1985. Picoplankton algal bloom causes a catastrophe mussel kill in Narragansett Bay, Rhode Island. *Transactions of the American Geophysical Union* 66: 1303.
- TRACEY, G.A., JOHNSON, P.W., STEELE, R.W., HARGRAVES, P.E. & SIEBURTH, J.M. 1988. A shift in photosynthetic picoplankton composition and its effect on bivalve mollusc nutrition: the 1985 "Brown Tide" in Narragansett Bay, Rhode island. *Journal of Shellfish Research* 7: 671–675.
- TUFTS, N.R. 1979. Molluscan transfectors of paralytic shellfish poisoning. Pp.403–408. In D.L. Taylor & H.H. Seliger, (eds), 'Toxic dinoflagellate blooms'. (Elsevier/North Holland: New York).
- WATSON-WRIGHT, W., RICHARD, D., BELLIVEAU, A., MCGUIRE, A. & MARSHALL, I. 1989. 'PSP content of roe cannot be predicted from that in other tissues of Bay of Fundy sea scallops (*Placopecten magellanicus*)'. Third Pan American Symposium on Plant, Animal and Microbial Toxins, Oaxtepec, Mexico. Abstract, p.66.
- WHITE, A.W., NASSIF, J., SHUMWAY, S.E. & WHITTAKER, D.K. in press. Recent occurrence of paralytic shellfish toxins in offshore shellfish in

- the northeastern United States. In T. Smayda & Y. Shimizu, (eds), 'Toxic algal blooms'. (Elsevier/North Holland: New York).
- WHITE, A.W., SHUMWAY, S.E., NASSIF, J. & WHITTAKER, D.K. in press. Variation in levels of paralytic shellfish toxins among individual shellfish. In T. Smayda and Y. Shimizu, (eds), 'Toxic algal blooms'. (Elsevier/North Holland: New York).
- WHITEFLEET-SMITH, J.L., DIVAN, C.L., SCHANTZ, E.J. & SCHNOES, H.K. 1985. Distribution of paralytic toxins in California shellfish. *Toxicon* 23: 346-349.
- WOOD, P.C. & MASON, J. 1968. Paralytic shellfish poisoning: a short account of an outbreak occurring on the north-east coast of Britain in May 1968. *International Council for the Exploration of the Sea CM 1968/K:16*: 1-6 (mimeo).
- YENTSCH, C.M. & INCZE, L.S. 1982. Progress of shellfish toxin research: implications of toxic resting cysts for aquaculture. Aquaculture: public health, regulatory and management aspects. *Proceedings of the Sixth U.S. Food and Drug Administration Sciences Symposium on Aquaculture Texas A&M Sea Grant Publication TAMU-SG-82-119*: 49-62.



# DILEMMA OF THE BOUTIQUE QUEENSLAND SCALLOP

B. HART

Hart, B. 1994 08 10: Dilemma of the boutique Queensland Scallop. *Memoirs of the Queensland Museum* 36(2): 373–376. Brisbane. ISSN 0079-8835.

With increased production of the saucer scallop (*Amusium balloti*) in Western Australia and Queensland over the past three years, great pressure has been placed on the Queensland scallop to maintain its share of two niche markets in the face of forces which are changing market conditions. Western Australian scallops have been sold in Singapore and Hong Kong beneath Queensland prices. Many buyers are now finding Western Australian scallop acceptable 'at the price'. To redress this situation and diversify into other markets, the Queensland scallop industry must be more price competitive.

*B. Hart, B. Hart Enterprises, 444 Queen Street, Brisbane, Queensland 4000; 9 March, 1994.*

The market for Australian saucer scallops (*Amusium balloti*) is unusually specialised. A niche market for roe-off saucer scallop meat commands a substantial price premium in Singapore and Hong Kong. Queensland and WA saucer scallops are closely related but not identical and have not been interchangeable in a market sense.

In this paper, I describe markets for saucer scallop meats. Costs associated with perishable commodities never decrease – there are unavoidable costs associated with interest, insurance, cold store charges and the like. Perishable commodity markets can be volatile. The main method of reducing risk is to sell as produced, providing cost was covered and hopefully a small profit margin maintained. If, on the other hand, marketing does not equate with product cost, withdrawal from that particular item, at least on a temporary basis, is indicated.

## THE QUEENSLAND SCALLOP FISHERY

In 1978, QLD scallop meat exported was 200–300 tonnes. The fishery was regarded as a short term 'fill-in' between prawn seasons. On a quantity - price basis, prawns were regarded as more attractive to fishermen. Since 1978 there has been a steady build-up of trawlers which now regard scallops as their main target. These are mainly smaller short-range vessels which lack specialised refrigeration. Large trawlers from far north Queensland still travel to scallop grounds off Hervey Bay, Bundaberg and Gladstone at times of the year when prawn catches are low or seasonal prawn closures are in place. These boats may work on scallops for 3–4 months.

Scallop catches usually increase from August, with peak catches in October–November; they

decline from January to May–June. These peaks coincide well with the period of increased purchases in Hong Kong and Singapore, leading up to Christmas and the Chinese New Year.

The main management commitment for QLD scallop is a size limit of 95mm between May 1 and November 1 to reduce fishing and ensure adequate breeding scallop for spat fall the next year. Otherwise the size limit is 90mm. Shell size, net length and mesh size, and a ban on daylight trawling, ensure adequate management so far as marketing is concerned.

## MEAT SIZE AND COUNTS

The market for roe-off scallop in SE Asia is structured in relation to meat size. Meat size has been expressed in count per pound, with 3 classes: 20–30 to the pound, 20–40 to the pound, and 41–60 to the pound. Larger meats (lower counts) attract a higher price, with the differential between top and second count meat 10–20% (Table 1). There has been discussion of introducing a minimum shell size of 95mm on a year round basis, to reduce the proportion of 41–60 scallop meat on the market. This size scallop is important in overseas sales, as the W.A. fishery produces little 41–60 count meat, and then normally at the end of their season. The QLD fishery is thus able to fill this gap. From a marketing perspective

TABLE 1. Scallop meat count from one processor's records (September 1992–March 1993).

Meat size-count per pound	Proportion of landings(%)
20/30	22
20/40	43
41/60	35

TABLE 2. Summary of scallop exports and prices from Australia. (\*=re-export)

Country		Total exports (Tonnes)	WA exports (tonnes)	Value (A\$/kg)	QLD exports (tonnes)	Value (A\$/kg)
Canada	1989	1			1	\$27
	1990	4			4	\$26.85
	1991	27	27	\$15.10		\$
	1992	36	36	\$13.44		\$
Hong Kong	1989	691	96	\$19.70	673	\$21.18
	1990	1375	214	\$23.03	737	\$24.08
	1991	1186	441	\$13.15	1161	\$21.06
	1992	1680	1004	\$14.69	568	\$20.45
Singapore	1989	137	43	\$19.30	921	\$21.92
	1990	192	65	\$15.70	123	\$20.70
	1991	222	177	\$14.65	43	\$20.01
	1992	326	242	\$15.17	78	\$19.67
Taiwan	1989	6	6	\$15.84		
	1990	13	13	\$17.54		
	1991	48	48	\$12.61		
	1992	116	116	\$15.57		
U. K.	1989					
	1990					
	1991	10	10	\$11.73		
	1992	70	70	\$12.90		
U.S.A.	1989					
	1990	15*				
	1991	487	483	\$11.40	4	\$27.62
	1992	1306	1289	\$13.01		
France	1989					
	1990					

nothing should be done to interfere with the natural run of size beyond size limits in force.

#### EXPORT DESTINATIONS

No information relevant to the quantity of scallop imported into Singapore was available from Austrade, but the following comment on export to Hong Kong is informative: 'Unfortunately there are no disintegrated statistics published by any local source, official or private, on imports of scallops into Hong Kong. Import figures covering this product are incorporated, with those relating

to all sorts of clams, mussels and other shell fish, under a composite category "Molluscs other than Cuttlefish, Squid and Octopus". We have discussed with a number of major seafood importers / distributors, all of whom unanimously agreed that Australia is presently the largest supplier of frozen scallops in this market, accounting for about 70% of the overall sales. Canada is the second major source, sharing, however, no more than 15% of the market. The balance is split between the U.S.A. and Japan. A number of major importers believe that total imports in 1992 could be 2,000–2,500t, of which 1,400–1,800t were from Australia. Consumption by the market in 1992 increased over 1991, probably by c.10%.

Re-exports are reported to be insignificant, almost all being made to Macau and Guangdong, southern China. The trade estimated re-exports averaging less than 5% of total imports.'

The Bureau of Statistics - Foreign Trade Interrogation Facility - supplied data on Australian scallop exports to major importing nations (Table 2). Apart from the 7 major destinations, minor export tonnages were made to 22 countries. The most significant were to Japan, Korea and Malaysia, and originated from Western Australia and Victoria. The main shipment to Japan was 20t in 1990, at the very good price of A\$43.83 FOB per kg. The main source of scallop exported to Malaysia has been Western Australia (56t, price average A\$12.37) and, surprisingly, South Australia (16t at A\$10.73). Australia imports a quantity of scallop in various forms, including frozen, dried, salted and brined (Table 3).

#### PRICE STRUCTURES

F.O.B. Brisbane prices of 20–40 count QLD scallops (median size) from February–early March shipments are compared with import prices (Table 4). If the 1993 US\$14.00 was converted at the .8205 rate of March 1989, the FOB value would have been A\$16.63 per kg rather than A\$19.62 attained. The declining A\$ has helped maintain prices in the Australian fishery.

There is little scope for price comparison between QLD and imported scallops, much of which is either bred or imported for breeding. The smallest meats (41–60 pieces per pound) produced in the QLD fishery are used only in times of slow sales for local marketing and breeding for the local trade. During 1992, W.A. scallops were purchased by QLD wholesalers for the restaurant trade and general distribution, due to excessive prices of the QLD product.

TABLE 3. Major imports of scallops into Australia

	Quantity (t)	Major supplying nation (t supplied)	Average Price
1989	1001	Thailand (356)	A\$11.68
1990	1527	Japan (606)	A\$13.25
1991	706	Japan (504)	A\$13.19
1992	447	Japan (335)	A\$11.29

### SUPPLY AND DEMAND

Production increases in W.A. and Queensland present a real dilemma to the QLD scallop fishery in the past three seasons. Annual production (Table 5) shows that the W. A. fishery has been well above average, exceeding QLD production.

Market prices (Table 2) indicate that scallop connoisseurs of the world are in Hong Kong and to a lesser extent in Singapore, where especially attractive prices have been paid for the QLD product. This is attributed to the good quality, colour and texture which has earned premiums of US\$6.00 per kg and more on occasions, above the same size W.A. product.

The Hong Kong market is of the order of 2,500t per year, with about 70–75% from Australia. Virtually no roe-on scallop is consumed in Hong Kong, but some is used in Singapore and Taiwan. If the Australian proportion of the Hong Kong market is assumed to be approximately 1,800t annually and the equivalent Singapore demand is 600t, the production position and distribution for 1990–1992 appears as in Table 6.

Total W.A. and QLD production probably offered a full supply in 1990 to the existing market demand for Australian product. In subsequent years production exceeded the quantity that Hong Kong plus Singapore could absorb. W.A. is supplying many more markets than Queensland (including the U.S.A., Taiwan, France and the U.K.) Wholesalers from these destinations balk at paying the premium price paid for QLD scallops which has been available in Hong Kong and Singapore; thus QLD wholesalers are left with

TABLE 4. FOB prices of 20–40 count scallop meats for February–early March shipments of Queensland saucer scallops.

	Price (US\$)	FOB Price (A\$)	Exchange Rate
1989	\$14.00	\$19.62	.6980
1990	\$17.00	\$21.97	.7590
1991	\$18.00	\$22.81	.7745
1992	\$19.60	\$25.20	.7646
1993	\$17.00	\$20.27	.8205

only two viable markets. During 1992, many Hong Kong buyers expressed the view that the high price premium of QLD scallop over W. A. scallop should be reduced, not because W. A. scallop meat quality had improved, but because many restaurants and other users were happy with the W.A. quality 'AT THE PRICE'. This has a most serious implication for QLD scallop (Table 7). These data illustrate Queensland's declining share in its two niche markets: so much so that Hong Kong buyers are advising the QLD scallop share of their market is about 30% (Table 7).

As Queensland again experienced very strong production during 1992 (approximately 2,000t) and excellent landings during January and February 1993, the conclusion that substantial unsold stocks of scallops exist in Queensland must be drawn.

TABLE 5. Annual production of saucer scallops in Australia.

	WA (tonnes)	QLD (tonnes)
1988	731	792
1989	121	745
1990	486	1539
1991	2532	820
1992	4144	2000 (estimate)

In the period between April and September sales of scallops in Hong Kong and Singapore will be reduced. The entertainment and festive occasions which is the period of highest demand start again in about September. There are two clouds on the horizon for QLD scallops: 1, the large stock of scallop stored and 2, an anticipated good season for the W.A. fishery.

### DISCUSSION

Boutique has been interpreted as being of special quality and attraction in a niche market situation. If this reasoning is correct, the markets which have been willing to pay a premium for QLD scallops are limited by that premium over other acceptable scallop qualities. The quality of W.A. scallop has been demonstrated to be acceptable 'at the price' and this has resulted in substantial erosion of Queensland's market share in the only markets willing to pay a premium for Queensland quality.

The dilemma arises as a consequence of strong production rises in both Australian producers of saucer scallops in much the same market period. How does Queensland defend its market share in

TABLE 6. Production, exports and imports of saucer scallops

	Total production (t)	W.A. production	QLD production	Hong Kong imports	Singapore imports
1990	2025	486	1539	1800	600
1991	3352	2532	820	1800	600
1992	2025	4144	c.2000	1800	600

its niche markets? Quality of handling and packing must be maintained at all times, but if higher production, in the order of the last few years, is maintained, Queensland must address the supply and demand effects of market forces by making strong attempts to diversify to other destinations.

Market diversification by QLD wholesalers at prices similar to, or at a slight premium over W.A. scallop is possible. One Hong Kong buyer has indicated that he would return to purchasing QLD scallop if the premium was reduced to about US\$1.50–2.00/kg. Should this occur, we could expect rationalisation in the catching sector, which could have marketing implications.

In the last 4 years, QLD scallop exports have been almost exclusively to Hong Kong and Singapore. W. A. sales, on the other hand, have been to 3 major markets, and to 5 other substantial markets in which QLD wholesalers do not participate.

Production and exports for 1992 (Table 8) indicate quantities of scallops from W.A. and QLD which have been sold locally or held in store. There is no way of estimating the local sale component of the 1250t which appear not to have been exported at the end of 1992, nor of the quantity shipped in early 1993, but whatever this amount may be there is still a substantial stock awaiting sale and export. Much of this stock will attract costs associated with cold storage, which cannot be recovered on the basis of current market prices from Hong Kong or Singapore. Stock purchased at lower prices subsequent to this time can still be profitable at current prices from Hong Kong and Singapore, but could not cover bare costs at prices in other markets.

TABLE 7. Market share of saucer scallops.

To:	Hong Kong		Singapore	
	WA	QLD	WA	QLD
From:				
1990	16%	84%	35%	65%
1991	37%	62%	80%	20%
1992	60%	40%	75%	25%

All of this presupposes continuing high production, which may be influenced by weather factors, rain, water temperature, currents and other variables. As if these variables were not enough to contend with, the exchange rate has had an adverse effect on prices. The A\$ strengthened against the U.S.\$ from .6785 to .7157 (bank to buy) at the end of March 1993. For one particular grade of scallop we sold at US\$14.31 candf Hong Kong this reduced the A\$ value by A\$1.09/kg.

Marketers of QLD scallop will continue to seek out and sell in the best world destinations. If these are restricted by price to two markets and market circumstances do not change, the present product in store may not be marketed until the end of 1993. Quite obviously, costs of product in store can never be reduced.

TABLE 8. Production and export destination of saucer scallops in 1992.

Product destination	W. A. production (t)	QLD production (t)
Hong Kong	1004	673
Singapore	242	78
Five substantial markets	1717	nil
Six minor markets	105	nil
Estimated unsold stock and local sales	1076	1250
Total production	4144	c. 2000

Comments from an overseas buyer who supplied pricing information to us include "Unfortunately most of us in the seafood commodity business operate on the basis of an infinite number of short run decisions and cannot afford (or believe we cannot afford) the luxury of long-range planning. The Queensland fisherman and 99.9% of the seafood industry, does not understand the problem if we lose our niche market. We allow the serene song of the highest beach price to destroy what maximises revenue over the long run. We believe the short run is the long run and are not prepared for logical results of our illogical assumption. If the W.A. scallop destroys Queensland's niche market, the long run revenue implications for the Queensland scallop are not promising.

In many ways the decade-long 80's bubble of Japanese stocks and properties poured gasoline onto the fire of supply driven seafood markets. We are now being forced to come to terms with the charred remains and it is not a joyful experience."

## CONTENTS

ZACHARIN, W. Scallop fisheries in southern Australia: managing for stock recovery . . . . .	241
FUENTES, H.R. Population biology of the commercial scallop ( <i>Pecten fumatus</i> ) in Jervis Bay, NSW . . . . .	247
JOLL, L.M. Unusually high recruitment in the Shark Bay saucer scallop ( <i>Amusium balloti</i> ) fishery . . . . .	261
CROPP, D.A. Hatchery production of Western Australian scallops . . . . .	269
DREDGE, M.C.L. Modelling management measures in the Queensland scallop fishery . . . . .	277
SHUMWAY, S.E. & CASTAGNA, M. Scallop fisheries, culture and enhancement in the United States . . . . .	283
ZACHARIN, W. Reproduction and recruitment in the doughboy scallop ( <i>Chlamys asperrimus</i> ) in the D'Entrecasteaux Channel, Tasmania. . . . .	299
MCLOUGHLIN, R.J. Sustainable management of Bass Strait scallops . . . . .	307
CURRIE, D.R. & PARRY, G.D. The impact of scallop dredging on a soft sediment community using multivariate techniques . . . . .	315
BLACK, K.P. & PARRY, G.D. Field measurements of natural sediment transport rates and the sediment disturbance due to scallop dredging in Port Phillip Bay . . . . .	327
COVER, P. & STIRLING, D. Scallop dredges: an engineering approach. . . . .	343
HEASMAN, M.P., O'CONNOR, W.A. & FRAZER, A.W. Improved hatchery and nursery rearing techniques for <i>Pecten fumatus</i> Reeve . . . . .	351
O'CONNOR, W.A., HEASMAN, M.P., FRAZER, A.W. & TAYLOR, J.J. Hatchery rearing the doughboy scallop, <i>Chlamys (Mimachlamys) asperrimus</i> (Lamarck). . . . .	357
SHUMWAY, S.E. & CEMBELLA, A.D. Toxic algal blooms: potential hazards to scallop culture and fisheries . . . . .	361
HART, B. Dilemma of the boutique Queensland scallop . . . . .	373