



***GALAXY GRS - SIMPLE SOLUTION OF BALISTIC RESCUE
SYSTEM FOR YOUR ULTRALIGHT HELICOPTER !!!***

Super modern efficient „Rescue unit GRS Heli 1“ for CH-7 Kompress.



CH-7 KOMPRESS with GRS Galaxy system: GRS Heli 1-2 for CH-7

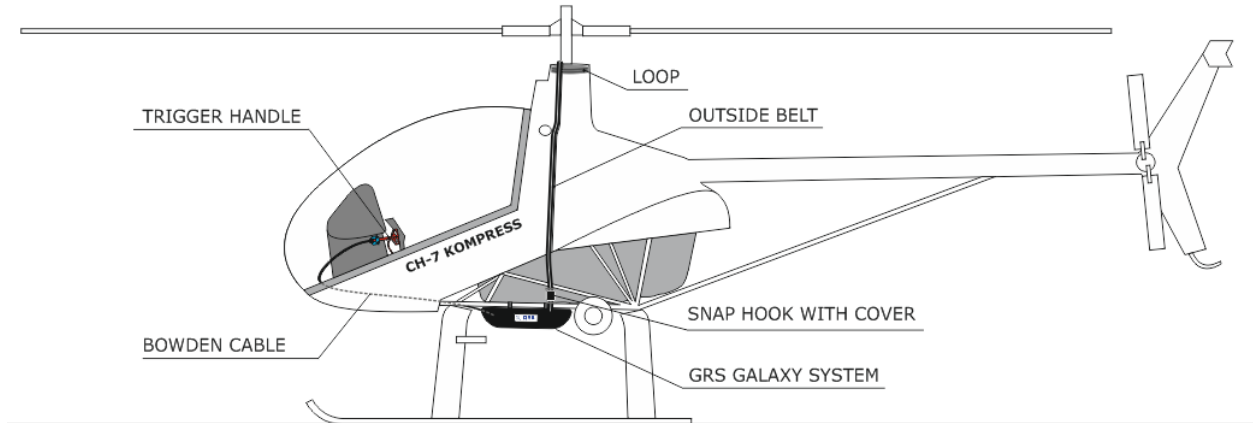

Figure 1

Complete KIT provided by Galaxy GRS s.r.o.:

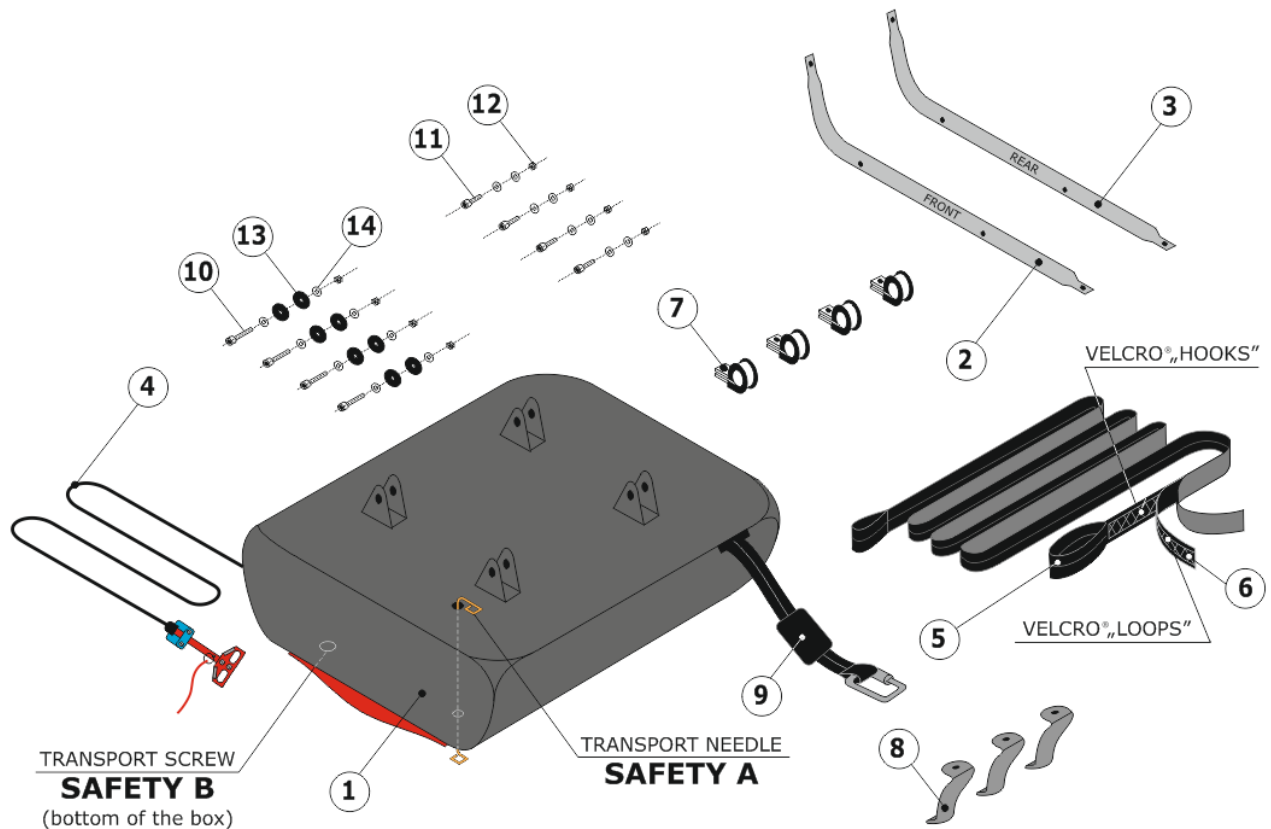

Figure 2

Parts list:

PART No.	Description	Qty
1	Carbon fibre box with GRS system	1
2	Cross beam front	1
3	Cross beam rear	1
4	Bowden cable with trigger handle	1
5	Outside belt with Velcro® hooks	1
6	Strap with Velcro® loops to stick to the CH-7 fuselage	1
7	Clamp, loop cushioned	4
8	Metal strap for upper belt hang sling loop securing	3
9	Snap hook cover	1
10	Screw M5x40	4
11	Screw M5x20	4
12	Self-locking nut M5	8
13	Rubber washer Ø25x2,5	8
14	Washer for M5 screw	16

INSTALLATION:

- 1) After unpacking you first **unscrew the safety B** from the bottom of carbon fibre container **but leave the needle - safety A and the red little flag attached until the system is installed!!!**
- 2) Attach the **front and rear cross beam** to the carbon fibre box by using M5x40 screws, rubber and metal washers and self-locking nuts according to figure 3.
- 3) Attach the carbon fibre box with installed cross beams to the longitudinal beams of the helicopter by using clamps, M5x20 screws, metal washers, and self-locking nuts (Figure 3). The longitudinal position of the box is shown in the photo of final assembly (Figure 4).

MAKE SURE THAT THERE IS NO HINDRANCE IN THE WAY OF GRS SYSTEM DEPLOYMENT!

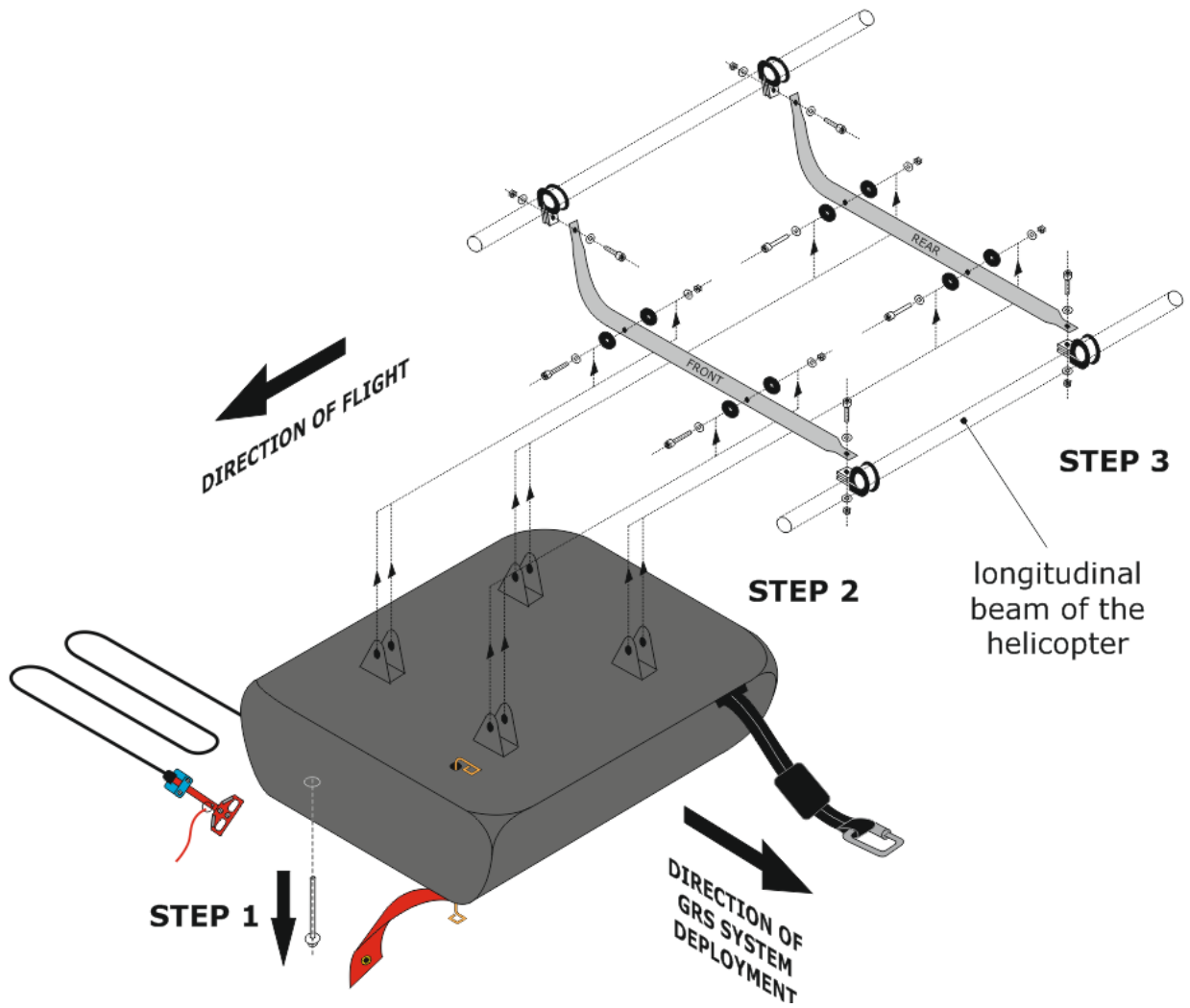

Figure 3



Figure 4

- 4) Disassemble the trigger handle. Instead of safety pin with little flag put a $\varnothing 2$ mm safety wire! Drill a $\varnothing 20$ mm hole through the helicopter fuselage and insert the handle body with bowden through the fuselage inside the cockpit. Assemble the trigger handle and **secure it with the safety pin with little flag agin!** Fasten the trigger handle to the left side of the instrument panel. The example of bowden installation is shown in the figure 5.



Figure 5

- 5) Stick the Velcro® strap with "loops" on the fuselage of the helicopter along the gap (between fiberglass parts of the fuselage) and inside the upper fuselage ending around the perimeter according to figure 6.

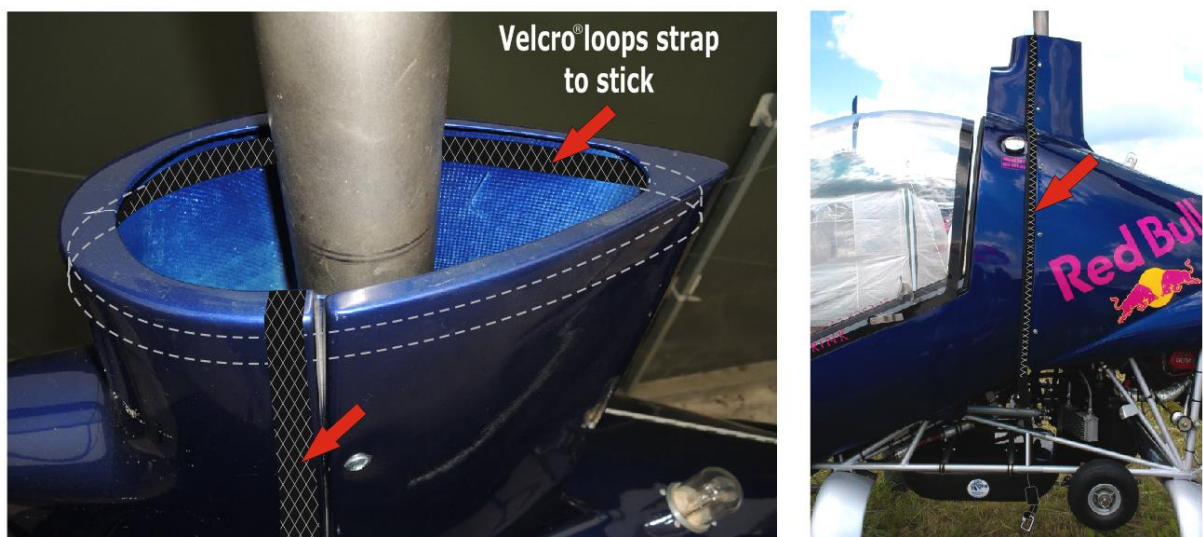

Figure 6

- 6) Make a hang sling loop around the rotor by using the outside belt with Velcro® “hooks” (figure 7). **NOTE:** For this hang sling loop use the end of the belt with bigger loop!



Figure 7

- 7) Stick the belt with the hang sling loop to the opposite Velcro® strap on the fuselage starting from the hang sling loop going down to the carbon fibre box according to figure 8.



Figure 8

- 8) Secure the hang sling loop with **3 metal straps** by using Ø3mm rivets. Make sure there is no contact with rotor.



Figure 9

- 9) Connect the outside belt with the belt, which is going from the carbon fibre box by using a snap hook and cover it with a snap hook cover. Make sure that the **position of the snap hook is vertical**. Attach the covered snap hook with 2 plastic tapes (approx. 3mm width) to short vertical support according to figure 10.

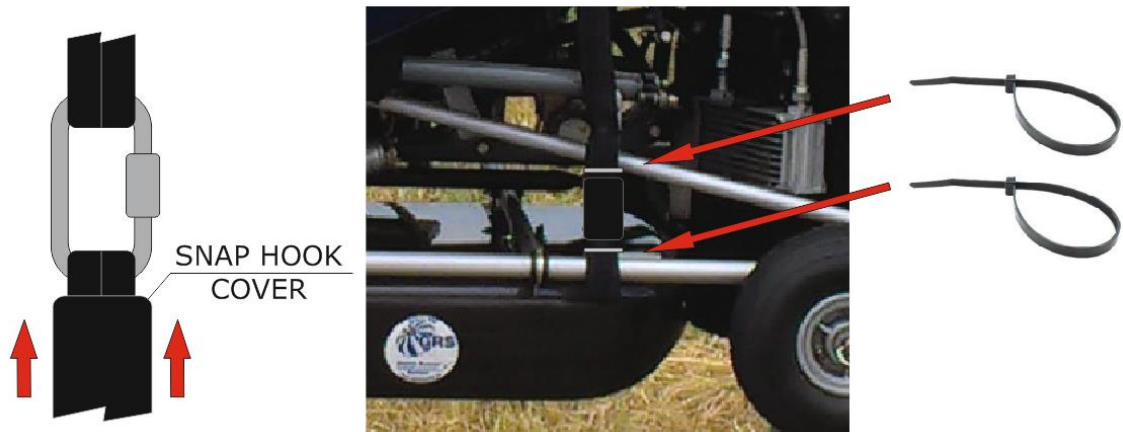

Figure 10

- 10) After the system installation you snip the **needle - safety A**, take it out, cover upper hole with a sticker, and remove the flag - the **system is now secured only by the operational pin with the flag on the handle**. It is released by pilot shortly before flight and after the flight applied again so that the handle is secured against possible activation.

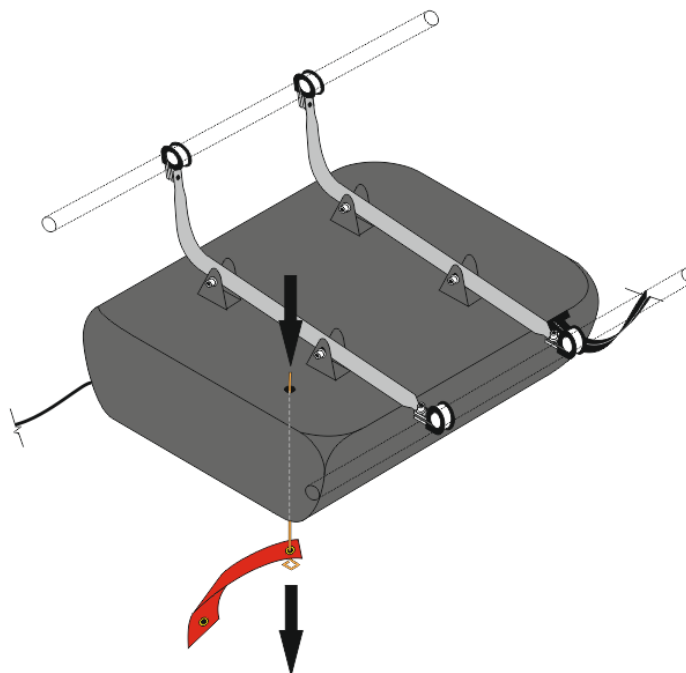

Figure 11

INNER ARRANGEMENT OF THE GRS SYSTEM:

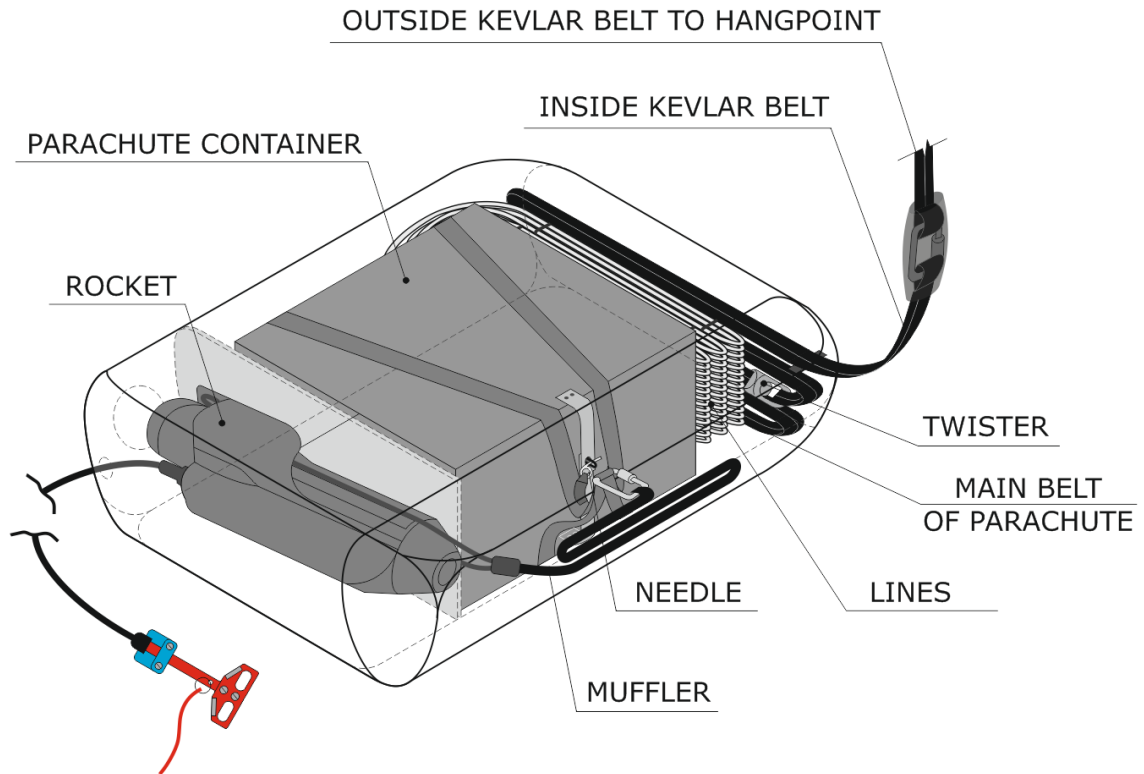
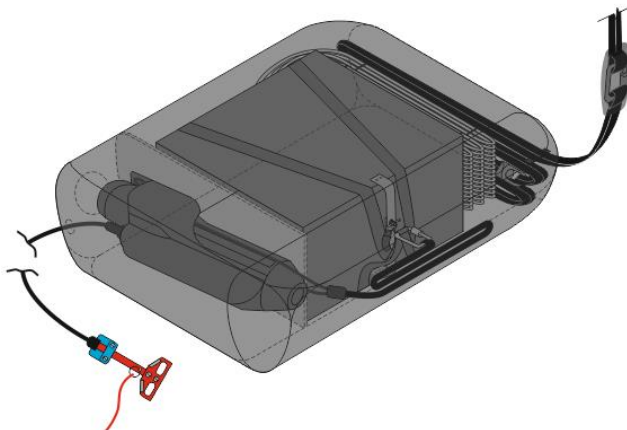
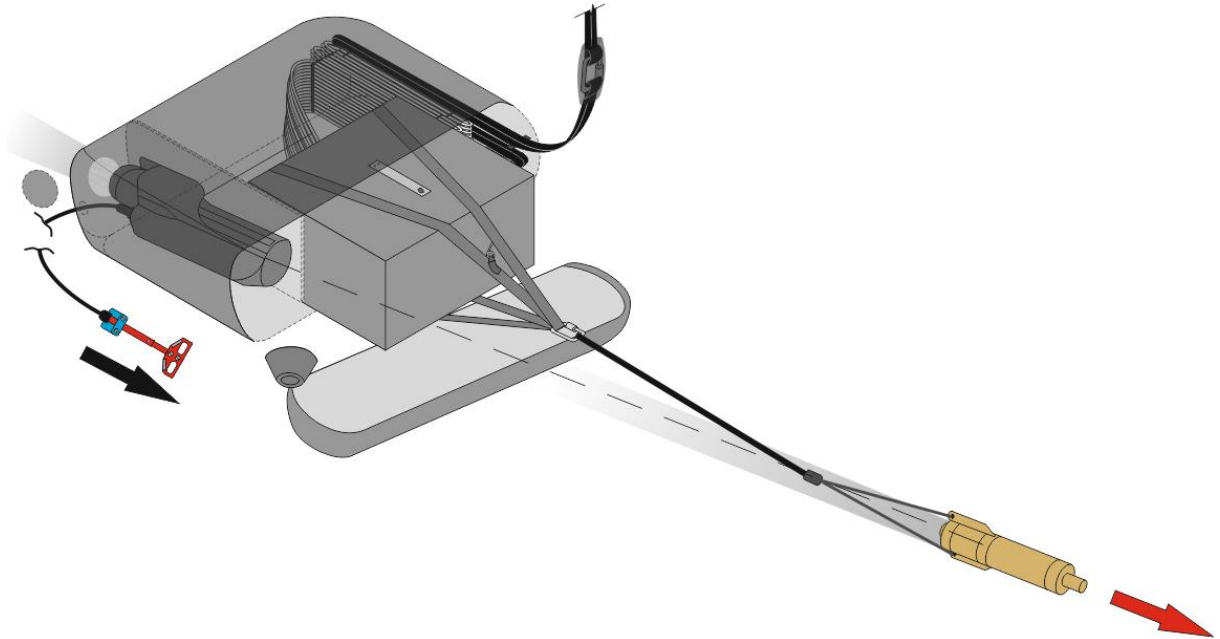

ILLUSTRATION OF OPERATION:

- 1) GRS System before activation



2) GRS System right after activation



3) GRS System is being stretched

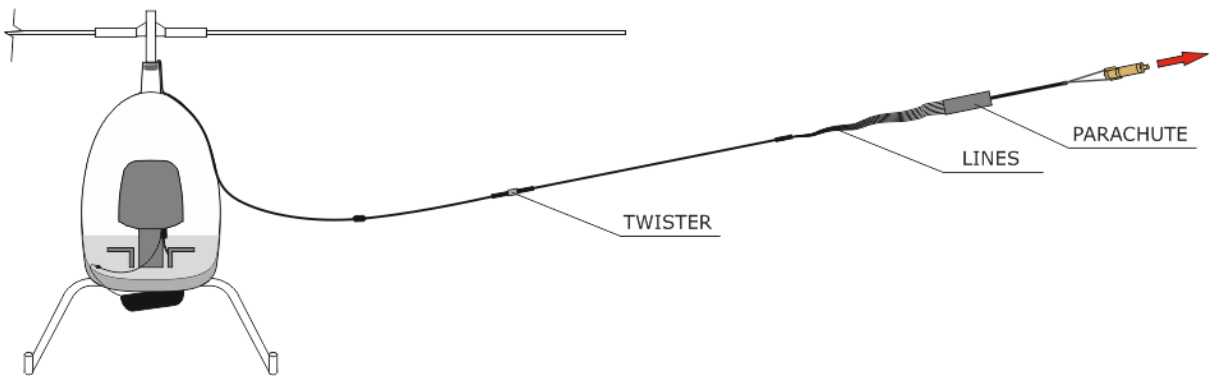

4) Stretched belts are passing through the rotor blades

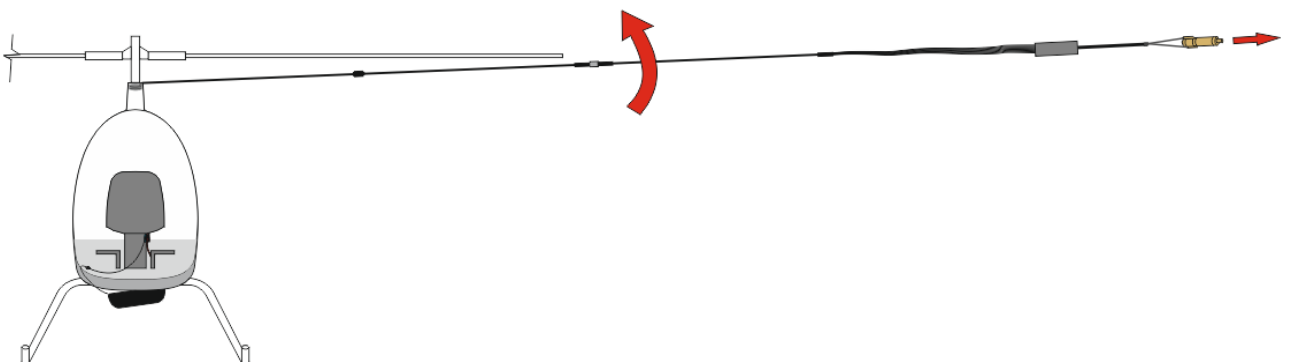

5) Hang sling loop is tightened around the rotor, parachute is opening

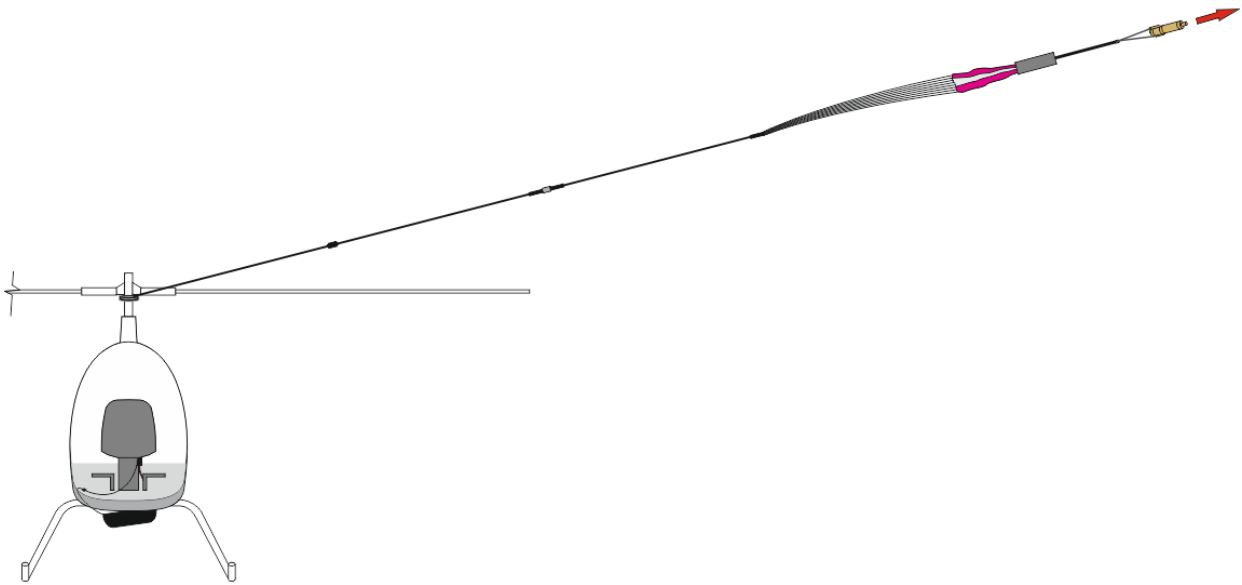

6) Rocket is slowly falling down with its own separate parachute

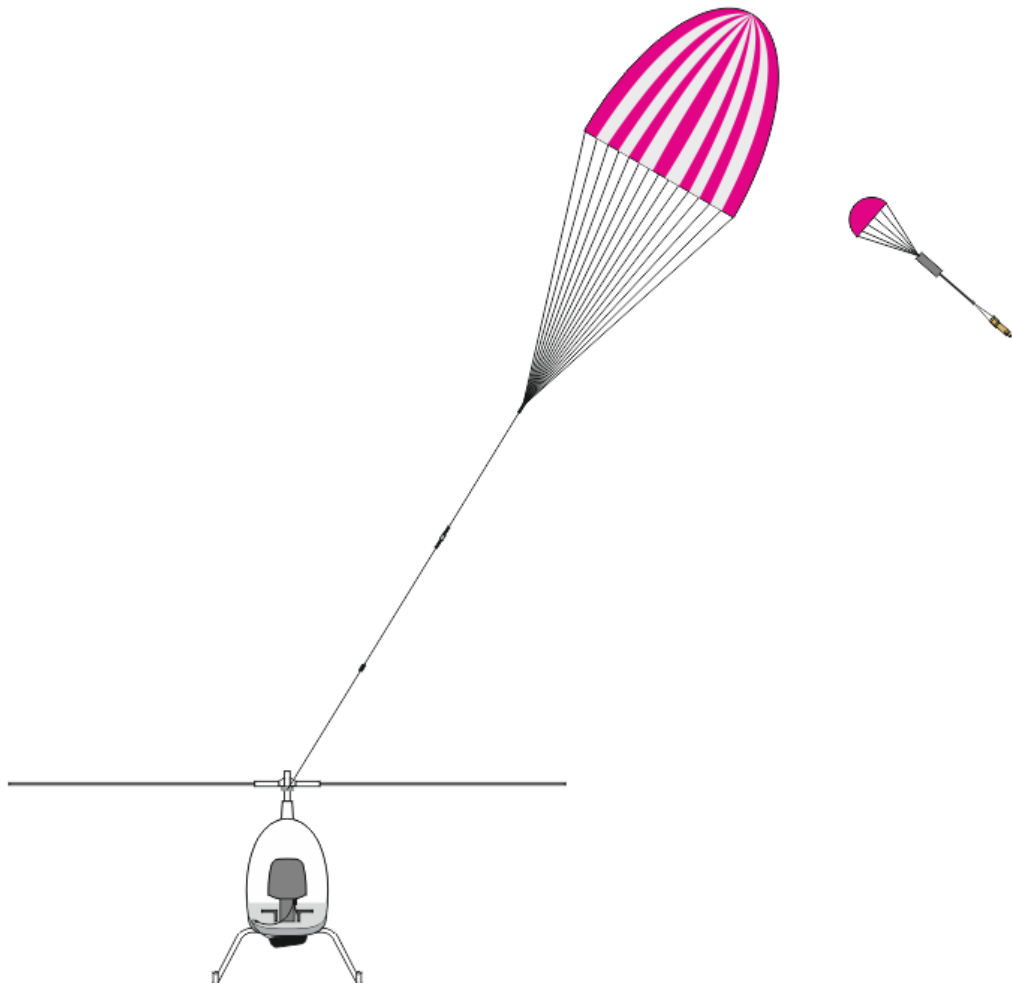

- 7) Deployment process is complete. The twister allows an independent rotation between the parachute and the rotor of the helicopter.

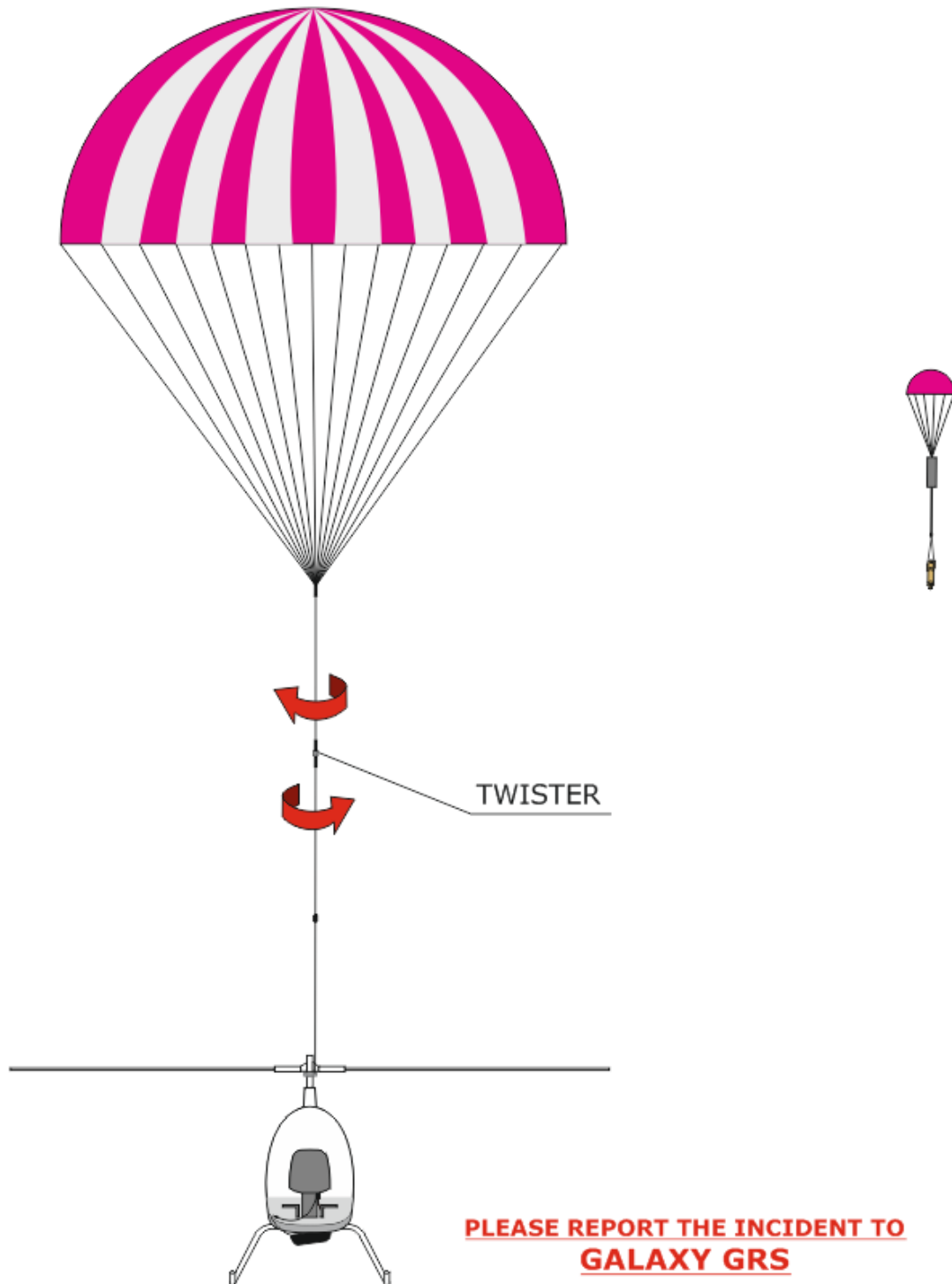

GRS Heli 1-2

TIME full open: 1,5 - 3,5 sec.

UNIT WEIGHT: 12,0 – 12,5 Kg

Super modern efficient „Rescue unit GRS Heli 1-2“ for CH-7 helicopter fully replaces the autorotation regime, with better sinking by 1-1,5m/sec.

Parameters for Heli 1 :

Flies at speed of 65 Km/h - projected rescue height 40 m above ground.

Projected rescue height in hover at very low forward speeds, already 50-60 m above ground

GRS System GRS 3/450 Soft 92 m2	Total time from firing a parachute to its full opening 1,5 - 2,5 sec.
GRS Heli 1 9,2 kg	
Accessories 3,3 kg	Descending recorded at 1000m ASTM by 473 Kg - 6,8 m/sec.
WEIGHT TOTAL	12,5 kg

Parameters for Heli 2 :

Flies at speed of 65 Km/h - projected rescue height 55 m above ground.

Projected rescue height in hover at very low forward speeds, already 65-75 m above ground

GRS System GRS 3/473 Soft 85 m2	Total time from firing a parachute to its full opening 2,2 – 3,5 sec.
GRS Heli 2 8,7 kg	
Accessories 3,3 kg	Descending recorded at 1000 m ASTM by 473 Kg – 7,5 m/sec.
WEIGHT TOTAL	12,0 kg

Notes :

- **Helicopter must be equipped with 4-point safety belts !**
- **Make a visual inspection of all parts and connections every 50 flight hours !**
- **Complete assembly can be done by the owner of the helicopter.**
- **Estimated installation time is 4 hours.**

Galaxy GRS s.r.o. Liberec 19.11.2014 Czech Republic