



**Hewlett Packard**  
Enterprise

# **HPE Integrity BL860c i4, BL870c i4 & BL890c i4 Server Blade User Service Guide**

## **Abstract**

This document contains specific information that is intended for users of this Hewlett Packard Enterprise product.

Part Number: 5200-2533  
Published: April 2018  
Edition: 7

## Notices

The information contained herein is subject to change without notice. The only warranties for Hewlett Packard Enterprise products and services are set forth in the express warranty statements accompanying such products and services. Nothing herein should be construed as constituting an additional warranty. Hewlett Packard Enterprise shall not be liable for technical or editorial errors or omissions contained herein.

Confidential computer software. Valid license from Hewlett Packard Enterprise required for possession, use, or copying. Consistent with FAR 12.211 and 12.212, Commercial Computer Software, Computer Software Documentation, and Technical Data for Commercial Items are licensed to the U.S. Government under vendor's standard commercial license.

Links to third-party websites take you outside the Hewlett Packard Enterprise website. Hewlett Packard Enterprise has no control over and is not responsible for information outside the Hewlett Packard Enterprise website.

## Acknowledgments

Intel®, Itanium®, Pentium®, Intel Inside®, and the Intel Inside logo are trademarks of Intel Corporation in the United States and other countries.

Microsoft® and Windows® are either registered trademarks or trademarks of Microsoft Corporation in the United States and/or other countries.

UNIX® is a registered trademark of The Open Group.

## Revision history

### Changes in this edition:

Added new part numbers for Adding **SAS disk drive LEDs : HBA mode** table under Troubleshooting" chapter

Document manufacturing part number	Operating systems supported	Supported product versions	Edition number	Publication Date
5992-1083	HP-UX	BL860c i4, BL870c i4 & BL890c i4	First	December 2012
5900-2663	HP-UX	BL860c i4, BL870c i4 & BL890c i4	Second	May 2013
5900-2673	HP-UX	BL860c i4, BL870c i4 & BL890c i4	Third	August 2013
5900-2673R	HP-UX	BL860c i4, BL870c i4 & BL890c i4	Fourth	November 2015
5200-2461	HP-UX	BL860c i4, BL870c i4 & BL890c i4	Fifth	January 2017
5200-2523	HP-UX	BL860c i4, BL870c i4 & BL890c i4	Sixth	September 2017
5200-2533	HP-UX	BL860c i4, BL870c i4 & BL890c i4	Seventh	April 2018

# Contents

<b>Overview.....</b>	<b>8</b>
Server blade overview.....	8
Server blade components.....	9
<b>Site preparation.....</b>	<b>10</b>
Server blade dimensions and weight.....	10
Enclosure information.....	10
Enclosure environmental specifications.....	11
Sample Site Inspection Checklist.....	11
Power subsystem.....	14
ESD handling information.....	15
Unpacking and inspecting the server blade.....	15
Verifying site preparation.....	15
Inspect the shipping containers for damage.....	16
Unpacking the server blade.....	16
Verifying the inventory.....	16
Returning damaged equipment.....	16
<b>Installing the server blade into the enclosure.....</b>	<b>17</b>
Installation sequence and checklist.....	17
Installing and powering on the server blade.....	17
Preparing the enclosure.....	17
Removing a c7000 device bay divider.....	18
Removing a c3000 device bay mini-divider or device bay divider.....	19
Installing interconnect modules.....	21
Installing the server blade into the enclosure.....	23
Server blade power states.....	24
Powering on the server blade.....	25
Powering off the server blade.....	25
Installing the Blade Link for BL860c i4, BL870c i4 or BL890c i4 configurations.....	26
Using iLO 3.....	30
Accessing UEFI or the OS from iLO 3 MP.....	30
UEFI Front Page.....	32
Saving UEFI configuration settings.....	34
Boot and installing the operating system.....	34
Operating system is loaded onto the server blade.....	34
Operating system is not loaded onto the server blade.....	34
OS login prompt.....	35
Installing the latest firmware using HP Smart Update Manager.....	35
<b>Operating system procedures.....</b>	<b>36</b>
Operating systems supported on the server blade.....	36
Installing the operating system onto the server blade.....	36
Installing the OS from an external USB DVD device or tape device.....	36
Installing the OS using Ignite-UX.....	37
Installing the OS using vMedia.....	38

Configuring system boot options.....	38
Booting and shutting down HP-UX.....	39
Adding HP-UX to the boot options list.....	39
HP-UX standard boot.....	40
Booting HP-UX from the UEFI Boot Manager.....	40
Booting HP-UX from the UEFI Shell.....	41
Booting HP-UX in single-user mode.....	41
Booting HP-UX in LVM-maintenance mode.....	41
Shutting down HP-UX.....	41
<b>Optional components.....</b>	<b>43</b>
Partner blades.....	43
Hot-plug SAS disk drives.....	43
Installing internal components.....	45
Removing the access panel.....	45
Processor and heatsink module.....	45
DIMMs.....	50
Mezzanine cards.....	56
HPE Smart Array P711m Controller.....	57
Supercap pack mounting kit.....	58
Installing the Supercap mounting bracket.....	59
Installing the P711m controller board.....	60
Installing the Supercap Pack.....	60
Replacing the access panel.....	61
Upgrading a conjoined configuration.....	62
Procedure summary.....	62
Upgrade kit contents.....	62
Before getting started.....	63
Upgrading the original server.....	69
Support.....	78
Blade link and system information parameters.....	78
Operating System Licenses.....	79
The Quick Boot option.....	79
Possible changes due to VC profile mapping on the upgraded blade server.....	80
Preserving VC-assigned MAC addresses in HP-UX by enabling Portable Image.....	85
<b>Troubleshooting.....</b>	<b>87</b>
Methodology.....	87
General troubleshooting methodology.....	87
Executing recommended troubleshooting methodology.....	89
Basic and advanced troubleshooting tables.....	90
Troubleshooting tools.....	97
Controls and ports.....	97
Front panel view.....	98
Rear panel view.....	98
Server blade LEDs.....	99
Front panel LEDs.....	99
SAS disk drive LEDs.....	100
Blade Link LEDs.....	103
Virtual Front Panel LEDs in the iLO 3 TUI.....	103
SUV Cable and Ports.....	106
Connecting to the serial port.....	106
Diagnostics.....	107

General diagnostic tools.....	107
Fault management overview.....	107
HP-UX Fault management.....	107
Errors and error logs.....	108
Event log definitions.....	108
Event log usage.....	108
iLO 3 MP event logs.....	109
SEL review.....	110
Troubleshooting processors.....	111
Processor installation order.....	111
Processor module behaviors.....	111
Enclosure information.....	111
Cooling subsystem.....	112
Firmware.....	112
Identifying and troubleshooting firmware issues.....	112
Verify and install the latest firmware.....	112
Troubleshooting the server interface (system console).....	113
Troubleshooting the environment.....	113
<b>Removing and replacing components.....</b>	<b>115</b>
Server blade components list.....	115
Preparing the server blade for servicing.....	118
Powering off the server blade.....	119
Blade Link for BL870c i4 or BL890c i4 configurations.....	119
Removing the Blade Link for BL870c i4 or BL890c i4 configurations.....	120
Replacing the Blade Link for BL870c i4 or BL890c i4 configurations.....	120
Blade Link for BL860c i4 configurations.....	122
Server blade.....	123
Access panel.....	124
Disk drive blanks.....	124
Removing a disk drive blank.....	124
Disk drives.....	125
DIMM baffle.....	126
DIMMs.....	127
CPU baffle.....	128
CPU and heatsink module.....	129
SAS backplane.....	132
Server battery.....	132
Mezzanine cards.....	133
ICH mezzanine board.....	134
System board.....	135
Blade Link.....	136
<b>Support and other resources.....</b>	<b>138</b>
Accessing Hewlett Packard Enterprise Support.....	138
Accessing updates.....	138
Websites.....	139
Customer self repair.....	139
Remote support.....	139
Documentation feedback.....	140
<b>RAID configuration and other utilities.....</b>	<b>141</b>
Configuring a Smart Array Controller.....	141

Using the <code>saupdate</code> command .....	141
Get mode.....	141
Set mode.....	142
Updating the firmware using <code>saupdate</code> .....	143
Determining the <i>Driver ID</i> and <i>CTRL ID</i> .....	143
Configuring RAID volumes using the ORCA menu-driven interface.....	144
Creating a logical drive.....	146
Deleting a logical drive.....	147
Useful UEFI command checks.....	149
UEFI.....	149
UEFI Shell and POSSE commands.....	150
Drive paths in UEFI.....	153
Using the Boot Maintenance Manager.....	154
Boot Options.....	155
Add Boot Option.....	156
Delete Boot Option.....	157
Change Boot Order.....	158
Driver Options.....	158
Add Driver Option.....	159
Delete Driver Option.....	160
Change Driver Order.....	161
Console Configuration.....	161
Boot From File.....	162
Set Boot Next Value.....	163
Set Time Out Value.....	164
Reset System.....	164
iLO 3 MP.....	165

## **Warranty and regulatory information..... 166**

Warranty information.....	166
Regulatory information.....	166
Belarus Kazakhstan Russia marking.....	166
Turkey RoHS material content declaration.....	167
Ukraine RoHS material content declaration.....	167

## **Standard terms, abbreviations, and acronyms..... 168**

A.....	168
B.....	168
C.....	168
D.....	168
E.....	169
F.....	169
H.....	169
I.....	169
L.....	169
M.....	170
N.....	170
O.....	170
P.....	170
Q.....	171
S.....	171
T.....	171
U.....	172
V.....	172



# Overview

The HPE Integrity BL860c i4 Server Blade is a dense, low-cost, Intel Itanium processor server blade. Using a Blade Link hardware assembly, multiple BL860c i4 Server Blades can be conjoined to create dual-blade, four socket and quad-blade, eight socket variants.

Name	Number of Conjoined Server Blades	Number of Processor Sockets
BL860c i4	1	2
BL870c i4	2	4
BL890c i4	4	8

The three blade configurations support the HP-UX operating system and are designed for deployment in HPE c-Class enclosures, specifically the 10U c7000 and the 6U c3000 Enclosures. The nPartition configuration feature is enabled from the factory, enabling the BL870c i4 and BL890c i4 to be partitioned into one more electrically isolated partitions. See the *nPartitions Administrator Users Guide* for more information.

---

**NOTE:**

For purposes of this guide, make sure that the c-Class server blade enclosure is powered on and running properly and that the OA and iLO 3 is operational.

---

## Server blade overview

Product	CPU cores (octo)	DIMM slots	max memory	PCIe I/O Mezzanine card capacity	SAS Hard Disk Drives
BL860c i4	16	24	364GB with 16GB DIMMs	3	2
BL870c i4	32	48	768GB with 16GB DIMMs	6	4
BL890c i4	64	96	1.5TB with 16GB DIMMs	12	8



# Server blade components

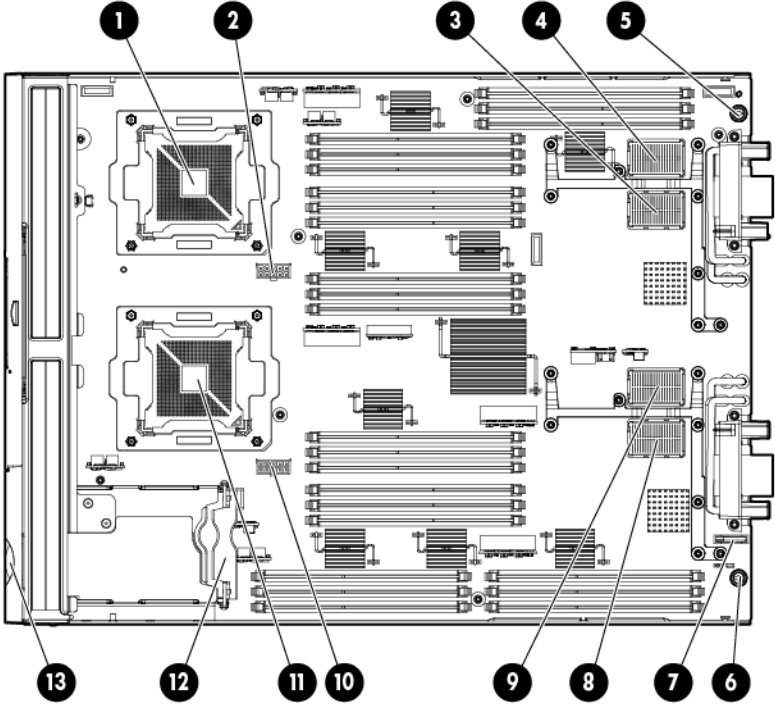

1	CPU0	8	ICH mezzanine connector
2	CPU0 power connector	9	Mezzanine connector 3 (type 1 or 2)
3	Mezzanine connector 1 (type 1)	10	CPU1 power connector
4	Mezzanine connector 2 (type 1 or 2)	11	CPU1
5	System board thumbscrew	12	SAS backplane
6	System board thumbscrew	13	Pull tab
7	Battery (CR2032)	<p><b>NOTE:</b></p> <p>The iLO 3 password is located on the pull tab.</p>	

# Site preparation

The BL860c i4 does not have cooling or power systems. Cooling and power is provided by the c-Class enclosure.

**ⓘ IMPORTANT:**

To avoid hardware damage, allow the thermal mass of the product to equalize to the temperature and humidity of the installation facility after removing the shipping materials. A minimum of one hour per 10°C (50°F) of temperature difference between the shipping facility and installation facility is required.

## Server blade dimensions and weight

**Table 1: Server blade dimensions and weight for the BL860c i4**

Dimensions	value
Height	36.63 cm (14.42 in.)
Width	5.14 cm (2.025 in.)
Depth	48.51 cm (19.1 in.)
Weight	Unloaded: 8.6 kg (19 lb) Fully loaded: 11.3 kg (25 lb)

**Table 2: Blade Link dimensions and weight**

Blade Link type	Height	Width	Weight
BL1 (BL860 i4)	44 mm (1.73 in)	51 mm (2 in)	.5 lb (.22 kg)
BL2 (BL870 i4)	44 mm (1.73 in)	106 mm (4.17 in)	1 lb (.45 kg)
BL4 (BL890 i4)	44 mm (1.73 in)	212 mm (8.34 in)	2 lb (.90 kg)

## Enclosure information

All three blade configurations are supported in HPE c7000 and c3000 Enclosures.

For more enclosure information see:

- [http://www.hpe.com/support/Bladesystem\\_c3000\\_Enclosures\\_Manuals](http://www.hpe.com/support/Bladesystem_c3000_Enclosures_Manuals)
- [http://www.hpe.com/support/Bladesystem\\_c7000\\_Enclosures\\_Manuals](http://www.hpe.com/support/Bladesystem_c7000_Enclosures_Manuals)

# Enclosure environmental specifications

**NOTE:**

This information is for both c3000 and c7000 Enclosures.

Specification	Value
<b>Temperature range</b>	
Operating	10°C to 35°C (50°F to 95°F)
Non-operating	-30°C to 60°C (-22°F to 140°F)
<b>Wet bulb temperature</b>	
Operating	28°C (82.4°F)
Non-operating	38.7°C (101.7°F)
<b>Relative humidity (noncondensing) <sup>1</sup></b>	
Operating	20% to 80%
Non-operating	5% to 95%

<sup>1</sup> Storage maximum humidity of 95% is based on a maximum temperature of 45°C (113°F). Altitude maximum for storage corresponds to a pressure minimum of 70 KPa.

For more information on the c-Class enclosures see:

- [http://www.hpe.com/support/Bladesystem\\_c3000\\_Enclosures\\_Manuals](http://www.hpe.com/support/Bladesystem_c3000_Enclosures_Manuals)
- [http://www.hpe.com/support/Bladesystem\\_c7000\\_Enclosures\\_Manuals](http://www.hpe.com/support/Bladesystem_c7000_Enclosures_Manuals)

For more site preparation information, go to <http://www.hpe.com/info/Blades-docs>, select **HPE Integrity BL860c i4 Server Blade** in the list of servers, and then select the **Generalized Site Preparation Guidelines**.

## Sample Site Inspection Checklist

**Table 3: Customer and Hewlett Packard Enterprise Information**

Customer Information	
Name:	Phone number:
Street address:	City or Town:
State or province:	Country
Zip or postal code:	

*Table Continued*

<b>Customer Information</b>	
Primary customer contact:	Phone number:
Secondary customer contact:	Phone number:
Traffic coordinator:	Phone number:
Hewlett Packard Enterprise information	
Sales representative	Order number:
Representative making survey	Date:
Scheduled delivery date	

**Table 4: Site Inspection Checklist**

<b>Check either Yes or No. If No, include comment number or date.</b>				<b>Comment or Date</b>
Computer Room				
Number	Area or condition	Yes	No	
1.	Is there a completed floor plan?			
2.	Is adequate space available for maintenance needs? Front 36 inches (91.4 cm) minimum and rear 36 inches (91.4 cm) minimum are recommended clearances.			
3.	Is access to the site or computer room restricted?			
4.	Is the computer room structurally complete? Expected date of completion?			
5.	Is a raised floor installed and in good condition?			
6.	Is the raised floor adequate for equipment loading?			
7.	Are channels or cutouts available for cable routing?			
8.	Is a network line available?			
9.	Is a telephone line available?			
10.	Are customer-supplied peripheral cables and LAN cables available and of the proper type?			
11.	Are floor tiles in good condition and properly braced?			

*Table Continued*

Check either Yes or No. If No, include comment number or date.				Comment or Date
12.	Is floor tile underside shiny or painted? If painted, judge the need for particulate test.			
Power and Lighting				
Number	Area or Condition	Yes	No	
13.	Are lighting levels adequate for maintenance?			
14.	Are AC outlets available for servicing needs (for example, laptop)?			
15.	Does the input voltage correspond to equipment specifications?			
15a.	Is dual source power used? If so, identify types and evaluate grounding.			
16.	Does the input frequency correspond to equipment specifications?			
17.	Are lightning arrestors installed inside the building?			
18.	Is power conditioning equipment installed?			
19.	Is a dedicated branch circuit available for equipment?			
20.	Is the dedicated branch circuit less than 75 feet (22.86 m)?			
21.	Are the input circuit breakers adequate for equipment loads?			
Safety				
Number	Area or Condition	Yes	No	
22.	Is an emergency power shutoff switch available?			
23.	Is a telephone available for emergency purposes?			
24.	Does the computer room have a fire protection system?			
25.	Does the computer room have antistatic flooring installed?			
26.	Do any equipment servicing hazards exist (loose ground wires, poor lighting, and so on)?			
Cooling				

Table Continued

Check either Yes or No. If No, include comment number or date.				Comment or Date
Number	Area or Condition	Yes	No	
27.	Can cooling be maintained between 5°C (41 °F) and 35°C (95 °F) (up to 1,525 m/5,000 ft)? Derate 1°C/305 m (34 °F/1,000 ft) above 1,525 m/5,000 ft and up to 3,048 m/10,000 ft.			
28.	Can temperature changes be held to 5°C (9 °F) per hour with tape media? Can temperature changes be held to 20°C (36 °F) per hour without tape media?			
29.	Can humidity level be maintained at 40% to 55% at 35°C (95 °F) noncondensing?			
30.	Are air-conditioning filters installed and clean?			
Storage				
Number	Area or Condition	Yes	No	
31.	Are cabinets available for tape and disc media?			
32.	Is shelving available for documentation?			
Training				
Number	Area or Condition			
33.	Are personnel enrolled in the System Administrator's Course?			
34.	Is on-site training required?			

## Power subsystem

The power subsystem is located on the system board. The BL860c i4 Server Blade receives 12 Volts directly from the enclosure. The voltage is immediately passed through an E-fuse circuit, which will immediately cut power to the blade if a short circuit fault or over current condition is detected. The E-fuse can also be intentionally power cycled through the manageability subsystem. The 12V is distributed to various points on the blade and is converted to lower voltages through power converters for use by integrated circuits and loads on the blade.

# ESD handling information

---

## **△ CAUTION:**

Wear an ESD wrist strap when handling internal server components. Acceptable ESD wrist straps include:

- The wrist strap that is included in the ESD kit with circuit checker (part number 9300-1609).
- The wrist strap that is included in the ESD kit without circuit checker (part number 9300-1608).

If the above options are unavailable, the throw away (one use only) strap that ships with some Hewlett Packard Enterprise memory products can also be used, with increased risk of electrostatic damage.

---

When removing and replacing server components, use care to prevent injury and equipment damage. Many assemblies are sensitive to damage by electrostatic discharge.

Follow the safety precautions listed to ensure safe handling of components, to prevent injury, and to prevent damage to the server blade:

- When removing or installing a server blade or server blade component, review the instructions provided in this guide.
- Do not wear loose clothing that might snag or catch on the server or on other items.
- Do not wear clothing subject to static charge build-up, such as wool or synthetic materials.
- If installing an internal assembly, wear an antistatic wrist strap, and use a grounding mat such as those included in the Electrically Conductive Field Service Grounding Kit.
- Handle components by the edges only. Do not touch any metal-edge connectors or electrical components on accessory boards.

## Unpacking and inspecting the server blade

Be sure that you have adequately prepared your environment for your new server blade, received the components that you ordered, and verified that the server and the containers are in good condition after shipment.

## Verifying site preparation

Verifying site preparation is an essential factor of a successful server blade installation, and includes the following tasks:

- Gather LAN information. Determine the two IP addresses for the iLO 3 MP LAN and the server blade LAN.
- Establish a method to connect to the server blade console. For more information on console connection methods, see **Using iLO 3** on page 30 for more information.
- Verify electrical requirements. Be sure that grounding specifications and power requirements are met.
- Confirm environmental requirements.

## Inspect the shipping containers for damage

Hewlett Packard Enterprise shipping containers protect their contents under normal shipping conditions. After the equipment arrives, carefully inspect each carton for signs of shipping damage. Shipping damage constitutes moderate to severe damage such as punctures in the corrugated carton, crushed boxes, or large dents. Normal wear or slight damage to the carton is not considered shipping damage. If you find shipping damage to the carton, contact your Hewlett Packard Enterprise customer service representative immediately.

## Unpacking the server blade

### Procedure

1. Use the instructions printed on the outside top flap of the carton.
2. Remove inner accessory cartons and the top foam cushions.

---

**!** **IMPORTANT:**

Inspect each carton for shipping damage as you unpack the server blade.

---

3. Place the server blade on an antistatic pad.

## Verifying the inventory

The sales order packing slip lists the equipment shipped from Hewlett Packard Enterprise. Use this packing slip to verify that the equipment has arrived.

---

### NOTE:

To identify each item by part number, see the sales order packing slip.

---

## Returning damaged equipment

If the equipment is damaged, immediately contact your Hewlett Packard Enterprise customer service representative. The service representative initiates appropriate action through the transport carrier or the factory and assists you in returning the equipment.



# Installing the server blade into the enclosure

## Installation sequence and checklist

Step	Description	Completed
1	Perform site preparation (see <a href="#">Site preparation</a> on page 10 for more information).	
2	Unpack and inspect the server shipping container and then inventory the contents using the packing slip.	
3	Install additional components shipped with the server. For these procedures, see the documentation that with the component or the user service guide.	
4	Install and power on the server blade.	
5	Configure iLO 3 MP access.	
6	Access iLO 3 MP.	
7	Access UEFI from iLO 3 MP.	
8	Download latest firmware and update using HP Smart Update Manager.	
9	Install and boot the OS.	

---

**NOTE:**

For more information regarding HPE Integrity Server Blade upgrades, see [Upgrading a conjoined configuration](#) on page 62 for more information.

---

## Installing and powering on the server blade

### Preparing the enclosure

HPE BladeSystem enclosures ship with device bay dividers to support half-height devices. To install a full height device, remove the blanks and the corresponding device bay divider.

---

**⚠ CAUTION:**

To prevent improper cooling and thermal damage, do not operate the server blade or the enclosure unless all hard drive and device bays are populated with either a component or a blank.

---

**Procedure**

1. Remove the device bay blank.

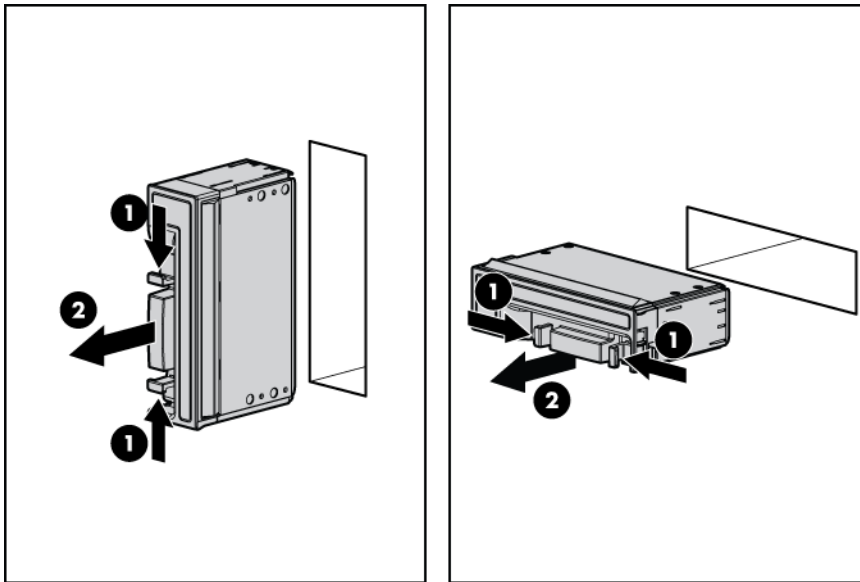

2. Remove the three adjacent blanks.

## Removing a c7000 device bay divider

### Procedure

1. Slide the device bay shelf locking tab to the left to open it.

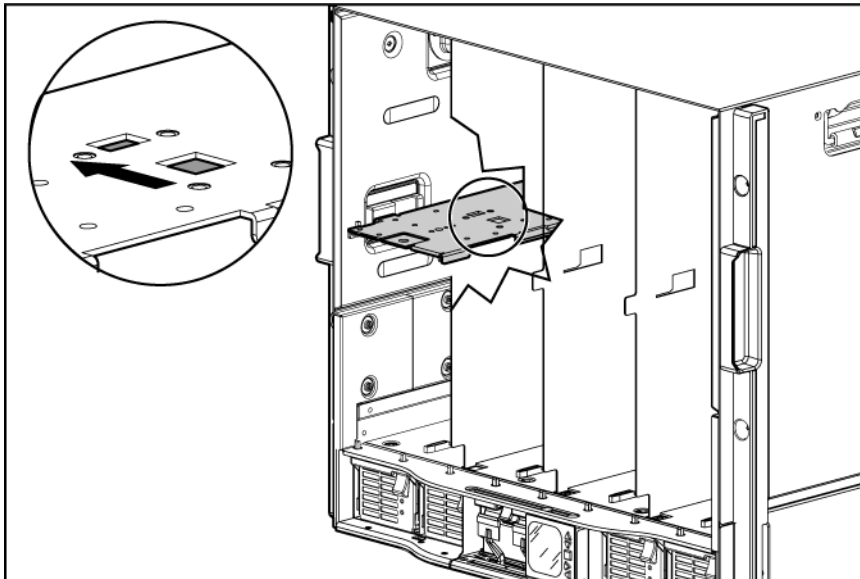

2. Push the device bay shelf back until it stops, lift the right side slightly to disengage the two tabs from the divider wall, and then rotate the right edge downward (clockwise).

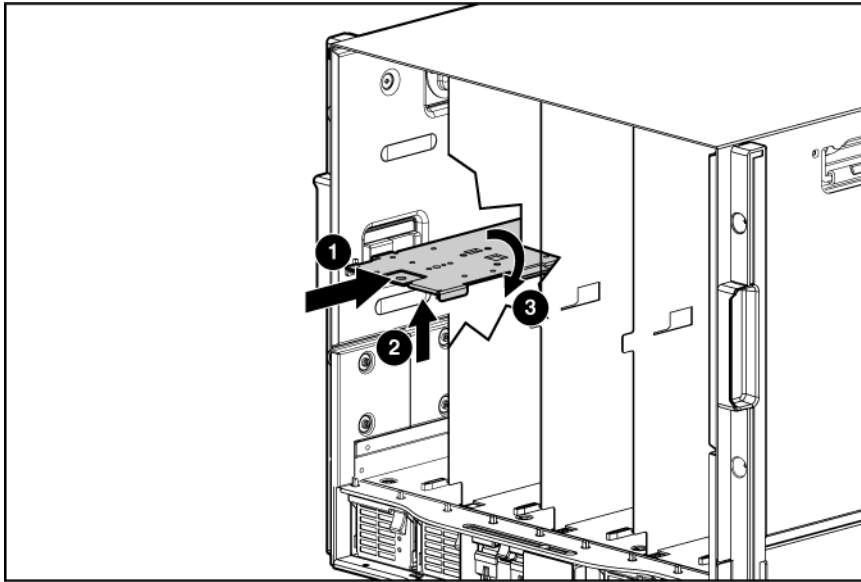

3. Lift the left side of the device bay shelf to disengage the three tabs from the divider wall, and then remove it from the enclosure.

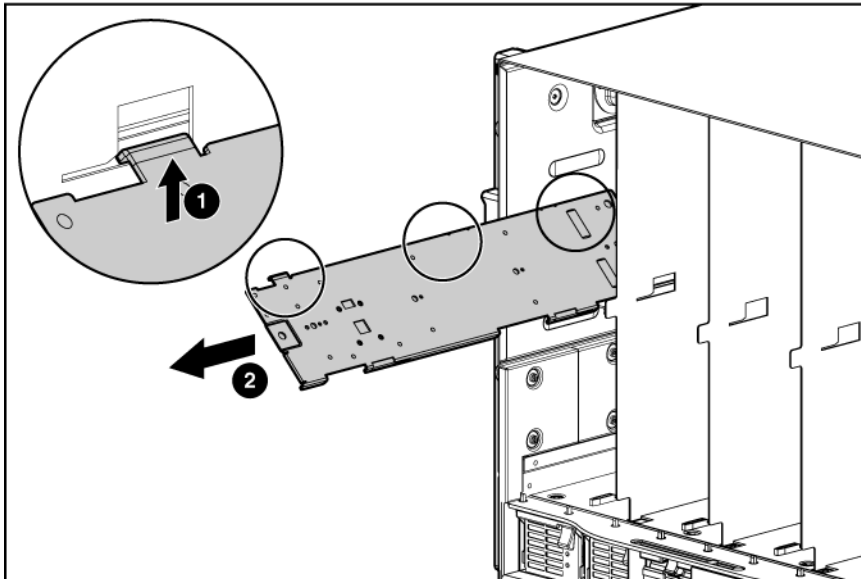

## Removing a c3000 device bay mini-divider or device bay divider

### Procedure

1. Slide the locking tab down.

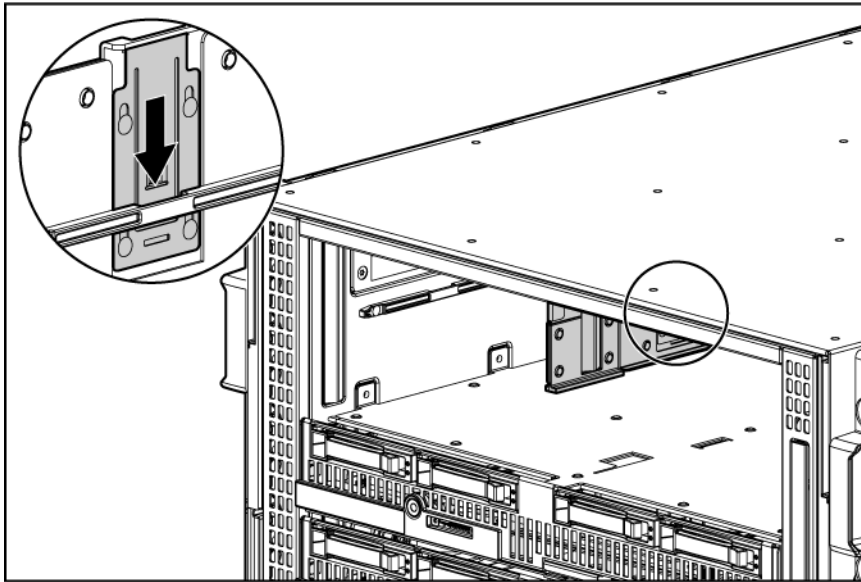

**2. Remove the mini-divider or divider:**

**a. c3000 mini-divider:**

Push the divider toward the back of the enclosure until the divider drops out of the enclosure.

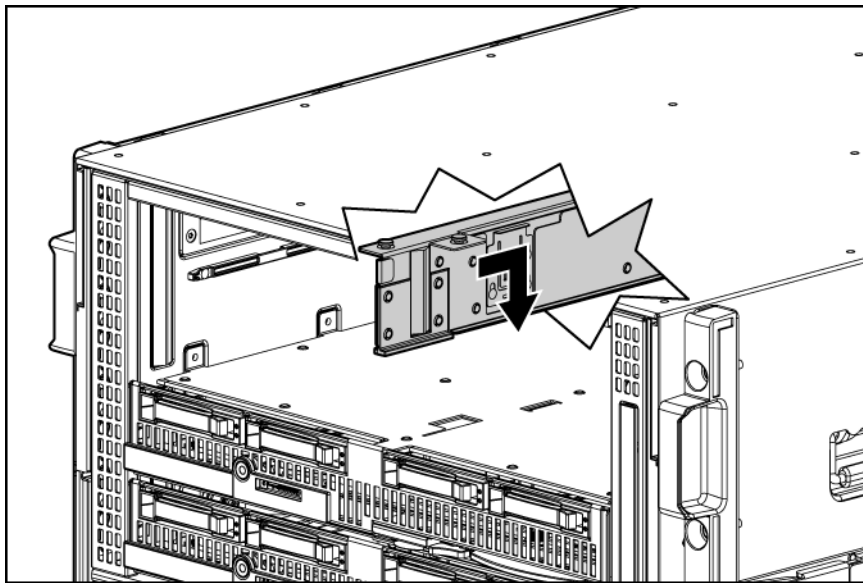

**b. c3000 divider**

- I.** Push the divider toward the back of the enclosure until it stops.
- II.** Slide the divider to the left to disengage the tabs from the wall.
- III.** Rotate the divider clockwise.
- IV.** Remove the divider from the enclosure.

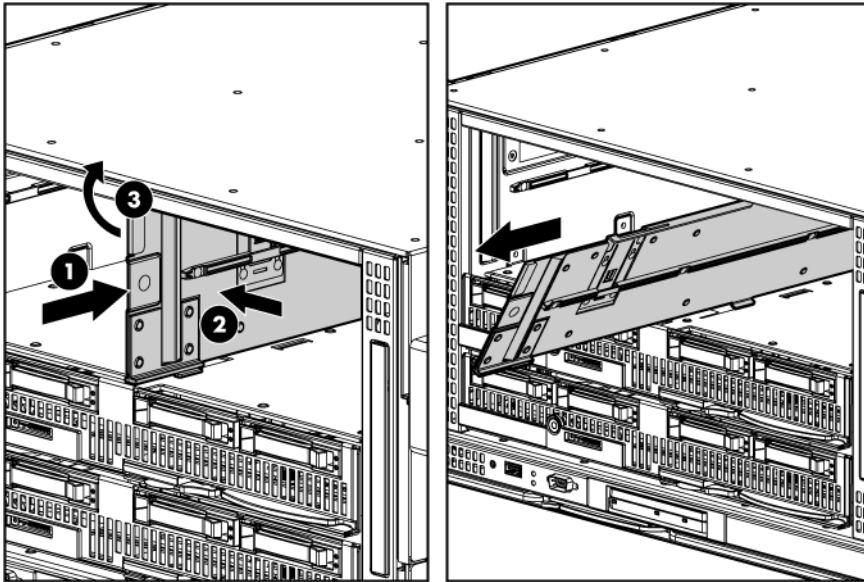

### Installing interconnect modules

For specific steps to install interconnect modules, see the documentation that ships with the interconnect module.

### Interconnect bay numbering and device mapping

- HPE BladeSystem c7000 Enclosure

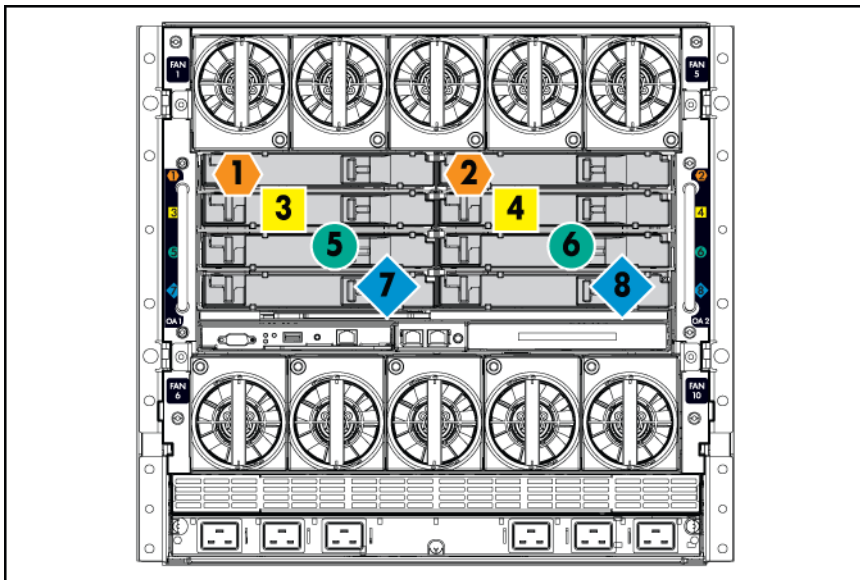

- HPE BladeSystem c3000 Enclosure

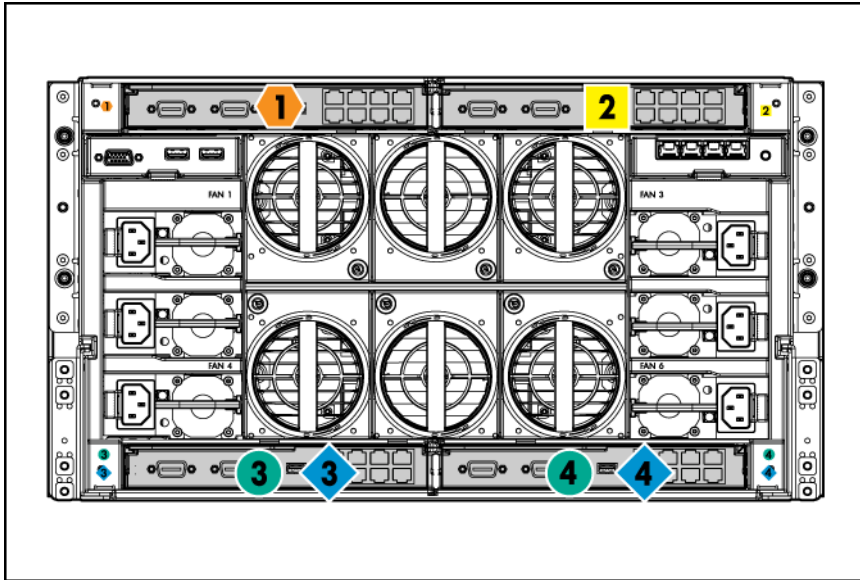

To support network connections for specific signals, install an interconnect module in the bay corresponding to the embedded NIC or mezzanine signals.

Server blade signal	c7000 interconnect bay	c3000 interconnect bay	Interconnect bay labels
NIC 1 (Embedded)	1	1	
NIC 2 (Embedded)	2	1	
NIC 3 (Embedded)	1	1	
NIC 4 (Embedded)	2	1	
Mezzanine 1	3 and 4	2	
Mezzanine 2	5 and 6	3 and 4	
	7 and 8	3 and 4	
Mezzanine 3	5 and 6	3 and 4	
	7 and 8	3 and 4	

For detailed port mapping information, see the BladeSystem enclosure installation poster or the BladeSystem enclosure setup and installation guide for your product on the Hewlett Packard Enterprise website (<http://www.hpe.com/info/Blades-docs>).

## Installing the server blade into the enclosure

---

**NOTE:**

When installing additional blades into an enclosure, additional power supplies might also be needed to meet power requirements. For more information, see the BladeSystem enclosure setup and installation guide for your product on the Hewlett Packard Enterprise website (<http://www.hpe.com/info/Blades-docs>).

---

**NOTE:**

Before installing and initializing the server blade, install any server blade options, such as an additional processor, hard drive, or mezzanine card.

---

**Procedure**

1. Remove the connector covers if they are present.

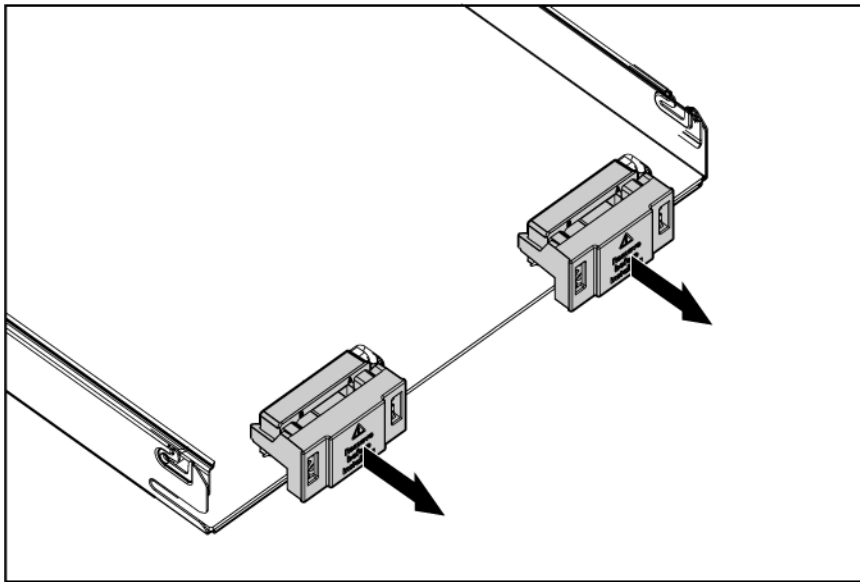

2. Prepare the server blade for installation.

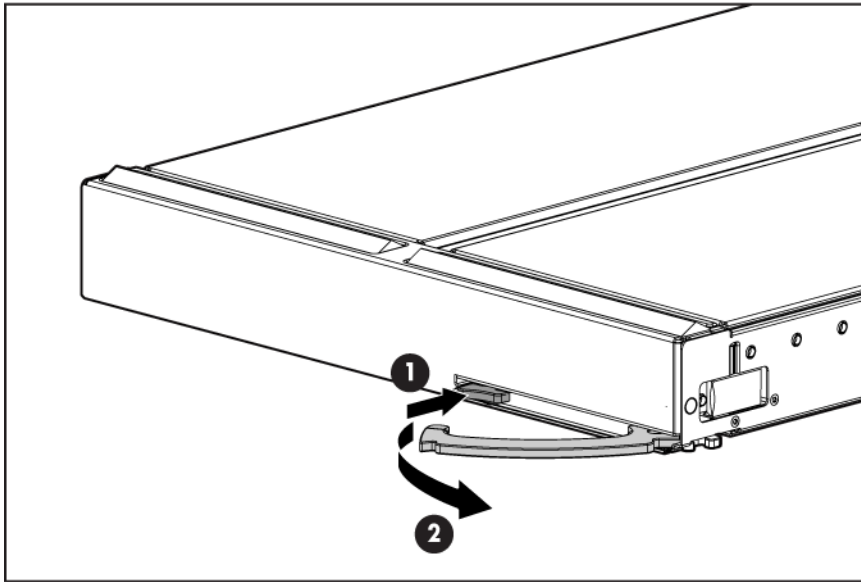

3. Install the server blade.

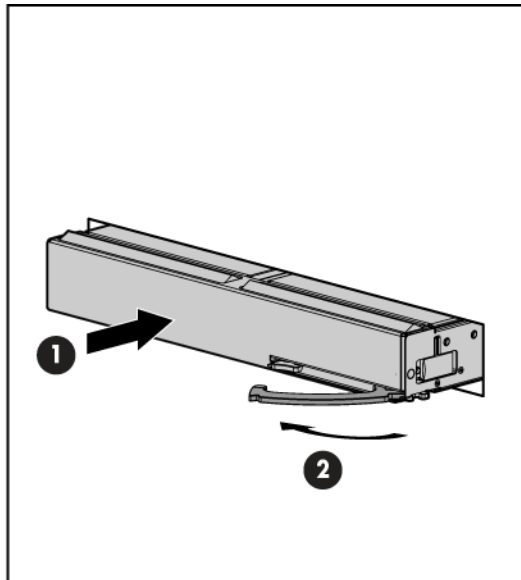
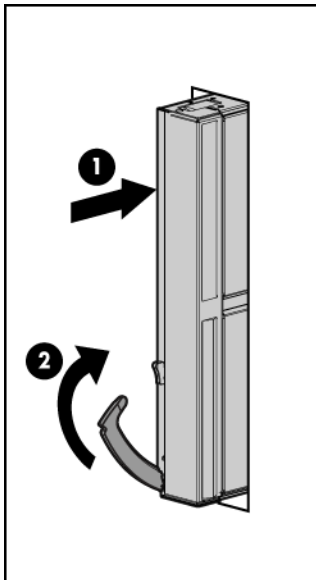

The server blade should come up to standby power. The server blade is at standby power if the blade power LED is amber.

## Server blade power states

The server blade has three power states: standby power, full power, and off. Install the server blade into the enclosure to achieve the standby power state. Server blades are set to power on to standby power when installed in a server blade enclosure. Verify the power state by viewing the LEDs on the front panel, and using [Table 5](#).



**Table 5: Power States**

Power States	Server Blade Installed in Enclosure?	Front Panel Power Button Activated?	Standby Power Applied?	DC Power Applied?
Standby power	Yes	No	Yes	No
Full power	Yes	Yes	Yes	Yes
Off	No	No	No	No

## Powering on the server blade

Use one of the following methods to power on the server blade:

---

### NOTE:

To power on blades in a conjoined configuration, only power on the Monarch blade. See [Blade Link bay location rules](#) for rules on the definition of the Monarch blade.

---

- Use a virtual power button selection through iLO 3.
- Press and release the Monarch power button.

When the server blade goes from the standby mode to the full power mode, the blade power LED changes from amber to green.

For more information about iLO 3, see [Using iLO 3](#) on page 30.

## Powering off the server blade

Before powering down the server blade for any upgrade or maintenance procedures, perform a backup of critical server data and programs.

Use one of the following methods to power off the server blade:

---

### NOTE:

To power off blades in a conjoined configuration, only power off the Monarch blade.

---

- Use a virtual power button selection through the iLO 3 GUI (Power Management, Power & Reset) or the iLO 3 TUI commands.  
This method initiates a controlled remote shutdown of applications and the OS before the server blade enter standby mode.
- Press and release the Monarch power button.  
This method initiates a controlled shutdown of applications and the OS before the server blade enter standby mode.
- Press and hold the Monarch power button for more than 4 seconds to force the server blade to enter standby mode.

This method forces the server blade to enter standby mode without properly exiting applications and the OS. It provides an emergency shutdown method in the event of a hung application.

## Installing the Blade Link for BL860c i4, BL870c i4 or BL890c i4 configurations

---

### **IMPORTANT:**

Without an attached Blade Link, the server blades will not power on.

---

### **NOTE:**

Before installing the Blade Link for BL870c i4 or BL890c i4, make sure the following statements are true:

- All blades have the same CPU SKUs
- All blades have the same hardware revision (only use BL860c i4, BL870c i4, or BL890c i4 Server Blades)
- All blades have CPU0 installed
- All blades have the same firmware revision set
- All blades follow the memory loading rules for your configuration, see **DIMMs** on page 50
- The enclosure OA firmware is compatible with the blade firmware
- The Monarch blade has an ICH mezzanine card installed
- The proper Blade Link is being used for your configuration

To check on the blade hardware revisions and CPU SKUs, go to the Command Menu in the iLO 3 TUI and enter the `DF` command. This dumps the FRU content of the blades.

---

### **NOTE:**

If you will be upgrading an initial installation, see the user service guide for more information on server blade upgrades.

---

**Table 6: Blade Link bay location rules**

Class	Number of conjoined blades	Supported enclosures	Blade location rules	Partner blade support?	Partner blade half-height bay number / Server blade full-height bay number
BL1	1 (standard for BL860c i4)	c7000	No specific bay location rules for blades	Yes	Bottom half-height adjacent bay, paired with the server blade in full-height bays 1&2, 3&4, 5&6, or 7&8
		c3000			Half-height bay 8, paired with the server blade in full-height bay 3.  <b>⚠ CAUTION:</b> The bay mini-divider must be installed in the c3000 enclosure to ensure the partner blade is inserted correctly. Failure to install the bay mini-divider might result in damage to the blade or enclosure when installing the partner blade. <sup>1</sup>
BL2	2 (BL870c i4)	c7000	Bays 1&2, 3&4, 5&6, or 7&8 with Monarch blade in odd bay	No	N/A
		c3000	Bays 1&2, 3&4 with Monarch blade in odd bay		
BL2E	2 (BL870c i4)	c7000 only	Bays 2&3, 4&5 or 6&7 with Monarch blade in even bay using full-height numbering	Yes	Bottom half-height bay 9 paired with full-height bays 2&3, bottom half-height bay 11 paired with full-height bays 4&5, bottom half-height bay 13 paired with full-height bays 6&7

*Table Continued*

Class	Number of conjoined blades	Supported enclosures	Blade location rules	Partner blade support?	Partner blade half-height bay number / Server blade full-height bay number
	2 (BL870c i4)	c3000 only	Bays 2&3 with Monarch blade in even bay using full-height numbering.	No	N/A
BL4	4 (BL890c i4)	c7000 only	Bays 1&2&3&4 or 5&6&7&8, with Monarch blade defaulting to slot 1 or slot 5, respectively	No	N/A
	4 (BL890c i4)	c3000 only	Bays 1&2&3&4 with Monarch blade defaulting to slot 1	No	N/A

<sup>1</sup> For information on installing the c3000 bay mini-divider, see the *HPE BladeSystem c3000 Enclosure Setup and Installation Guide*.

---

**⚠ CAUTION:**

Using the incorrect Blade Link can cause damage to the Blade Link and to the connectors on both the Blade Link and the server blades.

---

**❗ IMPORTANT:**

Failure to follow bay location rules can prevent server blade power on.

---

**NOTE:**

The manufacturing part numbers for the Blade Link is located on a sticker on the PCA.

---

**Upgrading a conjoined configuration** on page 62

To install the Blade Link:

**Procedure**

1. Log on to the OA.
  2. Install the first blade into the lowest bay number, this blade becomes the Monarch blade (**Installing the server blade into the enclosure** on page 23).
  3. Wait 10 seconds. The IP address of the installed blade appears in the OA.
  4. Insert each adjacent blade, waiting 10 seconds between blades.
- 

**NOTE:**

The blades will go into stand-by.

---

5. Using the OA, verify that the rest of the blades that will be conjoined have an IP address and are powered off.
6. Remove the plastic protectors from the connectors on the back of the Blade Link.
7. Push in the blue release latch on the handle to release the handle.
8. Pull the handle all the way out.
9. Align the guide pins on the back of the Blade Link to the holes on the front of the server blades. As you insert the pins into the holes, ensure the face on the Blade Link is evenly aligned parallel to the face of the server blades.
10. Press firmly on the left and right sides of the Blade Link face until the handle naturally starts to close.



**CAUTION:**

If not properly aligned, you can damage the Blade Link.

11. Close the handle when it has engaged.

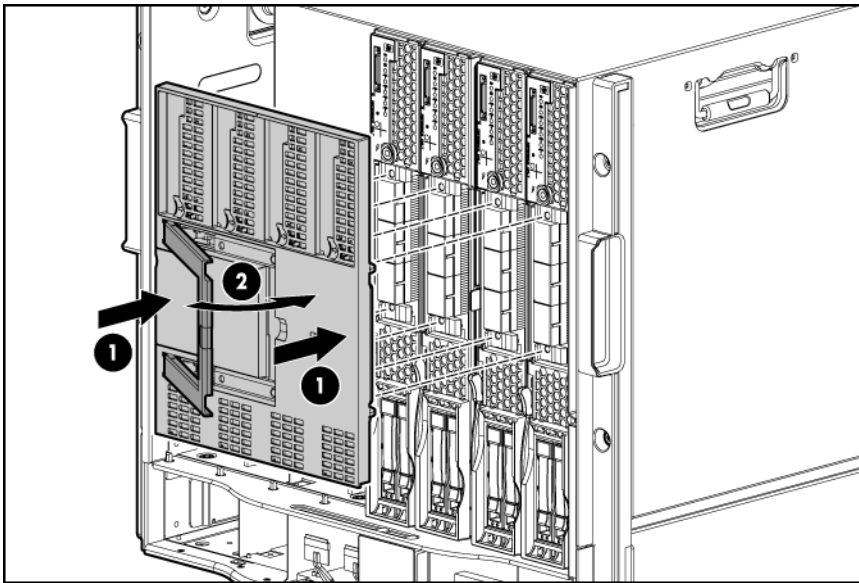

12. Log into iLO 3 on the Monarch blade. For more information, see the *HPE Integrity iLO3 Operations Guide*.
13. In iLO 3, go to the Command Menu and execute `xd -r` to reboot all of the iLO 3s in the conjoined set.
14. Run the conjoin checks

Integrity BL870c i4 and BL890c i4 systems go through a process called “conjoining” when the Blade Link is attached. The system cannot boot until that process is completed properly.

- a. Execute the following CM commands in the iLO 3 TUI to show data from all blades. This information can be used to determine if the blades are successfully conjoined:

- I. `DF` — Lists the FRUs on all of the blades (2 or 4).
  - II. `SR` — Shows a table of each blades firmware revisions.
  - III. `Blade` — Shows information about the OA and the bays used.
- b. Check to see if the OA shows a properly conjoined system from its GUI.



**IMPORTANT:**

The secondary UUID and other system variables are stored on the Monarch blade. If you do not put the Monarch blade in the leftmost slot, your system variables will not match. If you ever change your iLO 3 configuration (such as adding users) that data is also stored on the Monarch blade.

---

**NOTE:**

Auxiliary blades are not slot dependent after being installed and configured, however when the conjoined systems ship, they come with A, B, C, D stickers located under the Blade Links. While auxiliary blades are not slot dependent after being installed and configured, Hewlett Packard Enterprise recommends using the shipped order to ensure proper auxiliary blade function.

---

15. Still in the iLO 3 Command Menu, power on the Monarch blade with the `PC -on -nc` command. Powering on the Monarch blade will power the entire conjoined system on.
16. Boot the Monarch blade. Booting the Monarch blade boots the entire conjoined system.

## Using iLO 3

The iLO 3 subsystem is a standard component of selected server blades that monitors blade health and provides remote server manageability. The iLO 3 subsystem includes an intelligent microprocessor, secure memory, and a dedicated network interface. This design makes iLO 3 independent of the host server and operating system. The iLO 3 subsystem provides remote access to any authorized network client, sends alerts, and provides other server management functions.

Using iLO 3, you can:

- Remotely power on, power off, or reboot the host server.
- Subscribe to we-man alerts from iLO 3 regardless of the state of the host server.
- Access advanced troubleshooting features through the iLO 3 interface.
- Access Remote Console and vMedia functionality.

For more information about iLO 3 basic features, see the iLO 3 documentation on the Hewlett Packard Enterprise website ([http://www.hpe.com/support/Integrated\\_Lights-Out3\\_Manuals](http://www.hpe.com/support/Integrated_Lights-Out3_Manuals)).

## Accessing UEFI or the OS from iLO 3 MP

UEFI is an architecture that provides an interface between the server blade OS and the server blade firmware. UEFI provides a standard environment for booting an OS and running preboot applications.

Use this procedure to access UEFI or the OS from the iLO 3 MP. Your security parameters were set regarding remote access.

## Procedure

1. Retrieve the factory iLO 3 password from the iLO 3 Network pull tag located on the right side of the Monarch blade.
2. From the **MP Main Menu**, enter the `co` command to access the **Console**.

---

### NOTE:

Terminal windows should be set to a window size of 80 columns x 25 rows for optimal viewing of the console at UEFI.

---

3. After memory test and CPU late self test the following message appears:

```
Press Ctrl-C now to bypass loading option ROM UEFI drivers.
```

4. The prompt will timeout if **Ctrl-C** is not pressed within a few seconds. If **Ctrl-C** is pressed, you will be presented with two options: After selecting an option, boot will proceed.

---

### NOTE:

If no option is selected, normal boot will proceed after ten seconds.

---

- Bypass loading from I/O slots.
- Bypass loading from I/O slots and core I/O.

The Bypass loading from I/O slots and core I/O option may be useful if a bad core I/O UEFI driver is preventing system boot. USB drives can still be used at the UEFI shell to update core I/O drivers.

---

### CAUTION:

Hitting **Ctrl-C** before the prompt will not work and may even disable this feature, be sure wait for the prompt before hitting **Ctrl-C**.

---

### NOTE:

It can take several minutes for this prompt to appear, and the window of time when **Ctrl-C** can be pressed is very short. For typical boots, Hewlett Packard Enterprise recommends that you let the prompt time out.

---

5. Depending on how the server blade was configured from the factory, and if the OS is installed at the time of purchase, you are taken to:
  - a. UEFI shell prompt
  - b. OS login prompt
6. If the server blade has a factory-installed OS, you can interrupt the boot process to configure your specific UEFI parameters.
7. If you are at the UEFI shell prompt, go to **UEFI Front Page** on page 32.
8. If you are at the OS login prompt, go to **OS login prompt** on page 35.

## UEFI Front Page

If you are at the UEFI shell prompt, enter `exit` to get to the UEFI Front Page.

```
,947AA7BF-ED02-457A-9B8F-55161DF41DC2)
blk8 :Removable HardDisk - Alias (null)
        PciRoot(0x30304352)/Pci(0x2,0x0)/Pci(0x0,0x0)/Scsi(0x0,0x1)/HD(2,GPT
,6FE8C9E0-3CAE-11DE-8000-D6217B60E588)
blk9 :Removable HardDisk - Alias (null)
        PciRoot(0x30304352)/Pci(0x2,0x0)/Pci(0x0,0x0)/Scsi(0x0,0x1)/HD(3,GPT
,6FE8C9F4-3CAE-11DE-8000-D6217B60E588)
blkA :Removable HardDisk - Alias (null)
        PciRoot(0x30314352)/Pci(0x2,0x0)/Pci(0x0,0x0)/Scsi(0x0,0x0)/HD(2,GPT
,95C8557A-DFA3-11D4-8000-D6217B60E588)
blkB :Removable HardDisk - Alias (null)
        PciRoot(0x30314352)/Pci(0x2,0x0)/Pci(0x0,0x0)/Scsi(0x0,0x1)/HD(2,GPT
,1842AE78-E941-11DE-8000-D6217B60E588)
blkC :Removable BlockDevice - Alias (null)
        PciRoot(0x30304352)/Pci(0x2,0x0)/Pci(0x0,0x0)/Scsi(0x0,0x0)
blkD :Removable BlockDevice - Alias (null)
        PciRoot(0x30304352)/Pci(0x2,0x0)/Pci(0x0,0x0)/Scsi(0x0,0x1)
blkE :Removable BlockDevice - Alias (null)
        PciRoot(0x30304352)/Pci(0x1D,0x7)/USB(0x3,0x0)
blkF :Removable BlockDevice - Alias (null)
        PciRoot(0x30314352)/Pci(0x2,0x0)/Pci(0x0,0x0)/Scsi(0x0,0x0)
blk10 :Removable BlockDevice - Alias (null)
        PciRoot(0x30314352)/Pci(0x2,0x0)/Pci(0x0,0x0)/Scsi(0x0,0x1)
Shell> exit
```

```
(C) Copyright 1996-2012 Hewlett-Packard Development Company, L.P.

Note, menu interfaces might only display on the primary console device.
The current primary console device is:
Serial PciRoot(0x30304352)/Pci(0x1,0x0)/Pci(0x0,0x5)
The primary console can be changed via the 'conconfig' UEFI shell command,
or the 'Console Configuration' option in the Boot Maintenance Manager menu.

Press:  ENTER - Start boot entry execution
        B / b - Launch Boot Manager (menu interface)
        D / d - Launch Device Manager (menu interface)
        M / m - Launch Boot Maintenance Manager (menu interface)
        S / s - Launch UEFI Shell (command line interface)
        I / i - Launch iLO Setup Tool (command line interface)

*** User input can now be provided ***

Waiting for user input.
█
```

To view boot options, or launch a specific boot option, press **B** or **b** to launch the Boot Manager.



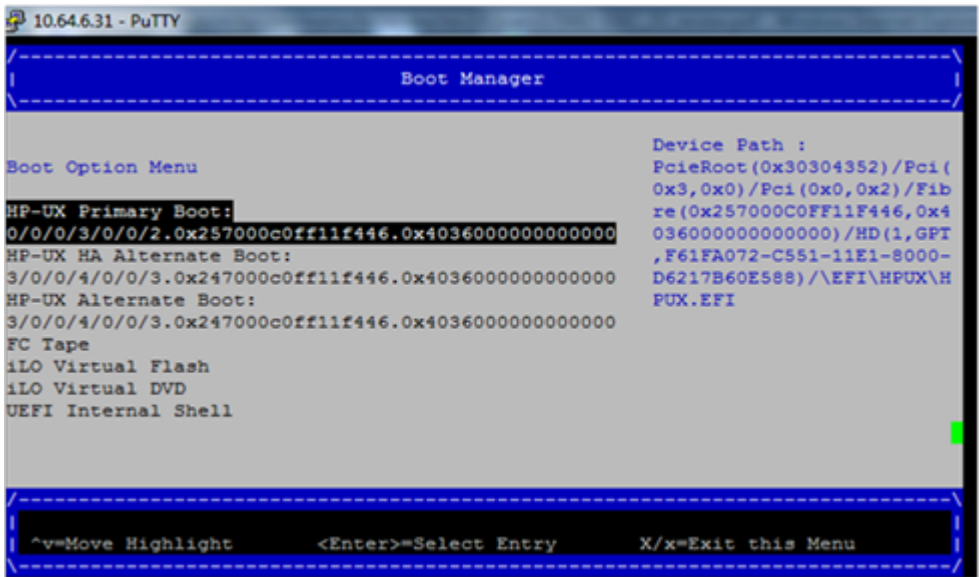

To configure specific devices, press **D** or **d** to launch the Device Manager. This is an advanced feature and should only be performed when directed.

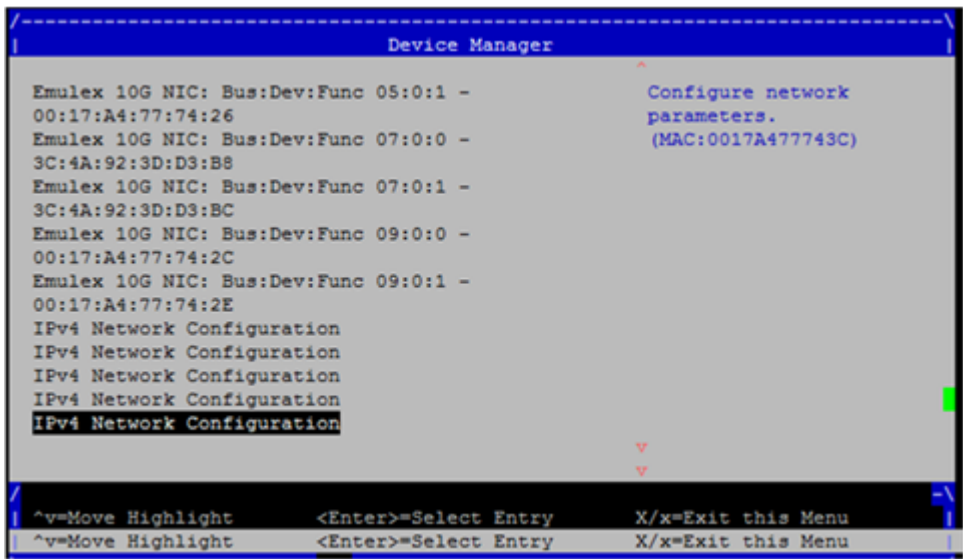

To perform maintenance on the system such as adding, deleting, or reordering boot options, press **M** or **m** to launch the Boot Maintenance Manager.

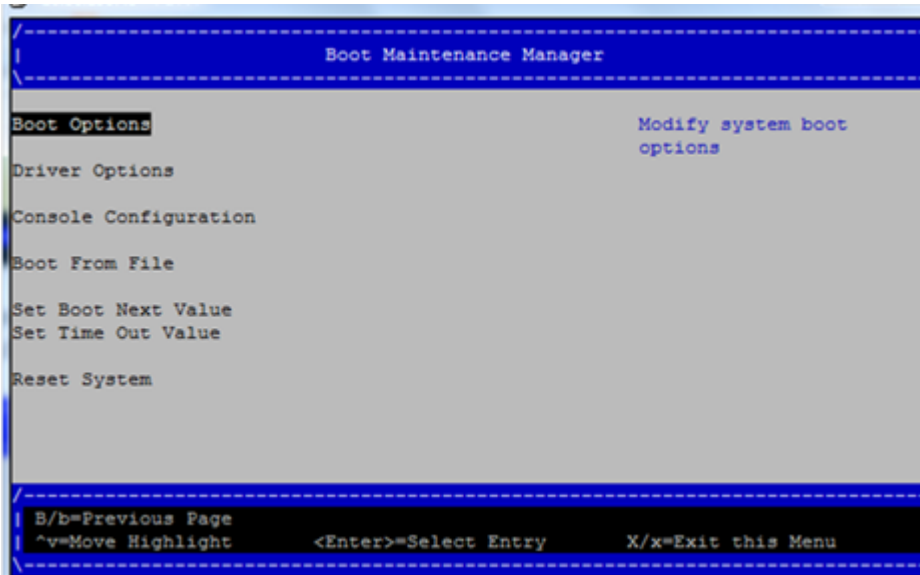

To perform more advanced operations, press **S** or **s** to launch the UEFI Shell.

To view the iLO 3 LAN configuration, press **I** or **i** to launch the iLO 3 Setup Tool.

## Saving UEFI configuration settings

There are other UEFI settings you can configure at this time. For more UEFI configuration options, see [RAID configuration and other utilities](#) on page 141.

## Booting and installing the operating system

From the **UEFI Front Page** prompt, you can boot and install in either of two manners:

- If your OS is loaded onto your server blade, see [Operating system is loaded onto the server blade](#) on page 34.
- If the OS is not installed onto your server blade, see [Operating system is not loaded onto the server blade](#) on page 34.

### Operating system is loaded onto the server blade

If the OS is loaded on your server blade, normally UEFI will automatically boot to the OS. If the UEFI Front Page is loaded, press **ENTER** to start auto boot, or **B** or **b** to select a specific boot option for your OS.

Use your standard OS logon procedures, or see your OS documentation to log on to your OS.

### Operating system is not loaded onto the server blade

There are two options on how to load the OS if it is not loaded onto your server blade.

- To load the OS from a DVD, see [Installing the OS from an external USB DVD device or tape device](#) on page 36.
- To load the OS using HP Ignite-UX, see [Installing the OS using Ignite-UX](#) on page 37.

## OS login prompt

If your server blade is at the OS login prompt after you establish a connection to the server blade, use your standard OS log in procedures, or see your OS documentation for the next steps.

# Installing the latest firmware using HP Smart Update Manager

The HP Smart Update Manager (HP SUM) utility enables you to deploy firmware components from either an easy-to-use interface or a command line. It has an integrated hardware discovery engine that discovers the installed hardware and the current versions of firmware in use on target servers. This prevents extraneous network traffic by only sending the required components to the target. HP SUM also has logic to install updates in the correct order and ensure all dependencies are met before deployment of a firmware update. It also contains logic to prevent version-based dependencies from destroying an installation and ensures updates are handled in a manner that reduces any downtime required for the update process. HP SUM does not require an agent for remote installations.

Key features of HP SUM are:

- GUI and CLI—command line interface
- Dependency checking, which ensures appropriate installation order and dependency checking between components
- Intelligent deployment deploys only required updates
- Support for updating firmware on network-based targets, such as the OA, iLO (through the Network Management Port), and VC Ethernet modules
- Improved deployment performance
- Remote command-line deployment
- Windows X86 or Linux X86 support

HP SUM is included in the firmware bundles download from <http://www.hpe.com>, and is supported on the BL860c i4, BL870c i4, and BL890c i4.

For more information about HP SUM, see the *HP Smart Update Manager User Guide* (<http://www.hpe.com/info/hpsum/documentation>).

# Operating system procedures

## Operating systems supported on the server blade

HP-UX 11i v3 HWE 1209

## Installing the operating system onto the server blade

The following procedures describe generalized operating system installation. For more details, see the operating system documentation.

### Installing the OS from an external USB DVD device or tape device

---

**NOTE:**

Tapeboot requires BL8x0c i4 system firmware bundle 42.06 or later and a partner tape blade, or an additional 51378-B21 Integrity Smart Array P711m HBA running 6.22 firmware or later to boot from an Ultrium 6250 tape drive.

---

**Procedure**

1. If using an external USB DVD device:
  - a. Connect the Integrity SUV cable to the front of the Monarch server blade.
  - b. Connect the USB DVD cable to one of the USB ports on the SUV cable.
2. Insert the OS media into the USB DVD device or tape device.
3. Power on the server blade and boot to UEFI. If the server blade is already powered on, then reboot to UEFI using the `reset` command at the UEFI prompt.
4. From the UEFI Front Page, press **S** or **s** to launch the UEFI Shell.

---

**NOTE:**

If the device is already selected or you already know the device name, then skip the following step.

---

If you are using a tape device, when the UEFI shell comes up, you should see a message similar to the following on the console:

```
HP Smart Array P212 Controller      (version 6.22)
  Tape Drive(s) Detected:
  Port: 1I, box:0, bay: 3 (SAS)
```

The message may also be similar to the following.

```
HP Smart Array P711m Controller (version 6.22) 0 Logical Drives
Tape Drive(s) Detected:
Port: 2E, box:1, bay: 9 (SAS)
```

---

**NOTE:**

If you do not see a line starting with `Port` and ending with `(SAS)`, the tape is not connected correctly or it is not responding.

---

**5. Locate the device you want to boot from.****a. For USB DVD, locate the device:**

- I. Use the `map` command to list all device names from the UEFI Shell prompt. The `map` command displays the following:

```
fs2:\> map
Device mapping table

fs6      :Removable CDRom - Alias cd66d0a blk6
          PcieRoot (0x30304352) /Pci (0x1D, 0x7) /USB (0x3, 0x0) /CDROM (0x0)
```

From the list generated by the `map` command, locate the device name (in this example, `fs6`)

---

**NOTE:**

Your DVD drive might not be named `fs6`. Make sure you verify the ID appropriate to your DVD device.

---

- II. At the UEFI shell prompt, specify the device name for the DVD-ROM and then enter the UEFI `install` command, as in the following example:

```
Shell> fs6:
fs6:\> install
```

**b. For tape, locate the device:**

- I. To boot from tape once you are at the UEFI shell:

```
Shell> tapeboot select
01 PcieRoot (0x30304352) /Pci (0x8, 0x0) /Pci (0x0, 0x0) /SAS (0x50060B00007F6FFC, 0x0, 0x1, NoTopology, 0, 0, 0, 0x0)
Select Desired Tape: 01 <<input 01
```

- If the correct media is installed, it will boot from tape when you enter the index number.
- If there is no media in the SAS tape drive and you select 1, the following message appears:

```
tapeboot: Could not load tapeboot image
```

**6. The OS now starts loading onto the server blade. Follow the on-screen instructions to install the OS fully.****7. Continue with [Configuring system boot options](#) on page 38**

## Installing the OS using Ignite-UX

Ignite-UX is an HP-UX administration toolset that enables:

- Simultaneous installation of HP-UX on multiple clients
- The creation and use of custom installations
- The creation of recovery media
- The remote recovery of clients

To install the OS onto the server blade using Ignite-UX, go to <http://www.hpe.com/info/Blades-docs>.

## Installing the OS using vMedia

---

### NOTE:

Installing the OS using vMedia might be significantly slower than installing using other methods.

---

vMedia enables connections of a DVD physical device or image file from the local client system to the remote server. The virtual device or image file can be used to boot the server with an operating system that supports USB devices.

vMedia depends on a reliable network with good bandwidth. This is especially important when you are performing tasks such as large file transfers or OS installations.

For more information regarding loading the OS with vMedia, see the vMedia Chapter of the *HPE Integrity Integrated Lights-Out Management Processor Operations Guide*.

---

### NOTE:

After the OS is loaded, make sure to save your nonvolatile memory settings to preserve boot entries in case of blade failure.

---

## Configuring system boot options

- **Boot Manager**

Contains the list of boot options available. Ordinarily the boot options list includes the UEFI Internal Shell and one or more operating system loaders.

To manage the boot options list for each server, use the UEFI Shell, the Boot Maintenance Manager, or operating system utilities.

- **Autoboot setting**

The `autoboot` setting determines whether a server automatically loads the first item in the boot options list or remains at the **UEFI Front Page** menu. With autoboot enabled, UEFI loads the first item in the boot options list after a designated timeout period.

Configure the autoboot setting for an Integrity server using either the `autoboot` UEFI Shell command or the Set Time Out Value menu item from the Boot Maintenance Manager.

Examples of autoboot commands for HP-UX:

- Disable autoboot from the UEFI Shell by issuing `autoboot off`
- Enable autoboot with the default timeout value by issuing `autoboot on`
- Enable autoboot with a timeout of 60 seconds by issuing the `autoboot 60`
- Set autoboot from HP-UX using `setboot`

- Enable autoboot from HP-UX using `setboot -b on`
- Disable autoboot from HP-UX using `setboot -b off`

For more information on the `autoboot` command, enter `help autoboot`.

## Booting and shutting down HP-UX

To boot HP-UX, use one of the following procedures:

- To boot HP-UX normally, see **HP-UX standard boot** on page 40. HP-UX boots in multi-user mode.
- To boot HP-UX in single-user mode, see **Booting HP-UX in single-user mode** on page 41.
- To boot HP-UX in LVM-maintenance mode, see **Booting HP-UX in LVM-maintenance mode** on page 41.

## Adding HP-UX to the boot options list

You can add the `\EFI\HPUX\HPUX.EFI` loader to the boot options list from the UEFI Shell or the Boot Maintenance Manager.

---

### NOTE:

On Integrity server blades, the operating system installer automatically adds an entry to the boot options list.

---

### NOTE:

To add an HP-UX boot option when logged in to HP-UX, use the `setboot` command. For more information, see the `setbootvolume(1M)` manpage.

---

To add HP-UX to the list:

### Procedure

1. Access the UEFI Shell environment.
  - a. Log in to iLO 3 for Integrity and enter the `co` command to access the system console.  
When accessing the console, confirm that you are at the **UEFI Front Page**.  
If you are at another UEFI menu, then choose the **Exit** option or press **X** or **x** to exit the menu. Exit until you return to the screen that lists the keys that can be pressed to launch various Managers.
  - b. Press **S** or **s** to launch the UEFI shell.
2. Access the UEFI System Partition (`fsX:` where *X* is the file system number) for the device from which you want to boot HP-UX.  
For example, enter `fs2:` to access the UEFI System Partition for the bootable file system number 2.  
The UEFI Shell prompt changes to reflect the file system currently accessed.  
The full path for the HP-UX loader is `\EFI\HPUX\HPUX.EFI` and it should be on the device you are accessing.
3. At the UEFI Shell environment, use the `bcfg` command to manage the boot options list.

The `bcfg` command includes the following options for managing the boot options list:

- a. `bcfg boot dump` – Display all items in the boot options list for the server.
- b. `bcfg boot rm #` – Remove the item number specified by `#` from the boot options list.
- c. `bcfg boot mv #a #b` – Move the item number specified by `#a` to the position specified by `#b` in the boot options list.
- d. `bcfg boot add # file.efi "Description"` – Add a new boot option to the position in the boot options list specified by `#`. The new boot option references `file.efi` and is listed with the title specified by `Description`.

For example, `bcfg boot add 1 \EFI\HPUX\HPUX.EFI "HP-UX 11i v3"` adds an HP-UX 11i v3 item as the first.

For more information, see the `help bcfg` command.

4. Exit the console and iLO 3 MP interfaces.

Press **Ctrl-B** to exit the system console and return to the iLO 3 MP Main Menu. To exit the MP, press **X** or **x** at the Main Menu.

## HP-UX standard boot

Use either of the following procedures to boot HP-UX:

- [Booting HP-UX from the UEFI Boot Manager](#) on page 40
- [Booting HP-UX from the UEFI Shell](#) on page 41

## Booting HP-UX from the UEFI Boot Manager

### Procedure

1. From the **UEFI Boot Manager** menu, choose an item from the boot options list to boot HP-UX.
2. Access the **UEFI Boot Manager** menu for the server on which you want to boot HP-UX.
3. Log in to iLO 3 MP and enter the `co` command to choose the system console.
4. Confirm you are at the **UEFI Front Page**. If you are at another UEFI menu, then choose the **Exit** option or press **X** or **x** to exit the menu. Exit until you return to the screen that lists the keys that can be pressed to launch various Managers. Press **B** or **b** to launch the Boot Manager.
5. At the **UEFI Boot Manager** menu, choose an item from the boot options list.  
Each item in the boot options list references a specific boot device and provides a specific set of boot options or arguments you use when booting the device.
6. Press **Enter** to initiate booting using your chosen boot option.
7. Exit the console and iLO 3 MP interfaces.
8. Press **Ctrl-B** to exit the system console and return to the **MP Main Menu**. To exit the **MP Main Menu**, press **X** or **x**.



## Booting HP-UX from the UEFI Shell

### Procedure

1. Access the UEFI Shell.
2. From the **UEFI Front Page**, press **S** or **s** to launch the UEFI shell.
3. Use the `map` command to list the file systems (fs0, fs1, and so on) that are known and have been mapped.
4. To select a file system to use, enter its mapped name followed by a colon (:). For example, to operate with the boot device that is mapped as fs0, enter `fs0:` at the UEFI Shell prompt.
5. Enter `HPUX` at the UEFI Shell command prompt to launch the `HPUX.EFI` loader from the currently selected boot device.

If needed, specify the full path of loader by entering `\EFI\HPUX\HPUX` at the UEFI Shell command prompt.

6. Allow the `HPUX.EFI` loader to proceed with the `boot` command specified in the `AUTO` file, or manually specify the `boot` command.

By default, the `HPUX.EFI` loader boots using the loader commands found in the `\EFI\HPUX\AUTO` file on the UEFI System Partition of the selected boot device. The `AUTO` file typically contains the `boot vmunix` command.

To interact with the `HPUX.EFI` loader, interrupt the boot process (for example, type a **space**) within the time-out period provided by the loader. To exit the loader, use the `exit` command, which returns you to UEFI.

## Booting HP-UX in single-user mode

### Procedure

1. Use steps 1–5 from **Booting HP-UX from the UEFI Shell** on page 41 to access the UEFI shell and launch the `HPUX.EFI` loader.
2. Access the HP-UX Boot Loader prompt (`HPUX>`) by pressing any key within the 10 seconds given for interrupting the HP-UX boot process. Use the `HPUX.EFI` loader to boot HP-UX in single-user mode in step 3.

After you press a key, the `HPUX.EFI` interface (the HP-UX Boot Loader prompt, `HPUX>`) launches. For help using the `HPUX.EFI` loader, enter the `help` command. To return to the UEFI Shell, enter `exit`.

3. At the `HPUX.EFI` interface (the HP-UX Boot loader prompt, `HPUX>`) enter the `boot -is vmunix` command to boot HP-UX (the `/stand/vmunix` kernel) in single-user (`-is`) mode.

## Booting HP-UX in LVM-maintenance mode

The procedure for booting HP-UX into LVM Maintenance Mode is the same as for booting into single user mode (**Booting HP-UX in single-user mode** on page 41), except use the `-lm` boot option instead of the `-is` boot option:

```
HPUX> boot -lm vmunix
```

## Shutting down HP-UX

For more information, see the `shutdownvolume(1M)` manpage.

## Procedure

1. Log in to HP-UX running on the server that you want to shut down or log in to iLO 3 MP for the server and use the Console menu to access the system console. Accessing the console through iLO 3 MP enables you to maintain console access to the server after HP-UX has shut down.
2. Issue the `shutdown` command with the appropriate command-line options.

The command-line options you specify determines the way in which HP-UX shuts down and whether the server is rebooted.

Use the following list to choose an HP-UX shutdown option for your server:

- a. Shut down HP-UX and halt (power off) the server using the `shutdown -h` command.  
Reboot a halted server by powering on the server using the `PC` command at the iLO 3 MP Command menu.
- b. Shut down HP-UX and reboot the server by issuing the `shutdown -r` command.

# Optional components

If your server blade has no additional components to install, go to [Installing and powering on the server blade](#) on page 17.

## Partner blades

The following partner blades are supported:

- Ultrium 448c Tape Blade
- SB920c Tape Blade
- SB1760c Tape Blade
- SB3000c Tape Blade
- SB40c Storage Blade
- D2200sb Storage Blade

---

**!** **IMPORTANT:**

In c7000 enclosures, partner blades are supported with BL860c i2 servers and BL870c i2 servers with BL2E blade links.

In c3000 enclosures, partner blades are supported with BL860c i2 servers.

Partner blades are not supported with BL890c i2 servers.

Partner blade slotting rules are dependent on the conjoined blade configuration. For more information on partner bay blade locations, see [Installing the Blade Link for BL860c i4, BL870c i4 or BL890c i4 configurations](#) on page 26.

---

**NOTE:**

SAS tape boot is now supported with tape blades on HPE Integrity BL860c i4, BL870c i4, and BL890c i4 server blades.

---

**NOTE:**

PCIe Gen-1 (driven from the ICH10 on the monarch blade's ICH mezzanine card) provides the interface to the partner blades. A separate mezzanine pass-thru card is not required.

---

## Hot-plug SAS disk drives

The server blade supports up to two hot-plug SAS drives.

---

**⚠** **CAUTION:**

To prevent improper cooling and thermal damage, do not operate the server blade or the enclosure unless all hard drive and device bays are populated with either a component or a blank.

---

**!** **IMPORTANT:**

The disk drive does not seat properly when 180° out of alignment. Verify the orientation before insertion.

---

---

**NOTE:**

For a list of supported disk drives for the server blade, see: [Server blade components list](#) on page 115.

---

**Procedure**

1. Remove the hard drive blank.

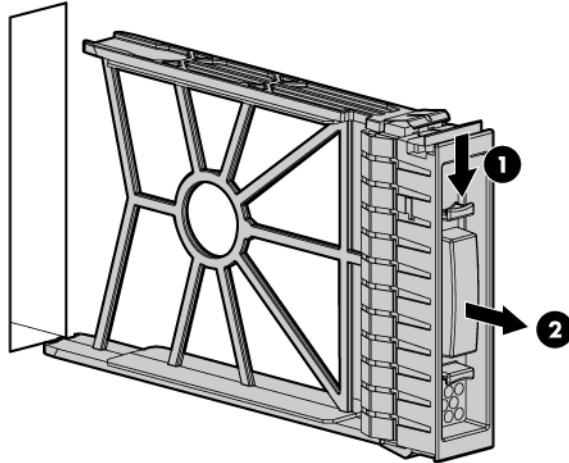

2. Prepare the hard drive.

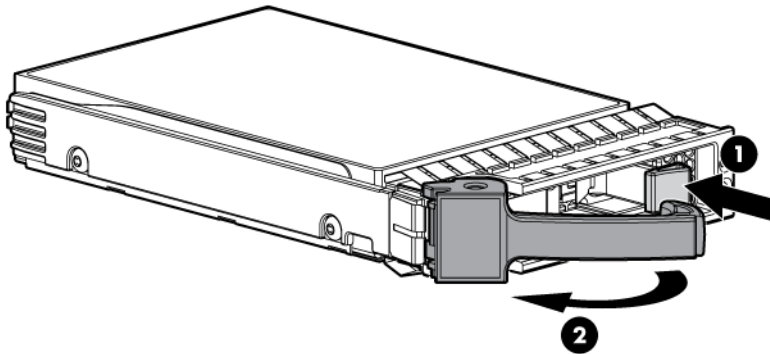

3. Slide the drive into the cage until it is fully seated.
4. Close the lever to lock the drive into place.

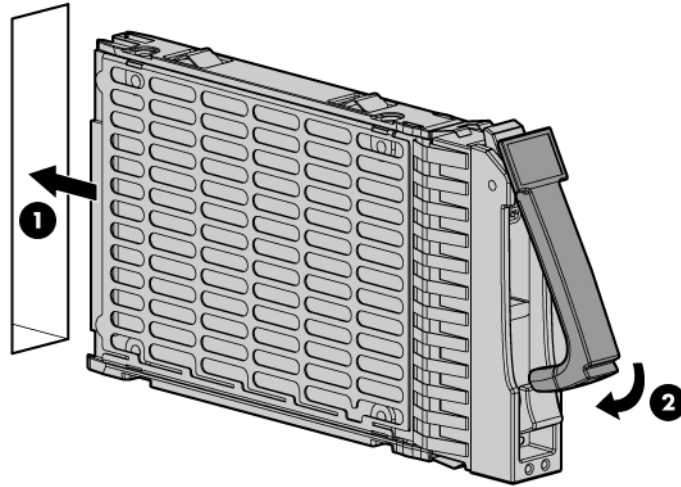

## Installing internal components

### Removing the access panel

#### Procedure

1. Lift the access panel latch.
2. Slide the access panel backwards approximately 2 cm (0.75 in).
3. Remove the access panel by lifting it straight up and off the server blade.

After the access panel is off, you can do the following:

- Add an additional processor (**Processor and heatsink module** on page 45).
- Add additional memory DIMMs (**DIMMs** on page 50).
- Add additional mezzanine cards (**Mezzanine cards** on page 56).

### Processor and heatsink module

#### Processor load order

Observe the following guidelines when installing additional processors:

- In a BL860c i4, CPU0 is installed before CPU1.
- In a BL870c i4 or BL890c i4, each blade must have CPU0 installed.
- When adding additional CPUs in a conjoined configuration:
  - Load both CPU0 and CPU1 in the Monarch blade first.
  - Load additional CPUs in sequence, from lowest slot-numbered blade to highest.

---

**⚠ CAUTION:**

The pins on the processor socket are very fragile. Any damage to them might require replacing the server blade base unit.

---

**⚠ CAUTION:**

To avoid damage to the processor, verify that the plastic tabs on the processor are pulled fully out before installation.

---

**⚠ CAUTION:**

To avoid damage to the processor, handle the processor only by the edges. Do not touch the bottom of the processor, especially the contact area.

---

**⚠ CAUTION:**

To prevent possible server blade malfunction and damage to the equipment, multiprocessor configurations must contain processors with the same part number.

---

The processor and heatsink ship as two separate units and are coupled together during installation into the server blade.

**Procedure**

1. Remove the CPU airflow baffle.

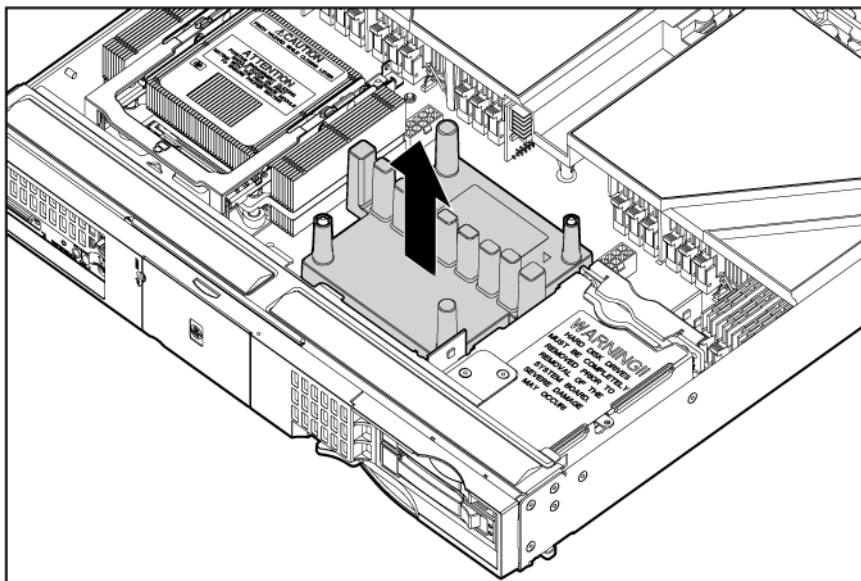

2. Transfer the duplicate part/serial numbers label from the processor module to the processor heatsink.
  - a. Remove the duplicate tear-away label that lists the part and serial numbers from the processor module.
  - b. Place the label on the top of the heatsink.
3. Install the processor over the load posts.

---

**NOTE:**

Ensure pin 1, indicated on the empty socket with an embossed triangle, matches the pin 1 marker on the processor module, the chamfered corner of its attached voltage regulator heatsink.

---

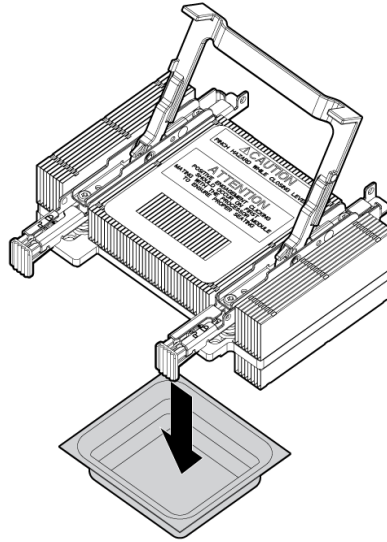
**4.** Remove the heatsink cover.**⚠ CAUTION:**

During installation, after removing the protective cover from the heatsink:

- Do not touch or come into contact with the thermal interface material.
  - Immediately install the heatsink.
- 

**⚠ CAUTION:**

To avoid damage to the server blade and processor, ensure the processor heatsink locking handle is fully back against the stops, rotated about 120° back. Also verify that the plastic tabs on the processor heatsink are pulled fully out before installation.

---

**5.** Install the heatsink over the load posts.**⚠ CAUTION:**

Do not lower the heatsink locking handle before pushing the plastic locking tabs into place.

---

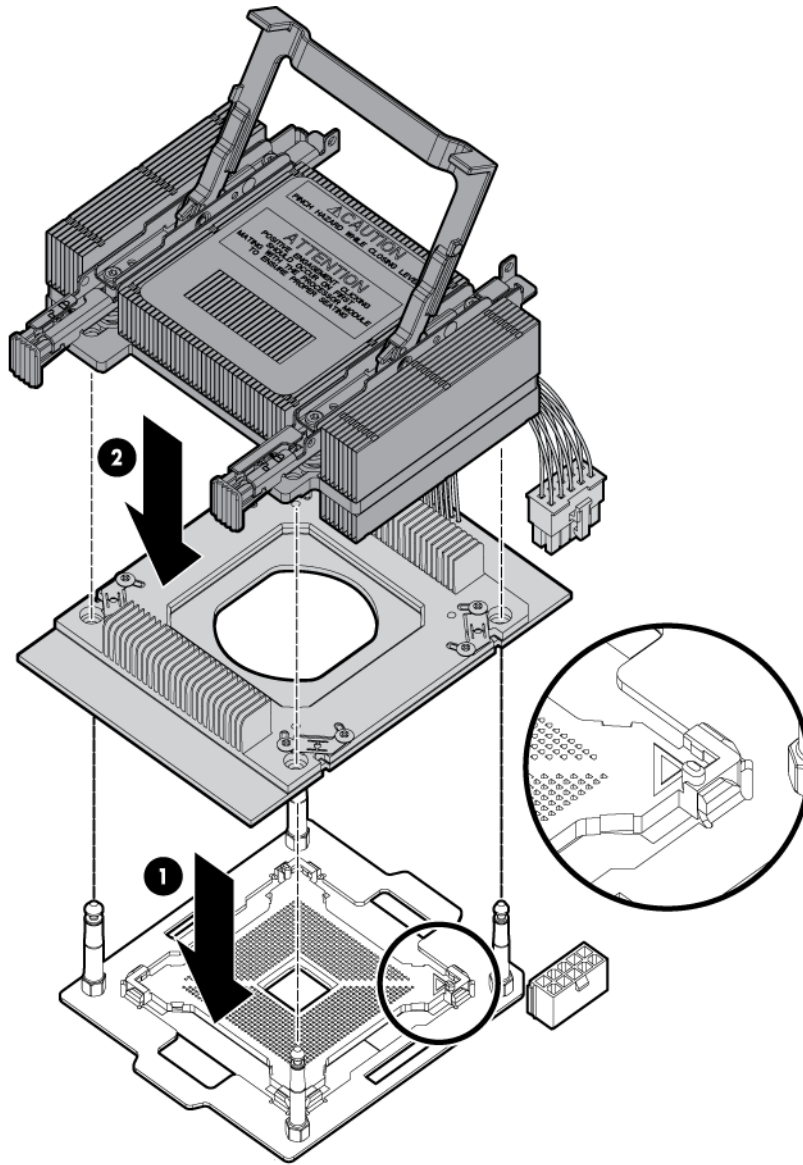

---

**⚠ CAUTION:**

To prevent thermal instability and damage to the server blade, do not separate the processor module from the processor's heatsink after they have been coupled.

---

6. Secure the heatsink to the processor
    - a. Slide both plastic locking tabs into place. (See callout 1 in the following figure).
    - b. Grasp and rotate the latch downward. (See callout 2 in the following figure.)
- 

**⚠ WARNING:**

The heatsink locking lever can constitute a pinch hazard, keep your hands on top of the lever during installation to avoid personal injury.

---



---

**NOTE:**

Positive engagement clicking should occur during mating of the processor heat sink and processor module onto the socket to ensure proper seating.

---

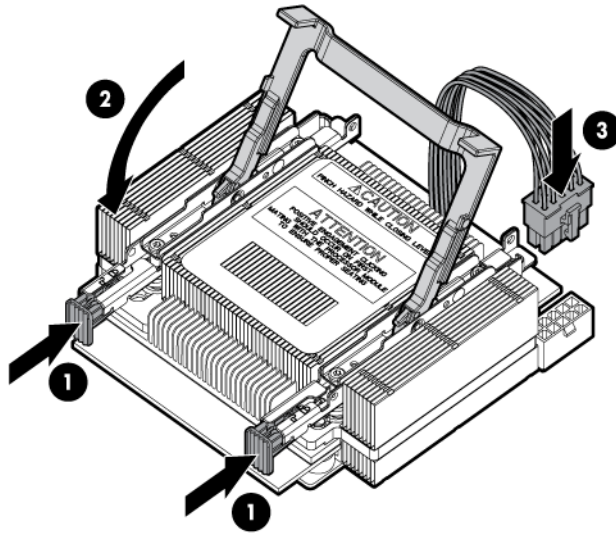

7. Connect the power cord. (See callout 3 in the previous figure).
8. Tie wrap the processor cable to the right tie point on the processor assembly.

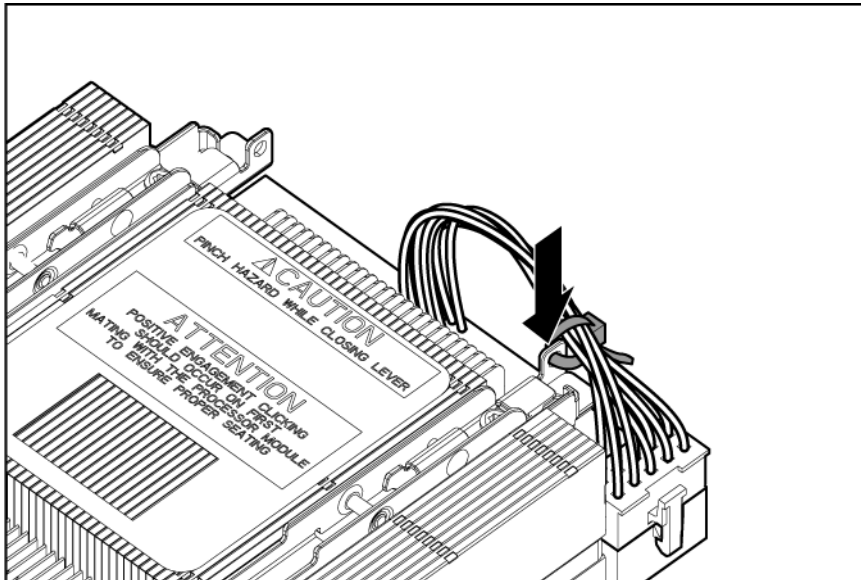

---

**⚠ CAUTION:**

When the CPU is installed, dress all slack in the power cable to the connector end of the cable. Failure to do so could result in pinched or damaged CPU power cables.

---

---

**!** **IMPORTANT:**

If you are adding an additional processor to your server blade, the DIMMs in the server blade must be reconfigured to support both CPUs. For more information, see [DIMM pair load order](#).

---

## DIMMs

### DIMM installation guidelines

Observe the following guidelines when installing memory:

- Use only Hewlett Packard Enterprise low-profile (1.2 in.) DIMMs.

---

**!** **IMPORTANT:**

DIMMs from other sources may adversely affect data integrity.

---

- In a BL860c i4 Server Blade, memory is loaded in identical pairs.
- In a BL870c i4 or BL890c i4 Server Blade, memory is loaded in quads that are systematically loaded between blades and processors.
  - The BL870c i4 has a single interleaving domain that allows mixing two DIMM types within the domain. The highest DIMMs get loaded first in quads, alternating between blades and processor sockets; then the lower DIMMs get loaded in quads, alternating between blades and processor sockets .
  - The BL890c i4 system has dual interleaving domains, with each interleave domain consisting of two adjacent blades. In this system different DIMM types cannot be mixed in the same interleaving domain. Higher capacity DIMMs are loaded in quads alternating between blades 1 and 2 and their processor sockets; then the lower capacity DIMMs are loaded in quads alternating between blades 3 and 4 and their processor sockets. This means there can never be more than 12 quads of either of the two DIMM types.

---

**!** **IMPORTANT:**

If loading a single DIMM type in an 8 socket system, the DIMMs have to be loaded alternating between blades and processor sockets since starting to load one interleaving domain first, then the second can result in an unbalanced memory configuration.

---

- Different densities in different pairs or quads are supported, provided the following rules are kept.

Only two DIMM sizes can be mixed in a BL870c i4 or BL890c i4 Server Blade. Mixing more than two DIMM pair capacities is only supported on the BL860c i4.

- In a BL870c i4 Server Blade, the two DIMM sizes must alternate between blades. Load all of one DIMM size, then repeat with the second DIMM size.
- In a BL890c i4 Server Blade, blades 1 and 2 must have one DIMM size and blades 3 and 4 must have the other DIMM size. If only one DIMM size is used on BL980c i4, alternate between all 4 blades.

---

**!** **IMPORTANT:**

If loading a single DIMM type in a BL980c i4, the DIMMs have to be loaded alternating between blades and processor sockets, since starting to load one interleaving domain first, then the second, can result in an unbalanced memory configuration.

---

---

**NOTE:**

Integrity Server Blade upgrades follow the same DIMM loading rules. See [Upgrading a conjoined configuration](#) on page 62 for more information on server blade upgrades.

---

**Performance**

The maximum number of usable DIMM slots, and therefore the maximum amount of memory for any particular configuration is tied to the number of processors used in the configuration. In addition, the conjoined blade products all have minimum processor recommendations (one per conjoined blade) for best performance.

There are 12 DIMMs associated with each processor. Each processor has DIMM pairs A through F. A processor must be installed to access its associated memory. A processor can be installed without memory as long as one of the processors in the conjoined system has memory.

For best performance, the minimum recommendation is a quad of DIMMs for each processor installed in a conjoined blade product. For best performance (not required), load only the same type (size) of DIMMs throughout the system. Uniform memory (selected in the `memconfig` interleaving options) is supported with a total memory capacity equal to a "power of two" (loading 4, 8, 16, 32, or 64 DIMMs at a time). Therefore, for best performance, if using the uniform memory selections, load a quad (even better two quads) of DIMMs for each processor. To obtain the fastest memory access, load a total memory capacity equal to a power of four (4, 16, 64).

---

**ⓘ IMPORTANT:**

The system will boot with memory loaded on only one processor. However, from a performance perspective, this is not a recommended configuration.

---

To enable Double DRAM chip sparing, for all the DIMMs loaded in the system, use only 4GB, 8GB, or 16GB DIMMs.

The 10GigE LOMs that have jumbo frames enabled require 1GB of main memory for each port (8GB/ server blade). Anything below this minimum results in insufficient memory and a hang either during the HP-UX boot or during the I/O configuration for the Integrity BL8x0c i4 systems. For example, the minimum memory configuration for the BL860c i4 is 8GB, for the BL870c i4 is 16GB, and for the BL890c i4 is 32GB.

Minimum memory requirements assume the Flex-10/FlexFabric adapters are not installed. Increase the minimum required memory by 2GB for each Flex-10/FlexFabric mezzanine card that is installed into the system.

**DIMM pair load order**

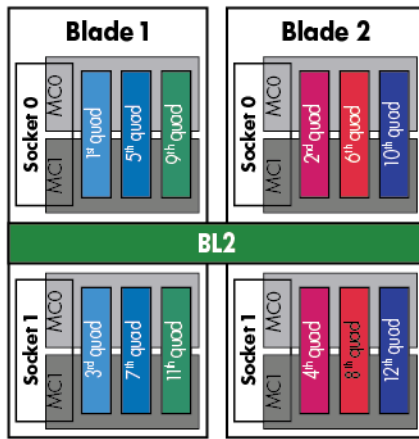

Figure 1: DIMM quad load order

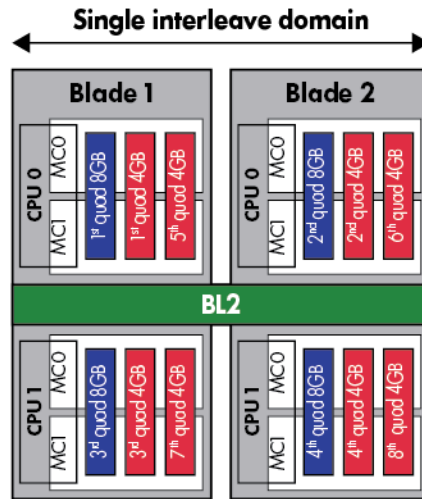

Figure 2: Mixed DIMM load order

Table 7: DIMM pair load order

		CPU0		CPU1	
CPU0 only	1st	3A	4A	—	—
	2nd	9B	10B	—	—
	3rd	1C	6C	—	—
	4th	7D	12D	—	—
	5th	2E	5E	—	—

Table Continued

		CPU0		CPU1	
<b>Both CPUs loaded</b>	6th	8F	11F	—	—
	1st	3A	4A	—	—
	2nd	—	—	1A	7A
	3rd	9B	10B	—	—
	4th	—	—	6B	10B
	5th	1C	6C	—	—
	6th	—	—	3C	9C
	7th	7D	12D	—	—
	8th	—	—	4D	12D
	9th	2E	5E	—	—
	10th	—	—	2E	8E
	11th	8F	11F	—	—
	12th	—	—	5F	11F

**DIMM quad load order rules**

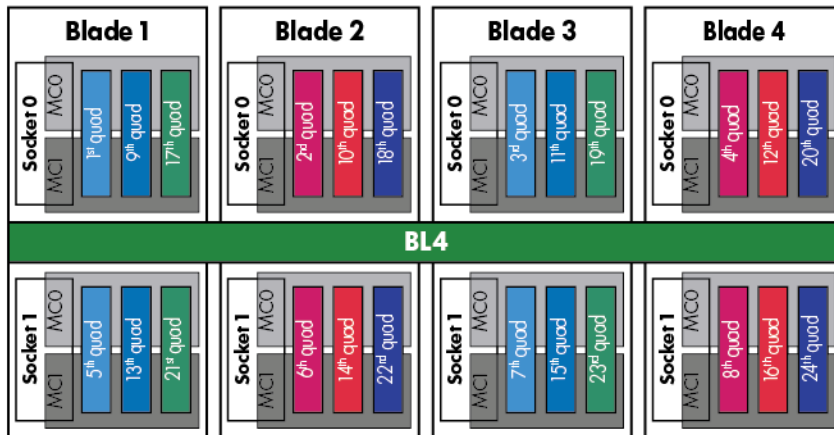

**Figure 3: DIMM quad load order**

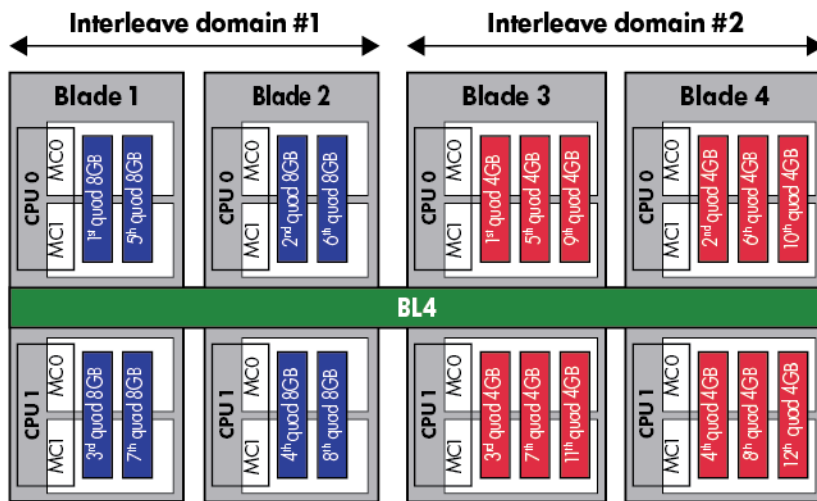

Figure 4: Mixed DIMM load order

Table 8: DIMM quad load order

		CPU0				CPU1			
Both CPUs loaded	1st	3A	4A	9B	10B	—	—	—	—
	2nd	—	—	—	—	1A	7A	6B	10B
	3rd	1C	6C	7D	12D	—	—	—	—
	4th	—	—	—	—	3C	9C	4D	12D
	5th	2E	5E	8F	11F	—	—	—	—
	6th	—	—	—	—	2E	8E	5F	11F

**NOTE:**

- If more than two DIMM types are installed in the BL870c i4 or BL890c i4 systems, the customer will receive a warning indicating that optimum interleaving is not possible and memory may be de-allocated. Mixing more than two DIMM types is only supported on the BL860c i4.
- If DIMMs are loaded in pairs in the BL870c i4 or BL890c i4 systems, the customer will receive a warning indicating that the memory is not configured according to the Hewlett Packard Enterprise loading rules and some memory may be de-allocated.

Once the memory loading rules have been satisfied, all memory installed in the system will be recognized.

**Installing DIMMS**

## Procedure

1. Power off the server blade.
2. For the conjoined products only, remove the Blade Link.
3. Remove the server blade from the enclosure.
4. Remove the access panel.
5. Remove the DIMM baffle (**DIMM baffle** on page 126).
6. Locate the DIMM slots on the server blade system board.

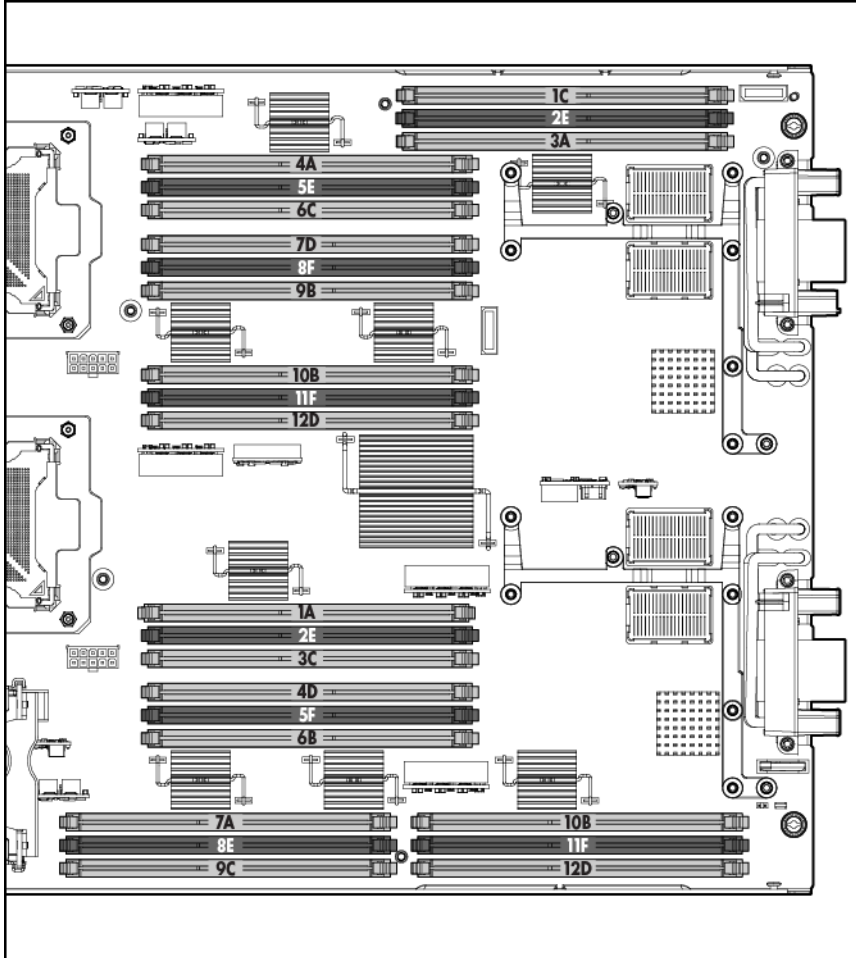

---

### NOTE:

The server blade ships with at least two DIMMs installed in slots 3A and 4A.

---

7. Ensure the DIMM slot latches are open.
8. Align the DIMM's notch with the slot's notch.

---

**⚠ CAUTION:**

Use only Hewlett Packard Enterprise low profile DIMMs. DIMMs from other sources might adversely affect data integrity.

DIMMs do not seat fully if turned the wrong way.

DIMMs in a pair or quad must be identical.

---

9. Insert a DIMM in a slot and push down firmly until the latches click shut, first one latch and then the other.
- 

**⚠ IMPORTANT:**

To ensure proper function of the memory baffle, all DIMM latched must be in the CLOSED position.

---

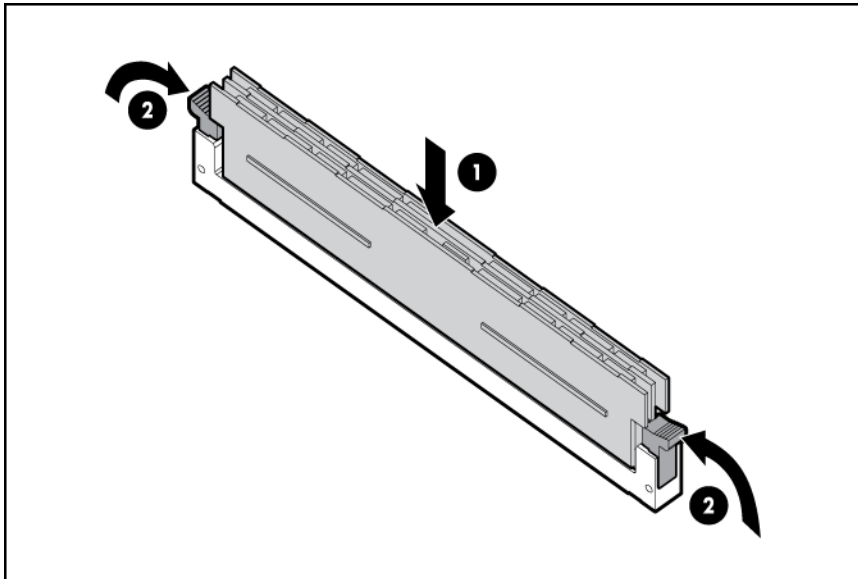

## Mezzanine cards

Optional mezzanine cards enable additional network connectivity and provide Fibre Channel support. For mezzanine card locations, see **Server blade components** on page 9.

Optional mezzanine cards are classified as Type I mezzanine cards and Type II mezzanine cards. The card type determines where it can be installed in the server blade:

- Install Type I mezzanine cards on any mezzanine connector.
- Install Type II mezzanine cards only on Mezzanine 2 connector or Mezzanine 3 connector.

To install a card:

### Procedure

1. Power off the server blade and remove it from the server blade enclosure (**Preparing the server blade for servicing** on page 118).
2. Remove the access panel (**Removing the access panel** on page 45).
3. Remove the mezzanine connector cover.



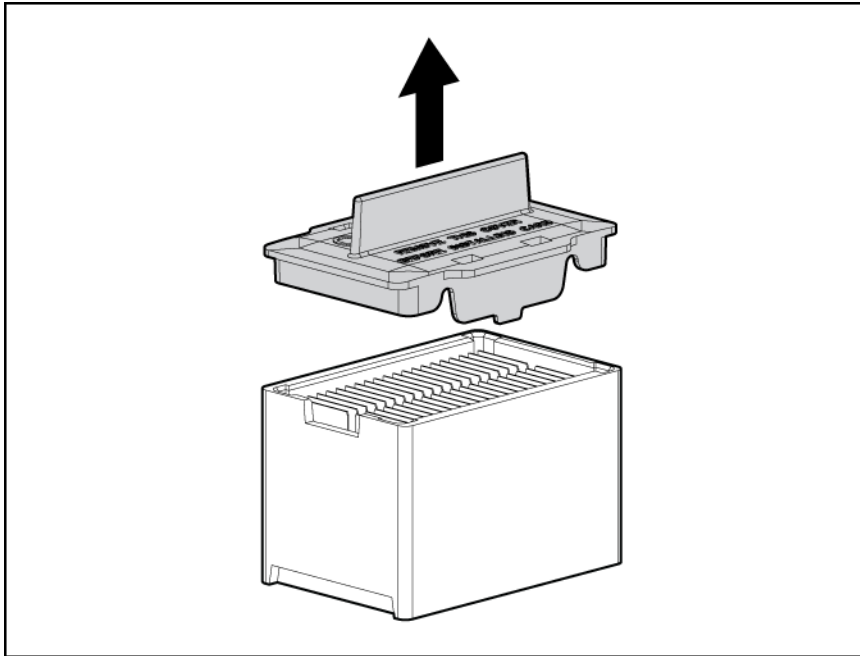

4. Align the mezzanine connector on the option card with the mezzanine connector on the system board.
5. Press down on the connector to seat the card.

**⚠ CAUTION:**

To prevent damage to the server blade, apply pressure over the mezzanine connector when installing the mezzanine card. Do not apply pressure to the edges of the card.

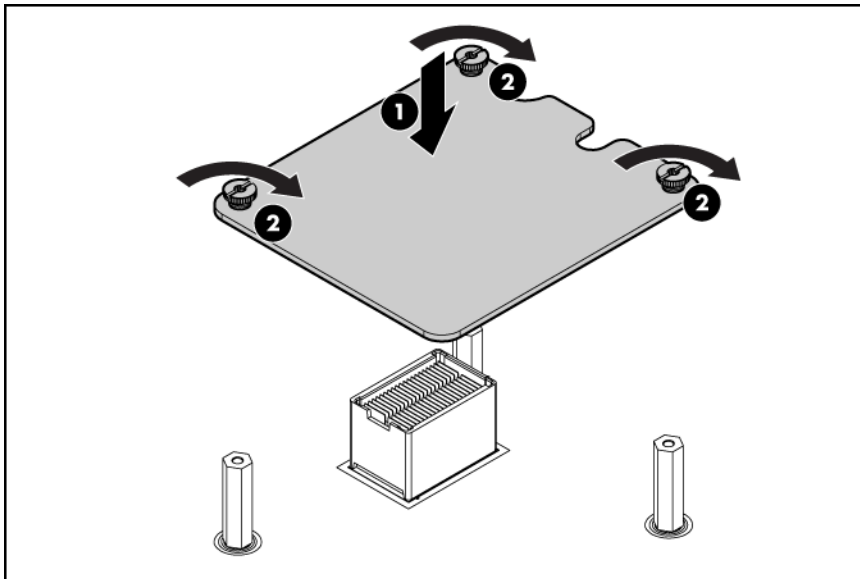

## HPE Smart Array P711m Controller

The Smart Array P711m is a PCIe card supporting direct attach and shared SAS Storage. This card is supported in slots 1, 2, and 3 on the BL860c i4, BL870c i4, and BL890c i4 server blades.

---

**NOTE:**

When a mixed configuration of BL860c i4, BL870c i4, and BL890c i4 server blades and other c-Class server blades is in the same enclosure, the preferred location for the P711m cards is slot 3.

---

## Supercap pack mounting kit

The Smart Array P711m Controller includes a cabled Supercap Pack which mounts inside the server using the orderable AM341A Mounting Kit for Low profile battery (Hewlett Packard Enterprise part number AD399-2132A KIT, RAID BATTERY HOLDER). This kit contains a black metal mounting bracket and a mezzanine card blank. The mounting bracket clips onto a mezzanine card in slot 1. If no card is used in slot 1, the mezzanine card blank included in the kit must be installed to mount the bracket.

For installing the bracket on to the server blade, the mounting bracket has:

- A mezzanine post loop that slides over the abutting mezzanine 2 post
- A thumbscrew clip that clips over the mezzanine 1 card or mezzanine blank thumbscrew located at the rear of the blade
- A mezzanine foot that clips over the edge of the mezzanine 1 card or mezzanine card blank that is installed closest to the center of the blade

For installing the Supercap Pack onto the bracket, the mounting bracket has:

- A C-hook to restrain the cable
- Two restraining clips to restrain the Supercap Pack

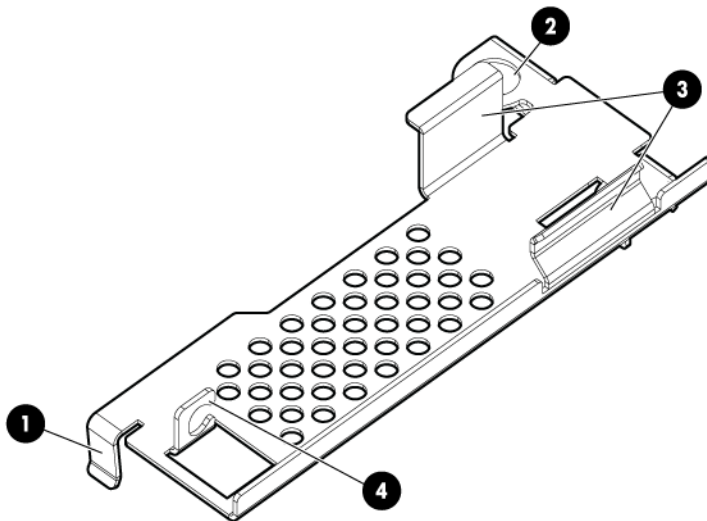

1	Mezzanine foot	3	Cable restraining clips
2	Mezzanine post loop	4	C-hook

## Installing the Supercap mounting bracket

### Procedure

1. Power off the server blade and remove it from the server blade enclosure (**Preparing the server blade for servicing** on page 118).
2. Remove the access panel (**Access panel** on page 124).
3. Remove the DIMM baffle (**DIMM baffle** on page 126).
4. Temporarily remove any mezzanine card installed in slot 2 (**Mezzanine cards** on page 133).

---

### NOTE:

Mezzanine slot 1 must contain the P711m Controller, another mezzanine card, or the mezzanine card blank. If you are installing the P711m card in mezzanine slot 1, do so now following the instructions “Installing the P711m Controller Board.” If you are not installing the P711m card in mezzanine slot 1, and no other mezzanine card is present in slot 1, then install the mezzanine card blank at this time.

- 
5. Clip the mounting bracket onto the mezzanine card or mezzanine card blank.
  6. Press the bracket thumbscrew clip over the thumbscrew closest to the mezzanine post.
  7. Push the remaining bracket foot over the other edge of the mezzanine card or mezzanine card blank.

---

### ⚠ CAUTION:

Push only enough to anchor the bracket, keeping the bracket level.

---

### ⚠ CAUTION:

To avoid damage to the power cable ensure the battery bracket does not pinch the power cable to the power connectors.

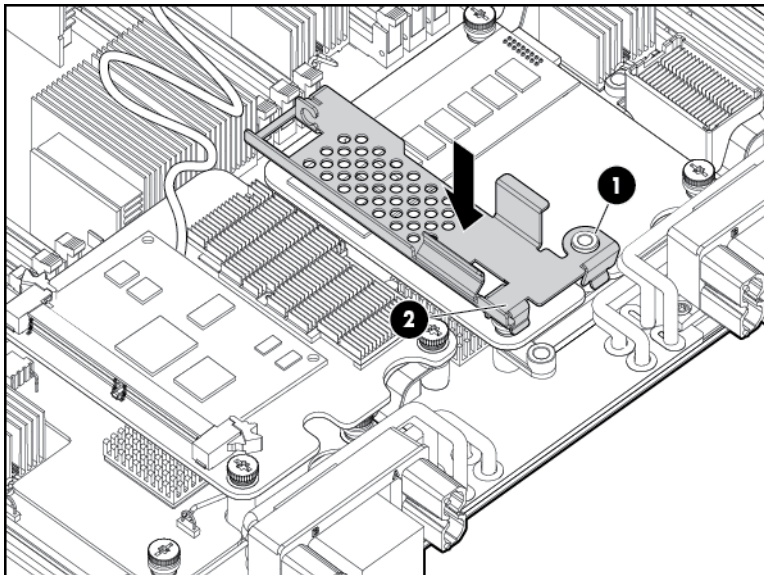

8. Replace any mezzanine cards that you had to remove from mezzanine slot 2 (**Mezzanine cards** on page 133).

To remove the component, reverse the procedure.

## Installing the P711m controller board

This card is supported in slots 1, 2, and 3 on the BL860c i4, BL870c i4, and BL890c i4 server blades.

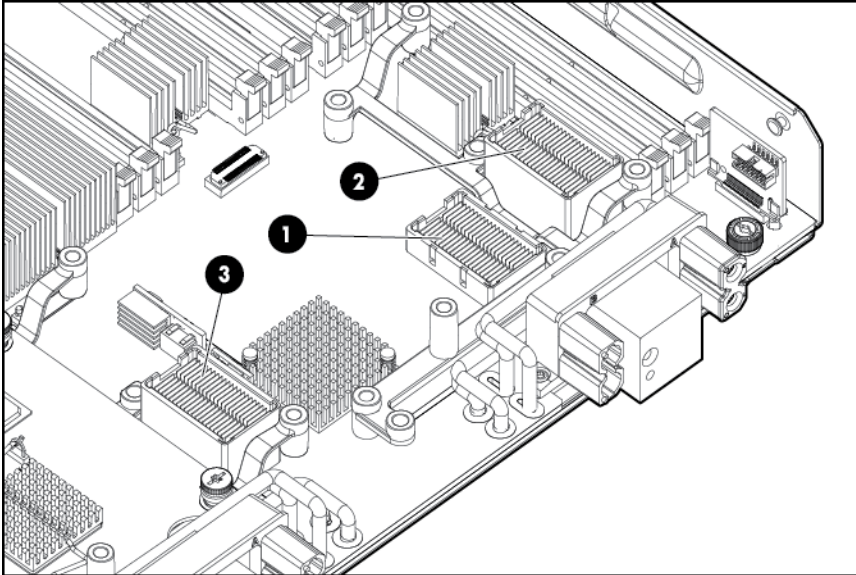

1	Slot 1	2	Slot 2	3	Slot 3
---	--------	---	--------	---	--------

---

### NOTE:

When a mixed configuration of BL860c i4, BL870c i4, and BL890c i4 server blades and other c-Class server blades are in the same enclosure, the preferred location for the P711m cards is slot 3.

Use the procedure for installing standard mezzanine cards to install the SAS controller board, see [Mezzanine cards](#) on page 56 for more information.

## Installing the Supercap Pack

The Supercap Pack snaps onto the mounting bracket to secure the Supercap Pack inside the server blade.

---

### NOTE:

The mounting bracket is installed either on top of a mezzanine card in slot 1, or the mezzanine blank in slot 1, depending upon the customer's configuration. If no card is used in slot 1, the mezzanine card blank must be installed for the bracket to clip onto.

---

### NOTE:

The Supercap Pack includes two plastic tabs that must be removed for proper fit in the BL860c i4, BL870c i4, and BL890c i4 server blades. One tab is located on the rounded end of the Supercap Pack, the other tab is directly above the cable as it exits the plastic housing of the Supercap Pack. To remove these tabs, squeeze them firmly toward each other (significant force is required). Optionally, these two tabs can be clipped off even with the rest of the Supercap Pack.

---

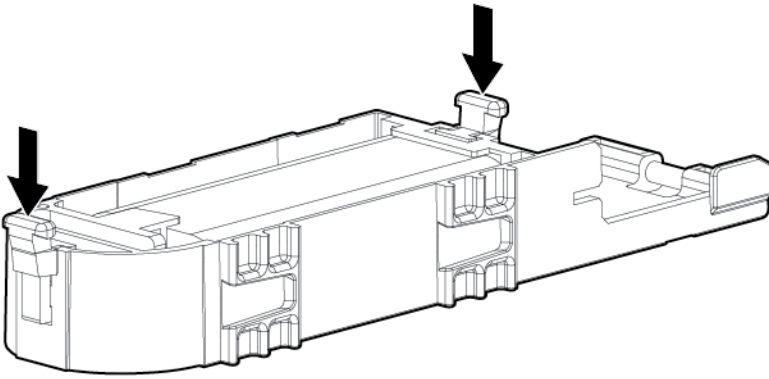

1. Position the Supercap Pack with the print side down and push the end of the cable that is connected to the Supercap Pack under the mounting bracket's C-hook, routing the cable so its supercap end is on the side of the hook that is away from slot 3.
2. Push the other end of the Supercap Pack down between the two restraining clips.
3. Consolidate and secure remaining cable length using tie wrap or similar retention method.

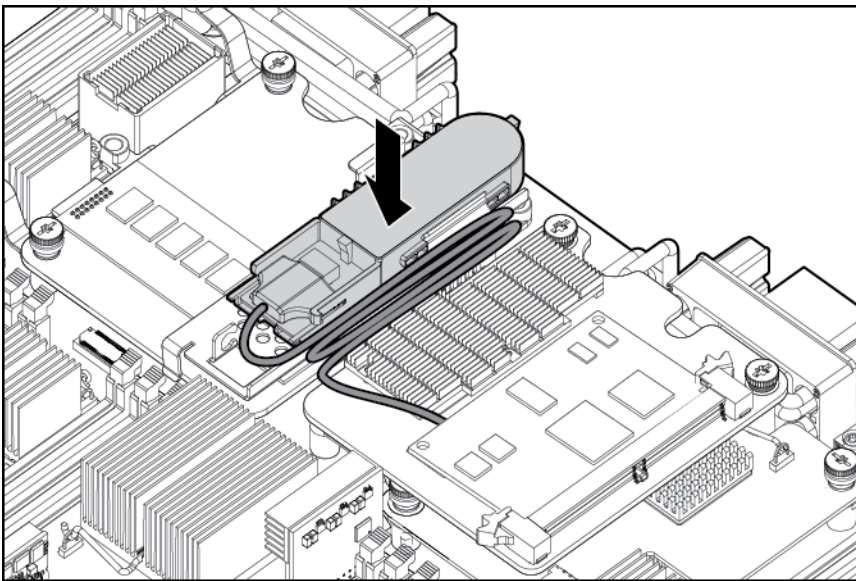

To remove the component, reverse the procedure.

## Replacing the access panel

### Procedure

1. Place the access panel onto the server blade by lining up the keyways on the panel to the posts on the server blade chassis.
2. Slide the access panel toward the front of the server blade until the panel lock button snaps into place.

# Upgrading a conjoined configuration

This section contains information required to complete an upgrade of a BL860c i4, BL870c i4, or BL890c i4 server blade. This document expands on the information provided in the Read This First document which is included in the upgrade kit.

## Procedure summary

### Procedure

#### 1. Original blade server check

The existing blade servers that will be upgraded are checked and prepared for the upgrade.

#### 2. Adding resources

The blades for the upgrade are placed together, internal component changes are made if necessary, blade firmware is updated if necessary, the Upgrade Blade Link is installed, System Information Parameters are exchanged between the server blades and the new Blade Link, and then the final system partitioning can be set.

#### 3. Final check

The upgraded sever partitions are booted to the UEFI shell and variables restored if necessary, the upgraded server is checked for normal operation at a low level, and finally the Operating System is booted and the system checked for normal operation.

#### 4. Warranty registration

Warranty and support are arranged to be transferred from the server being upgraded to the upgraded server.

## Upgrade kit contents

- The *HPE Integrity BL860c i4, BL870c i4 & BL890c i4 Server Blade Upgrades Read Me First*.
- One of the following Upgrade Blade Links:
  - AM395A HPE BL8x0c i4 Upgrade BL2 Blade Link
  - AM396A HPE Integrity BL870c i4 Upgrade BL2-c7E Blade Link
  - AM398A HPE BL8x0c i4 Upgrade BL4 Blade Link

---

### NOTE:

Each Blade Link will include a new Product Number label to attach to the system label carrier card; the actual part number will depend on the type of upgrade ordered.

---

- AM394A HPE Integrity BL8x0c i4 Upgrade Blade. One or more Upgrade Blades may be included depending on the type of upgrade ordered. These should be pre-installed with ordered processors, memory, and other components.

## Before getting started

---

### ⓘ IMPORTANT:

- Do not install or use the upgrade Blade Link until explicitly called for in the upgrade procedure. For more information, see **Blade link and system information parameters** on page 78.
- The server blade firmware may need to be updated on the existing server blades as part of the upgrade process, see **Determining your current firmware revisions** on page 64 for more information.
- Processor and memory DIMM loading and distribution follows applicable rules across the blades. For more information, see **Installing internal components** on page 45 and **Rules for server blade internal components** on page 68.
- Adding new Upgrade Blades to an enclosure may require additional power supplies in the enclosure to meet the new power requirements. This situation would be reported by the enclosure Onboard Administrator. For more information, see the BladeSystem setup and information guide for your enclosure at <http://www.hpe.com/info/Blades-docs>.
- If more than one existing blade server will be combined in the upgrade, one of them must be designated as the “Monarch Server”. This is the original server which is officially being upgraded, The Monarch blade from this server will become the Monarch blade in the upgraded server. Also, the Monarch Server UUID and Serial Number will be transferred to the upgraded server.
- The OS boot disk must be attached to the designated Monarch Server.
- When VC is used, some rearrangement of the VC server profile may be necessary. See **Possible changes due to VC profile mapping on the upgraded blade server** on page 80.
- Because the socket count of the upgraded server is likely to be greater than that of the server being upgraded, a new OS license will probably be required.
- At the end of the upgrade, the Blade Links removed from the original blade servers cannot be reused.

---

## Supported operating systems

HP-UX 11i v3 OE Update for September 2012

### ⓘ IMPORTANT:

If you will be using HP-UX, review the HP-UX errata documentation that is listed at <http://www.hpe.com/info/Blades-docs>.

---

## Minimum firmware versions

A minimum set of firmware is required for the blades and blade enclosures involved in the upgrade. Firmware on the server blades, the enclosure HPE Onboard Administrator, and the HPE Virtual Connect Manager (if Virtual Connect interconnect modules are installed) must be updated to at least the minimum firmware level. Every blade in the upgrade must be at the same firmware level.

### ⓘ IMPORTANT:

Any required updates must be checked for and completed during the upgrade process.

---

Product Name(s)	Minimum Firmware Version	Minimum Firmware Location
HPE Integrity BL860c i4 Server Blade HPE Integrity BL870c i4 Server Blade HPE Integrity BL890c i4 Server Blade	T42.02	Go to <a href="http://www.hpe.com">http://www.hpe.com</a> → <b>Support &amp; Drivers</b> → enter product name → select operating system → “Cross operating system”
HPE BladeSystem Onboard Administrator	3.55	Go to <a href="http://www.hpe.com">http://www.hpe.com</a> → <b>Support &amp; Drivers</b> → enter product name
HPE BladeSystem c-Class Virtual Connect	3.70  ⓘ <b>IMPORTANT:</b> VCSU version 1.7.0 must be used to update to VC 3.70.	Go to <a href="http://www.hpe.com">http://www.hpe.com</a> → <b>Support &amp; Drivers</b> → enter Interconnect Module product name

## Determining your current firmware revisions Server blade

### ⓘ **IMPORTANT:**

It is possible to access the iLO TUI before iLO has completed its initialization at power up. The indicator to know that iLO has completed initialization is the ability to access the nPartitions command via the TUI.

### Procedure

1. Log into the system iLO 3 MP.
2. From the Main Menu, enter the `cm` command to access the Command Menu.
3. Enter the `sr` command to view the system FW revisions.

```
Hewlett-Packard Integrated Lights-Out 3 for Integrity
(C) Copyright 1999-2010 Hewlett-Packard Development Company, L.P.

MP Host Name: ilo002264fee2de

iLO MP Firmware Revision 01.41.01

*****
MP ACCESS IS NOT SECURE
A default MP user Administrator/Admin is currently configured
and remote access is enabled. Modify the default password or
delete the default user (see UC command)
OR
Disable all types of remote access (see SA command)
*****

MP MAIN MENU:
```



```
CO: Console
VFP: Virtual Front Panel
CM: Command Menu
CL: Console Log
SL: Show Event Logs
HE: Main Help Menu
X: Exit Connection
```

```
[ilo002264fee2de] hpiLO-> cm
```

```
(Use Ctrl-B to return to MP main menu.)
```

```
[ilo002264fee2de] CM:hpiLO-> sr
```

```
SYSREV
```

Revisions	Active	Pending	Bay 5	Bay 6
iLO FW	: 01.41.01		01.41.01	01.41.01
System FW	: 01.80		01.80	01.80
MHW FPGA	: 02.00		02.00	02.00
Power Mon FW	: 03.04		03.04	03.04
Front Panel HW	: 04.00		04.00	04.00
PRS HW	: 02.07		02.07	02.07
IOH HW	: 02.02		02.02	02.02

4. Compare the first four Revisions lines with the version information listed in the release notes at <http://www.hpe.com> for the current server blade, HP Smart Update Manager firmware bundle. If any of the firmware revisions are less than those in the release notes, then the server firmware must be updated.

## OA

Use one of the following methods to determine the current OA firmware version:

- **OA GUI** — Connect to the OA GUI, expand the **Active Onboard Administrator** section of the left sidebar menu, and select **Firmware Update**. The Firmware Version is listed under **Firmware Information**.

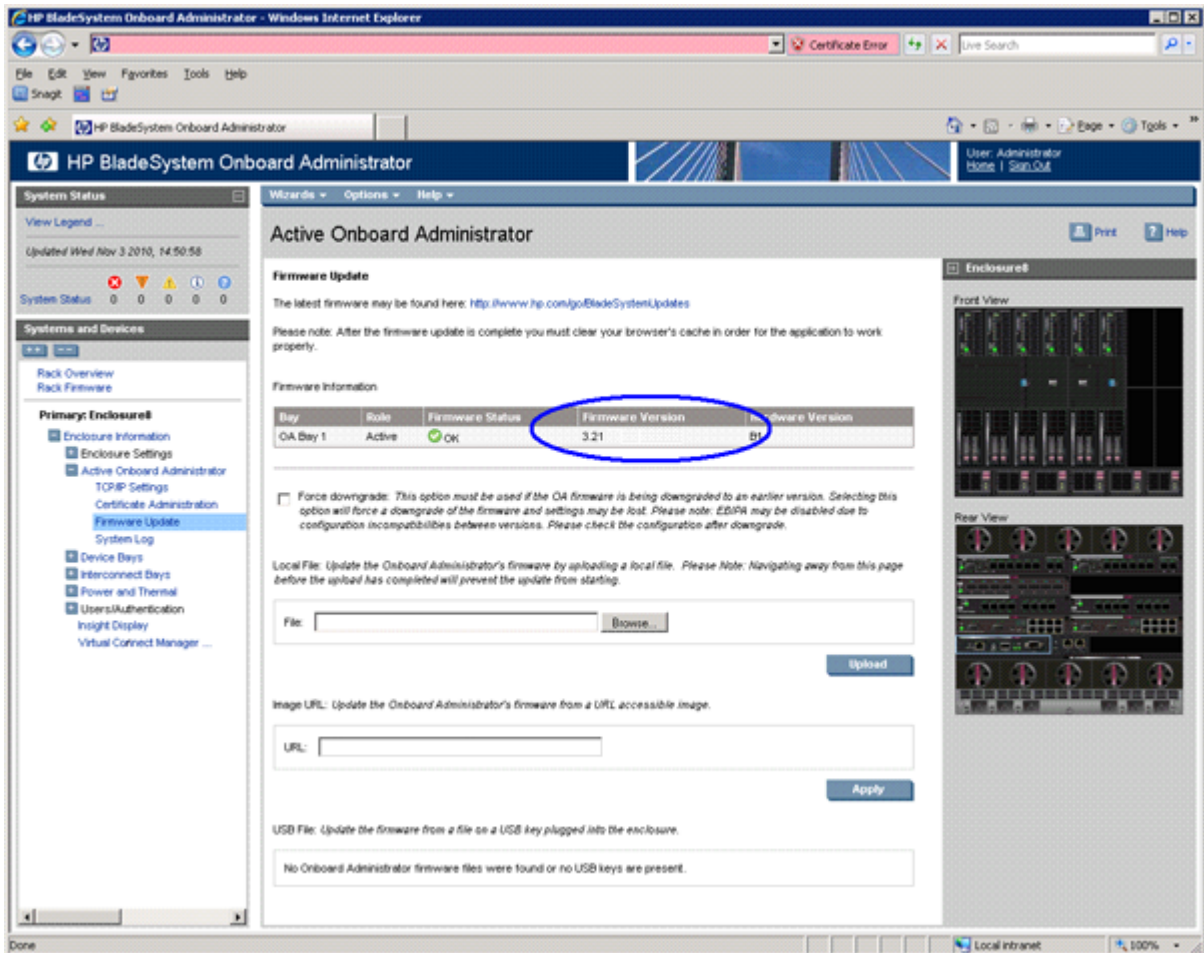

- **OA CLI** — Log in to the OA CLI through the serial console port or LAN and enter `show oa info` at the command prompt.

```
OA8> show oa info
```

```
Onboard Administrator #1 information:
Product Name   : BladeSystem c7000 Onboard Administrator with KVM
Part Number    : 456204-B21
Spare Part No. : 503826-001
Serial Number  : OB12BP7320
UUID           : 090B12BP7320
Manufacturer   : HP
Firmware Ver.  : 3.60 Jun 11 2012
Hw Board Type  : 0
Hw Version     : B1
```

## VCM

Use one of the following methods to determine the current VCM firmware version:

**OA GUI** — Select the **Interconnect Bay 1** device and then select the **Information** tab. Under **Information** there is a Firmware Version line which indicates the current VC FW version installed on the primary VC interconnect module.

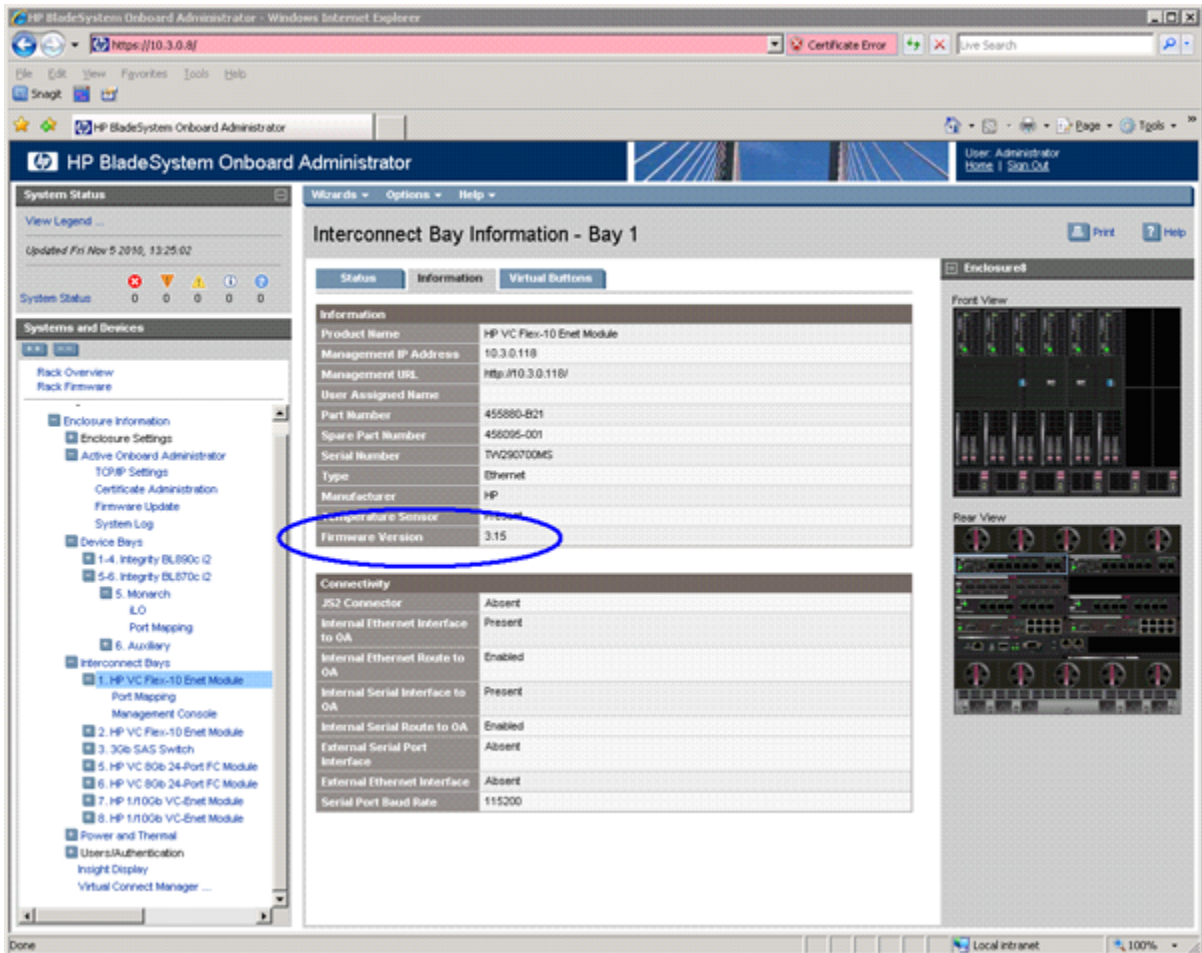

**VC Support Utility** — Launch VC Support Utility – Interactive and enter version.

```

-----
HP BladeSystem c-Class Virtual Connect Support Utility
Version 1.7.0 (Build 95)
Build Date: Oct 13 2010 07:03:49
Copyright (C) 2007-2010 Hewlett-Packard Development Company, L.P.
All Rights Reserved
-----

Please enter action ("help" for list): version
Please enter Onboard Administrator IP Address: 10.3.0.8
Please enter Onboard Administrator Username: Administrator
Please enter Onboard Administrator Password: *****
The target configuration is integrated into a Virtual Connect Domain. Please
enter the Virtual Connect Domain administrative user credentials to continue.
User Name: Administrator
Password: *****

=====
Enclosure   Bay   Module                                     Version
-----
USE827CYVC  1     HP VC Flex-10 Enet Module 3.15 2010-10-09T07:18:16Z
-----
USE827CYVC  2     HP VC Flex-10 Enet Module 3.15 2010-10-09T07:18:16Z
-----
USE827CYVC  3     3Gb SAS Switch
-----
USE827CYVC  4     Module not present       Not available
-----

```

```

USE827CYVC  5      HP VC 8Gb 24-Port FC      1.03 v6.1.0_49
              Module
-----
USE827CYVC  6      HP VC 8Gb 24-Port FC      1.03 v6.1.0_49
              Module
-----
USE827CYVC  7      HP 1/10Gb VC-Enet Module  3.15 2010-10-09T07:18:16Z
-----
USE827CYVC  8      HP 1/10Gb VC-Enet Module  3.15 2010-10-09T07:18:16Z
-----

Total execution time: 00:01:31
Press Return/Enter to exit...

```

## Rules for server blade internal components

You may need to remove or redistribute internal components across server blades to complete the upgrade. The following sections cover some key facts regarding internal components in upgraded servers and directs the reader to locations for additional information.

### Processor loading and matching rules

There are two processor sockets on each blade: socket 0 and socket 1. Socket 0 of each blade in the server must be filled. Any additional processors must be loaded in socket 1 of the blade in the lowest numbered enclosure bay which has an empty socket 1.

Every processor must be of the same type and must have the following:

- The same core count.
- The same core frequency.
- The same cache size.

This can be checked using the following methods:

- Examine the part number marked on each processor and each blade to make sure they are the same on each component.
- Examine the core count, core frequency, and cache size of each processor to ensure that every processor in the upgrade is the same. This can be done by logging into the Monarch iLO 3 MP, choosing the Command Menu, then entering `df` to display FRU information. Each processor of each blade (by enclosure bay number) can be chosen individually and the information displayed will include the information needed for comparison.

For more information, see **Processor and heatsink module** on page 45, and **CPU and heatsink module** on page 129.

### DIMM matching and loading rules

The rules regarding DIMM load order change, especially when upgrading from a BL860c i4 to either a BL870c i4 or BL890c i4. For more information on DIMM loading rules, see **DIMM quad load order rules**.

---

#### NOTE:

Memory loading rules apply across all blades in a sever depending on the server type (BL870c i4 or BL890c i4) regardless of nPartition configuration.

---

There are also minimum system memory and performance guidelines must be followed. See the *Memory subsystem information for HPE Integrity Server Blades (BL860c i4, BL870c i4, and BL890c i4) Technical White Paper* ([http://www.hpe.com/support/Integrity\\_i2\\_Blades\\_System\\_Errata](http://www.hpe.com/support/Integrity_i2_Blades_System_Errata)).

## Optional mezzanine cards

The HPE NC532m Dual Port 10GbE BL-c Adapter is restricted to two cards per blade on a BL890c i4. There are no additional rules regarding the number of cards installed or the order of their installation across the blades in an upgraded server blade. Ensure all mezzanine cards follow the mezzanine port to interconnect module mapping detailed in [Installing interconnect modules](#) on page 21.

## Upgrading the original server

### Existing server blade check



#### IMPORTANT:

Do not remove Blade Links or other components at this time.

#### Procedure

1. If not already booted, verify that the designated Monarch Server (in each partition) is able to boot its OS. For information on launching the OS from the UEFI shell, refer to [UEFI Front Page](#) on page 32.
2. If the Monarch Server is a HP Virtual Machines (VM) host with active guests or a Virtual Services Platform (VSP) with active Virtual Partitions (vPars), then either stop those guests or vPars now or migrate them to a temporary host server. Refer to the HP Integrity VM or vPar Administrator Guides regarding migration.
3. Backup any important OS data on the Monarch Server and any existing servers, as needed.
4. If the Monarch Server employs Virtual Connect and a partition will grow in size in the upgrade, then you may wish to use the Portable Image tool to assist with the upgrade. Refer to [Preserving VC-assigned MAC addresses in HP-UX by enabling Portable Image](#) on page 85 and if you choose to use PI, then execute the steps under “Pre-Upgrade Procedure for PI” in that section now.
5. Boot each partition of the Monarch Server, and every other existing blade server to be combined in the upgrade, to the UEFI shell and make sure no problems are seen.
6. Any existing secondary nPartition (that is, any partition which does not include the server Monarch blade, those designated as 'B', 'C', or 'D' partitions) which will be carried over into the upgraded server as secondary nPartitions, must have their UEFI variables backed up now so they can be restored later. See the *nPar Administrator Users Guide for BL870c i4 & BL890c i4* for instructions on how to do this. The primary nPartition in the Monarch Server (the partition which includes the server Monarch blade, the one designated as 'A') will not lose UEFI variable data.
7. Shutdown each existing blade server which will be combined into the upgraded server. See [Powering off the server blade](#) on page 25.
8. If the enclosure uses Virtual Connect, then unassign any VC server profiles assigned to enclosure bays occupied by existing servers and any other enclosure bays which will be occupied by the upgraded server. See the *HPE Virtual Connect for c-Class BladeSystem User Guide* for more information on VCM server profiles
9. If this system is managed using HPE Systems Insight Manager (HPE SIM), then it's recommended that all nodes associated with the original servers be deleted now. This would include the BLDomain node, if present. Rediscovery to incorporate the upgraded server will be executed after the upgrade has been completed.

## Adding resources

### Procedure

1. If not already in place, put the Monarch Server into its enclosure bay location for the upgrade. The Monarch blade of this server must be in the Monarch blade position of the upgraded server.
2. Place any other existing servers and Upgrade Blades to be combined in the upgrade into enclosure bays adjacent to the Monarch Server.

**!** **IMPORTANT:**

Existing servers other than the Monarch Server and also any Upgrade Blades must be placed into enclosure bays with higher numbers than those occupied by the Monarch Server.

3. Transfer the Monarch Server label carrier card to the Upgrade Blade Link:
  - a. Remove the label carrier card from behind the trap door of the Monarch Server Blade Link. See **Blade Link** on page 136 for the trap door location. The label carrier card will look like the image below:

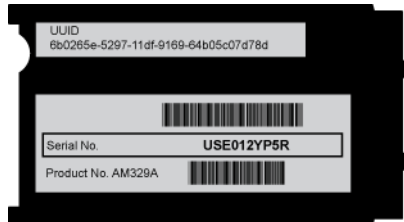

- b. Remove the product number portion of the Field Upgrade Only label on the Upgrade Blade Link. This label will look similar to the image below:



Below is an example showing upgrade Blade Link sticker locations for the BL870c i4.

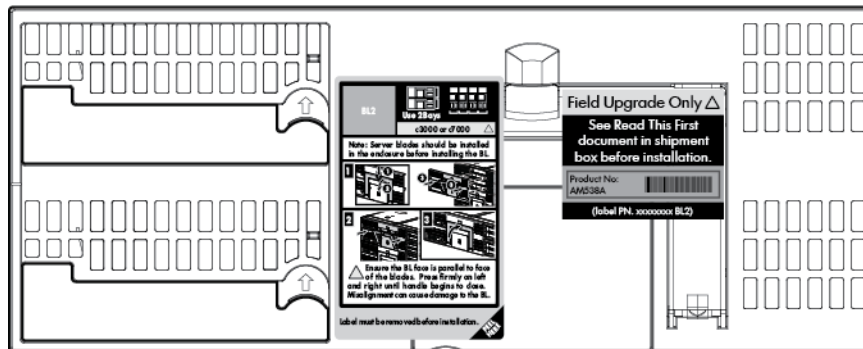

- c. Place the product number portion from the Field Upgrade Only label on top of the old product number and barcode on the label carrier card from the Monarch Server.

---

**!** **IMPORTANT:**

Do not cover the serial number on the label carrier card.

---

- d. Remove the position information label (the left hand label in the above picture) from the front of the upgrade Blade Link bezel.  
Temporarily remove the “Field Upgrade Only” label if it blocks the Blade Link trap door.
- e. Place the label carrier card behind the trap door of the Upgrade Blade Link, but do not install the Upgrade Blade link at this time.
- f. Reapply the “Field Upgrade Only” label to the upgrade Blade Link, making sure not to cover the Blade Link handle.

4. Remove the Blade Links from the existing servers that will be included in the upgrade (**Blade Link for BL870c i4 or BL890c i4 configurations** on page 119).

---

**!** **IMPORTANT:**

Mark the Monarch Server Blade Link and keep track of it until the upgrade is successfully completed. Do not reuse the old Blade Links after the upgrade has been completed.

---

5. Make any necessary blade internal component changes. The following hardware components have loading rules that can change after upgrading:
  - processors
  - DIMMs
  - optional mezzanine cards
  - ICH mezzanine boards

See **Rules for server blade internal components** on page 68 for more information.

6. Fully insert any unseated blades into the enclosure. Make sure all server blades that will be included in the upgraded server are now fully seated into the enclosure with no Blade Links installed.
7. Install the upgrade Blade Link by completing steps 1 through 11 in **Installing the Blade Link for BL860c i4, BL870c i4 or BL890c i4 configurations** on page 26.
8. Wait a couple of minutes for the blades to conjoin and then enter the `show server list` command at the Onboard Administrator command line interface. The output should show a status of “OK” for each blade in the upgraded server, or “OTHER” if there’s a current VC domain defined on the enclosure. The Monarch blade should have an iLO 3 IP address assigned.
9. Log into the iLO 3 MP interface and enter the `cm` command at the Main Menu to reach the Command Menu prompt.

```

MP MAIN MENU:

CO: Console
UFP: Virtual Front Panel
CM: Command Menu
CL: Console Log
SL: Show Event Logs
HE: Main Help Menu
X: Exit Connection

[ilo80c16e98772e]</> hpiLO-> cm

      <Use Ctrl-B to return to MP main menu.>

[ilo80c16e98772e] CM:hpiLO-> _

```

- Enter the `sr` command to view the system revision information. A sample output for a BL890c i4 is shown below. The BL890c i4 will show four blades composing the server blade, a BL870c i4 will show two. If the output does not show all of the blades expected, then there is a problem which must be resolved before proceeding. Reseating the Blade Link or individual blades may correct server blade conjoining problems.

```

[ilo002264fed1da] CM:hpiLO-> sr
SYSREV

```

Revisions	Active	Pending	Bay 5	Bay 6	Bay 7	Bay 8
iLO FW	: 01.30.30		01.30.30	01.30.30	01.30.30	
01.30.30						
System FW	: 01.24		01.24	01.24	01.24	01.24
MHW FPGA	: 01.14		01.14	01.14	01.14	01.14
Power Mon FW	: 03.04		03.04	03.04	03.04	03.04
Front Panel HW	: 03.00		03.00	03.00	03.00	03.00
PRS HW	: 02.07		02.07	02.07	02.07	02.07
IOH HW	: 02.02		02.02	02.02	02.02	02.02

**NOTE:**

This is just an example so actual version numbers may be different from what is shown.

- If the `sr` output indicates that the firmware is not consistent across all of the blades, which should only be due to a new Upgrade Blade with different firmware version being added, then complete a second server firmware update. Update the system to the same firmware version used previously for the existing servers. An example of `sr` output indicating a firmware inconsistency is shown below.

```

[ilo002264fee2de] CM:hpiLO-> sr
SYSREV

```

Revisions	Active	Pending	Bay 5	Bay 6	Bay 7	Bay 8
iLO FW	: --.---!		01.30.29	01.30.29	01.01.02	
01.01.02						
System FW	: --.---!		01.24	01.24	01.08	01.08



MHW FPGA	: --.--!	01.14	01.14	01.12	01.12
Power Mon FW	: 03.04	03.04	03.04	03.04	03.04
Front Panel HW	: 03.00	03.00	03.00	03.00	03.00
PRS HW	: 02.07	02.07	02.07	02.07	02.07
IOH HW	: 02.02	02.02	02.02	02.02	02.02

Note(s):  
! = FW mismatch, update needed

**NOTE:**

This is just an example so actual version numbers may be different from what is shown.

If an update is required, it may need to be completed using the HP SUM Force Install option for both the iLO 3 and system firmware bundles. HP SUM should detect the mismatch and set the Force Install option by default. When finished, log back into the iLO 3 MP of the Monarch blade and enter `sr` from the Command Menu to verify that the firmware levels on all conjoined blades are now consistent and up to date.

12. Exchange the System Information Parameters by following the steps below. For more information regarding the information contained in the System Information Parameters, see **Blade link and system information parameters** on page 78.

- a. Log into the Monarch iLO 3 MP, enter the Command Menu, and execute the command `sysset`. This will list the system information parameters stored in the Upgrade Blade Link (primary) and those stored on the server blade (secondary). Below is an example of the output when upgrading from a BL860c i4 to a BL870c i4.

```
[ilo002264feelbe] CM:hpiLO-> sysset
SYSSET
Current System Information Parameters:
Manufacturer           : HP
Product Name (prodname) : Integrity BL870c i2
Secondary Product Name  : Integrity BL860c i2
Product Number (prodnum) : AM358A
Secondary Product Number : AD399A
Serial number (serial)   : Uninitialized
Secondary Serial Number  : USA0003
UUID (uuid)             : FFFFFFFF-FFFF-FFFF-FFFF-FFFFFFFFFFFFFF
Secondary UUID           : 89742B3C-AD78-11DF-BB2A-5ABBD7A51B74
Product ID              : 0x702

An Upgrade Blade Link has been detected.
Primary and secondary system parameters values do not match.
Copy secondary UUID and serial number to primary? (Y/[N]):
```

The product name and product number from the Upgrade Blade Link reflect a BL870c i4, while the Secondary product name and number (from the Monarch Server) reflect the original BL860c i4.

- b. The system detects the Upgrade Blade Link and prompts you to make the required system information exchanges between Upgrade Blade Link and the server. Enter `y` to approve the exchange. You will then be informed that a reset of the iLO 3 MP is necessary for the changes to take effect.

```
Copy secondary UUID and serial number to primary? (Y/[N]): y
-> Secondary system parameters values have been copied to primary
system parameters.
```

```
->System Information parameters have been updated.
```

```
iLO MP needs to be reset in order for these changes to take effect
```

- c. Reset the iLO 3 MP by entering `xd -r -nc` at the Command Menu prompt.

```
[ilo002264feelbe] CM:hpiLO-> xd -r -nc
```

```
XD -r -nc
```

```
-> MP reset requested
```

```
MP is now being reset...
```

```
-> Command successful.
```

- d. After the iLO 3 MP reset (less than one minute), log back into the iLO 3 MP, go to the Command Menu, and enter `sysset` again to verify that the system information parameters have been set for correctly for both Primary and Secondary. The values between Primary and Secondary should now match.

```
[ilo002264feelbe] CM:hpiLO-> sysset
```

```
SYSSET
```

```
Current System Information Parameters:
```

```
Manufacturer           : HP
Product Name (prodname) : Integrity BL860c i4
Secondary Product Name  : Integrity BL860c i4
Product Number (prodnum) : AM377A
Secondary Product Number : AM377A
Serial number (serial)   : SGH2101LRY
Secondary serial number  : SGH2101LRY
UUID (uuid)             : 59F30FC7-8A4A-11E1-AF3F-DC6163A31240
Secondary UUID          : 59F30FC7-8A4A-11E1-AF3F-DC6163A31240
Product ID              : 0x711
```

13. Remove the Field Upgrade Only sticker from the bezel of the Upgrade Blade Link. This is no longer a Field Upgrade Blade Link because the Serial Number and UUID have now been programmed on the Blade Link.
14. As mentioned earlier, the nPartition configuration of the upgraded server defaults to a single partition. An example of what might be seen entering the `npar` command from the iLO 3 MP Command Menu is shown below for an upgrade to a BL890c i4.

```
[ilo80c16e9877f4] CM:hpiLO-> npar
```

```
NPAR
```

```
Current nPartition Configuration:
```

Bay	1	2	3	4
nPartition	A	A	A	A
Domain MP	yes	-	-	-
Power Off	yes	-	-	-
nPartition Unlocked	-	-	-	-

```
nPartition Menu:
```

```
Current -> AAAA - One 4-Blade System (default)
          AACC - Two 2-Blade nPartitions
          AACD - One 2-Blade nPartition, and Two 1-Blade nPartitions
```

```
ABCC - Two 1-Blade nPartitions, and One 2-Blade nPartition
ABCD - Four 1-Blade nPartitions
```

```
Enter new value, or [Q] to Quit:
```

15. When a blade is changed from one nPartition to another, the system variable and configuration information is cleared. This provides a convenient method for ensuring that all Auxiliary blades in the upgraded server are cleared of stale or inconsistent information. Set the nPartition configuration to the highest number of partitions possible for the upgraded server. For a BL870c i4 that will be two (AB) while for a BL890c i4 that will be four (ABCD). The iLO 3 MP will automatically reset for the change to take effect. An example output is shown below for a BL890c i4. Note that since the Monarch blade never changes partitions (it always remains in the 'A' partition), that blade will not have its system environment variables cleared.

```
[ilo80c16e9877f4] CM:hpiLO-> npar -config abcd -nc
NPAR -config abcd -nc
New nPartition Configuration (* marks modified systems):
  Bay                1          2          3          4
  -----
nPartition           :   * A      * B      * C      * D
-> nPartition Configuration has been updated.
-> iLO will now reset on all modified systems...
Note: System environment variables may be cleared on all modified
systems
for the nPartition configuration to take effect. This configuration
change
may take several minutes to appear on other manageability user
interfaces.
-> iLO reset succeeded.
-> Command successful.
[ilo80c16e9877f4] CM:hpiLO->
```

16. Wait a minute or so then log back into the iLO 3 MP and use the npar command from the Command Menu to set the nPartition configuration required for the upgraded server. If no nPartitioning is required, then set the configuration back to a single, domain-wide partition. See the *nPar Administrator Users Guide for BL870c i4 & BL890c i4* for information on configuring nPartitions. Below is an example of the output which could be seen setting a BL890c i4 back to a single nPartition.

```
[ilo80c16e9877f4] CM:hpiLO-> npar -config aaaa -nc
NPAR -config aaaa -nc
New nPartition Configuration (* marks modified systems):
  Bay                1          2          3          4
  -----
nPartition           :   * A      * A      * A      * A
-> nPartition Configuration has been updated.
-> iLO will now reset on all modified systems...
Note: System environment variables may be cleared on all modified
```

```
systems
  for the nPartition configuration to take effect. This configuration
change
  may take several minutes to appear on other manageability user
interfaces.

-> iLO reset succeeded.

-> Command successful.

[iilo80c16e9877f4] CM:hpiLO->
```

---

**NOTE:**

nPartitions allows some flexibility in timing the incorporation of new blade resources which allows the original Monarch Server to be brought back up quickly after the upgrade. This is referred to as "Quick Boot." See **The Quick Boot option** on page 79 and the *HPE Integrity server blade upgrade kits* whitepaper for more information about this option.

---

17. After a minute or so log back into the iLO 3 MP and enter `npar -nc` from the Command Menu to verify that the nPar configuration is now correct.
18. If the enclosure uses Virtual Connect, then the VCM server profiles for the partitions of the upgraded server should be assigned now. The Monarch Server VCM server profile should be assigned to the partition which includes the Monarch blade. Profiles which were previously assigned to existing servers may need some modifications after being assigned to the upgrade so that network assignments and other elements of the VC server profile match what is required. See **Possible changes due to VC profile mapping on the upgraded blade server** on page 80 for more information. If the HP-UX Portable Image tool is used (see **Preserving VC-assigned MAC addresses in HP-UX by enabling Portable Image** on page 85), then it's best not to make changes until after the entire upgrade is completed and any changes then should be made very carefully. Once assigned, verify that there are no errors indicated by VCM or by the OA. Any VCM Domain Status or OA System Status alerts or warnings should be resolved before proceeding. Sometimes, VCM problems can be corrected by unassigning then reassigning the VC server profile.

## Final hardware check

### Procedure

1. Log into the Monarch iLO 3 MP of each partition in the upgraded server and power on each partition by entering `pc -on` at the Command Menu prompt. Let each partition boot to the UEFI shell. Do not autoboot any currently installed Operating Systems.
  2. If UEFI variables need to be restored on secondary partitions, then take care of that now and reboot the partition to the UEFI shell. See the *nPar Administrator Users Guide for BL870c i4 & BL890c i4* for information on restoring the system environment variables.
  3. If there are any embedded I/O device or mezzanine card I/O FW updates needed, then take care of those now.
  4. If necessary, switch the onboard SmartArray SAS controller on new upgrade blades to RAID mode (**Configuring a Smart Array Controller** on page 141).
- 

**NOTE:**

All new Upgrade Blades come with the onboard SmartArray SAS controller in HBA mode.

---

5. Complete the following checks to be sure that the upgraded server blade is functioning properly. Any problems found in the steps immediately below should be resolved before proceeding.

- a. Check the iLO 3 MP SEL for any problems. See **Errors and error logs** on page 108 for more information on resolving any errors.

---

**!** **IMPORTANT:**

If any errors are found in the SEL, do not continue until resolving them.

---

- b. Execute the UEFI shell command `lanaddress` and verify that the expected number of LAN ports are shown and that there is a link indication for every port that is connected to a network or network switch.

---

**NOTE:**

You should see an `M` on each applicable line.

---

- c. Execute the UEFI shell command `map -r` to make sure that all of the expected disks are mapped.
  - d. Execute the UEFI shell command `cpuconfig` to make sure that all of the expected processors are there, indicate active, and that CPU threads are set as expected.
  - e. Execute the UEFI shell command `info mem -dimms` to make sure that all of the expected DIMMs are there and indicate active with the correct memory interleave setting.
6. If the upgraded server is to be incorporated into HPE SIM, and HPE SIM has not yet discovered the upgraded server, then execute rediscovery of the enclosure from SIM now. Ensure that the upgraded server is correctly incorporated and complete any configuration steps necessary.

## Booting the operating system

The server blade has now been physically upgraded and it may be ready to boot to the OS. Certain upgrade scenarios require OS reinstallation:

### Procedure

1. Boot the OS. See **Operating system procedures** on page 36 for more information.

---

**!** **IMPORTANT:**

A new Operating System license may be required for the upgraded server. See **Operating System Licenses** on page 79 for more information.

---

2. If the HP-UX Portable Image tool was used, execute the steps under “Post-Upgrade Procedure for PI” in the **Preserving VC-assigned MAC addresses in HP-UX by enabling Portable Image** on page 85 section.
3. Verify that the system, especially networking and storage, function as expected. If anything must be adjusted, then make those adjustments now.
4. If the Monarch Server is an HPVM host server or a Virtual Services Platform (VSP), then the VM guests or vPars can now be migrated back or started if they were stopped. Refer to the HP Integrity VM or vPar Administrator Guides document for information regarding guest and vPar migration. Test each VM guest or vPar to make sure each is functioning properly.
5. The upgrade has been completed. New resources can now be configured and used as needed.

## Warranty registration

After completing the upgrade, contact Hewlett Packard Enterprise with the server serial number and new product number. The warranty of the designated Monarch Server will be transferred to the upgraded server blade and the service time will be reset. Proof of purchase must be provided and the Hewlett Packard Enterprise warranty organization must be notified.

The proof of purchase should be a scanned copy or fax of a sales receipt or invoice from Hewlett Packard Enterprise or an authorized reseller. It can also be an order confirmation, shipping receipt, or reseller based purchase/shipping confirmation that contains the following:

- The purchase or shipping date.
- The Monarch Server Product Number or Product Name/product description.
- The Serial Number, but it is not required (some invoices do not have serial numbers).
- The vendor's name (the name of the business where the unit was purchased).

---

### ❗ IMPORTANT:

Be sure that all information is clearly readable.

---

More information regarding server blade warranties can be found at: <http://www.hpe.com/info/Blades-docs>.

## Support

A support Flex Care Pack with at least the same level of care as the server blade to be upgraded (the Monarch Server) should have been purchased when the Upgrade Kit was ordered. Your Hewlett Packard Enterprise sales representative will apply the support package to the upgraded server blade and provide credit for the unused portion of the package purchased for the original Monarch Server. The new Flex Care Pack must be registered with the serial number of the original Monarch Server (now attached to the upgraded server) included to ensure support entitlement. For more information, go to <http://cpc.hpe.com/>. You can also contact your Hewlett Packard Enterprise sales representative or contact Hewlett Packard Enterprise sales through the following link: <http://www.hpe.com/contact>.

## Blade link and system information parameters

Every BL860c i4, BL870c i4 and BL890c i4 server blade has a set of information called the System Information Parameters which helps to identify the server blade and is used for certain applications and for the server blade warranty. This information includes:

- product name
- product number
- UUID
- serial number

The System Information Parameters are stored in nonvolatile memory onboard the Blade Link and server blades. The System Information Parameters can be viewed from the iLO 3 MP interface Command Menu prompt by entering `sysset`.

```
[ilo002264fed1da] CM:hpiLO-> sysset  
  
SYSSET  
Current System Information Parameters:  
Manufacturer           : HP
```

```
product name (prodname) : Integrity BL860c i4
Secondary Product Name  : Integrity BL860c i4
Product Number (prodnum) : AM377A
Secondary Product Number : AM377A
Serial number (serial)   : SGH2101LRY
Secondary serial number  : SGH2101LRY
UUID (uuid)             : 59F30FC7-8A4A-11E1-AF3F-DC6163A31240
Secondary UUID          : 59F30FC7-8A4A-11E1-AF3F-DC6163A31240
Product ID              : 0x711
```

There are two sets of parameters shown:

- Primary values are stored on the Blade Link.
- Secondary values are those stored on the server blades.

When an existing blade server is upgraded, the system must retain the existing UUID and Serial Number, but the Product Name and Product Number will need to be changed to reflect the upgraded server type. The Upgrade Blade Link will come already installed with a Product Name and Number which reflects the upgrade configuration. This information will need to be copied to the server blades, and the UUID and Serial Number of the server blades will need to be copied to the Upgrade Blade Link. This exchange of System Information Parameters is executed by firmware but it's started by the user entering the `sysset` command.

The server UUID, serial number, and product number are printed on the label carrier card behind the Blade Link trapdoor which is described in **Blade Link** on page 136. The Upgrade Blade Link does not ship with a label carrier card, but has a trap door for one. It also has a Field Upgrade Only label on the front bezel which contains a peel-off sticker with the new Product Number.

## Operating System Licenses

HP-UX requires a License to Use (LTU) for each processor (socket) installed in a server and HP-UX uses tiered licensing levels based on the maximum processor socket count of the server it runs on. The tier level will rise when the upgraded server contains more sockets than the original Monarch Server. The “tiers” map to the blade servers as follows:

- BL860c i4 – 2 Socket Tier
- BL870c i4 – 4 Socket Tier
- BL890c i4 – 8 Socket Tier

LTUs must be purchased for each processor (socket) installed in the upgraded server at the tier level of the upgraded server type for the installed HP-UX OE. Your Hewlett Packard Enterprise sales representative must be contacted to get these new licenses. Full credit will be received when the original Monarch Server licenses are surrendered. The credit will reflect the current purchase price of the original licenses, not the original purchase price.

For more information contact your Hewlett Packard Enterprise sales representative. Hewlett Packard Enterprise sales can also be contacted at <http://www.hpe.com/contact>.

The HP-UX license is delivered physically or electronically by certificate. To contact your Hewlett Packard Enterprise sales representative for more information about software licensing agreements, go to <http://www.hpe.com/contact>.

## The Quick Boot option

The ability to scale up a blade server by adding more blade level resources is inherent to the BL8x0c architecture. This ability to scale up when needed provides flexibility and control over capital expenditures for your compute environment. The introduction of nPartition capability in the BL8x0c i4 blade server adds

another level of flexibility. New blade resources can be added to a blade server and then the original server can be quickly booted within its own partition with new resources allocated to a separate partition. The new resources can be configured and used separately or they can be added to the original server partition as time allows or need requires. This provides flexibility in managing system downtime.

For example, a BL870c i4 original server can be upgraded to a BL890c i4 by adding two Upgrade Blades. Let's say that the down-time of the BL870c i4 needs to be minimized with the new blade resources intended for a separate partition or to be incorporated into the original server at a later time. The BL870c i4 can be brought down, physically upgraded by the addition of two Upgrade Blades and Upgrade Blade Link, and then partitioned in such a way that the two blades of the original server are placed into an AA partition while the two new blades are placed into a CC partition. This is shown in the figure below.

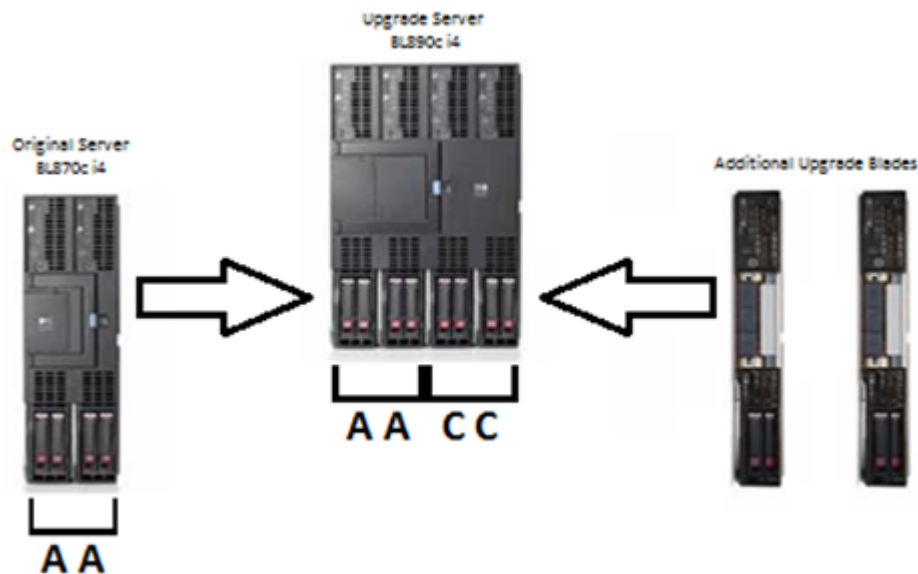

The original server blades in the AA partition can be rebooted immediately functioning just as they did before the upgrade. With the AA partition up and running, the new resources in the CC partition can be configured as an independent server partition without impact to the AA partition. Or the new blade resources can be incorporated into the AA partition at a later date when the need arises or time allows for it.

## Possible changes due to VC profile mapping on the upgraded blade server

Virtual Connect Manager supports assigning a VC server profile to each bladed server. Profiles can include VC-assigned:

- UUID
- serial number
- Ethernet port MAC addresses with network assignments
- FC HBA connection WWNs with FC SAN assignments.
- FCoE connection WWNs with FC SAN assignments

The VC-assigned MAC addresses, FC WWNs, FCoE WWNs, UUID and Serial Number can come from blocks of values supplied by VCM or from user-defined blocks of values. Alternatively, the factory-assigned default values for all of these can be used. The following information pertains to all of these options.

When performing an upgrade it is critical to understand how the server profile connection entries will be mapped to ports on the upgraded server as this may impact the OS. What happens for each of the three I/O assignment categories (Ethernet network assignments, FCoE SAN assignments, and FC SAN



assignments) is different for each category so each is described separately below. Stated briefly, the list of network and SAN assignments in the original server profile can map differently to upgraded server ports due to the increased number of blades. The discussion which follows contains a lot of detail, but the best way to check for and fix any problems with the server profile applied to the upgraded server may be to open the profile in VCM after it's assigned, see how the connection entries mapped to the upgraded server, and make adjustments if necessary. The VC server profile should always be checked after being applied to the upgrade to make sure that profile connection entries are mapped to ports as expected and to make sure there are no profile errors or warnings which must be resolved. See the *HPE Virtual Connect for c-Class BladeSystem User Guide* for more information on VCM server profiles. The only caution is that if you use the PI tool (more on that follows), then you must let HP-UX boot with the profile untouched and disable PI before making changes to the profile.

## FC SAN connections

The FC SAN connection entries in the VCM server profile should map to the same ports whether assigned to the original or the upgraded server. VCM will map entries first to all ports on blade 1, then blade 2, etc. So no adjustments to the FC SAN entries in the profile should be necessary.

The FC SAN connection entries in a profile should be thought of as sets of entries. If there are N Virtual Connect FC Interconnect modules in an enclosure (where N is rounded up to an even number) then there are N FC SAN connection entries per set. The first N entries are mapped to the FC HBA ports on the Monarch blade, the second set of N entries are mapped to the FC HBA ports on the first Auxiliary blade, the next set of N entries to the next Auxiliary blade, until all of the FC connection entries have been mapped to ports or until there are no more FC HBA ports available to map entries to. Below are a few examples of upgrading a BL860c i4 to a BL870c i4 in an enclosure with four Virtual Connect FC Interconnect modules where the BL860c i4 becomes the Monarch blade in the upgraded server.

- If the profile assigned to the BL860c i4 server had four or fewer FC SAN connection entries then those entries are still mapped to the FC HBA ports on the original BL860c i4 blade (since it is the Monarch in the new server). There will be no FC SAN connection entries mapped to any ports on the Auxiliary blade in the upgraded server.
- If the profile assigned to the BL860c i4 server had more than four FC SAN connection entries then the first four entries are still mapped to the FC HBA ports on the original BL860c i4 blade (since it is the Monarch in the new server). The additional FC SAN connection entries (up to four), that had not been mapped to any ports prior to the upgrade, will be mapped to FC HBA ports on the Auxiliary blade in the upgraded server.

## FCoE SAN connections

The mapping of FCoE connection entries is much the same as the FC connection entry mapping, but with a small twist. Each blade in the BL8x0c i4 family can have up to four embedded FCoE ports active which would appear in the VCM server profile mapping as LOM:1-b, LOM:2-b, LOM:3-b, and LOM:4-b. VCM will map FCoE connection entries from a profile to the Monarch blade LOM1 and LOM2 first, then to any FCoE mezzanine cards on the Monarch. If there are still entries in the profile, they will be mapped to the first Auxiliary blade LOM1 and LOM2 followed by any FCoE mezzanine card ports on that blade. After all blades have had connection entries mapped to LOM1, LOM2, and the FCoE mezzanine cards, if there are still entries left in the profile, they will be mapped to the Monarch blade LOM3 and LOM4, then to the first Auxiliary blade LOM3 and LOM4, and etc. until all FCoE connection entries have been mapped or the ports in the server have been exhausted. The twist, then, is only in the mapping of FCoE connection entries to LOM3 and LOM4 ports. If a profile assigned to the original server has no connection entries mapped to LOM3 and LOM4, then the FCoE entries will remain mapped to the same ports on the same blades after the upgrade. However, if there are FCoE connection entries mapped to LOM3 and LOM4 then those entries will get mapped to LOM1 and LOM2 ports on the new blades in the upgraded server.

Below is an example upgrading a BL860c i4 to a BL870c i4 where VC-assigned WWNs are used and the VCM server profile contains five FCoE connection entries. Notice that the first four entries map to the same ports on both the original and the upgraded server, but the fifth entry, mapped to LOM3 on the original server, is mapped to LOM1 of the Auxiliary blade in the upgrade.

Profile entry	Assigned SAN	VCM assigned WWN	Mapping to BL860c i4 ports	Mapping to BL870c i4 ports
1	SAN-1	50:06:0B: 00:00:C3:26:10	Monarch LOM:1-b	Monarch LOM:1-b
2	SAN-2	50:06:0B: 00:00:C3:26:12	Monarch LOM:2-b	Monarch LOM:2-b
3	SAN-3	50:06:0B: 00:00:C3:26:14	Monarch MEZZ1:1	Monarch MEZZ1:1
4	SAN-4	50:06:0B: 00:00:C3:26:16	Monarch MEZZ1:2	Monarch MEZZ1:2
5	SAN-5	50:06:0B: 00:00:C3:26:18	Monarch LOM:3-b	Auxiliary LOM:1-b

The WWN is assigned in this example by VCM (as opposed to using HW default WWNs) so the WWN does not change, but the HW path as seen by HP-UX is different so this would be seen as a new device. If the OS boot disk were attached on SAN-5, then the boot path in UEFI Boot Manager would no longer be valid. If it's okay that the HW path has changed, then HP-UX could be configured to use the new HW path and a new HP-UX boot path entry could be made in UEFI Boot Manager, if necessary. If the HW path must remain the same, then four connection entries can be added to the profile before assigning the profile to the upgraded server. This is shown below.

Profile entry	Assigned SAN	VCM assigned WWN	Mapping to BL870c i4 ports
1	SAN-1	50:06:0B: 00:00:C3:26:10	Monarch LOM:1-b
2	SAN-2	50:06:0B: 00:00:C3:26:12	Monarch LOM:2-b
3	SAN-3	50:06:0B: 00:00:C3:26:14	Monarch MEZZ1:1-b
4	SAN-4	50:06:0B: 00:00:C3:26:16	Monarch MEZZ1:2-b
5	unassigned	50:06:0B: 00:00:C3:26:18	Auxiliary LOM:1-b
6	unassigned	50:06:0B: 00:00:C3:26:1A	Auxiliary LOM:2-b
7	unassigned	50:06:0B: 00:00:C3:26:1C	Auxiliary MEZZ1:1-b

*Table Continued*

Profile entry	Assigned SAN	VCM assigned WWN	Mapping to BL870c i4 ports
8	unassigned	50:06:0B: 00:00:C3:26:1E	Auxiliary MEZZ1:2-b
9	SAN-5	50:06:0B: 00:00:C3:26:20	Monarch LOM:3-b

The Monarch blade LOM3 now has the correct SAN assignment so the HW path from the original server has been restored, but the WWN is changed so a change to the SAN infrastructure may be necessary so that the required storage devices associate with the new WWN. Also note that this enables FCoE on port 'b' of the Auxiliary blade LOM and MEZZ FlexFabric devices leaving only three ports on each device available for Ethernet connections. LOM3 and LOM4 belong to the same physical LOM device on the blade so because both 'b' ports on a LOM device must be configured with the same protocol, the Monarch LOM:4-b will be enabled as an FCoE port and not available as an Ethernet port since LOM:3-b has an FCoE entry mapped to it. The Auxiliary blade LOM3 and LOM4 'b' ports, however, remain available as Ethernet ports because neither of those ports have an FCoE connection entry mapped to them.

## Ethernet network connections

The Ethernet connection entries in a profile are handled differently from SAN entries in order to balance the use of Flex-10 ports (even if no Flex-10 ports are used, the same balanced approach is used). Virtual Connect manager distributes the Ethernet connection entries across all of the blades in a server, and on each blade it distributes connection entries across all of the Ethernet physical ports. This is done so that as few Flex-10 sub-ports are used as needed, which results in maximum band-width available to each Flex-10 sub-port. This distribution of Ethernet connection entries across all Ethernet ports is done for single-blade servers, too. The net result is that the mapping of Ethernet connection entries in a profile assigned to a server will likely change when that server is upgraded. Consider the following examples.

- If the upgrade is from a BL860c i4 to a BL870c i4 then every other Ethernet connection entry starting with the first entry (for example, the first, third, fifth, etc. entries) will be mapped to ports on the Monarch blade, and every other entry starting with the second entry (for example, the second, fourth, sixth, etc. entries) will be mapped to ports on the Auxiliary blade.
- If the upgrade is from a BL860c i4 to a BL890c i4, then every fourth Ethernet connection entry starting with the first entry (for example, the first, fifth, ninth, etc. entries) will be mapped to ports on the Monarch blade; every fourth entry starting with the second entry (for example, the second, sixth, tenth, etc. entries) will be mapped to the first Auxiliary blade; every fourth entry starting with the third entry (for example, the third, seventh, eleventh, etc. entries) will be mapped to the second Auxiliary blade; and finally every fourth entry starting with the fourth entry will be mapped to ports on the 3rd Auxiliary blade.

As an example, consider a profile with 8 Ethernet connection entries where each entry defines a connection to a different network (this makes it easy to see what happens when an upgrade is done). Assume that the profile is assigned to a BL860c i4 that is upgraded to a BL870c i4. Assume that VC Flex-10 Interconnect modules exist in bays 1 and 2, thus the FlexFabric LOM ports on the blades are utilized as Flex-10 ports. The following table shows how these entries are mapped to ports on the original server and to the blades in the upgraded server. The examples here assume that the LOM FlexFabric devices are not in FCoE mode. That is, there are no FCoE connection entries in the VCM server profile.

Profile entry	Assigned network	VCM assigned MAC address	Mapping to BL860c i4 ports	Mapping to BL870c i4 ports
1	LAN-1	00-17-A4-77-90-10	Monarch LOM1-a	Monarch LOM1-a
2	LAN-2	00-17-A4-77-90-12	Monarch LOM2-a	Auxiliary LOM1-a
3	LAN-3	00-17-A4-77-90-14	Monarch LOM3-a	Monarch LOM2-a
4	LAN-4	00-17-A4-77-90-16	Monarch LOM4-a	Auxiliary LOM2-a
5	LAN-5	00-17-A4-77-90-18	Monarch LOM1-b	Monarch LOM3-a
6	LAN-6	00-17-A4-77-90-1A	Monarch LOM2-b	Auxiliary LOM3-a
7	LAN-7	00-17-A4-77-90-1C	Monarch LOM3-b	Monarch LOM4-a
8	LAN-8	00-17-A4-77-90-1E	Monarch LOM4-b	Auxiliary LOM4-a

If it is important that each of the networks be mapped to the same ports on the Monarch blade after the upgrade, then the profile will need to be edited to add seven Ethernet connection entries, and then the entries must be edited to obtain the desired network connections aligned with the ports on the Monarch blade. The resulting set of Ethernet connection entries in the profile would be as follows.

Profile entry	Assigned network	VCM assigned MAC address	Mapping to BL870c i4 ports
1	LAN-1	00-17-A4-77-90-10	Monarch LOM1-a
2	unassigned	00-17-A4-77-90-12	Auxiliary LOM1-a
3	LAN-2	00-17-A4-77-90-14	Monarch LOM2-a
4	unassigned	00-17-A4-77-90-16	Auxiliary LOM2-a
5	LAN-3	00-17-A4-77-90-18	Monarch LOM3-a
6	unassigned	00-17-A4-77-90-1A	Auxiliary LOM3-a
7	LAN-4	00-17-A4-77-90-1C	Monarch LOM4-a
8	unassigned	00-17-A4-77-90-1E	Auxiliary LOM4-a
9	LAN-5	00-17-A4-77-90-20	Monarch LOM1-b
10	unassigned	00-17-A4-77-90-22	Auxiliary LOM1-b
11	LAN-6	00-17-A4-77-90-24	Monarch LOM2-b
12	unassigned	00-17-A4-77-90-26	Auxiliary LOM2-b
13	LAN-7	00-17-A4-77-90-28	Monarch LOM3-b

*Table Continued*

Profile entry	Assigned network	VCM assigned MAC address	Mapping to BL870c i4 ports
14	unassigned	00-17-A4-77-90-2A	Auxiliary LOM3–b
15	LAN-8	00-17-A4-77-90-2C	Monarch LOM4–b

**NOTE:**

While the network mapping has been adjusted to preserve the original mapping of networks to ports, it is not possible to adjust the MAC address assignment to preserve the same mapping of MAC addresses to ports. If your OS is HP-UX, see the section **Preserving VC-assigned MAC addresses in HP-UX by enabling Portable Image** on page 85 for a method which can be used to preserve VC-assigned MAC addresses.

## Preserving VC-assigned MAC addresses in HP-UX by enabling Portable Image

If your OS is HP-UX where the VC server profile does not use the hardware default MAC addresses and it is important that Ethernet connections configured in the OS retain their VC-assigned MAC addresses, then there is a package called “Portable Image” (PI) which can be used. The HP-UX Portable Image product is installed and enabled on the blade server before the upgrade. After the upgrade, PI will automatically modify the HP-UX network instance numbers of the new hardware environment so that they match the pre-upgrade environment. This takes advantage of the VCM interconnect stacking links to allow all of the Monarch Server network connections to function correctly with no corrections needed in the original VC server profile.

If you choose to use PI to assist the upgrade, there will be a pre-upgrade step to follow on the designated Monarch Server and then another step to follow after the upgrade. These two steps are detailed below but they must not be executed until they’re explicitly called for in the upgrade procedure steps.

### Pre-Upgrade Procedure for PI

These instructions are to be executed on the designated Monarch Server with the OS booted.

1. You need to obtain the PI package if it’s not already installed.
  - a. Check for it being already installed by executing the following command:
 

```
swlist|grep HPPortableImage
```
  - b. If nothing is returned, then the package must be installed now. Go to <http://www.hpe.com/support/softwaredepot> and search for “Portable Image”. Follow the link for HP-UX Portable Image in the product list and follow the instructions there for installing the depot.
2. Clear out any old PI data by executing the following command: `/opt/network/bin/hpuxpitol -r all`
3. Enable PI by executing the following command: `/opt/network/bin/hpuxpitol -e`

You should see the following:

```
* Future operations will ask whether to update the backup.
  * The requested changes have been applied to the currently
    running configuration.
Tunable                               Value  Expression  Changes
gio_portable_image (before)         0      Default     Immed
                   (now)           1       1
```

4. The PI state must be saved before starting the upgrade. This is done by explicitly executing the PI save command:

```
/opt/network/bin/hpuxpitol -s
```

5. Dump the saved PI state to a text file for possible use later. Obtain the dump by executing the following command:

```
/opt/network/bin/hpuxpitol -g
```

This will list out each network instance along with its pre-upgrade MAC address.

6. Shutdown the OS using a `shutdown` command.

## Post-Upgrade Procedure for PI

1. Dump the new PI state to a file for possible use later. Obtain the dump by executing the following command:

```
/opt/network/bin/hpuxpitol -g
```

This will list out each network instance along with its post-upgrade MAC address.

2. Disable PI by executing the following command:

```
/opt/network/bin/hpuxpitol -d
```

You should see the following:

```
* Future operations will ask whether to update the backup.
  * The requested changes have been applied to the currently
    running configuration.
Tunable                               Value  Expression  Changes
gio_portable_image (before)         1      1           Immed
                    (now)           0      0
```

3. The networking should be checked to make sure that the original system network instances function correctly. If the HP-UX boot reports a LAN interface configuration failure, then check the `/etc/rc.log` file for the failed instance number which may indicate something like the following example:

```
ERROR:   lan18 interface: ifconfig: no such interface
"/sbin/rc2.d/S340net start" FAILED
```

Get the MAC address for the failed instance number from the pre-upgrade PI dump and look for that MAC address in the post-upgrade PI state dump. From that entry, note the new instance number and edit the HP-UX networking configuration for the failed instance number so that it uses the new instance number.

# Troubleshooting

## Cause

This chapter provides strategies, procedures, and tools for troubleshooting server blade error and fault conditions.

## Methodology

### General troubleshooting methodology

#### Procedure

1. Review the following list of symptoms:
  - a. Front Panel LED blinking
  - b. System messages on the OA
  - c. System Alert present on system console
  - d. Server blade will not power-up
  - e. Server blade will not boot
  - f. Error/Event Message received
  - g. MCA occurred
2. Narrow down the observed issue to the specific troubleshooting procedure required. Isolate the failure to a specific part of the server blade to perform more detailed troubleshooting. For example:
  - a. Issue - Front Panel LED blinking

---

#### NOTE:

The front panel health LED flashes amber with a warning indication, or flashes red with a fault indication.

---

- Look for a system alert on the OA or system console.
- Analyze the alert by using the SEL, to identify the last error logged by the server blade. Use the iLO 3 MP commands to view the SEL, through the MP menu interface.

```
MP MAIN MENU:
CO: Console
VFP: Virtual Front Panel
CM: Command Menu
CL: Console Log
SL: Show Event Logs
HE: Main Help Menu
DB: Debug Shell
X: Exit Connection
[iilo3cd92b2fca24] MFG! hpiLO-> sl
Event Log Viewer Menu:
Log Name Entries % Full Latest Timestamped Entry
-----
```

```

E - System Event 489 18 % 03 Jan 2001 00:11:17
F - Forward Progress 13251 68 % 03 Jan 2001 00:11:17
I - iLO Event 136 27 % 03 Jan 2001 03:30:04
C - Clear All Logs
L - Live Events
Enter menu item or [Ctrl-B] to Quit: e
Log Name Entries % Full Latest Timestamped Entry
-----
E - System Event 489 18 % 03 Jan 2001 00:11:17
Event Log Navigation Help:
+ View next block (forward in time, e.g. from 3 to 4)
- View previous block (backward in time, e.g. from 3 to 2)
<CR> Continue to the next or previous block
D Dump the entire log
F First entry
L Last entry
J Jump to entry number
H View mode configuration - Hex
K View mode configuration - Keyword
T View mode configuration - Text
S View mode configuration - Cause/Action
A Alert Level Filter options
U Alert Level Unfiltered
? Display this Help menu
Q Quit and return to the Event Log Viewer Menu
Ctrl-B Exit command, and return to the MP Main Menu
# Location |Alert | Encoded Field | Data Field | Keyword/Timestamp
-----
480 SFW 1,0,2,0 *7 F480003709E1039B 000000000000000F BOOT_HALT_CELL
02 Jan 2001 22:29:12
479 SFW 1,0,2,0 *7 E48000D109E10399 FFFFFFF01FFFFFF94 MEM_NO_MEM_FOUND
02 Jan 2001 22:29:12
478 SFW 1,0,2,0 2 40801FB109E10397 0000000000000000 MEM_NON_OPTIMAL_CONFIG
02 Jan 2001 22:29:12
477 SFW 1,0,2,0 *5 BA801F9D09E10395 FFFFFFF0100100B74 MEM_DIMM_INFO_HW_DEALLOCATED
02 Jan 2001 22:29:11
476 SFW 1,0,2,0 *5 BA801F9D09E10393 FFFFFFF0100090B74 MEM_DIMM_INFO_HW_DEALLOCATED
02 Jan 2001 22:29:11
475 SFW 1,0,2,0 *3 688024FE09E10391 000000000100000F MEM_DDR_TRN_ERR
02 Jan 2001 22:29:11
474 SFW 1,0,2,0 *3 688024FE09E1038F 0000000001010100 MEM_DDR_TRN_ERR
02 Jan 2001 22:29:11
MFG! SL:hpiLO (+, -, <CR><CR>, D, F, L, J, H, K, T, S, A, U, ?, Q or Ctrl-B to Quit) ->

```

3. You should have a good idea about which area of the server blade requires further analysis. For example, if the symptom was “server blade will not power-up”, the initial troubleshooting procedure might have indicated a issue with the DC power rail not coming up after the power was turned on.
4. Your goal is to identify the failed FRU and replace it. You must now perform the specific removal and replacement procedure, and verification steps, see [Removing and replacing components](#) on page 115 for more details.

---

**NOTE:**

If multiple FRUs are identified as part of the solution, fix all identified failed FRUs.

---

5. You might have to perform specific recovery procedures to finish the repair.

If a failure occurs the front panel LEDs and the SEL helps you identify the issue or FRU:

- The front panel LEDs and LAN LEDs of the server blade change color and blink to help identify specific issues, and display LAN activity.



For information on LED locations and states, see **Front panel LEDs** on page 99.

- The SEL provides detailed information about the errors identified by the LEDs.

For server alerts of levels 3-5, the attention condition on the server LED can only be cleared by cycling DC power.

If the LEDs and SEL do not give you enough information for you to identify the issue you are experiencing, Hewlett Packard Enterprise also provides diagnostic tools with each operating system (see **Troubleshooting tools** on page 97 for more details).

---

**NOTE:**

Always examine the iLO 3 MP SEL in the case of a blinking yellow or red front panel health LED, before replacing any hardware.

---

## Executing recommended troubleshooting methodology

The recommended methodology for troubleshooting a server blade error or fault is as follows:

### Procedure

1. Consult the system console for any messages, emails, and so on, pertaining to a server blade error or fault.
2. View the front panel LEDs (power and health), locally or remotely through the iLO 3 MP `vfcp` command.
3. Read the symptom/condition information in the left column of **Table 10**.
4. Perform the actions specified in the Action column.

For more details, see the appropriate subsection of this chapter, where this information is provided in the Action column. The Action you are directed to perform might be to access and read one or more error logs (the event log and/or the FPL).

You can follow the recommended troubleshooting methodology, and use **Table 10** and **Table 11** or go directly to the subsection of this chapter which corresponds to your own entry point. **Table 9** provides the corresponding subsection or location title for these different entry points (for example, to start by examining the logs, go directly to **Errors and error logs** on page 108).

### Table 9: Troubleshooting Entry Points

Entry Point	Subsection or Location
Front panel LEDs	See <b>Basic and advanced troubleshooting tables</b> on page 90, <b>Troubleshooting tools</b> on page 97, and <b>Front panel LEDs</b> on page 99.
Virtual Front Panel LEDs in the iLO 3 TUI	See <b>Virtual Front Panel LEDs in the iLO 3 TUI</b> on page 103.
SEL and FPLs	See <b>Errors and error logs</b> on page 108.

*Table Continued*

Entry Point	Subsection or Location
Offline and Online Diagnostics	See <a href="#">Troubleshooting tools</a> on page 97.
System Event Analyzer	See <a href="http://www.hpe.com/support/WEBES_Overview">http://www.hpe.com/support/WEBES_Overview</a> for more information about this tool).

## Basic and advanced troubleshooting tables

Use the following troubleshooting tables to determine the symptoms or condition of a suspect server blade. The state of the front panel LEDs can be viewed locally.

---

### NOTE:

Virtual front panel LEDs in the iLO 3 TUI are not the same as the front panel LEDs, see [Virtual Front Panel LEDs in the iLO 3 TUI](#) on page 103 for more information about Virtual front panel LED troubleshooting.

---

**Table 10: Basic Low End Troubleshooting**

Step	Condition	Action
1	Server blade appears “dead” -- no front panel LEDs are on, and iLO 3 heartbeat isn't blinking green.	<p>Nothing is logged for this condition.</p> <ol style="list-style-type: none"> <li>1. For new server installations, review the installation procedures.</li> <li>2. Be sure that the enclosure power cords are connected to both the power supplies and to the AC receptacles.</li> <li>3. Be sure that AC power, at the proper AC voltage levels, is available to the receptacles.</li> <li>4. If the power button's integrated LED on front panel remains off, then reseal the server blade.</li> <li>5. As a last resort, replace the server blade. This issue is fixed when the front panel LED states are as follows: blade health is steady green.</li> </ol>
2	Server blade does not power on after front panel power button is momentarily pressed (less than four seconds).	<p>A fatal fault has been detected and logged, attempting to power on the server.</p> <ol style="list-style-type: none"> <li>1. Examine enclosure power supply LEDs. If they are not steady green, then replace power supply.</li> <li>2. If the enclosure power supply LED is green, then you might need an additional power supply to supply sufficient power to run the blades in the enclosure.</li> <li>3. Examine the iLO 3 MP subsystem logs for events related to DC power rails.</li> <li>4. An improper SBL or e-keying error can also cause power on to fail.</li> </ol> <p>This issue is fixed when the front panel LEDs are as follows: Health is steady green and power is steady green.</p>
3a	Blade health LED is off and iLO 3 LED is flashing amber or off.	<p>A fatal fault has been detected and logged while booting or running system firmware (SFW or iLO 3 firmware).</p> <ol style="list-style-type: none"> <li>1. Cannot access the iLO 3 MP at this time.</li> <li>2. Must reseal or replace the server blade. This issue is fixed when the iLO 3 MP logs can be read and both front panel health LED and server power LED states show: Flashing green or steady green, and steady green, respectively.</li> </ol>

*Table Continued*

Step	Condition	Action
3b	Blade health LED is flashing amber or red and iLO 3 MP is running.	A fatal error has been detected and logged while booting or running system firmware. Examine the iLO 3 MP logs for events related to switched DC power or cooling fans or configuration. This issue is fixed when both front panel health LED and server power LED states show: Flashing green or steady green, and steady green, respectively.
4a	Cannot see iLO 3 MP prompt on system console -- blade server power is on. iLO 3 MP heartbeat LED is flashing green.	<p>Nothing can be logged for this condition. The blade health LED state indicates that the server blade is either booting or running system FW, or booting or running OS.</p> <ol style="list-style-type: none"> <li>1. Check the MP LAN connection. If the connection is functioning, check the serial console connection.</li> <li>2. Look for loose, damaged, or disconnected signal cables between the system console device, and serial port connector on the front panel.</li> <li>3. Be sure that the RS232C configuration matches between the server blade and the local console (see <b>Troubleshooting the server interface (system console)</b> on page 113 for more details).</li> <li>4. As a last resort, replace the server blade. This issue is fixed when the iLO 3 MP menu appears on the system console.</li> </ol>
4b	Cannot see UEFI menu on system console. iLO 3 MP is running.	<ol style="list-style-type: none"> <li>1. Examine the iLO 3 MP logs for entries related to processors, processor power modules, and shared memory, and core I/O devices (see <b>Errors and error logs</b> on page 108 for more details).</li> <li>2. Check the console POST message to use if any unusual messages are reported.</li> <li>3. As a last resort, replace the server blade. This issue is fixed when the UEFI menu appears on the system console.</li> </ol>

*Table Continued*

Step	Condition	Action
4c	Cannot find a boot disk. The iLO 3 MP is running.	<p>Nothing can be logged for this condition.</p> <ol style="list-style-type: none"> <li>1. Check the disk drive LED.</li> <li>2. Examine the Smart Array POST message.</li> <li>3. If FC storage is used for boot, check the FC card status with the offline utility (<code>drvcfg</code>).</li> <li>4. Reinsert the boot disk into the drive bay.</li> <li>5. Search for the boot disk path using the UEFI shell (<code>map-r</code>) command.</li> <li>6. Examine the iLO 3 MP logs for entries related to processors, processor power modules, and shared memory, and core I/O devices (see <b>Errors and error logs</b> on page 108 for more details).</li> <li>7. As a last resort, replace the server blade. This issue is fixed when all boot paths are found.</li> </ol>
5	Cannot see OS prompt on system console. iLO 3 MP is running.	<p>Nothing can be logged for this condition.</p> <ol style="list-style-type: none"> <li>1. Examine the console message.</li> <li>2. Verify the console configuration with the UEFI <code>conconfig</code> command.</li> <li>3. Examine the iLO 3 MP logs for entries related to I/O devices (see <b>Errors and error logs</b> on page 108 for more details). This issue is fixed when the OS prompt appears on the system console.</li> </ol>
<p><b>NOTE:</b></p> <p>All events listed below are logged in both FPL and SEL unless otherwise noted. An event of alert level 2 or greater will be logged in both places, alert level 1 or 0 is logged in FPL only.</p>		
6a	"POWER_FAIL_NO_SBL" - Power command failed because no Blade Link is installed.	<ol style="list-style-type: none"> <li>1. Be sure that the Blade Link is properly installed and fully seated.</li> <li>2. Look for bent connector pins on the Blade Link</li> </ol>

*Table Continued*

Step	Condition	Action
6b	"SBL_REMOVED" - Blade Link was removed	<ol style="list-style-type: none"> <li>1. If the Blade Link was not removed, be sure that is properly installed and fully seated.</li> <li>2. Look for bent connector pins on the Blade Link.</li> </ol>
6c	"ILO_RST_REASON_SBL" - The iLO 3 was reset because the Blade Link was installed (FPL only).	<ol style="list-style-type: none"> <li>1. Be sure that the Blade Link is properly installed and fully seated.</li> <li>2. Look for bent connector pins on the Blade Link.</li> </ol>
6d	"SYSVARS_MISMATCH" - The system variable stored on the Blade Link does not match the system variable stored on the blade.	Use the <code>sysset</code> command.
6e	"SBL_DOMAIN_IMPROPER_SBL" - The Blade Link currently installed is not appropriate for the blade slot (even/odd) and enclosure (c7000/c3000) being used.	<ol style="list-style-type: none"> <li>1. Be sure that the Blade Link installed in the correct slot and enclosure, see <b><u>Installing the Blade Link for BL860c i4, BL870c i4 or BL890c i4 configurations</u></b> on page 26.</li> <li>2. Be sure that the Blade Link is properly installed and fully seated.</li> <li>3. Look for bent connector pins on the Blade Link.</li> </ol>
6f	"POWER_FAIL_IMPROPER_SBL" - Power command failed because the Blade Link currently installed is not appropriate for the blade slot (even/odd) and enclosure (c7000/c3000) being used.	<ol style="list-style-type: none"> <li>1. Be sure that the Blade Link installed in the correct slot and enclosure, see <b><u>Installing the Blade Link for BL860c i4, BL870c i4 or BL890c i4 configurations</u></b> on page 26.</li> <li>2. Be sure that the Blade Link is properly installed and fully seated.</li> <li>3. Look for bent connector pins on the Blade Link.</li> </ol>

*Table Continued*

Step	Condition	Action
6g	Incorrect number of processors displayed for the conjoined blades	<ol style="list-style-type: none"> <li>1. Be sure that the Blade Link is properly installed and fully seated.</li> <li>2. Look for bent connector pins on the Blade Link.</li> <li>3. Check the MP logs for CPUs that were de-configured by system firmware. The UEFI <code>cpuconfig</code> command can be used to show and re-configure hardware or software de-configured CPUs.</li> </ol>
6h	"QPI_CPU_LINK_DEGRADED"	Be sure that the Blade Link is properly installed and fully seated.

**Table 11: Advanced Low End Troubleshooting**

Step	Symptom/Condition	Action
6	Cannot read SEL from the system console.	<p>SEL logging has stopped (health is steady green and power is steady green).</p> <p>Examine console messages for any UEFI errors or warnings about operation or communications.</p> <p>This issue is fixed when the SEL resumes logging.</p>
7	OS is non-responsive (hung)	<p>Front panel LEDs indicate that the server blade power is turned on, and it is either booting or running the OS (for example, health is steady green and power is steady green).</p> <p>Nothing can be logged for this condition.</p> <ol style="list-style-type: none"><li>1. Use the iLO 3 MP Command Menu to initial a ToC, using the <code>tc</code> command.</li><li>2. Reboot the OS and escalate.</li><li>3. Use the following commands to obtain the system hardware status by capturing the logs.<ul style="list-style-type: none"><li>• <code>sl -e -nc</code></li><li>• <code>l -f -nc</code></li><li>• <code>df -d</code></li><li>• <code>ps</code></li><li>• <code>ss</code></li><li>• <code>sr</code></li><li>• <code>sysset</code></li><li>• <code>npar</code></li><li>• <code>UEFI info all</code></li><li>• <code>VFP</code></li></ul></li><li>4. Examine the iLO 3 MP logs for entries related to processors, processor power modules, shared memory, and core I/O devices (see <b>Errors and error logs</b> on page 108 for more details).</li></ol> <p>This issue is fixed when the root cause is determined.</p>

*Table Continued*



Step	Symptom/Condition	Action
8a	<p>MCA occurs during server blade operation. The server blade reboots the OS.</p> <hr/> <p><b>NOTE:</b></p> <p>The server blade reboots OS if enabled.</p> <hr/>	<p>Front panel LEDs indicate that the server blade detected a fatal error that it cannot recover from through OS recovery routines (for example, health is flashing red and power is steady green).</p> <ol style="list-style-type: none"> <li>1. Capture the MCA dump with the UEFI command, <code>errdump mca</code>. If the server blade can boot the OS, you can capture binary MCA dump files online.</li> <li>2. Examine the iLO 3 MP logs for entries related to processors, processor power modules, shared memory, and core I/O devices (See <b>Errors and error logs</b> on page 108 for more details).</li> </ol> <p>The issue is fixed when the MCA does not repeat or the source of the MCA has been eliminated.</p>
8b	<p>MCA occurs during server blade operation and it is repeated; server blade reboot of OS is prevented.</p> <hr/> <p><b>NOTE:</b></p> <p>The troubleshooting actions for this step are identical to those in Step 8a, except that the server blade in this step must be hard reset to begin the booting process.</p> <hr/>	<p>Front panel LEDs indicate that the server blade detected a fatal, front side bus error.</p> <p>System firmware is running to gather and log all error data for this MCA event.</p> <ol style="list-style-type: none"> <li>1. Examine the iLO 3 MP logs for entries related to processors, processor power modules, shared memory, and core I/O devices (see <b>Errors and error logs</b> on page 108 for more details).</li> </ol> <p>If the system repeats the MCA, it is unable to capture MCA dumps since the system is unable to boot to UEFI shell. Reduce the system configuration and try the boot with the minimum configuration. For the i4 server blades, you may need to manage the nPar configuration for the minimum configuration.</p> <ol style="list-style-type: none"> <li>2. Try dc power off/on.</li> <li>3. Try reseating the blades.</li> </ol> <p>This issue is fixed when the MCA does not repeat.</p>

## Troubleshooting tools

### Cause

The HPE Integrity BL860c i4 Server Blade uses LEDs and other tools to help troubleshoot problems that occur in the server blade.

## Controls and ports

## Front panel view

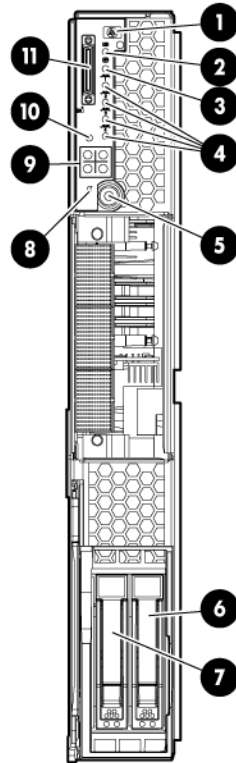

1	Monarch blade indicator	7	HDD bay 2
2	UID LED	8	Blade power LED
3	Blade health LED	9	Partition Identifier
4	NICs 1, 2, 3, 4	10	Physical Presence Button
5	Monarch power button	11	SUV connector
6	HDD bay 1		

## Rear panel view

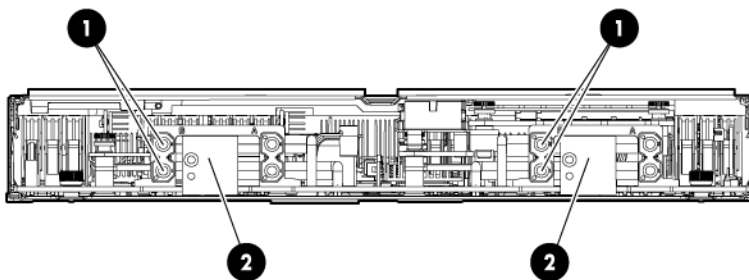

1	Power connectors
2	GBX signal connectors

## Server blade LEDs

### Front panel LEDs

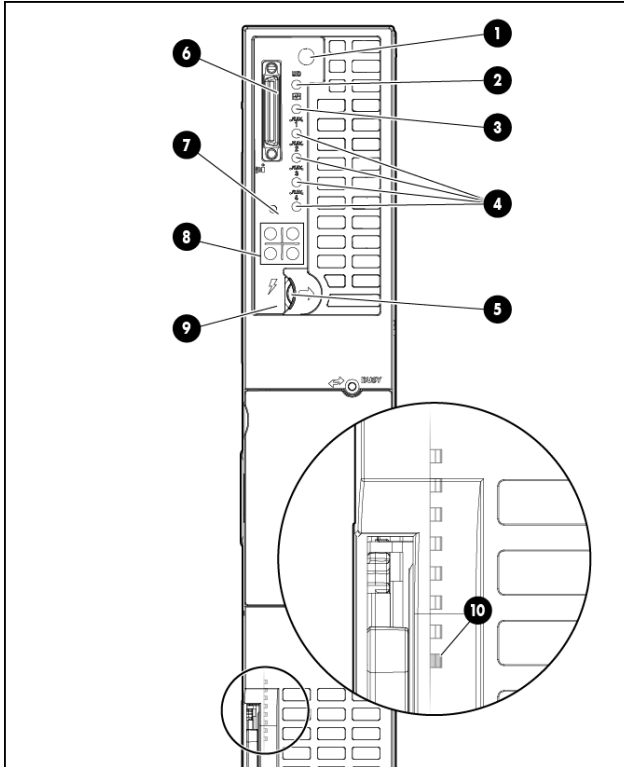

Item	Description	Status
1	Monarch blade indicator	Green = Blade is acting as Monarch blade Off = Blade is not Monarch or is not conjoined
2	UID LED	Blue = Identified Blue flashing = Active remote management Off = No active remote management
3	Blade health LED	Green = Normal operation Amber flashing = Degraded condition Red flashing = Critical condition

*Table Continued*

Item	Description	Status
4	NICs 1, 2, 3, 4	Green = Network linked Green flashing = Network activity Off = No link or activity
5	Monarch power button / Monarch power LED	Green = Blade is acting as Monarch and is powered on Amber = Blade is acting as Monarch and is in standby Off = Blade is not Monarch
6	SUV connector	N/A
7	Physical Presence Button	N/A
8	Partition Identifier	Green = Blade is in a partition Off = Blade is not in a partition
9	Blade power LED	Green = Server blade is powered on Amber = standby (auxiliary power available) <sup>1</sup> Off = Off
10	iLO 3 Heartbeat (behind grill)	Green flashing = iLO 3 Active Amber flashing = iLO 3 failure Off = no standby voltage

<sup>1</sup> If the Onboard Administrator denies power to the server blade, the server blade returns to Standby mode.

## SAS disk drive LEDs

The BL860c i4 Server Blade may have up to 2 hard disk drives installed. Each drive has two LEDs which display the drive status.

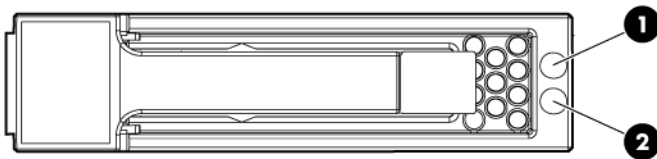

Item	Description
1	Fault/UID LED (amber/blue)
2	Online LED (green)

## SAS hard drive LED combinations

**NOTE:**

Predictive failure alerts only occur when the hard drive is connected to a Smart Array controller.

**Table 12: SAS disk drive LEDs: RAID mode**

Online/activity LED (green)	Fault/UID LED (amber/blue)	Interpretation
On, off, or flashing	Alternating amber and blue	The drive has failed, or a predictive failure alert has been received for this drive; it also has been selected by a management application.
On, off, or flashing	Steadily blue	The drive is operating normally, and it has been selected by a management application.
On	Amber, flashing regularly (1 Hz)	A predictive failure alert has been received for this drive. Replace the drive as soon as possible.
On	Off	The drive is online, but it is not active currently.
Flashing regularly (1 Hz)	Amber, flashing regularly (1 Hz)	<p><b>Do not remove the drive. Removing a drive might terminate the current operation and cause data loss.</b></p> <p>The drive is part of an array that is undergoing capacity expansion or stripe migration, but a predictive failure alert has been received for this drive. To minimize the risk of data loss, do not replace the drive until the expansion or migration is complete.</p>
Flashing regularly (1 Hz)	Off	<p><b>Do not remove the drive. Removing a drive might terminate the current operation and cause data loss.</b></p> <p>The drive is rebuilding, erasing, or it is part of an array that is undergoing capacity expansion or stripe migration.</p>

*Table Continued*

Online/activity LED (green)	Fault/UID LED (amber/blue)	Interpretation
Flashing irregularly	Amber, flashing regularly (1 Hz)	The drive is active, but a predictive failure alert has been received for this drive. Replace the drive as soon as possible.
Flashing irregularly	Off	The drive is active, and it is operating normally.
Off	Steadily amber	A critical fault condition has been identified for this drive, and the controller has placed it offline. Replace the drive as soon as possible.
Off	Amber, flashing regularly (1 Hz)	A predictive failure alert has been received for this drive. Replace the drive as soon as possible.
Off	Off	The drive is offline, a spare, or not configured as part of an array.

**Table 13: SAS disk drive LEDs : HBA mode**

Drive activity LED status	Drive status LED status	Indication
Off, or flashing	Alternating amber and blue	The drive has failed, or a predictive failure alert has been received for this drive; it also has been selected by a management application.
Off, or flashing	Blue	The drive is operating normally, and it has been selected by a management application.
Flashing irregularly	Regularly flashing amber(1 Hz)	The drive is active, but a predictive failure alert has been received for this drive. Replace the drive as soon as possible.
Flashing irregularly	Off	The drive is active, and it is operating normally.
Off	Amber	A critical fault condition has been identified for this drive. Replace the drive as soon as possible.
Off	Regularly flashing amber(1 Hz)	A predictive failure alert has been received for this drive. Replace the drive as soon as possible.
Off	Off	The drive is online.
Off	Off	Normal operation; no activity

## Blade Link LEDs

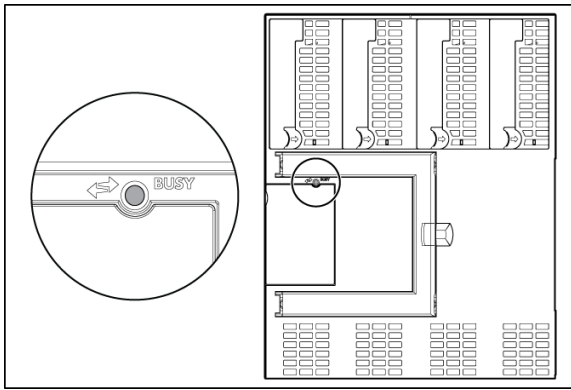

Description	Status
Busy LED	<p>Green = Blade Link is currently active. Do not remove.</p> <p>Off = Blade Link is not currently active. Safe to remove.</p>

## Virtual Front Panel LEDs in the iLO 3 TUI

iLO 3 has no LED that equates to the Blade Health LED located on the front panel of each individual BL860c i4 Server Blade. The Blade Health LED represents the health of the individual server blade. The virtual LEDs in the iLO 3 GUI and TUI reflect system/partition health. The closest equivalency to the Blade Health LED is a field called **Bay [x] Health** on the System Health page of the iLO 3 GUI.

The **VFP**, located in the iLO 3 TUI directly off the **MP MAIN MENU**, is a textual representation of the system/partition state as well as the system's status with respect to where it is in the boot process (running non-OS code, etc).

The following virtual LEDs are located in the VFP:

- HEALTH
- SYSTEM
- LOCATOR
- POWER

**Table 14: Indications for the iLO 3 TUI LEDs**

VFP LED	Purpose	Equivalent	Indications	Value
HEALTH	Represents the health of the entire system/partition. Shows the worst health case of any blade that is part of the partition.	System Health LED in the iLO 3 GUI's Virtual Front Panel	Flashing amber	<p>Health of the partition and the health of one or more blades within the partition is DEGRADED, meaning that:</p> <ul style="list-style-type: none"> <li>• A FRU has failed</li> <li>• A fatal event has been logged (Level seven alert events cause this indication if there are no FRU failures.)</li> </ul> <hr/> <p><b>NOTE:</b></p> <p>If the SYSTEM LED lights red, this counts as a FRU failure for the HEALTH LED.</p> <hr/>
			Flashing red	<p>Health of the partition is FATAL and the health of one or more blades within the partition are FATAL, meaning that:</p> <p>A FRU has failed and A fatal event has been logged (Level seven events cause this indication if there are FRU failures on one of the blades in the partition.)</p> <p>A reset will clear this LED of a fatal event, but not a FRU failure. A power cycle will clear both.</p>
			Steady green	All internal FRUs in the partition are healthy, there are no fatal events, and the system power is on.
			Off	Power to the system/partition is off and there were no AMBER or RED HEALTH indications on the last boot.

*Table Continued*



SYSTEM	There is only one SYSTEM LED per partition. The state will be the same for every blade in the partition.	<p><b>System Event Log Health</b> as displayed on the <b>System Health page</b> in the iLO 3 GUI</p> <p>There is no physical LED on the blade's front panel that represents this state.</p>	Flashing red	There has been a FATAL event since the last power on or system reset.  A reset or power on will clear this LED.
			Steady green	System is beginning to boot the OS.
			Off	OS is not booting and there are no fatal events.
LOCATOR	<p>Identifies the system/partition and will blink while a firmware update is in progress.</p> <hr/> <p><b>NOTE:</b> All blades in a partition show the same LOCATOR status at all times.</p> <hr/> <p><b>NOTE:</b> You can toggle the UID in software from either the iLO 3 TUI or web GUI. There is no UID hardware button on the server blade itself to turn it on or off.</p>	<ul style="list-style-type: none"> <li>• UID LED on the front panel of the individual blade</li> <li>• Locator UID in iLO 3</li> <li>• <b>Virtual Indicator</b> in the Onboard Administrator's interface</li> </ul>	On	The system/partition is identified.
			Off	System/partition is not identified and no firmware update is actively writing to any of the system ROMs.
			Flashing	Power should not be interrupted; firmware is actively burning a ROM.  <b>NOTE:</b> On ProLiant servers this LED blinks to indicate remote management; however this is not currently a supported indication on Integrity servers.
			ON/OFF toggle	<p>Toggles the current LED state to indicate transitional mode states activated by a push and hold of the Physical Presence button.</p> <p>If the Locator is off it will toggle on and then off, but if the Locator is on, it will toggle off and then on. If the Locator is flashing, no action will be taken.</p>
POWER	Identifies the system/partition power state.	<ul style="list-style-type: none"> <li>• Monarch Power button LED on the front panel of the Monarch blade</li> <li>• <b>System Power</b> LED in the iLO 3 GUI</li> </ul>	Steady green	System/partition is fully powered on.
			Steady amber	System/partition is in standby.
			Off	The system/partition is powered off.

## SUV Cable and Ports

The SUV port on the front of the server blade is used in conjunction with an SUV cable to connect the server to external devices such as a terminal emulator or monitor. In a conjoined server, only the SUV port on the Monarch Server is active.

### **⚠ CAUTION:**

The SUV cable is not designed to be used as a permanent connection.

Use caution when walking near the server blade when the SUV cable is installed. Hitting or bumping the cable might cause the port on the server blade to break. This can damage the system board.

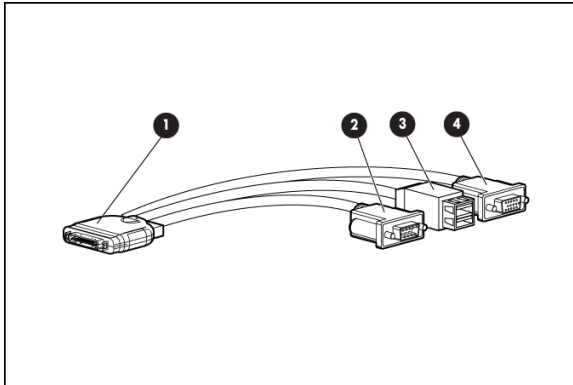

1	Server blade	3	USB ports (2)
2	Video	4	Serial

## Connecting to the serial port

### **ⓘ IMPORTANT:**

It is not necessary to physically connect to the Integrity iLO 3 via the serial port to perform any management task. The intention is that the iLO LAN port should be used to communicate with any iLO in the enclosure, as well as the Onboard Administrator. The LCD panel and the Onboard Administrator can be used to configure and determine the iLO LAN address.

To physically connect to Integrity iLO 3 using the serial port:

1. Connect the SUV cable to the SUV port (i.e., the diagnostic port).
2. Connect an RS-232 cable to the RS-232 port on the SUV cable. This is the local connection to the Integrity iLO 3 consoles.
3. Connect the other end of the RS-232 cable to your terminal emulator.

### **NOTE:**

The terminal emulator is typically software that runs on a PC, such as Putty, Reflections, or Hyper Terminal. This software enables a PC to communicate with the server using one of the PC's comm ports. If the PC has a RS-232 serial port then connect the cable to that port and then configure the terminal emulator software to use that serial port. However, if the PC does NOT have a serial port, then you will need a USB to Serial converter. These devices can be ordered from Hewlett Packard Enterprise and typically are in-expensive. The device has a USB connector that plugs into a USB port on the PC, and it has a RS-232 port for connecting to the SUV serial port.

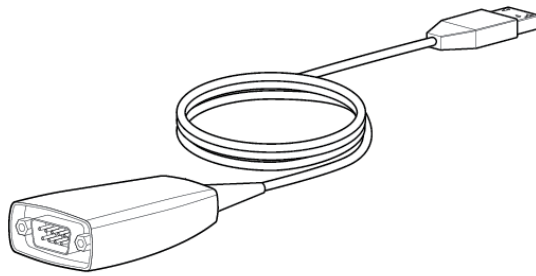

## Diagnostics

A suite of offline and online support tools are available to enable troubleshooting server blade issues. In general, if the operating system (HP-UX) is already running, Hewlett Packard Enterprise does not recommend shutting down the server blade. Use the online support tools.

If the OS cannot be booted, use the offline support tools to resolve the issue. The offline support tools are available from the UEFI partition. After you resolve the issue preventing booting, boot HP-UX, and use the online support tools for any further testing.

If it is not possible to reach the UEFI from either the main disk or from LAN, you must troubleshoot using the visual fault indicators, console messages, and system error logs that are available.

## General diagnostic tools

Diagnostic Tool	Description
IPMI Event Decoder	Provides detailed information about the IPMI event (Issue description, cause, action)

## Fault management overview

The goal of fault management and monitoring is to increase server blade availability, by moving from a reactive fault detection, diagnosis, and repair strategy to a proactive fault detection, diagnosis, and repair strategy. The objectives are:

- To detect issues automatically, as close as possible to the time of occurrence.
- To diagnose issues automatically, at the time of detection.
- To automatically report (in understandable text) a description of the issue, the likely causes of the issue, the recommended actions to resolve the issue, and detailed information about the issue.
- To be sure that tools are available to repair or recover from the fault.

## HP-UX Fault management

Proactive fault prediction and notification is provided on HP-UX by SFM and WBEM indications. WBEM is a collection of standards that aid large-scale systems management. WBEM allows management applications to monitor systems in a network.

SFM and WBEM indication providers enable users to monitor the operation of a wide variety of hardware products, and alert them immediately if any failure or other unusual event occurs. By using hardware

event monitoring, users can virtually eliminate undetected hardware failures that could interrupt server blade operation or cause data loss.

HPE SMH is the application used to query information about monitored devices and view indications and instances on WBEM. This WBEM-based network management application enables you to create subscriptions and view indications.

SysMgmtPlus functionality displays the property pages of various devices and firmware on SMH. SysMgmtPlus allows SMH to display improved property pages that contain dynamic content, providing the user to view and hide details of devices and firmware. The Health Tests are associated with components. The healthtest feature provides an option to perform health test on all the device instances of the component.

For complete information on installing, administrating, and troubleshooting SFM software and its components, see the *System Fault Management Administrator's Guide* ([http://www.hpe.com/support/HPUX\\_System\\_Fault\\_Management\\_Manuals](http://www.hpe.com/support/HPUX_System_Fault_Management_Manuals)).

## Errors and error logs

### Event log definitions

Often the underlying root cause of an MCA is captured by the server blade or firmware in both the SEL and FPL logs. These root causes are easily matched with MCA events by timestamps. For example, the loss of a processor VRM might cause a processor fault. Decoding the MCA error logs would only identify the failed processor as the most likely faulty FRU. Following are some important points to remember about events and event logs:

- Event logs are the equivalent of the old chassis logs for status or error information output.
- Symbolic names are used in the source code; for example, `MC_CACHE_CHECK`.
- The hex code for each event log is 128 bits long with an architected format:
  - Some enumerated fields can be mapped to defined text strings.
  - All can be displayed in hex, keyword, or text mode.
- Events are created by firmware or the OS and are stored in either or all of the SEL iLO, and forward progress event logs.

Events are sent by firmware or the OS over the PDH bus to iLO for storage in both of SEL and FPL logs. Also, events such as "System Soft Reset," which indicates error reset during MCA, is sent by iLO itself.

- The iLO 3 MP displays the SEL event logs.

### Event log usage

To consult the event logs:

1. Connect to the system console.
2. Enter **Ctrl-B** to access the **MP Main Menu**.
3. To view event logs, enter the `s1` command:

```
[tftp10mp]</>hpliLO-> s1
Event Log Viewer Menu:
```

```

Log Name          Entries    % Full    Latest %Full Latest Timestamped Entry
-----
E - System Event    30         1 %       03 May 2012 01:20:43
F - Forward Progress 18354      100 %     03 May 2012 01:20:43
I - iLO Event       500        100 %     03 May 2012 01:20:43
C - Clear SEL and FPL
L - Live Events

Enter menu item or [Ctrl-B] to Quit:

```

System Event (E) and Forward Progress (F) logs are useful to determine the context of an error.

## iLO 3 MP event logs

The iLO 3 MP provides diagnostic and configuration capabilities. For more information on the iLO 3 MP commands, see the *HPE Integrity and HPE 9000 Integrated Lights-Out Management Processor Operations Guide*. To access the MP:

### Procedure

1. Log in with the proper username and password.

#### NOTE:

The default login and password are:

login = **Administrator**

password = Randomly generated password found on the iLO 3 Network pull tab located on the right side of the Monarch blade.

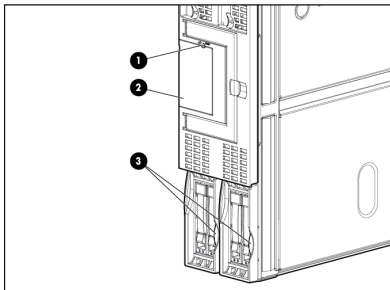

1	Busy LED	2	Label carrier door	3	Pull tab
---	----------	---	--------------------	---	----------

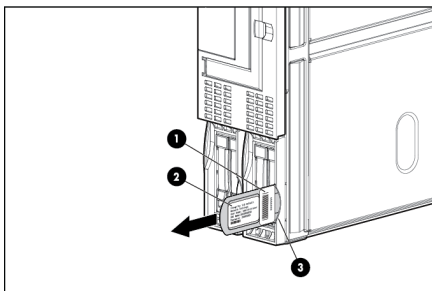

1	MP iLO 3 label	2	Factory tracking label	3	Blade chassis end
---	----------------	---	------------------------	---	-------------------

You are now at the **MP Main Menu**.

2. Enter `c1` to display the console history log. This log displays console history from oldest to newest.

3. Enter **Ctrl-B** to return to the **MP Main Menu**.
4. Enter **s1** to display the status logs. The status logs consist of:
  - a. System Event
  - b. Forward Progress
  - c. Current Boot
  - d. Previous Boot
  - e. Live Events
  - f. Clear SELs
5. Enter **Ctrl-B** to return to the **MP Main Menu**.

## SEL review

### Procedure

1. Access the iLO 3 MP command prompt.
2. Run the **s1** command. The Event Log Viewer menu displays:

```
[fp10mp]</>hpliLO-> s1

Event Log Viewer Menu:

      Log Name                Entries    % Full    Latest Timestamped Entry
-----
E - System Event              206        40 %      04 Dec 2009 20:30:31
F - Forward Progress          4096       100 %
I - iLO Event                  500        100 %      04 Dec 2009 20:50:57
C - Clear All Logs
L - Live Events

Enter menu item or [Ctrl-B] to Quit:
```

3. Select **E** to review the system events. The Event Log Navigation menu displays:

```
+      View next block      (forward in time, e.g. from 3 to 4)
-      View previous block (backward in time, e.g. from 3 to 2)
<CR>  Continue to the next or previous block
D      Dump the entire log
F      First entry
L      Last entry
J      Jump to entry number
H      View mode configuration - Hex
K      View mode configuration - Keyword
T      View mode configuration - Text
A      Alert Level Filter options
U      Alert Level Unfiltered
?      Display this Help menu
Q      Quit and return to the Event Log Viewer Menu
Ctrl-B Exit command, and return to the MP Main Menu

SL:hpiLO (+,-,<CR>,D,F,L,J,H,K,T,A,U,?,Q or Ctrl-B to Quit)->

# Location      |Alert| Encoded Field | Data Field | Keyword/Timestamp
```

```

-----
10  ILO  1          2  408022E400E10012 0000000000000000 EXIT_MFG_MODE
                                07 Jan 2010 22:42:00
 9  ILO  1          *3 6080253500E10010 0000000000000000 SYSVARS_MISMATCHED
                                07 Jan 2010 22:41:30
 8  ILO  1          *3 608022E600E1000E 0000000000000000 ILO_SPECIAL_MODE
                                07 Jan 2010 22:41:27
 7  ILO  1          2  408022E200E1000C 0000000000000000 ENTER_MFG_MODE
                                07 Jan 2010 22:41:27
 6  ILO  1          2  408022AE00E1000A 0000000000000000 ILO_IS_BOOTING
                                07 Jan 2010 22:41:19
 5  ILO  1          2  4080231200E10008 0000000000000000 FW_UPDATE_SUCCESS
                                07 Jan 2010 22:40:43
 4  ILO  1          2  4080236800E10006 0000000000000000 FW_UPDATE_SIG_OVERRIDE
                                07 Jan 2010 22:33:05
 3  ILO  1          2  4080230D00E10004 0000000000000000 FW_UPDATE_START
                                07 Jan 2010 22:31:23
 2  ILO  1          2  408022E200E10002 0000000000000000 ENTER_MFG_MODE
-----

```

4. Select **a**, then a threshold filter number to filter events to desired level.

```

MP:SL (+,-,<CR>,D, F, L, J, H, K, T, A, U, ? for Help, Q or Ctrl-B to Quit) >a
Alert Level Threshold Filter:
 1 : Major Forward Progress
 2 : Informational
 3 : Warning
 5 : Critical
 7 : Fatal
Enter alert level threshold or [Q] to quit filter setup: 3
-> Alert threshold level 3 filter will be applied.

```

5. To decode the blinking state of a blade server LED, review the entire SEL and look at events with alert level 2 and above.

## Troubleshooting processors

### Processor installation order

For a minimally loaded server blade, one processor must be installed in processor slot 0. Install a processor of the same version into processor slot 1 (if purchased). See **CPU and heatsink module** on page 129 for more information on processor installation.

### Processor module behaviors

All physical processors become functional after server power is applied.

Corrected errors and uncorrected errors in any physical processor core can cause a local MCA event, which can have one of the following consequences:

- Can cause the entire system to crash.
- The failure is corrected and the processor is restarted.
- The failure is corrected, but the processor which experiences excessive correctable errors is marked for deconfiguration.

## Enclosure information

This installation document covers only the BL860c i4, BL870c i4, and BL890c i4 server blades, and does not include any specific server blade enclosure information. For server blade enclosure information, go to:

- [http://www.hpe.com/support/Bladesystem\\_c3000\\_Enclosures\\_Manuals](http://www.hpe.com/support/Bladesystem_c3000_Enclosures_Manuals)
- [http://www.hpe.com/support/Bladesystem\\_c7000\\_Enclosures\\_Manuals](http://www.hpe.com/support/Bladesystem_c7000_Enclosures_Manuals)

## Cooling subsystem

The server blade does not contain any fans. Cooling is handled by the enclosure.

## Firmware

The server blade has two sets of firmware installed:

- Server blade firmware
- iLO 3 MP firmware

## Identifying and troubleshooting firmware issues

Erratic server blade operation, or unsuccessful boot to the **UEFI Boot Manager** or UEFI Shell, are symptoms of possible firmware issues.

---

### NOTE:

Firmware issues are relatively rare. Look for other problem causes first.

---

Probable firmware failure areas are:

### Procedure

1. Unsupported firmware installation
2. Corrupt firmware installation

To troubleshoot firmware issues:

- Verify that all server blade firmware components are from the same release (use the MP **sysrev** command).
- Reinstall server blade firmware.

## Verify and install the latest firmware

Hewlett Packard Enterprise recommends that all firmware on all devices in your c-Class Ecosystem be updated to the latest version anytime a new Integrity Server Blade or other hardware component is added.

To verify that you have the latest version of firmware for each component:

### Procedure

1. Go to <http://www.hpe.com>.
2. Locate and click the **Support & Drivers** link on the main page.
3. Click the button next to **Download drivers and software (and firmware)**.



4. Enter your product name (for example, BL860c i4) or number and click >>.
5. Choose the OS or Cross operating system (BIOS, Firmware, Diagnostics, etc.)
6. Refer to the Release Notes or Installation Instructions to verify the firmware version.

## Troubleshooting the server interface (system console)

### Cause

System console connections using the RS-232 cable are made through the port connectors on the front of the server blade, through the SUV cable. The MP LAN connection can be made via the network or OA.

HP-UX uses the RS-232 serial text connection to a dumb terminal, or to terminal emulator software running on a PC, to control server blade operations locally. All other connections are unsupported.

HP-UX alternatively uses the MP 10/100 BT LAN connection over a private network, to control one or more server blade operations locally through telnet or SSH, or remotely over a public network through a web GUI.

---

### NOTE:

RS-232 connection: If a dummy terminal/PC running terminal emulation software is attached to the iLO 3 MP local port and does not respond to a **Ctrl-B** key sequence then it is possible that the iLO 3 MP is not operational/functional, or the terminal/terminal emulation software is incorrectly configured (wrong baud rate for example).

---

## Troubleshooting the environment

### Cause

Ambient intake air temperature is often different from ambient room temperature; measure the operating temperature and humidity directly in front of the cabinet cooling air intakes, rather than measure only ambient room conditions.

Temperature sensors are found on:

- System board, where the processors provide an integrated temperature sensor
- Status panel, where a thermal sensor detects the ambient room temperature. This sensor's reading is the main parameter used to regulate fan speed, under normal conditions.

**Table 15: Server blade environmental specifications**

<b>Parameter</b>	<b>Operating Range</b>	<b>Recommended Operating Range</b>	<b>Maximum Rate of Change</b>	<b>Non-Operating Range</b>
Temperature	5°C to 35°C (41°F to 95°F) (up to 5000 feet)	20°C to 25°C (68°F to 77°F) (up to 5000 feet)	10°C (50°F) / hr with tape 20°C (68°F) / hr without tape	-40°C to 60°C (-40°F to 140°F)
Relative Humidity	15-80% at 35°C (95°F) noncondensing	40-60% at 35 degrees 35°C (95°F) noncondensing	30% per hour noncondensing	90% at 65°C (149°F) noncondensing

# Removing and replacing components

## Server blade components list

**NOTE:**

Part numbers are found by using the part nomenclature from this list to select the correct part from Hewlett Packard Enterprise Partsurfer (<http://partsurfer.hpe.com/>).

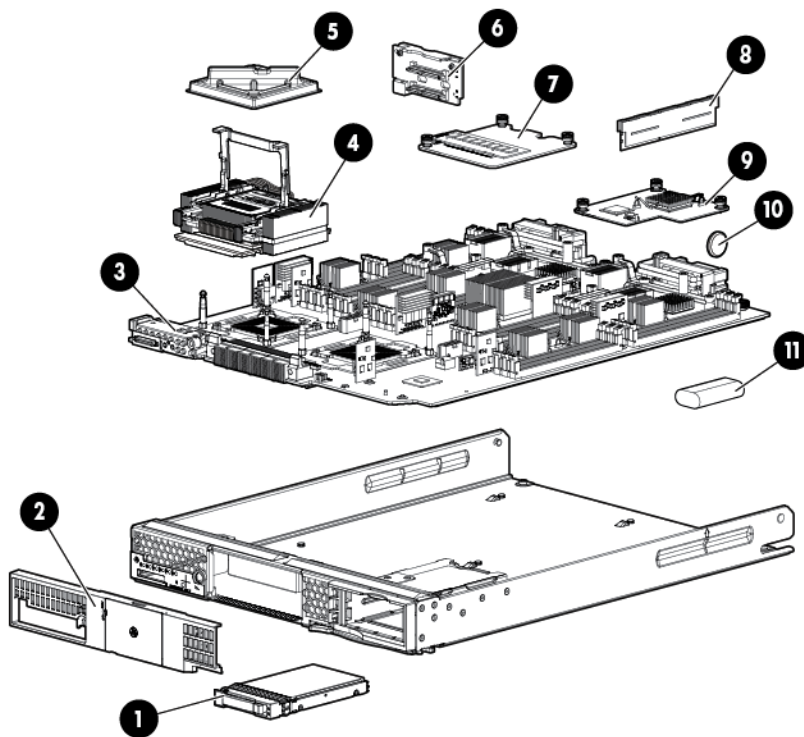

**Table 16: CRU List**

Description with Part Number	Spare Part Number
8	<b>Memory</b>
DIMM,4GB PC3L-10600R,512Mx4,RoHS (Old type)	708393-001
DIMM,8GB PC3L-10600R,512Mx4,RoHS (Old type)	708394-001
DIMM,16GB PC3L-10600R,1Gx4,RoHS (Old type)	708395-001
DIMM 4GB PC3L-10600R 512Mx4 RoHS (New type)	739926-001
DIMM 8GB PC3L-10600R 512Mx4 RoHS (New type)	739927-001

*Table Continued*

	DIMM 16GB PC3L-10600R 512Mx4 RoHS (New type)	739928-001
4	<b>Processors</b>	
	Intel Itanium 9520 Four Core processor - 1.73Ghz (part number AT085-2019A)	AT085-69023
	Intel Itanium 9550 Four Core processor - 2.40Ghz (part number AT085-2020A)	AT085-69024
	Intel Itanium 9540 Eight Core processor - 2.13Ghz (part number AT085-2021A)	AT085-69025
	Intel Itanium 9560 Eight Core processor - 2.53Ghz (part number AT085-2022A)	AT085-69026
1	<b>Internal Disks</b>	
	HPE 300GB 10k SAS 2.5" HPE DP HDD (part number 507127-B21)	507284-001
	HPE DP HDD HPE 146GB 15k SAS 2.5" HPE DP HDD (part number 512547-B21)	512744-001
	450GB/10k 2.5" SAS 6Gb Hard Disk Drive (AM316A) (part number 581285-B21)	581310-001
	600GB/10k 2.5" SAS 6Gb Hard Disk Drive (AM317A)	581311-001
	HPE 900GB 6G SAS 10K 2.5in DP E	619463-001
	HPE 300GB 6G SAS 15K 2.5in DP E (part number 627117-B21)	627195-001
	HPE 200GB SAS 2.5in SSD SLC Drive (part number 632492-B21)	632627-001
	HPE 400GB SAS 2.5in SSD SLC Drive (part number 632494-B21)	632630-001
<b>Boards and Cards</b>		
7	ICH Mezz Card w/ TPM (part number AM377-60013)	AM377-69013
7	ICH Mezz Card w/o TPM (part number AD399-60014)	AD399-69014
8	HPE NC552m - 10GbE Emulex 2-Port (part number 613431-B21)	610724-001
8	HPE BLc NC532m NIC Adapter Opt Kit (part number 467799-B21)	615317-001

*Table Continued*

8	HPE BLc NC551m DP FlexFabric Adptr Opt (part number 580151-B21)	580238-001
8	HPE SA P711M/1G PMC based Controller (part number 513778-B21)	537156-001
8	HPE 4X QDR IB CX-2 Dual Port Mezz HCA (part number 592519-B21)	593411-001
8	HPE BLc NC360m NIC Adapter Opt Kit (part number 445978-B21)	615319-001
8	HPE BLc NC364m NIC Adapter Opt Kit (part number 447883-B21)	615318-001
8	HPE Dual Port 8Gbps Fibre Channel HBA Mezzanine Card (Emulex) (part number 456972-B21)	456978-001
8	HPE NC553m 10Gb 2-port Flex-10 Ethernet Adapter (part number 610609-B21)	617727-001
8	HPE NCxxxm PCI Express Dual Port 10GbE RNIC (KR) (part number 618856-001)	615317-001
8	HPE NC364m PCI Express Quad Port 1Gb (Intel) (part number 618860-001)	615318-001
8	HPE NC360m PCI Express Dual Port 1Gb IC (part number 618861-001)	615319-001
8	HPE Dual Port 8Gbps Fibre Channel HBA Mezzanine Card (Q-Logic) (part number 6451871-B21)	708062-001
3	<b>Blade Links</b>	
	BL1 (1 blade per BL) (part number AM377-60002)	AM377-67002
	BL2 (2 blades/CoP - now called Blade Link ) (part number AM377-60003)	AM377-67003
	BL4-M (4 blades/CoP) (part number AM377-60006)	AM377-67006
	BL4-S (4 blades/CoP) (part number AM377-60007)	AM377-67007
	BL2E-M (part number AM377-60010)	AM377-67010
	BL2E-S (part number AM377-60011)	AM377-67011
	<b>Miscellaneous</b>	

*Table Continued*

3	BL8x0c i4 Base Unit (part number AM377-2001A)	AM377-6901A
7	SAS disk backplane (part number AD399-60009)	AD399-67009
10	System battery	—
11	Smart Array battery	—
2	Front bezel	—

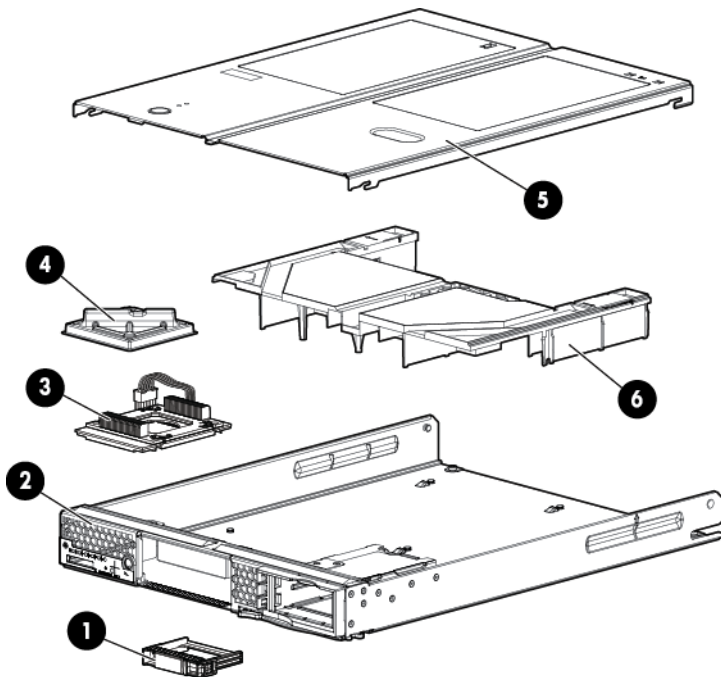

	Description with Part Number	Spare Part Number
1	SAS Hard Drive Blank	—
2	System Chassis (part number AD399-2102F)	AD399-2102F
3	CPU Heatsink (part number AD399-2120D)	612269-001
4	CPU Socket Dust Cover (& airflow baffle) (part number AD399-2134A)	AD399-2134A
5	Blade Top Cover (part number AD399-2101B)	AD399-2101B
6	Memory Airflow Baffle (part number AD399-2128B)	AD399-2128B

## Preparing the server blade for servicing

To service an internal server blade component, power off the server blade and remove it from the server blade enclosure.

---

**⚠ CAUTION:**

Electrostatic discharge can damage electronic components. Ensure you are properly grounded before beginning an installation procedure. For more information, see the **ESD handling information** on page 15.

---

**⚠ WARNING:**

Before proceeding with maintenance or service on a server blade that requires physical contact with electrical or electronic components, be sure that power is removed or safety precautions are followed to prevent electric shock and equipment damage. Observe all warning and caution labels on equipment.

---

## Powering off the server blade

Before powering down the server blade for any upgrade or maintenance procedures, backup critical server data and programs.

Use one of the following methods to power off the server blade:

---

**NOTE:**

To power off blades in a conjoined configuration, only power off the Monarch blade.

---

- Use a virtual power button selection through iLO 3 (Power Management, Power & Reset).  
This method initiates a controlled remote shutdown of applications and the OS before the server blade enter standby mode.
- Press and release the Monarch power button.  
This method initiates a controlled shutdown of applications and the OS before the server blade enter standby mode.
- Press and hold the Monarch power button for more than 4 seconds to force the server blade to enter standby mode.  
This method forces the server blade to enter standby mode without properly exiting applications and the OS. It provides an emergency shutdown in the event of a hung application.

## Blade Link for BL870c i4 or BL890c i4 configurations

---

**ⓘ IMPORTANT:**

The Blade Link holds the primary system definition data, system size and variables. If the blade link is moved, the serial number and system UUID (the identity of the system) and the nPartition description is also removed

---

**ⓘ IMPORTANT:**

If you are replacing a faulty Blade Link, you must transfer the label with the blade serial number from the failed Blade Link to the replacement.

---

## Removing the Blade Link for BL870c i4 or BL890c i4 configurations

---

### **⚠ CAUTION:**

To prevent damage to the Blade Link, make sure that the activity light is off before proceeding.

---

### **Procedure**

1. Power off the Monarch blade. (**Preparing the server blade for servicing** on page 118).
2. Push in the blue release latch on the handle to release it.
3. Pull the handle out to release the Blade Link.
4. Pull the Blade Link straight out, placing a free hand on the top right side of the bezel as you pull to provide a counterbalance.

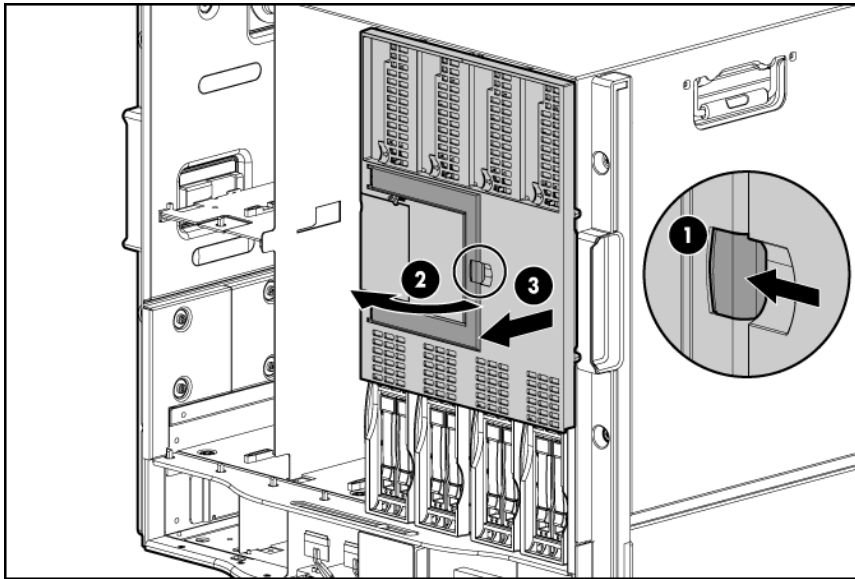

5. Place a plastic protector over the connector on the back of the Blade Link and place it in an antistatic bag.

### **NOTE:**

Plastic protectors are only provided with replacement Blade Links.

---

## Replacing the Blade Link for BL870c i4 or BL890c i4 configurations

---

### **⚠ IMPORTANT:**

If you are installing the Blade Link for the first time, see **Installing the Blade Link for BL860c i4, BL870c i4 or BL890c i4 configurations** on page 26 for more information regarding bay location rules and other pre-installation requirements.

---

### **Procedure**

1. Log on to the OA.
2. Install the first blade into the lowest bay number, this blade becomes the Monarch blade (**Installing the server blade into the enclosure** on page 23).



3. Wait 10 seconds. The IP address of the installed blade appears in the OA.
4. Insert each adjacent auxiliary blade, waiting 10 seconds between blades.

**NOTE:**

The blades will go into stand-by

5. Using the OA, verify that the rest of the blades that will be conjoined have an IP address and are powered off.
6. Remove the plastic protectors from the connectors on the back of the Blade Link.
7. Push in the blue release latch on the handle to release the handle.
8. Pull the handle all the way out.
9. Align the guide pins on the back of the Blade Link to the holes on the front of the server blades. As you insert the pins into the holes, ensure the face on the Blade Link is evenly aligned parallel to the face of the server blades.
10. Press firmly on the left and right sides of the Blade Link face until the handle naturally starts to close.

**CAUTION:**

If not properly aligned, you can damage the Blade Link.

11. Close the handle when it has engaged.

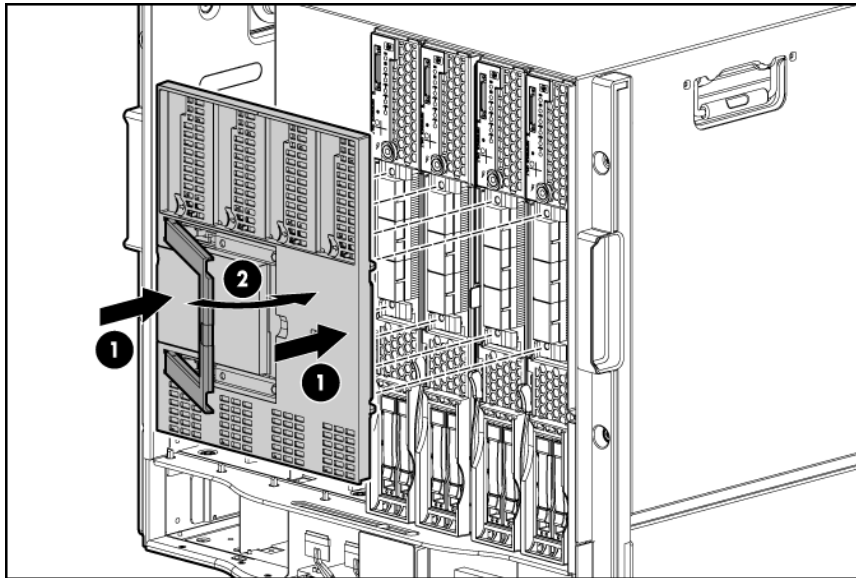

12. In addition to the system information, the nPartition description information is stored on the Blade Link. To retain the partitioning configuration information, after replacing a BL you must run `sysset` to copy the system variables from the secondary to the primary, and reset iLO before powering back on.
13. Log into iLO 3 on the Monarch blade. For more information, see the *HPE Integrity iLO3 Operations Guide*.
14. In iLO3, go to the command menu and execute `sr` to verify that inter-iLO communication is initialized, by having the monarch query all auxiliary iLOs.

15. In iLO 3, go to the Command Menu and execute `xd -r` to reboot all of the iLO 3s in the conjoined set.
16. Still in the iLO 3 Command Menu, power on the Monarch blade with the `PC -on -nc` command. Powering on the Monarch blade will power the entire conjoined system on.
17. Boot the Monarch blade. Booting the Monarch blade boots the entire conjoined system.

## Blade Link for BL860c i4 configurations

---

### ⓘ **IMPORTANT:**

Only remove a Blade Link from a BL860c i4 Server Blade in the following circumstances:

- The Blade Link is faulty.
  - You will be using the blade in a BL870c i4 /BL890c i4 configuration.
- 

### ⚠ **CAUTION:**

To prevent damage to the Blade Link, make sure that the activity light is off before proceeding.

---

### Procedure

1. Power off the server blade and remove it from the enclosure (**Preparing the server blade for servicing** on page 118).
2. Place the blade on a flat, level, antistatic surface on its side, with the access panel facing up.
3. Squeeze the blue button on the side of the bezel.
4. While holding in the release button, pull the Blade Link off the blade while applying counter pressure down on the blade to keep the blade from moving.

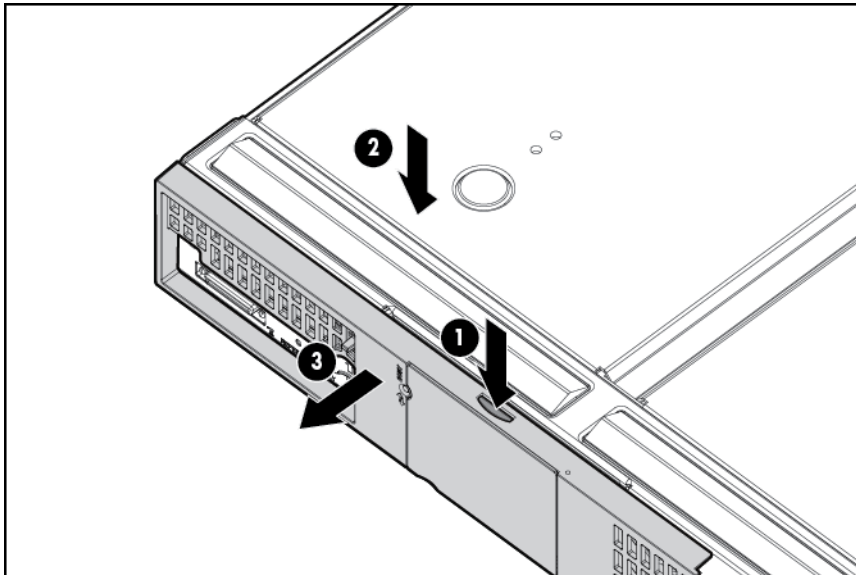

5. Place a plastic protector over the connector on the back of the Blade Link and place it in an antistatic bag.

---

**NOTE:**

Plastic protectors are only provided with replacement Blade Links.

---

**!** **IMPORTANT:**

If you are replacing a faulty Blade Link, take the label carrier card with the system ID values out of the faulty Blade Link and place it inside the label carrier door of the new Blade Link.

---

To replace the component, reverse the removal procedure.

## Server blade

---

**△ CAUTION:**

After you press the release button, the server blade is unlocked from the enclosure. Use both hands to support the server blade when you remove it from the rack. The server blade weighs approximately 9 kg (20 lb).

---

**△ CAUTION:**

The enclosure fans might still be running when the server blade is in standby mode. Opening the lever removes all power from the server blade.

---

### Procedure

1. Power off the server blade. (**Powering off the server blade** on page 25)
2. If the blade is conjoined, then remove the Blade Link (**Removing the Blade Link for BL870c i4 or BL890c i4 configurations** on page 120).
3. Remove the server blade.

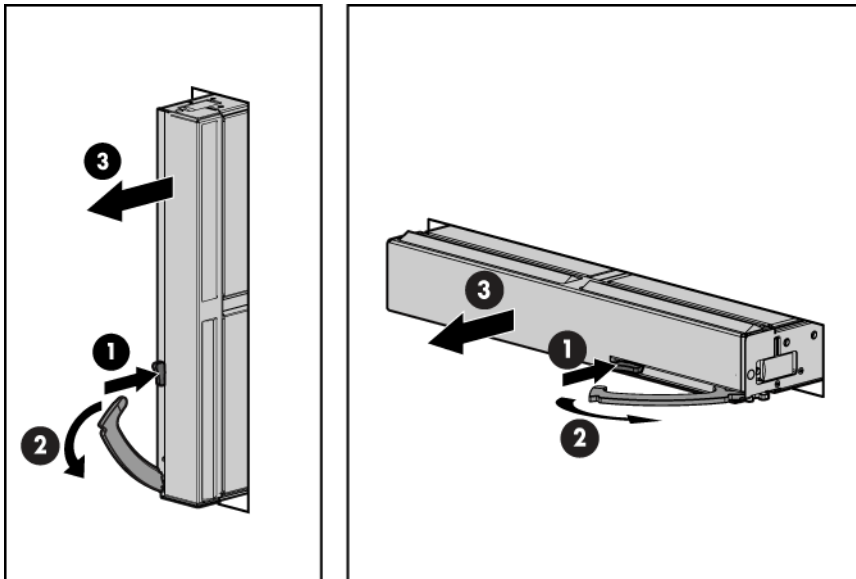

4. Place the server blade on a flat, level, and antistatic surface.

**WARNING:**

To reduce the risk of personal injury from hot surfaces, allow the drives and the internal system components to cool before touching them.

---

**CAUTION:**

Populate server blade enclosure bays with a server blade or server blade blank. Operating the enclosure without a server blade or server blade blank causes improper airflow and cooling which can lead to thermal damage.

---

To replace the component, reverse the removal procedure.

## Access panel

The access panel is located on the right side of the server blade (when mounted in an enclosure).

**Procedure**

1. Power off the server blade and remove it from the server blade enclosure. (**Preparing the server blade for servicing** on page 118).
2. Lift the access panel latch.
3. Slide the access panel backwards approximately 2 cm (0.75 in).
4. Remove the access panel by lifting it straight up and off the server blade.

To replace the component, reverse the removal procedure.

## Disk drive blanks

The server blade has two disk drive bays. If you only purchased one hard disk, then your server blade has a hard drive blank installed. Hard drive blanks maintain proper airflow throughout the server blade.

---

**CAUTION:**

Populate hard drive bays with a disk drive or a disk drive blank. Operating the server blade without a disk drive or disk drive blank causes improper airflow and cooling, which can lead to thermal damage.

---

## Removing a disk drive blank

Remove the component as indicated:

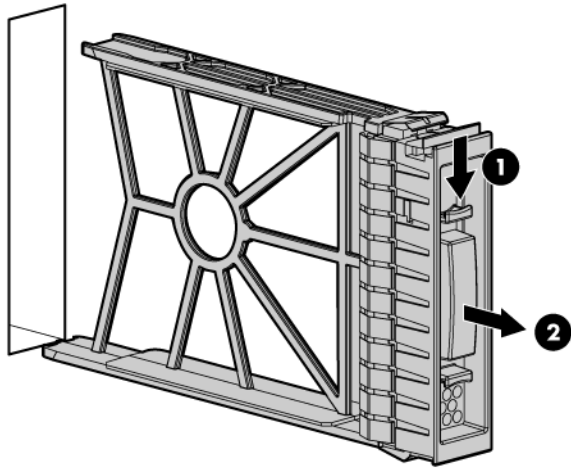

To replace the hard drive blank, slide the blank into the bay until it locks into place. The hard drive blank is keyed to fit only one way.

## Disk drives

The BL860c i4 Server Blade has SAS disk drive slots on the BL860c i4 server blade. The SAS disk drives have identical LEDs that display the drive status.

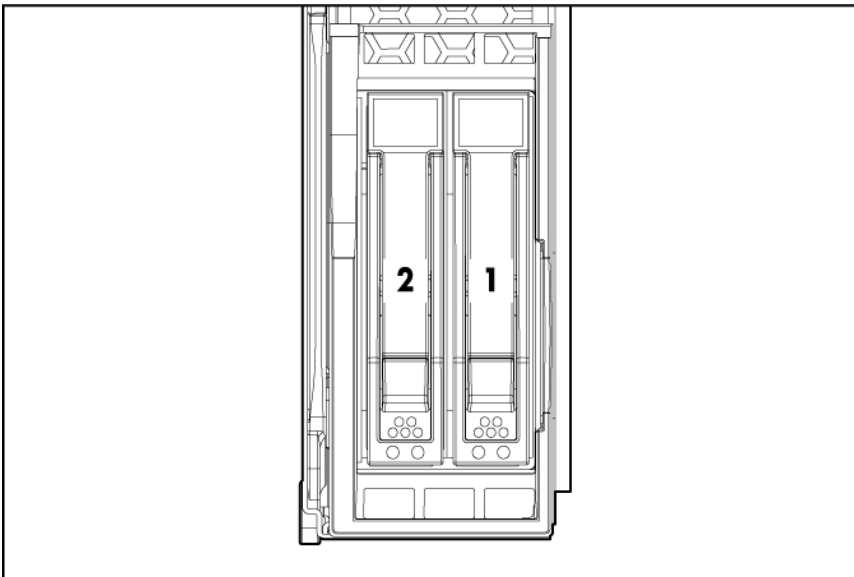

For the location of the SAS disk LEDs, see [SAS disk drive LEDs](#) on page 100.

To assess hard drive status, observe the SAS disk drive status LEDs. For an explanation of these LEDs, see [Front panel LEDs](#) on page 99.

---

**!** **IMPORTANT:**

Before removing a SAS disk drive, perform a complete data backup.

If disk drive mirroring is enabled, you do not have to power off the server blade before removing or replacing a SAS disk drive. If mirroring is not enabled, perform an OS shutdown before removing a disk drive to protect data.

You are not required to remove the server blade from the enclosure to remove and replace a SAS disk drive.

---

**Procedure**

1. Press the release button.
2. Open the ejector lever.
3. Slide the disk drive out of the drive cage.

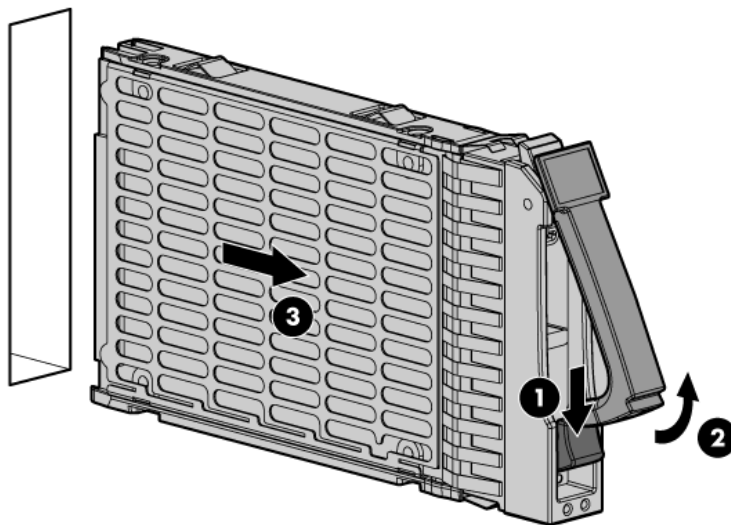

---

**⚠** **CAUTION:**

Populate hard drive bays with a SAS disk drive or a hard drive blank. Operating the server blade without a SAS disk drive or disk drive blank causes improper airflow and cooling, which can lead to thermal damage.

---

To replace the component, reverse the removal procedure.

## DIMM baffle

---

**⚠** **CAUTION:**

To avoid damage to the server blade and the enclosure, install the DIMM baffle in the proper location after adding or replacing DIMMs. DIMM baffles that are missing or installed incorrectly can compromise server blade and enclosure cooling.

---

## Procedure

1. Power off the server blade and remove it from the server blade enclosure (**Preparing the server blade for servicing** on page 118).
2. Remove the access panel (**Access panel** on page 124).
3. Pull the DIMM baffle straight up and out.

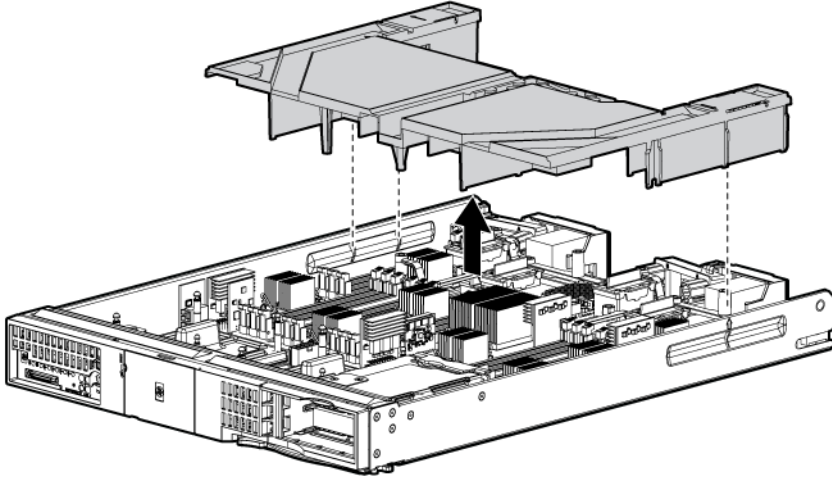

To replace the component, reverse the removal procedure.

## DIMMs

The memory subsystem supports only DDR3 SDRAM technology using industry-standard 1.2" high DIMMs.

Single DIMM sizes	BL860c i4 Min / Max Memory size	BL870c i4 Min / Max Memory size	BL890c i4 Min / Max Memory size
4 GB	8 GB / 96 GB	16 GB / 192 GB	32 GB / 384 GB
8 GB	16 GB / 192 GB	32 GB / 384 GB	32 GB / 768 GB
16 GB	32 GB / 384 GB	64 GB / 768 GB	64 GB / 1.5 TB

### ⚠ CAUTION:

When a single DIMM is removed it must either be replaced with a new matching DIMM, or the DIMM load order must be adjusted.

## Procedure

1. Power off the server blade. (**Preparing the server blade for servicing** on page 118).
2. For the conjoined products only, remove the Blade Link.

3. Remove the server blade from the enclosure (**Preparing the server blade for servicing** on page 118).
4. Remove the access panel (**Access panel** on page 124).
5. Remove the DIMM baffle (**DIMM baffle** on page 126).
6. Locate the DIMM slots on the server blade system board (**Step 6**).
7. Open the DIMM slot latches for the DIMMs that are to be removed.
8. Remove the DIMM from the slot.

---

❗ **IMPORTANT:**  
DIMMs do not seat fully if turned the wrong way.

---

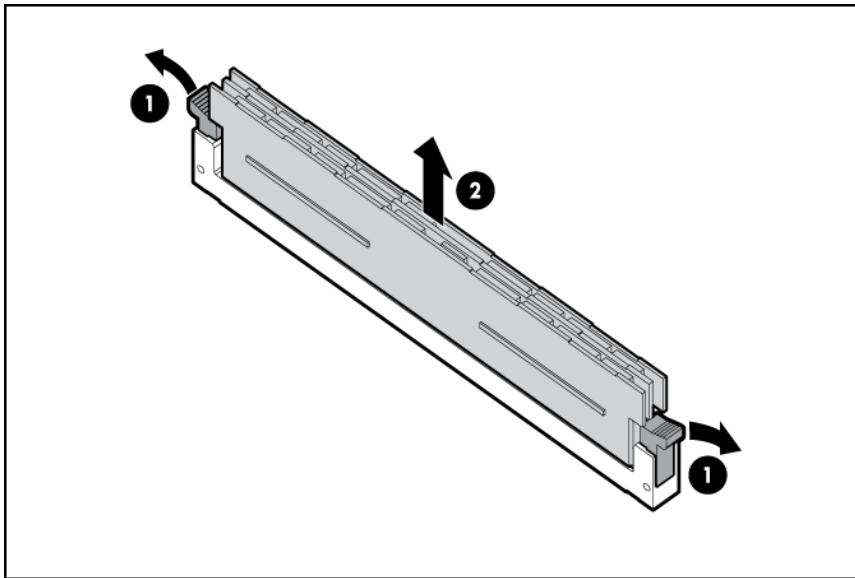

To replace the component, reverse the removal procedure.

---

❗ **IMPORTANT:**  
Follow the DIMM installation guidelines when replacing or adding DIMMs (**DIMMs** on page 50).

---

## CPU baffle

---

⚠ **CAUTION:**  
To prevent damage to the server blade, never power on a server blade without a CPU baffle or CPU in each CPU socket. The CPU baffle is needed for proper system cooling.

---

⚠ **CAUTION:**  
Immediately install a CPU baffle in an empty CPU socket. To avoid damage to the socket pins, the socket should never be uncovered for more than 5 seconds. If the socket is damaged, the entire base blade must be replaced.

---



## Procedure

1. Power off the server blade and remove it from the server blade enclosure (**Preparing the server blade for servicing** on page 118).
2. Remove the access panel (**Access panel** on page 124).
3. Pull the CPU baffle straight up and out.

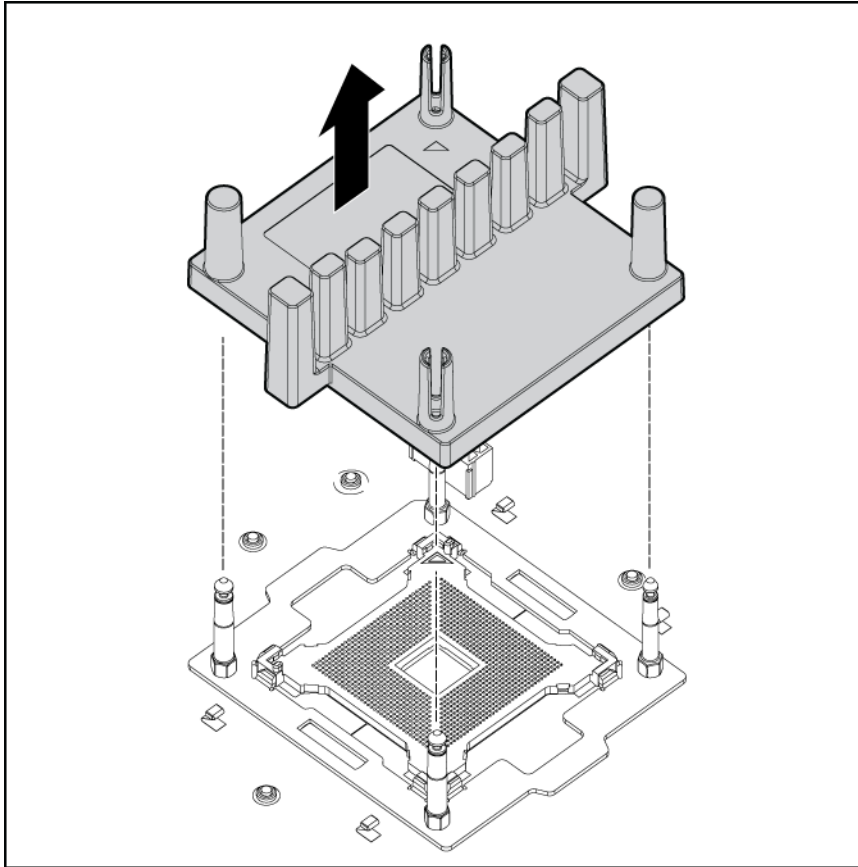

To replace the component, reverse the removal procedure.

## CPU and heatsink module

The BL860c i4 Server Blade contains a processor subsystem accommodating one or two Intel Itanium processor modules.

Each processor module consists of the following:

- CPU chip, including CPU cores, QPI links for CPU-CPU and CPU-IO Hub chip connections, and SMI links for CPU-Memory interface chip connections
- CPU power conversion module
- Heatsink, with mechanical attachment / assembly features



### WARNING:

To reduce the risk of personal injury from hot surfaces, allow the drives and the internal system components to cool before touching them.

---

---

**⚠ CAUTION:**  
To prevent possible server malfunction, do not mix CPUs of different speeds or cache sizes.

---

**⚠ CAUTION:**  
Removing a CPU will cause the DIMM loading rules to change. See **DIMMs** on page 50 and use the loading rules for two CPUs. If you do not perform these procedures, then any memory associated with the removed CPU will not be seen by the system.

---

**⚠ CAUTION:**  
To prevent thermal instability and damage to the server, do not separate the CPU module from the heatsink.

---

### Procedure

1. Power off the server, and remove it from the enclosure (**Preparing the server blade for servicing** on page 118).
  2. Remove the access panel (**Access panel** on page 124).
  3. Disconnect the power cord (see 1 below).
  4. Rotate the CPU locking handle up and back until it reaches a hard stop (see 2 below).
- 

**⚠ WARNING:**  
The heatsink locking lever can constitute a pinch hazard, keep your hands on top of the lever during installation to avoid personal injury.

---

5. Pull both plastic tabs out (see 3 below).

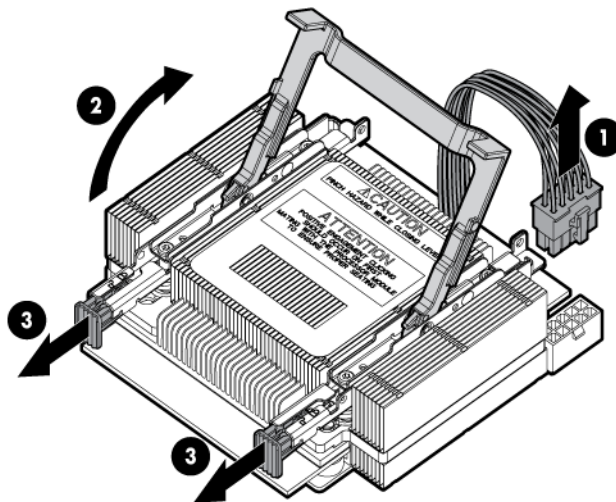

6. Lift the CPU and heatsink off of the socket, pulling straight up.

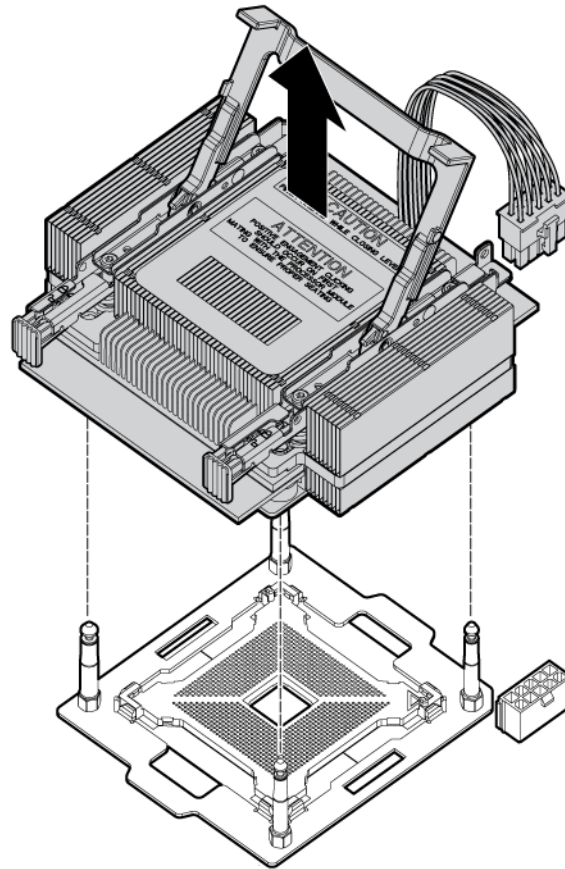

7. If the CPU is not being replaced, install a CPU baffle ( **CPU baffle** on page 128).

**⚠ CAUTION:**

To avoid damage to CPU socket pins and ensure proper system cooling, install a CPU baffle in an empty CPU socket.

The replacement CPU module is shipped from Hewlett Packard Enterprise without a heatsink. You will need to order and attach a heatsink to the processor module before installing them for repair. See **Processor and heatsink module** on page 45 for more information on the installation procedure.

**ⓘ IMPORTANT:**

- **DO NOT SEPARATE THE PROCESSOR FROM THE HEATSINK FOR A DEFECTIVE MATERIAL RETURN.**

The heat sink and processor must be returned as a unit to aid in testing and root cause analysis.

- Do not discard your heatsink packaging or processor ESD bag. Reuse this packaging to return any exchange material.
- You **MUST** use a new heatsink with an undisturbed thermal interface for processor installation.
- To receive credit for returning defective material, make sure to include the processor paperwork.

---

**NOTE:**

After replacing the processor and heatsink module use the `cpuconfig` from UEFI to verify the that the processor socket has been reconfigured.

---

## SAS backplane

The SAS disk backplane supports two small form factor hard disk drives. The backplane supports hot-plugging a single SAS drive at a time. The activity LEDs and drive present LEDs are controlled by a preprogrammed system-on-chip. The system board hosts the SAS controller and supplies 12 V, 5 V, and 3.3 V standby power to the backplane.

The SAS backplane is connected to the system board with a right angle connector. This connector is specifically designed for high-speed differential applications, and supports server speeds exceeding 5 Gigabits per second. Power, sense, and I<sup>2</sup>C signals are routed through this connector as well as the SAS differential pairs and SGPIO signals.

### Procedure

1. Power off the server blade and remove it from the enclosure (**Preparing the server blade for servicing** on page 118).
2. Remove the access panel (**Access panel** on page 124).
3. Remove the disk drives or disk drive blanks (**Disk drives** on page 125 or **Disk drive blanks** on page 124).
4. Lift the SAS back plane straight out of the server by the backplane handle.

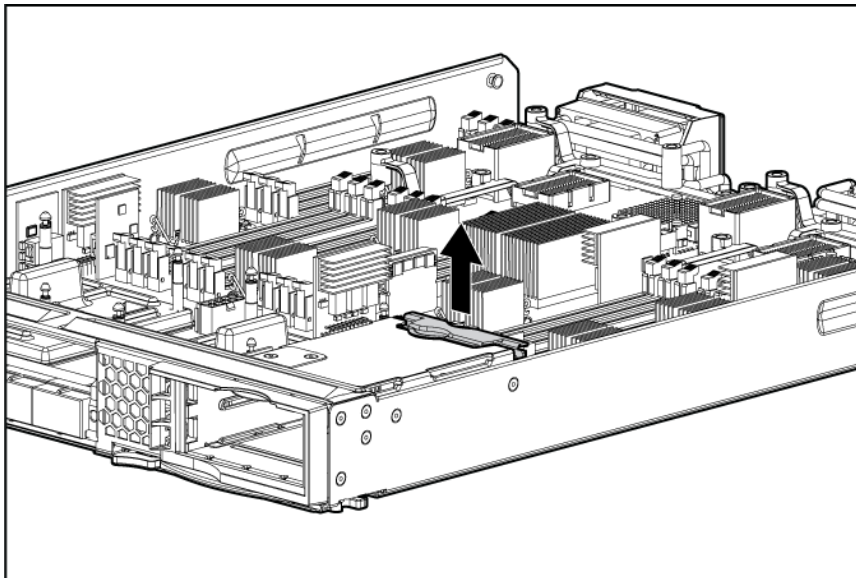

To replace the component, reverse the removal procedure.

## Server battery

If the server blade no longer automatically displays the correct date and time, you might have to replace the battery that provides power to the real-time clock. Under normal use, battery life is 5 to 10 years.

**WARNING:**

The computer contains an internal lithium manganese dioxide, a vanadium pentoxide, or an alkaline battery pack. A risk of fire and burns exists if the battery pack is not properly handled. To reduce the risk of personal injury:

- Do not attempt to recharge the battery.
  - Do not expose the battery to temperatures higher than 60°C (140°F).
  - Do not disassemble, crush, puncture, short external contacts, or dispose of in fire or water.
  - Replace only with the spare designated for this product.
- 

**Procedure**

1. Power off the server and remove it from the enclosure (**Preparing the server blade for servicing** on page 118).
2. Remove the access panel (**Access panel** on page 124).
3. Remove the battery.

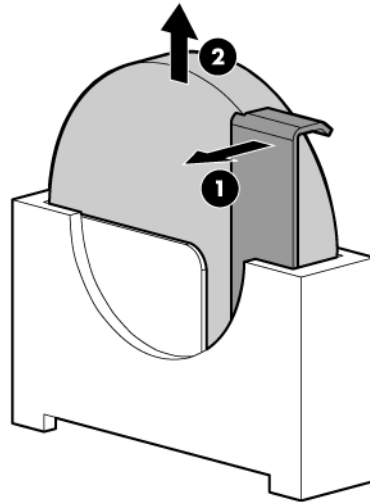

To replace the component, reverse the removal procedure.

## Mezzanine cards

The I/O subsystem is composed of embedded core I/O and up to three mezzanine cards. The server blade supports the following configurations:

- Up to three type I mezzanine cards using up to x8-PCIe Gen-2 links
- One type I and up to two type II mezzanine cards using up to x8-PCIe Gen-2 links

The server blade does not support PCI Hot Plug.

## Procedure

1. Power off the server and remove it from the enclosure (**Preparing the server blade for servicing** on page 118).
2. Remove the access panel (**Access panel** on page 124).
3. Remove the mezzanine card.

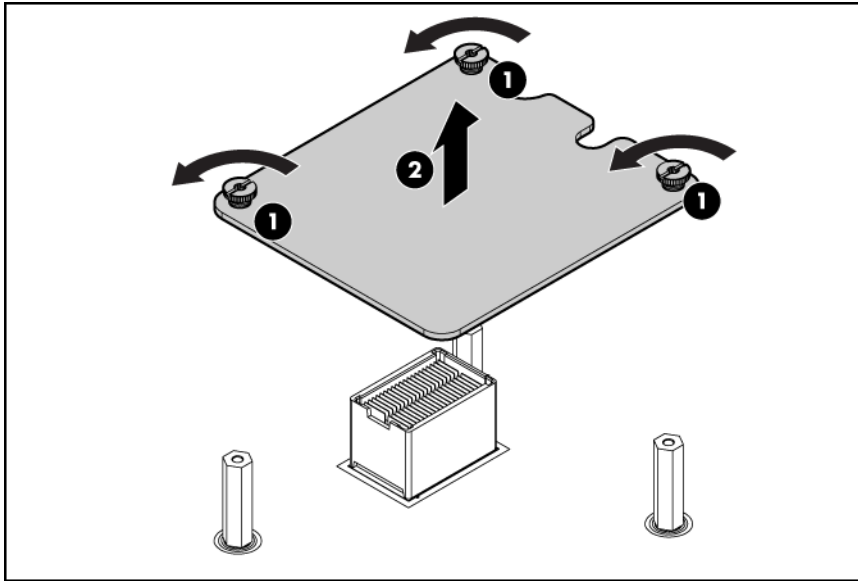

To replace the component, reverse the removal procedure.

## ICH mezzanine board

The ICH mezzanine card houses the following components:

- Intel ICH10 South Bridge
- ATI/AMD RN50/ES1000 Video Controller
- Embedded TPM 1.2<sup>1</sup>
- The internal USB port — **NOT SUPPORTED FOR USE**

One ICH mezzanine board is required per server blade in the BL860c i4. In the BL870c i4 and BL890c i4.

<sup>1</sup> Hewlett Packard Enterprise SPECIAL REMINDER: Before enabling TPM functionality on this system, you must ensure that your intended use of TPM complies with relevant local laws, regulations and policies, and approvals or licenses must be obtained if applicable. For any compliance issues arising from your operation/usage of TPM which violates the above mentioned requirement, you shall bear all the liabilities wholly and solely. Hewlett Packard Enterprise will not be responsible for any related liabilities.

惠普特别提醒：在您在系统中启用 TPM 功能前，请您务必确认，您将对 TPM 的使用遵守相关的当地法律、法规及政策，并已获得所需的一切事先批准及许可（如适用）。若因您未获得相应的操作/使用许可而发生的合规问题，皆由您自行承担全部责任，与惠普无涉。

## Procedure

1. Power off the server and remove it from the enclosure (**Preparing the server blade for servicing** on page 118).
2. Remove the access panel (**Access panel** on page 124).
3. Remove the ICH mezzanine card:

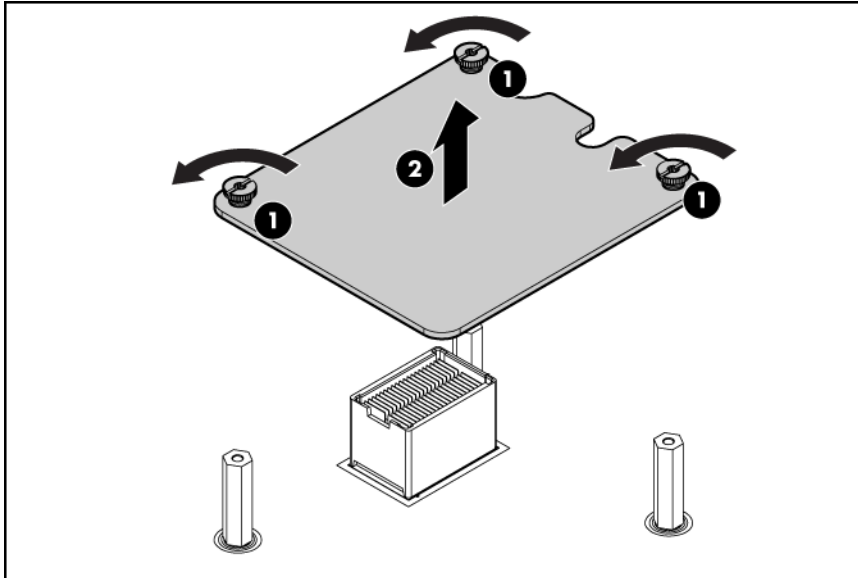

To replace the component, reverse the removal procedure.

## System board

### ⚠ CAUTION:

To prevent damage to the system board, do not remove the system board from the server blade.

In the event of a system board failure, both the system board and the server blade are replaced.

Before sending in the system board and server blade for replacement, remove the following components:

- The processor and heatsink module (**CPU and heatsink module** on page 129)
- The processor air baffle (**CPU baffle** on page 128)
- The DIMMs (**DIMMs** on page 127)
- The DIMM baffle (**DIMM baffle** on page 126)
- The Smart Array Supercap Pack (**Installing the Supercap Pack** on page 60)
- The Mezzanine cards (**Mezzanine cards** on page 133)
- The ICH mezzanine board (**ICH mezzanine board** on page 134)
- The hard disk drives (**Disk drives** on page 125)

Remove these items from the replacement base unit and place them on the defective base unit for protection during return shipment:

Item	Quantity
Protective processor covers	2
Mezzanine covers	4
Backplane connector covers	2

After replacing the system board and server blades:



**IMPORTANT:**

Replacement server blades are shipped with the RAID controller in HBA mode by default. If the server blade RAID controller was in RAID mode before replacement, you must change the mode using the `saupdate` utility before booting the OS. See [Configuring a Smart Array Controller](#) for instructions on using the `saupdate` utility.

- Be sure that the firmware on all conjoined blades matches ([Determining your current firmware revisions](#)).
- Be sure that the Stable storage info has transferred using the `sysset` command from the MP/iLO 3 TUI (CLI).

## Blade Link

Conjoining server blades using the Blade Link enables four (BL870c i4) and eight (BL890c i4) socket server blade variants.

In a conjoined configuration, one of the BL860c i4 Server Blades becomes the master blade, also referred to as the Monarch blade. The Monarch server blade is in the lowest numbered enclosure bay, communication to the conjoined server blade is done through the Monarch blade.

Conjoined configurations can be upgraded after the initial installation, see [Upgrading a conjoined configuration](#) on page 62 for more information on server blade upgrades.

Each Blade Link includes a trap door for the label carrier. To access the label carrier:

### Procedure

1. Locate the indentation on the upper-right corner of the access door.
2. Use the indent to pull the door open.



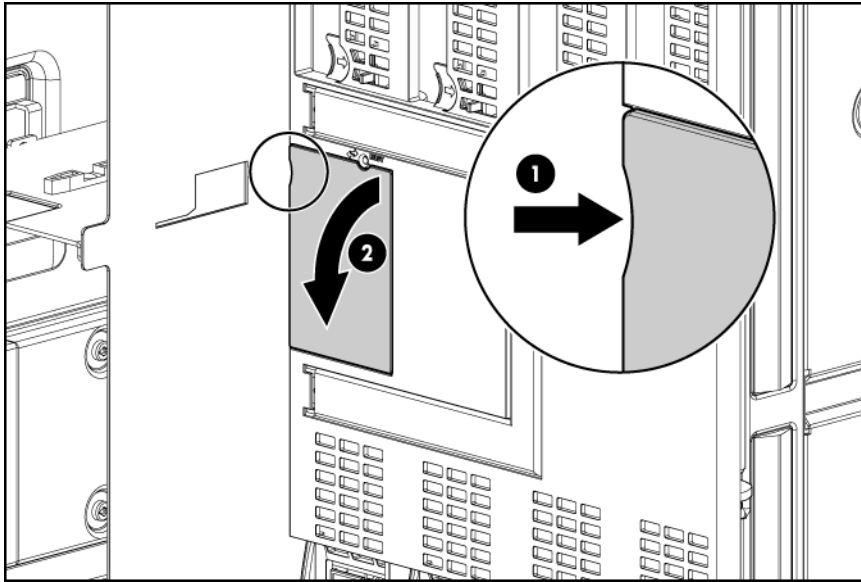

For more information see **Installing the Blade Link for BL860c i4, BL870c i4 or BL890c i4 configurations** on page 26.

# Support and other resources

## Accessing Hewlett Packard Enterprise Support

- For live assistance, go to the Contact Hewlett Packard Enterprise Worldwide website:  
[www.hpe.com/assistance](http://www.hpe.com/assistance)
- To access documentation and support services, go to the Hewlett Packard Enterprise Support Center website:  
[www.hpe.com/support/hpesc](http://www.hpe.com/support/hpesc)

### Information to collect

- Technical support registration number (if applicable)
- Product name, model or version, and serial number
- Operating system name and version
- Firmware version
- Error messages
- Product-specific reports and logs
- Add-on products or components
- Third-party products or components

## Accessing updates

- Some software products provide a mechanism for accessing software updates through the product interface. Review your product documentation to identify the recommended software update method.
- To download product updates, go to either of the following:
  - Hewlett Packard Enterprise Support Center **Get connected with updates** page:  
[www.hpe.com/support/e-updates](http://www.hpe.com/support/e-updates)
  - Software Depot website:  
[www.hpe.com/support/softwaredepot](http://www.hpe.com/support/softwaredepot)
- To view and update your entitlements, and to link your contracts and warranties with your profile, go to the Hewlett Packard Enterprise Support Center **More Information on Access to Support Materials** page:  
[www.hpe.com/support/AccessToSupportMaterials](http://www.hpe.com/support/AccessToSupportMaterials)

**IMPORTANT:**

Access to some updates might require product entitlement when accessed through the Hewlett Packard Enterprise Support Center. You must have an HP Passport set up with relevant entitlements.

## Websites

Website	Link
Hewlett Packard Enterprise Information Library	<a href="http://www.hpe.com/info/enterprise/docs">www.hpe.com/info/enterprise/docs</a>
Hewlett Packard Enterprise Support Center	<a href="http://www.hpe.com/support/hpesc">www.hpe.com/support/hpesc</a>
Contact Hewlett Packard Enterprise Worldwide	<a href="http://www.hpe.com/assistance">www.hpe.com/assistance</a>
Subscription Service/Support Alerts	<a href="http://www.hpe.com/support/e-updates">www.hpe.com/support/e-updates</a>
Software Depot	<a href="http://www.hpe.com/support/softwaredepot">www.hpe.com/support/softwaredepot</a>
Customer Self Repair	<a href="http://www.hpe.com/support/selfrepair">www.hpe.com/support/selfrepair</a>
Insight Remote Support	<a href="http://www.hpe.com/info/insightremotesupport/docs">www.hpe.com/info/insightremotesupport/docs</a>
Serviceguard Solutions for HP-UX	<a href="http://www.hpe.com/info/hpux-serviceguard-docs">www.hpe.com/info/hpux-serviceguard-docs</a>
Single Point of Connectivity Knowledge (SPOCK) Storage compatibility matrix	<a href="http://www.hpe.com/storage/spock">www.hpe.com/storage/spock</a>
Storage white papers and analyst reports	<a href="http://www.hpe.com/storage/whitepapers">www.hpe.com/storage/whitepapers</a>

## Customer self repair

Hewlett Packard Enterprise customer self repair (CSR) programs allow you to repair your product. If a CSR part needs to be replaced, it will be shipped directly to you so that you can install it at your convenience. Some parts do not qualify for CSR. Your Hewlett Packard Enterprise authorized service provider will determine whether a repair can be accomplished by CSR.

For more information about CSR, contact your local service provider or go to the CSR website:

[www.hpe.com/support/selfrepair](http://www.hpe.com/support/selfrepair)

## Remote support

Remote support is available with supported devices as part of your warranty or contractual support agreement. It provides intelligent event diagnosis, and automatic, secure submission of hardware event notifications to Hewlett Packard Enterprise, which will initiate a fast and accurate resolution based on your product's service level. Hewlett Packard Enterprise strongly recommends that you register your device for remote support.

For more information and device support details, go to the following website:

[www.hpe.com/info/insightremotesupport/docs](http://www.hpe.com/info/insightremotesupport/docs)

## Documentation feedback

Hewlett Packard Enterprise is committed to providing documentation that meets your needs. To help us improve the documentation, send any errors, suggestions, or comments to Documentation Feedback ([docsfeedback@hpe.com](mailto:docsfeedback@hpe.com)). When submitting your feedback, include the document title, part number, edition, and publication date located on the front cover of the document. For online help content, include the product name, product version, help edition, and publication date located on the legal notices page.

# RAID configuration and other utilities

## Configuring a Smart Array Controller

### Using the `saupdate` command

The `saupdate` command is used to query or change the mode of the Smart Array P410i and Smart Array P411 controllers to HBA or RAID. Querying or changing modes is not supported for other controllers.

The following are the newly added commands to `saupdate`:

- `get_mode`
- `set_mode`

### Get mode

This command displays the current mode of the controllers.

---

**NOTE:**

Terminal windows should be set to a window size of 80 columns x 25 rows for optimal viewing of the console at UEFI.

---

### Syntax

```
saupdate get_mode <controller>
```

`<controller>` can be any one of the strings listed in [Table 15](#).

**Table 17: `<controller>` strings**

<code>&lt;controller&gt;</code>	Meaning
<code>&lt;seg:bus:dev:func&gt;</code>	A controller having the PCI segment id, bus id, device id and function id is addressed
<code>all</code>	Addresses all controllers in the system
<code>&lt;model&gt;</code>	Controllers of a particular type indicated by the <code>&lt;model&gt;</code> string are addressed

```
fs2:\> saupdate get_mode 0:2:0:0

The controller at 0:2:0:0 is in HBA mode

fs2:\> saupdate get_mode p410i

The controller at 0:2:0:0 is in HBA mode

The controller at 0:42:0:0 is in HBA mode

The controller at 0:82:0:0 is in HBA mode

The controller at 0:C2:0:0 is in HBA mode

fs2:\> saupdate get_mode all

The controller at 0:2:0:0 is in HBA mode

The controller at 0:42:0:0 is in HBA mode

The controller at 0:82:0:0 is in HBA mode

The controller at 0:C2:0:0 is in HBA mode

fs2:\> █
```

## Set mode

---

❗ **IMPORTANT:**

If you are using HBA mode, do not install any disk that has previously been a part of a RAID volume into the system.

---

Use `set_mode` to change the mode of the controller. If the controller is already in the required mode the following message appears:

```
The controller at <seg:bus:dev:func> is already in HBA|RAID mode
```

### Syntax

```
saupdate set_mode <controller> <hba|raid> [-f]
```

`<controller>` can be any one of the strings listed in [Table 15](#).

An alert message about the possible data loss is displayed when a mode change command is issued. A confirmation is required before the actual mode change is made. This ensures unintentional change of mode does not happen.

The `-f` option indicates the user is aware of the changes that are being made and there is not need of a warning message or a confirmation regarding the mode change.

```
16.93.73.165 - PuTTY

fs2:\> saupdate set_mode all hba -f

Changing mode of the controller at 0:2:0:0 to HBA
Resetting and reinitializing controller,it may take several minutes
Controller mode change successful

Changing mode of the controller at 0:42:0:0 to HBA
Resetting and reinitializing controller,it may take several minutes
Controller mode change successful

Changing mode of the controller at 0:82:0:0 to HBA
Resetting and reinitializing controller,it may take several minutes
Controller mode change successful

Changing mode of the controller at 0:C2:0:0 to HBA
Resetting and reinitializing controller,it may take several minutes
Controller mode change successful

fs2:\> █
```



**IMPORTANT:**

After changing the mode, perform a `reconnect-r` command at UEFI.

**NOTE:**

Commands are not case-sensitive.

## Updating the firmware using saupdate

### Procedure

1. Download the firmware image file into the system's UEFI partition.
2. Boot the system to the UEFI Shell and change directories to the UEFI partition.
3. Use the `saupdate list` command to display all detected Smart Array controllers along with the active firmware versions, the identification information from this list is used to designate which controller is to be updated.
4. Use `saupdate update <seg:bus:dev:func:index> <firmware image>` to update the firmware.
5. Restart the system.

## Determining the *Driver ID* and *CTRL ID*

Use the `drvcfg` utility and UEFI shell commands to find the Driver ID corresponding Ctrl ID for the SAS Host Bus Adapter.

## Procedure

1. At the UEFI shell, use the `drivers` command.
2. Find the SAS Host Bus Adapter in the list of drivers, and make a note of the Driver ID from the left column.
3. Use the `drvcfg` command.
4. Find the SAS Host Bus Adapter's Driver ID in the list, and make a note of the corresponding Ctrl ID.

```
Shell> drivers
          T   D
D         Y C I
R         P F A
V  VERSION  E G G #D #C DRIVER NAME                IMAGE NAME
=====
23 0000000A B - - 1 61 PCI Bus Driver                PciBusDxe
92 00000010 D - - 1 - Usb Ehci Driver                EhciDxe
94 0000000A D - - 4 - Simple Network Protocol Driver  SnpDxe
A4 00000312 B X X 1 2 Smart Array SAS Driver v3.12   MemoryMapped(0xB,0x
A7 00050023 B X X 1 1 Broadcom 10 Gigabit Ethernet Driver MemoryMapped(0xB,0x
A9 00050023 B X X 1 1 Broadcom 10 Gigabit Ethernet Driver MemoryMapped(0xB,0x
B2 00050023 B X X 1 1 Broadcom 10 Gigabit Ethernet Driver MemoryMapped(0xB,0x
B4 00050023 B X X 1 1 Broadcom 10 Gigabit Ethernet Driver MemoryMapped(0xB,0x

Shell> drvcfg
Configurable Components
Drv[A7] Ctrl[A6] Lang[en-US;eng]
Drv[A9] Ctrl[A8] Lang[en-US;eng]
Drv[B2] Ctrl[B1] Lang[en-US;eng]
Drv[B4] Ctrl[B3] Lang[en-US;eng]
Drv[A4] Ctrl[A3] Lang[eng]

Shell> drvcfg -s a4 a3
```

### NOTE:

If the drivers listing shows X under CFG and DIAG, the drive is in RAID mode and you can run `drvcfg` against it.

If the drivers listing shows - under CFG and DIAG, the drive is in HBA mode.

## Configuring RAID volumes using the ORCA menu-driven interface

### NOTE:

The function keys cannot be used in ORCA if you are using a serial console. Substitute **ESC** followed by the corresponding number key. For example, **F3** would be **Esc-3**.

### NOTE:

ORCA will not launch if there is no hard disk drive in the server blade.

From the UEFI Shell, enter `drvcfg -s <Driver ID> <Ctrl ID>`. To locate this information, see [Determining the Driver ID and CTRL ID](#) on page 143.



```

Shell> drivers
          T   D
D         Y C I
R         P F A
V VERSION E G G #D #C DRIVER NAME          IMAGE NAME
=====
23 00000000A B - - 1 61 PCI Bus Driver      PciBusDxe
92 000000010 D - - 1 - Usb Ehci Driver      EhciDxe
94 00000000A D - - 4 - Simple Network Protocol Driver SnpDxe
a4 000000312 B X X 1 2 Smart Array SAS Driver v3.12 MemoryMapped<0xB,0x
a7 00050023 B X X 1 1 Broadcom 10 Gigabit Ethernet Driver MemoryMapped<0xB,0x
a9 00050023 B X X 1 1 Broadcom 10 Gigabit Ethernet Driver MemoryMapped<0xB,0x
B2 00050023 B X X 1 1 Broadcom 10 Gigabit Ethernet Driver MemoryMapped<0xB,0x
B4 00050023 B X X 1 1 Broadcom 10 Gigabit Ethernet Driver MemoryMapped<0xB,0x

Shell> drvcfg
Configurable Components
Drv[A7] Ctrl[A6] Lang[en-US;eng]
Drv[A9] Ctrl[A8] Lang[en-US;eng]
Drv[B2] Ctrl[B1] Lang[en-US;eng]
Drv[B4] Ctrl[B3] Lang[en-US;eng]
Drv[A4] Ctrl[A3] Lang[eng]

Shell> drvcfg -s a4 a3_

```

The ORCA main menu will appear.

```

Option Rom Configuration for Arrays, version 3.12
Copyright 2009 Hewlett-Packard Development Company, L.P.
Controller: HP Smart Array P410i

+-----Main Menu-----+
| Create Logical Drive   |
| View Logical Drive    |
| Delete Logical Drive  |
+-----+

<Enter> to create a new logical drive
<UP/DOWN ARROW> to select main menu option; <ESC> to exit

```

The ORCA main menu contains the following options:

- Create Logical Drive
- View Logical Drive
- Delete Logical Drive

---

**NOTE:**

If you are configuring the Smart Array P700m/512 Controller or the HPE StorageWorks SB40c storage blade (P400 controller), then you can enter ORCA from POST by pressing the **F8** key when prompted.

---

## Creating a logical drive

### Procedure

1. At the ORCA main menu, select Create Logical Drive.

```
Option Rom Configuration for Arrays, version 3.12
Copyright 2009 Hewlett-Packard Development Company, L.P.
Controller: HP Smart Array P410i

+-----Available Physical Drives-----+ +---Raid Configurations-----+
| [X] Port 1I, Box 1, Bay 1, 73.4 GB SAS | | [ ] RAID 1+0 |
| [X] Port 1I, Box 1, Bay 2, 73.4 GB SAS | | [X] RAID 0 |
+-----+ +-----+

+-----Spare-----+
| [ ] Use one drive as spare |
+-----+

<Enter> to create a logical drive; <Tab> to navigate
<UP/DOWN ARROW> to scroll; <ESC> to return
```

2. Select the physical disks to be included in the logical drive in the Available Physical Drives section.
3. To select the Raid Configurations section and select the RAID type for the logical drive, press **Tab**.
4. To select the Spare section and assign spare disks, as needed, press **Tab**.
5. To create the logical drive, press **Enter**. A summary of your choices appears.

```
Option Rom Configuration for Arrays, version 3.12
Copyright 2009 Hewlett-Packard Development Company, L.P.
Controller: HP Smart Array P410i
```

```
+-----+
| You have selected a logical drive with a total
| data size of 136.7 GB and RAID 0 fault tolerance.
|
| Press <F8> to save the configuration
| Press <ESC> to cancel
+-----+
```

```
<F8> to save the configuration
<ESC> to cancel
```

6. To save the configuration, press **F8**.
7. To acknowledge that the configuration was saved and return to the ORCA Main Menu, press **Enter**.

## Deleting a logical drive

---



### WARNING:

Back up all necessary data before deleting the logical drive. When you delete a logical drive, data on the drive is not preserved.

---

### Procedure

1. At the ORCA main menu, select Delete Logical Drive.

```
Option Rom Configuration for Arrays, version 3.12
Copyright 2009 Hewlett-Packard Development Company, L.P.
Controller: HP Smart Array P410i

+-----Main Menu-----+
| Create Logical Drive   |
| View Logical Drive    |
| Delete Logical Drive   |
+-----+

<Enter> to delete an existing logical drive
<UP/DOWN ARROW> to select main menu option; <ESC> to exit
```

- 2. Select a logical drive to be deleted.

```
Option Rom Configuration for Arrays, version 3.12
Copyright 2009 Hewlett-Packard Development Company, L.P.
Controller: HP Smart Array P410i

+-----Available Logical Drives-----+
| Logical Drive # 1, RAID 0, 136.7 GB,   | OK |
+-----+

<F8> to delete the logical drive
<UP/DOWN ARROW> to scroll; <ESC> to return
```

- 3. Press **F3** to delete the logical drive.

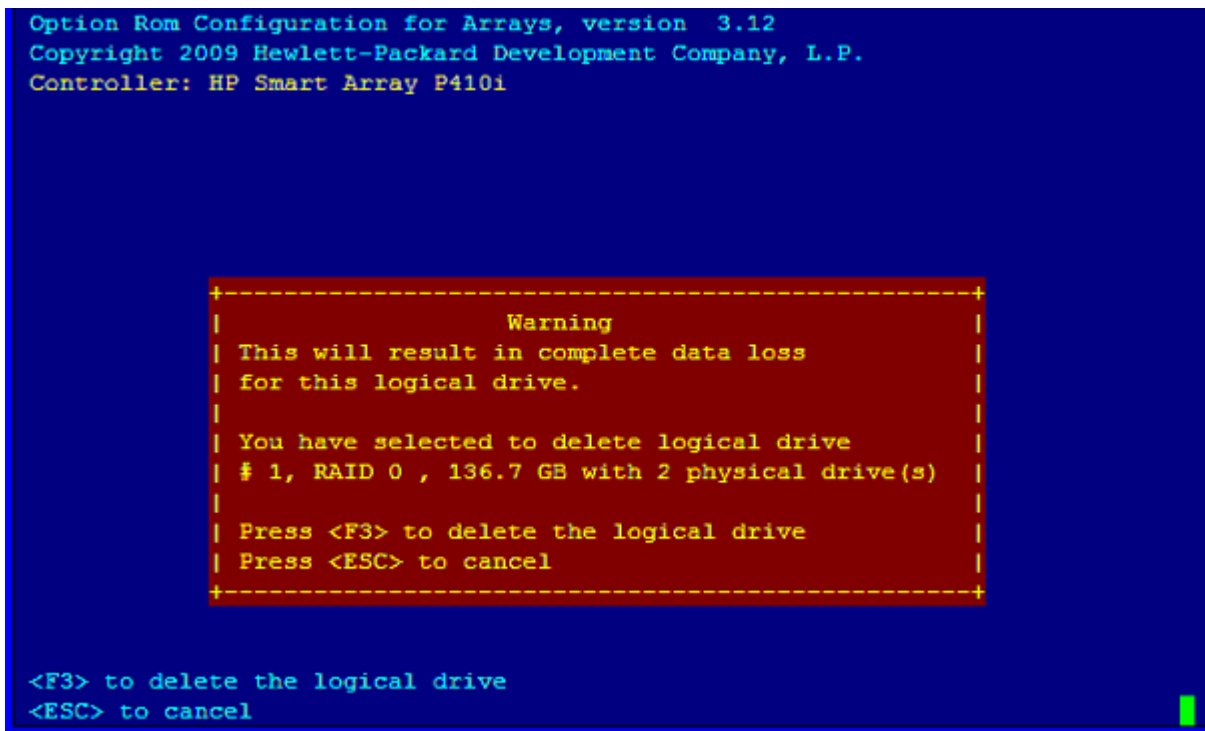

4. To acknowledge that the configuration was saved and return to the ORCA Main Menu, press **Enter**.

## Useful UEFI command checks

`saupdate.efi list`

Use `saupdate.efi list` to list controller information such as the controller version.

Seg	Bus	Dev	Func	Description	Version	Build
0	2	0	0	HP Smart Array P410i	3.00	0

`drivers`

Use `drivers` to find the driver version and DRV #.

94	00000000	D	-	4	-	Simple Network Protocol Driver	SnpDxe	
A4	00000312	B	X	X	1	2	Smart Array SAS Driver v3.12	MemoryMapped(0xB, 0x
02	00050023	B	X	X	1	1	Broadcom 10 Gigabit Ethernet Driver	MemoryMapped(0xB, 0x

`pci-i <path>`

Use `pci-i <path>` to find vendor information.

00	02	00	00	==>	Mass Storage Controller - RAID controller
					Vendor 103C Device 323A Prog Interface 0

## UEFI

UEFI is an OS and platform-independent boot and preboot interface. UEFI resides between the OS and platform firmware, allowing the OS to boot without having details about the underlying hardware and firmware. UEFI supports boot devices, uses a flat memory model, and hides platform and firmware details from the OS.

---

**NOTE:**

Unified EFI Forum, Inc. defines the specification used to implement UEFI. POSSE is a Hewlett Packard Enterprise extension to UEFI, which provides a common user interface architecture to better serve Hewlett Packard Enterprise customers, service, and manufacturing.

---

UEFI consolidates boot utilities similar to those found in PA-RISC based servers, such as the BCH, and platform firmware into a single platform firmware. UEFI allows the selection of any UEFI OS loader from any boot medium that is supported by UEFI boot services. An UEFI OS loader supports multiple options on the user interface.

UEFI supports booting from media that contain an UEFI OS loader or an UEFI-defined server partition. An UEFI-defined system partition is required by UEFI to boot from a block device.

The UEFI boot manager loads UEFI applications (including the OS first stage loader) and UEFI drivers from an UEFI-defined file system or image loading service. NVRAM variables point to the file to be loaded. These variables contain application-specific data that is passed directly to the UEFI application. UEFI variables provides system firmware a boot menu that points to all the operating systems, even multiple versions of the same operating systems.

The UEFI boot manager allows you to control the server booting environment. Depending on how you have configured the boot options, after the server is powered up the boot manager presents you with different ways to bring up the server blade. For example, you can boot to the UEFI shell, to an operating system located on the network or residing on media in the server, or the Boot Maintenance Manager.

## UEFI Shell and POSSE commands

For more information on these commands, enter `help` command at the UEFI Shell prompt.

**Table 18: UEFI Shell Commands**

UEFI Shell Command	Definition
?	Displays the UEFI Shell command list or verbose command help
alias	Displays, creates, or deletes UEFI Shell aliases
attrib	Displays or changes the attributes of files or directories
autoboot	Set/View autoboot timeout and retries
bcfg	Display/Modify the driver/boot configuration
boottest	Turn specific speedyboot bits on or off
cd	Displays or changes the current directory
cls	Clears standard output and optionally changes background color
comp	Compares the contents of two files
conconfig	Configure consoles and set/view primary operating system console

*Table Continued*

<b>UEFI Shell Command</b>	<b>Definition</b>
connect	Connects one or more UEFI drivers to a device
cp	Copies one or more files or directories to another location
cpuconfig	Deconfigure/Reconfigure processor sockets and threads
date	Displays or changes the current system date
dblk	Displays one or more blocks from a block device
dbprofile	Manage direct boot profiles
default	Set default values
devices	Displays the list of devices managed by UEFI drivers
devtree	Displays the UEFI Driver Model compliant device tree
dh	Displays UEFI handle information
disconnect	Disconnects one or more UEFI drivers from a device
dmem	Displays the contents of memory
dmpstore	Displays, saves, loads or deletes all UEFI NVRAM variables
drivers	Displays the UEFI driver list
drvcfg	Invokes the Driver Configuration Protocol
drvdiag	Invokes the Driver Diagnostics Protocol
echo	Controls batch file command echoing or displays a message
edit	Full screen editor for ASCII or UNICODE files
eficompress	Compress a file
efidecompress	Decompress a file
errdump	View/Clear logs
exit	Exits the UEFI Shell environment
for	Executes commands for each item in a set of items
ftp	Perform FTP operation
goto	Forces batch file execution to jump to specified location

*Table Continued*

<b>UEFI Shell Command</b>	<b>Definition</b>
guid	Displays all registered UEFI GUIDs
help	Displays the UEFI Shell command list or verbose command help
hexedit	Full screen hex editor
if	Executes commands in specified conditions
ifconfig	Modify the default IP address of UEFI network stack
info	Display hardware information
input	Take user input and place in UEFI variable
ioconfig	Deconfigure/Reconfigure IO components or settings
lanaddress	Display LAN devices
lanboot	LAN boot
load	Loads and optionally connects one or more UEFI drivers
loadpcirom	Loads a PCI Option ROM
ls	Displays a list of files and subdirectories in a directory
map	Displays or defines mappings
memconfig	Set/View memory configuration settings
memmap	Displays the memory map
mkdir	Creates one or more directories
mm	Displays or modifies MEM/MMIO/IO/PCI/PCIE address space
mode	Displays or changes the console output device mode
mount	Mounts a file system on a block device
mv	one or more files or directories to another location
openinfo	Displays the protocols and agents associated with a handle
palproc	Make a PAL procedure call
pause	Prints a message and waits for keyboard input
pci	Displays PCI device list or PCI function configuration space

*Table Continued*



UEFI Shell Command	Definition
ping	Ping a target machine with UEFI network stack
reconnect	Reconnects one or more UEFI drivers to a device
reset	Resets the system
rm	Deletes one or more files or directories
salproc	Make a SAL procedure call
seconfig	View/configure system security features
sermode	Sets serial port attributes
set	Displays or modifies UEFI Shell environment variables
setsize	Set the size of a file
shift	Shifts batch file input parameter positions
smbiosview	Displays SMBIOS information
stall	Stalls the processor for the specified number of microseconds
tapeboot	Boot from tape
tftp	Perform TFTP operation
time	Displays or changes the current system time
timezone	Displays or sets time zone information
touch	Updates filename timestamp with current system date and time
type	Displays file contents
unload	Unloads a UEFI driver
ver	Displays UEFI Firmware version information
vol	Displays or changes a file system volume label
xchar	Turn on/off extended character features

## Drive paths in UEFI

Devices in the server blade are represented by device paths in the UEFI shell. Each internal SAS drive could be configured either as:

- RAID mode
- HBA (raw) mode

**NOTE:**

A SAS drive in RAID mode is identified by "Scsi" in the device path A SAS drive in HBA mode is identified by "SAS" in the device path.

**NOTE:**

Unlike parallel SCSI, you cannot correlate UEFI device paths to internal SAS disk drive bays with SAS regardless of RAID/HBA mode. The UEFI device paths currently do not contain any information that could be used to determine the physical location of the drives.

Device	Path format	Path example
PCIe root bridge device path node	UID	PcieRoot(0x30304352)/Pci(0x2,0x0)/ Pci(0x0,0x0)/Scsi(0x0,0x0)  (RAID mode)
		PcieRoot(0x30304352)/Pci(0x2,0x0)/Pci(0x0,0x0)/ SAS(0x5000C500037688B9,0x0,0x1,NoTopology,0,0,0,0x0)  (HBA mode)
Hard drive partition device path	HD (Partition, Type, Signature)	PcieRoot(0x30304352)/Pci(0x2,0x0)/ Pci(0x0,0x0)/Scsi(0x0,0x0)/ HD(1,GPT,27C34F01-9F1E-11DE-A0BB-AA000400FEFF)  (RAID mode)
		PcieRoot(0x30304352)/Pci(0x2,0x0)/Pci(0x0,0x0)/ SAS(0x5000C500037688B9,0x0,0x1,NoTopology,0,0,0,0x0)/ HD(1,GPT,27C34F01-9F1E-11DE-A0BB-AA000400FEFF)  (HBA mode)
CD-ROM / DVD-ROM partition device path	CDROM(Entry)	PcieRoot(0x30304352)/Pci(0x1D,0x7)/ USB(0x3,0x0)/CDROM(0x1)

**NOTE:**

Everything after "Scsi" or "SAS" in the output can vary because each SAS drive/partition is unique

## Using the Boot Maintenance Manager

This menu allows you to change various boot options. The Boot Maintenance Manager Contains the following submenus:

- Boot Options
- Driver Options
- Console Configuration
- Boot From File
- Set Boot Next Value
- Set Time Out Value
- Reset System

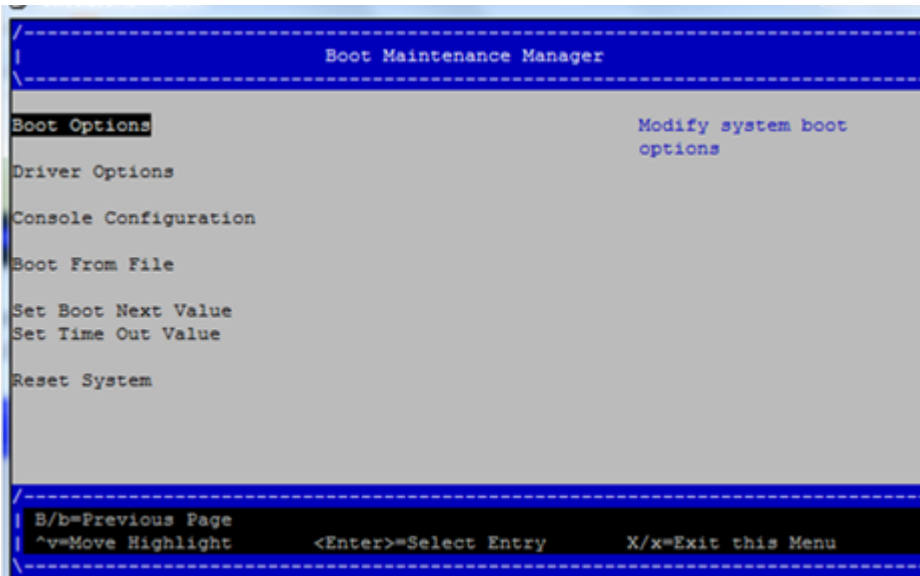

## Boot Options

The Boot Options menu contains the following options:

- Add Boot Option
- Delete Boot Option
- Change Boot Order



## Add Boot Option

Use this option to add items to the Boot Options list.

To add a boot option:

### Procedure

1. Select a boot device type.



2. Use the File Explorer menu to locate the correct boot device.

---

**NOTE:**

File Explorer will load with the appropriate devices for the selected boot device.

---

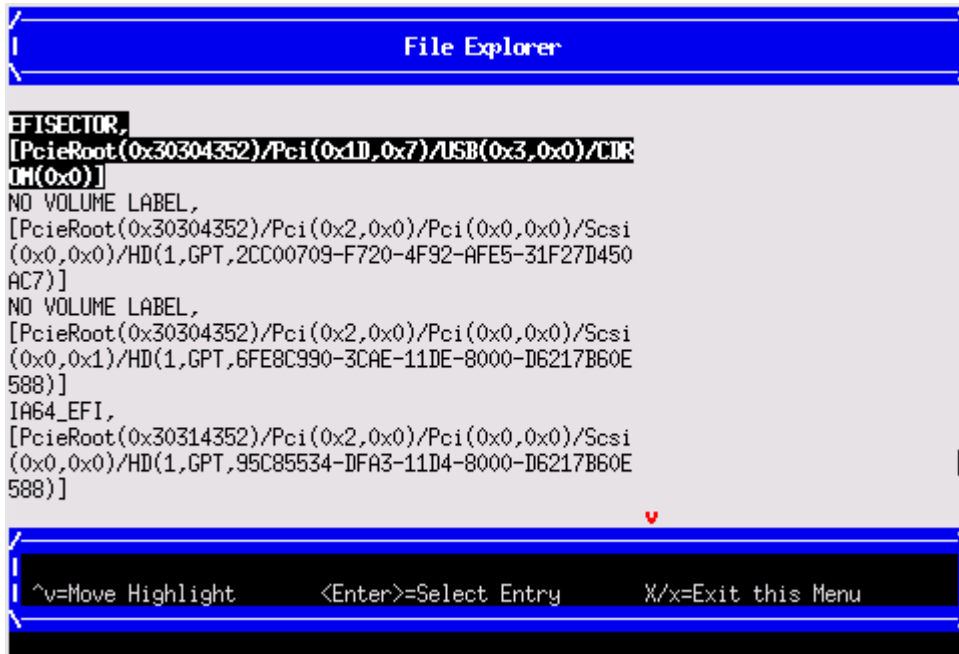

## Delete Boot Option

Use this option to remove boot options from the Boot Options list.

---

**NOTE:**

This does not delete any files, applications or drivers from your server.

---

To remove items from the boot list:



## Procedure

1. Press **spacebar** to toggle the checkbox for each boot options that you want to delete.
2. Select **Commit Changes and Exit** to save the new settings and return to the Boot Maintenance Manager.

## Change Boot Order

Use this option to change the order of boot options. If the first boot option fails, the server tries booting the second, then the third, and so forth, until a boot option succeeds or until all options have failed.

For example, if you normally boot using a configuration on your LAN but would like to boot from a local hard drive if the LAN is unavailable, move the LAN boot option to the top of the list, followed by the hard drive boot option.

To change the boot order:

## Procedure

1. Select an item on the boot order list.
2. Using the **+** and **-** keys, move the selection to the desired position in the book order list.

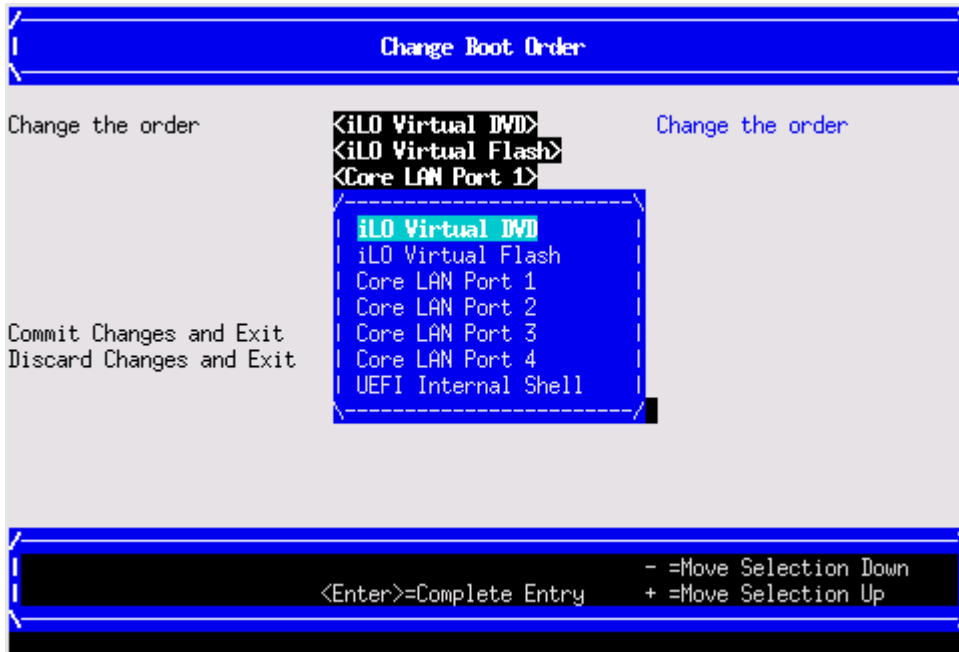

3. Press **Enter** when the item is in the desired position.
4. Select **Commit Changes and Exit** to save the new settings and return to the Boot Maintenance Manager.

## Driver Options

The Driver Options menu contains the following options:

- Add Driver Option
- Delete Driver Option
- Change Driver Order



## Add Driver Option

Use this option to add driver options.

To add a driver option:

### Procedure

1. Select **Add Driver Using File**.



2. Use the File Explorer menu to locate the correct driver.

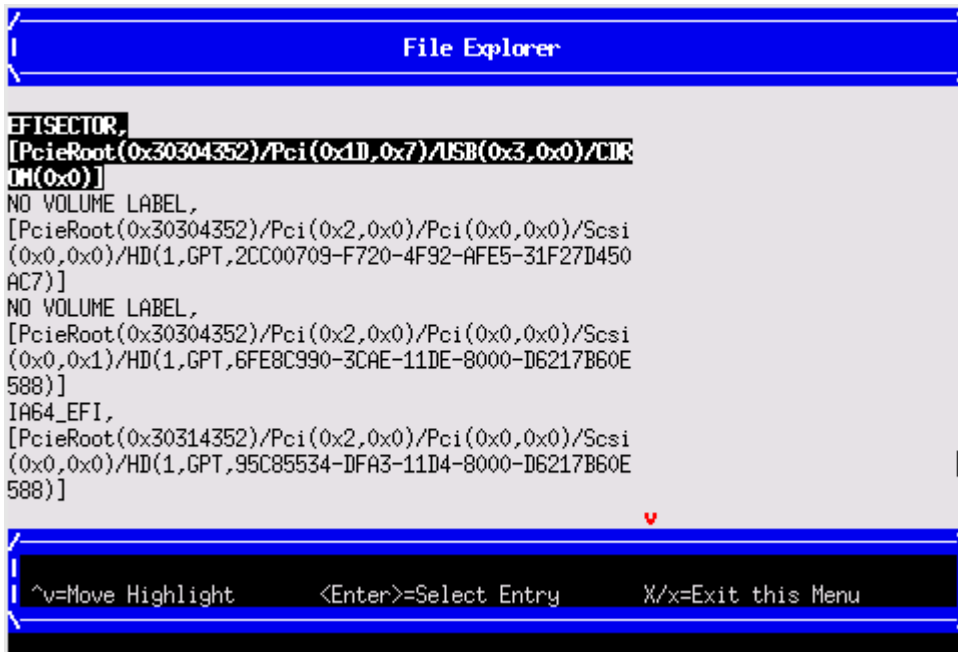

## Delete Driver Option

Use this option to remove driver options.

### NOTE:

This does not delete any files, applications or drivers from your server.

To remove driver options:



## Procedure

1. Press **spacebar** to toggle the checkbox for each driver that you want to delete.
2. Select **Commit Changes and Exit** to save the new settings and return to the Boot Maintenance Manager.

## Change Driver Order

Use this option to change the load order of driver options.

To change the driver load order:

### Procedure

1. Select an item on the driver list.
2. Using the **+** and **-** keys, move the selection to the desired position in the boot order list.
3. Press **Enter** when the item is in the desired position.
4. Select **Commit Changes and Exit** to save the new settings and return to the Boot Maintenance Manager.

## Console Configuration

BL8x0 i4 servers supports Console Configuration via GUI. The functionality is exactly the same as provided by the `conconfig` UEFI command which is available in i2 platforms as well. The console selection menu is implemented in the Boot Maintenance Manager. Selecting the **Console Configuration** from the Boot Maintenance Manager gives the different Console devices present in the system.

Select a console to configure.

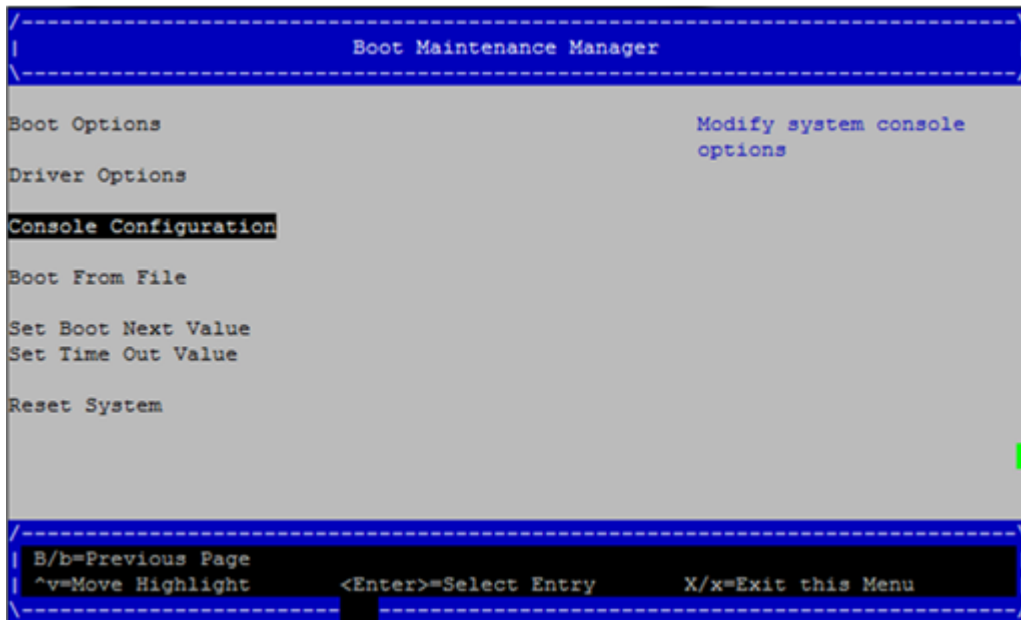

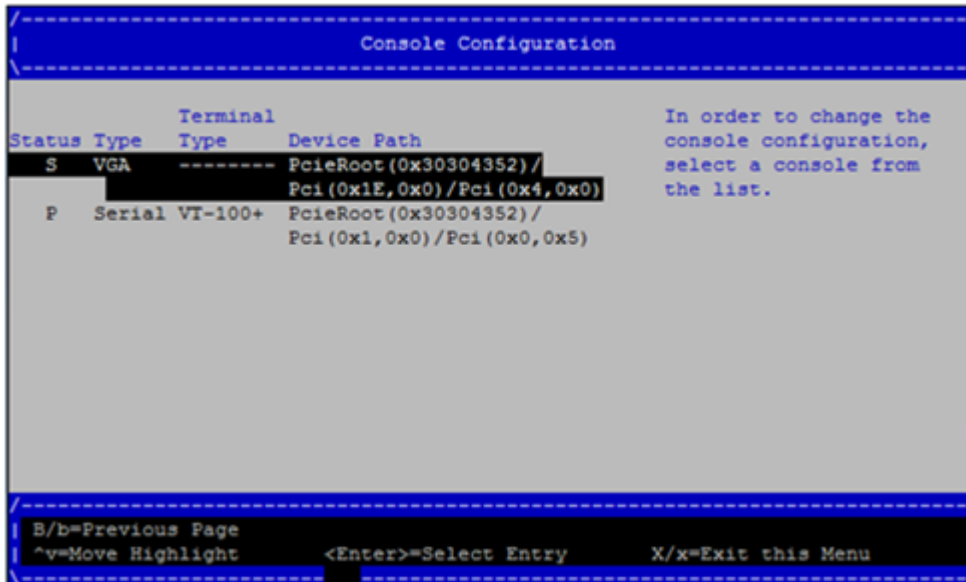

### Primary or Secondary

The console device can be marked as primary. Only one console device can be selected as primary. If the you set a console device as primary, then the rest of the console devices in the system becomes secondary (if NOT in Not Configured state).

### Enable or Disable

You can disable an active console, either primary or secondary, or enable a “Not Configured” console device.

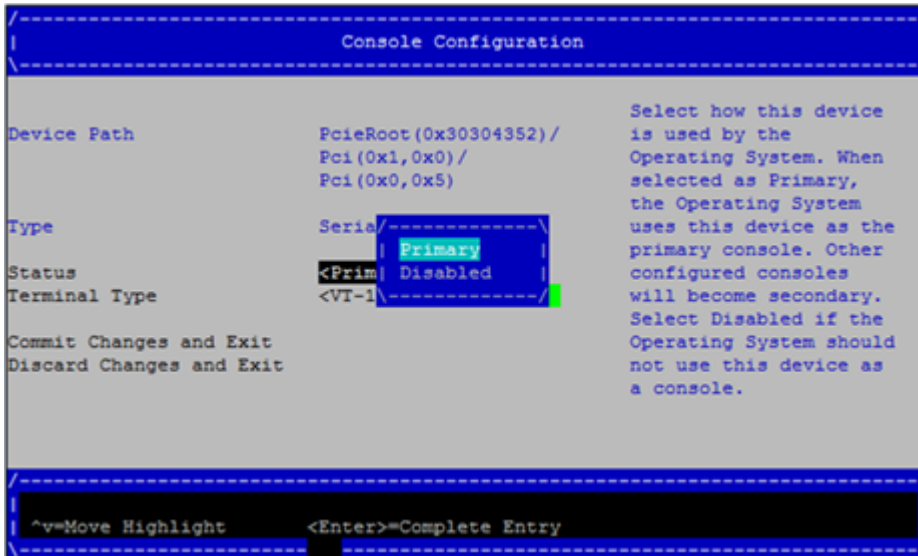

## Boot From File

Use this option to manually run a specific application or driver.

### NOTE:

This option boots the selected application or driver one time only. When you exit the application, you return to this menu.

## Procedure

1. Select a boot device type.



2. Use the File Explorer menu to locate the correct driver or file.

## Set Boot Next Value

Use this option to run the selected boot option immediately upon entering the main Boot Manager menu. This option is useful for booting an option that only needs to be booted once, without changing any other setting in the main Boot Manager menu. This is a one-time operation and does not change the permanent server boot settings.



## Set Time Out Value

Use this option to set the amount of time the server pauses before attempting to launch the first item in the Boot Options list.

Interrupting the timeout during the countdown stops the Boot Manager from loading any boot options automatically. If there is no countdown, boot options must be selected manually.

To set the auto boot timeout value, in seconds, select Set Timeout Value and enter the desired value.



## Reset System

Use this option to perform a system reset.



## iLO 3 MP

The iLO 3 MP is an independent support system for the server. It provides a way for you to connect to a server and perform administration or monitoring tasks for the server hardware.

The iLO 3 MP controls power, reset, ToC capabilities, provides console access, displays and records system events, and displays detailed information about the various internal subsystems. The iLO 3 MP also provides a virtual front panel used to monitor server status and the state of front panel LEDs. All iLO 3 MP functions are available through the LAN and the local RS-232 port.

The iLO 3 MP is available whenever the server is connected to a power source, even if the server main power switch is off.

Access to the iLO 3 MP can be restricted by user accounts. User accounts are password protected and provide a specific level of access to the server and MP commands.

For more information regarding the iLO 3 MP, see the *HPE Integrity iLO 3 Operations Guide*.

# Warranty and regulatory information

For important safety, environmental, and regulatory information, see *Safety and Compliance Information for Server, Storage, Power, Networking, and Rack Products*, available at [www.hpe.com/support/Safety-Compliance-EnterpriseProducts](http://www.hpe.com/support/Safety-Compliance-EnterpriseProducts).

## Warranty information

HPE ProLiant and x86 Servers and Options

[www.hpe.com/support/ProLiantServers-Warranties](http://www.hpe.com/support/ProLiantServers-Warranties)

HPE Enterprise Servers

[www.hpe.com/support/EnterpriseServers-Warranties](http://www.hpe.com/support/EnterpriseServers-Warranties)

HPE Storage Products

[www.hpe.com/support/Storage-Warranties](http://www.hpe.com/support/Storage-Warranties)

HPE Networking Products

[www.hpe.com/support/Networking-Warranties](http://www.hpe.com/support/Networking-Warranties)

## Regulatory information

### Belarus Kazakhstan Russia marking



**Manufacturer and Local Representative Information**

**Manufacturer information:**

Hewlett Packard Enterprise Company, 3000 Hanover Street, Palo Alto, CA 94304 U.S.

**Local representative information Russian:**

- **Russia:**

ООО «Хьюлетт Паккард Энтерпрайз», Российская Федерация, 125171, г. Москва, Ленинградское шоссе, 16А, стр.3, Телефон/факс: +7 495 797 35 00

- **Belarus:**

ИООО «Хьюлетт-Паккард Бел», Республика Беларусь, 220030, г. Минск, ул. Интернациональная, 36-1, Телефон/факс: +375 17 392 28 20

- **Kazakhstan:**

ТОО «Хьюлетт-Паккард (К)», Республика Казахстан, 050040, г. Алматы, Бостандыкский район, проспект Аль-Фараби, 77/7, Телефон/факс: + 7 727 355 35 52

#### Local representative information Kazakh:

- **Russia:**

ЖШС "Хьюлетт Паккард Энтерпрайз", Ресей Федерациясы, 125171,  
Мәскеу, Ленинград тас жолы, 16А блок 3, Телефон/факс: +7 495 797 35 00

- **Belarus:**

«HEWLETT-PACKARD Bel» ЖШС, Беларусь Республикасы, 220030, Минск қ.,  
Интернациональная көшесі, 36/1, Телефон/факс: +375 17 392 28 20

- **Kazakhstan:**

ЖШС «Хьюлетт-Паккард (К)», Қазақстан Республикасы, 050040, Алматы қ.,  
Бостандық ауданы, Әл-Фараби даңғылы, 77/7, Телефон/факс: +7 727 355 35 52

#### Manufacturing date:

The manufacturing date is defined by the serial number.

CCSYWWZZZZ (serial number format for this product)

Valid date formats include:

- YWW, where Y indicates the year counting from within each new decade, with 2000 as the starting point; for example, 238: 2 for 2002 and 38 for the week of September 9. In addition, 2010 is indicated by 0, 2011 by 1, 2012 by 2, 2013 by 3, and so forth.
- YYWW, where YY indicates the year, using a base year of 2000; for example, 0238: 02 for 2002 and 38 for the week of September 9.

## Turkey RoHS material content declaration

Türkiye Cumhuriyeti: EEE Yönetmeliğine Uygundur

## Ukraine RoHS material content declaration

Обладнання відповідає вимогам Технічного регламенту щодо обмеження використання деяких небезпечних речовин в електричному та електронному обладнанні, затвердженого постановою Кабінету Міністрів України від 3 грудня 2008 № 1057

# Standard terms, abbreviations, and acronyms

## A

### **ASIC**

Application-specific integrated circuit

### **Auxiliary**

Any blade in a conjoined server other than the lowest-numbered blade

## B

### **BBRAM**

Battery-backed RAM

### **BBWC**

Battery Backed Write Cache

### **BCH**

Boot console handler

## C

### **CE**

Customer engineer

### **CEC**

Core electronics complex

### **CMC**

Corrected machine check

### **CPE**

Corrected platform errors

### **CRU**

Customer replaceable unit

### **CSR**

Control status registers

## D

### **DDNS**

Dynamic domain name system

### **DHCP**

Dynamic host configuration protocol



**DLL**

Dynamic-link library

**DMA**

Direct memory access

**DMDC**

Data multiplexer/demultiplexer controller

**DNS**

Domain name system

**E****EFI**

Extensible Firmware Interface. See also **UEFI**.

**EMS**

Event management service

**ESD**

Electrostatic discharge

**F****FC**

Fibre Channel

**FPL**

Forward progress log

**FRU**

Field replaceable unit

**H****HBA**

Host bus adapter

**I****iLO 3**

Integrated Lights-Out

**IPF**

Itanium processor family

**L****LDAP**

Lightweight directory access protocol

**LVM**

Logical volume manager

**M****Monarch**

Designates a single-blade server, or lowest-numbered blade in a conjoined server

**MPS**

Maximum payload size

**MP**

Management processor

**N****NIC**

Network interface card

**NVRAM**

Non-Volatile RAM

**O****OA**

Onboard Administrator

**ORCA**

Option Rom Configuration for Arrays

**P****PA-RISC**

Precision Architecture, Reduced Instruction Set Computing

**PCA**

Printed circuit assembly

**PCI**

Peripheral component interface

**PCIe**

Peripheral component interconnect express

**PCI-X**

Peripheral component interconnect extended

**POL**

Point-of-load

**POSSE**

Pre-OS system startup environment

**POST**

Power-On Self-Test

**Q****QPI**

Intel QuickPath Interconnect

**S****SAL**

System abstraction layer

**SAS**

Serial attached SCSI

**SATA**

Serial ATA

**SBA**

System bus adapter

**SEL**

System event log

**SFM**

System fault management

**SMH**

System management homepage

**SGPIO**

Serial general purpose input/output

**SSH**

Secure Shell

**STM**

Support Tool Manager

**T****TLB**

Translation look-aside buffer

**ToC**

Transfer of control

**TPM**

Trusted platform module

**TUI**

Text user interface

## U

### **UART**

Universal asynchronous receiver-transmitter

### **UEFI**

Unified Extensible Firmware Interface, replaces **EFI**.

### **UID**

Unit identification

### **UPS**

Uninterruptible power supply

### **USB**

Universal serial bus

## V

### **VCM**

Virtual Connect Manager

### **vMedia**

Virtual media

### **VRM**

Voltage regulator module

## W

### **WBEM**

Web-Based enterprise management