

# Neuroscience

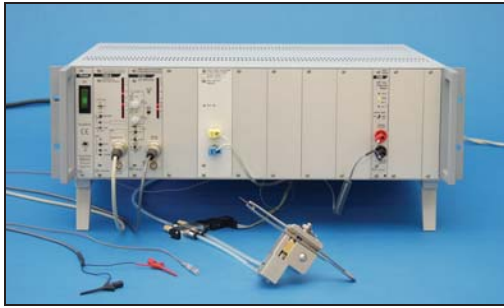

**NEW** Cerebral Autoregulation System, see page L11

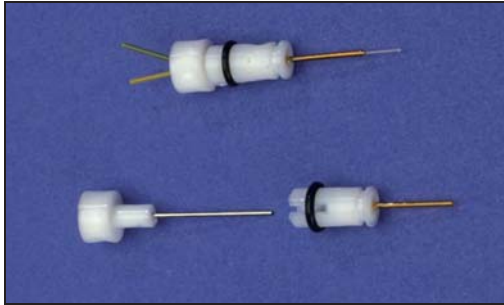

**NEW** BR Brain Microdialysis Probes, see page L20



**NEW** HoneyComb Fraction Collector, see page L28



**NEW** Benchmark Angle One™ Stereotaxic Instrument, see page L29



**NEW** Digital Lab Standard™ Stereotaxic Instrument, see page L32

- **Marsh Ganglion Bath and Peak Height Amplifier**.....see pages L2 - L3
- **NeuroPhore BH-2 System**.....see pages L4 - L8
- **Iontophoretic Electrode and Dye Marker**.....see page L9
- **Somatosensory Stimulation System**.....see page L10
- **Cerebral Autoregulation System**.....see page L11
- **HSE-HA Neurodyn for Neurological Studies**.....see pages L12 - L13
- **Harvard Microdialysis Probes**.....see pages L14 - L19
- NEW** • **Brain Microdialysis Probes**.....see pages L20 - L21
- NEW** • **Intracerebral Guide Cannula**.....see page L22
- NEW** • **Loop Microdialysis Probes**.....see page L23
- NEW** • **Linear Microdialysis Probes**.....see page L23
- NEW** • **IV Vascular Microdialysis Probes**.....see page L24
- NEW** • **In Vivo Ultrafiltration Probes**.....see page L24 - L25
- NEW** • **Bone Ultrafiltration Probes**.....see page L26
- NEW** • **Round Bottom Microdialysis Bowls**.....see page L27
- NEW** • **HoneyComb Fraction Collector**.....see page L28
- NEW** • **Benchmark Angle One™ Stereotaxic Instrument**.....see page L29
- NEW** • **Benchmark™ Deluxe Stereotaxic Instrument**.....see pages L30 - L31
- NEW** • **Digital Lab Standard Stereotaxic Instrument**.....see page L32
- **Full Line of Stoelting Stereotaxic Instruments**.....see pages L33 - L40
- NEW** • **Rodent Brain, Heart, Spinal Cord and Tumor Matrices**.....see pages L41 - L42
- NEW** • **Stereotaxic Bone Drills**.....see pages L42 - L43
- **Microdialysis Syringe Pumps and Accessories**.....see pages L44 - L45
- **Stereotaxic Books**.....see page L46 - L47

## HSE-HA Marsh Ganglion Bath and Peak Height Amplifier

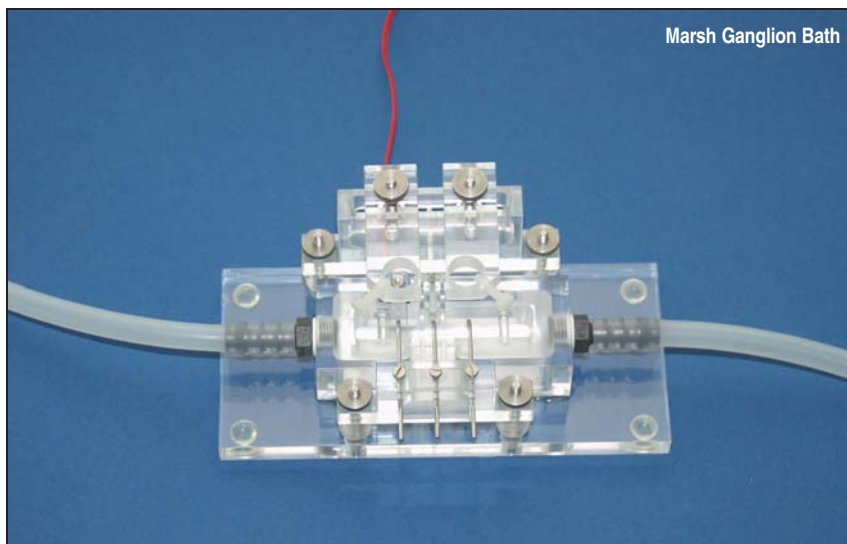

- For studying:
  - Synaptic transmission
  - Nerve conduction
- Applications include:
  - Vagus nerve
  - Cervical ganglion

### References:

- 1) Brown, D.A., Marsb, S.: Axonal GABA-receptors in mammalian peripheral nerve trunks. *Brain Res.* **156**, 187-191 (1978)
- 2) Brown, D.A., Adams, P.R., Higgins, A.J. and Marsb, S.: Distribution of gaba-receptors and gaba-carriers in the mammalian nervous system. *J.Physiol., Paris*, 1979, **75**, 667-671
- 3) Brown, D.A., Forward, A., Marsb, S.J.: Antagonists discrimination between ganglionic and ileal muscarinic receptors. *Br.J.Pharmac.* **71**, 362-364 (1980)
- 4) Brown, D.A., Forward, A., Marsb, S.J.: Possible electrophysiological mechanisms for modulating transmitter release. In: *Presynaptic Receptors, Mechanisms and Functions* (edited by J. de Belleroche), 207-218. Ellis Horwood Publishers (1982)
- 5) Marsb S.J.: Depolarization of rat vagal C-fibres and neurons by capsaicin *in-vitro*. *J.Physiol.(Lond.)* **360**, 14 P (1985)
- 6) Marsb, S.J., Stansfeld, C.E., Brown, D.A., Davey, R., McCarthy, D.: The mechanism of action of capsaicin on sensor C-type neurons and their axons *in-vitro*. *Neuroscience* **23**, 275-289 (1987)
- 7) Marsb, S.: An extracellular recording technique for monitoring drug induced changes in membrane polarization and evoked potential amplitudes from whole nerve bundles and ganglia. In: *FFB4, Electrodes for Stimulation and Bioelectric Potential Recording* (1988), 232-235. Publ. by Biomesstechnik-Verlag March, D-79232 March, Germany.
- 8) Marsb, S.: *Extracellular Recording from Rat Sympathetic Ganglia and Whole Nerve Bundles*. Biomesstechnik Series, Vol.VI. Publ. by Biomesstechnik-Verlag March, D-79232 March, Germany. (1989).
- 9) Newberry, N.R., Priestley, T., Woodruff, G.N.: Pharmacological distinction between two muscarinic responses on the isolated superior cervical ganglion of the rat. *Eur.J.Pharmacol.* **116**, 191-192 (1985)
- 10) Southam, E., Charles, S.L., Garthwaite, J.: The nitric oxide-cyclic GMP pathway and synaptic plasticity in the rat superior cervical ganglion. *Br.J.Pharmacol.* **119**, 527-532 (1996)

### Typical Setup of Marsh Ganglion Bath

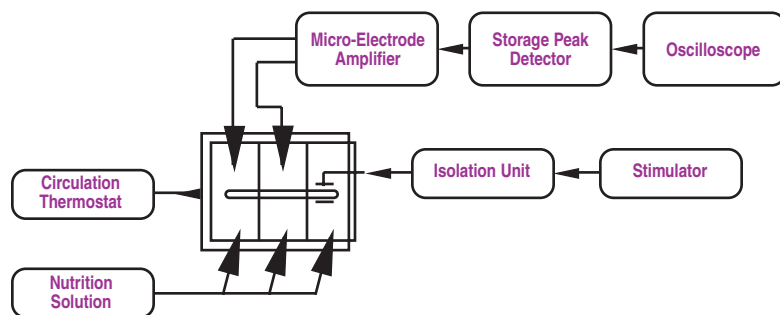

The HSE-HA Marsh Ganglion Bath is intended to test the action of drugs on the synaptic transmission or nerve conduction in the vagus nerve or the cervical ganglion. The bath is an open-top Perspex bath which is divided into three chambers by two sliding separators. Each of these separators consists of a lower and an upper part with a cutout to allow the nerve to pass through. The chambers are sealed against each other with Silicone paste. The first chamber contains two platinum electrodes for stimulation. In the second chamber the solution is fed in close to the bottom of the chamber and drawn off at the surface. The stainless steel inflow and outflow tubes are grounded in order to reduce electrical interference. The Marsh Ganglion Bath set (BS4 73-0387) includes the necessary components to produce two plastic recording electrodes filled with a conductive agar. A terminus Ag/AgCl plug with integrated 2 mm pin socket is used to interconnect the recording chamber and electrode with the PHDA headstage amplifier (BS4 73-1743). The prepared electrodes can be used for up to two weeks (with proper storage) to record extracellular potentials from the nerve preparation.

In addition to a stimulator, electronic equipment includes an amplifier with high-impedance input and a peak height detector (PLUGSYS module PHDA) in order to record the spike peaks. An oscilloscope, recorder or data acquisition system are useful accessories for determining the changes in membrane potential and the amplitudes of the evoked potentials in relation to the applied drug. The peak height detector allows the rapid spikes to be recorded on a relatively slow recorder.

### Specifications

<b>Weight of Marsh Ganglion Bath:</b>	0.2 kg (0.45 lb)
<b>Dimensions of Marsh Ganglion Bath:</b>	
<b>Basic Plate</b>	130 x 60 x 8 mm (5.1 x 2.4 x 0.3 in)
<b>Outer Dimensions</b>	73 x 30 x 18 mm (2.9 x 1.2 x 0.7 in)
<b>Inner Dimensions</b>	50 x 10 x 10 mm (2 x 0.4 x 0.4 in)
<b>Volume</b>	5 ml max.

## HSE-HA Marsh Ganglion Bath and Peak Height Amplifier

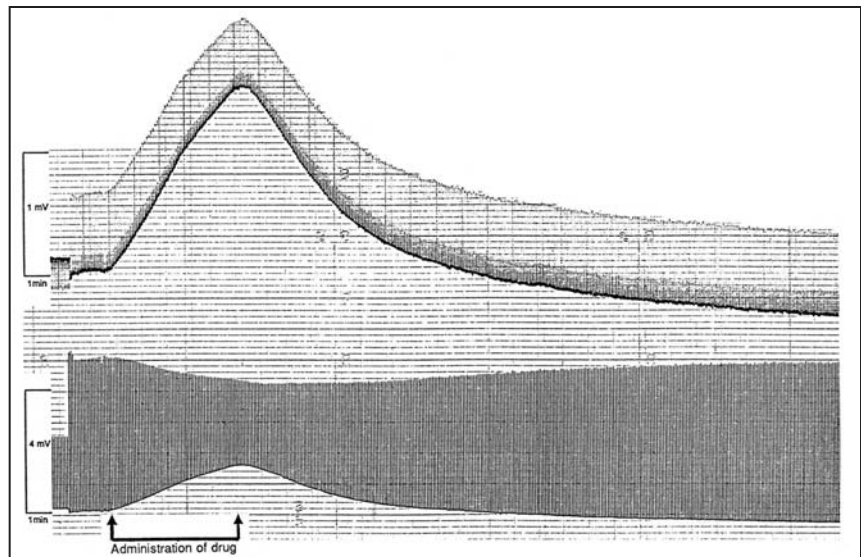
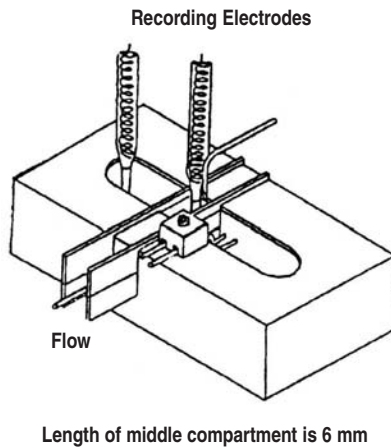

Use of peak height detector for monitoring capsaicin-induced (0.3  $\mu\text{mol}$ ) depolarization of adult vagus nerve. Amplified high-gain DC trace showing time course and amplitude of capsaicin-induced response. Amplified recording of both membrane polarization and reduction in C-spike amplitude induced by capsaicin.

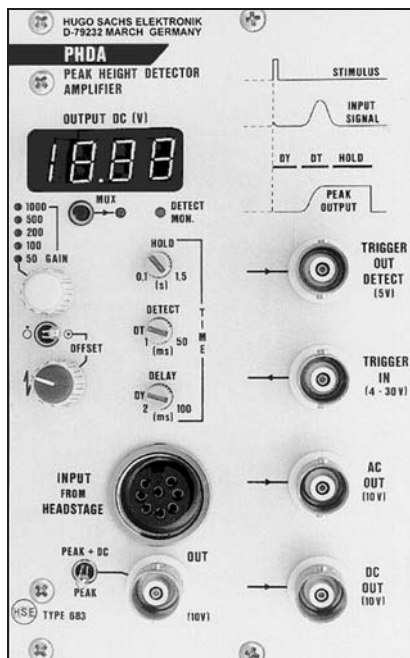

Peak Height Detector Amplifier plugs into Basic System Case Type 609

*For Stimulators, see Section I of this Catalog.*

Catalog No.	\$	Product
BS4 73-2414		Marsh Ganglion Bath Type 858
BS4 73-0387		Set of Electrode Components to Marsh Ganglion Bath
BS4 73-1523		PLUGSYS Minicase Type 609
BS4 73-1743		PHDA PLUGSYS Peak Height Detector Amplifier Module Type 683
BS4 73-2802		3 Liter Thermostat/Thermocirculator, E103, 115 V, 60 Hz
BS4 73-0125		3 Liter Thermostat/Thermocirculator, E103, 230 V, 50 Hz
BS4 73-0087		Stimulator P, 115 V, 60 Hz
BS4 73-0159		Stimulator P, 230 V, 50 Hz
BS4 73-2696		Universal Isolated Stimulation Unit, 115 V, 60 Hz
BS4 73-0504		Universal Isolated Stimulation Unit, 230 V, 50 Hz

Did you know?  
?

Harvard Apparatus now owns Hugo Sachs Elektronik. HSE isolated organ baths set the industry standard. They can be found in the Isolated Organ and Tissue Section L of this Catalog. Also, see the PLUGSYS System of Amplifiers in Section I of this Catalog

# Stimulation & Recording

## Harvard/Medical Systems Neuro Phore BH-2 System

The Neuro Phore BH2 System Unit pictured contains three IP-2 Pump Modules and two PPM-2 Pump Modules and one BM-2 Control and Balance Module



- Used by leading researchers for over 20 years
- Modular
- Minimal noise
- Up to 6 channels
- Digitally controlled eject and pause timing
- Mix and match pump types

### Features

- Successfully utilized in key laboratories around the world for over 20 years, with many journal articles published as a result
- Modular design; buy what you need now and add additional modules later as your protocol evolves
- Accommodates 7 barrel micropipettes, supports the most complex and demanding injection and recording protocols
- Extremely low noise,  $\pm 105$  volts compliance, allows rapid iontophoretic injection with even the smallest micropipette tips
- Automatic current neutralization for minimal electrical artifacts
- Digitally controlled eject and pause timing utilizes easy to read and set digital panel switches on each iontophoretic or pressure module/channel
- Unbalance and out of compliance indicators are a great aid in troubleshooting clogged pipettes and other problems
- External analog input control allows external programming of complex, or closed loop injection protocols
- Current and electrode resistance readout with large bright easy to read digital displays

### System Configuration

The Neuro Phore BH-2 System is modular and is comprised of the following components (all ordered separately):

- One BH-2 Mainframe Chassis, BS4 65-0600 that can accommodate 1 to 5 Iontophoretic Pump and/or Pressure Pump Modules; Mainframe Chassis can be rack mounted or set on table
- One BM-2 Control and Balance Module, BS4 65-0601
- IP-2 Iontophoretic Pump Modules, BS4 65-0606 and/or
- PPM-2 Pressure Pump Modules, BS4 65-0604
- One low noise MS-2 Power Supply, BS4 65-0602
- Blank Panel DP-1 Dummy Module, BS4 65-0605 used to maintain timing if less than 5 Pump Modules are installed

### Harvard/Medical Systems Neuro Phore BH-2 System

*In the past few decades, the application of drugs and other dissolved agents from multibarrel electrodes/pipettes has evolved into a practical method of testing their effects on cells or cellular systems. The versatile Neuro Phore BH-2 System is designed to facilitate controlled ejection of fluids from multibarrel micropipettes. Extracellular ejections of minute volumes can be delivered using up to five pumps in serial or parallel. The ejection schedule for each pump can be independently programmed for sequential or simultaneous output. Ejection cycles can be internally timed, triggered manually, or synchronized to external events. This flexible system allows the use of iontophoretic pump modules, pneumatic pump modules, or a combination of both. By interchanging the IP-2 Iontophoretic Pump Module with a PPM-2 pneumatic pressure pump, the overall system capability can be expanded for simultaneous pressure and iontophoretic injection of drugs from a multibarrel pipette.*

*The Neuro Phore BH-2 System was developed under the guidance of active researchers with extensive experience in iontophoresis techniques. These researchers needed a system to provide precise stimulation and quantitative control for ejection of drugs in their pharmacological studies of drug evoked responses such as neurosynaptic discharges, contraction, and changes in chemical concentration. What emerged was a reliable, accurate, easy to use, Neuro Phore BH-2 system that is capable of accommodating high impedance multi-barreled micro-electrode pipettes.*



**Harvard Apparatus also sells the Digitimer Neurolog System. See the Physiology Section I of this Bioscience Catalog.**

## Harvard/Medical Systems Neuro Phore BH-2 System

### BH-2 Mainframe Chassis

The BH-2 Mainframe Chassis is pre-wired to accept one Control and Balance module and five Iontophoretic Pump Modules and/or Pneumatic Pump Modules. The selected modules are specified by the researcher and depend on applications. Although all components are ordered separately, the unit is assembled, calibrated, and balanced by Harvard Apparatus before shipping.

### BM-2 Balance Module: Balance and More

In addition to providing current neutralization (automatic feedback and control of inverse sum of all pump currents), the balance module has independent capability of current pump settings with a working range of 0 to 500 nanoamperes. The Balance Module includes a digital display, time clock, provisions for electrical and manual cycle start/stop and single cycle/recycle switch, trigger, and gate input terminals to initiate externally controlled eject pumping action of respective modules. Analog input for balance or drive with override capability. Analog output for monitoring of unbalance currents.

#### Specifications

<b>Neutralization (balance) Pump Range</b>	Max. $\pm 2500$ nA automatically controlled
<b>Current Pump</b>	Compliance $\pm 105$ V linear constant current source; manually adjustable 0 to 500 nA by pump control; polarity selected +/OFF/- switch
<b>Digital Meter Display</b>	3 digits and sign
<b>Unbalance Current/Current Pump Switch:</b>	
<b>Unbalance</b>	Digital display reads unbalance (ground going) current in nA
<b>Current Mode</b>	In this mode, automatic current neutralization is provided
<b>Current Pump Mode</b>	Automatic balance feature is switched off; display reads amount of current in nanoamperes passed through balance barrel as adjusted by pump control
<b>Single Cycle Mode</b>	In single cycle mode, start switch or external trigger initiates each cycle
<b>Recycle Mode</b>	In recycle mode, once start switch or external trigger is actuated, repetitive cycles commence automatically
<b>Time Unit Switch</b>	Two basic time units can be selected, 10 msec or 1 sec. In 10 msec position, Eject and Pause time switches of IP-2 Modules can be set to cover time range from 10 to 990 msec with 10 msec resolution. In 1 sec position, time scale is expanded from 1 to 99 sec with 1 sec resolution.
<b>Inputs</b>	Cycle start, stop, trigger/gate #1 through #5; banana jacks terminals, floating input, optically coupled; input voltage $\pm 5$ to $\pm 15$ V TTL compatible
<b>Analog Input</b>	Lemo miniature receptacle, ground referenced 5 mV/nA; input impedance 100 k $\Omega$
<b>Analog Output</b>	Lemo miniature receptacle, 5 mV/nA ground referenced
<b>Sync Output</b>	Lemo miniature receptacle, TTL pulse
<b>Output Connector</b>	7-pin miniature connector, mates with ultra flexible cable leading to micro-electrode holder
<b>Dimensions, H x W x D</b>	21 x 47 x 35 cm (8.75 x 19 x 14 in)
<b>Weight</b>	8.2 kg (18 lb)

Catalog No.	\$	Product
BS4 65-0600		BH-2 Mainframe Chassis (does not include BM-2 Balance Module, see below)
BS4 65-0602		BM-2 Control and Balance Module with OC-01 and NL-952

#### Application Note: Working Unit:

One (1) each of BH-2 Main-Frame, MS-2 power supply, BM-2 Control & Balance module and any combination of one (1) to five (5) modules selected from IP-2 and/or PPM-2. If less than five (5), DP-1 module is required to fill the spaces.

### MS-2 Power Supply

The AC power supply is self contained in a rack-mounted cabinet and provides all voltages required to operate the Neuro Phore System. The power supply interconnects with the mainframe via flexible cable. The supply works with 115 or 220 VAC, 50/60 Hz mains source.

#### Specifications

<b>Outputs</b>	$\pm 125$ V at 0.1 A $\pm 15$ V at 0.5 A -5 V at 3 A Line operated 115 to 220 VAC, 50/60 Hz
<b>Dimensions, H x W x D</b>	13 x 47 x 35 cm (5-1/4 x 19 x 14 in)
<b>Weight</b>	11 kg (24 lb)

Catalog No.	\$	Product
BS4 65-0601		MS-2 Power Supply with Power Cord



**Harvard Apparatus now owns Clark Electromedical. See the Cell Biology Section M for the industry standard capillary glass.**



## Harvard/Medical Systems Neuro Phore BH-2 System

BS4 65-0206 PPS-2 Mini-Frame



### PPS-2 Mini-Frame

The rack mountable PPS-2 Mini-Frame was designed as a less expensive alternative to the BH-2 for those applications that require pressure injections only. The PPS-2 is a multichannel pneumatic pumping system, designed especially for short-term pressure ejection of small quantities of fluids through micropipettes. The system can operate with up to four PPM-2 different Pump Modules. Each module can be programmed to its own schedule of ejection and pause times, coordinated with the other modules. Ejection and pause times cover a range of 10 to 990 milliseconds with 10 millisecond resolution and 1 to 99 seconds with 1 second resolution. Continuous and cyclical modes of operation are also available.

### System Configuration

The PPS-2 system (Catalog No. BS4 65-0606) includes a Control Module and a power supply. It is pre-wired to accept up to four PPM-2 Pneumatic Pressure Modules (Catalog No. BS4 65-0604) which are ordered separately.

The Control Module CM-1 includes a time clock. Panel mounted push-buttons as well as TTL electrical inputs are provided to control the following functions: Cycle Start/Cycle Stop, Trigger (each PPM-2), and Gate (each PPM-2). In essence, the CM-1 Control Module provides all necessary signals to operate the sequential and single shot timing for the installed PPM-2 Pneumatic Pump Modules.

A Self Cycle mode/control switch controls independent self timing action of each of the pneumatic pump modules. The self-timing action permits each PPM-2 Pump Module to eject and pause for a predetermined period. Actuating any of the self cycle control switches causes the respective PPM-2 Module to be engaged into the self timing mode. The push buttons at the corresponding trigger/gate terminals initiate the self cycle timing action.

### Specifications

<b>Cycle Start, Cycle Stop, Trigger/Gate Inputs</b>	Push-button, and banana jack terminals; floating input, optically coupled
<b>Input Voltage</b>	±5 to ±15 V
<b>Minimum Trigger Pulse Width</b>	5 μsec at 5 V
<b>Sync Out</b>	Lemo miniature connector TTL pulse
<b>Single Cycle Mode</b>	In single cycle mode, start switch or external trigger initiates each cycle
<b>Recycle Mode</b>	In recycle mode, once start switch or external trigger is actuated, repetitive cycles will continue until stopped
<b>Time Unit Switch</b>	Two basic time units can be selected: 10 msec or 1 sec. In 10 msec position, Eject and Pause time switches of PPM-2 Modules can be set to cover time range from 10 to 990 msec with 10 msec resolution. In 1 sec position, time scale is expanded to 1 to 99 sec with 1 sec resolution
<b>Power</b>	115 VAC, 50/60 Hz (100 or 220 VAC optional)
<b>Dimensions, H x W x D</b>	21 x 47 x 35 cm (8.75 x 19 x 14 in)
<b>Weight</b>	5.5 kg (12 lb) PPS-2 Mini-Frame System: mainframe, power supply and CM-1 Control Panel. PPM-2 Modules not included.

### Application Note: Working Unit

Mini-Frame, Power Supply, and Control Panel plus four (4) modules selected from PPM-2 and DP-1

Catalog No.	\$	Product
BS4 65-0606		PPS-2 Mini-Frame with Power Supply, Control Module and NL-952 Power Cord and Manual
BS4 65-0604		PPM-2 Pneumatic Pump Module with OH-01 and IH-01, PPS-2 System can support 1 to 4 Modules
BS4 65-0605		DP-1 Dummy Module (to maintain timing) PPS-2 System can support 1 to 4 Modules
BS4 65-0210		Model SC-01, Tygon Flexible Hose Micropipette Interface Coupling for Pneumatic (PPM-2) Use
BS4 65-0211		Model SC-02, Tygon Flexible Hose Micropipette Interface Coupling for Current (IP-2)/Pneumatic (PPM-2) Use
BS4 65-0212		Model IH-01, Input Hose 2.7 m (9 ft) Coupling to PPM-2
BS4 65-0213		Model OH-01, Output Hose 2.7 m (9 ft) including SC-01 Coupling
BS4 65-0214		Model OH-02, Output Hose 2.7 m (9 ft) including SC-02 Coupling
BS4 65-0215		Model OC-01, Output Cable 2.7 m (9 ft) with (7) Seven-Pin Lemo Connector
BS4 65-0285		Model NL-952, Cable 2 m (6.5 ft) with Lemo Miniature Connector at one end and Tinned Leads at other (Sync. Output or Analog Input/Output Cable)

## Harvard/Medical Systems Neuro Phore BH-2 System

### IP-2 Iontophoresis Pump Module

Each IP-2 Module includes controls for precise settings of current magnitude and polarity (retention 0 to 50 nanoamperes, ejection 0 to 500 nanoamperes). The actual current and polarity is continuously displayed digitally and can be externally monitored at the analog output terminal.

#### Operating Modes

##### Ejection Timing and Mode Switch

The mode switch provides five push-button controls which include operations such as cycle, trigger, gate, continuous, and termination.

##### Cycle Mode

In the cycle mode by virtue of selecting single or recycle operation on the BM-2 Module an incoming trigger or cycle start push-button will initiate the current ejection pumping action. In this mode each succeeding Pump Module is automatically triggered after the pause time of the preceding event has been completed. Both eject and pause times can be preset to cover a range from 10 to 990 milliseconds with a 10 millisecond resolution and 1 to 99 seconds with a 1 second resolution.

##### Trigger Mode

When the TRIG. switch is energized the eject time interval will be started by virtue of the incoming trigger pulse applied to the respective inputs on the BM-2 Balance Module. Eject timing interval can be preset covering a range from 10 to 990 milliseconds with a 10 millisecond resolution and 1 to 99 seconds with a 1 second resolution.

##### Gate Mode

When the GATE switch is energized the eject current will be started by virtue of a gate input signal applied to the respective trigger/gate terminals on the BM-2 Balance Module. The eject and pause time settings are not operative in this mode, since the eject time function is slaved to the duration of the gate input.

##### Continuous Mode

When the CONT. switch is energized the ejection pump current is continuously maintained.

##### Termination Mode

When the TERM. switch is energized the output is automatically diverted from the preparation into an internal 'dummy load' (100 M $\Omega$ ). This function is particularly useful for testing of possible instability in the preparation pipette.

##### Analog Input

The analog input terminal is available to facilitate externally controlled current pumping action. An external voltage applied to the input will generate a pumping current at a ratio of 5 millivolts/nanoamperes. This current will be summated with any preset pump current governed by both the retention and ejection controls. The combined magnitude and sign of the summated pumping current is displayed on the digital display of each corresponding Pump Module. This input can be connected to a computer D/A converter when external programming is desired.

##### Analog Output

The analog output terminal provides a buffered voltage which is proportional in magnitude and polarity to the actual current passed from the current pump into the pipette. The conversion ratio is 5 mV/nA. This output can be polygraphically recorded to monitor progress of the experiment.

##### Sync Output

The sync output provides a TTL pulse that coincides with the eject time. This output is provided to trigger external devices such as a computer, event counter, etc.

### Specifications

<b>Current Pump</b>	Compliance $\pm 105$ V, linear constant current source
<b>Ejection Current</b>	Pulsing controlled by Ejection Timing Mode Switch; amplitude adjustable by 10-turn ejection control and range switch from 0 to 50 or 0 to 500 nA; polarity is selected by polarity switch; accuracy of $\pm 1$ nA
<b>Ejection Indicator</b>	Red LED lamp indicates Eject time period; green LED lamp indicates pause time period
<b>Retention Current</b>	Amplitude adjustable by front panel dial from 0 to 50 nA; polarity automatically set opposite to ejection current polarity, socket (x3)
<b>Analog Input</b>	Lemo miniature receptacle, ground referenced 5 mV/nA; input impedance 100 k $\Omega$ , socket (x3)
<b>Analog Output</b>	Lemo miniature receptacle, ground referenced 5 mV/nA, socket (x3)
<b>Sync Output</b>	Lemo miniature receptacle, TTL pulse time incident with eject pulse
<b>Current and Resistance Metering System</b>	Digital Meter Display 3 digits and sign
<b>Resistance/Current Switch:</b>	
<b>Current Mode</b>	Switch in center 'nA' position, digital display reads total current in nA passed through micro-electrode pipette (sum of retention and ejection current)
<b>Resistance Mode</b>	Switch in either (pos) or (neg) M $\Omega$ position, digital display reads actual electrode barrel resistance in M $\Omega$ derived by passing positive or negative constant current (50 nA) through electrode pipette
<b>Compliance Exceeded Indicator</b>	Digital display will flash whenever electrode barrel resistance exceeds working range of current pump (i.e., when electrode resistance times current exceeds compliance of $\pm 105$ V)
<b>Voltage Readout Switch</b>	Depressing switch will cause digital display to read voltage across pipette

Catalog No.	\$	Product
BS4 65-0603		IP-2 Iontophoresis Pump Module



**Harvard Apparatus now owns the Naviclyte line of Ussing and Diffusion Chambers. See Section M of this Catalog for complete details on those products and others.**

## Harvard/Medical Systems Neuro Phore BH-2 System

### PPM-2 Pneumatic Pump Module

Designed specifically for pressure injection of drugs in pharmacological studies of drug evoked responses (i.e. synaptic discharges, contraction, etc.) Emphasis has been given to pressure control and regulation (0 to 30 p.s.i.; optional 0 to 10 or 0 to 90 p.s.i.) as well as precise timing. The PPM-2 Module is comprised of a precise pressure regulator, digital display, transducer, and a timing mode switch. It connects to an external pressure source (such as a compressed bottle of N<sub>2</sub>) which can be set to provide continuous or periodic pressure pulses ranging from 0 to 30 p.s.i. Outputs include (0 to 1 volt) proportional to output pressure as well as a sync pulse coincident with pressure cycle.

### Operating Modes

#### Ejection Timing and Mode Switch

The mode switch provides five push-button controls which include operations such as cycle, trigger, gate, continuous, and termination.

#### Cycle Mode

In the cycle mode, after selecting single or recycle operation, the start push-button will initiate the ejection pumping action. In this mode each succeeding pump module is automatically triggered after the pause time of the preceding event has been completed. Both eject and pause times can be preset to cover a range from 30 to 990 milliseconds with a 10 millisecond resolution and 1 to 99 seconds with a 1 second resolution.

#### Trigger Mode

When the TRIG. switch is energized the eject time interval will be started by virtue of an externally applied trigger pulse fed to the respective inputs on the CM-1 control panel. Eject timing intervals can be preset to cover a range from 30 to 990 milliseconds with a 10 millisecond resolution and 1 to 99 seconds with a 1 second resolution.

#### Gate Mode

When the GATE switch is energized pumping action will be started by virtue of a gate input signal applied to the respective trigger/gate terminals on the CM-1 control panel. The eject and pause time settings are not operative in this mode, since the eject time function is slaved to the duration of the gate input.

#### Continuous Mode

Eject pump action is continuously maintained when CONT. switch is energized.

#### Termination Mode

When the TERM. switch is energized, the output pressure is automatically diverted from the preparation. This function is particularly useful for setting up the desired pressure range and timing while preventing ejection of any drug from the pipette.

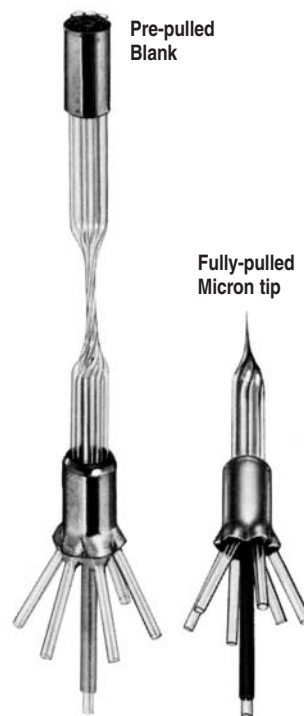

### 7-Barrel Iontophoresis Micropipette

- Easy filling
- Minimal tip resistance
- Minimal leakage
- Available pre-pulled or fully-pulled

The MS-7P Micropipette has been designed for iontophoretic use as well as pneumatic ejection of drugs. The standard blank consists of seven

barrels, Pyrex Omegadot tubing, 1.5 mm outer diameter and 1.2 mm inner diameter, pre-pulled to 2 mm formation as shown. For complete details, see the Cell Biology Section M of this Catalog.

### Specifications

Source Gas	Air or Nitrogen recommended (no explosive or combustible gases)
Input Pressure	125 p.s.i.g. (7.8 kg/cm <sup>2</sup> ) maximum
Input Filter	5 μm element
Output Pressure	0 to 99.9 p.s.i.g. (0 to 7 kg/cm <sup>2</sup> ), 30 p.s.i. standard
Output Pressure Display	Three decimal digits
Pressure Pulse Width:	
Minimum	30 msec
Maximum	99 sec (990 sec optional)
Gas Input and Output Couplings	Quick disconnect type
Analog Output	Lemo miniature connector, voltage proportional to output pressure, 0 to -999 mV full scale in p.s.i.g. setting; 0 to -700 mV full scale in kg/cm <sup>2</sup> setting
Sync Output	Lemo miniature connector TTL pulse, time incident with output pressure pulse
Eject Time Indicator	Red LED
Pause Time Indicator	Green LED

Catalog No.	\$	Model	Micropipettes
BS4 65-0207		MS-7PB	Micropipette 7-Barrel, 1.5 mm OD Borosilicate Glass, pre-pulled blank, 20 per box
BS4 65-0208		MS-7MT	Micropipette 7-Barrel, 1.5 mm OD Borosilicate Glass, fully-pulled approx. 20 μm tip, 10 per box

Catalog No.	\$	Product
BS4 65-0604		PPM-2 Pneumatic Pump Module with Input/Output Hose



## Dye Marker and Iontophoretic Electrode



### D380 Iontophoretic Dye Marker

For dye marking individual neurons in neuroanatomy research. This unit provides an isolated bipolar constant current output intended for the marking of individual neurons with dyes such as Lucifer Yellow via iontophoresis. Holding currents up to +6nA and injection currents up to +12nA are provided and set by single turn panel mounted dials. A compliance voltage in excess of +6nA allows the full injection current into electrodes with impedances up to 500 MΩ. An LCD continuously shows the polarity and magnitude of the requested injection and holding currents as well as the electrode resistance and the voltage applied. The unit is powered from a single, standard, 9 volt battery.

- Easily reverses injection current polarity
- Provides a precise, repeatable current
- Battery operated
- Low power micro-controller technology

### 4 Important Injection Parameters

<b>INJECT:</b>	Requested injection current
<b>HOLD:</b>	Requested hold current
<b>RESISTANCE:</b>	Measured electrode resistance
<b>POTENTIAL:</b>	Measured potential applied to electrode

Using the Deblock function allows the user to tell whether an electrode is becoming blocked using these injection parameters. If a rise in resistance is detected, press DEBLOCK button before the electrode is beyond its useful life.

### Specifications

<b>Output Current:</b>	
Holding Range	0 to 6.3 nA in 0.1 nA (100 pA) steps
Injection Range	0 to 12.7 nA in 0.1 nA (100 pA) steps
Compliance Voltage Range	> +6 V
<b>LCD Display:</b>	
Inject	Injection current requested, with 100 pA resolution
Hold	Holding current requested, with 100 pA resolution
Resistance	Electrode resistance, with 10 MΩ resolution
Potential	Voltage applied to the electrode, with 100 mV resolution
Out of Compliance	'Potential' display will invert and flash
Low Battery Voltage	Indicated by flashing LCD display
Gate In	TTL 'high' (> +3 V) places unit in inject mode for duration
Connection	Standard BNC socket- labeled 'Output'
Power Requirements	1 x PP3, IEC- 6R61 (9 V) battery, Alkaline recommended
Typical Battery Life	In excess of 100 hrs (continuous operation)
Dimensions, H x W x D	175 x 120 x 40 mm (6.9 x 4.7 x 1.5 in)
Weight	400 g (14.1 oz) including battery

### Catalog No. \$ Product

BS4 65-0336 Iontophoretic Dye Marker, Model D380

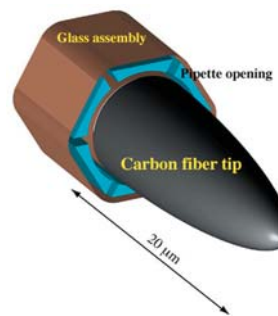

- Low noise recording
- 6 barrels for micro-iontophoresis injections

### NEW Combination Recording/Iontophoresis Electrode

Above is an illustration of the tip of a seven barrel combination recording/iontophoresis electrode. The carbon fiber electrode is closely surrounded by 6 fused-together micropipettes allowing combined microiontophoresis and extracellular recording.

Microiontophoresis injection is most often used in conjunction with extracellular recording of neuronal firing. Since extracellular 'spikes' generated by action potentials across the membranes of neurons are typically only a few hundred microvolts in amplitude. They require a low noise recording electrode. Traditional electrolyte-filled glass micropipettes in a multibarrel assembly are electrically very noisy. Solid conductor micro-electrodes such as carbon fiber electrodes show significantly less noise in extracellular recordings. Carbon fibers are 5-8 micrometer in diameter are perfect for recording with an excellent signal-to-noise ratio recordings. The Microiontophoresis electrode-pipette assemblies are manufactured from our high quality Harvard-Clark borosilicate capillary tubing. Two standard types of tapers are available: 15 to 25 mm and with a tip length of ~25 mm.

### Specifications

Tip Diameter	~7 μm
Tip Length	~25 μm
Tip Taper	Either 15 to 25 mm or 25 to 30 mm
Connector	0.8 mm
<b>Impedance at 1 kHz:</b>	
Carbon Fiber	300 to 500 KΩ
Iontophoresis Barrels	8 to 10 MΩ

### Catalog No. \$ Description

BS4 69-0520	Combination 7 Barrel Recording/Iontophoresis Electrode Standard Taper (Carbostar-7), pkg. of 3
BS4 69-0521	Combination 7 Barrel Recording/Iontophoresis Electrode Long Taper (Carbostar-7LT), pkg. of 3

# Stimulation & Recording

## **NEW** Somatosensory Stimulation (SEP and Cerebral Blood Flow)



The system has been setup to study the relationship between somatosensory stimulation, neuronal activity and vascular response.

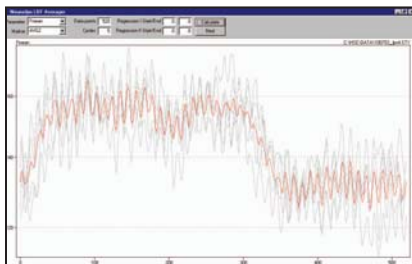
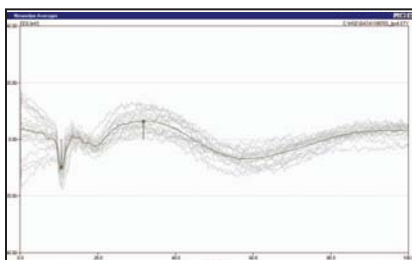

### System description

The complete system includes a specific hardware and a dedicated software package.

### The hardware consists of:

- A ventilator
- A PLUGSYS maincase equipped with:
  - A software controlled stimulator module PSM and a stimulation electrode
  - A blood pressure transducer (ISOTEC) and the relevant amplifier (TAM-A)
  - An EEG amplifier (EEGA)
  - An interface module to connect the laser doppler flowmeter
- A laser doppler flowmeter with adapted flow probe

The hardware can optionally be extended for other measurements like ECG, temperature and venous pressure.

### The software consists of:

- The NEURODYN data acquisition software
- The software module for somatosensory evoked potential (SEP) analysis and cerebral blood flow (CBF) averaging.

- Complete system for evaluating cerebral activity and vascular response to somatosensory stimulation
- Can be used as basic system for general EEG analysis
- Can be combined with system for cerebral autoregulation studies

### Catalog No. \$ Product

#### Ventilator

BS4 40-1003 Starling's Miniature 'Ideal' Ventilator 10 ml, 230 VAC, 50 Hz

#### Alternative To BS4 40-1003

BS4 40-1002 Starling's Miniature 'Ideal' Ventilator 10 ml, 115 VAC, 60 Hz

BS4 73-2833 Tracheal Cannula for Small Rat, OD 2.0 mm, L 25 mm, Includes Medium Y-Adapter OD 7.5 mm

#### Stereotaxic Frame

BS4 72-4792 Lab Standard Stereotaxic Equipment for Rats (Dual Manipulator) Model 51603, with 18 Degree Ear Bars

#### Alternative To BS4 72-4792 If Laser-Doppler Flow Is Not Used

BS4 72-4790 Lab Standard Stereotaxic Equipment for Rats (Single Manipulator), Model 51600, with 18 Degree Ear Bars

#### Basic System Case For The Multiple Amplifier Modules

BS4 73-0045 PLUGSYS Basic System Case Type 603

BS4 73-0065 TAM-A PLUGSYS Transducer Amplifier Module Type 705/1

BS4 73-0089 Isotec Pressure Transducer, Range -50 to 300 mmHg

BS4 73-0098 Stand for ISOTEC

BS4 73-0096 Three-Way Stopcock Type 9560 R

BS4 73-0097 One-Way Stopcock Type 9500

#### To Connect Laser Doppler Flowmeter And Up To 3 Other Devices

BS4 73-0222 EIM PLUGSYS External Input Module Type 673

#### Electrical Stimulation

BS4 73-0221 PSM PLUGSYS Programmable Stimulator Module Type 676

BS4 73-0224 Software Module for PSM and PPG Control for Windows

BS4 73-0336 Plexiglass Platinum Electrode, D = 0.5 mm

#### For High Frequency EEG Measuring

BS4 73-0153 BPA PLUGSYS Biopotential Amplifier Module Type 675

BS4 73-3005 EEG Cable with Clips for BPA or EEGA

#### Laser Doppler Flowmeter And Flowprobes

BS4 73-0748 Laser Doppler Flowmeter BRL-100

BS4 73-1202 Needle Type Laser Doppler Flow Probe BN-0.5

#### Data Acquisition With Computer

BS4 73-0161 HSE-HA Data Acquisition Hardware, PLUGSYS Version for Windows® NT/2000/XP

BS4 73-0223 DIM-D PLUGSYS Digital Bus Link for DIM Module Type 708/1

BS4 73-3004 HSE-HA NEURODYN Data Acquisition Software for Windows® NT/2000

BS4 73-3526 Software Option to NEURODYN for SEP Evaluation

## **NEW** Cerebral Autoregulation



- Complete system for evaluating cerebral autoregulation
- Can be used as basic system for general EEG analysis
- Can be combined with system for cerebral activity and vascular response to somatosensory stimulation

The system has been setup to study the cerebral autoregulation. A dedicated clamping system is used to occlude the carotid artery for a programmable period. The clamp is software controlled. The evaluation of the regional blood flow is synchronized to the clamping system. To allow reversible and repeated clamping without vascular damage a vessel clip of defined closing pressure of 0.25N is used.

### System description

The complete system includes a specific hardware and a dedicated software package.

The hardware consists of:

- A ventilator
- A PLUGSYS maincase equipped with:
  - The clamping system
  - A blood pressure transducer (ISOTEC) and the relevant amplifier (TAM-A)
  - An EEG amplifier (EEGA)
  - An interface module to connect the laser doppler flowmeter
- A laser doppler flowmeter with adapted flow probe

The hardware can optionally be extended for other measurements such as ECG, temperature and venous pressure.

The software consists of:

- The NEURODYN Data Acquisition software
- The software module for cerebral autoregulation evaluation using clamping control and blood flow (CBF) averaging.

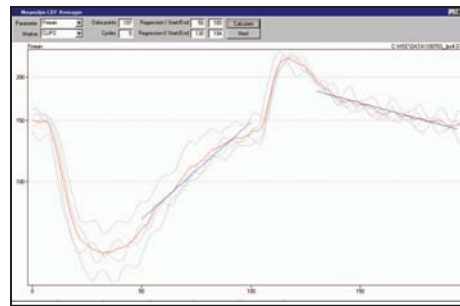

### Catalog No. \$ Product

#### Ventilator

**BS4 40-1003** Starling's Miniature 'Ideal' Ventilator 10 ml, 230 VAC, 50 Hz

#### Alternative To BS4 40-1003

**BS4 40-1002** Starling's Miniature 'Ideal' Ventilator 10 ml, 115 VAC, 60 Hz

**BS4 73-2833** Tracheal Cannula for Small Rat, OD 2.0 mm, L 25 mm, Includes Medium Y-Adapter OD 7.5 mm

#### Stereotaxic Frame

**BS4 72-4792** Lab Standard Stereotaxic Equipment for Rats (Dual Manipulator) Model 51603, with 18 Degree Ear Bars

#### Alternative To BS4 72-4792 If Laser-Doppler Flow Is Not Used

**BS4 72-4790** Lab Standard Stereotaxic Equipment for Rats (Single Manipulator), Model 51600, with 18 Degree Ear Bars

#### Basic System Case For The Multiple Amplifier Modules

**BS4 73-0045** PLUGSYS Basic System Case Type 603

**BS4 73-0065** TAM-A PLUGSYS Transducer Amplifier Module Type 705/1

**BS4 73-0089** ISOTEC Pressure Transducer, Range -50 to 300 mmHg

**BS4 73-0098** Stand for ISOTEC

**BS4 73-0096** Three-Way Stopcock Type 9560 R

**BS4 73-0097** One-Way Stopcock Type 9500

#### To Connect Laser Doppler Flowmeter And Up To 3 Other Devices

**BS4 73-0222** EIM PLUGSYS External Input Module Type 673

#### Clamping System For Carotid Artery

**BS4 73-3528** Vessel Clamping System for Cerebral Autoregulation Evaluating

#### For High Frequency EEG Measuring

**BS4 73-0153** BPA PLUGSYS Biopotential Amplifier Module Type 675

**BS4 73-3005** EEG Cable with Clips for BPA or EEGA

#### Laser Doppler Flowmeter And Flowprobes

**BS4 73-0748** Laser Doppler Flowmeter BRL-100

**BS4 73-1202** Needle Type Laser Doppler Flow Probe BN-0.5

#### Data Acquisition With Computer

**BS4 73-0161** HSE-HA Data Acquisition Hardware, PLUGSYS Version for Windows® NT/2000/XP

**BS4 73-0223** DIM-D PLUGSYS Digital Bus Link for DIM Module Type 708/1

**BS4 73-3004** HSE-HA NEURODYN Data Acquisition Software for Windows® NT/2000

**BS4 73-3527** Software Option to NEURODYN for Cerebral Autoregulation Evaluation

# Stimulation & Recording

## HSE-HA NEURODYN for Neurologic Studies

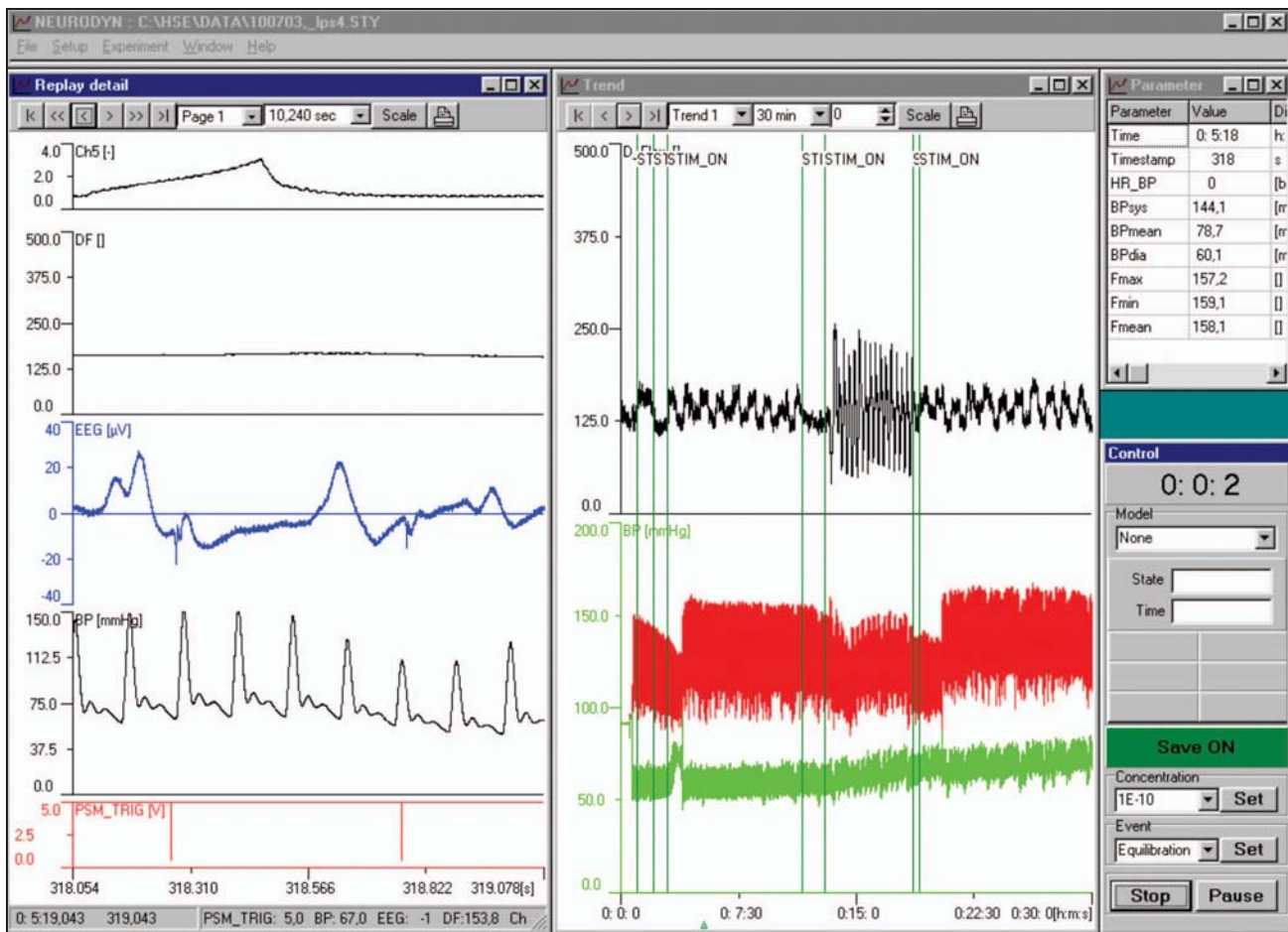

- 16-channel data acquisition software for Neurologic experiments For Windows®
- To measure and evaluate signals such as EEG, aortic and venous blood pressure, aortic blood flow, pO<sub>2</sub>, pCO<sub>2</sub>, pH, temperature, etc.
- Can be extended to other haemodynamic and respiratory parameters
- Analysis of somatosensory evoked potentials and cerebral autoregulation as option available
- Easy to use, reduced settings by using configuration files
- Storage of raw data with possibility for replay — complete experiments can be replayed
- Indication of the measured signals and parameters online in numerical tabular form or graphical detail and trend windows
- Allows data exchange interface by converting the data into the ASCII delimited format
- Monitors the experimental sequence by placing event markers and concentration information
- Very easy graphical selection of specific data points by cursors for evaluation, data reduction and export
- Export of a raw data sequence into ASCII delimited format

### Description

The HSE-HA NEURODYN software can be adapted to virtually any experimental investigation for neurologic experiments. Acquisition can cover signals such as EEG, aortic and venous blood pressure, aortic flow, pO<sub>2</sub>, pCO<sub>2</sub>, pH, temperature, etc. It can be extended to many other circulation or respiratory signals. Various parameters can be derived from these signals, e.g. systolic, diastolic, mean and heart rate, minimal, maximal, and mean flows, etc. During data acquisition, all acquired signals and derived parameters are stored on the hard disc and can be displayed on the screen. EEG analysis using FFT is done in the replay mode.

Dedicated options for controlling and evaluating somatosensory evoked potentials as well as cerebral autoregulation (or both) are available.

The HSE-HA NEURODYN software is available in a basic version which includes the minimal necessary algorithms that can be upgraded to a more complex system including all the available algorithms. The configuration of the system is defined in configuration files to reduce the amount of settings necessary and to ensure a stable and secure system. The user only needs to calibrate the signals and fix the graphics scaling. All the hardware definitions and algorithms used are defined in the configuration files. This reduces the amount of information necessary in the SOP and the possibility of wrong settings. The configuration files can be changed and the software used in combination with a set of different configuration files to match the different experiments.

## HSE-HA NEURODYN for Neurologic Studies

NEURODYN is a menu-controlled software and employs special algorithms to calculate the standard parameters. The HSE-HA NEURODYN software has a maximum of 16 channels, i.e. up to 16 different raw signals can be handled. The assignment of the signals to the individual channels is determined in the configuration files. The sample rate, the type of signals and the algorithm used for analysis are also defined in the configuration file. The arrangement of the graphic detail (raw signals) and trend (calculated parameters) is defined in the menu. The user has only to set up which of the available signals he wants to acquire and display, which of the possible parameters he wants to evaluate and display, enter the experimental protocol, and finally calibrate before he starts the data acquisition.

### The HSE-HA Data Acquisition Hardware for NEURODYN software is available in three versions:

- **PLUGSYS Version**

This version consists of the PCI A/D board DT301, ROM-DL, DIM and the cable for connecting to a DIM Data Interface Module installed in the PLUGSYS basic system case, see Section I

- **Stand Alone Version**

This version consists of the PCI A/D board DT301, connection cable and a BNC input box where signals from external amplifiers can be connected.

- **USB Stand Alone Version**

This version consists of a USB connection cable and a USB input box where signals from amplifiers can be connected.

### Hardware requirements for NEURODYN:

Both the PLUGSYS and stand alone versions require the following computer hardware:

- PENTIUM III PC, 500 MHz or more with one free PCI slot
- RAM 128 MB or better 256 Mbytes
- Hard disk space – at least 20 GB
- 19 inch standard monitor or 17-18 inch flat panel monitor
- Floppy Drive 1.44 Mbytes, CD-ROM drive
- Operating System Windows® NT/2000 or XP
- For data backup a CD-recorder (burner)

### Commonly used signals on neurologic experiments are:

- EEG Electroencephalogram
- AP Arterial Pressure
- VP Venous Pressure
- AF Arterial Blood Flow

It is also possible to acquire other signals such as temperature. The maximum number of signals is 16.

### The basic version of NEURODYN calculates the following parameters:

#### online:

- From All Pressure signals: Systolic, Diastolic and Mean Pressure, Heart Rate
- From All Flows signals: Mean, Max. and Min. Flow

#### After the experiment in replay mode:

- From EEG:
  - FFT evaluation with power spectrum
  - Bandpass Filter display and evaluation for Alpha, Beta, Theta and Delta wave activity

### Optional software modules are available for:

- Somatosensory stimulation control and evaluation only with PLUGSYS hardware and DIM-D
- Cerebral autoregulation control and evaluation only with PLUGSYS hardware
- Other cardiovascular signals
  - LVP module: LVPsys, LVPdia, LVPEDP, dP/dtmin, dP/dtmax, Heart Rate, Mean Pressure
  - LVP Advanced module: Tau, Time to Peak (Contractility Time), Relaxation Time and Contractility Index CI = dP/dtmax / P
  - Flow Advanced module: Endsystolic Flow, Enddiastolic Flow
- Respiration Module: Respiratory Rate, Max. Inspiratory Flow, Max. Expiratory Flow, Tidal Volume

Specific parameters which are not mentioned in this list are available by special order. Please call Harvard Apparatus Technical Customer Service for more details.

Catalog No.	\$	Product
BS4 73-3004		HSE-HA NEURODYN Data Acquisition software for Windows® NT/2000/XP
BS4 73-0161		HSE-HA Data Acquisition Hardware PLUGSYS Version
BS4 73-0235		HSE-HA Data Acquisition Hardware Stand Alone Version
BS4 73-3330		HSE-HA Data Acquisition Hardware USB Stand Alone Version
BS4 73-3526		Optional SEP Control and Evaluation Module
BS4 73-0223		DIM-D PLUGSYS Digital Bus Link for DIM
BS4 73-0221		PSM PLUGSYS Programmable Stimulator Module
BS4 73-3527		Optional Cerebral Autoregulation Control and Evaluation Module
BS4 73-3462		Optional LVP Module
BS4 73-0237		Optional LVP Advanced Software Module
BS4 73-0238		Optional Flow Advanced Software Module
BS4 73-0239		Optional Respiration Software Module

## Harvard Apparatus Microdialysis Probes

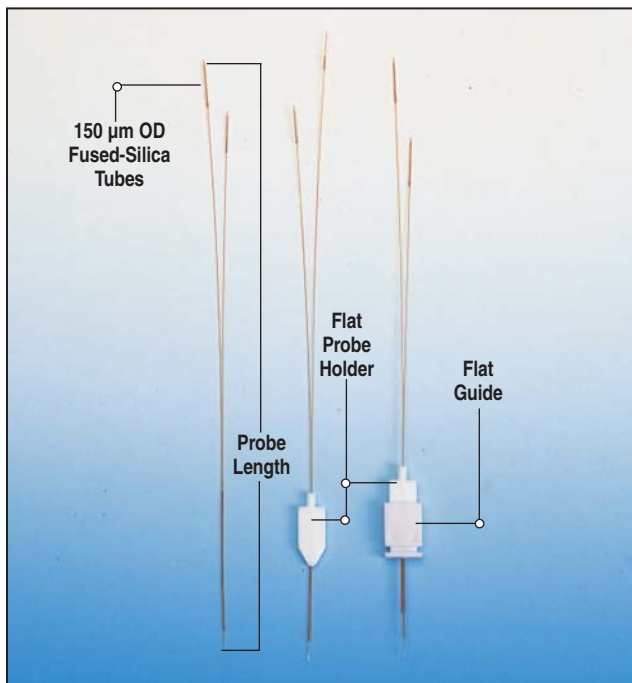

- Offers a higher *in vivo* recovery than competitor's probes
- Hardy construction; suitable for multiple insertions
- Refrigeration before use not required — indefinite shelf life
- Drying does not destroy pore structure
- Permeability is constant over time
- Reusable in the same configuration
- Adjustable projectile length
- Both loop-type and side-by-side are offered with standard 1, 2, 3 and 4 mm tip lengths
- Both types of probes are offered with either rigid or flexible shaft for straight or nonlinear insertions
- Membrane supported by fluid pressure for increased relative recovery

The Harvard Apparatus Microdialysis Probes are proprietary and patented (U.S. Patent No. 5,191,900). A unique feature of these patented Harvard Apparatus Microdialysis Probes is the way in which the membrane is supported – using only the fluid pressure inside the fiber. Since these Probes don't have an internal support structure, more of the membrane is exposed for increased relative recovery, especially in the Loop-Type Probes. During insertion, the fluid flow rate is adjusted to create a positive inside pressure between 100 and 500 mmHg to add rigidity to the fiber. This can be achieved by either selecting the appropriate outlet tubing for a given flow rate or using an increased flow rate during insertion. Once in place, these Probes operate at normal flow rates. They offer the following advantages:

### Probe Selection

The most important criteria in the selection of an appropriate Microdialysis Probe is the size of the desired site. The tip of the Probe must have smaller dimensions than the site itself. Harvard Apparatus's Probes have been optimized for the sensitivity of the analytical systems currently available which can routinely quantitate sub picogram levels of monoamines in the microdialysis sample.

### Adjustable Projectile Length

Another unique feature of these Probes is that the user can adjust the projectile length of the Probe. This adjustable length offers many advantages. For example, Guides which are non-invasive to the brain tissue may be implanted. Also, when dialyzing a superficial area in the brain, 'spacers' are not required.

### Shaft Length

The Microdialysis Probes have a 25 mm (1 in) shaft which is the optimal length for the microdialysis of the small animal brain. These Probes are typically used for microdialysis in mice and rats. The overall Probe length is 100 mm.

### Side-by-Side or Loop Type Configuration

Side-by-Side Probes offer the advantage of extremely small size – only 225 μm in diameter. Analytical limitations and occasional inconsistencies in recovery due to trapped air at the tip site are potential disadvantages of this design. Side-by-Side Probes are metal-free. Loop-Type Probes are also available in a metal-free configuration upon request. The 450 μm diameter Loop-Type Probes offer a larger membrane surface area for a given tip length, resulting in increased relative recovery. The Loop-Type Probes have an internal Formvar-coated nichrome wire to prevent kinking of the loop. We highly recommend the Loop-Type Probe in all applications where its size can be tolerated because of the major advantages of increased relative recovery.

### Flexible or Rigid Shaft

These Probes are available with either a rigid or flexible shaft. The rigid shaft Probes are commonly used in brain studies and other anesthetized animal applications where straight insertion is required. Alternatively, flexible shaft Probes are typically used when sampling from freely moving animals. They can be used in nonlinear guides and are appropriate for many non-nervous tissue applications.

### Harvard Apparatus Custom Microdialysis Probes

Custom Probes are available with either flexible or rigid shafts ranging in length from 10 to 100 cm and with Loop or Side-by-Side tips ranging in length from 1 to 20 mm. Call Harvard Apparatus for details.

## Harvard Apparatus Microdialysis Probes

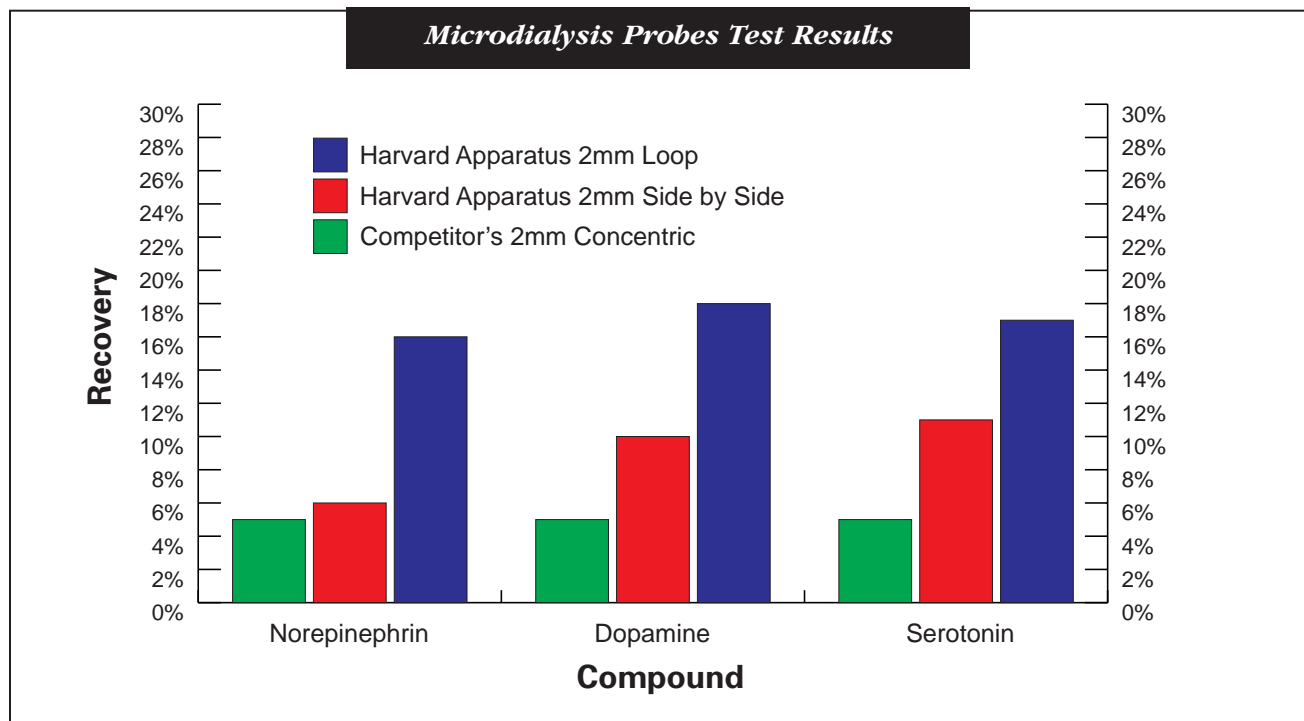

### Application Note: The Principle of Microdialysis

Modern medical science has found that extracellular fluid is significant in a number of important ways. The chemical content of these fluids can characterize normal and abnormal conditions of the brain, nervous tissue and other organs. It can also indicate the presence of desirable or undesirable chemical elements including pharmaceuticals.

The accurate and continuous in vivo measurement of brain interstitial substance concentration presents a major technical challenge. Among the many innovations that have appeared over the last decades, e.g. cortical cup, push-pull cannula, ion-selective micro-electrodes and carbon fiber electrodes, microdialysis is the only technique which can collect virtually any substance from remote brain regions with a limited amount of tissue trauma. Described as early as 1961, the microdialysis method has undergone several technical improvements. It is rapidly becoming a popular bioanalytic sampling technique for brain neurotransmitters and a sampling tool to monitor dynamically extracellular chemical events in liv-

ing tissue throughout the body. Brain tissue is ideally suited for microdialysis since the blood-brain barrier prevents a rapid exchange of the hydrophilic solutes with the vascular component. Dialysates from almost all other tissues include a vascular component in addition to the interstitial fluid.

Microdialysis also appears to be a promising technique in blood because the procedure provides a way of continuous sampling without blood withdrawal. Dialysis has also been performed in other non-nervous tissues including adipose, liver and muscle. In addition to its many applications in studying animals, researchers have found useful applications in the study of plants. Historically it has proven itself as a convenient and superior alternative to the push-pull cannula and cortical cup techniques. Its advantage over direct sampling techniques is indisputable.

Based on the principle of dialysis, the microdialysis technique involves flushing a fluid through a membrane material which is permeable to water and some small solutes. The fluid may be either devoid of substances of interest or may include exoge-

nous or endogenous substances which may be physiologically or pharmacologically active. The other side of the membrane is in direct contact with the interstitial space of the tissue. This creates a concentration gradient across the membrane which allows diffusion of substances from interstitial space or vice versa.

A 'Microdialysis Probe' consists of a dialysis membrane attached to a small diameter tube. Several shapes, sizes and designs of these microdialysis probes are available. The size and configuration of the probe's semipermeable membrane is generally optimized for the tissue region being studied.

1 Bito, L., Dawson, H., Levin, E., Murray, M. and Snider, N., The concentration of free amino acids and other electrolytes in the cerebrospinal fluid, in vivo dialysate of brain and of blood plasma of the dog. *J. Neurochem.*, 13 (1966) p 1057-1067.

2 Delgado, J.M.R., DeFeudis, F.V., Roth, R.H., Ryugo, D.K. and Mitruba, B.M. Dialytrode for long term intracerebral perfusion in awake monkeys. *Arch. Int. Pharmacodyn.*, 198 (1972) p 9-21.

## Harvard Apparatus Microdialysis Probes

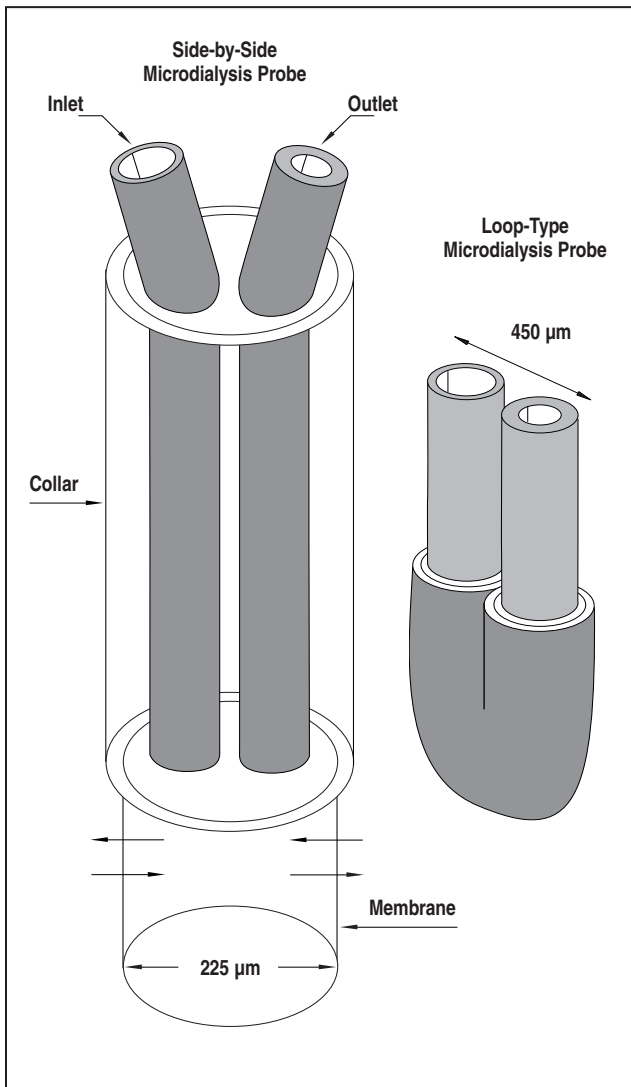

### Harvard Apparatus Microdialysis Probes

In Vitro Recovery Data is Useful to:

- Determine the optimal flow rate to use. Most microdialysis experiments are a compromise between the analytical detection limit and sampling period
- Indicate the presence of bubbles in the Probe; these have to be removed before implanting the Probe into the tissue
- Decide when probes should be changed; membrane pores are slowly blocked and the efficiency of the Probe decreases after being implanted into several animals
- Measure probe-to-probe variability

In vitro recovery for 3 mm Loop-Type Probe at 1.0 µl/minute, 24°C, illustrating how different molecular species show different relative recoveries.

The interpretation of microdialysis data should be approached with caution. Although the concentration of metabolites in the microdialysis sample reflects their concentration in the extracellular space, the exact relationship between these two entities is not exactly known. A growing body of evidence suggests that it may be inappropriate to use in vitro recoveries to estimate extracellular concentrations in vivo.

Monoamines	%
Dopamine (DA)	27.7
Norepinephrine (NE)	24.3
Serotonin (5HT)	30.7
Metabolites	%
DOPAC	23.9
HVA	27.6
5H1AA	22.8
Amino Acids	%
Glutamate (GLU), GABA	30 to 40
Taurine (TAU)	30 to 40
Glycine (GLY)	40 to 50

### Specifications

#### Membrane Tip:

**Material** Regenerated cellulose dialysis fibers; this material is isotropic; solute can diffuse through fiber wall in either direction; thus, probe can be used for simultaneously sampling dialyzable substances from tissue and delivering dialyzable drug

**Permeability Limit** 6000 daltons  
**Wall Thickness** 18 µm to 1.8 µm  
**ID** 215 µm to 15 µm  
**Dead Volume** 0.03 µl/mm of dialysis fiber  
**Probe Conditioning** 70% ethanol bath  
**Inlet/Outlet Tubes** Fused silica  
**Probe Length** 100 mm  
**Shaft Length** 25 mm

#### Maximum Projectile Length:

Probe in Probe Holder 20 mm  
 Probe in Probe Holder w/ Guide 15 mm

**Probes:** **Rigid Probes** **Flexible Probes**  
**Material** Fused-Silica Polyimide

### Microdialysis Probes, pkg. of 5

Shaft/Tip	Tip Length			
	1 mm	2 mm	3 mm	4 mm
<b>Flexible Shaft</b>				
Loop \$	BS4 59-7004	BS4 59-7005	BS4 59-7006	BS4 59-7001
Side-by-Side \$	BS4 59-7007	BS4 59-7008	-	-
<b>Rigid Shaft</b>				
Loop \$	BS4 59-7010	BS4 59-7011	BS4 59-7012	BS4 59-7305
Side-by-Side \$	BS4 59-7013	-	BS4 59-7015	-



## Microdialysis Probe Holders and Guides

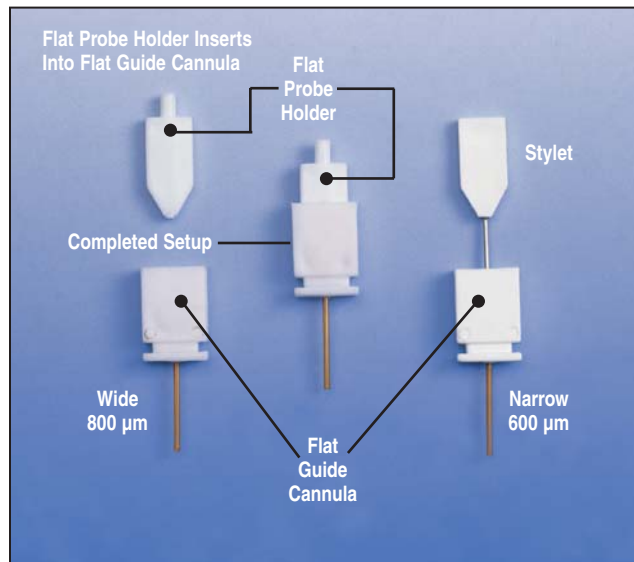

### Flat Probe Holder for Microdialysis

- Adjustable projectile length
- One piece design
- For anesthetized or freely moving\* animal applications

\* Flat Guide Cannula required.

The flat probe holder provides a simple method for attaching the microdialysis probe to the brain. The user attaches the microdialysis probe to the flat probe holder using Cyanoacrylate glue, offered as an accessory. This permits the user to decide on the exact projectile length required

(ventral coordinate). This is a unique feature of the Harvard Apparatus microdialysis probes.

The bottom end of the flat probe holder slides into the flat guide cannula. The shaft at the top end of the holder directly accepts the BS4 59-8405 Tether Adapter which then accepts the tether allowing complete enclosure of the microdialysis probe and tubing inside the tether. The flat probe holder is available in a package of 5 or 50.

Catalog No.	\$	Product
BS4 59-9870		Flat Probe Holder for Microdialysis, pkg. of 5

### Flat Guide Cannula for Microdialysis

This disposable, flat guide cannula is plastic and accommodates the flat probe holder, see to the left.

Two sizes are available:

- 1) 600  $\mu\text{m}$  to accommodate Harvard Apparatus flexible side-by-side probes
- 2) 800  $\mu\text{m}$  to accommodate Harvard Apparatus flexible loop-type probes and all Harvard Apparatus rigid probes

The deep penetrating guide has a 1 cm (0.39 in) long guide tube and the non-penetrating guide has a 1 mm (0.04 in) guide tube. The flat guide cannulae are available in a package of 5 or 50.

- Only 3 mm (0.12 in) thick allowing multiple guides to be implanted, side-by-side, in a single animal
- Available in both non-penetrating and deep penetrating styles

### Flat Guide Cannulae for Microdialysis

Quantity	Guide Tube Configuration	
	Narrow 600 $\mu\text{m}$	Wide 800 $\mu\text{m}$
<b>Deep Penetrating</b>		
Package of 5 \$	BS4 59-9872	BS4 59-9873
Package of 50 \$	BS4 59-9874	BS4 59-9875
<b>Non-Penetrating</b>		
Package of 5 \$	BS4 59-9877	BS4 59-9879
Package of 50 \$	BS4 59-9878	BS4 59-9880

Catalog No.	\$	Product
BS4 59-7307		Cyanoacrylate Glue, required to secure Probe to Probe Holder
BS4 59-8405		Tether Adapter for matching the Flat Probe Holder to Steel Spring Tether

### Application Note: Implantation of Guide and Attachment of Probe Holder

A stereotaxic frame is used to hold the animal during guide cannula attachment. After marking the desired site, a hole is drilled using a 0.0465 in (#56) drill bit, without penetrating the dura mater. The hole for the guide and additional holes for anchoring screws can be also be drilled. Once the guide and screws are in place, dental acrylate is mixed and poured. After the acrylate is fully cured, first the micromanipulator is raised and then the probe holder is detached. A stylet is then attached to keep the guide usable while the animal recovers from surgery.

To insert a probe when using a guide with a non-penetrating guide tube, a 25 gauge sharp needle is used to puncture the dura. Once the dura mater is ruptured as indicated by fresh blood on the needle, a probe is attached and ready for implantation. Insertion of the probe with a guide for deep-penetrating is achieved in an identical manner except the step for penetrating the durometer is not necessary. See our website for additional applications notes.

## Connecting Tubes and Adapters

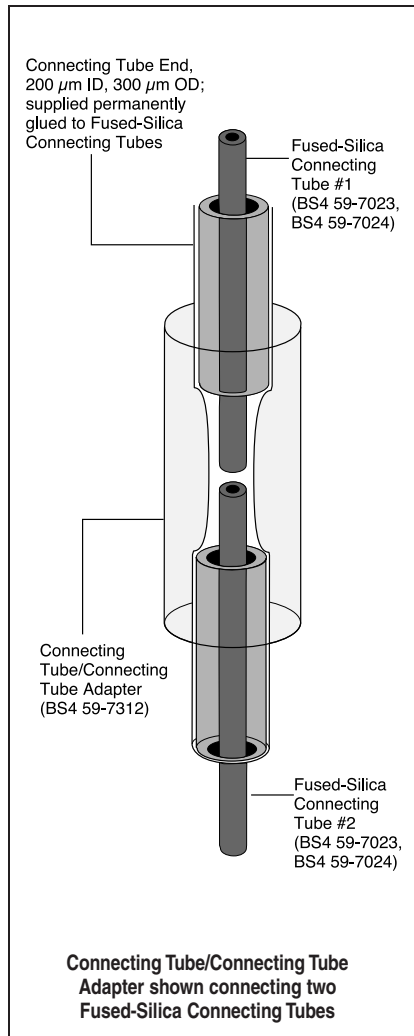

Three different types of connecting tubes are available for connecting probes to the fluid system.

- Fused-Silica
- Polyethylene
- Fused-Silica/Polyimide

This tubing connects to the different components of the microdialysis system using the adapters offered below.

### Fused-Silica Connecting Tube

The fused-silica connecting tubes feature flexibility and sturdy construction. They are highly recommended for 1 to 2  $\mu\text{l}/\text{min}$  flow rates. They are available in two lengths, 50 and 100 cm and are supplied with two 5 mm pieces of 200  $\mu\text{m}$  ID x 300  $\mu\text{m}$  OD fused-silica tubing permanently attached to both ends. This increases the outer diameter of the connecting tube to 300  $\mu\text{m}$  at its ends. These thicker end pieces allow connections to be made easily using connecting tube/connecting tube adapters, see below, while retaining the lowest possible dead volume in the connecting tube. Supplied as a package of 2.

#### Specifications

Material	All fused-silica
ID x OD	75 x 150 $\mu\text{m}$
Dead Volume	0.044 $\mu\text{l}/\text{cm}$
End Pieces	300 $\mu\text{m}$ OD fused-silica (equivalent to 30 gauge tubing)

#### Catalog No. \$ Product

BS4 59-7023	Connecting Tube Length, 50 cm (19.7 in), pkg. of 2
BS4 59-7024	Connecting Tube Length, 100 cm (39.4 in), pkg. of 2
BS4 59-7313	Replacement Connecting Tube End, for repairing Fused-Silica Connecting Tubes (75 $\mu\text{m}$ ID x 150 $\mu\text{m}$ OD); 300 $\mu\text{m}$ OD Replacement Connecting Tube End is attached to end of Connecting Tube using cyanoacrylate glue, see below. Recommended that open end of Connecting Tube be approximately 3 mm (0.1 in) away from Connecting Tube End and that glue be applied from distal end of Adapter. Permits two 150 $\mu\text{m}$ OD Fused-Silica Connecting Tubes to be joined together with BS4 59-7312 Connecting Tube/Connecting Tube Adapter, pkg. of 20.
BS4 59-7307	Cyanoacrylate Glue; Bonds Replacement Connecting Tube Ends to Connecting Tube, Supplied as 2 gram Tube
BS4 59-7314	23 Gauge Needle/Connecting Tube Adapter; for making press fit connections between 23 Gauge Needle (e.g. on the swivel and Harvard Apparatus Liquid Switch) and Fused-Silica Connecting Tubes or 26 Gauge Needles, pkg. of 5
BS4 59-7315	1/16 in OD Tubing/Connecting Tube Adapter; for making press fit connections between standard 1/16 in OD Tubing, as found in HPLC valves, and Fused-Silica Connecting Tube or 26 Gauge Needle, pkg. of 5

*These Fused-Silica Connecting Tubes are reusable for 4 to 5 times if flushed after each use. Order 1 pair for every 3 to 4 Probes you plan to use.*

## Connecting Tubes and Adapters

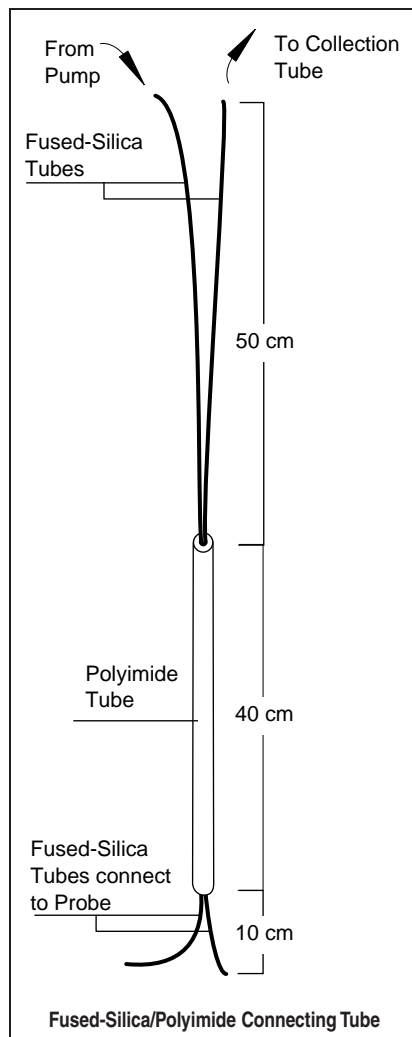

### Polyethylene Connecting Tube

The Polyethylene (PE) connecting tube is a 100 cm (39.4 in) ready-to-use piece of 250  $\mu\text{m}$  ID x 750  $\mu\text{m}$  OD polyethylene tubing. One end of this tubing can be directly connected to the probe. The other end of the tubing has been modified to accommodate 20 to 25 gauge needles. This connecting tube is recommended for applications where the required flow rate is higher than 5  $\mu\text{l}/\text{min}$ . This permits a safe back pressure to the membrane. Its thick wall prevents flow blockade due to kinking. Supplied as a package of 2.

#### Specifications

<b>Material</b>	Polyethylene
<b>ID x OD</b>	250 x 750 $\mu\text{m}$
<b>Length</b>	100 cm (39.4 in)
<b>Dead Volume</b>	0.49 $\mu\text{l}/\text{cm}$
<b>End Pieces</b>	None required if connections made directly to 26 Gauge Needle and Probe; To connect to 23 Gauge Needle/Connecting Tube Adapters or to 1/16 inch OD Tubing/Connecting Tube Adapters, order BS4 59-7313 Replacement Connecting Tube Ends; Adapter and Polyethylene Tube will both fit over Connecting Tube End

Catalog No.	\$	Product
BS4 59-7025		Polyethylene Connecting Tube, pkg. of 2

### 26 Gauge Blunt Needles

These blunt Needles are recommended for connecting the syringe to the system. Supplied as a package of 12.

Catalog No.	\$	Product
BS4 59-7310		26 Gauge Blunt Needles, pkg. of 12

#### Application Note: Calculating Dead Volume

The volume of a cylindrical tube can be calculated by the equation  $V = \pi r^2 h$ . Accordingly, the Fused Silica Tube has a dead volume of 0.044  $\mu\text{l}/\text{cm}$ . These tubes have a tolerance of < 5%. In practical situations, the 50 cm piece of the Fused-Silica Connecting Tube has a dead volume of approximately 2.2  $\mu\text{l}$ , and the 100 cm piece has a dead volume of approximately 4.5  $\mu\text{l}$ . Similarly, a 100 cm (39.4 in) length of the 250  $\mu\text{m}$  ID Polyethylene Tube has a dead volume of 50  $\mu\text{l}$ .

In order to test these dead space volumes, use an empty tube and connect it to an already running syringe pump. The elapsed time and flow rate would provide estimates of the actual dead volumes. The observed values should be within 10 to 15% of the estimated values.

## **NEW** BR Brain Microdialysis Probes

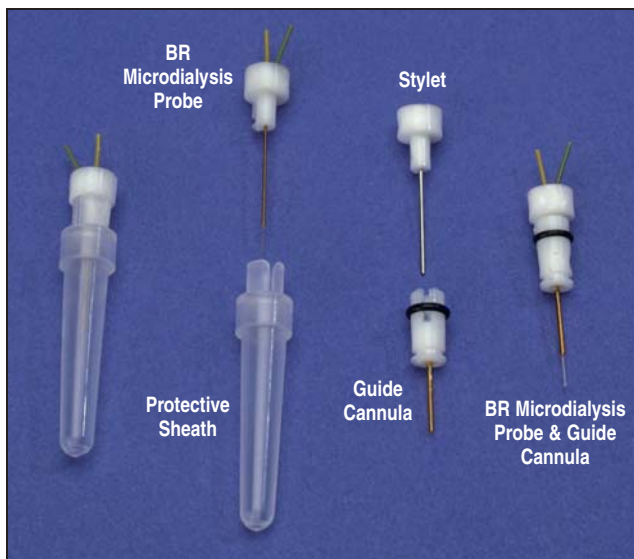

Microdialysis sampling was originally developed to study the chemistry of cerebrospinal fluid. The concept of continuous sampling by brain microdialysis was originally described at Yale University in 1972 (“Dialytrode for Long Term Intracerebral Perfusion in Awake Monkeys”, J. Delgado, E. DeFeurdi, R. Roth, D. Ryugo and B. Mitruka, *Arch Int. Pharmacodyn.* (1972) 198: 9-21.) Neuroscientists have employed brain microdialysis as a monitoring tool for more than two decades. The use of a brain microdialysis probe is therefore the best developed of all possible applications.

Several different probe styles have been used. The original transcerebral probes consisted of a single length of dialysis tubing which stretched from one side of the head to the other. This approach integrated the chemical activity of all brain tissue in contact with the membrane but was not useful for differentiating the activity of individual brain regions. In loop probes a length of dialysis tubing was bent in half to form a smaller probe which could be inserted within specific brain tissues. These tended to be easy for researchers to construct, but still created more tissue damage than desirable. Pin probes, which depend on a small cylinder of dialysis membrane mounted on a thin cannula, were favored as the design creating less tissue damage. Pin probes evolved from the push-pull cannula technique originally developed by Gaddum for sampling of cerebrospinal fluid. The earliest published reference to a pin probe was at Emory University, in 1982 in a thesis written by R.D. Johnson working under Prof. J.B. Justice. Pin probes can be placed into the target tissue with the greatest accuracy. They can be removed and reinserted into guides mounted on the skull. BR probes manufactured by BAS use the pin design.

BR probes offer a small profile (340 micrometer OD) to minimize tissue damage and use a membrane with excellent recovery characteristics and a long shelf life (Polyacrylonitrile, MWCO = 30,000 daltons).

The BR Microdialysis Probe is shown with its accessories. Starting at the left is a BR probe in the shipping vial. The probe can return to the vial for in vitro calibrations or short-term storage once wetted. The next view shows the probe removed from the vial. Notice the slot in the vial which secures the locking key on the probe head. The

optional intracerebral guide is shown next with the stylet removed. The stylet remains in place during stereotaxic insertion of the guide. It is removed just prior to insertion of the probe. The intracerebral guide is always placed just above the tissue to be studied. The probe is designed so that the membrane portion will extend beyond the end of the guide cannula. The target tissue will not be pierced until the probe is inserted in the guide for the first time. On the far right, a probe has been fully inserted into the guide. In this photograph, a rubber O-ring on the guide cannula is the feature which locks the probe. The rubber O-ring offers a “snap” fit and release. For studies in active animals, another type of guide cannula with a steel “Omega-ring” is used because of the strength of steel. The steel ring rotates to around the guide to lock or release the probe. Both types of guides permit the probe to be removed after the sampling experiment is completed and reinserted at another time. The combination of an O-ring guide and probe is completely non-metallic and suitable for NMR imaging. The Omega-ring guide is not used for NMR because of the steel in the Omega-ring.

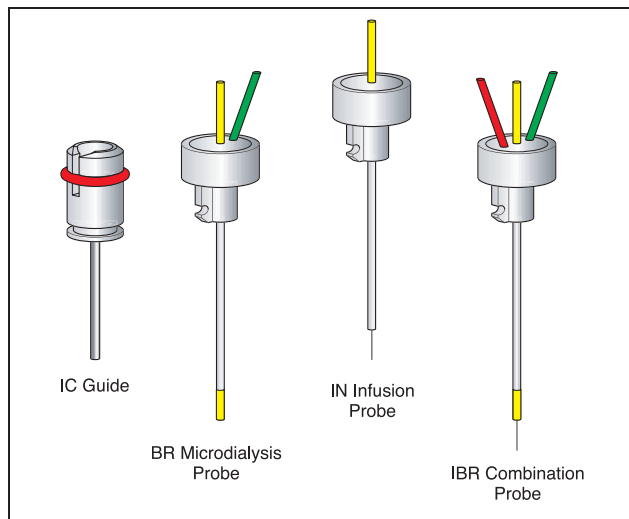

BAS also offers a pin style brain microdialysis probe (model IBR) with an additional cannula which can be used for infusions or injections of fluids directly to the tissue being dialyzed. Although many drugs can be administered to the tissue via addition to the dialysis perfusion fluid, this approach requires extra effort to determine the actual dosage of drug delivered. Compounds with a molecular weight above the MW cutoff of the membrane are too large to be dialyzed into the tissue. The infusion cannula in the IBR probe is an open cylinder with a volume of 0.2 microliters. Fluid injected or infused into this cylinder will exit at the tip of the dialysis membrane and contact the tissue directly. An IBR probe is therefore suitable for injections of high molecular weight compounds such as dyes, proteins, DNA, RNA, carbohydrates, etc.

The IBR Microdialysis Probe permits the delivery of fluid directly to a tissue being dialyzed. This is accomplished by including a third cannula inside a brain microdialysis probe which exits from the tip of the probe. Fluid injected into the brain tissue through this cannula is likely to travel upwards, along the path created by insertion of the probe, and wash the tissue in contact with the dialysis membrane.

## **NEW** BR Brain Microdialysis Probes

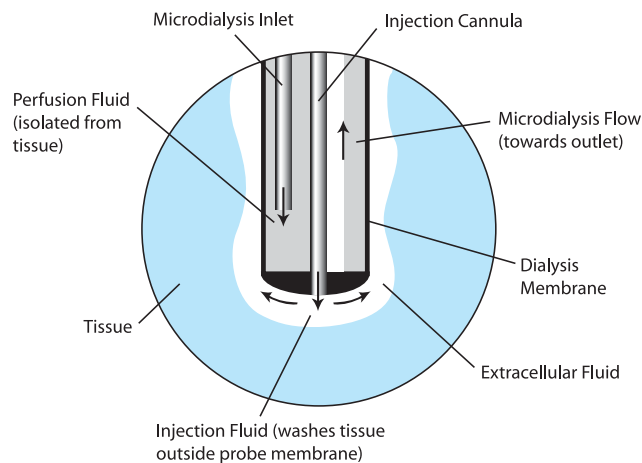

IBR probes fit into the same intracerebral guides used for BR brain microdialysis probes. The color-coded injection cannula (red) uses the same type of flanged tubing connector used to connect FEP or PEEK tubing to the probe inlet (yellow) and outlet (green).

### Applications of BR Brain Microdialysis Probes

- Monitor changes in levels of neurotransmitters or low molecular weight (< 5000 da) chemicals in the brain of a conscious animal.
- Non-metallic probe and intracerebral guide (O-ring) facilitates NMR imaging of implant site.
- Standard BR probes are suitable for rodents such as rats, hamsters and guinea pigs.
- Custom BR probes may be constructed for larger animals with longer cannula and membranes.
- Use the IBR infusion/dialysis probe to deliver drug directly to brain tissue while simultaneously monitoring tissue response to drug.
- Probes may be sterilized by the user using ethylene oxide (ETO) gas or plasma peroxide.
- Use shipping vial for in vitro calibration and short-term storage.

BAS Return software recorded animal activity during an experiment in which amphetamine was delivered directly to the striatum via an IBR probe, and biogenic amines were simultaneously monitored in dialysates from the same probe. The illustrations show the original Return data file, and graphs comparing left and right sensor data in 10 minute segments. In the Return, the left sensor signifies clockwise rotation and the right sensor signifies counter clockwise rotation.

### Specifications

<b>Cannulas</b>	Inert, biocompatible plastic
<b>Cannula Length</b>	15 mm
<b>Probe Volume</b>	2.1 to 2.3 $\mu$ l (BR-2 or BR-4)
<b>Use</b>	Lock into optional intracerebral guide with rubber O-ring or steel Omega-ring, or mount directly on skull using acrylic cement
<b>Fluid Connections</b>	Flanged plastic connectors and FEP Teflon or PEEK tubing, separate purchase
<b>Membrane</b>	PAN. 320 $\mu$ m OD, 2 or 4 mm lengths, standard, other membrane lengths available by special order
<b>Storage</b>	Store unopened blister trays at room temperature

Catalog No.	\$	Product
BS4 72-6910		Brain Microdialysis Probes, BR-2, 2 mm membrane, pkg. of 6
BS4 72-6911		Brain Microdialysis Probes, BR-4, 4 mm membrane, pkg. of 6
BS4 72-6912		Combination Brain Microdialysis/Infusion Probes, IBR-2, 2 mm membrane, pkg. of 6
BS4 72-6913		Combination Brain Microdialysis/Infusion Probes, IBR-4, 4 mm membrane, pkg. of 6
BS4 72-6914		Brain Infusion Probes, 2 mm Infusion Cannula Extension, pkg. of 6
BS4 72-6915		Brain Infusion Probes, 1 mm Infusion Cannula Extension, pkg. of 6
BS4 72-6916		O-Ring Intracerebral Guide Cannula and Stylet, pkg. of 6
BS4 72-6917		Omega-Ring Intracerebral Guide Cannula and Stylet, pkg. of 6
BS4 72-6918		Calibration Station, In Vitro Stand with Two Probe Clamps
BS4 72-6896		Clamp Rod - mounts probe clamp to Stoelting or ASI Stereotaxic Instruments
BS4 72-6919		Surgical Instruments Kit

## **NEW** Intracerebral Guide Cannula

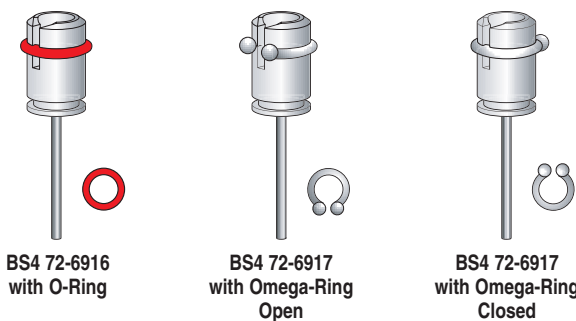
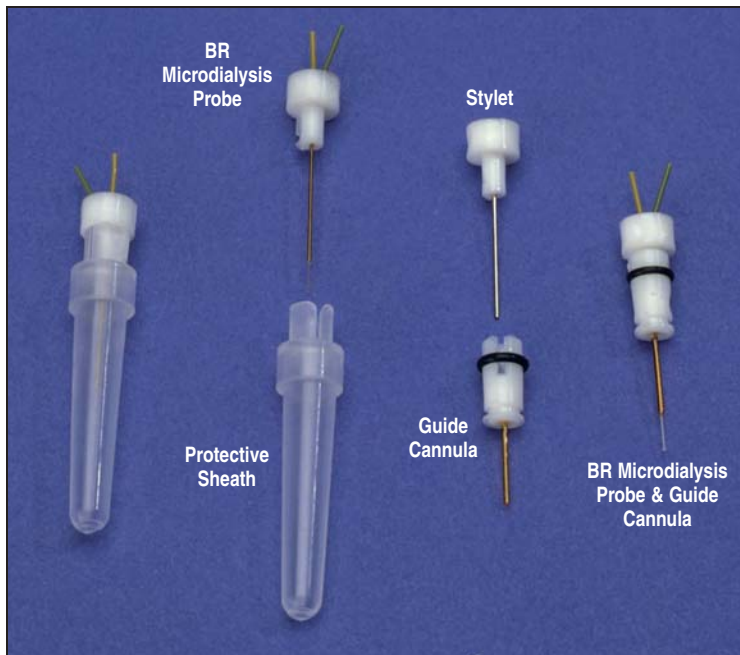

BS4 72-6916  
with O-Ring

BS4 72-6917  
with Omega-Ring  
Open

BS4 72-6917  
with Omega-Ring  
Closed

This Intracerebral Guide Cannula targets an implant site and support a microdialysis probe during in vivo sampling experiments in the brain. Guides are used for studies in awake, freely moving animals.

The guide is as long as the probe cannula. When a probe is placed inside, only the dialysis membrane extends beyond the end of the guide cannula. When the guide is implanted, it is placed just above the tissue that will eventually be sampled by microdialysis. After the animal recovers from the surgery (3-5 days), the edema will subside and ruptured blood vessels will have been sealed. Any glial cell formation will be restricted to the tissue disrupted by insertion of the guide and not the target site. Damage caused by insertion of the probe will be restricted to a small path that is the length and diameter of the dialysis membrane. This is considerably less trauma for the brain than the damage caused by drilling a hole in the skull, puncturing the dura, and then inserting the longer and wider intracerebral guide. In many cases, levels of targeted analytes will achieve steady state within a few hours. After sampling, the probe can be removed and reinserted at a later time.

The Intracerebral Guide Cannula can be mounted directly onto the skull using stereotaxic surgical techniques. It can be held by the clamp assembly as shown on the drawing above (far left). The clamp assembly mounts on the clamp rod which is in turn mounted onto the micromanipulator of the stereotaxic frame.

- Permits insertion and removal of a single BR brain microdialysis probe
- The guide is positioned above the tissue that will be sampled by the probe and thus "targets" the site. The guide itself does not penetrate the tissue that is eventually sampled by the probe membrane
- Results in less damage to the brain: the tissue recovers faster, the microdialysis experiment begins sooner
- Completely non-metallic guide/probe pair
- A "lock" secures the probe yet allows for later removal
- May be ETO sterilized

### Specifications

<b>Cannula</b>	Inert, biocompatible plastic
<b>Stylet</b>	Stainless steel, removed when probe is inserted into guide
<b>Cannula Length</b>	10 mm
<b>Lock</b>	Rubber O-ring is standard, optional steel collar available for active animals by special order

Catalog No.	\$	Product
BS4 72-6916		O-Ring Intracerebral Guide Cannula and Stylet, pkg. of 6
BS4 72-6917		Omega-Ring Intracerebral Guide Cannula and Stylet, pkg. of 6
BS4 72-6920		Clamp for BR Brain Probes
BS4 72-6896		Clamp Rod
BS4 72-6910		Brain Microdialysis Probes, BR-2, 2 mm Membrane, pkg. of 6
BS4 72-6911		Brain Microdialysis Probes, BR-4, 4 mm Membrane, pkg. of 6
BS4 72-6906		Dental Acrylic Cement
BS4 72-6900		Screw Bone Anchors, pkg. of 100
BS4 72-6901		Drill Bits for Screw Bone Anchors, pkg. of 5
BS4 72-6903		Trephine-Style Bone Drills, pkg. of 3
BS4 72-6921		High Speed Surgical Drill
BS4 72-6919		Surgical Instruments Kit

## **NEW** Loop Microdialysis Probes

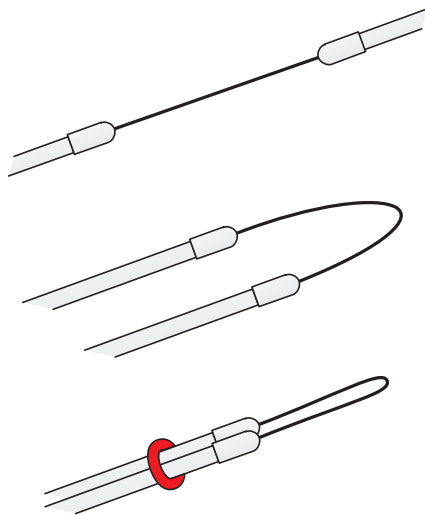

Loop Microdialysis Probes have been designed for both in vivo studies (subcutaneous tissue, peritoneal cavity) in experimental animals and in vitro studies in aqueous solutions (tissue homogenates, cell suspensions, plasma, biological fluids). Although the profile of a Loop Microdialysis Probe is thicker than other linear probes, it is a stronger probe with more reinforcement at the joint. The Loop Microdialysis Probe is a good choice for many in vitro applications, teaching, and first-time users.

Linear Microdialysis Probes offer a small profile (320  $\mu\text{m}$  OD) and are entirely flexible. Flexible plastic tubing brackets the membrane window. An internal fiber strengthens the probe and extends beyond the probe tubing to aid implantation in a variety of tissues including dermis, muscle, adipose tissue, liver and other organs. As shown in the figure above, the Loop Microdialysis Probe may be used in a linear approach (A), or folded in half to form a dialysis loop (B). A small slice of plastic tubing can be used to secure the loop (C) with the glue joints staggered to minimize the thickness of the looped probe.

### Catalog No.    \$    Product

BS4 72-6938		Loop Microdialysis Probe, DL-2, 2 cm Membrane for Loop or Linear Insertion, pkg. of 6
BS4 72-6939		Loop Microdialysis Probe, DL-5, 5 cm Membrane for Loop or Linear Insertion, pkg. of 6
BS4 72-6940		Loop Microdialysis Probe, DL-3, 3 cm Membrane, pkg. of 6
BS4 72-6941		Loop Microdialysis Probe, DL-1, 1 cm Membrane, pkg. of 6
BS4 72-6936		Tissue Introducer Needle
BS4 72-6907		FEP Teflon Tubing, 0.65 mm OD x 0.12 mm ID, 1 m (clear)
BS4 72-6908		Flanged Tubing Connectors (clear), pkg. of 20
BS4 72-6919		Surgical Instruments Kit

*Custom probes available by special order.*

## **NEW** Linear Microdialysis Probes

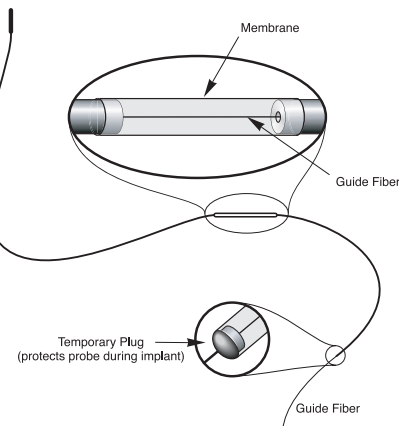

The Linear Microdialysis Probe consists of a short length of hollow dialysis fiber attached to narrow-bore inlet and outlet tubes. An aqueous perfusion solution, which closely matches the ionic composition of the surrounding extracellular fluid, is pumped through the probe at a constant flow rate. Low molecular weight analytes diffuse in or out of the probe lumen. Large molecules such as proteins or protein-bound analytes are excluded by the membrane. Molecules entering the lumen are swept away by the perfusion fluid. This dialysate is then collected for analysis.

Linear Microdialysis Probes offer a small profile (320  $\mu\text{m}$  OD) and are available with either 10 mm or 5 mm active lengths of dialysis membrane. Custom probes with other membrane lengths are also available. Flexible plastic tubing brackets the membrane window. Long inlet and outlet tubes facilitate subcutaneous externalization of the probes when used in awake animals. An internal fiber strengthens the probe and extends beyond the probe tubing to aid implantation. A plug seals the end of the probe from which the fiber skeleton extends. This plug keeps body fluids from entering the probe during surgery and is cut off before the probe is connected to a syringe pump and perfused. The linear probe is suitable for in vivo sampling from a variety of peripheral tissues, including dermis, subcutaneous tissue, muscle, adipose tissue, liver and other organs.

### Catalog No.    \$    Product

BS4 72-6932		Linear Microdialysis Probes, LM-10, 10 mm Membrane Window, pkg. of 6
BS4 72-6933		Spare Plastic Tubing for Probe End
BS4 72-6934		Linear Microdialysis Probes, LM-5, 5 mm Membrane Window, pkg. of 6
BS4 72-6935		Veterinary Bonding Glue, 3 ml
BS4 72-6936		Introducer Needle
BS4 72-6907		FEP Teflon Tubing, 0.65 mm OD x 0.12 mm ID, 1 m (clear)
BS4 72-6908		Flanged Tubing Connectors (clear), pkg. of 20
BS4 72-6919		Surgical Instruments Kit
BS4 72-6937		Tissue Matrix: 10 mm x 10 mm chamber for sectioning dissected tissue into slices for postmortem histology

*Custom sizes available by special order.*

## NEW IV Vascular Microdialysis Probe

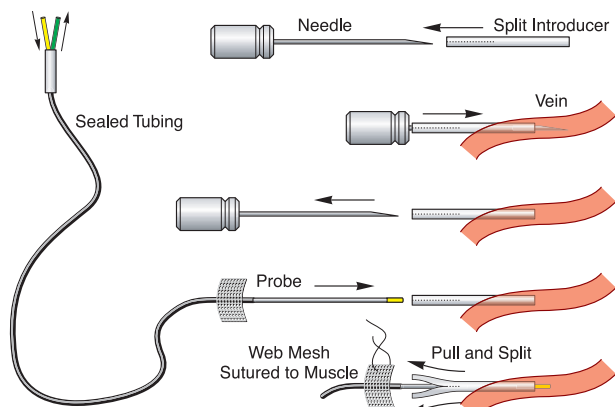

No study of pharmacokinetics, drug delivery, metabolism, or toxicity is complete without a determination of the drug concentration in blood. Blood sampling in small animals is necessarily limited by the volume of blood available. Sampling intervals of several hours are required to allow the subject to replenish fluids. Sampling frequency is therefore a primary advantage of vascular microdialysis. Since no blood or fluid is removed, the subject remains hydrated and the collected samples are more representative of a normal state.

IV Vascular Microdialysis Probes were designed for implantation into the rat jugular vein. They are also suitable for other soft tissues. Each probe includes a syringe needle and temporary cannula (split introducer) which aid placement. The thin-walled, plastic introducer slides over the syringe needle, which is then used to pierce the vein. The needle is removed and replaced with an IV Probe. A flexible wire mesh on the probe is sutured to the pectoral muscle. The cannula is then pulled out of the vein, leaving the probe behind. Inlet and outlet lines to the probe are housed within a single piece of flexible tubing, which is externalized by use of a surgical introducer needle.

The flexible probe, web, and connecting tube improve the comfort of a freely moving animal. The small OD of the probe is less likely to occlude the blood vessel.

Catalog No.	\$	Product
BS4 72-6929		Vascular Microdialysis Probe IV-5 with Needle and Introducer, 5 mm Dialysis Membrane, pkg. of 3
BS4 72-6930		Vascular Microdialysis Probe IV-10 with Needle and Introducer, 10 mm Dialysis Membrane, pkg. of 3
BS4 72-6931		Split Introducers for IV Vascular Microdialysis Probes, pkg. of 10
BS4 72-6919		Surgical Instruments Kit for Microdialysis, pkg. of 1

## NEW In Vivo Ultrafiltration Sampling Probes

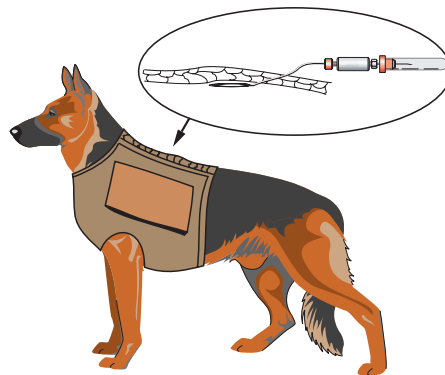

Microdialysis is not the only sampling method which relies on the use of an implanted semi-permeable membrane. Our In Vivo Ultrafiltration Probes utilize the same method. Microdialysis is an excellent method for monitoring changes in the concentration of a particular analyte, relative to some initial or basal level. However, when you are trying to determine the actual concentration of that analyte in the tissue itself, microdialysis methods require that you perform additional manipulations and extrapolate to determine that figure. In Vivo Ultrafiltration does not dilute the sample. Instead, it extracts the actual extracellular fluid and filters it to exclude high molecular weight compounds such as proteins. The concentration of an analyte in the ultrafiltrate represents the concentration of that analyte in the sampled tissue.

Ultrafiltration Probes are small, flexible tubes which can be sterilized and implanted subcutaneously into living animals. The surgery is simple, requiring the implant of the tubing under the skin through a needle-like introducer. A suture secures the probe. Once installed, an Ultrafiltration Probe can be used to painlessly remove fluid from the extracellular space of the surrounding tissue. A common vacuum chamber provides the motive force which pulls fluid through tiny probes in the probe membrane, up the probe tubing and into the vacuum chamber. The sampling rate is slow (1 to 3 mL/min) and can not exceed the rate at which the fluid is replaced by the blood vessels within the tissue. The fluid removed is clean, protein free and ready for immediate analysis. Whenever a new sample is needed, a new vacuum chamber is used. The vacuum chamber and probe tubing is protected in a lightweight jacket worn by the animal. Small creatures, such as laboratory rodents, are housed in the BAS Return system and continuously sampled.

### How does In Vivo Ultrafiltration Work?

A small and flexible probe is inserted into the tissue. This probe contains a sealed loop of semi-permeable plastic membrane. The membrane has tiny pores (holes) which allow water, salts and low molecular weight molecules (with molecular weights less than 30,000 daltons) to pass through the membrane and into the probe. Proteins and other large molecules can not pass and are left in the tissue. Tubing connects the membrane loop to the outside of the body. As vacuum is applied to the tubing, often by something as simple as a vacuum chamber, extracellular fluid is collected as it filters through the membrane, up the tubing and into the vacuum chamber. The concept of in vivo ultrafiltration and the design of probes is covered by USA patents: 4,777,953; 4,854,322; and 5,002,054.



## **NEW** In Vivo Ultrafiltration Sampling Probes

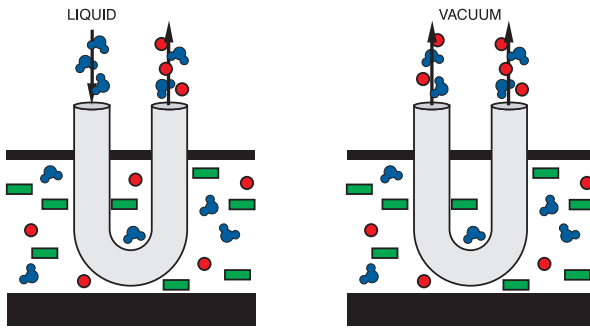

Glucose levels in ultrafiltrates collected from subcutaneous tissue parallel the blood glucose levels. Analysis can be conducted with the glucose strips and meters marketed for home use by human diabetics. The lack of proteins in the sample may, in techniques involving the use of a biosensor electrode, improve the reliability of the measurement. There is about a 30 minute lag time behind blood glucose levels due to the time required for the fluid to move down the probe tubing and into the collecting vessel. Studies have been conducted in dogs for periods of several months.

### Alternative Vacuum Source

Ultrafiltration Probes require a vacuum source in order to extract fluid from the tissue which surrounds the probe. There are two options for creating a vacuum: a vacuum tube of the type used for collection of blood, or a peristaltic pump.

Vacuum tubes provide a portable collection method which requires no electrical power, cords or tethering. When the hub device pierces the septum of the tube, the vacuum inside the tube is extended within the probe and fluid flow begins. The tube is replaced with a new vacuum tube whenever another sample is needed. Vacuum tubes might typically be replaced every 30 to 60 minutes. Vacuum tube collection can be used with a tethered small animal, or a freely-roaming large animal. In larger animals (horses, dogs, pigs, sheep) the vacuum tube is usually taped to the skin. The vacuum tube and probe site are protected by a coat or covering as the animal roams freely. To collect ultrafiltrates using vacuum tubes, please order the Ultrafiltration Starter Kit.

Peristaltic pumps provide a more convenient way of sampling from smaller animals housed in a container such as the BAS Return system. They can also deliver the sample to an automated, refrigerated fraction collector such as the BAS HoneyComb Fraction Collector. We offer a small peristaltic pump with small ID tubing which can be used for ultrafiltration sampling. To use a peristaltic pump, either order the pump and connectors described below, or determine a way to modify your existing peristaltic pump to create a gas-tight connection to the 0.65 mm OD tubing on the Ultrafiltration Probe.

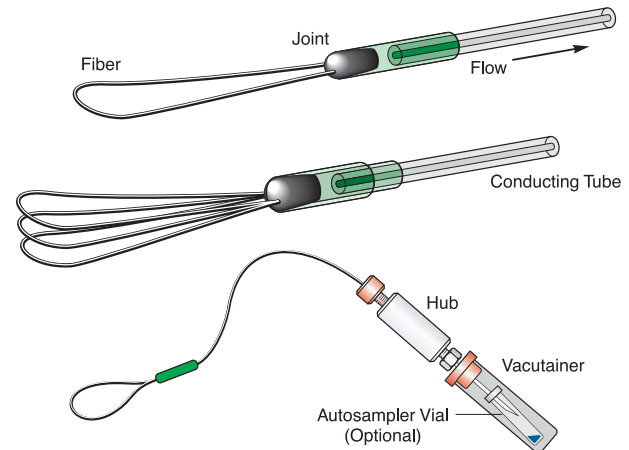

### Probe Sizes

Ultrafiltration Probes uses loops of membrane which are connected to a single collection tube. They are defined by the number of loops of membrane and the length of membrane in each loop. For example, the model UF-3-12 probe has 3 loops of membrane and each membrane loop contains 12 cm of membrane. Therefore, a UF-3-12 probe offers 36 cm of available membrane surface for ultrafiltration. Use a probe like this if you want to get maximum flow and study a uniform tissue such as subcutaneous tissue. Since the membrane is formed into a loop, the loop length is half the membrane length. So in a UF-3-12 (BS4 72-6942) probe, the length of the loop is 6 cm. You would use an introducer needle to tunnel under the subcutaneous tissue for a distance of approx. 7 cm in order to insert this probe. The OD of this membrane is 320 micrometers. Other probes models are named in the same manner: UF-1-2 (BS4 72-6945) has one loop containing 2 cm of membrane, UF-3-8 (BS4 72-6943) has three loops each containing 8 cm of membrane, etc.

Catalog No.	\$	Product
BS4 72-6942		Ultrafiltration Probes, UF-3-12, pkg. of 6
BS4 72-6943		Ultrafiltration Probes, UF-3-8, pkg. of 6
BS4 72-6944		Ultrafiltration Probes, UF-3-2, pkg. of 6
BS4 72-6945		Ultrafiltration Probes, UF-1-2, pkg. of 6
BS4 72-6946		Reinforced Ultrafiltration Probes, RUF-3-12, pkg. of 6
BS4 72-6947		Ultrafiltration Starter Kit
BS4 72-6958*		Vacutainers, 3 ml, pkg. of 12
BS4 72-6948*		300 µl Glass Sample Vials, pkg. of 12
BS4 72-6949*		Clearing Rod
BS4 72-6950*		Hub Assembly
BS4 72-6951*		Spare Hub Needle
BS4 72-6936*		Tissue Introducer Needle
BS4 72-6952*		Large Luer Syringe
BS4 72-6953*		Luer Needle for BS4 72-6952 Syringe
BS4 72-6954		Mini-Peristaltic Pump
BS4 72-6955		Space 0.020 Inch Peristaltic Tubing Set
BS4 72-6908		Flanged Tubing Connectors, pkg. of 20

\* Included in BS4 72-6947 Starter Kit

## **NEW** Bone Ultrafiltration Probe

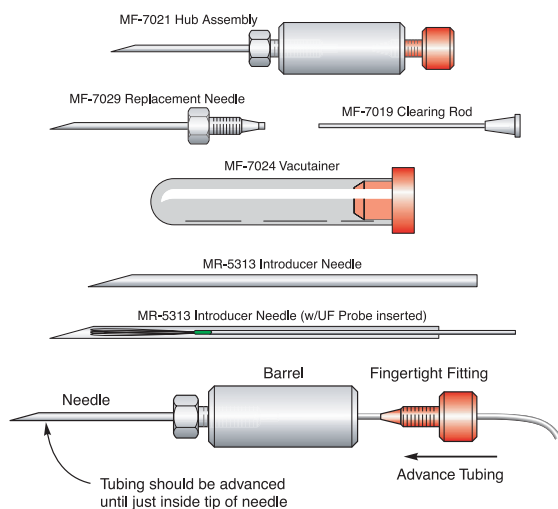
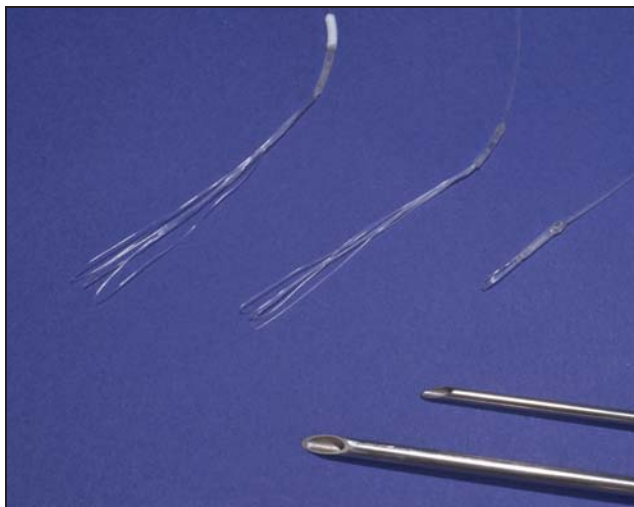

Specialized Tools For Bioresearch

- Ultrafiltration Probe
- Developed for NASA in collaboration with Purdue University
- Study chemical changes in bone interstitial fluid in vivo
- For use in larger animal models
- Permits long-term studies in the same subject

Some of the studies conducted by Purdue and BAS scientists using the new bone ultrafiltration probe include:

- Measurement of baseline concentrations of the bone minerals, calcium, magnesium and phosphate in bone, skeletal muscle, subcutaneous tissue and blood.
- Measurement of changes in interstitial calcium, magnesium and phosphate in bone, skeletal muscle, subcutaneous tissue and blood after infusion of either calcium or EDTA.
- Study of the effect of different dietary levels of calcium on interstitial bone minerals.

The Bone Ultrafiltration Probe consists of semi-permeable membrane fibers attached to a microbore conducting tube. The membrane fibers are implanted into the bone. On the tubing are two cuffs of porous

material, which promote tissue growth and help stabilize the position of the probe. In addition to the cuffs, there are suture retainers at 5-cm intervals to further facilitate anchoring of the probe in place. A kink resistant sheath at the fiber-tubing junction facilitates subcutaneous tunneling of the probe at the bone exit site.

After the probe has been implanted into the bone, there are two methods of sampling from an implanted bone probe. For studies in freely moving unrestrained animals the probes can be connected to a needle hub (BS4 72-6957) which can be inserted into a Vacutainer™ (BS4 72-6958) to provide the negative pressure. For this sampling method animals wear jackets with pockets to hold the Vacutainers.

If frequent samples will be collected over a short period of time the use of a mini-peristaltic pump (BS4 72-6954) and a fraction collector (BS4 72-6909) may be more convenient. To use the bone probe with the pump and fraction collector the hub adapter segment of the bone probe is removed and the probe tubing is connected directly to the mini-pump and the mini-pump is connected to the HoneyComb Refrigerated Fraction Collector.

### Uses of the BAS Bone Ultrafiltration Probe

It has long been possible to study the changes in bone structure and mineralization in the living animal with the use of such physical measurements as x-ray and ultrasound. However, it has not previously been possible to monitor ongoing chemical changes in the extracellular fluid of bone in the living, moving animal. That will now be possible with the BAS Bone Probe (BS4 72-6956) developed by a collaborative effort of BAS and Purdue University Scientists.

The Bone Probe adds to the BAS line of specialty membrane probes, which allow sampling from many different tissues in the awake, living animals. These probes are designed to be used in large animals and can be used for studies lasting for several weeks. The bone probes can be used with a hub assembly and Vacutainers™ to permit complete mobility of the subject or with a small peristaltic pump to permit automated fraction collection.

The Bone Probe was developed under a NASA contract using the sheep as a model. NASA's interest in bone physiology is related to the problems of bone loss suffered by astronauts during protracted weightlessness. For humans to spend protracted periods in space and return to gravity to live healthy normal lives, it will be necessary to prevent the microgravity induced bone loss. In order to do this it will be necessary to understand the physical and chemical changes induced by microgravity and to develop methods to prevent these changes. Prevention of bone loss will involve the evaluation of the effectiveness of a number of counter measures, both physical, nutritional and pharmaceutical.

It has been possible to monitor changes in bone density and mineralization by traditional methods but monitoring the chemical changes in the interstitial fluid of bone over time in the living animal has not previously been possible. With this new device one can monitor most low molecular weight chemicals of 3 kD or less.

Catalog No.	\$	Product
BS4 72-6956		Bone Ultrafiltration Probe
BS4 72-6957		Fingertight Fitting for Hub Assembly
BS4 72-6958		Vacutainer, 3 ml, pkg. of 12
BS4 72-6954		Mini-Peristaltic Pump for Ultrafiltration
BS4 72-6909		Honeycomb Fraction Collector, see page L28

**NEW** **Microdialysis Round Bottom Bowl Kit**



This round bottom bowl has been used for housing animals (rats or mice) for microdialysis or ultrafiltration studies where it is not necessary to collect urine and feces and where it is desirable for the animal to be housed with bedding vs. a wire mesh floor. This cage has been used for over 15 years in laboratories around the world. It is THE standard for microdialysis, there being no components which will interfere with an exteriorized brain probe.

BS4 72-6922 Microdialysis Round Bottom Bowl Kit Includes:

- Round Bottom Bowl
- Rodent Water Tube
- Microdialysis Bowl Lid

Catalog No.	\$	Product
BS4 72-6922		Microdialysis Round Bottom Bowl Kit (for use with rats or mice)
BS4 72-6923		Round Bottom Animal Bowl Only
BS4 72-6924		Lid Only for Round Bottom Animal Bowl
BS4 72-6925		Water Tube for Round Bottom Animal Bowl, glass with glass sipper

**NEW** **Microdialysis Round Bottom Bowl with Access Panel**



This round-bottomed bowl is used for caging rodents during microdialysis applications. It has a removable access panel to facilitate dosing, insertion of intracerebral probes and connection of IV catheters. This cage is intended for use with bedding materials. An access hole and stainless steel spring have been added for (user's choice) internal or external mounting of the included water tube (BS4 72-6928). An optional cage lid is available to discourage escapes.

Catalog No.	\$	Product
BS4 72-6926		Microdialysis Round-Bottomed Bowl with Access Panel for Dosing with Internal Water Bottle Mounting
BS4 72-6927		Microdialysis Round-Bottomed Bowl with Access Panel for Dosing with External Water Bottle Mounting
BS4 72-6924		Lid Only for Microdialysis Round Bottom Bowl
BS4 72-6928		Autoclavable Polycarbonate Plastic Water Tube with SS Sipper

## **NEW** HoneyComb Fraction Collector



Use the HoneyComb Fraction Collector to refrigerate up to 48 sample vials during the collection of microdialysates or other fluids. Cooling is accomplished by an efficient internal electronic device which requires no coolants or external accessories and reaches the preset temperature (4°C) within 20 minutes after powerup. The standard borosilicate glass autosampler vials used for collection of samples may be capped, open, or arranged in a combination of sealed or open vials according to the user's preference. Plastic vials may also be utilized in this fashion, but an optional carousel for these taller vials (6 x 35 mm) is required.

The HoneyComb Fraction Collector can collect samples from one or two different sources. One sampling needle assembly is provided with the unit. A second needle can be purchased separately. Vials can be advanced two at a time, when each needle is collected to a separate microdialysis probe. Vials can also be advanced one at a time, when only one probe is being sampled, or when one needle is used to collect and the second needle is used to dispense a reagent prior to, or after collection of the sample.

Simple fraction collection protocols are set via the front panel LCD display and keypad—computers are not required. Protocols may include a preset delay time, collection interval, number of samples, and cooling on/off. The fraction collector may also be controlled via rear panel input when more complex protocols are required.

- Standard autosampler vials facilitate transfer to autosampler after collection
- Borosilicate glass or plastic vials refrigerated at 4°C
- Collect from one or two separate microdialysis probes with optional second needle
- Reproducibly collect sample volumes from 5 to 200  $\mu$ l
- Efficient thermoelectric cooling—no liquids or gas required
- Use sealed vials or open vials, or any combination during collection
- Open architecture—remove/replace vials during operation
- Carousel removes easily for transfer of vials
- Easy access to vials without spillage
- Simple method setup via front panel keypad and LCD

Catalog No.	\$	Product
BS4 72-6909		HoneyComb Refrigerated Fraction Collector with one BS4 72-6959 and one BS4 72-6966
BS4 72-6959		Spare Carousel for Glass Sample Vials (6 x 32 mm), pkg. of 1
BS4 72-6960		300 $\mu$ l Borosilicate Glass Sample Vials (6 x 32 mm), pkg. of 1000
BS4 72-6961		Caps and Double-Sided Teflon/Silicone Seals for BS4 72-6960, pkg. of 1000
BS4 72-6962		Crimper for BS4 72-6961 Seals and BS4 72-6960 vials, pkg. of 1
BS4 72-6963		Optional Carousel for Plastic Sample Vials (6 x 35 mm), pkg. of 1
BS4 72-6964		250 $\mu$ l Plastic Sample Vials (6 x 35 mm), pkg. of 1000 (Note: Plastic sample vials can either be sealed like glass vials, using BS4 72-6961 and BS4 72-6962, or capped with BS4 72-6965 snap-on caps. Be advised that although snap-on caps are more convenient, they create more wear on the needle)
BS4 72-6965		Plastic Caps for BS4 72-6964 or BS4 72-6960 Vials, pkg. of 1000
BS4 72-6966		Complete Sampling Needle Assembly. Required for dual sampling option

## **NEW** Benchmark Angle One™ Stereotaxic Instrument - Autocalculation of Target Structure



- Single or Dual Manipulator Models Available
- Easily vary the angle of approach
- Automatically calculates the new coordinates of your target structure

The new BenchMark Angle One™ Stereotaxic Instrument is the most technologically advanced animal stereotaxic instrument manufactured. The Angle One allows you to easily vary the angle of approach and it automatically calculates the new coordinates of your target structure.

Because brain atlases are written, and the brain is mapped, in coordinates from skull flat and Bregma, most stereotaxic surgery is performed in this coordinate orientation. There are valid reasons for doing surgery from the Vertical approach. First, it is difficult to calculate how to reach a given point in the brain if the stereotaxic manipulator is tilted. And second, such calculations rely on the imprecise protractor on the stereotaxic instrument and, thus, create considerable risk for error. Using this coordinate orientation also means that the angle of approach is confounded with the manipulation at the target site in stereotaxic research. This is a problem whether the research involves injections of anatomical tracers, behavioral response to brain damage, or almost any manipulation. The correct control is initiating action at the target site without approaching over the vertical pathway.

Now you can improve the rigor and interpretation of your stereotaxic research without adding the extensive calculations and risk of error to the protocol. The BenchMark Angle One solves these problems.

### The Angle One performs as follows:

- The display panel box has a number and zeroing button for each of the three linear axes and the two angle measurements.
- Angle transducers (optical encoders) continuously display the angle position.
- Angle displays will be zeroed once at the vertical position and will remain set as long as the power is on.
- The manipulator is then tilted to the desired position with the angles displayed on the LCDs.

- The probe is moved to Bregma and the linear displays are zeroed.
- Scrolling buttons (up & down) are then used to enter the target in reference coordinates on the three linear axes displays.
- These target coordinates are stored and saved until reset. During the next surgery, they will reappear by simply pressing a button.
- By subsequently pressing mode button, the linear displays will switch from the target coordinates in the reference frame to the target coordinates in the new tilted, non-orthogonal frame.
- As the target is approached, the LCD display counts down to zero. When each linear display reaches zero, the target should be hit.
- Touching the mode button, at any time, will switch the linear displays back and forth between the reference frame and the tilted, non-orthogonal frame.

With the Angle One, it is easy to set the manipulator at any arbitrary angle and reach the same target point every time. No pilot studies. No calculations. Standard atlas coordinates. Every surgery in a group can be performed from a different angle— completely undoing the traditional confounding with experimental groups.

Of course, the Angle One still incorporates the fine drive and advanced features of the Benchmark Deluxe line of stereotaxic instruments. The Angle One is the third generation of advanced stereotaxic instruments. Due to the unique nature of this instrument, a second set of stereotaxic patents is currently pending at the U.S. patent office.

Catalog No.	\$	Product
BS4 72-6850		Dual Benchmark Angle One™ Stereotaxic Instrument
BS4 72-6851		Single Benchmark Angle One™ Stereotaxic Instrument

# Stereotaxic Frames

## **NEW** Benchmark™ Deluxe Stereotaxic Instrument - Digital Manipulators

Specialized Tools For Bioresearch



- Select from Single or Dual Manipulator Models
- No reading, aligning and estimating vernier scales
- No calculation errors after locating Bregma
- All readings in direct line of view – no body twisting
- Higher precision and reproducibility than conventional vernier scales
- High precision, vibration free placement of probe using the fine adjustment controls

Stereotaxic instruments with digital, as opposed to vernier, scales offer greater speed of operation with reduced opportunity for error. This compact instrument, with the same footprint and drive mechanisms as our standard stereotaxic instrument, features linear position-sensing digital scales and a convenient remote display center (Patent Pending). Operation is easy and precise. Simply move the probe to Bregma and touch the zeroing button. Once all displays read zero, move the probe

until each of the three axes displays the desired coordinates.

In addition to our innovative digital scales, the Deluxe model includes a new high stability manipulator design that is unique in the market. The Deluxe manipulator includes a dual drive system on the dorsal ventral manipulator. The dual drive system includes a coarse adjustment for quick movements toward the target area. In addition, a fine adjustment is available at the base of the manipulator to virtually eliminate the potential for any vibration to be transmitted to the probe from your hand. This system utilizes a high precision worm gear that provides for extremely fine and smooth movement with no vibration. In addition, the Deluxe manipulator includes a high torque clamp system on the tilt mechanism for the greatest stability. A quick release spring centering pin facilitates quick and repeatable centering at zero degrees. The Benchmark Deluxe manipulator system is one of the most advanced stereotaxic manipulator on the market today.

The Deluxe manipulator is compatible with standard species adaptors and probe holders from other stereotaxic instrument manufacturers. The Deluxe Stereotaxic includes 18 and 45 degree ear bars.

### Comments from Customers:

Charles River Laboratory's Dr. Steve Luo is in charge of a group doing stereotaxic surgeries for researchers. After a day of use of his 4 new Benchmark™ Digital Stereotaxic instruments, he made the following comments, and more:

*"A great invention, this saves enormously on surgery time and improves accuracy."*

*"The technicians all want to be using the Benchmark™ Digital's, for future purchases, we definitely will go digital".*

*"Fantastic results, faster and more accurate", why wasn't this done earlier?"*

*"This improves our group's efficiency, and lets us give better results to our customers"*

Dr. Miles Cunningham, McLane Hospital of Harvard University:

*"I ordered a digital stereotaxic instrument because it seemed like a logical advance. I didn't imagine how much of an improvement it would be in speed and convenience until I had actually used it myself in a surgery. "The time required to perform a surgery has reduced by about 20%, and the instrument's accuracy is unparalleled."*

Catalog No.	\$	Product
BS4 72-6852		Benchmark™ Deluxe Stereotaxic Instrument – Dual
BS4 72-6853		Benchmark™ Deluxe Stereotaxic Instrument – Single

For questions, see our Stereotaxic FAQ's on page L48.

**NEW** **Benchmark™ Deluxe Manipulator Upgrade Package**



- No reading, aligning and estimating vernier scales
- No calculation errors after locating Bregma
- All readings in direct line of view – no body twisting
- Higher precision and reproducibility than conventional vernier scales.

This compact manipulator features linear position-sensing digital scales and a convenient remote display center.

Operation is easy and precise. Simply move the probe to Bregma and touch the zeroing button. Once all displays read zero, move the probe until each of the three axes displays the desired coordinates.

In addition to our innovative digital scales, the Deluxe model includes a new high stability manipulator design that is unique in the market. The Deluxe manipulator includes a dual drive system on the dorsal ventral manipulator. The dual drive system includes a coarse adjustment for quick movements toward the target area. In addition, a fine adjustment is available at the base of the manipulator to virtually eliminate the potential for any vibration to be transmitted to the probe from your hand. This system utilizes a high precision worm gear that provides for extremely fine and smooth movement with no vibration. In addition, the Deluxe manipulator includes a high torque clamp system on the tilt mechanism for the greatest stability. A quick release spring centering pin facilitates quick and repeatable centering at zero degrees. The Benchmark Deluxe manipulator system is the most advanced stereotaxic manipulator on the market today.

This package includes a deluxe manipulator and the readout control console. It can be adapted for use with Stoelting or Kopf Instrument stereotaxic bases.

Catalog No.	\$	Product
BS4 72-6857		Benchmark™ Deluxe Manipulator Upgrade Package

**NEW** **Adjustable Stage for Stereotaxic Instruments**



- Helps to quickly and easily adjust animal to proper height
- 3 Models Available:
  - Stage Only
  - Stage with Homeothermic Heating Element
  - Stage with Simple Heating Element

This Adjustable stage attaches to the base plate of a stereotaxic instrument for additional support for the animal's body. May be tilted, raised or lowered to put the animal's body in an appropriately supported position. It is available alone or with either a homeothermic heating device or simple heater element.

The homeothermic model comes with an embedded heating pad under the table surface and a feedback controlled proportional current power supply to maintain a preset temperature on the table surface. The high heat conductivity of the aluminum table surface distributes the heat evenly to the animal's ventral surfaces.

The simple heated model comes with an embedded heating pad under the table surface. It has no feedback mechanism.

### Specifications

Table Surface	17.8 cm x 10.6 cm
Raise	Up to 2.54 cm
Tilt	±35 Degrees
Heater Impedance	6 Ω
Power Supply	Maximum Current 2 A

Catalog No.	\$	Product
BS4 72-6854		Adjustable Stage for Stereotaxic Instrument
BS4 72-6855		Adjustable Stage with Homeothermic Heated Setpoint Controller
BS4 72-6856		Adjustable Stage with Simple Heat Controller

# Stereotaxic Frames

## **NEW** Digital Lab Standard™ Stereotaxic Instrument

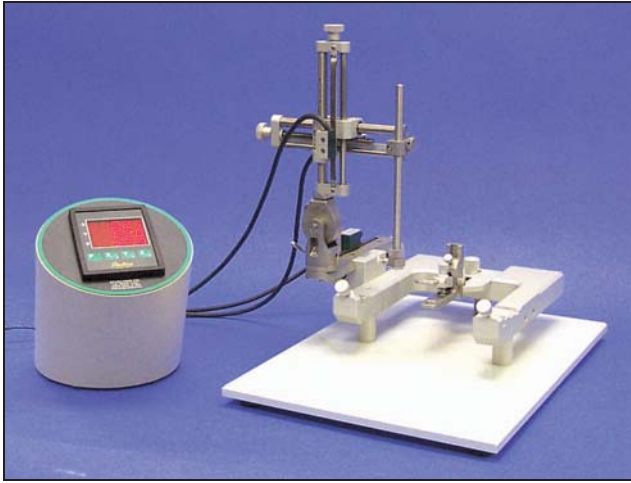

Specialized Tools For Bioresearch

- Saves time
- Improves accuracy

This latest innovation in Standard™ Stereotaxic Instruments features a sealed electronic sensor to each axis of the manipulator arm. This sensor is

highly immune to outside interference and environmental conditions. Measurements are accurate to 10 microns in all three directions. Movements in all three directions are now monitored by a large, easy-to-read LED display module, with a resolution selectable from 1 mm to 10 microns.

A zeroing function allows the user to set a reference point for targeting specific coordinates on the animal's skull for injection, implantation, etc. Calculation of distance measurements via the vernier scales is thus no longer necessary...saving the user valuable time and improving accuracy.

The classic design and high quality of our conventional Lab Standard™ manipulators are exactly the same on the new Digital Stereotaxic, with no drift and smooth movements. The Digital Lab Standard™ keeps the custom triple-start lead screws to allow fast positioning, while maintaining consistently smooth movement. The thin cords from the sensors do not interfere with movements, allowing the arm to move freely and be set at any angle.

### Your Choice of Three Options

1. New Digital Lab Standard™ Stereotaxic Instrument complete with LED Digital Display.
2. Add new Digital Manipulator Arms and an LED Display to your current Lab Standard™ or similar brand of stereotaxic.
3. Convert your existing Lab Standard™ (or most other brands) by adding digital sensors to their manipulator arms. LED Display Module included.

### Zeroing Function for Targeting Specific Coordinates

The display of each axis can be "ZERO"ed at any location, making operation simple and straightforward. To target a specific location, start at Bregma, and reset all coordinates to zero. Move the manipulator arm to the desired point and lower the electrode, probe, or micropipette into place.

### Memory

Target coordinates can be programmed into the memory of the BS4 72-6035 and BS4 72-6037 Digital Lab Standard™ Stereotaxics.

### Versatility of Positioning

The universal joint allows the investigator to angle the probe in either the anterior-posterior or the lateral-medial planes. The improved locking mechanism on the Lab Standard™ Stereotaxic Instruments will hold any angled position without slippage. Of course, it also provides an absolute lock at the vertical position. The manipulator arm may be swiveled out of the way for convenience in installing the animal or performing a procedure, then returned to the same point reliably with the aid of the locking face block above the swivel joint.

### Accessories

All of the accessories for the Lab Standard™ Small Animal Stereotaxic Instrument fit the BS4 72-6035 and BS4 72-6037 Digital Lab Standard™ Small Animal Stereotaxic Instrument. Probe holders and species adapters for "U" frame stereotaxic instruments made by other manufacturers are generally compatible with the Lab Standard frame.

The BS4 72-6035 and BS4 72-6037 Digital Lab Standard™ Small Animal Stereotaxic Instruments come complete with a standard probe holder with corner clamp and a Rat Adapter with nose holder and 18 degree taper ear bars. The BS4 72-6036 and BS4 72-6038 include the non-puncture (45°) ear bars instead of the 18-degree ear bars. They are otherwise identical to the BS4 72-6035 and BS4 72-6037.

The time-proven U-Frame design concept, rugged construction, and adaptability to most species used in the lab make Stoelting's Lab Standard™ series the best choice for stereotaxic instruments.

Catalog No.	\$	Product
-------------	----	---------

#### Complete System

BS4 72-6035		Digital Lab Standard™ Stereotaxic with LED Display, 18° Ear Bars
BS4 72-6036		Digital Lab Standard™ Stereotaxic with LED Display, 45° Ear Bars
BS4 72-6037		Digital Dual Manipulator Lab Standard™ Stereotaxic with LED Display, 18° Ear Bars
BS4 72-6038		Digital Dual Manipulator Lab Standard™ Stereotaxic with LED Display, 45° Ear Bars

#### Digital Manipulator Arm and LED Display

BS4 72-6039		Digital Manipulator Arm, 3 Axis, Left Hand, and LED Display
BS4 72-6040		Digital Manipulator Arm, 3 Axis, Right Hand, and LED Display

#### Existing Manipulator Arm Conversion, 3 Axis

BS4 72-6041		Factory Conversion of Existing Left Hand Manipulator Arm to Digital plus LED Display
BS4 72-6042		Factory Conversion of Existing Right Hand Manipulator Arm to Digital plus LED Display



# Stereotaxic Frames

**NEW**

Harvard Apparatus is pleased to offer the Stoelting line of stereotaxic instruments. This line represents the highest quality and most versatile frames on the market today. Some of the key benefits include:



- All scales are oriented to be read easily from the open end of the "U" (the preferred position for most researchers)
- Larger numbers on the scale line for easy readability
- Finely engraved lines for precise alignment with facing scales, for accurate resolution to 0.1mm
- Scale laser engraved for reliable, consistent quality
- All this and affordable too!

In order to properly select a stereotaxic frame to meet your needs, first determine what species you are working with.

The small species systems can be used with animals from mice to small monkeys. The basic 1 and 2 manipulator systems are supplied standard with a rat adaptor. In order to work with a different species, you must purchase the appropriate adaptor for that species. See the chart on the facing page for a listing of adaptors.







The large species systems can be used with any species from mice to dogs. Two standard systems are available. One is supplied with a cat/monkey adaptor. The second system is supplied with a dog adaptor. To use one of the large animal frames with a smaller species, you must purchase the appropriate adaptor for that species. See the chart on the facing page for a listing of adaptors.

Below is a chart that details what components are supplied with each system and the necessary adaptors for working with different species.

Standard Stereotaxic Systems		Small Species Systems				Large Species Systems	
	= Small Species Single Manipulator Systems BS4 72-4790 & BS4 72-4791						
	= Small Species Dual Manipulator Systems BS4 72-4792 & BS4 72-4793						
	= Large Species 4 Manipulator Systems BS4 72-4798 & BS4 72-4800						
		Std. System with 18° Ear Bars for Rat	Std. System with 45° Ear Bars for Rat	Std. System with 18° Ear Bars for Rat	Std. System with 45° Ear Bars for Rat	Standard System for Cat/Monkey	Standard System for Dogs
<b>Select Your Species</b>		* Note: Indicates required part number					
Mouse		*BS4 72-4819 *BS4 72-4794	*BS4 72-4819 or *BS4 72-4794	*BS4 72-4819 or *BS4 72-4794	*BS4 72-4819 or *BS4 72-4794	*BS4 72-4819	*BS4 72-4819
Rats		as listed	as listed	as listed	as listed	*BS4 72-4817	*BS4 72-4817
Guinea Pig		*BS4 72-4820	*BS4 72-4820	*BS4 72-4820	*BS4 72-4820	*BS4 72-4821	*BS4 72-4821
Small Birds		*BS4 72-4827	*BS4 72-4827	*BS4 72-4827	*BS4 72-4827	*BS4 72-4828	*BS4 72-4828
Cats		*BS4 72-4822 or BS4 72-4823	*BS4 72-4822 or *BS4 72-4823	*BS4 72-4822 or *BS4 72-4823	*BS4 72-4822 or *BS4 72-4823	as listed	*BS4 72-4824 or *BS4 72-4825
Monkey		*BS4 72-4822 or *BS4 72-4823	*BS4 72-4822 or *BS4 72-4823	*BS4 72-4822 or *BS4 72-4823	*BS4 72-4822 or *BS4 72-4823	as listed	*BS4 72-4824 or *BS4 72-4825
Dogs		n/a	n/a	n/a	n/a	*BS4 72-4826	as listed
<b>System Components</b>							
<b>Micromanipulators</b>	<b>Catalog No.</b>						
Left Hand, 51604	BS4 72-4855	1	1	1	1		
Right Hand, 51606	BS4 72-4856			1	1		
Left Hand, 51804	BS4 72-4804					2	2
Right Hand, 51806	BS4 72-4805					2	2
<b>Ear Bars</b>							
18° Ear Bars, 51611	BS4 72-4838	1		1			
45° Ear Bars, 51612	BS4 72-4839		1		1		
<b>Probe Holders</b>							
Standard Probe Holder with Corner Clamp, 51631	BS4 72-4829	1	1	1	1		
<b>Animal Adaptors</b>							
Rat, 51621	BS4 72-4815	1	1	1	1		
Cat / Monkey Adaptor with 18° Ear Bars, 51826	BS4 72-4822					1	
Dog/Monkey with Ear Bars, 51852	BS4 72-4826						1
<b>Other Components</b>							
Parallel Rail Frame Assembly Only	BS4 72-4799					1	1
Universal 4"x4" Mounting Support Stand	BS4 72-4797					1	1
<b>Model</b>		<b>51600</b>	<b>51650</b>	<b>51603</b>	<b>51653</b>	<b>51800</b>	<b>51850</b>
<b>Catalog No.</b>		<b>BS4 72-4790</b>	<b>BS4 72-4791</b>	<b>BS4 72-4792</b>	<b>BS4 72-4793</b>	<b>BS4 72-4798**</b>	<b>BS4 72-4800**</b>
see page		L35	L35	L35	L35	L36	L36

\*\* Note: Must select a base plate to complete system, either 13 x 17" (BS4 72-4802) or 12 x 36" (BS4 72-4803)

# Stereotaxic Frames

Stereotaxic System Components & Compatibility		Small Species Systems		Large Species Systems	
	= Small Species Single Manipulator Systems BS4 72-4790 & BS4 72-4791				
	= Small Species Dual Manipulator Systems BS4 72-4792 & BS4 72-4793				
	= Large Species Four Manipulator Systems BS4 72-4798 & BS4 72-4800				
Catalog No.	Product Description	Compatible With			see page
<b>Micromanipulators</b>					
BS4 72-4855	Left Hand, 51604	●	●		L33
BS4 72-4856	Right Hand, 51606	●	●		L33
BS4 72-4804	Left Hand, 51804			●	L36
BS4 72-4805	Right Hand, 51806			●	L36
<b>Ear Bars</b>					
BS4 72-4838	Rat 18° Ear Bars, 51611	●	●		L39
BS4 72-4839	Rat 45° Ear Bars, 51612	●	●		L39
BS4 72-4842	Cat 18° Ear Bars, 51613	●	●		L39
BS4 72-4843	Cat 45° Ear Bars, 51614	●	●		L39
BS4 72-4840	Rat 18° Ear Bars, 51811			●	L39
BS4 72-4841	Rat 45° Ear Bars, 51812			●	L39
BS4 72-4844	Cat 18° Ear Bars, 51813			●	L39
BS4 72-4845	Cat 45° Ear Bars, 51814			●	L39
<b>Probe Holders</b>					
BS4 72-4829	Standard Probe Holder with Corner Clamp, 51631	●	●	●	L40
BS4 72-4830	Standard Probe Holde with Side Clamp, 51632	●	●	●	L40
BS4 72-4831	Standard Probe Holde with "C" Clamp, 51634	●	●	●	L40
BS4 72-4832	Large Probe Holder, 51633	●	●	●	L40
BS4 72-4835	Microdialysis Probe Holder, 51637	●	●	●	L40
BS4 72-4836	Microdialysis Probe Holder, 51637-2.0	●	●	●	L40
BS4 72-4737	Cannula Holder, 51636	●	●	●	L40
<b>Animal Adaptors</b>					
BS4 72-4794	Cunningham Mouse & Neonatal Rat Adaptor, 51625	●	●	●	L37
BS4 72-4811	Cunningham Spinal Adaptor Mouse, 51690	●	●		L38
BS4 72-4812	Cunningham Spinal Adaptor Rat, 51695	●	●		L38
BS4 72-4819	Mouse Adaptor, 51624 (no ear bars)	●	●		L37
BS4 72-4815	Rat Adaptor with 18° Ear Bars, 51621	●	●		L37
BS4 72-4817	Rat Adaptor with 18° Ear Bars, 51821			●	L37
BS4 72-4816	Rat Adaptor with 45° Ear Bars, 51620	●	●		L37
BS4 72-4818	Rat Adaptor with 45° Ear Bars, 51820			●	L37
BS4 72-4827	Small Bird Adaptor with 45° Ear Bars, 51623	●	●		L38
BS4 72-4828	Small Bird Adaptor with 45° Ear Bars, 51823			●	L38
BS4 72-4820	Guinea Pig Adaptor with 45° Ear Bars, 51622	●	●		L38
BS4 72-4821	Guinea Pig Adaptor with 45° Ear Bars, 51822			●	L38
BS4 72-4822	Cat / Monkey Adaptor with 18° Ear Bars, 51626	●	●		L38
BS4 72-4823	Cat / Monkey Adaptor with 45° Ear Bars, 51627	●	●		L38
BS4 72-4824	Cat / Monkey Adaptor with 18° Ear Bars, 51826			●	L38
BS4 72-4825	Cat / Monkey Adaptor with 45° Ear Bars, 51827			●	L38
BS4 72-4826	Dog/Monkey Adaptor with Ear Bars, 51852			●	L38
<b>Other Components</b>					
BS4 72-4799	Parallel Rail Frame Assembly Only, 51801			●	L36
BS4 72-4797	Universal Mounting Support Stand, 51680	●	●	●	L36
BS4 72-4846	Probe Centering Device, 51607	●	●		L40
BS4 72-4847	Centering Stand, 51878			●	L39
BS4 72-4848	Stereomicroscope Kit, 51608	●	●		L39
BS4 72-4852	Gas Anesthesia Mask Adaptor Mice, 51609	●	●		L36
BS4 72-4853	Gas Anesthesia Mask Adaptor Rats, 51610	●	●		L36
BS4 72-6043	Gas Anesthesia Platform for Mice, 50266	●	●	●	L39

**NEW** Lab Standard™ Stereotaxic Instrument



- Available for mice or rats
- Numerals on scales are larger and easier to read
- Laser engraved scale lines provide precise position to 0.1mm
- Absolute lock at 90°
- Available both in single and dual manipulator models

### Smooth Movements

The Lab Standard's custom, triple-start lead screws allow the fastest positioning possible consistent with lining up the scales easily for a given position.

The universal joint allows the investigator to angle the probe in either the anterior-posterior or the lateral-medial planes. The improved locking mechanism on the Lab Standard Stereotaxic

Instruments will hold any angled position without slippage. Of course, it also provides an absolute lock at the vertical position. The manipulator arm may be swiveled out of the way for convenience in installing the animal or performing a procedure, then returned to the same point reliably with the aid of the locking face block above the swivel joint.

### Easy-to-Read Scales

All scales are oriented to be read most easily from the open end of the "U". This is the position from which most operators prefer to work. The numerals on the scales are larger and therefore more readable than on competing units. The scale lines are very finely drawn to allow precise alignment with facing scales, and are laser engraved for reliable, consistent quality.

### Species

These Stereotaxic Frame Systems are supplied with the necessary components to work with rats. In order to work with other species the appropriate adaptor must be purchased separately. see pages L37 and L38 for species adaptors.

### Single and Dual Manipulator Models

The time-proven U-Frame design concept, rugged construction, and adaptability to most species used in the lab make this the best choice for a stereotaxic instrument. The Lab Standard 51600, manufactured by Stoelting, offers several advantages over other U-Frame stereotaxic instruments.

### Dual Manipulator Model

The 51603 and 51653 Dual Manipulator Lab Standard are configured with 3-dimensional manipulator arms on both sides. The second manipulator arm is properly reversed as to handedness.

### Accessories

Both the 51600 and 51603 come complete with a standard probe holder with corner clamp (51631) and a Rat Adaptor (51621) with nose holder and 18 degree taper ear bars. The 51650 and 51653 include the non-puncture 45 degree ear bars instead of the 18 degree ear bars. They are otherwise identical to the 51600 and 51603.

Optional accessories are available. Probe holders and species adaptors for "U" frame stereotaxic instruments made by other manufacturers are generally compatible with the Lab Standard frame. If you are new to stereotaxic surgery, we would recommend you purchase BS4 72-4240 Stereotaxic Surgery in the Rat.

Catalog No.	\$	Model	Product
BS4 72-4790		51600	Lab Standard Stereotaxic Frame for Rats with 18° Ear Bars
BS4 72-4791		51650	Lab Standard Stereotaxic Frame for Rats with 45° Ear Bars
BS4 72-4792		51603	Dual Lab Standard Stereotaxic Frame for Rats with 18° Ear Bars
BS4 72-4793		51653	Dual Lab Standard Stereotaxic Frame for Rats with 45° Ear Bars
BS4 72-4796		51601	U-Frame, Base Plate and Rat Adaptor without Manipulator Arm
BS4 72-4797		51680	Tilt/Rotatable Stand for 51600
BS4 72-4819		51624	Mouse Adaptor, see page L37
BS4 72-4240		-	Stereotaxic Surgery in the Rat, see page L47

# Stereotaxic Frames

## **NEW** Lab Standard™ Large Animal Stereotaxic



- Reliable Locks
- Laser Engraved Scales
- Affordably Priced

The Lab Standard™ Large Animal Stereotaxic Instrument provides superior performance. Up to four manipulator arms may be conveniently positioned on the

two parallel rails. Thus, several probes may be independently positioned in one animal.

### Easily Read Scales

Precise, laser engraved graduation lines allow vernier scales to be aligned to a higher degree of accuracy than with other makes of stereotaxic instruments. The numbers are oriented to enhance readability from common user positions.

### Reliable Locks

It is at times necessary to tilt the stereotaxic frame to gain access to the animal's side or underside. A novel locking mechanism makes this tilt both easy to accomplish, and locks securely.

The tilting and angling universal joint on Lab Standard manipulators have the most secure, reliable locks of any stereotaxic instrument.

### Components Included

The 51800 comes equipped with:

- Two 51804 L.H. Manipulators
- Two 51806 R.H. Manipulators
- One 51826 Cat/Monkey Head Holder with 18° Ear Bars or One 5182 Dog/Monkey Adaptor
- One 51801 Parallel Rail Frame
- One 51680 4 x 4 in mounting support-stand.

Base plates are ordered separately. Adaptors for rat, mouse and other species are available.

The 51851 Dog Frame is longer, includes a highly adjustable dog head holder, and 2 sets of ear bar blocks to allow configuration for large dogs.

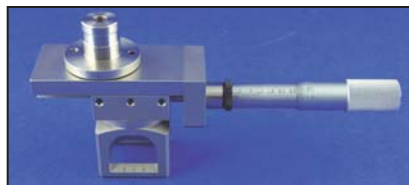

### Accessories

The scales for the 51800 series earbars are in a different position than on the 51600 series. All species adaptors and earbars manufactured by Stoelting are available for the 51600 and 51800 series of stereotaxic instruments, except the Dog Adaptor 51852.

The 51858 A-P Microdrive (pictured above) provides fine movement control in the anterior posterior dimension with 25 mm. range and 10µm graduations. It mounts between the rails and the manipulator. The 51858 includes a longer probe holder shaft to compensate for the extra height.

### Base Plates

To complete your Stereotaxic Frame you must purchase a base plate. Two different plates are available. The 51872 base plate has slots for mounting other instruments on the same base with a 51800 series stereotaxic. The 51871 is a 13 x 17 in flat base plate without slots. A 4 x 4 in mounting plate with 2 sets of four mounting holes is included with the 51800 series stereotaxics. One set of holes is on 2 in centers and the other set is on 3.5 in centers.

Catalog No.	\$	Model	Product
BS4 72-4798		51800	Stereotaxic Frame for Cat/Monkey, Complete with 4 Manipulators
BS4 72-4799		51801	Parallel Rail Fame Assembly Only
BS4 72-4800		51850	Stereotaxic Frame for Dog, Complete with 4 Manipulators
BS4 72-4801		51851	Stereotaxic Frame Assembly Only, Dog
BS4 72-4802		51871	Base Plate, 13 in x 17 in
BS4 72-4803		51872	Base Plate, Slotted, 12 in x 36 in
BS4 72-4804		51804	Manipulator, LH
BS4 72-4805		51806	Manipulator, RH
BS4 72-4806		51858	A/P Microdrive
BS4 72-4797		51680	Universal Mounting Support Stand

## Gas Anesthesia Mask Adaptors



Gas Anesthesia Mask shown with 51621 Rat Adaptor (not included)

- For Mice or Rats in a Stereotaxic Instrument

The Gas Anesthesia Mask Adaptors for Stereotaxic instruments, manufactured by Stoelting, enable gas anesthesia of rats

or mice in a Lab Standard,™ or other brands of stereotaxic instruments, without exposing the researcher to the anesthetic gas.

The Gas Anesthesia Mask Adaptor is installed by removing the nose clamp from the standard rat adaptor, sliding the mask over the incisor bar, with the cone opening toward the open "U". The animal's teeth are placed over the incisor bar and the adaptor is slid forward until the cone is snug about the animal's nose. The mask substitutes for the nose clamp. The teeth and the cone provide a very stable hold.

Gas flows in the tubing connector on one side, past the animal's nose, and out the tubing connector on the other side. From there, spent gas may be routed to recycling, exhaust, or gas analysis instruments.

Cat No.	\$	Model	Product
BS4 72-4852		51609	Gas Anesthesia Mask Adaptor, Mice
BS4 72-4853		51610	Gas Anesthesia Mask Adaptor, Rats

*See Gas Anesthesia Platform on page L39.*

## **NEW** Species Adaptors For Stereotaxic Instruments

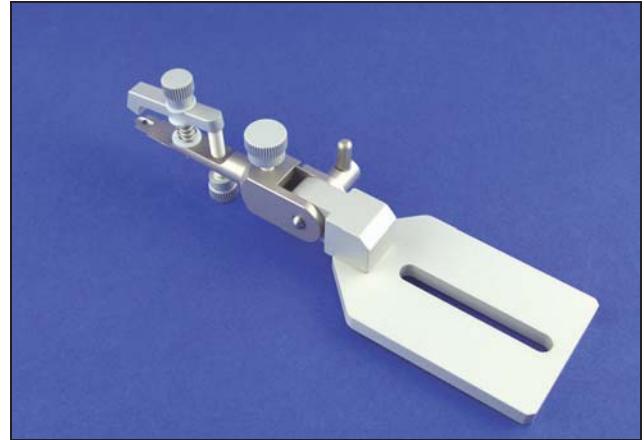
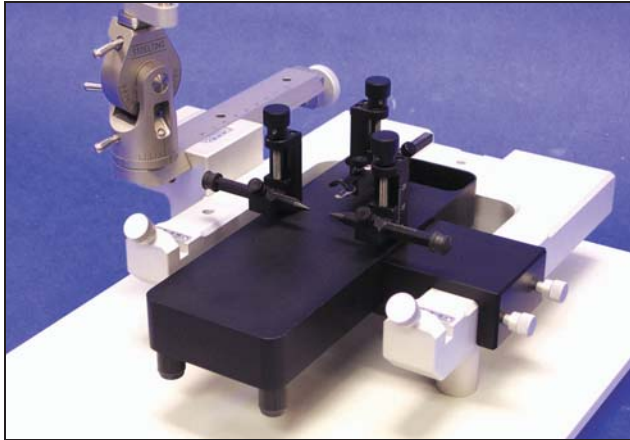

### **Cunningham™ Mouse and Neonatal Rat Adaptor**

Model organisms with soft skulls, such as the mouse and the neonatal rat, have traditionally been difficult to secure firmly in a stereotaxic instrument. The stainless

steel ear bars used for adult rats are too heavy to position precisely enough to provide a secure hold while still avoiding flexing the sides of the skull inward (which compresses the airways and impedes blood flow.) Further, the neonatal rat pup has no external opening of the auditory canal into which to insert the ear bar points.

The Cunningham™ Mouse and Neonatal Rat Adaptor, manufactured by Stoelting, employs light, Delrin® ear bars with tapered points on one end, and rubber pads on the other, to facilitate surgery on such animals. Neonatal surgery may be accomplished with minimally invasive procedure by using the rubber pad ends of the ear bars. Ear bars may be independently adjusted in height, a unique feature in stereotaxic instrumentation, to achieve the skull flat position. Laser engraved scales shows the vertical position of the ear bars. A tooth bar and nose clamp secures the nose. A well carved in the thick aluminum body may be filled with dry ice and alcohol for hypothermic anesthesia of neonatal animals. The Cunningham™ Mouse and Neonatal Rat Adaptor clamps securely on the right side of the “U” frame of the Lab Standard™, which provides the stereotaxic manipulator.

New improvements to this popular stereotaxic adaptor include an increased overall length to accommodate larger, more mature animals, and the addition of specialized jaw holder cuffs (51647), which securely clamp the zygomatic processes of the skull. The jaw holder cuffs fit over the ends of the ear bars, replacing the rubber pads, providing an alternative non-invasive means of securing the animal's head in the stereotaxic stage. These options for “triple point” securing of the animal's head in this adaptor make it the most versatile mouse stereotaxic available. Set of two jaw holder cuffs included.

Catalog No.	\$	Model	Product
BS4 72-4794		51625	Cunningham™ Mouse/Neonatal Rat Adaptor for 51600 Stereotaxic Frame
BS4 72-4795		51647	Jaw Holder Cuffs, set of 2

### **Mouse Adaptor**

Ear bars can cause breathing difficulties and bleeding in mice. The 51624 Mouse Adaptor holds the mouse head by means of a palate bar and nose clamp, without ear bars. Head angle may be adjusted to achieve skull flat or other approach angles. Since there are no earbars, the same 51624 Mouse Adaptor fits 51600 and 51800 series stereotaxic instruments.

If you want to use earbars to perform stereotaxic surgery on the mouse, Stoelting has designed the perfect miniature stereotaxic stage for mouse surgery: The Cunningham™ Mouse and Neonatal Rat Adaptor, pictured to the left.

Catalog No.	\$	Model	Product
BS4 72-4819		51624	Mouse Adaptor for 51600 and 51800 Stereotaxic Frames

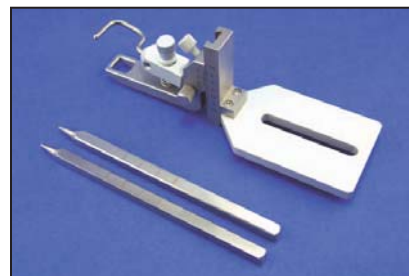

### **Rat Adaptor**

The 51621 Rat Adaptor is included with the 51600 and 51603 Lab Standard Stereotaxic instruments. The 51821 Rat Adaptor is an optional extra for the

51800 and 51850 Large Animal Stereotaxic Instruments. Both include the nose clamp assembly and ear bars.

Catalog No.	\$	Model	Product
BS4 72-4815		51621	Rat Adaptor with 18° Ear Bars for 51600 Stereotaxic Frame
BS4 72-4816		51620	Rat Adaptor with 45° Ear Bars (non-puncture) for 51600 Stereotaxic Frame
BS4 72-4817		51821	Rat Adaptor with 18° Ear Bars for 51800 Stereotaxic Frame
BS4 72-4818		51820	Rat Adaptor with 45° Ear Bars (non-puncture) for 51800 Stereotaxic Frame

# Stereotaxic Frames

## **NEW** Species Adaptors For Stereotaxic Instruments

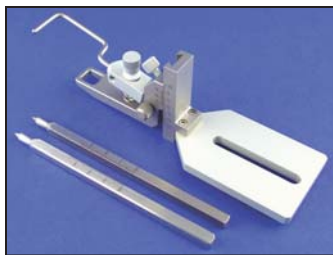

### Guinea Pig Adaptor

The 51622/51822 Guinea Pig Adaptors include the 45° ear bars required for guinea pigs. Also, the nose clamp reaches further back behind the incisors than on the rat adaptors.

The Guinea Pig Adaptor is available for the 51600 and 51800 Lab Standard series of stereotaxic instruments.



### Small Bird Adaptor

The 51623/51823 Small Bird Adaptors include the 45° ear bars required for birds. The Small Bird Adaptor uses a beak support and "V" shaped beak clamp to hold the beak down and centered, in place of the incisor bar/nose clamp arrangement used for rats.

Catalog No.	\$	Model	Product
BS4 72-4820		51622	Guinea Pig Adaptor with 45° Ear Bars for 51600 Stereotaxic Frame
BS4 72-4821		51822	Guinea Pig Adaptor with 45° Ear Bars for 51800 Stereotaxic Frame

Catalog No.	\$	Model	Product
BS4 72-4827		51623	Small Bird Adaptor with 45° Ear Bars for 51600 Stereotaxic Frame
BS4 72-4828		51823	Small Bird Adaptor with 45° Ear Bars for 51800 Stereotaxic Frame



### Cat/Monkey Adaptor

The Cat/Monkey Adaptor for the 51600 (optional) includes spacers and bolts to raise the "U" frame 2.5 inches above the base plate, as well as the eye socket/palate holder and 20 degree ear bars usually used for cats and monkeys.

The Cat/Monkey Adaptor is available with standard or non-puncture ear bars.

Catalog No.	\$	Model	Product
BS4 72-4822		51626	Cat/Monkey Adaptor with Standard Ear Bars for 51600 Stereotaxic Frame
BS4 72-4823		51627	Cat Adaptor with Non-Puncture Ear Bars for 51600 Stereotaxic Frame
BS4 72-4824		51826	Cat/Monkey Adaptor with Standard Ear Bars for 51800 Stereotaxic Frame
BS4 72-4825		51827	Cat Adaptor with Non-Puncture Ear bars for 51800 Stereotaxic Frame

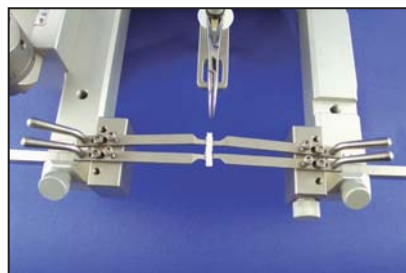

- Models to Hold Mice or Rats for Stereotaxic Spinal Surgery

### Cunningham™ Spinal Adaptor

The design of this instrument was inspired by the need for a practical, versatile, and economical instrument for reliably stabilizing the rodent spinal column. The Cunningham™ Spinal Adaptor is an accessory to be mounted on either the 51600 or the 51800 stereotaxic instrument or other brands of stereotaxic instruments, converting them for spinal surgery applications. It utilizes the manipulator and base plate of the stereotaxic instrument, thus enabling precision spinal preparations. The spinal column is secured by up to four independent transverse process clamps, as well as a spinous process clamp. The transverse process clamps are designed to minimize trauma while providing motionless support.

The instrument is engineered for one-handed control of gross and fine adjustment of the surgical preparation in the AP, ML, and DV planes.

Transverse process clamps are available to accommodate either the rat or the mouse. To work with both species, order the Spinal Adaptor for one species, and one set of transverse clamps for the other.



### Dog/Monkey Adaptor

The 51852 Dog/Monkey Adaptor is available only for the 51800 series stereotaxic instruments. To fit any size dog, it should be used with

51850/51851 instruments. The 51850/51851 Dog Stereotaxic Frames have two sets of ear bar holders at different spacings from the front to accommodate the wide size range of dogs.

Catalog No.	\$	Model	Product
BS4 72-4811		51690	Cunningham™ Mouse Spinal Adaptor
BS4 72-4812		51695	Cunningham™ Rat Spinal Adaptor
BS4 72-4813		51691	Mouse Transverse Clamps, Set of Four
BS4 72-4814		51692	Rat Transverse Clamps, Set of Four

Catalog No.	\$	Model	Product
BS4 72-4826		51852	Dog/Monkey Adaptor with Ear Bars for 51800 Stereotaxic Frame

## **NEW** Accessories for Stereotaxic Instruments

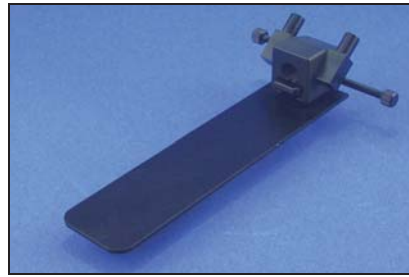
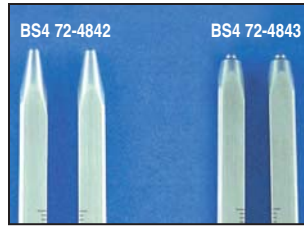
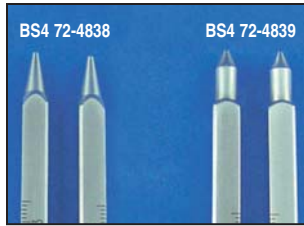

- Holds mice during anesthesia and surgery
- Precise and secure positioning

### Lab Standard™ Ear Bars

- For Mice or Rats in a Stereotaxic Instrument

Lab Standard Ear Bars have laser engraved scales. The ear bars are 6.2 mm square. Ear bars for the 51600 series of stereotaxic instruments have a different zero point than do those for the 51800 series.

Standard ear bars (included with the instrument) have an 18° taper at the tip to penetrate far into the ear canal for a more secure hold. They puncture the tympanic membrane. Non-puncture ear bars have a 45° taper, and do not puncture the tympanic membrane, but offer a slightly less stable hold.

Catalog No.	\$	Model	Product
BS4 72-4838		51611	Ear Bars, Rat, 18° for 51600 Stereotaxic Frame
BS4 72-4839		51612	Ear Bars, Rat, 45° Non-Puncture for 51600 Stereotaxic Frame
BS4 72-4840		51811	Ear Bars, Rat, 18° for 51800 Stereotaxic Frame
BS4 72-4841		51812	Ear Bars, Rat, 45° Non-Puncture for 51800 Stereotaxic Frame
BS4 72-4842		51613	Ear Bars, Cat, 18° for 51600 Stereotaxic Frame
BS4 72-4843		51614	Ear Bars, Cat, 45° Non-Puncture for 51600 Stereotaxic Frame
BS4 72-4844		51813	Ear Bars, Cat, 18° for 51800 Stereotaxic Frame
BS4 72-4845		51814	Ear Bars, Cat, 45° Non-Puncture for 51800 Stereotaxic Frame

### **NEW** Ear Bars for Auditory Testing

Hollow Ear Bars for auditory studies are now available. Please call for more information and pricing.



### Centering Stand

The Centering Stand allows centering of probes to ear bar zero away from the animal before placing them on the 51801 or 51851 frames. It also serves as a storage fixture for manipulator arms.

Catalog No.	\$	Model	Product
BS4 72-4847		51878	Centering Stand

### **NEW** Gas Anesthesia Platform for Mice

This Gas Anesthesia Platform for Mice allows for precise and secure positioning of an animal during anesthesia and surgery when used with the 51625 Mouse and Neonatal Rat Adaptor. After removing the animal from the induction chamber, it can be quickly mounted on the platform. The animal's teeth are placed over the incisor bar and the mouse mask slides forward until the cone is snug about the animal's nose, thereby substituting for the nose clamp. The platform is then lifted onto the Cunningham™ Mouse Adaptor, providing positioning of the animal that is perfect, automatic and effortless. The gas anesthesia platform and mask is also useful for non-stereotaxic related experimental applications. With the platform placed on your bench top, simply fix the head of the mouse or rat in the mask, attach appropriate tubing (1/4 inch I.D.) to the gas mask, and you're ready to perform surgery, injections, or implantations under gas anesthesia.

Catalog No.	\$	Model	Product
BS4 72-6043		50266	Gas Anesthesia Platform for Mice
BS4 72-6044		50264	Gas Anesthesia Platform plus Mouse Gas Mask Adaptor
BS4 72-6045		50267	Gas Anesthesia Platform plus Rat Gas Mask Adaptor

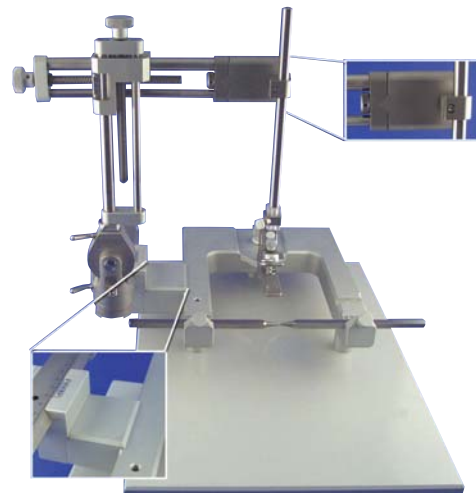

### Stereomicroscope Kit

The kit enables a stereomicroscope to be positioned above the animal without contacting the manipulator arm. Spacer blocks at top and bottom move the manipulator two inches lateral for clearance.

Catalog No.	\$	Model	Product
BS4 72-4848		51608	Stereomicroscope Kit

# Stereotaxic Frames

## **NEW** Lab Standard™ Probe Holders



### Standard Probe Holder

Standard Probe Holders come complete with mounting “V” blocks. The 11 mm square acrylic block on the bottom has grooves spaced 1mm apart. Three bottom clamp options are available. The corner clamp holds shafts from 0.2 to 2.0 mm. The side clamp holds probes from 0.2 to 4.5 mm, as does the “C” clamp, which is useful to release implanted probes. The 51631 Standard Probe Holder with Corner Clamp is included with each manipulator on complete instruments.

Catalog No.	\$	Model	Product
BS4 72-4829		51631	Holder with Corner Clamp
BS4 72-4830		51632	Holder with Side Clamp
BS4 72-4831		51634	Holder with “C” Clamp



### Large Probe Holder

Large Probe Holders support shafts with diameters from 6.5 mm. up to 13 mm. (0.5 in). This is sufficient to hold, and manipulate stereotaxically, Hamilton™ Microsyringes, either Stereotaxic Drill from Stoelting, and any accessories designed for the Stellar Stereotaxic Instrument.

A threaded drive pulls the sliding “U” holder against the outside of the probe, pulling the probe into a “V” notch for straight and reproducible positioning.

Catalog No.	\$	Model	Product
BS4 72-4832		51633	Large Probe Holder



### Cannula Holder

Holds standard 3.4 mm diameter cannula heads, as manufactured by Plastics One™, for cannula sets, and Alza® for minipumps. Tapered non-intrusive for easily cementing cannulae in place.

Catalog No.	\$	Model	Product
BS4 72-4837		51636	Cannula Holder



### Microdialysis Holder

The Microdialysis Probe Holder is customized at Stoelting to fit a specific size of probe. The hole in the stainless steel foot may be drilled to fit probes from 1.5 to 6.0 mm. Our standard sizes are 1.5 and 2.0 mm holes. Other sizes are available by special order.

Catalog No.	\$	Model	Product
BS4 72-4835		51637	Microdialysis Holder with 1.5 mm Hole
BS4 72-4836		51637-2.0	Microdialysis Holder with 2.0 mm Hole



### Probe Centering Device

This accessory mounts on the “U” frame of the 51600, and allows replacing and centering the probe (only for use with ear bar 0 coordinates), without removing the animal. Hole is 2.7 mm above 0.

Catalog No.	\$	Model	Product
BS4 72-4846		51607	Probe Centering Device Removable Zero Point



## **NEW** Rodent Brain Matrices

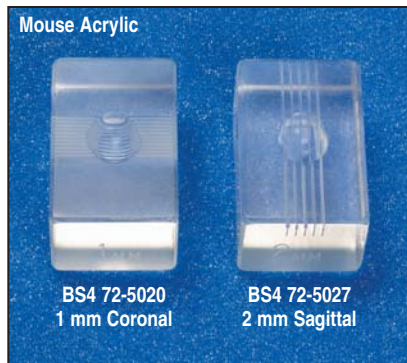

- Repeatable slices from 0.50 to 3.00 mm
- Coronal or sagittal sectioning
- Available in acrylic or stainless steel - (other materials upon request)
- Custom sizes and shapes
- Mouse, rat, gerbil, hamster, guinea pig and rabbit

These Rodent Brain Matrices aid in the dissection of discrete regions of a rodent brain or comparably sized organ. They allow the investigator to slice repeatable coronal or sagittal sections of the sample, enabling precise blocking prior to microtome sectioning and the removal of small, reproducible brain regions (i.e. discrete terminal fields or nuclei) for biochemical analysis, such as the determination of neurotransmitter and metabolite concentrations. Individual brain areas may be stained, dissected or micropunched (using micron biopsy punches) from the slices formed.

All matrices are designed for long-term use, and matrices of any given type are identical to insure reproducible sections. Channels are cut at precise intervals ranging from 0.50 mm to 3.00 mm and are 0.3 mm wide. Other species, sizes, and materials are available upon request.

### Brain Matrices

#### Coronal

Catalog No.	\$	Animal	Slice Width, mm
-------------	----	--------	-----------------

#### Sagittal

Catalog No.	\$	Animal	Slice Width, mm
-------------	----	--------	-----------------

#### Stainless Steel Brain Matrices

Catalog No.	\$	Animal	Slice Width, mm	Catalog No.	\$	Animal	Slice Width, mm
BS4 72-6225		Neonatal Rat	0.5	BS4 72-6229		Neonatal Rat	0.5
BS4 72-6226		Neonatal Rat	1.0	BS4 72-6230		Neonatal Rat	1.0
BS4 72-6227		Neonatal Rat	2.0	BS4 72-6231		Neonatal Rat	2.0
BS4 72-6228		Neonatal Rat	3.0	BS4 72-6232		Neonatal Rat	3.0
BS4 72-6235		Mouse	0.5	BS4 72-6236		Mouse	0.5
BS4 72-5032		Mouse	1.0	BS4 72-5038		Mouse	1.0
BS4 72-5033		Mouse	2.0	BS4 72-5039		Mouse	2.0
BS4 72-5034		Mouse	3.0	BS4 72-5040		Mouse	3.0
BS4 72-6233		Rat 200-300 gr	0.5	BS4 72-6234		Rat 200-300 gr	0.5
BS4 72-5029		Rat 200-300 gr	1.0	BS4 72-5035		Rat 200-300 gr	1.0
BS4 72-5030		Rat 200-300 gr	2.0	BS4 72-5036		Rat 200-300 gr	2.0
BS4 72-5031		Rat 200-300 gr	3.0	BS4 72-5037		Rat 200-300 gr	3.0
BS4 72-6237		Rabbit	1.0	BS4 72-6240		Rabbit	1.0
BS4 72-6238		Rabbit	2.0	BS4 72-6241		Rabbit	2.0
BS4 72-6239		Rabbit	3.0	BS4 72-6242		Rabbit	3.0

#### Acrylic Brain Matrices

Catalog No.	\$	Animal	Slice Width, mm	Catalog No.	\$	Animal	Slice Width, mm
BS4 72-6216		Neonatal Rat	1.0	BS4 72-5026		Mouse	1.0
BS4 72-6217		Neonatal Rat	2.0	BS4 72-5027		Mouse	2.0
BS4 72-6218		Neonatal Rat	3.0	BS4 72-5028		Mouse	3.0
BS4 62-0050		Mouse	1.0	BS4 72-5023		Rat 200-300 gr	1.0
BS4 62-0051		Mouse	2.0	BS4 72-5024		Rat 200-300 gr	2.0
BS4 72-5022		Mouse	3.0	BS4 72-5025		Rat 200-300 gr	3.0
BS4 62-0047		Rat 200-300 gr	1.0	BS4 72-6222		Gerbil	1.0
BS4 62-0048		Rat 200-300 gr	2.0	BS4 72-6223		Gerbil	2.0
BS4 62-0049		Rat 200-300 gr	3.0	BS4 72-6224		Gerbil	3.0
BS4 72-6219		Gerbil	1.0	-	-	-	-
BS4 72-6220		Gerbil	2.0	-	-	-	-
BS4 72-6221		Gerbil	3.0	-	-	-	-

# Tissue Sampling/Access

## Rodent Heart, Spinal Cord and Tumor Matrices

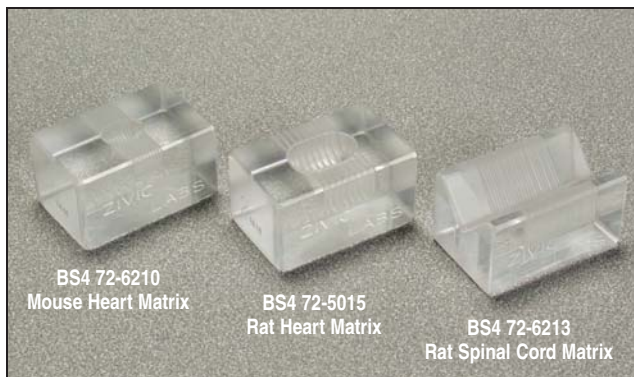

- Repeatable slices from 0.50 to 3.00 mm
- Mouse and rat
- Custom sizes and shapes available upon request

These Rodent Heart and Spinal Cord Matrices aid in the dissection of discrete regions of a rodent heart or spinal cord, or comparably sized organ. They allow the investigator to slice repeatable sections of the sample, enabling precise blocking

prior to microtome sectioning and the removal of small, reproducible brain regions (i.e. discrete terminal fields or nuclei) for biochemical analysis.

All matrices are designed for long-term use, and matrices of any given type are identical to insure reproducible sections. Channels are cut at precise intervals ranging from 0.50 to 3.00 mm and are 0.3 mm wide. Other species, sizes and materials are available upon request.

### Acrylic Heart Matrices

Catalog No.	\$	Animal	Slice Width
BS4 72-6210		Mouse	1.0
BS4 72-6211		Mouse	2.0
BS4 72-6212		Mouse	3.0
BS4 72-5014		Rat	1.0
BS4 72-5015		Rat	2.0
BS4 72-5016		Rat	3.0

### Acrylic Spinal Cord Matrices

Catalog No.	\$	Animal	Slice Width
BS4 72-6213		Rat	1.0
BS4 72-6214		Rat	2.0
BS4 72-6215		Rat	3.0

## **NEW** Ideal Micro-Drill™



- Rechargeable
- Light-weight design
- No special tools needed to charge burrs
- Hard plastic case with die-cut foam for convenient storage
- Excellent balance and handling

The Ideal Micro-Drill™ is designed for research applications that require surgical burrs and trephines. The drill is constructed of light-weight aluminum alloy for balance and control and is powered by a rechargeable 6-volt nickel cadmium battery (charger included). Under normal operating conditions the unit will function for 8 hours between recharging.

### Specifications

Length	17.5 cm (without burr)
Diameter	1.9 cm
Power	6 V DC
Speed	12,000 rpm
Stall Torque	1.25 oz/in

Catalog No.	\$	Product
BS4 72-6065		Ideal Micro-Drill™ Complete Kit
BS4 72-6066		Ideal Burr Set of 5 each

## **NEW** Bone Micro Drill System



This Micro Drill is a workhorse in a kit. This versatile powerhouse is ideal for milling, drilling, grinding and cutting. This drill quickly cuts through bone and other materials. It may also be used for general purpose work such as removing coatings, cutting, drilling holes, cutting slots, as well as performing many other procedures using various interchangeable bits. Unlike most hand-held tools, the Micro Drill has a tiny, high speed DC motor in the hand piece, eliminating bothersome drive cables and giving the researcher better control. A separate power supply keeps the hand piece lightweight and reduces fatigue. Power is supplied by a panel switch or foot switch for ease of use.

The Ball Mills are dental grade carbide steel for precision cutting and long life. All sizes have a 0.093 in diameter shank. The complete Micro Drill System is supplied with a variety of Ball Mills, but you may also purchase them separately.

This Micro Drill System is supplied complete with handpiece, cord, power supply, hand piece stand and BS4 72-4967 Accessory Kit. The contents of the Accessory Kit are listed in the chart below. Additional Ball Mills and accessories are also available separately in the quantities noted in the ordering information.

### BS4 72-4967 Accessory Kit Includes

Product	Qty.
Abrading Tip, Rubber	4
Abrading Tip, Stone	1
Accessory Stand	1
Ball Mill, Carbide, #1, .031 in Diameter	1
Ball Mill, Carbide, #2, .039 in Diameter	1
Ball Mill, Carbide, #3, .047 in Diameter	1
Ball Mill, Carbide, #4, .055 in Diameter	1
Ball Mill, Carbide, #5, .063 in Diameter	1
Ball Mill, Carbide, #6, .071 in Diameter	1
Ball Mill, Carbide, #7, .083 in Diameter	1
Ball Mill, Carbide, #1/4, .019 in Diameter	1
Ball Mill, Carbide, #1/2, .027 in Diameter	1
Cutoff Disk	4
Mandrel, Screw	1
Mandrel, Threaded	1

- Dental quality construction for delicate work
- Flexible telephone-style cord eliminates bothersome drive cables
- Quick change chuck for easy bit replacement
- Versatile forward, reverse, and variable speeds
- Small, lightweight, ergonomically designed hand piece reduces fatigue
- Complete - includes ball mills, abrasive bits, and cutting discs

Catalog No.	\$	Product
BS4 72-4950		Complete Bone Micro Drill System, 120 VAC
BS4 72-4951		Complete Bone Micro Drill System, 230 VAC
BS4 72-4967		Accessory Kit for Micro Drill
BS4 72-4952		Abrading Tip, Rubber, pkg. of 20
BS4 72-4953		Abrading Tip, Stone, pkg. of 5
BS4 72-4954		Accessory Stand
BS4 72-4955		Ball Mill, Carbide, #1, .031 in Diameter, pkg. of 5
BS4 72-4956		Ball Mill, Carbide, #2, .039 in Diameter, pkg. of 5
BS4 72-4957		Ball Mill, Carbide, #3, .047 in Diameter, pkg. of 5
BS4 72-4958		Ball Mill, Carbide, #4, .055 in Diameter, pkg. of 5
BS4 72-4959		Ball Mill, Carbide, #5, .063 in Diameter, pkg. of 5
BS4 72-4960		Ball Mill, Carbide, #6, .071 in Diameter, pkg. of 5
BS4 72-4961		Ball Mill, Carbide, #7, .083 in Diameter, pkg. of 5
BS4 72-4962		Ball Mill, Carbide, #1/4, .019 in Diameter, pkg. of 5
BS4 72-4963		Ball Mill, Carbide, #1/2, .027 in Diameter, pkg. of 5
BS4 72-4964		Cutoff Disk, pkg. of 20
BS4 72-4965		Mandrel, Screw, pkg. of 5
BS4 72-4966		Mandrel, Threaded, pkg. of 5

# Microdialysis Accessories

## Micron Biopsy Punches



- Stainless steel tips
- Circular sectioning diameters from 0.300mm
- Expulsion tube and syringe provided
- Can be used with sections from brain slicers and tissue matrices

These Micron Punches are ideal for dissection or removal (“punch”) of discrete brain regions. Enabling the removal of specific brain nuclei, tracts and other subdivisions, Micron Biopsy Punch applications include dissection for analysis of neurotransmitter concentrations of mRNA levels, preparation of regions prior to acute dissociation for patch recording, and tissue preparation for pharmacological analysis of neurotransmitters and metabolite changes in response to different pharmacological agents.

The Micron Punch has a stainless steel tip, brass handle, and punch diameters ranging from 0.30 mm to 2.0 mm.

Catalog No.	\$	Product
BS4 72-5041		2000 Micron Punch, 2.0 mm
BS4 62-0052		1000 Micron Punch, 1.0 mm
BS4 62-0053		750 Micron Punch, 0.75 mm
BS4 62-0054		500 Micron Punch, 0.50 mm
BS4 62-0055		300 Micron Punch, 0.30 mm

*For additional small volume flow pumps, see the Model 11 Pico Plus on page L45.*

## Artificial CSF Perfusion Fluid



Artificial cerebrospinal fluid (aCSF) is commonly used when sampling from brain interstitial fluid. This solution closely matches the electrolyte concentrations of CSF. It is prepared from high purity water and analytical grade reagents. It is microfiltered and sterile. Final Ion Concentrations (in mM): Na 150; K 3.0; Ca 1.4; Mg 0.8; P 1.0; Cl 155. Supplied as a package of six 25 ml vials.

Catalog No.	\$	Product
BS4 59-7316		Artificial CSF Perfusion Fluid

### Application Note: Perfusion Fluid

The perfusion fluid should be identical in composition to the interstitial fluid being sampled except that it is devoid of the substances of interest (or has excess concentration of the substance to be delivered). Perfusion fluids vary widely in terms of their composition and pH. Generally, they are prepared as iso-osmotic as possible.

## PHD 22/2000 Microliter Pump



- Lowest flow rates
- Highest accuracy
- Easy-to-use

The PHD 22/2000 Microlieter Syringe Pump when equipped with a microliter syringe rack offers an excellent tool for microdialysis infusion. A complete line

of microliter syringes are available, as well as all the tubing adapters and connectors for microdialysis or other cranial infusion applications, see Section A of this Catalog for more information on pumps and syringes.

- With the microliter syringe rack, each syringe is held by its own body clamp, allowing two different size syringes to be used simultaneously or positioned so that one starts before the other; individual syringes can be removed without disturbing the other
- Three models available: infusion only, infusion/withdrawal and programmable

The PHD 22/2000 Syringe Pump is designed to hold microliter syringes for ultra-low flow rates required for microdialysis and intracranial infusion.

Catalog No.	\$	Product
BS4 70-2005		PHD 22/2000 Syringe Pump, Infusion Only with Microliter Syringe Rack
BS4 70-2008		PHD 22/2000 Syringe Pump, Infusion/Withdrawal with Microliter Syringe Rack
BS4 70-2011		PHD 22/2000 Syringe Pump, Programmable with Microliter Syringe Rack

## **NEW** Pump 11 Pico Plus

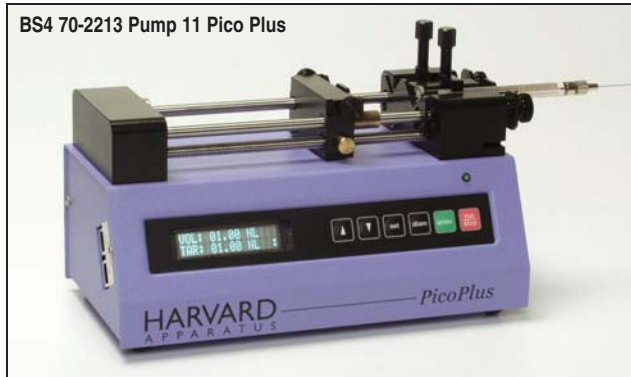

### Applications

- Cellular injection i.e. oocytes
- Micro flow for FIA or capillary LC
- Micro reaction delivery

### Features

- Infuse/ withdraw capability
- Dual syringes for broad flow rate range
- Easy-to-read display, the injection rate can be changed from 0.0550 pl/sec to 0.0073 ml/sec
- Remote to micromanipulator injections are easy non-obstructed viewing and no heavy weight to hinder positioning
- This pump has exceptional milliliter, microliter, nanoliter and picoliter smooth and accurate flow, easily set through the keyboard
- The injection can be controlled by initiating the manual start button, RS-232 through your computer or with the included foot pedal

### Specifications

<b>Pump Type</b>	Dual syringe infusion/withdraw
<b>Accuracy</b>	±0.5%
<b>Reproducibility</b>	±0.1%
<b>Syringes:</b>	
<b>Holder</b>	Dual
<b>Type</b>	Plastic or glass
<b>Size Minimum</b>	1 µl
<b>Size Maximum</b>	10 ml
<b>Flow Rate:</b>	
<b>Minimum</b>	3.3 pl/min (using 1 µl syringe)
<b>Maximum</b>	0.4394 ml/min (using 2 x 10ml syringes combined output)
<b>Non Volatile Memory</b>	Storage of all settings
<b>RS-232 Communication</b>	Yes
<b>Average Linear Force</b>	25 lbs*
<b>Input Power</b>	12 VDC 1.5 Amps
<b>Voltage Range</b>	Universal input 100/250 VAC, 50/60 Hz, 18 watts (Use only)
<b>(Power Supply)</b>	Harvard Apparatus approved supply and line cord)
<b>Dimensions, H x W x D</b>	11.4 x 22.9 x 11.4 cm (4.5 x 9 x 4.5 in)
<b>Weight</b>	2.3 kg (5 lbs)

*\* Actual force is higher. Not recommended for applications more than 25 lbs of force.*

An accessory pack is available for this pump. It contains 26 gauge blunt needles, fused silica connecting tube and connecting adaptors.

Catalog No.	\$	Product
BS4 70-2213		Pump 11 Pico Plus
BS4 70-2214		Accessory Pack for Pump 11 Pico Plus. Contains one each BS4 72-4684, BS4 59-7627 and BS4 59-7624

## Rodent Infusion Cages

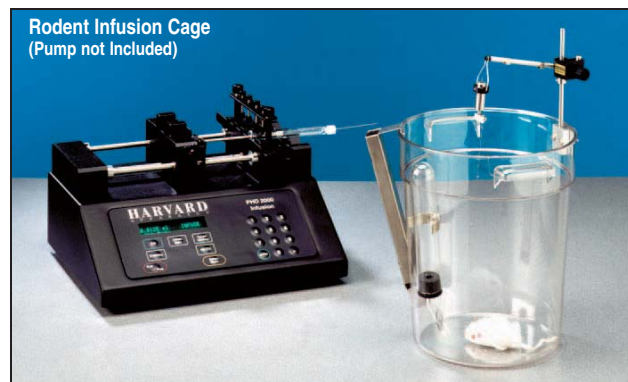

- No sharp corners
- Tethers less likely to tangle
- Probes less likely to dislodge
- Durable polycarbonate for long life
- Available for mice and rats

Durable polycarbonate cages designed to house tethered rodents during short-term infusion and microdialysis experiments. Since the cage is round, tethers will not tangle as they sometimes can in shoebox-type cages. Also, animals are less likely to dislodge sensitive probes since there are no sharp corners. Handles at the top

make it easy to move the animal around the lab.

These Animal Cages are frequently used with Counter-Balanced Lever Arms but are also compatible with the BS4 61-0020 Universal Cage Mounting System. This cage is available in two sizes and can be supplied with any combination of feeders and water bottles. Pictured above is a complete animal infusion system featuring our PHD 22/2000 Syringe Pump, BS4 61-0046 Mouse Cage with Water Bottle, Counter-Balanced Lever Arm, and a Stainless Steel Swivel. The pump, swivel and lever arm are sold separately.

Catalog No.	\$	Product
BS4 61-0046		Mouse Infusion Cage, polycarbonate, 21.6 cm (8.5 in) high
BS4 61-0048		Mouse Infusion Cage Cover
BS4 72-0014		Mouse Infusion Cage with Pellet Feeder
BS4 72-0015		Mouse Infusion Cage with Water Bottle
BS4 72-0016		Mouse Infusion Cage w/ Pellet Feeder and Water Bottle
BS4 61-0047		Bottom Screen for Mouse Infusion Cage
BS4 61-0024		3.5 in. Counter-Balanced Lever Arm for Mouse Infusion Cage
BS4 61-0042		Rat Infusion Cage, polycarbonate, 38.1 cm (15 in) high
BS4 61-0044		Rat Infusion Cage Cover
BS4 72-0017		Rat Infusion Cage with Pellet Feeder
BS4 72-0018		Rat Infusion Cage with Water Bottle
BS4 72-0019		Rat Infusion Cage with Pellet Feeder and Water Bottle
BS4 61-0023		6 in. Counter-Balanced Lever Arm for Rat Infusion Cage

## Books

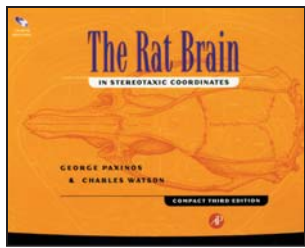

### The Rat Brain in Stereotaxic Coordinates, 4th Edition

George Paxinos and Charles Watson. This is the long-awaited revision of the most authoritative and widely cited atlas in neuroscience. It is an update of the 1986 full size edition. It contains fully revised nomenclature that has been standardized in the neuroscience community. Also included are new and updated photographs, enlarged coronal diagrams, and diagrams of the sagittal and horizontal sections. This atlas is available with or without a CD-ROM which allows you to print, copy, and search either labeled or unlabeled versions of the diagrams of coronal sections presented in the printed version. CD-ROM requires PC running Windows 3.1 or higher or Macintosh running System 7.0 or higher. Diagrams, or parts of diagrams, may be copied to most drawing or word processor programs for annotation and custom labeling. (280 pp; 1998)

Catalog No.	\$	Product
BS4 62-0013		The Rat Brain in Stereotaxic Coordinates, 4th Edition with CD ROM
BS4 62-0014		The Rat Brain in Stereotaxic Coordinates, 4th Edition

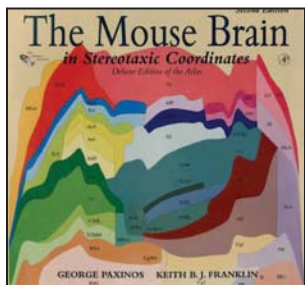

### The Mouse Brain Stereotaxic Coordinates, Deluxe 2nd Edition with CD-ROM

Key Features:

- A coronal set featuring 100 photographs and 100 matching detailed diagrams delineating the entire brain
- A sagittal set featuring 32 photographs and 32 matching detailed diagrams
- Photographs of Nissl- and Acetylcholinesterase sections alternate
- Thoroughly revised cortical delineations and improved subcortical delineations
- Deluxe Edition contains diagrams available on CD-ROM constructed by Paul Halasz Keith Franklin, McGill University

By George Paxinos, Keith B. J. Franklin. New edition of the most cited mouse atlas, now available with CD-ROM! The Mouse Brain in Stereotaxic Coordinates, Second Edition is the most comprehensive and accurate atlas of the mouse brain ever published. The first edition of this book has become the acknowledged reference in its field. In the second edition, the authors incorporated lower brainstem sections, an entire sagittal plane of section and revised all delineations, especially of the cortex. This guide is essential to those who study the brain of this species or any similar species, including hamsters. The large, spiral-bound format makes it easy to see the details in each illustration or photograph and compare them to animal models in the lab. Atlas illustrating the brain of a male mouse, for neurologists. This edition incorporates lower brainstem sections, with an entire sagittal plane section. All delineations, especially of the cortex have been revised. Wire-spiral binding.

Catalog No.	\$	Product
BS4 72-4230		The Mouse Brain in Stereotaxic Coordinates, Deluxe 2nd Edition with CD ROM

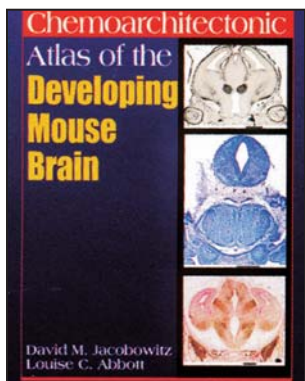

### Chemoarchitectonic Atlas of the Developing Mouse Brain

by David M. Jacobowitz, Louise C. Abbott. Representing the state-of-the-art in neurochemical mapping, Chemoarchitectonic Atlas of the Developing Mouse Brain provides a complete, full-color look at the developing mouse brain. Hundreds of coronal sections are presented, clearly illustrating structures at progressive stages of brain development. Hardcover - (December 29, 1997) 304 pages.

Catalog No.	\$	Product
BS4 72-4235		Chemoarchitectonic Atlas of the Developing Mouse Brain

## Books

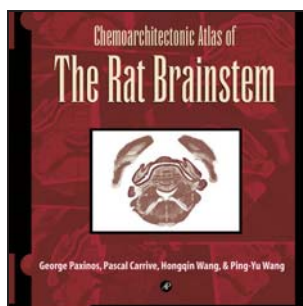

### Chemoarchitectonic Atlas of the Rat Brainstem

George Paxinos, Pascal Carrive, Hongqin Wang, and Ping-Yu Wang. Chemoarchitectonic Atlas of the Rat Brainstem is the most comprehensive atlas of the rat brainstem ever published. It features 243 fully labeled large photographs of the brainstem. It identifies brain structures not only on the conventional Nissl-stained sections, but also on an additional six stains of interest to neuroscientists. Chemoarchitectonic Atlas of the Rat Brainstem comprehensively displays them and concurrently sets new standards of accuracy in the delineations of brain regions. Major sections include: Introduction. Stereotaxic Surgery. Histology. Photography. Stereotaxic Reference System. The Basis of Delineation of Structures. References. Index of Abbreviations. Plates. List of Structures. (August 1998)

Catalog No.	\$	Product
BS4 63-0006		Chemoarchitectonic Atlas of the Rat Brainstem

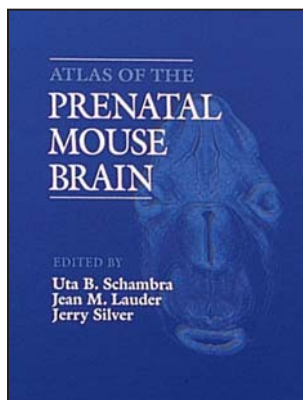

### Atlas of the Prenatal Mouse Brain

Uta B. Schambra, Jean M. Lauder and Jerry Silver. This text fills an urgent need for a comprehensive atlas of the developing mouse brain for use in studies of both normal and abnormal development. High quality photomicrographs of brain sections are depicted in sagittal, coronal, and horizontal planes for four gestational age groups. Each photomicrograph is accompanied by a fully labeled, precision-drawn diagram for easy identification of brain structures. Researchers and students using normal, transgenic, or mutant mouse preparations in developmental neurobiology, neurotoxicology, and biotechnology will welcome this meticulously assembled and accessible guide. (327 pp; 1991)

Catalog No.	\$	Product
BS4 60-1297		Atlas of the Prenatal Mouse Brain

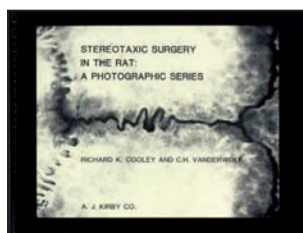

### Stereotaxic Surgery In The Rat: A Photographic Series

By Richard K. Cooley, C.H. Vanderwolf. Over the past few decades the use of stereotaxic procedures in animal laboratories has become commonplace throughout the world. But despite the widespread and increasing use of the stereotaxic instrument in research, very few adequate books of instruction have been published for the novice and student. There has been a need for a manual which provides a clear, step by step outline of the procedures involved in stereotaxic surgery with the most common laboratory animal, the rat. Richard K. Cooley and C.H. Vanderwolf have written such a book. Their manual combines excellent illustration with clear and well organized text. This 8.5 x 11 inch spiral bound paperback contains over 40 full page photographs illustrating each of the steps involved in the routine implantation of a chronic intracranial electrode. The photographs themselves are beautifully conceived and reproduced. Each photograph is accompanied by a facing page giving a clear outline of the procedure illustrated. The book developed in its present form as a result of the authors' experience in undergraduate laboratory teaching. Therefore, it is uniquely suitable for use by individuals who have had little or no previous surgical experience. Spiral-bound - 102 pages 1 edition (May 1, 1990).

Catalog No.	\$	Product
BS4 72-4240		Stereotaxic Surgery In The Rat: A Photographic Series

## General Stereotaxic FAQ's

### How can I tell if the earbars are positioned correctly?

Next to the ear sockets, there are skull recessions that can feel like the ear holes, but are not as stable. On the rat, grasp the end of the snout and attempt to rock it gently from side to side. If it moves at all, the ear bars are not correctly installed. Swivel the snout up, and let go, or down and let go. If it stays where you leave it and doesn't move up or down, the ear bars are installed correctly.

### How do I move the probe out of the way in order to drill the skull hole?

Always swivel from just above the universal joint tilting mechanism. At this point, flat tapered faces will allow you to swivel out and come back to exactly the same point. Or, do it the slow way and turn the knob until the probe is out of the way. Never use the swivel below the universal joint for this purpose. Without the alignment faces, with only graduation lines to guide you, you will not be able to align the lines perfectly enough. The distance from the center of rotation to the graduation marks is several multiples shorter than the distance from the center of rotation to the electrode tip. This multiple will apply to any errors of alignment of the graduation marks, and leave the electrode tip a biologically significant distance from the initial alignment.

### Single or Dual Manipulator: which is right for you?

To implant bilateral cannulas, one needs only a single manipulator, since this task is done sequentially anyway. To stimulate on the contralateral side, while recording on the ipsilateral side, requires two probes under independent and simultaneous stereotaxic control. This task requires a dual stereotaxic instrument.

## Benchmark Deluxe Digital Stereotaxic FAQ's

(see page L30 for equipment information)

### Do the Digital Scales cause me to lose any range of motion on the manipulators?

One of the main design criteria for the digital stereotaxic instrument was for low profile unobtrusive scales. This goal was accomplished in the final product. The instrument has the full range of motion required for practically all procedures. The total range of angle movement is 0 to 75 degrees.

### How stable is the manipulator? Will I lose any of my readings?

The manipulator is one of the most stable manipulators on the market today. The addition of the scales does nothing to reduce the stability you would have with a non-digital manipulator. The digital display will not change readings unless the manipulator advance knobs are moved. You also always have access to the standard vernier scales to verify your readings or utilize as a backup.

### Why does your display read to 0.005 mm? The brain atlases only read to 0.1 mm, and bregma is not that precise. What good are the last two decimals?

The atlases now read to 0.1 mm because that is the best that can be measured with today's stereotaxic instruments. Better atlases will follow better instruments. In the expanded scale of the printed atlases, it is reasonable to interpolate to 0.01 mm. The bregma argument is more interesting. Measuring from bregma to reach a point in brain, the start point has more error of determination than our instrument (we are working on a solution to the accuracy of the start point). The last two decimals probably do not do much to improve stereotaxic accuracy of initial placement. However, sometimes accuracy of distance moved within the brain is what is important, as when initial placement is determined by recording from brain, and then advancing a set distance, or as in knife cuts. In this case, all the resolution of this instrument is useful.

### How accurately does it measure? How often does it need to be recalibrated?

Measurements are not absolute, but relative to a selected zero point. From selected zero, distance along a linear scale is counted. This is not an analog or rotary scale, what is measured is actual distance moved. No calibration is necessary or possible. The instrument is accurate to 5 microns, and remains that accurate.

### The display box takes up space on my crowded counter. Couldn't it be smaller?

Many customers anxious to switch from verniers are having trouble reading them because of the tiny size and detail lines. We deliberately chose large, easily read, (even from a distance) 12 mm digit displays, and put large lettering on the silk screening identifying the scales. No mistakes due to imperfect vision. The large digits will be appreciated with use and time.