



Soundmate 1 MKII

ORDERCODE D3220



SHOWELECTRONICS FOR PROFESSIONALS

Congratulations!

You have bought a great, innovative product from DAP Audio.

The DAP Audio Soundmate 1 brings excitement to any venue. Whether you want simple plug-&-play action or a sophisticated show, this product provides the effect you need.

You can rely on DAP Audio, for more excellent audio products.

We design and manufacture professional audio equipment for the entertainment industry.

New products are being launched regularly. We work hard to keep you, our customer, satisfied.

For more information: iwant@dap-audio.info

You can get some of the best quality, best priced products on the market from DAP Audio.

So next time, turn to DAP Audio for more great audio equipment.

Always get the best -- with DAP Audio !

Thank you!



Warning..... 2
 Safety-instructions..... 2
 Operating Determinations..... 4

Description..... 5
 Features and Overview 5
 Backside..... 5

Set Up and Operation..... 6

Connection Cables..... 8

Maintenance..... 9
 Replacing the Fuse..... 9

Troubleshooting..... 9

Product Specifications..... 10

WARNING

**FOR YOUR OWN SAFETY, PLEASE READ THIS USER MANUAL CAREFULLY
BEFORE YOUR INITIAL START-UP!**

Unpacking Instructions

Immediately upon receiving this product, carefully unpack the carton and check the contents to ensure that all parts are present, and have been received in good condition. Notify the dealer immediately and retain packing material for inspection if any parts appear damaged from shipping or the carton itself shows signs of mishandling. Save the carton and all packing materials. In the event that a fixture must be returned to the factory, it is important that the fixture be returned in the original factory box and packing.

WARNING



CAUTION!

Keep this system away from rain and moisture!



**FOR YOUR OWN SAFETY, PLEASE READ THIS USER MANUAL CAREFULLY
BEFORE YOUR INITIAL START-UP!**

SAFETY INSTRUCTIONS

Every person involved with the installation, operation and maintenance of this system have to:

- be qualified
- follow the instructions of this manual



**CAUTION! Be careful with your operations.
With a dangerous voltage you can suffer
a dangerous electric shock when touching the wires!**



Before you initial start-up, please make sure that there is no damage caused by transportation. Should there be any, consult your dealer and do not use the system.

To maintain perfect condition and to ensure a safe operation, it is absolutely necessary for the user to follow the safety instructions and warning notes written in this manual.

Please consider that damages caused by manual modifications to the system are not subject to warranty.

This system contains no user-serviceable parts. Refer servicing to qualified technicians only.

IMPORTANT:

The manufacturer will not accept liability for any resulting damages caused by the non-observance of this manual or any unauthorized modification to the system.

- Never let the power-cord come into contact with other cables! Handle the power-cord and all connections with the mains with particular caution!
- Never remove warning or informative labels from the unit.
- Never use anything to cover the ground contact.
- Do not insert objects into air vents.
- Do not connect this system to a dimmerpack.
- Do not switch the system on and off in short intervals, as this would reduce the system's life.
- Do not open this device. Risk: hazardous radiation exposure.
- Do not run the output of any amplifier channel, back into another channel's input.

- Do not connect (parallel or series) an amplifier output with any other amplifier output.
- Only use system indoor, avoid contact with water or other liquids.
- Avoid flames and do not put close to flammable liquids or gases.
- Always disconnect power from the mains, when system is not used. Only handle the power-cord by the plug. Never pull out the plug by tugging the power-cord.
- Make sure you don't use the wrong kind of cables or defective cables.
- Make sure that the signals into the mixer are balanced, otherwise hum could be created.
- Make sure you use DI boxes to balance unbalanced signals; All incoming signals should be clear
- Make sure that there is sufficient room on all sides of the system for air circulation.
- Make sure that the available voltage is not higher than stated on the rear panel.
- Make sure that the power-cord is never crimped or damaged. Check the system and the power-cord from time to time.
- Before connecting or disconnecting the power cord, make certain the ON / OFF switch is in the OFF position.
- Before switching on or off make certain the sound system's amplifiers are off or turned down: this will avoid signal peaks, which are annoying and sometimes dangerous (particularly for speaker enclosures).
- Avoid installing your equipment very near radio or TV sets, mobile phones, etc., as these can cause RF (radio frequency) interference.
- When connecting the other parts of your sound system, watch out for the so-called "ground loops".
- The best way (even if not always feasible) to avoid ground loops is to connect the electric ground of all the equipment to a single central point ("star" system). In this case, the central point can be the mixer.
- To avoid or solve hum and buzzing troubles, try different combinations of lifting grounds on units that are supplied with ground lift switches or make sure all chassis are connected to earth ground, either through the A.C. power cord ground or by the front panel rack mount screws.
- Before changing your grounds around, always turn your amplifiers down.
- Keep this user's manual for future consultation. Also remember that the crossover will get a better price on the secondhand market if (as well as being in good condition) it has its original documentation and packaging.
- Always operate the unit with the AC ground wire connected to the electrical system ground.
- Do not drive the inputs with a signal level bigger, than required to drive the equipment to full output.
- In system setup, the amplifier's output power must be 50%-100% more than the loaded loudspeakers rated power.
- Please turn off the power switch, when changing the power cord or signal cable, or select the input mode switch.
- Sometimes, when you want to send one signal to more than one amplifier, you should use a signal distributor.
- Extreme frequency boosts in connection with a high input signal level may lead to overdriving your equipment. Should this occur, it is necessary to reduce the input signal level by using the INPUT control.
- To emphasize a frequency range, you don't necessarily have to move its respective sliding control upward; try lowering surrounding frequency ranges instead. This way, you avoid causing the next piece of equipment in your sound path to overdrive. You also preserve valuable dynamic reserve ("headroom")
- For replacement use fuses of same type and rating only.
- Prevent distortion! Make sure that all components connected to the Soundmate have sufficient power ratings. Otherwise distortion will be generated because the components are operated at their limits.
- Avoid ground loops! Always be sure to connect the power amps and the mixing console to the same electrical circuit to ensure the same phase!
- If system is dropped or struck, disconnect mains power supply immediately. Have a qualified engineer inspect for safety before operating.
- If the system has been exposed to drastic temperature fluctuation (e.g. after transportation), do not switch it on immediately. The arising condensation water might damage your system. Leave the system switched off until it has reached room temperature.
- Repairs, servicing and electric connection must be carried out by a qualified technician.
- WARRANTY: Till one year after date of purchase.

OPERATING DETERMINATIONS

This system is not designed for permanent operation. Consistent operation breaks will ensure that the system will serve you for a long time without defects.

If this system is operated in any other way, than the one described in this manual, the product may suffer damages and the warranty becomes void.

Any other operation may lead to dangers like short-circuit, burns, electric shock, etc.

You endanger your own safety and the safety of others!

Improper installation can cause serious damage to people and property !

Connection with the mains

Connect the device to the mains with the power-plug.

Always pay attention, that the right color cable is connected to the right place.

International	EU Cable	UK Cable	US Cable	Pin
L	BROWN	RED	YELLOW/COPPER	FASE
N	BLUE	BLACK	SILVER	NUL
	YELLOW/GREEN	GREEN	GREEN	EARTH

Make sure that the device is always connected properly to the earth!

Description of the device

Features

SoundMate Active 1 MKII is a fullrange active system with :

- 1 Bass and 2 satellite amplifiers (total 660W)
- 1 subwoofer 15" with 3" voice coil
- 2 mid/high (fullrange) satellites with 8" high efficiency mid speaker with 1.375" voice coil.
- 1.75" voice coil high driver mounted on an elliptical wave guide horn + 1" exit
- 2 Speaker cables
- 2 distance tubes
- 3 transport covers
- 4 Castor Wheels
- Cabinets 18 mm plywood (12 layers).

Overview

Backside Subwoofer

Backside Satellite

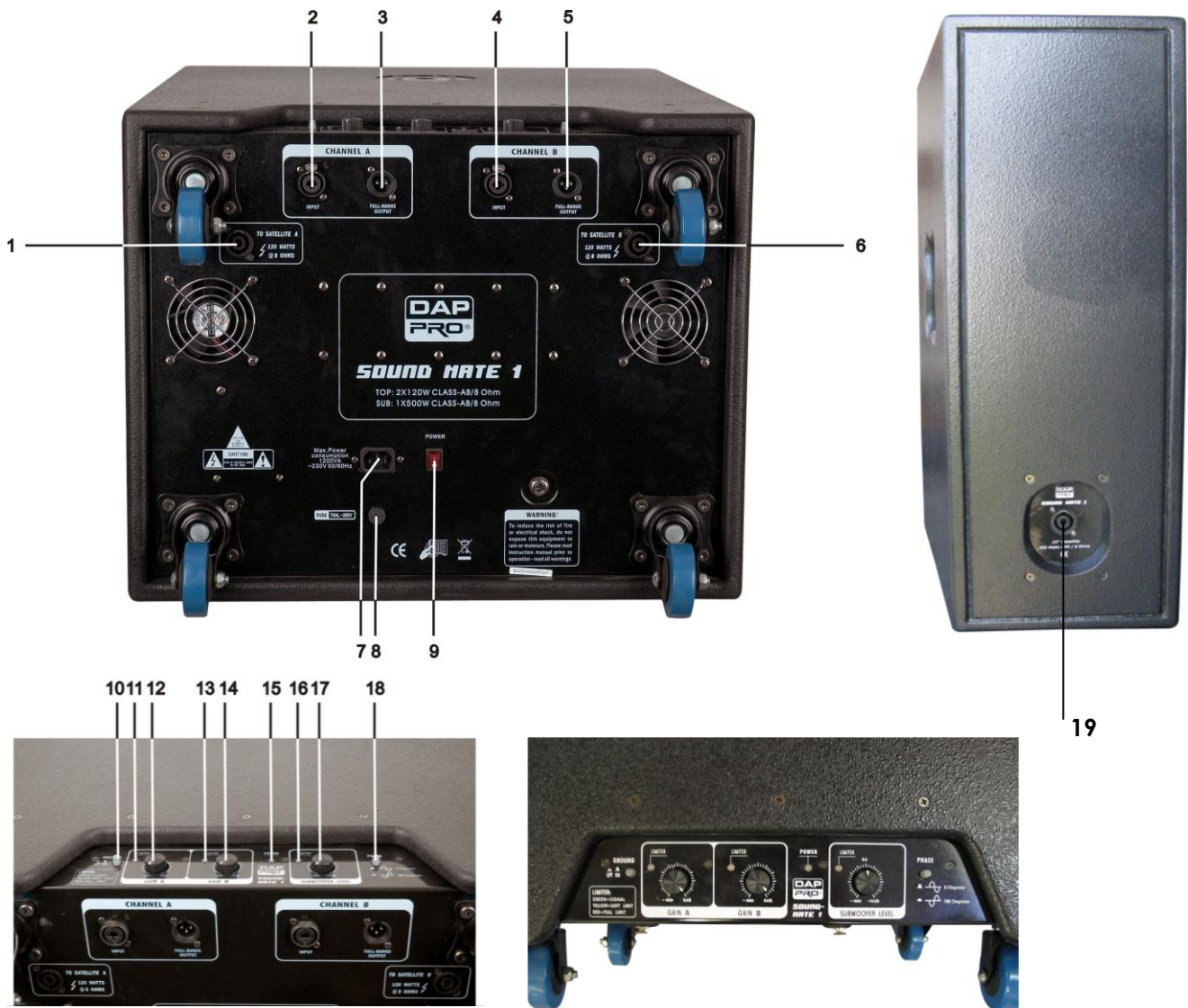

- 1) To Satellite A 120W @8Ohm (Speaker Output)
- 2) Channel A Input
- 3) Channel A Full-range Output
- 4) Channel B Input
- 5) Channel B Full-range Output
- 6) To Satellite B 120W @8Ohm (Speaker Output)
- 7) IEC Connector
- 8) Fuse 5A 250V
- 9) Power ON/OFF
- 10) Ground (On/Lift)

- 11) Limiter LED
- 12) Gain A, range -∞ / +6 dB
- 13) Limiter LED
- 14) Gain A, range -∞ / +6 dB
- 15) Power LED
- 16) Limiter LED
- 17) Subwoofer, range -∞ / +6 dB
- 18) Phase
- 19) Speakon connect to Satellite

Set Up and Operation

The new Soundmate 2 MKII is a further development of the immense popular Soundmate 1, which became a much used system among entertainers and musicians. The Soundmate 2 MKII has the same critical user-specs as the Soundmate 2, namely: compact, yet powerful, plug-and-play, roadproof and of course a neutral sound with an extra bass-punch. The amplifier-section is build into each subwoofer and consists of 3 separate power-amplifiers. It's easy to set up.

The satellite

The SoundMate Active I MKII satellite is designed to produce a full spectrum of sound. The satellite is equipped with a 8" LF loudspeaker and 1,375" HF driver with a horn with a dispersion of 90°x60°.

The subwoofer

Feel the bass with this 15" basscabinet. The cabinet is powered through a powerful 400W amplifier for the Subwoofer and a 2x130W amplifier for the Satellite. The castors makes the unit easy to move and thanks to this feature it is a real road proof system.

It's easy to set up; All you have to do is set up the system components, connect the signal-carrying cables and power cords and you're ready to roll. The set comes with ALL necessary accessories: cables and even dust-/raincovers!!!

Linking Satellites / Subwoofers

Connect the cables coming from the mixer to the Combo INPUT socket of the subwoofer. Depending on the mixer's output sockets use either a jack or XLR cable. Connect a speakon cable to the Speakon output **(11)** of the subwoofer and to the Speakon input of the satellite.

Note: Do not supply power before all components of the system are set up and connected properly. Make sure that the SoundMate system is always the last component, which is switched on! When shutting down, the SoundMate should be the first system, which is switched off.

Below you will find a short description of the features from the SoundMate Active 1 MKII :

To Satellite (1+6)

This output is used to connect the Satellite Speaker.

Input (2+4)

The input equipped with 3 pole XLR/ jack combo socket is electronically balanced to accept the (line) signal from any mixing console.

Full Range Through (3+5)

This parallel output allows you to connect more bass-cabinets together as well to connect other systems such as monitor power amplifiers, individual components etc.

Power Switch (9)

Do not supply power before the whole system is set up and connected properly. An external fuse protects your system from any damage caused by electrical failures.

IEC Power Inlet and Fuse (7+8).

This connector is meant for the connection of the supplied main cord. Connect one end of the power cord to the connector, the other end to the mains, then turn on the **Power** switch (1) to operate the unit.

Note: Please make sure that the supply voltage matches the operation voltage before connecting the unit to mains. Replace the fuse only with a fuse of same specification (T6,3A).

Ground Lift (10)

When this button is pressed, it separates the signal ground from the chassis ground, enabling you to eliminate potential ground loops or low-frequency hum.

Hi-Mid Limiter LED (11+13)

Lights if the Hi-Mid Limiter circuit is active.

- Green LED: Signal
- Orange LED: Soft Limit
- Red LED: Hard Limit

Gain (12+14)

This allows you to adjust the audio level.

Power LED (15)

Lights if the Power is on.

Sub Limiter LED (16)

Lights if the Subwoofer Limiter circuit is active.

- Green LED: Signal
- Orange LED: Soft Limit
- Red LED: Hard Limit

Subwoofer Level (17)

This allows you to adjust the Subwoofer level.

Phase Switch (18)

Used to inverse the phase of the Satellite output if necessary.

To Satellite (19)

This output is used to connect the Satellite Speaker.

Connection Cables

Take care of the connector cables, always holding them by the connectors and avoiding knots and twists when coiling them: This gives the advantage of increasing their life and reliability, which is always to your advantage.

Periodically check that your cables are in good condition, that they are correctly wired and that all their contacts are in good condition: a great number of problems (faulty contacts, ground hum, discharges, etc.) are caused entirely by using unsuitable or faulty cables.

Headphones plug

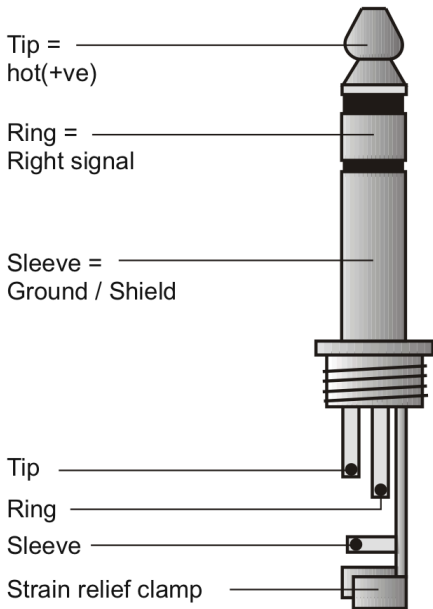

Unbalanced mono 1/4" jack plug

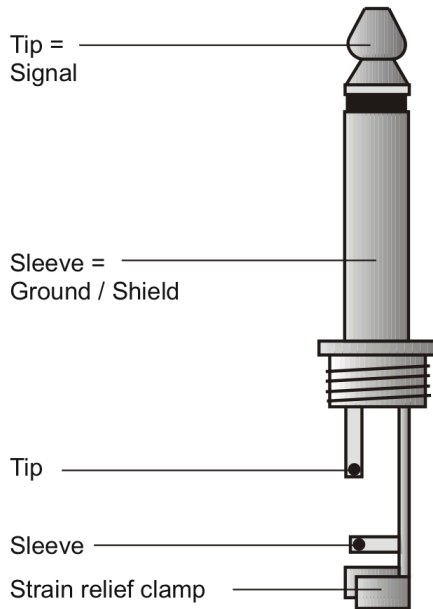

Balanced mono 1/4" jack

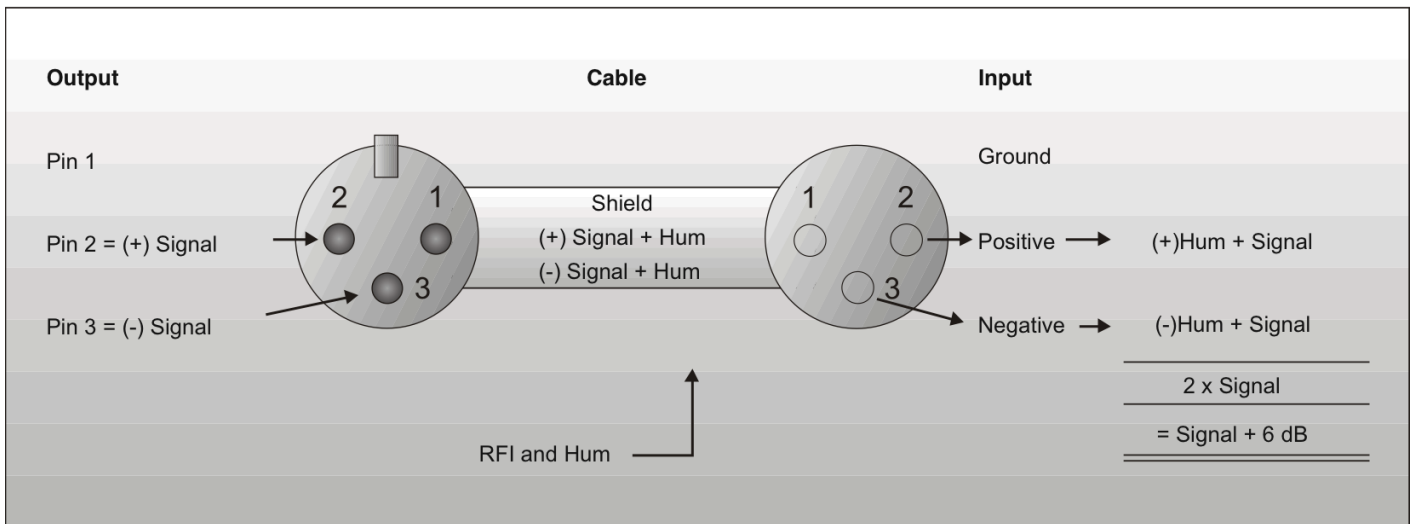
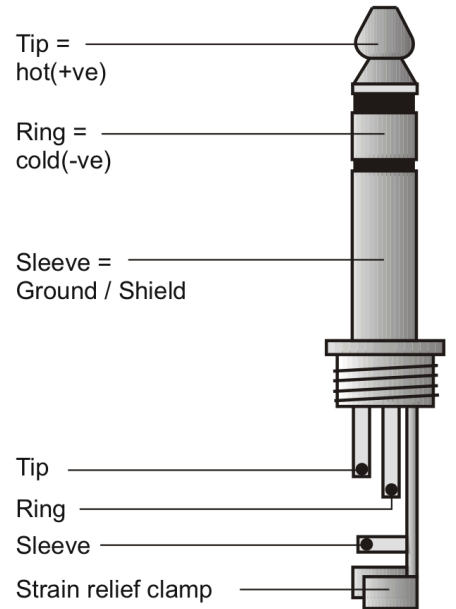

Compensation of interference with balanced connections

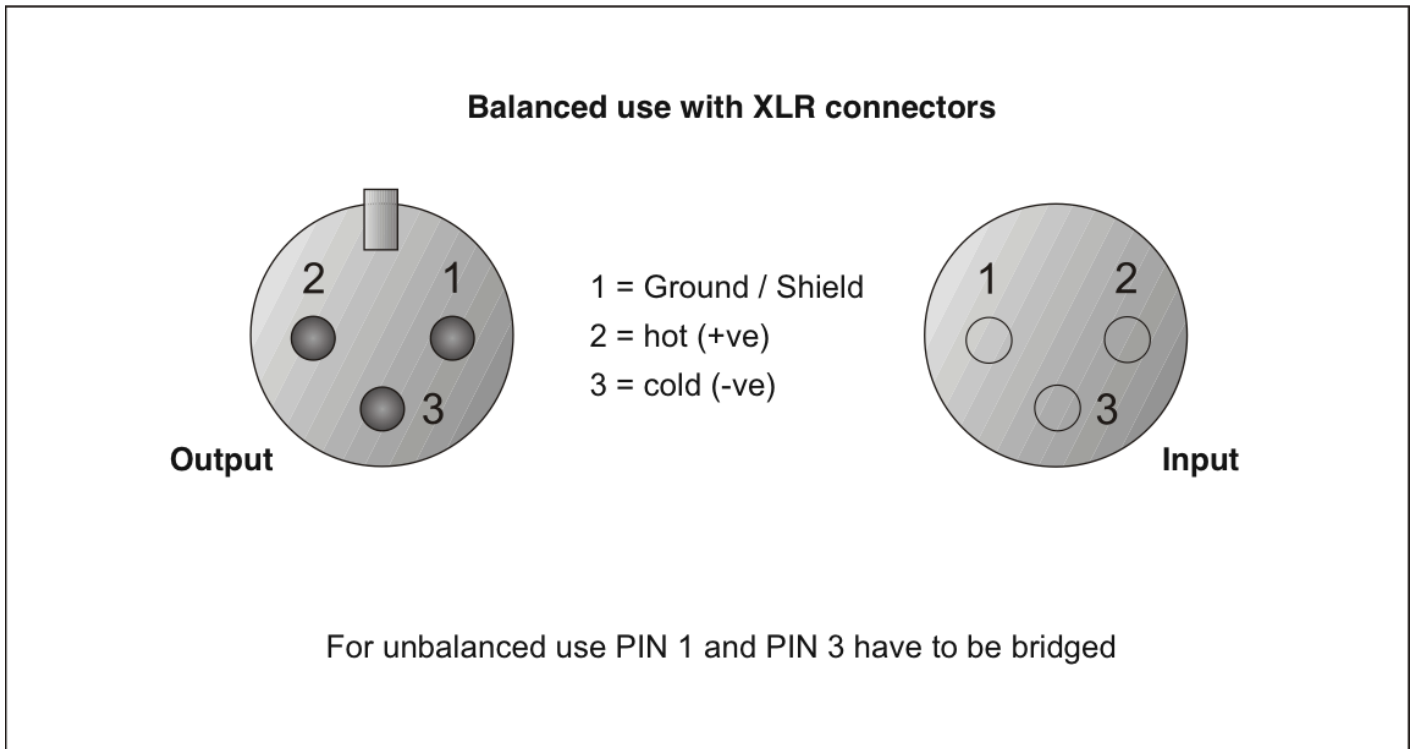

Maintenance

The DAP Audio SoundMate Active 1 MKII requires almost no maintenance. However, you should keep the unit clean. Disconnect the mains power supply, and then wipe the cover with a damp cloth. Do not immerse in liquid. Do not use alcohol or solvents. Keep connections clean. Disconnect electric power, and then wipe the audio connections with a damp cloth. Make sure connections are thoroughly dry before linking equipment or supplying electric power.

Replacing a Fuse

Power surges, short-circuit or inappropriate electrical power supply may cause a fuse to burn out. If the fuse burns out, the product will not function whatsoever. If this happens, follow the directions below to do so.

1. Unplug the unit from electric power source.
2. Insert a flat-head screwdriver into a slot in the fuse cover. Gently pry up the fuse cover. The fuse will come out.
3. Remove the broken fuse. If brown or unclear, it is burned out.
4. Insert the replacement fuse into the holder where the old fuse was. Reinsert the fuse cover.
Be sure to use a fuse of the same type and specification. See the product specification label for details.

Troubleshooting

This troubleshooting guide is meant to help solve simple problems. If a problem occurs, carry out the steps below in sequence until a solution is found. Once the unit operates properly, do not carry out following steps.

1. If the device does not operate properly, unplug the device.
2. Check the fuse, power from the wall, all cables, etc.
3. If all of the above appears to be O.K., plug the unit in again.
4. If you are unable to determine the cause of the problem, do not open the device, as this may damage the unit and the warranty will become void.
5. Return the device to your Dap Audio dealer.

Specifications

Inputs

Subwoofer

Line IN Connector XLR / jack combo socket female
 Input design electronically unbalanced
 Input impedance 47 kΩ
 Sensitivity 0 dB

Satellite

Speakon socket

Outputs

Subwoofer

Parallel Out Connector: XLR socket male
 To Satellite out connector: Speakon

Amplifiers

Power output Subwoofer 400 W / 8 Ω at 1% THD
 Power output to Satellite 2 x 130 W / 8 Ω at 1% THD

Speakers

Subwoofer Specifications

15" active vented PA subwoofer
 Built-in Limiter circuits
 Built-in Loudness circuits
 Woofer:

ER-1576L V2
76 mm Voice Coil
400 Watt RMS
2x 130 Watt RMS @ 8 Ohm
400 Watt RMS
50 – 160 Hz
42 – 200 Hz
160 Hz, 24 dB/oct
103 dB / W / m
129 dB
360° x 180°
790 x 535 x 430 mm
42,2 kg

Satellites

10/1 passive vented PA satellite speaker system

Mid Speaker:	ER-838M, 8 Ohm,
	38 mm Voice Coil
High Driver:	CT-345CS, 8 Ohm,
	1.375" Titanium Dome,
	34 mm Voice Coil

Nominal Impedance:	8 Ohm
Freq. Response (-6 dB, -3 dB):	160 – 16,000 Hz
Freq. Range (-10 dB):	125 – 20,000 Hz
Crossover Frequency:	2500 Hz, 18 dB/oct
Sensitivity (Full Space):	95 dB / W / m
Max SPL at 1 m (Theoretical):	116 dB
Nominal Dispersion (H x V):	90° x 60°
Dimensions (W x H x D):	265 x 430 x 230 mm
Net Weight:	9 kg

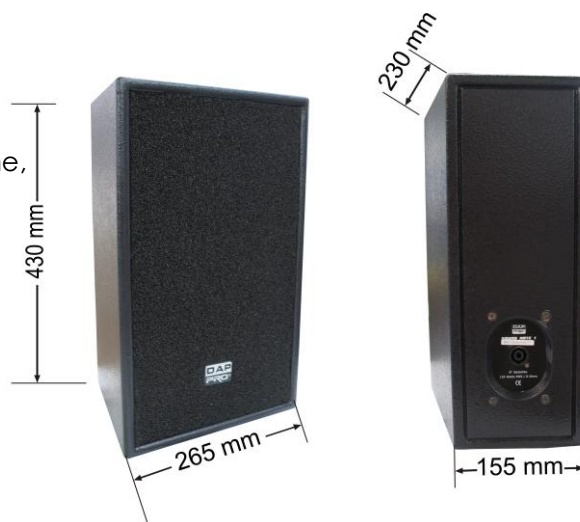
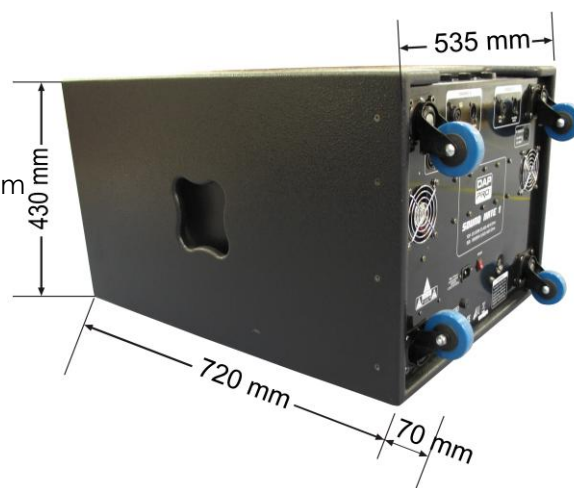

Included

2 Speakon cables
3 rain / dustcovers



Design and product specifications are subject to change without prior notice.



Website: www.Dap-audio.info
Email: service@highlite.nl



© 2008 DapAudio.