

Principles of Cathode-ray Tubes, Phosphors, and High-speed Oscillography

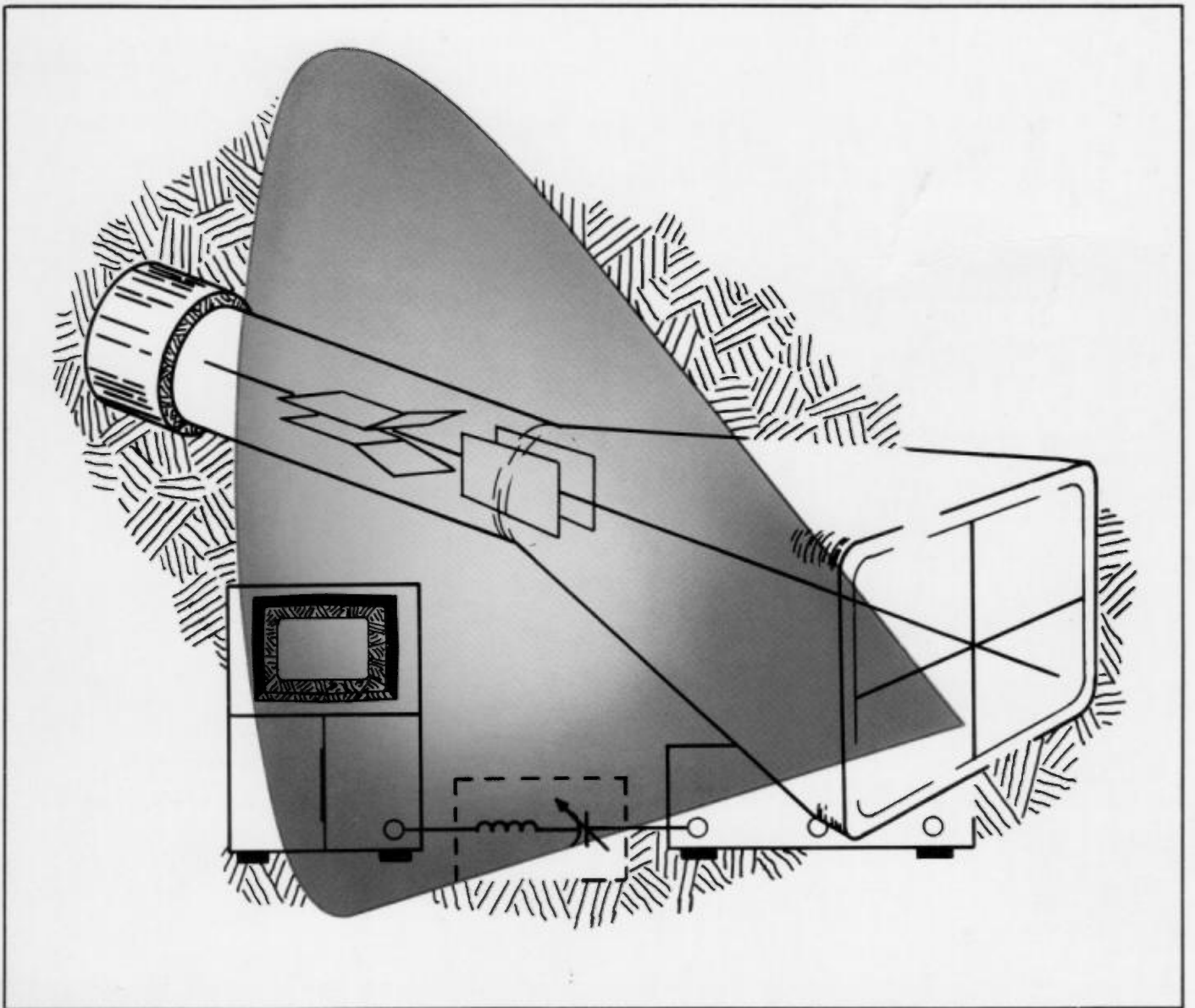

APPLICATION NOTE 115

Principles of Cathode-ray Tubes, Phosphors, and High-speed Oscillography

by
ROBERT A. BELL

HEWLETT  PACKARD
OSCILLOSCOPE SYSTEMS

W106

SECTION I INTRODUCTION

For some thirty years, the cathode-ray tube (CRT) has been the heart of oscilloscope, radar, television, and, more recently, computer displays. The cathode-ray tube has proven to be a reliable, easily understood, method for interpreting analog information even in this semiconductor age.

Recent innovations in oscilloscope CRT design have eliminated parallax error, increased the burn resistance

of phosphors, produced brighter traces, widened the selection of persistence and color, and even introduced new CRTs with persistence that can be adjusted to meet varying applications.

This application note is intended to help you select the proper phosphor for your application, explain cathode-ray tube fundamentals, and to assist you in making oscilloscope CRT measurements.

SECTION II CATHODE-RAY TUBE FUNDAMENTALS

ELECTROSTATIC CRT OPERATION

A CRT electron beam can be deflected by either electrostatic or electromagnetic forces. A magnetically deflected CRT has deflection coils attached to the outside of the CRT; whereas, an electrostatic CRT is entirely self-contained. The power needed to deflect electrons increases as the incoming signal frequency increases (since the capacitive reactance decreases with increasing frequency). With magnetic deflection, the size of the coils becomes prohibitive at higher frequencies, thus most oscilloscopes use electrostatic deflection. Although the high frequency performance with magnetic deflection is limited to less than approximately 5 MHz, the resolution and spot size are slightly better

than obtainable with electrostatic deflection.

A basic electrostatic CRT is shown in Figure 2-1. The glass envelope is made of a conical section that is flame sealed to a glass cylinder which encases the electron gun. A carbon paint (aquadag) coats the inside of the funnel and is used to achieve a uniform electrostatic field within the CRT and shield the CRT from external electrostatic fields.

The electron gun generates a beam of focused electrons that strike the phosphor and convert electrical energy to visible light. This gun consists of triode, focus, and deflection sections that are used to shape the electron beam.

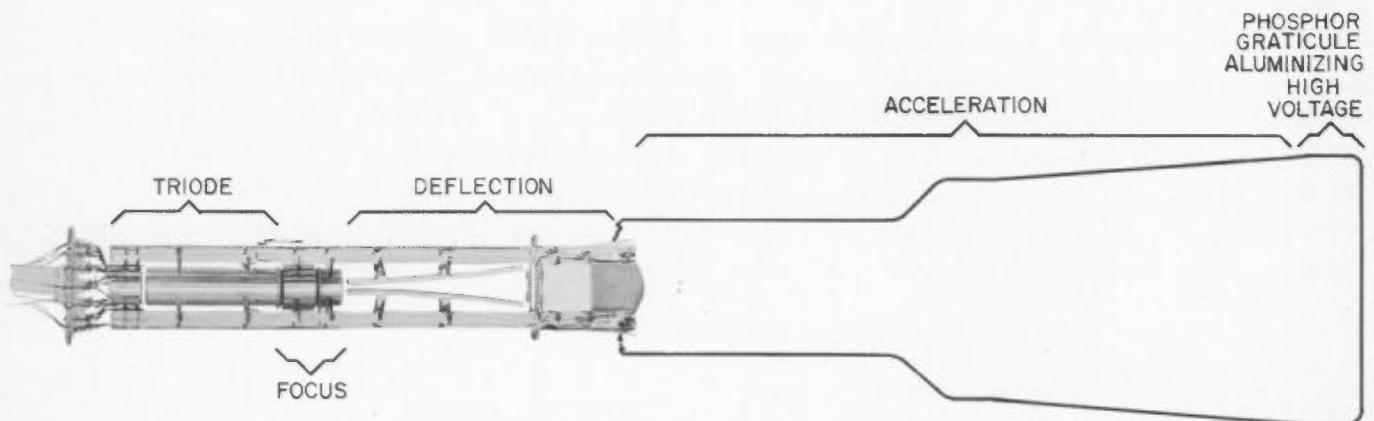

Figure 2-1

TRIODE ELECTRON GUN

The triode section shown in the X-ray (Figure 2-2) has a filament, cathode, grid, and first anode in addition to the various supports and spacers. The cathode

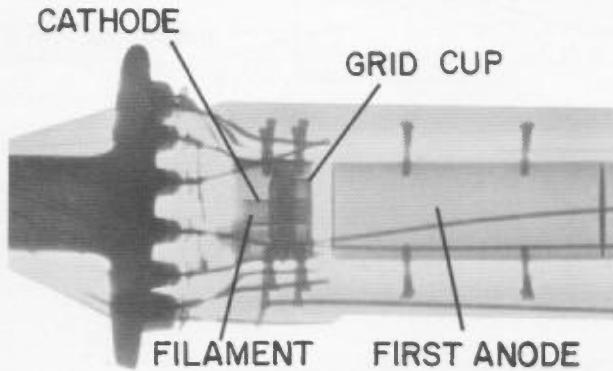

Figure 2-2

is a nickel cap that has oxides of barium and strontium deposited to its surface and is located inside the grid cup. The cathode is usually maintained at several thousand volts negative while the grid cup is held slightly more negative. The grid voltage can be varied with the scope intensity control and the difference in potential between grid and cathode sets the display intensity.

In the absence of a signal to the scope (or when the auto-sweep circuit is inoperative), the grid is biased

below cutoff and no electrons flow from cathode to phosphor. Keeping the grid below cutoff when no signals are present assures optimum life for the cathode. When the horizontal sweep starts, a positive-going pulse, called the unblanking gate, is applied to the grid, raising it above cutoff, which turns on the CRT. The first anode completes the triode section; with the cathode and grid it forms the accelerating scheme of the electron gun. This anode is usually biased between ground and several hundred volts positive.

Electrons leaving the cathode at angles less than 90° to the longitudinal axis of the CRT are shaped into a slightly divergent beam by the electrostatic field between anode, grid, and cathode (see Figure 2-3). Some of these electrons intercept the anode; however, most are bent toward the longitudinal axis and become further accelerated as they pass through the first anode aperture.

FOCUS LENS

The focus lens consists of the first anode, focus ring, and astigmatism aperture (also called the second anode). The purpose of this section is to converge the electron beam so that the minimum spot size is obtained at the phosphor. Both first and second anodes are operated near zero volts while the focus ring is held slightly more positive than the cathode potential (several thousand volts negative). The electron beam is slightly divergent within the first anode; however, the electrostatic field between first anode and focus ring diverges then converges the electron beam. Fields

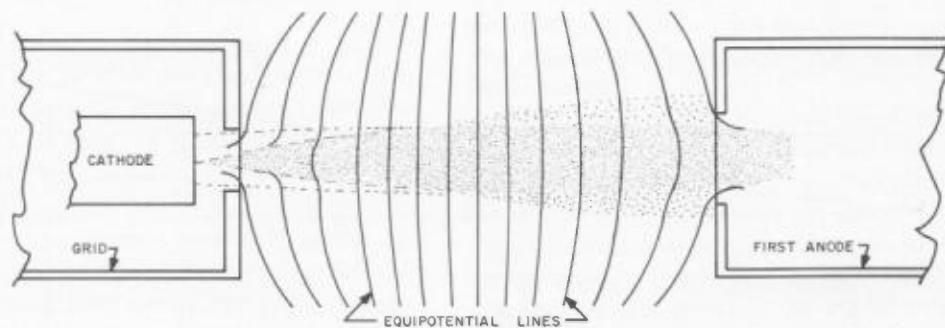

Figure 2-3

In the past, a CRT built with lumped parameter deflection structures had the inductors on the outside of the CRT which resulted in numerous metal to glass seals. Also, complex capacitive and inductive peaking adjustments were required to compensate for variations in the transmission line impedance.

The Hewlett-Packard devised Helical distributed deflection plates (see following photograph) eliminates the external components since the required inductance and capacitance is built-in. Each helix is analogous to a lumped-parameter transmission line. Each helix is a continuous strip of metal, mounted rigidly to glass beading rods in the electron-gun assembly. Once mounted, the helixes need no mechanical adjustment for electrical characteristics and only four feed throughs in the neck glass are needed to connect the vertical amplifier.

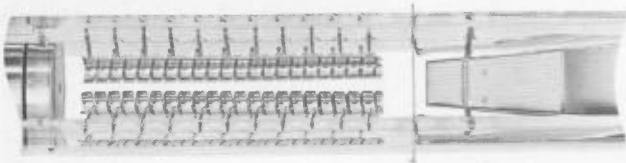

Figure 2-9B

ACCELERATION TECHNIQUES

Mono-Accelerator

Mono-accelerator CRTs (Figure 2-10A) are commonly used in oscilloscopes that have a bandwidth of less than 5 MHz. In this type CRT, electrons are accelerated within the electron gun only. Typically, mono-accelerator CRTs have an accelerating voltage that is under 5 kV. At higher writing rates, the trace brightness decreases significantly and other methods must be used to increase the energy of the electrons striking the phosphor. Two methods commonly used are:

- a. Increased cathode accelerating voltage.
- b. Post deflection acceleration.

Brightness can be improved by increasing the accelerating potential within the gun triode section. This increases the kinetic energy and velocity of the electrons; however, the deflection factor also increases since these electrons pass through the deflection plates with a greater velocity. If the deflection plates are lengthened to maintain the same deflection factor as a CRT with lower accelerating potential, the increased surface

area sharply increases the capacitance between deflection plates and limits the CRT high frequency performance.

Post Deflection Acceleration

Post deflection acceleration (PDA) CRTs (Figure 2-10B) provide the required brightness while sacrificing only minimal deflection factor. Bright displays are achieved by further accelerating the electron beam after it passes through the deflection plates. Early PDA tubes used a resistive helix wound to the inside of the envelope with a large positive voltage on the helix. Unfortunately, the accelerating field tends to bend the beam toward the longitudinal axis, thus demagnifying the display area, or in effect, increasing the deflection factor. To obtain a display equal in size to the mono-accelerator tube, the helix PDA tube must be made longer.

A spherical mesh inserted into the helix tube straightens the accelerating field and the compression present in the helix PDA tube is avoided. This tube (Figure 2-10C) is called a radial-field mesh CRT and its deflection factor and display size equals that of a mono-accelerator tube of the same length.

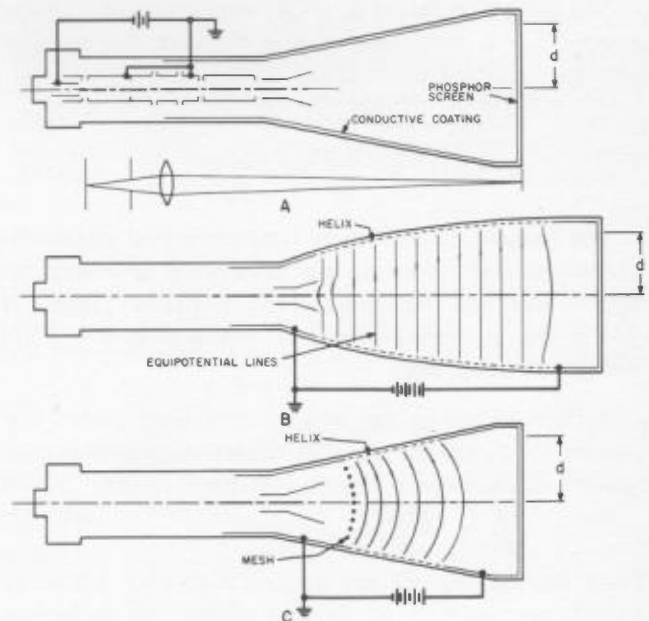

Figure 2-10

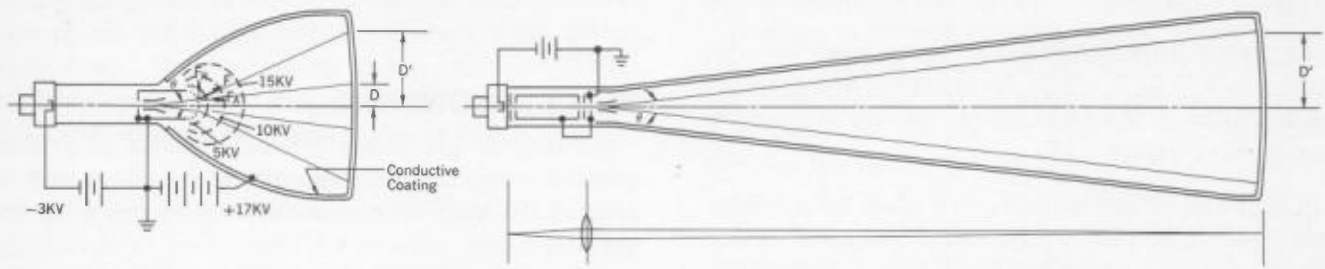

Figure 2-11

Oscilloscopes have become considerably smaller in the last few years with the advent of transistorized circuits; meanwhile, consumer needs for scopes with much greater bandwidths have skyrocketed. If older design techniques are used to fulfill these trends, the CRT display size must be decreased. Fortunately, significant advances in CRT design have also occurred which retains the large display without sacrificing spot size or deflection factor. Leading these advancements is the Hewlett-Packard designed, high-contoured expansion mesh.

As an example of the space savings that are made possible by an expansion mesh, consider a mono-accelerator CRT having an 8 inch by 10 inch display and deflection factor of 13.5 volts/inch. The required tube length for this display, without such a mesh, would normally be 42 inches.

By adding the high-contoured expansion mesh operating at gun potential and a separated conductive coating on the bulb wall (at higher potential), a strong field is formed between mesh and bulb wall with large radial as well as axial components. The beam is acted upon by forces in both axial, F_A , and radial, F_R , direc-

tions (Figure 2-11) resulting in acceleration and expansion of the beam. Field shape is critical and is controlled by the contour of the mesh in combination with the boundary shape of the bulb wall. Vertical expansion of the display is 3.3 and horizontal expansion is 2.7 (area expansion is 9.0). This results in shortening of the actual tube length from 42 inches to 17¼ inches. The tube is then relatively short in actual physical length, but appears long to the deflection plates.

GRATICULES

External Graticule

Until recently, most oscilloscope CRTs used a plastic scale (graticule) that attached over the front of the CRT face. This scale scratched easily and caused severe glare and considerable parallax error. Parallax error results when the scale and phosphor are not in the same plane as shown in Figure 2-12.

Any difference in the indices of refraction between glass and plastic scale also contributed to the parallax error.

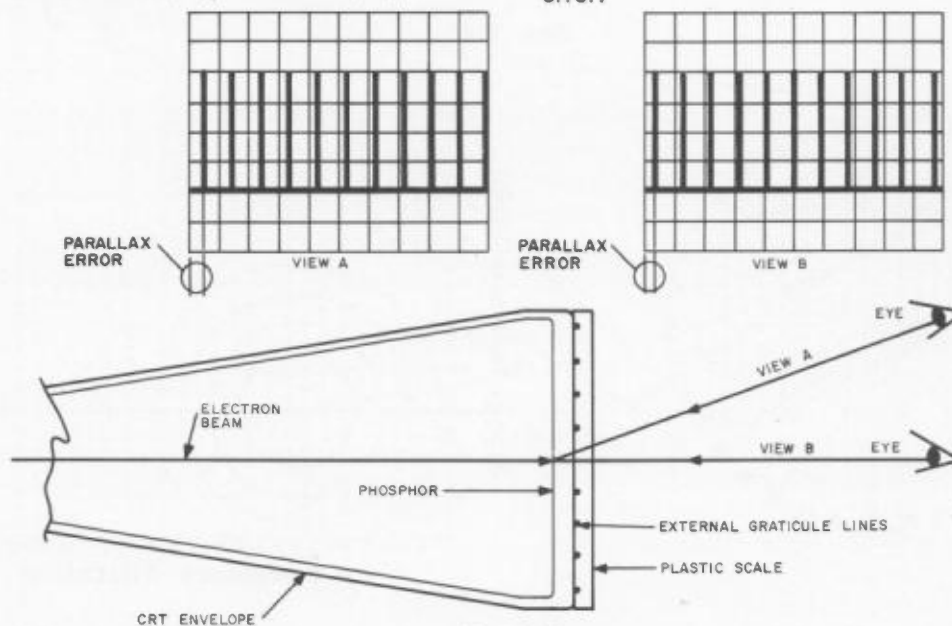

Figure 2-12

Internal Graticule

All standard Hewlett-Packard oscilloscopes have internal graticule CRTs where the phosphor and graticule are deposited in the same plane; thereby eliminating parallax error (Figure 2-13).

In addition, a special non-glare glass safety faceplate replaces the plastic scale and protects the viewer from any implosion hazard. Since both the phosphor and graticule are in the same plane, any refraction through the CRT glass and safety faceplate will not cause parallax error.

A wide selection of non-standard internal graticules is also available from Hewlett-Packard on special request. In addition, you can specify the configuration that solves your measurement requirement by submitting a rough sketch to your Hewlett-Packard field engineer. Two samples of special graticules are shown in

Figure 2-14.

TRACE ALIGNMENT

An internal graticule eliminates parallax error and gives the accuracy intended, providing the X and Y axes of the electron gun correspond to those of the scale.

This registration is easy for circular, external graticule CRTs since the tube can be physically rotated until the axes of the electron gun correspond to those on the scale. However, for round and rectangular internal graticule CRTs this method is not possible since both scale and electron gun are within a sealed glass envelope.

Typical production alignment error between the electron gun and scale axes can be up to 5° which is almost $\frac{1}{2}$ cm displacement at the sides (Figure 2-15).

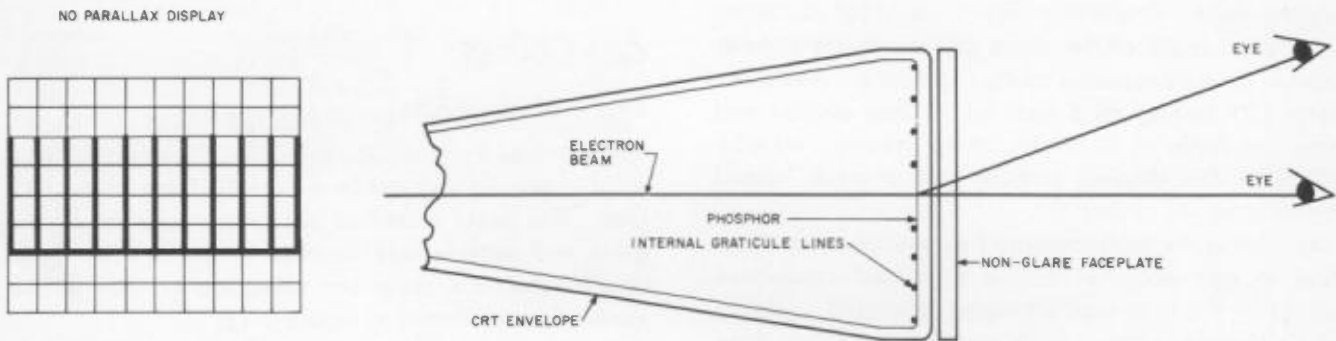

Figure 2-13

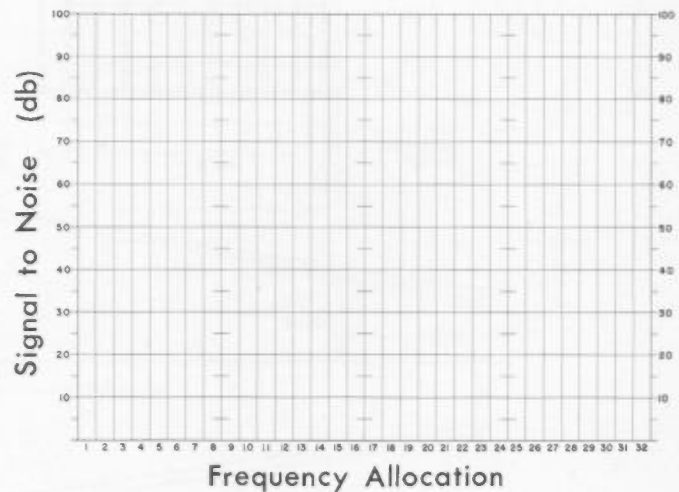
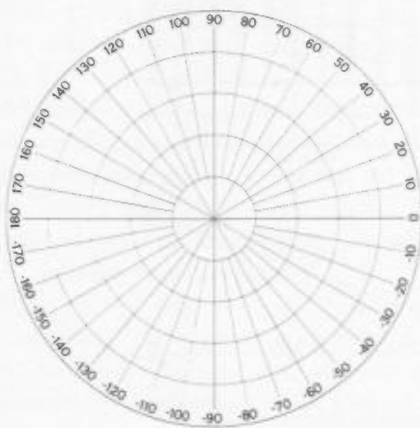

Figure 2-14

This misalignment is easily corrected by placing a wire-wound coil around the CRT just forward of the deflection plates. Current flowing in this coil produces an electro-magnetic force that rotates the beam into coincidence with the horizontal graticule axis.

Electrons passing through point A have velocity components in the X-Y-Z directions. The vertical force component of the coil acts in a direction opposite to the electron's vertical velocity component and the resultant moment arm restores the electron beam. Current through the coil is adjusted by a variable resistor (Trace

Align) usually located on the oscilloscope front panel.

Another alignment problem related to electrostatic CRTs is a possible lack of perpendicularity between the horizontal and vertical deflection plates caused during construction of the electron gun. By placing another coil over the vertical deflection plates, the orthogonality between X and Y axes can be obtained.

To better see how the coil works, consider point A (Figure 2-16) on the uncorrected beam from the electron gun. The force acting on point A, produced by current in the coil, is tangent to the circle passing through this point and has both vertical and horizontal components.

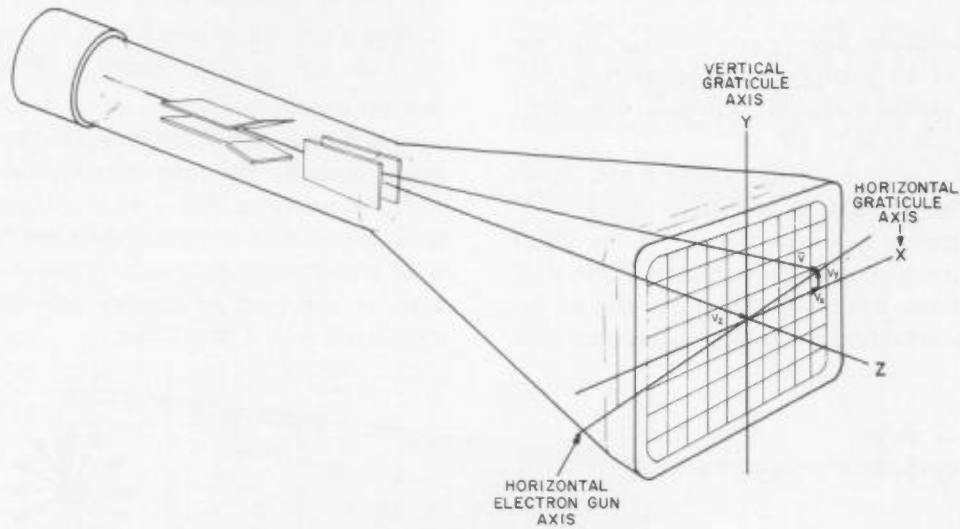

Figure 2-15

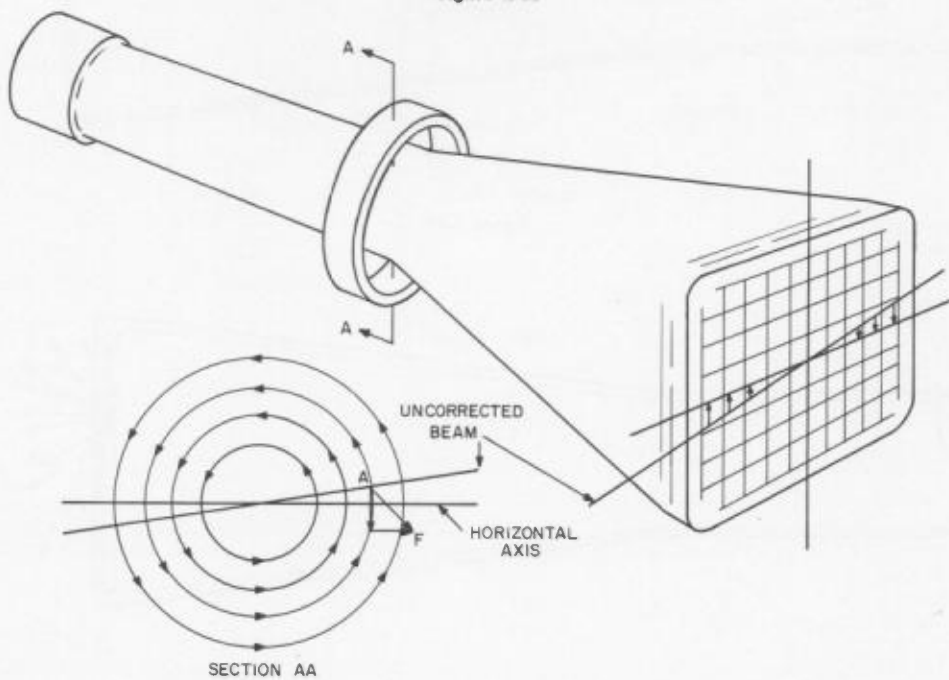

Figure 2-16

ALUMINIZING

Many oscilloscope applications require use where the ambient light is as bright as the viewed trace. For measurement ease, applications of this type require a CRT having a very bright trace to insure adequate contrast.

The lack of brightness in some CRTs can be explained with the help of the drawing shown in Figure 2-17.

When electrons strike the phosphor, light is radiated in **every** direction and the visible trace contains only a small portion of the total light energy emitted.

By evaporating a thin layer of aluminum over the rear surface of the phosphor, some of the scattered light can be reflected toward the front of the CRT, thus increasing the trace brightness, as illustrated in Figure 2-18.

Aluminizing produces significant increases in the trace brightness of all phosphors at accelerating voltages of 5kV and above. It typically increases the intensity of P31 about 2 fold at 10 kV.

In CRTs with acceleration voltages under 5 kV, aluminizing causes little net increase in trace brightness because the beam energy loss which occurs as the beam penetrates the aluminum is a significant part of the total kinetic energy of the beam. As the beam energy increases (higher accelerating potential), the energy loss

decreases in significance. For this reason, all standard Hewlett-Packard CRTs with post deflection acceleration are aluminized.

The thin aluminum layer also helps to dissipate the thermal energy that results when electrons strike the phosphor. This protects the less burn resistant phosphors from permanent damage.

LIGHT FILTERS

Plastic Filters

Until the internal graticule CRT was introduced, most oscilloscopes included a colored filter with the standard accessories. These filters give the trace and background a green appearance which is pleasing to the eye. Also, the contrast between trace and background can be improved since the ambient light is filtered twice while the trace light is only filtered once giving the wanted contrast improvement.

In addition, filters are used to separate the colors that a phosphor may produce. For example, P7 has an initial fluorescence that is blue and a phosphorescence (after glow) that is yellowish-green. The short persistence blue component can be eliminated with an amber filter, or the long persistence yellowish-green can be attenuated with a blue filter.

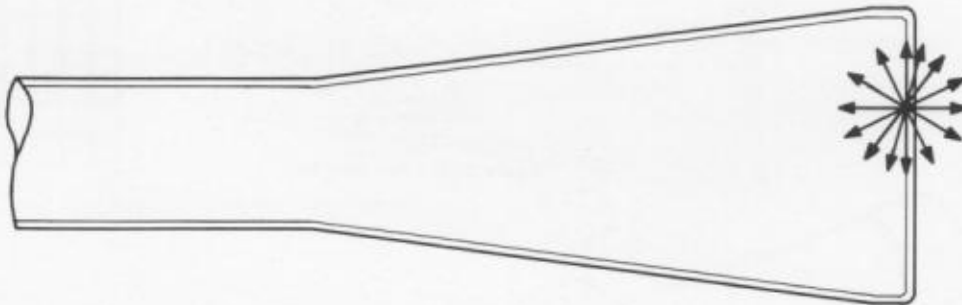

Figure 2-17

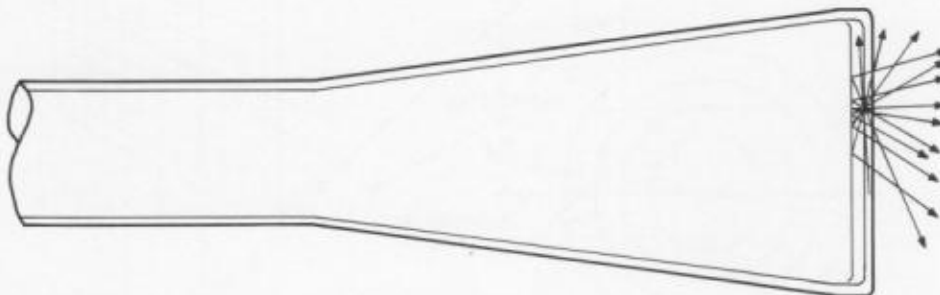

Figure 2-18

Wire and Plastic Screen Filters

Mesh filters are also used for general trace-to-background contrast improvement and are made from metal or plastic screen that is usually painted a non-reflecting black. Light transmission for the colored filters can vary from about 25% to 90% depending on the color, while the transmission through the mesh filters ranges from 30% to 50%.

Cathode-ray tubes should be aluminized if the anticipated use includes photographic time exposures. Light is radiated from the CRT filament and will fog the film unless the phosphor is aluminized. If an existing non-aluminized CRT is to be used, then a blue filter is needed to attenuate the predominantly red light emitted by the CRT filament.

Polarizing Filters

Circular polarizing filters offer the greatest trace to background contrast. Good contrast is achieved by preventing reflection of the ambient light from the CRT screen.

Unpolarized ambient light (Figure 2-19) is vertically

polarized by the polarizer layer. The $\frac{1}{4}$ wavelength retardation plate is a double refracting medium having ordinary (slow) and extraordinary (fast) axes that are at 45° to the vertically polarized light. Vertically polarized light passing through the $\frac{1}{4}$ wavelength layer is split into two mutually perpendicular components along the slow and fast axes.

The wavelength of the extraordinary component increases while passing through the $\frac{1}{4}$ wavelength retarder, resulting in a 90° phase shift between the ordinary and extraordinary waves. The resultant magnitude of the ordinary and extraordinary components remains constant at all points but rotates around the direction of propagation. Upon reflecting from the CRT face, the circularly-polarized light again enters the $\frac{1}{4}$ wavelength retarder where the extraordinary wave is shifted an additional 90° from the ordinary wave. The resultant reflected light is linearly polarized in a plane 90° from the original. Since the polarizing plane is vertical, the reflected light is cancelled. Contrast improvements vary from 5-30:1.

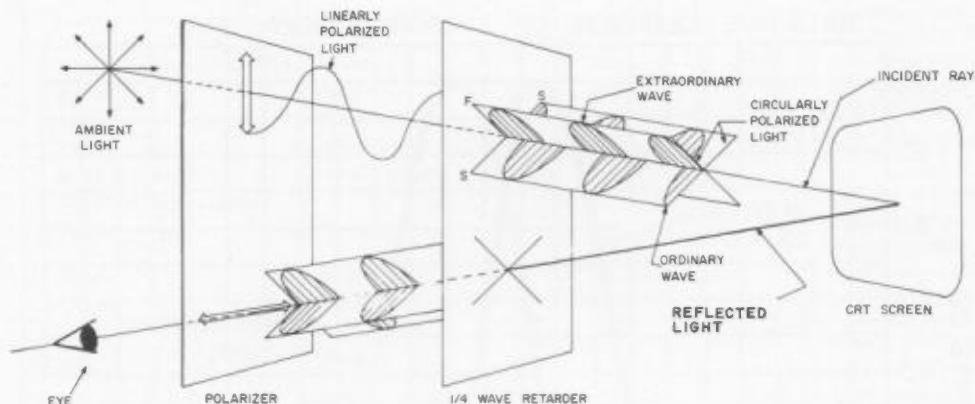

Figure 2-19

SECTION III PHOSPHOR SELECTION

RESPONSE OF THE EYE

The many applications of phosphors depend greatly on the characteristics of the human eye.

The normal, light-adapted (photopic) eye responds best to green light having a wavelength of 555 nanometers. The dark-adapted eye's response (scotopic) is shifted slightly toward the blue and has a peak response at 510 nanometers. A chart depicting the complete response of the eye is shown in Figure 3-1.

Another phenomenon of the eye is its tendency to fuse a string of flashes occurring at rates of approximately 10-40 flashes/sec or greater into a single time-invariant source.

Remembering these properties of the eye will help considerably when selecting a phosphor for a specific

application.

PHOSPHORS

Phosphors are, by definition, materials that luminesce after electron bombardment. The luminescence consists of an initial light emission during electron excitation (fluorescence) and a continued emission after excitation is removed (phosphorescence). The apparent color of the initial and afterglow traces is often confusing since there is a noticeable variation among phosphor manufacturers and also the over-all color appearance is rather subjective. Phosphors registered with the Joint Electron Device Engineering Council (JEDEC) have a complete spectral output curve showing relative radiant energy of phosphors throughout the visible spectrum.

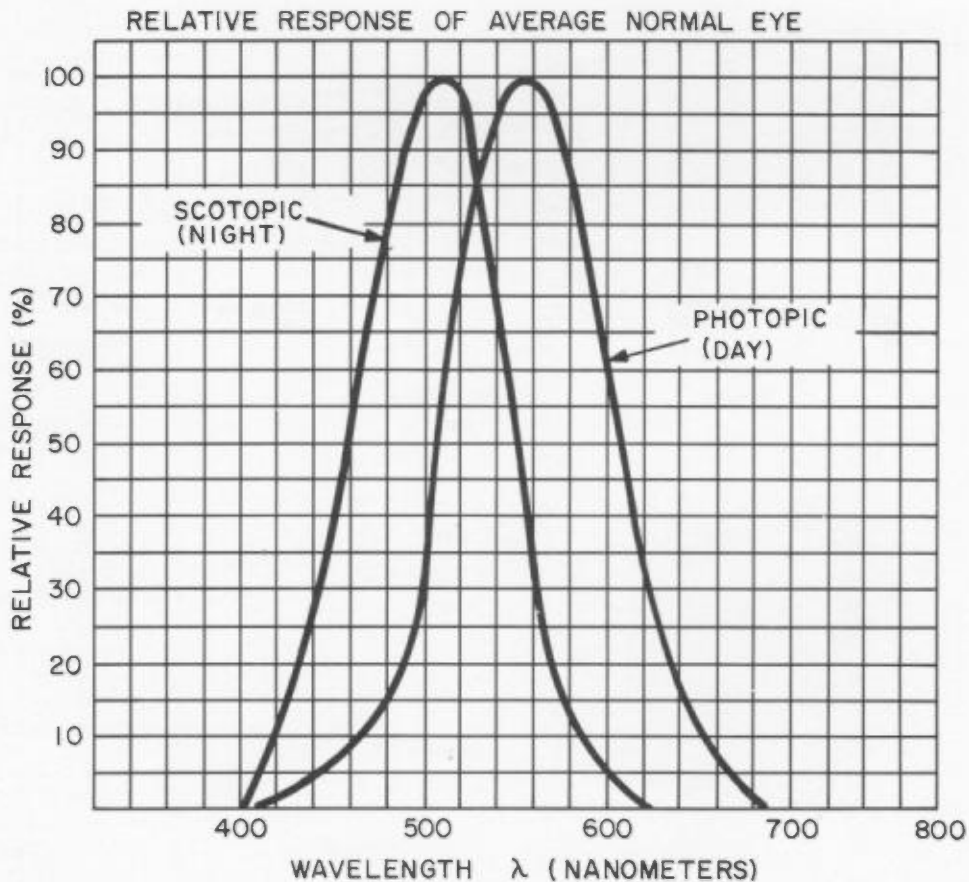

Figure 3-1

Registered phosphors also have curves showing the decay characteristics — often called persistence. Although persistence generally refers to the decay characteristics of a phosphor, the 10% level is about the

minimum discernible brightness in a brightly lighted room. However, the 1% level is easily discernible in a dimly lighted room. A brief summary of characteristics for registered phosphors is shown in Table 3-1.

STANDARD REGISTERED PHOSPHORS

E. I. A. PHOSPHOR	EMISSION COLOR		PERSISTENCE		APPLICATION
	FLUORESCENCE	PHOSPHORESCENCE	10%	1%	
P-1	Yellowish green	Yellowish green	24 ms	48 ms	Used in cathode-ray oscilloscopes and radar.
P-2	Yellowish green	Yellowish green	~ 75 μ s		Used in cathode-ray oscilloscopes.
P-3	Yellowish orange	Yellowish orange			
P-4	White	White	60 μ s	470 μ s	Used in monochrome television picture tubes.
P-5	Blue	Blue	26 μ s	52 μ s	Photographic recording.
P-6	White — Obsolete	White			Obsolete — Originally used in television receivers.
P-7	White	Yellowish green	0.3 s	3 s	Used for radar.
P-8	Obsolete	Replaced by P-7			
P-9	Obsolete				
P-10					Outside source of light is used for observation. Persistence from seconds to several months.
P-11	Blue	Blue	80 μ s		Photographic recording.
P-12	Orange	Orange	0.21 s	0.42 s	Used for radar.
P-13	Reddish orange	Reddish orange			
P-14	Purplish blue	Yellowish orange	5 ms	115 ms	Used for military displays where repetition rate is 2 to 4 seconds after excitation is removed.
P-15	Green	Green	2.8 μ s		Television pick-up of photographs by Flying Spot Scanning.
P-16	Bluish purple	Bluish purple	0.12 μ s		Television pick-up of photograph by Flying Spot Scanning.
P-17	Yellow white to blue white	Yellow	0.4 s	10.5 s	Used for military displays.
P-18	White	White	13 ms	37 ms	Low frame rate television.
P-19	Orange	Orange	0.22 s	0.53 s	Radar indicators.
P-20	Yellow green	Yellow green	0.35 ms	1 ms	High visibility displays.
P-21	Reddish orange	Reddish orange			
P-22	Tricolor phosphor screen				Used for color television.
P-23	White	White			Low temperature white — (Sepia) interchangeable with P-4.
P-24	Green	Green	1.5 μ s		Used in Flying Spot Scanner tubes.
P-25	Orange	Orange	45 ms	115 ms	Used for military displays where repetition rate is 10 seconds, to 2 minutes after excitation is removed.
P-26	Orange	Orange	17 s	190 s	Used for radar display.
P-27	Reddish orange	Reddish orange	27 ms	55 ms	Color Television Monitor Service.
P-28	Yellow green	Yellow green	0.6 s	6.8 s	Used for radar display.
P-29	Two color phosphor screen				Used as indicator in aircraft instruments.
P-30	Registration request withdrawn.				
P-31	Green	Green	38 μ s	250 μ s	Used in oscilloscope tubes.
P-32	Purplish blue	Yellowish green	0.7 s	6 s	Used for radar display.
P-33	Orange	Orange	2.2 s	15 s	Used for radar display.
P-34	Bluish green	Yellow green	100 s		Used for oscillography, radar, — visual information storage.
P-35	Green	Green	0.8	5 ms	Used for photographic recording on orthochromatic film and visual observation.
P-36	Yellow Green	Yellow green	250 ns	700 ns	Used for Flying Spot Scanners.
P-37	Blue	Blue	150 ns	400 ns	Used for Flying Spot Scanner and photographic recording.
P-38	Orange		1 s		Low Frame Rate Displays.
P-39	Yellowish green		150 ms		Medium Frame Rate Displays and Radar.
P-40	White		150 μ s	0.5 s	Reduced Flicker Console Displays.

Table 3-1

Following are the complete spectral output and persistence curves (Figures 3-2 through 3-32) for all phosphors registered with JEDEC. These curves represent data from the original phosphor registration and

should be used only as a guide in selecting a particular phosphor. Phosphors used by Hewlett-Packard are procured from several different manufacturers and may vary from the registered data.

PHOSPHOR CHARACTERISTICS SPECTRAL OUTPUT AND PERSISTENCE CHARTS

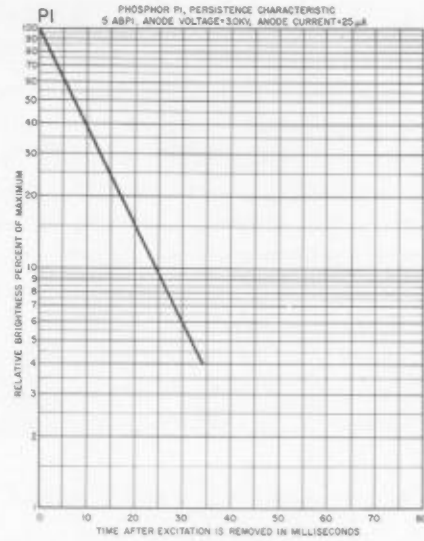
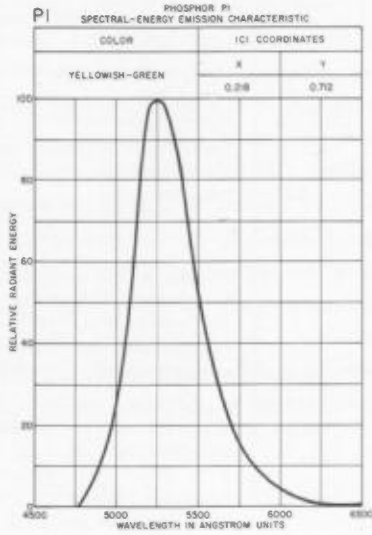

Figure 3-2

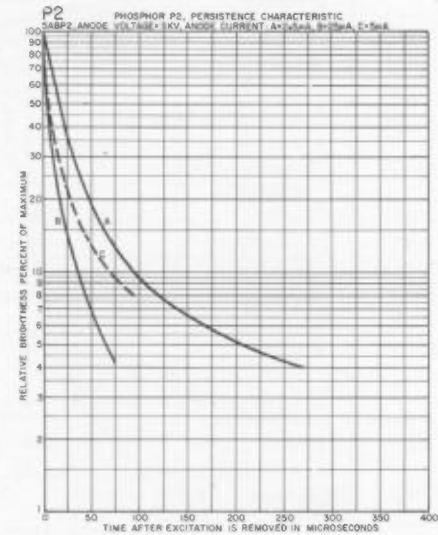
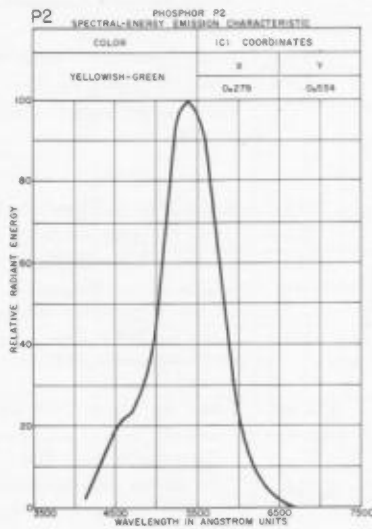

Figure 3-3

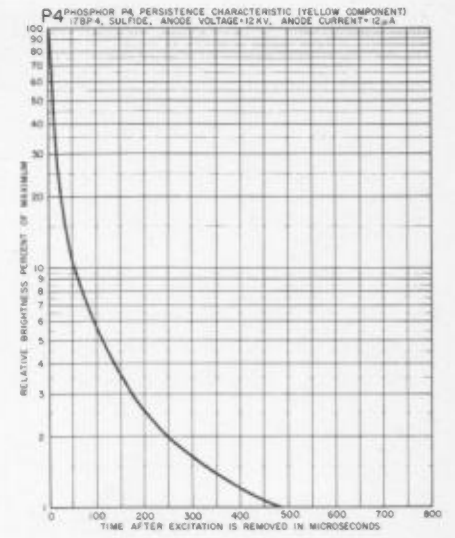
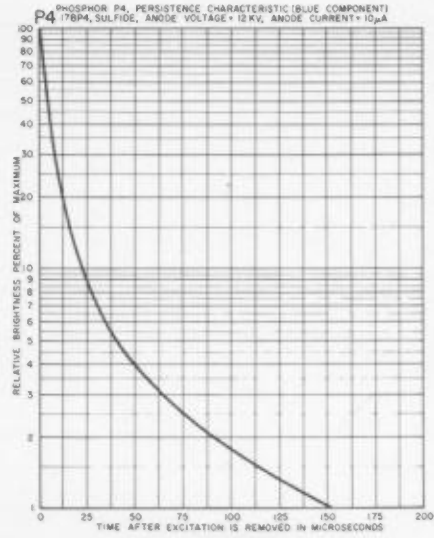
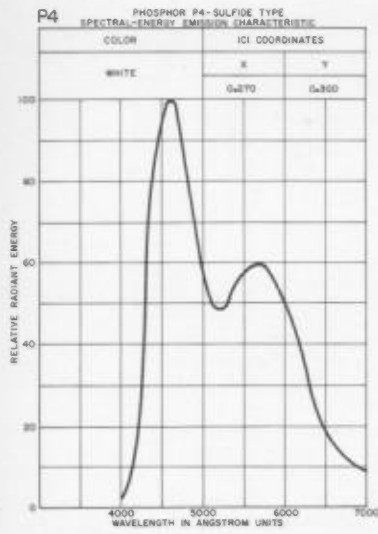

Figure 3-4

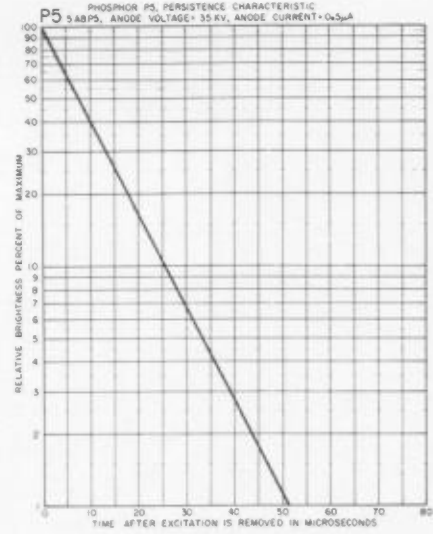
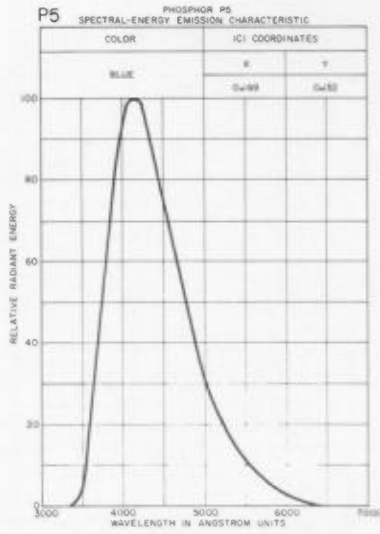

Figure 3-5

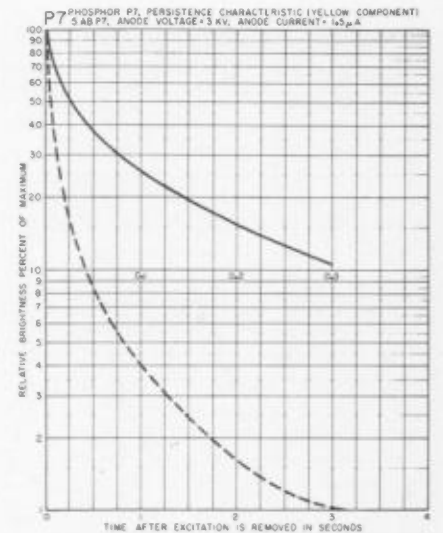
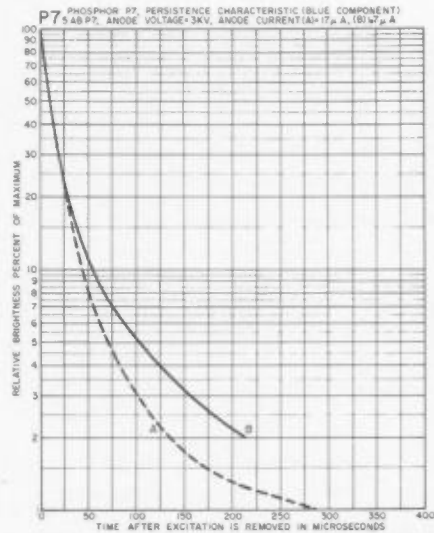
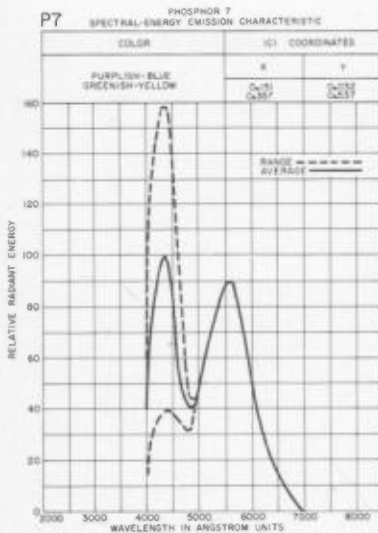

Figure 3-6

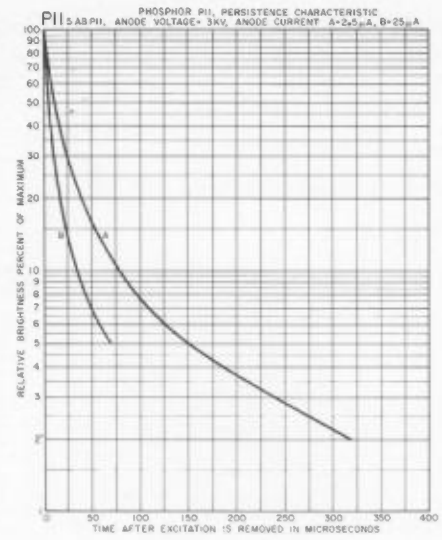
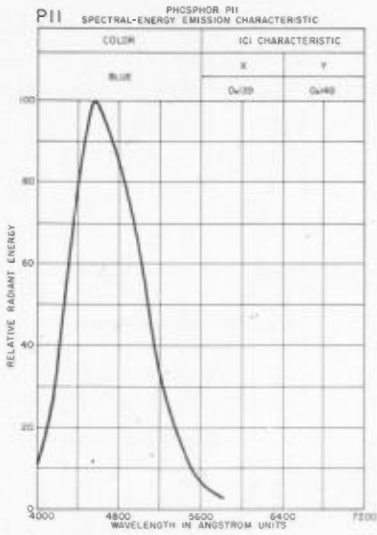

Figure 3-7

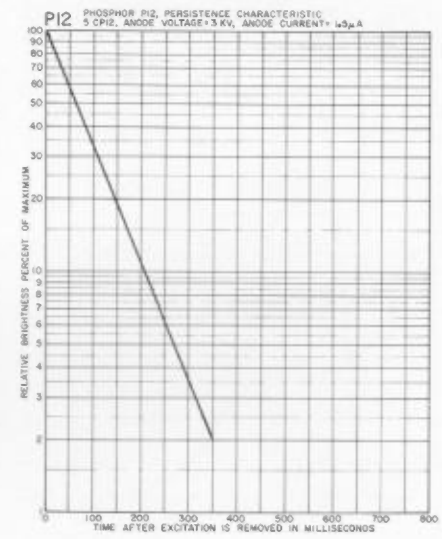
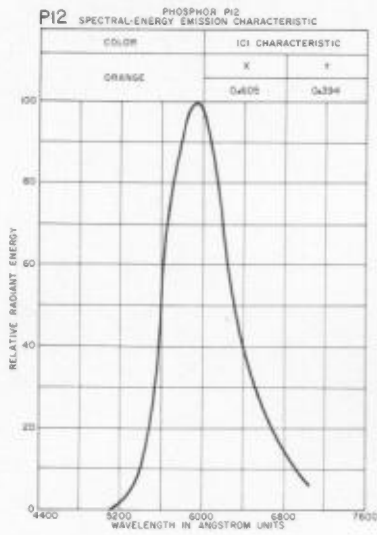

Figure 3-8

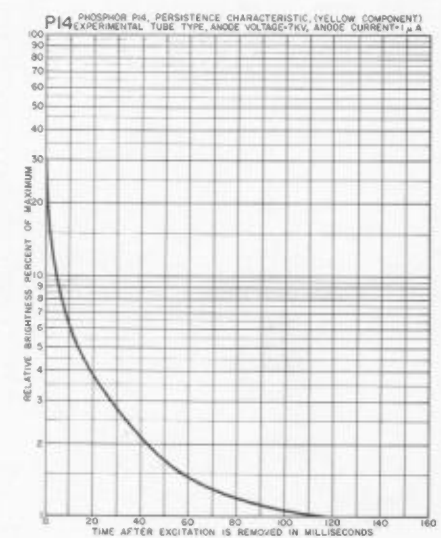
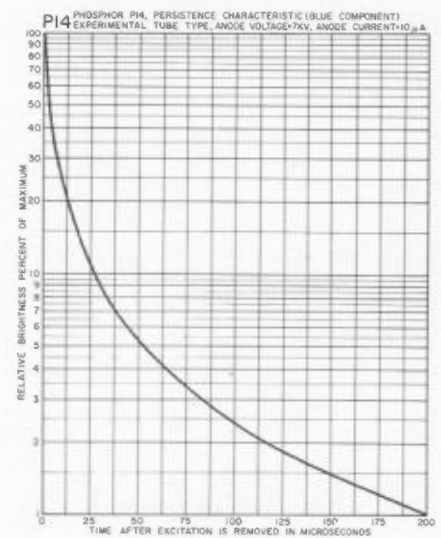
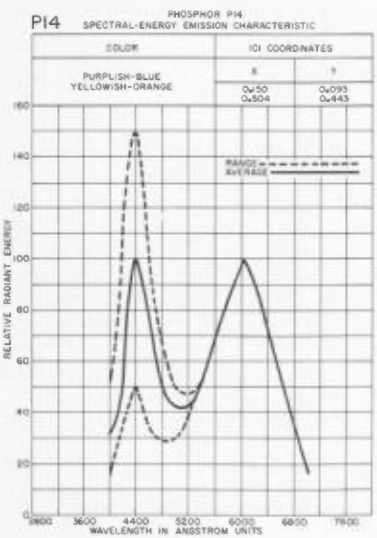

Figure 3-9

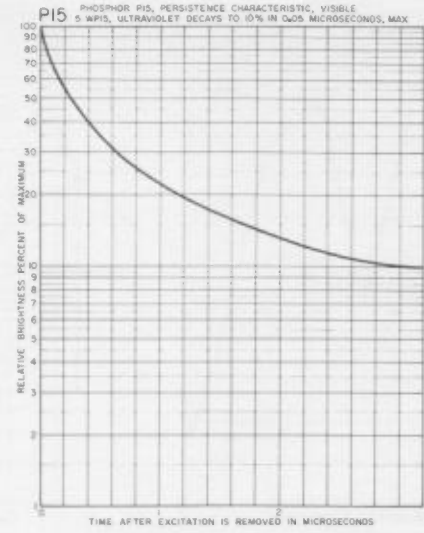
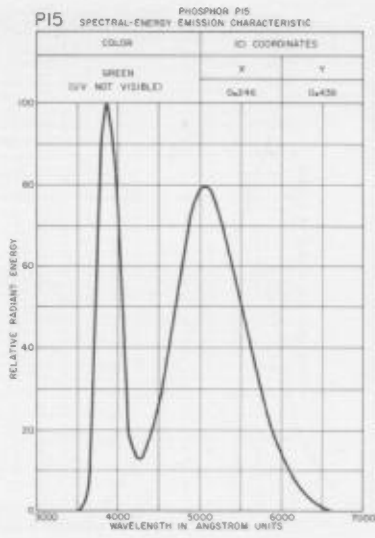

Figure 3-10

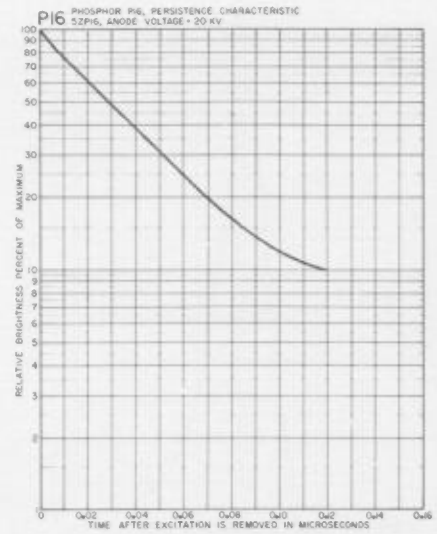
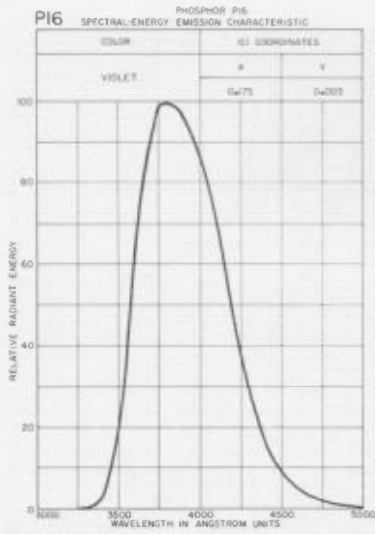

Figure 3-11

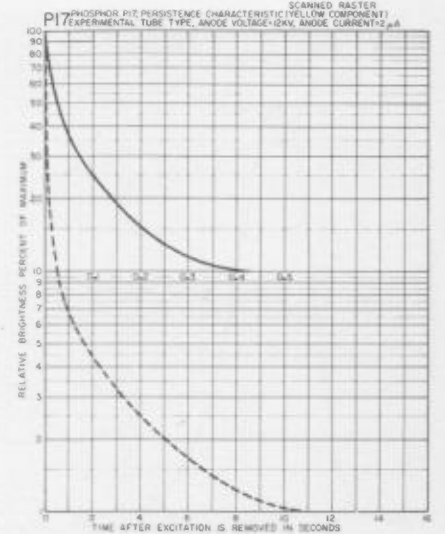
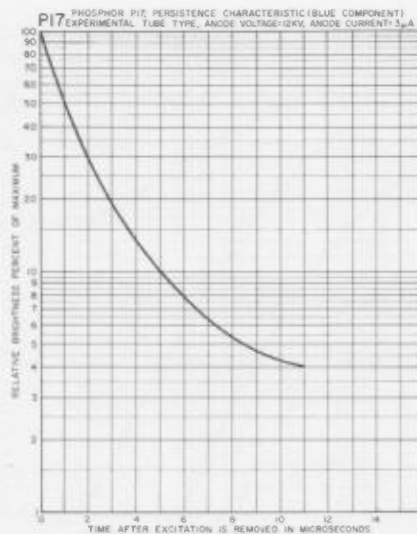
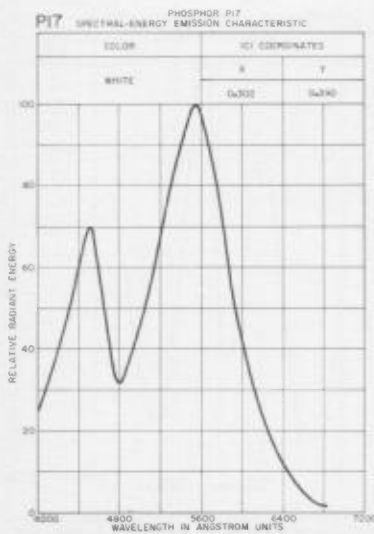

Figure 3-12

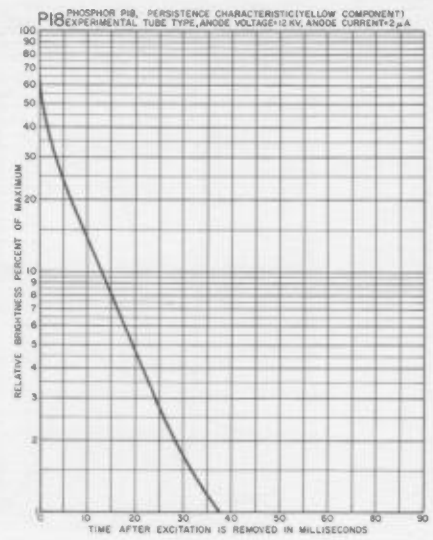
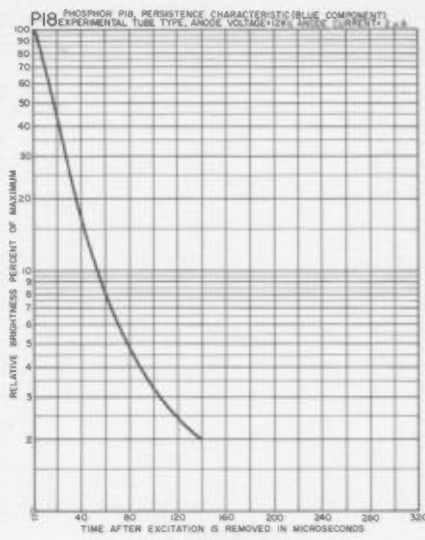
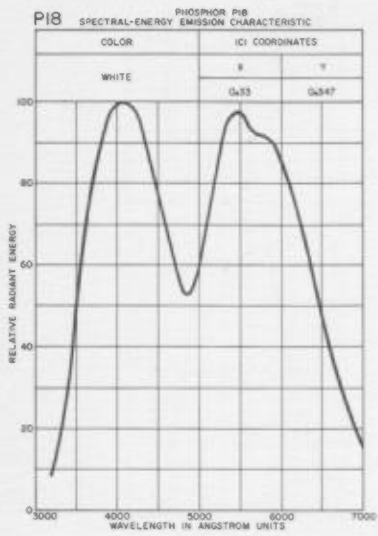

Figure 3-13

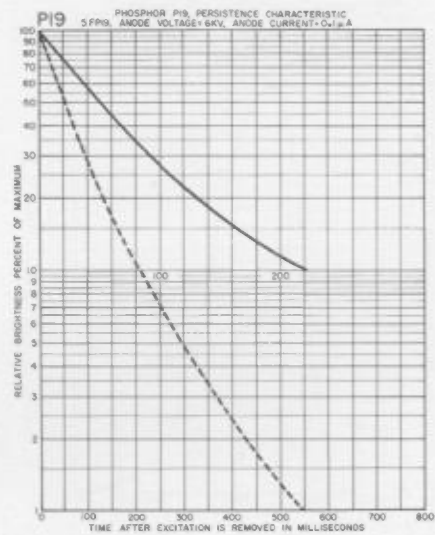
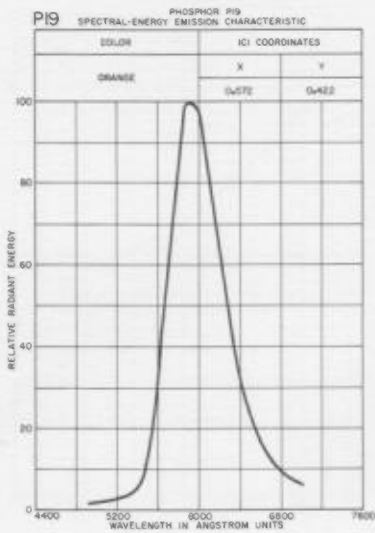
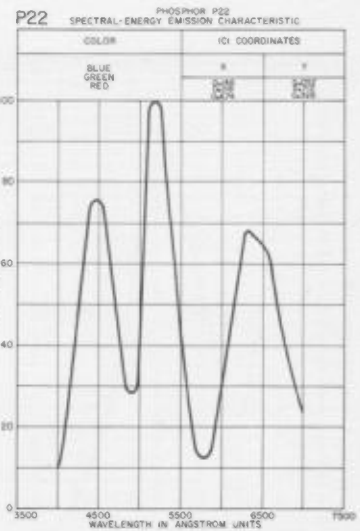
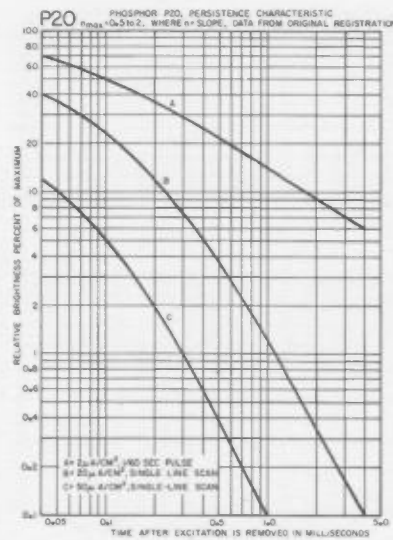
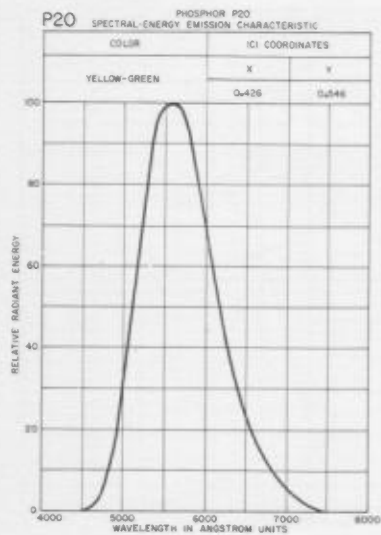

Figure 3-14



P22 IS TRI-COLOR USING 3 DISTINCT PHOSPHORS
BLUE-SIM TO ALL SULFIDE P4, GREEN-P1, RED-P27

Figure 3-15

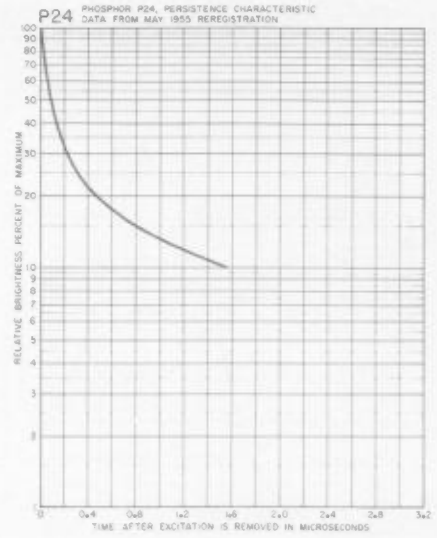
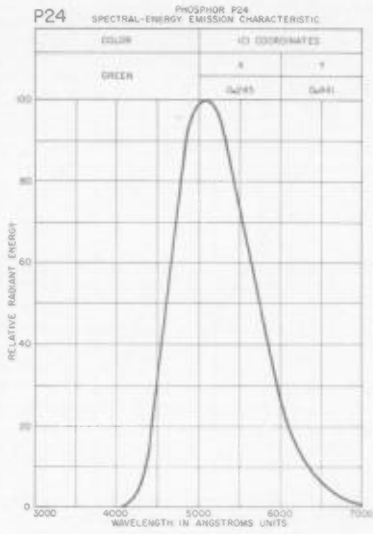

Figure 3-16

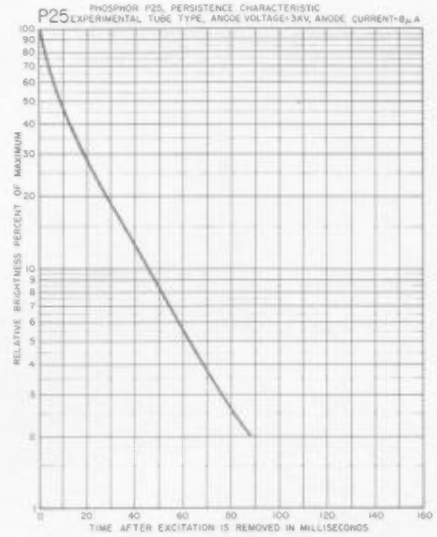
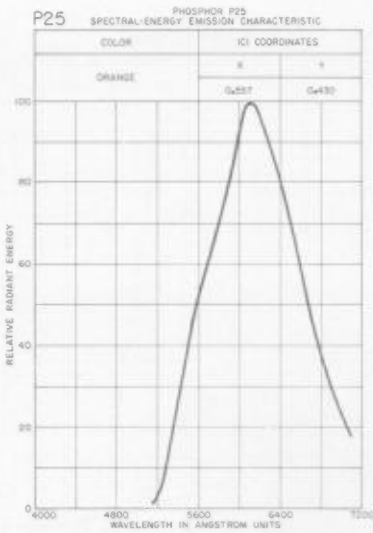

Figure 3-17

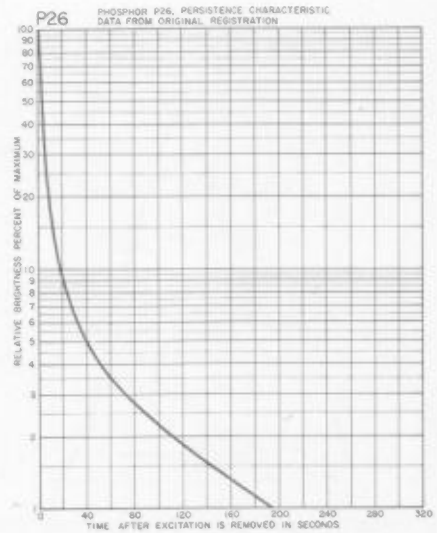
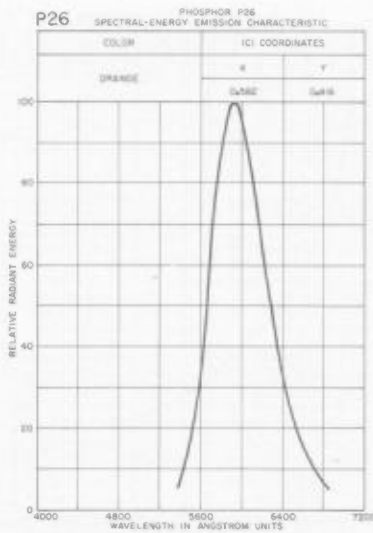

Figure 3-18

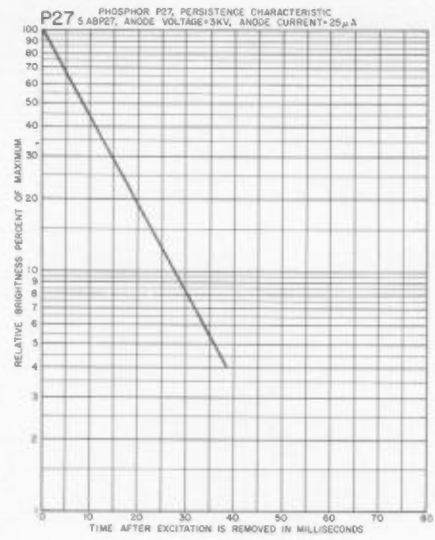
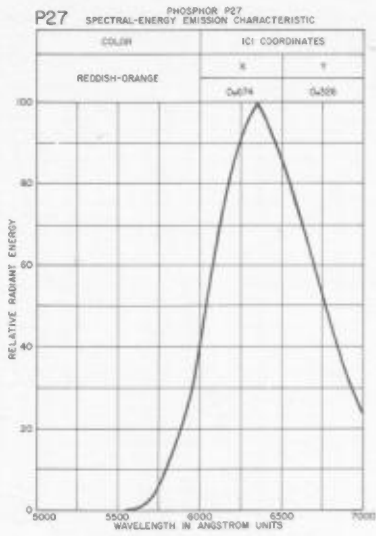

Figure 3-19

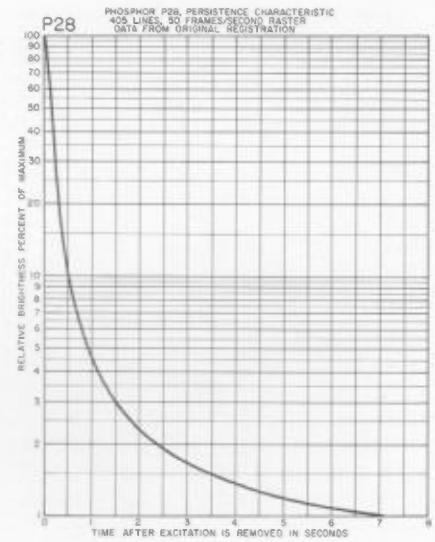
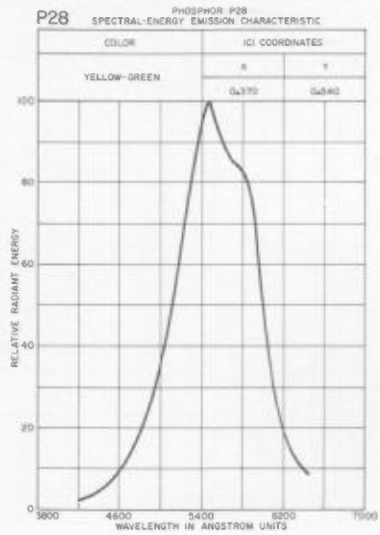

Figure 3-20

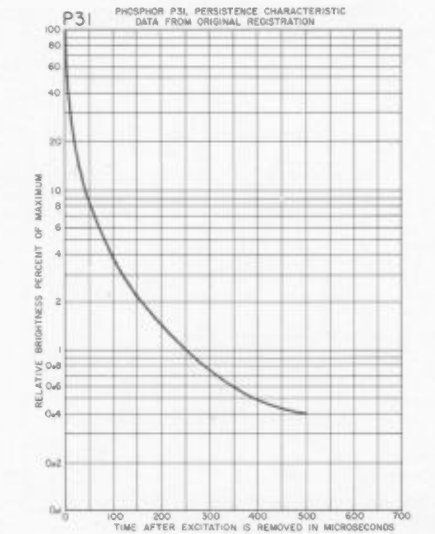
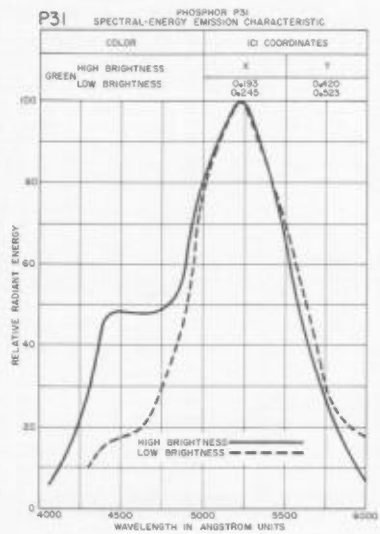

Figure 3-21

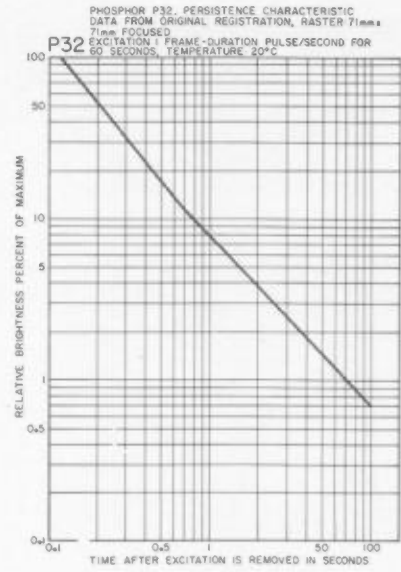
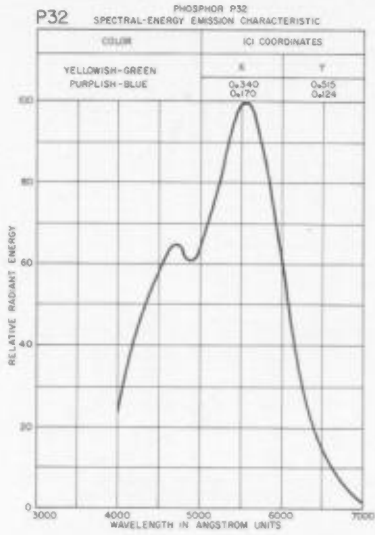

Figure 3-22

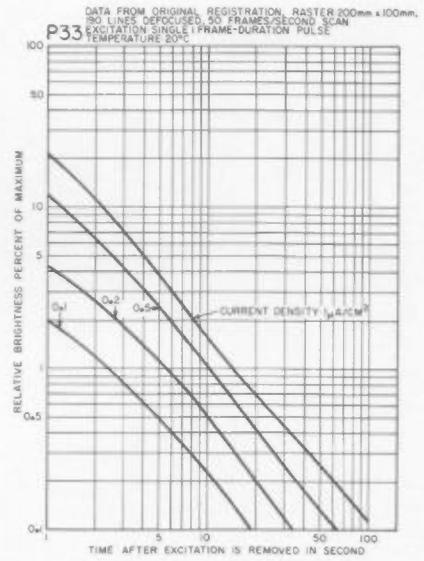
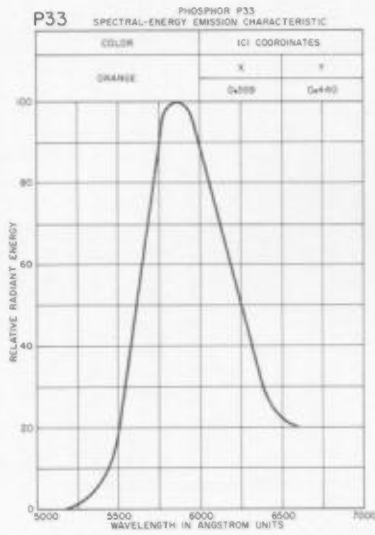

Figure 3-23

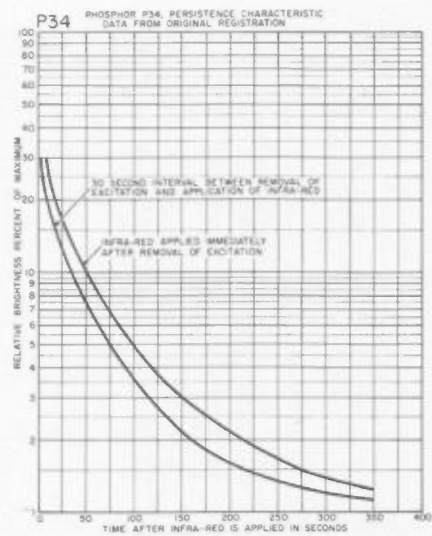
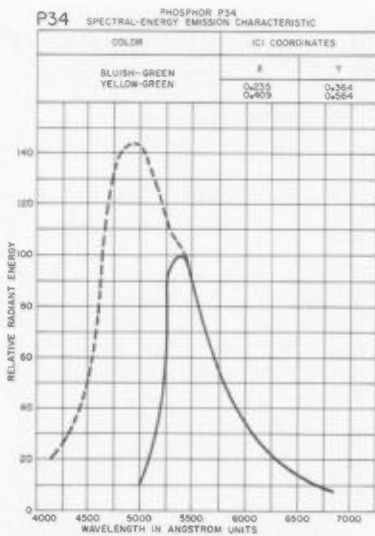

Figure 3-24

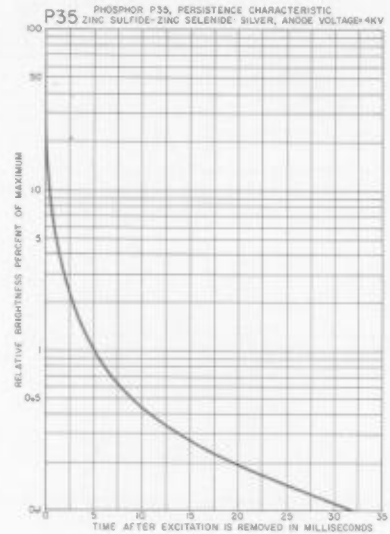
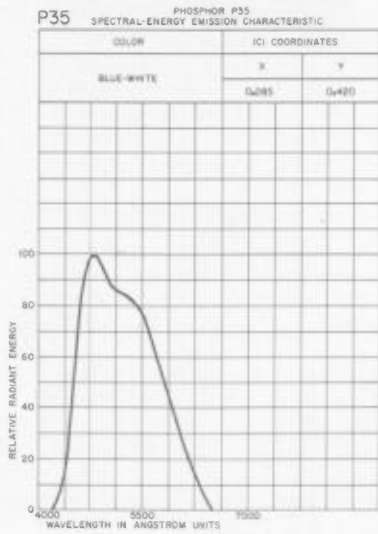

Figure 3-25

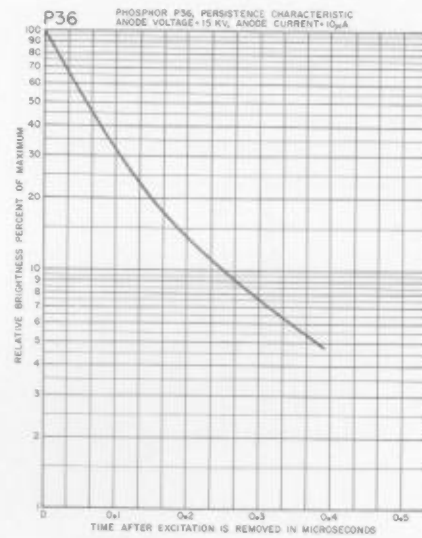
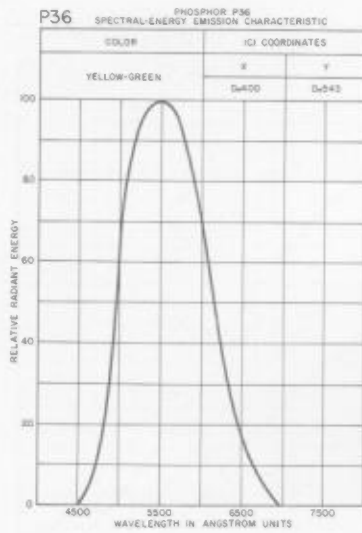

Figure 3-26

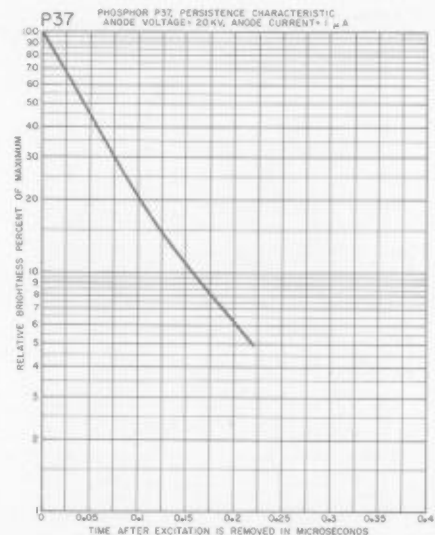
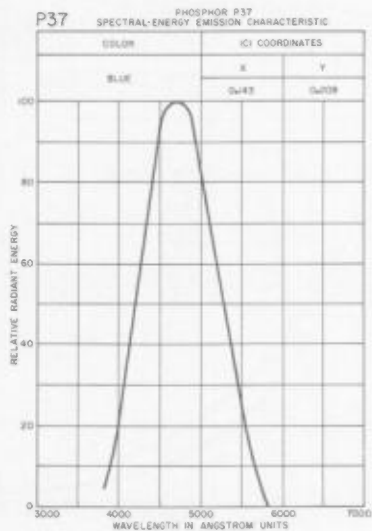

Figure 3-27

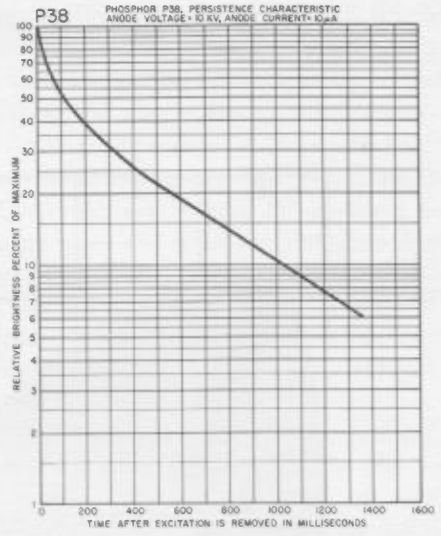
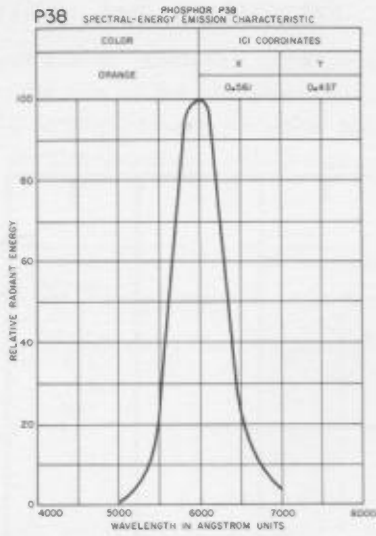

Figure 3-28

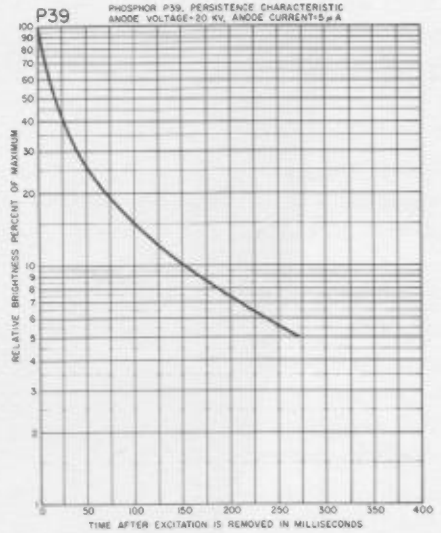
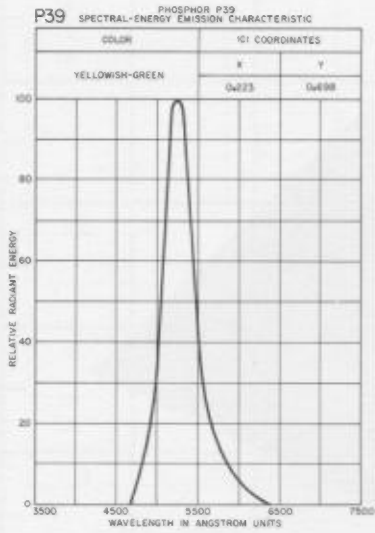

Figure 3-29

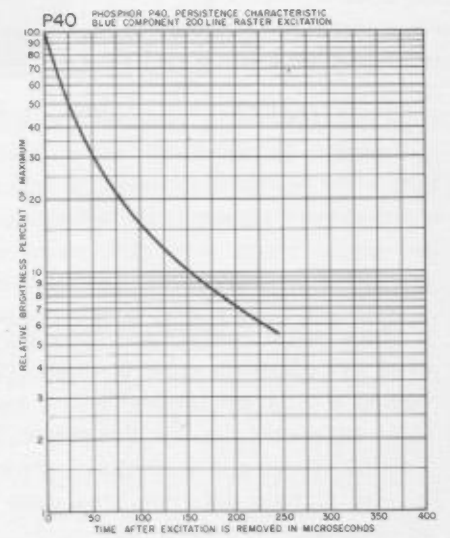
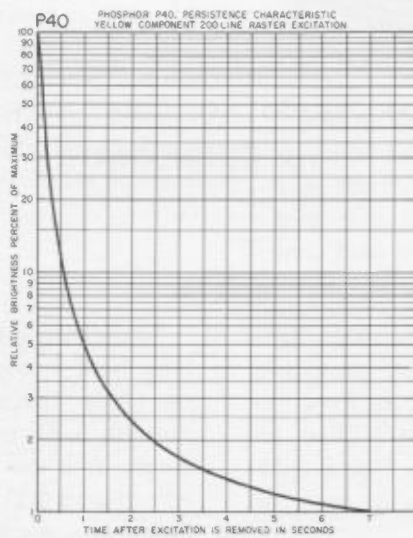
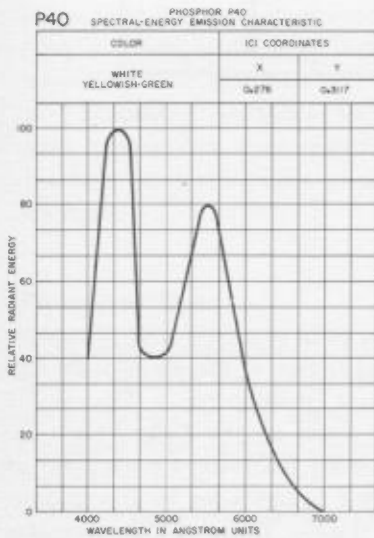

Figure 3-30

CHROMATICITY DIAGRAM

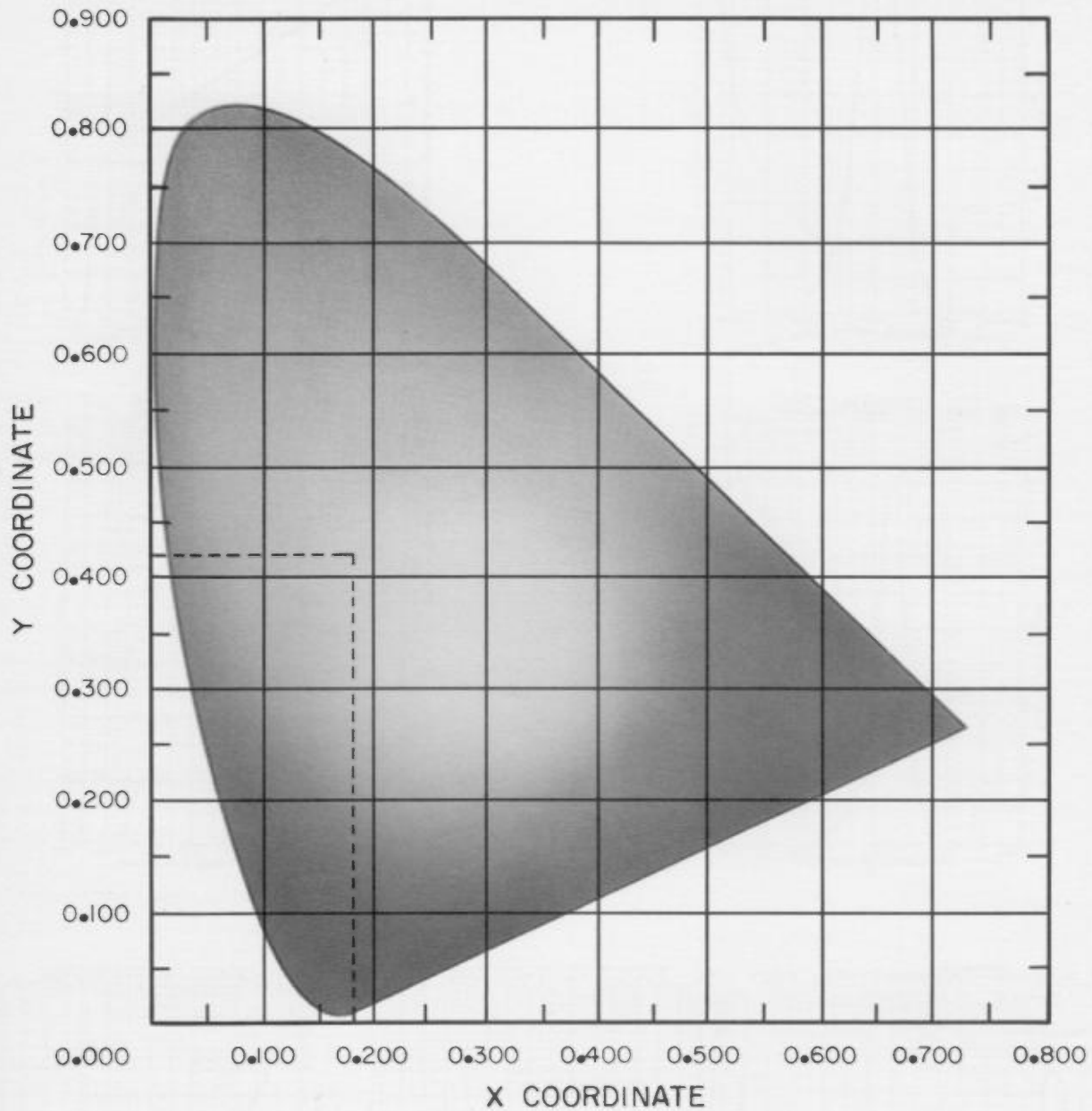

Figure 3-31

The spectral output curve for a given phosphor identifies the complete color content; however, phosphors having a different spectral output curve may have the same apparent color. For this reason the Kelly Chart, or standard chromaticity diagram, shown in Figure 3-31 is used to help determine the trace color as seen by an observer.

To determine the trace color of a particular phosphor, take the X-Y co-ordinates shown in the upper right corner of the Spectral-Energy Emission curve (Figures 3-2 through 3-30) and plot them on the Kelly Chart. Example: find the approximate fluorescent trace color of P31 (Figure 3-21). The X-Y co-ordinates for the fluorescent traces are (0.193, 0.420). These X-Y co-ordinates for P31 fall in the green area of the chart.

RESOLUTION AND BRIGHTNESS

The spot size or resolution obtainable in a CRT depends on the size of the phosphor particles. There is a noticeable variation among phosphor manufacturers, so consider the size shown in Table 3-2 as an average size.

Phosphor	Median Particle Size (Microns)	Brightness (Ft. Lamberts)			
		10 kV Anode		16kV Anode	
		.10 $\mu\text{A}/\text{cm}^2$.50 $\mu\text{A}/\text{cm}^2$	1.0 $\mu\text{A}/\text{cm}^2$.2 $\mu\text{A}/\text{cm}^2$
P1 standard	10.5	25	125		
P1 Fine	5.2	23	115		
P4	10.7				135
P5 Standard	11	8	15	15	
P5 Fine	5.2	7	13		
P7 Blue	15				
Yellow	24				
P11 Standard	10.5	12	50	90	
P11 Fine	6.2	10	48	84	
P11 Very Fine	4.0	8	31	54	
P12	18.6				
P14 Blue	15				
Yel-Orn	20				
P15	11				
P16	5				
P17					
P18					
P19	10		37	72	
P20 Standard	11		41	210	
P20 Very Fine	4.0		41	156	
P21					
P22					
P23					
P24	19				
P25	9		19	38	
P26					
P27	13				
P28	17				
P29*					
P31	11.5	44	181	330	

*See text

Table 3-2

A fine or very fine grain size is also available from some phosphor manufacturers, as shown in table 3-2. Also included, is the brightness of a few phosphors at varying power densities. P31 is considerably brighter than most other phosphors and with its other characteristics (persistence, burn resistance, and color output), is the best general-purpose phosphor available for oscilloscopes.

Phosphor Uses

Some phosphors initially emit one color, then emit a second color as they phosphoresce. Most of these use several phosphors that are deposited in separate layers. Cascaded (multi-layer) phosphors include P7, P14, P17, and P32.

P29 is somewhat unusual because it is composed of alternate strips of P2 and P25. CRTs using P29 are gen-

erally used with navigational beacons, IFF radar, elevation indicators, and collision course indicators.

P4 is used for monochromatic television and there are at least three different types in common use. P4 silicate is used for low frame rate TV and is identical to P18. P4 sulfide is 30-50% brighter than P4 silicate; however, it is less burn resistant. A third P4 combines both sulfide and silicate types and results in a brighter, burn-resistant phosphor. P23 is also used in monochromatic TV; however, it has a sepia coloring.

P1 was used as the standard oscilloscope phosphor for many years; but, it has been completely replaced by P31 which has superior characteristics.

P11 has the greatest photographic writing rate of the registered phosphors. Coincidentally, the sensitivity of most photographic films occurs at or near the peak spectral output (blue) of P11. Other phosphors used for capturing high-speed transients include P4, P7, P31.

P15, P16, P24, P36, and P37 have very short persistence, typically under 1 μs and are used in flying spot scanner applications. This technique is used in conjunction with transparencies to provide a televised image of information which was in slide form. It is commonly employed for video mapping (putting background map information on a radar or computer-generated display) in addition to its conventional use in commercial television.

The basic principles employed in a flying spot scanner are shown in Figure 3-32. A standard cathode-ray tube, employing a short persistence phosphor (such as P16 or P24), is used as the light source. This tube is scanned with a spot and the light produced is focused on a film transparency. The amount of light transmitted through the film is an accurate point-by-point representation of the image on the film. This light is picked up by a photomultiplier tube, and the resultant signal output is the scanned representation of the transparency scene. To prevent light from a previously scanned portion of film being imaged on the photomultiplier, the phosphor must have a very fast decay time (short persistence).

Another application involving phosphors having a very fast decay time is the conversion of analog data from the oscilloscope to digital information for a computer. This is accomplished by replacing the horizontal time base of the scope with high speed movie film moving at a predetermined horizontal speed. The analog data from the developed film is then analyzed by an automatic reader and converted to digital information. The very fast decay of the phosphor prevents multiple images from appearing on the film.

P7, P12, P14, P17, P19, P25, P26, P28, P32, P33, P38, and P39 phosphors have the common characteristic of medium long to long persistence. All are used in radar or military displays where the information refresh rate

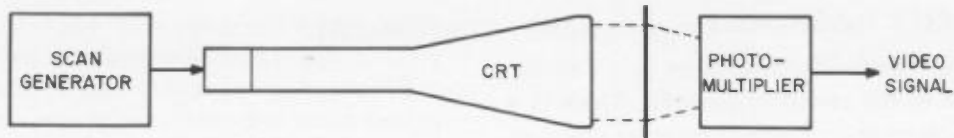

Figure 3-32

is fairly slow. P12, P19, P25, P26, P33, and P38 have orange fluorescence and phosphorescence.

P40 uses the same phosphor components as P7; however, the different phosphors are mixed together and deposited in a single layer. The apparent color is white and the persistence is similar to P7.

BURNING OF PHOSPHORS

Phosphors are doped crystalline elements that luminesce under electron bombardment. Their efficiency (ratio of output light energy to input electron beam energy) is typically less than 10%, so large amounts of heat must be dissipated by the phosphor or it will burn. An area that has been burned usually appears discolored and has a lower light efficiency than the surrounding areas.

Burns are caused by applying excessive power over some area of the phosphor. This power results from the combination of post accelerator potential, high screen current and the dwell time of the electron beam on some very small area. The anode voltage is fixed in most CRTs; however, the beam current and dwell time are controlled by the front panel Intensity, Focus, Astigmatism, and Sweep Time controls. Since good focus is always desired, the Intensity and Sweep Time settings contribute most to the possibility of burning the phosphor.

Standard phosphors can be classified by burn resistance, as shown in Figure 3-33.

Note: P33 is extremely susceptible to burning. A non-moving or slowly moving trace should never be displayed.

The key to preventing phosphor burns is to:

- a. Use the minimum intensity needed for observing the display.
- b. Turn the intensity down if a slower sweep time setting is required.
- c. Try not to leave an intense, sharply-focused, immobile, or slowly-moving spot on the screen.

FLICKER

When the refresh rate of a display reaches a certain minimum frequency, the display appears to flash on and off (flicker). Although the display flicker frequency varies among phosphors (see Table 3-3), the apparent rate seen by the eye is independent of the actual rate and is approximately 15-20 Hz.

PHOSPHOR	FLICKER FREQUENCY* (HZ)
P1	42
P4	46
P7	30
P12	25
P19	25

*at 30 ft-lamberts brightness

Table 3-3

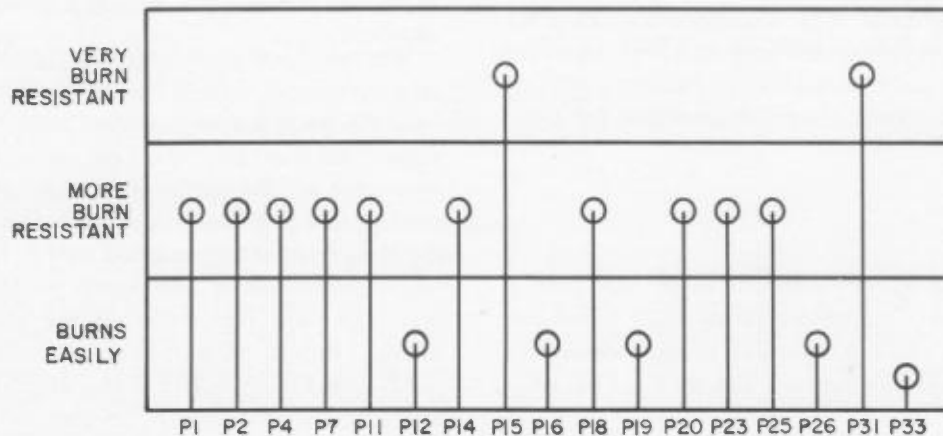

Figure 3-33

Various portions of the eye have differing response to flicker with peripheral areas of the visual field being more responsive to flicker than the central areas (fovea). Flicker becomes more annoying as the display gets

brighter and is accompanied by an increase in the minimum flicker frequency. In addition, the minimum perceptible flicker frequency increases with the viewers age.

SECTION IV

HIGH-SPEED OSCILLOSCOPE MEASUREMENTS

PHOTOGRAPHIC WRITING SPEED

Measurement of the maximum spot speed which can be adequately photographed is an index of the effectiveness of an oscilloscope, camera, and film system for recording high-speed, single-shot phenomena. Photographic writing speed describes this ability of an oscilloscope/camera/film system to capture a high speed one-time occurrence and is usually measured in velocity units (i.e. cm/ μ s, cm/ms, cm/s, in/s . . .). It is important to remember that when talking about writing speed (e.g. 300 cm/ μ s) the oscilloscope and type of CRT, the camera and type of film used must be specified. Otherwise, you can talk only about relative numbers such as one lens being capable of twice the writing speed of another.

Many factors affect the writing speed of a scope/camera/film system. Some of the more important are shown in Table 4-1.

OSCILLOSCOPE	CAMERA	FILM
CRT Gun Design	Lens aperature	Age
Phosphor type	Lens transmission	Sensitivity
Spectral output	Object-to-image ratio	Fog level
Persistence	Focus	Temperature
Grain size		Exposure time
Intensity setting		
Focus		
Vertical amplifier response		
Spot size		
Beam current density		

Table 4-1

Several methods are available for measuring the writing speed of a scope/camera/film system:

- Single-shot Sine Wave
- Single-shot Damped Sine Wave
- Single-shot Pulse
- Single-shot Triangular Wave

Single-shot Sinewave Technique.

A single-shot sine wave may be used to measure the writing speed of an oscilloscope/camera/film combination. This method is relatively easy since sine wave signal sources are common (see Figure 4-1).

Writing speed can be found from the mathematical description of a sine wave (refer to Figure 4-1): $Y = \frac{A}{2} \sin(\omega t)$. The velocity of a point on the sine wave is:

$$\bar{V} = \bar{V}_y + \bar{V}_x$$

$$|\bar{v}|^2 = \bar{v}_y^2 + \bar{v}_x^2 = \left(\frac{dy}{dt}\right)^2 + \left(\frac{1}{\text{sweeptime}}\right)^2$$

since

$$\frac{dy}{dt} = \frac{A}{2} \omega \cos(\omega t)$$

$$|v|^2 = \left[\frac{A\omega}{2} \cos(\omega t)\right]^2 + \left[\frac{1}{\text{sweeptime}}\right]^2$$

To properly evaluate the single-shot performance of a system, the point on the sine wave having the fastest spot velocity must be located. Since V_x is constant, the maximum velocity occurs when $\cos(\omega t) = 1$. The cosine = 1 at 0° , 180° , and 360° , so:

$$|v|^2 \text{ max} = \left[\left(\frac{A\omega}{2}\right)^2 + \left(\frac{1}{\text{sweeptime}}\right)^2\right]$$

since $\omega = 2\pi f$, and $A = \text{peak-to-peak amplitude}$

$$v \text{ max} = \left[(\pi A f)^2 + \left(\frac{1}{\text{sweeptime}}\right)^2 \right]^{1/2} \quad (1)$$

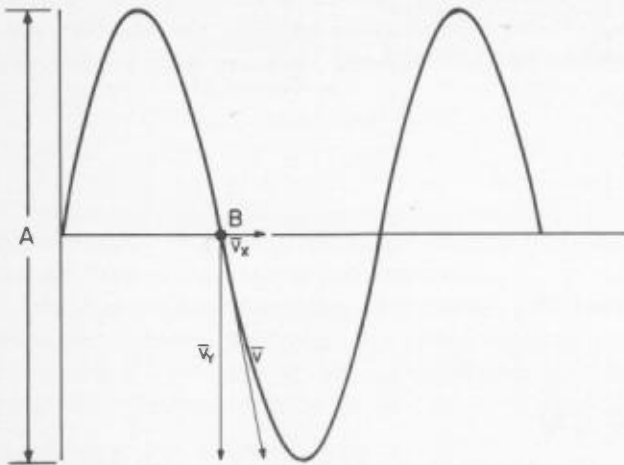

Figure 4-1

This maximum velocity occurs at the crossover (point B) on the sine wave shown in Figure 4-1. The technique for finding the scope/camera/film writing speed is to incrementally vary the sine wave frequency and take a single-shot photograph at each setting. The frequency should be increased until point B just disappears from the photograph. Writing speed can then be found by substituting the frequency, into equation 1, where point B just disappears. The sweep speed term can be dropped if approximately 10 cycles are displayed on the CRT (for this case, the horizontal component of velocity is negligible compared to the vertical component).

Example:

An 8-cm high sine wave is used to find the actual writing speed of a scope/camera/film system. The frequency where point B just disappears is 26 MHz; find the system writing rate.

$$v \text{ max} = \left[(\pi Af)^2 + \left(\frac{1}{\text{sweeptime}} \right)^2 \right]^{1/2}$$

Since 10 cycles are displayed,

$$v \text{ max} \approx \text{photographic writing speed} \approx \pi Af \\ \approx 3.14 (8) 26 \times 10^6 \approx 650 \text{ cm}/\mu\text{s}$$

The obvious disadvantage of this method is that too much film is needed to photograph the single-shot trace each time the frequency is changed. Also, operator time is too long. Another disadvantage is that the velocity along the sine wave varies drastically throughout its period, thus the slow portions of the sine wave (peaks) are almost always captured by the film. In interpreting the photograph, the eye tends to fuse the space between peaks and give the illusion that the trace is still there when, in fact, it isn't (this phenomenon is generally called closure).

Single-Shot Damped Sine Wave Technique

The single-shot damped sine wave is the most commonly used method for determining the photographic writing speed of a scope/camera/film system. It overcomes the film usage and long operator time since the velocity at successive crossover points decreases directly with the exponentially decaying peak amplitudes. Thus, a complete range of maximum spot velocities is generated in this type of single-shot waveform.

The simple relationship developed earlier for the sine wave

$$\text{writing speed} = \sqrt{(\pi Af)^2 + \left(\frac{1}{\text{sweeptime}} \right)^2}$$

can be used for finding the writing speed when a damped sine wave is used.

Remember, however, that the peak amplitude A is actually a function of time so use the amplitude of the last continuous peak to peak excursion when calculating writing speed. The writing speed simplifies to πAf , providing the slope on the last continuous waveform is almost entirely vertical (i.e. less than 15 degrees from the vertical). In this case, the horizontal component of velocity is much smaller than the vertical component (see Figure 4-2).

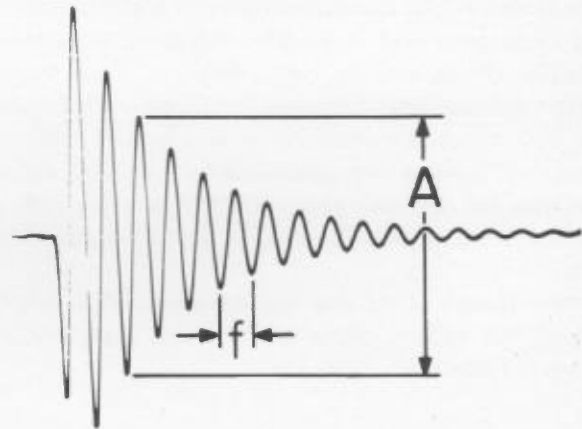

Figure 4-2

This exponentially damped sinusoid can be generated by using a pulse or square wave generator and adding a small LC circuit to the output (see Figure 4-3). The resultant ringing on the pulse constitutes the damped sine wave which has a frequency: $f = \frac{1}{2\pi\sqrt{LC}}$

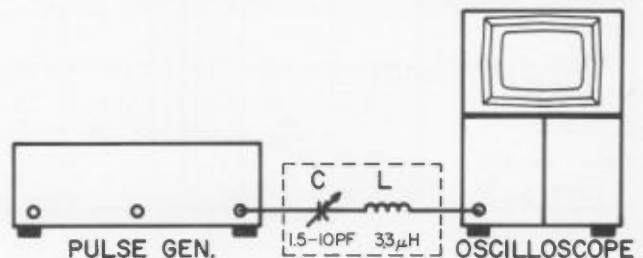

Figure 4-3

For most high frequency scopes a damped sine wave of approximately 50 MHz is adequate for finding the scope/camera/film writing speed. Use a 3.3 μh inductor and a 1.5-10 pF variable capacitor. Although, in theory, C must be 3 pF for a frequency of 50 MHz, the actual frequency can be measured from the scope.

Try to display enough complete cycles on screen so that the velocity at the crossover point is almost completely vertical.

Example: the 50 MHz damped sine wave shown in Figure 4-4 is to be used for finding the writing speed of a scope/camera/film system. After properly setting up the intensity, focus, and camera, a single-shot is triggered and recorded on the photograph in Figure 4-5. Find the system writing speed.

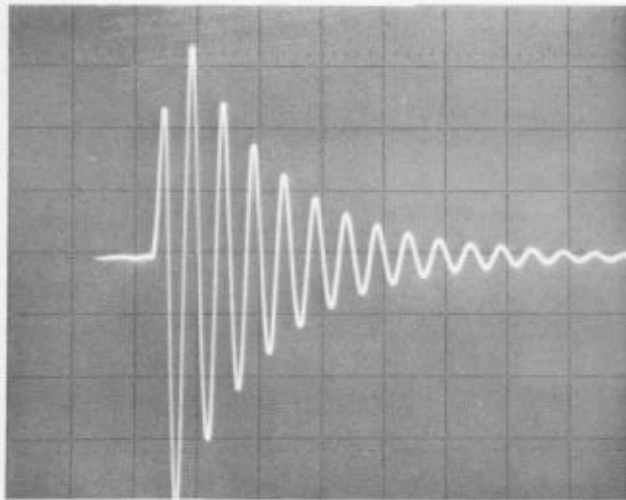

Figure 4-4

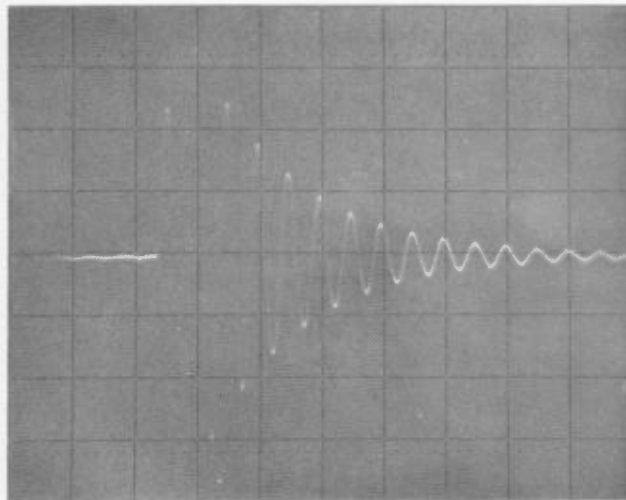

Figure 4-5

The photograph of the single-shot shows that the 4th cycle is the first complete cycle recorded. The peak-to-peak amplitude of this sine wave is 2.3 cm. Therefore:

$$\text{writing speed} = \sqrt{(\pi Af)^2 + \left(\frac{1}{\text{sweeptime}}\right)^2}$$

$$= \left\{ [3.14 (2.3) 50 \times 10^6]^2 + \left(\frac{1}{\text{sweeptime}}\right)^2 \right\}^{1/2}$$

$$\approx 360 \text{ cm}/\mu\text{s}$$

Actually, the slope at the point of maximum velocity on the sine wave should be less than 15° from the vertical if the horizontal velocity component is to be neglected. In the previous example, the slope is almost 0° so the horizontal component was neglected.

The simple relationship between amplitude, frequency, and writing speed is shown on the nomograph in Figure 4-6. Using a straight edge, connect the fre-

Refer to appendix for a full page copy of this nomograph.

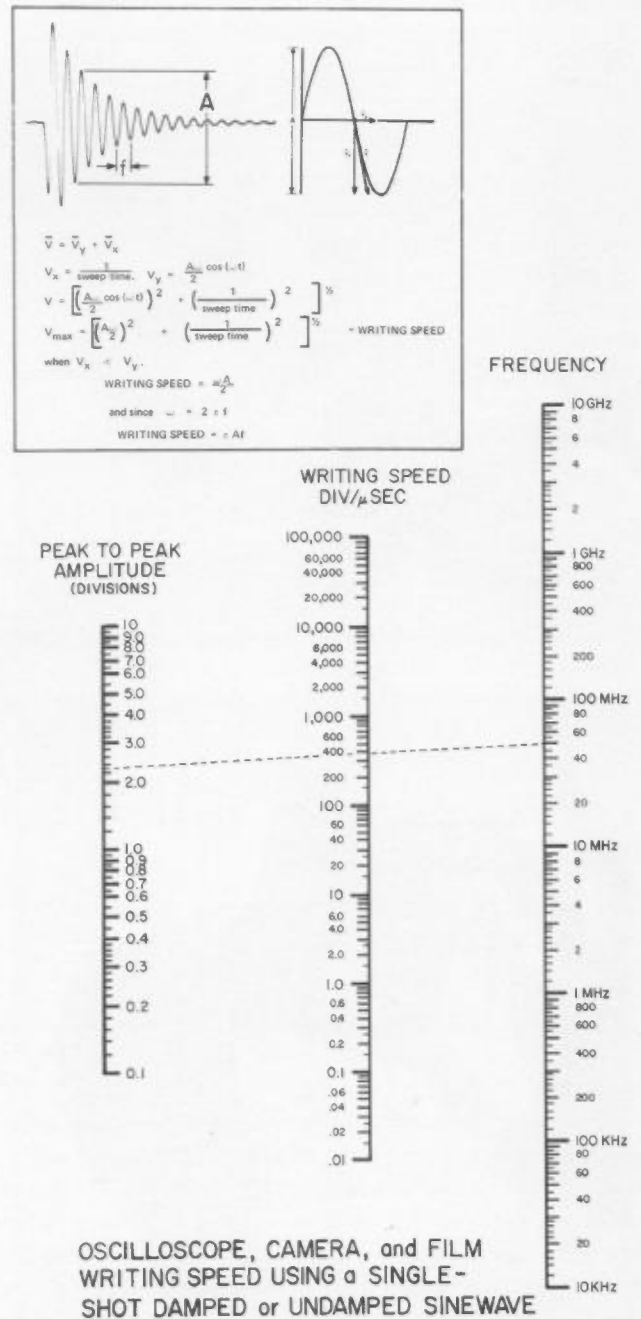

OSCILLOSCOPE, CAMERA, and FILM WRITING SPEED USING a SINGLE-SHOT DAMPED or UNDAMPED SINEWAVE

Figure 4-6

the sweep generator of a high frequency oscilloscope. Many scopes have an external sweep output available that can be used to drive the scope under test.

$$\text{writing speed} = \frac{d}{t}$$

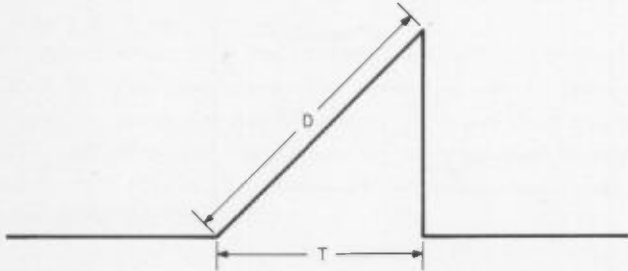

Figure 4-10

Even high frequency scopes do not have an adequate sawtooth frequency for measuring the writing speed of other high frequency scopes. Another disadvantage is that the film usage is excessive because the signal amplitude must be varied after each photo until the trace just disappears.

PHOTOGRAPHIC TECHNIQUES

Consistent single-shot results are possible if a little care is taken while making these measurements. However, a certain amount of knowledge about the techniques must be learned before good results become a reality.

When comparing the writing speed capability of many different oscilloscopes, try to use the same camera since differences between cameras, even same models, can significantly affect the comparative results.

Film Types

The most commonly used film is the Polaroid® positive print type having an ASA speed of 3000. For best results, try to use film that has the same age and maintain it at a constant temperature (refrigerate). The film speed may vary somewhat between prints so it is best to take several pictures and use the average where possible. Added care should be taken to properly develop the film since the development time of Polaroid® film varies inversely with temperature as shown in Figure 4-11. Development for longer than the recommended time will increase contrast slightly but will not damage the print. Development for less than 10 seconds produces a print which may be objectionably faint.

POLAROID FILM (TYPE 107, 410) DEVELOPMENT TIMES

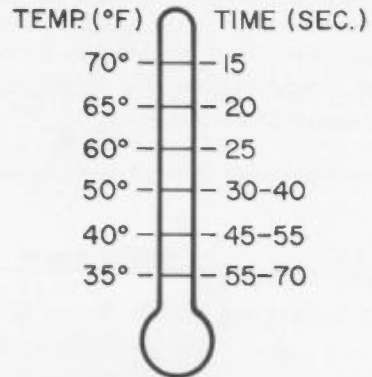

Figure 4-11

The Polaroid® film is almost equally sensitive throughout the visible spectrum as shown on the curves in Figure 4-12.

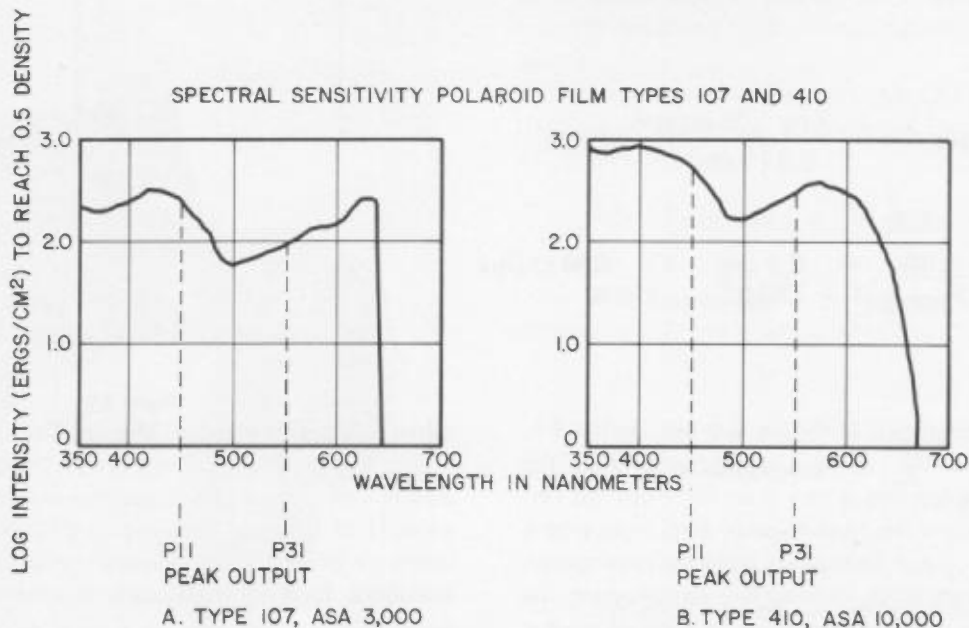

Figure 4-12

The type 410 Polaroid® film has an ASA speed rating of 10,000 and will give a writing capability of approximately twice that of the Polaroid® 3000 film under comparable conditions. The Polaroid® ASA 10,000 film has a grainier appearance and a higher contrast than Polaroid® ASA 3000, thus it is not commonly used for general purpose photography.

Although Polaroid® film can be used for photographing traces from almost any common phosphor, it is most effective when used with a P11 phosphor. The unexcelled writing speed capability of P11, and the preferential sensitivity of Polaroid® film to the peak color output of P11, makes it the most desirable phosphor for fast writing, single-shot experiments. Generally, P11 will increase writing capability 30-50% over P31. In some cases improvements of 100 to 200% have been achieved.

Many oscilloscopes use colored filters or meshes to improve the trace-to-background contrast when viewing. Unfortunately, these filters also reduce the amount of light transmitted by the cathode-ray tube and should be removed before any high speed, single-shot photographic measurements are attempted. Some cameras also use snap-on filters that should be removed during these measurements.

Focusing the Camera

Make sure the camera is focused properly, since any defocusing will cause a reduction in the measured writing speed. When maximum writing speed is needed, always use an internal graticule CRT. Never use an external graticule CRT since most of these have a scale made of plastic that drastically attenuates the light transmitted by the phosphor.

The next step is to carefully adjust the focus and astigmatism controls on the oscilloscope. This is done at maximum intensity setting just prior to overriding the unblanking gate. The intensity and focus should be set while observing a fast risetime, low repetition rate signal. A 60 Hz square wave or pulse with a risetime of 200 ns or less works very well. The reason for going to all this trouble is that the trace focus can vary at different sweep rates, so it should be focused at a low repetition rate to approximate the actual single sweep.

Post-Fogging the Film

A controlled exposure of each Polaroid® Land film frame to a light source, after exposure to the trace, will increase the writing speed by as much as two to three times. Post-fogging is the most effective method of increasing the writing speed of Polaroid® films.

A typical Exposure-Density curve is shown in Figure 4-13. If the film is used in the lower portion of the

curve (as would be the case for high-speed, single-shot transient photos), the change in density versus exposure is quite small, but if the film is sensitized to the point shown on the curve by exposing the film to a light source, the change in density versus exposure will be much larger due to the steeper slope of the curve.

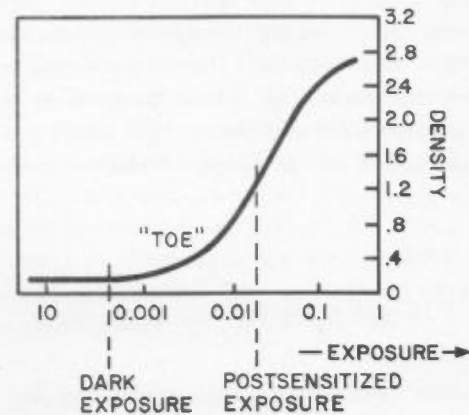

Figure 4-13

Post-fogging Polaroid® film with an internal graticule CRT is done with the phosphor illumination feature on the oscilloscope (e.g. the HP 180A Oscilloscope) or by exciting the phosphor externally with an ultra violet lamp (HP 196B and 197A cameras have UV lamps). The necessary technique takes some experimentation, so take a few practice exposures before the real event. Start by setting the camera f-number to f/16 and the shutter speed to several seconds. For the proper amount of post-fogging, try some different shutter speeds. The best post-fogging settings will be reflected in the highest measured writing speed using a single-shot signal (damped sine wave is used most frequently). Single-shot writing capability can be improved markedly if the camera used has a very large lens opening such as f/1.3 or f/1.4 rather than f/1.9 that is more commonly used in scope cameras.

When taking photos of fast single-shot waveforms, be sure to leave the camera lens open at least five seconds after the transient is displayed to take full advantage of the light generated during the phosphor's decay.

A fast-slow exposure sequence should be followed between trace and post-fogging; that is, if the transient to be photographed is very fast, then the post-fog period should be much longer and vice versa.

Camera Reduction Ratio

The object being photographed and the image produced on the film in the previous discussions were of

equal size. Significant improvements in the system writing speed can be easily made by reducing the image size. The light passing through the camera lens is focused on a similar area, thus the film "sees" an increased exposure. When calculating writing speed retain the amplitude units of the object (CRT graticule) rather than those on the photograph.

Example:

A damped 50 MHz sine wave is used to determine the photographic writing speed of an oscilloscope/camera/film combination. The camera has a 1:0.3 object-to-image ratio. The fastest portions of the sine wave disappear from the photograph when the amplitude decays to 4 cm peak-to-peak (actual units from the CRT).

$$ws = \pi Af$$

$$ws = \pi (4 \text{ cm}) 50 \times 10^6 \approx 630 \text{ cm}/\mu\text{s}$$

This linear relationship is generally true for reductions up to about 10:1. There is a practical limit, beyond which the improvement in writing speed is overshadowed by the small image size and need for complex magnifying devices. This limit is somewhat subjective, but traces reduced more than 4:1 become unreadable without magnifying glasses.

Storage Writing Speed

When the writing speed refers to the storage ability of an oscilloscope having a storage cathode-ray tube, a camera and film are usually not required. The purpose of the camera and film in measuring the photographic writing speed of a scope/camera/film system is to record an event that is usually too fast for the eye. For measuring the storage writing speed, the CRT records the trace, thus permitting accurate trace interpretation by the human eye and eliminating the need for a camera. Storage writing speed describes the ability of a storage CRT to capture and display a single-shot signal.

All of the methods explained under Photographic writing speed apply to measuring storage writing speed. Since no film is used, the best method is that of using the triangular waveform. The sine wave method is more extensively used, however, since there are more sine wave generators available than triangular wave sources. The maximum storage writing speed capability of most storage CRT's is well within the frequency range of triangular and sine wave sources that are readily available. The maximum storage writing speed CRT, presently available, can capture a speed of approximately 5 cm/us. Substituting this value into the writing speed equation, $V_y = \pi Af$, will give the approximate sine wave frequency range of the source needed. Refer

to Figure 4-14.

$$5 \text{ cm/ns} = \pi Af$$

$$f = \frac{5 \text{ cm/ns}}{\pi A}$$

$$\text{Let } A = 8 \text{ cm}$$

$$f \approx \frac{5}{25} \approx 200 \text{ kHz}$$

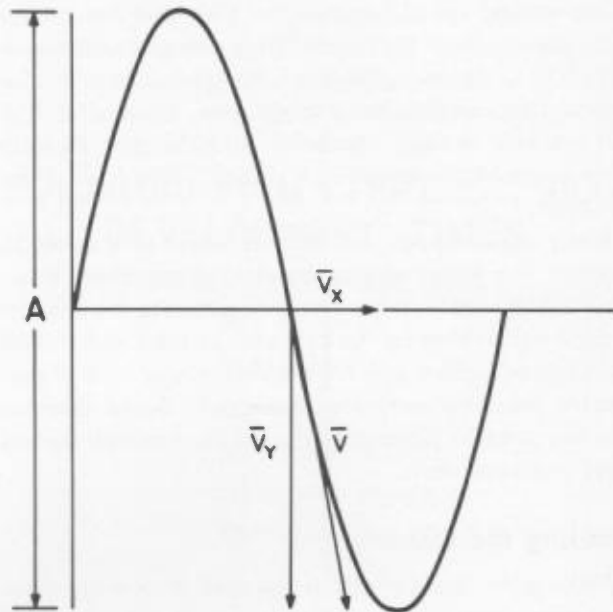

Figure 4-14

A practical example of single-shot storage is shown in Figure 4-15 where a technician is seen examining the opening and closing characteristics of production camera shutters. A dual trace scope is required to simultaneously measure the time difference (lag) between operator initiation of the switch that actuates the shutter solenoid and the actual opening of the shutter. Actual opening and closing time of the shutter is measured by passing light through the lens and into a fast photocell.



Figure 4-15

SECTION V

VARIABLE PERSISTENCE/STORAGE CATHODE-RAY TUBES

In 1965 Hewlett-Packard introduced the first commercially available oscilloscopes with a variable persistence CRT. Previously, persistence was regarded as a constant related to the phosphor used in the CRT. Phosphors having a short persistence are commonly selected for general use since most signals are repetitive and occur at a rate fast enough where flicker is not bothersome. However, long persistence is often sought to display slowly moving bio-medical phenomena and applications where the traces must persist after the moving spot. Although many long persistence phosphors are available, most do not properly accommodate the signal and are easily burned. Hewlett-Packard achieves the usefulness of short and long persistence in a single CRT by using a P31 phosphor in its variable persistence CRT. P31 has a very high burn resistance, rather short persistence, and its green color is preferred for viewing. Variable persistence is achieved by artificial means and is continuously variable from approximately 200 ms to 1 minute or more. Actually, variable persistence is a storage process where the trace is stored, then erased at a rate compatible with the users displayed information.

A typical mesh type storage CRT is shown in Figure 5-1.

CRT CONSTRUCTION

In addition to the normal CRT components, a flood gun assembly, collimator, collector mesh, and storage mesh are added. The write gun usually operates at several thousand volts negative while the flood gun

emits low velocity electrons toward the phosphor at zero volts. The collimator is a conductive coating on the inside wall of the CRT that adjusts the size of the flood gun beam pattern. The collector mesh is made of a fine wire screen and is always held at a constant positive voltage. The storage mesh is located slightly ahead of the collector mesh and is also made of fine wire mesh; however, an added insulating surface is evaporated to the rear surface of the storage mesh. The secondary emission characteristics of this layer (Figure 5-2) provide the CRT variable persistence and storage capabilities.

STORAGE

When portions of the storage surface are hit by primary electrons having more energy than approximately 40 electron volts, a greater number of secondary electrons are emitted from the insulating storage surface. Thus, a positively charged pattern is retained within the insulating layer of the storage mesh. If primary electrons strike the surface with less than 40 electron volts, fewer secondary electrons are generated and the surface tends to charge negatively.

The normal dc voltage on the metal portion of the storage mesh, during variable persistence and storage, is +3 volts while the insulating surface is capacitively coupled to approximately -10 volts.

When traces are written by the write gun, high energy electrons (typically several thousand electron volts) strike the storage surface causing secondary emission

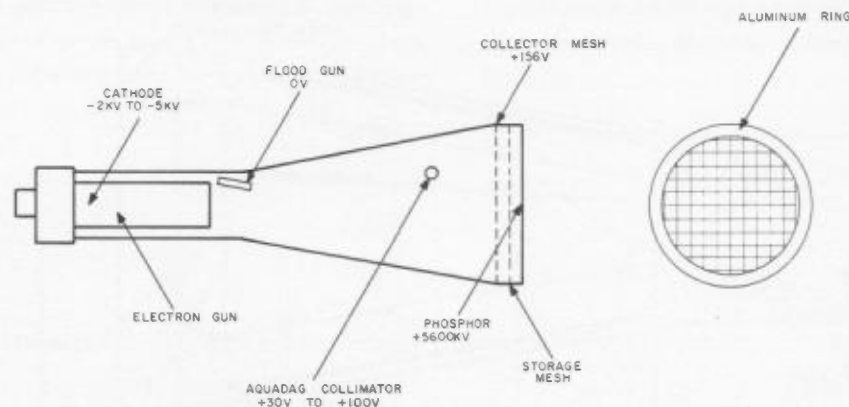

STORAGE CATHODE-RAY TUBE

Figure 5-1

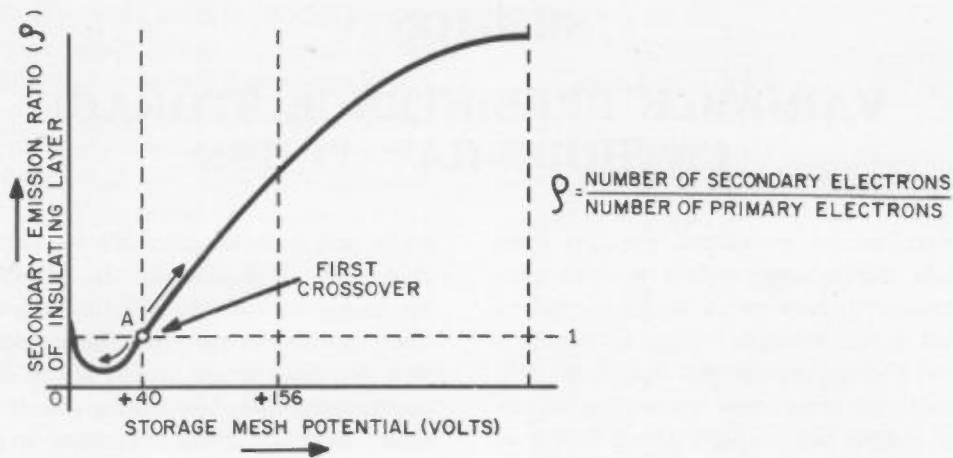

Figure 5-2

which charges local areas of the surface to approximately zero volts.

The stored charge pattern can be displayed by switching the write gun off (set instrument to store or turn off the intensity). A cloud of flood gun electrons, emitted at zero volts, is accelerated toward the mesh assembly by the positive field of the collimator lens. Although the positive charge on the collector mesh tends to collect 70-80% of these electrons (Figure 5-3), the main purpose of this mesh is to orient these low velocity electrons perpendicular to the phosphor and parallel to the CRT's longitudinal axis, (b).

Electrons that pass through the positively charged areas of the storage mesh are accelerated by the post accelerator potential on the phosphor (nominally +5 kV to +10 kV) to an impact velocity that causes the phosphor to glow. This phenomenon is called storage and without additional circuits the CRT will store from 1 to 3 minutes.

The storage time is limited because gas molecules within the tube are ionized by the flood-gun electrons.

Positive ions collect on the storage mesh negative (unwritten) areas and increase the potential of these areas enough to allow flood-gun electrons to pass through to the phosphor. This process, which limits the storage time, is called fading positive. An example of fading positive is shown in Figure 5-4.

Electrons that penetrate the collector mesh can only pass through the storage mesh at points previously charged positive by the write beam (b). Flood electrons approaching areas that are unwritten (-10 volts) are repelled, by the storage mesh, back to the collector mesh, and (c) become a part of the collector mesh current.

A technique for extending the storage time is to pulse the flood guns on for a short time, which reduces the number of electrons that can ionize the gas molecules and collect on the storage mesh. Since the electron density is sharply reduced, the trace brightness is correspondingly decreased; however, the storage time is increased.

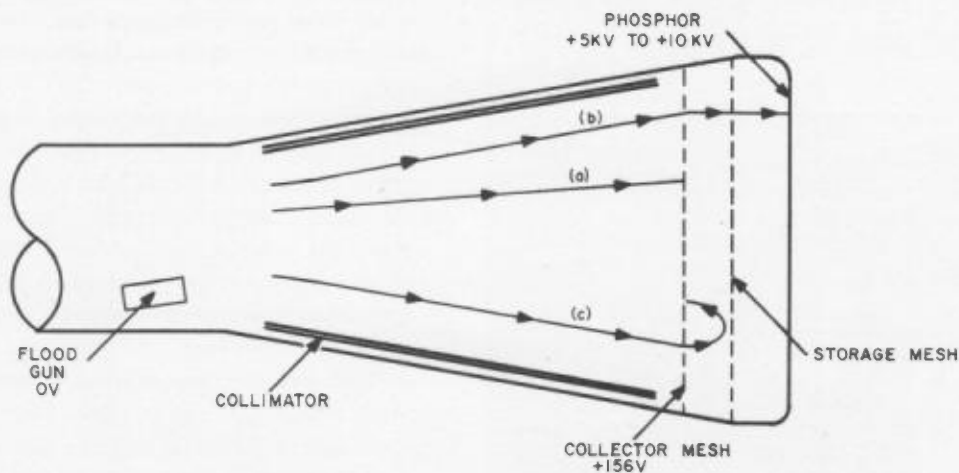

Figure 5-3

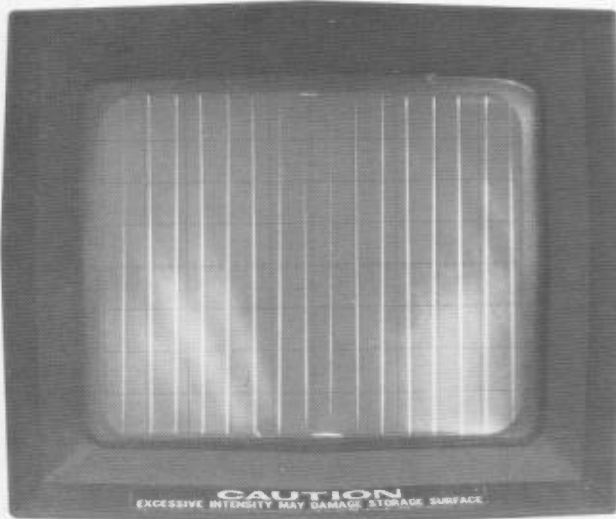

Figure 5-4

VARIABLE PERSISTENCE

As mentioned earlier, variable persistence is accomplished by erasing a stored trace at a rate selected by the operator. A diagram showing the potentials on the storage surface is shown in Figure 5-5 to help explain this process.

Unwritten areas of the storage surface are at -10 volts while those written through by the write beam are charged near zero volts. In the variable persistence mode, positive going pulses are applied to the storage mesh in addition to the normal dc level. These pulses have a low duty cycle (usually under 5%) and the pulse amplitude is always held below the first crossover voltage (see Figure 5-2 for secondary emission characteristics). During the time a positive going pulse is applied, the unwritten areas (approximately 10 volts) are raised to approximately zero volts, while the more positively charged written areas are raised between zero volts and the peak pulse amplitude. During a pulse interval, flood-gun electrons tend to discharge the posi-

tive areas of the storage mesh toward zero volts; however, one pulse duration is usually too short to completely discharge the mesh so, a train of pulses is required to successively lower the potential to zero volts. The rate at which the mesh is erased is determined by the pulse width (duty cycle) and is discharged faster with the greatest pulse width. After each pulse, the storage mesh written areas approach the potential in the unwritten areas. Fewer flood gun electrons penetrate the storage mesh and the viewed brightness decreases until written areas are discharged to -10 volts where no flood-gun electrons penetrate the storage mesh.

During the time the storage mesh is pulsed positive, flood-gun electrons pass through the mesh to the phosphor/viewing screen and supplies a light background glow that is visible when the CRT is used in the variable persistence mode.

The storage process can be thought of as an extension of variable persistence. That is; when the pulse width goes to zero the written areas are not discharged so the pattern remains stored.

ERASE

Stored traces can be erased with the persistence control; however, this takes several seconds and is somewhat inconvenient. A faster method that can be performed manually or programmed, erases the stored display in several hundred milliseconds.

When the ERASE pushbutton is pressed, the storage mesh is switched to the same potential as the collector mesh ($+156$ volts). The storage surface is also changed to nearly this same potential by capacitive coupling. Since the surface is then being bombarded by electrons with energies much higher than first crossover energy, the entire storage surface potential becomes equal to $+156$ volts. The storage surface potential cannot increase beyond $+156$ volts because the collector mesh would then repel the emitted electrons back to the storage surface, tending to decrease the surface potential.

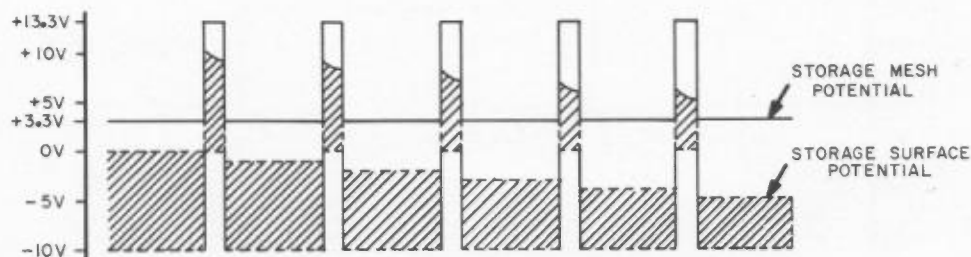

Figure 5-5

When the ERASE pushbutton is released, the storage mesh changes to +3.3 volts and the storage surface follows to the same potential by capacitive coupling. The surface potential then decays to zero volts by action of the flood-gun electrons (surface below first crossover, brought to flood-gun cathode potential). After 100 milliseconds, the storage mesh is raised to +13.3 volts and held there for 200 milliseconds. The storage surface follows to +10 volts by capacitive coupling, but immediately starts decaying toward zero volts by capturing flood-gun electrons. After the 200 milliseconds, the storage mesh returns to +3.3 volts and the storage surface is reduced from zero volts to -10 volts by capacitive coupling.

The write gun electrons reach the storage surface with energy much higher than first crossover energy; wherever they strike, the storage surface is charged in a positive direction. This charge pattern on the storage surface remains for a considerable length of time since the storage material is a very good insulator.

Those areas of the storage surface which are charged to near zero volts allow the field created by a high positive potential on the post accelerator to "reach through" and capture flood-gun electrons, accelerating them to strike the phosphor viewing screen, causing the phosphor to emit light, and makes the charge pattern on the storage surface visible.

The secondary electrons emitted by the storage surface, where the write gun electrons strike, must charge the surface from its erased potential to about -5 volts before flood electrons can be captured by the post accelerator. Thus, the CRT storage writing speed is enhanced by erasing the surface to just below this

"cutoff" level and occurs in the MAX WRITE mode. The disadvantages of operating in this mode are reduced storage time and reduced contrast ratio. The "cutoff" potentials of various areas of the storage surface may not be exactly the same because of variations in the mesh-to-phosphor spacing and thickness of the insulating layer. This results in non-uniform background illumination when the storage surface is erased in the MAX WRITE mode.

CONVENTIONAL OPERATION

Although variable persistence permits viewing slow moving phenomenon and eliminates flicker, it may be desired to have the shorter standard phosphor persistence.

If the storage mesh potential is reduced to -25 volts (conventional operation) it becomes a control grid and stops flood-gun electrons from reaching the phosphor, but has little effect on write gun electrons. The write gun electrons pass through the storage mesh to the phosphor viewing screen and the CRT operates as a conventional CRT with the phosphors persistence. While passing through the storage mesh, the write gun electrons charge the mesh positive but considerably less than the zero volts needed to permit flood gun electrons to pass through. When the storage mesh is returned to +3.3 volts (variable persistence and storage operation), areas of the storage surface that were struck by write gun electrons now allow flood-gun electrons to pass through the storage mesh since the surface potential is raised near zero volts. Thus, it is possible to store and display a waveform that was written during conventional operation.

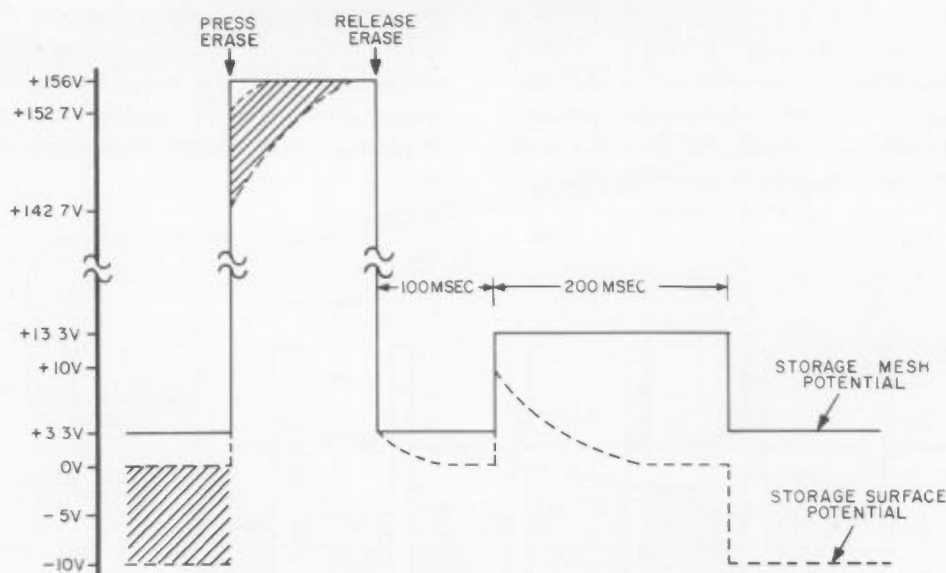

Figure 5-

SUMMARY

Hewlett-Packard has selected a mesh type storage CRT for oscilloscopes because of the many customer benefits. Most of these benefits are not possible or offered in CRTs that store in the phosphor.

Advantages of Mesh Storage CRTs:

- Writing speed remains constant throughout the CRT's lifetime.
- Stored brightness remains constant throughout the CRT's life.
- CRT storage characteristics have a life that is equivalent to non-storage Hewlett-Packard CRTs.
- Stored traces are 20-100 times brighter.
- Variable persistence.
- Gray shade storage capability (z-axis modula-

tion).

- Internal graticule.
- Post accelerator CRT has greater bandwidth and display size.
- Uses standard P31 phosphor . . . fast writing speed . . . very burn resistant phosphor . . . brightest phosphor.
- Aluminized CRT for brighter traces.
- Storing longer than the specified storage time will not burn the CRT.
- P31 phosphor with aluminizing prevents filament light from reaching the film in a camera.

Disadvantages:

- No split-screen storage capability.
- More complex internally — higher cost.

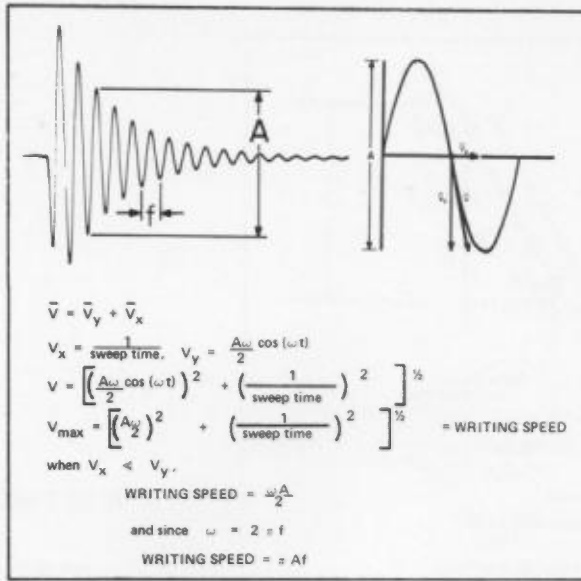

Tear along the dotted line.

PEAK TO PEAK
AMPLITUDE
(DIVISIONS)

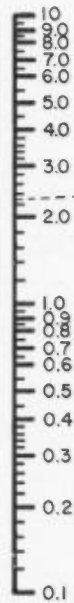

WRITING SPEED
DIV/μSEC

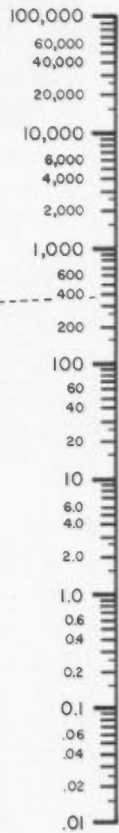

FREQUENCY



OSCILLOSCOPE, CAMERA, and FILM
WRITING SPEED USING a SINGLE-
SHOT DAMPED or UNDAMPED SINEWAVE

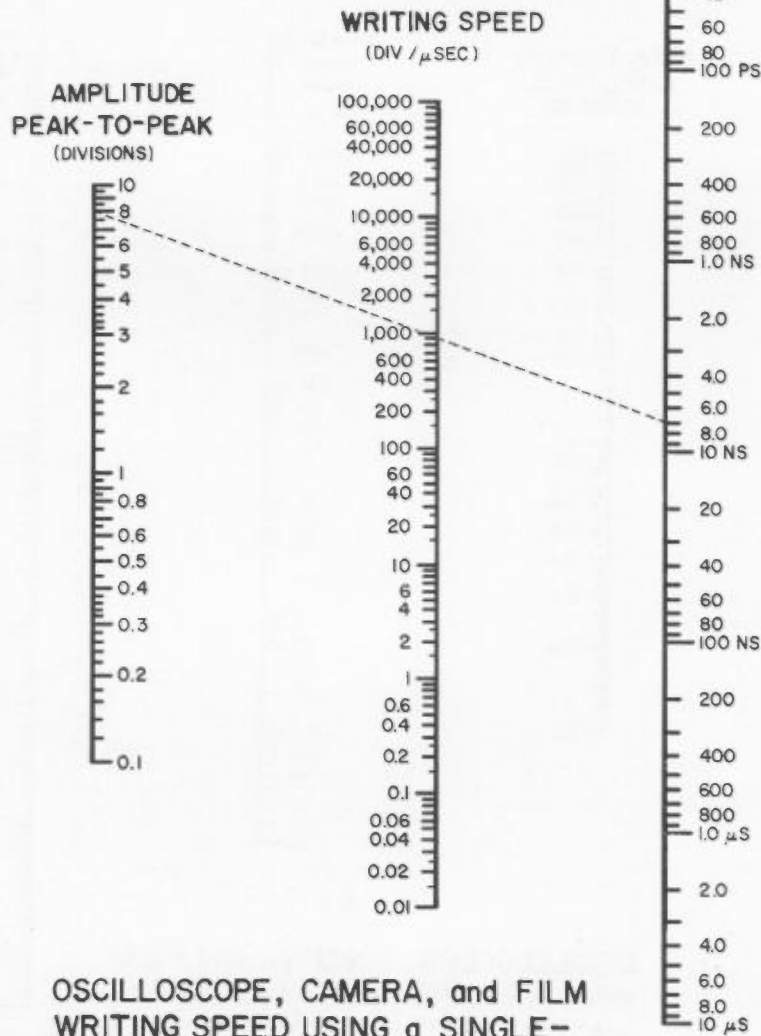
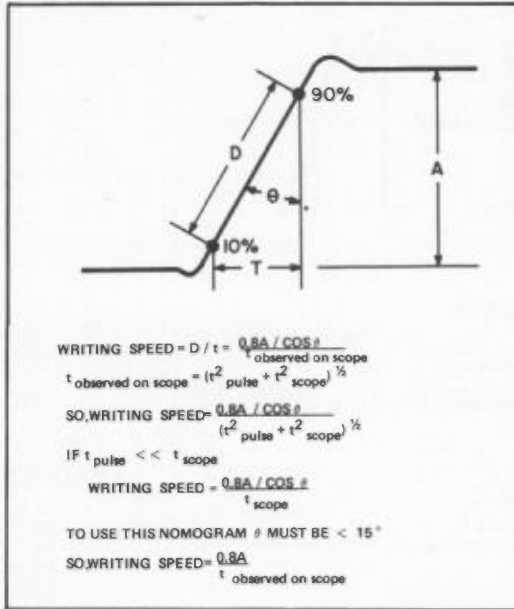

Tear along the dotted line.

OSCILLOSCOPE, CAMERA, and FILM WRITING SPEED USING a SINGLE-SHOT PULSE



For more information, call your local HP Sales Office or East(201) 265-5000 . Midwest (312) 677-0400 . South (404) 436-6181
West (213) 877-1282. Or, write: Hewlett-Packard, 1501 Page Mill Road, Palo Alto, California 94304. In Europe, 1217 Meyrin-Geneva