

HP Designjet 4000 and 4000ps Printers

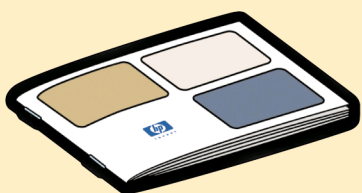

User's guide

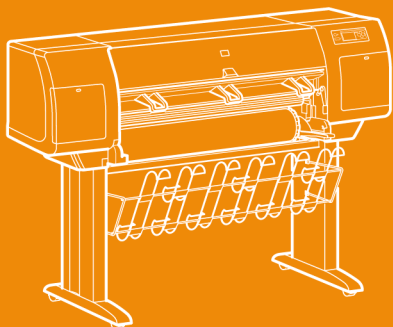

i n v e n t

Legal notices

The information contained in this document is subject to change without notice.

Hewlett-Packard makes no warranty of any kind with regard to this material, including, but not limited to, the implied warranties of merchantability and fitness for a particular purpose.

Hewlett-Packard shall not be liable for errors contained herein or for incidental or consequential damages in connection with the furnishing, performance, or use of this material.

No part of this document may be photocopied or translated to another language without the prior written consent of Hewlett-Packard Company.

Trademarks

Adobe®, Acrobat®, Adobe Photoshop®, and PostScript® are trademarks of Adobe Systems Incorporated.

Microsoft® and Windows® are U.S. registered trademarks of Microsoft Corporation.

PANTONE® is Pantone, Inc.'s check-standard trademark for color.

Company address

Hewlett-Packard Company

Inkjet Commercial Division

Avenida Graells, 501

08174 Sant Cugat del Vallès

Barcelona, Spain

Contents

1	Introduction	7
	Using this guide	7
	The printer's main features	8
	The printer's main components	9
	The front panel	10
	Printer software	12
2	How do I assemble the printer?	13
	Getting started	13
	How do I unpack the printer?	14
	How do I assemble the stand?	16
	How do I attach the stand to the printer?	22
	How do I remove packaging materials from the printer?	26
	How do I assemble the bin?	29
	How do I switch on the printer for the first time?	34
	How do I install ink cartridges?	36
	How do I remove the setup printheads?	40
	How do I install the printheads?	42
	How do I install the printhead cleaners?	45
	How do I load a roll of paper onto the spindle?	47
	How do I load the paper into the printer?	50
	How do I connect the printer?	56
	How do I install accessories?	58
3	How do I set up my printer software?	63
	How do I choose which connection method to use?	63
	How do I connect my printer to a network (Windows)?	64
	How do I connect my printer to a network (Mac OS X)?	66
	How do I connect my printer to a network (Mac OS 9)?	68
	How do I connect my printer directly to a computer (Windows)?	69
	How do I connect my printer directly to a computer (Mac OS X)?	70
	How do I connect my printer directly to a computer (Mac OS 9)?	71
	How do I uninstall the printer driver (Windows)?	72
	How do I uninstall the printer driver (Mac OS 9)?	72
4	How do I operate the printer?	73
	How do I switch the printer on and off?	73
	How do I restart the printer?	74
	How do I change the language of the front panel?	74
	How do I access the Embedded Web Server?	75
	How do I change the language of the Embedded Web Server?	76
	How do I password-protect the Embedded Web Server?	76
	How do I request e-mail notification of specific error conditions?	77
	How do I change the sleep mode setting?	77
	How do I turn off the buzzer?	77
	How do I change the front panel contrast?	77
	How do I change the units of measurement?	77
	How do I adjust for altitude?	78

5	How do I handle paper?	79
	How do I load a roll onto the spindle?	79
	How do I load a roll into the printer?	83
	How do I unload a roll from the printer?	88
	How do I load a single sheet?	89
	How do I unload a single sheet?	93
	How do I select supported paper types?	94
	How do I view information about the paper?	95
	How do I download media profiles?	96
	How do I use non-HP paper?	96
	How do I cancel the drying time?	96
	How do I change the drying time?	97
6	How do I handle the ink system?	99
	How do I remove an ink cartridge?	99
	How do I insert an ink cartridge?	104
	How do I remove a printhead?	106
	How do I insert a printhead?	110
	How do I manage printhead monitoring?	113
	How do I recover (clean) the printheads?	113
	How do I clean a printhead's electrical connections?	113
	How do I align the printheads?	119
	How do I remove a printhead cleaner?	120
	How do I insert a printhead cleaner?	122
	How do I check the status of the ink system?	124
	How do I get ink cartridge statistics?	124
	How do I get printhead statistics?	125
	How do I check printer usage statistics?	125
7	How do I adjust my printed images?	127
	How do I change the page size?	127
	How do I create a custom page size?	127
	How do I change the print quality?	129
	How do I choose print quality settings?	130
	How do I print at maximum speed?	132
	How do I adjust the margins?	132
	How do I print on oversize page sizes?	133
	How do I change the paper's orientation?	133
	How do I rotate an image?	134
	How do I print a mirror image?	134
	How do I scale an image?	134
	How do I change the palette settings?	135
	How do I change the treatment of overlapping lines?	136
	How do I change the graphic language setting?	137
8	How do I get accurate colors from my printer?	139
	How do I perform color calibration?	139
	How do I perform black point compensation?	140
	How do I set the rendering intent?	140
	How do I select the color emulation mode?	141
	How do I produce matching prints from different HP Designjets?	141
	How do I get accurate colors from Adobe Photoshop CS (HP–GL/2 & RTL driver)?	141

	How do I get accurate colors from Adobe Photoshop CS (PostScript driver)?	146
	How do I get accurate colors from Adobe InDesign CS?	151
	How do I get accurate colors from QuarkXPress 6?	155
	How do I get accurate colors from Autodesk AutoCAD 2002?	158
	How do I get accurate colors from Microsoft Office 2003?	158
	How do I get accurate colors from ESRI ArcGIS 9?	158
9	How do I manage print jobs?	163
	How do I submit a job?	163
	How do I save a job?	164
	How do I print a saved job?	164
	How do I check ink and paper usage for a job?	164
	How do I cancel a job?	164
	How do I manage the print queue?	165
	How do I nest jobs to save roll paper?	167
10	How do I maintain my printer?	169
	How do I clean the exterior of the printer?	169
	How do I clean the platen?	169
	How do I lubricate the printhead carriage?	171
	How do I maintain the ink cartridges?	172
	How do I move or store my printer?	172
	How do I update my printer's firmware?	173
11	How do I use the Image Diagnostics Print?	175
	How do I print the Image Diagnostics Print?	175
	How do I respond to the Image Diagnostics Print?	176
	How do I interpret Image Diagnostics part 1?	176
	How do I interpret Image Diagnostics part 2?	178
	How do I interpret Image Diagnostics part 3?	180
	How do I proceed if I still have a problem?	181
12	How do I perform paper advance calibration?	183
13	The problem is print quality	189
	General advice	189
	The problem is banding (horizontal lines across the image)	190
	The problem is lines are missing or thinner than expected	191
	The problem is solid bands or lines printed over the image	192
	The problem is graininess	193
	The problem is the paper is not flat	193
	The problem is the print smudges when touched	194
	The problem is ink marks on the paper	194
	The problem is a defect near the start of a print	195
	The problem is lines are stepped	195
	The problem is lines are printed double or in wrong colors	196
	The problem is lines are discontinuous	197
	The problem is lines are blurred (ink bleeds from lines)	197
	The problem is lines are slightly warped	197
	The problem is color accuracy	198
	The problem is PANTONE color accuracy	198
	The problem is color matching between different HP Designjets	199
14	The problem is an image error	203
	The problem is the print is completely blank	203

	The problem is the output contains only a partial print	203
	The problem is the image is clipped	204
	The problem is the image is in one portion of the printing area	204
	The problem is the image is unexpectedly rotated	205
	The problem is the print is a mirror image of the original	205
	The problem is the print is distorted or unintelligible	205
	The problem is one image overlays another on the same sheet	206
	The problem is pen settings seem to have no effect	206
15	The problem is with the ink system	207
	The problem is I cannot insert an ink cartridge	207
	The problem is I cannot insert a printhead	207
	The problem is I cannot insert a printhead cleaner	207
	The problem is the front panel keeps telling me to reseal or replace a printhead	207
	The problem is an ink cartridge status message	208
	The problem is a printhead status message	208
	The problem is a printhead cleaner status message	208
16	The problem is with the paper	209
	The problem is the paper cannot be loaded successfully	209
	The problem is a paper jam (paper stuck in the printer)	211
	The problem is prints do not stack properly in the bin	213
	The problem is the printer uses a lot of paper to align the printheads	213
17	The problem is something else	215
	The problem is the printer's start-up process does not complete	215
	The problem is a front panel message	215
	The problem is a "printhead monitoring" message	218
	The problem is a "printheads are limiting performance" message	218
	The problem is the printer does not print	219
	The problem is a print job is waiting for a time-out	219
	The problem is the printer seems slow	219
	The problem is communication failures between computer and printer	220
	The problem is I cannot access the Embedded Web Server from my browser	221
	The problem is an out-of-memory error	221
	The problem is an AutoCAD 2000 memory allocation error	222
	The problem is the platen rollers squeak	222
18	Tell me about the printer	225
	Tell me about color emulation modes	225
	Tell me about connecting the printer	227
	Tell me about the printer's rear lights	228
	Tell me about the printer's internal prints	228
	Tell me about preventive maintenance	229
19	Tell me about the Embedded Web Server	231
20	Tell me about the ink system	233
	Tell me about ink cartridges	233
	Tell me about printheads	235
	Tell me about printhead cleaners	236
	Tell me about ink system tips	236
21	Tell me about paper	237
	Tell me about using paper	237

Contents

	Tell me about drying time	238
22	Tell me about printer specifications	239
	Tell me about functional specifications	239
	Tell me about physical specifications	242
	Tell me about memory specifications	242
	Tell me about power specifications	242
	Tell me about ecological specifications	242
	Tell me about environmental specifications	242
	Tell me about acoustic specifications	243
23	Tell me about ordering supplies and accessories	245
	Tell me about ordering ink supplies	245
	Tell me about ordering paper	245
	Tell me about ordering accessories	248
24	Tell me about getting help	249
	Tell me about HP Instant Support	249
	Tell me about HP Customer Care	249
	Tell me about HP Designjet Online	250
	Tell me about other sources of information	251
25	Legal information	253
	Worldwide Limited Warranty—HP Designjet 4000 Printer series	253
	Hewlett-Packard Software License Agreement	256
	Open source acknowledgments	257
	Regulatory notices	258
	DECLARATION OF CONFORMITY	261
	Index	263

1 Introduction

- “Using this guide” on page 7
- “The printer’s main features” on page 8
- “The printer’s main components” on page 9
- “The front panel” on page 10
- “Printer software” on page 12

Using this guide

The *User’s Guide* and *Quick Reference Guide* are organized into the following chapters.

Introduction

This chapter provides a brief introduction to the printer and its documentation for new users.

How do I ...

These chapters help you to carry out various procedures such as loading paper or changing an ink cartridge. Many of these procedures are illustrated with drawings, and some are also illustrated with animations (in the *User’s Guide* only).

The problem is ...

These chapters help you to solve problems that may occur while printing.

Tell me about ...

Available in the *User’s Guide* only, these chapters contain reference information, including the specifications of the printer, and the part numbers of paper types, ink supplies, and other accessories.

Legal information

This chapter contains HP’s limited warranty statement, software license agreement, open source acknowledgments, regulatory notices, and declaration of conformity.

Index

In addition to the table of contents, there is an alphabetical index to help you to find topics quickly.

The printer's main features

Your printer is a color inkjet printer designed for printing high-quality images on paper up to 42 in (1.06 m) wide. Some major features of the printer are shown below:

- Production speeds of up to 1.5 m²/min (16 ft²/min), using HP Universal InkJet Bond Paper with the **Fast** print quality option and the **Optimize for Lines and Text** option
- Print resolution of up to 2400×1200 optimized dpi, from a 1200×1200 dpi input, using the **Best** print quality option, the **Maximum Detail** and **Optimize for Images** options, and glossy paper (for more information on print resolution, see “Tell me about functional specifications” on page 239)
- Unattended printing using 400 cm³ ink cartridges and rolls of paper up to 90 m or 300 ft in length (see “Tell me about ink cartridges” on page 233)
- High productivity features such as multi-file job submitting, job previewing, queueing, and nesting using the printer's Embedded Web Server (see “Tell me about the Embedded Web Server” on page 231)
- Ink and paper usage information is available from the front panel, and on the Web from the Embedded Web Server
- Accurate and consistent color reproduction features:
 - Press emulations for U.S., European, and Japanese standards; and color monitor RGB emulations (see “Tell me about color emulation modes” on page 225)
 - Automatic color calibration

The printer's main components

The following front and rear views of the printer illustrate the main components.

Front view

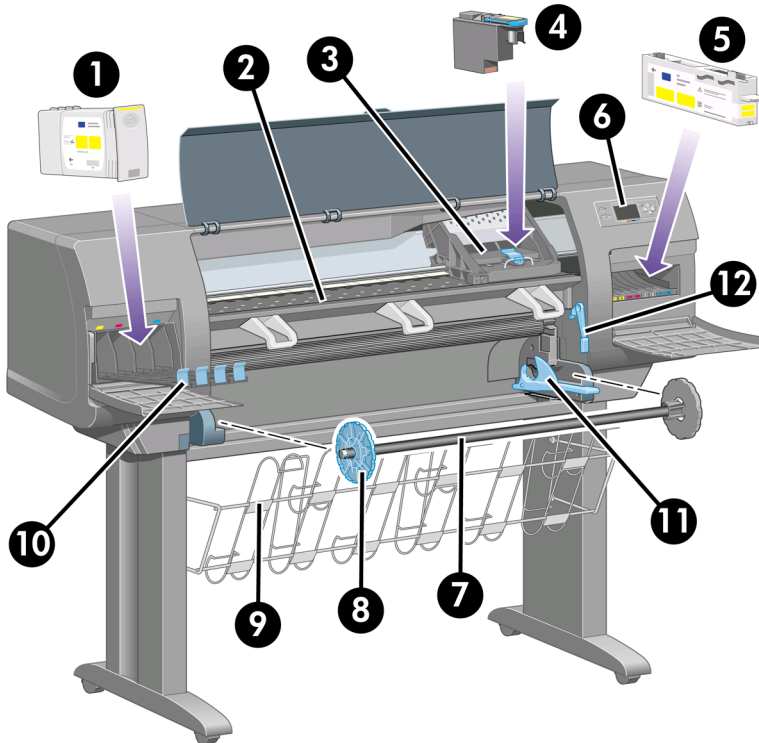

1. Ink cartridge
2. Platen
3. Printhead carriage
4. Printhead
5. Printhead cleaner
6. Front panel
7. Spindle
8. Blue removable paper stop
9. Bin
10. Ink cartridge drawer
11. Spindle lever
12. Paper load lever

Rear view

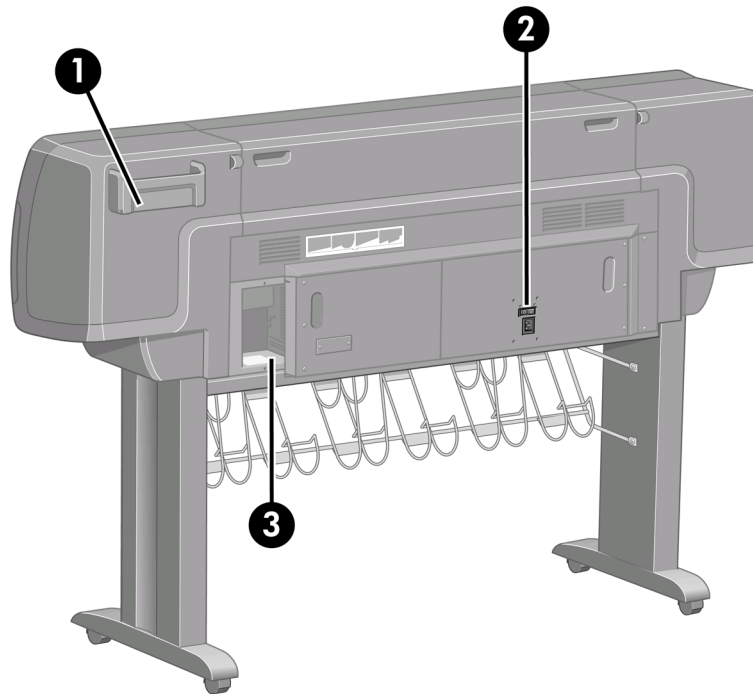

1. Quick Reference Guide holder
2. Power socket and on/off switch
3. Sockets for communication cables and optional accessories

The front panel

Your printer's front panel is located on the front of the printer, on the right-hand side. It has the following important functions:

- It must be used to perform certain operations, such as loading and unloading paper.
- It can display up-to-date information about the status of the printer, the ink cartridges, the printheads, the paper, the print jobs, etc.
- It can provide guidance in using the printer.
- It displays warning and error messages when appropriate.
- It can be used to change the values of printer settings and thus change the operation of the printer. However, settings in the printer are overridden by settings in the Embedded Web Server or in the driver.

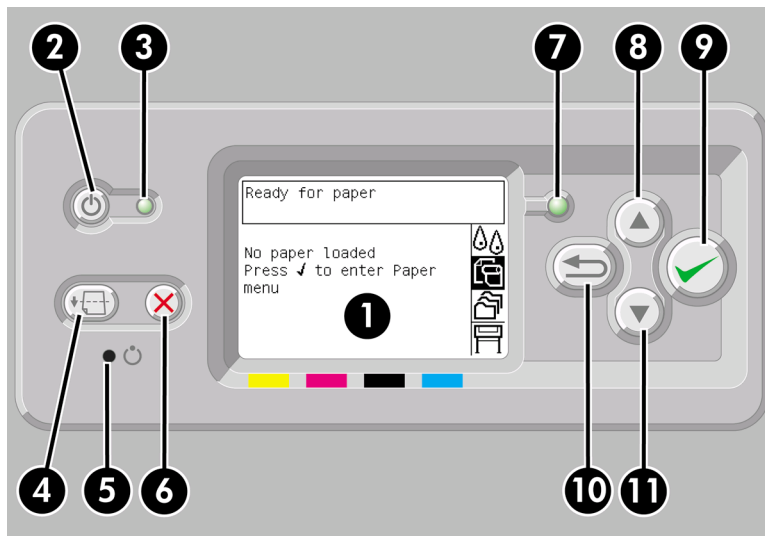

The front panel has the following components:

1. The display area, where information, icons, and menus are displayed.
2. The **Power** key turns the printer on and off. If the printer is in sleep mode, this key will wake it up.
3. The Power light is off when the printer is off; amber when the printer is in sleep mode; green when the printer is on; green and flashing when the printer is in transition between off and on.
4. The **Form Feed and Cut** key normally ejects the sheet (if a sheet is loaded) or advances and cuts the roll (if a roll is loaded). However, if the printer is waiting for more pages to be nested, this key cancels the waiting time and prints the available pages immediately.
5. The **Reset** key restarts the printer (as if it were switched off and switched on again). You will need an implement with a narrow tip to operate the **Reset** key.
6. The **Cancel** key cancels the current operation. It is often used to stop printing the current print job.
7. The Status light is off when the printer is not ready to print: it may be off, or in sleep mode. It is green when the printer is ready and idle; green and flashing when the printer is busy; amber when a serious internal error has occurred; amber and flashing when awaiting human attention.
8. The **Up** key moves to the previous item in a list, or increases a numerical value.
9. The **Select** key selects the item that is currently highlighted.
10. The **Back** key goes back to the previous menu. If you press it repeatedly, or hold it down, you will soon return to the main menu.
11. The **Down** key moves to the next item in a list, or decreases a numerical value.

To **highlight** an item in the front panel, press the **Up** or **Down** key until the item is highlighted.

To **select** an item in the front panel, first highlight it and then press the **Select** key.

Chapter 1

The four front-panel icons are all found in the main menu. If you need to select or highlight an icon, and you don't see the icons in the front panel, press the **Back** key until you can see them.

When this guide shows a series of front panel items like this: **Item1 > Item2 > Item3**, it means that you should select **Item1**, then select **Item2**, then select **Item3**.

Information about specific uses of the front panel can be found throughout this guide.

Printer software

The following software is provided with your printer:

- The Embedded Web Server, which runs in the printer and enables you to use a Web browser on any computer to submit and manage print jobs, and check ink levels and printer status
- The HP-GL/2 and RTL driver for Windows
- The PostScript driver for Windows
- The PostScript driver for Mac OS 9 and Mac OS X
- The ADI driver for AutoCAD 14

2 How do I assemble the printer?

- “Getting started” on page 13
- “How do I unpack the printer?” on page 14
- “How do I assemble the stand?” on page 16
- “How do I attach the stand to the printer?” on page 22
- “How do I remove packaging materials from the printer?” on page 26
- “How do I assemble the bin?” on page 29
- “How do I switch on the printer for the first time?” on page 34
- “How do I install ink cartridges?” on page 36
- “How do I remove the setup printheads?” on page 40
- “How do I install the printheads?” on page 42
- “How do I install the printhead cleaners?” on page 45
- “How do I load a roll of paper onto the spindle?” on page 47
- “How do I load the paper into the printer?” on page 50
- “How do I connect the printer?” on page 56
- “How do I install accessories?” on page 58

Getting started

The following topics describe how to assemble your new printer (also described in the *Setup instructions*).

Because some of the components of the printer are bulky, you may need up to four people to lift them. You will also need at least 3 × 5 m (10 × 16 ft) of empty floor space, and about two hours.

The symbols on the boxes identify the contents. Refer to the table below:

Symbol on box	Contents of box
■	Printer body
●	Stand and bin assembly
☾	Consumables box, including ... ★ Maintenance Kit (please keep this safe)
▲	Spare box (used while attaching the stand to the printer)

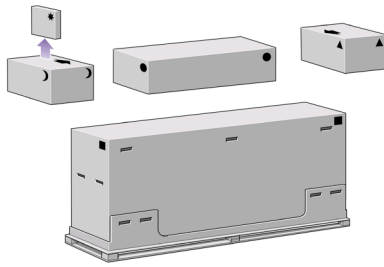

How do I assemble the printer?

How do I unpack the printer?

Before you start unpacking, consider where you are going to put the assembled printer. You should allow some clear space at the back and at the front of the printer. The recommended clearances are shown in the illustration below.

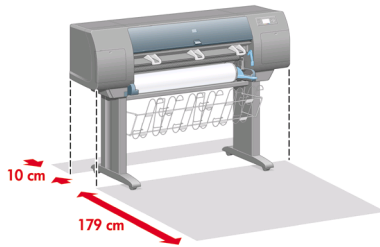

When you have identified a suitable location, you can begin unpacking.

1. Remove the two side lids. Then remove all the upper four plastic handles from both sides of the box (two each side).

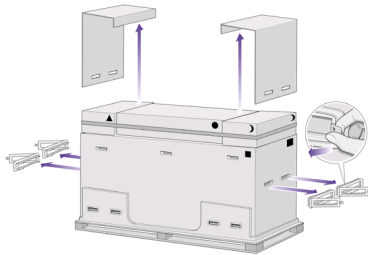

2. Cut the strap around the boxes carefully, as the boxes may fall as soon as the strap is cut.

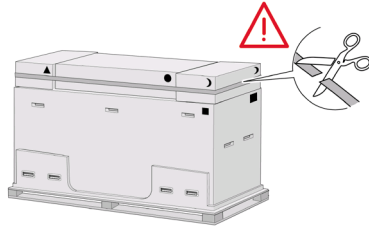

3. Remove the boxes from the top of the main printer box.

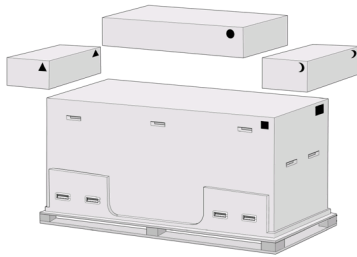

4. Remove all eight plastic handles from both sides of the box.

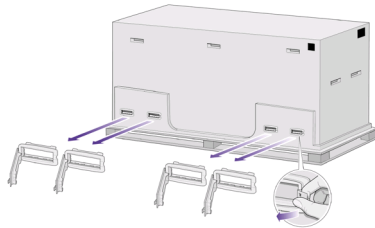

5. Remove the main printer box.

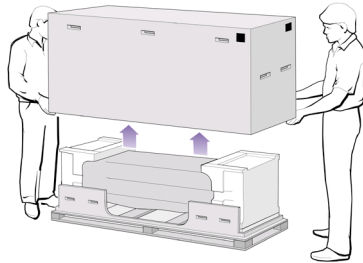

6. Remove the two packing pieces.

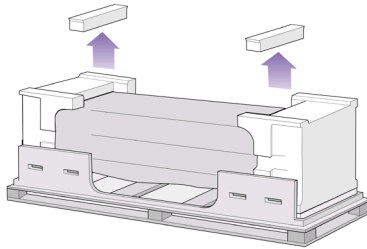

How do I assemble the printer?

How do I assemble the stand?

Warning When you are unpacking the leg assembly, you will see that there is **anti-slip** material around two of the wheels on the feet. **Do not remove** this material yet.

1. Remove the first tray from the stand and bin assembly box.

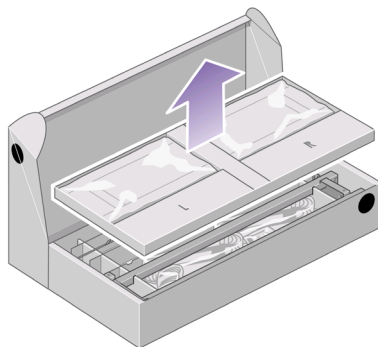

- From the first tray, remove the two boxes marked with L and R. Place them on the floor as shown.

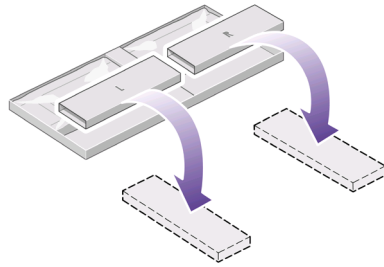

- Lower the cross-brace on to the L and R boxes.

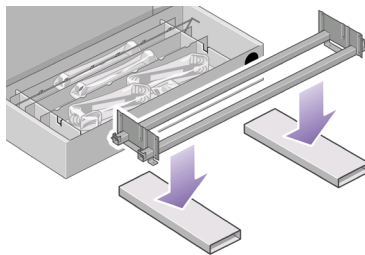

- You now need to identify which is the left and the right side of the cross-brace.

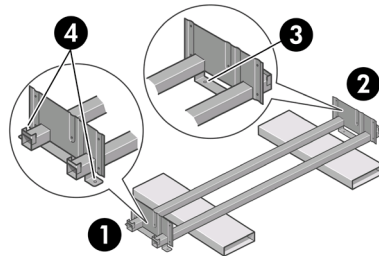

(1) left (2) right (3) one hole (4) two holes

5. Now you will need the bag of screws and the screwdriver provided. You may notice that the screwdriver is slightly magnetic.

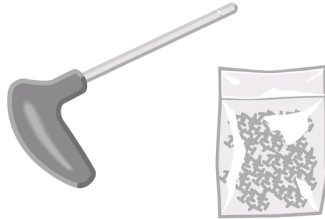

6. Remove the two leg covers from the left leg.

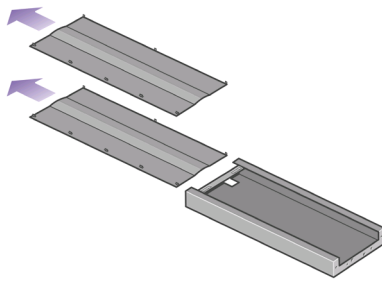

7. Lower the left leg onto the left side of the cross-brace. The left leg will fit only on the left side of the cross-brace.

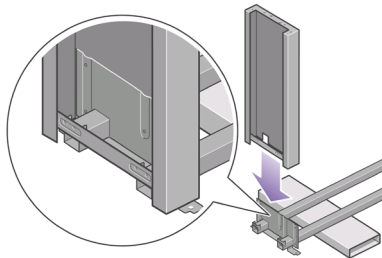

How do I assemble the printer?

8. Fix the left leg to the cross-brace using four screws on the inner side of the leg.

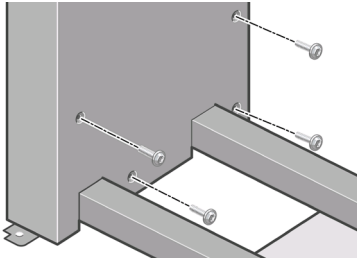

9. Fix the left leg to the cross-brace using two screws on the outer side of the leg.

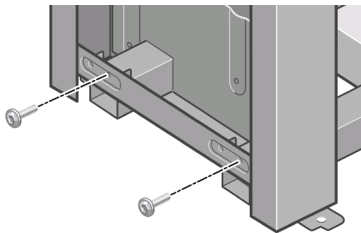

10. Lower the right leg onto the right side of the cross-brace. The right leg will fit only on the right side of the cross-brace.

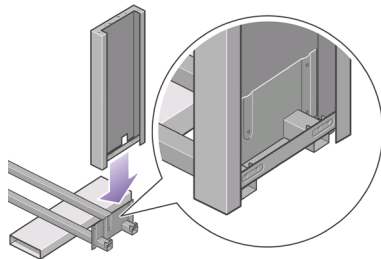

11. Fix the right leg to the cross-brace using four screws on the inner side of the leg.

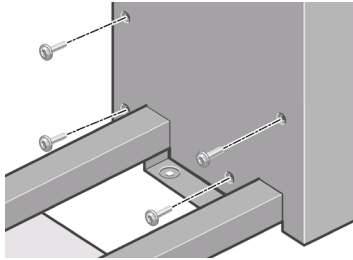

12. Fix the right leg to the cross-brace using two screws on the outer side of the leg.

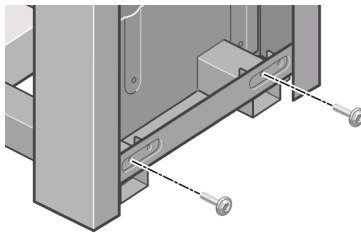

13. Position a foot on the left leg. There are pins to help you to position the foot correctly.



Note Do not remove the anti-slip material from the wheel.

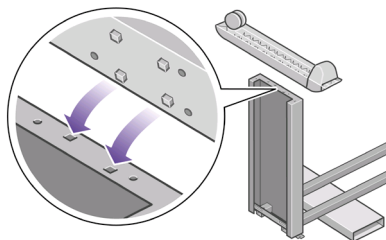

14. Fix the left foot using four screws.

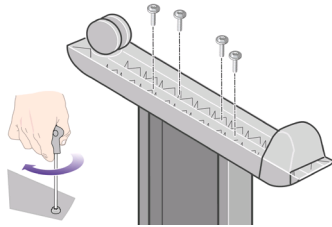

15. Position a foot on the right leg. There are pins to help you to position the foot correctly.



Note Do not remove the anti-slip material from the wheel.

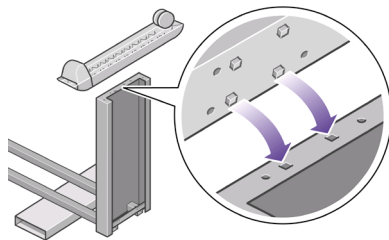

16. Fix the right foot using four screws.

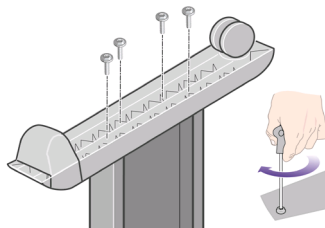

How do I attach the stand to the printer?

1. You now need to identify the left and right of the printer. This information is shown on the foam end packs. Also identify the rear of the printer.

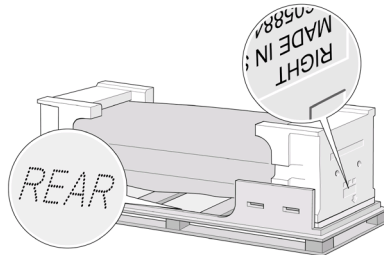

2. Pull open the protective plastic from the base of the printer. Please ensure that there is a three-meter space clear of obstructions to the rear of the printer. Remove the two desiccant bags from the printer.

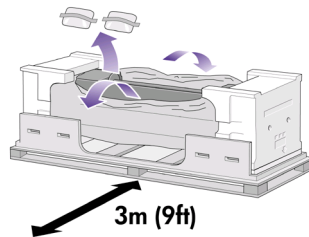

3. In this step, make sure you position the stand pins in the holes in the center of the printer body brackets.

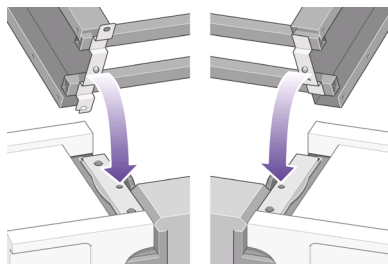

How do I assemble the printer?

Lift the stand assembly onto the printer body. The anti-slip material should face to the rear of the printer.

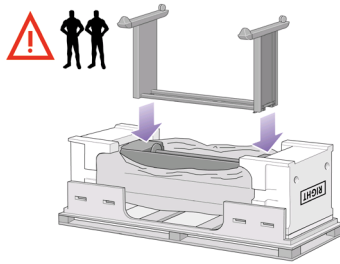

4. Fix the right side of the stand to the printer using one screw. Make sure that the screw is fully tightened.

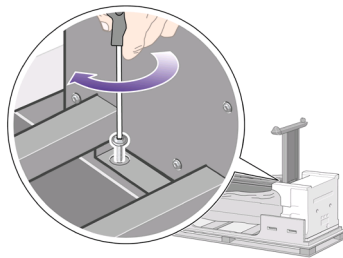

5. Fix the left side of the stand to the printer using two screws. Make sure that the screws are fully tightened.

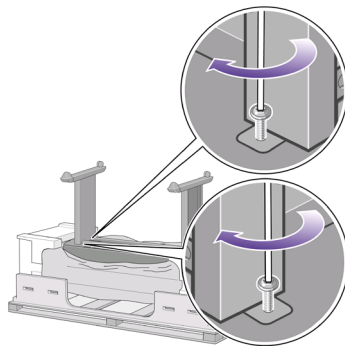

6. Place the spare and consumables boxes against the rear of the printer box. The arrows on the boxes must point towards the printer box. Check that the anti-slip material is still fixed to the two rear wheels.

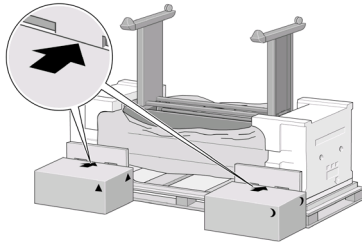

7. Using four people, rotate the printer on to the spare and consumables boxes.

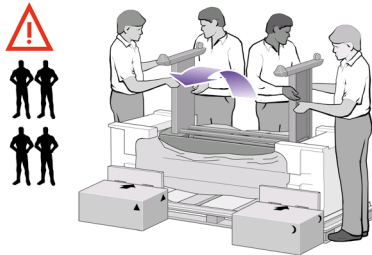

Rotate the printer until its rear rests on the spare and consumables boxes and the wheels with the anti-slip material touch the floor.

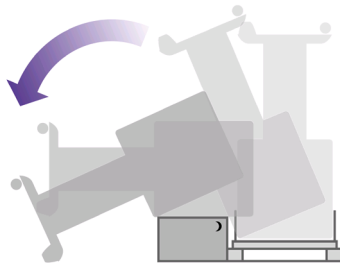

How do I assemble the printer?

8. Remove the pallet before trying to lift the printer into an upright position.

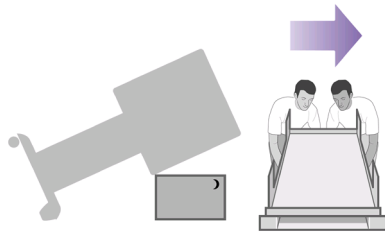

9. Using four people and the hand holds on the rear of the printer body, carefully lift the printer into an upright position. The anti-slip material should stop the printer from sliding forwards.

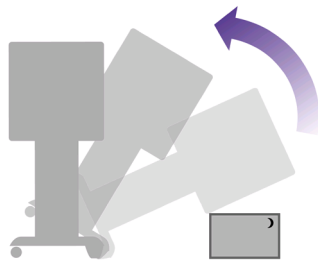

How do I remove packaging materials from the printer?

1. Remove the two foam end packs and the plastic covering the printer.

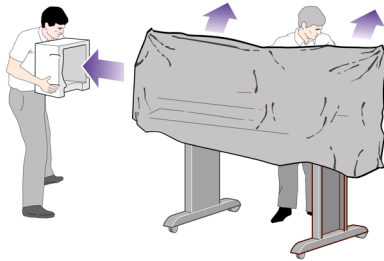

2. Position the left leg cover on the front of the left leg (1), then clip the rear edge (2) into place.

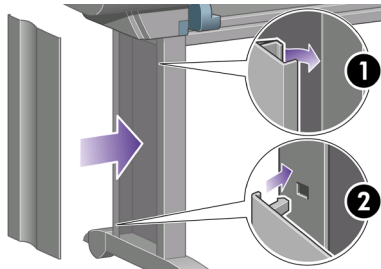

3. Position the right leg cover on the front of the right leg (1), then clip the rear edge (2) into place.

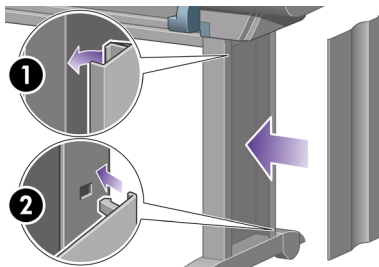

How do I assemble the printer?

4. Remove the anti-slip material from the two rear wheels on the stand assembly.



5. Remove the packing tapes 1 to 8. Open the printer window and remove the two window inserts 9 and 10.

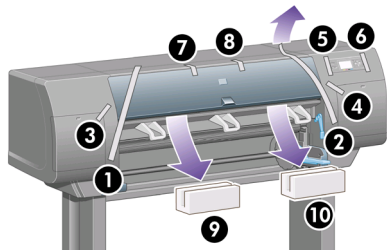

6. Remove the protective covering from the printer window and the front panel screen.

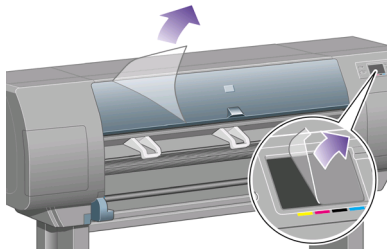

7. Remove the spindle lock.

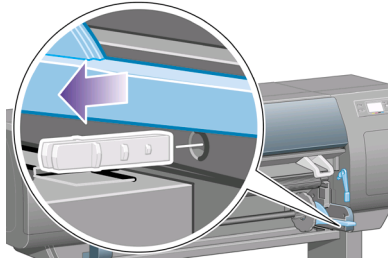

8. Open the printhead cleaner door and remove the carriage packing material. Then close the cleaner door.

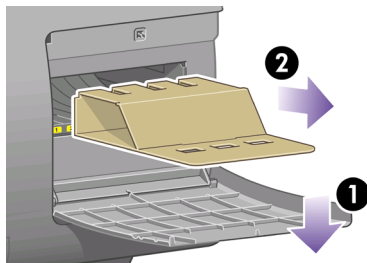

9. Press the spindle lever down, which will unseat the right-hand end of the spindle. Remove that end of the spindle first, and then the left. Do not insert your fingers into the spindle supports during the removal process.

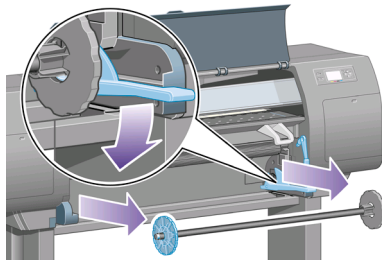

How do I assemble the printer?

10. Remove the spindle lock foam piece. Then replace the spindle.

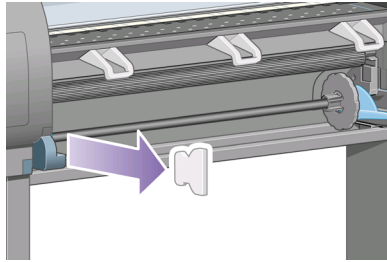

11. Install the Quick Reference Guide holder. Angle the holder at the top (1), then position the two hooks and clip the lower part (2) to the rear of the printer.

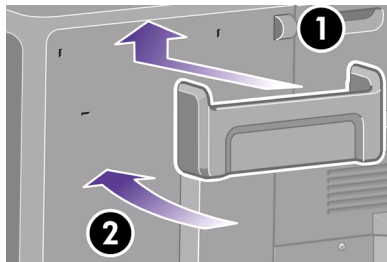

How do I assemble the bin?

1. Locate the bin components.

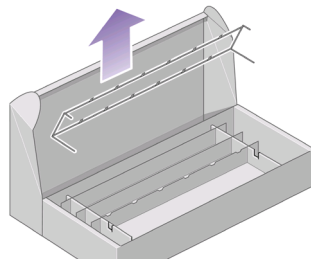

2. Fix one screw to the inside of the stand's left leg.

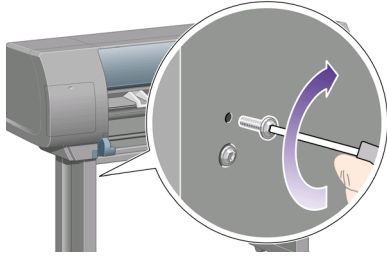

3. Do not fully fit the screw.

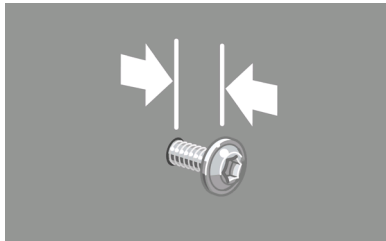

4. Fix one screw to the inside of the stand's right leg.

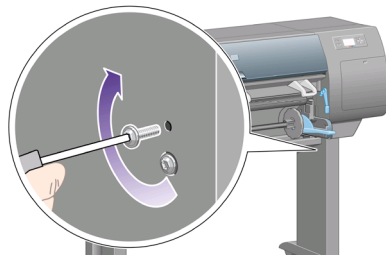

5. Do not fully fit the screw.

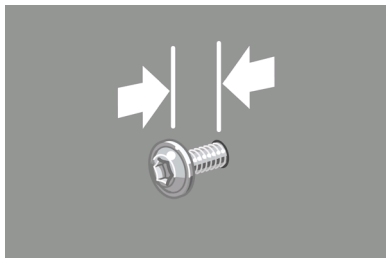

How do I assemble the printer?

6. Lift the supporting framework of the bin into position in front of the printer.

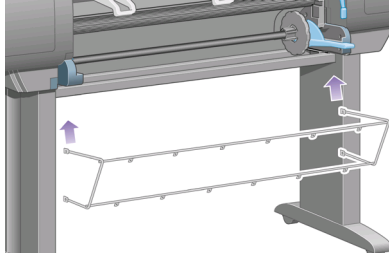

7. Fix the top arms of the bin to the two screws that you have just fitted.

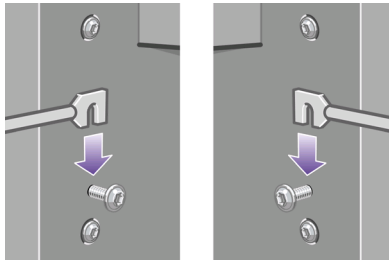

8. Fix the lower arms of the bin to the stand using one screw for each leg.

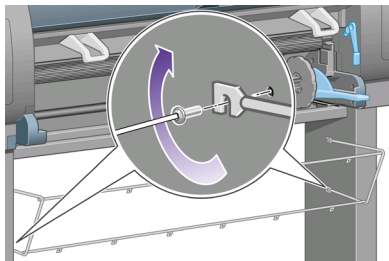

9. Now tighten the two top screws.

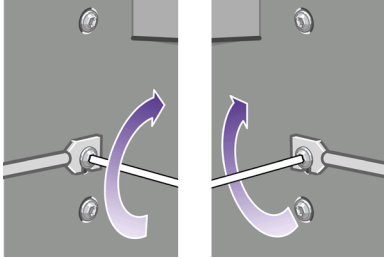

10. Clip all six loops to the frame of the bin. Locate the loops with rear extensions in positions 2, 4, and 6.

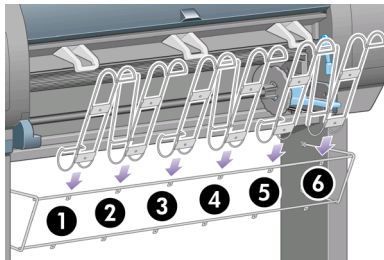

11. Secure all six loops to the frame, using two clips on each loop.

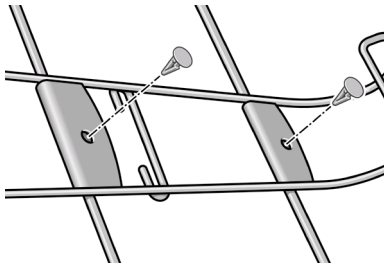

How do I assemble the printer?

12. Fit all three mobile stoppers to the three loops as indicated.

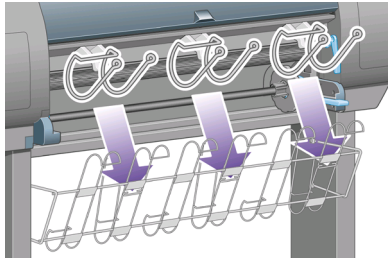

13. Carefully squeeze the mobile stopper and then fit it onto the loop.

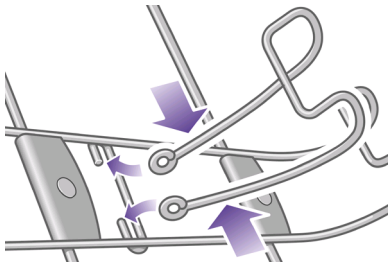

14. When the mobile stopper is engaged with the loop, release your grip.

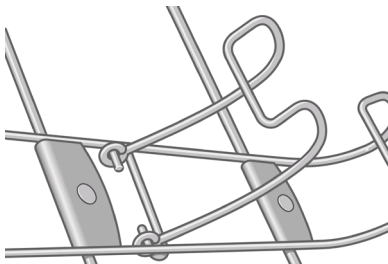

15. Move the three mobile stoppers into their parked position. These stoppers are used only when printing on sheets of paper less than 900 mm in length (up to A1 size).

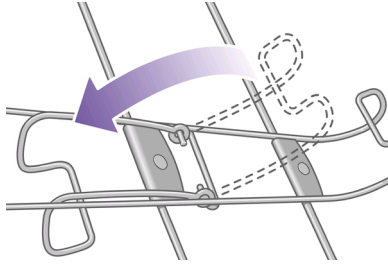

How do I assemble the printer?

How do I switch on the printer for the first time?

1. Plug the power cable into the rear of the printer, then plug the other end into the AC power outlet.

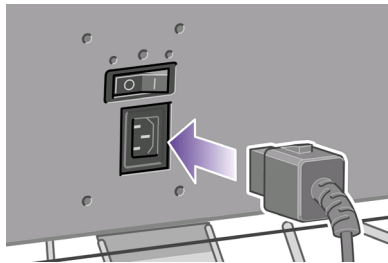

2. Turn the power switch at the rear of the printer to the on position.

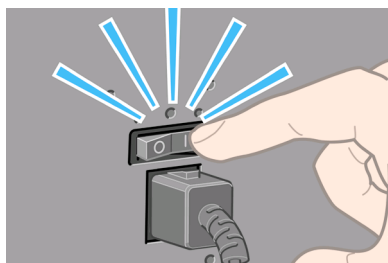

3. If the power light on the front panel remains off, press the **Power** key to switch on the printer.

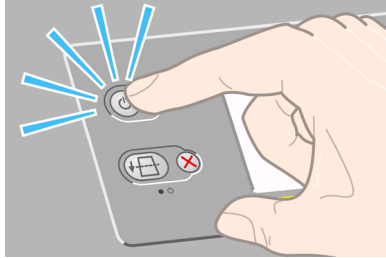

4. Wait until you see this front panel message. Highlight your language on the front panel using the **Up** and **Down** keys. Press the **Select** key.

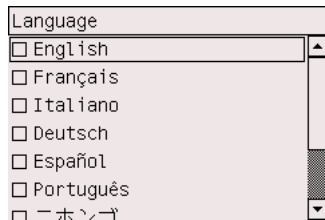

5. The front panel will now display how to install the ink supplies.

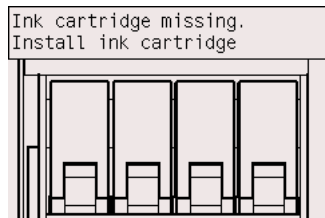

How do I install ink cartridges?

1. Remove the printheads, printhead cleaners, and ink cartridges from the consumables box.

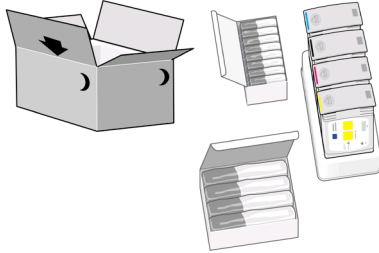

2. Find the ink cartridge door, which is on the left side of the printer.

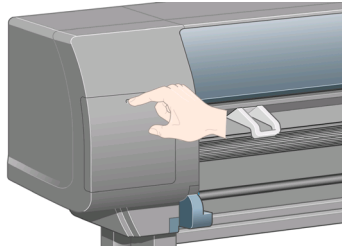

3. Press the ink cartridge door until it clicks.

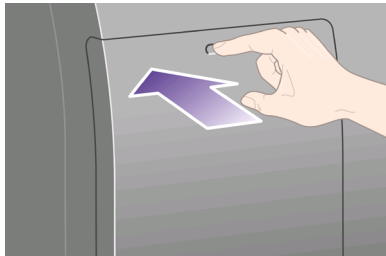

4. Open the ink cartridge door.

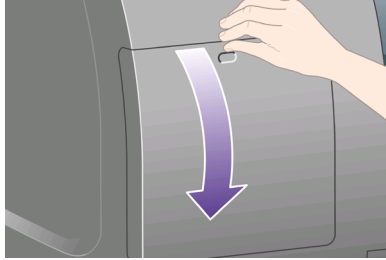

5. To release the ink cartridge drawer, pull the blue handle down.

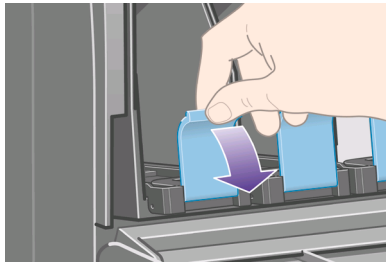

6. Slide the ink cartridge drawer out.

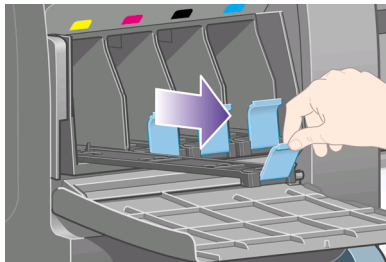

7. Place the ink cartridge onto the ink cartridge drawer.



Note There are marks on the drawer showing the correct location.



8. Position the ink cartridge at the rear of the drawer as indicated.



9. Push the ink cartridge drawer back into the printer until it locks into position.



If you have difficulty, see “The problem is I cannot insert an ink cartridge” on page 207.

10. Install the other three ink cartridges in the same way.

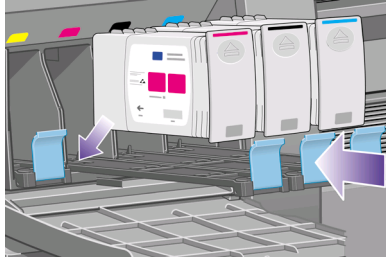

11. Close the ink cartridge door (push it until it clicks shut).

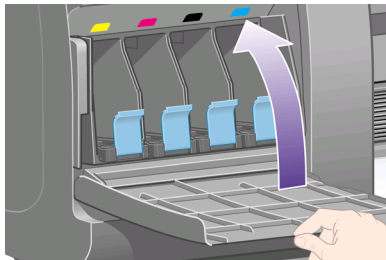

12. Wait (about a minute) until you see this front panel message.

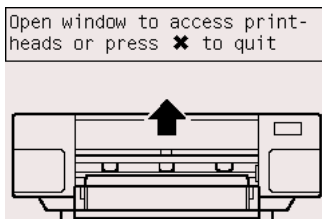

How do I remove the setup printheads?

1. Open the printer window.

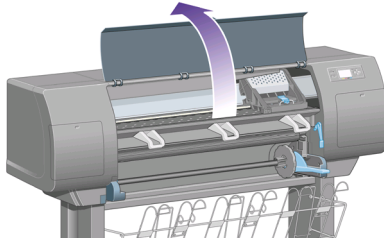

2. Remove the packing tape that is holding down the printhead carriage latch.

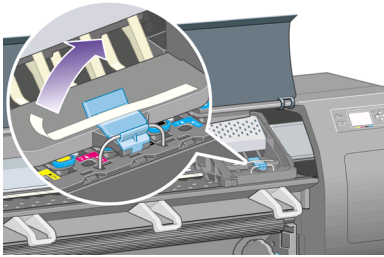

3. Pull up and release the latch on top of the carriage.

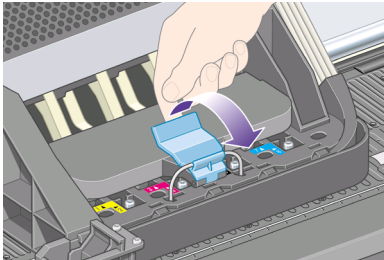

How do I assemble the printer?

4. Lift up the cover. This will give you access to the setup printheads.

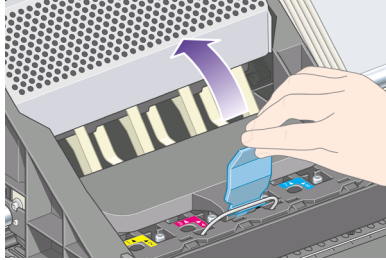

5. Before removing the setup printheads, look at the window on top of each one and check that the printhead contains ink. If it does not, contact your customer service representative.

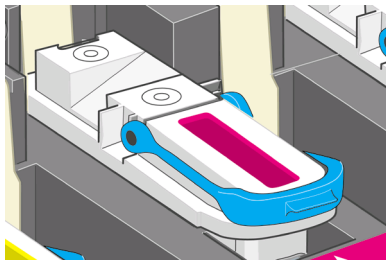

6. To remove a setup printhead, lift up the blue handle.

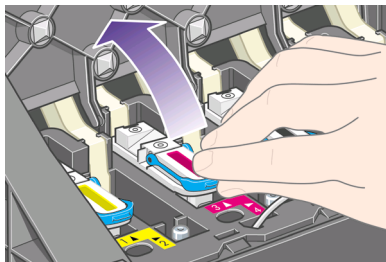

7. Using the blue handle, gently disengage the setup printhead from the carriage.

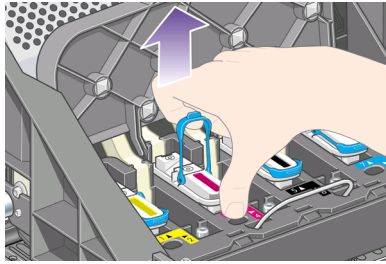

8. Lift the setup printhead until it is released from the carriage. Then remove the other setup printheads.

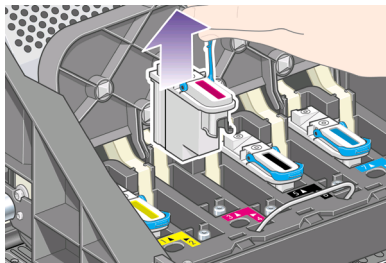

How do I assemble the printer?

How do I install the printheads?

1. Remove the blue protective cap and the clear protective tape from the printhead.

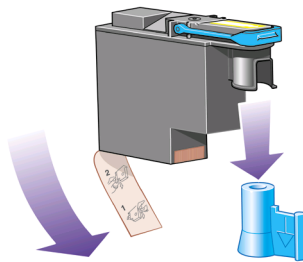

2. Lower all the printheads vertically into their correct positions.

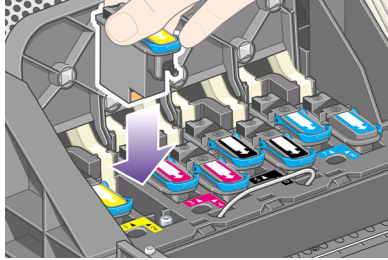

3. Seat the printheads slowly and carefully.

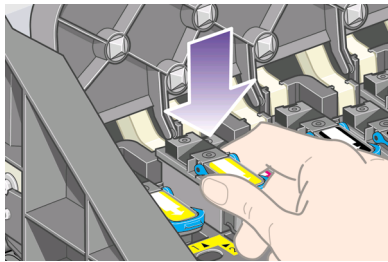

If you have difficulty, see “The problem is I cannot insert a printhead” on page 207.

4. Make sure the printheads are correctly seated. When all the printheads are installed, the front panel prompts, “Close printhead cover and window”.

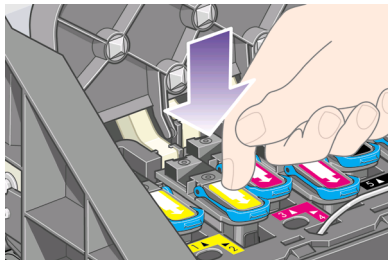

5. If **Reseat** is displayed on the front panel, see “The problem is the front panel keeps telling me to reseat or replace a printhead” on page 207.

6. Close the carriage cover.

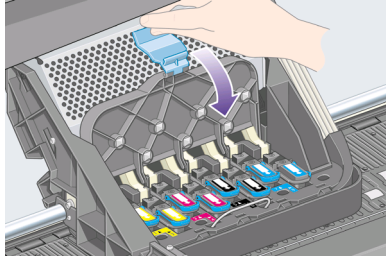

7. Make sure the latch engages correctly.

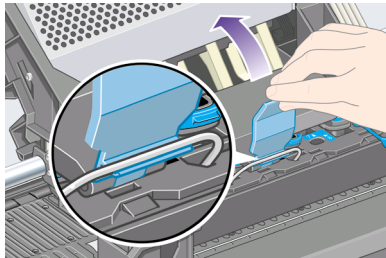

8. Close the printer window.

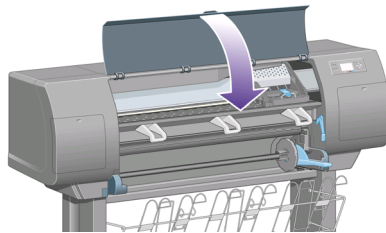

9. Please wait (about a minute) while the printer checks the printheads.

How do I assemble the printer?

How do I install the printhead cleaners?

1. Wait until you see this front panel message.

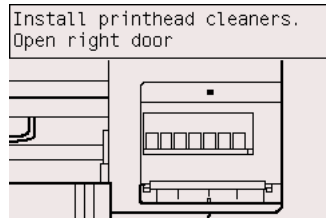

2. Press the printhead cleaner door, which is on the right side of the printer.

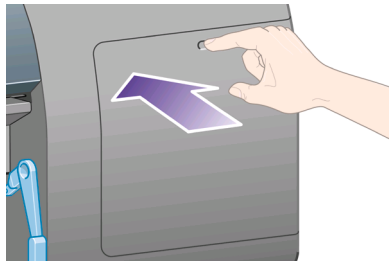

3. Open the printhead cleaner door.

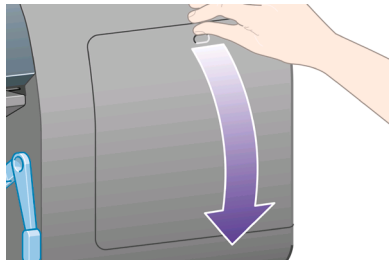

4. Insert the printhead cleaner into the slot of the correct color.

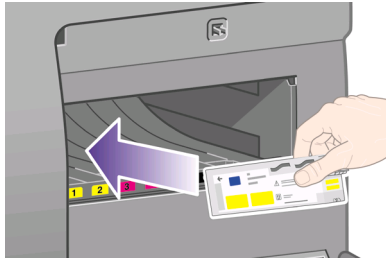

5. Push the printhead cleaner in and down until it clicks into place.

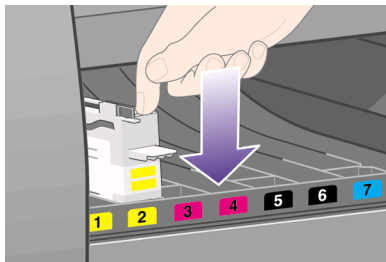

If you have difficulty, see “The problem is I cannot insert a printhead cleaner” on page 207.

6. Insert the other seven printhead cleaners into the correct slots.



How do I assemble the printer?

7. Close the printhead cleaner door.

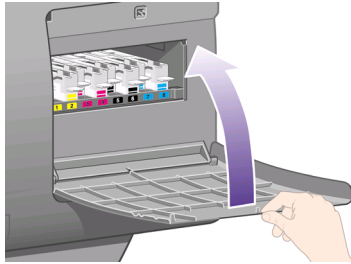

8. Wait until you see this front panel message, then press the **Select** key.

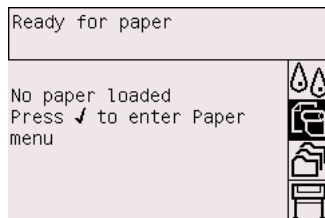

How do I load a roll of paper onto the spindle?

1. Lower the spindle lever.

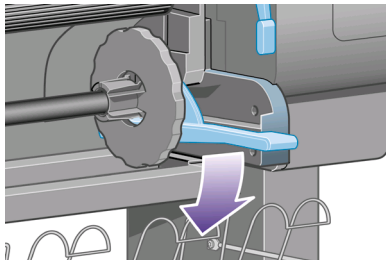

2. Remove the right-hand end of the spindle (1) from the printer, then move it to the right in order to extract the other end (2). Do not insert your fingers into the spindle supports during the removal process.

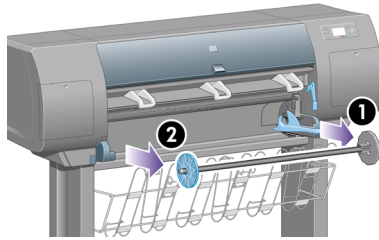

3. Remove the blue paper stop (1) from the left-hand end of the spindle. Keep the spindle horizontal.



4. Slide the roll of paper that came with your printer onto the spindle. Make sure the paper is oriented exactly as shown.



Note There is also a label on the spindle showing the correct orientation.

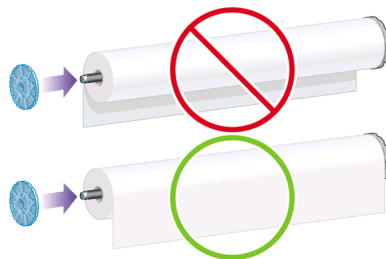

How do I assemble the printer?

- Put the blue paper stop onto the spindle and push it on as far as it will go without using excessive force.

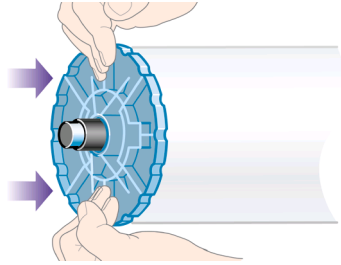

- Make sure the stop is seated correctly.

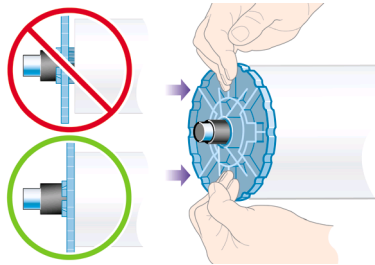

- With the blue paper stop on the left, slide the spindle into the printer. The blue spindle lever will drop down automatically as you insert the spindle.

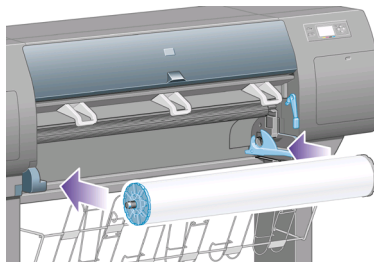

8. When you meet resistance, lift the blue lever to seat the spindle properly.

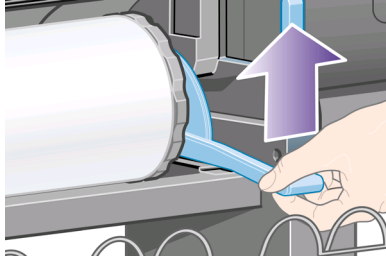

9. The spindle lever will be in the horizontal position when the spindle has been correctly inserted.

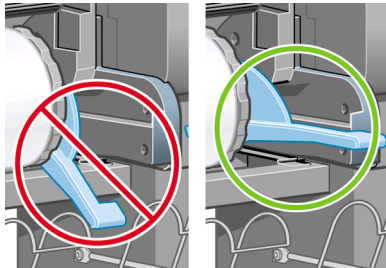

How do I assemble the printer?

How do I load the paper into the printer?

1. At the front panel, highlight the  icon and press the **Select** key.

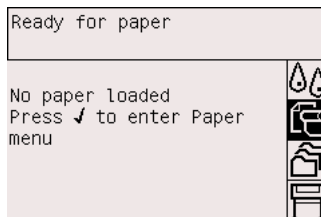

2. Highlight **Roll** and press the **Select** key.

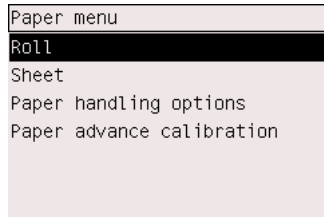

3. Highlight **Load roll now** and press the **Select** key.

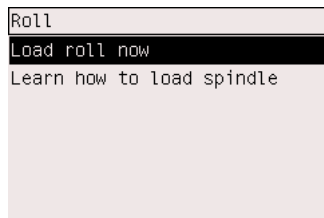

4. Highlight the paper type you have loaded and press the **Select** key.

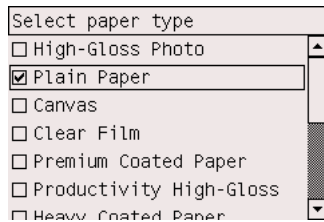

5. Wait until you see the 'Open window' message.

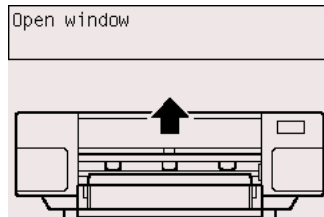

6. Open the printer window.

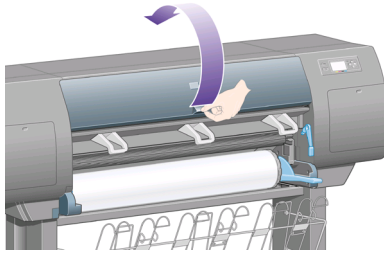

7. Lift the paper load lever.

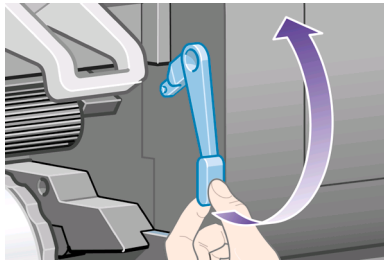

8. Pull out approximately 1 m (3 ft) of the roll.

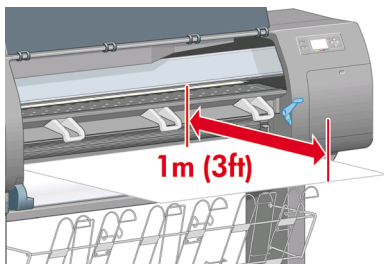

How do I assemble the printer?

9. Insert the edge of the roll above the black roller.

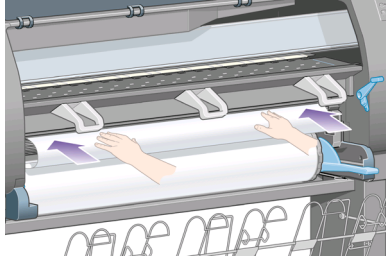

Warning Take care not to touch the rubber wheels on the platen while loading paper: they may rotate and trap skin, hair, or clothing.

10. Wait until the paper emerges from the printer as shown below.

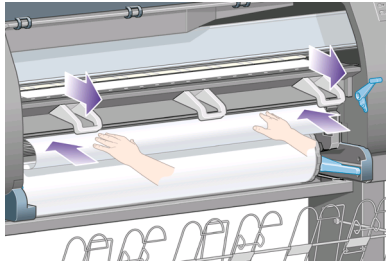

Note If you have an unexpected problem at any stage of the paper loading process, see “The problem is the paper cannot be loaded successfully” on page 209.

11. Make sure the paper is aligned with the blue line and half-circle on the platen.

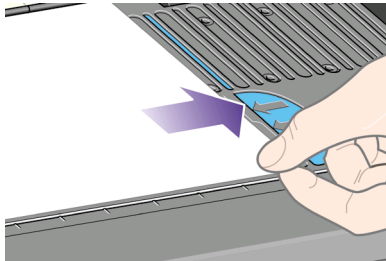

12. Lower the paper load lever.

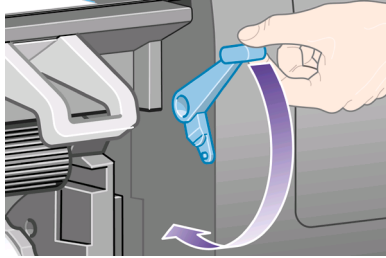

13. You should see the front panel message below.

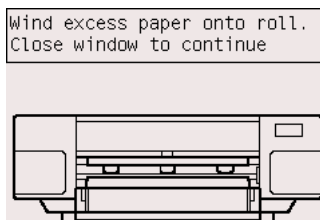

14. Using the stops, carefully wind the excess paper back onto the spindle.

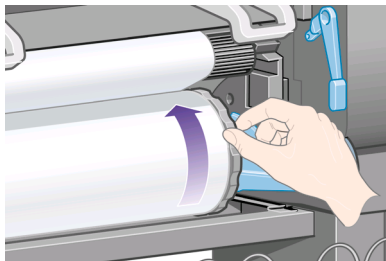

15. Close the printer window.

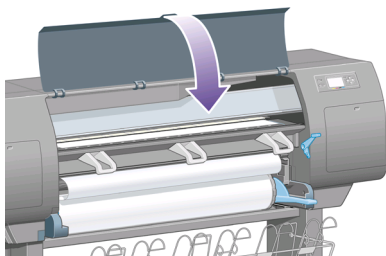

How do I assemble the printer?

16. The printer will adjust the paper by winding it back and forth, after which you can expect the front panel message below.

```
Loading roll
Wind any excess paper onto
roll to ensure image quality
when printing.
Press ✓ to continue
```

17. Using the stops, carefully wind the excess paper back onto the spindle.

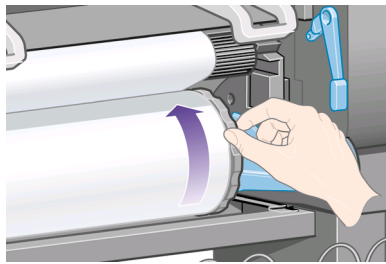

18. The printer will automatically perform printhead alignment and a color calibration for the paper type that you have loaded. During this process the printer will advance the paper by up to 3 m (≈10 ft) before printing. Please do not try to stop the paper advance; it is necessary to ensure a successful printhead alignment. The whole alignment and calibration process will take about twenty minutes; while it is going on, you can start connecting the printer. See “How do I connect the printer?” on page 56.

How do I connect the printer?

1. Your printer can be connected to a computer directly or to one or more computers via a network.

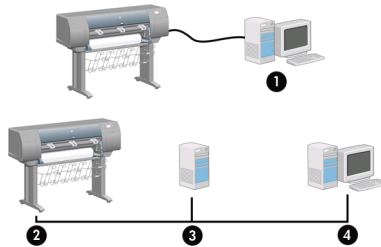

- (1) PC, Macintosh, or workstation
- (2) Printer
- (3) Server
- (4) PC, Macintosh, or workstation

2. Locate the area at the back of the printer where you can connect the printer to your computer or network, or install an optional accessory.

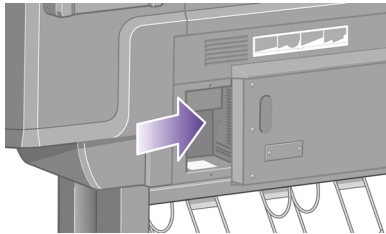

3. A Fast Ethernet socket is provided for connection to a network.

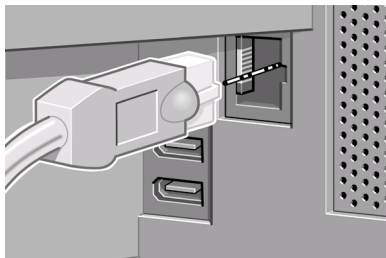

How do I assemble the printer?

- Two FireWire sockets are provided for direct connection to computers.

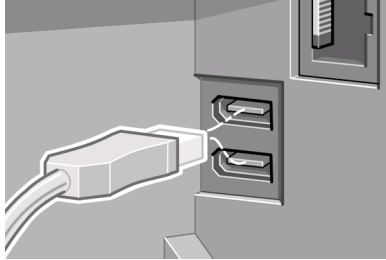

Note A FireWire cable is not provided with the printer. Any cable recommended by the 1394 Trade Association may be used.

- A larger socket is provided to connect an optional accessory.



Caution Do not attempt to use this socket for any other purpose.

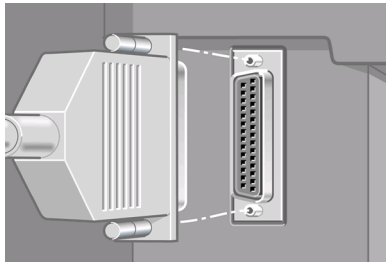

- Pass the network cable through the hook at the rear of the printer.

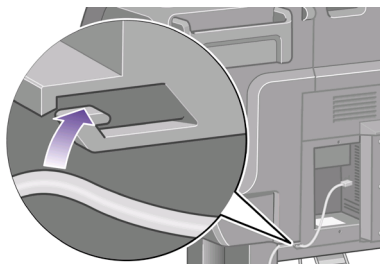

How do I install accessories?

There are various optional accessories that you can buy and install at any time during the life of your printer. The physical installation of each accessory is graphically illustrated on the poster provided with the accessory (except in the case of the Jetdirect print server; see below). Here are some further steps to follow after completing the physical installation process.

Gigabit Ethernet socket

To check that the Gigabit Ethernet socket has been correctly installed, go to the front panel and select the  icon, then **I/O setup** > **Gigabit Ethernet**.

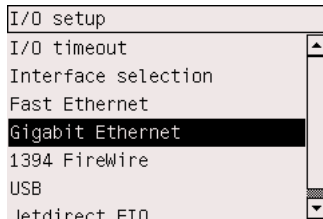

The front panel will reveal whether the socket is **Installed** or **Not installed**.

Please follow the appropriate instructions to connect the printer to your network:

- “How do I connect my printer to a network (Windows)?” on page 64
- “How do I connect my printer to a network (Mac OS X)?” on page 66
- “How do I connect my printer to a network (Mac OS 9)?” on page 68

You can plug in your network cable as illustrated below.

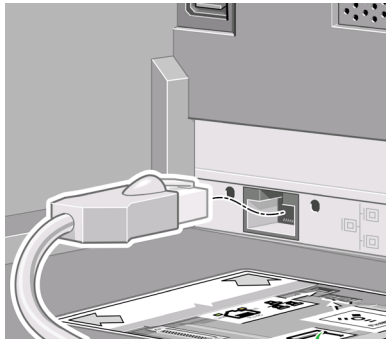

USB 2.0 socket

To check that the USB 2.0 socket has been correctly installed, go to the front panel and select the  icon, then **I/O setup > USB**.

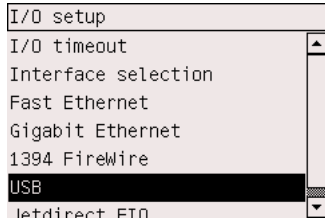

The front panel will reveal whether the socket is **Installed** or **Not installed**.

Please follow the appropriate instructions to connect the printer to your computer:

- “How do I connect my printer directly to a computer (Windows)?” on page 69
- “How do I connect my printer directly to a computer (Mac OS X)?” on page 70
- “How do I connect my printer directly to a computer (Mac OS 9)?” on page 71

You can plug in your USB cable as illustrated below.

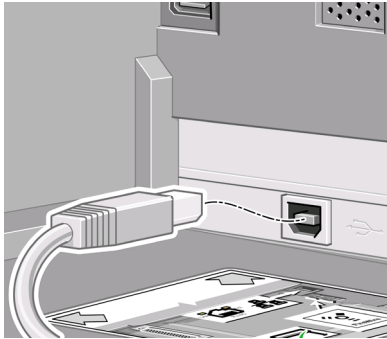

Jetdirect print server

To install the Jetdirect card:

1. Go to the rear of the printer and remove a small cover plate secured by two screws near the left-hand side.

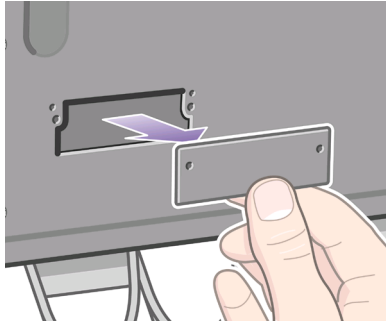
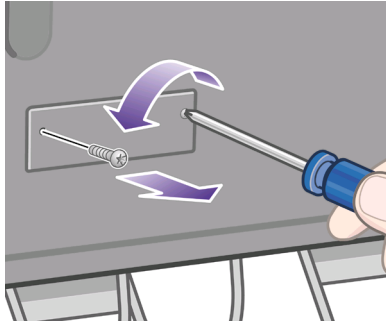

How do I assemble the printer?

2. Insert the Jetdirect card and secure it with the screws that accompany the card.

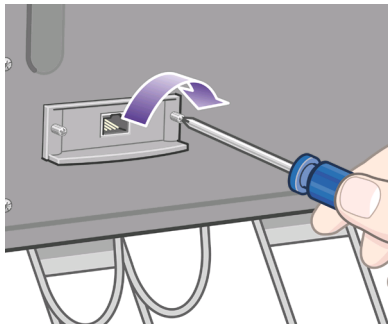
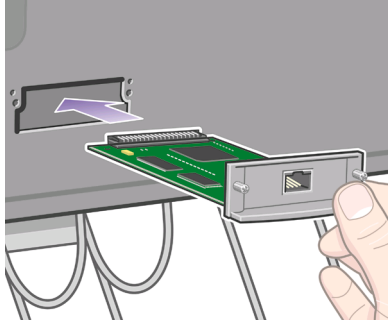

3. Save the cover plate and screws in case you decide to remove the Jetdirect card later.

To check that the card has been correctly installed, go to the front panel and select the  icon, then **I/O setup > Jetdirect EIO**.

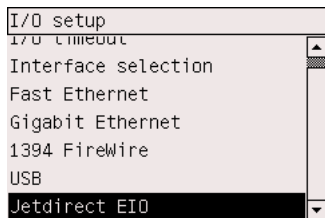

The front panel will reveal whether the print server is **Installed** or **Not installed**.

Please follow the appropriate instructions to connect the printer to your network:

- “How do I connect my printer to a network (Windows)?” on page 64
- “How do I connect my printer to a network (Mac OS X)?” on page 66
- “How do I connect my printer to a network (Mac OS 9)?” on page 68

You can plug in your network cable as illustrated below.

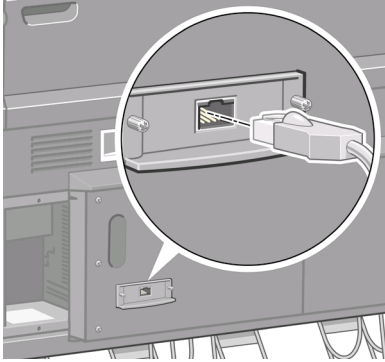

How do I assemble the printer?

Memory expansion card

To check that the 256 MB memory expansion card has been correctly installed, go to the front panel and select the  icon, then **Information > Show printer information**. The front panel will display various items of information about the printer, including **Memory size (MB)**.

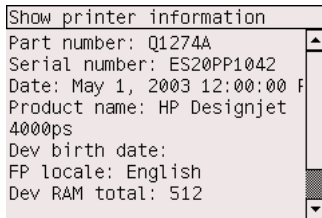

If the memory size is now shown as 512 MB, your memory expansion card has been correctly installed.

3 How do I set up my printer software?

- “How do I choose which connection method to use?” on page 63
- “How do I connect my printer to a network (Windows)?” on page 64
- “How do I connect my printer to a network (Mac OS X)?” on page 66
- “How do I connect my printer to a network (Mac OS 9)?” on page 68
- “How do I connect my printer directly to a computer (Windows)?” on page 69
- “How do I connect my printer directly to a computer (Mac OS X)?” on page 70
- “How do I connect my printer directly to a computer (Mac OS 9)?” on page 71
- “How do I uninstall the printer driver (Windows)?” on page 72
- “How do I uninstall the printer driver (Mac OS 9)?” on page 72

How do I choose which connection method to use?

The following methods can be used to connect your printer.

Connection type	Speed	Cable length	Other factors
Fast Ethernet	Fast; varies according to network traffic	Long (100 m=328 ft.)	Requires extra equipment (switches).
Gigabit Ethernet (optional accessory)	Very fast; varies according to network traffic	Long (100 m=328 ft.)	Requires extra equipment (switches).
Jetdirect print server (optional accessory)	Moderate; varies according to network traffic	Long (100 m=328 ft.)	Requires extra equipment (switches). Useful for wireless or AppleTalk connection, and for Novell printing.
FireWire	Very fast	Short (4.5 m=15 ft.)	
USB 2.0 (optional accessory)	Very fast	Short (5 m=16 ft.)	



Note 1 The speed of any network connection depends on all components used in the network, which may include network interface cards, hubs, routers, switches, and cables. If any one of these components is not capable of high-speed operation, you will find that you have a low-speed connection. The speed of your network connection can also be affected by the total amount of traffic from other devices on the network.

Note 2 The Gigabit Ethernet and USB 2.0 accessories are installed in the same slot in the printer, so they cannot both be installed at the same time. This

How do I set up my printer software?

does not affect the Jetdirect print server accessory, which is installed elsewhere.

Note 3 There are various possible ways of connecting the printer to a network, but only one of them can be active at a time; with the exception of the Jetdirect print server, which can be active at the same time as one other network connection.

How do I connect my printer to a network (Windows)?

In order to set up a network connection, you must configure the IP address of your printer. There are two cases, depending on the kind of IP address configuration on your network. You need only to follow the steps of the case that applies to your network architecture:

- Automatic IP address configuration: the printer obtains an IP address automatically
- Manual IP address configuration: you need to enter an IP address manually

Automatic IP address configuration

In this case, once the network cable is connected and the printer is powered up, it automatically takes an IP address. You need to get this value and perform the following steps to configure the printer in the network:

1. Go to the front panel and select the  icon, then **I/O setup > Fast Ethernet (or Gigabit Ethernet) > Show configuration**.
2. The front panel will display some information, including the printer's IP address. Make a note of the IP address.

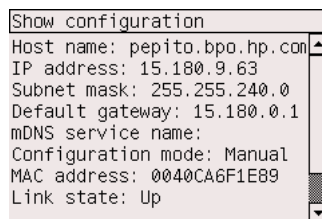

```

Show configuration
Host name: pepito.bpo.hp.com
IP address: 15.180.9.63
Subnet mask: 255.255.240.0
Default gateway: 15.180.0.1
mDNS service name:
Configuration mode: Manual
MAC address: 0040CA6F1E89
Link state: Up
  
```

3. Insert the *Printer Software Setup for Windows* CD into your computer.
4. Choose the language.
5. Read the information in the Welcome dialog and click **Next**.
6. Read and accept the license agreement.
7. Choose **Connected via the network**.
8. Choose **Basic network setup for a PC or server**.
9. Wait while the configuration program looks for printers connected to your network. When the search has finished, a list of printers will be displayed. Identify your printer by its IP address, select it from the list, and click **Next**.
10. Wait while the configuration program analyzes the network and the printer. The program will detect the network settings and will suggest the settings to be used when configuring the printer. Normally, it is not necessary to change any of these settings, so click **Next**.

11. Choose your printer model and click **Next**.
12. Continue following instructions on the screen until the installation is complete.

Manual IP address configuration

In this case, there is no IP address at the moment of starting the installation. The installation process will consist of detecting the printer, configuring its IP address, and installing the driver with these settings. Perform the following steps:

1. Go to the front panel and select the  icon, then **I/O setup > Fast Ethernet (or Gigabit Ethernet) > Show configuration**.
2. The front panel will display some information, including the printer's MAC address. Make a note of the MAC address.

```

Show configuration
Host name: pepito.bpo.hp.com
IP address: 15.180.9.63
Subnet mask: 255.255.240.0
Default gateway: 15.180.0.1
mDNS service name:
Configuration mode: Manual
MAC address: 0040CA6F1E89
Link state: Up

```

3. Insert the *Printer Software Setup for Windows* CD into your computer.
4. Choose the language.
5. Read the information in the Welcome dialog and click **Next**.
6. Read and accept the license agreement.
7. Choose **Connected via the network**.
8. Choose **Basic network setup for a PC or server**.
9. Wait while the configuration program looks for printers connected to your network. When the search has finished, a list of printers will be displayed. Identify your printer by its MAC address, select it from the list, and click **Next**.
10. Wait while the configuration program analyzes the network and the printer. As there are no TCP/IP parameters configured, the program will ask you to enter the IP address, the subnet mask, and the gateway. Enter these values according to your network configuration and take care, when choosing the IP address and the subnet mask, that you select values that will not create conflicts with the current network devices. It is recommended that you get these values from your network administrator.
11. Choose your printer model and click **Next**.
12. At the end of the installation, you will have drivers configured to work with your printer and your printer will have a valid IP address. You can see this IP address on the front panel when you select the  icon, then **I/O setup > Fast Ethernet (or Gigabit Ethernet) > Show configuration**.

How do I set up my printer software?

How do I connect my printer to a network (Mac OS X)?

You can connect your printer to a network under Mac OS X using the following methods:

- Rendezvous
- AppleTalk
- TCP/IP



Note The Printer Setup Utility was known as the Print Center in versions of Mac OS X earlier than 10.3.

Using Rendezvous

Before you begin, make sure the following are true:

- The printer is set up and on.
- The Ethernet hub or router is on and functioning properly.
- All computers on the network are on and connected to the network.
- The printer is connected to the network.
- The printer drivers are installed. To install the drivers, insert the drivers CD and follow the instructions on the screen.

To connect your printer using Rendezvous:

1. Go to the front panel, select the  icon, and then **I/O setup > Fast Ethernet** (or **Gigabit Ethernet**, if you are using that option) > **Show configuration**. Note the mDNS service name of your printer, as shown on the front panel. You may need it later on.
2. Open the Printer Setup Utility by selecting the Finder icon on your desktop. Click the Applications icon in the top right corner of the Finder window, then select **Utilities** from the list. Select **Printer Setup Utility** from the Utilities list.
3. Click the Add button. The Add Printer dialog is displayed.
4. Select **Rendezvous** from the popup menu.
5. Click on the name of the printer. If you cannot identify the printer by its name, use the mDNS Service Name that you noted earlier.
6. The connection is configured automatically, and the printer is now available on the network.

Using AppleTalk



Note AppleTalk is supported only with the optional Jetdirect print server.

Before you begin, make sure the following are true:

- The printer is set up and on.
- The Ethernet hub or router is on and functioning properly.
- All computers on the network are on and connected to the network.
- The printer is connected to the network.
- The printer drivers are installed. To install the drivers, insert the drivers CD and follow the instructions on the screen.

To connect your printer using AppleTalk:

1. Go to the front panel and select the  icon, then **I/O setup > Jetdirect EIO > Show configuration**.
2. The front panel will display some information, including the printer's Appletalk name. Make a note of the Appletalk name.
3. Make sure that the AppleTalk protocol is active by double-clicking the System preference icon on the Dock menu bar and selecting **Network**. Select **Built-in Ethernet** as well as **AppleTalk** from the Show menu to confirm that AppleTalk is active.
4. Open the Printer Setup Utility by selecting the Finder icon on your desktop. Click the Applications icon in the top right corner of the Finder window, then select **Utilities** from the list. Select **Printer Setup Utility** from the Utilities list.
5. In the Printer List, click the Add button to add a printer. The Add Printer List dialog box is displayed.
6. Select **AppleTalk** from the pop-up menu. Select the Appletalk zone.
7. Click the Create button, and select the printer from the list. You may need the AppleTalk name that you noted in step 2.
8. Click the Add button and close the Printer Setup Utility.

Using TCP/IP

Before you begin, make sure the following are true:

- The printer is set up and on.
- The Ethernet hub or router is on and functioning properly.
- All computers on the network are on and connected to the network.
- The printer is connected to the network.
- The printer drivers are installed. To install the drivers, insert the drivers CD and follow the instructions on the screen.

To connect your printer using TCP/IP:

1. Go to the front panel and select the  icon, then **I/O setup > Fast Ethernet (or Gigabit Ethernet) > Show configuration**.
2. The front panel will display some information, including the printer's IP address. Make a note of the IP address.

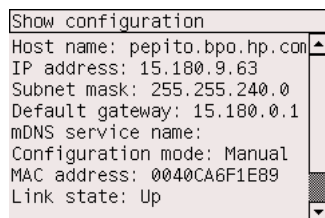

3. Open the Printer Setup Utility by selecting the Finder icon on your desktop. Click the Applications icon in the top right corner of the Finder window, then select **Utilities** from the list. Select **Printer Setup Utility** from the Utilities list.
4. Click the Add button. The Add Printer List dialog box is displayed.

5. Select **IP Printing** from the popup menu.
6. Type the printer's IP address (which you noted in step 2) into the Printer Address field.
7. Select the **HP Designjet 4000 PS3** PostScript Printer Description (PPD) file.
8. In the Printer Model field, select **HP** and then **HP Designjet 4000ps**.
9. Click the Add button. Close the Printer Setup Utility.

How do I connect my printer to a network (Mac OS 9)?

You can connect your printer to a network under Mac OS 9 using the following methods:

- TCP/IP
- AppleTalk

Using TCP/IP

Before you begin, make sure that your printer is switched on and connected to the network.

To connect your printer using TCP/IP:

1. Go to the front panel and select the  icon, then **I/O setup > Fast Ethernet (or Gigabit Ethernet) > Show configuration**.
2. The front panel will display some information, including the printer's IP address. Make a note of the IP address.

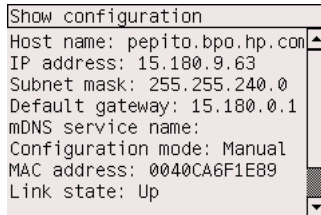

```

Show configuration
Host name: pepito.bpa.hp.com
IP address: 15.180.9.63
Subnet mask: 255.255.240.0
Default gateway: 15.180.0.1
mDNS service name:
Configuration mode: Manual
MAC address: 0040CA6F1E89
Link state: Up
  
```

3. Go to your computer and open the Desktop Printer Utility located in the **HP Designjet 4000ps** folder on the hard disk.
4. Choose the AdobePS driver and the Printer (LPR) connection. Click OK.
5. Use the first Change button to select the **HP Designjet 4000 PS3** PostScript Printer Description (PPD) file.
6. Use the second Change button to enter the printer's IP address into the Printer Address field. Click Verify and then OK.
7. Check that your changes appear correctly on the screen, then click Create.
8. Click Save to save your new printer setup on the Desktop.

Using AppleTalk



Note AppleTalk is supported only with the optional Jetdirect print server.

Before you begin, make sure that your printer is switched on and connected to the network.

To connect your printer using AppleTalk:

1. Go to the front panel, select the  icon, and then **I/O setup > Jetdirect EIO > Show configuration**. Note the AppleTalk name of your printer, as shown on the front panel. You may need it later on.
2. Select **Chooser** from the Apple menu.
3. Click the Adobe PostScript driver icon.



4. In the AppleTalk Zones list, select the AppleTalk zone where your printer is located (if it exists). Make sure that the AppleTalk protocol is Active.
5. The Chooser will check all the printers that are connected by AppleTalk in your zone.
6. Select your printer. If you have several similar printers, you can identify the correct one by its AppleTalk name.
7. Click the Create button in the Chooser to set up the printer.
8. The type of printer is selected automatically. A new printer icon will appear on your desktop.
9. Close the Chooser. An icon will appear on your desktop.

How do I connect my printer directly to a computer (Windows)?

You can connect your printer directly to a computer without going through a network, by using the printer's built-in FireWire socket (supported under Windows 2000, XP, and 2003 Server) or the optional USB 2.0 socket (supported under Windows 98 SE, Me, 2000, XP, and 2003 Server).

1. **Do not connect the computer to the printer yet.** You must first install the printer driver software on the computer, as follows.
2. Insert the *Printer Software Setup for Windows* CD into your CD drive. If the CD does not autorun, run the SETUP.EXE program in the root folder of the CD.
3. Follow the instructions that appear on your screen.
4. When asked how the printer is connected, choose **Connected directly to this computer**.
5. Choose your connection method and click **Next**.
6. Choose your printer model and click **Next**.
7. When prompted to do so, connect your computer to the printer, using a FireWire or USB cable. Ensure that the printer is switched on. When the printer software has detected the printer, the installation process will be completed automatically.

How do I connect my printer directly to a computer (Mac OS X)?

You can connect your printer directly to a computer without going through a network, by using the printer's built-in FireWire socket or the optional USB 2.0 socket.

1. Make sure the printer is powered off.
2. Insert the *Software Setup* CD into your CD drive.
3. In Finder, navigate to the CD.
4. Double-click on **OS X HP DJ 4000ps Install** to launch the installer.
5. The installer takes you through various steps until you reach the main install dialog box.
6. Click the Install button.
7. The printer driver installs and a status bar is displayed. Follow any instructions given by the installer, then quit the installer when the installation is complete.

Connecting with FireWire

1. Connect the FireWire cable between your printer and the computer.
2. Power on the printer.
3. Open the Printer Setup Utility by selecting the Finder icon on your desktop. Click the Applications icon in the top right corner of the Finder window, then select **Utilities** from the list. Select **Printer Setup Utility** from the Utilities list.
4. Click the Add button. The Add Printer dialog is displayed.
5. Select **HP FireWire** from the popup menu.
6. Click the name of the printer.
7. Click the Add button.

Connecting with USB

1. Connect the USB cable between your printer and the computer.
2. Power on the printer.
3. Open the Printer Setup Utility by selecting the Finder icon on your desktop. Click the Applications icon in the top right corner of the Finder window, then select **Utilities** from the list. Select **Printer Setup Utility** from the Utilities list.
4. The printer icon is automatically added to the list of available printers.



Note Under Mac OS X 10.2 only, the new printer appears as a Generic printer. To correct this, first delete the Generic printer icon. Then click the Add button, select USB from the popup menu in the Add Printer dialog, select the name of your printer, and click the Add button.

Sharing the printer



Note Printer sharing between users is supported under Mac OS X 10.2.x and 10.3.

If your computer is connected to a network, you can make your directly-connected printer available to other computers on the same network.

1. Double-click the System Preferences icon in the Dock menu bar on your desktop.
2. Enable printer sharing by going to **Sharing > Services > Printer Sharing**.

3. From the client computer, the printer will now be displayed in the list of available printers in the Printer Setup Utility.

How do I connect my printer directly to a computer (Mac OS 9)?

You can connect your printer directly to a computer without going through a network, by using the optional USB 2.0 socket.

1. Make sure the printer is powered off.
2. Insert the *Software Setup* CD into your CD drive.
3. In Finder, navigate to the CD.
4. Double-click on **OS 9 HP DJ 4000ps Install** to launch the installer.
5. The installer takes you through various steps until you reach the main install dialog box. We recommend that you choose the **Easy install** option.
6. Click the Install button.
7. The printer driver installs and a status bar is displayed.
8. Click **Restart** to restart the computer.
9. Connect the USB cable between your printer and the computer.
10. Power on the printer.
11. Run the Desktop Printer Utility in the **HP Designjet 4000ps** folder.
12. Choose the AdobePS driver and the USB connection.
13. Click the Change button in the USB Printer Selection section to select the printer.
14. Click the Auto Setup button to set up the printer automatically. You can click the Change button to select the PostScript Printer Description (PPD) file.
15. Once you have selected the correct PPD file, click the Create button to save the desktop printer.

Sharing the printer

If you have Mac OS 9.1 or later, and your computer is connected to a network through TCP/IP, you can make your directly-connected printer available to other computers on the same network.

1. In the Apple menu, go to **Control Panels > USB Printer Sharing**.
2. Click the Start button.
3. Click the My Printers tab. The printer will be displayed. Check the box next to the printer name to enable sharing.
4. To connect to the printer from another Macintosh, first install the printer driver software: insert the drivers CD and follow the instructions on the screen.
5. In the Apple menu, go to **Control Panels > USB Sharing**.
6. Click the Network Printers tab. You will see a list of shared printers.
7. If your printer is in the list, click the Use checkbox next to the printer's name. If your printer is not in the list, click the Add button, open the neighborhood where the printer is shared, and choose the printer.
8. Run the Desktop Printer Utility in the **HP Designjet 4000ps** folder.
9. Choose the AdobePS driver and the USB connection.
10. Click the Change button in the USB Printer Selection section to select the printer.

11. Click the Auto Setup button to set up the printer automatically. You can click the Change button to select the PostScript Printer Description (PPD) file.
12. Once you have selected the correct PPD file, click the Create button to save the desktop printer.

How do I uninstall the printer driver (Windows)?

1. Insert the *Printer Software Setup for Windows* CD into your CD drive. If the CD does not autorun, run the SETUP.EXE program in the root folder of the CD.
2. Follow the instructions on your screen to uninstall the printer driver.

How do I uninstall the printer driver (Mac OS 9)?

1. Insert the *Software Setup* CD into your CD drive.
2. In Finder, navigate to the CD.
3. Double-click on **OS 9 HP DJ 4000ps Install** to launch the installer.
4. The installer takes you through various steps until you reach the main install dialog box. You have two options:
 - **Easy install**
 - **Uninstall driver**Choose **Uninstall driver**.
5. The printer driver uninstalls and a status bar is displayed. Quit the installer when the uninstallation is complete.

4 How do I operate the printer?

- “How do I switch the printer on and off?” on page 73
- “How do I restart the printer?” on page 74
- “How do I change the language of the front panel?” on page 74
- “How do I access the Embedded Web Server?” on page 75
- “How do I change the language of the Embedded Web Server?” on page 76
- “How do I password-protect the Embedded Web Server?” on page 76
- “How do I request e-mail notification of specific error conditions?” on page 77
- “How do I change the sleep mode setting?” on page 77
- “How do I turn off the buzzer?” on page 77
- “How do I change the front panel contrast?” on page 77
- “How do I change the units of measurement?” on page 77
- “How do I adjust for altitude?” on page 78

How do I switch the printer on and off?

The normal and recommended way to switch the printer on and off is to use the **Power** key on the front panel.

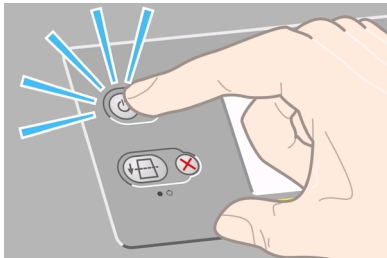

When you switch off the printer this way, the printheads are automatically stored with the printhead cleaners, which prevents them from drying out.

If you are not planning to use the printer for a long time (for instance, a day or more), you are recommended to switch it off using the **Power** key, and then also switch off the power switch at the rear.

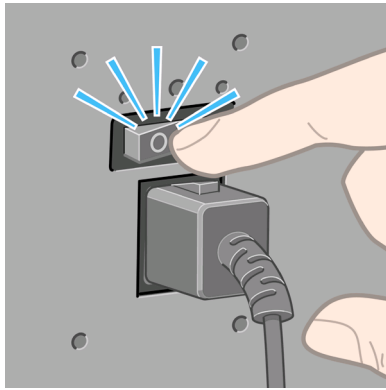

To switch it back on later, use the power switch at the rear, and then the **Power** key. When the printer has not been used for a certain period of time (30 minutes by default), it will save power by going into sleep mode. However, any interaction with the printer will return it to active mode, and it can resume printing immediately.

How do I restart the printer?

In some circumstances you may be advised to restart the printer. Please proceed as follows:

1. Press the **Power** key on the front panel to switch the printer off, wait a few moments, then press the **Power** key again. This should cause the printer to restart; if not, continue with step 2.
2. Use the **Reset** key on the front panel. You will need an implement with a narrow tip to operate the **Reset** key. This normally has the same effect as step 1 above, but may work if step 1 does not.
3. If neither of the above steps seem to have any effect, you should switch off the printer using the power switch at the rear of the printer.
4. Remove the power cord from the power socket.
5. Wait for 10 seconds.
6. Insert the power cord into the power socket and switch on the printer using the power switch.
7. Check that the Power light on the front panel comes on. If it does not, use the **Power** key to switch the printer on.

How do I change the language of the front panel?

To change the language of the front-panel menus and messages, start with the printer powered off.

1. At the front panel, press the **Select** key and hold it down.
2. While holding the **Select** key down, press the **Power** key and hold it down.
3. Continue to hold down both keys until the green light on the left side of the front panel starts flashing. You can expect a delay of about one second. If the green light starts flashing without any delay, you may need to start again.
4. Release the **Select** and **Power** keys.

The language selection menu should now appear on the front panel.

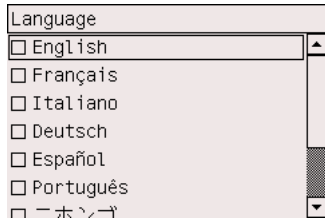

How do I access the Embedded Web Server?

The Embedded Web Server enables you to manage your printer and your printing jobs remotely using an ordinary Web browser running on any computer.



Note In order to use the Embedded Web Server, you must have a TCP/IP connection to your printer. If you have an Appletalk, Novell, or USB connection to your printer, you will not be able to use the Embedded Web Server.

The following browsers are known to be compatible with the Embedded Web Server:

- Internet Explorer 5.5 or later, for Windows.
- Internet Explorer 5.2.1 or later, for Mac OS 9.
- Internet Explorer 5.1 or later, for Mac OS X.
- Netscape Navigator 6.01 or later.
- Mozilla 1.5 or later.
- Safari.

There are several ways to access the Embedded Web Server:

- On any computer, open your Web browser and give the address of your printer. You can find out the address of your printer (starting with **http:**) from the front panel, by highlighting the  icon.
- Select **Status of my printer**, **Check media available**, or **Manage my printer's queue** from the Services tab of your Windows printer driver, or from the Services panel of your Mac OS printer driver.
- On a computer running Windows with your printer software installed, double-click the Printer Access Utility icon on your desktop, then select your printer.

If you have followed these instructions but failed to get through to the Embedded Web Server, see “The problem is I cannot access the Embedded Web Server from my browser” on page 221.

Using IP over FireWire with Mac OS X 10.3

If you are using Mac OS X 10.3 and have a FireWire connection to your printer, it is possible to set up an IP address for the printer in order to use the Embedded Web Server. To do this:

1. Open **System Preferences** and click **Network**.
2. Choose **Network Port Configurations** from the **Show** pop-up menu.

3. Click **New**, and then choose **FireWire** from the **Port** pop-up menu. You can give the new port configuration a name, FireWire.
4. Drag the port configuration to the top of the Port Configuration list. This ensures that the port is assigned an IP address.
5. Click **Apply Now**.

If you don't drag the FireWire port configuration to the top of the Port Configuration list, you need to choose **Manually** (or **DHCP with manual address**) from the **Configure IPv4** pop-up menu, and then enter an IP address. See <http://www.apple.com/> for more detail or updated information on activating IP over FireWire.

When the printer is connected through FireWire, we recommend adding the printer using the FireWire modules in order to take full advantage of FireWire printing, and to use the IP over FireWire only to visit the printer's Embedded Web Server.

If you connect your printer through FireWire and the printer is also connected to the network through Fast Ethernet or Gigabit Ethernet, the printer's IP over FireWire will not be available and you will not be able to access the Embedded Web Server from the Printer Dialog. However, you will be able to print through FireWire.

Also in the case of printer sharing over FireWire, remote users will not be able to access the Embedded Web Server from the Printer Dialog, although they will be able to print.

How do I change the language of the Embedded Web Server?

The Embedded Web Server can work in the following languages: English, Portuguese, Spanish, French, Italian, German, Simplified Chinese, Traditional Chinese, Korean, and Japanese. It will choose whichever language you have specified in your Web browser's options. If you have specified a language that it cannot support, it will work in English.

To change the language, you must change your Web browser's language setting. For example, in Internet Explorer version 6, go to the Tools menu and select **Internet Options, Languages**. Then ensure that the language you want is at the top of the list in the dialog box.

How do I password-protect the Embedded Web Server?

1. In the Embedded Web Server, go to the Security page, which you can find in the Settings tab.
2. Enter a password of your own choice in the **New password** field.
3. Enter it again in the **Confirm password** field to guard against misspelling.
4. Click **Set password**.

Now no-one will be able to perform the following actions with the Embedded Web Server without giving the password:

- Manage print jobs in the queue (cancel, delete)
- View previews of print jobs
- Delete stored jobs

- Clear accounting information
- Update the printer's firmware



Note If you forget the password, see “The problem is I cannot access the Embedded Web Server from my browser” on page 221.

How do I request e-mail notification of specific error conditions?

1. In the Embedded Web Server, go to the E-mail server page, which you can find in the Settings Tab, and ensure that the following fields are correctly filled in:
 - **SMTP server:** the IP address of the outgoing mail server (SMTP) that will process all e-mail messages from the printer. If the mail server requires authentication, e-mail notifications will not work.
 - **Printer e-mail address:** each e-mail message sent by the printer must include a return address, which does not need to be a real, functional e-mail address, but it should be unique, so that recipients of the message can identify the printer that sent it.
2. Go to the Notification page, which is also in the Settings tab.
3. Click **New** to request new notifications (or **Edit** to edit notifications that have already been set up). Then fill in the e-mail addresses to which notifications should be sent, and select the incidents that should result in notification messages. Initially the most commonly-specified incidents are shown; to see all the possibilities, click **Show all alerts**.

How do I change the sleep mode setting?

If the printer is left switched on but unused for a certain period of time, it will go automatically into sleep mode to save power. To change the time the printer waits before it goes into sleep mode, go to the front panel and select the  icon, then **Configuration menu > Sleep mode wait time**.

How do I turn off the buzzer?

To turn the printer's buzzer on or off, go to the front panel and select the  icon, then **Configuration menu > Buzzer**.

How do I change the front panel contrast?

To change the contrast of the front panel display, select the  icon, then **Configuration menu > Display contrast**, and choose a value using the **Up** or **Down** key. Press the **Select** key to set the value you have chosen.

How do I change the units of measurement?

To change the units of measurement displayed in the front panel, select the  icon, then **Configuration menu > Unit selection**, and select **English** or **Metric**.

How do I adjust for altitude?

Your printer will work better if you tell it roughly at what altitude it is. To set the altitude, go to the front panel and select the  icon, then **Configuration menu > Altitude**, and select a range.

5 How do I handle paper?

- “How do I load a roll onto the spindle?” on page 79
- “How do I load a roll into the printer?” on page 83
- “How do I unload a roll from the printer?” on page 88
- “How do I load a single sheet?” on page 89
- “How do I unload a single sheet?” on page 93
- “How do I select supported paper types?” on page 94
- “How do I view information about the paper?” on page 95
- “How do I download media profiles?” on page 96
- “How do I use non-HP paper?” on page 96
- “How do I cancel the drying time?” on page 96
- “How do I change the drying time?” on page 97

How do I load a roll onto the spindle?

1. Make sure the printer wheels are locked (the brake lever is pressed down) to prevent the printer from moving.
2. Lower the spindle lever.

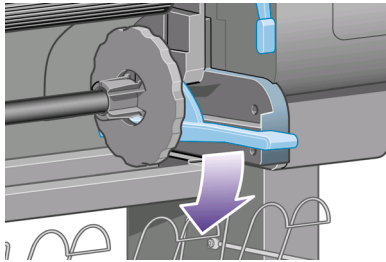

3. Remove the right-hand end of the spindle (1) from the printer, then move it to the right in order to extract the other end (2). Do not insert your fingers into the spindle supports during the removal process.

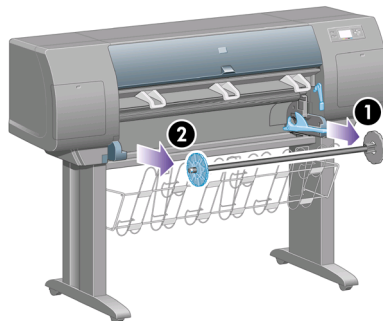

The spindle has a stop at each end to keep the roll in position. The stop at the left-hand end can be removed to mount a new roll, it slides along the spindle to hold rolls of different widths.

4. Remove the blue paper stop (1) from the left-hand end of the spindle.



5. If your roll has a three-inch cardboard core, ensure that the core adaptors supplied with the printer have been installed. See below:

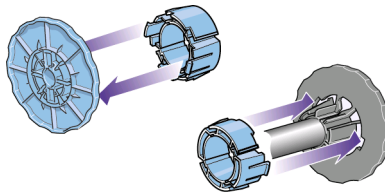

6. The roll may be very long; rest the spindle horizontally on a table and load the roll on the table. Bear in mind that you may need two people to handle it.
7. Slide the new roll onto the spindle. Make sure the paper type is oriented as shown. If it is not, remove the roll, turn it 180 degrees and slide it back on to the spindle.



Note There is also a label on the spindle showing the correct orientation.

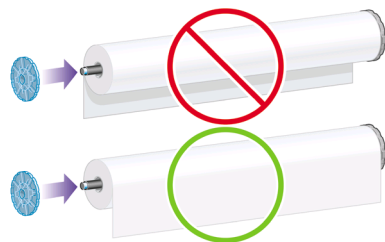

- Put the blue paper stop on to the upper end of the spindle, and push it towards the end of the roll.

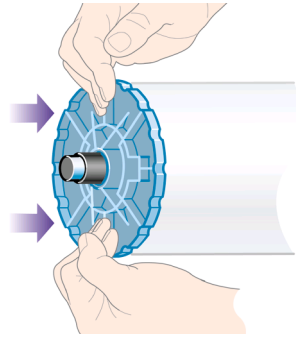

- Ensure the blue paper stop is pushed in as far as it will go, without using excessive force.

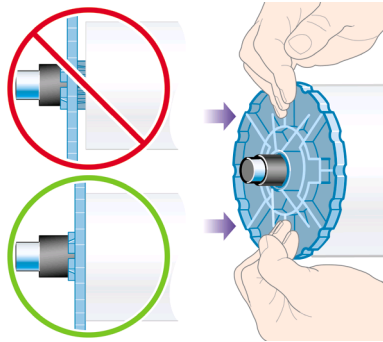

10. With the blue paper stop on the left, slide the spindle into the printer left and then right as shown by the arrows 1 and 2.

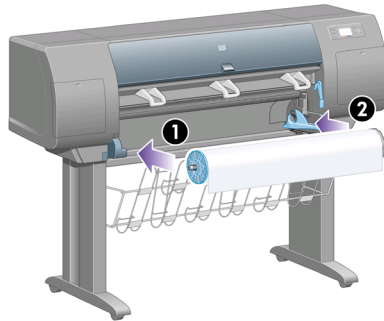

11. To make sure that the right end of the spindle is in place, check that the spindle lever is in its top position (horizontal). You can move the lever yourself if necessary.

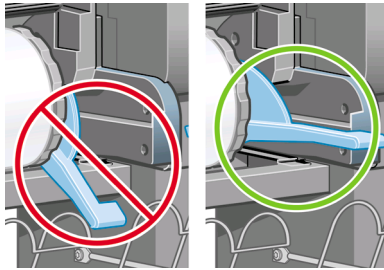

If you are a regular user of different paper types, you can change rolls more quickly if you pre-load rolls of different paper types on different spindles. Extra spindles are available for purchase.

How do I load a roll into the printer?



Note To start this procedure you need to have a roll loaded on the spindle. See “How do I load a roll onto the spindle?” on page 79.

1. At the printer's front panel, select the  icon, then **Roll > Load roll now**.

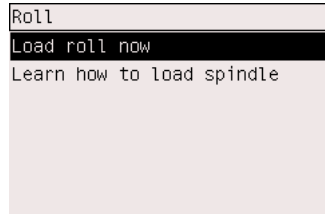

2. The front panel displays a list of paper types.

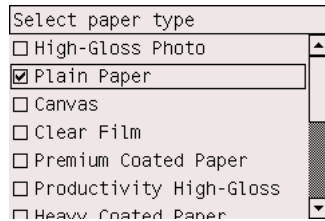

3. Select the paper type you are using. If it is not clear which you should select, see “How do I select supported paper types?” on page 94.
4. Wait until the front panel prompts you to open the window.

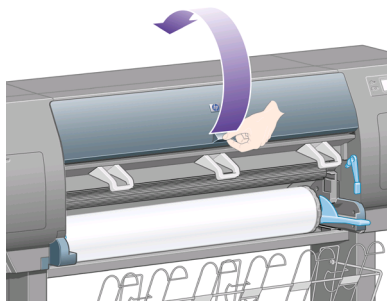

Chapter 5

5. Lift the paper load lever.

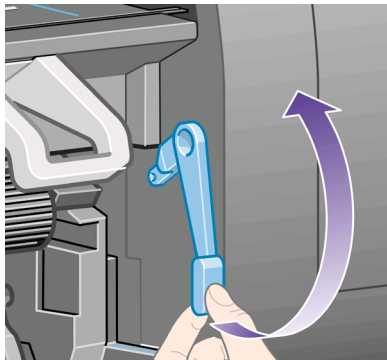

6. Pull out approximately 1 m (3 ft.) of paper.

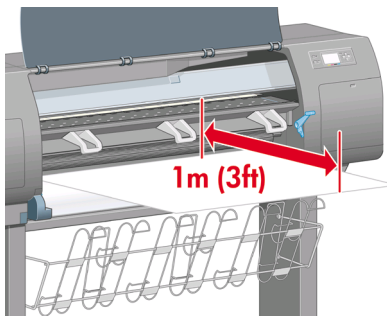

- Carefully insert the leading edge of the roll above the black roller.



Warning 1 Take care not to touch the rubber wheels on the platen while loading paper: they may rotate and trap skin, hair, or clothing.

Warning 2 Take care not to push your fingers inside the printer's paper path. It is not designed to accommodate fingers, and the results may be painful.

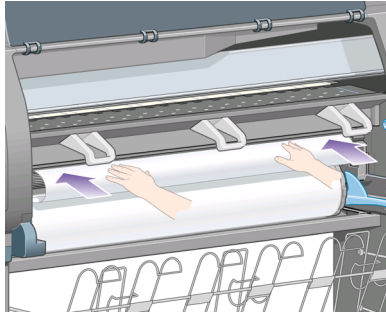

- Wait until the paper emerges from the printer as shown below.

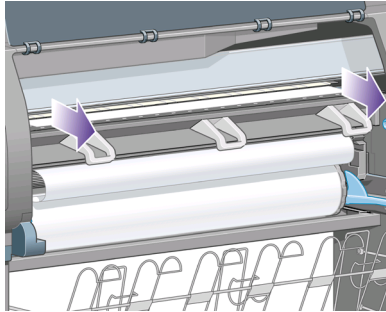

Note If you have an unexpected problem at any stage of the paper loading process, see “The problem is the paper cannot be loaded successfully” on page 209.

9. Align the right-hand edge of the paper with the blue line and the left edge of the half-circle on the right of the platen.

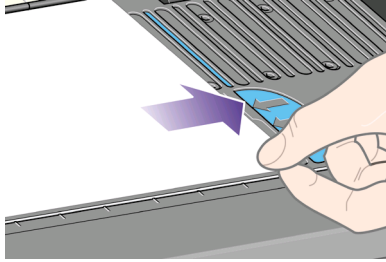

10. When the paper is correctly aligned with the blue line and half-circle, lower the paper load lever.

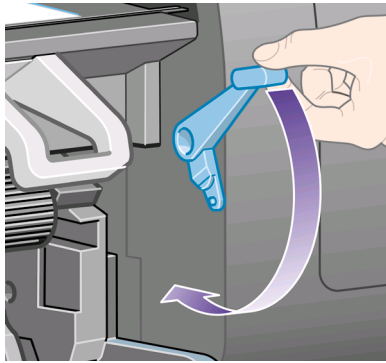

11. The front panel prompts you to wind excess paper onto the roll.

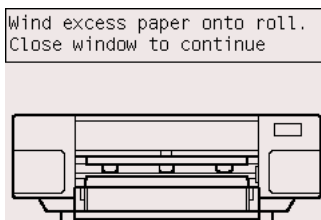

12. Wind the excess paper onto the roll. Use the paper stop to turn the roll in the direction shown.

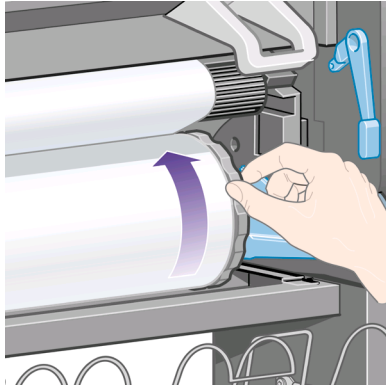

13. Lower the window.
14. The front panel again prompts you to wind excess paper onto the roll.

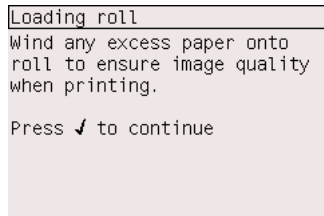

15. The printer will perform a color calibration, if it has not already calibrated the paper type you are using, and if color calibration is turned on. See "How do I perform color calibration?" on page 139.
16. The front panel displays the **Ready** message and the printer is ready to print.

How do I unload a roll from the printer?

If there is more than 30 cm of paper remaining of the roll, use the following procedure.

1. At the printer's front panel, select the  icon, then **Unload paper now**.
2. The paper will normally be removed from the printer.
If the paper is not automatically removed from the printer, the front panel will prompt you to lift the paper load lever and turn the paper stop (1) by hand until the paper is removed from the printer. When you have finished, lower the paper load lever.
3. Turn the paper stop (1) by hand, until the paper is fully wound onto the roll.
4. Press the **Select** key.
5. Press the spindle lever (2) down and remove the roll from the printer, pulling out the right-hand end first. Do not insert your fingers into the spindle supports during the removal process.

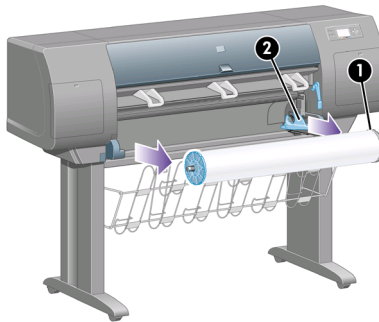

If there is less than 30 cm remaining of the roll, use the following procedure:

1. If you have already selected **Unload paper now** at the front panel, press the **Cancel** key to cancel that procedure.
2. Ensure that the paper load lever is in the down position, and press the **Form Feed and Cut** key twice (or until the paper advances).
3. Raise the paper load lever and pull the paper out manually.
4. Press the spindle lever (2) down and remove the empty spindle from the printer, pulling out the right-hand end first. Do not insert your fingers into the spindle supports during the removal process.

How do I load a single sheet?

Any loaded roll must be unloaded before loading a sheet. See “How do I unload a roll from the printer?” on page 88.

1. At the printer's front panel, select the  icon, then **Sheet > Load sheet now**.

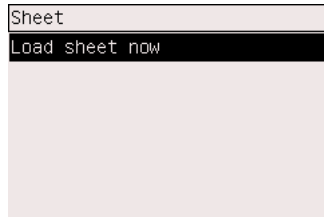

Note As usual, you must press the **Select** key to select this option.

2. The front panel displays a list of paper types.

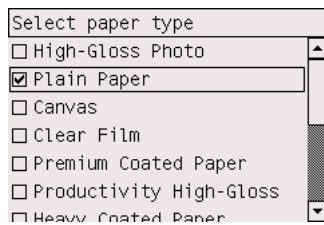

3. Select the paper type you are using. If it is not clear which you should select, see “How do I select supported paper types?” on page 94.

Chapter 5

4. Wait until the front panel prompts you to open the window.

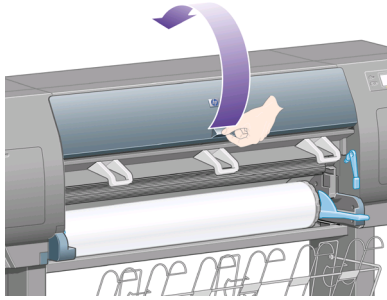

5. Lift the paper load lever.

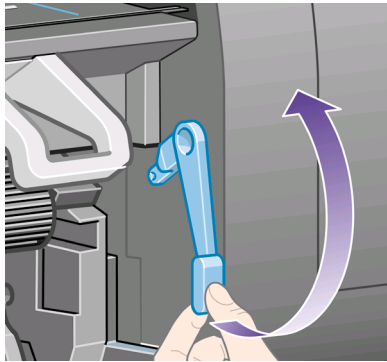

6. Insert the sheet into the printer as shown below.



7. Insert the sheet until it reappears from the printer as shown below.



Warning 1 Take care not to touch the rubber wheels on the platen while loading paper: they may rotate and trap skin, hair or clothing.

Warning 2 Take care not to push your fingers inside the printer's paper path. It is not designed to accommodate fingers, and the results may be painful.

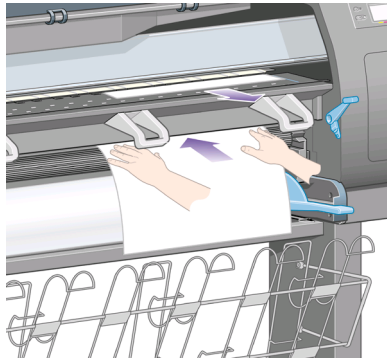

8. Pull the sheet out from the top.

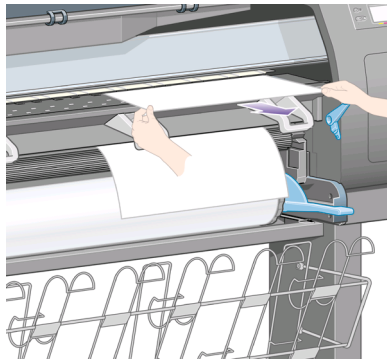

Chapter 5

9. Align the leading edge of the sheet with the metal bar in the platen.
Align the right-hand edge of the sheet with the left edge of the half-circle on the platen, as shown below.

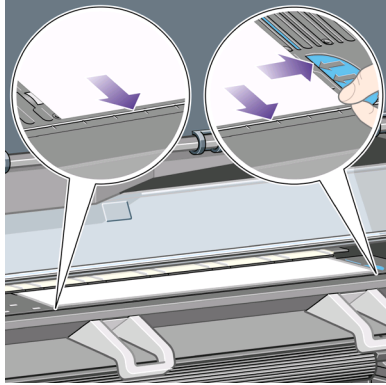

10. Lower the window.
11. Lower the paper load lever.

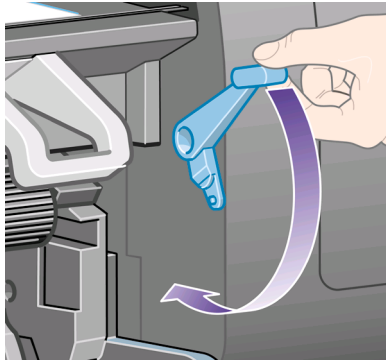

12. If the paper has been loaded successfully, the front panel displays the **Ready** message and the printer is ready to print. If something has gone wrong (paper mispositioned or misaligned), follow the instructions on the front panel.

13. If you are printing on a sheet of paper less than 900 mm in length (up to A1 size), deploy the three mobile stoppers on the bin.

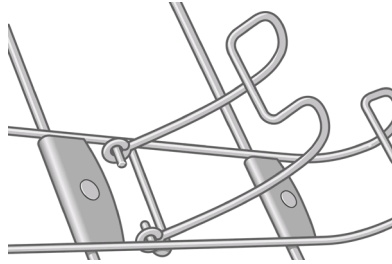

Note 1 When printing on sheet paper you are recommended to select **Normal** or **Best** print quality, see “How do I change the print quality?” on page 129.

Note 2 If you have an unexpected problem at any stage of the paper loading process, see “The problem is the paper cannot be loaded successfully” on page 209.

How do I unload a single sheet?

At the printer's front panel, select the  icon, then **Unload paper now**.

To give the ink time to dry, the printer holds the sheet for some time (see “Tell me about drying time” on page 238).

How do I select supported paper types?

The following tables list the HP paper types that are suitable for use with your printer, and show the name that you should select in the front panel when loading each paper type. The “recommended” paper types, listed first, have been thoroughly tested and are known to provide the best print quality when used with your printer. The “other supported” paper types can be used with your printer but are not guaranteed to provide the best print quality. For the part numbers, widths, and weights of these papers, see “Tell me about ordering paper” on page 245.



Note This list is likely to change over the course of time. For the latest information, see <http://www.hp.com/go/designjet>.



Recommended paper types

Product name	Front panel name
HP Bright White Inkjet Bond Paper	Bright White Max Speed Bright White
HP Matte Film	Matte Film
HP Clear Film	Clear Film
HP Natural Tracing Paper	Natural Tracing Paper
HP Translucent Bond	Translucent Bond
HP Vellum	Vellum
HP Coated Paper	Coated Paper
HP Heavyweight Coated Paper	Heavyweight Coated Paper
HP Heavyweight Coated Paper—long roll	Heavyweight Coated Paper
HP Productivity Photo Gloss	Productivity Photo Gloss
HP Productivity Photo Semi-Gloss	Productivity Photo Gloss
HP Photo Paper RC Matte	High-Gloss Photo Paper
HP Proofing Paper RC Satin	High-Gloss Photo Paper
HP Universal High-Gloss Photo Paper	High-Gloss Photo Paper
HP Universal Semi-Gloss Photo Paper	High-Gloss Photo Paper
HP Universal Inkjet Bond Paper	Bond Paper Max Speed Bond Paper

Other supported paper types

Product name	Front panel name
HP Polyester Film Opaque White Glossy	High-Gloss Photo Paper
HP Universal Coated Paper	Bright White Max Speed Bright White
HP Universal Heavyweight Coated Paper	Heavyweight Coated Paper
HP Super Heavyweight Coated Paper	Super Heavy Coated Paper
HP Banners with Tyvek	Super Heavy Coated Paper
HP Colorfast Adhesive Vinyl	High-Gloss Photo Paper
HP Backlit Film Reverse Print Matte	Matte Film
HP Studio Canvas	Canvas
HP Outdoor Billboard Paper Blue Back	Super Heavy Coated Paper
HP Canvas Matte	Canvas
HP Outdoor Paper	Super Heavy Coated Paper
HP Canvas Paper 140 gsm	Canvas
HP Canvas Paper 180 gsm	Canvas
HP Fine Art Paper Aquarella	Super Heavy Coated Paper
HP Fine Art Paper Cream	Super Heavy Coated Paper
HP Fine Art Paper Sahara	Super Heavy Coated Paper
HP Indoor Paper Self-Adhesive	Super Heavy Coated Paper

How do I view information about the paper?

At the printer's front panel, highlight the  or  icon.

You will see the following information displayed on the front panel:

- The paper source (roll or sheet)
- The paper manufacturer's name
- The paper type you have selected
- The total width of the paper in millimeters (as measured by the printer)

If no paper is loaded, the message **Out of paper** is displayed.

The same information (apart from the manufacturer's name) is displayed on the Embedded Web Server's Supplies page.

How do I download media profiles?

Each supported paper type has its own characteristics. For optimum print quality, the printer changes the way it prints on each different paper type. For example, some may need more ink and some may require a longer drying time. So the printer must be given a description of the requirements of each paper type. This description is called the “media profile”. The media profile contains the ICC profile, which describes the color characteristics of the paper; it also contains information on other characteristics and requirements of the paper that are not directly related to color. Existing media profiles for your printer are already installed in the printer’s software.

However, you would find it inconvenient to scroll through a list of all paper types available for your printer, so your printer contains media profiles for only the most commonly used paper types. If you buy a paper type for which your printer has no media profile, you will find that you cannot select that paper type in the front panel. To download the correct media profile, go to <http://www.hp.com/support/designjet-downloads/>, select the name of your printer, then select **Media profiles**.

If you do not find the media profile you want on the Web, you may find that it has been added to the latest firmware for your printer. You can check the firmware release notes for information. See “How do I update my printer’s firmware?” on page 173.

How do I use non-HP paper?

HP’s own paper types have been fully tested with the printer and can be expected to give the best print quality.

However, you can print on paper from any manufacturer. In that case, you should select (in the front panel) the HP paper type that is most similar to the paper you will be using. If in doubt, try several different HP paper type settings, and choose the one that provides you with the best print quality. If results are not entirely satisfactory with any paper type setting, see “General advice” on page 189.

How do I cancel the drying time?

Press the **Form Feed and Cut** key (1) on the front panel.

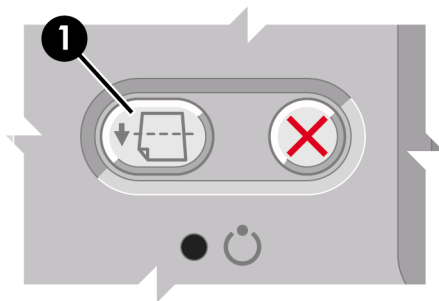

Caution A print that has had insufficient time to dry can suffer from quality problems.

How do I change the drying time?

You may wish to change the drying time setting to suit special printing conditions.

Select the  icon, then **Drying options** > **Drying time**. You can then select Extended, Optimal, Reduced, or None.

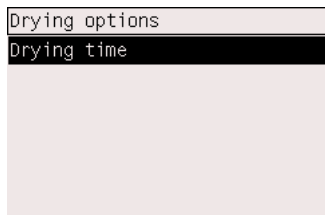

See “Tell me about drying time” on page 238.

6 How do I handle the ink system?

- “How do I remove an ink cartridge?” on page 99
- “How do I insert an ink cartridge?” on page 104
- “How do I remove a printhead?” on page 106
- “How do I insert a printhead?” on page 110
- “How do I manage printhead monitoring?” on page 113
- “How do I recover (clean) the printheads?” on page 113
- “How do I clean a printhead's electrical connections?” on page 113
- “How do I align the printheads?” on page 119
- “How do I remove a printhead cleaner?” on page 120
- “How do I insert a printhead cleaner?” on page 122
- “How do I check the status of the ink system?” on page 124
- “How do I get ink cartridge statistics?” on page 124
- “How do I get printhead statistics?” on page 125
- “How do I check printer usage statistics?” on page 125

How do I remove an ink cartridge?

There are two types of ink cartridge removal.

- The ink cartridge is very low and you want to replace it with a full cartridge for unattended printing (you can use up the remaining ink in the first cartridge at a more convenient time).
- The ink cartridge is empty or faulty, and you must replace it to continue printing.

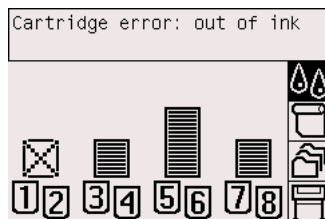

Caution 1 Do not try to remove an ink cartridge while printing.

Caution 2 Remove an ink cartridge only if you are ready to insert another one.



Warning Make sure the printer wheels are locked (the brake lever is pressed down) to prevent the printer from moving.

1. At the printer's front panel, select the  icon, then **Ink cartridges > Replace ink cartridges now**.

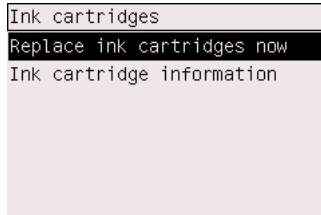

2. The ink cartridge door is on the left-hand side of the printer.

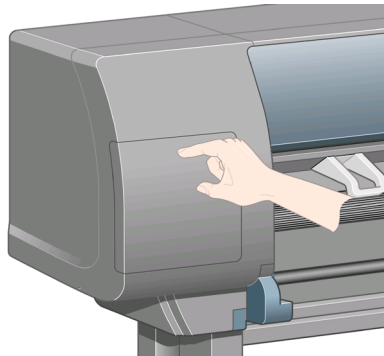

3. Release the door catch by pressing on the top until it clicks.

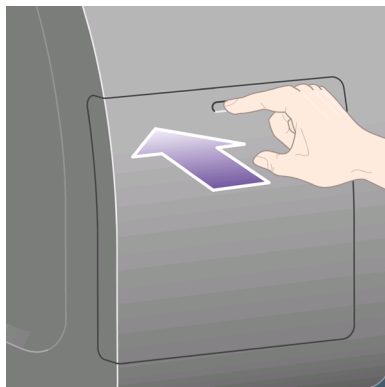

How do I handle the ink system?

4. Pull the door fully open.

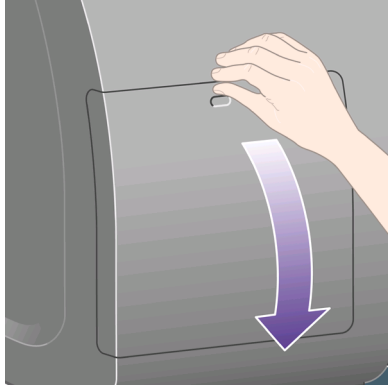

5. Grip the blue tab in front of the cartridge you wish to remove.

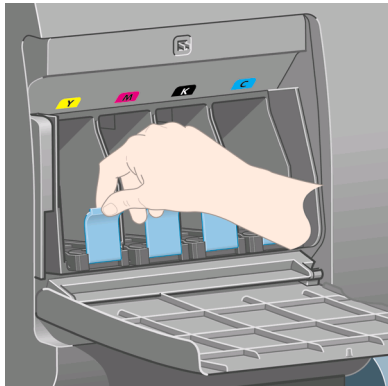

6. Pull the blue tab down.

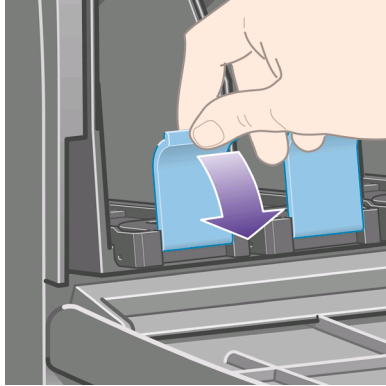

7. Then pull it outwards, towards you.

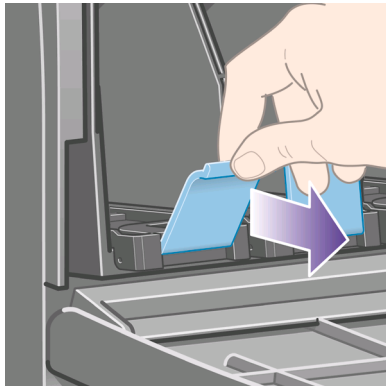

How do I handle the ink system?

8. The cartridge comes out, in its drawer.

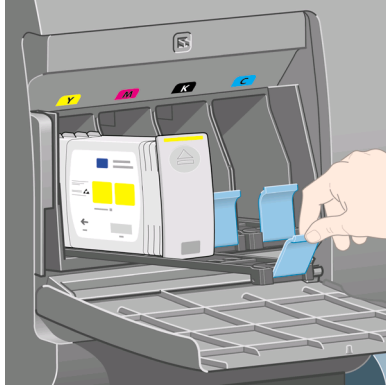

9. Lift the cartridge out of its drawer.

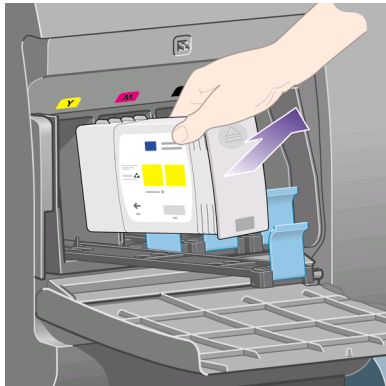

Note 1 Avoid touching the end of the cartridge that is inserted into the printer, as there may be ink on the connection.

Note 2 Avoid storing partially used ink cartridges on their ends.

10. The front panel display will identify the missing ink cartridge.

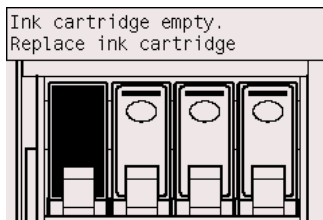

How do I insert an ink cartridge?

1. Pick up the new ink cartridge and find the label identifying the ink color. Hold the ink cartridge so that you can see the identifying colored label at the top of the side facing you.
2. Check that the colored label above the empty slot in the printer matches the color of the label on the cartridge.
3. Insert the ink cartridge into the cartridge drawer.



Position the cartridge at the rear of the drawer as indicated below.

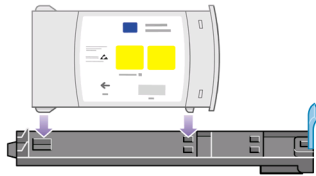

How do I handle the ink system?

- Slide the drawer and cartridge into the slot until it locks into position.



If you have difficulty, see “The problem is I cannot insert an ink cartridge” on page 207.

- When all cartridges have been inserted, close the door (push it until it clicks shut).

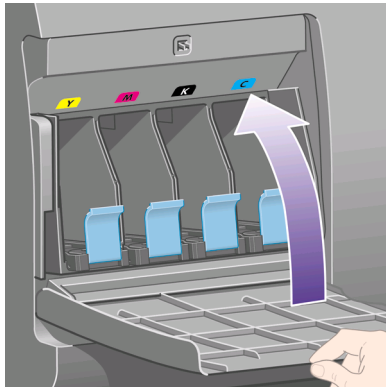

- The front panel display confirms that all cartridges have been correctly inserted.

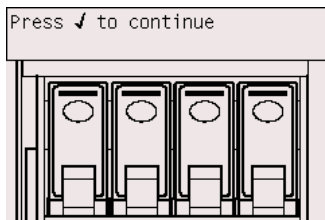

How do I remove a printhead?

 **Warning** Make sure the printer wheels are locked (the brake lever is pressed down) to prevent the printer from moving.

Printhead replacement must be performed with the printer switched on at the power isolation switch.

1. At the printer's front panel, select the  icon, then **Printheads > Replace printheads now**.

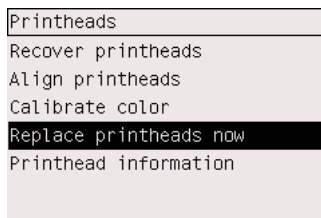

2. The printer moves the carriage into the correct position.

 **Caution** If the carriage is left in the central part of the printer for more than seven minutes, it will try to move back to its normal position in the right-hand end.

3. When the carriage has stopped moving, the front panel will ask you to open the window.

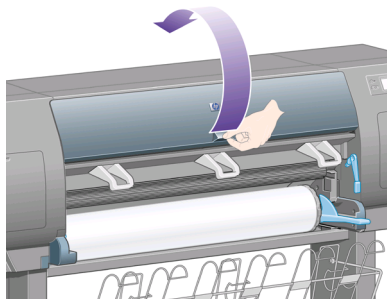

4. Locate the carriage.

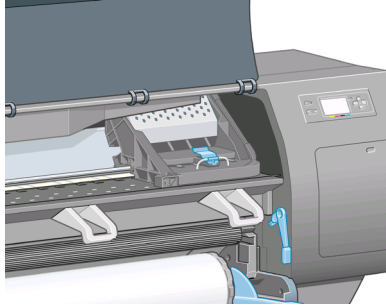

5. Pull up and release the latch on top of the carriage.

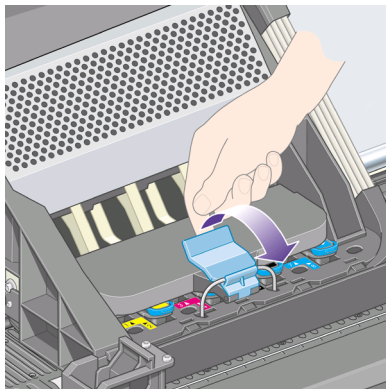

6. Lift up the cover. This will now give you access to the printheads.

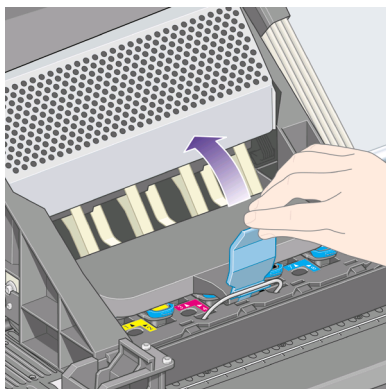

7. To remove a printhead, lift up the blue handle.

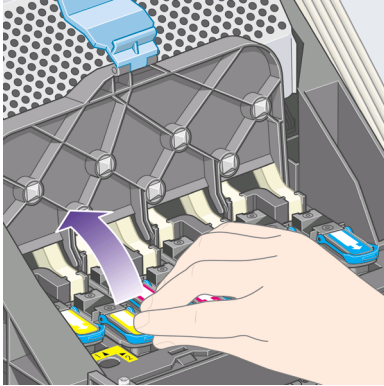

8. Using the blue handle, gently disengage the printhead.

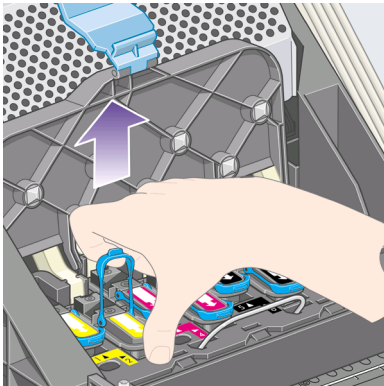

How do I handle the ink system?

- Gently pull the blue handle upward until the printhead is released from the carriage.



Caution Do not pull abruptly because this can damage the printhead.

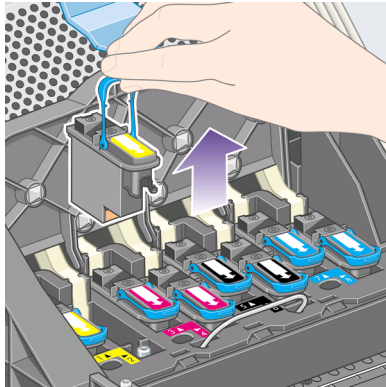

- The front panel display identifies the missing printhead.

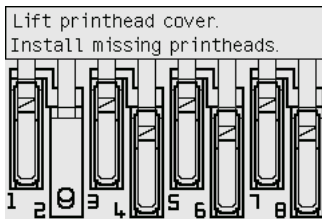

How do I handle the ink system?

How do I insert a printhead?

1. If the printhead is new:
 - a. Remove the blue protective cap by pulling down on it.
 - b. Remove the clear protective tape from the printhead's nozzles by pulling on the paper tab.

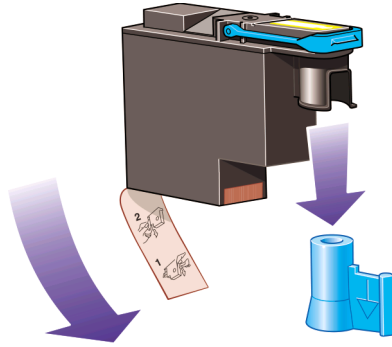

The printhead is designed to prevent you from accidentally inserting it into the wrong position. Check that the colored label on the printhead matches the colored label of the carriage position into which the printhead is to be inserted.

2. Insert the new printhead into its correct position in the carriage.

Caution Insert the printhead slowly and vertically, straight down. It may be damaged if you insert it too fast, or at an angle, or if you turn it as you insert it.

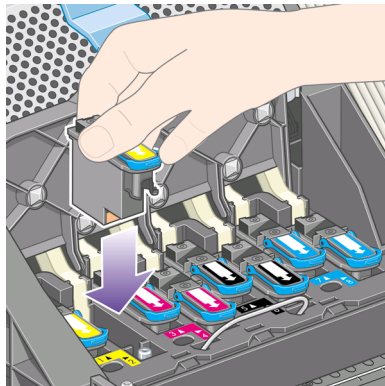

How do I handle the ink system?

3. Push down as indicated by the arrow shown below.

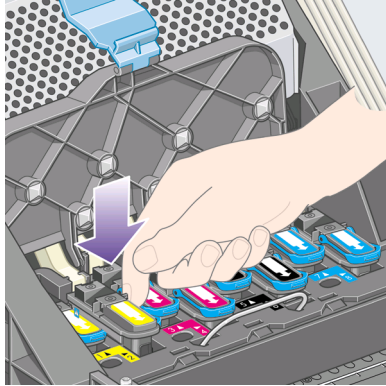

When installing the new printhead there may be some resistance, so you need to press it down firmly but smoothly.

If you have difficulty, see “The problem is I cannot insert a printhead” on page 207.

4. Insert any other printheads that need to be installed, and close the carriage cover.

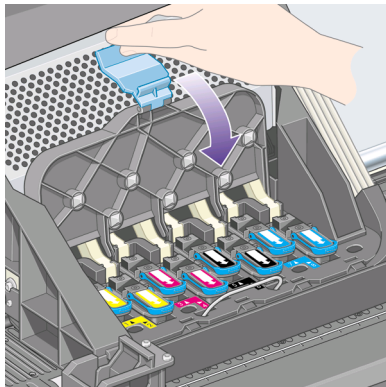

When all the printheads have been inserted correctly and accepted by the printer, the printer will beep.



Note If the printer does not beep when you insert the printhead and the **Replace** message appears on the front panel, the printhead may need to be reset.

5. Latch the carriage cover.

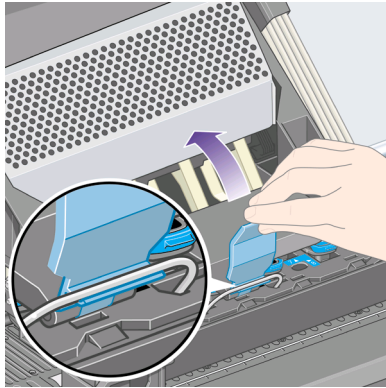

When the carriage has been correctly latched, it looks like this:

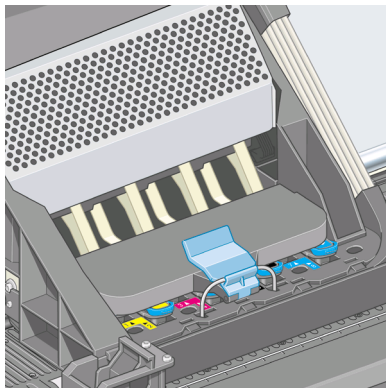

6. Close the window.
7. The front panel display confirms that all printheads are correctly inserted.

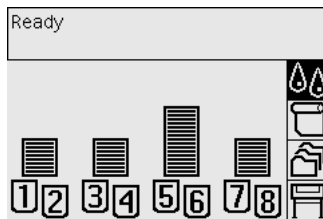

How do I handle the ink system?

- Now replace the printhead cleaners for any printheads that have been changed. See “How do I remove a printhead cleaner?” on page 120 and “How do I insert a printhead cleaner?” on page 122.



Caution Leaving the old printhead cleaner in the printer will shorten the new printhead's life and possibly damage the printer.

How do I manage printhead monitoring?

The printer automatically checks the status of the printheads from time to time in order to monitor their health and detect any problems that might affect print quality. The frequency of these checks is optimized to maintain good throughput.

If you want to increase the frequency of printhead monitoring in order to detect any problems sooner, select the  icon, then **Configuration menu > Printhead monitoring > Intensive**. When the printer is printing and printhead monitoring is set to **Intensive**, the front panel and the Embedded Web Server printer status line will display the following message: **Printing. Printhead monitoring** (instead of just **Printing**).



Note When **Intensive** is selected, the throughput of the printer will be reduced because of the increased frequency of printhead checks.

To return to the default printhead monitoring frequency, select the  icon, then **Configuration menu > Printhead monitoring > Optimized**.

How do I recover (clean) the printheads?

To clean the printheads (which often enables them to recover from problems), go to the printer's front panel and select the  icon, then **Printheads > Recover printheads**. Cleaning takes about two to four minutes.

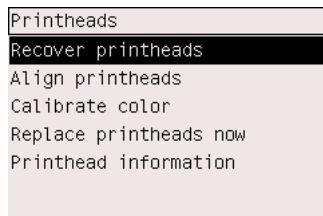

How do I clean a printhead's electrical connections?

In some extreme cases it is possible that the printer will not recognize a printhead after it has been installed. This is due to the build-up of ink deposits on the electrical connections between the printhead and the printhead carriage. Under these circumstances you are recommended to clean the printhead's electrical connections. Routine cleaning of the connections when there are no apparent problems is not recommended.

Included with your printer (in the Maintenance Kit box) is a carriage interconnect wiper.

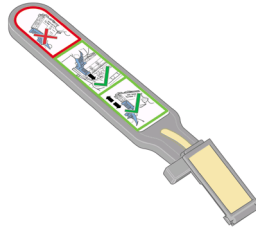

This should be used for cleaning the electrical interconnects of both the printhead carriage and the printhead, which should be done if the front panel persistently displays the **Reseat** or **Replace** message next to the printhead.

1. Remove a new pre-moistened replacement sponge from its pouch.

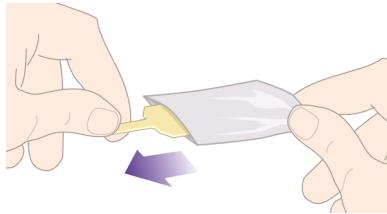

A supply of sponges is included in the box with the wiper. If all sponges have been used, more can be obtained by contacting your customer service representative.

2. Open the carriage interconnect wiper.

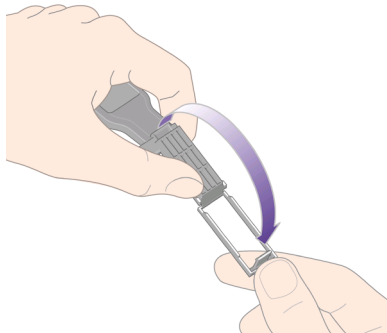

How do I handle the ink system?

3. Load the sponge into the carriage interconnect wiper by positioning the sponge on the face of the carriage interconnect wiper with the shorter tab in the locating slot.

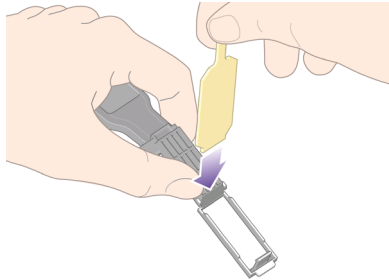

4. Close the carriage interconnect wiper, trapping the sponge in place.

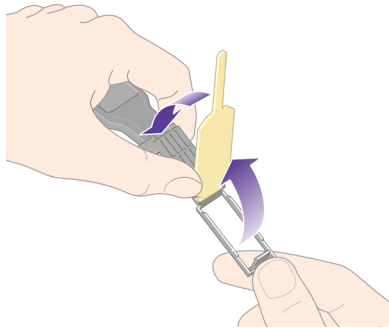

5. Open the printhead carriage latch and extract the printhead that has the problem, as indicated on the front panel. See "How do I remove a printhead?" on page 106.

6. Insert the carriage interconnect wiper into the printhead slot at the back. Wipe the electrical contacts by inserting the tool between the electrical connections at the back of the slot and the steel spring with the sponge facing away from you and towards the electrical contacts. Try to avoid picking up any ink deposit which may have accumulated on the bottom surface of the slot.

 **Caution** If the carriage is left in the central part of the printer for more than seven minutes, it will try to move back to its normal position in the right-hand end.

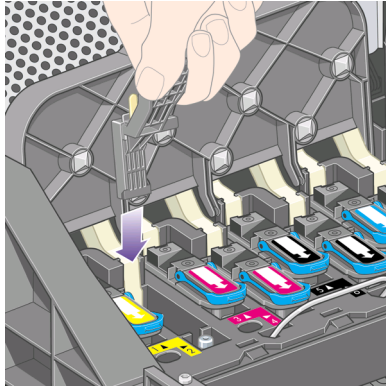

7. Rub the sponge against the contacts with a **light** force along the entire depth of the flex connector as allowed by the mechanical stop on the tool.

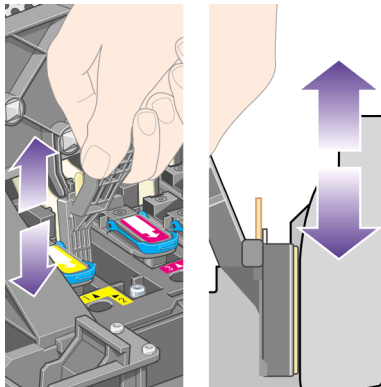

8. Take special care to clean all contacts thoroughly, including the ones at the lowest point of the connector.

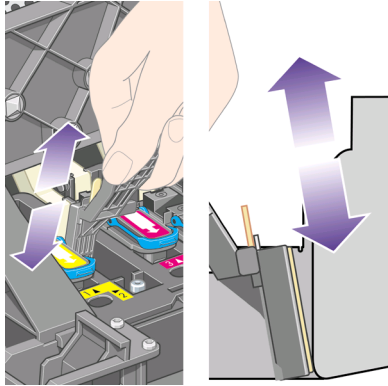

9. Using the same sponge, clean the lower strip of electrical contacts on the printhead (unless the printhead is new), avoid touching the upper set of electrical contacts.

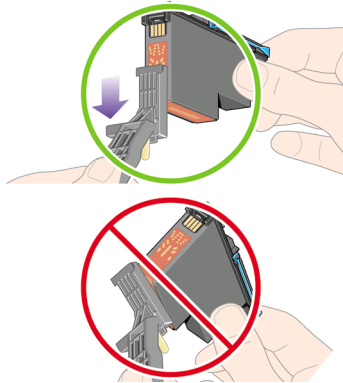

 **Caution** Do not touch the surface of the printhead containing the nozzles, which are easily damaged.

10. After waiting a few moments to allow both connectors to dry, replace the printhead into the printhead carriage. See “How do I insert a printhead?” on page 110.

11. On completion of the cleaning process, open the carriage interconnect wiper by pulling on the sponge tab.

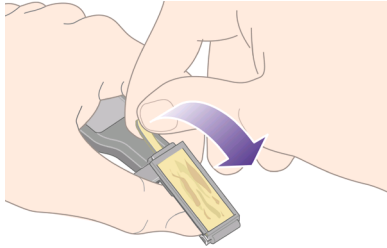

12. Remove the soiled sponge from the carriage interconnect wiper.

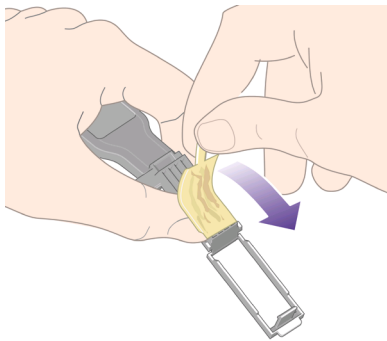

13. Dispose of the soiled sponge in a safe place to prevent the transfer of ink onto hands and clothing.

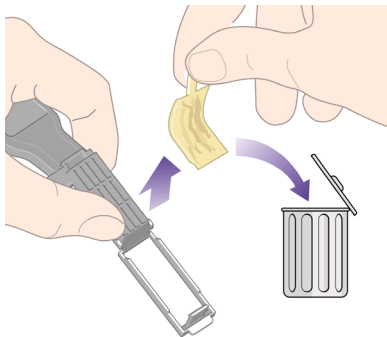

If the front panel continues to display the **Reset** or **Replace** message, replace the printhead or contact your customer service representative.

How do I handle the ink system?

How do I align the printheads?

The printer will normally perform printhead alignment whenever printheads are replaced. If there is no paper loaded when a printhead is replaced, the printer will perform the alignment the next time you load paper.



Note You can turn off these automatic printhead alignments from the front panel: select the  icon, then **Configuration menu > Auto. printhead alignment: Off**.

In addition, you should align the printheads if the Image Diagnostics Print indicates an alignment error. See “How do I use the Image Diagnostics Print?” on page 175.

1. Make sure that you have a roll of opaque paper loaded in the printer; the best results will be achieved with the type of paper that you normally use for printing. Single sheets of paper, and transparent materials such as translucent bond, clear film, matte film, tracing paper, and vellum are not suitable for printhead alignment.
2. To request printhead alignment (if the alignment is not being performed automatically), go to the front panel, select the  icon, and then **Printheads > Align printheads**.

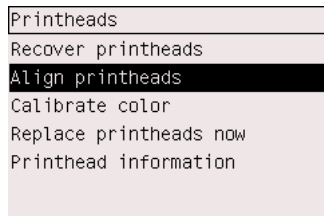

3. If you are close to the beginning of a roll, the front panel will report that the printer may need to feed up to 3 m (≈ 10 ft) of paper before starting the printhead alignment. This is necessary to ensure a successful alignment. In this case, you will be given the following options:
 - To continue with the printhead alignment, allowing the printer to feed as much paper as necessary
 - To schedule the printhead alignment to be performed later, after you have used a few meters of paper for printing
 - To cancel the printhead alignment
4. If you choose to continue with the printhead alignment, the process will start immediately, unless an image is currently being printed, in which case the alignment will be done as soon as the current print job is finished. The alignment process takes about twelve minutes.

How do I remove a printhead cleaner?

After you have replaced a printhead, the front panel will prompt you to replace the printhead cleaner.

 **Caution** When replacing a printhead, always replace the corresponding printhead cleaner. Leaving the old cleaner in the printer will seriously shorten the new printhead's life and possibly damage the printer. A new printhead cleaner is provided with each new printhead.

When removing a printhead cleaner:

- Be careful not to get ink on your hands. There may be ink on, around, and inside the replaced printhead cleaner.
- Always handle and store the replaced printhead cleaner upright to avoid spilling any ink.

 **Warning** Make sure the printer wheels are locked (the brake lever is pressed down) to prevent the printer from moving.

1. The printhead cleaners are located in slots underneath the front panel, at the front of the printer. Press the top of the service station door to release the catch.

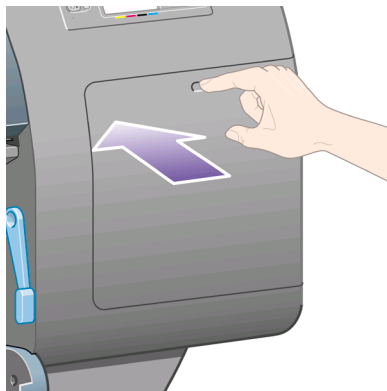

2. Open the door.

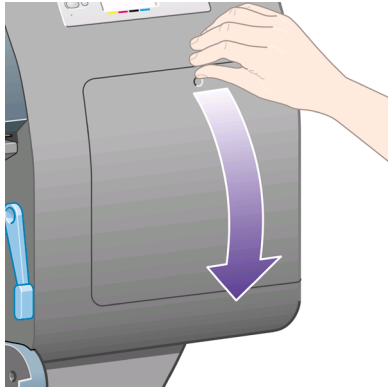

3. Each printhead cleaner has a handle on the front. To remove the cleaner, press inward and upward as indicated by the arrow shown here, until the cleaner is released.

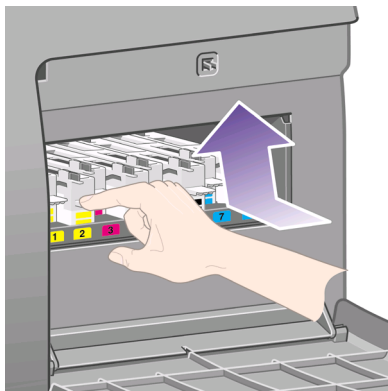

4. Lift up the printhead cleaner to remove it from the slot, and slide it out horizontally as shown below.

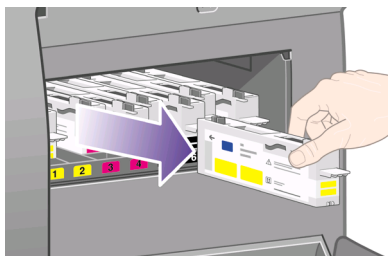

See also “How do I insert a printhead cleaner?” on page 122.

How do I insert a printhead cleaner?

The plastic bag in which the new printhead cleaner comes can be used to dispose of the old printhead and printhead cleaner.

1. Insert each printhead cleaner into the correct color slot location, in the service station, in the direction indicated by the arrow shown here.

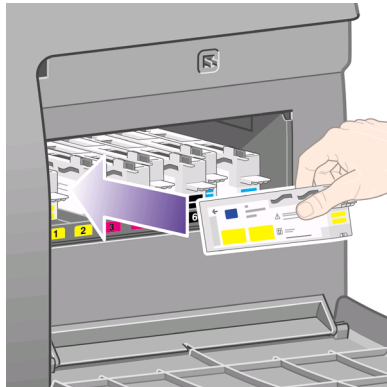

2. When the printhead cleaner has been pushed all the way in, press inwards and downwards as indicated by the arrow shown here, until it clicks into place.

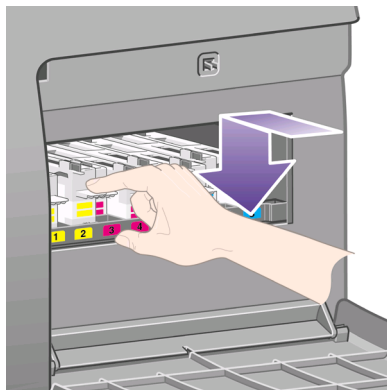

If you have difficulty, see “The problem is I cannot insert a printhead cleaner” on page 207.



Note The front panel will not show the new printhead cleaner until the right-hand door is closed.

How do I handle the ink system?

3. When you have inserted the printhead cleaner(s) into the printer, close the door.



Note The printer needs all the ink cartridges, printheads, and printhead cleaners to be installed before it can continue.

4. If no paper is loaded, the front panel will instruct you to load some.

Whenever you insert a new printhead and cleaner, the printer will normally perform a printhead alignment and color calibration. Both are recommended for best print quality. In some cases, you may decide to postpone printhead alignment until after some further printing has been done.



Note If you prefer to save some time at the expense of print quality, you can turn off these automatic procedures from the front panel, by selecting the  icon, then **Configuration menu > Auto. printhead alignment > Off** and **Configuration menu > Color calibration > Off**.

The front panel may request that you load paper that is suitable for printhead alignment. The printhead alignment procedure requires a roll of opaque paper: not a single sheet, and not any kind of transparent or translucent material.

When the front panel displays **Ready**, you are ready to print.



Note Make sure the printer window and the right-hand door are closed after you replace the supplies. The printer will not print while these are open.

How do I check the status of the ink system?

1. Access the Embedded Web Server (see “How do I access the Embedded Web Server?” on page 75).
2. Go to the **Supplies** page.

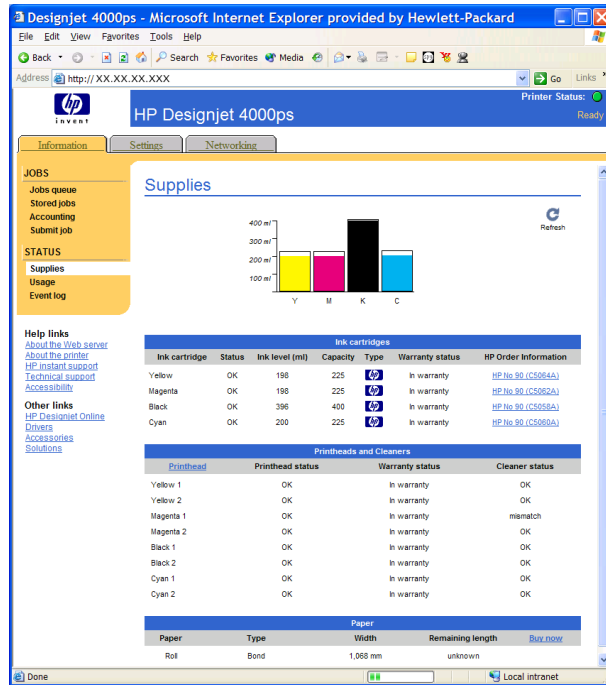

The **Supplies** page shows you the status of the ink cartridges (including the ink levels), the printheads, the printhead cleaners, and the loaded paper.

How do I get ink cartridge statistics?

To get information on your ink cartridges:

1. Go to the front panel and select the icon.
2. Select **Ink cartridges** > **Ink cartridge information**, then select the cartridge on which you want information.
3. The front panel displays:
 - Its color
 - Its product name
 - Its serial number
 - Its status
 - Its ink level, if known
 - Its total ink capacity in milliliters
 - Its warranty status

You can also get most of this information without leaving your computer by using the Embedded Web Server.

For an explanation of the ink cartridge status messages, see “The problem is an ink cartridge status message” on page 208.

How do I get printhead statistics?

To get information on your printheads:

1. Go to the front panel and select the  icon.
2. Select **Printheads > Printhead information**, then select the printhead on which you want information.
3. The front panel displays:
 - Its color
 - Its product number
 - Its serial number
 - Its status
 - The volume of ink it has used
 - Its warranty status
 - The status of its cleaner

You can also get most of this information without leaving your computer by using the Embedded Web Server.

For an explanation of the printhead and printhead cleaner status messages, see “The problem is a printhead status message” on page 208 and “The problem is a printhead cleaner status message” on page 208.

If the warranty status is **See warranty note**, this indicates that non-HP ink is being used. See “Worldwide Limited Warranty—HP Designjet 4000 Printer series” on page 253 for details of the warranty implications.

How do I check printer usage statistics?

1. Access the Embedded Web Server (see “How do I access the Embedded Web Server?” on page 75).
2. Go to the **Usage** page.
3. Go to the **Historical** tab to see the accumulated usage of the printer since the first day.
4. Go to the **Snapshot** tab to save a record of the accumulated usage since the first day, and reset the **Accumulated** tab's counters to zero.
5. Go to the **Accumulated** tab to view the accumulated usage since the last snapshot.

How do I handle the ink system?

7 How do I adjust my printed images?

- “How do I change the page size?” on page 127
- “How do I create a custom page size?” on page 127
- “How do I change the print quality?” on page 129
- “How do I choose print quality settings?” on page 130
- “How do I print at maximum speed?” on page 132
- “How do I adjust the margins?” on page 132
- “How do I print on oversize page sizes?” on page 133
- “How do I change the paper's orientation?” on page 133
- “How do I rotate an image?” on page 134
- “How do I print a mirror image?” on page 134
- “How do I scale an image?” on page 134
- “How do I change the palette settings?” on page 135
- “How do I change the treatment of overlapping lines?” on page 136
- “How do I change the graphic language setting?” on page 137

How do I change the page size?

The page size can be specified in the following ways:

- Using a Windows printer driver: select the Paper/Quality tab, then **Size is**.
- Using a Mac OS printer driver: select the Page Attributes panel, then **Paper size**.
- Using the Embedded Web Server: go to the Page Size section of the Submit Job page.
- Using the front panel: select the  icon, then **Printing defaults menu > Paper options > Size**.



Note If a page size is set with the printer driver or with the Embedded Web Server, it overrides the page size set with the front panel.

How do I create a custom page size?

You can create a custom page size using a printer driver or the Embedded Web Server.

Using the HP-GL/2 & RTL printer driver for Windows

1. Select the Paper/Quality tab.
2. Press the **Custom** button.
3. Choose one of the selectable names (**Custom 1** to **Custom 5**) for your custom page size.
4. Enter its width and height.
5. Press the **OK** button.

Using the PostScript printer driver for Windows XP or Windows 2000

1. Select the Paper/Quality tab.
2. Press the **Custom** button.
3. Enter your choice of name for your custom page size.
4. Enter its width and height.
5. Press the **Save** button.

Using the PostScript printer driver for Windows Me or Windows 98

1. Select the Paper/Quality tab.
2. Select **Custom page 1**, **Custom page 2**, or **Custom page 3** from the **Size is** list.
3. Choose the width and height of your custom page.
4. Press the **OK** button.

Using the PostScript printer driver for Windows NT

1. Select the Page Setup tab.
2. Select **PostScript Custom Page Size** from the list of page sizes.
3. Choose the width and height of your desired page size.
4. Press the **OK** button.

Using the PostScript printer driver for Mac OS X

1. Select **Page Setup** from the **File** menu.
2. Select the Custom Paper Size panel.
3. Press the **New** button.
4. Enter your choice of name for your custom page size.
5. Enter its width and height.
6. Press the **Save** button.

Using the PostScript printer driver for Mac OS 9

1. Select **Page Setup** from the **File** menu.
2. Select the Page Attributes panel.
3. Select the Custom Page Default panel.
4. Enter your choice of name for your custom page size.
5. Enter its width and height.
6. Press the **Add** button.

Using the Embedded Web Server

1. Go to the Page Size section of the Submit Job page.
2. Select the **Custom** option.
3. Choose the width and height of your desired page size.

How do I change the print quality?

Your printer has three different print quality options: **Best**, **Normal**, and **Fast**. There are also two supplementary options that have an effect on print quality: **Optimize for drawings/text** or **Optimize for images**, and **Maximum detail**. See “How do I choose print quality settings?” on page 130 for guidance on choosing among these options.

You can specify the print quality in the following ways:

- Using a Windows printer driver: go to the Print Quality section of the Paper/Quality tab.
- Using a Mac OS printer driver: go to the Image Quality panel.
- Using the Embedded Web Server: go to the Image Quality section of the Submit Job page.
- Using the front panel: select the  icon, then **Printing defaults menu > Image quality**.



Note 1 If a print quality is set with the printer driver or with the Embedded Web Server, it overrides the print quality setting from the front panel.

Note 2 You cannot change the print quality of pages that the printer is already receiving or has already received (even if they have not started to print yet).

How do I choose print quality settings?



The following table shows suggested print quality settings and paper types for various different kinds of prints, assuming that you are using roll paper. You are not obliged to follow these suggestions, but you may find them helpful.

If you are using sheet paper, you are recommended to set print quality to **Best**.



If you are not sure how to change the print quality settings, see “How do I change the print quality?” on page 129.

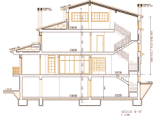
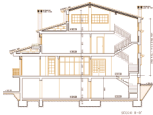

Note High-density images should be printed on heavier paper (heavyweight or glossy).

Print content	Image quality settings			Paper types (front panel)
	Print quality	Optimized for	Maximum detail	
Lines (draft) 	Fast	Drawings/text	On	Bright White Bond Paper Translucent materials* Coated Paper
Lines 	Normal	Drawings/text	Off	Bright White Bond Paper Translucent materials* Coated Paper
Lines and area fills 	Best	Drawings/text	Off	Bright White Bond Paper Translucent materials* Coated Paper Heavyweight Coated Paper Productivity Photo Gloss

How do I adjust my printed images?

Print content	Image quality settings			Paper types (front panel)
	Print quality	Optimized for	Maximum detail	
Lines and images 	Best	Drawings/ text	On	Coated Paper Heavyweight Coated Paper Productivity Photo Gloss
In-store advertising 	Normal	Images	Off	Coated Paper Heavyweight Coated Paper Productivity Photo Gloss
Renderings 	Best	Images	Off	Heavyweight Coated Paper Productivity Photo Gloss
Photographs 	Best	Images	Off	Productivity Photo Gloss

How do I adjust my printed images?

* Translucent materials include Vellum, Translucent Bond, Natural Tracing Paper, Clear Film, and Matte Film.

For technical details of print resolution, see “Tell me about functional specifications” on page 239.

How do I print at maximum speed?

There are two paper type settings in the front panel especially designed for printing at maximum speed.

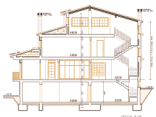
Print content	Image quality settings			Paper types (front panel)
	Print quality	Optimized for	Maximum detail	
Lines (draft) 	Fast	Drawings/text	Off	Max Speed Bright White* Max Speed Bond Paper†

* To use Max Speed Bright White, load HP Bright White Inkjet Bond Paper and select Max Speed Bright White from the list of paper types in the front panel.

† To use Max Speed Bond Paper, load HP Universal Inkjet Bond Paper and select Max Speed Bond Paper from the list of paper types in the front panel.

How do I adjust the margins?

The printer margins determine the printable area of the page that can be used by your application. There are two margin options: Extended and Normal. For the dimensions of the margins, see “Tell me about functional specifications” on page 239.

You can specify the margins in the following ways:

- Using the Windows HP-GL/2 printer driver: Normal margins are selected by default. To select Extended margins, select the Paper/Quality tab and check the **Extended margins** box.
- Using the Windows PostScript printer driver: select the Paper/Quality tab, then **Size is**. You select the page size and the margins at the same time.
- Using a Mac OS printer driver: select the Page Attributes panel, then **Paper size**. You select the paper size and then select the margins. With the Mac OS 10.1 driver, you can select only Normal margins.
- Using the Embedded Web Server: select the Submit Job page, then **Margins**.
- Using the front panel: select the  icon, then **Printing defaults menu > Paper options > Margins**.



Note If margins are set with the printer driver or with the Embedded Web Server, they override the margins set with the front panel.

How do I print on oversize page sizes?

For technical reasons, it is impossible to print an image that covers the full width or length of the paper. There must always be a margin around the image. If you want to print, for example, an A3-sized image with no margins around it, you must print on paper larger than A3 (leaving margins around the image as usual), and then cut off the margins after printing.

Oversize page sizes are designed to meet this need. Each oversize page size is large enough to accommodate a standard paper size plus margins.

You can specify an oversize page size in the following ways:

- Using the Windows HP-GL/2 printer driver: select one of the oversize paper sizes from the **Size is** list.
- Using the Windows PostScript printer driver: select the Paper/Quality tab, then **Size is**. You select the oversize page size and the margins at the same time.
- Using a Mac OS 9 or 10.1 printer driver: create a custom paper size with zero margins, and take into account that the margins added to the final job will be the ones that are set in the printer's front panel.
- Using a newer Mac OS printer driver: select the Page Attributes panel, then **Paper size**. You select the oversize paper size and then select the margins.
- Using the Embedded Web Server: for PDF, TIFF, and JPEG jobs, oversize page sizes are automatically selected if you leave margins set to **Default**. If you select Normal or Extended margins, normal page sizes will be used.
The Embedded Web Server does not support the use of oversize page sizes for HP-GL/2, RTL, CALS G4, or PostScript jobs (you must use a printer driver).
- Using the front panel: for PDF, TIFF, and JPEG jobs, front panel margin settings are ignored and you are assumed to be using oversize pages in all cases.
The front panel does not support the use of oversize page sizes for HP-GL/2, RTL, CALS G4, or PostScript jobs (you must use a printer driver).

How do I change the paper's orientation?

You can select portrait or landscape orientation of the paper using a printer driver or the Embedded Web Server.

- Using the PostScript printer driver for Windows NT: go to the Orientation section of the Page Setup tab.
- Using any other printer driver for Windows: go to the Orientation section of the Finishing tab.
- Using the PostScript printer driver for Mac OS: select **Page Setup** from the **File** menu, then go to the Orientation section of the Page Attributes panel.
- Using the Embedded Web Server: go to the Orientation section of the Submit Job page.

How do I rotate an image?

Images are normally printed in portrait orientation. You may wish to rotate an image by 90 degrees in order to save paper. You can do this in the following ways:

- Using a Windows printer driver: select the Finishing tab, then **Rotate by 90 degrees**.
- Using a Mac OS printer driver: select the Finishing panel, then **Rotate by 90 degrees**.
- Using the Embedded Web Server: select the Submit Job page, then **Rotate**.
- Using the front panel: select the  icon, then **Printing defaults menu > Paper options > Rotate**.



Note 1 If rotation is set with the printer driver or with the Embedded Web Server, it overrides the setting in the front panel.

Note 2 When you rotate a job, the page length may be increased to avoid clipping, because the top and bottom margins are usually larger than the side margins.

Possibility of clipped images

With either rolls or sheets, if you rotate an image to landscape whose original orientation was portrait, the paper may not be wide enough for the image, and it may be clipped. For example, rotating a portrait D/A1-size image on D/A1-size paper by 90 degrees will probably result in a clipped image. If you are using the Embedded Web Server, the preview screen will confirm this with a warning triangle.

How do I print a mirror image?

If you are using clear imaging paper, sometimes called backlit, you may want to print a mirror image of your drawing, so that when the paper is lit from behind it is in the correct orientation. To do this without changing the image in your application:

- Using a Windows printer driver: select the Finishing tab, then **Mirror image**.
- Using a Mac OS printer driver: select the Finishing panel, then **Mirror image**.
- Using the Embedded Web Server: select the Submit Job page, then **Mirror**.
- Using the front panel: select the  icon, then **Printing defaults menu > Paper options > Mirror**.



Note If mirror image is set with the printer driver or with the Embedded Web Server, it overrides the setting in the front panel.

How do I scale an image?

You can send an image to the printer at a certain size but tell the printer to rescale it to a different size (normally larger). This may be useful:

- If your software does not support large formats
- If your file is too large for the printer's memory—in this case you can reduce the page size in your software and then scale it up again using the front panel option

You can rescale an image in the following ways:

- Using a Windows printer driver: select the Effects tab, then **Resizing options**.
 - The **Print document on** option (with **Scale to fit** checked) adjusts the image size to the page size selected for your printer. For example, if you have selected ISO A2 as the page size and you print an A4-size image, it will be enlarged to fit the A2 page. If the ISO A3 page size is selected, the printer would reduce a larger image to fit the A3 size.
 - The **% of normal size** option enlarges the printable area of the original page by the percentage indicated and adds the printer margins to make up the output page size.
- Using a Mac OS printer driver: select the Finishing panel, then **Print document on**. No **Scale to fit** option is displayed, because it is permanently on: the driver always adjusts the image size to the page size selected for your printer.
- Using the Embedded Web Server: select the Submit Job page, then **Scaling**.
- Using the front panel: select the  icon, then **Printing defaults menu > Paper options > Scale**.

If you are printing to a single sheet, you must ensure that the image can actually fit onto the page, otherwise clipping will occur.

How do I change the palette settings?

You cannot change the Factory palette, but you can define Palettes A and B to be whatever you choose.

These palettes will be applied only to HP-GL/2 jobs with no software palette embedded.



Note All HP-GL/2 jobs generated by the HP-GL/2 driver that comes with the printer will include an embedded software palette, and thus any palette settings in the front panel will be ignored.

To redefine Palette A:

1. Go to the front panel, select the  icon, then **Printing defaults menu > HP-GL/2 options > Define palette > Palette A**.

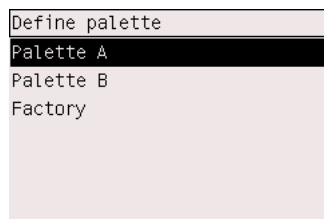

2. Scroll to the pen number you want to change and press **Select**.
3. The current width assigned to this pen is displayed, for example **Width=0.35 mm**. If you want to change it:
4. Press **Select**.
5. Scroll to the width you want.

6. Press **Select** again.
7. Press **Back** to get to the previous menu: **Color/Width**. Otherwise, scroll to **Color**.
8. The current color assigned to the pen is displayed, for example **Color=110**. If you want to change it:
9. Press **Select**.
10. Scroll to the color you want.
11. Press **Select** again.
12. Press **Back** to get to the previous menu.
13. When both width and color are correct, press **Back**.
14. Scroll to the next pen number you want to change, press **Select** and then repeat the above process.
15. When all pen definitions are correct, press **Back** to exit the menus.



Note The palette you have just defined will take effect only when you select it to be the current palette.

If you do not get the results you expect, see “The problem is pen settings seem to have no effect” on page 206.

How do I change the treatment of overlapping lines?

The Merge setting controls the overlapping lines in an image. There are two settings, Off and On.

- If Merge is Off, where the lines cross only the color of the top line is printed.
- If Merge is On, where the lines cross the colors of the two lines are merged.

To turn Merge on, select the  icon, then **Printing defaults menu > HP-GL/2 options > Merge: On**. You can set the merge setting from your software in some applications. Settings in your software override the front-panel settings.

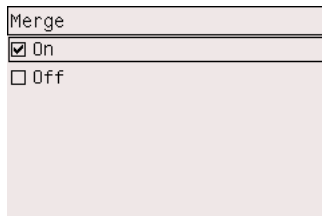

Note Merge settings have no effect on PostScript files.

How do I change the graphic language setting?

Unless you are troubleshooting one of the problems mentioned below, you should not need to change the default setting (**Automatic**), and you are not recommended to do so, because setting a specific graphic language means that you will be able to print only files in that language.

To change the graphic language setting, select the  icon, then **Printing defaults menu > Graphic language**, where the following options are available.

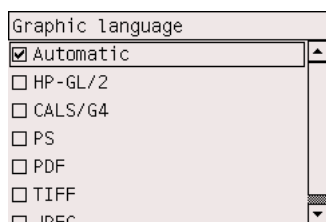

- Select **Automatic** to let the printer determine which type of file it is receiving. This setting works for most software applications.
- Select **HP-GL/2** if you are not working with PostScript files, and you have experienced image position problems or timing problems.
- Select **PS** if you are printing only PostScript files and your PostScript jobs do not start with the standard PostScript header (%!PS) and do not include PjL language switching commands.

Alternatively, select **PS** if you have experienced problems while downloading PostScript fonts. In this case, please reselect **Automatic** after you have downloaded the fonts.

If you are downloading fonts over a USB connection, select the  icon, then **Printing defaults menu > PS options > Encoding > ASCII**.

- Select **TIFF**, **JPEG**, **PDF**, or **CALS G4** only if you are sending a file of the appropriate type directly to the printer without going through a printer driver. This is normally done only from the Embedded Web Server, in which case the language setting is done by the Embedded Web Server and you do not have to do it yourself.



Note The **PS** and **PDF** options are available with PostScript printers only.

How do I adjust my printed images?

8 How do I get accurate colors from my printer?

- “How do I perform color calibration?” on page 139
- “How do I perform black point compensation?” on page 140
- “How do I set the rendering intent?” on page 140
- “How do I select the color emulation mode?” on page 141
- “How do I produce matching prints from different HP Designjets?” on page 141
- “How do I get accurate colors from Adobe Photoshop CS (HP–GL/2 & RTL driver)?” on page 141
- “How do I get accurate colors from Adobe Photoshop CS (PostScript driver)?” on page 146
- “How do I get accurate colors from Adobe InDesign CS?” on page 151
- “How do I get accurate colors from QuarkXPress 6?” on page 155
- “How do I get accurate colors from Autodesk AutoCAD 2002?” on page 158
- “How do I get accurate colors from Microsoft Office 2003?” on page 158
- “How do I get accurate colors from ESRI ArcGIS 9?” on page 158

How do I perform color calibration?

Color calibration improves color consistency between prints, and from one printer to another.

It is normally performed whenever a printhead is replaced, and whenever a new paper type is introduced that has not been calibrated yet with the new printhead(s). However, this automatic behavior can be turned off, and a default color correction used for each of the known paper types.

1. From the front panel, select the  icon, then **Configuration menu > Color calibration**.

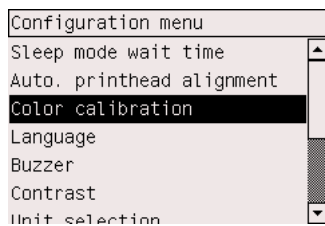

2. The available options for color calibration are:
 - **On:** the printer performs color calibration whenever you introduce a new paper type that has not yet been calibrated with the current set of printheads.

The color correction resulting from the calibration is then used for subsequent prints on that paper type with the same print quality setting.

- **Off:** the printer uses a default color correction, different for each paper type and print quality setting.
3. The printer calibrates the colors by printing a calibration strip, scanning the strip with a built-in optical sensor, and calculating the color corrections required. The color calibration strip is 269 mm wide, and 18 mm long when using glossy paper; on other paper types, it is 109 mm long. Color calibration takes about three to six minutes, depending on the paper type.



Note Color calibration can be requested manually at any time from the front panel, by selecting the  icon, then **Printheads > Calibrate color**.

How do I perform black point compensation?

The black point compensation option controls whether to adjust for differences in black points when converting colors between color spaces. When this option is selected, the full dynamic range of the source space is mapped into the full dynamic range of the destination space. It can be very useful in preventing blocking shadows when the black point of the source space is darker than that of the destination space. This option is allowed only when the relative colorimetric rendering intent is selected (see “How do I set the rendering intent?” on page 140).

Black point compensation can be specified in the following ways:

- Using a Windows printer driver: select the Color tab, then **Black point compensation**.
- Using a Mac OS printer driver: select the Color Options panel, then **Black point compensation**.
- Using the Embedded Web Server: select the Submit Job page, then **Black point compensation**.
- Using the front panel: select the  icon, then **Printing defaults menu > Color options > Black point compensation**.

How do I set the rendering intent?

Rendering intent is one of the settings used when doing a color transformation. As you probably know, some of the colors you want to print may not be reproducible by the printer. The rendering intent allows you to select one of four different ways of handling these so-called out-of-gamut colors.

- **Saturation (graphics):** best used for presentation graphics, charts, or images made up of bright, saturated colors.
- **Perceptual (images):** best used for photographs or images in which colors blend together. It tries to preserve the overall color appearance.
- **Relative colorimetric (proofing):** best used when you want to match a particular color. This method is mainly used for proofing. It guarantees that, if a color can be printed accurately, it will be printed accurately. The other methods will probably provide a more pleasing range of colors but do not guarantee that any particular

color will be printed accurately. It maps the white of the input space to the white of the paper on which you are printing.

- **Absolute colorimetric (proofing):** the same as relative colorimetric, but without mapping the white. This rendering is also used mainly for proofing, where the goal is to simulate the output of one printer (including its white point).

The rendering intent can be specified in the following ways:

- Using a Windows printer driver: select the Color tab, then **Rendering intent**.
- Using a Mac OS printer driver: select the Color Options panel, then **Rendering intent**.
- Using the Embedded Web Server: select the Submit Job page, then **Rendering intent**.
- Using the front panel: select the  icon, then **Printing defaults menu > Color options > Rendering intent**.

How do I select the color emulation mode?

You can set the color emulation mode in the following ways:

- Using a Windows printer driver: select the Color Management section of the Color tab.
- Using a Mac OS printer driver: select the Color Options panel.
- Using the Embedded Web Server: select the Color Management section of the Submit Job page.
- Using the front panel: select the  icon, then **Printing defaults menu > Color options**.

See “Tell me about color emulation modes” on page 225.

How do I produce matching prints from different HP Designjets?

See “The problem is color matching between different HP Designjets” on page 199.

How do I get accurate colors from Adobe Photoshop CS (HP–GL/2 & RTL driver)?

This topic outlines one way to have good control over the printed colors you will obtain from your printer; there are many other ways. Before starting, ensure that your paper type has already been calibrated.

Application settings

1. Open Adobe Photoshop and select **Color Settings** from the **Edit** menu.
 - **Working spaces:** the working space is the color space you want to use when manipulating the image. We recommend using the color space that comes with the image (see Color Management Policies below), if any; otherwise, our recommended default settings are: RGB: Adobe RGB 1998, CMYK: SWOP for the USA and Euroscale Coated v2 for the rest of the world.
 - **Color Management Policies:** select 'Preserve Embedded Profiles'.

- **Rendering Intent:** see “How do I set the rendering intent?” on page 140.
- **Black Point Compensation:** this option is recommended if you have chosen the Relative Colorimetric rendering intent. See “How do I perform black point compensation?” on page 140.

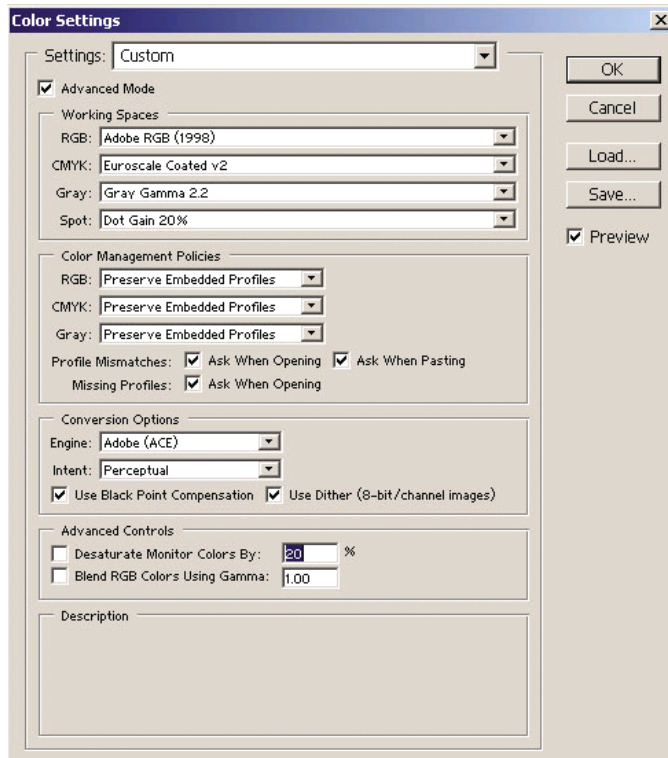

2. Open the image. Accept the embedded color profile if there is one:

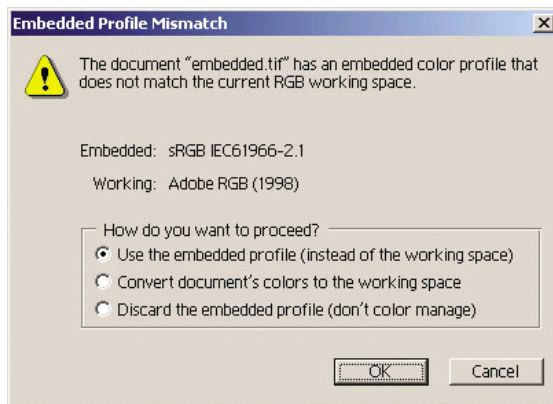

How do I get accurate colors from my printer?

Otherwise accept the default that Adobe Photoshop proposes:

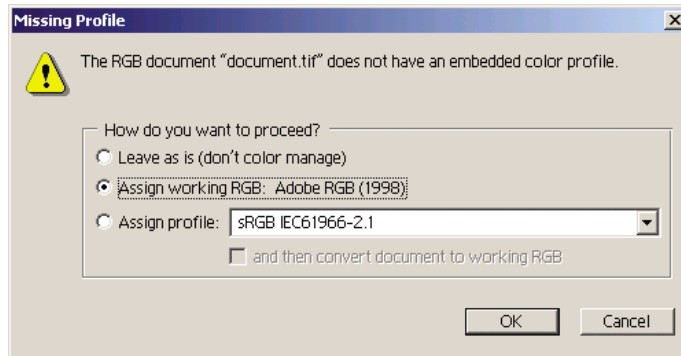

3. Once you have defined the color space in which you are going to work, you can if you like make a soft proof, which means emulating on the screen how the image will look when printed. To do this, you will need an ICC profile for your monitor. Select **View > Proof Setup > Custom**. Use the following information to select options in the Proof Setup window.
 - **Profile:** choose the profile based on the printer model and paper type you intend to use.
 - **Preserve Color Numbers:** this checkbox tells the application how to simulate the document's appearance without converting colors from the Document Space to the Proof Profile Space. It simulates the color shifts that may occur when the document's color values are interpreted using the Proof Profile instead of the Document Profile. This option is not recommended.
 - **Intent:** this menu allows you to choose a rendering intent for the conversion from document space to simulation space, letting you preview the effects of different renderings. See “How do I set the rendering intent?” on page 140.
 - **Use Black Point Compensation:** this option is recommended if you have chosen the Relative Colorimetric rendering intent. See “How do I perform black point compensation?” on page 140.
 - **Paper White:** this checkbox emulates the whiteness of the paper on the monitor. The effect is the same as using the Absolute Colorimetric rendering intent.
 - **Ink Black:** this checkbox turns off the black point compensation for the rendering from simulation to the monitor. So, if the simulation space black is lighter than the monitor black, you will see the washed-out blacks on the monitor. This option is not recommended.
 - **Preview:** if this checkbox is enabled (recommended), the changes you make in this window are reflected in the image immediately.

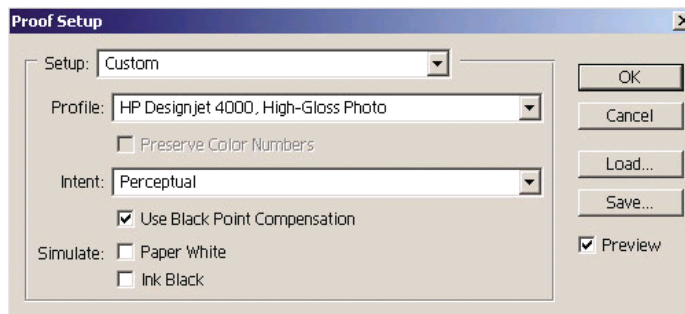

4. When you are ready to print the image, open the Print with Preview window from the File menu. In the Color Management tab you can select:
 - **Source Space:** 'Document' (automatically assigned for you).
 - **Profile:** select the profile you will use. We recommend using Adobe RGB. If neither Adobe RGB or sRGB is selected, then choose the appropriate ICC profile for the paper loaded, and remember to select later on in the driver the option **Managed by Application**.
 - **Intent:** See “How do I set the rendering intent?” on page 140.

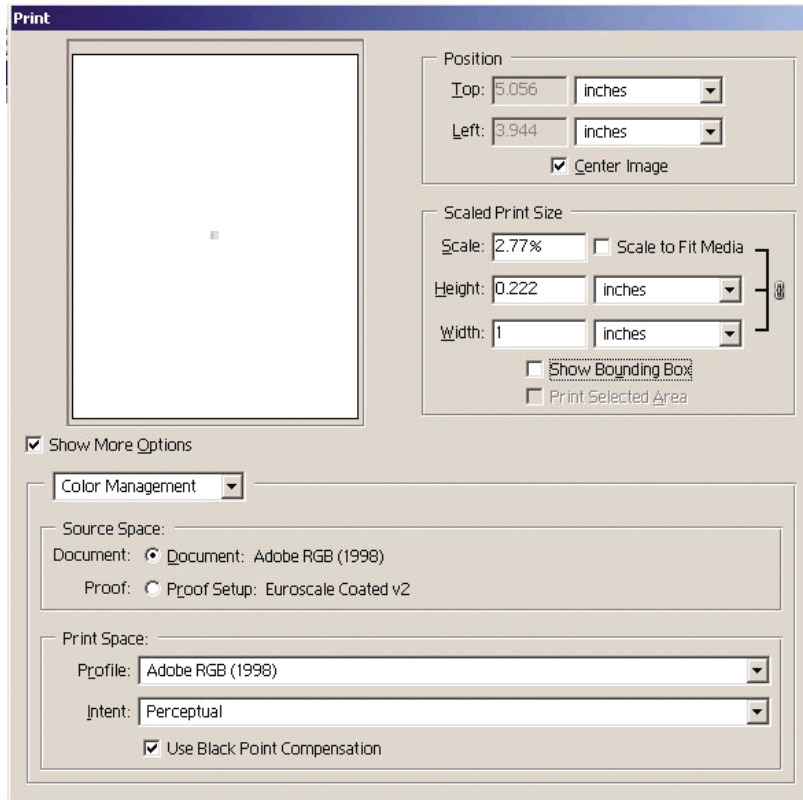

Driver settings

In the Paper/Quality tab (Windows) or Image Quality panel (Mac OS), set **Print Quality** to **Best**.

In the Color tab (Windows) or Color Options panel (Mac OS), you have the following Color Management options. Select the same option that you selected in the Print dialog box above (Print Space section, Profile option).

- **sRGB:** this is the default color space. The input RGB data are converted to CMYK using the printer's internal color maps, which depend on the paper type and print quality selected. These are the most “versatile” color maps, producing

How do I get accurate colors from my printer?

saturated colors for CAD and office applications and also producing good results with photographic images.

- **AdobeRGB:** similar to sRGB, but using the AdobeRGB to CMYK internal color maps, which are designed for AdobeRGB input data with a bigger source gamut. Best suited to digital photography.
- **Managed by Application:** the driver will not perform any color correction. This path can be used when building custom RGB printer profiles and applying them within the application (the application is responsible for applying the right color management by using the custom RGB printer profiles). In this case, make sure that you have selected the right media profile in the "Print Space, Profile" option in the application print command (see above).

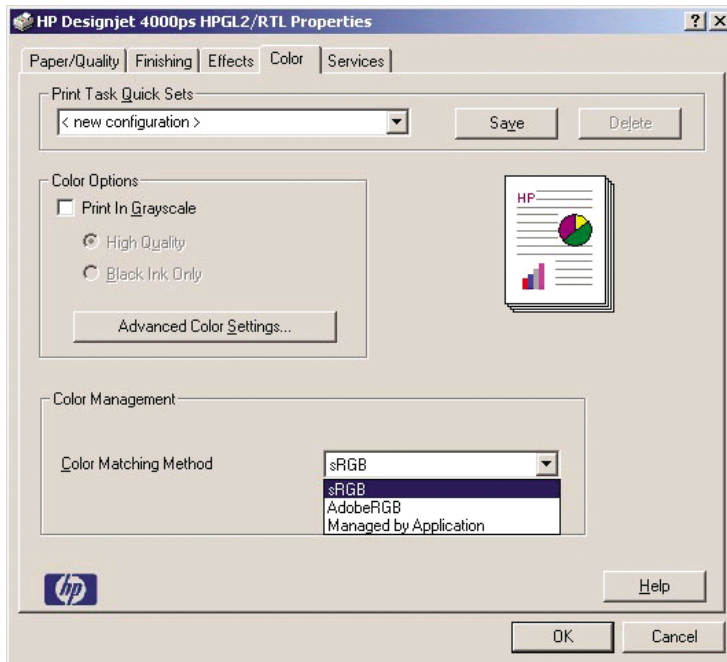

Printer settings

Ensure that the Paper Type setting on the front panel corresponds to the paper you intend to use.

How do I get accurate colors from Adobe Photoshop CS (PostScript driver)?

This topic outlines one way to have good control over the printed colors you will obtain from your printer; there are many other ways. Before starting, ensure that your paper type has already been calibrated.

Application settings

1. Open Adobe Photoshop and select **Color Settings** from the **Edit** menu (Windows) or from the **Photoshop** menu (Mac OS).
 - **Working spaces:** the working space is the color space you want to use when manipulating the image. We recommend using the color space that comes with the image (see Color Management Policies below), if any; otherwise, our recommended default settings are: RGB: Adobe RGB 1998, CMYK: SWOP for the USA and Euroscale Coated v2 for the rest of the world.
 - **Color Management Policies:** select 'Preserve Embedded Profiles'.
 - **Rendering Intent:** see “How do I set the rendering intent?” on page 140.
 - **Black Point Compensation:** this option is recommended if you have chosen the Relative Colorimetric rendering intent. See “How do I perform black point compensation?” on page 140.

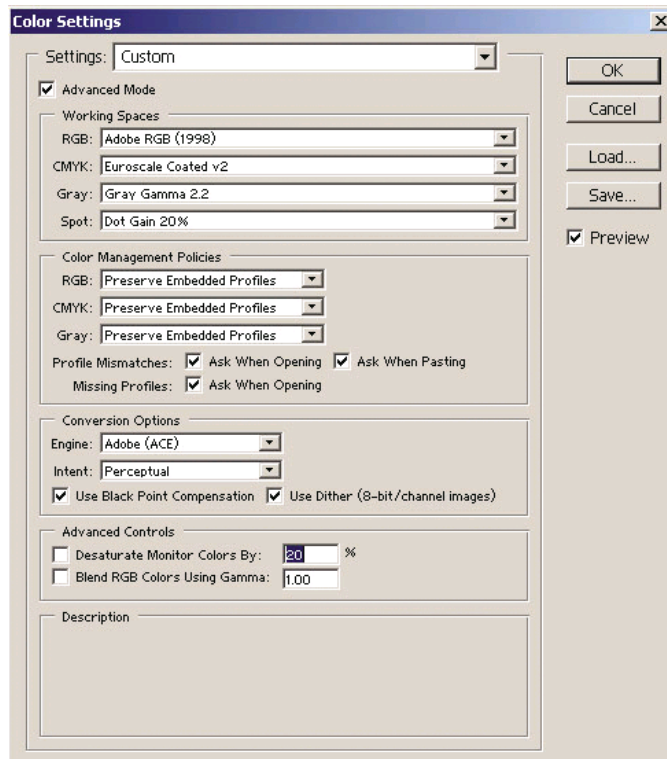

- Open the image. Accept the embedded color profile if there is one:

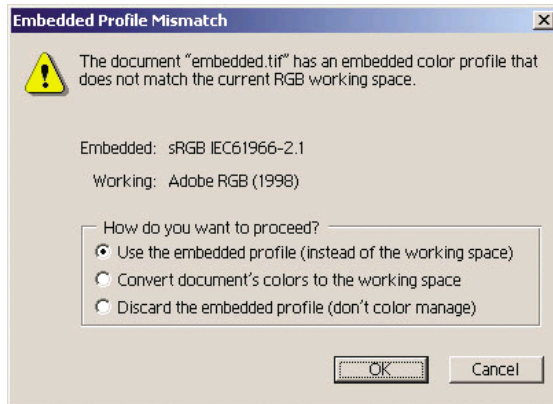

Otherwise accept the default that Adobe Photoshop proposes:

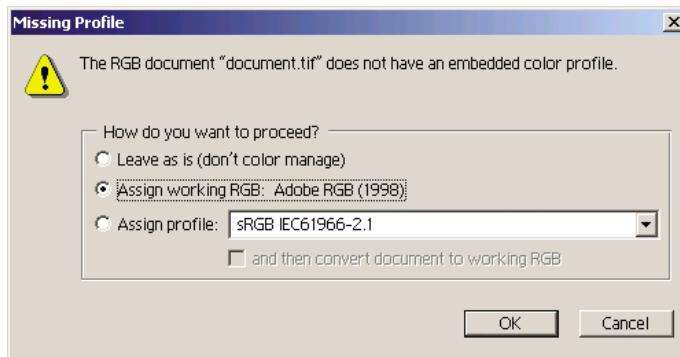

- Once you have defined the color space in which you are going to work, you can if you like make a soft proof, which means emulating on the screen how the image will look when printed. To do this, you will need an ICC profile for your monitor. Select **View > Proof Setup > Custom**. Use the following information to select options in the Proof Setup window.
 - Profile:** choose the profile based on the printer model and paper type you intend to use.
 - Preserve Color Numbers:** this checkbox tells the application how to simulate the document's appearance without converting colors from the Document Space to the Proof Profile Space. It simulates the color shifts that may occur when the document's color values are interpreted using the Proof Profile instead of the Document Profile. This option is not recommended.
 - Intent:** this menu allows you to choose a rendering intent for the conversion from document space to simulation space, letting you preview the effects of different renderings. See "How do I set the rendering intent?" on page 140.

- **Use Black Point Compensation:** this option is recommended if you have chosen the Relative Colorimetric rendering intent. See “How do I perform black point compensation?” on page 140.
- **Paper White:** this checkbox emulates the whiteness of the paper on the monitor. The effect is the same as using the Absolute Colorimetric rendering intent.
- **Ink Black:** this checkbox turns off the black point compensation for the rendering from simulation to the monitor. So, if the simulation space black is lighter than the monitor black, you will see the washed-out blacks on the monitor. This option is not recommended.
- **Preview:** if this checkbox is enabled (recommended), the changes you make in this window are reflected in the image immediately.

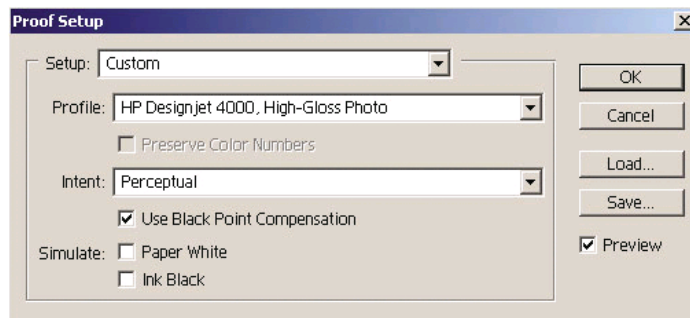

4. When you are ready to print the image, open the Print with Preview window from the File menu. In the Color Management tab you can select:
 - **Source Space:** 'Document' (automatically assigned for you). This is the color space in which you have been working while editing the image.
 - **Profile:** select PostScript Color Management. With this option, the application tells the driver which source profile and rendering intent should be used for the conversion to the print space. In this case the driver will use the 'Document' profile and the rendering intent selected below. The driver's Input Profile and Rendering Intent settings are overridden.
 - **Intent:** see “How do I set the rendering intent?” on page 140.

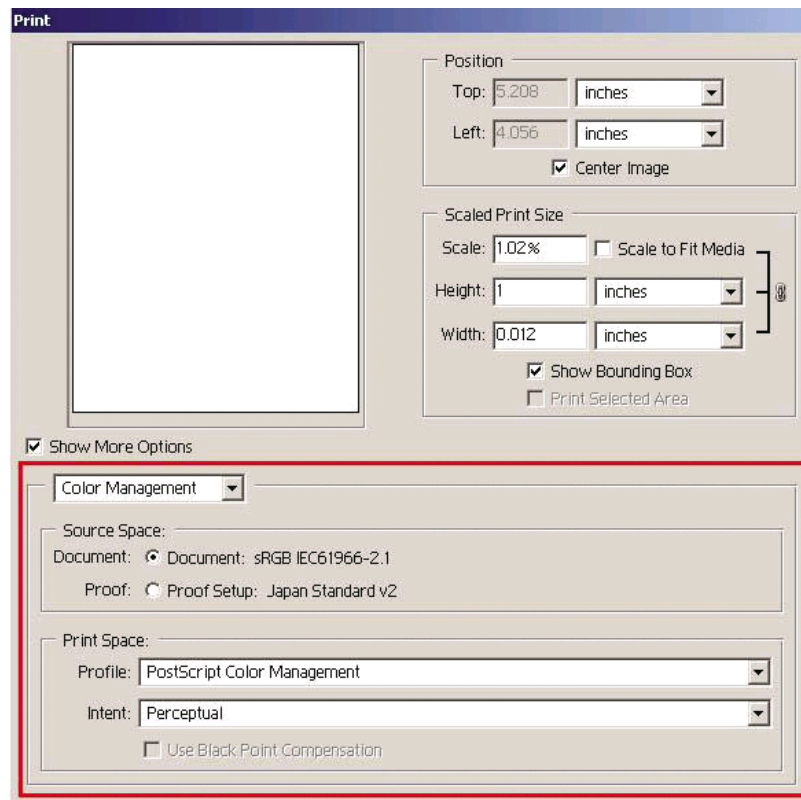

Driver settings

The application's PostScript Color Management option will override the color settings of the driver (Input Profile and Rendering Intent). In this case, the driver will use the application's "Document" profile and selected rendering intent. Then, we have only to select in the driver:

- In the Paper/Quality tab (Windows) or Image Quality panel (Mac OS), set **Print Quality to Best**.
- In the Color tab (Windows) or Color Options panel (Mac OS), check the Automatic PANTONE Calibration box.

Printer settings

Ensure that the Paper Type setting on the front panel corresponds to the paper you intend to use.

How do I get accurate colors from Adobe InDesign CS?

This topic outlines one way to have good control over the printed colors you will obtain from your printer; there are many other ways. We describe the hard-proofing technique that shows you on your printer how your colors will appear when reproduced in a press. Before starting, ensure that your paper type has already been calibrated.



Note EPS, PDF, and grayscale images don't allow page-layout applications to manage their colors. In addition, such images are displayed very poorly on a monitor.

Application settings

1. Open Adobe InDesign and select **Color Settings** from the **Edit** menu.
 - **Working spaces:** the working space is the color space you want to use when manipulating the image. We recommend using the color space that comes with the image (see Color Management Policies below), if any; otherwise, our recommended default settings are: RGB: Adobe RGB 1998, CMYK: SWOP for the USA and Euroscale Coated v2 for the rest of the world.
 - **Color Management Policies:** select 'Preserve Embedded Profiles'.
 - **Rendering Intent:** see “How do I set the rendering intent?” on page 140.
 - **Black Point Compensation:** this option is recommended if you have chosen the Relative Colorimetric rendering intent. See “How do I perform black point compensation?” on page 140.

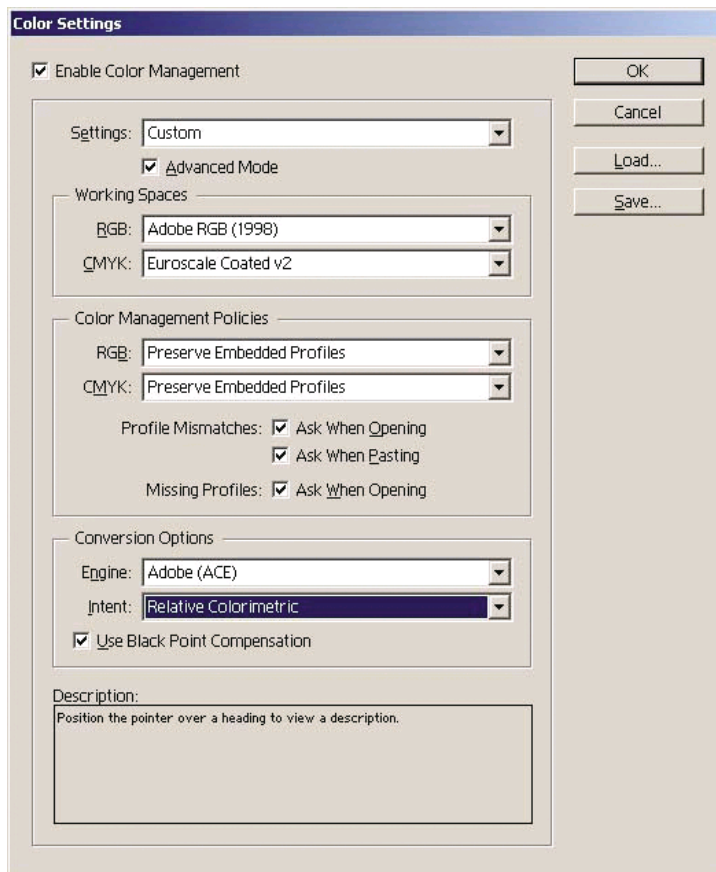

2. Create or open the image with its own or the most appropriate color space. Then retouch the image as needed.
3. When you have the image ready to send to the output device, that is the moment to simulate on your printer what will appear on the output device. You must

convert the image from the source or work profile to the output CMYK device, and then again from the output CMYK device to the printer profile (calibrated). In InDesign we recommend the Proof Setup command (**View > Proof Setup -> Custom**). This command lets you select the "proof profile" in the source space when printing. You can also see a simulation on your monitor. We recommend as follows:

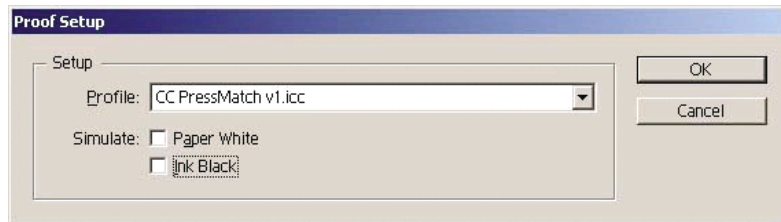

Each object in InDesign has its own color management. The InDesign elements (native) use the working spaces (default profiles) and the rendering intent defined in Color Settings , and the placed objects have their own assigned profile and rendering intent. Then, each element is converted from its own color space to the simulation color space, using its own rendering intent.

- **Profile:** select the profile that corresponds to the device you want to emulate (usually a particular press profile or an standard press profile)
- **Paper White:** this checkbox emulates the whiteness of the paper on the monitor. The effect is the same as using the Absolute Colorimetric rendering intent.
- **Ink Black:** this checkbox turns off the black point compensation for the rendering from simulation to the monitor. So, if the simulation space black is lighter than the monitor black, you will see the washed-out blacks on the monitor. This option is not recommended.

4. Select **File > Print** to print the image, converting it to an output space that depends on the printer, the paper type, and the print quality.
 - Select the Output tab (on the left), and then select **Composite CMYK**, in order to see the CMYK profiles.
 - Select the Color Management tab to see the following options.
 - **Source Space**: select 'Proof' to emulate the proof color space.
 - **Profile**: choose the profile based on the printer model and paper type you intend to use.
 - **Intent**: select Relative or Absolute Colorimetric. The only difference is that Absolute Colorimetric emulates the background color of the paper to be used by the press, while Relative Colorimetric maps the paper color of the press to the paper color of the printer.

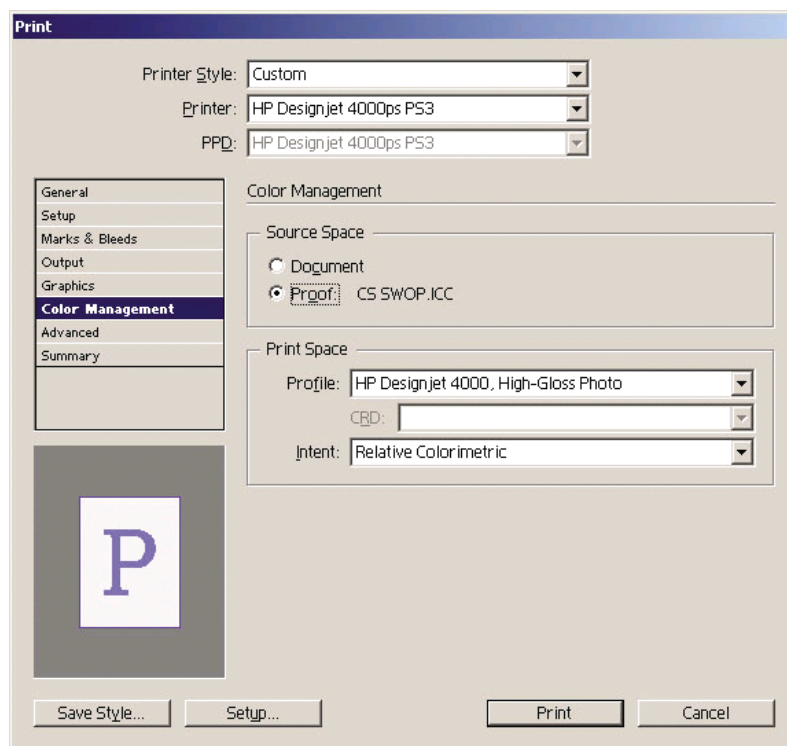

Driver settings

The PostScript driver is recommended for page-layout applications because it can color-manage CMYK data, RGB data, or both simultaneously.

In the Paper/Quality tab (Windows) or Image Quality panel (Mac OS), set **Print Quality to Best**.

In the Color tab (Windows) or Color Options panel (Mac OS), select 'Application Managed Colors' and check the Automatic PANTONE Calibration box. When the application performs color conversion to the printer's color space, the printer should

accept these colors without changing them. Make sure you have selected the right media profile in “Print Space, Profile” above.

Printer settings

Ensure that the Paper Type setting on the front panel corresponds to the paper you intend to use.

How do I get accurate colors from QuarkXPress 6?

This topic outlines one way to have good control over the printed colors you will obtain from your printer; there are many other ways. We describe the hard-proofing technique that shows you on your printer how your colors will appear when reproduced in a press. Before starting, ensure that your paper type has already been calibrated.



Note EPS, PDF, and grayscale images don't allow page-layout applications to manage their colors. In addition, such images are displayed very poorly on a monitor.

Application settings

1. Open QuarkXPress and select **Properties** from the Edit menu (Windows) or the QuarkXPress menu (Mac OS). Then select **Quark CMS** from the Properties dialog box.
 - Ensure that the Color Management Active box is checked.
 - The Destination Profiles area lets you choose profiles that correspond to your devices: Monitor profile, Composite Output profile, and Separation Output profile. Select in the Separation Output profile the profile of your output device (press) which you want to emulate on your printer later. Select in the Composite Output profile your printer profile; remember that it depends on the printer model, paper type, and print quality option.
 - In the Default Source Profiles you must set the default profiles for solid colors and images that don't have embedded profiles. The following default profiles are recommended: RGB: Adobe RGB 1998, CMYK: SWOP for the USA and Euroscale Coated v2 for the rest of the world. Also select the rendering intent, which QuarkXpress uses for all conversions; if in doubt, select Relative Colorimetric. See “How do I set the rendering intent?” on page 140.
 - Check the box **Color Manage RGB sources to RGB destinations** in the RGB Default Source Profiles and **Color Manage CMYK sources to CMYK destinations** in the CMYK Default Source Profiles.
 - The Display Simulation tells QuarkXPress how the display simulation should behave:
 - **None** means that it doesn't simulate anything on the display.
 - **Monitor Color Space** means that it converts from the source profile to the display profile for display only.

- **Composite Output Color Space** makes the display simulate a composite printer: that is, a printer without separate plates for different colors, such as an inkjet printer.
- **Separation Output Color Space** makes the display simulate a separations printer: that is, a printer with separate plates for different colors, such as a digital press.

You can select **Monitor Color Space** if you want to display only, or you can select the **Separation Output Color Space** if you also want to see the simulation of the output device on the monitor. You can simulate the final output with the printer (hard-proofing) and with the monitor (soft-proofing).

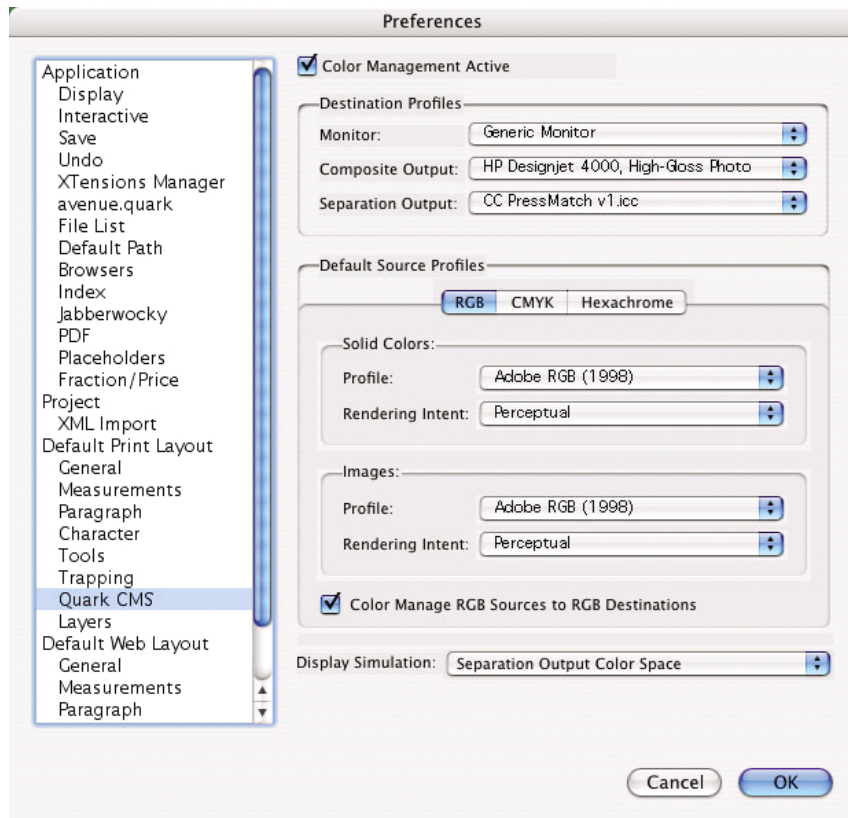

2. Open and retouch the document as you like.
3. Select **File > Print > Setup > Printer Description**, and select your printer.
4. Select **File > Print > Profiles**.
 - Select the appropriate Separation Output Profile (emulation) and Composite Output Profile (printer).
 - Check the Composite Simulates Separation box, then Quark will perform the simulation.

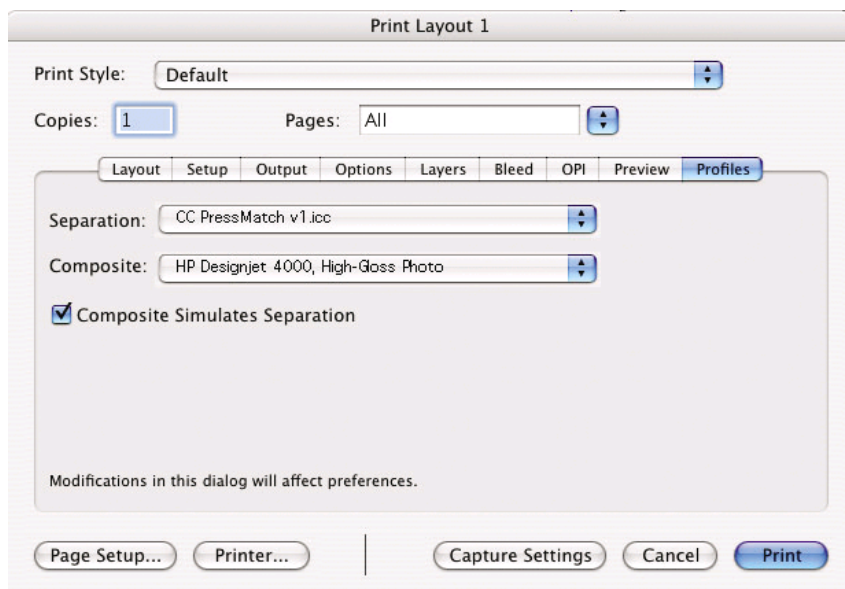

Note Each object in QuarkXpress has its own color management. The solid colors use the color profile and rendering intent selected in the default source profiles for Solid Colors (RGB, CMYK, or Hexachrome) of the Color Management Preferences dialog box. The imported objects have their own assigned profile and rendering intent. QuarkXPress will use the rendering intent assigned to the image for both conversions, from the image color space to the simulation color space, and from the simulation color space to the printer color space.

Driver settings

The PostScript driver is the best choice for page-layout applications because it can color-manage CMYK data, RGB data, or both simultaneously.

In the Image Quality panel, set **Print Quality** to **Best**.

In the Color Options panel, select **Application Managed Colors** and check the **Automatic PANTONE Calibration** box. When the application performs color conversion to the printer's color space, the printer should accept these colors without changing them. Make sure you have selected the right media profile in **Composite Output** in the Preferences dialog box.

Printer settings

Ensure that the **Paper Type** setting on the front panel corresponds to the paper you intend to use.

How do I get accurate colors from my printer?

How do I get accurate colors from Autodesk AutoCAD 2002?

AutoCAD has no color management settings, so the best you can do is to configure the driver correctly. If you are using the HP-GL/2 and RTL driver, click the Properties button and configure the driver as follows.

- In the Paper/Quality tab, set **Print Quality** to **Best**.
- In the Color tab, ensure that the **Print In Grayscale** box is unchecked, and set **Color Matching Method** to 'sRGB'.

How do I get accurate colors from Microsoft Office 2003?

Microsoft Office has no color management settings, so the best you can do is to configure the driver correctly. If you are using the HP-GL/2 and RTL driver, click the Properties button and configure the driver as follows.

- In the Paper/Quality tab, set **Print Quality** to **Best**.
- In the Color tab, ensure that the **Print In Grayscale** box is unchecked, and set **Color Matching Method** to 'sRGB'.

How do I get accurate colors from ESRI ArcGIS 9?

ArcGIS is a scalable system of software for geographic data creation, management, integration, analysis, and dissemination for every organization, from an individual to a globally distributed network of people.

The application always sends RGB data to the printer driver; you can choose between several different printer engines. The printer engine determines the format and method used by ArcMap to send the print job to the printer. There are from one to three options available, depending on license and printer configurations.

- **Windows** is the default and is always available, regardless of the printer in use. It allows the application to use the installed HP-GL/2 and RTL driver.
- **PostScript** is available only if your printer supports PostScript and the PostScript driver was selected in the Name section. This allows you to output the file as a Postscript file. This option may be useful in certain specific cases, but in general it is **not recommended**.
- **ArcPress** is an extension that can be purchased for printing from ArcGIS. It is a software RIP that takes the original metafile and rasterizes it before sending it to the printer, so that the printer does not need to rasterize it. This is beneficial because some printers are not capable of rasterization or do not have enough memory to process large jobs. **Use ArcPress always with HP RTL (RGB) TrueColor.**

Printing with the Windows printer engine

1. Ensure that you have installed the HP-GL/2 and RTL driver.
2. When you are ready to print, select **File > Page and Print Setup**, and select the HP-GL/2 and RTL driver.

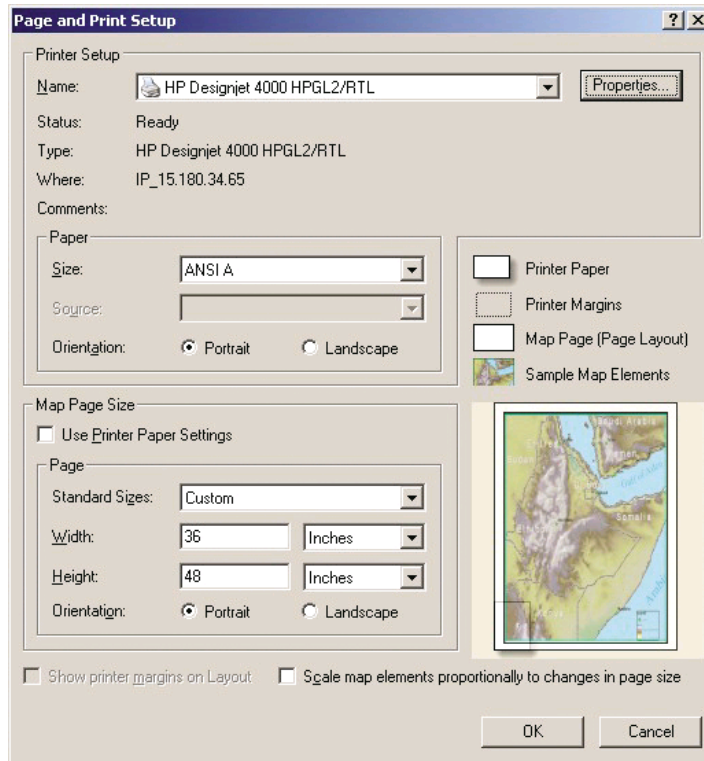

3. Click the Properties button and configure the driver as follows.
 - In the Paper/Quality tab, set **Print Quality** to **Best**.
 - In the Color tab, ensure that the **Print In Grayscale** box is unchecked, and set **Color Matching Method** to 'sRGB'.
4. Click the OK button.
5. Select **File > Print**.
 - **Printer Engine**: select Windows Printer (it will use the selected raster driver).
 - **Output Image Quality (Resample Ratio)**: this setting alters the number of pixels sampled when an ArcMap print file is generated; it determines how many pixels in the map document will be used to create the file sent to the printer.
 - Fast = 1:5
 - Normal = 1:3
 - Best = 1:1 (as is)

The 'Best' choice requires a lot of resources to process the print job, and could cause long processing times and perhaps out-of-memory messages,

depending on the map size. If you have these problems, select an Output Image Quality lower than 'Best'. Bear in mind that you will gain no advantage in print quality by sending an image whose resolution is higher than the printer's input resolution.

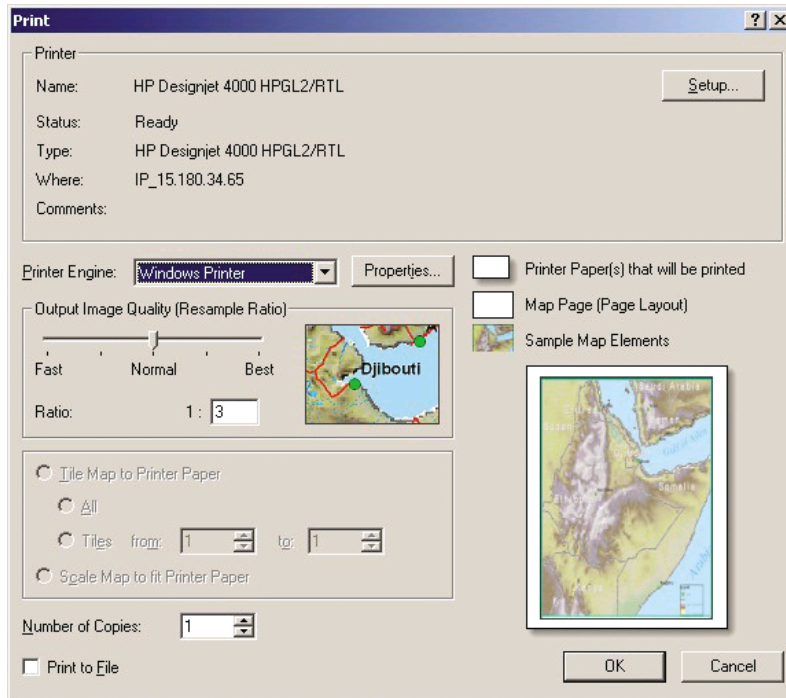

6. You can print now (click the OK button).

Printing with the ArcPress printer engine

1. You must have the driver you need installed, although it will function only as a port.
2. When you are ready to print, select **File > Page and Print Setup**, select the driver (the driver settings have no effect), and click the OK button.
3. Select **File > Print**.
 - **Printer Engine:** select ArcPress.
 - Click the **Properties** button, select the HP RTL (RGB) TrueColor driver, and select the resolution that will be sent to the printer.

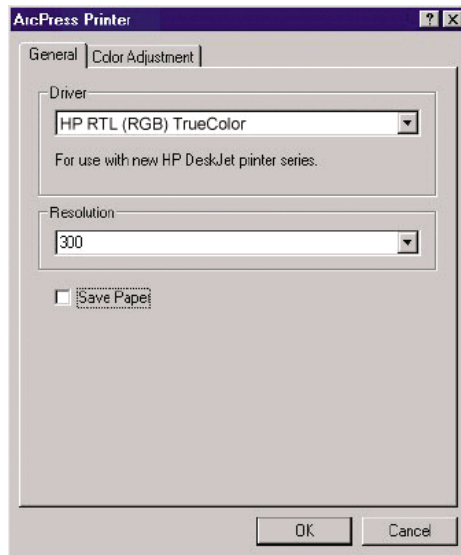

- Select the Color Adjustment tab if you want to adjust gamma, brightness, contrast, or saturation. You can preview the changes.

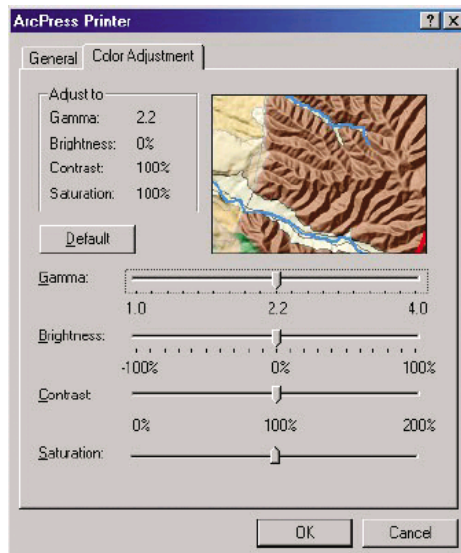

4. You can print now: click the OK button in this dialog box and in the Print dialog box.

How do I get accurate colors from my printer?

How do I get accurate colors
from my printer?

9 How do I manage print jobs?

- “How do I submit a job?” on page 163
- “How do I save a job?” on page 164
- “How do I print a saved job?” on page 164
- “How do I check ink and paper usage for a job?” on page 164
- “How do I cancel a job?” on page 164
- “How do I manage the print queue?” on page 165
- “How do I nest jobs to save roll paper?” on page 167

How do I submit a job?

1. Access the Embedded Web Server (see “How do I access the Embedded Web Server?” on page 75).
2. Go to the **Submit job** page.

The screenshot shows the HP Designjet 4000ps Embedded Web Server interface. The main heading is "Submit job". Below the heading, there is a text input field for "Enter the names of the files you want to submit" and a "Browse..." button. There is also an "Add another file" button. Below this, there is a note: "Select the settings for the job(s) and press the Print button to start printing. Note: when you press the Print button, a new window will be opened with submit progress information. When your job(s) is(are) submitted this window will be closed automatically." The "Job settings" section includes: "User name" (Please enter your username... Mandatory field), "Store job in printer" (checkbox), "Disk free space 8.92 GB", "Control settings" (Copies, Hold for preview), "Image quality" (Print quality, Optimize for, Maximum detail), and "Paper" (Page size (1), Standard/Custom, Orientation, Paper source, Margins).

3. Browse your computer and select the file to print.



Note Submitting a job to be printed via the Embedded Web Server does not require you to have the printer driver nor the file's native application installed on your computer.

4. If you want to submit more than one file, click the **Add another file** button to add another file.
5. Set the job options.

If you leave an option set to **Default**, the setting saved in the job will be used. If the job contains no setting for that option, the setting in the printer will be used. The setting in the printer can be changed from the front panel, or in some cases from the Device Setup page in the Embedded Web Server.

6. Click the **Print** button.

How do I save a job?

If you intend to reprint a job later with some changes to the job settings (such as size or quality), you can store the job inside your printer so that you will not need to resubmit it later.



Note If you want to reprint a job without changes, you can do that from the print queue without needing to save the job.

You can save a job only while submitting it for printing:

1. Access the Embedded Web Server (see “How do I access the Embedded Web Server?” on page 75).
2. Go to the **Submit job** page.
3. Browse your computer and select the file to print.
4. If you want to submit more than one file, click the **Add another file** button to add another file. All files submitted together will have the same job settings.
5. In the job options, check the **Store job in printer** option.
6. Set the rest of the job options.
7. Click the **Print** button.

How do I print a saved job?

1. Access the Embedded Web Server (see “How do I access the Embedded Web Server?” on page 75).
2. Go to the **Stored jobs** page.
3. Select the job or jobs that you want to print, using the check box beside each job name.
4. Click the **Print** button to print the job with the original settings, or **Advanced Print** to change the settings.

How do I check ink and paper usage for a job?

1. Access the Embedded Web Server (see “How do I access the Embedded Web Server?” on page 75).
2. Go to the **Accounting** page, which shows you all the information regarding the jobs recently printed by the printer.
Alternatively, go to the **Jobs Queue** page, and click on the name of the job on which you want information. Its properties page will then be displayed.

How do I cancel a job?

A job can be canceled from the front panel by pressing the **Cancel** key, or from the Embedded Web Server by selecting the job and clicking the **Cancel** icon..

The printer advances the paper as though the print were finished.



Note A multi-page job or a big file may take longer to stop printing than other files.

How do I manage the print queue?

This information below applies only if you are using the drivers that came with your printer or the Embedded Web Server to submit printing jobs.

Your printer can store pages in a queue while it is printing the current page. The queue may contain pages from more than one job.



Note If the printer hangs up while printing a job, and the queue facility is turned on, the partially printed job will appear in the queue as “On hold” when the printer is next turned on. When you resume the job, it will start printing at the page at which it was interrupted.

Turning off the queue

If you wish, you can turn off the queue from the Web server (**Settings** tab > **Device setup** > **Queue**), or from the front panel: select the  icon and then **Queue**.

Queue
<input type="checkbox"/> On
<input checked="" type="checkbox"/> Off

The When To Start Printing options



Note The When To Start Printing options cannot be used with PostScript jobs.

You can select at what point you want to print a file you have in the queue. From the Web server, select the **Settings** tab > **Device setup** > **When to start printing**; or, from the front panel, select the  icon and then **When to start printing**.

There are three options you can select:

- When **After Processing** is selected, the printer waits until the whole page has been processed and then it starts to print. This is the slowest setting but offers the best print quality.
- When **Immediately** is selected, the printer prints the page as it is processed. This is the quickest setting, but the printer may stop halfway through a print to process data. This setting is not recommended for complex images with dense color.
- When **Optimized** is selected (this is the default setting), the printer calculates the best time to begin printing the page. It is usually the best compromise between the **After Processing** and **Immediately** settings.

Identifying a job in the queue

The best way to look at the queue is in the Embedded Web Server (**Information > Jobs queue**), where you can manage the queue and get full information on every job (by clicking the name of the file).

However, you can also manage the queue from the front panel. To do so, select the  icon and then **Queue management**, where you can see a list of the jobs in the queue.

Each has an identifier, comprising:

<position in queue>: <image name>

The job currently being printed is in position 0. The next job to be printed is in position 1, the previous job already printed is in position -1.

Prioritizing a job in the queue

To make any job in the queue the next one to be printed, select it and choose **Reprint** (in the Embedded Web Server) or **Move to front** (in the front panel).

If nesting is turned on, the prioritized job may still be nested with others. If you really want this job to be printed next, and on its own on the roll, first turn nesting off and then move it to the front of the queue as described above.

Deleting a job from the queue

Under normal circumstances, there is no need to delete a job from the queue after printing it, as it will just fall off the end of the queue as more files are sent. However, if you have sent a file in error, and want to avoid any chance of it being reprinted, you can simply delete it, by selecting it and choosing **Delete** (in the Embedded Web Server or in the front panel).

In the same way, you can delete a job that has not been printed yet.

If the job is currently being printed (Status = **printing** in the Web server, or its queue position is 0 in the front panel), and you want both to cancel the job and to delete it, first click the Cancel icon in the Web server, or press the **Cancel** key on the front panel, and then delete it from the queue.

Making copies of a job in the queue

To make extra copies of any job in the queue, select the job in the Embedded Web Server and click the **Reprint** icon, then specify the number of copies you want. The job will be moved to the top of the queue.

You can also do this from the front panel: select the job and choose **Copies**, then specify the number of copies required and press the **Select** key. This overrides any value set by your software.



Note If **Rotate** was **On** when you sent the file, every copy will be rotated.

If the job has already been printed, use **Move to front** to move it to the top of the queue.

How do I nest jobs to save roll paper?

Nesting means placing pages side by side on the paper, rather than one after the other. This is done to avoid wasting paper.

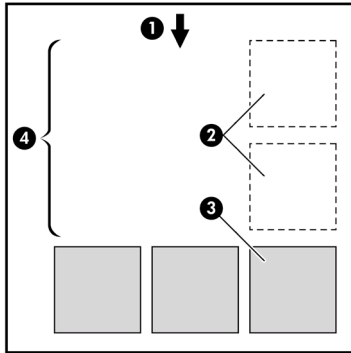

1. Direction of paper flow
2. Nesting off
3. Nesting on
4. Paper saved by nesting

When does the printer try to nest pages?

When both of the following are true:

- The printer is loaded with roll paper, not sheet paper.
- In the front panel's Job Management menu or the Embedded Web Server's Device Setup page, **Nest** is On.

Which pages can be nested?

All pages can be nested, unless they are so large that two of them cannot fit side by side on the roll.

Which pages qualify for nesting?

In order to be in the same nest, the individual pages must be compatible in all of the following ways:

- All pages must have the same print quality setting (Fast, Normal, or Best).
- Pages must be all Optimized for Drawings/Text or all Optimized for Images.
- The Maximum Detail setting must be the same on all pages.
- The Margins setting must be the same for all pages (Extended or Normal).
- The Mirror setting must be the same for all pages.
- The Rendering Intent must be the same for all pages.
- The Cutter setting must be the same for all pages.

- The color adjustment settings must be the same for all pages. These are known as Advanced Color Settings in the Windows driver, and CMYK Settings in the Mac OS driver.
- Pages must be all color, or all grayscale: not some in color and some in grayscale.
- All pages must be in one or other of the following two groups (the two groups cannot be mixed in the same nest):
 - HP-GL/2, RTL, CALS G4
 - PostScript, PDF, TIFF, JPEG
- JPEG, TIFF, and CALS G4 pages with resolutions greater than 300 dpi may not nest with other pages in some cases.

How long does the printer wait for another file?

So that the printer can make the best nest possible, it waits after a file has been received to check whether a subsequent page will nest with it or with pages already in the queue. This waiting period is the nest wait time; the factory default nest wait time is two minutes. This means that the printer waits for up to two minutes after the last file is received before printing the final nest. You can change this waiting time from the printer's front panel: select the  icon, then **Nest options > Wait time**. The available range is 1 to 99 minutes.

While the printer is waiting for nesting to time out, it displays the remaining time on the front panel. You can print the nest (cancel the nest wait) by pressing the **Cancel** key.

10 How do I maintain my printer?

- “How do I clean the exterior of the printer?” on page 169
- “How do I clean the platen?” on page 169
- “How do I lubricate the printhead carriage?” on page 171
- “How do I maintain the ink cartridges?” on page 172
- “How do I move or store my printer?” on page 172
- “How do I update my printer's firmware?” on page 173

How do I clean the exterior of the printer?

Clean the outside of the printer and all other parts of the printer that you regularly touch as part of normal operation (e.g. ink cartridge drawer handles) as required with a damp sponge or a soft cloth and a mild household cleaner such as non-abrasive liquid soap.

 **Warning** To avoid an electric shock, make sure that the printer is switched OFF and unplugged before you clean it. Do not let water get inside the printer.

 **Caution** Do not use abrasive cleaners on the printer.

How do I clean the platen?

You should plan to clean your printer's platen on a regular basis, every few months or when needed.

 **Note** If you print on wide paper after using narrower paper for some time, you may find that the left side of the platen has become dirty and will leave marks on the back of the paper if not cleaned.

Follow these instructions to clean the platen.

1. Unload all paper from the printer.
2. Open the window.

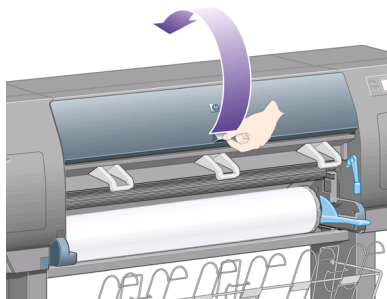

3. With a dry brush, remove ink deposits from the cutter groove.

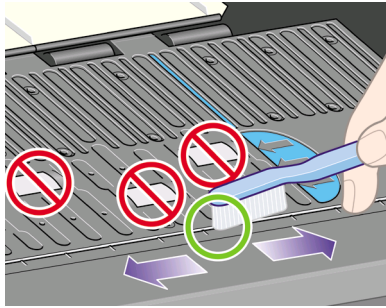

4. With the same dry brush, remove ink deposits from the platen surface.

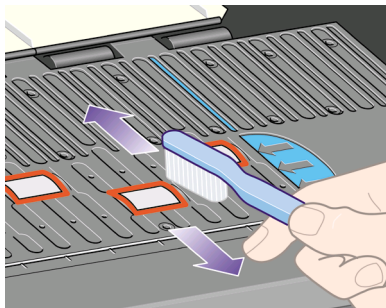

5. Use a clean, absorbent lint-free cloth, slightly dampened with isopropyl alcohol, to wipe off loosened ink deposits from the platen.



Note Isopropyl alcohol is not provided in the Maintenance Kit.

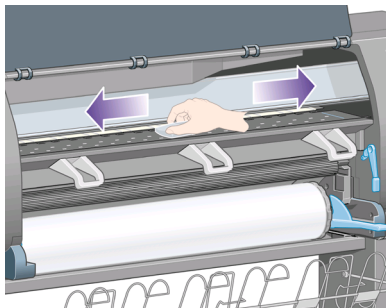

How do I maintain my printer?

 **Caution** Do not use commercial cleaners or abrasive cleaners. Do not wet the platen directly because you will leave too much moisture behind. Do not wet the rubber wheels at all (not even with the cloth).

6. Clean the cutter ramp with the damp cloth.

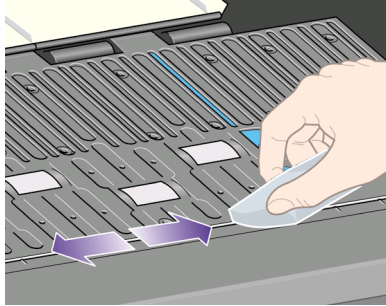

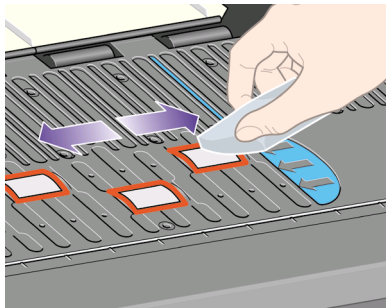

7. Clean the exposed part of the wheels with a dry cloth. Ideally you should clean the whole circumference of these wheels.



How do I lubricate the printhead carriage?

The printhead carriage occasionally (about once a year) needs lubrication to slide easily along the slider rod.

1. To gain access to the carriage, go to the front panel and select the  icon, then **Printheads > Replace printheads now**. The carriage will slide into the middle section of the printer.

 **Caution** If the carriage is left in the central part of the printer for more than seven minutes, it will try to move back to its normal position in the right-hand end.

2. Take the bottle of oil from the Maintenance Kit that is supplied with your printer. A replacement kit can be ordered if necessary.
3. Open the window and apply a few drops of oil from the Maintenance Kit to the pads on either side of the carriage.

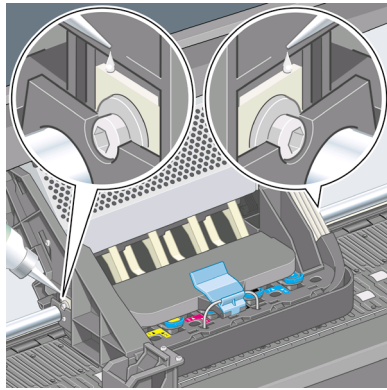

4. Apply a few drops of oil directly to the slider rod on either side of the carriage.

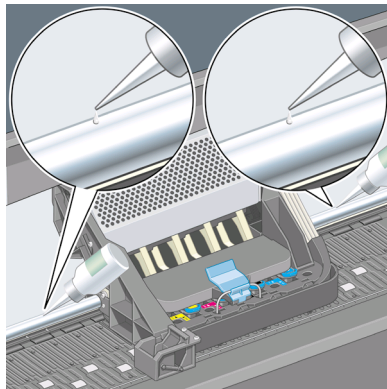

How do I maintain the ink cartridges?

During the normal lifetime of a cartridge, no specific maintenance is required. However, in order to maintain the best print quality, you should replace a cartridge when it has reached its expiration date, which is the date marked on the cartridge plus 6 months.

How do I move or store my printer?

If you need to move your printer or store it for an extended period of time, you need to prepare it properly to avoid possible damage to it. To prepare your printer, follow the instructions below.

1. Do not remove the ink cartridges, printheads, or printhead cleaners.
2. Make sure that no paper is loaded.
3. Make sure that the printhead carriage is located in the service station (the right-hand end of the printer).
4. Make sure that the front panel displays **Ready**.
5. Switch off the power using the **Power** key on the front panel.

6. Also switch off the power switch at the rear of the printer.
7. Disconnect any cables connected to the printer.
8. Repack the printer in its original packaging.

How do I update my printer's firmware?

Your printer's various functions are controlled by software that resides in the printer, otherwise known as firmware.

From time to time firmware updates will be available from Hewlett-Packard. These updates increase your printer's functionality and enhance the features that your printer already possesses. Firmware can be downloaded from the Internet and installed into your printer using the Embedded Web Server's **Firmware update** page (found in the **Settings** tab).

If you are unable to use the Embedded Web Server because you do not have a TCP/IP connection to your printer (for instance, when using USB or Appletalk), you can obtain firmware updates and installation software from these Web pages:

- <http://www.hp.com/support/designjet/fw4000/> or
- <http://www.hp.com/support/designjet/fw4000ps/>

How do I maintain my printer?

11 How do I use the Image Diagnostics Print?

- “How do I print the Image Diagnostics Print?” on page 175
- “How do I respond to the Image Diagnostics Print?” on page 176
- “How do I interpret Image Diagnostics part 1?” on page 176
- “How do I interpret Image Diagnostics part 2?” on page 178
- “How do I interpret Image Diagnostics part 3?” on page 180
- “How do I proceed if I still have a problem?” on page 181

How do I print the Image Diagnostics Print?

The Image Diagnostics Print consists of patterns designed to highlight print quality problems. It helps you to check whether you have a print quality problem, and if you have, what the cause of the problem is and how to resolve it.

Before using the Image Diagnostics Print, check that you have been using appropriate print quality settings (see “How do I choose print quality settings?” on page 130).

To print the Image Diagnostics Print:

1. Ensure that you have paper of at least A3 size (29.7 × 42 cm = 11.7 × 16.5 in) loaded into the printer. Use the same paper type that you were using when you detected a problem.
2. Ensure that the front panel has the same print quality settings that you were using when you detected the problem (see “How do I change the print quality?” on page 129). In the Image Diagnostics Print, the only difference between **Drawings/text** and **Images** is that the latter uses more ink in part 2, so that the colors appear darker.

To print the Image Diagnostics Print will take about two minutes if you choose **Images**; sometimes less if you choose **Drawings/text** (depending on the paper type).

3. At the printer's front panel, select the  icon, then **Information > Internal prints > Print image diagnostics > Drawings/text** or **Images**.

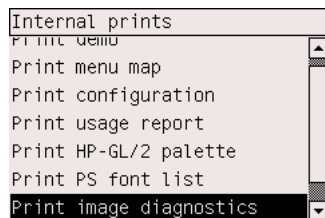

When the print is ready, see “How do I respond to the Image Diagnostics Print?” on page 176.

How do I respond to the Image Diagnostics Print?

The Image Diagnostics Print is in three numbered parts.

1. Part 1 tests printhead alignment. See “How do I interpret Image Diagnostics part 1?” on page 176.
2. Part 2 tests printhead performance and the paper advance mechanism. See “How do I interpret Image Diagnostics part 2?” on page 178.
3. If Part 2 has revealed a printhead problem, Part 3 identifies which of the eight printheads is responsible for it. See “How do I interpret Image Diagnostics part 3?” on page 180.

If Part 2 has not revealed any problem, you can and should ignore Part 3.

How do I interpret Image Diagnostics part 1?

The purpose of part 1 is to identify color-to-color alignment and bidirectional alignment problems.

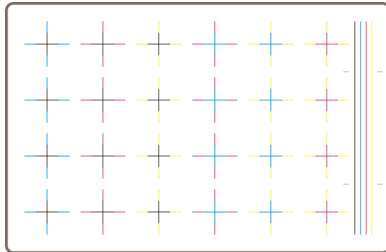

If you have horizontal misalignment, you will see something like this:

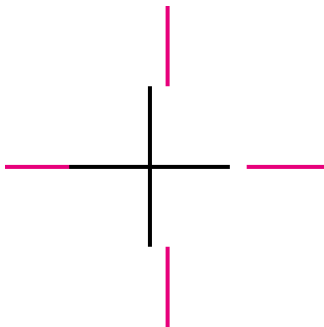

If you have vertical misalignment, you will see something like this:

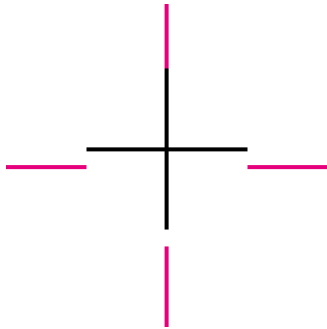

If you have bidirectional misalignment, you will see something like this:

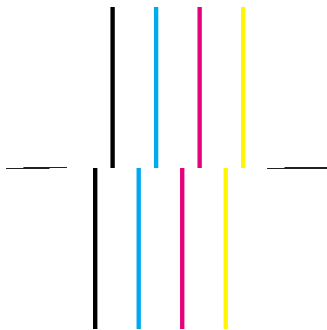

Corrective action

1. Align the printheads, using the same paper type with which you were experiencing unacceptable print quality, if feasible (some paper types are not suitable for printhead alignment). See "How do I align the printheads?" on page 119.
2. If there is no improvement in print quality, contact your customer service representative.

How do I interpret Image Diagnostics part 2?

The purpose of part 2 is to test whether the printheads and the paper advance mechanism are working correctly. This part of the print should not be used to check for color consistency or accuracy.

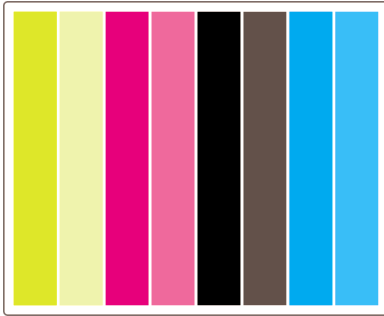

Banding

Banding has occurred when you see repetitive horizontal bands within the printed image. They can appear as light bands:

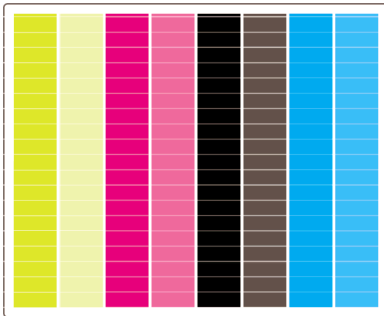

or dark bands:

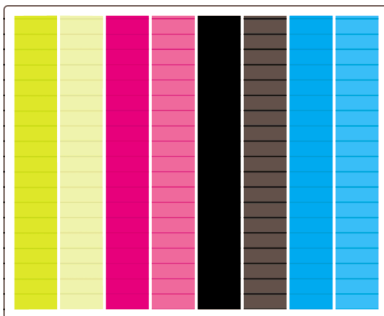

or as a more gradual wave effect:

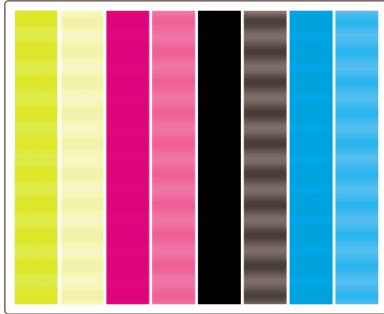

Horizontal bands across strips of one color only

If a printhead is faulty, you will see horizontal bands across strips of one color only; or at least the horizontal bands will be much more noticeable in one color than in the others.



Note Banding in the green strips is more difficult to see; and it may be caused by a yellow printhead or by a cyan printhead. If you see banding only in the green strip, it is caused by a yellow printhead; if you see banding in the green and cyan strips, it is caused by a cyan printhead.

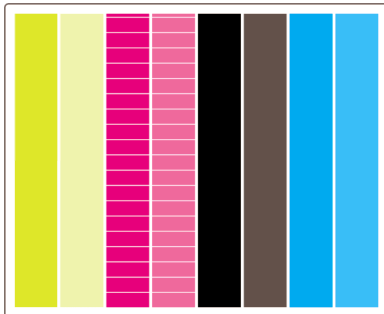

Corrective action

1. Check that you are using appropriate print quality settings. See “How do I choose print quality settings?” on page 130.
2. Clean the printheads. See “How do I recover (clean) the printheads?” on page 113.
3. Reprint the Image Diagnostics Print. If you still see banding, continue with steps 4 and 5.
4. As there are two printheads for each color, check exactly which printhead is responsible for the problem, using Part 3 of the Image Diagnostics Print. See “Part 3” on page 180.
5. Replace the printhead that shows the problem. See “How do I remove a printhead?” on page 106 and “How do I insert a printhead?” on page 110.

Horizontal bands across all the colored strips

If the printer has paper advance problems you will see horizontal bands across all the colored strips.



Note Banding in the green strips is more difficult to see.

Corrective action

1. Check that you are using appropriate print quality settings. See “How do I choose print quality settings?” on page 130.
2. If you are using low-quality paper, try better-quality paper. The performance of your printer can be guaranteed only if you use recommended papers. See “How do I select supported paper types?” on page 94.
3. Perform paper advance calibration with the same paper type that you intend to use for the final print. See “How do I perform paper advance calibration?” on page 183.
4. If there is no improvement in print quality, contact your customer service representative.

How do I interpret Image Diagnostics part 3?

If part 2 has revealed a printhead problem, the purpose of part 3 is to identify which particular printhead is faulty. Each rectangle in this plot is labelled with the number of the printhead that produced it.

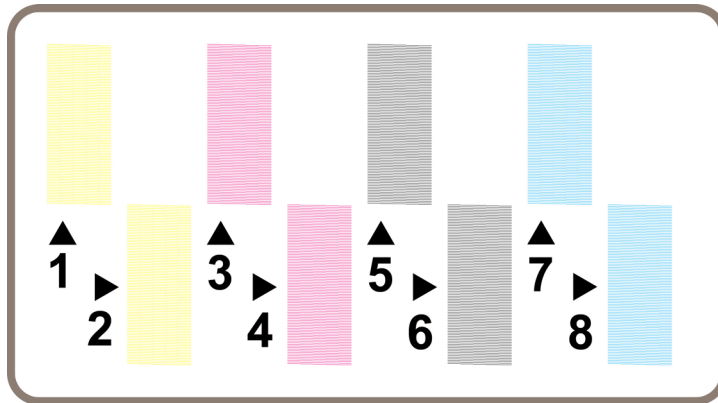

Here are three examples of a black rectangle in close-up, showing the fine lines of which it is made:

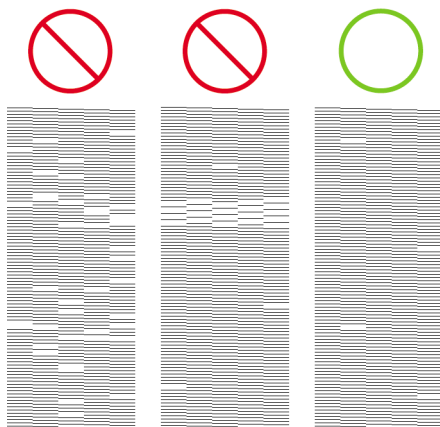

In the first two examples above, there are so many missing lines that the printhead may be faulty. In the third case there are only a few missing lines, which are acceptable, because the printer can compensate for such minor problems.

Corrective action

If part 3 shows a problem with one printhead, but part 2 shows no problem, there is no immediate need to take any corrective action, because the printer is able to compensate for the problem and maintain print quality. However, if part 2 also shows a problem, continue as follows:

1. Clean the printheads. See “How do I recover (clean) the printheads?” on page 113.
2. If there is no improvement in print quality, replace the printhead that shows the problem. See “How do I remove a printhead?” on page 106 and “How do I insert a printhead?” on page 110.

How do I proceed if I still have a problem?

If the entire Image Diagnostics Print contains no defects and you still experience print quality problems, here are some things to check:

- Try using a higher print quality option. See “How do I choose print quality settings?” on page 130 and “How do I change the print quality?” on page 129.
- Check the driver you are using to print with. If it is a non-HP driver, go to <http://www.hp.com/go/designjet/> and download the correct HP driver.
- If you are using a non-HP RIP, its settings may be incorrect. Refer to the documentation that came with the RIP.
- Check that your printer's firmware is up to date. See “How do I update my printer's firmware?” on page 173.
- Check that you have the right settings in your software application.
- If you are seeing a problem only at the top of the page, see “The problem is a defect near the start of a print” on page 195.

How do I use the Image
Diagnostics Print?

12 How do I perform paper advance calibration?



Your printer was calibrated at the factory to ensure that it advances the paper accurately when using supported paper types in normal environmental conditions. However, you may find it useful to recalibrate in certain circumstances:

- **Unsupported paper:** different paper manufacturers provide papers with a wide range of properties such as paper thickness or stiffness, which may benefit from calibration. You can expect the best print quality when using HP's recommended papers (see "How do I select supported paper types?" on page 94).
- **Abnormal but stable environmental conditions:** if you are printing in unusual conditions of temperature or humidity (see "Tell me about environmental specifications" on page 242), and those conditions are expected to remain stable, recalibration may be worthwhile.

However, paper advance calibration assumes that you have an image quality problem and that you have already followed the appropriate troubleshooting procedure for that problem. If you have no particular problem, there is no need to perform the calibration.

Before performing paper advance calibration, use the Image Diagnostics Print to check that the printheads are correctly aligned (see "How do I print the Image Diagnostics Print?" on page 175).



Note In theory, paper advance calibration should improve print quality. However, if you find the calibration print difficult to interpret, you may choose the wrong paper advance setting and thus degrade print quality. In this case, you can restore the original factory settings by selecting the  or  icon at the front panel, and then **Paper advance calibration > Drawings/text or Images > Select Pattern > Factory Default**.

Overview of the calibration process

1. Use the front panel to print a colored pattern stored in the printer seven times, each time with a different paper advance setting.
2. Decide which pattern has been printed most successfully.
3. Use the front panel to tell the printer which pattern was best—and therefore which paper advance setting to use in future.





Note 1 There are separate paper advance settings for each paper type name in the front panel: each must be calibrated separately. When you calibrate a particular paper type, the settings for all other paper types are unaffected.

Note 2 There are separate paper advance settings for **Optimized for drawings/text** and **Optimized for images**: each must be calibrated separately.

Note 3 Papers from different manufacturers may require different paper advance settings even if they are of the same type, therefore the calibration will be useful only for the particular paper you calibrated. Remember that, when you perform the calibration, you will overwrite any previous paper advance settings for this paper type.

The calibration process in detail

1. Load the printer with the type of paper that you plan to use for printing subsequently. The paper must be at least 41 cm wide (16 in) and 75 cm long (30 in).
2. Select the  or  icon, and then **Paper advance calibration**.

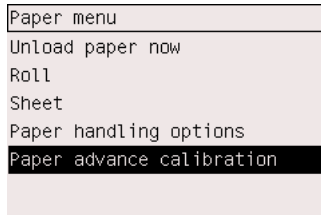

3. Select **Drawings/text** or **Images**, depending on the type of prints you wish to make subsequently.



Note It is **very important** to use the same setting that you will later use for printing in the driver, the Embedded Web Server, or the front panel (**Optimized for drawings/text** or **Optimized for images**). Otherwise the calibration has no effect.

4. Select **Print Patterns**. The printer will print a series of numbered patterns (1 to 7), each looking like this if you selected **Drawings/text**:

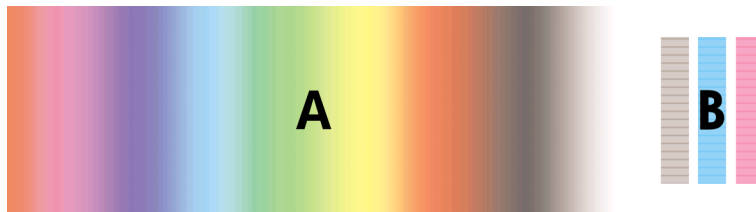

or like this if you selected **Images**:



5. The **Drawings/text** print takes about three minutes, the **Images** print takes about five minutes. When the calibration print has finished printing, the printer will cut the paper.

6. Look at each of the printed patterns (1 to 7) and decide which one shows the best quality. Each pattern has one part on the left that is a continuous color gradient (A), and another part on the right (B). Either part can be used to help you decide which is the best of the series of patterns; it will depend on your circumstances. However, if you are using glossy paper or canvas, you are recommended to ignore part A and make your selection by looking at part B only.
- In the color gradient, part A, you should look for light or dark horizontal bands (banding), which indicate that the paper advance is not quite right. Usually you will see dark bands across the first pattern and light bands across the last pattern (see the examples below). The best pattern is one with no banding; if in doubt, select the pattern in the middle, between the last pattern with dark bands and the first pattern with light bands.

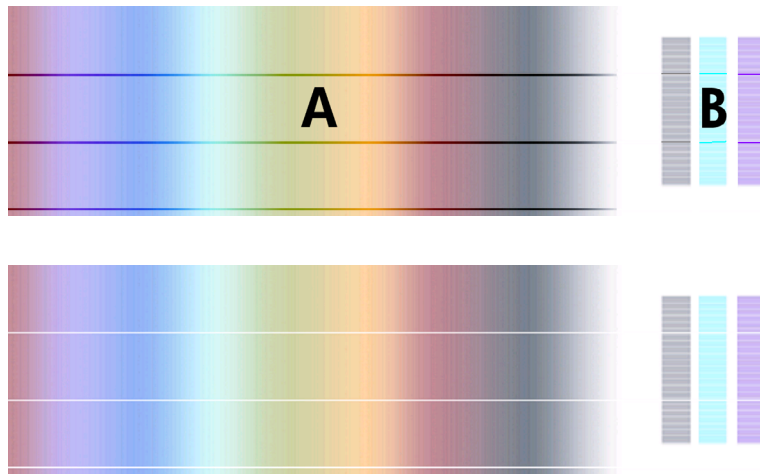

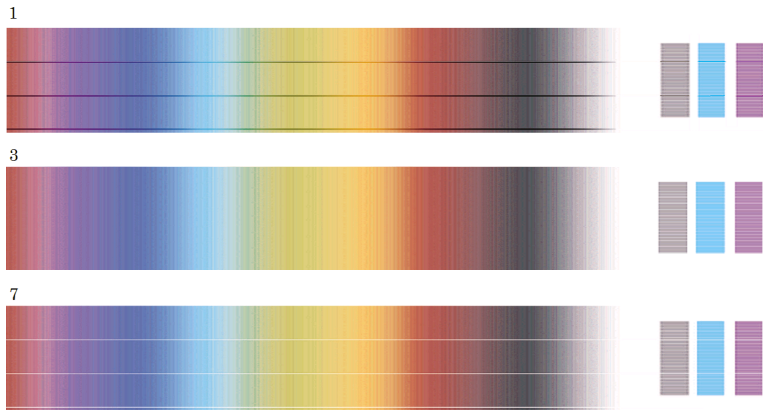

If you find it difficult to identify the best pattern, the following scenario descriptions may help you.

- Where you have only one pattern which is clearly the best and the ones above and below contain light/dark bands, select this pattern.

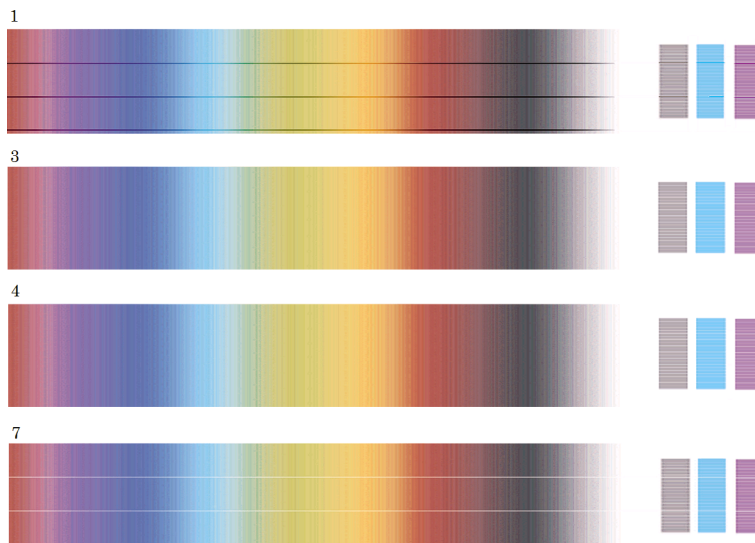

- Where you have two patterns next to each other which do not show signs of banding, see below, use the patterns above and below these two to help you select. For example, if the pattern above the two equal ones contains less banding then choose the pattern just below it.





- Where you have three patterns which show no signs of banding, select the middle pattern.
 - If you look at part B of the print, you will probably see that it appears darker in some patterns than in others. The best pattern is the one that appears lightest, most uniform, and least grainy.
7. Select the  or  icon, and then **Paper advance calibration > Drawings/text or Images > Select Pattern**.
 8. Select the number of the pattern (1 to 7) that printed best. If you found it difficult to choose between two patterns e.g. patterns 3 and 4, then select “Between pattern 3 and 4”

The calibration is complete.

After calibration

If you find that the paper advance calibration has reduced but not eliminated your print quality problem, you could try step 7 again and select a different number. If you are seeing light bands, try selecting a lower number than your original selection; if you are seeing dark bands, try a higher number.

If you later want to cancel your calibration and restore the paper advance setting with which the printer left the factory, select the  or  icon, and then **Paper advance calibration > Drawings/text or Images > Select Pattern > Factory Default**.



How do I perform paper advance calibration?

13 The problem is print quality

- “General advice” on page 189
- “The problem is banding (horizontal lines across the image)” on page 190
- “The problem is lines are missing or thinner than expected” on page 191
- “The problem is solid bands or lines printed over the image” on page 192
- “The problem is graininess” on page 193
- “The problem is the paper is not flat” on page 193
- “The problem is the print smudges when touched” on page 194
- “The problem is ink marks on the paper” on page 194
- “The problem is a defect near the start of a print” on page 195
- “The problem is lines are stepped” on page 195
- “The problem is lines are printed double or in wrong colors” on page 196
- “The problem is lines are discontinuous” on page 197
- “The problem is lines are blurred (ink bleeds from lines)” on page 197
- “The problem is lines are slightly warped” on page 197
- “The problem is color accuracy” on page 198
- “The problem is PANTONE color accuracy” on page 198
- “The problem is color matching between different HP Designjets” on page 199

General advice

When you have any print quality problem:

- To achieve the best performance from your printer, use only genuine manufacturer’s supplies and accessories, whose reliability and performance have been thoroughly tested to give trouble-free performance and best-quality prints. For details of recommended papers, see “How do I select supported paper types?” on page 94.
- Make sure that the **paper type** selected in the front panel is the same as the paper type loaded into the printer. To check this, highlight the  or  icon on the front panel.
- Bear in mind that roll paper will generally give better print quality than a single sheet of the same kind of paper. When you are using single sheets of paper, we strongly recommend that you always set the print quality to **Best**.
- Check that you are using the most appropriate print quality settings for your purposes (see “How do I choose print quality settings?” on page 130). You are most likely to see print quality problems if you have set the print quality to **Fast**.
- To maintain the best print quality at the expense of speed, change the **Printhead monitoring** setting to **Intensive**. See “How do I manage printhead monitoring?” on page 113.
- Check that your environmental conditions (temperature, humidity) are suitable for high-quality printing. See “Tell me about environmental specifications” on page 242.

The problem is banding (horizontal lines across the image)

If your printed image suffers from added horizontal lines as shown (the color may vary):

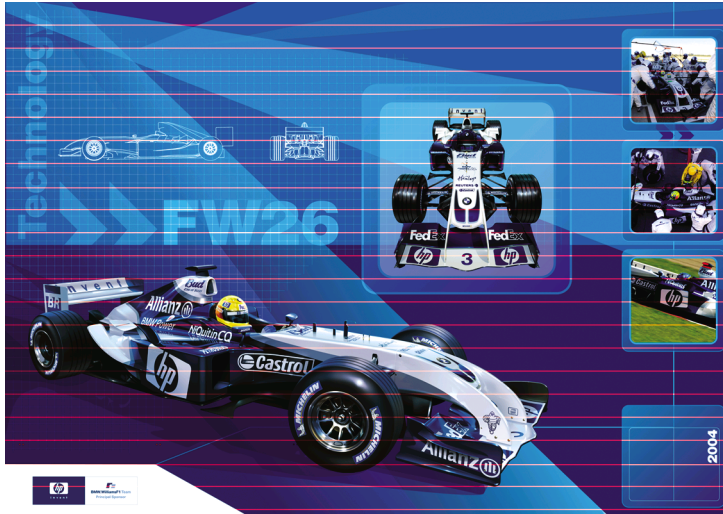

1. Check that you are using appropriate print quality settings. See “How do I choose print quality settings?” on page 130.
2. If the problem persists, clean the printheads. See “How do I recover (clean) the printheads?” on page 113.
3. Consider changing to a heavier paper type: we recommend HP Heavyweight Coated Paper or HP Productivity Photo Gloss when printing dense colors.
4. If the problem persists, use the Image Diagnostics Print to find out more about it. See “How do I use the Image Diagnostics Print?” on page 175.

The problem is lines are missing or thinner than expected

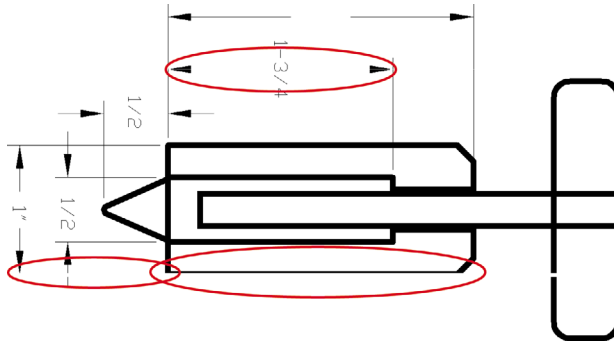

The problem is print quality

1. Check that the line thickness and color settings are correct in your application.
2. Check that you are using appropriate print quality settings. See “How do I choose print quality settings?” on page 130.
3. If the problem persists, clean the printheads. See “How do I recover (clean) the printheads?” on page 113.
4. Consider changing to a heavier paper type: we recommend HP Heavyweight Coated Paper or HP Productivity Photo Gloss when printing dense colors.
5. If the problem persists, use the Image Diagnostics Print to find out more about it. See “How do I use the Image Diagnostics Print?” on page 175.

The problem is graininess



1. Check that you are using appropriate print quality settings. See “How do I choose print quality settings?” on page 130.
2. Use the Image Diagnostics Print to find out more about the problem. See “How do I use the Image Diagnostics Print?” on page 175.

The problem is the paper is not flat

If the paper does not lie flat when it comes out of the printer, but has shallow waves in it, you are likely to see visible defects in the printed image, such as vertical stripes. This can happen when you use thin paper that becomes saturated with ink.



Try changing to a heavier paper type: we recommend HP Heavyweight Coated Paper or HP Productivity Photo Gloss for printing dense colors. See also “How do I choose print quality settings?” on page 130.

The problem is the print smudges when touched

The black ink pigment can smudge when touched by a finger or pen. This is particularly noticeable on the following materials: vellum, translucent bond, films, productivity photo paper, and natural tracing paper.

To reduce the smudging:

- Try to print in an environment which is not too humid for the printer. See “Tell me about environmental specifications” on page 242.
- Change pure black objects in your image to a dark color, such as dark brown, so that they will be printed with colored inks instead of black ink.
- Use HP Heavyweight Coated Paper.
- Increase the drying time (see “How do I change the drying time?” on page 97).

The problem is ink marks on the paper

This problem may occur for several different reasons.

Smears on the front of coated paper

If a lot of ink is used on coated paper, the paper absorbs the ink quickly and expands. As the printheads move over the paper, the printheads come into contact with the paper and the printed image is smeared.

Whenever you notice this problem, you should cancel the printing job immediately. Press the **Cancel** key and also cancel the job from your computer application. Otherwise the soaked paper may damage the printheads.

Try the following suggestions to avoid this problem:

- Use a recommended paper type (see “How do I select supported paper types?” on page 94).
- If the image you are printing contains intense color, try using HP Heavyweight Coated Paper.
- Use extended margins (see “How do I adjust the margins?” on page 132), or try to increase the margins by relocating the image within the page using your software application.
- If necessary, try changing to a non-paper-based material such as transparent film.

Smears or scratches on the front of glossy paper

Glossy paper may be extremely sensitive to the bin or to anything else that it contacts soon after printing. This will depend on the amount of ink printed and the environmental conditions at the time of printing. Avoid any contact with the paper and handle the print with care.

It is a good idea to leave a sheet of paper in the bin so that freshly-printed sheets do not make direct contact with the bin.

Ink marks on the back of the paper

Ink on the platen is likely to mark the back of the paper. See “How do I clean the platen?” on page 169.

The problem is a defect near the start of a print

There is a type of defect that affects only the start of a print, within 5.5 cm of the leading edge of the paper. You may see a thin or thick band of inconsistent color:

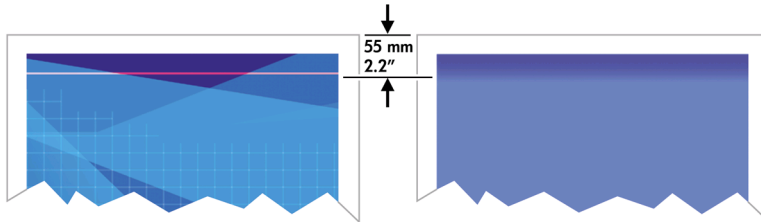

To avoid this problem:

1. The easiest solution is to select the **Extended Margins** option in the driver, the Embedded Web Server, or the front panel. This means that the area of the paper affected by the problem (at the start of the page) will no longer be printed on. See “How do I adjust the margins?” on page 132.
2. Check that you are using appropriate print quality settings. See “How do I choose print quality settings?” on page 130.

The problem is lines are stepped

If lines in your image appear stepped or jagged when printed:

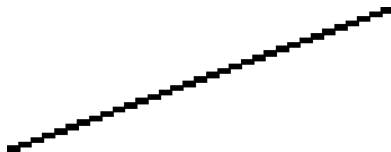

1. The problem may be inherent in the image. Try to improve the image with the application you are using to edit it.
2. Check that you are using appropriate print quality settings. See “How do I choose print quality settings?” on page 130.
3. Turn on the Maximum Detail option.

The problem is lines are printed double or in wrong colors

This problem can have various visible symptoms:

- Colored lines are printed double, in different colors.

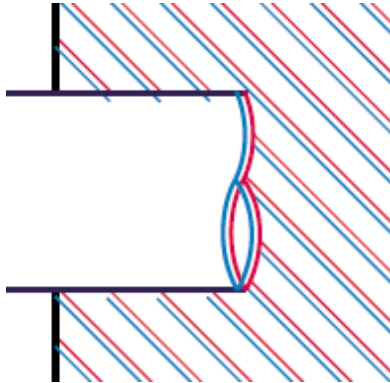

- The borders of colored blocks are wrongly colored.

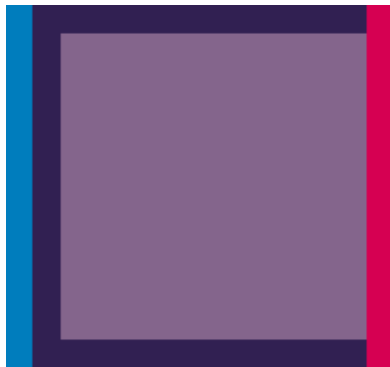

To correct this kind of problem:

1. Check that you are using appropriate print quality settings. See “How do I choose print quality settings?” on page 130.
2. Align the printheads. See “How do I align the printheads?” on page 119.

The problem is lines are discontinuous

If your lines are broken in the following way:



1. Check that you are using appropriate print quality settings. See “How do I choose print quality settings?” on page 130.
2. You are more likely to get good vertical lines with roll paper than with sheet paper. If you must use sheet paper, set the print quality to **Best**.
3. Consider changing to a heavier paper type, such as HP Heavyweight Coated Paper or HP Productivity Photo Gloss. See “How do I choose print quality settings?” on page 130.
4. Align the printheads. See “How do I align the printheads?” on page 119.

The problem is lines are blurred (ink bleeds from lines)

If you see that the ink is soaking into the paper, making the lines blurred and fuzzy, this could be because of humidity in the air. Try the following:

1. Check that your environmental conditions (temperature, humidity) are suitable for high-quality printing. See “Tell me about environmental specifications” on page 242.
2. Try changing to a heavier paper type, such as HP Heavyweight Coated Paper or HP Productivity Photo Gloss. See “How do I choose print quality settings?” on page 130.



Note Glossy photo paper types are especially difficult to dry. Take extra care with them.

3. Check that the paper type selected in the front panel is the same as the paper type you are using.
4. Perhaps you have adjusted the drying time at the front panel to speed up the printer output. Select the  icon, then **Drying options > Drying time**, and make sure it is set to **Optimal**.
5. Allow the prints time to dry separately; do not cover or stack them.

The problem is lines are slightly warped

The paper itself may be warped. This can happen if it has been used or stored in an extreme environment. See “Tell me about environmental specifications” on page 242.

The problem is color accuracy

There are two basic requirements for color accuracy:

1. Ensure that your paper type has been calibrated, which will give you consistency from print to print, and from printer to printer. See “How do I perform color calibration?” on page 139.
2. Select suitable options in your application: see “How do I get accurate colors from my printer?” on page 139.



Note If you are not using PostScript, remember that your printer may be configured to use one of its internal pen palettes instead of your software's palette (which is the default). See “The problem is pen settings seem to have no effect” on page 206.

Color accuracy using EPS or PDF images in page layout applications

Page layout applications such as Adobe InDesign and QuarkXPress do not support color management of EPS, PDF, or grayscale files.

If you have to use such files, try to ensure that the EPS, PDF, or grayscale images are already in the same color space that you intend to use later on in Adobe InDesign or QuarkXPress. For instance, if your final goal is to print the job in a press that follows the SWOP standard, at the time of creating the EPS, PDF or grayscale you should convert the image into SWOP.

The problem is PANTONE color accuracy

Spot colors are special premixed inks to be used directly in the press, and the best-known spot colors are PANTONE colors.

If you have the PostScript model, your printer provides a facility called Automatic PANTONE Calibration, which can easily match most of the PANTONE Solid Coated spot colors. When an application sends a PANTONE color to print, it sends the PANTONE name together with its own estimate of equivalent CMYK values. The Automatic PANTONE Calibration facility recognizes the PANTONE name and converts it to CMYK in a way that depends on the printer model and the selected paper type, enabling the color to be rendered with greater precision than is possible with the generic CMYK values sent by the application.

Even when using Automatic PANTONE Calibration, you cannot expect the printer to match the PANTONE colors exactly. Your printer is certified by Pantone for some papers, but this does not mean that it can reproduce 100% of the PANTONE colors.

Using Automatic PANTONE Calibration (the best choice)

In order to use Automatic PANTONE Calibration, you need an application that recognizes the PANTONE colors, and a calibrated PostScript printer.

The Automatic PANTONE Calibration facility emulates PANTONE Solid Coated colors only (suffix C). Other PANTONE colors will be printed using the CMYK values sent by the application.

Converting PANTONE colors manually

If you have a non-PostScript printer, or if you are using an application (such as Adobe Photoshop) that does not send the name of the PANTONE color to the printer, you will not be able to use Automatic PANTONE Calibration. Instead, if you wish, you can convert each PANTONE color manually to CMYK values in the application, using tables produced especially for your printer and paper type.

If your application has a facility to convert PANTONE colors to CMYK values automatically, it probably does not take account of printer or paper type, so you will get better results with a manual conversion using the tables.

You can also obtain a PANTONE calibrated color chart in EPS, TIFF, and PDF format, which can be convenient if your application has an eyedropper tool with which you can pick up colors from an imported graphic.

Tips

- Automatic PANTONE Calibration works with PostScript printers only.
- Ensure that Automatic PANTONE Calibration is turned on in the driver.
- Some applications may not support PANTONE colors fully; for example, Photoshop 7.0 does not send the PANTONE Color with its name, it sends only the CMYK values from its standard table.
- Some colors may be out of gamut and impossible to match precisely with your printer and paper type.

The problem is color matching between different HP Designjets

If you print an image on two different printer models (for instance, on an HP Designjet 4000 Printer series and an HP Designjet 1000 Printer series), you may find that the colors of the two prints do not match well.

Matching two printing devices that use different ink chemistry, paper chemistry, and printheads is unlikely to be completely successful. The information provided here is the best way to emulate one printer with another. Even so, the end result may not be a perfect match.

Printing via separate PostScript drivers

The situation is that you are printing on each printer using the PostScript driver installed for that printer. In this example, we are using an HP Designjet 4000 Printer series and an HP Designjet 1000 Printer series.

1. Ensure that both printers have been updated to the latest firmware version. See “How do I update my printer’s firmware?” on page 173.
2. Ensure that you have the latest printer driver for both printers. You can download the latest versions for any HP printer from <http://www.hp.com/go/designjet>.
3. Ensure that Color Calibration is turned on. At the front panel of the HP Designjet 4000 series, select the  icon, then **Configuration menu > Color Calibration > On**.
4. Load the printers with similar paper types.

5. Ensure that the Paper Type setting on the front panel corresponds to the paper you have loaded.
6. Print your image on the HP Designjet 1000 Printer series using your normal settings.
7. Now prepare to print the same image on the HP Designjet 4000 Printer series.
8. In your application, set the color space of the image to emulate the HP Designjet 1000 Printer series and the specific paper type that you used in that printer. The data sent to the driver must be already converted to this emulation color space, which is a CMYK color space. See your application's online help for information on how to do this. In this way, the 4000 series will emulate the colors that the 1000 series can produce when printing on that paper type.
9. In the PostScript driver for the HP Designjet 4000 Printer series, go to the Color Management section and set the CMYK input profile to the same HP Designjet 1000 Printer series color space that you selected in the application (the emulation color space).



Note When trying to emulate another printer you should always use CMYK colors, not RGB.

10. Set the rendering intent to Relative Colorimetric, or to Absolute Colorimetric if you want to emulate the whiteness of the paper.
11. Print the image on the HP Designjet 4000 Printer series.

Printing via separate HP-GL/2 drivers



The situation is that you are printing on each printer using the HP-GL/2 driver installed for that printer.

1. Ensure that both printers have been updated to the latest firmware version. See “How do I update my printer's firmware?” on page 173.
2. Ensure that you have the latest printer driver for both printers. You can download the latest versions for any HP printer from <http://www.hp.com/go/designjet>.
3. Ensure that Color Calibration is turned on. At the front panel of the HP Designjet 4000 Printer series, select the  icon, then **Configuration menu > Color Calibration > On**.
4. Load the printers with similar paper types.
5. Ensure that the Paper Type setting on the front panel corresponds to the paper you have loaded.
6. With the HP-GL/2 driver for the HP Designjet 4000 Printer series, select the Color tab, and set the **Color Matching Method to sRGB**.
7. With the HP-GL/2 driver for the HP Designjet 1000 series, select the Options tab, then **Manual Color > Color Control > Match Screen**. You should also select the Paper Size tab, then **Paper Type**, and select an Enhanced Colors paper type.

Printing the same HP-GL/2 file

The situation is that you have produced an HP-GL/2 file (also known as a PLT file) using the HP-GL/2 driver installed for one printer, and you intend to send the same file to both printers.

1. Ensure that both printers have been updated to the latest firmware version. See “How do I update my printer's firmware?” on page 173.

2. Ensure that Color Calibration is turned on. At the front panel of the HP Designjet 4000 Printer series, select the  icon, then **Configuration menu > Color Calibration > On** .
3. Load the printers with similar paper types.
4. Ensure that the Paper Type setting on the front panel corresponds to the paper you have loaded.
5. If you have an HP-GL/2 file produced for an HP Designjet 1000 Printer series and you want to print it on an HP Designjet 4000 Printer series, proceed as follows using the Embedded Web Server or the front panel.
 - Using the Embedded Web Server: in the Color Management section of the Submit Job page, set the **Input Profiles: RGB** to **None (Native)**.
 - Using the front panel: select the  icon, then **Printing defaults menu > Color Options > RGB Input Profile: None (Native)**.

For other HP Designjet Printers, set both printers to match the screen colors (sRGB if selectable), as when printing with separate HP-GL/2 drivers.

14 The problem is an image error

- “The problem is the print is completely blank” on page 203
- “The problem is the output contains only a partial print” on page 203
- “The problem is the image is clipped” on page 204
- “The problem is the image is in one portion of the printing area” on page 204
- “The problem is the image is unexpectedly rotated” on page 205
- “The problem is the print is a mirror image of the original” on page 205
- “The problem is the print is distorted or unintelligible” on page 205
- “The problem is one image overlays another on the same sheet” on page 206
- “The problem is pen settings seem to have no effect” on page 206

The problem is the print is completely blank

If the front-panel graphic language setting is **Automatic** (the default), try the other settings: **PostScript** for a PostScript file, **HP-GL/2** for an HP-GL/2 file, etc. (see “How do I change the graphic language setting?” on page 137). Then send the file again.

When you have finished this particular print, remember to reset the graphic language to **Automatic**.

The problem is the output contains only a partial print

- Did you press **Cancel** before all the data were received by the printer? If so, you have ended the data transmission and will have to print the page again.
- The **I/O timeout** setting may be too short. From the front panel, you can increase the **I/O timeout** setting to a longer period and then send the print again. Select the  icon, then **I/O setup > I/O timeout**.

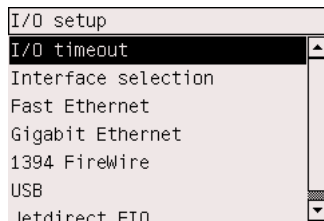

- There may be a communications problem between your computer and the printer. Check your interface cable.
- Check to make sure that your software settings are correct for your current page size (e.g. long-axis prints).
- If you are using network software, make sure it has not timed out.

The problem is the image is clipped

This normally indicates a discrepancy between the actual printable area on the loaded paper and the printable area as understood by your software.

- Check the actual printable area for the paper size you have loaded.
printable area = paper size – margins
The Windows HP-GL/2 driver displays the printable area in the Paper/Quality tab.
- Check what your software understands to be the printable area (which it may call "printing area" or "imageable area"). For example, some software applications assume standard printable areas that are larger than those used in this printer.
- If you are trying to print a very long image on a roll, check that your software is capable of printing an image of that size.
- Check that the orientation of the paper is the same as that assumed by your software. The front-panel **Printing defaults menu > Paper options > Rotate** option changes both the orientation of a print and the orientation of the page. It is possible that a rotated image on a roll may be slightly clipped in order to retain the correct page size.
- You may have asked to rotate the page from portrait to landscape on a paper size that is not wide enough.
- If necessary, change the printable area in your software.

There is another possible explanation for a clipped image. Some applications, such as Adobe Photoshop, Adobe Illustrator, and CorelDRAW, use an internal 16-bit coordinate system which means that they cannot handle an image of more than 32,768 pixels. If you try to print an image larger than this from these applications, the bottom of the image will be clipped. In this case, the only way to print the whole image is to reduce the resolution so that the whole image requires fewer than 32,768 pixels. The HP-GL/2 printer driver contains an option called **Compatibility with 16-bit applications**, which can be used to reduce the resolution of such images automatically. You can find this option by clicking the Troubleshooting button in the driver's Services tab.

The problem is the image is in one portion of the printing area

- Have you selected too small a page size in your application?
- Does your application think that the image is in one portion of the page?

The problem is the image is unexpectedly rotated

At the front panel, select the  icon, then **Printing defaults menu** > **Paper options** > **Rotate**. Check that the setting is what you wanted.

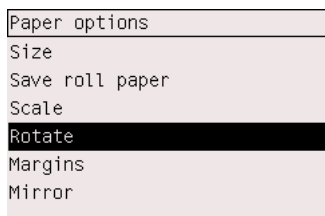

For non-PostScript files: if **Nesting** is **On**, pages may be automatically rotated to save paper. See "How do I rotate an image?" on page 134.

The problem is the print is a mirror image of the original

At the front panel, select the  icon, then **Printing defaults menu** > **Paper options** > **Mirror**. Check that the setting is what you wanted.

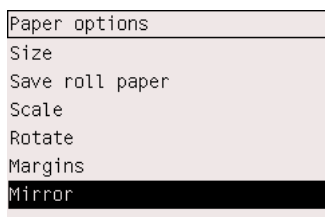

The problem is an image error

The problem is the print is distorted or unintelligible

- The interface cable connecting your printer to your network (or to your computer) could be faulty. Try another cable.
- If the front-panel graphic language setting is **Automatic** (the default), try the other settings: **PostScript** for a PostScript file, **HP-GL/2** for an HP-GL/2 file etc. (see "How do I change the graphic language setting?" on page 137). Then send the file again.
- Depending on the software, drivers, and RIPs you are using with your printer, there will be different ways of solving this problem. Refer to the vendor's user documentation for details.

The problem is one image overlays another on the same sheet

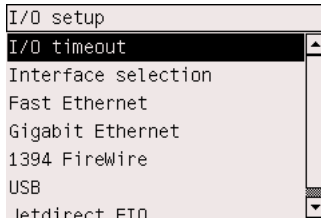

The **I/O timeout** setting may be too long. From the front panel, decrease the setting and print again. Select the  icon, then **I/O setup > I/O timeout**.



The problem is an image error

The problem is pen settings seem to have no effect

Here are some possible explanations:

- You have changed the settings in the front panel by selecting the  icon followed by **Printing defaults menu > HP-GL/2 settings > Define palette**, but you have forgotten to select that palette in **Printing defaults menu > HP-GL/2 settings > Palette**.
- If you want the software-driven pen settings, you must remember to go to the front panel and select the  icon followed by **Printing defaults menu > HP-GL/2 settings > Palette**, and set it to Software.

15 The problem is with the ink system

- “The problem is I cannot insert an ink cartridge” on page 207
- “The problem is I cannot insert a printhead” on page 207
- “The problem is I cannot insert a printhead cleaner” on page 207
- “The problem is the front panel keeps telling me to reseal or replace a printhead” on page 207
- “The problem is an ink cartridge status message” on page 208
- “The problem is a printhead status message” on page 208
- “The problem is a printhead cleaner status message” on page 208

The problem is I cannot insert an ink cartridge

1. Check that you have the correct type of cartridge (model number).
2. Check that the colored label on the cartridge is the same color as the label on the slot.
3. Check that the cartridge is correctly oriented, with the colored label at the top.



Caution Never clean inside the ink cartridge slots.

The problem is I cannot insert a printhead

1. Check that you have the correct type of printhead (model number).
2. Check that you have removed the blue protective cap and the clear protective tape from the printhead.
3. Check that the colored label on the printhead is the same color as the label on the slot.
4. Check that the printhead is correctly oriented (compare with the others).
5. Check that you have closed and latched the printhead cover.

The problem is I cannot insert a printhead cleaner

1. Check that you have the correct type of cleaner (model number).
2. Check that the colored label on the cleaner is the same color as the label on the slot.
3. Check that the cleaner is correctly oriented (compare with the others).

The problem is the front panel keeps telling me to reseal or replace a printhead

1. Remove the printhead and check that its protective film has been removed.
2. Try cleaning the electrical connections between the printhead and the carriage. See “How do I clean a printhead's electrical connections?” on page 113.
3. Reinsert the printhead into the carriage and check the front panel message.
4. If the problem remains, try a new printhead.

The problem is an ink cartridge status message

These are the possible ink cartridge status messages:

- **OK:** the cartridge is working normally, with no known problems
- **Missing:** there is no cartridge present, or it is not properly connected to the printer
- **Low:** the ink level is low
- **Very low:** the ink level is very low
- **Empty:** the cartridge is empty
- **Reseat:** you are recommended to remove the cartridge and then reinsert it
- **Replace:** you are recommended to remove the cartridge and then reinsert it; if that fails, replace the cartridge with a new cartridge
- **Altered:** there is something unexpected about the cartridge's status—perhaps it has been refilled

The problem is a printhead status message

These are the possible printhead status messages:

- **OK:** the printhead is working normally, with no known problems
- **Missing:** there is no printhead present, or it is not properly installed in the printer
- **Reseat:** you are recommended to start the printhead removal process from the front panel (see “How do I remove a printhead?” on page 106), but instead of removing the printhead, just press the **Select** key on the front panel
- **Replace:** you are recommended to remove the printhead and then reinsert it; if that fails, clean the electrical connections; if that fails, replace the printhead with a new printhead
- **Remove:** the printhead is not a suitable type for use in printing (for instance, a setup printhead)

The problem is a printhead cleaner status message

These are the possible printhead cleaner status messages:

- **OK:** the cleaner is working normally, with no known problems
- **Missing:** there is no cleaner present, or it is not properly installed in the printer
- **Reseat cleaner:** you are recommended to remove the cleaner and then reinsert it
- **Wrong stall:** the cleaner has been installed in the wrong place
- **End of life:** the cleaner has reached the end of its planned lifetime
- **Not replaced with printhead:** you have installed a new printhead without installing the new cleaner that came with it

If a printhead cleaner needs to be removed or resealed, you must start the printhead replacement process (see “How do I remove a printhead?” on page 106). Open the window when prompted to do so by the front panel. If the front panel shows the printheads with no printhead blinking, you do not need to touch the printheads. Just close the window again, and the printer will proceed to printhead cleaner replacement.

16 The problem is with the paper

- “The problem is the paper cannot be loaded successfully” on page 209
- “The problem is a paper jam (paper stuck in the printer)” on page 211
- “The problem is prints do not stack properly in the bin” on page 213
- “The problem is the printer uses a lot of paper to align the printheads” on page 213

The problem is the paper cannot be loaded successfully

- The paper may be loaded at an angle (skewed). Check that the right-hand edge of the paper is aligned with the half-circle on the right-hand side of the platen and, particularly in the case of sheet paper, that the leading edge is aligned with the metal bar in the platen.
- The paper may be crumpled or warped, or may have irregular edges.

Rolls

- If the paper gets stuck in the paper path to the platen, it may be that the leading edge of the paper is not straight or clean, and needs to be trimmed. Remove the initial 2 cm (1 in) from the roll and try again. This may be necessary even with a new roll of paper.
- Check that the spindle is correctly inserted. The blue spindle lever on the right should be in the horizontal position.
- Check that the paper is correctly loaded on the spindle, and that it loads over the roll towards you.
- Check that the paper is wound tightly on the roll.

Sheets

- Check that the leading edge of the sheet is aligned with the cutter channel in the platen.
- Do not use hand-cut sheets, which may be of irregular shapes. Use only purchased sheets.

Here is a list of front panel messages related to paper loading, with the suggested corrective action.

Front panel message	Suggested action
Right edge of roll too far from load line.	The roll has not been loaded correctly, the right-hand edge was not aligned with the half-circle on the platen. Press the Select key to try to load the roll again.
Right edge of sheet too far from load line.	The sheet has not been loaded correctly, the right-hand edge was not aligned with the half-circle on the platen. Press the Select key to try to load the sheet again.

Front panel message	Suggested action
Right edge not found.	The printer cannot locate the right-hand edge of the paper, the paper may be badly positioned. Press the Select key and try to load the roll again.
Sheet edge not found.	The printer cannot locate the edges of the paper, the paper may be badly positioned. Press the Select key and try to reload the sheet.
Paper not found.	During the paper load process the printer did not detect any paper. Press the Select key to retry.
Paper loaded with too much skew.	During the paper load process the printer detected that the paper had too much skew. Press the Select key to try to load the paper again.
Paper too small.	During the load process the printer detected that the paper is too narrow or too short to be loaded in the printer. Press the Cancel key to stop the load process. See “Tell me about functional specifications” on page 239.
Paper too big	During the load process the printer has detected that the paper is either too wide or too long (sheet only) to be loaded properly. Press the Cancel key to stop the load process. See “Tell me about functional specifications” on page 239.
Sheet too long.	During the load process the printer has detected that the sheet is too long to be loaded properly. Make sure that the printer expects sheet and not roll. Press the Select key to try to load the paper again. See “Tell me about functional specifications” on page 239.
Lever lifted.	During the load process the blue paper load lever was lifted. This prevents the printer from loading the paper. Press the Select key to load the paper again.

The problem is a paper jam (paper stuck in the printer)

When a paper jam occurs, you will normally see the **Possible paper jam** message in the front panel, with one of two error codes:

- 81:01 indicates that paper cannot advance into the printer.
- 86:01 indicates that the printhead carriage cannot move from side to side.

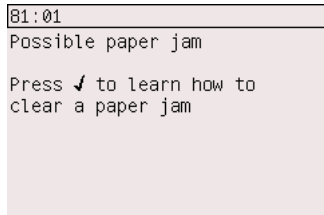

Check printhead path

1. Switch off the printer using the switch at the rear.

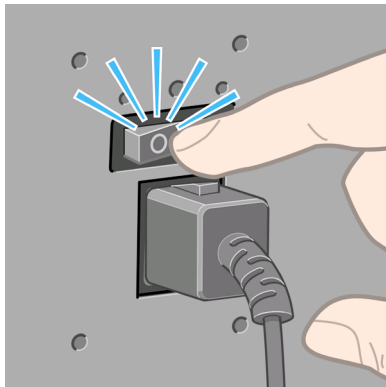

2. Open the window.

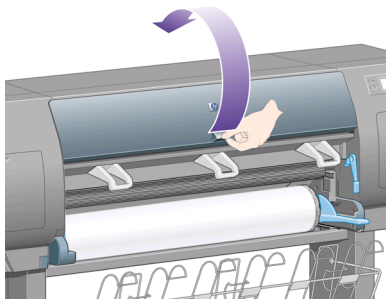

The problem is with the paper

3. Try to move the printhead carriage out of the way.

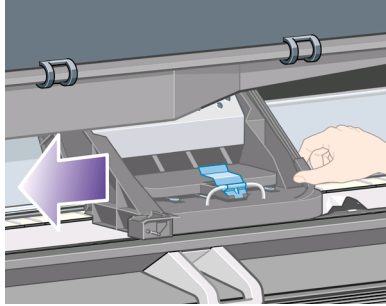

4. Lift the paper load lever as far up as it will go.

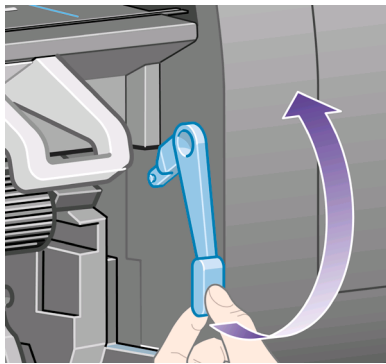

5. Carefully remove any of the jammed paper that you can lift up and out from the top of the printer.

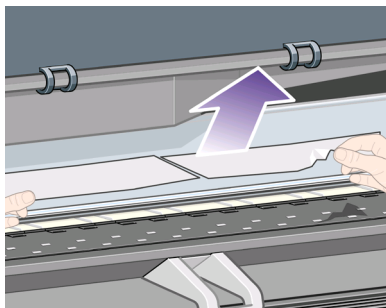

6. Carefully pull the rest of the roll or sheet down and out of the printer.
7. Switch on the printer.
8. Reload the roll, or load a new sheet. See “How do I load a roll into the printer?” on page 83 or “How do I load a single sheet?” on page 89.

9. If you find that there is still some paper causing an obstruction within the printer, it can often be cleared by loading a rigid paper type into the printer.
10. If you find that you have print quality problems after a paper jam, try realigning the printheads. See “How do I align the printheads?” on page 119.

Check paper path

- This problem can occur when a roll has finished and the end of the roll is stuck to the cardboard core. If this has happened, cut the end of the roll away from the core; you should then be able to feed the paper through the printer, and load a new roll.
- Otherwise, follow the procedure described above, under “Check printhead path” on page 211.

The problem is prints do not stack properly in the bin

- Lift up the three loop stoppers when printing small sheets.
- Paper often tends to curl near the end of a roll, which can cause stacking problems. Load a new roll, or remove prints manually as they are completed.
- If you are mixing prints or nesting sets of several different sizes, you may have stacking problems because of the different sizes of paper in the bin.

The problem is the printer uses a lot of paper to align the printheads

In order to align the printheads accurately, the printer sometimes needs to feed through up to 3 m (≈10 ft) of paper before starting the printhead alignment process. This is normal behavior and you should not try to interrupt or prevent it. See “How do I align the printheads?” on page 119.

The problem is with the paper

17 The problem is something else

- “The problem is the printer’s start–up process does not complete” on page 215
- “The problem is a front panel message” on page 215
- “The problem is a “printhead monitoring” message” on page 218
- “The problem is a “printheads are limiting performance” message” on page 218
- “The problem is the printer does not print” on page 219
- “The problem is a print job is waiting for a time-out” on page 219
- “The problem is the printer seems slow” on page 219
- “The problem is communication failures between computer and printer” on page 220
- “The problem is I cannot access the Embedded Web Server from my browser” on page 221
- “The problem is an out-of-memory error” on page 221
- “The problem is an AutoCAD 2000 memory allocation error” on page 222
- “The problem is the platen rollers squeak” on page 222

The problem is the printer's start–up process does not complete



If the printer's start-up process stops when the front panel is displaying the number 17, this indicates that there is a problem with the file system on the printer's hard disk, so the printer is checking the whole file system and making any necessary corrections. This problem can arise when there has been a power cut while the printer was switched on, or if there is a physical problem with the hard disk.

Checking the whole file system normally takes about half an hour. There is nothing you can do to speed it up. If you turn off the printer, the file system check will restart whenever you turn it on again.

If you experience this problem repeatedly when there has been no power cut, contact your customer service representative.

The problem is a front panel message

The front panel displays messages of many kinds; some allow you to continue using the printer while others require you to take action before you can continue.

- If the printer detects a condition of which you should be aware, it displays a message for your information. Examples of information messages are

performance limiting conditions, and printer maintenance requirements. Once you have read the message you can remove it by pressing the **Select** key and continue to use the printer.

- If the printer detects an error, an error code and short message are displayed on the front panel. The following table provides suggested actions to recover from these error conditions:

Code	Short message	Suggested action
13:01	Reseat all cartridges	Remove and re-insert all the print cartridges; see “How do I remove an ink cartridge?” on page 99 and “How do I insert an ink cartridge?” on page 104 for help. If the problem persists, please contact your customer service representative.
26.0:01	Reseat yellow cartridge	The yellow cartridge is not detected, please try to re-install it; see “How do I remove an ink cartridge?” on page 99 and “How do I insert an ink cartridge?” on page 104. If the problem persists, please contact your customer service representative.
26.1:01	Reseat magenta cartridge	The magenta cartridge is not detected, please try to re-install it; see “How do I remove an ink cartridge?” on page 99 and “How do I insert an ink cartridge?” on page 104. If the problem persists, please contact your customer service representative.
26.2:01	Reseat black cartridge	The black cartridge is not detected, please try to re-install it; see “How do I remove an ink cartridge?” on page 99 and “How do I insert an ink cartridge?” on page 104. If the problem persists, please contact your customer service representative.
26.3:01	Reseat cyan cartridge	The cyan cartridge is not detected, please try to re-install it; see “How do I remove an ink cartridge?” on page 99 and “How do I insert an ink cartridge?” on page 104. If the problem persists, please contact your customer service representative.
27:03	Restart the printer. If problem persists, call HP support.	An error has been detected during printhead detection. Reseat all the printheads; see “How do I remove a

(continued)

Code	Short message	Suggested action
		printhead?" on page 106 and "How do I insert a printhead?" on page 110 and "How do I restart the printer?" on page 74 for help. If the problem persists, please contact your customer service representative.
61:01	Wrong file format. The printer cannot process the job.	The file format is wrong and the printer cannot process the job. Check the graphic language setting of your printer (see "How do I change the graphic language setting?" on page 137). If you are sending PostScript from Mac OS over a USB connection, select ASCII encoding in both the driver and the application. Check for the latest firmware and driver releases.
61:04.1	Update system software (firmware)	Even if you have the latest version installed on your printer, you are recommended to repeat the update process to clear this error. See "How do I update my printer's firmware?" on page 173.
61:08.1	File with password cannot be printed.	Resend this file without password protection.
62:04	Restart the printer. If problem persists, call HP support.	An error has been detected with the parallel port. See "How do I restart the printer?" on page 74 If the problem persists, check for the latest firmware release.
63:04	Restart the printer. If problem persists, call HP support.	An error has been detected with a LAN port. See "How do I restart the printer?" on page 74 If the problem persists, check for the latest firmware release.
64:04	Restart the printer. If problem persists, call HP support.	An error has been detected with the USB port. See "How do I restart the printer?" on page 74 If the problem persists, check for the latest firmware release.
66:08	Please resubmit the job as the paper type has changed	The paper type has changed since the job was submitted. The job cannot be printed on the paper that is loaded; please resubmit the job or change the paper.

(continued)

Code	Short message	Suggested action
71:03	Restart the printer. If problem persists, call HP support.	Out of memory failure. You are recommended to remove any unnecessary files from the hard disk using the Embedded Web Server. See “How do I restart the printer?” on page 74.
76:03	Restart the printer. If problem persists, call HP support.	The hard disk is full. If the problem persists, you are recommended to remove any unnecessary files from the hard disk, using the Web server. See “How do I restart the printer?” on page 74.
77:04	Restart the printer. If problem persists, call HP support.	The Embedded Web Server does not seem to be working. See “How do I restart the printer?” on page 74. If the problem persists, check for the latest firmware release.
81:01	Possible paper jam	See “The problem is a paper jam (paper stuck in the printer)” on page 211 for help.
86:01	Possible paper jam	See “The problem is a paper jam (paper stuck in the printer)” on page 211 for help.

If your printer front panel is displaying an error code which is not in the list above, try the following: restart the printer see “How do I restart the printer?” on page 74 and/or check to make sure you have the latest firmware and driver versions; see “How do I update my printer’s firmware?” on page 173 for help. If the problem persists, contact your customer service representative.

The problem is a “printhead monitoring” message

This is not an error message. The message is displayed whenever the **Printhead monitoring** option is set to **Intensive**. If you change the setting to **Optimized**, the message will not appear. See “How do I manage printhead monitoring?” on page 113.

The problem is a “printheads are limiting performance” message

This message appears on the front panel during printing when the printer has detected that one or more printheads are not performing optimally, and so it needs to make extra passes to maintain print quality. To eliminate this message, choose one of the following:

- Select a higher print quality; see “How do I change the print quality?” on page 129.
- Clean the printheads; see “How do I recover (clean) the printheads?” on page 113.
- Use the Image Diagnostics Print to identify which printhead is causing the problem; see “How do I use the Image Diagnostics Print?” on page 175.

The problem is the printer does not print

Here are some possible explanations. See also “The problem is a print job is waiting for a time-out” on page 219.

- You may have an electrical power problem. If there is no activity at all from the printer, and the front panel does not respond, check that the power cable is connected correctly and that there is power available at the socket.
- In the presence of unusual electromagnetic phenomena, such as strong electromagnetic fields or severe electrical disturbances, the printer may behave strangely, or even stop working. In this case, turn off the printer using the **Power** key on the front panel, wait until the electromagnetic environment has returned to normal, and then turn it on again. If you still experience problems, please contact your customer service representative.
- Ensure that the graphic language setting is correct. See “How do I change the graphic language setting?” on page 137.
- Have you installed in your computer the correct driver for your printer? See the Setup instructions.
- If you are using Mac OS with a FireWire or USB connection, you may find that you need to change the data encoding. Select the  icon, then **Printing defaults menu > PS options > Encoding > ASCII**. Then configure your application to send ASCII data.

The problem is a print job is waiting for a time-out

If all is in order (paper loaded, all ink components installed, and no file errors), there are still reasons why a file you have sent from your computer may not start printing when expected:

- The print file may lack a proper file terminator and the printer is therefore waiting for the specified I/O time-out period before assuming it is complete.
If you are using Mac OS with a FireWire or USB connection, select the , then **Printing defaults menu > PS options > Encoding > ASCII**. Then configure your application to send ASCII data.
- Nesting may be on and the printer is waiting for the specified nest wait time-out period before calculating the appropriate nests. In this case, the printer display shows the remaining time for the nesting time-out.
- You may have requested a print preview from your printer driver. This is a function you can use to check that the image is the one you want. In this case, the preview is displayed in a Web browser window, and you must click a button to start printing.

The problem is the printer seems slow

Here are some possible explanations.

- Did you set the print quality to Best? Best-quality prints take longer.
- Did you specify the correct paper type when loading the paper? To find out the printer's current paper type setting, see “How do I view information about the paper?” on page 95.

- Are you using the printer with the Appletalk serial port on a Macintosh computer? It is normal for the Appletalk port to be slow. Consider using the Ethernet interface to connect your printer to your Macintosh.
- Do you have a network connection to your printer? Check that all components used in the network (network interface cards, hubs, routers, switches, cables) are capable of high-speed operation. Is there a lot of traffic from other devices on the network?
- Did you specify Extended drying time in the front panel? Try changing the drying time to Optimal; see “Tell me about drying time” on page 238.
- Are your printheads in good condition? The printer may print slower to maintain print quality when a printhead is faulty. Check the printhead status in the front panel or in the Embedded Web Server, and recover or replace printheads if necessary.
- Do you have high-density black areas in your image? In this case, the printer may change temporarily to a slower print quality option in order to maintain quality.

The problem is communication failures between computer and printer

Some symptoms are:



- The front-panel display does not show the “Receiving” message when you have sent an image to the printer.
- Your computer displays an error message when you are trying to print.
- Your computer or printer “hangs” (stays idle) while communication is taking place.
- Your printed output shows random or inexplicable errors (misplaced lines, partial graphics etc.)

To solve a communication problem:

- Ensure that you have selected the correct printer in your software.
- Ensure that the printer works correctly when printing from other software.
- Remember that very large prints may take some time to receive, process, and print.
- If the printer is connected to a network, try using it when connected directly to your computer through a FireWire or USB cable.
- If your printer is connected to your computer through any other intermediate devices, such as switch boxes, buffer boxes, cable adapters, cable converters, etc., try using it when connected directly to your computer.
- Try another interface cable. For details of supported cables, see “Interface specifications”.
- Ensure that the graphic language setting is correct. See “How do I change the graphic language setting?” on page 137.

The problem is I cannot access the Embedded Web Server from my browser

If you have not done so already, please read “How do I access the Embedded Web Server?” on page 75.

- Have you set a password for the Embedded Web Server, and then forgotten the password? If so, select the  icon, then **Configuration menu > Reset EWS password**.
- At the printer's front panel, select the  icon, then **Configuration menu > Allow EWS**. If this option is off, turn it on.
- Check that you have a TCP/IP (network or FireWire) connection to your printer. If you connect directly to your printer with a USB cable, you cannot use the Embedded Web Server.
- If you are using a FireWire connection, make sure that your computer's operating system supports IP over IEEE-1394 (FireWire). For example, Windows XP and Windows 2003 Server support IP over FireWire, but Windows 2000 does not. Mac OS X 10.3 also supports IP over FireWire (see “How do I access the Embedded Web Server?” on page 75). Make sure that your operating system is configured to use IP over FireWire.
- At the printer's front panel, check that IP is enabled for the type of connection you are using. Select the  icon, then **I/O setup**, then the type of connection you are using, and check that you see **IP enabled**. If not, you may need to use a different type of connection.
- If you normally access the Web through a proxy server, try bypassing the proxy server and accessing the Web server directly. You can do this by modifying your browser settings.
For instance, if you are using Internet Explorer 6 for Windows, go to **Tools > Internet Options > Connections > LAN Settings**, and check the 'Bypass proxy server for local addresses' box. Alternatively, for more precise control, click the **Advanced** button and add the printer's IP address to the list of Exceptions for which the proxy server is not used.
- Try switching off the printer (with the **Power** key on the front panel) and then switching it on again.

The problem is an out-of-memory error

There is no direct relationship between the size of a file in your computer and the amount of memory needed in the printer to print the file. In fact, because of file compression and other complicating factors it is often impossible to estimate how much memory will be needed. So it is possible that a print will fail for lack of memory even though you may have successfully printed larger files in the past. In this case you may need to consider adding more memory to your printer.

If you are using the Windows HP-GL/2 driver, you can often solve printer memory problems by selecting the Services tab, then **Troubleshoot software problems**, then **Print job as a bitmap (process in computer)**.



Note If you select this option, the time needed to process the job in your computer may be considerably longer.

The problem is an AutoCAD 2000 memory allocation error

After installing the printer driver, when you try to print for the first time from AutoCAD 2000, you may see a message saying **Memory allocation error**, after which your image is not printed.

This is due to a problem in AutoCAD 2000, and it can be fixed by downloading the Plotting Update Patch (**plotupdate.exe**) from the Autodesk Web site, <http://www.autodesk.com/>.

This patch is also worth trying if you have any other strange problems when printing from AutoCAD 2000.

The problem is the platen rollers squeak

It may occasionally be necessary to oil the rollers. The Maintenance Kit, which came with your printer, contains a bottle of suitable oil.

1. Open the window.

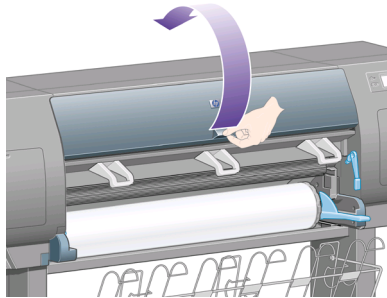

2. There are small holes in the platen beside some of the rollers.

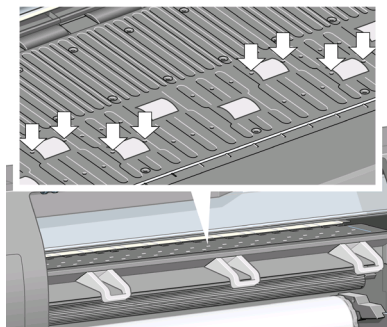

Using the bottle of oil supplied with the Maintenance Kit, insert the pointed end of the bottle into each hole in turn, and put three drops of oil into each hole.

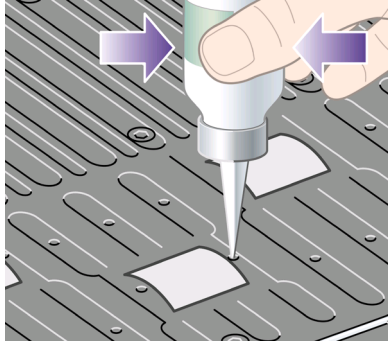

3. Repeat the process until all of the holes in the platen have had three drops of oil placed in them.
4. Be careful not to spill oil onto the platen.

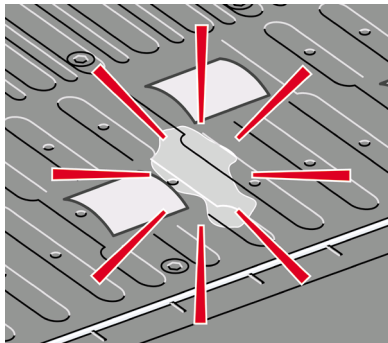

Chapter 17

5. If there is oil on the platen, wipe it away with the cloth supplied with the kit.

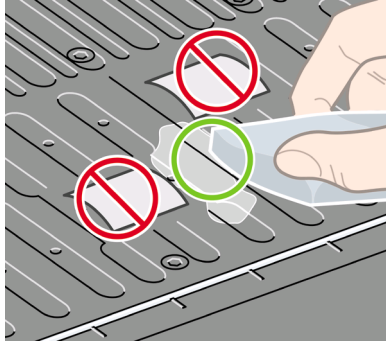

6. Lower the window.

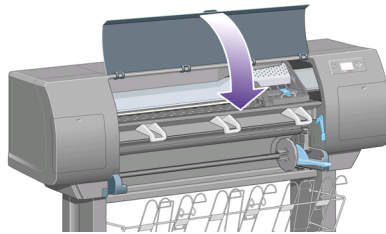

18 Tell me about the printer

- “Tell me about color emulation modes” on page 225
- “Tell me about connecting the printer” on page 227
- “Tell me about the printer’s rear lights” on page 228
- “Tell me about the printer’s internal prints” on page 228
- “Tell me about preventive maintenance” on page 229

Tell me about color emulation modes

Your printer can emulate the color behavior of other devices: RGB devices such as monitors, and CMYK devices such as presses and printers. See “How do I select the color emulation mode?” on page 141.

If you have problems making your printer emulate another HP Designjet printer, see “The problem is color matching between different HP Designjets” on page 199.

For a good emulation, the printer needs a specification of the colors these devices can reproduce. The standard way of encapsulating such information is in ICC profiles. As part of the solution, we provide the most common standards for the different devices. Apart from selecting the appropriate ICC profile, you should select the appropriate rendering intent depending on the type of print: business presentation, photography, or proof. See “How do I set the rendering intent?” on page 140. For reference information on the broader aspects of color printing refer to: http://www.hp.com/hpinfo/community/environment/productinfo/psis_inkjet.htm

The options are as follows.



Note PDF and PostScript files can be used with PostScript printers only.

CMYK color emulation

All CMYK emulation options apply to PDF, PostScript, TIFF, and JPEG files only.

- **None (Native):** no emulation, for use when the color conversion is done by the application or operating system, and therefore the data arrive at the printer already color-managed.
- **HP CMYK Plus:** a set of HP proprietary re-rendering rules that will produce a good result for most digital commercial printing jobs, by expanding the reduced gamut of your press into the wider gamut of your printer.
- **U.S. Sheetfed Coated 2** uses specifications designed to produce quality separations using U.S. inks under the following printing conditions: 350% total area of ink coverage, negative plate, bright white offset stock
- **U.S. Sheetfed Uncoated 2** uses specifications designed to produce quality separations using U.S. inks under the following printing conditions: 260% total area of ink coverage, negative plate, uncoated white offset stock
- **U.S. Web Coated (SWOP) 2** uses specifications designed to produce quality separations using U.S. inks under the following printing conditions: 300% total area of ink coverage, negative plate, coated publication-grade stock

- **U.S. Web Uncoated 2** uses specifications designed to produce quality separations using U.S. inks under the following printing conditions: 260% total area of ink coverage, negative plate, uncoated white offset stock
- **Euroscale Coated 2** uses specifications designed to produce quality separations using Euroscale inks under the following printing conditions: 350% total area of ink coverage, positive plate, bright white coated stock
- **Euroscale Uncoated 2** uses specifications designed to produce quality separations using Euroscale inks under the following printing conditions: 260% total area of ink coverage, positive plate, uncoated white offset stock
- **JMPA**: Japanese standard for offset press
- **Photoshop 4 Default CMYK**
- **Photoshop 5 Default CMYK**
- Other **HP Designjet** printers can be emulated

In the front panel and the Embedded Web Server, some further options are available:

- **Japan Color 2001 Coated** uses the Japan Color 2001 specification for type 3 (coated) paper. It is designed to produce quality separations using 350% total ink coverage, positive film, and coated paper
- **Japan Color 2001 Uncoated** uses the Japan Color 2001 specification for type 4 (uncoated) paper. It is designed to produce quality separations using 310% total ink coverage, positive film, and uncoated paper
- **Japan Web Coated (Ad)** uses specifications developed by the Japan Magazine Publisher Association for digital proofing of images in the Japanese magazine/advertising market
- **Toyo** is designed to produce quality separations for Toyo printing presses
- **DIC** is designed to produce quality separations for Dainippon Ink Company printing presses



Note These options have no effect if the application is defining its own CMYK space, known as calibrated CMYK or CIEBasedDEFB in PostScript terminology.

RGB color emulation

These options apply to PDF, PostScript, TIFF, and JPEG files. For HP-GL/2 and RTL files, only sRGB and AdobeRGB are supported.

If you want to print an RGB image, it must be converted to CMYK data (although you may be able to do it in the application or operating system). To perform this conversion, your printer is provided with the following color profiles:

- **None (Native)**: no emulation. The printer will use its default internal conversion from RGB to CMYK, without following any color standard. This does not imply that results will be bad.
- **sRGB IEC61966-2.1** emulates the characteristics of the average PC monitor. This standard space is endorsed by many hardware and software manufacturers, and is becoming the default color space for many scanners, printers, and software applications.
- **ColorMatch RGB** emulates the native color space of Radius Pressview monitors. This space provides a smaller gamut alternative to Adobe RGB (1998) for print production work.

- **Apple RGB** emulates the characteristics of the average Apple monitor, and is used by a variety of desktop publishing applications. Use this space for files that you plan to display on Apple monitors, or for working with old desktop publishing files.
- **Adobe RGB (1998)** provides a fairly large gamut of RGB colors. Use this space if you need to do print production work with a broad range of colors.

Tell me about connecting the printer

Your printer comes with a 100base-TX network interface (Fast Ethernet) for network connections, and a FireWire interface for direct connection to your computer.

A USB 2.0 interface, 1000base-T (Gigabit Ethernet) network interface, or Jetdirect print server may be installed as optional accessories.

If you are not sure which interface to use, see “How do I choose which connection method to use?” on page 63.

To find the sockets for these interfaces on your printer, see “How do I connect the printer?” on page 56.

To set up your operating system to use the printer, see one of the following:

- “How do I connect my printer to a network (Windows)?” on page 64
- “How do I connect my printer to a network (Mac OS X)?” on page 66
- “How do I connect my printer to a network (Mac OS 9)?” on page 68
- “How do I connect my printer directly to a computer (Windows)?” on page 69
- “How do I connect my printer directly to a computer (Mac OS X)?” on page 70
- “How do I connect my printer directly to a computer (Mac OS 9)?” on page 71

Tell me about the printer's rear lights

At the rear of the printer, above the power switch, are three small lights:

- The amber light on the left is on when the printer is in sleep mode.
- The blue light in the center is on when the printer is on (when it has electrical power).
- The green light on the right is on when the printer is printing.

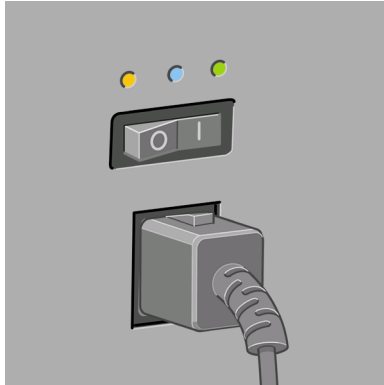

Tell me about the printer



Note You should never see all three lights on at the same time, because the printer cannot print in sleep mode.

Tell me about the printer's internal prints

The internal prints give various kinds of information about your printer. They can be requested from the front panel without using a computer.

Before requesting any internal print, make sure that paper is loaded (roll or sheet), and that the front panel displays the **Ready** message.

To print any internal print, select the  icon, then **Information > Internal prints**, then select whichever internal print you want.

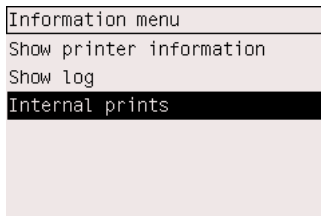

The following internal prints are available:

- Demo: shows some of the capabilities of the printer.
- Menu map: shows details of all the front panel menus.
- Configuration: shows all the current front panel settings.

- Usage report: shows estimates of the total number of prints, number of prints by paper type, number of prints by print quality option, and total amount of ink used per color.
- HP-GL/2 palette: shows the color or grayscale definitions in the currently-selected color palette.
- PostScript font list: lists the PostScript fonts installed in the printer (PostScript printers only).
- Image diagnostics: helps you to solve print quality problems. See “How do I use the Image Diagnostics Print?” on page 175.
- Service information: provides information needed by service engineers.

Tell me about preventive maintenance

During the life of your printer, components that are used constantly can wear out with time and use.

To avoid these components being so worn that the printer breaks down, the printer keeps track of the number of cycles the printer carriage makes across the axis of the printer and on the total quantity of ink printed.

The printer uses this number to advise you of the need for preventive maintenance, displaying one of the following messages on the front panel:

- Maintenance #1 required
- Maintenance #2 required

These messages mean that some components are nearing the end of their lives. You can continue printing for quite some time, depending on your use of the printer. However it is strongly recommended that you contact your customer service representative and arrange for a preventive maintenance on-site visit. The service engineer can then replace the worn parts, which will prolong the life of the printer for a further period.

The benefits of arranging a service engineer's visit when the front panel displays these messages are two-fold:

- The printer components can be replaced at a time that is convenient for you and so will not disturb your daily workflow.
- When the service engineer performs a preventive maintenance visit he will replace several parts at once. This will avoid the need for repeat visits.

Tell me about the printer

19 Tell me about the Embedded Web Server

The Embedded Web Server is the control center for remote management of your printer. From any computer, you can use an ordinary Web browser to contact your printer's Embedded Web Server (see “How do I access the Embedded Web Server?” on page 75).

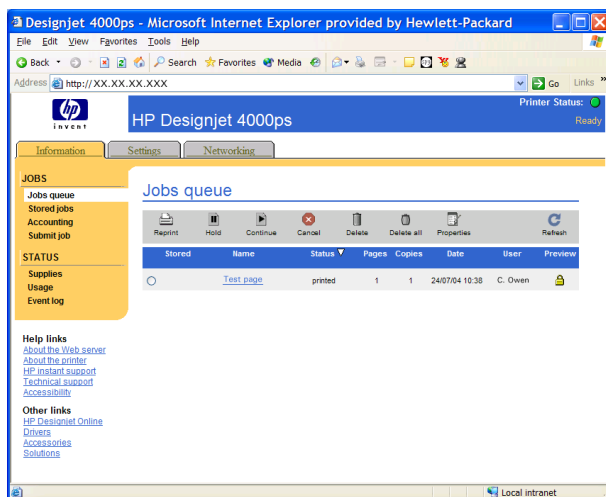

With the Embedded Web Server, you can:

- Submit jobs to the printer in various file formats (HP-GL/2, HP-RTL, PostScript, PDF, JPEG, TIFF, CALS G4) without the need of a driver nor an application: see “How do I submit a job?” on page 163.



Note PostScript and PDF formats can be used with PostScript printers only.

- Control and manage all aspects of your print jobs: see “How do I manage the print queue?” on page 165.
- View the status of the ink cartridges, the printheads, the printhead cleaners, and the paper: see “How do I check the status of the ink system?” on page 124.
- View statistics on ink and paper usage: see “How do I check printer usage statistics?” on page 125.
- Request e-mail notification when specified warning or error conditions occur (such as low ink level): see “How do I request e-mail notification of specific error conditions?” on page 77.
- Update the printer's firmware: see “How do I update my printer's firmware?” on page 173.

Chapter 19

- Change various printer settings (on the Device Setup page)
- Set a password to restrict Web access to the printer: see “How do I password-protect the Embedded Web Server?” on page 76.

20 Tell me about the ink system

- “Tell me about ink cartridges” on page 233
- “Tell me about printheads” on page 235
- “Tell me about printhead cleaners” on page 236
- “Tell me about ink system tips” on page 236

Tell me about ink cartridges

The printer's four ink cartridges provide yellow, magenta, black, and cyan ink to the printheads. The color cartridges supplied with the printer have a capacity of 225 cm³, and the black cartridge has a capacity of 400 cm³. It is also possible to buy and use color cartridges with a capacity of 400 cm³.



Note All these cartridges are physically the same size: only the internal capacity varies.

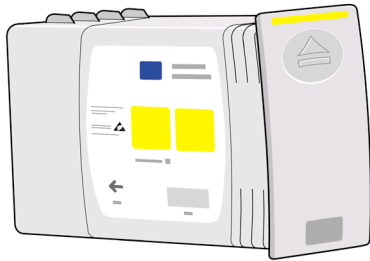

Ink cartridges require no maintenance or cleaning. As long as each ink cartridge is inserted correctly into its slot, the ink will flow to the printheads. Because the printheads control the amount of ink transferred to the page, you will continue to see high-quality printing results even when the ink levels are getting low.

Replacing ink cartridges

You can highlight the  icon at any time to check the ink levels of all the ink cartridges (as illustrated below).

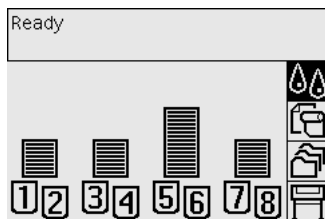

The front panel warns you when a cartridge's ink level is low. When a cartridge is empty, the printer stops printing and the front panel explains why:

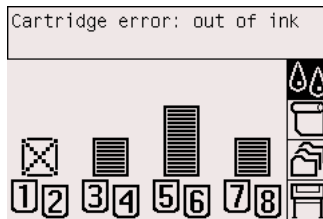

You are recommended to replace the empty cartridge with a new HP cartridge: see “How do I remove an ink cartridge?” on page 99 and “How do I insert an ink cartridge?” on page 104.

Although it is possible to use refilled or non-HP ink cartridges, either choice has several serious disadvantages:

- There is some risk of damaging the printer. In this case the printer warranty will not be valid for any printer repairs that are related to the cartridge, nor for any problems due to ink contamination.
- You will invalidate the warranty of all printheads of the same color used in the printer subsequently, unless and until the whole ink system (including ink tubes) is replaced.
- Print quality may be impaired.
- The printer will be unable to estimate the ink level in the cartridge, and will report it as empty.

If you decide to use refilled or non-HP ink cartridges, you will need to follow these instructions to make the printer use a cartridge that it believes to be empty.

1. Install the cartridge in the printer (see “How do I insert an ink cartridge?” on page 104).
2. The front panel will complain that the cartridge is empty, and the cartridge removal process will start. Press the **Cancel** key to stop this automatic process.
3. At the front panel, select the  icon, then **Ink cartridges**.
4. Highlight **Replace ink cartridges now**, but do not select it.
5. Press the **Cancel** key and the **Up** key at the same time, and hold them down for at least two seconds.
6. The front panel will display a series of warning messages. In response to each message, press the **Cancel** key to cancel the process, or the **Select** key to confirm that you wish to continue.

When you have pressed **Select** in response to all warning messages, the front panel will give the usual ink cartridge status display, but the refilled or non-HP cartridge will be shown as empty with a warning sign.

Tell me about printheads

In order to increase printing speed, two printheads are connected to each ink cartridge, giving eight printheads in total.

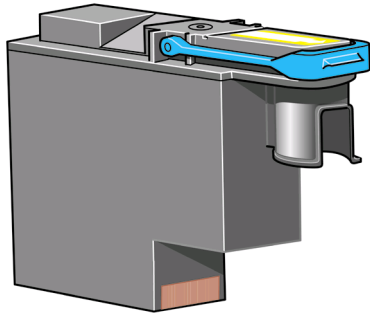

The printheads are extremely durable and do not need to be replaced every time an ink cartridge is replaced. They will continue giving excellent results even if the ink cartridges are low in ink.

To maintain optimum print quality, the printheads are automatically tested at regular intervals, and automatically serviced if necessary. This takes a little time and will occasionally delay printing.

When a printhead eventually needs to be replaced, the front panel identifies the printhead with a cross in place of the printhead number:

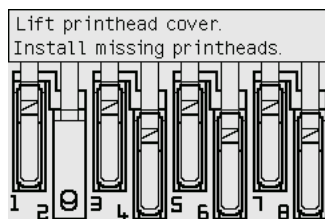

Caution Whenever you buy a new printhead, you get a new printhead cleaner with it. When you replace a printhead, always replace the printhead cleaner at the same time. Leaving the old printhead cleaner in the printer will shorten the new printhead's life and possibly damage the printer.

Tell me about printhead cleaners

Each printhead has its own printhead cleaner, so there are eight printhead cleaners in the printer. Printhead cleaners are used to clean and maintain the printheads, to ensure the best possible print quality, and to seal the printheads when they are not in use to prevent them from drying out.

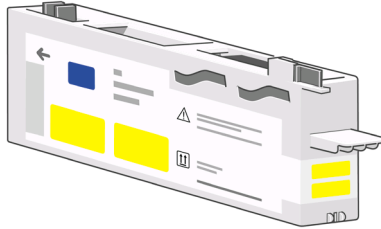

 **Caution** Whenever you buy a new printhead, you get a new printhead cleaner with it. When you replace a printhead, always replace the printhead cleaner at the same time. Leaving the old printhead cleaner in the printer will shorten the new printhead's life and possibly damage the printer.

Tell me about ink system tips

For best results, always follow these guidelines:

- Install the ink cartridges, printheads, and printhead cleaners before the install-by date, which is printed on the packaging.
- Install a new printhead cleaner every time you install a new printhead.
- Follow the instructions on the front panel during installation.
- Allow the printer and printhead cleaners to clean the printheads automatically.
- Avoid unnecessary removal of the ink cartridges and printheads.
- The ink cartridges should never be removed while the printer is printing. They should be removed only when the printer is ready for you to replace them. The front panel will guide you through the removal and installation procedures (or see “How do I remove an ink cartridge?” on page 99 and “How do I insert an ink cartridge?” on page 104).



21 Tell me about paper

- “Tell me about using paper” on page 237
- “Tell me about drying time” on page 238

Tell me about using paper

Choosing the correct paper type for your needs is an essential step in ensuring good print quality. For best printing results, use only recommended papers (see “How do I select supported paper types?” on page 94), whose reliability and performance have been developed and thoroughly tested. All printing components (printer, ink system, and paper) have been designed to work together to give trouble-free performance and optimal print quality.

Here are some further tips about paper usage:

- Always keep unused rolls wrapped in the plastic wrap to prevent discoloration. Rewrap partially used rolls if they are not being used.
- Do not stack rolls.
- Allow all paper types to adapt to room conditions out of the packaging for 24 hours before printing.
- Handle film and glossy paper by the edges or wear cotton gloves. Skin oils can be transferred to the printing material, leaving fingerprint marks.
- Keep the paper tightly wound on the roll throughout the loading and unloading procedures. If it starts to unwind, it can become difficult to handle.
- Whenever you load a roll or a sheet, the front panel prompts you to specify the paper type you are loading. For good print quality, it is essential to specify this correctly. If paper is already loaded, you can check the paper type at the front panel by highlighting the  or  icon.
- The quality of some images may be reduced if you use a paper type that is unsuitable for your image.
- If you load a paper type described on the front panel as **Super Heavy Coated Paper** (note: currently there are no recommended papers of this type), you should turn off the cutter to avoid cutter failure. To do this, select the  icon, then **Paper handling options > Cutter > Off**.
Whenever you decide to stop using Super Heavy Coated Paper and load a different paper type, remember to turn the cutter back on.
- Make sure the appropriate print quality setting (Fast, Normal, or Best) is selected. You can set the print quality from the driver, from the Embedded Web Server, or from the front panel. Driver or Embedded Web Server settings override front panel settings. The combination of paper type and print quality settings tells the printer how to place the ink on the paper—for example, the ink density, halftoning method, and number of passes of the printheads. See “How do I choose print quality settings?” on page 130.
- Although the ink systems supplied with this printer have good light-fastness, colors will eventually fade or change if exposed to sunlight over a long period of time.

Tell me about drying time

With some printing materials and environmental conditions the ink needs some time to dry before the printing material is unloaded. The following settings are available.

- **Optimal:** the printer automatically determines the appropriate drying time, based on the printing material you have selected and the current temperature and humidity. If any drying time is required, a “drying time to go” countdown will be displayed on the front panel.
- **Extended:** the default drying time is extended. This can be used if you find that the default drying time is not enough to dry the ink sufficiently in your environment.
- **Reduced:** the default drying time is reduced. This can be used if you are keen to get prints as fast as possible, and you find that the reduced drying time causes no significant problem in your environment.
- **None:** no drying time is provided. This can be used, for example, if you are manually removing the prints as fast as the printer is producing them.

To change the drying time, see “How do I change the drying time?” on page 97.

22 Tell me about printer specifications

- “Tell me about functional specifications” on page 239
- “Tell me about physical specifications” on page 242
- “Tell me about memory specifications” on page 242
- “Tell me about power specifications” on page 242
- “Tell me about ecological specifications” on page 242
- “Tell me about environmental specifications” on page 242
- “Tell me about acoustic specifications” on page 243

Tell me about functional specifications

HP No. 90 ink supplies

Printheads	Yellow, magenta, black, and cyan (two of each)
Printhead cleaners	Yellow, magenta, black, and cyan (two of each)
Ink cartridges	Yellow, magenta, and cyan cartridges containing 225 or 400 cm ³ of ink, and a black cartridge containing 400 cm ³ of ink

Paper sizes

	Minimum	Maximum
Width	11 in (279 mm)	42 in (1.066 m)
Length	16.5 in (420 mm)	60 in (1.5 m) for sheet and 300 ft (90 m) for roll

Print resolution

Print quality	Max detail	Optimized for lines and text		Optimized for images	
		Rendering resolution (dpi)	Printing resolution (dpi)	Rendering resolution (dpi)	Printing resolution (dpi)
Best	On	1200×1200	2400×1200 (High-Gloss Photo Paper, Canvas) 1200×1200 (other papers)	1200×1200	2400×1200 (Productivity Photo Gloss, High-Gloss Photo Paper, Canvas) 1200×1200 (other papers)
	Off	600×600	1200×1200 (High-Gloss Photo Paper, Canvas) 1200×600 (other papers)	600×600	1200×1200 (High-Gloss Photo Paper, Canvas) 1200×600 (other papers)
Normal	On	600×600	1200×1200 (High-Gloss Photo Paper, Canvas) 1200×600 (other paper types)	600×600	1200×1200 (High-Gloss Photo Paper, Canvas) 1200×600 (other paper types)
	Off	600×600	1200×1200 (High-Gloss Photo Paper, Canvas) 1200×600 (other paper types)	300×300	1200×1200 (Productivity Photo Gloss, High-Gloss Photo Paper, Canvas) 1200×600 (other paper types)
Fast	On	600×600	1200×1200 (High-Gloss Photo Paper) 1200×600 (other paper types)	600×600	1200×1200 (High-Gloss Photo Paper) 600×600 (Max Speed, Bright White, Bond Paper) 1200×600 (other paper types)

Tell me about printer specifications

Print resolution (continued)

Print quality	Max detail	Optimized for lines and text		Optimized for images	
		Rendering resolution (dpi)	Printing resolution (dpi)	Rendering resolution (dpi)	Printing resolution (dpi)
	Off	300×300	1200×1200 (High-Gloss Photo Paper) 600×600 (Max Speed) 1200×600 (other paper types)	300×300	1200×1200 (High-Gloss Photo Paper) 600×600 (Max Speed, Bright White, Bond Paper) 1200×600 (other paper types)

Margins

Side margins	5 mm (normal) 15 mm (extended)
Top margin (leading edge)	11.5 mm (normal) 55 mm (extended)
Bottom margin (trailing edge)	5 mm (roll) 25 mm (sheet, normal) 55 mm (sheet, extended)

Mechanical accuracy

±0.1% of the specified vector length or ±0.1 mm (whichever greater) at 23°C (73°F), 50-60% relative humidity, on A0 printing material in Best or Normal mode with HP Matte Film.

Graphic languages supported

HP Designjet 4000 and 4000ps Printers	HP-GL/2, RTL, TIFF, JPEG, CALS G4
HP Designjet 4000ps Printer only	Adobe PostScript level 3, PDF 1.5

Tell me about printer specifications

Tell me about physical specifications

Weight (including stand)	≈ 115 kg
Width	< 1930 mm
Depth	< 800 mm
Height	≈ 1350 mm

Tell me about memory specifications

Memory (DRAM) supplied	256 MB
Memory (DRAM) maximum	512 MB
Hard disk	40 GB

Tell me about power specifications

Source	100-240 V ac ±10%, autoranging
Frequency	50–60 Hz
Current	< 6 A
Consumption	< 1 kW

Tell me about ecological specifications

For the up-to-date ecological specifications of your printer, please go to <http://www.hp.com/> and search for “ecological specifications”.

Tell me about environmental specifications

Relative humidity range for best print quality	20 to 80%, depending on paper type
Temperature range for best print quality	15 to 35°C (59 to 95°F), depending on paper type
Temperature range for printing	5 to 40°C (41 to 104°F)
Temperature range when not in operation	-20 to +50°C (-4 to +122°F)
Maximum altitude when printing	3000 m

Tell me about acoustic specifications

Idle sound power	≤ 5.7 B (A)
Operating sound power	≤ 7.0 B (A)
Idle sound pressure	≤ 39 dB (A)
Operating sound pressure	≤ 53 dB (A)

Tell me about printer specifications

23 Tell me about ordering supplies and accessories

- “Tell me about ordering ink supplies” on page 245
- “Tell me about ordering paper” on page 245
- “Tell me about ordering accessories” on page 248

Tell me about ordering ink supplies

The following ink supplies can be ordered for your printer.

Ink cartridges

Cartridge	Capacity (cm ³)	Part number
HP 90 Cyan	225	C5060A
HP 90 Magenta	225	C5062A
HP 90 Yellow	225	C5064A
HP 90 Black	400	C5058A
HP 90 Cyan	400	C5061A
HP 90 Magenta	400	C5063A
HP 90 Yellow	400	C5065A

Printheads and printhead cleaners

Printhead & cleaner	Part number
HP 90 Black	C5054A
HP 90 Cyan	C5055A
HP 90 Magenta	C5056A
HP 90 Yellow	C5057A

Tell me about ordering paper

The following paper types are currently provided for use with your printer.



Note This list is likely to change over the course of time. For the latest information, see <http://www.hp.com/go/designjet>.

Premium Technical

Name	g/m ²	24 in wide	36 in wide	42 in wide
HP Bright White Inkjet Bond Paper	90	C1860A* C6035A†	C1861A* C6036A†	none
HP Bright White Inkjet Bond Paper (long roll)	90	none	C6810A	none
HP Matte Film	163	51642A	51642B	none
HP Clear Film	170	C3876A	C3875A	none
HP Natural Tracing Paper	90	C3869A	C3868A	none
HP Translucent Bond	67	C3860A	C3859A	none
HP Polyester Film Opaque White Glossy	170	C7955A	C7956A	C7957A
HP Vellum	75	C3862A	C3861A	none
HP Coated Paper	91	C6019B	C6020B	C6559B* C6567B†
HP Coated Paper (long roll)	91	none	C6980A	none
HP Heavyweight Coated Paper	133	C6029C	C6030C	C6569C
HP Heavyweight Coated Paper (long roll)	130	none	none	Q1956A†

Premium Photographic

Name	g/m ²	24 in wide	36 in wide	42 in wide
HP Productivity Photo Gloss	245	none	Q1938A	Q1939A
HP Productivity Photo Semi-Gloss	245	none	Q1943A	Q1944A
HP Photo Paper RC Matte	200	none	C7946A	none
HP Proofing Paper RC Satin	200	none	C7952A	none

Universal Line

Name	g/m ²	24 in wide	36 in wide	42 in wide
HP Universal High-Gloss Photo Paper	179	Q1426A	Q1427A	Q1428A

Universal Line (continued)

Name	g/m²	24 in wide	36 in wide	42 in wide
HP Universal Semi-Gloss Photo Paper	179	Q1420A	Q1421A	Q1422A
HP Universal Inkjet Bond Paper	80	Q1396A†	Q1397A†	Q1398A†
HP Universal Coated Paper	95	Q1404A†	Q1405A†	Q1406A†
HP Universal Heavyweight Coated Paper	120	Q1412A†	Q1413A†	Q1414A†
HP Super Heavyweight Coated Paper	160	C7929A*	C7930A*	C7931A*

Display Graphics

Name	g/m²	24 in wide	36 in wide	42 in wide
HP Banners with Tyvek	140	none	C6787A	none
HP Colorfast Adhesive Vinyl	328	none	C6775A	none
HP Backlit Film Reverse Print Matte	160	none	C7960A	none
HP Studio Canvas	368	none	C6771A	none
HP Outdoor Billboard Paper Blue Back	140	none	C7949A	none

Graphics Arts/Indoor/Fine Art

Name	g/m²	24 in wide	36 in wide	42 in wide
HP Canvas Matte	340	C7966A	C7967A	C7968A
HP Outdoor Paper	145	none	Q1730A	none
HP Canvas Paper 140 gsm	140	none	Q1718A	none
HP Canvas Paper 180 gsm	180	none	Q1724A	none
HP Fine Art Paper Aquarella	240	none	Q1703A	none
HP Fine Art Paper Cream	140	none	Q1709A	none
HP Fine Art Paper Sahara	140	none	Q1715A	none
HP Indoor Paper Self-Adhesive	170	none	Q1733A	none

* available only in North and South America

† available only in Europe, the Middle East, and Africa

Tell me about ordering supplies and accessories

Tell me about ordering accessories

The following accessories can be ordered for your printer.

Name	Product number
HP Jetdirect 40d Gigabit Print Server for the Designjet 4000 Printer series (provides the highest capacity network connection to your printer)	Q5679A
HP Designjet 4000 Printer series High Speed USB 2.0 Card (provides a high speed direct connection to your printer)	Q5680A
HP Jetdirect 620n Fast Ethernet print server	J7934A
HP Designjet 4000 Printer series 256 MB Memory Upgrade (to increase the memory capacity of your printer to work with complex files)	Q5673A
HP Designjet Roll Feed Spindle 42" (spare spindles ease the process of switching between different types of roll paper)	Q5675A

24 Tell me about getting help

- “Tell me about HP Instant Support” on page 249
- “Tell me about HP Customer Care” on page 249
- “Tell me about HP Designjet Online” on page 250
- “Tell me about other sources of information” on page 251

Tell me about HP Instant Support

HP Instant Support is HP's suite of troubleshooting tools that collect diagnostic information from your printer and match it with intelligent solutions from HP's knowledge bases, allowing you to resolve problems as quickly as possible.

You can start an HP Instant Support session by clicking on the link provided by your printer's Embedded Web Server. See “How do I access the Embedded Web Server?” on page 75.

To be able to use HP Instant Support:

- You must have a TCP/IP connection to your printer, because HP Instant Support is accessible only through the Embedded Web Server.
- You must have access to the World Wide Web, because HP Instant Support is a Web-based service.

HP Instant Support is currently available in English, Korean, Simplified Chinese, and Traditional Chinese.

Tell me about HP Customer Care

As your strategic support partner, we make it our business to help keep your business running smoothly. HP Customer Care offers award-winning support to ensure you get the most from your HP Designjet.

HP Customer Care provides comprehensive, proven support expertise and leverages new technologies to give customers unique end-to-end support. Services include setup and installation, troubleshooting tools, warranty upgrades, repair and exchange services, phone and Web support, software updates, and self-maintenance services.

To find out more about HP Customer Care, please visit us at:

<http://www.hp.com/go/designjet/>

or call the phone number in the *Customer Service Guide* provided with your printer.

What to do before you call:

- Review the “The problem is” troubleshooting suggestions in this guide.
- Review the relevant driver documentation supplied with this printer (for users sending PostScript files or those using Microsoft Windows).
- If you have installed third-party software drivers and RIPs, refer to their documentation.
- If the problem appears to be related to your software application, first contact your software vendor.

- If you still have difficulty, refer to the HP Support Services booklet provided with your printer. This document contains a comprehensive list of various support services available to help solve printer problems.
- If you call one of the Hewlett-Packard offices, please have the following information available to help us answer your questions more quickly:
 - The printer you are using (the product number and the serial number, found on the label at the back of the printer)
 - The printer's Service ID: select the  icon, and then **Information > Show printer information > Service ID**
 - If there is an error code on the front panel, note it down; see “Status codes and error messages”
 - The computer you are using
 - Any special equipment or software you are using (for example, spoolers, networks, switch-boxes, modems, or special software drivers)
 - The cable you are using (by part number) and where you purchased it
 - The type of interface used on your printer (FireWire, USB, or network)
 - The software name and version you are currently using
 - If the problem is a system error it will have a error number; record the error number and have it ready
 - If possible, print out the following reports; you may be asked to fax them to the support center helping you: Configuration, Usage Report, and “all pages above” from Service Information (see “Tell me about the printer's internal prints” on page 228)

Tell me about HP Designjet Online

Enjoy a world of dedicated services and resources to ensure you always get the best performance from your HP Designjet products and solutions.

Register at HP Designjet Online, your large-format printing community at <http://www.hp.com/go/designjet/> for unrestricted access to:

- Downloads — the latest printer firmware, drivers, software, media profiles, etc.
- Technical support — online troubleshooting, customer care contacts, and more
- Forums for direct contact with the experts, both HP and your colleagues
- Warranty tracking online, for your peace of mind
- Technical documentation and training videos
- Latest product information — printers, supplies, accessories, software, etc.
- Supplies Center for all you need to know about ink and paper

By customizing your registration for the products you have purchased and your type of business, and by setting your communication preferences: you decide the information you need.

Register at HP Designjet Online for the best performance.

HP Designjet Online is available in English, German, French, Italian, Spanish, Portuguese, Japanese, Korean, Simplified Chinese, and Traditional Chinese.

Tell me about other sources of information

More information is available from the following sources:

- The Embedded Web Server provides information about your printer status, technical support, on-line documentation, etc.—see “Tell me about the Embedded Web Server” on page 231.
- The setup instructions that came with your printer

25 Legal information

- “Worldwide Limited Warranty—HP Designjet 4000 Printer series” on page 253
- “Hewlett-Packard Software License Agreement” on page 256
- “Open source acknowledgments” on page 257
- “Regulatory notices” on page 258
- “DECLARATION OF CONFORMITY” on page 261

Worldwide Limited Warranty—HP Designjet 4000 Printer series

HP product	Limited Warranty Period
Printer and related HP hardware	1 year (from the date of purchase by the customer)
Software	90 days (from the date of purchase by the customer)
Printhead	Until the “end of warranty” date printed on the product is reached, or 1000 cm ³ of HP ink have been cycled through the printhead, whichever occurs first
Ink cartridge	Until the genuine HP ink is depleted as indicated by the printer, or the “end of warranty” date printed on the product is reached, whichever occurs first

A. Extent of HP Limited Warranty

1. This Hewlett-Packard (HP) Limited Warranty gives you, the end-customer, express limited warranty rights from HP, the manufacturer. In addition, you may also have other legal rights under the applicable local law or special written agreement with HP.
2. HP warrants to you that the HP products specified above will be free from defects in materials and workmanship during the Limited Warranty Period specified above. The Limited Warranty Period starts on the date of purchase. Your dated sales or delivery receipt, showing the date of purchase of the product, is your proof of purchase date. You may be required to provide proof of purchase as a condition of receiving warranty service. You are entitled to warranty service according to the terms and conditions of this document if a repair or replacement of your HP Products is required within the Limited Warranty Period.
3. For software products, HP’s Limited Warranty applies only to a failure to execute programming instructions. HP does not warrant that the operation of any product will be uninterrupted or error free.
4. HP’s Limited Warranty covers only those defects that arise as a result of normal use of the HP products, and does not apply to any:

- a. Improper or inadequate maintenance or modification;
- b. Software, interfacing, media, parts, or supplies not provided or supported by HP; or
- c. Operation outside the product's specifications.

Routine printer maintenance operations in the HP Designjet 4000 Printer series, such as cleaning and preventive maintenance services (including parts contained in any preventive maintenance kit and HP service engineer visits), are not covered by HP's Limited Warranty, but in some countries may be covered under a separate support contract.

5. YOU SHOULD MAKE PERIODIC BACKUP COPIES OF THE DATA STORED ON THE PRINTER'S HARD DISK OR OTHER STORAGE DEVICES AS A PRECAUTION AGAINST POSSIBLE FAILURES, ALTERATION, OR LOSS OF THE DATA. BEFORE RETURNING ANY UNIT FOR SERVICE, BE SURE TO BACK UP DATA AND REMOVE ANY CONFIDENTIAL, PROPRIETARY, OR PERSONAL INFORMATION. HP IS NOT RESPONSIBLE FOR DAMAGE TO OR LOSS OF ANY FILES, STORED BY YOU ON THE PRINTER'S HARD DISK OR OTHER STORAGE DEVICES. HP IS NOT RESPONSIBLE FOR THE RECOVERY OF LOST FILES OR DATA.
6. For HP printer products, the use of a refilled or non-original HP consumable product (ink, printhead or ink cartridge) does not affect either HP's Limited Warranty to you or any HP support contract with you. However, if printer failure or damage is attributable to the use of a non-HP or refilled ink cartridge, HP will charge its standard time and materials charges to service the printer for the particular failure or damage.
7. Your exclusive remedies for defective HP products are the following:
 - a. During the Limited Warranty Period, HP will replace any defective HP software, media, or consumable product which is covered by this Limited Warranty, and deliver another product to you to replace the defective one.
 - b. During the Limited Warranty Period, HP, at its sole discretion, shall either repair on site or replace any defective hardware product or component part. If HP elects to replace any component part, HP will provide to you (i) a replacement part, in return of the defective one, and (ii) remote part installation assistance, if needed.
 - c. In the unlikely event that HP is unable to repair or replace, as applicable, a defective product which is covered by this Limited Warranty, HP shall, within a reasonable time after being notified of the defect, refund the purchase price for the product.
8. HP shall have no obligation to replace or refund until you return the defective product or component part to HP. All components, parts, or hardware products removed under this Limited Warranty become the property of HP. Notwithstanding the above mentioned, HP may waive the requirement for you to return the defective part.
9. Unless otherwise stated, and to the extent permitted by local law, HP products may be manufactured using new materials or new and used materials equivalent to new in performance and reliability. HP may repair or replace products (i) with equivalent products to the products being repaired or replaced but which may have been subject to prior use; or (ii) with an equivalent product to an original product that has been discontinued.

10. THIS LIMITED WARRANTY IS APPLICABLE IN ALL COUNTRIES AND MAY BE ENFORCED IN ANY COUNTRY WHERE HP OR ITS AUTHORIZED SERVICE PROVIDERS OFFER WARRANTY SERVICE AND HP HAS MARKETED THIS PRODUCT, SUBJECT TO THE TERMS AND CONDITIONS SET FORTH IN THIS LIMITED WARRANTY. HOWEVER, WARRANTY SERVICE AVAILABILITY AND RESPONSE TIME MAY VARY FROM COUNTRY TO COUNTRY. HP WILL NOT ALTER FORM, FIT, OR FUNCTION OF THE PRODUCT TO MAKE IT OPERATE IN A COUNTRY FOR WHICH IT WAS NEVER INTENDED TO FUNCTION FOR LEGAL OR REGULATORY REASONS.
11. Contracts for additional services may be available for any authorized HP service facility where the listed HP product is distributed by HP or an authorized importer.
12. TO THE EXTENT ALLOWED BY LOCAL LAW, EXCEPT AS EXPRESSLY SET FORTH IN THIS LIMITED WARRANTY NEITHER HP NOR ITS THIRD PARTY SUPPLIERS MAKE ANY OTHER WARRANTY OR CONDITION OF ANY KIND, WHETHER EXPRESS OR IMPLIED, WITH RESPECT TO THE HP PRODUCTS, AND SPECIFICALLY DISCLAIM THE IMPLIED WARRANTIES OR CONDITIONS OF MERCHANTABILITY, SATISFACTORY QUALITY, AND FITNESS FOR A PARTICULAR PURPOSE.

B. Limitations of liability

TO THE EXTENT ALLOWED BY LOCAL LAW, EXCEPT FOR THE OBLIGATIONS SPECIFICALLY SET FORTH IN THIS LIMITED WARRANTY, IN NO EVENT SHALL HP OR ITS THIRD PARTY SUPPLIERS BE LIABLE FOR DIRECT, INDIRECT, SPECIAL, INCIDENTAL, OR CONSEQUENTIAL DAMAGES (INCLUDING ANY LOSS OF PROFITS OR SAVINGS), WHETHER BASED ON CONTRACT, TORT, OR ANY OTHER LEGAL THEORY AND WHETHER ADVISED OF THE POSSIBILITY OF SUCH DAMAGES.

C. Local law

1. This Limited Warranty gives you specific legal rights. You may also have other rights which vary from state to state in the United States, from province to province in Canada, and from country to country elsewhere in the world. You are advised to consult applicable state, province, or national laws for full determination of your rights.
2. To the extent that this Warranty Statement is inconsistent with local law, this Warranty Statement shall be deemed modified to be consistent with such local law. THE WARRANTY TERMS CONTAINED IN THIS LIMITED WARRANTY, EXCEPT TO THE EXTENT LAWFULLY PERMITTED, DO NOT EXCLUDE, RESTRICT, OR MODIFY AND ARE IN ADDITION TO THE MANDATORY STATUTORY RIGHTS APPLICABLE TO THE SALE OF THIS PRODUCT TO YOU.

Revision: August 1st, 2004

Hewlett-Packard Software License Agreement

ATTENTION: USE OF THE SOFTWARE IS SUBJECT TO THE HP SOFTWARE LICENSE TERMS SET FORTH BELOW. USING THE SOFTWARE INDICATES YOUR ACCEPTANCE OF THESE LICENSE TERMS. IF YOU DO NOT ACCEPT THESE LICENSE TERMS, YOU MUST RETURN THE SOFTWARE FOR A FULL REFUND. IF THE SOFTWARE IS SUPPLIED WITH ANOTHER PRODUCT, YOU MAY RETURN THE ENTIRE UNUSED PRODUCT FOR A FULL REFUND.

HP SOFTWARE LICENSE TERMS

The following terms govern your use for the software of your HP Designjet 4000 Printer series unless you have a separate agreement with HP.

Definitions. HP Designjet 4000 Printer series software includes HP software product ("the Software") and Open Source Software components.

"Open Source Software" means various open source software components including, but not limited to, Apache, Tomcat, MySQL, and omniORB, licensed under terms of applicable open source license agreements included in the materials relating to such software (please see "Open Source Software" section below).

License Grant. HP grants you a license to Use one copy of the Software pre-installed in the HP Designjet 4000 Printer series. "Use" means storing, loading, executing or displaying the Software. You may not modify the Software or disable any licensing or control features of the Software.

Ownership. The Software is owned and copyrighted by HP or its third party suppliers. Your license confers no title to, or ownership in, the Software and is not a sale of any rights in the Software. HP's third party suppliers may protect their rights in the event of any violation of these License Terms.

Copies and Adaptations. You may only make copies or adaptations of the Software for archival purposes or when copying or adaptation is an essential step in the authorized Use of the Software. You must reproduce all copyright notices in the original Software on all copies or adaptations. You may not copy the Software onto any public network.

No Disassembly or Decryption. You may not disassemble or decompile the Software unless HP's prior written consent is obtained. In some jurisdictions, HP's consent may not be required for limited disassembly or decompilation. Upon request, you will provide HP with reasonably detailed information regarding any disassembly or decompilation. You may not decrypt the Software unless decryption is a necessary part of the operation of the Software.

Transfer. Your license will automatically terminate upon any transfer of the Software. Upon transfer, you must deliver the Software, including any copies and related documentation, to the transferee. The transferee must accept these License Terms as a condition to the transfer.

Termination. HP may terminate your license upon notice for failure to comply with any of these License Terms. Upon termination, you must immediately destroy the Software, together with all copies, adaptations and merged portions in any form.

Export Requirements. You may not export or re-export the Software or any copy or adaptation in violation of any applicable laws or regulations.

U.S. Government Restricted Rights. The Software and any accompanying documentation have been developed entirely at private expense. They are delivered and licensed as "commercial computer software" as defined in DFARS 252.227-7013 (Oct 1988), DFARS 252.211-7015 (May 1991) or DFARS 252.227-7014 (Jun 1995), as a "commercial item" as defined in FAR 2.101(a), or as "Restricted computer software" as defined in FAR 52.227-19 (Jun 1987)(or any equivalent agency regulation or contract clause), whichever is applicable. You have only those rights provided for such Software and any accompanying documentation by the applicable FAR or DFARS clause or the HP standard software agreement for the product involved.

Open Source Software. The Open Source Software is composed of individual software components, each of which has its own copyright and its own applicable license conditions. You must review the licenses within the individual packages to understand your rights under them. The licenses can be found in the folder called **licenses** on the *Using your printer* CD that came with your printer. Copyrights to the Open Source Software are held by the copyright holders.

Open source acknowledgments

- This product includes software developed by the Apache Software Foundation (<http://www.apache.org/>).
- The source code, object code, and documentation in the com.oreilly.servlet package is licensed by Hunter Digital Ventures, LLC.

Regulatory notices

You can obtain current Material Safety Data Sheets for the ink systems used in the printer by mailing a request to this address: Hewlett-Packard Customer Information Center, 19310 Pruneridge Avenue, Dept. MSDS, Cupertino, CA 95014, U.S.A.

There is also a Web page: http://www.hp.com/hpinfo/community/environment/productinfo/psis_inkjet.htm

Regulatory Model Number

For regulatory identification purposes, your product is assigned a Regulatory Model Number. The Regulatory Model Number for your product is BCLAA-0401. This regulatory number should not be confused with the marketing name (HP Designjet 4000 Printer series) nor with the product numbers (Q1273X, Q1274X, where X is any single letter).

ELECTROMAGNETIC COMPATIBILITY (EMC)



Warning This is a class A product. In a domestic environment this product may cause radio interference, in which case the user may be required to take adequate measures.

FCC statements (U.S.A.)

The U.S. Federal Communications Commission (in 47 cfr15.105) has specified that the following notices be brought to the attention of users of this product.

Shielded cables

Use of shielded data cables is required to comply with the Class A limits of Part 15 of the FCC Rules.



Caution Pursuant to Part 15.21 of the FCC Rules, any changes or modifications to this equipment not expressly approved by the Hewlett-Packard Company may cause harmful interference and void the FCC authorization to operate this equipment.

This equipment has been tested and found to comply with the limits for a Class A digital device, pursuant to part 15 of the FCC Rules. These limits are designed to provide reasonable protection against harmful interference in a commercial environment. This equipment generates, uses, and can radiate radio frequency energy and, if not installed and used in accordance with the instructions, may cause harmful interference to radio communications. Operation of this equipment in a residential area is likely to cause harmful interference, in which case users will be required to correct the interference at their own expense.

Normes de sécurité (Canada)

Le présent appareil numérique n'émet pas de bruits radioélectriques dépassant les limites applicables aux appareils numériques de Classe A prescrites dans le

réglement sur le brouillage radioélectrique édicté par le Ministère des Communications du Canada.

DOC statement (Canada)

This digital apparatus does not exceed the Class A limits for radio noise emissions from digital apparatus set out in the Radio Interference Regulations of the Canadian Department of Communications.

Korean EMI statement

사용자 안내문 : A 급 기기

이 기기는 업무용으로 전자파적합등록을 받은 기기이오니, 판매자 또는 사용자는 이 점을 주의 하시기 바라며, 만약 잘못 구입 하셨을 때에는 구입한 곳에서 비업무용으로 교환 하시기 바랍니다.

VCCI Class A (Japan)

この装置は、情報処理装置等電波障害自主規制協議会（VCCI）の基準に基づくクラスA情報技術装置です。この装置を家庭環境で使用すると電波妨害を引き起こすことがあります。この場合には使用者が適切な対策を講ずるよう要求されることがあります。

Safety power cord warning

製品には、同梱された電源コードをお使い下さい。
同梱された電源コードは、他の製品では使用出来ません。

Taiwanese EMI statement

警告使用者：這是甲類的資訊產品，在居住的環境中使用時，可能會造成射頻干擾，在這種情況下，使用者會被要求採取某些適當的對策。

Chinese EMI statement

此为A级产品，在生活环境中，该产品可能会造成无线电干扰。在这种情况下，可能需要用户对其干扰采取切实可行的措施。

Sound

Geräuschemission (Germany) LpA < 70 dB, am Arbeitsplatz, im Normalbetrieb, nach DIN45635 T. 19.

DECLARATION OF CONFORMITY

according to ISO/IEC Guide 22 and EN 45014

Supplier's name:	Hewlett-Packard Company
Supplier's address:	Avenida Graells, 501 08174 Sant Cugat del Vallès Barcelona, Spain

declares that the product

Regulatory Model ⁽³⁾ :	BCLAA-0401
Product family:	HP Designjet 4000 Printer series
Product options:	All

conforms to the following product specifications

Safety:	IEC 60950-1:2001 / EN 60950-1:2001
EMC:	CISPR 22:1997 / EN 55022:1998 Class A ⁽¹⁾ EN 55024:1998 + A1 EN 61000-3-2:2000 EN 61000-3-3:1995 + A1:2001 FCC Title 47 CFR, Part 15 Class A ⁽²⁾

Additional information

The product herewith complies with the requirements of the Low-Voltage Directive 73/23/EEC and the EMC Directive 89/336/EEC, and carries the CE marking accordingly.

1. The product was tested in a typical configuration with HP Personal Computer systems and peripherals.
2. This device complies with Part 15 of the FCC Rules. Operation is subject to the following two conditions:
 - This device may not cause harmful interference.
 - This device must accept any interference received, including interference that may cause undesired operation.
3. The product is assigned a Regulatory Model Number which stays with the regulatory aspect of the design. The Regulatory Model Number is the main product identifier in the regulatory documentation and test reports; this number should not be confused with the marketing name or the product numbers.

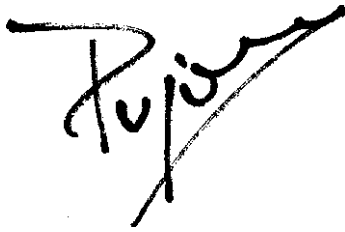

Josep-Maria Pujol
Hardware Quality Manager
Sant Cugat del Vallès (Barcelona)
July 9th, 2004

Local contacts for regulatory topics only

European contact: Hewlett-Packard GmbH, HQ-TRE, Herrenberger Strasse 140, D-71034 Böblingen, Germany.

United States contact: Hewlett-Packard Company, Corporate Product Regulations Manager, 3000 Hanover Street, Palo Alto, CA 94304, USA. Tel: (650) 857 1501.

Australian contact: Hewlett-Packard Australia Ltd, Product Regulations Manager, 31-41 Joseph Street, Blackburn, Victoria, 3130, Australia.

Index

A

- accessories
 - installing 58
 - ordering 248
- acoustic specifications 243
- altitude setting 78
- ArcGIS 158
- assembling the printer 13
- AutoCAD 158

B

- bin
 - stacking problems 213
- black point compensation 140
- blank page 203
- blurred lines 197
- buzzer on/off 77

C

- calibration
 - color 139
- CALS G4 137
- cannot load paper 209
- carriage lubrication 171
- cleaning the platen 169
- cleaning the printer 169
- clipped image 204
- color accuracy
 - between printers 199
 - in general 198
 - PANTONE 198
- color calibration 139
- color emulation mode
 - about 225
 - selecting 141
- communication problems 220
- components of printer 9
- connecting the printer
 - choosing a method 63
 - hardware 56
 - Mac OS 9 direct 71
 - Mac OS 9 networking 68
 - Mac OS X direct 70
 - Mac OS X networking 66
 - overview 227
 - Windows direct 69

- Windows networking 64
- contrast in front panel 77
- core adaptors 80
- custom page size 127
- Customer Care 249

D

- Declaration of Conformity 261
- Designjet Online 250
- diagnostics 175
- distorted print 205
- downloading media profiles 96
- drying time
 - canceling 96
 - changing 97
 - overview 238

E

- e-mail alerts 77
- ecological specifications 242
- Embedded Web Server
 - accessing 75
 - canceling a job 164
 - cannot access 221
 - e-mail alerts 77
 - features 231
 - ink and paper usage 164
 - ink system status 124
 - language 76
 - password 76
 - printer usage statistics 125
 - printing a saved job 164
 - queue management 165
 - saving a job 164
 - submitting a job 163
- environmental specifications 242
- error messages 215
- Ethernet connection 56

F

- fast printing 132
- features of printer 8
- FireWire connection 56
- firmware update 173
- front panel

- contrast 77
- error messages 215
- language 74
- units 77

G

- Gigabit Ethernet accessory
 - installing 58
- graininess 193
- graphic languages 241
- guarantee 253

H

- hard disk specification 242
- HP Customer Care 249
- HP Designjet Online 250
- HP Instant Support 249
- HP-GL/2 137

I

- image diagnostics print 175
- image problems
 - blank page 203
 - clipped image 204
 - distorted print 205
 - overlapping images 206
 - partial print 203
 - pen settings ineffective 206
 - small image 204
 - unexpected mirror image 205
 - unexpected rotation 205
 - unintelligible print 205
- InDesign 151
- ink cartridge
 - about 233
 - cannot insert 207
 - getting information 124
 - inserting 104
 - maintenance 172
 - non-HP 233
 - ordering 245
 - refilling 233
 - removing 99
 - specification 239
- ink system status 124

- ink system tips 236
 - Instant Support 249
 - internal prints 228
- J**
- Jetdirect print server
 - installing 60
 - JPEG 137
- L**
- landscape orientation 133
 - language 74
 - lights at rear 228
 - loading a sheet 89
 - loading paper problems 209
 - loading roll into printer 83
 - loading roll onto spindle 79
 - lubricating the carriage 171
 - lubricating the platen rollers 222
- M**
- maintenance 229
 - margins
 - changing 132
 - specification 241
 - zero width 133
 - maximum speed 132
 - mechanical accuracy 241
 - media profiles
 - downloading 96
 - memory error 221
 - memory error (AutoCAD) 222
 - Memory expansion accessory
 - installing 62
 - memory specifications 242
 - Microsoft Office 158
 - mirror image 134
 - mirror image unexpected 205
 - misaligned colors 196
 - moving the printer 172
- N**
- nesting 167
 - non-HP ink cartridges 233
 - non-HP paper 96
- O**
- ordering
 - accessories 248
 - ink cartridges 245
 - paper 245
- printhead cleaners 245
 - printheads 245
 - orientation 133
 - out-of-memory error 221
 - overlapping images 206
 - overlapping lines 136
 - oversize page sizes 133
- P**
- page size
 - custom 127
 - palette
 - changing settings 135
 - paper
 - cannot load 209
 - displaying information 95
 - non-HP 96
 - orientation 133
 - tips 237
 - paper jam 211
 - paper not flat 193
 - paper sizes (max & min) 239
 - paper types
 - front panel names 94
 - ordering 245
 - recommended 94
 - supported 94
 - weights 245
 - widths 245
 - partial print 203
 - PDF 137
 - pen settings ineffective 206
 - Photoshop
 - HP-GL/2 & RTL driver 141
 - PostScript driver 146
 - physical specifications 242
 - portrait orientation 133
 - PostScript 137
 - power specifications 242
 - preventive maintenance 229
 - print job
 - canceling 164
 - ink usage 164
 - nesting 167
 - paper usage 164
 - queue management 165
 - reprinting 164
 - saving 164
 - submitting 163
 - print quality
 - changing 129
 - choosing 130
 - print quality problems
 - banding 190
 - blurred lines 197
 - discontinuous lines 197
 - general 189
 - graininess 193
 - horizontal lines 190
 - ink bleeding 197
 - ink marks 194
 - misaligned colors 196
 - paper not flat 193
 - smudging 194
 - solid bands/lines 192
 - stepped lines 195
 - thin lines 191
 - top of print 195
 - warped lines 197
 - print resolution 240
 - printer does not print 219
 - printer driver
 - Mac OS 9 uninstall 72
 - Windows uninstall 72
 - printer software 12
 - printer's main components 9
 - printer's main features 8
 - printhead
 - about 235
 - aligning 119
 - cannot insert 207
 - cleaning 113
 - cleaning connections 113
 - getting information 125
 - inserting 110
 - monitoring 113
 - ordering 245
 - recovery 113
 - removing 106
 - reseal, reseal 207
 - specification 239
 - printhead cleaner
 - about 236
 - cannot insert 207
 - inserting 122
 - ordering 245
 - removing 120
 - specification 239
 - printheads are limiting performance 218
- Q**
- QuarkXPress 155
 - Quick Reference Guide holder 29

Index

R

- rear lights 228
- recommended papers 94
- refilling ink cartridges 233
- regulatory notices 258
- rendering intent 140
- resolution 240
- restarting the printer 74
- roll paper
 - loading into the printer 83
 - loading onto the spindle 79
 - unloading 88
- roller lubrication 222
- rotating an image 134
- rotation unexpected 205

S

- scaling an image 134
- sheet paper
 - loading 89
 - unloading 93
- sleep mode wait time 77
- slow printing 219
- small image 204
- smudging 194
- software 12
- software license 256
- space required for the printer 14
- specifications
 - acoustic 243
 - ecological 242
 - environmental 242
 - graphic languages 241
 - hard disk 242
 - ink supplies 239
 - margins 241
 - mechanical accuracy 241
 - memory 242
 - paper size 239
 - physical 242
 - power 242
 - print resolution 240
- squeaky rollers 222
- stacking problems in bin 213
- statistics
 - ink cartridge 124
 - printer usage 125
 - printhead 125
- stepped lines 195
- storing the printer 172
- support services
 - HP Customer Care 249

- HP Designjet Online 250
- HP Instant Support 249
- supported papers 94
- switching the printer on/off 73
- symbols on printer boxes 13

T

- thin lines 191
- TIFF 137
- time to assemble the printer 13

U

- unintelligible print 205
- unloading a sheet 93
- unloading roll from printer 88
- unpacking the printer 14
- USB 2.0 accessory
 - installing 59
- using this guide 7

W

- waiting for time-out 219
- warped lines 197
- warranty note 125
- warranty statement 253
- Web access to printer 231

