



IBM® TS7700 Series
Grid To Grid Migration User's Guide
Version 1.7

Takeshi Nohta
nohta@jp.ibm.com
IBM Systems Development, IBM Japan

Joseph Swingle
swinglej@us.ibm.com
IBM Systems Development, IBM USA

James Mitchell
jmitche@us.ibm.com
IBM GTS, System Service, IBM USA

Contents

1	Introduction.....	4
2	Summary of Changes	5
3	Definitions and Keywords	6
4	Configurations Supported with Release 3.3 and later.....	8
5	Code Requirements.....	9
6	GGM Operation Overview	10
6.1	Customer setup or prep.....	10
6.2	IBM Service Representative Enablement.....	11
6.3	Execute GGM functions	11
6.4	Complete GGM operation	13
7	GGM Operational Details.....	14
7.1	The IBM Service Representative work.....	14
7.2	GGM operation	14
7.2.1	Enable GGM function	16
7.2.2	Set up several GGM options for GGM	18
7.2.3	Start GGM function.....	22
7.2.4	Execute GGM copy job.....	23
7.2.5	Stop GGM function.....	39
7.2.6	Disable GGM function	40
7.2.7	Terminate proxy server	42
7.2.8	Other new LI REQ commands for the GGM function.....	42
7.2.9	Existing LI REQ commands for the GGM copy	57
7.2.10	GGM Copy activity in the statistical data	58
7.2.11	Deferred Copy Read Throttle to CSG copy	59
7.2.12	CSG and CTG link paths handling.....	60
7.2.13	Using Write Protect Mode on the CSG copy source/target cluster	63
8	z/OS operation scenarios.....	65
8.1	Scenario 1 (Single LPAR/Plex connected to both CSG and CTG)	65
8.2	Scenario 2 (Independent LPAR/Plexes are connected to the CSG and CTG).....	70
8.3	Tapetools.....	73
9	Appendix A. Check lists	78
10	Appendix B. GGM Library Request commands.....	82
1.	Supported keywords	82
2.	“GGM, CTG, ENABLE DISABLE” command.....	84
3.	“GGM, CTG, START, IDLE” command.....	86
4.	“GGM, CTG, STOP, CLEAR” command	87
5.	“GGM, CTG, RECOVER” command.....	88
6.	“GGM, MC/SC/DC/SG, INHERIT/DEFFAULT/FIXED, <name>” command.....	89
7.	“GGM, TGTCAT, INHERIT/FIXED, <hex category>” command.....	90
8.	“GGM, SRCCAT, <hex category>” command.....	91
9.	“GGM, QUEUE, <volser>, <CSG composite library sequence number>” command	92
10.	“GGM, REMOVEQ, <volser>” command.....	94
11.	“GGM, CPYCNT, <copy count>” command	95
12.	“GGM, FORCECMP, <volser>” command	96
13.	“GGM, SRCVLCHG, <volser>, <hex category>” command	96
14.	“GGM, BVIRHIST, CLEAR, ALL <volser>” command	98

15.	“GGM, OPMSG, ENABLE DISABLE” command.....	98
16.	“GGM, COPY, SUMMARY” command.....	99
17.	“GGM, COPY, DETAIL, <volser>” command	107
18.	General error messages of GGM LI REQ commands	113
11	Appendix C. GGM BVIR request and response	114
1.	Request Data Format	114
2.	Response Data Format.....	114
2.1.	GGM COPY RESULT Information	116
2.2.	GGM COPY STATUS Information	119
12	Appendix D. GGM network health check	122
13	Disclaimers	124

1 Introduction

The IBM TS7700 Series is the latest in the line of tape virtualization products that has revolutionized the way mainframe customers utilize their tape resources. As older TS7700s sold since 2006 are looking to be refreshed in the field, the process of refreshing that hardware is becoming more difficult. There may be a few reasons that make the hardware refresh complicated:

- Older levels of hardware may have limitations supported code levels.
- More than three code levels are not supported in the same Grid.
- Grid configurations are limited to eight clusters total.
- Grid merge requires all clusters be at the same code level.

Due to one or more of these limitations, upgrading to newer hardware, which often includes grid consolidation, can become difficult. In addition, workloads are often needing to be moved between grid configurations, whether under the same client or at times between independent clients where workloads are acquired. Host replication through a volume copy utility can be used in these cases, but not ideal. Therefore, the TS7700 solution needs a more flexible method to help with hardware and workload migration.

Grid to Grid Migration (GGM) introduces a mechanism for two independent Grid configurations to intercommunicate for the purpose of replicating content from one Grid to another and addresses many of the migration issues described above. The two grid configurations rely on their existing Grid WAN/LAN networks be temporarily interconnected allowing grid volume replication techniques to copy data between grids. A volume serial or VOLSER is retained through the migration process, though host catalog and Tape Management System (TMS) updates may also be required given the volume location has changed. Two major use-cases are supported.

- Migration of logical volumes between grid configurations under the same system plex
- Migration of logical volumes between grid configurations under independent system plexes.

Both methods require creation and/or updates of TCDB entries given all migrated volumes have changed library location. TMS updates may also be required when content is moved between independent system plexes.

This is the first release of GGM and some interactions between the TS7700 and the z/OS are not yet automated. Several enhancements are planned for the upcoming releases.

Throughout this white paper, it's assumed the reader has a good understanding of the TS7700 Grid functionality.

2 Summary of Changes

- Version 1.0 – First Release
- Version 1.1 – Changes applied at the code level of 8.40.x.x are updated.
 - Add the description that all GGM settings are preserved when GGM is disabled.
 - Add new messages introduced in R4.0 (8.40.x.x).
 - Fix typo of the error message “REACHEABLE”.
 - Add the description of the QUEUE command handling improvement.
 - Add GGM CSG copy performance which requires the recall.
 - Add the description that the GGM copy target cluster cannot be put to Write Protect Mode.
 - Add the description how to use PRESTAGE tool to recall the migrated CSG copy source volume.
- Version 1.2 – Remove R1.7 support description in Code Requirement chapter.
- Version 1.3 – Changes applied at the code level of 8.41.200.x are updated.
- Version 1.4 – Changes applied at the code level of 8.42.x.x are updated.
- Version 1.5 – Changes applied at the code level of 8.50.x.x (Secure Data Transfer and DS8000 Object Store support) are updated.
 - Add an attention to perform GGM operation while running the cluster join/merge operation.
 - Add an attention to put 3 seconds delay between GGM, QUEUE commands from zOS viewpoint too.
- Version 1.6 – Add the warning when GGM operation is terminated to prevent the possible data loss. Add the description about Cloud Tier Grid Awareness of Volumes function which is supported at the code level of 8.51.x.x..
- **Version 1.7 – Changes applied at the code level of 8.51.1.x (5.1PGA1) are updated.**

3 Definitions and Keywords

The following definitions and keywords are used throughout this document.

Diagram 1 below shows an example of a GGM configuration. To simplify the explanation, the host or hosts attached to the Grids are not included. The diagram displays the process of a volume replicating from the grid on the left to the grid on the right and then replicating among the peers on the right.

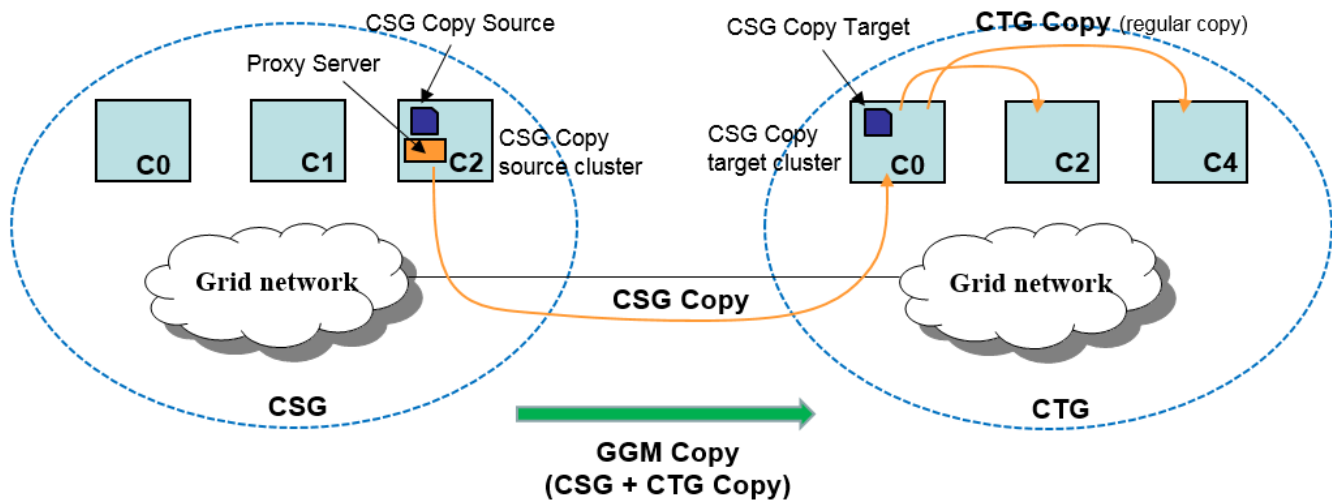

Diagram 1. An example of GGM configuration

GGM

Grid To Grid Migration. A logical volume is replicated from one Grid to another Grid through their existing Grid LAN/WAN TCP/IP network.

CSG

Copy Source Grid. The source Grid which contains the one or more volumes to be replicated to the Copy Target Grid.

CTG

Copy Target Grid. The target Grid which will receive the replicated volumes which are sourced from the Copy Source Grid.

CSG Copy

A volume copy from the CSG to the CTG. Then subsequent regular Grid copies in the CTG may or may not occur based off of the copy mode settings in the CTG.

CTG Copy

A volume copy to one or more peers in the CTG after the CSG copy completes.

GGM Copy

The entire copy activity from the CSG to CTG and then among the CTG peers. When it is mentioned that “GGM copy completes”, it means that CSG copy and the required CTG copies have completed.

CSG Copy Source

A copy source volume of the CSG copy.

CSG Copy source cluster

A cluster which provides the CSG Copy Source in the CSG.

CSG Copy Target

A copy target volume of the CSG copy.

CSG Copy target cluster

A cluster which receives the CSG copy (CSG Copy Target) in the CTG.

Proxy Server

An application which needs to be installed on one cluster in the CSG. It works as a proxy server for the CTG to communicate with the CSG.

4 Configurations Supported with Release 3.3 and later

- The GGM is supported on TS7700 Grid configuration only for both CSG and CTG.
- No standalone cluster is supported on either CSG or CTG.
- Each CSG or CTG can have up to 6 clusters.
- Only one cluster pair between the CSG and CTG can be defined at a time. Meaning, one cluster in the CSG and one cluster in the CTG must be chosen for the GGM volume replication. The cluster in the CSG must contain a local copy of the volumes needing to be replicated. GGM can be reconfigured and run with a new pair when either the source or target location must change, for example when the source content is spread across multiple clusters in a grid. The currently chosen source cluster in the CSG will be the cluster which requires the proxy application be installed and activated.
- The clusters in the CTG may be brand new or already in use.
- A Flash Copy volume can't be a CSG copy source volume.
- The existing Grid Ethernet adapters in the CSG and CTG are used for GGM operation. No additional Ethernet adapter is required. This requires the customer configure the network of the two grids to have visibility of each other.
- The volume VOLSER being replicated from the CSG to the CTG cannot already exist in the CTG. Meaning, a volume VOLSER conflict cannot exist. The exception is if the volume exists in the CTG due to a GGM replication and it has never been modified by a host in the CTG. Once modified, additional GGM copies of the same volume are denied. Re-replicating the same volume through GGM is supported so long as the CTG instance is never host modified while within the CTG.
- It is required that all clusters in the CTG need to be available when a GGM copy job needs to be re-replicated. If a peer in the CTG is not available, queuing a GGM copy job fails and it's required to wait for the eject completion when the unavailable cluster becomes online in order to queue the GGM copy of the same volume.
- Write Protect Mode can be enabled on the CSG copy source cluster. Then a CSG copy source volume will not be modified while the GGM copy is performed, then the CSG copy source and target volume must be the same when the host TCDB/TMS is updated.
- As part of the code release level 8.41.200.x (R4.1.2 GA), a new logical volume format was introduced. This new format must be supported by all clusters in a grid before it can be used. Therefore, any CTG must support this new format when a CSG has one or more volumes using the new format. It's prohibited to GGM copy any data from a 4.1.2 or later CSG to a CTG then the CTG has one or more clusters running a level prior to 4.1.2.
- As part of the code release level 8.42.x.x (R4.2), a cloud tier was supported and the additional cloud information is taken from a peer cluster when a logical volume is checked during the copy, mount and other operations. When the CSG proxy server cluster is at 8.42.x.x or above, it uses the extended data structure to include cloud information then the CSG copy target cluster in the CTG must be at 8.42.x.x or above too because it needs to know the extended data structure properly.
- As part of the code release level 8.50.x.x (R5.0), the Secure Data Transfer feature was supported. This feature encrypts logical volume data that is transferred in the form of Grid Copies and Remote Mount Reads/Writes over the Grid links. The data encryption is effective between two clusters in a Grid when both clusters have feature code 5281 activated and the encryption settings are enabled. GGM CSG copies are done between two different Grids but the Secure Data Transfer function cannot be used even though the CSG copy source cluster in the CSG and CSG copy target cluster in the CTG both have the encryption setting enabled. Note that CTG copies in the CTG are encrypted if the clusters in the CTG have the feature code activated and encryption setting is enabled correctly.

- As part of the code release level 8.50.x.x (R5.0), DS8000 Object Store function was officially supported. Any TS7700 which is used to copy object data from a DS8000 using the DS8000 Object Store function cannot be a part of the CSG nor CTG. Object data written by DS8000 is not supported by the GGM function in this release. Although logical volumes can be still copied from the CSG, unexpected situations may arise if DS8000 object data exists, therefore this feature is restricted.

Note: there is no software mechanism that prevents configuring a TS7700 as part of the CSG and/or CTG even if the DS8000 Object Store feature is enabled on a cluster. However, doing so is at your own risk with unknown consequences.

- As part of the code release level 8.51.x.x (R5.1), a cloud tier improvement on Grid awareness of volumes was supported. When the CSG is at R5.1 and supports Grid awareness of volumes function, the CTG also needs to be at R5.1 to get the benefit of Grid awareness of volumes function for the CSG copy. When CSG proxy server cluster is aware of the volume in the cloud tier but it doesn't have the consistent data in the cache/physical tape by the host I/O or copy operation, the CTG can still recall the data from the cloud tier from the CSG only when the CTG is also at R5.1. If CTG is not at R5.1, it just views the volume in the CSG is inconsistent and no recall (i.e. CSG copy) is done.
- As part of the code level of 8.51.1.x (R5.1PGA1), LWORM retention function is supported. Only when the entire Grid (CSG or CTG) is at R5.1PGA1, the Grid starts supporting the LWORM retention function. When the CSG is at R5.1PGA1 and supports the LWORM retention function, the CTG also needs to be at R5.1PGA1 to inherit the LWORM retention state/settings from the CSG to CTG. If the CSG is at R5.1PGA1 but CTG is at pre-R5.1PGA1, enabling GGM fails.

5 Code Requirements

- All clusters in the CSG must be at R2.1 PGA7 or above.
- All clusters in the CTG must be at R2.1 PGA7 or above.
- The chosen target cluster in the CTG must be running R3.3 or later.
- No code upgrade is required on the existing clusters in the CSG as long as they are at R2.1 PGA7 or above. Only the proxy application must be installed and activated concurrently.
- If all clusters in the CSG are at R4.1.2 or above, all clusters in the CTG must be at R4.1.2 or above.
- If the CSG proxy server cluster is at R4.2 or above, CSG copy target cluster in the CTG must be at R4.2 or above too.
- If the CSG is at R5.1PGA1 or above, the CTG must be at R5.1PGA1 or above too.

6 GGM Operation Overview

This chapter provides basic steps and general considerations for using the GGM function. Details of the usage of library request (LI REQ) commands are provided later within this document.

There are four main steps required to complete a GGM operation.

1. First, the customer needs to set up the infrastructures for GGM network so that both the CSG and CTG can communicate with each other through their existing Grid LAN/WAN networks.
2. Second, the IBM Service Representative needs to complete a GGM configuration and setup which includes installing the application proxy on the CSG source cluster and enabling the CTG target cluster mechanism.
3. The customer can then start GGM operation, which may include IBM services if needed. This portion can last days, weeks or months if needed.
4. The customer can stop and disable GGM once all required GGM copies have completed. All outstanding GGM copies should be completed before attempting to stop/disable GGM function, and any issue must be resolved prior to removing the GGM links between the CSG and CTG or initiating a new GGM pair. The CSG can only be disposed after all issues have been resolved and the final check to verify all required data has been copied to the CTG. Otherwise, the data loss may occur if any data is not copied from the CSG to CTG yet then the CSG is disposed.
5. IBM Service Representative disables the function within the CSG and CTG configurations by terminating the proxy server. If another source or target is required, it can be re-enabled with the new pair and the process would go back to the step 1 from the beginning.

6.1 Customer setup or prep

The CSG proxy server/copy source cluster in the CSG and CSG copy target cluster in the CTG need to be able to communicate with each other through the existing CSG and CTG Grid networks. GGM uses the existing Grid Ethernet interfaces for this purpose, so the customer is required to make sure that the CSG and CTG can communicate with each other's Grid adapter assigned IP addresses. Given that only one source cluster can be configured at a time, multiple network changes may be required if the source and/or target cluster must change for different subsets of volumes. For example, when the source cluster does not contain a copy of all volumes needing to be replicated, which requires the GGM to be configured more than once per required source cluster.

For example, in Diagram 1,

- CSG proxy server/copy source cluster C2 (in the CSG) has two existing Grid IP addresses (primary=10.11.100.16, alternate=10.11.101.16).
- CSG copy target cluster C0 (in the CTG) has two existing Grid IP addresses (primary=10.11.130.11, alternate=10.11.131.11).
- Primary-Primary=10.11.100.16-10.11.130.11 and Alternate-Alternate=10.11.101.16-10.11.131.11 are the network pairs for GGM. Up to four pairs can be used for GGM communication between the CSG and CTG.

Two network ports in Table 1 are used for the GGM operation:

Table 1. GGM WAN TCP/IP port assignments

TCP/IP port	Role
-------------	------

350	TS7700 GGM file replication (shared with the existing Grid replication processes).
XXX	TS7700 GGM proxy server communication. Defined by the customer, but should be exclusive with other ports described in TS7700 Introduction and Planning Guide (GA32-0567-xx). Note: The well-known ports (0 – 1023) are not allowed to use for GGM proxy server communication.

(*) The IBM Service Representative needs to input the proxy server ports during the setup of GGM, so a port value must be chosen ahead of time by the customer. The well-known ports (0-1023) cannot be used for GGM proxy server communication.

(*) The ICMP port is not used for GGM volume replication, but the TS7700 will periodically perform a ping health check from the CTG to CSG. If the ICMP port is not usable, the resulting failed ping health check will create a corresponding operator intervention. ICMP test on the Grid network can be disabled by IBM Service Representative to avoid the operator intervention if ICMP port is not opened between the CSG and CTG.

Customer responsibility prior to GGM enablement:

1. If CSG and CTG Grid IP addresses are not physically connected, they need to be connected.
2. If the pair of the IP addresses are not communicating due to the network setting (gateway etc.), they should be changed or configured so that they can route traffic between them.
3. Open the two network ports (350 and XXX) for the communication between the CSG and CTG.

Appendix A Table 1 provides a checklist which helps the customer and the IBM Service Representative setup GGM.

6.2 IBM Service Representative Enablement

After the setups in 6.1 complete by the customer, the IBM Service Representative needs to complete GGM setups on the CSG proxy server as well as CSG copy target cluster. For the purpose, the customer needs to complete the checklists in Appendix A Table 1 prior to this operation.

Once the IBM Service Representative completes GGM setups, the GGM function is ready for use and can be controlled through LI REQ commands.

Note: If the code level on the CSG proxy server has updated, IBM Service Representative needs to set up the proxy server again because the proxy server setting is not persistent over the code update.

6.3 Execute GGM functions

After the IBM Service Representative has completed the steps described in 6.2, the GGM function becomes ready for use. All operations during this phase rely only on Library Request (LI REQ) commands, either through the z/OS command line or through the MI LI REQ panel.

Prior to initiating GGM LI REQ commands, the customer needs to know ahead of time what constructs and categories should be used by the source volumes once they arrive in the target cluster. The GGM

function provides a means to honor different construct and category use cases as volumes replicate. For example, a volume may retain the construct names assigned to the source volume, be overridden with new fixed construct names or inherit the default constructs of the target cluster. Each of the four constructs can use a different assignment rule. It's the customer's responsibility to make sure all storage construct names (management class, storage class, data class and storage group) which will be assigned or inherited are defined within all clusters of the CTG using the MI panels. This way, the correct policy behavior results once a volume replicates into the CTG. Any changes to policies after a volume is copied into the CTG will not be honored without an additional mount/demount or COPYRFSH request. Therefore, it's important to set this up correctly ahead of any GGM copy activity. In addition, the volume's assigned category can be inherited from the source cluster or assigned to a new fixed category code as part of the replication into the CTG.

Write Protect Mode can be enabled on the CSG copy source cluster, so that a CSG copy source volume will not be modified while the GGM copy is performed. The section 7.2.13 "Using Write Protect on the CSG copy source cluster" discusses the possible use cases in detail.

Here is the simplified chart of the GGM based LI REQ command. All GGM based LI REQ commands need to be executed against the chosen CSG copy target cluster in the CTG, which is configured by the IBM Service Representative. GGM based LI REQ commands won't work if they are issued to the CTG target peer clusters or any of the CSG clusters. CTG peer cluster devices may be used to receive the GGM based LI REQ commands, but the target distributed library or the first parameter of the LI REQ command must be the CSG copy target cluster in the CTG.

Configure GGM settings:

Note: <target cluster> in the following LI REQ commands must be the CSG copy target cluster in the CTG.

- "LI REQ, <target cluster>, GGM, MC/SC/SG/DC, INHERIT/DEFAULT/FIXED, <value>" to set which storage construct names will be assigned to replicated volumes in the CTG. **
- "LI REQ, <target cluster>, GGM, TGTCAT, INHERIT/FIXED, <value>" to set which category value will be assigned to replicated volumes in the CTG. **
- "LI REQ, <target cluster>, GGM, SRCCAT, <value>" to set an optional category which will be assigned to a source volume once the entire GGM process completes for a given volume. **
- "LI REQ, <target cluster>, GGM OPMSG, ENABLE/DISABLE to set whether an operator message is to be surfaced to all CTG connected hosts at GGM copy completion (failure or not). **
- "LI REQ, <target cluster>, GGM, CPYCNT, <value>" to set up the number of the concurrent copy jobs for the CSG copies. These copy processes are in addition to regular TS7700 Grid replication copy tasks. Meaning, dedicated to the GGM function.
- "LI REQ, <target cluster>, GGM, COPY, SUMMARY" to view the current settings.

**These settings are persistent for a given volume at the time it's queued for GGM replication. Changes to these settings will only apply to volumes queued for GGM replication after the changes are made. Volumes already queued will retain the settings which were configured at the time they were queued.

Execute GGM replication functions:

- "LI REQ, <target cluster>, GGM, CTG, ENABLE" to enable GGM function in the CTG. This starts up the GGM copy tasks processes and initiates the first handshakes between the CTG and CSG clusters. If any GGM network settings are invalid, this is when they will be discovered.
- "LI REQ, <target cluster>, GGM, CTG, START (, IDLE) to start GGM copy queuing function in the CTG. Until started, any GGM queued copies will not be serviced.

- “LI REQ, <target cluster>, GGM, QUEUE, <volser>, <CSG composite library sequence number>” to queue a GGM copy job in the CTG queue.
- “LI REQ, <target cluster>, GGM, REMOVEQ, <volser>” to remove a previously queued GGM copy job which was queued but not yet attempted.
- “LI REQ, <target cluster>, GGM, COPY, DETAIL, <volser>” to monitor an already queued, active or completed GGM copy job.

6.4 Complete GGM operation

It's important to check if no pending issues exist and all required data is surely copied to the CTG as a final check prior to stopping/disabling GGM, removing the GGM links between the CSG and CTG then disposing the CSG. Otherwise, the data loss could possibly occur at the CTG.

Note: Prior to removing the GGM links and disposing CSG, GGM function must be disabled. It failed to disable it if any pending CSG copy exists. LI REQ, GGM, CTG, STOP, CLEAR and REMOVEQ, <volser> can be used to remove the pending CSG copy and allow to disable GGM function. But running these LI REQs just remove the pending CSG copies and it results in no copies in the CTG.

Complete GGM functions:

- “LI REQ, <target cluster>, GGM, CTG, STOP” to stop GGM copy tasks from servicing additional GGM queued copies.
- “LI REQ, <target cluster>, GGM, CTG, DISABLE” to disable GGM function in the CTG and give back any resource allocated during the initial enablement.
- “LI REQ, <target cluster>, GGM, CTG, RECOVER” to recover after an error state in communications between the CTG cluster and CSG proxy server.

All supported LI REQs are listed in the Appendix B, GGM Library Request commands.

7 GGM Operational Details

This chapter provides detailed steps and general considerations for using the GGM function. Details of the usage of library request (LI REQ) commands are also provided later within this document.

7.1 The IBM Service Representative work

As described in the section 6.1, the customer will be required to provide the network infrastructures (physical Ethernet connections and routers etc.) and also the checklist in Appendix A Table 1 needs to be provided.

IBM Service Representative needs to complete the GGM setups first by referring to the checklist.

7.2 GGM operation

Once the IBM Service Representative completes the setup mentioned in the section 7.1 and it was successfully verified through enablement, the customer should be able to re-enable (if needed) and start GGM replication.

This chapter uses the sample picture below to explain the entire GGM operation. This sample describes a use case where:

- The CSG (left side Grid. Composite Library "0000A") is connected to the host and the logical volume "A00000" is a private volume in the CSG.
- The CTG (right side Grid. Composite Library "000B") is also connected to the same host and the logical volume "B00000" is a private volume in the CTG.
- Configure GGM configuration and copy the logical volume "A00000" from the CSG to CTG.

(A) The CSG and CTG Grid networks are connected.

(B) IBM Service Representative completes the installation of the proxy server on a CSG cluster (C1 in the CSG).

(C) IBM Service Representative completes the setup on a CTG cluster (C0 in the CTG).

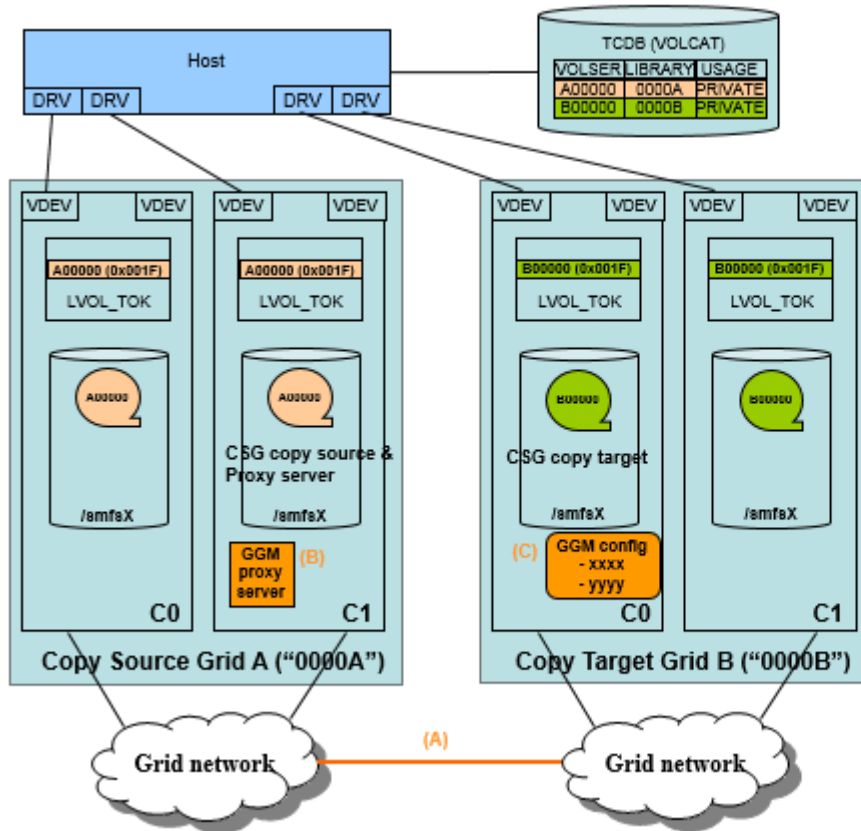

Original state:

A host is connected to two different Grids (Composite Library "000A" and "000B").

- Volume "A00000" (category 0x001F): Private volume in CSG.
- Volume "B00000" (category 0x000F) : Private volume in CTG.

Trying to copy the volume "A00000" from the CSG to CTG.

Customer/CSR setup:

- (A) Configure GGM network between CSG and CTG (cable, port, gateway) by the customer.
- (B) Install proxy server via `vtd_exec` by the CSR.
- (C) Configure GGM configuration from SMIT by CSR.

Note: The command syntax provided in this section shows "<C0 in the CTG>" as the LI REQ command target cluster. This is because the CTG target cluster is configured and enabled on C0 within the CTG. It's required to specify the valid distributed library name based off of your GGM setup.

LI REQ, <C0 in the CTG>, GGM, CTG, ENABLE

7.2.1 Enable GGM function

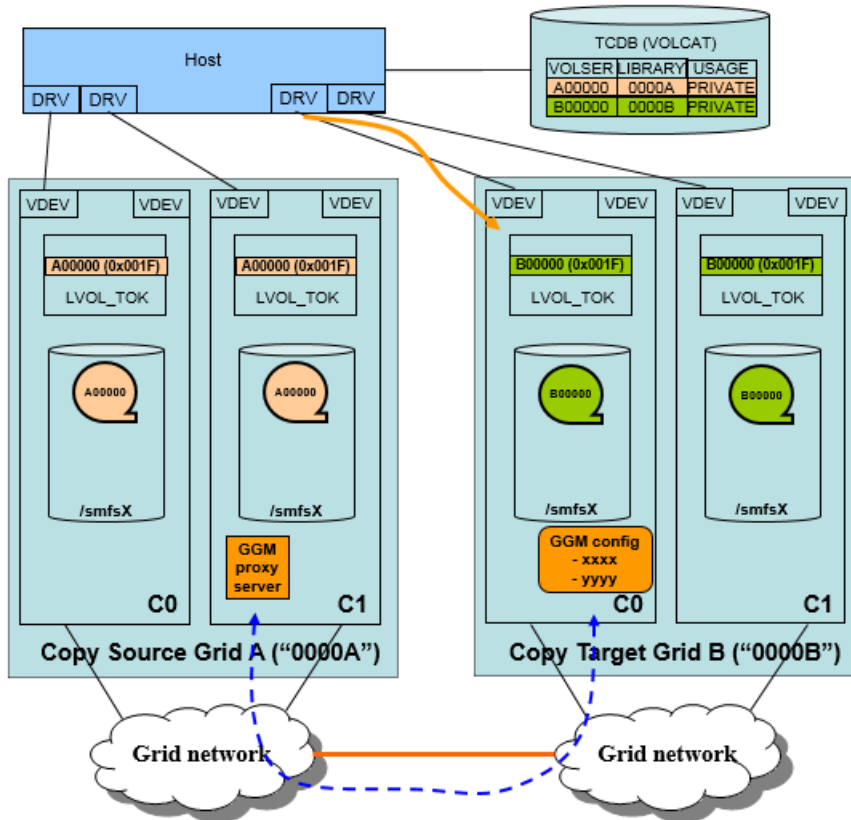

7.2.1 Issue LI REQ to enable GGM function.

- (*) When GGM is enabled,
- Grid checks the configuration/settings.
 - Create the copy threads for GGM copy.
 - Drop the firewall for port X.
 - Set up the network route.
 - Update VPD.
- etc.

When GGM is enabled successfully, the communication between C0 in the CTG and C1 in the CSG is working fine through the GGM WAN/LAN TCP/IP port.

In order to activate the GGM function, GGM needs to be enabled using the following LI REQ command:

```
LI REQ, <C0 in the CTG>, GGM, CTG, ENABLE
```

The result of the LI REQ command is shown below:

```
0210 LI REQ,BARR92B,GGM,CTG,ENABLE
0010 CBR1020I PROCESSING LIBRARY COMMAND: REQ,BARR92B,GGM,CTG,ENABLE.
0010 CBR1280I LIBRARY BARR92B REQUEST. 864
0010 KEYWORDS: GGM,CTG,ENABLE
0010 -----
0010 GGM OPERATION CHANGE REQUEST V1 .0
0010 OPERATION SUCCESSFULLY COMPLETED
```

This command may take some time to perform given several functions are carried out, which are listed below:

- Validate the GGM configuration setup by the IBM Service Representative.
- Configure network routing in the CTG to talk with the CSG proxy server cluster.
- Update the firewall settings on the CSG copy target cluster.
- Verify successful communications between the CTG and the CSG proxy server activated in the CSG..
- Allocate additional resources in the CSG copy target cluster for the GGM operations.
- Update the current GGM status.

Once GGM is enabled, communication between the CTG cluster (C0 in the CTG) and CSG cluster (C1 in the CSG) should be working without any problem. In addition, an IBM Service Representative can further validate the configuration from the service panel. This test option is only available if the GGM function is enabled on the CSG copy target cluster. Last, the CSG copy target cluster begins to initiate periodic health checks with the CSG once GGM is enabled. Please refer to Appendix D (GGM network health check) for the details.

The LI REQ command below needs to be used to check the current state of the GGM function:

```
LI REQ, <C0 in the CTG>, GGM, COPY, SUMMARY
```

Please refer to Appendix B to interpret COPY, SUMMARY output.

An example of the result of the LI REQ command is listed below:

```
0010 GGM COPY SUMMARY V1 .0
0010 CTG SETTING:
0010   CL:5   FUNCTION:ENABLED   STATUS:STOP   STATE:ENABLED
0010   IP_ADDR (PRI/ALT)   =   10.11.130.40/   10.11.131.40
0010   IP_ADDR (PRI2/ALT2) =   0.0.0.0/   0.0.0.0
0010   MC/SC/DC/SG = *inherit/*inherit/*inherit/*inherit
0010   TGT_CAT/SRC_CAT = 0000x/0000x SEND_OP_MSG = ENABLE
0010   CPYCNT = 20 CPYCNT_CHG_STATUS = NONE
0010   COPY_PROXY_ERR_CNT = 0 RESET_TIME = 1970-01-01-00.00.00.000000
0010 -----
0010 CSG SETTING:
0010   COMPOSITELIB = BA045
0010   PROXY = 4 PORT = 13616:
0010   IP_ADDR (PRI/ALT)   =   10.11.100.16/   10.11.101.16
0010   IP_ADDR (PRI2/ALT2) =   0.0.0.0/   0.0.0.0
0010   COPY_SRC = 4:
0010   IP_ADDR (PRI/ALT)   =   10.11.100.16/   10.11.101.16
0010   IP_ADDR (PRI2/ALT2) =   0.0.0.0/   0.0.0.0
0010 -----
0010 CONNECTION STATUS:
0010   PROXY CONFIGURED_PORTS: 2 LAST_USED_PORT: -1
0010   INTFC: N           ADDRESS / ST /   ERR / LAST_FAILED_TIME
0010     : 0     10.11.100.16 / 0 /   0 / 1970-01-01-00.00.00.000000
0010     : 1     10.11.101.16 / 0 /   0 / 1970-01-01-00.00.00.000000
0010   COPYSRC CONFIGURED_PORTS: 2 LAST_USED_PORT: -1
0010   INTFC: N           ADDRESS / ST /   ERR / LAST_FAILED_TIME
0010     : 0     10.11.100.16 / 0 /   0 / 1970-01-01-00.00.00.000000
0010     : 1     10.11.101.16 / 0 /   0 / 1970-01-01-00.00.00.000000
0010 -----
0010 CSG COPY SUMMARY:
0010   PENDING_CSG_COPY = 0 PENDING_CTG_COPY = 0
0010 -----
0010 VOLSER POSTED_TIME           ST
0010 -----
0010 NO PENDING CSG COPY EXISTS
```

Note: Once GGM is enabled, no CSG/CTG configuration change is allowed. Prior to changing the configuration, the GGM function must first be disabled at the CSG copy target cluster first.

Note: CSG copy target cluster online processing may take a few additional minutes when the GGM function is enabled given the CTG target cluster must do additional checks between it and the CSG.

7.2.2 Set up several GGM options for GGM

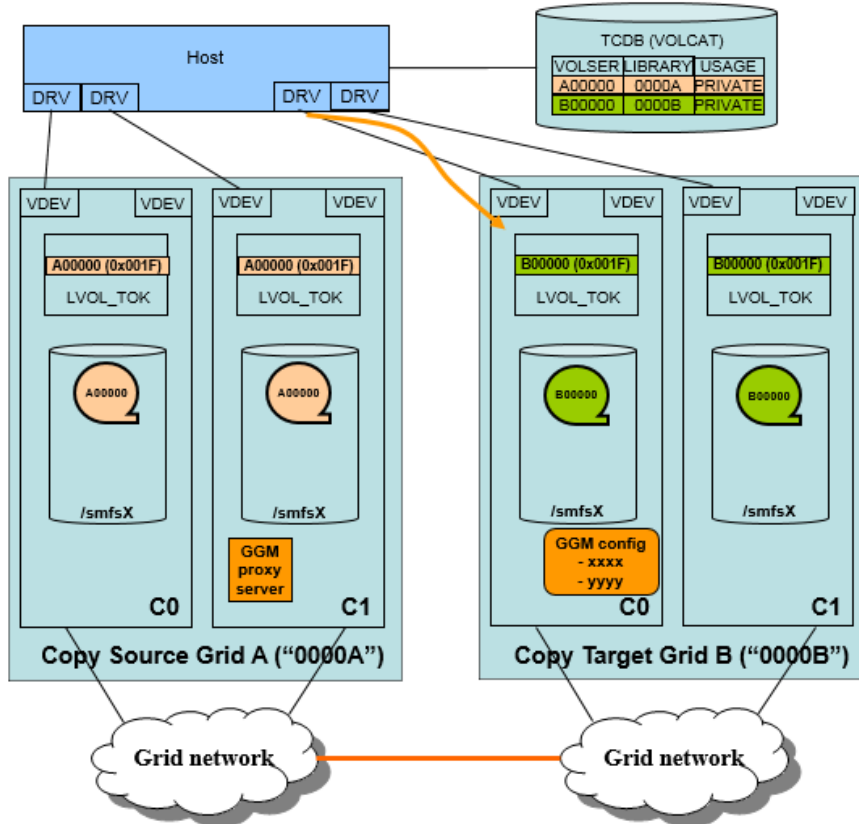

7.2.2 Issue LI REQ to configure various settings to determine how GGM copy should behave. The provided options are:

- (A) Storage constructs
- (B) Category in the CTG (target volume)
- (C) Operator message required
- (D) GGM copy job count
- (E) Category in the CSG (source volume)

Before starting to queue GGM copy jobs, several options should be configured so that the copy behavior and resulting constructs and categories are handles as expected. These options can be changed concurrently while GGM copy jobs are running.

The setting of the copy target volume attributes (storage constructs name, category) and also copy source volume attribute (category) are assigned to a volume when the GGM copy job is queued. For example, setup a series of options and queue (options 1) and queue 100 GGM copy jobs. Then change the options (option 2) and put another 100 GGM copy jobs. The first 100 GGM copy jobs will have (options 1) when they complete even though (option 2) is the current set of options. The second 100 GGM copy jobs will use option 2 or what they were set to when they were originally queued. Repeating the operation (change options and queue GGM copy jobs) can control the different options to be assigned to the specific volumes. If an already queued volume needs to change its settings, it must first be removed from the queue and then re-queued with the proper settings.

Note: These settings are preserved persistently over offline/online sequences.

An example of the results of the LI REQ command (set management class name to "inherit") are listed below:

```

0210  LI REQ,BARR92B,GGM,MC,INHERIT
0010  CBR1020I PROCESSING LIBRARY COMMAND: REQ,BARR92B,GGM,MC,INHERIT.
0010  CBR1280I LIBRARY BARR92B REQUEST. 925
0010  KEYWORDS: GGM,MC,INHERIT
0010  -----
0010  GGM VOLUME ATTRIBUTE CHANGE REQUEST V1 .0
0010  OPERATION SUCCESSFULLY COMPLETED

```

(A) Storage Constructs

The four storage construct names (management class, storage class, storage group and data class name) are assigned to the copy target volume in the CTG when the GGM copy completes. Each of the four constructs can use different rules. There are three options to choose to determine which storage construct name is assigned to the volume:

- Inherit the 8 character construct name assigned to source volume at the time of volume queue. The same storage construct name is assigned to the copy target volume in the CTG
 - (LI REQ third keyword is “INHERIT”).
- Assign the default storage construct name to the copy target volume in the CTG
 - (LI REQ third keyword is “DEFAULT”).
- Assign a specific storage construct name to the copy target volume in the CTG
 - (LI REQ third keyword is “FIXED” and the fourth keyword of the storage construct name is required).

The command syntax is:

```

LI REQ, <C0 in the CTG>, GGM, MC/SC/SG/DC, [INHERIT|DEFAULT|FIXED],
SC name
MC: Management Class name, SC: Storage Class name
SG: Storage Group name, DC: Data Class name

```

When the “INHERIT” or “FIXED” option is used, it’s required to define the necessary storage construct name and its attributes on the Management Interface Constructs menu within all clusters in the CTG. If the inherited (or specified) storage construct name is missing, the default storage construct is automatically assigned.

The data class name and attributes (LWORM and the volume size) must be set up correctly to be in sync with the CSG copy source volume. Changes to these settings after the volume copy completes are either impossible or difficult, so make sure the construct settings are correct prior to starting GGM replication.

(B) Category of the copy target volume

Configure which category is assigned to the copy target volume in the CTG when the GGM copy completes. While the GGM copy is in progress, xFF15 (import pending category) is assigned to the volume making it inaccessible to any CTG connected hosts. There are two options to choose to determine what category is assigned to the volume once the GGM copy completes:

- Inherit the category of the volume in the CSG. The same category is assigned to the copy target volume in the CTG
 - (LI REQ third keyword is “INHERIT”).
- Assign a specific category to the copy target volume in the CTG
 - (LI REQ third keyword is “FIXED” and the fourth keyword of the hex category is required).

The command syntax is:

```
LI REQ, <C0 in the CTG>, GGM, TGTCAT, [INHERIT|FIXED], Hex category
```

The hardware reserved categories (x0000 – x00FF) and NULL (x0000) are not valid categories to set as a fourth keyword with the third keyword “FIXED”.

(C) Operator message

This option is provided to surface an operator message when a GGM copy completes or fails. Also, additional messages can be surfaced for every 1,000 CSG copy failures, due to the communication failure between CTG and CSG via proxy server.

- G0036 message when the GGM copy completes.
- G0037 message when GGM copy fails.
- G0038 message when every 1,000 communication error between CTG and CSG proxy server occurs.

The command syntax is:

```
LI REQ, <C0 in the CTG>, GGM, OPMSG, ENABLE/DISABLE.
```

For the G0038 operator message, the communication failure count is incremented regardless of the OPMSG setting. But the operator message is surfaced for the CSG copy failure whose OPMSG setting is enabled only. For example, OPMSG is set to DISABLE and 1,000 CSG copy failures occur due to the communication failure. The count is incremented to 1,000, but no G0038 message is surfaced because the OPMSG setting is DISABLED for the volumes.

GGM (CSG or CTG) copies could temporarily fail due to the communication failure, etc. But the copy is retried internally and doesn't result in an external failure unless it's determined that the copy can't complete (for example, the CSG copy source cluster does not have the data).

Please refer to Appendix B “15. GGM, OPMSG, ENABLE | DISABLE command” for the message format.

(D) GGM copy job count

This is an option to configure how many copy tasks can concurrently work on GGM copies within the CSG copy target cluster.

The independent copy resources (threads) are allocated for GGM CSG copies when the GGM function is enabled. They work separately with other copy threads for RUN and Deferred copy jobs. The count of the copy threads can be changed from 5 to 128 (default is 20) as same as RUN and DEF threads for a two 1Gb port configuration.

The command syntax is:

```
LI REQ, <C0 in the CTG>, GGM, CPYCNT, <GGM copy count>
```

If any CPYCNT change operation (RUN, DEF or GGM) is running, another CPYCNT change attempt fails, because only one CPYCNT change can be running at a time.

(E) Category assignment of source volume at GGM copy completion

This is the option to change the category of the CSG copy source volume.

After the volume is copied from the CSG to CTG, copied among any CTG peers and the target host TCDB is updated to indicate the volume resides in the CTG, the host is no longer able to access the volume in the CSG. Reminder, this is the use case where it's all under the same system/plex. If the volume in the CSG is no longer required, there is no method to eject the volume from the CSG. This option may be used to put the volume in the CSG into a unique category to differentiate it from those volumes not yet migrated. This unique category can be private or scratch. When it's set to a scratch category, delete-expire and delete-expire-hold processing would apply as if the host moved the volume into the scratch category. When delete-expire is enabled (with or without hold), the content will eventually be deleted within the CSG, including any content which may exist on back end tapes. But, the volume definition will remain.

When the CSG is at R5.1PGA1 and the logical volume in the CSG is the LWORM-retained volume, changing the category assignment to the scratch category fails if the LWORM retention setting of the volume does not allow to change the category to scratch.

The command syntax is:

```
LI REQ, <C0 in the CTG>, GGM, SRCCAT, <hex category>
```

The hardware reserved category (x0000 – x0000) can't be set. If it's set to the NULL (x0000) category, it means the category of the copy source volume won't be changed.

This category change is attempted only when GGM (CSG and CTG) copy completes with no error. If any error occurs during the GGM copy (for example, if the GGM process can't verify if the total process completed successfully), this category change is skipped.

7.2.3 Start GGM function

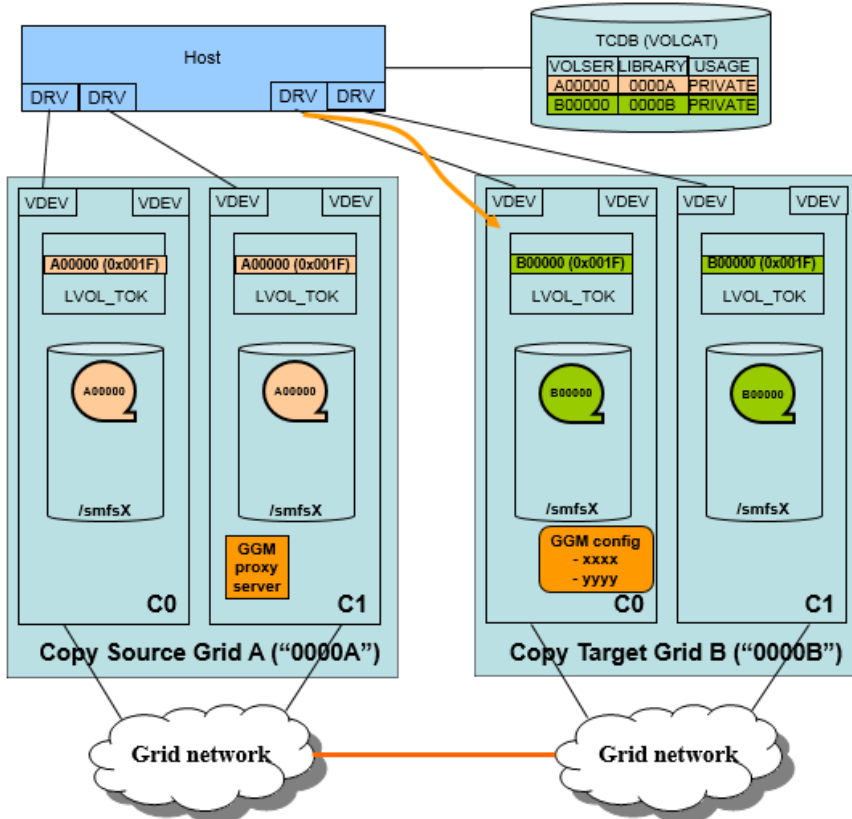

7.2.3 Issue LI REQ to start GGM function.

(*) START, IDLE option can be used to perform CSG copy only when the CSG copy target cluster has no other regular Grid copies.

Before adding GGM copy jobs, GGM needs to be started through the LI REQ command. START (also STOP) can be used to control the actual GGM copy job process.

GGM copy jobs can be queued only when the GGM function is started (just enabling GGM function is not enough). If the GGM function is stopped, copies already started and those copies among CTG peers which were already queued will also continue. Issuing a STOP only halts the GGM function from handling GGM jobs which are still queued and not yet started.

The command syntax is:

```
LI REQ, <C0 in the CTG>, GGM, CTG, START (, IDLE)
```

If the fourth keyword IDLE is specified (optional) when START is provided, the CSG target cluster will only dequeue GGM jobs when all regular copies into that CSG copy target cluster from its own peers have completed. This option may be useful when the user would like to have GGM copies arrive into the CSG grid during idle periods of operation with respect to copies. For example, it will only work on GGM copies when regular production created copies queued into the CSG copy target cluster have completed. Once a GGM copy process starts working on a volume, it will continue to the completion point and will not stop when IDLE is enabled. It's only the GGM function's ability to pull a new GGM job off of the queue which alters its behavior if IDLE is set. If IDLE is not provided when the function is started, the dedicated GGM copy threads will process any GGM queued jobs in parallel to regular deferred and immediate mode copy jobs which have their own dedicated copy processes too.

An example of the result of the LI REQ command (the fourth keyword IDLE is specified) is listed below:

```

0010 CBR1280I LIBRARY BARR92C REQUEST. 122
0010 KEYWORDS: GGM,CTG,START,IDLE
0010 -----
0010 GGM OPERATION CHANGE REQUEST V1 .0
0010 OPERATION SUCCESSFULLY COMPLETED

```

This is a sample output of LI REQ, GGM, COPY, SUMMARY output after GGM is started (with IDLE keyword):

```

0010 GGM COPY SUMMARY V1 .0
0010 CTG SETTING:
0010   CL:2  FUNCTION:ENABLED  STATUS:START_IDLE  STATE:IDLE_STARTED
0010   IP_ADDR (PRI/ALT) = 10.11.130.11/ 10.11.131.11
0010   IP_ADDR (PRI2/ALT2) = 0.0.0.0/ 0.0.0.0
0010   MC/SC/DC/SG = *inherit/*inherit/*inherit/*inherit
0010   TGT_CAT/SRC_CAT = 0000x/0000x  SEND_OP_MSG = ENABLE
0010   CPYCNT = 20 CPYCNT_CHG_STATUS = NONE
0010   COPY_PROXY_ERR_CNT = 0 RESET_TIME = 1970-01-01-00.00.00.000000
0010 -----
0010 CSG SETTING:
0010   COMPOSITELIB = BA045
0010   PROXY = 4 PORT = 13616:
0010   IP_ADDR (PRI/ALT) = 10.11.100.16/ 10.11.101.16
0010   IP_ADDR (PRI2/ALT2) = 0.0.0.0/ 0.0.0.0
0010   COPY_SRC = 4:
0010   IP_ADDR (PRI/ALT) = 10.11.100.16/ 10.11.101.16
0010   IP_ADDR (PRI2/ALT2) = 0.0.0.0/ 0.0.0.0
0010 -----
0010 CONNECTION STATUS:
0010   PROXY CONFIGURED_PORTS: 2  LAST_USED_PORT: -1
0010   INTFC: N  ADDRESS / ST /  ERR / LAST_FAILED_TIME
0010   : 0  10.11.100.16 / 0 /  0 / 1970-01-01-00.00.00.000000
0010   : 1  10.11.101.16 / 0 /  0 / 1970-01-01-00.00.00.000000
0010   COPYSRC CONFIGURED_PORTS: 2  LAST_USED_PORT: -1
0010   INTFC: N  ADDRESS / ST /  ERR / LAST_FAILED_TIME
0010   : 0  10.11.100.16 / 0 /  0 / 1970-01-01-00.00.00.000000
0010   : 1  10.11.101.16 / 0 /  0 / 1970-01-01-00.00.00.000000
0010 -----
0010 CSG COPY SUMMARY:
0010   PENDING_CSG_COPY = 0  PENDING_CTG_COPY = 0
0010 -----
0010 VOLSER POSTED_TIME  ST

```

7.2.4 Execute GGM copy job

7.2.4.1 Queue GGM CSG copy

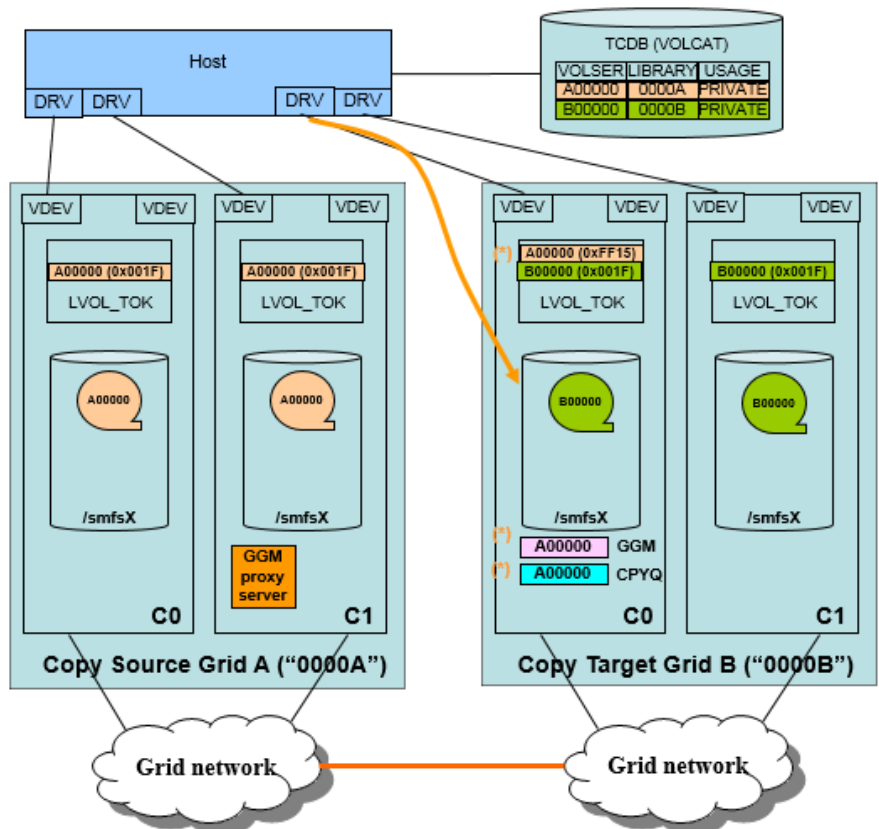

7.2.4.1 Issue LI REQ to queue a single GGM copy job. It doesn't wait for the copy completion.

(*) LVOL_TOK, COPY_QUEUE, and GGM entry are created:

LVOL_TOK entry is created with:

- xFF15 (import pending) category
- locked status
- Peer cluster in the CTG doesn't have the LVOL_TOK entry

COPY_QUEUE entry is created with:

- special priority queue for GGM
- No file size.
- Deferred delayed task

GGM entry (BVIR record) is created with:

- all volume attributes set by (7.2.2)
- some status fields are filled

Once GGM function is started, it's ready to attempt the GGM copy operation.

The command syntax is:

```
LI REQ, <C0 in the CTG>, GGM, QUEUE, <volser>, <composite lib sequence number of the CSG>
```

The third keyword is the volser required to be copied. The fourth keyword is the composite library sequence number of the CSG.

The following is displayed when GGM copy job is queued successfully:

```
0010 CBR1280I LIBRARY BARR92C REQUEST. 149
0010 KEYWORDS: GGM,QUEUE,ZGS002,BA045
0010 -----
0010 GGM COPY QUEUE REQUEST V1 .0
0010 OPERATION SUCCESSFULLY COMPLETED
```

The LI REQ command GGM, COPY, SUMMARY will show up to 10 pending CSG copy jobs:

```

0010 GGM COPY SUMMARY V1 .0
0010 CTG SETTING:
0010 CL:2 FUNCTION:ENABLED STATUS:START_IDLE STATE:IDLE_STARTED
0010 IP_ADDR (PRI/ALT) = 10.11.130.11/ 10.11.131.11
0010 IP_ADDR (PRI2/ALT2) = 0.0.0.0/ 0.0.0.0
0010 MC/SC/DC/SG = RUN /*inherit/*inherit/*inherit
0010 TGT_CAT/SRC_CAT = 0000x/0000x SEND_OP_MSG = ENABLE
0010 CPYCNT = 20 CPYCNT_CHG_STATUS = NONE
0010 COPY_PROXY_ERR_CNT = 0 RESET_TIME = 1970-01-01-00.00.00.000000
0010 -----
0010 CSG SETTING:
0010 COMPOSITELIB = BA045
0010 PROXY = 4 PORT = 13616:
0010 IP_ADDR (PRI/ALT) = 10.11.100.16/ 10.11.101.16
0010 IP_ADDR (PRI2/ALT2) = 0.0.0.0/ 0.0.0.0
0010 COPY_SRC = 4:
0010 IP_ADDR (PRI/ALT) = 10.11.100.16/ 10.11.101.16
0010 IP_ADDR (PRI2/ALT2) = 0.0.0.0/ 0.0.0.0
0010 -----
0010 CONNECTION STATUS:
0010 PROXY CONFIGURED_PORTS: 2 LAST_USED_PORT: 1
0010 INTFC: N ADDRESS / ST / ERR / LAST_FAILED_TIME
0010 : 0 10.11.100.16 / 0 / 0 / 1970-01-01-00.00.00.000000
0010 : 1 10.11.101.16 / 0 / 0 / 1970-01-01-00.00.00.000000
0010 COPYSRC CONFIGURED_PORTS: 2 LAST_USED_PORT: 1
0010 INTFC: N ADDRESS / ST / ERR / LAST_FAILED_TIME
0010 : 0 10.11.100.16 / 1 / 3 / 2015-06-17-06.45.43.000000
0010 : 1 10.11.101.16 / 0 / 0 / 1970-01-01-00.00.00.000000
0010 -----
0010 CSG COPY SUMMARY:
0010 PENDING_CSG_COPY = 1 PENDING_CTG_COPY = 0
0010 -----
0010 VOLSER POSTED_TIME ST
0010 -----
0010 ZGS005 2015-06-17-06.55.08.250125 0

```

Also, the LI REQ command below can be used to check the GGM copy job status for a specific volser:

```
LI REQ, <C0 in the CTG>, GGM, COPY, DETAIL, <volser>
```

Please refer to Appendix B to interpret COPY, DETAIL output.

An example of the LI REQ command results is listed below:

```

0010 GGM COPY QUEUE DETAIL V1 .0
0010 GGM VOLUME:ZGS005 CLUSTER:2 TOTAL:1 RECORD FOUND
0010 ENTRY:0 -----
0010 QUEUED TIME : 2015-06-17-06.55.08.250125
0010 CSG LAST TIME : 1970-01-01-00.00.00.000000
0010 COMPLETED TIME: 1970-01-01-00.00.00.000000
0010 CURRENT_GGM_STATUS: S FINAL_GGM_STATUS: N
0010 COMPLETION_CODE: x0000000000000000
0010 TVC_CLUSTER: -1 CSG_COPY_STATE: 0 CLUSTER : 01234567
0010 IMPORT_STATE: I RECALL_REQUIRED: N COPY_REQUIRED: NNNNNNNN
0010 CONSISTENT_COUNT: 0 VOLSIZE: 000000000000 CONSISTENT : NNNNNNNN
0010 CSG_DATA_LEVEL: 0000000000000000 CTG_DATA_LEVEL: 0000000000000000
0010 CONSTRUCTS: MC='RUN ' SC='*inherit' DC='*inherit' SG='*inherit'
0010 CTG_VOL_CAT: 0x0000 CSG_VOL_CAT: 0x0000 OP_MSG_REQUIRED: Y

```

When a GGM copy job is successfully queued, the corresponding logical volume as well as a GGM history record is created on the CSG copy target cluster.

There may be three types of scenarios of the QUEUE operation:

(A) Brand-new logical volume unique to the CTG is queued.

The volser of the GGM CSG copy does not exist in the CTG. The GGM CSG copy queue operation will succeed and the corresponding logical volume will be inserted/imported as a new volume.

(B) The logical volume, by volser, already exists in the CTG

The volser of the GGM CSG copy already exists in the CTG and it was inserted from MI. The GGM CSG copy queue operation will fail given the GGM function cannot replace an existing volume that shares a common volume serial.

(C) The logical volume already exists, by volser, in the CTG but the volume was imported as a result of a previous GGM operation.

In this case, the GGM CSG copy will either succeed or fail based on whether it was modified within the CTG after the previous GGM process completed.

- If the logical volume with the same volser in the CTG has been updated (written) since the previous GGM copy process completed, the GGM copy queue operation will fail.
- If the logical volume in the CTG was not yet updated (if the volume was just mounted/read, it is considered as “not yet updated”), the GGM copy queue operation will succeed. In this case, the previously copied volume is first ejected from the CTG, then the new logical volume is inserted/imported. When the volume needs to be ejected, some things to be aware of are:

When the volume needs to be ejected at the GGM CSG copy re-insert case, it is recommended that all clusters in the CTG are available and healthy due to two reasons:

- ◆ When the volume is ejected, the CSG copy target cluster needs to own a special token (**IEE). If the CTG target cluster can't obtain the ownership of the insert/eject lock due to an unavailable peer cluster in the CTG, the GGM CSG copy queue operation fails. The error message “CAN NOT GET INSERT LOCK BEFORE VOLUME VVVVVV RE-INSERT” is returned.
- ◆ When the insert-eject lock is obtained, a peer outage can still prevent a successful eject. When the volume is ejected and any peer cluster is down, the pending eject operation remains and the

subsequent volume insert operation is inhibited until the peer cluster becomes available. The error message “VOLUME VVVVVV EJECT INCOMPLETE AT RE-INSERT. TRY LATER” is returned. When this error text is returned, the copied volume will be in the eject pending status (category shows xFF10 (eject category)) until the eject operation completes when the down cluster becomes online and the volume is reconciled. Here is the sample output of “LI REQ, <composite library>, LVOL, <volser>” to get the logical volume status:

```

0010 LOGICAL VOLUME INFORMATION V4 .1
0010 LOGICAL VOLUME:                ZGG000
0010 MEDIA TYPE:                     ECST
0010 COMPRESSED SIZE (MB):           0
0010 MAXIMUM VOLUME CAPACITY (MB): 1000
0010 CURRENT OWNER:                  Arabian
0010 MOUNTED LIBRARY:
0010 MOUNTED VNODE:
0010 MOUNTED DEVICE:
0010 TVC LIBRARY:
0010 MOUNT STATE:
0010 CACHE PREFERENCE:              PG0
0010 CATEGORY:                      FF10
0010 LAST MOUNTED (UTC):             2015-07-15 02:01:38
0010 LAST MODIFIED (UTC):           2015-07-15 01:51:58
0010 LAST MODIFIED VNODE:
0010 LAST MODIFIED DEVICE:
0010 TOTAL REQUIRED COPIES:           2
0010 KNOWN CONSISTENT COPIES:        1
0010 KNOWN REMOVED COPIES:          0
0010 IMMEDIATE-DEFERRED:            N
0010 DELETE EXPIRED:                N
0010 RECONCILIATION REQUIRED:         Y
0010 LWORM VOLUME:                  N
0010 FLASH COPY:                    NOT ACTIVE
0010 -----
0010 LIBRARY  RQ CACHE PRI PVOL  SEC PVOL  COPY ST  COPY Q  COPY CP  REM
0010 cluster0 DISTRIBUTED LIBRARY UNAVAILABLE
0010   Oak    DISTRIBUTED LIBRARY UNAVAILABLE
0010   Arabian N    N    -----  -----  CMPT  -    RUN    N
0010 Palomino DISTRIBUTED LIBRARY UNAVAILABLE

```

When both CSG and CTG are at R5.1PGA1 or above and the CSG has the LWORM-retained logical volumes, the copied volume from the CSG to CTG inherits the existing LWORM retention state then the copied CTG volume also becomes LWORM-retained too. The LWORM-retained volume can't be ejected from the host operation basically. But GGM CSG copy re-insert case which requires the logical volume eject always allows the volume eject to re-queue the CSG copy job.

A summary of facts about the queue and insert processing of a GGM copy volume.

- If the global insert-eject lock can't be obtained, the operation fails.
- The same global insert-eject lock is used when a volume is inserted from MI. If the logical volume insert or eject is being performed from MI, QUEUE command should keep failing until the MI

operation completes. It's required to make sure that the volume insert from MI and QUEUE command are not done at the same time.

- The global insert-eject lock must be locked during a cluster/Grid join/merge operation too. The join/merge operation may fail if QUEUE command already gets the lock. To avoid the unexpected join/merge failure, please pause the GGM process if the GGM copies are already queued or simply refrain from queuing new GGM CSG copies before initiating the join/merge.
- If the volume, by volser, already exists in the CSG, it is first ejected and re-inserted so long as it is a previously completed GGM copy which was never modified in the CTG. If it already exists and doesn't meet this criterion, the queue request will fail.
- Back to back QUEUE requests can conflict with one other when attempting the global insert-eject lock. Therefore, it's required that all previous QUEUE request complete before issuing a subsequent QUEUE request. A 3 seconds delay between QUEUE requests can help accommodate the required serialization. "VOLUME VVVVVV INSERT FAILURE" will be returned when a collision occurs and the failed QUEUE request must be issued again at a later time.

Note: At the code level of R4.0 (8.40.x.x), GGM QUEUE command handling is improved. When the back to back QUEUE requests are received, each request retries to get the global insert-eject lock internally up to 3.5 minutes if another GGM QUEUE command currently holds the lock. If the retries end up unsuccessfully after 3.5 minutes, "VOLUME VVVVVV INSERT FAILURE" will be returned and the QUEUE command fails eventually. If the global insert-eject lock is held by the virtual volume insert/eject operation invoked from MI (Management Interface), the QUEUE command immediately fails with the error message "ANOTHER LOGICAL VOLUME INSERT OR EJECT IN PROGRESS".

- zOS can handle up to 50 LI REQ commands concurrently at a time. The commands are assigned to zOS command class M2 and if more than 50 LI REQ commands are sent to the class at a time, the commands start being queued and the message below starts showing up:

IEE806A COMMANDS EXCEED LIMIT IN COMMAND CLASS M2

The same command class M2 is used for other commands such as LOGON and START. If a large amount of QUEUE requests are issued at a time and they take long to complete or are timed out after 4 minutes via the IEA439I FOUR MINUTE I/O TIMEOUT message, this can prevent the other commands queued in the M2 class from being processed in a timely manner. If needed, the queued LI REQ commands can be removed from the queue by the command "CMDS REMOVE, CLASS=M2, CMD=LI" or by IPLing the zLPAR. To avoid such an unexpected situation, a 3 seconds delay between issuing QUEUE requests is recommended.

- The logical volume is created on the CSG copy target cluster only. No peer cluster in the CTG has the logical volume until CSG copy completes. Hot token reconcile is used to insert and queue copies at CTG peers.
- The volser can't conflict with any physical volume name in the CTG.
- A GGM copy job for the same volume by volser can be re-queued repeatedly once its CSG copy completes. For example, "A00000" was queued and completed GGM (CSG) copy. The same volser "A00000" can be re-queued in order to get a newer version from the CSG. Once the CTG created instance is modified by a host attached to the CTG, a future re-queue will fail.
- Up to 10,000 pending CSG copy jobs can be queued. The QUEUE command starts failing if CSG copy target cluster already has 10,000 queued CSG copy jobs. Once a CSG copy completes and becomes the CTG copy process, that volume is no longer counted against the 10,000 limit.

The logical volume has the following state:

- The import pending category (xFF15) is assigned to the logical volume and it's changed to the expected category (set by LI REQ, GGM, TGTCAT) when GGM copy completes (or LI REQ,

FORCECMP is accepted). The volume is not visible to CTG attached hosts until the final target category is assigned.

- The logical volume is locked until CSG copy completes.
- The "Deferred" copy mode is always assigned to the CSG copy target cluster temporarily.
- A GGM history record is inserted on the CSG copy target cluster only. The record is updated when CSG and CTG copy completes.
- The GGM copy job is not visible from the MI Incoming Copy Queue page. Only the LI REQ command or BVIR GGM history request provides the GGM copy job status.

Until the GGM copy completes to the CSG copy target cluster, the MI Virtual Volume Details page shows the error when trying to get the details of the volume and also LI REQ LVOL shows an unavailable cluster state for all peers of the CSG copy target cluster until they too complete their reconcile and copy.:

(MI virtual volume detail page shows an error in the CTG)

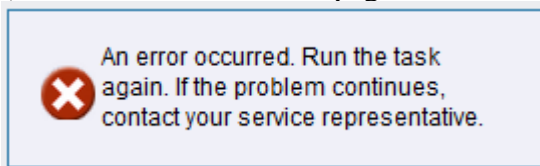

(LVOL library request command in the CTG shows the unavailable cluster state)

Note: The LVOL library request command to the copy source volume in the CSG provides the correct status.

```

0010 LOGICAL VOLUME INFORMATION V4 .1
0010 LOGICAL VOLUME:          ZGS005
0010 MEDIA TYPE:              ECST
0010 COMPRESSED SIZE (MB):     0
0010 MAXIMUM VOLUME CAPACITY (MB): 800
0010 CURRENT OWNER:           Oak
0010 MOUNTED LIBRARY:         Oak
0010 MOUNTED VNODE:
0010 MOUNTED DEVICE:
0010 TVC LIBRARY:
0010 MOUNT STATE:
0010 CACHE PREFERENCE:        PG0
0010 CATEGORY:                FF15
0010 LAST MOUNTED (UTC):      1970-01-01 00:00:00
0010 LAST MODIFIED (UTC):     2015-06-17 06:55:08
0010 LAST MODIFIED VNODE:
0010 LAST MODIFIED DEVICE:
0010 TOTAL REQUIRED COPIES:    1
0010 KNOWN CONSISTENT COPIES: 0
0010 KNOWN REMOVED COPIES:   0
0010 IMMEDIATE-DEFERRED:     N
0010 DELETE EXPIRED:         N
0010 RECONCILIATION REQUIRED:  N
0010 LWORM VOLUME:           N
0010 FLASH COPY:             NOT ACTIVE
0010 -----
0010 LIBRARY RQ CACHE PRI PVOL SEC PVOL COPY ST COPY Q COPY CP REM
0010 Oak N N -----
0010 Arabian DISTRIBUTED LIBRARY UNAVAILABLE
0010 Palomino DISTRIBUTED LIBRARY UNAVAILABLE
0010 -----
0010 LIBRARY CP
0010 Oak -1
0010 Arabian DISTRIBUTED LIBRARY UNAVAILABLE
0010 Palomino DISTRIBUTED LIBRARY UNAVAILABLE

```

7.2.4.2 CSG copy execution

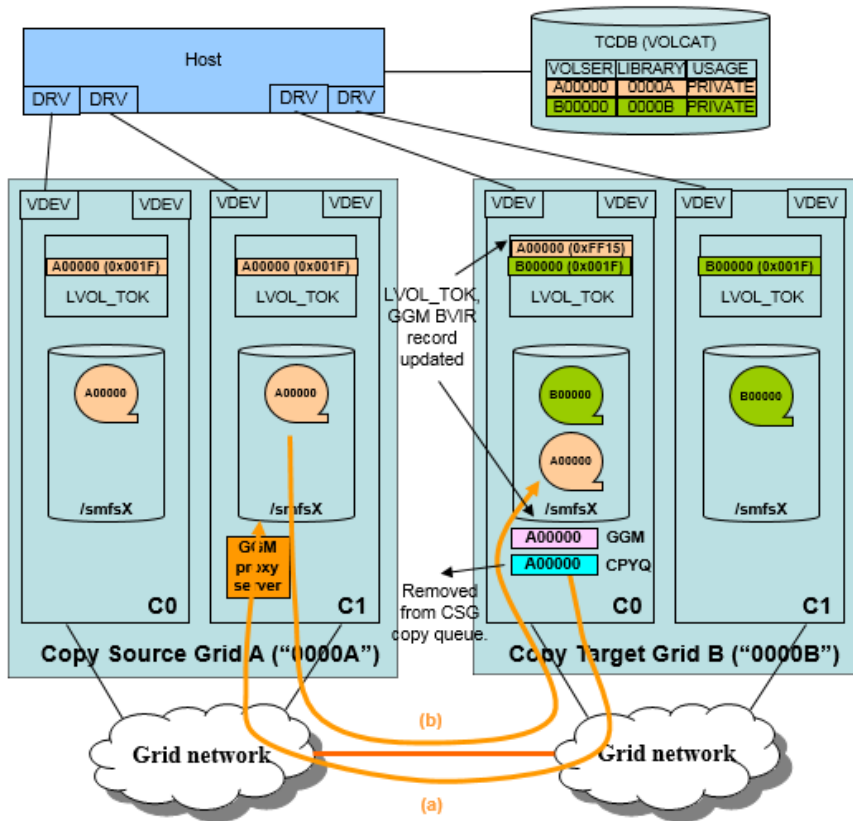

7.2.4.2 CSB copy execution

(a) Dequeue GGM copy job and perform an volume audit via GGM proxy server in the CSB cluster. Audit checks if the copy can be made from the sole CSB copy source cluster or not. Also retrieve the volume attributes from the CSB.

(b) CSB copy is made from CSB to CTG. The data level check is done at the end of the copy completion.

- (*) Once CSB copy is done:
- LVOL_TOK/GGM entry is updated with the retrieved attributes accordingly.
 - CSB copy job is removed from COPY_QUEUE.
 - LVOL_TOK is unlocked. (xFF15 category is still remained)
 - LVOL_TOK is marked hot and asynchronously reconciled to the peer clusters in the CTG.

A CSB copy is handled as a deferred copy after it's queued through with the LI REQ, GGM, QUEUE command. The maximum number of concurrent CSB copy deferred copies is determined by the GGM, CPYCNT parameter. These copy processes are in addition to regular deferred and rewind unload copy processes..

When a CSB copy is attempted, a volume audit from the CTG to CSB via the proxy server is made. It determines if the copy can be made or not. Also it retrieves volume attributes such as the storage constructs, category and consistency version. In the following conditions, CSB (GGM) copy fails permanently and no retry is made:

- CSB does not have the volser which was queued by LI REQ, GGM, QUEUE command.
- The CSB copy source volume is in a scratch category (to be identified as "scratch category", the category needs to be defined in the MI as "Scratch")..
- The CSB copy source cluster does not have a consistent copy of the volume. The *reason* could be:
 - The volume is expired.
 - The volume is in the damaged category.
 - The volume is removed on the CSB copy source cluster.
 - No Copy mode is set to the volume at the CSB copy source volume (if it has a valid copy mode but the copy is not made to the CSB copy source volume, CSB copy is delayed and retried later).

For the (A) case, the CTG inserted logical volume is deleted when the CSB copy fails.

For the (B) and (C) case, the logical volume remains inserted in the CTG even though no data is copied. It will continue to inherit the constructs and category of the original source volume. This allows volumes awareness to be migrated, yet without any data. For example, scratch volumes.

If there is a temporary CSB copy failure (for example, CSB-CTG network error or the copy source volume in the CSB is mounted etc.), the CSB copy will halt and be retried at a later time automatically.

If the copies are disabled at the CSG copy source cluster by LI REQ, cluster, GRIDCNTL, COPY, DISABLE command, the CSG copy will halt and be retried as well. Once the copies are enabled by LI REQ, cluster, GRIDCNTL, COPY, ENABLE command, the CSG copy will be attempted automatically.

When one of the CSG-CTG grid to grid connection links fail, CSG copies using those links will fail and be retried at a later time automatically. An immediate retry by using alter links will not be performed. If basic communications with the CSG proxy server fails due to a link outage, the GGM function will immediately retry down alternate grid to grid connections.

While the CSG copy is in progress from the CSG to the CTG and the source volume in the CSG is mounted by a host, the GGM copy will abort and be attempted at a later time. This is to give priority to the host which is attempting to access the original source volume.

Once the CSG to CTG copy completes into the CTG (not yet among the CTG peers), the corresponding logical volume, as well as GGM history record is updated on the CTG copy target cluster:

- GGM copy job is removed from the queue.
- The expected storage construct names are assigned to the logical volume.
- The data_level, data_level_current, mount_operation_time, last_data_modify_time, media_type, category_time, file_size, world_id (if LWORM volume), write_mount_count (if LWORM volume), last_data_creation_time (if CSG copy source cluster (= CSG proxy server cluster)) is at R3.1 or above, last_host_data_modify_time/LWORM retention values (if LWORM retention is supported at both CSG and CTG with R5.1PGA1) are inherited from the CSG copy source volume.
- The logical volume is unlocked and marked hot to reconcile the logical volume for the peer cluster(s) in the CTG (the hot is reconciled asynchronously with the CSG copy completion). MI Pending Updates page may show the hot status until the logical volume completes the reconciliation. A task which indicates the insert reconciliation is attempted is created.

Start Time	Status	Task	User
07/07/2015, 16:02:43	Completed, with Information, 4 seconds	Insert/Eject Virtual Volume Reconciliation	service

- The expected copy modes are assigned to the clusters in the CTG. If the CSG copy target cluster is assigned to a “No Copy” mode, the copy mode is changed from “Deferred” to “Exists”. The data on the CSG copy target cluster may need to be deleted by LI REQ, <CSG copy target cluster>, SETTING, EXISTDEL, WHEN, AUTO or LI REQ, <CTG composite library>, LVOL, <volser>, REMOVE command after the GGM copy completes.
- GGM BVIR record is updated on the CSG copy target cluster to indicate the CSG copy completed.
- The CSG copy job is not visible from MI Incoming Copy Queue page. Only LI REQ command or BVIR request provides the GGM copy job status.

While the CSG copy is in progress, LI REQ, <CSG copy target cluster>, GGM, COPY, SUMMARY should show the status ‘4’ (copy is now in progress):

```

0010
0010  CSG COPY SUMMARY:
0010  PENDING_CSG_COPY =      1 PENDING_CTG_COPY =      0
0010  -----
0010  VOLSER POSTED_TIME          ST
0010  -----
0010  ZGS005 2015-06-17-06.55.08.250125  4
    
```

When the CSG copy completes and the subsequent CTG copy (copies) is required, LI REQ, <CSG copy target cluster>, GGM, COPY, SUMMARY should provide "PENDING_CTG_COPY" count incremented:

```
0010 -----
0010 CSG COPY SUMMARY:
0010 PENDING_CSG_COPY = 0 PENDING_CTG_COPY = 1
0010 -----
0010 VOLSER POSTED_TIME          ST
0010 -----
0010 NO PENDING CSG COPY EXISTS
```

The below is the example of LI REQ command (GGM, COPY, DETAIL) result after the CSG copy completed:

```
0010 GGM COPY QUEUE DETAIL V1 .0
0010 GGM VOLUME:ZGS005 CLUSTER:2 TOTAL:1 RECORD FOUND
0010 ENTRY:0 -----
0010 QUEUED TIME      : 2015-06-17-06.55.08.250125
0010 CSG LAST TIME   : 2015-06-17-07.01.29.000000
0010 COMPLETED TIME: 1970-01-01-00.00.00.000000
0010 CURRENT_GGM_STATUS: T FINAL_GGM_STATUS: N
0010 COMPLETION_CODE: x0000000000000000
0010 TVC_CLUSTER: 4 CSG_COPY_STATE: 2 CLUSTER      : 01234567
0010 IMPORT_STATE: I RECALL_REQUIRED: N COPY_REQUIRED: NNNNNYH
0010 CONSISTENT_COUNT: 1 VOLSIZE: 06283451484 CONSISTENT : NNYNNNNN
0010 CSG_DATA_LEVEL: 0000000000000104 CTG_DATA_LEVEL: 0000000000000000
0010 CONSTRUCTS: MC='RUN' SC=' ' DC=' ' SG=' '
0010 CTG_VOL_CAT: 0x000F CSG_VOL_CAT: 0x0000 OP_MSG_REQUIRED: Y
```

Please refer to the section 7.2.8.6 GGM, COPY, DETAIL or Appendix B (17. "GGM, COPY, DETAIL") to check the values in each field of the output.

If subsequent CTG copy or copies are not required (i.e. the copy mode is set to have only one copy on the CSG copy target cluster in the CTG), the GGM copy completes and the corresponding logical volume as well as GGM history record is updated on the CSG copy target cluster:

- D. The category of the volume is changed from the import pending category (xFF15) to the expected one in the CTG.
- E. The GGM history record is updated on the CSG copy target cluster in the CTG to indicate the GGM copy completed.
- F. The data level check with the CSG proxy server is done when CSG copy completes. If it's detected that the CSG copy source was modified by a host attached to the CSG while the CSG copy has been running, CSG copy fails and re-attempted again later..
- G. An operator message which notifies the host of the GGM copy completion is surfaced from the CTG if OPMSG setting is set to ENABLE. Please refer to Appendix B "15. GGM, OPMSG, ENABLE | DISABLE command" for the message format.
- H. The CSG copy source volume category change against the source volume in the CSG could occur based off of SRCCAT setting.

[CSG copy requiring a recall on a CSG copy source cluster]

If the CSG copy source volume is already migrated on the CSG copy source cluster, a recall of the volume is required prior to starting the actual CSG copy (i.e. GGM CSG copy recall). Unlike the recall of the normal Grid copy source volume in the same Grid (i.e. Grid copy recall), GGM CSG copy recall is less efficient and the performance will be much slower based off of the following recall mechanisms:

- When a Grid copy recall is attempted, multiple logical volumes on the same physical volume which are also marked as copy required are recalled at a time (it is called as “bulk recall”). Then multiple Grid copies receive the benefit of the bulk recall and the large amount copies requiring the recall initially can start without actual recalls.
- When a GGM CSG copy recall is attempted, one logical volume is recalled from the physical volume at a time and no mechanism such as “bulk recall” is done. Then all GGM CSG copies requiring the recall initially always need the actual recalls.

In order to speed up the GGM CSG copies which require the recalls, CSG copy source volumes need to be recalled prior to starting the GGM CSG copies so that GGM CSG copies will not require the recalls. This can be done by using PRESTAGE tool to recall the migrated CSG copy source volume. The Chapter 8 (z/OS operation scenarios) will discuss the usage of the PRESTAGE tool in detail.

If the advanced recall by PRESTAGE tool is not possible, the following method can be used to get a little better performance of the CSG copies requiring the recalls.

Regarding GGM CSG copies requiring the recall, up to 4 recalls can be in progress at the same time on the CSG copy target cluster. The recall completion is checked from the CSG copy target cluster once in every 3 minutes periodically and once it's found to be completed, the copy is attempted. Because recalls are limited to 4 at a time, it's ideal to have all four working on different physical volumes at the CSG source cluster. Therefore, knowing a recall is required at the time of QUEUE is ideal and rotating logical volumes across four physical volumes in the order they are stacked will provide the most optimal performance. For example, 100 logical volumes (LVOL00 – LVOL99) will be copied from the CSG to CTG. All logical volumes are migrated and a total of 4 physical volumes are used to contain all 100 volumes (LVOL00 – LVOL24 on PVOL00, LVOL25 – LVOL49 on PVOL01, LVOL50 – LVOL74 on PVOL02 and LVOL75 – LVOL99 on PVOL03). Under such a condition, it may be recommended to issue QUEUE command (LI REQ, < CSG copy target cluster >, GGM, QUEUE, <volser>, < CSG composite library sequence number >) in the following <volser> order:

LVOL00->LVOL25->LVOL50->LVOL75->LVOL01->LVOL26->LVOL51->LVOL76...

Instead of

LVOL00->LVOL01...->LVOL25->LVOL26...->LVOL50->LVOL51...->LVOL75->LVOL76...

Then, 4 concurrent recalls from the different physical volumes (PVOL00, PVOL01, PVOL02 and PVOL03) will be performed efficiently. Once a volume is recalled on the CSG copy source cluster, its corresponding GGM copy job in the queue on the CSG copy target cluster is moved up in priority over other GGM copy jobs in the queue.

7.2.4.3 CTG copy execution

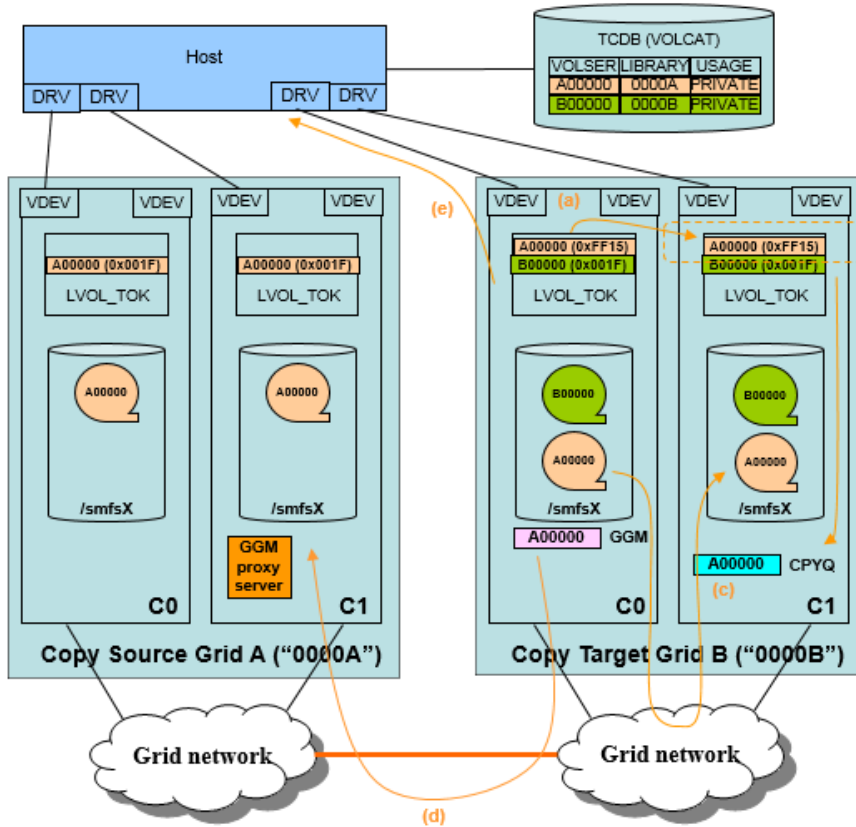

7.2.4.3 CTG copy execution

(a) LVOL_TOK is reconciled and the logical volume is created on C1.

(b) CTG copy is queued. The queue priority is the normal deferred copy if C1 is at R3.2 or below. If C1 is at R3.3, lower priority than COPYRFSH is assigned.

(c) The CTG copy (normal Grid copy) is made from C0 to C1 in the CTG. Once all the required CTG copies complete in the CTG:

- LVOL_TOK category is changed from xFF15 to the expected (inherited or fixed) one.
- GGM entry is updated to indicate the completion.
- The last data level check is done to make sure the data level is not changed since the CSG copy completed.

(d) The category of the CSG copy source volume is updated based off of SRCAT setting (optional).

(e) The operator message is surfaced to the host based off of OPMSG setting (optional).

When the subsequent CTG copy is required in the CTG based off of the copy modes assigned to the CSG copy target volume, peer clusters in the CTG create the logical volume tokens and queues a normal Grid copy job as a result of the volume reconciliation.

The CTG copy among the CTG peers are handled as a deferred copy. If the peer cluster in the CTG is at R3.3 or later code, the CTG copy job has lower priority. If the peer cluster is at R3.2 or below, the CTG copy job has a normal deferred copy priority. In either case, the CTG copy can be seen in MI Incoming Copy Queue page as a normal deferred copy job and will choose a source just the same as regular copy jobs do, including family deferred behaviors if configured.

Once all the required CTG copies complete, the corresponding logical volume as well as GGM history record (in the CSG copy target cluster in the CTG) is updated:

- I. GGM CTG copy job is removed.
- J. The category of the logical volume in the CTG will be changed from xFF15 to the expected value as defined in TGTCAT setting.
- K. The GGM history record is updated on the CSG copy target cluster to indicate the CTG (i.e. GGM) copy completed.
- L. The data level check with the CSG proxy server is done when GGM copy completes. If it's detected that the CSG copy source volume was modified by a host attached to the CSG at any point between when the volume was originally queued, copied into the CTG and then copied among the CTG peers, a version check failure status is set in the history record. This provides a method to inform the user that the copied version to the CTG is likely now stale.
- M. If OPMSG is set to enabled, an operator message is sent to all attached hosts in the CTG. The message includes the completion code as well. Please refer to Appendix B "15. GGM, OPMSG, ENABLE | DISABLE command" for the message format.

- N. If SRCCAT is set to a value other than NULL, the category of the CSG copy source volume is changed when GGM copy completes with no error. If any error occurs (for example, the data level check fails due to the network error, CSG changed the volume during the process etc.), the category of the CSG copy source is not changed although SRCCAT is set.

Note: If the category of the CSG copy source volume is changed at GGM copy completion (same with using LI REQ, <CSG copy target cluster>, GGM, SRCVLCHG command), a Task (Operation History) entry is always created in the CSG. This is the example output of MI task which indicates this category change activity from the CSG:

Operation	Modify Logical Volumes
ID	520
Start Time	2015/6/17 17:15:17
End Time	2015/6/17 17:15:17
Duration	0 hours, 0 minutes, 0 seconds
Initiating User	service
Result	<input checked="" type="checkbox"/> Completed

Operation details:

```
The following constructs have been modified for the logical volume range, ZGS005 to ZGS005:
Storage group: "No Change"
Management class: "No Change"
Storage class: "No Change"
Data class: "No Change"
```

When the GGM copy completes, you will see through the LI REQ, <CSG copy target cluster>, GGM, COPY, SUMMARY output that the of PENDING_CTG_COPY count decreases by one:

```
0010 -----
0010 CSG COPY SUMMARY:
0010 PENDING_CSG_COPY =      0 PENDING_CTG_COPY =      0
0010 -----
0010 VOLSER POSTED_TIME          ST
0010 -----
0010 NO PENDING CSG COPY EXISTS
```

The below is the example of LI REQ command (GGM, COPY, DETAIL) result after the CSG copy completed:

```

0010 GGM COPY QUEUE DETAIL V1 .0
0010 GGM VOLUME:ZGS005 CLUSTER:2 TOTAL:1 RECORD FOUND
0010 ENTRY:0 -----
0010 QUEUED TIME : 2015-06-17-06.55.08.250125
0010 CSG LAST TIME : 2015-06-17-07.01.29.000000
0010 COMPLETED TIME: 2015-06-17-08.02.23.000000
0010 CURRENT_GGM_STATUS: C FINAL_GGM_STATUS: S
0010 COMPLETION_CODE: x0000000000000000
0010 TVC_CLUSTER: 4 CSG_COPY_STATE: 2 CLUSTER : 01234567
0010 IMPORT_STATE: I RECALL_REQUIRED: N COPY_REQUIRED: NNNNNYYN
0010 CONSISTENT_COUNT: 3 VOLSIZE: 06283451484 CONSISTENT : NNYNNYYN
0010 CSG_DATA_LEVEL: 0000000000000104 CTG_DATA_LEVEL: 0000000000000104
0010 CONSTRUCTS: MC=' RUN ' SC=' ' DC=' ' SG=' '
0010 CTG_VOL_CAT: 0x000F CSG_VOL_CAT: 0x0000 OP_MSG_REQUIRED: Y

```

Please refer to the section 7.2.8.6 GGM, COPY, DETAIL or Appendix B (17. “GGM, COPY, DETAIL”) to check the values in each field of the output.

It may be possible that the clusters in the CTG which require a copy change after the original CSG copy completes. For example:

- CTG is 2-way Grid (C0 and C1). The CSG copy completes on C0 while C1 is unavailable.
- While C1 still requires the CTG copy, LI REQ, <CSG copy target cluster>, GGM, FORCECMP is used and the GGM copy is forcibly completed. This can happen when the user does not want to wait for peer to be back to complete the CTG copies (i.e. C1 comes back and completes the CTG copy in this case. Please refer to the section 7.2.8.2 or Appendix B for the usage of FORCECMP keyword.
- The volume is accessed before C1 returns and the access changes the volume's copy policies. For example, “No Copy” mode is applied to C1.
- C1 becomes available eventually but C1 no longer requires a CTG copy.

With the above use case, a CTG copy to C1 was originally required when the CSG copy completed, but it was changed and C1 no longer required the CTG copy. As a result, the GGM function won't automatically complete because the required CTG copy never occurred. This may be a rare case, but in order to prevent the incomplete GGM copy job forever, a GGM CTG copy monitoring function runs once every 12 hours. It checks all pending CTG copy jobs when they are older than 24 hours since the CSG copy completed. If the monitoring function detects the CTG copy is no longer required (or already completed), the GGM copy status is updated correctly so that the GGM copy is marked “completed” correctly in the history entry.

- Regarding the volume's storage construct attributes, they are assigned at the time of the original CSG copy, therefore the CSG copy target cluster and the CTG peer clusters will all utilize the correct constructs when they receive their copy. For example:
 - CSG copy target cluster applies the storage constructs attributes as if it's the host mount TVC cluster when it creates the first copy in the CTG.
 - Other clusters (CTG copy target clusters) also apply the storage constructs attributes. Note: if “Copied to Follow Storage Class Reference” setting which can be set by CACHE, COPYFSC library request command is disabled (default), the copied volume is managed as PGO if the cluster is 7740 or 7720T with the tape cache partition.

7.2.4.4 Host TCDB (also other tape management system) update

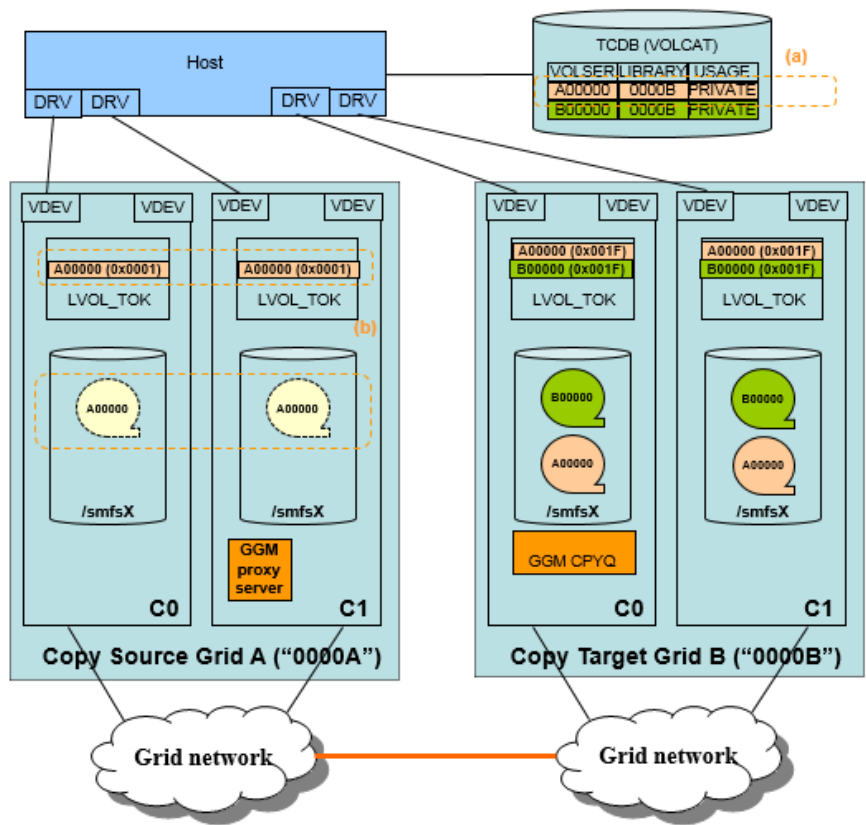

7.2.2.4 Host TCDB update

(a) Host TCDB (VOLCAT) needs to be updated manually to indicate now A00000 belongs to the CTG.

(*) In R3.3, this is the user's responsibility to update the host TCDB. Other tape management system (RMM, CA1 etc.) needs updates too.

(b) If the category of the volume in the CSG is set to the fast ready with expired setting, the volume will be deleted from the CSG once the volume is expired.

After GGM copy completes, the host TCDB (VOLCAT), as well as other tape management system settings, need to be updated manually. In R3.3, this is the user's responsibility and the automation is planned to be implemented in a future release. Once the host side change is done, the host is able to access the logical volume "A00000" in the CTG. Given this example is a host under a common system/plex, the host no longer has access to the original copy in the CSG.

If the category of the CSG copy source volume is set to the scratch category with the expire setting, the volume's content will be deleted from the CSG once the volume is expired, then the cache as well as physical volume space is freed up. The logical volume definition will still remain in the CSG.

The required steps at the host are described in chapter 8 "z/OS operation to access the copied logical volumes in the CTG".

7.2.5 Stop GGM function

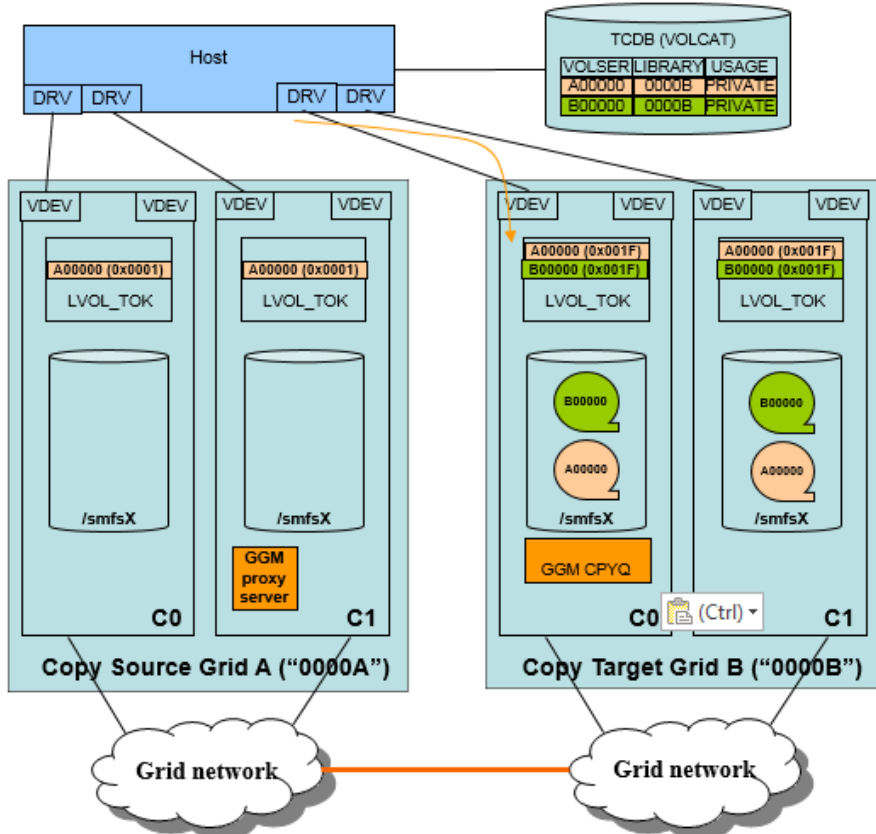

7.2.5 Stop GGM function

(*) STOP, CLEAR option can be used to stop CSG copy and also remove all pending CSG copies.

When GGM function is no longer required and needs to be disabled, it must first be stopped. Once stopped, CSG copies already in flight and CTG copies will be allowed to continue.

The command syntax is:

```
LI REQ, <C0 in the CTG>, GGM, CTG, STOP (, CLEAR)
```

If the fourth keyword "CLEAR" is specified (optional), the pending CSG copies (i.e. queued but not in-flight CSG copies) are removed as well as the GGM function is stopped. Therefore, use "CLEAR" only if you don't want the remaining queued entries to be handled at a later time. If you simply want to stop the copy activity and start it back up where it left off at a later time, do not use "CLEAR". If already stopped, requesting an additional STOP with CLEAR will clear out the queue if queued entries still exist. If only selective volumes need to be cleared from the queue, use the REMOVEQ option. Please be careful running STOP, CLEAR or REMOVEQ commands leave the volumes uncopied in the CTG and need to recopy them if required.

The result of the LI REQ command (the fourth keyword CLEAR is specified) is shown below:

```
0010 CBR1280I LIBRARY BARR92C REQUEST. 381
0010 KEYWORDS: GGM,CTG,STOP,CLEAR
0010 -----
0010 GGM OPERATION CHANGE REQUEST V1 .0
0010 OPERATION SUCCESSFULLY COMPLETED
```

When GGM function is successfully stopped, LI REQ, <CSG copy target cluster>, GGM, COPY, SUMMARY shows:

```

0010 GGM COPY SUMMARY V1 .0
0010 CTG SETTING:
0010 CL:2 FUNCTION:ENABLED STATUS:STOP_CLEAR STATE:STOPPED
0010 IP_ADDR (PRI/ALT) = 10.11.130.11/ 10.11.131.11
0010 IP_ADDR (PRI2/ALT2) = 0.0.0.0/ 0.0.0.0
0010 MC/SC/DC/SG = RUN /*inherit/*inherit/*inherit
0010 TGT_CAT/SRC_CAT = 0000x/0001x SEND_OP_MSG = ENABLE
0010 CPYCNT = 20 CPYCNT_CHG_STATUS = NONE
0010 COPY_PROXY_ERR_CNT = 0 RESET_TIME = 1970-01-01-00.00.00.000000
    
```

7.2.6 Disable GGM function

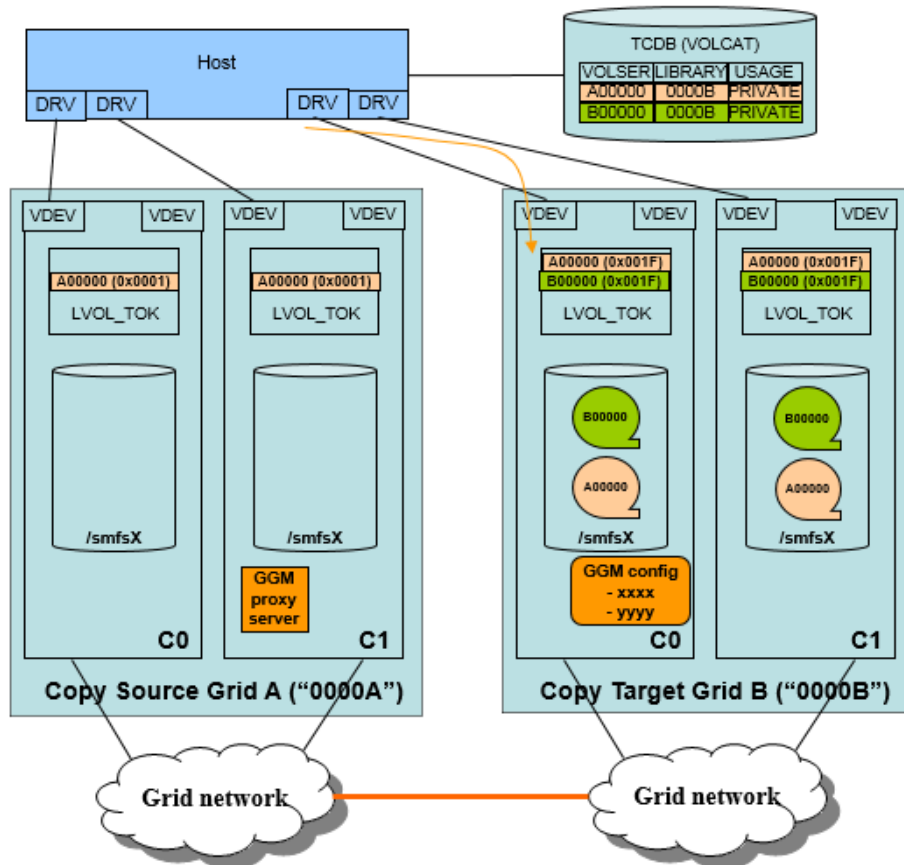

7.2.6 Disable GGM function

- (*) When GGM is disabled,
- Delete the copy threads for GGM copy.
 - Delete the routing.
 - Update VPD.
 - etc.

When GGM function is no longer required and all queued entries have completed or have been cleared, GGM can be disabled through the “LI REQ, <CSG copy target cluster>, GGM, CTG, DISABLE” command in the CTG. This command will:

- Check if any pending or in-flight CSG copies exist.
- Deallocate the resources for the GGM operations.
- Delete the routing to the CSG proxy server cluster.
- Update the firewall settings on the CSG copy target cluster.
- All GGM settings (CSG/CTG IP addresses, proxy port number, storage constructs, target/source volume categories, operator message, GGM copy job count) are preserved. When GGM is re-enabled, the same settings are applied automatically.

Note: In order to disable the GGM function, no pending CSG copies must exist in the CTG. If the GGM function needs to be disabled while any pending CSG copies still exist, they must be removed first by “LI REQ, <CSG copy target cluster>, GGM, REMOVEQ” or “LI REQ, <CSG copy target cluster>, GGM, STOP, CLEAR” commands. Please be careful running these commands leave the volumes uncopied in the CTG and need to recopy them if required.

The command syntax is:

```
LI REQ, <C0 in the CTG>, GGM, CTG, DISABLE
```

An example of the result of the LI REQ command is listed below:

```
0010 CBR1280I LIBRARY BARR92C REQUEST. 387
0010 KEYWORDS: GGM,CTG,DISABLE
0010 -----
0010 GGM OPERATION CHANGE REQUEST V1 .0
0010 OPERATION SUCCESSFULLY COMPLETED
```

When GGM function is successfully disabled, LI REQ, <CSG copy target cluster>, GGM, COPY, SUMMARY shows:

```
0010 GGM COPY SUMMARY V1 .0
0010 CTG SETTING:
0010 CL:2 FUNCTION:DISABLED STATUS:STOP_CLEAR STATE:DISABLED
0010 IP_ADDR (PRI/ALT) = 10.11.130.11/ 10.11.131.11
0010 IP_ADDR (PRI2/ALT2) = 0.0.0.0/ 0.0.0.0
0010 MC/SC/DC/SG = RUN /*inherit/*inherit/*inherit
0010 TGT_CAT/SRC_CAT = 0000x/0001x SEND_OP_MSG = ENABLE
0010 CPYCNT = 20 CPYCNT_CHG_STATUS = NONE
0010 COPY_PROXY_ERR_CNT = 0 RESET_TIME = 1970-01-01-00.00.00.000000
```

Note: If any CSG or CTG configuration change is required and the IBM Service Representative needs to change the setting from the service panel in the CSG copy target cluster, the GGM function must always be stopped and also disabled first. If it's enabled, it will not allow the configuration change.

7.2.7 Terminate proxy server

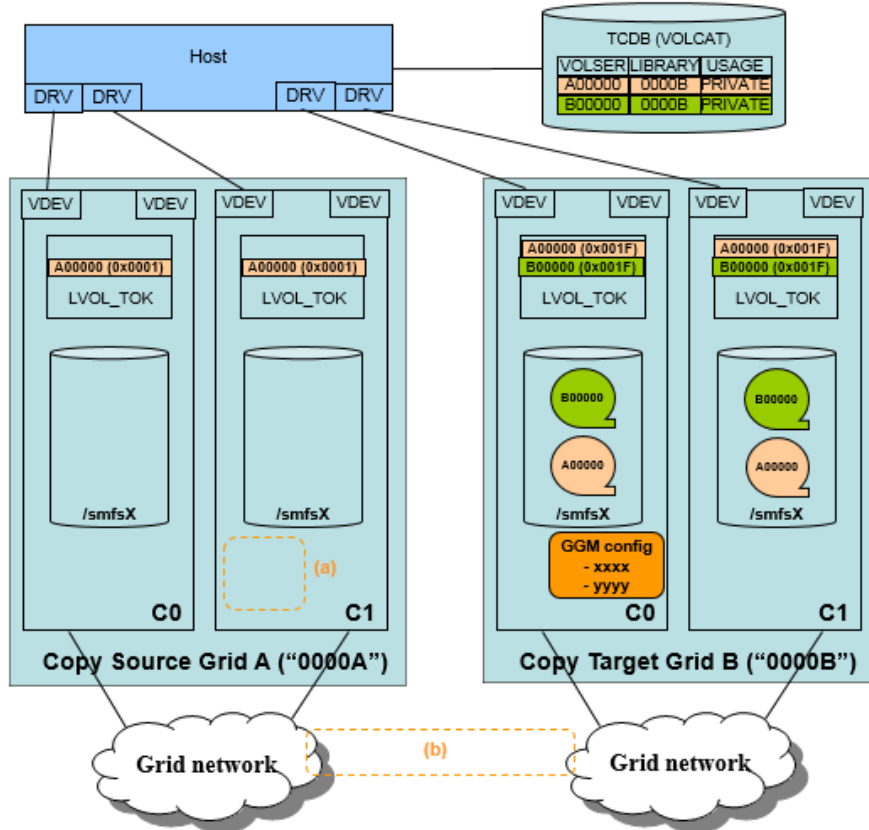

7.2.7 Terminate proxy server

(a) Terminate the proxy server by running `vtd_exec` in the CSG by the CSR.

(*) When `vtd_exec` is uninstalled,

- Delete the routing.
- Delete the firewall setting.
- etc.

(b) The connection between the CSG and CTG can be removed by the customer.

This last step requires the IBM Service Representative to terminate the CSG proxy server in the CSG.

The customer may want to remove the connection between the CSG and CTG if he additionally prepared it when GGM was set up.

7.2.8 Other new LI REQ commands for the GGM function

This section introduces other LI REQ commands which can be used to control/monitor GGM activity.

7.2.8.1 GGM, REMOVEQ, <volser>

If the CSG copy job is no longer required or the copy job should be removed for a later attempt, this command can be used to remove a pending (i.e. queued but not yet in-flight or completed) CSG copy job. A CSG copy job which is already in flight can't be removed by this LI REQ command.

When the following CSG copy (volser is 'ZGS000') is no longer required, the copy job can be removed by REMOVEQ command.

```
0010 CSG COPY SUMMARY:
0010 PENDING_CSG_COPY = 1 PENDING_CTG_COPY = 0
0010 -----
0010 VOLSER POSTED_TIME ST
0010 -----
0010 ZGS000 2015-06-22-06.26.14.051200 0
0010 -----
```

The command syntax is:

```
LI REQ, <C0 in the CTG>, GGM, REMOVEQ, Volser
```

An example of the result of the LI REQ command is listed below:

```
0210 LI REQ,BARR92C,GGM,REMOVEQ,ZGS000
0010 CBR1020I PROCESSING LIBRARY COMMAND: REQ,BARR92C,GGM,REMOVEQ,ZGS000.
0010 CBR1280I LIBRARY BARR92C REQUEST. 809
0010 KEYWORDS: GGM,REMOVEQ,ZGS000
0010 -----
0010 GGM COPY QUEUE REQUEST V1 .0
0010 OPERATION SUCCESSFULLY COMPLETED
```

When the pending CSG copy job is successfully removed, the corresponding logical volume is also removed from the CSG copy target cluster in the CTG. It can be checked if the CSG copy job is removed by GGM, COPY, DETAIL command (please refer to the section 7.2.8.6 or Appendix B to check the values of the fields):

```
0010 GGM COPY QUEUE DETAIL V1 .0
0010 GGM VOLUME:ZGS000 CLUSTER:2 TOTAL:1 RECORD FOUND
0010 ENTRY:0 -----
0010 QUEUED TIME : 2015-06-22-06.26.14.051200
0010 CSG LAST TIME : 2015-06-22-06.35.29.000000
0010 COMPLETED TIME: 2015-06-22-06.35.29.000000
0010 CURRENT_GGM_STATUS: C FINAL_GGM_STATUS: W
0010 COMPLETION_CODE: x00000000000000002
0010 TVC_CLUSTER: -1 CSG_COPY_STATE: 2 CLUSTER : 01234567
0010 IMPORT_STATE: I RECALL_REQUIRED: N COPY_REQUIRED: NNNNNNNN
0010 CONSISTENT_COUNT: 0 VOLSIZE: 000000000000 CONSISTENT : NNNNNNNN
0010 CSG_DATA_LEVEL: 000000000000000000 CTG_DATA_LEVEL: 000000000000000000
0010 CONSTRUCTS: MC='RUN' SC='*inherit' DC='*inherit' SG='*inherit'
0010 CTG_VOL_CAT: 0x0000 CSG_VOL_CAT: 0x0001 OP_MSG_REQUIRED: Y
```

The copy job state can also be retrieved through the history table by using BVIR (COPY, RESULT). Please refer to Appendix C for the supported GGM BVIR request.

Please make sure to put the CSG copy job by LI REQ, QUEUE command later if the removed volume still needs to be copied from the CSG to CTG.

7.2.8.2 GGM, FORCECMP, <volser>

Normally, a GGM copy completes only after all peers in the CTG have completed their CTG copies. If that is not possible due to an outage or other reason, this last peer copy step can be skipped by issuing the FORCECMP command. Once completed, the GGM function will temporarily treat it as a completed CTG copy and surface the final status to the host and history table showing that it completed due to a force. The history entry will remain and continue to be used to monitor the final CTG copy completion status once the outage is corrected.

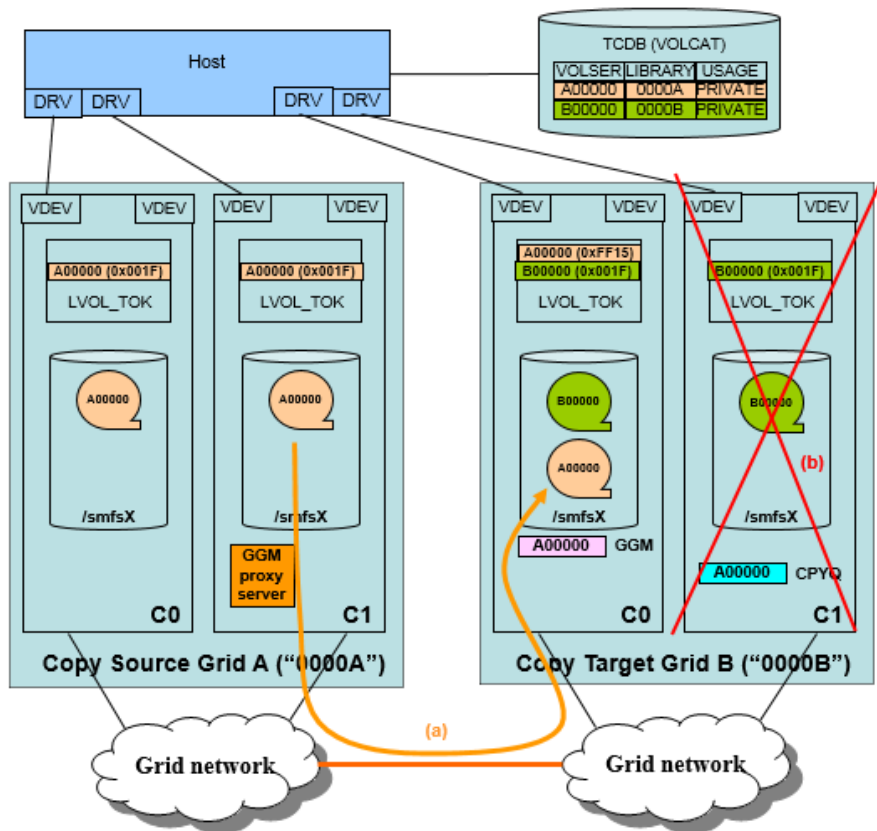

7.2.8.2 LI REQ, GGM, FORCECMP

- (a) The CSG copy completes and C1 in the CTG requires the CTG copy.
- (b) C1 is not available.
- (*) GGM copy doesn't complete until C1 becomes available and CTG copy completes.

The command syntax is:

LI REQ, <C0 in the CTG>, GGM, FORCECMP, Volser

An example of the result of the LI REQ command is listed below:

```
0210 LI REQ,BARR92C,GGM,FORCECMP,ZGS000
0010 CBR1020I PROCESSING LIBRARY COMMAND: REQ,BARR92C,GGM,FORCECMP,ZGS000.
0010 CBR1280I LIBRARY BARR92C REQUEST. 872
0010 KEYWORDS: GGM,FORCECMP,ZGS000
0010 -----
0010 GGM COPY QUEUE REQUEST V1 .0
0010 OPERATION SUCCESSFULLY COMPLETED
```

Once the LI REQ, <CSG copy target cluster>, GGM, FORCECMP command completes, LI REQ, <CSG copy target cluster>, GGM, COPY, SUMMARY and DETAIL output still show that the CTG copy is still in progress but the COMPLETION_CODE shows x0001 (CTG copy completes forcibly by FORCECMP command). The example below shows LI REQ, COPY, SUMMARY and DETAIL output after FORCECMP is executed. CL2 is the CSG copy target cluster and C5 is unavailable when LI REQ, FORCECMP command is executed:

```
0010 CSG COPY SUMMARY:
0010 PENDING_CSG_COPY = 0 PENDING_CTG_COPY = 1
0010 -----
0010 VOLSER POSTED_TIME ST
0010 -----
0010 NO PENDING CSG COPY EXISTS
```

```

0010 GGM COPY QUEUE DETAIL V1 .0
0010 GGM VOLUME:ZGS000 CLUSTER:2 TOTAL:1 RECORD FOUND
0010 ENTRY:0 -----
0010 QUEUED TIME      : 2015-06-22-06.46.50.778754
0010 CSG LAST TIME   : 2015-06-22-06.51.13.000000
0010 COMPLETED TIME : 1970-01-01-00.00.00.000000
0010 CURRENT_GGM_STATUS: T FINAL_GGM_STATUS: N
0010 COMPLETION_CODE: x0000000000000001
0010 TVC_CLUSTER: 4      CSG_COPY_STATE: 2      CLUSTER      : 01234567
0010 IMPORT_STATE: N      RECALL_REQUIRED: N      COPY_REQUIRED: NNNNNYYN
0010 CONSISTENT_COUNT: 2  VOLSIZE: 00000000763  CONSISTENT   : NNYNNN|N
0010 CSG_DATA_LEVEL: 000000000000103  CTG_DATA_LEVEL: 0000000000000000
0010 CONSTRUCTS: MC='RUN      ' SC='      ' DC='      ' SG='      '
0010 CTG_VOL_CAT: 0x000F  CSG_VOL_CAT: 0x0001  OP_MSG_REQUIRED: Y

```

When FORCECMP command completes, the category of the volume is changed from xFF15 to the expected one, the corresponding operator message is surfaced to the host if OPMSG is enabled and the copied volume can be accessed from the host. But the category of the CSG copy volume isn't changed at this point although SRCCAT is set. The category is changed when all required CTG copies complete without any errors.

Once the unavailable cluster becomes online state, the volume is reconciled and the required CTG copy is made to the cluster automatically. Because the operator message is already surfaced when FORCECMP command completes, no additional operator message is surfaced when the CTG (GGM) copy finally completes sometime later when the outage is corrected. But, the history entry is updated.

7.2.8.3 GGM, SRCVLCHG, <volser>, <hex category>

This command can be used to selectively change the category of the CSG copy source volume from the CTG copy target cluster. It is only needed, if either SRCAT was not set by the user, or if the category change to the logical volume has failed.

The example below shows the situation:

- CTG copy completes.
- The last version check fails then the category of the CSG copy source volume is not changed though SRCCAT is set.
- The version check failed simply due to a network issue versus a real version check, so the TCDB update still occurs.
- The host TCDB is updated then the host has no access to the CSG copy source volume.

This command can be sent from a CTG attached host to the CTG then the command is forwarded to the CSG proxy server to change the category of the CSG copy source volume. Then, it should work as same as SRCCAT setting at a later point.

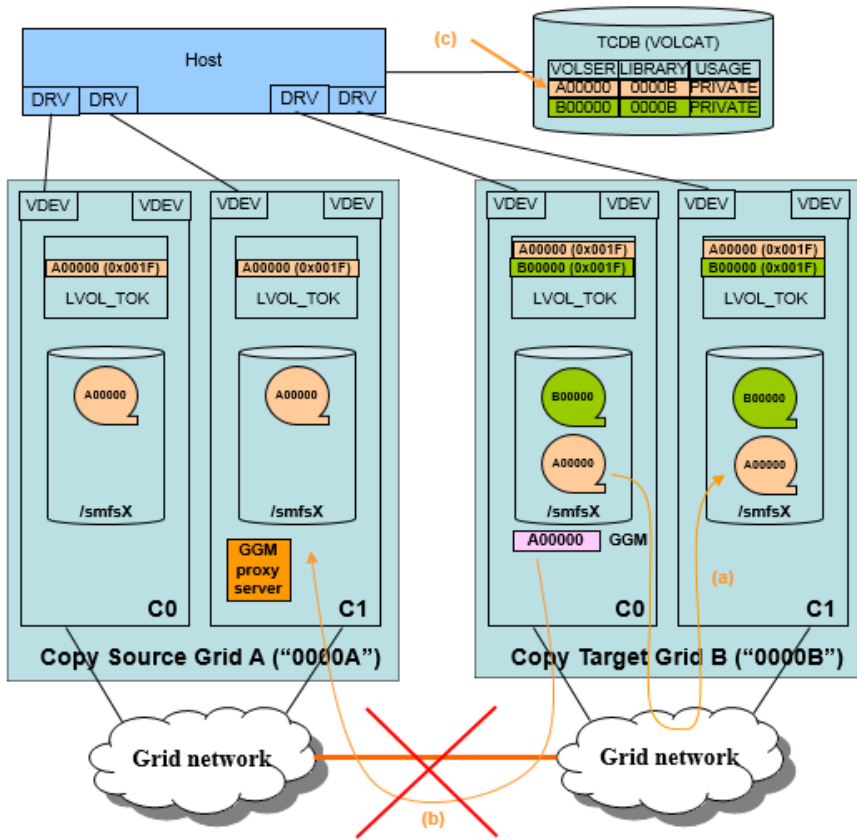

7.2.8.3 LI REQ, SRCVLCHG

(a) CTG copy completes

(b) The last version check fails to verify if the CSG still has the same data level when the CSG copy completes (due to the network error etc.).

- The category change of the CSG copy source volume is not done although SRCCAT is defined.

(c) The host TCDB is already updated and the host has no access to the CSG copy source volume.

When the CSG is at R5.1PGA1 and the logical volume in the CSG is the LWORM-retained volume, this command to change the CSG copy source volume's category to the scratch category fails if the LWORM retention setting of the volume does not allow to change the category to scratch.

The command syntax is:

LI REQ, <C0 in the CTG>, GGM, SRCVLCHG, Volser, Hex Category

An example of the result of the LI REQ command is listed below:

```
0010 CBR1020I PROCESSING LIBRARY COMMAND: REQ,BARR92C,GGM,SRCVLCHG,ZGS000,
0010 0001.
0010 CBR1280I LIBRARY BARR92C REQUEST. 063
0010 KEYWORDS: GGM,SRCVLCHG,ZGS000,0001
0010 -----
0010 GGM COPY QUEUE REQUEST V1 .0
0010 OPERATION SUCCESSFULLY COMPLETED
```

Note: If the category of the CSG copy volume is changed by LI REQ, SRCVLCHG command, a Task (Operation History) entry is always created in the CSG as same as at the successful GGM copy completion with SRCCAT setting:

Operation	Modify Logical Volumes
ID	520
Start Time	2015/6/17 17:15:17
End Time	2015/6/17 17:15:17
Duration	0 hours, 0 minutes, 0 seconds
Initiating User	service
Result	<input checked="" type="checkbox"/> Completed

Operation details:

The following constructs have been modified for the logical volume range, ZGS005 to ZGS005:
 Storage group: "No Change"
 Management class: "No Change"
 Storage class: "No Change"
 Data class: "No Change"

7.2.8.4 GGM, BVIRHIST, CLEAR, <ALL | volser>

GGM copy job history records are saved on the CSG copy target cluster persistently and they will not be deleted until the deletion is executed by LI REQ intentionally. These history records can be read through the BVIR process. If one million GGM copies are completed over a period of time, the BVIR request (GGM RESULT (refer to Appendix C)) will continue to surface all 1 million entries. If new jobs are queued, future requests will return the new entries as well as the previous 1 million. At some point, the user will likely want to clear this history table.

This LI REQ provides the capability to delete the unnecessary older history entries so they will no longer be returned in the BVIR request.

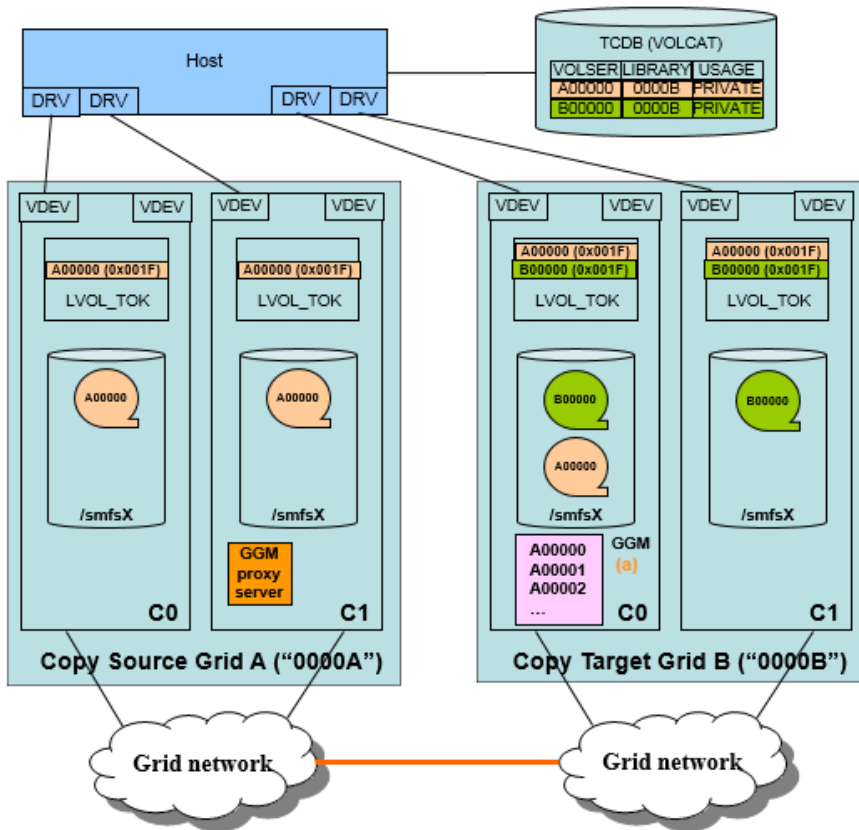

7.2.8.4 LI REQ, GGM, BVIRHIST, CLEAR

(a) All the pending and completed GGM copy job BVMR records are saved on the CSG copy target cluster only (i.e. C0 in the CTG).

(*) The BVMR records are not deleted unless BVIRHIST, CLEAR command clears them.

The command syntax is:

LI REQ, <C0 in the CTG>, GGM, BVIRHIST, CLEAR, <ALL | Volser>

A user can clear an entry for a specific volume or clear the entire log.

An example of the result of the LI REQ command is listed below:

```
0010 CBR1020I PROCESSING LIBRARY COMMAND: REQ,BARR92C,GGM,BVIRHIST,CLEAR,
ZGS000.
0010 CBR1280I LIBRARY BARR92C REQUEST. 071
0010 KEYWORDS: GGM,BVIRHIST,CLEAR,ZGS000
0010 -----
0010 GGM COPY QUEUE REQUEST V1 .0
0010 OPERATION SUCCESSFULLY COMPLETED
```

7.2.8.5 GGM, COPY, SUMMARY

This command is used to get the current GGM copy summary (CSG/CTG configuration/connection status/copy jobs).

The command syntax is:

LI REQ, <C0 in the CTG>, GGM, COPY, SUMMARY

An example of the result of the LI REQ command is listed below:

```

0010 GGM COPY SUMMARY V1 .0
0010 CTG SETTING: (A)
0010 CL:2 FUNCTION:ENABLED STATUS:START STATE:STARTED (1)
0010 IP_ADDR (PRI/ALT) = 10.11.130.11/ 10.11.131.11 (2)
0010 IP_ADDR (PRI2/ALT2) = 0.0.0.0/ 0.0.0.0
0010 MC/SC/DC/SG = RUN /*inherit/*inherit/*inherit (3)
0010 TGT_CAT/SRC_CAT = 0000x/0001x SEND_OP_MSG = ENABLE
0010 CPYCNT = 20 CPYCNT_CHG_STATUS = NONE (4)
0010 COPY_PROXY_ERR_CNT = 0 RESET_TIME = 1970-01-01-00.00.000000
-----
0010 CSG SETTING: (B)
0010 COMPOSITELIB = BA045
0010 PROXY = 4 PORT = 13616:
0010 IP_ADDR (PRI/ALT) = 10.11.100.16/ 10.11.101.16
0010 IP_ADDR (PRI2/ALT2) = 0.0.0.0/ 0.0.0.0
0010 COPY_SRC = 4:
0010 IP_ADDR (PRI/ALT) = 10.11.100.16/ 10.11.101.16
0010 IP_ADDR (PRI2/ALT2) = 0.0.0.0/ 0.0.0.0
-----
0010 CONNECTION STATUS: (C)
0010 PROXY CONFIGURED_PORTS: 2 LAST_USED_PORT: 0
0010 INTFC: N ADDRESS / ST / ERR / LAST_FAILED_TIME
0010 (1) : 0 10.11.100.16 / 0 / 0 / 1970-01-01-00.00.000000
0010 : 1 10.11.101.16 / 0 / 0 / 1970-01-01-00.00.000000
0010 COPYSRC CONFIGURED_PORTS: 2 LAST_USED_PORT: 0
0010 INTFC: N ADDRESS / ST / ERR / LAST_FAILED_TIME
0010 (2) : 0 10.11.100.16 / 0 / 0 / 1970-01-01-00.00.000000
0010 : 1 10.11.101.16 / 0 / 0 / 1970-01-01-00.00.000000
-----
0010 CSG COPY SUMMARY: (D)
0010 PENDING_CSG_COPY = 13 PENDING_CTG_COPY = 2
0010 ----- (1)
0010 VOLSER POSTED_TIME ST (2)
0010 -----
0010 ZGS005 2015-06-22-09.20.34.394222 0
0010 ZGS002 2015-06-22-09.20.19.427286 4
0010 ZGS004 2015-06-22-09.20.28.694142 4
0010 ZGS006 2015-06-22-09.20.56.136712 0
0010 ZGS007 2015-06-22-09.21.01.923147 0
0010 ZGS008 2015-06-22-09.21.07.527304 0
0010 ZGS009 2015-06-22-09.21.12.289713 0
0010 ZGS010 2015-06-22-09.21.18.293875 0
0010 ZGS011 2015-06-22-09.21.22.753986 0
0010 ZGS012 2015-06-22-09.21.27.767920 0
0010 MORE CSG COPIES EXIST

```

(A) This area provides the setting and status of the CSG copy target cluster in the CTG.

- (1) The cluster ID of the CSG copy target cluster in the CTG, the GGM function setting (enabled/disabled, start (idle)/stop (clear)) and the current state status are provided. The example shows:

- The CSG copy target cluster ID is CL2.
 - GGM is enabled and started.
- (2) The Grid network interface IP addresses which are used for the GGM function are provided. The example shows only two network interfaces (Primary and Alternate) are configured for the GGM function.
- (3) The GGM options set by LI REQ commands are provided. The example shows:
- Management Class/Storage Class/Data Class/Storage Group settings are FIXED (“RUN”)/INHERIT/INHERIT/INHERIT.
 - The target volume category is set to INHERIT (x0000) and the source volume category is set to x0001.
 - The operator message setting is ENABLE.
 - The number of the GGM copy count is 20. Currently, no CPYCNT request (including RUN/DEF) is running.
- (4) The communication failure status with the CSG proxy server is provided. The current error count and the last timestamp when the error count is reset because the count exceeds 1,000 and G0038 operator messages is surfaced. The example shows no error since the cluster becomes online.
- (B) This area provides the setting/configuration of the CSG.
- The example shows:
- The CSG composite library sequence number is “BA045”.
 - The proxy server cluster ID in the CSG is CL4. The port# for the proxy communication is 13616.
 - Only two network interfaces (Primary and Alternate) are configured for the GGM function at the CSG proxy server.
 - In R3.3, the CSG proxy server is the same cluster with the CSG copy source cluster. Same cluster ID and IP addresses must be seen at COPY_SRC values.
- (C) This area provides the network connection status from the CSG copy target cluster in the CTG to the CSG copy source (also proxy server) cluster in the CSG. The CSG copy tries to communicate with the proxy server to get the volume status first. Once it successfully completes, the actual copy is made. If the communication with the proxy server fails, no actual copy is attempted. Then, this area provides the network connection status for both the proxy and copy separately.
- (1) The proxy connection status. The example shows:
- 2 ports are configured (interface 0 and 1). The last used ports for the proxy communication is 0.
 - Both interfaces doesn't show any proxy error. When an error occurs, ST (status)/ERR (error count)/LAST_FAILED_TIME(error timestamp) is updated.
- (2) The CSG copy connection status. In R3.3, the same interfaces with the proxy communication should be seen. The example shows no error copy error.
- (D) This area provides the CSG copy summary.
- (1) The number of the pending GGM (CSG and CTG) copies (logical volumes) are provide. The example shows:
- Total 13 pending CSG copies exist on the CSG copy target cluster in the CTG.
 - Total 2 pending CTG copies exist in the CTG.
- (2) Up to 10 pending CSG copies status is provided. The volser, the timestamp when the CSG copy is queued and the copy job status are provided. The example shows:
- ZGS002/ZGS004 are just getting CSG copy (ST = 4). Others are ready for the CSG copy, but not yet attempted.

- More than 10 pending CSG copies exist (“MORE CSG COPIES EXIST” at the bottom of the lines).

Please refer to the Appendix B (16. “GGM, COPY, SUMMARY” command) for more details.

7.2.8.6 GGM, COPY, DETAIL, <volser>

This command is used to get the current GGM copy job details for the specific volser.

The command syntax is:

```
LI REQ, <C0 in the CTG>, GGM, COPY, DETAIL, Volser
```

An example of the result of the LI REQ command is listed below.

- The volume ZGS017 is copied from the CSG to CTG.
- CTG is 3-way Grid. CL2, CL5 and CL6 exist in the CTG.
- CL2 is the CSG copy target cluster in the CTG.
- CL4 is the CSG copy source cluster in the CSG.
- The storage construct name settings (MC/SC/DC/SG) are set to “RUN (FIXED)”/”INHERIT”/”INHERIT”/”INHERIT”.
- The management class “RUN” has the copy mode setting to have the copy on all clusters in the CTG (CL2/CL5/CL6).
- TGTCAT is set to “INHERIT”.
- SRCCAT is set to “x0001 (FIXED)”.
- OPMSG is set to “ENABLE”.

(A) CSG copy is queued and does not yet complete.

```
0010 GGM COPY QUEUE DETAIL V1 .0
0010 GGM VOLUME:ZGS017 CLUSTER:2 TOTAL:1 RECORD FOUND
0010 ENTRY:0 -----(1)----- (2)-----
0010 QUEUED TIME : 2015-06-23-03.26.21.498506 (3)
0010 CSG LAST TIME : 1970-01-01-00.00.00.000000
0010 COMPLETED TIME: 1970-01-01-00.00.00.000000
0010 CURRENT_GGM_STATUS: S(4)INAL_GGM_STATUS: N
0010 COMPLETION_CODE: x0000000000000000
0010 TVC_CLUSTER: -1 CSG_COPY_STATE: 0(5) CLUSTER : 01234567
0010 IMPORT_STATE: I RECALL_REQUIRED: N COPY_REQUIRED: NNNNNNNN
0010 CONSISTENT_COUNT: 0 VOLSIZE: 000000000000 CONSISTENT : NNNNNNNN
0010 CSG_DATA_LEVEL: 0000000000000000 CTG_DATA_LEVEL: 0000000000000000
0010 CONSTRUCTS: MC='RUN ' SC='*inherit' DC='*inherit' SG='*inherit' (6)
0010 CTG_VOL_CAT: 0x0000 CSG_VOL_CAT: 0x0001 OP_MSG_REQUIRED: Y
```

- (1) The volser is provided.
- (2) The cluster ID of the CSG copy target cluster in the CTG is provided.
- (3) The timestamp when the GGM (CSG) copy job was queued by LI REQ, <CSG copy target cluster>, GGM, QUEUE command is provided.
- (4) The current GGM copy status is provided. ‘S’ means “CSG copy is pending”.
- (5) The current CSG copy state is provided. 0 means “CSG copy is ready for the execution”.
- (6) GGM options set by LI REQ command AND this copy job inherited are provided. The example shows:

- Management Class/Storage Class/Data Class/Storage Group settings are FIXED (“RUN”)/INHERIT/INHERIT/INHERIT.
- The target volume category is set to INHERIT (x0000) and the source volume category is set to x0001.
- The operator message setting is ENABLE.

(B) CSG copy completes. CTG copy does not yet complete.

```

0010 GGM COPY QUEUE DETAIL V1 .0
0010 GGM VOLUME:ZGS017 CLUSTER:2 TOTAL:1 RECORD FOUND
0010 ENTRY:0 -----
0010 QUEUED TIME : 2015-06-23-03.26.21.498506
0010 CSG LAST TIME : 2015-06-23-03.30.05.000000 (1)
0010 COMPLETED TIME: 1970-01-01-00.00.00.000000
0010 CURRENT GGM STATUS: T (T) FINAL_GGM_STATUS: N
0010 COMPLETION_CODE: x0000000000000000 (9)
0010 TVC_CLUSTER: 4 (2) CSG_COPY_STATE: 2 (3) CLUSTER : 01234567
0010 (4) IMPORT_STATE: I (10) RECALL_REQUIRED: N (5) COPY_REQUIRED: NNNNNYYN
0010 CONSISTENT COUNT: 1 VOLSIZE: 06283377680 CONSISTENT : NNYNNNNN
0010 (6) CSG_DATA_LEVEL: 0000000000000104 CTG_DATA_LEVEL: 0000000000000000
0010 CONSTRUCTS: MC='RUN' SC=' ' DC=' ' SG=' ' (8)
0010 (7) CTG_VOL_CAT: 0x000F CSG_VOL_CAT: 0x0001 OP_MSG_REQUIRED: Y
    
```

- (1) The timestamp when the CSG copy completed is provided.
- (2) The copy source cluster ID (it's always the same CSG copy source cluster ID in R3.3) is provided.
- (3) Once the CSG copy completes, this field should show 2 (CSG copy completed).
- (4) This field provides the number of the consistent cluster count in the CTG. Once CSG copy completed, it should be 1.
- (5) The volume size is provided once the CSG copy completed.
- (6) The data level of the CSG copy source volume when the CSG copy completed is provided.
- (7) If TGTCAT is set to “INHERIT”, the CSG copy source volume category queried at the volume audit is set once the CSG copy completed.
- (8) If “INHERIT” is set to the storage construct by GGM, MC/SC/SG/DC library request command, the storage construct name which is assigned to the CSG copy source volume (retrieved at the volume audit when the CSG copy is attempted) is set once the CSG copy successfully completed. The volume of this example has “INHERIT” setting to SC/SG/DC but the default storage construct name is assigned when the CSG copy completes. This is because these storage construct names assigned to the CSG copy source volume are not defined on the CSG copy target cluster in the CTG. In that case, the default storage construct name is assigned (the missing storage construct name will not be created) automatically.
- (9) This area shows which cluster in the CTG requires the copy when the CSG copy completed, and which cluster in the CTG is consistent. The example shows CL2 is consistent (CL2 is the CSG copy target cluster), and CL5 and CL6 need the CTG copy but they are not yet consistent.
- (10) If a recall was required to copy the volume from the CSG copy source to target cluster, this field is ‘Y’. If no recall is required, it is ‘N’.
- (11) The current GGM copy status updated to ‘T’ means “CTG copy is pending”.

(C) One of two required CTG copies completes.

```

0010 GGM COPY QUEUE DETAIL V1 .0
0010 GGM VOLUME:ZGS017 CLUSTER:2 TOTAL:1 RECORD FOUND
0010 ENTRY:0 -----
0010 QUEUED TIME : 2015-06-23-03.26.21.498506
0010 CSG LAST TIME : 2015-06-23-03.30.05.000000
0010 COMPLETED TIME: 1970-01-01-00.00.00.000000
0010 CURRENT_GGM_STATUS: T FINAL_GGM_STATUS: N
0010 COMPLETION_CODE: x0000000000000000
0010 TVC_CLUSTER: 4 CSG_COPY_STATE: 2 CLUSTER : 01234567
0010 IMPORT_STATE: I (2) RECALL_REQUIRED: N COPY_REQUIRED: NNNNNYYN (1)
0010 CONSISTENT_COUNT: 2 VOLSIZE: 06283377680 CONSISTENT : NNYNNYYN
0010 CSG_DATA_LEVEL: 0000000000000104 CTG_DATA_LEVEL: 0000000000000000
0010 CONSTRUCTS: MC='RUN ' SC=' ' DC=' ' SG=' '
0010 CTG_VOL_CAT: 0x000F CSG_VOL_CAT: 0x0001 OP_MSG_REQUIRED: Y
    
```

- (1) The example shows CL5 completed the CTG copy and it's consistent.
- (2) The number of the consistent cluster count in the CTG is now 2 (CL2 and CL5).

(D) All CTG copies completes. GGM copy completes.

```

0010 GGM COPY QUEUE DETAIL V1 .0
0010 GGM VOLUME:ZGS017 CLUSTER:2 TOTAL:1 RECORD FOUND
0010 ENTRY:0 -----
0010 QUEUED TIME : 2015-06-23-03.26.21.498506
0010 CSG LAST TIME : 2015-06-23-03.30.05.000000
0010 COMPLETED TIME: 2015-06-23-03.36.32.000000 (1)
0010 (2) CURRENT_GGM_STATUS: C FINAL_GGM_STATUS: S (3)
0010 COMPLETION_CODE: x0000000000000000 (7)
0010 TVC_CLUSTER: 4 CSG_COPY_STATE: 2 CLUSTER : 01234567
0010 IMPORT_STATE: I (4) RECALL_REQUIRED: N COPY_REQUIRED: NNNNNYYN (6)
0010 CONSISTENT_COUNT: 3 VOLSIZE: 06283377680 CONSISTENT : NNYNNYYN
0010 CSG_DATA_LEVEL: 0000000000000104 CTG_DATA_LEVEL: 0000000000000104 (5)
0010 CONSTRUCTS: MC='RUN ' SC=' ' DC=' ' SG=' '
0010 CTG_VOL_CAT: 0x000F CSG_VOL_CAT: 0x0001 OP_MSG_REQUIRED: Y
    
```

- (1) The timestamp when the GGM copy completed (i.e. all the required CTG copies completed).
- (2) Once the CTG copies completed, this field should be 'C' (GGM copy completed).
- (3) This status should be 'S' (GGM copy successfully completed) when no error was found during the GGM copy activity.
- (4) The number of the consistent cluster count in the CTG is now 3 (CL2, CL5 and CL6).
- (5) This field provides the data level of the CSG copy source volume in the CSG when it's checked when the last CTG copy completed. The example shows the same data level (104) in CSG_DATA_LEVEL and CTG_DATA_LEVEL. This means the data level of the CSG copy source volume didn't change since the CSG copy started till the GGM (all required CTG) copy completed.
- (6) CL6 shows it's consistent.
- (7) The completion code (x0000 means SUCCESS).

When the GGM copy completes, it's called "the volume is imported" and IMPORT_STATE is set to 'I' (imported). While the state is "imported", GGM copy on the same volume can be executed (the data is re-copied) repeatedly. This is required when the volume's data is updated in the CSG and the data needs to be copied to the CTG again. Later, the copied volume in the CTG may be updated (written), then it's

no longer allowed to re-copy the data from the CSG to CTG. When the volume is updated in the CTG, the `IMPORT_STATE` is changed from 'I' to 'N'.

```

0010 GGM COPY QUEUE DETAIL V1 .0
0010 GGM VOLUME:ZGS017 CLUSTER:2 TOTAL:1 RECORD FOUND
0010 ENTRY:0 -----
0010 QUEUED TIME      : 2015-06-23-03.26.21.498506
0010 CSG LAST TIME   : 2015-06-23-03.30.05.000000
0010 COMPLETED TIME: 2015-06-23-03.36.32.000000
0010 CURRENT_GGM_STATUS: C FINAL_GGM_STATUS: S
0010 COMPLETION_CODE: x000000000000000000
0010 TVC_CLUSTER: 4      CSG_COPY_STATE: 2      CLUSTER      : 01234567
0010 IMPORT_STATE: N      RECALL_REQUIRED: N      COPY_REQUIRED: NNNNNYYN
0010 CONSISTENT_COUNT: 3 VOLSIZE: 06283377680 CONSISTENT  : NNYNNYYN
0010 CSG_DATA_LEVEL: 00000000000000104 CTG_DATA_LEVEL: 00000000000000104
0010 CONSTRUCTS: MC='RUN      ' SC='      ' DC='      ' SG='      '
0010 CTG_VOL_CAT: 0x000F  CSG_VOL_CAT: 0x0001  OP_MSG_REQUIRED: Y

```

Please refer to the Appendix B (17. “GGM, COPY, DETAIL” command) for more details.

7.2.8.7 GGM, CTG, RECOVER

During online processing or when GGM is initially configured and enabled, certain network configuration settings and tasks are completed allowing the CTG and CSG configurations to communicate. If the target cluster in the CTG is unable to communicate with the CSG proxy server in the CSG, it will no longer accept any GGM operations. The GGM state becomes `ONLINE_ERROR` as shown in the example:

```

0010 GGM COPY SUMMARY V1 .0                                GGM function is in ERROR state.
0010 CTG SETTING:
0010   CL:2   FUNCTION:ENABLED   STATUS:ERROR   STATE:ONLINE_ERROR
0010   IP_ADDR (PRI/ALT)   =   10.11.130.11/   10.11.131.11
0010   IP_ADDR (PRI2/ALT2) =   0.0.0.0/   0.0.0.0
0010   MC/SC/DC/SG = RUN   /*inherit/*inherit/*inherit
0010   TGT_CAT/SRC_CAT = 001Fx/0003x SEND_OP_MSG = ENABLE
0010   CPYCNT = 20 CPYCNT_CHG_STATUS = NONE
0010   COPY_PROXY_ERR_CNT = 0 RESET_TIME = 1970-01-01-00.00.00.000000
0010 -----
0010 CSG SETTING:
0010   COMPOSITELIB = BA045
0010   PROXY = 4 PORT = 13616:
0010   IP_ADDR (PRI/ALT)   =   10.11.100.16/   10.11.101.16
0010   IP_ADDR (PRI2/ALT2) =   0.0.0.0/   0.0.0.0
0010   COPY_SRC = 4:
0010   IP_ADDR (PRI/ALT)   =   10.11.100.16/   10.11.101.16
0010   IP_ADDR (PRI2/ALT2) =   0.0.0.0/   0.0.0.0
0010 -----
0010 CONNECTION STATUS:
0010   PROXY CONFIGURED_PORTS: 2 LAST_USED_PORT: -1
0010   INTFC: N   ADDRESS / ST / ERR / LAST_FAILED_TIME
0010     : 0   10.11.100.16 / 0 / 0 / 1970-01-01-00.00.00.000000
0010     : 1   10.11.101.16 / 0 / 0 / 1970-01-01-00.00.00.000000
0010   COPYSRC CONFIGURED_PORTS: 2 LAST_USED_PORT: -1
0010   INTFC: N   ADDRESS / ST / ERR / LAST_FAILED_TIME
0010     : 0   10.11.100.16 / 0 / 0 / 1970-01-01-00.00.00.000000
0010     : 1   10.11.101.16 / 0 / 0 / 1970-01-01-00.00.00.000000
0010 -----
0010 CSG COPY SUMMARY:
0010   PENDING_CSG_COPY = 1 PENDING_CTG_COPY = 0
0010 -----
0010   VOLSER POSTED_TIME   ST
0010 -----
0010   ZGS000 2015-06-29-09.16.23.186214 0 CSG copy is not processed.

```

In order to get out of this ONLINE_ERROR state, the communication with the CSG proxy server needs to be recovered. Possible causes may be:

- The network between the CSG copy target cluster and CSG proxy server cluster through the specific port is unavailable.
- The CSG proxy server in the CSG is down due to some reasons.

If the network is OK but the communication to the CSG proxy server is still not working, call IBM support to check the CSG proxy server status in the CSG.

Once the communication is restored, the following command can be used to repeat the network configuration and tasks portion which will then allow GGM functions to continue. The command syntax is:

```
LI REQ, <C0 in the CTG>, GGM, CTG, RECOVER
```

An example of the result of the LI REQ command is listed below:

```
0010 CBR1020I PROCESSING LIBRARY COMMAND: REQ,BARR92C,GGM,CTG,RECOVER.
0010 CBR1280I LIBRARY BARR92C REQUEST. 001
0010 KEYWORDS: GGM,CTG,RECOVER
0010 -----
0010 GGM OPERATION CHANGE REQUEST V1 .0
0010 OPERATION SUCCESSFULLY COMPLETED
```

Once the recovery succeeds, the GGM function state is changed from ONLINE_ERROR to STOPPED automatically:

```
0010 GGM COPY SUMMARY V1 .0
0010 CTG SETTING:
0010 CL:2 FUNCTION:ENABLED STATUS:STOP STATE:STOPPED
0010 IP_ADDR (PRI/ALT) = 10.11.130.11/ 10.11.131.11
0010 IP_ADDR (PRI2/ALT2) = 0.0.0.0/ 0.0.0.0
0010 MC/SC/DC/SG = RUN /*inherit/*inherit/*inherit
0010 TGT_CAT/SRC_CAT = 001Fx/0003x SEND_OP_MSG = ENABLE
0010 CPYCNT = 20 CPYCNT_CHG_STATUS = NONE
0010 COPY_PROXY_ERR_CNT = 0 RESET_TIME = 1970-01-01-00.00.00.000000
```

Then, the GGM function can again be started by LI REQ, <CSG copy target cluster>, GGM, CTG, START (, IDLE):

```
0010 CBR1020I PROCESSING LIBRARY COMMAND: REQ,BARR92C,GGM,CTG,START.
0010 CBR1280I LIBRARY BARR92C REQUEST. 007
0010 KEYWORDS: GGM,CTG,START
0010 -----
0010 GGM OPERATION CHANGE REQUEST V1 .0
0010 OPERATION SUCCESSFULLY COMPLETED
```

```
0010 GGM COPY SUMMARY V1 .0
0010 CTG SETTING:
0010 CL:2 FUNCTION:ENABLED STATUS:START STATE:STARTED
0010 IP_ADDR (PRI/ALT) = 10.11.130.11/ 10.11.131.11
0010 IP_ADDR (PRI2/ALT2) = 0.0.0.0/ 0.0.0.0
0010 MC/SC/DC/SG = RUN /*inherit/*inherit/*inherit
0010 TGT_CAT/SRC_CAT = 001Fx/0003x SEND_OP_MSG = ENABLE
0010 CPYCNT = 20 CPYCNT_CHG_STATUS = NONE
0010 COPY_PROXY_ERR_CNT = 0 RESET_TIME = 1970-01-01-00.00.00.000000
```

Note: If the GGM function is no longer required, it is possible to disable the GGM function from the ONLINE_ERROR state by LI REQ, <CSG copy target cluster>, GGM, CTG, DISABLE command directly. But if any pending CSG copy job still remains, it's required to remove them by LI REQ, <CSG copy target cluster>, GGM, REMOVEQ or LI REQ, <CSG copy target cluster>, GGM, CTG, STOP, CLEAR command prior to disabling the GGM function.

7.2.9 Existing LI REQ commands for the GGM copy

In order to avoid any confusion how existing LI REQ commands and behaviors are affected by the GGM activity, this section describes how GGM activity affects existing LI REQ command outputs.

7.2.9.1 LI REQ, cluster, COPY, SUMMARY

- The CSG copy count is not included in the COPY, SUMMARY output.
- The CTG copy count (copies among CTG peers) is included in the COPY, SUMMARY output.

7.2.9.2 LI REQ, cluster, COPY, ACTIVITY

- The CSG copy count is not included in the COPY, ACTIVITY output.
- The CTG copy count (copies among CTG peers) is include in the COPY, ACTIVITY output

7.2.9.3 LI REQ, cluster (composite), STATUS, GRID

- Both the CSG and CTG copy count are included in the STATUS, GRID output.
- The CSG copy doesn't provide the volume size (size is always 0).

7.2.9.4 LI REQ, cluster, GRIDCNTL, COPY, ENABLE/DISABLE

- Both CSG and CTG copy are affected by GRIDCNTL, COPY, ENABLE / DISABLE command. Therefore, if the CSG copy target cluster in the CTG has copies disabled, it will have the same effect as GGM STOP for inbound CSG copies. CTG copies will honor the copy disable state for both inbound copies and source selection.
- If the copies are disabled within the CSG copy source cluster, the CSG copy doesn't proceed because the only copy source cluster becomes unavailable for the copies. It can be used as a way to prevent/allow the outbound copies at the CSG copy source (i.e. proxy server) cluster if it is required at the CSG side to turn off/on the ability for GGM copies to be pulled.

7.2.9.5 LI REQ, cluster (composite), LVOL

- The LVOL information provided by an incomplete CSG copy may be misleading, so its contents should be ignored until the CSG copy completes with success.

7.2.9.6 LI REQ, cluster, SETTING, ALERT, PCPYLOW/PCPYCRIT, <value>

- Any pending CSG copy in the queue are not included in the threshold alert settings PCPYLOW and PCPYCRIT.
- The CTG copy (copies among CTG peers) is included in the threshold alert settings PCPYLOW and PCPYCRIT.

7.2.9.7 LI REQ, cluster, SETTING, THROTTLE, DCOPYT/DCTAVGTD, <value>

- The DCOPYT settings on the CSG copy source cluster are applied to the CSG copy as it's pulled from the CSG to the CTG.
- CTG copies (copies among the CTG peers) will honor all DCOPYT settings within the CTG clusters.

7.2.9.8 LI REQ, cluster, SETTING, CPYCNT, RUN/DEF, <value>

- The setting of CPYCNT does not alter the CSG copy processes. The CSG copy process have their own dedicated count parameter as part of the LI REQ GGM settings.
- The setting of CPYCNT will affected to the copy job count for the CTG copy (copies among the CTG peers) given they use standard grid replication processes.

7.2.9.9 *LI REQ, cluster, SETTING, COPY, TIMEOUT, <value>*

- This TIMEOUT value is used for both CSG copies and CTG copies.

7.2.9.10 *LI REQ, cluster, SETTING, COPY, SCRATCH, ALWAYS/NEVER/NONTDLY*

- The SCRATCH setting is ignored by CSG and CTG copies. But if FORCECMP is issued and the volume's category is changed to the scratch category while a peer cluster in the CTG is unavailable, the CTG copy which is attempted later will honor SCRATCH setting.

7.2.9.11 *LI REQ, cluster, SETTING, EXISTDEL, [CRITERIA, STALE/ALL/NONE] or [WHEN, ATCLOSE/AUTO]*

- As described in the section 7.2.4.2, the CSG copy target cluster assigns the 'E' (Exist) copy mode to the completed CSG copy target volume if it has the 'N' (No) copy mode. The setting of EXISTDEL can be used to delete such CSG copy target volume's which transition to the 'E' copy mode. But, all CTG copies must be completed before the 'E' instance or instances can be removed through this setting.

7.2.10 *GGM Copy activity in the statistical data*

The outbound CSG copy activity is recorded within the statistical data on the CSG copy source cluster (Hnode Grid Historical Record (Data Type x33)). The Grid-Cluster Container X (X is the cluster ID of the CSG copy source cluster) "Data Transferred From a Cluster's Cache to Other Clusters as part of a Copy Operation" record contains the number of bytes transferred from the cluster as part of a copy operation. In order to distinguish the CSG copy from the other normal Grid copies in the CSG, the CSG copy activity is recorded in the record for the local cluster itself. A standard grid cluster will never copy to itself, so this self-index position is free to be used by outbound CSG copy activity. For example, if the ID of the CSG copy source cluster is X, the record for cluster X to X includes the CSG copy activity. MI historical summary provides the CSG activity as "Link Copy Out MiB/s" as shown below, which includes all copy activity to its own CSG peers.

"[4]" (#BA54A): Historical Summary

Grid Summary > Cluster Summary > Historical Summary

Current cluster selected:

Clusters

- "[1]" (#BA45B)
- "[4]" (#BA54A)

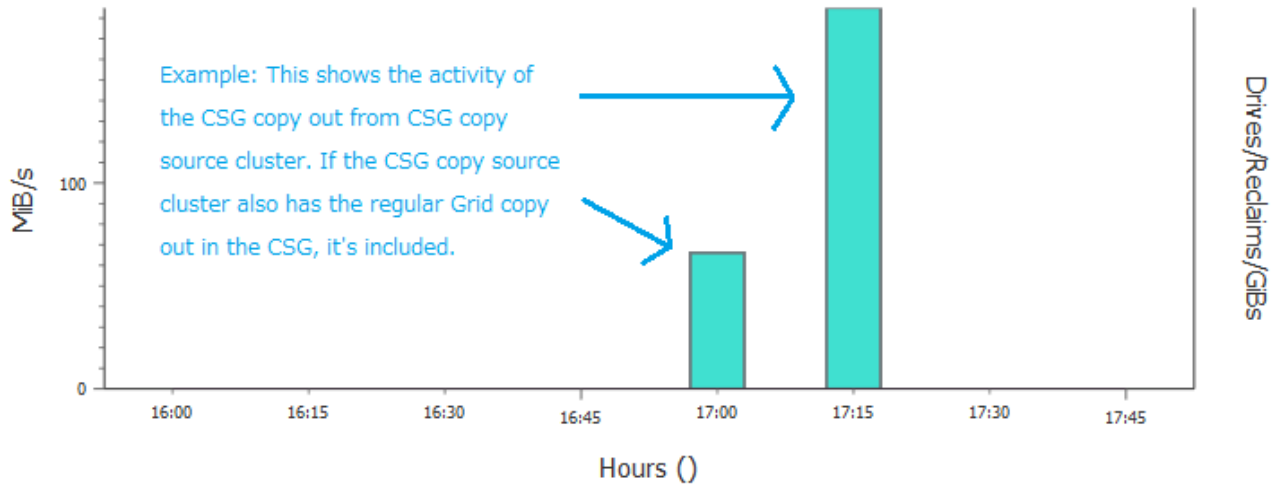

Start Date: 7/7/2015 Start Time: 4:00 PM

End Date: 7/7/2015 End Time: 6:00 PM

LEGEND

- Link Copy Out MIB/s
- Link Copy In MIB/s
- Read From Tape MiB/s
- GiBs to Copy

Configure Chart

Note: The CSG copy activity is recorded in the statistical data in the CSG (CSG copy source cluster) as regular outbound copy activity, but not in the CTG (CSG copy target cluster).

VEHSTATS reports GGM copy activity from the CSG statistics data. This is an example of the output from H33GRID (the values in red show the GGM (CSG) copy activity):

```
(C) IBM REPORT=H33GRID (15254) HNODE HISTORICAL PEER-TO-PEER ACTIVITY RUN ON 28SEP2015 @ 22:32:31 PAGE 1
GRID#=C1077 DIST_LIB_ID= 0 VNODE_ID= 0 NODE_SERIAL=CL09088G VE_CODE_LEVEL=008.021.000.0178 UTCPLUS=09
MIB is 1024 based, MB is 1000 based
```

TO RECEIVE	MIB TO RECEIVE	AV. DEF. TO QUEUE	AV. RUN TIME	# LVOLS	LVOLS	MB TO RUN	LVOLS	MB TO DEF	LVOLS	MB TO SYNC	LVOLS	MB TO COPY	CALC MIB/SEC	MIB TO GGM COPY	GGM MIB/SEC	V. MNTS DoneBy DLT	V. MNTS DoneBy DLT	V. MNTS DoneBy DLT	
12:00:00	0	0	0	0	0	0	0	0	0	0	0	0	0	0	0	0	0	0	0
12:15:00	0	0	0	0	0	0	0	0	0	0	0	0	0	0	0	0	0	0	0
12:30:00	0	0	0	0	0	0	0	0	0	0	0	0	0	173575	192.8	0	0	0	0
12:45:00	0	0	0	0	0	0	0	0	0	0	0	0	0	193955	215.5	0	0	0	0
13:00:00	0	0	0	0	0	0	0	0	0	0	0	0	0	182828	203.1	0	0	0	0
13:15:00	0	0	0	0	0	0	0	0	0	0	0	0	0	47442	52.7	0	0	0	0
13:30:00	0	0	0	0	0	0	0	0	0	0	0	0	0	0	0	0	0	0	0

The CTG copy activity (copies among CTG peers) is recorded in the CTG just as regular copies are recorded.

7.2.11 Deferred Copy Read Throttle to CSG copy

The CSG copy or pull from the CSG to the CTG appears to the CSG copy source cluster as a standard deferred outbound copy. Therefore, if the CSG copy source cluster is busy, the deferred copy read throttle is applied to the CSG copies on the CSG copy source cluster, this ensures that the host I/O to the

CSG copy source cluster is not impacted by deferred outgoing CSG copies. The standard DCTAVGT and DCOPYT settings within the CSG source cluster are honored for this activity. There is no dedicated throttle just for CSG copy activity.

7.2.12 CSG and CTG link paths handling

7.2.12.1 CSG and CTG link path selection

Up to four GGM CSG to CTG links can be configured to be used by the GGM replication function. When multiple links are configured and operational between the CSG and CTG, the CSG copy processes will choose a link using a simple random selection technique. Therefore, each link should be selected equally. The standard TS7700 link selection algorithm with automatic load balancing is not used for CSG copies, so each link should be fairly similar in capabilities (e.g. bandwidth, latency, error rate). Which link is used for the non-data movement related proxy communications is selected in a round robin fashion.

The last used port for either copy or proxy activity can be viewed in the connection status field of the GGM, COPY, SUMMARY output. The example below shows the last used port for the proxy communication is 1 (configured to the CSG cluster's address 10.11.101.16) and the port for the data copy is 0 (configured to the CSG cluster's address 10.11.100.16).

```
0010 -----
0010 CONNECTION STATUS:
0010  PROXY CONFIGURED_PORTS: 2  LAST_USED_PORT: 1
0010    INTFC: N          ADDRESS / ST /   ERR / LAST_FAILED_TIME
0010      : 0          10.11.100.16 / 0 /   0 / 1970-01-01-00.00.00.000000
0010      : 1          10.11.101.16 / 0 /   0 / 1970-01-01-00.00.00.000000
0010  COPYSRC CONFIGURED_PORTS: 2  LAST_USED_PORT: 0
0010    INTFC: N          ADDRESS / ST /   ERR / LAST_FAILED_TIME
0010      : 0          10.11.100.16 / 0 /   0 / 1970-01-01-00.00.00.000000
0010      : 1          10.11.101.16 / 0 /   0 / 1970-01-01-00.00.00.000000
0010 -----
```

7.2.12.2 CSG and CTG link error handling

When a CSG copy fails when attempting to use a selected link (either for the proxy communication or data copy), GGM function will mark the link status as degraded and subsequent CSG copies will avoid using the degraded link so long as other links exist and are marked as non-failed.

The example below shows the proxy server communication using the port 0 failed once (ERR count = 1) at LAST_FAILED_TIME and the status (ST) is changed to the degraded state (ST=1).

```

0010 -----
0010 CONNECTION STATUS:
0010 PROXY CONFIGURED_PORTS: 2 LAST_USED_PORT: 1
0010 INTFC: N ADDRESS / ST / ERR / LAST_FAILED_TIME
0010 : 0 10.11.100.16 / 1 / 1 / 2015-07-09-08.10.54.000000
0010 : 1 10.11.101.16 / 0 / 0 / 1970-01-01-00.00.00.000000
0010 COPYSRC CONFIGURED_PORTS: 2 LAST_USED_PORT: 1
0010 INTFC: N ADDRESS / ST / ERR / LAST_FAILED_TIME
0010 : 0 10.11.100.16 / 0 / 0 / 1970-01-01-00.00.00.000000
0010 : 1 10.11.101.16 / 0 / 0 / 1970-01-01-00.00.00.000000
0010 -----

```

The example below shows replicating a volume using port 0 failed once (ERR count = 1) at LAST_FAILED_TIME and the status (ST) is changed to the degraded state (ST=1).

```

0010 -----
0010 CONNECTION STATUS:
0010 PROXY CONFIGURED_PORTS: 2 LAST_USED_PORT: 1
0010 INTFC: N ADDRESS / ST / ERR / LAST_FAILED_TIME
0010 : 0 10.11.100.16 / 1 / 1 / 2015-07-09-08.10.54.000000
0010 : 1 10.11.101.16 / 0 / 0 / 1970-01-01-00.00.00.000000
0010 COPYSRC CONFIGURED_PORTS: 2 LAST_USED_PORT: 0
0010 INTFC: N ADDRESS / ST / ERR / LAST_FAILED_TIME
0010 : 0 10.11.100.16 / 1 / 1 / 2015-07-09-08.21.17.000000
0010 : 1 10.11.101.16 / 0 / 0 / 1970-01-01-00.00.00.000000
0010 -----

```

To help re-introduce failed links back into the selection algorithm, a background CSG and CTG link check routine runs once per fifteen minutes. It will attempt a link check handshake against those links which are marked degraded. If the link check also fails, the link status is updated from the degraded state to the dead state (ST=2).

The example below shows that link 0 for the proxy communication is in the dead state because both a communication failure occurred and the later link check also failed. The error count is incremented due to the link check failure (ERR=2).

```

0010 -----
0010 CONNECTION STATUS:
0010 PROXY CONFIGURED_PORTS: 2 LAST_USED_PORT: 1
0010 INTFC: N ADDRESS / ST / ERR / LAST_FAILED_TIME
0010 : 0 10.11.100.16 / 2 / 2 / 2015-07-09-08.25.52.000000
0010 : 1 10.11.101.16 / 0 / 0 / 1970-01-01-00.00.00.000000
0010 COPYSRC CONFIGURED_PORTS: 2 LAST_USED_PORT: 1
0010 INTFC: N ADDRESS / ST / ERR / LAST_FAILED_TIME
0010 : 0 10.11.100.16 / 1 / 1 / 2015-07-09-08.21.17.000000
0010 : 1 10.11.101.16 / 0 / 0 / 1970-01-01-00.00.00.000000
0010 -----

```

If the good (ST=0) and degraded (ST=1) (or dead (ST=2)) links exist, the link with good state is always selected. But when all links between the CSG and CTG fail (ST=1 or 2), CSG copies still try to use them regardless of the current link state (the link may or may not be already recovered). The order in which state of the link is selected is good (ST=0), degraded (ST=1) then dead (ST=2).

The background link check routine will continue to attempt a link test against dead links too every 15 minutes allowing dead links to also transition back to an operational state. If the link check routine finds the degraded or dead link is OK, the status and error count is reset.

```

0010 -----
0010 CONNECTION STATUS:
0010 PROXY CONFIGURED_PORTS: 2 LAST_USED_PORT: 1
0010 INTFC: N ADDRESS / ST / ERR / LAST_FAILED_TIME
0010 : 0 10.11.100.16 / 2 / 2 / 2015-07-09-08.25.52.000000
0010 : 1 10.11.101.16 / 0 / 0 / 1970-01-01-00.00.00.000000
0010 COPYSRC CONFIGURED_PORTS: 2 LAST_USED_PORT: 1
0010 INTFC: N ADDRESS / ST / ERR / LAST_FAILED_TIME
0010 : 0 10.11.100.16 / 0 / 0 / 1970-01-01-00.00.00.000000
0010 : 1 10.11.101.16 / 0 / 0 / 1970-01-01-00.00.00.000000
0010 -----

```

Note: The background process which runs each 15 minutes will only attempt to verify degraded links which have been marked degraded for at least 10 minutes. It will also attempt to verify dead links which have been marked dead for at least 20 minutes. When the link is marked dead by the background process, the link may take up to 30 minutes before it's checked again because the background process runs each 15 minutes and the dead link won't be checked for 20 minutes at least ($20 < 15 * 2 = 30$ minutes).

When a proxy communication fails when attempting to initiate a CSG copy, the CSG copy target cluster will quickly attempt to retry down all configured links. If all attempts fail, the CSG copy is delayed and the copy proxy error count (COPY_PROXY_ERR_CNT) is incremented. When this count is incremented, a complete outage of the network, the proxy server or problem within the CTG is occurring. If the network between the CSG and CTG and the CSG copy source cluster are believed to be working properly, it may require an IBM Support Representative to verify the GMM settings and initiate a network test.

The example below shows the CSG copy fails five times due to the proxy communication failure.

```

0010
0010 GGM COPY SUMMARY V1 .0
0010 CTG SETTING:
0010   CL:5   FUNCTION:ENABLED   STATUS:START   STATE:STARTED
0010   IP_ADDR (PRI/ALT)   =   10.11.130.40/   10.11.131.40
0010   IP_ADDR (PRI2/ALT2) =   0.0.0.0/   0.0.0.0
0010   MC/SC/DC/SG = *default/*inherit/*inherit/*inherit
0010   TGT_CAT/SRC_CAT = 000F×/0003× SEND_DP_MSG = DISABLE
0010   CPYCNT = 20 CPYCNT_CHG_STATUS = NONE
0010   COPY_PROXY_ERR_CNT = 5 RESET_TIME = 1970-01-01-00.00.00.000000
0010 -----
0010 CSG SETTING:
0010 COMPOSITELIB = BA045
0010 PROXY = 4 PORT = 13616:
0010   IP_ADDR (PRI/ALT)   =   10.11.100.16/   10.11.101.16
0010   IP_ADDR (PRI2/ALT2) =   0.0.0.0/   0.0.0.0
0010 COPY_SRC = 4:
0010   IP_ADDR (PRI/ALT)   =   10.11.100.16/   10.11.101.16
0010   IP_ADDR (PRI2/ALT2) =   0.0.0.0/   0.0.0.0
0010 -----
0010 CONNECTION STATUS:
0010 PROXY CONFIGURED_PORTS: 2 LAST_USED_PORT: 1
0010   INTFC: N   ADDRESS / ST /   ERR / LAST_FAILED_TIME
0010   : 0   10.11.100.16 / 1 /   5 / 2015-07-09-09.05.08.000000
0010   : 1   10.11.101.16 / 1 /   5 / 2015-07-09-09.06.23.000000
0010 COPYSRC CONFIGURED_PORTS: 2 LAST_USED_PORT: 1
0010   INTFC: N   ADDRESS / ST /   ERR / LAST_FAILED_TIME
0010   : 0   10.11.100.16 / 0 /   0 / 1970-01-01-00.00.00.000000
0010   : 1   10.11.101.16 / 0 /   0 / 1970-01-01-00.00.00.000000
0010 -----

```

Note: When the proxy communication fails during the initial steps of a CSG copy, no actual volume copy is attempted and therefore the data error counts won't increase.

When the COPY_PROXY_ERR_CNT exceeds 1,000 and the OPMSG setting is enabled for the failed CSG copy, the operator message (G0038) is surfaced to notify the excessive CSG copy failures due to the proxy communication. Please refer to the Appendix B “15. GGM, OPMSG, ENABLE | DISABLE command” for the actual message to be surfaced.

Also, TS7700 GGM network health check is periodically performed and will surface an intervention message when it detects the communication failure with the proxy server. Please refer to Appendix D for the details.

7.2.13 Using Write Protect Mode on the CSG copy source/target cluster

7.2.13.1 Write Protect Mode on the CSG copy source cluster

The CSG copy source cluster can be put to Write Protect Mode in order to prevent the CSG copy volume from being updated during or after the GGM. This section provides three use cases regarding the Write Protect Mode state of the CSG copy source cluster.

7.2.13.1.1 Write Protect Mode is disabled

Write Protect Mode is disabled on the CSG copy source cluster. The host attached to the CSG copy source cluster is able to update the CSG copy source volume during and after GGM copy.

The host can update the CSG copy volume after GGM copy completes and before the host TCDB/TMS update occurs. And this will give the timing window that the CTG has the older data than the CSG copy source volume when the host TCDB/TMS is updated even if the manual data level check is done after GGM copy completes.

7.2.13.1.2 Write Protect Mode is enabled (no excluded category is defined)

Write Protect Mode is enabled with no excluded category defined on the CSG copy source cluster. The host attached to the CSG copy source cluster is not able to update the CSG copy source volume during and after GGM copy at all.

This completely eliminates the timing window that CTG has the older data than the CSG copy source volume when the host TCDB/TMS is updated. But the host attached to the CSG copy source cluster can't modify any tapes in the CSG copy source cluster and it may not be allowed for some customers.

Note: LI REQ, <cluster>, GGM, SRCCAT, <hex category> will not work because the source volume category change fails due to the write protect mode, then the corresponding completion code (x0040) is set.

7.2.13.1.3 Write Protect Mode is enabled (excluded categories are defined)

Write Protect Mode is enabled with the excluded categories defined on the CSG copy source cluster. This use case will ensure the data level check result after GGM copy completes:

- The CSG copy source volumes before the GGM copies complete as well as the volumes which do not require the GGM copies on the CSG are in the excluded category, so the host still can update these volumes.
- LI REQ, <cluster>, GGM, SRCCAT, <hex category> is used to change the source volume category after GGM copy completes. The <hex category> must be the write protect category on the CSG copy source cluster.
- After GGM copy completes, the category of the CSG copy source volume is changed to the write protect category set by SRCCAT command. The CSG copy source volume will not be updated once its category is changed.
- The manual data level check is done to verify if the CSG copy source and target volumes still have the same data or not, then the host TCDB/TMS is updated based off of the check result securely.

7.2.13.2 Write Protect Mode on the CSG copy target cluster

The CSG copy target cluster cannot be put to Write Protect Mode. When a GGM CSG copy job is queued, its category is set to xFF15 (import pending category) initially and the category is changed to the expected one once GGM copy completes. If the CSG copy target cluster is in Write Protect Mode, the category change fails then GGM copy doesn't complete. You cannot put the CSG copy target cluster to Write Protect Mode.

8 z/OS operation scenarios

This chapter describes z/OS operations related to supporting GGM. The first operation deals with selecting which logical volumes should be copied by GGM. The next involves an operation that helps automate the GGM copy for each candidate volume. Last, an operation is described which will help update the host catalogs so that the volumes which are successfully replicated can be accessed from their new location in the CTG.

After a logical volume is copied from the CSG to the CTG, a z/OS instance which is connected to the CTG is not initially aware of the newly accessible volume. A manual update of the z/OS TCDB (Tape Configuration Database) and TMS (Tape Management System (DFSMSrmm, CA-1 etc.)) is required before the volume is accessible within its new location.

There are several scenarios that may present themselves in the customer environment. Each scenario may require different tasks to be performed. Within this document, different scenarios are described. For simplicity, each scenario assumes single LPAR system/plexes with a common TCDB and TMS per system/plex.

8.1 Scenario 1 (Single LPAR/Plex connected to both CSG and CTG)

The customer's LPAR is connected to both Grids (CSG and CTG). The customer wants to move some or all of the data from the CSG to CTG. Since it is a single LPAR/Plex, the tape volume catalog, tape management system (TMS) and user catalogs are all on the same system and shared between the CSG and CTG. This is the simplest scenario given only the volume's location needs to be updated in the host catalogs.

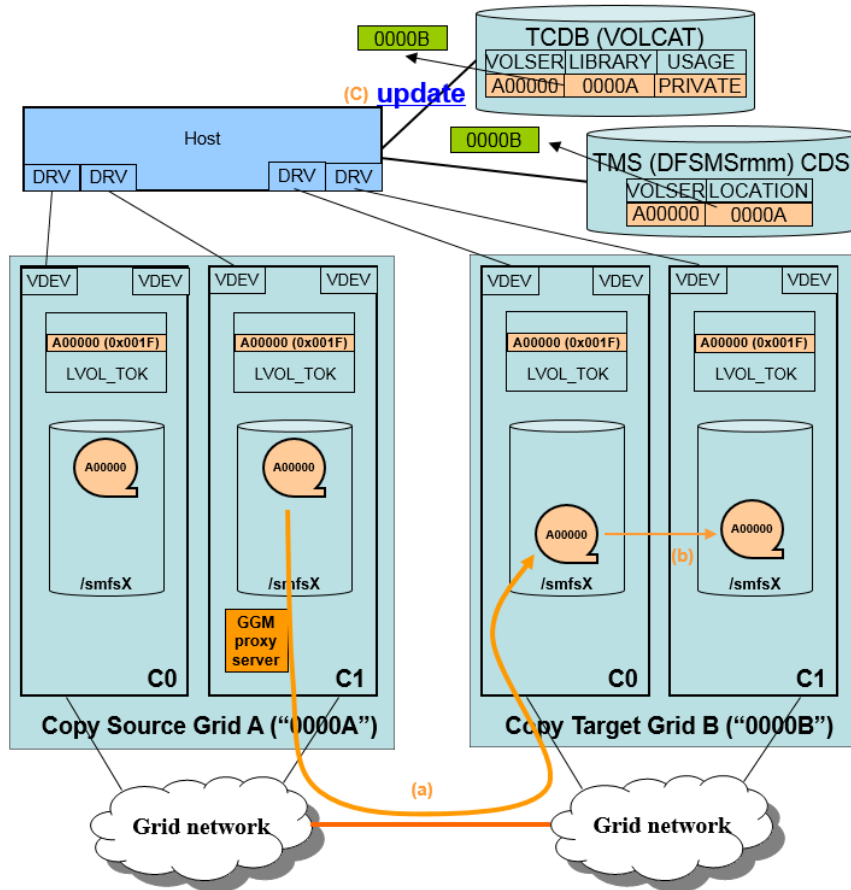

8.1 LPAR is connected to the both CSG and CTG

(a) CSG copy completes

(b) CTG copy completes

(c) TCDB/TMS is updated.

[Volume candidate list generation]

You must first generate a list of logical volumes to be copied by GGM. Even if all volumes will be copied, a volume list is still required. You can use the VOLLIST tool in tapetools which supports a wide range of TMS products such as DFSMSrmm, CA-1, TLMS, Control-T and ZARA to select the logical volumes needing to be copied. Many selection criteria variables are provided in the VOLLIST tool, such as:

- LOCATION(composite library name)
- STATUS(private only or include scratch)
- EXPDT
- CREDIT
- VOLSER range
- Catalog status
- Program name
- Job name
- System name
- DSNNAME etc,

These parameters can be used to create a more selective volume list. If your TMS is not supported or you do not want to rely on a list generated off of your TMS, you can create a volume list manually. In all cases, a list must be used for input into the next step.

More than 10,000 GGM QUEUE commands cannot be queued at a time. When VOLLIST tool generates more than 10,000 candidate volume list, you should reduce the generated volume list by changing the selection criteria.

[GGM copy operation]

The low level GGM function requires that the LIBRARY REQUEST GGM QUEUE command be invoked for each candidate logical volume. The GGMT00L1 is provided to help automate this process. The volume list created previously is used as input into the GGMT00L1 which generates a list of LIBRARY REQUEST GGM QUEUE commands in the DDNAME=GGMQE. If the CSG source cluster is a TS7720 (or contains most of its source content in disk cache), you can use the ISSUECMD tool to issue the LIBRARY REQUEST GGM QUEUE commands that were generated by the GGMT00L1 tool. When using the ISSUCMD tool, you can specify a wait interval between each command with the LRDELAY parameter. Given each QUEUE request must complete before the next is issued, a delay is recommended. The default LRDELAY=3(sec) is recommended to avoid such a collision that would produce the following failure:

"VOLUME VVVVVV INSERT FAILURE".

Note: Even though GGM QUEUE command handling is improved at the code level of R4.0 (8.40.x.x), it is still recommended to use 1 or more seconds LRDELAY for continuous operation in safety.

If the CSG copy source cluster is a TS7720T or TS7740 and much of the source content resides on back end physical tape, you should use the GGMSORT tool first. The GGMSORT tool will sort the LIBRARY REQUEST GGM QUEUE commands generated by the GGMT00L1 tool into an order that optimizes the volume locations on back end physical tape. GGMSORT uses BVIR Volume Map output to sort the logical volumes to be copied by GGM based off of the logical and physical volume relationship. BVIR Volume Map can be gotten by BVIRVTS tapetool with TYPE=VOL parameter. Up to 4 concurrent physical volume recalls can occur on the CSG copy source cluster if multiple GGM QUEUE requests are running and the logical volumes are stacked on different physical volumes. If the physical drive resource usage should be restricted on the CSG copy source cluster, it may be required to control issuing GGM QUEUE commands so that the GGM copy recalls can occur from only 1 physical tape volume at a time. On this situation, you can select logical volumes on a physical volume by filtering BVIR Volume Map output with DFSORT etc. prior to using GGMSORT.

Additionally, GGMSORT checks if the CSG copy source cluster has a valid copy on it. Even if the CSG copy source cluster is TS7720, you should execute GGMSORT prior to ISSUCMD. GGMSORT uses BVIR Volume Status. This can be gotten by BVIRMES tapetool.

Even though GGMSORT prepares 4 concurrent recalls at a time, recall by GGM is not so efficient. So if you need more recall speed, you might consider to use PRESTAGE tapetools in order to recall the required logical volumes prior to GGM CSG copies instead of GGMSORT.

If any GGM copy candidate volumes are reported that they have no valid copy on the CSG copy source cluster, you must make sure the reason why it is reported. If the reason is valid (for example, the CSG copy source cluster is assigned to "No copy mode"), it is required to copy the data to the CSG copy source cluster, or reconfigure GGM configuration to have the new CSG copy source cluster which has the valid copy in the CSG (IBM SSR is required to reconfigure GGM). If you bypass this GGMSORT step, GGM copy will fail with the copy completion code with 0x0080 (CSG copy failed because no copy source data was found) if the CSG copy source cluster has no valid copy. Please refer to Appendix B "17 GGM, COPY, DETAIL, <volser>, command" to check the GGM copy completion code.

Once the list is sorted, it should then be used as input into the ISSUECMD.

Once one or more volumes are queued for GGM copy, you can monitor the status and check the copy result using one or more of the following methods.

(1) Checking the status

(A) LI REQ, distlib, GGM, COPY, SUMMARY command

Use this command to check the current pending GGM copy status. The PENDING_CSG_COPY and PENDING_CTG_COPY count fields can be used to determine if the queued copies have completed or not. But, keep in mind that a completion may not mean success and you should check that each GGM copy has successfully completed by using one of the following methods (C) or (D).

(B) BVIR GGM COPY STATUS

You can use this tool to check the current pending GGM copy status in batch like the above (1) method. When all the requested GGM copy complete, BVIR GGM STATUS reports "NO GGM COPY RECORD(S) EXIST." But you must check the each GGM copy has successfully completed or not by using the following (C) or (D).

(2) Checking the result

(C) Completion messages surfaced to the host when OPMSG=ENABLE

Using LI REQ, distlib, OPMSG, ENABLE, you can allow a completion message for each copied volume to be surfaced to all connected hosts of the CTG. Within the message, CC provides the final GGM copy completion code. Please refer to Appendix B (17. "GGM, COPY, DETAIL") to check the value reported in CC field.

```
CBR3750I Message from library ctg-distlib: G0036 Distributed Library
Ctg-libid completed GGM copy of volume volser from the composite library
Csg-libid with CC 0.
```

(D) BVIR GGM COPY RESULT

This BVIR tool provides the GGM history status of all previously queued GGM copies, including details about the volume as well as the completion status. This is the preferred method to find the final status of GGM copies.

2 tapetools are provided:

- BVIRGGM kicks a BVIR GGM COPY RESULT job.
- GGMINFO summarizes the output of BVIRGGM.

Note: Keep in mind that the history will continue to be returned for each request until the BVIR history is cleared using the LI REQ BVIRHIST CLEAR ALL option.

The TS7700 GGM function provides many options which allow each GGM copy to have different behaviors when replicated to the CTG. For example, which constructs to use, which target category should be assigned or whether the source volume should have its category changed once the GGM copy completes. Such settings need to be manually updated through the LI REQ command ahead of calling the ISSUECMD. If different settings or behaviors are required for different volumes, the volume list

generated should use criteria to find common volumes which will use the same settings. This way, all volumes queued for GGM will inherit the same settings. Once queued through the ISSUECMD, the GGM settings can be altered and a new generated volume list can be issued. The GGM volumes queued as part of the previous list do not need to complete before the settings are changed. All GGM queued volumes will retain the setting values at the time they were queued. This allows the GGM queue to contain many volumes with different GGM settings. The GGM function will continue to process the GGM queue in first in first out order.

Attention: Before continuing to the next steps of this scenario, it's the user's responsibly to use one or more of the methods mentioned above to determine which volumes have successfully completed the GGM copy processes with successful status. The generated command lists mentioned within the next major steps should be manually filtered down to only those volume granular commands for GGM volume copies which completed with success. The default command lists generated assume all queued volumes completed with success, which may not match the actual result.

[Volume catalog updates]

Once a volume completes the GGM copy process, the volume's catalog information must be updated to point the host to its new location in the CTG. The IDCAMS ALTER VOLUMEENTRY command is used to update the volume's location.

```
//ALTERV EXEC PGM=IDCAMS,REGION=OM
//SYSTSPRT DD SYSOUT=*
//SYSIN DD *
ALTER Vvolser VOLUMEENTRY LIBRARYNAME(ctglib) STORGRP(newstore)
/*
```

In the above example, Vvolser is the volser of the volume being moved, ctglib is the composite library name of the target Grid (CTG) as defined in ISMF 10.3 and newstore is the storage group name which includes the ctglib. You must execute the above IDCAMS command for each successfully copied GGM volume. You can use the GGMTOOL1 to help automate this process. When the GGMTOOL1 was previously used to generate the LIBRARY REQUEST GGM QUEUE command list, it also created the IDCAMS ALTER VOLUMEENTRY commands in the **DDNAME=ALTERV**.

[Tape management system updates]

In a single system plex scenario, the TMS only needs to be updated if the Grid name (composite name) is embedded within the TMS record of the logical volume. DFSMSrmm is one of these TMS systems which requires the update. Computer Associates CA-1 and TLMS do not contain this information and will not need to be updated. The RMM update must occur after the previous IDCAMS update has already completed.

Sample DFSMSrmm update job 1

```
//RMMCV1 EXEC PGM=IKJEFT01,REGION=OM
//SYSTSPRT DD SYSOUT=*
//SYSTSIN DD *
RMM CV volser LOCATION(ctglib) HOME(ctglib) STORGRP(newstore)
/*
```

In the above example, volser, ctglib and newstore are the same values used in the IDCAMS update.

A second RMM update is also required to allow return to scratch processing or housekeeping to run successfully.

Sample DFSMSrmm update job 2

```
//RMMCV2 EXEC PGM=IKJEFT01,REGION=0M
//SYSTSPRT DD SYSOUT=*
//SYSTSIN DD *
  RMM CV volser LOCATION(ctglib) FORCE
/*
```

You must execute both of the above DFSMSrmm commands for each successfully GGM copied volume. But you can again use the GGMT00L1 to help automate this process. In addition to the QUEUE and IDCAMDS commands being generated, GGMT00L1 will also create the RMM CV commands (both 1 and 2) which can be used as input to a TSO batch job in the **DDNAME=RMMCV1** and **DDNAME=RMMCV2**.

[Replication of volume scratch – Optional Step]

Given most of the volumes replicated through the above steps contains active content, you will be left with many volumes in the CSG which are viewed as scratch. To move these volume definitions too, so that you have contiguous volume ranges within the CTG, GGM can be used to replicate the volume definitions. If the volume is in scratch category even when data exists before expiration, then only a volume place holder is replicated. But you should take consideration for scratch volume copy because the completion code for GGM copy is “100” as follows. G0037 Distributed Library csglibid failed GGM copy of volume volser from the composite library
ctglibid with CC 100.

The GGMT00L2 is provided to help automate the process of replicating these scratch volume definitions. Like GGMT00L1, it too creates LI REQ QUEUE, TCDB and TMS commands to help automate this process.

8.2 Scenario 2 (Independent LPAR/Plexes are connected to the CSG and CTG)

In this scenario, the CSG and CTG are connected to independent system/plexes with independent TCDB and TMS catalogues. This less common scenario is more complex to manage given the TCDB and TMS information must be exported from the source system/plex and imported into the target system/plex. There are several REXX exec samples available “as is” which can be modified either by the customer or the IBM services group assigned to the account.

To reduce repeated content, this scenario assumes the reader has an understanding of Scenario 1 in section 8.1 given there are many similarities. The differences between scenario 1 and scenario 2 will be emphasized in this section, so an initial understanding of scenario 1 is a prerequisite.

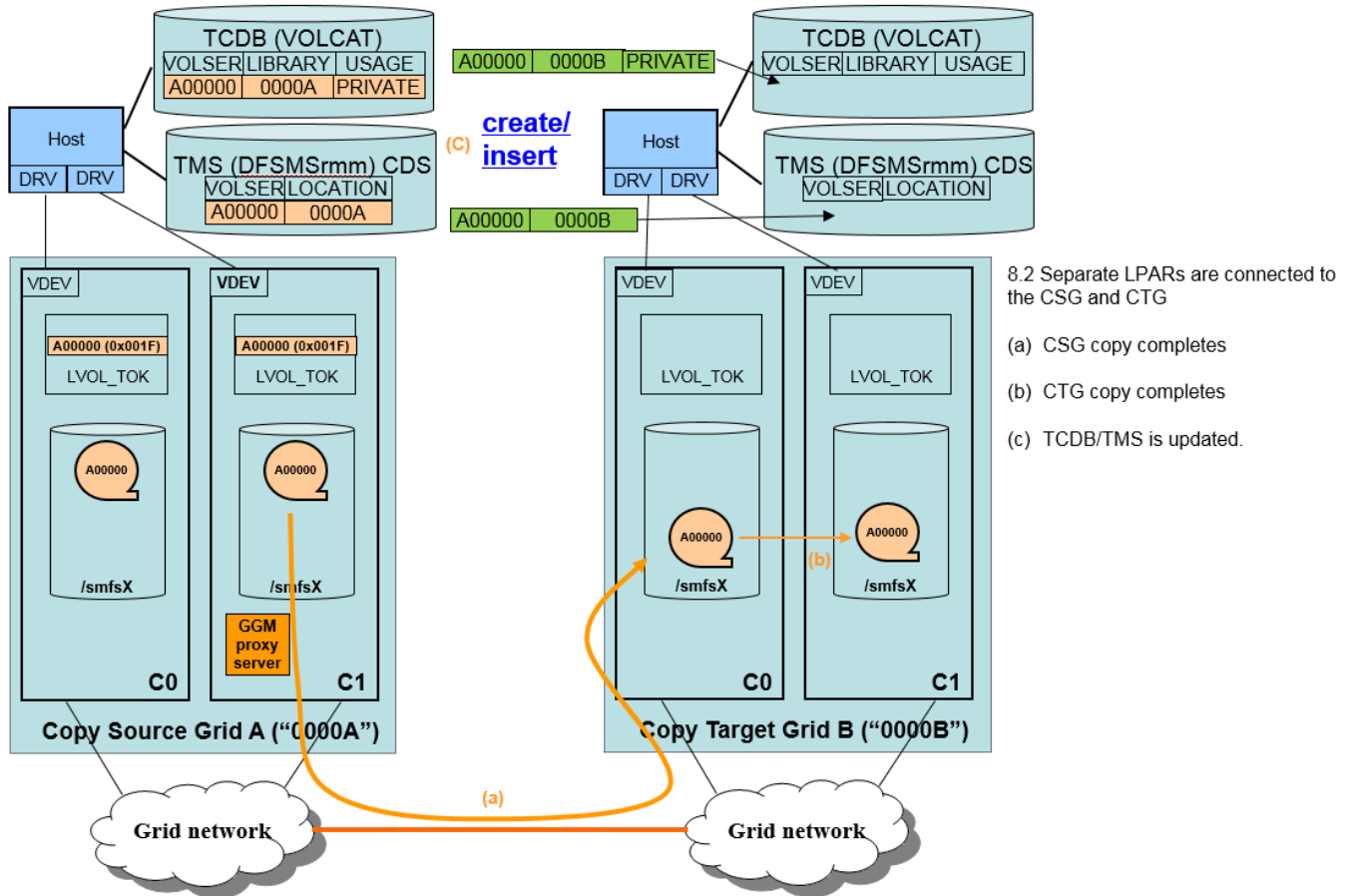

[Volume selection for GGM copy]

The same method can be used to select the logical volumes to be copied by GGM as in the section 8.1 Scenario 1. The resulting volume list must be copied from the source system/plex to the target system/plex given all GGM commands must be issued to the CTG.

Attention: Before continuing to the next steps of this scenario, it's the user's responsibly to use one or more of the methods mentioned in section 8.1 to determine which volumes have successfully completed the GGM copy processes with successful status. The generated command lists mentioned within the next major steps should be manually filtered down to only those volume granular commands for GGM volume copies which completed with success. The default command lists generated assume all queued volumes completed with success, which may not match the actual result.

[GGM copy operation]

A similar method can be used to issue LI REQ GGM QUEUE commands as in the section 8.1 Scenario 1, but a different tool called GGMToola is provided to handle the unique requirements of this more complex scenario.

[Volume catalog creation (CTG)]

The volume catalog information for each successfully copied volume must be created within the target system/plex. The IDCAMS CREATE VOLUMEENTRY command can be used to add these volumes to the volume catalog.

```
CREATE VOLUMEENTRY (NAME (Vvolser) -
```

In the above example, Vvolser is the volser of the volume being copied and libname is composite library name of the target grid (CTG) as defined in ISMF 10.3. The newstore is the storage group name defined in SMS on the CTG. The MEDIAx can be either Media1 or Media2 and should match the media type of the source volume in the CSG. You must execute the above IDCAMS command for each successfully copied GGM volume. The GGMTOLA can help automate this process. When the GGMTOLA was previously used to generate the LIBRARY REQUEST GGM QUEUE command list, it also created the IDCAMS CREATE VOLUMEENTRY commands in the DDNAME=ALTERV. // CRTERV?

[ICF User catalog updates (CTG)]

The ICF user catalog(s) and potentially the master catalog will need to be updated for the alias of the new datasets being moved to the CTG. The IDCAMS define command is used to add these datasets to the user catalog.

```
DEFINE NVSAM -  
(NAME(XXX.YYY.B.DAILY.ABC.G3045V00) -  
VOLUMES(123456) -  
DEVT(3490))
```

Other methods, such as split merge catalog can be used or a REXX exec can be created to build the define cards.

[Tape management system updates (CTG)]

Given this scenario requires the movement of content from one system/plex to another, the TMS will need to be updated, created or imported for all volumes copied from the CSG to CTG. There are several commercially available tape management systems and each has its own way to update respective catalog/control data sets (CDS). In addition, the TMS product in target/plex may be different than the source plex, so it's difficult to describe all methods to support this scenario. It's recommended that you work with your TMS vendor or vendors to help with this scenario. If using DFSMSrmm, the following two options may be helpful.

The first option is to execute the DFSMSrmm ADDVOLUME commands for each successfully copied GGM volume. In order to build the appropriate RMM ADDVOLUME commands with all the appropriate values, you must use the RMM CDS extract file from the CSG. Also you might need to add the existing VRS definitions, OWNER records, DATASET records etc. in the CSG from the CTG RMM CDS. No GGM specific tools are provided at this time to help automate this process.

The second option is to use the RMM CDS Merge method. Multiple RMM CDSes can be merged and the method to merge multiple RMM CDSes is described in the following Redbook.

DFSMSrmm Primer (SG24-5983-04)

Chapter 15. Splitting and merging your DFSMSrmm control data set

<http://www.redbooks.ibm.com/abstracts/sg245983.html?Open>

In addition, an older method within the following Redbook might be useful for merging. It describes how to merge systems into a Sysplex for most of the z/OS components and might help you in this scenario.

Merging Systems into a Sysplex (SG24-6818-00)

<http://www.redbooks.ibm.com/abstracts/sg246818.html?Open>

[Replication of volume scratch – Optional Step]

Given most of the volumes replicated through the above steps contains active content, you will be left with many volumes in the CSG which are viewed as scratch. To move these volume definitions too, so that you have contiguous volume ranges within the CTG, GGM can be used to replicate the volume definitions. If the volume is in scratch category even when data exists before expiration, then only a volume place holder is replicated. But you should take consideration for scratch volume copy because the completion code for GGM copy is “100”.

The GGMTOOLB tool is provided to help automate the process of replicating these scratch volume definitions. Like GGMTOOLA, it too creates LI REQ QUEUE and TCDB commands to help automate this process.

8.3 Tapetools

This chapter summarizes the different tools in the Tapetools library which support the GGM copy scenarios. The ‘Tapetools’ library are ad-hoc tools developed by IBM and provided to customers, business partners and IBMers without any license fee. Tapetools can be downloaded from the following site.

<ftp://ftp.software.ibm.com/storage/tapetool/>

To be informed of major changes to any of the tools distributed via this ftp site, send an email message to: TAPETOOL@US.IBM.COM In the subject, specify NOTIFY. Nothing else is required in the body of the note. This will add your email address to the TAPETOOLS distribution list.

Within the Tapetools library, you can find many useful tools related to mainframe tape operations, including the tools used for GGM processing. You need to download the following files to install the Tapetools library.

- ibmtools.txt (for installation information)
- ibmcntl.xmi
- ibmjcl.xmi
- ibmload.xmi
- ibmpat.xmi

Based on the installation instructions in ibmtools.txt, you can install ibmtools in your z/OS environment. Here is a short description for each tool used in the two GGM copy scenarios.

[VOLLIST]

VOLLIST is a tool which has existed prior to GGM support and has no added function related specifically to GGM. This tool can create volume list from the extracted TMS catalog by using the selection criteria you choose.

[GGMTOOL1]

The GGMTOOL1 is the primary new tool used specifically for GGM use. It's used to help generate the necessary commands one would have to manually enter. This tool can create the following command lists using the provided volume list which is created through VOLLIST or manually produced.

- (1) GGM QUEUE commands (DDNAME=GGMQUE)
This command is the main LIBRARY REQUEST command used to queue individual volumes for GGM copy. This output file can become the input file for the ISSUECMD tool.
- (2) IDCAMS ALTER VOLUMEENTRY commands (DDNAME=ALTERV)
These lists of commands are used to update TCDB volume entry. This output file can become the input file for IDCAMS program.
- (3) RMM CV LOCATION HOME STORAGEEGROUP commands (DDNAME=RMMCV1)
This is used to update RMM volume records. This output file can become the input file for TSO batch (IKJEFT01). In other TMS products, you should consult the vendor as to whether a TMS update is required. If required, you can modify the DFSORT BUILD statement in GGMTOOL1 to accommodate the generated command to your TMS user interface.
- (4) RMM CV LOCATION FORCE commands (DDNAME=RMMCV2)
This is used to complete the RMM volume record update. This output file can become the input file for TSO batch (IKJEFT01). In other TMS products, you should consult the vendor as to whether a TMS update is required. If required, you can modify the DFSORT BUILD statement in GGMTOOL1 to accommodate the generated command to your TMS user interface.

[GGMTOOL2]

GGMTOOL2 can be used to migrate scratch status volumes in the scenario 1 (8.1).

Though you don't have to copy scratch status volumes by GGM, you may want to in order to maintain a continuous volume range within the CTG. GGM will not copy scratch volume content. Instead, it will only import the volume serial and category and constructs configured as part of GGM. Similar to the steps carried out in Scenario 1 using GGMTOOL1, this tool creates the following command lists.

- (1) GGM QUEUE commands (DDNAME=GGMQUE)
This is used to issue LIBRARY REQUEST commands to queue each GGM copy scratch volume request. This output file can become the input file for ISSUECMD.
If you don't want to copy scratch volumes by GGM, you can re-insert the required volumes in the TS7700 Management Interface after the following TCDB/TMS updates. The TS7700 can support inserts ranges of up to 10,000 volumes at a time and will accept ranges that already contain volumes. The insert will simply fill in the gaps or those not brought in through the GGM copy process. You will still be required to update the host catalogue entries for these volumes.
- (2) IDCAMS ALTER VOLUMEENTRY commands (DDNAME=ALTERV)
This is used to update the TCDB volume entry. This output file can become the input file for IDCAMS program.
- (3) RMM CV LOCATION HOME commands (DDNAME=RMMCV1)
This is used to update RMM volume records. The output file can become the input file for TSO batch (IKJEFT01). In other TMS products, you should consult the vendor as to whether a TMS update is required. If required, you can modify the DFSORT BUILD statement in GGMTOOL1 to accommodate the generated command to your TMS user interface.

[ISSUECMD]

ISSUECMD is an existing tool and has no new function specific to GGM. This tool can issue any MVS commands in batch mode. In a GGM migration scenario, you can use this tool to issue GGM QUEUE commands generated by any of the GGMTOLx tools. You can specify a wait interval between the commands with LRDELAY parameter. When used for the LI REQ QUEUE commands, a LRDELAY=3(sec) is recommended to avoid a collision that might make the request fail with "VOLUME VVVVVV INSERT FAILURE". TCDB and TMS updates should not require such a delay. ISSUECMD needs to be APF authorized.

[GGMSORT]

When the CSG source cluster is TS7720 or the source volumes are primarily resident within disk cache, the ISSUCMD can usually be provided the unsorted volume list. But, if the CSG copy source cluster is a TS7740 or a TS7720T and much of the source content is stacked on back end physical tape, it is usually not efficient to issue GGM QUEUE requests randomly. Instead, they should be queued in an order that best matches the way they are stacked on physical tape. The GGMSORT tool can be used to sort the command list to match the order of which they are stacked on physical tape. GGMSORT uses BVIR Volume Map output to sort the logical volumes to be copied by GGM based off of the logical and physical volume relationship. BVIR Volume Map can be gotten by BVIRVTS tapetool with TYPE=VOL parameter. Up to 4 concurrent physical volume recalls can occur on the CSG copy source cluster if multiple GGM COPY requests are running and the logical volumes are located on different physical volumes. If the physical drive resource usage is restricted on the CSG copy source cluster, it may be required to control issuing GGM QUEUE commands so that the GGM copy recalls can occur from only 1 physical tape volume at a time. On this situation, you can select logical volumes on a physical volume by filtering BVIR Volume Map output with DFSORT etc. prior to using GGMSORT.

Additionally GGMSORT checks if the CSG copy source cluster has a valid copy on it. Even if the CSG copy source cluster is TS7720, you should execute GGMSORT prior to ISSUCMD. GGMSORT uses BVIR Volume Status. This can be gotten by BVIRMES tapetool.

If any GGM copy candidate volumes are reported that they have no valid copy on the CSG copy source cluster, you must make sure the reason why it is reported. If the reason is valid (for example, the CSG copy source cluster is assigned to "No copy mode"), it is required to copy the data to the CSG copy source cluster, or reconfigure GGM configuration to have the new CSG copy source cluster which has the valid copy in the CSG (IBM SSR is required to reconfigure GGM).

[BVIRVTS]

BVIRVTS with TYE=VOL parameter produces BVIR Volume Map which is used by GGMSORT.

[BVIRMES]

BVIRMES produces BVIR Volume Status which is used by GGMSORT.

[BVIRGGM]

BVIRGGM kicks BVIR GGM COPY RESULT function. The output of BVIRGGM is used as an input to GGMINFO.

[GGMINFO]

GGMINFO summarizes the output of BVIRGGM. You can see the GGM COPY RESULT summary at a glance with GGMINFO output.

[GGMTOOLA]

GGMTOOLA is used to migrate private status volumes in the scenario 2 (8.2).

This tool can create the following command list for all candidate volumes from the volume list VOLLIST produced.

- (1) GGM QUEUE commands (DDNAME=GGMQUE)
This is used to issue LIBRARY REQUEST commands to queue each GGM copy request.
This output file can become the input file for ISSUECMD.
- (2) IDCAMS CREATE VOLUMEENTRY commands (DDNAME=CREATV)
This is used to create TCDB volume entry. This output file can become the input file for IDCAMS program.

[GGMTOOLB]

GGMTOOLB can be used to migrate scratch status volumes for scenario 2 (8.2).

Though you don't have to copy scratch status volumes by GGM, you may want to in order to maintain a continuous volume range within the CTG. GGM will not copy scratch volume content. Instead, it will only import the volume serial and category and constructs configured as part of GGM. Similar to the steps carried out in Scenario 2 using GGMTOOLA, this tool creates the following command lists.

- (1) GGM QUEUE commands (DDNAME=GGMQUE)
This is used to issue LIBRARY REQUEST commands to queue each GGM copy request.
This output file can become the input file for ISSUECMD.
If you don't want to copy scratch volumes by GGM, you can re-insert the required volumes in the TS7700 Management Interface after the following TCDB/TMS updates. The TS7700 can support inserts ranges of up to 10,000 volumes at a time and will accept ranges that already contain volumes. The insert will simply fill in the gaps or those not brought in through the GGM copy process. You will still be required to update the host catalogue entries for these volumes.
- (2) IDCAMS CREATE VOLUMEENTRY commands (DDNAME=CREATV)
This is used to create TCDB volume entry. This output file can become the input file for IDCAMS program.

[PRESTAGE]

PRESTAGE can be used to recall the specified logical volumes from physical tapes to tape volume cache instead of GGMSORT prior to GGM QUEUE commands if GGMSORT is not enough for the required copy/recall performance. The input to PRESTAGE is the output by VOLLIST. But the output from VOLLIST must be adjusted to the input format of PRESTAGE. This can be done the following SORT.

```
//SORT      EXEC PGM=SORT
//SYSOUT    DD SYSOUT=*
//SORTIN    DD <output from VOLLIST>
//SORTOUT   dd <input to PRESTAGE>
//SYSIN     DD *
OPTION COPY
INCLUDE COND=(74,1,CH,NE,C'S',          SELECT NONE SCRATCH VOLUMES
*                                         IN CASE VOLLIST INPUT FILE

                                AND,2,1,CH,NE,C' ',          |THESE STATEMENTS ARE
                                AND,2,6,CH,NE,C'SEQ=VO',      |TO EXCLUDE HEADERS
```

AND,2,6,CH,NE,C'FSTVOL',
AND,2,6,CH,NE,C'MOST R')

|AND TRAILERS
|IN VOLLIST INPUT FILE

OUTFIL BUILD=(2,6,80:C' ')
/*

|MOVE VOLSER TO 1ST BYTE

9 Appendix A. Check lists

Table 1 provides a checklists of items which must be completed in order to help the customer and IBM Support Representative to setup the GGM function. An example value is provided within each “Notes” column ((example. 13616) etc.).

Table 1. GGM configuration information checklists

Field	Value	Notes
Common settings (Settings applicable to both CSG and CTG)		
GGM WAN/LAN TCP/IP port		TCP/IP port assignment used for all GGM proxy server communication between the CTG and CSG. The value should be exclusive with other ports described in TS7700 Introduction and Planning Guide (GA32-0567-xx) and also exclusive to any known ports currently used by any other network devices in the interconnected WAN. This value must be populated for all use cases. (example: 13616) Note: The well-known ports (0-1023) are not allowed to use for GGM proxy server communication.
How many Grid IP addresses or physical links will be used for GGM communication? (link count)		The number of physical grid links that will be used for CSG to CTG communication. This value must be 1 to 4. If only two links are configured at either the CSG source cluster or CSG target cluster, the value can’t exceed 2. When the value is less than what is physically present between on the CSG and CTG source/target clusters, only those links which are configured for GGM will be used. (CSG/CTG Primary-Primary, Alternate-Alternate, Primary2-Primary2, Alternate2-Alternate2). This value must be populated for all use cases. (example: 2)
CTG settings (Settings only applicable to the CTG)		
CTG copy target cluster ID		CSG copy target cluster ID or the cluster index of the target cluster which will receive all initial copies at the CTG. 0 – 7 is applicable. The cluster must be at 8.33.0.xx or

		above. This value must be populated for all use cases. (example: 4)
Primary Grid Interface IP Address for the target cluster in the CTG		The primary Grid interface is the Ethernet adapter located in slot C1 (upper port) of the 3957-Vxx. Primary IO drawer (left side) of the CSG copy target cluster. This primary Grid interface connects to the primary Grid interface of the CSG copy source cluster in the CTG. This value must be populated for all use cases. (example: 10.11.130.18)
Alternate Grid Interface IP Address for the target cluster in the CTG		The alternate Grid interface is the Ethernet adapter located in slot C1 (upper port) of the 3957-Vxx Alternate IO drawer (right side) of the CSG copy target cluster. This alternate Grid interface connects to the alternate Grid interface of the CSG copy source cluster in the CTG. This value must be populated if the link count is 2 or greater. (example: 10.11.131.18)
Primary2 Grid Interface IP Address for the target cluster in the CTG.		The primary2 Grid interface is the Ethernet adapter located in slot C1 (lower port) of the 3957-Vxx Primary IO drawer (left side) of the CSG copy target cluster. This primary2 Grid interface connects to the primary2 Grid interface of the CSG copy source cluster in the CTG. This value must be populated if the link count is 3 or greater. (example: N/A)
Alternate2 Grid Interface IP Address for the target cluster in the CTG.		The alternate2 Grid interface is the Ethernet adapter located in slot C1 (lower port) of the 3957-Vxx Alternate IO drawer (right side) of the CSG copy target cluster. This alternate2 Grid interface connects to the alternate2 Grid interface of the CSG copy source cluster in the CTG. This value must be populated if the link count is set to 4.

		(example: N/A)
CSG settings (Settings applicable to the CSG or proxy cluster)		
Composite Library Sequence Number		This is 5-character hexadecimal composite library sequence number of the CSG. This value must be populated for all use cases. (example: BA045)
Proxy Server (CSG Copy Source) cluster ID		Proxy server (CSG copy source) cluster ID or the cluster in the CSG which will act as the source and proxy cluster. 0 – 7 is applicable. This value must be populated for all use cases. (example: 1)
Primary Grid Interface IP Address for the source cluster in the CSG.		The primary Grid interface is the Ethernet adapter located in slot C1 (upper port) of the 3957-Vxx Primary IO drawer (left side) of the CSG copy source cluster. This primary Grid interface connects to the primary Grid interface of the CSG copy target cluster in the CTG. This value must be populated for all use cases. (example: 10.11.100.19)
Alternate Grid Interface IP Address for the source cluster in the CSG.		The alternate Grid interface is the Ethernet adapter located in slot C1 (upper port) of the 3957-Vxx Alternate IO drawer (right side) of the CSG copy source cluster. This alternate Grid interface connects to the alternate Grid interface of the CSG copy target cluster in the CTG. This value must be populated if the link count is 2 or greater. (example: 10.11.101.19)
Primary2 Grid Interface IP Address for the source cluster in the CSG.		The primary2 Grid interface is the Ethernet adapter located in slot C1 (lower port) of the 3957-Vxx Primary IO drawer (left side) of the CSG copy source cluster. This primary2 Grid interface connects to the primary2 Grid interface of the CSG copy target cluster in the CTG. This value must be populated if the link count is 3 or greater. (example: N/A)

<p>Alternate2 Grid Interface IP Address for the source cluster in the CSG.</p>		<p>The alternate2 Grid interface is the Ethernet adapter located in slot C1 (lower port) of the 3957-Vxx Alternate IO drawer (right side) of the CSG copy source cluster. This alternate2 Grid interface connects to the alternate2 Grid interface of the CSG copy target cluster in the CTG. This value must be populated if the link count is equal to 4. (example: N/A)</p>
--------------------------------------------------------------------------------	--	------------------------------------------------------------------------------------------------------------------------------------------------------------------------------------------------------------------------------------------------------------------------------------------------------------------------------------------------------------------------------------

10 Appendix B. GGM Library Request commands

1. Supported keywords

Table 2 provides all the supported keywords for GGM based LI REQ commands.

Like all LI REQ commands, a host based library name must be provided when issuing the commands from the host. For all the GGM based LI REQ commands, only a distributed library name is supported. The target distributed library must be the 8 character host name of the CSG copy target cluster. Any logical device in the CTG can be used to receive the LI REQ commands, but they will be forwarded to the correct CSG copy target cluster before being processed.

All GGM based LI REQ commands are supported across all TS7700 models..

Table 2. Supported LI REQ commands for GGM function

KW1	KW2	KW3	KW4	Description	Comp	Dist
GGM	CTG	ENABLE DISABLE		Enable/Disable GGM function within the CTG. This only allocates resource and initiates the communication path. No copy activity starts when only enabled. Before it can be disabled, all copies queued or in flight must be completed or cleared and the GGM function must be stopped.	N	Y
		START	IDLE	Start GGM function on the CTG. 4 th KW IDLE is the option. This starts the actual process of handling queued copy jobs. When IDLE, the GGM copies are started only during idle periods or when other CTG regular copy activity has completed.		
		STOP	CLEAR	STOP GGM function on the CTG. 4 th KW CLEAR is optional. This simply stops the GGM function from starting more GGM queued copies. Copies already started will be allowed to finish. When CLEAR is included, all non-started queued entries are also cleared.		
		RECOVER		Recover the error status when CTG communication fails during the online phase.		
	MC/SC/ DC/SG**	INHERIT/ DEFAUT/ FIXED	<storage construct name>	Determine what storage construct names are assigned to the replicated logical volume once it arrives in the CTG. When FIXED is provided for any of the four constructs, the 8 character construct name must be included as the 4 th keyword for that construct. Each construct can use a unique 3 rd keyword.		
	TGTCAT**	INHERIT/	<category>	Determine what host category is assigned to the replicated logical volume once it		

KW1	KW2	KW3	KW4	Description	Comp	Dist
		FIXED		arrives in the CTG. When FIXED is provided, the 4 th keyword must be a 16 bit hexadecimal value for the category code. (e.g. 00F2)		
	SRCCAT**	<category>		Determine if the volume in the CSG should be moved to a category once a successful GGM copy has completed. When set to 0000, no category change occurs to the source volume at GGM copy completion.		
	QUEUE	<volser>	<CSG composite library sequence number>	Queue the specified volume for GGM copy into the CTG. The GGM function must be enabled and started (started via IDLE OK too) before a volume can be queued.		
	REMOVEQ	<volser>		Remove the specified volume from the CTG GGM copy queue.		
	CPYCNT	<count>		Set the number of dedicated GGM copy tasks.		
	FORCECMP	<volser>		Force the GGM completion of a volume unable to complete CTG copies. Essentially, when the only portion remaining for the volume is to complete the peer copies within the CTG.		
	SRCVLCHG	<volser>	<category>	Provides the ability to change the copy source volume's category in the CSG after the fact. This is a manual method to change a CSG volume's category and is not related to any previous GGM copy activity that may or may not have completed against the provided volume.		
	BVIRHIST	CLEAR	<volser> ALL	Clear history record of the <volser> which is requested through BVIR. If ALL is specified in the 4 th KW, clear all the persistent history entries for all previously attempted GGM based copies.		
	OPMSG**	ENABLE/ DISABLE		Determine if a host console operator message is surfaced when a copy This includes all successful and failures and is redundant to what is provided in the history record. This may be used to help with setting up automation to make TCDB or TSM entry updates as part of the GGM process.		
	COPY	SUMMARY		Display the summary of the current GGM status.		
		DETAIL	<volser>	Display the current GGM activity/status of the <volser>.		

**These settings are persistent for a given volume at the time it's queued for GGM replication. Changes to these settings will only apply to volumes queued for GGM replication after the changes are made. Volumes already queued will retain the settings which were configured at the time they were queued.

When the first keyword “GGM” is only specified (or invalid second/third/fourth character keyword is specified, the supported keywords are provided with the error text:

```
INVALID XXX KEYWORD
GGM, CTG, ENABLE | DISABLE
GGM, CTG, START (, IDLE)
GGM, CTG, STOP (, CLEAR)
GGM, CTG, RECOVER
GGM, MC | SC | SG | DC , INHERIT | DEFAULT | FIXED (, SCName)
GGM, TGTCAT, INHERIT | FIXED (, HexCategory)
GGM, SRCCAT, HexCategory
GGM, QUEUE, Volser, CSGCompLibSeqNum
GGM, REMOVEQ, Volser
GGM, CPYCNT, GGMCopyCount
GGM, FORCECMP, Volser
GGM, BVIRHIST, CLEAR, ALL | Volser
GGM, SRCVLCHG, Volser, HexCategory
GGM, COPY, SUMMARY
GGM, COPY, DETAIL, Volser
GGM, OPMSG, ENABLE | DISABLE
```

2. “GGM, CTG, ENABLE | DISABLE” command

When the third keyword “ENABLE”, the following steps/checks are performed:

- CTG configuration check.
- Network settings (routing/firewall) are updated.
- CTG configuration check.
- Ping test against the proxy server and CSG configuration check.
- Start the dedicated threads for the GGM functions.

When all the steps above are successfully complete, the GGM function moves to the enabled state.

When the third keyword “DISABLE”, the following steps/checks are performed:

- Check if the GGM function can be disabled.
 - The GGM function should be currently in the stopped state (i.e. STOP).
 - No pending CSG copies exist in the queue or in flight. (if any pending CSG copy exist, it must be completed or removed first).

Note: It doesn't matter if we still have the pending CTG copies in the CTG. GGM can be disabled even if we have the pending CTG copies in the CTG.
- Stop and deallocate the dedicated copy processes/tasks used for the GGM functions.
- Network settings (routing/firewall) are reverted to pre GGM state.

Note: All GGM settings (CSG/CTG IP addresses, proxy port number, storage constructs, target/source volume categories, operator message, GGM copy job count) are preserved. When GGM is re-enabled, the same settings are applied automatically.

When the steps above are successful, the GGM function moves to the disabled state.

Following table details the format of the data reported:

Line	Bytes	Name	Description
1	0:29	Header Info	'GGM OPERATION CHANGE REQUEST V'
	30:31	Version	The version number for the response. The number is left justified and padded with blanks. Starts with 1.
	32	Dot	','
	33:34	Revision	The revision number for the response. The number is left justified and padded with blanks. The revision is introduced at 8.33.x.x and starts with 0.
	35:69	Blanks	
2	0:31		'OPERATION SUCCESSFULLY COMPLETED'
	32:69	Blanks	

The following error messages will be returned for each of the following conditions:

When "GGM, CTG, ENABLE" is issued, but GGM is already enabled:

"GGM IS ALREADY ENABLED"

When "GGM, CTG, DISABLE" is issued, but GGM is already disabled:

"GGM IS ALREADY DISABLED"

When "GGM, CTG, ENABLE" is issued but an existing CPYCNT change request (RUN/DEF) is already in progress and not yet processed:

"PREVIOUS CPYCNT CHANGE REQUEST STILL IN PROGRESS"

When "GGM, CTG, ENABLE" is issued, but the CSG copy target cluster in the CTG can't communicate with the CSG proxy server cluster:

"CSG PROXY IS NOT REACHABLE"

When "GGM, CTG, ENABLE" is issued, but the CSG proxy server or CSG copy source clusters are not configured correctly:

"CSG PROXY SETUP IS NOT CORRECT"

When "GGM, CTG, ENABLE" is issued, but the GGM function is not currently disabled:

"GGM IS NOT YET DISABLED"

When "GGM, CTG, ENABLE" is issued, but the overall GGM function is in an error status:

"INVALID ENABLE REQUEST BECAUSE GGM IS IN ERROR STATUS"

When "GGM, CTG, DISABLE" is issued, but the GGM function is not currently in a stopped state:

"GGM IS NOT YET ENABLED OR STOPPED"

When "GGM, CTG, DISABLE" is issued, but one or more CSG copies remained queued or are still in flight:

"ACTIVE CSG COPY STILL EXISTS"

When "GGM, CTG, ENABLE" is issued, but there exists an invalid configuration, unsupported code level or a CSG composite library sequence number mismatch is found on either CSG or CTG:

When "GGM, CTG, ENABLE" is issued and all clusters in the CSG are at R4.1.2 or above while all clusters in the CTG are not at R4.1.2 or above (a down-level cluster exists in the CTG):

"CODE LEVELS ON LVOL FORMAT BETWEEN CSG AND CTG ARE INCOMPATIBLE"

When "GGM, CTG, ENABLE" is issued and the CSG proxy server cluster is at R4.2 or above while the CSG copy target cluster in the CTG is not at R4.2 or above:

"CODE LEVELS ON CLOUD SUPPORT BETWEEN CSG AND CTG ARE INCOMPATIBLE"

When "GGM, CTG, ENABLE" is issued and all clusters in the CSG are at R5.1PGA1" or above while all clusters in the CTG are not at R5.1PGA1 or above (a down-level cluster exists in the CTG):

"CODE LEVELS ON LWORM RET SUPPORT BETWEEN CSG AND CTG ARE INCOMPATIBLE"

3. "GGM, CTG, START, IDLE" command

When the "GGM, START" command is issued, the current state is verified and the GGM function is started.

- GGM can't be started until it's first enabled.
- A future CSG copy can't be queued until the GGM function is started.
- Any previously pending CSG copies that existed when last stopped will continue to be processed once it's again started.
- The CTG copies (copies among CTG peers) are not affected by this START state. Meaning, once they are queued in peer CTG clusters at the completion of a CSG copy, stopping the GGM function will not prevent these CTG copies from starting.

The fourth keyword "IDLE" is optional. When it's specified, the GGM CSG copy is executed only when the CSG copy target cluster has no regular non-GGM related incoming copy jobs. This option is helpful for the customer what want to prevent any impact on regular production Grid copy jobs that may be queued during GGM operations. Once a CSG copy is pulled from the queue and starts a transfer, it will go to completion even if regular non-GGM related copies become queued before the CSG copy completes. If already started, the IDLE condition can be set or cleared by issuing an additional START with IDLE included or excluded. It's not required to first stop it to change the IDLE behavior.

The following table details the format of the data reported:

Line	Bytes	Name	Description
1	0:29	Header Info	'GGM OPERATION CHANGE REQUEST V'
	30:31	Version	The version number for the response. The number if left justified and padded with blanks. Starts with 1.
	32	Dot	'.'
	33:34	Revision	The revision number for the response. The number is left justified and padded with blanks. The revision is introduced at 8.33.x.x and starts with 0.
	35:69	Blanks	
2	0:31		'OPERATION SUCCESSFULLY COMPLETED'
	32:69	Blanks	

The following error messages will be returned for each of the following conditions:

When "GGM, CTG, START" is issued, but the GGM function is currently disabled:

"INVALID START REQUEST BECAUSE GGM IS IN DISABLED STATUS"

When "GGM, CTG, START (, IDLE)" is issued, but the GGM has been started already with the IDLE parameter:

"GGM STATUS IS NOT CHANGED"

When "GGM, CTG, START" is issued, but the GGM is still in a transient state (enabling/disabling/stopping state):

"GGM IS STILL IN TRANSIENT STATE"

When "GGM, CTG, START" is issued, but the GGM is not yet enabled:

"GGM IS STILL DISABLED"

When "GGM, CTG, START (, IDLE)" is issued but GGM function is in error status:

"INVALID START REQUEST BECAUSE GGM IS IN ERROR STATUS"

4. "GGM, CTG, STOP, CLEAR" command

When the "GGM, STOP" command is issued, the GGM function de-queue function is stopped and existing entries in the queue can be optionally cleared..

- When the GGM function is stopped, future CSG copies won't be initiated or pulled off of the queue (the copy jobs in flight is still executed).
- Any CTG copies among peers will also continue to be handled by all peer clusters in the CTG. Stopping the GGM function only stops future CSG Copies from being started between the CSG and CTG.

The fourth keyword "CLEAR" is optional. When it's specified, the GGM function is stopped and any pending CSG copies that are still queued are removed from the queue and the corresponding logical volume and its token in the CTG is deleted (i.e. the logical volume no longer exists in the CTG). This option is helpful for when a user wants to stop the GGM function and cancel the pending CSG copies as well. The in-flight CSG copy will continue and complete. If already stopped, but without using the CLEAR keyword, it can be stopped again with the CLEAR keyword in order to clear the queue contents.

When a pending CSG copy is removed by "CLEAR" option, the BVIR record of the GGM copy is updated as it completed with the indication of the "CLEAR" command (i.e. GGM copy completion code is updated to 0x0002 (CSG copy is cleared by this "CLEAR" option)). The CSG copy removed by this command are not copied from the CSG to CTG. Please make sure to put the CSG copy job by LI REQ, QUEUE command and complete the GGM copy later if the copy of the volume is required in the CTG.

The following table details the format of the data reported:

Line	Bytes	Name	Description
1	0:29	Header Info	'GGM OPERATION CHANGE REQUEST V'

Line	Bytes	Name	Description
	30:31	Version	The version number for the response. The number is left justified and padded with blanks. Starts with 1.
	32	Dot	'.'
	33:34	Revision	The revision number for the response. The number is left justified and padded with blanks. The revision is introduced at 8.33.x.x and starts with 0.
	35:69	Blanks	
2	0:31		'OPERATION SUCCESSFULLY COMPLETED'
	32:69	Blanks	

The following error messages be returned for each of the following conditions:

When “GGM, CTG, STOP” is issued, but GGM is still disabled:

“INVALID STOP REQUEST BECAUSE GGM IS IN DISABLED STATUS”

When “GGM, CTG, STOP (, CLEAR)” is issued, but GGM has already been stopped with the CLEAR keyword:

“GGM STATUS IS NOT CHANGED”

When “GGM, CTG, STOP” is issued, but the GGM is still in a transient state (enabling/disabling/stopping state):

“GGM IS STILL IN TRANSIENT STATE”

When “GGM, CTG, STOP” is issued, without CLEAR and the GGM function is in an error status:

“INVALID STOP REQUEST BECAUSE GGM IS IN ERROR STATUS”

5. “GGM, CTG, RECOVER” command

When the cluster transitions to the offline and then online state when already enabled, the GGM function should transition to the automatically enabled state. If the enablement is not possible due to the state of the GGM network when the cluster online process was initiated, the status is marked “ONLINE_ERROR” to notify the user of the problem state.

In order to recover from the status, “GGM, CTG, RECOVER” can be used. This mimics most of the same steps carried out during the enablement. If all steps complete successfully, the GGM function transitions to the enabled and stopped state. The user must issue START to have the process being working on any currently queued CSG copies.

If the status becomes “ONLINE_ERROR”, the GGM function can be completely disabled if needed.

The following table details the format of the data reported:

Line	Bytes	Name	Description
1	0:29	Header Info	'GGM OPERATION CHANGE REQUEST V'
	30:31	Version	The version number for the response. The number is left justified and padded with blanks. Starts with 1.
	32	Dot	'.'

Line	Bytes	Name	Description
	33:34	Revision	The revision number for the response. The number is left justified and padded with blanks. The revision is introduced at 8.33.x.x and starts with 0.
	35:69	Blanks	
2	0:31		'OPERATION SUCCESSFULLY COMPLETED'
	32:69	Blanks	

The following error messages be returned for each of the following conditions:

When “GGM, CTG, RECOVER” is issued, but the GGM is still in a transient state (enabling/disabling/stopping state):

“GGM IS STILL IN TRANSIENT STATE”

6. “GGM, MC/SC/DC/SG, INHERIT/DEFFAULT/FIXED, <name>” command

These commands provide an option for how to assign a volume's constructs when it's copied into the CTG. Each construct can use a different set of properties. This setting is read and applied to a volume at the time it's queued allowing groups of volumes to use different construct settings as they are queued.

The second keyword specifies which construct is to have its setting changed:

- MC: Management Class
- SC: Storage Class
- DC: Data Class
- SG: Storage Group

The third keyword determines what setting should be used for the construct provided in the second keyword. Each of the four constructs can have a different third keyword setting:

- INHERIT: The storage construct name assigned to the volume within the CSG is applied to the volume once it arrives in the CTG.
- DEFAULT: The default storage construct name (8 blanks) is assigned to the volume once it arrives in the CTG.
- FIXED: The storage construct name provided in the fourth keyword is assigned to the volume once it arrives in the CTG.

The fourth keyword is only applicable if the “FIXED” keyword is provided. It's the construct name which should be assigned, which is limited to 8 characters.

The default is INHERIT for all four constructs.

The default storage construct name is also assigned under the following cases:

- INHERIT is assigned, but the storage construct name assigned to the copy source volume in the CSG is not currently defined in the CTG. All constructs which are to be inherited must be pre-defined in the CTG prior to initiating GGM copies. Especially the CSG copy target cluster, though peers in the CTG should already have the construct names defined to ahead of the GGM process.
- FIXED is used. But the storage construct name specified in the fourth keyword is not defined in the CTG. All constructs which are to be assigned through the FIXED parameter must be pre-defined in

the CTG prior to initiating GGM copies. Especially the CSG copy target cluster, though peers in the CTG should already have the construct names defined to ahead of the GGM process.

Attention:

In order to prevent unexpected storage construct assignments or behaviors at any cluster within the CTG, it's required that all constructs be defined ahead of time. Once the CSG copy complete, any future construct changes will require mount/demount activity or COPYRFSH/PARTRFSH requests to utilize the new settings. Therefore, make sure they are setup correctly ahead of time so the correct constructs and settings are used when the volume initially arrives as part of the GGM function.

The following table details the format of the data reported:

Line	Bytes	Name	Description
1	0:36	Header Info	'GGM VOLUME ATTRIBUTE CHANGE REQUEST V'
	37:38	Version	The version number for the response. The number if left justified and padded with blanks. Starts with 1.
	39	Dot	'.'
	40:41	Revision	The revision number for the response. The number is left justified and padded with blanks. The revision is introduced at 8.33.x.x and starts with 0.
	42:69	Blanks	
2	0:31		'OPERATION SUCCESSFULLY COMPLETED'
	32:69	Blanks	

7. "GGM, TGTCAT, INHERIT/FIXED, <hex category>" command

This command is used to determine which category value is assigned to a volume once it arrives in the CTG and the GGM Copy Completes successfully, or just the CSG copy completes and the FORCECMP is used to force the early completion.

The third keyword can be:

- **INHERIT:** The category currently assigned to the volume within the source CSG is inherited within the CTG.
- **FIXED:** The user provided category is assigned to the volume when the CSG Copy completes to the CTG.

The fourth keyword is required when the "FIXED" keyword is provided. It's the 16bit hexadecimal value for the category to be assigned.

Any hardware reserved category (xFF00 -xFFFE) and the NULL category (x0000) is not supported.

The default is INHERIT.

The following table details the format of the data reported:

Line	Bytes	Name	Description
1	0:36	Header Info	'GGM VOLUME ATTRIBUTE CHANGE REQUEST V'
	37:38	Version	The version number for the response. The number if left justified and padded with blanks. Starts with 1.

Line	Bytes	Name	Description
	39	Dot	‘.’
	40:41	Revision	The revision number for the response. The number is left justified and padded with blanks. The revision is introduced at 8.33.x.x and starts with 0.
	42:69	Blanks	
2	0:31		‘OPERATION SUCCESSFULLY COMPLETED’
	32:69	Blanks	

The following error messages be returned for each of the following conditions:

When the invalid category (x0000 – xFFFE or x0000) is specified in the fourth keyword when FIXED is provided as the third parameter:

“INVALID 4TH KEYWORD”

8. “GGM, SRCCAT, <hex category>” command

This command provides an option to allow a successfully completed GGM copy to automatically update the CSG source volume’s category to a unique category. This can help with isolating the successfully completed volumes in the CSG by category. The category can include scratch categories which can optionally enable delete-expire processing, which will be honored as if the CSG host moved the volume to scratch. It can also be used if an IBM service will later delete and/or eject these volumes. Having them exist in a unique category helps isolate them from volumes not needing to be copied or those that have not yet copied successfully to the CTG.

The hardware reserved category (x0000 – FFFE) is not supported for the third keyword. The default is NULL (x0000) which means not category change will occur.

The category change against the source logical volume is initiated when the following conditions are satisfied:

- The SRCCAT value is set to a category other than NULL (x0000).
- The GGM copy (CSG copy and CTG copies) completes without any errors. If any error occurs, the category change is not performed.
- The TGTCAT category change also completed successfully within the CTG when the GGM copy completed.

The following table details the format of the data reported:

Line	Bytes	Name	Description
1	0:36	Header Info	‘GGM VOLUME ATTRIBUTE CHANGE REQUEST V’
	37:38	Version	The version number for the response. The number if left justified and padded with blanks. Starts with 1.
	39	Dot	‘.’
	40:41	Revision	The revision number for the response. The number is left justified and padded with blanks. The revision is introduced at 8.33.x.x and starts with 0.
	42:69	Blanks	
2	0:31		‘OPERATION SUCCESSFULLY COMPLETED’

Line	Bytes	Name	Description
	32:69	Blanks	

The following error messages be returned for each of the following conditions:

When the invalid specified category (x0000 – x00FF) is specified for the third keyword:

"INVALID 3RD KEYWORD"

9. "GGM, QUEUE, <volser>, <CSG composite library sequence number>" command

This command is the main command used to queue up a GGM copy job into the CSG copy target cluster in the CTG.

The third keyword is the volser to be copied and the fourth keyword is the CSG composite library sequence number.

Some considerations to take into account when using this command:

- The GGM copy job can be queued for a volume that currently does not exist in the CTG by volser, including any conflicting volser values with physical tape volumes which may exist in the CTG. If the volume already exists by volser due to a previous GGM copy process, it can be re-copied through the GGM so long as it wasn't modified in the CTG after it previously arrived in the CTG. This re-copy first initiates an eject and re-insert of the volume. If CTG Copies are still queued, they will be removed during the eject and re-insert steps.
- The copied volume attributes (for example, the storage construct names, and copied logical volume's category) are bound to the volume when it's queued by this command. For example, if you set TGTCAT=x000F and then queue 100 GGM copies and then change TGTCAT=x001F and queue another 100 GGM copies, the first 100 will use 000F and the next 100 will use 001F.
- Up to 10,000 CSG copy jobs can be queued at any given time. If there are already 10,000 pending CSG copy jobs, the command should fail. Once a CSG Copy completes and becomes the CTG Copy process, that volume is no longer counted against the 10,000 limit.
- If a volume is already queued, a second request to queue the same volume will fail.
- The GGM copy job insert processing uses the same mechanism which is used by an MI initiated insert. Therefore, the same global insert-eject lock needs to be locked during the insert operation. If the global lock can't be obtained, queuing the GGM copy job fails.

The following table details the format of the data reported:

Line	Bytes	Name	Description
1	0:23	Header Info	'GGM COPY QUEUE REQUEST V'
	24:25	Version	The version number for the response. The number is left justified and padded with blanks. Starts with 1.
	26	Dot	'.'
	27:28	Revision	The revision number for the response. The number is left justified and padded with blanks. The revision is introduced at 8.33.x.x and starts with 0.
	29:69	Blanks	
2	0:31		'OPERATION SUCCESSFULLY COMPLETED'

Line	Bytes	Name	Description
	32:69	Blanks	

The following error messages be returned for each of the following conditions:

When the specified 4th keyword (CSG composite library sequence number) does not match with the actual or configured composite name:

"PROVIDED CSG LIB SEQ LLLLL DOES NOT MATCH WITH CCCCC"

When the command is issued, but the GGM function is still in a transient state (enabling/disabling/stopping state):

"GGM IS STILL IN TRANSIENT STATE"

When the command is issued, but the GGM function is disabled or not yet started:

"GGM STATE IS NOT YET READY TO START"

When the command is issued, but the GGM function is in the ONLINE_ERROR state:

"GGM IS STILL IN ERROR STATE"

When the command is issued for a volume and there are already 10,000 pending CSG copies are queued:

"MORE THAN 10000 PENDING GGM CSG COPIES EXIST"

When the command is issued for a volume which was previously copied using GGM, but yet it isn't in a state that allows the GGM function to handle it. This may be given when the volume is mounted in the CTG or has pending updates against it which can't be resolved at the time the queue command was issued.

"VOLUME VVVVVV IS NOT IN A PROPER STATE"

When the command is issued for a volume which was previously copied using GGM, but it appears that it was since modified by a CTG attached host:

"VOLUME VVVVVV IS ALREADY UPDATED IN THE CTG"

When the command is issued for a volume which was previously copied using GGM, but the eject and re-insert is unsuccessful given the global lock can't be obtained:

"CAN NOT GET INSERT LOCK BEFORE VOLUME VVVVVV RE-INSERT"

When the command is issued for a volume which was previously copied using GGM, but the eject and re-insert is rejected given a CTG peer cluster is unavailable:

"VOLUME VVVVVV EJECT INCOMPLETE AT RE-INSERT. TRY LATER"

When the command is issued for a volume which was previously copied using GGM, but the eject failed due to an internal failure reason:

"VOLUME VVVVVV EJECT FAILURE BEFORE RE-INSERT"

When the command is issued for a volume, but the volume insert or RE-INSERT operation fails. This typically happens when another logical volume insert operation (either by the normal logical volume insert from MI or GGM, QUEUE operation) is running:

```
"VOLUME VVVVVV INSERT FAILURE"
```

When the command is issued for a volume which was previously queued and the CSG copy is currently in flight:

```
"VOLUME VVVVVV CSG COPY IS IN PROGRESS"
```

10. "GGM, REMOVEQ, <volser>" command

This command provides a method to remove a GGM volume that is still queued within the CSG copy target cluster. It will fail under the following situations:

- The CSG copy or full GGM copy already completed.
- GGM CSG copy is already in flight.

If the command is used to remove the GGM volume temporarily, please make sure to put the CSG copy job by LI REQ, QUEUE command and complete the GGM copy later.

This command is used to cancel and remove a pending CSG copy when it's no longer required. It removes the GGM copy job as well as the inserted logical volume. Though the GGM copy job and logical volume is removed, the GGM history record (read through BVIR) remains and will state it was removed with the completion code 0x0002.

The third keyword is the volser which needs to be removed from the CSG copy queue target cluster within the CTG.

The following table details the format of the data reported:

Line	Bytes	Name	Description
1	0:23	Header Info	'GGM COPY QUEUE REQUEST V'
	24:25	Version	The version number for the response. The number is left justified and padded with blanks. Starts with 1.
	26	Dot	'.'
	27:28	Revision	The revision number for the response. The number is left justified and padded with blanks. The revision is introduced at 8.33.x.x and starts with 0.
	29:69	Blanks	
2	0:31		'OPERATION SUCCESSFULLY COMPLETED'
	32:69	Blanks	

The following error messages be returned for each of the following conditions:

When the 3rd keyword (volser) is for a volume that isn't currently queued or already being processed in flight:

```
"GGM COPY VOLSER VVVVVV DOES NOT EXIST"
```

When the command is issued, but the GGM function is still in a transient state (enabling/disabling/stopping state):

```
"GGM IS STILL IN TRANSIENT STATE"
```

11. "GGM, CPYCNT, <copy count>" command

This command provides the option to adjust the number of concurrent copy job count for GGM CSG copy. It may be effective to get better GGM CSG copy performance by increasing the number of the concurrent copy count for GGM if CSG copy source and target cluster has a long distance or the network is not so stable.

The copy count from 5 to 128 can be set and the default value is 20. This command used the same mechanism with another LI REQ, cluster, CPYCNT, RUN / DEF, <copy count> internally then only one instance of changing the copy count (RUN, DEF or GGM) can be running at a time. LI REQ, <CSG copy target cluster>, GGM, COPY, SUMMARY "CPYCNT_CHG_STATUS" field shows the current in-progress CPYCNT operation if any.

The corresponding resources for the GGM copies are allocated when GGM is enabled, then de-allocated when GGM is disabled.

The following table details the format of the data reported:

Line	Bytes	Name	Description
1	0:23	Header Info	'GGM COPY QUEUE REQUEST V'
	24:25	Version	The version number for the response. The number is left justified and padded with blanks. Starts with 1.
	26	Dot	'.'
	27:28	Revision	The revision number for the response. The number is left justified and padded with blanks. The revision is introduced at 8.33.x.x and starts with 0.
	29:69	Blanks	
2	0:31		'OPERATION SUCCESSFULLY COMPLETED'
	32:69	Blanks	

The following error messages be returned for each of the following conditions:

When the specified 3rd keyword (copy count) is not in the range from 5 to 128:

```
"CPYCNT XXX IS INVALID"
```

When the command is issued but GGM is still in a transient state (enabling/disabling/stopping state):

```
"GGM IS STILL IN TRANSIENT STATE"
```

When the command is issued and the same value with the specified count is already set:

```
"GGM CPYCNT IS ALREADY XXX"
```

12. "GGM, FORCECMP, <volser>" command

This command forcibly complete the pending GGM CTG copy. It can be used when CTG copy can't finish but it's required to use the copied volume in the CTG.

For example, one of the clusters in the CTG has been in the failed state and it won't come to online state in days or more. CSG copy already completed but the required CTG copy won't complete because the valid copy mode is assigned to the failing cluster in the CTG. When this command is issued to such a volume, the volume's category is changed from xFF15 to the expected one and GGM copy completed without copying the data to the failing cluster (the operator message will be surfaced if it's set, too). Once the failing cluster comes to the online, the volume is reconciled and the necessary CTG copy will be executed.

The following table details the format of the data reported:

Line	Bytes	Name	Description
1	0:23	Header Info	'GGM COPY QUEUE REQUEST V'
	24:25	Version	The version number for the response. The number is left justified and padded with blanks. Starts with 1.
	26	Dot	','
	27:28	Revision	The revision number for the response. The number is left justified and padded with blanks. The revision is introduced at 8.33.x.x and starts with 0.
	29:69	Blanks	
2	0:31		'OPERATION SUCCESSFULLY COMPLETED'
	32:69	Blanks	

The following error messages be returned for each of the following conditions:

When the specified 3rd keyword (volser) is not in the GGM CTG copy job:

```
"GGM COPY VOLSER VVVVVV DOES NOT EXIST"
```

When the command is issued but GGM is still in a transient state (enabling/disabling/stopping state):

```
"GGM IS STILL IN TRANSIENT STATE"
```

When the command is issued but GGM is disabled:

```
"GGM STATE IS NOT YET READY TO START"
```

When the command is issued but GGM is in ONLINE_ERROR state:

```
"GGM IS STILL IN ERROR STATE"
```

13. "GGM, SRCVLCHG, <volser>, <hex category>" command

This command attempts to change the category of the <volser> to the <hex category> in the CSG. When it's issued to the CTG cluster, the request is forwarded to the proxy server in the CSG and the proxy server drives the category change in the CSG.

The typical use case may be that there is a network error between the CTG and CSG (or could be CSG cluster is unavailable) when GGM copy completes. In that case, even if SRCCAT is set and the category

of the copy source volume is supposed to be changed, the category change can't be attempted. The copy source category change is performed only when GGM copy completes without any error including the last data level check between CSG and CTG. If the host TCDB change is done, there will be no way for the host to change the category of the volume in the CSG, then this command issued to the CTG can be used.

The third keyword <volser> is required.

The hardware reserved category (xFF00 -xFFFE) and NULL category (x0000) can't be used as the fourth keyword.

The following table details the format of the data reported:

Line	Bytes	Name	Description
1	0:23	Header Info	'GGM COPY QUEUE REQUEST V'
	24:25	Version	The version number for the response. The number is left justified and padded with blanks. Starts with 1.
	26	Dot	'.'
	27:28	Revision	The revision number for the response. The number is left justified and padded with blanks. The revision is introduced at 8.33.x.x and starts with 0.
	29:69	Blanks	
2	0:31		'OPERATION SUCCESSFULLY COMPLETED'
	32:69	Blanks	

The following error messages be returned for each of the following conditions:

When the command is issued to the volume but the volume state is not appropriate to change the category (for example, the copy source volume is in the write protected mode, or the CSG copy source volume is the LWORM-retained volume and the setting does not allow to change the category to scratch):

"VOLUME VVVVVV IS NOT IN A PROPER STATE"

When the command is issued but CSG copy target cluster in the CTG can't communicate with the CSG proxy server cluster:

"CSG PROXY IS NOT REACHABLE"

When the command is issued but GGM is still in a transient state (enabling/disabling/stopping state):

"GGM IS STILL IN TRANSIENT STATE"

When the command is issued but GGM is disabled:

"GGM STATE IS NOT YET READY TO START"

When the command is issued but GGM is in ONLINE_ERROR state:

"GGM IS STILL IN ERROR STATE"

When the invalid category (xFF00 – xFFFE or x0000) is specified in the fourth keyword:

"INVALID 4TH KEYWORD"

14. "GGM, BVIRHIST, CLEAR, ALL | <volser>" command

All GGM copy activity records are preserved per each logical volume in the TS7700 internal database and can be retrieved by LI REQ, GGM,COPY,DETAIL,<volser> and/or GGM BVIR GGM COPY RESULT/STATUS. The record will not be removed although the corresponding logical volume is even ejected. The record can be retrieved from the CSG copy target cluster only.

If the fourth keyword "ALL" is specified, all completed GGM copy records are removed. If the <volser> is specified in the fourth keyword, the completed GGM copy records for the logical volume is removed. No GGM copy record whose GGM copy is still in-progress is removed.

The following table details the format of the data reported:

Line	Bytes	Name	Description
1	0:23	Header Info	'GGM COPY QUEUE REQUEST V'
	24:25	Version	The version number for the response. The number is left justified and padded with blanks. Starts with 1.
	26	Dot	'.'
	27:28	Revision	The revision number for the response. The number is left justified and padded with blanks. The revision is introduced at 8.33.x.x and starts with 0.
	29:69	Blanks	
2	0:31		'OPERATION SUCCESSFULLY COMPLETED'
	32:69	Blanks	

The following error messages be returned for each of the following conditions:

When the specified 4th keyword is <volser> and no GGM copy activity record of the volser to clear exist:

"GGM COPY VOLSER VVVVVV DOES NOT EXIST"

When the specified 4th keyword is "ALL" and no GGM copy activity record to clear exist:

"NO GGM COPY VOLSER TO CLEAR HISTORY EXISTS"

When the command is issued but GGM is still in a transient state (enabling/disabling/stopping state):

"GGM IS STILL IN TRANSIENT STATE"

When the command is issued but GGM is disabled:

"GGM STATE IS NOT YET READY TO START"

15. "GGM, OPMSG, ENABLE | DISABLE" command

This command provides the option to surface the following operator messages or not when the GGM copy completes or fails. Also if it's enabled and the CSG copy fails with the reason of the CSG-CTG communication failure, additional operator message is surfaced every 1,000 copy failure.

- G0036 Distributed Library DDDDD completed GGM copy of volume VVVVVV from the composite library CCCCC with CC XXXXX
- G0037 Distributed Library DDDDD failed GGM copy of volume VVVVVV from the composite library CCCCC with CC XXXXX
- G0038 Distributed Library DDDDD failed GGM copy of volume VVVVVV from the composite library CCCCC due to communication failure

DDDDD: Distributed Library Sequence Number of the CSG copy target cluster in the CTG

VVVVVV: GGM copy volser

CCCCC: Composite Library Sequence Number of the CSG

XXXXX: Completion Code of the GGM copy. Please refer to Appendix B “17 GGM, COPY, DETAIL, <volser> command” – GGM copy completion code.

The default is DISABLE.

The following table details the format of the data reported:

Line	Bytes	Name	Description
1	0:31	Header Info	'GGM HOST NOTIFY CHANGE REQUEST V'
	32:33	Version	The version number for the response. The number is left justified and padded with blanks. Starts with 1.
	34	Dot	‘.’
	35:36	Revision	The revision number for the response. The number is left justified and padded with blanks. The revision is introduced at 8.33.x.x and starts with 0.
	37:69	Blanks	
2	0:31		'OPERATION SUCCESSFULLY COMPLETED'
	32:69	Blanks	

When the command is issued but the setting is already the same status:

“OPMSG SETTING IS ALREADY ENABLED/DISABLED”

16. “GGM, COPY, SUMMARY” command

This command provide the overall GGM function, copy and error status.

The following table details the format of the data reported:

Line	Bytes	Name	Description
1	0:17	Header Info	'GGM COPY SUMMARY V'
	18:19	Version	The version number for the response. The number is left justified and padded with blanks. Start with 1 (at the code level 8.33.0.xx).
	20	Dot	‘.’
	21:22	Revision	The revision number for the response. The number is left justified and padded with blanks. Starts with 0 (at the code level 8.33.0.xx).
	23:69	Blanks	
2	0:11	Header Info	'CTG SETTING:'

	12:69	Blanks	
3	0:4	Header Info	` [CL:'
	5	CTG cluster ID	The GGM CTG cluster ID (0 – 7).
	6:17	Header Info	`] [FUNCTION:'
	18:25	Current GGM function enable/disable state	`DISABLED': GGM is disabled by LI REQ. `ENABLED ': GGM is enabled by LI REQ.
	26:35	Header Info	`] [STATUS:'
	36:45	Current GGM start/stop setting status	`STOP ': LI REQ GGM,CTG,STOP is requested. `STOP_CLEAR': LI REQ GGM,CTG,STOP,CLEAR is requested. `START ': LI REQ GGM,CTG,START is requested. `START_IDLE': LI REQ GGM,CTG,START,IDLE is requested. `ERROR ': GGM is now in ERROR state because the communication with proxy server in the CSG is not established during the last online phase. Need to recovery by LI REQ, GGM, RECOVER command, or disabled.
	46:54	Header Info	`] [STATE:'
	55:66	Current GGM state	`STOPPED ': GGM function is stopped. `STOPPING ': GGM function is stopping (transient state). `STARTED ': GGM function is started. `IDLE_STARTED': GGM function is started with IDLE option. `ENABLED ': GGM function is enabled (not started yet). `ENABLING ': GGM function is enabling (not fully enabled yet. Transient state.). `DISABLED ': GGM function is disabled. `DISABLING ': GGM function is disabling (not fully disabled yet. Transient state.). `ONLINE_ERROR': GGM function is now in ERROR state because the communication with proxy server in the CSG is not established during the last online phase. Need to recovery by LI REQ, GGM, RECOVER command, or disabled.
	67	Header Info	`]'
	68:69	Blanks	
4	0:22	Header Info	` IP_ADDR (PRI/ALT) = '
	23:37	CTG cluster primary Grid IP address for GGM communication	` xx.xx.xxx.xxx' : CTG cluster primary Grid IP address for GGM communication configured by the IBM Service Representative.

	38	Slash	`/'
	39:53	CTG cluster alternate Grid IP address for GGM communication	` xx.xx.xxx.xxx' : CTG cluster alternate Grid IP address for GGM communication configured by the IBM Service Representative.
	54:69	Blanks	
5	0:22	Header Info	` IP_ADDR (PRI2/ALT2) = '
	23:37	CTG cluster second primary Grid IP address for GGM communication	` xx.xx.xxx.xxx' : CTG cluster second primary Grid IP address for GGM communication configured by the IBM Service Representative.
	38	Slash	`/'
	39:53	CTG cluster second alternate Grid IP address for GGM communication	` xx.xx.xxx.xxx' : CTG cluster second alternate Grid IP address for GGM communication configured by the IBM Service Representative.
	54:69	Blanks	
6	0:14	Header Info	` MC/SC/DC/SG = '
	15:22	GGM copy target volume management class setting	` *inherit' : Inherit the management class name from the CSG. ` *default' : Use the default management class name. `xxxxxx' : Set by FIXED keyword
	23	Slash	`/'
	24:31	GGM copy target volume storage class setting	Same with management class setting.
	32	Slash	`/'
	33:40	GGM copy target volume data class setting	Same with management class setting.
	41	Slash	`/'
	42:49	GGM copy target volume storage group setting	Same with management class setting.
	50:69	Blanks	
7	0:18	Header Info	` TGT_CAT/SRC_CAT = '
	19:23	GGM copy target volume category setting	`0000x' : Inherit the category from the CSG. `CCCCx' : Set by TGTCAT keyword.

	24	Slash	`/`
	25:29	GGM copy source volume category setting	`0000x` : No SRCCAT is set, then the copy source volume category is not changed. `CCCCx` : Set by SRCCAT keyword.
	30:45	Header Info	` SEND_OP_MSG = `
	46:53	Current OPMSG setting	`DISABLED` : OPMSG is disabled by LI REQ. `ENABLED` : OPMSG is enabled by LI REQ.
	54:69	Blanks	
8	0:9	Header Info	` CPYCNT = `
	10:12	GGM copy CPYCNT setting	The current GGM CPYCNT setting (5-128)
	13:33	Header Info	` CPYCNT_CHG_STATUS = `
	34:37	Current GGM CPYCNT change status	`NONE` : No CPYCNT change is ongoing. `RUN` : RUN copy CPYCNT change request is ongoing. `DEF` : DEF copy CPYCNT change request is ongoing. `GGM` : GGM copy CPYCNT change request is ongoing. (Note) The same CPYCNT mechanism used for all RUN, DEF and GGM. Then, GGM and RUN/DEF CPYCNT requests can't be running concurrently.
	38:69	Blanks	
9	0:21	Header Info	` COPY_PROXY_ERR_CNT = `
	22:26	GGM CSG copy proxy error count	This is the error count incremented when GGM CSG copy is attempted and it encounters an error to communicate with the proxy server in the CSG (i.e. prior to attempting the actual copy). If the count reaches to 1,000 and the volume in error is set to "OPMSG = ENABLE", an operator message G0038 is surfaced. If the volume in error is set to "OPMSG = DISABLE", no operator message is surfaced and the count 1,000 remains.
	27:40	Header Info	` RESET_TIME = `
	41:66	GGM CSG copy proxy error count reset time	This is the last timestamp when GGM CSG copy proxy error count is reset and the operator message G0038 is surfaced.
	67:69	Blanks	
10	0:69	Separator	All dash '-' characters
11	0:11	Header Info	`CSG SETTING:`
12	0:15	Header Info	` COMPOSITELIB = `
	16:20	CSG composite library sequence number	The GGM CSG composite library sequence number configured by the IBM Service Representative.
	21:69	Blanks	

13	0:9	Header Info	` PROXY = '
	10	CSG proxy cluster ID	The GGM CSG proxy cluster ID (0 – 7) configured by the IBM Service Representative.
	11:18	Header Info	` PORT = '
	19:23	Port number for CSG proxy communication	The GGM port number for CSG proxy communication configured by the IBM Service Representative.
	24:69	Blanks	
14	0:22	Header Info	` IP_ADDR (PRI/ALT) = '
	23:37	CSG proxy cluster primary Grid IP address for GGM communication	` xx.xx.xxx.xxx' : CSG proxy cluster primary Grid IP address for GGM communication configured by the IBM Service Representative.
	38	Slash	`/'
	39:53	CSG proxy cluster alternate Grid IP address for GGM communication	` xx.xx.xxx.xxx' : CSG proxy cluster alternate Grid IP address for GGM communication configured by the IBM Service Representative.
	54:69	Blanks	
15	0:22	Header Info	` IP_ADDR (PRI2/ALT2) = '
	23:37	CSG proxy cluster second primary Grid IP address for GGM communication	` xx.xx.xxx.xxx' : CSG proxy cluster second primary Grid IP address for GGM communication configured by the IBM Service Representative.
	38	Slash	`/'
	39:53	CSG proxy cluster second alternate Grid IP address for GGM communication	` xx.xx.xxx.xxx' : CSG proxy cluster second alternate Grid IP address for GGM communication configured by the IBM Service Representative.
	54:69	Blanks	
16	0:11	Header Info	` COPY_SRC = '
	12	CSG copy source cluster ID	The GGM CSG copy source cluster ID (0 – 7). In R3.3, a single copy source cluster is only supported and it's the same cluster with the proxy server.
	13:69	Blanks	
17	0:22	Header Info	` IP_ADDR (PRI/ALT) = '
	23:37	CSG copy source cluster primary Grid IP address for GGM CSG	` xx.xx.xxx.xxx' : CSG copy source cluster primary Grid IP address for GGM CSG copy. In R3.3, it's the same IP address with the proxy server.

		copy	
	38	Slash	'/'
	39:53	CSG copy source cluster alternate Grid IP address for GGM CSG copy	' xx.xx.xxx.xxx' : CSG copy source cluster alternate Grid IP address for GGM CSG copy. In R3.3, it's the same IP address with the proxy server.
	54:69	Blanks	
18	0:22	Header Info	' IP_ADDR (PRI2/ALT2) = '
	23:37	CSG copy source cluster second primary Grid IP address for GGM CSG copy	' xx.xx.xxx.xxx' : CSG copy source cluster second primary Grid IP address for GGM CSG copy. In R3.3, it's the same IP address with the proxy server.
	38	Slash	'/'
	39:53	CSG copy source cluster second alternate Grid IP address for GGM CSG copy	' xx.xx.xxx.xxx' : CSG copy source cluster second alternate Grid IP address for GGM CSG copy. In R3.3, it's the same IP address with the proxy server.
	54:69	Blanks	
19	0:69	Separator	All dash '-' characters
20	0:17	Header Info	'CONNECTION STATUS:'
	18:69	Blanks	
21	0:24	Header Info	' PROXY_CONFIGURED_PORTS: '
	25	Total number of configured IP addresses for CSG proxy communication	1 - 4.
	26:43	Header Info	' LAST_USED_PORT: '
	44:45	The last used interface for CSG proxy communication	'-1' : If no proxy communication is done yet. Could be 0 - 3.
	46:69	Blanks	
22	0:58	Header Info	' INTFC: N ADDRESS / ST / ERR / LAST_FAILED_TIME'
	59:69	Blanks	
23	0:8	Header Info	' : '
	9	Interface number	0 - 3
	10:26	IP address used for CSG proxy	' xx.xx.xxx.xxx' : IP address used for CSG

		communication	proxy communication
	27:30	Delimiter	` / '`
	31	Current communication status to the IP address	0/1/2 : Communication is OK/degraded/dead. When the communication attempt is failed to this IP address, the status is changed from OK to degraded. If the internal error recovery for the degraded one also fails, the status is changed from degraded to dead. Once it's confirmed to be OK, the status is changed to OK.
	32:34	Delimiter	` / '`
	35:39	Current error count for the usage of the IP address	The current error count for the usage of the IP address. The maximum value is 65535. Once the communication path is recovered, it's reset to 0.
	40:42	Delimiter	` / '`
	43:68	The timestamp when the last error occurs	The timestamp when the last communication error occurs to the IP address. Once the communication path is recovered, it's reset to EPOC.
	69	Blank	
			N : The number of the configured IP addresses for the proxy communication. Until the line of (23 + N - 1), the same contents of the line 23 continues for all the configured IP addresses for proxy communication.
M	0:26	Header Info	This line M starts from the line of (23 + N). ` COPYSRC CONFIGURED_PORTS: '`
	27	Total number of configured IP addresses for CSG copy source cluster	1 - 4. In R3.3, it's the same number with proxy communication.
	26:45	Header Info	` LAST_USED_PORT: '`
	46:47	The last used interface for CSG copy attempt	`-1' : If no copy attempt is done yet. Could be 0 - 3.
	48:69	Blanks	
M+1	0:58	Header Info	` INTFC: N ADDRESS / ST / ERR / LAST_FAILED_TIME '`
	59:69	Blanks	
M+2	0:8	Header Info	` : '`
	9	Interface number	0 - 3
	10:26	IP address used for CSG copy	` xx.xx.xxx.xxx' : IP address used for CSG copy. In R3.3, it's the same with proxy communication.
	27:30	Delimiter	` / '`

	31	Current communication status to the IP address	0/1/2 : Communication is OK/degraded/dead. When the communication attempt is failed to this IP address, the status is changed from OK to degraded. If the internal error recovery for the degraded one also fails, the status is changed from degraded to dead. Once it's confirmed to be OK, the status is changed to OK.
	32:34	Delimiter	` / '`
	35:39	Current error count for the usage of the IP address	The current error count for the usage of the IP address. The maximum value is 65535. Once the communication path is recovered, it's reset to 0.
	40:42	Delimiter	` / '`
	43:68	The timestamp when the last error occurs	The timestamp when the last communication error occurs to the IP address. Once the communication path is recovered, it's reset to EPOC.
	69	Blank	
			N : The number of the configured IP addresses for the proxy communication. Until the line of (M + N + 1), the same contents of the line (M + 2) continues for all the configured IP addresses for CSG copy.
L	0:69	Separator	This line L starts from the line of (M + N + 2). All dash '-' characters
L+1	0:16	Header Info	`CSG COPY SUMMARY: '`
L+2	0:19	Header Info	` PENDING_CSG_COPY = '`
	20:24	Total count of the current pending CSG copies	Total count of the CSG copy volsers which are currently in progress.
	25:44	Header Info	` PENDING_CTG_COPY = '`
	45:49	Total count of the current pending CTG copies	Total count of the CTG copy volsers which are currently in progress.
	50:69	Blanks	
L+3	0:38	Separator	` -----`
	39:69	Blanks	
L+4	0:36	Header Info	` VOLSER POSTED_TIME ST`
	37:69	Blanks	
L+5	0:38	Separator	` -----`
	39:69	Blanks	
L+6	0	Blank	
	1:6	volser	Volser of the pending CSG copy.
	7	Blank	
	8:33	Posted time	The timestamp when the pending CSG copy job of this volume is

			created.
	34	Blank	
	35:38	Current status	The current status of the pending CSG copy job of this volume. The possible values are: 0: The copy job is ready and wait for the execution. 1: The copy job is dequeued for the execution. 4: The copy job is now in progress.
			Up to 10 pending CSG copy jobs are displayed. If no pending CSG copy job exist, ' NO PENDING CSG COPY EXISTS' is displayed. If more than 10 pending CSG copy jobs exist, ' MORE CSG COPIES EXIST' is displayed at the end of the volser list.

17. "GGM, COPY, DETAIL, <volser>" command

This command provide GGM copy status for the specified <volser>.

The following table details the format of the data reported:

Line	Bytes	Name	Description
1	0:22	Header Info	'GGM COPY QUEUE DETAIL V'
	23:24	Version	The version number for the response. The number is left justified and padded with blanks. Start with 1 (at the code level 8.33.0.xx).
	25	Dot	','
	26:27	Revision	The revision number for the response. The number is left justified and padded with blanks. Starts with 0 (at the code level 8.33.0.xx).
	28:69	Blanks	
2	0:10	Header Info	'GGM VOLUME:'
	11:16	Volser	Volser specified by the LI REQ command.
	17:25	Header Info	' CLUSTER:'
	26	CTG cluster ID	The GGM CTG cluster ID (0 – 7) configured by the IBM Service Representative.
	27:33	Header Info	' TOTAL:'
	34	Number of GGM copy history recorded in this CTG cluster.	The current number of GGM copy history recorded in this CTG cluster. GGM CTG cluster can preserve up to two GGM copy history records. When a single GGM copy request is requested for the first time, one GGM copy history is preserved. Then, when another GGM copy is requested to the same volser, the new attempt is newly recorded and the previous completed (or could be failed) record will be kept until the new one is completed (or could be failed). The possible value is 1 or 2.

	35:47	Header Info	` RECORD FOUND`
	48:69	Blanks	
3	0:5	Header Info	`ENTRY :`
	6	Record Entry number	If the number of GGM copy history records is 1, only entry number 0 is provided. If the number of GM copy history records is 2, the entry number 0 and 1 are provided and the completed GGM copy record is always provided as entry number 0, then the pending GGM copy record is provided as entry number 1.
	7:69	Delimiter	` -----` `-----`
4	0:16	Header Info	`QUEUED TIME :`
	17:42	GGM copy queued time	The timestamp when the GGM copy job is queued by LI REQ. The timestamp is formatted as follows: YYYY-MM-DD-HH:MM:SS.DDDDDD YYYY: Year, MM: Month, DD:Day, HH:Hour, MM:Minute, SS:Second, DDDDDD: subsecond The time zone is UTC (TS7700 internal time)
	43:69	Blanks	
5	0:16	Header Info	`CSG LAST TIME :`
	17:42	GGM CSG copy completed /failed time	The timestamp when the GGM CSG coy job completed or failed. The timestamp is formatted as follows: YYYY-MM-DD-HH:MM:SS.DDDDDD YYYY: Year, MM: Month, DD:Day, HH:Hour, MM:Minute, SS:Second, DDDDDD: subsecond The time zone is UTC (TS7700 internal time)
	43:69	Blanks	
6	0:16	Header Info	`COMPLETED TIME :`
	17:42	GGM CTG copy completed /failed time	The timestamp when the GGM CTG coy job completed or failed. The timestamp is formatted as follows: YYYY-MM-DD-HH:MM:SS.DDDDDD YYYY: Year, MM: Month, DD:Day, HH:Hour, MM:Minute, SS:Second, DDDDDD: subsecond The time zone is UTC (TS7700 internal time)
	43:69	Blanks	
7	0:19	Header Info	`CURRENT_GGM_STATUS :`
	20	Current GGM copy status	The current GGM copy status. The possible values are: C: GGM copy completed. S: Pending CSG copy exists. T: Pending CTG copy exists (i.e. CSG copy already completed).

	21:40	Header Info	` FINAL_GGM_STATUS: `
	41	The final GGM copy status	The final GGM copy status. The possible values are: N: GGM copy doesn't yet completed. S: GGM copy successfully completed. F: GGM copy failed (Need to check COMPLETION_CODE for the detail). W: GGM copy completed but some warning existed (Need to check COMPLETION_CODE for the detail).
	42:9	Blanks	
8	0:17	Header Info	`COMPLETION_CODE: x`
	17:33	GGM copy completion code	The final GGM copy completion code provided by hex value. This field includes the valid value only when GGM copy completes (i.e. CURRENT_GGM_STATUS is 'C') The each value could be ORed and multiple copy reasons can be provided. The possible values are: 0x0000000000000000: GGM copy completed without any error. 0x0000000000000001: CTG copy completed forcibly by LI REQ, FORCECMP command. 0x0000000000000002: GGM copy job is reinserted during CTG copy in progress. Or the pending CSG copy is cleared by LI REQ, STOP, CLEAR or LI REQ, REMOVEQ command. 0x0000000000000004: CTG copy completed, but the final volume data level check failed due to proxy communication issue. It's unknown if the copy source and target volume have the same data level or not. 0x0000000000000008: CTG copy completed, but the final data level check failed due to unknown reason. It's unknown if the copy source and target volume have the same data level or not. 0x0000000000000010: CTG copy completed, and the final data level check found the data level was already stale. This means after CSG copy completed and when all GGM CTG copies completed, the data of the copy source volume was already updated. 0x0000000000000020: The copy source volume category change after GGM copy completed failed due to proxy communication issue. Then the copy source volume category was not changed. The copy source volume category is changed only when a valid category is set by LI REQ, SRCCAT command. 0x0000000000000040: The copy source volume category change after GGM copy completed failed due to unknown reason (the volume may be in write protect mode, or the source volume is in the LWORM-retained state with the option not to allow the category change to scratch). Then the copy source volume category was not changed. The copy source volume

			<p>category is changed only when a valid category is set by LI REQ, SRCCAT command.</p> <p>0x0000000000000080: CSG copy failed because no copy source data was found. The copy source data could have been expired, damaged, removed, etc. or reside elsewhere in the CSG (for example, CSG copy source cluster had 'No Copy' mode. The volume still remains in the CTG, but no data is copied from the CSG to CTG.</p> <p>0x0000000000000100: CSG copy failed because the copy source volume was in a scratch category. The volume still remains in the CTG, but no data is copied from the CSG to CTG.</p> <p>0x0000000000000200: CSG copy failed because no volser exists in the CSG. The volume is deleted from the CTG then it does not remain in the CTG.</p> <p>0x0000000000000400: CSG copy failed due to unknown reason.</p>
	34:69	Blanks	
9	0:12	Header Info	'TVC_CLUSTER: '
	13:14	TVC cluster ID	CSG copy TVC cluster ID. If CSG copy is not yet attempted, -1 is provided. In R3.3, only one CSG copy source cluster is valid and this TVC cluster ID is always the same with the proxy cluster ID.
	15:36	Header Info	' CSG_COPY_STATE: '
	37	Current CSG copy state	<p>Current CSG copy state. The possible values are:</p> <p>0: The copy job is ready and wait for the execution.</p> <p>2: The copy job already completed.</p> <p>1: The copy job is dequeued for the execution.</p> <p>4: The copy job is now in progress.</p>
	38:65	Header Info	' CLUSTER : 01234567'
	66:69	Blanks	
10	0:13	Header Info	'IMPORT_STATE: '
	14	GGM copy volume import state	<p>GGM copy volume import state. The possible values are:</p> <p>'I': Imported state. This means GGM copy was (or is being) attempted/failed/completed.</p> <p>'N' : Not imported state. 'I' state is cleared to 'N' when the data is written on the imported GGM copy target volume and no more GGM copy attempt is allowed to this volume.</p>
	15:37	Header Info	' RECALL_REQUIRED: '
	38	GGM CSG copy recall	<p>This flag provides the CSG copy required a recall on the CSG copy source cluster:</p> <p>'Y' : A recall was required to perform a CSG copy.</p>

		state	'N' : A recall was (or is not yet) required to perform a CSG copy.
	39:57	Header Info	' COPY_REQUIRED: '
	58:65	CTG copy required flag	Each flag shows that the cluster in the CTG requires the CTG copy to complete GGM copy: 'Y' : The cluster requires a CTG copy. 'N' : The cluster doesn't require a CTG copy. This flag isn't cleared even if the required CTG copy completes
	56:69	Blanks	
11	0:17	Header Info	'CONSISTENT_COUNT: '
	18	Consistent copy count	The current consistent copy counts in the CTG.
	19:29	Header Info	' VOLSIZE: '
	30:40	The volume size	The size of the GGM CSG copy volume. The size will remain 0 until CSG copy completes because the volume size is queried and filled when the CSG copy completes.
	41:57	Header Info	' CONSISTENT :'
	58:65	Current CSG/CTG copy complete status flag	Each flag shows that the cluster in the CTG already completed the required CSG/CTG copy: 'Y' : The cluster already completed a CSG/CTG copy. 'N' : The cluster doesn't yet complete a CSG/CTG copy or CSG/CTG copy is not required. When the copy required flag is 'Y' but this copy complete status flag is 'N', the cluster still needs a CTG copy to complete. When the copy required flag is 'Y' and this copy complete status flag is 'Y', the cluster already completed a CTG copy. When the copy required flag is 'N' and this copy complete status flag is 'N', the cluster doesn't require CSG nor CTG copy. When the copy required flag is 'N' and this copy complete status flag is 'Y', the cluster received a CSG copy.
	66:69	Blanks	
12	0:15	Header Info	'CSG_DATA_LEVEL: '
	16:31	CSG volume data level at CSG copy	This is the CSG volume data level when the CSG copy completed.
	32:49	Header Info	' CTG_DATA_LEVEL: '
	50:65	CSG volume data level	This is the CSG volume data level when all required CTG copies completed. If CSG_DATA_LEVEL and CTG_DATA_LEVEL differ, the completion code x0000000000000010 should be provided. If they differ, the copied

		at CTG copy	data is already stale compared to the CSG copy source volume, then it needs to copy the data from the CSG to CTG again if the latest data is required.
	66:69	Blanks	
13	0:11	Header Info	'CONSTRUCTS: '
	12:14	Header Info	'MC='
	15:24	Management class setting	This is the management class setting (attribute) of the GGM copy target volume. The value is interleaved with ','. The possible values are: '*inherit': INHERIT attribute is set. Once the CSG copy completes, this field is filled with the actual management class name inherited from the CSG copy source volume. '*default': DEFAULT attribute is set. Othres: The specified value with FIXED attribute is set.
	25:28	Header Info	' SC='
	29:38	Storage class setting	This is the storage class setting (attribute) of the GGM copy target volume. Same with management class setting with the possible values.
	39:42	Header Info	' DC='
	43:52	Data class setting	This is the data class setting (attribute) of the GGM copy target volume. Same with management class setting with the possible values.
	53:56	Header Info	' SG='
	57:66	Storage group setting	This is the storage group setting (attribute) of the GGM copy target volume. Same with management class setting with the possible values.
	67:69	Blanks	
14	0:14	Header Info	'CTG_VOL_CAT: 0x'
	15:18	GGM copy target volume category setting	This is the GGM copy target volume category setting (attribute). This is hex and the possible values are: '0000': INHERIT attribute is set. Once the CSG copy completes, this field is filled with the actual category value inherited from the CSG copy source volume. Others: The specified value with FIXED attribute is set.
	19:35	Header Info	' CSG_VOL_CAT: 0x'
	36:39	GGM copy source volume category setting	This is the GGM copy source volume category setting (attribute). This is hex and the possible values are: '0000': The copy source volume is not changed when GGM copy completes. Others: The specified value with FIXED attribute

			is set.
40:58	Header Info		' OP_MSG_REQUIRED: '
59	OPMSG setting		This is the GGM copy target volume OPMSG setting (attribute). The possible values are: 'Y': An operator message is surfaced when the GGM copy of this volumen completes/fails. 'N': No operator message is surfaced when the GGM copy of this volumen completes/fails.
60:69	Blanks		

When the command is issued but no GGM record for the specified volume exists:

"NO GGM COPY VOLUME VVVVVV BVIR RECORD FOUND"

18. General error messages of GGM LI REQ commands

The following general error messages be returned for each of the following conditions:

When any LI REQ, <composite library>, GGM command is issued to a composite library target:

"REQUEST INVALID FOR COMPOSITE LIBRARY"

When any LI REQ, <CSG copy target cluster>, GGM command specifies the invalid keyword:

"INVALID 2ND|3RD|4TH KEYWORD"

When any LI REQ, <cluster>, GGM command is issued to a distributed library which is not configured as a CSG copy target cluster:

"CLUSTER NNNNN IS NOT A GGM CTG COPY TARGET CLUSTER"

When CTG is in ONLINE_ERROR state and "GGM, CTG, ENABLE/START/STOP (No 4TH KW "CLEAR" is specified)":

"INVALID ENABLE|START|STOP REQUEST BECAUSE GGM IS IN ERROR STATUS"

When any unexpected internal error occurs:

"AN ERROR OCCURED PROCESSING THE HOST REQUEST. RETURN CODE = X"

11 Appendix C. GGM BVIR request and response

Two new BVIR requests are supported to retrieve GGM copy activity records. The GGM copy activity records are retained only on the GGM CSG copy target cluster. A single valid copy mode against the GGM CSG copy target cluster must be assigned to get the expected result.

1. Request Data Format

Record 1

VTS BULK VOLUME DATA REQUEST

Bytes	Name	Description
1-28	Request Identifier	'VTS BULK VOLUME DATA REQUEST'
29-80	Blanks	Blank character padding

Record 2

Bytes	Name	Description
1-80	Request	'GGM COPY RESULT' or 'GGM COPY STATUS' Left justified, padded with blanks on the right.

'GGM COPY RESULT' provides the response of all the GGM copy activity records which already completed the GGM copies.

'GGM COPY STATUS' provides the response of all the GGM copy activity records whose GGM copy (CSG or CTG copy) are still in progress.

For example, CTG is 3-way configuration (C0/C1/C2) and C0 is configured as a CSG copy target cluster. As for all BVIR reports which are cluster dependent, you need to define a management class and define a copy policy for it to only have a copy on cluster0. As example:

MCGGM001

- Copy Consistency Point for Cluster 0: Rewind/Unload
- Copy Consistency Point for Cluster 1: No Copy
- Copy Consistency Point for Cluster 2: No Copy

2. Response Data Format

The response data format for the two GGM BVIR requests is described in this chapter.

The general format for the response data set is:

Records 1-2

Contents of request records 1-2.

Record 3

This record contains the date and time the response data set was created as well as a format version number for the results as follows:

04/20/2015 12:27:00 VERSION 08

Bytes	Name	Description																		
1:10	Date	The date the response was generated in the format of MM/DD/YYYY																		
11	Field Delimiter	Blank character																		
12-19	Time	The time the response was generated in the format HH:MM:SS																		
20	Field Delimiter	Blank character																		
21-27		'VERSION'																		
28	Field Delimiter	Blank character																		
29-30	Version Number	The Version Number of this response right justified and zero filled. <table border="0"> <thead> <tr> <th>Version Number</th> <th>Code Level Supported</th> </tr> </thead> <tbody> <tr> <td>01</td> <td>Original VTS</td> </tr> <tr> <td>02</td> <td>Release 1.5, Release 1.5PGA1-PGA3</td> </tr> <tr> <td>03</td> <td>Release 1.5 levels PGA4 and later, Release 1.6</td> </tr> <tr> <td>04</td> <td>Release 1.7, Release 2.0, Release 2.1</td> </tr> <tr> <td>05</td> <td>Release 3.0</td> </tr> <tr> <td>06</td> <td>Release 3.1</td> </tr> <tr> <td>07</td> <td>Release 3.2</td> </tr> <tr> <td>08</td> <td>Release 3.3</td> </tr> </tbody> </table>	Version Number	Code Level Supported	01	Original VTS	02	Release 1.5, Release 1.5PGA1-PGA3	03	Release 1.5 levels PGA4 and later, Release 1.6	04	Release 1.7, Release 2.0, Release 2.1	05	Release 3.0	06	Release 3.1	07	Release 3.2	08	Release 3.3
Version Number	Code Level Supported																			
01	Original VTS																			
02	Release 1.5, Release 1.5PGA1-PGA3																			
03	Release 1.5 levels PGA4 and later, Release 1.6																			
04	Release 1.7, Release 2.0, Release 2.1																			
05	Release 3.0																			
06	Release 3.1																			
07	Release 3.2																			
08	Release 3.3																			
31-80	Blanks	Blank character padding																		

The version number of GGM BVIR requests start from 08:

Request record	Version Number
GGM COPY RESULT	01
GGM COPY STATUS	01

(Note) The version number is currently provided as 01.

Record 4

S/N: 2758P LIB ID: BA92C

Bytes	Name	Description
1-4		'S/N:'
5	Field Delimiter	Blank character
6-10	Serial Number	Hardware serial number of the TS7700
11-12	Blanks	Blank character padding
13-19		'LIB ID:'
20	Field Delimiter	Blank character
21-25	Distributed Library ID	Distributed library sequence number of the TS7700
26-80	Blanks	Blank character padding

Record 5

This record contains all character blanks.

Record 6-N

Request	Record Length of Record 6-N
GGM COPY RESULT	400 bytes

GGM COPY STATUS	400 bytes
-----------------	-----------

2.1. GGM COPY RESULT Information

'GGM COPY RESULT' provides the response of all the GGM copy activity records for already completed the GGM copies.

A response record consists of the database fields defined in the following table. Fields are presented in the order defined in the table and are comma (,) separated. The overall length of each record is 400 bytes with blank padding after the last field as needed.

For example, the first few fields of the record returned for volser ZGS000 would be:

```
ZGS000,2015-06-09-08.59.16.753745,106,N,N,Y,N,N,N,Y,N,4,513,100,2015-06-09-09.00.58.000000,106,3,S,00000000,I,RUN,...
```

Note: The generation of the response may take several minutes to complete depending on the number of the GGM copy activity records and how busy the TS7700 cluster is at the time of the request.

Record 6-N

If no completed GGM copy activity records exist on the target cluster, the following record is returned:

```
NO GGM COPY RECORD(S) EXIST
```

Bytes	Name	Description
1-27		'NO GGM COPY RECORD(S) EXIST'
28-80	Blanks	Blank character padding

If GGM copy activity records exist in the target cluster's database, each of these records provide information for one GGM copy volume.

Note: The size of each field does not include the byte needed for the comma that separates each field.

Field Name	Description
volser	6 character GGM copy volume serial number
time_posted	Timestamp of when the GGM copy volume was inserted to the CSG copy target cluster. The format of the timestamp is: Year-Month-Day-Hour.Minute.Second.Microsecond for example: 2015-04-20-19.34.23.876129
csg_data_level	This field represents the data level value for the CSG copy source volume when the CSG copy completed successfully.
cluster0_copy_required	This field represents whether cluster 0 needed to make a CTG copy of the volume from the CSG copy target cluster. 'Y' indicates it did, 'N' indicates that a copy was not required.
cluster1_copy_required	This field represents whether cluster 1 needed to make a CTG copy of the volume from the CSG copy target cluster. 'Y' indicates it did, 'N' indicates that a copy was not required.
cluster2_copy_required	This field represents whether cluster 2 needed to make a CTG copy of the volume from the CSG copy target cluster. 'Y' indicates it did, 'N' indicates that a copy was not required.

cluster3_copy_required	This field represents whether cluster 3 needed to make a CTG copy of the volume from the CSG copy target cluster. 'Y' indicates it did, 'N' indicates that a copy was not required.
cluster4_copy_required	This field represents whether cluster 4 needed to make a CTG copy of the volume from the CSG copy target cluster. 'Y' indicates it did, 'N' indicates that a copy was not required.
cluster5_copy_required	This field represents whether cluster 5 needed to make a CTG copy of the volume from the CSG copy target cluster. 'Y' indicates it did, 'N' indicates that a copy was not required.
cluster6_copy_required	This field represents whether cluster 6 needed to make a CTG copy of the volume from the CSG copy target cluster. 'Y' indicates it did, 'N' indicates that a copy was not required.
cluster7_copy_required	This field represents whether cluster 7 needed to make a CTG copy of the volume from the CSG copy target cluster. 'Y' indicates it did, 'N' indicates that a copy was not required.
copy_source_cluster	This field represents the CSG copy source cluster ID when CSG copy completed. If the CSG copy failed, -1 is indicated.
volume_size	This field represents the size of the GGM copy volume expressed in bytes as a decimal value.
consistent_clusters	<p>This field represents the mask of the clusters which got the consistent volume by the GGM (both CSG and CTG) copy as a decimal value. If the CSG copy failed, 0 is indicated.</p> <p>[Cluster ID <=> Mask value]</p> <p>CL0 <=> 1 CL1 <=> 2 CL2 <=> 4 CL3 <=> 8 CL4 <=> 16 CL5 <=> 32 CL6 <=> 64 CL7 <=> 128</p> <p>If the value is 41 (B101001), CL0, CL3 and CL5 got the consistent volume by the GGM copy.</p>
last_csg_copy_timestamp	Timestamp of when the CSG copy completed or failed. The format of the timestamp is: Year-Month-Day-Hour.Minute.Second.Microsecond for example: 2015-04-20-19.34.23.876129
ctg_data_level	This field represents the data level value for the CSG copy source volume when the GGM copy completed. If the data level check when GGM copy completed failed, -0 is indicated.
consistent_copy_count	This field represents the total consistent copy count in the CTG including the CSG copy target cluster.
final_copy_state	<p>This field represents the final GGM copy state:</p> <p>S: GGM copy completed without any errors. F: GGM copy failed. The completion code should explain the warning reason. W: GGM copy completed with warning status. The completion code should explain the warning reason.</p>
copy_completion_code	<p>This field represents the final GGM copy completion code in hexadecimal and the following bit values are ORed:</p> <p>0x0000: GGM copy completed without any error. 0x0001: CTG copy completed forcibly by LI REQ,FORCECMP command. 0x0002: GGM copy job is reinserted during CTG copy in progress. Or the pending CSG copy is cleared by LI REQ, STOP, CLEAR or LI REQ, REMOVEQ</p>

	<p>command.</p> <p>0x0004: CTG copy completed, but the final volume data level check failed due to proxy communication issue. It's unknown if the copy source and target volume have the same data level or not.</p> <p>0x0008: CTG copy completed, but the final data level check failed due to unknown reason. It's unknown if the copy source and target volume have the same data level or not.</p> <p>0x0010: CTG copy completed, and the final data level check found the data level was already stale. This means after CSG copy completed and when all GGM CTG copies completed, the data of the copy source volume was already updated.</p> <p>0x0020: The copy source volume category change after GGM copy completed failed due to proxy communication issue. Then the copy source volume category was not changed. The copy source volume category is changed only when a valid category is set by LI REQ, SRCCAT command.</p> <p>0x0040: The copy source volume category change after GGM copy completed failed due to unknown reason (the volume may be in write protect mode, or the source volume is in the LWORM-retained state with the option not to allow the category change to scratch). Then the copy source volume category was not changed. The copy source volume category is changed only when a valid category is set by LI REQ, SRCCAT command.</p> <p>0x0080: CSG copy failed because no copy source data was found. The copy source data could have been expired, damaged, removed, etc. or reside elsewhere in the CSG (for example, CSG copy source cluster had 'No Copy' mode. The volume still remains in the CTG, but no data is copied from the CSG to CTG.</p> <p>0x0100: CSG copy failed because the copy source volume was in a scratch category. The volume still remains in the CTG, but no data is copied from the CSG to CTG.</p> <p>0x0200: CSG copy failed because no volser exists in the CSG. The volume is deleted from the CTG then it does not remain in the CTG.</p> <p>0x0400: CSG copy failed due to unknown reason.</p>
import_status	<p>This field represents the GGM copy volume import status:</p> <p>'I': The volume was imported (copied from the CSG to CTG).</p> <p>'N': The volume was imported then the volume in the CTG was updated.</p>
management class	<p>This field represents the management class name assigned to this logical volume by GGM copy. If a default management class is assigned to this logical volume, the field is NULL. If INHERIT is set but CSG copy failed, '*inherit' is filled.</p>
storage class	<p>This field represents the storage class name assigned to this logical volume by GGM copy. If a default storage class is assigned to this logical volume, the field is NULL. If INHERIT is set but CSG copy failed, '*inherit' is filled.</p>
data class	<p>This field represents the data class name assigned to this logical volume by GGM copy. If a default data class is assigned to this logical volume, the field is NULL. If INHERIT is set but CSG copy failed, '*inherit' is filled.</p>
storage group	<p>This field represents the storage group name assigned to this logical volume by GGM copy. If a default storage group is assigned to this logical volume, the field is NULL. If INHERIT is set but CSG copy failed, '*inherit' is filled.</p>
target_volume_category	<p>This field represents the category the volume is to be set to in the CTG in a hexadecimal value.</p>
recall_required	<p>This field represents if the CSG copy required a recall on the CSG copy source cluster:</p> <p>'Y': Recall was required.</p> <p>'N': Recall was not required.</p>
time_completed	<p>Timestamp of when the GGM copy completed or failed in the CTG. The format of</p>

	the timestamp is: Year-Month-Day-Hour.Minute.Second.Microsecond for example: 2015-04-20-19.34.23.876129
op_msg_required	This field represents the setting if the operator message needs to be surfaced when the GGM copy completed or failed: 'Y': Operator message was required. 'N': Operator message was not required.
source_volume_category	This field represents the category the volume is to be set to in the CSG after the GGM copy completed in a hexadecimal value. If no source volume category change is required, the field is 0000.

2.2. GGM COPY STATUS Information

'GGM COPY STATUS' provides the response of all the GGM copy activity records whose GGM copy (CSG or CTG copy) are still in progress. The report has to run on the CTG copy target cluster.

A response record consists of the database fields defined in the following table. Fields are presented in the order defined in the table and are comma (,) separated. The overall length of each record is 400 bytes with blank padding after the last field as needed.

For example, the first few fields of the record returned for volser ZGS000 would be:

```
ZGS000,2015-06-09-08.59.16.753745,0,N,N,N,N,N,N,N,N,0,-1,0,0,1970-01-01-00.00.00.000000,0,RUN,*inherit,...
```

Note: The generation of the response may take several minutes to complete depending on the number of the GGM copy activity records and how busy the TS7700 cluster is at the time of the request.

Record 6-N

If no completed GGM copy activity records exist on the target cluster, the following record is returned:

```
NO GGM COPY RECORD(S) EXIST
```

Bytes	Name	Description
1-27		'NO GGM COPY RECORD(S) EXIST'
28-80	Blanks	Blank character padding

If GGM copy activity records exist in the target cluster's database, each of these records provide information for one GGM copy volume.

Note: The size of each field does not include the byte needed for the comma that separates each field.

Field Name	Description
volser	6 character GGM copy volume serial number
time_posted	Timestamp of when the GGM copy volume was inserted to the CSG copy target cluster. The format of the timestamp is: Year-Month-Day-Hour.Minute.Second.Microsecond for example: 2015-04-20-19.34.23.876129
csg_data_level	This field represents the data level value for the CSG copy source volume when the CSG copy completed. If the CSG copy does not yet complete, the field is 0.

cluster0_copy_required	This field represents whether cluster 0 needs to make a CTG copy of the volume from the CSG copy target cluster. 'Y' indicates it did, 'N' indicates that a copy was not required. If the CSG copy does not yet complete, the field is 'N'.
cluster1_copy_required	This field represents whether cluster 1 needs to make a CTG copy of the volume from the CSG copy target cluster. 'Y' indicates it did, 'N' indicates that a copy was not required. If the CSG copy does not yet complete, the field is 'N'.
cluster2_copy_required	This field represents whether cluster 2 needs to make a CTG copy of the volume from the CSG copy target cluster. 'Y' indicates it did, 'N' indicates that a copy was not required. If the CSG copy does not yet complete, the field is 'N'.
cluster3_copy_required	This field represents whether cluster 3 needs to make a CTG copy of the volume from the CSG copy target cluster. 'Y' indicates it did, 'N' indicates that a copy was not required. If the CSG copy does not yet complete, the field is 'N'.
cluster4_copy_required	This field represents whether cluster 4 needs to make a CTG copy of the volume from the CSG copy target cluster. 'Y' indicates it did, 'N' indicates that a copy was not required. If the CSG copy does not yet complete, the field is 'N'.
cluster5_copy_required	This field represents whether cluster 5 needs to make a CTG copy of the volume from the CSG copy target cluster. 'Y' indicates it did, 'N' indicates that a copy was not required. If the CSG copy does not yet complete, the field is 'N'.
cluster6_copy_required	This field represents whether cluster 6 needs to make a CTG copy of the volume from the CSG copy target cluster. 'Y' indicates it did, 'N' indicates that a copy was not required. If the CSG copy does not yet complete, the field is 'N'.
cluster7_copy_required	This field represents whether cluster 7 needs to make a CTG copy of the volume from the CSG copy target cluster. 'Y' indicates it did, 'N' indicates that a copy was not required. If the CSG copy does not yet complete, the field is 'N'.
copy_state	This field represents the current CSG copy state: 0: The copy job is ready and wait for the execution. 1: The copy job is dequeued for the execution. 4: The copy job is in progress. 2: The copy job already completed.
copy_source_cluster	This field represents the CSG copy source cluster ID when CSG copy completed. If the CSG copy does not yet complete, -1 is indicated.
volume_size	This field represents the size of the GGM copy volume expressed in bytes as a decimal value. If the CSG copy does not yet complete, the field is 0.
consistent_clusters	This field represents the mask of the clusters which got the consistent volume by the GGM (both CSG and CTG) copy as a hexadecimal value. If the CSG copy does not yet complete, 0 is indicated. [Cluster ID <=> Mask value] CL0 <=> 1 CL1 <=> 2 CL2 <=> 4 CL3 <=> 8 CL4 <=> 16 CL5 <=> 32 CL6 <=> 64 CL7 <=> 128 If the value is 41 (B101001), CL0, CL3 and CL5 got the consistent volume by the GGM copy.
last_csg_copy_timestamp	Timestamp of when the CSG copy completed. The format of the timestamp is: Year-Month-Day-Hour.Minute.Second.Microsecond for example: 2015-04-20-19.34.23.876129 If the CSG copy does not yet complete, this field is set to 1970-01-01-00.00.00.000000.
consistent_copy_count	This field represents the total consistent copy count in the CTG including the CSG copy target cluster. If the CSG copy does not yet complete, the field is 0.
management class	This field represents the management class name assigned to this logical volume by

	<p>GGM copy. If a default management class is assigned to this logical volume, the field is NULL.</p> <p>If the CSG copy does not yet complete, the following value could be provided: '*inherit': LI REQ, GGM, MC is set to "INHERIT". The actual management class name is not fixed until the CSG copy completes.</p>
storage class	<p>This field represents the storage class name assigned to this logical volume by GGM copy. If a default storage class is assigned to this logical volume, the field is NULL.</p> <p>If the CSG copy does not yet complete, the following value could be provided: '*inherit': LI REQ, GGM, SC is set to "INHERIT". The actual storage class name is not fixed until the CSG copy completes.</p>
data class	<p>This field represents the data class name assigned to this logical volume by GGM copy. If a default data class is assigned to this logical volume, the field is NULL.</p> <p>If the CSG copy does not yet complete, the following value could be provided: '*inherit': LI REQ, GGM, DC is set to "INHERIT". The actual data class name is not fixed until the CSG copy completes.</p>
storage group	<p>This field represents the storage group name assigned to this logical volume by GGM copy. If a default storage group is assigned to this logical volume, the field is NULL.</p> <p>If the CSG copy does not yet complete, the following value could be provided: '*inherit': LI REQ, GGM, SG is set to "INHERIT". The actual storage group name is not fixed until the CSG copy completes.</p>
target_volume_category	<p>This field represents the category the volume is to be set to in the CTG in a hexadecimal value.</p> <p>If the CSG copy does not yet complete, the following value could be provided: 0000: LI REQ, GGM, TGTCAT is set to "INHERIT". The actual target volume category is not fixed until the CSG copy completes.</p>
recall_required	<p>This field represents if the CSG copy required a recall on the CSG copy source cluster:</p> <p>'Y': Recall was required.</p> <p>'N': Recall was not required.</p>
op_msg_required	<p>This field represents the setting if the operator message needs to be surfaced when the GGM copy completed or failed:</p> <p>'Y': Operator message was required.</p> <p>'N': Operator message was not required.</p>
source_volume_category	<p>This field represents the category the volume is to be set to in the CSG after the GGM copy completed in a hexadecimal value. If no source volume category change is required, the field is 0000.</p>

12 Appendix D. GGM network health check

Once GGM is enabled by LI REQ in the CTG, the CSG copy target cluster in the CTG starts the periodical GGM network health check. It is automatically disabled when GGM is disabled by LI REQ.

The GGM network health check is done by pinging from the CSG copy target cluster in the CTG to CSG proxy server cluster (i.e. same with CSG copy source cluster) in the CSG. The health check is done via two methods:

- (a) The check through the ICMP port by ping command.
- (b) The check through the dedicated port for GGM proxy server communication.

If the health check fails, an event is posted in the Management Interface Events panel:

- (a) The health check failure through the ICMP port

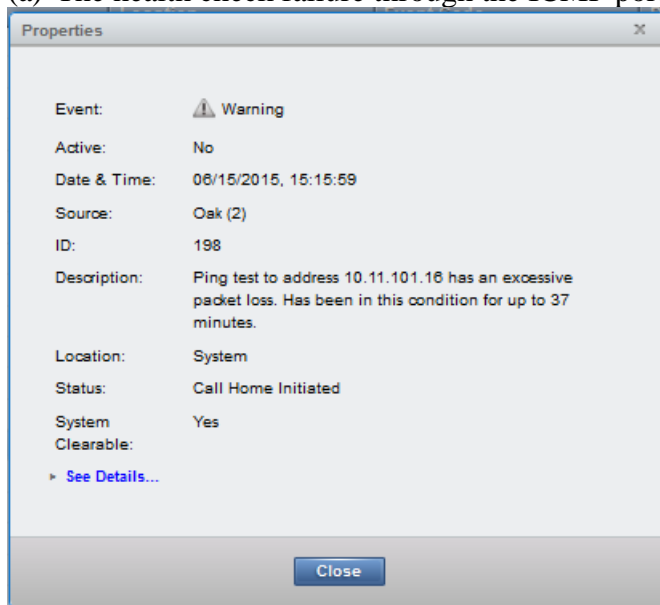

- (b) The health check failure through GGM proxy server communication port

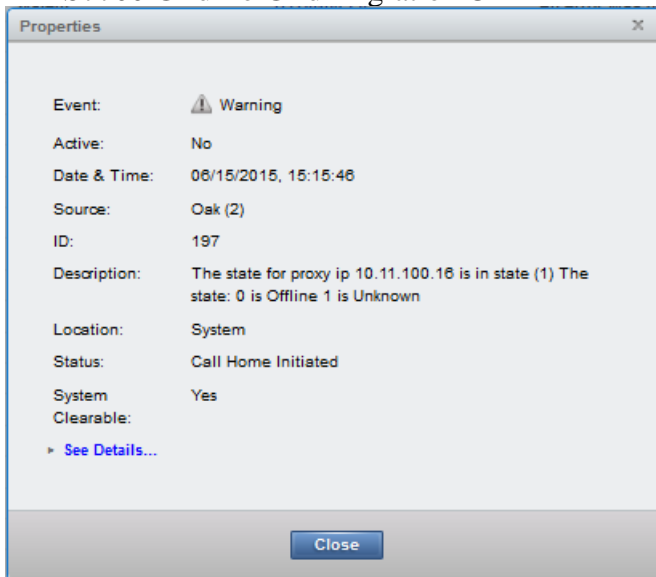

If the ICMP port is not opened between the CTG and CSG, the ICMP ping check always fails and the event is created. In order to prevent the event from being created, IBM Service Representative needs to disable the ping check on the Grid network. Even the check is disabled, the Grid network issue in the CTG is still notified by the alternative check method.

13 Disclaimers

© Copyright 2007 - 2015 by International Business Machines Corporation.

No part of this document may be reproduced or transmitted in any form without written permission from IBM Corporation.

Product data has been reviewed for accuracy as of the date of initial publication. Product data is subject to change without notice. This information could include technical inaccuracies or typographical errors. IBM may make improvements and/or changes in the product(s) and/or programs(s) at any time without notice.

References in this document to IBM products, programs, or services does not imply that IBM intends to make such products, programs or services available in all countries in which IBM operates or does business. Any reference to an IBM Program Product in this document is not intended to state or imply that only that program product may be used. Any functionally equivalent program, that does not infringe IBM's intellectually property rights, may be used instead. It is the user's responsibility to evaluate and verify the operation of any non-IBM product, program or service.

The information provided in this document is distributed "AS IS" without any warranty, either express or implied. IBM EXPRESSLY DISCLAIMS any warranties of merchantability, fitness for a particular purpose OR NON INFRINGEMENT. IBM shall have no responsibility to update this information. IBM products are warranted according to the terms and conditions of the agreements (*e.g.*, IBM Customer Agreement, Statement of Limited Warranty, International Program License Agreement, etc.) under which they are provided. IBM is not responsible for the performance or interpretability of any non-IBM products discussed herein. The customer is responsible for the implementation of these techniques in its environment.

Information concerning non-IBM products was obtained from the suppliers of those products, their published announcements or other publicly available sources. Unless otherwise noted, IBM has not tested those products in connection with this publication and cannot confirm the accuracy of performance, compatibility or any other claims related to non-IBM products. Questions on the capabilities of non-IBM products should be addressed to the suppliers of those products.

The provision of the information contained herein is not intended to, and does not grant any right or license under any IBM patents or copyrights. Inquiries regarding patent or copyright licenses should be made, in writing, to:

IBM Director of Licensing
IBM Corporation
North Castle Drive
Armonk, NY 10504-1785
U.S.A.

Trademarks

The following are trademarks or registered trademarks of International Business Machines in the United States, other countries, or both.

IBM, TotalStorage, DFSMS/MVS, S/390, z/OS, and zSeries.

Other company, product, or service names may be the trademarks or service marks of others.