

CATALOG H

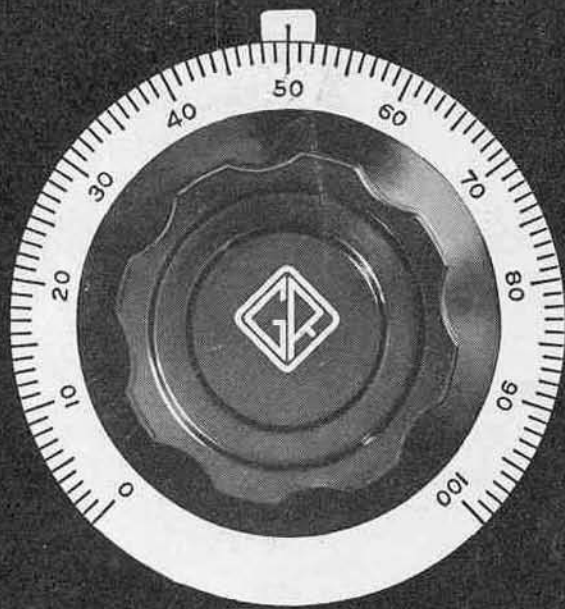

GENERAL RADIO CO.
CAMBRIDGE, MASS.
U. S. A.

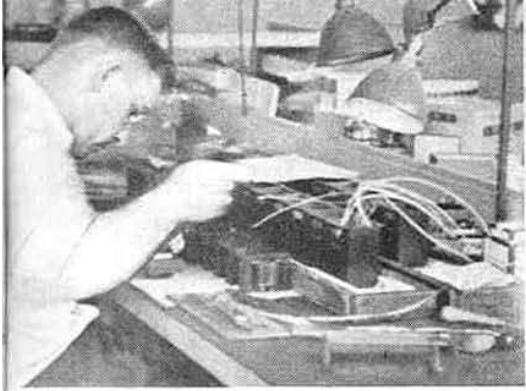

GENERAL RADIO COMPANY

CAMBRIDGE

MASSACHUSETTS



CATALOG H

APRIL, 1935

© 1935, GENERAL RADIO COMPANY

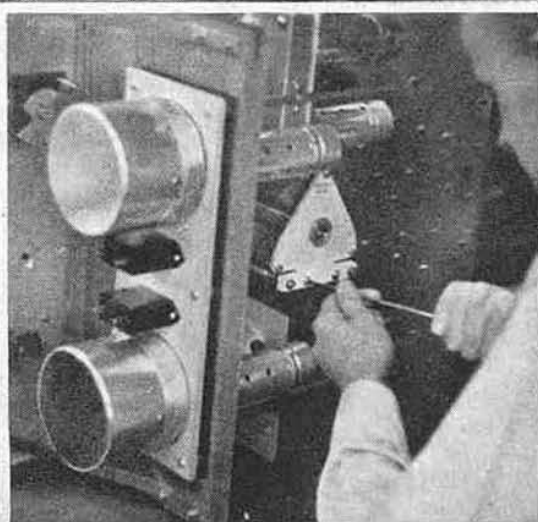
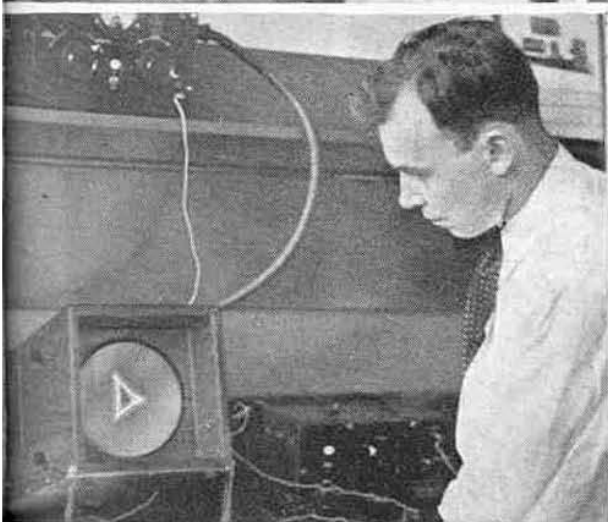
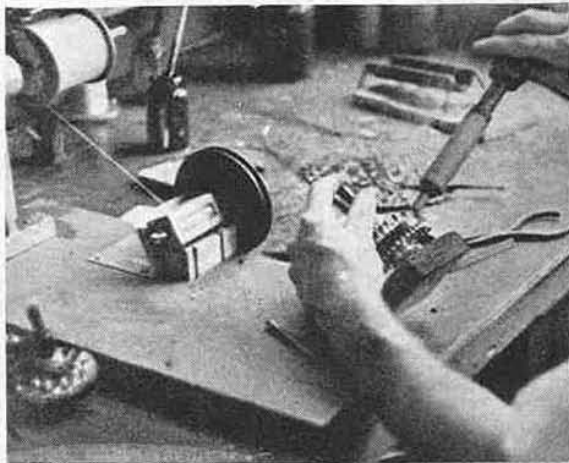
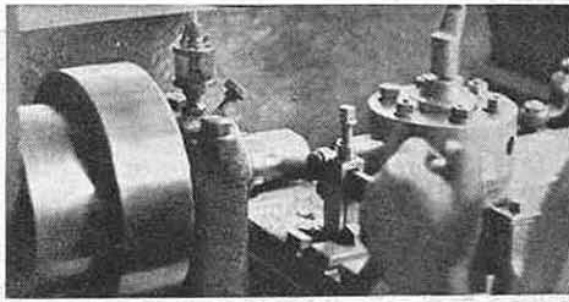
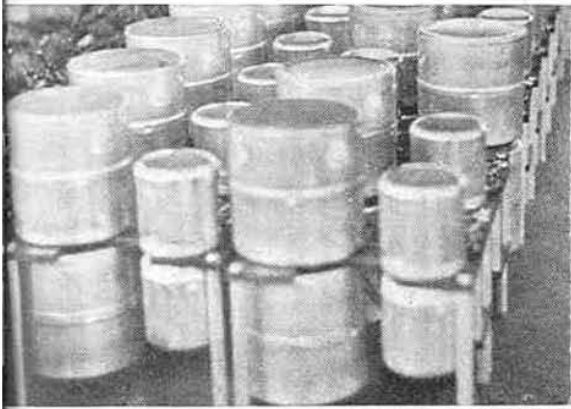

QUICK INDEX

INDUSTRIAL DEVICES	1
RESISTORS	7
CONDENSERS	21
INDUCTORS	31
FREQUENCY- AND TIME-MEASURING DEVICES	33
OSCILLATORS	57
AMPLIFIERS	67
BRIDGES AND ACCESSORIES	69
STANDARD-SIGNAL GENERATORS	89
OSCILLOGRAPHS, CAMERAS, AND ANALYZERS	97
METERS	117
POWER SUPPLIES	125
PARTS AND ACCESSORIES	127
APPENDIX AND DATA TABLES	177
INDEX BY TYPE NUMBER	187
INDEX BY TITLE	189

INDUSTRIAL DEVICES

THE section on Industrial Devices appears in this issue of the General Radio Company catalog for the first time. Application of electronic apparatus and technique, once confined to the communications industry, is expanding increasingly into other fields. Recognizing this fact, the General Radio Company has extended its development program somewhat beyond the limits of the communication industry, to include more general applications of electrical measurement technique. The instruments described in this section are the first result of this program.

Applications of our equipment to general industrial problems are by no means confined to those described in this section. Cathode-ray oscillographs and high-speed cameras, included in other portions of the catalog, have many applications outside of the communications industry, and there is a growing recognition of the correlation between chemical and electrical properties of materials so that the alternating-current bridge has become a powerful tool in chemical analyses. The Variac auto-transformer, too, has obvious applications throughout industry.

GENERAL RADIO COMPANY

INDUSTRIAL DEVICES

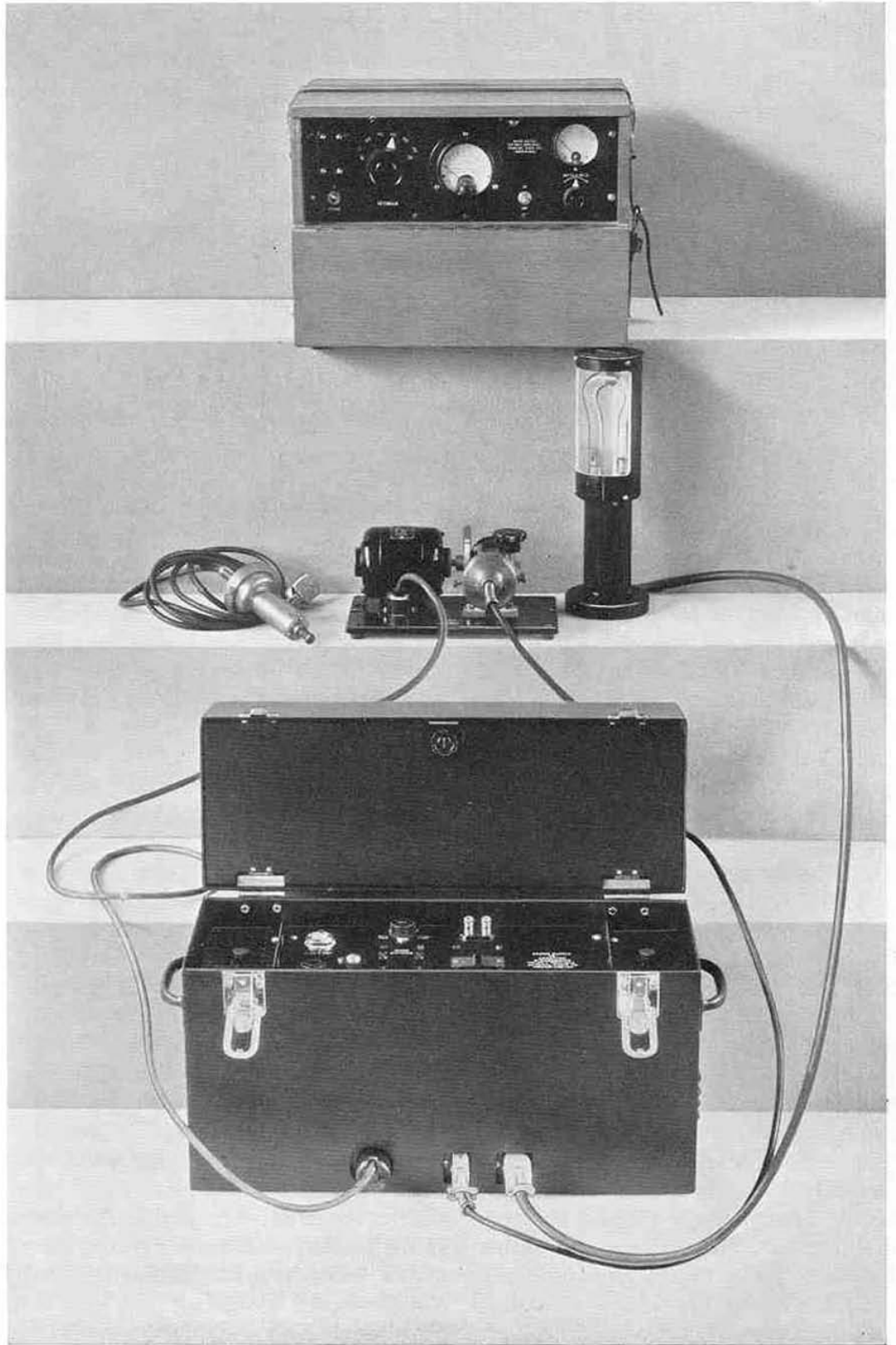

TYPE 548-A EDGERTON STROBOSCOPE

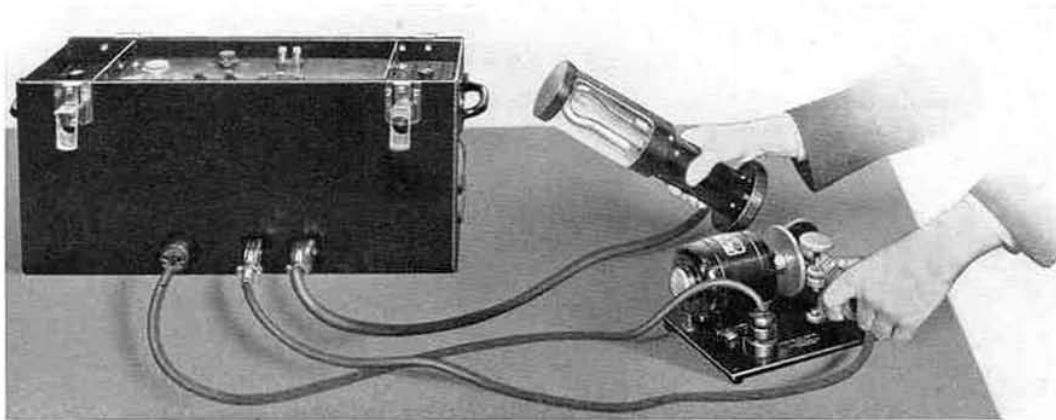

TYPE 548-A Edgerton Stroboscope (power supply and lamp) with TYPE 549-B Synchronous-Motor Contactor

Vision, the ability to see what is happening, is a proverbial preliminary to finding a solution for difficulties. Most modern mechanical operations have not been subject to this fundamental method of analysis because they take place at speeds too rapid for the eye to follow.

The stroboscope, however, depending upon the principles of intermittent viewing and retention of vision, makes this possible. If a rotating object is instantaneously viewed at only one point in its motion, the optical impression is of a stationary object. If the viewing point of successive observations progresses smoothly, the optical impression is that of an object rotating slowly at the rate of progression of the viewing point.

The Edgerton Stroboscope greatly simplifies the mechanics of the stroboscopic principle. Instead of using rotating discs, shutters, or other mechanical means, intermittent viewing is accomplished by flashing a light of high intensity and very brief duration. This stroboscope consists of a lamp, power source, and means for accurately timing the flash. The flash is of sufficient intensity to override moderate background illumination, and its duration

is so brief that sharply defined views of objects moving at high linear velocities are obtained.

The stroboscope may be used as a light source in the photography of rapidly moving mechanisms. In this application it is used with a shutterless camera (such as the General Radio TYPE 651-AM Assembly) in which the exposure is obtained by means of the brilliant flash instead of a shutter.

While the normal means for controlling the flash rate is the TYPE 549-B Synchronous-Motor Contactor, the rate can also be controlled (1) by closing any pair of electrical contacts, (2) by the 60-cycle supply mains (sixty flashes per second), or (3) by any external source of alternating current capable of maintaining 100 volts across 5000 ohms.

All parts of the stroboscope equipment except the lamp and tripping contacts are built into the metal cabinet which constitutes the power-supply unit. The cover stores the detachable mercury-vapor lamp and a TYPE 549-B Synchronous-Motor Variable-Speed Contactor which is optional equipment and is not included in the price of the instrument.

STROBOSCOPE

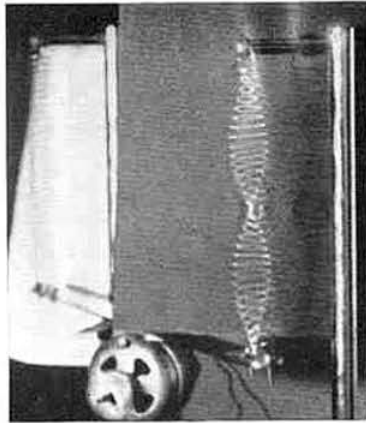

THE STROBOSCOPE STOPS MOTION

Two views of the same
oscillating spring

BY ORDINARY LIGHT



BY
STROBOSCOPE LIGHT



*from unretouched sections of
35-mm motion-picture film*

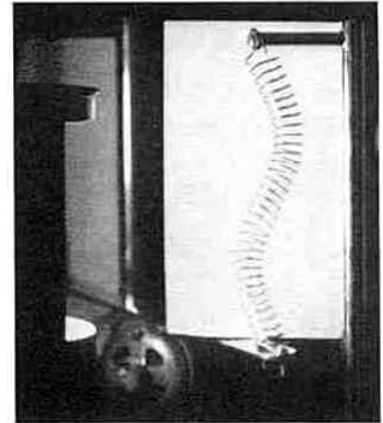

SPECIFICATIONS

Flashing Range: From 0 to 12,000 flashes per minute for fundamental synchronism.

Lamp: U-shaped mercury-vapor lamp mounted in a bakelite protective housing which may be stood upright or held in the operator's hand.

Illumination: The light intensity will permit good visual observations in a semi-darkened room with the lamp from 12 to 18 inches from the object.

Spectral Distribution: Practically all of the radiant energy is in the blue portion of the visible spectrum, a decided advantage in photography.

Tubes: One FG-17 thyratron and two UX-281 rectifier tubes are supplied with the instrument.

Power Supply: 115 volts, 50-60 cycles.

Power Consumption: 0.25 kw., maximum.

Mounting: The power supply is housed in a metal

cabinet having a detachable cover in which the lamp, motor-driven contactor, and cables may be stored.

Dimensions: (Length) 23 x (width) 7½ x (height) 16½ inches, over-all, with cover closed. Dimensions of lamp housing, (height) 12 x (diameter) 4 inches.

Net Weight: 56 pounds, including lamp but not the TYPE 549-B Synchronous-Motor Contactor.

Type	Code Word	Price
*548-A	MAGIC	

*Includes lamp assembly. Hand contactor or synchronous-motor contactor must be ordered separately.

TUBE REPLACEMENTS

Type	Description	Code Word	Price
550-P1	Lamp	MAJOR	
FG-17	Thyratron		

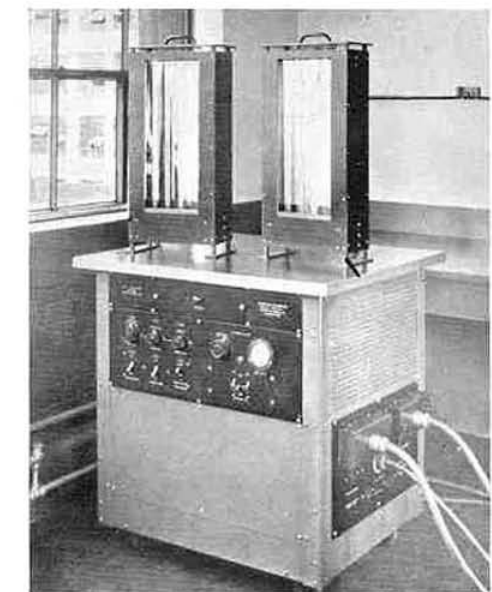

TYPE 621-A EDGERTON POWER STROBOSCOPE

Where illumination greater than can be obtained with the TYPE 548-A Edgerton Stroboscope is required, we can build larger models like the one shown in the accompanying photograph. With it a fair-sized room can be literally flooded with stroboscopic light. The larger units are particularly desirable when high-speed motion pictures are to be taken with a considerable field of view.

Since each of the large units is built to order, modifications in construction can be made to suit the user's requirements. Specific performance data will gladly be sent on request. A statement of the proposed operating conditions should be included.

CONTACTORS FOR USE WITH EDGERTON STROBOSCOPE

Two commutator-type contactors are available for controlling the flashing rate of an Edgerton Stroboscope. One is a motor-driven device having the flashing rate adjustable over a wide range. The other is for pressing against the end of a shaft, tachometer-fashion. It makes one flash for every revolution of the shaft.

TYPE 549-B SYNCHRONOUS-MOTOR CONTACTOR

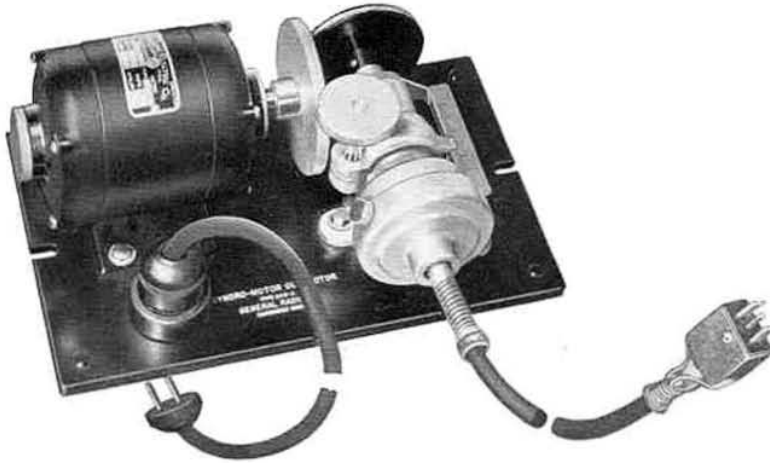

TYPE 549-B Synchronous-Motor Contactor

This unit, when driven from a 115-volt 60-cycle line, is capable of flashing an Edgerton Stroboscope at any rate between 500 and 3000 flashes per minute. The contactor is driven by an 1800-r.p.m. self-starting synchronous motor. Flashing rate adjustment is made by turning the knurled handle which changes the ratio of the friction-drive mechanism. A calibrated scale gives the flashing rate in flashes per minute. Phase can be adjusted independently at the contactor head.

It should be remembered that the contactor can be used for speed measurements as high as 30,000 r.p.m. If one flash occurs for every second turn of the observed phenomenon, the effective range becomes 1000 to 6000 r.p.m.; if one flash occurs for every third turn, the effective range becomes 1500 to 9000 r.p.m.; etc.

By removing the contactor head and substituting a rubber driving tip which is supplied, a hand contactor equivalent to TYPE 549-P2 is obtained.

SPECIFICATIONS

Range of Flashing Rate: 500 to 3000 flashes per minute. The contactor may be used for observing and measuring speeds up to at least 30,000 r.p.m. A calibrated scale (500 to 3000 r.p.m.) is provided.

Cords: Connecting cords are furnished.

Controls: One knob for adjusting speed and the movable contactor head for adjusting the phase.

Each is provided with a locking arrangement to hold it firmly in the desired position.

Frequency Stability: Determined by stability of the 60-cycle supply mains.

Dimensions: (Length) $9\frac{3}{4}$ x (width) $6\frac{3}{4}$ x (height) $4\frac{3}{8}$ inches, over-all.

Net Weight: $10\frac{5}{8}$ pounds.

<i>Type</i>	<i>Code Word</i>	<i>Price</i>
549-B	MACAW	

TYPE 549-P2 HAND CONTACTOR

This is the uncalibrated head of the TYPE 549-B Synchronous-Motor Contactor previously described. It is fitted with a rubber tip so that it can be driven from the counter center of a rotating shaft as shown in the accompanying illustration. Phase may be varied by rotating the adjustable head. A clamp for mounting the contactor in the cover of a TYPE 548-A Edgerton Stroboscope is furnished.

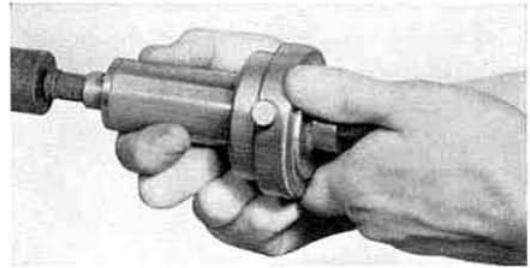

TYPE 549-P2 Hand Contactor

SPECIFICATIONS

Dimensions: (Length) 7 x (diameter) $3\frac{1}{4}$ inches, over-all.

Cord: Connecting cord is furnished.
Net Weight: $2\frac{2}{5}$ pounds.

Type	Code Word	Price
549-P2	MADAM	

TYPE 559-A NOISE METER

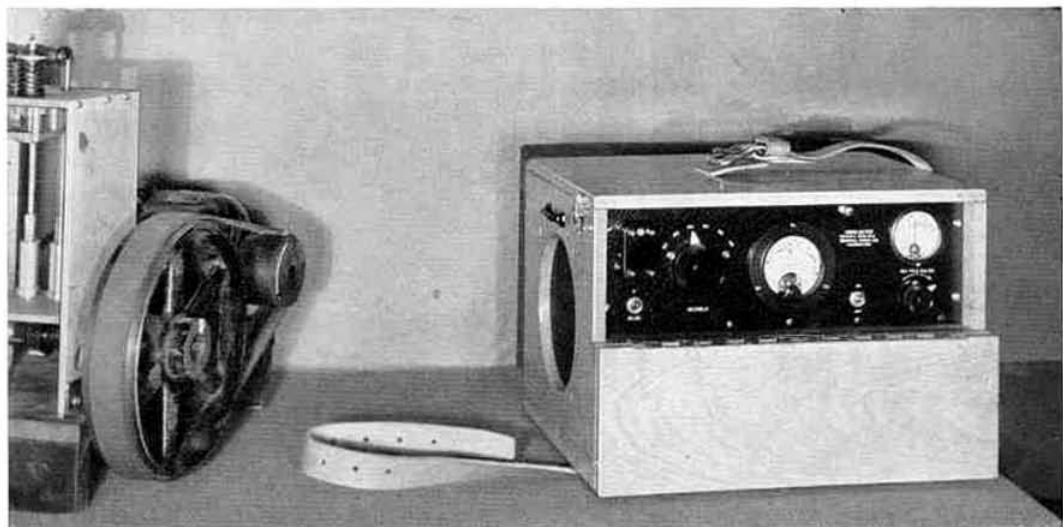

This instrument is an inexpensive meter intended to meet the demand for a simple device for making commercial noise measurements. It can be used successfully for urban noise-level surveys or to ascertain the amount of audible disturbance caused by machinery, and the effectiveness of efforts to eliminate noise can be judged. Conversely, the effectiveness of noise-

producing devices can be quantitatively determined. Since the frequency characteristic of the noise meter closely approximates that of the human ear, the observed meter readings are directly proportional to the aural stimulus of the noise being measured.

The noise meter consists essentially of a rugged dynamic-pickup unit, a frequency-

weighting network to provide a frequency response similar to that of the human ear, attenuators, an amplifier, and a meter to indicate the noise level. The instrument is calibrated directly in decibels above the average threshold of hearing at 1000 cycles. To convert the scale to another

reference level it is only necessary to add or subtract a constant number of decibels to any observed reading of the meter.

The instrument is sensitive enough to show a deflection at a pin drop, and its range extends to sound intensities sufficiently great to cause pain.

SPECIFICATIONS

Sound Level Range: Calibrated in decibels from +30 db to +146 db above the average threshold of hearing at 1000 cycles. This corresponds to a range of +23 db to +139 db above a reference level of 1 millibar at 1000 cycles, and to a range of +37 db to +153 db above a reference level of 10^{-16} watts per square centimeter.

Frequency Characteristic: The over-all frequency characteristic is similar to the response of the human ear.

Pickup Unit: A dynamic noise-pickup unit similar in construction to the usual permanent-magnet dynamic speaker, and of rugged construction, is built into the end of the cabinet.

Circuit: A stable high-gain screen-grid amplifier is employed. A removable plug in a 600-ohm input circuit allows filters of various characteristics to be inserted, and permits the use of an external microphone in place of the noise-pickup unit supplied. A step-by-step attenuator is provided in addition to a fixed T-pad attenuator which is connected into the circuit for the measurement of high noise levels.

The attenuators precede the amplifier, reducing overload and errors due to possible non-linearity.

Tubes: One 32-type and one 33-type, supplied with the instrument.

Meters: A double-range voltmeter for measuring filament and plate voltages is provided in addition to the noise-indicating meter which is a d'Arsonval movement with copper-oxide rectifier, calibrated in decibels.

Power Supply: Two No. 6 dry cells, three 45-volt Burgess No. 5308 or equivalent, and one 7.5-volt Burgess No. 5540 or equivalent batteries are required. Space for these batteries is provided in the mounting case, but batteries are not included in price of the instrument.

Mounting: The noise meter is built into an oak cabinet and provided with a heavy leather carrying strap.

Dimensions: (Width) $16\frac{1}{2}$ x (height) 11 x (depth) $12\frac{1}{4}$ inches, over-all.

Net Weight: 33 pounds, without batteries; $47\frac{1}{2}$ pounds with batteries.

<i>Type</i>	<i>Code Word</i>	<i>Price</i>
559-A	-MITER	

RESISTORS

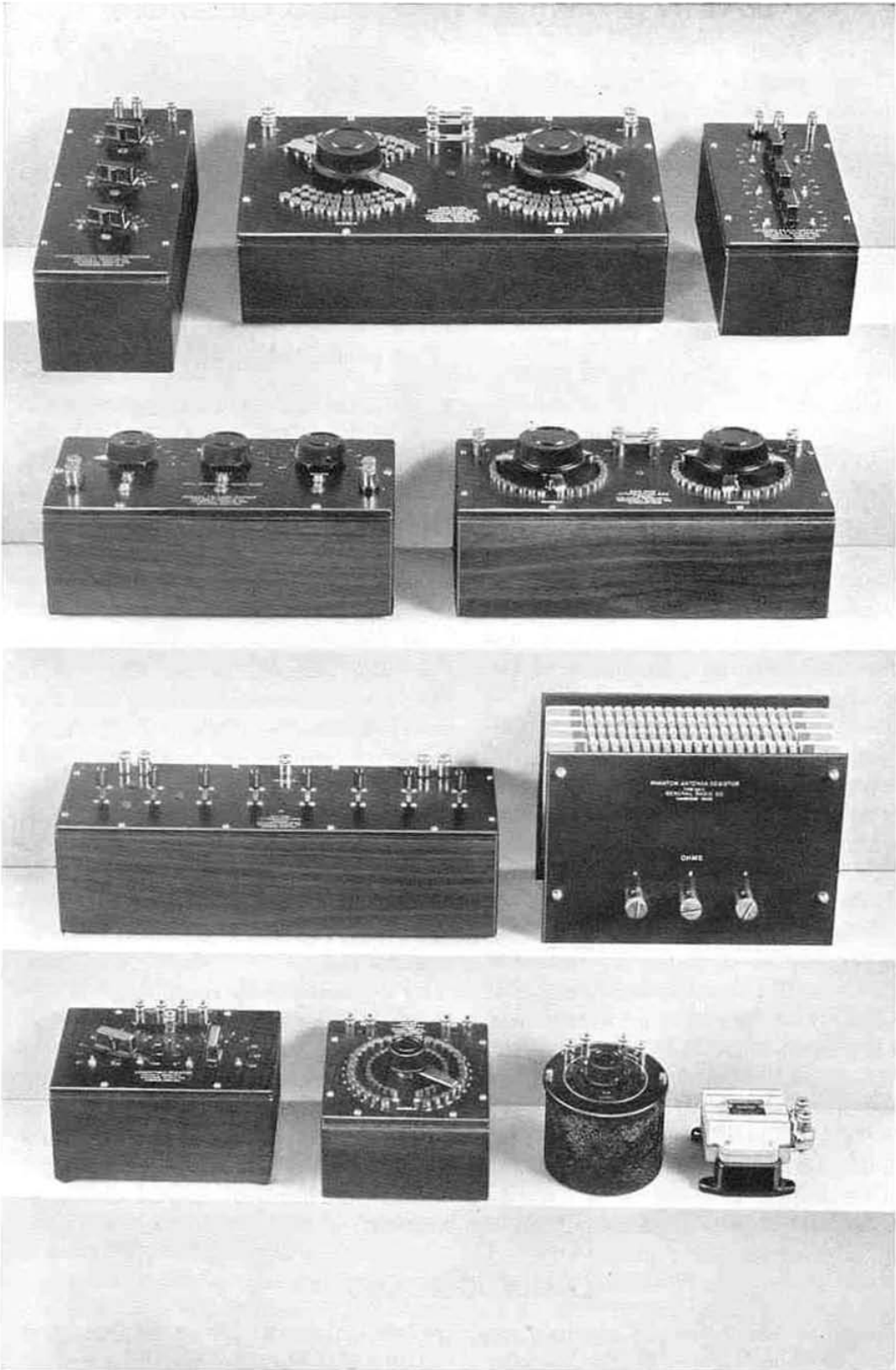

GENERAL INFORMATION ON PRECISION RESISTORS

General Radio precision resistors are built up around several types of units which have been developed in the course of the company's twenty years of experience in this field. These units have no considerable change in resistance over ordinary temperature ranges, and the calibration changes only slowly with time.

Permanence of original calibrated values is assured by the use of low-temperature-coefficient materials and careful aging in order to relieve strains set up in winding. Winding forms are designed for permanence so as to resist any deformation which would impose stresses in the windings.

Permanence of calibration with time and temperature is not sufficient, however, for resistors which are to be used at high frequencies. The General Radio Company has designed units which are to a large degree free from reactance effects, and whose resistance is independent of frequency between wide limits. All of these units may be used throughout the wide frequency range from 0 to 50 kc without regard to frequency effects, and those of smaller resistance values are free from serious errors well into the radio-frequency region.

Complete specifications covering the more common values of the different windings are given in the description of the TYPE 602 Decade-Resistance Box (page 9). The desirable results come from the appropriate use of the three types of winding described herewith.

(a) *Ayrton-Perry Method.* (Used on low-resistance precision cards.) On a thin bakelite strip a single wire is wound, leaving a space between turns equal to the diameter of the wire. A second wire is



Ayrton-Perry

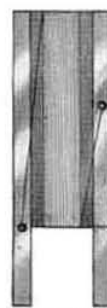

Mica-Card

These are the two principal types of construction used in building General Radio precision resistors

wound in the space between turns, in parallel with the first wire but in the opposite direction, so that units wound by this method are nearly non-inductive. Unlike the usual non-inductive bifilar winding, the distributed capacitance is also very small because adjacent wires are at nearly the same potential.

(b) *Mica-Card Method.* (Used on high-resistance precision cards.) The wire is closely wound in a single layer on a thin mica form, the ends of which are reinforced by copper terminal strips. The small wire and the thin form give units made by this method an exceptionally low phase angle at high frequencies. Modifications of this design are used successfully on the attenuation networks used in our standard-signal generators at frequencies as high as 25 megacycles.

(c) *Bifilar Method.* (Used only on 0.1-ohm precision steps.) This method of winding consists of a short length of ribbon bent sharply back upon itself.

The completed cards are assembled in bridges, voltage dividers, and attenuation networks, as well as on decade switches mounted in boxes of several dial combinations.

OTHER RESISTORS

Where precision-winding methods are not required, the General Radio Company makes use of modifications which, because they do not involve such careful handling,

are less expensive. Where accuracy and stability of calibration demand precision resistors, however, precision resistors are always used.

TYPE 602 DECADE-RESISTANCE BOX

A convenient assembly of resistance cards with switches in a single unit is a laboratory staple. Such boxes are in constant use in circuits where a wide range of resistance values is required. They are used as laboratory standards, bridge arms, and loads. All General Radio boxes are equally useful on direct or alternating current and maintain their usefulness for many applications into the high radio frequencies.

The methods of assembly of the individual units into a resistance box are of as much importance as the characteristics of the units themselves, for the unit characteristics may be greatly affected by the mounting.

The TYPE 602 Decade-Resistance Box has been designed to provide a convenient assembly of resistance units, to protect the units and switching contacts, and to avoid alteration of the characteristics of the individual units.

Two-, three-, four-, and five-dial decade assemblies are provided. Each decade has eleven contact studs and ten resistance units so that dials overlap. A detent assists in setting squarely on the contacts.

Mechanical and electrical protection of the units is provided by the shielded walnut box and aluminum panel which completely enclose both units and switch contacts.

Quadruple-leaf switch blades running over large contacts insure a low and constant contact resistance. The arrangement of cards and wiring is such as to keep at a minimum the added resistance and reactance which are unavoidable in assembling units into a box.

These resistors are adjusted to have their specified values at their own terminals and not at the terminals of the box.

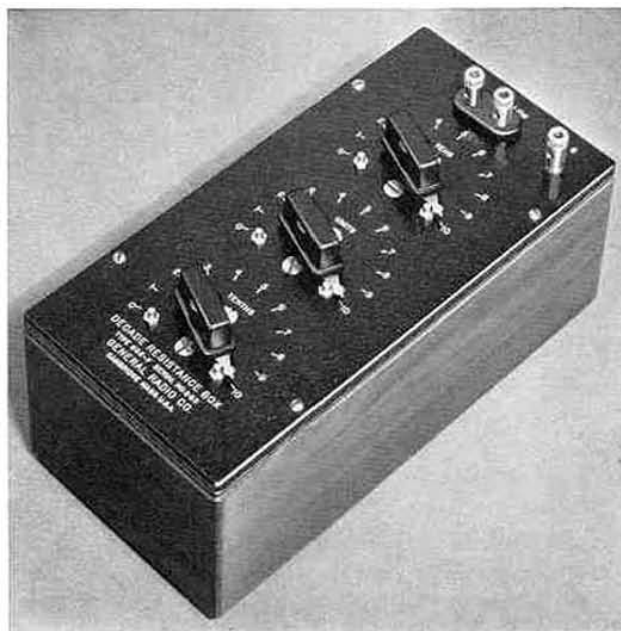

A 3-dial TYPE 602 Decade-Resistance Box. Boxes having 2, 4, and 5 dials are also available

The resistance measured at the box terminals will, therefore, be high by the switch contact and wiring resistance, which amounts to about 0.002 ohm per dial. This method of adjustment has been adopted primarily because no method in which the switch resistance is absorbed in some one unit of a decade can give the correct value of the total resistance for all settings of the various decades. There are also many types of measurement (voltage divider measurements, for example) in which the difference in two settings of a resistance box is significant. This difference is given correctly only when the individual resistors have been adjusted independently of switch resistance. The wiring also adds a small inductance, about 0.1 microhenry per decade.

When the boxes are used on alternating currents, particularly as the frequency is raised, the box wiring and the switch capacitances affect the value of resistance between the box terminals by adding to the frequency effect in the cards them-

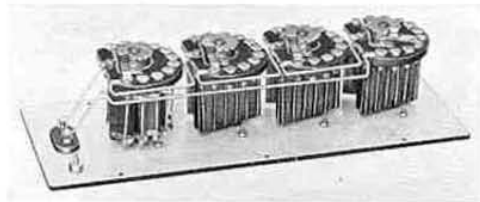

Typical internal construction of a
TYPE 602 Decade-Resistance Box

selves. These effects vary with frequency and are generally greater for the larger dials. They do not appear at audio frequencies but do affect resistance values at carrier and radio frequencies.¹

¹More detailed information on the performance of these boxes at high frequencies will be given on application.

Generally speaking, the 1-, 10-, and 100-ohm dials are most satisfactory at high frequencies.

When the boxes are used in tuned circuits, only changes in resistance due to skin effect and, in some high-resistance cards, to effective capacitance need be considered. When the boxes are used as drop wires, the reactance of wiring and cards at high frequencies will affect the apparent impedance of the box. Data on these effects will be found in the specifications under "Frequency Characteristics."

SPECIFICATIONS

Type of Winding: The non-reactive precision resistors, described on page 8, are used: Bifilar type on the 0.1-ohm units; Ayrton-Perry on 1-, 10-, and 100-ohm decades; and the unifilar mica type on the 1000- and 10,000-ohm decades.

Accuracy of Adjustment: All cards are adjusted to within 0.1% of the stated value between card terminals, except the 1-ohm cards which are adjusted to within 0.25% and the 0.1-ohm cards which are adjusted to within 1%. Where necessary, add 0.002 ohm for each dial to allow for contact and wiring resistance.

Frequency Characteristics: There is no serious frequency error below 50 kc. At higher frequencies the error results from changes in resistance and the effect of the reactance in the cards, and from the inductance of the box wiring (about 0.1 μ h per dial).

Table II lists increase in resistance for single decades as error in percentage of the stated value of resistance as a function of the frequency.

Table III lists change in impedance for single decades as error in percentage of the stated value of resistance as a function of the frequency.

Maximum Current: The upper limit of temperature rise is 40 degrees C. Values of current for 20 degrees C. and 40 degrees C. rises follow.

TABLE I
Current for Temperature Rise
of 20° C. and 40° C.

Decade	20° C. Rise	40° C. Rise
0.1-ohm steps	1 a	1.5 a
1 -ohm steps	600 ma	1 a
10 -ohm steps	170 ma	250 ma
100 -ohm steps	50 ma	80 ma
1000 -ohm steps	15 ma	23 ma
10,000 -ohm steps	5 ma	7 ma

Switches: Quadruple-leaf, phosphor-bronze switches bear on contact studs $\frac{3}{8}$ -inch in diameter. Switch brushes are bent so as not to be tangent to the arc of travel, thus avoiding cutting. A cam-type detent is provided. There are eleven contact points (0 to 10 inclusive).

TABLE II
Percentage Error in Resistance
for Maximum Setting of Each Decade as a Function of Frequency

Decade	Frequency in kc						
	50	100	200	500	1000	2000	5000
0.1-ohm steps	0	0.1%	0.2%	1.5%	5 %	—	—
1 -ohm steps	0	0	0.1%	0.3%	1 %	4 %	—
10 -ohm steps	0	0	0	0.1%	0.5%	2 %	11%
100 -ohm steps	0	0	0	0.1%	0.3%	0.8%	4%
1000 -ohm steps	0	-0.1%	-0.5%	-3 %	-11 %	—	—
10,000 -ohm steps	-1%	-5 %	—	—	—	—	—

TABLE III
Change in impedance (as a percentage of nominal resistance)
for Maximum Setting of Each Decade as a Function of Frequency

Decade	Frequency in kc						
	50	100	200	500	1000	2000	5000
0.1-ohm steps	0.2%	0.7%	2%	—	—	—	—
1 -ohm steps	0.1%	0.2%	1%	5%	—	—	—
10 -ohm steps	0	0	0.1%	0.2%	2%	—	—
100 -ohm steps	0	0	0	0.1%	0.3%	1%	5%
1000 -ohm steps	0	-0.1%	-0.5%	-2%	-6%	—	—
10,000 -ohm steps	-2%	-10%	—	—	—	—	—

Temperature Coefficient: The temperature coefficient is less than $\pm 0.002\%$ per degree C. except on the 10,000-ohm cards where it is $+0.013\%$ per degree C. at room temperature.

Terminals: Jack-top binding posts set on General Radio standard $\frac{3}{4}$ -inch spacing for resistance connections. There is an extra post at the corner of the panel for connections to the shield.

Mounting: A copper-lined walnut cabinet, with

aluminum panel, completely encloses switches and resistance units. The panel finish is black crackle lacquer.

Dimensions: Panel length depends on the number of dials (see price list), being $7\frac{3}{4}$ for 2-dial, $10\frac{3}{8}$ for 3-dial, 13 for 4-dial, and $15\frac{5}{8}$ inches for 5-dial boxes. Panel width, 5 inches. Over-all height, 5 inches.

Net Weight: $3\frac{1}{4}$ for 2-dial, $4\frac{1}{4}$ for 3-dial, 5 for 4-dial, and $6\frac{1}{4}$ pounds for 5-dial boxes.

Type	Resistance	No. of Dials	Code Word	Price
602-D	11 ohms, total, in steps of 0.1 ohm	2	DECOY	
602-E	110 ohms, total, in steps of 1 ohm	2	DECRY	
602-F	111 ohms, total, in steps of 0.1 ohm	3	DELTA	
602-G	1110 ohms, total, in steps of 1 ohm	3	DIGIT	
602-K	1111 ohms, total, in steps of 0.1 ohm	4	DEFER	
602-J	11,110 ohms, total, in steps of 1 ohm	4	DEBIT	
602-N	11,111 ohms, total, in steps of 0.1 ohm	5	DEMON	
602-M	111,110 ohms, total, in steps of 1 ohm	5	DEMIT	
602-L	111,100 ohms, total, in steps of 10 ohms	4	DECAY	



DECADE-RESISTOR ASSEMBLIES

like those used in the TYPE 602 Decade-Resistance Boxes. See the description of the TYPE 510 Decade-Resistance Unit, page 130.



INDIVIDUAL PRECISION RESISTORS

Precision resistance cards, mounted and sealed in moulded bakelite cases. See the description of the TYPE 500 Resistor, page 129.

TYPE 670 COMPENSATED DECADE RESISTOR



The TYPE 670 Compensated Decade Resistor consists of a decade-resistance box having completely non-reactive resistance increments.

While the TYPE 602 Decade-Resistance Boxes have such low reactance as to be serviceable for many applications, even at radio frequencies, it is recognized that no type of resistance box can be made entirely non-reactive. In methods of measurement requiring a variable non-reactive resistance, a pure resistance increment is sought rather than a pure resistance, that is, a residual constant

inductance can be taken care of through a preliminary balance.

The TYPE 670 Resistors were designed to take advantage of this fact. A double card system is used, the switching arrangement being such that a copper coil of proper magnitude to keep the inductance constant is substituted when a resistance coil is switched out of circuit. In this way the resistance can be changed without producing any change in circuit inductance.

It will be observed from the data tables that a relatively high residual inductance is produced by this method of construction. This factor does not, however, detract from the value of the resistor since the boxes will be used either in substitution methods, where the preliminary balance of the circuit will take care of the residual inductance, or in bridge circuits where the residual inductance can be balanced by a compensating inductance in the opposite bridge arm.

The value of these boxes is, perhaps, best demonstrated by the fact that it was this development which made possible the TYPE 516-C Radio-Frequency Bridge and the TYPE 667-A Inductance Bridge, both of which are described elsewhere in this catalog, and neither of which would be possible without the use of pure resistance increments in the bridge arms.

SPECIFICATIONS

Type of Winding: The 10-ohm and 1-ohm steps are Ayrton-Perry-wound resistance cards as described on page 8. The 0.1-ohm steps are bifilar units. The decades are compensated by copper coils and a substitution switching arrangement which keep the box inductance constant at all settings.

The construction of the continuously-adjustable compensated slide wire is illustrated on page 131.

Accuracy of Adjustment: Resistance increments are correct to within 0.1% for the 10-ohm cards, 0.25% for the 1-ohm cards, and 1% for the 0.1-ohm decade steps and the 1-ohm slide wire.

Maximum Current: The upper limit of temperature rise is 40 degrees C. Values of current for 20 degrees C. and 40 degrees C. rises follow.

TABLE I
Current for Temperature Rise
of 20° C. and 40° C.

Decade	20° C. Rise	40° C. Rise
0.1-ohm steps	900 ma	1.5 a
1 -ohm steps	300 ma	500 ma
10 -ohm steps	96 ma	160 ma

Switches: Quadruple-leaf, phosphor-bronze switches bear on contact studs $\frac{3}{8}$ -inch in diameter. Switch brushes are bent so as not to be tangent to the arc of travel, thus avoiding cutting. A cam-type detent is provided. There are eleven contact points (0 to 10 inclusive).

Frequency Characteristics: There is no serious frequency error below 50 kc. At higher frequencies the errors are those shown in Table II. The compensation is good at frequencies as high as 5 megacycles.

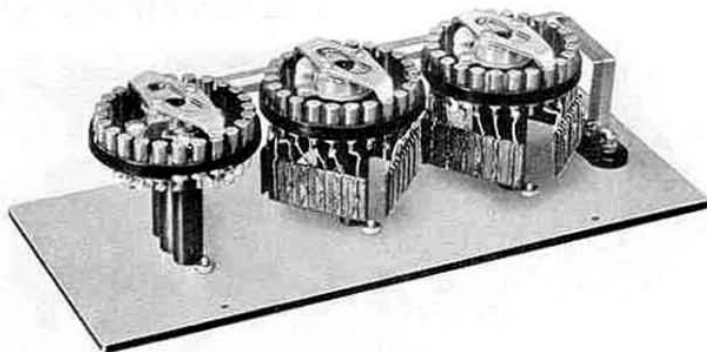

Interior view of the TYPE 670-F Compensated Decade Resistor

TABLE II
Percentage Error in Resistance for Maximum Setting of Each Decade as a Function of Frequency

Decade	Frequency in kc						
	50	100	200	500	1000	2000	5000
0.1-ohm steps	0	0.1%	0.2%	1.5%	5%	—	—
1 -ohm steps	0	0	0.1%	0.3%	1%	4%	—
10 -ohm steps	0	0	0	0.1%	0.5%	2%	11%

Temperature Coefficient: Less than $\pm 0.002\%$ per degree C. except on 10,000-ohm cards where it is $+0.013\%$ per degree C.

Mounting: The dials are mounted on aluminum

panels in copper-lined walnut cabinets.

Dimensions: Panel, (length) 13 x (width) 5 inches. Cabinet (height) 5 inches, over-all.

Net Weight: 5 pounds (all types).

Type	Resistance	Zero Resistance	Zero Inductance	Code Word	Price
*670-BW	0 to 11 ohms, total, with slide wire	0.050 ohm	0.70 μ h	ABRID	
670-F	0 to 111 ohms, total, in steps of 0.1 ohm	0.045 ohm	1.05 μ h	ABYSS	
*670-FW	0 to 111 ohms, total, with slide wire	0.085 ohm	1.05 μ h	ADOWN	

*Built to order only and not carried in stock. Normal delivery, two weeks.



SINGLE COMPENSATED DECADES

Pure resistance increments, total inductance constant. See description TYPE 668 Compensated Decade-Resistance Unit, page 131.



SINGLE COMPENSATED SLIDE WIRES

Continuously adjustable with 1- or 0.1-ohm total resistance. See description TYPE 669 Compensated Slide-Wire Resistor, page 131.

TYPE 646-A LOGARITHMIC RESISTOR



This is a resistance box of a new type from which a large number of known values of resistance between 0 and 100.1 megohms are available. Obtainable values are distributed in approximately logarithmic steps over this range, so that the unit can be used to replace a number of decade-resistance boxes. A decade resistor gives a large number of values in a narrow range; the TYPE 646-A Logarithmic Resistor gives fewer values distributed over a tremendously wide range.

There are numberless laboratory uses for the TYPE 646-A Logarithmic Resistor. It can be used in measuring circuits where a wide range of resistance values must be covered, and where, though each value used must be accurately known, using, for example, 5000 ohms instead of 6000 ohms would cause no trouble. It can be used for a test load in transformer measurements, and, because the switches are brought out to terminals, it can be used as a logarithmic voltage divider.

SPECIFICATIONS

Range: 0 to 100.1 megohms in approximately logarithmic steps.

Accuracy of Adjustment: Individual resistors are adjusted as follows:

Between 0.1 k Ω and 2 k Ω , 0.1%; between 5 k Ω and 0.1 M Ω , 0.25%; 2 M Ω to 100 M Ω , 5%.

Type of Winding: The construction of the units below the 20,000-ohm point is similar to the standard resistance-card construction described on page 8. Between the 20,000-ohm and the 1-megohm steps IRC wire-wound units are used.

Frequency Characteristic: The impedance for alternating currents of any frequency is given approximately by considering a capacitance of 20 μf with a power factor of 0.05 to be in parallel with the used portion of the "Megohms" dial. Second order corrections may be made for a 2 μf capaci-

tance between the high-resistance terminal of the "Megohms" dial and ground. For resistance uses the unused portion of the "Megohms" dial should be short-circuited.

Maximum Current: Individual resistors between 0.1 k Ω and 0.5 k Ω will safely carry 70 ma. Between 1 k Ω and 1 M Ω each resistor will dissipate 1 watt. Resistors greater than 1 M Ω will dissipate 2 watts.

Terminals: Separate binding posts are brought out from each switch and from one end of each group of resistors. A separate binding post for the shield is also provided.

Mounting: A copper-lined cabinet with an aluminum panel completely encloses both switches and resistors. The panel finish is black crackle lacquer.

Dimensions: (Length) 7 $\frac{3}{4}$ x (depth) 5 x (height) 5 inches.

Net Weight: 3 $\frac{1}{4}$ pounds.

Type	Code Word	Price
646-A	AWAKE	

TYPES 249, 329-J, and 429-H ATTENUATION BOXES

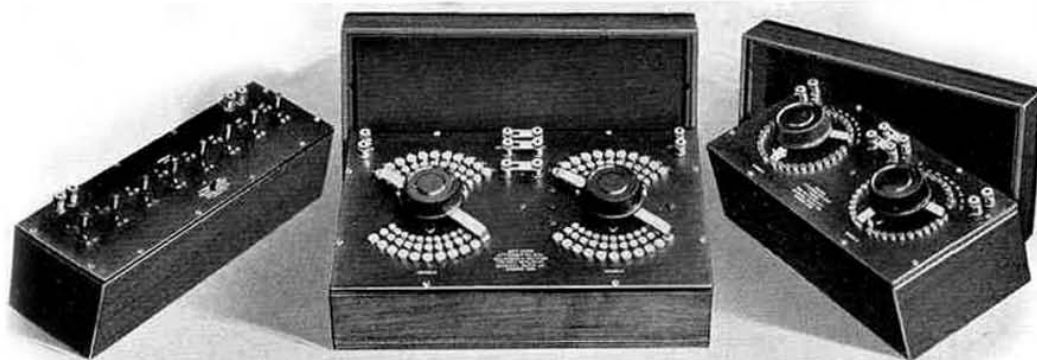

TYPE 249-T

TYPE 329-J

TYPE 429-H

Balanced-H- and T-section precision attenuation networks are made in 3 types

General Radio manufactures precision attenuation networks under three type numbers; distinguished by the type of section (T or balanced-H) and by the switching mechanism. TYPE 249 has key switches, TYPES 329-J and 429-H, rotary switches. The latter style is usually preferred, although many engineers make the claim that the key switch is faster to operate.

An attenuation network is a combination of resistance elements so arranged that it introduces a definite and known amount of power loss when put into a circuit between certain specified values of external output and input impedance. These three factors completely specify its performance at all frequencies for which the effects of reactance in the resistors and spurious admittances between them can be considered negligible.

These networks, when constructed with a switching mechanism for changing the amount of attenuation, are called "attenuation boxes" and have long been in common use throughout the communication engineering industries for making all kinds of transmission-efficiency and power-level measurements. Their value is now becoming well known in other fields as accessories of the vacuum-tube amplifier and voltmeter. They permit the use of substitution methods which eliminate the need

for calibrated low-range-indicating instruments, difficult things to obtain for audio- and carrier-frequency work.

In one sense they are similar in use to the shunts and multipliers used with galvanometers, ammeters, and voltmeters, except that, whereas the ordinary shunts and multipliers change the values of total resistance presented to the circuit and to the meter, the attenuation boxes present a constant resistance of 600 ohms, independent of setting, in both directions to a 600-ohm circuit into which they are inserted. This means that in accurate measurements the changes necessary in the indicating device to cover wide ranges cannot react on the apparatus under test, or rather, inasmuch as the attenuation box is itself accurately calibrated, all settings may be read directly therefrom at a selected arbitrary deflection of the indicator. The calibration and non-linearity errors of the indicating system are thereby eliminated.

The networks are, however, normally treated as non-reactive artificial transmission lines of variable attenuation constant and are used either to vary the loss in a 600-ohm circuit for purposes other than to change a meter scale, or to be the variable standard in substitution methods of measurement of attenuation in real lines.

RESISTORS

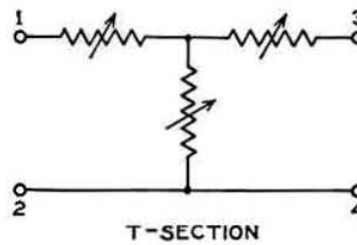
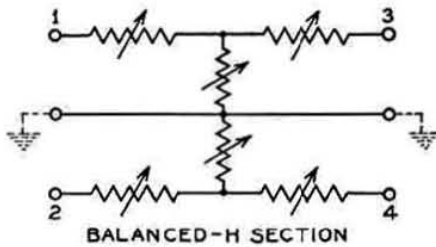

Balanced-H-section networks are used when impedances must be matched in both directions and balanced to ground. T-type sections maintain constant impedance in both directions, but they are not balanced to ground.

SPECIFICATIONS

Attenuation Range: Boxes having a maximum attenuation range of 55 db or 110 db are listed in the price list. TYPES 329-J and 429-H are each composed of two sections in series, one of 50 db total attenuation in steps of 5 db, and the other of 5 db, total, in steps of 0.5 db. Removable external links make either section separately available.

TYPES 249-H and -T each have eight series sections with attenuations of 1, 2, 3, 4, 10, 20, 30, and 40 db, respectively.

Type of Section: T-section and balanced-H-section models are available. Both present a constant impedance in both directions, but the balanced-H should be used where both sides of the circuit must be balanced to ground.

Type of Windings: All resistors are of the precision type described on page 8: Ayrton-Perry for the low-resistance elements and mica cards for the high-resistance elements.

Terminal Impedance: Boxes to operate between 600-ohm impedances are listed. Boxes for other impedance values can be made on special order.

The names, image impedance, characteristic impedance, iterative impedance, and surge impedance, which are encountered in the literature, are all equivalent for the attenuation boxes here listed. If the wrong value of terminal impedance is used at

either or both ends of the network, the calibration will be in error. The amount of this error can be computed, as demonstrated in Shea, *Transmission Networks and Wave Filters*, Chapter IV, pp. 100-121.

Accuracy of Adjustment: Each individual resistor is adjusted to within 0.25% of its correct value, so that the entire box is accurate to within 0.5% at frequencies up to at least 50 kc.

Switching: TYPE 249 has 8 key switches to control the 8 network sections.

TYPES 329-J and 429-H have multiple-blade switches and a positive detent which centers the switch blades on the contact points at each step.

Mounting: TYPES 249-H and 249-T are mounted in copper-lined walnut cabinets, with aluminum panels finished in black crackle lacquer.

The TYPE 329 and TYPE 429 Boxes have walnut cabinets with engraved bakelite panels.

Dimensions: TYPE 249: Panel, (length) 16 x (width) 5¼ in. Cabinet, (depth) 5¼ in., over-all.

TYPE 329: Panel, (length) 16⅞ x (width) 10¾ inches. Cabinet, (depth) 6 inches, over-all.

TYPE 429: Panel, (length) 14 x (width) 7 inches. Cabinet, (depth) 7 inches, over-all.

Net Weight: TYPE 249, 7⅞ pounds; TYPE 329, 12 pounds; TYPE 429, 8 pounds, approximately.

Type	Attenuation Range	Impedance	Type of Section	Code Word	Price
249-H	110 db in steps of 1.0 db	600 ohms	Balanced-H	NETWORKROD	
249-T	110 db in steps of 1.0 db	600 ohms	T	NETWORKTOP	
329-J	55 db in steps of 0.5 db	600 ohms	Balanced-H	TENUTORPIG	
429-H	55 db in steps of 0.5 db	600 ohms	T	ADMIT	

TYPE 529 ATTENUATION BOX AUDIBILITY METER

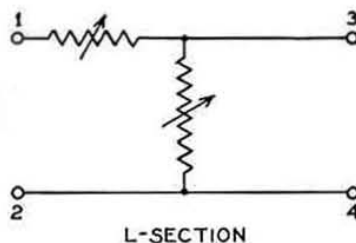
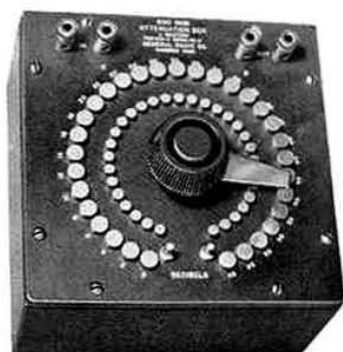

The TYPE 529 Attenuation Box is made as an L-type section which maintains constant impedance at the 1-2 terminals

Relative audibility is commonly measured by reducing the received signal until it can be barely heard. The amount of reduction required to reach this "threshold" value is taken as a measure of the relative audibility of the signal. A shunt, calibrated for attenuation when used between

specified impedances, and which will not affect input circuit conditions as it is varied, is required. The TYPE 529 Attenuation Box will meet these requirements, and is calibrated in decibels, the now generally accepted unit of relative audibility.

SPECIFICATIONS

Range: 60 db in steps of 2 db.

Type of Section: Available in the L-type section which maintains constant impedance in one direction only.

Type of Winding: Random winding on bakelite cards.

Accuracy of Adjustment: Values of resistance are adjusted to within $\pm 0.25\%$.

Frequency Characteristic: An accuracy of $\pm 2\%$ is maintained up to a frequency of 10 kc.

Mounting: Mounted in hand-rubbed walnut cabinet with engraved bakelite panel.

Dimensions: Panel, (length) 8 x (width) 8 inches. Cabinet, (depth) 4 inches, over-all.

Net Weight: $2\frac{3}{8}$ pounds.

<i>Type</i>	<i>Attenuation Range</i>	<i>Impedance</i>	<i>Type of Section</i>	<i>Code Word</i>	<i>Price</i>
529-A	60 db in steps of 2 db	600 ohms	L	ADULT	
529-B	60 db in steps of 2 db	6000 ohms	L	AFFIX	

TYPE 529-P1 60-DB ATTENUATOR

This is a convenient L-type pad for extending the range of a TYPE 529-B Attenuation Box by 60 db. The component resistors are mounted in a small

bakelite case, with plugs which fit the attenuation-box input terminals, and with jack-top binding posts set on $\frac{3}{4}$ -inch spacing for the input circuit connections.

<i>Type</i>	<i>Impedance</i>	<i>Weight</i>	<i>Code Word</i>	<i>Price</i>
529-P1	6000 ohms	$2\frac{1}{2}$ oz.	ACCESSOART	

TYPE 654-A DECADE VOLTAGE DIVIDER



This is a precision-type decade voltage divider which will supply exact voltage ratios between 0.001 and 1.000 in steps of 0.001. The internal input impedance of the instrument remains constant at 10,000

ohms for all settings of the decade dials.

This instrument may be thought of as a pair of TYPE 602 Decade-Resistance Boxes connected in series and manipulated so that as resistance is taken out of one box it is added to the other to maintain the total series resistance constant. This is accomplished for each dial through the use of two TYPE 510 Decade-Resistance Units operated from the control knob by means of a chain drive.

Performance specifications are identical in every respect with those for the TYPE 602 Decade-Resistance Boxes previously given on pages 10 and 11.

SPECIFICATIONS

Range: Voltage ratios of 0.001 to 1.000 in steps of 0.001 can be obtained by setting up the desired result on the three switches.

Dimensions: Panel, (length) 13 x (width) 7 inches. Cabinet, (depth) 5 1/4 inches, over-all.

Net Weight: 8 1/4 pounds.

Type	Input Impedance	Code Word	Price
654-A	10,000 ohms	ABACK	

TYPE 125 PHANTOM-ANTENNA RESISTOR

The TYPE 125 Phantom-Antenna Resistor is useful for tests on radio transmitters where it is desired to replace the antenna by a local circuit whose constants are more easily determined. By this means interference with other stations is prevented. This instrument is also useful about the laboratory where a reasonably accurate resistor of high current-carrying capacity is required.



SPECIFICATIONS

Maximum Power Dissipation: 400 watts, total, for TYPE 125-A; 900 watts, total, for TYPE 125-G.

Temperature Coefficient: Less than ± 0.002% per degree C.

Accuracy of Adjustment: 0.5%.

Mounting: Ribbon-wound on asbestos-board cards held vertically between bakelite end plates.

Type	No. of Sections	Resistance per Section	Current per Section	Dimensions	Net Weight	Code Word	Price
125-A	4	4 ohms	5 a	7 3/4 x 6 x 4 1/4 in.	3 7/8 lb.	RAVEN	
125-G	2	2 ohms	15 a	10 3/4 x 7 5/8 x 5 1/2 in.	7 3/8 lb.	REBEL	

TYPE 525 RESISTOR

This is a precision-type resistor capable of dissipating a large amount of power. It is intended for use in testing the output power of radio transmitters in dummy-antenna service and for use in general laboratory work where a resistor of fairly high precision must dissipate a large amount of power. The TYPE 525 Resistor consists of a mica card wound with resistance wire, clamped between two aluminum castings, and insulated from them by two thin sheets of mica, the whole unit being supported on porcelain insulators. The aluminum castings are heavily ribbed to give a large radiating surface.

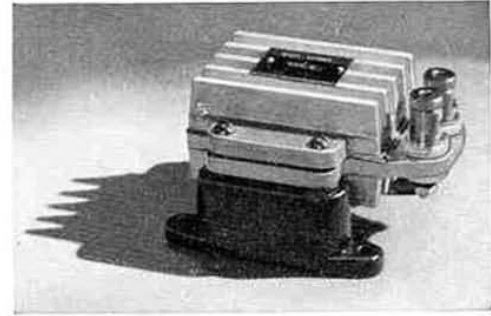

This unit is conservatively rated at 50 watts, although a considerably greater amount of power can be dissipated for long periods, without damage, if a large temperature rise can be tolerated.

SPECIFICATIONS

Power Rating: All units will dissipate 50 watts for a 100° C. rise in temperature and 100 watts for a 150° C. rise.

Maximum Current: Values of current for a 100° C. rise in temperature are given in the price list.

Accuracy: All units are adjusted to be within 0.1% of the rated values specified in the price list.

Temperature Coefficient: Less than $\pm 0.002\%$ per degree C. for temperatures below 100° C.

Frequency Characteristic: Good radio-frequency characteristics. See the April-May, 1933, *Experimenter* for curves. The resistance of the 10-ohm size is within 20% of rated value at 5 Mc.

Shielding: The aluminum castings can be used as an electrostatic shield, both resistor terminals being insulated from them.

Terminals: Jack-top binding posts mounted on isolantite washers on standard General Radio spacing of $\frac{3}{4}$ inch.

Mounting: Resistors are wound unifilarly on mica and clamped between two pieces of mica and two heavily ribbed aluminum castings, the whole unit being supported on porcelain insulators.

Dimensions: (Length) 4 x (width) 4 x (height) $2\frac{1}{2}$ inches.

Net Weight: $1\frac{1}{4}$ pounds.

Type	Resistance	Current, 100° C. Rise	Code Word	Price
525-C	4 ohms	3.5 a	CABAL	
525-D	10 ohms	2.2 a	CABIN	
525-F	40 ohms	1.1 a	CABOB	
525-H	100 ohms	0.7 a	CADDY	
525-L	600 ohms	0.09 a	CADET	



VOLUME CONTROLS

General Radio volume controls are described in the Parts section; TYPE 653, page 132, TYPE 552, page 133, and TYPE 642-D, page 134.

TYPE 526 MOUNTED RHEOSTAT-POTENTIOMETER

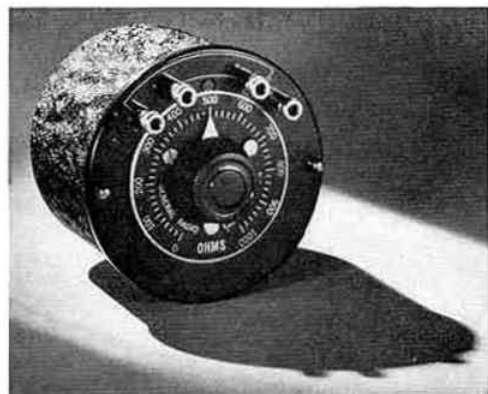

The TYPE 526 Mounted Rheostat-Potentiometer is supplied for measurements where a calibrated rheostat-potentiometer is sufficiently accurate. The total resistance is adjusted to within $2\frac{1}{2}$ per cent of the rated value, and a direct-reading scale with a calibration accurate to within 5 per cent is provided.

The resistance unit uses a four-finger contact-arm construction which averages out the variations of the individual finger contact resistances and so gives a smooth and linear resistance-rotation curve upon which settings may be easily repeated.

A mounted resistor of this type is recommended for power-factor measurements with the TYPE 625-A Bridge, described on page 85 of this catalog, or for the variable standard in approximate measurements of resistance values by bridge methods.

On order, any General Radio standard three-hole mounting rheostat-potentiometer, including tapered models, may be obtained mounted in this manner using the TYPE 318-A Dial Plate described on page 170 for the scale. Calibrations are extra; prices will be supplied on request.

SPECIFICATIONS

Winding: The winding is a carefully adjusted TYPE 471-A Rheostat-Potentiometer (see page 137).

Accuracy: The total resistance has been adjusted to within 2.5% of the rated value in the price list. The calibration is accurate to within 5% of full scale.

Mounting: Drawn-steel cases with hard-rubber panel for protection of unit and for convenience in wiring into experimental circuits. The case may be used as an electrostatic shield.

Terminals: Two pairs of jack-top binding posts,

one for input and one for output, on standard General Radio spacing of $\frac{3}{4}$ inch, are provided.

Dial Plate: Each unit has a 3-inch photo-engraved dial plate with 50 divisions and is calibrated directly in ohms.

Finish: Black crystalline lacquer.

Dimensions: (Diameter) $4\frac{1}{2}$ x (height) $4\frac{3}{8}$ inches, over-all.

Net Weight: $1\frac{1}{2}$ pounds.

Type	Resistance	Max. Current	Code Word	Price
526-D	0- 100 ohms	330 ma	ETHER	
526-A	0- 1000 ohms	104 ma	EVADE	
526-B	0- 10,000 ohms	33.0 ma	EVENT	
526-C	0-100,000 ohms	10.4 ma	EVOKE	



RHEOSTAT-POTENTIOMETERS

From 0.75 ohm to 200,000 ohms maximum resistance, 5 watts to 250 watts maximum power rating. See descriptions, pages 135 to 139.

CONDENSERS

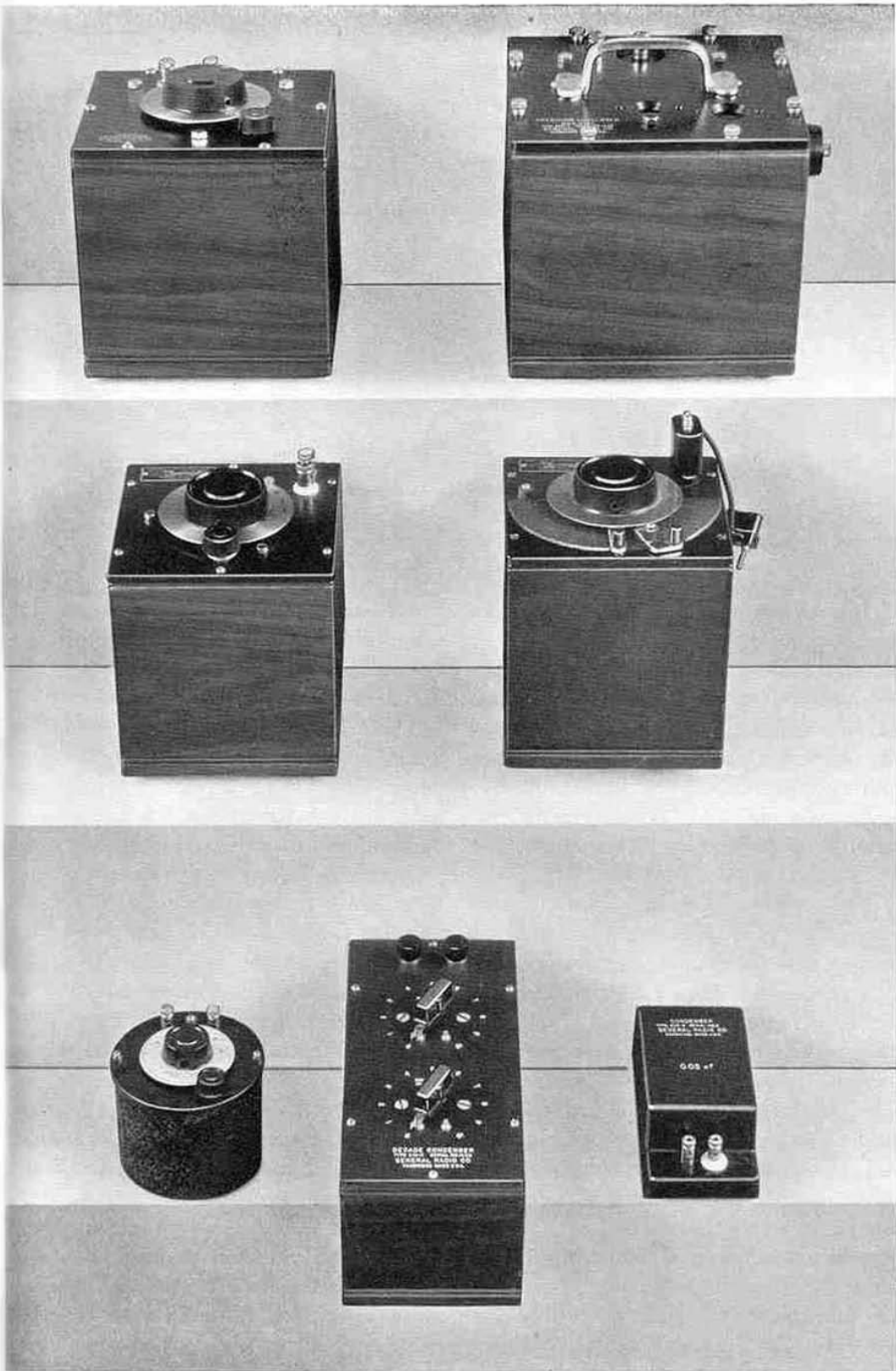

CONDENSERS

TYPE 222-F and TYPE 222-L PRECISION CONDENSERS

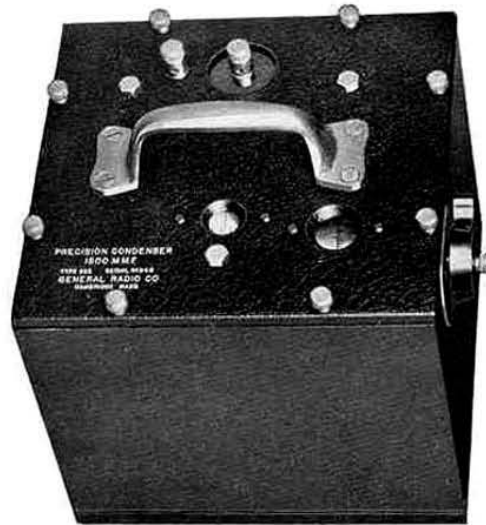

TYPE 222 Precision Condensers have the worm-type micrometer drive operated by the knob at the right. The main scale and micrometer drive are observed through the two windows in the panel

This condenser is for use in measurements where the very highest order of calibration stability, precision of setting, and electrical performance are essential. Yet it is rugged enough for general laboratory work by students. It is used as a reference standard of capacitance in bridge circuits and as the calibrated variable in oscillators, wavemeters, and heterodyne-frequency meters,¹ etc.

The losses are low and constant with setting, and calibrations can be relied on for long periods of time. Any setting can, with care, be duplicated to within one part in 10,000.

Low and constant losses are secured by using as little supporting dielectric as possible (consistent with mechanical rigidity) and by placing it in a weak and unvarying field whose intensity is independent of rotor position. This feature is especially important when the condenser is to be used for determining dielectric loss by the bridge-substitution method.²

For applications where the need for extremely low losses is acute, precision condensers can now be furnished with

fused-quartz supports instead of the isolantite supports ordinarily used. The figure of merit ($R\omega C^2$) is thereby improved to one twenty-fifth of the isolantite value.

The excellent precision of setting is made possible by the micrometer-type drive. The worm is lapped into place and held against the wheel by a spring, a method used in precision dividing engines for reducing backlash.

Standard calibrations for TYPES 222-F and 222-L Precision Condensers give the capacitance to the nearest micromicrofarad, but improvements enable us to supply on order a calibration accurate for total or difference capacitances to 0.1 $\mu\mu\text{f}$ or 0.1 per cent, whichever is larger. This fine calibration and correction consider the effect of eccentricity in the worm-drive mechanism and appear in the price list as the "Worm-Correction Calibration."

A TYPE 222 Precision Condenser will hold its calibration over long periods of time to better than 1 part in 1500. The plates are of thick aluminum, widely separated by accurately turned (not cast) spacers. They are clamped on the stator

¹ See pages 47 and 50 for some examples

² See the discussion of condenser losses in the Appendix.

METERS

CONDENSERS

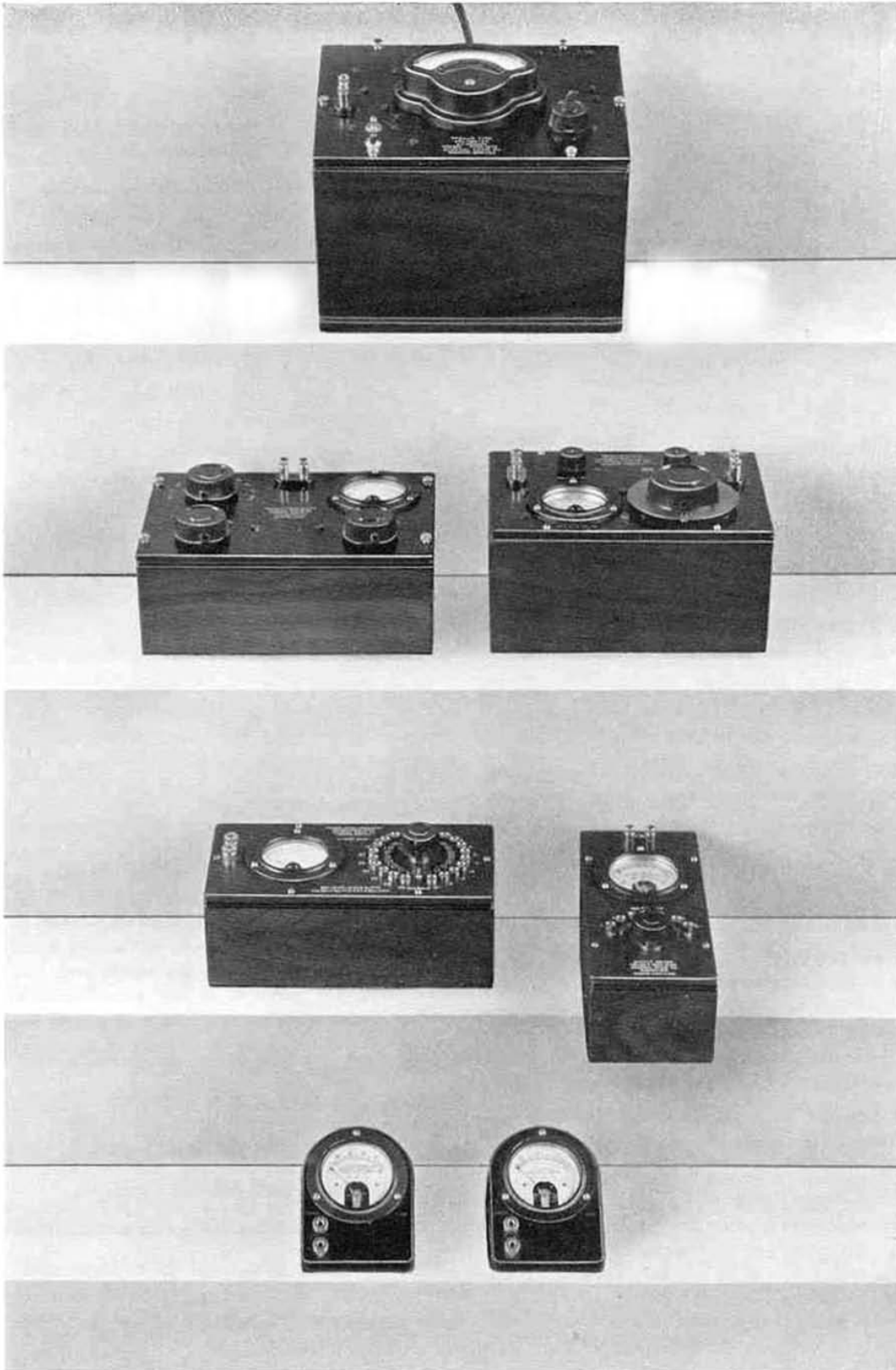

mitted to the
for calibration
no time in the
ration changed
icrofarad. Per-
h order is not

s give the more
ations.

on the chart to

t giving the capaci-
to the nearest 0.1
on special order.
ction Calibration"

s mounted on an
ck crackle lacquer
et.

nel and a copper
ective electrostatic
he shield.

are provided. The
d is brought out
e rotor terminal is
rel.

ndenser is not in-
out it can be safely

is supplied with a
t lock and carrying

9½ x (width) 8¼
ches, over-all. Stor-
10 x (height) 12½

mounted condenser
ise and calibration

Price

TYPE 222-M PRECISION CONDENSER

(See illustration, page 22)

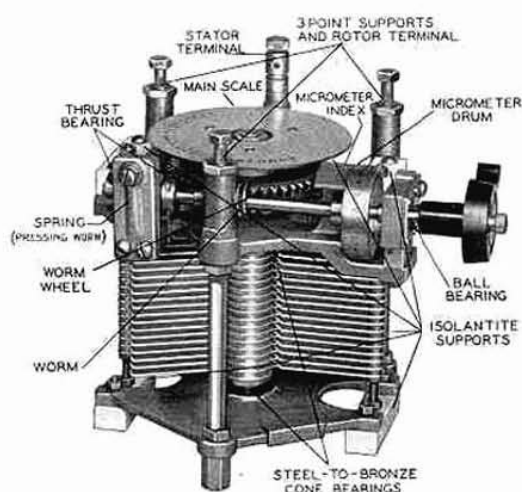

The internal constructions of all precision-type condensers show the same excellent quality of workmanship

This condenser has been designed to provide a direct-reading, adjustable standard of capacitance for use in the substitution measurement of capacitance.

In this method, which is ideal for small values of capacitance, the calibrated standard is connected in parallel with the unknown. Two balances are required, the unknown capacitance being given by the difference between the values of the standard when the unknown is connected and when it is disconnected.

The TYPE 222-M Precision Condenser

is arranged so that the capacitance difference may be read directly from the engraved scale, thus eliminating the use of a calibration chart and the computation of the unknown capacitance by subtraction. Zero scale reading corresponds to nearly maximum capacitance (about 1200 micromicrofarads), the first bridge balance being taken with this setting. The scale reading for the second balance may extend to a maximum difference-capacitance of 1000 micromicrofarads, corresponding to an actual capacitance of about 200 micromicrofarads.

The micrometer drum is divided into 100 divisions, each corresponding to a change in capacitance of 1 micromicrofarad. Ten turns of the drum cover the range (1000 micromicrofarads).

The mechanical construction of the condenser is similar to that of the TYPE 222 Precision Condenser, described on the preceding page. The differences consist in the use of a 25:1 worm, a reduced number of plates, and means for the adjustment (in our laboratory) of two of these plates to give the desired calibration.

The following specifications list the details in which TYPE 222-M differs from the TYPES 222-F and 222-L Precision Condensers described on the preceding page.

SPECIFICATIONS

Capacitance Range: Total change in capacitance 1000 $\mu\mu\text{f}$; capacitance at zero scale reading (maximum capacitance) about 1200 $\mu\mu\text{f}$, the exact value being given with each instrument.

Drive: Ten turns of the worm cover the entire range of the condenser, about 144° . Backlash is less than $\frac{1}{2}$ of one division. For other drive details consult

the preceding description of TYPES 222-F and 222-L.

Calibration: Each of the 100 divisions on the micrometer drum corresponds to 1 $\mu\mu\text{f}$. Each condenser is individually adjusted in our laboratory so that all values of incremental capacitance are accurate to within 1 $\mu\mu\text{f}$.

Type	Capacitance Change	Dielectric Supports	Code Word	Price
222-M	1000 $\mu\mu\text{f}$	Isolantite	COBRA	
222-MQ	1000 $\mu\mu\text{f}$	Quartz	COBRAQUATZ	

Worm-Correction Calibration Data for above Condensers | WORMY |

TYPE 246 VARIABLE AIR CONDENSER

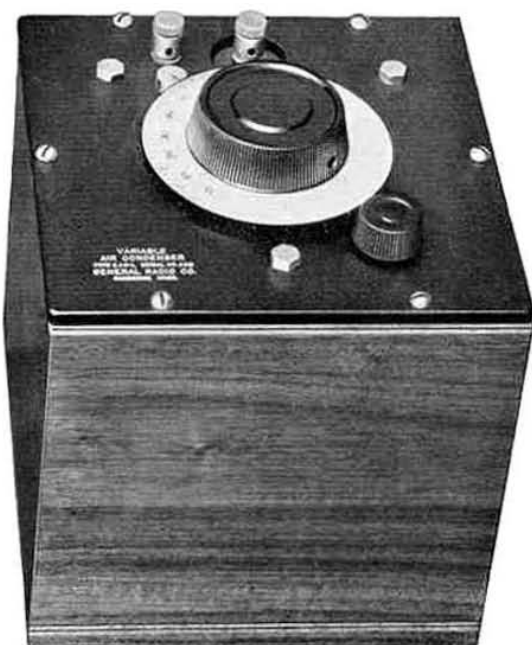
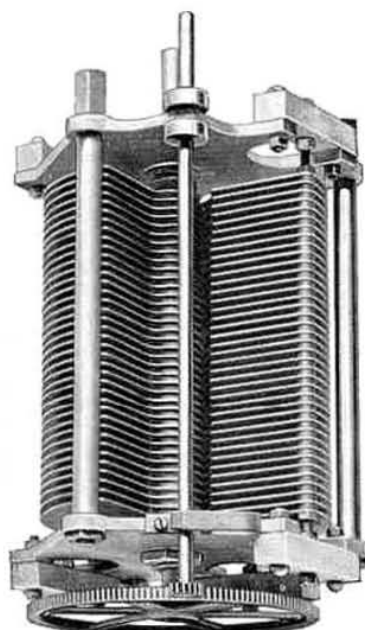

The TYPE 246 Condenser is like the TYPE 222 Precision Condenser, but it has no micrometer drive

This condenser is for use in measuring and experimental circuits requiring a high-grade unit in which extreme precision of setting and accuracy of calibration are not required: as the "balancing condenser" in the substitution method of capacitance measurement, for example.

Electrically it is identical with the TYPE 222 Precision Condenser. It cannot be set with as great precision, but once set it should hold a setting almost as well.

The following detailed specifications show the points in which this condenser differs from TYPES 222-F and 222-L.

SPECIFICATIONS

Capacitance Range: Three sizes, 1500 $\mu\mu\text{f}$, 3000 $\mu\mu\text{f}$, and 5000 $\mu\mu\text{f}$, are carried in stock.

Drive: A spur-gear slow-motion drive having a ratio of 10:1 is an auxiliary control for the large knob and dial mounted on the rotor shaft.

Calibration: No calibration is supplied with this condenser, but a mounted calibration curve accurate to within 0.5% of full-scale or a mounted calibration table for 11 points, accurate to 0.5% of full-scale, can be prepared to order. See the price list.

Maximum Voltage: TYPE 246-L and TYPE 246-M are conservatively rated at 800 volts, peak; TYPE 246-P, 500 volts, peak.

Storage Case: No storage case is supplied.

Dimensions: Panel, $7\frac{1}{2} \times 7\frac{1}{2}$ inches. Cabinet, (height) for TYPE 246-L, $8\frac{3}{8}$ inches; for TYPES 246-M and 246-P, $11\frac{3}{8}$ inches, over-all.

Net Weight: TYPE 246-L, $11\frac{1}{4}$ pounds; TYPES 246-M and 246-P, 15 pounds.

Type	Nominal Capacitance		Code Word	Price
	Maximum	Minimum		
*246-L	1500 $\mu\mu\text{f}$	55 $\mu\mu\text{f}$ CEDAR	
*246-M	3000 $\mu\mu\text{f}$	70 $\mu\mu\text{f}$ CHAOS	
*246-P	5000 $\mu\mu\text{f}$	72 $\mu\mu\text{f}$ CHARY	
	Mounted Calibration Curve		CURVE	
	Mounted 11-point Calibration Table		CHART	

*Calibrations supplied only when ordered. Use compound code words, e.g., CEDARCHART, CHAOSCHART, etc.

CONDENSERS

SPECIFICATIONS

Range: 30 μf to 500 μf .

Plate Shape: Straight-line capacitance.

Low Losses: $R\omega C^2$ is approximately 0.08×10^{-12} .

Maximum Voltage: 500 volts, peak.

Drive: The drive is of the pinion-gear type with a reduction ratio of 6:1.

Calibration: The dial has a direct-reading cali-

bration, as shown in the illustration, accurate to within 4%.

Mounting: The hard-rubber cover of the drawn-steel case supports the condenser and two binding-post terminals. To mount on a baseboard, drill suitable holes in the bottom of the case.

Dimensions: Panel, (diameter) $4\frac{1}{2}$ inches; case, (height) $4\frac{1}{4}$ inches, over-all.

Net Weight: TYPE 247-G, $2\frac{1}{2}$ pounds.

Type	Nominal Capacitance		Code Word	Price
	Maximum	Minimum		
247-G	500 μf	30 μf	COLIC	

TYPE 509 STANDARD CONDENSER



TYPE 509 Standard Condensers are compact fixed laboratory standards of capacitance ranging in value from 0.001 to 1 microfarad. The use of these condensers in conjunction with a TYPE 222-L or TYPE 222-M Precision Condenser extends the range of precision measurement by a direct substitution method well into the large capacitance values. The error in a composite capacitance standard so formed is less than 0.1 per cent or 1 micromicrofarad, whichever is the greater.

Large fixed-capacitance standards with air dielectric are prohibitive in cost and are inconvenient in the weight and size necessitated by the mechanical requirements of rigidity. The use of solid dielectrics, although reducing the bulk per microfarad, leads to a long-period instability in the value of capacitance and to

variations that are functions of temperature, pressure, and humidity.

Each TYPE 509 Standard Condenser consists of two TYPE 505 Condenser Units which have been put through an additional aging process. The stability of the units after the repeated aging cycles is better than the accuracy of the final calibration, 0.1 per cent. Adjustment of one unit brings the total capacitance to within 0.25 per cent of the engraved value without disturbing the section responsible for the larger proportion of the capacitance.

The final value of the finished condenser is measured with an error of less than 0.1 per cent or 1 micromicrofarad, whichever is the larger, and is entered with the date on a calibration certificate supplied with each condenser.

These condensers are mounted in cast aluminum cases which act as shields. The terminals are jack-top binding posts (one of which is mounted directly on the case). Auxiliary TYPE 274-P Plugs fit directly into the jack tops of the terminals immediately below. When plugged in in this way the capacitance values are added by being placed in parallel, and the cases are all connected together, thus reducing to a minimum the proximity effects between condensers.

SPECIFICATIONS

Capacitance: Ten values of capacitance between 0.001 μf and 1.0 μf are available in stock.

Accuracy of Adjustment: Each condenser is carefully adjusted to within 0.25% of the nominal capacitance value engraved on the case.

Accuracy of Calibration: After each condenser has been aged, adjusted, and mounted, its capacitance is measured as carefully as possible, and the value of capacitance, accurate to within 0.1%, is entered on a certificate of calibration which is packed with each unit.

Stability: Over reasonable periods of time (e.g. 1 year) each condenser can be expected to maintain its calibrated value to within 0.1%.

Temperature Coefficient: Approximately +0.01% per degree C.

Power Factor: The power factor of all sizes listed is less than 0.05%.

Maximum Voltage: See price list. This rating means that the condenser will withstand safely the

a-c voltage whose peak equals the given rating up to the given frequency. Above that frequency, the allowable voltage decreases inversely with the square root of the frequency because of the power loss.

Mounting: Two sizes of cast aluminum cases are used, depending upon the physical dimensions of the condenser stack. The price list shows the type of case used.

Terminals: Two jack-top binding posts spaced $\frac{3}{4}$ of an inch apart are mounted on the case. One terminal is grounded, and the other one is insulated by means of an isolantite bushing.

Dimensions: Small case, (length) $4\frac{7}{8}$ inches x (width) $2\frac{1}{2}$ inches x (height) $1\frac{7}{8}$ inches, over-all. Large case, (length) 6 inches x (width) $3\frac{3}{8}$ inches x (height) $2\frac{3}{8}$ inches, over-all.

Net Weight: One and one-half pounds for all condensers mounted in small cases; $2\frac{1}{2}$ pounds to $3\frac{1}{2}$ pounds for all condensers mounted in large cases.

Type	Capacitance	Maximum		Case	Code Word	Price
		Voltage	Frequency			
509-F	0.001 μf	1200 v	440 kc	Small	GOODCONBOY	
509-G	0.002 μf	700 v	640 kc	"	GOODCONBUG	
509-K	0.005 μf	700 v	260 kc	"	GOODCONCAT	
509-L	0.01 μf	700 v	180 kc	"	GOODCONDOG	
509-M	0.02 μf	700 v	65 kc	"	GOODCONEYE	
509-R	0.05 μf	700 v	60 kc	Large	GOODCONPIG	
509-T	0.1 μf	700 v	30 kc	"	GOODCONROD	
509-U	0.2 μf	700 v	16 kc	"	GOODCONSIN	
509-X	0.5 μf	500 v	12 kc	"	GOODCONSUM	
509-Y	1.0 μf	500 v	6 kc	"	GOODCONTOP	

MICA CONDENSERS



Handy, plug-in mounting, fixed capacities, 0.0001 μf to 0.5 μf , accuracy 1% or 10 μf . See description TYPE 505 Condenser, page 148.

UNMOUNTED VARIABLE AIR CONDENSERS



ranging from 15 μf to 2000 μf maximum capacitance and from 500 to 3500 volts, peak voltage rating, will be found on pages 142 to 146.

TYPE 219 DECADE CONDENSER



The TYPE 219 Decade Condenser can be supplied in 2- and 3-dial sizes

This decade condenser consists of two or three TYPE 380 Decade-Condenser Units mounted on a panel in a cabinet for convenience in the laboratory. Each one is direct reading in capacitance. They are

useful as capacitance standards where work of ordinary commercial accuracy is being done.

For individual TYPE 380 Decade-Condenser Units, refer to page 147.

SPECIFICATIONS

Capacitance: Three decade combinations are available in stock as shown in the price list.

Calibration: Making allowance for a zero capacitance of $30 \mu\text{mf}$ for the complete box, the boxes are accurate to within 1% for the $0.01 \mu\text{f}$ and $0.001 \mu\text{f}$ steps and to within 2% for the $0.1 \mu\text{f}$ steps.

Maximum Voltage: 300 volts, peak. At frequencies higher than 1000 kc, 100 kc, and 1 kc for the 0 to $0.010\text{-}\mu\text{f}$, 0 to $0.10\text{-}\mu\text{f}$, and 0 to $1.0\text{-}\mu\text{f}$ decades, respectively, the maximum voltage permissible for continuous duty decreases inversely with the square root of the frequency.

Power Factor: $R\omega C$, the power factor, is 0.002,

0.001, and 0.010 for the 0 to $0.010\text{-}\mu\text{f}$, 0 to $0.10\text{-}\mu\text{f}$, and the 0 to $1.0\text{-}\mu\text{f}$ decades, respectively. When all the switches are at zero, the power factor is 0.05.

Mounting: Units are assembled on an engraved bakelite panel and mounted in a polished walnut cabinet.

Dimensions: Panel width, 5 inches. Height of cabinet, including knob, 6 inches, over-all. Panel length: for TYPES 219-F and 219-J, $9\frac{1}{2}$ inches; for TYPE 219-G, $12\frac{3}{4}$ inches.

Net Weight: For TYPES 219-F and 219-J, $5\frac{1}{4}$ pounds; for TYPE 219-G, 8 pounds.

Type	Capacitance	No. of Dials	Code Word	Price
219-F	1.10 μf total, in steps of 0.01	2	COVER	
219-G	1.110 μf total, in steps of 0.001	3	BRIER	
219-J	0.110 μf total, in steps of 0.001	2	CRONY	

TYPE 106 STANDARD INDUCTANCE

This fixed standard is accurately adjusted at 1000 cycles. Low and nearly constant resistance at audio frequencies is insured by the use of stranded wire having the separate strands insulated from each other.

Interaction between the field of an inductor and external fields is practically eliminated by the use of an astatic form of winding in which the fields of two coil sections neutralize each other in regions external to the case. This construction is used in TYPE 106 Standard Inductances to make their values independent of surroundings. Conversely, disturbing voltages induced by an external field will practically cancel out in the two halves of the coil.

Coils are form wound, bound with tape, and impregnated with wax. There is no metal in the concentrated field of the coil.

SPECIFICATIONS

Inductance Calibration: The 0.1 mh size is adjusted to within 0.2%; all other sizes are adjusted to within 0.1% of their labeled values at 1000 cycles.

Resistance: Resistance at 1000 cycles is the same as the d-c resistance, the value of which, measured at room temperature, is entered on a certificate mounted on the bottom of the cabinet. See price list for approximate values.

Maximum Current: See price list.

Mounting: All units are assembled in walnut cabinets with bakelite panels.

Dimensions: Panel, $5\frac{7}{8}$ x $5\frac{7}{8}$ inches. Cabinet, (height) $3\frac{1}{2}$ inches, over-all, except TYPE 106-M which is $5\frac{5}{8}$ inches, over-all.

Net Weight: Approximately $2\frac{5}{8}$ pounds, except TYPE 106-M which is 5 pounds.

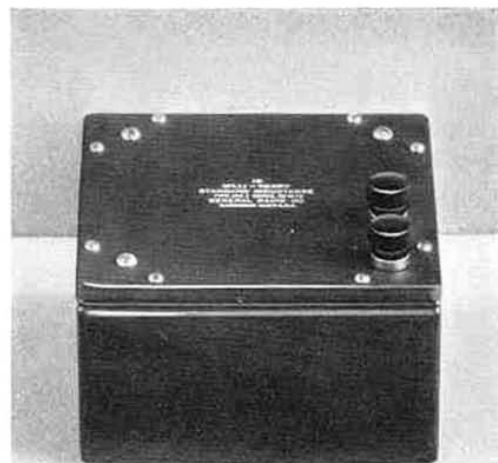

Top illustration:
TYPE 106 Standard Inductance

Bottom illustration:
TYPE 107 Variable Inductor
(described on the next page)

Type	Inductance	Resistance	Maximum Current	Code Word	Price
106-L	0.1 mh	0.18 Ω	3.5 a	INNER	
106-G	1 mh	1.80 Ω	1.0 a	INERT	
106-J	10 mh	12.2 Ω	0.5 a	IRATE	
106-K	100 mh	85.3 Ω	250 ma	ISLET	
106-M	1 henry	545 Ω	150 ma	ISSUE	

TYPE 107 VARIABLE INDUCTOR

(Illustrated on page 31)

This inductor is now supplied with the inductance calibration engraved on the dial. It provides a high-grade variable laboratory inductor. Permanence, low high-frequency resistance, an increased range, and an unusually high current-carrying capacity have been obtained by a recent redesign.

Separate terminals are brought out for rotor and stator so that they may be connected in series or in parallel as a self-inductor, or used separately as a mutual inductor. The inductances of rotor and stator have been carefully equalized to eliminate losses from circulating currents when the parallel connection is used.

SPECIFICATIONS

Inductance Range: Five sizes are available in stock covering a total range of approximately 1.3 μ h to 500 mh by the use of both the series and parallel connections. The price list shows nominal maximum values for the series connection and minimum values for the parallel connection in each size. Actual values will be greater than the nominal maximum and less than the nominal minimum, respectively.

A range of approximately 10 to 1 is covered with either connection alone. The inductance with the parallel connection is one-quarter that for the series connection to within 1%.

Calibration: The inductance for the series connection, accurate to within 1% at 1000 cycles, is engraved on the dial.

Resistance: D-c resistance for the series connection of each unit at room temperature is engraved on its nameplate. Approximate values are given in the price list. D-c resistance of rotor and stator are approximately equal.

Low Losses: The excellent high-frequency characteristics of this inductor are best expressed by its ratio of reactance to resistance (or Q) at a given frequency.

Representative values for the series connection are given in the table, next paragraph.

Natural Frequency: See the following table.

Type	Maximum Inductance	Q at f		Natural Frequency
107-J	0.05 mh	110	400 kc	5000 kc
107-K	0.5 mh	140	200 kc	1500 kc
107-L	5 mh	125	60 kc	500 kc
107-M	50 mh	65	20 kc	150 kc
107-N	500 mh	20	7 kc	30 kc

Maximum Current: The maximum allowable current for a dissipation of 15 watts and temperature rise of 40° C. (series connection) is engraved on each nameplate. See price list for a list of values.

Drive: All sizes have a 100-division, 4-inch, TYPE 703-F (friction drive) Dial directly connected to the rotor shaft.

Mounting: All units are mounted on bakelite panels and enclosed in walnut cabinets.

Dimensions: Panel, 6½ x 6½ inches. Cabinet, (height) 8¾ inches, over-all.

Net Weight: 5 pounds, all ranges.

Type	Inductance		D-C Resistance	Maximum Current	Code Word	Price
	Maximum	Minimum				
107-J	0.05 mh	0.0013 mh	0.17 Ω	8.5 a	HAREM	
107-K	0.5 mh	0.013 mh	0.7 Ω	4.0 a	HARPY	
107-L	5 mh	0.13 mh	4 Ω	1.7 a	HARRY	
107-M	50 mh	1.3 mh	40 Ω	.60 a	HOTEL	
107-N	500 mh	13 mh	640 Ω	.14 a	HOVER	

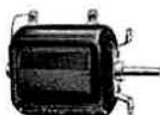

VARIOMETER, INDUCTORS,

and shielded or unshielded inductor forms, for transmitting and receiving, all plug-in mounting. See descriptions, pages 164 to 166.

FREQUENCY AND TIME

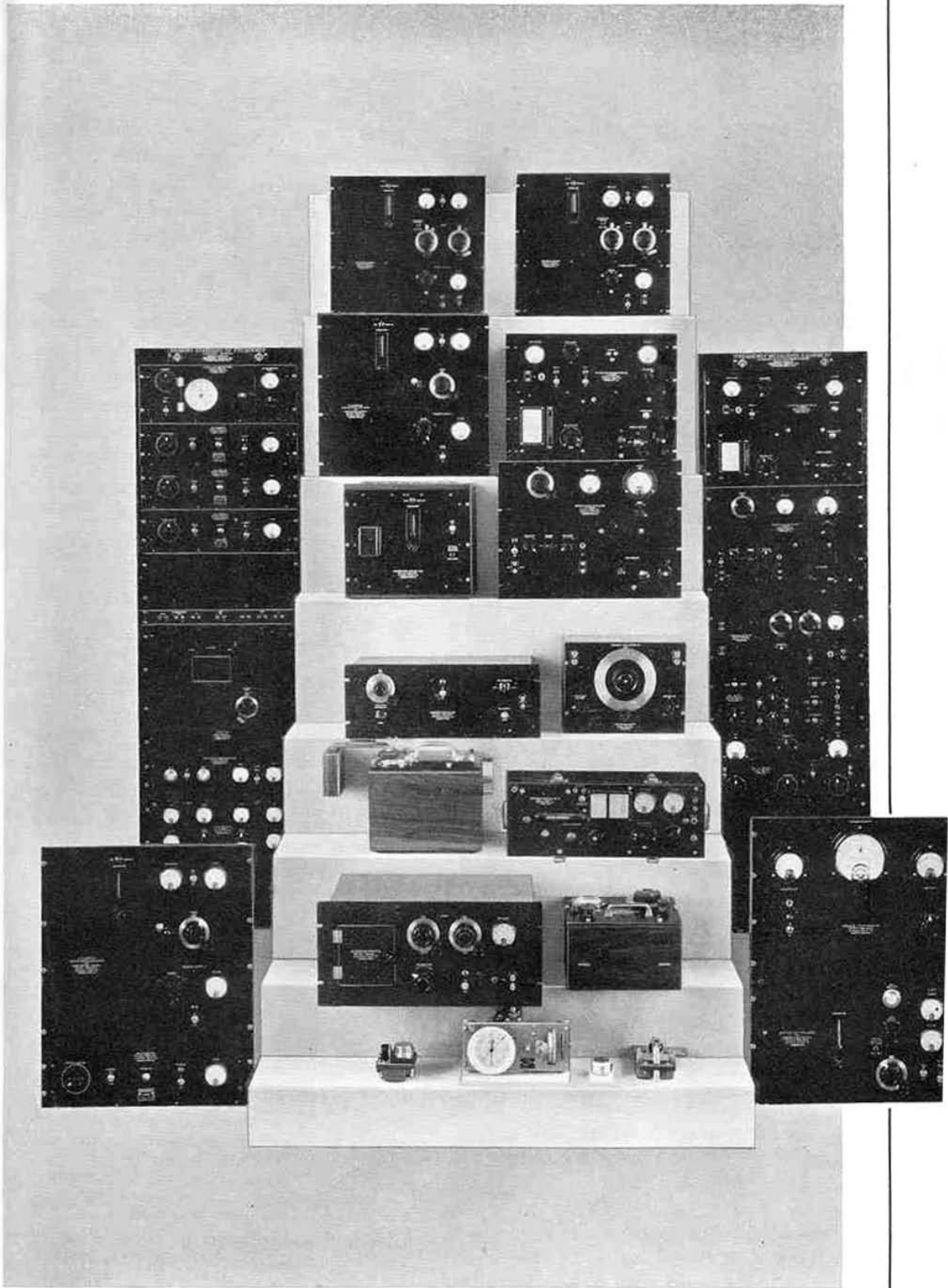

CLASS C-21-H STANDARD-FREQUENCY ASSEMBLY
(SERIES 690)

The Class C-21-H Standard-Frequency Assembly is a complete and highly precise primary standard of frequency. It is also a crystal-controlled clock of high precision. More than 38 units have been installed and are now operating in all parts of the world in industrial organizations, research laboratories, observatories, and frequency monitoring stations. Many of them are used as national standards of frequency by communications administrations in North American, European, and Asiatic countries.

The assembly is provided with a means of measuring its output frequencies in terms of standard time without reference to any other standard of frequency. Harmonic series based on fundamentals of 1, 10, and 50 kilocycles are available at its output terminals to furnish standard frequencies over the entire communication-frequency spectrum. From it can also be obtained one-second pulses and standard time. The accuracy of all output frequencies is better than ± 5 parts in ten million over periods of several months. Each of the output frequencies is known with the same accuracy.

The assembly is furnished with either of two types of power supply. If line failure is rare, or if certainty of continuous timing is not demanded, the TYPE 696-A Power Supply operates the assembly satisfactorily. The TYPE 695-A Battery Charging Equipment furnishes filament and plate power to operate the complete assembly and maintains a full charge on floating batteries which will supply emergency power. The price of the floating battery assembly does not include the batteries.

On the opposite page is shown a photograph of the a-c operated assembly. It differs only slightly in appearance from the floating-battery assembly. The captions describe the function of each group of instruments in the assembly.

Complete detailed descriptions of the apparatus and the operation and uses of a Class C-21-H Standard-Frequency Assembly appear in the General Radio Company's Bulletin 10, "Frequency Measurements at Radio Frequencies." Copies of this manual of frequency measurement and monitoring technique may be had without charge upon application to the company.

SPECIFICATIONS

Frequency Range: The available outputs are seconds pulses, standard time, and standard frequencies at harmonic intervals between 1 kilocycle and 30 megacycles.

Accuracy: The accuracy obtainable after installation and adjustment in a short aging period is often better than one or two parts in 10 million. Frequency stability of the same high order can be expected. The equipment is conservatively guaranteed for an accuracy of ± 5 parts in 10 million.

Power Supply: Either one of two types of equipment are supplied, depending upon the type of power supply to be used. One system operates directly from the 115-volt, 60-cycle, a-c line; the other system operates on storage batteries trickle charged from rectifiers. The power input is approximately 225 watts with heater circuits in operation.

Mounting: The entire installation with the excep-

tion of batteries is mounted on a single 19-inch relay rack. All interconnecting wiring is by means of a fully formed cable equipped with plugs which fit jacks built into each unit.

Dimensions: (Height) $69\frac{1}{8}$ x (width) 20 x (depth) 24 inches, over-all.

Net Weight: $370\frac{1}{2}$ pounds for floating-battery assembly, $352\frac{3}{8}$ pounds for completely a-c operated assembly, relay rack included.

<i>Description</i>	<i>Code Word</i>	<i>Price</i>
Assembly for operation from floating batteries.....	LYRIC	
Assembly for complete a-c operation.....	LAYER	

Type 693-A Syncro-Clock and Amplifiers

This unit consists of an input amplifier, a 1000-cycle synchronous-motor-driven clock, and an output distribution amplifier. The clock generates one-second pulses and compares clock time with radio time signals to within 0.01 second.

A starting motor operated by a push button from the 60-cycle line brings the clock motor up to synchronous speed.

Type 692-A Multivibrators

Two of these units are used as frequency dividers to reduce the 50-kilocycle crystal frequency to 1000 cycles for driving the timing unit. They also generate harmonic series of 1000 cycles and 10 kilocycles; a third unit generates 50-kilocycle harmonics. All of these frequencies are entirely controlled by the frequency of the crystal oscillator. The multivibrators are designed to be extremely stable in operation and positive in control, in order to minimize syncro-clock interruptions.

Blank Panel and Terminal Strip

Blank panels are provided in order to fill out the rack space. The terminal strip makes available at the front of the rack all the output frequencies of the assembly.

Type 690-B Piezo-Electric Oscillator, Type 676-A Quartz Bar, and Type 691-B Temperature-Control Unit

A new oscillator circuit, designed to operate the quartz bar at or very near its resonant frequency improves the oscillator frequency stability.

The temperature of the quartz bar is held to within narrow limits by means of a two-stage temperature-control box. The inner box houses the 50-kilocycle quartz bar and keeps its temperature within 0.01° C. The outer box contains the other oscillator circuit elements and controls their temperature to within 0.1° C.

The frequency is adjustable over a narrow range.

Type 694-B Control Panel

This panel contains the necessary controls for the crystal oscillator and the temperature control system. Lamps which light when the relays are closed give a visual check of heater operation.

Power Supply

The power supply equipment for the assembly is mounted at the base of the rack. Either of two types can be supplied.

Type 695-A Charging Equipment (used for floating-battery operation). The rectifiers, filters, and controls for trickle-charging the filament- and plate-voltage-supply batteries are mounted in this unit. It contains a 6-volt rectifier for filaments and a 200-volt rectifier for the plates. This unit is used with batteries where the greatest possible freedom from service-mains interruption is desired.

Type 696-A Power Supply (used for complete a-c operation, as illustrated). The rectifiers, filters, and controls for obtaining suitable a-c voltages for the tube filaments and suitable rectified and filtered plate voltages are mounted in this unit. The unit being smaller than the Type 695-A Charging Equipment, a blank panel is furnished to complete the assembly in the rack. This unit is employed where

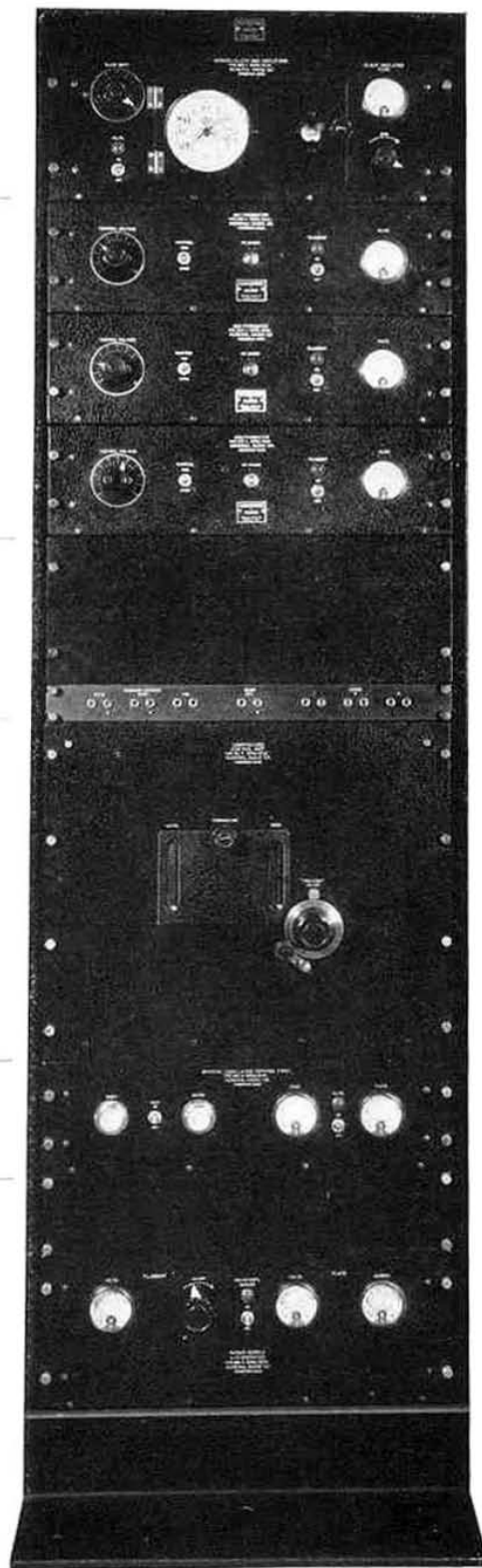

the infrequent service interruption is not serious enough to warrant the installation of batteries. When operated with the Type 696-A Power Supply, no batteries of any kind are required.

INTERPOLATION AND AUXILIARY EQUIPMENT FOR USE WITH CLASS C-21-H STANDARD-FREQUENCY ASSEMBLY

This interpolation and auxiliary equipment used in conjunction with a Class C-21-H Standard-Frequency Assembly makes possible the direct precision measurement of any radio frequency up to 25,000 kc. For frequencies above 25,000 kc measurements can be made with almost equal ease by utilizing heterodyne methods.

The Class C-21-H Standard-Frequency Assembly supplies reference standards of frequency at 10-kc intervals between 100 kc and 5000 kc, as well as standard frequencies which are harmonics of 1 kc in the audio range. All of these frequencies are accurate to within five parts in ten million.

The Interpolation and Auxiliary Equipment shown on the opposite page measures unknown frequencies by a process of finding the difference between the unknown frequency and the nearest standard-frequency harmonic, and then measuring this difference by a zero-beat method with a calibrated oscillator.

Frequencies which differ from the standard harmonics by only a few cycles can be measured with the accuracy of the standard itself, the measurements of other

frequencies are subject to two slight errors, that in the final interpolation, ± 2 cycles, and that from inaccurate zero-beat settings of not more than one cycle for each such setting.

Where the unknown signals are to be picked up from distant transmitters, suitable receivers are required, but for measurements on local oscillators or transmitters no additional equipment is necessary.

The equipment is composed of the following individual instruments which are described on the pages indicated.

1—TYPE 616-B Heterodyne Frequency Meter . . .	Page 50
1—TYPE 617-B Interpolation Oscillator	Page 47
1—TYPE 619-C Heterodyne Detector	Page 48
1—TYPE 612-B Coupling Panel	Page 37
1—TYPE 614-A Selective Amplifier (Optional)	Page 48
TYPE 480-P Blank Panels (Not Supplied Unless Ordered)	Page 37
1—TYPE 480-A Relay Rack .	Page 160

SPECIFICATIONS

Terminals: All instruments are fitted with multi-point protected plug connectors on the rear of the units. A complete inter-connecting cable is furnished.

Power Supply: 110-115 volts, 50-60 cycles. Other voltages or other frequencies on special order only.

Mounting: The complete assembly mounts on a standard 19-inch, TYPE 480-A, relay rack.

Dimensions: (Height) $69\frac{1}{8}$ x (width) 20 x (depth) 18 inches, over-all. With the TYPE 614-A Selective Amplifier the rack has 6 rack units, or $10\frac{1}{2}$ inches, of empty rack space that will take other equipment. Without the TYPE 614-A Selective Amplifier the empty rack space is 11 rack units, or $19\frac{1}{4}$ inches in height.

Net Weight: $205\frac{1}{4}$ pounds with TYPE 614-A Selective Amplifier; $167\frac{1}{4}$ pounds without TYPE 614-A Selective Amplifier.

Interpolation and Auxiliary Equipment for use with Class C-21-H Standard- Frequency Assembly, with TYPE 614-A Selective Amplifier	
Blank Panel to completely fill rack . .	
Total	
Interpolation and Auxiliary Equipment, as above, without TYPE 614-A Selective Amplifier	
Blank Panel to completely fill rack . .	
Total	

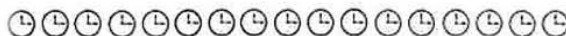

Type 616-B Heterodyne Frequency Meter

This unit is a combination of calibrated oscillator, detector, and audio amplifier. The oscillator has a voltage-stabilized circuit, and is temperature controlled in order to preserve the calibration.

As the oscillator-frequency is varied, audio-frequency beats with the standard-frequency harmonics or with unknown frequencies are heard. These frequencies may be separated and identified with the aid of the calibration chart of the oscillator. The fundamental or one of the harmonics of the oscillator is set to zero beat with the unknown signal by means of a local receiver, and thereafter the fundamental is used in place of the distant signal during the rest of the frequency measurement.

Type 617-B Interpolation Oscillator

A 0-5000 cycle, direct-reading, straight-line-frequency scale beat-frequency oscillator, this unit measures by a zero-beat method frequencies within its range to an accuracy of ± 2 cycles. The audio-frequency beat between the unknown signal and one of the standard-frequency harmonics always falls within the range of this unit, for the standard harmonics are spaced at 10-kc intervals throughout the radio-frequency spectrum, and hence are never more than 5000 cycles from the unknown frequency or one of its sub-harmonics.

Type 619-C Heterodyne Detector

This unit, a tuned regenerative detector, combines the standard and unknown frequencies, furnishing from the combination an audio-frequency-output signal of between 0 and 5000 cycles which is then fed to the TYPE 617-B Interpolation Oscillator, above, for measurement.

Type 612-B Coupling Panel

This unit is the central control panel of the auxiliary equipment. The switches permit the interconnections necessary for a complete frequency measurement.

Type 614-A Selective Amplifier

For central installations to supply many laboratories, the selective amplifier provides exact even-kilocycle frequencies between 1 kc and 10 kc for timing, testing, and calibration purposes. All frequencies are accurate to within 5 parts in 10 million when the amplifier is excited from a Class C-21-H Standard-Frequency Assembly.

Type 480-P Blank Panels

Panels to match apparatus finish and to fill in empty rack space may be had in heights of any whole number of $1\frac{3}{4}$ -inch rack units. Prices on opposite page are for a single panel to fill vacant space.

Type 480 Relay Rack

This is the standard telephone relay rack for 19-inch panels and will take apparatus of all other manufacturers laid out in accordance with the method outlined on page 160 of this catalog.

Cable Assembly

The price of the Auxiliary and Interpolation Equipment includes a complete multi-connector cable assembly which connects all units to the coupling panel and provides for all necessary interconnections. The multi-plug connections and the assembly of the equipment on a rack permit easy accessibility from front and rear.

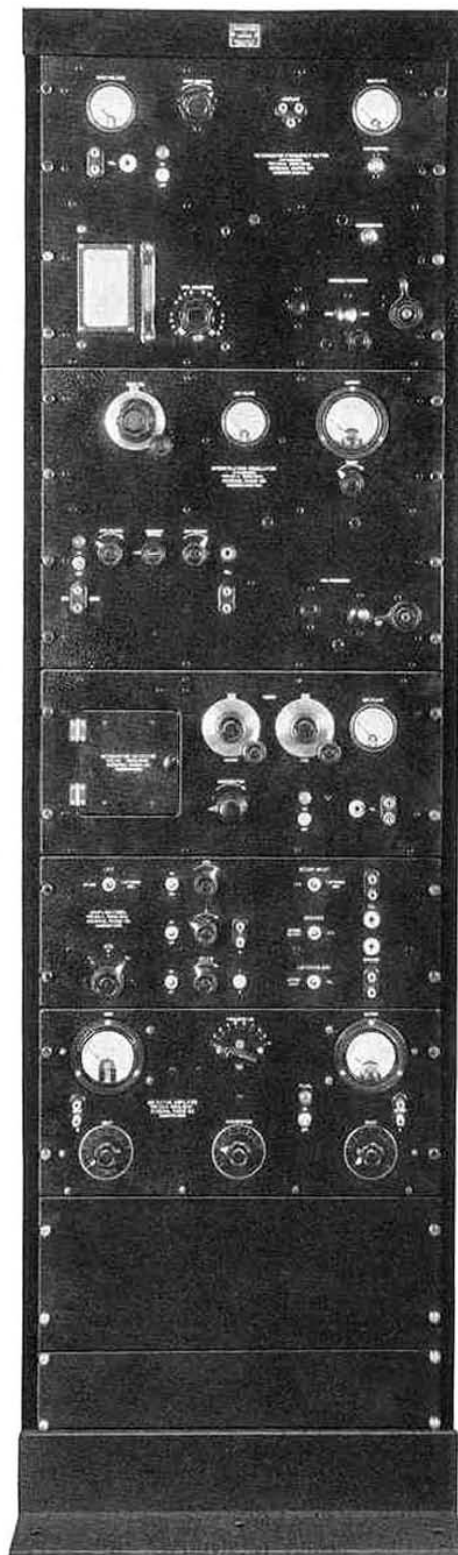

Complete Interpolation and Auxiliary Equipment for use with a CLASS C-21-H Standard-Frequency Assembly

CLASS C-10 STANDARD-FREQUENCY ASSEMBLY (SERIES 690)
 SECONDARY FREQUENCY STANDARD

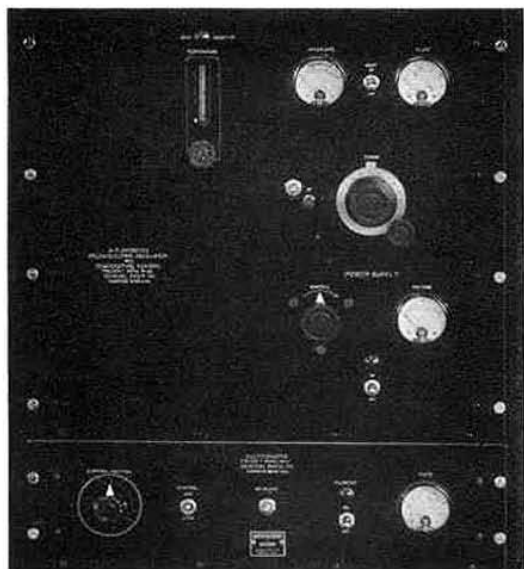

A good secondary standard of frequency is satisfactory for many uses where the reliability and extreme precision of a primary standard are not absolutely essential. It can be equipped with one or more multivibrators to yield a wide range of harmonic frequencies, and the reliability of its frequency can be of fairly high order, especially if the standard is checked at frequent intervals against the standard-frequency transmissions of the United States Bureau of Standards or some other accurate source.

The Class C-10 Standard-Frequency Assembly consists of a temperature-controlled piezo-electric oscillator and one multivibrator. Ordinarily, the assembly is supplied with a 50-kc or 100-kc crystal oscillator which controls a 10-kc multivibrator at its fifth or tenth harmonic.

Unless the 100-kc harmonics are desired for some particular purpose, it is recommended that the assembly be purchased with the TYPE 676-A 50-kc Bar because of the greater absolute accuracy and stability of the standard so formed.

In addition to the harmonics of ten kilocycles obtainable from the multivibrator, harmonics of the crystal frequency are produced by a harmonic amplifier in the crystal oscillator unit.

This standard is particularly recommended for the needs of the small college laboratory and of communication companies furnishing a limited class of service. When used in conjunction with either a TYPE 615-A or a TYPE 616-B Heterodyne-Frequency Meter, measurements to better than 0.01% can be made on transmitters and on received signals from below 100 kc to 30,000 kc.

The change from the Class C-21-H Standard-Frequency Assembly is accomplished by dropping the timing unit, two multivibrators, and one stage of temperature control from the piezo-electric oscillator of that assembly. The Class C-10 Assembly can at any time be converted to a primary frequency standard by the addition of a TYPE 692-A 1-kc Multivibrator and a TYPE 693-A Timing Unit. These changes enable an absolute determination of the frequency to be made in terms of mean solar time taken from the radio time signals broadcast by the United States Naval Observatory in Washington.

A complete a-c operated power-supply unit is included in the crystal oscillator, and this is capable of supplying filament and plate power to a maximum of three TYPE 692-A Multivibrators.

The assembly consists of:

- TYPE 675-L Piezo-Electric Oscillator
- TYPE 692-A Multivibrator (10 kc)
- TYPE 676-A Quartz Bar (50 kc) or
- TYPE 476-A Quartz Bar (100 kc) with
- TYPE 476-P1 Mounting
- TYPE 480-B Relay Rack

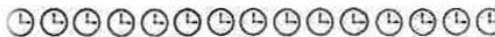

SPECIFICATIONS

Frequency Range: With 10-ke multivibrator, the assembly supplies useful standard-frequency harmonics of 10 ke between 10 ke and 4000 ke.

Accuracy: ± 20 parts per million.

Stability: ± 5 parts per million.

Tubes: The necessary tubes are supplied.

Power Supply: 115-volt, 60-cycle, a-c line. The power consumption is 145 watts with heater circuits in operation.

Mounting: Both units are mounted on standard 19-inch relay-rack panels, finished in black crackle lacquer. Nickel-plated brass dust covers are included.

Dimensions: Panels, (width) 19 x (height) $22\frac{3}{4}$ inches. Behind panels, (depth) $10\frac{3}{4}$ inches. Rack, (height) 44 x (width) 20 x (depth) 15 inches. There are 21 inches, or twelve $1\frac{3}{4}$ -inch units, of empty rack space.

Net Weight: 100 pounds.

Class	Description	Code Word	Price
C-10	With 50-ke quartz bar.....	EPOCH	
C-10	With 100-ke quartz bar.....	EPODE	

TYPE 618-A HARMONIC OSCILLATOR



The TYPE 618-A Harmonic Oscillator consists of a 50-ke oscillator, whose frequency is adjustable over a narrow range, and a multivibrator operating at a fundamental frequency of either 10 ke or 50 ke, selection of the frequency being made by means of a switch. It is intended for use in conjunction with standard-frequency

radio transmissions to produce a series of standard-frequency harmonics when one of its output frequencies is set to zero beat with the standard frequency.

It is also useful as a device for measuring frequency deviation when the frequency under measurement lies within 100 cycles of a 10-ke harmonic.

SPECIFICATIONS

Range: Although designed for use in the broadcast band (550-1500 ke), it can be used at frequencies between 10 ke and 10,000 ke, approximately.

Accuracy: Since the harmonic oscillator is purely a conversion device, the accuracy obtainable with it is essentially that of the standard frequency in conjunction with which it is used. The frequency drift after a preliminary warming-up period is negligible.

Tubes: The necessary tubes are supplied.

Power Supply: 115 volts, 50-60 cycles.

Power Input: 25 watts.

Mounting: This instrument is available for either

rack mounting (TYPE 618-AR) or mounted in a walnut cabinet (TYPE 618-AM). The panel is engraved "TYPE 618-A" and is finished in General Radio standard black crackle lacquer in both models. TYPE 618-AR has a dust cover removable from the rear.

Dimensions: Panel, (length) 19 x (height) 7 inches; behind panel, (depth) $9\frac{1}{8}$ inches.

Net Weight: 26 pounds.

Type	Description	Code Word	Price
618-AM	Cabinet Model . .	SLACK	
618-AR	Relay-Rack Model	SIROL	

VISUAL-TYPE FREQUENCY MONITOR FOR RADIO BROADCASTING STATIONS

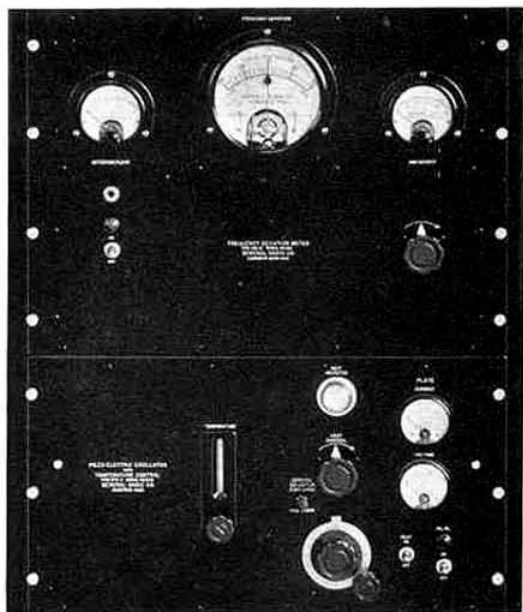

This monitor was designed for use in conjunction with broadcast transmitters operating within a 50-cycle frequency tolerance where government regulations require a visual indication of the deviation of the transmitter frequency from its assigned channel. It has been approved by the Federal Communications Commission (Approval No. 1452) and the Canadian Radio Broadcasting Commission and is used in nearly two hundred stations in the United States and foreign countries.

The frequency indicator is a large meter which shows the frequency deviation from the assigned channel directly in cycles per second, high or low. The meter scale is of

the zero-center type, graduated in 10-cps steps from -100 cps to +100 cps, and which, because of its large size, is easily read from across the operating room. Terminals at the rear allow an additional remote deviation indicator to be connected to the instrument.

The frequency standard used in the monitor is a TYPE 575-E Piezo-Electric Oscillator (see page 46) whose frequency differs from that of the assigned channel by 1000 cycles. Voltages from this oscillator and from the *unmodulated* master oscillator of the transmitter are applied to a TYPE 581-B Frequency-Deviation Meter which reads zero when the beat tone between the two frequencies is 1000 cycles. Deviations from the 1000-cycle beat tone are indicated on the meter as cycles off channel for the transmitter. A jack is provided on the panel to listen to the 1000-cycle tone by a loudspeaker or head telephones, thus providing an aural check on the operation of the monitor.

The monitor is entirely a-c operated. Filament and plate power for the crystal oscillator is obtained from the power supply included in the frequency-deviation meter. The necessary cable for interconnections is supplied, as are all vacuum tubes. A small pick-up coil or condenser and a line to an unmodulated stage of the transmitter are all the auxiliary apparatus that is required.

SPECIFICATIONS

Range: Direct reading, ± 100 cycles.

Accuracy: The absolute accuracy of the piezo-electric oscillator is guaranteed to within $\pm 0.002\%$ (20 cycles at 1000 kc). The frequency-deviation meter is accurate to ± 5 cycles below 50 cycles deviation and to ± 10 cycles between 50 cycles and 100 cycles deviation. Means are provided for adjusting the indication of the system to agree with measurements made by frequency-monitoring stations.

Power Supply: The monitor operates from a 115-volt, 60-cycle, a-c line. The input power is 140 watts.

Dimensions: (Width) 19 x (height) $24\frac{1}{2}$ x (depth behind panel) 11 inches, over-all.

Net Weight: 84 pounds.

Description	Code Word	Price
Broadcast Frequency Monitor	DEVOR	

TYPE 376 QUARTZ PLATES



These are piezo-electric quartz crystals for operation with General Radio piezo-electric oscillators as standards of frequency in laboratory measurements and in frequency monitoring installations. Since the high order of frequency stability required in such services is not compatible with high power output from the oscillator, the frequencies of all plates are guaranteed for operation only at a low power level.

TYPE 376 Quartz Plates are not sold for direct frequency control of radio transmitters.

The frequencies of TYPE 376-H, TYPE 376-J, and TYPE 376-K are adjusted very closely to the ordered frequency, and they are guaranteed to be accurate to within a very few parts in a million. They are recommended for monitoring radio transmitters and as laboratory frequency standards. TYPE 376-H and TYPE 376-K are suitable for use in monitors for commercial radio telegraph channels. For monitoring a broadcast frequency a higher accuracy is required, and the TYPE 376-J Quartz Plate is intended for this service.

TYPE 376-C and TYPE 376-D Quartz Plates are not adjusted so closely to the ordered frequency, and for that reason they require less grinding and are lower in price. They are recommended for use in laboratories requiring an accurate standard, the frequency of which does not

need to have a definite preassigned value. These plates operate at room temperature.

All plates are manufactured from high grade, piezo-electric quartz, free from twinning. The plates are cut by modern optical manufacturing methods, and the parallelism of the surfaces and their orientations with respect to the crystallographic axes are held to extremely small tolerances.

The General Radio Company's guarantee of accuracy of adjustment of frequency becomes void when other types of holders or oscillators are used, or other temperature ranges are tolerated, than those named in the accompanying detailed specifications. This policy insures a known reliability of performance and permits a much closer accuracy guarantee than would otherwise be possible.

The TYPE 376 Quartz Plate holder supplied is designed to maintain the greatest stability of the oscillator frequency. The holder is of the air-gap type with a sealed electrode-spacing adjustment, an isolantite base, and has accurately plane and parallel electrodes. The quartz plate is held securely so that changes in orientation or mechanical jars will not shift the frequency.

Two TYPE 274-P Plugs set on standard $\frac{3}{4}$ -inch spacing give plug-in mounting in General Radio oscillators or temperature-control boxes.

SPECIFICATIONS

Frequency Range: All plates (except TYPE 376-J) can be made for any frequency in the range between 100 kc and 4000 kc.

TYPE 376-J is supplied only for frequencies which are multiples of 1 kc.

Accuracy of Adjustment: The frequency of the plate is adjusted until it differs in our laboratory from the ordered frequency by an amount less than the amount given in the column headed "Adjusted Within" in the table.

Accuracy of Calibration: After the frequency of the plate has been adjusted as described in the preceding paragraph, the frequency is accurately measured in terms of standard frequencies from a General Radio Class C-21-II Standard-Frequency Assembly, and the result of this measurement is entered in the calibration certificate.

Certified Accuracy: The certificate mentioned in the preceding paragraph also states the limits to within which the frequency is guaranteed to be, as specified in the third column of the table, the one headed "Maximum Deviation from Certified Frequency." This column gives the maximum deviation of the crystal from the certified frequency, as measured by us, when the plate and oscillator are operated within the temperature and other operating limits specified by us.

Frequency Tolerance: To find the amount by which the actual frequency of the plate may differ from the frequency ordered, add the figures in the second and third columns ("Adjusted Within" and "Maximum Deviation"). For example, if a TYPE 376-D Quartz Plate is ordered, the user can rely on its frequency's being within 0.13% of the frequency which he specified when ordering and within 0.1%

of the frequency entered in the certificate of calibration.

Oscillator: Contrary to the common assumption, the frequency and the frequency stability of a piezo-electric frequency standard depend upon the design and construction of the oscillator. Hence, the performance of all General Radio quartz plates is specified in a given type of oscillator.

TYPE 376-C and TYPE 376-D are calibrated in and are intended for use with Pierce circuit oscillators (similar to TYPE 275 or TYPE 375 Piezo-Electric Oscillators) which have no provision for temperature control of the quartz plate. These instruments are no longer held in stock.

TYPE 376-H is ordinarily calibrated in the oscillator and temperature-control box in which it is intended to be used, which should be of General Radio manufacture.

TYPE 376-J and TYPE 376-K Quartz Plates are sold for use only in TYPE 575-D, TYPE 575-E, or TYPE 675-H Piezo-Electric Oscillators or in the TYPE 475-A Frequency Monitor. These oscillators use a new type of circuit in which the crystal operates nearer its resonant frequency than in the conventional type of piezo-electric oscillator.

Mounting: The crystal holder consists of an isolantite base carrying an aluminum cap with a means for adjusting, locking, and sealing the air gap. It is practically dust proof and is fitted with plugs for use in General Radio piezo-electric oscillators.

Dimensions: Base, (width) $2\frac{3}{4}$ x (depth) 2 x (height) $1\frac{1}{4}$ inches, over-all.

Net Weight: 10 ounces.

Type	Adjusted Within	Maximum Deviation from Certified Frequency	Temperature	Code Word	Price
*376-C	5% of frequency ordered	0.1 %	18°-32°C.	LAPEL	
*376-D	0.03% of frequency ordered	0.1 %	18°-32°C.	LARVA	
*376-H	0.001% of frequency ordered	0.009%	50°±0.25°C.	LEVEL	
*376-J	0.0001% or 1 cycle of frequency ordered, whichever is smaller	0.002%	50°±0.1°C.	AGAPE	
*376-K	0.0005% or 5 cycles of frequency ordered, whichever is smaller	0.002%	50°±0.1°C.	AFOWL	
Credit allowance for returned TYPE 376 Quartz Plates, Serial No. 2000 and higher.....					

*Before ordering quartz plates, read carefully the above specifications. Our Engineering Sales Department will be glad to make suggestions regarding the type of quartz plate required for a specific purpose.

TYPE 747-A TEMPERATURE-CONTROL BOX

This instrument is designed for use in controlling the temperature of quartz plates in order to assure constant frequency.

A terminal plate carrying two sets of jacks for TYPE 376 Quartz Plates is provided within the temperature-controlled space. The operation of a switch from the front of the panel connects either pair of jacks to the external connections, thus allowing quartz plates for two separate frequencies to remain at their operating temperatures and ready for immediate use. Interleaved heaters and distributing and insulating layers formed of aluminum and balsa wood, respectively, form the walls of the temperature-controlled space. They maintain the air temperature of the quartz-plate chamber constant to within $\pm 0.1^{\circ}\text{C}$. for external temperature variations of $\pm 16^{\circ}\text{C}$. ($\pm 29^{\circ}\text{F}$).

A thermometer, graduated in 0.5°C . divisions from 40° to 60°C ., is mounted behind a slot in the panel and is illuminated by the heat-control indicating lamp. This thermometer indicates the air temperature of the inner space.

The thermostat is of the fixed mercury type and is normally supplied for operation at 50°C . Thermostats for operation at other temperatures that are called for

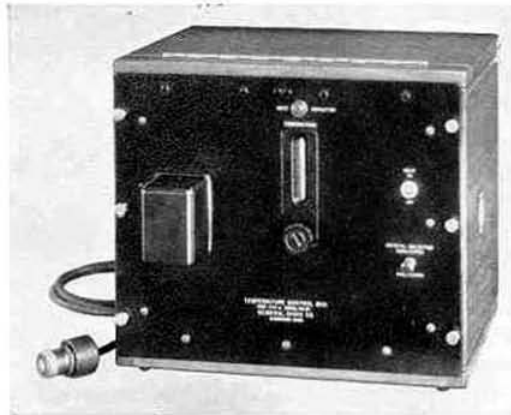

by the manufacturer of the quartz plate used can be supplied when ordered.

This instrument can be supplied mounted in a cabinet or on a standard 19-inch relay-rack panel. When supplied for relay-rack mounting, space is available at the right of the temperature-control box for the construction of oscillator circuits or for other associated circuit elements. The leads from the quartz plate are brought out at the right-hand side of the box, making it convenient to attach leads to other circuits and at the same time reducing the length of leads necessary.

The power supply is a 115-volt line, either ac or dc. A plug and cord for connecting the instrument to the 115-volt line are provided.

SPECIFICATIONS

Accuracy of Temperature Control: The unit will control the temperature of the inner space to within $\pm 0.1^{\circ}\text{C}$. for changes in room temperature of $\pm 16^{\circ}\text{C}$. (29°F). Where the crystal is operated at a power level so high that it generates heat, the temperature can be held to within the same limits if the heat generated by the crystal remains constant.

Operating Temperature: Normally 50°C ., but other temperatures can be supplied on special order.

Mounting: Two types of mounting can be supplied, a walnut cabinet or a standard 19-inch relay-rack panel. See price list below.

Dimensions: TYPE 747-AM, (width) $13\frac{1}{4}$ x (height) $11\frac{5}{8}$ x (depth) $13\frac{1}{2}$ inches.

TYPE 747-AR, (width) 19 x (height) $10\frac{1}{2}$ x (depth) $12\frac{5}{8}$ inches.

Net Weight: TYPE 747-AM, $31\frac{1}{4}$ pounds; TYPE 747-AR, 29 pounds.

Type	Description	Code Word	Price
747-AM	Cabinet Mounting.....	BURLY	
747-AR	Relay-Rack Mounting.....	BATHE	

TYPE 676-A QUARTZ BAR AND MOUNTING

This quartz bar is intended for use in standard-frequency assemblies. It is supplied as standard equipment with the Class C-21-H Assembly, and its use is optional in the Class C-10 Assembly when a 50-ke crystal of great stability is required.

The mounting has been designed to have a minimum of effect on the frequency of the bar. Electrodes are deposited directly on the quartz, thus eliminating the effect of air gaps. Baffles are provided to eliminate the effects of high-frequency sound energy radiated from the ends of the bar, making the frequency practically independent of changes in atmospheric

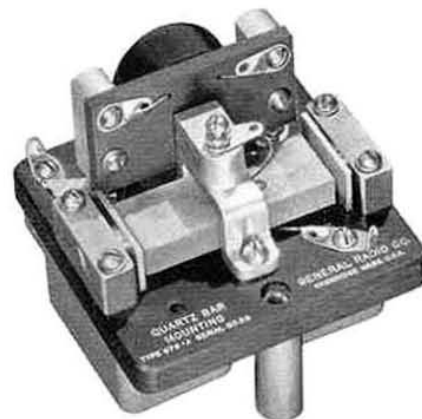

pressure. The bar is zero-angle cut, and it vibrates along its longest dimension in a direction normal to the electric axis.

SPECIFICATIONS

Frequency: 50 kc.
Accuracy: ± 5 parts in 10 million, when used in a Class C-21-II Standard-Frequency Assembly.
Mounting: This bar can be mounted in either a Class C-10 or a Class C-21-H Standard-Frequency Assembly or in a TYPE 675-L Piezo-Electric Oscillator.

Dimensions: (Length) $3\frac{1}{4}$ x (width) $3\frac{1}{4}$ x (height) $3\frac{3}{8}$ inches, over-all.
Net Weight: $1\frac{1}{8}$ pounds.

Type	Code Word	Price
676-A	PIEZOMUSHY	

TYPE 476-A QUARTZ BAR



This is a 100-ke bar to which all of the descriptive information given above for the TYPE 676-A Quartz Bar and Mounting applies, except that it is mounted in a plug-type case similar to the ones in which TYPE 376 Quartz Plates are mounted.

A TYPE 476-P1 Adapter, which also mounts the inductance coil and tuning condensers, is required when a TYPE 476-A Quartz Bar is to be mounted in a Class C-10 or in a Class C-21-H Standard-Frequency Assembly.

SPECIFICATIONS

Frequency: 100 kc.
Mounting: TYPE 476-A, plug-type case.
Dimensions: TYPE 476-A, (length) 2 x (width) 2 x (height) $1\frac{3}{8}$ inches, over-all exclusive of plugs.

TYPE 476-P1, (length) $3\frac{1}{4}$ x (width) $3\frac{1}{4}$ x (height) 3 inches, over-all.
Net Weight: TYPE 476-A, 5 ounces; TYPE 476-P1, 14 ounces.

Type	Description	Code Word	Price
476-A	100-ke Quartz Bar.....	MOCHA	
476-P1	Adapter.....	ADAPTORCOP	

TYPE 575-E PIEZO-ELECTRIC OSCILLATOR

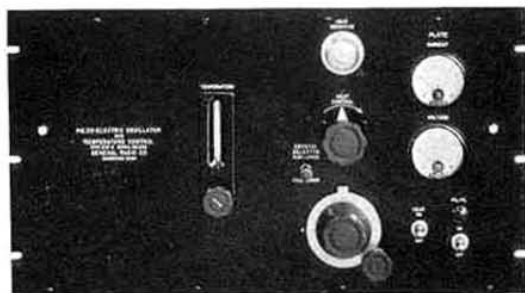

This instrument is a temperature-controlled piezo-electric oscillator designed for use in a monitor or a laboratory secondary standard of high precision.

Through the use of a new type of oscillator circuit the effect on frequency of varying the operating voltages and changing tubes is greatly reduced over previous designs. The difficulty of adjusting the oscillator circuit elements to duplicate the conditions under which the quartz plate was calibrated is eliminated, because the proper operating point corresponds to a minimum value of plate current.

TYPE 376-J or TYPE 376-K Quartz Plates are recommended for use in this instrument.

SPECIFICATIONS

Frequency Range: 50 kc to 4000 kc.

Accuracy: That of the TYPE 376 Quartz Plate used.

Frequency Stability: ± 5 parts per million (0.0005%) with TYPE 376-J or -K Quartz Plate.

Tubes: Necessary tubes are supplied.

Power Supply: Filament: 6 volts, $\frac{1}{3}$ a, ac or dc. Plate: 135 volts, 10 ma, dc. Heat: 115 volts, ac or dc.

Mounting: Standard 19-inch relay rack.

Dimensions: Panel, (width) 19 x (height) $10\frac{1}{2}$ inches. Behind panel, (depth) 10 inches.

Net Weight: 30 pounds.

Type	Code Word	Price
575-E	ADEPT	

TYPE 675-H PIEZO-ELECTRIC OSCILLATOR

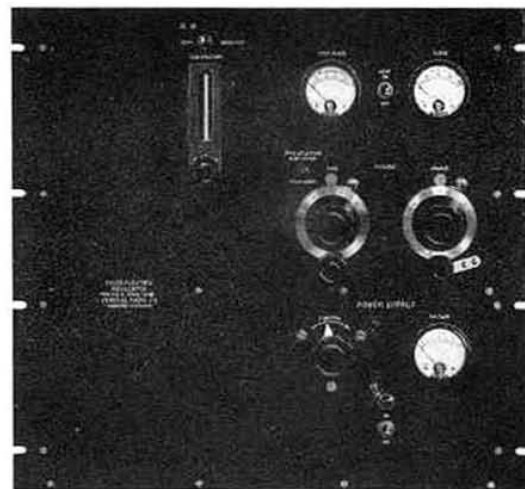

This oscillator uses the same easily adjusted circuit of the TYPE 575-E Piezo-Electric Oscillator and has in addition two separate amplifiers and a self-contained a-c power supply. One amplifier operating at the fundamental frequency supplies a fundamental output for monitoring purposes, and a separate harmonic-generating amplifier furnishes many frequencies used in laboratory work. The oscillator uses TYPE 376-J or TYPE 376-K Quartz Plates.

The a-c power supply will provide filament and plate power for auxiliary apparatus.

SPECIFICATIONS

Frequency Range: 100 kc to 4000 kc.

Accuracy: See specifications for TYPE 376-J or TYPE 376-K Quartz Plate.

Frequency Stability: ± 5 parts in one million.

Tubes: Necessary tubes are supplied.

Power Input: 125 watts with heaters operating.

Power Supply: 115 volts, 50-60 cycles.

Mounting: Standard 19-inch relay rack.

Dimensions: Panel, (width) 19 x (height) $17\frac{1}{2}$ inches. Behind panel, (depth) $10\frac{3}{4}$ inches.

Net Weight: 65 pounds.

Type	Code Word	Price
675-H	AVOWD	

TYPE 619 HETERODYNE DETECTOR



This instrument consists of a tuned regenerative detector and a two-stage audio amplifier covering a frequency range of from 90 to 6000 kilocycles. It is designed for use as a local receiver in a frequency-measuring system to produce

beats between standard harmonic frequencies and frequencies under measurement. Twelve plug-in coils cover the normal range. Additional coils are available to extend the range to include all frequencies between 25 and 25,000 kilocycles. A twelve-coil rack to hold those not in use and a frequency calibration accurate to within one per cent for all coils purchased with the instrument are included.

The complete unit mounts on a standard relay rack and is available in either a-c or battery-operated models.

SPECIFICATIONS

Range: 90 kc to 6000 kc.

Tubes: The necessary tubes are supplied.

Power Supply: For TYPE 619-C, 115-volts, 50-60 cycles, input 25 watts. For TYPE 619-D, 6 volts for filament supply, 90 to 135 volts plate supply.

Mounting: Standard 19-inch relay rack.

Dimensions: Panel, (length) 19 x (height) 8 $\frac{3}{4}$

inches. Behind panel, (depth) 10 $\frac{3}{4}$ inches.

Net Weight: TYPE 619-C, 41 pounds; TYPE 619-D, 35 pounds, without batteries.

Type	Description	Code Word	Price
619-C	A-c Operated	MATIN	
619-D	Battery Operated	MAXIM	

TYPE 614-A SELECTIVE AMPLIFIER



This instrument is particularly useful in conjunction with the Class C-21-H Standard-Frequency Assembly where it is used to produce, select, and deliver multiples of the standard 1-ke output of

the assembly. Selection is accomplished by a 10-point switch, and covers the first 10 harmonics of the applied 1-ke frequency. Regeneration is employed to increase the discrimination against the 1-ke fundamental frequency. The unit may be used with other 1-ke sources if desired.

Panel meters show harmonic generator grid current and amplifier output voltage. The output impedance of 20,000 ohms matches the telephones used in frequency calibrations.

SPECIFICATIONS

Frequency Range: 1 to 10 kc inclusive, 10 points.

Calibration: Adjusted at factory for response at each multiple of 1 kc. Trimming adjustments are provided within the instrument, which may be used for realignment, if necessary.

Tubes: The necessary tubes are supplied.

Power Supply: 110-120 volts, 50-60 cycles. Other voltages or other frequencies on special order.

Mounting: Standard 19-inch relay rack. Panel finished in black crackle lacquer. Dust cover supplied.

Dimensions: Panel, (length) 19 x (height) 8 $\frac{3}{4}$ inches. Behind panel, (depth) 9 $\frac{3}{4}$ inches.

Net Weight: 38 pounds.

Type	Code Word	Price
614-A DICKY	

TYPE 615-A HETERODYNE FREQUENCY METER

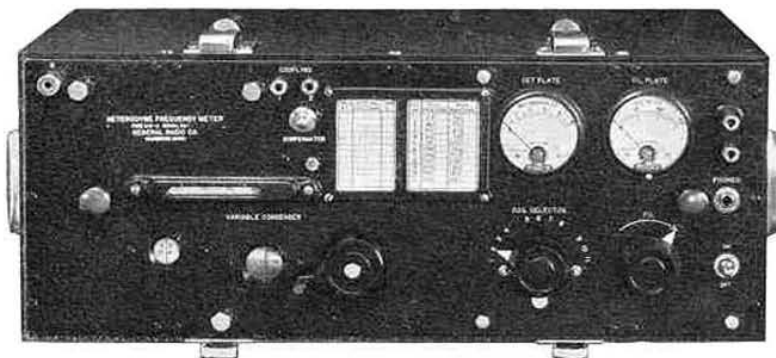

The TYPE 615-A Heterodyne Frequency Meter is an oscillating type of frequency meter designed for use in the measurement of frequency by heterodyne methods. Although its tuned circuit is subject to slight drifts in frequency due to temperature and aging effects, it can be checked

against a local frequency standard or standard-frequency radio signals for measurements of high accuracy.

It consists of a highly stable vacuum-tube oscillator and a detector. It is portable, operating from self-contained batteries, which are not supplied.

SPECIFICATIONS

Range: 275 to 5000 kc.

Accuracy: 0.1% if a correction is made for the difference between calibrating and operating temperatures.

Tubes: The necessary tubes are supplied.

Power Supply: Self-contained batteries.

Mounting: Portable carrying case.

Dimensions: (Length) 19½ x (width) 8 x (height) 13½ inches, over-all.

Net Weight: 34 pounds.

<i>Type</i>	<i>Code Word</i>	<i>Price</i>
615-A	MANLY	

TYPE 616-B HETERODYNE FREQUENCY METER

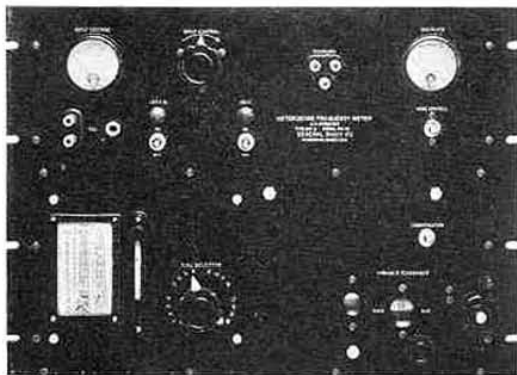

The TYPE 616-B Heterodyne Frequency Meter utilizes the same oscillating circuit as the TYPE 615-A Heterodyne Frequency Meter just described. It includes a single-stage audio-frequency amplifier as well as a detector, and is designed for relay-rack mounting and complete a-c operation.

The elements of the oscillator circuit are temperature controlled in order to reduce the effect of changes in ambient temperature on the oscillator frequency.

SPECIFICATIONS

Frequency Range: 100 to 5000 kc, fundamental. Harmonics can be used up to 30 megacycles.

Accuracy: 0.1%, independent of temperature.

Tubes: The necessary tubes are supplied.

Power Supply: 115 volts, 50-60 cycles.

Power Input: 130 watts with heater circuits in operation.

Mounting: Standard 19-inch relay rack.

Dimensions: Panel, (length) 19 x (height) 14 inches. Behind panel, (depth) 10¾ inches.

Net Weight: 63 pounds.

<i>Type</i>	<i>Code Word</i>	<i>Price</i>
616-B	MANOR	

TYPE 624-A PRECISION WAVEMETER

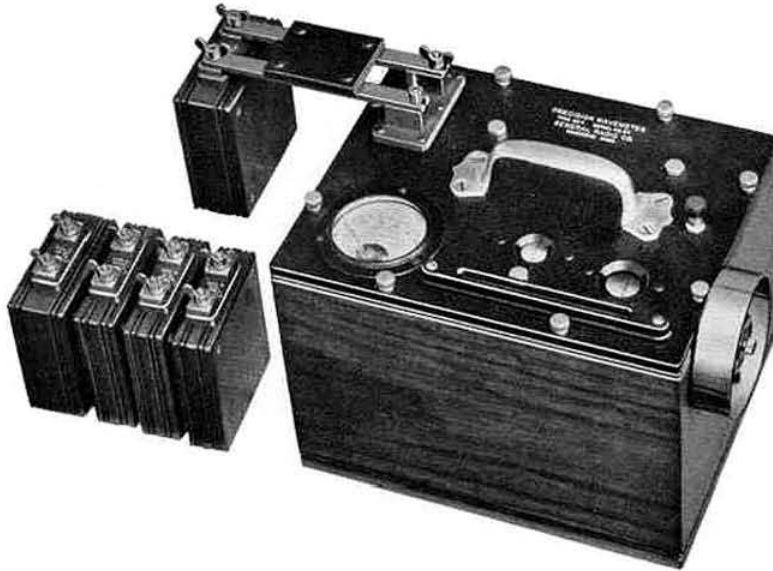

This instrument is a high-frequency wavemeter intended for use under service conditions where the greatest accuracy obtainable with commercial tuned-circuit wavemeters is required. It covers the range from 25,000 to 5670 kilocycles (12 to 53 meters).

Settings are made by the incremental capacitance method which allows settings to be made with high precision. Operation of a "push button" throws in or out of circuit a small condenser in parallel with the main tuning condenser. The main condenser is adjusted until operation of the push button causes no change in the

deflection of the thermogalvanometer. With this method, a precision of setting of the order of one part in 20,000 can be obtained.

The condenser is of the precision worm-drive type and has plates shaped to give a straight-line-frequency variation.

A thermometer is mounted on the panel to indicate the temperature of the wavemeter when used. Data are provided for correcting the calibration for the effect of temperature changes.

The guaranteed accuracy is 0.1 per cent for a period of one year from date of purchase.

SPECIFICATIONS

Range: 5670 kc-25,000 kc.

Accuracy: 0.1% if temperature correction is made.

Mounting: A wooden storage case, fitted with lock and carrying handle, is furnished. This has compart-

ments for holding the condenser, inductors, and calibration charts.

Dimensions: Carrying case, (length) 20 x (width) 12 x (depth) 11 inches, over-all.

Net Weight: 36 pounds, including carrying case.

Type	Description	Frequency Range	Equivalent		Code Word	Price
			Wavelength Range	Calibration Curve		
*624-A	Wavemeter	25,000-5670 kc	12-53 meters		AGATE	CURVE
		Mounted Capacitance				
†624-P7	Extension Inductor	5670-4270 kc	53-70 meters		ALIVE	ALLAY
†624-P8	Extension Inductor	4270-3200 kc	70-94 meters			

*Capacitance calibration supplied only when ordered. Use compound code word: AGATECURVE.

†Wavemeter with which inductors are to be used must be supplied with order so that calibration can be made.

TYPE 574 WAVEMETER

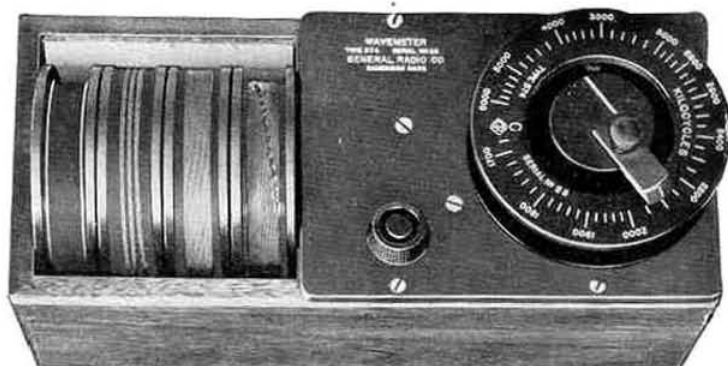

This direct-reading, tuned-circuit wavemeter is well adapted for general purpose work in commercial, experimental, and educational laboratories. It is unusually compact, and its wide frequency range and direct-reading feature make it useful for determining quickly the frequencies of transmitters, receivers, and oscillators.

Its precision is adequate for most routine frequency measurements. Even in high-precision work the time-wasting and bothersome process of locating an unknown frequency on a precision wavemeter can often be simplified by first determining the approximate frequency with the TYPE 574 Wavemeter.

SPECIFICATIONS

Frequency Range: 166 kc to 70,000 kc (1800 meters to 4.3 meters), by using the five plug-in inductors supplied with the instrument.

Accuracy: The construction and calibration of this wavemeter are such that, if carefully made, measurements can be relied upon to within 1% of the indicated frequency.

Calibration: Each inductor is individually calibrated at five points in terms of the General Radio Company's primary standard of frequency, and intermediate points are secured by interpolation. The scales themselves are engraved on the inductors, thus making the instrument direct reading. Coil A and Coil B are engraved in units of megacycles per second, others in kilocycles per second.

Condenser: A special TYPE 334 Variable Air Condenser modified by a reduction gear is used to spread the calibration scale over approximately 345°. This facilitates precise settings. The condenser is driven by a slow-motion knob geared to the condenser shaft.

Mounting: The condenser is mounted on a bakelite panel attached to the polished walnut case, at one end of which is the storage compartment for spare inductors which are held in place by a spring clamp.

Dimensions: (Length) 11 x (width) 5 x (height) 5½ inches, over-all.

Net Weight: 4⅝ pounds.

Type	Frequency Range	Equivalent Wavelength Range	Code Word	Price
574	166-70,000 kc	1800-4.3 meters	CARRY	



GENERAL PURPOSE WAVEMETER

for round-the-laboratory use. Flashlight-bulb resonance indicator. See the description of TYPE 358 Wavemeter, page 152.

ⓄⓄⓄⓄⓄⓄⓄⓄⓄⓄⓄⓄⓄⓄⓄⓄⓄⓄⓄⓄⓄⓄⓄⓄⓄ AUDIO FREQUENCY METER

TYPE 434-B AUDIO FREQUENCY METER

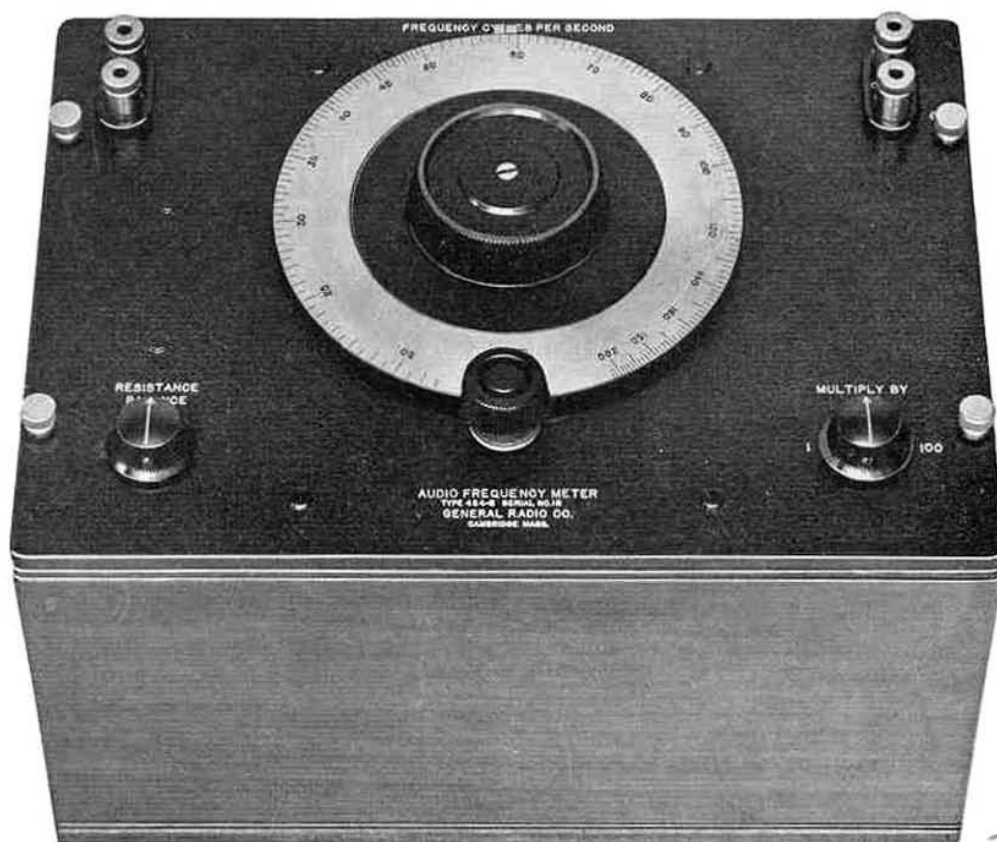

The TYPE 434-B Audio Frequency Meter was developed to provide a means for measuring, with an accuracy of 0.5 per cent, audio frequencies in the range from 20 to 20,000 cycles. It makes use of the Wien bridge, which contains only resistances and capacitances. This eliminates the magnetic pickup which exists in all frequency meters containing self- or mutual inductance.

The meter is direct reading with an extremely long scale. The meter has three frequency ranges differing by ratios of 10:1, obtained by varying the condensers by ratios of 10:1. Thus the same scale is used for all three frequency ranges with decimal multiplying factors. The different frequencies are distributed along the scale logarithmically, *i.e.*, equal frequency ratios occupy equal scale lengths. This makes the fractional accuracy constant over the

entire scale. This very desirable feature is obtained by a suitable shaping of the tapered resistors which are the variable units in the meter. The inductors used in other types of frequency meters cannot be shaped to yield any desired frequency distribution.

The resistance balance of the bridge is approximately maintained for all scale settings. Exact balance is made by means of a suitable potentiometer. The setting of the frequency dial is not changed by lack of resistance balance, but merely dulled.

The null detector is usually a pair of high-resistance head telephones. They are sufficiently sensitive to enable the dial to be set to 0.5 per cent with 2 volts input to the bridge within the frequency range 300–3000 cycles, if the waveform is pure. The dial may be set to 0.1 per cent by applying a higher voltage to the bridge or by using

FREQUENCY AND TIME

an amplifier such as the TYPE 514-A Amplifier between the bridge and the telephones. When the harmonic content of the supply is large, a low-pass filter, such as TYPE 330 Filter Sections, or a tuned circuit may be used for frequencies less

than the natural frequency of the telephones (about 900 cycles). The TYPE 488-DM Alternating Current Voltmeter, preceded by the TYPE 514-A Amplifier and a TYPE 330 Filter Section, may also be used as a null detector.

SPECIFICATIONS

Frequency Range: 20–20,000 cycles in three ranges by means of a selector switch, 20–200 cycles, 200–2000 cycles, 2000–20,000 cycles.

Calibration: Each instrument is individually calibrated with more than sufficient accuracy in terms of the General Radio Company's primary standard of frequency. Each dial is then individually engraved.

Accuracy: The null point is narrow enough so that, with sufficient supply voltage or sufficient amplification on the null detector and with a fairly pure waveform, the dial may be set to 0.1%. The calibration on the dial may be relied upon to within 0.5% at all positions.

Drive: The 6-inch dial turns through an angle of 320° which gives a scale length of about 17 inches for each 10 to 1 frequency range. The whole scale length is 4 feet 2¼ inches. The dial has a slow-motion drive.

Impedances: Input, 3–10 kilohms; output, 1–4 kilohms, the smaller values corresponding to the higher frequencies.

Input Voltage: 110 volts, maximum.

Accessories: A null detector will be required to operate the instrument. This may be head telephones such as the Western Electric Type 1002-C or an amplifier-meter combination such as a TYPE 514-A Amplifier and a TYPE 488-DM Alternating Current Voltmeter or a TYPE 626-A Thermionic Voltmeter, used in conjunction with TYPE 330 Filter Sections. Even with head telephones an amplifier and filter sections may prove useful.

Controls: Frequency dial, range selector switch, resistance balance knob.

Mounting: Aluminum panel, ¼ inch thick, finished in black crackle lacquer, mounted in copper-lined walnut cabinet.

Dimensions: (Length) 12 x (width) 8¾ x (height) 8¼ inches, over-all.

Net Weight: 15¼ pounds.

Type	Frequency Range	Code Word	Price
434-B	20–20,000 cycles	COLOR	



FREQUENCY METER-MONITOR

for the amateur, heterodyne type, batteries self-contained. See the description TYPE 535-A Frequency Meter-Monitor, page 153.

OSCILLATORS

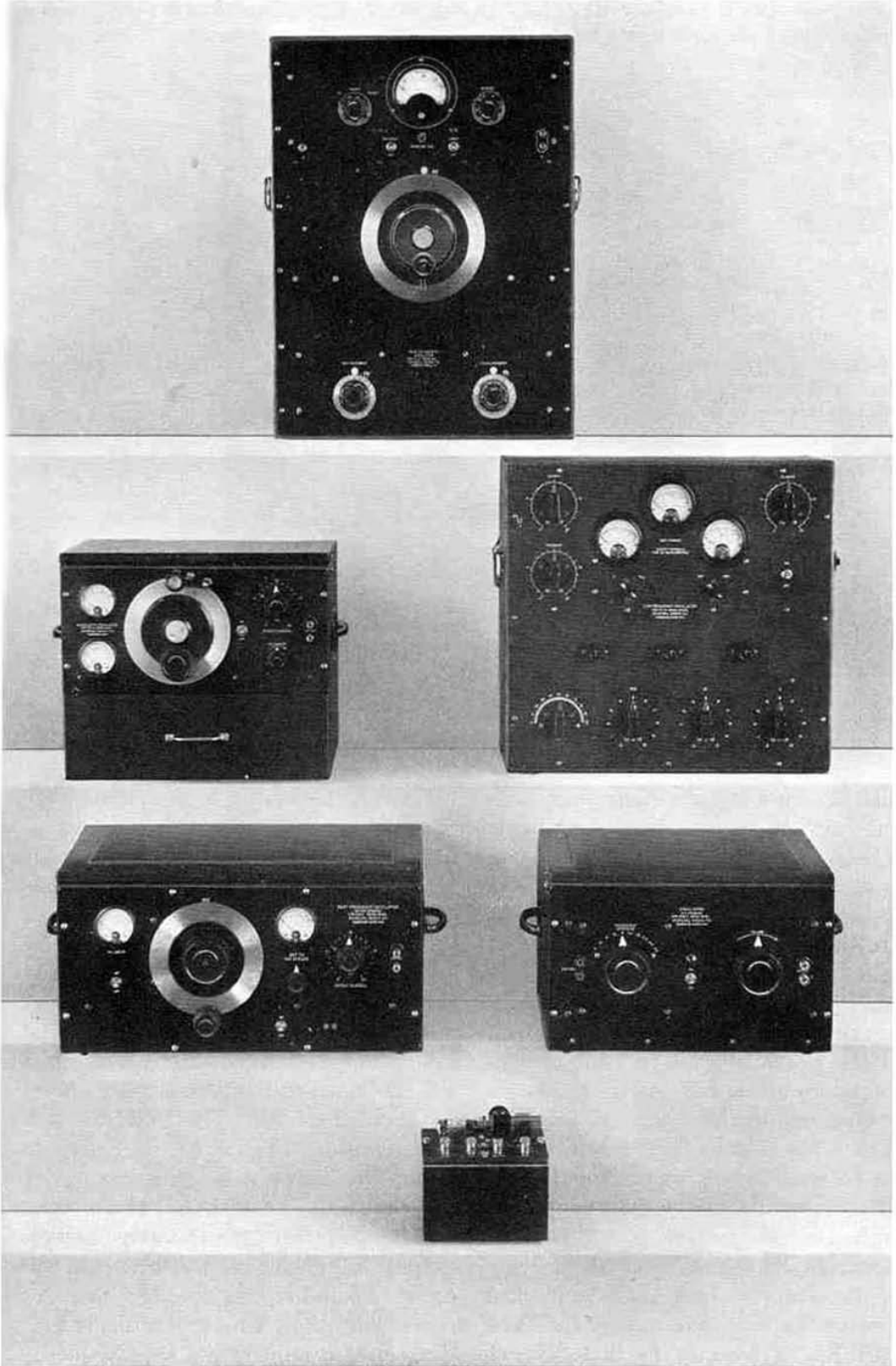

TYPE 713-A BEAT-FREQUENCY OSCILLATOR



The usefulness of audio-frequency oscillators previously commercially available has been seriously limited by low power output which has necessitated the use of amplifiers.

In the TYPE 713-A Beat-Frequency Oscillator the power output has been increased to two watts, a gain of twenty times over the highest power output previously available in a continuously adjustable audio-frequency oscillator manufactured by this company. This output, with 130 volts on open circuit, is sufficient for testing many types of equipment and for modulating present types of standard-signal generators without additional amplification. This large increase in output power accompanies a marked improvement in waveform over the TYPE 513-B Beat-Frequency Oscillator which this instrument replaces.

In general design the TYPE 713-A Beat-

Frequency Oscillator is an alternating-current-operated oscillator operating on the beat principle in which the output results from the beat between two high-frequency oscillators, one of which is fixed, the other continuously adjustable. A frequency range of 10 to 16,000 cycles is covered. The dial carries an accurate, individually engraved calibration. The calibration may be checked by means of a self-contained, calibrated tuned reed.

The distinguishing characteristic of a beat-frequency oscillator is its ability to cover continuously a wide frequency range with one control and, at the same time, to maintain approximately constant output. By means of such a circuit, the entire audio-frequency range may be covered by the rotation of a single dial. This feature renders the beat-frequency type of oscillator useful for the rapid study of all types of equipment.

The main dial is supplemented by an incremental condenser, calibrated over a range of -50 to $+50$ cycles, which facilitates accurate setting of frequency. It is also of value in obtaining small pitch variations, as are frequently required in physiological and psychological studies.

The design of the instrument is such that the waveform and power output are

ample for practically all experimental uses. When it is used in accordance with the operating instructions, the reliability of the frequency calibration is excellent. Both oscillators operate near 160 kilocycles, and the circuits are adjusted so that the difference frequency may be reduced to 1 cycle without their "pulling into step" with each other.

SPECIFICATIONS

Frequency Range: Although calibrated between 10 cycles and 16,000 cycles only, it will deliver power over a slightly wider range.

Frequency Control: The main control dial is engraved at least at every one-hundred-cycle interval, the total scale length being approximately 18 inches. There is an additional auxiliary control covering a band 50 cycles wide on either side of the frequency determined by the setting of the main dial. This is useful for making resonance curves, measuring pitch increments, and the like.

Frequency Calibration: A tuned 100-cycle reed is provided to supply a checking point. In operation, the main tuning control is set to 100 cycles, and a zero-adjusting condenser is adjusted until the oscillator frequency and the reed frequency are in agreement, as shown by maximum deflection of the reed. The reed adjustment is correct to within 1 cycle.

Each instrument is individually calibrated, and the main tuning-control dial is then engraved.

The auxiliary dial is marked with one division for every 1-cycle interval.

The calibration can be relied upon to within 2% after the oscillator has been adjusted to the reed frequency at the 100-cycle point, within one year from the date of purchase.

Frequency Stability: Great care in design has been taken to provide adequate thermal insulation and ventilation, thereby practically eliminating frequency drifts from this cause.

The frequency may drift 5 to 10 cycles in the first two hours from heating, but it is negligible thereafter in the absence of a marked change in room temperature. A 15-volt change in supply voltage causes less than 1 cycle shift in output frequency. If the accuracy of the work justifies such a precaution, the oscillator may at any time be checked against the tuned reed.

Output: Maximum open-circuit voltage is 130 volts, approximately; maximum power output is about 2 watts. The output control is a 30,000-ohm tapered voltage divider. Output voltage is measured by a linear-scale vacuum-tube voltmeter.

For any resistive load the output voltage varies by less than 0.5 db (5%) between 30 and 10,000 cycles; less than 1.4 db (15%) between 10 and 16,000 cycles.

Waveform: At frequencies above 100 cycles, total harmonic content is less than 1% of the fundamental amplitude. At 10 cycles, harmonics are less than 5% (introduced by the iron-core output transformer).

By throwing a switch on the panel, the output voltage is reduced to 1/10 of its normal value, and the harmonic content is brought down to less than 1% over the entire range of the instrument. Power-supply ripple is approximately 0.1% on full output; 1% when the output voltage has been reduced by 10:1.

A means of checking the performance of the oscillator is provided so that improper load conditions, which would increase the harmonic content, can be detected.

Power Supply: 100-120 volts, 40-60 cycles, ac. The power consumption is about 85 watts.

Mounting: All apparatus is mounted on the engraved panel which is finished in black crackle lacquer. The panel is mounted in a heavy oak case with brass carrying handles and lock. It may be bolted to the wall, hinges allowing the cabinet to swing out for replacing tubes, etc.

Tubes: The necessary tubes, 3 type 41, 3 type 6C6, 2 type 2A3, and 1 type 80, are supplied.

Accessories: 7-foot connecting cord is supplied.

Dimensions: Panel, (width) 19 x (height) 24 $\frac{1}{4}$ inches. Over-all cabinet size, including handles, (width) 20 $\frac{1}{2}$ x (height) 25 x (depth) 11 inches.

Screw holes in the panel are the standard spacing for mounting the instrument in a TYPE 480 (standard 19-inch) Relay Rack.

Net Weight: 87 pounds.

<i>Type</i>	<i>Code Word</i>	<i>Price</i>
713-A	DEBAR	

TYPE 613-B BEAT-FREQUENCY OSCILLATOR



This is a battery-operated instrument which possesses the desirable features of good waveform, frequency stability, and open scale which characterize the TYPE 713-A Beat-Frequency Oscillator previously described.

This oscillator is adjusted to the calibrated conditions by setting to resonance with a one-hundred-cycle tuned reed. The dial of each instrument is individually calibrated and engraved.

The TYPE 613-B Oscillator has been

found especially valuable in physiological and psychological research at audio frequencies. A useful accessory to the oscillator in this application is the TYPE 539-P Incremental-Pitch Condenser (see page 27). This condenser is calibrated in single-cycle frequency increments and can be used to vary the output frequency repeatedly over any range of less than 100 cycles above the main dial setting.

The output has been carefully filtered to eliminate spurious high frequencies.

SPECIFICATIONS

Frequency Range: Calibrated between 10 cycles and 11,500 cycles, it will actually deliver power at frequencies slightly lower and higher, respectively, than these.

Frequency Calibration: A reference calibration is secured by setting the main tuning control to the 100-cycle graduation, marked "REED," and then adjusting the compensating condenser until the calibrated tuned reed vibrates at maximum amplitude.

Each instrument is individually calibrated in terms of the General Radio Company's standard of frequency, and the dial of the main tuning control is then engraved. The dial is 6 inches in diameter and has a spread of 270° so that the scale is spread out over almost 14 inches.

For one year from the date of purchase, the calibration can be relied upon to within 2% after the oscillator has been checked at the zero-beat point.

Frequency Stability: The radio-frequency oscillators are stable, and under uniform temperature conditions the beat frequency will stay within a few cycles over a period of several hours. Changes in ambient temperature will cause slight changes in frequency because of the temperature coefficient of the tuned circuits. When a drift in frequency is observed, it can be corrected by readjusting for maximum amplitude of the tuned reed.

Output: The open-circuit output voltage does not depart from a 13-volt average by more than 20% over the entire frequency range.

Internal Output Impedance: 5000 ohms.

Waveform: On open circuit the total harmonic content is less than 2% of the fundamental above 100 cycles. With a 5000-ohm load it is less than 5% above 100 cycles; below 100 cycles it increases rapidly as the frequency is reduced, reaching 10% at 20 cycles.

Controls: In addition to the main tuning control and the auxiliary control for adjusting to the 100-cycle reference frequency, there are the output voltage divider and the filament and tuned-reed ON-OFF switches.

Meters: A filament voltmeter and a detector plate-current meter are mounted on the panel.

Tubes: Three 330-type and one 331-type (RCA or equivalent) tubes are required and are supplied as initial equipment.

Terminals: Two binding posts on the panel are provided for making connections to the oscillator.

Power Supply: Space for mounting three 45-volt plate batteries and two No. 6 dry cells for filament supply is provided inside the cabinet.

Mounting: The instrument is mounted on an aluminum panel finished in black crackle lacquer and contained in a polished walnut cabinet with carrying handles.

Dimensions: Panel, (width) 19 x (height) 8¾ inches. Cabinet, (width) 22 x (height) 12¼ x (depth) 9 inches, over-all.

Net Weight: 33¼ pounds without batteries.

<i>Type</i>	<i>Code Word</i>	<i>Price</i>
613-B	NAVAL	

TYPE 377-B LOW-FREQUENCY OSCILLATOR

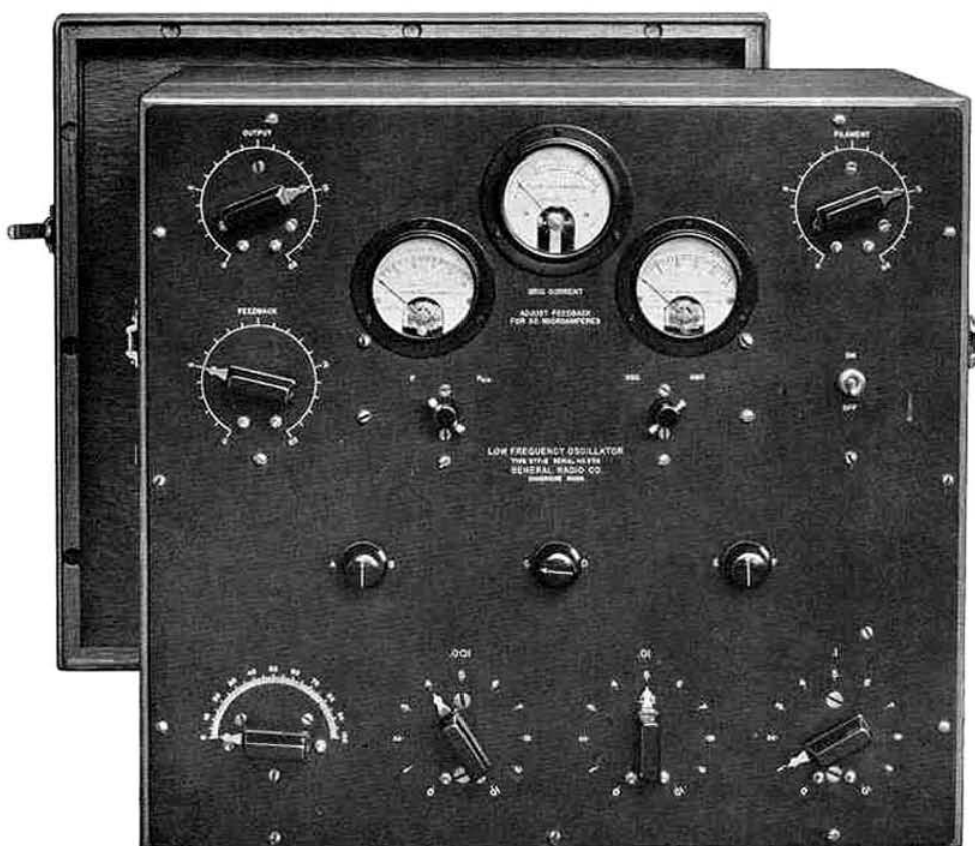

In the communication laboratory a general purpose oscillator is an extremely useful instrument. An oscillator for general

use must meet more rigid specifications than any other type because of the wide range of uses to which it is put. The Type

377-B Low-Frequency Oscillator is designed to meet the demand for an instrument of this sort. Its frequency range extends from the low audio to low radio frequencies. Frequency stability and low harmonic content are other important characteristics. Among its uses are bridge measurements of all kinds, studies of the response curves of transformers and loudspeakers, the study of filter characteristics, and the study of cable and other

dielectric behavior. Since the frequency goes to 70 kilocycles, power level and attenuation measurements on lines and networks can be made at carrier as well as audio frequencies.

This type of oscillator is useful in general scientific work as well as in the more specialized problems of electrical communication and is recommended for general use in college and industrial laboratories.

SPECIFICATIONS

Frequency Range: Any frequency between 25 cycles and 70,000 cycles can be obtained. The range can be extended downward to 10 cycles for a small additional charge.

Power Output: 50 milliwatts with one amplifier tube; 100 milliwatts with two amplifier tubes. It is adjustable by means of a voltage divider. The internal output impedance with the voltage divider set for maximum output is approximately 2000 ohms with two amplifier tubes and 3500 ohms with one amplifier tube.

Waveform: The maximum harmonic content is about 3% of fundamental amplitude. Most of it is introduced by the amplifier.

This may be reduced to about 1% for loads of 8000 ohms or more by reducing the signal level applied to the amplifier. The method of doing this involves changing coupling resistors and is described in the instructions accompanying the instrument.

Calibration: A calibration for 50 points, accurate to within 1%, is made in terms of the General Radio primary standard of frequency for each instrument. The corresponding settings of the condensers and the inductor switches are entered on two charts. One is mounted inside the back cover, the other in an aluminum chart holder.

Frequency Stability: Changes in tubes and operating voltages have a minor effect on the frequency, a change of 25% in plate voltage, for example, producing about 0.1% change in frequency. Changing tubes causes about the same amount of shift. This is

unusually good performance for a power oscillator of so wide a frequency range.

Controls: All controls are located on the panel. They are: inductor selector switches, condenser switches, variable condenser, feed-back adjustment, output power adjustment, and filament rheostat.

Meters: Meters are provided for reading oscillator grid current as an index to correct feed-back adjustment, filament and plate voltage, and oscillator and amplifier plate current.

Mounting: All parts are mounted on an engraved bakelite panel in a heavy oak case with carrying handles and a cover. The case may be bolted to the wall, hinges allowing the cabinet to swing out for replacing tubes, etc.

Terminals: All battery and output terminals are inside the case, which has holes in its side for the connecting wires.

Tubes: Two or three 112-A-type (RCA or equivalent) tubes are used, one as an oscillator and either one or two as amplifiers. Tubes are supplied with the instrument as initial equipment.

Power Supply: 135 volts, 16 ma (plate) and 6 volts, 0.75 a (filament) are required to operate 3 tubes in addition to the grid-biasing battery mounted inside the case. Only the latter is included in the price of the instrument.

Dimensions: Cabinet with cover, (width) 19 $\frac{1}{8}$ x (height) 18 x (depth) 10 $\frac{1}{2}$ inches, over-all.

Net Weight: 55 pounds.

Type		Code Word	Price
*377-B	OMEGA	
	Alteration to extend range downward to 10 cycles	EXTRA	

*Use the compound code word OMEGAEXTRA when ordering an oscillator with the alteration.

TYPE 508-A OSCILLATOR



This is an alternating-current operated instrument of medium power, yielding 10 frequencies separated by approximately equal percentage intervals to cover the more commonly used portion of the audio range. It is intended for use in bridge measurements and in measurements on electrical communication apparatus and systems where it is necessary that measurements be made at a number of different frequencies.

The 0.5-watt power delivered by the TYPE 508-A Oscillator is a distinct advantage in increasing the sensitivity of bridge measurements, since it is considerably in excess of that available from the

small electro-mechanical type of oscillator often used.

This oscillator is entirely alternating-current operated, as in this way the power required is obtained at a minimum expense, and the necessity of maintaining an external power-supply system is avoided.

Both frequency stability and output waveform are good for an oscillator delivering this power output. There is no direct current in the output circuit.

It is normally supplied mounted in a cabinet, but a model adapted for mounting in a standard 19-inch relay rack is available.

SPECIFICATIONS

Frequency Range: The 10 frequencies available are 200, 300, 400, 600, 800, 1000, 1600, 2000, 3000, and 4000 cycles. Selection is made by a single 10-point switch. Frequencies between these values can be secured by the use of an external condenser which can be plugged into the jack terminals on the panel at the left. For frequencies between 250 cycles and 4000 cycles a TYPE 219-G Decade Condenser with a TYPE 335-Z Variable Air Condenser is suitable. Between 200 cycles and 250 cycles an additional 0.5 μ f condenser is required. These condensers are not supplied with the instrument.

Frequency Stability: Any frequency of this oscillator can be relied upon to remain constant to

within 1% over a period of several hours in spite of changes in load or line voltage.

Waveform: On open circuit, the total harmonic content of the output wave is less than 8% of the fundamental amplitude. This increases as the load impedance is reduced, approaching a maximum of 11% when the output terminals are short-circuited. The maximum open-circuit hum voltage across the terminals is 0.5 volt.

Frequency Calibration: Each instrument is adjusted in our laboratory to within 5% of the frequencies engraved on the panel.

Output: Approximately 0.5 watt into a load of 2000 ohms. This maximum power output varies

OSCILLATORS

between approximately 0.3 watt and 0.8 watt as the frequency is changed. A high-impedance voltage divider for adjusting the power output is included.

Internal Output Impedance: 2000 ohms at maximum output.

Controls: An ON-OFF switch for the power supply is the only control except for the frequency selector and the VOLUME voltage divider.

Tubes: One 245-type tube and one 280-type rectifier tube (RCA or equivalent) are supplied.

Power Supply: 100 to 120-volt, 50 to 60-cycle line. The power drain is about 40 watts.

Terminals: The terminals for connecting the output and for attaching an external condenser (see "Frequency Range") are mounted on the panel.

Mounting: All apparatus is mounted on a metal shelf secured to the aluminum front panel. The cir-

cuit is entirely enclosed in a metallic shield to prevent pickup to associated apparatus. As normally supplied, the shielded oscillator unit is mounted in a hand-rubbed walnut cabinet. This is known as TYPE 508-AM.

When a model mounted in a standard 19-inch relay rack is required, the unit can be removed from the cabinet and provided with panel extension plates to secure the standard width. An oscillator so modified is known as TYPE 508-AR.

Accessories: 7-foot connecting cord is supplied.

Dimensions: For TYPE 508-AM: Panel, (width) 15 x (height) 8 $\frac{3}{4}$ inches. Cabinet, (width) 18 x (height) 10 x (depth) 12 $\frac{1}{2}$ inches, over-all.

For TYPE 508-AR: (Width) 19 x (height) 8 $\frac{3}{4}$ x (depth behind panel) 10 inches, over-all.

Net Weight: 38 pounds for TYPE 508-AM and 30 $\frac{1}{4}$ pounds for TYPE 508-AR.

Type	Description	Code Word	Price
508-AM	Cabinet Mounting	ARROW	
508-AR	For Relay-Rack Mounting .	ARSON	

TYPE 213 AUDIO OSCILLATOR

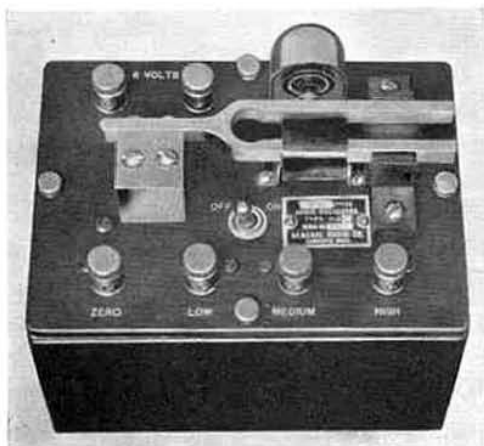

The TYPE 213 Audio Oscillator is a battery-operated, electro-mechanical oscillator in which the frequency is stabilized by a tuning fork. It is intended for de-

livering small amounts of power in bridge measurements and telephone line tests. The 400-cycle model when used with a TYPE 530 Band-Pass Filter is recommended for use in broadcasting stations where a test signal of good waveform is required for measuring modulation percentage, distortion factor, and speech-amplifier gain.

Because of its reliability this oscillator has been used in police radio systems and airplane beacon transmitters to furnish a test signal.

The frequency is determined by the frequency of the tuning fork which drives a microphone button. The advantages of this oscillator are simplicity, reliable operation, and rugged construction.

SPECIFICATIONS

Frequency: Two models, one operating at 1000 cycles and one at 400 cycles, are carried in stock, but special instruments can be constructed for any 100-cycle multiple between 400 cycles and 1500 cycles. Designs are on file; prices on request.

Frequency Stability: The maximum change in frequency with load is about 0.1%. This and variations introduced by temperature are entirely negligible for practically all purposes for which this oscillator is likely to be used.

Calibration: The actual frequency will be less than the rated value by about 0.5% because of the loading of the fork by the microphone button.

Output: A maximum of 50 milliwatts can be obtained.

Internal Output Impedance: The power output is delivered through a transformer-filter. Three taps are provided permitting the use of loads from 20 to 10,000 ohms.

Waveform: The harmonic content varies with the load impedance. With normal resistive loads it will vary from about 3% to 8%.

Tubes: This is an electro-mechanical oscillator and requires no tubes of any kind.

Power Supply: Normally obtained from a 6-volt, d-c source such as a storage battery or dry cells. Drain approximately 125 ma.

Terminals: Two binding posts for the power supply and four binding posts for the output circuit are mounted on the panel.

Mounting: All parts are mounted on a bakelite panel in a polished walnut cabinet.

Dimensions: Panel, (width) 6 $\frac{1}{8}$ x (length) 4 $\frac{3}{4}$ inches. The over-all height of the instrument depends upon the frequency, being 5 inches for frequencies between 1000 and 1500 cycles and 6 $\frac{1}{8}$ inches between 400 and 900 cycles.

Net Weight: Approximately 5 $\frac{1}{2}$ pounds.

Type	Frequency	Code Word	Price
*213-B	1000 cycles	ANGEL	
*213-C	400 cycles	AMUSE	

*Specify frequency as well as type number when ordering. Prices for other frequencies will be supplied on request.

TYPE 484-A MODULATED OSCILLATOR

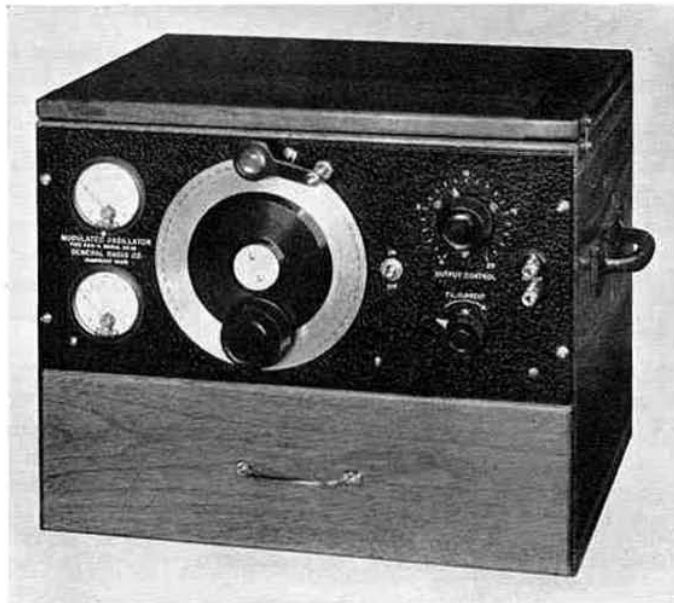

This is a portable, general-purpose, radio-frequency oscillator covering the wide range of frequencies so often required for the laboratory. It is modulated and sufficiently well shielded to permit of its use in radio-frequency bridge-circuit measurements where the expense of a perfectly shielded standard-signal generator is neither necessary nor justifiable.

As a matter of fact, this oscillator was designed with the particular requirements of the TYPE 516-C Radio-Frequency Bridge in mind.

A straight-line-frequency condenser driven by a precision dial is used for tuning. All inductors are plug-in as is the modulating oscillator unit. Space is provided inside the cabinet for batteries.

SPECIFICATIONS

Frequency Range: 10 kc to 40 Mc by means of ten plug-in inductors. In addition, two band-spread inductors are available. Inductors are not included in the price of the instrument and must be ordered separately. See TYPE 484-P Inductors below.

Calibration: Calibrations are not included. On special order, however, a calibration curve accurate to within 1% can be supplied for any inductor. (See price list.) Inductors must be calibrated in the oscillator with which they are to be used.

Voltage Output: For frequencies in the broadcast band and below, the maximum output is 2.0 volts. At higher frequencies the voltage progressively decreases until at the highest frequencies it is approximately 0.2 volt. Over the range of one coil the output voltage varies by a ratio of approximately 1.5 to 1.

Modulation: Internal 1000-cycle vacuum-tube oscillator, providing approximately 30% modulation. Provision is made for modulating at other frequencies by either plugging in another modula-

tion-oscillator unit in place of the 1000-cycle unit or by connecting a separate oscillator in the circuit.

Tubes: Two 30-type tubes, supplied with the instrument.

Batteries: Two No. 6 dry cells and three 45-volt Burgess No. 5308 batteries, or equivalent, are necessary. These are not included in the price of the instrument. Space for batteries is provided in the cabinet.

Mounting: The oscillator is assembled on a black crackle-finish aluminum panel and mounted in a shielded walnut cabinet. A drawer is provided for the inductors not in use.

Dimensions: (Length) 18 x (depth) 14½ x (height) 12¾ inches.

Net Weight: 32½ pounds, without batteries; 46½ pounds with batteries.

Type	Code Word	Price
484-A	CREST	

TYPE 484-P INDUCTORS

SPECIFICATIONS

Dimensions: TYPE 484-P1 to TYPE 484-P14, 484-P21, (length) 2⅞ x (width) 2⅞ x (height) (length) 3 x (diameter) 3¼ inches, over-all. TYPE 5⅜ inches, including plugs.

Type	Frequency Range	Net Weight	Code Word	Price
*484-P1	25 Mc to 40 Mc	6 ounces	MODOSCBIRD	
*484-P2	9.4 Mc to 25 Mc	6 ounces	MODOSCDISK	
*484-P3	3.55 Mc to 9.4 Mc	9 ounces	MODOSCFORD	
*484-P4	1500 kc to 3550 kc	8 ounces	MODOSCGIRL	
*484-P5	500 kc to 1500 kc	10 ounces	MODOSCGOAT	
*484-P8	160 kc to 500 kc	7½ ounces	MODOSCARMY	
*484-P9	60 kc to 160 kc	6 ounces	MODOSCALLY	
*484-P10	27 kc to 60 kc	6½ ounces	MODOSCEYRE	
*484-P11	160 kc to 270 kc	9 ounces	MODOSCHYMN	
*484-P12	100 kc ± 2 kc	9 ounces	MODOSCMILK	
*484-P13	15 kc to 27 kc	7 ounces	MODOSCITCH	
*484-P14	10 kc to 15 kc	7 ounces	MODOSCONLY	
484-P21	400-Cycle Modulating Unit	3⅞ pounds	MODOSCPALM	
	Frequency Calibration (per Inductor)		CURVE	

*Frequency calibration supplied only when ordered. To order calibrated inductors, use compound code words, e.g., MODOSCBIRD CURVE, etc.



1000-CYCLE BRIDGE SOURCE

Vibrating-reed type, carbon-button drive from 4.5 volts. See the description of the TYPE 572-B Microphone Hummer, page 152.

TYPE 514-A AMPLIFIER

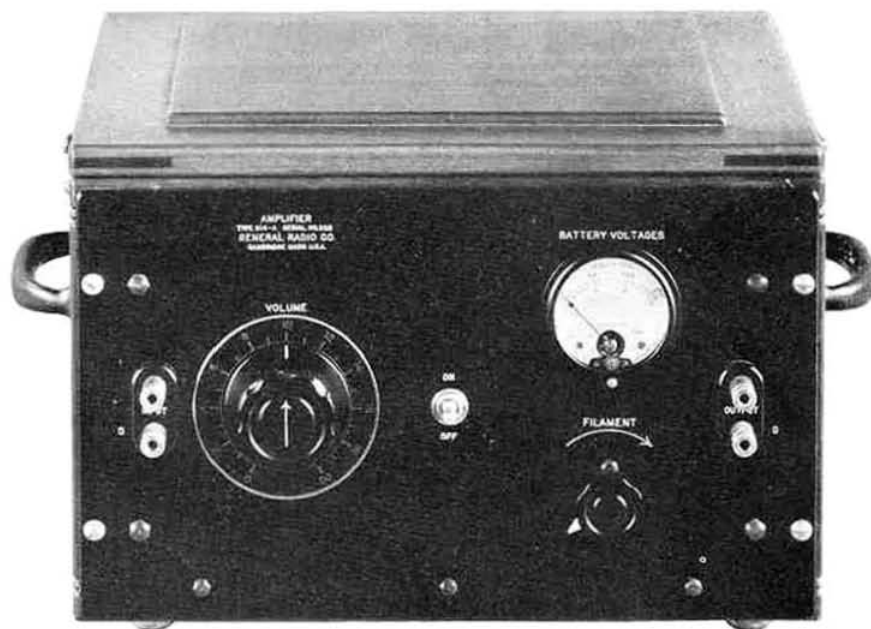

As methods for making electrical measurements at various frequencies increase in accuracy, there has arisen a demand for an amplifier somewhat different in performance from those generally available. For work in connection with precision measurements, such an amplifier must be capable of operating on signals of extremely low intensity and should cover a wide range of frequencies with fairly uniform efficiency. It will be recognized that these operating characteristics are essential where an amplifier is to be used in determining the null point in bridge measurements and in similar work. It is also necessary that the amplification be stable in order that the amplifier may be used for comparison methods. These same requirements must also be met when the amplifier is to be used with photo-electric cells and with microphones.

The TYPE 514-A Amplifier, designed to meet these operating requirements, employs a three-stage resistance-capacitance-coupled circuit operated entirely by dry batteries. The input impedance may be varied to meet external circuit conditions

and may have values sufficiently high to permit the amplifier to be used for observations of voltage across high impedances. The output is designed to work into load impedances of 20,000 ohms. It is, therefore, suitable for use with headphones or with a copper-oxide-rectifier voltmeter. When used with the latter instrument it functions admirably as a high-impedance high-sensitivity voltmeter. By means of a volume control having a numbered scale, it is possible to adjust the sensitivity to some predetermined calibration.

A multi-contact plug receptacle is mounted in such a way that external circuits, such as condenser transmitters, photo-electric cells, and similar devices, together with their associated amplifying tubes, may be connected to the amplifier by means of a single cable. Where such auxiliary equipment is used, the entire power supply may be obtained from the batteries associated with the TYPE 514-A Amplifier through connections to the multi-contact receptacle by means of a TYPE 514-P1 7-Contact Plug Unit.

AMPLIFIERS → → → → → → → → → → → → → → → → → → →

SPECIFICATIONS

Frequency Range: The gain of this amplifier is practically constant over the frequency band between 50 cycles and 50 kc although the actual upper limits are determined to a large extent by the tube and value of load resistance used. More specific data are available on request.

Amplification: With a 230-type tube and an external load of 20,000 ohms the voltage amplification is in excess of 200 to 1. With a 231-type tube and an external load of 5000 ohms the voltage amplification is in excess of 50 to 1. Amplification is adjustable by means of a potentiometer in the grid circuit of the second tube.

Internal Output Circuit: With a 230-type tube 12 volts may be obtained across an external load of 20,000 ohms. With a 231-type tube 15 volts may be obtained across an external load of 5000 ohms.

Input Impedance: One megohm. Interchangeable coupling units may be used to give other values as required. Complete information is given in the instruction book accompanying the instrument.

Tubes: Three 230-type tubes, or two 230-type and one 231-type tubes, are required. Tubes are included in the price of the amplifier.

Power Supply: Two 1.5-volt No. 6 dry cells, three 45-volt block batteries, and one 4.5-volt or one

22.5-volt block battery with tap at 4.5 volts are required for filament-, plate-, and grid-circuit supplies, respectively. The filament-current drain is 180 ma at 2 volts; 250 ma at 2 volts, if the 231-type tube is used. The total plate current is 2.4 ma at 135 volts; or 3.4 ma, if the 231-type tube is used. Batteries are not included in the price of the amplifier.

Mounting: The apparatus is mounted on a metal shelf secured to an aluminum front panel and is entirely enclosed in a metal shield to prevent pickup from associated apparatus.

The unit may be furnished mounted in a walnut cabinet having space for batteries (TYPE 514-AM) or it can be supplied fitted with panel extensions for mounting in a standard 19-inch (TYPE 480) relay rack. The rack-mounting model is known as TYPE 514-AR.

Dimensions: Panel size, (width) 12 x (height) 7 inches. Cabinet size for TYPE 514-AM, (width) 15 x (height) 8 $\frac{1}{4}$ x (depth) 12 $\frac{1}{4}$ inches, over-all. Size for TYPE 514-AR, (width) 19 x (height) 7 x (depth) 6 inches, over-all.

Net Weight: TYPE 514-AM, 15 $\frac{3}{4}$ pounds; TYPE 514-AR, 10 $\frac{1}{2}$ pounds. The necessary batteries weigh approximately 14 $\frac{1}{2}$ pounds.

Type	Description	Code Word	Price
514-AM	Cabinet Mounting.....	ARGUS	
514-AR	For Relay-Rack Mounting	ARMOR	
514-P1	7-Contact Plug Unit	ARRAY	

TYPE 714-A AMPLIFIER

The TYPE 714-A Amplifier is a high-gain, wide-range, a-c operated amplifier designed mainly for use with cathode-ray oscillographs. With its use TYPE 635-B

and TYPE 687-A Cathode-Ray Oscillograph deflection sensitivities become as great as one-hundred inches per volt, without distortion.

SPECIFICATIONS

Gain: 80 db maximum, adjustable continuously between 20 db and 80 db.

Frequency Characteristic: Down 3 db from flat portion at 5 cycles and at 50 kc.

Output Voltage: 140 volts, maximum peak (100 volts rms on sinusoidal wave).

Load Impedance: 100,000 ohms or greater (one terminal grounded).

Input Resistance: Over 1 megohm (one terminal grounded).

Power Supply: Operates from 110-120 volt, 40-60 cycle, a-c mains.

Power Consumption: 25 watts.

Mounting: Supplied with wooden ends which may be removed for relay-rack mounting.

Tubes: Two 6C6-type, one 89-type, and one 80-type tubes are supplied as initial equipment.

Accessories Supplied: Set of tubes, 7-foot power cord, and spare pilot light.

Dimensions: (Length) 19 x (depth) 10 $\frac{1}{2}$ x (height) 7 inches, over-all.

Net Weight: 40 pounds.

Type	Code Word	Price
*714-A	AURAL	

* Not available until May 1st, 1935.

BRIDGES

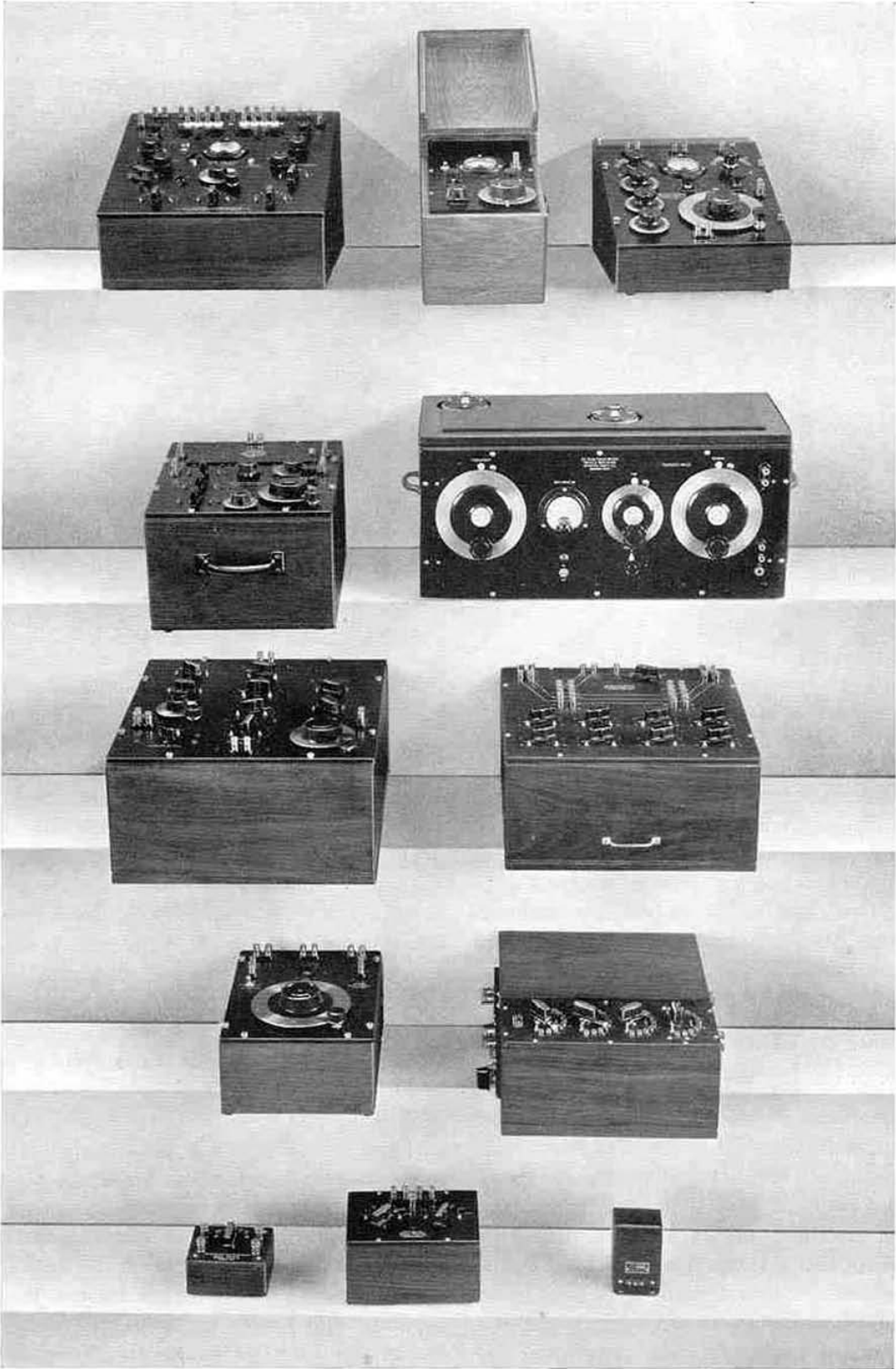

TYPE 650-A IMPEDANCE BRIDGE

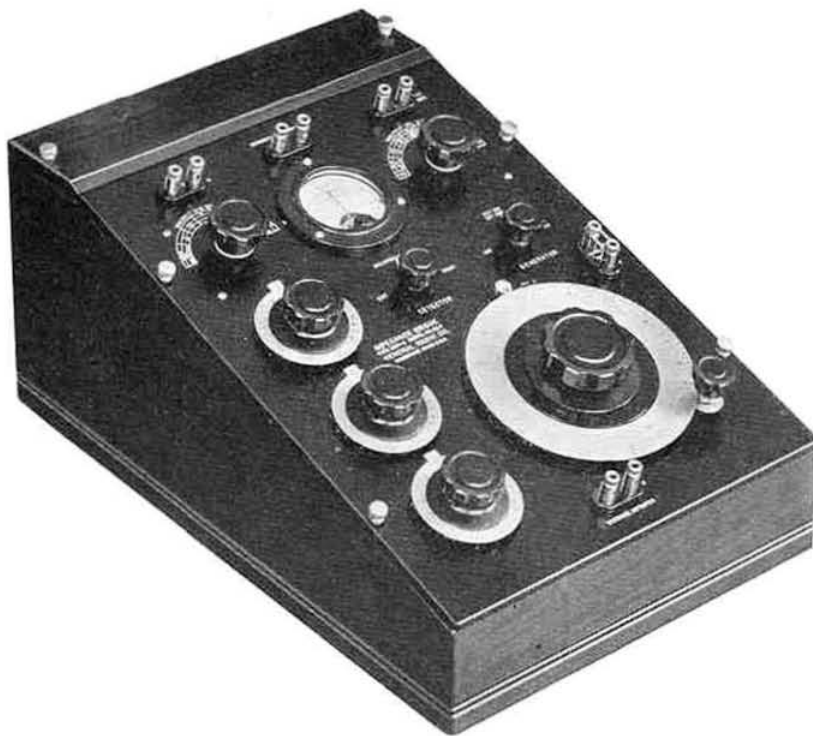

A bridge capable of measuring resistance, inductance, and capacitance over wide ranges and which is always set up and ready for operation is a valuable adjunct in many laboratories.

The TYPE 650-A Impedance Bridge is entirely self-contained, including standard and tone source, and is direct reading over wide ranges of d-c resistance, a-c resistance at 1000 cycles, capacitance and dissipation factor ($\frac{R}{X}$) at 1000 cycles, and inductance and energy factor (Q) at 1000 cycles.

Results are read directly from dials having approximately logarithmic scales. The position of the decimal point and the electrical unit in terms of which the measurement is made are indicated by the positions of two selector switches.

Resistances are measured in terms of a standard resistance arm, reactances are measured in terms of a mica condenser standard, similar in construction to the

TYPE 505 Condensers. The accuracy of calibration of the dial on which inductance, resistance, and capacitance are read is 1 per cent. This dial may be set with a precision of 0.2 per cent. The over-all accuracy of results is 1 per cent for capacitance and resistance, 2 per cent for inductance. The smallest measurable quantities are 1 milliohm, 1 micromicrofarad, and 1 microhenry. Power is supplied from four No. 6 dry cells which operate a 1000-cycle hummer for a-c measurements. The bridge may also be used with an external generator of any audio frequency.

The particular value of this bridge lies in its complete availability and the speed with which it can obtain such information as the inductance and power factor of coils, the range of tuning condensers, the capacity and power factor of filter condensers, and similar information which is often suddenly required in the course of other work.

The simplicity of operation of this bridge can best be judged from an inspection of the panel. The power supply for the self-contained tone source is in the compartment at the rear of the sloping panel. The actual balancing is done on two dials. In impedance measurements the main dial at the right balances for reactance, and one of the three smaller dials at the left balances for resistance. In resistance measurements only the main dial requires adjustment to obtain bridge balance. The two knobs at the top extend the ranges of the balancing dials by the decimal multiplying factors indicated on the engraved sectors. The bridge dials are direct reading, and the balance is indicated by telephones for the 1000-cycle measurements. A galvanometer for d-c balances is included on the panel.

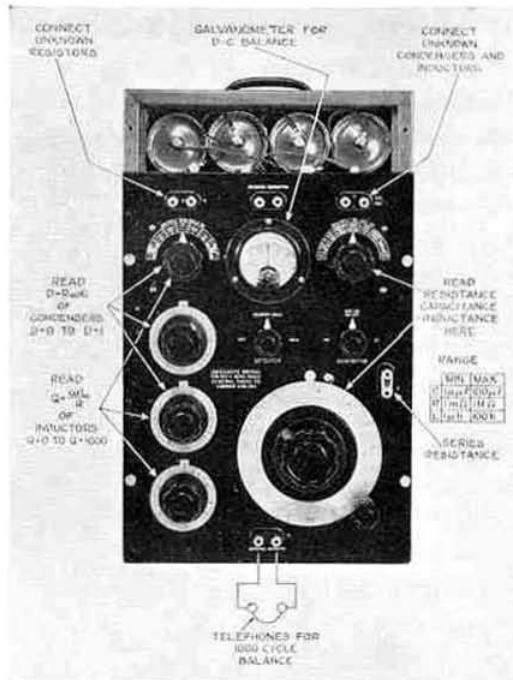

SPECIFICATIONS

Range: The ranges of the instrument are given in the following table. The numerical values are the readings of the calibrated dials multiplied by the settings of the decade selector switches.

	<i>Minimum</i>	<i>Maximum</i>
<i>Resistance</i>	1 milliohm	1 megohm
<i>Capacitance</i>	1 micromicrofarad	100 microfarads
<i>Inductance</i>	1 microhenry	100 henrys
<i>Dissipation Factor</i> ($\frac{R}{X}$)	.002	1
<i>Energy Factor</i> ($\frac{X}{R}$ or Q)	.02	1000

Accuracy: The large direct-reading dial covers two decades, the main decade being spread out over 12 inches (three-quarters of the dial). It may be set to 0.2%.

Accuracy of readings for resistance and capacitance is 1% for the intermediate multiplier decades; for inductance, 2%. The accuracy falls off in the lower ranges because of the extremely small values to be measured. It decreases to 5% for very large values of resistance and capacitance, and to 10% for large values of inductance.

Accuracy of reading for dissipation factor or for energy factor in terms of its reciprocal is either 20% or 0.005, whichever is the larger.

The frequency of the microphone hummer is 1000 cycles to within $\pm 5\%$.

External Generator: Provision has been made for using an external generator, although its capacitance to ground may introduce some error. Subject to this limitation, the frequency may be varied over a wide range from a few cycles to 10 kc. The reading of the main dial is independent of frequency, while the readings of the energy and dissipation factor dials must be multiplied by or divided by the generator frequency in kilocycles to give the correct values. Provision is made for adding external resistance if it is necessary to increase their ranges.

Power Supply: Four No. 6 dry cells for the d-c measurements and for driving the microphone hummer are required, and space for them is provided in the cabinet. Batteries are not supplied with the instrument. A higher d-c voltage may be connected to the bridge for high-resistance measurements.

Mounting: Black crackle-finish aluminum panel mounted in a shielded walnut cabinet.

Dimensions: (Width) 12 x (depth) 20 x (height) 8½ inches, over-all.

Net Weight: 22 pounds without batteries; 30½ pounds with batteries.

<i>Type</i>	<i>Code Word</i>	<i>Price</i>
650-A	BEAST	

TYPE 516-C RADIO-FREQUENCY BRIDGE

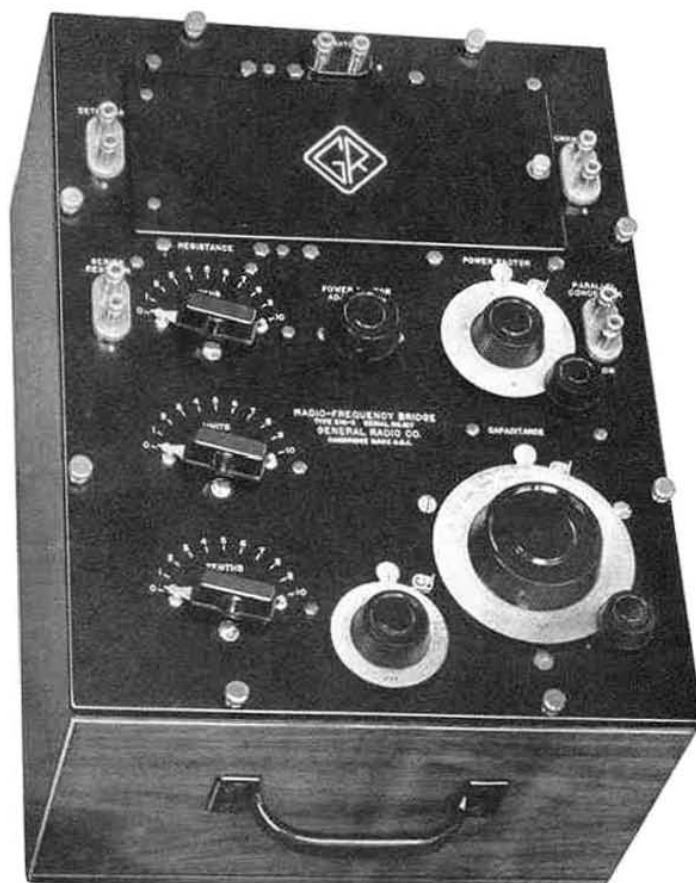

While bridge methods have been standard practice for direct-current and audio-frequency measurements, bridge circuits suitable for use at high frequencies have not been available. Beyond a vaguely defined limit of about 50 kc, volt-ammeter and resonant methods have yielded somewhat ambiguous results, and there has been a need of some more satisfactory measurement means at these frequencies.

The General Radio Company has directed its efforts to this problem for a number of years. The principal problems have involved the elimination of spurious impedances existing between bridge elements and between elements and ground, as well as those inherent in the elements themselves. These sources of error have

been removed one by one, the process involving the gradual improvement of technique, the discovery and the elimination of many sources of error, and the compensation of other sources which could not be entirely eliminated.

This work has produced a commercial type of impedance bridge which extends the familiar and recognized bridge method of impedance measurement to frequencies as high as 5 Mc. This constitutes, we believe, a major accomplishment in the development of measuring methods.

Perhaps the most important single development in connection with the bridge is that of the constant-inductance decade resistor. This device permits compensation of the residual inductance in the resistance

arm by means of a constant inductance in an opposite arm, and results in a resistance arm which can be changed in balancing the bridge without introducing any change in the inductance or capacitance relation.

The TYPE 516-C Bridge is direct reading up to 110 ohms and 1150 $\mu\mu\text{f}$. For the measurement of inductance or of higher values of capacitance, a small fixed condenser may be placed in series with the unknown. When the resistance of the unknown is above 111 ohms a parallel condenser or a combination of series or parallel units can be selected to produce a balance. While in neither of these cases is the bridge direct reading, the necessary calculations are not difficult. The substitution method for capacitance and resistance measurements is recommended where precise results are desired. When the bridge is used as a direct-reading instrument, some accuracy is sacrificed. The over-all accuracy obtainable is, however, extremely good in the range where the bridge is direct reading. Even at frequencies in the vicinity of 5 Mc, the direct-reading accuracy is about 5 per cent. At broadcast frequencies it is about 1 per cent.

A particularly important application of the bridge is in the measurement of antenna characteristics. The bridge method has several advantages over resistance-substitution or resistance-variation methods. These include low power requirements with a general simplicity of the apparatus and procedure. Other types of measurement conveniently made with the bridge include frequency characteristics of radio-frequency coils and chokes, and inductance and power-factor measurements on all classes of impedance at high frequencies.

The accuracy, wide range, and ease of operation of the TYPE 516-C Radio-Frequency Bridge make it the most satisfactory device available for radio-frequency impedance measurement. It should be emphasized, however, that the bridge requires an appreciation of the fundamental problems involved in high-frequency measurement on the part of the user if erroneous results are not to be obtained. In the hands of those possessing experience in the technique of high-frequency measurements, it will fill a long recognized need and will give dependable and accurate results.

SPECIFICATIONS

Capacitance Range: Main dial, 40 $\mu\mu\text{f}$ -1150 $\mu\mu\text{f}$; vernier dial, $\pm 0.1 \mu\mu\text{f}$ - 10 $\mu\mu\text{f}$. The range can be extended indefinitely by using a series condenser.

Resistance Range: 0.1 ohm to 111 ohms. The range can be extended indefinitely by using a known condenser in parallel with the unknown.

Power-Factor Range: 0.005% to 3% at 1 Mc.

Frequency Range: 500 kc to 5000 kc with output transformer furnished. With suitable output transformer (information on request), range can be extended down to include audio frequencies.

Accuracy: As a direct-reading bridge, 1% at 1 Mc. With direct substitution methods, greater accuracy can be obtained.

Accessories Recommended: The bridge is supplied with 100-ohm ratio arms and the .5 Mc to 5 Mc output transformer for the 500-kc to 5000-kc band.

A suitable radio-frequency generator and detector are required. The TYPE 484-A Modulated Oscillator (see page 65) is suggested. As a detector, a radio receiver covering the desired range, or a TYPE 619-C or TYPE 619-D Heterodyne Detector, may be used (see page 48 or Bulletin 10).

Condensers: If measurements outside the direct-reading range of the bridge are to be made, plug-in fixed condensers are required. TYPE 505 Condensers are recommended. A set of four of these with capacitances of 100 $\mu\mu\text{f}$, 200 $\mu\mu\text{f}$, 500 $\mu\mu\text{f}$, and 1000 $\mu\mu\text{f}$, respectively, is adequate for most purposes. (See page 148.)

Dimensions: (Length) 18 x (width) 12 x (height) 8 inches, over-all.

Net Weight: 21 $\frac{3}{4}$ pounds.

<i>Type</i>	<i>Code Word</i>	<i>Price</i>
516-C	BATCH	

TYPE 421-A REACTANCE METER

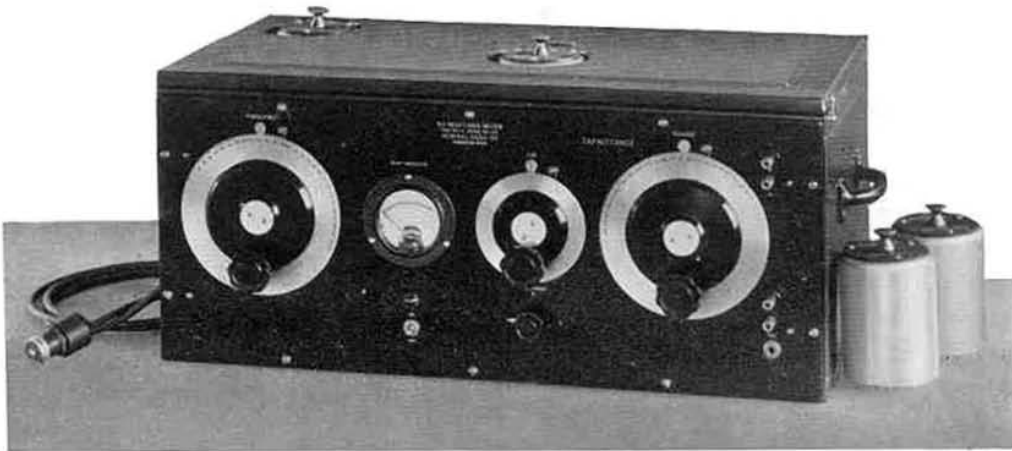

In the General Radio TYPE 421-A Reactance Meter is presented a method for measuring circuit elements at radio frequencies rapidly and accurately. The fundamental design was worked out by the Hazeltine Corporation, and the instrument is manufactured under their patents.

Two important advantages are presented in the measurement of coils and condensers. It is possible to check them at the frequency of use. The check is extremely rapid and, because no power-factor balance is required, needs only a capacitance tuning adjustment.

The reactance meter consists essentially of two radio-frequency oscillators. In operating the instrument both are set to the frequency at which the measurement is to be made, and the unknown reactance is connected across the tuning circuit of one oscillator. This oscillator is then retuned to zero beat with the first oscillator by means of a variable condenser. The condenser dial carries a micromicrofarad calibration. The reading of the dial, if negative, corresponds directly to the capacitance of the unit connected to the instrument. If the reading is positive, an inductance is indicated.

In the matching of coils and checking of inductors against an acceptance standard it is not necessary to convert the reading

of the capacitance dial into inductance units. When this information is required, it can be obtained by a simple formula.

The range of the instrument in frequency and reactance is adequate for receiver-testing requirements. The direct-reading dial on the instrument provides a range of 40 micromicrofarads. For measuring large reactances an additional condenser is provided which has a total capacitance of 2000 micromicrofarads. Reactances as high as 500 micromicrofarads can be read on the dial of this condenser under most conditions. Extremely large capacitances or small inductances can be measured by placing them in series with larger reactances.

Two coils, plugged in directly through the top of the cabinet, are required for each frequency range. Coils are supplied to cover intermediate, broadcast, and high-frequency ranges. Calibrations are furnished for all coils, and important frequencies in the broadcast band are spotted directly on the frequency dial.

A visual beat indicator of the oxide-rectifier type is included on the panel, as are telephone output posts and jack.

Each of the oscillators is provided with a separate pentode amplifier, thus electrically isolating the oscillator circuits, minimizing any tendency of the two oscillators to pull into step as zero beat is approached.

Oscillator and amplifier tubes and coils are individually shielded. The circuit has been designed so that the operation is uniform over a wide range of frequencies, and the readings of the instrument are independent of ordinary line fluctuations.

SPECIFICATIONS

Capacitance Range: Direct reading 0 to 40 micromicrofarads; with calibration chart, approximately 0 to 500 micromicrofarads. This range can be extended by means of an external precision condenser, if desired.

Inductance Range: Inductance range depends upon frequency. It can be calculated for any frequency from the formula $L=1/\omega^2 \Delta C$ where ΔC is the capacitance range and where ω is 2π times the frequency of measurement.

Frequency Range: 125 to 300 kilocycles, 550 to 4000 kilocycles. These ranges are covered with three sets of coils which are supplied.

Accuracy: On direct-reading scale 0.2 micromicrofarads, on 500-micromicrofarad scale 1.5 micromicrofarads.

Calibrations Supplied: A capacity calibration table and curve are supplied for the 2000-micromicrofarad condenser. Frequency calibrations good to 0.5% are supplied for each set of coils.

Power Supply: The instrument is designed for operation from 50- to 60-cycle, 115-volt alternating-current lines. It draws about 30 watts.

Tubes: Four 56-type, two 57-type, and one 80-type tubes are supplied with the instrument.

Mounting: This instrument is assembled on a black crackle-finish aluminum panel and mounted in a shielded walnut cabinet.

Dimensions: Cabinet, (length) $27\frac{1}{2}$ x (depth) 14 x (height) $11\frac{1}{2}$ inches.

Net Weight: $74\frac{3}{4}$ pounds, including tubes, charts, coils, and connecting cord.

<i>Type</i>	<i>Code Word</i>	<i>Price</i>
421-A	MINUS	

TYPE 544-A MEGOHM METER

Convenient portable instruments have not previously been available for the direct measurement of high resistances. The equipment available has involved either a sensitive detector in the form of a wall galvanometer, or a high impressed voltage taken from a hand-cranked generator. The application of vacuum-tube methods to this problem has resulted in a materially simplified device. The TYPE 544-A Megohm Meter consists of a resistance bridge having a vacuum-tube voltmeter as the null detector.

The sensitivity is sufficient so that the indicating meter may be a pointer-type galvanometer. The bridge is balanced by means of a logarithmically tapered rheostat calibrated directly in megohms over two decades from 0.1 megohm to 10 megohms. The larger decade from 1 megohm to 10 megohms covers three-quarters of the dial, or $5\frac{3}{4}$ inches, and

provides approximately constant fractional accuracy of reading. Five multiplying factors (0.1, 1, 10, 100, and 1000) are provided by a switch which varies the resistances in two arms of the bridge in decimal steps. The complete range of the bridge is six decades from 0.01 megohm to 10,000 megohms, with a total scale length of 44 inches.

This range of resistance covers most of the high resistances met with in practice. All grid leaks and coupling resistors for vacuum tubes may be measured. The insulation resistance of all low-voltage electrical apparatus, such as motors, transformers, and heating devices; of sufficiently long lengths of high-voltage cables; of paper condensers; and of slabs of most insulators may be determined. The extremely long scale allows the effects of temperature and humidity on insulating materials to be studied.

SPECIFICATIONS

Range: 10,000 Ω to 10,000 MΩ covered by a dial and 5-position multiplier switch. Resistances up to 100,000 MΩ can be measured by simple, indirect methods.

Accuracy: To within 3% between 10,000 Ω and 100 MΩ and to within 5% between 100 MΩ and 10,000 MΩ.

Dial: The 2-decade dial is individually engraved with an approximately logarithmic scale, thus giving the same precision of setting over the entire range.

Null Indicator: Balance is indicated by the zero-center galvanometer on the panel.

Tubes: One 32-type, supplied with the instrument.



Extraneous Voltages: The megohm meter operates to best advantage on resistors across which there are neither a-c nor d-c voltage drops. The effects of constant amplitude a-c voltages up to about 10 volts, rms, and steady d-c voltages up to about 0.5 volt can be allowed for, but erratic voltage variations and voltages greater than those mentioned above render the instrument inoperative.

Power Supply (Batteries): *Filament*, two No. 6 dry cells. *Plate*, two 45-volt block batteries, Burgess No. 5308 or equivalent. Space for mounting all batteries is provided inside the cabinet. Connections are made by a 7-prong plug and coded cable supplied. Batteries are not supplied with the instrument.

Power Supply (60-cycle ac):

A TYPE 544-P1 Power-Supply Unit that fits the battery compartment can be ordered separately to supply both plate and filament power from a 115-volt line. The one 82-type tube, one 874-type tube, and the line cord required are supplied. *Power Consumption*, about 44 watts. *Dimensions*, 7¾ x 7¾ x 5½ inches. *Net Weight*, 9¼ pounds. (See price list below.)

Mounting: Mounted in shielded oak cabinet.

Dimensions: Cabinet with cover closed, (width) 8½ x (length) 22½ x (height) 8 inches, over-all.

Net Weight: 15¾ pounds without batteries or TYPE 544-P1 Power-Supply Unit; 26½ pounds with batteries; 25 pounds with TYPE 544-P1 Power-Supply Unit.

Type	Description	Code Word	Price
544-A	Megohm Meter	A LOOF	
544-P1	Power-Supply Unit	A LOOFAPACK	

TYPE 293-A UNIVERSAL BRIDGE

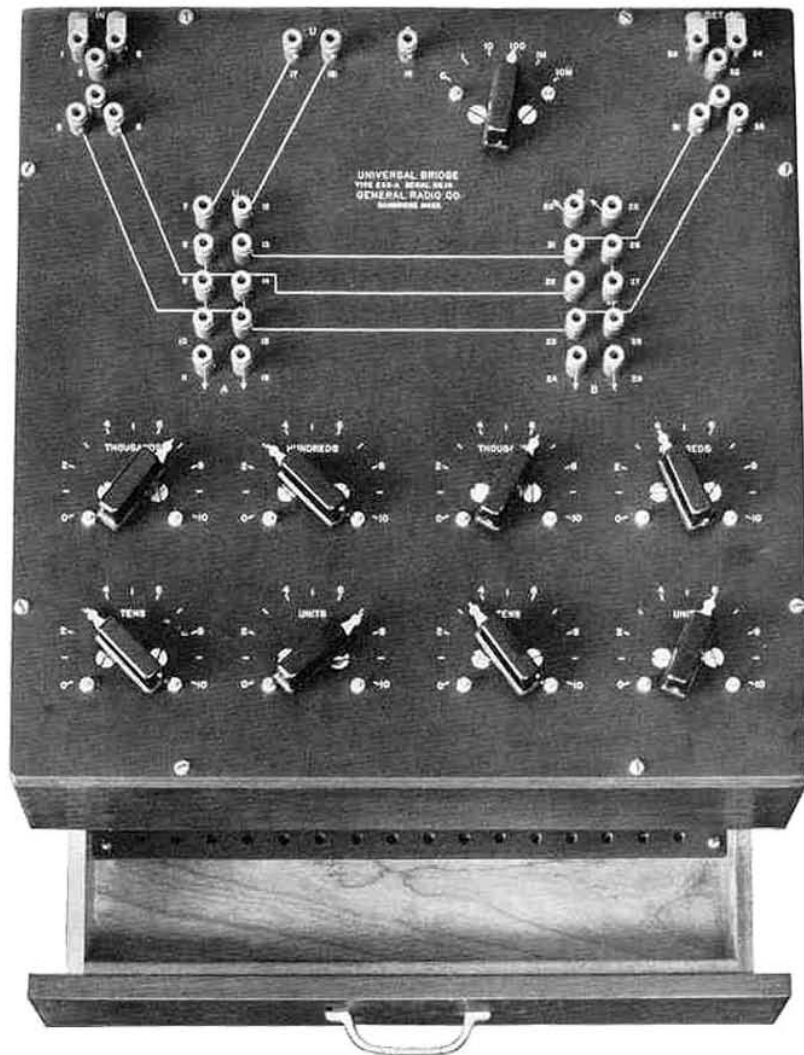

The TYPE 293-A Universal Bridge is designed to present a fundamental circuit which may be connected to produce a wide variety of standard direct- and alternating-current bridges. The instrument consists of three resistance arms and a terminal board by means of which the various circuits can be set up with plugs and jacks. The bridge arrangement permits the measurement of inductance, capacitance, and resistance over a wide frequency range (0-50,000 cycles). It can also be set up as a frequency meter. The instrument has, therefore, a much wider general usefulness

in a college or measurement laboratory than the usual form of permanently connected bridge circuit.

The resistance arms of the bridge consist of two similar arms, each having a total resistance of 11,110 ohms in four decade dials (1, 10, 100, and 1000 ohms), and a third arm having resistances of 1, 10, 100, 1000, and 10,000 ohms.

The bridge elements are shown diagrammatically in the accompanying drawing, which illustrates the points in the circuits where terminals are located. The bridge circuit is shown connected for the

BRIDGES

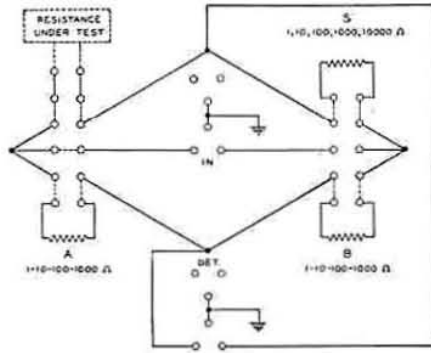

Schematic diagram of a TYPE 293-A Universal Bridge set up for measuring resistance

standard Wheatstone bridge. The dotted lines are connections made by means of the plug connectors on the terminal board.

SPECIFICATIONS

Bridge Arms: The *A* and *B* arms each consist of four decade resistors covering a range of 1 ohm to 11,110 ohms in 1-ohm steps. The *S* arm is a resistor with 1-, 10-, 100-, 1000-, and 10,000-ohm sections. The characteristics are similar to those of the TYPE 602 Decade-Resistance Box.

Accuracy: All resistors are adjusted to within 0.1% of the specified value except the 1-ohm units which are adjusted to within 0.25%.

The absolute accuracy of measurement, of course, will depend upon the accuracy of the standard.

Frequency Range: The bridge can be used at all frequencies from direct current up to 50,000 cycles.

Shielding: The cabinet is copper lined, and the *A*, *B*, and *S* arms are shielded from each other. The panel is shielded over the *A* and *B* arms.

The plugs are arranged in two groups, each group terminating elements of one side of the bridge. The plug arrangement permits the connection of additional elements in series with any of the bridge arms. The input and output (power and null detector) circuits can be brought out directly or through transformers for which plug-in jacks are provided.

When used for resistance measurements no additional standard is required, the *S* arm of the bridge being used as a standard. For inductance and capacitance measurements, an external standard is required. The bridge does not include a null detector or power supply.

Accessories: To facilitate making the connections required by this flexible bridge, there are supplied with each instrument 10 double plugs, 2 double shielded connector cords, and 2 single cords.

For suggestions as to the choice of suitable standards, sources of power, and null indicators, consult the section on bridge accessories, page 87. Shielded input and output transformers and TYPE 293-P3 Slide-Wire Resistors are described below.

Dimensions: Panel, (width) 15½ x (depth) 16¾ inches. Cabinet, (height) 8¾ inches, over-all.

Net Weight: 21½ pounds.

Type	Code Word	Price
293-A	BACON	

TYPE 293-P ACCESSORIES

In using the TYPE 293-A Bridge for alternating-current measurements, shielded input and output transformers are desirable. The following transformers are available and are satisfactory for measurements in the audio-frequency range. Both transformers can be used with either coil as input or output.

When the impedance under measure-

ment is low, it is desirable to extend the range of the bridge arms downward. This may be done by the use of one or two TYPE 293-P3 Slide-Wire Resistors, a shielded resistor calibrated directly and having a range of 0-1.3 ohm. The slide-wire calibration is accurate to 0.02 ohm at any setting. The unit is arranged for plug mounting on the bridge terminal board.

Type	Turns Ratio	Inductance High Side	Frequency Range	Circuit Impedance		Net Weight	Code Word	Price
				High Side	Low Side			
293-P1	3:1	2.5 h	50-5000 cycles	2700 Ω	300 Ω	2 lb.	BADGE	
293-P2	2.55:1	2.5 h	50-5000 cycles	25,000 Ω	4000 Ω	2 lb.	BAFFY	
293-P3	Slide-Wire Resistor, 0-1.3 Ω					8 oz.	BAGGY	

TYPE 667-A INDUCTANCE BRIDGE



The problem of the accurate measurement of small inductors of low Q , such as are used in increasing numbers in modern radio receivers, has not been satisfactorily met by the standard types of bridge circuits which have been available.

Their measurement, when made on the usual type of bridge, is subject to three sources of error: The sliding zero balance occurring when two inductors having energy factors (Q) between 0.1 and 10 are compared, the inductance variation of any decade resistor altered in either arm, and the energy factor of the resistance in any bridge arm because of capacitance in parallel with it.

All inductance bridges have been subject to one or more of these errors, but they have been negligible in measurements of large inductances of relatively small resistance. When dealing with small coils of low Q , however, they may cause errors

of several per cent in the measured result.

In the usual inductance bridge the balances for resistance and inductance are not independent. The final balance point, therefore, is not unique and can be recognized only after comparing a succession of balances, *i.e.*, a sliding zero balance is encountered. In the TYPE 667-A Bridge this difficulty is eliminated by placing a small variable inductor in series with the unknown inductance, thus allowing an inductance balance which is entirely independent of the resistance balance.

A new design of decade resistor has been found to eliminate the effect of reactance changes effected in the course of obtaining the resistance balance of the bridge. In the TYPE 670 Compensated Decade Resistor (described elsewhere in this catalog) inductance compensation is provided so that the resistance increment between dial settings is non-reactive. The



residual inductance of the decade is allowed for by a small change in the standard inductor. The result is a bridge that has independent balance for re-

sistance and inductance, is capable of measuring inductance and resistance of inductors as small as 0.1 microhenry, and which is direct reading.

SPECIFICATIONS

Range: Inductances from 1 microhenry to 1 henry. This inductance may be associated with a value of Q as low as 0.06.

Accuracy of Measurement: Inductances can be measured with an accuracy of 0.2% or 0.1 microhenry, whichever is the larger. For measurements with the multiplier set at "x 1000," the accuracy is 0.4%.

Frequency Range: The frequency range extends from 60 cycles to 10,000 cycles when proper power source and null detector are used.

Ratio Arms: One ratio arm consists of 4 values: 1 ohm, 10 ohms, 100 ohms, or 1000 ohms. The other arm is a continuously adjustable decade resistor of 1111 ohms. The self-contained inductance standard is a 1-millihenry toroid wound on an isolantite form. The resistance standard is a compensated decade resistance with a range of 0 to 111 ohms.

Accuracy of Standards: Resistance standards accurate to 0.05% above 10 ohms, 0.1% on the 1-ohm steps, 0.25% on the 0.1-ohm steps. The inductance standard is adjusted to 0.1%.

Shielding: The cabinet is completely shielded and the bridge arms are shielded from each other. The input and output transformers are completely shielded.

Accessories Required: Power supply—General Radio TYPE 213 Oscillator recommended; amplifier—General Radio TYPE 514-A recommended; headphones.

Mounting: The instrument is supplied in cabinet mounting only.

Dimensions: (Length) $17\frac{1}{2}$ x (width) 16 x (height) $9\frac{1}{2}$ inches.

Net Weight: $30\frac{5}{8}$ pounds.

<i>Type</i>	<i>Code Word</i>	<i>Price</i>
*667-A	AEIRE	

*Not available until June 1, 1935.

TYPE 216 CAPACITY BRIDGE

The precise measurement of small values of capacitance and power factor requires a bridge circuit that is carefully and thoroughly shielded. The TYPE 216 Capacity Bridge is suited for precision measurements of this type at audio frequencies.

This bridge is an equal-arm shielded bridge designed primarily for the measurement of small capacitances over a range of audio frequencies from 200 to 10,000 cycles. The ratio arms are 5000 ohms each. A third resistance variable up to 11,110 ohms by 1-ohm steps may be connected into either of the other two arms, thus providing the resistance adjustment necessary for a complete balance.

This bridge is not self-contained, in the sense that the power source, null indicator, and standards of capacitance must be provided and connected externally.

The ratio arms are made equal within 0.05 per cent. Errors from capacitances to ground of the various arms of the bridge, the power source, and the null indicator are minimized by the symmetry of the bridge and by the use of shielded input and output transformers which are themselves symmetrical with respect to their cores and shields, thus making them astatic to external fields. These transformers are completely shielded from the rest of the bridge, as is also the added resistance. Such precautions enable capacitances placed in adjacent arms to be compared with a maximum error of 0.2 per cent or one micromicrofarad, whichever is the larger.

Using a substitution method in which two capacitances are used alternately in the same arm of the bridge, so that errors

TYPE 561-C VACUUM-TUBE BRIDGE

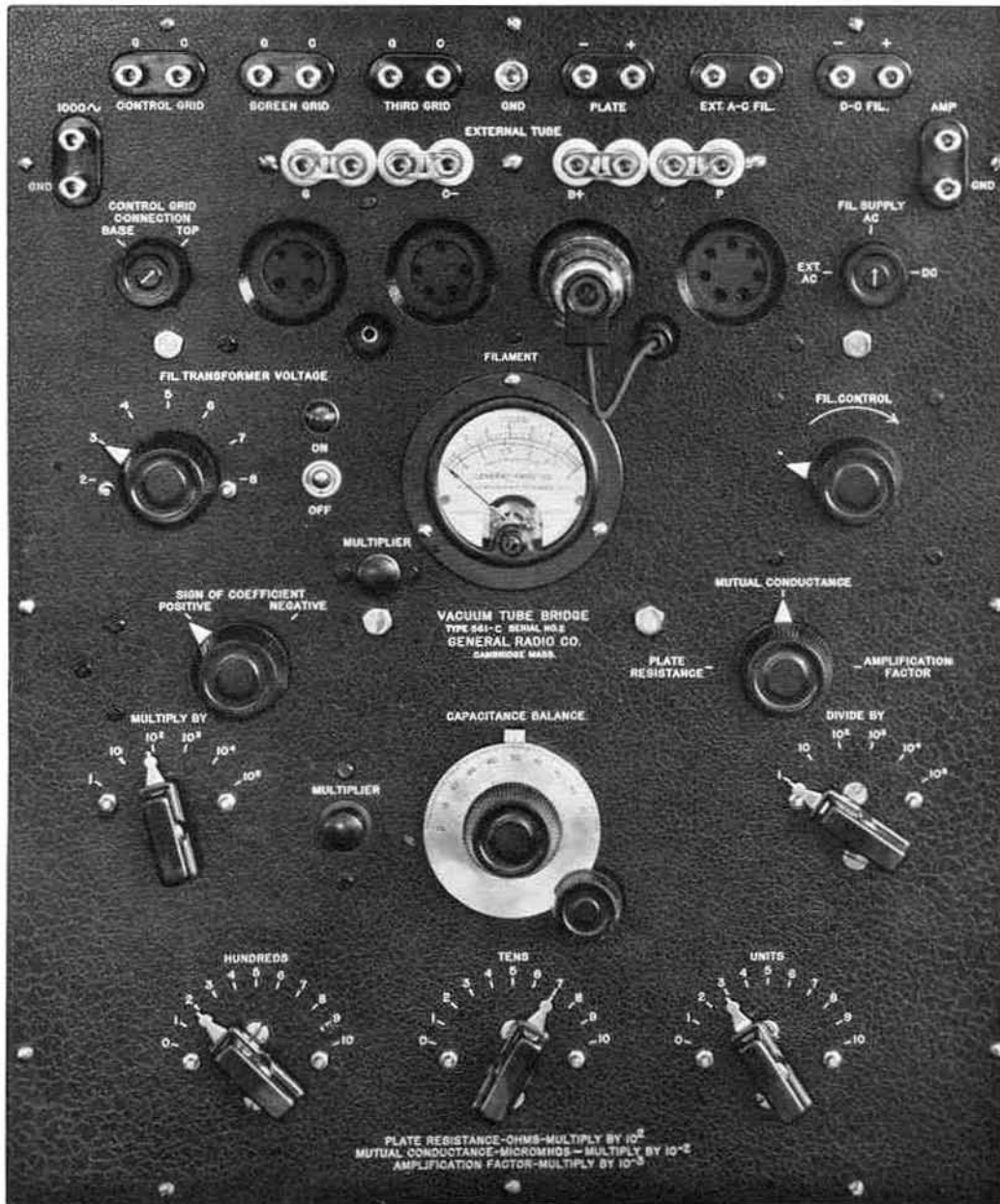

Panel view of a TYPE 561-C Vacuum-Tube Bridge with a 57-type tube in position for measurement

An important group of measurements ordinarily taken by means of bridge methods is that of the dynamic characteristics of vacuum tubes. These parameters, amplification constant, mutual conductance, and plate resistance, change under the influence of electrode potentials, and the manner in which these changes take

place determines the usefulness of the tube for many applications. A knowledge of the behavior of these parameters is of particular importance in the case of the new multiple-element tubes where automatic volume control, silent tuning, and similar devices depend for their effectiveness on tube characteristics. Both the

tube and set manufacturers require a simple and accurate means of obtaining data as to these characteristics.

The procedure in making measurements is simple and straightforward, and is exactly the same for the three coefficients: amplification factor, plate resistance, and transconductance. A three-position switch is turned to whichever quantity is desired, multiplier switches are set at the appropriate value for the tube being tested, and balance is obtained by adjusting a three-decade attenuator and a variable condenser. At balance the decades read directly, to three significant figures, the quantity being measured.

The three main tube parameters are measured independently, *i. e.*, none of the balances depends in any way on any other so that independent cross checks can be obtained from the circuit equations.

Negative values of the tube coefficients may be measured as readily as positive values, except in regions where dynatron oscillations cannot be prevented.

The bridge embodies new measuring

circuits and a more satisfactory method of balancing out the effects of the tube inter-electrode capacitances than has heretofore been available. Not only is the accuracy of the measurement thereby considerably improved, but all three of the usual parameters may be measured independently over a much wider range. For instance, the mutual conductance of a tube having a high value of grid to plate capacitance can be measured without any error from this capacitance.

The measuring circuits and the tube-control circuits may be separated by opening link connectors on the top of the panel. This not only facilitates the testing of tubes associated with other control apparatus, but also makes it possible by changing the cross connections in a very simple manner to measure grid-circuit parameters, or parameters referred to any pair of electrodes.

The tube circuits have large enough current-carrying capacity and sufficient insulation so that low-power transmitting tubes may be tested in addition to receiving tubes.

SPECIFICATIONS

Range: Amplification factor (μ); 0.001 to 10,000.

Dynamic internal plate resistance (r_p); 50 ohms to 20 megohms.

Mutual conductance (s_m); 0.02 to 20,000 micromhos (volts per micro-ampere).

Under proper conditions, the above ranges can be exceeded. The various parameters can also be measured with respect to various elements, such as screen grids, etc. Negative, as well as positive, values can be measured.

Range of Tubes Covered: All standard four-, five-, six-, and seven-prong receiving tubes can be measured on this instrument without the use of adapters, except that five-, six-, or seven-prong tubes not having separate heaters require the use of a single TYPE 561-P1 Universal Adapter furnished with the bridge. A switch is provided for switching the control-grid connection from the base to the cap.

The Universal Adapter supplied permits the testing of tubes with non-standard base connections, while debase or unmounted tubes are connected directly to the panel binding posts for test measurements.

The tube circuits have large enough current-

carrying capacity and sufficient insulation so that low-power transmitting tubes may be tested in addition to receiving tubes. Maximum allowable plate current is 150 milliamperes and maximum plate voltage is 1500 volts.

Filament Supply Circuits: A double-range rectifier-type alternating-current and direct-current filament voltmeter and a source of alternating-current heater power are contained in the instrument. No external filament connections need be made for alternating-current tubes, unless voltage greater than 8 volts or current greater than 3.5 amperes is required. The filament rheostat for direct-current filament supply has a capacity of 750 milliamperes.

When measuring alternating-current heated tubes, the bridge requires connection to a source of 115-volt, 60-cycle alternating current.

Electrode Voltage Supply: Batteries or suitable power supplies are necessary for providing the various voltages required by the tube under test.

Power Supply: A source of 1000 cycles is required. The TYPE 213-B Audio Oscillator is suitable for this purpose.

Null Indicator: A suitable null indicator is required. The TYPE 514-A Amplifier used in conjunction with a sensitive pair of telephones is recommended for this purpose.

Constructional Features: The lower half of the front panel of the instrument contains the special bridge circuit used in measuring the coefficients. The upper half of the panel contains tube sockets, alternating-current filament supply, filament voltmeter, rheostats, terminals for various voltages, and terminals for direct connection of an external tube

to the bridge circuit. This arrangement provides the greatest flexibility for general use.

Mounting: The instrument is mounted on a black crackle lacquered aluminum panel and is furnished in a polished walnut cabinet. A leatherette dust cover is supplied to cover the instrument when not in use.

Dimensions: (Length) 18 $\frac{3}{8}$ inches x (width) 15 $\frac{3}{4}$ inches x (height) 11 inches.

Net Weight: 45 pounds.

Type	Code Word	Price
561-C	BEIGE	

TYPE 229 GALVANOMETER SHUNT



This galvanometer shunt is of the Ayrton-Mather "Universal" type, which provides an amount of shunting (ratio of galvanometer current at any setting to

that at maximum setting) which is independent of the resistance of the galvanometer. For other reasons, however, the shunt must be matched to the galvanometer. The total resistance of the shunt must be large compared to that of the galvanometer, so that the sensitivity of the galvanometer is not appreciably reduced when the shunt is connected and set at unity. This total shunt resistance should be approximately the external critical damping resistance of the galvanometer. Most galvanometers are so designed that both these conditions may be fulfilled. This instrument can also be used as a voltage divider.

SPECIFICATIONS

Total Resistance: See price list.

Shunt Ratios: 0.000; 0.001; 0.01; 0.1; 1.0.

Accuracy of Adjustment: 0.1%.

Type of Winding: Unifilar, manganin wire for all resistances except the 9000-ohm unit of TYPE 229-H which is wound with nichrome wire.

Temperature Coefficient: The temperature coefficient is less than $\pm 0.002\%$ per degree C. except on the nichrome wire card where it is $+0.013\%$ per degree C. at room temperature.

Switch: TYPE 202, 5-points.

Finish: Resistances and terminals mounted on bakelite panel and enclosed in hand-rubbed walnut cabinet. All exposed metal parts (except contact faces) nickel plated.

Dimensions: Panel, 3 $\frac{1}{2}$ x 5 $\frac{1}{2}$ inches; depth, 3 $\frac{1}{2}$ inches.

Net Weight: 1 pound.

Type	Resistance	Code Word	Price
229-L	1000 ohms	GAVOT	
229-H	10,000 ohms	GIANT	

TYPE 625-A BRIDGE

This instrument consists of a skeleton bridge circuit, of which one arm contains a 10,000-ohm direct-reading logarithmic rheostat, and the other three arms are brought out to pairs of terminals on the panel, making provision for plugging in standard and unknown units to obtain a variety of circuits. A 1000-cycle a-c voltage source is contained in the bridge. When assembled with the proper standards this bridge substantially duplicates the TYPE 650-A Impedance Bridge in performance.

SPECIFICATIONS

Range: With the recommended accessories the ranges are: for resistance, 1 milliohm to 1 megohm; for capacitance, 1 micromicrofarad to 100 microfarads; for inductance, 1 microhenry to 100 henrys.

Accuracy: The accuracy of results depends upon the type of standards used. With the accessories recommended, an accuracy of 2% for measurements of resistance, inductance, and capacitance can be obtained. The accuracy of the component parts of the bridge itself is 1%. The frequency of the microphone hummer is 1000 cycles to within $\pm 5\%$.

Accessories Recommended: In addition to head telephones for a-c measurements and a zero-center, 200- μ a, full-scale galvanometer for d-c measurements, purchase of the following units is recommended if the full range is to be covered. Omission of some items is possible if narrower ranges are satisfactory.

Resistors		Condensers	
1—TYPE 500-A	1 Ω	1—TYPE 505-F	0.001 μ f
1—TYPE 500-B	10 Ω	1—TYPE 505-L	0.01 μ f
1—TYPE 500-D	100 Ω	1—TYPE 625-P1	1- μ f
1—TYPE 500-H	1000 Ω	Condenser	
2—TYPE 500-J	10,000 Ω	(Adjusted to within $\pm 2\%$. Dimensions: $2\frac{3}{8}$ x $1\frac{1}{2}$ x $3\frac{1}{8}$ inches, over-all. Net Weight: 4 ounces.)	
1—TYPE 526-B	Mounted Rheostat and Potentiometer required for Dissipation and Energy Factor Measurements.		

Power Supply: Two 4½-volt batteries (Burgess No. 2370, Eveready No. 711, or equivalent) for the d-c measurements, and for driving the microphone



hummer, are required, and space for them is provided in the cabinet. Batteries are not supplied with the instrument. An external a-c voltage source having any frequency up to 5000 cycles may be used.

Mounting: This instrument is assembled on a black crackle-finish aluminum panel and mounted in a shielded walnut cabinet. A drawer in the lower part of the cabinet provides space for storing the standards suggested.

Dimensions: (Width) 9 x (depth) 13 x (height) 7 inches, over-all.

Net Weight: 9 pounds without batteries; 11 pounds with batteries.

Type	Description	Code Word	Price
625-A	Bridge.....	BEACH	
625-P1	1- μ f Condenser.....	BAIZE	

TYPE 610-A RATIO-ARM BOX

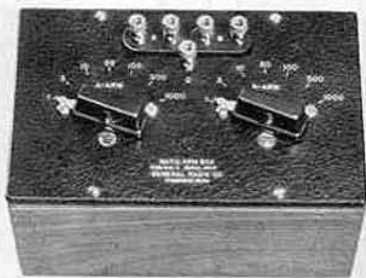

A ratio-arm box is a suitable nucleus around which to design any bridge circuit. It contains a pair of ratio arms giving ratios from 0.001 to 1000 in twelve steps. The switches as well as the individual precision resistance cards used in the ratio-arm box are similar to those employed in the TYPE 602 Decade-Resistance Box. (See description on pages 8 and 9.)

SPECIFICATIONS

Resistances: Each arm, 1, 3, 10, 30, 100, 300, 1000 ohms.
Type of Winding: Ayrton-Perry, manganin wire.
Accuracy: Correct at box terminals to within 0.25% for 1-ohm and 0.1% for other units, respectively.
Switches: TYPE 510-P1, 7-point. Enclosed contacts.
Mounting: Switches and terminals mounted on

black crackle-finish aluminum panel and enclosed in a shielded walnut cabinet.
Terminals: Jack-top binding posts with separate ground terminal.
Dimensions: (Length) 7 $\frac{3}{4}$ x (width) 5 x (height) 5 $\frac{1}{4}$ inches, over-all.
Net Weight: 3 $\frac{5}{8}$ pounds.

Type	Code Word	Price
610-A	RAB10	

TYPE 578-A SHIELDED TRANSFORMER

This is an audio-frequency bridge transformer having two shields, one around each winding. The shields are separated by an air gap.

The primary and secondary windings have less than 0.3 $\mu\mu\text{f}$ direct inter-capacitance and hence will isolate a bridge from changes of electrostatic potential in the generator circuit. At the same time the correct connection of the shields places less than 15 $\mu\mu\text{f}$ across either the unknown

or the standard arm of the bridge in exchange for the large generator-to-ground capacitance that normally exists. A third shield, surrounding the core, effectively grounds each of the core laminations.

The wide frequency range and the fact that the same transformer may be used in either direction adapt this transformer to the requirements of a large proportion of bridge measurements at audio frequencies.

SPECIFICATIONS

Ratio: The transformer has a turns ratio of 4:1. It may be used in either direction.
Frequency and Impedance Range: Within 6 db between 50 and 10,000 cycles when working between low and high impedances of 50 to 5000 ohms and 1000 to 100,000 ohms respectively.
Capacitance: The direct capacitance between primary and secondary windings is less than 0.3 $\mu\mu\text{f}$; that between the primary and secondary shields is less than 30 $\mu\mu\text{f}$.

Shielding: Each winding is separately shielded, and the core is separated from the winding by a third shield.
Mounting: The transformer is mounted in a Model B case (see page 156). The leads are brought out to 6 screw terminals, each winding shield being brought out separately.
Dimensions: See dimensioned drawing, page 157, Model B case.
Net Weight: 2 $\frac{1}{2}$ pounds.

Type	Frequency Range	Code Word	Price
578-A	50 to 10,000 cycles	TABLE	

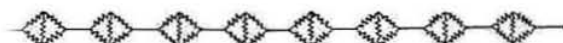

BRIDGE ACCESSORIES

All bridges require for their operation a power source, a null indicator, and comparison standards. Other accessories are transformers for matching the impedances of the power source and null indicator to the bridge, amplifiers, filters, Wagner

ground, galvanometer shunt, and separate ratio arms. These accessories are listed in this section with a brief discussion of their relative merits and a reference to the section where they are fully described.

POWER SOURCES

The TYPE 213 Audio Oscillators are satisfactory as single-frequency power sources. They may be obtained for any 100-cycle multiple in the range from 400 to 1500 cycles. The TYPE 572-B Microphone Hummer has a smaller power output, a higher harmonic content, and is less stable in frequency. It is, however, satisfactory for routine bridge measurements and is used in the TYPE 650-A Impedance Bridge and the TYPE 625-A Bridge.

The TYPE 377-B Low-Frequency Oscillator is satisfactory as a variable-frequency power source.

TYPE 613-B Beat-Frequency Oscillator has a small power output and is not so stable in frequency, but its dial is direct-reading in frequency. The TYPE 713-A Beat-Frequency Oscillator will be found especially convenient because of its large power output, and because it is operated directly from the 115-volt 60-cycle a-c mains. Where the frequency does not need to be continuously adjustable, the use of the TYPE 508-A Oscillator is suggested. It has good waveform, 0.5-watt output, and is alternating-current operated.

<i>Instrument</i>	<i>Frequency</i>	<i>Page</i>	<i>Price</i>
TYPE 213-B Audio Oscillator	1000 cycles	64	
TYPE 213-C Audio Oscillator	400 cycles	64	
TYPE 572-B Microphone Hummer	1000 cycles	152	
TYPE 377-B Low-Frequency Oscillator	25-70,000 cycles	61	
TYPE 508-A Oscillator	{ 200, 300, 400, 600, 800, 1000, 1600, 2000, 3000 and 4000 cycles	63	
TYPE 713-A Beat-Frequency Oscillator	10-16,000 cycles	58	
TYPE 613-B Beat-Frequency Oscillator	10-11,500 cycles	60	

STANDARDS AND BALANCING REACTANCES

The TYPE 602 Decade-Resistance Boxes, TYPE 525 Resistors, TYPE 500 Resistors, TYPE 106 Standard Inductances, TYPE 222 Precision Condensers, TYPE 505 Condensers, and TYPE 509

Standard Condensers may be used as primary standards. The other reactances listed below may be calibrated in terms of these standards or used as balancing reactances in substitution methods.

<i>Instrument</i>	<i>Page</i>	<i>Price</i>
TYPE 602 Decade-Resistance Box	9	
TYPE 500 Resistor	129	
TYPE 525 Resistors	19	
TYPE 106 Standard Inductances	31	
TYPE 107 Variable Inductors	32	
TYPE 219 Decade Condensers	30	
TYPE 222 Precision Condensers	22	
TYPE 246 Condensers	25	
TYPE 505 Condensers	148	
TYPE 509 Standard Condensers	28	

NULL INDICATORS

Head telephones are the most satisfactory null indicators, both because of their great sensitivity and because of the ability of the human ear to discriminate between a fundamental tone, its harmonics, and noise. They are highly selective, with a resonant frequency around 1 kc. This prevents their use below 200-400 cycles. The TYPE 626-A Thermionic Voltmeter may be used over the whole range of audio frequencies for up to perhaps 1500 kc, but is much less sensitive than other null detectors and is not selective. The TYPE 636-A Wave Analyzer is an extremely selective and sensitive null detector for constant-frequency audio signals.

Oxide-rectifier voltmeters may be used as null detectors over the entire audio-frequency range. The TYPE 483-C (20,000 ohm) Output Meter is particularly recommended.

An amplifier is generally needed to increase the sensitivity when using any form of visual null indicator, and the use of an amplifier is advised for precise measurements even when using telephones. The TYPE 514-AM Amplifier has been designed for this purpose. It gives a sensitivity with the TYPE 483-C Output Meter that is about equivalent to that obtainable with telephones without an amplifier.

<i>Instrument</i>	<i>Range</i>	<i>Page</i>	<i>Price</i>
Western Electric Head Telephones (W. E. Type Number 1002-C).....	200 cycles- 10,000 cycles		
TYPE 626-A Vacuum-Tube Voltmeter.....	10 cycles- 1500 kc	118	
TYPE 636-A Wave Analyzer.....	20 cycles- 16,000 cycles	108	
TYPE 483-C Output Meter.....	10 cycles- 10,000 cycles	121	
TYPE 514-AM Amplifier.....	50 cycles- 50,000 cycles	67	

TRANSFORMERS AND FILTER SECTIONS

The TYPE 578-A Shielded Transformer and the TYPE 666-A Variable-Ratio Transformer are specially designed for matching the power source and null detector to a bridge. The TYPE 166 Telephone Transformer is a less expensive variable-ratio transformer of narrower range in both ratio and frequency. The TYPE 585-R Transformer is a unity-ratio transformer designed primarily as a line-isolating transformer, but is suitable for use with many bridges.

TYPE 330 Filter Sections may be connected between the bridge and null detector to suppress harmonics and ground noise. The combination of high- and low-pass sections of suitable cut-off frequencies provides a band-pass filter. The TYPE 534 Band-Pass Filter is a single unit for filtering in either the generator or the null indicator. It is made for 400-cycle and for 1000-cycle operation.

<i>Instrument</i>	<i>Page</i>	<i>Price</i>
TYPE 578-A Shielded Transformer.....	86	
TYPE 166 Telephone Transformer.....	158	
TYPE 666-A Variable-Ratio Transformer.....	158	
TYPE 585-R Transformer.....	158	
TYPE 330 Filter Section.....	116	
TYPE 534 Band-Pass Filter.....	115	

WAGNER GROUNDS

Since a Wagner ground of the resistance type is merely a fixed resistance with a variable tap, the TYPES 471, 314, 371, 214, 410, and 301 Potentiometers may be used as Wagner grounds. With

slight alterations TYPES 334-Z or 335-Z Condensers, having balanced sections, become satisfactory Wagner grounds of the capacitance type.

<i>Instrument</i>	<i>Page</i>	<i>Price</i>
TYPES 471-A and 314-A Rheostat-Potentiometers.....	137	
TYPES 371 and 214-A Rheostat-Potentiometers.....	136	
TYPES 410-A and 301-A Rheostat-Potentiometers.....	139	
TYPES 334-Z and 335-Z Variable-Air Condensers.....	144	

SIGNAL GENERATORS

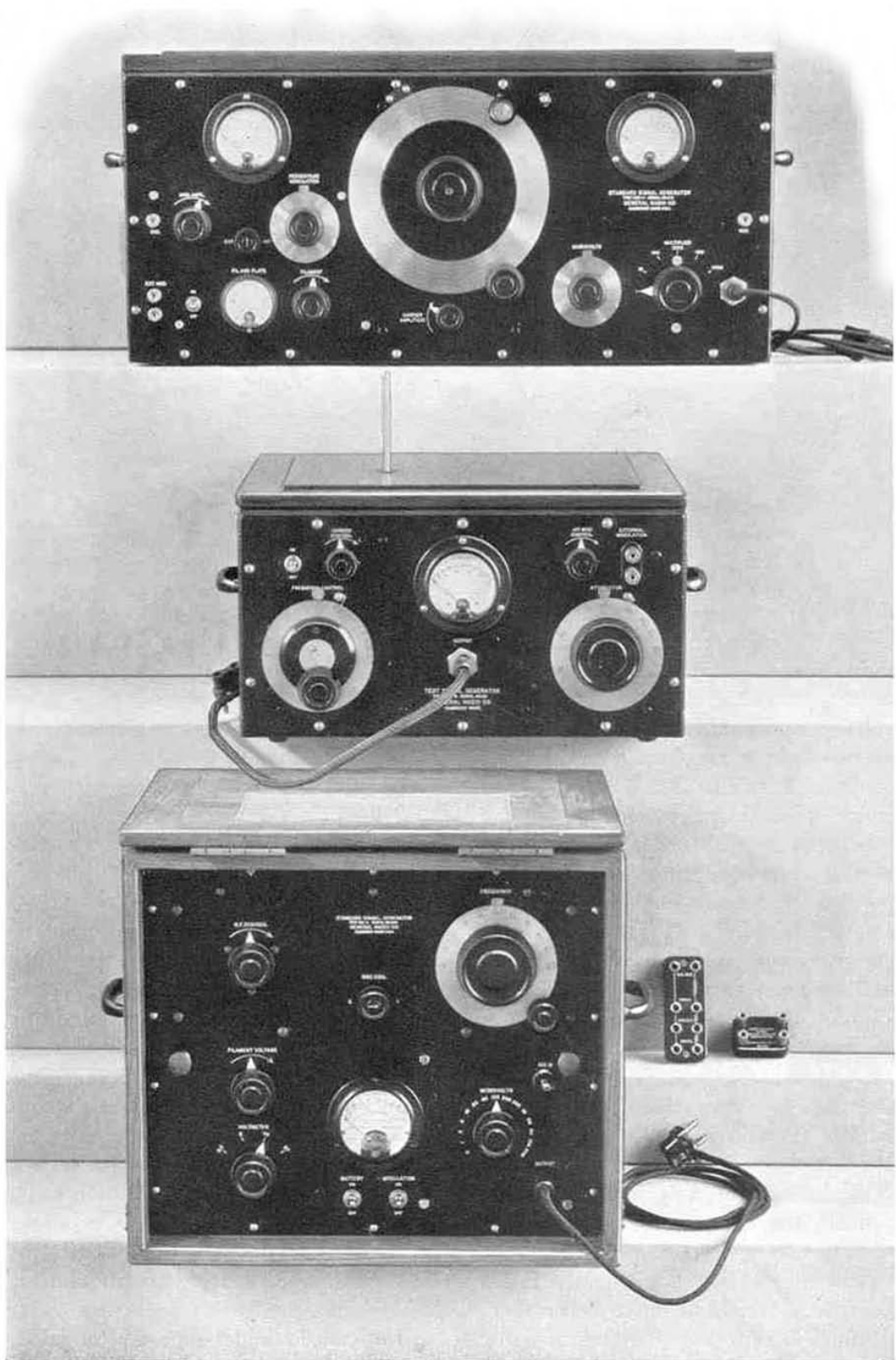

TYPE 603-A STANDARD-SIGNAL GENERATOR

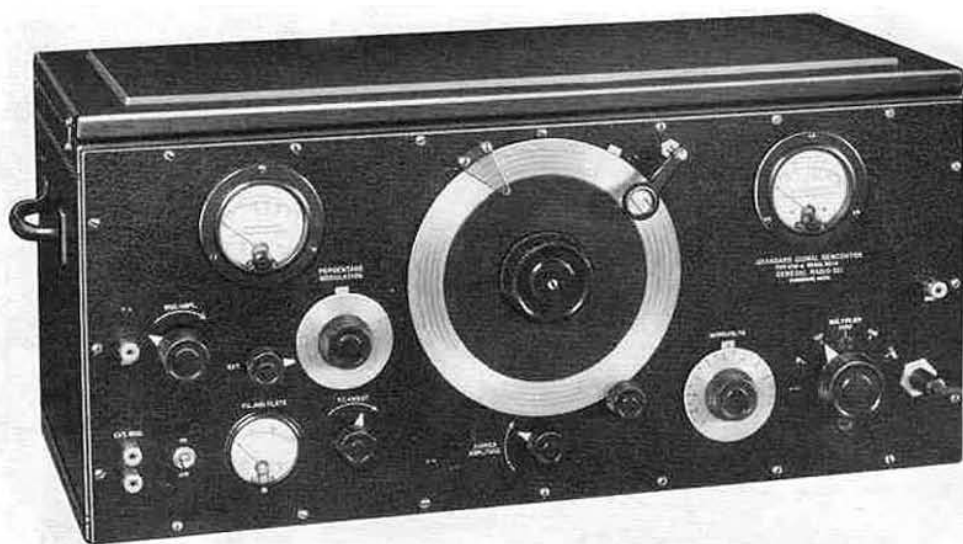

A source of accurately known and modulated radio-frequency voltage is required in many types of radio research work. Such a voltage source should deliver a voltage continuously adjustable over an extremely wide range from a minimum of less than 1 microvolt. It should also provide a continuous indication of the adjustment to the standard output level and should have a minimum number of operations necessary for changes in the frequency range. The TYPE 603-A Signal Generator, with its precision attenuator and its single plug-in coil per range, is presented as a suitable general laboratory instrument for these requirements. It will be found valuable both in the radio receiver development laboratory, in field-strength measurements, and in other general investigations at radio frequencies.

This instrument may be used over a frequency range extending from 100 kilocycles to 25 megacycles. Over this range its performance is well within the limits of accuracy which we have become accustomed to expect from standard-signal generators in the broadcast-frequency range. It is capable of modulation up to

90 per cent at broadcast and higher frequencies. Internal modulation at 400 cycles is provided, and provision is made for external modulation as well.

The TYPE 603-A Standard-Signal Generator is used for the usual fidelity, sensitivity, and selectivity tests on receivers throughout the very wide frequency range for which it is adapted. It is also suitable for field-strength measurements throughout this wide range, since it is semi-portable and can easily be transferred in an automobile.

This standard-signal generator has a number of interesting design features. The shield has been so modified without increase of leakage that it is not necessary to remove any screws in order to change coils. Immediate access to the coil compartment is obtained by raising the lid on the cabinet. Space for the extension coils is also provided inside of the cabinet. Leakage around the lid is avoided by a refrigerator-door type of construction in the shielding.

An advanced ladder-type of attenuator and shield has been evolved. The usual resistance type of attenuator has been



used with a modified construction as made necessary by the much higher frequencies involved. The attenuator is enclosed in a sectionalized shield which makes possible very large attenuations even at frequencies of 25 megacycles without serious errors.

The controls are shown on the front of the panel. Those at the right govern the radio-frequency circuit, those at the left the modulation circuit. The carrier frequency is controlled by a large dial with slow-motion adjustment. This dial carries an accurately engraved scale of 600 divisions, spread around 270° of its circumference. The use of this dial in conjunction with a coil spread of approximately 2 to 1 in frequency makes possible a direct use of the main frequency scale for use in selectivity and band-width determination. Calibration charts are provided, and they are of such size as to be read to the same accuracy as the dial scale.

Two additional convenience features will be noted on this dial: The magnifying glass over the main index greatly assists in setting and reading the scale. The

secondary index, together with the space on the dial rim for extra scales, permits calibration of the instrument at special points to suit the user's requirements.

The carrier-frequency output voltage is controlled by the three adjustments in the lower right section of the panel. The carrier amplitude is adjusted, by means of the middle control, to a reference line on the right-hand meter. Maintaining this adjustment constant, the output is adjusted by means of the slide wire labeled MICROVOLTS and the multiplier. Continuous variation from one volt to $\frac{1}{2}$ microvolt is provided. The output is taken off from the shielded plug terminals in the lower right edge of the cabinet.

The modulation-control system is shown at the left. The meter indicates the modulation voltage and is set by means of the modulation amplitude control to a reference line. Setting the per cent modulation dial then gives the desired modulation percentage. External modulation may be connected at the terminals indicated and controlled in the same manner.

SPECIFICATIONS

Carrier-Frequency Range: Inductors are available for a range of 100 kc to 25,000 kc.

Modulation: An internal removable modulator provides a frequency of 400 cycles. Units for other frequencies can be provided. Modulation characteristics change somewhat over the wide operating range of the instrument. Modulation up to 90% may be obtained under most conditions of operation without exceeding 10% harmonics. Provision is made for external modulation. The input impedance at the external modulation terminals is approximately 5000 ohms, and a power of about 60 milliwatts will modulate the instrument to 30% throughout its range. The TYPE 713-A (a-c operated) Beat-Frequency Oscillator or the TYPE 377-B Low-Frequency Oscillator are suitable sources of modulation voltage. One stage of amplification, using a power tube, is required for high modulation percentages from the latter oscillator. Low modulations are measured by means of a voltmeter in the audio-frequency circuit. High modulation percentages are read on the output meter, using the change in carrier amplitude as a measure of modulation percentage. The accuracy of this measurement is $\pm 10\%$ for modulation fre-

quencies less than 1.5% of the carrier frequency.

Frequency Calibration: Calibration curves are available, accurate to 0.5%. The dial spread and chart interval are such that frequency intervals for selectivity curves may be read directly from the main dial which is provided with a magnifying glass. In the broadcast range intervals of 200 cycles may be set. The dial has 600 divisions.

Output System: The input current to the attenuator is adjusted to a standard value, using a reference line on the radio-frequency current meter. A non-reactive rheostat is used for this adjustment. The attenuator consists of a slide wire at the input end followed by a step-by-step divider. This arrangement permits the use of a sturdy slide-wire construction. The output is continuously adjustable. The output impedance is 10 ohms up to the 10,000-microvolt setting, 37.5 ohms at 10,000, and 220 ohms at the 100,000-microvolt setting.

Output-Voltage Range: The output voltage is continuously adjustable from 0.5 microvolt to 1 volt, except on the P-1 coil, where the usable range is from 1 microvolt to 0.5 volt.

SIGNAL GENERATORS



Output Voltage Accuracy: At broadcast and lower frequencies the error is that involved in meter calibration and adjustment of the cards. This aggregates 3% at 1 microvolt output. There is no frequency error at these frequencies. At 10 megacycles the error at 1 microvolt becomes 10% and at 15 megacycles it is 12%. At 25 megacycles it is 40%.

Frequency Modulation: Frequency modulation is a function of frequency and of the inductor used. In the broadcast band it will not exceed 200 cycles total swing at any point and is less than 50 cycles at the standard test frequencies for 30% modulation. If the TYPE 603-P11 Inductor is used frequency modulation will be about 500 cycles at 1500 kc.

Stray Fields: There is no detectable stray field at a distance of 5 inches from the instrument, even at 25 Mc.

Construction Features: The radio-frequency oscillator is isolated in a shielded compartment. The attenuator is divided into several sections, shielded from each other.

A refrigerator-door type of shielding has been worked out for the shielding about the lid which makes a tight shield without screws. Coils can be changed by simply lifting the cover.

Accessories: The instrument is supplied with calibrated TYPE 603-P5 and TYPE 603-P6 Inductors covering the broadcast band, with a TYPE 418-B and TYPE 418-C Dummy Antenna, with the necessary tubes, but without batteries.

Terminals: The output voltage is brought out through a shielded plug and test lead. Terminals are also provided on the panel for the external modulation source.

Tubes: Two tubes (one 230-type and one 231-type of standard characteristics) are required and are included in the price of the instrument.

Power Supply: Four 45-volt blocks for plate battery and 3 volts for filament are required. Space is provided in the cabinet for two 6-inch dry cells and four 45-volt blocks of the Burgess 5308 size. Batteries are not included in the price.

Mounting: The instrument is enclosed in a completely shielded walnut cabinet with black lacquer aluminum panel.

Dimensions: Cabinet, (height) 12 $\frac{1}{4}$ x (depth) 11 $\frac{3}{4}$ x (length) 29 inches, over-all.

Net Weight: 65 pounds, without batteries.

Type	Frequency Range	Output Range	Code Word	Price
*603-A	100 kc-25,000 kc	0.5 microvolts to 1 volt	EXACT	

*Price includes 2 calibrated inductors for broadcast band (420 kc to 1900 kc).

TYPE 603-P INDUCTORS

These are intended for use with the TYPE 603-A Standard-Signal Generator. We particularly recommend that, if calibrated inductors are required, they be ordered with the standard-signal genera-

tor with which they are to be used. The TYPE 603-P Inductors are stocked without calibration, but a calibration curve can be made to order. The calibration is accurate to plus or minus 0.5 per cent.

Type	Frequency Range	Code Word	Price
*603-P1	15-25 Mc	SIGPARTANT	
*603-P2	10-15 Mc	SIGPARTBIB	
*603-P3	4.4-10 Mc	SIGPARTBOY	
*603-P4	1.9-4.4 Mc	SIGPARTCAT	
*603-P5	850-1900 kc	SIGPARTCUP	
*603-P6	420-850 kc	SIGPARTDOG	
*603-P7	210-420 kc	SIGPARTEYE	
*603-P8	100-210 kc	SIGPARTFLY	
*603-P11	550-1500 kc	SIGPARTGAS	
Frequency Calibration (per Inductor)		CURVE	

*Frequency calibration supplied only when ordered. Use compound code words, SIGPARTANTCURVE, SIGPARTBIBCURVE, etc.

TYPE 601-A STANDARD-SIGNAL GENERATOR



This instrument is designed to provide a generator of radio frequencies for use in the frequency range from 100 kilocycles to 6000 kilocycles, to be easily portable, and to deliver either a modulated or unmodulated signal having an amplitude adjustable from one to 150,000 microvolts.

Since it is often desirable to cover two frequency bands in one instrument without the time delay and inconvenience usually involved in changing inductors, the TYPE 601-A Standard-Signal Generator is provided with internal mountings for two inductors and a convenient switch for transferring from one to the other. Any two inductor combinations may be used; for example, the intermediate-frequency and broadcast bands (150-200 kilocycles and 550-1500 kilocycles), or the broadcast and aircraft bands (550-1500 kilocycles and 1400-4000 kilocycles). All inductors are mounted on plug bases and are easily removable if other combinations are required.

The inductors are toroidal in form, which reduces their external field to a negligible amount, and the whole unit is carefully shielded so that it may be used to test the most sensitive unshielded receivers.

The TYPE 601-A Standard-Signal Generator may be used for making accurate sensitivity tests on all types of receivers, either regenerative or non-regenerative, operating within its frequency range. It may be used for lining and adjustment tests for superheterodyne intermediate-frequency amplifiers. Because of its relatively low price, simplicity of operation, and ruggedness, it is quite suitable for production testing work of radio receivers. The particular value of the TYPE 601-A Standard-Signal Generator is for portable work, such as the periodical testing of receivers already installed on police cars, ships, airplanes, and other places where receivers are apt to get severe usage which may gradually put them out of adjustment.

SIGNAL GENERATORS

SPECIFICATIONS

Carrier-Frequency Range: 100 kc to 6000 kc covered by the use of the six TYPE 601-P Inductors.

Modulation: An internal 400-cycle vacuum-tube oscillator of good waveform, adjusted to give 30% modulation, is provided. Circuit may be adjusted for 50% modulation on special order at no additional charge. External modulation sources cannot be used.

Output System: Input to the attenuator is read by vacuum-tube voltmeter which is calibrated at two points to provide a multiplying factor of 1 or 1.5 for the attenuator reading. The attenuator, which has a resistive ladder structure, is calibrated directly in microvolts. The resistance units are wound on very small, thin, mica cards and have essentially no reactance. The internal resistance of the output circuit is constant at 10 ohms, except at the 10M, 20M, and 100M points, where it is 20, 40, and 200 ohms, respectively.

The attenuator is tapped near the high-potential end for a separate "high output" terminal brought out on the panel above the attenuator control knob.

TYPE 601-A is not recommended for field-strength measurements.

Output Voltage Range: The attenuator is calibrated in the following steps which correspond to a meter setting of 1: 0-1-2-5-10-20-50-100-200-500-1M-2M-5M-10M-20M.

The voltmeter multiplying factor of 1.5 makes available microvolt readings between these points from 1.5 to 30,000 microvolts. The "high output" tap gives an output of 100,000 or 150,000 microvolts depending upon the voltmeter reading. The output of the attenuator when set at zero is never as large as one-tenth of the one-microvolt output.

Output Voltage Accuracy: For outputs below 10 microvolts the calibration is good within 10% from 100 kc to 1500 kc, 20% from 1500 kc to 6000 kc,

between adjacent attenuator ratios. For outputs above 10 microvolts the corresponding figures are 5% and 10%. When no tubes have been changed the instrument will repeat readings to within 1%.

Frequency Modulation: Varies with the inductor and frequency adjustment. It is less at frequencies above 1500 kc. For 30% modulation it is always less than 0.03% at more than half scale on tuning condenser; at highest frequency on any inductor not more than 0.1%. For 50% modulation, figures are proportionally higher.

Terminals: The attenuator output and the "high output" terminals are jacks located behind the panel to which connections are made by means of a shielded plug and test lead.

Tubes: Three 230-type tubes, included in the price of the instrument, are supplied.

Power Supply: From dry batteries placed inside shielded cabinet. For plate, block batteries, 45 and 67.5 volts, 2 ma. For filament, two No. 6 dry cells, 180 ma. Only a 4.5-volt C battery is supplied.

Accessories: A shielded plug and test lead, but no dummy antenna, are furnished as regular equipment. A TYPE 418-B or TYPE 418-C Dummy Antenna must be ordered separately.

Mounting: Aluminum panel, 1/4 inch, finished in black crackle lacquer, mounted in natural-finish oak cabinet, with five-ply veneer hinged oak cover and carrying handles. Panel is slightly recessed into the cabinet for protection.

Dimensions: Panel, (width) 15 x (height) 12 inches. Over-all, (width) 16 x (height) 13 1/2 x (depth) 12 1/2 inches.

Net Weight: 50 1/2 pounds with batteries, 40 pounds without batteries.

Type	Frequency Range	Output Range	Code Word	Price
601-A	100-6000 kc	1-150,000 microvolts	JUROR	

*Inductors must be ordered separately.

TYPE 601-P INDUCTORS

Type	Frequency Range	Code Word	Price
*601-P1	2500-6000 kc	STANSIGTOP	
*601-P2	1400-4000 kc	STANSIGBIB	
*601-P3	550-1500 kc	STANSIGHUM	
*601-P4	200- 550 kc	STANSIGSUN	
*†601-P5	150- 200 kc	STANSIGSIN	
*601-P6	100- 200 kc	STANSIGGAS	
Frequency Calibration, accuracy ±1% (per Inductor)		CURVE	

*Frequency calibrations supplied only when ordered. When ordering calibrated inductors by telegraph, use compound code words, e.g., STANSIGTOPCURVE, etc.

†Has a fixed shunt capacitance in order to spread out the calibration through the superheterodyne intermediate-frequency range.

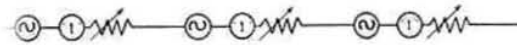

TYPE 604-B TEST-SIGNAL GENERATOR

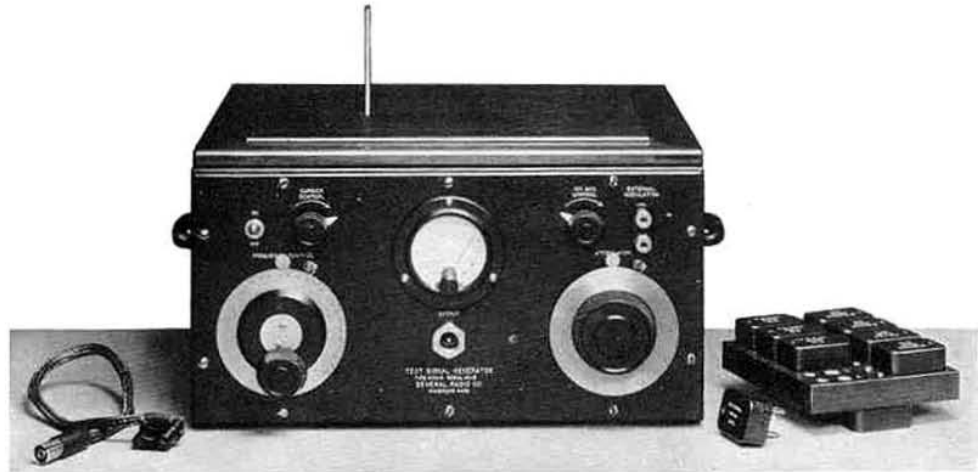

The development of receiving equipment for use in the higher frequency bands has resulted in the need for a suitable source of test voltage at the very high frequencies.

The general considerations surrounding work at these frequencies suggested that an instrument of high precision would not be justified because of the controlling effect of lead impedances and similar factors. It was decided, therefore, to design a rugged instrument of high reliability which would give reproducible results but not necessarily possess a high absolute accuracy, and which would have a low cost.

The TYPE 604-B Test-Signal Generator was designed with these considerations in mind. It operates at frequencies from 3 megacycles (100 meters) to 100 megacycles (3 meters).

The unit consists of the elements which have become familiar in this type of apparatus: a modulated radio-frequency oscillator, a meter for reading the voltage impressed on the attenuator, and an attenuator, in this instance composed of capacitance elements.

Self-modulation at 400 cycles is provided for, as well as external modulation. Provision is made for an unusually high modulation band (200 kc), which makes this signal generator a suitable source for

examination of receivers intended for operation in television systems.

The capacitance attenuator was selected because of its small frequency error and simplicity of construction. It is built in two sections, the first of which reduces the voltage from 10 volts to 1 volt for the rod antenna. The second section delivers an output voltage adjustable between 5 microvolts and 10,000 microvolts which is available at the usual panel-output shielded jack terminal. The rod antenna is sectionalized into such lengths as to produce field strengths in the ratio of 1, 10, and 100. The total antenna length is 15 inches.

The TYPE 604-B Test-Signal Generator is thoroughly shielded, and the stray field is insufficient to affect the accuracy of any measurement on a receiver whose sensitivity lies within the output voltage range of the instrument.

Within the audio-frequency range the percentage modulation is set by the grid-current micro-ammeter. At higher modulating frequencies the voltage applied to the external modulation terminals is to be set to a value to be taken from a calibration chart furnished with the instrument. The normal modulation percentage is 30 per cent. Input impedance of the external modulation terminals is about 5000 ohms at audio frequencies.

SIGNAL GENERATORS

SPECIFICATIONS

Carrier-Frequency Range: 3 Mc to 100 Mc, covered with 13 plug-in inductors supplied with the instrument. Special inductors can be built to order for frequencies as low as 300 kc. Prices on request.

Output: Capacitance-type attenuator furnishes continuously adjustable voltage from 5 to 10,000 microvolts. A rod antenna in three sections provides field strengths in the ratio of 1, 10, and 100. The input to the antenna is constant at 1 volt.

Accuracy of Output Voltage: The accuracy of the voltage at the antenna terminal up to frequencies of 10 megacycles is $\pm 5\%$; up to frequencies of 30 megacycles, $\pm 20\%$. The accuracy of the voltage at the OUTPUT terminal up to 10 megacycles is $\pm 10\%$; up to 30 megacycles, $\pm 30\%$; above 30 Mc, no brief statement as to the voltage accuracy would be useful, since the error introduced by connecting any lead to the output of the generator is much greater than that inherent in the instrument itself.

Modulation: The internal modulating oscillator

is adjusted to 400 cycles ($\pm 5\%$). External modulation circuit passes frequencies up to 200 kc. Input impedance, 5000 ohms. Voltage required, approximately 6 volts for 30% modulation.

Accessories: A shielded connecting cable and 13 inductors with storage rack are provided, as well as an antenna which is in three sections.

Tubes: Two 31-type tubes are supplied.

Power Supply: Two No. 6 dry cells and four 45-volt Burgess No. 5308 batteries or equivalent. Batteries are not supplied with the instrument.

Mounting: The unit is mounted on a black crackle aluminum panel and placed in a shielded walnut cabinet. Space has been provided inside the cabinet for batteries and inductor storage rack.

Dimensions: (Width) $18\frac{3}{4}$ x (height) 9 x (depth) $16\frac{1}{2}$ inches.

Net Weight: 42 pounds, without batteries; $57\frac{1}{4}$ pounds, with batteries.

Type	Code Word	Price
*604-B	DENSE	
Frequency Calibration (per Inductor)		

*Frequency calibrations supplied only when specifically ordered with the instrument. Use code word DENSECURVE when the entire set of 13 inductors is to be calibrated.

TYPE 418 DUMMY ANTENNA



TYPE 418-C



TYPE 418-B

Tests on radio receivers with the standard-signal generator require the use of a dummy antenna connected between the generator and the receiver under test. The two dummy antennas listed here are made in accordance with the specifications of the Institute of Radio Engineers.

TYPE 418-B is for work in the broadcast range (550 kc to 1500 kc). The effective height is taken as 4 meters. TYPE 418-C is designed for work above 1500 kc.

SPECIFICATIONS

Resistance: TYPE 418-B, 15 ohms; TYPE 418-C, 390 ohms, tapped at 362.5 and 280 ohms. These values give the specified circuit impedance of 25 ohms and 400 ohms when used with General Radio standard signal generators.

Reactance: TYPE 418-B, 20 μ h inductance, 200 μ mf capacitance; TYPE 418-C, none.

Mounting: Both types are mounted in moulded bakelite cases with jack terminals to take TYPE 274-M Plugs. See illustration.

Dimensions: TYPE 418-B, (length) $2\frac{1}{8}$ x (width) $1\frac{3}{8}$ x (height) 2 inches, over-all.

TYPE 418-C, (length) $3\frac{3}{4}$ x (width) $1\frac{1}{2}$ x (height) $\frac{3}{4}$ inches, over-all.

Net Weight: TYPE 418-B, 4 ounces; TYPE 418-C, 2 ounces.

Type	Code Word	Price
418-B	EPHOD	
418-C	DEUCE	

WAVEFORM

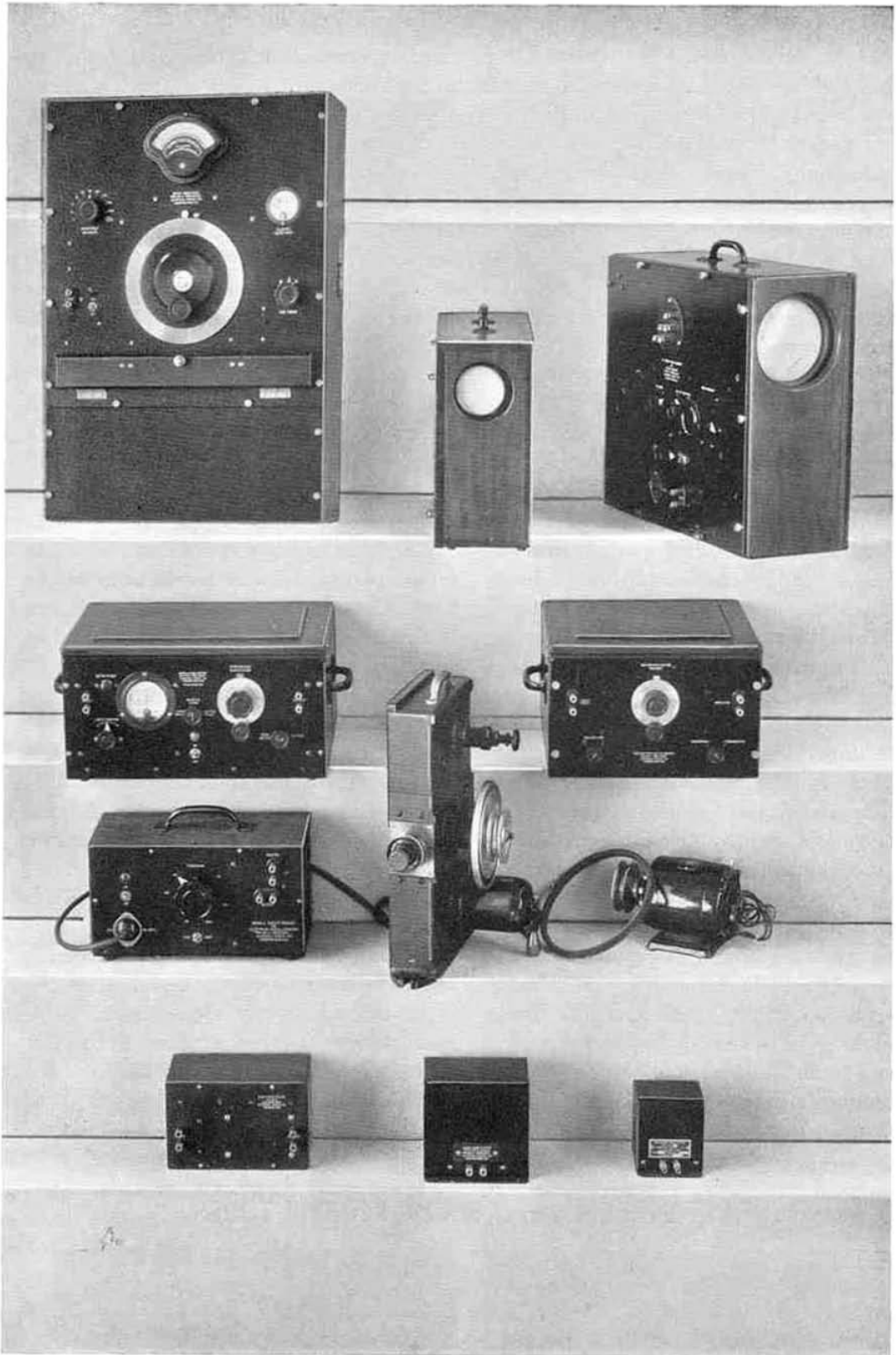

CATHODE-RAY OSCILLOGRAPHS

Many developments in cathode-ray tubes and associated equipment in recent years have resulted in making this instrument generally available for all types of oscillography. Tubes of greatly increased life are available at low cost, and accessory equipment has been greatly simplified.

The cathode-ray type of oscillograph is characterized by a high input impedance and wide frequency range. The observed trace is formed by directing an electron stream against a screen which becomes luminescent under electron bombardment. The stream can be deflected from its course either by an electrostatic or by an electromagnetic field, and in a practical oscillograph provision is made for such deflection in horizontal and vertical directions. Under combined fields the beam will trace an irregular pattern which will indicate the relative field strengths.

The moving element, *i.e.*, the electron beam, is of small mass and can, therefore, be made to follow very rapid variations. The upper frequency limit of the oscillograph is, in fact, determined by such factors as length of leads external to the tube rather than by any inherent limitations of the tube itself. Moreover, because of the very small amount of power required for the deflection of the beam, a high input impedance may be obtained. The electrostatic deflection type of cathode-ray oscillograph (all General Radio models are of this type) may be connected across practically any electrical circuit without altering its impedance. Previously

existing current and voltage relationships are not disturbed, and hence each is shown on the screen in its normal state.

Several types of luminescent screens have been developed, and two are commonly used. These differ in the persistence of the pattern after the beam has passed and in actinic quality. Tubes having low persistence and a color characteristic best adapted for photography are normally supplied with General Radio electron oscillographs. These tubes are suitable for the photography of rapid transients with a moving-film camera. When specified, a type of tube having longer persistence of pattern, suitable where identical patterns are repeated, can be supplied.

The effect of screen persistence is shown in the photographs at the bottom of the page. The relative photographic brilliance of the two types of screen is illustrated in the specifications for each oscillograph.

Where it is desired to study the time-amplitude characteristic of a variable field with the cathode-ray tube, a convenient means of producing a time displacement or time axis is required. This apparatus has either been developed in a separate portable form or has been incorporated into the oscillograph. Each oscillograph contains the necessary filament and high-potential power sources.

The following sections describe several types of cathode-ray oscillograph equipment which have been planned to offer wide differences in apparatus to meet varying requirements.

FAST-SCREEN versus SLOW-SCREEN TUBES

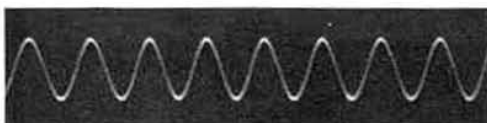

Spread-out traces from a 60-cycle voltage obtained by swinging the camera on a pivot. Fast-screen tube on the left, slow-screen tube on the right. Note the absence of blur in the fast-screen trace

TYPE 687-A ELECTRON OSCILLOGRAPH AND BEDELL SWEEP CIRCUIT

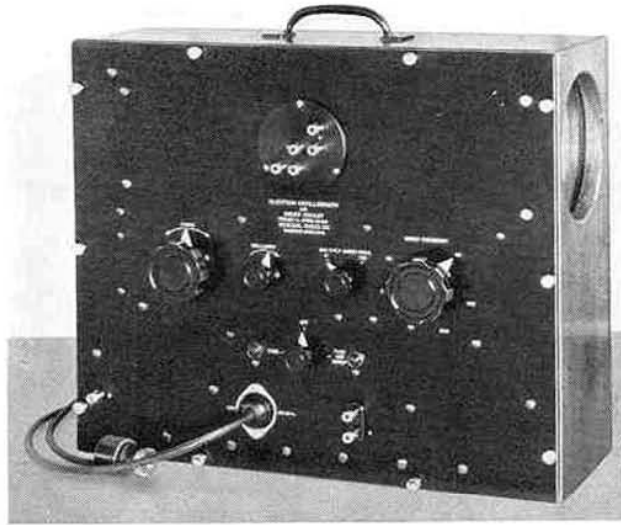

The TYPE 687-A Electron Oscilloscope is designed to present in a simple, portable, and inexpensive form all of the elements required for using the cathode-ray tube as an oscilloscope. The unit includes a power supply providing for all voltage requirements as well as a sweep circuit which furnishes a saw-tooth deflecting voltage.

This instrument will be found to meet the great majority of requirements for a general-purpose oscilloscope. It can be used in the examination of all types of waveform. In this application the sweep circuit is connected to the horizontal plates and performs the function of the revolving mirror in the mechanical type of oscilloscope. The equipment is as convenient to use as a voltmeter. It requires only connection to the line and to the source of voltage which is being examined.

This General Radio cathode-ray oscilloscope has two particular advantages. The internal sweep circuit is of the self-synchronizing type, that is, it will lock in step with a recurrent waveform of any audio frequency. The steady screen pattern so obtained is invaluable in careful visual study, measurement, and photography of complex waveforms with simple camera equipment.

The short, direct leads from the deflecting-plate cap terminals to the panel remove the normal frequency limitations and make the oscilloscope ideal for measurements up to 130 megacycles (2.3 meters). These accessible panel terminals permit the operation of either or both pairs of plates balanced or unbalanced to ground.

As a radio-frequency voltmeter the deflection sensitivity is constant over the same wide frequency range, making the oscilloscope ideally suited for modulation measurements. If the linear sweep circuit is used, a continuous check upon modulation is provided, since a single glance at the modulation-envelope pattern will show whether or not over-modulation is taking place. With the modulating voltage applied to the horizontal plates, the familiar trapezoidal modulation patterns are obtained on which accurate measurements may be made for steady state conditions.

The power supply is designed to provide all necessary voltages for the cathode-ray tube which is provided as initial equipment. Mechanically, the equipment is assembled in a carrying case of convenient dimensions with a handle, making it easily portable.

SPECIFICATIONS

Tube: All tube specifications are the manufacturers' latest published data.

Spot Intensity: A so-called fast-screen tube (TYPE 687-P2) will be furnished unless otherwise specified. This type of screen is recommended for photography and is essential when rapid transients are involved. The figures below show the relative photographic brilliancy of the two types. Length of trace, sweep frequency, shutter speed, and emulsion are identical for each trace.

TYPE 687-P1 Slow-Screen Tube

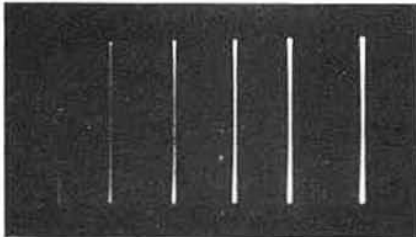

TYPE 687-P2 Fast-Screen Tube

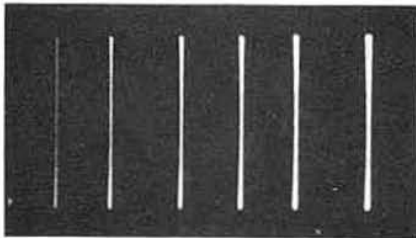

$f/22$ $f/16$ $f/11$ $f/8$ $f/5.6$ $f/4.5$
Lens Aperture

Maximum Spot Speed: With TYPE 687-P1, 6400 inches per second; with TYPE 687-P2, 16,500 inches per second.*

Screen Diameter: 5 inches.

Voltage Sensitivity: 75 volts per inch (vertical), 90 volts per inch (horizontal).

Impedance of Deflecting Plates: Capacitance is approximately 15 micromicrofarads between deflection terminals (measured at the instrument panel).

Frequency Characteristic: The circuits of the deflecting plates show no frequency effects below 130 megacycles.

Power Supply: All voltages necessary are obtained from the self-contained power supply. These are *Anode Voltage*, 1500 volts; *Focusing Anode Voltage*, 0 to 400 volts, positive; *Grid*, 0 to -40 volts; *Heater Voltage*, 2.5 volts; *Heater Current*, 2.1 amperes. The power supply operates from the 115-volt, 50-60 cycle, a-c line. It draws 50 watts when the sweep circuit is operating and 20 watts when the sweep circuit is not operating.

Terminals: Jack-top binding posts, mounted on the panel of the oscillograph as shown in the illustration.

Tubes Required: The following tubes are required and are supplied as initial equipment: one 80-type, one 885-type, one 58-type, one General Radio TYPE 143-D, and one General Radio TYPE 687-P2.

Sweep Circuit: Self-contained Bedell Sweep Circuit range: 30 to 3000 sweeps per second, permitting observation of frequencies up to 21,000 cycles. Sweep is stabilized, requiring a control voltage of 5 to 100 volts r.m.s. Impedance of the control circuit is about 200,000 ohms.

Mounting: The instrument is mounted in a walnut case with carrying handle. There is an opening for the tube screen at one end of the case. The control panel is situated at the side.

Dimensions: (Length) $19\frac{5}{8}$ x (width) $8\frac{1}{4}$ x (height) $17\frac{3}{4}$ inches, over-all.

Net Weight: $37\frac{1}{4}$ pounds.

Type	Code Word	Price
687-A	CRISP	

*These values are maximum workable spot speeds S for Verichrome film, on the basis of a hypothetical aperture $f/1.0$ and with the screen at infinite distance from the lens. The maximum speed S' for any other aperture f/N and a ratio k between length of trace on screen and on the camera plate is:

$$S' = \frac{S}{N^2 \left(\frac{1+k}{k} \right)^2}$$

REPLACEMENT TUBES

Type	Description	Code Word	Price
687-P1	Slow-Screen Tube	ACCESSOBY	
687-P2	Fast-Screen Tube	ACCESSOCAT	
143-D	Rectifier Tube	FAIRY	

TYPE 635-B ELECTRON OSCILLOGRAPH



The TYPE 635-B Electron Oscillograph is presented in an effort to reduce the cathode-ray oscillograph to its lowest terms in simplicity of operation and price. Like the TYPE 687-A Electron Oscillograph and Bedell Sweep Circuit, the instrument is a complete portable unit, but it does not include a sweep circuit.

The smaller instrument makes use of a 3-inch tube. Tube mounting and power-supply unit are combined in one case. Access to the tube may be obtained by removing four thumb screws. Terminals for the deflecting plates are brought out to the panel, as is a focusing control. The anode voltage remains fixed at 1000 volts.

SPECIFICATIONS

Tube: All tube specifications are the manufacturers' latest published data.

Spot Intensity: A so-called fast-screen tube (TYPE 635-P3) will be furnished unless otherwise specified. This type of screen is recommended for photography and is essential when rapid transients are involved. The figures (right) show the relative photographic brilliancy of the two types. Length of trace, sweep frequency, shutter speed, and emulsion are identical for each trace.

Voltage Sensitivity: Approximately 75 volts per inch for horizontal deflecting plates and 100 volts per inch for the vertical deflecting plates.

Frequency Characteristics: Because the leads from the deflecting plates are not brought out separately but are brought out together through the base of the tube, inter-action between these circuits results at high radio frequencies, causing an error in amplitude and phase. The actual resonant frequency of either deflecting plate circuit is in the neighborhood of 45 megacycles.

TYPE 635-P2 Slow-Screen Tube



TYPE 635-P3 Fast-Screen Tube

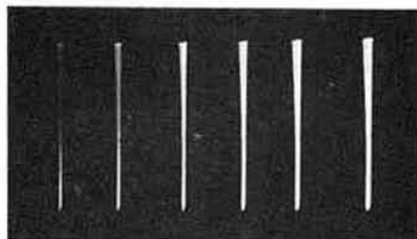

f/22 f/16 f/11 f/8 f/5.6 f/4.5
Lens Aperture

WAVEFORM

Maximum Spot Speed: With TYPE 635-P2, 4100 inches per second; with TYPE 635-P3, 11,000 inches per second.*

Screen Diameter: 3 inches.

Impedance of Deflecting Plates: Capacitance is 35 μf to 45 μf between panel terminals.

Tubes Supplied: One General Radio TYPE 143-D and one General Radio TYPE 635-P3.

Power Supply: All of the voltages necessary are obtained from the self-contained power supply operating from the 115-volt, 40-60 cycle, a-c line. *Anode Voltage*, fixed at 1000 volts. *Focusing Voltage*, adjustable between 0 and 300 volts either positive or negative by reversing connections. *Cathode-heater*

supply, maximum of 2.5 volts or 2.2 amperes, ac. Adjusted by means of a rheostat inside the cabinet. Supplied complete with ON-OFF switch and 7-foot attachment cord.

Terminals: Jack-top binding posts, mounted on the panel of the oscillograph as shown in the illustration.

Power Consumption: 25 watts.

Mounting: The instrument is mounted in a walnut case with carrying handle. There is an opening for the tube screen at one end of the case. The control panel is situated at the side.

Dimensions: (Height) 13½ x (width) 16 x (depth) 6¼ inches, over-all.

Net Weight: 19¼ pounds, including tubes.

Type	Code Word	Price
635-B	CUPID	

*These values are maximum workable spot speeds S for Verichrome film, on the basis of a hypothetical aperture $f/1.0$ and with the screen at infinite distance from the lens. The maximum speed S' for any other aperture f/N and a ratio k between length of trace on screen and on the camera plate is:

$$S' = \frac{S}{N^2 \left(\frac{1+k}{k} \right)^2}$$

REPLACEMENT TUBES

Type	Description	Code Word	Price
635-P2	Slow-Screen Tube	CUMIN	
635-P3	Fast-Screen Tube	CUDDY	
143-D	Rectifier Tube	FAIRY	

OSCILLOGRAPH AMPLIFIER (TYPE 714-A)

See page 68 for specifications

IN many applications it is found desirable to increase the voltage under observation before applying it to the deflecting plates of an electron oscillograph. The amplifier used for this purpose must be of high input impedance and excellent frequency characteristic if the advantages of the electron type of oscillograph are not to be sacrificed.

The TYPE 714-A Amplifier has been designed for use with the TYPES 687-A and 635-B Electron Oscillographs.

- Sensitivity of combination, 100 inches per volt
- Range, 5 cycles to 50 kilocycles

TYPE 655-A BEDELL SWEEP CIRCUIT



Oscillographic equipment which does not have a built-in sweep circuit will usually require an external sweep circuit as an accessory for many types of work. The sweep circuit performs the function of spreading out the pattern resulting from a periodic voltage on one pair of plates (which would appear as a straight line were the sweep circuit not used). This is the function performed by the revolving mirror in mechanical types of oscillograph.

In the design of the TYPE 655-A Bedell Sweep Circuit, simplicity and low cost have been the paramount considerations, yet an instrument has resulted which includes all the necessary adjustments for a flexible, general-purpose sweep circuit.

The length of sweep has been made fixed and is adapted to a 3-inch oscillograph tube. The only adjustable element in the sweep circuit is frequency, which may be adjusted for the examination of waveforms of fundamental frequencies as high as 21,000 cycles.

Provision is made for controlling the sweep frequency by means of a control voltage introduced from the voltage source being examined. This results in a stabilized pattern even when the observed voltage is shifting somewhat in frequency. This feature is of great value since it facilitates the visual examination of waveforms and also permits the photography of repeating cycles with ordinary cameras.

SPECIFICATIONS

Sweep Frequency: The sweep frequency may be adjusted over a range of 30 to 3000 cycles, permitting observation of frequencies up to 21,000 cycles. Lower sweep frequencies can be obtained by use of an external condenser.

Sweep Voltage: The sweep voltage is fixed at 140 volts.

Frequency Stabilization: The sweep frequency can be stabilized at the frequency of the voltage being studied by the introduction of a stabilizing potential of 5 to 100 volts on the binding posts marked "CONTROL."

Controls: A single control is provided for the sweep frequency. This is supplemented by a two-position multiplier switch.

Tubes: One each of TYPES 885, 58, and 80 Tubes are required. The initial equipment of tubes is

supplied with the instrument and is included in the price.

Power Supply: The Bedell Sweep Circuit is designed for operation from 110- to 120-volt, 50- to 60-cycle supply. It draws about 25 watts.

Accessories: A 7-foot connector cord and pilot lamp are provided.

Mounting: The instrument is mounted in a walnut cabinet with black crackle-finish panel.

Dimensions: (Length) 12½ x (height) 8½ x (depth) 7½ inches.

Net Weight: 11 pounds.

Type	Description	Code Word	Price
655-A	Cabinet Mounting	CROOK	

CLASS 651 CAMERA ASSEMBLIES

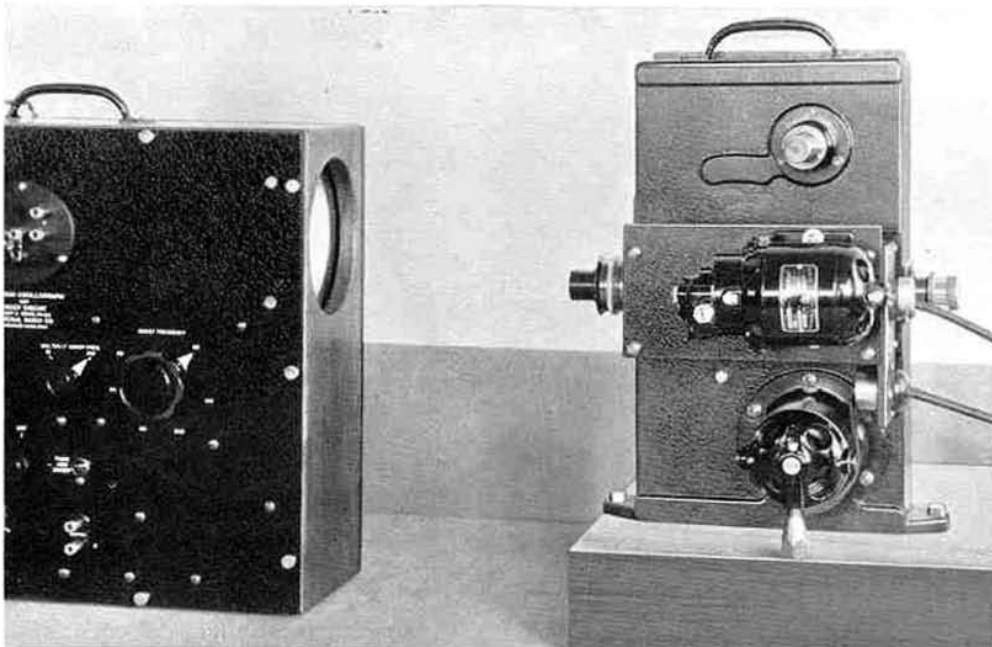

The high film speeds at which the new continuous-film camera will operate make it possible to take cathode-ray oscillograms of high-frequency transients. The photograph shows the CLASS 651-A-E Camera Assembly and a TYPE 687-A Electron Oscillograph and Bedell Sweep Circuit

The two types of assembly listed will meet most of the usual applications. The A-E group is designed for medium speeds, while the A-M assembly offers a camera suitable for extremely high film speeds. Interchangeable motors provide wide speed ranges, and a number of commercial lenses may be fitted to meet inflexible conditions without departing from the standard camera design.

The section headed "Special Camera Assemblies" lists individual units and indicates the possible variations in design the better to meet particular requirements.

The many applications of high-speed photography to industrial research have prompted the manufacture of a new continuous-film camera based on the designs of Professor Harold E. Edgerton of the Massachusetts Institute of Technology. Originally designed to photograph rapid mechanical actions by the light from an Edgerton Stroboscope for subsequent projection at normal speed to give the effect of slow motion, the camera is also ideal for recording high-speed transients with a cathode-ray oscillograph.

The General Radio camera differs from conventional motion-picture cameras in its lack of a shutter and intermittent film feed and in its ability to drive at speeds as high as 85 miles per hour (2000 frames per second) without damage to the film. Careful attention to the dynamical design of all moving parts has made this possible. Separate motors are used to drive the film and the take-up reel on which the exposed film is wound. Provision has been made for operation at different film speeds over a wide range so that the new camera can be made to fill almost every research need for a moving-film camera.

CLASS 651-A-E CAMERA ASSEMBLY

This assembly is recommended for low- and medium-speed work. It is the one that would ordinarily be used for making records with a cathode-ray oscillograph, but it can also be used for medium-speed stroboscopic photography. Readers interested in the latter use should, however, submit their requirements to the General Radio Company for suggestions before coming to a final decision.

The illustration on this page shows the TYPE 651-A High-Speed Camera of the CLASS 651-A-E Camera Assembly, illustrated on the opposite page, with its side removed to show the internal design. The manner in which the camera is focused and in which the film is threaded is shown by the illustration. The large central driving sprocket and the bottom take-up reel are each driven by separate motors. The type of main-sprocket drive determines the assembly class letter to which the camera belongs. The camera is focused by viewing the image through the focusing

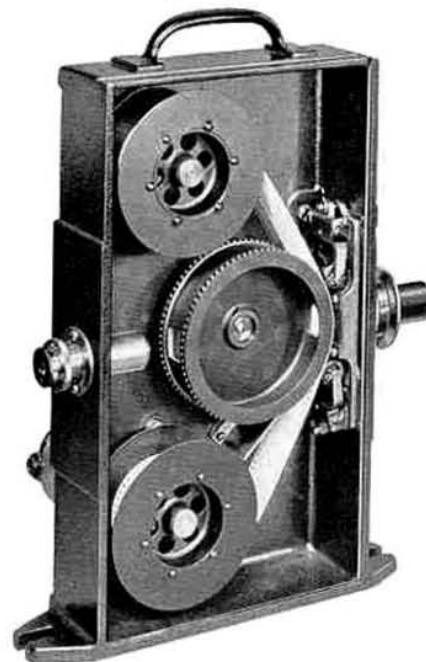

Interior View of the High-Speed Camera

eyepiece when the two apertures in the driving sprocket are aligned as shown. The image forms on a small piece of translucent film inserted in the gate.

SPECIFICATIONS

Film: Any 35-mm film or paper with standard perforations can be run. Daylight loading and unloading with negligible waste. Capacity of reels, 100 feet.

Film-Speed Range: When the motors are operated at the voltages mentioned in "Power Supply" below, film speeds between 3 feet per second and 35 feet per second are obtainable.

Lens Systems: An $f/2.5$, 47-mm lens from the Bell and Howell "Eyemo" series is supplied in an adjustable mounting that permits focusing for distances between 8 and 20 inches. The image for focusing is observed directly on the equivalent of a ground glass in the plane of the film.

The lens is sufficiently "fast" to permit the recording of traces from a TYPE 687-A Electron Oscillograph on super-sensitive panchromatic film at a

speed of 35 feet per second, when the ratio of total length along the trace to length of film is less than 5 to 1 (also see note on spot speed, page 100).

Drive System: The film-drive sprocket is driven through a reducing gear by a universal (a-c or d-c) motor. The take-up reel on which the exposed film is wound is driven by a second universal motor.

Power Supply: The wide range of film speeds is obtained by applying voltages between 50 volts and 230 volts to both the driving and take-up motors. When 115-volt or 230-volt 50- to 60-cycle service is available, voltage control over the entire range can be obtained by using a Variac. When d-c service only is available, a rheostat must be used.

Dimensions: (Length) $11\frac{7}{8}$ x (width) $6\frac{1}{2}$ x (height) $16\frac{1}{2}$ inches, over-all.

Net Weight: 32 pounds.

Class	Description	Code Word	Price
*651-A-E	Camera Assembly	DINER	

*Consists of camera (including take-up motor), lens, and driving motor, as described.

CLASS 651-A-M CAMERA ASSEMBLY

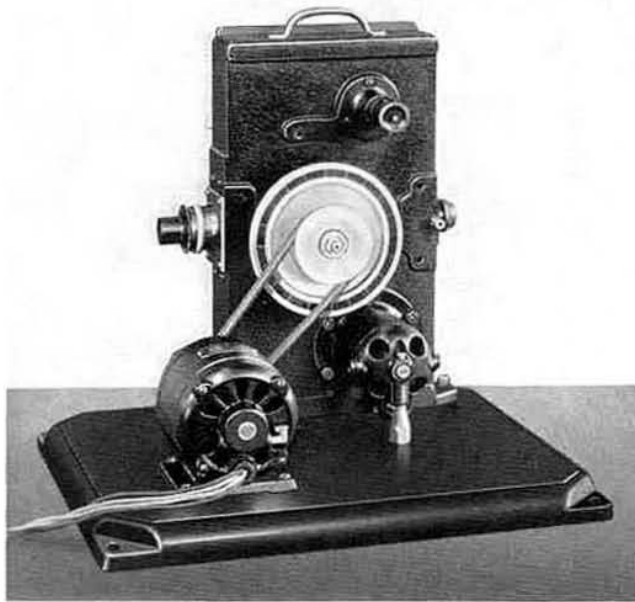

The Class 651-A-M Camera Assembly is designed particularly for super-high-speed stroboscopic photography where the film is later to be printed and projected for study or demonstration purposes. At maximum film speed this equipment gives "slow-motion" results in the ratio of about 120 to 1 when compared with the original action.

Inasmuch as the camera is of the shutterless continuous-film type, an intermittent flashing light source is required to produce the individual exposures. Because of the speeds involved, a TYPE 621-A Edgerton Power Stroboscope, il-

lustrated on page 3, is recommended for the source of illumination.

Where high-speed films are to be projected to give slow-motion action, provision for accurately framing the separate exposures is required. A commutator is provided for this purpose. Mounted on the shaft of the main film-drive sprocket, it is connected to the stroboscope circuit and provides the impulse which sets off the flash for each exposure. The exposures are thus accurately spaced on the film, and the film may be projected, without jumping of the image, using standard projection equipment.

SPECIFICATIONS

Film: Any 35-mm film or paper with standard perforations can be run. Daylight loading and unloading with negligible waste; no waste if film has paper leaders. Capacity of reels, 100 feet.

Film Speed: Using the $\frac{3}{4}$ -inch masking gate and the commutator supplied with the assembly, 1200 standard-size frames per second are exposed. This corresponds to a linear speed for the film of about 75 feet per second. The speed is fixed by the motor speed and can only be changed by using a different pulley-drive ratio. Other pulleys are available, but are not included in the assembly described here.

Lens System: An $f/2.5$, 47-mm lens from the Bell and Howell "Eyemo" series is supplied in an adjustable mounting that permits focusing for distances between 8 and 20 inches. The image for focusing is observed directly on the equivalent of a ground glass in the plane of the film.

This assembly has been used to take photographs at the rate of 1200 per second, using a TYPE 621-A Edgerton Power Stroboscope for illumination. The moving object should be small and bright; larger objects require even more powerful stroboscopes, information concerning which is obtainable on request.

Drive System: The drive motor is a 115-volt, 3600 r.p.m., 60-cycle, 3-phase, induction motor that drives the sprocket through a 1-to-1 belt drive. The take-up motor is a 115-volt universal motor.

Power Supply: In order to secure rapid acceleration of the film, both motors should be operated from a 220-volt, 60-cycle, 3-phase supply. Changes in camera film speed are secured by a change of pulley ratio; see "Film Speed."

Commutator: If high-speed stroboscopic motion pictures are taken for subsequent projection, the stroboscope must flash at the instant an unexposed frame of film comes into position. This is accomplished by means of a commutator on the shaft of the driving sprocket. The commutator supplied is for full-size, $\frac{3}{4}$ -inch frames; see "Masking Gates."

Masking Gates: The masking gate determines the amount of film exposed for each "stroboscope" flash. Three are available: $\frac{3}{4}$ -inch for a full-size motion picture frame, $\frac{3}{8}$ -inch, and $\frac{1}{4}$ -inch.

If pictures taken are for individual analysis and not for projection, exact synchronism between film and flash need not be accurately maintained. By using the $\frac{3}{8}$ -inch masking gate and a flashing rate adjusted to approximately 2400 flashes per second, the number of exposures per second can be effectively doubled at the expense of narrowing the field of view. By using the $\frac{1}{4}$ -inch gate, in a similar manner, the exposure rate can be tripled.

Dimensions: Camera, (length) $11\frac{7}{8}$ x (width) $6\frac{1}{2}$ x (height) $16\frac{1}{2}$ inches, over-all; base, (length) 18 x (width) 15 x (height) $1\frac{1}{2}$ inches, over-all.

Net Weight: 60 pounds.

<i>Class</i>	<i>Description</i>	<i>Code Word</i>	<i>Price</i>
*651-A-M	Camera Assembly	DIRGE	

*Consists of camera (including take-up motor), driving motor, base, commutator, and lens, as described.

SPECIAL CAMERA ASSEMBLIES

The following paragraphs list some of the optional accessories which are available. They may be used with the TYPE 651-A High-Speed Camera to build up camera assemblies for particular require-

ments differing from the two assemblies previously described. All equivalent or substitute accessories are interchangeable with each other and with those originally furnished with the camera.

SPECIFICATIONS

Film: Cameras using 16-mm instead of 35-mm film or paper can be supplied. The smaller height of the standard 16-mm frame is sometimes an advantage for stroboscopic photography at extremely high speeds.

Lens: Lenses as fast as $f/1.5$ and with focal lengths between 47 mm and 6 inches (telephoto) are obtainable to fit the standard mounting. When used with either a string- or a conventional moving-coil-type oscillograph, no lens at all is needed.

Drive: There are many possible combinations of driving motors with belt or gear drives that make it possible to obtain film speeds anywhere between $\frac{3}{4}$ inch per second and 75 or more feet per second. For some applications, no driving motor is required, the take-up motor supplied with the camera being used to pull the film through.

Chronographic Work: Many acceleration and speed studies can be made when a timing record is photographed directly on the film, or when a synchronous-motor drive is used. Optical units for a

photographed time axis mount directly on the camera and are available for either 60- or 1000-cycle traces.

Some index to the cost of the different elements in a special assembly can be obtained from the following list of components of the CLASS 651-A-E and CLASS 651-A-M Camera Assemblies previously described:

TYPE 651-A High-Speed Camera with take-up motor	
Bell and Howell "Eyemo" Lens, $f/2.5$, 47 mm	
Gear-drive motor as used with CLASS 651-A-E	
Belt-drive motor and base as used with CLASS 651-A-M	
Commutator used with CLASS 651-A-M	

If you have a problem that General Radio camera equipment might help to solve, state your requirements and allow us to suggest an assembly that will meet them. Please give all pertinent information.

TYPE 636-A WAVE ANALYZER



The TYPE 636-A Wave Analyzer is a superheterodyne vacuum-tube voltmeter with a very sharply tuned intermediate-frequency amplifier which makes use of two quartz-crystal filters. The range of alternating-current voltages that may be measured with the analyzer is from 200 microvolts to 200 volts.

Functionally, the instrument consists of two parts. The first is a voltmeter of adjustable sensitivity which responds to a single frequency only, and the second is a means of placing this single frequency at any point in the audio-frequency spectrum that is desired.

With the TYPE 636-A Wave Analyzer a complex waveform may be explored by adjusting the voltmeter to respond to all audio frequencies in succession and observing the voltage of each particular frequency that is present in the wave.

The operation of the device to obtain

this information is extremely simple. It consists of rotating the large dial, which controls the response frequency of the voltmeter, slowly through its range, and observing each deflection of the voltmeter which occurs.

The most serious problem in the design of this type of instrument is to secure a sufficiently sharp filtering action so that the voltmeter will respond only to a very narrow band of frequencies. This has been accomplished in the TYPE 636-A Wave Analyzer by the use of a two-stage mechanical filter using quartz bars tuned to 50 kc. The use of the fixed-frequency mechanical filter results in avoidance of the circuit complications of variable-frequency filters and in a great increase in filter selectivity. In order to vary the response frequency of the analyzer while making use of a fixed-frequency filter a heterodyne method is used. The ad-

justable element in the system is the frequency of the heterodyning oscillator which is controlled by the large dial.

The output of the local oscillator and the whole of the complex waveform to be examined are fed to a balanced modulator where their combination produces both the sum and difference frequencies, or side bands, in the output. The original of the complex waveform is not passed by the modulator intermediate-frequency output transformer, and the local oscillator carrier frequency is suppressed in the output because of the two-tube balanced modulator employed.

The 50-kilocycle component of the upper side band, proportional to the voltage of that frequency to which the main dial is set present in the original wave, is selected and amplified by the intermediate stages. The adjustable gain control of the amplifier gives the many

values listed below for full-scale deflections of the output meter. The standards for the voltage and frequency calibration are self-contained within the instrument.

The input impedance of the analyzer is normally 100,000 ohms. Under these conditions the multiplier range is such as to produce full-scale readings on the meter from 0.001 volt to 2 volts. An external 10-megohm multiplier is supplied which alters this range to from 0.1 volt to 200 volts. Since the meter can be used at one-tenth full scale, the total voltage range of the instrument is 0.2 millivolt to 200 volts.

The analyzer is not only useful for the measurement of harmonic distortion, but also for the study of induced voltages in a complex waveform. Examples of this type of work include hum measurements in radio-receiver outputs and induction studies on telephone lines.

SPECIFICATIONS

Frequency Range: 20 to 16,000 cycles.

Selectivity: Extreme selectivity permits discrimination of voltages differing by only a few cycles. The response is down 6 db at 2 cycles, 40 db at 30 cycles, and 60 db at 90 cycles from the peak. The selectivity is constant throughout the operating frequency range.

Voltage Range: 0.2 millivolt to 200 volts. The meter in conjunction with its multiplier has a full-scale range of 0.001, 0.002, 0.005, 0.010, 0.020, 0.050, 0.1, 0.2, 0.5, 1, and 2 volts. An external 100 to 1 multiplier is provided to increase the input impedance and to extend the range to 200 volts. Range with multiplier, 0.02 volt to 200 volts.

Voltage Accuracy: Within 5% on all ranges except on the 1-mv and 2-mv (full-scale) settings of the multiplier switch where the accuracy is within 10%. Spurious voltages from higher order modulation products introduced by the detector are suppressed by at least 70 db.

Input Impedance: 100,000 ohms; 10 megohms with the external multiplier. The 100 to 1 external multiplier is well shielded and has such a high input

impedance that the analyzer may be connected almost anywhere in a circuit without using series condensers or taking any other precautions usually necessary with harmonic analyzers.

Accuracy of Calibration: The frequency scale of the main tuning control is individually engraved and is approximately logarithmic over its full spread of almost 18 inches. For one year from the date of purchase, the calibration can be relied upon to within 2% when the analyzer has been carefully set to zero.

Tubes Required: Three 41-type, two 78-type, and one 37-type tubes, supplied with the instrument.

Power Supply: The filament supply is obtained from a 6-volt storage battery by means of cable provided. The plate supply is obtained from three 45-volt Eveready No. 872 batteries or equivalent, space for which is provided in the lower compartment of the instrument. Batteries are not included in the price of the instrument.

Dimensions: (Height) 27 $\frac{1}{4}$ x (width) 21 x (depth) 12 $\frac{1}{2}$ inches, over-all.

Net Weight: 68 $\frac{1}{2}$ pounds.

<i>Type</i>	<i>Code Word</i>	<i>Price</i>
636-A ABOVE	

TYPE 457-B MODULATION METER

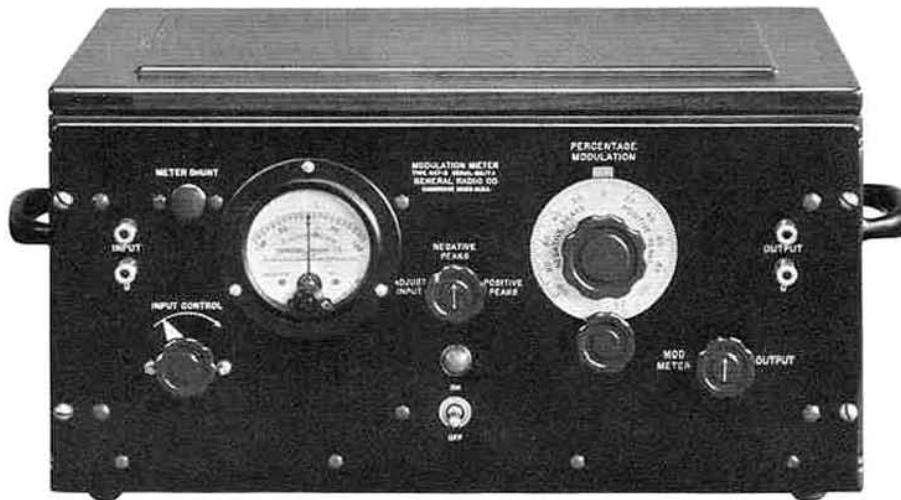

Proper operation of a broadcast transmitter requires more knowledge about the performance of the modulation system than the operating engineer has been able to obtain readily. Measurements of the percentage of modulation and the adjustment of the transmitter for the maximum amount of undistorted modulation have been difficult, involving as they have a well-developed, experimental technique and relatively complex equipment. The advantages of a simple and accurate modulation meter will be apparent to every broadcast engineer.

The TYPE 457-B Modulation Meter is a direct-reading instrument for the accurate measurement of percentage modulation. It has a number of important uses. Determinations can be made while a program is in progress so that it may be used by the monitoring operator to indicate when the maximum allowable percentage modulation is being exceeded. This modulation meter is no more difficult to operate than a power-level indicator.

The maximum allowable percentage of modulation for any given adjustment of the transmitter can be determined by increasing the audio-frequency input voltage until further increases no longer produce proportional increases in percentage

modulation. Greater values of percentage modulation indicate that the transmitter is being overloaded with distortion resulting. Since the percentage modulation can be measured on the negative peaks of the audio-frequency wave as well as on the positive peaks, lack of symmetry in the modulation or shifts in the average value of the carrier voltage during modulation can be detected and steps taken to correct the maladjustment.

About 75 volts of modulated carrier voltage may conveniently be introduced into the modulation meter from a pickup inductor coupled to the output circuit of the transmitter. The power required to operate it (approximately 0.5 watt) is negligible even in low-power transmitters.

The instrument consists essentially of a linear rectifier for obtaining a wave identical in form with the envelope of the modulated radio-frequency wave and a means, including a vacuum-tube peak voltmeter, for examining the maximum and minimum values of the rectified wave. The circuit is arranged so that, after a preliminary adjustment of the radio-frequency voltage applied to the rectifier, percentage modulation for either positive or negative peaks is given directly by a dial reading.

SPECIFICATIONS

Accuracy: In ordinary use the error is less than 5% in modulation at audio frequencies up to about 3000 cycles. The inherent error of the instrument is considerably less than this, and, if sufficient care is used in setting it up and in taking observations, the error may be reduced to below 2% in modulation. For example, when the modulation meter reads 75% modulation, the true value will be between 73% and 77%.

The accuracy is greater at high modulation percentages than at low, and is greater at low modulation frequencies than at high.

Range: The above values of accuracy may be expected for carrier frequencies in the range between 120 kc and 40 Mc (2500 meters to 7.5 meters, approximately).

Tubes: Two UY-227 tubes are supplied with the instrument.

Power Supply: Two Burgess No. 5308 block batteries or equivalent 90-volt battery are required to deliver about 2 ma. A battery compartment is provided inside the cabinet. Filament-heater power is supplied from the 115-volt, 50-60 cycle, a-c line.

Terminals: A receptacle for plugging in the 115-volt supply is provided on the right-hand side of the cabinet. Battery connections are made to flexible

leads. On the front panel and on terminal plates at the back, duplicate pairs of binding posts are provided for the radio-frequency input and for the output of the linear rectifier, so that it can be used with other analyzing equipment if desired.

Shielding: A shield of nickel-plated brass protects the circuit from stray electric fields.

Mounting: All parts are mounted on an aluminum panel finished in black crackle lacquer. The instrument can be supplied mounted in a polished walnut cabinet or with panel extensions suitable for mounting it in a standard 19-inch (TYPE 480) relay rack.

The cabinet-mounting model is known as TYPE 457-BM; the rack-mounting model is known as TYPE 457-BR.

Accessories: The instrument is supplied with tubes and a 7-foot connecting cord but without battery or pickup inductor.

Dimensions: Panel size, (length) 15 x (height) 7 inches. Cabinet size for TYPE 457-BM, (length) 18 1/8 x (height) 8 1/4 x (depth) 10 7/8 inches, over-all, including handles. Panel size for TYPE 457-BR, (length) 19 x (height) 7 x (depth) 10 inches, over-all.

Net Weight: 25 pounds for TYPE 457-BM; 19 pounds for TYPE 457-BR.

<i>Type</i>	<i>Description</i>	<i>Code Word</i>	<i>Price</i>
457-BM	Cabinet Mounting	MANGE	
457-BR	Relay-Rack Mounting	MANGY	



NOW!

% MODULATION

% HARMONIC DISTORTION

-DB NOISE AND HUM LEVEL

All are given directly on the panel meters of the CLASS 730-A Transmission Monitoring Assembly.

- High-speed meters
- Automatic over-modulation alarm

Code Word: EXILE

Bulletin 381-A on request

TYPE 536-A DISTORTION-FACTOR METER



Most of the methods of measuring harmonic distortion that have been employed either have been laborious or have involved elaborate equipment. The TYPE 536-A Distortion-Factor Meter has been developed to enable distortion measurements to be made accurately and rapidly. This instrument has a further important advantage over earlier apparatus in that its input impedance is very high. It may, therefore, be connected almost anywhere without causing appreciable disturbance of the circuit under test.

In order that these ends might be achieved, two important simplifications of the problem have been made at the outset. Only a single fundamental frequency is employed, and only the total harmonic distortion is measured.

The first of these limitations is not serious because harmonic production is essentially an amplitude phenomenon. Frequency usually enters into the problem only secondarily. For this reason a study at a single frequency of the harmonic production in a given piece of apparatus under various operating conditions yields valuable information.

The measurement of total harmonic content is for most purposes preferable to the measurement of the several components separately. We obtain in this way a single quantity as a measure of the impurity of the voltage source. The "Distortion Factor" measured by the instrument is

$$D = \frac{\sqrt{E_2^2 + E_3^2 + E_4^2 + \dots}}{E_1}$$

This is the ratio to the fundamental of the effective value of the combined harmonics. This quantity is an excellent measure of the objectionableness of the distortion present in the transmission of speech or music. For example, a second harmonic of 5 per cent with a third harmonic of 5 per cent is seen to give a smaller distortion factor than a single harmonic of 10 per cent, and is correspondingly less objectionable.

The present general use of the pentode output tube makes a dependable means of studying the output capabilities of an amplifier especially desirable. Output measurements without some indication of the distortion present are of doubtful

significance. The use of the TYPE 536-A Distortion-Factor Meter in conjunction with the TYPE 483 Output Meter in making these measurements gives truly reliable data for the comparison of various types of amplifiers.

If a suitable linear rectifier is available for demodulation, the TYPE 536-A Distortion-Factor Meter provides a means of measuring the impurity of the modulated output of a radio-telephone transmitter. Such a high-quality linear rectifier is contained in the TYPE 457-B Modulation Meter, and terminals are provided for connection to the distortion-factor meter.

The principal elements of the instrument are an excellent high-pass filter and a calibrated resistance network by means of which the filter output is compared with the input voltage. A dial is

rotated until the same indication is obtained for two positions of a switch. The distortion factor is then given directly by the dial reading. Two ranges are provided giving 3 per cent and 30 per cent, respectively, at the maximum dial setting. The characteristics of the filter are such that the fundamental is attenuated about 75 decibels more than the harmonics. Power-supply hum voltages are likewise suppressed. All harmonics up to the fifteenth are transmitted equally within 0.4 decibel. The filter is so designed that no appreciable harmonic distortion is produced by the inductors, even when large input voltages are applied. A resistance pad is provided ahead of the filter so that the calibration is not altered by the impedance out of which the instrument works.

SPECIFICATIONS

Range and Sensitivity: With the recommended auxiliary equipment, 10 volts across the input terminals makes possible the measurement of distortion factors as low as 0.02%. If larger distortion factors are to be measured, the input voltage may be reduced in the same proportion. Similarly, if larger input voltages are available, proportionately smaller distortion factors may be measured.

For special uses, the range and sensitivity may be very greatly extended by employing more amplification. If desired, two TYPE 514-A Amplifiers may be used in tandem for special work.

Frequency Range: 330-420 cycles.

Input Impedance: About 175,000 ohms.

Accuracy: When the TYPE 488-HM Alternating-Current Galvanometer is used as indicator, the error is less than 5% for distortion factors as low as 0.005. If necessary, greater accuracy can be obtained by substituting an instrument of the thermocouple type, as this indicates more accurately the effective value of a composite voltage. Inasmuch as the thermocouple instrument is less sensitive, more sluggish, and has a much smaller overload capacity, the TYPE 488-HM Alternating-Current Galvanometer is usually to be preferred.

Auxiliary Equipment: The distortion-factor meter must be used with a suitable amplifier and indicating instrument. The TYPE 514-A Amplifier and TYPE 488-HM Alternating-Current Galvanometer are recommended for general use. The amplifier must have a flat characteristic, variable gain, and an input impedance greater than half a megohm. The indicating instrument should be sensitive and have a square-law characteristic in order to indicate the effective value of the combined harmonics.

Where a 400-cycle voltage is applied to the apparatus under test, it must usually be filtered to obtain sufficient purity. The extent to which this is necessary depends, of course, on the magnitudes of the distortion factors to be measured.

One or more TYPE 330-A or TYPE 330-C Filter Sections may be employed if extreme purity is not required. A special band-pass filter TYPE 530-A and TYPE 530-C has been developed for use with the TYPE 536-A Distortion-Factor Meter. This filter is described on the next page.

Dimensions: Panel, (length) 12 x (height) 7 inches. Cabinet, (length) 14½ x (height) 8¼ x (depth) 12¼ inches, over-all.

Net Weight: 30 pounds.

<i>Type</i>	<i>Code Word</i>	<i>Price</i>
536-A	DRAFT	

TYPE 530 BAND-PASS FILTER



This filter is designed primarily for use with the TYPE 536-A Distortion-Factor Meter to purify the voltage applied to apparatus under test. It is useful in any other cases where an extremely pure 400-cycle voltage is desired. The use of one of these filters reduces the harmonic content by at least 50 decibels. They may be used with a fundamental frequency of from 375 to 425 cycles. Sufficient attenuation is provided at the low-frequency end to remove any power-supply hum voltage

which may be present. The two types differ only in characteristic impedance. These filters are not carried in stock but are supplied on order.

Inasmuch as the type of filter section employed is unbalanced to ground, this band-pass filter may not be used in balanced-circuit inputs to the apparatus under test. For balanced-line inputs the use of a TYPE 585-R Transformer, described on page 158, between the filter section and the apparatus input is recommended. This transformer is designed for the interconnection of balanced and unbalanced lines and will not introduce harmonics into a 400-cycle test signal of moderate amplitude.

A 400-cycle, vacuum tube, a-c operated oscillator with an output waveform of purity equal to that obtained from other sources through a TYPE 530 Band-Pass Filter is a component part of the CLASS 730-A Transmission Monitoring Assembly mentioned on page 111. This 400-cycle TYPE 731-A Oscillator is separately available in rack-mounting form.

SPECIFICATIONS

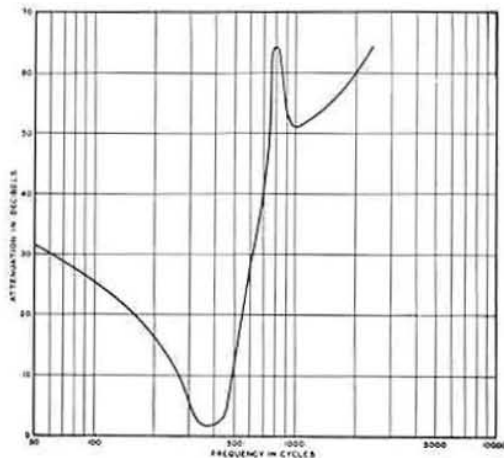

Attenuation Characteristic: See accompanying curve. A peak of maximum attenuation is set for rejection of the 800-cycle second harmonic.

Impedance: Designs are on file for a filter of 600-ohm characteristic impedance for line use and for a 6000-ohm filter for use, with a blocking condenser, directly on the output of an oscillator or an amplifier stage. Filters ordered for other impedances are obtainable at a slight increase in cost.

Mounting: Filters are mounted in standard drawn steel, wax-filled Model D cases.

Dimensions: Case (width) $5\frac{3}{4}$ x (height) $5\frac{1}{2}$ x (depth) $5\frac{1}{2}$ inches, over-all. See also dimensioned drawing, page 157.

Net Weight: 8 pounds.

Type	Impedance	Pass Band	Code Word	Price
*530-A	600 ohms	375-425 cycles	FOCAL	
*530-C	6000 ohms	375-425 cycles	FURRY	

*Built to order—not carried in stock.

TYPE 534 BAND-PASS FILTER

This filter contains in a single unit an entire band-pass filter.

This filter is designed primarily for use in connection with bridge measurements in order to suppress harmonics and also any hum which may be present in the generator. It may be used either in the generator output or in the detector input.

The transmission characteristic is similar to that of a simple resonant circuit, except that it offers appreciably higher discrimination to frequencies outside the transmitted region. The minimum transmission loss is approximately 3 decibels. Discrimination against the second harmonic is normally 33 decibels. For the 400-cycle filter the discrimination against low-

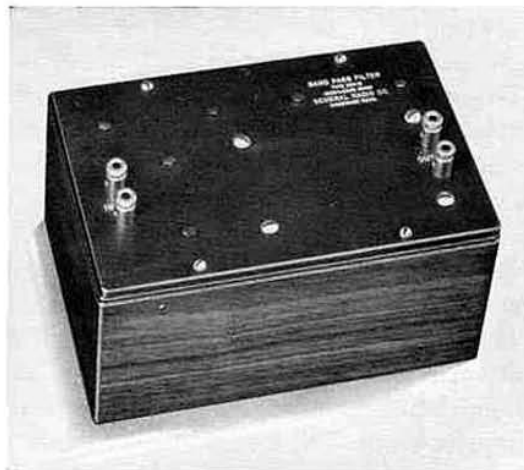

frequency hum is in excess of 16 decibels, for the 1000-cycle filter it is in excess of 25 decibels.

SPECIFICATIONS

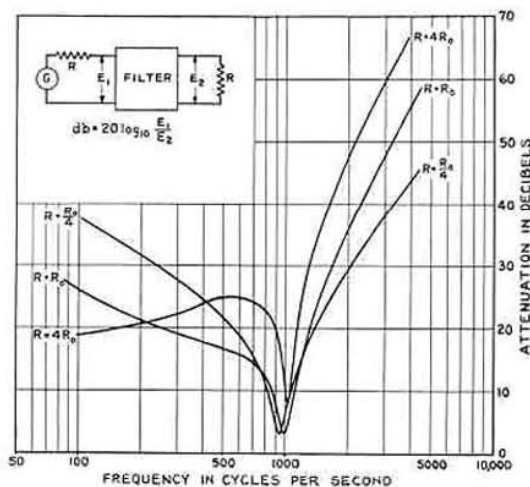

Attenuation Characteristic: See accompanying curve.

Impedance: The filters listed are designed on the basis of generator and load impedances of 2000 ohms. Formulae are available for computing filters for other impedances.

It should be noted that the discrimination of the filter and its maximum transmission point are dependent upon the terminal impedances. At the second harmonic, for example, the discrimination is increased 12 db when working between four times normal impedances, and decreased 6 db when working between one-quarter normal terminal impedances. Discrimination against low-frequency hum may vary as much as 22 db as the generator and load impedances are varied between four times the nominal value and one-quarter the nominal value. Over this same range the minimum attenuation point may vary approximately 10% in frequency and 5 db in attenuation.

Calibration: Filters are adjusted by selecting condensers of the series resonant circuit so that the minimum attenuation point is within 1% of the value engraved on the panel.

Mounting: The filter is attached to a bakelite panel and enclosed in a walnut cabinet.

Dimensions: (Length) $7\frac{3}{4}$ x (width) 5 x (height) $3\frac{3}{8}$ inches, over-all.

Net Weight: 4 pounds.

Type	Frequency	Code Word	Price
*534-A	400 cycles EXCEL	
534-B	1000 cycles EXERT	

*Not carried in stock—delivery two weeks.

TYPE 330 FILTER SECTION

This series of simple high-pass and low-pass filter sections includes high-pass T-type filter sections and the low-pass π -type sections. These individual sections, including a laminated iron-core inductor and two condensers, are built into shielded metal cans. Any number of similar or different sections may, of course, be joined in series to produce a multi-section filter. The accompanying curves give an idea of their transmission characteristics. The important influence of the terminating impedance on sharpness of cut-off, shown

in the right-hand figure, should be noted.

A group of filters with convenient values of impedance and cut-off frequency is listed below. The General Radio Company specializes in equipment of this sort, and similar sections having any desired electrical constants may be obtained on special order. The theoretical cut-off frequency, f_o , and the iterative impedance should be specified when ordering such special sections. Low-pass and high-pass sections may be combined to make band-pass and band-elimination filters.

SPECIFICATIONS

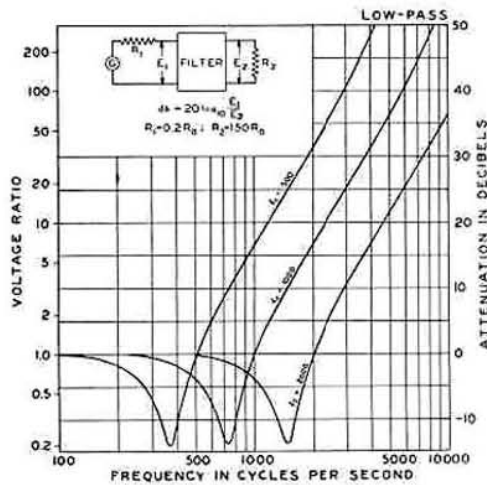
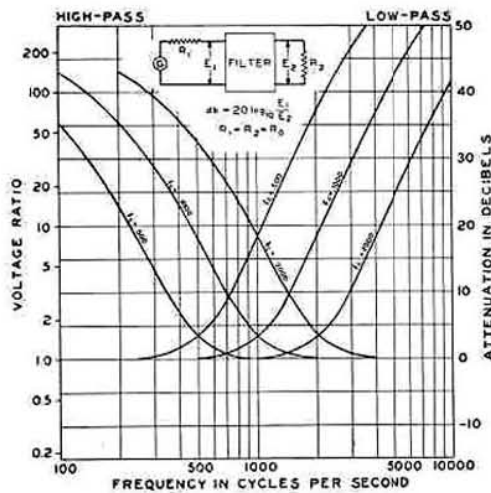

Mounting: All are mounted in Model C cases, dimensions for which are given on page 157.

Net Weight: Approximately 3 1/8 pounds for all sizes.

Type	f_o	Impedance		Code Word	Price
330-A	500 cycles	600 ohms	Low Pass	FILTERGOAT	
330-C	500 cycles	6000 ohms	Low Pass	FILTERSHOE	
330-E	1000 cycles	600 ohms	Low Pass	FILTERTOAD	
330-G	1000 cycles	6000 ohms	Low Pass	FILTERSIGN	
330-J	2000 cycles	600 ohms	Low Pass	FILTERHEAD	
330-L	2000 cycles	6000 ohms	Low Pass	FILTERBELL	
330-B	500 cycles	600 ohms	High Pass	FILTERGIRL	
330-D	500 cycles	6000 ohms	High Pass	FILTERSEAT	
330-F	1000 cycles	600 ohms	High Pass	FILTERMUSH	
330-H	1000 cycles	6000 ohms	High Pass	FILTERPIPE	
330-K	2000 cycles	600 ohms	High Pass	FILTERFOOT	
330-M	2000 cycles	6000 ohms	High Pass	FILTERWALK	

METERS

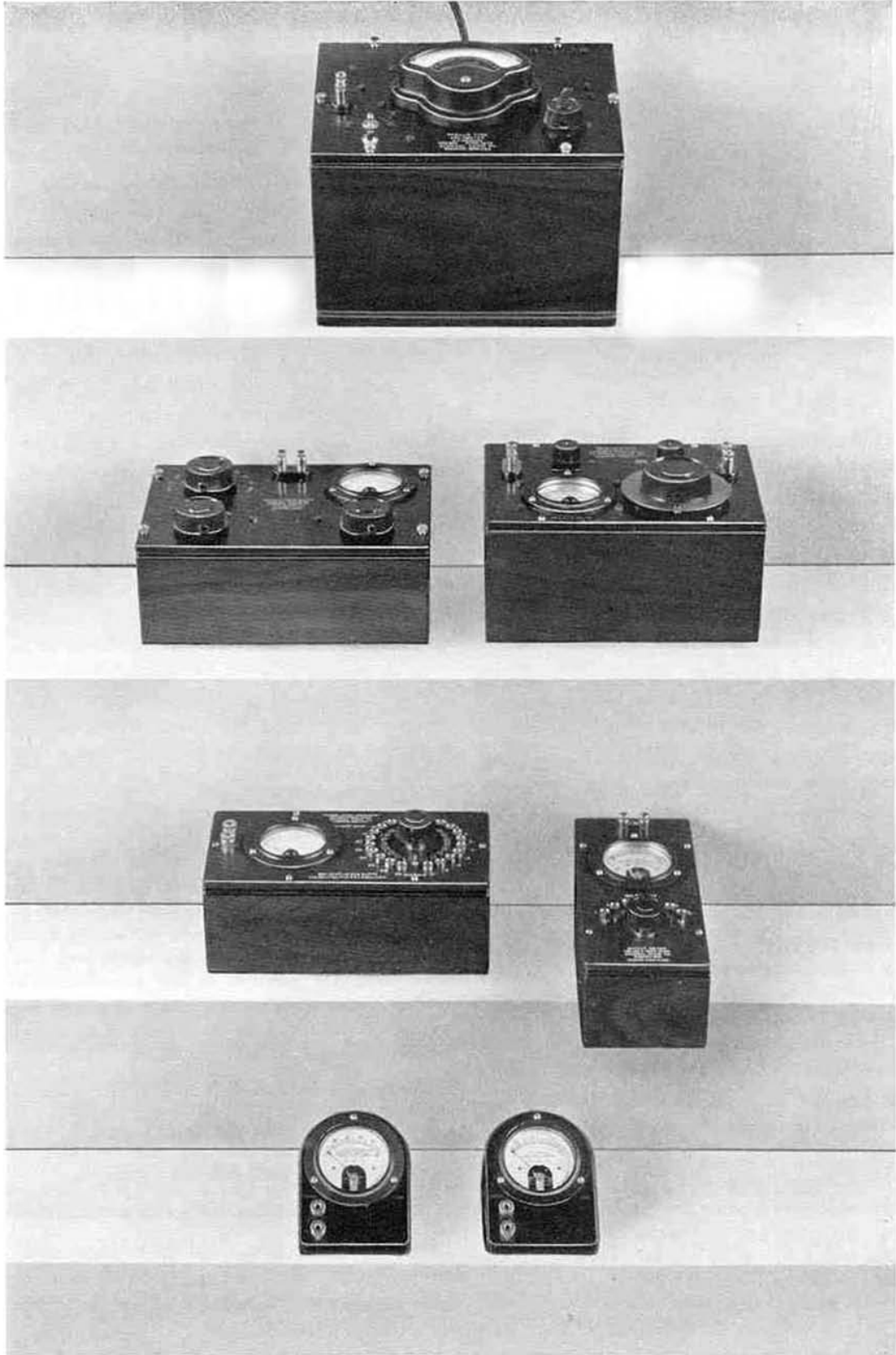

TYPE 626-A VACUUM-TUBE VOLTMETER



The wide applicability of the thermionic type of alternating-current voltmeter introduced the need for such an instrument designed to be operated wholly from the 60-cycle, 115-volt, a-c mains.

The TYPE 626-A Voltmeter is a direct-reading, convenient, moderately precise

instrument of the compensated, depressed-zero type. The filaments of the tubes used are run at subnormal voltages so that their normal life is considerably increased. A rugged d'Arsonval type of meter having a full-scale deflection of 300 microamperes is the indicating device.

The design of the circuits and the type of tubes used result in a minimum wandering of the zero point from aging, the chief source of error being fluctuations in the line voltage (see below). A rheostat is provided on the panel for adjusting the instrument so that all values of line voltage between 100 and 120 volts may be used. Sudden erratic changes in line voltage are not in general detrimental, owing to the large thermal capacity of the cathode of the thermionic tube.

SPECIFICATIONS

Range: 0 to 3 volts, root-mean-square.

Input Impedance: 10 megohms. No external direct-current path is required.

Power Supply: Alternating current, 50-60 cycles, 100-120 volts. The instrument draws a current of approximately 0.15 amperes from the power supply. A pilot lamp and "ON-OFF" switch are mounted on the panel.

Tubes: One 227-type for the thermionic voltmeter, one 171-type for the rectifier unit, and one 874-type ballast tube for stabilizing the plate voltage are required. These are supplied with the instrument. In the event of failure of the voltmeter tube, the instrument should be returned to us for recalibration.

Calibration: Each instrument is individually calibrated and is accurate to within 1% of full-scale value.

Line-Voltage Error: A drop of one volt in the power supply will reduce the reading of the meter at any given point on the scale by 0.015 volts (0.5% of full-scale). This error is linear. The meter is adjusted for different values of line voltage by a control rheostat which restores the needle to zero.

Frequency Error: Below 1500 kc, this error is negligible. At 3000 kc, the frequency error is less than 2%, and at 4000 kc, it is less than 4%.

Waveform Error: The instrument is calibrated in terms of r-m-s values of a pure sinusoidal wave. The deflection is proportional to the r-m-s value of the positive half wave (the scale is calibrated for the full wave). Waveform error from odd harmonics, which do not affect the symmetry of the waveform, is, therefore, negligible, while appreciable error will result from the presence of any even harmonic content. This error may be almost wholly corrected by reversing the leads to the meter and averaging the two readings obtained.

Ground: It is desirable to ground the low potential input terminal.

Accessories: A seven-foot attachment cord and the three tubes are supplied with the instrument.

Mounting: Aluminum panel, polished walnut case.

Dimensions: (Length) $11\frac{1}{4}$ x (width) $8\frac{1}{2}$ x (height) $8\frac{3}{4}$ inches, over-all.

Net Weight: $15\frac{1}{4}$ pounds.

Type	Range	Code Word	Price
626-A	0-3 volts, r.m.s.	ETHIC	



TYPE 586 POWER-LEVEL INDICATOR

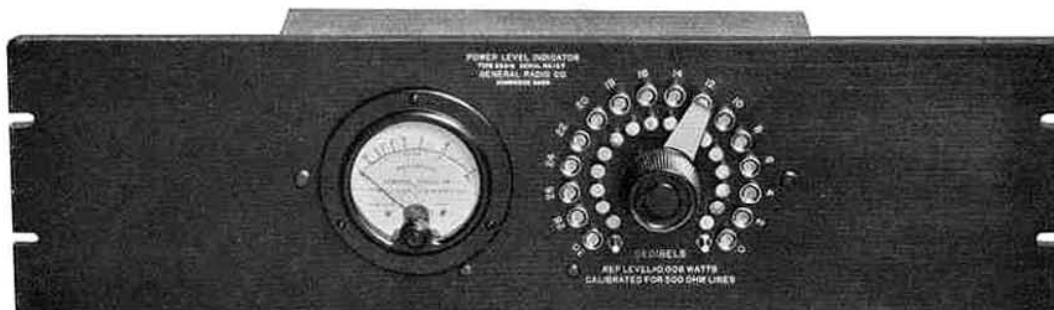

The importance of maintaining a careful check upon the signal amplitude at various points in voice-transmission circuits is well recognized by acoustic engineers. Too low a level means interference from background noises; too high a level means overloading of amplifiers and reproducers, and the introduction of cross-talk into nearby channels.

The TYPE 586 Power-Level Indicator has many advantages for work of this kind. It is portable, compact, rugged,

accurate, low in price, and requires no batteries or replacements.

The moving element, slightly damped to prevent any undue overthrow on sudden surges, is particularly rugged, and it will withstand hard usage either for monitoring or for general testing service. An adjustable L-type attenuator is inserted between the input terminals and the indicating voltmeter. It acts as a multiplier while maintaining constant the input resistance of the power-level indicator.

SPECIFICATIONS

Power-Level Range: See price list. All ratings are for a zero level of 6 milliwatts in a 500-ohm line.

Internal Input Impedance: 5000 ohms resistance. There is, therefore, no distortion or appreciable power loss introduced into the line.

Frequency Characteristic: There is no appreciable error for frequencies up to 10,000 cycles.

Scale Reading: For TYPE 586-A and TYPE 586-B. Zero level at mid-scale. The meter is graduated in 2-db steps between -10 db and +6 db. The multiplier is adjustable in 2-db steps.

For TYPE 586-CM and TYPE 586-CR: -10 db level occurs at mid-scale. Multiplier covers range from -10 db to +30 db in 2-db steps.

Indicating Element: Copper-oxide-rectifier voltmeter calibrated to read power level in decibels.

Accuracy: Average error is from 0.1 db to 0.2 db,

an entirely negligible amount. Near the -10 db mark the reading may be as much as 0.5 db low.

Correction Chart: Supplied for use when the meter is connected across impedances other than 500 ohms.

Mounting: TYPE 586-A and TYPE 586-CM are mounted on a bakelite panel in a polished walnut cabinet. TYPE 586-B and TYPE 586-CR are intended for mounting on a standard 19-inch, TYPE 480, relay rack.

Dimensions: For TYPE 586-A and TYPE 586-CM; (length) 10 x (height) 5 x (depth) 5 inches, over-all. For TYPE 586-B and TYPE 586-CR; (length) 19 x (height) 5¼ x (back of panel depth) 3¼ inches, over-all. Panel thickness, ¼ inch.

Net Weight: 3¾ pounds for cabinet models, 4 pounds for rack-mounting models.

Type	Power-Level Range	Mounting	Code Word	Price
586-A	-10 db to +36 db	Cabinet Model	HABIT	
586-B	-10 db to +36 db	Relay-Rack Model	HANDY	
586-CM	-20 db to +36 db	Cabinet Model	HONEY	
586-CR	-20 db to +36 db	Relay-Rack Model	HONOR	
586-P1	Meter only for Types 586-A and 586-B		POWLEVGOAT	
586-P4	Meter only for Types 586-CM and 586-CR		POWLEVSHOE	

TYPE 483 OUTPUT METER

This is the constant-impedance voltmeter employing a copper-oxide-rectifier indicator that was introduced by the General Radio Company about five years ago for measuring the performance of radio receivers. It is, of course, useful wherever audio-frequency voltages are to be measured.

Three impedance values have been selected as the ones most generally needed. Particular attention is directed to the TYPE 483-C Output Meter which has a voltage range of 0-200 volts and an internal impedance of 20,000 ohms.

SPECIFICATIONS

Voltage Range: 200 volts (2-volt meters with multipliers of 2, 5, 10, 20, 50, and 100).

Impedance Characteristic: With the multiplier set at "1" the impedance of the instrument is that of the rectifier and meter only and hence varies somewhat with applied voltage. The impedance of the 8000-ohm instrument increases approximately 50% and that of the 20,000-ohm instrument approximately 30% for 0.5 volt applied. With increase in multiplier setting the impedance approaches a pure resistance of the rated value. The multiplier resistors are adjusted to within $\pm 2\%$.

Accuracy of Calibration: Because of the characteristics of the self-contained rectifier, the meters are subject to errors other than that of the d-c meter movement.

With the multiplier at unity, the 4000-ohm and 8000-ohm instruments are accurate to within 0.1 volt (5%) at frequencies below 2000 cycles when used at room temperatures in the neighborhood of 20° C. The deflections on this unmultiplied scale decrease by approximately 0.5% for each 1000-cycle increase in frequency up to 30,000 cycles.

With a multiplier setting of two the error in multiplication, because of the impedance variation of the rectifier with applied voltage, is a maximum. The 4000- and 8000-ohm meters will be within 5% and 10% and the 20,000-ohm meter within 3% and



6% for 2-volt and 1-volt inputs, respectively. This network error is zero on the upper third of the scale and decreases rapidly for the small deflections as the multiplier setting is increased.

The frequency and temperature errors on the 20,000-ohm instrument are considerably larger than those for the 4000-ohm and 8000-ohm units. Over extreme ranges of temperature and frequency the error may be as great as 25%.

Scale Length: 2½ inches.

Mounting: The copper-oxide-rectifier voltmeter and the multiplier switch are mounted on a bakelite panel which, in turn, is mounted in a polished walnut case.

Dimensions: (Length) 9 x (width) 4¼ x (height) 4¾ inches, over-all.

Net Weight: 3 pounds.

Type	Impedance	Voltage Range	Power Range	Power for Half-Scale Deflection	Code Word	Price
483-A	4000 ohms	0-200 volts	0-10 watts	0.25 mw	AVAST	
483-B	8000 ohms	0-200 volts	0-5 watts	0.125 mw	AVERT	
483-C	20,000 ohms	0-200 volts	0-2 watts	0.05 mw	AVOID	

TYPE 546-A MICROVOLTER

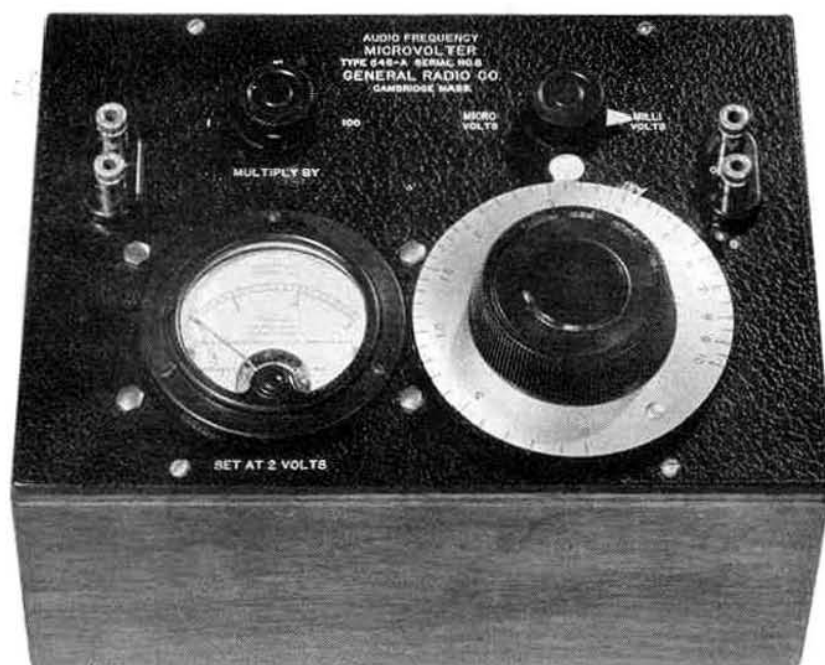

The measurement of small a-c voltages presents a problem of some difficulty in consequence of the absence of instruments of sufficient sensitivity for direct measurements. This has resulted in the adoption of a substitution method with which we are more familiar in direct-current measurements. A voltage of sufficient magnitude to be measured accurately on available instruments is impressed upon an accurate calibrated resistance network which can then be adjusted to vary the output voltage to equality with the unknown for which it has been substituted.

In the TYPE 546-A Microvolter an instrument has been designed incorporating these elements in a form suitable for use over the audio-frequency range.

The attenuator, which is the essential element of the design, consists of a sectionalized network of constant output impedance. The output ratio is controlled by switches for large steps and by a continuously adjustable dial for small steps. The latter consists of a slide-wire covering a range of two decades and having an exponential scale.

The instrument is completed by a voltmeter on which the input voltage is measured and a coupling transformer at the input end.

Although the transformer has been designed to have a reasonably flat characteristic for audio frequencies, it is evident, since it precedes the voltmeter, that transformer losses do not enter into the measurements in any way. For convenience the switching arrangement provides for maintaining constant the impedance of the attenuator as seen from the generator side. This is not essential from the standpoint of voltage computations, but it is convenient in avoiding the necessity of readjusting the input power as the attenuation is altered.

This new unit has many applications in measurements involving low voltages. It is useful for conveniently adjusting the output of vacuum-tube oscillators or other sources of alternating current. Used with the TYPE 483 Output Meters or a TYPE 583-A Output Power Meter it provides all the equipment necessary for measuring gain characteristics.

SPECIFICATIONS

Output Voltage Range: From 1 volt to 1 micro-volt for a "reference voltage" of 2 volts.

Accuracy: For output voltage ratios the error is less than 2% above 100-microvolt settings. The error is somewhat greater for smaller output voltages. In absolute measurements the characteristics of the copper-oxide voltmeter must be considered. For output voltages greater than 100 microvolts the error is less than 10%, 12.5% or 17% at 1000, 5000, or 10,000 cycles, respectively.

Power Source: An audio-frequency source having an output control and capable of maintaining approximately 9 volts across 7000 ohms is required. The use of other than the 2-volt standard reference level produces proportional deviations in output.

Input Transformer: The transformer is designed to have a reasonably flat characteristic over the audio-frequency range, but, since it precedes the voltmeter, its losses do not enter into the measurements.

Output Impedance: The internal output impedance of 200 ohms must be taken into account when supplying voltage to low-impedance loads.

Mounting: The instrument is mounted on an aluminum panel in a shielded walnut cabinet.

Dimensions: (Length) 10 x (width) 7 $\frac{1}{4}$ x (height) 6 $\frac{1}{8}$ inches, over-all.

Net Weight: 8 $\frac{3}{8}$ pounds.

<i>Type</i>	<i>Code Word</i>	<i>Price</i>
546-A	CROWN	

TYPE 488-DM ALTERNATING-CURRENT METER OXIDE-RECTIFIER TYPE

These instruments are designed for the measurement of alternating-current voltages at frequencies from 10 to 20,000 cycles per second. The indicating element consists of four small copper-oxide units arranged in the form of a bridge for obtaining full-wave rectification. The alternating-current voltage applied to the input terminals of this type of structure results in a direct current through a d'Arsonval galvanometer proportional to the root-mean-square value of the alternating voltage.

A change of impedance with applied voltage is a characteristic of all copper-oxide rectifiers, and hence it is desirable that some means be provided for main-



taining the input impedance to this type of instrument at a constant value. The proper choice of resistances external to the indicating element will provide a satisfactory means for meeting this problem.

SPECIFICATIONS

Voltage Range: 0 to 2 volts.

Impedance: 20,000 ohms.

Impedance Characteristic: Same as for TYPE 483-C Output Meter. See page 121.

Accuracy of Calibration: Refer as above.

Length of Scale: 2 $\frac{1}{2}$ inches.

Mounting: Supplied mounted as illustrated.

Dimensions: (Length) 5 $\frac{7}{8}$ x (width) 3 $\frac{13}{16}$ x (height) 2 $\frac{7}{8}$ inches, over-all.

Net Weight: 16 ounces.

<i>Type</i>	<i>Range</i>	<i>Impedance</i>	<i>Code Word</i>	<i>Price</i>
488-DM	0-2 volts, r.m.s.	20,000 ohms	OURMETSHOE	

TYPE 488-HM ALTERNATING-CURRENT GALVANOMETER SQUARE-LAW TYPE



The usual rectifier-type voltmeter has a nearly linear characteristic and is subject to some waveform error. By carefully re-designing the rectifier circuit it has been practical to eliminate this defect. The TYPE 488-HM Alternating-Current Galvanometer was developed for use with the TYPE 536-A Distortion-Factor Meter to replace the less rugged thermocouple instrument usually employed for such work. Since it is used for a comparison instrument, no calibration is required.

SPECIFICATIONS

Range: 0 to approximately 600 millivolts full scale.

Resistance: Approximately 700 ohms.

Scale: The 2.5-inch scale is divided into fifty equal divisions marked 0-100.

Calibration: The meter is adjusted so that full-scale deflection is approximately 600 millivolts.

Waveform Error: The approach to a square-law characteristic is sufficiently close so that even when two equal voltages of different frequencies are simultaneously applied, the waveform error is less than 3%. This means that the effective value of the composite voltage causing a certain deflection will be within 3% of the single frequency voltage causing the same deflection.

Frequency Characteristic: The meter will give the same deflection to within 2% for alternating-current voltages up to 2000 cycles, to within 5% up to 5000 cycles, and within 10% up to 10,000 cycles.

Adjustment: A screw is provided under the glass face for making the zero adjustment. The glass may be removed by unscrewing the bezel.

Mounting: The meter is supplied mounted in a moulded bakelite case with sloping front.

Dimensions: Mounting, (length) $5\frac{7}{8}$ x (width) $3\frac{1}{16}$ x (height) $2\frac{7}{8}$ inches; meter, (diameter) $3\frac{1}{2}$ x (depth) $2\frac{1}{4}$ inches, over-all.

Net Weight: 16 ounces.

<i>Type</i>	<i>Range</i>	<i>Code Word</i>	<i>Price</i>
488-HM	0-600 millivolts, square law.	OURMETHEAD	



THERMOCOUPLES, RECTIFIERS,

(oxide type). A-c measurements with d-c instruments. Bakelite cases for plug-in mounting. See descriptions, pages 149, 150.



DIRECT-CURRENT METER

500 μ a full scale, mounts thermocouples and rectifiers. See description, TYPE 588-AM Direct-Current Meter, page 151.

POWER SUPPLIES

TYPE 672-A POWER SUPPLY



The TYPE 672-A Power-Supply unit is designed for general laboratory use. It delivers d-c power up to 45 watts at 150 ma and 300 volts, with a no-load voltage of over 400 volts. An additional rectifier circuit supplies 2 ma dc at 100 volts. Two separate a-c supplies are also provided at 6.3 and 2.5 volts, from which a total of 45 watts may be taken.

The unit is primarily designed for vacuum-tube circuits but will be found useful in other capacities. The high-voltage input is controlled by a Variac (adjustable auto-transformer) with a

control on the panel so that continuous variation of the d-c output voltage (0 to over 400 volts) is possible. Meters on the panel indicate the output voltage and current. The low-voltage dc is convenient as a grid supply, and a ground connection can be used on any of the d-c supply terminals. A calibrated potentiometer mounted on the panel controls the low-voltage supply.

Excellent regulation at any output setting is assured by the Variac control and a carefully designed filter, which also insures a very low residual hum voltage.

SPECIFICATIONS

Output Range:

High Voltage: 150 ma at 300 volts, dc. No load voltage, over 400 volts, dc.

Low Voltage: 2 ma at 100 volts dc.

A-C Voltage: 2.5 and 6.3 volts, giving a total of 45 watts.

Meters: The high-voltage supply output is indicated by an ammeter and a voltmeter mounted on the panel.

Regulation: The regulation of the high-voltage supply corresponds to an internal output resistance of 700 ohms for direct current. The 1000-cycle internal output impedance of the high-voltage supply is equivalent to 3.9 μ f in series with 1.13 ohms. That of the low-voltage supply is equivalent to 2.12 μ f in series with 0.82 ohm.

Supply: The power-supply unit will operate from a 105-120 volt, 50-60 cycle, a-c line.

Power Consumption: With the a-c and d-c supplies operating at full load, the power consumption from the mains is about 175 watts. Under these conditions the loss in the power-supply unit is about 85 watts, including rectifier cathode power.

Hum Voltage: At full-load current the hum voltage of the high-voltage supply is less than 0.1% for all voltages above 150 volts. For lower voltages the per cent is slightly higher.

At full-load current the hum voltage of the low-voltage supply is less than 0.1% for all voltages. For a load current of 1 ma, the hum decreases to 0.03%.

Tubes: One 25Z5-type and one 80-type are supplied.

Mounting: The instrument is suitable for either table or relay-rack mounting.

Dimensions: (Length) 19½ x (depth) 11½ x (height) 7⅞ inches, over-all. Panel 19 x 7 inches.

Net Weight: 41 pounds.

Type	Code Word	Price
672-A	AFOOT	

TYPE 673-A POWER SUPPLY



This is a power-supply unit for general laboratory use. It has a d-c open-circuit voltage of over 2000 volts and delivers 150 ma at 1500 volts. Provision is also made for supplying a maximum of 6.5 amperes at 10 volts ac with a 5-volt center tap.

Several distinguishing features make the TYPE 673-A Power-Supply unit a very handy piece of apparatus about the laboratory. A knob on the panel gives a continuous control of the high voltage, which is indicated by a meter on the panel. The output current is also indicated by a panel

meter. Consequently, besides using the unit as a supply for, say, two 852-type tubes, it can be operated as a continuously-variable-voltage d-c supply (from below 50 to over 2000 volts). Transformer control in the high-voltage input and careful design of the filter have produced good regulation and low hum voltage. The power-supply unit is equipped with a time switch so that the a-c supply is on about 30 seconds before the d-c supply begins to operate. An auxiliary switch, for the sake of convenience and safety, is supplied to control the high voltage separately.

SPECIFICATIONS

Output Range: The power supply will deliver direct current up to 150 ma at 1500 volts. The open-circuit voltage is over 2000 volts.

The power supply also gives 6.5 amperes at 10 volts ac. The 10-volt supply is center-tapped at 5 volts.

Meters: The d-c voltage and the load current are indicated by meters mounted on the panel. A panel knob controls the input to the rectifiers.

Regulation: The internal output resistance of the power-supply unit corresponds to about 1100 ohms for load currents of 50-150 ma. For lower load currents the internal output resistance increases to about 20,000 ohms at no load. The 1000-cycle internal output impedance is equivalent to 1.1 μ f.

Supply: The power-supply unit will operate from

a 105-120 volt, 50-60 cycle line. A suitable power cord is supplied with the instrument.

Power Consumption: With the a-c and d-c supplies operating at full load, the power consumption from the mains is about 380 watts. Under these conditions the loss in the power-supply unit is about 90 watts including rectifier cathode power.

Hum Voltage: At full-load current the hum voltage is less than 3 volts or 0.2% of full-load voltage. For lower load currents, the hum decreases.

Tubes: Two 866-type rectifiers are supplied.

Mounting: The instrument is suitable for table or relay-rack mounting.

Dimensions: (Length) 19½ x (depth) 11½ x (height) 9 inches, over-all. Panel, 19 x 8¾ inches.

Net Weight: 73 pounds.

Type	Code Word	Price
673-A	AGONY	

PARTS AND ACCESSORIES

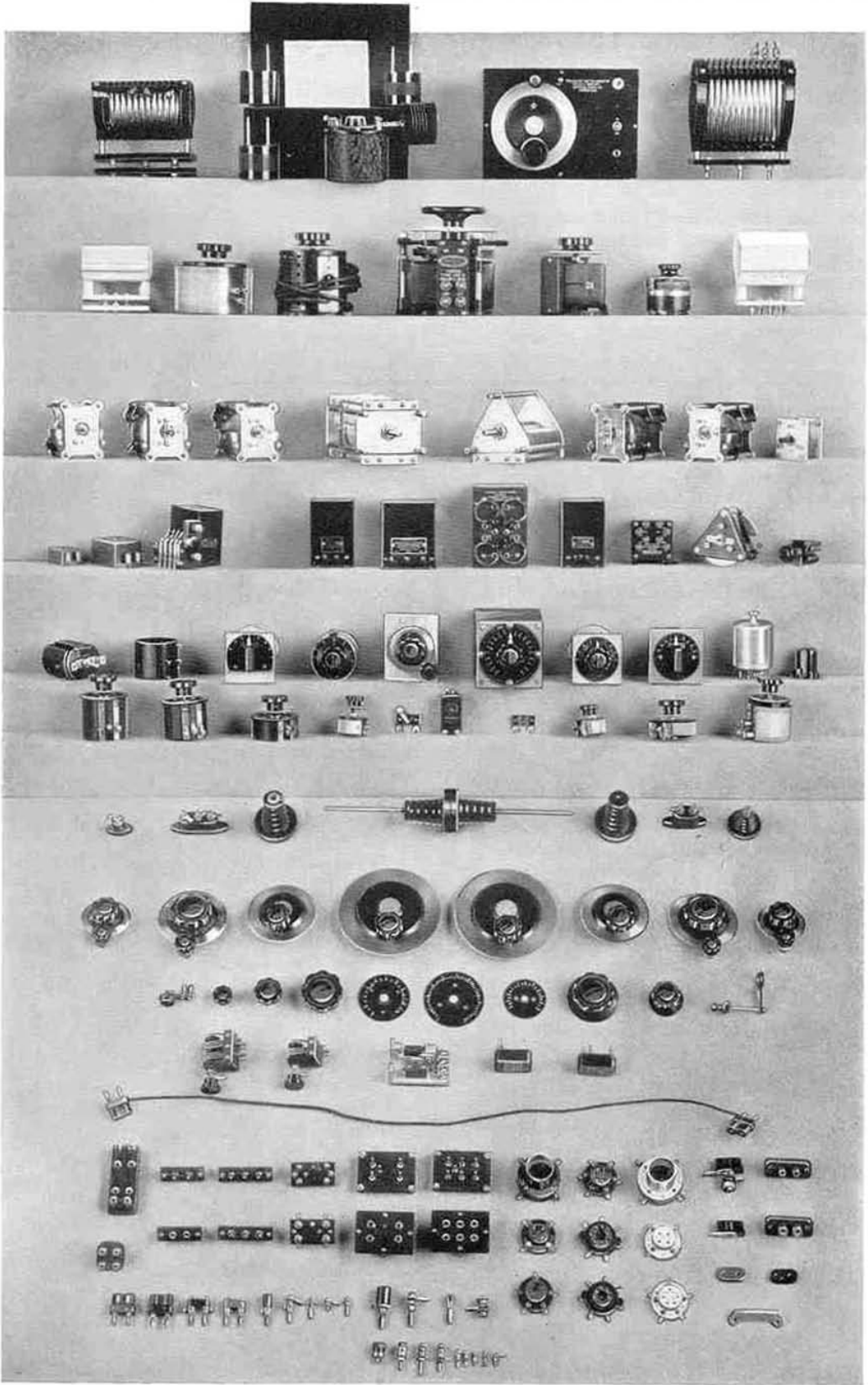

PARTS AND ACCESSORIES

DESIGN engineers and experimentalists in the radio, electrical, and allied industrial fields will find in this section a variety of unusual accessories that are obtainable nowhere else.

Since 1915 General Radio has manufactured laboratory equipment, frequency-measuring equipment, and components for the Navy, Army, Coast Guard, and other Government services; and for commercial and broadcast

companies, educational institutions, laboratories, and other manufacturers. A reputation has been acquired for building instruments of ruggedness, precision, and dependability.

The parts and accessories which this section will introduce to many new customers have all been designed for use in our own equipment. They measure up in every way to the quality standards on which our excellent reputation is based.

The following list summarizes the contents of this section

RESISTANCE DEVICES

Resistors	Page 129
Decade-Resistance Units	130
Compensated Decade-Resistance Units	131
Compensated Slide-Wire Resistors	131
Volume Controls	132-134
Rheostat-Potentiometers	135-139
Center-Tap Resistance Units	139

VARIACS

Adjustable Auto-transformers	140
------------------------------	-----

CONDENSERS

Variable Air Condensers	142-146
Decade-Condenser Units	147
Fixed Mica Condensers	148

METERS AND ACCESSORIES

Oxide Rectifier	149
Vacuum Thermocouples	150
Direct-Current Galvanometer	151

AUDIO OSCILLATORS

Microphone Hummer	152
-------------------	-----

WAVEMETERS

Absorption Wavemeter	152
Heterodyne Wavemeter	153

AUDIO TRANSFORMERS

Input and Interstage Transformers	154
Output Transformers	156
Impedance-Matching Transformers	158

RACKS AND PANELS

Relay Racks	Page 160
Universal Rack	161
Unit Panels	161, 162

INDUCTORS

Plug-in Inductors	164
Transmitting Inductors	165
Inductor Forms	165, 166
Variometer	166

DIALS

Precision Dials	167
Friction-Drive Dials	168, 170
Plain Dials	168, 170

KNOBS

169

PANEL ACCESSORIES

Dial Plates	170
Switches	170
Switch Contacts	171
Binding Posts	171

INSULATORS

Jack-Top Insulators	172
Stand-Off Insulators	172

SOCKETS

For all receiving tubes	173
-------------------------	-----

PLUGS AND JACKS

Large and small, single- and double-plug units	174
Mounting Bases	175

TYPE 500 RESISTOR

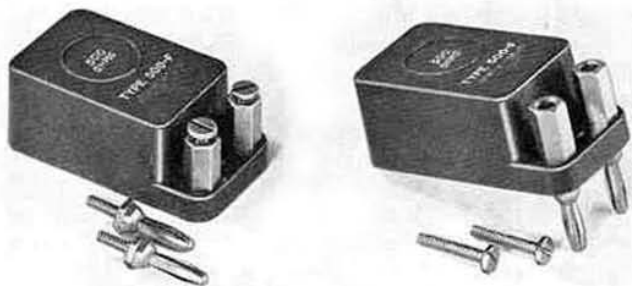

Both screw-type and plug-jack terminals are supplied with TYPE 500 Resistors

This is a precision-type resistance card, the equal in quality of the ones used in TYPE 510 Decade-Resistance Units and in General Radio decade-resistance boxes, mounted in a moulded bakelite case. It is suitable for use in either experimental or permanently assembled equipment requiring a single accurately adjusted

resistor, since it has both screw-type and plug-type terminals. Units may be stacked in series by making use of a TYPE 274-SB Short-Circuit Plug. The terminals are set on standard $\frac{3}{4}$ -inch spacing.

TYPE 500 Resistors are particularly recommended for use as resistance standards in plug-in type impedance bridges. They are also useful in test equipment (*e.g.*, as terminating impedances in transmission line measurements).

Their excellent high-frequency characteristics make them useful in receivers and low-power transmitters when stable performance is of primary importance.

Nine values of resistance are normally carried in stock, but others can be built to order. Quotations on request.

SPECIFICATIONS

Accuracy of Adjustment: Each resistor is adjusted to within 0.1% of its stated value at the terminals of the unit, except the 1-ohm unit which is adjusted to within 0.25%.

Maximum Current: All units will dissipate a maximum power of 1 watt, current corresponding to which is given in the price list.

Frequency Characteristic: The error is less than 0.1% below 50 kc. At higher frequencies errors result from skin effect and the effect of reactance in the resistor. The tables on pages 10 and 11 represent accurately the performance of the 1-ohm through 600-ohm values. For the higher values, the errors are much less than those tabulated because of the relatively negligible shunt capacitance of an isolated resistor.

Temperature Coefficient: Less than 0.002% per degree C. except on the 10,000-ohm cards where it is +0.013% per degree C. at room temperature.

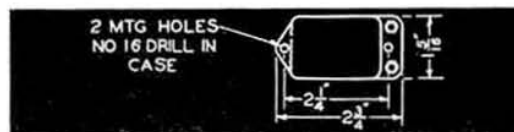

Type of Winding: Ayrton-Perry when resistance is less than 1000 ohms; 1000 ohms and over, unifilar winding on mica cards.

Terminals: Both terminal screws and plugs are supplied, and either can be used. Each terminal stud is recessed as a jack to accommodate a plug.

Mounting: Each resistor is sealed in a case of brown moulded bakelite with an impregnating wax that protects the unit from moisture. Two mounting holes are provided (see drawing).

Dimensions: See accompanying drawing. Over-all height, exclusive of plugs, 1 inch.

Net Weight: 2 ounces.

Type	Resistance	Maximum Current	Code Word	Price
500-A	1 Ω	1.0 a	RESISTBIRD	
500-B	10 Ω	310 ma	RESISTDESK	
500-C	50 Ω	140 ma	RESISTFORD	
500-D	100 Ω	100 ma	RESISTFROG	
500-E	200 Ω	70 ma	RESISTGIRL	
500-F	500 Ω	45 ma	RESISTGOAT	
500-G	600 Ω	40 ma	RESISTGOOD	
500-H	1000 Ω	30 ma	RESISTHYMN	
500-J	10,000 Ω	10 ma	RESISTMILK	

TYPE 510 DECADE-RESISTANCE UNIT

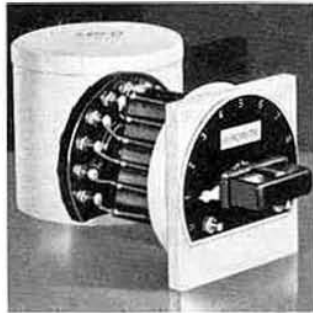

One or more precision decade resistors are frequently required for integral assembly into apparatus operating at low, voice, carrier, or radio frequencies, and in which it is not convenient to incorporate a complete TYPE 602 Decade-Resistance Box. The individual units described herewith are available for such use, and, when permanently installed, give the same convenience of a variable, shielded

standard without the unavoidable lead and wiring inductance and consequent errors at high frequencies of the external decade-box construction.

Each resistor is carefully adjusted and aged, the construction being such that there is no serious error at frequencies as high as 50 kc.* Quadruple-leaf switches running over large contacts insure a low and constant contact resistance. Operation is equally satisfactory in d-c circuits.

Each decade is enclosed in an aluminum shield, and a knob and an etched-metal dial plate are supplied. The unit is also available, complete as illustrated with shield, shield cover, blank dial plate, and switch stops, but without resistors, as the TYPE 510-P1 Switch.

SPECIFICATIONS

Accuracy of Adjustment: All resistors are adjusted to within 0.1% of the stated value between card terminals, except the 1-ohm and 0.1-ohm cards, which are adjusted to within 0.25% and 1%, respectively. Where necessary, add 0.002 ohm for each decade to allow for contact resistance.

Maximum Current: Maximum allowable temperature rise is 40°C. The currents for a 20°C. rise are approximately 0.6 of those for a 40°C. rise; values of current for each of the above conditions for each of the decades are shown in the table at the foot of the page.

Frequency Characteristic: The frequency error is less than 0.1% below 50 kc. At higher frequencies errors result from skin effect and the effect of reactance in the resistors.*

Temperature Coefficient: Less than 0.002% per degree C. except on 10,000-ohm cards where it is +0.013% per degree C. at room temperature.

Type of Winding: Bifilar type on 0.1-ohm,

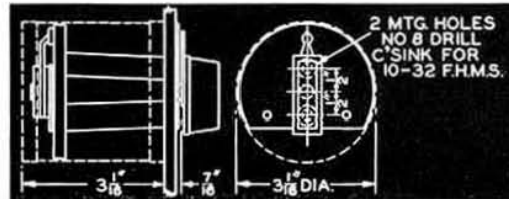

Ayrton-Perry on 1-, 10-, and 100-ohm, and the unifilar mica type on 1000- and 10,000-ohm cards.

Switch: Quadruple-leaf, phosphor-bronze blades, canted to provide a non-cutting, wiping contact, bear on 3/8-inch studs. A cam-type detent is provided. There are 11 contacts.

Mounting: Adaptable to any panel between 1/4 and 3/8 inch. See sketch.

Dimensions: See sketch. Shaft diameter, 3/8 inch.

Net Weight: TYPE 510 units, 11 ounces; TYPE 510-P1, 9 1/2 ounces.

Type	Resistance		Maximum Current		Code Word	Price
	Total	Per Step	20°C. Rise	40°C. Rise		
510-A	1 Ω	0.1 Ω	1 a	1.5 a	ELATE	
510-B	10 Ω	1 Ω	600 ma	1 a	ELDER	
510-C	100 Ω	10 Ω	170 ma	250 ma	ELEGY	
510-D	1000 Ω	100 Ω	50 ma	80 ma	ELBOW	
510-E	10,000 Ω	1000 Ω	15 ma	23 ma	ELECT	
510-F	100,000 Ω	10,000 Ω	5 ma	7 ma	ELVAN	
510-P1	Switch				ENVOY	

*See pages 10, 11.

TYPE 668 COMPENSATED DECADE-RESISTANCE UNIT

Although the inductance of TYPE 510 Decade-Resistance Units has been reduced to a very small value, it is still large enough to introduce errors in precise capacitance measurements at radio frequencies and inductance measurements at audio frequencies. It is impossible to build an ideal, inductance-free resistor, and the next best thing is a unit in which the inductance is kept constant.

The TYPE 668 Compensated Decade-Resistance Unit is equipped with a double set of switch contacts, by means of which a copper winding is exchanged, step by step, for the resistive turns in order to keep the total inductance independent of the resistance setting. The total inductance of each unit is given in

the price list.

The method of mounting is identical with that of the TYPE 510 Decade-Resistance Unit, except that no aluminum shield is provided. The three types of this unit, when mounted together or combined with TYPES 669-A or -R as a resistance box, are available as the TYPE 670 Compensated Decade Resistor.*

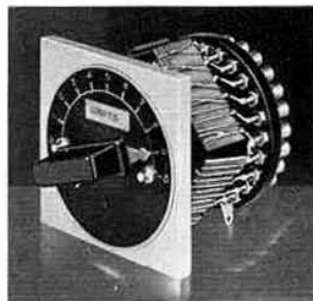

*Detailed information on request.

SPECIFICATIONS

Type of Winding: Same as for TYPE 510 Units.

Switch: A double switch, similar in construction to the single switch used with TYPE 510, is used.

Maximum Current: Maximum allowable temperature rise is 40° C. for which the maximum currents are 1.5 a, 0.5 a, and 0.16 a, for the 0.1-, 1-, and 10-ohm steps, respectively. The currents for a 20° rise are approximately 0.6 of these values.

Accuracy of Adjustment: For 0.1-ohm steps, 1%; for 1-ohm steps, 0.25%; for 10-ohm steps, 0.1%. Where necessary, add the value of "Zero Resistance" given in the price list. Inductance constant to within 0.05 μh.

Frequency Characteristic: Approximately the same as for TYPE 510.

Mounting: A combination dial plate and drilling template are furnished. Interchangeable (except for stops) with TYPE 510, *q.v.*

Dimensions: Diameter, 3 1/8 inches; depth behind panel, 3 inches, over-all; shaft diameter, 3/8 inch.

Net Weight: 10 ounces.

Type	Resistance			Total L	Code	Word Price
	Total	Steps	Zero			
668-A	1 Ω	0.1 Ω	0.005 Ω	0.15 μh	GABLE	
668-B	10 Ω	1.0 Ω	0.020 Ω	0.3 μh	GAILY	
668-C	100 Ω	10.0 Ω	0.015 Ω	0.5 μh	GALOP	

TYPE 669 COMPENSATED SLIDE-WIRE RESISTOR

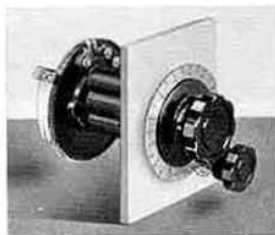

TYPE 668 Compensated Decade-Resistance Unit.*

*A description of the constructional details is available on request.

SPECIFICATIONS

Maximum Current: For 1-ohm unit, 1.6 a; for 0.1-ohm unit, 5 a.

Accuracy of Calibration: Each unit is fitted

This unit is a slide wire, compensated for inductance, for use where it is desired to secure a closer adjustment of resistance than is possible with a

with a dial individually engraved at 11 points, giving the slide-wire resistance to within 1% for the 1-ohm and 5% for the 0.1-ohm units. Where necessary, add the value of "Zero Resistance" given in the price list. Inductance constant to within 0.005 μh.

Mounting: Interchangeable with TYPE 510, except for the use of dial and slow-motion drive. A dial indicator is supplied.

Dimensions: Diameter, 3 1/2 inches; depth behind panel, 3 inches, over-all.

Net Weight: 8 ounces.

Type	Resistance		Total L	Code	Word Price
	Max.	Zero			
669-A	1 Ω	0.045 Ω	0.15 μh	GAMIN	
669-R	0.1 Ω	0.020 Ω	0.15 μh	GAZEL	

TYPE 653 VOLUME CONTROL

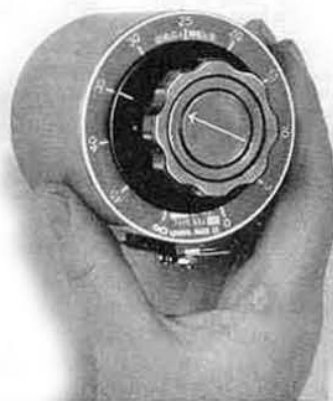
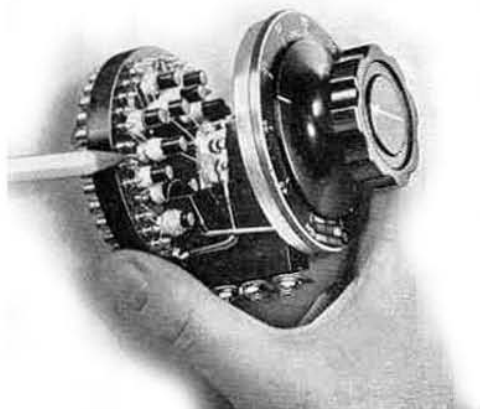

This volume control is an ideal mixer-circuit unit where the noise-level restrictions are especially severe. Many are in use in broadcasting and recording studios where low cost and trouble-free operation make them the ideal solution to the speech-input control problem.

Of particular importance is the extremely low noise level, even when the unit is used in a microphone mixer circuit without pre-amplification as is usually the case in dynamic- and velocity-type installations. There is only

one sliding contact (reducing by half the inherent contact noise over that in double-contact controls), and this one contact has been made practically noiseless through the correct choice of materials. The impedance remains practically constant in both directions throughout the attenuation range.

Another feature, found only in a volume control of this type, is the ability to "fade out" completely without disturbing associated channels.

SPECIFICATIONS

Attenuation Range: 0 db to complete cut-off. Attenuation is linear with dial setting and adjustable from 0 to 45 db in steps of about $\frac{3}{4}$ db. (Attenuation between contacts is 1.5 db, but the switch bridges two contacts in passing from one to the other.) Above 45 db, the rate of attenuation increases rapidly to "infinity" (about 120 db with the usual type of mixer wiring). There is an initial insertion loss of 6 db.

Type of Section: A ladder-type network is employed. Has advantage of only one sliding contact while maintaining essentially constant impedance.

Type of Winding: Resistors are wound on cylindrical spools which are part of the bakelite moulding.

Terminal Impedance: 50-, 200-, and 500-ohm units are carried in stock, but others can be built to order at a slight additional cost.

Shielding: An aluminum cover is a protection against dust and acts as an electrostatic shield.

Switch: A 3-bladed phosphor-bronze switch makes firm contact with bronze alloy contact points.

Terminals: Screw terminals are provided.

Dial Plate: A dial plate calibrated directly in decibels also serves as a drilling template in mounting volume control.

Knob: TYPE 637-K, with engraved white arrow.

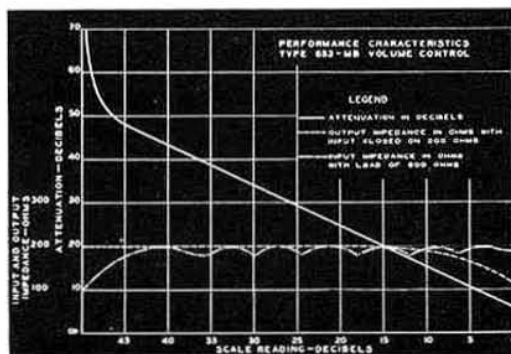

Mounting: The unit is arranged for panel mounting by means of two screws which are supplied. The volume control may be mounted on panels up to $\frac{3}{8}$ inch in thickness. Holes are spaced $1\frac{1}{2}$ inches apart.

Dimensions: Maximum over-all radius, $1\frac{3}{4}$ inches. Maximum depth behind panel, $2\frac{5}{8}$ inches. Shield diameter, $2\frac{3}{4}$ inches.

Net Weight: 13 ounces.

Type	Impedance	Code Word	Price
653-MA	50 Ω	CLUMP	
653-MB	200 Ω	COACH	
653-MC	500 Ω	COAST	

TYPE 552 VOLUME CONTROL

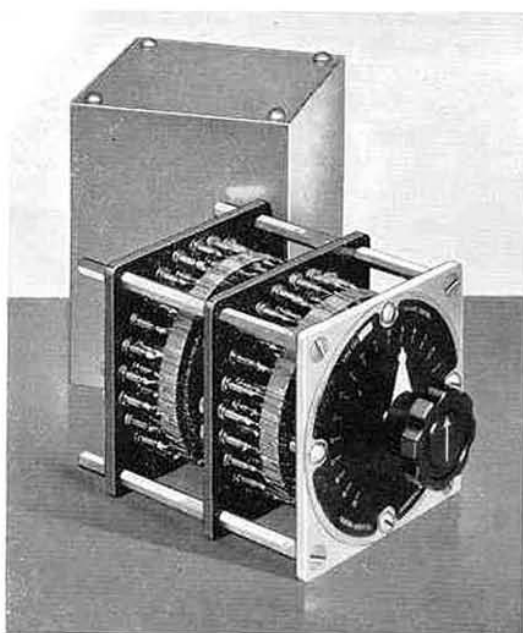

TYPE 552-HB

This unit has been designed primarily as a master gain control in high-grade broadcast transmission, sound-recording and projection, and public-address systems. Where the very finest equipment is being installed, its use is also recommended in mixer circuits. Because of its accuracy, excellent frequency characteristic, and compactness, it will be found useful in measuring circuits where the expense of our high-precision attenuation networks is not justified.

The design of the individual resistors makes a very rigid mechanical construction. The whole assembly is built to withstand the most severe service requirements.

No slide-wire contacts are used; the action is entirely step by step. This increases the reliability of the unit, at the same time making exact duplication of attenuation settings easily possible. The step-by-step contacts used in this volume control also have a slightly lower noise level than the best of sliding contact. Contacts have been run for 200,000 operations without showing signs of appreciable wear.

SPECIFICATIONS

Range: One range, 0 db to 30 db, in steps of 1.5 db is carried in stock, but special ranges can be built to order.

Type of Section: T-section and balanced-H-section models are available.

Type of Winding: Unifilar winding on bakelite strips as shown in the accompanying illustration.

Terminal Impedance: Units for working in 200-ohm and 500-ohm circuits are carried in stock, but others can be built to order.

Accuracy: All resistors are adjusted to within 2%, which makes the error in attenuation less than 1 db at all settings up to 20 kc.

Switch: A multiple blade switch is used.

Mounting: The entire unit is supported on a square aluminum sub panel that can be mounted on a panel by means of the same four machine screws that hold the etched-metal dial plates.

Terminals: A terminal strip mounted with soldering lugs is mounted behind the sub panel.

Dimensions: Sub panel, 4 1/4 x 4 1/4 inches; depth behind panel: 3, for T-section models; 5 1/2 inches for balanced-H-section models.

Net Weight: 2 pounds for T-section, 3 pounds for balanced-H-section models.

Type	Attenuation	Impedance	Section	Code Word	Price
552-TB	30 db in steps of 1.5 db	200 Ω	T	ALIEN	
552-TC	30 db in steps of 1.5 db	500 Ω	T	ALARM	
552-HB	30 db in steps of 1.5 db	200 Ω	Balanced-H	ALBUM	
552-HC	30 db in steps of 1.5 db	500 Ω	Balanced-H	AGAIN	

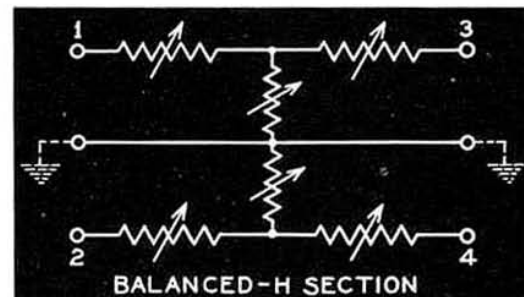
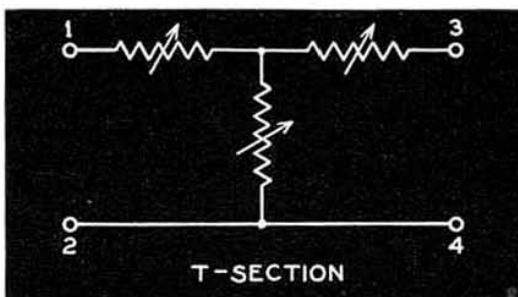

Both networks maintain constant impedance in both directions, but the balanced-H-section is used where the transmission circuit must be balanced to ground

TYPE 642-D VOLUME CONTROL

This high-impedance voltage-divider unit is intended for use as a gain control in the input circuit of a vacuum tube or as a multiplier for a vacuum-tube voltmeter. It is compact and ruggedly constructed, the contact noise level being sufficiently low to



permit of its use in the highest quality circuits. With sufficient care in keeping down the stray capacitances in the wiring between the volume control output and the socket, the

calibration is accurate to within 0.1 db at all frequencies up to 10,000 cycles.

Only one type is available in stock, but units having different values of impedance or of attenuation per step can be built to order. Designs are, in general, limited to a total of 10 steps. Prices on request.

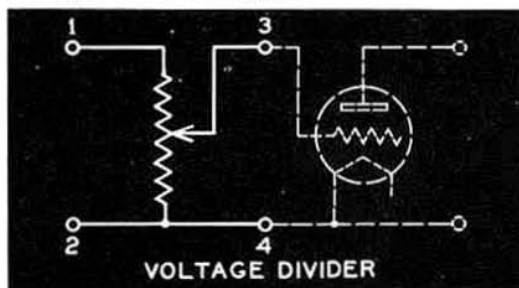

SPECIFICATIONS

Range: One range, 0 db to 30 db, in steps of 3 db is carried in stock, but other sizes can be built to order.

Type of Section: Voltage divider for working into a high-impedance circuit such as the grid of a tube.

Type of Winding: Individual random-wound, non-inductive resistors are used.

Terminal Impedance: The input impedance of the unit is 200,000 ohms when the switch side is connected across the grid-filament circuit of a vacuum tube or other essentially infinite-impedance load.

Accuracy: All resistors are adjusted to within 1%, which makes attenuation ratios accurate to within 0.1 db. If capacitance of tube, socket, and wiring is less than 20 μf , as is usually the case, the rated accuracy limit of 0.1 db holds to approximately 10,000 cycles.

Maximum Current: Although normally used in circuits drawing no current, a current of 4 ma will not cause a temperature rise sufficient to affect the rated accuracy.

Switch: The switch arm is constructed of four-leaf phosphor bronze, which provides for long wear and exceptionally low contact noise. The cam-type detent may be easily removed if smooth switch action is required.

Mounting: This unit is similar in construction to the TYPE 510 Decade-Resistance Units. The form supporting the resistors and the switch is made of moulded bakelite, and this is attached to a panel by the same two screws which hold the etched-metal dial plate as in TYPE 510 Decade-Resistance Units.

Terminals: Three soldering lugs are placed at the end of the unit for making connections, and the shield has a small opening for connecting wires.

Dimensions: Shield diameter, 3 $\frac{1}{16}$ inches; depth behind panel, 3 $\frac{1}{16}$ inches.

Net Weight: 16 ounces.

Type	Attenuation		Impedance	Code	
	Total	Steps		Word	Price
642-D	30 db	3 db	200,000 Ω	EXALT	

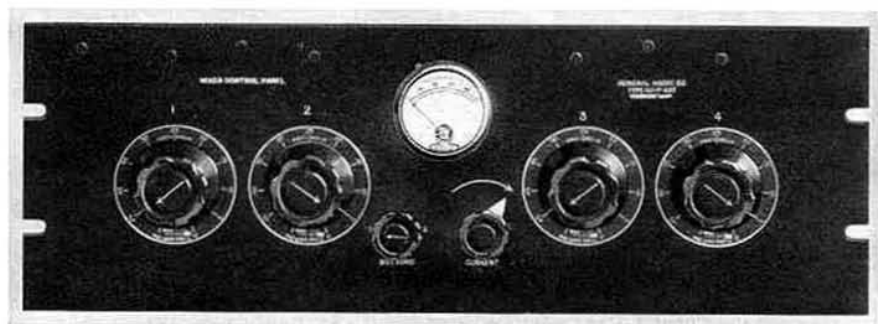

A four-channel mixer panel assembled from TYPE 653 Volume Controls

RHEOSTAT-POTENTIOMETERS

(VOLTAGE DIVIDERS)

The complete line of adjustable resistors described on the following pages is the direct outgrowth of the need for filament-current controls in vacuum-tube circuits. Other applications are found in all kinds of electrical apparatus where vacuum tubes, resistance bridges and thermocouples are involved.

Units are available from stock with power-dissipation ratings as high as 250 watts and maximum-resistance ranges extending from 0.75 ohm to 200,000 ohms.

Because of the "straight through" shaft construction, these rheostat-potentiometers may be ganged up on the same shaft to provide simultaneous variations of many separate elements under single control. Complicated fader networks may be built up by using flexible couplings or by the substitution of a single shaft of insulating material passing through all of the controls.

All but largest and smallest types are interchangeable on the standard three-hole mounting shown below. When ganged, they may be set up back to back on either side of a sheet support.

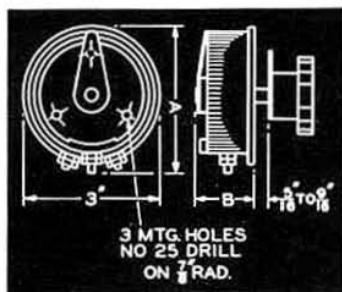

Standard 3-hole mounting method for rheostat-potentiometers

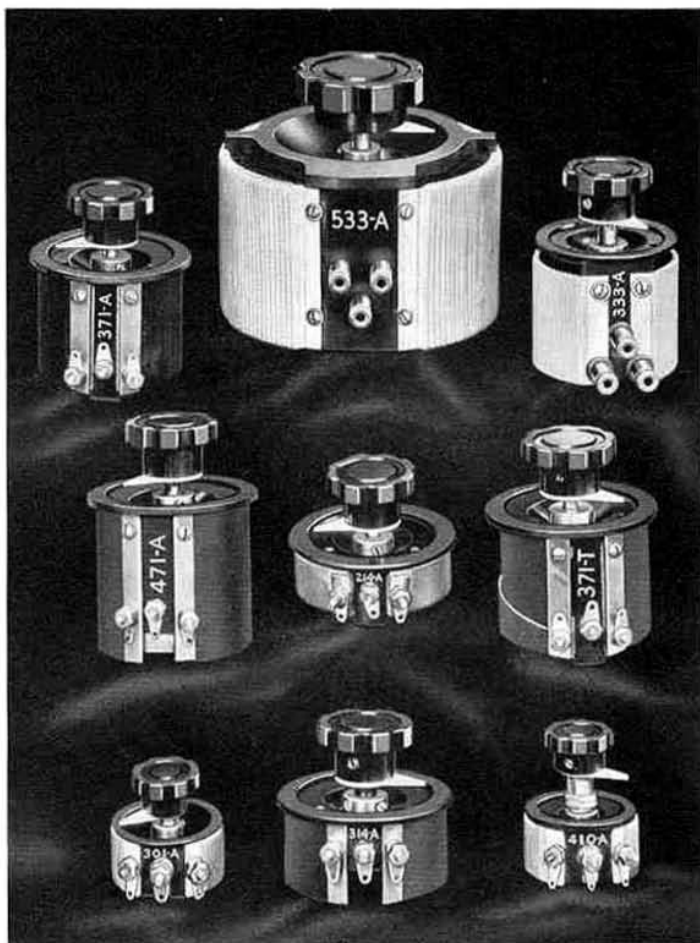

AS PANEL-MOUNTING MODELS

Every General Radio rheostat-potentiometer is furnished ready for panel mounting, as shown in the above photograph, but every type except one

(TYPE 410) can, by a few moments' work with a screwdriver, be converted for top-of-table mounting as shown on the following pages in photographs accompanying the detailed description of each unit.

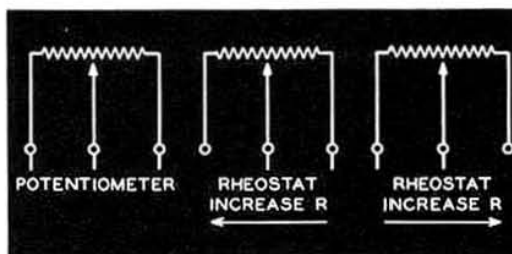

Any potentiometer can also be used as a rheostat for either direction of rotation. There is no off position.

TYPE 371 RHEOSTAT-POTENTIOMETER



Rheostat-potentiometers in this series have their resistors wound on a thin linen-bakelite strip which is then bent around the bakelite supporting form. The contact arm is a single blade that wipes the edge of the resistor.

Allowable power dissipation is 20 watts.

Values of maximum resistance between 1 ohm and 50,000 ohms can be supplied from stock, but others within the power-rating limit can be built to order.

In addition to the so-called "linear" units in which resistance is proportional to the angle through which the blade has turned, a unit having a tapered winding is available. In this (TYPE 371-T) the resistance is approximately proportional to the square of the angle, increasing with clockwise rotation of the knob in a panel-mounted unit. Other resistor shapes, such as logarithmic tapers, may be ordered.

SPECIFICATIONS

Power Rating: 20 watts; TYPE 371-T, 8 watts.
Rotation Angle: 303° (approx.). No OFF position.
Shaft: Steel, 1/4-inch diameter.
Knob: TYPE 637-G.
Mounting: Standard 3-hole; machine screws, nuts, and template furnished. Supplied as panel type, easily converted for table mounting.
Dimensions: See sketch on preceding page: A = 3 1/8, B = 2 1/2 inches.
Net Weight: 6 ounces.

Type	Maximum Resistance	Maximum Current	Code Word	Price
371-A	1 Ω	4.5 a	RALLY	
371-A	5 Ω	2.0 a	RELAY	
371-A	1000 Ω	140 ma	REDAN	
371-A	2500 Ω	90 ma	REFIT	
371-A	5000 Ω	60 ma	ROTOR	
371-A	10,000 Ω	45 ma	ROWDY	
371-A	18,000 Ω	30 ma	RULER	
371-A	50,000 Ω	20 ma	SATYR	
*371-T	10,000 Ω	28 ma	SULLY	

*Tapered model.

TYPE 214-A RHEOSTAT-POTENTIOMETER



This unit has the same type of construction as the TYPE 371 Rheostat-Potentiometer described above, except that the winding form is narrower and the power rating and maximum resistance

values are, accordingly, smaller.

The resistor is wound on a linen-bakelite strip and the contact member is a single blade that wipes the edge of the winding. Maximum power dissipation is conservatively placed at 9 watts, values of current corresponding to which are given in the price list. Maximum resistance values range from 0.75 to 2500 ohms, but other sizes within the power-rating limit can be built to order.

Units of this type are more suitable for battery-operated installations where space is at a premium or where critical filament potentials must be maintained.

SPECIFICATIONS

Power Rating: 9 watts, see current rating below.
Rotation Angle: 315°. No OFF position.
Shaft: Steel, 1/4-inch diameter.
Knob: TYPE 637-G.
Mounting: Standard 3-hole; machine screws, nuts, and template furnished. Supplied as panel type, easily converted for table mounting.
Dimensions: See sketch on preceding page: A = 3 1/4, B = 1 1/4 inches.
Net Weight: 5 ounces.

Type	Maximum Resistance	Maximum Current	Code Word	Price
214-A	0.75 Ω	3.5 a	SHINY	
214-A	2 Ω	2.1 a	RUDDY	
214-A	7 Ω	1.1 a	RURAL	
214-A	20 Ω	0.67 a	RAZOR	
214-A	50 Ω	425 ma	RAPID	
214-A	100 Ω	300 ma	RIVET	
214-A	200 Ω	210 ma	EMPTY	
214-A	400 Ω	160 ma	ROBIN	
214-A	1000 Ω	95 ma	ENACT	
214-A	2500 Ω	60 ma	SYRUP	

TYPE 471-A RHEOSTAT-POTENTIOMETER

This rheostat-potentiometer is one of two types that have constructional features which adapt them for use in high-impedance vacuum-tube circuits. The requirements for this service are severe in that not only must the unit itself have a high resistance, but, because of the low power levels and amplification of all disturbances by the later stages, no contact noise can be tolerated.

In order to meet these requirements the high resistance is obtained by winding the card with fine wire and then protecting it externally from mechanical damage or derangement of the turns by means of a securely anchored band of linen bakelite.

Low noise levels are assured through the use of a contact arm bearing four separate wiping fingers whose average contact resistance is essentially constant for any position of the knob. The unit may be mounted directly on a

metal panel without the necessity of insulating bushings, for the insulated shaft removes all possibility of short circuits as well as any hum that would be introduced by the operator's hand.

The winding form has the same diameter with a slightly greater depth than that of the TYPE 371 Rheostat-Potentiometer described on the opposite page, but the allowable power dissipation is smaller because of the bakelite protecting strip. Values of total resistance as high as 200,000 ohms are available. Special sizes or tapered models with various characteristics can be built to order.



SPECIFICATIONS

Power Rating: 12 watts.
Rotation Angle: 294° (approx.). No OFF position.
Shaft: Bakelite, 3/8-inch diameter.
Knob: TYPE 637-H.
Mounting: Standard 3-hole; machine screws, nuts, and template furnished. Supplied as panel type, easily converted for table mounting.
Dimensions: See sketch on second preceding page: A = 3 1/8, B = 2 5/8 inches.
Net Weight: 9 ounces.

Type	Maximum Resistance	Maximum Current	Code Word	Price
471-A	100 Ω	330.0 ma	EQUIP	
471-A	1000 Ω	104.0 ma	ERASE	
471-A	10,000 Ω	33.0 ma	ERECT	
471-A	50,000 Ω	14.7 ma	ERODE	
471-A	100,000 Ω	10.4 ma	ERUPT	
471-A	200,000 Ω	7.3 ma	ESKER	

TYPE 314-A RHEOSTAT-POTENTIOMETER

Of the same mechanical and electrical design as the TYPE 471-A Rheostat-Potentiometer described above, this unit differs from it in having the shorter winding form. It has the protected resistor, the bakelite shaft, and the 4-finger contact arm.

The winding form has the same depth, diameter, and arrangement of mounting holes as the TYPE 214-A Rheostat-Potentiometer described at the bottom of the opposite page,

but because the winding is protected, the allowable power dissipation is smaller. Resistances as high as 20,000 ohms are available from stock, and special sizes within the power-rating limit can be built to order.



SPECIFICATIONS

Power Rating: 6 watts.
Rotation Angle: 294° (approx.). No OFF position.
Shaft: Bakelite, 3/8-inch diameter.
Knob: TYPE 637-H.
Mounting: Standard 3-hole; machine screws, nuts, and template furnished. Supplied as panel type, easily converted for table mounting.
Dimensions: See sketch on second preceding page: A = 3 1/4, B = 1 3/8 inches.
Net Weight: 6 ounces.

Type	Maximum Resistance	Maximum Current	Code Word	Price
314-A	200 Ω	165 ma	ENATE	
314-A	600 Ω	95 ma	ENDOW	
314-A	2000 Ω	52 ma	ENEMY	
314-A	6000 Ω	30 ma	ENJOY	
314-A	20,000 Ω	16 ma	ENROL	

TYPE 533-A RHEOSTAT-POTENTIOMETER

This is a heavy-duty unit, which can dissipate 250 watts under continuous load. The frame is of moulded bakelite, and the resistance element is wound on an asbestos-covered aluminum strip that serves to distribute the heat to be dissipated to all portions of the element for better radiation. This unit, and the one listed below, should not be used in closed compartments or where a means of ventilation has not been provided to keep the temperature of associated apparatus at a reasonable value.

Both types are equipped with three TYPE 138-V combination binding post and plug jacks set on standard spacing so that tight plug-in connections may be made to obtain immediately a rheostat of either direction of rotation for increased resistance, or a fixed resistance from which a variable tap is to be taken.

Seven maximum resistance values are carried in stock but others of the same power rating can be built to order.

SPECIFICATIONS

Power Rating: 250 watts, see current rating below.
Rotation Angle: 305° (approx.). No OFF position.

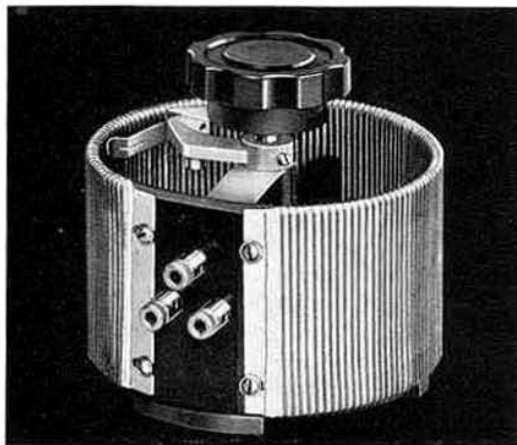

Shaft: Steel, 3/8-inch diameter.

Knob: TYPE 637-Q.

Mounting: Table type supplied, easily converted for panel mounting; see accompanying sketch. Machine screws, nuts, and a drilling template are furnished.

Dimensions: See accompanying sketch.

Net Weight: 1 7/8 pounds.

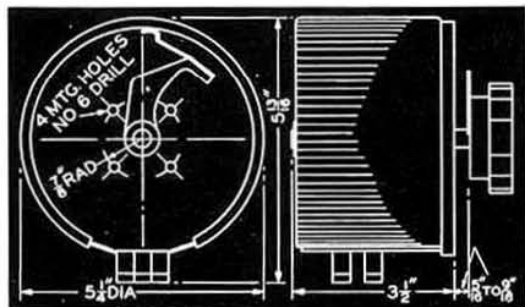

Type	Maximum Resistance	Maximum Current	Code Word	Price
533-A	1 Ω	15.8 a	MOLAR	
533-A	3 Ω	9.1 a	MONAD	
533-A	10 Ω	5.0 a	MORAL	
533-A	30 Ω	2.9 a	MOTTO	
533-A	100 Ω	1.6 a	MUGGY	
533-A	300 Ω	0.9 a	MUMMY	
533-A	600 Ω	0.6 a	MUSTY	

TYPE 333-A RHEOSTAT-POTENTIOMETER



This unit, although smaller, has the same constructional features as the TYPE 533-A Rheostat - Potentiometer described above. It has the standard 3-hole mounting which makes it interchangeable with the units shown on the next page.

Its power dissipation rating is 100 watts.

SPECIFICATIONS

Power Rating: 100 watts.

Rotation Angle: 289° (approx.). No OFF position.

Shaft: Steel, 3/8-inch diameter.

Knob: TYPE 637-H.

Mounting: Standard 3-hole; machine screws, nuts, and template furnished. Supplied as panel type, easily converted for table mounting.

Dimensions: See sketch on third preceding page: A = 4, B = 2 5/8 inches.

Net Weight: 11 ounces.

Type	Maximum Resistance	Maximum Current	Code Word	Price
333-A	1 Ω	10.0 a	VALOR	
333-A	3 Ω	5.8 a	VAPID	
333-A	10 Ω	3.2 a	VENUS	
333-A	30 Ω	1.9 a	VIGIL	
333-A	100 Ω	1.0 a	VIGOR	
333-A	300 Ω	0.6 a	VILLA	
333-A	600 Ω	0.4 a	VIPER	

TYPE 301-A RHEOSTAT-POTENTIOMETER



Rated at a maximum power dissipation of 5 watts, this is the smallest rheostat-potentiometer we manufacture. Because of its compactness it is ideal for filament controls on small tubes.

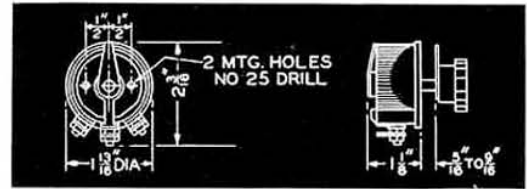

Dimensions: See accompanying sketch.
Net Weight: 3 ounces.

SPECIFICATIONS

Power Rating: 5 watts; 3 watts on 10,000 Ω and 20,000 Ω models.

Rotation Angle: 254° (approx.). No OFF position.

Shaft: Steel, 1/4-inch diameter. **Knob:** TYPE 637-A.

Mounting: Panel type supplied; easily converted for table mounting. Machine screws, nuts, and template furnished.

Type	Maximum Resistance	Maximum Current	Code Word	Price
301-A	6 Ω	1 a	PALSY	
301-A	12 Ω	0.7 a	REMIT	
301-A	25 Ω	0.5 a	RENEW	
301-A	200 Ω	175 ma	REBUS	
*301-A	10,000 Ω	17 ma	CURRY	
*301-A	20,000 Ω	12 ma	CRUMB	

*Supplied with linen-bakelite protecting strip.

TYPE 410-A RHEOSTAT-POTENTIOMETER



This is identical with the TYPE 301-A Rheostat-Potentiometer described above, except that it is equipped for single-hole mounting, often a convenient feature. This unit cannot ordinarily be used on metal panels.

SPECIFICATIONS

Power Rating: 5 watts.

Rotation Angle: 254° (approx.). No OFF position.

Shaft: Steel, 1/4-inch diameter. **Knob:** TYPE 637-A.

Mounting: Single-hole panel type only.

Dimensions: See accompanying sketch.

Net Weight: 3 ounces.

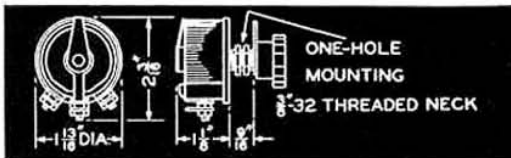

Type	Maximum Resistance	Maximum Current	Code Word	Price
410-A	6 Ω	1 a	SABOT	
410-A	12 Ω	0.7 a	SALON	
410-A	25 Ω	0.5 a	SALTY	
410-A	200 Ω	175 ma	SATIN	

TYPE 437 and TYPE 439 CENTER-TAP RESISTANCE UNITS

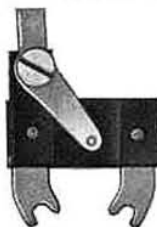

TYPE 437

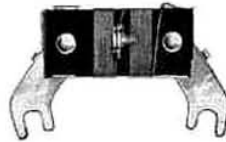

TYPE 439

These two units mount directly on the terminals of a General Radio tube socket, offering a means of connecting a grid- or plate-return lead to the mid-potential point of the filament or heater. TYPE 437 has the adjustable mid-point.

SPECIFICATIONS

Resistance: 60 ohms.

Maximum Current: 200 ma.

Dimensions: TYPE 437, 1 3/4 x 1 1/2 x (thickness) 3/8 inches. TYPE 439, 1 3/8 x 1 1/4 x (thickness) 5/8 inches.

Net Weight: 1/2 ounce.

Type	Center Tap	Code Word	Price
437	Adjustable	PERIL	
439	Fixed	PASTY	

VARIAC

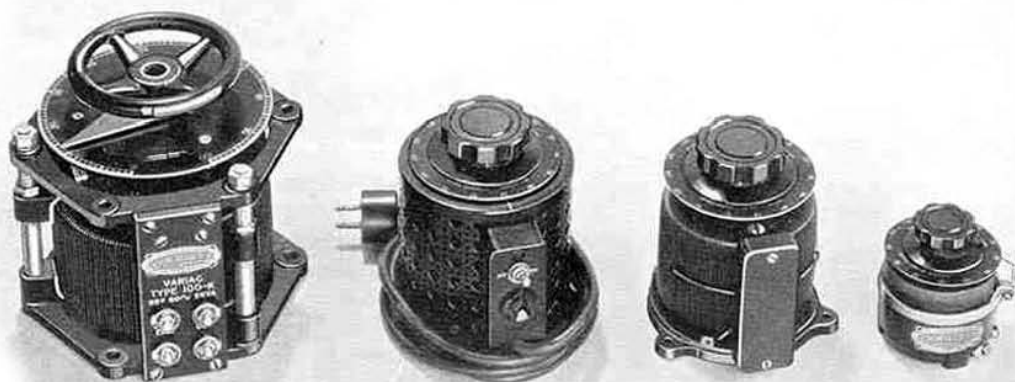

TYPE 100-K

TYPE 200-CM

TYPE 200-CU

TYPE 200-B

The Variac is an adjustable transformer that delivers any voltage between zero and line voltage with as smooth and uninterrupted control as that obtainable from any rheostat. (On one model any voltage between zero and 135 volts can be obtained from the 115-volt, 60-cycle line.)

The applications of the Variac to industrial control and to experimental problems in the laboratory are literally numberless. In general, it can be stated that the Variac is the ideal a-c voltage control device because of its high efficiency, low heat dissipation, and good voltage regulation. It has many advantages over the usual rheostat or potentiometer. The output voltage is essentially independent of load. Voltages in the vicinity of zero are obtainable, and it is possible to increase the voltage and thus provide a means of compensating for low line voltage.

This combination of qualities has been obtained by means of design features of considerable interest. The Variac in its simplest form consists of a laminated iron core built up of toroidal punchings. A single-layer winding traversed by a moving blade provides both the transformer effect and a convenient means of voltage adjustment. Since each turn of the winding can be reached by the switch, a continuous adjustment of voltage is obtained. The transformers are designed to have about 0.25 to 0.5 volt between turns. A carbon brush on the switch limits the current in the short-circuited turn so that no undue heating results.

The following are a few suggested uses:

Voltage Control on Rectifier Systems — A power pack for supplying dc to vacuum tubes with a Variac in the primary of the supply transformer gives d-c voltage control over the complete range with equally low percentage regulation at all output voltages.

Over- and Under-Voltage Testing — Operating tests on radio receivers and other socket-power household devices are facilitated.

Low Line Voltage Compensation — Line voltage can be restored to normal when, because of heavy loading or a long line, full voltage cannot be obtained otherwise.

Meter Calibration — Calibration, by comparison with a standard, of a-c voltmeters and ammeters.

Motor Speed Control — The Variac is a convenient means of adjusting speed on small voltage-sensitive motors like those used on jewelers' lathes.

Theater-Lighting Control — Especially useful on "little theater" and drama-club stages.

Soldering Iron Control — Economical maintenance of operating temperature. One can heat a cold iron quickly by applying over-voltage.

Photoflood Lamps — Photographers use the Variac to reduce brilliancy during preliminary adjustments and lengthen lamp life.

Transformer Testing — Variac control in transformer primary circuits eliminates the third harmonic component of output voltage that is present when magnetizing current flows in a resistive control.

The Variac is carried in stock in the five types described in the following specifications. We can, however, build on order other sizes within the limits imposed by available core structures. Prices will be furnished on request.

SPECIFICATIONS

Load Rating: The value of "Load Rating" specified in the price list for each model is the full-voltage volt-ampere rating of a constant-impedance load. In other words, TYPE 100-K will control at any setting a bank of lamps rated 2 kva at 115 volts.

Current: The "Rated Current" specified in the price list can be drawn safely at any point in the output-voltage range, but at some settings this rated value of load current may be exceeded. This increased current is the "Maximum Current" given in the price list.

Since the Variac is an auto-transformer, maximum loss (which determines the rating) occurs at one-half line voltage. In the vicinity of full-line voltage, however, there is no transformer action, and the allowable current is limited only by heating in the brush, which permits the "Maximum Current" rating at this point.

Consequently, a Variac can handle, for any setting, a constant-impedance load (such as a bank of lamps) which draws at full voltage a current no greater than the specified "Maximum Current."

Calibration: Dials giving a voltage calibration accurate to $\pm 2\%$ when the line voltage has its rated value are furnished on all but TYPES 100-K and 100-L. These two have a 100-division dial plate which gives an approximate calibration, as the indicated percentage of line voltage.

Knob: TYPES 100-K and 100-L have a hand wheel with a fixed dial plate.

TYPES 200-B, 200-CM, and 200-CU have dials permanently attached to TYPE 637 Knobs.

Voltage increases with clockwise rotation of the control wheel on TYPES 100-K and 100-L. On TYPES 200-B, 200-CM, and 200-CU voltage increases with counter-clockwise rotation of the dial when arranged for table mounting.

Direction of rotation for increased voltage may be reversed by a change of connections on TYPES 200-B, 200-CM, and 200-CU, but not on TYPES 100-K or 100-L.

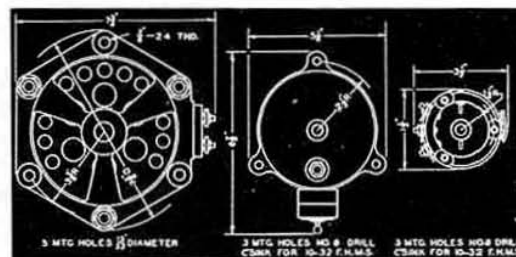

100-K, -L 200-CM, -CU 200-B
VARIAC TYPES

Terminals: TYPE 100-K and TYPE 100-L have threaded terminal studs and are supplied with soldering lugs.

TYPE 200-B has threaded terminal studs, nuts on which hold soldering lugs.

TYPE 200-CM is furnished complete with attachment cord and plug for the input connection to the mains, an ON-OFF switch, and a standard plug receptacle for the output circuit.

TYPE 200-CU is provided with soldering lugs placed inside the bakelite housing.

Mounting: All models are readily converted from the table mounting illustrated to back-of-panel mounting. TYPES 100-K and 100-L can be mounted back-to-back in cascade for operation by a single shaft. See accompanying drawing for mounting dimensions.

TYPES 100-K, 100-L, 200-CU, and 200-B are supplied without a case. TYPE 200-CM has a protecting case.

Dimensions: See sketch. Over-all height: TYPE 100-K, $7\frac{3}{8}$; TYPE 100-L, 8; TYPE 200-B, $3\frac{3}{4}$; and TYPES 200-CM and 200-CU, $5\frac{1}{2}$ inches.

Net Weight: TYPE 100-K, $20\frac{3}{8}$; TYPE 100-L, $23\frac{3}{4}$; TYPE 200-B, $2\frac{3}{4}$; TYPE 200-CM, 10; and TYPE 200-CU, 9 pounds.

Type	Load Rating	Primary Voltage*	Current		Output Voltage	Code Word	Price
			Rated	Maximum			
100-K	2 kva	115 v	15 a	17 a	0-115 v	BEAMY	
100-L	2 kva	115 v 230 v	8 a	9 a	0-230 v	BEARD	
200-B	170 va	115 v	1 a	1.5 a	0-115 v	BALSA	
200-CM	850 va	115 v	5 a	7.5 a	0-130 v	BALMY	
200-CU	850 va	115 v	5 a	7.5 a	0-130 v	BAKER	

*50-60 cycles, ac only.

TYPE 539 VARIABLE AIR CONDENSER (UNMOUNTED MODELS)

This is a high-grade laboratory-type condenser that is used in many laboratories where permanently assembled experimental equipment is being built. It has the lowest losses of any General Radio laboratory-type condenser and these losses remain practically constant with setting.

Three brass rods, extensions of which serve as mounting pillars, rigidly support the two end plates on each of which is a block of isolantite carrying the two rods to which the stator is attached. This construction facilitates the use of special plate shapes, like those in the TYPE 539-T (straight-line frequency, 270° angle of rotation) Condenser and the TYPE 539-X which is used to spread out the scale of beat-frequency oscillators.

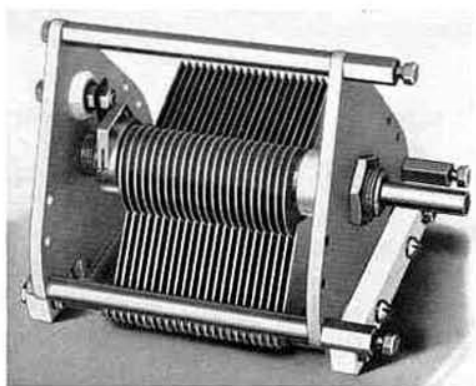

This TYPE 539-TA Condenser is of interest because the entire rotor assembly (as well as the stator) is insulated from the end plates

SPECIFICATIONS

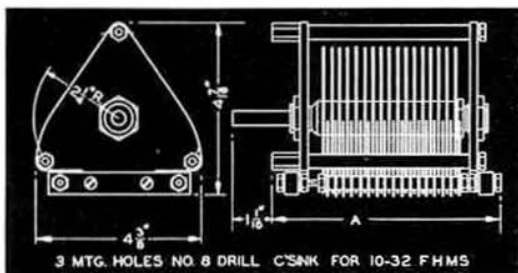

Capacitance Range: See price list.

Plate Shape: Semicircular rotor plates giving linear capacitance variation with setting are used on TYPES 539-J, 539-K, and 539-L.

Rotor plates for TYPES 539-T and 539-TA are cut to give a linear frequency variation with setting over 250° of a possible 270° angle of rotation when a capacitance of 25 μmf is connected in parallel with the condenser. They are assembled on the shaft so that counter-clockwise rotation produces an increase in frequency. The resulting frequency ratio is 3:1 starting from a setting corresponding to a condenser capacitance of 33 μmf , approximately.

TYPE 539-X has a spread-out scale for use on a beat-frequency oscillator. When it is used in a beat-frequency oscillator having a carrier in the vicinity

of 165 kc and an associated zero capacitance of 1500 μmf , a frequency range of from 0-10,000 cycles is covered by approximately 230° on the dial: 0-100 cycles is covered by 40°, 100-1000 cycles by 50°, and 1000-10,000 cycles by 140°, approximately.

Supports: Two bars of isolantite, treated to prevent absorption of moisture, support the stator assembly.

Low Losses: $R\omega C^2$ is approximately 0.03×10^{-12} .

Maximum Voltage: TYPE 539-J is conservatively rated at 1100 volts, peak; TYPE 539-K at 800 volts, peak; and TYPES 539-L, 539-T, 539-TA, and 539-X at 550 volts, peak.

Knobs and Dials: None are supplied. Note that all models have $\frac{3}{8}$ -inch shafts and that TYPES 539-T, 539-TA, and 539-X require a scale spread over 270°, instead of the 180° required by the other types.

Terminals: Soldering lugs are mounted on the lower isolantite support of all except TYPE 539-TA. The rotor connection for this condenser is brought out through an isolantite bushing in the rear end plate.

Mounting: See accompanying outline drawing.

Dimensions: See accompanying outline drawing. Depth behind panel (A), $5\frac{15}{16}$ inches, over-all.

Net Weight: Approximately $2\frac{3}{4}$ pounds.

Type	Nominal Capacitance		Description	Code Word	Price
	Maximum	Minimum			
539-J	500 μmf	50 μmf	Straight-line capacitance	ATLAS	
539-K	1000 μmf	55 μmf	Straight-line capacitance	ATONE	
539-L	2000 μmf	60 μmf	Straight-line capacitance	ATTIC	
539-T	500 μmf	30 μmf	Straight-line frequency	CLOSE	
539-TA	500 μmf	30 μmf	Straight-line frequency, insulated rotor	CLOTH	
539-X	900 μmf	50 μmf	Special spread-out scale	AUGER	

TYPE 568 VARIABLE AIR CONDENSER

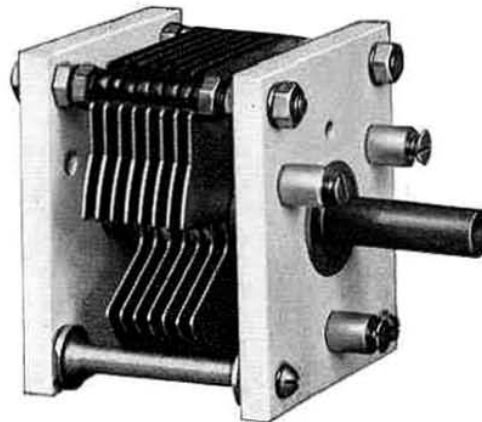

This is a condenser of rugged construction for use as a tuning element in short-wave receivers, transmitters, and wavemeters. It is designed for tandem mounting, a hollow shaft permitting the use of a single long bakelite or metal shaft for driving several units. The isolantite end plates help to keep the losses at a minimum. Contact to the rotor is made through

an eight-fingered conical bearing kept under heavy spring pressure, and, in order to reduce resistance, each plate stack is soldered into an integral piece before assembly.

Two sizes are available, one of 175- $\mu\mu\text{f}$ with straight-line-capacitance plates and the other of 50- $\mu\mu\text{f}$ with straight-line-frequency plates of decreasing frequency with clockwise rotation.

SPECIFICATIONS

Plate Shape: Straight-line capacitance for TYPE 568-D; approximately straight-line frequency for TYPE 568-K.

Supports: End plates are of isolantite, treated to prevent moisture absorption.

Low Losses: $R\omega C^2$ is approximately 0.03×10^{-12} .

Maximum Voltage: 500 volts, peak.

Knobs: None supplied. Shaft diameter, $\frac{3}{8}$ -inch; rotation angle 180° for TYPE 568-D, 270° for TYPE 568-K.

Mounting: See accompanying sketch. Drilling template and 3 flat-head screws are furnished.

Dimensions: See sketch.

Net Weight: $\frac{3}{4}$ pound.

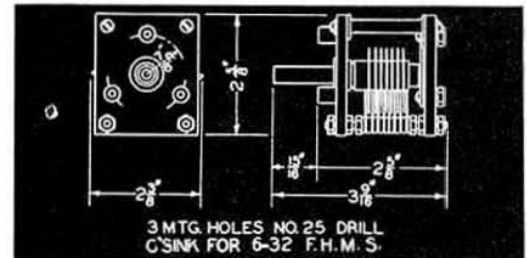

Type	Nominal Capacitance		Code	Price
	Maximum	Minimum		
568-D	175 $\mu\mu\text{f}$	12 $\mu\mu\text{f}$	CLOVE	
568-K	50 $\mu\mu\text{f}$	12 $\mu\mu\text{f}$	CLOUD	

SPECIAL CONDENSERS FOR SPECIAL NEEDS

We are equipped to build to order condensers with values of maximum capacitance other than those of the stock models described here. Non-semicircular plate shapes include those to give accurate straight-line-frequency scales or to give a logarithmic output-frequency scale in

beat-frequency oscillators. The addition of circular rotor plates will produce condensers with band-spread characteristics, variable within a fixed range, without the use of trimmer or padding capacitances. Shafts, shields, and insulating materials are supplied to specifications.

TYPES 334 and 335-Z VARIABLE AIR CONDENSERS

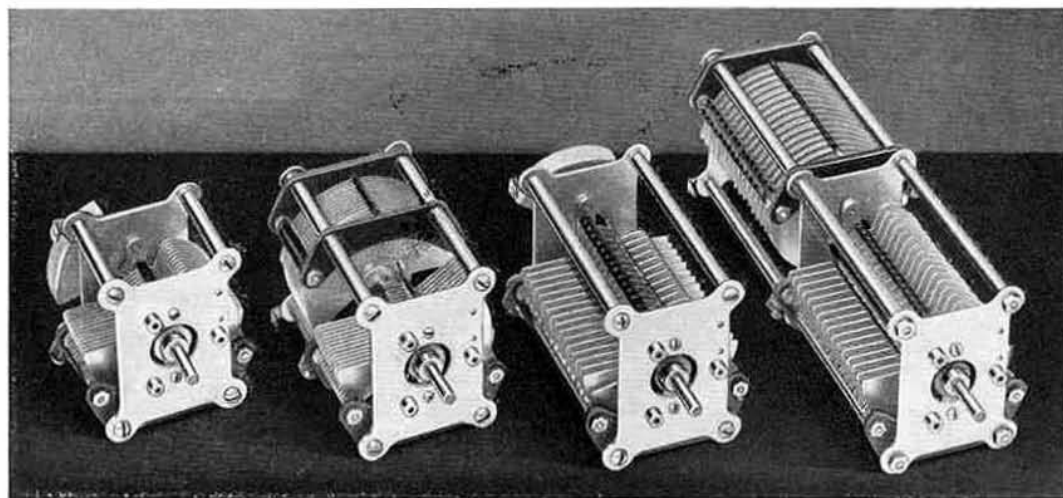

Left to right: TYPE 334-F, TYPE 335-Z, TYPE 334-R, and TYPE 334-Z

This group of condensers is available in a variety of sizes for general experimental use. They have soldered brass plates and metal end plates which are grounded to the rotor stack and to the shaft. Insulation is of hard rubber.

Models rated in the price list at 1500 volts, peak, have double the plate spacing of those rated at 500 volts, peak. The former are intended for use in power oscillators or intermediate stages of medium-power transmitters.

SPECIFICATIONS

Plate Shape: Approximately straight-line wavelength, decreasing wavelength for clockwise rotation, for all except TYPE 335-Z which has straight-line-capacitance plates.

Supports: Two small sections of first-quality hard rubber support the stator.

Low Losses: $R\omega C^2$ is approximately 0.07×10^{-12} .

Knobs and Dials: None are supplied. Shaft diameter, $\frac{1}{4}$ inch; rotation angle, 180° for all sizes.

Types 334-Z and 335-Z have balanced rotors; all others, a counterweight.

Mounting: Standard General Radio 3-hole mounting. See accompanying sketch. Drilling template and 3 flat-head screws are furnished.

Four removable feet are furnished with each of the high-voltage models.

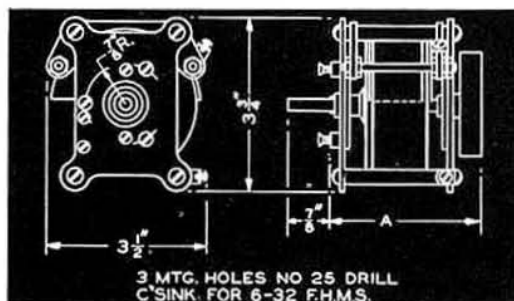

Terminals: See illustration.

Dimensions: See accompanying outline drawing. Depth (dimension A) is given in the price list.

Type	Nominal Capacitance		Maximum Peak Voltage	Depth (A)	Net Weight	Code Word	Price
	Maximum	Minimum					
335-Z	1150 $\mu\mu\text{f}$	50 $\mu\mu\text{f}$	500 v	5 $\frac{1}{4}$ in.	2 $\frac{1}{8}$ lb.	BOGUS	
334-F	500 $\mu\mu\text{f}$	20 $\mu\mu\text{f}$	500 v	3 $\frac{5}{16}$ in.	1 $\frac{1}{2}$ lb.	BEGIN	
334-N	350 $\mu\mu\text{f}$	20 $\mu\mu\text{f}$	500 v	3 $\frac{3}{8}$ in.	1 $\frac{3}{8}$ lb.	BESET	
334-K	250 $\mu\mu\text{f}$	15 $\mu\mu\text{f}$	500 v	2 $\frac{5}{8}$ in.	1 lb.	BELOW	
334-Z	500 $\mu\mu\text{f}$	35 $\mu\mu\text{f}$	1500 v	10 $\frac{1}{8}$ in.	3 $\frac{3}{8}$ lb.	BOGEY	
334-R	250 $\mu\mu\text{f}$	30 $\mu\mu\text{f}$	1500 v	6 $\frac{1}{2}$ in.	2 lb.	BISON	
334-T	100 $\mu\mu\text{f}$	15 $\mu\mu\text{f}$	1500 v	3 $\frac{1}{4}$ in.	1 $\frac{1}{8}$ lb.	BILLY	
334-V	50 $\mu\mu\text{f}$	10 $\mu\mu\text{f}$	1500 v	2 $\frac{5}{8}$ in.	$\frac{5}{8}$ lb.	BIPED	

TYPE 639-A VARIABLE AIR CONDENSER

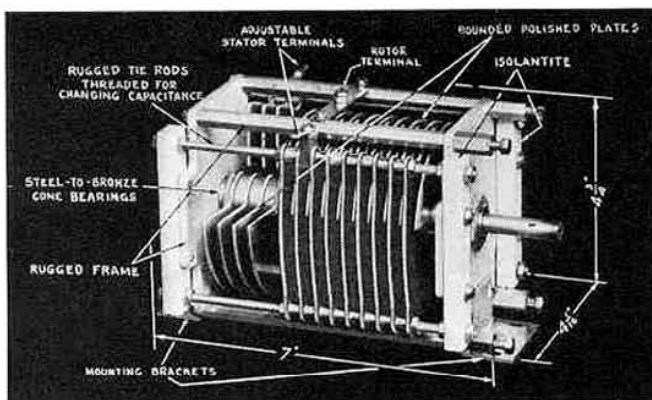

This condenser is of the double-section, high-voltage type for use in power oscillators. It has $\frac{3}{16}$ -inch aluminum end plates, large hexagonal tie-rods, and self-aligning conical bearings. The insulation is of isolantite.

Either section of the condenser can be readily taken apart and one or more plates shifted from one section to the other, thereby adjusting the capacitance, as for optimum excitation ratio in Colpitts oscillator circuits.

SPECIFICATIONS

Capacitance Range: Two sections are provided. Maximum capacitance of either section is readily adjustable from $25 \mu\text{f}$ to $305 \mu\text{f}$, or the condenser may be used as a single-section type having a maximum capacitance of $330 \mu\text{f}$.

Plate Shape: Semicircular rotor plates, giving a linear capacitance variation with setting, and requiring a dial with a scale spread over 180° .

Plate Spacing: 0.098 inch.

Isolantite Supports: Four bars of isolantite, treated to prevent absorption of moisture, support the stator assembly.

Low Losses: $R\omega C^2$ is approximately 0.03×10^{-12} .

Maximum Voltage: 3500 volts, peak.

Dimensions: Panel space, $4\frac{3}{4} \times 4\frac{1}{4}$ inches, over-all; depth behind panel, 7 inches; shaft length measured from back of panel, 1 inch.

Knob: None supplied. Shaft diameter, $\frac{3}{8}$ inch, rotation angle, 180° .

Mounting: Four nickel-plated hex-head bolts and two mounting brackets with machine screws are supplied for either back of panel or table mounting.

Net Weight: $3\frac{3}{4}$ pounds.

Type	Code Word	Price
639-A	BARGE	

TYPE 247-F VARIABLE AIR CONDENSER

This is an experimental-type condenser having soldered brass plates and hard-rubber end plates.

SPECIFICATIONS

Plate Shape: Approximately straight-line wavelength, decreasing for clockwise rotation.

Supports: Two plates of first-grade hard rubber support the assembly.

Low Losses: $R\omega C^2$ is approximately 0.08×10^{-12} .

Maximum Voltage: 500 volts, peak.

Knob: None supplied. Shaft diameter, $\frac{1}{4}$ inch; rotation angle, 180° .

Terminals: See illustration.

Mounting: See sketch. Drilling template and 3 flat-head screws furnished.

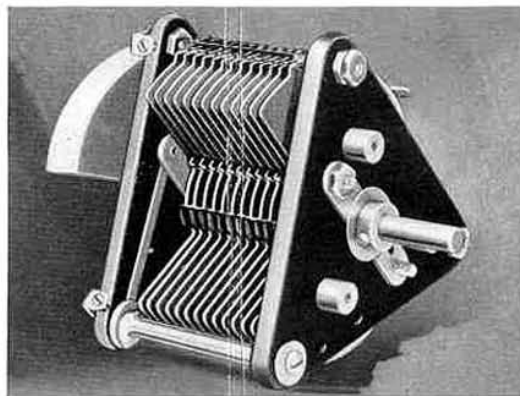
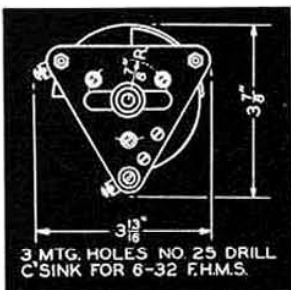

Dimensions: See sketch. Over-all depth behind panel, $3\frac{3}{8}$ inches.

Net Weight: $1\frac{3}{8}$ pounds.

Type	Nominal Capacitance		Code Word	Price
	Maximum	Minimum		
247-F	$500 \mu\text{f}$	$20 \mu\text{f}$	COCOA	

TYPE 368 VARIABLE AIR CONDENSER

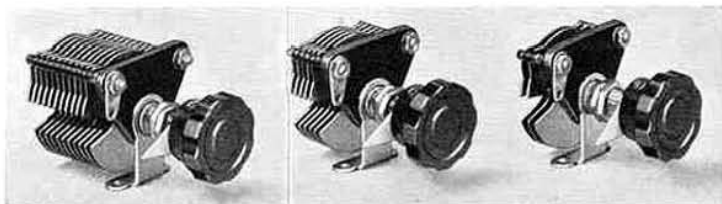

TYPE 368-C

TYPE 368-B

TYPE 368-A

This condenser is useful as a balancing or vernier condenser in various vacuum-tube cir-

uits, and many amateurs use it as a tuning condenser in receivers for the high-frequency (short-wave) bands. It has a single, hard-rubber end plate, single bearing, and can be used for single-hole panel mounting as well as for mounting on a baseboard by means of the angle bracket.

SPECIFICATIONS

Capacitance Range: See price list.

Plate Shape: Straight-line capacitance.

Support: A single, hard-rubber end plate supports the entire assembly.

Low Losses: $R\omega C^2$ is approximately 0.004×10^{-12} .

Maximum Voltage: 500 volts, peak.

Knob: TYPE 637-A Knob supplied.

Mounting: Bushing for single-hole panel mounting; bracket for baseboard mounting. See sketch.

Dimensions: See sketch and price list.

Net Weight: Approximately 3 ounces, all sizes.

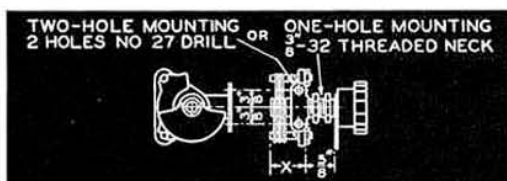

Type	Capacitance		Depth (X)	Code Word	Price
	Max.	Min.			
368-A	15 $\mu\mu f$	2 $\mu\mu f$	1 1/16 in.	BULLY	
368-B	50 $\mu\mu f$	3 $\mu\mu f$	1 5/16 in.	BURIN	
368-C	100 $\mu\mu f$	4 $\mu\mu f$	1 1/2 in.	AZURE	

TYPE 756-A VARIABLE AIR CONDENSER

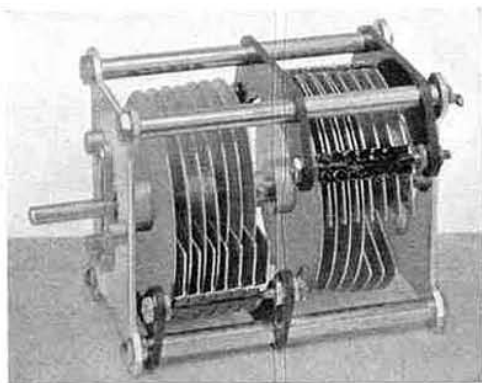

TYPE 756-A

This condenser is a double-section, band-spread type for use in circuits where two band-spread variable capacitances are required. Four of the seven rotor plates are complete circles. The position of several is adjustable along the shaft to give any desired spread.

SPECIFICATIONS

Capacitance Range: See price list.

Plate Shape: Approximately straight-line frequency; 180° dial required.

Direction of Rotation: Counter-clockwise for increasing frequency.

Supports: Two small sections of first-quality hard rubber support the stator.

Low Losses: $R\omega C^2$ is approximately 0.07×10^{-12} .

Maximum Voltage: 1500 volts, peak.

Mounting: Identical with TYPE 334 Condensers described previously.

Dimensions: Same as TYPE 334 Condensers described previously. Dimension A, 5 inches.

Net Weight: 2 pounds.

Type	Capacitance per Section		Code Word	Price
	Maximum	Minimum		
756-A	225 $\mu\mu f$	140 $\mu\mu f$	METAL	

TYPE 380 DECADE-CONDENSER UNIT

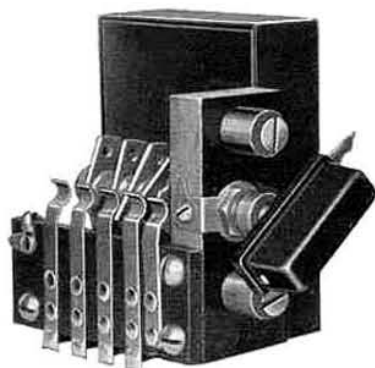

The TYPE 380 Decade-Condenser Unit is an assembly of individual paper or mica con-

densers and a selector switch arranged so that any one of 10 decade values may be chosen. It is made in three individual decade series, each with 10 steps of 0.001 μf , 0.01 μf , or 0.1 μf , respectively.

The excellence of these units is due, in large measure, to care in manufacture and aging. All mica is carefully selected and units built of them are moulded in bakelite. Paper condensers are thoroughly impregnated with molten paraffin during winding. Succeeding layers of the conducting foil make contact, thus avoiding the increase in power factor with frequency which occurs when only the ends of the winding are connected.

SPECIFICATIONS

Capacitance: Three sizes are available with decade steps of 0.001 μf , 0.01 μf , and 0.1 μf per step. See the price list. The desired value of capacitance is secured by various combinations of four condensers having values of 1, 2, 3, and 4, respectively.

Dielectric: Mica is used for the two smaller sizes and paraffin paper for the largest one.

Maximum Voltage: The maximum peak alternating-current voltage should never be allowed to exceed the rated direct-current voltage, *i.e.*, 300 volts. The losses in any condenser with the solid dielectric are a function of the applied frequency and it is necessary to consider frequency when placing a maximum voltage limit, since excessive heat can cause temperature increases that are disastrous in a calibrated unit. The peak voltage may be kept at the 300-volt maximum for frequencies below 1000 kc for the 0.001- μf decade, below 100 kc for the 0.01- μf decade, and below 1 kc for the 0.1- μf decade. At higher frequencies the voltage should be reduced in inverse proportion to the square root of the frequency.

Power Factor: $R\omega C$, the power factor, is 0.002, 0.001, and 0.010 for the 0.001- μf , 0.01- μf , and 0.1- μf units, respectively.

Calibration: The shaft of each unit is provided with a detent device to make definite the position

of the switch for each setting. Units will be found to be accurate to within 1% for the 0.001- μf and 0.01- μf decade units, and to within 2% for the 0.1- μf decade unit.

Knob: TYPE 202-Z supplied.

Mounting: Individual decades are mounted in brass cans with a bakelite panel. Combinations of decades, mounted together in the same box, are available as the TYPE 219 Decade Condenser.

Dimensions: Panel space, height, $3\frac{3}{4}$ inches; width A is shown in price list. Each unit will extend $3\frac{7}{8}$ inches behind the back face of the panel on which it is mounted.

Net Weight: Approximately $1\frac{3}{4}$ pounds, all sizes.

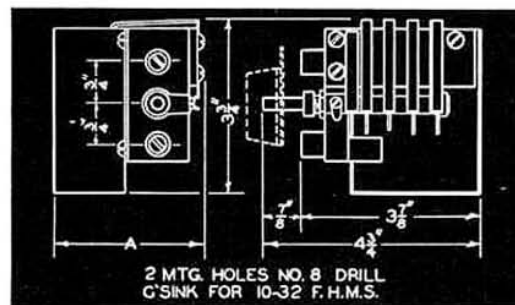

Type	Capacitance	Width (A)	Code Word	Price
380-A	1.0 μf total, in steps of 0.1 μf	$3\frac{5}{8}$ in.	ADAGE	
380-B	0.10 μf total, in steps of 0.01 μf	$3\frac{5}{8}$ in.	ADDER	
380-C	0.010 μf total, in steps of 0.001 μf	$3\frac{1}{8}$ in.	ADDLE	

TYPE 505 CONDENSER

This is a small, handy, mica condenser having low losses and excellent stability of calibration. It is temperature compensated and its price is low.

The General Radio Company has felt for some time that there is need for a well-designed condenser falling in the

quality scale between accurately adjusted primary standards on the one hand and the inexpensive moulded types on the other.

India mica was chosen as the dielectric because of its excellent characteristics and a mounting method was developed that makes capacitance practically independent of temperature and power factor of humidity.

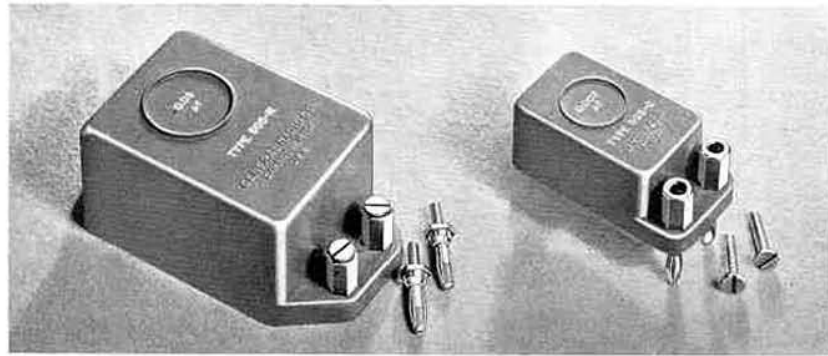

All models have both screw-type and plug-type terminals.
Left, large case; right, small case

Every piece of mica is carefully inspected for mechanical defects and other imperfections which cause large dielectric losses. Residual losses are reduced by the use of yellow low-loss bakelite for the cases.

The plug-type terminals permit these condensers to be stacked in parallel to build up any required value of capacitance.

SPECIFICATIONS

Capacitance: Sizes are available in stock as shown in the price list. (Other sizes can be built to order, prices on request.)

Accuracy of Adjustment: See price list.

Temperature Coefficient: Less than 0.006% per degree C. between 0° and 50° C.

Maximum Voltage: See price list. This rating means that the condenser will safely withstand the a-c voltage whose peak equals the given rating up to the given frequency. Above that frequency, the

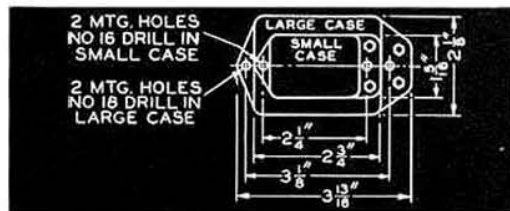

allowable voltage decreases inversely with the square root of the frequency because of the power loss.

Power Factor: Less than 0.05% for frequencies below 2 Mc, except for the three small sizes. Special precautions are taken in assembling and sealing the condensers to insure against change in capacitance or power factor due to varying moisture content of the air, and to aging. The chart shows the value of the equivalent series resistance in ohms that would have to be placed in series with a perfect condenser to give the real power loss of a TYPE 505 400- μ f Condenser.

Terminals: Screw terminals spaced 3/4 inch apart. Two TYPE 274-P Plugs are supplied with each condenser so that it may be converted to plug-terminal model.

Mounting: Low-loss (yellow) bakelite cases in two sizes as shown in the sketch. TYPES 505-R, 505-T, 505-U, and 505-X take the large case.

Dimensions: See sketch.

Net Weight: 4 ounces for small, 12 ounces for large size.

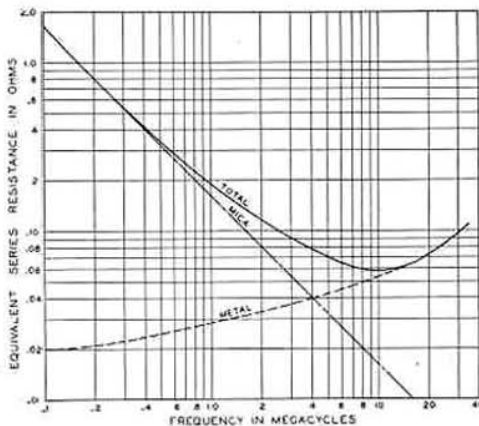

Equivalent-resistance-versus-frequency characteristic of a typical TYPE 505 Condenser

Type	Capacitance	Adjusted to		Maximum Voltage		Code Word	Price
		Within	Power Factor	Voltage at Frequency			
505-A	100 $\mu\mu\text{f}$	10%	0.1 %	1200 v	2200 kc	CONDENALLY	
505-B	200 $\mu\mu\text{f}$	5%	0.1 %	1200 v	1100 kc	CONDENBELL	
505-E	500 $\mu\mu\text{f}$	2%	0.08 %	1200 v	880 kc	CONDENCOAT	
505-F	0.001 μf	1%	0.05 %	1200 v	440 kc	CONDENDRAM	
505-G	0.002 μf	1%	0.05 %	700 v	640 kc	CONDENEYRE	
505-K	0.005 μf	1%	0.05 %	700 v	260 kc	CONDENFACT	
505-L	0.01 μf	1%	0.05 %	700 v	130 kc	CONDENGIRL	
505-M	0.02 μf	1%	0.05 %	700 v	65 kc	CONDENHEAD	
*505-R	0.05 μf	1%	0.05 %	700 v	60 kc	CONDENCALM	
*505-T	0.1 μf	1%	0.05 %	700 v	30 kc	CONDENCROW	
*505-U	0.2 μf	1%	0.05 %	700 v	16 kc	CONDENWIPE	
*505-X	0.5 μf	1%	0.05 %	500 v	12 kc	CONDENWILT	

*Mounted in large case.

TYPE 492-A OXIDE RECTIFIER

One kind of junction of copper oxide has the property of unilateral conductivity. The TYPE 492-A Oxide Rectifier consists of four copper-oxide rectifier units arranged in the form of a bridge, thus providing full-wave rectification of an applied alternating voltage. The rectifier is useful for operating relays and for measuring alternating voltages by means of d-c instruments.

The unit is offered in its present form for experimental purposes and it must be realized in this connection that changes in both sensitivity and frequency response with output load and impressed voltage are to be expected. Fixed resistors can be inserted in series or in shunt with the rectifier unit to reduce these

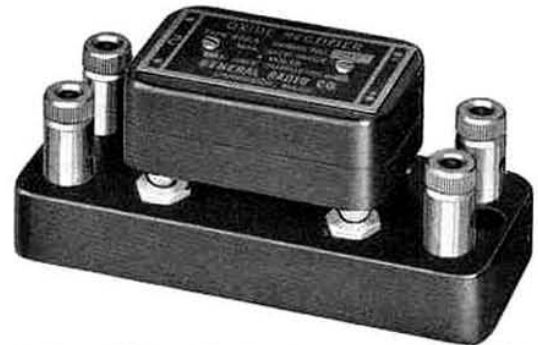

A TYPE 492-A Oxide Rectifier and a TYPE 274-RJ Mounting Base

apparent variations. TYPE 500 Resistors are recommended.

SPECIFICATIONS

Frequency Error: The rectifier may be used without appreciable frequency error at frequencies below 5000 cycles per second.

Temperature Error: Temperature errors of about 5% may be expected between normal extreme temperatures. Maximum sensitivity is obtained with a load of 5000 to 7000 ohms. This value should be used when the instrument is operating a relay. If a 1-milliamper meter of 400- or 500-ohms resistance is used, full-scale deflection will be obtained at about 2 volts across the rectifier input.

The maximum current output from the rectifier should not exceed 15 ma, nor should the impressed voltage exceed 3 volts.

Obviously, the apparent change of impedance with resistance can be greatly reduced by proper use of series and shunt resistance on the input side.

Mounting: As illustrated. Plugs fit TYPE 274-RJ Mounting Base (which is not supplied).

Dimensions: (Length) $2\frac{1}{8}$ x (breadth) $1\frac{3}{8}$ x (depth) $\frac{3}{4}$ inches, exclusive of plugs.

Net Weight: 2 ounces.

Type	Code Word	Price
492-A	FLORA	

TYPE 493 VACUUM THERMOCOUPLE

The vacuum thermocouple presents a convenient means for measuring high-frequency current. It consists of a junction of two dissimilar metals which, when heated, sets up a direct voltage capable of actuating a d-c indicating meter.

This type of instrument is a true integrating ammeter since the d-c meter reading is a function of the r. m. s. current in the heater circuit. For this reason a thermocouple and meter give results that are independent of waveform, and frequency errors can occur only at frequencies so high that the stray capacitances in the couple mounting become significant (beyond 20 Mc). The couple may be calibrated on direct current.

Both the contact type and the separate-heater type are available. In the contact type the heater circuit is in electrical contact with the couple circuit. In the separate-heater type the heating element is separated from the couple junction by a small bead of glass, thus electrically insulating the two circuits while providing good thermal contact.

The contact-type couples are easier to build and consequently less expensive, and yet our method of building the separate-heater models



TYPE 493 Thermocouples are mounted in a bakelite case with plugs to fit a TYPE 274-RJ Mounting Base

has been so greatly improved that a comparable degree of sensitivity is obtained. Separate-heater couples can, of course, be used at high frequencies with fewer precautions against the effects of stray capacitances to ground.

Thermo-junctions are mounted in an evacuated glass bulb. The vacuum reduces heat conduction from the couple as well as the effect of external temperature variations. The glass bulb is surrounded by felt and mounted in the bakelite container shown in the illustration, ready for mounting in a TYPE 274-RJ Mounting Base.

SPECIFICATIONS

Type of Couple: The type number "493" is used to designate all thermocouples described here. Contact-type thermocouples are indicated by means of a single letter which also designates the heater current, e.g., 493-A. The letter "H" is used to indicate a separate-heater type of couple, e.g., 493-HA.

Couple Resistance: The resistance of all couples is adjusted to between 10 and 12 ohms, the value engraved on each nameplate being accurate to 0.1 ohm of the actual couple resistance. This is a significant specification since the user can select a meter of the proper resistance and sensitivity to give full-scale deflection without overloading the thermoelement by considering the couple to be a generator of internal resistance equal to the couple resistance and developing an open-circuit voltage of 10 millivolts when the heater current is that given in the table on the next page.

Heater Resistance: Heaters are adjusted to within $\pm 10\%$ of the values given in the table. The actual value engraved on the nameplate is given to within 0.01 ohm for TYPES 493-A, 493-C, 493-HA, and 493-HC; to within 0.1 ohm for TYPES 493-E and 493-HE; and to within 1 ohm for TYPES 493-H, 493-K, 493-IHH, and 493-HK.

Electrical Sensitivity: The price list gives the heater current required to produce 10 millivolts across the couple terminals on open circuit. This value is held to within $\pm 10\%$.

Thermal Sensitivity: 26 microvolts per degree Fahrenheit.

Overload: All heaters will withstand a continuous overload of 50% of the current given in price list.

Coefficient of Resistance: Couple elements, 0.00013 per degree Fahrenheit; heater 0.00009 per degree Fahrenheit.

Meter: TYPE 588-AM Direct-Current Meter is recommended for use with these couples.

Mounting: Mounted in bakelite case, as illustrated, with plugs to fit TYPE 274 Mounting Bases having four jacks. The TYPE 274-RJ Mounting Base is recommended.

Dimensions: (Length) $2\frac{1}{8}$ x (breadth) $1\frac{3}{8}$ x (depth) $\frac{3}{4}$ inches, exclusive of plugs.

Net Weight: 2 ounces.

CONTACT-TYPE COUPLES

<i>Type</i>	<i>Heater Resistance</i>	<i>Current to Give 10 Millivolts Open Circuit</i>	<i>Code Word</i>	<i>Price</i>
493-A	0.5 Ω	300 ma	FUNNY	
493-C	2 Ω	100 ma	FOCUS	
493-E	10 Ω	25 ma	FOLLY	
493-H	100 Ω	8 ma	FORAY	
493-K	450 Ω	4.5 ma	FORUM	

SEPARATE-HEATER TYPE COUPLES

<i>Type</i>	<i>Heater Resistance</i>	<i>Current to Give 10 Millivolts Open Circuit</i>	<i>Code Word</i>	<i>Price</i>
493-HA	0.5 Ω	300 ma	EAGER	
493-HC	2 Ω	100 ma	EDICT	
493-HE	10 Ω	25 ma	EARLY	
493-HH	100 Ω	8 ma	EASEL	
493-HK	450 Ω	4.5 ma	EDIFY	

TYPE 588-AM DIRECT-CURRENT METER

This is a direct-current galvanometer having full-scale sensitivity of 500 microamperes and a resistance of 10.0 ohms (5 millivolts) which adapts it for use in conjunction with TYPE 493 Thermocouples. Since each thermocouple must be individually calibrated, the scale is laid out with 50 equal divisions marked from 0 to 50, thus making easy the preparation and reading of calibration curves. The meter is supplied with the TYPE 298-B Meter Mounting which has jacks for plugging in the thermocouple.

The input terminals are set on the General Radio standard 3/4-inch spacing to take all double plugs of the TYPE 274 series.



A TYPE 588-AM Direct-Current Meter showing how a TYPE 493 Thermocouple or a TYPE 492-A Oxide Rectifier can be plugged in

This meter may also be used with the TYPE 492-A Oxide Rectifier, described previously.

SPECIFICATIONS

Range: 0 to 500 microamperes full scale.

Resistance: 10 ohms, $\pm 0.5\%$.

Scale: The 2 1/2-inch scale is divided into 50 equal divisions marked 0 to 50.

Calibration: Full-scale deflection is adjusted to within 2% of the specified value of 500 microamperes. Other points are not calibrated, but de-

flection is approximately proportional to current over the entire range.

Adjustment: A screw is provided in the glass face for making the zero adjustment.

Dimensions: (Length) 5 7/8 x (width) 3 13/16 x (height) 2 7/8 inches.

Net Weight: 1 1/8 pounds.

<i>Type</i>	<i>Range</i>	<i>Code Word</i>	<i>Price</i>
588-AM	0-500 microamperes	OURMETMUSH	

**TYPE 572-B
MICROPHONE HUMMER**

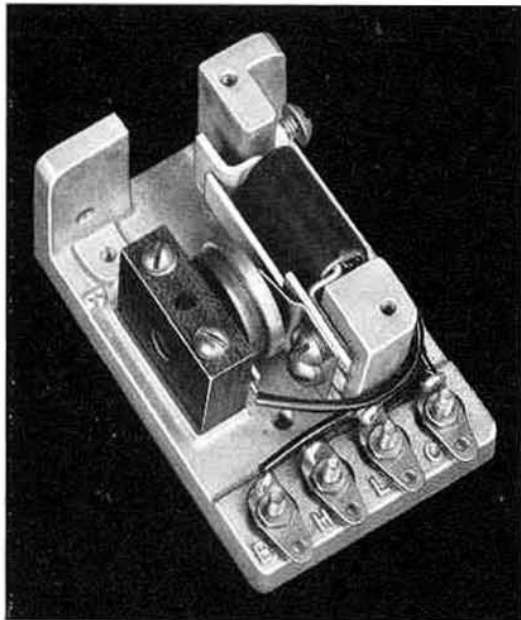

This is an electro-mechanical oscillator in which the frequency is determined by a tuned reed. It is intended for use as a low-power, a-c source for bridge and other measurements where extreme purity of waveform and frequency stability are not essential. The waveform may be improved by the addition of a 0.5- μ f condenser, mounting holes for which are provided.

SPECIFICATIONS

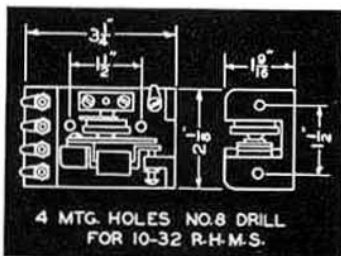

Frequency: 1000 cycles $\pm 10\%$.
Output: 20 milliwatts, maximum.
Internal Output Impedance: 10 or 300 ohms.
Power Supply: This oscillator is designed to operate from a 4½-volt battery, Burgess No. 2370, or equivalent.
Mounting: Supplied unmounted as illustrated.
Dimensions: (Length) 3¼ x (width) 2⅛ x (height) 1⅝ inches, over-all.
Net Weight: 9 ounces.

Type	Code Word	Price
572-B	APHIS	

TYPE 358 WAVEMETER

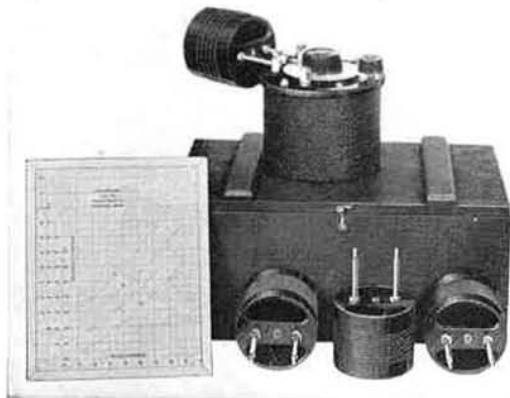

The TYPE 358 Wavemeter is a compact, general-purpose instrument of moderate accuracy covering a wide frequency range and it is particularly well adapted to general-purpose checking work around the laboratory. The normal wavelength range of 15 to 220 meters (20,000 kc to 1364 kc) can be extended to 630 meters (476 kc) by ordering the two additional coils mentioned in the price list.

SPECIFICATIONS

Range: 15 to 220 meters (20,000 kc to 1364 kc). By ordering the two extra inductors* mentioned in the price list, the range can be extended to 630 meters (476 kc).

Accuracy of Calibration: 1%. Calibrated in wavelength.

Condenser: TYPE 247 Condenser with slow-motion pinion-gear drive in drawn-steel case.

Inductors: Four, on bakelite forms, fitted with pins to fit condenser terminals.

Resonance Indicator: Small flashlight bulb in special socket which closes circuit on removal of bulb.

Carrying Case: Space provided in wooden case for four inductors, condenser, and calibration chart.

Dimensions: Carrying case, (length) 11¾ x (width) 7 x (height) 5¼ inches, over-all.

Net Weight: 4½ pounds.

Type	Frequency Range	Code Word	Price
358	15 m to 220 m	UPPER	
Additional inductors for extending range to 630 m		*COILY	

*Use compound code word UPPERCOILY when wavemeter with extra inductors is wanted.

TYPE 535-A FREQUENCY METER-MONITOR

This instrument combines a monitor and an accurate heterodyne-frequency meter for use in all the amateur bands including 56 Mc. It is calibrated at 13 points in the 1715-ke to 2000-ke band, harmonics being used for the higher frequencies. A voltage-stabilized electron-coupled Colpitts oscillator is used to insure the best possible frequency stability. The mechanical construction is the same high quality as that used in General Radio laboratory apparatus. The 6-inch precision dial allows setting to be made to within 1 part in 1500.



TYPE 535-A Frequency Meter-Monitor

The 6-inch precision dial allows setting to be made to within 1 part in 1500.

SPECIFICATIONS

Frequency Range: 1700 kc to 2000 kc and all harmonics of this range up to at least the 32nd, equivalent to 54.4 Mc to 69 Mc.

Calibration: Each instrument is calibrated at 13 points against a primary standard of frequency. Calibrations can be readily checked against ARRL standard-frequency transmissions or against broadcast stations.

Frequency Stability: Excellent. Bulletin No. 315-B, giving information in detail, will be mailed on request.

Condenser: Two-section, band-spread type.

Resonance Indicator: Phones can be plugged into the standard telephone jack on the panel.

Dimensions: (Length) 11 x (height) 7½ x (width) 8½ inches, over-all.

Net Weight: 11 pounds.

Type	Frequency Range	Code Word	Price
535-A	All amateur bands	MERRY	

TYPE 560-A CRYSTAL HOLDER

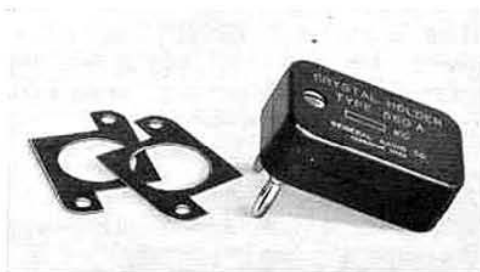

TYPE 560-A Crystal Holder

This is a pressure-type quartz-crystal holder primarily designed for operation with crystals in the amateur bands. It has a dust- and

moisture-proof bakelite case with the spring pressure on the top plate adjustable. Any amateur crystal up to 1½ inches square can be used. Electrodes are of chromium-plated brass, tarnish and corrosion proof. Three blank bakelite retention plates which may be cut to fit the crystal used are provided. The spacing between the two terminal plugs is General Radio standard ¼ inch.

Net Weight: 4 ounces.

Type	Code Word	Price
560-A	ABAFT	

AUDIO-FREQUENCY TRANSFORMERS

In this section is described a complete line of high-quality audio-frequency transformers, including models designed for vacuum-tube-input, vacuum-tube-interstage, vacuum-tube-output, impedance-matching, and circuit-isolation uses.

These transformers have lap-jointed laminated cores of the best grade of silicon steel, the use of which results in the unusually good frequency characteristics that are obtained. By reason of the high current that can be tolerated before saturation occurs, parallel plate feed does not have to be used under normal operating conditions. The transformers are unaffected by mechanical shock, are shielded against electrostatic fields, and, because of thorough 1000-volt insulation, they are proof against breakdown under transient surge peaks. They may be used in permanent installations with the knowledge that they will retain their characteristics through years of use.

To preserve the symmetry of push-pull tapped windings so that subsequent stages

may be truly balanced, the coils of the vacuum-tube-interstage transformers are built up in alternate primary and balanced secondary layers. This construction increases the coupling coefficient of the transformer and decreases the distributed capacitance of both windings, therefore extending the upper-frequency limit without introducing high-frequency resonance peaks on open circuit (interstage) operation.

For use in high-fidelity circuits with unbalanced stages, the light additional loadings recommended in the tables will preserve the frequency characteristics to well within the limits stated. All ratings are conservative and represent the performance that may be expected under the most unpromising conditions.

Experimenters and development engineers will find in these transformers reliable units having negligible insertion losses when they are properly terminated. They may be used without fear of distortion in the many communication, amplifier, line, bridge, balanced, and unbalanced circuits encountered in engineering work.

VACUUM-TUBE-INPUT AND -INTERSTAGE TRANSFORMERS

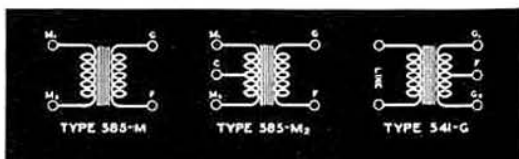

INPUT TYPES

Carbon microphones, pickups, and mixer sources of from 50 ohms to 400 ohms internal impedance may be matched to a grid through the use of the TYPE 585-M or TYPE 585-M2 Transformers diagramed above.

Reflectionless line termination for lines between 400 and 600 ohms and coupling to either balanced or unbalanced amplifiers may be obtained with the TYPE 541-G Transformer which is designed especially for this service.

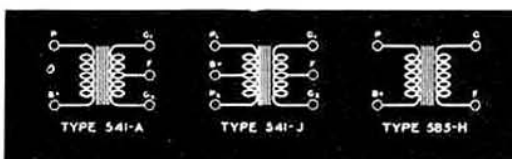

INTERSTAGE TYPES

For the intermediate stages the TYPE 541-J Transformer will meet all possible arrangements of either single-tube or push-pull connections. It will work from sources ranging from 1000 to 5000 ohms in impedance by using half the primary winding.

Where a greater interstage voltage step-up is desired for unbalanced amplifiers at the expense of a narrowed frequency range, TYPES 541-A and 585-H are recommended.

SPECIFICATIONS

Use: The most common uses of the transformers are suggested in the second column of the following table. Values of source impedance and primary direct current have been chosen for tubes that are most frequently encountered in practice.

Frequency Range: The table gives the frequency range over which the voltage ratio is less than 2 db

below its value on the flat portion of the characteristic. This range holds for operation "Out of" a source having the impedance shown in column three and into the grid or grids of the succeeding stage. For values of source impedance between those tabulated, the frequency range may be found by direct interpolation.

AUDIO-FREQUENCY TRANSFORMERS

The "Pri. DC" column gives the normal primary current for the transformer when working out of a single tube or the permissible current unbalance when working out of tubes in push-pull. The specified frequency range will be obtained with this value of current. The low-frequency limit is decreased by approximately 25% when no direct current flows. The effect on the frequency characteristic of a 100% increase in "Pri. DC" is negligible at frequencies greater than 80 cycles.

Turns Ratio: The ratio of turns of the whole primary winding to the whole secondary winding is given in the "Turns Ratio" column of the table.

Primary Winding: The 60-cycle inductance of the whole primary as measured with the tabulated value of "Pri. DC" flowing, is given in the "L" column. The maximum value of current that may be applied to any part of the primary is stated in the "I Max." column.

Mounting: Each transformer is mounted in a standard drawn-steel, wax-filled Model B case, illustrated on the next page.

Dimensions: See dimensioned drawing, Model B case.

Net Weight: All types, 3 pounds.

Type	Use	Frequency Range (Down 2 db) ¹				Primary		Code Word	Price
		Out of (ohms)	Pri. DC (ma)	From (cycles)	To (cycles)	Turns ¹ Ratio	L ¹ I Max. (h) (ma)		
541-J	P-P Plates to P-P Grids	20,000 ³ 10,000	0.25 ² 0.4 ²	30 25	10,000 13,000		150 140		
	One Plate ⁴ to P-P Grids	16,000 10,000	2.5 5	30 35	11,000 13,000	1 to 2.1	75 65	15	ABHOR
	One Plate ⁴ to One Grid ⁴	16,000 ⁵ 10,000 ⁶ 5000	2.5 5 8	30 35 28	11,000 11,000 12,000		75 65 55		
	541-A	One Plate to P-P Grids	10,000 5000	5 8	60 40	8000 12,000	1 to 3.0	35 30	15
585-H	One Plate to One Grid	10,000	5	50	7000	1 to 3.2	40	15	TIPSY
541-G	Line or Mixer ⁸ to P-P Grids	400-600 ⁷	—	30	13,000	1 to 9.7	8	30	ABEAM
	Line or Mixer ⁸ to One Grid ⁴	400-600 ⁹	—	30	13,000				
585-M2	Single- or Double-Button Microphone to Single Grid	400 200 ¹	5 ² 20	40 40	7000 7500	1 to 13.8	3 2	80	TARRY
585-M	Single-Button Microphone to Single Grid	200 50	20	45 40	7000 8000	1 to 27.8	0.7	100	TARDY

¹ Data are for whole of tapped windings.

² Dc for 10% unbalance in push-pull connection.

³ Connect 250,000Ω across each half of secondary.

⁴ Use whole winding, P₁ or G₁ to plate or grid.

⁵ Connect 75,000Ω between G₁ and F.

⁶ Connect 100,000Ω between G₁ and F.

⁷ Connect 100,000Ω across each half of secondary. Without resistors response is up 2 db at 11,000 cycles.

⁸ To reflect exactly 500Ω to primary, connect 25,000Ω across each half of secondary; for single-grid use, high-frequency limit is then 10,000 cycles.

⁹ Connect 35,000Ω between G₁ and F.

SPECIAL TRANSFORMERS

The General Radio Company has had wide experience in the custom design and production of transformers to meet requirements not covered by stock models. Among these types are transformers with extra and monitoring windings, transformers to operate in mixer circuits of unusual impedance, and to simulate the characteristic of the human ear. Special

transformers for the tripping of control circuits as well as transformers for inclusion in recording seismographs and other scientific research instruments can also be supplied.

Prices will be quoted on inquiry. Please state desired frequency characteristic and the values of generator and load impedances between which the transformer is to work.

VACUUM-TUBE OUTPUT TRANSFORMERS

An output transformer may be selected from the four shown below to couple a vacuum tube to all but the most unusual values of line or speaker impedances. For a large number of these special cases designs are already on hand with the result that these types may be furnished without undue expense or delay.

Type 541-C

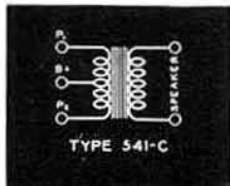

The TYPE 541-C Transformer is available for output uses where it is desired to couple a push-pull, 4000- to 12,000-ohm output stage to the voice coils of one or more dynamic speakers. With multiple loads the optimum impedance ratio of 1300 to 1 should govern the choice of arrangement of secondary connections.

This is the transformer recommended for use with tubes of the following types: 10, 31, 45, 46 (Class A), 49 (Class A), 59 (Class A), 71-A, 89 (Class A), and 112-A.

Type 541-D

The TYPE 541-D Transformer is a universal output transformer for use with two 2A3 tubes in a balanced (push-pull) stage, although use of generator impedances between 700 and 2000 ohms will cause no appreciable change in the frequency characteristic.

The choice of a secondary tap and the arrangement of the speaker connections should be such as to load correctly the output stage. The load presented to the tubes will be the transformer load multiplied by the square of

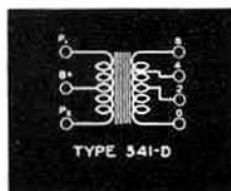

the turns ratio of the transformer for the particular secondary tap used. In particular, the correct load for the 2A3 tubes varies, depending on whether fixed bias or self-bias is used. The table shows the best connections.

Load Impedance		Terminals to Which Load is Connected
(Self-Bias)	(Fixed Bias)	
1.5- 3 ohms	1- 2 ohms	0-2
3 - 5.7 ohms	2- 4 ohms	0-4
5.7-12 ohms	4-10 ohms	0-8

Type 541-P

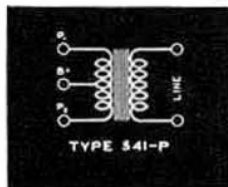

TYPE 541-P Transformer will feed lines of from 400 to 600 ohms impedance from a push-pull stage of output tubes. Its excellent characteristic allows it to be used

indiscriminately to interconnect high-fidelity systems with no loss in the over-all frequency range. This transformer is also recommended for feeding any balanced or unbalanced amplifier output into a line-impedance-level mixer system, or for use in the output stage of a microphone pre-amplifier.

Type 541-B

TYPE 541-B is a speaker-coupling device making use of the greater efficiency of auto-transformers to drive a magnetic speaker or other 4000- to 10,000-ohm load from balanced or unbalanced output stages. Blocking condensers are included in the case to keep the high plate potential off the output terminals and direct current out of the load.

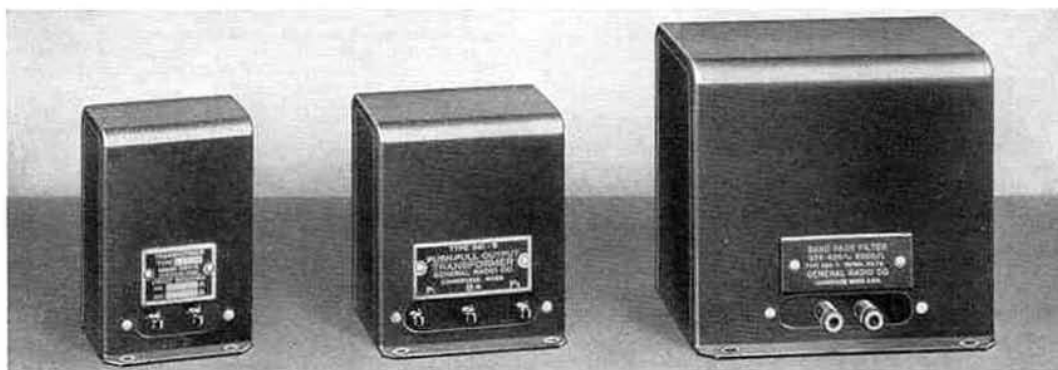
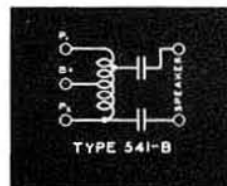

MODEL B

MODEL C

MODEL D

General Radio transformers are mounted in the three sizes of cases shown by the samples above

AUDIO-FREQUENCY TRANSFORMERS

SPECIFICATIONS

Use: The most common uses of the transformers are suggested in the second column of the following table. Values of source and load impedances and primary direct current have been chosen for conditions that will most frequently be met in practice.

Frequency Range: The table gives the frequency range over which the voltage ratio is less than 2 db below its value on the flat-top portion of the characteristic. This range holds for operation "Out of" a source having the impedance shown in column three and "Into" a load of value shown in column four. For values of source and load impedances between those tabulated, the frequency range may be found by direct interpolation.

The "Pri. DC" column gives the normal primary current for the transformer when working out of a single tube or the permissible current unbalance with push-pull input circuits. The specified frequency range will be obtained with this value of current. The low-frequency limit is decreased by approximately 25% when no direct current flows.

Turns Ratio: The ratio of turns of the whole primary winding to the whole secondary winding is given in the "Turns Ratio" column of the table.

Primary Winding: The 60-cycle inductance of the whole primary as measured with the tabulated value of "Pri. DC" flowing, is given in the "L" column of the table. The maximum value of current that may be applied to any part of the primary is stated in the "I Max." column.

Mounting: Each transformer is mounted in a standard drawn-steel, wax-filled Model B case except TYPE 541-B, which is mounted in a Model C case. Both are illustrated on the opposite page.

Dimensions: See the dimensioned drawing, this page, Models B and C cases.

Net Weight: TYPE 541-B, 4 pounds; all other types, 3 pounds.

Type	Use	Frequency Range (Down 2 db) ¹					Primary				Code Word	Price
		Out of (ohms)	Into (ohms)	Pri. DC (ma) ²	From (cycles)	To (cycles)	Turns Ratio	L ³ (h)	I Max. (ma)			
541-C	P-P Plates to Voice Coil	10,000	4-15	1	30	12,000	35.6 to 1	45	50	TAPER		
		4000	4-15	3	25	10,000		30				
541-D	P-P Plates to Voice Coil	4000	4-16 ³	3	40	15,000	23.6 (33.3) ³ (47.2) ³ to 1	12	70	TULIP		
		2000	1-12 ³	3	30	15,000		12				
541-P	P-P Plates to Line or Mixer	32,000	400-600	0.13	15	18,000	4.4 to 1	75	25	ABIDE		
		20,000	400-600	0.25	25	16,000		70				
		10,000	400-600	0.4	20	12,000		65				
	One ⁴ Plate to Line, Mixer	16,000	400-600	2.5	30	16,000	30	25	ABIDE			
10,000	400-600	5.0	30	16,000	27							
541-B	P-P Plates to Magnetic Speaker	10,000	4000-10,000	1	30	8500	1.4 to 1	45	50	TORSO		
		4000	4000	3	35	8000		25				

¹ Data are for whole of tapped windings.

² De for 10% unbalance, when push-pull connection is used.

³ Using taps on windings.

⁴ Use whole winding, P₁ to plate.

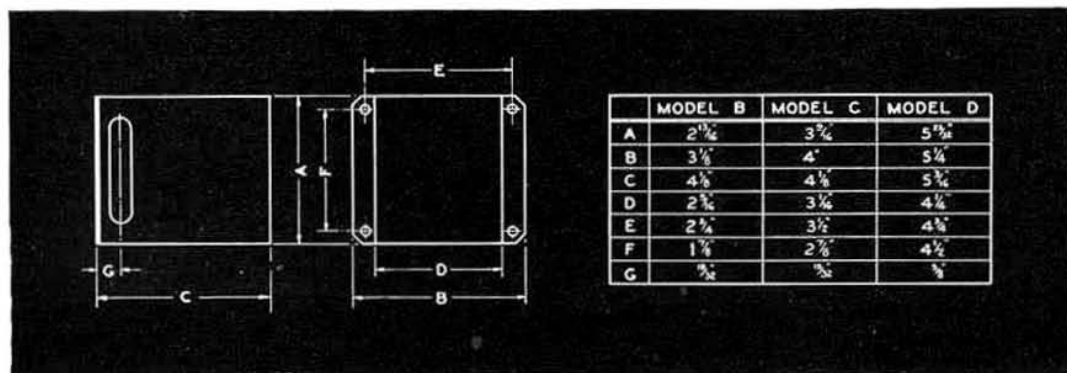

Dimensions for standard general audio transformer-mounting cases

IMPEDANCE-MATCHING TRANSFORMERS

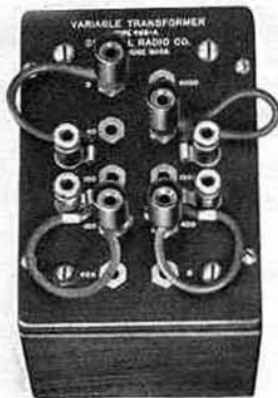

TYPE 666-A

They may be used in either direction, that is, as step-up or step-down impedance-matching transformers. The frequency ranges given in the tables hold for this use of the transformers as well, and the "Pri. DC" limit still holds. If the "secondary" winding is connected to the source and the frequency range is to be maintained, the number of aiding d-c milliampere-turns for the whole transformer must not exceed the value it has under rated conditions.

Type 585-R

The TYPE 585-R Transformer is a high-quality, unity-ratio, circuit isolator for use between transmission lines of from 500 to 700 ohms impedance. The primary and secondary windings are thoroughly shielded from each other to minimize electrostatic coupling with the result that on balanced lines the parallel component of interference energy is filtered from the signal. The provision of center-tapped windings allows interchangeable use between balanced and unbalanced systems and also for their interconnection.

In bridge measurements the use of this transformer makes the bridge balance independent of electrical or locational changes in the detector circuit, assuring greater accuracy and ease of balance.

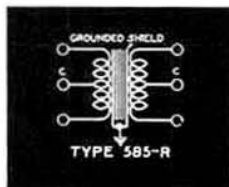

All General Radio transformers may be used as impedance-matching transformers. They will transform impedances in the square of their turns ratio which will be found in the "Turns Ratio" column of the tables.

Type 585-C

For line-interconnection and mixer problems the TYPE 585-C Transformer presents the facilities of an impedance changing device with impedance transformation ratios of 1 to 10, 1 to 2.5, 1 to 1.56, 1 to 0.64, 1 to 0.25, and 1 to 0.10, allowing the transformations shown in the table to be taken in either direction. The desired ratios are obtained as shown in the diagrams at the foot of the opposite page. The terminals are so arranged that only adjacent ones need be strapped.

LABORATORY TRANSFORMERS

The following two transformers are not to be used for impedance matching in quality communication or program circuits. They are valuable in alternating-current measurements not dependent on relative response at widely separated frequencies.

Type 666-A

Where it is desired to have the impedance ratio easily adjustable over a wide range by means of a plug arrangement at the expense of attenuation of the high and low frequencies, the TYPE 666-A Variable Transformer is recommended. Primarily a laboratory instrument, this transformer is provided with jack-top binding posts to receive a TYPE 274 Plug and has multi-tapped windings with the included turns from one end marked plainly on the panel. Any portions of the windings may be used; not only is the impedance ratio adjustable but approximate ratios may be obtained through different arrangements, allowing a choice of a favorable value of primary inductance.

Type 166

For use in a-c bridge circuits with telephone detectors, where the frequency characteristic is subordinate to the requirement of a detector of the correct impedance for maximum sensitivity, the TYPE 166 Telephone Transformer should be employed.

The various connections are made directly to binding posts mounted on the terminal plate of the instrument.

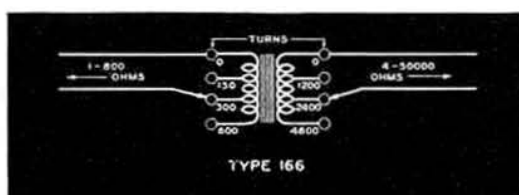
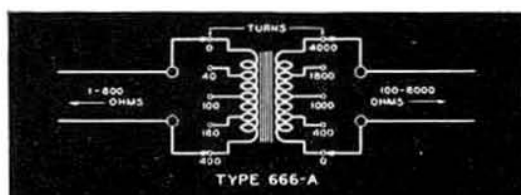

AUDIO-FREQUENCY TRANSFORMERS

SPECIFICATIONS

Use: The most common uses of the impedance-matching transformers are suggested in the second column of the following table. The associated data are chosen for conditions that will most frequently be met in the suggested uses.

Frequency Range: The table gives the frequency range over which the voltage ratio is less than 2 db below its value on the flat portion of the characteristic. This range holds for operation "Out of" a source and "Into" a load having the impedances shown in columns three and four. For intermediate values of source and load impedances the frequency range may be found by direct interpolation.

Turns Ratio: The turns ratio of the whole primary winding to the whole of the secondary winding is given in the "Turns Ratio" column of the table. For the adjustable-ratio transformers, TYPES 666-A and 166, the turns included between the tap and one end are shown in the individual diagrams at the foot of the opposite page.

Primary Winding (Higher Impedance Winding): The nominal 60-cycle inductance of the whole primary is given in the "L" column of table.

The maximum current that may be applied to any part of the windings is stated under "I Max."

Mounting: TYPES 585-C and 585-R are mounted in standard drawn-steel, wax-filled Model B cases.

For TYPES 666-A and 166 see illustrations.

Dimensions: For TYPES 585-C and 585-R see dimensioned drawing, Model B case. TYPE 666-A: 3½ x 4½ x 5 in.; TYPE 166: 2¼ x 2¾ x 3½ in.

Net Weight: TYPES 585-C and 585-R, 3 pounds; TYPE 666-A, 3½ pounds; TYPE 166, 1½ pounds.



TYPE 166

Type	Use	Frequency Range (Down 2 db) ¹				Turns ¹ Ratio	Fig.	Primary		Code Word	Price
		Out of (ohms)	Into (ohms)	From (cycles)	To (cycles)			L ¹ (h)	I Max. (ma)		
585-C	Line, Mixer to Line, Mixer	400-600	150-250	25	10,000	1.6	A	6	50 (pri.)	ABODE	
		400-600	40-60	25	11,000	(3.2) ²	B		100 (sec.)		
		100-150	150-250	25	11,000	(0.8) ²	C				
		100-150	40-60	25	12,000	to 1	D				
585-R	Line, Mixer to Line, Mixer	800	800	30	16,000	1 to 1		3	75 (pri. & sec.)	ABOMA	
		400	400	25	18,000						
166	Bridge to Detector	4-50,000 ²	1-800 ²			1 to 8			9 (pri.) 90 (sec.)	TOPIC	
666-A	General Purpose Matching	100-8000 ²	1-800 ²			1 to 10			60 (pri.) 150 (sec.)	ABOON	

¹ Data are for whole of split or tapped windings.

² Using taps on windings.

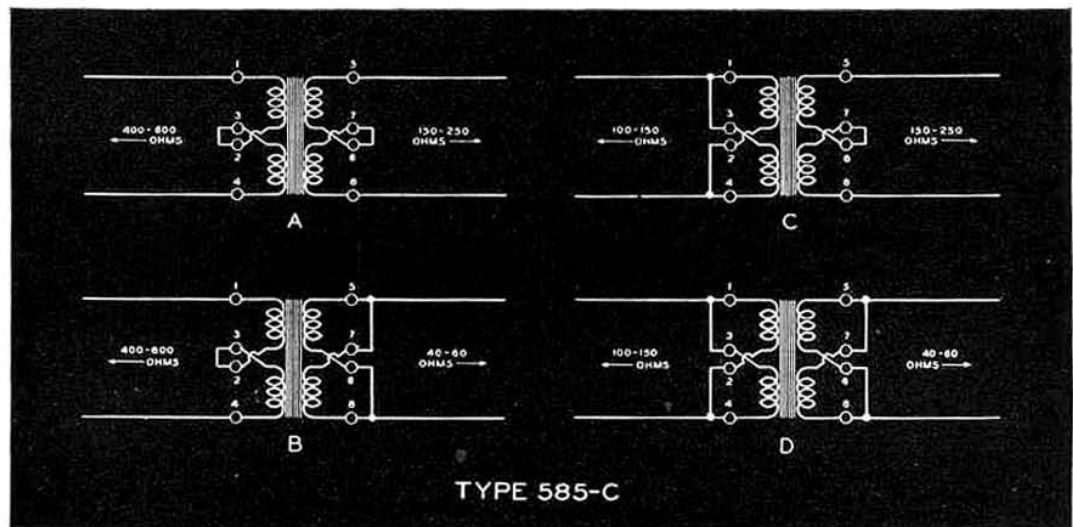

TYPE 480 RELAY RACK

This rack is intended for mounting standard 19-inch panels whose heights are integral multiples of $1\frac{3}{4}$ inches. Racks of this type have been in use in telephone plants for many years, and they are fast becoming standard in laboratories for mounting apparatus. Two sizes are available.

Attention is also directed to the TYPE 660-A Rack described on opposite page.

SPECIFICATIONS

Construction: Steel frame with welded joints. Both models have provision for bolting them to the floor or table, but they are stable enough to stand without fastening for all ordinary service.

Drilling: Standard drilling for 19-inch relay-rack panels is employed. Holes are tapped and cleaned for a 10-32 panel-mounting screw (TYPE 738-D).

Accessories: Panel-mounting screws, panel-protecting washers, and bridle rings for cabled wiring are supplied.

Dimensions: TYPE 480-A: Frame, (height) $69\frac{1}{8}$ x (width) 20 x (depth) 3 inches, over-all. Base, (width) 20 x (depth) 15 inches. Panel-mounting space, 63 inches or 36 "rack units."

TYPE 480-B: Frame, (height) 44 x (width) 20 x (depth) $1\frac{1}{2}$ inches, over-all. Base, (width) 20 x (depth) 15 inches. Panel-mounting space, $43\frac{3}{4}$ inches or 25 "rack units."

Net Weight: TYPE 480-A, 94 pounds. TYPE 480-B, 20 pounds.

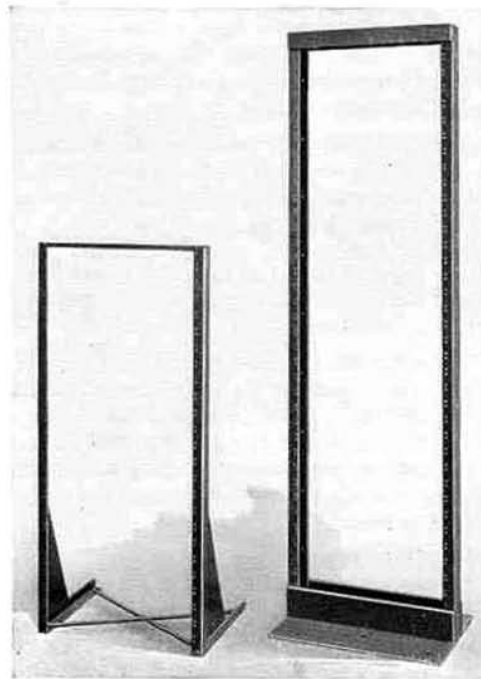

Left: TYPE 480-B; right: TYPE 480-A

Type	Panel Space		Code	Price
	Inches	Rack Units		
480-A	63	36	NEEDY	
480-B	$43\frac{3}{4}$	25	NEGRO	

NOTES ON LAYING OUT RELAY-RACK PANELS

1. Make panel height a multiple of $1\frac{3}{4}$ inches less $\frac{1}{2}$ inch for clearances.
2. Both top and bottom edges of a properly mounted panel will, neglecting clearances, always fall half way between a pair of holes spaced $\frac{1}{2}$ inch apart on the rack.
3. It is seldom necessary to cut all the possible mounting-screw slots in a panel, but it can be done if desired.
4. Any panel laid out to fit the rack will also fit if the panel is turned end-for-end or back-for-front.

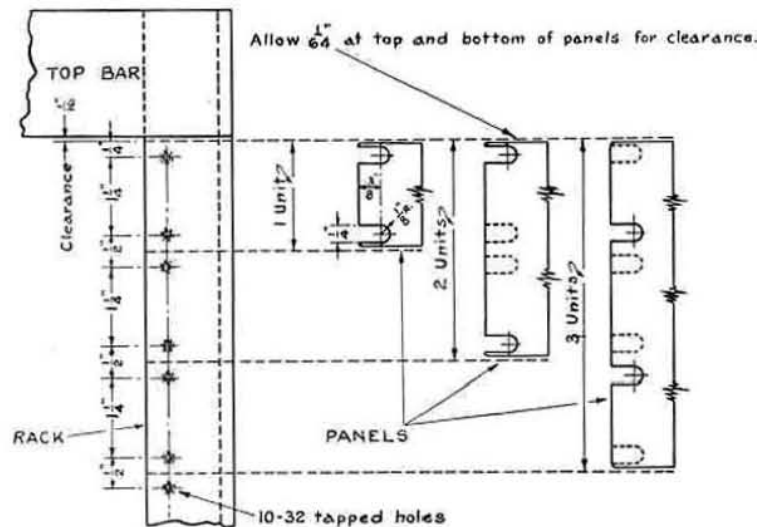

Note: Clearance between vertical supports on rack $17\frac{1}{2}$ inches.

UNIT PANELS

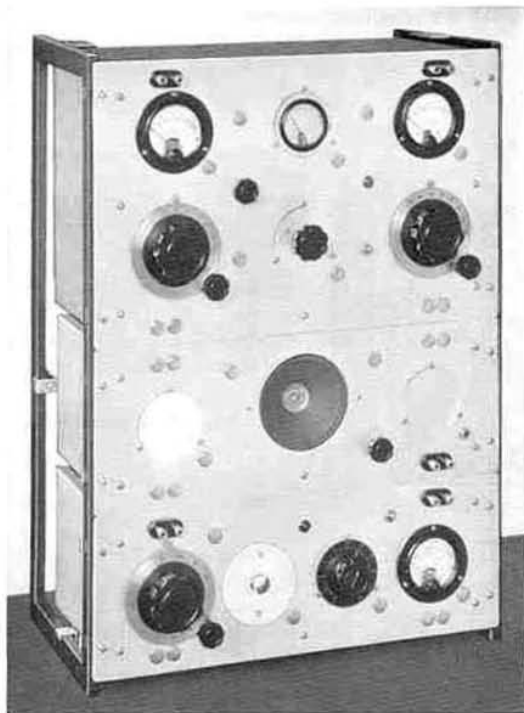

An assembly of TYPE 661 Unit Panel equipment on a TYPE 660 Rack

General Radio has recently developed a series of unit panels designed to facilitate the fabrication of experimental and semi-permanent assemblies. All parts are interchangeable. Layout changes can be made at any time without disfiguring the panel, and a unit is easily disassembled for conversion into an entirely different instrument.

The parts required for a complete metal box are a base, two end plates, a dust cover, and a panel (with the accessories accompanying it). All principal parts are made of Eraydo, a non-magnetic, non-corrosive alloy of copper, silver, and zinc, which is stronger than materials commonly used for such parts. One face is satin finished and coated with clear lacquer.

The drawings on the next page show to scale the location of all holes. Each panel has several $2\frac{7}{8}$ -inch diameter holes symmetrically placed, around each of which are three small holes for mounting the standard bakelite (Navy type) meter case, or for fastening mounting discs to the panel. Adjacent to each large panel hole is a $\frac{1}{2}$ -inch hole for the slow-motion mechanism of a 4-inch, TYPE 703 Dial.

At both top and bottom near either end are located pairs of $\frac{1}{2}$ -inch holes on $\frac{3}{4}$ -inch centers to fit TYPE 274 Panel Insulators with TYPE 138-VD Binding Posts for input and output connections. Other holes are intended for single-hole-mounting parts such as rheostats, telephone jacks, etc. Bushings for reducing the diameter of the holes to $\frac{7}{16}$ inch or $\frac{3}{8}$ inch are furnished with the panel. Unused holes are plugged with TYPE 661-P4 Snap Buttons.

One panel is furnished with a 5-inch, permanent-magnet dynamic loudspeaker, the input impedance of which is 3000 ohms.

Four types of mounting discs are available. TYPE 661-P1 Blank Mounting Discs are used either to cover the large panel holes not in use, or to mount parts other than those manufactured by General Radio. The center of each is pricked on the reverse to facilitate layout.

The TYPE 661-P2 3-Hole Mounting Discs have three small holes drilled on a $\frac{7}{8}$ -inch radius for mounting General Radio parts having the standard 3-hole mounting. Short spacers which provide clearance for the disc-mounting screws are furnished. Discs can be mounted at 30° angles around 360°.

The TYPE 661-P3 Adapter Disc has a $2\frac{1}{8}$ -inch hole and is designed to mount meters such as the Weston type 506.

Dust covers for the two sizes of end plates are available. They fit tightly and slide on from the rear so that they may be removed when the panel assemblies are mounted one above another on a relay rack.

All prices and illustrations on next two pages

TYPE 660-A UNIVERSAL RACK

This is the rack shown in the cut on this page. It consists of two rectangular steel frames which mount parallel to each other. These frames may be screwed to the bench, or they may be fastened to the bench and wall by the four clamps supplied with each rack.

TYPE 661-P5 Panel Clamps will clamp a panel to the rack in any desired position. Four

of these are supplied with each unit panel, but none are supplied with the rack. The rack can be used for panels of any width.

The height of the TYPE 660-A Rack is $26\frac{1}{2}$ inches (fifteen $1\frac{3}{4}$ -inch rack units).

Type	Rack Units	Code Word	Price
660-A	15	NINNY	

PARTS AND ACCESSORIES

UNIT PANELS AND ACCESSORIES (Drawings 1/6th Actual Size)

19 x 12-INCH UNIT PANELS

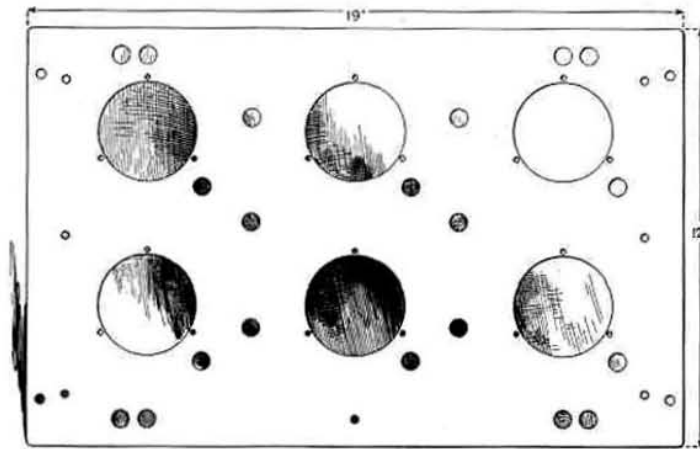

Type 661-A, with accessories,

Number Supplied	Type	Description
3	661-P1	Blank Mounting Discs
3	661-P2	3-Hole Mounting Discs
20	661-P4	Snap Buttons
2 pr.	661-P5	Panel Clamps
12	661-P6	Mounting Spacers
6	661-P8	3/8-inch Bushing
6	661-P9	7/16-inch Bushing
25	Machine screws and nuts (for base, ends, and discs)	

Type 661-AX, blank panel only,

19 x 7-INCH UNIT PANELS

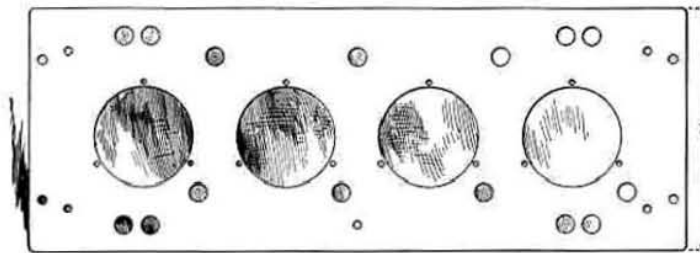

Type 661-B, with accessories,

2	661-P1	Blank Mounting Discs
2	661-P2	3-Hole Mounting Discs
15	661-P4	Snap Buttons
2 pr.	661-P5	Panel Clamps
9	661-P6	Mounting Spacers
4	661-P8	3/8-inch Bushing
4	661-P9	7/16-inch Bushing
17	Machine screws and nuts (for base, ends, and discs)	

Type 661-BX, blank panel only,

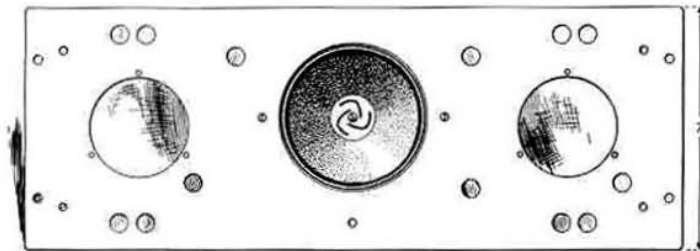

Type 661-C, with accessories,

1	661-P1	Blank Mounting Disc
1	661-P2	3-Hole Mounting Disc
13	661-P4	Snap Buttons
2 pr.	661-P5	Panel Clamps
6	661-P6	Mounting Spacers
4	661-P8	3/8-inch Bushing
4	661-P9	7/16-inch Bushing
13	Machine screws and nuts (for base, ends, and discs)	
1	5-inch Dynamic Speaker and Clamp	

ACCESSORIES (1/3rd Actual Size)

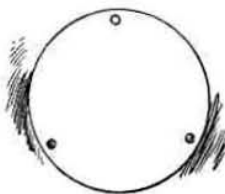

Type 661-P1
Blank Mounting Disc
For use as blank cover or "drill your own." Center prick-punched for easy layout.

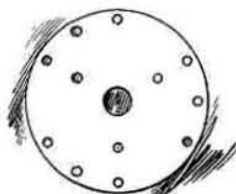

Type 661-P2
3-Hole Mounting Disc
For 3-hole mounting, 120° apart on 3/8-inch radius. 12 possible positions.

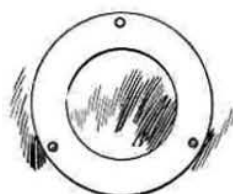

Type 661-P3
Adapter Disc
For 2 1/16-inch meters (e.g., Weston 506).



Type 661-P11
Cover Plate
For use with Type 177-B Inductor Form and Type 177-K Inductor Shield.

ENDS, BASES, DUST COVERS (Drawings 1/6th Actual Size)

**Type 661-K
End- and Base-Plate
Assembly**
For 19 x 12-inch Panels

Base plate can be mounted in any one of four positions. Machine screws and spacing pillars supplied. Order panel (shown dotted) and dust cover separately.

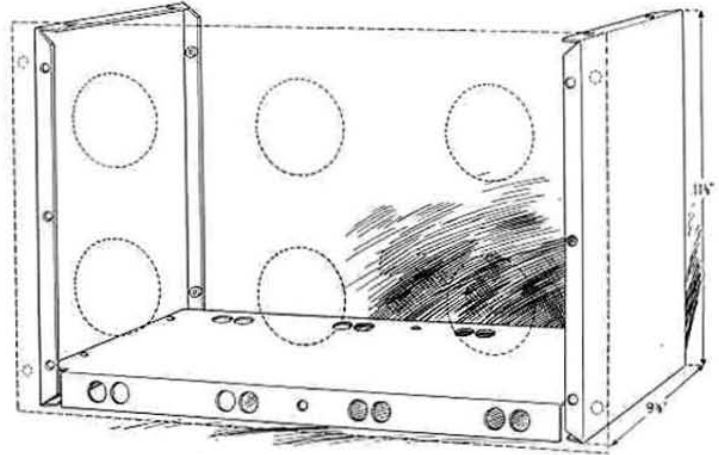

**Type 661-L
End- and Base-Plate
Assembly**
For 19 x 7-inch Panels

Base plate can be mounted in any one of four positions. Machine screws and spacing pillars supplied. Order panel (shown dotted) and dust cover separately.

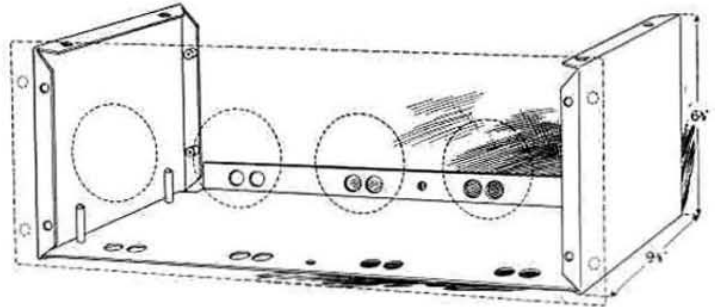

Type 661-R Dust Cover
For 12-inch Panels

Type 661-S Dust Cover
For 7-inch Panels

Fit closely. Can be attached and removed when panels are mounted one above another on a rack. Machine screws for back supplied.

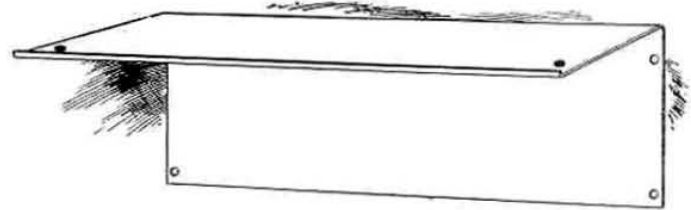

ACCESSORIES (Shown Actual Size)

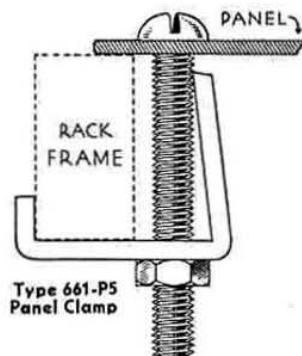

**Type 661-P5
Panel Clamp**



Type 661-P8
3/8-in. Bushing
Fits 1/2-in. holes

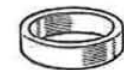

Type 661-P9
7/16-in. Bushing
Fits 1/2-in. holes



Type 661-P4
Snap Button
Fits 1/2-in. holes



Type 661-P6
Mounting Spacers
Provide clearance for parts interfering with dis-mounting screws

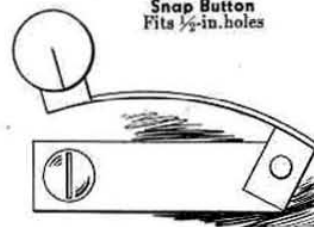

Type 661-P7
Dial Indicator
For G. R. dial. Supplied free with each dial when order specifically requests it.

PLUG-IN INDUCTORS FOR UNIT PANELS

The three basic components shown below, together with a TYPE 661-P11 Cover Plate can be assembled in three ways to make up an effective shielded plug-in inductor for use in high-frequency experimental work. The TYPE 177-B Inductor Form can be used alone or, if desired, a TYPE 177-K Inductor Shield can be attached to make one integral unit. Then, when a shielded inductor is required for use with unit-panel assemblies, the cover plate is added, as shown in the photograph below. The shield base is securely locked to the shield top by the three bayonet catches. In the center is a threaded rod which engages a threaded insert in the TYPE 661-P10 Jack Base and draws the cover plate firmly against the panel.

The TYPE 661-P10 Jack Base can be used behind the panel or mounted horizontally on a shelf using short spacer studs.

An important feature in short-wave work is the excellent noise-free contact provided by the use of spring-type plugs and jacks. The eight sets of contacts are adequate for the most elaborate circuit. Both plugs and jacks can be removed if fewer contacts are needed. Complete assembly instructions are supplied.

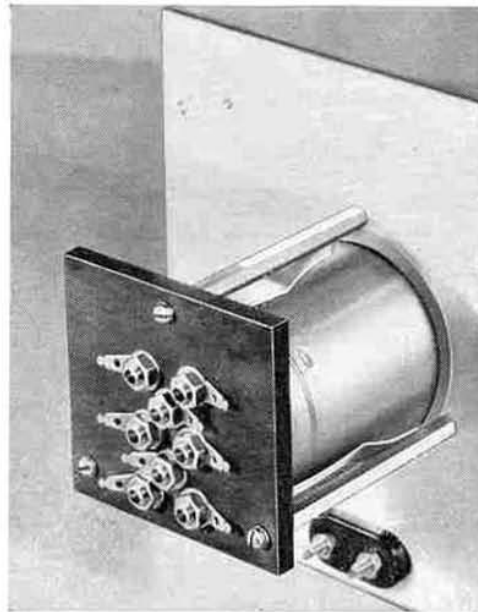

The complete shielded inductor mounts in this manner on a unit panel. The three springs on the TYPE 661-P10 Jack Base guide the inductor into place.

Type 177-K Inductor Shield



with complete assembly instructions.

Code Word: INDUCTKEMP

Aluminum. Fastens to TYPE 177-B Inductor Form with two machine screws supplied. The knob, clamping rod, etc., are included together



Type 177-B Inductor Form

Can be used alone, with shield, or with shield and cover plate for unit-panel mounting. See photographs. Supplied with eight removable plugs (with lock-washers and lugs). Winding form: 1 1/4 inches (diameter), 1 3/4 inches (length). Moulded bakelite.

Code Word: INDUCTBOAT



A shielded inductor-form assembly, made up from a TYPE 177-B Inductor Form, a TYPE 177-K Inductor Shield, and a TYPE 661-P11 Cover Plate.



Type 661-P10 Jack Base

Includes eight removable jacks and lugs. Unique locating device makes plugging in coils extremely easy. Spacer bars fit unit panels. Base may, if desired, be mounted on shelf base (short spacers not included). Designed for shielded or unshielded TYPE 177-B Inductor Form.

Code Word: UNIPANBASE

TYPE 679 INDUCTOR

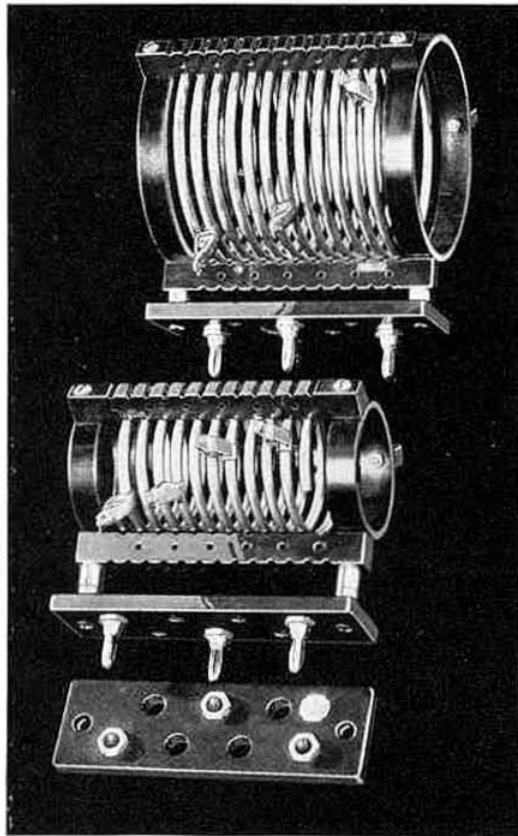

This plug-in inductor is wound with $\frac{1}{4}$ -inch, tarnish-resisting, nickel-plated copper tubing, and is externally clamped by three moisture-proof glazed porcelain bars, ribbed and holed for the support and termination of external coupling windings.

Copper clips with semicircular formed jaws and three 25-ampere TYPE 674-P Plugs are provided with each inductor. As many as four additional plugs may be added as desired.

SPECIFICATIONS

	Type 679-A	Type 679-B
Turns	12	7 and 4
Number of sections	1	2
Inductance	10 μ h	2 μ h, 1.5 μ h
Clips supplied	3	4
Outside diameter of coil	5 $\frac{3}{4}$ in.	3 $\frac{1}{4}$ in.
Length, over-all	7 $\frac{1}{4}$ in.	7 $\frac{1}{4}$ in.
Height, over-all	8 $\frac{1}{2}$ in.	6 $\frac{3}{4}$ in.
Depth, over-all	6 $\frac{1}{2}$ in.	4 $\frac{1}{2}$ in.
Net weight	3 $\frac{1}{8}$ lbs.	2 $\frac{3}{8}$ lbs.

Type	Description	Code Word	Price
679-A	Inductor	CANAL	
679-B	Inductor	CANDY	
680-J	Base	CANOE	

TYPE 677 INDUCTOR FORM

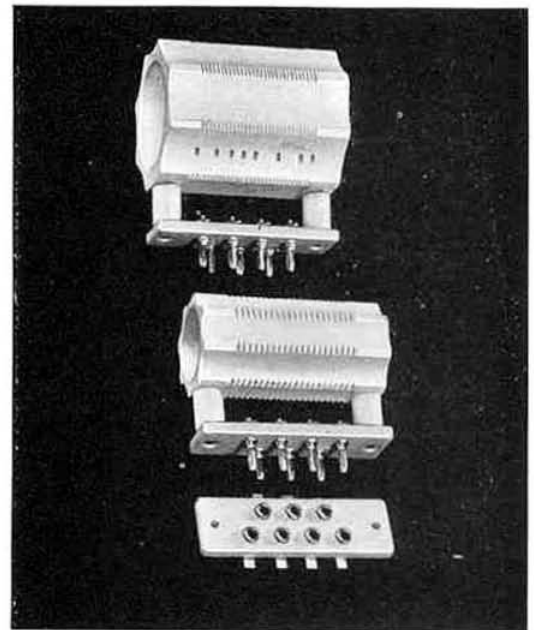

These coil forms are made of moulded porcelain in two convenient sizes. The eight notched ribs provide permanent winding spacing while the series of small holes gives adequate anchorage. Taps and separate windings up to a total of seven terminals are accommodated by a matched plug-in base and jack, separately available.

For complete assembly two TYPE 677-P1 Coil Form Spacers, with which are included the necessary machine screws, nuts and lead washers, are required. These spacers may also be used to support the jack plate.

The V-cut threads permit use of wire size up to #10 B. & S., and extend over three inches.

SPECIFICATIONS

Dimensions: Length, all units, 4 $\frac{5}{8}$ inches. Diameter, TYPE 677-U, 2 $\frac{1}{2}$ inches; TYPE 677-Y, 3 $\frac{3}{8}$ inches. Width, TYPES 678-P, 678-J, 1 $\frac{1}{2}$ inches. Height, TYPE 677-P1, 1 inch.

Net Weight: TYPE 677-U, 10 ounces. TYPE 677-P1 (per pair), 2 ounces. TYPE 677-P, 4 ounces. TYPE 677-J, 4 ounces. TYPE 677-Y, 1 $\frac{1}{8}$ pounds.

Type	Description	Code Word	Price
677-U	Coil Form	MIMIC	
677-Y	Coil Form	MISER	
677-P1	Spacer (2 req'd)	MINIM	
678-P	Base with 7 Plugs	MINOR	
678-J	Base with 7 Jacks	MINNY	

TYPE 577-U INDUCTOR FORM



The TYPE 577-U moulded bakelite inductor form is available to meet the need for convenient laboratory inductors. It is provided with four lugs, which may be pried loose if not required, and is drilled for TYPE 274-P Plugs and a TYPE 274-Q Locating Pin which are not supplied.

SPECIFICATIONS

Dimensions: (Diameter) $3\frac{1}{4}$ x (height) $2\frac{1}{4}$ inches.
Mounting: Holes are provided in the web to take 4 TYPE 274-P Plugs and a locating pin (not furnished). Drilled to fit TYPE 274-CJ or 274-EJ Mounting Bases.
Net Weight: 3 ounces.

Type	Code Word	Price
577-U	NATAL	

TYPE 520-A DIAL LOCK



Any General Radio dial may be firmly clamped in any position by means of the TYPE 520-A Dial Lock which holds the edge of the dial in a vise-like grip, without exerting appreciable force on the shaft on which the dial is mounted. The lock does not alter the dial setting and may be unclamped by loosening the knurled knob when it is desired to change dial to a new setting.

SPECIFICATIONS

Dimensions: (Length) 2 x (width) 1 x (height) $1\frac{1}{2}$ inches over-all, Height above panel, 1 inch.
Mounting: Two No. 28 holes, $\frac{3}{8}$ inch apart, are required for mounting.
Net Weight: $1\frac{1}{2}$ ounces.

Type	Code Word	Price
520-A	ABATE	

TYPE 269 VARIOMETER

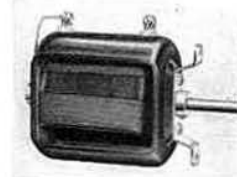

This unit is intended for use as a variable inductor, but it can also be used to vary the coupling between two circuits. It is readily mounted on a panel, and it offers a very satisfactory means of adjusting the total inductance in a circuit.

SPECIFICATIONS

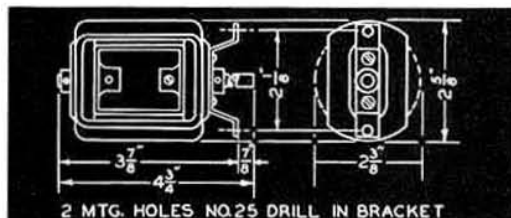

Inductance: With rotor and stator connected in series the maximum inductance is approximately 820 μ h; the minimum, 100 μ h.

Shaft Diameter: $\frac{1}{4}$ inch.

Mounting: Two holes in bracket. See accompanying sketch.

Dimensions: See accompanying sketch. (Depth) $4\frac{3}{4}$ inches over-all.

Net Weight: 7 ounces.

Type	Code Word	Price
269	VALID	

TYPE 519-A DIAL LENS

(See Illustration Opposite Page)

This consists of a small lens with an adjustable holder to mount on a panel over the dial indicator, and makes possible the reading of a dial (especially those shown on the opposite page) to a high degree of precision. When not in use the arm can be swung out of the way and the lens pushed against the panel to minimize space requirements. When in use the lens is held in proper position by a detent device.

SPECIFICATIONS

Dimensions: (Height above panel) 2 x (width) $1\frac{1}{8}$ x (length or radius) $2\frac{3}{8}$ inches.

Focal length, $1\frac{1}{4}$ inches.

Mounting: One $\frac{3}{8}$ -inch hole required for mounting.

Net Weight: 2 ounces.

Type	Code Word	Price
519-A	ABASH	

TYPES 704 AND 706 PRECISION DIALS

These are high-grade precision dials, with scales individually engraved on an automatic self-indexing engraving machine in fine, radial, and accurately located lines. The dial scale and the slow-motion knob rotate in the same direction.

The accuracy of the engraving and the precision of setting obtainable justify the use of a TYPE 519-A Dial Lens.

Backlash has been eliminated in the construction of these long-scale dials by setting the scale permanently and securely on the main shaft which thus has its angular position accurately indicated. The tension of the friction drive is adjustable to suit the load and the preference of the operator, and the position of the friction drive shaft may be adjusted to compensate for errors in the centering of the main shaft in the center hole by means of an eccentric bushing.

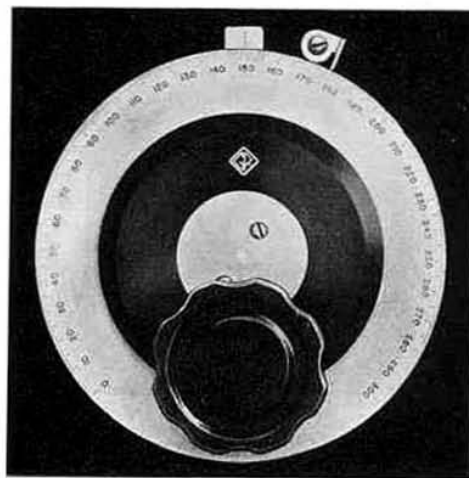

TYPE 704-D

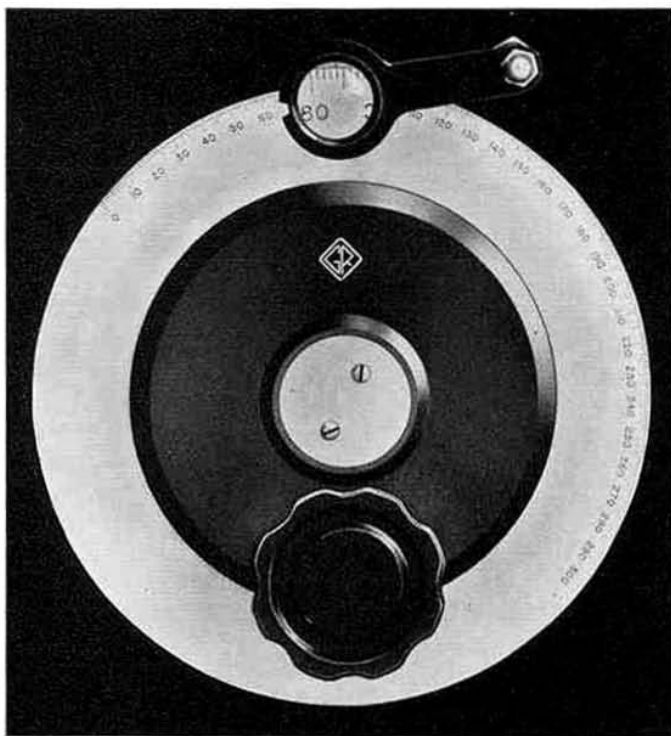

TYPE 706-C

These dials are secured to their shafts through the use of two set-screws separated by 120° and are supplied bored to receive a 3/8-inch shaft. For use with a 1/4-inch shaft, a split collar bushing is provided which securely grips the shaft throughout one inch of its length, averting all possibility of slipping.

Settings of these dials may consistently be duplicated to one-fifth of a division, allowing an accuracy of resetting, for the TYPE 706-D, of better than 0.05%. Parallax is eliminated through the use of an indicator which always remains flush with the surface of the dial, and at the same time absorbs the slight eccentricities of the main shaft through the flexibility of its mounting arm.

Only one additional hole in the panel is required for mounting; the drilling template furnished enables it to be accurately located.

The dial indicator is supplied.

● 4-INCH DIAMETER PRECISION DIALS

Type	Dial		Friction Drive Ratio	Net Weight	Code Word	Price
	Arc	Divisions				
704-C	180°	200	1:6	9 ounces	DABBY	
704-D	270°	300	1:6	9 ounces	DAIRY	

● 6-INCH DIAMETER PRECISION DIALS

Type	Dial		Friction Drive Ratio	Net Weight	Code Word	Price
	Arc	Divisions				
706-C	180°	300	1:8	1 pound	DASHY	
706-D	270°	450	1:8	1 pound	DATUM	

FRICION-DRIVE AND PLAIN DIALS

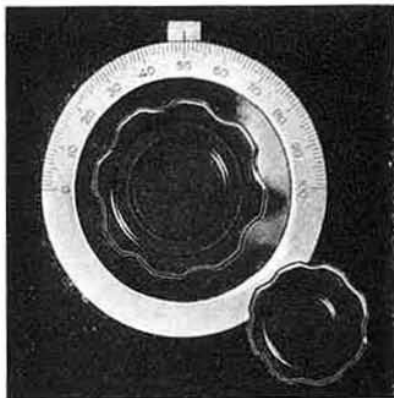

TYPES 702-A and 702-F

The dials described here have photo-etched, nickel-silver scales and use the fluted bakelite knob described on the opposite page.

Two diameters are available either with or without the friction drive. An indicator and drilling template are supplied.

All dials are insulated from the shaft.

See page 170 for new 3 1/4-inch dials.

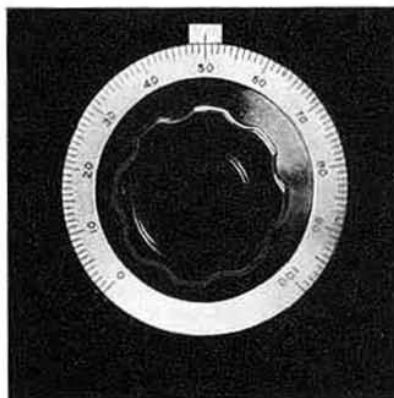

TYPES 710-B and 710-G

● 2 3/4-INCH DIAMETER — TYPE 702 FRICTION-DRIVE DIALS

Type	Shaft		Dial		Friction-Drive Ratio	Net Weight	Code Word	Price
	Diameter	Arc	Divisions					
702-A	1/4 in.	180°	100		1:3.3	4 oz.	DIACK	
702-B	1/4 in.	270°	100		1:3.3	4 oz.	DIBOG	
702-F	3/8 in.	180°	100		1:3.3	4 oz.	DIFAG	
702-G	3/8 in.	270°	100		1:3.3	4 oz.	DIGOD	

● 2 3/4-INCH DIAMETER — TYPE 710 PLAIN DIALS

710-A	1/4 in.	180°	100	2 1/2 oz.	DIALY	
710-B	1/4 in.	270°	100	2 1/2 oz.	DIBIN	
710-G	3/8 in.	270°	100	2 1/2 oz.	DIGUT	

● 4-INCH DIAMETER — TYPE 703 FRICTION-DRIVE DIALS

703-A	1/4 in.	180°	100		1:5	8 oz.	DIANT	
703-B	1/4 in.	270°	200		1:5	8 oz.	DIBUT	
703-F	3/8 in.	180°	100		1:5	8 oz.	DIFUN	
703-G	3/8 in.	270°	200		1:5	8 oz.	DIGUM	

● 4-INCH DIAMETER — TYPE 717 PLAIN DIALS

717-A	1/4 in.	180°	100	5 oz.	DIARM	
717-B	1/4 in.	270°	200	5 oz.	DIBAR	
717-F	3/8 in.	180°	100	5 oz.	DIFIT	
717-G	3/8 in.	270°	200	5 oz.	DIGAR	

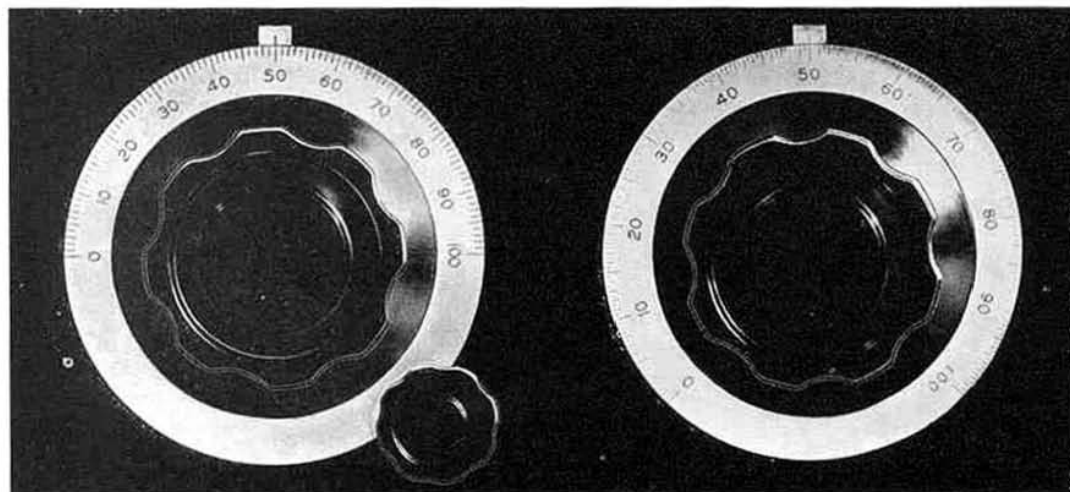

TYPES 703-A and 703-F

TYPES 717-B and 717-G

TYPE 637 FLUTED KNOBS

The moulded bakelite knobs in this type series are now used on all new General Radio apparatus. They were chosen from among dozens of preliminary designs as the ones best suited to the requirements of measuring instruments. The smoothed fluted knurling

affords a positive, cramp-free grip for the most delicate adjustments.

The white pointers are made of non-conducting material, and they can be pried off when knobs alone are required. Each knob has two setscrews to insure permanence of setting.

1 1/8-INCH DIAMETER—WITH POINTER

<i>Shaft</i>				
<i>Type</i>	<i>Diameter</i>	<i>Net Weight</i>	<i>Code Word</i>	<i>Price</i>
637-A	1/4 inch	1/2 ounce	NURLNOBANT	
637-B	3/8 inch	1/2 ounce	NURLNOBBOY	

1 5/8-INCH DIAMETER—WITH POINTER

<i>Shaft</i>				
<i>Type</i>	<i>Diameter</i>	<i>Net Weight</i>	<i>Code Word</i>	<i>Price</i>
637-G	1/4 inch	1 ounce	NURLNOBGUN	
637-H	3/8 inch	1 ounce	NURLNOBHAT	

1 5/8-INCH DIAMETER—WITH SKIRT

<i>Shaft</i>				
<i>Type</i>	<i>Diameter</i>	<i>Net Weight</i>	<i>Code Word</i>	<i>Price</i>
637-J	1/4 inch	2 ounces	NURLNOBJIM	
637-K	3/8 inch	2 ounces	NURLNOBKOP	

(Diameter of skirt, 2 1/16 inches)

2 3/8-INCH DIAMETER—WITH POINTER

<i>Shaft</i>				
<i>Type</i>	<i>Diameter</i>	<i>Net Weight</i>	<i>Code Word</i>	<i>Price</i>
637-P	1/4 inch	3 ounces	NURLNOBPIG	
637-Q	3/8 inch	3 ounces	NURLNOBQUO	

2 3/8-INCH DIAMETER—WITH SKIRT

<i>Shaft</i>				
<i>Type</i>	<i>Diameter</i>	<i>Net Weight</i>	<i>Code Word</i>	<i>Price</i>
637-R	1/4 inch	4 ounces	NURLNOBRAM	
637-S	3/8 inch	4 ounces	NURLNOBSUM	

(Diameter of skirt, 3 inches)

TYPE 202 SWITCH KNOB

This is the bakelite knob that is used on our resistance boxes and decade condensers because it enables the operator to estimate the value of a setting by his sense of touch. The pointer is of nickel-plated brass. It is not insulated from the shaft.

<i>Type</i>	<i>Shaft Diam.</i>	<i>Net Weight</i>	<i>Code Word</i>	<i>Price</i>
202-Y	3/8 inch	1 ounce	SWITCHARMY	
202-Z	1/4 inch	1 ounce	SWITCHBURG	



All illustrations 1/2 actual size

NEW 3 1/4-INCH DIALS

A new series of friction-drive and plain dials like those shown on page 168, but 3 1/4 inches in diameter, is now available. Each has 100 divisions spread over 180°. Dial insulated from shaft. Indicator and drilling template supplied.

Type	Shaft	Drive	Code Word	Price
705-A	1/4 in.	Friction	DIARK	
705-F	3/8 in.	Friction	DIFAL	
712-A	1/4 in.	Plain	DIAPE	
712-F	3/8 in.	Plain	DIFAR	

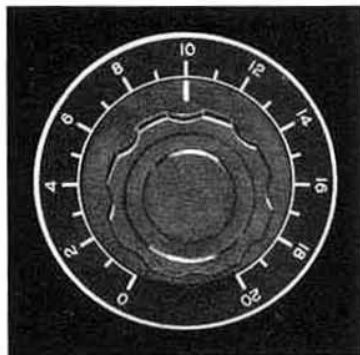

Type 318-A

A 3-inch diameter plate for use with a 1 5/8-inch knob, either pointer or skirt, and with any rheostat-potentiometer having standard 3-hole mounting. Marked with 20 divisions around 298°.

Code Word: DEVIL

DIAL PLATES

These two dial plates have photo-etched scales with raised nickel-silver graduations on a flat black background. Each can be attached to the panel with the same screws which hold the rheostat-potentiometer with which the dial plate is used.

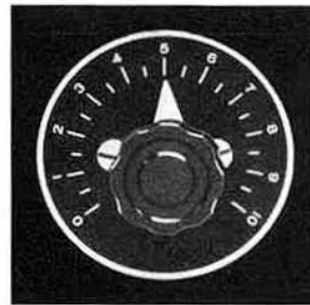

Type 522-A

A 2 1/2-inch diameter plate for use with a TYPE 637-A Knob and a TYPE 301-A or 410-A Rheostat-Potentiometer. Marked with 20 divisions around 254°.

Code Word: DOGMA

SWITCHES

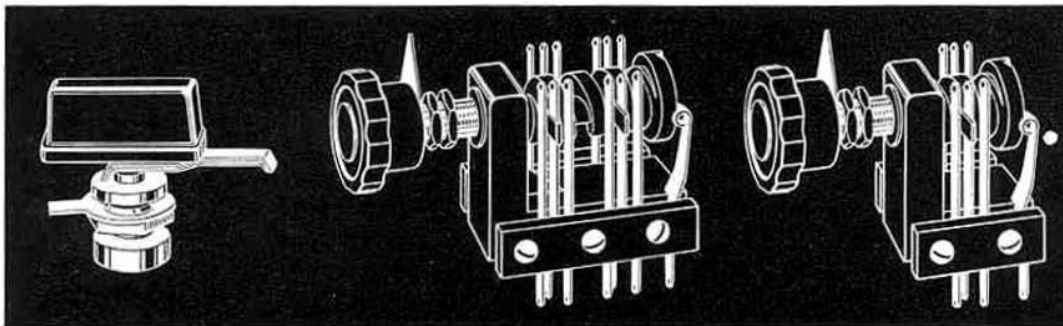

Type 202

This is a quadruple-leaf phosphor-bronze switch which makes wiping contact on both the switch points and the fixed bushing. It is intended for use with TYPE 138-B or TYPE 138-C Switch Contacts mounted on a 1 3/8-inch radius.

Type 339-A and Type 339-B

This is a rotary, 3-position switch for all applications where a toggle-switch-action "anti-capacity" switch would ordinarily be used. The entire throw is 180°, from one position through "off" to the third position, each position being marked by a detent device. The movable switch blades are actuated by a moulded bakelite worm.

Only one mounting hole is required for all panels up to 3/8-inch thick. Both 4-pole double-throw and 2-pole double-throw models are available. The contact springs can be bent for switching in unusual circuits.

The capacitance between switch elements is low. The switch itself is insulated for all voltages up to 250 volts, and the contacts will safely break 2 amperes.

Type	Panel Thickness	Code Word	Price	Type	Description	Code Word	Price
202-A	1/8 to 1/4 in.	SWITCHTOAD		339-A	4-Pole, Double Throw	PUPPY	
202-B	1/4 to 3/8 in.	SWITCHGOOD		339-B	2-Pole, Double Throw	PUTTY	

SWITCH CONTACTS AND STOPS

Switch contacts are available made of nickel-plated bronze and are either with plane faces or with cupped-shaped depressions which act as detents definitely to center the switch blade in position. Each switch contact has a

knurled shoulder which, when drawn into the panel by tightening the nut, prevents rotation of the contact head.

The switch stop is made of nickel-plated brass, and is without a knurled shoulder.

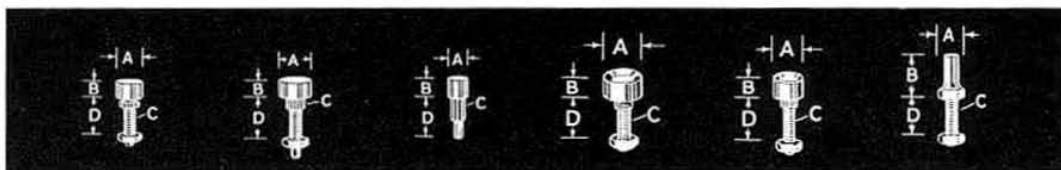

138-B 138-C 138-D 138-PD 138-CD 138-Q

Type	Description	Dimensions				Code Word	Price
		A	B	C	D		
138-B	Plane Switch Contact	1/4"	3/16"	#10 drill	3/8" max.	CONTACTANT	
138-C	Plane Switch Contact	5/16"	3/16"	#10 drill	1/2" max.	CONTACTBUG	
138-D	Plane Switch Contact	3/16"	3/16"	#28 drill	1/2"	CONTACTCAT	
138-CD	Detent Switch Contact	5/16"	3/16"	#10 drill	1/2" max.	STANPARMUD	
138-PD	Detent Switch Contact	3/8"	3/16"	#10 drill	1/2" max.	STANPARNUT	
138-Q	Switch Stop	5/16"	7/16"	6-32 stud	3/8" max.	STANPARBUL	

BINDING POSTS AND ASSEMBLIES

Particular attention is directed to the three binding posts having jack tops which take plugs of the TYPE 274 series. (TYPE 138-VD, TYPE 138-V with longer stud, is not illustrated.)

The binding-post assemblies are convenient means for mounting binding posts on metal panels. The TYPE 738-A is designed for mounting, by drive fit, in a bakelite panel.

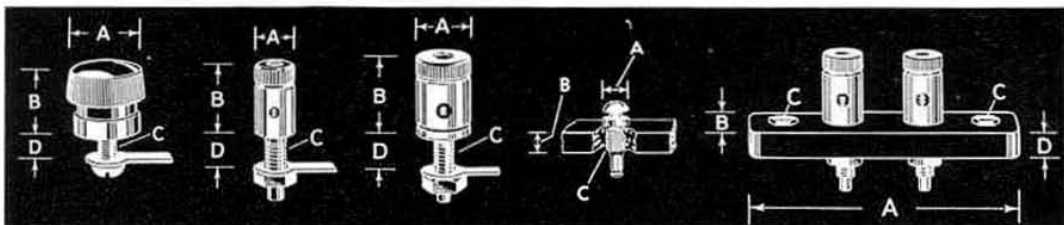

138-A 138-V 138-X 738-A 274-K

Type	Description	Dimensions				Code Word	Price
		A	B	C	D		
138-A	Binding Post (bakelite top)	3/4"	3/4" min.	10-32	3/8" max.	STANPARCUP	
138-V	Binding Post (small jack top)	3/8"	1 1/16" min.	10-32	1/2" max.	STANPARANT	
138-VD	Binding Post (small jack top, long stud)	3/8"	1 1/16" min.	10-32	7/8" max.	STANPARFUN	
138-X	Binding Post (large jack top)	1/2"	1 1/16" min.	10-32	1/2" max.	STANPARBOY	
274-K	Assembly (with 138-V Posts)	2 9/16"	1"	6-32	1/4"	STANPARBAG	
274-L	Assembly (with 138-X Posts)	2 9/16"	1"	6-32	1/4"	STANPARTAG	
738-A	Insert Terminal	1/4"	1/4" max.	#10 drill	—	UNIPARTAPE	

PORCELAIN INSULATORS

These ceramic insulators are made of high-grade brown glazed porcelain and they are intended for use in wiring circuits in both

inside and outside installations. Each insulator is supplied with wood screws and lead washers which will prevent breakage in mounting.

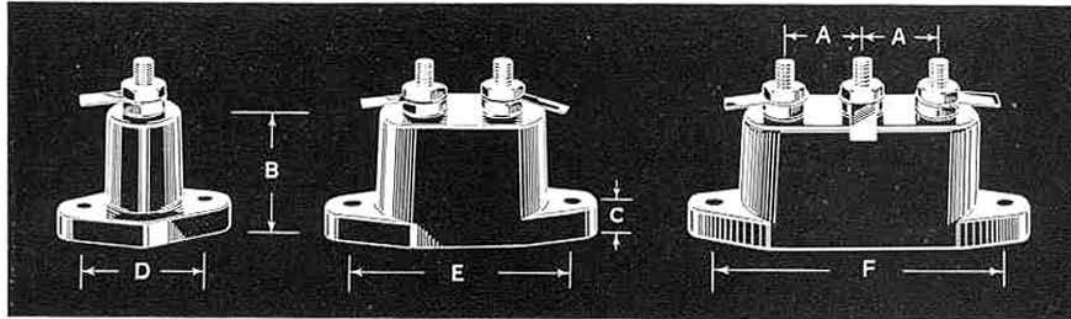

TYPE 630-A

TYPE 630-B

TYPE 630-C

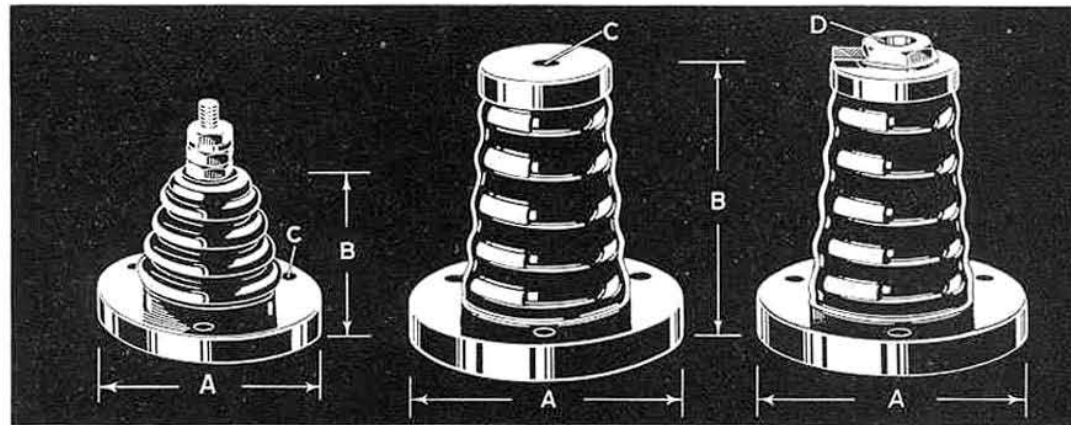

TYPE 260

TYPE 628-A

TYPE 627-A

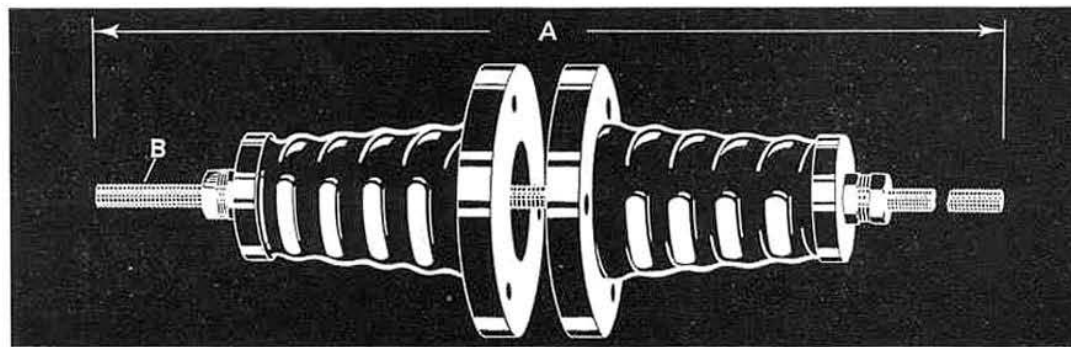

TYPE 629-A

Type	Description	Dimensions						Code Word	Price
		A	B	C	D	E	F		
260	Porcelain Insulator	2 1/16"	1 3/4"	1/8"	—	—	—	CONIC	
627-A	Jack-Top Insulator	2 5/8"	2 3/4"	—	674-J	—	—	MAYOR	
628-A	Insulator	2 5/8"	2 3/4"	1/4"	—	—	—	MEDAL	
629-A	Lead-In Assembly	15"	1/4"	For walls up to 9" thick				MERCY	
630-A	1-Terminal Insulator	—	1 1/4"	7/8"	1 1/8"	—	—	EDUCE	
630-B	2-Terminal Insulator	3/4"	1 1/4"	7/8"	—	2 1/8"	—	EGRET	
630-C	3-Terminal Insulator	3/4"	1 1/4"	7/8"	—	—	2 7/8"	EJECT	

GENERAL RADIO VACUUM-TUBE SOCKETS

Here is a complete line of high-grade sockets designed particularly for use in measuring-instrument assemblies both in the "bread-board" and final model stages. Contacts are spring tempered and will make firm connection with the tube prongs even after long periods of repeated tube replacements.

Sockets are available with either bakelite or glazed isolantite bases. For most work bakelite

bases are preferable because of their lower cost, but where low high-frequency losses and high surface resistivity are essential, isolantite bases are recommended. The illustrations with the dimensions given in the price list completely describe each unit.

The net weight of all sockets is 2 ounces, except TYPES 156 and 656 which weigh 4 ounces.

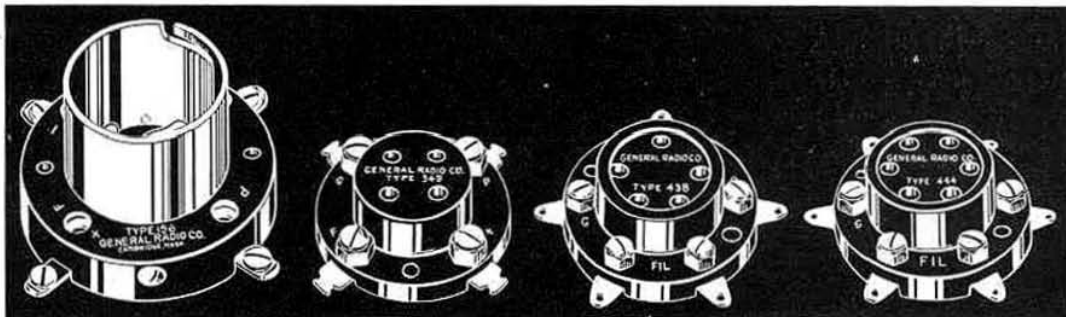

TYPE 156

TYPE 349

TYPE 438

TYPE 444

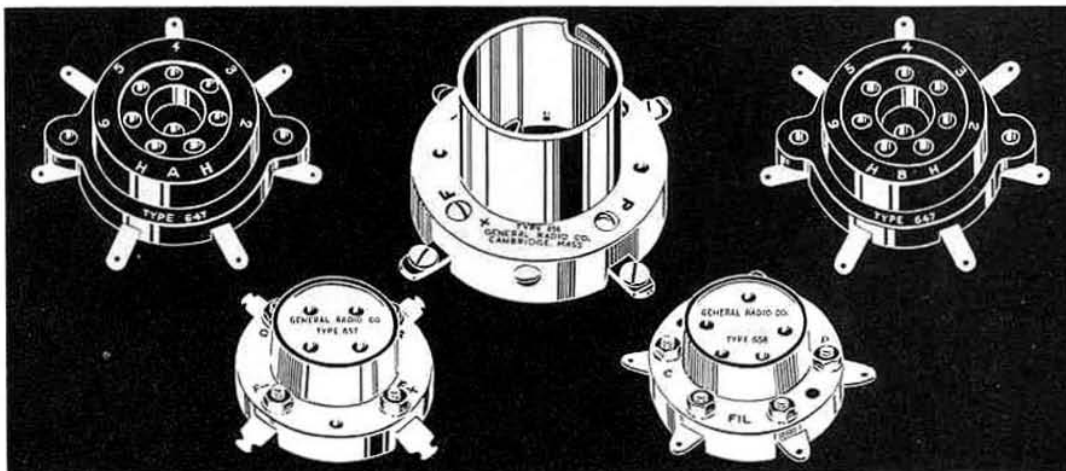

TYPE 647-A

TYPE 657

TYPE 656

TYPE 658

TYPE 647-B

Type	Base Material	Type of Tube	Base Diameter	Height	Code Word	Price
156	Bakelite	UV, UX, West. Elec. E Tube	2 ⁷ / ₁₆ inches	1 ¹³ / ₁₆ inches	SOBER	
349	Bakelite	UX—Small 4-prong	1 ⁷ / ₈ inches	3 ³ / ₄ inch	SEDAN	
438	Bakelite	UY—Small 5-prong	1 ⁷ / ₈ inches	7 ⁷ / ₈ inch	STUDY	
444	Bakelite	Small 6-prong	1 ⁷ / ₈ inches	7 ⁷ / ₈ inch	NOVEL	
647-A	Bakelite	Small 7-prong	2 ⁵ / ₁₆ inches	7 ⁷ / ₈ inch	GIPSY	
647-B	Bakelite	Medium 7-prong	2 ⁵ / ₁₆ inches	7 ⁷ / ₈ inch	GUNNY	
656	Isolantite	UV, UX, West. Elec. E Tube	2 ⁷ / ₁₆ inches	1 ²⁷ / ₃₂ inches	SOLID	
657	Isolantite	UX—4-prong	1 ⁷ / ₈ inches	1 ⁵ / ₁₆ inch	AMAZE	
658	Isolantite	UY—5-prong	1 ⁷ / ₈ inches	1 ⁵ / ₁₆ inch	AMONG	

PLUGS AND JACKS

The following section lists small parts which the laboratory worker and amateur will find useful in the construction of his equipment.

All multiple plugs and jacks have the General Radio standard $\frac{3}{4}$ -inch spacing between centers.



Type 274-P Plug

Basic plug unit — Max. current, 8 a.

- A = $\frac{5}{16}$ inch max.
- B = $\frac{1}{8}$ inch
- C = 6-32
- D = $\frac{3}{8}$ inch

Code Word: STANPARCAT

Type 274-J Jack

Basic jack unit.

- A = $\frac{1}{16}$ inch
- B = $\frac{3}{8}$ inch max.
- C = $\frac{1}{4}$ inch—28

Code Word: STANPARTOP

Type 274-E Single Plug

As illustrated, with jack opening in stem.

- A = $\frac{1}{16}$ inch
- B = $\frac{3}{8}$ inch max.
- C = $\frac{1}{4}$ inch—28
- D = $\frac{1}{4}$ inch

Code Word: STANPARDOG

Type 274-U Single Plug

Like TYPE 274-E but without thumbscrew.

- A = $\frac{1}{16}$ inch
- B = $\frac{3}{8}$ inch max.
- C = $\frac{1}{4}$ inch—28
- D = $\frac{1}{4}$ inch

Code Word: STANPARGOT

Type 274-D Insulated Plug

Similar to TYPE 274-E but with bakelite sleeve.

- A = $\frac{1}{2}$ inch
- B = $\frac{15}{16}$ inch

Code Word: STANPAREYE

Type 274-M, -ML Double Plugs

Moulded bakelite with jacks in top and setscrews for cord tips. $\frac{3}{4}$ -inch spacing.

- A = $1\frac{1}{4}$ inch
- B = $1\frac{3}{4}$ inch

Code Word: STANPARBUG

Type 274-M,

Low-loss (yellow) bakelite.

Code Word: STANPARBUY

Type 274-ML,

Type 274-G Double Plug

Two TYPE 274-E Plugs separated by a bakelite spacer. $\frac{3}{4}$ -inch spacing. A = $1\frac{3}{8}$ inch.

Code Word: STANPARPIG

Type 674-P Jumbo Plug

Basic jumbo-plug unit — Max. current, 25 a.

- A = $\frac{3}{4}$ inch
- B = $\frac{3}{8}$ inch
- C = $\frac{3}{8}$ inch—32
- D = $1\frac{1}{16}$ inch

Code Word: STANPARAPE

Type 674-J Jumbo Jack

Basic jumbo-jack unit.

- A = $\frac{3}{4}$ inch
- B = $\frac{3}{16}$ inch max.
- C = $\frac{1}{2}$ inch—20

Code Word: STANPARAYE

Type 674-C Jumbo Plug

With solder-filled cup in shank for sweating-in. $\frac{1}{4}$ -inch tubing.

- A = $\frac{1}{2}$ inch
- B = $\frac{3}{4}$ inch

Code Word: STANPARCOX

Type 674-D Insulated Jumbo Plug

With insulated shank and soldering lug — jack in top.

- A = $\frac{3}{4}$ inch
- B = $1\frac{1}{16}$ inch

Code Word: STANPARARK

Type 274-BL Series Plate

Permits connecting two circuits in series with a third having two jack-top binding posts on standard spacing.

- A = $1\frac{1}{2}$ inch

Code Word: STANPARSAM

Type 274-SB Short-Circuit Plug

TYPE 274-U Plugs with a nickel-plated brass bar.

Code Word: STANPARZIP

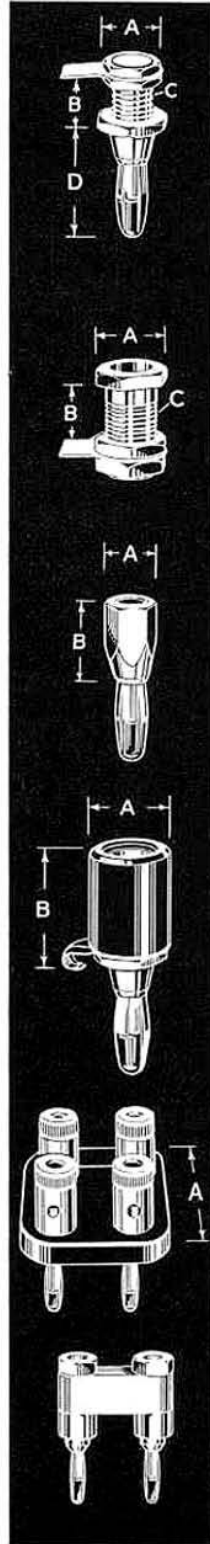

MOUNTING BASES

These units extend the possibilities of "plug in" to coils, condensers, transformers, etc.

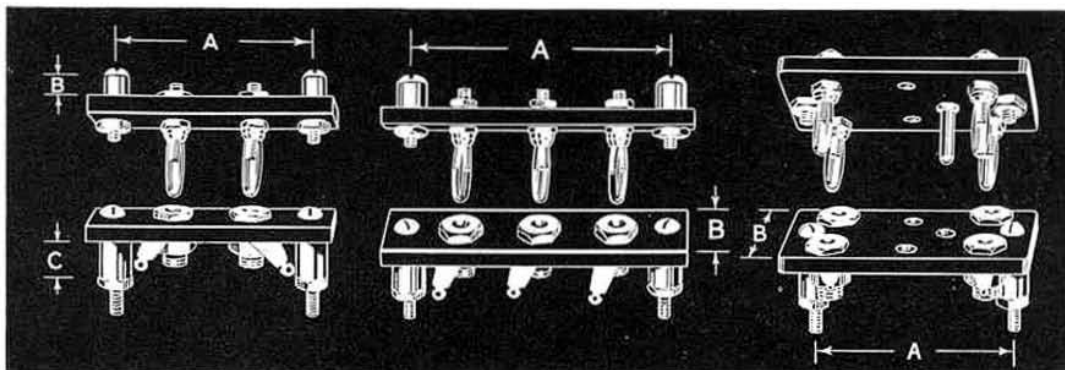

TYPE 274-AP
TYPE 274-AJ

TYPE 274-BP
TYPE 274-BJ

TYPE 274-CP
TYPE 274-CJ

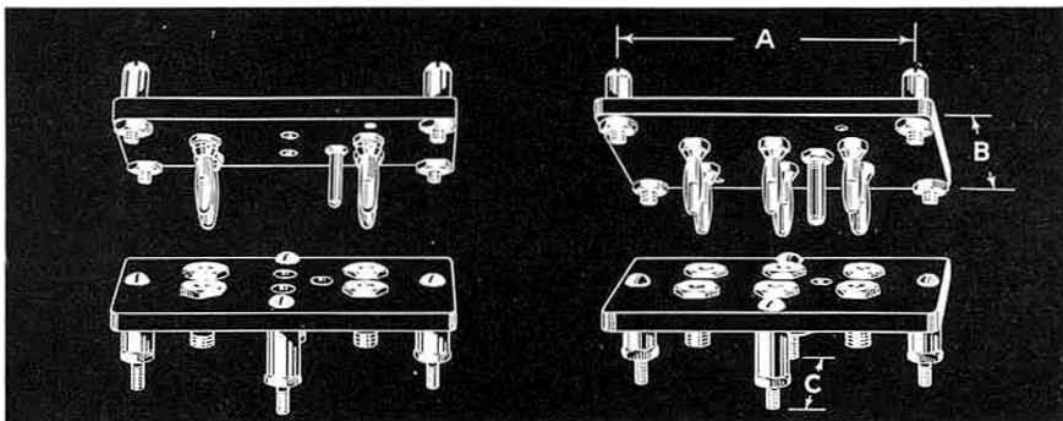

TYPE 274-EP
TYPE 274-EJ

TYPE 274-HP
TYPE 274-HJ

Type	Description	Dimensions			Code Word	Price
		A	B	C		
274-AP 274-AJ	2-Gang Plug 2-Gang Jack	1 ⁵ / ₁₆ "	1/4"	3/16"	STANPARBIB STANPARHUM	
274-BP 274-BJ	3-Gang Plug 3-Gang Jack	2 ¹ / ₂ "	3/4"	3/16"	STANPARSUN STANPARSIN	
274-CP 274-CJ	4-Gang Plug 4-Gang Jack	1 ⁵ / ₁₆ "	1 ¹ / ₄ "	3/16"	STANPARSUM STANPARGIN	
274-EP 274-EJ	4-Gang Plug 4-Gang Jack	See TYPES 274-HP and -HJ			STANPARGAS STANPARFAD	
274-HP 274-HJ	6-Gang Plug 6-Gang Jack	2 ³ / ₄ "	1 ⁷ / ₈ "	1 ⁷ / ₈ "	STANPARBED STANPARNOT	
274-Q	Locating Pin (To insure correct orientation)	—	—	—	STANPARCAD	

PARTS AND ACCESSORIES

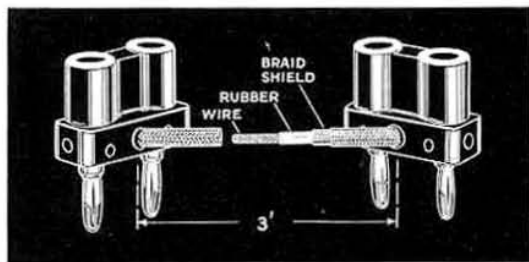

Type 274-NC Shielded Conductor

A concentric-shielded conductor with plugs.
 Capacitance: 100 μ f per foot
 Impedance: About 30 ohms
 Code Word: STANPARZOO

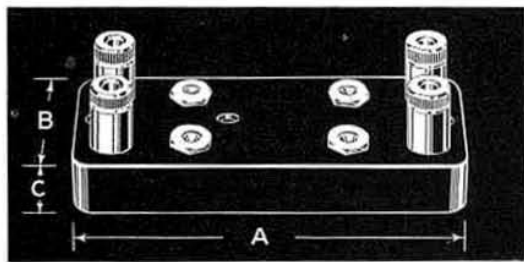

Type 274-RJ Four-Gang Jack Base

For mounting thermocouples, oxide rectifiers, etc.
 A = 3 $\frac{3}{4}$ inches C = $\frac{9}{16}$ inch
 B = 1 $\frac{1}{2}$ inches
 Code Word: STANPARPUP

Type 738-M Bracket

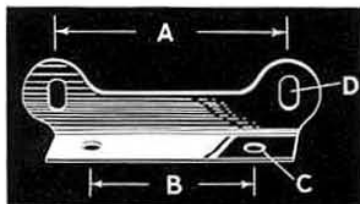

Mounting foot for TYPE 334 Condensers.
 A = 2 $\frac{1}{4}$ inch
 B = 1 $\frac{1}{2}$ inch
 C = For #8 machine screw
 D = For a #10 machine screw

Code Word: DOUBT

Type 738-D Panel Screw

A nickel-plated brass machine screw for fastening panels to a relay rack.

A = $\frac{7}{16}$ inch
 B = 1 $\frac{1}{32}$ inch
 C = 10-32
 D = $\frac{5}{8}$ inch

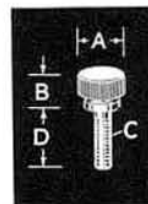

Code Word: UNIPARTBAT

Type 274 Panel Terminal Insulators

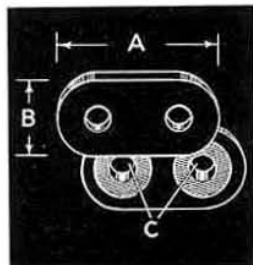

TWO
 TYPE
 138-
 VD

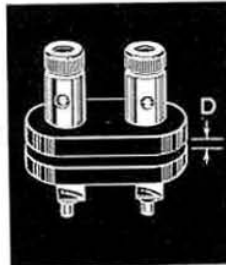

Bakelite insulators, used in pairs with TYPE 138-VD Binding Posts, for mounting on a metal panel.

A = 1 $\frac{1}{2}$ inches C = $\frac{3}{16}$ inch diam.
 B = $\frac{3}{4}$ inch D = $\frac{1}{8}$ inch to $\frac{5}{16}$ inch

Type	Bakelite Material	Code Word	Price (Pair)
274-Y	Black	STANPARBEL	
274-Z	Yellow	STANPARHOD	

TYPE 379 RADIO-FREQUENCY CHOKE



The TYPE 379 Radio-Frequency Chokes are available in two models, one of low inductance to carry a heavy current, and one of high inductance to carry a lower current. In both, the capacity does not exceed 4 micromicrofarads.

SPECIFICATIONS

Dimensions: 2 x 1 $\frac{3}{4}$ x 1 $\frac{3}{4}$ inches.

Net Weight: 2 $\frac{1}{2}$ ounces.

Mounting: See drawing.

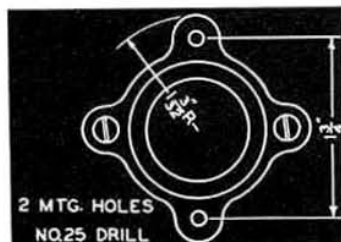

Type	In-ductance	Allowable Current		Frequency Range	D-C Resistance	Code Word	Price
		Intermit.	Continuous				
379-T	8 mh	300 ma	140 ma	1500-15,000 kc	35 Ω	JIMMY	
379-R	60 mh	90 ma	65 ma	400- 2000 kc	140 Ω	JEWEL	

APPENDIX

LOSSES IN AIR CONDENSERS

Low air-condenser losses are, of course, desirable, but they cannot be reduced indefinitely without sacrificing mechanical rigidity and the ability of the condenser to hold a calibration. Fortunately, practically all of the laboratory measurements in which the loss of the condenser must be known can be arranged so that it is merely necessary to know how they change as the condenser capacitance is varied.

The higher-grade laboratory condensers manufactured by the General Radio Company are designed so that the small amount of solid dielectric used is placed in an electric field that is unvarying with respect to rotor position. Hence the losses are constant with setting. It is then possible to assume that the condenser behaves as a loss-free variable condenser in parallel with a fixed condenser having all the losses. This means that, when using one of these condensers to measure the loss in some other condenser, the loss introduced by the standard condenser, since it does not change with rotor setting, can be eliminated from the measurement by the choice of a suitable method.

This quality of having approximately constant losses with changes in rotor setting is possessed by all General Radio condensers, and this leads to our choice of the quantity $R\omega C^2$ as the figure of merit for expressing the energy loss in an air condenser. It turns out that $R\omega C^2$ is constant for all values of ω and C . $R\omega C^2$ is therefore preferred to power factor $R\omega C$ as a figure of merit for the condenser.

The equivalent series resistance R of an air condenser may be calculated for any frequency when the figure of merit $R\omega C^2$ is known. Thus for a figure of merit of 0.06×10^{-12} the resistance of a condenser of 1000 μmf capacitance at a frequency of 1000 cycles is 10 ohms.

Normally the energy loss in an air condenser is composed of the energy losses in the solid dielectric supports and in the resistance of the conducting materials, but the presence of any solid dielectric material, such as dust, between the plates will increase the loss by a measurable amount. With high voltages, the ionization losses in the air dielectric and in the gas occluded at the plate surfaces cease to be negligible.

The choice of $R\omega C^2$ as the figure of merit is based upon the following considerations: Any air condenser C having an equivalent series resistance R may be represented by a condenser C_0 formed of the solid dielectric circuits and supports and having all the losses R_0 in parallel with a loss-free condenser C' (see the accompanying diagram).

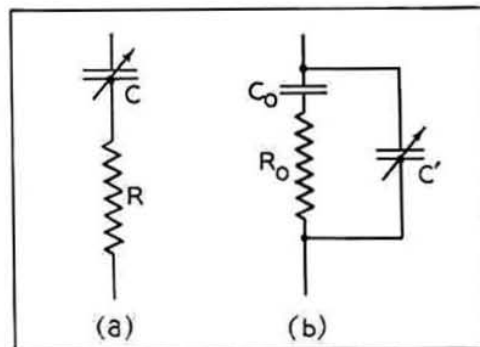

By working out the energy relations in (a) and in (b) on the assumption that all the losses are very small, it is found that

$$R = \frac{R_0 \omega C_0^2}{\omega(C' + C_0)^2} = \frac{R_0 \omega C_0^2}{\omega C^2},$$

and $R\omega C^2 = R_0 \omega C_0^2.$

If the energy losses in the condenser are constant with setting, then C_0 is a fixed condenser with an isolantite or hard-rubber dielectric, depending upon the actual construction of the condenser C . For different frequencies the power factor of this solid dielectric is essentially constant, hence the quantity $R\omega C^2$ is constant for all ordinary values of ω and C , and is a characteristic of the condenser.

REACTANCE CHART

Always use corresponding scales

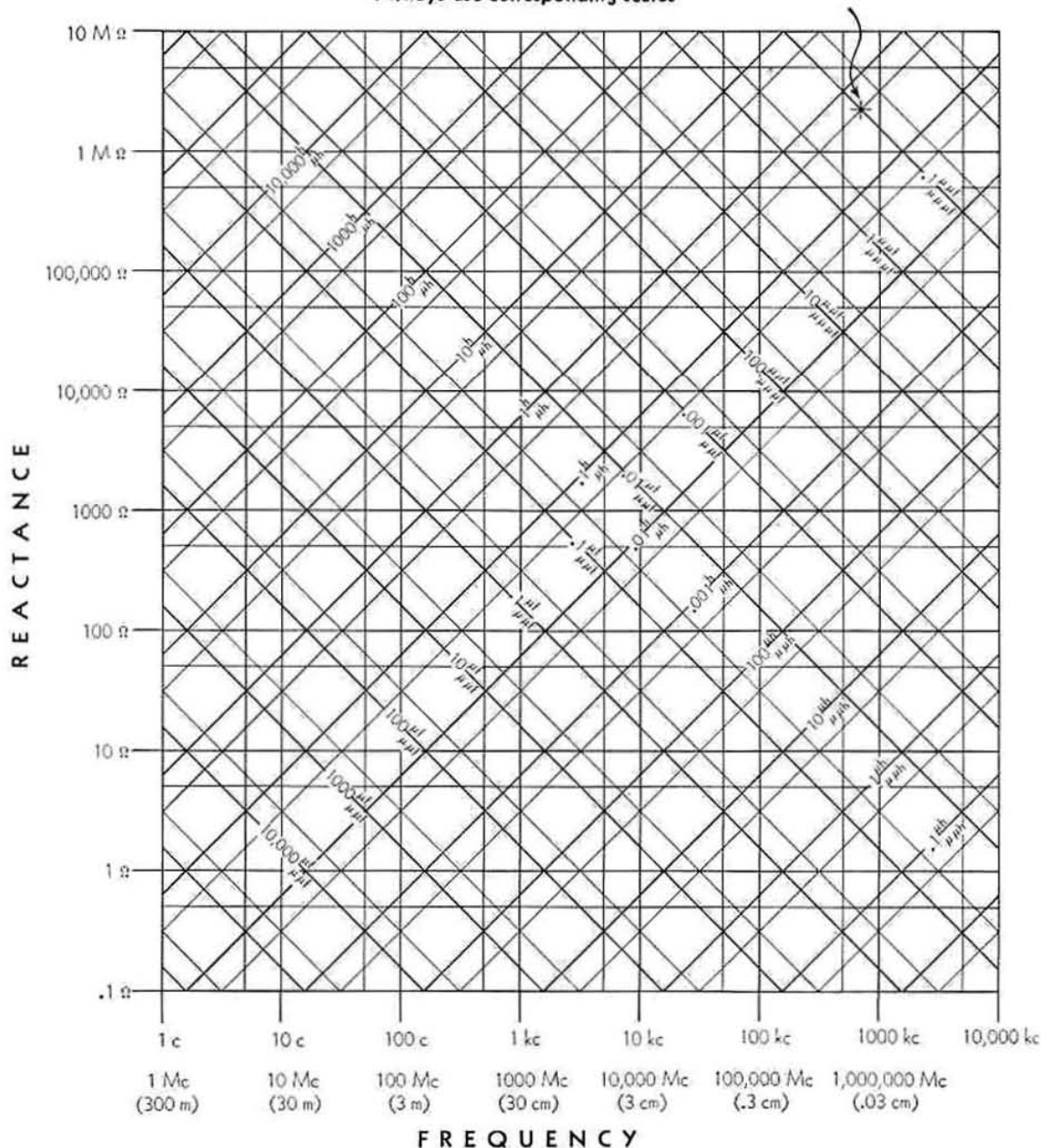

The accompanying chart may be used to find:

- (1) The reactance of a given inductance at a given frequency.
- (2) The reactance of a given capacitance at a given frequency.
- (3) The resonant frequency of a given inductance and capacitance.

In order to facilitate the determination of magnitude of the quantities involved to two or three significant figures the chart is divided into two parts. Figure 1 is the complete chart to be used for rough

calculations. Figure 2, which is a single decade of Figure 1 enlarged approximately 7 times, is to be used where the significant two or three figures are to be determined.

TO FIND REACTANCE

Enter the charts vertically from the bottom (frequency) and along the lines slanting upward to the left (inductance) or to the right (capacitance). Corresponding scales (upper or lower) must be used throughout. Project horizontally to the left from the intersection and read reactance.

Always obtain approximate value from Figure 1 before using Figure 2

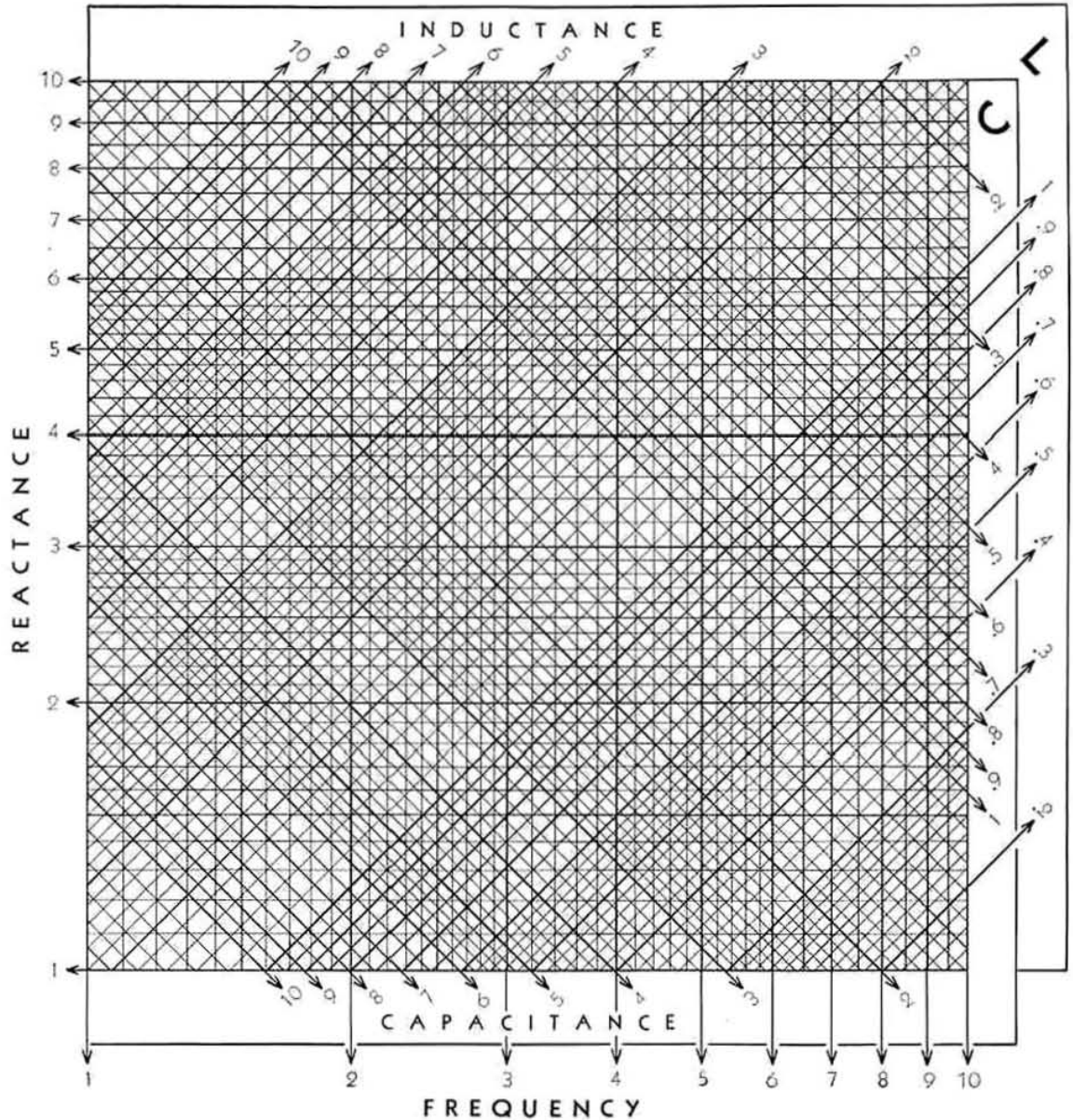

FIG. 2

TO FIND RESONANT FREQUENCY

Enter the slanting lines for the given inductance and capacitance. Project downward from their intersection and read resonant frequency from the bottom scale. Corresponding scales (upper or lower) must be used throughout.

Example: The sample point indicated (Figure 1) corresponds to a frequency of about 700 kc and an inductance of 0.5 henry, or a capacitance of 0.1 $\mu\mu\text{f}$, giving in either case a reactance of about 2,000,000 ohms. The resonant frequency of a circuit containing these values of inductance and capacitance is, of course, 700 kc, approximately.

USE OF FIGURE 2

Figure 2 is used to obtain additional precision of reading but does not place the decimal point which must be located from a preliminary entry on Figure 1. Since the chart necessarily requires two logarithmic decades for inductance and capacitance for every single decade of frequency and reactance, unless the correct decade for L and C is chosen, the calculated values of reactance and frequency will be in error by a factor of 3.16.

Example: (Continued.) The reactance corresponding to 0.5 henry or 0.1 $\mu\mu\text{f}$ is 2,230,000 ohms at 712 kc, their resonant frequency.

DECIBEL CONVERSION TABLES

It is convenient in measurements and calculations on communications systems to express the ratio between any two amounts of electric or acoustic power in units on a logarithmic scale. The *decibel* (1/10th of the *bel*) on the briggsian or base-10 scale and the *neper* on the napierian or base- e scale are in almost universal use for this purpose.

Since voltage and current are related to power by impedance, both the *decibel* and the *neper* can be used to express voltage and current ratios, if care is taken

to account for the impedances associated with them. In a similar manner the corresponding acoustical quantities can be compared.

Table I and Table II on the following pages have been prepared to facilitate making conversions in either direction between the number of *decibels* and the corresponding power, voltage, and current ratios. Both tables can also be used for *nepers* and the *mile of standard cable* by applying the conversion factors from the table on the opposite page.

Decibel—The number of decibels N_{db} corresponding to the ratio between two amounts of power P_1 and P_2 is

$$N_{db} = 10 \log_{10} \frac{P_1}{P_2} \quad (1)$$

When two voltages E_1 and E_2 or two currents I_1 and I_2 operate in the same or equal impedances,

$$N_{db} = 20 \log_{10} \frac{E_1}{E_2} \quad (2)$$

and
$$N_{db} = 20 \log_{10} \frac{I_1}{I_2} \quad (3)$$

If E_1 and E_2 or I_1 and I_2 operate in unequal impedances,

$$N_{db} = 20 \log_{10} \frac{E_1}{E_2} + 10 \log_{10} \frac{Z_2}{Z_1} + 10 \log_{10} \frac{k_2}{k_1} \quad (4)$$

and
$$N_{db} = 20 \log_{10} \frac{I_1}{I_2} + 10 \log_{10} \frac{Z_1}{Z_2} + 10 \log_{10} \frac{k_1}{k_2} \quad (5)$$

where Z_1 and Z_2 are the absolute magnitudes of the corresponding impedances and k_1 and k_2 are the values of power factor for the impedances. Note that Table I and Table II can be used to evaluate the impedance and power factor terms, since both are similar to the expression for power ratio, equation (1).

Neper—The number of nepers N_{nep} corresponding to a power ratio $\frac{P_1}{P_2}$ is

$$N_{nep} = \frac{1}{2} \log_e \frac{P_1}{P_2} \quad (6)$$

For voltage ratios $\frac{E_1}{E_2}$ or current ratios $\frac{I_1}{I_2}$ working in the same or equal impedances,

$$N_{nep} = \log_e \frac{E_1}{E_2} \quad (7)$$

and
$$N_{nep} = \log_e \frac{I_1}{I_2}$$

When E_1 and E_2 or I_1 and I_2 operate in unequal impedances,

$$N_{nep} = \log_e \frac{E_1}{E_2} + \frac{1}{2} \log_e \frac{Z_2}{Z_1} + \frac{1}{2} \log_e \frac{k_2}{k_1} \quad (8)$$

and

$$N_{nep} = \log_e \frac{I_1}{I_2} + \frac{1}{2} \log_e \frac{Z_1}{Z_2} + \frac{1}{2} \log_e \frac{k_1}{k_2} \quad (9)$$

where Z_1 and Z_2 and k_1 and k_2 are as in equations (4) and (5).

RELATIONS BETWEEN DECIBELS, NEPERS, AND MILES OF STANDARD CABLE

<i>Multiply</i>	<i>By</i>	<i>To Find</i>
decibels.....	.1151	nepers
decibels.....	1.056	miles of standard cable
miles of standard cable	.947	decibels
miles of standard cable	.109	nepers
nepers.....	8.686	decibels
nepers.....	9.175	miles of standard cable

TO FIND VALUES OUTSIDE THE RANGE OF CONVERSION TABLES

Values outside the range of either Table I or Table II on the following pages can be readily found with the help of the following simple rules.

TABLE I: DECIBELS TO VOLTAGE AND POWER RATIOS

Number of decibels positive (+): Subtract +20 decibels successively from the given number of decibels until the remainder falls within range of Table I. *To find the voltage ratio*, multiply the corresponding value from the right-hand voltage-ratio column by 10 for each time you subtracted 20 db. *To find the power ratio*, multiply the corresponding value from the right-hand power-ratio column by 100 for each time you subtracted 20 db.

Example—Given: 49.2 db
 $49.2 \text{ db} - 20 \text{ db} - 20 \text{ db} = 9.2 \text{ db}$
Voltage ratio: 9.2 db →
 $2.884 \times 10 \times 10 = 288.4$
Power ratio: 9.2 db →
 $8.318 \times 100 \times 100 = 83180$

Number of decibels negative (—): Add +20 decibels successively to the given number of decibels until the sum falls within the range of Table I. *For the voltage ratio*, divide the value from the left-hand voltage-ratio column by 10 for each time you added 20 db. *For the power ratio*, divide the value from the left-hand power-ratio column by 100 for each time you added 20 db.

Example—Given: -49.2 db
 $-49.2 \text{ db} + 20 \text{ db} + 20 \text{ db} = -9.2 \text{ db}$
Voltage ratio: -9.2 db →
 $.3467 \times 1/10 \times 1/10 = .003467$
Power ratio: -9.2 db →
 $.1202 \times 1/100 \times 1/100 = .00001202$

TABLE II: VOLTAGE RATIOS TO DECIBELS

For ratios smaller than those in table—Multiply the given ratio by 10 successively until the product can be found in the table. From the number of decibels thus found, subtract +20 decibels for each time you multiplied by 10.

Example—Given: Voltage ratio = .0131
 $.0131 \times 10 = .131 \times 10 = 1.31$
 From Table II, 1.31 →
 $2.345 \text{ db} - 20 \text{ db} - 20 \text{ db} = -37.655 \text{ db}$

For ratios greater than those in table—Divide the given ratio by 10 successively until the remainder can be found in the table. To the number of decibels thus found, add +20 db for each time you divided by 10.

Example—Given: Voltage ratio = 712
 $712 \times 1/10 = 71.2 \times 1/10 = 7.12$
 From Table II, 7.12 →
 $17.050 \text{ db} + 20 \text{ db} + 20 \text{ db} = 57.050 \text{ db}$

TABLE I

GIVEN: Decibels

TO FIND: Power and $\left\{ \begin{matrix} \text{Voltage} \\ \text{Current} \end{matrix} \right\}$ Ratios

TO ACCOUNT FOR THE SIGN OF THE DECIBEL

For positive (+) values of the decibel—Both voltage and power ratios are greater than unity. Use the two right-hand columns.

For negative (−) values of the decibel—Both voltage and power ratios are less than unity. Use the two left-hand columns.

Example—Given: ± 9.1 db. Find:

	Power Ratio	Voltage Ratio
+9.1 db	8.128	2.851
−9.1 db	0.1230	0.3508

← -db+ →					← -db+ →				
Voltage Ratio	Power Ratio	db	Voltage Ratio	Power Ratio	Voltage Ratio	Power Ratio	db	Voltage Ratio	Power Ratio
1.0000	1.0000	0	1.000	1.000	.5623	.3162	5.0	1.778	3.162
.9886	.9772	.1	1.012	1.023	.5559	.3090	5.1	1.799	3.236
.9772	.9550	.2	1.023	1.047	.5495	.3020	5.2	1.820	3.311
.9661	.9333	.3	1.035	1.072	.5433	.2951	5.3	1.841	3.388
.9550	.9120	.4	1.047	1.096	.5370	.2884	5.4	1.862	3.467
.9441	.8913	.5	1.059	1.122	.5309	.2818	5.5	1.884	3.548
.9333	.8710	.6	1.072	1.148	.5248	.2754	5.6	1.905	3.631
.9226	.8511	.7	1.084	1.175	.5188	.2692	5.7	1.928	3.715
.9120	.8318	.8	1.096	1.202	.5129	.2630	5.8	1.950	3.802
.9016	.8128	.9	1.109	1.230	.5070	.2570	5.9	1.972	3.890
.8913	.7943	1.0	1.122	1.259	.5012	.2512	6.0	1.995	3.981
.8810	.7762	1.1	1.135	1.288	.4955	.2455	6.1	2.018	4.074
.8710	.7586	1.2	1.148	1.318	.4898	.2399	6.2	2.042	4.169
.8610	.7413	1.3	1.161	1.349	.4842	.2344	6.3	2.065	4.266
.8511	.7244	1.4	1.175	1.380	.4786	.2291	6.4	2.089	4.365
.8414	.7079	1.5	1.189	1.413	.4732	.2239	6.5	2.113	4.467
.8318	.6918	1.6	1.202	1.445	.4677	.2188	6.6	2.138	4.571
.8222	.6761	1.7	1.216	1.479	.4624	.2138	6.7	2.163	4.677
.8128	.6607	1.8	1.230	1.514	.4571	.2089	6.8	2.188	4.786
.8035	.6457	1.9	1.245	1.549	.4519	.2042	6.9	2.213	4.898
.7943	.6310	2.0	1.259	1.585	.4467	.1995	7.0	2.239	5.012
.7852	.6166	2.1	1.274	1.622	.4416	.1950	7.1	2.265	5.129
.7762	.6026	2.2	1.288	1.660	.4365	.1905	7.2	2.291	5.248
.7674	.5888	2.3	1.303	1.698	.4315	.1862	7.3	2.317	5.370
.7586	.5754	2.4	1.318	1.738	.4266	.1820	7.4	2.344	5.495
.7499	.5623	2.5	1.334	1.778	.4217	.1778	7.5	2.371	5.623
.7413	.5495	2.6	1.349	1.820	.4169	.1738	7.6	2.399	5.754
.7328	.5370	2.7	1.365	1.862	.4121	.1698	7.7	2.427	5.888
.7244	.5248	2.8	1.380	1.905	.4074	.1660	7.8	2.455	6.026
.7161	.5129	2.9	1.396	1.950	.4027	.1622	7.9	2.483	6.166
.7079	.5012	3.0	1.413	1.995	.3981	.1585	8.0	2.512	6.310
.6998	.4898	3.1	1.429	2.042	.3936	.1549	8.1	2.541	6.457
.6918	.4786	3.2	1.445	2.089	.3890	.1514	8.2	2.570	6.607
.6839	.4677	3.3	1.462	2.138	.3846	.1479	8.3	2.600	6.761
.6761	.4571	3.4	1.479	2.188	.3802	.1445	8.4	2.630	6.918
.6683	.4467	3.5	1.496	2.239	.3758	.1413	8.5	2.661	7.079
.6607	.4365	3.6	1.514	2.291	.3715	.1380	8.6	2.692	7.244
.6531	.4266	3.7	1.531	2.344	.3673	.1349	8.7	2.723	7.413
.6457	.4169	3.8	1.549	2.399	.3631	.1318	8.8	2.754	7.586
.6383	.4074	3.9	1.567	2.455	.3589	.1288	8.9	2.786	7.762
.6310	.3981	4.0	1.585	2.512	.3548	.1259	9.0	2.818	7.943
.6237	.3890	4.1	1.603	2.570	.3508	.1230	9.1	2.851	8.128
.6166	.3802	4.2	1.622	2.630	.3467	.1202	9.2	2.884	8.318
.6095	.3715	4.3	1.641	2.692	.3428	.1175	9.3	2.917	8.511
.6026	.3631	4.4	1.660	2.754	.3388	.1148	9.4	2.951	8.710
.5957	.3548	4.5	1.679	2.818	.3350	.1122	9.5	2.985	8.913
.5888	.3467	4.6	1.698	2.884	.3311	.1096	9.6	3.020	9.120
.5821	.3388	4.7	1.718	2.951	.3273	.1072	9.7	3.055	9.333
.5754	.3311	4.8	1.738	3.020	.3236	.1047	9.8	3.090	9.550
.5689	.3236	4.9	1.758	3.090	.3199	.1023	9.9	3.126	9.772

DB TO POWER AND VOLTAGE RATIOS

TABLE I (continued)

← -db+ →					← -db+ →				
Voltage Ratio	Power Ratio	db	Voltage Ratio	Power Ratio	Voltage Ratio	Power Ratio	db	Voltage Ratio	Power Ratio
.3162	.1000	10.0	3.162	10.000	.1585	.02512	16.0	6.310	39.81
.3126	.09772	10.1	3.199	10.23	.1567	.02455	16.1	6.383	40.74
.3090	.09550	10.2	3.236	10.47	.1549	.02399	16.2	6.457	41.69
.3055	.09333	10.3	3.273	10.72	.1531	.02344	16.3	6.531	42.66
.3020	.09120	10.4	3.311	10.96	.1514	.02291	16.4	6.607	43.65
.2985	.08913	10.5	3.350	11.22	.1496	.02239	16.5	6.683	44.67
.2951	.08710	10.6	3.388	11.48	.1479	.02188	16.6	6.761	45.71
.2917	.08511	10.7	3.428	11.75	.1462	.02138	16.7	6.839	46.77
.2884	.08318	10.8	3.467	12.02	.1445	.02089	16.8	6.918	47.86
.2851	.08128	10.9	3.508	12.30	.1429	.02042	16.9	6.998	48.98
.2818	.07943	11.0	3.548	12.59	.1413	.01995	17.0	7.079	50.12
.2786	.07762	11.1	3.589	12.88	.1396	.01950	17.1	7.161	51.29
.2754	.07586	11.2	3.631	13.18	.1380	.01905	17.2	7.244	52.48
.2723	.07413	11.3	3.673	13.49	.1365	.01862	17.3	7.328	53.70
.2692	.07244	11.4	3.715	13.80	.1349	.01820	17.4	7.413	54.95
.2661	.07079	11.5	3.758	14.13	.1334	.01778	17.5	7.499	56.23
.2630	.06918	11.6	3.802	14.45	.1318	.01738	17.6	7.586	57.54
.2600	.06761	11.7	3.846	14.79	.1303	.01698	17.7	7.674	58.88
.2570	.06607	11.8	3.890	15.14	.1288	.01660	17.8	7.762	60.26
.2541	.06457	11.9	3.936	15.49	.1274	.01622	17.9	7.852	61.66
.2512	.06310	12.0	3.981	15.85	.1259	.01585	18.0	7.943	63.10
.2483	.06166	12.1	4.027	16.22	.1245	.01549	18.1	8.035	64.57
.2455	.06026	12.2	4.074	16.60	.1230	.01514	18.2	8.128	66.07
.2427	.05888	12.3	4.121	16.98	.1216	.01479	18.3	8.222	67.61
.2399	.05754	12.4	4.169	17.38	.1202	.01445	18.4	8.318	69.18
.2371	.05623	12.5	4.217	17.78	.1189	.01413	18.5	8.414	70.79
.2344	.05495	12.6	4.266	18.20	.1175	.01380	18.6	8.511	72.44
.2317	.05370	12.7	4.315	18.62	.1161	.01349	18.7	8.610	74.13
.2291	.05248	12.8	4.365	19.05	.1148	.01318	18.8	8.710	75.86
.2265	.05129	12.9	4.416	19.50	.1135	.01288	18.9	8.811	77.62
.2239	.05012	13.0	4.467	19.95	.1122	.01259	19.0	8.913	79.43
.2213	.04898	13.1	4.519	20.42	.1109	.01230	19.1	9.016	81.28
.2188	.04786	13.2	4.571	20.89	.1096	.01202	19.2	9.120	83.18
.2163	.04677	13.3	4.624	21.38	.1084	.01175	19.3	9.226	85.11
.2138	.04571	13.4	4.677	21.88	.1072	.01148	19.4	9.333	87.10
.2113	.04467	13.5	4.732	22.39	.1059	.01122	19.5	9.441	89.13
.2089	.04365	13.6	4.786	22.91	.1047	.01096	19.6	9.550	91.20
.2065	.04266	13.7	4.842	23.44	.1035	.01072	19.7	9.661	93.33
.2042	.04169	13.8	4.898	23.99	.1023	.01047	19.8	9.772	95.50
.2018	.04074	13.9	4.955	24.55	.1012	.01023	19.9	9.886	97.72
.1995	.03981	14.0	5.012	25.12	.1000	.01000	20.0	10.000	100.00
.1972	.03890	14.1	5.070	25.70					
.1950	.03802	14.2	5.129	26.30					
.1928	.03715	14.3	5.188	26.92					
.1905	.03631	14.4	5.248	27.54					
.1884	.03548	14.5	5.309	28.18					
.1862	.03467	14.6	5.370	28.84					
.1841	.03388	14.7	5.433	29.51					
.1820	.03311	14.8	5.495	30.20					
.1799	.03236	14.9	5.559	30.90					
.1778	.03162	15.0	5.623	31.62					
.1758	.03090	15.1	5.689	32.36					
.1738	.03020	15.2	5.754	33.11					
.1718	.02951	15.3	5.821	33.88					
.1698	.02884	15.4	5.888	34.67					
.1679	.02818	15.5	5.957	35.48					
.1660	.02754	15.6	6.026	36.31					
.1641	.02692	15.7	6.095	37.15					
.1622	.02630	15.8	6.166	38.02					
.1603	.02570	15.9	6.237	38.90					

← -db+ →				
Voltage Ratio	Power Ratio	db	Voltage Ratio	Power Ratio
3.162×10^{-1}	10^{-1}	10	3.162	10
10^{-1}	10^{-2}	20	10	10^2
3.162×10^{-2}	10^{-3}	30	3.162×10	10^3
10^{-2}	10^{-4}	40	10^2	10^4
3.162×10^{-3}	10^{-5}	50	3.162×10^3	10^5
10^{-3}	10^{-6}	60	10^4	10^6
3.162×10^{-4}	10^{-7}	70	3.162×10^4	10^7
10^{-4}	10^{-8}	80	10^4	10^8
3.162×10^{-5}	10^{-9}	90	3.162×10^4	10^9
10^{-5}	10^{-10}	100	10^5	10^{10}

To find decibel values outside the range of this table, see page 181

TABLE II

GIVEN: $\left\{ \begin{array}{l} \text{Voltage} \\ \text{Current} \end{array} \right\}$ Ratio TO FIND: Decibels

POWER RATIOS

To find the number of decibels corresponding to a given power ratio—Assume the given power ratio to be a voltage ratio and find the corresponding number of decibels from the table. The desired result is exactly

one-half of the number of decibels thus found.

Example—Given: a power ratio of 3.41.
Find: 3.41 in the table:

$$3.41 \rightarrow 10.655 \text{ db} \times \frac{1}{2} = 5.328 \text{ db}$$

Voltage Ratio	.00	.01	.02	.03	.04	.05	.06	.07	.08	.09
1.0	.000	.086	.172	.257	.341	.424	.506	.588	.668	.749
1.1	.828	.906	.984	1.062	1.138	1.214	1.289	1.364	1.438	1.511
1.2	1.584	1.656	1.727	1.798	1.868	1.938	2.007	2.076	2.144	2.212
1.3	2.279	2.345	2.411	2.477	2.542	2.607	2.671	2.734	2.798	2.860
1.4	2.923	2.984	3.046	3.107	3.167	3.227	3.287	3.346	3.405	3.464
1.5	3.522	3.580	3.637	3.694	3.750	3.807	3.862	3.918	3.973	4.028
1.6	4.082	4.137	4.190	4.244	4.297	4.350	4.402	4.454	4.506	4.558
1.7	4.609	4.660	4.711	4.761	4.811	4.861	4.910	4.959	5.008	5.057
1.8	5.105	5.154	5.201	5.249	5.296	5.343	5.390	5.437	5.483	5.529
1.9	5.575	5.621	5.666	5.711	5.756	5.801	5.845	5.889	5.933	5.977
2.0	6.021	6.064	6.107	6.150	6.193	6.235	6.277	6.319	6.361	6.403
2.1	6.444	6.486	6.527	6.568	6.608	6.649	6.689	6.729	6.769	6.809
2.2	6.848	6.888	6.927	6.966	7.008	7.044	7.082	7.121	7.159	7.197
2.3	7.235	7.272	7.310	7.347	7.384	7.421	7.458	7.495	7.532	7.568
2.4	7.604	7.640	7.676	7.712	7.748	7.783	7.819	7.854	7.889	7.924
2.5	7.959	7.993	8.028	8.062	8.097	8.131	8.165	8.199	8.232	8.266
2.6	8.299	8.333	8.366	8.399	8.432	8.465	8.498	8.530	8.563	8.595
2.7	8.627	8.659	8.691	8.723	8.755	8.787	8.818	8.850	8.881	8.912
2.8	8.943	8.974	9.005	9.036	9.066	9.097	9.127	9.158	9.188	9.218
2.9	9.248	9.278	9.308	9.337	9.367	9.396	9.426	9.455	9.484	9.513
3.0	9.542	9.571	9.600	9.629	9.657	9.686	9.714	9.743	9.771	9.799
3.1	9.827	9.855	9.883	9.911	9.939	9.966	9.994	10.021	10.049	10.076
3.2	10.103	10.130	10.157	10.184	10.211	10.238	10.264	10.291	10.317	10.344
3.3	10.370	10.397	10.423	10.449	10.475	10.501	10.527	10.553	10.578	10.604
3.4	10.630	10.655	10.681	10.706	10.731	10.756	10.782	10.807	10.832	10.857
3.5	10.881	10.906	10.931	10.955	10.980	11.005	11.029	11.053	11.078	11.102
3.6	11.126	11.150	11.174	11.198	11.222	11.246	11.270	11.293	11.317	11.341
3.7	11.364	11.387	11.411	11.434	11.457	11.481	11.504	11.527	11.550	11.573
3.8	11.596	11.618	11.641	11.664	11.687	11.709	11.732	11.754	11.777	11.799
3.9	11.821	11.844	11.866	11.888	11.910	11.932	11.954	11.976	11.998	12.019
4.0	12.041	12.063	12.085	12.106	12.128	12.149	12.171	12.192	12.213	12.234
4.1	12.256	12.277	12.298	12.319	12.340	12.361	12.382	12.403	12.424	12.444
4.2	12.465	12.486	12.506	12.527	12.547	12.568	12.588	12.609	12.629	12.649
4.3	12.669	12.690	12.710	12.730	12.750	12.770	12.790	12.810	12.829	12.849
4.4	12.869	12.889	12.908	12.928	12.948	12.967	12.987	13.006	13.026	13.045
4.5	13.064	13.084	13.103	13.122	13.141	13.160	13.179	13.198	13.217	13.236
4.6	13.255	13.274	13.293	13.312	13.330	13.349	13.368	13.386	13.405	13.423
4.7	13.442	13.460	13.479	13.497	13.516	13.534	13.552	13.570	13.589	13.607
4.8	13.625	13.643	13.661	13.679	13.697	13.715	13.733	13.751	13.768	13.786
4.9	13.804	13.822	13.839	13.857	13.875	13.892	13.910	13.927	13.945	13.962
5.0	13.979	13.997	14.014	14.031	14.049	14.066	14.083	14.100	14.117	14.134
5.1	14.151	14.168	14.185	14.202	14.219	14.236	14.253	14.270	14.287	14.303
5.2	14.320	14.337	14.353	14.370	14.387	14.403	14.420	14.436	14.453	14.469
5.3	14.486	14.502	14.518	14.535	14.551	14.567	14.583	14.599	14.616	14.632
5.4	14.648	14.664	14.680	14.696	14.712	14.728	14.744	14.760	14.776	14.791
5.5	14.807	14.823	14.839	14.855	14.870	14.886	14.902	14.917	14.933	14.948
5.6	14.964	14.979	14.995	15.010	15.026	15.041	15.056	15.072	15.087	15.102
5.7	15.117	15.133	15.148	15.163	15.178	15.193	15.208	15.224	15.239	15.254
5.8	15.269	15.284	15.298	15.313	15.328	15.343	15.358	15.373	15.388	15.402
5.9	15.417	15.432	15.446	15.461	15.476	15.490	15.505	15.519	15.534	15.549

TABLE II (continued)

Voltage Ratio	.00	.01	.02	.03	.04	.05	.06	.07	.08	.09
6.0	15.563	15.577	15.592	15.606	15.621	15.635	15.649	15.664	15.678	15.692
6.1	15.707	15.721	15.735	15.749	15.763	15.778	15.792	15.806	15.820	15.834
6.2	15.848	15.862	15.876	15.890	15.904	15.918	15.931	15.945	15.959	15.973
6.3	15.987	16.001	16.014	16.028	16.042	16.055	16.069	16.083	16.096	16.110
6.4	16.124	16.137	16.151	16.164	16.178	16.191	16.205	16.218	16.232	16.245
6.5	16.258	16.272	16.285	16.298	16.312	16.325	16.338	16.351	16.365	16.378
6.6	16.391	16.404	16.417	16.430	16.443	16.456	16.469	16.483	16.496	16.509
6.7	16.521	16.534	16.547	16.560	16.573	16.586	16.599	16.612	16.625	16.637
6.8	16.650	16.663	16.676	16.688	16.701	16.714	16.726	16.739	16.752	16.764
6.9	16.777	16.790	16.802	16.815	16.827	16.840	16.852	16.865	16.877	16.890
7.0	16.902	16.914	16.927	16.939	16.951	16.964	16.976	16.988	17.001	17.013
7.1	17.025	17.037	17.050	17.062	17.074	17.086	17.098	17.110	17.122	17.135
7.2	17.147	17.159	17.171	17.183	17.195	17.207	17.219	17.231	17.243	17.255
7.3	17.266	17.278	17.290	17.302	17.314	17.326	17.338	17.349	17.361	17.373
7.4	17.385	17.396	17.408	17.420	17.431	17.443	17.455	17.466	17.478	17.490
7.5	17.501	17.513	17.524	17.536	17.547	17.559	17.570	17.582	17.593	17.605
7.6	17.616	17.628	17.639	17.650	17.662	17.673	17.685	17.696	17.707	17.719
7.7	17.730	17.741	17.752	17.764	17.775	17.786	17.797	17.808	17.820	17.831
7.8	17.842	17.853	17.864	17.875	17.886	17.897	17.908	17.919	17.931	17.942
7.9	17.953	17.964	17.975	17.985	17.996	18.007	18.018	18.029	18.040	18.051
8.0	18.062	18.073	18.083	18.094	18.105	18.116	18.127	18.137	18.148	18.159
8.1	18.170	18.180	18.191	18.202	18.212	18.223	18.234	18.244	18.255	18.266
8.2	18.276	18.287	18.297	18.308	18.319	18.329	18.340	18.350	18.361	18.371
8.3	18.382	18.392	18.402	18.413	18.423	18.434	18.444	18.455	18.465	18.475
8.4	18.486	18.496	18.506	18.517	18.527	18.537	18.547	18.558	18.568	18.578
8.5	18.588	18.599	18.609	18.619	18.629	18.639	18.649	18.660	18.670	18.680
8.6	18.690	18.700	18.710	18.720	18.730	18.740	18.750	18.760	18.770	18.780
8.7	18.790	18.800	18.810	18.820	18.830	18.840	18.850	18.860	18.870	18.880
8.8	18.890	18.900	18.909	18.919	18.929	18.939	18.949	18.958	18.968	18.978
8.9	18.988	18.998	19.007	19.017	19.027	19.036	19.046	19.056	19.066	19.075
9.0	19.085	19.094	19.104	19.114	19.123	19.133	19.143	19.152	19.162	19.171
9.1	19.181	19.190	19.200	19.209	19.219	19.228	19.238	19.247	19.257	19.266
9.2	19.276	19.285	19.295	19.304	19.313	19.323	19.332	19.342	19.351	19.360
9.3	19.370	19.379	19.388	19.398	19.407	19.416	19.426	19.435	19.444	19.453
9.4	19.463	19.472	19.481	19.490	19.499	19.509	19.518	19.527	19.536	19.545
9.5	19.554	19.564	19.573	19.582	19.591	19.600	19.609	19.618	19.627	19.636
9.6	19.645	19.654	19.664	19.673	19.682	19.691	19.700	19.709	19.718	19.726
9.7	19.735	19.744	19.753	19.762	19.771	19.780	19.789	19.798	19.807	19.816
9.8	19.825	19.833	19.842	19.851	19.860	19.869	19.878	19.886	19.895	19.904
9.9	19.913	19.921	19.930	19.939	19.948	19.956	19.965	19.974	19.983	19.991

Voltage Ratio	0	1	2	3	4	5	6	7	8	9
10	20.000	20.828	21.584	22.279	22.923	23.522	24.082	24.609	25.105	25.575
20	26.021	26.444	26.848	27.235	27.604	27.959	28.299	28.627	28.943	29.248
30	29.542	29.827	30.103	30.370	30.630	30.881	31.126	31.364	31.596	31.821
40	32.041	32.256	32.465	32.669	32.869	33.064	33.255	33.442	33.625	33.804
50	33.979	34.151	34.320	34.486	34.648	34.807	34.964	35.117	35.269	35.417
60	35.563	35.707	35.848	35.987	36.124	36.258	36.391	36.521	36.650	36.777
70	36.902	37.025	37.147	37.266	37.385	37.501	37.616	37.730	37.842	37.953
80	38.062	38.170	38.276	38.382	38.486	38.588	38.690	38.790	38.890	38.988
90	39.085	39.181	39.276	39.370	39.463	39.554	39.645	39.735	39.825	39.913
100	40.000	—	—	—	—	—	—	—	—	—

To find ratios outside the range of this table, see page 181

INDEX BY TYPE NUMBER

INDEX BY TYPE NUMBER

<i>Type</i>	<i>Item</i>	<i>Page</i>	<i>Type</i>	<i>Item</i>	<i>Page</i>
100	Variac	140	419-A	Rectifier-Type Wavemeter	53
106	Standard Inductance	31	421-A	Reactance Meter	74
107	Variable Inductor	32	429-H	Attenuation Box	15
125	Phantom-Antenna Resistor	18	434-B	Audio Frequency Meter	55
138	Binding Posts	171	437	Center-Tap Resistance Unit	139
138	Switch Contacts and Stops	171	438	Socket	173
143-D	Rectifier Tube	100, 102	439	Center-Tap Resistance Unit	139
156	Socket	173	444	Socket	173
166	Telephone Transformer	158	457-B	Modulation Meter	110
177	Inductor Assembly	164	471-A	Rheostat-Potentiometer	137
200	Variac	140	475-A	Frequency Monitor	41
202	Switch	170	476-A	Quartz Bar	45
202	Switch Knob	169	480	Relay Rack	160
213	Audio Oscillator	64	483	Output Meter	121
214-A	Rheostat-Potentiometer	136	484-A	Modulated Oscillator	65
216	Capacity Bridge	80	484-P	Inductors	66
219	Decade Condenser	30	488-DM	Alternating-Current Meter	123
222	Precision Condenser	22, 24	488-HM	Alternating-Current Galvanometer	124
224	Precision Wavemeter	51	492-A	Oxide Rectifier	149
229	Galvanometer Shunt	84	493	Vacuum Thermocouples	150
246	Variable Air Condenser	25	500	Resistor	129
247-F	Variable Air Condenser	145	505	Condenser	148
247-G	Variable Air Condenser	27	508-A	Oscillator	63
249	Attenuation Box	15	509	Standard Condenser	28
260	Porcelain Insulator	172	510	Decade-Resistance Unit	130
269	Variometer	166	514-A	Amplifier	67
274	Plugs and Jacks	174	516-C	Radio-Frequency Bridge	72
274	Mounting Bases	175	519-A	Dial Lens	166
274	Panel Terminal Insulators	176	520-A	Dial Lock	166
274-NC	Shielded Conductor	176	522-A	Dial Plate	170
293-A	Universal Bridge	77	525	Resistor	19
293-P	Accessories	78	526	Mounted Rheostat-Potentiometer	20
301-A	Rheostat-Potentiometer	139	529	Attenuation Box	17
314-A	Rheostat-Potentiometer	137	529-P1	60-DB Attenuator	17
318-A	Dial Plate	170	530	Band-Pass Filter	114
329-J	Attenuation Box	15	533-A	Rheostat-Potentiometer	138
330	Filter Section	116	534	Band-Pass Filter	115
333-A	Rheostat-Potentiometer	138	535-A	Frequency Meter-Monitor	153
334	Variable Air Condenser	144	536-A	Distortion-Factor Meter	112
335-Z	Variable Air Condenser	144	539	Variable Air Condenser	26, 142
339	Switch	170	539-P	Incremental-Pitch Condenser	27
349	Socket	173	541	Audio-Frequency Transformer	154, 156
358	Wavemeter	152	544-A	Megohm Meter	75
368	Variable Air Condenser	146	544-P1	Power-Supply Unit	76
371	Rheostat-Potentiometer	136	546-A	Microvolter	122
376	Quartz Plates	42	548-A	Edgerton Stroboscope	2
377-B	Low-Frequency Oscillator	61	549-B	Synchronous-Motor Contactor	4
379	Radio-Frequency Choke	176	549-P2	Hand Contactor	5
380	Decade-Condenser Unit	147	552	Volume Control	133
410-A	Rheostat-Potentiometer	139	559-A	Noise Meter	5
418	Dummy Antenna	96			

INDEX BY TYPE NUMBER (continued)

<i>Type</i>	<i>Item</i>	<i>Page</i>	<i>Type</i>	<i>Item</i>	<i>Page</i>
560-A	Crystal Holder	153	654-A	Decade Voltage Divider	18
561-C	Vacuum-Tube Bridge	82	655-A	Bedell Sweep Circuit	103
568	Variable Air Condenser	143	656	Socket	173
572-B	Microphone Hummer	152	657	Socket	173
574	Wavemeter	54	658	Socket	173
575-E	Piezo-Electric Oscillator	46	660-A	Universal Rack	161
577-U	Inductor Form	166	661	Unit Panels and Accessories 162, 163	
578-A	Shielded Transformer	86	666-A	Variable Transformer	158
581-B	Frequency-Deviation Meter	40	667-A	Inductance Bridge	79
583-A	Output Power Meter	119	668	Compensated Decade-Resistance Unit	131
585	Audio-Frequency Transformer	154, 158	669	Compensated Slide-Wire Resistor	131
586	Power-Level Indicator	120	670	Compensated Decade Resistor	12
588-AM	Direct-Current Meter	151	672-A	Power Supply	125
601-A	Standard-Signal Generator	93	673-A	Power Supply	126
601-P	Inductors	94	674	Plugs and Jacks	174
602	Decade-Resistance Box	9	675-H	Piezo-Electric Oscillator	46
603-A	Standard-Signal Generator	90	675-L	Piezo-Electric Oscillator	47
603-P	Inductors	92	676-A	Quartz Bar and Mounting	45
604-B	Test-Signal Generator	95	677	Inductor Form	165
610-A	Ratio-Arm Box	86	678	Plug and Jack Base	165
611	Synero-Clock	49	679	Inductor	165
612-B	Coupling Panel	37	680-J	Jack Base	165
613-B	Beat-Frequency Oscillator	60	687-A	Electron Oscillograph and Bedell Sweep Circuit	99
614-A	Selective Amplifier	48	687-P1	Cathode-Ray Tube	100
615-A	Heterodyne Frequency Meter	50	687-P2	Cathode-Ray Tube	100
616-B	Heterodyne Frequency Meter	50	690-B	Piezo-Electric Oscillator	35
617-B	Interpolation Oscillator	47	691-B	Temperature-Control Unit	35
618-A	Harmonic Oscillator	39	692-A	Multivibrator	35
619	Heterodyne Detector	48	693-A	Synero-Clock and Amplifiers	35
621-A	Edgerton Power Stroboscope	3	694-B	Control Panel	35
624-A	Precision Wavemeter	52	695-A	Charging Equipment	35
625-A	Bridge	85	696-A	Power Supply	35
626-A	Vacuum-Tube Voltmeter	118	702	Friction-Drive Dial	168
627-A	Jack-Top Insulator	172	703	Friction-Drive Dial	168
628-A	Insulator	172	704	Precision Dial	167
629-A	Lead-In Assembly	172	705	Friction-Drive Dial	170
630	Stand-Off Insulator	172	706	Precision Dial	167
635-B	Electron Oscillograph	101	710	Plain Dial	168
635-P2	Cathode-Ray Tube	102	712	Plain Dial	170
635-P3	Cathode-Ray Tube	102	713-A	Beat-Frequency Oscillator	58
636-A	Wave Analyzer	108	714-A	Amplifier	68
637	Fluted Knobs	169	717	Plain Dial	168
639-A	Variable Air Condenser	145	730-A	Transmission Monitoring As- sembly	111
642-D	Volume Control	134	738-A	Insert Terminal	171
646-A	Logarithmic Resistor	14	738-D	Panel Screw	176
647	Socket	173	738-M	Bracket	176
650-A	Impedance Bridge	70	747-A	Temperature-Control Box	44
651-A-E	Camera Assembly	105	756-A	Variable Air Condenser	146
651-A-M	Camera Assembly	106			
653	Volume Control	132			

INDEX BY TITLE

	<i>Page</i>		<i>Page</i>
Adjustable transformer (Variac)	140	Decade condenser	30
Alternating-current meter	121, 123	-condenser unit	147
galvanometer	124	-resistance box	9
Amplifier	67, 68	-resistance unit	130
oscillograph	102	voltage divider	18
selective	37, 48	Detector, heterodyne	37, 48
Analyzer, wave	108	Dial, friction-drive	168, 170
Antenna, dummy	96	lens	166
resistor, phantom	18	lock	166
Attenuation box	15, 17, 122	plain	168, 170
Audibility meter	17	plates	170
Audio-frequency meter	55	precision	167
transformer	154-159	Direct-current meter	151
Audio oscillator	61-64, 152	Distortion-factor meter	112
Band-pass filter	114, 115	Dummy antenna	96
Band-spread condenser	146	Edgerton stroboscope	2, 3
Bar, quartz	55, 45	Electron oscillograph	99, 101
Base, jack	164, 165, 176	Filter, band-pass	114, 115
mounting	175	section	116
Beat-frequency condenser	142	Frequency-deviation meter	40
oscillator	58, 60	Frequency meter, audio	55
Bedell sweep circuit	103	meter, heterodyne	37, 50
Binding posts and assemblies	171	meter-monitor	153
Bridge accessories	87	monitor	40, 41
capacity	80	standard	34, 38
decade	77	Friction-drive dial	168, 170
frequency	55	Galvanometer, alternating-current	124
high-resistance	75	direct-current	151
impedance	70	shunt	84
inductance	79	Generator, standard-signal	90, 93
radio-frequency	72	test-signal	95
resistance	70, 77, 85	Harmonic analyzer	108, 111, 112
skeleton-type	77, 85	oscillator	39
transformer	78, 86, 158	Heterodyne detector	37, 48
universal	77	frequency meter	37, 50
vacuum-tube	82	Hummer, microphone	152
Cable, shielded	176	Impedance bridge	70
Calibrated condenser	22, 24, 27, 28, 30, 147, 148	Incremental-pitch condenser	27
inductor	31, 32	Indicator, power-level	120
resistor	9, 18-20, 129	Inductance bridge	79
Camera assembly	104-107	standard	31
Capacity bridge	80	Inductor form	164-166
Cathode-ray oscillograph	99, 101	plug-in	164, 165
tube	100, 102	variable	32, 166
Center-tap resistance unit	139	Insert terminal	171
Charging equipment	35	Insulator, jack-top	172
Choke, radio-frequency	176	panel terminal	176
Clock, synchro	35, 49	stand-off	172
Compensated decade-resistance unit	131	Interpolation equipment	36
decade resistor	12	oscillator	37, 47
slide-wire resistor	131	Jack base	164, 165, 175, 176
Condenser, air dielectric	22-27, 142-146	Jack-top insulator	172
band-spread	146	Jacks	174
beat-frequency	142	Knob, fluted	169
decade	30, 147	Lead-in assembly	172
fixed	28, 30, 147, 148	Lens, dial	166
incremental-pitch	27	Lock, dial	166
precision	22, 24	Logarithmic resistor	14
standard	28, 148	Low-frequency oscillator	61
straight-line-frequency	142, 143, 146	Megohm meter	75
transmitting	143-145	Meter, alternating-current	121, 123, 124
two-section	144-146	audibility	17
Contactors, Edgerton stroboscope	4, 5	audio frequency	55
Contacts, switch	171	direct-current	151
Control panel	35	distortion-factor	112
Copper-oxide rectifier	149	frequency-deviation	40
voltmeter	121, 123, 124	heterodyne frequency	37, 50
Coupling panel	37	megohm	75
Crystal holder	153	modulation	110, 111
Decade bridge	77	noise	5

INDEX BY TITLE (continued)

	<i>Page</i>		<i>Page</i>
Meter, output	121	Resistance unit, compensated decade	131
output power	119	decade	130
oxide-rectifier	121, 123, 124	Resistor, calibrated	9, 14, 18-20, 129-131
reactance	74	compensated decade	12
thermocouple	151	compensated slide-wire	131
Microphone hummer	152	decade	9, 12, 130, 131
mixing control	132	fixed	18, 19, 129
transformer	154	heavy-duty	18, 19
Microvolter	122	logarithmic	14
Modulated oscillator	65	phantom-antenna	18
Modulation meter	110, 111	standard	9, 19, 129
Monitor, frequency	40, 41	Rheostat-potentiometer	20, 135-139
frequency meter-	153	Selective amplifier	37, 48
Mounted rheostat-potentiometer	20	Shielded conductor	176
Mounting base	175, 176	transformer	86
transformer	175	Shunt, galvanometer	84
Multivibrator	35	Signal generator	90, 93, 95
Mutual inductance standard	32	Slide-wire resistor	78
Network, attenuation	15, 17, 122	compensated	131
Noise meter	5	Sockets	173
Oscillator, audio	61-64, 152	Square-law galvanometer	124
beat-frequency	58, 60	Stand-off insulator	172
harmonic	39	Standard condenser	28, 148
interpolation	37, 47	-frequency assembly	34, 38
low-frequency	61	inductance	31
modulated	65	mutual inductance	32
piezo-electric	35, 46, 47	resistor	19, 129
radio-frequency	65, 90, 93, 95	-signal generator	90, 93
tuning-fork	64	Stroboscope, Edgerton	2, 3
Oscillograph amplifier	68	sweep circuit, Bedell	103
camera	105	Switch contacts and stops	171
cathode-ray	99, 101	Switch knob	169
electron	99, 101	Switches	170
Output meter	121	Synchronous-motor contactor	4
power meter	119	Syncro-clock	49
Oxide rectifier	149	Syncro-clock and amplifiers	35
Panel, blank	37, 162	Telephone transformer	158
screw	176	Temperature-control box	44
terminal insulator	176	unit	35
unit	161-163	Test-signal generator	95
Phantom-antenna resistor	18	Thermocouple, vacuum	150
Piezo-electric oscillator	35, 46, 47	Transformer, adjustable (Variac)	140
Plates, quartz	42	audio-frequency	154-159
Plug and jack base	165	bridge	78, 86, 158
Plugs	174	mounting bases	175
Potentiometer, mounted	20	shielded	86
unmounted	135-139	telephone	158
Power-level indicator	120	variable	158
meter, output	119	Transmission monitoring assembly	111
supply	35, 125, 126	Transmitting condenser	143-145
-supply unit	76	inductor	165
Precision condenser	22, 24	Unit-panel equipment	161-164
dial	167	Universal bridge	77
wavemeter	51, 52	rack	161
Primary standard of frequency	34	Vacuum-tube bridge	82
Quartz bar	35, 45	voltmeter	118
plates	42	Variable air condenser	22-27, 142-146
Rack, relay	160, 161	inductor	32
Radio-frequency bridge	72	transformer	158
choke	176	Variac	140
oscillator	65	Variometer	166
Ratio-arm box	86	Voltage divider, decade	18
Reactance meter	74	Voltmeter, oxide-rectifier	121, 123, 124
Rectifier, oxide	149	vacuum-tube	118
laboratory	125, 126	Volume control	132-134
Rectifier-type wavemeter	53	indicator	130
Relay rack	160, 161	Wave analyzer	108
Resistance box, decade	9	Wavemeter	51-54, 152, 153
bridge	70, 77, 85	precision	51, 52
unit, center-tap	139	rectifier-type	53

