

Evaluation of Inclined Plate Metering Mechanism for Direct Seeded Rice

Manisha Sahu

Department of Farm Machinery and
Power Engineering
SV College of Agricultural Engineering and
Technology & Research Station
IGKV, Raipur -492012, INDIA

Ajay Verma

Department of Farm Machinery and
Power Engineering
SV College of Agricultural Engineering and
Technology & Research Station
IGKV, Raipur -492012, INDIA

Abstract - For broadcasting a higher seed rate (80-100 kg/ha) is required. Hence, there is need to reduce these huge amount of seed rate in direct seeding of rice. It is necessary for seeds to be placed at equal intervals within rows. So selection of metering mechanism is crucial for singulation of seeds and uniform distribution within the row to meet the requirements of timeliness of operation in farms. The inclined plate has provision for changing the plate rpm at the given forward speed. A test setup was design to mount the inclined metering plate and vary the plate rpm. In lab test the metering device is tested at all three inclination angle and rotor speed viz. 50°, 45°, 40° and 15, 23 and 28 rpm, respectively at the forward speed of 4.5 km/h. The variation in seed rate depends on inclination angle and rotor speed of seed plate. Average spacing obtained at plate inclination angle of 50°, 45° and 40° were (19.13, 14.13 and 8.86 cm), (20.13, 15.03 and 10.03 cm) and (19.23, 14.6 and 9.46 cm) respectively for an average spacing of 20 cm, 15 cm and 10 cm at different rotor speed and all three varieties. Metering device inclined at 45° gave the best seed spacing with all varieties of paddy seeds. Optimum seed rate of all three varieties of paddy was about 13.3 kg/ha at 45° inclination angle and lower rotor rpm. Multiple index 8.77% was highest at 40° inclination of metering plate with higher rotor speed at lab setup planter. The least multiple index 4.00 % was observed at 45° inclination and minimum rpm of seed plate. The general mean and standard error of quality of index was 86.33% and 0.86. Highest feed index 88.33% was obtained at plate inclination of 45° with all varieties of paddy seeds. Least seed damage of 0.19% was found at 45° of inclination angle for all three varieties of paddy. The selection of plate inclination of metering mechanism was purely based on average spacing, miss index multiple index, quality of feed index and seed damage. Metering mechanism at an inclination of 45° was recommended for sowing of all three varieties of paddy seeds.

Key words: Paddy, Inclined metering plate, Sticky belt test, Angle of inclination, Rotor speed, Seed rate.

I. INTRODUCTION

Seeding depth plays key role for good germination. It is necessary for seeds to be placed at equal intervals within rows. In manual seeding with conventional practice, the higher and non-uniform plant population adversely affect grain yield of different crops. Planting equipment with inclined plate seed metering device used for sowing sunflower (*Helianthus annuus*) [1]. They recommended a forward speed 3.5 km/h for the planting equipment and a rotary speed of 33rpm for the metering plate for achieving uniform seed distribution and seed rate. The seed delivery per revolution of feed shaft for small seed size varieties has more seed delivery rate as compared to medium and bold seed varieties [2]. For singulation and uniform placement

of carrot seeds with inclined plate meter mechanism, the slant type cell plate at inclination of 50° was better for sowing of coated seed of carrot [3]. Study on feasibility of precision planting by cell type metering mechanism for radish seed was reported [4]. However, in recent times due to climate variability and lack of sufficient moisture in the soil for reasonably sufficient time in the sowing window period, farmers prefer to operate the planters at higher speeds to complete the sowing operation of various rainfed crops within a short period. A variety of method evolved to assess the performance of planter metering mechanism. When observing the spacing between the plants once they emerge, considerable variability often exists in the plant to plant distance. The second most common method to evaluate the metering mechanism of planter is the grease belt test stand under laboratory conditions, which is unaffected by crop and soil conditions. Based upon the in-between spacing of 50 seeds, five measures of performance parameters viz. average spacing, multiple index, miss index, quality of feed index and precision were determined [5]. The ultimate objective of seed planting using improved sowing equipment is to achieve precise seed distribution within the row. The achievement of the set seed spacing majorly depends on the machine technical variables such as the type of seed pickup mechanism, the machine operating speed, overall gear ratio between drive wheel and seed rotor, and to some extent on seed quality. Keeping in view the above, the present study was undertaken to evaluate inclined plate metering mechanism for direct seeding of rice.

II. MATERIALS AND METHODS

Seed metering mechanism

A metering device draws seed from bulk and delivers them at the desired rates in the seed tubes for sowing in soil, uniformly. Commonly recommended metering systems on planters are horizontal plate, inclined plate, vertical rollers with cells, and cups over the periphery [6]. Since paddy seeds are very small in size and very susceptible to mechanical damages, metering with horizontal and vertical plate metering device were not considered. Hence laboratory experiment was conducted with inclined plate type metering mechanism (Fig.2b).



(a) Variety - V1 (b) Variety - V2 (c) Variety - V3

Fig.1. Paddy seeds used for evaluation of metering mechanism
 Table 1 Physical and engineering properties of the selected variety of paddy

Property	Paddy variety			
	V1	V2	V3	Avg.
Length, mm	9.02	9.28	9.25	9.81
Width, mm	2.54	2.53	2.06	2.38
Thickness, mm	1.96	2.10	2.56	2.20
Weight of 1000 gm seeds, g	25.00	26.00	27.00	26.00
Geometry mean dia., mm	3.51	3.62	3.60	3.57
Sphericity, Ø	0.38	0.39	0.39	0.38
Bulk Density, kg/m ³	550.55	532.70	533.35	538.86
Angle of repose, deg	35.31	36.14	36.47	35.97
Moisture content, %db	14.00	15.21	16.62	15.28

Note: V1-Indira Barani; V2-GKV R2; V3-MTU 1010.



(a)

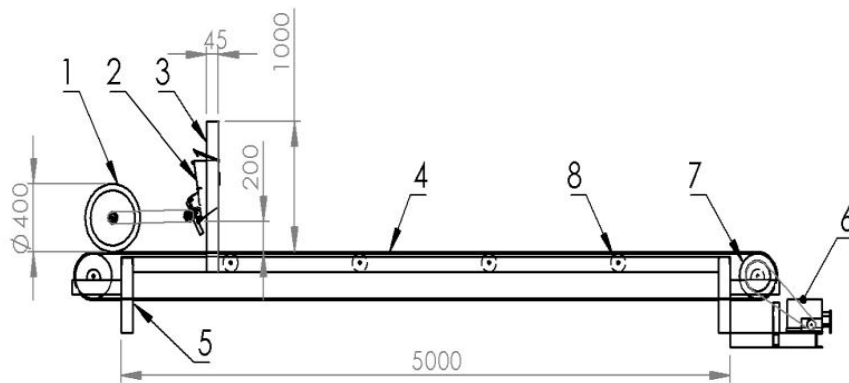

(b)

Fig.2. (a) Inclined metering plate (b) Laboratory setup for inclined plate metering mechanism (b)1.Transmission wheel, 2. Direct seeding system, 3.Frame direct seeding system, 4.Sticky belt, 5.Frame of sticky belt set up, 6.5hp motor, 7.Rollers, 8.Idlers (All dimensions in mm)

Fabrication and development of experimental lab test setup (Sticky belt test)

A grease belt test stand that provides an environment for the determination of seed rate and seed placement of selected metering mechanism was developed to carry out the tests under the laboratory conditions. The test stand consisted of a rectangular frame of 5000x600 mm made of 35x35x5 mm M S angle iron. Four legs of 600 mm length were welded to the frame to give stability and proper ground clearance for work place. Two rollers of 400 mm length and 100 mm in diameter were fabricated and fitted over the frame. The distance between the two rollers is

adjustable in 25 mm increments to tighten the belt when required. To mount different seed planter boxes for testing, a 1000 mm height and 450 mm rectangular angle iron frame was fabricated and fitted near the drive roller. This frame allows for rotating the seed box at different inclination angle. The drive transmission from the motor to the drive roller of endless belt and feed shaft is through sprocket and chain at speed ratio of 1:1. An electric motor of 5 hp was used to drive the sticky belt and the rotational speed of the sticky belt transmitted to the transmission wheel, through which it was transmitted to the inclined metering shaft with the help of belt and pulley

arrangement. The variable speeds were obtained by two sets of variable belt and pulley drive have three pairs of pulley, one set was connect to the motor and another one fitted with feed shaft of metering mechanism. A specially fabricated 5 mm thick and 600 mm wide endless belt was used to observe the actual seed distribution pattern in laboratory.

The rotating action of inclined plate picking the seeds from seed box and falls it freely from the cell. The seeds, which fall from the cell due to gravity action, are guided to the grease belt or on the dry soil surface by the funnels. It is the most convenient and simplest method as such it allows easy recording of the test parameter viz. average spacing, seed rate, multiple index, miss index, quality of feed index and seed damage were determined.

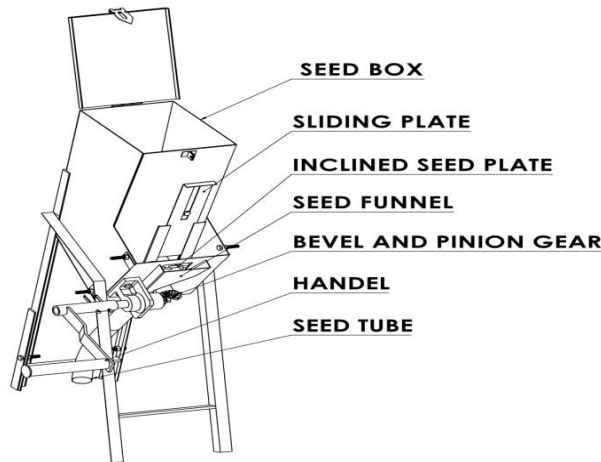

Figure 3 Seed planter box for Inclined metering unit

DEVELOPMENT OF SEED PLANTER BOX

The cross section of the seed box may be trapezoidal, rectangular, triangular or cylindrical; in this work trapezoidal shape was considered for seed box. Seed box of 400 mm height and 200 mm top width and 150 mm bottom width made of MS sheet 18 was fitted over the top portion of the lab test mechanism to keep the seeds. The bottom was kept inclined from the horizontal. A slider was fitted to the seed box to facilitate movement of seed towards the feed box of metering devices. The rear wall of seed box must be flat vertical and front wall has greater than maximum angle of repose for emptying the seeds. To carry out the study on different variety of paddy seeds, inclined metering mechanism was selected and evaluated using test stand. A set of bevel gear used to drive the inclined metering mechanism. The inclined metering mechanism has 120 mm diameter and 5 mm thickness made up of aluminum. It consists of 25 numbers edge cell on its periphery. These cells are inclined to 50° from vertical axis.

Cross section of sliding baffle has 21.2 cm × 5.5 cm. Sliding baffle on the seed box is provided to maintain the uniform depth of paddy seeds in the feed box for easily picking the seed by the cell of inclined metering plate. The depth of paddy seeds is maintained about 3-4 cm in the front part of the seed box at metering device unit. Transparent plastic tubes of 25 mm diameter and 2 mm thick was selected for seed tube. Seed tube angle is 15° rearward from vertical. Improved uniformity has been obtained in tests with plate type planters by angling the seed tube rearward 15 to 30° from the vertical [7]. Seeds fall freely from the inclined plate type metering mechanism through the small opening of rectangular shape provided on the hopper's inclined plate and here the seed was dropping

continue to the seed funnel and does not need any cutoff device to the edge cell of metering plate. The seed dropping funnel was designed on the basis of angle of repose of paddy seeds. The values of angle of repose for variety (V1), (V2) and (V3) seeds were 35.3°, 36.13° and 36.46°, respectively Table 1. Slope of funnel was decided 40° by considering the greater angle of repose for easy flow of seed to the seed tube. Bevel and pinion gear was selected of 18 and 10 number of teeth. Inclined metering plate is fitted to the bevel gear shaft, which takes drive from pinion gear shaft (Fig.3).

Selection of variables for tests

To test the inclined seed metering mechanism using a grease belt test rig, few field trials were taken up with existing planter to verify and select the planter operating speed ranges in Indian conditions and ground wheel dimensions for seed rotor rpm calculation. It was observed that, in our field trials, different tractor operated planters were operated at forward speeds ranging from 2 – 5 km/h [8]. The planter / seed drill ground wheels (drive transmission) effective diameters ranged from 30 – 45 cm. Hence, we selected the planter forward speed 4.5 km/h and ground wheel effective diameter as 40 cm for laboratory evaluation. Accordingly, the variable drives speeds were calculated and set for both belt and seed rotor (Table 2).

Lab test procedure

Before laboratory testing of inclined plate metering system, the 3/4th capacity of seed box was filled with the paddy seeds, unit was mounted on the test stand and fitted firmly. The hopper height was kept at 30 cm above the belt and was maintained constant throughout the experiment for each test run. With the revolution of the metering

mechanism, 40 cycles of feed shaft were collected by seed guiding funnel, through which felled on the sticky belt due to gravity. Seeds dropped and seeds damaged were counted manually and weight was noted using the electronic balance. The grease was smeared on the conveyor belt at the section where seed had to fall to determine the seed spacing interval of metering mechanism. These testing were carried out at different inclination angle to the

horizontal followed by different seed plate rpm at 4.5 km/h forward speed of lab setup planter for selected varieties of paddy seeds. During test runs, the actual spacing between two consecutive seeds dropped on the grease belt were measured using a 100 cm length steel rule for a row length of 300 cm for each set of run [9].

Table 2- Plan of experiment on metering device

S. N.	System variable	Parameter consider
1.	Seed plate rotor speed (rpm)	R1-15 R2-23 R3-28
2.	Paddy seeds	V1-Indira Barani V2-IGKV R2 V3-MTU 1010
3.	Inclination of seed plate to Horizontal	01-50° 02-45° 03-40°

Performance Parameters

Seeding mass rate

The total mass of paddy seeds planted per hectare expressed in Mg/ha was calculated by using the following relationship (Bakhtiari and Loghavi, 2009):

$$R_{sm} = \left[\frac{M}{W \times x_s} \right] \times 100 \times 2 \quad (1)$$

Where,

R_{sm} = Seeding mass rate, Mg/ha

M = Average mass of one seed, g

W = Row width, cm; and

x_s = Seed spacing along the row, cm.

Multiple index

It is the total number of spacing, which are less than 0.5 times theoretical spacing.

$$MI = \frac{\psi}{N} \times 100 \quad (2)$$

Where,

MI = Multiple index, %

ψ = Total number of observations with spacing, which are less than 0.5 times theoretical spacing

N = Total number of observations.

Miss index

It is the total number of observation with spacing more than 1.5 times theoretical spacing. High value of miss index is mainly due to the failure of seed picking system or, due to lack of positive release of the seeds.

$$Ms.I = \frac{\xi}{N} \times 100 \quad (3)$$

Where,

ξ = the total number of observation with spacing more than 1.5 times theoretical spacing

N = Total number of observations.

Quality of feed index

Quality of feed index is the measure of how often the seed spacing's were close to the theoretical spacing [5]. It is the number of observations, which are 0.5 to 1.5 times theoretical spacing. Higher is the quality of feed index, better is the performance of the metering mechanism.

$$QI = \frac{\tau}{N} \times 100 \quad (4)$$

Where,

QI = Quality of feed Index, %

τ = Number of observation, which are 0.5 to 1.5 times theoretical spacing

N = Total number of observations.

Each test run with the grease belt yielded different seed spacing (i.e. 20 cm, 15 cm and 10 cm), and each seed spacing was measured using a tape measure with the seeds on the grease belt.

III. RESULT AND DISCUSSION

Average seed spacing

Average seed spacing was highly influenced by peripheral speed of metering plate followed by inclination angle. Average spacing obtained at plate inclination angle of 50°, 45° and 40° were (19.13, 14.13 and 8.86 cm), (20.10, 15.06

and 10.03 cm) and (18.53, 13.68 and 8.76 cm) respectively for an average spacing of 20 cm, 15 cm and 10 cm at different rotor speed for all three varieties. The similar results were reported [3] for carrot seeds. General mean and standard error of seed spacing at lower rotor speed was 19.57 cm and 0.181, respectively. Inclination angle of 45° gave average spacing close to the theoretical spacing at all rotor speed. In case of 40° inclination angle (θ_1), the average spacing was less than the theoretical spacing and multiple seed dropping was more than the other two inclination angle (Fig.4).

Performance indices

The distance between plants with in the row is influenced by a number of factors including multiple index, miss index, failure of a seed to emerge, and variability around the drop point. Hence the edge cells of inclined plate metering mechanism drop tow number of seeds per hill.

Seed rate

At the lower rotor speed general mean and standard error of seed rate was 14.62 kg/ha and 3.98. The coefficient of variation was 27.71%. It was observed that the highest seed rate (28.94 kg/h) at 40° inclination angle and higher peripheral speed of metering plate. The optimum seed rate was found 13.23 kg/ha, 17.11 kg/ha and 26.25 kg/ha at 45° inclination angle for seed spacing of 20 cm, 15 cm and 10cm, respectively.

Multiple index

The general mean and standard error of multiple index was 4.14% and 0.26. The coefficient of variation was 33.23%. Multiple index 8.77% was highest at 40° inclination of metering plate with higher rotor speed in lab setup planter. This was because multiple seeds were picked by each cell. The least multiple index 4.00 % was observed at 45° inclination and minimum rpm of seed plate (Fig.7). Improve the performance value of multiple index at lower rotor speed of seed plate. This result was also achieved [10] for cotton and maize seeds.

Miss Index

Miss index was influenced most by plate angle followed by rotor speed. The general mean and standard error of miss

index was 1.22% and 0.70, respectively at lower rotor speed. The coefficient of variation was 80.30%. The miss index 2.68% was higher for 50° of inclination angle with and maximum rotor rpm. This was because the metering mechanism failed to pick and drop a seed resulting in a large spacing between seeds. There was no miss index observed at 40° inclination angle at all rotor speed of seed plate in lab setup planter. The average miss index of 1.50% was obtained at 45° inclination angle at different rotor speed and all varieties of paddy seeds.

Quality of feed index

Quality of feed index was highly influenced by angle of the metering plate followed by rotor rpm and forward speed (Fig.6, 7 and 8). The general mean and standard error of quality of index was 86.33% and 0.86. The coefficient of variation was 5.19%. The similar result was reported [3] for carrot seeds. Average quality of feed index and coefficient of variation were 83.44% and 5.49% in case of 40° of metering device inclination angle, while those with inclination angle 45° of metering device were 88.33% and 3.70%, respectively at lower rotor speed. It was observed that lower rotor speed improves the performance of quality of feed index. This result was also reported [10] for cotton and maize seeds.

Seed damage

From (Fig. 9) the percent of seed damage for different combinations of metering system is presented. The general mean and standard error of seed damage were 0.28% and 0.006, respectively. The maximum percent of seed damage at 40° inclination and higher rotor rpm of metering plate was 0.30 %, with coefficient of variation was 12.90% because more inclination and higher peripheral speed of seed plate. Least seed damage of 0.19% was observed at 45° inclination angle of metering plate with lower rotor rpm for all three varieties of paddy seeds. This is less than the maximum allowable seed damage (0.5%) in a seed metering device of the seed drill and planter [6].Seed damage in all cases ranged between 0.1 - 0.30 %, and was low, probably due to the inclination of seed plate. The similar results were reported [8] and [3] for peanuts and carrot seeds, respectively.

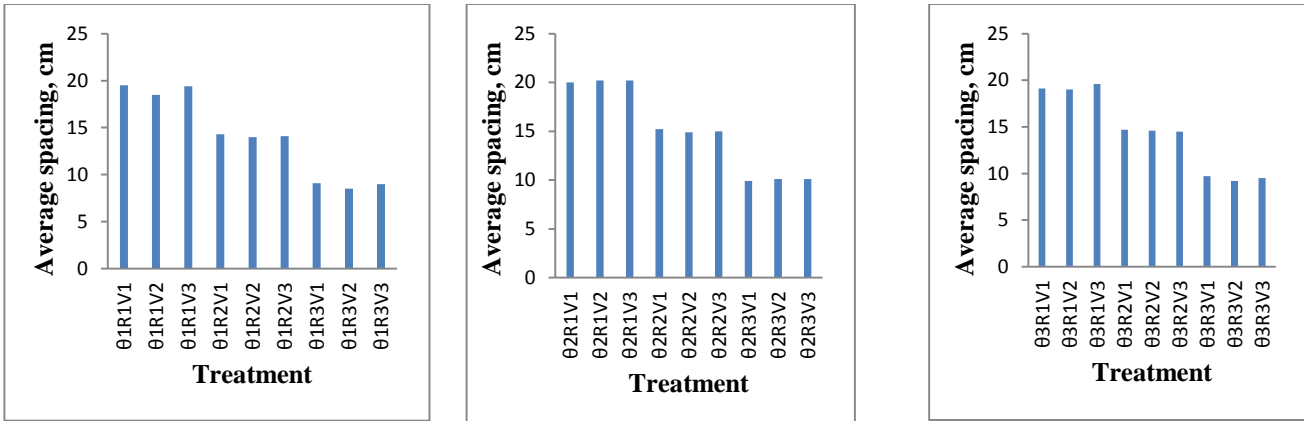

Fig.4: Average spacing of metering plate for combination of independent variables at $\theta 1$, $\theta 2$ and $\theta 3$

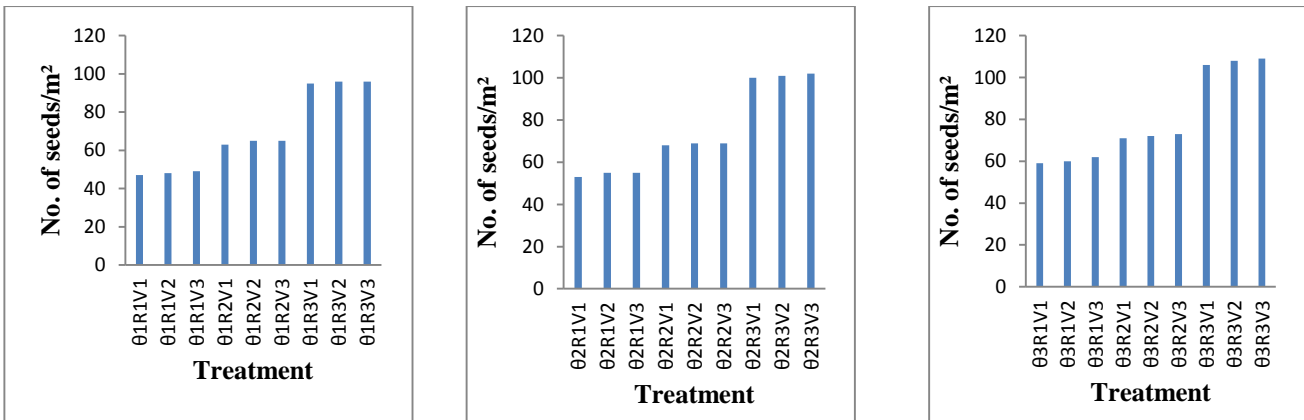

Fig.5: Seed rate, No. of seeds/m² of metering plate for combination of independent variables at $\theta 1$, $\theta 2$ and $\theta 3$

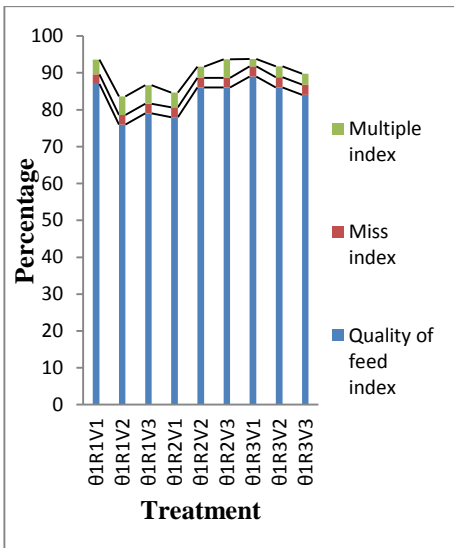

Fig.6: Performance of metering plate for combinations of different independent variables at $\theta 1$

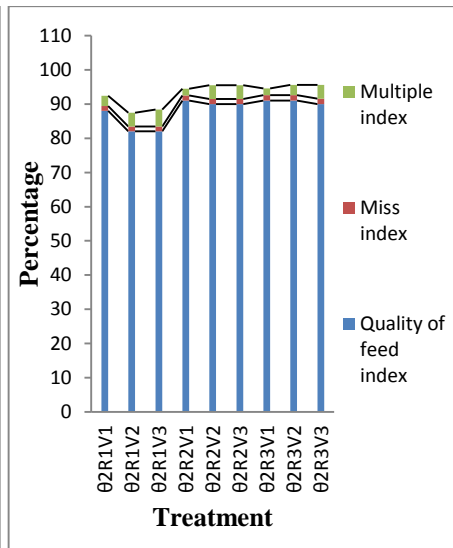

Fig.7: Performance of metering plate for combinations of different independent variables at $\theta 2$

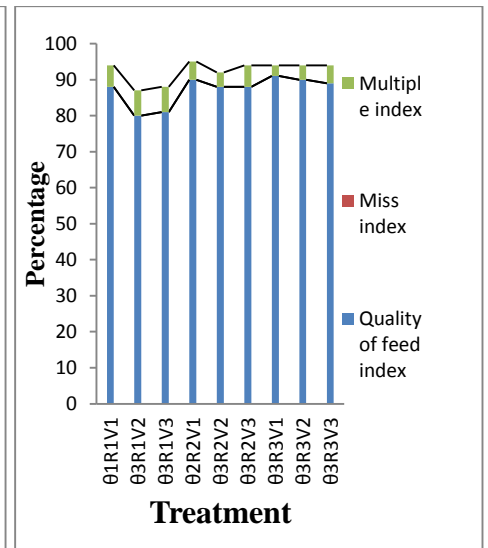

Fig.8: Performance of metering plate for combinations of different independent variables at $\theta 3$

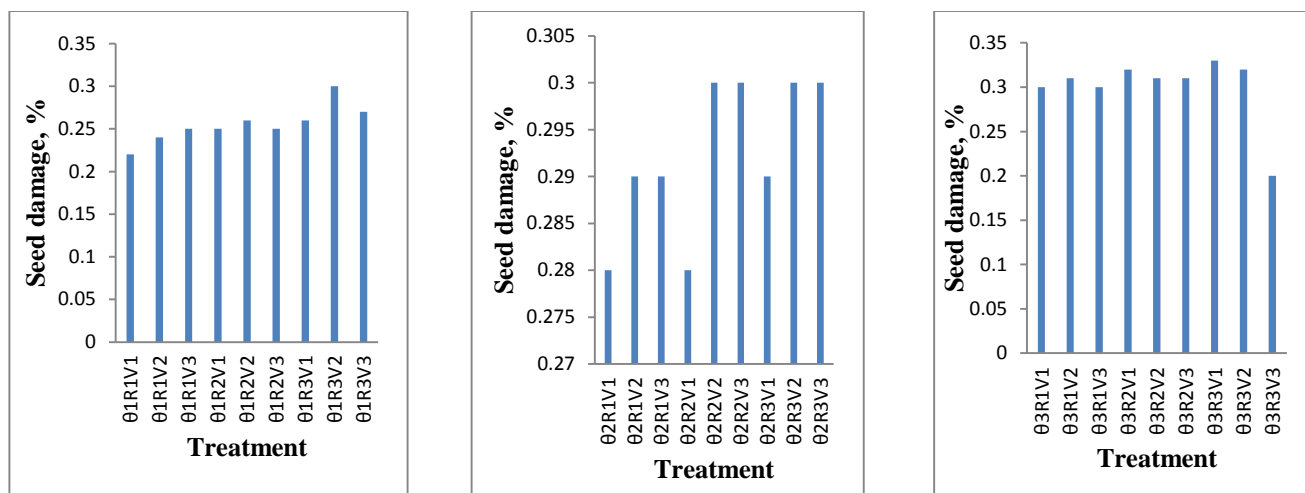

Fig.9: Seed damage by metering device with combinations of independent variables at $\theta 1$, $\theta 2$ and $\theta 3$

IV. CONCLUSION

The peripheral speed of the metering plate has the highest influence on the performance parameters of the metering device followed by inclination angle. Minimum multiple index 4.00% was found in 45° of inclination and lower rotor speed for all three varieties. Average value of miss index 1.50% was found at 45° of inclination angle with different rotor speed for all three varieties of paddy. Highest feed index 88.33 % was obtained at plate inclination of 45° with all varieties of paddy seeds. Least seed damage of 0.19% was found at 45° of inclination angle for all three varieties of paddy. Optimum value of dependent parameter (i.e. seed spacing, seed rate, multiple index, miss index, quality of feed index and seed damage data obtained at 45° inclination angle at lower rotor speed and constant forward speed.

REFERENCES

- [1] A.M. Chauhan, H.S. Dingra, and B.S. Bhatia, "Seed Placement Behavior of Sunflower Planter". *Agric. Mech. Asia Africa Latin Am.* 3 (4), 9-11, 1999.
- [2] P. K. Guru, P. S. Tiwari, and R. K. Naik, "Physical properties of seeds and its effect on seed drill performance". *International Journal of Agricultural Engineering.* 7(1), 2014.
- [3] S. Yadachi, I. Mani, M.S. Karla, A. Kumar, and P.K. Sahoo, "Development and Evaluation of Inclined Plate Metering Mechanism for Carrot Seed". *Journal of Agricultural Engineering* Vol. 50 (2), 2013.
- [4] K. Otsuka, H. Kurota, and O. Kobori, "Feasibility of precision planting by cell type metering devices". *J. Jap. Soc. Agric. Machinery*, 48(3-4), 361-367, 1986.
- [5] S. D. Kachman, and J. A. Smith, "Alternative measures of accuracy in plant spacing for planters using single seed metering". *Transactions of the ASAE*, Vol 38 (2): 379-387, 1995.
- [6] Anon. "Agricultural Machinery Design and Data Handbook (Seeders and Planters)". RNAM, Bangkok, Thailand, 1991.
- [7] R.A. Kepner, R. Bainer, and E.L. Barger, "Principles of farm machinery". CBS publishers and distributors pvt. Ltd., 1987.

- [8] M. Anantachara, P.G.V. Kumar, and T. Guruswamy, "Neural Network Prediction of Performance Parameters of an Inclined Plate Seed Metering Device and its Reverse Mapping for the Determination of Optimum Design and Operational Parameters". *Computers and Electronics in Agriculture* 72 87-98, 2010.
- [9] B.S. Reddy, Satyanarayana, R.V. Adake, and M. Anantachar, "Performance of seed planter metering mechanisms under simulated conditions Indian". *J. Dryland Agric. Res. & Dev.* 27(2) : 36-42, 2012.
- [10] I. Onal, A. Degirmencioglu, and A. Yazgi, "An Evaluation of Seed Spacing Accuracy of a Vacuum Type Precision Metering Unit based on Theoretical Considerations and Experiments". *Turk J Agric For* 36 : 133-144, 2012.