

Physical and Biological Aspects of Fracture Healing with Special Reference to Internal Fixation

S. M. PERREN, M.D.

Fractures and fracture treatment both produce marked changes in the physical environment of bone. It therefore seemed interesting to analyze the physical environment of healing bone and to study the reaction of bone and soft tissue to forces and deformation.

Though this certainly one-sided view of fracture healing has revealed information applicable to bone healing after various types of treatment including non-operative, special emphasis is given to the tolerance of various tissues to strain *i. e.* relative deformation in the fracture gap. With respect to tissue repair, the important mechanical characteristics of the end product are strength and rigidity.

In view of tissue reaction to mechanical input, a unified biomechanical theory of fracture healing based on the concept of strain, rigidity and strength seems possible and will also be outlined.

Animal experimentation regarding fracture healing permits breaking down of the complex clinical problem into different phys-

ical elements, their interrelation and biological reaction to a given physical environment. The question whether or not in a specific clinical situation internal fixation is indicated, will be answered from the clinical result of such a treatment. Research, however, can contribute to a better understanding of bone reaction and can help to optimize procedures, techniques, instrumentation and implants.

PHYSICAL ENVIRONMENT OF A FRACTURE SITE

The [redacted], to support the organs and to enable locomotion. The strength and rigidity of bone are therefore its prime qualities. Single or repeated mechanical overload produces a fracture and a completely new situation develops: bone elements which were held rigidly in place before the fracture can now move freely. Relative motion is now present and the transmission of forces as the main function of bone is now abolished.

[redacted] Bone then will have to be able to transmit forces without gross deformation. Any treatment aims at

From the Laboratory for Experimental Surgery, CH7270, Davos, Switzerland.

Received: June 7, 1978.

reduction of the fracture fragments and maintenance of the more or less reduced fragments in a more or less rigid way. In non-operative treatment, sometimes perfect alignment and motionless fixation are neither sought for nor judged to be necessary. While angular deformation can in some instances be prevented even with a short plaster cast, the prevention of torsional deformation necessitates the bridging of neighboring articulations preferably in a bent position.

Here, accurate reduction and motionless fixation are not self-standing goals, but they are prerequisites for the efficient use of implants.

The mechanical difference between the 2 different treatments basically is that non-operative treatment maintains the overall reduction to permit bone formation and biological fixation. Internal fixation produces stable fixation relying first on the implant and after the bone has solidly united, the implant is removed.

MECHANICAL CHARACTERISTICS OF INTACT CORTICAL BONE

The mechanical characteristics of intact cortical bone will be mentioned with reference only to its importance in fracture healing and internal fixation. The data is taken from Evans¹⁷ and Yamada.⁷⁴ The strength of cortical bone averages 10–15 kp/mm.²* This enables a segment of the tibia shaft to withstand more than a tone of compressive load before failure. The strength is of practical importance in the late stages of fracture healing and in intact bone since the strength of the soft tissue in the early stage of fracture healing is about 1000 times less than that of bone and can for practical purposes be neglected (Fig. 1).

* 1Kp = 1Kg force = 2.2 lbs force = 9.81 N (Newton Si)

The rigidity of cortical bone is 1000–2000 Kp/mm²** (Young's modulus). However, this term does not tell us much. For practical purposes let us therefore look at 2 clinical examples: a tibial shaft loaded with 100 kp will shorten some 10 μm (=∅ of an average cell). If we support the lower leg at the knee and the heel only, the midshaft deflection of the intact tibia will be about 20 μm. Bone deformation under load is unimportant in non-operative treatment while the elasticity of bone is an important element in maintaining compression in internal fixation.

The elongation at rupture is a parameter which characterizes the tolerance of a material to deformation. It tells us how much relative deformation a material can tolerate before it breaks. Granulation tissue acts like a very thin rubber band. It can elongate to twice its original length but will almost be unable to fight motion due to its lack of rigidity and will break under low tensile stress.

(in comparison cold worked steel will tolerate an elongation of some 20%, be at least 10 times more rigid as a material and about 10 times stronger than bone).

APPLICATION OF THE MECHANICAL CHARACTERISTICS OF CORTICAL BONE TO FRACTURED BONE AND ITS TREATMENT

The comparably high strength of cortical bone permits an anchoring of implants in bone to achieve good holding power. The holding power of a 4.5 mm cortical screw with asymmetric thread (according to ISO TC 150 draft HA 4.5) is 25–45 kp/mm of cortical thickness.^{8,24,25,29,60} This means for practical application that per cortex, 85 to 250 kp of axial force can be transmitted between bone and a lag screw. The screw is therefore a very powerful tool for fixation

** 1Kp/mm²=9.81 MPa=1423 p.s.i.

of fractures as we will see later. Furthermore, the compressive strength of cortical bone permits the anchorage of external pins where *e. g.* a pin of 5 mm in 2 cortices each 6 mm thick (femur) rests on a surface area of 60 mm² and can therefore withstand several hundred kp of axial load (5 × 12 × 13 kp/mm²).

The rigidity of bone is comparably high (Fig. 2): it deforms minimally under load.

Metal is even stiffer, though the higher material stiffness is offset by a smaller cross sectional area and area moment of inertia. The spring action in an internal fixation determines how sensitive the system is to fragment shortening due to resorption. Even though bone and metal deform only 10–20 μm under 100 kp of load, in a transverse osteotomy fragment end shortening of one to 2 cell layers thickness will abolish the compression achieved. In comparison, an osteoclast is able to resorb some 100 μm of bone per day.⁶⁷ In summary,

STRAIN TOLERANCE OF THE REPAIR TISSUES

i. e. will deform only minimally before it ruptures (Fig. 3). If we visualize the gap of a shaft fracture with or without external treatment the dynamic deformation of the interfragmentary tissue (dynamic strain) is many times greater than bone would tolerate. For example, we can assume that

* In non-operative treatment an angulation of

* Assuming bone to be a hollow tube of 30 mm outer Ø and a smaller gap width would even worsen the situation.

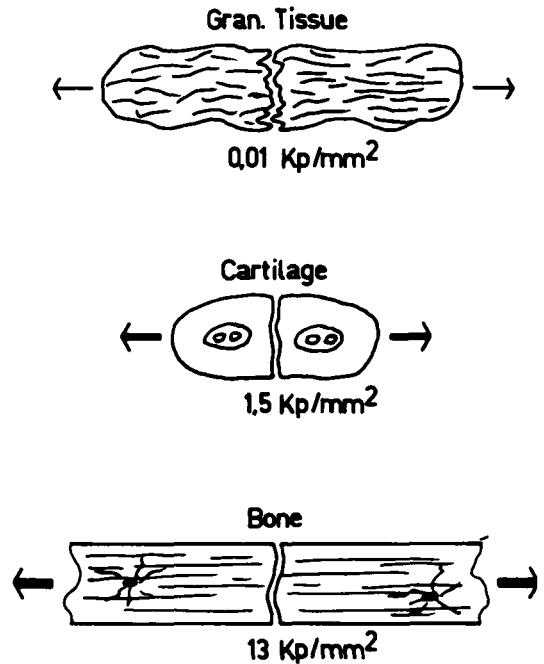

FIG. 1. Strength of tissue. The strength is a capacity to withstand force without rupture. Strength is given as force per unit area (kp/mm²). Intact bone is strong, while the strength of the initial repair tissues is negligible; If functional load deforms a fracture, the forces which can be produced surpass by far the strength of the initial tissues.

0.5° cannot be prevented even with a very tight fitting cast. In operative treatment 0.5° angulation seems to be preventable, but due to the fact that here the gap width is more likely to be 10 μm rather than 10 mm, even smaller angular deformation is critical.**

In respect to the concept of strain, it seems reasonable that initial repair tissue tolerates a great amount of elongation before rupture occurs. We estimate that

Fibrous tissue, tendon and cartilage tolerate appreciably less amounts of elongation and they also have a non linear

** A gap width of 10 μm will tolerate 1/1000 of the number given above for the angulation of a 10 mm wide gap.

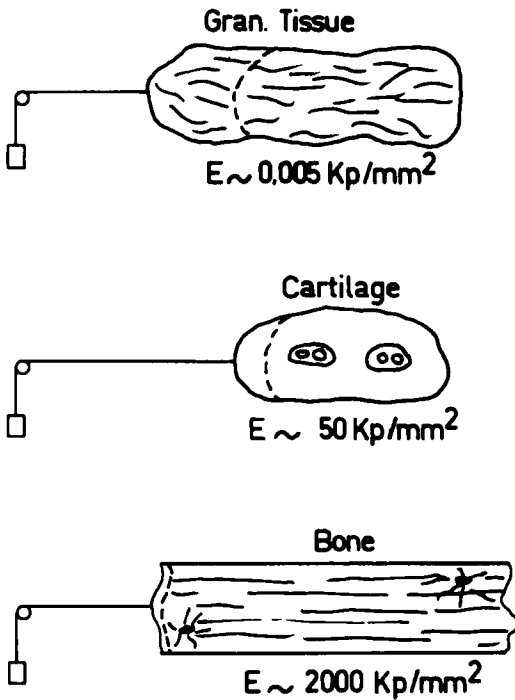

FIG. 2. Rigidity of the repair tissues. The rigidity is the capacity to fight deformation and therefore motion. In secondary fracture healing (enchondral ossification), the reduction of the fracture mobility is based on the increasing rigidity of the bridging tissues. The rigidity of the repair tissue increases from granulation tissue to bone by a factor of 1:400,000. Rigidity is the prime quality which enables bone to fulfill (without gross deformation) its role as a supporting tissue. Rigidity is the important quality of repair tissues in an intermediary stage of secondary bone healing.

stress/strain relation.*

Thus, the precursor tissues prepare the fracture gap mechanically and biologically for solid bone union.

THE EFFECT OF FRAGMENT END SHORTENING DUE TO RESORPTION

In spontaneously healing bone and in healing under relative fixation, fragment end shortening due to resorption is a com-

* The rigidity of cartilage increases drastically while the tissue is deformed about a certain limit.

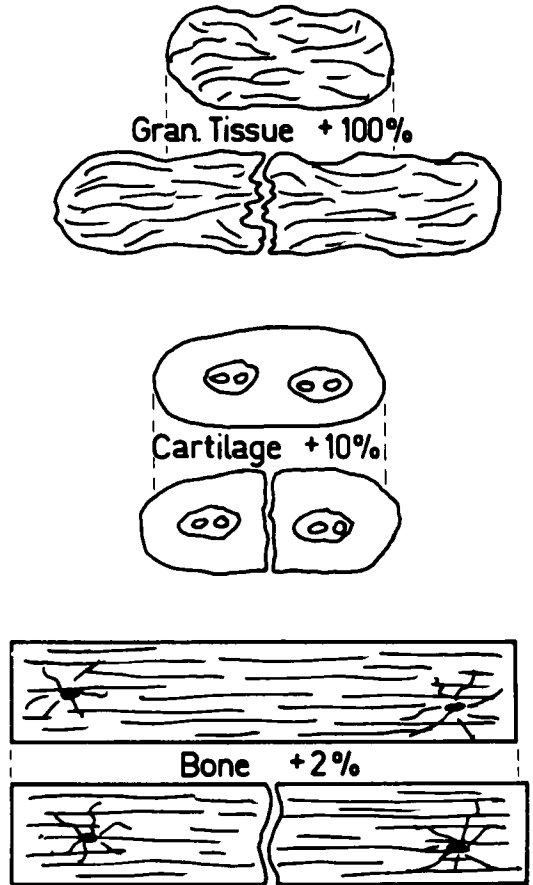
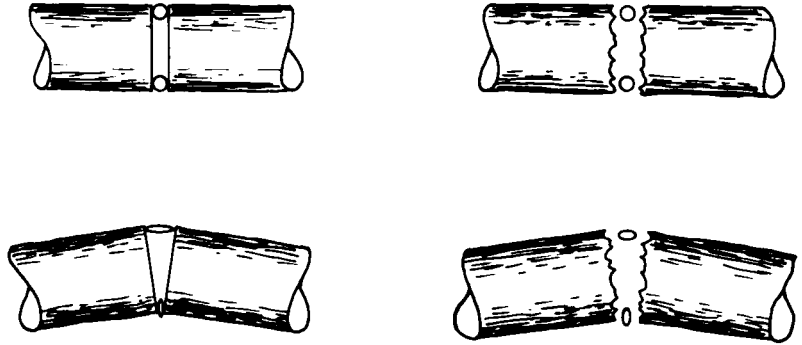

FIG. 3. Strain tolerance of the repair tissues. Elongation or strain tolerance is the capacity to tolerate a certain amount of deformation before rupture occurs. The strain tolerance is the primary quality of the initial repair tissue in secondary fracture healing, when tissue rigidity does not yet contribute to reduction of mobility at the fracture area. The assumption is that a certain tissue simply cannot exist in an environment where strain (relative deformation) exceeds the limit of elongation at rupture of the tissue under consideration.

mon phenomenon.⁷ Küntscher³³ even postulated that bone surface resorption would be a common finding in rigid internal fixation. As we will see later this postulate holds true for external fixation, and for some kinds of internal fixation which permit a certain amount of interfragmentary motion. If the reduction of interfragmentary strain is a goal or a prerequisite in fracture

FIG. 4A. Reduction of interfragmentary strain by bone resorption at the fragment ends. Provided that the fragments are kept from sintering together, for a given amount of fracture angulation, resorption reduces the interfragmentary strain. The reason for this is, that strain or relative deformation of the interfragmentary



tissue though proportional to absolute deformation is at the same time inversely proportional to the initial difference between the fragment ends. The figure visualizes that cells in a narrow gap are heavily deformed while tissues in a wide gap are less strained for the same amount of angulation.

healing, then the shortening of the fragment ends by resorption makes sense: it reduces for a given amount of motion the interfragmentary strain because it depends on motion (DL) and gap width (L) (Fig. 4).* The occurrence of surface resorption therefore makes sense in secondary bone healing. It should be prevented whenever primary bone healing is of an advantage *i. e.* in fixation with rigid plate.**

[REDACTED], all this provided the quality of the repair tissue and its area are kept constant.

TISSUE RIGIDITY AND INTERFRAGMENTARY STRAIN

[REDACTED]. Once a tissue has been formed, it will in turn due to its rigidity, influence the motion possible and therefore reduce strain. Thus, the next step of tissue differentiation may be made possible: deformation of fibrous tissue may reduce the strain to a level where cartilage formation is possible. Tissue rigidity can only be effective if the bending moment does not "out-number" by far the stiffness. The influence of tissue rigidity is negligible if the rigidity of the tissue is small in comparison with that of external or internal appliances and vice versa.

THE EFFECT OF INCREASED CROSS SECTION AT THE FRACTURE LEVEL DUE TO FORMATION OF CALLUS CUFF

[REDACTED] The increase in diameter provides the tissue with better leverage in respect to bending and torque.⁴⁰ The rigidity efficiency of the tissue increases with the fourth power of the distance from the center of rotation or bending, the strength efficiency with the third power (Fig. 5).

TISSUE INDUCTION AND STRAIN

It is generally accepted that one* of the elements inducing callus formation is mobil-

* Strain $\xi = DL/L$.

** The shortening of the fragment ends is only helpful in reducing interfragmentary strain if the fragment ends are not allowed to sinter together. This can be achieved by interposed tissue *e. g.* cartilage or if the shortened part of the fragment ends are protected from sintering because other parts are still in contact.

* Callus has been reported to depend also on irritation of the periosteum^{23,57}; Küntscher³³ has demonstrated callus formation after irritation of the medullary space with corroding metals.



FIG. 4B. The resorption of the fragment ends in this tibial osteotomy of the sheep has widened the gap and granulation tissue is seen between the gaping ends. In the narrow original gap only a morphorous material is found. Thus, resorption may permit the presence of initial repair tissues or may enhance further differentiation. During resorption of the fragment ends, the osteoclasts are not located at the high strain area between the fragment ends, but within their lacunae in a strain protected area.

ity of the fracture *i. e.* interfragmentary dynamic strain. Hutzschenreuter *et al.*³¹ have visualized this using internal fixation of a standard transverse osteotomy in the sheep tibial shaft. Plates of varying stiffness were used to bridge an osteotomy with pre-determined gap width. The amount of callus was shown to depend on the rigidity of fixation or as we would now say, interfragmentary strain.

At the other end of the

scale, large gaps in adult shaft bones after leg lengthening are known not to unite with bone. More work with respect to tissue induction and mechanical strain would be of interest.

INTERFRAGMENTARY STRAIN IN INTERNAL FIXATION

Let us assume that we plate a transverse osteotomy of the tibia. We do this without application of any kind of compression and leave a gap of 0.01 mm between the fragment ends (Fig. 6). During the operation such a procedure would appear to offer enough stability of fixation. If we do the mechanical analysis*

Hutzschenreuter *et al.*³¹ have actually observed under similar conditions a pronounced resorption of the fragment ends prior to bony union. This analysis demonstrates that in internal fixation we may unexpectedly run into problems concerning interfragmentary strain. To understand primary bone formation under rigid internal fixation we will have to discuss the principle of "absolute" stability of fixation.

MECHANICAL PRINCIPLES OF FRACTURE FIXATION

SPLINTAGE

The oldest type of fracture fixation consisted of tying a piece of wood to the injured limb. The wood acts as an external splint: due to its rigidity it helps to reduce (not abolish) the motion at the fracture site. The wooden splint is inefficient due to its deformability, its asymmetric positioning and

* See Perren and Cordey⁴⁶ for details of the underlying assumption. In summary: only flexural moments have been assumed to exist, their magnitude was derived from the fact that a plate bridging an open fracture gap is known to fail in fatigue after some 100,000 cycles. For a plate made of steel 12 mm wide and 4 mm thick the fatigue limit is about 600 kp mm.

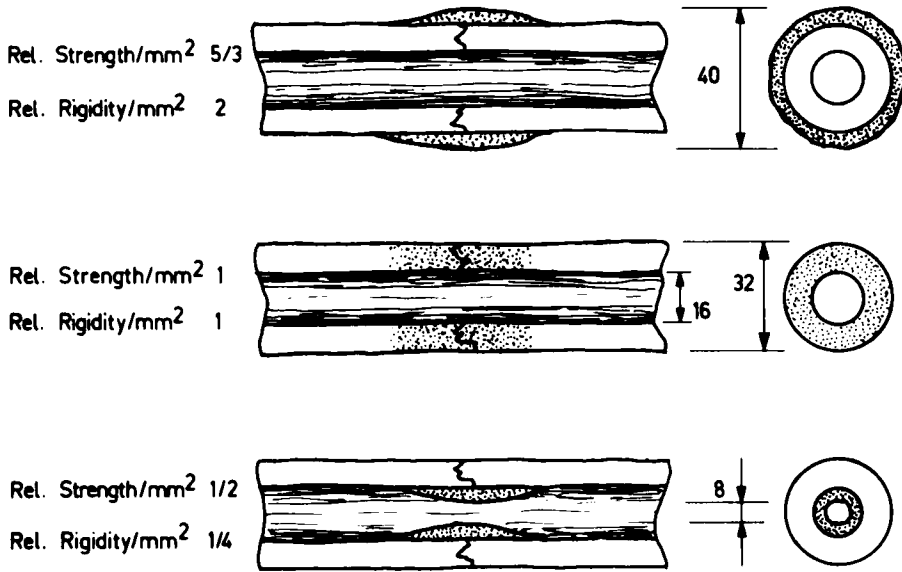

FIG. 5. The geometrical repartition of the repair tissue determines the efficiency of a given tissue to fight or resist motion. The figure visualized the situation for a midshaft of the femur with either 4 mm thickness of endosteal or periosteal callus. To compensate for the different area of cross section under repair, the rigidity and strength are compared as per unit area. Provided that the quality of the repair tissue remains the same then endosteal callus is much less efficient and resistant than interfracture callus which in turn is less efficient than periosteal callus.

the lack of a rigid connection between wood and bone. The plaster cast and similar devices are more rigid and by surrounding the bone, are more efficient. However, due to the deformability of the tissues between plaster and bone, the bone fixed by plaster cast can move, especially in an axial direction. If the plaster cast is long enough, it will reduce angulation efficiently, but needs the help of angulated articulations for reducing rotational movement.

Internal fixation implants can act as splints as well. In general, while a wire or a screw is too deformable in bending and torque to act as a good splint (the K-wire is under certain circumstances an exception to this), the medullary nail, the plate and the external fixation clamps provide good splintage. The stiffness of the plate and nail in respect to bending and torque rely on the stiffness of the material rather than on the element of its construction *i. e.* the metal in these cases is somewhat inefficiently placed

near the center of bending and rotation. The transmission of torque between bone and medullary nail is poor. The nail therefore relies on interdigitation of the fracture for control of rotation. External fixation clamps, provided the construction is adequate, can control bending and torque but the deformability of the connecting pins forgoes part of this advantage. In summary

A pure splint fixation will always permit some motion which is proportional to the load and inversely proportional to the overall stiffness of the device and transmission (Fig. 7). As we will see, this minute amount of motion under internal splintage is important in respect to the onset of bone resorption.

COMPRESSION

Danis¹² was the first to our knowledge to advocate the use of compression for stabili-

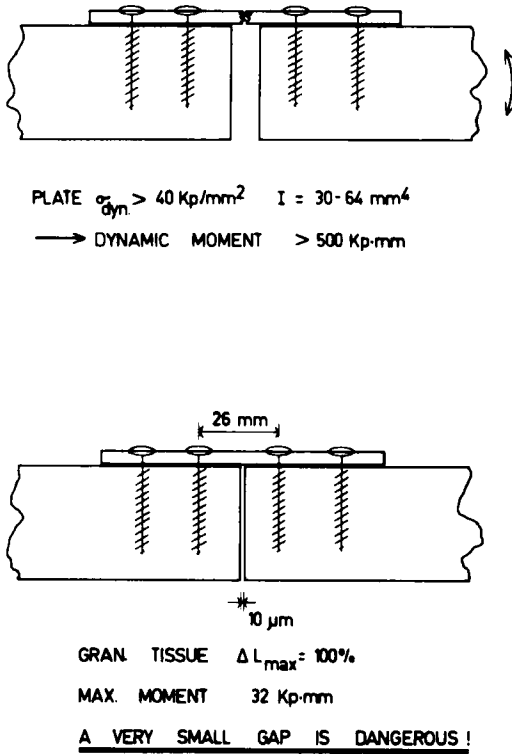

FIG. 6. Strain in internal fixation without close adaptation and compression of the fragment ends. (A; top) The amount of bending load at a fracture site can be approximated on the basis of the fact, that an internal fixation plate bridging an open fracture gap without bone support is known to fail in fatigue after 3-5 months (ca. 300'000 cycles). The fatigue characteristics of the plate indicate a dynamic load of $> 500 \text{ kp/mm}$ to be present. Torque is disregarded in this analysis dealing with orders of magnitude rather than exact figures. (B, bottom) Demonstration of load-strain relation in a small gap bridged with an internal fixation plate where no contact and no compression of the fragment ends exists. The strain tolerance of the initial repair tissue (granulation tissue with 100% elongation) allows only 32 kp/mm bending moment (see Perren and Cordey, 1977, for exact model assumption).⁴⁶ Though a stiff implant is bridging the gap, here at the micromechanical level, dangerous strain conditions can develop and may lead to resorption and gross instability with the risk of delayed union or pseudarthrosis and including the danger of implant fatigue failure.

zation of bone fractures. The actual use of compression is much older: any screw or any implant which is fixed to bone (without glue) can only function through application of local compression. If we visualize the mode of action of a screw at the screw thread, there is compressive load of the contacting surface metal-bone and at the screw head undersurface. Here, the implant itself is under tension, but the contacting surface is under compression.* Basically, we differentiate between 2 different applications of compression.

This is a screw

* For further analysis we will differentiate between static compression and dynamic compression. Static compression is a compression which remains mainly constant, while dynamic compression is a force which changes its magnitude and possibly direction due to functional loads.

The part of the screw near the head is either a non threaded shaft or the screw thread glides in a widened drill hole.

He achieved longitudinal compression using a special plate with incorporated compression device.* Muller *et al.*⁴¹ have developed a removable compression device to be used until the plate is fixed at both ends to the bone and then is removed. Bagby and Janes³ in 1956 described a so-called self compressing plate in which a sloped surface

* The names given to implants used in internal fixation are not consistent: a compression plate is a plate which produces compression in bone due to the fact that it is applied under tension. A tension band wire is loaded in tension but also produces compression in bone. A better proposition would be to name the implants according to their function: compression screw, compression wire, etc.

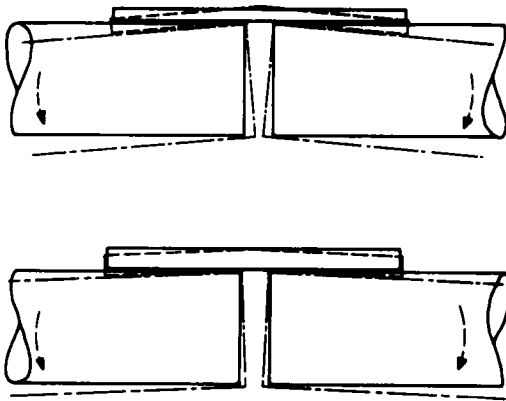

FIG. 7. Implant stiffness and interfragmentary mobility. Increasing the stiffness of an implant (to double the thickness of a plate increases the stiffness in this mode of loading by a factor of $16\times$) reduces motion and strain, but does not at all abolish it. For a certain combination of load and gap width bony union can take place, but is more risky in respect to incidence of healing and fatigue of implant.

and an edge produce at insertion of the plate screw, a displacement of the screw or plate along the plate axis and therefore adaptation and compression. Several similar designs followed: some of which have been widely used.^{13,38,68} The plate of Bertolin⁴ depends on oblique positioning of the screw for production of compression between plate and proximal bone fragment but not between fracture fragments. All the self-compressing plates with the exception of the one of Bertolin are based on the contact between a conical surface and an edge. The conical surface may be in the plate as in the early design of Bagby or in the screw as in his later design. The dynamic compression

plate (DCP) relies on a geometry with a spherical undersurface of the screw lying congruently in a sloped or horizontal cylinder in the plate hole. With maintained congruent fit, this design permits the application of the screw in an inclined position.^{1,49} This plate therefore places more emphasis on the compression of the fracture by lag screws. This is because plate screws can be used simultaneously as lag screws provided that they can be tilted to cross the fracture line more or less perpendicularly.

THE MECHANICAL EFFECT OF COMPRESSION OF A FRACTURE

Compression is applied to fracture surfaces or contact surface bone-metal in 2 ways. (1) The compression preloads the contact surfaces and keeps them in motionless adaptation (Fig. 8). Under functional load (bending) at the convex side of the bend traction is installed and tries to pull the contact surfaces apart. The preload will now prevent any such dislocation as long as the static compression is greater than the dynamic traction (at the place which we observe). (2) Compression of any 2 surfaces produces friction. If we press the contacting fracture surfaces together (or press a plate to bone), friction is installed and prevents displacement along the fracture surface (or along the underside of the plate) (Fig. 9). The maximum amount of friction produced equals the normal force times the coefficient of friction. For 2 smooth bone surfaces *e. g.* after an osteotomy with very fine

FIG. 8. Preload as a stabilizing principle in compression fixation. Compression holds fragments together, tension pulls them apart. For any given point of the contact surface, the relative amount of the 2 forces determines

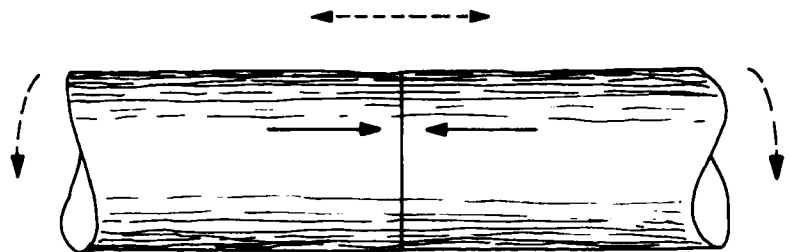

whether the contacting surfaces remain motionless (absolute stability). Compression acting in this example is static and does not change (on a short term basis). With time, the bending producing tension is dynamic and it changes magnitude and possibly direction within seconds.

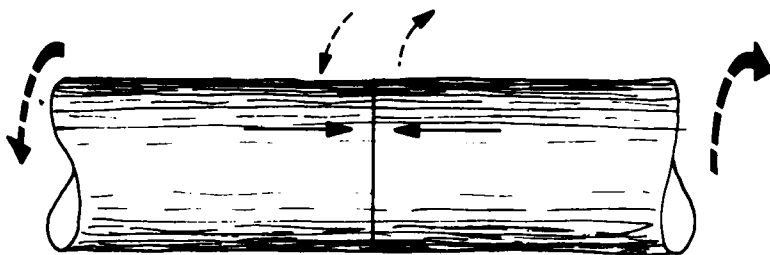

FIG. 9. Friction as a stabilizing principle in compression fixation. Compression of contacting surfaces produced friction. Friction prevents any tangential displacement of the contact surfaces as long as

possible when friction is greater than or equals shear. Local shear is produced mostly as a result of torque applied to the limb. Absolute stability under torque load depends entirely on interfragmentary friction. Compressed interdigitation of the fracture fragments may be understood as a specially efficient combination of preload and friction.

saw blade, the coefficient of friction of bone to bone is around 0.4.¹⁵ For metal to bone friction, Hayes and Perren²⁸ have found under low load and static conditions the coefficient to be 0.38. Enzler¹⁵ had shown that friction metal to bone depends on time of duration and magnitude of the normal force. The coefficient of friction *in vivo* is contained between 0.2 dynamically and 0.4 statically.²⁰ Friction is important and nearly the only tool which stabilizes against shearing influences produced mainly by torsion applied to the limb. In fractures placed under compression, we can expect a high degree of torsional stability due to interdigitation of the fracture surfaces. The friction is—as compression and preload—a widespread principle of stable fixation.

ABSOLUTE STABILITY

This term describes a state where there is

As long as sufficient compression acts upon the surfaces there will be no displacement of the fracture surfaces in relation to each other, provided the dynamic load superimposed does not reach the level of preload or friction. Under a superimposed dynamic load, the overall system will deform according to Hooks law, but between the contacting compressed surfaces there will be no relative motion

(distraction or shear) and therefore no inter-fragmentary strain.

While a splint will always allow some relative motion of the fracture which it bridges, through application of compression relative motion at the fracture site can be completely abolished.

As outlined earlier, in a very small fracture gap a dangerously high strain condition can develop despite a rigid implant such as a plate acting as a splint. The application of compression is a powerful mechanical tool to prevent this.

BONE HEALING

The bone healing under relative immobilization after non-operative treatment has been outlined in detail and will not be repeated.^{5,10,52} We will restrict ourselves to the special aspects of bone healing under rigid internal fixation and to the aspects of strain in bone healing in general.

HISTORY OF BONE HEALING IN INTERNAL FIXATION

Lane³⁴ mentioned the term "as per primam intentionem." Danis¹² used the term "soudure autogen" (internal welding) and advocated the callus free healing as a goal (see the classic article in this volume).

CONTACT HEALING

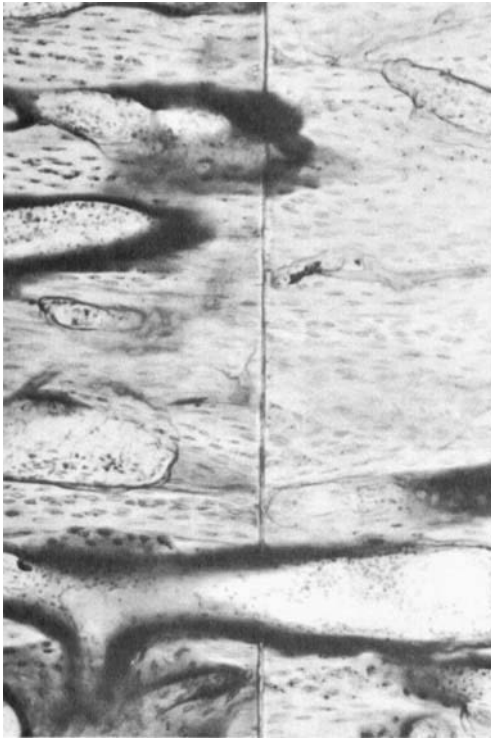

FIG. 10A. Primary healing: Contact healing. Under absolute stable fixation of closely adapted and compressed surfaces, the osteons of the lamellar bone cross directly through the fracture surface. No indication of pressure necrosis and consequent resorption of the compressed surfaces is seen. Transverse osteotomy, sheep tibia 2 weeks p.o. Perren *et al.* 1969.⁴⁸

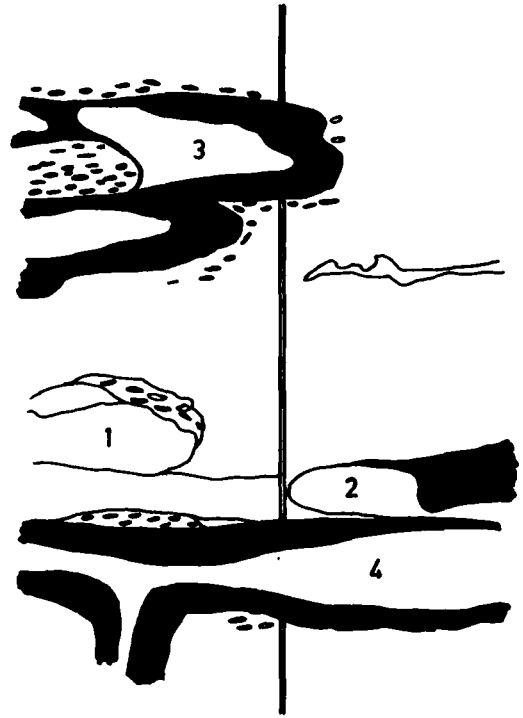
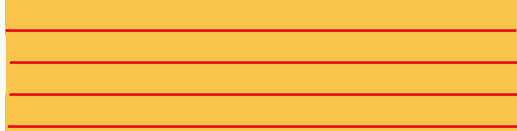

FIG. 10B. Primary healing: Contact healing. The schematic drawing visualizes the consecutive stages of Haversian remodeling (1-4). The Haversian canals cross the contact area under compression which is absolutely stable. New lamellar bone is directly deposited across the fracture surface. Note the three dimensional plugging of the osteons.

healing (Fig. 10). This consisted basically of



The direct union of fragments in close contact and under compression is achieved through remodelling of the Haversian canals, and 7 cutting heads⁴⁴: drill a hole along the long axis of bone crossing the fracture. Behind the cutterheads which contain osteoclasts a conical surface of osteoblasts produces new osteons with incorporated new living osteocytes. These osteocytes are connected among themselves and to the vascular supply in the Haversian canal by a network of canaliculi. This ingenious inter-

nal change of a supporting structure while maintaining external mechanical strength is common to all types of fracture healing.



Although primary bone healing foregoes the intermediate stages of tissue differentiation it is not faster healing than secondary healing (enchondral ossification). Per unit of material primary bone healing is more efficient than callus. It thus compensates for its less efficient positioning in relation to external callus (area moment of inertia), by being a more mature and more resistant lamellar bone and by being well anchored in

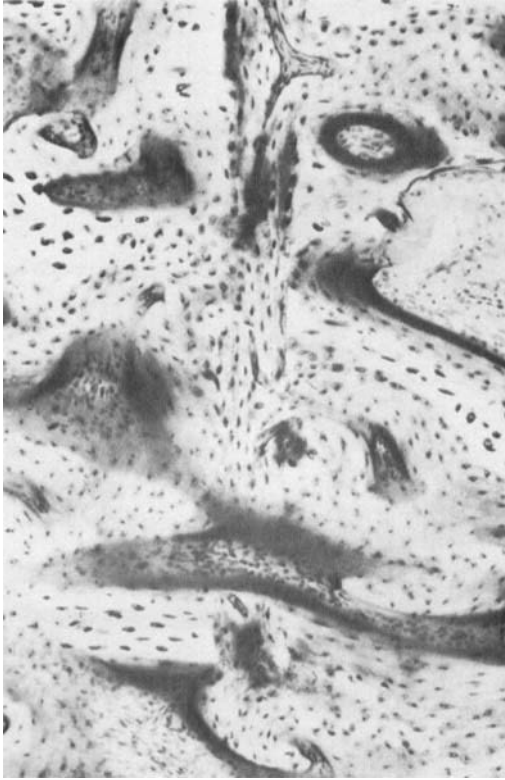

FIG. 11A. Primary healing: Gap healing. Alternating with contact areas in fracture gap areas are seen. Such gap areas profit from the support of neighboring contact areas and therefore in spite of a narrow gap width, low strain is present. This permits direct bone formation which takes place in the form of lamellar bone oriented perpendicularly to the long axis of bone.

both bone fragments through 3 dimensional interlocked contact.

GAP HEALING

A special type of fracture healing is the so called gap healing (Fig. 11). In closely adapted and compressed fracture surfaces not all parts of the surface are in contact.

Small gaps—high strain? There is low strain in these gaps as they profit from nearby contact areas supporting and stabilizing the fragment contact. The histological picture seen in gaps up to some 100 μm wide is the one of di-

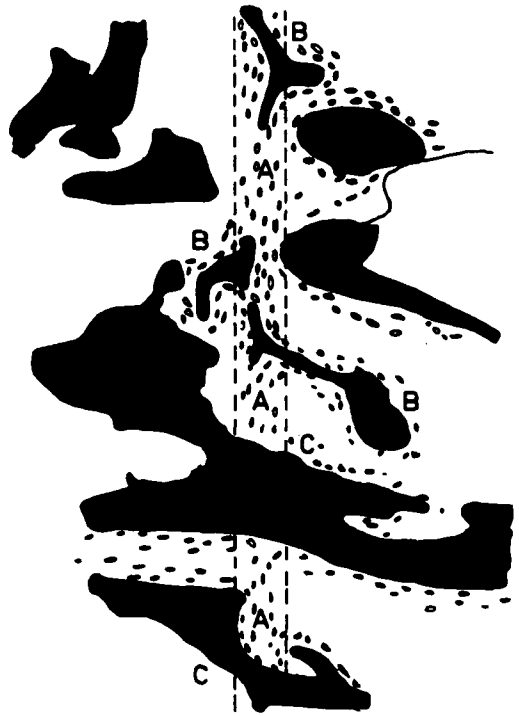

FIG. 11B. Primary healing: Gap healing. The bone (A) in the gap is of lamellar structure but its orientation is perpendicular to the long axis of bone. Plugs (B) extend from the inter-fragmentary lamellar bone (A) into the fragment ends. Two osteons (C) are seen which cross the gap area from fragment end to the fragment end.

rect formation of lamellar bone, a mature bone, although deposited at right angle to its normal direction within the cortex.

first formation of lamellar bone in the gap is seen and then this bone is remodeled along the axis of bone through Haversian remodeling starting from the gap into the fragment and from the fragments into the gap. It would seem that this early and complete filling of the fracture surface is advantageous. Kinzl *et al.*³² have shown that the strength of the gap areas is low per unit of contact surface compared with contact healing with crossing osteons. This is mainly due to the weak anchorage of bone

within the gap to the surface of fracture fragments without interlocking.

GENERAL ASPECTS OF PRIMARY BONE HEALING

In the early days following the demonstration of primary bone healing by Schenk and Willenegger,⁶⁷ an argument was made that this type of fracture healing would only be observed in rigid fixation of a single forearm bone which would be well protected from stresses by the twin bone. Subsequently, primary healing has been demonstrated in the tibia of the sheep, dog, rabbit and to some extent in the rat.^{30,48,57} All of these animals were left to unrestricted weight-bearing. Muller, J., and Schenk³⁹ demonstrated primary healing in a human fracture which was kept from weight-bearing after operation and Puddu⁵³ showed primary bone healing in experimental fractures in the rabbit tibia with unrestricted weight-bearing. The occurrence of primary bone healing in the rabbit was denied some years earlier in experiments using cerclage wire fixation which showed that primary healing is not produced as an alternative after periosteal damage by the surgical intervention or due to damage to the periosteum by corrosion products. Primary bone healing in spontaneously stable fractures without internal fixation was demonstrated radiologically.

FIG. 13A. Behavior of compression in stable internal fixation of cortical bone. Method of measuring compression by determination of the tension in the internal fixation plate. This tension produces an equal amount of compression provided external forces are excluded or compensated for. The measurement of tension gives a direct indication of the total amount of compression at the fracture surface.

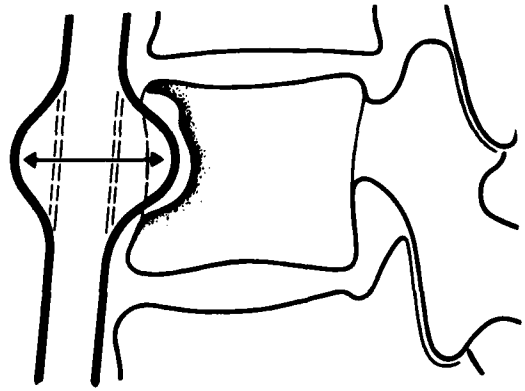
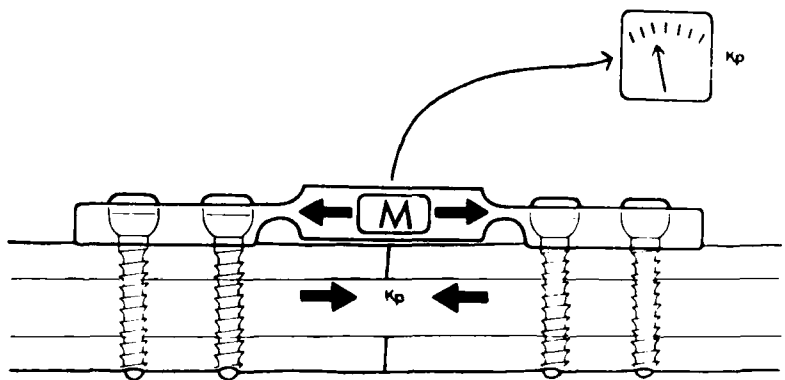

FIG. 12. "Pressure Necrosis." The old term pressure necrosis of bone is derived from the observation of bone resorption in the vicinity of pulsating tumors (e.g. here resorption of the vertebral body in the vicinity of an aortic aneurysm). This mechanism is not seen in stable internal fixation.

PRESSURE NECROSIS IN INTERNAL FIXATION?

For mechanical reasons compression is helpful in internal fixation. How about pressure necrosis?⁶⁴ Pressure necrosis is seen in soft tissues where a constant even low pressure leads to necrosis i. e. pressure sores. The observation that the bone of a vertebral body is resorbed near a pulsating tumor (Fig. 12) was interpreted as pressure necrosis of bone; compression-necrosis-resorption. Considering mechanics, we



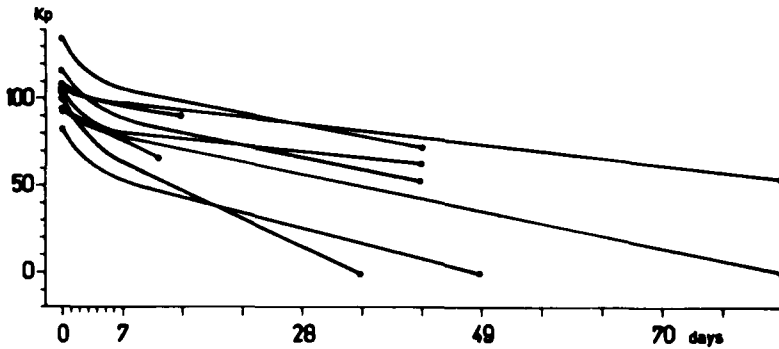

FIG 13B. Behavior of compression in stable internal fixation of cortical bone. Compression (ordinate) as function of time (Abcissa). Despite slowly decreasing, compression remains active until far beyond the time of primary bone union.

know that in internal fixation the slightest resorption could abolish all compression because of the rigidity of bone and metal. It seemed therefore of interest to study the changes of compression applied to living bone in internal fixation and to find out what condition might induce bone to resorb at contacting surfaces.

To help answer our question is to again point out the differences between static (minimal change with short-term observation) and dynamic (frequently changing magnitude and direction) compression.

compression applied to a transverse osteotomy was maintained over a 72 day period of measurement (Fig. 13B).

Similar experiments were performed in the sheep using instrumented washers to measure changes in axial force exerted by screws. The compression applied up to 200 kp decreased very slowly just as the compression exerted by the plate had done.⁶ These measurements indicated that static compression *per se* even if it generates high stress does not induce bone surface resorption at the compressed interfaces of bone-to-bone and metal-to-bone contact. It may be noteworthy that since 1963 when we started this kind of testing, we have not found one single case of pressure necrosis under stable conditions in multiple such experiments.

THE CHANGES OF COMPRESSION *IN VIVO*

To measure *in vivo* the magnitude and possible changes of static compression applied to living cortical bone, internal fixation plates were instrumented using strain gauges. With a wire connection it was possible to measure for 12 weeks following surgery the rate of compression applied to a transverse osteotomy in the sheep tibia (Fig. 13A).⁴⁸ As the measuring device did not interfere with healing, (it was contained within the compression plate and not inserted between the fracture surfaces) the changes of compression during healing could be determined.⁵¹ It was found that

How about too much compression? We will have to distinguish between conditions of gross overload which lead to breakdown of the overall integrity of bone on one hand and local overload leading to only local breakdown with maintained overall structural integrity and stability at the fracture surface. The effect of gross overload has been demonstrated by Gallinaro *et al.*²¹ and Rahn *et al.*⁵⁹ who have shown that local

breakdown due to overload at points of contact will not necessarily be followed by resorption. The Haversian remodeling even crosses the areas of local overload without appreciable changes in the remodeling pattern. Does this observation indicate that bone is much more sensitive to mechanical conditions of deformation and relative motion than to failure with maintained stability? More work will have to be performed to find out how much information is gained from a stable fixed fracture to induce healing processes.

The measurements of compression have been undertaken to find out about pressure necrosis and to find the value for optimal compression.

In respect to optimal compression we could find biological limits within the overall limits of maintained stability up to gross overload of bone. There seems to be a contradiction between our findings and those of Friedenbergl and French.¹⁸ The different findings can be explained by the fact that in an experimental model using spring loading of transverse osteotomies of the

ulna, the stability of fixation depends almost entirely on the amount of compression. There was no reported surface resorption of contacting surfaces in groups of higher compression; the term pressure necrosis as far as we can see, applied to the absence of secondary bone reaction. Our findings are in line with the early measurements of Wickstrom⁷³ and with the measurements of Hutzschenreuter³⁰ *et al.* in segmental replacements of cortical bone.

BONE RESORPTION AND INTERFRAGMENTARY INSTABILITY

Not finding the classical picture of pressure necrosis⁶⁴ led us to study the reaction of osteoclasts at a surface under intermittent contact. Intermittent contact (instability) is present when 2 forces, a static and a dynamic one, of appropriate magnitude are superimposed and act against each other. Let us assume that we preload with only a small amount of compression a contacting surface, *i.e.* a bone screw perpendicular to its long axis. If now a dynamic force of opposite direction is added, the contact surfaces will

FIG. 14A. Mechanical induction of bone resorption in contact surfaces. Continuous unilateral contact pressure which does not permit relative motion does not lead to bone resorption. Here bone is in direct contact with the metal of the screw.

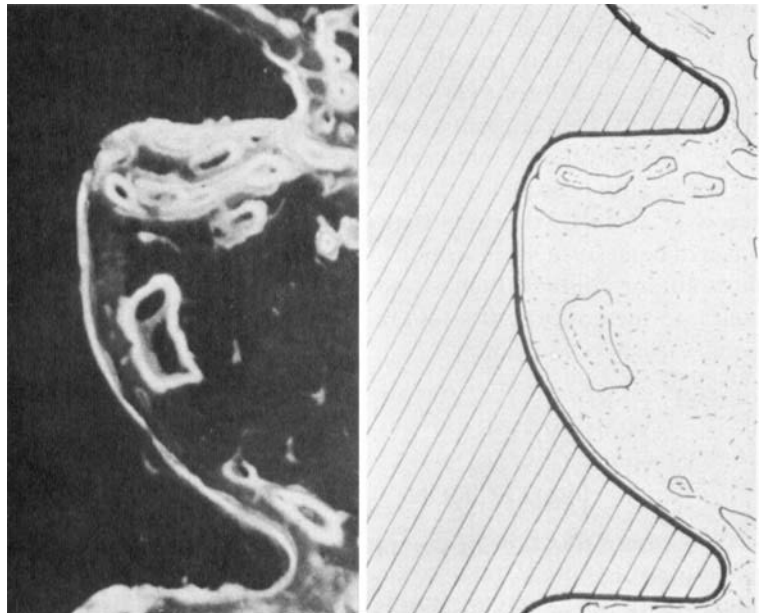

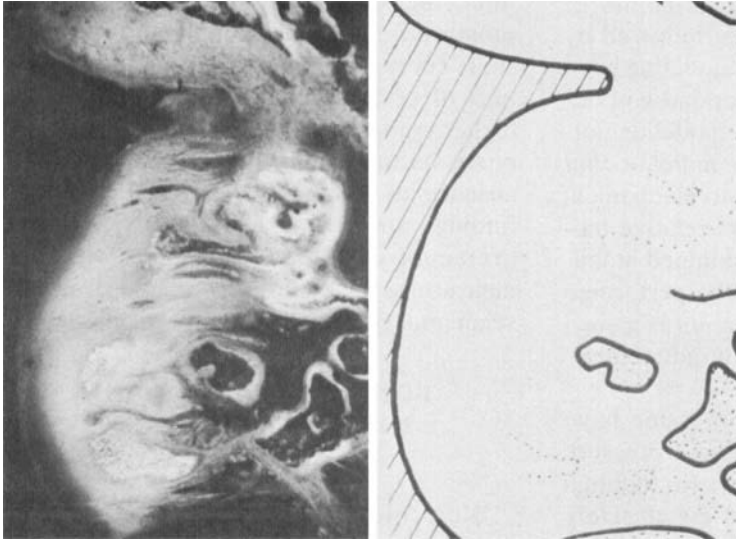

FIG. 14B. Contact pressure changing in magnitude *and* direction produces relative motion in the micro environment. Massive bone resorption and replacement of the resorbed bone by strain insensitive fibrous and cartilagenous tissue is seen.

separate whenever the dynamic force tends to pull the contact surfaces apart. This is when the dynamic force becomes larger than the static preload. Experimentally, this was achieved using an instrumented plate bridging a bone segment under weight bearing conditions.²² The control experiment consisted of screws under the same amount of dynamic, but higher static compression. The latter condition did not allow motion. The screws with initial micromotion (instability) showed massive bone resorption and filling in of the completely resorbed bone thread with fibrous and fibrous cartilagenous tissue (Fig. 14A). At the contacting surface where a large preload did prevent motion, bone stayed in direct contact with the metal of the screw (Fig. 14B). It seems that overall the onset of bone surface resorption in areas with intermittent contact (high strain areas) fits well into the concept of strain reduction by bone surface resorption.

THE EFFECT OF COMPRESSION ON HAVERSIAN BONE REMODELING AND STRESS PROTECTION

Together with the observation of bone porosis immediately beneath the internal fixation

plate,⁷⁰ it seemed therefore of interest to correlate the rate of bone remodeling with known amounts of static force. The problem in this experiment was that using round hole plates with removable compression device would result in unexpected changes of compression achieved during the operation.¹⁹ Using an instrumented, self compressing DCP, Matter *et al.*³⁵ evaluated the rate of remodeling with polychrome sequential labeling⁵⁵ at 4, 7 and 9 weeks after plating of an intact sheep tibia. They found that the rate of remodeling of the Haversian system could be observed at 4 weeks, peaked at 7 weeks but did not show an influence of static preload under conditions which were similar in respect to dynamic unloading of bone. Recently, Gunst²⁷ tried a correlation between vascular changes of cortical bone beneath the internal fixation plate and the pattern of remodeling. He showed extensive avascular areas which would mostly recover within 4 weeks but no direct correlation between avascularity and remodeling (porosis) was possible. The term stress protection remodeling indicates that one tries to explain the unloading of bone due to a rigid implant according to Wolff's law to produce bone porosis. Until now we could find no direct correlation in the sense of Wolff's law. The porosis seen is more probably a temporary

porosis due to the remodeling process which passes through a stage of porosis (Fig. 15). The short-term changes as those described by Uthoff,⁷⁰ Coutts,¹¹ Matter³⁵ and Kinzl³² do not fit with a concept of explaining bone porosis beneath the internal fixation plate as adaptation to unloading. The porosis is of special importance after plating with 2 plates.³²

FRACTURE HEALING IN INTERNAL FIXATION AFTER INFECTION

A study performed on the sheep tibia with different types of internal fixation

plates, including instrumented plates, has been published in great detail.⁶³ I

In 18 out of 19 internal fixations of a transverse tibia osteotomy in the sheep with persistent infection, bony bridging of the osteotomy could be demonstrated. In the group with 2 instrumented compression plates some of the infected cases healed without sequestration of the fragment ends. Further experimentation will have to show what the exact conditions are for preventing sequestration. The importance of avoiding sequestration is

FIG. 15. Bone porosis beneath the internal fixation plate. Stress protection porosis? (left insert) In a defined area beneath the plate porosis of bone is seen at 10 weeks after plating an intact bone. (right insert) The Structure of the Unchanged Bone. Temporary bone porosis is a regular finding after two-three months in a plated intact or fractured bone. Although its significance is still debatable, two explanations have been offered for its occurrence: 1) The mechanical unloading (stress Protection) is inducing the porosis or 2) other factors as *i.e.* changes in vascularity or a combination thereof produce the porosis which accompanies internal remodeling of bone.

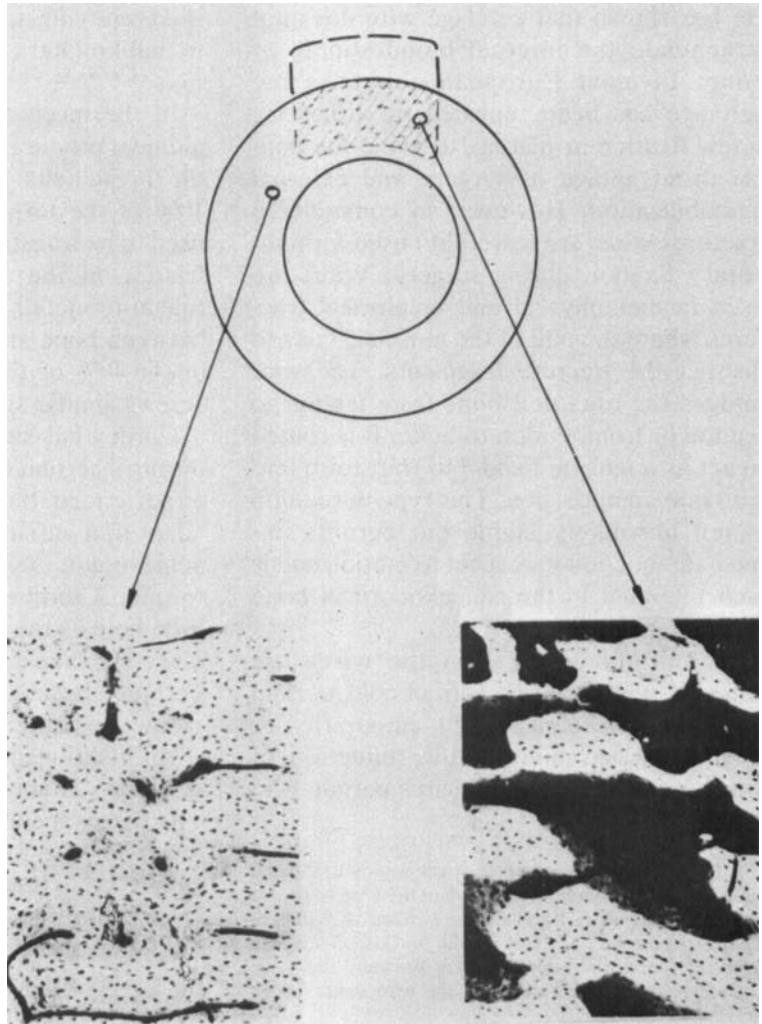

evident: as long as a sequestrum is present, the patient will periodically need medical attention.

SPECIAL CHARACTERISTICS OF SOME IMPLANTS

The wire was used some 30 years ago extensively as cerclage wire *i.e.* as a wire loop holding the fragments especially of spiral fractures together. An additional plaster cast was regularly necessary due to the limited strength and stability of this fixation.* Free immediate joint motion was not achieved.

Rhineland⁶¹ advocates the use of cerclage wire as minimal osteosynthesis. He has shown that cerclage wire does not strangulate the internal blood supply of bone. In most European countries the cerclage has been replaced by either lag screw fixation or plating, to avoid the double disadvantage of surgery and external immobilization. However, in comminuted fractures wires are (carefully) used for temporary fixation during surgery. Wires are used in metaphyseal and epiphyseal fractures where the pull of the muscles tends to distract the fracture fragments.

This type of fixation is not absolutely stable but permits immediate function in respect to motion and is well tolerated in the cancellocortical bone of the bone ends.

In another application the wires are called K-wires. Here a wire of cold worked steel acts as a splint to hold temporarily, or less often permanently the reduction of small fragments. Parallel wires permit, *e.g.*

* The loosening of cerclage wires seems to depend on a mechanical phenomenon: when the wire twister is released and especially when the twisted wire is bent flat to rest on the bone surface the tension on the wire drops.⁶⁴ Once microinstability is present, the bone surface resorption in the bed of the wire seems to aggravate the situation.

the fracture to be compressed by a tension band whereas crossed wires counter compression and distraction.

SCREWS

A screw can be used to fix a plate to bone. Here the axial force produced by the screw gives rise to friction between the plate undersurface and bone and keeps the plate in stable contact with bone. Von Arx⁷¹ has determined that an average surgeon would apply 30–60 kp-cm of torque to a screw (ISO HA 4.5). This will produce about 200–350 kp of axial force in each screw. Per screw, a frictional force of *i.e.* 300×0.4 is produced. A 6-hole plate will therefore withstand a tangential force of up to 360 kp ($300 \times 0.4 \times 3$) without dislocation.^{14, 30, 43, 65, 66, 69}

In the mechanics of a screw, torsional moment produces translation of the slope of the thread helix. In a plate screw only about 10% of the torque applied to the head is used to be transformed into axial force. The friction at the undersurface of the head (metal-to-metal) uses 50% and the friction between bone and metal at the thread uses about 40% of the applied torque. For lag screws similar statements hold true.⁹

Cordey has studied the control of torque during insertion of the screw. He found that experienced bone surgeons are able to adapt to a variety of bone strengths and to achieve quite regularly 70–80% of possible torque. A torque limiting screw driver is of little help as the bone quality changes from place to place and from patient to patient. Perhaps the use of densitometry on X-ray picture^{36, 59} may be of help.

As mentioned earlier the holding power of screws is about 40 kp/mm of thickness. The figure according to Gotzen^{25, 26} will be lower for the forearm and humerus. Cancellous bone is much weaker and we expect 0.4 kp/mm² of surface.

With respect to positioning of lag screws: a screw should in general be positioned in a direction to produce together with the superimposed functional load, a normal force on the fracture surface. The position of lag screws in combination with compression plates has been studied by Gotzen.²⁶

INTERNAL FIXATION PLATES

To understand the mode of action of internal fixation plates one can think of the plate as being a very thick wire.

A plate is furthermore, an asymmetric appliance: the material properties of a plate are by far not used most efficiently from a technical point of view. Compression by internal fixation plate alone is therefore asymmetric as Askew, *et al.* have shown.² It would be a misunderstanding of the clinical reality to look at asymmetric compression of the plate alone. For many years the Swiss study group has advocated the use of compression plates either as tension band plates, together with lag screws or if no other possibility exists, the disadvantage of the

The plate is not only deformable in bending and torque, but is as well weak in fatigue, particularly if the surgeon does not use the load bearing capacity of bone. A plate bridging an open gap without bone formation, *i.e.* when medial support in a femur fracture is lacking, will run the risk of fatigue and breakage. Stronger plates would be too stiff and not desirable because of possible stress protection. The solution to this problem clearly is to use a reasonably small amount of metal but with the best technique of application available including compression and making use of the load bearing capacity of bone.

If a bone fixation is slightly unstable bone resorption will start at the fracture surfaces. The plate will not allow the fragment ends to sinter together especially when circularly fitting plate holes are used.⁵⁰ This condition has been used regularly to produce nonunion in animal experiments by J. Muller.³⁹ In this context it must be understood that callus after a so-called stable internal fixation with plate and screw is undesirable, as it indicates some condition of unwanted instability.

Callus *per se* is not undesirable at all because it helps in many instances, but its appearance with screws and plates is related to dangerous conditions of instability and infection.

INTRAMEDULLARY NAIL

Several different techniques of intramedullary fixation and different types of rods are used.

One must nevertheless keep in mind that the rotational stability provided by the nail itself and especially its connection to the inner surface of bone is restricted. Rotational stability in intramedullary nailing relies mostly on interdigitation of the fracture surfaces.

We therefore expect and see callus formation and some minor shortening at the fragment ends. Due to the property of the medullary nail as a gliding internal splint, the fragments can sinter together under functional load and therefore resorption here is not deleterious.

While rigidity of the medullary nail is often low, its strength is nevertheless great enough to tolerate early weight-bearing and late healing, if ever this should occur.

SUMMARY

Fracture healing is a repair process of a mechanical discontinuity loss of force

transmission, and pathological mobility of bone. Through a sequence of changes of tissue development and geometry, the original structural integrity is restored.

In unified theory of non-operative and operative stabilized fractures, the mechanics of primary bone healing involves a complex interplay of physical and biological factors. The different patterns of bone repair respond to physical influences including strain tolerance.

ACKNOWLEDGMENT

The work in the Laboratory for Experimental Surgery at the Swiss Research Institute in Davos, Switzerland, had been supported for the past 20 years through royalties of implant manufacturers to the Swiss Study Group for Internal Fixation, "(Arbeitsgemeinschaft für Osteosynthese Fragen AO.)" The biophysical basic work is supported by grants of the Swiss National Foundation for Scientific Research, Credit: 3.526.075.

REFERENCES

- Allgöwer, M., Ehrsahm, R., Ganz, R., Matter, P. and Perren, S. M.: Clinical experience with a new compression plate "DCP," *Acta. Clin. Orthop. Scand. Suppl.* 125:45, 1969.
- Askew, M. J., van Mow, C., Wirth, C. R. and Campbell, C. J.: Analysis of the intraosseous stress field due to compression plating, *J. Biomech.* 8:203, 1975.
- Bagby, G. W. and James, J. M.: An impacting bone plate. Staff meeting at the Mayo Clinic 32:55, 1957.
- Bertolin, A.: L'impiego della mia placca a compressione, *La Clinica Orthop.* 18:221, 1966.
- Block, W.: Die Normale und Gestörte Knochenbruchheilung, Ferdinand Enke Verlag, 1940.
- Blümlein, H., Cordey, J., Schneider, U. A., Rahn, B. A. and Perren, S. M.: Langzeitmessungen der axialkraft von knochenschrauben in vivo, *Z. Orthop.* 115:603, 1977, Stuttgart, F. Enke Verlag.
- Böhler, L.: Die Technik der Knochenbruchbehandlung, Wein, Maudrich, 1953.
- Claes, L., and Huntzscheneuter, P.: Dash durchdrehmoment an zugschrauben mit vorgeschnittem kortikalissgewinde (mechanik und histologie), *Z. Orthop.* 113:237, 1975.
- Cordey, J., Widmer, W., Rohner, A. and Perren, S. M.: Dosierung des drehmoments beim einsetzen von knochenschrauben. Experimentelle studie an kortikalisschrauben mit hilfe elektronischen drehmomentschraubenziehers, *Z. Orthop.* 115:601, 1977, Stuttgart, F. Enke Verlag.
- Coutelier, L.: Recherches sur la guerison des fractures, Edition Arscia S. A., 1969.
- Coutts, R. D., Harris, W. H. and Weinberg, E. H.: Compression plating: experimental study of the effect on bone formation rates, *Acta. Orthop. Scand.* 44:256, 1973.
- Danis, R.: Theorie et pratique de l'osteosynthese, Masson & Cie, 1949.
- Denham, R. A.: Compression and coaptation, *J. Bone Joint Surg.* 57B:177, 1969.
- Diehl, K., Hanser, U., Hort, W. and Mittelmeier, H.: Biomechanische untersuchungen über die maximalen vorspannkkräfte der knochenschrauben in verschiedenen knochenabschnitten (biomechanic researches of maximum initial tension forces of bone screws on various bone sections, *Arch. Orthop. Unfall-Chir.* 80:89, 1974.
- Enzler, M.: personal communication.
- Enzler, M. and Perren, S. M.: The coefficient of plate-bone friction *in vitro*: the effect of duration and amount of load, *In* Asmussen and Jørgensen (eds.) *Biomechanics V*, Baltimore, University Park Press, 1978.
- Evans, G. F.: *Stress and Strain in Bones*, Springfield, Charles C Thomas, 1957.
- Friedenberg, Z. B. and French, C.: The effect of known compression forces on fracture healing, *Surg. Gynecol. and Obstet.* 94:743, 1952.
- Galeazzi, J.: Experimentelle Untersuchungen zur intraoperativen Druckveränderung bei der Plattenosteosynthese, *Med. Diss.*, Bern, 1972.
- Galgoczy, E., Cordey, J., Blümlein, H., Schneider, U. and Perren, S. M.: Der reibungskoeffizient metall-knochen bei der plattenosteosynthese im tierexperiment, *Z. Orthop.* 115:601, 1977.
- Gallinaro, P., Perren, S. M., Crova, M. and Rahn, B. A.: La osteosintesi con placca a compressione estratto da: moderni orientamenti nelle osteosintesi delle fratture diafisarie, Bologna, F. Roasenda, G. L. Lorenzi, Relaz LIV Congresso Aulo Gaggi, 1969.
- Ganz, R., Rüter, A. and Perren, S. M.: Mechanisch induzierte knochenresorption, *In* Schuchardt, K. (ed.) *Fortschr. Kiefer- und Gesichtschirurgie*, 19:45, 1975.
- Geiser, M.: Beiträge zur Biologie der Knochenheilung, Verlag, Ferdinand Enke, 1963.
- Gorzen, L.: Untersuchungen zur Neutralisationsplattenosteosynthese, Habilitation, Hannover, Med. Hochschule, 1978.
- Gotzen, L.: Personal communication.
- Gotzen, L., Muhr, G., Anna, O.: Biomechanische untersuchungen zur vorbiegung von AO-Osteosyntheseplatten, *Hefte z. Unfallheilkunde* 126:387, 1976.
- Gunst, M.: Die blutversorgung der kortikalis nach verplattung der intakten kaniscentibia, *Med. Diss.* Basel, 1977.
- Hayes, W. C. and Perren, W. M.: Plate-bone friction in the compression fixation of fractures, *Clin. Orthop.* 89:236, 1972.
- Hughes, A. N. and Jordan, B. A.: Some mechani-

- cal properties of surgical bone screws of French manufacture (stainless steel) and UK manufacture (titanium alloy), *Engl. Med.* 3:3, 1974.
30. Huntzschentreuter, P., Allgöwer, M., Borel, J. F. and Perren, S. M.: Second-set reaction favoring incorporation of bone allografts, *Experientia* 29:103, 1973.
 31. Huntzschentreuter, P., Steinemann, S., Perren, S. M., Geret, V. and Klebl, M.: some effects of rigidity of internal fixation on the healing pattern of osteotomies, *Injury* 1:77, 1969.
 32. Kinzl, L., Perren, S. M. and Burri, C.: Veränderungen mechanischer Qualität der unter druckplatten liegenden knochenkortikalis (stress protection), *Lagenb. Arch. Chir. Suppl. Chir. Forum* 48:215, 1974.
 33. Küntscher, G.: Das Kallus-Problem, Stuttgart, F. Enke Verlag, 1970.
 34. Lane, W. A.: The Operative Treatment of Fractures, London, The Medical Publishing Co., 1914.
 35. Matter, P., Brennwald, J. and Perren, S. M.: The effect of static compression and tension on internal remodelling of cortical bone, *Helv. Chir. Acta. Suppl.* 12, Basel, Schwabe & Co. Verlag, 1975.
 36. Matter, T., Rahn, B. A., Cordey, J., Mikuschka-Galgoczy, E. and Perren, S. M.: Die beziehung zwischen Röntgendichte und maximal erreichbarer axialkraft von AO-Schrauben im knochen, *Hefte z. Unfallheilkunde* 80:165, 1977.
 37. Mittelmeier, H.: Piezoelektrische und spannungsoptische untersuchungen zur biomechanik der schraubenosteosynthe, *Z. Orthop.* 110:893, 1972.
 38. Mittelmeier, H.: Prinzipien der osteosynthese mit selbstspannenden druckplatten, *Med. Orthop. Tech.* 4:90, 1974.
 39. Mueller, J., Schenk, R. and Willenegger, H.: Experimentelle untersuchungen über die entstehung reaktiver pseudarthrosen am hunderadius, *Helv. Chir. Acta.* 35:301, 1968.
 40. Müller, M. E. and Perren, S. M.: Callus und primäre knochenheilung, *M Schr. Unfallheilk* 75:442, 1972.
 41. Müller, M. E., Allgöwer, M. and Willenegger, H.: Technik der operativen frakturenbehandlung, Berlin, Springer-Verlag, 1963.
 42. Müller, M. E., Allgöwer, M., Schneider, R. and Willenegger, H.: Manuel der Osteosynthese, AO-Technik. New York, Springer-Verlag, 1977.
 43. Nunamaker, D. M. and Perren, S. M.: Force measurements in screw fixation, *J. Biomechanics* 9:669, 1976.
 44. Olerud, S. and Danckwardt-Lillieström, G.: Fracture healing in compression osteosynthesis, *Acta. Orthop. Scand. Suppl.* 137, 1971.
 45. Perren, S. M. and Boitzy, A.: Cellular differentiation and biomechanics of bone during fracture healing, *Anatomia clinica* 1:000, 1978.
 46. Perren, S. M. and Cordey, J.: Die gewebisdifferenzierung in der fracturheilung 80:161, 1977.
 47. Perren, S. M. and Hayes, W. C.: Biomechanik der plattenosteosynthese, *Med. Orthop. Technik* 94:56, 1974.
 48. Perren, S. M., Russenberger, M., Steinemann, S., Müller, M. E. and Allgöwer, M.: The reaction of cortical bone to compression, *Acta. Orthop. Scand. Suppl.* 125:19, 1969.
 49. Perren, S. M., Russenberger, M., Steinemann, S., Müller, M. E. and Allgöwer, M.: A dynamic compression plate, *Acta. Orthop. Scand. Suppl.* 125:31, 1969.
 50. Perren, S. M., Cordey, J., Enzler, M., Matter, P., Rahn, B. A. and Schläpfer, F.: Die mechanik der plattenstellschraube, *Hefte z. Unfallheilkunde (Traumatology)* 81:211, 1978.
 51. Perren, S. M., Hügler, A., Russenberger, M., Straumann, F., Müller, M. E. and Allgöwer, M.: A method of measuring the change in compression applied to living cortical bone, *Acta. Orthop. Scand. Suppl.* 125:7, 1969.
 52. Pritcard, J. J.: Histology of fracture repair, *In Clark, J. M. P. (ed.) Modern Trends in Orthopaedics*, 4, London, Butterworths, 1964.
 53. Puddi, G. C.: Personal communication.
 54. Rahn, B. A.: Personal communication.
 55. Rahn, B. A.: Die polychrone fluoreszenzmarkierung des knochens, *Nova Acta Leopoldina* 44:233:249, 1976.
 56. Rahn, B. A., Cordey, J., Prein, J. and Russenberger, M.: Zur biomechanik der osteosynthese an der mandibula, *In Schuchardt, K., Spiessl, B., Fortschr. Kiefergesichts chir* 19:37, 1975.
 57. Rahn, B. A., Gallinaro, P., Baltensperger, A. and Perren, S. M.: Primary bone healing. An experimental study in the rabbit, *J. Bone Joint Surg.* 53A:783, 1971.
 58. Rahn, B. A., Gallinaro, P., Schenk, R. K., Baltensperger, A. and Perren, S. M.: Compression interfragmentaire et surcharge locale de l'os surcharge, *In Boitzy, A. (ed.) Osteogenese et compression.* Bern-Huber, 1972.
 59. Rahn, B. A., Matter, T., Mikuschka-Galgoczy, E., Ziegler, W. J., Cordey, J. and Perren, S. M.: Relationship between radiological density, hardness, holding power of screws and microscopic structure in human cortical bone. *In Biomechanics VI*, Baltimore, University Park Press, in press.
 60. Rohner, B. A.: Der einfluss des gewindeauslaufs auf die haltekräft von knochenschrauben, *Med. Diss.* Basel, 1977.
 61. Rhinelander, F. W.: Minimal internal fixation of tibial fractures, *Clin. Orthop.* 107:188, 1975.
 62. Rhinelander, F. W. and Baragry, R. A. Microangiography in bone healing. I. Undisplaced closed fractures, *J. Bone Joint Surg.* 44A:1273, 1962.
 63. Rittmann, W. W. and Perren, S. M.: Cortical bone healing after internal fixation and infection, New York, Springer-Verlag, 1974.
 64. Rustizky, Z. N. and Matzen, P. F.: Lässt sich der physiol. Heilablauf des knochenbruches beschleunigen? *Wiss. Z. Univ. Halle, Math.Njat.* 4/:1111, 1965.
 65. Schatzker, J., Horne, J. G. and Sumner-Smith, G.: The effect of movement on the holding power of screws in bone, *Clin. Orthop.* 111:257, 1975.

66. Schatzker, J., Sanderson, R. and Murnghan, J. P.: The holding power of orthopedic stress *in vivo* Clin. Orthop. 108:115, 1975.
67. Schenk, R. and Willenegger, H.: Histologie der primären knochenheilung, Arch. Klin. Chir. 19:593, 1963.
68. Tamai, T. and Hoshiko, W.: A new compression plate for osteosynthesis, Klin. Orthop. Surg. 2:941, 1967.
69. Uhthoff, H. K.: Mechanical factors influencing the holding power of screws in compact bone, J. Bone Joint Surg. 55B:633, 1973.
70. Uhthoff, H. K. and Dubus, F. L.: Bone structure changes in the dog under rigid internal fixation, Clin. Orthop. 81:165, 1971.
71. von Arx, C.: Schubübertragung durch reibung bei der plattenosteosynthese, Med. Diss., Basel, 1973.
72. Wagner, H.: Die einbettung von metallschrauben im knochen und die heilungsvorgänge des knochengewebes unter dem einfluss der stabilen osteosynthese, Langenb. Arch. Klin. Chir. 305:28, 1963.
73. Wickstrom, J., Hamilton, L. and Rodriguez, R.: Evaluation of the AC compression apparatus, J. Trauma 7:210, 1967.
74. Yamada, H.: Strength of Biological Materials, Baltimore, Williams and Wilkins, 1970.

reduction of the fracture fragments and maintenance of the more or less reduced fragments in a more or less rigid way. In non-operative treatment, sometimes perfect alignment and motionless fixation are neither sought for nor judged to be necessary. While angular deformation can in some instances be prevented even with a short plaster cast, the prevention of torsional deformation necessitates the bridging of neighboring articulations preferably in a bent position. Internal fixation aims at accurate reduction and rigid maintenance of the fragments to permit immediate mobilization of the articulations without any external splints. Here, accurate reduction and motionless fixation are not self-standing goals, but they are prerequisites for the efficient use of implants.

The mechanical difference between the 2 different treatments basically is that non-operative treatment maintains the overall reduction to permit bone formation and biological fixation. Internal fixation produces stable fixation relying first on the implant and after the bone has solidly united, the implant is removed.

MECHANICAL CHARACTERISTICS OF INTACT CORTICAL BONE

The mechanical characteristics of intact cortical bone will be mentioned with reference only to its importance in fracture healing and internal fixation. The data is taken from Evans¹⁷ and Yamada.⁷⁴ The strength of cortical bone averages 10–15 kp/mm.^{2*} This enables a segment of the tibia shaft to withstand more than a tone of compressive load before failure. The strength is of practical importance in the late stages of fracture healing and in intact bone since the strength of the soft tissue in the early stage of fracture healing is about 1000 times less than that of bone and can for practical purposes be neglected (Fig. 1).

* 1Kp = 1Kg force = 2.2 lbs force = 9.81 N (Newton Si)

The rigidity of cortical bone is 1000–2000 Kp/mm^{2**} (Young's modulus). However, this term does not tell us much. For practical purposes let us therefore look at 2 clinical examples: a tibial shaft loaded with 100 kp will shorten some 10 μ m (=1/10 of an average cell). If we support the lower leg at the knee and the heel only, the midshaft deflection of the intact tibia will be about 20 μ m. Bone deformation under load is unimportant in non-operative treatment while the elasticity of bone is an important element in maintaining compression in internal fixation.

The elongation at rupture is a parameter which characterizes the tolerance of a material to deformation. It tells us how much relative deformation a material can tolerate before it breaks. Granulation tissue acts like a very thin rubber band. It can elongate to twice its original length but will almost be unable to fight motion due to its lack of rigidity and will break under low tensile stress. Cortical bone will rupture when elongated only 2% (in comparison cold worked steel will tolerate an elongation of some 20%, be at least 10 times more rigid as a material and about 10 times stronger than bone).

APPLICATION OF THE MECHANICAL CHARACTERISTICS OF CORTICAL BONE TO FRACTURED BONE AND ITS TREATMENT

The comparably high strength of cortical bone permits an anchoring of implants in bone to achieve good holding power. The holding power of a 4.5 mm cortical screw with asymmetric thread (according to ISO TC 150 draft HA 4.5) is 25–45 kp/mm of cortical thickness.^{8,24,25,29,60} This means for practical application that per cortex, 85 to 250 kp of axial force can be transmitted between bone and a lag screw. The screw is therefore a very powerful tool for fixation

** 1Kp/mm²=9.81 MPa=1423 p.s.i.

of fractures as we will see later. Furthermore, the compressive strength of cortical bone permits the anchorage of external pins where *e. g.* a pin of 5 mm in 2 cortices each 6 mm thick (femur) rests on a surface area of 60 mm² and can therefore withstand several hundred kp of axial load (5 × 12 × 13 kp/mm²).

The rigidity of bone is comparably high (Fig. 2): it deforms minimally under load. Bone, compressed by an internal fixation implant (*i. e.* screw or plate) will deform about the thickness of one to 2 cell layers. Metal is even stiffer, though the higher material stiffness is offset by a smaller cross sectional area and area moment of inertia. The spring action in an internal fixation determines how sensitive the system is to fragment shortening due to resorption. Even though bone and metal deform only 10–20 μm under 100 kp of load, in a transverse osteotomy fragment end shortening of one to 2 cell layers thickness will abolish the compression achieved. In comparison, an osteoclast is able to resorb some 100 μm of bone per day.⁶⁷ In summary, internal fixation is very sensitive to bone resorption if maintenance of stable fixation is an important goal.

STRAIN TOLERANCE OF THE REPAIR TISSUES

Elongation at rupture of lamellar bone is a mere 2% *i. e.* will deform only minimally before it ruptures (Fig. 3). If we visualize the gap of a shaft fracture with or without external treatment the dynamic deformation of the interfragmentary tissue (dynamic strain) is many times greater than bone would tolerate. For example, we can assume that in a long bone with a wide fracture gap, bone could not bridge from fragment end to fragment end if bending produced more than 0.5° of angulation.* In non-operative treatment an angulation of

* Assuming bone to be a hollow tube of 30 mm outer Ø and a smaller gap width would even worsen the situation.

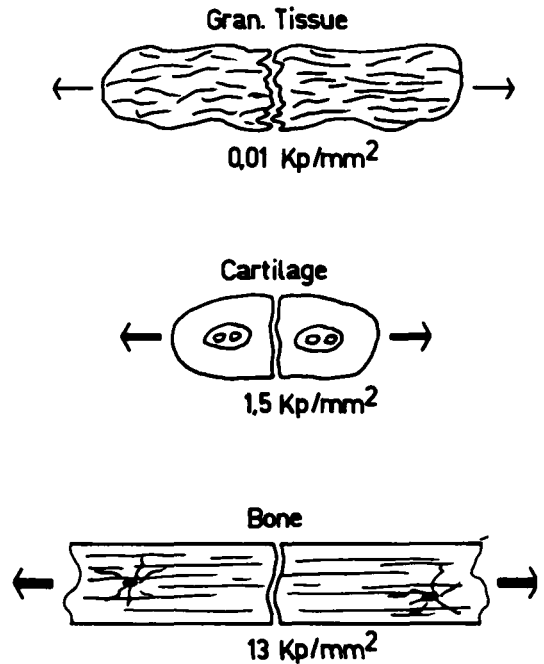

FIG. 1. Strength of tissue. The strength is a capacity to withstand force without rupture. Strength is given as force per unit area (kp/mm²). Intact bone is strong, while the strength of the initial repair tissues is negligible; If functional load deforms a fracture, the forces which can be produced surpass by far the strength of the initial tissues.

0.5° cannot be prevented even with a very tight fitting cast. In operative treatment 0.5° angulation seems to be preventable, but due to the fact that here the gap width is more likely to be 10 μm rather than 10 mm, even smaller angular deformation is critical.**

In respect to the concept of strain, it seems reasonable that initial repair tissue tolerates a great amount of elongation before rupture occurs. We estimate that granulation tissue (analogous to parenchyma), tolerates 100% of strain before rupture occurs. Fibrous tissue, tendon and cartilage tolerate appreciably less amounts of elongation and they also have a non linear

** A gap width of 10 μm will tolerate 1/1000 of the number given above for the angulation of a 10 mm wide gap.

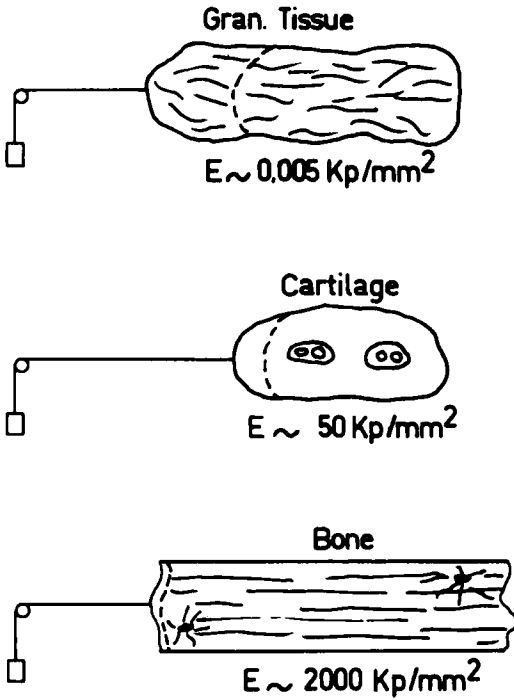

FIG. 2. Rigidity of the repair tissues. The rigidity is the capacity to fight deformation and therefore motion. In secondary fracture healing (enchondral ossification), the reduction of the fracture mobility is based on the increasing rigidity of the bridging tissues. The rigidity of the repair tissue increases from granulation tissue to bone by a factor of 1:400,000. Rigidity is the prime quality which enables bone to fullfill (without gross deformation) its role as a supporting tissue. Rigidity is the important quality of repair tissues in an intermediary stage of secondary bone healing.

stress/strain relation.* This nonlinear relation favors reduction of relative motion at the fracture site.⁴⁵ Thus, the precursor tissues prepare the fracture gap mechanically and biologically for solid bone union.

THE EFFECT OF FRAGMENT END SHORTENING DUE TO RESORPTION

In spontaneously healing bone and in healing under relative fixation, fragment end shortening due to resorption is a com-

* The rigidity of cartilage increases drastically while the tissue is deformed about a certain limit.

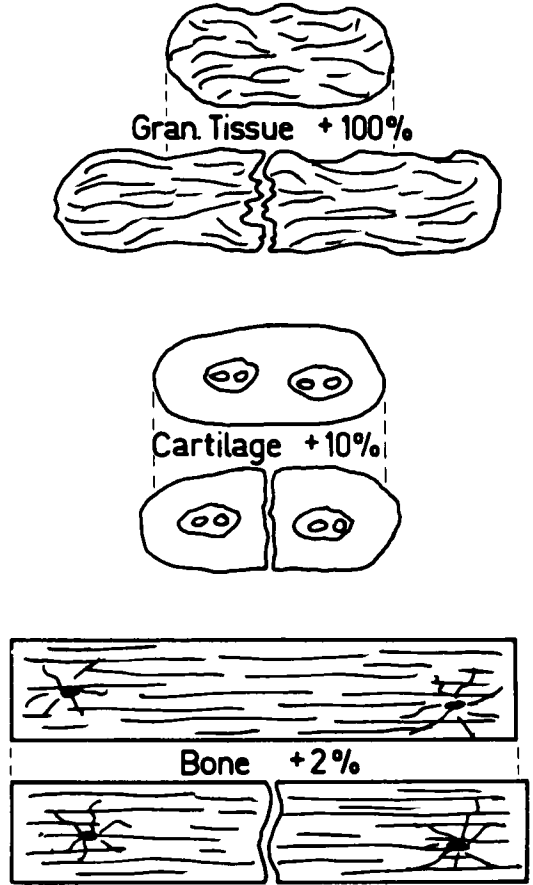
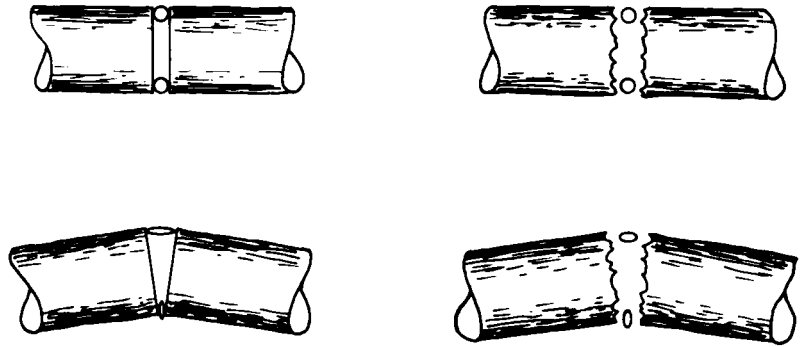

FIG. 3. Strain tolerance of the repair tissues. Elongation or strain tolerance is the capacity to tolerate a certain amount of deformation before rupture occurs. The strain tolerance is the primary quality of the initial repair tissue in secondary fracture healing, when tissue rigidity does not yet contribute to reduction of mobility at the fracture area. The assumption is that a certain tissue simply cannot exist in an environment where strain (relative deformation) exceeds the limit of elongation at rupture of the tissue under consideration.

mon phenomenon.⁷ Küntscher³³ even postulated that bone surface resorption would be a common finding in rigid internal fixation. As we will see later this postulate holds true for external fixation, and for some kinds of internal fixation which permit a certain amount of interfragmentary motion. If the reduction of interfragmentary strain is a goal or a prerequisite in fracture

FIG. 4A. Reduction of interfragmentary strain by bone resorption at the fragment ends. Provided that the fragments are kept from sintering together, for a given amount of fracture angulation, resorption reduces the interfragmentary strain. The reason for this is, that strain or relative deformation of the interfragmentary



tissue though proportional to absolute deformation is at the same time inversely proportional to the initial difference between the fragment ends. The figure visualizes that cells in a narrow gap are heavily deformed while tissues in a wide gap are less strained for the same amount of angulation.

healing, then the shortening of the fragment ends by resorption makes sense: it reduces for a given amount of motion the interfragmentary strain because it depends on motion (DL) and gap width (L) (Fig. 4).* The occurrence of surface resorption therefore makes sense in secondary bone healing. It should be prevented whenever primary bone healing is of an advantage *i. e.* in fixation with rigid plate.**

THE EFFECT OF INCREASED CROSS SECTION AT THE FRACTURE LEVEL DUE TO FORMATION OF CALLUS CUFF

The increasing cross section of a fracture site, due to formation of a cuff of callus renders the tissues bridging the fracture gap more efficient. The increase in diameter provides the tissue with better leverage in respect to bending and torque.⁴⁰ The rigidity efficiency of the tissue increases with the fourth power of the distance from the center of rotation or bending, the strength efficiency with the third power (Fig. 5). We therefore consider internal (endosteal) cal-

lus as less efficient than interfragmentary bone which in turn is less efficient than external (periosteal) callus, all this provided the quality of the repair tissue and its area are kept constant.

TISSUE RIGIDITY AND INTERFRAGMENTARY STRAIN

We have postulated that a tissue can only be formed in the fracture gap (as anywhere) if the tissue to be formed tolerates the strain present. Once a tissue has been formed, it will in turn due to its rigidity, influence the motion possible and therefore reduce strain. Thus, the next step of tissue differentiation may be made possible: deformation of fibrous tissue may reduce the strain to a level where cartilage formation is possible. Tissue rigidity can only be effective if the bending moment does not "out-number" by far the stiffness. The influence of tissue rigidity is negligible if the rigidity of the tissue is small in comparison with that of external or internal appliances and vice versa.

TISSUE INDUCTION AND STRAIN

It is generally accepted that one* of the elements inducing callus formation is mobil-

* Strain $\xi = DL/L$.

** The shortening of the fragment ends is only helpful in reducing interfragmentary strain if the fragment ends are not allowed to sinter together. This can be achieved by interposed tissue *e. g.* cartilage or if the shortened part of the fragment ends are protected from sintering because other parts are still in contact.

* Callus has been reported to depend also on irritation of the periosteum^{23,57}; Küntscher³³ has demonstrated callus formation after irritation of the medullary space with corroding metals.



FIG. 4B. The resorption of the fragment ends in this tibial osteotomy of the sheep has widened the gap and granulation tissue is seen between the gaping ends. In the narrow original gap only a morphorous material is found. Thus, resorption may permit the presence of initial repair tissues or may enhance further differentiation. During resorption of the fragment ends, the osteoclasts are not located at the high strain area between the fragment ends, but within their lacunae in a strain protected area.

ity of the fracture *i. e.* interfragmentary dynamic strain. Hutzschenreuter *et al.*³¹ have visualized this using internal fixation of a standard transverse osteotomy in the sheep tibial shaft. Plates of varying stiffness were used to bridge an osteotomy with predetermined gap width. The amount of callus was shown to depend on the rigidity of fixation or as we would now say, interfragmentary strain. Similarly, the observed lack of callus in spontaneously stable fractures without internal fixation can be interpreted in the same way.^{57,62} At the other end of the

scale, large gaps in adult shaft bones after leg lengthening are known not to unite with bone. More work with respect to tissue induction and mechanical strain would be of interest.

INTERFRAGMENTARY STRAIN IN INTERNAL FIXATION

Let us assume that we plate a transverse osteotomy of the tibia. We do this without application of any kind of compression and leave a gap of 0.01 mm between the fragment ends (Fig. 6). During the operation such a procedure would appear to offer enough stability of fixation. If we do the mechanical analysis* we find that due to the small distances between the fragment ends strain is high and no tissue is tolerated in the interfragmentary space. Hutzschenreuter *et al.*³¹ have actually observed under similar conditions a pronounced resorption of the fragment ends prior to bony union. This analysis demonstrates that in internal fixation we may unexpectedly run into problems concerning interfragmentary strain. To understand primary bone formation under rigid internal fixation we will have to discuss the principle of "absolute" stability of fixation.

MECHANICAL PRINCIPLES OF FRACTURE FIXATION

SPLINTAGE

The oldest type of fracture fixation consisted of tying a piece of wood to the injured limb. The wood acts as an external splint: due to its rigidity it helps to reduce (not abolish) the motion at the fracture site. The wooden splint is inefficient due to its deformability, its asymmetric positioning and

* See Perren and Cordey⁴⁶ for details of the underlying assumption. In summary: only flexural moments have been assumed to exist, their magnitude was derived from the fact that a plate bridging an open fracture gap is known to fail in fatigue after some 100,000 cycles. For a plate made of steel 12 mm wide and 4 mm thick the fatigue limit is about 600 kp mm.

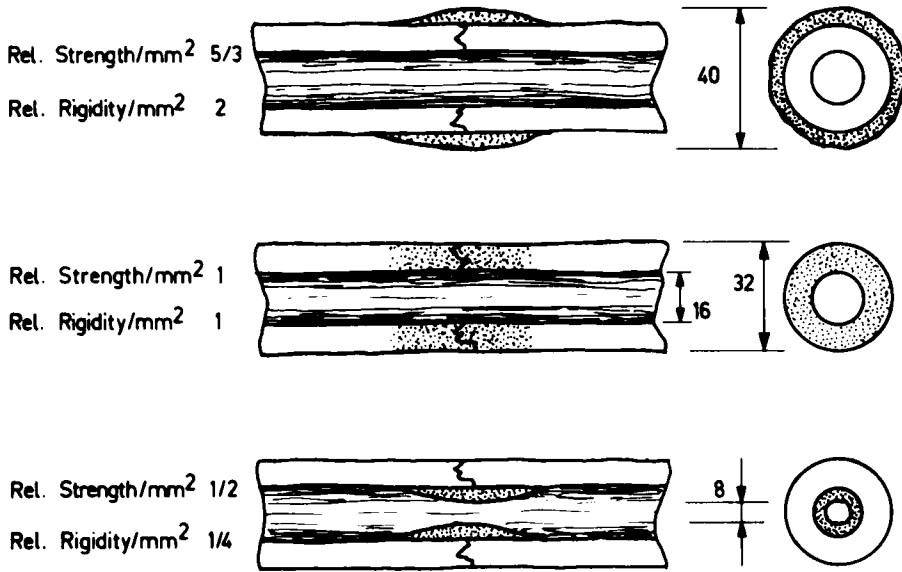

FIG. 5. The geometrical repartition of the repair tissue determines the efficiency of a given tissue to fight or resist motion. The figure visualized the situation for a midshaft of the femur with either 4 mm thickness of endosteal or periosteal callus. To compensate for the different area of cross section under repair, the rigidity and strength are compared as per unit area. Provided that the quality of the repair tissue remains the same then endosteal callus is much less efficient and resistant than interfracture callus which in turn is less efficient than periosteal callus.

the lack of a rigid connection between wood and bone. The plaster cast and similar devices are more rigid and by surrounding the bone, are more efficient. However, due to the deformability of the tissues between plaster and bone, the bone fixed by plaster cast can move, especially in an axial direction. If the plaster cast is long enough, it will reduce angulation efficiently, but needs the help of angulated articulations for reducing rotational movement.

Internal fixation implants can act as splints as well. In general, while a wire or a screw is too deformable in bending and torque to act as a good splint (the K-wire is under certain circumstances an exception to this), the medullary nail, the plate and the external fixation clamps provide good splintage. The stiffness of the plate and nail in respect to bending and torque rely on the stiffness of the material rather than on the element of its construction *i. e.* the metal in these cases is somewhat inefficiently placed

near the center of bending and rotation. The transmission of torque between bone and medullary nail is poor. The nail therefore relies on interdigitation of the fracture for control of rotation. External fixation clamps, provided the construction is adequate, can control bending and torque but the deformability of the connecting pins forgoes part of this advantage. In summary splintage relies on the rigidity of the splint and on that of the transmission between the splint and bone. A pure splint fixation will always permit some motion which is proportional to the load and inversely proportional to the overall stiffness of the device and transmission (Fig. 7). As we will see, this minute amount of motion under internal splintage is important in respect to the onset of bone resorption.

COMPRESSION

Danis¹² was the first to our knowledge to advocate the use of compression for stabili-

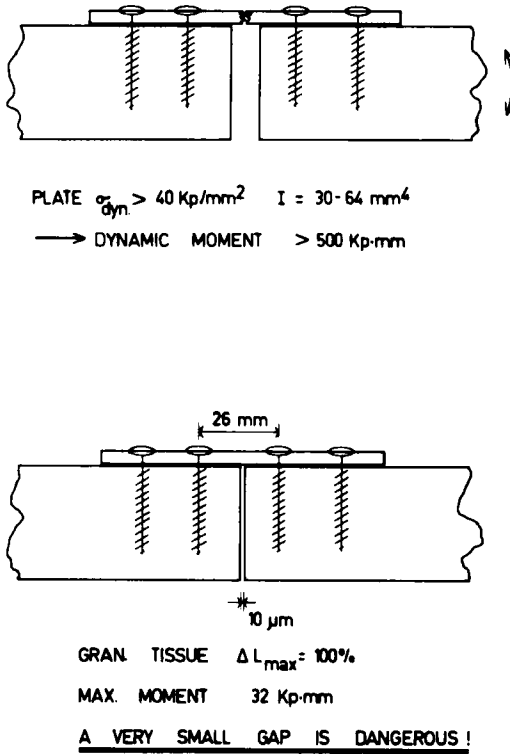

FIG. 6. Strain in internal fixation without close adaptation and compression of the fragment ends. (A; top) The amount of bending load at a fracture site can be approximated on the basis of the fact, that an internal fixation plate bridging an open fracture gap without bone support is known to fail in fatigue after 3–5 months (ca. 300'000 cycles). The fatigue characteristics of the plate indicate a dynamic load of $> 500 \text{ kp/mm}$ to be present. Torque is disregarded in this analysis dealing with orders of magnitude rather than exact figures. (B, bottom) Demonstration of load-strain relation in a small gap bridged with an internal fixation plate where no contact and no compression of the fragment ends exists. The strain tolerance of the initial repair tissue (granulation tissue with 100% elongation) allows only 32 kp/mm bending moment (see Perren and Cordey, 1977, for exact model assumption).⁴⁶ Though a stiff implant is bridging the gap, here at the micromechanical level, dangerous strain conditions can develop and may lead to resorption and gross instability with the risk of delayed union or pseudarthrosis and including the danger of implant fatigue failure.

zation of bone fractures. The actual use of compression is much older: any screw or any implant which is fixed to bone (without glue) can only function through application of local compression. If we visualize the mode of action of a screw at the screw thread, there is compressive load of the contacting surface metal-bone and at the screw head undersurface. Here, the implant itself is under tension, but the contacting surface is under compression.* Basically, we differentiate between 2 different applications of compression.

Static compression can be used to fix an implant to bone. This is a widely used principle achieved with screws, plates and external fixation clamps. The second use of static compression is to press bone surfaces together with a lag screw. This is a screw

which crosses a fracture line and due to its design (shaft) but more often due to the way of application (gliding hole) is anchored only in the bone thread near the tip of the screw. The part of the screw near the head is either a non threaded shaft or the screw thread glides in a widened drill hole. Danis¹² advocated the use of compression especially along the long axis of bone. He achieved longitudinal compression using a special plate with incorporated compression device.* Muller *et al.*⁴¹ have developed a removable compression device to be used until the plate is fixed at both ends to the bone and then is removed. Bagby and Janes³ in 1956 described a so-called self compressing plate in which a sloped surface

* For further analysis we will differentiate between static compression and dynamic compression. Static compression is a compression which remains mainly constant, while dynamic compression is a force which changes its magnitude and possibly direction due to functional loads.

* The names given to implants used in internal fixation are not consistent: a compression plate is a plate which produces compression in bone due to the fact that it is applied under tension. A tension band wire is loaded in tension but also produces compression in bone. A better proposition would be to name the implants according to their function: compression screw, compression wire, etc.

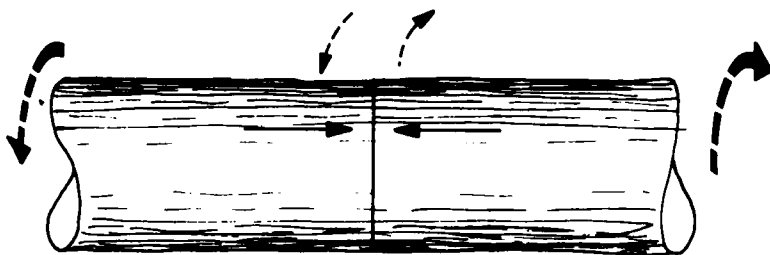

FIG. 9. Friction as a stabilizing principle in compression fixation. Compression of contacting surfaces produced friction. Friction prevents any tangential displacement of the contact surfaces as long as

possible when friction is greater than or equals shear. Local shear is produced mostly as a result of torque applied to the limb. Absolute stability under torque load depends entirely on interfragmentary friction. Compressed interdigitation of the fracture fragments may be understood as a specially efficient combination of preload and friction.

saw blade, the coefficient of friction of bone to bone is around 0.4.¹⁵ For metal to bone friction, Hayes and Perren²⁸ have found under low load and static conditions the coefficient to be 0.38. Enzler¹⁵ had shown that friction metal to bone depends on time of duration and magnitude of the normal force. The coefficient of friction *in vivo* is contained between 0.2 dynamically and 0.4 statically.²⁰ Friction is important and nearly the only tool which stabilizes against shearing influences produced mainly by torsion applied to the limb. In fractures placed under compression, we can expect a high degree of torsional stability due to interdigitation of the fracture surfaces. The friction is—as compression and preload—a widespread principle of stable fixation.

ABSOLUTE STABILITY

Compression produces (be it by preload and/or friction) a condition which we call absolute stability. This term describes a state where there is no relative motion at the location of the interfragmentary contact under observation. As long as sufficient compression acts upon the surfaces there will be no displacement of the fracture surfaces in relation to each other, provided the dynamic load superimposed does not reach the level of preload or friction. Under a superimposed dynamic load, the overall system will deform according to Hooke's law, but between the contacting compressed surfaces there will be no relative motion

(distraction or shear) and therefore no interfragmentary strain.

While a splint will always allow some relative motion of the fracture which it bridges, through application of compression relative motion at the fracture site can be completely abolished.

As outlined earlier, in a very small fracture gap a dangerously high strain condition can develop despite a rigid implant such as a plate acting as a splint. The application of compression is a powerful mechanical tool to prevent this.

BONE HEALING

The bone healing under relative immobilization after non-operative treatment has been outlined in detail and will not be repeated.^{5,10,52} We will restrict ourselves to the special aspects of bone healing under rigid internal fixation and to the aspects of strain in bone healing in general.

HISTORY OF BONE HEALING IN INTERNAL FIXATION

Lane³⁴ mentioned the term "as per primam intentionem." Danis¹² used the term "soudure autogen" (internal welding) and advocated the callus free healing as a goal (see the classic article in this volume).

CONTACT HEALING

Schenk and Willenegger⁶⁷ outlined the histological aspects of primary fracture

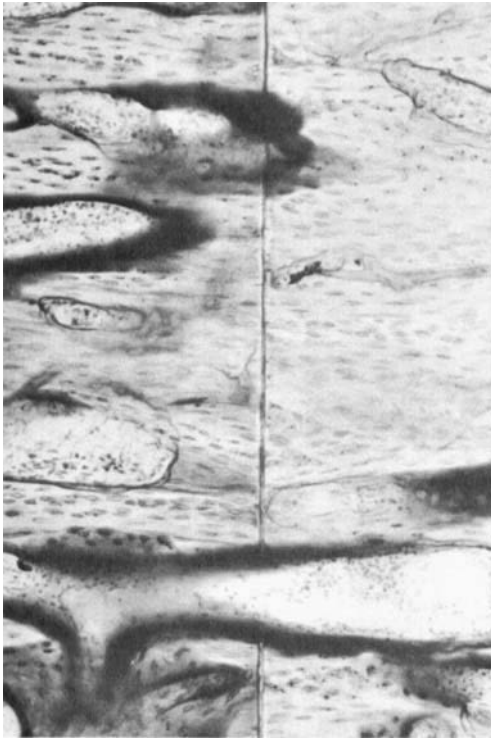

FIG. 10A. Primary healing: Contact healing. Under absolute stable fixation of closely adapted and compressed surfaces, the osteones of the lamellar bone cross directly through the fracture surface. No indication of pressure necrosis and consequent resorption of the compressed surfaces is seen. Transverse osteotomy, sheep tibia 2 weeks p.o. Perren *et al.* 1969.⁴⁸

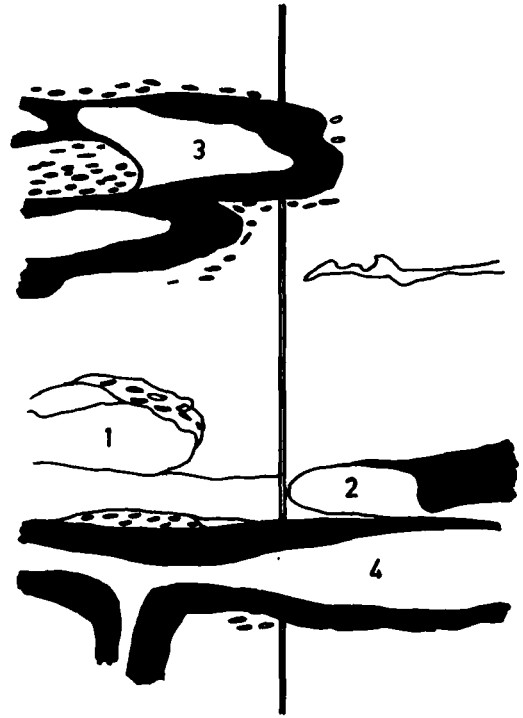

FIG. 10B. Primary healing: Contact healing. The schematic drawing visualizes the consecutive stages of Haversian remodeling (1-4). The Haversian canals cross the contact area under compression which is absolutely stable. New lamellar bone is directly deposited across the fracture surface. Note the three dimensional plugging of the osteons.

healing (Fig. 10). This consisted basically of direct bone formation without the classical multistage differentiation of connective tissue and cartilage; callus is minimal and surface resorption of the fragment ends is absent. The direct union of fragments in close contact and under compression is achieved through remodelling of the Haversian canals, and 7 cutting heads⁴⁴: drill a hole along the long axis of bone crossing the fracture. Behind the cutterheads which contain osteoclasts a conical surface of osteoblasts produces new osteons with incorporated new living osteocytes. These osteocytes are connected among themselves and to the vascular supply in the Haversian canal by a network of canaliculi. This ingenious inter-

nal change of a supporting structure while maintaining external mechanical strength is common to all types of fracture healing. Haversian remodelling is necessary in all fracture healing to achieve restoration of the original integrity and it is the only step in fracture healing under absolute stability. Although primary bone healing foregoes the intermediate stages of tissue differentiation it is not faster healing than secondary healing (enchondral ossification). Per unit of material primary bone healing is more efficient than callus. It thus compensates for its less efficient positioning in relation to external callus (area moment of inertia), by being a more mature and more resistant lamellar bone and by being well anchored in

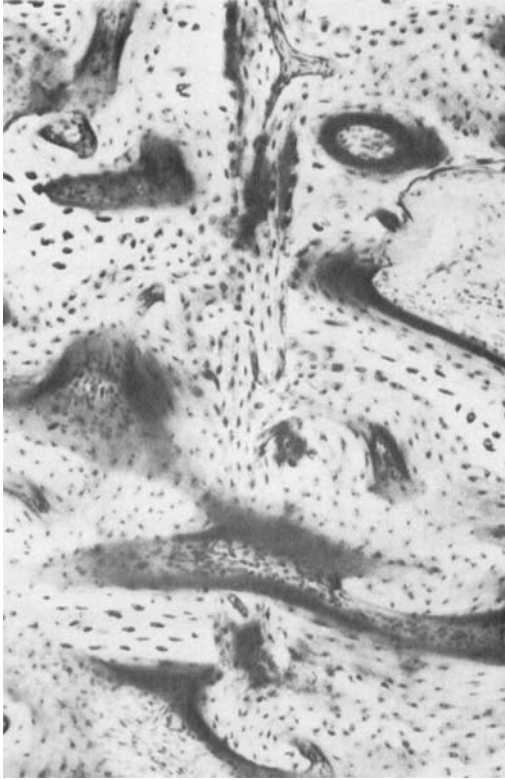

FIG. 11A. Primary healing: Gap healing. Alternating with contact areas in fracture gap areas are seen. Such gap areas profit from the support of neighboring contact areas and therefore in spite of a narrow gap width, low strain is present. This permits direct bone formation which takes place in the form of lamellar bone oriented perpendicularly to the long axis of bone.

both bone fragments through 3 dimensional interlocked contact.

GAP HEALING

A special type of fracture healing is the so called gap healing (Fig. 11). In closely adapted and compressed fracture surfaces not all parts of the surface are in contact. Between the areas of contact exist areas where gaps are found. Small gaps—high strain? There is low strain in these gaps as they profit from nearby contact areas supporting and stabilizing the fragment contact. The histological picture seen in gaps up to some 100 μm wide is the one of di-

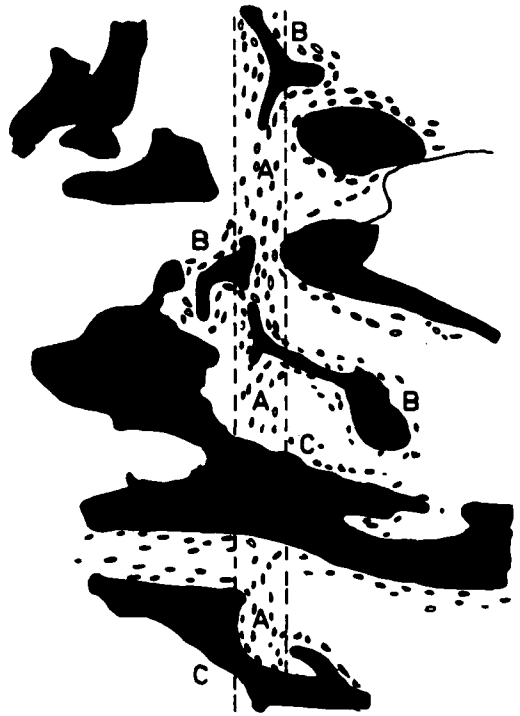

FIG. 11B. Primary healing: Gap healing. The bone (A) in the gap is of lamellar structure but its orientation is perpendicular to the long axis of bone. Plugs (B) extend from the inter-fragmentary lamellar bone (A) into the fragment ends. Two osteons (C) are seen which cross the gap area from fragment end to the fragment end.

rect formation of lamellar bone, a mature bone, although deposited at right angle to its normal direction within the cortex. Final healing is therefore achieved in a 2 stage procedure; first formation of lamellar bone in the gap is seen and then this bone is remodeled along the axis of bone through Haversian remodeling starting from the gap into the fragment and from the fragments into the gap. It would seem that this early and complete filling of the fracture surface is advantageous. Kinzl *et al.*³² have shown that the strength of the gap areas is low per unit of contact surface compared with contact healing with crossing osteons. This is mainly due to the weak anchorage of bone

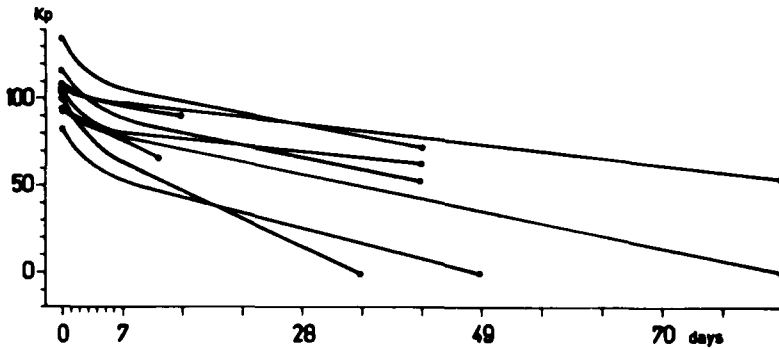

FIG 13B. Behavior of compression in stable internal fixation of cortical bone. Compression (ordinate) as function of time (Abscissa). Despite slowly decreasing, compression remains active until far beyond the time of primary bone union.

know that in internal fixation the slightest resorption could abolish all compression because of the rigidity of bone and metal. It seemed therefore of interest to study the changes of compression applied to living bone in internal fixation and to find out what condition might induce bone to resorb at contacting surfaces.

To help answer our question is to again point out the differences between static (minimal change with short-term observation) and dynamic (frequently changing magnitude and direction) compression. Dynamic compression can be compared to the functional loading of a bone during gait which varies periodically. Static forces represent a stabilizing principle while dynamic forces tend to produce instability, deformation and motion.

THE CHANGES OF COMPRESSION *IN VIVO*

To measure *in vivo* the magnitude and possible changes of static compression applied to living cortical bone, internal fixation plates were instrumented using strain gauges. With a wire connection it was possible to measure for 12 weeks following surgery the rate of compression applied to a transverse osteotomy in the sheep tibia (Fig. 13A).⁴⁸ As the measuring device did not interfere with healing, (it was contained within the compression plate and not inserted between the fracture surfaces) the changes of compression during healing could be determined.⁵¹ It was found that

compression applied to a transverse osteotomy was maintained over a 72 day period of measurement (Fig. 13B). Histology revealed that during this time the surfaces remained in contact and under pressure had united with lamellar bone by Haversian remodelling. The applied compression decreased only slowly and the surfaces under compression did not show any fragment end shortening due to resorption.

Similar experiments were performed in the sheep using instrumented washers to measure changes in axial force exerted by screws. The compression applied up to 200 kp decreased very slowly just as the compression exerted by the plate had done.⁶ These measurements indicated that static compression *per se* even if it generates high stress does not induce bone surface resorption at the compressed interfaces of bone-to-bone and metal-to-bone contact. It may be noteworthy that since 1963 when we started this kind of testing, we have not found one single case of pressure necrosis under stable conditions in multiple such experiments.

How about too much compression? We will have to distinguish between conditions of gross overload which lead to breakdown of the overall integrity of bone on one hand and local overload leading to only local breakdown with maintained overall structural integrity and stability at the fracture surface. The effect of gross overload has been demonstrated by Gallinaro *et al.*²¹ and Rahn *et al.*⁵⁹ who have shown that local

breakdown due to overload at points of contact will not necessarily be followed by resorption. The Haversian remodeling even crosses the areas of local overload without appreciable changes in the remodeling pattern. Does this observation indicate that bone is much more sensitive to mechanical conditions of deformation and relative motion than to failure with maintained stability? More work will have to be performed to find out how much information is gained from a stable fixed fracture to induce healing processes.

The measurements of compression have been undertaken to find out about pressure necrosis and to find the value for optimal compression. We would show conclusively that there is no pressure necrosis under stable fixation with even high amounts of static load. In respect to optimal compression we could find biological limits within the overall limits of maintained stability up to gross overload of bone. There seems to be a contradiction between our findings and those of Friedenbergs and French.¹⁸ The different findings can be explained by the fact that in an experimental model using spring loading of transverse osteotomies of the

ulna, the stability of fixation depends almost entirely on the amount of compression. There was no reported surface resorption of contacting surfaces in groups of higher compression; the term pressure necrosis as far as we can see, applied to the absence of secondary bone reaction. Our findings are in line with the early measurements of Wickstrom⁷³ and with the measurements of Hutzschenreuter³⁰ *et al.* in segmental replacements of cortical bone.

BONE RESORPTION AND INTERFRAGMENTARY INSTABILITY

Not finding the classical picture of pressure necrosis⁶⁴ led us to study the reaction of osteoclasts at a surface under intermittent contact. Intermittent contact (instability) is present when 2 forces, a static and a dynamic one, of appropriate magnitude are superimposed and act against each other. Let us assume that we preload with only a small amount of compression a contacting surface, *i.e.* a bone screw perpendicular to its long axis. If now a dynamic force of opposite direction is added, the contact surfaces will

FIG. 14A. Mechanical induction of bone resorption in contact surfaces. Continuous unilateral contact pressure which does not permit relative motion does not lead to bone resorption. Here bone is in direct contact with the metal of the screw.

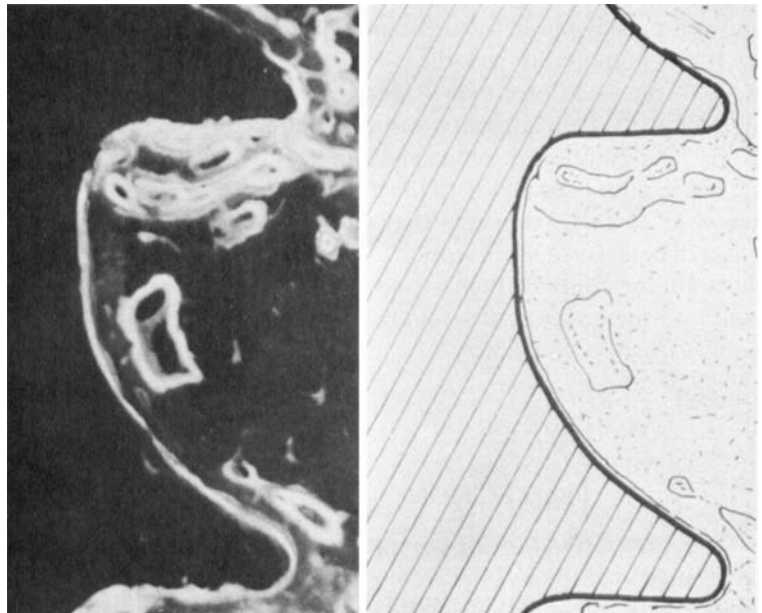

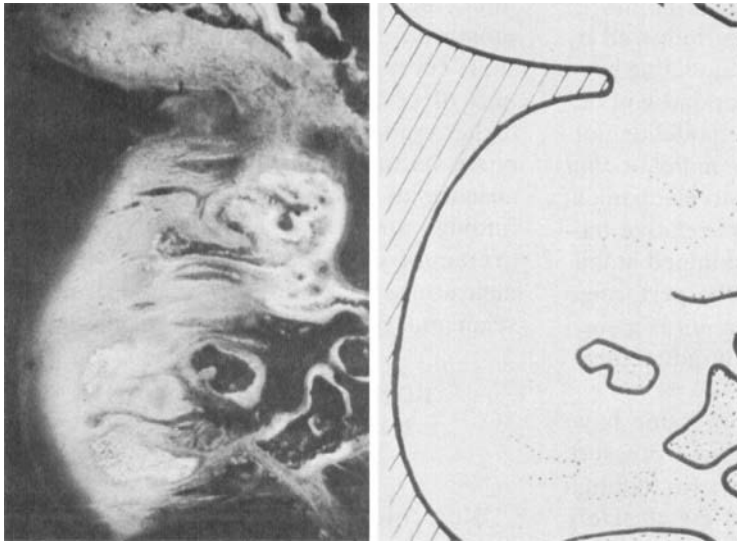

FIG. 14B. Contact pressure changing in magnitude *and* direction produces relative motion in the micro environment. Massive bone resorption and replacement of the resorbed bone by strain insensitive fibrous and cartilagenous tissue is seen.

separate whenever the dynamic force tends to pull the contact surfaces apart. This is when the dynamic force becomes larger than the static preload. Experimentally, this was achieved using an instrumented plate bridging a bone segment under weight bearing conditions.²² The control experiment consisted of screws under the same amount of dynamic, but higher static compression. The latter condition did not allow motion. The screws with initial micromotion (instability) showed massive bone resorption and filling in of the completely resorbed bone thread with fibrous and fibrous cartilagenous tissue (Fig. 14A). At the contacting surface where a large preload did prevent motion, bone stayed in direct contact with the metal of the screw (Fig. 14B). It seems that overall the onset of bone surface resorption in areas with intermittent contact (high strain areas) fits well into the concept of strain reduction by bone surface resorption.

THE EFFECT OF COMPRESSION ON HAVERSIAN BONE REMODELING AND STRESS PROTECTION

The slow reduction of compression was attributed mainly to bone remodeling. Together with the observation of bone porosis immediately beneath the internal fixation

plate,⁷⁰ it seemed therefore of interest to correlate the rate of bone remodeling with known amounts of static force. The problem in this experiment was that using round hole plates with removable compression device would result in unexpected changes of compression achieved during the operation.¹⁹ Using an instrumented, self compressing DCP, Matter *et al.*³⁵ evaluated the rate of remodeling with polychrome sequential labeling⁵⁵ at 4, 7 and 9 weeks after plating of an intact sheep tibia. They found that the rate of remodeling of the Haversian system could be observed at 4 weeks, peaked at 7 weeks but did not show an influence of static preload under conditions which were similar in respect to dynamic unloading of bone. Recently, Gunst²⁷ tried a correlation between vascular changes of cortical bone beneath the internal fixation plate and the pattern of remodeling. He showed extensive avascular areas which would mostly recover within 4 weeks but no direct correlation between avascularity and remodeling (porosis) was possible. The term stress protection remodeling indicates that one tries to explain the unloading of bone due to a rigid implant according to Wolff's law to produce bone porosis. Until now we could find no direct correlation in the sense of Wolff's law. The porosis seen is more probably a temporary

porosis due to the remodeling process which passes through a stage of porosis (Fig. 15). The short-term changes as those described by Uthoff,⁷⁰ Coutts,¹¹ Matter³⁵ and Kinzl³² do not fit with a concept of explaining bone porosis beneath the internal fixation plate as adaptation to unloading. The porosis is of special importance after plating with 2 plates.³²

FRACTURE HEALING IN INTERNAL FIXATION AFTER INFECTION

A study performed on the sheep tibia with different types of internal fixation

plates, including instrumented plates, has been published in great detail.⁶³ It could be shown that bone union can be achieved in the presence of a maintained infection with *staphylococcus aureus*. In 18 out of 19 internal fixations of a transverse tibia osteotomy in the sheep with persistent infection, bony bridging of the osteotomy could be demonstrated. In the group with 2 instrumented compression plates some of the infected cases healed without sequestration of the fragment ends. Further experimentation will have to show what the exact conditions are for preventing sequestration. The importance of avoiding sequestration is

FIG. 15. Bone porosis beneath the internal fixation plate. Stress protection porosis? (left insert) In a defined area beneath the plate porosis of bone is seen at 10 weeks after plating an intact bone. (right insert) The Structure of the Unchanged Bone. Temporary bone porosis is a regular finding after two-three months in a plated intact or fractured bone. Although its significance is still debatable, two explanations have been offered for its occurrence: 1) The mechanical unloading (stress Protection) is inducing the porosis or 2) other factors as *i.e.* changes in vascularity or a combination thereof produce the porosis which accompanies internal remodeling of bone.

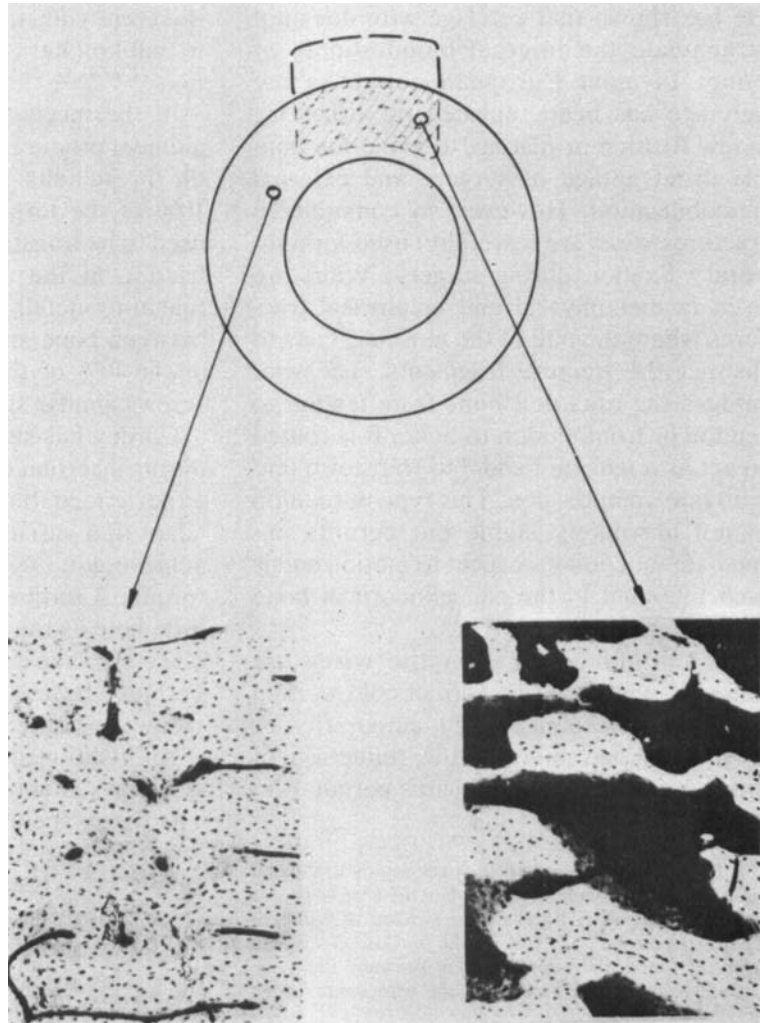

evident: as long as a sequestrum is present, the patient will periodically need medical attention.

SPECIAL CHARACTERISTICS OF SOME IMPLANTS

The wire was used some 30 years ago extensively as cerclage wire *i.e.* as a wire loop holding the fragments especially of spiral fractures together. An additional plaster cast was regularly necessary due to the limited strength and stability of this fixation.* Free immediate joint motion was not achieved.

Rhineland⁶¹ advocates the use of cerclage wire as minimal osteosynthesis. He has shown that cerclage wire does not strangulate the internal blood supply of bone. In most European countries the cerclage has been replaced by either lag screw fixation or plating, to avoid the double disadvantage of surgery and external immobilization. However, in comminuted fractures wires are (carefully) used for temporary fixation during surgery. Wires are used in metaphyseal and epiphyseal fractures where the pull of the muscles tends to distract the fracture fragments. The wire bridges the fractured bone from tendon to tendon or from tendon to bone. It is routed to act as a tension band⁴² to transform tension into compression. This type of fixation is not absolutely stable but permits immediate function in respect to motion and is well tolerated in the cancellocortical bone of the bone ends.

In another application the wires are called K-wires. Here a wire of cold worked steel acts as a splint to hold temporarily, or less often permanently the reduction of small fragments. Parallel wires permit, *e.g.*

the fracture to be compressed by a tension band whereas crossed wires counter compression and distraction.

SCREWS

A screw can be used to fix a plate to bone. Here the axial force produced by the screw gives rise to friction between the plate undersurface and bone and keeps the plate in stable contact with bone. Von Arx⁷¹ has determined that an average surgeon would apply 30–60 kp-cm of torque to a screw (ISO HA 4.5). This will produce about 200–350 kp of axial force in each screw. Per screw, a frictional force of *i.e.* 300×0.4 is produced. A 6-hole plate will therefore withstand a tangential force of up to 360 kp ($300 \times 0.4 \times 3$) without dislocation.^{14, 30, 43, 65, 66, 69}

In the mechanics of a screw, torsional moment produces translation of the slope of the thread helix. In a plate screw only about 10% of the torque applied to the head is used to be transformed into axial force. The friction at the undersurface of the head (metal-to-metal) uses 50% and the friction between bone and metal at the thread uses about 40% of the applied torque. For lag screws similar statements hold true.⁹

Cordey has studied the control of torque during insertion of the screw. He found that experienced bone surgeons are able to adapt to a variety of bone strengths and to achieve quite regularly 70–80% of possible torque. A torque limiting screw driver is of little help as the bone quality changes from place to place and from patient to patient. Perhaps the use of densitometry on X-ray picture^{36, 59} may be of help.

As mentioned earlier the holding power of screws is about 40 kp/mm of thickness. The figure according to Gotzen^{25, 26} will be lower for the forearm and humerus. Cancellous bone is much weaker and we expect 0.4 kp/mm² of surface. Screws for cancellous bone therefore must have a wide and deep thread which goes together with a comparably high pitch.⁷²

* The loosening of cerclage wires seems to depend on a mechanical phenomenon: when the wire twister is released and especially when the twisted wire is bent flat to rest on the bone surface the tension on the wire drops.³⁴ Once microinstability is present, the bone surface resorption in the bed of the wire seems to aggravate the situation.

With respect to positioning of lag screws: a screw should in general be positioned in a direction to produce together with the superimposed functional load, a normal force on the fracture surface. The position of lag screws in combination with compression plates has been studied by Gotzen.²⁶

INTERNAL FIXATION PLATES

To understand the mode of action of internal fixation plates one can think of the plate as being a very thick wire. The plate is therefore strong in tension but comparably weak and deformable in bending and torque. A plate is furthermore, an asymmetric appliance: the material properties of a plate are by far not used most efficiently from a technical point of view. Compression by internal fixation plate alone is therefore asymmetric as Askew, *et al.* have shown.² It would be a misunderstanding of the clinical reality to look at asymmetric compression of the plate alone. For many years the Swiss study group has advocated the use of compression plates either as tension band plates, together with lag screws or if no other possibility exists, the disadvantage of the asymmetric compression can be compensated for by prebending of the plate as Bagby⁵⁷ has proposed. The prebending has been proved to be an efficient tool *in vitro*^{24, 25, 37, 43, 47} but *in vivo* requires skilled application.

The plate is not only deformable in bending and torque, but is as well weak in fatigue, particularly if the surgeon does not use the load bearing capacity of bone. A plate bridging an open gap without bone formation, *i.e.* when medial support in a femur fracture is lacking, will run the risk of fatigue and breakage. Stronger plates would be too stiff and not desirable because of possible stress protection. The solution to this problem clearly is to use a reasonably small amount of metal but with the best technique of application available including compression and making use of the load bearing capacity of bone.

If a bone fixation is slightly unstable bone resorption will start at the fracture surfaces. The plate will not allow the fragment ends to sinter together especially when circularly fitting plate holes are used.⁵⁰ This condition has been used regularly to produce nonunion in animal experiments by J. Muller.³⁹ In this context it must be understood that callus after a so-called stable internal fixation with plate and screw is undesirable, as it indicates some condition of unwanted instability.

Callus *per se* is not undesirable at all because it helps in many instances, but its appearance with screws and plates is related to dangerous conditions of instability and infection.

INTRAMEDULLARY NAIL

Several different techniques of intramedullary fixation and different types of rods are used. Common to all techniques is the reaming of the medullary cavity and the fitting of a nail which is deformable in respect to bending and torque but also in respect to compression of the diameter. One must nevertheless keep in mind that the rotational stability provided by the nail itself and especially its connection to the inner surface of bone is restricted. Rotational stability in intermedullary nailing relies mostly on interdigitation of the fracture surfaces.

The medullary nail acts as a splint: it reduces motion but does not abolish it completely. We therefore expect and see callus formation and some minor shortening at the fragment ends. Due to the property of the medullary nail as a gliding internal splint, the fragments can sinter together under functional load and therefore resorption here is not deleterious.

While rigidity of the medullary nail is often low, its strength is nevertheless great enough to tolerate early weight-bearing and late healing, if ever this should occur.

SUMMARY

Fracture healing is a repair process of a mechanical discontinuity loss of force

transmission, and pathological mobility of bone. Through a sequence of changes of tissue development and geometry, the original structural integrity is restored. The recovery of rigidity and strength is related to tissue differentiation. In unified theory of non-operative and operative stabilized fractures, the mechanics of primary bone healing involves a complex interplay of physical and biological factors. The different patterns of bone repair respond to physical influences including strain tolerance.

ACKNOWLEDGMENT

The work in the Laboratory for Experimental Surgery at the Swiss Research Institute in Davos, Switzerland, had been supported for the past 20 years through royalties of implant manufacturers to the Swiss Study Group for Internal Fixation, "(Arbeitsgemeinschaft für Osteoynthese Fragen AO.)" The biophysical basic work is supported by grants of the Swiss National Foundation for Scientific Research, Credit: 3.526.075.

REFERENCES

- Allgöwer, M., Ehrsahm, R., Ganz, R., Matter, P. and Perren, S. M.: Clinical experience with a new compression plate "DCP," Acta. Clin. Orthop. Scand. Suppl. 125:45, 1969.
- Askew, M. J., van Mow, C., Wirth, C. R. and Campbell, C. J.: Analysis of the intraosseous stress field due to compression plating, J. Biomech. 8:203, 1975.
- Bagby, G. W. and James, J. M.: An impacting bone plate. Staff meeting at the Mayo Clinic 32:55, 1957.
- Bertolin, A.: L'impiego della mia placca a compressione, La Clinica Orthop. 18:221, 1966.
- Block, W.: Die Normale und Gestörte Knochenbruchheilung, Ferdinand Enke Verlag, 1940.
- Blümlein, H., Cordey, J., Schneider, U. A., Rahn, B. A. and Perren, S. M.: Langzeitmessungen der axialkraft von knochenschrauben in vivo, Z. Orthop. 115:603, 1977, Stuttgart, F. Enke Verlag.
- Böhler, L.: Die Technik der Knochenbruchbehandlung, Wein, Maudrich, 1953.
- Claes, L., and Huntzscheneuter, P.: Dash durchdrehmoment an zugschrauben mit vorgeschnittem kortikalissgewinde (mechanik und histologie), Z. Orthop. 113:237, 1975.
- Cordey, J., Widmer, W., Rohner, A. and Perren, S. M.: Dosierung des drehmoments beim einsetzen von knochenschrauben. Experimentelle studie an kortikalisschrauben mit hilfe elektronischen drehmomentschraubenziehers, Z. Orthop. 115:601, 1977, Stuttgart, F. Enke Verlag.
- Coutelier, L.: Recherches sur la guerison des fractures, Edition Arscia S. A., 1969.
- Coutts, R. D., Harris, W. H. and Weinberg, E. H.: Compression plating: experimental study of the effect on bone formation rates, Acta. Orthop. Scand. 44:256, 1973.
- Danis, R.: Theorie et pratique de l'osteosynthese, Masson & Cie, 1949.
- Denham, R. A.: Compression and coaptation, J. Bone Joint Surg. 57B:177, 1969.
- Diehl, K., Hanser, U., Hort, W. and Mittelmeier, H.: Biomechanische untersuchungen über die maximalen vorspannkkräfte der knochenschrauben in verschiedenen knochenabschnitten (biomechanic researches of maximum initial tension forces of bone screws on various bone sections, Arch. Orthop. Unfall-Chir. 80:89, 1974.
- Enzler, M.: personal communication.
- Enzler, M. and Perren, S. M.: The coefficient of plate-bone friction *in vitro*: the effect of duration and amount of load, In Asmussen and Jørgensen (eds.) Biomechanics V, Baltimore, University Park Press, 1978.
- Evans, G. F.: Stress and Strain in Bones, Springfield, Charles C Thomas, 1957.
- Friedenberg, Z. B. and French, C.: The effect of known compression forces on fracture healing, Surg. Gynecol. and Obstet. 94:743, 1952.
- Galeazzi, J.: Experimentelle Untersuchungen zur intraoperativen Druckveränderung bei der Plattenosteosynthese, Med. Diss., Bern, 1972.
- Galgoczy, E., Cordey, J., Blümlein, H., Schneider, U. and Perren, S. M.: Der reibungskoeffizient metall-knochen bei der plattenosteosynthese im tierexperiment, Z. Orthop. 115:601, 1977.
- Gallinaro, P., Perren, S. M., Crova, M. and Rahn, B. A.: La osteosintesi con placca a compressione estratto da: moderni orientamenti nelle osteosintesi delle fratture diafisarie, Bologna, F. Roasenda, G. L. Lorenzi, Relaz LIV Congresso Aulo Gaggi, 1969.
- Ganz, R., Rüter, A. and Perren, S. M.: Mechanisch induzierte knochenresorption, In Schuchardt, K. (ed.) Fortschr. Kiefer- und Gesichtschirurgie, 19:45, 1975.
- Geiser, M.: Beiträge zur Biologie der Knochenheilung, Verlag, Ferdinand Enke, 1963.
- Gorzen, L.: Untersuchungen zur Neutralisationsplattenosteosynthese, Habilitation, Hannover, Med. Hochschule, 1978.
- Gotzen, L.: Personal communication.
- Gotzen, L., Muhr, G., Anna, O.: Biomechanische untersuchungen zur vorbiegung von AO-Osteosyntheseplatten, Hefte z. Unfallheilkunde 126:387, 1976.
- Gunst, M.: Die blutversorgung der kortikalis nach verplattung der intakten kaniscentibia, Med. Diss. Basel, 1977.
- Hayes, W. C. and Perren, W. M.: Plate-bone friction in the compression fixation of fractures, Clin. Orthop. 89:236, 1972.
- Hughes, A. N. and Jordan, B. A.: Some mechani-