



itgstore

Let us optimize you!



YOUR PARTNER
in the digitalization process.



Zebra® QLn420™

Maintenance Manual



Proprietary Statement

This manual contains proprietary information of Zebra Technologies Corporation. It is intended solely for the information and use of parties operating and maintaining the equipment described herein. Such proprietary information may not be used, reproduced, or disclosed to any other parties for any other purpose without the expressed written permission of Zebra Technologies Corporation.

Product Improvements

Since continuous product improvement is a policy of Zebra Technologies Corporation, all specifications and signs are subject to change without notice.

FCC Compliance Statement

Class B digital devices. Tested to comply with FCC standards for home or office use.

WARNING: Exposure to Radio Frequency radiation. To conform to FCC RF exposure requirements these devices shall be used in accordance with the operating conditions and instructions listed in this manual. Note that there are several radio options available with these printers. Refer to the Users Guide for more complete regulatory information.

NOTE: These units were tested with shielded cables on the peripheral devices. Shielded cables must be used with the units to insure compliance.

Changes or modifications to this unit not expressly approved by Zebra Technologies Corporation could void the user's authority to operate this equipment.

Canadian Compliance Statement

These Class B digital apparatus comply with Canadian ICES-003.

Cet appareil numérique de la classe B est conforme à la norme NMB-003 du Canada.

"IC:" before the equipment certification number signifies that the Industry Canada technical specifications were met. It does not guarantee that the certified product will operate to the user's satisfaction.

Agency Approvals and Regulatory Information

- Design certified by TUV
- Canadian STD RSS-210
- EN60950: 2006 Safety Standard
- C-Tick (Australia)
- IP54 Certified
- FCC part 15 Class B
- EN55024:2003 European Immunity Standard
- NOM (Mexico)
- EN55022:2006 Class B European Electromagnetic Radiation Standard

Liability Disclaimer

Inasmuch as every effort has been made to supply accurate information in this manual, Zebra Technologies Corporation is not liable for any erroneous information or omissions. Zebra Technologies Corporation reserves the right to correct any such errors and disclaims liability resulting therefrom.

No Liability for Consequential Damage

In no event shall Zebra Technologies Corporation or anyone else involved in the creation, production, or delivery of the accompanying product (including hardware and software) be liable for any damages whatsoever (including, without limitation, damages for loss of business profits, business interruption, loss of business information, or other pecuniary loss) arising out of the use of or the results of use of or inability to use such product, even if Zebra Technologies Corporation has been advised of the possibility of such damages. Because some states do not allow the exclusion of liability for consequential or incidental damages, the above limitation may not apply to you.

Copyrights

The copyrights in this manual and the label print engine described therein are owned by Zebra Technologies Corporation. Unauthorized reproduction of this manual or the software in the label print engine may result in imprisonment of up to one year and fines of up to \$10,000 (17 U.S.C.506). Copyright violators may be subject to civil liability.

This product may contain ZPL®, ZPL II®, and ZebraLink™ programs; Element Energy Equalizer® Circuit; E3®; and AGFA fonts. Software © ZIH Corp. All rights reserved worldwide.

ZebraLink and all product names and numbers are trademarks, and Zebra, the Zebra logo, ZPL, ZPL II, Element Energy Equalizer Circuit, and E3 Circuit are registered trademarks of ZIH Corp. All rights reserved worldwide.

Monotype®, Intellifont® and UFST® are trademarks of Monotype Imaging, Inc. registered in the United States Patent and Trademark Office and may be registered in certain jurisdictions.

Andy™, CG Palacio™, CG Century Schoolbook™, CG Triumvirate™, CG Times™, Monotype Kai™, Monotype Mincho™ and Monotype Sung™ are trademarks of Monotype Imaging, Inc. and may be registered in some jurisdictions.

HY Gothic Hangul™ is a trademark of Hanyang Systems, Inc.

Angsana™ is a trademark of Unity Progress Company (UPC) Limited.

Andale®, Arial®, Book Antiqua®, Corsiva®, Gill Sans®, Sorts® and Times New Roman® are trademarks of The Monotype Corporation registered in the United States Patent and Trademark Office and may be registered in certain jurisdictions.

Century Gothic™, Bookman Old Style™ and Century Schoolbook™ are trademarks of The Monotype Corporation and may be registered in certain jurisdictions.

HGPGothicB is a trademark of the Ricoh company, Ltd. and may be registered in some jurisdictions.

Unifers™ is a trademark of Heidelberger Druckmaschinen AG, which may be registered in certain jurisdictions, exclusively licensed through Linotype Library GmbH, a wholly owned subsidiary of Heidelberger Druckmaschinen AG.

Futura® is a trademark of Bauer Types SA registered in the United States Patent and Trademark Office and may be registered in some jurisdictions.

TrueType® is a trademark of Apple Computer, Inc. registered in the United States Patent and Trademark Office and may be registered in certain jurisdictions.

All other brand names, product names, or trademarks belong to their respective holders.

©2013 ZIH Corp.

Contents

Proprietary Statement	ii
Section 1: QLn420 Introduction	1-5
Printing Technology	1-6
Direct Thermal.....	1-6
Diagnostic Tools	1-8
Configuration Label Printout.....	1-8
Zebra Setup Utilities.....	1-8
Unit Test and Calibration Software	1-8
Factory Technical Support.....	1-8
Printing a Diagnostic Label.....	1-9
Creating a Configuration Label.....	1-9
Sample Configuration Label	1-9
Introduction to	
Equipment Required For Zebra Setup Utilities	1-12
Starting Zebra Setup Utilities	1-12
QLn420 Series Unit Test & Calibration	1-13
Equipment Required	1-13
Running The Software	1-13
Section 2: Replacement Procedures.....	2-14
Tools and Supplies	2-14
ASSEMBLY/DISASSEMBLY OF QLn420.....	2-15
Repair Kit P1050667-004- Media Cover Lined	2-17
Accessory Kit P1050667-008 Platen Lined & -006 Platen Linerless	2-20
Replacement Kit P1050667-005 Motor Assembly	2-24
Repair Kit P1050667-001 Printhead Assembly	2-26
Repair Kits P1031365-002 Main Logic Board (MLB) & .P1050667-013/014	
Dock Board	2-32
Repair Kit P1050667-012 802.11N/BT3.0 Radio.....	2-35
Repair Kit P1050667-003 Media Guide Assembly	2-36
Repair Kit P1031365-009 LCD Assembly	2-38
Repair Kit P1050667-002 Keypad Assembly	2-40

Section 3: QLn420 Series Configurator and Repair Kits.....	3-41
Using The Product Configuration Code.....	3-41
Component Replacement Procedures.....	3-41
Factory Repair And Parts Ordering Procedure.....	3-42
Repair Services Contact Information.....	3-42
QLn Series Product Configuration Code (PCC).....	3-43
QLn420 Replacement Kits.....	3-44
QLn420 Accessory Kits.....	3-45
QLn420 Replacement Kits-Exploded View.....	3-46

Section 1: QLn420 Introduction

Thank you for choosing our Zebra® QLn420™ Mobile Printer. You will find this rugged printer will become a productive and efficient addition to your workplace thanks to its innovative design. Zebra Technologies is the leader in industrial printers with world-class support for all of your bar code printers, software, and supplies.

This repair manual gives you the information you will need to repair the QLn420 printer. The QLn420 printer uses CPCL and ZPL programming languages. To create and print labels using the CPCL and ZPL languages, refer to the Mobile Printing Systems CPCL Programming Manual and ZPL Programming Guide (available at www.zebra.com/manuals)

QLn Series Software Utilities:

- Zebra Net Bridge™ : printer configuration, fleet management
- Zebra Setup Utility: single printer configuration, quick setup
- Zebra Designer Pro: label design
- Zebra Designer Drivers: Windows® driver
- OPOS Driver: Windows driver
- Multiplatform SDK

(These utilities can be found at www.zebra.com and on the product CD.)

Unpacking and Inspection

Inspect the printer for possible shipping damage:

- Check all exterior surfaces for damage.
- Open the media cover (refer to “Loading the Media” in the Getting Ready to Print section) and inspect the media compartment for damage.

In case shipping is required, save the carton and all packing material.

Reporting Damage

If you discover shipping damage:

- Immediately notify and file a damage report with the shipping company. Zebra Technologies Corporation is not responsible for any damage incurred during shipment of the printer and will not cover the repair of this damage under its warranty policy.
- Keep the carton and all packing material for inspection.
- Notify your authorized Zebra re-seller.

Printing Technology

The QLn420 uses the Direct Thermal method to print human readable text, graphics and barcodes. It incorporates a sophisticated print engine for optimal printing under all operational conditions.

Direct Thermal

Direct thermal printing uses heat to cause a chemical reaction on specially treated media. This reaction creates a dark mark wherever a heated element on the printhead comes in contact with the media. Since the printing elements are arranged very densely at 203 d.p.i. (dots per inch) horizontal and 200 d.p.i. vertical, highly legible characters and graphic elements may be created a row at a time as the media is advanced past the printhead. This technology has the advantage of simplicity, as there is no requirement for consumable supplies such as ink or toner. However, since the media is sensitive to heat, it will gradually lose legibility over long periods of time, especially if exposed to environments with relatively high temperatures.

User Guide

Use of this manual presumes a familiarity with the QLn420 printer. Complete information regarding the operation, features and specifications of the QLn420 printer can be found in the QLn Series User Guide which can be found on-line at www.zebra.com/manuals.

1. Platen Roller
2. Bar Sensor
3. Media Support Disks
4. Tear Bar
5. Peeler Sensor
6. Peeler Button
7. Peeler Bail
8. Media Cover Button
9. Key Pad
10. Strap Post
11. Status Screen
12. Printhead
13. Media Cover
14. Gap Sensor
15. Belt Clip
16. Battery
17. DC Input
18. MAC Address Label
19. Docking Contacts
20. USB/ RS-232 Comm Ports

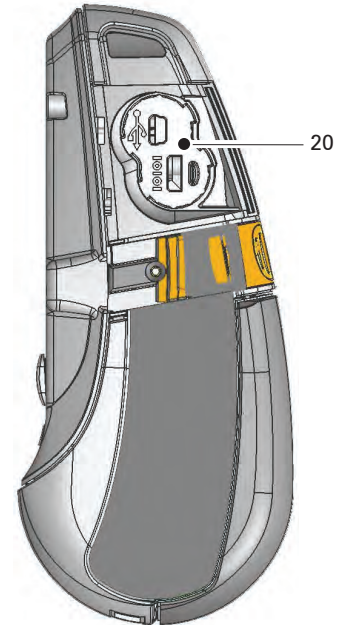
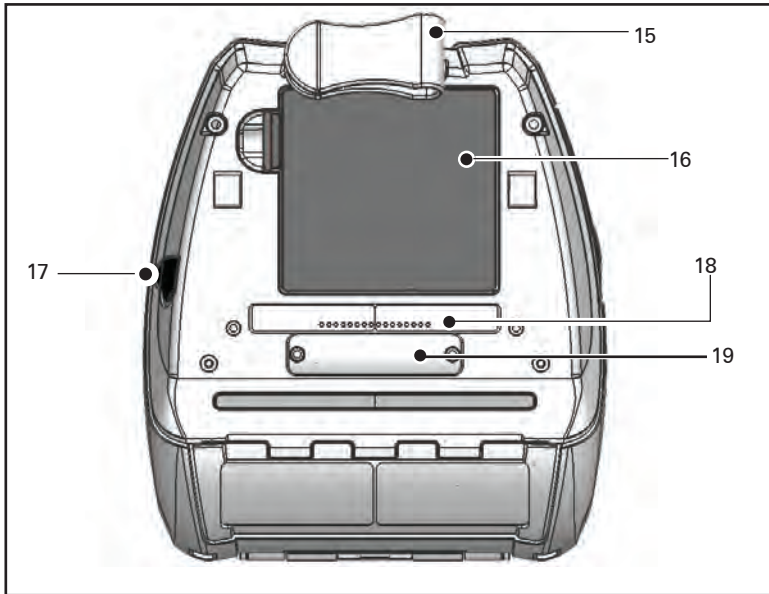
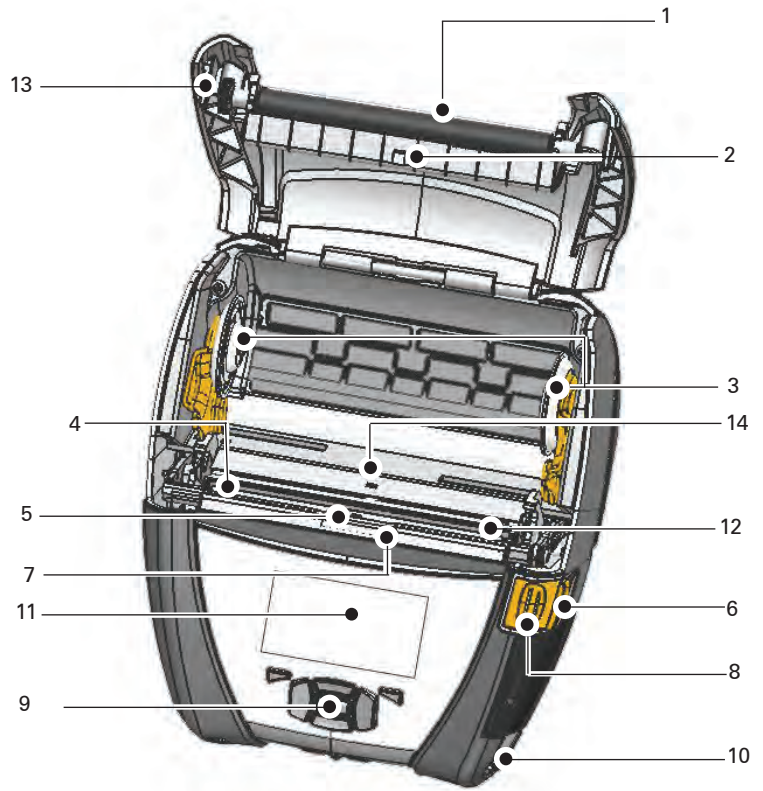

FIGURE 1 - QLN420 OVERVIEW

Diagnostic Tools

This section of the Printer Repair Manual contains instructions for using the various diagnostic tools available from Zebra and instructions on contacting technical support services offered by Zebra.

Following sections contains explanations on the products configuration structure, troubleshooting guide for isolating common printer problems, illustrated parts breakdowns for specific models and specialized component replacement procedures.

Configuration Label Printout

The printer can create a configuration label which exercises all of the printhead's thermal elements and create a detailed report of the printer's settings and any special files that may be loaded into memory.

This Diagnostic label can be used as an initial tool to diagnose such basic printer problems as missing printhead elements, missing or incorrect application files or incorrect settings.

Zebra Setup Utilities

Zebra Setup Utilities is a Windows™ based one-stop installation and setup software tool, which also offers diagnostic and utility routines. Setup Utilities also allows the user to easily configure network and/or Bluetooth connectivity settings, configure print quality, and download fonts and graphics.

Zebra Setup Utilities may be downloaded from: www.zebra.com.

Unit Test and Calibration Software

Zebra authorized service organizations have access to powerful test and calibration software which allows them to perform more advanced procedures. These procedures are identified by the following message:



The following procedure can only be performed by Zebra authorized service organizations using approved equipment and software.

If you do not have this approval, do not attempt to perform these procedures. If they are performed improperly or incompletely, the printer will not function properly.

Factory Technical Support

Refer to the "Factory Repair & Parts Ordering Procedure" topic in this Section for information on contacting technical support, ordering parts or returning your printer for repair.

Printing a Diagnostic Label

Creating a Configuration Label

1. Turn the printer off. Load the media compartment with journal media (media with no black bars printed on the back)
2. Press and hold the Feed Button.
3. Press and release the Power button and keep the Feed button pressed. When printing starts, release the Feed button.

The printer will generate a configuration label similar to the following examples:

Sample Configuration Label

Printhead Test

Zebra Technologies
QLn420
Serial Number: 

Identifies Printer as a QLn420

XXQVJ122800069
Name: Draw
Program:
OS: 6.4.1
PLD: 2 Rev. 3
Firmware: V68.18.7ZP18012
Checksum: 69EB

Unit Serial Number

Application Number

Cable Communications:
115200 BPS, null, 8, 1
Handshake: rts/cts
DSR: 0

Settings for RS232 and USB communications via cable

Universal Serial Bus:
2.0 Full Speed Device
Vendor ID No: 0x0A5F
Product ID No: 0x00E9
Manufacturer String: Zebra Technologies
Product String: ZTC QLn420-203
dpi CPCL
ID string: on

Report appears only on units with wireless options installed. Units with no wireless options will print an empty line and resume.

Wireless:
Radio: 802.11 a/b/g/n
Region: usa/canada
Country: usa/canada
Enabled: on
MAC Address: 00:00:00:00:00:00
IP Address: 0.0.0.0
Netmask: 255.255.255.0
Gateway: 0.0.0.0
Operating Mode: infrastructure
International Mode: off
Preamble Length: long
Security: none
Stored ESSID: TestLanOpen
Associated: no
DHCP: on
DHCP CID type: 1
DHCP CID: 000000000000
Power Save: on

This unit has a 802.11a/b/g/n radio option installed. This section details the radio's network settings.

Ethernet:
MAC Address: 00:07:40:44:2C:44
IP Address: 0.0.0.0
Netmask: 255.255.255.0
Gateway: 0.0.0.0
DHCP: on
DHCP CID type: 1
DHCP CID: 000740442C44

Information on TCP/IP and LAN addresses and settings.

FIGURE 2: CONFIGURATION LABEL EXAMPLE

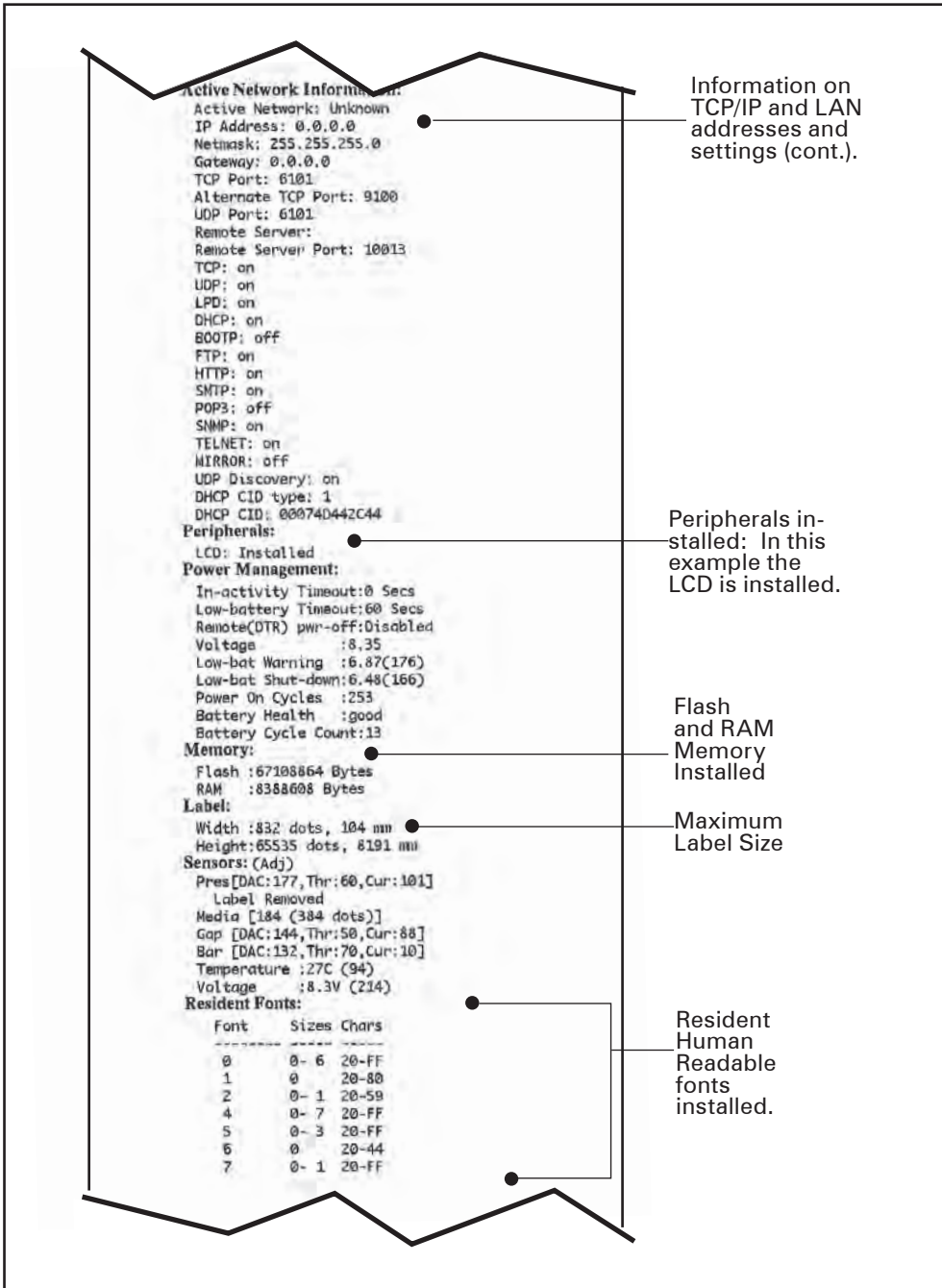

FIGURE 2A: CONFIGURATION LABEL EXAMPLE (CONTINUED)

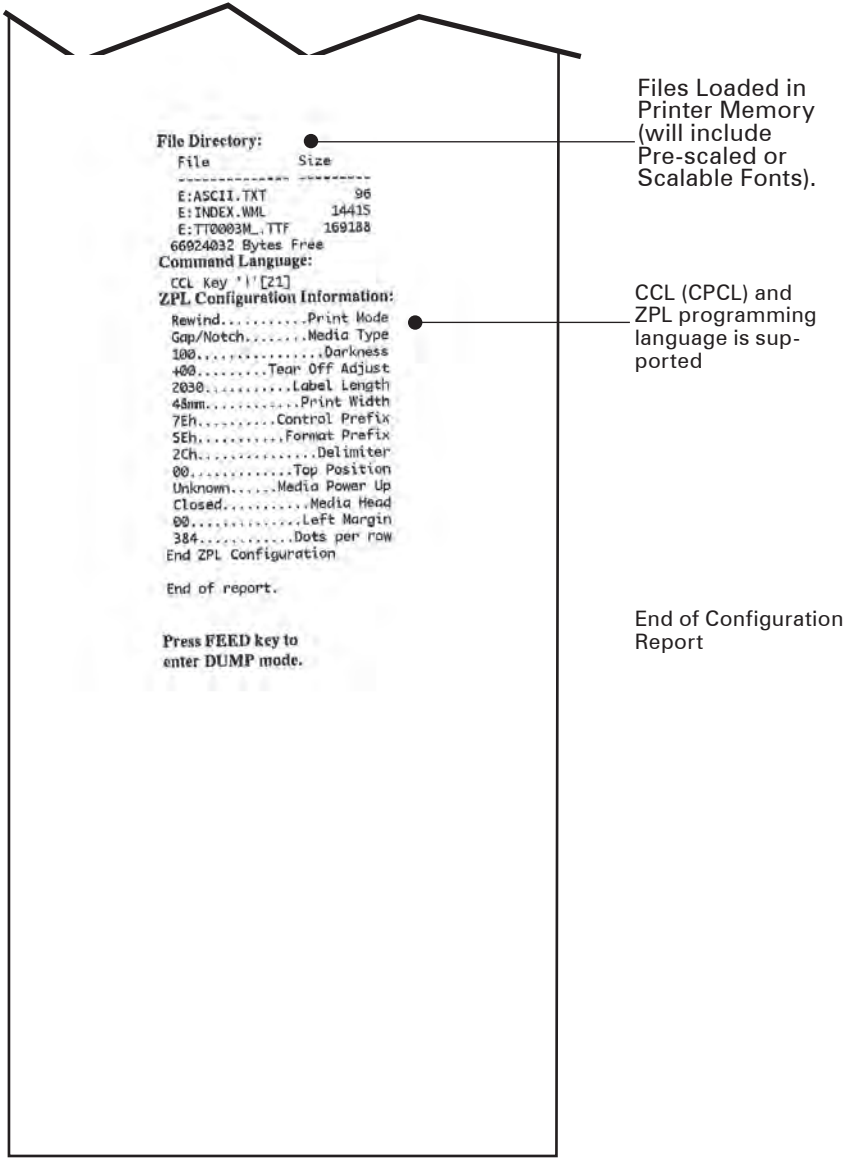

FIGURE 2B: CONFIGURATION LABEL EXAMPLE (CONTINUED)

Introduction to Zebra Setup Utilities

Zebra Setup Utilities is a Windows™ based one-stop installation and setup software tool, which also offers diagnostic and utility routines. Setup Utilities also allows the user to easily configure network and/or Bluetooth connectivity settings, configure print quality, and download fonts and graphics.

Equipment Required For Zebra Setup Utilities

1. A PC with the following minimum system requirements:
 - 32-bit or 64-bit version of the following:
 - Windows XP
 - Windows 2003
 - Windows 2008
 - Windows Vista
 - Windows 7
 - Windows 8
 - VGA monitor or better
 - Hard Drive with at least 25 MB free disk space
 - A Communication Port (serial, parallel, USB, or Ethernet)

Starting Zebra Setup Utilities

1. Plug the USB cable into a USB port on your PC
2. Plug the other end of the interface cable into the printer's USB port.
3. Start the Setup Utilities program by either clicking on the Setup Utilities shortcut on your desk top, or using the "Start" button.
4. Follow the System Prepare Wizard to identify a printer driver port and to access the Setup Utilities interface to use its many design, editing and diagnostic features.

QLn420 Series Unit Test & Calibration

Equipment Required

1. A computer with the following minimum configuration:
 - Pentium CPU
 - 256 MB RAM
 - 1 GB Hard Drive
 - CD-ROM drive
 - SVGA 14 in. monitor and SVGA card
 - 2 Serial Ports
 - USB Port
 - Windows XP
 - Unit Test Software version 3.3 or higher installed with the “euro” configuration.
2. A bar code scanner, using either RS232 (serial) keyboard “wedge” or USB communications. (Example: Symbol Model LS1908 series)
3. USB Interface Cable part number AT17010-1 or a Zebra approved equivalent.
4. Spare batteries, chargers and test media specific to the printer. Refer to the table in the “Tools and Supplies” topic in Section 2 of this manual.

Running The Software

CAUTION: DO NOT disconnect the communications cable at any time during the Unit Test procedure unless prompted to do so by the software!



IMPORTANT: Certain replacement procedures in this manual will require running the test procedure to verify a repair. It is recommended that you perform the entire unit test sequence for these procedures to ensure all printer functions are functional after the replacement.

To Start

- Launch the Unit Test Application.
- Plug the Serial Interface Cable into the printer’s communication port.
- Follow the on-screen instructions.

Section 2: Replacement Procedures

Tools and Supplies

Make use of the following tools and supplies for maintaining the printer and installing the repair kits:

Hand Tools

- Torque Driver (4.7 +/- 1 in. lb. & 2.5 +/- 1 in. lb.) #0 or #1 Phillips bit
- 3/32" hex driver

Supplies

- Isopropyl alcohol
- Media, Batteries, and Chargers for QLn420 printer per table below:

Mobile Printer Model #	Tag Media (for Life Test)	Gap Media (for Gap test)	Battery Replacement Kit	Chargers / Quad Charger
QLn420	LD-L4TM5B (1.25" x 3")	LD-R7MU5P (2" x 1") LD-R2AL5B (2" x 1.25") LD-R7AO5B (2" x 2") LD-R7AM5R (2" x 3")	P1050667-016	SC2, QLn420-EC, AC Power Adapter (P1031365-024), AC18177-5

Handling

The use of an ESD wrist strap at a properly grounded workstation is required when handling printed circuit boards or other sensitive electronic components. The ESD strap prevents any electrostatic damage to occur while assembling these components. The use of the ESD strap will be noted in the applicable instructions.



This symbol indicates that the operator must wear a properly grounded ESD strap to perform the repair procedure.

Storage

Replacement kits which are sensitive to ESD damage are supplied in static resistant packaging. Always keep these parts in their original packaging until they are to be installed.

ASSEMBLY/DISASSEMBLY OF QLn420



The operator must wear a properly grounded ESD strap to perform the following repair procedure.

Tools Required

- Torque Driver (4.7 +/- 1 in. lb.) #0 or #1 Phillips bit

Cautions



Caution • This installation must be performed only by a qualified service technician.

Unless otherwise specified:

- Always turn the printer off
- Remove the battery before installing any Replacement Kits.
- Remove media before installing this Replacement Kit

Disassembling the QLn420 Printer

1. Turn the printer off and remove the battery pack.
2. Press the latch release button and open the Media Cover. Remove any media from the printer.
3. To separate the Main Housing from the Lower Housing, use a torque driver to remove four (4) Phillips screws on the bottom of the printer (where shown).
4. Lift up on the front of the Lower Housing to separate it from the Upper Housing.

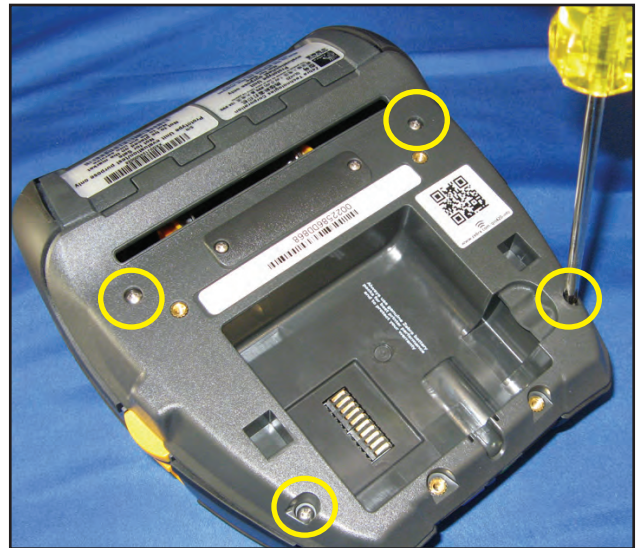

5. Slide the back end of the Lower Housing from the Main Housing (as shown).

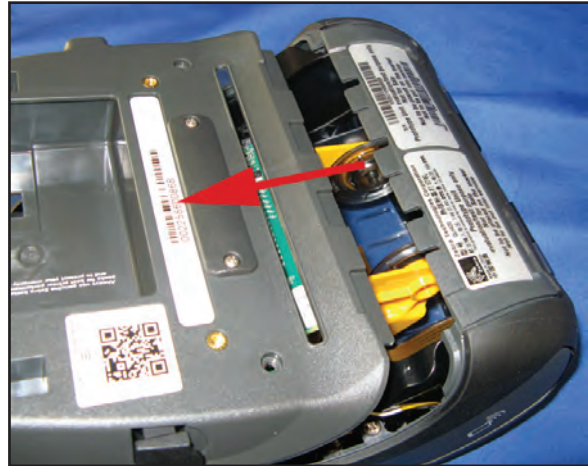

6. Use a torque driver to remove the (4) screws on the inside of the Main Housing (where shown).

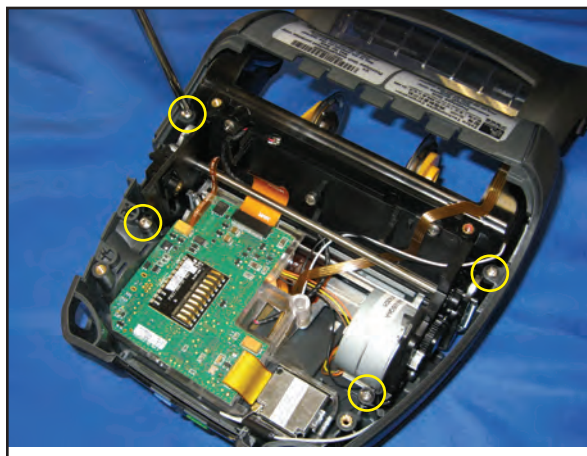

7. Remove the (2) screws located inside the media compartment (where shown).

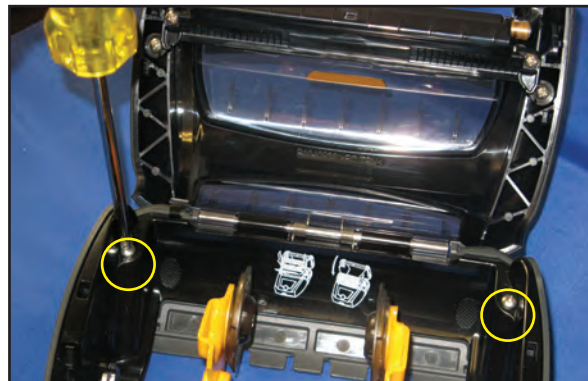

8. Disconnect the keyboard cable and antennae from top of Main Logic Board (MLB), and the LCD cable from the bottom of the MLB. Rotate the Main Housing away from the printer frame.



Repair Kit P1050667-004- Media Cover Lined

Installation Instructions

This kit includes the parts necessary to install the P1050667-004 Media Cover Kit Lined in the QLn420 model printer. Read these instructions thoroughly before attempting to install this kit.

Tools Required

- 3/32" Hex Driver
- Torque Driver (4.7 +/- 1 in. lb.) #0 or #1 Phillips bit

Removing the Media Cover

1. Remove the Main Housing from the Lower Housing as previously described.
2. Remove the Printer Frame from the Main Housing as described on Page 2-16.
3. Using a 3/32" hex driver, push the Hinge Pin out of the Printer Frame (as shown).
4. Remove the Torsion Spring from the mounting holes (circled) on the Media Guide Plate.
5. Disconnect the Black Bar Cable (J8) from the MLB, then route it through the frame to detach the Media Cover from the Media Guide Plate.

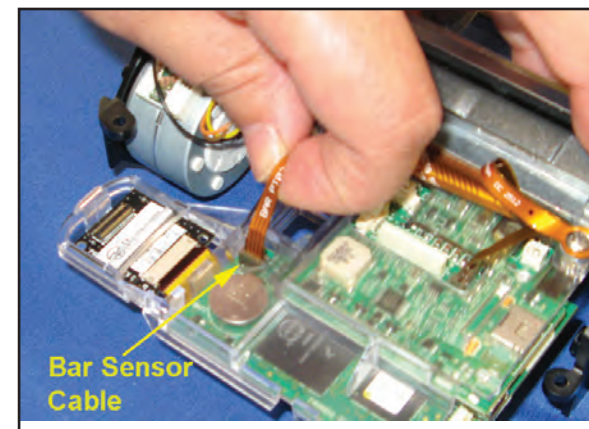
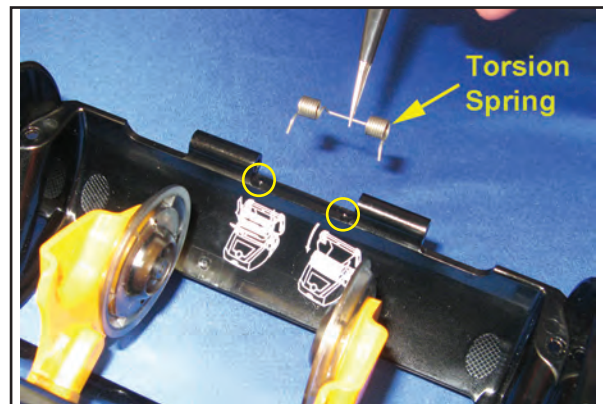
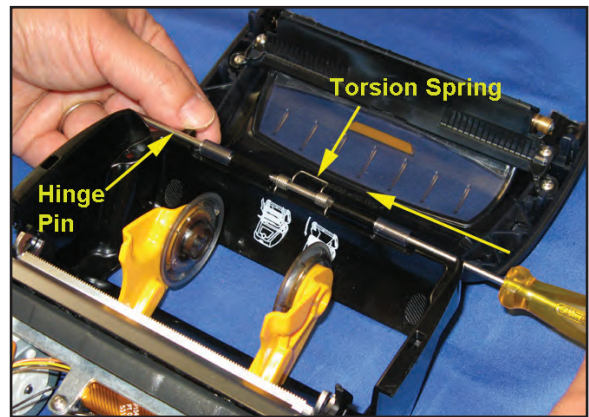

Installing the Media Cover

1. The Media Cover Assembly consists mainly of the Cover, Platen Holder, Platen (with bearings and gears), and Black Bar Flex Cable (as shown).

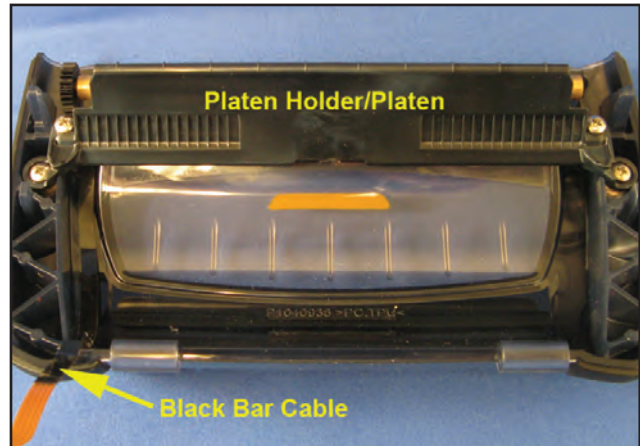

2. Align the hinges of the Media Cover Assembly with the hinges on the Media Guide Plate (where shown).

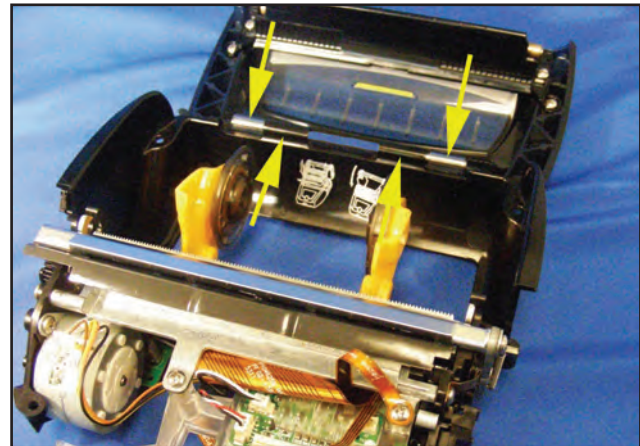

3. Insert the Torsion Spring in the two holes on the Media Guide Plate (where shown).

4. Slide the Hinge Pin through the hinge slots and through the torsion spring (as shown).

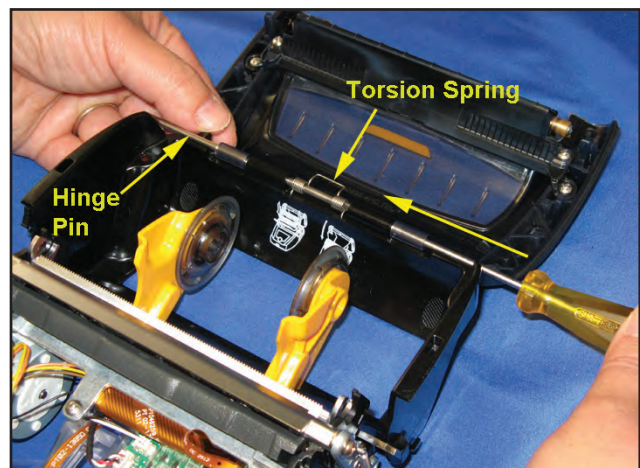

5. Ensure the Hinge Pin is centered and flush with the end of each hinge slot (where shown).

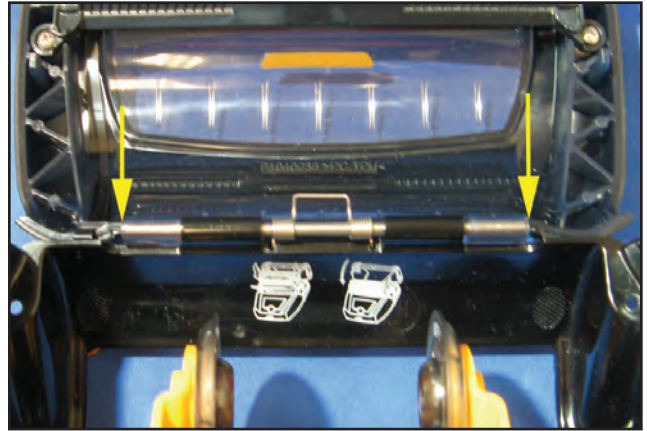

6. Peel the backing off the Black Bar Cable and press it firmly in the recess on the back, and along the bottom (inset image), of the Media Guide Plate.

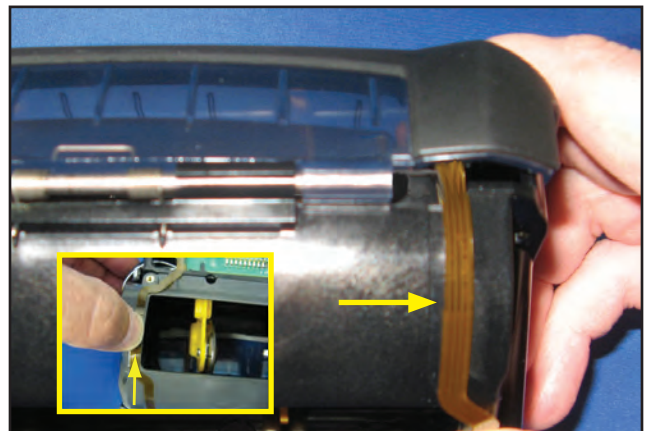

7. After assembling the printer, connect the Black Bar Cable to J8 on the MLB.

Accessory Kit P1050667-008 Platen Lined & -006 Platen Linerless

Installation Instructions

This kit includes the parts necessary to install the P1050667-008 Lined Platen Kit and the P1050667-006 Linerless Platen Kit in the QLn420 model printer. Read these instructions thoroughly before attempting to install this kit.

Tools Required: Torque Driver (4.7 +/- 1 in. lb. & 2.5 +/- 1 in. lb.) #0 or #1 Phillips bit

Removing the Platen

1. Use a torque driver (4.7 +/- 1 in. lb.) to remove the (4) screws securing the Platen Holder Assembly to the Media Cover.
2. Peel the Black Bar Cable from inside the Media Cover.
3. Remove the Peeler Bar from the holes located on opposite ends of the Platen subassembly.
4. Use a torque driver (2.5 +/- 1 in. lb.) to remove the screw on the non-gear end of the Platen roller.

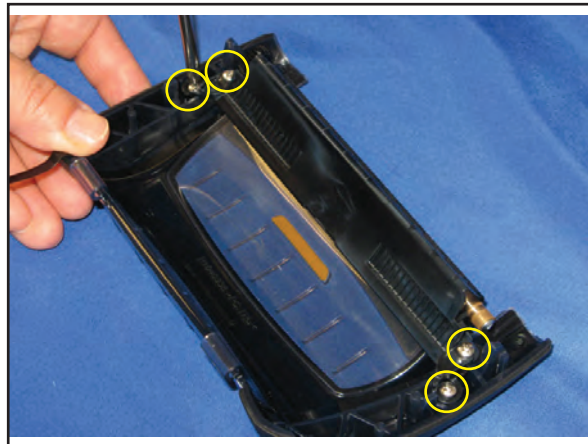

5. Use a torque driver (2.5 +/- 1 in. lb.) to remove the Platen gear on the opposite end of the roller.

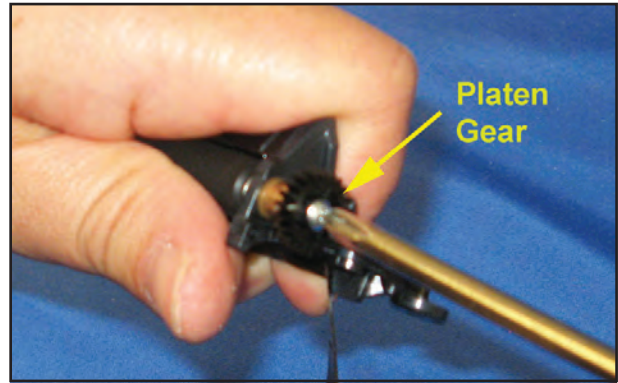

6. After removing the gear, slide the bearing sleeve from the end of the roller (as shown).



7. Slide the Platen roller from the subassembly frame.

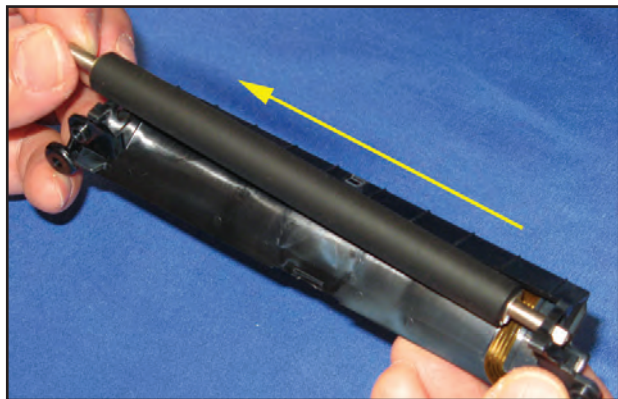

Installing the Platen

1. Press the Black Bar Flex Cable firmly to adhere to the holder.

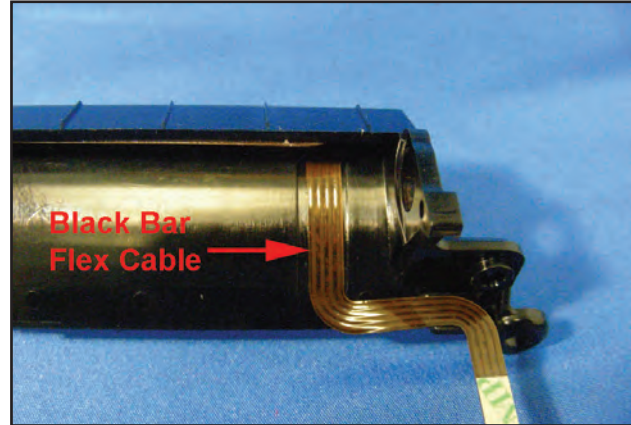

2. Slide the bearing sleeve on the long end of the Platen (as shown).



3. Insert the bearing sleeve through the hole on the end of the Platen Holder.

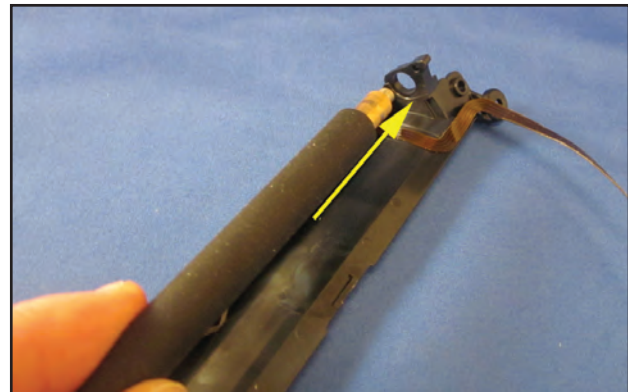

4. Place the shorter end of the Platen into the notch on the opposite end of the Platen Holder..

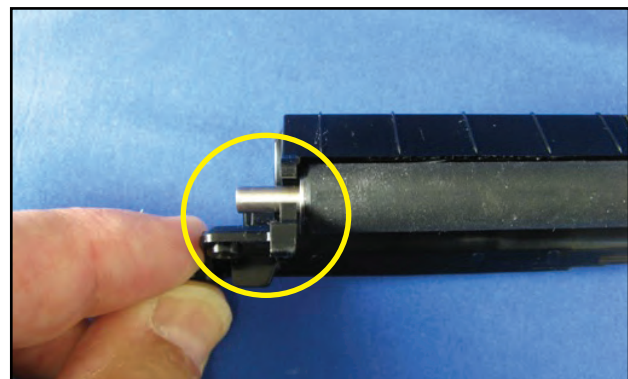

5. Place the gear on the longer end of the Platen with the flange facing toward the bearing.

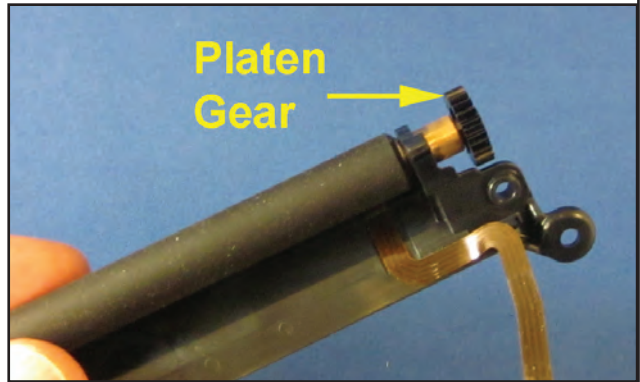

6. Using a torque driver (2.5 +/- 1 in. lb.), secure the gear to the shaft with a 2-56 x 3/16 TR Hd screw.

7. Install a bearing sleeve over the opposite end of the Platen shaft. Secure with a 2-56 x 3/16 TR Hd screw.

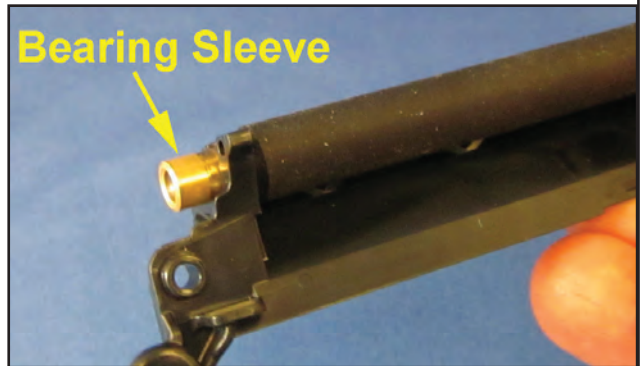

8. Install the Peel Bar into the hole on one end of the Platen Holder. Flex the opposite end of the holder to insert the other end of the Peel Bar.

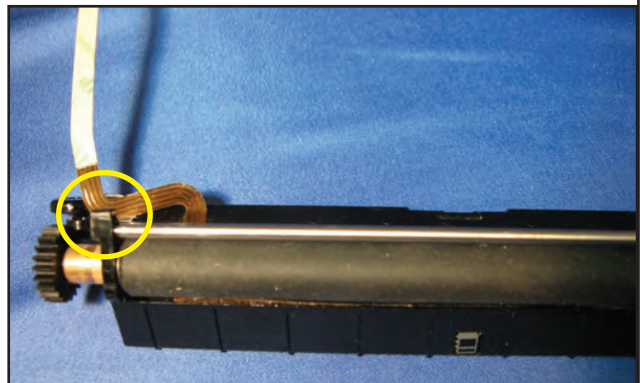

9. For linerless, replace the BA16937-1 Media Disks with BA16695-2 Media Disks by removing a screw and washer.

Replacement Kit P1050667-005 Motor Assembly

Installation Instructions

This kit includes the parts necessary to install the P1050667-005 Motor Assembly Kit in the QLn420 model printer. Read these instructions thoroughly before attempting to install this kit.

Tools Required: Torque Driver (4.7 +/- 1 in. lb.) #0 or #1 Phillips bit

Removing the Motor Assembly

1. Disassemble the unit as previously described on Page 2-15.
2. Remove the Printer Frame from Lower Housing as previously described on Page 2-16.
4. Disconnect the Motor Cable at J12 on the Top PCBA.

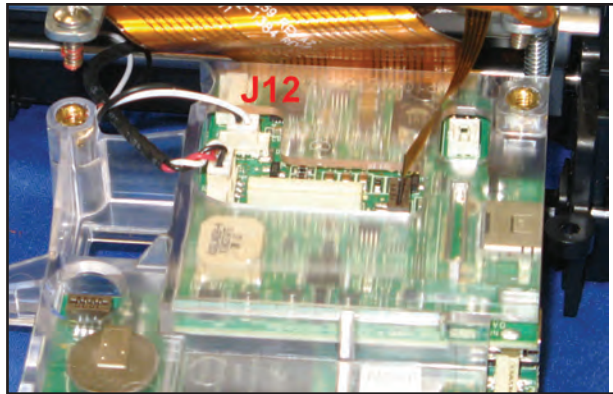

5. Use a torque drive to remove the screw holding the Motor to the Frame as shown.

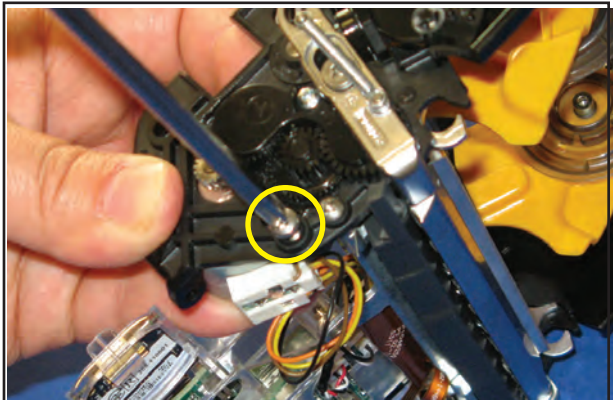

6. Rotate the motor to remove one end from the plastic tab on the Frame.

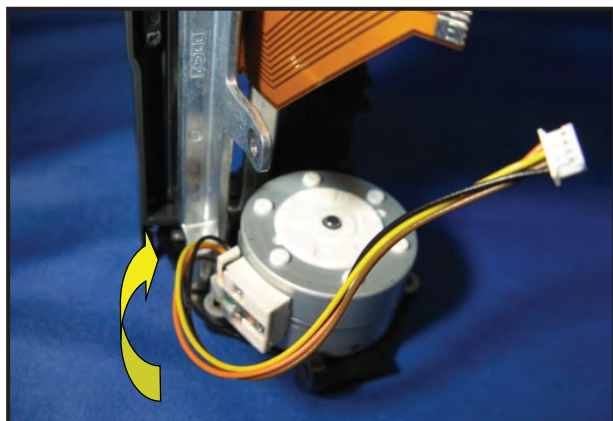

7. Pull the Motor pinion gear from the slot on the Frame to remove the Motor from the Frame.

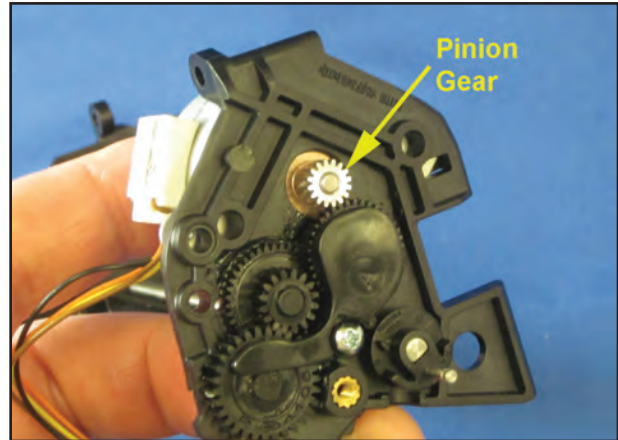

Installing the Motor Assembly

1. Install the Motor Assembly by inserting the pinion gear through the opening in the Frame (where shown).
2. Rotate the Motor so that the hole on one end of the Motor lines up with the screw hole on the frame, and the other end slides into the tab on the Frame (where shown).
3. Use a torque driver to secure the Motor to the Frame with the screw provided (where shown).
4. Connect the Motor Cable to J12 on the Top PCBA.
5. Reassemble the printer as previously described.

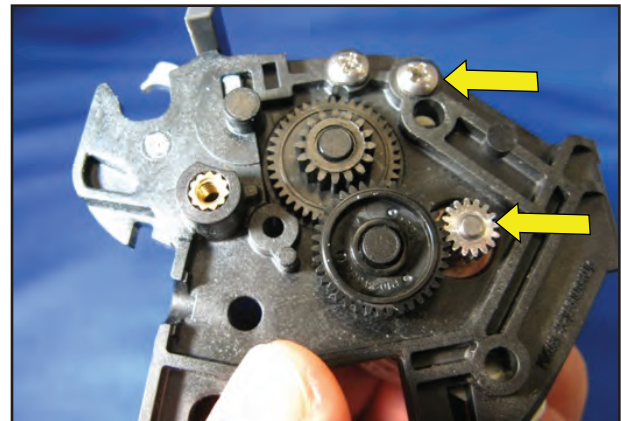
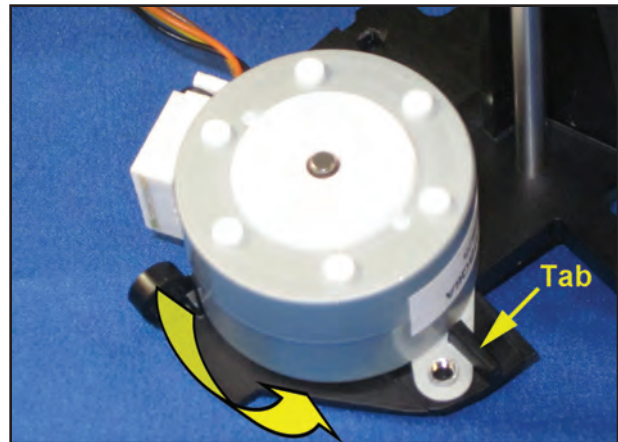

Repair Kit P1050667-001 Printhead Assembly

Installation Instructions

This kit includes the parts and documentation necessary to install the P1050667-001 Printhead Assembly. Read these instructions thoroughly before attempting to install this kit.



This symbol indicates that the operator must wear a properly grounded ESD strap to perform the repair procedure.

Tools Required: Torque Driver (4.7 +/- 1 in. lb.) #0 or #1 Phillips bit

Removing the Printhead Assembly and Peeler

1. Disassemble the printer as described on 2-15, including disconnecting the Printhead Cable from the MLB.
2. Use a torque driver to remove the (3) screws located on the Frame above the Printhead (where shown).
3. Separate the Frame from the Media Guide Plate while carefully re-routing all cables.
4. Remove the grounding screw on each end of the Spring Bar (where shown).
5. The Spring Bar is held in the Frame by (2) tabs on each end of the bar. Flex the Frame on one end to remove the tabs from the corresponding holes in the Frame.
6. Remove the Spring Bar ensuring not to lose the (3) springs on the back.

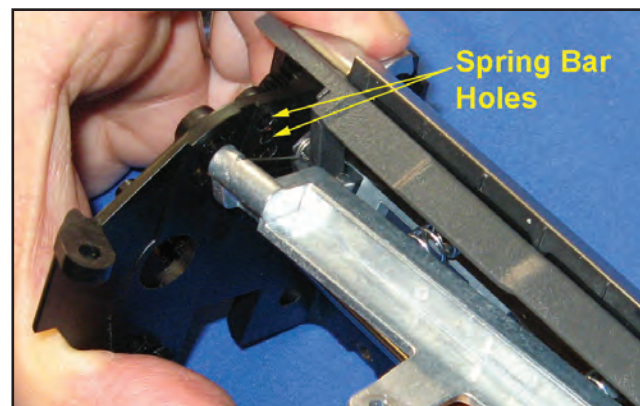
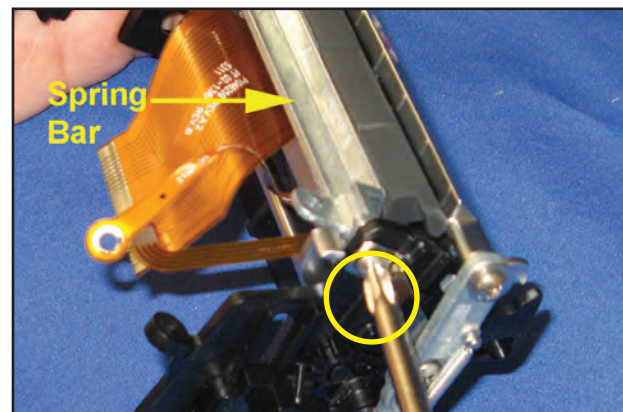
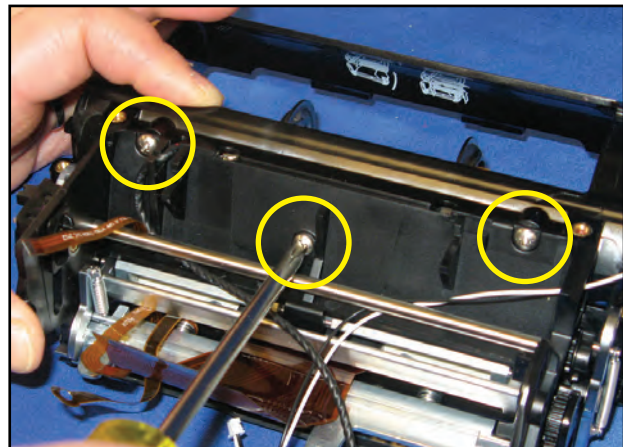

7. Remove the spring on each end of the Peeler assembly.

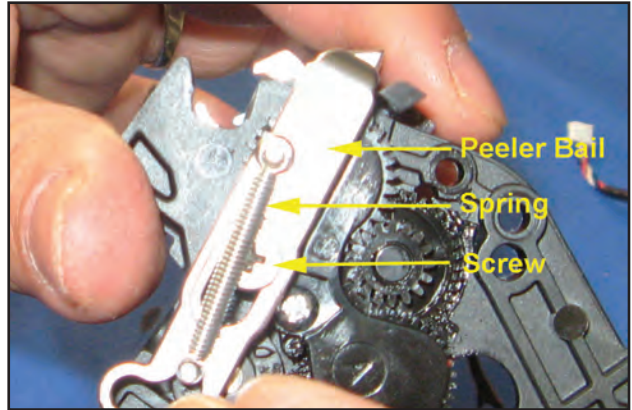

8. Use a torque driver to remove (2) screws holding the Peeler Arm to the Frame and (1) screw holding the Peeler Bail to the Frame.

9. Lift the Peeler from the Frame.

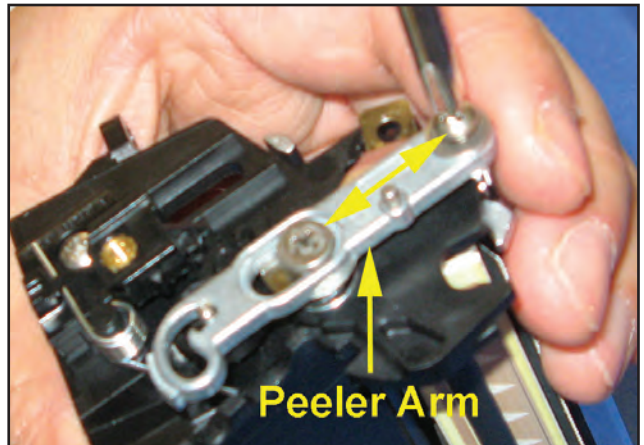

10. Flex the Frame to disengage the tab on each end of the Printhead Assembly from the slot on the Frame.

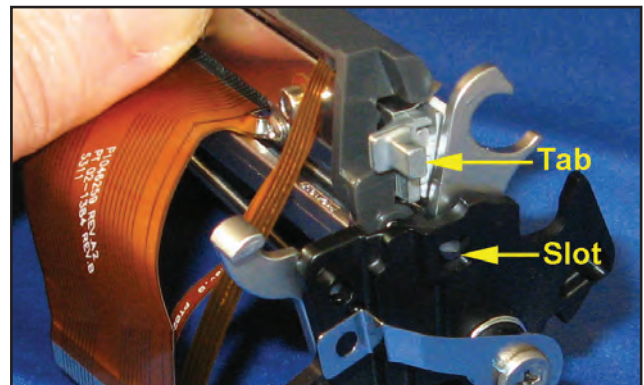

11. Slide the pivot shaft from the latch fork of the Peel Sensor Bracket and the printhead bracket to remove the Printhead.

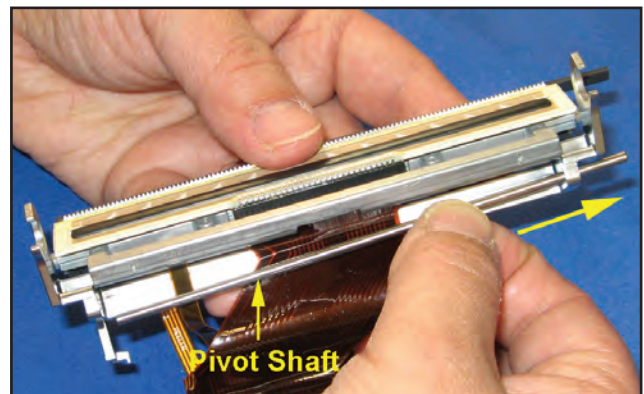

Installing the Printhead Assembly and Peeler

1. Slide Printhead Assembly between Latch Fork as shown.

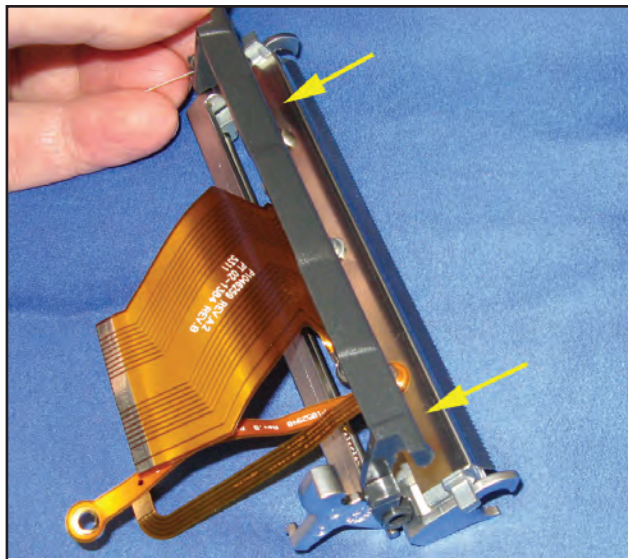

2. Slide the pivot shaft through the Latch Fork and Printhead bracket until the shaft exits through the opposite end. Ensure that the pivot shaft is centered in the bracket.

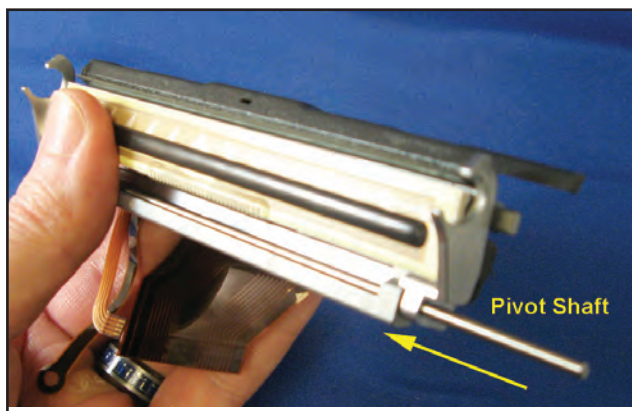

3. Place the Printhead Assembly into the slot on the Frame (where shown). Flex the other end of the Frame in order to slide the tab into the opposing slot in the Frame.

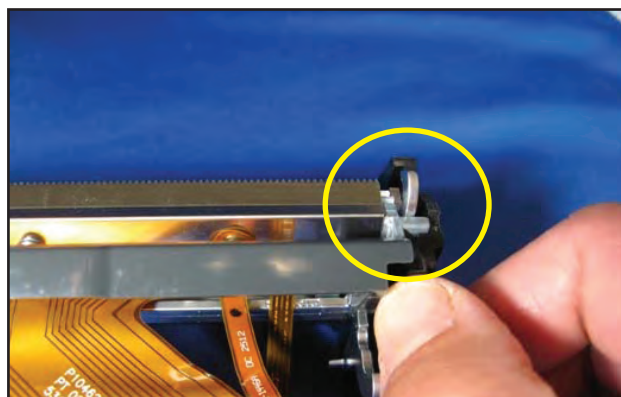

4. Place (3) springs on the posts located on the back of the Spring Bar as shown.

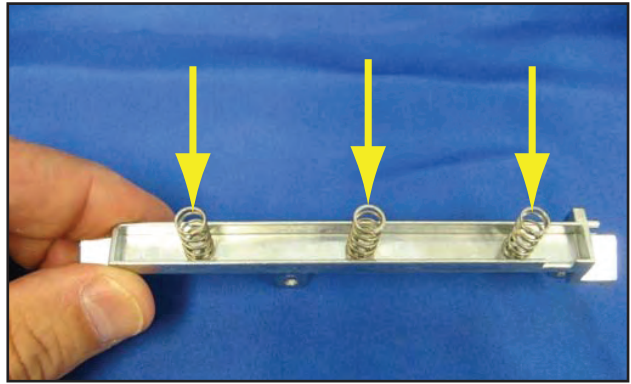

5. Install the Spring Bar Assembly by placing the springs over the cap screws on the back of the Printhead Assembly.

6. Snap the two tabs (shown) on each end of the spring bar into their corresponding holes on the printer frame (circled).

7. Secure the Spring Bar on each end with a 4-40 x 5/16 PN HD screw using a torque driver.

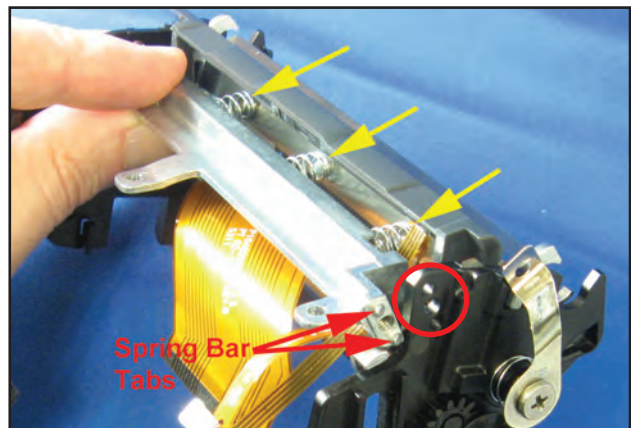

8. Install the Extension Spring from the post on the Spring Bar to the post on the Latch Fork (as shown).

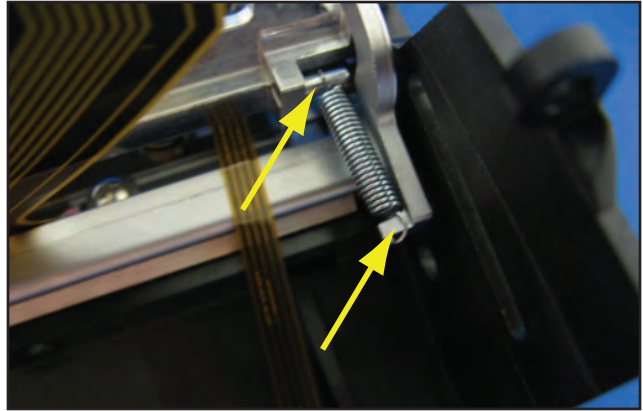

9. Secure the Frame to the Media Guide Plate with (3) screws in the locations shown. Be sure to route the Gap Sensor Flex Cable through the slot on the back of the Frame (circled).

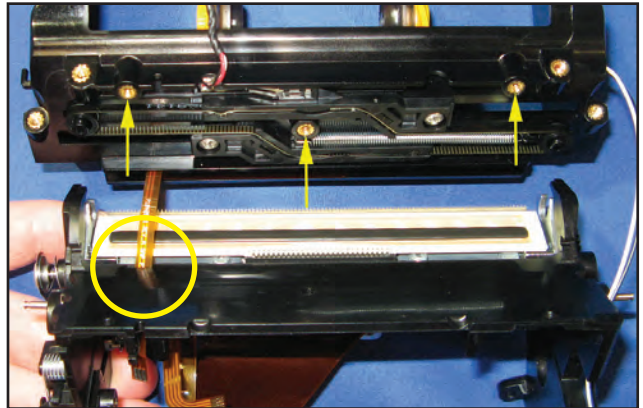

10. Route the Head-up Switch Cable through the hole on the side of the Frame (yellow arrow) and the Black Bar Cable in the channel on the Frame (red arrow). Both cables must be routed behind the peeler bar as shown.

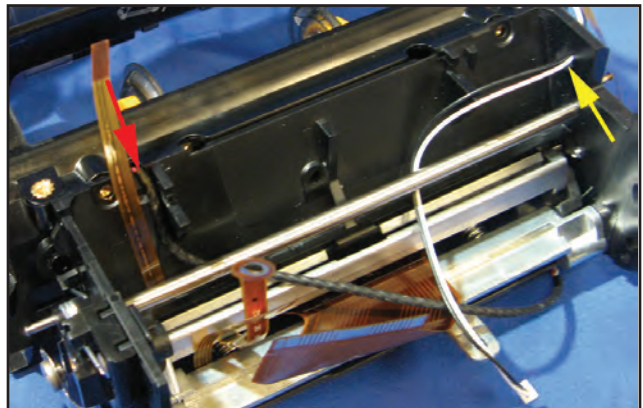

11. Install Peeler Assembly over the pin on the actuator (circled) and use a torque driver to secure with a shoulder screw (where indicated).

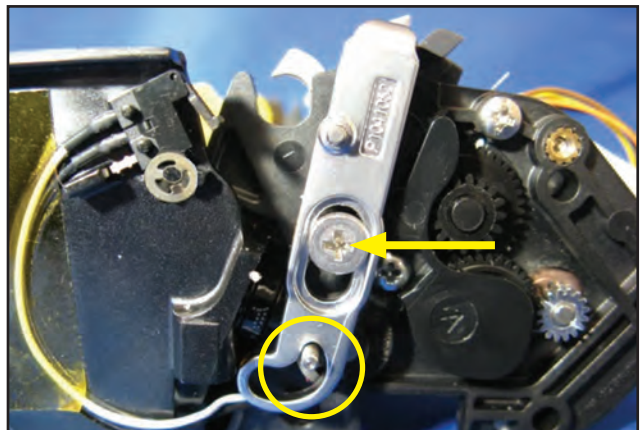

12. On the opposite side of the Frame, place the Wave Spring over the screw post as shown.

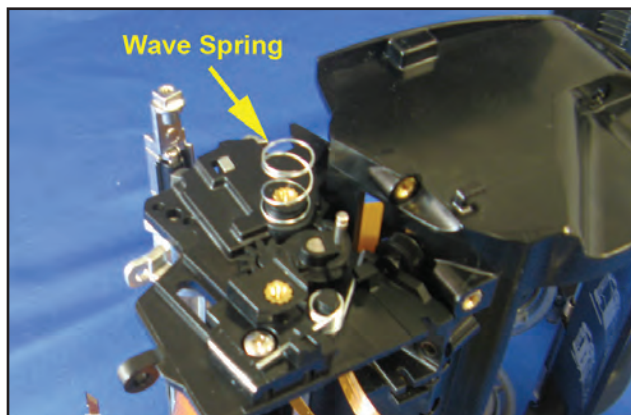

13. Place the Ground Strap and the Peeler Arm over the Wave Spring and secure the shoulder screw with a torque driver.

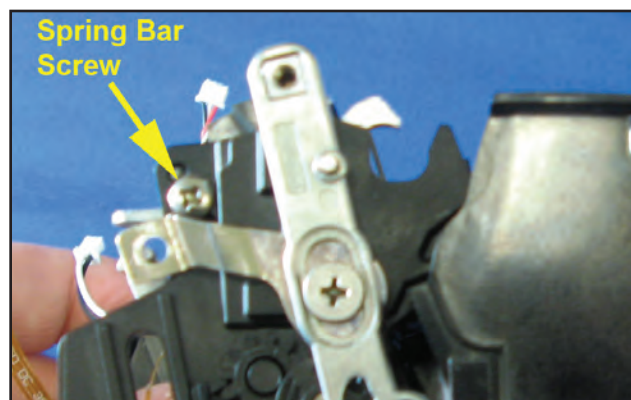

14. Secure the ground strap with the spring bar screw (where shown). Secure the Peeler Arm to the Peeler Assembly with a 4-40 x 1/4 PAN HD screw and washer.

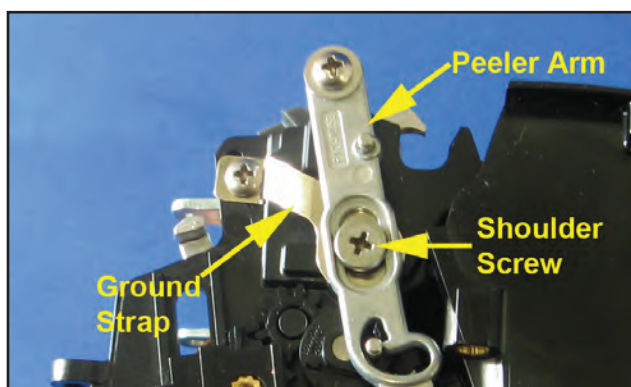

15. Install Peeler Spring on pins where shown. Do the same on the opposite side of the Peeler Assembly (inset).

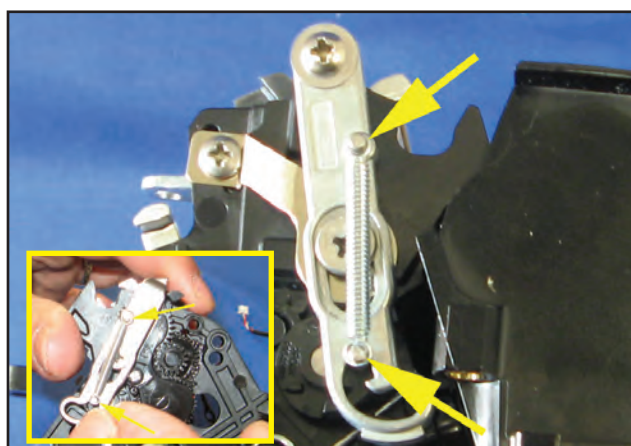

Repair Kits P1031365-002 Main Logic Board (MLB) & .P1050667-013/014 Dock Board

Installation Instructions

This kit includes the parts and documentation necessary to install the P1031365-002 Main Logic Board (MLB) and P1050667-013/-014 Dock Board. Read these instructions thoroughly before attempting to install this kit.



This symbol indicates that the operator must wear a properly grounded ESD strap to perform the repair procedure.

Tools Required: Torque Driver (4.7 +/- 1 in. lb.) #0 or #1 Phillips bit

Removing the Main Logic Board and Dock Board

1. Remove the Main Housing from the Lower Housing as previously described.
2. Remove the Printer Frame from the Lower Housing as described on Page 2-16.
3. Disconnect the Dock Board from the Docking Flex Cable and slide the board from the tabs on the Frame.
4. Use a torque driver to remove (2) screws securing the MLB to the printer frame. (The screw on the right also secures the ground strap from the printhead.)
5. Disconnect the Label Sensor Flex Cable (J10), the Head Up Switch Cable (J5) and Black Bar (lined) Cable (J11) from the Top Board.
6. Disconnect the MLB from the Top Board and remove from the plastic PCB mounting bracket.

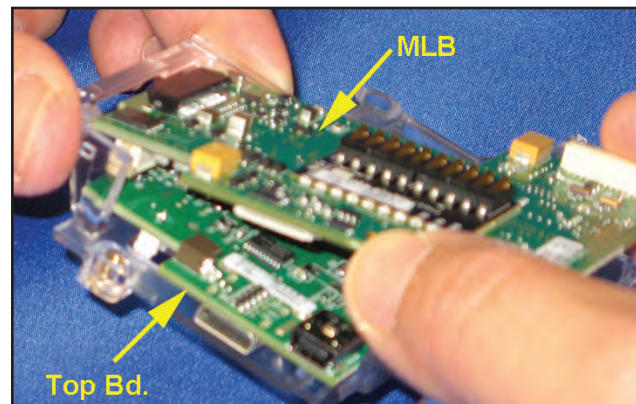
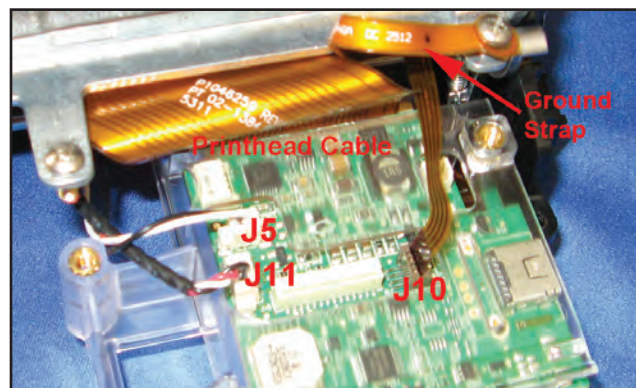
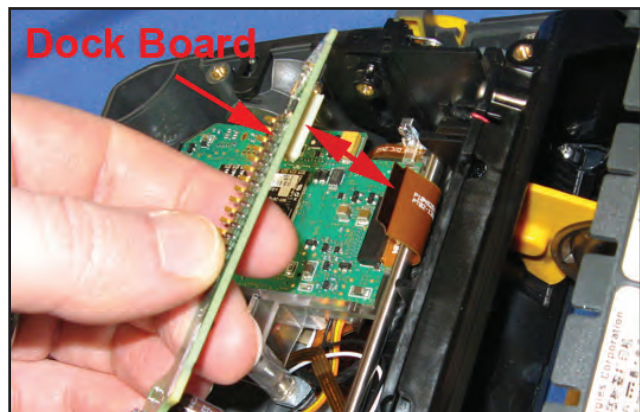

Installing the MLB and Dock Board

1. Connect the Top Board to the MLB.
2. Insert the two PCBA's into the mounting bracket by sliding them under the two tabs (where shown) and snapping the assembly into place.
3. Connect Printhead cable to the MLB at J13. Be sure to latch the connector on both ends.
4. Connect the Motor Cable (J12) to the Top PCBA.
5. Use a torque driver to secure one side of the PCB holder to the Spring Bar (as shown) with (1) 4-40 x 5/16 PAN HD screw.
6. Route the Gap Sensor Cable through the slot behind the MLB (shown) and connect to Top Board at J9. Make sure to route the cable under the plastic tab on the PCB mounting bracket (inset).

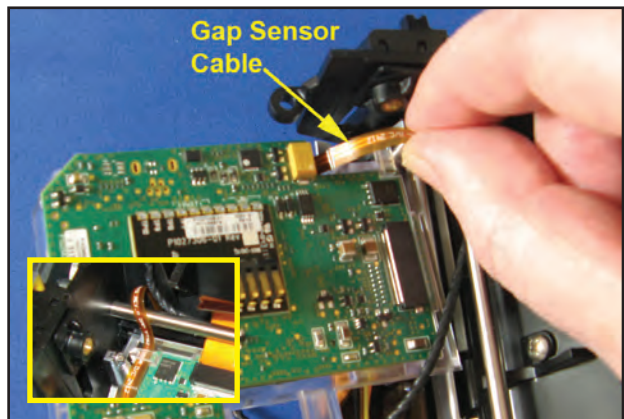
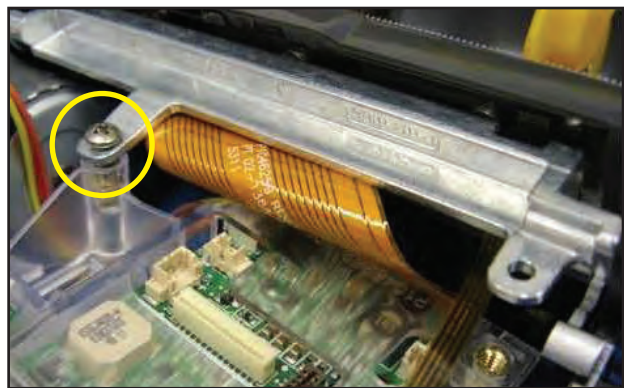
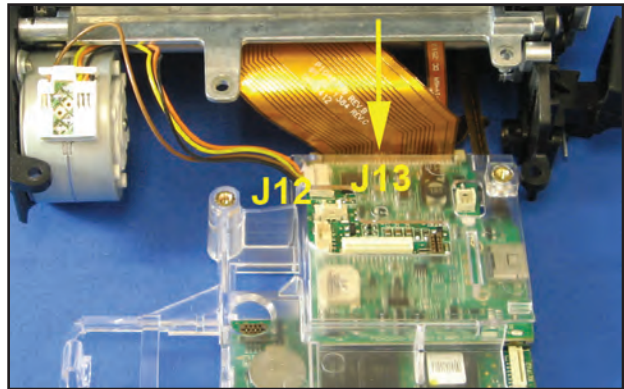
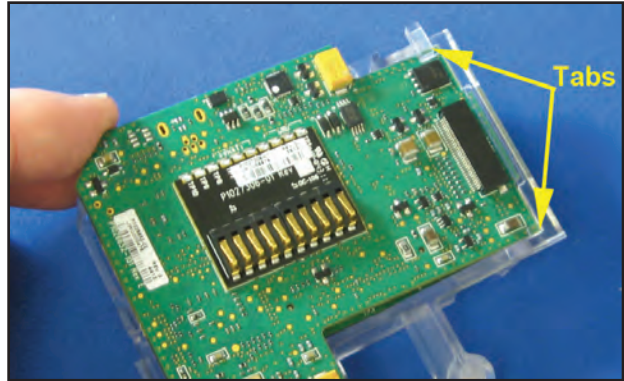

7. Secure opposite side of the PCB Mounting Bracket (along with printhead ground strap) to the Spring Bar with a screw (circled).

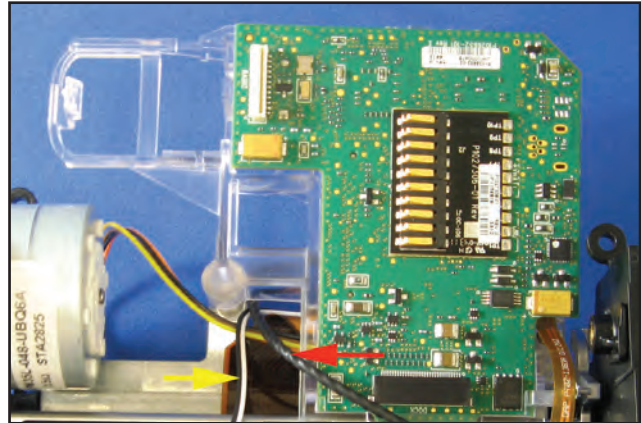

8. Connect the Peeler Cable to J10 on the Top Board.
9. Route the Media Width Cable (red arrow) and Head Up Switch Cable (yellow arrow) through the opening next to the MLB. Connect at J11 and J5 on the Top Board respectively.

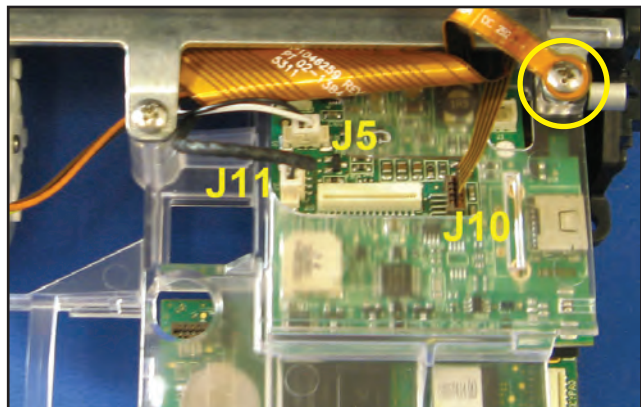

10. Plug the Docking Flex Cable into the Dock Board.

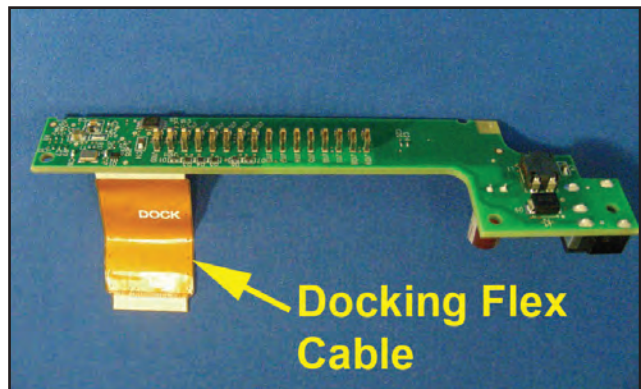

11. Slide the Dock Board into the tabs on the Frame (circled). Plug the Docking Flex Cable into the docking connector on the MLB ensuring that it's routed behind the shaft (as shown).
12. Connect the Black Bar Cable at J8 on the MLB.

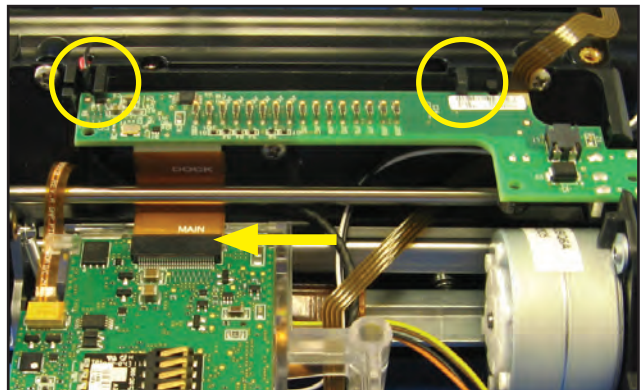

Repair Kit P1050667-012 802.11N/BT3.0 Radio

Installation Instructions

This kit includes the parts and documentation necessary to install the P1050667-012 802.11N/BT3.0 Radio Kit. Read these instructions thoroughly before attempting to install this kit.



This symbol indicates that the operator must wear a properly grounded ESD strap to perform the repair procedure.

Removing the 802.11n/BT3.0 Radio

1. Remove the Main Housing from the Lower Housing as previously described on Page 2-15.
2. Disconnect the Radio Flex Cable from the radio connector on the MLB.
3. Disconnect the Antenna Coax Cable from the Radio (where shown).
3. Pull back on the tab of the PCB Mounting Bracket and slide the Radio PCBA from the bracket.

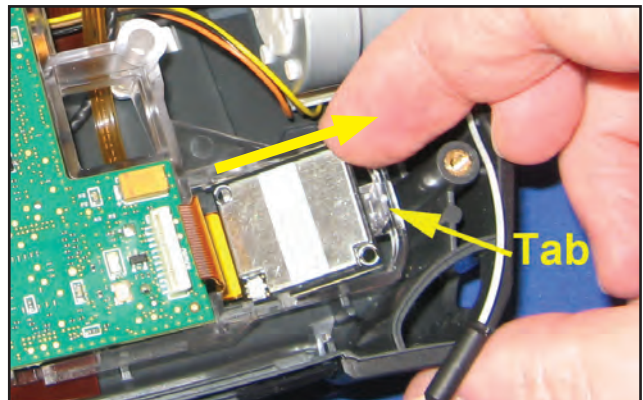
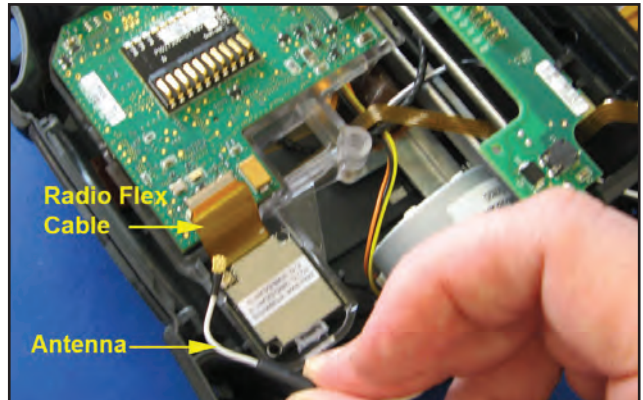

Installing the 802.11n/BT3.0 Radio

1. Connect the Radio Cable to Radio PCB ensuring that the cable contacts are facing the PCB.
2. Slide the Radio PCBA into the PCB Mounting Bracket (as shown) and snap into place.
3. Connect the Radio Cable to the MLB radio connector.
5. Connect the Antenna Coax Cable to the Radio.

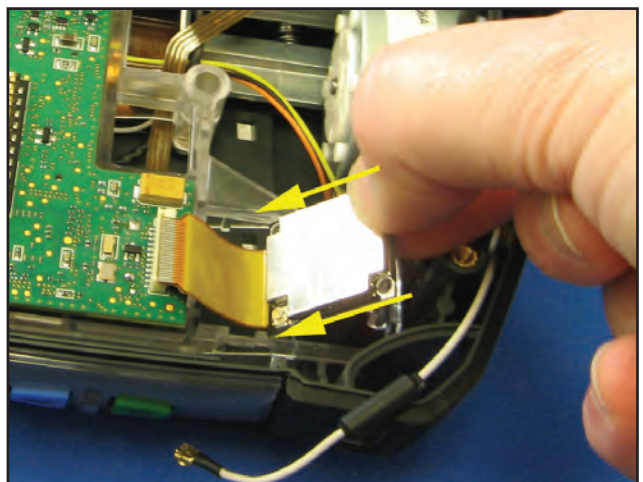

Repair Kit P1050667-003 Media Guide Assembly

Installation Instructions

This kit includes the parts and documentation necessary to install the P1050667-003 Media Guide Assembly. Read these instructions thoroughly before attempting to install this kit.



This symbol indicates that the operator must wear a properly grounded ESD strap to perform the repair procedure.

Tools Required: Torque Driver (4.7 +/- 1 in. lb.) #0 or #1 Phillips bit

Removing the Media Guide Assembly

1. Disassemble the Main Housing and Lower Housing as previously described on Page 2-15.
2. Remove the Media Cover as detailed on Page 2-17.
3. Remove the Dock Board and Main Logic Board as previously described on Page 2-32.
4. The Media Guide Assembly appears as shown.

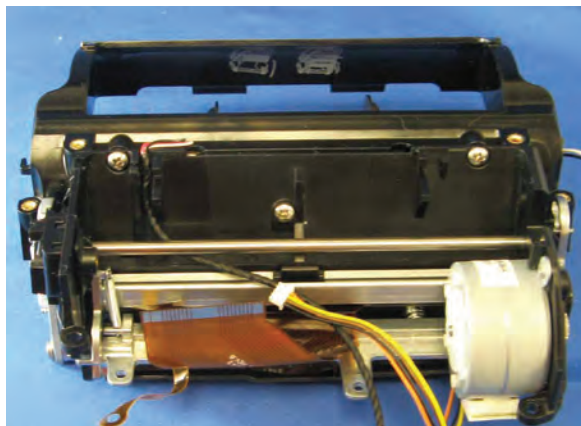
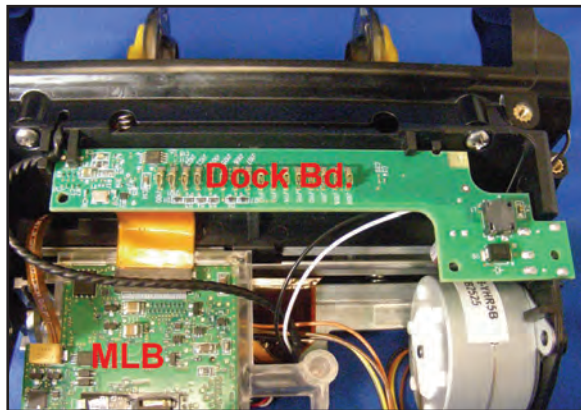

Installing the Media Guide Assembly

1. Install the Dock Board and MLB to the Media Guide Assembly as previously described on Page 2-33.
2. Rotate the Media Guide Assembly (with PCBA's) into the Main Housing and connect the Keyboard cable to the top of the MLB, the Antennae Coax cable to the radio, and the LCD cable to the bottom of the MLB.
3. Use a torque driver to secure the Media Guide Assembly to the Main Housing with four (4) screws (circled) and two (2) screws located inside the media compartment.
4. Install the Media Cover as previously described on Page 2-18.
5. Slide the back end of the Lower Housing into the Main Housing and snap the front in place.
6. Secure the Main Housing to the Lower Housing by removing four (4) Phillips screws on the bottom of the printer (where shown).

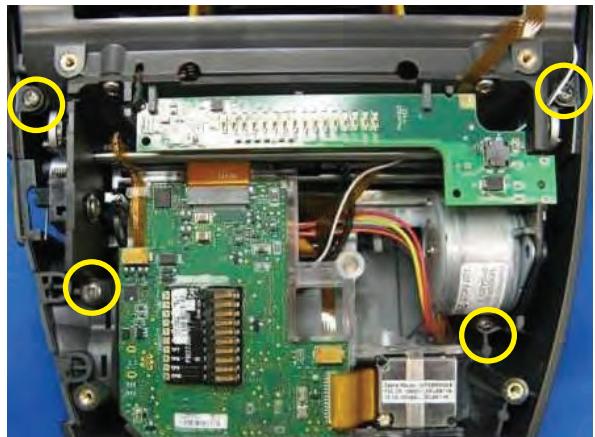

Repair Kit P1031365-009 LCD Assembly

Installation Instructions

This kit includes the parts and documentation necessary to install the P1031365-009 LCD Assembly. Read these instructions thoroughly before attempting to install this kit.

Tools Required: Torque Driver (4.7 +/- 1 in. lb.) #0 or #1 Phillips bit

Removing the LCD Assembly

1. Disassemble the printer as previously described on Page 2-15. This includes disconnecting the LCD flex cable from J15 on Top PCBA, the Keypad cable, Antenna Coax Cable.
2. Remove the Faceplate from the Main Housing by first pressing the two plastic tabs on the inside front of the Main Housing in the direction shown.
3. Lift up on the front of the Faceplate and slide the two (2) top tabs from the Main Housing (inset) to remove.
4. Lift the LCD Assembly from the tabs (circled) and slide the cable from the slot on the Main Housing to remove the assembly.

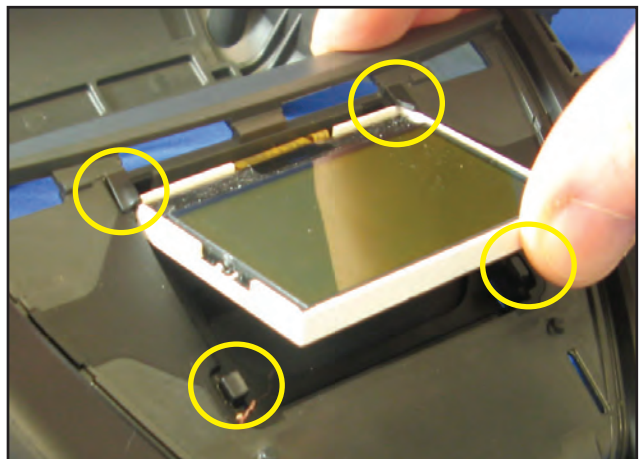
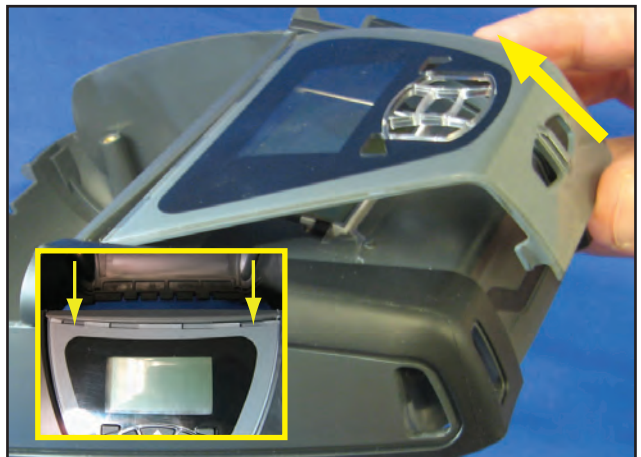

Installing the LCD Assembly

1. Slide the LCD flex cable through the slot on the Main Housing as shown.

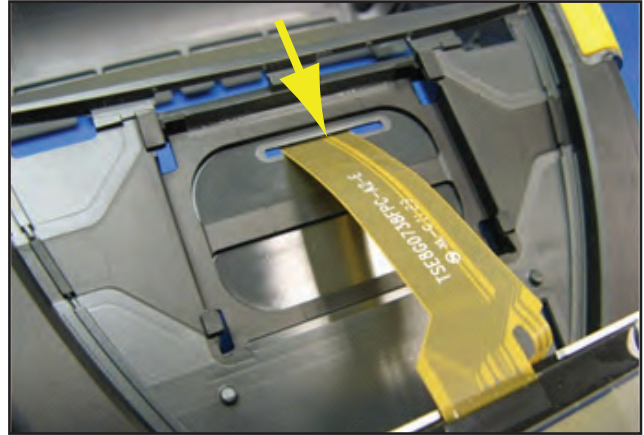

2. Slide the LCD beneath the two (2) rubber tabs (circled) and continue to slide the display in place under bottom two (2) rubber tabs (inset).
3. Remove the protective film from the LCD.

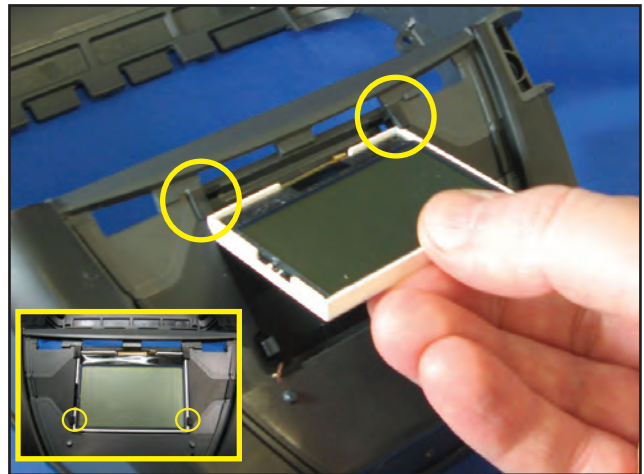

4. Install the Faceplate by sliding the top tabs into the Main Housing as shown.
5. Snap the front tabs into place to secure the Faceplate to the Main Housing.
6. Verify that the Keypad buttons are in their respective openings.
7. Reassemble the printer as previously described.

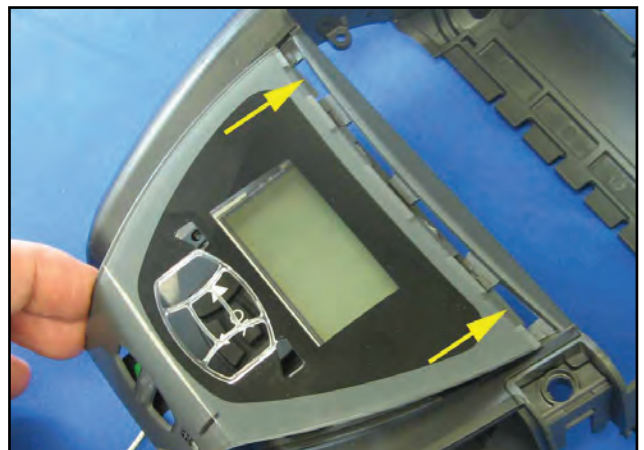

Repair Kit P1050667-002 Keypad Assembly

Installation Instructions

This kit includes the parts and documentation necessary to install the P1050667-002 Keypad. Read these instructions thoroughly before attempting to install this kit.

Tools Required: Torque Driver (4.7 +/- 1 in. lb.) #0 or #1 Phillips bit

Removing the Keypad

1. Disassemble the printer as previously described on Page 2-15. This includes disconnecting the Keypad ribbon cable from its connector on the MLB.
3. Remove the Faceplate as previously described.
4. Lift and peel the Keypad off its locating posts where indicated. (Third locating post not visible.)
5. Remove the Keypad cable through the slot in the frame to remove.



Installing the Keypad

1. Remove the adhesive backing from the Keypad.
2. Slide the Keypad cable through the slot (where shown).
3. Place the Keypad over the locating posts located on the Upper Housing.
4. Press down firmly on the Keypad to ensure adhesion.
5. Reassemble the printer as previously described.



Section 3: QLn420 Series Configurator and Repair Kits

Using The Product Configuration Code

Each QLn420 series printer has a Product Configuration Code (PCC). When ordering replacement parts, use the PCC code to determine the features installed on your printer. Then use the replacement kit part numbers to determine which kit to order.

Contact Customer Service if you are unsure of the correct part or assembly number.

Refer to “Factory Repair & Parts Ordering Procedure” for further information on ordering parts.

Component Replacement Procedures

Follow the kit replacement procedures as detailed in Section 2. Always replace a component or assembly with the same part number. If you install a part on an RW series printer different from the originally installed component (e.g. a different radio assembly or CPU board), you may have to change the configuration status (PCC code) of the printer. A change in the printer’s configuration status will require an update to the configuration part number on the serial number label. Accurate configuration numbers enable service and technical support personnel to accurately diagnose any problems which may occur with your printer.

If you need to send your printer to the Factory Service Center (FSC), your printer will be updated as necessary to conform with the Product Configuration Code on the serial number label.



Notes: If the label does not properly identify the printer’s current configuration, any changes you have made to the printer’s configuration may be removed should it be returned to Zebra.

If you contact Zebra’s technical support staff, you will be asked for your unit’s configuration number. If the configuration number you supply does not correspond to the printer’s actual status, any technical support you receive may not be accurate.

Factory Repair And Parts Ordering Procedure

If you need to return a printer to the factory for repair or upgrade, a Return Material Authorization (RMA) must be issued from Repair Services prior to returning any assemblies, PC boards, printers, cables, etc. for repair or replacement. The name, address, contact and phone number of the company that equipment is to be returned to must also be provided. A problem description is also necessary.

When replacing items always refer to the Product Configuration Code to insure the correct part for your specific unit is being ordered. If you are unsure of the correct part, contact Zebra Customer Service with the unit serial number, and the Product Configuration Code to obtain the appropriate part number(s). The serial number label and Product Configuration Code label are either on the bottom or the back of the printer. Refer to the QLn Series User Guide for more information on label location.

Equipment received without return authorization will not be accepted.

Repair Services Contact Information

IN THE USA	IN EUROPE
Zebra Technologies Corporation, LLC	Zebra Technologies Europe, Limited
475 Half Day Road, Suite 500 Lincolnshire, Illinois 60069 USA	Dukes Meadow Millboard Road Bourne End Buckinghamshire SL8 5XF, UK
Phone: +1.847.913.2259	Telephone: +44 (0)1628 556000
Fax: +1.847.913.8766	Fax: +44 (0)1628 556001
e-mail: repair@zebra.com	e-mail: tseurope@zebra.com
RMA requests: repair@zebra.com	RMA requests: ukrma@zebra.com Ask for Customer Support

IN ASIA PACIFIC REGION	Technical Support	Customer Service
Zebra Technologies Asia Pacific Pte Ltd 120 Robinson Road #06-01 Parakou Building Singapore 068913 T: +65 6858 0722 F: +65 6885 0838	T: +65 6858 0722 F: +65 6885 0838 E: tsasiapacific@zebra.com	For printers, parts, media, and ribbon, please call your distributor, or contact us. T: +65 6858 0722 F: +65 6885 0837

QLn Series Product Configuration Code (PCC)



Zebra Technologies International, LLC
QLn Family

Product Configuration Sheet/QL Series



Series: _____

PRINTHEAD WIDTH

2 Inch.....	2	_____
3 Inch.....	3	_____
4 Inch.....	4	_____

RAM/FLASH (Choose one)

128M/256M.....	A	_____
----------------	---	-------

CHARACTER SET (Choose one)

English/Latin 1 & 5 (Incl. Turkish), base incl on all versions.....	U	_____
Chinese 16x16 (traditional), Add'l CPCL char set.....	D	_____
Japanese 24x24, Add'l CPCL char set.....	G	_____
Chinese 16x16 (simplified), Add'l CPCL char set.....	H	_____
Korean Mincho , Add'l CPCL char set.....	J	_____
Korean Myeong , Add'l CPCL char set.....	K	_____
Japanese, Andele, Add'l ZPL char set.....	1	_____
Korean, Andele, Add'l ZPL char set.....	2	_____
Chinese, Andele, (both simplified and traditional), Add'l ZPL char set.....	3	_____
SimSun GB18030, ZPL only.....	4	_____

COMMUNICATION (Choose one)...

None (serial cable ready).....	1	_____
*Bluetooth.....	B	_____
*Zebra Premium 802.11b/g (QLn2/3 only).....	G	_____
*802.11a/b/g/n.....	N	_____
*Bluetooth 3.0.....	C	_____
*Combo 802.11a/b/g/n/Bluetooth 3.0.....	D	_____
*802.11a/b/g/n MIMO (QLn420 only).....	M	_____
*802.11a/b/g/n MIMO/Bluetooth 3.0 Combo (QLn420 only).....	P	_____

MEDIA HANDLING (Choose one)

Direct Thermal/Linerless Platen 0.75" Media core Size.....	A	_____
Direct Thermal/Linerless Platen 1.375" Media Core Size.....	B	_____
Direct Thermal/Linerless Platen 1.375" Media Core Size.....	1	_____
Direct Thermal/Linerless Platen 0.75" Media Core Size.....	2	_____

COUNTRY CODE (Choose one)

Group "0" (US/CA).....	0	_____
Group "L" (AR/BR/HN/SV/GT/CR/NI/CL/MX).....	L	_____
Group "E" (EU/EFTA/RU/IL/EG/TR/UA).....	E	_____
<small>(Austria / Belgium / Cyprus / Czech / Denmark / Estonia / Finland / France / Germany / Greece / Hungary / Iceland / Ireland / Italy / Latvia / Liechtenstein / Lithuania / Luxembourg / Malta / Netherlands / Norway / Poland / Portugal / Slovakia / Slovenia / Spain / Sweden / Switzerland / UK)</small>		
Group "A" (TW/KR/MY/AU/NZ/IN).....	A	_____
Group "B" (CN/SG/TH/PH/HK).....	B	_____
Group "J" (JP).....	J	_____

Ethernet Options (Choose one)

No Ethernet.....	0	_____
Ethernet Support.....	E	_____

Hardware Options (Choose one)

Belt Clip.....	0	_____
Shoulder Strap and Belt clip (EMEA only).....	1	_____
Extended Battery (N/A QLn4).....	B	_____
Extended Battery and Shoulder Strap (EMEA only).....	C	_____

OTHER OPTIONS (Choose one)

None.....	0	_____
Media Width Sensor (N/A QLn2).....	1	_____

00 = Default: 19.2Baud; 120 Sec Time Out; DTR Pwr-Off Enable; Handshake HW(CTS/RTS); Zebra Label Set

XX = CUSTOM CONFIG, CAG Request

Refer to product's price list for configurations and prices. All trademarks are the property of their respective owners.
SPECIFICATIONS AND PRICES SUBJECT TO CHANGE WITHOUT NOTICE F.O.B.

*Country Code

0	US - Country code cannot change
J	JP - Country code cannot change
All Others	Default country code - 2.4GHz only; Channels 1-13 Customer/End User can update default code (if not 0 or J), to the specific country code Restore Defaults will set back to default country code

All country codes If 802.11d enabled, country code is gleaned from access point

QLn420 Replacement Kits

ITEM	PART #	DESCRIPTION
1	P1031365-002	KIT RPR QLN MLB
2	P1031365-009	KIT RPR QLN LCD DISPLAY (2)
3	P1050667-001	KT RPR QLN420 PRINTHEAD
4	P1050667-002	KIT RPR QLN420 KEY PAD (2)
5	P1050667-003	KIT RPR QLN420 MEDIA GUIDE/MW
6	P1050667-004	KIT RPR QLN420 MEDIA COVER LINERED
7	P1050667-005	KIT RPR QLN420 MOTOR ASSY (2)
8	P1050667-011	KIT RPR QLN420 TOP PCBA
9	P1050667-012	KIT RPR QLN420 802.11N/BT3.0 RADIO
10	P1050667-013	KIT REPAIR PCBA QLN420 DOCK W/O ETHERNET
11	P1050667-014	KIT RPR PCBA QLN4 DOCK W/ ETHERNET
12	P1050667-006	KIT ACC QLN420 PLATEN/GEAR LINERLESS
13	P1050667-016	KIT ACC QLN420 SPARE BATTERY

QLn420 Accessory Kits

PART NUMBER	DESCRIPTION
P1050667-007	KIT ACC QLN420 RUBBER DOOR I/O (15)
P1050667-008	KIT ACC QLN420 PLATEN/GEAR W/HOLDER LINERED
P1050667-009	KIT ACC PLATEN GEAR 48P 22T FOR QLN420 (25)
P1050667-010	KIT ACC QLN420 RUBBER DOOR DC JACK (15)
P1050667-015	KIT ACC PKG DETAIL QLN420
P1050667-017	KIT ACC QLN420 SOFT CASE (INCLUDES SHOULDER STRAP)
P1050667-018	KIT ACC QLN420-EC AC ADAPTER US (TYPE A) CORD
P1050667-019	KIT ACC QLN420-EC AC ADAPTER UK (TYPE G) CORD
P1050667-020	KIT ACC QLN420-EC AC ADAPTER EU/CHILE (TYPE C) CORD
P1050667-021	KIT ACC QLN420-EC, AC ADAPTER, JAPAN CORD
P1050667-022	KIT ACC QLN420-EC AC ADAPTER BRAZIL CORD
P1050667-023	KIT ACC QLN420-EC AC ADAPTER ARGENTINA CORD
P1050667-024	KIT ACC QLN420-EC AC ADAPTER AUSTRALIA (TYPE L) CORD
P1050667-025	KIT ACC QLN420-EC, AC ADAPTER, CN CORD
P1050667-026	KIT ACC QLN420-VC – 15V – 60V TO 12V
P1050667-027	KIT ACC QLN420-EC, AC ADAPTER, TAIWAN CORD
P1050667-028	KIT ACC QLN420-EC AC ADAPTER, ISRAEL CORD
P1050667-029	KIT ACC QLN420-EC (NO ADAPTER, NO CORD)
P1050667-030	KIT ACC QLN420-VC (NO ADAPTER, NO CORD)
P1050667-031	KIT, ACC METAL BELT CLIP QLN420
P1050667-032	KIT ACC_HANDI-MOUNT (COMPACT, FLEXIBLE RAM ARM) WITH BASE PLATE QLN420
P1050667-033	KIT ACC_QL420 HANDI-MOUNT (COMPACT, FLEXIBLE RAM ARM) WITHOUT BASE PLATE
P1050667-034	KIT ACC ASSY HARD CASE W/METAL BELT CLIP, QLN4
P1050667-035	KIT ACC QLN4 MOBILE MOUNT FOR FORKLIFTS (WITH U-ARM BRACKET AND FANFOLD BIN)
P1050667-036	KIT ACC QLN420 SCREEN SCRATCH PROTECTOR OVERLAY (25)
P1031365-024	KIT ACC QLN AC ADAPTER US (TYPE A) CORD
P1031365-051	KIT ACC QLN SOFTWARE AND DOCUMENTATION USER CD

PART NUMBER	DESCRIPTION
P1031365-060	KIT ACC QLN 11 PIN SERIAL CABLE (WITH STRAIN RELIEF) TO MC3000
P1031365-061	KIT ACC QLN SERIAL DEX CABLE (WITH STRAIN RELIEF)
P1031365-062	KIT ACC QLN SERIAL CABLE (WITH STRAIN RELIEF) TO RJ45
P1031365-063	KIT ACC SC2 LI-ION SMART CHARGER, US (TYPE A) CORD
P1031365-064	KIT ACC SC2 LI-ION SMART CHARGER, UK (TYPE G) CORD
P1031365-065	KIT ACC SC2 LI-ION SMART CHARGER, EU/CHILE (TYPE C) CORD
P1031365-066	KIT ACC SC2 LI-ION SMART CHARGER, AUSTRALIA (TYPE I) CORD
P1031365-067	KIT ACC SC2 LI-ION SMART CHARGER, BRAZIL
P1031365-068	KIT ACC SC2 LI-ION SMART CHARGER, CHINA CORD
P1031365-083	KIT ACC QLN AC ADAPTER, ARGENTINA CORD
P1031365-088	KIT ACC SC2 LI-ION SMART CHARGER, ISREAL CORD
P1031365-089	KIT ACC SC2 LI-ION SMART CHARGER, ARGENTINA CORD
P1031365-093	KIT ACC QLN AC ADAPTER TAIWAN CORD
P1031365-094	KIT ACC QLN AC ADAPTER JAPAN CORD
P1031365-095	KIT ACC SC2 LI-ION SMART CHARGER, TAIWAN CORD
P1031365-096	KIT ACC SC2 LI-ION SMART CHARGER, JAPAN CORD



Refer to the QLn Series User Guide for a complete list of interface cables related to this printer.

QLn420 Replacement Kits - Exploded View

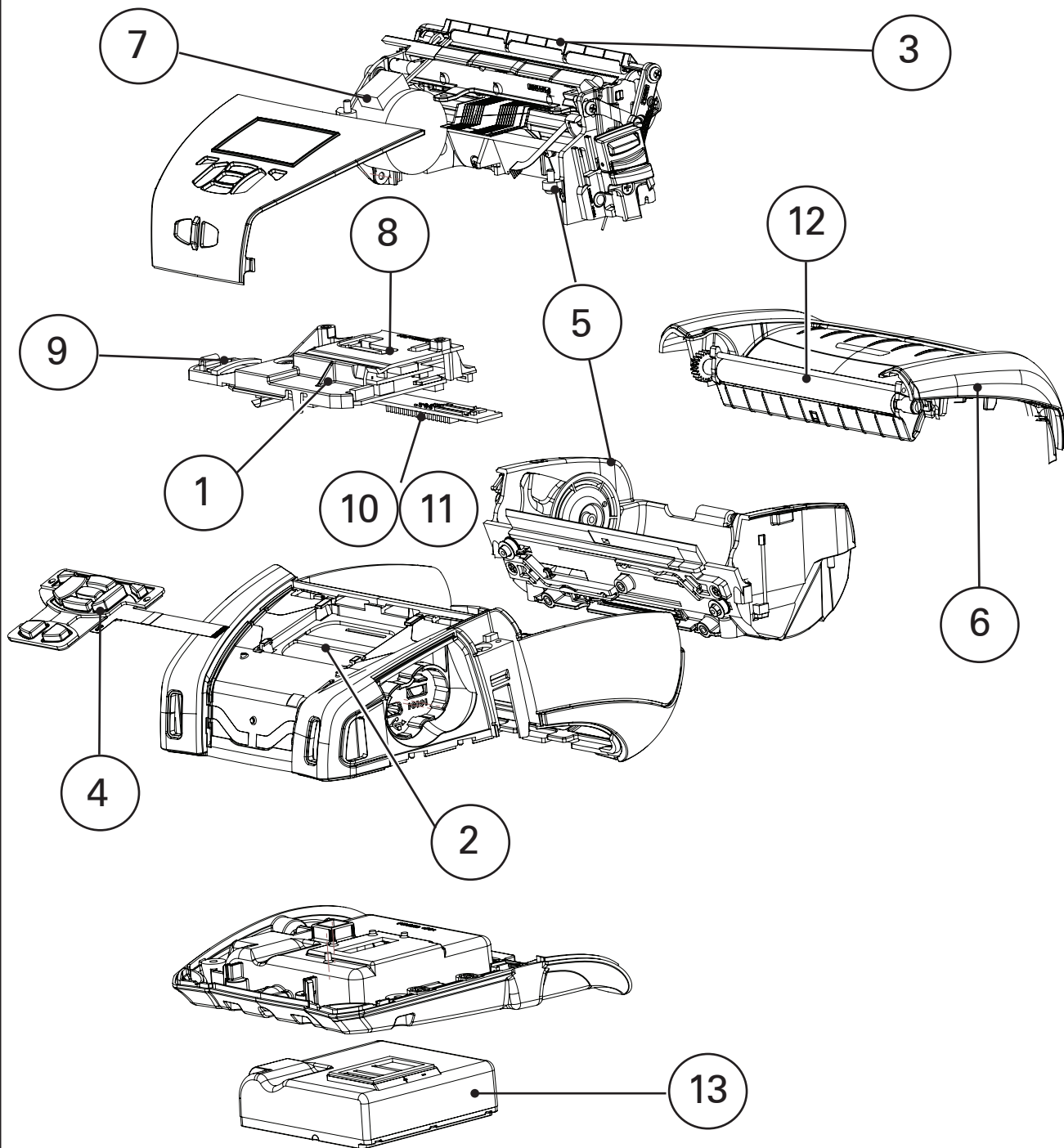



Zebra Technologies Corporation

475 Half Day Road, Suite 500

Lincolnshire, IL 60069 USA

T: +1 847.634.6700 or +1 800.423.0442