



E200 Series Projectors

E200 Series XGA and
WXGA resolution
projectors with
2600-3700 lumens
brightness

SONY
make.believe

E200 Series XGA and WXGA resolution projectors with 2600-3700 lumens brightness



VPL-EW225 / VPL-EX225
WXGA and XGA with 2600~2700 Colour Brightness



VPL-EW245 / VPL-EX245
WXGA and XGA with 3100~3200 Colour Brightness



VPL-EW275 / VPL-EX275
WXGA and XGA with 3700 Colour Brightness

Just as teaching methods are adapted to match student ability levels, so we design our AV technology for the education sector to meet specific requirements. Sony have worked closely with teachers and purchasing departments within the education sector to create the E200 Series education projectors. Now schools can benefit from reliable, long-lasting projectors with a low cost of ownership that truly enhance the learning experience.

With a range of eco conscious features that ensure an outstandingly low total cost of ownership, the new Sony E200 Series projectors combine superb image quality and performance with ease of use.

The new E200 Series feature Sony BrightEra™ 3LCD technology which delivers higher picture quality, substantially brighter images, improved contrast, consistent colour stability and increased durability.

All E200 series models offer standard, XGA or WXGA resolution, 3000:1 contrast ratio, 2 XRGB, HDMI, USB, S-Video, Video in, LAN/RJ45, RS232, monitor out, microphone input, audio and 16W internal speaker. 7000 hours of lamp life, three brightness mode, auto lamp dimming, auto picture dimming and an ECO Gauge to ensure an outstandingly low total cost of ownership.

The E200 Series education projectors offer a brightness range from 2600 lm colour brightness (VPL-EW225) all the way up to 3700 lm colour brightness (VPL-EX275/VPL-EW275).

Other Features Continued

Vertical Keystone Adjustment

The projectors can correct keystone distortion by +/- 30% for perfect installation adjustment to the screen. (Note that since this is an electronic correction, it will reduce the picture quality slightly.)

Digital Zoom

With Digital Zoom, teachers can enlarge a selected area of a computer-sourced image on the screen up to four times.

Six Picture Modes

All the projectors within the E200 Series family have six available picture modes for correct picture quality; Dynamic, Standard, Game, Blackboard, Cinema and Presentation. With six picture modes and 3 brightness modes combined, teachers can select the most suitable picture/brightness mode according to the picture source and environment for the perfect image.

3LCD BrightEra Technology

The Sony BrightEra inorganic TFT 3LCD panels deliver improved panel light resistance, higher resolution, high brightness and increased panel reliability.

Smart APA (Auto Pixel Alignment)

When a computer is used as a picture source, APA automatically optimises Phase, Pitch and Shift values. These can also be adjusted manually.

Auto Input Search

Auto Input Search detects which input has an incoming signal and automatically switches to it. This makes it easier for teachers to set up the projector prior to making a presentation.

Picture Muting/Audio Muting

If there is a need to blackout the image or turn off the audio from the projector, all it takes is a single button-press on the remote control. One button will mute audio and image at the same time. There is also a separate "mute audio" button for audio-only muting.

Audio Switcher Facility

To avoid the need for a separate audio switcher, the projector can be used to select between two audio sources, routing them via a variable audio output to the room amplification system.

Off and Go

At the end of a presentation, teachers can turn off the power supply to the projector immediately, instead of going through a 'power down' cycle.

Direct Power On/Off

With this function, there is no need to go through 'Standby' mode when powering up the projector. The projector can be set to activate as soon as power is supplied.

Built-in Security Measures

The E200 Series projectors have a package of security measures, including password protection and physical anti-theft anchor points.

Optional Accessories



IPN-WLN3
USB wireless module



LMP-E212
Replacement Projector Lamp



442670201 (FILTER)
Replacement Filter

Connector Panels

Rear connector panel for the VPL-EW225, VPL-EW245, VPL-EW275, VPL-EX225, VPL-EX245 & VPL-EX275 projectors

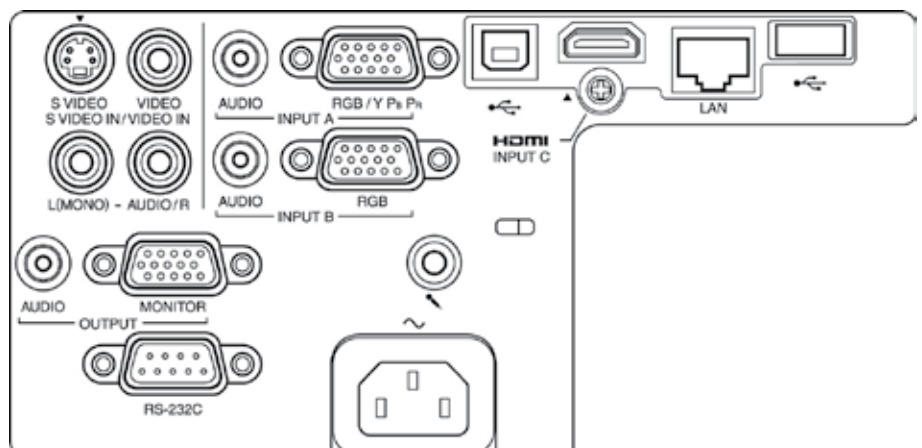

Front Dimensions for the VPL-EW225, VPL-EW245, VPL-EW275, VPL-EX225, VPL-EX245 & VPL-EX275 projectors

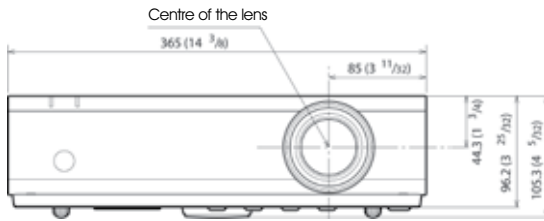

Bottom Dimensions for both the VPL-EW225 & VPL-EX225

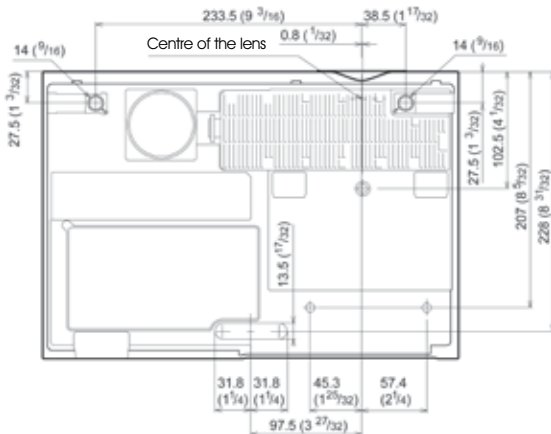

Bottom Dimensions for both the VPL-EW245 & VPL-EX245

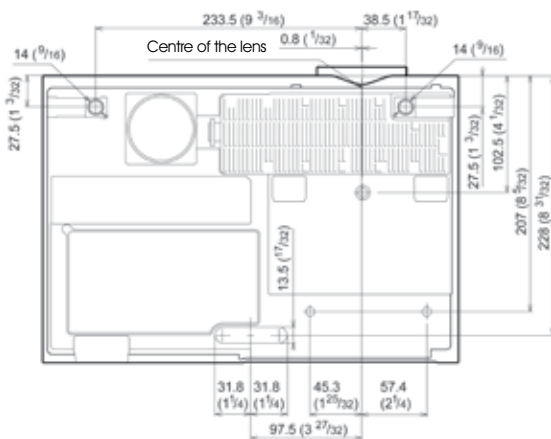

Bottom Dimensions for both the VPL-EW275 & VPL-EX275

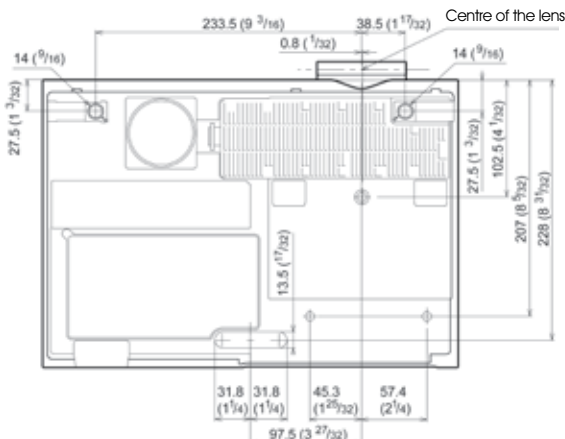

All Sony Professional's education projectors sold into the EU, Norway and Switzerland come supplied with a 3 Year projector and 3 year/3000 hour lamp cover PrimeSupport pack. This offers unique services and benefits over and above standard warranty:-

3 Year projector and 3 year/3000 hour PrimeSupport Cover

Freephone telephone helpdesk support (00800 7898 7898) in 5 languages. Collection, repair and return anywhere in EU, Norway and Switzerland.

In addition, optional PrimeSupport Plus packs can be purchased which can further enhance the 3 year support to give extra peace of mind:-

- A 2 year extension of the standard 3 year PrimeSupport to give long-term assurance of expert support, technical assistance and repairs for 5 years from purchase date.
- Provision of a loan unit for 3 or 5 years cover to ensure minimal impact to the customer's business in case of product failure.

Key Features

ECO Mode Key

Teachers can easily select power-saving ECO Modes. The most energy-efficient mode is accessible through a single button-push, with further adjustments available through an easily understood menu system.

ECO Picture Mute - (Instant Off/Instant On)

The new ECO Picture Mute feature reduces power consumption down to 30%, saving cost and lamp hours. This feature can be used in the classroom as instant off/instant on in-between classes. There is no need to power completely off and turn back on, which is time consuming and a significant problem with projectors in the classroom.

Auto Dimming Mode

The new E200 Series projectors automatically adjust brightness depending on the image. The darker the image, the less energy used by the lamp. (Maximum 70% lamp power reduction based on the image.)

ECO Lamp Dimming

These projectors (if this function is selected) can reduce power consumption and brightness by 10-15%. After a user pre-set time, the brightness and power consumption will reduce to 30% power usage, with instant 100% brightness returning as soon as a new signal input is detected.

ECO Gauge

When the projector is shut down, an ECO achievement indication (gauge) appears to show the teacher how well they have used the projector. The more ECO features that have been used, the better the ECO green leaf mark. (Calculated by the use of ECO functions and actual lamp wattage.)

Other Features

WXGA Resolution

The VPL-EW225, VPL-EW245 and VPL-EW275 have a native WXGA (1280 x 800) 16:10 screen resolution panel, perfect for presentations direct from a laptop or PC.

XGA Resolution

The VPL-EX225, VPL-EX245 and VPL-EX275 have a native XGA (1024 x 768) 4:3 screen resolution panel, perfect for presentations direct from a laptop or PC.

7000 Hours Lamp Life

A new driving scheme reduces gap expansion which minimises brightness gradation. A new cooling system allows uniformity in the temperature of the glass bulb which prevents the glass from clouding.

Filter Cleaning Cycle at the same time as lamp

The filter only needs to be changed when a new lamp is fitted, potentially halving disruption due to maintenance.



 **BrightEra™**

Specifications

		VPL-EW225	VPL-EW245	VPL-EW275	VPL-EX225	VPL-EX245	VPL-EX275	
Display system		3 LCD system						
Display device	Size of effective display area	0.59" (15 mm) x 3, BrightEra, Aspect ratio: 16:10		0.75" (19 mm) x 3, BrightEra, Aspect ratio: 16:10	0.63" (16 mm) x 3, BrightEra, Aspect ratio: 4:3			
	Number of pixels	3,072,000 (1280 x 800 x 3) pixels			2,359,296 (1024 x 768 x 3) pixels			
Projection lens	Zoom (Manual)	X1.3	X1.6		X1.3	X1.6		
	Focus	Manual						
	Digital Zoom	x4						
	Light source	High-pressure mercury lamp 210 W type						
	Recommended lamp replacement time*1	3000 H / 5000 H / 7000 H (Lamp mode: High / Standard / Low)						
	Filter cleaning cycle	Max. 7000 (Lamp Mode: Low) Same time as the lamp replacement is recommended						
	Screen size	30" to 300" (0.762 m to 7.62m)						
	Light output (Lamp mode: High / Standard / Low)	2600 lm / 1900 lm / 1500 lm	3100 lm / 2000 lm / 1600 lm	3700 lm / 2800 lm / 2100 lm	2700 lm / 2100 lm / 1600 lm	3200 lm / 2200 lm / 1700 lm	3700 lm / 2700 lm / 2100 lm	
	Color light output	2600 lm / 1900 lm / 1500 lm	3100 lm / 2000 lm / 1600 lm	3700 lm / 2800 lm / 2100 lm	2700 lm / 2100 lm / 1600 lm	3200 lm / 2200 lm / 1700 lm	3700 lm / 2700 lm / 2100 lm	
	Contrast ratio (full white / full black)	2300:1			3000:1			
Speaker	16 W x 1 (mono)							
Displayable scanning frequency	Horizontal	19 kHz to 92 kHz						
	Vertical	48 Hz to 92 Hz						
Display resolution	Computer signal input	Maximum input signal resolution: UXGA 1600 x 1200 IV:60Hz (resizing display), Panel display resolution: 1280 x 800 pixels			Maximum input signal resolution: UXGA 1600 x 1200 IV:60Hz (resizing display), Panel display resolution: 1024 x 768 pixels			
	Video signal input	Video (composite), 15k (480/60i, 576/50i), DTV (480/60p, 576/50p, 720/60p, 720/50p, 1080/60i, 1080/50i 1080/60p, 1080/50p)						
	Color system	NTSC3.58, PAL, SECAM, NTSC4.43, PAL-M, PAL-N						
	Keystone correction	Vertical: Max. +/- 20 degrees			Vertical: Max. +/- 30 degrees			
	OSD language	23-language (English, French, German, Italian, Spanish, Portuguese, Japanese, Chinese (簡・繁), Korean, Russian, Dutch, Norwegian, Swedish, Thai, Arabic, Turkish, Polish, Vietnamese, Farsi, Finnish*, Indonesian*, Hungary*) * From August 2012						
Computer and video signal input/output	INPUT A	RGB / Y PB PR input connector: Mini D-sub 15-pin (female), Audio: Stereo mini jack						
	INPUT B	RGB / Y PB PR input connector: Mini D-sub 15-pin (female), Audio: Stereo mini jack						
	INPUT C	HDMI (Digital RGB/Y Pb Pr, Digital Audio) HDCP Support						
	VIDEO IN	Video input connector: Pin jack, Audio: Pin jack X2 / Shared with S-Video						
	S VIDEO IN	Mini DIN 4-pin Audio: Pin jack X2 / Shared with Video						
	MONITOR OUT	Mini D-Sub 15-pin (From Input A and Input B)						
	AUDIO OUT	Stereo mini jack (variable out)						
	RS232C	D-sub 9-pin (male)						
	LAN	RJ-45 10BASE-T/100BASE-TX						
	USB	Type A, Type B						
Operating temperature (Operating humidity)		0°C to 40°C / 32°F to 104°F (35% to 85% (no condensation))						
Storage temperature (Storage humidity)		-20°C to +60°C / -4°F to +140°F (10% to 90%)						
Power requirements (Approx)		AC 100 V to 240 V, 3.2 - 1.3A 50 Hz / 60 Hz						
Power consumption	AC 100 V to 120 V	287W / 251W / 228W	311W / 255W / 226W	303W / 256W / 226W	293W / 257W / 228W	315W / 254W / 225W	306W / 256W / 226W	
	AC 220 V to 240 V	277W / 242W / 218W	299W / 246W / 218W	294W / 247W / 218W	285W / 250W / 222W	305W / 248W / 220W	298W / 249W / 220W	
Standby mode power consumption	AC 100 V to 120 V	5.9W / 0.1W (standby mode: Standard / Low)						
	AC 220 V to 240 V	5.9W / <0.2W (standby mode: Standard / Low)						
Heat dissipation	AC 100 V to 120 V	980 BTU	1016 BTU	1034 BTU	1000 BTU	1075 BTU	1044 BTU	
	AC 220 V to 240 V	945 BTU	1020 BTU	1003 BTU	973 BTU	1041 BTU	1017 BTU	
Standard outside dimensions		W 365 x H 96.2 x D 252 mm (without protrusion) W 365 x H 105.3 x D 252.5 mm (With Protrusion)						
Mass (Approx)		4kg / 8lb 11oz						
Supplied Accessories		Remote Commander (1), CR2025, Lithium Battery (1), Mini D-sub 15-pin cable (1), Operating Instructions (1), AC Power Cord, WEEE, EU Battery Info, Service Documentation, Quick Reference Manual (1)						
Optional Accessories		IPN-WLN3, USB wireless module, LMP-E212, Replacement Projector Lamp, 442670201 (FILTER), Replacement Filter						

*1 Hours are approximate

© 2012 Sony Corporation. All rights reserved. Reproduction in whole or in part without permission is prohibited. Features and specifications are subject to change without notice. All non-metric weights and measurements are approximate. Sony and make.believe are trademarks of Sony Corporation. All other trademarks are the property of their respective owners.

Distributed by

Professional Solutions Europe is the leading supplier of AV/IT solutions to businesses across a wide variety of sectors including, **Media and Broadcast, Video Security and Retail, Transport & Large Venue markets**. It delivers products, systems and applications to enable the creation, manipulation and distribution of digital audio-visual content that add value to businesses and their customers. With over 25 years' experience in delivering innovative market-leading products, **Professional Solutions Europe** is ideally placed to deliver exceptional quality and value to its customers. **Sony's Professional Services** division, its systems integration arm, offers its customers access to the expertise and local knowledge of skilled professionals across Europe. Collaborating with a network of established technology partners, Professional Solutions Europe delivers end to end solutions that address the customer's needs, integrating software and systems to achieve each organisations' individual business goals. For more information please visit www.pro.sony.eu

HCT_VPL-E200-Series_J792_UK_09/08/2012

SONY
make.believe