

Confidential

EPSON

ink-jet receipt printer

TM-J7000/J7100

Specification

STANDARD	
Rev. No.	B
Notes	

Copied Date	, ,
Copied by	

SEIKO EPSON CORPORATION

MATSUMOTO MINAMI PLANT
2070 KOTOBUKI KOAKA, MATSUMOTO-SHI, NAGANO, 399-8702 JAPAN
PHONE(0263)86-5353 FAX(0263)86-9925

REVISION SHEET

Be sure to check the contents before utilizing the specification. This specification has the history shown below.

Revisions		Design Section			Sheet Rev. No.							
Rev.	Document	WRT	CHK	APL	Sheet	Rev.	Sheet	Rev.	Sheet	Rev.		
A	Enactment	Fujikawa	--	Takeuchi	I	B	13	B	37	B		
B	Change	Nishioka	Yamagishi	Takeuchi	II	B	14	B	38	B		
					III	B	15	B	39	B		
					IV	B	16	B	40	B		
					V	B	17	B	41	B		
					VI	B	218	B	42	B		
					VII	B	19	B	43	B		
					VIII	B	20	B	44	B		
					IX	B	21	B	45	B		
							22	B	46	B		
							23	B	47	B		
							24	B	48	B		
					1	B	25	B	49	B		
					2	B	26	B	50	B		
					3	B	27	B	51	B		
					4	B	28	B	52	B		
					5	B	29	B	53	B		
					6	B	30	B	54	B		
					7	B	31	B	55	B		
					8	B	32	B	56	B		
					9	B	33	B	57	B		
					10	B	34	B	58	B		
					11	B	35	B	59	B		
					12	B	36	B	60	B		
TITLE TM-J7000/J7100 Specification (STANDARD)					Front Part					Contents Appendix Total	Contents Appendix Total	Contents Appendix Total
					Cover	Rev. Sheet	Scope	General Features	Table of Contents			
					1	4	--	3	6			

Confidential

REVISION SHEET

Be sure to check the contents before utilizing the specification. This specification has the history shown below.

Revisions		Design Section			Sheet Rev. No.						
Rev.	Document	WRT	CHK	APL	Sheet	Rev.	Sheet	Rev.	Sheet	Rev.	
A	Enactment				61	B	85	B	109	B	
B	Change				62	B	86	B	110	B	
					63	B	87	B	111	B	
					64	B	88	B	112	B	
					65	B	89	B	113	B	
					66	B	90	B	114	B	
					67	B	91	B	115	B	
					68	B	92	B	116	B	
					69	B	93	B	117	B	
					70	B	94	B	118	B	
					71	B	95	B	119	B	
					72	B	96	B	120	B	
					73	B	97	B	121	B	
					74	B	98	B	122	B	
					75	B	99	B	123	B	
					76	B	100	B	124	B	
					77	B	101	B	125	B	
					78	B	102	B	126	B	
					79	B	103	B	127	B	
					80	B	104	B	128	B	
					81	B	105	B	129	B	
					82	B	106	B	130	B	
					83	B	107	B	131	B	
					84	B	108	B	132	B	
TITLE TM-J7000/J7100 Specification (STANDARD)				Front Part					Contents	Appendix	Total
				Cover	Rev. Sheet	Scope	General Features	Table of Contents			
				1	4	--	3	6			

Confidential

REVISION SHEET

Be sure to check the contents before utilizing the specification. This specification has the history shown below.

Revisions		Design Section			Sheet Rev. No.						
Rev.	Document	WRT	CHK	APL	Sheet	Rev.	Sheet	Rev.	Sheet	Rev.	
A	Enactment				133	B	157	B	181	B	
B	Change				134	B	158	B	182	B	
					135	B	159	B	183	B	
					136	B	160	B	184	B	
					137	B	161	B	185	B	
					138	B	162	B	186	B	
					139	B	163	B			
					140	B	164	B			
					141	B	165	B			
					142	B	166	B	App. 1	B	
					143	B	167	B	App. 2	B	
					144	B	168	B	App. 3	B	
					145	B	169	B	App. 4	B	
					146	B	170	B	App. 5	B	
					147	B	171	B	App. 6	B	
					148	B	172	B	App. 7	B	
					149	B	173	B	App. 8	B	
					150	B	174	B	App. 9	B	
					151	B	175	B	App.10	B	
					152	B	176	B	App.11	B	
					153	B	177	B	App.12	B	
					154	B	178	B	App.13	B	
					155	B	179	B	App.14	B	
					156	B	180	B	App.15	B	
TITLE TM-J7000/J7100 Specification (STANDARD)				Front Part					Contents	Appendix	Total
				Cover	Rev. Sheet	Scope	General Features	Table of Contents			
				1	4	--	3	6			

REVISION SHEET

REV.	SHEET	CHANGED CONTENTS
B	All	All pages are revised.
	II	General Description This specification describes (added)
	67	3.10.3 Paper Roll Cover Open Sensor NOTES: • Whether the paper roll cover..... → While the cover is open,
	80	DLE EOT <i>n</i> Bit 5 and 6: The cover closed status → while the cover is open,
	118	GS (E <Function 1> [Description] and notifies that → and transmits data that notice
	136	GS (L <Function 51> [Description] ... the NV user memory → ... the NV graphics memory
	168	GS a <i>n</i> Bit 2 and 3: The cover closed status → While the cover is open, ...
	174	GS r <i>n</i> Bit 2 and 3: The cover closed status → While the cover is open, ...
<p>TITLE</p> <p style="text-align: center;">TM-J7000/J7100 Specification (STANDARD)</p>		

Confidential

CONFIDENTIALITY AGREEMENT

BY USING THIS DOCUMENT, YOU AGREE TO ABIDE BY THE TERMS OF THIS AGREEMENT. **PLEASE RETURN THIS DOCUMENT IMMEDIATELY IF YOU DO NOT AGREE TO THESE TERMS.**

1. This document contains confidential, proprietary information of Seiko Epson Corporation or its affiliates. You must keep such information confidential. If the user is a business entity or organization, you must limit disclosure to those of your employees, agents, and contractors who have a need to know and who are also bound by obligations of confidentiality.
2. On the earlier of (a) termination of your relationship with Seiko Epson, or (b) Seiko Epson's request, you must stop using the confidential information. You must then return or destroy the information, as directed by Seiko Epson.
3. If a court, arbitrator, government agency, or the like orders you to disclose any confidential information, you must immediately notify Seiko Epson. You agree to give Seiko Epson reasonable cooperation and assistance in the negotiation.
4. You may use confidential information only for the purpose of operating or servicing the products to which the document relates, unless you obtain the prior written consent of Seiko Epson for some other use.
5. Seiko Epson warrants that it has the right to disclose the confidential information. SEIKO EPSON MAKES NO OTHER WARRANTIES CONCERNING THE CONFIDENTIAL INFORMATION OR ANY OTHER INFORMATION IN THE DOCUMENT, INCLUDING (WITHOUT LIMITATION) ANY WARRANTY OF TITLE OR NON-INFRINGEMENT. Seiko Epson has no liability for loss or damage arising from or relating to your use of or reliance on the information in the document.
6. You may not reproduce, store, or transmit the confidential information in any form or by any means (electronic, mechanical, photocopying, recording, or otherwise) without the prior written permission of Seiko Epson.
7. Your obligations under this Agreement are in addition to any other legal obligations. Seiko Epson does not waive any right under this Agreement by failing to exercise it. The laws of Japan apply to this Agreement.

CAUTIONS

1. This document shall apply only to the product(s) identified herein.
2. No part of this document may be reproduced, stored in a retrieval system, or transmitted in any form or by any means, electronic, mechanical, photocopying, recording, or otherwise, without the prior written permission of Seiko Epson Corporation.
3. The contents of this document are subject to change without notice. Please contact us for the latest information.
4. While every precaution has been taken in the preparation of this document, Seiko Epson Corporation assumes no responsibility for errors or omissions.
5. Neither is any liability assumed for damages resulting from the use of the information contained herein.
6. Neither Seiko Epson Corporation nor its affiliates shall be liable to the purchaser of this product or third parties for damages, losses, costs, or expenses incurred by the purchaser or third parties as a result of: accident, misuse, or abuse of this product or unauthorized modifications, repairs, or alterations to this product, or (excluding the U.S.) failure to strictly comply with Seiko Epson Corporation's operating and maintenance instructions.
7. Seiko Epson Corporation shall not be liable against any damages or problems arising from the use of any options or any consumable products other than those designated as Original EPSON Products or EPSON Approved Products by Seiko Epson Corporation.

TRADEMARKS

EPSON® and ESC/POS® are registered trademarks of Seiko Epson Corporation.
Windows® is a registered trademark of Microsoft Corporation.

General Notice: Other product and company names used herein are for identification purposes only and may be trademarks of their respective companies.

EPSON	TITLE TM-J7000/J7100 Specification (STANDARD)	SHEET REVISION B	NO.	
			NEXT II	SHEET I

GENERAL DESCRIPTION

1) This specification applies to the following models of the TM-J7000/J7100 series printer.

TM-J7000 (without a MICR reader and an endorsement mechanism)

TM-J7000 (with a MICR reader and an endorsement mechanism)

TM-J7100 (without a MICR reader and an endorsement mechanism)

TM-J7100 (with a MICR reader and an endorsement mechanism)

This specification describes only the outline of the general functions and the model-dependent functions of the commands. For detailed specifications and usage of the commands, please refer to the ESC/POS APG (Application Programming Guide) that is separately issued.

2) Features

The TM-J7000/J7100 series printer is a high-end ink-jet POS printer that can print on receipt paper (roll paper) and slip paper. The TM-J7000 is a single-color (black) printing model, and the TM-J7100 is a two-color printing model. The printer has the following features:

<General>

- Small footprint
 - Can print both on roll and slip paper
- Low acoustic noise
 - Performs with low acoustic noise suitable for exclusive stores
- Printing on normal paper
 - Printing on normal paper using ink jet technology brings a low running cost.
- Printability
 - The TM-J7000, using a multi-nozzle, high-density ink jet head (64 nozzles / 180 dpi × 1 line), is designed for high printability.
 - The TM-J7100, using a multi-nozzle high density ink jet head (64 nozzles / 180 dpi × 2 lines) and supporting two-color printing with a two-color ink cartridge, is capable of many types of printing such as logo printing (dpi: dots per 25.4 mm {1"}).
- Interface
 - Various interface boards (EPSON UB series) can be used.
- NV graphics
 - NV user memory: 384KB
- Counter function that enables the printer to be checked by remote maintenance.
- Control commands
 - Based on the ESC/POS[®] Proprietary Command System.
- Printer driver
 - OPOS ADK and Windows[®] printer drivers are available.
- Epson customer display (DM-D series) can be connected (only for serial interface model)

EPSON	TITLE TM-J7000/J7100 Specification (STANDARD)	SHEET REVISION B	NO.	
			NEXT III	SHEET II

Confidential

- Ink cartridge
 - Equipped with an ink near-end sensor that indicates that the ink is almost ended before the ink end.
The TM-J7000, uses a large-capacity, single-color ink cartridge, SJIC6(K), that makes the ink's life long and the running operation's cost low.
The TM-J7100, uses a replaceable ink cartridge, SJIC8(K) or SJIC(R), (B), (G), that makes the ink's life long.

<Receipt printer section>

- High-speed printing on normal paper
 - Approximately 15 lps (69.5 mm paper width, font B) (lps: lines per second)
- Easy to operate
 - Easy paper loading by just dropping in.
- Autocutter
 - Long life (guaranteed to 1.5 million cuts)
- Sensors for roll paper
 - Paper-end sensor and paper near-end sensor are standard
- Can print various bar codes and two-dimensional code (PDF417)

<Slip printer section>

- High-speed printing with a low acoustic noise
 - Printing with a high speed and a low acoustic noise using ink jet technology.
- A factory-installed optional Magnetic Ink Character Recognition (MICR) reader that enables the printer to perform consecutive reading and processing of MICR characters and a factory-installed optional endorsement printer (EP) that enables high-speed printing of endorsements can be installed.
- The a wide slip entrance and mechanical form stopper allow the slip to be set stably.

EPSON	TITLE TM-J7000/J7100 Specification (STANDARD)	SHEET REVISION B	NO.	
			NEXT IV	SHEET III

Table of Contents

1. GENERAL SPECIFICATIONS	1
1.1 Printing Specifications	1
1.1.1 Printing Specifications (common to paper roll, slip, endorsement printing).....	1
1.1.2 Character Specifications.....	4
1.2 Receipt Printer Section	6
1.2.1 Autocutter	6
1.2.2 Paper Roll Supply Device	6
1.2.3 Paper Feeding Mechanism.....	6
1.2.4 Paper Roll Specifications.....	6
1.2.5 Printable Area	7
1.2.6 Printing and Cutting Positions.....	8
1.3 Slip Printer Section.....	9
1.3.1 Paper Feeding Specifications	9
1.3.2 Paper Specifications.....	9
1.3.3 Printable Area	10
1.4 MICR Reader Section (Factory-Installed Option)	11
1.4.1 Reading Method	11
1.4.2 Recognition Rate	11
1.4.3 Insertion Direction and Endorsement Printing	11
1.4.4 Notes on Using the MICR Reader.....	12
1.5 Endorsement Mechanism Section (Factory-Installed Option)	13
1.5.1 Paper Specifications	13
1.5.2 Printable Area	13
1.5.3 Notes on Using the Endorsement Mechanism	14
1.6 Ink Cartridges.....	15
1.6.1 TM-J7000 Single-Color Print Model	15
1.6.2 TM-J7100 Two-Color Print Model.....	15
1.6.3 General Specifications for Both Ink Cartridges	15
1.7 General Section	16
1.7.1 Internal Buffer	16
1.7.2 Electrical Characteristics	16
1.7.3 EMI and Safety Standards Applied.....	16
1.7.4 Reliability.....	17
1.7.5 Environmental Conditions.....	17
1.7.6 Installation.....	18
2. CONFIGURATION	19
2.1 Interfaces	19
2.1.1 RS-232 Serial Interface	19
2.1.2 IEEE 1284 Bidirectional Parallel Interface (Parallel Interface Specifications)	24
2.1.3 Other Interfaces.....	31
2.2 Connectors.....	32
2.2.1 Interface Connectors	32
2.2.2 Power Supply Connector	32
2.2.3 Drawer Kick-out Connector (Modular Connector)	33
2.2.4 Customer Display Connector.....	35
3. FUNCTIONS.....	36
3.1 List of Commands	36
3.2 Character Code Tables.....	40
3.2.1 Page 0 (PC437: USA, Standard Europe) (International Character Set: U.S.A.)	40
3.2.2 Page 1 (Katakana).....	41

EPSON	TITLE	TM-J7000/J7100 Specification (STANDARD)	SHEET REVISION	NO.	
			B	NEXT V	SHEET IV

Confidential

3.2.3 Page 2 (PC850: Multilingual)	42
3.2.4 Page 3 (PC860: Portuguese)	43
3.2.5 Page 4 (PC863: Canadian-French)	44
3.2.6 Page 5 (PC865: Nordic)	45
3.2.7 Page 16 (WPC1252)	46
3.2.8 Page 17 (PC866: Cyrillic #2)	47
3.2.9 Page 18 (PC852: Latin2)	48
3.2.10 Page 19 (PC858: Euro)	49
3.2.11 Page 255 (User-defined Page)	50
3.2.12 International Character Sets	51
3.3 Switches and Buttons	52
3.3.1 Power Button	52
3.3.2 Panel Button	52
3.3.3 DIP Switches	53
3.3.4 Memory Switches	54
3.4 Indicators	57
3.4.1 Panel LED Indicators	57
3.5 Self-Test.....	59
3.6 Hexadecimal Dumping.....	60
3.7 Memory Switches Setting Mode.....	61
3.8 Error Processing	62
3.8.1 Error Types.....	62
3.8.2 Printer Operation When an Error Occurs	64
3.8.3 Data Receive Error	64
3.9 Paper Sensors	65
3.9.1 Sensors and LED Indicators.....	65
3.9.2 Sensors and Printing	66
3.10 Printer Cover Sensors and Cover Opening/Closing Operation.....	67
3.10.1 Carriage Cover Open Sensor	67
3.10.2 Opening/Closing the Carriage Cover.....	67
3.10.3 Paper Roll Cover Open Sensor	67
3.10.4 Opening/Closing the Paper Roll Cover.....	67
3.11 Ink Cartridge Sensor and Exchanging the Ink Cartridge	68
3.11.1 Ink Cartridge Sensor.....	68
3.11.2 Ink Near-end Sensor	68
3.11.3 Exchanging the Ink Cartridge	68
3.12 Print Buffer-full Printing	68
3.13 Paper Jam Removal	69
3.13.1 Slip.....	69
3.13.2 Paper Roll.....	69
3.14 Reading MICR Characters and Printing Endorsements	70
3.15 Cleaning the MICR Mechanism.....	71
4. CASE SPECIFICATIONS	72
4.1 External Dimensions and Mass	72
4.2 Color	72
4.3 External Appearance	72
4.4 Installing the Customer Display Fixing Plate.....	73
5. OPTIONS AND CONSUMABLES	74
5.1 Standard Accessories	74
5.2 Options.....	74
5.3 Consumables	74

EPSON	TITLE	TM-J7000/J7100 Specification (STANDARD)	SHEET REVISION	NO.	
			B	NEXT VI	SHEET V

Confidential

6. COMMANDS	75
6.1 Command Notation	75
6.2 Explanation of Terms	75
6.3 Control Commands	76
HT	76
LF	76
FF	76
CR	77
CAN	77
DLE EOT <i>n [a]</i>	78
DLE ENQ <i>n</i>	83
DLE DC4 <i>fn m t (fn = 1)</i>	84
DLE DC4 <i>fn a b (fn = 2)</i>	85
DLE DC4 <i>fn m (fn = 7)</i>	86
DLE DC4 <i>fn d1...d7 (fn = 8)</i>	87
ESC FF	88
ESC SP <i>n</i>	88
ESC ! <i>n</i>	89
ESC \$ <i>nL nH</i>	89
ESC % <i>n</i>	90
ESC & <i>y c1 c2 [x1 d1...d(y × x1)]...[xk d1...d(y × xk)]</i>	90
ESC * <i>m nL nH d1...dk</i>	91
ESC - <i>n</i>	91
ESC 2	92
ESC 3 <i>n</i>	92
ESC <	92
ESC = <i>n</i>	93
ESC ? <i>n</i>	94
ESC @	94
ESC D <i>n1...nk NUL</i>	95
ESC E <i>n</i>	95
ESC F <i>n</i>	96
ESC G <i>n</i>	96
ESC J <i>n</i>	96
ESC K <i>n</i>	97
ESC L	97
ESC M <i>n</i>	97
ESC R <i>n</i>	98
ESC S	99
ESC T <i>n</i>	99
ESC U <i>n</i>	99
ESC W <i>xL xH yL yH dxL dxH dyL dyH</i>	100
ESC \ <i>nL nH</i>	101
ESC a <i>n</i>	101
ESC c 0 <i>n</i>	102
ESC c 1 <i>n</i>	102
ESC c 3 <i>n</i>	103
ESC c 4 <i>n</i>	104
ESC c 5 <i>n</i>	104
ESC d <i>n</i>	105
ESC e <i>n</i>	105
ESC f <i>t1 t2</i>	105
ESC p <i>m t1 t2</i>	106

EPSON	TITLE	SHEET REVISION	NO.	
	TM-J7000/J7100 Specification (STANDARD)	B	NEXT VII	SHEET VI

Confidential

ESC q	106
ESC t n	107
ESC { n	107
FS (e pL pH m n	108
GS ! n	109
GS \$ nL nH	109
GS (A pL pH n m	110
GS (B pL pH m [a1 b1]...[ak bk]	111
GS (C pL pH m fn b [c1 c2] [d1...dk]	112
<Function 0> GS (C pL pH m fn b c1 c2 (fn = 0, 48)	113
<Function 1> GS (C pL pH m fn b c1 c2 d1...dk (fn = 1, 49)	113
<Function 2> GS (C pL pH m fn b c1 c2 (fn = 2, 50)	114
<Function 3> GS (C pL pH m fn b (fn = 3, 51)	114
<Function 4> GS (C pL pH m fn b (fn = 4, 52)	114
<Function 5> GS (C pL pH m fn b (fn = 5, 53)	115
<Function 6> GS (C pL pH m fn b d1 d2 d3 (fn = 6, 54)	115
GS (D pL pH m [a1 b1]...[ak bk]	116
GS (E pL pH fn [parameters]	117
<Function 1> GS (E pL pH fn d1 d2 (fn = 1)	118
<Function 2> GS (E pL pH fn d1 d2 d3 (fn = 2)	118
<Function 3> GS (E pL pH fn [a1 b18...b11]...[ak bk8...bk1] (fn = 3)	119
<Function 4> GS (E pL pH fn a (fn = 4)	121
<Function 5> GS (E pL pH fn [a1 n1L n1H]...[ak nKL nkH] (fn = 5)	121
<Function 6> GS (E pL pH fn a (fn = 6)	122
<Function 7> GS (E pL pH fn a d1 d2 (fn = 7)	122
<Function 8> GS (E pL pH fn y c1 c2 [x d1...d(y ' x)]k (fn = 8)	123
<Function 9> GS (E pL pH fn x c1 c2 [y d1...d(x ' y)]k (fn = 9)	123
<Function 10> GS (E pL pH fn c1 c2 (fn = 10)	124
<Function 11> GS (E pL pH fn a d1...dk (fn = 11)	124
<Function 12> GS (E pL pH fn a (fn = 12)	125
GS (G pL pH fn [parameters]	126
<Function 32> GS (G pL pH fn m (fn = 32)	127
<Function 48> GS (G pL pH fn m (fn = 48)	128
<Function 80> GS (G pL pH fn m (fn = 80)	128
<Function 81> GS (G pL pH fn m (fn = 81)	129
<Function 82> GS (G pL pH fn m (fn = 82)	129
<Function 83> GS (G pL pH fn m (fn = 83)	129
<Function 84> GS (G pL pH fn m (fn = 84)	130
<Function 85> GS (G pL pH fn m (fn = 85)	130
GS (H pL pH fn [parameters]	131
<Function 48> GS (H pL pH fn m d1 d2 d3 d4 (fn = 48)	131
<Function 49> GS (H pL pH fn m d (fn = 49)	131
GS (K pL pH fn [parameters]	132
<Function 48> GS (K pL pH fn m (fn = 48)	132
GS (L pL pH m fn [parameters]	133
GS 8 L p1 p2 p3 p4 m fn [parameters]	133
<Function 48> GS (L pL pH m fn (fn = 0, 48)	135
<Function 50> GS (L pL pH m fn (fn = 2, 50)	135
<Function 51> GS (L pL pH m fn (fn = 3, 51)	136
<Function 52> GS (L pL pH m fn (fn = 4, 52)	136
<Function 64> GS (L pL pH m fn d1 d2 (fn = 64)	136
<Function 65> GS (L pL pH m fn d1 d2 d3 (fn = 65)	137
<Function 66> GS (L pL pH m fn kc1 kc2 (fn = 66)	137

EPSON	TITLE	TM-J7000/J7100 Specification (STANDARD)	SHEET REVISION	NO.	
			B	NEXT VIII	SHEET VII

Confidential

<Function 67> GS (L pL pH m fn a kc1 kc2 b xL xH yL yH [c d1...dk]1...[c d1...dk]b (fn = 67) 138

<Function 68> GS (L pL pH m fn a kc1 kc2 b xL xH yL yH [c d1...dk]1...[c d1...dk]b (fn = 68) . 139

<Function 69> GS (L pL pH m fn kc1 kc2 x y (fn = 69) 140

<Function 80> GS (L pL pH m fn d1 d2 (fn = 80) 140

<Function 81> GS (L pL pH m fn d1 d2 d3 (fn = 81) 141

<Function 82> GS (L pL pH m fn kc1 kc2 (fn = 82) 141

<Function 83> GS (L pL pH m fn a kc1 kc2 b xL xH yL yH [c d1...dk]1...[c d1...dk]b (fn = 83) . 142

<Function 84> GS (L pL pH m fn a kc1 kc2 b xL xH yL yH [c d1...dk]1...[c d1...dk]b (fn = 84) . 143

<Function 85> GS (L pL pH m fn kc1 kc2 x y (fn = 85) 144

<Function 112> GS (L pL pH m fn a bx by c xL xH yL yH d1...dk (fn = 112) 144

<Function 113> GS (L pL pH m fn a bx by c xL xH yL yH d1...dk (fn = 113) 145

GS (M pL pH fn m 146

<Function 1> GS (M pL pH fn m (fn = 1,49) 147

<Function 2> GS (M pL pH fn m (fn = 2,50) 147

<Function 3> GS (M pL pH fn m (fn = 3,51) 148

GS (N pL pH fn [parameters] 149

<Function 48> GS (N pL pH fn m (fn = 48) 149

<Function 49> GS (N pL pH fn m (fn = 49) 150

<Function 50> GS (N pL pH fn m a (fn = 50) 150

GS (P pL pH fn [parameters] 150

<Function 48> GS (P pL pH fn wxL wxH wyL wyH oxL oxH c (fn = 48) 151

GS (k pL pH cn fn [parameters] 153

<Function 065> GS (k pL pH cn fn n (fn = 65) 154

<Function 066> GS (k pL pH cn fn n (fn = 66) 154

<Function 067> GS (k pL pH cn fn n (fn = 67) 155

<Function 068> GS (k pL pH cn fn n (fn = 68) 155

<Function 069> GS (k pL pH cn fn n (fn = 69) 156

<Function 070> GS (k pL pH cn fn m (fn = 70) 157

<Function 080> GS (k pL pH cn fn m d1...dk (fn = 80) 157

<Function 081> GS (k pL pH cn fn m (fn = 81) 158

<Function 082> GS (k pL pH cn fn m (fn = 82) 159

GS * x y d1...dk [obsolete command] 159

GS / m [obsolete command] 160

GS B n 160

GS H n 161

GS I n 162

GS L nL nH 163

GS P x y 163

GS Q 0 m xL xH yL yH d1...dk [obsolete command] 164

GS T n 164

① GS V m ② GS V m n 165

GS W nL nH 165

GS \ nL nH 166

GS a n 166

GS f n 169

GS g 0 m nL nH 169

GS g 2 m nL nH 170

GS h n 171

GS j n 171

① GS k m d1...dk NUL ② GS k m n d1...dn 173

GS r n 174

GS v 0 m xL xH yL yH d1...dk [obsolete command] 177

GS w n 177

EPSON	TITLE	SHEET REVISION	NO.	
	TM-J7000/J7100 Specification (STANDARD)	B	NEXT XI	SHEET VIII

Confidential

6.4 MICR Control Commands (for models with a MICR reader)	178
DLE EOT <i>n a</i> (<i>n</i> = 8).....	178
FS (<i>f pL pH [n m]1...[n m]k</i>	179
FS a 0 <i>n</i> [obsolete command].....	181
FS a 1 [obsolete command].....	182
FS a 2 [obsolete command].....	182
FS b [obsolete command].....	183
FS c	183
GS (<i>G pL pH fn [parameters]</i>	183
<Function 60> GS (<i>G pL pH fn nL nH m</i> (<i>fn</i> = 60).....	184
<Function 61> GS (<i>G pL pH fn nL nH</i> (<i>fn</i> = 61).....	186
APPENDIX A MISCELLANEOUS NOTES	App.1
APPENDIX B CHANGING THE INK CARTRIDGE	App.6
APPENDIX C INSTALLING OR REPLACING THE PAPER ROLL	App.7
APPENDIX D: ADJUSTING THE PAPER ROLL NEAR-END SENSOR LOCATION	App.8
APPENDIX E: DESCRIPTION OF THE MAINTENANCE COUNTERS.....	App.10
APPENDIX F: NOTES ON USING THE DRAWER KICK-OUT CONNECTOR.....	App.12
APPENDIX G: NOTES ON TURNING THE PRINTER'S POWER ON/OFF	App.13
APPENDIX H: REPLACING THE PUMP UNIT AND THE INK SUPPLY UNIT	App.14
APPENDIX I: CHANGING THE PAPER WIDTH	App.15

EPSON	TITLE	TM-J7000/J7100 Specification (STANDARD)	SHEET REVISION	NO.	
			B	NEXT 1	SHEET IX

1. GENERAL SPECIFICATIONS

(Items without any identification in the product name are common to both two-color and single-color models.)

1.1 Printing Specifications**1.1.1 Printing Specifications** (common to paper roll, slip, and endorsement printing)

- 1) Printing method: Serial ink-jet dot matrix
TM-J7000 single-color model: Single-color printing
TM-J7100 two-color model: Two-color printing
- 2) Head nozzle: TM-J7000 single-color model:
64 nozzles × 1 line,
Nozzle pitch: Approximately 0.141 mm {1/180"}
TM-J7100 two-color model:
64 nozzles × 2 lines,
Corresponds to one line for one color,
Nozzle pitch: Approximately 0.141 mm {1/180"}
- 3) Printing direction: Bidirectional logic seeking
- 4) Printable area: Refer to Table 1.1.1, 1.1.2, 1.1.3.
- 6) Characters per line: Refer to Table 1.1.1, 1.1.2, 1.1.3
- 7) Printing speed: Refer to Table 1.1.4
- 8) Paper feeding speed: Approximately 150 mm/s {5.9"/s}
(with continuous paper feed)
- 9) Print control mode: Refer to Table 1.1.5.
- 10) Line spacing: Approximately 4.23 mm {1/6"} (default),
Approximately 3.18 mm {1/8"}; possible to print in three lines
simultaneously, selectable by a command.

Table 1.1.1 Characters per Line and Printable Area for Roll Paper

Paper width (mm)	57.5 {2.26"}	69.5 {2.74"}	76 {2.99"}	82.5 {3.25"}	Remarks
Number of dots for printing (dots)	360	432	480	512	
Printable width (mm) {"}	50.8 {2.00"}	61 {2.40"}	67.7 {2.67"}	72.2 {2.84"}	
Characters per line					
Font A (12 × 24)	30	36	40	42	When printing at 15 cpi
Font B (9 × 17)	40	48	53	56	When printing at 20 cpi
* Font A (11 × 24)	32	39	43	46	When printing at 16.3 cpi
* Font B (8 × 17)	45	54	60	64	When printing at 22.5 cpi

*: Selectable by a memory switch

cpi: characters per 25.4 mm {1"}

EPSON	TITLE TM-J7000/J7100 Specification (STANDARD)	SHEET REVISION B	NO.	
			NEXT 2	SHEET 1

Table 1.1.2 Characters per Line and Printable Area for Slips

Number of dots for printing (dots)		576	
Printable width (mm)		81.3 {3.20"}	
Character per line	Font A (12 × 24)	48	When printing at 15 cpi
	Font B (9 × 17)	64	When printing at 20 cpi
	* Font A (11 × 24)	52	When printing at 16.3 cpi
	* Font B (8 × 17)	72	When printing at 22.5 cpi

*: Selectable by a memory switch

Table 1.1.3 Characters per Line for and Printable Area Endorsement (Factory-installed Option)

Number of dots for printing (dots)		552	
Printable width (mm)		77.9 {3.06"}	
Character per line	Font A (12 × 24)	46	When printing at 15 cpi
	Font B (9 × 17)	61	When printing at 20 cpi
	* Font A (11 × 24)	50	When printing at 16.3 cpi
	* Font B (8 × 17)	69	When printing at 22.5 cpi

*: Selectable by a memory switch (same as the setting for slip)

Table 1.1.4 General Printing Speed

Print control mode	Font		Paper width (mm)				Slip
			57.5 {2.26"}	69.5 {2.74"}	76 {2.99"}	82.5 {3.25"}	
Normal	Font A (6 lpi)	lps	7.4	6.7	6.3	6.0	6.0
	Font B (8 lpi)	lps	10.7	9.5	8.9	8.6	8.6
	Graphics	mm/s	32	29	27	26	26
High speed	Font A (6 lpi)	lps	11.6	10.5	10.1	9.7	9.6
	Font B (8 lpi)	lps	16.4	15.0	14.3	13.8	13.7
	Graphics	mm/s	50	45	43	41	40
Economy	Font A (6 lpi)	lps	11.6	10.5	10.1	9.7	9.6
	Font B (8 lpi)	lps	16.4	15.0	14.3	13.8	13.7
	Graphics	mm/s	50	45	43	41	40

lpi: lines per 25.4 mm {1"}

lps: lines per second

- NOTES: 1. All values listed above are the printing speed without character modification when the printing is performed continuously for all columns without cleaning.
2. Printing speed may be slower, depending on the data transmission speed and the combination of control commands. If the data transmission speed is slow, the printing becomes intermittent. Therefore, it is recommended to use high-speed data transmission.

EPSON	TITLE	TM-J7000/J7100 Specification (STANDARD)	SHEET REVISION	NO.	
			B	NEXT	SHEET
			3	2	

Table 1.1.5 Print Control Mode

Print control mode	Number of carriage passes (*1)	Vertical resolution (dpi)	Horizontal resolution (dpi)	Dot structure (number of pulses to the head)
Normal	1	180	180	6
High speed	1	180	180	3
Economy	1	180	180	2

dpi: dots per 25.4 mm {1"}

*1 Pass: To move the carriage from the left to the right or from the right to the left.

- NOTES:
- Normal mode: Print control mode that prints in fine (high-density) quality.
 - High-speed mode: Print control mode that saves ink, prints at a high speed, and is selected as default.
 - Economy mode: Print control mode that saves more ink than high-speed mode.

EPSON	TITLE TM-J7000/J7100 Specification (STANDARD)	SHEET REVISION B	NO.	
			NEXT 4	SHEET 3

1.1.2 Character Specifications

- 1) Number of characters: Alphanumeric characters: 95
 Extended graphics: 128 × 11 pages
 (including one user-defined page)
 International characters: 37
- 2) Character structure: Font A: 12 × 24
 Font B: 9 × 17
- Using the memory switch for characters per line:
- Font A: 11 × 24
 Font B: 8 × 17

- NOTES:
- The number of characters (columns) per line is selectable by a memory switch.
 - Selection of characters per line can be performed for receipt and slip (including endorsement) respectively.
 - If memory switch changing of characters per line is performed, one dot on the right side of a graphic character or user-defined character may be missed.

3) Character size (character area):

Table 1.1.6 Character Size for ANK/Multilingual Model

	Standard	Double-height	Double-width	Double-width / Double-height
	W × H (mm)	W × H (mm)	W × H (mm)	W × H (mm)
Font A (12 × 24)	1.69 × 3.38	1.69 × 6.77	3.38 × 3.38	3.38 × 6.77
Font B (9 × 17)	1.27 × 2.40	1.27 × 4.80	2.54 × 2.40	2.54 × 4.80
Font A (11 × 24)	1.55 × 3.38	1.55 × 6.77	3.10 × 3.38	3.10 × 6.77
Font B (8 × 17)	1.13 × 2.40	1.13 × 4.80	2.26 × 2.40	2.26 × 4.80

- NOTES:
1. The actual print character may be smaller than the size shown in the table above, because the above size includes spaces in the font.
 2. Characters can be scaled up to 64 times as large as the standard size.
 3. Character size not including the horizontal spacing in the standard scale is as follows:
 Font A: 1.41 (W) × 3.384 (H) mm
 Font B: 0.987 (W) × 2.397 (H) mm
 4. ANK = alphanumeric

EPSON	TITLE TM-J7000/J7100 Specification (STANDARD)	SHEET REVISION B	NO.	
			NEXT 5	SHEET 4

4) Bar code printing

The following types of bar codes can be printed:

- UPC-A
- UPC-E
- JAN13 (EAN13)
- JAN8 (EAN8)
- CODE39
- ITF
- CODABAR (NW7)
- CODE93
- CODE128

- NOTES:
1. When bar code printing is selected, the printer automatically sets the print control mode to normal and unidirectional printing.
 2. In page mode containing a bar code, regardless of any settings for the print control mode, all print areas including the bar code are set to normal mode and unidirectional print.
 3. In a ladder bar code print, it is recommended to set 0.423 or more ($n = 3$ of **GS w**) as the minimum module length.
 4. Never print a ladder bar code on a slip.

5) Two-dimensional code printing

The following two-dimensional code can be printed:

- PDF417

- NOTES:
1. When two-dimensional code printing is selected, the printer automatically sets the print control mode to normal and unidirectional printing.
 2. In page mode containing a two-dimensional code, regardless of any settings for the print control mode, all print areas including the two-dimensional code are set to normal mode and unidirectional print.
 3. In a ladder bar code print, it is recommended to set 0.423 or more ($n = 3$ of **GS (k <Function 067>**) as the minimum module length.
 4. Never print a two-dimensional code on a slip.

EPSON	TITLE	TM-J7000/J7100 Specification (STANDARD)	SHEET REVISION	NO.	
			B	NEXT 6	SHEET 5

1.2 Receipt Printer Section

1.2.1 Autocutter

- 1) Cutting method: Circular-type cutting method
- 2) Cutting type: One point left uncut (called "partial cut").

1.2.2 Paper Roll Supply Device

- 1) Supply method: Easy-to-load drop-in mechanism
- 2) Paper roll end sensor: By microswitch
- 3) Near-end sensor: By microswitch (adjusted by users)
- 4) Paper roll spool diameter: Inside: 10 mm {0.39"} or more
- 5) Near-end adjustment mechanism: Adjustable with an adjusting screw (Refer to Appendix D)
- 6) Paper width selection: Any of four types of paper width – 57.5, 69.5, 76, 82.5 mm {2.26", 2.74", 2.99", 3.25"} can be selected.

- NOTES:
- To change the paper width, you must set the memory switch appropriately.
 - When the paper width is changed from narrow to wide, the autocutter blade must be replaced with a new one, since the ends of the blade are worn even though they have not been used.

1.2.3 Paper Feeding Mechanism

- 1) Paper feeding method: Friction feed method
- 2) Paper feeding direction: Unidirectional
- 3) Minimum paper feeding pitch: Possible to set 0.1411 mm {1/180"} minimum
- 4) Continuous paper feeding speed: Approximately 150 mm/s {5.9"/s}, 35.4 lps {1/6" feed} (lps: lines per second)

1.2.4 Paper Roll Specifications

- 1) Paper type: Normal quality paper (only single-ply rolls can be used)
- 2) Form: Paper roll
- 3) Paper width: Can be selected any of the following:
82.5 ± 0.5 mm
76 ± 0.5 mm
69.5 ± 0.5 mm
57.5 ± 0.5 mm
- 4) Paper thickness: 0.06 – 0.09 mm
- 5) Paper weight: 52.3 – 64.0 g/m² {14 – 17 lb} (JIS P8124)
(45 ~ 55 kg / 1000 pcs / 788 mm × 1091 mm)
- 6) Spool diameter: Inside: 10 mm {0.39"} or more
- 7) Paper roll diameter: Outside: 83 mm {3.27"} or less

EPSON	TITLE	TM-J7000/J7100 Specification (STANDARD)	SHEET REVISION	NO.	
			B	NEXT 7	SHEET 6

1.2.5 Printable Area

1) Printable area

Refer to Figure 1.2.1. and Table 1.2.1

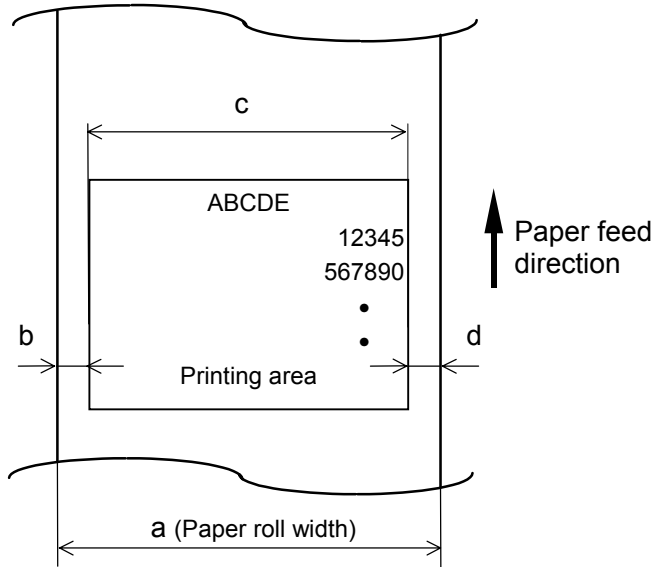

Figure 1.2.1 Printable Area

Table 1.2.1 Dimensions in Figure 1.2.1 [Units: mm]

a (paper roll width)	b (left margin)	c (printable area)	d (right margin)
57.5 {2.26"}	(3.4) {0.13"}	50.8 {2.00"} (360 dots)	3.3 {0.13"}
69.5 {2.74"}	(4.2) {0.17"}	61.0 {2.40"} (432 dots)	4.3 {0.17"}
76 {2.99"}	(4.3) {0.17"}	67.7 {2.67"} (480 dots)	4.2 {0.17"}
82.5 {3.25"}	(6.0) {0.24"}	72.2 {2.84"} (512 dots)	4.3 {0.17"}

EPSON	TITLE TM-J7000/J7100 Specification (STANDARD)	SHEET REVISION B	NO.	
			NEXT 8	SHEET 7

1.2.6 Printing and Cutting Positions

1) Relationship between the printing and cutting positions. (Refer to Figure 1.2.2).

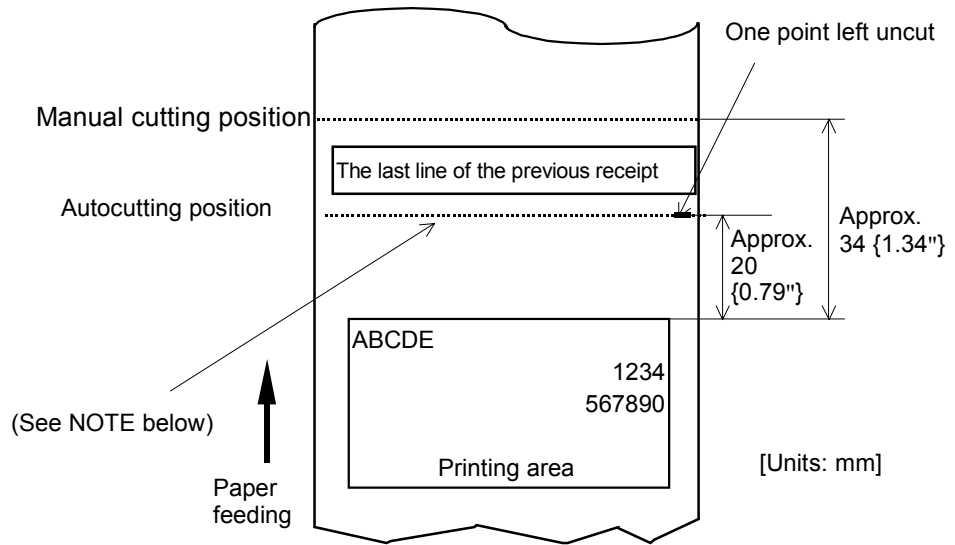

Figure 1.2.2 Printing and Cutting Positions

NOTE: Numeric values used here are typical values; the values may vary slightly as a result of paper slack or variations in the paper. Take this note into account when setting the cutting position of the autocutter.

EPSON	TITLE	TM-J7000/J7100 Specification (STANDARD)	SHEET REVISION	NO.	
			B	NEXT 9	SHEET 8

1.3 Slip Printer Section

1.3.1 Paper Feeding Specifications

- 1) Feeding method: Friction feed
- 2) Feeding direction: Bidirectional (possible to feed in forward and reverse direction)
- 3) Feeding pitch: Approximately 0.1411 mm {1/180"}
- 4) Continuous feeding speed: Approximately 150 mm/s {5.9"/s}
35.4 lps {1/6" feed}
[lps: lines per second]

1.3.2 Paper Specifications

- 1) Paper types: Normal paper
- 2) Paper sizes: 68 – 230 mm (W) × 68 – 297 mm (L) {2.7 – 9.1"(W) × 2.7 – 11.7"(L)}

NOTE: The minimum paper size is 68 × 152 mm {2.7 – 6.0"}.

- 3) Paper thickness: 0.09 mm – 0.2 mm {0.0035 – 0.0079"} (only single-ply can be used).
- 4) Notes on slip paper

- The slip paper must be flat, without curls or wrinkles, especially at the top edges. Otherwise, the paper may rub against the nozzles and become dirty.
- Since the slip BOF sensor uses a photo sensor, do not use paper that has holes at the sensor position, or is translucent.
- Since the slip TOF sensor uses a reflective photo sensor and it detects from the back of slip paper, do not use paper that has holes or dark portions with low reflection (less than 40% reflection) at the sensor position.

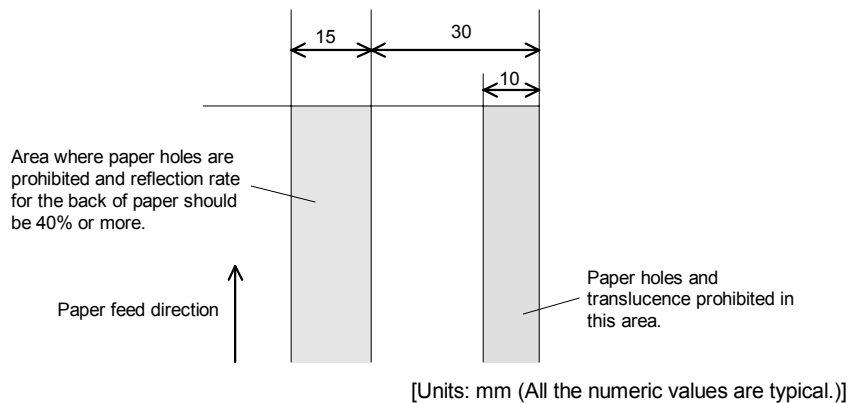

Figure 1.3.1 Area with No Paper Holes and Low Reflection

EPSON	TITLE	TM-J7000/J7100 Specification (STANDARD)	SHEET REVISION	NO.	
			B	NEXT 10	SHEET 9

1.3.3 Printable Area

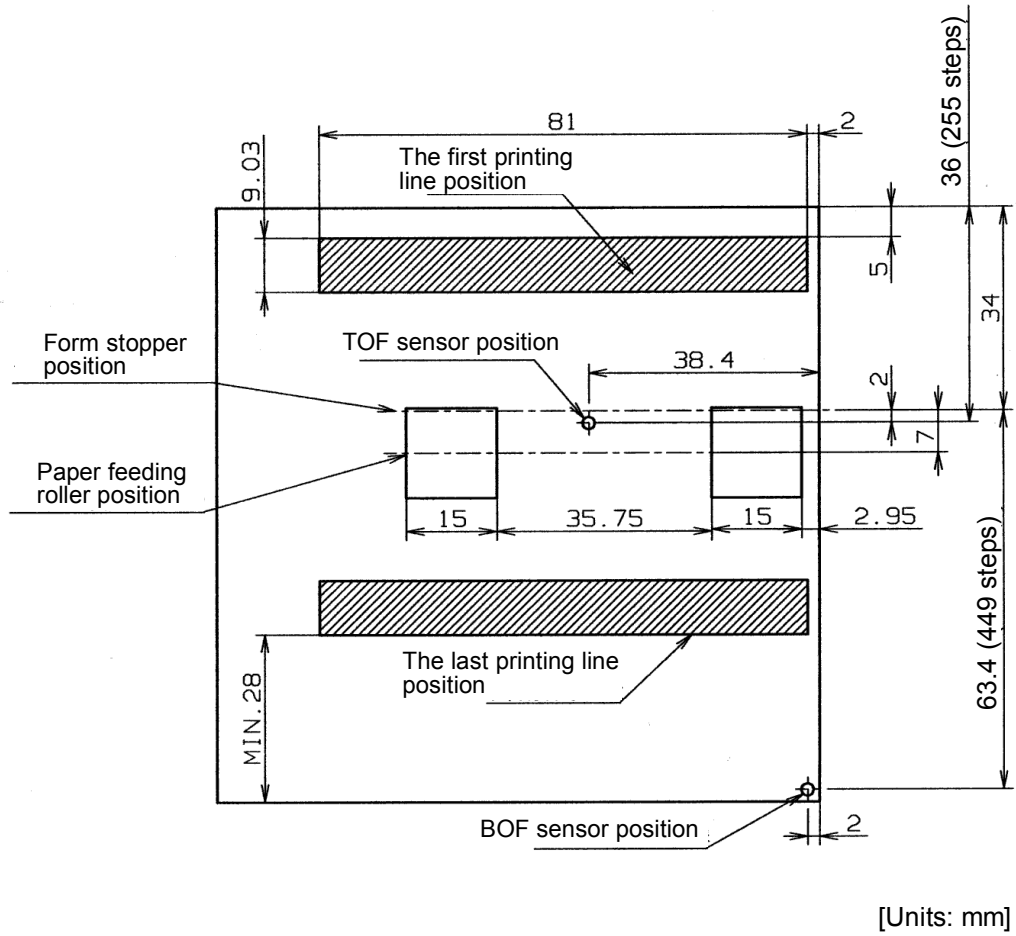

Figure 1.3.2 Printable Area (Slip)

NOTE: The values shown in Figure 1.3.2 are calculated ones. Consider this for the user design for the print starting position in the paper feeding direction.

EPSON	TITLE TM-J7000/J7100 Specification (STANDARD)	SHEET REVISION B	NO.	
			NEXT 11	SHEET 10

1.4 MICR Reader Section (Factory-Installed Option)

1.4.1 Reading Method

Permanent magnetic bias

1.4.2 Recognition Rate

98% or more at 25°C {77°F}

Recognition rating is defined as follows

$$\text{Recognition rating (\%)} = \frac{\text{Total number of checks} - (\text{number of sheets misread or not identified.})}{\text{Total number of checks}} \times 100$$

- Check paper used for test is EPSON standard check paper.
- Checks must be flat, without curls, folds, or wrinkles.

1.4.3 Insertion Direction and Endorsement Printing

- Insert the check with the surface printed with the magnetic ink facing upward, following the slip side guide.

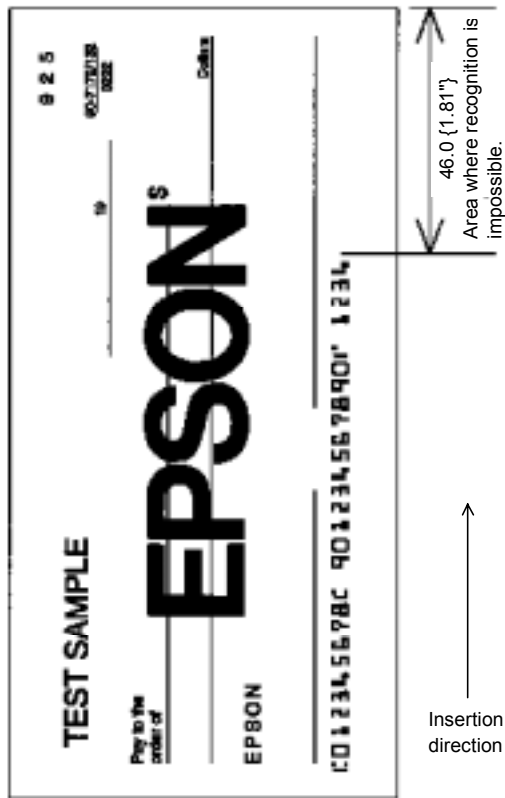

Figure 1.4.1 Area of Personal Check Where MICR Character Recognition is Impossible

EPSON	TITLE TM-J7000/J7100 Specification (STANDARD)	SHEET REVISION B	NO.	
			NEXT 12	SHEET 11

1.4.4 Notes on Using the MICR Reader

- Do not install the printer near any magnetic fields, because this may cause MICR reading errors. (Especially when the printer is used near the display device, the user must check the recognition rate of the MICR.)
- The MICR characters may not be recognized when impact or vibration is applied to the printer.
- Multiple fold checks are not supported.
- The personal checks must be flat, without curls, folds, or wrinkles (especially at the edges). Otherwise, the check may rub against the nozzles and become ink-stained.
- Do not insert checks that have clips or staples. These may cause paper jams, MICR reading errors, and damage to the MICR head.
- Let go of the check immediately as soon as the printer starts feeding it. Otherwise, the paper is not fed straight, causing paper jams and MICR reading errors. Also, do not operate the covers.

EPSON	TITLE TM-J7000/J7100 Specification (STANDARD)	SHEET REVISION B	NO.	
			NEXT 13	SHEET 12

1.5 Endorsement Mechanism Section (Factory-Installed Option)

The endorsement mechanism enables printing of endorsements as part of a sequence that is automatically processed: MICR reading, printing an endorsement on the back of the personal check, and printing on the surface of it.

1.5.1 Paper Specifications

- 1) Paper type: High-quality paper (only single-ply paper can be used.)
- 2) Paper sizes: 68 – 101.6 mm (W) × 150 – 223 mm (L)
{2.68 – 4.17"(W) × 5.90 – 8.98"(L)}
- 3) Paper thickness: 0.09 – 0.13 mm {0.0035 – 0.0051"}

1.5.2 Printable Area

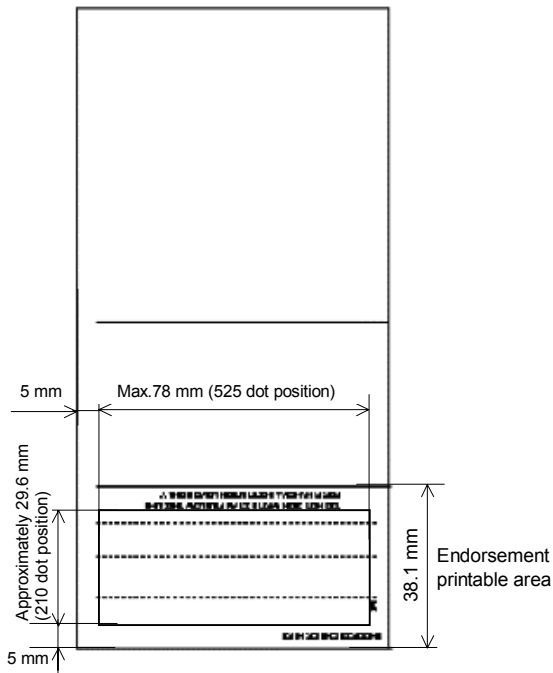

Figure 1.5.1 Printable Area for Endorsement Printing

NOTE: The values in Figure 1.5.1 are calculated ones. Consider this for the user design for the print starting position in the paper feeding direction.

EPSON	TITLE TM-J7000/J7100 Specification (STANDARD)	SHEET REVISION B	NO.	
			NEXT 14	SHEET 13

1.5.3 Notes on Using the Endorsement Mechanism

- 1) The endorsement mechanism enables printing of endorsements on the back of a personal check. Do not use paper that is over 101.6 mm {4"} in width. Otherwise, paper may be jammed.
- 2) Do not operate the covers while the sequence of check reading and endorsement printing is processed. Otherwise, the paper is not fed straight, causing paper jams and MICR reading errors.
- 3) Observe the same limitations as for slips for the position of paper holes and the reflection ratio of the check (refer to Figure 1.5.2).

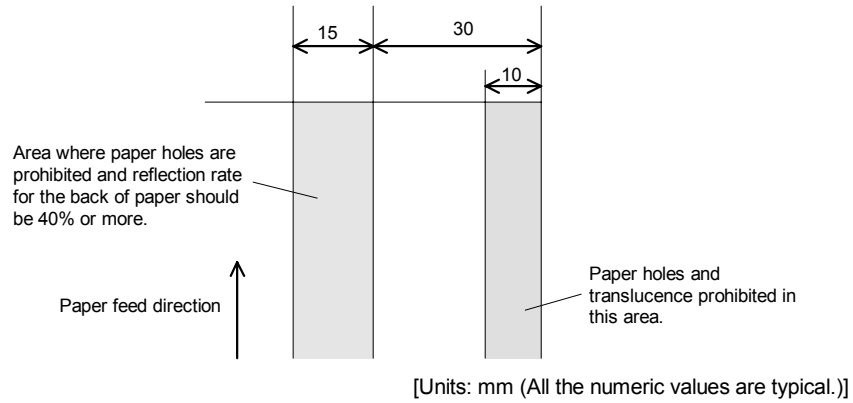

Figure 1.5.2 Area with No Paper Holes and Low Reflection

EPSON	TITLE TM-J7000/J7100 Specification (STANDARD)	SHEET REVISION B	NO.	
			NEXT 15	SHEET 14

1.6 Ink Cartridges

1.6.1 TM-J7000 Single-Color Print Model

- 1) Type of cartridge: Exclusive ink cartridge
- 2) Color of ink: SJIC8 (K): Black
- 3) Life of ink: 20,000,000 characters
(Using font B with EPSON standard print pattern in economy mode)

1.6.2 TM-J7100 Two-Color Print Model

- 1) Type of cartridge: Exclusive ink cartridge
For color 1: SJIC6 (K)
For color 2: SJIC7 (R), (B), (G)
- 2) Color of ink] SJIC6 (K): Black
SJIC7 (R): Red
SJIC7 (B): Blue
SJIC7 (G): Green
- 3) Life of ink: Total approximately 15,000,000 characters with SJIC6 and SJIC7
(Using font B with EPSON standard print pattern in economy mode)

1.6.3 General Specifications for Both Ink Cartridges

- 1) Expiration data
Use up the cartridge within six months after opening the packing. (when kept at room temperature) and use up the cartridge within two years after production (when stored at room temperature). This two years includes six months after opening the packing.
The expiration date for two years after production is printed on the individual box containing the ink cartridge and on the ink cartridge itself.
- 2) Other
Refer to the ink cartridge SJIC6, 7, 8 specifications for details.

EPSON	TITLE	TM-J7000/J7100 Specification (STANDARD)	SHEET REVISION	NO.	
			B	NEXT 16	SHEET 15

1.7 General Section

1.7.1 Internal Buffer

- 1) Receive buffer: 4KB
- 2) User-defined buffer (both for user-defined characters and downloaded bit images): 12KB
- 3) NV graphics + NV user memory: 384KB

1.7.2 Electrical Characteristics

- 1) Power source: Optional AC adapter PS-180
- 2) Supply voltage: 24 V ± 2.4 V
- 3) Current consumption: (except when the drawer kick-out is used.)
 - Operating: Mean: Approximately 0.5 A
(Printing alphanumeric characters in font A, all columns)
 - Peak: Approximately 2.7 A
 - Stand by: Mean: Approximately 70 mA

1.7.3 EMI and Safety Standards Applied

EMC is measured using SEIKO EPSON's AC adapter PS-180.

- 1) Europe: CE marking:
 - Directive: 89/336/EEC
 - EN55022 Class B
 - EN55024
 - IEC61000-4-2
 - IEC61000-4-3
 - IEC61000-4-4
 - IEC61000-4-5
 - IEC61000-4-6
 - IEC61000-4-8
 - IEC61000-4-11
 Safety standards: TÜV (EN60950)
- 2) North America: EMI: FCC / ICES-003 Class A
Safety standards: UL60950 / CSA C22.2 No.60950
- 3) Japan: EMI: VCCI Class A
JEIDA 52
- 4) Oceania: EMC: AS/NZS 3548 Class B

EPSON	TITLE	TM-J7000/J7100 Specification (STANDARD)	SHEET REVISION	NO.	
			B	NEXT 17	SHEET 16

1.7.4 Reliability

- 1) Life:
 - Mechanism: Receipt: 15,000,000 lines
Slip: 5,000,000 lines
 - Print head: 1600 million shots/nozzle
(Shots are defined as the numbers of pulses energized for the print head)
 - Autocutter: 1,500,000 cuts
(End of life: the printer is defined to have reached the end of its life when it reaches the beginning of the wearout period.)
 - MICR reader mechanism (factory-installed option):
240,000 passes (when used with U.S. personal checks)
 - Endorsement mechanism (factory-installed option):
240,000 passes (when used with U.S. personal checks)
- 2) MTBF: 180,000 hours
(Failure is defined as a random failure occurring during the random failure period.)
- 3) MCBF: 50,000,000 lines
(This is an average failure interval based on failures relating to wearout and random failures up to the life of 20,000,000 lines (receipt: 15,000,000 lines + slip: 5,000,000 lines))

1.7.5 Environmental Conditions

- 1) Temperature and Humidity:
 - Printing: 10 to 35°C {50 to 95°F}, 20 - 80% RH (non-condensing)
(Shaded area in Figure 1.7.1.)
 - Operating: 5 to 40°C {41 to 104°F}, 20 - 80% RH (non-condensing)
(Area drawn with a solid line in Figure 1.7.1.)
 - Storage:
 - a) When packed (ink not installed)
-20 to 60°C {-4 to 140°F}, 5 - 85% RH (non-condensing)
(within 120 hours at -20°C {68°F} or 60°C {140°F})
 - b) When ink is loaded
-20 to 40°C {-4 to 104°F}, 20 - 85% RH

EPSON	TITLE	TM-J7000/J7100 Specification (STANDARD)	SHEET REVISION	NO.	
			B	NEXT 18	SHEET 17

2) Maximum absolute rated temperature: 70°C {158°F}
 (The printer must be kept at or below 70°C {158°F} whenever it is operating or in storage.)

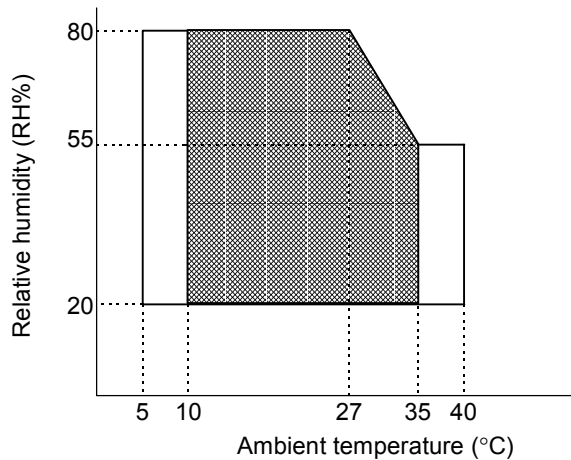

Figure 1.7.1 Operating Temperature and Humidity Range

3) Operating pressure: 700 - 1050 hPa
 (approximately -20 m to 2000 m {-66 to 6562 feet} in height above sea level)

4) Vibration resistance: When packed: Frequency: 5 to 55 Hz
 Acceleration: Approximately 19.6 m/s² {2G}
 Sweep: 10 minutes (half cycle)
 Duration: 1 hour
 Directions: x, y, and z

EPSON has confirmed that no unexpected conditions will occur in operation of the mechanism after vibration under the above conditions.

5) Impact resistance: When packed: Package: EPSON standard package
 Height: 60 cm {23.6"}
 Directions: 1 corner, 3 edges, and 6 surfaces
 When unpacked: Height: 5 cm {2"}
 Directions: Lift one edge and release it (for all 4 edges).

EPSON has confirmed that no unexpected conditions will occur in operation of the mechanism after impact under the above conditions.

6) Acoustic noise: Operating: Approximately 50 dB (ANSI bystander position)
 (when using the autocutter in normal mode)

1.7.6 Installation

This printer must be installed horizontally.

EPSON	TITLE	TM-J7000/J7100 Specification (STANDARD)	SHEET REVISION	NO.	
			B	NEXT 19	SHEET 18

2. CONFIGURATION

2.1 Interfaces

2.1.1 RS-232 Serial Interface

2.1.1.1 Specifications (RS-232-compatible)

Data transmission:	Serial
Synchronization:	Asynchronous
Handshaking:	DTR/DSR or XON/XOFF control
Signal levels:	MARK = -3 to -15 V: Logic "1" / ON SPACE = +3 to +15 V: Logic "0" / OFF
Data word length:	7 or 8 bits
Baud rate:	2400, 4800, 9600, 19200, 38400, 57600, 115200 bps (bps: bits per second)
Parity settings:	None, even, odd
Stop bits:	1 or more
Connector (printer side):	Female DSUB-25 pin connector

The data word length, baud rate, and parity depend on the DIP switch settings or the memory switch set with the **GS (E** command. (Refer to Section 3.3.3.) The number of stop bits for the printer side is fixed to 1.

2.1.1.2 Switching between online and offline

The printer does not have an online/offline switch. The printer goes offline:

- 1) Between when the power is turned on or the printer is reset and when the printer mechanism is finished initializing.
- 2) During the self-test.
- 3) When the paper roll cover is open.
- 4) When the carriage cover is open.
- 5) During paper feeding using the paper FEED button.
- 6) When the printer stops printing due to a paper-end (in cases when an empty paper supply is detected by either the paper roll end detector or the paper roll near-end detector with a printing halt feature set by **ESC c 4**).
- 7) When an error has occurred.
- 8) When head cleaning is performed.
- 9) When no ink cartridge is installed.
- 10) Between when an ink cartridge is exchanged due to the ink end detection and when the ink end is canceled.
- 11) When the printer is waiting for insertion of another slip to be printed while waiting for removal of a cut sheet.
- 12) After performing the power off sequence (**DLE DC4 (fn = 2)**).

EPSON	TITLE	TM-J7000/J7100 Specification (STANDARD)	SHEET REVISION	NO.	
			B	NEXT 20	SHEET 19

2.1.1.3 Interface connector terminal assignments and signal functions

Interface connector terminal assignments and signal functions are described in Table 2.1.1.

Table 2.1.1 Printer Interface Connector Status and Signals

Pin no.	Signal name	Signal direction	Function																																									
1	FG	—	Frame ground																																									
2	TXD	Output	Transmit data																																									
3	RXD	Input	Receive data																																									
4	RTS	Output	Memory switch Msw 1-6 OFF: Same as DTR signal (pin 20) Memory switch Msw 1-6 ON: Logical product of DTR signals of DM-D and TM (if both are SPACE, the printer can receive data (SPACE).)																																									
6	DSR	Input	This signal indicates whether the host computer can receive data. SPACE indicates that the host computer can receive data, and MARK indicates that the host computer cannot receive data. When DTR/DSR control is selected, the printer transmits data after confirming this signal (except when transmitting data by DLE EOT , FS (e, GS a, and GS j)). When XON/XOFF control is selected, the printer does not check this signal. Changing the setting of memory switch Msw 1-7 enables this signal to be used as a reset signal for the printer (refer to Section 3.3.3). The printer is reset when the signal remains MARK for 1 ms or more (refer to Section 2.1.1.16).																																									
7	SG	—	Signal ground																																									
20	DTR	Output	<p>1) When DTR/DSR control is selected, this signal indicates whether the printer is busy. SPACE indicates that the printer is ready to receive data, and MARK indicates that the printer is busy. The busy condition can be changed by using memory switch Msw 1-3 as follows (refer to Section 3.3.4):</p> <table border="1"> <thead> <tr> <th rowspan="2">Printer status</th> <th colspan="2">Memory switch Msw 1-3 status</th> </tr> <tr> <th>ON</th> <th>OFF</th> </tr> </thead> <tbody> <tr> <td>1. Between when the power is turned on or the printer is reset and when the printer becomes ready to receive data.</td> <td>BUSY</td> <td>BUSY</td> </tr> <tr> <td>2. Between when the printer becomes ready to receive data and when the printer mechanism is finished initializing.</td> <td>—</td> <td>BUSY</td> </tr> <tr> <td>3. During the self-test.</td> <td>BUSY</td> <td>BUSY</td> </tr> <tr> <td>4. When the cover is open.</td> <td>—</td> <td>BUSY</td> </tr> <tr> <td>5. During paper feeding using the paper FEED button.</td> <td>—</td> <td>BUSY</td> </tr> <tr> <td>6. When the printer stops printing due to a paper-end (only when the paper roll is not present).</td> <td>—</td> <td>BUSY</td> </tr> <tr> <td>7. When an error has occurred.</td> <td>—</td> <td>BUSY</td> </tr> <tr> <td>8. When head cleaning is performed.</td> <td>—</td> <td>BUSY</td> </tr> <tr> <td>9. When an ink cartridge is removed, or while an ink cartridge is exchanged due to ink end detection (ink cartridge is empty).</td> <td>—</td> <td>BUSY</td> </tr> <tr> <td>10. When the printer is waiting for printing or insertion of another slip to be printed while the printer is waiting for removal of a cut sheet</td> <td>—</td> <td>BUSY</td> </tr> <tr> <td>11. After performing the power off sequence.</td> <td>—</td> <td>BUSY</td> </tr> <tr> <td>12. When the receive buffer becomes full. (*1)</td> <td>BUSY</td> <td>BUSY</td> </tr> </tbody> </table>	Printer status	Memory switch Msw 1-3 status		ON	OFF	1. Between when the power is turned on or the printer is reset and when the printer becomes ready to receive data.	BUSY	BUSY	2. Between when the printer becomes ready to receive data and when the printer mechanism is finished initializing.	—	BUSY	3. During the self-test.	BUSY	BUSY	4. When the cover is open.	—	BUSY	5. During paper feeding using the paper FEED button.	—	BUSY	6. When the printer stops printing due to a paper-end (only when the paper roll is not present).	—	BUSY	7. When an error has occurred.	—	BUSY	8. When head cleaning is performed.	—	BUSY	9. When an ink cartridge is removed, or while an ink cartridge is exchanged due to ink end detection (ink cartridge is empty).	—	BUSY	10. When the printer is waiting for printing or insertion of another slip to be printed while the printer is waiting for removal of a cut sheet	—	BUSY	11. After performing the power off sequence.	—	BUSY	12. When the receive buffer becomes full. (*1)	BUSY	BUSY
Printer status	Memory switch Msw 1-3 status																																											
	ON	OFF																																										
1. Between when the power is turned on or the printer is reset and when the printer becomes ready to receive data.	BUSY	BUSY																																										
2. Between when the printer becomes ready to receive data and when the printer mechanism is finished initializing.	—	BUSY																																										
3. During the self-test.	BUSY	BUSY																																										
4. When the cover is open.	—	BUSY																																										
5. During paper feeding using the paper FEED button.	—	BUSY																																										
6. When the printer stops printing due to a paper-end (only when the paper roll is not present).	—	BUSY																																										
7. When an error has occurred.	—	BUSY																																										
8. When head cleaning is performed.	—	BUSY																																										
9. When an ink cartridge is removed, or while an ink cartridge is exchanged due to ink end detection (ink cartridge is empty).	—	BUSY																																										
10. When the printer is waiting for printing or insertion of another slip to be printed while the printer is waiting for removal of a cut sheet	—	BUSY																																										
11. After performing the power off sequence.	—	BUSY																																										
12. When the receive buffer becomes full. (*1)	BUSY	BUSY																																										

EPSON	TITLE	TM-J7000/J7100 Specification (STANDARD)	SHEET REVISION	NO.	
			B	NEXT 21	SHEET 20

Table 2.1.1 Printer Interface Connector Status and Signals (Continued)

Pin No.	Signal name	Signal direction	Function
			2) When XON/XOFF control is selected: The signal indicates whether the printer is correctly connected and is ready to receive data. SPACE indicates that the printer is ready to receive data. The signal is always SPACE except in the following cases: <ul style="list-style-type: none"> • During the period from when the power is turned on to when the printer is ready to receive data • During the self-test
25	INIT	Input	Changing the setting for memory switch Msw 1-8 enables this signal to be used as a reset signal for the printer. The printer is reset when the signal remains SPACE for 1 ms or more.

NOTE: (*1) • Condition of “receive buffer full”
 The printer status when the space in the receive buffer drops to 128 bytes (or less) or until the space in the receive buffer reaches 256 bytes.

- The printer ignores the data received when the remaining space in the receive buffer is 0 bytes.

2.1.1.4 XON/XOFF transmission timing

When XON/XOFF control is selected, the printer transmits XON or XOFF signals as follows. Transmission timing differs depending on the memory switch Msw 1-3 setting.

Table 2.1.2 XON/XOFF Transmission Timing

	Printer status	Memory Switch Msw 1-3	
		ON	OFF
XON transmission	① When the printer goes online after turning on the power or resetting	Transmit	Transmit
	② When the receive buffer is released from the buffer full state	Transmit	Transmit
	③ When the printer switches from offline to online	—	Transmit
	④ When the printer recovers from an error using the commands	—	Transmit
XOFF transmission	⑤ When the receive buffer becomes full	Transmit	Transmit
	⑥ When the printer switches from online to offline	—	Transmit

NOTES: • The XON code is <11>H and the XOFF code is <13>H.

- In case ③, XON is not transmitted when the receive buffer is full.
- In case ⑥, XOFF is not transmitted when the receive buffer is full.
- When memory switch Msw 1-3 is set to OFF, XON is not transmitted if the printer is in the offline state in case ②.

EPSON	TITLE	TM-J7000/J7100 Specification (STANDARD)	SHEET REVISION	NO.	
			B	NEXT	SHEET
			22	21	

2.1.1.5 Notes on setting memory switch Msw 1-3 to ON

- 1) The printer mechanism stops but does not become busy when: an error has occurred, the cover is open, printing stops due to a paper-end, or paper is fed using the paper FEED button.
- 2) When setting memory switch Msw 1-3 to ON to enable handshaking with the printer, be sure to check the printer status using the **FS (e**, **GS a**, and **GS j** commands and the ASB function. In this setting, the default value of *n* for the **FS (e** command is 0, for the **GS a** command is 2, and for the **GS j** command is 1. The printer automatically transmits the printer status, depending on online/offline changes.
- 3) When using **DLE EOT**, **DLE ENQ**, and **DLE DC4**, be sure that the receive buffer does not become full.
 - When using a host that cannot transmit data when the printer is busy:

If an error has occurred, **DLE EOT**, **DLE ENQ**, and **DLE DC4** cannot be used when the printer is busy due to a receive buffer-full state.
 - When using a host that can transmit data when the printer is busy:

When the receive buffer becomes full during transmission of bit-image data, if **DLE ENQ**, **DLE EOT**, or **DLE DC4** is used the command is also processed as bit-image data. Data transmitted when the receive buffer is full may be lost.

Hint: Check the printer status using **GS I** or **GS r** after transmitting each line of data. Transmit one line of data at a time so that the receive buffer does not become full.

2.1.1.6 Notes on Resetting the Printer Using the Interface

The printer can be reset using interface pins 6 and 25 by changing the memory switch setting (refer to Table 3.3.7, Memory Switch Msw 1).

Table 2.1.3 Reset Switching

Signal line	Memory switch	Reset condition
Pin 6 (DSR)	Msw 1-7: ON	MARK level input
Pin 25 (INIT)	Msw 1-8: ON	SPACE or TTL-HIGH level input

To reset the printer, the following requirements must be satisfied.

- DC characteristics:

Table 2.1.4 Reset DC Characteristics

		Pin 6 (DSR)	Pin 25 (INIT)
Input HIGH voltage	V _{IH}	-15 to -3 V	+2 to +15 V
Input LOW voltage	V _{IL}	+3 to +15 V	-15 to + 0.8 V
Input HIGH current:	I _{IH}	-5.3 mA (maximum)	1 mA (maximum)
Input LOW current:	I _{IL}	-5 mA (maximum)	-2 mA (maximum)
Input impedance:	R _{IN}	3 kΩ (minimum)	

EPSON	TITLE	TM-J7000/J7100 Specification (STANDARD)	SHEET REVISION	NO.	
			B	NEXT 23	SHEET 22

- AC characteristics:
Minimum reset pulse width: TRS 1 ms (minimum)

- When using pin 6 (DSR) (Msw 1-7 is ON):

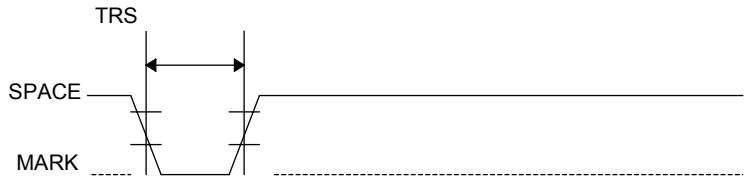

Figure 2.1.1 Minimum Reset Pulse Width (Pin 6)

- When using pin 25 (INIT) (Msw 1-8 is ON):

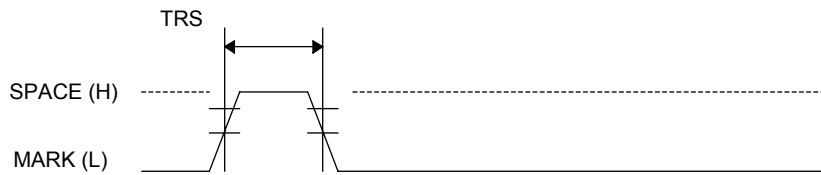

Figure 2.1.2 Minimum Reset Pulse Width (Pin 25)

- NOTES:
- When a signal is input that does not satisfy the requirements above, printer operation is not guaranteed. When a signal is input to pin 25 (INIT) at the TTL level, the requirements above must also be satisfied. Although a signal is input to pin 6 (DSR) at the TTL level, according to the DC characteristics described above, the operation is not guaranteed and pin 6 cannot be controlled.
 - When pin 6 (DSR) and pin 25 (INIT) are open, the printer is operating.

EPSON	TITLE	TM-J7000/J7100 Specification (STANDARD)	SHEET REVISION	NO.	
			B	NEXT	SHEET
			24	23	

2.1.2 IEEE 1284 Bidirectional Parallel Interface (Parallel Interface Specifications)

Copyright © 1994 by the Institute of Electrical and Electronic Engineers, Inc.

2.1.2.1 Compatibility Mode

1) Compatibility Mode is Data Transmission from Host to Printer only: Centronics compatible.

2) Specifications

- Data transmission: 8-bit parallel
- Synchronization: Externally supplied nStrobe signals*
- Handshaking: nAck and Busy signals*
- Signal levels: TTL compatible
- Connector: ADS-B36BLFDR176 (HONDA) or equivalent (IEEE 1284 Type B)

* n before the signal name indicates active LOW.

3) Switching between online and offline

The printer is not equipped with any online/offline switch. The printer is placed into offline status in any of the following cases:

- 1) Between when the power is turned on or the printer is reset and when the printer mechanism is finished initializing.
- 2) During the self-test.
- 3) When the paper roll cover is open.
- 4) When the carriage cover is open.
- 5) During paper feeding using the paper FEED button.
- 6) When the printer stops printing due to a paper-end (in cases when an empty paper supply is detected by either the paper roll end detector or the paper roll near-end detector with a printing halt feature set by **ESC c 4**).
- 7) When an error has occurred.
- 8) When head cleaning is performed.
- 9) When no ink cartridge is installed.
- 10) Between when an ink cartridge is exchanged due to the ink end detection and when the ink end is canceled.
- 11) When the printer is waiting for insertion of another slip to be printed while waiting for removal of a cut sheet.
- 12) After performing the power off sequence (**DLE DC4 (fn = 2)**).

EPSON	TITLE	TM-J7000/J7100 Specification (STANDARD)	SHEET REVISION	NO.	
			B	NEXT	SHEET
			25	24	

2.1.2.2 Reverse mode (data transmission from printer to host)

The status data transmission from the printer to the host proceeds in the Nibble or Byte mode.

- Description

This mode allows data transmission from the asynchronous printer under the control of the host. Data transmissions in the Nibble Mode are made via the existing control lines in units of four bits (a Nibble). In the Byte Mode, data transmissions proceed by making the eight-bit data lines bidirectional.

Both modes fail to proceed concurrently with the Compatibility Mode, thereby causing half-duplex transmission.

EPSON	TITLE TM-J7000/J7100 Specification (STANDARD)	SHEET REVISION B	NO.	
			NEXT 26	SHEET 25

2.1.2.3 Interface connector pin assignments for each mode

Table 2.1.5 Interface Connector Pin Assignments for Each Mode

Pin	Source	Compatibility mode	Nibble mode	Byte mode
1	Host	nStrobe	HostClk	HostClk
2	Host/Ptr	Data0 (LSB)	Data0 (LSB)	Data0 (LSB)
3	Host/Ptr	Data1	Data1	Data1
4	Host/Ptr	Data2	Data2	Data2
5	Host/Ptr	Data3	Data3	Data3
6	Host/Ptr	Data4	Data4	Data4
7	Host/Ptr	Data5	Data5	Data5
8	Host/Ptr	Data6	Data6	Data6
9	Host/Ptr	Data7 (MSB)	Data7 (MSB)	Data7 (MSB)
10	Printer	nAck	PtrClk	PtrClk
11	Printer	Busy	PtrBusy/Data3, 7	PtrBusy
12	Printer	Perror	AckDataReq/Data2, 6	AckDataReq
13	Printer	Select	Xflag/Data1, 5	Xflag
14	Host	nAutoFd	HostBusy	HostBusy
15		NC	ND	ND
16		GND	GND	GND
17		FG	FG	FG
18	Printer	Logic-H	Logic-H	Logic-H
19		GND	GND	GND
20		GND	GND	GND
21		GND	GND	GND
22		GND	GND	GND
23		GND	GND	GND
24		GND	GND	GND
25		GND	GND	GND
26		GND	GND	GND
27		GND	GND	GND
28		GND	GND	GND
29		GND	GND	GND
30		GND	GND	GND
31	Host	nInit	nInit	nInit
32	Printer	nFault	nDataAvail/Data0, 4	nDataAvail
33		GND	ND	ND
34	Printer	DK_STATUS	ND	ND
35	Printer	+5V	ND	ND
36	Host	nSelectIn	1284-Active	1284-Active

NC: Not connected
 ND: Not defined

EPSON	TITLE	TM-J7000/J7100 Specification (STANDARD)	SHEET REVISION	NO.	
			B	NEXT 27	SHEET 26

- NOTES: 1. A prefix "n" to signal names refers to "L" active signals. If the host is not equipped with all of the signal lines listed above, two-way communication is not possible.
2. For interfacing, signal lines shall use twisted pair cables with the return sides connected to signal ground level.
3. Interfacing conditions shall all be based on the TTL level to meet the characteristics described below. In addition, both rise time and fall time of each signal shall be 0.5 μ s or less.
4. Data transmission shall not ignore the signals nAck or Busy. An attempt to transmit data with either signal, nAck or Busy, ignored can cause lost data. (Data transmissions to the printer shall be made after verifying the nAck signal or while the Busy signal is at the "L" level.)
5. Interface cables shall be below the maximum length and as short as possible.

2.1.2.4 Electrical characteristics

Table 2.1.6 DC Characteristics (Except Logic-H, +5 V signals)

Characteristics	Symbol	Specifications		Conditions
		Min	Max	
Output HIGH voltage	VOH	*2.4 V	5.5 V	*IOH=0.32 mA
Output LOW voltage	VOL	-0.5 V	*0.4 V	*IOL=-12 mA
Output HIGH current	IOH	0.32 mA	-	VOH=2.4 V
Output LOW current	IOL	-12 mA	-	VOL=0.4 V
Input HIGH voltage	VIH	2.0 V	-	
Input LOW voltage	VIL	-	0.8 V	
Input HIGH current	IiH	-	-0.32 mA	VIH=2.0 V
Input LOW current	IiL	-	12 mA	VIL=0.8 V

Table 2.1.7 Logic-H Signal Sender Characteristics

Characteristics	Symbol	Specifications		Conditions
		Min	Max	
Output HIGH voltage	VOH	0 V	5 V	
Output LOW voltage	VOL	-	2.0 V	While the power is OFF

Table 2.1.8 +5 V Signal Sender Characteristics

Characteristics	Symbol	Specifications		Conditions
		Min	Max	
Output HIGH voltage	VOH	*2.4 V	5.5 V	*IOH=0.32 mA
Output LOW voltage	VOL	-	- **	While the power is OFF
Output HIGH current	IOH	-	0.32 mA	VOH=2.4 V
Output LOW current	IOL	- **	-	While the power is OFF

** No guarantee is offered to VOL and IOL while the power is OFF.

EPSON	TITLE	TM-J7000/J7100 Specification (STANDARD)	SHEET REVISION	NO.	
			B	NEXT 28	SHEET 27

2.1.2.5 Data receiving timing (compatibility mode)

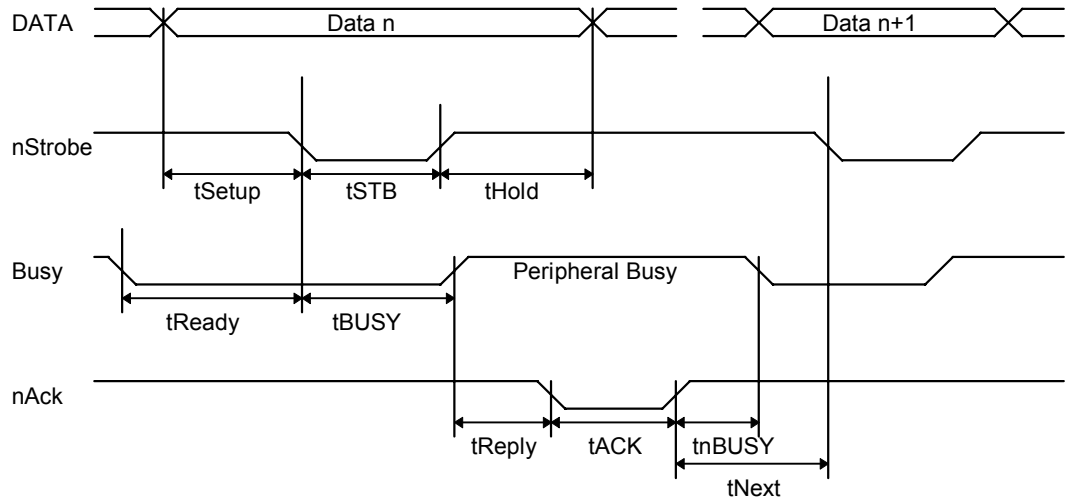

Figure 2.1.3 Data Receiving Timing

Table 2.1.9 Data Receiving Timing

Characteristics	Symbol	Specifications	
		Minimum [ns]	Maximum [ns]
Data Hold Time (host)	tHold	750	--
Data Setup Time	tSetup	750	--
STROBE Pulse Width	tSTB	750	--
READY Cycle Idle Time	tReady	0	--
BUSY Output Delay Time	tBUSY	0	500
Data Processing Time	tReply	0	∞
ACKNLG Pulse Width	tACK	500	10μs
BUSY Release Time	tnBUSY	0	∞
ACK Cycle Idle Time	tNext	0	--

*The printer latches data at the nStrobe rising edge.

EPSON	TITLE	TM-J7000/J7100 Specification (STANDARD)	SHEET REVISION	NO.	
			B	NEXT 29	SHEET 28

2.1.2.6 Notes on resetting the printer through the interface

When the printer is reset through the interface nInit signal (pin # 31) in compatibility mode, satisfy the following characteristics; however, note that the reset signal is ignored in Reverse Mode (pin # 36 nSelectIn (1284-Active: "H")).

DC Characteristics TTL level
 AC Characteristics Minimum reset pulse width TR: 50 μs (minimum)

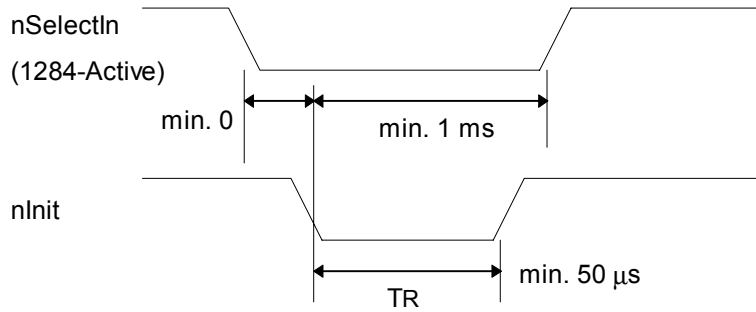

Figure 2.1.4

EPSON	TITLE	TM-J7000/J7100 Specification (STANDARD)	SHEET REVISION	NO.	
			B	NEXT 30	SHEET 29

2.1.2.7 Reception of status from the printer through the bidirectional parallel interface

In the bidirectional parallel interface specifications, the printer status transmission is available by using the two-way communication facility in the Nibble/Byte Modes in accordance with IEEE 1284.

In this case, as opposed to the RS-232 serial interface specifications, the real-time interruptions from the printer to the host are disabled and thus precautions must be taken for the following:

- 1) The allowable capacity of the printer internal buffer is 99 bytes (except ASB status). The status signals exceeding this capacity will be discarded. To prevent possible loss of status, the host shall be ready to accept data (Reverse Mode).
- 2) When ASB is used, the host is preferably in the wait state for accepting data (Reverse Idle Mode). When this state is not available, the host shall enter the Reverse Mode to constantly monitor the presence of data.
- 3) When ASB is used in the Reverse Mode, preference shall be given to the ASB status for transmission over the other status signals. Any accumulated ASB status signals left for transmission from the last to the newest ASB status transmission shall be transmitted together at one time as one ASB status, showing the presence of change, followed by the latest ASB status.

Example: In the normal (wait) state, the ASB status is configured as follows.

First Status	Second Status	Third Status	Fourth Status
0001 0000	0000 0000	0000 0000	0110 1111

After this sequence of operations, if, for example, the near end is detected, the printer cover is opened, and the printer cover is closed, the following pieces of data are accumulated.

	First Status	Second Status	Third Status	Fourth Status	
①	0001 0000	0000 0000	0000 0011	0110 1111	Near end detection
②	0011 1000	0000 0000	0000 0011	0110 1111	The printer cover is opened.
③	0001 0000	0000 0000	0000 0011	0110 1111	The printer cover is closed.

When the ASB status is received following this, a total of eight bytes of ASB will be transmitted as follows.

	First Status	Second Status	Third Status	Fourth Status
Accumulated ASB (①+②+③)	0011 1000	0000 0000	0000 0011	0110 1111
+				
The latest ASB (③)	0001 0000	0000 0000	0000 0011	0110 1111

EPSON	TITLE	SHEET REVISION	NO.	
	TM-J7000/J7100 Specification (STANDARD)	B	NEXT 31	SHEET 30

2.1.2.8 Notes on setting memory switch Msw 1-3 to ON

1) The printer mechanism stops but does not become BUSY in the following cases:

- When an error occurs.
- When the cover is open.
- When the printer stops printing due to a paper end.
- When paper is fed using the paper FEED button.

2) When handshaking with the printer while using this switch setting, make sure to monitor the printer with the **FS (e**, **GS a**, and **GS j** commands and the ASB function.

With this switch setting, the default value of *n* for the **FS (e** command is 0, for the **GS a** command is 2, and for the **GS j** command is 1. This automatically transmits the printer status, depending on online/offline changes.

3) When using **DLE EOT**, **DLE ENQ**, or **DLE DC4** make sure that the receive buffer does not become full.

If an error occurs when the receive buffer is full and the printer is BUSY, **DLE EOT**, **DLE ENQ**, or **DLE DC4** cannot be used.

2.1.3 Other Interfaces

Various interface boards (EPSON UB series) can be used (except UB-P02).

EPSON	TITLE	TM-J7000/J7100 Specification (STANDARD)	SHEET REVISION	NO.	
			B	NEXT 32	SHEET 31

2.2 Connectors

2.2.1 Interface Connectors

Refer to Section 2.1, Interfaces.

2.2.2 Power Supply Connector

This connector is used to connect the printer to an external power source.

1) Pin assignments: Refer to Table 2.2.1.

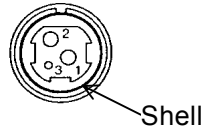

Figure 2.2.1 Power Supply Connector

Table 2.2.1 Power Supply Connector Pin Assignments

Pin number	Signal name
1	+24 VDC
2	GND
3	NC
Shell	Frame GND

NC: Not Connected

2) Connector model: Printer side: Hosiden TCS7960-532010 or equivalent
 User side: Hosiden TCP8927-631100 or equivalent
 TCP8927-531100 or equivalent

EPSON	TITLE TM-J7000/J7100 Specification (STANDARD)	SHEET REVISION B	NO.	
			NEXT 33	SHEET 32

2.2.3 Drawer Kick-out Connector (Modular Connector)

The pulse specified by **ESC p** or **DLE DC4** ($fn = 1$) is output to this connector. The host can confirm the status of the input signal by using the **DLE EOT**, **GS r**, or **GS a** (ASB status) commands.

- 1) Pin assignments: Refer to Table 2.2.2
- 2) Connector model: Printer side: MOLEX 52065-6615 or equivalent
User side: 6-position, 6-contact (RJ12 telephone jack)

Table 2.2.2 Drawer Kick-out Connector Pin Assignments

Pin number	Signal name	Direction
1	Frame GND	—
2	Drawer kick-out drive signal 1	Output
3	Drawer open/close signal	Input
4	+24 V	—
5	Drawer kick-out drive signal 2	Output
6	Signal GND	—

Pin 4 must be used only for the drawer.

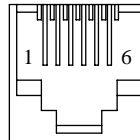

Figure 2.2.2 Drawer Kick-out Connector

3) Drawer kick-out drive signal

Output signal: Output voltage: Approximately 24 V
Output current: 1 A or less

CAUTION: To avoid an overcurrent, the resistance of the drawer kick-out solenoid must be 24 Ω or more.

Output waveform: Outputs the waveforms in Figure 2.2.3 to points A and B in Figure 2.2.4.

ON time and OFF time are specified by **ESC p** or **DLE DC4**.

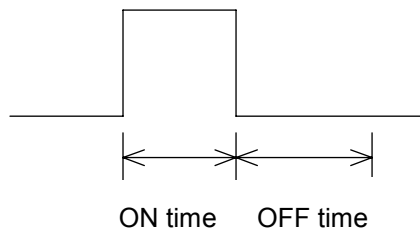

Figure 2.2.3 Drawer Kick-out Drive Signal Output Waveform

EPSON	TITLE	TM-J7000/J7100 Specification (STANDARD)	SHEET REVISION	NO.	
			B	NEXT	SHEET
			34	33	

4) Drawer open/close signal

Input signal level (connector pin 3):

"L" = 0 to 0.8 V

"H" = 2 to 5 V

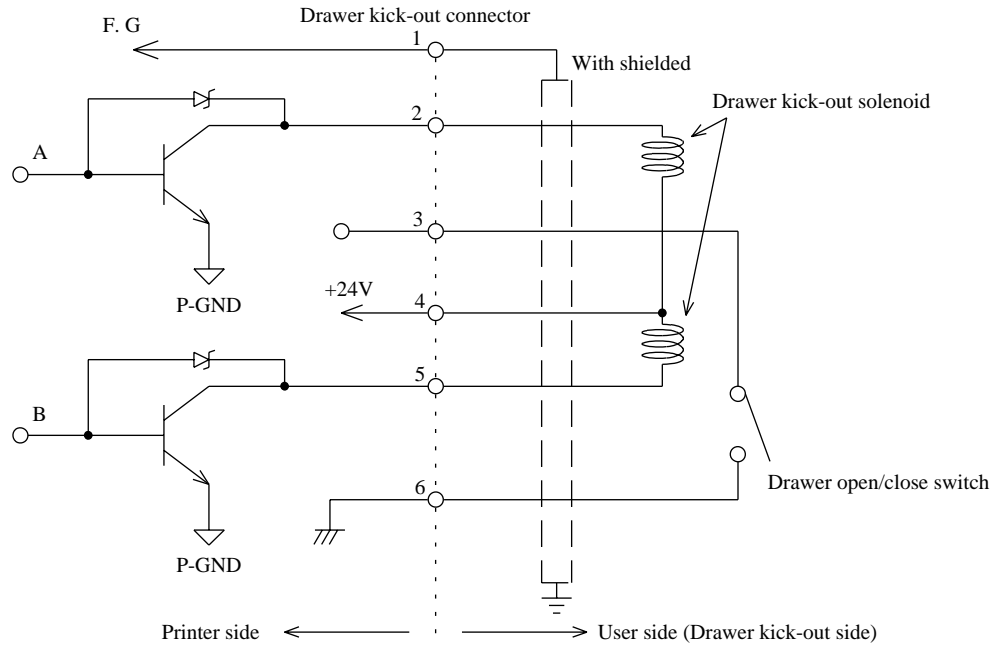

Figure 2.2.4 Drawer Circuitry

- NOTES:
1. Use a shielded cable as the drawer connector cable.
 2. Two driver transistors cannot be energized simultaneously.
 3. The drawer drive duty must be as shown below.

$$\frac{\text{ON time}}{(\text{ON time} + \text{OFF time})} \leq 0.2$$

4. Be sure to use the printer power supply (connector pin 4) for the drawer power source.
5. The resistance of the drawer kick-out solenoid must not be less than specified. Otherwise, an overcurrent could damage the solenoid.
6. Do not connect a telecommunication network to the drawer kick-out connector.

EPSON	TITLE	TM-J7000/J7100 Specification (STANDARD)	SHEET REVISION	NO.	
			B	NEXT	SHEET
			35	34	

2.2.4 Customer Display Connector

(Available only for the serial interface model)

1) Model:

Receptacle: MOLEX 52065-8845 or equivalent

2) Pin assignments:

Table 2.2.3 Customer Display Connector Pin Assignments

Pin number	Signal name	Direction
1	FG	—
2	NC	—
3	TXD	Output
4	DTR	Output
5	DSR	Input
6	SG	—
7	+24	—
8	PG	—

NC: Not connected

+24 V is always output through pin 7. The driving capability is 350 mA or less. Be sure not to use customer displays other than the Seiko Epson DM-D series.

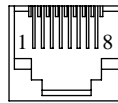

Figure 2.2.5 DM-D Connector

EPSON	TITLE	TM-J7000/J7100 Specification (STANDARD)	SHEET REVISION	NO.	
			B	NEXT 36	SHEET 35

3. FUNCTIONS

3.1 List of Commands

Command	Name
HT	Horizontal tab
LF	Print and line feed
FF	1) Print and eject cut sheet
	2) Print data in page mode and change to standard mode
CR	Print and carriage return
CAN	Cancel print data in page mode
DLE EOT	Real-time status transmission
DLE ENQ	Real-time request to printer
DLE DC4	1) Generate pulse in real-time ($fn = 1$)
	2) Execute power off ($fn = 2$)
	3) Transmit specified status in real-time ($fn = 7$)
	4) Clear buffer(s) ($fn = 8$)
ESC FF	Print data in page mode
ESC SP	Set right-side character spacing
ESC !	Select print mode(s)
ESC \$	Set absolute print position
ESC %	Select/cancel user-defined character set
ESC &	Define user-defined characters
ESC *	Select bit-image mode
ESC -	Turn underline mode on/off
ESC 2	Select default line spacing
ESC 3	Set line spacing
ESC <	Return home
ESC =	Select peripheral device
ESC ?	Cancel user-defined characters
ESC @	Initialize printer
ESC D	Set horizontal tab positions
ESC E	Turn emphasized mode on/off
ESC F	Set/cancel cut sheet reverse eject
ESC G	Turn double-strike mode on/off
ESC J	Print and feed paper
ESC K	Print and reverse feed
ESC L	Select page mode

EPSON	TITLE TM-J7000/J7100 Specification (STANDARD)	SHEET REVISION B	NO.	
			NEXT 37	SHEET 36

Command	Name
ESC M	Select character font
ESC R	Select an international character set
ESC S	Select standard mode
ESC T	Select print direction in page mode
ESC U	Turn unidirectional printing mode on/off
ESC W	Set printing area in page mode
ESC \	Set relative print position
ESC a	Select justification
ESC c 0	Select paper type(s) for printing
ESC c 1	Select paper type(s) for command settings
ESC c 3	Select paper sensor(s) to output paper-end signals
ESC c 4	Select paper sensor(s) to stop printing
ESC c 5	Enable/disable panel buttons
ESC d	Print and feed <i>n</i> lines
ESC e	Print and reverse feed <i>n</i> lines
ESC f	Set cut sheet wait time
ESC p	Generate pulse
ESC q	Paper release
ESC t	Select character code table
ESC {	Turn upside-down printing mode on/off
FS (e	Enable/disable Automatic Status Back (ASB) for operational function(s)
GS !	Select character size
GS \$	Set absolute vertical print position in page mode
GS (A	Execute test print
GS (B	Customize ASB status bits
GS (C	Edit NV user memory
GS (D	Enable/disable real-time commands
GS (E	User setup commands
GS (G	Select cut sheet control function(s)
GS (H	Request response transmission
GS (K	Select print control method(s)
GS (L	Set graphics data
GS 8 L	
GS (M	Customize printer control value(s)
GS (N	Select character style(s)

EPSON	TITLE	SHEET REVISION	NO.	
	TM-J7000/J7100 Specification (STANDARD)		B	NEXT 38

Confidential

Command	Name
GS (P	Select page mode control function(s)
GS (k	Setup and print symbol
GS B	Turn white/black reverse printing mode on/off
GS H	Select printing position of HRI characters
GS I	Transmit printer ID
GS L	Set left margin
GS P	Set horizontal and vertical motion units
GS T	Set print position to the beginning of print line
GS V	Select cut mode and cut paper
GS W	Set printing area width
GS \	Set relative vertical print position in page mode
GS a	Enable/disable Automatic Status Back (ASB)
GS f	Select font for HRI characters
GS g 0	Initialize maintenance counter
GS g 2	Transmit maintenance counter
GS h	Set bar code height
GS j	Enable/disable Automatic Status Back (ASB) for ink
GS k	Print bar code
GS r	Transmit status
GS w	Set bar code width

Command list for models with the MICR option

Command	Name
DLE EOT (n = 8)	Real-time MICR status transmission
FS (f	Select MICR data handling
FS c	MICR mechanism cleaning
GS (G	Select cut sheet control function(s) (for MICR mechanism)

EPSON	TITLE TM-J7000/J7100 Specification (STANDARD)	SHEET REVISION B	NO.	
			NEXT 39	SHEET 38

Confidential

The commands listed below in the first column are defined as “obsolete commands” in the ESC/POS® command system. This printer supports both upward-compatible commands and obsolete commands. However, the upward-compatible commands are recommended for use.

Obsolete command	Upward-compatible command
FS a 0: Read check paper	GS (G <Function 80> + <Function 83> + <Function 60>
FS a 1: Load check paper to print starting position	GS (G <Function 80> + <Function 48> + <Function 84>
FS a 2: Eject check paper	GS (G <Function 85>
FS b: Request retransmission of check paper reading result	GS (G <Function 61>
GS *: Define downloaded bit image	GS (L <Function 83> or <Function 84>
GS /: Print downloaded bit image	GS (L <Function 85>
GS Q 0: Print variable vertical size bit image	GS (L <Function 113> + <Function 50>
GS v 0: Print raster bit image	GS (L <Function 112> and <Function 50>

NOTE: “Obsolete commands” are commands that are supported by legacy models; however it is recommended to replace them with upward-compatible commands, because they will not be supported in the future products.

EPSON	TITLE TM-J7000/J7100 Specification (STANDARD)	SHEET REVISION B	NO.	
			NEXT 40	SHEET 39

3.2 Character Code Tables

3.2.1 Page 0 (PC437: USA, Standard Europe) (International Character Set: U.S.A.)

HEX	O	1	2	3	4	5	6	7	8	9	A	B	C	D	E	F
0000	0000	0001	0010	0011	0100	0101	0110	0111	1000	1001	1010	1011	1100	1101	1110	1111
NUL	DLE	SP	@	P	Q	R	S	T	U	V	W	X	Y	Z	[]
00	16	32	48	64	80	96	112	128	144	160	176	192	208	224	240	256
0001	XON	!	"	#	\$	%	&	'	()	*	+	,	-	.	/
01	17	33	49	65	81	97	113	129	145	161	177	193	209	225	241	257
0010		18	34	50	66	82	98	114	130	146	162	178	194	210	226	242
0011	XOFF	19	35	51	67	83	99	115	131	147	163	179	195	211	227	243
0100	EOT	20	36	52	68	84	100	116	132	148	164	180	196	212	228	244
0101	ENQ	21	37	53	69	85	101	117	133	149	165	181	197	213	229	245
0110		22	38	54	70	86	102	118	134	150	166	182	198	214	230	246
0111		23	39	55	71	87	103	119	135	151	167	183	199	215	231	247
1000	BS	24	40	56	72	88	104	120	136	152	168	184	200	216	232	248
1001		25	41	57	73	89	105	121	137	153	169	185	201	217	233	249
1010	LF	26	42	58	74	90	106	122	138	154	170	186	202	218	234	250
1011	ESC	27	43	59	75	91	107	123	139	155	171	187	203	219	235	251
1100	FF	28	44	60	76	92	108	124	140	156	172	188	204	220	236	252
1101	GS	29	45	61	77	93	109	125	141	157	173	189	205	221	237	253
1110		30	46	62	78	94	110	126	142	158	174	190	206	222	238	254
1111		31	47	63	79	95	111	127	143	159	175	191	207	223	239	255

3.2.2 Page 1 (Katakana)

	HEX	8	9	A	B	C	D	E	F
HEX	BIN	1000	1001	1010	1011	1100	1101	1110	1111
0	0000	ー 128	↑ 144	SP 160	ー 176	タ 192	ミ 208	ニ 224	× 240
1	0001	ー 129	↑ 145	。 161	ア 177	チ 193	ム 209	ト 225	円 241
2	0010	ー 130	↑ 146	「 162	イ 178	ツ 194	メ 210	キ 226	年 242
3	0011	■ 131	↑ 147	」 163	ウ 179	テ 195	モ 211	コ 227	月 243
4	0100	■ 132	↑ 148	、 164	エ 180	ト 196	ヤ 212	▲ 228	日 244
5	0101	■ 133	ー 149	・ 165	オ 181	ナ 197	ユ 213	▲ 229	時 245
6	0110	■ 134	150	ヲ 166	カ 182	ニ 198	ヨ 214	▲ 230	分 246
7	0111	■ 135	151	ア 167	キ 183	ヌ 199	ラ 215	▲ 231	秒 247
8	1000	136	↑ 152	イ 168	ク 184	ネ 200	リ 216	♠ 232	〒 248
9	1001	137	↑ 153	ウ 169	ケ 185	ノ 201	ル 217	♥ 233	市 249
A	1010	138	↑ 154	エ 170	コ 186	ハ 202	レ 218	♦ 234	区 250
B	1011	139	↑ 155	オ 171	サ 187	ヒ 203	ロ 219	♣ 235	町 251
C	1100	■ 140	↑ 156	ヤ 172	シ 188	フ 204	ワ 220	● 236	村 252
D	1101	■ 141	↑ 157	ユ 173	ス 189	ヘ 205	ン 221	○ 237	人 253
E	1110	■ 142	↑ 158	ヨ 174	セ 190	ホ 206	。 222	／ 238	■ 254
F	1111	↑ 143	↑ 159	ツ 175	ソ 191	マ 207	。 223	＼ 239	SP 255

EPSON	TITLE	TM-J7000/J7100 Specification (STANDARD)		SHEET REVISION	NO.	
				B	NEXT 42	SHEET 41

3.2.3 Page 2 (PC850: Multilingual)

	HEX	8	9	A	B	C	D	E	F
HEX	BIN	1000	1001	1010	1011	1100	1101	1110	1111
0	0000	Ç 128	É 144	á 160	⌘ 176	⌘ 192	ð 208	Ó 224	— 240
1	0001	ü 129	æ 145	í 161	⌘ 177	⌘ 193	Ð 209	β 225	± 241
2	0010	é 130	Æ 146	ó 162	⌘ 178	⌘ 194	Ê 210	Ô 226	= 242
3	0011	â 131	ô 147	ú 163	 179	† 195	Ë 211	Ò 227	$\frac{3}{4}$ 243
4	0100	ä 132	ö 148	ñ 164	† 180	— 196	È 212	ō 228	¶ 244
5	0101	à 133	ò 149	Ñ 165	Á 181	† 197	ı 213	Ö 229	§ 245
6	0110	å 134	û 150	ä 166	Â 182	ã 198	í 214	μ 230	÷ 246
7	0111	ç 135	ù 151	ó 167	À 183	Ä 199	î 215	þ 231	ˆ 247
8	1000	ê 136	ÿ 152	¿ 168	© 184	⌘ 200	ï 216	ƒ 232	° 248
9	1001	ë 137	ÿ 153	® 169	† 185	⌘ 201	ƒ 217	Ú 233	ˆ 249
A	1010	è 138	ÿ 154	¬ 170	 186	⌘ 202	⌘ 218	Û 234	· 250
B	1011	ï 139	ø 155	$\frac{1}{2}$ 171	¶ 187	⌘ 203	■ 219	Ü 235	¹ 251
C	1100	î 140	£ 156	$\frac{1}{4}$ 172	¶ 188	† 204	■ 220	Ý 236	³ 252
D	1101	ì 141	Ø 157	ı 173	φ 189	= 205	ı 221	Ÿ 237	² 253
E	1110	Ä 142	× 158	« 174	¥ 190	† 206	Ï 222	— 238	■ 254
F	1111	Å 143	f 159	» 175	⌘ 191	⌘ 207	■ 223	' 239	SP 255

EPSON	TITLE	TM-J7000/J7100 Specification (STANDARD)		SHEET REVISION	NO.	
				B	NEXT 43	SHEET 42

3.2.4 Page 3 (PC860: Portuguese)

	HEX	8	9	A -	B	C	D	E	F
HEX	BIN	1000	1001	1010	1011	1100	1101	1110	1111
0	0000	Ç 128	É 144	á 160	█ 176	Ł 192	⊥ 208	α 224	≡ 240
1	0001	ü 129	À 145	í 161	█ 177	⊥ 193	⊥ 209	β 225	± 241
2	0010	é 130	È 146	ó 162	█ 178	⊥ 194	⊥ 210	Γ 226	≥ 242
3	0011	â 131	ô 147	ú 163	 179	⊥ 195	⊥ 211	π 227	≤ 243
4	0100	ã 132	õ 148	ñ 164	⊥ 180	- 196	⊥ 212	Σ 228	↑ 244
5	0101	à 133	ò 149	Ñ 165	⊥ 181	⊥ 197	⊥ 213	σ 229	J 245
6	0110	Á 134	Ú 150	ã 166	⊥ 182	⊥ 198	⊥ 214	μ 230	÷ 246
7	0111	ç 135	ù 151	ó 167	⊥ 183	⊥ 199	⊥ 215	τ 231	≈ 247
8	1000	ê 136	î 152	ô 168	⊥ 184	⊥ 200	⊥ 216	Φ 232	° 248
9	1001	Ê 137	Ï 153	ò 169	⊥ 185	⊥ 201	⊥ 217	θ 233	• 249
A	1010	è 138	Û 154	¬ 170	 186	⊥ 202	⊥ 218	Ω 234	· 250
B	1011	í 139	ϕ 155	½ 171	⊥ 187	⊥ 203	█ 219	δ 235	√ 251
C	1100	ô 140	£ 156	¼ 172	⊥ 188	⊥ 204	█ 220	∞ 236	n 252
D	1101	ì 141	Û 157	i 173	⊥ 189	= 205	█ 221	∅ 237	z 253
E	1110	Ã 142	Pt 158	« 174	⊥ 190	⊥ 206	█ 222	€ 238	■ 254
F	1111	Â 143	Ó 159	» 175	⊥ 191	⊥ 207	█ 223	∩ 239	SP 255

EPSON	TITLE	TM-J7000/J7100 Specification (STANDARD)		SHEET REVISION	NO.	
				B	NEXT 44	SHEET 43

3.2.5 Page 4 (PC863: Canadian-French)

	HEX	8	9	A	B	C	D	E	F
HEX	BIN	1000	1001	1010	1011	1100	1101	1110	1111
0	0000	Ç 128	É 144	Ì 160	Ñ 176	Ò 192	Ó 208	α 224	≡ 240
1	0001	ü 129	È 145	Í 161	Ë 177	Ô 193	Õ 209	β 225	± 241
2	0010	é 130	Ê 146	Ó 162	Ï 178	Ô 194	Õ 210	Γ 226	≥ 242
3	0011	â 131	ô 147	ú 163	ñ 179	ô 195	π 211	π 227	≤ 243
4	0100	À 132	Ë 148	Ì 164	Ñ 180	Ò 196	Ó 212	Σ 228	∫ 244
5	0101	à 133	ë 149	í 165	ñ 181	ò 197	ó 213	σ 229	∫ 245
6	0110	ñ 134	û 150	³ 166	ñ 182	ò 198	ó 214	μ 230	÷ 246
7	0111	ç 135	ù 151	ì 167	ñ 183	ò 199	ó 215	τ 231	≈ 247
8	1000	ê 136	œ 152	î 168	ñ 184	ò 200	ó 216	φ 232	° 248
9	1001	ë 137	ô 153	í 169	ñ 185	ò 201	ó 217	θ 233	• 249
A	1010	è 138	Û 154	ï 170	ñ 186	ò 202	ó 218	Ω 234	• 250
B	1011	ï 139	φ 155	½ 171	ñ 187	ò 203	■ 219	δ 235	√ 251
C	1100	î 140	£ 156	¼ 172	ñ 188	ò 204	■ 220	∞ 236	n 252
D	1101	≡ 141	Û 157	¾ 173	ñ 189	ò 205	■ 221	∅ 237	² 253
E	1110	À 142	Û 158	« 174	ñ 190	ò 206	■ 222	∈ 238	■ 254
F	1111	§ 143	f 159	» 175	ñ 191	ò 207	■ 223	∩ 239	SP 255

EPSON	TITLE	TM-J7000/J7100 Specification (STANDARD)	SHEET REVISION	NO.	
	B		NEXT 45	SHEET 44	

3.2.6 Page 5 (PC865: Nordic)

	HEX	8	9	A	B	C	D	E	F
HEX	BIN	1000	1001	1010	1011	1100	1101	1110	1111
0	0000	Ç 128	É 144	á 160	⌘ 176	⌚ 192	⌛ 208	α 224	≡ 240
1	0001	ü 129	æ 145	í 161	⌘ 177	⌚ 193	⌛ 209	β 225	± 241
2	0010	é 130	Æ 146	ó 162	⌘ 178	⌚ 194	⌛ 210	Γ 226	≥ 242
3	0011	â 131	ô 147	û 163	⌘ 179	⌚ 195	⌛ 211	π 227	≤ 243
4	0100	ä 132	ö 148	ñ 164	⌘ 180	⌚ 196	⌛ 212	Σ 228	∫ 244
5	0101	à 133	ò 149	Ñ 165	⌘ 181	⌚ 197	⌛ 213	σ 229	J 245
6	0110	å 134	û 150	ä 166	⌘ 182	⌚ 198	⌛ 214	μ 230	÷ 246
7	0111	ç 135	ù 151	ó 167	⌘ 183	⌚ 199	⌛ 215	τ 231	≈ 247
8	1000	ê 136	ÿ 152	¿ 168	⌘ 184	⌚ 200	⌛ 216	Φ 232	° 248
9	1001	ë 137	Ö 153	ƒ 169	⌘ 185	⌚ 201	⌛ 217	θ 233	• 249
A	1010	è 138	Û 154	ƒ 170	⌘ 186	⌚ 202	⌛ 218	Ω 234	• 250
B	1011	ï 139	ø 155	½ 171	⌘ 187	⌚ 203	■ 219	δ 235	√ 251
C	1100	î 140	£ 156	¼ 172	⌘ 188	⌚ 204	■ 220	∞ 236	n 252
D	1101	ì 141	Ø 157	ı 173	⌘ 189	⌚ 205	■ 221	∅ 237	² 253
E	1110	Ä 142	Pt 158	« 174	⌘ 190	⌚ 206	■ 222	€ 238	■ 254
F	1111	Å 143	f 159	α 175	⌘ 191	⌚ 207	■ 223	∩ 239	SP 255

EPSON	TITLE	TM-J7000/J7100 Specification (STANDARD)		SHEET REVISION	NO.	
				B	NEXT 46	SHEET 45

3.2.7 Page 16 (WPC1252)

	HEX	8	9	A	B	C	D	E	F
HEX	BIN	1000	1001	1010	1011	1100	1101	1110	1111
0	0000	€ 128	SP 144	SP 160	° 176	À 192	Ð 208	à 224	ð 240
1	0001	SP 129	‘ 145	í 161	± 177	Á 193	Ñ 209	á 225	ñ 241
2	0010	, 130	, 146	¢ 162	² 178	Â 194	Ò 210	â 226	ò 242
3	0011	f 131	“ 147	£ 163	³ 179	Ã 195	Ó 211	ã 227	ó 243
4	0100	” 132	” 148	¤ 164	´ 180	Ä 196	Ô 212	ä 228	ô 244
5	0101	… 133	• 149	¥ 165	µ 181	Å 197	Õ 213	å 229	õ 245
6	0110	† 134	– 150	¦ 166	¶ 182	Æ 198	Ö 214	æ 230	ö 246
7	0111	‡ 135	— 151	§ 167	· 183	Ç 199	× 215	ç 231	÷ 247
8	1000	^ 136	˘ 152	¨ 168	˙ 184	È 200	Ø 216	è 232	ø 248
9	1001	‰ 137	™ 153	© 169	¹ 185	É 201	Û 217	é 233	ù 249
A	1010	Š 138	š 154	ª 170	º 186	Ê 202	Ü 218	ê 234	û 250
B	1011	‹ 139	› 155	« 171	» 187	Ë 203	Û 219	ë 235	ü 251
C	1100	Œ 140	œ 156	¬ 172	¼ 188	Ì 204	Ù 220	ì 236	ü 252
D	1101	SP 141	SP 157	· 173	½ 189	Í 205	Ý 221	í 237	ý 253
E	1110	Ž 142	ž 158	® 174	¾ 190	Î 206	Þ 222	î 238	þ 254
F	1111	SP 143	ÿ 159	— 175	¿ 191	Ï 207	ß 223	ï 239	ÿ 255

EPSON	TITLE	TM-J7000/J7100 Specification (STANDARD)	SHEET REVISION	NO.	
			B	NEXT 47	SHEET 46

3.2.8 Page 17 (PC866: Cyrillic #2)

	HEX	8	9	A	B	C	D	E	F
HEX	BIN	1000	1001	1010	1011	1100	1101	1110	1111
0	0000	А 128	Р 144	а 160	▣ 176	▣ 192	▣ 208	Р 224	Ё 240
1	0001	Б 129	С 145	б 161	▣ 177	▣ 193	▣ 209	с 225	ё 241
2	0010	В 130	Т 146	в 162	▣ 178	▣ 194	▣ 210	т 226	ѐ 242
3	0011	Г 131	У 147	г 163	▣ 179	▣ 195	▣ 211	у 227	ѓ 243
4	0100	Д 132	Ф 148	д 164	▣ 180	▣ 196	▣ 212	ф 228	ї 244
5	0101	Е 133	Х 149	е 165	▣ 181	▣ 197	▣ 213	х 229	і 245
6	0110	Ж 134	Ц 150	ж 166	▣ 182	▣ 198	▣ 214	ц 230	ѣ 246
7	0111	З 135	Ч 151	з 167	▣ 183	▣ 199	▣ 215	ч 231	ѝ 247
8	1000	И 136	Ш 152	и 168	▣ 184	▣ 200	▣ 216	ш 232	° 248
9	1001	Й 137	Щ 153	й 169	▣ 185	▣ 201	▣ 217	щ 233	• 249
A	1010	К 138	Ъ 154	к 170	▣ 186	▣ 202	▣ 218	ъ 234	• 250
B	1011	Л 139	Ы 155	л 171	▣ 187	▣ 203	▣ 219	ы 235	✓ 251
C	1100	М 140	Ь 156	м 172	▣ 188	▣ 204	▣ 220	ь 236	№ 252
D	1101	Н 141	Э 157	н 173	▣ 189	▣ 205	▣ 221	э 237	□ 253
E	1110	О 142	Ю 158	о 174	▣ 190	▣ 206	▣ 222	ю 238	■ 254
F	1111	П 143	Я 159	п 175	▣ 191	▣ 207	▣ 223	я 239	SP 255

EPSON	TITLE	SHEET REVISION	NO.	
	TM-J7000/J7100 Specification (STANDARD)	B	NEXT 48	SHEET 47

3.2.9 Page 18 (PC852: Latin2)

	HEX	8	9	A	B	C	D	E	F
HEX	BIN	1000	1001	1010	1011	1100	1101	1110	1111
0	0000	Ç 128	É 144	á 160	⌘ 176	⌘ 192	đ 208	Ó 224	- 240
1	0001	ü 129	Ĺ 145	í 161	⌘ 177	⌘ 193	Đ 209	ß 225	" 241
2	0010	é 130	í 146	ó 162	⌘ 178	⌘ 194	Ď 210	Ô 226	´ 242
3	0011	â 131	ô 147	ú 163	⌘ 179	⌘ 195	Ě 211	Ń 227	˘ 243
4	0100	ä 132	ö 148	À 164	⌘ 180	⌘ 196	ď 212	ń 228	˘ 244
5	0101	ù 133	Ĺ 149	ą 165	Á 181	⌘ 197	Ň 213	ň 229	§ 245
6	0110	ć 134	ĩ 150	ž 166	Â 182	Ă 198	í 214	š 230	÷ 246
7	0111	ç 135	ś 151	ż 167	Ĕ 183	ă 199	î 215	ş 231	· 247
8	1000	ı 136	ś 152	ƒ 168	Ş 184	⌘ 200	č 216	Ŕ 232	° 248
9	1001	ë 137	Ö 153	ε 169	⌘ 185	⌘ 201	⌘ 217	Ú 233	˘ 249
A	1010	Ö 138	Ü 154	SP 170	⌘ 186	⌘ 202	⌘ 218	ı 234	· 250
B	1011	õ 139	Ŧ 155	ź 171	⌘ 187	⌘ 203	⌘ 219	Û 235	û 251
C	1100	î 140	ĩ 156	č 172	⌘ 188	⌘ 204	⌘ 220	ý 236	ř 252
D	1101	Ž 141	Ł 157	š 173	Ž 189	⌘ 205	Ŧ 221	Ý 237	ř 253
E	1110	Ä 142	× 158	« 174	ž 190	⌘ 206	Û 222	ı 238	■ 254
F	1111	Ć 143	č 159	» 175	⌘ 191	⌘ 207	⌘ 223	’ 239	SP 255

EPSON	TITLE	TM-J7000/J7100 Specification (STANDARD)	SHEET REVISION	NO.	
			B	NEXT 49	SHEET 48

3.2.10 Page19 (PC858: Euro)

	HEX	8	9	A	B	C	D	E	F
HEX	BIN	1000	1001	1010	1011	1100	1101	1110	1111
0	0000	Ç 128	É 144	á 160	⌘ 176	Ł 192	Š 208	Ó 224	— 240
1	0001	ü 129	æ 145	í 161	⌘ 177	ł 193	Đ 209	ß 225	± 241
2	0010	é 130	Æ 146	ó 162	⌘ 178	Ṭ 194	Ê 210	Ô 226	= 242
3	0011	â 131	ô 147	ú 163	 179	ł 195	Ë 211	Ò 227	¾ 243
4	0100	ä 132	ö 148	ñ 164	† 180	— 196	È 212	Ö 228	¶ 244
5	0101	à 133	ò 149	Ñ 165	Á 181	† 197	€ 213	Ø 229	§ 245
6	0110	â 134	û 150	ä 166	Â 182	ã 198	í 214	µ 230	÷ 246
7	0111	ç 135	ù 151	ó 167	À 183	Ä 199	î 215	þ 231	ˆ 247
8	1000	ê 136	ÿ 152	¿ 168	© 184	Ł 200	ï 216	ƒ 232	° 248
9	1001	ë 137	ÿ 153	® 169	† 185	ŕ 201	ĵ 217	Ů 233	˙ 249
A	1010	è 138	Û 154	¬ 170	 186	ł 202	ŕ 218	Ů 234	· 250
B	1011	ï 139	ø 155	½ 171	¶ 187	Ŧ 203	■ 219	Ù 235	¹ 251
C	1100	î 140	£ 156	¼ 172	¶ 188	ł 204	■ 220	Ÿ 236	³ 252
D	1101	ì 141	Ø 157	ı 173	ϕ 189	— 205	ı 221	Ÿ 237	² 253
E	1110	Ä 142	× 158	« 174	¥ 190	† 206	î 222	— 238	■ 254
F	1111	Å 143	ƒ 159	» 175	¶ 191	¤ 207	■ 223	' 239	SP 255

EPSON	TITLE	TM-J7000/J7100 Specification (STANDARD)	SHEET REVISION	NO.	
			B	NEXT 50	SHEET 49

3.2.11 Page 255 (User-defined Page)

	HEX	8	9	A	B	C	D	E	F
HEX	BIN	1000	1001	1010	1011	1100	1101	1110	1111
0	0000	UD 128	UD 144	UD 160	UD 176	UD 192	UD 208	UD 224	UD 240
1	0001	UD 129	UD 145	UD 161	UD 177	UD 193	UD 209	UD 225	UD 241
2	0010	UD 130	UD 146	UD 162	UD 178	UD 194	UD 210	UD 226	UD 242
3	0011	UD 131	UD 147	UD 163	UD 179	UD 195	UD 211	UD 227	UD 243
4	0100	UD 132	UD 148	UD 164	UD 180	UD 196	UD 212	UD 228	UD 244
5	0101	UD 133	UD 149	UD 165	UD 181	UD 197	UD 213	UD 229	UD 245
6	0110	UD 134	UD 150	UD 166	UD 182	UD 198	UD 214	UD 230	UD 246
7	0111	UD 135	UD 151	UD 167	UD 183	UD 199	UD 215	UD 231	UD 247
8	1000	UD 136	UD 152	UD 168	UD 184	UD 200	UD 216	UD 232	UD 248
9	1001	UD 137	UD 153	UD 169	UD 185	UD 201	UD 217	UD 233	UD 249
A	1010	UD 138	UD 154	UD 170	UD 186	UD 202	UD 218	UD 234	UD 250
B	1011	UD 139	UD 155	UD 171	UD 187	UD 203	UD 219	UD 235	UD 251
C	1100	UD 140	UD 156	UD 172	UD 188	UD 204	UD 220	UD 236	UD 252
D	1101	UD 141	UD 157	UD 173	UD 189	UD 205	UD 221	UD 237	UD 253
E	1110	UD 142	UD 158	UD 174	UD 190	UD 206	UD 222	UD 238	UD 254
F	1111	UD 143	UD 159	UD 175	UD 191	UD 207	UD 223	UD 239	UD 255

UD: Undefined

EPSON	TITLE	TM-J7000/J7100 Specification (STANDARD)	SHEET REVISION	NO.	
			B	NEXT	SHEET
			51	50	

3.2.12 International Character Sets

Country	ASCII code (Hex)											
	23	24	40	5B	5C	5D	5E	60	7B	7C	7D	7E
U.S.A	#	\$	@	[\]	^	`	{		}	~
France	#	\$	à	°	ç	§	^	`	é	ù	è	¨
Germany	#	\$	§	Ä	Ö	Ü	^	`	ä	ö	ü	ß
U.K.	£	\$	@	[\]	^	`	{		}	~
Denmark I	#	\$	@	Æ	Ø	Å	^	`	æ	ø	å	~
Sweden	#	¤	É	Ä	Ö	Å	Ü	é	ä	ö	å	ü
Italy	#	\$	@	°	\	é	^	ù	à	ò	è	ì
Spain I	Pt	\$	@	ı	Ñ	ı	^	`	¨	ñ	}	~
Japan	#	\$	@	[¥]	^	`	{		}	~
Norway	#	¤	É	Æ	Ø	Å	Ü	é	æ	ø	å	ü
Denmark II	#	\$	É	Æ	Ø	Å	Ü	é	æ	ø	å	ü
Spain II	#	\$	á	ı	Ñ	ı	é	`	ı	ñ	ó	ú
Latin America	#	\$	á	ı	Ñ	ı	é	ü	ı	ñ	ó	ú
Korea	#	\$	@	[₩]	^	`	{		}	~

EPSON	TITLE	TM-J7000/J7100 Specification (STANDARD)	SHEET REVISION	NO.	
	B		NEXT 52	SHEET 51	

3.3 Switches and Buttons

3.3.1 Power Button

1) The power button (rocker type) located on the front of the printer turns the power on or off.

NOTE: Turn on/off the power only after connecting the power supply.

<Disabling the power button>

A power button cover option is available. Use this cover to avoid turning power off accidentally.

<Executing the power-off sequence>

It is recommended to turn the power off only after executing the power-off command (**DLE DC4 fn = 2**). If the power is turned off without executing the power-off command, the ink will be wasted since the cleaning is done when the printer is turned on the next time, or the ink nozzle will be clogged if unused period exceeds two weeks. (Refer to Appendix G for details.)

3.3.2 Panel Button

The panel button of the printer is located beside the slip entrance.

The paper FEED button can be disabled with the **ESC c 5** command. When it is disabled, the paper roll FEED button cannot function.

1) Paper FEED button (PAPER FEED SW) (non-locking push button)

[Function] The printer feeds paper based on the line spacing set by the **ESC 2** or **ESC 3** command. The printer feeds the paper roll if the paper roll mechanism is enabled, or feeds the slip if the slip mechanism is enabled. The back of the slip is fed by the PAPER FEED button in the reverse direction of the feeding direction of the endorsement printing.

However, paper feeding using the paper FEED button cannot be performed under the following conditions:

- Between when the printer starts to eject a cut sheet and when the printer finishes waiting for removal of the cut sheet.
- Between when the printer waits for insertion of a cut sheet and when the printer finishes setting the print starting position.
- Between when the printer waits for insertion of a cut sheet and when the MICR function is set to "disable."
- When head cleaning is performed, an error has occurred, or when the paper roll cover is open.

2) Cleaning button (CLEANING SW) (non-locking push button)

[Function] The printer performs the manual cleaning operation if the button is pressed for 3 seconds or more. Perform the manual cleaning when the print result is not dark enough.

EPSON	TITLE	TM-J7000/J7100 Specification (STANDARD)	SHEET REVISION	NO.	
			B	NEXT 53	SHEET 52

3.3.3 DIP Switches

The DIP switch is located on the main board inside the bottom cover of the printer.

3.3.3.1 Serial interface specifications

Table 3.3.1 DIP Switches

SW 1	Function	ON	OFF
1	Reserved	--	Fixed to Off
2	Interface condition selection	By DIP switch	By memory switch
3	Handshaking	XON/XOFF control	DTR/DSR control
4	Word length	7 bits	8 bits
5	Parity check	Yes	No
6	Parity selection	Even	Odd
7	Transmission speed selection	Refer to Table 3.3.2	
8			

Table 3.3.2 Transmission Speed

Transmission speed (bps)	SW1-7	SW1-8
9600	ON	ON
19200	OFF	ON
38400	ON	OFF
115200	OFF	OFF

bps: bits per second

NOTE: Changes in DIP switch settings are recognized only when the printer power is turned on or when the printer is reset by using the interface. If the DIP switch setting is changed after the printer power is turned on, the change does not take effect until the printer is turned on again or is reset.

3.3.3.2 Parallel interface specifications

Table 3.3.3 DIP Switches

SW 1	Function	ON	OFF
1-8	Reserved	--	Fixed to Off.

EPSON	TITLE TM-J7000/J7100 Specification (STANDARD)	SHEET REVISION B	NO.	
			NEXT 54	SHEET 53

3.3.4 Memory Switches

Memory switches are defined:

- Memory switches: Msw 1, Msw 2, Msw 8
- Customized value
- Communication conditions of the serial interface

Customized value and communication conditions of the serial interface refer to **GS (E**.

1) Memory switches

Msw 1 is defined as follows:

Table 3.3.4 Memory Switch Msw 1

Bit	Function	0 (Off)	1 (On)
1	Transmits the power ON information	Does not transmit	Transmits
2	Reserved	--	--
3	Conditions for BUSY	Receive buffer-full or offline	Receive buffer-full
4	Data processing for receiving error	Prints "?"	Ignored
5	Automatic line feed	Disabled	Enabled
6	Connection of DM-D	Not connected	Connected
7	Pin #6: Selection of reset signal	Not used	Used
8	Pin #25: Selection of reset signal	Not used	Used

NOTE: Msw 1-7 and 1-8 are effective only when the serial interface is used.

Msw 2 is defined as follows:

Table 3.3.5 Memory Switch Msw 2

Bit	Function	0 (Off)	1 (On)
1	Reserved (the setting must not be changed)	--	Fixed to On.
2	Autocutter operation	Disabled	Enabled
3	Reserved	--	--
4	Reserved	--	--
5	Reserved	--	--
6	Reserved	--	--
7	Reserved	--	--
8	Reserved	--	--

EPSON	TITLE TM-J7000/J7100 Specification (STANDARD)	SHEET REVISION B	NO.	
			NEXT 55	SHEET 54

Msw 8 is defined as follows:

Table 3.3.6 Memory Switch Msw 8

Bit	Function	0 (Off)	1 (On)
1	Reserved	--	--
2	Reserved	--	--
3	Reserved	--	--
4	Reserved	--	--
5	Reserved	--	--
6	Slip print columns (for font A / font B)		
	Face of the slip	48 / 64	52 / 72
	Endorsement (back of the slip)	46 / 61	50 / 69
7	Receipt print columns (for font A / font B)		
	Paper width 57.5 mm {2.26"}	30 / 40	32 / 45
	69.5 mm {2.74"}	36 / 48	39 / 54
	76 mm {2.99"}	40 / 53	43 / 60
	82.5 mm {3.25"}	42 / 56	46 / 64
8	Paper roll cover open during printing	Automatically recoverable error	Recoverable error

2) Customized value

Table 3.3.7 Customized Value

Function	Value
Paper width selection	57.5 mm {2.26"}
	69.5 mm {2.74"}
	76 mm {2.99"}
	82.5 mm {3.25"}

Refer to **GS (E** for setting the customized value.

EPSON	TITLE	TM-J7000/J7100 Specification (STANDARD)	SHEET REVISION	NO.	
			B	NEXT 56	SHEET 55

3) Communication conditions for the serial interface

Table 3.3.8 Communication Conditions for the Serial Interface

Function	Value
Baud rate	2400 bps
	4800 bps
	9600 bps
	19200 bps
	38400 bps
	57600 bps
	115200 bps
Parity	None
	Odd
	Even
Handshaking	DTR/DSR control
	XON/XOFF control
Data length	7 bits
	8 bits

Refer to **GS (E** for setting the communication conditions of the serial interface.

EPSON	TITLE TM-J7000/J7100 Specification (STANDARD)	SHEET REVISION B	NO.	
			NEXT 57	SHEET 56

3.4 Indicators

3.4.1 Panel LED Indicators

1) Power supply (POWER) LED: Green

On: Power is stable.

Off: Power is not stable.

Flashing: While some operations (power-on process, power-off process, or cleaning) are executed.
(Refer to Figure 3.4.1 and 3.4.2)

Power on (an operation is executed): Flashing

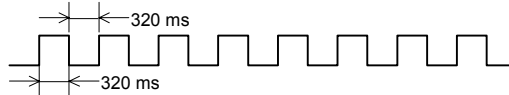

Figure 3.4.1 Power LED Flashing Pattern

Power off process (after **DLE DC4 fn = 2** is executed) Flashing

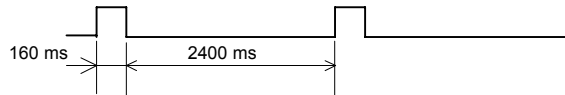

Figure 3.4.2 Power LED Flashing Pattern

2) Error (ERROR) LED: Red

On: Offline (except during paper feeding using the paper FEED button, during self-test, and cleaning)

Off: Online

Flashing: Error (refer to Section 3.8, Error Processing)

3) Ink out (INK OUT) LED: Red

Single-color model: Has one LED - for color 1 (SJIC8(K))

Two-color model: Has two LEDs - for color 1 (SJIC6(K)) and color 2 (SJIC7 (R), (B), (G)) (INK OUT LED)

The INK OUT LED indicates the following status:

Flashing: Ink near end.

Off: Ink cartridge is installed and ink remains adequate.

On: Ink cartridge is not installed or ink end. (Need to replace the ink cartridge.)

- NOTES:
- The number of the printable characters from when the ink near end is detected to when the ink is ended differs depending on the conditions. If the ink near end is detected, prepare to replace the ink cartridge.
 - Detection of ink cartridge installation and the ink near end status is performed only when the carriage cover is closed. If the carriage cover is open, the INK OUT LED keeps the same status as before the carriage cover was opened.

EPSON	TITLE	TM-J7000/J7100 Specification (STANDARD)	SHEET REVISION	NO.	
			B	NEXT 58	SHEET 57

4) Paper roll end (PAPER OUT) LED: Red

- On: The paper is empty or the paper roll near end is detected.
- Off: Paper roll is loaded.
- Flashing: Self-test standby state.

5) Cut sheet (CUT SHEET) LED: Green

- On: When the cut sheet (slip, check) is set as the paper source.
- Off: When the paper roll is set as the paper source.
- Flashing: Cut sheet insertion / removal waiting state (refer to Figure 3.4.3).

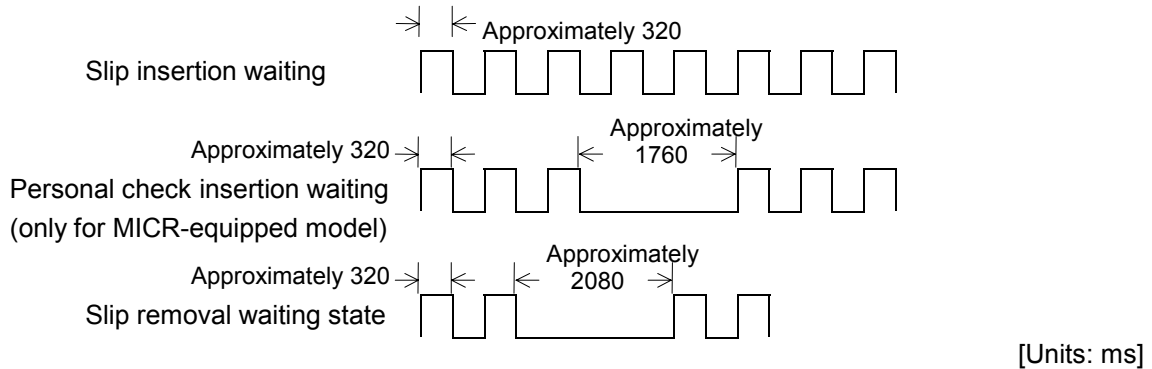

Figure 3.4.3 CUT SHEET LED Flashing Pattern

NOTE: If the cut sheet is removed during in the cut sheet removal waiting state, the SLIP LED light is on for one second.

EPSON	TITLE	TM-J7000/J7100 Specification (STANDARD)	SHEET REVISION	NO.	
			B	NEXT	SHEET
			59	58	

3.5 Self-test

1) The printer has a self-test function that checks the following:

- Control circuit functions
- Printer mechanisms
- Print quality
- Control software version
- DIP switch settings
- Memory switch settings
- Paper width to be set

2) Starting the self-test

a) Self-test on a paper roll

To start the self-test on a paper roll, hold down the FEED button while turning on the printer with the cover closed.

b) Self-test on a cut sheet

To start the self-test on a cut sheet, hold down the CLEANING button while turning on the printer with the cover closed. The printer flashes the CUT SHEET LED and enters the paper insertion waiting state. Insert a cut sheet to begin printing the printer status.

- NOTES:
- The self-test on the cut sheet is performed with full-column printing regardless of the paper width that is currently selected. If the width of the cut sheet is narrower than full-column print width, the ink may make the platen dirty beyond the edge of the paper. Make sure to use a cut sheet with a width wider than 85 mm {3.35"}
 - When the self-test is performed on the cut sheet, the paper roll also must be loaded.

c) Self-test of the endorsement mechanism (only for the endorsement-equipped model)

To start the self-test of the endorsement mechanism, hold down the CLEANING button while turning on the printer with the cover open and then close the cover. The printer flashes the CUT SHEET LED and enters the paper waiting state. Insert paper to begin printing the test printing with the endorsement mechanism.

- NOTES:
- User paper with a width narrower than 101.6 mm {4"} for the endorsement self-test. Otherwise, the paper may be jammed.
 - When the self-test is performed with the endorsement mechanism, the paper roll also must be loaded.

3) Self-test standby state

a) Self-test on a paper roll

After printing the current printer status, the printer prints the message "If you want to continue SELF-TEST printing, please press FEED button." The PAPER OUT LED indicator flashes and the printer enters the test printing standby state.

b) Self-test on a cut sheet

After printing the current printer status, the printer ejects the cut sheet and waits for the next sheet of paper to be inserted. Insert another cut sheet to begin printing the test.

EPSON	TITLE	TM-J7000/J7100 Specification (STANDARD)	SHEET REVISION	NO.	
			B	NEXT 60	SHEET 59

4) Ending the self-test

After a number of lines are printed, the printer indicates the end of the self-test by printing "**** completed ***, " initializes, and goes into the normal mode.

The printer then enters the normal print mode.

3.6 Hexadecimal Dumping

1) Hexadecimal dumping function

This function prints the data transmitted from the host computer in hexadecimal numbers and in their corresponding characters.

2) Starting hexadecimal dumping

Open the paper roll cover and turn the power on while pressing the paper FEED button; then close the paper roll cover. The printer first prints "Hexadecimal Dump" on the paper roll and prints the received print data in hexadecimal numbers and their corresponding characters.

- NOTES:
- If no characters correspond to the data received, the printer prints "."
 - During hexadecimal dumping, any commands other than **DLE EOT**, **DLE ENQ**, or **DLE DC4** do not function.

3) Ending hexadecimal dumping

Hexadecimal dumping ends by turning the power off, pressing the paper FEED button three times with the cover closed, or resetting the printer through the interface after printing has finished.

<Printing example>

Hexadecimal Dump																
1B	21	00	1B	26	02	40	40	:	.	!	.	.	&	.	@	@
1B	25	01	1B	63	34	00	1B	:	.	%	.	.	c	4	.	.
41	42	43	44	45	46	47	48	:	A	B	C	D	E	F	G	H

EPSON	TITLE	TM-J7000/J7100 Specification (STANDARD)	SHEET REVISION	NO.	
			B	NEXT 61	SHEET 60

3.7 Memory Switches Setting Mode

1) Memory switches setting function

This function sets memory switches using the panel button and the paper roll cover.

Memory switches can be set to control the following:

- ① Enable or disable autocutter operation
- ② Set the communication condition of the serial interface
- ③ Setting the conditions for communication
 - Handling a reception error occurs
 - Conditions for BUSY
- ④ Automatic line feed
- ⑤ Interface reset signal

2) Mode start

Open the paper roll cover and turn the power on while pressing the paper FEED button; then press the paper FEED button twice and close the paper roll cover. Press the paper FEED button once more, and the instructions for setting the memory switches are printed. Follow these instructions.

3) Mode end

At the end of the setting mode, save the setting contents, and initialize the printer. After initializing the printer, the printer is ready to print.





EPSON	TITLE TM-J7000/J7100 Specification (STANDARD)	SHEET REVISION B	NO.	
			NEXT 62	SHEET 61

3.8 Error Processing

3.8.1 Error Types

1) Errors that automatically recover

Table 3.8.1 Errors that Automatically Recover

Error	Description	ERROR LED flashing pattern  Approximately 320 ms	Recovery condition
Paper roll cover open error (*1)	Printing on the paper roll is not performed correctly due to a cover-open		Recovers automatically when the cover is closed.
Print head high temperature error (*2)	The temperature of the print head is extremely high (expected temperature in normal operation).		Recovers automatically when the print head cools.
Print head low temperature error (*2)	The temperature of the print head is extremely low (expected temperature in normal operation).		Recovers automatically when the print head temperature increases.





*1: This is selectable with the memory switch as an error that automatically recovers.

*2: If the head temperature is only slightly out of range the printer can recover, but a large deviation from the appropriate range causes an unrecoverable error as an internal circuit error.

EPSON	TITLE	TM-J7000/J7100 Specification (STANDARD)	SHEET REVISION	NO.	
			B	NEXT 63	SHEET 62

2) Errors that have the possibly of recovery

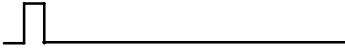
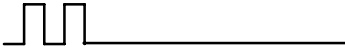
Table 3.8.2 Errors that Have the Possibility of Recovery

Error	Description	ERROR LED flashing pattern  Approximately 320 ms	Recovery condition
Paper roll cover open error (*1)	Printing on the paper roll is not performed correctly due to a cover-open.		Recovers by DLE ENQ (n = 1) or DLE ENQ (n = 2) when the cover is closed.
Autocutter error	The autocutter does not work correctly.		Recovers by DLE ENQ (n = 1) or DLE ENQ (n = 2) when the cover is closed.
Carriage home position detection error	The home position cannot be detected due to a paper jam.		Recovers by DLE ENQ (n = 1) or DLE ENQ (n = 2) when the cover is closed.
Carriage out of phase detection error	The carriage is out of phase.		Recovers by DLE ENQ (n = 1) or DLE ENQ (n = 2) when the cover is closed.
Cut sheet ejection error	The cut sheet cannot be ejected even if a certain amount of feeding is tried.		Recovers by DLE ENQ (n = 1) or DLE ENQ (n = 2) when the cover is closed.





*1: This is selectable with a memory switch as an error that has the possibility of recovery.

- NOTES:
- If the printer recovers from an error that has the possibility of recovery with **DLE ENQ (n = 1)** when the printer has selected the slip as the paper source and an error has occurred while printing on the slip, the printer ejects the slip first if it is still remains, and enters the paper waiting state. However, if the printer recovers from a cut sheet ejection error, the printer ejects the slip only, and does not enter the paper insertion waiting state.
 - If the printer recovers from an error that has the possibility of recovery with **DLE ENQ (n = 1)** when the printer has selected the slip as the paper source and an error has occurred except when printing on the slip, the printer ejects the slip first if it is still remains, and selects the slip as the paper source, and does not enter the paper insertion waiting state.
 - If the printer recovers from an error that has the possibility of recovery with **DLE ENQ (n = 2)** when slip is set as the paper source, the printer ejects the slip only if it still remains.

EPSON	TITLE	TM-J7000/J7100 Specification (STANDARD)	SHEET REVISION	NO.	
			B	NEXT 64	SHEET 63

3) Errors that are impossible to recover

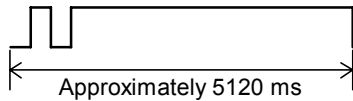
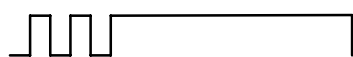
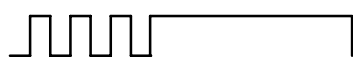
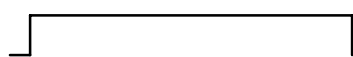
Table 3.8.3 Errors that are Impossible to Recover

Error	Description	ERROR LED flashing pattern  Approximately 320 ms	Recovery condition
CPU execution error	The CPU executes an incorrect address or the I/F board is not connected.		Impossible to recover.
R/W error	After R/W checking, the printer does not work correctly.		Impossible to recover.
High voltage error	The power supply voltage is extremely high.		Impossible to recover.
Low voltage error	The power supply voltage is extremely low.		Impossible to recover.
Internal circuit error	Internal circuit does not work correctly.		Impossible to recover.
UIB error	UIB does not work correctly.		Impossible to recover.

NOTE: When any error shown above occurs, turn off the power as soon as possible.

3.8.2 Printer Operation When an Error Occurs

The printer executes the following operations when detecting an error.

- Stops all printer operations for the selected paper section.
- Goes BUSY (Refer to Section 3.3.4 Memory Switches, when the printer is set to offline if the printer is set offline with memory switch Msw 1-3).
- Flashes the ERROR LED.

3.8.3 Data Receive Error

If one of the following errors occurs during serial interface communication, the printer prints "?" or ignores the data, depending on the setting memory switch Msw 1-4.

- Parity error
- Framing error
- Overrun error

EPSON	TITLE	TM-J7000/J7100 Specification (STANDARD)	SHEET REVISION	NO.	
			B	NEXT 65	SHEET 64

3.9 Paper Sensors

The printer has four paper sensors, as follows:

Slip:

- TOF (top of form) sensor
- BOF (bottom of form) sensor

Receipt:

- Paper roll near-end sensor
- Paper roll end sensor

3.9.1 Sensors and LED Indicators

1) TOF sensor

The slip TOF sensor is located in the slip paper path and detects the presence of a cut sheet at the slip stopper in the paper path. The CUT SHEET LED comes on, goes off, and flashes accordingly in each printer status. The TOF sensor also detects whether the cut sheet is removed or not after finishing printing (related to the BOF sensor).

2) BOF sensor

The slip BOF sensor is located in the slip entrance and detects whether the cut sheet is inserted correctly. If the printer waits for insertion of a cut sheet, the printer does not proceed to the next operation until the paper has been removed. (The CUT SHEET LED indicator continues flashing.)

The BOF sensor is enabled in the following three cases and changes its status when it detects a BOF:

- When the TOF sensor detects paper presence
- Between the cut sheet insertion waiting state and the removal waiting state.
- When the printer is clamping (regardless of the paper source)

At all other times, the BOF sensor is not enabled and will not change its status and always reports that paper is not present.

Example: If a cut sheet is inserted while the paper roll is selected, the BOF sensor is not enabled and will not change its status when the paper is detected only by the BOF sensor.

3) Paper roll near-end sensor

The near-end sensor is located on the roll paper supply device. It detects the near-end of the paper roll by detecting the paper roll diameter. When it detects the near-end of the paper, the PAPER OUT LED indicator lights.

4) Paper roll end sensor

The paper end sensor is located in the paper path. It detects the presence of paper from the paper roll in the paper path of the printer mechanism. When there is no paper in the paper path (paper end status), the PAPER OUT LED and ERROR LED indicator light.

EPSON	TITLE	TM-J7000/J7100 Specification (STANDARD)	SHEET REVISION	NO.	
			B	NEXT 66	SHEET 65

3.9.2 Sensors and Printing

When the printer detects a paper near-end, it either stops or continues printing, depending on the **ESC c 4** setting. The corresponding sensors are as follows:

- Paper roll near-end sensor

Since the paper roll end sensor is used for paper-end detection, the printer stops printing when the paper-end is detected. Use the paper roll near-end sensor for detecting a roll paper end, and also use the paper roll end sensor, if necessary.

When a printing stop is enabled and the paper roll near-end sensor detects a paper near end, the printer automatically stops after printing the line being printed. To restart printing, load the paper and close the printer cover. The printer starts initializing and continues printing data stored in the print buffer.

EPSON	TITLE TM-J7000/J7100 Specification (STANDARD)	SHEET REVISION B	NO.	
			NEXT 67	SHEET 66

3.10 Printer Cover Sensors and Cover Opening/Closing Operation

3.10.1 Carriage Cover Open Sensor

The carriage cover open sensor monitors the carriage cover for slips. When the sensor detects a cover open, the printer stops printing after finishing printing on the sheet in the current print, even though the printer is printing on the paper roll, and the carriage moves to the home position, then stops, and automatically goes offline. The printer is set back online by closing the carriage cover. Since opening/closing the carriage cover causes misalignment of the print position, do not open/close the carriage cover while printing.

3.10.2 Opening/Closing the Carriage Cover

To open the carriage cover, lift up the cover open hooks (located in both ends of the carriage cover). When closing the carriage cover, make sure that the hooks fit the carriage cover by holding the cover gently with your hands.

3.10.3 Paper Roll Cover Open Sensor

The cover-open sensor monitors the paper roll cover. When the sensor detects a cover open, the printer stops printing immediately, even though the printer is printing on the paper roll or the slip, and automatically goes offline. The ERROR LED (automatic error recovery) flashes when the cover is open while the printer is printing. When the printer cover is closed, the ERROR LED goes off, and the printer starts initializing automatically and begins printing at the beginning of the line it was printing when the cover was opened.

When memory switch Msw 8-8 is On (possible error recovery is selected), it is an error if the paper roll cover is opened while printing. (It is an error that has the possibility to recover.)

<For models with the MICR reader installed>

If the paper roll cover is open while the MICR reader is reading, the printer completes reading and goes offline. Closing the paper roll cover recovers the printer from the offline state; however, a MICR reading error or paper jam may occur. Never open the paper roll cover while the MICR reader is used. If the paper roll cover is open while the MICR reader is used, remove the check by opening the carriage cover and close the paper roll cover and the carriage cover; then retry the MICR reading.

- NOTES:
- To open the paper roll cover, be sure to press the paper roll cover open button.
 - While the cover is open, the status isn't changed and is kept as same as when the cover was opened.

3.10.4 Opening/Closing the Paper Roll Cover

To open the paper roll cover, press the paper roll open button, which is located in the right side of the printer upper case. To close the paper roll cover, be sure to press the upper side of the paper roll cover gently with your hands. (When closing the paper roll cover, make sure that internal lever hooks are used to fix the paper roll cover.)

EPSON	TITLE	TM-J7000/J7100 Specification (STANDARD)	SHEET REVISION	NO.	
			B	NEXT 68	SHEET 67

3.11 Ink Cartridge Sensor and Exchanging the Ink Cartridge

The installation of the ink cartridge is detected when the cartridge passes the carriage by a reflection photo sensor along the cartridge.

- NOTES:
- While the carriage cover is open, the status of the ink cartridge remains in the same status as before the carriage cover was opened.
 - If **DLE EOT** ($n = 7$) is performed while the carriage cover is open, the printer's response may differ from the current cartridge status.
 - To detect the status of the ink with **DLE EOT** ($n = 7$) or **GS j**, be sure to close the carriage cover.
 - If the carriage cover is open, there is a possibility that the ink ASB (**GS j**) may not be the same as the actual state of the ink cartridge.

3.11.1 Ink Cartridge Sensor

The ink cartridge sensor detects whether the ink cartridge is installed or not. If the ink cartridge is not installed, both the INK OUT LED and ERROR LED light and the printer goes offline. (In a two-color printer model, when both ink cartridges for the main color and the sub color are not installed, the printer goes offline.)

3.11.2 Ink Near-End Sensor

The ink near-end sensor monitors the ink remaining in the ink cartridge and the INK OUT LED lights if the ink near-end is detected. After detection of the ink near-end, the printer ink end sensor determines when the specified ink amount is consumed by counting the number of ink shots in printing or cleaning. If the ink ends, both the INK OUT LED and ERROR LED light and the printer goes offline.

The total number of printable characters after the ink near-end is detected and till the ink end is detected depends on the printing conditions. Prepare to exchange the ink cartridge when the printer signals the ink near-end.

3.11.3 Exchanging the Ink Cartridge

To exchange the ink cartridge, open the carriage cover, and take the ink cartridge out by the upper tab with your fingers. Peel the upper seal of the new ink cartridge and push the upper side of the ink cartridge to fix it correctly.

After installing the new ink cartridge, closing the carriage cover lets the carriage move, and the printer detects the status of the ink cartridge. Then, the printer recovers from the offline state and becomes ready to print. Refer to Appendix B for details.

NOTE: Since ink may still remain in the ink supply part (protrusion of the lower part of the ink cartridge) after the ink cartridge has been installed, do not touch that part. Take this into consideration when discarding the used ink cartridge.

3.12 Print Buffer-full Printing

When subsequent data is received after the printer processes one line of data in the print buffer, the printer automatically prints the processed line and feeds the paper by one line.

EPSON	TITLE	TM-J7000/J7100 Specification (STANDARD)	SHEET REVISION	NO.	
			B	NEXT 69	SHEET 68

3.13 Paper Jam Removal

3.13.1 Slip

Remove the jammed paper from the slip paper entrance if the paper is jammed. When the jammed paper cannot be removed, open the carriage cover, then remove the jammed paper.

3.13.2 Paper Roll

Press the paper roll cover open button; then remove the jammed paper.

EPSON	TITLE TM-J7000/J7100 Specification (STANDARD)	SHEET REVISION B	NO.	
			NEXT 70	SHEET 69

3.14 Reading MICR Characters and Printing Endorsements

(for models with a MICR reader and endorsement printer)

Use the following single-pass process to read MICR characters, print endorsements, and print on the face of a check.

Step	User Operation	Printer Operation
1	Transmit GS (G <Function 80> [GS (G 2 0 80 32]	Selects the check as the paper source.
2	Transmit GS (G <Function 83> [GS (G 2 0 83 48]	Waits for a check to be loaded. The CUT SHEET LED flashes
3	Insert a check. (*1)	Clamps the check when it is detected. The CUT SHEET LED flashes.
4	Transmit GS (G <Function 60> [GS (G 4 0 60 1 0 m]	Reads MICR characters and transmits the reading status. <i>m</i> specifies the type of MICR characters. (<i>m</i> = 0: E13B / <i>m</i> = 1: CMC7)
5	Transmit GS (G <Function 48> [GS (G 2 0 48 68]	Selects the back of the check as the paper source. (The back of the check which has been read for MICR becomes the side to be printed.)
6	Transmit GS (G <Function 84> [GS (G 2 0 84 1]	Feeds the print starting position on the back of the check.
7	Transmit endorsement printing data.	Prints data on the back of the check and feeds the check.
8	Transmit GS (G <Function 48> [GS (G 2 0 48 4]	Selects the face of the check to be printed. (The face of the check which has been read becomes the side to be printed.)
9	Transmit GS (G <Function 84> [GS (G 2 0 84 1]	Feeds the print starting position on the face of the check.
10	Transmit check printing data	Prints on the face of the check and feeds the check.
11	Transmit GS (G <Function 85> [GS (G 2 0 85 m]	Ejects to release the check, and selects the paper roll as the paper source. <i>m</i> specifies the type of operation (<i>m</i> = 48: eject / <i>m</i> = 49: release) The CUT SHEET LED flashes.
12	Remove the check. (*2)	The CUT SHEET LED is off.

NOTES: *1: Insert the check correctly by aligning the upper and right side of the check with the upper and right side of the printer's paper insertion position and inserting it until it is stopped by the form stopper.

The check insertion waiting state is canceled using **DLE ENQ** (*n* = 3).

The check waiting time and the interval from when a check is inserted to when the operation starts can be set using **ESC f**.

*2: After processing **GS (G <Function 85>**, the printer flashes the CUT SHEET LED and does not take the next action until the paper is removed.

Remarks: To get the information of the MICR function correctly, it is recommended to refer to the extended ASB status of **FS (e** or the status of **DLE EOT** (*n* = 0, *a* = 1).

<h1>EPSON</h1>	TITLE	TM-J7000/J7100 Specification (STANDARD)	SHEET REVISION	NO.	
			B	NEXT 71	SHEET 70

3.15 Cleaning the MICR Mechanism

(for models with a MICR reader)

When the MICR mechanism, such as the MICR head, rollers, paper paths, becomes dirty, MICR reading errors may occur. To clean the MICR mechanism, either one of the following methods must be done.

- Execute the cleaning command (**FS c**)
- Press the button or open/close the cover.

After performing one of the above methods, the printer enters the cleaning sheet insertion wait state, in the same way as for a check. Then, insert a cleaning sheet to clean the MICR head, roller, and the paper path.

Cleaning interval: Once per 12 months or every 72,000 passes
Example cleaning paper: KIC products PRESAT brand check reader cleaning card (recommended)
Cleaning paper size: 63 mm {2.48"} (W) × 152 mm {5.98"} (H)

<Cleaning procedure using the button and opening/closing the cover>

Open the paper roll cover and turn the power on while holding down the CLEANING button. Next, press the CLEANING button seven times, and close the cover. Then, the printer goes into the cleaning sheet insertion wait state.

EPSON	TITLE TM-J7000/J7100 Specification (STANDARD)	SHEET REVISION B	NO.	
			NEXT 72	SHEET 71

4. CASE SPECIFICATIONS

4.1 External Dimensions and Mass

- Height: 188 mm {7.40"}
- Width: 195 mm {7.68"}
- Depth: 237 mm {9.33"}
- Mass: Approximately 4.4 kg {9.7 lb} (including the ink cartridge and excluding a paper roll)
[All numeric values are typical.]

4.2 Color

EPSON standard color (E.C.W), (E.D.G)

4.3 External Appearance

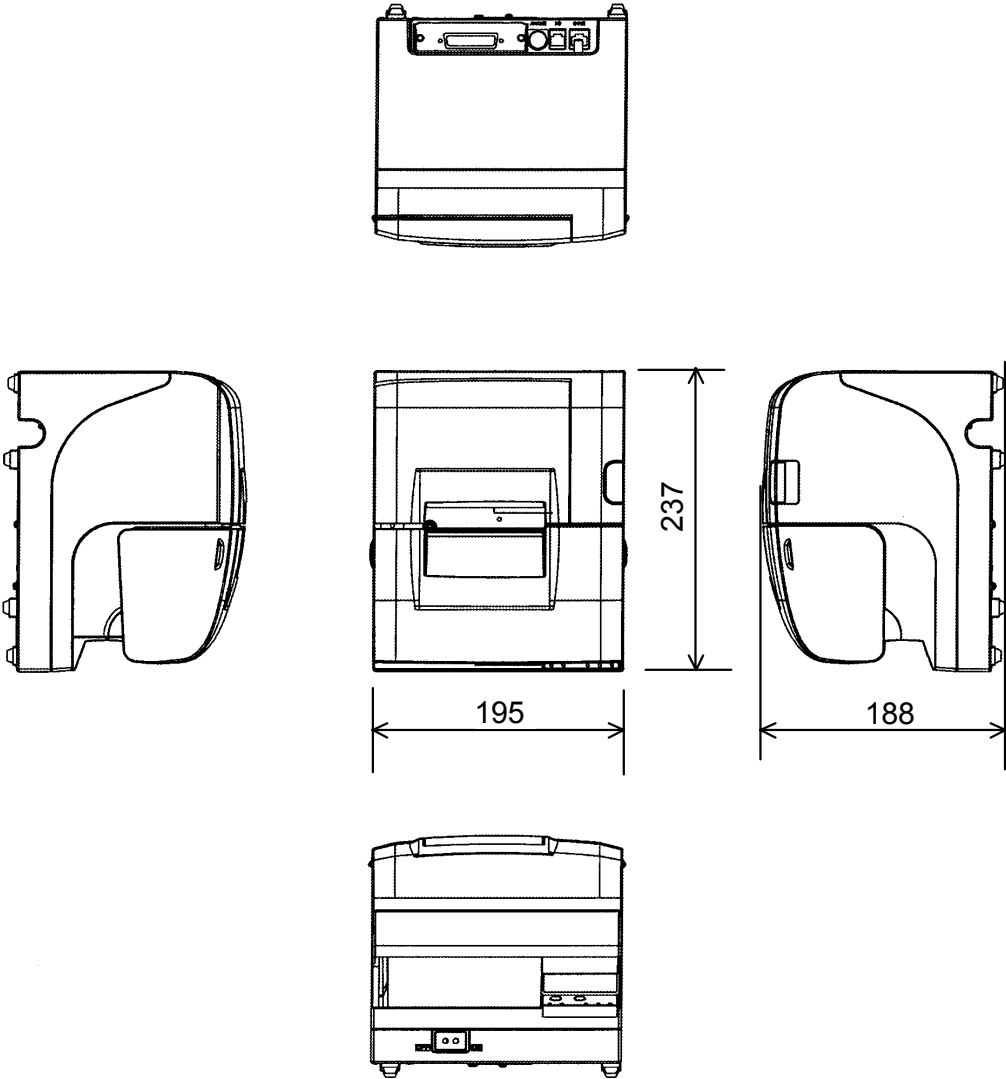

[Units: mm]

Figure 4.3.1 External Appearance

EPSON	TITLE TM-J7000/J7100 Specification (STANDARD)	SHEET REVISION B	NO.	
			NEXT 73	SHEET 72

4.4 Installing the Customer Display Fixing Plate

The user can attach the customer display fixing plate to the bottom of the printer. The customer display fixing plate can be attached to one of the two sides – left or right. To fix the plate, secure two resinoid screws attached to the DP-502 on the bottom of the customer display. (Refer to Figure 4.4.1.)

NOTE: The customer display fixing plate for the DP-502 must be used.

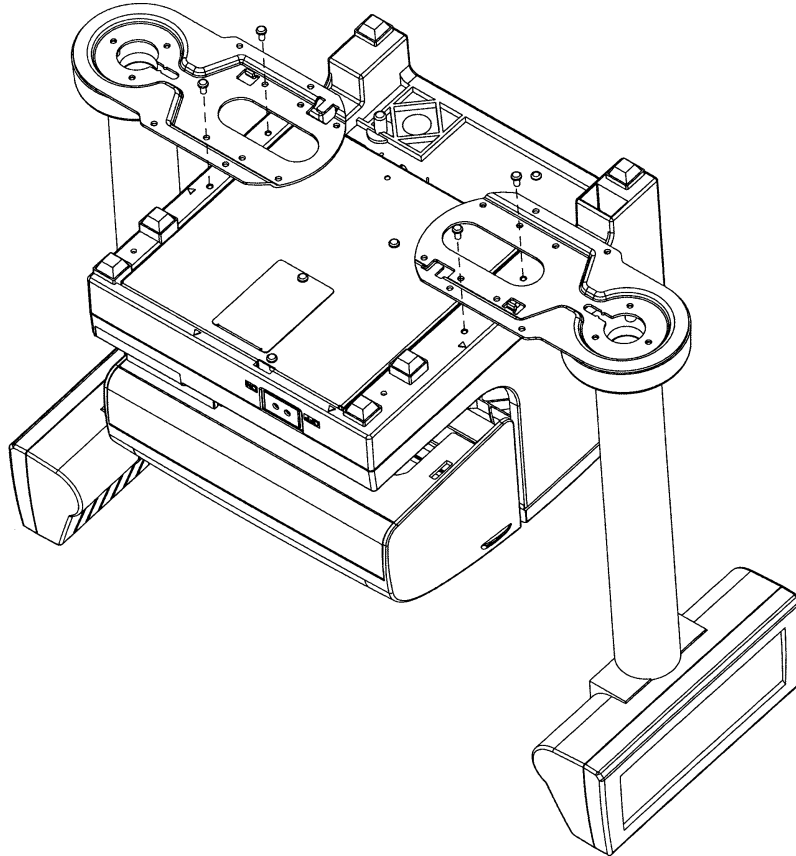

Figure 4.4.1 Installing the Customer Display Fixing Plate

EPSON	TITLE TM-J7000/J7100 Specification (STANDARD)	SHEET REVISION B	NO.	
			NEXT 74	SHEET 73

5. OPTIONS AND CONSUMABLES

5.1 Standard Accessories

- Paper roll (diameter 60 mm {2.36"}) × 1 roll
- Exclusive ink cartridge(s) TM-J7000: SJIC8 (K) × 1
TM-J7100: SJIC6 (K) × 1
SJIC7 (any one of (R), (B), or (G)) × 1
- User's manual × 1
- Power switch cover × 1

5.2 Options

- 1) Power supply: EPSON PS-180
- 2) UB series interface boards (except UB-P02)

5.3 Consumables

- 1) Ink cartridges TM-J7000: SJIC8 (K)
TM-J7100: SJIC6 (K)
SJIC7 (R), (B), (G)

EPSON	TITLE TM-J7000/J7100 Specification (STANDARD)	SHEET REVISION B	NO.	
			NEXT 75	SHEET 74

6. COMMANDS

6.1 Command Notation

XXXX

[Name]	The name of the command.
[Format]	The code sequence. The numbers denoted by < >H are hexadecimal. [] <i>k</i> indicates the contents of the [] should be repeated <i>k</i> times.
[Range]	Gives the allowable ranges, if any, for the arguments.
[Default]	Gives the default values, if any, for the command parameters.
[Description]	Describes the function of the command.
[Notes]	Provides important information on setting and using the printer command, if necessary.

6.2 Explanation of Terms

- 1) Descriptions are common to both TM-J7100 and TM-J7000 unless otherwise specified.
- 2) Real-time command
The real-time commands are identified with a **DLE** extension. The printer executes this command upon receiving it. The real-time commands are stored in the print buffer after executing, and print data transmitted after that is ignored.
- 3) Ignore a command
The state in which all codes, including parameters, are read in and discarded, and nothing happens.
- 4) Printing area
Printing range is set by command.
- 5) Inch
A unit of length. One inch is 25.4 mm.
- 6) dpi
dpi (dots per inch) is the number of dots per 25.4 mm.
- 7) Obsolete commands
We recommend replacing them with upward-compatible commands that have the same functions. Obsolete commands are supported by a few legacy printer models, we recommend upward-compatible commands.

EPSON	TITLE	TM-J7000/J7100 Specification (STANDARD)	SHEET REVISION	NO.	
			B	NEXT 76	SHEET 75

6.3 Control Commands

HT

[Name] Horizontal tab

[Format] ASCII HT
Hex 09
Decimal 9

[Description] • Moves the print position to the next horizontal tab position.

LF

[Name] Print and line feed

[Format] ASCII LF
Hex 0A
Decimal 10

[Description] • In standard mode

- Prints the data in the print buffer and feeds one line, based on the current line spacing.
- In page mode
- Feeds one line, based on the current line spacing.

FF

[Name] ① Print and eject cut sheet (in standard mode)
② Print and return to standard mode (in page mode)

[Format] ASCII FF
Hex 0C
Decimal 12

[Description] For ①

- When slip paper is selected as the active sheet, the printer prints the data in print buffer and ejects the slip paper.
- After the slip is ejected, the printer selects the paper roll as the active sheet.

For ②

- In page mode, prints the data in the print buffer collectively and returns to standard mode.

EPSON	TITLE	TM-J7000/J7100 Specification (STANDARD)	SHEET REVISION	NO.	
			B	NEXT 77	SHEET 76

CR

[Name] Print and carriage return

[Format] ASCII CR
Hex 0D
Decimal 13

- [Description]
- When automatic line feed is enabled
 - Functions the same as **LF**
 - When automatic line feed is disabled and when using serial interface model
 - Prints the data in the print buffer in standard mode.
 - Sets the print starting position to the beginning of the print line in page mode.

CAN

[Name] Cancel print data in page mode

[Format] ASCII CAN
Hex 18
Decimal 24

- [Description]
- In page mode, deletes all the print data in the current printable area.

EPSON	TITLE TM-J7000/J7100 Specification (STANDARD)	SHEET REVISION B	NO.	
			NEXT 78	SHEET 77

DLE EOT *n* [*a*]

[Name] Transmit real-time status
 [Format] ASCII DLE EOT *n* [*a*]
 Hex 10 04 *n* [*a*]
 Decimal 16 4 *n* [*a*]

[Range] $1 \leq n \leq 5, n = 7$
 $a = 1 (n = 0)$
 $a = 1, 2 (n = 7)$

[Description] • Transmits the status specified by *n* in real time as follows:

<i>n</i>	<i>a</i>	Function
0	1	Specifies cut sheet status.
1	--	Specifies printer status.
2	--	Specifies offline cause status.
3	--	Specifies error cause status.
4	--	Specifies continuous paper (paper roll) sensor status.
5	--	Specifies slip status.
7	1	Transmits color 1 ink status.
	2	Transmits color 2 ink status.

• When $1 \leq n \leq 5$ is specified, *a* is not necessary.

• This printer transmits the following status in real time.

• $n = 0, a = 1$: Cut sheet status

Bit	Off/On	Hex	Decimal	Function
0	Off	00	0	Fixed.
1	On	02	2	Fixed.
2, 3	Off	00	0	Reserved.
4	On	10	16	Fixed.
5	Off	00	0	Face of slip is selected.
	On	20	32	Back of slip is selected.
6	Off	00	0	Reserved.
7	Off	00	0	Fixed.

• $n = 1$: Printer status

Bit	Off/On	Hex	Decimal	Function
0	Off	00	0	Fixed.
1	On	02	2	Fixed.
2	Off	00	0	Drawer kick-out connector pin 3 is LOW.
	On	04	4	Drawer kick-out connector pin 3 is HIGH.
3	Off	00	0	Online.
	On	08	8	Offline.
4	On	10	16	Fixed.
5	Off	00	0	Reserved.
6	Off	00	0	Paper FEED button is turned Off.
	On	40	64	Paper FEED button is turned On.
7	Off	00	0	Fixed.

• $n = 2$: Offline cause status

Bit	Off/On	Hex	Decimal	Function
0	Off	00	0	Fixed.
1	On	02	2	Fixed.
2	Off	00	0	Cover is closed.
	On	04	4	Cover is open.
3	Off	00	0	Paper is not being fed by using the paper FEED button.
	On	08	8	Paper is being fed by the paper FEED button.
4	On	10	16	Fixed.
5	Off	00	0	No paper roll end stop.
	On	20	32	Printing on paper roll is being stopped.
6	Off	00	0	No error.
	On	40	64	Error has occurred.
7	Off	00	0	Fixed.

Bit 2: While the paper roll cover or the carriage cover is open, the bit indicates "cover is open."

EPSON	TITLE TM-J7000/J7100 Specification (STANDARD)	SHEET REVISION B	NO.	
			NEXT 80	SHEET 79

• *n* = 3: Error cause status

Bit	Off/On	Hex	Decimal	Function
0	Off	00	0	Fixed.
1	On	02	2	Fixed.
2	Off	00	0	No mechanical error.
	On	04	4	Mechanical error has occurred.
3	Off	00	0	No autocoder error.
	On	08	8	Autocoder error occurred.
4	On	10	16	Fixed.
5	Off	00	0	No unrecoverable error.
	On	20	32	Unrecoverable error has occurred.
6	Off	00	0	No automatically recoverable error.
	On	40	64	Automatically recoverable error has occurred.
7	Off	00	0	Fixed.

Bit 2: If "paper roll cover open" is set as a recoverable error using the memory switch, a mechanical error occurs if the cover is open while printing on the paper roll.

Bit 6: If "paper roll cover open" is set as an automatically recoverable error using the memory switch, an automatically recoverable error occurs if the cover is open while printing on the paper roll. The head high/low temperature errors are also regarded as automatically recoverable errors.

• *n* = 4: Continuous paper sensor status

Bit	Off/On	Hex	Decimal	Function
0	Off	00	0	Fixed
1	On	02	2	Fixed
2, 3	Off	00	0	Paper roll near-end sensor: paper adequate.
	On	0C	12	Paper roll near-end sensor: paper near end.
4	On	10	16	Fixed
5, 6	Off	00	0	Paper roll end sensor: paper present.
	On	60	96	Paper roll end sensor: paper not present.
7	Off	00	0	Fixed

Bits 5 and 6: While the cover is open, the status isn't changed and is kept as same as when the cover was opened.

EPSON	TITLE TM-J7000/J7100 Specification (STANDARD)	SHEET REVISION B	NO.	
			NEXT 81	SHEET 80

• $n = 5$: Slip paper status

Bit	Off/On	Hex	Decimal	Function
0	Off	00	0	Fixed.
1	On	02	2	Fixed.
2	Off	00	0	Slip paper selected.
	On	04	4	Slip paper not selected.
3	Off	00	0	Does not wait for slip paper insertion.
	On	08	8	Waits for slip paper insertion.
4	On	10	16	Fixed.
5	Off	00	0	TOF sensor: paper present.
	On	20	32	TOF sensor: paper not present.
6	Off	00	0	BOF sensor: paper present.
	On	40	64	BOF sensor: paper not present.
7	Off	00	0	Fixed.

• $n = 7, a = 1$: Color 1 ink status

Bit	Off/On	Hex	Decimal	Function
0	Off	00	0	Fixed.
1	On	02	2	Fixed.
2	Off	00	0	Ink near-end sensor: ink adequate (color 1).
	On	04	4	Ink near-end sensor: ink near end (color 1).
3	Off	00	0	Ink present (color 1).
	On	08	8	Ink not present (color 1).
4	On	10	16	Fixed.
5	Off	00	0	Ink cartridge sensor: cartridge present (color 1).
	On	20	32	Ink cartridge sensor: cartridge not present (color 1).
6	Off	00	0	Cleaning not performed.
	On	40	64	Cleaning performed.
7	Off	00	0	Fixed.

• $n = 7, a = 2$: Color 2 ink status

Bit	Off/On	Hex	Decimal	Function
0	Off	00	0	Fixed.
1	On	02	2	Fixed.
2	Off	00	0	Ink near-end sensor: ink adequate (color 2).
	On	04	4	Ink near-end sensor: ink near end (color 2).
3	Off	00	0	Ink present (color 2).
	On	08	8	Ink not present (color 2).
4	On	10	16	Fixed.
5	Off	00	0	Ink cartridge sensor: cartridge present (color 2).
	On	20	32	Ink cartridge sensor: cartridge not present (color 2).
6	Off	00	0	Reserved.
7	Off	00	0	Fixed.

The status for the single-color printer (TM-J7000) should always be "ink present," "ink adequate," and "cartridge present."

EPSON	TITLE TM-J7000/J7100 Specification (STANDARD)	SHEET REVISION B	NO.	
			NEXT 82	SHEET 81

[Notes]

- If print data includes a character string with this command, the printer performs this command. Users must consider this.
For example: Bit image data accidentally might include a data string with this command.
- Do not embed this command within another command.
For example: Bit image data might include this command.
- This command is ignored when block data is transmitted.
- Transmit the real-time commands **DLE EOT**, **DLE DC4 (fn=7)** using the following method:
<Transmission method for the real-time commands>
 - When a real-time status command is transmitted, the following data must not be transmitted until the status is received.
 - However, if the real-time commands are required to transmit continuously, it is possible to transmit up to nine real-time commands at once.
In this case, the following data must not be transmitted until the all status information is received.
If the real-time command is transmitted without using the above method, the status may not be received.

If the status is not received for 2 seconds (maximum period when operating the autocutter) and this state occurs several times, probably the printer power is not turned on or the interface cable is not connected.
- Refer to Section 3.9.1, Sensors and LED Indicators, part 2) BOF sensor, for the status of the BOF sensor.

EPSON	TITLE	TM-J7000/J7100 Specification (STANDARD)	SHEET REVISION	NO.	
			B	NEXT 83	SHEET 82

DLE ENQ *n*

[Name] Real-time request to printer
 [Format] ASCII DLE ENQ *n*
 Hex 10 05 *n*
 Decimal 16 5 *n*

[Range] $1 \leq n \leq 3$

[Description] • Responds to a request from the host computer.
 • *n* specifies the requests as follows:

<i>n</i>	Request
1	Recovers from an error and restarts printing from the line where the error occurred.
2	Recovers from an error after clearing the receive and print buffers.
3	Cancel the slip waiting status after clearing the receive and print buffers.

[Notes]

- Specify *n* = 1 or 2 after removing the cause of the error.
- If print data includes a character string with this command, the printer performs the command. Users must consider this.
 For example: Graphic data accidentally might include a data string with this command.
- Do not embed this command within another command.
 For example: Graphic data might include this command.
- This command is ignored when block data is transmitted.

EPSON	TITLE	TM-J7000/J7100 Specification (STANDARD)	SHEET REVISION	NO.	
			B	NEXT 84	SHEET 83

DLE DC4 *fn m t* (*fn* = 1)

[Name] Generate pulse in real-time

[Format] ASCII DLE DC4 *fn* *m* *t*
 Hex 10 14 *fn* *m* *t*
 Decimal 16 20 *fn* *m* *t*

[Range] *fn* = 1
m = 0, 1
 1 ≤ *t* ≤ 8

[Description] • Outputs the pulse specified by *t* in real-time to the connector pin specified by *m* as follows:

<i>m</i>	Connector pin
0	Drawer kick-out connector pin 2.
1	Drawer kick-out connector pin 5.

The pulse ON time or OFF time is set to [*t* × 100 ms].

- [Notes]
- If print data includes a character string containing this command, the printer performs the command. Users must consider this.
 For example: Graphic data accidentally might include the same data string as this command.
 - Do not embed this command within another command.
 - This command is ignored in the following states.
 - During transmission of block data.
 - During driving of drawer kick-out.
 - When an unrecoverable error has occurred.
 - If the printer receives this command while the printer mechanism is operating, such as printing or cleaning, the printer processes this command after finishing the mechanism's operation.
 - This command can be enabled or disabled by setting the **GS (D** command.

EPSON	TITLE	TM-J7000/J7100 Specification (STANDARD)	SHEET REVISION	NO.	
			B	NEXT	SHEET
			85	84	

DLE DC4 *fn a b* (*fn* = 2)

[Name]	Execute power-off sequence					
[Format]	ASCII	DLE	DC4	<i>fn</i>	<i>a</i>	<i>b</i>
	Hex	10	14	<i>fn</i>	<i>a</i>	<i>b</i>
	Decimal	16	20	<i>fn</i>	<i>a</i>	<i>b</i>
[Range]	<i>fn</i> = 2 <i>a</i> = 1 <i>b</i> = 8					
[Description]	<ul style="list-style-type: none"> • Executes the printer power-off sequence. <ul style="list-style-type: none"> • Stores the values of the maintenance counter. • Sets the interface to BUSY. • Sets the printer in standby mode. • Transmits the following power-off status when the power-off sequence has been completed. 					
[Notes]	<ul style="list-style-type: none"> • If this command is encountered, the printer will not continue to process anything. To recover the printer to print again, it is necessary to turn the power on again or execute a hardware reset. • If print data includes a character string with this command, the printer performs the command. Users must consider this. For example: Graphic data accidentally might include a data string with this command. • Do not embed this command within another command. For example: Graphic data might include this command. • This command is ignored when block data is transmitted. • This command can be enabled or disabled by setting the GS (D command). 					
[Reference]	Appendix G					

EPSON	TITLE	TM-J7000/J7100 Specification (STANDARD)	SHEET REVISION	NO.	
			B	NEXT 86	SHEET 85

DLE DC4 *fn m* (*fn* = 7)

[Name] Transmit specified real-time status

[Format] ASCII DLE DC4 *fn* *m*
 Hex 10 14 *fn* *m*
 Decimal 16 20 *fn* *m*

[Range] *fn* = 7
 $1 \leq m \leq 4$

[Description] • Transmit specified status or response in real-time.

<i>m</i>	Function	Related command
1	Transmitting basic ASB	GS a
2	Transmitting extended ASB	FS (e
3	Transmitting ink ASB	GS j
4	Transmitting offline response	GS (H <Function 49>

• The status or response format is the same as the format of the related command in the table above.

See the description of the related command corresponding to *m*.

[Notes] • If print data includes a character string with this command, the printer performs the command. Users must consider this.

For example: Graphic data accidentally might include a data string with this command.

• Do not embed this command within another command.

For example: Graphic data might include this command.

• This command is ignored when block data is transmitted.

• Transmit the real-time commands **DLE EOT**, **DLE DC4 (*fn*=7)** using the following method:

<Transmission method for the real-time commands>

• When the real-time status command is transmitted, the following data must not be transmitted until the status is received.

• However, if the real-time commands are required to transmit continuously, it is possible to transmit up to nine real-time commands at once.

In this case, the following data must not be transmitted until the all status information is received.

If the real-time command is transmitted without using the above method, the status may not be received.

• If the status is not received for 2 seconds (maximum period when operating the autocutter) and this state occurs several times, probably the printer power is not turned on or the interface cable is not connected.

EPSON	TITLE	TM-J7000/J7100 Specification (STANDARD)	SHEET REVISION	NO.	
			B	NEXT	SHEET
			87	86	

DLE DC4 *fn d1...d7* (*fn* = 8)

[Name]	Clear buffer(s)															
[Format]	<table border="0" style="margin-left: 20px;"> <tr> <td>ASCII</td> <td>DLE</td> <td>DC4</td> <td><i>fn</i></td> <td><i>d1...d7</i></td> </tr> <tr> <td>Hex</td> <td>10</td> <td>14</td> <td><i>fn</i></td> <td><i>d1...d7</i></td> </tr> <tr> <td>Decimal</td> <td>16</td> <td>20</td> <td><i>fn</i></td> <td><i>d1...d7</i></td> </tr> </table>	ASCII	DLE	DC4	<i>fn</i>	<i>d1...d7</i>	Hex	10	14	<i>fn</i>	<i>d1...d7</i>	Decimal	16	20	<i>fn</i>	<i>d1...d7</i>
ASCII	DLE	DC4	<i>fn</i>	<i>d1...d7</i>												
Hex	10	14	<i>fn</i>	<i>d1...d7</i>												
Decimal	16	20	<i>fn</i>	<i>d1...d7</i>												
[Range]	<p><i>fn</i> = 8</p> <p><i>d1</i> = 1, <i>d2</i> = 3, <i>d3</i> = 20, <i>d4</i> = 1, <i>d5</i> = 6, <i>d6</i> = 2, <i>d7</i> = 8</p>															
[Description]	<ul style="list-style-type: none"> • Clears all data stored in the receive buffer and the print buffer. • Selects roll paper as the paper source, and selects standard mode. • If a recoverable error occurs, the printer clears data in the receive buffer and the print buffer first, then recovers from the error. • Transmits clear response 25. 															
[Notes]	<ul style="list-style-type: none"> • This command must be inhibited for use in a system using this printer and the EPSON OPOS or JavaPOS driver. • If print data includes a character string with this command, the printer performs the command. Users must consider this. <div style="margin-left: 40px;">For example: Graphic data accidentally might include a data string with this command.</div> • Do not embed this command within another command. <div style="margin-left: 40px;">For example: Graphic data might include this command.</div> • This command is ignored when block data is transmitted. 															

EPSON	TITLE	TM-J7000/J7100 Specification (STANDARD)	SHEET REVISION	NO.	
			B	NEXT 88	SHEET 87

ESC FF

[Name] Print data in page mode
 [Format] ASCII ESC FF
 Hex 1B 0C
 Decimal 27 12
 [Description] • In page mode, prints all buffered data in the printing area collectively.

ESC SP *n*

[Name] Set right-side character spacing
 [Format] ASCII ESC SP *n*
 Hex 1B 20 *n*
 Decimal 27 32 *n*
 [Range] $0 \leq n \leq 255$
 [Default] $n = 0$
 [Description] • Sets the character spacing for the right side of the character to [$n \times$ horizontal motion unit].
 • The maximum right-side character spacing is 35.983 mm {255/180"}.

EPSON	TITLE	SHEET REVISION	NO.	
	TM-J7000/J7100 Specification (STANDARD)	B	NEXT 89	SHEET 88

ESC ! n

[Name] Select print mode(s)
 [Format] ASCII ESC ! n
 Hex 1B 21 n
 Decimal 27 33 n
 [Range] 0 ≤ n ≤ 255
 [Default] n = 0
 [Description] Selects the character font and styles (emphasized, double-height, double-width, and underlined) together.

Bit	Off/On	Hex	Decimal	Function
0	Off	00	0	Character font A (12 × 24) selected.
	On	01	1	Character font B (9 × 17) selected.
1, 2	Off	00	0	Reserved.
3	Off	00	0	Emphasized mode not selected.
	On	08	8	Emphasized mode selected.
4	Off	00	0	Double-height mode not selected.
	On	10	16	Double-height mode selected.
5	Off	00	0	Double-width mode not selected.
	On	20	32	Double-width mode selected.
6	Off	00	0	Reserved.
7	Off	00	0	Underline mode not selected.
	On	80	128	Underline mode selected.

ESC \$ nL nH

[Name] Set absolute print position
 [Format] ASCII ESC \$ nL nH
 Hex 1B 24 nL nH
 Decimal 27 36 nL nH
 [Range] 0 ≤ (nL+nH × 256) ≤ 65535 (0 ≤ nL ≤ 255, 0 ≤ nH ≤ 255)
 [Description] • Sets the next print starting position, and the absolute print position, in reference to the left margin. The distance from the beginning of the line to the left margin is [(nL + nH × 256) × (vertical or horizontal motion units)].

EPSON	TITLE	TM-J7000/J7100 Specification (STANDARD)	SHEET REVISION	NO.	
			B	NEXT 90	SHEET 89

ESC % n

[Name]	Select/cancel user-defined character set			
[Format]	ASCII	ESC	%	<i>n</i>
	Hex	1B	25	<i>n</i>
	Decimal	27	37	<i>n</i>
[Range]	$0 \leq n \leq 255$			
[Default]	$n = 0$			
[Description]	<ul style="list-style-type: none"> • Selects or cancels the user-defined character set. <ul style="list-style-type: none"> • When the LSB of <i>n</i> is 0, the user-defined character set is canceled. • When the LSB of <i>n</i> is 1, the user-defined character set is selected. 			

ESC & y c1 c2 [x1 d1...d(yxx1)]...[xk d1...d(yxxk)]

[Name]	Define user-defined characters					
[Format]	ASCII	ESC	&	<i>y</i>	<i>c1</i>	<i>c2</i> [x1 d1...d(yxx1)]...[xk d1...d(yxxk)]
	Hex	1B	26	<i>y</i>	<i>c1</i>	<i>c2</i> [x1 d1...d(yxx1)]...[xk d1...d(yxxk)]
	Decimal	27	38	<i>y</i>	<i>c1</i>	<i>c2</i> [x1 d1...d(yxx1)]...[xk d1...d(yxxk)]
[Range]	$y = 3$ $32 \leq c1 \leq c2 \leq 126$ $0 \leq x \leq 12$ (when font A (12 × 24) is selected) $0 \leq x \leq 9$ (when font B (9 × 17) is selected) $0 \leq d \leq 255$ $k = c2 - c1 + 1$					
[Description]	<ul style="list-style-type: none"> • Assigns the user-defined character pattern for the specified character codes. <ul style="list-style-type: none"> • <i>y</i> specifies the number of bytes in the vertical direction. • <i>c1</i> specifies the beginning character code for the definition, and <i>c2</i> specifies the final code. • <i>x</i> specifies the number of dots in the horizontal direction. • <i>d</i> specifies the defined data. 					

EPSON	TITLE	TM-J7000/J7100 Specification (STANDARD)	SHEET REVISION	NO.	
			B	NEXT 91	SHEET 90

ESC * m nL nH d1...dk

[Name] Select bit image mode

[Format] ASCII ESC * *m* *nL* *nH* *d1...dk*
 Hex 1B 2A *m* *nL* *nH* *d1...dk*
 Decimal 27 42 *m* *nL* *nH* *d1...dk*

[Range] *m* = 0, 1, 32, 33
 $0 \leq (nL+nH \times 256) \leq 1023$ ($0 \leq nL \leq 255, 0 \leq nH \leq 3$)
 $0 \leq d \leq 255$
 $k = nL + nH \times 256$ (when $m = 0, 1$)
 $k = (nL + nH \times 256)$ (when $m = 32, 33$)

[Description] • Specifies the bit image in *m* mode for the number of dots specified by *nL* and *nH*.

<i>m</i>	Mode	Number of Dots in Vertical Direction	Vertical Dot Density	Horizontal Dot Density
0	8-dot single-density	8	60 dpi	90 dpi
1	8-dot double-density	8	60 dpi	180 dpi
32	24-dot single-density	24	180 dpi	90 dpi
33	24-dot double-density	24	180 dpi	180 dpi

dpi: dots per 25.4 mm {1"}

ESC – n

[Name] Turn underline mode on/off

[Format] ASCII ESC – *n*
 Hex 1B 2D *n*
 Decimal 27 45 *n*

[Range] $0 \leq n \leq 2, 48 \leq n \leq 50$

[Default] $n = 0$

[Description] • Turns underline mode on or off, based on the following values of *n*:

<i>n</i>	Function
0, 48	Turns off underline mode
1, 49	Turns on underline mode, set at 1-dot width
2, 50	Turns on underline mode, set at 2-dot width

EPSON	TITLE	TM-J7000/J7100 Specification (STANDARD)	SHEET REVISION	NO.	
			B	NEXT 92	SHEET 91

ESC 2

[Name] Select default line spacing
 [Format] ASCII ESC 2
 Hex 1B 32
 Decimal 27 50
 [Description] • Sets the current line spacing to approximately 4.23 mm {1/6"}.

ESC 3 *n*

[Name] Set line spacing
 [Format] ASCII ESC 3 *n*
 Hex 1B 33 *n*
 Decimal 27 51 *n*
 [Range] $0 \leq n \leq 255$
 [Default] Equivalent to approximately 4.23 mm {1/6"}.
 [Description] • Sets the current line spacing to [*n* × vertical or horizontal motion units] inches.
 • The maximum is 1016 mm {40"}.

ESC <

[Name] Return home
 [Format] ASCII ESC <
 Hex 1B 3C
 Decimal 27 60
 [Description] • Moves the print head to the standby position.

EPSON	TITLE	TM-J7000/J7100 Specification (STANDARD)	SHEET REVISION	NO.	
			B	NEXT 93	SHEET 92

ESC = *n*

[Name] Select peripheral device
 [Format] ASCII ESC = *n*
 Hex 1B 3D *n*
 Decimal 27 61 *n*

[Range] $1 \leq n \leq 3$

[Default] Serial interface model:

- When turning on the printer:

Memory switch [Msw 1-6] status	<i>n</i>
OFF	1
ON	2

- When executing **ESC @**:

Peripheral device status Default value to be set		<i>n</i>		
		1	2	3
After ESC @ Processing	Memory switch [Msw 1-6] is set to OFF	1	2	1
	Memory switch [Msw 1-6] is set to ON	1	2	2

Parallel interface model: $n = 1$

[Description] Selects device to which the host computer sends data, using *n* as follows:

<i>n</i>	Function
1	Specifies printer only.
2	Specifies customer display only.
3	Specifies printer and customer display.

- When the customer display only is selected, specified by $n = 2$, all data except this command and the real-time commands are ignored.

EPSON	TITLE	TM-J7000/J7100 Specification (STANDARD)	SHEET REVISION	NO.	
			B	NEXT 94	SHEET 93

ESC ? n

[Name] Cancel user-defined characters

[Format] ASCII ESC ? *n*
 Hex 1B 3F *n*
 Decimal 27 63 *n*

[Range] $32 \leq n \leq 126$

[Description] • Cancels user-defined characters, specified with character codes on the selected page.
 • *n* specifies the character code for which the pattern defined is to be canceled.

ESC @

[Name] Initialize printer

[Format] ASCII ESC @
 Hex 1B 40
 Decimal 27 64

[Description] • Clears the data in the print buffer and resets the printer modes to the modes that were in effect when the power was turned on. Keeps the following data:

- ASB status bit assignment
- Contents stored in the NV user memory
- Contents defined for the NV graphics (NV bit image)
- Maintenance counter's value

EPSON	TITLE	TM-J7000/J7100 Specification (STANDARD)	SHEET REVISION	NO.	
			B	NEXT 95	SHEET 94

ESC D $n_1...n_k$ NUL

[Name]	Set horizontal tab positions				
[Format]	ASCII	ESC	D	$n_1...n_k$	NUL
	Hex	1B	44	$n_1...n_k$	00
	Decimal	27	68	$n_1...n_k$	0
[Range]	$1 \leq n_1 \leq n_2 \leq \dots \leq n_k \leq 255$ $0 \leq k \leq 32$				
[Default]	$n = 8, 16, 24, 32, 40, \dots, 232, 240, 248$ (for font A in a standard character size width)				
[Description]	<ul style="list-style-type: none"> • Sets horizontal tab positions from the left margin to [$n \times$ (the current setting character width)]. • n specifies the number of digits from the setting position to the left margin or the beginning of the line. • k specifies the number of bytes set for the horizontal tab position. 				

ESC E n

[Name]	Turn emphasized mode on/off			
[Format]	ASCII	ESC	E	n
	Hex	1B	45	n
	Decimal	27	69	n
[Range]	$0 \leq n \leq 255$			
[Default]	$n = 0$			
[Description]	<ul style="list-style-type: none"> • Turns emphasized mode on or off. • When the LSB of n is 0, emphasized mode is turned off. • When the LSB of n is 1, emphasized mode is turned on. 			

EPSON	TITLE	TM-J7000/J7100 Specification (STANDARD)	SHEET REVISION	NO.	
			B	NEXT 96	SHEET 95

ESC F *n*

[Name]	Set/cancel cut sheet reverse eject			
[Format]	ASCII	ESC	F	<i>n</i>
	Hex	1B	46	<i>n</i>
	Decimal	27	70	<i>n</i>
[Range]	$0 \leq n \leq 255$			
[Default]	$n = 0$			
[Description]	<ul style="list-style-type: none"> • Sets or cancels the cut sheet reverse eject. <ul style="list-style-type: none"> • When the LSB of <i>n</i> is 0, cancels the cut sheet reverse eject. • When the LSB of <i>n</i> is 1, sets the cut sheet reverse eject. • This command affects printing on the face or the back of the slip. 			

ESC G *n*

[Name]	Turn double-strike mode on/off			
[Format]	ASCII	ESC	G	<i>n</i>
	Hex	1B	47	<i>n</i>
	Decimal	27	71	<i>n</i>
[Range]	$0 \leq n \leq 255$			
[Default]	$n = 0$			
[Description]	<ul style="list-style-type: none"> • Turns double-strike mode on or off. <ul style="list-style-type: none"> • When the LSB of <i>n</i> is 0, double-strike mode is turned off. • When the LSB of <i>n</i> is 1, double-strike mode is turned on. 			

ESC J *n*

[Name]	Print and feed paper			
[Format]	ASCII	ESC	J	<i>n</i>
	Hex	1B	4A	<i>n</i>
	Decimal	27	74	<i>n</i>
[Range]	$0 \leq n \leq 255$			
[Description]	<ul style="list-style-type: none"> • Prints the data in the print buffer and feeds the paper [<i>n</i> × vertical motion unit] inches. • The maximum paper feed amount is approximately 1016 mm {40"}. 			

EPSON	TITLE	TM-J7000/J7100 Specification (STANDARD)	SHEET REVISION	NO.	
			B	NEXT 97	SHEET 96

ESC K *n*

[Name] Print and reverse feed

[Format] ASCII ESC K *n*
 Hex 1B 4B *n*
 Decimal 27 75 *n*

[Range] $0 \leq n \leq 255$

[Description] • When slip is selected as the paper source, the printer prints the data in the print buffer and feeds the paper [$n \times$ vertical motion unit] inches in the reverse direction.
 • When roll paper is selected as the paper source, this command is ignored.
 • The maximum paper feed amount is 1016 mm {40"}.
 • This command controls printing on the face or the back of the slip.

ESC L

[Name] Select page mode

[Format] ASCII ESC L
 Hex 1B 4C
 Decimal 27 76

[Description] • Switches from standard mode to page mode.
 • When the back of the slip is selected as the paper source, this command is ignored.

ESC M *n*

[Name] Select character font

[Format] ASCII ESC M *n*
 Hex 1B 4D *n*
 Decimal 27 77 *n*

[Range] $n = 0, 1, 48, 49$

[Default] $n = 0$

[Description] • Selects character fonts.

<i>n</i>	Function
0, 48	Character font A selected.
1, 49	Character font B selected.

EPSON	TITLE	TM-J7000/J7100 Specification (STANDARD)	SHEET REVISION	NO.	
			B	NEXT	SHEET
			98	97	

ESC R *n*

[Name] Select an international character set

[Format] ASCII ESC R *n*
 Hex 1B 52 *n*
 Decimal 27 82 *n*

[Range] $0 \leq n \leq 13$

[Default] $n = 0$

[Description] • Selects international character set *n* from the following table:

	Character set
0	U.S.A.
1	France
2	Germany
3	U.K.
4	Denmark I
5	Sweden
6	Italy
7	Spain I
8	Japan
9	Norway
10	Denmark II
11	Spain II
12	Latin America
13	Korea

EPSON	TITLE	TM-J7000/J7100 Specification (STANDARD)	SHEET REVISION	NO.	
			B	NEXT 99	SHEET 98

ESC S

[Name] Select standard mode
 [Format] ASCII ESC S
 Hex 1B 53
 Decimal 27 83
 [Description] • Switches from page mode to standard mode.

ESC T *n*

[Name] Select print direction in page mode
 [Format] ASCII ESC T *n*
 Hex 1B 54 *n*
 Decimal 27 84 *n*
 [Range] $0 \leq n \leq 3, 48 \leq n \leq 51$
 [Default] $n = 0$
 [Description] • Selects the print direction and starting position in page mode.

<i>n</i>	Print Direction	Starting Position
0, 48	Left to right	Upper left
1, 49	Bottom to top	Lower left
2, 50	Right to left	Lower right
3, 51	Top to bottom	Upper right

ESC U *n*

[Name] Turn unidirectional printing mode on/off
 [Format] ASCII ESC U *n*
 Hex 1B 55 *n*
 Decimal 27 85 *n*
 [Range] $0 \leq n \leq 255$
 [Default] $n = 0$
 [Description] • Turns unidirectional printing mode on or off.
 • When the LSB of *n* is 0, turns off unidirectional printing mode.
 • When the LSB of *n* is 1, turns on unidirectional printing mode.
 [Notes] • Bar code printing or two-dimensional code printing is performed with one directional print in the normal mode, regardless of the settings with this command.
 • In page mode, if multiple types of print modes are mixed, such as bar codes, two-dimensional codes, or others, the printer prints the bar code, or two-dimensional code with one directional print in the normal print mode regardless of the setting of this command.

EPSON	TITLE	SHEET REVISION	NO.	
	TM-J7000/J7100 Specification (STANDARD)	B	NEXT 100	SHEET 99

ESC W xL xH yL yH dxL dxH dyL dyH

[Name]	Set printing area in page mode											
[Format]	ASCII	ESC	W	xL	xH	yL	yH	dxL	dxH	dyL	dyH	
	Hex	1B	57	xL	xH	yL	yH	dxL	dxH	dyL	dyH	
	Decimal	27	87	xL	xH	yL	yH	dxL	dxH	dyL	dyH	
[Range]	$0 \leq (xL + xH \times 256) \leq 65535$ ($0 \leq xL \leq 255, 0 \leq xH \leq 255$) $0 \leq (yL + yH \times 256) \leq 65535$ ($0 \leq yL \leq 255, 0 \leq yH \leq 255$) $1 \leq (dxL + dxH \times 256) \leq 65535$ ($0 \leq dxL \leq 255, 0 \leq dxH \leq 255$) $1 \leq (dyL + dyH \times 256) \leq 65535$ ($0 \leq dyL \leq 255, 0 \leq dyH \leq 255$)											
[Default]	<For TM-J7100>											
	$(xL + xH \times 256) = 0$				$(xL = 0, yH = 0)$				[Paper roll / slip]			
	$(yL + yH \times 256) = 0$				$(yL = 0, yH = 0)$							
	$(dxL + dxH \times 256) = 360$				$(dxL = 104, dxH = 1)$				[Roll paper: paper width 57.5 mm]			
	$(dyL + dyH \times 256) = 584$				$(dyL = 72, dyH = 2)$							
	$(dxL + dxH \times 256) = 432$				$(dxL = 176, dxH = 1)$				[Roll paper: paper width 69.5 mm]			
	$(dyL + dyH \times 256) = 488$				$(dyL = 232, dyH = 1)$							
	$(dxL + dxH \times 256) = 480$				$(dxL = 224, dxH = 1)$				[Roll paper: paper width 76 mm]			
	$(dyL + dyH \times 256) = 440$				$(dyL = 184, dyH = 1)$							
	$(dxL + dxH \times 256) = 512$				$(dxL = 0, dxH = 2)$				[Roll paper: paper width 82.5 mm]			
	$(dyL + dyH \times 256) = 416$				$(dyL = 160, dyH = 1)$							
	$(dxL + dxH \times 256) = 576$				$(dxL = 64, dxH = 2)$				[Slip]			
	$(dyL + dyH \times 256) = 368$				$(dyL = 112, dyH = 1)$							
[Default]	<For TM-J7000>											
	$(xL + xH \times 256) = 0$				$(xL = 0, yH = 0)$				[Paper roll / slip]			
	$(yL + yH \times 256) = 0$				$(yL = 0, yH = 0)$							
	$(dxL + dxH \times 256) = 360$				$(dxL = 104, dxH = 1)$				[Roll paper: paper width 57.5 mm]			
	$(dyL + dyH \times 256) = 1176$				$(dyL = 152, dyH = 4)$							
	$(dxL + dxH \times 256) = 432$				$(dxL = 176, dxH = 1)$				[Roll paper: paper width 69.5 mm]			
	$(dyL + dyH \times 256) = 984$				$(dyL = 216, dyH = 3)$							
	$(dxL + dxH \times 256) = 480$				$(dxL = 224, dxH = 1)$				[Roll paper: paper width 76 mm]			
	$(dyL + dyH \times 256) = 880$				$(dyL = 112, dyH = 3)$							
	$(dxL + dxH \times 256) = 512$				$(dxL = 0, dxH = 2)$				[Roll paper: paper width 82.5 mm]			
	$(dyL + dyH \times 256) = 832$				$(dyL = 64, dyH = 3)$							
	$(dxL + dxH \times 256) = 576$				$(dxL = 64, dxH = 2)$				[Slip]			
	$(dyL + dyH \times 256) = 736$				$(dyL = 224, dyH = 2)$							
[Description]	<ul style="list-style-type: none"> • This command sets the position and the size of the printing area in page mode. • xL, xH specify the horizontal starting position with $[(xL + xH \times 256) \times (\text{horizontal motion units})]$. • yL, yH specify the vertical starting position with $[(yL + yH \times 256) \times (\text{vertical motion units})]$. • dxL, dxH specify the horizontal printing area width with $[(dxL + dxH \times 256) \times (\text{horizontal motion units})]$. • dyL, dyH specify the vertical printing area height with $[(dyL + dyH \times 256) \times (\text{vertical motion units})]$. 											

EPSON	TITLE	TM-J7000/J7100	SHEET REVISION	NO.	
	Specification (STANDARD)	B	NEXT 101	SHEET 100	

ESC \ nL nH

[Name] Set relative print position

[Format] ASCII ESC \ nL nH
 Hex 1B 5C nL nH
 Decimal 27 92 nL nH

[Range] $-32768 \leq (nL + nH \times 256) \leq 32767$

[Description] • Sets the next print starting position to $[(nL + nH \times 256) \times (\text{vertical or horizontal motion units})]$ from the current position.
 • A positive number specifies movement to the right, and a negative number specifies movement to the left.

ESC a n

[Name] Select justification

[Format] ASCII ESC a n
 Hex 1B 61 n
 Decimal 27 97 n

[Range] $0 \leq n \leq 2, 48 \leq n \leq 50$

[Default] $n = 0$

[Description] • In standard mode, aligns all the data in one line to the position specified by n as follows:

n	Justification
0, 48	Left justification
1, 49	Centering
2, 50	Right justification

EPSON	TITLE	TM-J7000/J7100 Specification (STANDARD)	SHEET REVISION	NO.	
			B	NEXT 102	SHEET 101

ESC c 0 n

[Name] Select paper type(s) for printing
 [Format] ASCII ESC c 0 n
 Hex 1B 63 30 n
 Decimal 27 99 48 n

[Range] $1 \leq n \leq 4$

[Default] $n = 3$

[Description] • Selects the type of paper for printing, using n as follows:

Bit	Off/On	Hex	Decimal	Function
0	Off	00	0	Paper roll disabled.
	On	01	1	Paper roll enabled.
1	Off	00	0	Paper roll disabled.
	On	02	2	Paper roll enabled.
2	Off	00	0	The face of slip paper disabled.
	On	04	4	The face of slip paper enabled.
3~7	Off	00	0	Reserved.

ESC c 1 n

[Name] Select paper type(s) for command settings
 [Format] ASCII ESC c 1 n
 Hex 1B 63 31 n
 Decimal 27 99 49 n

[Range] $1 \leq n \leq 7, 64 \leq n \leq 71$

[Default] $n = 71$

[Description] • Selects the paper type(s), using n as follows:

Bit	Off/On	Hex	Decimal	Function
0	Off	00	0	Paper roll disabled.
	On	01	1	Paper roll enabled.
1	Off	00	0	Paper roll disabled.
	On	02	2	Paper roll enabled.
2	Off	00	0	The face of slip paper disabled.
	On	04	4	The face of slip paper enabled.
3~5	Off	00	0	Reserved.
6	Off	00	0	The back of slip paper disabled.
	On	40	64	The back of slip paper enabled.
7	Off	00	0	Reserved.

- This command affects the **ESC 2**, **ESC 3**, **GS (K)**, **GS L**, and **GS W** commands.

EPSON	TITLE	TM-J7000/J7100 Specification (STANDARD)	SHEET REVISION	NO.	
			B	NEXT 103	SHEET 102

ESC c 3 n

[Name] Select paper sensor(s) to output paper-end signals

[Format] ASCII ESC c 3 n
 Hex 1B 63 33 n
 Decimal 27 99 51 n

[Range] $0 \leq n \leq 255$

[Default] $n = 0$

- [Description]
- Selects the paper sensor(s) to output paper end signals when the specified sensor(s) detect(s) the paper end.
 - Each bit of n specifies the paper sensor(s) as follows:

Bit	Off/On	Hex	Decimal	Function
0	Off	00	0	Paper roll near-end sensor disabled.
	On	01	1	Paper roll near-end sensor enabled.
1	Off	00	0	Paper roll near-end sensor disabled.
	On	02	2	Paper roll near-end sensor enabled.
2	Off	00	0	Paper roll end sensor disabled.
	On	04	4	Paper roll end sensor enabled.
3	Off	00	0	Paper roll end sensor disabled.
	On	08	8	Paper roll end sensor enabled.
4	Off	00	0	TOF sensor disabled.
	On	10	16	TOF sensor enabled.
5	Off	00	0	BOF sensor disabled.
	On	20	32	BOF sensor enabled.
6, 7	Off	00	0	Reserved.

- [Notes]
- This command is ignored with a serial interface model.

EPSON	TITLE	TM-J7000/J7100 Specification (STANDARD)	SHEET REVISION	NO.	
			B	NEXT 104	SHEET 103

ESC c 4 n

[Name] Select paper sensor(s) to stop printing

[Format] ASCII ESC c 4 n
Hex 1B 63 34 n
Decimal 27 99 52 n

[Range] $0 \leq n \leq 255$

[Default] $n = 0$

[Description] • Selects the paper sensor(s) to use to stop printing when a paper end is detected.

Bit	Off/On	Hex	Decimal	Function
0	Off	00	0	Paper roll near-end sensor disabled.
	On	01	1	Paper roll near-end sensor enabled.
1	Off	00	0	Paper roll near-end sensor disabled.
	On	02	2	Paper roll near-end sensor enabled.
2 ~ 7	Off	00	0	Reserved.

ESC c 5 n

[Name] Enable/disable panel buttons

[Format] ASCII ESC c 5 n
Hex 1B 63 35 n
Decimal 27 99 53 n

[Range] $0 \leq n \leq 255$

[Default] $n = 0$

[Description] • Enables or disables the panel buttons.
• When the LSB of n is 0, the panel buttons are enabled.
• When the LSB of n is 1, the panel buttons are disabled.

EPSON	TITLE TM-J7000/J7100 Specification (STANDARD)	SHEET REVISION B	NO.	
			NEXT 105	SHEET 104

ESC d n

[Name]	Print and feed n lines			
[Format]	ASCII	ESC	d	n
	Hex	1B	64	n
	Decimal	27	100	n
[Range]	$0 \leq n \leq 255$			
[Description]	<ul style="list-style-type: none"> • Prints the data in the print buffer and feeds [$n \times$ current line spacing]. • The maximum paper feed amount is 1016 mm {40"}. 			

ESC e n

[Name]	Print and reverse feed n lines			
[Format]	ASCII	ESC	e	n
	Hex	1B	65	n
	Decimal	27	101	n
[Range]	$0 \leq n \leq 255$			
[Description]	<ul style="list-style-type: none"> • When the back of the slip is selected as the paper source, the printer prints the data in the print buffer and feeds the paper [$n \times$ current line spacing] inches in the reverse direction. • When roll paper is selected as the paper source, this command is ignored. • The maximum paper feed amount is 1016 mm {40"}. • This command controls printing on the face or the back of the slip. 			

ESC f t1 t2

[Name]	Set cut sheet wait time				
[Format]	ASCII	ESC	f	$t1$	$t2$
	Hex	1B	66	$t1$	$t2$
	Decimal	27	102	$t1$	$t2$
[Range]	$0 \leq t1 \leq 15$ $0 \leq t2 \leq 64$				
[Default]	$t1 = 0, t2 = 10$				
[Description]	<ul style="list-style-type: none"> • Sets the time that the printer waits for slip paper to be inserted and the time from insertion of the slip to the start of printing. • $t1$ specifies the wait time for slip paper to be inserted as [$t1 \times 1$] minutes. When $t1$ is set to 0, the printer cancels the setting of the wait time. In this case, the waiting time to insert a sheet is set to "infinite." • $t2$ specifies the time from insertion of the slip to the start of printing as [$t2 \times 0.1$] seconds. 				

EPSON	TITLE	TM-J7000/J7100 Specification (STANDARD)	SHEET REVISION	NO.	
			B	NEXT 106	SHEET 105

ESC p m t1 t2

[Name] Generate pulse
 [Format] ASCII ESC p m t1 t2
 Hex 1B 70 m t1 t2
 Decimal 27 112 m t1 t2
 [Range] m = 0, 1, 48, 49
 0 ≤ t1 ≤ 255
 0 ≤ t2 ≤ 255

[Description] • Outputs the pulse specified by t1 and t2 to connector pin m, as follows:

m	Function
0, 48	Drawer kick-out connector pin 2.
1, 49	Drawer kick-out connector pin 5.

- t1 specifies the pulse ON time as [t1 × 2 ms].
- t2 specifies the pulse OFF time as [t2 × 2 ms].

[Notes] • Specify a value so that the OFF time is longer than the ON time (t1 < t2).

ESC q

[Name] Release
 [Format] ASCII ESC q
 Hex 1B 71
 Decimal 27 113
 [Description] • Releases the slip paper.

EPSON	TITLE	SHEET REVISION	NO.	
	TM-J7000/J7100 Specification (STANDARD)	B	NEXT 107	SHEET 106

Confidential

ESC t n

- [Name] Select the character code table
- [Format] ASCII ESC t n
Hex 1B 74 n
Decimal 27 116 n
- [Range] $0 \leq n \leq 5, 16 \leq n \leq 19, n = 255$
- [Default] $n = 0$
- [Description] • Selects a page n from the character code table.

n	Selected character code
0	PC437 (USA: Standard Europe)
1	Katakana
2	PC850 (Multilingual)
3	PC860 (Portuguese)
4	PC863 (Canadian-French)
5	PC865 (Nordic)
16	WPC1252
17	PC866 (Cyrillic #2)
18	PC852 (Latin 2)
19	PC858 (Euro)
255	User-defined page

ESC { n

- [Name] Turn upside-down printing mode on/off
- [Format] ASCII ESC { n
Hex 1B 7B n
Decimal 27 123 n
- [Range] $0 \leq n \leq 255$
- [Default] $n = 0$
- [Description] • Turns upside-down printing mode on or off.
• When the LSB of n is 0, upside-down printing mode is turned off.
• When the LSB of n is 1, upside-down printing mode is turned on.

EPSON	TITLE TM-J7000/J7100 Specification (STANDARD)	SHEET REVISION B	NO.	
			NEXT 108	SHEET 107

FS (e pL pH m n

[Name] Enable/disable Automatic Status Back (ASB) for optional functions

[Format] ASCII FS (e pL pH m n
 Hex 1C 28 65 pL pH m n
 Decimal 28 40 101 pL pH m n

[Range] $(pL + pH \times 256) = 2 (pL = 2, pH = 0)$
 $m = 51$
 $0 \leq n \leq 255$

[Default] $n = 0$

[Description] • Enables or disables Automatic Status Back for optional functions (extended ASB).
 • n specifies enabling or disabling of the status bit of the extended ASB as follows:

Bit	Off/On	Hex	Decimal	Function
0	Off	00	0	Disables the status bit for MICR.
	On	01	1	Enables the status bit for MICR.
1	Off	00	0	Disables the status bit for printing on the face of a slip.
	On	02	2	Enables the status bit for printing on the face of a slip.
2 ~ 7	Off	00	0	Reserved.

• The extended ASB status that is transmitted consists of the following four bytes.

Extended ASB status	Hex	Decimal	Amount of data
Header	39H	57	1 byte
Status A	See Table below		1 byte
Status B	40H	64	1 byte
NUL	00H	0	1 byte

<Status A>

Bit	Off/On	Hex	Decimal	Function
0	Off	00	0	MICR function is selected.
	On	01	1	MICR function is not selected.
1 - 4	Off	00	0	Reserved.
5	Off	00	0	Face of slip is selected.
	On	20	32	Back of slip is selected.
6	On	40	64	Fixed.
7	Off	00	0	Fixed.

GS ! n

[Name] Select character size
 [Format] ASCII GS ! n
 Hex 1D 21 n
 Decimal 29 33 n
 [Range] $0 \leq n \leq 255$
 (where $1 \leq \text{Enlargement in vertical direction} \leq 8$,
 $1 \leq \text{Enlargement in horizontal direction} \leq 8$)
 [Default] $n = 0$
 [Description] • Selects character size (enlargement in vertical and horizontal directions) .

Bit	Function	Setting
0	Specifies the times enlarged in the vertical direction	Refer to Table 2 [Enlarged in vertical direction]
1		
2		
3		
4	Specifies the times enlarged in the horizontal direction	Refer to Table 1 [Enlarged in horizontal direction]
5		
6		
7		

Table 1 [Enlarged in horizontal direction]

Hex	Decimal	Enlargement
00	0	1 time (standard)
10	16	2 times
20	32	3 times
30	48	4 times
40	64	5 times
50	80	6 times
60	96	7 times
70	112	8 times

Table 2 [Enlarged in vertical direction]

Hex	Decimal	Enlargement
00	0	1 time (standard)
01	1	2 times
02	2	3 times
03	3	4 times
04	4	5 times
05	5	6 times
06	6	7 times
07	7	8 times

GS \$ nL nH

[Name] Set absolute vertical print position in page mode
 [Format] ASCII GS \$ nL nH
 Hex 1D 24 nL nH
 Decimal 29 36 nL nH
 [Range] $0 \leq (nL + nH \times 256) \leq 65535$ ($0 \leq nL \leq 255, 0 \leq nH \leq 255$)
 [Description] • Sets the absolute vertical print starting position for buffered character data in page mode.
 • This command sets the absolute print position to $[(nL + nH \times 256) \times (\text{vertical or horizontal motion units})]$.

EPSON	TITLE	TM-J7000/J7100 Specification (STANDARD)	SHEET REVISION	NO.	
			B	NEXT	SHEET
			110	109	

GS (A pL pH n m

[Name]	Execute test print							
[Format]	ASCII	GS	(A	pL	pH	n	m
	Hex	1D	28	41	pL	pH	n	m
	Decimal	29	40	65	pL	pH	n	m

[Range] $(pL + pH \times 256) = 2$ ($pL = 2, pH = 0$)
 $0 \leq n \leq 5, 48 \leq n \leq 53$
 $1 \leq m \leq 3, 49 \leq m \leq 51$ (when $0 \leq n \leq 2, 48 \leq n \leq 50$)
 $m = 2, 3, 50, 51$ (when $n = 3, 4, 51, 52$)
 $m = 3, 51$ (when $n = 5, 53$)

- [Description] • Executes a test print with a specified test pattern on a specified paper source (roll or slip).
 • *n* specifies the paper source as listed below to be tested:

<i>n</i>	Paper source
0, 48	Basic sheet (paper roll)
1, 49 2, 50	Paper roll
3, 51 4, 52	Face of the slip paper
5, 53	Back of the slip paper

- *m* specifies a test pattern as listed below:

<i>m</i>	Test pattern
1, 49	Hexadecimal dump
2, 50	Printer status print
3, 51	Rolling pattern print

- The printer executes a hardware reset after the procedure to place the image into the non-volatile memory. The printer clears the receive and print buffers, and resets all settings (user-defined characters, and the character style) to the mode that was in effect at power on.

EPSON	TITLE	TM-J7000/J7100 Specification (STANDARD)	SHEET REVISION	NO.	
			B	NEXT 111	SHEET 110

GS (B p_L p_H m [a_1 b_1]...[a_k b_k]

[Name] Customize ASB status bits

[Format] ASCII GS (B p_L p_H m [a_1 b_1]...[a_k b_k]
 Hex 1D 28 42 p_L p_H m [a_1 b_1]...[a_k b_k]
 Decimal 29 40 66 p_L p_H m [a_1 b_1]...[a_k b_k]

[Range] ($p_L + p_H \times 256$) = 2, 3, 5 ($p_L = 2, 3, 5, p_H = 0$)
 $m = 97$
 $a = 0, 49, 51$
 $b = 44$ (when $a = 49$)
 $b = 45$ (when $a = 51$)

[Description] • Changes the bit assignments of the basic ASB status bit specified with the **GS a** command (bit customization).
 • The combinations of a and b that can be set are as follows:

a	b	Function	
		Bit of ASB status	ASB status to be assigned
0	--	Cancels the setting of bit assignment	---
49	44	Bit 1 of the third byte	Cut sheet insertion waiting status
51	45	Bit 3 of the third byte	Cut sheet removal waiting status

- p_L, p_H specify ($p_L + p_H \times 256$) for the number of bytes after p_H (m and [a_1 b_1]...[a_k b_k]).
- a specifies the bit of the ASB to be customized.
- b specifies the ASB status.

EPSON	TITLE	TM-J7000/J7100 Specification (STANDARD)	SHEET REVISION	NO.	
			B	NEXT 112	SHEET 111

GS (C pL pH m fn b [c1 c2] [d1...dk]

[Name] Edit NV user memory

[Range] Refer to the function-specific specifications.

[Description] • Deletes, stores, and moves data in the NV user memory specified by the function code (*fn*).

<i>fn</i>	Format	Function	
0, 48	GS (C pL pH m fn b c1 c2	0	Deletes the specified record.
1, 49	GS (C pL pH m fn b c1 c2 d1...dk	1	Stores data in the specified record.
2, 50	GS (C pL pH m fn b c1 c2	2	Sends the data in the specified record.
3, 51	GS (C pL pH m fn b	3	Sends the number of bytes of memory used.
4, 52	GS (C pL pH m fn b	4	Sends the number of bytes of remaining memory (unused area).
5, 53	GS (C pL pH m fn b	5	Transmits the key code list identifying the stored data.
6, 54	GS (C pL pH m fn b d1 d2 d3	6	Deletes all data in the NV user memory.

- *pL*, *pH* specify ($pL + pH \times 256$) for the number of bytes after *pH* (*m*, *fn*, *b*, [*c1 c2*], and [*d1...dk*]).
- *c1*, *c2* specify the key code (which identifies the record).
- *d1...dk* specify the stored data (contents of the record) or the fixed value to enact a function.

- [Notes]
- Frequent write command executions by an NV memory write command (**GS (C, GS (E, GS (L/GS 8 L, GS (M, or GS g 0**) may damage the NV memory. Therefore, it is recommended to write to the NV memory no more than 10 times a day.
 - While processing this command, the printer is BUSY while writing data to the NV user memory and stops receiving data. Therefore it is prohibited to transmit data including the real-time commands during the execution of this command.

EPSON	TITLE	B	SHEET REVISION		NO.
	TM-J7000/J7100 Specification (STANDARD)		NEXT	SHEET	
			113	112	

<Function 0> **GS (C pL pH m fn b c1 c2 (fn = 0, 48)**

[Format]	ASCII	GS	(C	pL	pH	m	fn	b	c1	c2
	Hex	1D	28	43	pL	pH	m	fn	b	c1	c2
	Decimal	29	40	67	pL	pH	m	fn	b	c1	c2

[Range] $(pL + pH \times 256) = 5$ ($pL = 5, pH = 0$)
 $m = 0$
 $fn = 0, 48$
 $b = 0$
 $32 \leq c1 \leq 126$
 $32 \leq c2 \leq 126$

[Description] • Deletes the record specified by *c1*, *c2* in the NV user memory.

<Function 1> **GS (C pL pH m fn b c1 c2 d1...dk (fn = 1, 49)**

[Format]	ASCII	GS	(C	pL	pH	m	fn	b	c1	c2	d1...dk
	Hex	1D	28	43	pL	pH	m	fn	b	c1	c2	d1...dk
	Decimal	29	40	67	pL	pH	m	fn	b	c1	c2	d1...dk

[Range] $6 \leq (pL + pH \times 256) \leq 65535$ ($0 \leq pL \leq 255, 0 \leq pH \leq 255$)
 $m = 0$
 $fn = 1, 49$
 $b = 0$
 $32 \leq c1 \leq 126$
 $32 \leq c2 \leq 126$
 $32 \leq d \leq 254$
 $k = (pL + pH \times 256) - 5$

[Description] • Stores the data (*d1...dk*) as the record specified by *c1*, *c2* in the NV user memory.
 • If a record already is specified by *c1* and *c2*, the current record is replaced with new data.

EPSON	TITLE	TM-J7000/J7100 Specification (STANDARD)	SHEET REVISION	NO.	
			B	NEXT 114	SHEET 113

<Function 2> **GS (C pL pH m fn b c1 c2 (fn = 2, 50)**

[Format]	ASCII	GS	(C	pL	pH	m	fn	b	c1	c2
	Hex	1D	28	43	pL	pH	m	fn	b	c1	c2
	Decimal	29	40	67	pL	pH	m	fn	b	c1	c2

[Range] (pL + pH × 256) = 5 (pL = 5, pH = 0)
 m = 0
 fn = 2, 50
 b = 0
 32 ≤ c1 ≤ 126
 32 ≤ c2 ≤ 126

[Description] • Transmits data for the record specified by c1, c2 in the NV user memory.

<Function 3> **GS (C pL pH m fn b (fn = 3, 51)**

[Format]	ASCII	GS	(C	pL	pH	m	fn	b
	Hex	1D	28	43	pL	pH	m	fn	b
	Decimal	29	40	67	pL	pH	m	fn	b

[Range] (pL + pH × 256) = 3 (pL = 3, pH = 0)
 m = 0
 fn = 3, 51
 b = 0

[Description] • Transmits the number of bytes of memory used in the NV user memory.

<Function 4> **GS (C pL pH m fn b (fn = 4, 52)**

[Format]	ASCII	GS	(C	pL	pH	m	fn	b
	Hex	1D	28	43	pL	pH	m	fn	b
	Decimal	29	40	67	pL	pH	m	fn	b

[Range] (pL + pH × 256) = 3 (pL = 3, pH = 0)
 m = 0
 fn = 4, 52
 b = 0

[Description] • Transmits the number of bytes of remaining memory (unused area) in the NV user memory.

EPSON	TITLE	TM-J7000/J7100 Specification (STANDARD)	SHEET REVISION	NO.	
			B	NEXT 115	SHEET 114

Confidential

<Function 5> **GS (C pL pH m fn b (fn = 5, 53)**

[Format]	ASCII	GS	(C	pL	pH	m	fn	b
	Hex	1D	28	43	pL	pH	m	fn	b
	Decimal	29	40	67	pL	pH	m	fn	b

[Range] (pL + pH × 256) = 3 (pL = 3 , pH = 0)
 m = 0
 fn = 5, 53
 b = 0

[Description] • Transmits the key code list identifying the records in the stored data.

<Function 6> **GS (C pL pH m fn b d1 d2 d3 (fn = 6, 54)**

[Range]	ASCII	GS	(C	pL	pH	m	fn	b	d1	d2	d3
	Hex	1D	28	43	pL	pH	m	fn	b	d1	d2	d3
	Decimal	29	40	67	pL	pH	m	fn	b	d1	d2	d3

[Range] (pL + pH × 256) = 6 (pL = 6, pH = 0)
 m = 0
 fn = 6, 54
 b = 0
 d1 = 67
 d2 = 76
 d3 = 82

[Description] • Deletes all data in the NV user memory.

EPSON	TITLE	TM-J7000/J7100 Specification (STANDARD)	SHEET REVISION	NO.	
			B	NEXT 116	SHEET 115

GS (D pL pH m [a1 b1]...[ak bk]

[Name] Enable/disable real-time commands

[Format] ASCII GS (D pL pH m [a1 b1]...[ak bk]
 Hex 1D 28 44 pL pH m [a1 b1]...[ak bk]
 Decimal 29 40 68 pL pH m [a1 b1]...[ak bk]

[Range] $3 \leq (pL + pH \times 256) \leq 65535$ ($0 \leq pL \leq 255, 0 \leq pH \leq 255$)
 $m = 20$
 $a = 1,2$
 $b = 0,1,48,49$

[Default]

a	Type(s) of real-time commands	Default
1	DLE DC4 fn m t ($fn = 1$): Generate pulse in real-time	Enabled ($b = 1$)
2	DLE DC4 fn a b ($fn = 2$): Execute power-off sequence	Disabled ($b = 0$)

[Description] • Enables or disables the following real-time commands.

a	b	Function
1	0, 48	DLE DC4 fn m t ($fn = 1$): Not processed (disabled)
	1, 49	DLE DC4 fn m t ($fn = 1$): Processed (enabled)
2	0, 48	DLE DC4 fn a b ($fn = 2$): Not processed (disabled)
	1, 49	DLE DC4 fn a b ($fn = 2$): Processed (enabled)

- pL, pH specify ($pL + pH \times 256$) as the number of bytes after pH (m and [a1 b1]...[ak bk]).
- a specifies the type of real-time command.
- b specifies enable or disable.

[Note] • If bit image data accidentally includes a character string with this command, it is recommended to use this command in advance to disable the real-time commands.

EPSON	TITLE	TM-J7000/J7100 Specification (STANDARD)	SHEET REVISION	NO.	
			B	NEXT 117	SHEET 116

GS (E pL pH fn [parameters]

[Name] Customize NV memory area

[Description] • Customizes the NV user memory area. The table below explains the functions available in this command. The value of *fn* specifies the function.

<i>fn</i>	Format	Function No.	Function
1	GS (E pL pH fn d1 d2	1	Changes into the user setting mode.
2	GS (E pL pH fn d1 d2 d3	2	Ends the user setting mode session. (Performs a soft reset.)
3	GS (E pL pH fn [a1 b1₈...b1₁] ..[ak bk₈...bk₁]	3	Sets value(s) for the memory switch.
4	GS (E pL pH fn a	4	Transmits the settings of the memory switch to the host.
5	GS (E pL pH fn [a1 n1L n1H]...[ak nkL nkH]	5	Changes the customized setting values.
6	GS (E pL pH fn a	6	Transmits the customized setting values.
7	GS (E pL pH fn a d1 d2	7	Copies the user defined page.
8	GS (E pL pH fn y c1 c2 [x d1...d(y × x)]k	8	Defines the data (column format) for the character code page in the work area.
9	GS (E pL pH fn x c1 c2 [y d1...d(y × x)]k	9	Defines the data (raster format) for the character code page in the work area.
10	GS (E pL pH fn c1 c2	10	Deletes the data for the character code page in the work area.
11	GS (E pL pH fn a d1...dk	11	Sets the communication conditions for the serial interface.
12	GS (E pL pH fn a	12	Transmits the communication conditions for the serial interface.

• *pL*, *pH* specify (*pL* + *pH* × 256) as the number of bytes after *pH* (*fn* and [parameters]).

• If the printer is not in the user setting mode, only <Function 1>, <Function 4>, <Function 6>, or <Function 12> is enabled.

• While the printer is in the user setting mode, <Function 2> though <Function 12> are enabled.

[Notes] • Frequent write commands to NV memory, (**GS (C**, **GS (E**, **GS (L/GS 8 L**, **GS (M**, or **GS g 0**), may damage the NV memory. Therefore, it is recommended to write to NV memory 10 times or less a day.

• In processing this command, the printer is BUSY while writing data to the NV user memory and stops receiving data. Therefore it is prohibited to transmit data, including the real-time commands, during the execution of this command.

EPSON	TITLE	TM-J7000/J7100 Specification (STANDARD)	SHEET REVISION	NO.	
			B	NEXT 118	SHEET 117

<Function 1> **GS (E pL pH fn d1 d2 (fn = 1)**

[Format]	ASCII	GS	(E	pL	pH	fn	d1	d2
	Hex	1D	28	45	pL	pH	fn	d1	d2
	Decimal	29	40	69	pL	pH	fn	d1	d2

[Range] (pL + pH × 256) = 3 (pL = 3 , pH = 0)
 fn = 1
 d1 = 73
 d2 = 78

[Description] • Enters the user setting mode and transmits data that notice the mode has changed.

<Function 2> **GS (E pL pH fn d1 d2 d3 (fn = 2)**

[Format]	ASCII	GS	(E	pL	pH	fn	d1	d2	d3
	Hex	1D	28	45	pL	pH	fn	d1	d2	d3
	Decimal	29	40	69	pL	pH	fn	d1	d2	d3

[Range] (pL + pH × 256) = 4 (pL = 4 , pH = 0)
 fn = 2
 d1 = 79
 d2 = 85
 d3 = 84

[Description] • Ends the user setting mode and performs a software reset. Therefore, the printer clears the receive and print buffers, and resets all settings (user-defined characters, the print mode, and others) to the mode that was in effect at power on.

EPSON	TITLE	TM-J7000/J7100 Specification (STANDARD)	SHEET REVISION	NO.	
			B	NEXT 119	SHEET 118

<Function 3> **GS (E pL pH fn [a1 b18...b11]...[ak bk8...bk1] (fn = 3)**

[Format] ASCII GS (E pL pH fn [a1 b18 ... b11] ... [ak bk8 ... bk1]
 Hex 1D 28 45 pL pH fn [a1 b18 ... b11] ... [ak bk8 ... bk1]
 Decimal 29 40 69 pL pH fn [a1 b18 ... b11] ... [ak bk8 ... bk1]

[Range] $10 \leq (pL + pH \times 256) \leq 65530$ ($0 \leq pL \leq 255, 0 \leq pH \leq 255$)
 $fn = 3$
 $a = 1, 2, 8$
 $b = 48, 49, 50$

[Default (upon shipment)] Msw 2-2 are set to On (49) and all other switches are set to Off (48).

[Description] Changes the memory switch specified by *a* to the values specified with *b*.

- When *b* = 48, the applicable bit is turned Off.
- When *b* = 49, the applicable bit is turned On.
- When *b* = 50, the applicable bit is not changed.
- When *a* =1, the memory switch 1 is set as follows.

Msw	Function	Setting value
1-1	Does not transmit the power ON information.	48
	Transmits the power ON information.	49
1-2	Reserved.	50
1-3	Conditions for BUSY: the receive buffer is full or offline.	48
	Conditions for BUSY: the receive buffer is full.	49
1-4	Data processing for receiving error: prints “?”	48
	Data processing for receiving error: ignores the data.	49
1-5	Automatic line feed is disabled.	48
	Automatic line feed is enabled.	49
1-6	Connection of DM-D: not connected.	48
	Connection of DM-D: connected.	49
1-7	Pin #6: Not used for reset signal.	48
	Pin #6: Used for reset signal.	49
1-8	Pin #25: Not used for reset signal.	48
	Pin #25: Used for reset signal.	49

- Set *b* = 50 as the reserved bit.

EPSON	TITLE TM-J7000/J7100 Specification (STANDARD)	SHEET REVISION B	NO.	
			NEXT 120	SHEET 119

- When $a = 2$, memory switch 2 is set as follows.

Msw	Function	Setting value
2-1	Reserved.	50
2-2	Autocutter is not installed.	48
	Autocutter is installed.	49
2-3 ~ 2-8	Reserved.	50

- Set $b = 50$ as the reserved bit(s).

- When $a = 8$, memory switch 8 is set as follows:

Msw	Function	Setting value
8-1 ~ 8-5	Reserved.	50
8-6	Number of columns (characters) per line printed on a slip: standard.	48
	Number of columns (characters) per line printed on a slip: increased.	49
8-7	Number of columns (characters) per line printed on roll paper: standard.	48
	Number of columns (characters) per line printed on roll paper: increased.	49
8-8	During printing, a paper roll cover open is treated as an error that automatically recover.	48
	During printing, a roll paper cover open is treated as an error that has the possibility of recovery.	49

- Set $b = 50$ for the reserved bit(s).

[Msw 8-6: Print columns on a slip]

Setting of Msw 8-6	Standard	Increased
Font	Font A / font B	Font A / font B
Font structure (dots)	12 × 24 / 9 × 17	11 × 24 / 8 × 17
Maximum printing columns (characters)	Face: 48/64 Back: 46/61	Face: 52/72 Back: 50/69

[Msw 8-7: Print columns on a paper roll]

Setting of Msw 8-7	Standard	Increased
Font	Font A / font B	Font A / font B
Font structure (dots)	12 × 24 / 9 × 17	11 × 24 / 8 × 17
Maximum printing columns (paper width: characters)	57.5 mm: 30/40 69.5 mm: 36/48 76 mm: 40/53 82.5 mm: 42/56	57.5 mm: 32/45 69.5 mm: 39/54 76 mm: 43/60 82.5 mm: 46/64

EPSON	TITLE	SHEET REVISION	NO.	
	TM-J7000/J7100 Specification (STANDARD)		B	NEXT 121

<Function 4> **GS (E pL pH fn a (fn = 4)**

[Format]	ASCII	GS	(E	pL	pH	fn	a
	Hex	1D	28	45	pL	pH	fn	a
	Decimal	29	40	69	pL	pH	fn	a

[Range] $(pL + pH \times 256) = 2$ ($pL = 2, pH = 0$)
 $fn = 4$
 $a = 1, 2, 8$

[Description] • Transmits the setting value(s) of the memory switch specified by a.

<Function 5> **GS (E pL pH fn [a1 n1L n1H]...[ak nkL nkH] (fn = 5)**

[Format]	ASCII	GS	(E	pL	pH	fn	[a1	n1L	n1H]	...	[ak	nkL	nkH]
	Hex	1D	28	45	pL	pH	fn	[a1	n1L	n1H]	...	[ak	nkL	nkH]
	Decimal	29	40	69	pL	pH	fn	[a1	n1L	n1H]	...	[ak	nkL	nkH]

[Range] $4 \leq (pL + pH \times 256) \leq 65533$ ($0 \leq pL \leq 255, 0 \leq pH \leq 255$)
 $fn = 5$
 $a = 3$

$(nL + nH \times 256) = 2, 4, 5, 6$ ($nL = 2, 4, 5, 6, nH = 0$)

[Default] $(nL + nH \times 256) = 5$ ($nL = 5, nH = 0$)

[Description] • Changes the customized value specified by a according to the value $(nL + nH \times 256)$.

a	Customized value
3	Selection of paper width

• When a = 3, the paper width is selected as follows:

Value of $(nL + nH \times 256)$	Paper Width
2	57.5 mm {2.26"}
3	out of range
4	69.5 mm {2.74"}
5	76 mm {2.99"}
6	82.5 mm {3.25"}

[Reference] Appendix I

EPSON	TITLE	TM-J7000/J7100 Specification (STANDARD)	SHEET REVISION	NO.	
			B	NEXT 122	SHEET 121

<Function 6> **GS (E pL pH fn a (fn = 6)**

[Format]	ASCII	GS	(E	pL	pH	fn	a
	Hex	1D	28	45	pL	pH	fn	a
	Decimal	29	40	69	pL	pH	fn	a

[Range] (pL + pH × 256) = 2 (pL = 2, pH = 0)
 fn = 6
 a = 3

[Description] • Transmits the customized value corresponding to the number specified by a.

a	Customized value
3	Paper width setting

<Function 7> **GS (E pL pH fn a d1 d2 (fn = 7)**

[Format]	ASCII	GS	(E	pL	pH	fn	a	d1	d2
	Hex	1D	28	45	pL	pH	fn	a	d1	d2
	Decimal	29	40	69	pL	pH	fn	a	d1	d2

[Range] (pL + pH × 256) = 4 (pL = 4, pH = 0)
 fn = 7
 a = 10, 12
 d1 = 30, 31
 d2 = 30, 31 (where d1 ≠ d2)

[Description] • Copies the data in the user-defined code page.

<Specifications of data to be copied>

d1	d2	Function
31	30	Loads the character code page data for font No. (a) from the storage area to the active area.
30	31	Saves the character code page data in the active area to the storage area specified by font No. (a).

- Active area: Volatile memory (RAM)
- Storage area: Non-volatile memory (Flash ROM)
- User-defined code page: Page 255 (space page)

<Specifications of font No. (a) >

Font No. (a)	Font Type	Data Configuration	
		Dots in Horizontal Direction	Dots in Vertical Direction
10	9 × 17	9	17
12	12 × 24	12	24

- Clears the active area so that no data is loaded after saving the data (d1 = 30, d2 = 31).

EPSON	TITLE	TM-J7000/J7100 Specification (STANDARD)	SHEET REVISION	NO.	
			B	NEXT 123	SHEET 122

<Function 8> GS (E pL pH fn y c1 c2 [x d1...d(y × x)]k (fn = 8)

[Format]	ASCII	GS	(E	pL	pH	fn	y	c1	c2	[x	d1...d(y × x)]k
	Hex	1D	28	45	pL	pH	fn	y	c1	c2	[x	d1...d(y × x)]k
	Decimal	29	40	69	pL	pH	fn	y	c1	c2	[x	d1...d(y × x)]k
[Range]	$5 \leq (pL + pH \times 256) \leq 65535$ ($0 \leq pL \leq 255, 0 \leq pH \leq 255$) $fn = 8$ $y = 3$ $128 \leq c1 \leq c2 \leq 255$ $0 \leq x \leq 12$ (when font A (12 × 24) is selected) $0 \leq x \leq 9$ (when font B (9 × 17) is selected) $0 \leq d \leq 255$ $k = c2 - c1 + 1$												
[Description]	<ul style="list-style-type: none"> Defines the data for each character in the character code page in the active area of (RAM). The data configuration (d) is column format. 												

<Function 9> GS (E pL pH fn x c1 c2 [y d1...d(x × y)]k (fn = 9)

[Format]	ASCII	GS	(E	pL	pH	fn	x	c1	c2	[y	d1...d(x × y)]k
	Hex	1D	28	45	pL	pH	fn	x	c1	c2	[y	d1...d(x × y)]k
	Decimal	29	40	69	pL	pH	fn	x	c1	c2	[y	d1...d(x × y)]k
[Range]	$5 \leq (pL + pH \times 256) \leq 65535$ ($0 \leq pL \leq 255, 0 \leq pH \leq 255$) $fn = 9$ $x = 2$ $128 \leq c1 \leq c2 \leq 255$ $0 \leq y \leq 24$ (when font A (12 × 24) is selected) $0 \leq y \leq 17$ (when font B (9 × 17) is selected) $0 \leq d \leq 255$ $k = c2 - c1 + 1$												
[Description]	<ul style="list-style-type: none"> Defines the data for each character in the character code page in the active area of (RAM). The data configuration (d) is raster format. 												

EPSON	TITLE	TM-J7000/J7100	SHEET REVISION	NO.	
	Specification (STANDARD)	B	NEXT 124	SHEET 123	

<Function 10> **GS (E pL pH fn c1 c2 (fn = 10)**

[Format]	ASCII	GS	(E	pL	pH	fn	c1	c2
	Hex	1D	28	45	pL	pH	fn	c1	c2
	Decimal	29	40	69	pL	pH	fn	c1	c2

[Range] (pL + pH × 256) = 3 (pL = 3, pH = 0)
 fn = 10
 128 ≤ c1 ≤ 255
 128 ≤ c2 ≤ 255 (where c1 ≤ c2)

[Description] • Deletes the data for each character in the character code page in the active area of (RAM).

<Function 11> **GS (E pL pH fn a d1...dk (fn = 11)**

[Format]	ASCII	GS	(E	pL	pH	fn	a	d1 ... dk
	Hex	1D	28	45	pL	pH	fn	a	d1 ... dk
	Decimal	29	40	69	pL	pH	fn	a	d1 ... dk

[Default (upon shipment)]
 19200 bps, no parity, DTR/DSR control, 8 bits

[Range] 3 ≤ (pL + pH × 256) ≤ 65535 (0 ≤ pL ≤ 255, 0 ≤ pH ≤ 255)
 fn = 11
 1 ≤ a ≤ 4
 48 ≤ d ≤ 57

[Description] • Sets the communication conditions for the serial interface specified by a according to value d.

a	Communication Condition	Specification of d
1	Baud rate	k bytes of (d1...dk)
2	Parity	1 byte of (d1)
3	Flow control	1 byte of (d1)
4	Data length	1 byte of (d1)

<Baud rate setting (d1...dk) >

Baud rate (bps)	d1	d2	d3	d4	d5	d6
2400	50	52	48	48	--	--
4800	52	56	48	48	--	--
9600	57	54	48	48	--	--
19200	49	57	50	48	48	--
38400	51	56	52	48	48	--
57600	53	55	54	48	48	--
115200	49	49	53	50	48	48

EPSON	TITLE	TM-J7000/J7100 Specification (STANDARD)	SHEET REVISION	NO.	
			B	NEXT 125	SHEET 124

<Parity setting (*d1*) >

<i>d1</i>	Parity
48	No parity
49	Odd parity
50	Even parity

<Flow control setting (*d1*) >

<i>d1</i>	Flow control
48	DTR/DSR
49	XON/XOFF

<Data length setting (*d1*) >

<i>d1</i>	Data length
55	7 bits
56	8 bits

[Notes]

- New communication conditions will become effective the next time the printer is booted. Note that the host must be set to enable the printer to communicate with the host.

<Function 12> **GS (E *pL pH fn a* (*fn* = 12)**

[Format]	ASCII	GS	(E	<i>pL</i>	<i>pH</i>	<i>fn</i>	<i>a</i>
	Hex	1D	28	45	<i>pL</i>	<i>pH</i>	<i>fn</i>	<i>a</i>
	Decimal	29	40	69	<i>pL</i>	<i>pH</i>	<i>fn</i>	<i>a</i>

[Range] $(pL + pH \times 256) = 2$ ($pL = 2, pH = 0$)
 $fn = 12$
 $1 \leq a \leq 4$

[Description] • Transmits the communication conditions of the serial interface specified by *a*.

<i>a</i>	Communication conditions
1	Baud rate
2	Parity
3	Flow control
4	Data length

GS (G *pL pH fn* [*parameters*]

[Name] Select cut sheet control function

[Description] • Various processes are performed to the cut sheet.

<i>fn</i>	Format	Function No.	Function
32	GS (G <i>pL pH fn m</i>	Function 32	Transmits the status of the cut sheet.
48	GS (G <i>pL pH fn m</i>	Function 48	Specifies the slip side (face or back) to be printed.
80	GS (G <i>pL pH fn m</i>	Function 80	Selects the active sheet (paper source).
81	GS (G <i>pL pH fn m</i>	Function 81	Starts pre-process for cut sheet insertion.
82	GS (G <i>pL pH fn m</i>	Function 82	Ends pre-process for cut sheet insertion.
83	GS (G <i>pL pH fn m</i>	Function 83	Performs waiting process for cut sheet insertion.
84	GS (G <i>pL pH fn m</i>	Function 84	Feeds to the print starting position for the slip.
85	GS (G <i>pL pH fn m</i>	Function 85	Ends the processing for the cut sheet.

• *pL*, *pH* specify (*pL* + *pH* × 256) as the number of bytes after *pH* (*fn* and [*parameters*]).

- See 6.4, "MICR Control Commands" for MICR-related commands for <Function 60> and <Function 61> of the **GS (G** command.

EPSON	TITLE	TM-J7000/J7100 Specification (STANDARD)	SHEET REVISION	NO.	
			B	NEXT 127	SHEET 126

Confidential

<Function 32> **GS (G pL pH fn m (fn = 32)**

[Format]	ASCII	GS	(G	pL	pH	fn	m
	Hex	1D	28	47	pL	pH	fn	m
	Decimal	29	40	71	pL	pH	fn	m

[Range] $(pL + pH \times 256) = 2$ ($pL = 2, pH = 0$)
 $fn = 32$
 $m = 48$

[Description] • Transmits the status of the cut sheet.

Transmission data block	Hexadecimal	Decimal	Amount of data
Header	37H	55	1 byte
Identifier	3AH	58	1 byte
Status	(See table below)		1 byte
NUL	00H	0	1 byte

<Status>

Bit	Off/On	Hex	Decimal	Function
0	Off	00	0	It is possible to feed to the starting position to process the slip.
	On	01	1	It is impossible to feed to the starting position to process the slip.
1	Off	00	0	It is possible to process MICR for the check.
	On	02	2	It is impossible to process MICR for the check.
2	On	04	4	Reserved.
3 - 5	Off	00	0	Reserved.
6	On	40	64	Fixed.
7	Off	00	0	Fixed.

EPSON	TITLE	TM-J7000/J7100 Specification (STANDARD)	SHEET REVISION	NO.	
			B	NEXT 128	SHEET 127

<Function 48> **GS (G pL pH fn m (fn = 48)**

[Format]	ASCII	GS	(G	pL	pH	fn	m
	Hex	1D	28	47	pL	pH	fn	m
	Decimal	29	40	71	pL	pH	fn	m

[Range] $(pL + pH \times 256) = 2$ ($pL = 2, pH = 0$)
 $fn = 48$
 $m = 4, 68$

[Description] • Selects slip as the paper source and selects the side of the slip to be printed.
 • m specifies the side for printing as follows:

m	Function
4	Specifies the face of the slip.
68	Specifies the back of the slip.

<Function 80> **GS (G pL pH fn m (fn = 80)**

[Format]	ASCII	GS	(G	pL	pH	fn	m
	Hex	1D	28	47	pL	pH	fn	m
	Decimal	29	40	71	pL	pH	fn	m

[Range] $(pL + pH \times 256) = 2$ ($pL = 2, pH = 0$)
 $fn = 80$
 $1 \leq m \leq 4, m = 32$

[Default] $m = 3$

[Description] • Selects the paper source to be targeted for processing data by m .

Bit	Off/On	Hex	Decimal	Function
0	Off	00	0	Does not specify roll paper as the paper source.
	On	01	1	Specifies roll paper as the paper source.
1	Off	00	0	Does not specify roll paper as the paper source.
	On	02	2	Specifies roll paper as the paper source.
2	Off	00	0	Does not specify the slip as the paper source.
	On	04	4	Specifies the slip as the paper source.
3, 4	Off	00	0	Reserved.
5	Off	00	0	Does not specify a check as the paper source.
	On	20	32	Specifies a check as the paper source.
6, 7	Off	00	0	Reserved.

EPSON	TITLE	TM-J7000/J7100 Specification (STANDARD)	SHEET REVISION	NO.	
			B	NEXT 129	SHEET 128

<Function 81> **GS (G pL pH fn m (fn = 81)**

[Format]	ASCII	GS	(G	pL	pH	fn	m
	Hex	1D	28	47	pL	pH	fn	m
	Decimal	29	40	71	pL	pH	fn	m

[Range] $(pL + pH \times 256) = 2$ ($pL = 2, pH = 0$)
 fn = 81
 m = 48

- [Description]
- Starts the pre-processing for the cut sheet (slip or check) selected as the paper source for insertion.
 - The printer executes release, and flashes the SLIP LED.

<Function 82> **GS (G pL pH fn m (fn = 82)**

[Format]	ASCII	GS	(G	pL	pH	fn	m
	Hex	1D	28	47	pL	pH	fn	m
	Decimal	29	40	71	pL	pH	fn	m

[Range] $(pL + pH \times 256) = 2$ ($pL = 2, pH = 0$)
 fn = 82
 m = 48

- [Description]
- Ends the pre-processing for the cut sheet (slip or check) selected as the paper source for insertion.
 - The printer executes clamp, and lights the SLIP LED.

<Function 83> **GS (G pL pH fn m (fn = 83)**

[Format]	ASCII	GS	(G	pL	pH	fn	m
	Hex	1D	28	47	pL	pH	fn	m
	Decimal	29	40	71	pL	pH	fn	m

[Range] $(pL + pH \times 256) = 2$ ($pL = 2, pH = 0$)
 fn = 83
 m = 48

- [Description]
- Performs the processing for the cut sheet (slip or check) selected as the paper source for insertion.
 - The printer executes release, and flashes the SLIP LED.
 - The printer executes clamp, and lights the SLIP LED.

EPSON	TITLE	TM-J7000/J7100 Specification (STANDARD)	SHEET REVISION	NO.	
			B	NEXT 130	SHEET 129

<Function 84> GS (G pL pH fn m (fn = 84)

[Format]	ASCII	GS	(G	pL	pH	fn	m
	Hex	1D	28	47	pL	pH	fn	m
	Decimal	29	40	71	pL	pH	fn	m

[Range] $(pL + pH \times 256) = 2$ ($pL = 2, pH = 0$)
 fn = 84
 m = 1

[Description] • Feeds to the print starting position on the currently selected paper side when slip is selected as the paper source.

[Notes] • The print starting position can be set once per each printing face of the slip.

<Function 85> GS (G pL pH fn m (fn = 85)

[Format]	ASCII	GS	(G	pL	pH	fn	m
	Hex	1D	28	47	pL	pH	fn	m
	Decimal	29	40	71	pL	pH	fn	m

[Range] $(pL + pH \times 256) = 2$ ($pL = 2, pH = 0$)
 fn = 85
 m = 48, 49

[Description] • Finishes the processing for the cut sheet (slip or check) after performing the function specified by *m*.

• *m* specifies the function to perform:

<i>m</i>	Function
48	The printer ejects the clamped cut sheet.
49	The printer executes release of the clamped cut sheet.

• After the executing eject or release, the printer awaits removal of the paper and flashes the SLIP LED. When the printer detects that the paper is removed, the printer turns off the SLIP LED.

• The printer selects roll paper as the paper source.

EPSON	TITLE	TM-J7000/J7100 Specification (STANDARD)	SHEET REVISION	NO.	
			B	NEXT 131	SHEET 130

GS (H *pL pH fn* [*parameters*]

[Name] Require transmitting response

[Description] • Various processes are performed as the response.

<i>fn</i>	Format	Function No.	Function
48	GS (H <i>pL pH fn m d1 d2 d3 d4</i>	Function 48	Specifies the process ID response.
49	GS (H <i>pL pH fn m d</i>	Function 49	Specifies the offline response.

• *pL, pH* specify (*pL* + *pH* × 256) as the number of bytes after *pH* (*fn* and [*parameters*]).

[Note] • Do not use this command in a system in which the printer is used with the OPOS driver or the JavaPOS driver that are provided by Seiko Epson Corporation.

<Function 48> **GS (H *pL pH fn m d1 d2 d3 d4* (*fn* = 48)**

[Format]	ASCII	GS	(H	<i>pL</i>	<i>pH</i>	<i>fn</i>	<i>m</i>	<i>d1</i>	<i>d2</i>	<i>d3</i>	<i>d4</i>
	Hex	1D	28	48	<i>pL</i>	<i>pH</i>	<i>fn</i>	<i>m</i>	<i>d1</i>	<i>d2</i>	<i>d3</i>	<i>d4</i>
	Decimal	29	40	72	<i>pL</i>	<i>pH</i>	<i>fn</i>	<i>m</i>	<i>d1</i>	<i>d2</i>	<i>d3</i>	<i>d4</i>

[Range] (*pL* + *pH* × 256) = 6 (*pL* = 6, *pH* = 0)
fn = 48
m = 48
32 ≤ *d* ≤ 126

[Description] • Transmits the specified process ID response.
• *d1, d2, d3, d4* specifies process ID.

<Function 49> **GS (H *pL pH fn m d* (*fn* = 49)**

[Format]	ASCII	GS	(H	<i>pL</i>	<i>pH</i>	<i>fn</i>	<i>m</i>	<i>d</i>
	Hex	1D	28	48	<i>pL</i>	<i>pH</i>	<i>fn</i>	<i>m</i>	<i>d</i>
	Decimal	29	40	72	<i>pL</i>	<i>pH</i>	<i>fn</i>	<i>m</i>	<i>d</i>

[Range] (*pL* + *pH* × 256) = 3 (*pL* = 3, *pH* = 0)
fn = 49
m = 48
0 ≤ *d* ≤ 2, 48 ≤ *d* ≤ 50

[Default] *d* = 0

[Description] • Specifies or turns off the offline response transmission.

<i>d</i>	Function
0, 48	Turns off the offline response transmission.
1, 49	Specifies the offline response transmission (not including the offline cause).
2, 50	Specifies the offline response transmission (including the offline cause).

EPSON	TITLE	TM-J7000/J7100 Specification (STANDARD)	SHEET REVISION	NO.	
			B	NEXT	SHEET
			132	131	

GS (K pL pH fn [parameters]

[Name] Print control method(s)

[Function] • Specifies the settings for the miscellaneous print control or mechanism operations.

<i>fn</i>	Format	Function No.	Function
48	GS (K pL pH fn m	Function 48	Specifies the print control mode.

<Function 48> **GS (K pL pH fn m (fn = 48)**

[Format] ASCII GS (K pL pH fn m
Hex 1D 28 4B pL pH fn m
Decimal 29 40 75 pL pH fn m

[Range] $(pL + pH \times 256) = 2$ ($pL = 2, pH = 0$)
 $fn = 48$
 $1 \leq m \leq 3, 49 \leq m \leq 51$

[Default] $m = 2$

[Function] • Prints the print data on the currently selected sheet using the print control mode specified with *m*.

<i>m</i>	Print control mode
1, 49	Normal
2, 50	High speed
3, 51	Economy

[Notes] • Bar code printing or two-dimensional code printing is performed with one directional print in the normal mode, regardless of the settings with this command.
• In page mode, if multiple types of print modes are mixed, such as bar codes, two-dimensional codes, or others, the printer prints the bar code or two-dimensional code with one directional print in the normal print mode regardless of the setting of this command.

EPSON	TITLE	TM-J7000/J7100 Specification (STANDARD)	SHEET REVISION	NO.	
			B	NEXT 133	SHEET 132

GS (L pL pH m fn [parameters]

GS 8 L p1 p2 p3 p4 m fn [parameters]

[Name]	Select graphics data										
[Format]	ASCII	GS	(L	pL	pH	m	fn	[parameters]		
	Hex	1D	28	4C	pL	pH	m	fn	[parameters]		
	Decimal	29	40	76	pL	pH	m	fn	[parameters]		
	ASCII	GS	8	L	p1	p2	p3	p4	m	fn	[parameters]
	Hex	1D	38	4C	p1	p2	p3	p4	m	fn	[parameters]
	Decimal	29	56	76	p1	p2	p3	p4	m	fn	[parameters]

* In the description below, only **GS (L** is used for explanation.

- Note that **GS (L** and **GS 8 L** have the same function.
- If the [parameters] in the Format column in the table below exceed 65533 bytes, use **GS 8 L**.
- The only difference between **GS (L** and **GS 8 L** is as listed below. The format for **GS 8 L** is not provided in the following descriptions; however, [Description], [Notes], [Range], and [Default] for parameters other than those listed in the table below are the same as for **GS (L**.

<Parameters specifying the number of parameters after m>

Command	Parameters	Structure	Maximum value
GS (L	pL, pH	2 bytes	65,535
GS 8 L	p1, p2, p3, p4	4 bytes	4,294,967,295

EPSON	TITLE	TM-J7000/J7100 Specification (STANDARD)	SHEET REVISION	NO.	
			B	NEXT 134	SHEET 133

[Description] • Processes graphics data according to the function code (*fn*).

<i>fn</i>	Format	Function No.	Function
0, 48	GS (L <i>pL pH m fn</i>	48	Transmits the NV graphics memory capacity.
2, 50	GS (L <i>pL pH m fn</i>	50	Prints the graphics data in the print buffer.
3, 51	GS (L <i>pL pH m fn</i>	51	Transmits the remaining capacity of the NV graphics memory.
4, 52	GS (L <i>pL pH m fn</i>	52	Transmits the remaining capacity of the downloaded graphics memory.
64	GS (L <i>pL pH m fn d1 d2</i>	64	Transmits the defined NV graphics key code list.
65	GS (L <i>pL pH m fn d1 d2 d3</i>	65	Deletes all NV graphics data.
66	GS (L <i>pL pH m fn kc1 kc2</i>	66	Deletes the specified NV graphics data.
67	GS (L <i>pL pH m fn a kc1 kc2 b xL xH yL yH [c d1...dk]1...[c d1...dk]b</i>	67	Defines the raster graphics data in the non-volatile memory.
68	GS (L <i>pL pH m fn a kc1 kc2 b xL xH yL yH [c d1...dk]1...[c d1...dk]b</i>	68	Defines the column graphic data in the non-volatile memory.
69	GS (L <i>pL pH m fn kc1 kc2 x y</i>	69	Prints the specified NV graphics data.
80	GS (L <i>pL pH m fn d1 d2</i>	80	Transmits the defined downloaded graphics key code list.
81	GS (L <i>pL pH m fn d1 d2 d3</i>	81	Performs batch deletion of all NV graphics data.
82	GS (L <i>pL pH m fn kc1 kc2</i>	82	Deletes the specified download graphics data.
83	GS (L <i>pL pH m fn a kc1 kc2 b xL xH yL yH [c d1...dk]1...[c d1...dk]b</i>	83	Defines (in raster format) download graphics data.
84	GS (L <i>pL pH m fn a kc1 kc2 b xL xH yL yH [c d1...dk]1...[c d1...dk]b</i>	84	Defines (in column format) download graphics data.
85	GS (L <i>pL pH m fn kc1 kc2 x y</i>	85	Prints the specified download graphics.
112	GS (L <i>pL pH m fn a bx by c xL xH yL yH d1...dk</i>	112	Stores graphics data in the print buffer (in raster format).
113	GS (L <i>pL pH m fn a bx by c xL xH yL yH d1...dk</i>	113	Stores graphics data in the print buffer (in column format).

• *pL*, *pH* specify ($pL + pH \times 256$) as the number of bytes after *pH* (*m*, *fn*, and [*parameters*]).

EPSON	TITLE	TM-J7000/J7100 Specification (STANDARD)	SHEET REVISION	NO.	
			B	NEXT 135	SHEET 134

- [Notes]
- Frequent write command executions with functions 65, 66, 67, and 68 by an NV memory write command (**GS (C, GS (E, GS (L/GS 8 L, GS (M, GS g 0**) may damage the NV memory. Therefore, it is recommended to write to the NV memory 10 times or less a day.
 - During processing of functions 65, 66, 67, and 68, the printer is BUSY while writing the data to the NV memory and stops receiving data. Therefore, it is prohibited to transmit data, including real-time commands, during the execution of this command.

<Function 48> GS (L pL pH m fn (fn = 0, 48)

[Format]	ASCII	GS	(L	pL	pH	m	fn
	Hex	1D	28	4C	pL	pH	m	fn
	Decimal	29	40	76	pL	pH	m	fn

[Range] $(pL + pH \times 256) = 2$ ($pL = 2, pH = 0$)
 $m = 48$
 $fn = 0, 48$

[Description] • Transmits the total capacity of the NV graphics memory (number of bytes in the memory area).

<Function 50> GS (L pL pH m fn (fn = 2, 50)

[Format]	ASCII	GS	(L	pL	pH	m	fn
	Hex	1D	28	4C	pL	pH	m	fn
	Decimal	29	40	76	pL	pH	m	fn

[Range] $(pL + pH \times 256) = 2$ ($pL = 2, pH = 0$)
 $m = 48$
 $fn = 2, 50$

[Description] • Prints the buffered graphics stored by the process of <Function 112> or <Function 113>.
 • Feeds paper for the amount corresponding to the number of dots in the y direction of the buffered graphics.

EPSON	TITLE	TM-J7000/J7100 Specification (STANDARD)	SHEET REVISION	NO.	
			B	NEXT 136	SHEET 135

<Function 51> **GS (L pL pH m fn (fn = 3, 51)**

[Format]	ASCII	GS	(L	pL	pH	m	fn
	Hex	1D	28	4C	pL	pH	m	fn
	Decimal	29	40	76	pL	pH	m	fn

[Range] $(pL + pH \times 256) = 2$ ($pL = 2, pH = 0$)
 $m = 48$
 $fn = 3, 51$

[Description] • Transmits the number of bytes of remaining memory (unused area) in the NV graphics memory.

<Function 52> **GS (L pL pH m fn (fn = 4, 52)**

[Format]	ASCII	GS	(L	pL	pH	m	fn
	Hex	1D	28	4C	pL	pH	m	fn
	Decimal	29	40	76	pL	pH	m	fn

[Range] $(pL + pH \times 256) = 2$ ($pL = 2, pH = 0$)
 $m = 48$
 $fn = 4, 52$

[Description] • Transmits the number of bytes of remaining memory (unused area) in the downloaded graphics area.

<Function 64> **GS (L pL pH m fn d1 d2 (fn = 64)**

[Format]	ASCII	GS	(L	pL	pH	m	fn	d1	d2
	Hex	1D	28	4C	pL	pH	m	fn	d1	d2
	Decimal	29	40	76	pL	pH	m	fn	d1	d2

[Range] $(pL + pH \times 256) = 4$ ($pL = 4, pH = 0$)
 $m = 48$
 $fn = 64$
 $d1 = 75$
 $d2 = 67$

[Description] • Transmits the defined NV graphics key code list.

EPSON	TITLE	TM-J7000/J7100 Specification (STANDARD)	SHEET REVISION	NO.	
			B	NEXT 137	SHEET 136

<Function 65> **GS (L pL pH m fn d1 d2 d3 (fn = 65)**

[Format]	ASCII	GS	(L	pL	pH	m	fn	d1	d2	d3
	Hex	1D	28	4C	pL	pH	m	fn	d1	d2	d3
	Decimal	29	40	76	pL	pH	m	fn	d1	d2	d3

[Range] $(pL + pH \times 256) = 5$ ($pL = 5, pH = 0$)
 $m = 48$
 $fn = 65$
 $d1 = 67$
 $d2 = 76$
 $d3 = 82$

[Description] • Deletes all defined NV graphics data.

<Function 66> **GS (L pL pH m fn kc1 kc2 (fn = 66)**

[Format]	ASCII	GS	(L	pL	pH	m	fn	kc1	kc2
	Hex	1D	28	4C	pL	pH	m	fn	kc1	kc2
	Decimal	29	40	76	pL	pH	m	fn	kc1	kc2

[Range] $(pL + pH \times 256) = 4$ ($pL = 4, pH = 0$)
 $m = 48$
 $fn = 66$
 $32 \leq kc1 \leq 126$
 $32 \leq kc2 \leq 126$

[Description] Deletes the NV graphics data defined by the key codes ($kc1$ and $kc2$) .

EPSON	TITLE	TM-J7000/J7100 Specification (STANDARD)	SHEET REVISION	NO.	
			B	NEXT 138	SHEET 137

<Function 67>

GS (L pL pH m fn a kc1 kc2 b xL xH yL yH [c d1...dk]1...[c d1...dk]b (fn = 67)

[Format]	ASCII	GS	(L	pL	pH	m	fn	a	kc1	kc2	b
			xL	xH	yL	yH	[c	d1...dk]1...	[c	d1...dk]b		
	Hex	1D	28	4C	pL	pH	m	fn	a	kc1	kc2	b
			xL	xH	yL	yH	[c	d1...dk]1...	[c	d1...dk]b		
	Decimal	29	40	76	pL	pH	m	fn	a	kc1	kc2	b
			xL	xH	yL	yH	[c	d1...dk]1...	[c	d1...dk]b		

[Range] $12 \leq (pL + pH \times 256) \leq 65535$ ($0 \leq pL \leq 255, 0 \leq pH \leq 255$)
 $m = 48$
 $fn = 67$
 $a = 48$
 $32 \leq kc1 \leq 126$
 $32 \leq kc2 \leq 126$
 $b = 1, 2$
 $1 \leq (xL + xH \times 256) \leq 8192$ ($0 \leq xL \leq 255, 0 \leq xH \leq 32$)
 $1 \leq (yL + yH \times 256) \leq 2304$ ($0 \leq yL \leq 255, 0 \leq yH \leq 9$)

If these values are greater than the remaining capacity for NV graphics, NV graphics are not defined.

$49 \leq c \leq 51$ (for TM-J7100)
 $c = 49$ (for TM-J7000)
 $0 \leq d \leq 255$
 $k = (\text{int}((xL + xH \times 256) + 7) / 8) \times (yL + yH \times 256)$

The entire capacity size = 384KB.

- [Description]
- Defines the raster graphics data in the NV graphics area.
 - b specifies the number of the color of the defined data.
 - xL, xH specify the defined data in the horizontal direction as $(xL + xH \times 256)$ dots.
 - yL, yH specify the defined data in the vertical direction as $(yL + yH \times 256)$ dots.
 - c specifies the color of the defined data.

c	Defined data color
49	Color 1
50	Color 2
51	Color 3 (color 1 + color 2)

- d specifies the defined data.

EPSON	TITLE	TM-J7000/J7100 Specification (STANDARD)	SHEET REVISION	NO.	
			B	NEXT 139	SHEET 138

<Function 68> **GS (L pL pH m fn a kc1 kc2 b xL xH yL yH [c d1...dk]1...[c d1...dk]b**
(fn = 68)

[Format]	ASCII	GS	(L	pL	pH	m	fn	a	kc1	kc2	b
			xL	xH	yL	yH	[c d1...dk]1...	[c d1...dk]b				
	Hex	1D	28	4C	pL	pH	m	fn	a	kc1	kc2	b
			xL	xH	yL	yH	[c d1...dk]1...	[c d1...dk]b				
	Decimal	29	40	76	pL	pH	m	fn	a	kc1	kc2	b
			xL	xH	yL	yH	[c d1...dk]1...	[c d1...dk]b				
[Range]	$12 \leq (pL + pH \times 256) \leq 65535$ ($0 \leq pL \leq 255, 0 \leq pH \leq 255$) $m = 48$ $fn = 68$ $a = 48$ $32 \leq kc1 \leq 126$ $32 \leq kc2 \leq 126$ $b = 1, 2$ $1 \leq (xL + xH \times 256) \leq 8192$ ($0 \leq xL \leq 255, 0 \leq xH \leq 32$) $1 \leq (yL + yH \times 256) \leq 2304$ ($0 \leq yL \leq 255, 0 \leq yH \leq 9$) If these values are greater than the remaining capacity for NV graphics, NV graphics are not defined. $49 \leq c \leq 51$ (for TM-J7100) $c = 49$ (for TM-J7000) $0 \leq d \leq 255$ $k = (xL + xH \times 256) \times (\text{int}((yL + yH \times 256) + 7) / 8)$ The entire capacity size = 384KB.											

[Description] Defines the column graphics data in the NV graphics area.

- b specifies the number of the color of the defined data.
- xL, xH specify the defined data in the horizontal direction as (xL + xH × 256) dots.
- yL, yH specify the defined data in the vertical direction as (yL + yH × 256) dots.
- c specifies the color of the defined data.

c	Defined data color
49	Color 1
50	Color 2
51	Color 3 (color 1 + color 2)

- d specifies the defined data.

EPSON	TITLE	SHEET REVISION	NO.	
	TM-J7000/J7100 Specification (STANDARD)	B	NEXT 140	SHEET 139

<Function 69> **GS (L pL pH m fn kc1 kc2 x y (fn = 69)**

[Format]	ASCII	GS	(L	pL	pH	m	fn	kc1	kc2	x	y
	Hex	1D	28	4C	pL	pH	m	fn	kc1	kc2	x	y
	Decimal	29	40	76	pL	pH	m	fn	kc1	kc2	x	y

[Range] $(pL + pH \times 256) = 6$ ($pL = 6, pH = 0$)
 $m = 48$
 $fn = 69$
 $32 \leq kc1 \leq 126$
 $32 \leq kc2 \leq 126$
 $x = 1, 2$
 $y = 1, 2$

[Description] • Prints the NV graphics data defined by the key codes (*kc1* and *kc2*) . The graphics data is enlarged by *x* and *y* in the horizontal and vertical directions.

<Function 80> **GS (L pL pH m fn d1 d2 (fn = 80)**

[Format]	ASCII	GS	(L	pL	pH	m	fn	d1	d2
	Hex	1D	28	4C	pL	pH	m	fn	d1	d2
	Decimal	29	40	76	pL	pH	m	fn	d1	d2

[Range] $(pL + pH \times 256) = 4$ ($pL = 4, pH = 0$)
 $m = 48$
 $fn = 80$
 $d1 = 75$
 $d2 = 67$

[Description] • Transmits the defined downloaded graphics key code list.

EPSON	TITLE	TM-J7000/J7100 Specification (STANDARD)	SHEET REVISION	NO.	
			B	NEXT 141	SHEET 140

<Function 81> **GS (L pL pH m fn d1 d2 d3 (fn = 81)**

[Format]	ASCII	GS	(L	pL	pH	m	fn	d1	d2	d3
	Hex	1D	28	4C	pL	pH	m	fn	d1	d2	d3
	Decimal	29	40	76	pL	pH	m	fn	d1	d2	d3

[Range] (pL + pH × 256) = 5 (pL = 5, pH = 0)
 m = 48
 fn = 81
 d1 = 67
 d2 = 76
 d3 = 82

[Description] • Deletes all defined downloaded graphics.

<Function 82> **GS (L pL pH m fn kc1 kc2 (fn = 82)**

[Format]	ASCII	GS	(L	pL	pH	m	fn	kc1	kc2
	Hex	1D	28	4C	pL	pH	m	fn	kc1	kc2
	Decimal	29	40	76	pL	pH	m	fn	kc1	kc2

[Range] (pL + pH × 256) = 4 (pL = 4, pH = 0)
 m = 48
 fn = 82
 32 ≤ kc1 ≤ 126
 32 ≤ kc2 ≤ 126

[Description] • Deletes the downloaded graphics data defined by the key codes (kc1 and kc2) .

EPSON	TITLE	TM-J7000/J7100 Specification (STANDARD)	SHEET REVISION	NO.	
			B	NEXT 142	SHEET 141

<Function 83> **GS (L pL pH m fn a kc1 kc2 b xL xH yL yH [c d1...dk]1...[c d1...dk]b**
(fn = 83)

[Format]	ASCII	GS (L pL pH m fn a kc1 kc2 b xL xH yL yH [c d1...dk]1... [c d1...dk]b
	Hex	1D 28 4C pL pH m fn a kc1 kc2 b xL xH yL yH [c d1...dk]1... [c d1...dk]b
	Decimal	29 40 76 pL pH m fn a kc1 kc2 b xL xH yL yH [c d1...dk]1... [c d1...dk]b

[Range] $12 \leq (pL + pH \times 256) \leq 65535$ ($0 \leq pL \leq 255, 0 \leq pH \leq 255$)
 $m = 48$
 $fn = 83$
 $a = 48$
 $32 \leq kc1 \leq 126$
 $32 \leq kc2 \leq 126$
 $b = 1, 2$
 $1 \leq (xL + xH \times 256) \leq 8192$ ($0 \leq xL \leq 255, 0 \leq xH \leq 32$)
 $1 \leq (yL + yH \times 256) \leq 2304$ ($0 \leq yL \leq 255, 0 \leq yH \leq 9$)

If these values are greater than the remaining capacity for NV graphics, NV graphics are not defined.

$49 \leq c \leq 51$ (for TM-J7100)
 $c = 49$ (for TM-J7000)
 $0 \leq d \leq 255$
 $k = (\text{int}((xL + xH \times 256) + 7) / 8) \times (yL + yH \times 256)$

The entire capacity size = 12304 bytes.

- [Description]
- Defines the raster graphics data in the volatile memory (RAM) .
 - b specifies the number of the color of the defined data.
 - xL, xH specify the defined data in the horizontal direction as $(xL + xH \times 256)$ dots.
 - yL, yH specify the defined data in the vertical direction as $(yL + yH \times 256)$ dots.
 - c specifies the color of the defined data.

c	Defined data color
49	Color 1
50	Color 2
51	Color 3 (color 1 + color 2)

- d specifies the defined data.

EPSON	TITLE	TM-J7000/J7100 Specification (STANDARD)	SHEET REVISION	NO.	
			B	NEXT 143	SHEET 142

<Function 84> **GS (L pL pH m fn a kc1 kc2 b xL xH yL yH [c d1...dk]1...[c d1...dk]b**
(fn = 84)

[Format]	ASCII	GS (L pL pH m fn a kc1 kc2 b xL xH yL yH [c d1...dk]1... [c d1...dk]b
	Hex	1D 28 4C pL pH m fn a kc1 kc2 b xL xH yL yH [c d1...dk]1... [c d1...dk]b
	Decimal	29 40 76 pL pH m fn a kc1 kc2 b xL xH yL yH [c d1...dk]1... [c d1...dk]b

[Range] $12 \leq (pL + pH \times 256) \leq 65535$ ($0 \leq pL \leq 255, 0 \leq pH \leq 255$)
 $m = 48$
 $fn = 84$
 $a = 48$
 $32 \leq kc1 \leq 126$
 $32 \leq kc2 \leq 126$
 $b = 1, 2$
 $1 \leq (xL + xH \times 256) \leq 8192$ ($0 \leq xL \leq 255, 0 \leq xH \leq 32$)
 $1 \leq (yL + yH \times 256) \leq 2304$ ($0 \leq yL \leq 255, 0 \leq yH \leq 9$)

If these values are greater than the remaining capacity for NV graphics, NV graphics are not defined.

$49 \leq c \leq 51$ (for TM-J7100)
 $c = 49$ (for TM-J7000)
 $0 \leq d \leq 255$
 $k = (xL + xH \times 256) \times (\text{int}((yL + yH \times 256) + 7) / 8)$

The entire capacity size = 12304 bytes.

- [Description]
- Defines the column graphics data in the volatile memory (RAM).
 - b specifies the number of the color of the defined data.
 - xL, xH specify the defined data in the horizontal direction as $(xL + xH \times 256)$ dots.
 - yL, yH specify the defined data in the vertical direction as $(yL + yH \times 256)$ dots.
 - c specifies the color of the defined data.

c	Defined data color
49	Color 1
50	Color 2
51	Color 3 (color 1 + color 2)

- d specifies the defined data.

EPSON	TITLE	TM-J7000/J7100 Specification (STANDARD)	SHEET REVISION	NO.	
			B	NEXT 144	SHEET 143

<Function 85> **GS (L pL pH m fn kc1 kc2 x y (fn = 85)**

[Format]	ASCII	GS	(L	pL	pH	m	fn	kc1	kc2	x	y
	Hex	1D	28	4C	pL	pH	m	fn	kc1	kc2	x	y
	Decimal	29	40	76	pL	pH	m	fn	kc1	kc2	x	y

[Range] $(pL + pH \times 256) = 6$ ($pL = 6, pH = 0$)
 $m = 48$
 $fn = 85$
 $32 \leq kc1 \leq 126$
 $32 \leq kc2 \leq 126$
 $x = 1, 2$
 $y = 1, 2$

[Description] • Prints the downloaded graphics data defined by the key codes (*kc1* and *kc2*). The graphics data is enlarged by *x* and *y* in the horizontal and vertical directions.

<Function 112> **GS (L pL pH m fn a bx by c xL xH yL yH d1...dk (fn = 112)**

[Format]	ASCII	GS	(L	pL	pH	m	fn	a	bx	by	c	xL	xH	yL	yH	d1...dk
	Hex	1D	28	4C	pL	pH	m	fn	a	bx	by	c	xL	xH	yL	yH	d1...dk
	Decimal	29	40	76	pL	pH	m	fn	a	bx	by	c	xL	xH	yL	yH	d1...dk

[Range] $11 \leq (pL + pH \times 256) \leq 65535$ ($0 \leq pL \leq 255, 0 \leq pH \leq 255$)
 $m = 48$
 $fn = 112$
 $a = 48$
 $bx = 1, 2$
 $by = 1, 2$
 $49 \leq c \leq 51$ (for TM-J7100)
 $c = 49$ (for TM-J7000)
 $1 \leq (xL + xH \times 256) \leq 2048$ ($0 \leq xL \leq 255, 0 \leq xH \leq 8$)
 $1 \leq (yL + yH \times 256) \leq 64$ ($1 \leq yL \leq 64, yH = 0$)
 $0 \leq d \leq 255$
 $k = (\text{int}((xL + xH \times 256) + 7) / 8) \times (yL + yH \times 256)$

[Description] • Stores the raster graphics data, enlarged by *bx* and *by* in the horizontal and vertical directions.

- *xL, xH* specify the defined raster graphics data in the horizontal direction as $(xL + xH \times 256)$ dots.
- *yL, yH* specify the defined raster graphics data in the vertical direction as $(yL + yH \times 256)$ dots.
- *c* specifies the color for the stored data.

c	Printing color
49	Color 1
50	Color 2
51	Color 3 (color 1 and color 2)

EPSON	TITLE	TM-J7000/J7100 Specification (STANDARD)	SHEET REVISION	NO.	
			B	NEXT 145	SHEET 144

<Function 113> **GS (L pL pH m fn a bx by c xL xH yL yH d1...dk (fn = 113)**

[Format] ASCII GS (L pL pH m fn a bx by c xL xH yL yH d1...dk
 Hex 1D 28 4C pL pH m fn a bx by c xL xH yL yH d1...dk
 Decimal 29 40 76 pL pH m fn a bx by c xL xH yL yH d1...dk

[Range] $11 \leq (pL + pH \times 256) \leq 65535$ ($0 \leq pL \leq 255, 0 \leq pH \leq 255$)
 $m = 48$
 $fn = 113$
 $a = 48$
 $bx = 1, 2$
 $by = 1, 2$
 $49 \leq c \leq 51$ (for TM-J7100)
 $c = 49$ (for TM-J7000)
 $1 \leq (xL + xH \times 256) \leq 2048$ ($0 \leq xL \leq 255, 0 \leq xH \leq 8$)
 $1 \leq (yL + yH \times 256) \leq 64$ ($1 \leq yL \leq 64, yH = 0$)
 $0 \leq d \leq 255$
 $k = (xL + xH \times 256) \times (\text{int}((yL + yH \times 256) + 7) / 8)$

- [Description] • Stores the column graphics data in the print buffer. The graphics data is enlarged by *bx* and *by* in the horizontal and vertical directions.
- *xL, xH* specify the defined column graphics data in the horizontal direction as $(xL + xH \times 256)$ dots.
 - *yL, yH* specify the defined column graphics data in the vertical direction as $(yL + yH \times 256)$ dots.
 - *c* specifies the color of the stored data.

c	Printing color
49	Color 1
50	Color 2
51	Color 3 (color 1 and color 2)

EPSON	TITLE	TM-J7000/J7100 Specification (STANDARD)	SHEET REVISION	NO.	
			B	NEXT 146	SHEET 145

GS (M pL pH fn m

[Name] Customize printer

[Description] • Executes the functions shown in the table below, using the function code defined by *fn*.

<i>fn</i>	Function No.	Descriptions
1, 49	Function 1	Saves the setting values in the work area to the archive area.
2, 50	Function 2	Loads the setting values stored in the archive area to the work area.
3, 51	Function 3	Specifies the setting values for the work area after the initialization process.

- *pL*, *pH* specify (*pL* + *pH* × 256) for the number of bytes after *pH* (*fn* and *m*).
- *fn* specifies the function.
- *m* specifies the process of each function
- Data stored in the work area is erased by power off or reset because volatile RAM is used. On the other hand, data stored in the archive area is kept, even if the power is turned off or reset is executed, because non-volatile RAM is used. "Setting values" are the values specified or defined by commands.

<Applied setting values for this command>

Setting value	Command
Status	ESC c 3, FS (e, GS (B, GS a, GS j
Characters	
Font of character set	ESC M, ESC R, ESC t
Character format (emphasized, underlined, etc.)	ESC !, ESC -, ESC E, ESC G, ESC {, GS !, GS (N, GS B
Other characteristics	ESC SP, ESC 2, ESC 3
Print position	ESC D, ESC T, ESC a, GS L, GS W
Cut sheet operation	ESC F, ESC f
Bar code	GS H, GS f, GS h, GS w
2-dimensional code	GS (k <Function 065> through <Function 070>
MICR function	FS (f
Other characteristics	ESC U, ESC c 4, ESC c 5, GS (D, GS (H <Function 49>, GS (K, GS P

EPSON	TITLE	TM-J7000/J7100 Specification (STANDARD)	SHEET REVISION	NO.	
			B	NEXT 147	SHEET 146

<Function 1> **GS (M pL pH fn m (fn = 1,49)**

[Format]	ASCII	GS	(M	pL	pH	fn	m
	Hex	1D	28	4D	pL	pH	fn	m
	Decimal	29	40	77	pL	pH	fn	m
[Range]	(pL + pH × 256) = 2 (pL = 2, pH = 0) fn = 1, 49 m = 1, 49							
[Description]	<ul style="list-style-type: none"> Saves the setting values of commands listed in the table on the previous page and stored in the work area to the archive area. 							
[Notes]	<ul style="list-style-type: none"> Frequent write commands to NV memory, (GS (C, GS (E, GS (L/GS 8 L, or GS (M GS g 0), may damage the NV memory. Therefore, it is recommended to write to NV memory 10 times or less a day. In processing this command, the printer is BUSY while writing data to the NV memory and stops receiving data. Therefore it is prohibited to transmit data, including the real-time commands, during the execution of this command. 							

<Function 2> **GS (M pL pH fn m (fn = 2,50)**

[Format]	ASCII	GS	(M	pL	pH	fn	m
	Hex	1D	28	4D	pL	pH	fn	m
	Decimal	29	40	77	pL	pH	fn	m
[Range]	(pL + pH × 256) = 2 (pL = 2, pH = 0) fn = 2, 50 m = 0, 1, 48, 49							
[Description]	<ul style="list-style-type: none"> Loads the values specified with <i>m</i> as the current command settings in the work area. <ul style="list-style-type: none"> When <i>m</i> = 0 or 48, the default values described in this specification are applied. When <i>m</i> = 1 or 49, this command loads the setting values stored in the archive area. Data not listed among the above commands or data stored in the receive buffer is not affected. If no data in the storage area is protected, the default values described in this specification are applied. 							

EPSON	TITLE	TM-J7000/J7100 Specification (STANDARD)	SHEET REVISION	NO.	
			B	NEXT 148	SHEET 147

<Function 3> **GS (M pL pH fn m (fn = 3,51)**

[Format]	ASCII	GS	(M	pL	pH	fn	m
	Hex	1D	28	4D	pL	pH	fn	m
	Decimal	29	40	77	pL	pH	fn	m

[Range] (pL + pH × 256) = 2 (pL = 2, pH = 0)
 fn = 3, 51
 m = 0, 1, 48, 49

[Default (upon shipment)]
 m = 0

- [Description]
- Loads the values specified by *m* as the current command settings in the work area after the printer performs the initialization process.
 - When *m* = 0 or 48, the default values described in this specification are applied.
 - When *m* = 1 or 49, this command loads the setting values stored in the archive area.
 - For values not listed among the above commands the default values described in this specification are applied.
 - “Initialization process” is when the printer performs the following operations:
 - Power is turned on with the switch or a hardware reset is performed.
 - Software reset is performed.
 - **ESC @** is executed.

EPSON	TITLE	TM-J7000/J7100 Specification (STANDARD)	SHEET REVISION	NO.	
			B	NEXT 149	SHEET 148

GS (N pL pH fn [parameters]

[Name] Select character style

[Description] • Executes commands for the character style as specified by the function code (*fn*) .

<i>fn</i>	Format	Function No.	Description
48	GS (N pL pH fn m	Function 48	Selects character color.
49	GS (N pL pH fn m	Function 49	Selects background color.
50	GS (N pL pH fn m a	Function 50	Selects or cancels "shadow".

<Function 48> **GS (N pL pH fn m (fn = 48)**

[Format] ASCII GS (N pL pH fn m
 Hex 1D 28 4E pL pH fn m
 Decimal 29 40 78 pL pH fn m

[Range] ($pL + pH \times 256$) = 2 ($pL = 2, pH = 0$)
 fn = 48
 $48 \leq m \leq 51$ (for TM-J7100)
 $m = 48, 49$ (for TM-J7000)

[Default] *m* = 49

[Description] • Prints characters in the color specified by *m*.

<i>m</i>	Color
48	Not printing
49	Color 1
50	Color 2
51	Color 3 (color 1 + color 2)

[Details] • Color 1 is selected for the bit image after this command is executed (except for graphics defined by **GS (L)** .

EPSON	TITLE	TM-J7000/J7100 Specification (STANDARD)	SHEET REVISION	NO.	
			B	NEXT	SHEET
			150	149	

<Function 49> **GS (N pL pH fn m (fn = 49)**

[Format]	ASCII	GS	(N	pL	pH	fn	m
	Hex	1D	28	4E	pL	pH	fn	m
	Decimal	29	40	78	pL	pH	fn	m

[Range] $(pL + pH \times 256) = 2$ ($pL = 2, pH = 0$)
 $fn = 49$
 $48 \leq m \leq 51$ (for TM-J7100)
 $m = 48, 49$ (for TM-J7000)

[Default] $m = 48$

[Description] Prints characters in the color specified by m .

m	Color
48	Not printing
49	Color 1
50	Color 2
51	Color 3 (color 1 + color 2)

<Function 50> **GS (N pL pH fn m a (fn = 50)**

[Format]	ASCII	GS	(N	pL	pH	fn	m	a
	Hex	1D	28	4E	pL	pH	fn	m	a
	Decimal	29	40	78	pL	pH	fn	m	a

[Range] $(pL + pH \times 256) = 3$ ($pL = 3, pH = 0$)
 $fn = 50$
 $m = 0, 1, 48, 49$
 $a = 48$

[Default] $m = 0$

[Description] • Selects or cancels "shadow" as the character style.
 • When $m = 0, 48$, "shadow" is canceled for the succeeding characters.
 • When $m = 1, 49$, "shadow" is applied to the succeeding characters.
 • When "shadow" is selected, the shadowed portion is printed with no color (no printing).

GS (P pL pH fn [parameters]

[Name] Control page mode

[Description] • Executes commands for the character style as specified by the function code (fn).

fn	Format	Function No.	Description
48	GS (P pL pH fn wxL wxH wyL wyH oxL oxH c	Function 48	Sets size of printable area for page mode.

EPSON	TITLE	TM-J7000/J7100 Specification (STANDARD)	SHEET REVISION	NO.	
			B	NEXT 151	SHEET 150

<Function 48> **GS (P pL pH fn wxL wxH wyL wyH oxL oxH c (fn = 48)**

[Format]	ASCII	GS	(P	pL	pH	fn	wxL	wxH	wyL	wyH	oxL	oxH	c
	Hex	1D	28	50	pL	pH	fn	wxL	wxH	wyL	wyH	oxL	oxH	c
	Decimal	29	40	80	pL	pH	fn	wxL	wxH	wyL	wyH	oxL	oxH	c
[Range]	$(pL + pH \times 256) = 8$ ($pL = 8, pH = 0$) $fn = 48$ $1 \leq (wxL + wxH \times 256) \leq 65535$ ($0 \leq wxL \leq 255, 0 \leq wxH \leq 255$) $1 \leq (wyL + wyH \times 256) \leq 65535$ ($0 \leq wyL \leq 255, 0 \leq wyH \leq 255$) $0 \leq (oxL + oxH \times 256) \leq 65535$ ($0 \leq oxL \leq 255, 0 \leq oxH \leq 255$) $0 \leq c \leq 3$ (for TM-J7100) $c = 1$ (for TM-J7000)													
[Default]	<For TM-J7100>													
	$(wxL + wxH \times 256) = 360$		$(wxL = 104, wxH = 1)$		[Roll paper: paper width 57.5 mm]									
	$(wyL + wyH \times 256) = 584$		$(wyL = 72, wyH = 2)$											
	$(wxL + wxH \times 256) = 432$		$(wxL = 176, wxH = 1)$		[Roll paper: paper width 69.5 mm]									
	$(wyL + wyH \times 256) = 488$		$(wyL = 232, wyH = 1)$											
	$(wxL + wxH \times 256) = 480$		$(wxL = 224, wxH = 1)$		[Roll paper: paper width 76 mm]									
	$(wyL + wyH \times 256) = 440$		$(wyL = 184, wyH = 1)$											
	$(wxL + wxH \times 256) = 512$		$(wxL = 0, wxH = 2)$		[Roll paper: paper width 82.5 mm]									
	$(wyL + wyH \times 256) = 416$		$(wyL = 160, wyH = 1)$											
	$(wxL + wxH \times 256) = 576$		$(wxL = 64, wxH = 2)$		[Slip]									
	$(wyL + wyH \times 256) = 368$		$(wyL = 112, wyH = 1)$											
	$(oxL + oxH \times 256) = 0$		$(oxL = 0, oxH = 0)$		[Roll paper / Slip]									
	$c = 3$				[Roll paper / Slip]									
	<For TM-J7000>													
	$(wxL + wxH \times 256) = 360$		$(wxL = 104, wxH = 1)$		[Roll paper: paper width 57.5 mm]									
	$(wyL + wyH \times 256) = 1176$		$(wyL = 152, wyH = 4)$											
	$(wxL + wxH \times 256) = 432$		$(wxL = 176, wxH = 1)$		[Roll paper: paper width 69.5 mm]									
	$(wyL + wyH \times 256) = 984$		$(wyL = 216, wyH = 3)$											
	$(wxL + wxH \times 256) = 480$		$(wxL = 224, wxH = 1)$		[Roll paper: paper width 76 mm]									
	$(wyL + wyH \times 256) = 880$		$(wyL = 112, wyH = 3)$											
	$(wxL + wxH \times 256) = 512$		$(wxL = 0, wxH = 2)$		[Roll paper: paper width 82.5 mm]									
	$(wyL + wyH \times 256) = 832$		$(wyL = 64, wyH = 3)$											
	$(wxL + wxH \times 256) = 576$		$(wxL = 64, wxH = 2)$		[Slip]									
	$(wyL + wyH \times 256) = 736$		$(wyL = 224, wyH = 2)$											
	$(oxL + oxH \times 256) = 0$		$(oxL = 0, oxH = 0)$		[Roll paper / Slip]									
	$c = 1$				[Roll paper / Slip]									

EPSON	TITLE	TM-J7000/J7100 Specification (STANDARD)	SHEET REVISION	NO.	
			B	NEXT 152	SHEET 151

Confidential

- [Description]
- This command sets the position and the size of the printable area for page mode.
 - wxL , wxH specify the horizontal starting position with $[(wxL + wxH \times 256) \times (\text{horizontal motion units})]$.
 - wyL , wyH specify the vertical starting position with $[(wyL + wyH \times 256) \times (\text{vertical motion units})]$.
 - oxL , oxH specify the horizontal offset of the printable area with $[(oxL + oxH \times 256) \times (\text{horizontal motion units})]$.
 - c specifies the color for printing page mode.

c	Color
1	Color 1
2	Color 2
3	Color 3 (color 1 + color 2)

- On the TM-J7100, if c is specified as 1 or 2, the printer can use the same printable area size as for the TM-J7000.
- This command sets the size of the printable area both for the paper roll and slip.

EPSON	TITLE TM-J7000/J7100 Specification (STANDARD)	SHEET REVISION B	NO.	
			NEXT 153	SHEET 152

GS (k pL pH cn fn [parameters]

[Name] Setup and print symbol

[Description] • Various processes are performed according to the function code (*fn*).

<i>cn</i>	Type of Symbol
48	PDF417 (2-dimensional code)

<i>fn</i>	Code	Function No.	Description
65	GS (k pL pH cn fn n	Function 065	Sets the number of columns to one per (step size) of the PDF417.
66	GS (k pL pH cn fn n	Function 066	Specifies PDF417 step number.
67	GS (k pL pH cn fn n	Function 067	Sets PDF417 module width.
68	GS (k pL pH cn fn n	Function 068	Sets PDF417 step height.
69	GS (k pL pH cn fn m n	Function 069	Sets PDF417 error correction level.
70	GS (k pL pH cn fn m	Function 070	Specifies PDF417 options.
80	GS (k pL pH cn fn m d1...dk	Function 080	Receives and stores data (<i>d1...dk</i>) in the symbol storage area.
81	GS (k pL pH cn fn m	Function 081	Prints symbol data in the symbol storage area.
82	GS (k pL pH cn fn m	Function 082	Transmits the size information of the symbol data in the symbol storage area.

- *pL*, *pH* specify ($pL + pH \times 256$) as the number of bytes after *pH* (*cn*, *fn*, and [parameters]).
- *fn* specifies the function.
- "Symbol data" refers to the data received with <Function 080> before encoding.
- "Symbol storage area" refers to the range for storing data received with <Function 080> before encoding.

[Reference] Appendix A

EPSON	TITLE	TM-J7000/J7100 Specification (STANDARD)	SHEET REVISION	NO.	
			B	NEXT 154	SHEET 153

<Function 065> **GS (k pL pH cn fn n (fn = 65)**

[Format]	ASCII	GS	(k	pL	pH	cn	fn	n
	Hex	1D	28	6B	pL	pH	cn	fn	n
	Decimal	29	40	107	pL	pH	cn	fn	n
[Range]	$(pL + pH \times 256) = 3$ (pL = 3, pH = 0)								
	cn = 48								
	fn = 65								
	$0 \leq n \leq 30$								
[Default]	n = 0								
[Description]	<ul style="list-style-type: none"> • Sets the number of digits (step size) for the data area for PDF417 symbols. • When $n = 0$, specifies automatic processing • When $n \neq 0$, sets the number of digits for the data area to n code words. • When automatic processing ($n = 0$) is specified, the number of columns per row is calculated with the number of code words or the range of printable area. 								
[Notes]	<ul style="list-style-type: none"> • The following data is not included in the line number. • Start and stop patterns • Left and right indicator code words 								

<Function 066> **GS (k pL pH cn fn n (fn = 66)**

[Format]	ASCII	GS	(k	pL	pH	cn	fn	n
	Hex	1D	28	6B	pL	pH	cn	fn	n
	Decimal	29	40	107	pL	pH	cn	fn	n
[Range]	$(pL + pH \times 256) = 3$ (pL = 3, pH = 0)								
	cn = 48								
	fn = 66								
	$n = 0, 3 \leq n \leq 90$								
[Default]	n = 0								
[Description]	<ul style="list-style-type: none"> • Sets the step size of PDF417 symbols • When $n = 0$, specifies automatic processing • When $n \neq 0$, sets the height of the symbol steps to n. • When automatic processing ($n = 0$) is specified, the number of columns per row is calculated with the number of code words or the range of printable area. 								

EPSON	TITLE	TM-J7000/J7100 Specification (STANDARD)	SHEET REVISION	NO.	
			B	NEXT 155	SHEET 154

<Function 067> **GS (k pL pH cn fn n (fn = 67)**

[Format]	ASCII	GS	(k	pL	pH	cn	fn	n
	Hex	1D	28	6B	pL	pH	cn	fn	n
	Decimal	29	40	107	pL	pH	cn	fn	n
[Range]	$(pL + pH \times 256) = 3$ ($pL = 3, pH = 0$) $cn = 48$ $fn = 67$ $2 \leq n \leq 8$								
[Default]	$n = 3$								
[Description]	<ul style="list-style-type: none"> • Sets the dot width of one PDF417 symbol module to n dots. 								

<Function 068> **GS (k pL pH cn fn n (fn = 68)**

[Format]	ASCII	GS	(k	pL	pH	cn	fn	n
	Hex	1D	28	6B	pL	pH	cn	fn	n
	Decimal	29	40	107	pL	pH	cn	fn	n
[Range]	$(pL + pH \times 256) = 3$ ($pL = 3, pH = 0$) $cn = 48$ $fn = 68$ $2 \leq n \leq 8$								
[Default]	$n = 3$								
[Description]	<ul style="list-style-type: none"> • Sets the height of one PDF417 symbol step to n times the module width. • The module width is set with <Function 067> of this command. 								

EPSON	TITLE	TM-J7000/J7100 Specification (STANDARD)	SHEET REVISION	NO.	
			B	NEXT 156	SHEET 155

<Function 069> **GS (k pL pH cn fn n (fn = 69)**

[Format]	ASCII	GS	(k	pL	pH	cn	fn	m	n
	Hex	1D	28	6B	pL	pH	cn	fn	m	n
	Decimal	29	40	107	pL	pH	cn	fn	m	n

[Range] $(pL + pH \times 256) = 4$ ($pL = 4, pH = 0$)
 $cn = 48$
 $fn = 69$
 $m = 48, 49$
 $48 \leq n \leq 56$ (when $m = 48$)
 $1 \leq n \leq 40$ (when $m = 49$)

[Default] $m = 49, n = 1$

- [Description] • Sets the error correction level for PDF417 symbols.
 • When $m = 48$, the error correction level is set by the “Level Setting” error correction code word shown in the table below.

n	Function	Error Correction Code Word
48	Select error correction level 0	2
49	Select error correction level 1	4
50	Select error correction level 2	8
51	Select error correction level 3	16
52	Select error correction level 4	32
53	Select error correction level 5	64
54	Select error correction level 6	128
55	Select error correction level 7	256
56	Select error correction level 8	512

- When $m = 49$, the error correction level is set to the level indicated by the data code word value. The rate is set to $[n \times 10\%]$.
- The error correction levels in the following table are determined by the calculation $[Data\ code\ word \times n \times 0.1 = (A)]$ (fractions of 0.5 and over are rounded up, and others are truncated.)

Result (A)	Error Correction Level	Error Correction Code Word
0 - 3	1	4
4 - 10	2	8
11 - 20	3	16
21 - 45	4	32
46 - 100	5	64
101 - 200	6	128
201 - 400	7	256
401 or more	8	512

EPSON	TITLE	TM-J7000/J7100 Specification (STANDARD)	SHEET REVISION	NO.	
			B	NEXT 157	SHEET 156

<Function 070> **GS (k pL pH cn fn m (fn = 70)**

[Format]	ASCII	GS	(k	pL	pH	cn	fn	m
	Hex	1D	28	6B	pL	pH	cn	fn	m
	Decimal	29	40	107	pL	pH	cn	fn	m
[Range]	$(pL + pH \times 256) = 3$ ($pL = 3, pH = 0$)								
	cn = 48								
	fn = 70								
	m = 0, 1								
[Default]	m = 0								
[Description]	<ul style="list-style-type: none"> • Specifies or cancels various PDF417 symbol options • When $m = 0$, the simple PDF417 symbol processing is canceled and the standard PDF417 symbol processing is specified. • When $m = 1$, the simple PDF417 symbol processing is specified. 								

<Function 080> **GS (k pL pH cn fn m d1...dk (fn = 80)**

[Format]	ASCII	GS	(k	pL	pH	cn	fn	m	d1...dk
	Hex	1D	28	6B	pL	pH	cn	fn	m	d1...dk
	Decimal	29	40	107	pL	pH	cn	fn	m	d1...dk
[Range]	$4 \leq (pL + pH \times 256) \leq 65535$ ($0 \leq pL \leq 255, 0 \leq pH \leq 255$)									
	cn = 48									
	fn = 80									
	m = 48									
	$0 \leq d \leq 255$									
	$k = (pL + pH \times 256) - 3$									
[Description]	<ul style="list-style-type: none"> • Writes symbol data (d1...dk) in the PDF417 symbol storage area. • Bytes of $((pL + pH \times 256) - 3)$ after d1 are processed as symbol data. Received symbol data is stored raw in the symbol storage area (unencoded). 									
[Note]	<ul style="list-style-type: none"> • The symbol data in the PDF417 symbol storage is not affected by GS (M. 									

EPSON	TITLE	TM-J7000/J7100 Specification (STANDARD)	SHEET REVISION	NO.	
			B	NEXT 158	SHEET 157

<Function 081> **GS (k pL pH cn fn m (fn = 81)**

[Format]	ASCII	GS	(k	pL	pH	cn	fn	m
	Hex	1D	28	6B	pL	pH	cn	fn	m
	Decimal	29	40	107	pL	pH	cn	fn	m

[Range] (pL + pH × 256) = 3 (pL = 3, pH = 0)
 cn = 48
 fn = 81
 m = 48

- [Description]
- Encodes and prints symbol data in the symbol storage area.
 - If the printer is in any of the following conditions during processing of this command, the symbol printing cannot be performed, and the printer does not work:
 - No symbol data in symbol storage area.
 - In standard mode, when this command is executed while data still remains in the print buffer.
 - The number of code words in the data area exceeds 928.
 - When the number of columns and rows is not automatically processed; that is, (number of columns × number of rows) < number of code words.
 - When the number of columns is automatically processed, the data in the data area cannot be printed because of lack of print area.
 - If the symbol size is larger than the printable area, the printer processes the following without printing.

Status	Standard mode	Page mode
Print area	Horizontal direction: Specified with the setting values and printing position by GS L and GS W . Vertical direction: 831 dots	Horizontal direction: Specified with the setting values and printing position by ESC W . Vertical direction: Specified with the setting values and printing position by ESC W .
Operation	Paper feeds for 3 rows of spacing for the symbol	Printing position moves to the buffer-full position.

- [Notes]
- Users must consider the quiet zone for the PDF417 symbols (upward and downward spaces and left and right spaces for the PDF417 symbols described in the specifications for the PDF417 symbols.)

EPSON	TITLE	TM-J7000/J7100 Specification (STANDARD)	SHEET REVISION	NO.	
			B	NEXT 159	SHEET 158

<Function 082> **GS (k pL pH cn fn m (fn = 82)**

[Format]	ASCII	GS	(k	pL	pH	cn	fn	m
	Hex	1D	28	6B	pL	pH	cn	fn	m
	Decimal	29	40	107	pL	pH	cn	fn	m

[Range] (pL + pH × 256) = 3 (pL = 3, pH = 0)
 cn = 48
 fn = 82
 m = 48

[Description] • Sends the size of the encoded symbol data in the symbol storage area.

- [Notes]
- This command doesn't print.
 - Users must consider the quiet zone for the PDF417 symbols (upward and downward spaces and left and right spaces for the PDF417 symbols described in the specifications for the PDF417 symbols.)

GS * x y d1...dk

[obsolete command]

GS (L <Function 83> or <Function 84>, which is the upward-compatible command replacing **GS ***, is recommended for use, since **GS *** is an obsolete command in the ESC/POS® command system.

[Name] Define downloaded bit image

[Format]	ASCII	GS	*	x	y	d1...dk
	Hex	1D	2A	x	y	d1...dk
	Decimal	29	42	x	y	d1...dk

[Range] 1 ≤ x ≤ 255
 1 ≤ y ≤ 48 (where 1 ≤ x × y ≤ 1536)
 0 ≤ d ≤ 255
 k = x × y × 8

- [Description]
- Defines the downloaded bit image using the number of dots specified by x and y.
 - x specifies the horizontal size of the downloaded bit image as a number of bytes.
 - y specifies the vertical size of the downloaded bit image as a number of bytes.
 - d specifies the defined data.

EPSON	TITLE	TM-J7000/J7100 Specification (STANDARD)	SHEET REVISION	NO.	
			B	NEXT 160	SHEET 159

GS / m

[obsolete command]

GS (L <Function 85>, which is the upward-compatible command replacing **GS /**, is recommended for use, since **GS /** is an obsolete command in the ESC/POS[®] command system.

[Name] Print downloaded bit image
 [Format] ASCII GS / m
 Hex 1D 2F m
 Decimal 29 47 m

[Range] $0 \leq m \leq 3, 48 \leq m \leq 51$

[Description] • Prints the defined downloaded bit image in *m* mode.

<i>m</i>	Mode	Enlargement in vertical direction	Enlargement in horizontal direction
0, 48	Normal	1	1
1, 49	Double-width	1	2
2, 50	Double-height	2	1
3, 51	Quadruple	2	2

GS B n

[Name] Turn white/black reverse printing mode on/off
 [Format] ASCII GS B n
 Hex 1D 42 n
 Decimal 29 66 n

[Range] $0 \leq n \leq 255$

[Default] $n = 0$

[Description] • Turns white/black reverse printing mode on or off.
 • When the LSB of *n* is 0, white/black reverse mode is turned off.
 • When the LSB of *n* is 1, white/black reverse mode is turned on.

EPSON	TITLE	TM-J7000/J7100 Specification (STANDARD)	SHEET REVISION	NO.	
			B	NEXT 161	SHEET 160

GS H *n*

[Name] Select printing position for HRI characters

[Format] ASCII GS H *n*
 Hex 1D 48 *n*
 Decimal 29 72 *n*

[Range] $0 \leq n \leq 3, 48 \leq n \leq 51$

[Default] $n = 0$

[Description] • Selects the printing position of HRI characters when printing a bar code.
 • *n* selects the execution of printing and the printing position as follows:

<i>n</i>	Printing position
0, 48	Not printed.
1, 49	Above the bar code.
2, 50	Below the bar code.
3, 51	Both above and below the bar code.

EPSON	TITLE TM-J7000/J7100 Specification (STANDARD)	SHEET REVISION B	NO.	
			NEXT 162	SHEET 161

GS I n

- [Name] Transmit printer ID
- [Format] ASCII GS l n
 Hex 1D 49 n
 Decimal 29 73 n
- [Range] $1 \leq n \leq 3, 49 \leq n \leq 51, 65 \leq n \leq 68, n = 112$
- [Description] • Transmits the printer ID specified.
 • n specifies the types of the printer ID.

n	Printer ID type	ID
1, 49	Printer model ID	Hexadecimal: 43H Decimal: 67
2, 50	Type ID	See table [Type ID].
3, 51	Firmware version ID	Depends on firmware version.

- Transmits the printer information specified.

n	Type of printer information	Contents
65	Firmware version	Depends on firmware version.
66	Manufacturer	"EPSON"
67	Printer name	"TM-J7100" (two-color model). "TM-J7000" (single-color model).
68	Product ID	Serial number.
112	Type ID (B)	See table [Type ID (B)].

[Type ID]

Bit	Off/On	Hex	Decimal	Function
0	Off	00	0	Multi byte code not supported.
1	Off	00	0	Autocutter not installed. (Memory switch [Msw2-2] is set to Off.)
	On	02	2	Autocutter installed. (Memory switch [Msw2-2] is set to On.)
2	Off	00	0	DM-D series customer display not connected. (Memory switch [Msw 1-6] is set to Off.)
	On	04	4	DM-D series customer display connected. (Memory switch [Msw 1-6] set to On.)
3	Off	00	0	MICR not installed.
	On	08	8	MICR installed.
4	Off	00	0	Fixed.
5, 6	--	00	0	Reserved.
7	Off	00	0	Fixed

EPSON	TITLE	TM-J7000/J7100 Specification (STANDARD)	SHEET REVISION	NO.	
			B	NEXT 163	SHEET 162

[Type ID (B)]

Bit	Off/On	Hex	Decimal	Function
0	Off	00	0	Single-color model TM-J7000
	On	01	1	Two-color model TM-J7100
1	Off	00	0	Endorsement printer not installed
	On	02	2	Endorsement printer installed.
2 ~ 5	--	00	0	Reserved.
6	On	40	64	Fixed.
7	Off	00	0	Fixed.

GS L nL nH

[Name]	Set left margin				
[Format]	ASCII	GS	L	nL	nH
	Hex	1D	4C	nL	nH
	Decimal	29	76	nL	nH
[Range]	$0 \leq (nL + nH \times 256) \leq 65535$ ($0 \leq nL \leq 255, 0 \leq nH \leq 255$)				
[Default]	$(nL + nH \times 256) = 0$ ($nL = 0, nH = 0$)				
[Description]	<ul style="list-style-type: none"> • Sets the left margin specified by nL and nH. • The left margin is $[(nL + nH \times 256) \times (\text{vertical or horizontal motion units})]$. 				

GS P x y

[Name]	Set horizontal and vertical motion units				
[Format]	ASCII	GS	P	x	y
	Hex	1D	50	x	y
	Decimal	29	80	x	y
[Range]	$0 \leq x \leq 255$ $0 \leq y \leq 255$				
[Default]	$x = 180, y = 360$				
[Description]	<ul style="list-style-type: none"> • Sets the horizontal and vertical motion units to approximately $25.4/x$ mm $\{1/x''\}$ and approximately $25.4/y$ mm $\{1/y''\}$, respectively. • When x and y are set to 0, the default setting of each value is used. 				

EPSON	TITLE	TM-J7000/J7100 Specification (STANDARD)	SHEET REVISION	NO.	
			B	NEXT 164	SHEET 163

GS Q 0 m xL xH yL yH d1...dk

[obsolete command]

GS (L <Function 113> and <Function 50>, which is the upward-compatible command replacing **GS Q 0**, is recommended for use, since **GS Q 0** is an obsolete command in the ESC/POS® command system.

[Name] Print variable vertical size bit image
 [Format] ASCII GS Q 0 m xL xH yL yH d1...dk
 Hex 1D 51 30 m xL xH yL yH d1...dk
 Decimal 29 81 48 m xL xH yL yH d1...dk
 [Range] $0 \leq m \leq 3, 48 \leq m \leq 51$
 $1 \leq (xL + xH \times 256) \leq 4256$ ($0 \leq xL \leq 255, 0 \leq xH \leq 12$)
 $1 \leq (yL + yH \times 256) \leq 8$ ($1 \leq yL \leq 8, yH = 0$)
 $0 \leq d \leq 255$
 $k = (xL + xH \times 256) \times (yL + yH \times 256)$

[Description] Prints a bit image that can have a variable vertical length.

- *m* specifies the bit image mode.

<i>m</i>	Mode	Enlargement in vertical direction	Enlargement in horizontal direction
0, 48	Normal	1	1
1, 49	Double-width	1	2
2, 50	Double-height	2	1
3, 51	Quadruple	2	2

GS T n

[Name] Set print position to the beginning of print line
 [Format] ASCII GS T n
 Hex 1D 54 n
 Decimal 29 84 n

[Range] $n = 0, 1, 48, 49$

- [Description]
- Sets the print position to the beginning of the print line.
 - *n* specifies how data in the print buffer is processed when this command is executed.

<i>n</i>	Function
0, 48	Sets the print position after the data in the print buffer is deleted.
1, 49	Sets the print position after the data in the print buffer is printed.

EPSON	TITLE	TM-J7000/J7100 Specification (STANDARD)	SHEET REVISION	NO.	
			B	NEXT 165	SHEET 164

Confidential

① GS V m

② GS V m n

[Name]	Select cut mode and cut paper				
[Format]	① ASCII	GS	V	<i>m</i>	
	Hex	1D	56	<i>m</i>	
	Decimal	29	86	<i>m</i>	
	② ASCII	GS	V	<i>m</i>	<i>n</i>
	Hex	1D	56	<i>m</i>	<i>n</i>
	Decimal	29	86	<i>m</i>	<i>n</i>
[Range]	① <i>m</i> = 0, 1, 48, 49				
	② <i>m</i> = 65, 66, 0 ≤ <i>n</i> ≤ 255				
[Description]	• Cuts paper in the specified mode.				

<i>m</i>	Function
0, 48 1, 49	Cuts paper
65, 66	Feeds specified length of paper (cut position + [<i>n</i> x vertical or horizontal motion units]) and cuts the paper.

GS W nL nH

[Name]	Set printing area width				
[Format]	ASCII	GS	W	<i>nL</i>	<i>nH</i>
	Hex	1D	57	<i>nL</i>	<i>nH</i>
	Decimal	29	87	<i>nL</i>	<i>nH</i>
[Range]	0 ≤ (<i>nL</i> + <i>nH</i> × 256) ≤ 65535 (0 ≤ <i>nL</i> ≤ 255, 0 ≤ <i>nH</i> ≤ 255)				
[Default]	(<i>nL</i> + <i>nH</i> × 256) = 360	(<i>nL</i> = 104, <i>nH</i> = 1)	[Roll paper: paper width 57.5mm]		
	(<i>nL</i> + <i>nH</i> × 256) = 432	(<i>nL</i> = 176, <i>nH</i> = 1)	[Roll paper: paper width 69.5mm]		
	(<i>nL</i> + <i>nH</i> × 256) = 480	(<i>nL</i> = 224, <i>nH</i> = 1)	[Roll paper: paper width 76mm]		
	(<i>nL</i> + <i>nH</i> × 256) = 512	(<i>nL</i> = 0, <i>nH</i> = 2)	[Roll paper: paper width 82.5mm]		
	(<i>nL</i> + <i>nH</i> × 256) = 576	(<i>nL</i> = 64, <i>nH</i> = 2)	[face of slip]		
	(<i>nL</i> + <i>nH</i> × 256) = 552	(<i>nL</i> = 40, <i>nH</i> = 2)	[back of slip]		
[Description]	• Sets the printing area width as [(<i>nL</i> + <i>nH</i> × 256) × vertical or horizontal motion unit].				

EPSON	TITLE	TM-J7000/J7100 Specification (STANDARD)	SHEET REVISION	NO.	
			B	NEXT 166	SHEET 165

GS \ nL nH

[Name] Set relative vertical print position in page mode

[Format] ASCII GS \ nL nH
 Hex 1D 5C nL nH
 Decimal 29 92 nL nH

[Range] $-32768 \leq (nL + nH \times 256) \leq 32767$

[Description] • Sets the next vertical print starting position to $[(nL + nH \times 256) \times (\text{vertical or horizontal motion units})]$ from the current position.
 • A positive number specifies movement to the down, and a negative number specifies movement to the upper.

GS a n

[Name] Enable/Disable Automatic Status Back (ASB)

[Format] ASCII GS a n
 Hex 1D 61 n
 Decimal 29 97 n

[Range] $0 \leq n \leq 255$

[Default] $n = 0$ when memory switch [Msw 1-3] is Off.
 $n = 2$ when memory switch [Msw 1-3] is On.

[Description] • Specifies the status items for basic ASB (Automatic Status Back) .

Bit	Off/On	Hex	Decimal	Function
0	Off	00	0	Drawer kick-out connector pin 3 disabled.
	On	01	1	Drawer kick-out connector pin 3 enabled.
1	Off	00	0	Online/offline status disabled.
	On	02	2	Online/offline status enabled.
2	Off	00	0	Error status disabled.
	On	04	4	Error status enabled.
3	Off	00	0	Paper roll sensor status disabled.
	On	08	8	Paper roll sensor status enabled.
4	Off	00	0	Reserved.
5	Off	00	0	Cut sheet sensor status disabled.
	On	20	32	Cut sheet sensor status enabled.
6	Off	00	0	Panel button status disabled.
	On	40	64	Panel button status enabled.
7	Off	00	0	Reserved.

EPSON	TITLE	TM-J7000/J7100 Specification (STANDARD)	SHEET REVISION	NO.	
			B	NEXT 167	SHEET 166

- The basic ASB status to be transmitted is the four bytes that follow:
 - First byte (printer information)

Bit	Off/On	Hex	Decimal	Function
0, 1	Off	00	0	Fixed.
2	Off	00	0	Drawer kick-out connector pin 3 is LOW.
	On	04	4	Drawer kick-out connector pin 3 is HIGH.
3	Off	00	0	Online.
	On	08	8	Offline.
4	On	10	16	Fixed.
5	Off	00	0	Cover is closed.
	On	20	32	Cover is open.
6	Off	00	0	Paper is not being fed by using the paper FEED button.
	On	40	64	Paper is being fed by using the paper FEED button.
7	Off	00	0	Fixed.

Bit 5: While the paper roll cover or the carriage cover is open, the bit indicates "cover is open."

- Second byte (printer information)

Bit	Off/On	Hex	Decimal	Function
0	Off	00	0	Reserved.
1	Off	00	0	Paper FEED button is turned Off.
	On	02	2	Paper FEED button is turned On.
2	Off	00	0	No mechanical error.
	On	04	4	Mechanical error has occurred.
3	Off	00	0	No autocutter error.
	On	08	8	Autocutter error occurred.
4	Off	00	0	Fixed.
5	Off	00	0	No unrecoverable error.
	On	20	32	Unrecoverable error has occurred.
6	Off	00	0	No automatically recoverable error.
	On	40	64	Automatically recoverable error has occurred.
7	Off	00	0	Fixed.

Bit 2: If "paper roll cover open" is set as a recoverable error using the memory switch, a mechanical error occurs if the cover is open while printing on the paper roll.

Bit 6: If "paper roll cover open" is set as an automatically recoverable error using the memory switch, an automatically recoverable error occurs if the cover is open while printing on the paper roll. The head high/low temperature errors are also regarded as automatically recoverable errors.

EPSON	TITLE	TM-J7000/J7100 Specification (STANDARD)	SHEET REVISION	NO.	
			B	NEXT 168	SHEET 167

• Third byte (paper sensor information)

Bit	Off/On	Hex	Decimal	Function
0, 1	Off	00	0	Paper roll near-end sensor: paper adequate.
	On	03	3	Paper roll near-end sensor: paper near end.
2, 3	Off	00	0	Paper roll end sensor: paper present.
	On	0C	12	Paper roll end sensor: paper not present.
4	Off	00	0	Fixed.
5	Off	00	0	TOF sensor: paper present.
	On	20	32	TOF sensor: paper not present.
6	Off	00	0	BOF sensor: paper present.
	On	40	64	BOF sensor: paper not present.
7	Off	00	0	Fixed.

Bits 2 and 3: While the cover is open, the status isn't changed and is kept as same as when the cover was opened.

Bit 6: Refer to Section 3.9.1, Sensors and LED Indicators, part 2) BOF sensor, for the status of the BOF sensor.

• Fourth byte (paper sensor information)

Bit	Off/On	Hex	Decimal	Function
0	Off	00	0	Slip is selected.
	On	01	1	Slip is not selected.
1	Off	00	0	Can print on slip.
	On	02	2	Cannot print on slip.
2, 3	On	0C	12	Reserved.
4	Off	00	0	Fixed.
5, 6	On	60	96	Reserved.
7	Off	00	0	Fixed.

EPSON

TITLE

TM-J7000/J7100
Specification
(STANDARD)SHEET
REVISION

B

NO.

NEXT

169

SHEET

168

GS f n

[Name] Select font for HRI characters
 [Format] ASCII GS f n
 Hex 1D 66 n
 Decimal 29 102 n
 [Range] $n = 0, 1, 48, 49$
 [Default] $n = 0$
 [Description] • Selects a font for the HRI characters used when printing a bar code.
 • n specifies the font of the HRI characters as follows:

n	Font
0, 48	Font A
1, 49	Font B

GS g 0 m nL nH

[Name] Initialize maintenance counter
 [Format] ASCII GS g 0 m nL nH
 Hex 1D 67 30 m nL nH
 Decimal 29 103 48 m nL nH
 [Range] $m = 0$
 $(nL + nH \times 256) = 30, 31, 32, 33, 34, 35, 50, 60, 61, 70$
 $(nL = 30, 31, 32, 33, 34, 35, 50, 60, 61, 70, nH = 0)$
 [Description] • Sets the specified resettable maintenance counter to 0.
 • nL, nH set the maintenance counter number to $(nL + nH \times 256)$.

Counter number		Counter [Units]
Hex	Decimal	
1E	30	Number of line feeds (for roll paper) [Lines].
1F	31	Average number of head shots (color 1) [Shots].
20	32	Average number of head shots (color 2) [Shots].
21	33	Number of carriage operations [Cycles].
22	34	Number of pump operations [Cycles].
23	35	Number of line feeds (for slip) [Lines].
32	50	Number of autocutter operations [Cycles].
3C	60	Number of MICR reads [Cycles].
3D	61	Number of endorsement printing [Cycles].
46	70	Printer operation time [Hours].

[Note] • Frequent write commands using NV memory write commands (**GS (C**, **GS (E**, **GS (L / GS 8 L**, **GS (M**, or **GS g 0**) may damage the NV memory. Therefore, it is recommended to write to the NV memory 10 times or less a day.
 [Reference] Appendix E

EPSON	TITLE	TM-J7000/J7100 Specification (STANDARD)	SHEET REVISION	NO.	
			B	NEXT 170	SHEET 169

GS g 2 m nL nH

[Name] Transmit maintenance counter value

[Format] ASCII GS g 2 m nL nH
 Hex 1D 67 32 m nL nH
 Decimal 29 103 50 m nL nH

[Range] $m = 0$
 $(nL + nH \times 256) = 30, 31, 32, 33, 34, 35, 50, 60, 61, 70$
 $(nL = 30, 31, 32, 33, 34, 35, 50, 60, 61, 70, nH = 0)$
 $(nL + nH \times 256) = 158, 159, 160, 161, 162, 163, 178, 188, 189, 198$
 $(nL = 158, 159, 160, 161, 162, 163, 178, 188, 189, 198, nH = 0)$

[Description] • Transmits the value of the specified maintenance counter.
 • nL, nH set the maintenance counter number to $(nL + nH \times 256)$.

Counter number		Counter [Units]	Kind of counter
Hex	Decimal		
1E	30	Number of line feeds (for roll paper) [Lines].	Can be reset
1F	31	Average number of head shots (color 1) [Shots].	
20	32	Average number of head shots (color 2) [Shots].	
21	33	Number of carriage operations [Cycles].	
22	34	Number of pump operations [Cycles].	
23	35	Number of line feeds (for slip) [Lines].	
32	50	Number of autocutter operations [Cycles].	
3C	60	Number of MICR reads [Cycles].	
3D	61	Number of endorsement printing [Cycles].	
46	70	Printer operation time [Hours].	
9E	158	Number of line feeds (for roll paper) [Lines].	Cumulative
9F	159	Average number of head shots (color 1) [Shots].	
A0	160	Average number of head shots (color 2) [Shots].	
A1	161	Number of carriage operations [Cycles].	
A2	162	Number of pump operations [Cycles].	
A3	163	Number of line feeds (for slip) [Lines].	
B2	178	Number of autocutter operations [Cycles].	
BC	188	Number of MICR reads [Cycles].	
BD	189	Number of endorsement printing [Cycles].	
C6	198	Printer operation time [Hours].	

[Notes] • The counter values may be different from actual counting, depending on the time difference or the error occurring.

[Reference] Appendix E

EPSON	TITLE	TM-J7000/J7100 Specification (STANDARD)	SHEET REVISION	NO.	
			B	NEXT 171	SHEET 170

GS h n

[Name]	Select bar code height			
[Format]	ASCII	GS	h	<i>n</i>
	Hex	1D	68	<i>n</i>
	Decimal	29	104	<i>n</i>
[Range]	$1 \leq n \leq 255$			
[Default]	$n = 162$			
[Description]	• Selects the height of the bar code as <i>n</i> dots.			

GS j n

[Name]	Enable/Disable Automatic Status Back (ASB) related to ink.			
[Format]	ASCII	GS	j	<i>n</i>
	Hex	1D	6A	<i>n</i>
	Decimal	29	106	<i>n</i>
[Range]	$0 \leq n \leq 255$			
[Default]	$n = 0$ when memory switch [Msw 1-3] is Off. $n = 1$ when memory switch [Msw 1-3] is On.			
[Description]	• Enables or disables Automatic Status Back (ASB) . • <i>n</i> specifies enabling or disabling of the status bit of ink ASB as follows:			

Bit	Off/On	Hex	Decimal	Function
0	Off	00	0	Online/offline status of ink unit disabled.
	On	01	1	Online/offline status of ink unit enabled.
1	Off	00	0	Ink sensor status disabled.
	On	02	2	Ink sensor status enabled.
2 ~ 7	Off	00	0	Reserved.

- Ink ASB status to be transmitted is the four bytes that follow:

Ink ASB status	Hex	Decimal	Amount of data
Header	35H	53	1 byte
Status A	See table [Status A]		1 byte
Status B	See table [Status B]		1 byte
NUL	00H	0	1 byte

EPSON	TITLE	TM-J7000/J7100 Specification (STANDARD)	SHEET REVISION	NO.	
			B	NEXT 172	SHEET 171

• Status A

Bit	Off/On	Hex	Decimal	Function
0	Off	00	0	Ink near-end sensor: ink adequate (color 1).
	On	01	1	Ink near-end sensor: ink near end (color 1).
1	Off	00	0	Ink present (color 1).
	On	02	2	Ink not present (color 1).
2	Off	00	0	Ink cartridge sensor: cartridge present (color 1).
	On	04	4	Ink cartridge sensor: cartridge not present (color 1).
3	Off	00	0	Ink cartridge sensor: cartridge present (color 2).
	On	08	8	Ink cartridge sensor: cartridge not present (color 2).
4	Off	00	0	Reserved.
5	Off	00	0	Cleaning not performed.
	On	20	32	Cleaning performed.
6	On	40	64	Fixed.
7	Off	00	0	Fixed.

Bit 3: The status for the single-color printer (TM-J7000) should always be "cartridge present."

• Status B

Bit	Off/On	Hex	Decimal	Function
0	Off	00	0	Ink near-end sensor: ink adequate (color 2).
	On	01	1	Ink near-end sensor: ink near end (color 2).
1	Off	00	0	Ink present (color 2).
	On	02	2	Ink not present (color 2).
2 ~ 5	Off	00	0	Reserved.
6	On	40	64	Fixed.
7	Off	00	0	Fixed.

Bit 0: The status for the single-color printer (TM-J7000) should always be "ink adequate."

Bit 1: The status for the single-color printer (TM-J7000) should always be "ink present."

[Notes]

- The carriage cover closed status is maintained while the carriage cover is open.

EPSON	TITLE	TM-J7000/J7100 Specification (STANDARD)	SHEET REVISION	NO.	
			B	NEXT 173	SHEET 172

① **GS k m d1...dk NUL**

② **GS k m n d1...dn**

[Name] Print bar code

[Format] ① ASCII GS k m d1...dk NUL
 Hex 1D 6B m d1...dk 00
 Decimal 29 107 m d1...dk 0
 ② ASCII GS k m n d1...dn
 Hex 1D 6B m n d1...dn
 Decimal 29 107 m n d1...dn

[Range] ① $0 \leq m \leq 6$ (k and d depend on the bar code system used)
 ② $65 \leq m \leq 73$ (n and d depend on the bar code system used)

[Description] • Selects a bar code system and prints the bar code.

For ①

m	Bar code system	Range of k	Range of d
0	UPC-A	$11 \leq k \leq 12$	$48 \leq d \leq 57$
1	UPC-E	$11 \leq k \leq 12$	$48 \leq d \leq 57$
2	JAN13 (EAN13)	$12 \leq k \leq 13$	$48 \leq d \leq 57$
3	JAN8 (EAN8)	$7 \leq k \leq 8$	$48 \leq d \leq 57$
4	CODE39	$1 \leq k$	$48 \leq d \leq 57, 65 \leq d \leq 90,$ $d = 32,36,37,42,43,45,46,47$
5	ITF	$1 \leq k$ (even number)	$48 \leq d \leq 57$
6	CODABAR (NW7)	$1 \leq k$	$48 \leq d \leq 57, 65 \leq d \leq 68,$ $d = 36,43,45,46,47,58$

For ②

m	Bar code system	Range of n	Range of d
65	UPC-A	$11 \leq n \leq 12$	$48 \leq d \leq 57$
66	UPC-E	$11 \leq n \leq 12$	$48 \leq d \leq 57$
67	JAN13 (EAN13)	$12 \leq n \leq 13$	$48 \leq d \leq 57$
68	JAN8 (EAN8)	$7 \leq n \leq 8$	$48 \leq d \leq 57$
69	CODE39	$1 \leq n \leq 255$	$48 \leq d \leq 57, 65 \leq d \leq 90,$ $d = 32,36,37,42, 43,45,46,47$
70	ITF	$2 \leq n \leq 254$ (even number)	$48 \leq d \leq 57$
71	CODABAR (NW7)	$1 \leq n \leq 255$	$48 \leq d \leq 57, 65 \leq d \leq 68,$ $d = 36,43,45,46,47,58$
72	CODE93	$1 \leq n \leq 255$	$0 \leq d \leq 127$
73	CODE128	$2 \leq n \leq 255$	$0 \leq d \leq 127$

[Notes] • Consider that a quiet zone (left or right side space area, depending on the bar code specifications) must be ensured for bar code printing.

[Reference] Appendix A

EPSON	TITLE	TM-J7000/J7100 Specification (STANDARD)	SHEET REVISION	NO.	
			B	NEXT 174	SHEET 173

GS r n

[Name] Transmit status
 [Format] ASCII GS r n
 Hex 1D 72 n
 Decimal 29 114 n

[Range] $1 \leq n \leq 4, 49 \leq n \leq 52, n = 80$

[Description] • Transmits the normal status specified by *n* as follows:

<i>n</i>	Function
1, 49	Specifies paper sensor status.
2, 50	Specifies drawer kick-out connector status.
3, 51	Specifies slip status.
4, 52	Specifies ink status.
80	Specifies the remaining print area on a slip in dots.

• The status types to be transmitted are shown in the tables below:

• Paper sensor status (*n* = 1, 49) :

Bit	Off/On	Hex	Decimal	Function
0, 1	Off	00	0	Paper roll near-end sensor: paper adequate.
	On	03	3	Paper roll near-end sensor: paper near end.
2, 3	Off	00	0	Paper roll end sensor: paper present.
	On	0C	12	Paper roll end sensor: paper not present.
4	Off	00	0	Fixed.
5	Off	00	0	TOF sensor: paper present.
	On	20	32	TOF sensor: paper not present.
6	Off	00	0	BOF sensor: paper present.
	On	40	64	BOF sensor: paper not present.
7	Off	00	0	Fixed.

Bits 2 and 3: While the cover is open, the status isn't changed and is kept as same as when the cover was opened (this command cannot be executed).

• Drawer kick-out connector status (*n* = 2, 50):

Bit	Off/On	Hex	Decimal	Function
0	Off	00	0	Drawer kick-out connector pin 3 is LOW.
	On	01	1	Drawer kick-out connector pin 3 is HIGH.
1 ~ 3	Off	00	0	Reserved.
4	Off	00	0	Fixed.
5, 6	Off	00	0	Reserved.
7	Off	00	0	Fixed.

EPSON	TITLE	TM-J7000/J7100 Specification (STANDARD)	SHEET REVISION	NO.	
			B	NEXT 175	SHEET 174

• Slip Status ($n = 3, 51$)

The remaining print area (the number of dots in the vertical direction for one character) is transmitted using values from the table below:

<When the face of a slip is selected>

The number of remaining dots	Slip status	
	Hex	Decimal
Impossible to print on the slip or 0 – 23	00	0
24 – 47	01	1
48 – 71	02	2
72 – 95	03	3
360 dots or more	0F	15

• Ink status ($n = 4, 52$)

The cover closed status is maintained while the carriage cover is open.
(This command cannot be executed.)

Bit	Off/On	Hex	Decimal	Function
0	Off	00	0	Ink near-end sensor: ink adequate (color 1).
	On	01	1	Ink near-end sensor: ink near end (color 1).
1	Off	00	0	Ink near-end sensor: ink adequate (color 2).
	On	02	2	Ink near-end sensor: ink near end (color 2).
2, 3	Off	00	0	Reserved.
4	Off	00	0	Fixed.
5, 6	Off	00	0	Reserved.
7	Off	00	0	Fixed.

Bit 1: The status for the single-color printer (TM-J7000) should always be "ink adequate."

EPSON	TITLE TM-J7000/J7100 Specification (STANDARD)	SHEET REVISION B	NO.	
			NEXT 176	SHEET 175

• Slip dot status ($n = 80$)

The remaining print area in slip printing is transmitted as a number of dots based on the normal dot pitch.

	Hexadecimal	Decimal	Amount of data
Header	37H	55	1 byte
Identifier	2BH	43	1 byte
Number of dots	30H–39H	48–57	1~4 bytes
NUL	00H	0	1 byte

If slip is not selected or printing is not enabled, the number of dots is set to 0.

	Hexadecimal	Decimal	Amount of data
Header	37H	55	1 byte
Identifier	2BH	43	1 byte
Number of dots	30H	48	1 byte
NUL	00H	0	1 byte

If paper is detected by the BOF sensor when the face of a slip is selected, the number of dots is set to 9999.

	Hexadecimal	Decimal	Amount of data
Header	37H	55	1 byte
Identifier	2BH	43	1 byte
Numbers of dots	39H, 39H, 39H, 39H	57, 57, 57, 57	4 bytes
NUL	00H	0	1 byte

GS v 0 m xL xH yL yH d1...dk

[obsolete command]

[Name] Print raster bit image

[Format] ASCII GS v 0 m xL xH yL yH d1...dk
 Hex 1D 76 30 m xL xH yL yH d1...dk
 Decimal 29 118 48 m xL xH yL yH d1...dk

[Range] $0 \leq m \leq 3, 48 \leq m \leq 51$
 $1 \leq (xL + xH \times 256) \leq 255$ ($1 \leq xL \leq 255, xH = 0$)
 $1 \leq (yL + yH \times 256) \leq 4607$ ($0 \leq yL \leq 255, 0 \leq yH \leq 17$)
 $0 \leq d \leq 255$
 $k = (xL + xH \times 256) \times (yL + yH \times 256)$

[Description] Prints a raster bit image in *m* mode.

<i>m</i>	Mode	Enlargement in vertical direction	Enlargement in horizontal direction
0, 48	Normal	1	1
1, 49	Double-width	1	2
2, 50	Double-height	2	1
3, 51	Quadruple	2	2

- *xL, xH* specify $(xL + xH \times 256)$ byte(s) in the horizontal direction for the bit image.
- *yL, yH* specify $(yL + yH \times 256)$ dot(s) in the vertical direction for the bit image.
- *d* specifies the definition data of the bit image.

GS w n

[Name] Set bar code width

[Format] ASCII GS w n
 Hex 1D 77 n
 Decimal 29 119 n

[Range] $2 \leq n \leq 6$

[Default] $n = 3$

[Description] Set the horizontal size of the bar code, using *n* as follows:

<i>n</i>	Multi-level bar code	Binary-level bar code	
	Module width (mm)	Thin element width (mm)	Thick element width (mm)
2	0.282	0.282	0.706
3	0.423	0.423	1.129
4	0.564	0.564	1.411
5	0.706	0.706	1.834
6	0.847	0.847	2.258

- Multi-level bar codes are as follows:
 UPC-A, UPC-E, JAN13 (EAN13), JAN8 (EAN8), CODE93, CODE128
- Binary-level bar codes are as follows:
 CODE39, ITF, CODABAR

EPSON	TITLE	TM-J7000/J7100 Specification (STANDARD)	SHEET REVISION	NO.	
			B	NEXT 178	SHEET 177

6.4 MICR Control Commands (for models with a MICR reader)

DLE EOT *n a* (*n* = 8)

[Name] Transmit real-time MICR status
 [Format] ASCII DLE EOT *n a*
 Hex 10 04 08 *a*
 Decimal 16 4 8 *a*

[Range] *a* = 1

[Description] • Transmits the selected MICR status specified by *n* in real time as follows:

<i>n</i>	Function
1	Transmit MICR status

- The status information to be transmitted is shown in the following table.
- *a* = 1: MICR status

Bit	Off/On	Hex	Decimal	Status
0	Off	00	0	Fixed.
1	On	02	2	Fixed.
2	Off	00	0	MICR function selected.
	On	04	4	MICR function not selected.
3	Off	00	0	Does not wait for check paper or a cleaning sheet to be inserted.
	On	08	8	Waits for check paper or a cleaning sheet to be inserted.
4	On	10	16	Fixed.
5	Off	00	0	TOF sensor: paper present.
	On	20	32	TOF sensor: paper not present.
6	Off	00	0	BOF sensor: paper present.
	On	40	64	BOF sensor: paper not present.
7	Off	00	0	Fixed.

- [Notes]
- If print data includes a character string with this command, the printer performs this command. Users must consider this.
 For example: Graphic data accidentally might include a data string with this command.
 - Do not embed this command within another command.
 For example: Graphic data might include this command.
 - This command is ignored when block data is transmitted.

EPSON	TITLE	TM-J7000/J7100 Specification (STANDARD)	SHEET REVISION	NO.	
			B	NEXT 179	SHEET 178

- Transmit the **DLE EOT**, **DLE DC4** ($fn = 7$) real-time commands using the following method:
 - <Transmission method for the real-time command>
 - When the real-time status command is transmitted, the following data must not be transmitted until the status is received.
 - However, if the real-time commands must be transmitted continuously, it is possible to transmit up to nine real-time commands at once. In this case, the following data must not be transmitted until the all status information is received. If the real-time command is transmitted without using the above method, the status may not be received.
- If the status is not received for 2 seconds (maximum period when operating the autocutter) and this state occurs several times, probably the printer power is not turned on or the interface cable is not connected.

FS (f pL pH [n m]1...[n m]k

[Name] Select MICR data handling

[Format] ASCII FS (f pL pH [n m]1...[n m]k
 Hex 1C 28 66 pL pH [n m]1...[n m]k
 Decimal 28 40 102 pL pH [n m]1...[n m]k

[Range] $2 \leq (pL + pH \times 256) \leq 65535$ ($0 \leq pL \leq 255, 0 \leq pH \leq 255$)
 $0 \leq n \leq 3, 48 \leq n < 51$
 $0 \leq m \leq 255$ (when $n = 0, 48$)
 $0 \leq m \leq 255$ (when $n = 1, 49$)
 $m = 0, 1, 48, 49$ (when $n = 2, 50$)
 $m = 0, 1, 48, 49$ (when $n = 3, 51$)

[Default] Always $m = 0$ for each n

[Description] • Selects MICR reading operations as follows:

n	Function
0, 48	Specifies the process for characters that cannot be recognized.
1, 49	Specifies adding detailed information to the reading result.
2, 50	Specifies the condition to disable/enable the MICR function when a reading error has occurred.
3, 51	Specifies the header of the transmitted data.

- When $n = 0$ or 48 , the command specifies the process for characters that cannot be recognized.
 - When $m = 0$, the recognition process is aborted when a character that cannot be recognized is detected. The reading result in this case does not have data.
 - When $m \neq 0$, the recognition process is continued and the character that cannot be recognized is replaced with the character ‘?’.’ If the number of the characters replaced with ‘?’ is less than m , the data is added to the reading result.
 - When the printer processes characters that cannot be recognized, even though those characters are replaced with ‘?’,’ the status of the reading result becomes ‘Error ending.’

EPSON	TITLE	TM-J7000/J7100 Specification (STANDARD)	SHEET REVISION	NO.	
			B	NEXT 180	SHEET 179

- When $n = 1$ or 49, the command specifies whether detailed information for the reading result is added or not.

Bit	Off/On	Hex	Decimal	Status
1	Off	00	0	Adds detailed information.
	On	01	1	Does not add detailed information.
2 ~ 8	Off	00	0	Reserved.

<Detailed information when an error occurs>

Information	Hex	Decimal
No error has occurred.	40	64
The MICR reading process is not executed yet.	41	65
The check insertion waiting state has been canceled with the command.	42	66
The check insertion waiting state has been canceled because the time set with the ESC f command has passed.	43	67
A check whose size is out of the specified range is inserted.	44	68
A magnetic waveform cannot be detected.	45	69
A character cannot be recognized.	46	70
An error has occurred during the processing of reading magnetic ink characters.	47	71
An error has been detected when noise is observed.	48	72

- When $n = 2$ or 50, the command specifies whether the MICR function is disabled or not if an error has occurred.

n	Function
0, 48	The MICR function is disabled if an error has occurred when the MICR function is set to be disabled if an error has occurred without addition of the reading data.
1, 49	The MICR function is continuously enabled after the reading result has been transmitted if the MICR function is set to be disabled due to the following causes. <ul style="list-style-type: none"> • The check size is out of the specified range. • The magnetic waveform cannot be detected. • A character cannot be recognized. • An error has been detected when noise is observed.

- The MICR function is continuously enabled when MICR is processed normally or the reading result is added, even if an error has occurred.

- When $n = 3$ or 51, the command specifies the header of the transmitted data.

m	Function
0, 48	The header is set as follows: Hexadecimal = 5FH / Decimal = 95
1, 49	The header (one byte) is added with an identifier (one byte) as follows: 1st byte: Hexadecimal = 37H / Decimal = 55 2nd byte: Hexadecimal = 2AH / Decimal = 42

[Note]

- This command does not execute reading of the check.

EPSON	TITLE	TM-J7000/J7100 Specification (STANDARD)	SHEET REVISION	NO.	
			B	NEXT 181	SHEET 180

FS a 0 n

[obsolete command]

GS (G <Function 60> which is the upward-compatible command replacing **FS a 0**, is recommended for use, since **FS a 0** is an obsolete command in the ESC/POS® command system.

[Name] Read check paper

[Format] ASCII FS a 0 n
 Hex 1C 61 30 n
 Decimal 28 97 48 n

[Range] $0 \leq n \leq 255$

[Description] • Selects and transmits the MICR function and reads magnetic ink characters specified by *n* as follows:

Bit	Off/On	Hex	Decimal	Function
0	Readable fonts.			
1	See the table below.			
2 - 7	Off	00	0	Reserved.

Readable Fonts

Hex	Decimal	Font
00	0	E13B
01	1	CMC7
02	2	Reserved.
03	3	Reserved.

- When this command is executed, the printer waits for slip paper insertion.
- When the printer ends reading and recognizing the magnetic ink characters normally, it transmits "header + reading status + data + NUL" to the host computer as follows:

	Hexadecimal	Decimal	Amount of data
Header	5FH	95	1 byte
	37H, 2AH	55, 42	2 bytes
Status	See the table "reading status".		1 byte
Data	Recognized character strings.		0 ~ 80 bytes
NUL	00H	0	1 byte

EPSON	TITLE TM-J7000/J7100 Specification (STANDARD)	SHEET REVISION B	NO.	
			NEXT 182	SHEET 181

- The “reading status” is as follows:

Bit	Off/On	Hex	Decimal	Function
0	Off	00	0	Readable font: E13B
	On	01	1	Readable font: CMC7
1, 2	Off	00	0	Reserved.
3	Off	00	0	Detailed information: not added.
	On	08	8	Detailed information: added.
4	Off	00	0	Re-reading: possible.
	On	10	16	Re-reading: impossible.
5	Off	00	0	The reading processing ended normally.
	On	20	32	The reading processing ended abnormally.
6	On	40	64	Fixed.
7	Off	00	0	Fixed.

- [Notes]
- The readable characters with CMC7 are numeric (0 – 9) and five kinds of special characters only. Refer description of **GS (G <Function 60>** later in this section.

FS a 1

[obsolete command]

GS (G <Function 48> and **<Function 84>** which are the upward-compatible commands replacing **FS a 1**, are recommended for use, since **FS a 1** is an obsolete command in the ESC/POS® command system.

[Name] Load check paper to the print starting position

[Format]

ASCII	FS	a	1
Hex	1C	61	31
Decimal	28	97	49

- [Description]
- Loads check paper to the print starting position in MICR mode.
 - After loading check paper to the print starting position, the printer cancels the MICR function and selects slip paper as the paper source automatically.

FS a 2

[obsolete command]

GS (G <Function 85> which is the upward-compatible command replacing **FS a 2**, is recommended for use, since **FS a 2** is an obsolete command in the ESC/POS® command system.

[Name] Eject check paper

[Format]

ASCII	FS	a	2
Hex	1C	61	32
Decimal	28	97	50

- [Description]
- Ejects check paper in MICR mode.
 - After ejecting check paper, the printer cancels the MICR function and selects the roll paper as the paper source.

EPSON	TITLE	TM-J7000/J7100 Specification (STANDARD)	SHEET REVISION	NO.	
			B	NEXT 183	SHEET 182

FS b

[obsolete command]

GS (G <Function 61> which is the upward-compatible command replacing **FS b**, is recommended for use, since **FS b** is an obsolete command in the ESC/POS® command system.

[Name] Request retransmission of check paper reading results

[Format] ASCII FS b
 Hex 1C 62
 Decimal 28 98

[Description] • Retransmits the previous check (magnetic ink characters) reading results by **FS a 0**.
 • Refer to the description of **FS a 0** for the transmitted data.

FS c

[Name] MICR mechanism cleaning

[Format] ASCII FS c
 Hex 1C 63
 Decimal 28 99

[Description] • Cleans the MICR mechanism.
 • When this command is executed, the printer enters the cleaning sheet wait status.
 • If the cleaning is ended, the printer ejects the cleaning sheet, and selects the paper roll as the paper source.

GS (G pL pH fn [parameters]

[Name] Select cut sheet control function

[Description] • Various processes are performed to the cut sheet.

<i>fn</i>	Format	Function No.	Function
60	GS (G pL pH fn nL nH m	Function 60	Executes reading of magnetic ink characters and transmitting the reading result.
61	GS (G pL pH fn nL nH	Function 61	Resends result of the reading of magnetic ink characters.

- *pL, pH* specify (*pL* + *pH* × 256) as the number of bytes after *pH* (*fn* and [*parameters*]).
- See Section 6.3, "Control Commands"; for control function commands, except for MICR-related commands.

EPSON	TITLE TM-J7000/J7100 Specification (STANDARD)	SHEET REVISION B	NO.	
			NEXT 184	SHEET 183

<Function 60> **GS (G pL pH fn nL nH m (fn = 60)**

[Format]	ASCII	GS	(G	pL	pH	fn	nL	nH	m
	Hex	1D	28	47	pL	pH	fn	nL	nH	m
	Decimal	29	40	71	pL	pH	fn	nL	nH	m

[Range] (pL + pH × 256) = 4 (pL = 4, pH = 0)
 fn = 60
 (nL + nH × 256) = 1 (nL = 1, nH = 0)
 m = 0, 1

[Description] • Reads magnetic ink characters in the font specified by m, and transmits the reading result.

Bit	Off/On	Hex	Decimal	Function
0	Off	00	0	Readable font: E13B is specified.
	On	01	1	Readable font: CMC7 is specified.
1 - 7	Off	00	0	Reserved.

• The following block data is transmitted to the host as the reading result.

Transmission data block	Hexadecimal	Decimal	Amount of data
Header	37H	55	1 byte
Identifier	3FH	63	1 byte
Reading status (See table below.)	(See [Reading status] table below)		1 byte
Detailed information	(See [Detailed information] table below)		1 byte
Separator	1FH	31	1 byte
Fixed value	31H	49	1 byte
Separator	1FH	31	1 byte
Data	Recognized character string		0 ~ 80 bytes
NUL	00H	0	1 byte

[Reading status]

Bit	Off/On	Hex	Decimal	Function
0	Off	00	0	Readable font: E13B
	On	01	1	Readable font: CMC7
1, 2	Off	00	0	Reserved.
3	Off	00	0	Detailed information: not added.
	On	08	8	Detailed information: added.
4	Off	00	0	Re-reading: possible.
	On	10	16	Re-reading: impossible.
5	Off	00	0	The reading processing ended normally.
	On	20	32	The reading processing ended abnormally.
6	On	40	64	Fixed.
7	Off	00	0	Fixed.

EPSON	TITLE	TM-J7000/J7100 Specification (STANDARD)	SHEET REVISION	NO.	
			B	NEXT 185	SHEET 184

[Detailed information]

Hex	Decimal	Function
40	64	The reading process had a normal ending.
41	65	This function has never executed.
42	66	The check paper insertion waiting process is canceled by a command.
43	67	The check paper insertion waiting process is canceled because the time set by ESC f lapsed.
44	68	Check paper with a length other than that specified is inserted.
45	69	Normal waveform reading cannot be detected.
46	70	The waveform cannot be converted to characters of the specified readable fonts.
47	71	An error occurred during the period from the start of command processing to the transmission of a header.
48	72	An error is detected by noise measurement.

The recognizable CMC7 fonts are numerical (0 ~ 9) and special marks (5 kinds) only.

The recognizable fonts are shown in the table below.

- The identified characters consist of the following:

① E13B

MICR	Character	Hex	Decimal	MICR	Character	Hex	Decimal
	NULL	0 0	0	□	0	3 0	4 8
	SP	2 0	3 2	┆	1	3 1	4 9
	?	3 F	6 3	2	2	3 2	5 0
				3	3	3 3	5 1
┆	T	5 4	8 4	4	4	3 4	5 2
┆	A	4 1	6 5	5	5	3 5	5 3
┆	O	4 F	7 9	6	6	3 6	5 4
┆	D	4 4	6 8	7	7	3 7	5 5
				8	8	3 8	5 6
				9	9	3 9	5 7

② CMC7

MICR	Character	Hex	Decimal	MICR	Character	Hex	Decimal
	NULL	0 0	0	0	0	3 0	4 8
	SP	2 0	3 2	1	1	3 1	4 9
	?	3 F	6 3	2	2	3 2	5 0
				3	3	3 3	5 1
┆	/	2 F	4 7	4	4	3 4	5 2
┆	#	2 3	3 5	5	5	3 5	5 3
┆	=	3 D	6 1	6	6	3 6	5 4
┆	>	3 E	6 2	7	7	3 7	5 5
┆	^	5 E	9 4	8	8	3 8	5 6
				9	9	3 9	5 7

<h1>EPSON</h1>	TITLE TM-J7000/J7100 Specification (STANDARD)	SHEET REVISION B	NO.	
			NEXT 186	SHEET 185

<Function 61> **GS (G pL pH fn nL nH (fn = 61)**

[Format]	ASCII	GS	(G	pL	pH	fn	nL	nH
	Hex	1D	28	47	pL	pH	fn	nL	nH
	Decimal	29	40	71	pL	pH	fn	nL	nH
[Range]	$(pL + pH \times 256) = 3 \quad (pL = 3, pH = 0)$ $fn = 61$ $(nL + nH \times 256) = 1 \quad (nL = 1, nH = 0)$								
[Description]	<ul style="list-style-type: none"> Transmits the result of reading the magnetic ink characters which were read and transmitted previously by GS (G <Function 60>. See the description of GS (G <Function 60> for transmitted data. 								

EPSON	TITLE	TM-J7000/J7100 Specification (STANDARD)	SHEET REVISION	NO.	
			B	NEXT App.1	SHEET 186

APPENDIX A MISCELLANEOUS NOTES

A1. Precautions

- 1) Notes on using the ink cartridge
 - a) Keep ink cartridges out of the reach of children. Ink is harmful if swallowed.
 - b) Do not disassemble the ink cartridge.
 - c) The ink can permanently stain clothing.
 - d) Do not refill the ink cartridge. Spills can result, causing damage to the printer.
 - e) Do not apply petroleum benzine, paint thinner, toluene, or ketone-based solvents to the ink cartridge. These solvents may cause damage to plastic components.
 - f) The ink within the ink cartridge may freeze if stored at temperatures under 0°C {32°F}, but once thawed at temperatures over 5°C {41°F}, it can be used normally.
 - g) If water-repellent paper such as an art paper is used for printing, ink dries very slowly and the print may smear. Use paper that does not cause this problem.
 - h) Disposal handling must be in accordance with any relevant national or local laws, ordinances, and regulations.
 - i) The ink cartridge must not be used as the maintenance cartridge that is used for repair.
 - j) EPSON recommends the use of genuine EPSON ink cartridges. Other products not manufactured by EPSON may cause damage to your printer that is not covered by EPSON's warranties.
 - k) Be sure to use the specified ink cartridge. Otherwise, ink may leak or the printing may be affected.
 - l) Do not open the ink cartridge until you are ready to install it. If an opened cartridge is left out for an extended period of time, print quality may be adversely affected.
 - m) After installing an ink cartridge, use it up within 6 months. Leaving the same cartridge in the printer for more than about 6 months may result in degraded print quality.
 - n) Use the ink cartridge by the date indicated on the box containing the ink cartridge and on the ink cartridge itself.
 - o) Do not bump the ink supply port (the projecting part at the bottom of the ink cartridge). Doing so may cause ink to leak from the cartridge.
 - p) Once you begin using an ink cartridge, there will be a residue of ink around the ink supply port. When you remove the ink cartridge from the printer, avoid touching the ink supply port and be careful where you put the cartridge to avoid getting ink on your hands or other objects.
 - q) Be careful to avoid scratching the transparent window on the lower side of the ink cartridge or getting it dirty. Doing so may render the ink cartridge unusable.

EPSON	TITLE TM-J7000/J7100 Specification (STANDARD)	SHEET REVISION B	NO.	
			NEXT App. 2	SHEET App. 1

2) Notes on installing and removing an ink cartridge

- a) For good printing quality, do not remove the ink cartridge from its clear plastic packing until immediately before installing it.
- b) When the ink cartridge is installed, make sure to push the ink cartridge in until it stops.
- c) The ink supply needle in the ink cartridge holder that supplies ink to the printer is covered with ink. To avoid getting your fingers dirty, keep them out of the ink cartridge holder.
- d) Before installing the ink cartridge, be sure to peel off the yellow color tape from the top of the ink cartridge. If the tape is not removed, printouts will contain missing dots. If this occurs, peel off the tape, then perform cleaning until the missing dots go away.
- e) You must not remove any tape on which the EPSON logo is printed.

3) Notes on using the autocutter

- a) The emergency cutter on the paper roll exit part is only for cutting paper, make sure not to touch the cutter blade. Otherwise, you may be injured.
- b) When the paper roll cover is opened, it is possible to touch the blades of the autocutter. Make sure not to touch the cutter blade. Otherwise, you may be injured.
- c) Do not insert your fingers into the paper exit, since the cutter blade is installed inside the paper exit. Otherwise, you may be injured.

4) Notes on handling the paper roll cover

- a) Do not touch the plastic gears located on the left side in the front of the printer, and do not use excessive force when opening the paper roll cover.
- b) When the paper is jammed, do not pull the jammed paper or use tools. Make sure to remove the paper by hand after opening the paper roll cover.
- c) Do not open the printer cover while the printer is operating. Otherwise, the paper may be jammed.

5) Notes on cleaning the print head

- a) The printer takes about one minute for initial ink filling when the printer is first used. Never turn the printer off during an initial ink filling operation. The POWER LED flashes during the ink filling operation; then it stays on when filling is finished.
If the printer is turned off during the ink filling operation, it is necessary to perform this ink filling operation again. This will waste ink. In particular, poor print quality is likely to result if you remove the ink cartridge from the printer and then reinstall it when the cartridge is approaching the ink end condition (when the INK status LED is flashing).
- b) It is recommended that the printer be left to operate by itself during initial ink filling operation, and that the interface reset not be performed.
- c) Do not use the manual CLEANING button unless there is a problem with print quality.
- d) When the POWER LED is flashing, the printer is in a cleaning or in an ink filling state. Do not open the printer cover or turn the printer off when the POWER LED is flashing. However, if the POWER LED flashes slowly after performing the power-off command (**DLE DC4 fn = 2**), it is OK to turn the power off with the power button.

EPSON	TITLE	SHEET REVISION	NO.	
	TM-J7000/J7100 Specification (STANDARD)		B	NEXT App. 3

6) Notes on printing bar codes

- a) When bar code reading is executed, the recognition rate may differ, depending on the paper material and the characteristics of the bar code reader.
- b) When the bar code is printed, it is recommended to print the HRI characters also.
- c) Note that the recognition rate for bar code reading may be affected by different paper materials, the characteristics of the bar code reader, or other factors. Therefore, design the program so that the HRI characters can also be recognized if the bar code is not readable.
- d) If page mode is used while printing a bar code, all passes that include the bar code are printed using unidirectional printing and the normal mode. Since the print density varies according to print mode, it is recommended that all pages be printed in the normal mode.
- e) When printing a ladder bar code, a minimum module width of 0.423 mm (**GS w n = 3**) is recommended.
- f) Do not use ladder bar codes with cut sheets.
- g) The user is responsible for securing appropriate quiet zones (the blank areas before and after the bar code that are required by the specifications for various bar code types).

7) Notes on printing a 2-dimensional bar code (PDF417)

- a) When printing PDF417, it is recommended that the row height be set to 3~5 times the module width. It is also recommended that the overall height of the code be greater than about 5 mm {0.2"}
- b) If the page mode is used while printing a bar code, all passes that include the bar code are printed using unidirectional printing and the normal mode. Since the print density varies according to the print mode, it is recommended that all pages be printed in the normal mode.
- c) A minimum module width of at least 0.423 mm (specifying $n = 3$ for **GS (k <Function 067>**) is recommended when printing a 2-dimensional bar code in the 90° or 270° orientation.
- d) Do not use 2-dimensional codes with cut sheets.
- e) The user is responsible for securing appropriate PDF417 quiet zones (the blank areas above, below, and to the sides of the bar code that are required by the PDF417 specification).

8) Notes on cut sheet forms

- a) Set cut sheet forms so that the edge is aligned flush with the right guide and the form stopper. If inserted diagonally, the paper cannot be clamped properly because slip sensing is not possible (by the TOF and BOF sensors). When inserting the paper, let go of it promptly once it is clamped by the printer.
- b) Use **ESC f** to set the amount of time that the printer waits for paper insertion and the amount of time that it waits before starting operation after insertion of a cut sheet.
- c) Use **DLE ENQ (n = 3)** to cancel the cut sheet insertion waiting time.
- d) Once the cut sheet has been delivered, the slip LED flashes continually, and no further operation takes place until the cut sheet has been removed.
- e) Use **GS r (n = 3, 80)** to check the amount of remaining print area on a cut sheet.
- f) The slip part of the printer uses ink jet printing, and cannot be used with pressure-sensitive forms.
- g) The slip part of this printer is for use only with single-sheet paper. Do not insert multi-part forms, as this may cause paper jams.
- h) The paper feeding pitch will be shortened, if the paper feeding direction is changed, when the face of the slip is selected as the paper source. Therefore, the user must consider this (**ESC K, ESC e**).

EPSON	TITLE	TM-J7000/J7100 Specification (STANDARD)	SHEET REVISION	NO.	
			B	NEXT App. 4	SHEET App. 3

- 9) Notes on printing with an endorsement mechanism
 (The descriptions below are the notes on printing using the back of the slip as the paper source with an endorsement mechanism by the **GS (G command.)**)
- a) Page mode is disabled when printing with an endorsement mechanism.
 - b) All commands related with **ESC c 1** are enabled when printing with an endorsement mechanism (**ESC 2, ESC 3, GS (K, GS L, GS W).**)
 - c) The setting commands, such as font or font style selection, are still effective even when printing on the back of the slip as paper source with an endorsement mechanism. If you want to disable the settings, set them with the command again:
(ESC SP, ESC !, ESC –, ESC E, ESC G, ESC M, ESC {, GS !, GS (N, GS B).
 - d) Do not use the execution commands (bit image, graphics, and so on) as listed below:
(ESC *, GS (L <Function 50>, <69>, <85>, <112>, <113>, GS (k, GS /, GS Q 0, GS k, GS v 0).
 - e) Do not use the reverse feeding commands:
(ESC K, ESC e).
 - f) If a folded check is printed with an endorsement mechanism, some print dots may overlap, since the print feeding pitch will be shortened.
- 10) Notes on setting up the printer
- a) The printer must be horizontal during operation.
 - b) Do not set the printer in a dusty place.
 - c) Protect the printer from impact. Otherwise, there may be printing problems.
 - d) Make sure that the cords or other foreign objects are not caught on the printer base when the printer is installed.
- 11) Notes on the power supply of the printer
- a) The ERROR LED flashes if the power voltage rises above 26.4 V for a certain period of time, causing a high-voltage error, or if the power voltage drops below 21.6 V for a certain period of time, causing a low-voltage error.
 - b) When either a high- or low-voltage error occurs, turn off the power and unplug the power cable as soon as possible.
 - c) Do not turn on the external power supply until after connecting it to the power supply connector on the printer. Do not reverse the polarity of the external power supply. Doing so could destroy the printer circuit or the external power supply.
- 12) Notes on transporting the printer
- a) Remove the ink cartridge from the printer before transporting it.
 - b) Do not turn the printer upside down during transport.
 - c) Do not transport an ink cartridge that has been unpacked from its envelope. Doing so could leak ink.

EPSON	TITLE	TM-J7000/J7100	SHEET REVISION	NO.	
	Specification (STANDARD)	B	NEXT App. 5	SHEET App. 4	

13) Notes on the customer display connector

- a) Do not connect a telephone jack (RJ11) or the drawer kickout (DKD) connector plug to the customer display (DM-D) connector. Otherwise, the printer or the drawer may be damaged.

14) Others

- a) Because this printer uses plated steel, the cutting edges are subject to rust. However, this does not affect the printer performance.
- b) Because this printer is supported only on one side, do not apply excessive force to the printer case.
- c) Do not place food or beverages such as coffee on the case of the printer.

EPSON	TITLE TM-J7000/J7100 Specification (STANDARD)	SHEET REVISION B	NO.	
			NEXT App. 6	SHEET App. 5

APPENDIX B CHANGING THE INK CARTRIDGE

Follow the procedure below when changing the ink cartridge.

- 1) Check that the printer power is turned on. If the printer power is turned off, turn the power switch ON.
- 2) Check that the INK OUT LED on the printer is flashing or lit. When using 2 colors, determine which ink cartridge is empty from the INK OUT LED and remove the empty ink cartridge.
- 3) Open the ink cartridge cover.
- 4) Pull back the ink cartridge lever and pull it upwards. When using 2 colors, check which ink cartridge is empty from the INK OUT LED and remove the empty ink cartridge.
- 5) Take out the new ink cartridge from the box and the bag. Next, peel off the (yellow color) tape from the top of the ink cartridge. (Be sure to peel off the (yellow color) tape).
- 6) Insert the new cartridge label-side up. Push the upper side of the ink cartridge, and insert until you hear a click. Take special care to the direction of the ink cartridge. Also, do not push in forcefully.
- 7) Close the carriage cover.
- 8) The printer may start the ink changing process automatically. It takes approximately one minute, during which time the POWER LED flashes. During this operation, do not turn the printer power off. If the printer is turned off during the ink filling operation, it is necessary to perform this ink filling operation again. This will waste ink.
- 9) When the ink cartridge changing process is finished, the POWER LED stays on and the printer stands by for normal printing.

EPSON	TITLE TM-J7000/J7100 Specification (STANDARD)	SHEET REVISION B	NO.	
			NEXT App. 7	SHEET App. 6

APPENDIX C INSTALLING OR REPLACING THE PAPER ROLL

Follow the procedure below when installing or replacing the paper roll.

- 1) Confirm that the printer power is ON. (If the power is OFF, turn the power ON)
- 2) Lift the paper ejection table upward and pull it toward the front of the printer; then open the paper roll cover.
- 3) After removing the core of the used paper roll, load a new paper roll. Load the paper roll so that the paper unrolls from the bottom.
- 4) Pull out the paper roll straight, and close the paper roll cover. The paper roll cover should be inserted until the cover is completely locked. (Afterwards, the printer feeds paper automatically to put some slack in the paper.)

EPSON	TITLE TM-J7000/J7100 Specification (STANDARD)	SHEET REVISION B	NO.	
			NEXT App. 8	SHEET App. 7

APPENDIX D: ADJUSTING THE PAPER ROLL NEAR-END SENSOR LOCATION

The remaining detectable amount of paper on the paper roll varies with the inside and outside diameters of the paper core. The minimum detectable amount of paper on the paper roll can be set using the following method:

- 1) The inside diameter (ϕd) of the paper spool should be 10 mm {0.4"} or more.
- 2) Set paper roll diameter A to obtain the corresponding adjustment position from the table below.

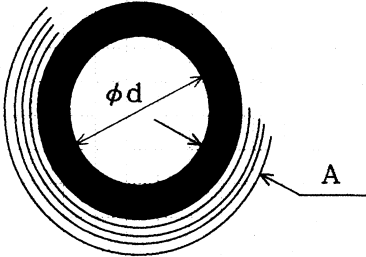

Figure D.1 Paper Spool

Table D.1 Adjusting the detectable amount

A	Adjustment position
Approximately 10 mm	#1
Approximately 8.5 mm	#2
Approximately 7 mm	#3
Approximately 5 mm	#4

- NOTES:
1. Since diameter A corresponding to the adjustment position in the table is a calculated value, there may be some variations depending on the printer.
 2. If a paper roll is used with an end mark at the paper end, the mark may stick, causing the paper to pull up. If this occurs, diameter A differs from the values in the table.
 3. Be sure that the sensor lever operates smoothly after finishing the adjustment.
 4. If the paper on the paper roll becomes loose due to the paper quality, the paper roll near-end sensor may operate incorrectly.

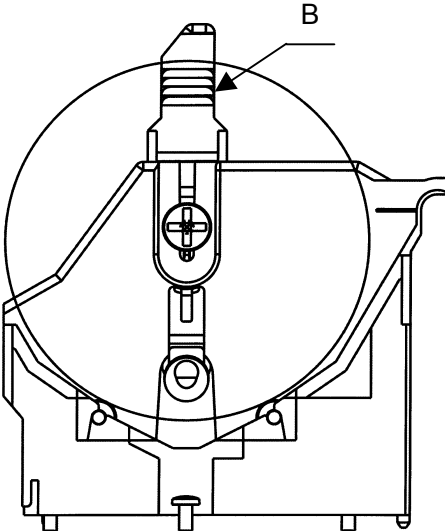

Figure D.2 Paper Roll Near-end Sensor

EPSON	TITLE	TM-J7000/J7100 Specification (STANDARD)	SHEET REVISION	NO.	
			B	NEXT App. 9	SHEET App. 8

5. The adjustment must be performed as follows:

- Loosen the detection adjustment screw so that the near-end adjustment holder can slide.
- Then set position B of the near-end adjustment holder by aligning to the difference in level of the desired paper roll.

EPSON	TITLE TM-J7000/J7100 Specification (STANDARD)	SHEET REVISION B	NO.	
			NEXT App. 10	SHEET App. 9

APPENDIX E: DESCRIPTION OF THE MAINTENANCE COUNTERS

The printer has maintenance counters supported by software.

Counter	Types of counter	Unit	Counter value		Counter number	
			Acquire	Initialize	Hex	Decimal
Number of line feeds	Reset Possible	Lines	Possible	Possible	1E	30
Average number of times of energizing the head for the 1st color	Reset possible	Shots	Possible	Possible	1F	31
Average number of times of energizing the head for the 2nd color	Reset possible	Shots	Possible	Possible	20	32
Number of cartridge operations	Reset possible	No. of times	Possible	Possible	21	33
Number of pump motor operations	Reset possible	No. of times	Possible	Possible	22	34
Number of slip feeds	Reset possible	Lines	Possible	Possible	23	35
Number of autocutter operations	Reset possible	No. of times	Possible	Possible	32	50
Number of check paper scans	Reset possible	No. of times	Possible	Possible	3C	60
Number of endorsement mechanism operations	Reset possible	No. of times	Possible	Possible	3D	61
Product operation time	Reset possible	Hours	Possible	Possible	46	70
Number of line feeds	Cumulative	Lines	Possible	Impossible	9E	158
Average number of times of energizing the head for the 1st color	Cumulative	Shots	Possible	Impossible	9F	159
Average number of times of energizing the head for the 2nd color	Cumulative	Shots	Possible	Impossible	A0	160
Number of carriage operations	Cumulative	No. of times	Possible	Impossible	A1	161
Number of pump motor operations	Cumulative	No. of times	Possible	Impossible	A2	162
Number of slip feeds	Cumulative	Lines	Possible	Impossible	A3	163
Number of autocutter operations	Cumulative	No. of times	Possible	Impossible	B2	178
Number of check paper scans	Cumulative	No. of times	Possible	Impossible	BC	188
Number of endorsement mechanism operations	Cumulative	No. of times	Possible	Impossible	BD	189
Product operation time	Cumulative	Hours	Possible	Impossible	C6	198

EPSON	TITLE TM-J7000/J7100 Specification (STANDARD)	SHEET REVISION B	NO.	
			NEXT App. 11	SHEET App. 10

Confidential

- NOTES:
- All values of the maintenance counter are transmitted to the host PC with the **GS g 2** command.
 - The counters that are possible to reset can be initialized (cleared to zero) with the **GS g 0** command.
 - All counters count up for updating. If the counter value reaches the maximum number, the counter value (for a counter that is possible to reset) does not change until the counter is initialized.

Counter	Counting method	Unit	Maximum value
The number of paper feed lines for roll paper	Counts a paper feed of 4.23 mm {1/6"} as one line (+1) when printing on the roll paper.	Lines	143,165,576
The average number of head shots for color 1	Counts 64 shots of head driving as one shot (+1).	Shots	4,294,967,295
The average number of head shots for color 2	Counts 64 shots of head driving as one shot (+1).	Shots	4,294,967,295
The number of head carriage movements	Counts the number of times of head carriage passing when printing	Times	4,294,967,295
The number of ink pumping	Counts the number of ink pumping times	Times	4,294,967,295
The number of paper feed lines for slip paper	Counts a paper feed of 4.23 mm {1/6"} as one line (+1) when printing on the slip.	Lines	143,165,576
The number of autocutter operations	Counts an autocutter operation (+1).	Times	4,294,967,295
The number of times reading magnetic ink characters	Counts the times reading magnetic ink characters on check paper (+1).	Times	4,294,967,295
The number of endorsement mechanism operations	Counts the times the print starting position is set (+1) when selecting the back of the slip as paper source.	Times	4,294,967,295
Period of printer operation	Counts the number of hours power has been on.	Hours	71,582,788

- NOTES:
- Commands used after the maximum values in the table above are not included in the transmission data.
 - If the printer is turned off without executing the power-off command (DLE DC4 (fn=2)), the values of the counters may be less than the actual ones.

EPSON	TITLE TM-J7000/J7100 Specification (STANDARD)	SHEET REVISION B	NO.	
			NEXT App. 12	SHEET App. 11

APPENDIX F: NOTES ON USING THE DRAWER KICK-OUT CONNECTOR

1) Drawer kick-out connector use conditions (refer to Section 2.2.3, Drawer Kick-out Connector)

Because drawer specifications differ depending on the manufacturer and the part number, make sure that the specifications of the drawer to be used meet the following conditions before connecting it to the drawer kick-out connector.

Any devices that do not satisfy all the following conditions must not be used.

[Conditions]

- A load, such as a drawer kick-out solenoid, must be provided between drawer kick-out connector pins 4 and 2 or between pins 4 and 5. (*1)
- When the drawer open/close signal (causes the open/close of the drawer) is used, a switch, such as a drawer, must be provided between drawer kick-out connector pins 3 and 6. (*2)
- The resistance of the load, such as for the drawer kick-out solenoid, must be 24 Ω or more, or the input current must be 1 A (24V) or less. (*3)
- Be sure to use drawer kick-out connector pin 4 (24 V power output) to drive the device. Never connect any other power supply to the drawer kick-out connector. (*4)

NOTES: (*1) Operating the printer with incorrectly installed devices voids the warranty.

(*2) Connecting devices other than the drawer open/close switch voids the warranty.

(*3) If a device with a resistance of less than 24 Ω or an input current of over 1 A is used, the resulting overcurrent may damage the device.

(*4) Connecting a power supply other than that specified voids the warranty.

EPSON	TITLE	TM-J7000/J7100 Specification (STANDARD)	SHEET REVISION	NO.	
			B	NEXT App. 13	SHEET App. 12

APPENDIX G: NOTES ON TURNING THE PRINTER'S POWER ON/OFF

G.1 Power On Control

To avoid from wasting ink, in the printer that the reset signal is supplied from the host PC while the printer's mechanism is initialized at the power on, the printer initializing operation is controlled to be delayed after the reset signal is received (during this period, the POWER LED flashes and the maximum delay period is 2 minutes).

- NOTES:
- If the power is turned off while initializing, the initialization of the mechanism is delayed at the next time the power is turned. If the power is turned off after finishing initializing, the initializing delay function as above is reset (no delay).
 - If the printer goes offline due to the printer's cover open or other causes while the printer's mechanism is initialized at the power on, the initializing delay function may not work correctly. For this reason, do not make the printer become offline while the mechanism is initialized, or turn the power off after initializing, or reset the initializing delay function when the delay function becomes abnormal.

G.2 Power Off Control

It is recommended to turn the power off only after executing the power-off command (**DLE DC4 fn = 2**). If the power is turned off without executing the power-off command, the ink will be wasted since the cleaning is done when the printer is turned on the next time, or the ink nozzle will be clogged if unused period exceeds two weeks.

The following is an example of the printer power off process when the printer is turned off using the **DLE DC4 (fn = 2)** command.

- 1) Performs the following procedure without interruption before the system is turned off.
 1. Executes **GS (D pL pH m a b (pL=3, pH=0, m =20, a =2, b =1)**
 2. Executes **GS r n (n =1)**
- 2) Waits for the paper sensor status from the printer by the **GS r n** command.
- 3) Transmits **DLE DC4 n a b (fn =2, a =1, b =8)**
- 4) Waits for the power off status.
 - The power off status is transmitted by the power-off sequence within 10 seconds after transmitting **DLE DC4 n a b**.
 - If the power off status is not checked, waits for 10 seconds or more after transmitting **DLE DC4 n a b**.
 - For the serial interface model, the printer status is transmitted regardless of the condition of the host.
 - For the bidirectional parallel interface model, after transmitting **DLE DC4 n a b**, the printer is required to be ready for receiving data from the host.

NOTE: The printer executes the software sequence, but the power is not cut.

- 5) Turn the system power (the host and the printer) off.

NOTE: Do not execute a reset to the printer until the printer power is turned off after transmitting **DLE DC4 (fn = 2)**.

 - * Do not perform the power-off command while the printer is cleaning.

EPSON	TITLE	TM-J7000/J7100	SHEET REVISION	NO.	
	Specification (STANDARD)	B	NEXT App. 14	SHEET App. 13	

APPENDIX H: REPLACING THE PUMP UNIT AND THE INK SUPPLY UNIT

When the pump unit is near the end of life, a warning message is printed every time the external power supply is turned on. When the warning message is printed, that means that the mechanism has reached its end of life.

Printed messages:

Pump unit: "Caution: The pump unit must be replaced. Contact a qualified service person."

EPSON	TITLE TM-J7000/J7100 Specification (STANDARD)	SHEET REVISION B	NO.	
			NEXT App. 15	SHEET App. 14

APPENDIX I: CHANGING THE PAPER WIDTH

It is possible to change the paper width of the paper roll for this printer. Selections can be made from 82.5 mm {3.25"}, 76 mm {2.99"}, 69.5 mm {2.74"}, and 57.5 mm {2.26"}. (The default setting is 76 mm {2.99"})

Change the paper width as follows.

- 1) Open the paper roll cover.
- 2) Unscrew the screw holding the guide (black, plastic part) on the left side of the paper roll holder.
- 3) Change the position of the guide part, aligning it with the width of the paper to be used.
- 4) Using the screw, fasten the guide.

NOTES:

- When changing the paper width, change the setting of the paper width memory switch (customized value) using **GS (E <Function 5>)**.
- When changing to a wider paper after using a narrow paper width, replacement of the autocutter is necessary because parts other than the paper cutter will deteriorate.

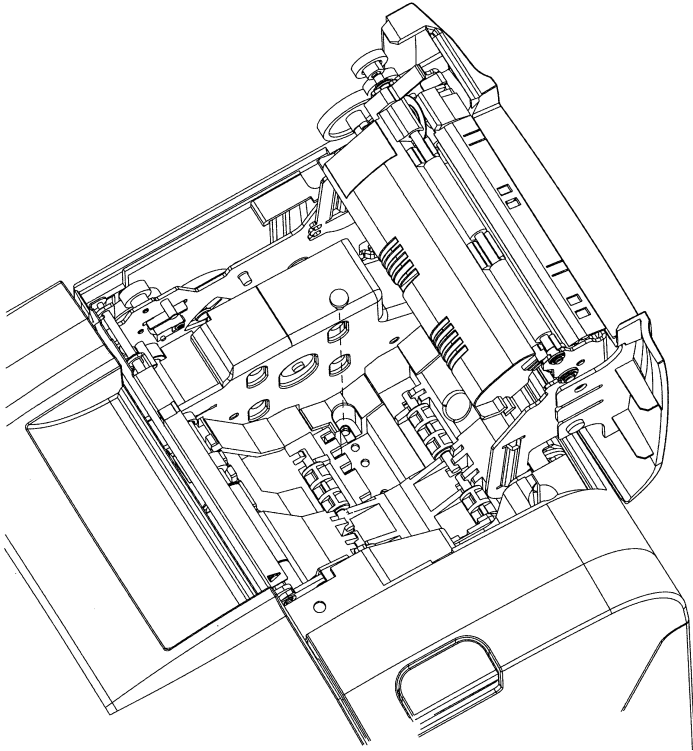

Figure. I.1 Changing Paper Width

EPSON	TITLE TM-J7000/J7100 Specification (STANDARD)	SHEET REVISION B	NO.	
			NEXT END	SHEET App. 15