

Confidential

Developer's Guide TM-J7000/J7100

Copied Date	, ,
Copied by	



EPSON

English

403221801

Confidential

CONFIDENTIALITY AGREEMENT

BY USING THIS DOCUMENT, YOU AGREE TO ABIDE BY THE TERMS OF THIS AGREEMENT. PLEASE RETURN THIS DOCUMENT IMMEDIATELY IF YOU DO NOT AGREE TO THESE TERMS.

- This document contains confidential, proprietary information of Seiko Epson Corporation or its affiliates. You must keep such information confidential. If the user is a business entity or organization, you must limit disclosure to your employees, agents, and contractors who have a need to know and who are also bound by obligations of confidentiality.
- On the earlier of (a) termination of your relationship with Seiko Epson, or (b) Seiko Epson's request, you must stop using the confidential information. You must then return or destroy the information, as directed by Seiko Epson.
- If a court, arbitrator, government agency, or the like orders you to disclose any confidential information, you must immediately notify Seiko Epson. You agree to give Seiko Epson reasonable cooperation and assistance in resisting disclosure.
- You may use confidential information only for the purpose of operating or servicing the products to which the document relates, unless you obtain the prior written consent of Seiko Epson for some other use.
- Seiko Epson warrants that it has the right to disclose the confidential information. SEIKO EPSON MAKES NO OTHER WARRANTIES CONCERNING THE CONFIDENTIAL INFORMATION OR ANY OTHER INFORMATION IN THE DOCUMENT, INCLUDING (WITHOUT LIMITATION) ANY WARRANTY OF TITLE OR NON-INFRINGEMENT. Seiko Epson has no liability for loss or damage arising from or relating to your use of or reliance on the information in the document.
- You may not reproduce, store, or transmit the confidential information in any form or by any means (electronic, mechanical, photocopying, recording, or otherwise) without the prior written permission of Seiko Epson.
- Your obligations under this Agreement are in addition to any other legal obligations. Seiko Epson does not waive any right under this Agreement by failing to exercise it. The laws of Japan apply to this Agreement.

CAUTIONS

- This document shall apply only to the product(s) identified herein.
- No part of this document may be reproduced, stored in a retrieval system, or transmitted in any form or by any means, electronic, mechanical, photocopying, recording, or otherwise, without the prior written permission of Seiko Epson Corporation.
- The contents of this document are subject to change without notice. Please contact us for the latest information.
- While every precaution has been taken in the preparation of this document, Seiko Epson Corporation assumes no responsibility for errors or omissions.
- Neither is any liability assumed for damages resulting from the use of the information contained herein.
- Neither Seiko Epson Corporation nor its affiliates shall be liable to the purchaser of this product or third parties for damages, losses, costs, or expenses incurred by the purchaser or third parties as a result of: accident, misuse, or abuse of this product or unauthorized modifications, repairs, or alterations to this product, or (excluding the U.S.) failure to strictly comply with Seiko Epson Corporation's operating and maintenance instructions.
- Seiko Epson Corporation shall not be liable against any damages or problems arising from the use of any options or any consumable products other than those designated as Original EPSON Products or EPSON Approved Products by Seiko Epson Corporation.

TRADEMARKS

EPSON® and ESC/POS® are registered trademarks of Seiko Epson Corporation.

General Notice: Other product and company names used herein are for identification

Confidential

purposes only and may be trademarks of their respective companies.

General Notice: Other product and company names used herein are for identification purposes only and may be trademarks of their respective companies.

ESC/POS® Proprietary Command System

EPSON took the initiative by introducing ESC/POS, a proprietary POS printer command system including patented commands and enabling versatile POS system construction with high scalability. Compatible with all types of EPSON POS printers and displays, this proprietary control system also offers the flexibility to easily make future upgrades. Its popularity is worldwide.

Revision Information

Revision	Page	Altered Items and Contents
Rev. A	all page	newly authorized

About This Booklet

This booklet was created to provide the information only on the features specific to the TM-J7000/J7100 printer for anyone who needs the information before the mass production.

Key to Symbols

The symbols in this booklet are identified by their level of importance, as defined below. Read the following carefully before handling the product.

WARNING:

You must follow warnings carefully to avoid serious bodily injury.

CAUTION:

Provides information that must be observed to prevent damage to the equipment or loss of data.

- Possibility of sustaining physical injuries.*
- Possibility of causing physical damages.*
- Possibility of causing information loss.*

Note:

Provides important information and useful tips on handling the equipment.

Safety Precautions

This section presents important information to ensure safe and effective use of this product. Please read this section carefully and store it in an accessible location.

 WARNING:

- ❑ *Shut down your equipment immediately if it produces smoke, a strange odor, or unusual noise. Continued use may lead to fire or electric shock. Immediately unplug the equipment and contact your dealer or a Seiko Epson service center for advice.*
- ❑ *Never attempt to repair this product yourself. Improper repair work can be dangerous.*
- ❑ *Never disassemble or modify this product. Tampering with this product may result in injury, fire, or electric shock.*
- ❑ *Be sure to use the specified power source. Connection to an improper power source may cause fire or shock.*
- ❑ *Never insert or disconnect the power plug with wet hands. Doing so may result in severe shock.*
- ❑ *Do not allow foreign matter to fall into the equipment. Penetration by foreign objects may lead to fire or shock.*
- ❑ *If water or other liquid spills into this equipment, do not continue to use it. Continued use may lead to fire or shock. Unplug the power cord immediately and contact your dealer or a Seiko Epson service center for advice.*
- ❑ *Do not place multiple loads on the power outlet (wall outlet). Overloading the outlet may lead to fire.*
- ❑ *Always supply power directly from a standard domestic power outlet.*
- ❑ *Handle the power cord with care. Improper handling may lead to fire or shock.*
 - *Do not modify or attempt to repair the cord.*
 - *Do not place any object on top of the cord.*
 - *Avoid excessive bending, twisting, and pulling.*
 - *Do not place cord near heating equipment.*
 - *Check that the plug is clean before plugging it in.*
 - *Be sure to push the prongs all the way in.*
- ❑ *If the cord becomes damaged, obtain a replacement from your dealer or a Seiko Epson service center.*

Confidential

CAUTION:

- ❑ *Do not connect cables in ways other than those mentioned in this manual. Different connections may cause equipment damage and burning.*
- ❑ *Be sure to set this equipment on a firm, stable, horizontal surface. Product may break or cause injury if it falls.*
- ❑ *Do not use in locations subject to high humidity or dust levels. Excessive humidity and dust may cause equipment damage, fire, or shock.*
- ❑ *Do not place heavy objects on top of this product. Never stand or lean on this product. Equipment may fall or collapse, causing breakage and possible injury.*
- ❑ *To ensure safety, unplug this product before leaving it unused for an extended period.*
- ❑ *Before moving the product, unplug it and unplug all cables connected to it.*
- ❑ *If ink leaks out of the printer, wipe up the ink with a cloth or similar material immediately and contact your dealer or a Seiko Epson service center for advice.*

Safety Label

WARNING:

Do not connect a telephone line to the drawer kick out connector or to the display module connector; otherwise, the printer and the telephone line may be damaged.

**Developer's Guide
TM-J7000/J7100**

Revision Information	ii
About This Booklet	ii
Key to Symbols	ii
Safety Precautions	iii
Safety Label	iv

Chapter 1 Product Overview

Product Structure	1
Part Names	1
Models	2
Accessories	2
Options	2
Consumables	2
Printer Specifications	3
Printing	3
Print method	3
Interfaces	3
Reliability	3
Buffer Sizes	3
Environmental Conditions	4
Electrical Characteristics	4
Overall Dimensions	4
Product Handling	5
Control Panel (LEDs and Buttons)	5
LEDs	6
Buttons	7
Power Switch and Power Switch Cover	8
Executing the power-off sequence	8
Power Switch Cover	9
Installing or Replacing Roll Paper	9
Inserting Slip Paper	11
Installing or Replacing an Ink Cartridge	11
Instructions	12
Disposal of Used Cartridges	15
Ink Cartridge Life	15
MICR Printing (Factory installed option)	15
Cleaning the MICR Mechanism	16
Notes on using the MICR reader	16
Self test	16
Self-test on roll paper	17
Self-test on a cut sheet	17
Self-test of the endorsement mechanism	18
Hexadecimal Dumping	18
Shipping Procedure	19
Troubleshooting	20
Cleaning	20
Error LED Codes	21
Errors that Automatically Recover	21
Errors that are Possible to Recover	22
Errors that are Impossible to Recover	23
Printer Operation When an Error Occurs	23
Data Receive Error	24

Confidential

Chapter 2 Adjustments and Settings

Using Different Paper Width	1
Paper Near-End Sensor	1
DIP Switches	3
Memory Switches	4
Memory switch setting mode	7
Starting the memory switch setting mode	8
Ending memory switch setting mode	8
Operating procedure	9
Connection Form and Cables	12
Serial Connection	12
Parallel Connection	15
USB	15
Ethernet	16
For IBM POS systems	17

Chapter 3 Application Development Information

Key words in Q & A	2
Miscellaneous Information in a Q & A Format	4
Single-Pass Processing	5

Chapter 4 Specifications

Product Specifications	1
Print Specifications	2
Character Specifications	4
Receipt Printer Section	5
Characters per Line and Printable Area for Roll paper	5
Paper Feed Specifications	5
Printable Area	6
Printing Position Versus Cutter Position	7
Slip Printer Section	7
Characters per Line and Printable Area for Slips	7
Paper Feed Specifications	8
Printable Area	8
MICR Reader Section (Factory-Installed Option)	9
Reading Method	9
Recognition Rate	9
Insertion Direction and Endorsement Printing	10
Notes on Using the MICR Reader	10
Endorsement Mechanism Section (Factory-Installed Option)	11
Characters per Line and Printable Area for Endorsement	11
Printable Area	11
Notes on Using the Endorsement Mechanism	12
Paper Specification	13
Paper Roll Specification	13
Slip Paper Specification	13
Notes on slip paper	13
Endorsement Paper Specification	14

Chapter 1

Product Overview

Product Structure

Part Names

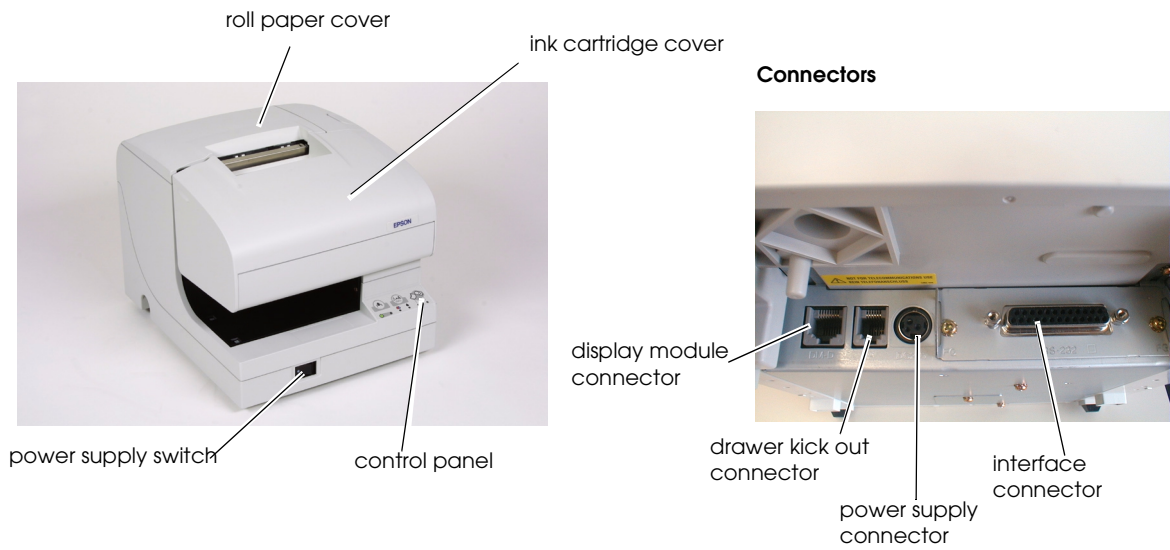

Control Panel

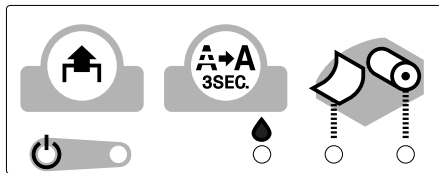

TM-J7000

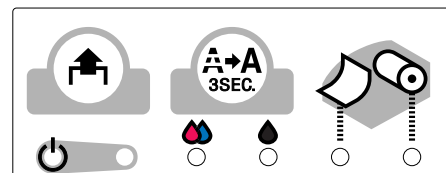

TM-J7100

* For detailed information for the control panel, see "Control Panel (LEDs and Buttons)" in this chapter.

Confidential

Models

Product name	Ink system	Supplied ink cartridge
TM-J7000 series	Monochrome	SJIC8 (K): (black)
TM-J7100 series	2-color	One of the following SJIC6 (K) + SJIC7 (R): (black) + (red) SJIC6 (K) + SJIC7 (G): (black) + (green) SJIC6 (K) + SJIC7 (B): (black) + (blue)

Accessories

- Paper roll (60 mm in diameter)
- Ink cartridge
[TM-J7000] SJIC8 × 1
[TM-J7100] SJIC6 × 1, SJIC7 × 1
- User's manual
- Hexagonal millimeter screws (only for the serial interface printer) (2)
- Power switch cover
- Instruction sheets

Options

- Power supply: EPSON PS-180
- Universal interface boards (except for UB-P02)

Interface	Product name
Serial	UB-S01 (RS-232) UB-S02 (RS-485)
Parallel	UB-P02II
USB	UB-U01 / U01II (Downstream hub provided) UB-U02 / U02II (Downstream hub not provided)
Ethernet	UB-E01

Consumables

- Ink cartridge
[TM-J7000] SJIC8
[TM-J7100] SJIC6, SJIC7



Note:

Use Seiko Epson specified ink cartridges. Performance of the printer when other ink cartridges are used is not guaranteed.

Printer Specifications

Printing

Print method

Serial inkjet dot matrix

- ❑ TM-J7000: single-color, 64 nozzles × 1 line
- ❑ TM-J7100: two-color, 64 nozzles × 2 lines
- ❑ Density: 180 × 180 dpi

Interfaces

- ❑ Standard: RS-232 and IEEE 1284 parallel
- ❑ Options: RS-485, all UB boards, except the UB-P02, 10Base-T

Reliability

- ❑ Life
 - Mechanism: Receipt: 15,000,000 lines, Slip: 5,000,000 lines
 - Print head: 1600 million shots/nozzle (Shots are defined as the numbers of pulses energized for the print head.)
 - Autocutter: 1,500,000 cuts (End of life: the printer is defined to have reached the end of its life when it reaches the beginning of the Wearout Period.)
 - MICR reader mechanism (factory-installed option): 240,000 passes (when used with US personal checks)
 - Endorsement mechanism: 240,000 passes (when used with US personal checks)
- ❑ MTBF: 180,000 hours (Failure is defined as a random failure occurring during the random failure period.)
- ❑ MCBF: 50,000,000 lines (This is an average failure interval based on failures relating to wearout and random failures up to the life of 20,000,000 lines (receipt: 15,000,000 lines plus slip: 5,000,000 lines)

Buffer Sizes

- ❑ Receive: 4KB
- ❑ User-defined (both for user-defined characters and downloaded bit images): 12KB
- ❑ NV graphics and user NV memory: 384KB

Confidential

Environmental Conditions

- ❑ Temperature and Humidity:
 - Printing: 10 to 35°C {50 to 95°F}, 20 - 80% RH (non-condensing)
(Shaded area in figure "Operating Temperature and Humidity Range.")
 - Operating: 5 to 40°C {41 to 104°F}, 20 - 80% RH (non-condensing)
(Area drawn with a solid line in figure "Operating Temperature and Humidity Range.")
 - Storage: When packed (ink not installed)
-20 to 60°C {-4 to 140°F}, 5 - 85% RH (non-condensing) (within 120 hours at -20°C {68°F} or 60°C {140°F})
 - Storage: When ink is loaded
-20 to 40°C {-4 to 104°F}, 20 - 85% RH
 - Maximum absolute rated temperature: 70°C {158°F}
(The printer must be kept at or below 70°C {158°F} whenever it is operating or in storage.)

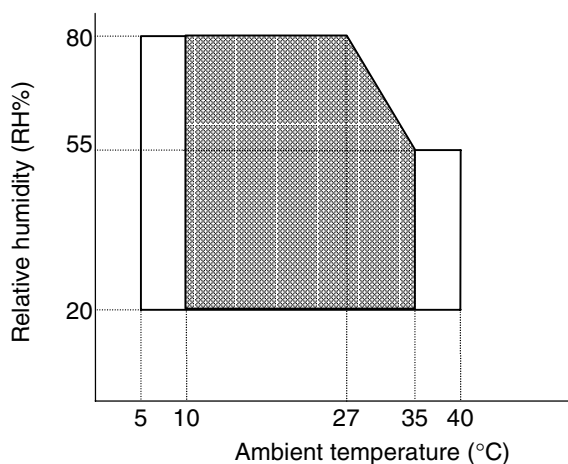

Operating Temperature and Humidity Range

Electrical Characteristics

- ❑ Supply voltage 24 V \pm 2.4 V (using optional EPSON power supply 180)
- ❑ Current consumption (except when the drawer kick-out is used):

Operating	Mean:	Approximately 1A
		(all lines contain character font A α -N)
Standby	Mean:	Approximately 50mA

Overall Dimensions

- ❑ Height: 188 mm {7.40"}

Confidential

- ❑ Width: 195 mm {7.68"}
- ❑ Depth: 237 mm {9.33"}
- ❑ Mass: Approximately 4.4 kg

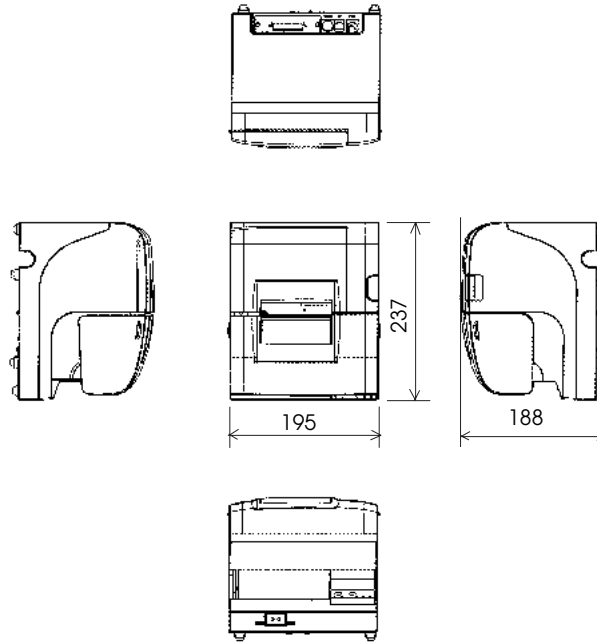

Product Handling

Control Panel (LEDs and Buttons)

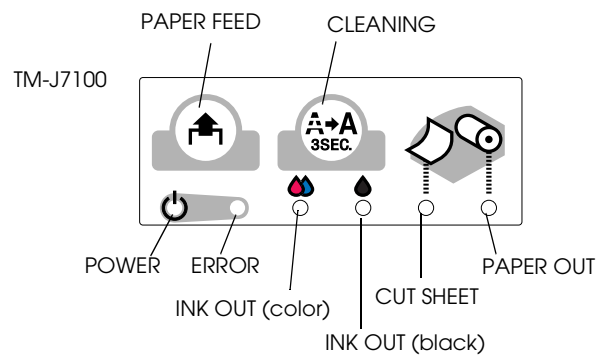
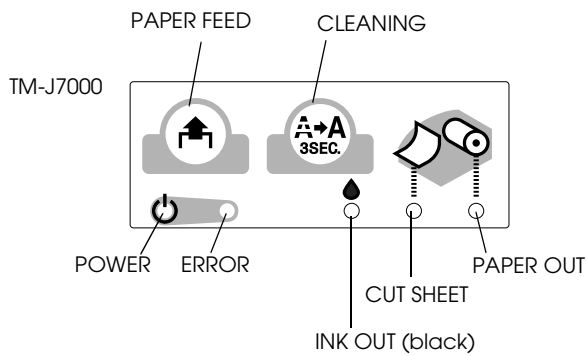

Confidential

LEDs

POWER

Lights when the power is on and is off when the power is off; flashes during cleaning and other operations such as power-on and power-off.

Power on process (when an operation is being executed): Flashing

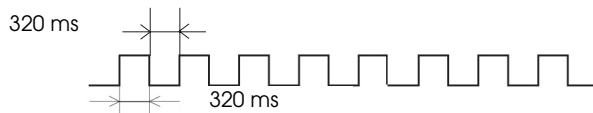

Power off process (after DLE DC4, $fn = 2$ is executed): Flashing

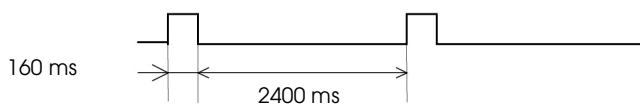

Note:

Never open the printer cover or turn off the printer when the POWER LED is flashing.

ERROR

Lights when the printer is offline except during paper feeding using the PAPER FEED button, during self-test, or cleaning. Off when the printer is online. Flashes when an error occurs. See the Error LED Codes section in this Chapter.

INK OUT

Lights when the ink cartridge is not installed or ink is out. The ink cartridge needs to be replaced. Off when the ink cartridge is installed and ink is adequate. Flashes when the ink is nearly out. (If the ink is out, the printer also goes offline and the ERROR LED lights.) The TM-J7000 has two INK OUT LEDs, one for the color cartridge and one for the black cartridge.)



Note:

The number of printable characters from when the ink near end status is detected to when the ink is out differs depending on the conditions. When ink near end is detected, prepare to replace the ink cartridge.

Detection of ink cartridge installation and the ink near end status is performed only when the carriage cover is closed. If the carriage cover is open, the INK OUT LED keeps the same status as before the carriage cover was opened.

PAPER OUT

Lights when roll paper is out or nearly out. Flashes when the printer is in the self test standby state.

CUT SHEET

Lights when cut sheet (slip, check) is selected as print sheet. Off when roll paper is selected as print sheet. Flashes when the printer is in the cut sheet insertion or removal waiting state.

Slip insertion waiting



Personal check insertion waiting

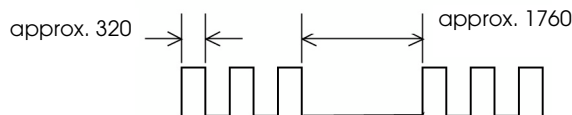

Slip removal waiting state

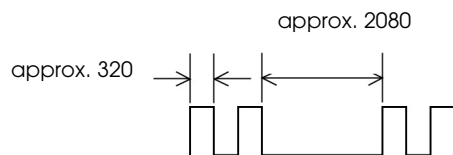
**Buttons****PAPER FEED**

PAPER FEED feeds the roll paper based on the line spacing set by the **ESC 2** or **ESC 3** command.

The printer feeds the roll paper if the roll paper is selected as the paper source or feeds the cut sheet when the cut sheet is selected as the paper source.

The back of a slip is fed by the PAPER FEED button in the reverse direction to when the paper is fed in the forward direction.

**Note:**

Paper cannot be fed using this button in the following cases:

- When check is selected as the print sheet.
- Roll paper cover is open when roll paper is selected as print sheet.
- Printer is in the slip insertion or removal state when slip is selected as print sheet.

Confidential

- When cleaning is being performed or an error has occurred with any sheet selected.
- When it is disabled with the ESC c 5 command.

There is the case that even if the paper source is changed, the printer may feed the previously selected paper source.

A slip will be fed in the following case; if roll paper is selected as the paper source with the slip paper clamped and the PAPER FEED button is pressed before the printer receives data from the host.

CLEANING

If printing becomes faint or uneven and the INK OUT LED is not on or flashing, use this button to clean the print head. Press the button until the printer mechanism begins to clean the print head (more than 3 seconds). When the cleaning stops, the printer is ready for normal printing.



Note:

Do not use the CLEANING button unless there is a problem with print quality. Unnecessary cleaning will waste ink.

Power Switch and Power Switch Cover

The power switch is on the front of the printer. Press the power switch to turn on the printer.



Note:

Turn on the power only after connecting the power supply.

Executing the power-off sequence

It is recommended to turn the power off only after executing the power-off command (**DLE DC4 fn = 2**). If the power is turned off without executing the power-off command, the ink will be wasted since the cleaning is done when the printer is turned on the next time, or the ink nozzle will be clogged if the unused period exceeds two weeks.



Note:

Never open the printer cover or turn off the printer when the POWER LED is flashing.

Power Switch Cover

You can use the enclosed power switch cover to make sure that the power switch is not accidentally pressed. Just press the cover into place to install it. If you need to turn the power switch on or off with the cover attached, you can insert a thin tool into one of the holes in the cover to operate the switch.

⚠ WARNING:

If an accident occurs when the power switch cover is attached, immediately unplug the power supply cable to avoid fire.



If you are going to store the printer or leave it unused for a long time, turn it off using the power switch on the printer.

Installing or Replacing Roll Paper

⚠ CAUTION:

Be careful not to insert your fingers into the paper exit. The cutter blade is installed inside the paper exit and you might be injured.

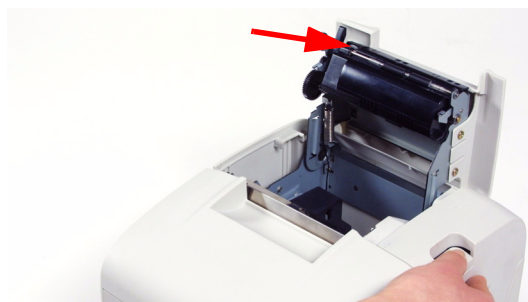

Confidential

CAUTION:

Be sure to use roll paper that meets the specifications.

Follow these steps to install or replace paper:

1. Make sure the printer is on.
2. Open the roll paper cover by pressing the cover open button.

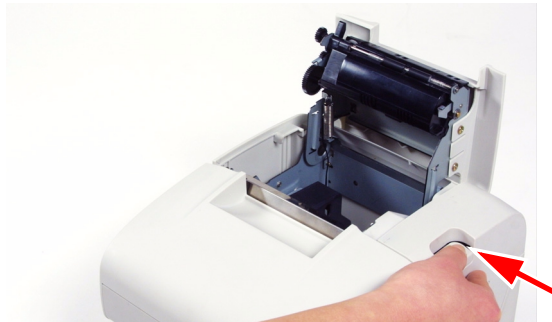

3. Remove the used roll paper core if there is one.
4. Put the roll paper inside the printer in the correct direction, as shown in the illustrations below.

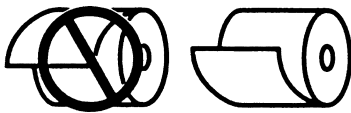

5. Pull out the leading edge of the roll paper; then close the roll paper cover until it is firmly locked by pushing the top of the cover.
6. The printer will automatically feed the roll paper to remove any slack in the paper.



Note:

Do not open the roll paper cover during printing or paper feeding.

Inserting Slip Paper

**Note:**

Be sure the paper is flat, without curls, folds, or wrinkles.

Do not insert any multiple sheet paper because this may cause a paper jam. Use only single sheet paper.

Because the printer is an inkjet printer, pressure sensitive copy paper cannot be used.

To prevent jams, roll paper must be installed even for printing on slip paper.

Be sure to insert a slip with the right side of the paper against the right side of the paper guide as far as it will go, as shown in the illustration. See the label instructions attached to the printer as a guide.



Installing or Replacing an Ink Cartridge

**CAUTION:****Usage:**

Do not disassemble the cartridge. The ink can permanently stain clothing.

Do not refill ink cartridges. Spills can result, causing damage to the printer.

Do not remove the cartridge except to replace it or to prepare the printer for shipment. Otherwise, ink may be wasted and the life of the ink cartridge may be reduced.

For good printing quality, do not remove the ink cartridge from its packing until immediately before installing it.

Use up the ink cartridge within 6 months after unpacking it.

The expiration date is indicated on the cartridge box or the ink cartridge itself.

Print quality problems may occur if an ink cartridge that is almost empty (the INK OUT LED flashes) is removed and reinstalled.

Confidential

A used cartridge may have some ink on the convex part of the bottom of the cartridge. Avoid touching that part to keep your hands clean.

Do not puncture the convex part of the bottom of the ink cartridge or remove the transparent film on the bottom of the ink cartridge; otherwise the ink might leak.

Once the ink cartridge is used, the ink supply needle (plastic projection) in the ink cartridge holder that supplies ink to the printer is covered with ink. Avoid touching the cartridge holder to keep your hands clean.

Use Seiko Epson specified ink cartridges. Performance of the printer when other ink cartridges are used is not guaranteed.

Do not open or close the ink cartridge cover during printing. Misalignment of the print position will occur.

Storage:

Keep the ink cartridge out of the reach of children. Do not drink the ink.

Do not store the ink cartridge where it will be subject to high temperatures or freezing.

Instructions

When the INK OUT LED flashes, it is almost time to change the ink cartridge. Change the cartridge as soon as it is convenient. When the INK OUT LED is on, printing stops and you must change the cartridge.

The TM-J7100 has two separate cartridges, one each for black and colored ink (either red, green, or blue). Therefore, the TM-J7100 has two INK OUT LEDs, one for the black and one for the color.

Follow these steps to install an ink cartridge for the first time or to replace an empty ink cartridge.

1. Make sure the printer is on. If it is not on, plug in the power supply cable and turn on the power using the switch on the front of the printer.
2. Make sure an INK OUT LED is on or flashing. When using two colors, notice which ink cartridge INK OUT LED is on or flashing; this indicates which cartridge is empty.
3. Be sure that roll paper is installed.

4. Open the ink cartridge cover using the tabs on the sides of the cover.



5. Lift up the empty ink cartridge by using the tab.

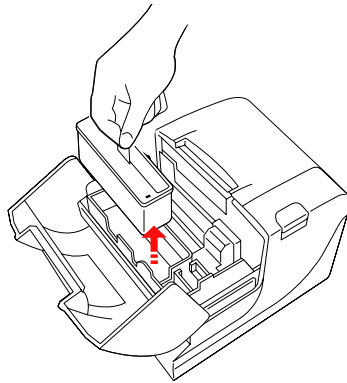

TM-J7000

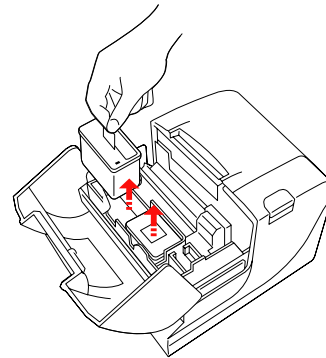

TM-J7100

⚠ CAUTION:

Do not put your fingers inside the ink cartridge compartment or you may be injured by a plastic projection.

Once the ink cartridge is used, the ink supply needle (plastic projection) in the ink cartridge holder that supplies ink to the printer is covered with ink. Avoid touching the cartridge holder to keep your hands clean.

Confidential

6. Take a new ink cartridge out of its packing and remove the yellow tape.

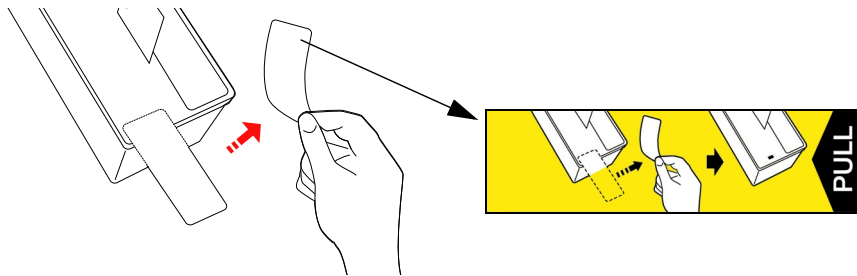

CAUTION:

You must not remove any tape on which the EPSON logo is printed.

7. Carefully insert a new ink cartridge from the top and push it firmly but gently until it clicks into place. Be sure the inserting direction is correct, as shown in the illustrations below.

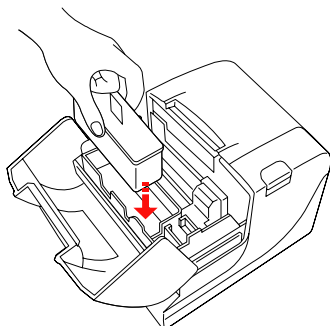

TM-J7000

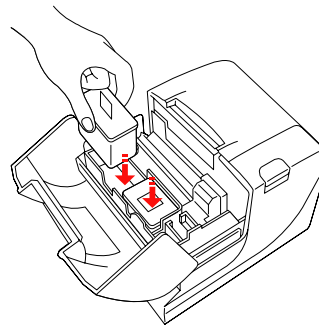

TM-J7100

8. Close the ink cartridge cover completely.



Note:

The INK OUT LED will now be off.

The POWER LED flashes for approximately 1 minute as the ink delivery system is charged. To save ink, this sequence will not be executed every time you replace an ink cartridge. The time to execute the sequence is controlled by the printer.



Note:

Do not turn off the power while the POWER LED is flashing. This will waste ink because the printer has to re-start the ink charging process. Be sure not to open the printer cover while the POWER LED is flashing.

When the POWER LED quits flashing and stays on, the printer is ready for printing.

Disposal of Used Cartridges

Dispose of used ink cartridges as industrial waste products. Obey the laws and regulations of your country and district.

Ink Cartridge Life

To make your ink cartridges last as long as possible, follow these simple rules:

- ❑ Don't turn off the power supply switch immediately after printing is completed.
- ❑ Don't remove an ink cartridge unless you are replacing the cartridge.
- ❑ Don't turn the printer on and off unnecessarily.
- ❑ Don't press the CLEANING button unless the print is faint or uneven.

MICR Printing (Factory installed option)

⚠ CAUTION:

Do not insert checks with staples in them. This may cause paper jams, MICR reading errors, and damage to the MICR head.

Never open the roll paper cover while the MICR reader is being used.

Be sure the checks are flat, without curls, folds, or wrinkles.

Do not use multipart checks.

1. Wait until the CUT SHEET LED blinks. Then insert the check *face up* with the right side of the check against the right side of the paper guide as far as it will go. Be sure that the MICR characters are on the right.



MICR
characters
on this side
face up

Confidential

2. The printer will detect the check and start drawing it in. When the printer starts drawing it in, let go of the check immediately. When the printer ejects the check and the CUT SHEET LED starts blinking again; remove the check by pulling it straight up; do not pull it at an angle.

Cleaning the MICR Mechanism

Approximately every 12 months clean the MICR head with a moistened cleaning sheet.

Use the following or an equivalent commercially available cleaning sheet:

PRESAT brand (KIC) "CHECK READER CLEANING CARD."



Note:

Be sure not to use an adhesive cleaning sheet.

Follow the steps below:

1. Load roll paper in the printer; turn off the power; then open the roll paper cover and turn the power back on while holding down the CLEANING button.
2. Press the CLEANING button 7 times; then close the paper roll cover. The printer prints the following message on the roll paper and the CUT SHEET LED flashes.

**** RECOGNITION MODE ****

Please set check.

3. Insert the cleaning sheet like a standard check.



CAUTION:

Be sure that the sheet is inserted with the correct side up and that it is inserted in the correct direction. Use a cleaning sheet only one time; then discard it.

Notes on using the MICR reader

Do not install the printer near any magnetic fields. Be especially careful where you install your display device and be sure to check the recognition rate of the MICR reader with the display device in place.

Make sure that the printer is not subjected to any impact or vibration when it is performing a MICR reading.

Self test

The printer has a self-test function that checks the following:

- Control circuit functions

- Printer mechanisms
- Print quality
- Control software version
- DIP switch settings
- Memory switch settings
- Paper width to be set

Self-test on roll paper

Follow the following procedure to start the self-test on roll paper.

1. To start the self-test on roll paper, hold down the receipt FEED button while turning on the printer with the cover closed.
2. When all printer states have been printed, make sure that the following message is printed and the PAPER OUT LED blinks.

“If you want to continue SELF-TEST printing, please press FEED button.”

The printer is now in the self-test wait mode.

3. To continue the self-test, press the FEED button when the printer is in the self-test wait mode.
4. Make sure that the following message is printed.

***** completed *****

The printer will now be initialized and returned to the normal operating mode.

Self-test on a cut sheet

Follow the following procedure to start the self-test on a cut sheet.

1. Hold down the CLEANING button while turning on the printer with the cover closed.
2. The printer flashes the CUT SHEET LED and enters the paper insertion waiting state. Insert a cut sheet to begin printing the printer status.
3. After printing the current printer status, the printer ejects the cut sheet and waits for the next sheet of paper to be inserted. Insert another cut sheet to begin printing the test.
4. After a number of lines are printed, the printer indicates the end of the self-test by printing **“*** completed ***”**, initializes, and goes into the normal mode.

Confidential

NOTES:

Make sure to use a cut sheet with a width wider than 85 mm {3.35"} because the self-test on the cut sheet is full-column printing regardless of the paper width that is currently selected. If the width of the cut sheet is narrower than full-column print width, the ink may make the platen dirty beyond the edge of the paper.

When the self-test is performed on the cut sheet, roll paper also must be loaded.

Self-test of the endorsement mechanism (only for the endorsement-equipped model)

Follow the following procedure to start the self-test of the endorsement mechanism.

1. Hold down the CLEANING button while turning on the printer with the cover open and then close the cover.
2. The printer flashes the CUT SHEET LED and enters the paper waiting state. Insert paper to begin printing the test printing with the endorsement mechanism.

NOTES:

User paper with a width narrower than 101.6 mm {4"} for the endorsement self-test. Otherwise, the paper may be jammed.

When the self-test is performed with the endorsement mechanism, roll paper also must be loaded.

Hexadecimal Dumping

In hexadecimal dump mode, the data transmitted from the host computer is printed in hexadecimal numbers and in their corresponding characters. Use the following procedure to output a hexadecimal dump.

1. With the paper roll cover open, press and hold down the FEED button while turning on the printer.
2. Close the paper roll cover.

Data received after this is printed in hexadecimal numbers and their corresponding characters.

NOTES:

If no characters correspond to the data received, the printer prints "."

During hexadecimal dumping, any commands other than DLE EOT, DLE ENQ, and DLE DC4 do not function.

3. When printing stops, turn off the power, or press the FEED button three times, or perform a reset.

<Printing example>

Hexadecimal Dump

1B	21	00	1B	26	02	40	40	:	.	!	.	.	&	.	@	@
1B	25	01	1B	63	34	00	1B	:	.	%	.	.	c	4	.	.
41	42	43	44	45	46	47	48	:	A	B	C	D	E	F	G	H

Shipping Procedure

To ship the printer, follow these steps:

1. Remove the roll paper and ink cartridge.
2. Turn off the power supply.
3. Check that the POWER LED is off.
4. Remove the power supply connector and other connectors.

Keep the printer upright and horizontal while you pack it.

Confidential

Troubleshooting

Check the following cases. See also the “Error LED Codes” item to locate the causes.

- ✓ The print head temperature may be high or low. Wait until the print head cools or warms and the printer resumes printing automatically.
- ✓ Make sure that the roll paper cover is properly closed.
- ✓ If a paper jam has occurred, open the roll paper cover or the ink cartridge cover and remove the jammed paper. Do not pull the jammed paper by force or use tools. Be sure to remove it manually.
- ✓ Turn off the power, wait several seconds, and then turn it on again.

Cleaning

If printing becomes faint or uneven and the INK OUT LED is not on or flashing, press the CLEANING button until the printer mechanism begins to clean the print head (more than 3 seconds). The POWER LED flashes during cleaning. When the cleaning stops, the printer is ready for normal printing.







Note:

Do not use the CLEANING button unless there is a problem with print quality. Unnecessary cleaning will waste ink.

Do not turn off the power or open any covers while the POWER LED is flashing.

Error LED Codes





Errors that Automatically Recover

		ERROR LED Flashing Pattern approx. 320 ms 	
Error	Description		Recovery Condition
Roll paper cover open error (when auto recovery is selected by the memory switch)	Roll paper cover open is detected during printing on the roll paper.		Recovers automatically when the cover is closed.
Print head high temperature error (*)	The temperature of the print head is too high.		Recovers automatically when the print head cools.
Print head low temperature error (*)	The temperature of the print head is too low.		Recovers automatically when the print head temperature increases.

(*) If the head temperature is only slightly out of range the printer can recover, but a large deviation from the appropriate range causes an unrecoverable error as an internal circuit error.

Confidential

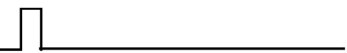
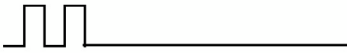
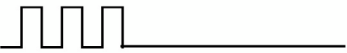
Errors that are Possible to Recover

Error	Description	ERROR LED Flashing Pattern approx. 320 ms 	Recovery Condition
Paper roll cover open error (when Possible recovery is selected by the memory switch)	Roll paper cover open is detected during printing on the roll paper.		Recovers by DLE ENQ (n = 1) or DLE ENQ (n = 2) with the cover closed.
Autocutter error	The autocutter does not work correctly.		Recovers by DLE ENQ (n = 1) or DLE ENQ (n = 2) with the cover closed.
Carriage home position detection error	The home position cannot be detected because of a paper jam.		Recovers by DLE ENQ (n = 1) or DLE ENQ (n = 2) with the cover closed.
Carriage out of phase detection error	The carriage is out of phase.		Recovers by DLE ENQ (n = 1) or DLE ENQ (n = 2) with the cover closed.
Cut sheet ejection error	The cut sheet cannot be ejected even if a certain amount is fed.		Recovers by DLE ENQ (n = 1) or DLE ENQ (n = 2) with the cover closed.







Note:

If the printer recovers from an error that has the possibility of recovery with **DLE ENQ (n = 1)** when the printer has selected the slip as the paper source and an error has occurred while printing on the slip, the printer ejects the slip first if it is still remains, and enters the paper waiting state. However, if the printer recovers from a cut sheet ejection error, the printer ejects the slip only, and does not enter the paper insertion waiting state.

If the printer recovers from an error that has the possibility of recovery with **DLE ENQ (n = 1)** when the printer has selected the slip as the paper source and an error has occurred except when printing on the slip, the printer ejects the slip first if it is still remains, and selects the slip as the paper source, and does not enter the paper insertion waiting state.

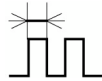
If the printer recovers from an error that has the possibility of recovery with **DLE ENQ (n = 2)** when slip is set as the paper source, the printer ejects the slip only if it still remains.

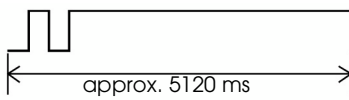
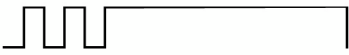
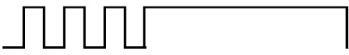
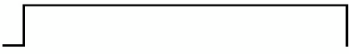
Errors that are Impossible to Recover

Error	Description	ERROR LED Flashing Pattern approx. 320 ms 	Recovery Condition
CPU execution error	The CPU executes an incorrect address or the interface board is not connected.		Impossible to recover.
R/W error	After R/W checking, the printer does not work correctly.		Impossible to recover.
High voltage error	The power supply voltage is extremely high.		Impossible to recover.
Low voltage error	The power supply voltage is extremely low.		Impossible to recover.
Drive circuit error	Drive circuit does not work correctly.		Impossible to recover.
UIB error	UIB does not work correctly.		Impossible to recover.



Note:

When any errors shown above occurs, turn off the power as soon as possible.

Printer Operation When an Error Occurs

The printer executes the following operations when detecting an error.

- ❑ Stops all printer operations.
- ❑ Goes to BUSY mode (if the printer is set to BUSY in offline state by memory switch 1-3. See "Memory Switches" in Chapter 2.)

Confidential

- The ERROR LED flashes.

Data Receive Error

If one of the following errors occurs during serial interface communication, the printer prints “?” or ignores the data, depending on the setting memory switch 1-4.

- Parity error
- Framing error.
- Overrun error

Chapter 2

Adjustments and Settings

Using Different Paper Width

This printer accommodates 76 mm wide paper rolls with no adjustment; however you can change the roll paper width to 82.5 mm, 69.5 mm, or 57.5 mm.

Follow the instructions below to change the roll paper width.

1. Open the roll paper cover.
2. Loosen the screw that holds the roll paper guide.
3. Slide the guide to the desired position.
4. Tighten the screw.

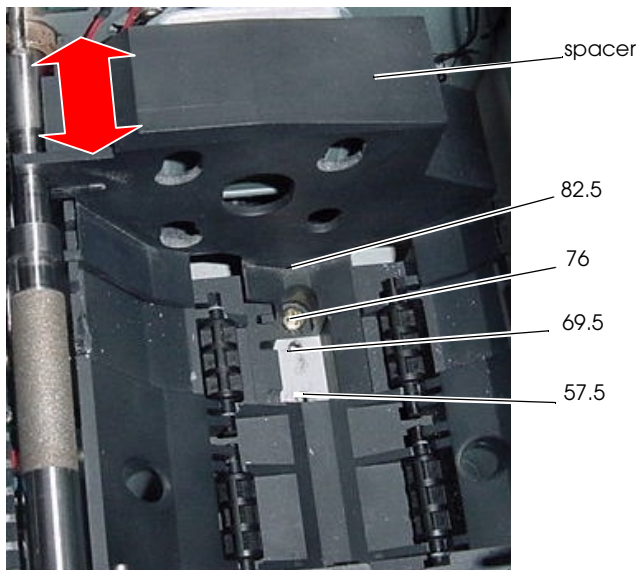

5. After setting the paper width, you need to change the memory switch setting. See **xx** for instructions.

Paper Near-End Sensor

The diameter of the paper remaining on the roll paper can be detected at one of four levels by the adjustment described below.

Confidential



Note:

The amount of paper remaining on roll paper varies depending on the outer and inner diameters of the roll paper core.

1. Set the roll paper diameter A to obtain the corresponding adjustment shown in the table below.

Note:

The inner diameter of the paper core should be 10 mm {0.4 in.} or more.

Since diameter A in the table below is a calculated value, there may be some variations depending on the printer.

If roll paper with an end mark at the paper end is used, the mark may stick. If this occurs, diameter A differs from the values in the table below.

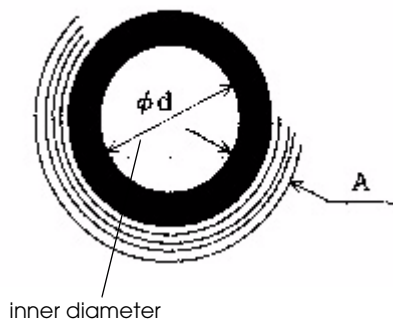

A	Position
Approx. 10 mm	# 1
Approx. 8.5 mm	# 2
Approx. 7 mm	# 3
Approx. 5 mm	# 4

2. Loosen the adjustment screw and use the handle to slide the sensor lever to an appropriate position.

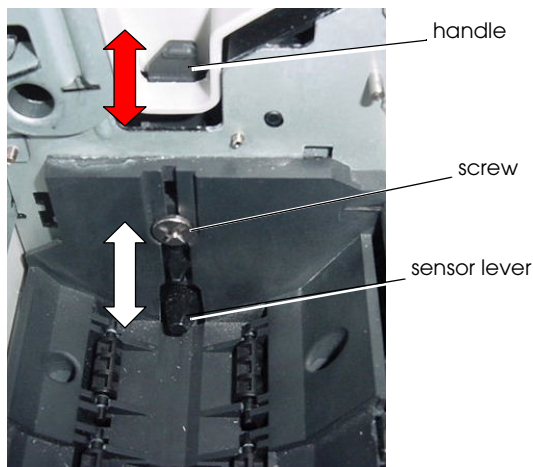

3. Be sure that the sensor lever operates smoothly after setting.



Note:
If the roll paper becomes loose due to the paper quality, the near-end sensor may operate incorrectly.

DIP Switches

The DIP switches are located on the main board inside the bottom cover of the printer.

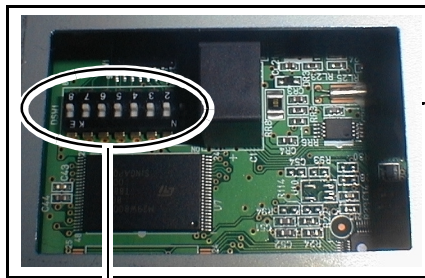

DIP switch

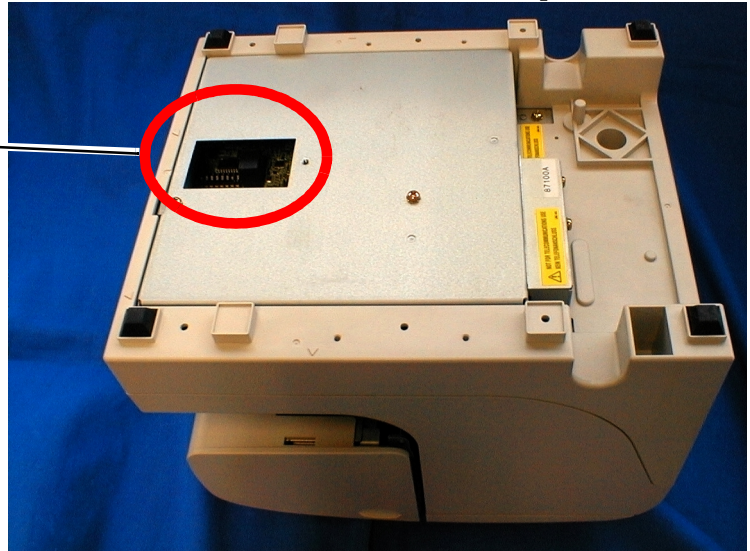

DIP Switch Settings for Serial Interface Specifications

SW 1	Function	On	Off
1	Reserved	--	Fixed to Off
2	Interface condition selection	By DIP switch	By memory switch
3	Handshaking	XON/XOFF control	DTR/DSR control
4	Word length	7 bits	8 bits
5	Parity check	Yes	No
6	Parity selection	Even	Odd
7	Transmission speed selection	See the following table "Transmission Speed."	
8			

Confidential

Transmission Speed

Transmission speed (bps)	SW1-7	SW1-8
9600	On	On
19200	Off	On
38400	On	Off
115200	Off	Off

bps: bits per second



Note:

Changes in DIP switch settings are recognized only when the printer power is turned on or when the printer is reset by using the interface. If a DIP switch setting is changed after the printer power is turned on, the change does not take effect until the printer is turned on again or is reset.

DIP Switch Settings for Parallel Interface specifications

SW 1	Function	On	Off
1 ~ 8	Reserved	--	Fixed to Off

Memory Switches

The printer unit has the following memory switches in NV memory.

- Memory switches: MSW1, MSW2, MSW8
- Customized value
- Serial communication conditions

These settings can be set by using the ESC/POS command **GS (E)**, or the Memory Switch Setting Utility. For detail of the ESC/POS command, see the ESC/POS Application Programming Guide. For details about the utility, see the user's manual for the utility.

Some of these settings also can be set by panel operation (Memory switch setting mode). (See "Memory switch setting mode" on page 7.)

Msw 1 is defined as follows:

Memory Switch Msw 1

Bit	Function	0 (Off)	1 (On)
1	Transmits the power ON information	Does not transmit	Transmits
2	Reserved	--	--
3	Conditions for BUSY	Receive buffer-full or offline	Receive buffer-full
4	Data processing for receiving error	Prints "?"	Ignored
5	Automatic line feed	Disabled	Enabled
6	Connection of DM-D	Not connected	Connected
7	Pin #6: Selection of reset signal	Not used	Used
8	Pin #25: Selection of reset signal	Not used	Used

NOTE:Msw 1-7 and 1-8 are effective only when the serial interface is used.

Msw 2 is defined as follows:

Memory Switch Msw 2

Bit	Function	0 (Off)	1 (On)
1	Reserved (the setting must not be changed)	--	Fixed to On.
2	Autocutter operation	Disabled	Enabled
3	Reserved	--	--
4	Reserved	--	--
5	Reserved	--	--
6	Reserved	--	--
7	Reserved	--	--
8	Reserved	--	--

Msw 8 is defined as follows:

Memory Switch Msw 8

Bit	Function	0 (Off)	1 (On)
1	Reserved	--	--
2	Reserved	--	--
3	Reserved	--	--
4	Reserved	--	--
5	Reserved	--	--

Confidential

Bit	Function	0 (Off)	1 (On)
6	Slip print columns (for font A / font B) Face of the slip Endorsement (back of the slip)	 48 / 64 46 / 61	 52 / 72 50 / 69
7	Receipt print columns (for font A / font B) Paper width 57.5 mm {2.26"} 69.5 mm {2.74"} 76 mm {2.99"} 82.5 mm {3.25"}	 30 / 40 36 / 48 40 / 53 42 / 56	 32 / 45 39 / 54 43 / 60 46 / 64
8	Paper roll cover open during printing	Automatically recoverable error	Recoverable error

Customized value is defined as follows:

Customized Value

Item	Value
Paper width selection	57.5 mm {2.26"}
	69.5 mm {2.74"}
	76 mm {2.99"}
	82.5 mm {3.25"}

Communication conditions for the serial interface are defined as follows:

Communication Conditions for the Serial Interface

Item	Value
Baud rate	2400 bps
	4800 bps
	9600 bps
	19200 bps
	38400 bps
	57600 bps
	115200 bps
Parity	None
	Odd
	Even
Handshaking	DTR/DSR control
	XON/XOFF control
Data length	7 bits
	8 bits

Memory switch setting mode

In the Memory switch setting mode you can set some Memory switches using printer buttons. This mode can set following settings.

- Enable or disable autocutter operation (Msw 2-1)
- Set the communication condition of the serial interface (Communication conditions for the serial interface)
- Setting the conditions for communication
 - Conditions for BUSY (Msw1-3)

Confidential

- Data processing for receiving error (Msw1-4)
- ❑ Automatic line feed (Msw 1-5)
- ❑ Interface reset signal (Msw1-7, Msw1-8)

Starting the memory switch setting mode

Use the following procedure to start the memory switch setting mode.

1. Open the roll paper cover.
2. Turn the power on while pressing the paper FEED button until the POWER, ERROR, and PAPER OUT LEDs are all on.
3. Press the FEED button twice while POWER, ERROR, and PAPER OUT LEDs are on.
4. Close the roll paper cover.

The printer is now in the memory switch setting wait mode.

5. Press the FEED button. The printer prints the enabled settings of the memory switches and instructions.
6. Follow the instructions to make the switch settings.

Ending memory switch setting mode

Once the setting is performed, the contents of the setting are stored. Then the printer initializes. When initialization is finished, the printer returns to normal operating mode.

Operating procedure

The procedures used for this process are described below.

Entering Memory Switch Setting Mode

1. Open the roll paper cover and turn the power on while pressing the paper FEED button until POWER, ERROR, and PAPER OUT LED are on.
2. Press the paper FEED button twice while POWER, ERROR, and PAPER OUT LED are on.
3. Close the roll paper cover.
4. Press the paper FEED button.

The printer prints the current settings and setting instructions.

Selecting Items to Set

Open the roll paper cover.
Press the FEED button the number of times required to select the desired item (as shown below); then close the roll paper cover.
Pressing the paper FEED button 0 times or 7 or more times and then closing the cover will terminate this procedure.

<input type="checkbox"/> 1 time: Autocutter	<input type="checkbox"/> 0 times:
<input type="checkbox"/> 3 times: Basic Serial Interface Settings	<input type="checkbox"/> 2 times:
<input type="checkbox"/> 4 times: Advanced Interface Settings	<input type="checkbox"/> 7 or more times: Unused
<input type="checkbox"/> 6 times: Interface Reset Signal	

Selecting Individual Settings

Open the roll paper cover.
Press the FEED button the number of times required to select the setting for each item; then close the paper roll cover.

Autocutter (page 2-10)	Basic Serial Interface Baud Rate Setup (page 2-10) Data Length, Handshake, or Parity (page 2-11)	Advanced Interface Setting (page 2-10)	Automatic Line Feed (page 2-11)	Interface reset signal (page 2-12)
---------------------------	---	---	---------------------------------------	--

Ending Memory Switch Setting Mode

The printer prints the new settings and saves the settings to NV memory. Then, the printer is reset and enter the normal printable status. Begin using the printer or turn the power supply OFF.

Confidential

Selecting individual settings

Autocutter

Press the FEED button the number of times required to select the desired Autocutter setting.

Press FEED button	Setting to select
0 times:	No change
1 time:	Autocutter enabled (Note: "Installed" is printed in the setting guidance)
2 times:	Autocutter disabled (Note: "Not installed" is printed in the setting guidance)
3 or more times:	No change

Basic serial interface setting

To select transmission conditions, first choose "Serial interface settings"; then select "Data length, handshake, or parity."

Press the FEED button the number of times required to select the desired "Serial interface settings" used for transmission conditions.

Press FEED button	Setting selected
0 times:	No change
1 time:	115200 bps
2 times:	57600 bps
3 times:	38400 bps
4 times:	19200 bps
5 times:	9600 bps
6 times:	4800 bps
7 times:	2400 bps
8 or more times:	No change

bps: Indicates the number of transmitted bits per second (bps).

Data length, handshake, or parity

Press the FEED button the number of times required to select the desired “Data length, handshake, or parity” setting used for transmission conditions.

Press FEED button	Setting selected		
	Data Length	Handshake	Parity
0 times:	No change		
1 time:	8 bits	DTR/DSR control	None
2 times:			Even
3 times:			Odd
4 times:		XON/XOFF control	None
5 times:			Even
6 times:			Odd
7 times:	7 bits	DTR/DSR control	None
8 times:			Even
9 times:			Odd
10 times:		XON/XOFF control	None
11 times:			Even
12 times:			Odd
13 or more times:	No change		

Transmission-related conditions (Advanced Interface Setup)

Press the FEED button the number of times required to select the desired “Receive buffer size, receive error sequence, or busy condition” setting used for transmission-related conditions.

Press FEED button	Setting selected	
	Receive error sequence	BUSY condition
0 times:	No change	
1 time:	Change to '?'	Offline or receive buffer full
2 times:		Receive buffer full
3 times:	Ignore	Offline or receive buffer full
4 times:		Receive buffer full
5 or more times:	No change	

Automatic line feed (CR command function)

Confidential

Press the FEED button the number of times required to select the desired auto carriage return setting.

Press FEED button	Setting selected
0 times:	No change
1 time:	Enabled
2 times:	Disabled
3 or more times:	No change

Interface reset signal

Pins #25 and #6 on the RS-232 I/F circuit board unit (UB-S01/02) are used to input the reset signal. This item is used to "Enable (acknowledge)" or "Disable (not acknowledge)" input of the reset signal from one of these pins. Press the FEED button the number of times required to select the desired interface reset signal setting.

Press FEED button	Setting selected	
	Pin #25	Pin #6
0 times:	No change	
1 time:	Disabled	Disabled
2 times:		Enabled
3 times:	Enabled	Disabled
4 times:		Enabled
5 or more times:	No change	

Connection Form and Cables

Serial Connection

When the TM printer is connected to the host PC with a serial interface, the following connection forms are possible:

- Stand alone
- Y-connection
- Pass-through connection

Connections for usable serial cross cables are as follows:

Type A

D-Sub 25P(TM)			D-Sub 9P(PC)	
Pin No	Signal		Signal	Pin No
1	FG		DCD	1
2	TXD		TXD	3
3	RXD		RXD	2
20	DTR		DTR	4
6	DSR		DSR	6
4	RTS		RTS	7
5	CTS		CTS	8
7	GD		GD	5
25	RESET		RI/RESET	9

Type B

D-Sub 25P(TM)			D-Sub 9P(PC)	
Pin No	Signal		Signal	Pin No
1	FG		DCD	1
2	TXD		TXD	3
3	RXD		RXD	2
20	DTR		DTR	4
6	DSR		DSR	6
4	RTS		RTS	7
5	CTS		CTS	8
7	GD		GD	5
25	RESET		RI/RESET	9

The type of cable that should be used depends on the operation and the handshake method for the TM printer. You can operate the TM printer with the Windows driver, OPOS, or ESC/POS commands. XON/XOFF, DTR/DSR, or RTS/CTS are available as handshake controls. See tables in the following sections for the cable type for each connection.

Stand alone

Both TM printer and customer display (DM-D) are connected to the host PC via serial port.

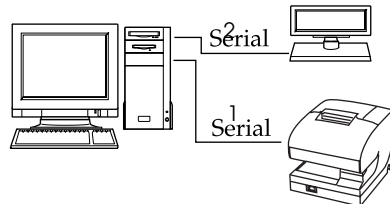

Application control setting		XON/XOFF (except OPOS)	DTR/DSR (DOS, OPOS, Visual C)	RTS/CTS (DOS, Windows driver, Visual C, Visual Basic, MSComm)
XON/XOFF	1	Type A or B	—	—

Confidential

	2	DM-D500: A,B Other DM-D: not available	—	—
DTR/DSR	1	—	Type A or B	Type B
	2	—	Type A or B	Type B

Y-connection

TM printer is connected to the host PC via serial port and the customer display (DM-D) is connected to TM printer via modular connector.

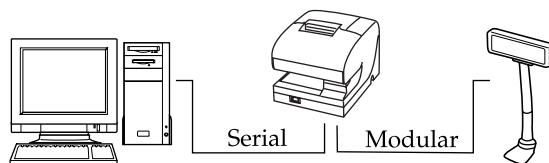

Application control setting	XON/XOFF (except OPOS)	DTR/DSR (DOS, OPOS, Visual C)	RTS/CTS (DOS, Windows driver, Visual C, Visual Basic, MSComm)
TM side control setting	Not available	—	—
XON/XOFF	Not available	—	—
DTR/DSR	—	Type B (*)	Type B

(*) When RTS/CTS control is used between the TM and DM.



Note:

You need to use the UB-S09 interface when you use a modular connector.

On the DM-D (DM-D500 etc...) which has a DIP switch to select Y-type connection, confirm that the DIP switch has been set to "Y-type connection: Enable."

Pass-through connections

The TM printer is connected to the customer display (DM-D) via a serial port, and the DM-D is connected to the host PC via a serial port.



Note:

On the DM-D (DM-D500 etc...) which has DIP switch to select Y-type connection, confirm that the DIP switch has been set to "Y-type connection: Disable."

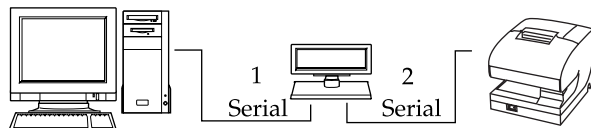

Application control setting		XON/XOFF (except OPOS)	DTR/DSR (DOS, OPOS, Visual C)	RTS/CTS (DOS, Windows driver, Visual C, Visual Basic, MSComm)
XON/XOFF		Not available	—	—
DTR/DSR	1	—	Type A or B	Type B
	2	—	Type A or B	Type A or B

Parallel Connection

The TM printer is connected to the host PC via a parallel interface board (UB-P02II). The customer display (DM-D) is connected to the host PC via a serial port.

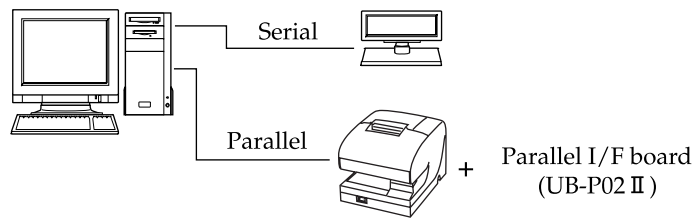

USB

The TM printer can be connected to the host PC via a USB connector, and other TM printers can be connected to the first printer via USB.

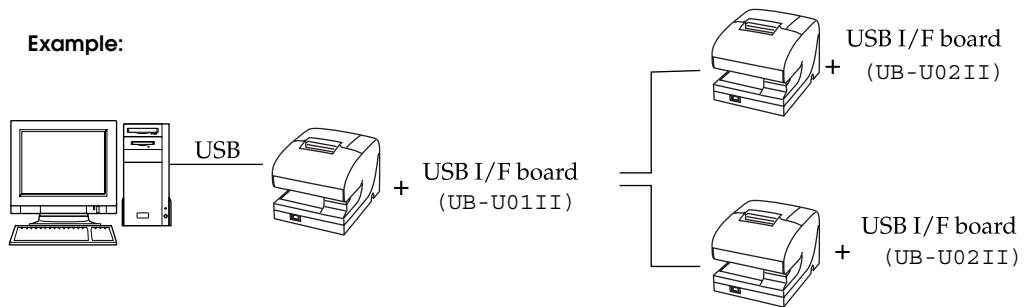

Confidential

Ethernet

TM printers are connected to a network via a hub using an Ethernet cable.

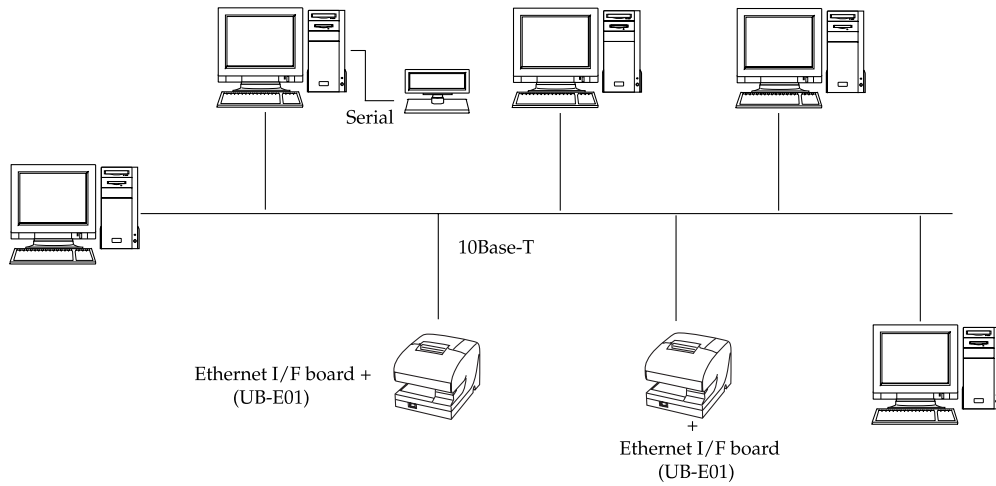

Note:

If the TM printer is connected to the host PC via the Ethernet interface, a DM-D cannot be connected to the TM printer.

For IBM POS systems

When installing this printer on an IBM POS system (IBM Sure POS 700 series, or IBM 4694 models 041, 044, and 144), follow the procedure below.

1. Remove the rubber feet.
2. Install new rubber feet as shown in the following illustration.

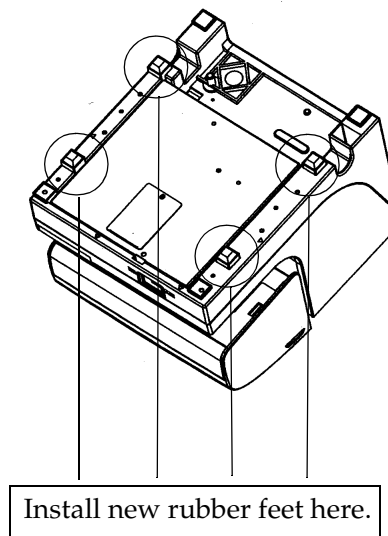
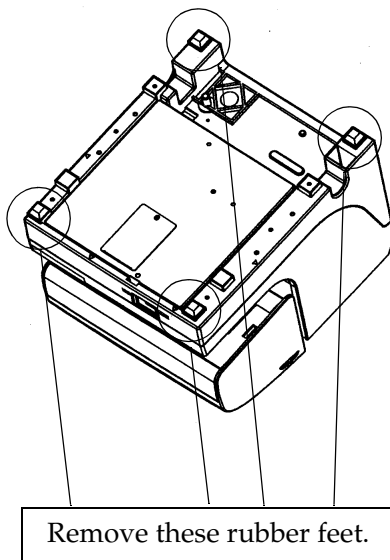
**Note:**

You can get rubber feet separately by using the part numbers in the brackets as follows.

- ❑ Rubber foot <1075187>

Confidential

Chapter 3

Application Development Information

This section explains key words and miscellaneous information in a question and answer format and the single-pass processing for developing a system with the TM-J7000/J7100.

Confidential

Key words in Q & A

Category	Question	Answer
Active sheet	What is an active sheet?	Any one of the types of paper the printer can process, such as roll paper, a slip sheet, or a check.
	Why the active sheet is selected?	To select the functions the printer can use. For example, roll paper requires certain functions that the other types of paper do not require.
	What commands are related to the active sheet?	<p>GS (G function 80 selects the active sheet. For the following actions, the active sheet will be selected automatically without being selected by GS (G function 80.</p> <ul style="list-style-type: none">• A print sheet will automatically be the active sheet when a print sheet selected by ESC c 0.• Check will automatically be the active sheet when FS a 0 (read check paper) is executed• Slip will automatically be the active sheet when FS a 1 (Load check paper to print starting position) is executed.• Slip will automatically be the active sheet when GS (G function 48 (Specifies slip as the paper type and the side to be printed) is executed.• Roll paper is will automatically be the active sheet when the slip is ejected by FF (Print and eject cut sheet) after printing on the slip.• Roll paper is will automatically be the active sheet when a cut sheet is release by ESC q is executed.• Roll paper is will automatically be the active sheet when a check is ejection by FS a 2 is executed.

Category	Question	Answer
Active sheet	When do you need to select the active sheet with GS (G function 80) ?	Before image scanning you need to select a check as the active sheet.
	A check is automatically selected as the active sheet with FS a 0 , read check paper; however the check is not selected automatically by GS (G function 65) when reading an image of a check. Why?	The current command, FS a 0 has multiple functions so that it automatically selects the active sheet; then reads the MICR; however GS (G function 65) has only one function so that there is flexibility of command combination, which follows the policy of the ESC/POS that one command has one function.
Print sheet and print side	What is the difference between GS (G function 48) , select slip as the paper type and the side of the sheet to be printed, and ESC c 0 , select paper type(s) for printing?	Print sheet and print side to be selected are different. GS (G function 48) is exclusively for a slip, selecting surface or back of the sheet, not for selecting roll paper. After executing FS a 0 , read check paper, even if GS (G function 48) is executed, the slip will not be ejected; therefore, it is possible to check the single-pass processing. ESC c 0 can select roll paper or the surface of a slip; however the back of the slip cannot be selected. After executing FS a 0 , read check paper, if the slip is selected by ESC c 0 , the slip is ejected and the printer will be in the slip insertion waiting state.

FS a 0, FS a 1, FS a 2 are obsolete commands; therefore, we recommend using other commands instead of these commands. See following descriptions.

Obsolete command

There are more suitable substitute commands for the following commands. These obsolete commands will not be supported by future printer models. More suitable substitute commands follow.

GS (G <Function 60> is a substitute for **FS a 0**

GS (G <Function 48> and **GS (G <Function 84>** are a substitute for **FS a 1**

GS (G <Function 85> is a substitute for **FS a 2**

GS V is a substitute for **ESC i** and **ESC m**

GS r is a substitute for **ESC u** and **ESC v**

GS (C is a substitute for **FS g 1** and **FS g 2**

GS (L is a substitute for **FS p** and **FS q**

Confidential

Miscellaneous Information in a Q & A Format

The following Q & A will help you understand more about the printer.

Question	Answer
What happens when an ink out occurs?	The printer prints all data in the line being printed when the ink out signal is received; then it stops printing.
With two ink cartridges (main color and sub color), how does the printer work if only one cartridge is empty?	The printer stops printing. If either one of the ink cartridges is empty, it is impossible to continue printing.
If one color is never used for printing, the color ink isn't consumed?	No. Even if one color is never used, both ink head nozzles are cleaned periodically. The cleaning consumes a small amount of ink.
Disposed ink absorption material is provided only for the sub color side. if only the main color is used frequently, might the capacity of the ink absorption material exceed its tolerance?	No. If the only the main color is used frequently, cleaning of the sub color is also performed, which reduces the sub color ink. If the sub-color is never used for printing and all ink is used only by cleaning while the main color ink is replaced a few times, there will be enough disposed ink absorption material capacity until the sub color ends.
What happens when a pump unit reaches the end of its life (when a message of pump unit life end is printed)?	The life of the pump unit is approximately twice as much as that of the printer; usually the pump unit will last 10 years.
What is the method of extending the printing area on a slip in page mode?	You should use the Function 48 of the GS(P) command. A. Adjust the horizontal offset of page mode to the edge of your designed printing area. B. Choose single color using the parameter c .

Single-Pass Processing

EPSON recommends the following sequence of MICR reading, endorsement printing, and printing on front for single-pass processing.

Step	User Operation	Printer Operation
1	Transmit GS (G <Function 80> [GS (G 2 0 80 32]	Selects the check as the paper source.
2	Transmit GS (G <Function 83> [GS (G 2 0 83 48]	Waits for a cut sheet to be loaded. The CUT SHEET LED flashes
3	Insert a cut sheet. (*1)	Clamps the cut sheet when it is detected. The CUT SHEET LED flashes.
4	Transmit GS (G <Function 60> [GS (G 4 0 60 1 0 m]	Reads MICR characters and transmits the reading status. <i>m</i> specifies the type of MICR characters. (<i>m</i> = 0: E13B / <i>m</i> = 1: CMC7)
5	Transmit GS (G <Function 48> [GS (G 2 0 48 68]	Selects the back of the slip (cut sheet) as the paper source. (The back of the cut sheet which has been read for MICR becomes the side to be printed.)
6	Transmit GS (G <Function 84> [GS (G 2 0 84 1] (*3)	Feeds the print starting position on the back of the slip (cut sheet).
7	Transmit endorsement printing data.	Prints data on the back of the cut sheet and feeds the cut sheet.
8	Transmit GS (G <Function 48> [GS (G 2 0 48 4]	Selects the face of the slip (cut sheet) to be printed. (The face of the cut sheet which has been read becomes the side to be printed.)
9	Transmit GS (G <Function 84> [GS (G 2 0 84 1] (*3)	Feeds the print starting position on the face of the cut sheet.
10	Transmit cut sheet printing data	Prints on the face of the cut sheet and feeds the cut sheet.
11	Transmit GS (G <Function 85> [GS (G 2 0 85 m]	Ejects or releases the cut sheet, and selects the paper roll as the paper source. <i>m</i> specifies the type of operation (<i>m</i> = 48: eject / <i>m</i> = 49: release) The CUT SHEET LED flashes.
12	Remove the cut sheet. (*2)	The CUT SHEET LED is off.

- (*1) Insert the cut sheet correctly by aligning the upper and right side of the cut sheet with the upper and right side of the printer's paper insertion position and inserting it until it is stopped by the form stopper.
The cut sheet insertion waiting state is canceled using **DLE ENQ** (*n* = 3).
The cut sheet waiting time and the interval from when a cut sheet is inserted to when the operation starts can be set using **ESC f**.

Confidential

(*2) After processing **GS (G <Function 85>**, the printer flashes the CUT SHEET LED and does not take the next action until the paper is removed.

(*3) The print starting position can be set once per each printing of face of the slip.

NOTE:

The following shows the paper position and paper feeding directions for the single-pass processing. The number of the picture corresponds to the number of the step in the table above.

- You can omit the processes you do not need.

Example: You can omit steps 5, 6, and 7 if you are not doing endorsement printing.
You can omit steps 8, 9 and 10 if there is handwriting on the surface side.

- For details of the commands and the programming samples, see the ESC/POS Application Programming Guide.

The following shows the paper position and paper feeding directions for the single-pass processing. The number of the picture corresponds to the number of the step in the table above.

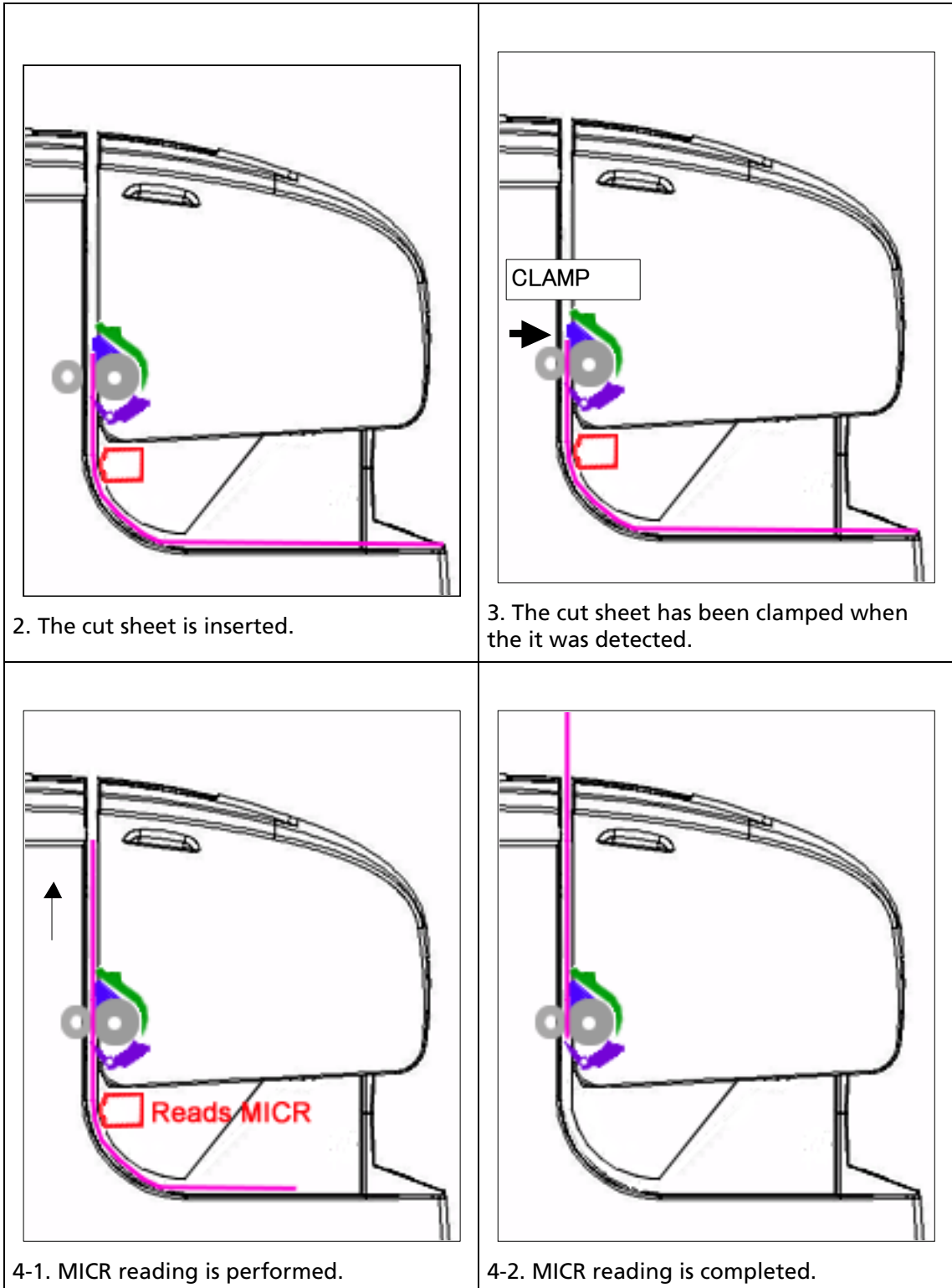

Confidential

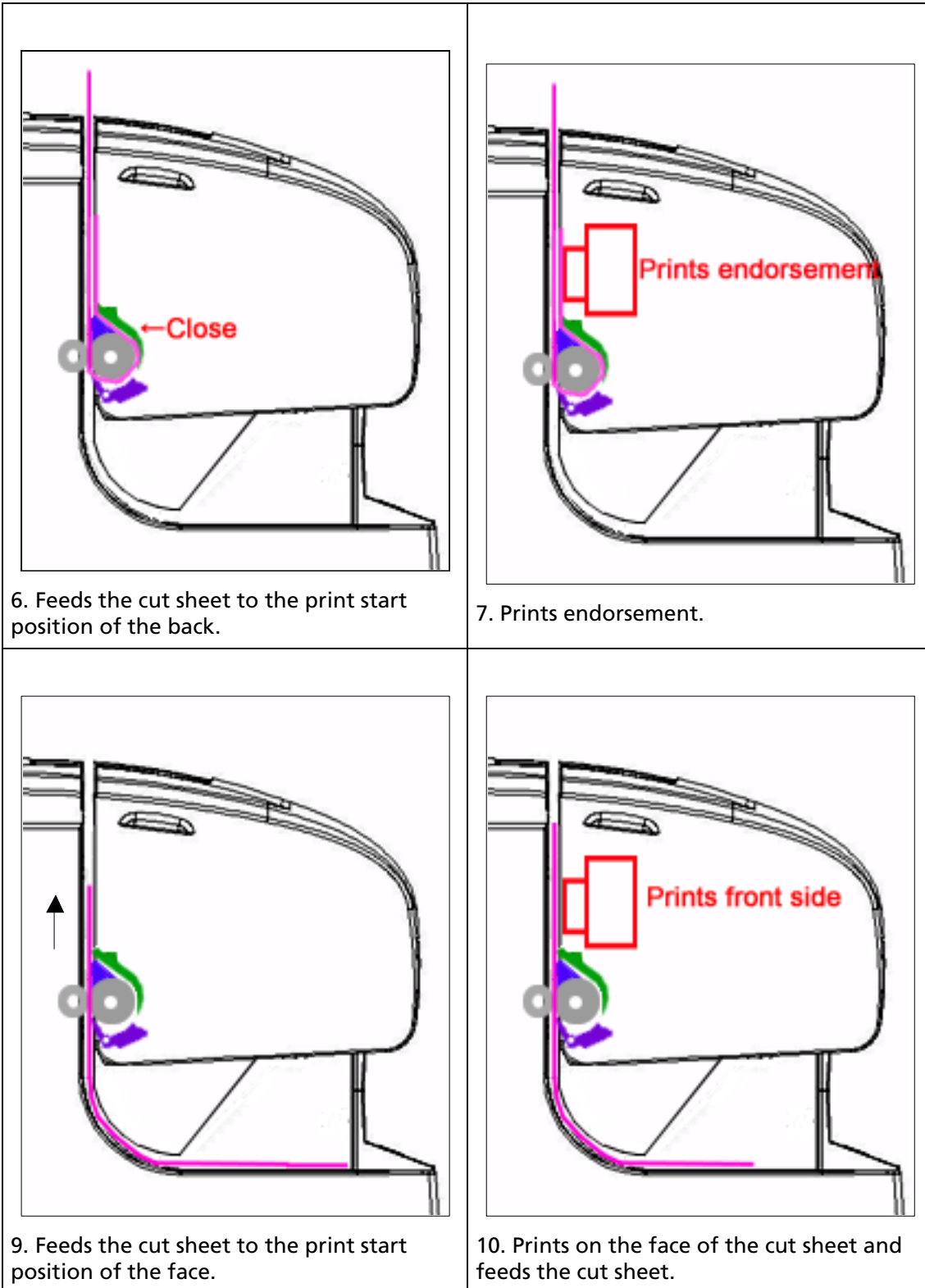

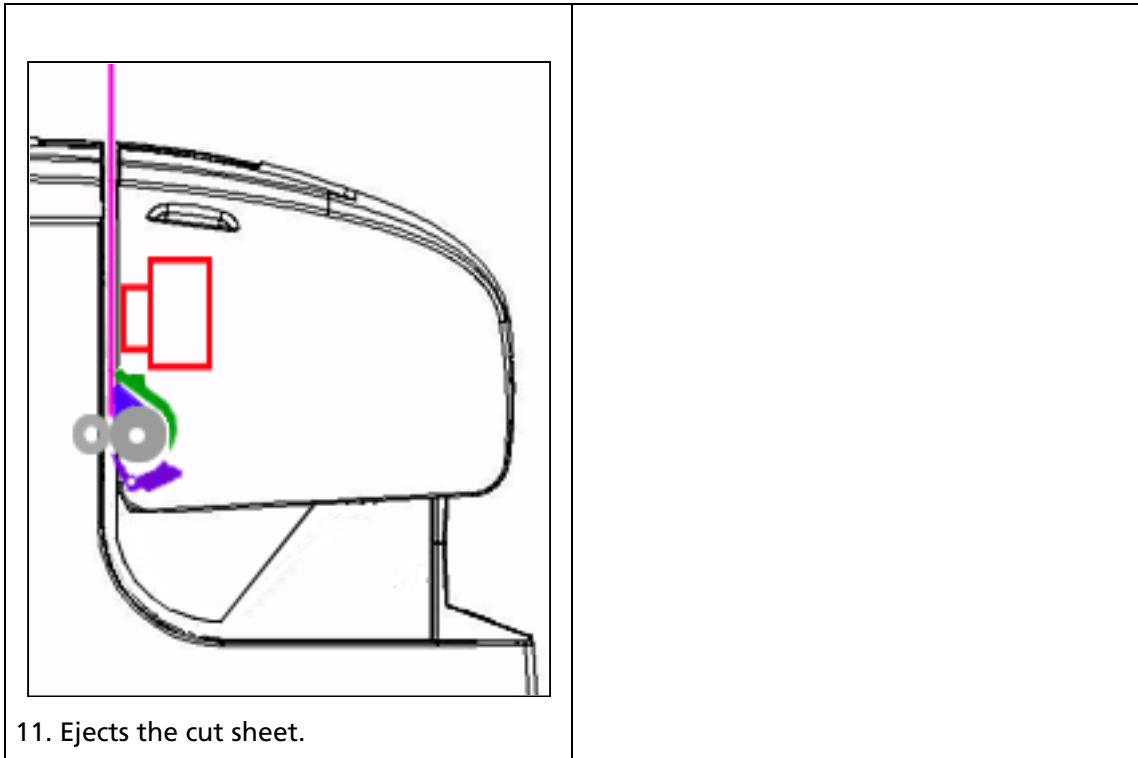

Confidential

*Chapter 4***Specifications****Product Specifications**

Item	Specifications
Printing method	Serial ink jet dot matrix
Paper width	Roll paper: 82.5 ± 0.5 mm, 76 ± 0.5 mm, 69.5 ± 0.5 mm, 57.5 ± 0.5 mm
Autocutter	Circular-type cutting method One point left uncut (partial cut)
Connector	Interface connector, power connector, drawer kick connector, DM-D connector (Available only for the serial interface model)
Switch and Button	Power switch, paper feed Button, cleaning Button
LED	Power LED, Error LED, Ink out LED, Paper out LED, Cut sheet LED
Reception buffer	4 kbytes
Download buffer	12 kbytes for both download characters and download bit images
NV graphics and user NV memory	384 kbytes
Power supply	Power supplied by AC adapter PS-180 (option)
Operating voltage	24V±2.4V
Current consumption (excluding drawer kick drive)	Operating: Mean: Approximately 0.5A (Printing alphanumeric characters in font A, all columns) Peak: Approximately 2.7A Standby: Mean: Approximately 70 mA
External dimensions	188 × 195 × 237 mm (H × W × D)
Weight (mass)	Approximately 4.4 kg

Confidential

Print Specifications

Item		Specifications
Print method		Serial inkjet dot matrix
Head nozzle array	TM-J7000	64 nozzles X 1 line Nozzle pitch approx. 0.141 mm (1/180 inch)
	TM-J7100	64 nozzles X 2 lines (one line for each color) Nozzle pitch approx. 0.141 mm (1/180 inch)
Printing direction		Bidirectional logical seeking
Paper feed		See each printer section
Printing width (Roll paper)		See each printer section. (roll paper printer, slip printer, and endorsement printer)
Character count		See each printer section. (roll paper printer, slip printer, and endorsement printer)
Printing speed		See "Print Speed." table.
Paper feed speed		Approx. 150 mm/s (approx. 5.9 inches/s) at 35.4 lps (lps: lines per second)
Print Control mode		See "Print Control Modes." table. Normal, high-speed, or economy mode can be set using software commands.
Line spacing		Approx. 4.23 mm or 1/6 inch (default) 3.18 mm (1/8 inch) (when printing 3 lines at a time) Set using software commands

Print Control Modes

Print mode		Number of carriage passes (*1)	Vertical resolution (dpi)	Horizontal resolution (dpi)	Dot structure (number of pulses to the head)
Name	Description				
Normal	Offers high-density (high quality) printing.	1	180	180	6
High-speed	Features high-speed printing and ink saving. (Is the default mode)	1	180	180	3
Economy	Features even greater ink saving than high-speed mode.	1	180	180	2

(dpi: Dots per inch (25.4 mm) {1"})

(*1) Pass: To move the carriage from the left to the right or from the right to the left.

Print Speed

Print mode	Font	Unit	Paper width (mm)				Slip
			57.5 {2.26"}	69.5 {2.74"}	76 {2.99"}	82.5 {3.25"}	
Normal	Font A (6 lpi)	lps	7.4	6.7	6.3	6.0	6.0
	Font B (8 lpi)	lps	10.7	9.5	8.9	8.6	8.6
	Graphics	mm/s	32	29	27	26	26
High-speed	Font A (6 lpi)	lps	11.6	10.5	10.1	9.7	9.6
	Font B (8 lpi)	lps	16.4	15.0	14.3	13.8	13.7
	Graphics	mm/s	50	45	43	41	40
Economy	Font A (6 lpi)	lps	11.6	10.5	10.1	9.7	9.6
	Font B (8 lpi)	lps	16.4	15.0	14.3	13.8	13.7
	Graphics	mm/s	50	45	43	41	40

 **Note:**

All values listed above are the printing speed without character modification when the printing is performed continuously for all columns without cleaning.

Printing speed may be slower, depending on the data transmission speed and the combination of control commands. If the data transmission speed is slow, the printing becomes intermittent. Therefore, it is recommended to use high-speed data transmission.

Confidential

Character Specifications

Character Specifications

Item		Specifications
Character type	Alphanumeric	95 characters
	International	37 types
	Extended graphics	128 characters × 11 pages (including one user-defined page)
Character structure		See "Character Configurations and Dimensions" table below. (Default is Font A.)
Character dimensions		See "Character Configurations and Dimensions" table below. (Spaces between characters not included.)

Character structure

	Font A	Font B	* Font A	* Font B
Dot configuration H × V (includes 2-dot H space)	12 × 24	9 × 17	11 × 24	8 × 17

* : Using the memory switch for characters per line



Note:

The number of characters (columns) per line is selectable by a memory switch.

Selection of characters per line can be performed for receipt and slip (including endorsement).

If memory switch changing of characters per line is performed, one dot on the right side of a graphic character or user-defined character may be missed.

Character size

	Standard	Double-height	Double-width	Double-width / Double-height
	W × H (mm)	W × H (mm)	W × H (mm)	W × H (mm)
Font A (12 × 24)	1.69 × 3.38	1.69 × 6.77	3.38 × 3.38	3.38 × 6.77
Font B (9 × 17)	1.27 × 2.40	1.27 × 4.80	2.54 × 2.40	2.54 × 4.80
* Font A (11 × 24)	1.55 × 3.38	1.55 × 5.77	3.10 × 3.38	3.10 × 6.77
* Font B (8 × 17)	1.13 × 2.40	1.13 × 4.80	2.26 × 2.40	2.26 × 4.80

The actual print character may be smaller than the size shown in the table above, because the above size includes spaces in the font.

Characters can be scaled up to 64 times as large as the standard size.

Character size not including the horizontal spacing in the standard scale is as follows:

Font A: 1.41 (W) × 3.384 (H) mm

Font B: 0.987 (W) × 2.397 (H) mm

Receipt Printer Section**Characters per Line and Printable Area for Roll paper**

Paper roll width (mm)		57.5 {2.26"}	69.5 {2.74"}	76 {2.99"}	82.5 {3.25"}	Remarks
Number of dots for printing (dots)		360	432	480	512	
Printable width (mm)		50.8 {2.00"}	61 {2.40"}	67.7 {2.67"}	72.2 {2.84"}	
Characters per line	Font A (12 × 24)	30	36	40	42	When printing at 15 cpi
	Font B (9 × 17)	40	48	53	56	When printing at 20 cpi
	* Font A (11 × 24)	32	39	43	46	When printing at 16.3 cpi
	* Font B (8 × 17)	45	54	60	64	When printing at 22.5 cpi

*: Selectable by a memory switch
(cpi: Characters per inch (25.4 mm) {1 "})

Paper Feed Specifications*Paper Feed Specifications*

Item	Specifications
Paper feed method	Friction feed
Paper feed direction	Unidirectional
Feeding pitch	Min. approx. 0.1411 mm (1/180 inch)
Continuous feed speed	Approx. 150 mm/s (approximately 5.9 inches/s) at 35.4 lps

lps: lines per second

Confidential

Printable Area

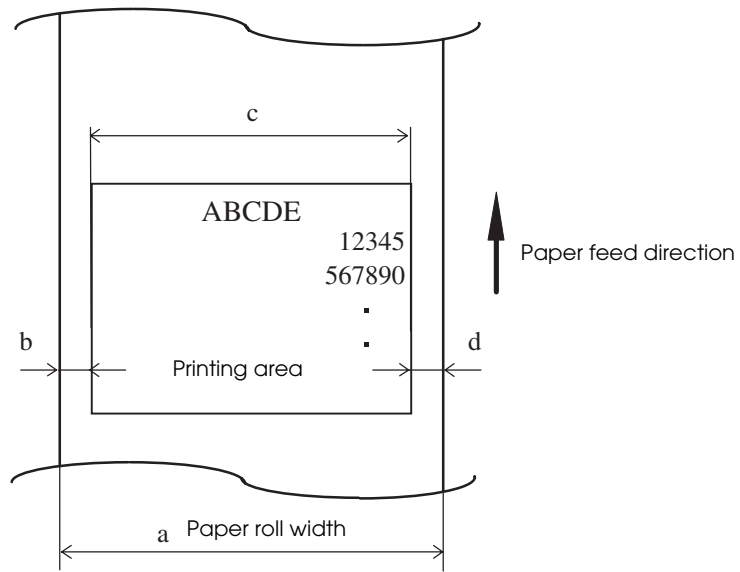

Printable Area

Dimensions

a (paper roll width)	b (left margin)	c (printing area)	d (right margin)
57.5 {2.26"}	3.4 {0.13"}	50.8 {2.00"} (360 dots)	3.3 {0.13"}
69.5 {2.74"}	4.2 {0.17"}	61.0 {2.40"} (432 dots)	4.3 {0.17"}
76 {2.99"}	4.3 {0.17"}	67.7 {2.67"} (480 dots)	4.2 {0.17"}
82.5 {3.25"}	6.0 {0.24"}	72.2 {2.84"} (512 dots)	4.3 {0.17"}

Printing Position Versus Cutter Position

The printing position in relation to cutter position is shown in the figure below.

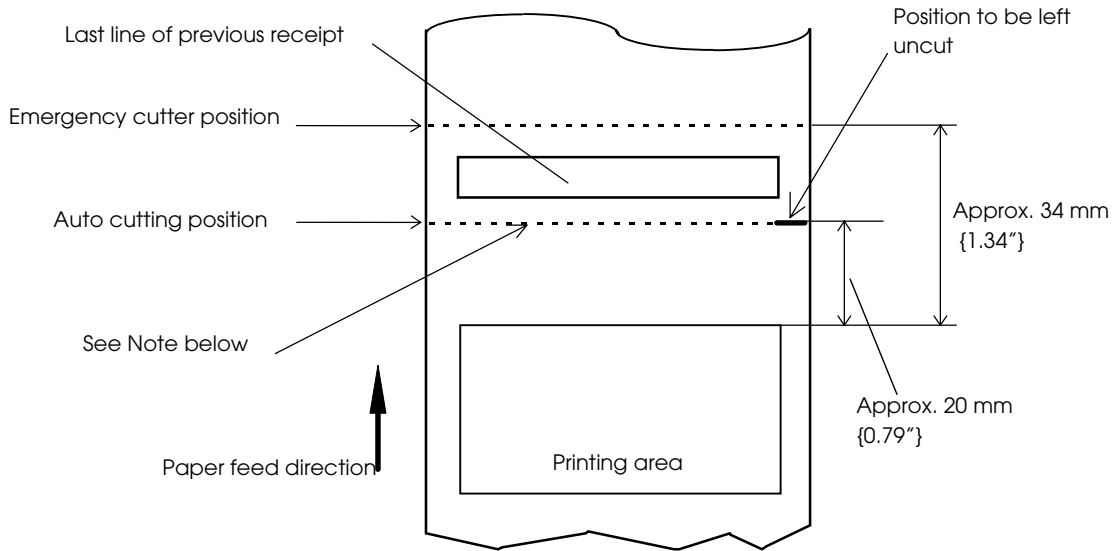

Printing Position Versus Cutter Position

 **Note:**

Numeric values used here are typical values; the values may vary slightly as a result of paper slack or variations in the paper. Take this note into account when setting the cutting position of the autocutter.

Slip Printer Section

Characters per Line and Printable Area for Slips

Number of dots for printing (dots)		576	
Printable width (mm)		81.3 {3.20"}	
Characters per line	Font A (12 × 24)	48	When printing at 15 cpi
	Font B (9 × 17)	64	When printing at 20 cpi
	* Font A (11 × 24)	52	When printing at 16.3 cpi
	* Font B (8 × 17)	72	When printing at 22.5 cpi

*: Selectable by a memory switch

Confidential

Paper Feed Specifications

Paper Feed Specifications

Item	Specifications
Paper feed method	Friction feed
Paper feed direction	Bidirectional
Feeding pitch	Approx. 0.1411 mm (1/180 inch)
Continuous feed speed	Approx. 150 mm/s (approximately 5.9 inches/s) at 35.4 lps

lps: lines per second

Printable Area

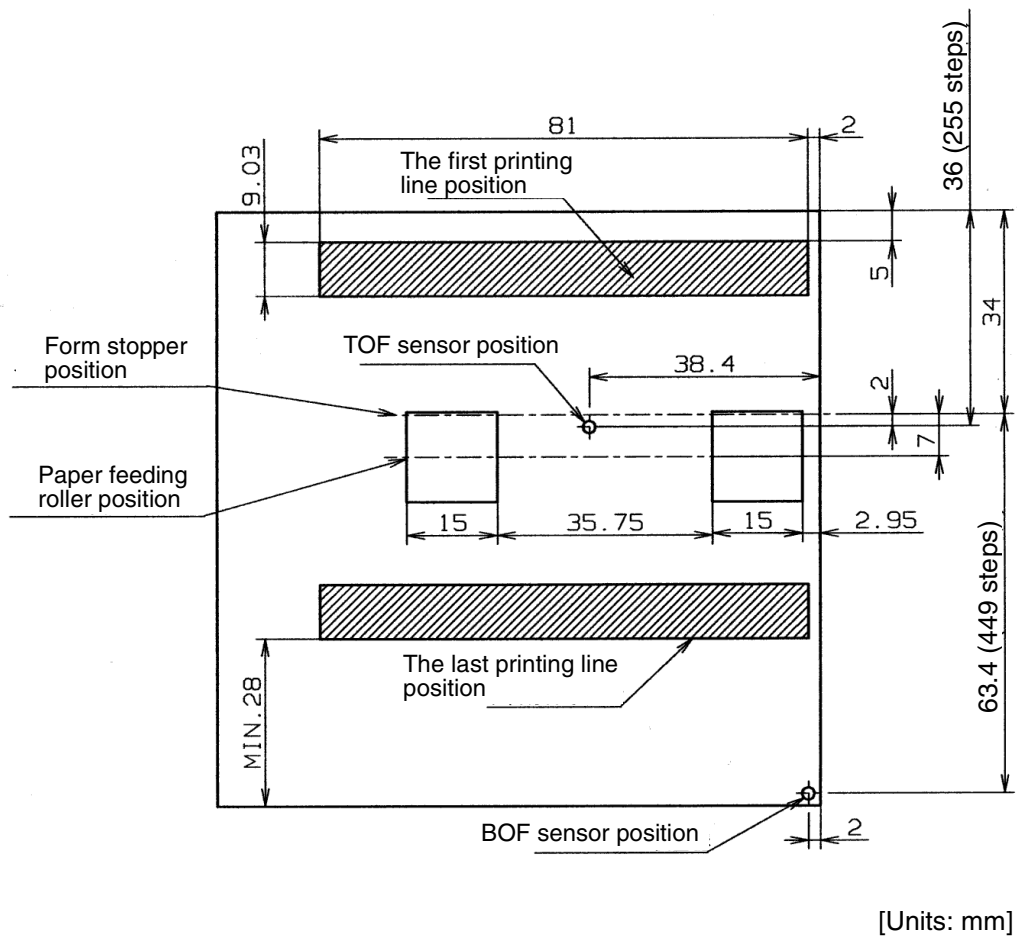

Printable area



Note:

The values shown in this figure are calculated ones. Consider this for the user design for the print starting position in the paper feeding direction.

MICR Reader Section (Factory-Installed Option)**Reading Method**

Permanent magnetic bias

Recognition Rate

98% or more at 25°C {77°F}

Recognition rating is defined as follows

$$\text{Recognition rating (\%)} = \frac{\text{Total number of checks} - (\text{number of sheets misread or not identified.})}{\text{Total number of checks}} \times 100$$

- Check paper used for test is EPSON standard check paper.
- Checks must be flat, without curls, folds, or wrinkles.

Confidential

Insertion Direction and Endorsement Printing

Insert the check with the surface printed with the magnetic ink facing upward, following the slip side guide.

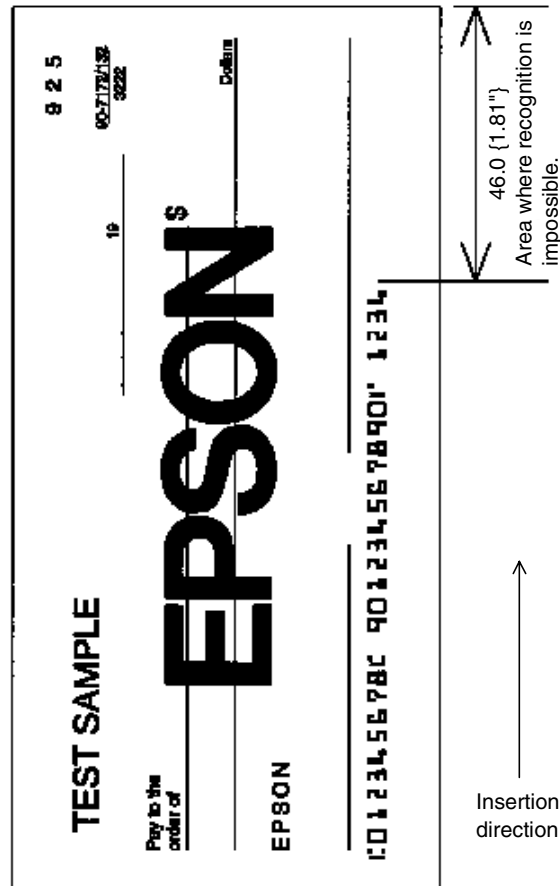

Area of Personal Check where MICR Character Recognition is Impossible

Notes on Using the MICR Reader

- ❑ Do not install the printer near any magnetic fields, because this may cause MICR reading errors. (Especially when the printer is used near the display device, the user must check the recognition rate of the MICR.)
- ❑ The MICR characters may not be recognized when impact or vibration is applied to the printer.
- ❑ Multiple fold checks are not supported.
- ❑ The personal checks must be flat, without curls, folds, or wrinkles (especially at the edges). Otherwise, the check may rub against the nozzles and become ink-stained.
- ❑ Do not insert checks that have clips or staples. These may cause paper jams, MICR reading errors, and damage to the MICR head.

- ❑ Let go of the check immediately as soon as the printer starts feeding it. Otherwise, the paper is not fed straight, causing paper jams and MICR reading errors. Also, do not open any covers.

Endorsement Mechanism Section (Factory-Installed Option)

The endorsement mechanism enables printing of endorsements as part of a sequence that is automatically processed: MICR reading, printing an endorsement on the back of the personal check, and printing on the face of the check.

Characters per Line and Printable Area for Endorsement (Factory- installed Option)

Number of dots for printing (dots)		552	
Printable width (mm)		7739 {3.06"}	
Characters per line	Font A (12 × 24)	46	When printing at 15 cpi
	Font B (9 × 17)	61	When printing at 20 cpi
	* Font A (11 × 24)	50	When printing at 16.3 cpi
	* Font B (8 × 17)	69	When printing at 22.5 cpi

*: Selectable by a memory switch (same as the setting for slip)

Printable Area

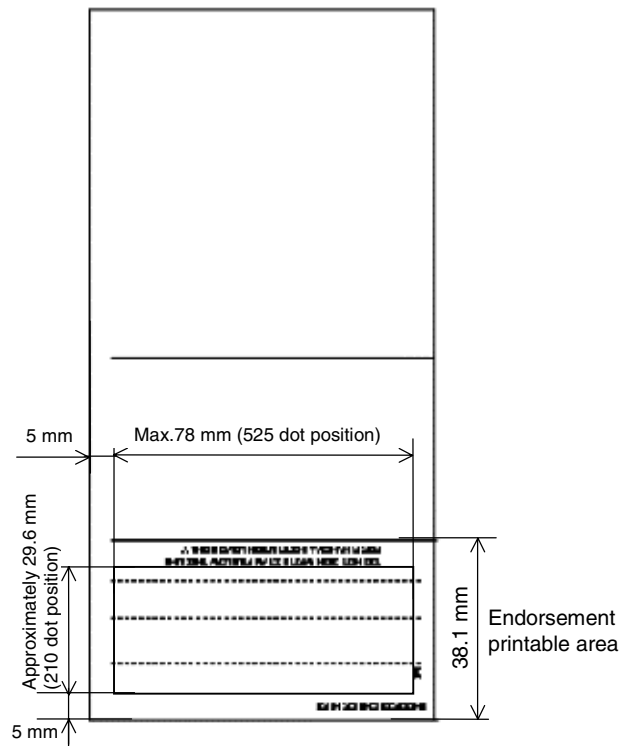

Printable Area for Endorsement Printing

Confidential



Note:

The values shown in this figure are calculated ones. Consider this for the user design for the print starting position in the paper feeding direction.

Notes on Using the Endorsement Mechanism

- ❑ The endorsement mechanism enables printing of endorsements on the back of a personal check. Do not use paper that is over 101.6 mm {4"} in width. Otherwise, paper may be jammed.
- ❑ Do not open any covers while the sequence of check reading and endorsement printing is processed. Otherwise, the paper is not fed straight, causing paper jams and MICR reading errors.
- ❑ Observe the same limitations as for slips for the position of paper holes and the reflection ratio of the check.

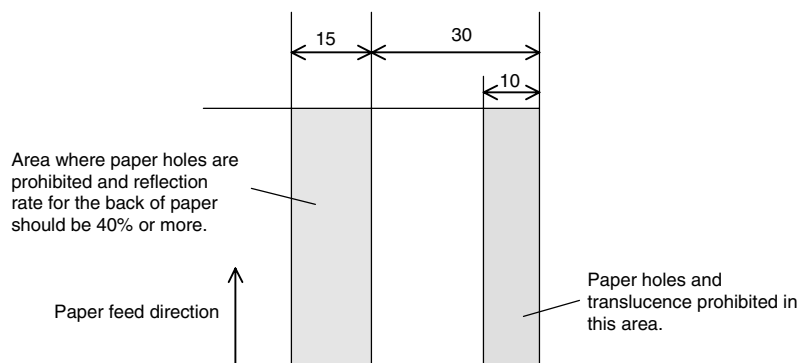

[Units: mm (All the numeric values are typical.)]

Paper Specification**Paper Roll Specification**

Paper type	Normal quality paper (only single-ply rolls can be used)
Form	Roll paper
Paper width	Can be selected an any of the following: 82.5 ± 0.5mm 76 ± 0.5mm 69.5 ± 0.5mm 57.5 ± 0.5mm
Paper thickness	0.06 ~ 0.09mm
Paper weight	52.3 ~ 64.0 g/m ² {14 ~ 17 lb} (JIS P8124) (45 ~ 55 kg / 1000pcs / 788mm × 1091mm)
Spool diameter	inside: 10mm {0.39"} or more
Roll paper diameter	Outside: 83mm {3.27"} or less

Slip Paper Specification

Paper type	Normal paper
Paper size	68 ~ 230mm (W) × 68 ~ 297mm (L) {2.7 ~ 9.1" (W) × 2.7 ~ 11.7" (L)} * The minimum paper size is 68mm (W) × 152mm (L) {2.7" (W) × 6.0" (L)}
Paper thickness	0.09 ~ 0.2mm {0.0035 ~ 0.0079"} (only single-ply can be used)

Notes on slip paper

- ❑ The slip paper must be flat, without curls or wrinkles, especially at the top edges. Otherwise, the paper may rub against the nozzles and become dirty.
- ❑ Since the slip BOF sensor uses a photo sensor, do not use paper that has holes at the sensor position, or is translucent.

Confidential

- Since the slip TOF sensor uses a reflective photo sensor and it detects from the back of slip paper, do not use paper that has holes or dark portions with low reflection (less than 40% reflection) at the sensor position.

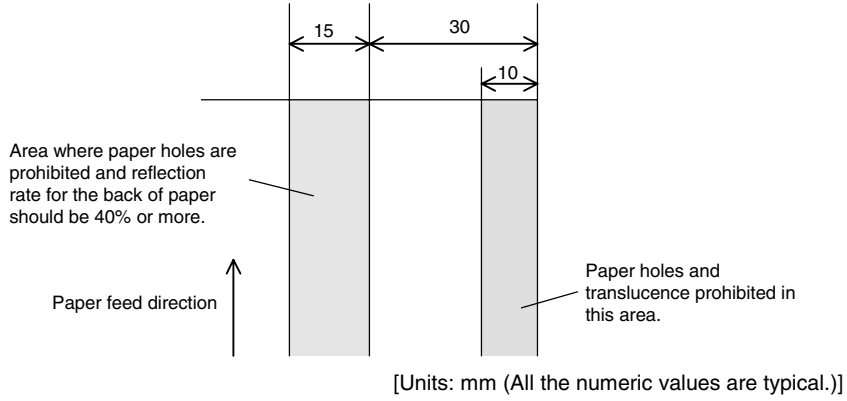

Area with No Paper Holes and Low Reflection

Endorsement Paper Specification

Paper type	High- quality paper (only single-ply paper can be used)
Paper size	68 ~ 101.6mm (W) × 150 ~ 223mm (L) {2.68 ~ 4.17" (W) × 5.90 ~ 8.98" (L)}
Paper thickness	0.09 ~ 0.13mm {0.0035 ~ 0.0051"} (only single-ply can be used)