

pick-up current. No precise adjustment is required as a little above the required amount is always allowed so as to safeguard against wet weather, but if too high the other circuit may be robbed. The best way to adjust the resistance is to connect an ammeter in series with

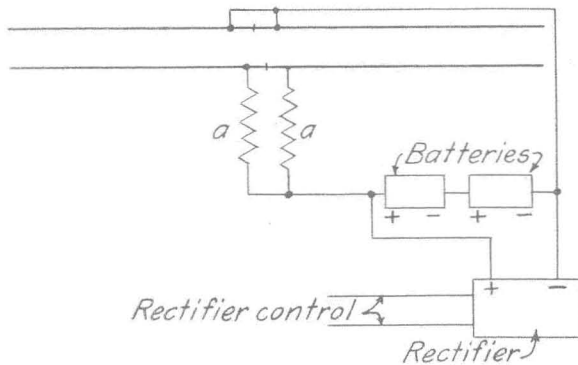

Circuit Using Cells In Series

the circuit and adjust until the meter registers a little above that specified on the relay chart.

Philadelphia CLIFFORD S. BOZORTH,  
Signal Maintainer, Philadelphia & Reading.

### Permissive Block Signal Circuits

Will one of the readers of the *Railway Signal Engineer* please explain in detail the operation of the A. P. B. signal system.—B. A.

#### Answer

Absolute Permissive Block signal circuits for single track are so designed as to give permissive signal indication for following train movements yet at the same time to give absolute stop indications for opposing movements between sidings. The track layout and circuit diagram of a typical installation of A. P. B. signaling on the single track line of the Los Angeles & Salt Lake, between Lyнды, Utah and Salt Lake City, is explained as follows:

In Fig. a with no trains between stations X and Y, the normal position of all signals is proceed. In Fig. b a train at Y has entered the block thus setting all west bound signals from Y to X at stop. The manner in which this is brought about is as follows:

When the train passes the starting signal S at station Y the track relay T is shunted thereby opening the con-

trol wire WHDR3 and cutting off current on this wire. This causes relay H at signal F to drop, opening up the control wire WHDR5 and also opening the motor circuit for signal F causing it to go to stop.

When the control wire WHDR5 at signal F is opened, it in turn causes relay H at signal G to drop, putting signal G to stop and opening the control wire for signal H, which causes the control relay H for signal H to drop. This puts signal H to stop and opens control wire for signal I, causing control relay H at signal I to drop, which in turn puts signal I to stop. When signal I gets below 44 deg. on the way down, it pole changes the battery, making the control WHDR3 negative and the CLE wire positive. This in turn causes the polar contacts on the control relay for signal J to reverse putting signal J to the caution or the 45 deg. position. Thus any westbound train approaching siding at X would receive a caution signal at signal J, indicating to the engine-man that an eastbound train was out of Y, the station at Boulter.

In order to allow trains to follow each other safely with a spacing of only one automatic block rather than

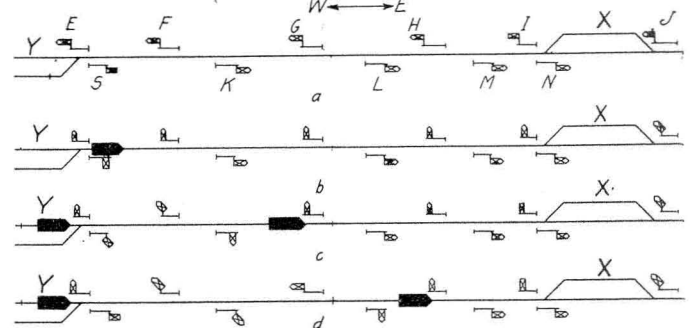

Track and Signal Plans of Typical A. P. B. Signaling

having one train wait until the other clears the next station, a special stick relay circuit is so connected as to permit the signal to clear after a train passes into the second block.

Referring to Fig. c, when the train passes signal K track relay T drops which puts current on the ES wire, picking up relay STK. Relay H also drops and when the signal reaches the stop position the ES1 wire is opened. However, the ES2 wire is energized through a back contact on relay H and holds relay STK up through its own front contact. Wire EHDR4 then gets

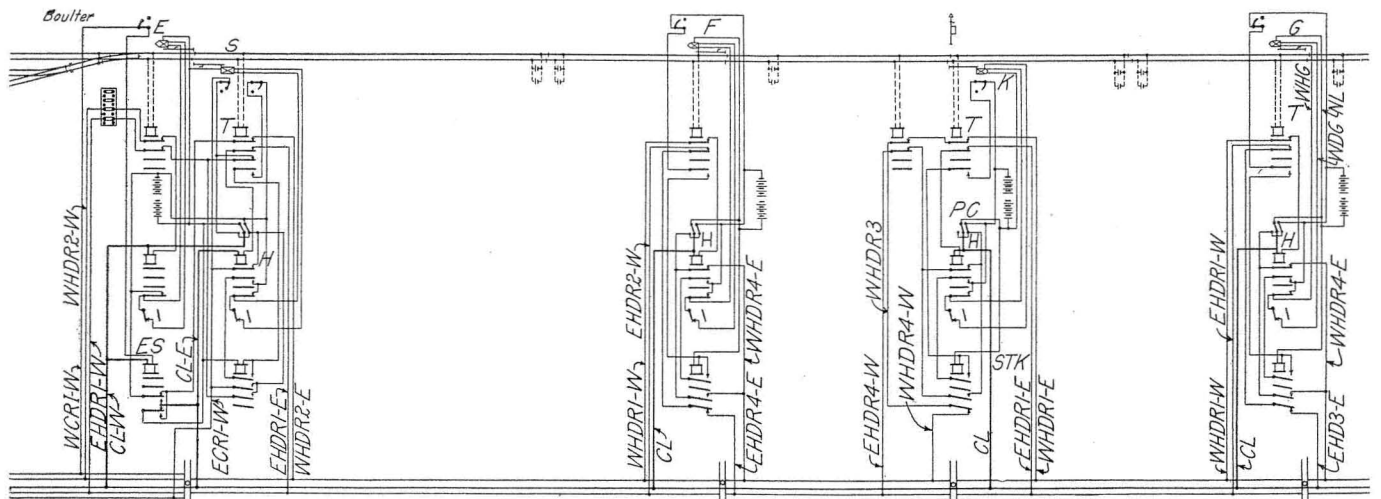

Complete Circuit Diagram of Absolute Permissive Block Signaling

negative current through a front contact on relay STK and the pole changer PC reversed. The CL wire is made positive which causes the H relay at signal S to pick up with the polar contacts reversed. This in turn allows S to go to the caution or 45 deg. position allowing another eastbound train at Y to follow. If, however, this train does not enter Y or waits until the first train is beyond signal L the STK relay at L will put current on relay H at signal K opening up this STK relay and causing signal K to go to caution. This will change the polarity of the current going to relay H at signal S, closing the polar contacts and causing signal S to go to clear.

Chicago. C. M. BRE MILLER,  
Superintendent of Construction, Federal Signal Company.

### Approach Lighting Circuits

*How are the control circuits for approach lighting of signals arranged when using primary batteries? Is an extra line wire required?—B. A. M.*

**Answer**

The approach lighting circuits can be controlled in several different ways, four successful methods being herewith described.

Approach lighting may be controlled by an extra low-

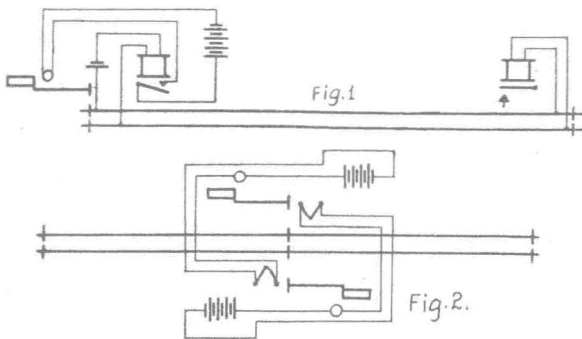

Fig. 1.—Light Relay In Series With Track Feed

Fig. 2.—On Single-Track, Circuit Is Controlled Through Opposite Signal

resistance relay connected in series with the track battery leads of the track circuit, which is occupied by a train when approaching the signal, as shown in Fig. 1. Normally, the contacts of this relay are open; however, when an approaching train enters the opposite end of the

track section, the current through the coils increases and the contacts then close. The coils of this relay serve as a part of the external limiting resistance for each track circuit. The value at which the armature picks up and drops away may be adjusted; in this way the relay is adapted to track circuits of different characteristics.

Approach lighting at a double location on single track is illustrated in Fig. 2, showing how the lighting circuits for either signals may be opened by a circuit controller on the opposing signal. When a train enters the block sec-

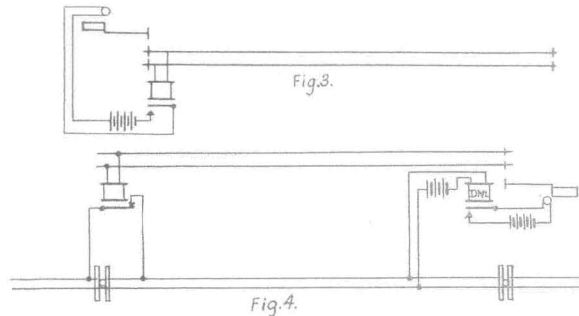

Fig. 3.—Light Circuit Through Regular Track Relay

Fig. 4.—Special Relay Used In Series with Line Battery

tion the signal governing an opposite move will go to danger and mechanically close the lighting circuit for the opposite signal.

Approach lighting by use of a back point of the track relay is shown in Fig. 3. This circuit may be used conveniently when the relay for the approach track section is located close to the signal, and such is often the case on single-track and on double-track where the line control is used. When a train shunts the battery end of the track section the track relay opens and closes the light circuit through one of its back points.

The approach light on the signal in Fig. 4, is controlled by a special relay in series with the line battery. The control wire is opened by all track relays in the approaching block section and, when open, the armature of the light relay is down, closing the lighting circuit through a back contact.

The typical sketches cover a separate four cell primary battery with a 3.5 volt, .3 amp. incandescent lamp, but the motor battery may be used with a 13.5 volt lamp.

Bloomfield, N. J. R. E. TROUT, Vice-President.  
Primary Battery Division, Thomas A. Edison, Inc.

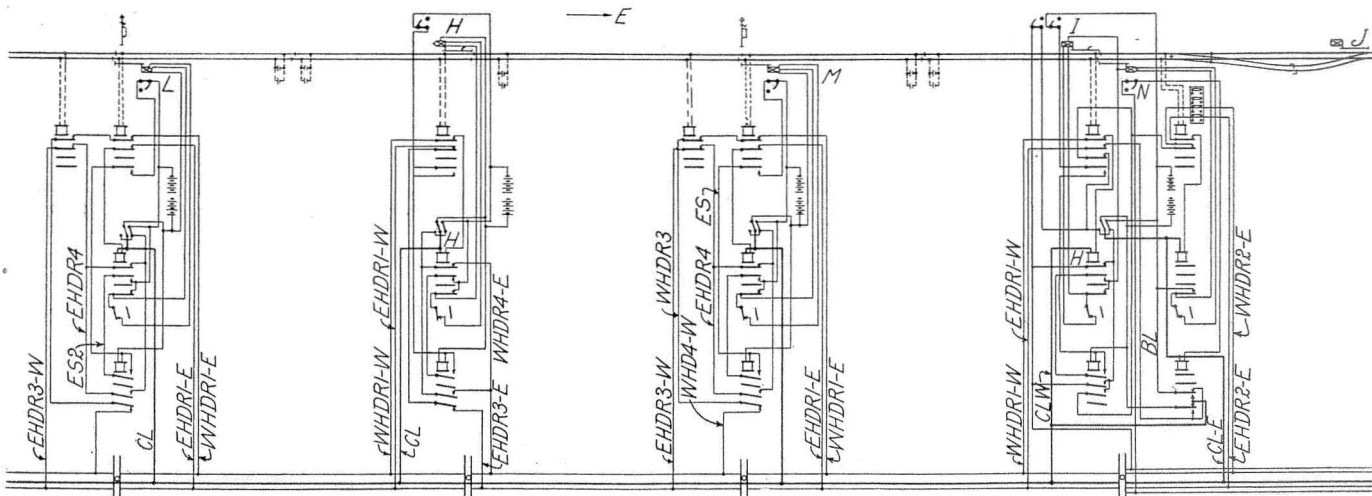

missive Block Signal Circuits Between Sidings