



2016 Student Formula Japan Competition Winner
Kyoto Institute of Technology



2017

Monozukuri Design Competition Since 2003

Student Formula Japan

Official Program

9.5 TUE - 9 SAT

Ogasayama Sports Park

-ECOPA-



Contents



Message of Congratulations/President's Message

1

Outline of Events

2

Registered Teams

3

Schedule of Events

4

Sponsors

5

Notices

6

Awards

7

Organizer/Support/Committee Members

8

Team Information (Vehicle Specifications)

10 ~ 19

Team Information (Members and Sponsors)

20 ~ 44

Message of Congratulations/President's Message

Celebrating the 15th Student Formula Japan

I would like to extend my heartfelt congratulations on the occasion of the 15th Student Formula Japan.

As innovation progresses at a breakneck pace and technology makes bewildering advances, it is necessary to nurture the talent to spur the structural industrial reforms that will tie technological breakthroughs such as artificial intelligence, big data, or the Internet of things (IoT) into the fabric of society and move us closer to the fourth industrial revolution and the “super smart society” (Society 5.0).

In light of the rising expectations placed on the engineering-related education provided by universities playing a central role in that respect, the Ministry of Education, Culture, Sports, Science and Technology established an internal review committee on approaches to engineering-related education at the university level in January 2017. After studying the educational framework and processes at faculties and graduate schools for future engineering-related education, approaches to industry-academia cooperative education, and other issues, the committee prepared an interim report on university-level approaches to that education. The next step will involve finishing assessments of concrete system reforms by the end of the current fiscal year. These reforms will be gradually applied starting in the next fiscal year and fully implemented by 2019.

In that context, this competition, where students hone their overall monozukuri skill by competing not only in terms of vehicle driving performance and production cost, but also on various aspects such as the design and presentation skill required to promote the vehicle they designed, offers an extremely significant contribution to the development of engineers with practical skills who will support Japan in the future.

I am convinced that the competition will provide students with a concrete opportunity to experience the wonders and fascination of monozukuri through the planning, designing and production of a racing car, as well as to learn about the importance of identifying and solving problems, project management, and leadership through communication with other team members. This represents a high-level challenge that goes beyond the knowledge of engineering they learn on a day-to-day basis, and will provide a valuable experience when they later join society to work as engineers.

This 15th edition of the competition, I am told, features a combined total of 98 entrant teams, including 24 from outside Japan for the ICV and EV classes, while last year's competition had a record total of 18,071 participants. This is a splendid testimonial to the recognition and regard enjoyed by this competition both in and outside Japan.

In closing, I would like to wish the best of luck to all participants, instructors, and educational institution staff, as well as express my respect and reiterate my congratulations to the Society of Automotive Engineers of Japan and all other parties engaged in the planning and running of the competition.



Hirokazu Matsuno
Minister of Education, Culture,
Sports, Science and Technology

Welcome to 2017 Student Formula Japan

118 teams (77 from inside Japan and 41 from outside Japan) have applied for 2017 Student Formula Japan. There are 98 official registered teams from that. We have 1 team from Hokkaido, 2 from Tohoku, 31 from Kanto-Koshin'etsu, 16 from Tokai, Chubu and Hokuriku, 17 from Kansai, Chugoku and Shikoku, and 7 from Kyushu by region. From outside Japan, we have 4 from Thailand, 6 from China, 2 from India, 1 from Bangladesh, 7 from Indonesia, 3 from Taiwan, 1 from Europe. These include some world major teams we are very interested in. This event is gradually turning into the Asian hub for student formula competitions.

I hope that Japanese students will see this as a great opportunity to interact with students from many countries and actively engage them in technological and personal exchanges.

This competition was inaugurated in 2003 to provide training in practical monozukuri. Student teams compete over the full range of monozukuri proficiency, which encompasses conceptualizing and designing a vehicle, its performance in terms of acceleration, handling, and durability, its final concept and design, manufacturing, cost, and even presentation skills. Experiencing the hardships, fascination, and enjoyment of monozukuri allows the students to cultivate team management and communication skills.

Over 15,000 students from the previous competitions have benefited from that experience and are now active on the front lines of monozukuri. I fervently hope that in the future, society will come to recognize this competition as a springboard that brings talented people to the automotive industry.

Finally, I wish the best of luck to everyone on the participating teams. I would also like to express my sincere thanks to the representatives from industry, academia and government for their support, collaboration and sponsorship, to the organizers in the host cities of Kakegawa and Fukuroi in Shizuoka Prefecture, to the corporations and universities who dispatched staff members to help run the competition and, last but not least, to each and every one of those staff members.



Yoshiyuki Matsumoto
President, Society of Automotive
Engineers of Japan, Inc.

Outline of Events

1. Purpose of Competition

To develop human resources that, through the support of government, industry, and academia, will contribute to the development and promotion of both automobile technology and industry by having the students play the main role in planning, designing, and constructing an automobile on their own in a competition of comprehensive monozukuri skills.

2. Fundamental Policies of the Competition

As an engineering society, to provide students with an opportunity for monozukuri for the purpose of:

- 1) helping the students to independently develop their comprehensive monozukuri skills.
- 2) increasing the educational value of the experience by providing the students with an opportunity for the practical application of skills and knowledge that are connected to their classroom studies.

3. Operating Guidelines of the Competition

- 1) To be a place where monozukuri skills are verified while placing the highest priority on ensuring safety.
- 2) To conduct the competition in connection with representatives of industry, government, and academia.
- 3) To conduct the competition with a wide range of both individual and corporate volunteers.
- 4) To conduct the competition as a non-profit, public enterprise.
- 5) To build a network of student formula competition participants that will contribute to exchange between engineers that transcends corporate frameworks.

Registered Teams

<ICV Class>

Car No	School Name	Country
1	Kyoto Institute of Technology	Japan
2	Yokohama National University	Japan
3	Nagoya Institute of Technology	Japan
5	Nihon Automobile College	Japan
6	Doshisha University	Japan
7	Kobe University	Japan
8	Shibaura Institute of Technology	Japan
9	Chiba University	Japan
10	Ritsumeikan University	Japan
11	Nippon Institute of Technology	Japan
12	Osaka University	Japan
13	Kyushu Institute of Technology	Japan
14	Ibaraki University	Japan
15	Utsunomiya University	Japan
16	Waseda University	Japan
17	Tongji University	China
18	TOYOTA TECHNICAL COLLEGE NAGOYA	Japan
19	Tokyo University of Science,Yamaguchi	Japan
20	Tokyo University of Science	Japan
21	University of Yamanashi	Japan
22	Gifu University	Japan
23	Kyoto University	Japan
24	Universitas Gadjah Mada	Indonesia
25	Institut Teknologi Sepuluh Nopember	Indonesia
26	Kanazawa University	Japan
27	UNIVERSITAS NEGERI YOGYAKARTA	Indonesia
28	Toyohashi University of Technology	Japan
29	Sophia University	Japan
30	Tokyo City University	Japan
31	Shizuoka Institute of Science and Technology	Japan
32	King Mongkut's University of Technology Thonburi	Thailand
33	College of Industrial Technology, Nihon University	Japan
34	Institute of Technologists	Japan
35	Tokai University	Japan
36	University of Fukui	Japan
37	Okayama University of Science	Japan
38	Kanazawa Institute of Technology	Japan
39	Meijo University	Japan
40	Tokyo University of Agriculture and Technology	Japan
41	Osaka Institute of Technology	Japan
42	Osaka Sangyou University	Japan
43	Harbin Institute of Technology at Weihai	China
44	Kasetsart University	Thailand
45	Shizuoka University	Japan
46	Niigata University	Japan
47	Okayama University	Japan
48	Kurume Institute of Technology	Japan
49	Seikei University	Japan
50	Setsunan University	Japan
51	Hokkaido University/Hokkaido University of Science	Japan

Car No	School Name	Country
52	College of Science and Technology, Nihon University	Japan
53	Meisei University	Japan
54	Aichi Institute of Technology	Japan
55	Honda Technical College Kanto	Japan
56	National Tsing Hua University	Taiwan
57	Tottori University	Japan
58	Honda Technical college Kansai	Japan
59	Sojo University	Japan
60	The University of Kitakyushu	Japan
61	Kyushu University	Japan
62	Chiba Institute of Technology	Japan
63	Kindai University	Japan
64	Sinhgad Technical Education Society	India
65	Aoyama Gakuin University	Japan
67	Kokushikan University	Japan
68	Aso College of Automotive Engineering and Technology	Japan
69	Shizuoka Professional College of Automobile Technology	Japan
70	Southern Taiwan University of Science & Technology/Xiamen University of Technology	Taiwan
71	National Taipei University of Technology	Taiwan
72	Hiroshima Institute of Technology	Japan
73	University of Toyama	Japan
75	Tokyo Technical College Setagaya Campus	Japan
76	Sebelas Maret University	Indonesia
77	Hubei University Of Automotive Technology	China
78	Graz Technical University	Austria
79	The University of Tokyo	Japan
80	Saitama University	Japan
82	Teikyo University	Japan
83	Nishinippon Institute of Technology	Japan
85	Osaka Prefecture University	Japan
86	RAJSHAHI UNIVERSITY OF ENGINEERING & TECHNOLOGY	Bangladesh
96	Universitas Indonesia	Indonesia
98	Prince of Songkla University	Thailand

<ICV Class>

E1	National Institute of Technology, Ichinoskei College / Iwate University/ Iwate Prefectural University EV	Japan
E2	TOYOTA TECHNICAL CALLEGE NAGOYA EV	Japan
E3	Tohoku University EV	Japan
E4	Harbin Institute of Technology at Weihai EV	China
E5	Nagoya University EV	Japan
E6	Shizuoka Institute of Science and Technology EV	Japan
E8	Kanagawa University EV	Japan
E9	R V College of Engineering EV	India
E10	Tongji University EV	China
E11	Liaoning University of Technology EV	China
E12	King Mongkut's University of Technology Thonburi EV	Thailand
E13	Universitas Gadjah Mada EV	Indonesia
E15	Niigata Institute of Technology EV	Japan
E16	Toyota Technical College Tokyo EV	Japan
E17	Universitas Islam Indonesia EV	Indonesia

Schedule of Events

2017 Student Formula Japan Event Schedule

	7:00	8:00	9:00	10:00	11:00	12:00	13:00	14:00	15:00	16:00	17:00	18:00	19:00	Venue
Sep 5 Tue DAY 1														
														Stadium Reception
														Stadium
														Stadium
Sep 6 Wed DAY 2														Stadium Reception
														Stadium
														Stadium
														Stadium
														Dynamic Area
Sep 7 Thu DAY 3														Stadium
														Dynamic Area
														Dynamic Area
														Dynamic Area
Sep 8 Fri DAY 4														Dynamic Area
														Dynamic Area
														Arena
Sep 9 Sat DAY 5														Dynamic Area
														Dynamic Area
														Front of Stadium
														Arena
														Arena

Sponsors

■ S Class

Toyota Motor Corporation
Nissan Motor Co.,Ltd.
Honda Motor Co.,Ltd.
Hitachi Metals, Ltd.

■ A Class

Fuji Heavy Industries Ltd.
Mazda Motor Corporation
Mitsubishi Motors Corporation
Tamadic Co., Ltd.
IPG Automotive K.K.
NOK Corporation
VSN, Inc.
AISIN SEIKI CO.,LTD.
HKS Co., Ltd.
Kawasaki Heavy Industries, Ltd.
SUZUKI MOTOR CORPORATION
DENSO CORPORATION
DOME.,CO.LTD.
NSK Ltd.
Hitachi Automotive Systems, Ltd.
Honda Techno Fort Co.,Ltd.
Yamaha Motor Co.,Ltd.

■ B Class

HORIBA, Ltd.
YOROZU Corporation.
UD Trucks Corporation
Nifco Inc.
Hino Motors, Ltd.
Bosch Corporation
dSPACE Japan
KYB Corporation
MAGNETI MARELLI JAPAN K.K.
NTN Corporation
Siemens-Mentor Automotive
TBK Co., Ltd.
AISIN AW CO.,LTD.
ADVICS CO.,LTD.
Altair Engineering, Inc.
ANSYS Japan K.K.
ETAS K.K.
Isuzu Motors Limited
Intertechno.Co.,Ltd.
AVL JAPAN
EXEDY Corporation
Autech Japan, Inc.
AutoTechnicJapan co.,LTD
AUTOBACS SEVEN CO., LTD.
Calsonic Kansei Corporation
KYGUS SEKIYU K.K.
Cataler Corporation
Keihin Corporation
JTEKT Corporation
JATCO Ltd.
JATCO Engineering Ltd
Shin Nippon Tokki Co.,LTD.
Sumitomo Wiring Systems,Ltd.
ZF Japan Co.,Ltd.
Sensata Technologies Japan Limited
Software Cradle Co., Ltd.
SolidWorks Japan K.K.
Tyco Electronics Japan G.K.
Daihatsu Motor Co.,Ltd.
Topy Industries, Ltd.
Nissan Shatai Co.,Ltd.
ESI Japan
HARADA INDUSTRY CO., LTD.
FORCIA, Inc.
Fujikura Ltd.
MAHLE Japan Ltd.
Mitsubishi Electric Corporation
YANASE & CO.,LTD.

■ C Class

ICHIKOH INDUSTRIES,LTD.

Origin Electric Co., Ltd.
TAISEISHA LTD.
Toyota Industries Corporation
iPX co.ltd.
VT HOLDINGS CO.,LTD.
Witzenmann Japan K.K.
ASMO Co.,Ltd.
Idemitsu Kosan Co.,Ltd.
Valeo Japan Co., Ltd.
H-one CO.,LTD.
ATS Japan
F.C.C. Co.,Ltd.
FTTechno.,Inc.
OILES CORPORATION
OKITSURASEN Co.LTD
SANNO TEC CO.,LTD.
JBM Corporation.
General Engineering Co., Ltd.
DaikyoNishikawa Corporation
TMC CO., LTD
Toyota Motor East Japan, Inc.
TOYOTA AUTO BODY CO.,LTD.
Toyota Boshoku Corporation
Nabtesco Automotive Corporation
Nisshinbo Brake Inc.
Japan Automobile Research Institute
Japan Auto Parts Industries Association
NHKSPRINGCO.,LTD.
PERSOL RESEARCH & DEVELOPMENT CO., LTD.
Primearth EV Energy Co., Ltd.
BRIDE CO.,LTD
BorgWarner Morse Systems Japan KK.
Mitsubishi Automotive Engineering Co.,Ltd.
MITSUBOSHI BELTING LTD.
Musashi Seimitsu Industry Co.,Ltd.
YAZAKI Corporation
YAMADA MANUFACTURING CO.,LTD.
UNIVANCE CORPORATION
G sense
GS Yuasa International Ltd.
HPC SYSTEMS Inc.
JTB CHUBU Corp.
JX Nippon Oil & Energy Corporation
NSK-Warner K.K.
SUBARU TECHNO-SERVICE Co.,LTD.
THK RHYTHM CO., LTD.
TPR CO.,LTD.
Aichi Machine Industry Co.,Ltd.
ALPS ELECTRIC CO., LTD.
igus k.k.
ISUZU ADVANCED ENGINEERING CENTER,LTD.
Autoliv Inc.
OKAYA & CO., LTD.
ONO SOKKI CO.,LTD.
Kyosei Driving School.
THine Electronics,Inc.
SANGO Co.,Ltd.
CK Engineering corporation.
SHINBA IRON WORKS CO.,LTD.
Sumitomo Rubber Industries,Ltd.
TS TECH CO.,LTD
TEIN, INC.
TOKAIRIKA,CO, LTD
Toyo Tire & Rubber Co.,Ltd.
Total Technical Solutions
TOYODA GOSEI CO.,LTD.
NISSAN TECHNO CO.,LTD.
NISSIN KOGYO CO.,LTD.
Delphi Automotive Systems Japan, Ltd.
Nihon Michelin Tire Co.,Ltd.
HINO Hutech
FUKAI MFG. CO., LTD.
Bridgestone Corporation
Magna Powertrain Magna International Japan Inc.
Mazda Engineering & Technology Co., LTD.
MOBITEC CO., LTD.
Yashika Body Company, Ltd
YANMAR Co., Ltd.

Yutaka Giken Company Limited.

■ D Class

FUKUROI CHAMBER OF COMMERCE AND INDUSTRY
MathWorks Japan
AISAN INDUSTRY CO.,LTD.
AISIN TAKAOKA CO.,LTD
AKASHI KIKAI INDUSTRY Co., Ltd.
Acarterial
Akebono Brake Industry Co.,Ltd.
ISHIHARA-METAL MANUFACTURING co.,Ltd..
ISUZU ENGINEERING Co.,Ltd.
Iwafuji Industrial Co., Ltd.
USUI KOKUSAI SANGYO KAISYA LTD.
UCHIYAMA MANUFACTURING CORP.
AW ENGINEERING CO.,LTD.
A&D Company, Limited
OTICS Corporation
KINOKUNI Enterprise co.,Ltd.
Gifu Auto Body Co., Ltd.
KYOWA KOGYO CO.,LTD.
KIRIU CORPORATION
CHROMA ATE INC.
Sankin Corporation
Global Active Technology Co.,Ltd.(GAT)
CCI Corporation.
JI Accident &Fire Insurance Co.,Ltd.
SHOWA CORPORATION
Suzuyo&Co.,Ltd
Sohshin
Taiseiplas co.,Ltd
DAIDO METAL CO.,LTD.
Pacific Industrial Co.,Ltd
Pacific Engineering Corporation.
Taiho Kogyo Co.,Ltd.
Takada kogyo
TACHI-S CO., LTD.
DAD co.,Ltd.
TANAKA SEIMITSU KOGYO CO.,LTD.
TSUCHIYA CO.,LTD.
DEWE Japan Co.,Ltd.
DENSOTECHNO CO.,LTD.
Tokyo R&D Co.,Ltd.
TOKYO R&D Composite Industry Co.,Ltd.
Tokyo Gasket Industry Co., Ltd.
TOKYO BOEKI TECNO-SYSTEM LTD.
TOHNICHI Mfg Co.,Ltd.
Toyo Denso CO.,LTD.
TOTECH AMENITY LIMITED
TODA RACING Co.,Ltd.
TOYODA IRON WORKS CO.,LTD.
TOYOTA MODELLISTA INTERNATIONAL CORPORATION.
NANJO Auto Interior Co.,Ltd
NISHIKAWA RUBBER CO.,LTD.
NICHIRIN CO.,LTD.
Nippon Seiki Co., Ltd.
NGK SPARK PLUG Co.,Ltd.
National Instruments Corporation.
Virtual Mechanics Corporation
PIOLAX, INC.
HAMANAKODENSO CO.,LTD.
Bando Chemical Industries, Ltd.
PUES Corporation
FUJITSU TEN LIMITED
PRESS KOGYO CO.,LTD.
MIYACO HYDRAULIC BRAKE MFG. CO.,LTD
Yamaha Motor Engineering Co., Ltd.
YAMAHA MOTOR POWERED PRODUCTS CO.,LTD.
The Yokohama Rubber Company, Limited
RYOBI LIMITED
Resonic
WATANABE Industrial Co.,Ltd

■ E Class

Tokyo-to Jidousha Jigyō Kyōkai
Hattasan Meibutsu Dango

We appreciate your cooperation for assuring a safe and pleasant event.

[Attention]

- ⚠ You must not enter the Dynamic Events Area ("Dynamic Events Area" on the map) (except team members and examiners in possession of a pass permitting entry to the area).
- ⚠ Please watch the dynamic events and practices from the designated areas. To prevent accidents, do not use flash when taking pictures while vehicles are being driven.
- ⚠ People without permission are not allowed to enter the Team Pit.
- ⚠ Please smoke in the designated smoking areas only. It is prohibited to smoke anywhere other than the designated areas.
- ⚠ Please sort and throw trash into the appropriate bins.
- ⚠ In hot weather, please take sufficient liquids and pay attention to your physical condition. If you feel sick, contact event staff as soon as possible to receive treatment from the nurses and doctors on call at the First Aid Station.
- ⚠ Do not approach hornets and snakes that live in the area around the site. If you are bitten or stung, please contact event staff nearby or the organizer's office.
- ⚠ Please follow instructions given by competition staff members.

[Disclaimer Notice]

- ⚠ The organizers and sponsors, co-sponsors do not take any responsibility for damages or losses.
- ⚠ The organizers are not liable for any changes made to the program.

Awards

	Award Name	Outline	Place	Prize *10K JPY	Provided by
Outstanding Performance Awards	Minister of Economy, Trade and Industry Award	Top finisher overall	1st	(Diploma)	Ministry of Economy, Trade and Industry
	Minister of Land, Infrastructure, Transport and Tourism Award	Top team overall rating in safety, environmentally friendly and advanced technology	1st	(Diploma)	Ministry of Land, Infrastructure, Transport and Tourism
	Governor of Shizuoka Prefecture Award	Top team overall rating in Static Events, Acceleration, Skid-pad, Autocross, Noise, Fuel Economy, Safety, and Weight Reduction	1st	(Goods)	Shizuoka Prefecture
	Mayor of Kakegawa City Award	Top team overall rating in Dynamic Events	1st	(Goods)	Kakegawa City
	Mayor of Fukuroi City Award	Top team overall rating in Static Events	1st	(Goods)	Fukuroi City
	JAMA Chairman Awards	Teams accomplished all Static & Dynamic Events (exc.penalized by Noise or document submission delay)	—	70 divided equally (w/ Goods)	Japan Automobile Manufacturers Industry
	JAPIA Chairman Awards	Top team overall rating in Cost & Manufacturing, Presentation, and Weight Reduction in all teams which accomplished Endurance	1st	5	Japanese Auto Parts Industries Association
	Spirit of Excellence Awards for ICV class	Top 6 finishers overall in ICV	1 ~ 6th	1st:10, 2nd:9, 3rd:8, 4th:6, 5th:5, 6th:4	ONO SOKKI
	Spirit of Excellence Award for EV class	Top finisher overall in EV	1st	4 (w/Goods)	PUSE Shizuoka Pref.
Categorized Awards	Cost Awards	Top 3 teams in Cost & Manufacturing	1 ~ 3rd	1st:2.5, 2nd:1, 3rd:0.5	DEWE Japan
	Design Awards	Top 3 teams in Design	1 ~ 3rd	1st:5, 2nd:3, 3rd:2	Autech Japan
	Presentation Awards	Top 3 teams in Presentation	1 ~ 3rd	1st:4, 2nd:3, 3rd:1	TOYO TIRE and RUBBER
	Acceleration Awards	Top 3 teams in Acceleration	1 ~ 3rd	1st:5, 2nd:3, 3rd:2	Sumitomo Rubber Industries
	Skid-Pad Awards	Top 3 teams in Skid-pad	1 ~ 3rd	1st:2.5, 2nd:1, 3rd:0.5	THE YOKOHAMA RUBBER
	Autocross Awards	Top 3 teams in Autocross	1 ~ 3rd	1st:4, 2nd:3, 3rd:1	Bridgestone
	Endurance Awards	Top 3 teams in Endurance	1 ~ 3rd	(Goods)	MOTUL
	Efficiency Awards	Top 3 teams in Fuel Economy	1 ~ 3rd	1st:5, 2nd:3, 3rd:2	Nihon Michelin Tire
Special Awards	Rookie Awards	Top teams from the SFJ first-timers	ICV1st & EV1st	2 each	JI Accident & Fire Insurance
	CAE Awards	Top 3 teams in terms of CAE in Design Event	1 ~ 3rd	1st:5, 2nd:3, 3rd:2	Altair Engineering
	Lightweight Engineering Awards	The lightest vehicle attended whole events (exc.Endurance)	ICV1 ~ 3rd & EV1st	1st:3, 2nd:2, 3rd:1 EV1st:2	FUKAI MFG.
	Best Suspension Awards	Top 3 teams in terms of suspension performance in Design Event	1 ~ 3rd	1st:3, 2nd:2, 3rd:1	ZF Japan
	Best Improvement Awards	The most improving teams participated for the second consecutive year	1 ~ 3rd	(Goods)	Nicole Racing Japan, Fukuroi Chamber of Commerce and Industry
	Best Three-View Drawing Award	Top team on Three-View Drawing	1st	5	TOKYO R&D
	Best Aerodynamics Award	Top team on Aerodynamics and Thermo-fluid analysis	1st	5	TOKYO R&D
	Best Lap Awards	Top 3 teams recorded the fastest lap in Endurance	3 teams	1st:3, 2nd:3, 3rd:2	KYGNUS SEKIYU
	Best Composit Award	Top team made high-quality composit parts	1st	5	TOKYO R&D Composit
	Best Electrical System Awards	Candidates from top tier of Static Design.(Bonus points for EV)	1 ~ 3rd	1st:8, 2nd:4, 3rd:2	Sisemens-Mentor Automotive
Ergonomics Awards	Top 3 teams who achieve superior ergonomic design as a racing car. (Driving position, steering/pedal maneuverability, instruments visibility, etc)	1 ~ 3rd	1st:3, 2nd:2, 3rd:1	BRIDE	

Organizer/Support/Committee Members

2017 Student Formula Japan is

Organized by

Society of Automotive Engineers of Japan (JSAE)

Under the patronage of

Ministry of Education, Culture, Sports, Science and Technology; Ministry of Economy, Trade and Industry; Ministry of Land, Infrastructure and Transport; Shizuoka Prefecture; Kakegawa City; Fukuroi City; Kakegawa Chamber of Commerce and Industry; Fukuroi Chamber of Commerce and Industry; Japan Automobile Manufacturers Association; Japan Auto Parts Industries Association; NHK; Tokyo Broadcasting System Television; Shizuoka Broadcasting System; Shizuoka Asahi TV; Shizuoka Daiichi Television; Shizuoka Telecasting; Shizuoka FM Broadcasting; Asahi Shimbun Publishing; The Yomiuri Shimbun; The Mainichi Newspapers; Nihon Keizai Shimbun; Nikkan Kogyo Shimbun; Fuji Sankei Business i.; The Shizuoka Shimbun; Nikkan Jidosha Shimbun

In association with

National Institute of Advanced Industrial Science and Technology; National Agency for Automobile and Land Transport Technology; Japan Automobile Research Institute; Association of Private Universities of Japan; The Japan Association of Private Colleges and Universities; The Japan Association of Public Universities; Institute of National College of Technology; The Japan Federation of Engineering Societies; The Japan Rubber Manufacturers Association; The Society of Instrument and Control Engineers; Japan Lubricating Oil Society; The Japan Society of Mechanical Engineers; Japanese Society for Engineering Education; Japan Machine Tool Builders Association; The Society of Rubber Industry, Japan; The Society of Materials Science, Japan; Japan Automobile Tyre Manufacturers Association; Japan Society for Design Engineering; Japan Land Engine Manufacturers Association; The Japan Welding Society; Japan Auto-Body Industries Association; Japan Automobile Service Promotion Association; Japan Automotive Machinery & Tool Manufacturers Association; Japan Automobile Federation; Japan Automobile Dealers Association; Japan Society of Civil Engineers; Japan Automobile Maintenance Colleges Association; The Institute of Electrical Engineers of Japan

■ Board of Student Formula Japan

Chairman	Hiroshi Takemura	Honda Motor Co.,Ltd.
Vice Chairman	Seigo Kuzumaki	Toyota Motor Corporation
	Takao Kubozuka	Society of Automotive Engineers of Japan, Inc.
Members	Kouji Aoki	Aisin Seiki Co.,Ltd.
	Ichizo Aoyama	Suzuki Motor Corporation
	Miki Ibaraki	Daihatsu Motor Co.,Ltd.
	Masashi Oshita	Japan Auto Parts Industries Association
	Tetsuo Onuki	SUBARU
	Masahiro Ono	Hino Motors, Ltd.
	Hajime Kumabe	DENSO Corporation
	Makoto Shimamoto	Yamaha Motor Co.,Ltd.
	Shunichi Toyomasu	Nissan Motor Co.,Ltd.
	Isao Torii	Mitsubishi Motors Corporation
	Hiroshi Nakahara	Kawasaki Heavy Industries, Ltd.
	Mitsuo Hitomi	Mazda Motor Corporation
	Masaaki Fujisawa	Hitachi Automotive Systems, Ltd.
	Hirohide Furutani	National Institute of Advanced Industrial Science and Technology
	Yasuhiro Honda	Kokushikan University
	Kazutoshi Yoshida	Japan Auto-Body Industries Association Inc.

■ Student Formula Japan Implementation Committee

Chairman	Tadashi Tamasho	Nissan Motor Co.,Ltd.
Vice Chairman	Hiroataka Nakazawa	Honda R&D Co.,Ltd.
Members	Kiyoshi Ito	Yamaha Motor Co.,Ltd.
	Masahiro Egami	Nissan Motor Co.,Ltd.
	Hiroshi Enomoto	Kanazawa University
	Masakatsu Ohsugi	Mazda Motor Corporation
	Hideki Oka	Suzuki Motor Corporation
	Hideki Kaseyama	Honda Motor Co.,Ltd.
	Yoshio Kano	Kanagawa Institute of Technology
	Akira Kabasawa	Honda R&D Co.,Ltd.
	Hirohiko Kuroda	SUBARU
	Takanori Sasaki	Toyota Motor Corporation
	Yoshikazu Suzumura	Aisin Seiki Co.,Ltd.
	Takashi Tsuchiya	National Institute of Technology, Ichinoseki College
	Hirohito Hayashi	Toyota Industries Corporation
	Masao Hayashi	Daihatsu Motor Co.,Ltd.
	Mitsuhiro Fukuta	Shizuoka University
	Yasuhiro Honda	Kokushikan University
	Yoshihiro Masuda	ZEST Co.,Ltd.
	Takanari Matsuura	HORIBA, Ltd.
	Yasushi Matsumoto	Toyota Motor Corporation
	Kouichi Yamagishi	Toyota Motor Corporation
	Takashi Yamamoto	DENSO CORPORATION

■ Student Formula Japan Rules Committee

Chairman	Kouichi Yamagishi	Toyota Motor Corporation
Vice Chairman	Yasushi Matsumoto	Toyota Motor Corporation
Members	Akira Kabasawa	Honda R&D Co.,Ltd.
	Ken Suzuki	Volunteer
	Ryoji Taneda	Mitsubishi Automotive Engineering Co.,Ltd.
	Tadashi Tamasho	Nissan Motor Co.,Ltd.
	Hiroataka Nakazawa	Honda R&D Co.,Ltd.
	Yasuhiro Honda	Kokushikan University
	Takanari Matsuura	HORIBA, Ltd.

Team Information (Vehicle Specifications)

Car No	School Name	Color s	Frame	Body-work	Suspension ①Front ②Rear	①Overall Length	②Overall Height	③Gross Vehicle Mass
						③Wheelbase	④Front Track	②Fr.Rr Weight Dist.
1	Kyoto Institute of Technology	GDF Blue	Steel spaceframe	CFRP	① Double unequal length A-arm push rod ② Double unequal length A-arm push rod	① 3150 mm ③ 1750 mm ⑤ 1250 mm	② 1180 mm ④ 1250 mm	① 190 kg ② 45 : 55 ③ 40 mm
2	Yokohama National University	wine red & black	steel spaceframe	Fiber-glass	① Double unequal length A-arm Push rod ② Double unequal length A-arm Push rod	① 2775 mm ③ 1560 mm ⑤ 1270 mm	② 1145 mm ④ 1270 mm	① 198 kg ② 45 : 55 ③ 27 mm
3	Nagoya Institute of Technology	Blue	steel spaceframe	Fiber-glass	① Double unequal length A-arm Push rod ② Double unequal length A-arm Push rod	① 3100 mm ③ 1620 mm ⑤ 1250 mm	② 1162 mm ④ 1300 mm	① 190 kg ② 50 : 50 ③ 20 mm
5	Nihon Automobile College	Sky Blue	Steel spaceframe	GFRP	① Double unequal length A-Arm Push rod ② Double unequal length A-Arm Push rod	① 3025 mm ③ 1650 mm ⑤ 1200 mm	② 1145 mm ④ 1200 mm	① 260 kg ② 49 : 51 ③ 40 mm
6	Doshisha University							
7	Kobe University	Black & Blue	steel spaceframe	GFRP	① Double unequal length A-arm Pull rod ② Double unequal length A-arm Push rod	① 2897 mm ③ 1620 mm ⑤ 1200 mm	② 1180 mm ④ 1200 mm	① 230 kg ② 50 : 50 ③ 30 mm
8	Shibaura Institute of Technology	black & yellow	steel spaceframe	Fiber-glass Carbon	① Double unequal length A-arm Direct damper ② Double unequal length A-arm Push rod	① 2643.5 mm ③ 1530 mm ⑤ 1060 mm	② 1186.8 mm ④ 1060 mm	① 202 kg ② 46 : 54 ③ 30 mm
9	Chiba University	Blue	steel spaceframe	Fiber-glass	① Double unequal length A-arm Pull rod ② Double unequal length A-arm Pull rod	① 3000 mm ③ 1800 mm ⑤ 1275 mm	② 1200 mm ④ 1275 mm	① 295 kg ② 42 : 58 ③ 30 mm
10	Ritsumeikan University	Black/Red/White	steel spaceframe	CFRP	① Double unequal length A-arm Push rod ② Double unequal length A-arm Push rod	① 3040 mm ③ 1750 mm ⑤ 1200 mm	② 1240 mm ④ 1200 mm	① 240 kg ② 50 : 50 ③ 31 mm
11	Nippon Institute of Technology	Pink	Steel Spaceframe	CFRP	① Double unequal length A-arm Pull rod ② Double unequal length A-arm Pull rod	① 2757 mm ③ 1540 mm ⑤ 1250 mm	② 1283 mm ④ 1250 mm	① 222 kg ② 50 : 50 ③ 38 mm
12	Osaka University	Black & Metallic Gray & Lime Green	Steel spaceframe with CFRP-Al. Honeycomb Sandwich Panel	GFRP	① Double unequal length A-arm Push rod ② Double unequal length A-arm Push rod	① 3120 mm ③ 1620 mm ⑤ 1200 mm	② 1190 mm ④ 1250 mm	① 235 kg ② 47 : 53 ③ 30 mm
13	Kyushu Institute of Technology	Red	steel spaceframe	GFRP	① Double unequal length A-arm Push rod ② Double unequal length A-arm Push rod	① 2722 mm ③ 1700 mm ⑤ 1200 mm	② 1178 mm ④ 1200 mm	① 240 kg ② 45 : 55 ③ 50 mm
14	Ibaraki University	Navy blue White Yellow	steel spaceframe	Fiber-glass	① Double unequal length A-arm Pull rod ② Double unequal length A-arm Push rod	① 3035 mm ③ 1620 mm ⑤ 1250 mm	② 1230 mm ④ 1250 mm	① 210 kg ② 48 : 52 ③ 25.4 mm
15	Utsunomiya University	British Green	steel spaceframe	CFRP	① Double unequal length A-arm Push rod ② Double unequal length A-arm Push rod	① 3000 mm ③ 1540 mm ⑤ 1200 mm	② 1200 mm ④ 1200 mm	① 250 kg ② 45 : 55 ③ 35 mm
16	Waseda University	Crimson & White	Steel Spaceframe	GFRP	① Double Unequal Length A-arm, Pull Rod ② Double Unequal Length A-arm, Push Rod	① 2800 mm ③ 1720 mm ⑤ 1300 mm	② 1075 mm ④ 1300 mm	① 235 kg ② 48.4 : 51.6 ③ 30 mm
17	Tongji University	black, red & white	steal spaceframe	monocoque	① Double unequal length A-arm Pull rod Anti roll bar ② Double unequal length A-arm Pull rod Anti roll bar	① 3017 mm ③ 1547 mm ⑤ 1185 mm	② 1183 mm ④ 1215 mm	① 210 kg ② 45 : 55 ③ 30 mm
18	Toyota Technical College Nagoya	Blue, White, Red	steel spaceframe	FRP	① Double unequal length A-arm Push rod ② Double unequal length A-arm Pull rod	① 2835 mm ③ 1640 mm ⑤ 1250 mm	② 1180 mm ④ 1300 mm	① 280 kg ② 44 : 56 ③ 50 mm
19	Tokyo University of Science, Yamaguchi	Orange	Steel Spaceframe	GFRP	① Double unequal length A -arm Pull rod ② Double unequal length A -arm Pull rod	① 2695 mm ③ 1625 mm ⑤ 1200 mm	② 1160 mm ④ 1200 mm	① 245 kg ② 47 : 53 ③ 42 mm
20	Tokyo University of Science	Black and Pink	Steel Spaceframe	Fiber-glass	① Double unequal length A-arm Pull rod ② Double unequal length A-arm Push rod	① 3086 mm ③ 1700 mm ⑤ 1160 mm	② 1195 mm ④ 1220 mm	① 236 kg ② 45 : 55 ③ 35 mm
21	University of Yamanashi	Blue	steel spaceframe	FRP	① Double unequal length A-arm Pull rod ② Double unequal length A-arm Push rod	① 2900 mm ③ 1580 mm ⑤ 1240 mm	② 1270 mm ④ 1240 mm	① 270 kg ② 40 : 60 ③ 30 mm
22	Gifu University	black	steel spaceframe	CFRP	① Double unequal length A-arm Push rod ② Double unequal length A-arm Push rod	① 2881 mm ③ 1570 mm ⑤ 1200 mm	② 1161 mm ④ 1200 mm	① 225 kg ② 48 : 52 ③ 36.4 mm

Wheels & Tires	① Engine ② Displacement ③ max. power ④ max.torque	Induction type Fuel tank Volume	Shifter	Final Drive & Differential	Brakes ① Front ② Rear	Unique Features & Notes
10 inch Hoosier 18.0 × 6.0-10	① SUZUKI LT-R450 K6 L404 bore-up ② 474 cc ③ 42.51 kW/9300 rpm ④ 5.3 Nm/6100 rpm	Naturally aspirated 3.2 L	Manual	Chain drive LSD	① 2 outboard ② 2 outboard Nissin calipers	Single-piece machined rear bulkhead and front/rear wing
10 inch BRAID STURACE 10 18.0 × 7.5-10 Hoosier R25B	① PC40E HONDA CBR600RR ② 599 cc ③ 82 ps/11000 rpm ④ 6.3 kgf/8500 rpm	Naturally aspirated 4.5 L	Manual Electric Shifter	Shaft & bevel gear drive Cam type LSD	① 2 outboard ② 2 outboard Nissin calipers	Removable and replaceabl seat
10 inch KEIZER WHEEL Fr 18.0 × 7.0-10 Rr 18.0 × 7.0-10 R25B Hoosier	① YAMAHA YZ450FX ② 449 cc ③ 50 PS/9500 rpm ④ 4.6 kgf/7500 rpm	Naturally aspirated 3.5 L	Manual	Shaft drive & F.C.C Track	① 2 outboard ② 2 outboard Wilwood calipers	Hi down force and Light weight vehicle
13 inch TWS 20.0 × 7.5-13 Hoosier	① PC40E HONDA CBR600RR ② 599 cc ③ 78.6 ps/9415 rpm ④ 5.6 kgf/9155 rpm	Naturally aspirated 4.2 L	Electric Shifter	Chain Drive & Drexler Motorsport LSD	① 2 outboard ② 2 outboard Wilwood calipers	Long Wheelbase and Safety
13 inch Braide Aluminium 20.5/7.0-10 Hoosier Bias	① ZX600P9F Kawasaki ZX-6R ② 599 cc ③ 75 ps/11000 rpm ④ 5.4 kgf/9000 rpm	Naturally aspirated 3.8 L	Manual	Chain Drive F.C.C Trac LSD	① 2 outboard ② 2 outboard Nissin calipers	Front & Rear Wing
13 inch OZ Racing Continental	① PC40EHONDA CBR600RR ② 599 cc ③ 73 ps/11000 rpm ④ 5.5 kgf/9000 rpm	Naturally aspirated 4.5 L	Sequential	Chain Drive & Locking Differential	① 2 outboard ② 1 inboard	
10 inch Briad STURACE 18.0 × 7.5-10 R25B Hoosier	① YAMAHA YZF-R6 4 cylinder ② 599 cc ③ 77 ps/11400 rpm ④ 55 Nm/9000 rpm	Naturally aspirated 5.0 L	Manual	Chain Drive Drexler L.S.D.	① 2 outboard ② 2 outboard Nissin calipers	Mechanical Paddle Shift Launch & Traction Control
13 inch OZ racing 20.5 × 7.0-13 Hoosier	① Kawasaki ZX-6R 09 ② 599 cc ③ 70 ps/10000 rpm ④ 6.5 kgf/9000 rpm	Naturally aspirated 4.2L	Manual	Chain Drive & LSD ATS	① 2 outboard Nissin calipers ② 2 outboard Nissin calipers	
13 inch Rays TE37 & 20.5 × 7.0-13 Hoosier	① PC44E HONDA CB500F ② 471 CC ③ 35 kW/8500 rpm ④ 43 Nm/7000 rpm	Naturally aspirated 3.5 L	Manual	Chain Drive F.C.C TRAC	Brakes ① 2outboard ② 2 outboard calipers	Parallel Twin
10 × 7.0 Keizer 18.0 × 7.5-10 R25B Hoosier	① ZX636E Kawasaki ZX-6R ② 636 cc ③ 88 ps/12000 rpm ④ 6.3 kgf/8000 rpm	Naturally aspirated 5.0 L	Pneumatic Shifter	Chain Drive 3.3 : 1 Clutch-type Drexler L.S.D	① 2 outboard ② 2 outboard Wilwood GP200 calipers	• Variable Intake System • Launch & Traction Control System • Dry Sump • Double Decker Wing • Unsprung Mount Wing • Pumping-loss Reduction System
13 inch RS Watanabe Hoosier 20.5/7.0-13 R25B	① Kawasaki ZX600PE ② 599 cc ③ 69 ps/11000 rpm ④ 5.3 kgf/9000 rpm	Naturally aspirated 5.3 L	Manual	Chain Drive & FCC TRAC	① 2 outboard brems calipers ② 2 outboard brems calipers	Ignition Cut
10 × 8.0 Keizer 18.0 × 7.5-10 R25B Hoosier	① Husqvarna 701 supermoto ② 692 cc ③ 49 kW/7500 rpm ④ 65 Nm/5500 rpm	Naturally aspirated 4.2 L	Manual	Chain Drive LSD (DREXLER)	① 2 outboard ② 2 outboard Nissin calipers	Variable Stabilizer
13 inch OZ 205/60-13 Hoosier	① PC40E HONDA CBR600RR ② 600 cc ③ 71.5 ps/12000 rpm ④ 5.2 kgf/7500 rpm	Naturally aspirated 5.0 L	Manual	Chain Drive/ Carbon LSD (ATS)	① 4 outboard ② 2 outboard Nissin calipers	• Dry Sump • Intake manifold
13 inch O.Z. Racing 7J 20.5 × 7.0-13 Hoosier R25B, Bias	① SUZUKI GSX-R600 L4 ② 599 cc ③ 61 ps/8800 rpm ④ 5.7 kgf/7400 rpm	Naturally Aspirated 6.0 L	6-Speed Sequential	Chain Drive F.C.C TRAC LSD, Cam & Pawl	① 2 Outboard, Brembo Calipers ② 2 Outboard, Brembo Calipers	Full Stainless-Steel Tubing Brake Line
10 × 7 inch, offset 1.5 inch, cast aluminum 18x6.0-10 LC0 Hoosier	① Suzuki GSX-R600 ② 599 cc ③ 55 kW/12000 rpm ④ 49 Nm/7500 rpm	Naturally Aspirated 4.6 L	pneumatic paddle shifting	Chain drive CUSCO LSD Differential	① Floating disk ② Floating disk ISR calipers	Full set of aerodynamic package Launch Control Monocoque Electronic Throttle 3rd Spring
Wheels RS Watanabe 13-6.5J + 14.5 Tires Goodyear EAGLE RS 20 × 7.0J-13	① 13ST YAMAHA YZF-R6 ② 599 cc ③ 75 ps/11500 rpm ④ 5.8 kgf/8000 rpm	Naturally aspirated 6.0 L	Manual	Chain Drive FCC LSD	① 4 outboard Advics calipers ② 2 outboard Nissin calipers	variable length intake runner
13 inch RAYS TE37 20.5 × 7.0-13 inch R25B Hoosier	① PC40E HONDA CBR600RR ② 600 cc ③ 75 ps/11500 rpm ④ 5.4 kgf/7000 rpm	Naturally sspirated 5.5 L	Manual	SSURE TRAC Limited Slip Defferential Gear	① 2 opposing piston Nissin calipers ② 2 opposing piston Nissin calipers	
13 inch Center-Locking O · Z Wheel	① PC40EHONDA CBR600RR ② 599 cc ③ 65 ps/10000 rpm ④ 5.4 kgf/6000 rpm	Naturally Aspirated 4.2 L	Manual Sequential paddle shift	Chain Drive LSD (DREXLER)	① 2 inboard Nissin Calipers ② 2 outboard Nissin Calipers	
13 inch RAYS VOLK RACING TE37 20.5/6.0-13 Hoosier	① SUZUKI GSR600 ② 599.4 cc ③ 72 ps/9000 rpm ④ 5.2 kgf/7500 rpm	Naturally aspirated 5.5 L	Manual	Chain Drive LSD	① 2 outboard ② 2 outboard Nissin calipers	Front Foop is made of a bended square pipe
VOLK TE37 13 × 6.0J + 42 CNC processed 20.5 × 6.0-13 R25A Hoosier	① SUZUKI/GSX-R 600 ② 599 cc ③ 80 kW/11000 rpm ④ 5.65kgf·m/8000 rpm	Naturally aspirated 5.0 L	Electric acuated shift	Bevel Geardrive LSD	① 2 outboard ② 2 outboard	

Team Information (Vehicle Specifications)

Car No	School Name	Color s	Frame	Body-work	Suspension ①Front ②Rear	①Overall Length ②Overall Height ③Wheelbase ④Front Track ⑤Rear Track				①Gross Vehicle Mass ②Fr.Rr Weight Dist. ③Ground Clearance		
						①	②	③	④	⑤	①	②
23	Kyoto University	black, white & navy	carbon monocoque & steel spaceframe	CFRP	① Double unequal length A-arm Push rod ② Double unequal length A-arm Push rod	① 3053 mm ② 1020 mm ③ 1700 mm ④ 1350 mm ⑤ 1350 mm				① 185 kg ② 45 : 55 ③ 28 mm		
24	Universitas Gadjah Mada	Red and White	Steel Spaceframe	Vacuum Infused CFRP	① Double unequal length A-arm Push rod ② Double unequal length A-arm Push rod	① 2057 mm ② 1163 mm ③ 1536 mm ④ 1170 mm ⑤ 1150 mm				① 220 kg ② 50 : 50 ③ 60 mm		
25	Institut Teknologi Sepuluh Nopember	Blue and Black	steel spaceframe	Fiber-carbon	① Double unequal length A-arm Pull rod ② Double unequal length A-arm Push rod	① 2819 mm ② 1034 mm ③ 1730 mm ④ 1260 mm ⑤ 1250 mm				① 250 kg ② 50 : 50 ③ 40 mm		
26	Kanazawa University	Black, Blue	steel spaceframe	Wet lay-up GFR	① Double unequal length A-arm Pull rod ② Double unequal length A-arm Push rod	① 2800 mm ② 1030 mm ③ 1600 mm ④ 1250 mm ⑤ 1250 mm				① 186 kg ② 48 : 52 ③ 30 mm		
27	UNIVERSITAS NEGERI YOGYAKARTA	White & Black with Blue Lines	steel spaceframe	Carbon Fiber	① Double unequal length A-arm Pull rod ② Double unequal length A-arm Push rod	① 2800 mm ② 1600 mm ③ 1050 mm ④ 1140 mm ⑤ 1150 mm				① 210 kg ② 48 : 52 ③ 68 mm		
28	Toyohashi University of Technology	Carbon Black	CFRP Monocoque and spaceframe	CFRP	① Double unequal length A-arm Push rod ② Double unequal length A-arm Push rod	① 3032 mm ② 1224mm ③ 1700 mm ④ 1200 mm ⑤ 1200 mm				① 215 kg ② 45 : 55 ③ 30 mm		
29	Sophia University	Red & Black & White	Carbon monocoque	CFRP	① Double unequal length A-arm Push rod ② Double unequal length A-arm Push rod	① 2940 mm ② 1250 mm ③ 1550 mm ④ 1200 mm ⑤ 1180 mm				① 235 kg ② 47 : 50 ③ 25 mm		
30	Tokyo City University	black & blue	steel spaceframe	GFRP	① Double unequal length A-arm Push rod ② Double unequal length A-arm Push rod	① 3130 mm ② 1185 mm ③ 1700 mm ④ 1200 mm ⑤ 1200 mm				① 265 kg ② 45 : 55 ③ 25 mm		
31	Shizuoka Institute of Science and Technology	leyton blue	steel spaceframe	CFRP	① Double unequal length A-arm Push rod ② Double unequal length A-arm Pull rod	① 2795 mm ② 2223 mm ③ 1578 mm ④ 1217 mm ⑤ 1200 mm				① 180 kg ② 45 : 55 ③ 40 mm		
32	King Mongkut' s University of Technology Thonburi	Black and Blue	Hybrid Chassis	Carbon Fiber	① Double unequal length A-arm Pull rod ② Double unequal length A-arm Pull rod	① 2750 mm ② 1205 mm ③ 1550 mm ④ 1260 mm ⑤ 1210 mm				① 200 kg ② 45.7 : 54.3 ③ 32 mm		
33	College of Industrial Technology, Nihon University	Navy Yellow White	steel spaceframe	Fiber-glass	① Double unequal length A-arm Pull rod ② Double unequal length A-arm Push rod	① 2870 mm ② 1170 mm ③ 1600 mm ④ 1200 mm ⑤ 1200 mm				① 230 kg ② 45 : 55 ③ 40 mm		
34	Institute of Technologists	dark blue	steel spaceframe	CFRP	① Double unequal length A-arm Push rod ② Double unequal length A-arm Push rod	① 2779 mm ② 1135.5 mm ③ 1650 mm ④ 1240 mm ⑤ 1240 mm				① 240 kg ② 50 : 50 ③ 20 mm		
35	Tokai University	White and Blue	Full CFRP Monocoque	CFRP	① Double unequal length A-arm Pull rod ② Double unequal length A-arm Pull rod	① 3080 mm ② 1237 mm ③ 1700 mm ④ 1200 mm ⑤ 1200 mm				① 220 kg ② 50 : 50 ③ 35 mm		
36	University of Fukui	Orange & Black	steel spaceframe	GFRP	① Double unequal length A-arm Pull rod ② Double unequal length A-arm Pull rod	① 2600 mm ② 1300 mm ③ 1800 mm ④ 1200 mm ⑤ 1200 mm				① 250 kg ② 43 : 57 ③ 35 mm		
37	Okayama University of Science	Gray & Green, orange line	steel spaceframe	Fiber-glass	① Double unequal length A-arm Push rod ② Double unequal length A-arm Push rod	① 3040 mm ② 1118 mm ③ 1700 mm ④ 1300 mm ⑤ 1300 mm				① 250 kg ② 45 : 55 ③ 50 mm		
38	Kanazawa Institute of Technology	Red & Black	steel spaceframe	CFRP	① Double unequal length A-arm Pull rod ② Double unequal length A-arm Push rod	① 2979 mm ② 1185 mm ③ 1550 mm ④ 1200 mm ⑤ 1200 mm				① 225 kg ② 48 : 52 ③ 30 mm		
39	Meijo University	yellow	steel spaceframe	Fiber-glass	① Double unequal length A-arm Push rod ② Double unequal length A-arm Push rod	① 2958 mm ② 1200 mm ③ 1550mm ④ 1250 mm ⑤ 1250 mm				① 200 kg ② 45 : 55 ③ 30 mm		
40	Tokyo University of Agriculture and Technology	blue	steel spaceframe	GFRP	① Double unequal length A-arm Push rod ② Double unequal length A-arm Push rod	① 2950 mm ② 1200 mm ③ 1650 mm ④ 1260 mm ⑤ 1260 mm				① 245 kg ② 45 : 55 ③ 30 mm		
41	Osaka Institute of Technology	Blue & Black	Steel Spaceframe	CFRP and GFRP	① Double unequal length A-arm Push rod ② Double unequal length A-arm Push rod	① 3092 mm ② 1166 mm ③ 1550 mm ④ 1400 mm ⑤ 1400 mm				① 320 kg ② 50 : 50 ③ 50 mm		
42	OSAKA SANGYO UNIVERSITY	red/black/white	steel spaceframe	CFRP	① Double unequal length A-arm Push rod ② Double unequal length A-arm Push rod	① 2650 mm ② 1179 mm ③ 1700 mm ④ 1240 mm ⑤ 1240 mm				① 315 kg ② 45 : 55 ③ 40 mm		

Wheels & Tires	① Engine ② Displacement ③ max. power ④ max.torque	Induction type Fuel tank Volume	Shifter	Final Drive & Differential	Brakes ① Front ② Rear	Unique Features & Notes
10 inch Douglas ATV 18.0/6.0-10 Hoosier Bias	① YAMAHA WR450F ② 449 cc ③ 46 ps/9000 rpm ④ 3.9 kgf/7200 rpm	Naturally aspirated 5.0 L	Semi-automatic	Shaft Drive & ATS LSD	① 2 outboard Frando Calipers ② 2 outboard Willwood Calipers	Seamless Transmission
10" Keizer Aluminum Wheels, Hoosier 6.0/18.0-10 LC0	① KTM 450 SX-F ② 450 cc ③ 31.23 kW/11500 rpm ④ 32.34 Nm/9100 rpm	Naturally aspirated 4.5 L	Manual	Drexler Limited Slip Differential	① 2 outboard ② 2 outboard AP Racing Calipers	Rekluse Auto Clutch with Gear Change Ignition Cut
10 inch KEIZER HOOSIER 180/60-10 Road Racing	① Kawasaki ZX6R ② 599 cc ③ 81.6 kW/12500 rpm ④ 65.6 Nm/10000 rpm	5.5 L	Manual	Trd Sport	① TDR Racing ② TDR Racing	Adjustable Ackerman
10 inch keizer6J 2.0 slick 18.0 x 6.0-10 Hoosier Bias rain 19.5 x 6.5-10 Hoosier Bias	① SUZUKI LT-R450 ② 450 cc ③ 40 ps/9000 rpm ④ 33.5 Nm/3500 rpm	Naturally aspirated 4.0 L	Manual	Chain Drive, Mechanical LSD	① 2 outboard ② 2outboard AP calipers	
10 inch Keizer Front Tire HOOSIER 6.0/18.0-10 LC0, Rear Tire HOOSIER 6.0/18.0-10 R25B	① HUSQVARNA SM 630 2011 ② 600 cc ③ 46 ps/8000 rpm ④ 45 Nm/5200 rpm	Naturally aspirated 5 L	Manual	Drive Chain with Drexler LSD	① 2 outboard ② 2 outboard Wilwood calipers	Telemetri & Data Acquisition
13 inch RAYS TE37 R25B 20.5 x 7.0-13 Hoosier Bias	① PC40E HONDA CBR600RR ② 599 cc ③ 68 ps/10000 rpm ④ 5.3 kgf/8500 rpm	Naturally aspirated 5.2 L	Manual	Chain Drive Carbon limited slip differential (ATS)	① 2 outboard ② 2 outboard Brembo calipers	Carbon fiber monocoque
Carbon wheel, CL10 Forged center lock 6.0/18.0-10, LC0, Hoosier	① YZ450FX ② 450 cc ③ 49.6 kW@10000 rpm ④ 58.8 Nm@7000 rpm	NA, 3.0 L	Manual	Chain Drive	① ISR Brake22-048 4-piston caliper ② ISR Brake22-049 2-piston caliper	
13 inch Watanabe Mag EIGHT SPOKE 20.5 x 7.0-13 Hoosier Bias	① PC40E HONDA CBR600RR ② 599 cc ③ 78.5 ps/10500 rpm ④ 6.1 kgf/8500 rpm	Naturally aspirated 5.0 L	Manual	Chain Drive Mechanical LSD	① 2 outboard ② 2 outboard Nissin calipers	Front Wing & Rear Wing
10 inch DOUGLAS 7.0/18.0-10 Hoosier	① SUZUKI RM-X450Z ② 449 cc ③ 38 ps/9000 rpm ④ 3.6 kgf-m/7300 rpm	Naturally aspirated 3.5 L	Manual	Chain Drive LSD	① 2 outboard ② 2 outboard	Moveable Pedal Box
10 inch Radius, 8 inch wide, Hoosier 18.0 x 7.5-10, R25B	① 2012 Yamaha YZF-R6 ② 599 cc ③ 43.5 kW/10000 rpm ④ 54.5 Nm/6500 rpm ⑤ 75 ps/11500 rpm ⑥ 5.4 kgf/7000 rpm	Naturally aspirated 3.5 L	Manual and Pnumatic shifter	Final drive ratio 2.928 : 1 with limited slip differential	① Brembo Rear CNC caliper P4 24 ② Brembo Rear CNC caliper P2 24	Variable Intake System and Telemetry
13 inch RAYS VOLK 175/60-13 DUNLOP DIREZZA03G	① PE06E HONDA CRF450X ② 449 cc ③ 49 ps/9000 rpm ④ 4.2 kgf/5500 rpm	Naturally aspirated 6.5 L	Manual	Chain Drive F.C.C. LSD	① 2 outboard ② 1 outboard Nissin calipers	Carburetor
10 inch RS Watanabe EIGHT SPOKE Hoosier FORMULA S.A.E. Slick	① ホンダ CBR600RR PC40E ② 599 cc ③ 78 ps ④ 5.3 kgm	NA 5.0 L	Manual	chain FCC TRAC	① opposed type caliper wilwood GP200 ② opposed type caliper wilwood GP200	High in-team production rate.
10inch Keizer Aluminium 18 x 7.5-10 Hoosier R25B	① SUZUKI SV650 Bore up ② 693.8 cc ③ 73 ps/9500 rpm ④ 6.9 kgf/7500 rpm	Naturally aspirated 7.5 L	Paddle Shift by Air	Shaft Drive & Drexler Motorsport LSD	① 2 outboard ② 2 outboard AP racing calipers	Full CFRP Monocoque Student desinged original Bore up piston zero jack up suspension Geometry
13 inch RAYS 20.5 x 7.0-13 Hoosier R25B	① SUZUKI GSX-R600 L3 ② 600 cc ③ 60 kW/9500 rpm ④ 58 Nm/9100 rpm	Naturally aspirated 6.2 L	Manual	chain drive F.C.C. TRAC	① 2 outboard ② 2 outboard Nissin calipers	Accumulator Oil Sump System
10 inch Kaizer and Dagrass ATV 6.0/18.0-10 Hoosier Bias LC0	① LE650A versys 650 ② 650 cc ③ 50 ps/7,500 rpm ④ 5.2 kgf/5,500 rpm	Naturally aspirated 4.5 L	Manual Electric Shifter	Chain drive & F.C.C. TRAC	① 2 outboard ② 2 outboard Wilwood calipers	Fuel Injection Debut
13 inch TWS Mg Wheel, 20.5 x 7.0-13 R25B Hoosier	① N735 SUZUKI GSX-R600 K9 ② 599 cc ③ 80 ps/8400 rpm ④ 7.0 kgf/6900 rpm	Naturally aspirated 5.5 L	Manual	Chain Drive, F.C.C. TRAC, LSD	① 2 outboard Brembo calipers ② 2 outboard Nissin calipers	Full Aero Device
F : 10 inch Kizer wheel 7J R : 10 inch Douglas wheel 6.0/18.0-10 Hoosier	① YAMAHA WR450F J333E ② 449 cc ③ 33.1 kW/7800 rpm ④ 38.4 Nm/7000 rpm	Naturally aspirated 3.8 L	Sequential Manual	Chain Drive LSD	① 2 outboard Nissin calipers ② 2 outboard Nissin calipers	Aero device High compression engine
13 inch OZ Racing 190/505-13 Dunlop SLICK Radial	① PC40E HONDA CBR600RR ② 599 cc ③ 78 ps/12000 rpm ④ 5.8 kgf/8000 rpm	Naturally aspirated 6.0 L	Electric semi automatic shifter	Chain Drive F.C.C TRAC	① 2 outboard ② 2 outboard Nissin calipers	3D Printed Intake System, Electric Assisted Water Pump
13 inch OZ-Racing 20.5 x 7.0-13 Hoosier R25B	① 2012 SUZUKI GSX-R600 ② 599 cc ③ 70 Ps/10500 rpm ④ 5.4 kgh/8000 rpm	Naturally aspirated 4.5 L	Pneumatic Shifter	Chain Drive F.C.C. TRAC	① 2 outboard ② 2 outboard calipers	Front & Rear Wing Diffuser
13 inch RAYS VOLK TE-37 20.5/7.0-13 Hoosier Bias	① KAWASAKI ZX636E ② 636 cc ③ 131 ps/13500 rpm ④ 6.2 kgf/10800 rpm	Naturally aspirated 5.0 L	Electric acuated shift	Chain Drive & FCCTRAC limited slip differential	① 2 Outboard Disk ② 2 Outboard Disk Nissin Calipers	

Team Information (Vehicle Specifications)

Car No	School Name	Color s	Frame	Body-work	Suspension ①Front ②Rear	①Overall Length ②Overall Height ③Wheelbase ④Front Track ⑤Rear Track			①Gross Vehicle Mass ②Fr.Rr Weight Dist. ③Ground Clearance		
43	Harbin Institute of Technology at Weihai	Black & Blue & Yellow	Semi-monocoque & frame	Carbon fiber	① Double unequal length A-arm Push rod ② Double unequal length A-arm Push rod	① 2980 mm ② 1490 mm ③ 1580 mm ④ 1180 mm ⑤ 1160 mm	① 210 kg ② 47 : 53 ③ 35 mm				
44	Kasetsart University	White-Green	Steal spaceframe	CFRP	① Double unequal length A-arm Pull rod ② Double unequal length A-arm Push rod	① 3265 mm ② 1215 mm ③ 1600 mm ④ 1220 mm ⑤ 1170 mm	① 230 kg ② 45 : 55 ③ 30 mm				
45	Shizuoka University	black & orange	steel spaceframe	Fiber-carbon	① Double unequal length A-arm Pull rod ② Double unequal length A-arm Push rod	① 2590 mm ② 1390 mm ③ 1800 mm ④ 1200 mm ⑤ 1200 mm	① 230 kg ② 45 : 55 ③ 30 mm				
46	Niigata University	Deep green	steel spaceframe	GFRP	① Double unequal length A-arm Pull rod ② Double unequal length A-arm Push rod	① 2920 mm ② 1120 mm ③ 1690 mm ④ 1220 mm ⑤ 1220 mm	① 262 kg ② 50 : 50 ③ 35 mm				
47	Okayama University	Lime Green	steel spaceframe	Fiber-glass	① Double unequal length A-arm Push rod ② Double unequal length A-arm Push rod	① 2962 mm ② 1168 mm ③ 1650 mm ④ 1300 mm ⑤ 1300 mm	① 190 kg ② 50 : 50 ③ 30 mm				
48	Kurume Institute of Technology	White, Black	steel spaceframe	Fiber-glass	① Double unequal length A-arm Acting ② Double unequal length A-arm Push rod	① 2750 mm ② 1185 mm ③ 1540 mm ④ 1205 mm ⑤ 1205 mm	① 185 kg ② 40 : 60 ③ 50 mm				
49	Seikei Univarcity	Black	steel spaceframe	Fiber-glass	① Double unequal length A-arm Push rod ② Double unequal length A-arm Push rod	① 2850 mm ② 1260 mm ③ 1650 mm ④ 1230 mm ⑤ 1230 mm	① 248.6 kg ② 50 : 50 ③ 30 mm				
50	Setsunan University	White	steel spaceframe	Fiber-glass	① Double unequal length A-arm Pull rod ② Double unequal length A-arm Push rod	① 3038 mm ② 1133 mm ③ 1660 mm ④ 1200 mm ⑤ 1200 mm	① 330 kg ② 40 : 60 ③ 40 mm				
51	Hokkaido University/ Hokkaido University of science	green	steel spaceframe	GFRP	① Double unequal length A-arm Push rod ② Double unequal length A-arm Push rod	① 2700 mm ② 1200 mm ③ 1800 mm ④ 1300 mm ⑤ 1300 mm	① 240 kg ② 47 : 53 ③ 48 mm				
52	College of Science and Technology, Nihon University	navy blue and pink	steel spaceframe	Fiber-glass	① Double unequal length A-arm Push rod ② Double unequal length A-arm Push rod	① 2960 mm ② 1330 mm ③ 1870 mm ④ 1128 mm ⑤ 1128 mm	① 250 kg ② 45 : 55 ③ 55 mm				
53	Meisei University	Black & Yellow	Steel space frame	Styrene Board	① Double unequal length A-arm and Push rod ② Double unequal length A-arm and Push rod	① 2780 mm ② 1324.3 mm ③ 1620 mm ④ 1200 mm ⑤ 1200 mm	① 199kg ② 50 : 50 ③ 64mm				
54	Aichi Institute of Technology	Rad and black	steel spaceframe	CFRP	① Double unequal length A-arm Push rod ② Double unequal length A-arm Push rod	① 2750 mm ② 1245 mm ③ 1557 mm ④ 1232 mm ⑤ 1232 mm	① 220kg ② 45 : 55 ③ 50 mm				
55	Honda Technical College Kanto	White	steel spaceframe	PET	① Double unequal length A-arm Pushrod rod ② Double unequal length A-arm Push rod	① 2717 mm ② 1185 mm ③ 1620 mm ④ 1210 mm ⑤ 1210 mm	① 170 kg ② 49 : 51 ③ 40 mm				
56	National Tsing Hua University	Black & Purple	Steal spaceframe	Carbon fiber	① Double unequal length A-arm Push rod ② Double unequal length A-arm Push rod	① 2834 mm ② 1145 mm ③ 1595 mm ④ 1250 mm ⑤ 1200 mm	① 225 kg ② 47 : 53 ③ 35 mm				
57	Tottori University	Black	steel spaceframe	Fiber-glass	Suspension ① Double unequal length A-arm Push rod ② Double unequal length A-arm Push rod	① 2830 mm ② 1280 mm ③ 1600 mm ④ 1260 mm ⑤ 1260 mm	① 250 kg ② 40 : 60 ③ 50 mm				
58	Honda Technical College Kansai	orange & silver	steel spaceframe	GFRP	① Double unequal length A-arm Pull rod ② Double unequal length A-arm Pull rod	① 2748 mm ② 1107 mm ③ 1550 mm ④ 1200 mm ⑤ 1200 mm	① 170kg ② 40 : 60 ③ 37 mm				
59	Sojo University	Black & Red	steel spaceframe	GFRP	① Double unequal length A-arm Push rod ② Double unequal length A-arm Push rod	① 2970 mm ② 1148 mm ③ 1600 mm ④ 1270 mm ⑤ 1270 mm	① 265 kg ② 46 : 54 ③ 45 mm				
60	The University of Kitakyushu	White and Green	steel spaceframe	GFRP	① Double unequal length A-arm Push rod ② Double unequal length A-arm Push rod	① 2656 mm ② 1220 mm ③ 1600 mm ④ 1200 mm ⑤ 1200 mm	① 270 kg ② 45 : 55 ③ 95 mm				
61	Kyushu University	Blue & Yellow	steel spaceframe	Fiber-glass	① Double unequal length A-arm Pull rod ② Double unequal length A-arm Pull rod	① 2600 mm ② 1300 mm ③ 1550 mm ④ 1200 mm ⑤ 1200 mm	① 220 kg ② 45 : 55 ③ 25 mm				
62	Chiba Institute of Technology	navy blue	steel space frame	Fiber-glass	① Double unequal length A-arm push rod ② Double unequal length A-arm rocking arm	① 2800 mm ② 1150 mm ③ 1600 mm ④ 1200 mm ⑤ 1200 mm	① 250 kg ② 50 : 50 ③ 45 mm				

Wheels & Tires	① Engine ② Displacement ③ max. power ④ max.torque	Induction type Fuel tank Volume	Shifter	Final Drive & Differential	Brakes ① Front ② Rear	Unique Features & Notes
10 inch Keizer & Hoosier 18.0*7.5	① Suzuki_GSX-R600 ② 599 cc ③ 58 kW/11500 rpm ④ 50 Nm/10500 rpm	Naturally aspirated 5 L	Pneumatic	Shaft & Drexler	① 4 piston ② 2 piston AP calipers	Monocoque, carbon fiber suspension
10 inch SSR Hoosier Tires	① Kawasaki ZX-6R 2008 ② 599 cc ③ 85.4 Hp/11000 rpm ④ 75 Nm/9000 rpm	Naturally aspirated 5 L	Pneumatic Shifter	drexler limited slip differential formula student	① Willwood PS-1 calipers ② Willwood PS-1 calipers	Unique suspension system
13 inch O.Z Racing Wheel Hoosier	① SUZUKI GSX-R600 L5 ② 600 cc ③ 70 ps/12000 rpm ④ 56 Nm/7750 rpm	Naturally aspirated 6.5 L	Manual	Shaft Torsen	① 2 outboard ② 2 outboard Nissn calipers AP calopers	Low center of gravity & long Wheelbase
13inch OZ Racing Magnesium 190/505_13 DUNLOP	① SUZUKI GSX-R600 (L 5) ② 599 cc ③ 69.4 ps/10,163 rpm ④ 5.4 kgf/9402 rpm	Naturally aspirated 6.0 L	Manual	Chain Drive & ATS	① 2 outbord ② 2 outbord Nissin calipers	
10 inch DOUGLAS & 18.0 x 6.0-10 R25B Hoosier	① KLX450R ② 449 cc ③ 40 ps/8000 rpm ④ 41 Nm/7500 rpm	Naturally aspirated 3.5 L	Manual	Chain Drive & F.C.C Track	① 2 outboards Nissin calipers ② 2 outboards AP raceing calipers	
Front 10 inch Suzuki ATV Rear 10 inch Watanabe competition only 10-6.0 Hoosier R25B	① L404 Suzuki LT-R450 ② 450 cc ③ 69 ps/9000 rpm ④ 6.1 kgf/7500 rpm	Turbo charged 5.0 L	Manual	Chain Drive trac tpe	① 2 outboard Nissin calipers ② 1 inboard Brenbo calipers	Boost controled stepping motor
13 inch Watanabe Mg 20.5/7.0-13 Hoosier	① PC40EHONDA CBR600RR ② 600 cc ③ 80 ps/10000 rpm ④ 5.8 kgf/8000 rpm	Naturally aspirated 5.1 L	Manual	Chain Drive F.C.C.TRAC LSD	① 2 outboard ② 2 outboard Nissin calipers	shallow oil pan suitable drivability
13 inch RAYS 180/520-13 HOOSIER	① SUZUKI GSX-R600 K6 ② 599 cc ③ 126 ps/13500 rpm ④ 6.9 kg-m/11500 rpm	Naturally aspirated 8 L	Manual Electromagnetic shifter	Shaft Torsen	① 2 Pot Nissin Calipers ② 2 Pot Brembo Calipers	
10 x 6 RS Watanabe 18.0 x 6.0-10 Hoosier R25B	① PC40E HONDA CBR600RR ② 599 cc ③ 85 ps/10500 rpm ④ 6.0 kgf/8000 rpm	Naturally aspirated 5.4 L	Manual	Chain Drive F.C.C. LSD	① 2 outboard ② 2 outboard Nissin calipers	
13 inch watanabe 8spoke Mg20.5 x 7.0 Hoosier R25B	① 2008 YAMAHA YZF-R6 ② 599 cc ③ 80 ps/10000 rpm ④ 5.5 kgf/9000 rpm	Naturally aspirated 5.0 L	Manual Electric shifte	Chain Drive F.C.C TRAC	① 2 outboard ② 2 outboard Brembo calipers	Electric water pump
13 inch RAYS TE37 160/55VR13 YOKOHAMA ADVAN A005	① PE06E HONDA CRF450X ② 449 cc ③ 37.9 ps/8,000 rpm ④ 4.1 kgf/8,000 rpm	Naturally aspirated 5 L	Manual	Chain Drive F.C.C. TRAC	① 2 outboard ② 1 inboard Brembo calipers	Carburetor F & R Mono shock
13 inch OZ Racing 7J of 22 DUNLOP SLICK Radial 190/190/50R13	① YAMAHA YZ450FX ② 449 cc ③ 60 ps/8000 rpm ④ 4.0 kgf/7500 rpm	Naturally aspirated 4.8 L	Manual	Chain Drive Mechanical LSD	① 2 outboard ② 2 outboard Nissin calipers	CFRP cowl and New power train system
10inch Hoosier18.0 x 6.0-10 Hoosier Bias	① PE07 (HONDA CRF450RX) ② 450 cc ③ 75 ps/11500 rpm ④ 5.4 kgf/7000 rpm	Naturally aspirated 4.0 L	Manual	Chain Drive F.C.C TRAC	① 2 outboard ② 2 outboard Nissin calipers	very light PET Cowl
Rays 13" 6 inch width, Aluminum, Forged 1pc, 38 mm offset Front Hoosier 20.5 x 6.0-13 Rear Hoosier 20.5 x 7.0-13	① kawasaki ER6n ② 649 (cc) ③ 56.7 ps/7750 rpm ④ 5.842 kgf/6800 rpm	Naturally aspirated 4.5 L	Manual	limited slip differential	① 2 outboard ② 2 outboard Trioes calipers	Titanium A-arms
KOSEI 1360FT Hoosier 4316 20.5 x 7.0-13 (C2500)	① KAWASAKI ZX600R (09model) ② 599 cc ③ 94.1 kW/14000 rpm ④ 66.7 Nm/11800 rpm	Naturally aspirated 6.0 L	Manual	Chain Drive F.C.C TRAC	① 2 outboard ② 2 outboard Nissin calipers	
10 inch RS Watanabe A10-60 Mg Wheel Hoosier 6.0/18.0-10 LCO	① PE05 HONDA CRF450X ② 449 cc ③ 20.0 kW/7500 rpm ④ 25.0 Nm/6000 rpm	Naturally aspirated 3.3 L	Manual Paddle Shift	Chain Drive F.C.C TRAC	① 2 outboard ② 2 outboard Nissin calipers	paddle shift carburetor
13 inch OZ-Racing 20.5 x 7.0-13 Hoosier R25	① PC40E HONDA CBR600RR ② 599 cc ③ 75 ps/11500 rpm ④ 5.4 kgf/8200 rpm	Naturally aspirated 5.5 L	Manual	Chain Drave F.C.C TRAC	① 2 outboard Brembo Calipers ② 1 inboard Nissin Calipers	
13 inch OZ Formula Student DUNLOP SLICK Radial 190/505R13 13 inch RAYS TE37 DUNLOP DIREZZA 03G 175/60R13	① ER650H Kawasaki Z650 ② 649 cc ③ 54 ps/7800 rpm ④ 5.5 kgf/6900	Naturally aspirated 5.6 L	Manual	ChainDrive F.C.C TRAC	① 2 outboard ② 2 outboard Nissin calipers	
13 inch WATANABE 190/505-13 DUNLOP DIREZZA 03G	① PE06EHONDA CRF450X ② 450 cc ③ 36 ps/8300 rpm ④ 36.8 Nm/6000 rpm	Naturally aspirated 4.5 L	Manual	Chain Drive F.C.C TRAC	① 2 outboard ② 1 inboard Nissin calipers	
13 inch RS watanabe Hoosier 20.5 x 7.0-13 R25	① YAMAHA Venture Multi P-RPZ50MP ② 499 cc ③ 80 ps/11250 rpm ④ 5.2 kgf/9000 rpm	Naturally aspirated 7.1 L	CVT	Chain Drive	① outboard ② inboard Nissin 製両押し 2 pot	

Team Information (Vehicle Specifications)

Car No	School Name	Color s	Frame	Body-work	Suspension ①Front ②Rear	①Overall Length ②Overall Height ③Wheelbase ④Front Track ⑤Rear Track	①Gross Vehicle Mass ②Fr.Rr Weight Dist. ③Ground Clearance
63	Kinki University	black	steel spaceframe	GFRP	① Double wishbone unequal length A-arm Pushrod ② Double wishbone unequal length A-arm Pushrod	① 2780 mm ② 1135 mm ③ 1600 mm ④ 1200 mm ⑤ 1200 mm	① 220 kg ② 43 : 57 ③ 30 mm
64	Sinhgad Technical Education Society	Carbon Fiber	Steel Spaceframe	Carbon Fiber	① Double wishbone, coil over suspension, push-rod type ② Double wishbone, coil over suspension, push-rod type	① 2800 mm ② 1250 mm ③ 1580 mm ④ 1200 mm ⑤ 1150 mm	① 180 kg ② 45 : 55 ③ 45 mm
65	Aoyama Gakuin University	emerald green	steel spaceframe	FRP	① Double unequal length A-arm Push rod ② Double unequal length A-arm Push rod	① 2225 mm ② 1110 mm ③ 1600 mm ④ 1250 mm ⑤ 1250 mm	① 240 kg ② 40 : 60 ③ 65 mm
67	Kokushikan University						
68	ASO College of Automotive Engineering and Technology	blue	steel spaceframe	aluminum	Suspension ① Double unequal length A-arm Push rod ② Double unequal length A-arm Push rod	① 2830 mm ② 1198 mm ③ 1700 mm ④ 1200 mm ⑤ 1200 mm	① 250 kg ② 40 : 60 ③ 35 mm
69	Shizuoka Professional College of Automobile Technology	Yellow	steel spaceframe	Fiber-glass	① Double wishbone A-arm Push rod ② Double wishbone A-arm Push rod	① 2765 mm ② 1160 mm ③ 1650 mm ④ 1250 mm ⑤ 1250 mm	① 250 kg ② 40 : 60 ③ 35 mm
70	Southern Taiwan University of Science & Technology/ Xiamen University of Technology						
71	National Taipei University Of Technology	Carbon Black, Red	Steel Spaceframe	CFRP	① Double unequal length A-arm Push rod ② Double unequal length A-arm Push rod	① 2815 mm ② 1210 mm ③ 1535 mm ④ 1200 mm ⑤ 1180 mm	① 225 kg ② 47 : 53 ③ 25 mm
72	Hiroshima Institute of Technology	White	steel spaceframe	GFRP	① Double unequal length A-arm Pull rod with Torsionbar ② Double unequal length A-arm Pull rod with Torsionbar	① 2593 mm ② 1261 mm ③ 1570 mm ④ 1100 mm ⑤ 1050 mm	① 185 kg ② 47 : 53 ③ 39.3 mm
73	University of Toyama	Yellow	steel spaceframe	GFRP	① Double unequal length A-arm Pull rod ② Double unequal length A-arm Pull rod	① 2750 mm ② 1100 mm ③ 1600 mm ④ 1250 mm ⑤ 1250 mm	① 270 kg ② 45 : 55 ③ 50 mm
75	Tokyo Technical Collage/ Setagaya Formula Team	Navy Blue	steel spaceframe	GFRP	① Double unequal length A-arm Wishbone ② Double unequal length A-arm Wishbone	① 2900 mm ② 1425 mm ③ 1720 mm ④ 1304 mm ⑤ 1412 mm	① 280 kg ② 45 : 55 ③ 70 mm
76	Sebelas Maret University	Black carbon and golden yellow	steel space frame	Fiber-glass & Fiber-carbon	① Double unequal length A-arm Push rod ② Double unequal length A-arm Push rod	① 2946 mm ② 1346 mm ③ 1565 mm ④ 1440 mm ⑤ 1500 mm	① 250 kg ② 40 : 60 ③ 70 mm
77	Hubei University Of Automotive Technology	White-based, black red supplemented by	steal spaceframe	Carbon fiber composite material	① Double unequal length A-arm Push rod ② Double unequal length A-arm Push rod	① 2995 mm ② 1280 mm ③ 1540 mm ④ 1200 mm ⑤ 1700 mm	① 216 kg ② 45 : 55 ③ 40 mm
78	Graz Technical University						
79	The University of Tokyo	Metallic Blue	Steel Spaceframe	Fiber-glass	① Double unequal length A-arm Push rod ② Double unequal length A-arm Push rod	① 2780 mm ② 1100 mm ③ 1525 mm ④ 1250 mm ⑤ 1250 mm	① 200 kg ② 48 : 52 ③ 30 mm
80	Saitama University	White and Red	steel spaceframe	CFRP	① Double unequal length A-arm Outboard ② Double unequal length A-arm Outboard	① 2770 mm ② 1192 mm ③ 1675 mm ④ 1275 mm ⑤ 1225 mm	① 240 kg ② 48 : 52 ③ 60 mm
82	Teikyo University	blue	steel spaceframe	aluminium	① Double A-arm Push rod ② Double A-arm Push rod	① 2408 mm ② 1268 mm ③ 1536 mm ④ 989 mm ⑤ 989 mm	① 270 kg ② 40 : 60 ③ 140 mm
83	Nishinippon Insutite of Technology	Carbon Black	steel spaceframe	CFRP	① Double unequal length A-arm Pull rod ② Double unequal length A-arm Push rod	① 3000 mm ② 1220 mm ③ 1778 mm ④ 1388 mm ⑤ 1388 mm	① 295 kg ② 40 : 60 ③ 50 mm
85	Osaka Prefecture University	navy blue	steel spaceframe	Fiber-glass	① Double unequal length A-arm Push rod ② Double unequal length A-arm Push rod	① 2805 mm ② 1193 mm ③ 1600 mm ④ 1200 mm ⑤ 1200 mm	① 200 kg ② 40 : 60 ③ 67 mm
86	Rajshahi University of Engineering and Technology	Black, Green and Red	steel spaceframe	Fiber-glass	① Double A-arm Pushrod ② Double A-arm Pushrod	① 2566.56 mm ② 1282 mm ③ 1501.23 mm ④ 1238.05 mm ⑤ 1255.1 mm	① 321.5 kg ② 58.5 : 41.5 ③ 95 mm

Wheels & Tires	① Engine ② Displacement ③ max. power ④ max.torque	Induction type Fuel tank Volume	Shifter	Final Drive & Differential	Brakes ① Front ② Rear	Unique Features & Notes
13 inch RAYS 20.5 × 7.0-13 Hoosier R25B	① Kawasaki EN650A ② 649 cc ③ 53 ps/5000 rpm ④ 7.2 kg-m/3900 rpm	Naturally aspirated 4.0 L	Manual Electric Shifter	Chain Drive F.C.C TRAC LSD	① 2 outboard ② 2 outboard Nissin calipers	Passive wing
Hoosier R25B 20.5 × 7-R13 OZ Racing Rims R13 × 7	① KTM Duke 390, Single cylinder ② 373.2 cc ③ 43 BHP/9600 rpm ④ 35 Nm/7000 rpm	Naturally aspirated 6 L	Manual	Shaft Torsen	① 2 outboard ② 2 Outboard Bybre Calipers	
1 inch Watanabe 165/70R10 72H YOKOHAMA	① YAMAHA YZ450F J339E ② 449 cc ③ 60 ps/7500 rpm ④ 5.4 kgf/6500 rpm	Naturally aspirated 6.0 L	Manual	Shaft Drive & FCCTRAC i.s.d	① 2 outboard ② 2 outboard Nissin calipers	
13 inch RAYS VOLK RACING 175/60R13 YOKOHAMA ADVAN	① RC61EHONDA NC700S ② 669 cc ③ 50 ps/6,250 rpm ④ 6.2 kgf/4,750 rpm	Naturally aspirated 7 L	5DCT	Chain Drive & FCCTRAC	Brakes ① 2 outboard ② 2 outboard	Notes
13 inch VOLK RACING TE37 175/60 KUMHO ECSTA V700	① SUZUKI LT-R450 ② 450 cc ③ 16.2 kW/8000 rpm ④ 28 Nm/6000 rpm	Naturally aspirated 8.0 L	Manual	Chain Drive & F.C.C TRAC	① 2 outboard Nissin calipers ② 2 outboard Nissin calipers	
13 inch RAYS TE37 Hoosier 20.5/7.0-13 R25B	① PC40 HONDA CBR600RR ② 599 cc ③ 75 ps/12000 rpm ④ 5.3 kgf/7000 rpm	Naturally aspirated 4.2 L	Electric Shifter	Chain Drive F.C.C LSD	① 2 outboard Triones calipers ② 2 outboard Triones calipers	Electric Shifter
13 inch Aluminium Wheel 180/510-13 & BRIDGESTONE bias	① Kawasaki LX450AE (KLX450R) ② 449 cc ③ 40 ps/9000 rpm ④ 4.0 kgf/7000 rpm	Naturally aspirated 2.5 L	Manual	Chain Drive & No Diff	① 2 Outboard Steel Diskbrake ② 1 Inboard Steel Diskbrake Nissin calipers	Torsionbar suspension
13 inch 7J Tan-ei-sya Alm One Piece 20.5 × 7.0-13 Hoosier R25B	① PC40E HONDA CBR600RR ② 599 cc ③ 78.0 ps/12000 rpm ④ 5.3 kgf/10000 rpm	Naturally aspirated 6.2 L	Manual	Chain drive & LSD	① 2 outboard ② 2 outboard Nissin calipers	All automated cooling system, Electric water pump.
13 inch SPEED STAR AI Wheel 175/60R13 ADVAN A050	① ER400BE ② 399 cc ③ 44 ps/9500 rpm ④ 3.8 kgf/7500 rpm	Naturally aspirated 5.6 L	Manual	Chain Drive & LSD	① 2 outboard ② 2 outboard Brembo calipers	
10 inch Hoosier Drag slick & WRS-2	① KTM 450 SX-F ② 450 cc ③ 58 hp/9600 rpm ④ 36.5 Nm/7400 rpm	Naturally aspirated 7.5 L	Manual Electrical shifter	Shaft Torsen	① 2 outboard ② 1 inboard Nissin calipers	Variable Intake System (Plenum)
Keizer 10 inch aluminum alloy rims & Hoosier 18.0 × 7.5-10	① Honda CBR600 F4 ② 599 cc ③ 50 kW/11500 rpm ④ 45 Nm/7500 rpm	Naturally aspirated 5.0 L	6-speed manual gearbox (Pneumatic dial)	Chain drive, limited slip differential	① 2 outboard ② 2 outboard	pneumatic paddle shift, vehicle data acquisition, high efficiency aerodynamics kits
10 inch YAMAHA ATV 18.0 × 6.0-10 R25B Hoosier	① P515SUZUKI DL650 ② 645 cc ③ 50 ps/8500 rpm ④ 4.5 kgf/6500 rpm	Naturally aspirated 4 L	Manual	Shaft & FCCTRAC	① 2 outboard Nissin calipers ② 2 outboard Nissin calipers	
13 inch 175/60/13 DUNLOP DIREZZA03G	① PC40E HONDA CBR600RR ② 599 cc ③ 78 ps/12000 rpm ④ 5.3 kgf/10000 rpm	Naturally aspirated 6.0 L	1-6TH Speed Manual Mission	Chain Drive F.C.C TRAC	① 2 Outboard ② 2 Outboard Nissin Calipers	We have challenge spirits.
13 inch OZ Racing Hoosier 205/60-13	① PC40E HONDA CBR600RR ② 599 cc ③ 60 ps/9000 rpm ④ 5.0 kgf/8000 rpm	Naturally aspirated 5.5 L	Manual	Chain Drive LSD	① 2 outboard ② 2 outboard Nissin caliper	High in-house production ratio
10 inch RS WATANABE 6.0/18.0-10 Hoosier Racing Tire	① PC37E HONDA CBR600RR ② 600 cc ③ 69 ps/11500 rpm ④ 5.2 kgf/7500 rpm	Naturally aspirated 10.0 L	Manual	FCCTRAC limited slip differential	① 2 outboard ② 2 outboard Frando calipers	Flat bottom Frame
13 inch RS Watanabe DUNLOP DIREZZA 03G	① Kawasaki VERSYS650ABS ② 649 cc ③ 69 ps/8500 rpm ④ 6.5 kgf/7000 rpm	Naturally aspirated 4.8 L	Manual	Chain Drive & FCC TRAC	① 2 outboard ② 1 inboard Nissin calipers	
13 inch Hoosier 20.*7.5-13, R25	① HONDA CBR600RR ② 600 cc ③ 118 hp/13500 rpm ④ 66 Nm/11250 rpm	Naturally aspirated 10 L	Manual	Shaft Torsen	① 2 outboard ② 1 inboard Bajaj 150 cc DTS-I calipers	N/A

Team Information (Vehicle Specifications)

Car No	School Name	Color s	Frame	Body-work	Suspension ①Front ②Rear	①Overall Length ②Overall Height ③Wheelbase ④ Front Track ⑤Rear Track	① Gross Vehicle Mass ② Fr.Rr Weight Dist. ③ Ground Clearance
96	Universitas Indonesia		steel spaceframe	Carbon Fiber	① Double Wishbone with adjustable shock absorber ② Double Wishbone		
98	Prince of Songkla University	Black	Tubular spaceframe	Carbon-fiber	① Double unequal length A-arm. Push rod actuated horizontal spring, and damper ② Double unequal length A-arm. Push rod actuated horizontal spring, and damper	① 2880 mm ② 1075 mm ③ 1590 mm ④ 1200 mm ⑤ 1180 mm	① 225 kg ② 40 : 60 ③ 70 mm
E1	National Institute of Technology, Ichinoseki College/Iwate University/Iwate Prefectural University	blue	steel spaceframe	GFRP CFRP	① Double unequal length A-arm Push rod ② Double unequal length A-arm Push rod	① 2680 mm ② 1400 mm ③ 1760 mm ④ 1300 mm ⑤ 1300 mm	① 415 kg ② 30 : 70 ③ 40 mm
E2	Toyota Technical College Nagoya	blue, white, red	steel spaceframe	Fiber-glass	① Double unequal length A-arm Push rod ② Double unequal length A-arm Pull rod	① 2492.5 mm ② 1490 mm ③ 1756 mm ④ 1311.5 mm ⑤ 1243 mm	① 340 kg ② 40 : 60 ③ 55 mm
E3	Tohoku University	White	steel spaceframe	Fiber-glass	① Double unequal length A-arm Push rod ② Double unequal length A-arm Push rod	① 2800 mm ② 1250 mm ③ 1700 mm ④ 1300 mm ⑤ 1300 mm	① 330 kg ② 42 : 58 ③ 40 mm
E4	Harbin Institute of Technology at Weihai	Orange/Silvery/Black	One Piece CFRP Monocoque	CFRP	① Double Unequal Length A-arm/Pull Rod ② Double Unequal Length A-arm/Pull Rod	① 2950 mm ② 1200 mm ③ 1530 mm ④ 1180 mm ⑤ 1160 mm	① 200 kg ② 44 : 56 ③ 30 mm
E5	Nagoya University	White Pearl and Black Line	steel spaceframe	CFRP	① Double unequal length A-arm Push rod on upright ② Double unequal length A-arm Push rod, third element	① 2963 mm ② 1263 mm ③ 1650 mm ④ 1350 mm ⑤ 1300 mm	① 395 kg (with 60 kg driver) ② 45 : 55 ③ 32 mm
E6	Shizuoka Institute of Science and Technology	Leyton Blue	steel spaceframe	CFRP	① Double unequal length A-arm Push rod ② Double unequal length A-arm Push rod	① 2640 mm ② 1170 mm ③ 1725 mm ④ 1300 mm ⑤ 1300 mm	① 310 kg ② 50 : 50 ③ 50 mm
E8	Kanagawa University	Jindai' 17 blue	steel spaceframe	Fiber-glass	① Double unequal length A-arm Push rod ② Double unequal length A-arm Push rod	① 2730 mm ② 1222 mm ③ 1650 mm ④ 1250 mm ⑤ 1250 mm	① 340 kg ② 49 : 51 ③ 40 mm
E9	R V College of Engineering	Red and black	AISI 4130 spaceframe	Fiber-glass	① Double wishbone Push rod ② Double wishbone Push rod	① 2820 mm ② 1200 mm ③ 1600 mm ④ 1250 mm ⑤ 1200 mm	① 230 kg ② 40 : 60 ③ 70 mm
E10	Tongji University	black, white	carbon fiber monocoque	carbon fiber	① Double unequal length A-arm Push rod ② Double unequal length A-arm Push rod	① 2775 mm ② 1076 mm ③ 1525 mm ④ 1436 mm ⑤ 1374 mm	① 244 kg ② 45 : 55 ③ 30 mm
E11	Liaoning University of Technology	White blue	steel spaceframe	carbon fiber	① Double unequal length A-arm Push rod ② Double unequal length A-arm Push rod	① 2648.7 mm ② 1178.6 mm ③ 1550 mm ④ 1220 mm ⑤ 1200 mm	① 219 kg ② 45 : 55 ③ 50 mm
E12	King Mongkut's University of Technology Thonburi	black and blue	Hybrid chassis (Carbon fiber monocoque and rear steel space frame)	Carbon fiber reinforced polymer or CFRP	① Double unequal length A-arm Pull rod ② Double unequal length A-arm Push rod	① 2800 mm ② 1172 mm ③ 1550 mm ④ 1250 mm ⑤ 1200 mm	① 280 kg ② 45 : 55 ③ 30 mm
E13	Universitas Gadjah Mada	Blue + Orange Stripe	steel spaceframe	Fiber-glass	① Double unequal length A-arm Push rod ② Double unequal length A-arm Push rod	① 2955 mm ② 1280 mm ③ 1545 mm ④ 1100 mm ⑤ 1100 mm	① 300 kg ② 60 : 40 ③ 60 mm
E15	Niigata Inst of Technology	red	Alumi spaceframe	Fiber-glass	① Double Wishbone with Push rod ② Double Wishbone with Push rod	① 2570 mm ② 1150 mm ③ 1824 mm ④ 1300 mm ⑤ 1300 mm	① 293 kg ② 46 : 54 ③ 40 mm
E16	Toyota Technical College Tokyo						
E17	Universitas Islam Indonesia						

Wheels & Tires	① Engine ② Displacement ③ max. power ④ max.torque	Induction type Fuel tank Volume	Shifter	Final Drive & Differential	Brakes ① Front ② Rear	Unique Features & Notes
14" aluminium wheels	① Kawasaki Ninja 650 ② 649 cc ③ 52 kW/8500 rpm ④ 64 Nm/7000 rpm		Manual	limited slip differential	①, ② Disc Brake with ventilated disc	
10 inch BRAIDSturace, AluminumTire, Hoosier, R25B, 10"-18.0 × 7.5	① Suzuki dl650, 2 Cylinder ② 645 cc ③ 49 hp/7500 rpm ④ 50 Nm/6200 rpm	Naturally aspirated 3 liter	Electric	Shaft Torsen	① 2 outboard ② outboard Brembo caliper	Turbocharger system
13 inch RAYS TE37 20.5 × 6.0-13R25A & 20.5 × 7.0-13R25A Hoosier	① Mitsuba SR Motor × 2 ② 4[kW] ③ 16[kW] ④ 45[Nm]	① Li-ion ② 74 V/82 V ③ 7.4 kwh/50 Ah	N/A	Torque Difference Amplification Differential	① 2 outboard ② 2 outboard NISSIN calipers	Two Motor Torque Difference Amplification TVD
Wheel : RS Watanabe 13-6.5 J + 14.5 Tires : Goodyear EAGLE RS20 × 7.0 J-13	① Hi-Performance, AC35-26.25, 1 個 ② 33[kW] ③ 69.20[kW] ④ 128[Nm]	① Li-Po ② 155.4 V/176.4 V ③ 6.216 kWh/40 Ah	none	Chain Drive FCC LSD	① 4 outboards Advics calipers ② 2 outboards Brembo calipers	① Hi Power Motor ② Double Reduction ③ PCB made by TTCNF-EV
13 inch OZ Racing 20.5 × 7.0-13 Hoosier R25B	①永久磁石式同期モーター (ブラシレス), 41201-WV5C-0000, 1 個 Permanent magnet synchronous (Non brush), 41201-WV5C-0000, 1unit ② 26[kW] ③ 54[kW] ④ 146[Nm]	① Li-ion ② 266 V/284 V ③ 7.4 kwh/27.8 Ah	N/A	Planetary Gear	① 2 outboard Nissin Calipers ② 2 outboard Nissin Calipers	Twin Motor Unit
10 inch Keizer Wheel & 18.0 × 7.5-10 Hoosier R25B	① Permanent magnet synchronous (Non brush), Emrax 207, 2units ② 40[kW] ③ 80[kW] ④ 320[Nm]	① Lithium-Polymer ② 444 V/502 V ③ 7.4 kwh/16 Ah	None	Single Reduction Helical Gears & Electronic Differential	① 2 piston ISR Calipers ② 2 piston ISR Calipers	Monocoque/Aerodynamic Device/LC/TC/ Self-assembly Battery/EDS/Break Energy Regeneration System
13 inch O.Z Racing 205/510 & 20.0-7.5-13 Hoosier R25B	① 3 相交流同期モーター, EM57, 1 個 ② 33 kW ③ 80 kW ④ 254 Nm	① Li-Po ② 333 V/378 V ③ 5.5 kWh/16.5 Ah	None	Chain Drive, Carbon LSD (ATS)	① 2 outboard ② 2 outboard Nissin calipers	Low Yaw Moment of Inertia Packaging, Heave Suspension Element, Aero Device, Traction Control System, Regenerative brake
13 inch RAYS TE37 20.5/6.0-13 Hoosier	①永久磁石型同期モーター (ブラシレス), DAIKIN Original, 1 個 ② 37.6[kW] ③ 53[kW] ④ 179[Nm]	① Li-ion ② 327.6 V/382.2 V ③ 4.3 kwh/13 Ah	No	direct shaft LSD	① 2 outboard ② 2 outboard	① Single Keel ② MR Damper ③ Torque full motor
13 inch Rays VOLK TE37 Hoosier 20.5 inch	① Permanent magnet synchronous (Non brush), Motoenegy, 1unit ② 15 kW ③ 38 kW ④ 100 Nm	① Li-ion ② 90 V/100 V ③ 5.7 kwh/65 Ah	none	LSD (バギー用)	① 2 outboard ② 2 outboard Brembo calipers	two-step-deceleration
13 inch 175/60 R13 77H Bridgestone Wets	① HPEVs AC20 3 phase Induction Motor, 1unit ② 14.8[kW] ③ 62.4[kW] ④ 111[Nm]	① Li-Fe Phosphate ② 3.2 V/3.65 V ③ 5.76 kwh/60 Ah	No shifter	Limited Slip Differential	① TVS Apache 180 RTR calipers Outboard brakes ② TVS Apache 180 RTR calipers, Outboard brakes	Stylish LCD display system on the steering wheel
10 inch Keizer & Hoosier 18.0 × 7.5-10	① Permanent magnet synchronous (Non brush), EC2045A01,4 unit ② 10[kW] ③ 20[kW] ④ 40[Nm]	① Li-ion ② 532V/600V ③ 6.7 kwh/12.6 Ah	N/A	N/A	① 2 outboard NSR calipers ② 2 outboard NSR calipers	four wheel drive, torque vectoring, regenerate, co-developed motors and inverters
10 inch Keizer Aluminum alloy rims & Hoosier 43105	① Permanent magnet synchronous (Non brush), ermax 228, 1 unit ② 68[kW] ③ 80[kW] ④ 160[Nm]	① Lithium cobalt oxide ② 325.6 V/374 V ③ 23 Ah	none	Chain Drexler & Drexler LSD	① 2 ISR Full floating disc brakes ② 2 Wilwood Full floating disc brakes	Carbon fiber suspension & Independent development of vehicle controller
13 inch Hoosier 20.5 × 7-13 R25B	① Advanced Axial Flux Synchronous Motors, EMRAX 228, 2unit ② 35[kW] ③ 100[kW] ④ 240[Nm]	① Li-ion ② 380 V/372 V ③ 7.408 kwh/19.3 Ah	Fixed planetary geartrain	None	① BREMBO P2 34 mm brake pads/sintered metal ② BREMBO P2 34 mm brake pads/sintered metal	Independent rear wheel drive
13 inch Keizer Wheels 20.5 × 7.0-13 Hoosier tires	① Axial Flux Synchronous 3-Phase AC Motor, Emrax208, 1unit ② 20-32[kW] ③ 80[kW] ④ 150[Nm]	① Li-ion ② 88.8 V/100.8 V ③ 6.66 kwh/75 Ah	None	Drive chain & Limited Slip Differential	① 2 outboard ② 2 outboard APRacing	Self Developed BMS, ECU, Dashboard
13 inch 5J + 35 175/60R13 YOKOHAMA ADVAN A050	① 3 Phase Brushless Synchronous motor, MITSUBA, 4units ② 1.2[kW] ③ 20[kW] ④ 24[Nm]	① Li-ion ② 75 V/82 V ③ 4.5 kwh/60 Ah	N/A	N/A	① 2 outboard ② 2 outboard Frando	In-wheel motor 4WD

Team Information (Members and Sponsors)

[CP] Team Captain [FA] Faculty Advisor [MBR] Team Member: As of xxxx 1, 2017

1 Kyoto Institute of Technology

● Members

[CP] Shohei Nobuchi [FA] Minoru Ota [FA] Daisuke Iba [FA] Yasumasa Komaki [MBR] Kenichi Yanagida, Kotaro Nakatsuji, Akio Hayashi, Yutaro Nagai, Shunsuke Akahori, Hikaru Matsuyama, Nobuyuki Miyaoka, Kaoru Takehama, Takashi Miyake, Koichi Hasegawa, Masahiro Itatani, Yuma Ishihara, Yoshiaki Isobe, Masahiro Ueda, Ryosuke Minami, Kohei Yoshioka, Yuta Yoshimura, Yusuke Nakata, Yuki Inagaki, Mio Hatakenaka, Mishio Omori, Junpei Kishi, Kosuke Shimizu, Maki Nakaguchi, Naoki Higashine, Tatsuki Furukawa, Hidenori Miyajima, Genri Yamanaka, Naoki Yoshioka, Tatsuya Muto, Ryosuke Yokoyama, Maoto Kawano, Hikari Miyaki, Ritsuka Gomi, Kureha Takasaki, Yoshifumi Saji, Kensho Nishizaki, Ryo Nishiyama, Ryuichi Nakajima, Hayato Taduke, Ryo Watanabe, Daiki Doi, Takayuki Zukawa, Saki Kinoshita, Yusuke Kimura, Shunpei Noike, Yuhi Kudo, Ryota Takaoka, Masaya Daimon, Tatsuhiro Hirano, Takuya Tani, Ryoa Maruyama

● Car Features and Team Aspirations

Last year, we could achieve overall victory with successful design change of a machine. But there were many parts where we were not able to hammer out the design. This year, we will do our best aiming for 2nd consecutive win and the third time win for our team with brush up on the winning machine!

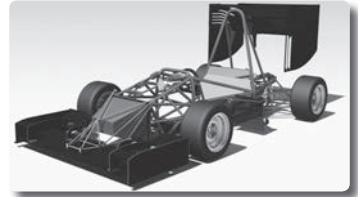

● Team sponsors

SUZUKI, HILLTOP, Tango Techno-Center, Dassault Systèmes, Tango-Giken, EXEDY, Project μ , Nisso Kogyo, Biwako Sports Land, PHOENIX's POWER Kyoto, OXISO, THK, Nissin Kogyo, NTN, Daiwa Gear Manufacturing, DMM.com, TechnoGuild, MISUMI, GAT, Fuji Seimitsu, Sumitomo Wiring Systems, NUTECH Japan, Henkel Japan, Kyowa Kogyo, Tohnichi Manufacturing, SEKISUI PLASTICS, Nissho Manufacturing, Calsonic Kansei, Nifco, Cybernet Systems, JFE Steel, Highlight Labs LLC, Kinokuni Enterprise, Daido Kogyo, Daito Radiator, Nicole Racing Japan, Hi-Lex, Plus μ , Kyoto Wheel Senter, Nitto Denko, Kyoto Teisan, Kinoshita Shoten, AVO/MoTeC JAPAN, Matsuda Seiko, Matsumoto Kinzoku Kogyo, Kinki Car Rental Service, TAMADIC, KIC Engineering, VI-grade Japan, igus, ITW PP&F Japan, Fukai Manufacturing, umihira, TAKATA

2 Yokohama National University

● Members

[CP] Takeyuki Fukuchi [FA] Yasukazu Sato [FA] Suguru Matsuzawa [FA] Akihiro Sakakida [MBR] Naoki Hanawa, Yusuke Shiibashi, Kentaro Nishikawa, Hiroaki Sugiyama, Shunta Osawa, Mayu Tanaka, Akito Yoshida, Sakuya Imoto, aoyama hirotosugu, Tomoya Suzuki, Yuki Yokoyama, Yoshikatsu Furusawa, Yusuke Miyokawa, Yuki Takimoto, Fukuda Shotaro, Takayuki Ichikawa, Mikito Kawase, Yasuto Tanaka, Haruto Shinomiya, Aki Nakata, Naoki Akiyama

● Car Features and Team Aspirations

Based on the concept of YNFP-17, "Pleasure to be an owner", we set up a person figure of customer target, and we aimed to produce a vehicle that has the performance to satisfy the desires of the person. We aim to win the championship in the Student Formula Japan.

● Team sponsors

RS Components, IRS, IDAJ, ASAHI SPRING, igus, ISHIHARA KINZOKU, evoltex japan, ACM, S=GRID, F.C.C., NMB, NTN, Autodesk, KAIMEI, Kanagawa Atsuta, KANEKO GEAR, KANTO Industrial College, Kinokuni Enterprise, KYOWA KOGYO, KURE Engineering, CROSSLLOAD Koyama, KOIWA, KOBELCO, KOTORA, KOMATSU, CYBERNET SYSTEMS, SANWA, GAT, Job Hatch, Sanko, SHINSEIKIKO, jushireadmodel, QUICKHANYUU, Sumitomo Wiring Systems, ZF Japan, SOLIDWORKS Japan, Taiseiplas, TIRE FITTER, Tashiro, Tabata Radiator, TECHNOIL Japan k.k., TOHNICHI Mfg, TOHO Tsushin Systems, TOYO DENGYO, TRUMPF, YOKOHAMA DIY, Nakamuraougyou, Namekawa Keido, Niigata, Nikken, Nissin Kogyo, NATS NIHON AUTOMOBILE COLLEGE, NSK, NHK SPRING, VI-grade Japan, NEXT, VSN, FUKAI MFG, Fuji Seimitsu, Honda Motor, Makita, MISUMI Group, MITSUI KINZOKU ACT, Mitutoyo, Yasuhisa-KOKI, YANASE, YANASE AUTOMOTIVE SYSTEMS, YUVEK, Yokohama high-frequency wave, YNU machineshop, meikyoushubikai

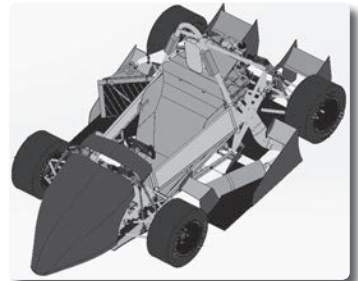

3 Nagoya Institute of Technology

● Members

[CP] Seiji Hattori [FA] Kazuhiko Kitamura [FA] Youjiro Ishino [FA] Shinya Hayakawa [MBR] Hayato Demura, Kouta Yamamoto, Takeru Hikichi, Kouichirou Yoshioka, Yu Otuka, Yu Yoshida, Takaaki Sawada, Hirohumi Yamaguchi, Asuka Shimodaira, Miyu Shibusawa, Kanta Imazu, Hiroyuki Shimizu, Syo Kikuchi, Yoshiaki Taguchi, Yuki Sakamoto, Yusuke Yoshiyasu, Akihumi Kawai, Kenta Kawabe, Takaya Saito, Miharu Yahata, Kosuke Banno, Humila Hayashi, Kazuma Kobayashi, Kanami Uemura, Ami Ogiso, Hayato Nakagawa, Yuta Fujiwara, Toshihiro Masaki, Daishi Katagiri

● Car Features and Team Aspirations

N.I.T-15 is the lightweight, low center of gravity and low inertia car. Furthermore, we introduce new technology for high power and cornering speed. With the

entire team working together, we aim at victory.

● Team sponsors

ONDOLAB, IHI, IME Corporation, Aisan, Aoyama, ACCEL, ASPROS INC, AZAPA, enable, ALTECH, ISHIKAWA, ISOWA, IDEMITSU, Ito Akira Sangyo, IBRIDA CELL, IWAKURA Radiator, wit, EXCEED, NOK, NKN, NTN, FC design, F.C.C., OTSUKA Factory, OKAJIMA PIPE, AUTOBACS SEVEN, KATO GEAR, CARRERA CLINIC, CARVEK, KIKUCHI Sheet, GIFU plastic, GIFU GEAR, KYOWA KOGYO, KYOWASEIKO, Kyowa Electronic Instruments, KURE Engineering, KOITO MANUFACTURING, ZEAL by TS-SUMIYAMA, SAKAI OVEX, SAKURA KOGYO, SIX VOICE, SHINANO INC, SHOWA aircraft, Single Heart, SHINKO Casing, Shinko North, SHINBORI, SUZUKI, SUZUHIRO FORKLIFT, Sumitomo Wiring System, SEKISUI PLASTIC, Senzairou, Sensata Technologies Japan, Software Cradle, SolidWorks, DAIDO METAL, Daihen Welding & Mechatronics System, DOW, TAKATA, TAMADIC, TSUGE Process, THK, DAYTONA, TECHNO ASSIST, Teshima Printing, TOKAI RIKAI, Tohnichi Manufacturing, TOTECH, TOMOEKAI, TOTECH AMENITY, NAKAYA SEISAKUSYO, NAGOYAKOGYOKAI, NAGOYAJUSHI Industry, NIKKAL, NISSIN, NISSIN Kokan, NISSIN Kogyo, NIPPON SEIKI, NHK SPRING, Fibex, Blenry, PRO-TECTA, PLOT, Henkel Japan, Makita, MIKUNI, Misumi, MIDORI PRECISIONS, MIHAMA CIRCUIT, MIROKU, Meito Gear, YAMAHA MOTOR,



5 Nihon Automobile College

● Members

[CP] Yuuta Iyama [FA] Yuichi Uwai [FA] Mitsunori Yabe [FA] Makoto Kanai [FA] Hiroki Okawa [FA] Motoki Waki [FA] Hiroshi KADONO [FA] Shinichi Azuma [FA] Keisuke Hldaka [MBR] Yusuke Aoki, Ryo Agata, Daisuke Igarashi, Syohei Otaki, Takumi Omori, Yoshiaki Okino, Yuki Osakabe, Osamu Onodera, Tetsuya Kimura, Syota Shiba, Tatsuhiro Suzuki, Tomohiro Takahashi, Yo Takahara, Rui Tanaka, Ryota Tsuchiya, Yuki Fujino, Yoshihiko Hosaka, Fumiaki Yanaka, Atsushi Watanabe, Ryosuke Owada, Kaisyu Kikugawa, Yuji Kobayashi, Akio Takeuchi, Yuki Hishinuma, Yusuke Yamaguchi, Tomoya Ueno, Hiromasa Tada, Shouta Yanagihori, Takumi Tadokoro

● Car Features and Team Aspirations

"Deepening of turning characteristics" is the primary concept and "Enjoyable,

drive friendly machine for all" is the secondary concept. Under these banners, FFN-08 features more enhanced cornering performance than previous machine, as a result its drivability has been improved. In order to accomplish overall victory, our earnest wish, we will try the competition with the team as one.

● Team sponsors

IRS, R-A, RAC, WEST RACING CARS, AVO / MoTeC JAPAN, KINOKUNI Enterprise, Software Cradle, WFN, TAN-EI-SYA WHEEL SUPPLY, TMC, NISSAN PARTS CHIBA SALES, FUKAI MFG, Honda Motor, Honda Techno Fort, MAC MECHANICS TOOLS, Moriaki Engineering, Uniauto, WAKO CHEMICAL



6

Doshisha University

● Members

[CP] Hiroki Seguchi [FA] Kazuya Okubo [MBR] Hiroki Seguchi, Ryunosuke Kikui, Kaoru Wada, Ryusei Okuyama, Daiki Murai

● Car Features and Team Aspirations

● Team sponsors

NO DATA

7

Kobe University

● Members

[CP] Kenta Nanke [FA] Keiichi Shirase [FA] Hidenori Nakatsuji [FA] Hitoshi Asano [FA] Shigeo Hosokawa [MBR] Kazuki Kobayashi, Takaya Nakamura, Aya Sato, Yuuta Naawa, Iwao Nishimura, Atsushi Hujita, Shunsuke Miyake, Ryo Shinohara, Daiki Hironaka, Junnosuke Yoshida, Shinichiro Nagai, Daiki Asaoka, Taiga Kanda, Natsuha Okami, Ryouya Kobayashi, Tatsushi Hirayama, Taisei Hashimoto, Kouhei Maeyama, Kenta Tsuji, Gouki Kimura, Yu Igarashi, Ryoga Yamasaki

● Car Features and Team Aspirations

● Team sponsors

RAC RACING GEAR SHOP, IDAJ, ALTAIR ENGINEERING, IDEMITSU, AIR LIQUIDE Kogyo Gas, EXEDY, NA-PROTECH, NTN, F.C.C., OKAYAMA International Circuit, Kawasaki Heavy Industries, KINOKUNI Enterprise, CAST, KYOWA, KTC, KTCM, Kobe Steel, SUMICO LUBRICANT, Sumitomo Electric Industries, Sumitomo Wiring Systems, settsukinzoku kougyousyo, SOLIDWORKS Japan, DAIHATSU MOTOR, DAIHEN, TSURUGA, DIC, THK, TOHO TENAX, TOTANI, TOYOTA HYOGO RENTAL & LEASING, Neis, Nagase ChemteX, NICHIRIN, NISSIN KOGYO, NHK SPRING, HI-LEX CORPORATION, VI-grade Japan, FUKAI MFG, Fuji Kasei Kogyo, frantz, MISUMI, Minebea, YAMATO-SCALE, ROCK PAINT, WAKO CHEMICAL

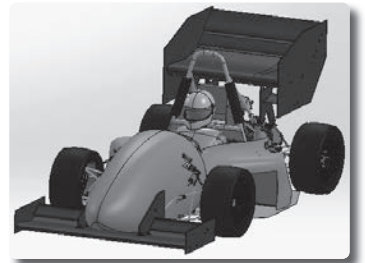

8

Shibaura Institute of Technology

● Members

[CP] Kai Kobayashi [FA] Dai Watanabe [FA] Hiroshi Okamura [MBR] kouhei maruyama, Ryusei Mashimo, Nao Yamashita, Yusuke Shimizu, Renma Suzuki, Akari Nagakura, Masaya Kuroki, Hideto Kobayashi, Shota Inoue, Yudai Igarashi, Ken Matsumoto, Itsuki Suwa, Yu Oishi, Shunsuke Murai, Kaito Hosoda, Shusuke Ishihara, Kouki Yamada, Humiya Yamaguchi, Yuki Mitsui, Masataka Nakamura, Naoki Numano, Misuzu Matsukawa, Tatsuhiko Suga, Ryo Shirasaki, Kaito Yamashita, Yoshiki Kinase, Kimito Kanai, Yota Moteki, Miyuu Hamanaka, Kei Yamaguchi, Yushi Suzuki, Yuya Sato

● Car Features and Team Aspirations

Our vehicle "S014" of this fiscal year had "The Goblin" as its concept

and brought out a greatly new model. SHIBA-4 will try our best for OVERALL VICTORY.

● Team sponsors

RAC, RS-Components, RK Japan, ULVAC, Igus, Inoue tekkousyo, NMB hanbai, NOK, NTN, M-TEC, O.Z, KANEKO Manufacturing, Kanto Industrial College, Carvek, KYOWA KOGYO, Cool Nuts, KEIHIN, Koganei Seiki, Kobayashi Kiko, Continental, SAKAI OVEX, SANKYO RADIATOR, QUICK HANYU, Sumitomo Wiring Systems, Software CLADLE, TAIYO Stainless Spring, DAITO DENKI, DENSO, Toa Corporation, Tokyo R&D, Tokyo Titanium, TOKOROZAWA KEIGOKIN, NISSIN KOGYO, Nifco, HI-LEX CORPORATION, PHIARO CORPORATION, FUKAI MFG, Future Technology, PLUS-μ, Blenny Giken, PLOT, Honda Motors, Honda R&D, Honda Techno Fort, Honda Meister Klub, MISUMI Group, Yasuhisa KOKI, UD Trucks, Yutaka Giken, Yokogawa Construction, RIDEZ International, Lightning Suppression Systems, RAYS, Works Bell, WAKO CHEMICAL

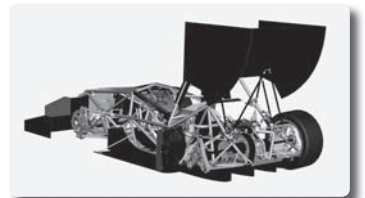

9

Chiba University

● Members

[CP] Yuya Ishiduka [FA] Yasuo Moriyoshi [FA] Kazuyoshi Kono [MBR] Kazuya Ogawa, Takumi Nagashima, Naoto Yoshida, Takahiro Ito, Yousuke Kanesaka, Tomoya Watanabe, Akari Matsufuji, Tomoki Oikawa, Shigeya Kubota, Tomohiro Shimizu, Masato Yamagishi, Ryouhei Ueki, Naruki Ezawa, Ryousuke Ogane, Kazuhiro Okada, Riku Fukagawa, Akira Motomiya

● Car Features and Team Aspirations

Set the concept of "Make A Wish ~Always evolving to fulfill hope~", to the development goals of the "pursuit of cornering performance and traction", had updated based on last year machine. Aiming for a podium in the team's first overall ranking, the team will challenge the tournament.

● Team sponsors

Idemitsu Kosan, NMB, NTN, NIHON AUTOMOBILE COLLEGE, F.C.C., LPA, KINOKUNI Enterprise, Kusaka Mfg, KOTORA, Sasaki Kogyo, TMC, DENSO, TOHNICHI Mfg, Toyota RENTAL & LEASING Chiba, VI-grade Japan, NOVUM, HI-LEX, FUKAI MFG, MISUMI, Metal works, Yutaka Giken, Iobtex, Works Bell, Calsonic Kansei, KYOUWA Kogyo, KEIYO BEND, AoiFudousan, Cybernet Systems, Sumitomo Wiring Systems, SolidWorks Japan, Alumni Association of Faculty of Engineering, Chiba University, TOHOKU RADIATOR, Nippon Light Metal, NISSIN Kogyo, NSK, NHK SPRING, Build Damage, Henkel Japan, MARUBENI INFORMATION SYSTEMS, Yamaha Motor, RAC, Altrack, PLUS-MYU, MOBARA TWIN CIRCUIT, Raycraft racing service

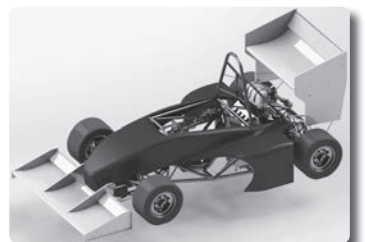

[Spetial Thanks]

Chiba University Faculty of Engineering, Chiba University Faculty of Engineering Practice Workshop, Chiba University Car Club, Chiba University Formula Project OBGO, Honda Meister Club, Racing Garage ENOMOTO.

Team Information (Members and Sponsors)

10 Ritsumeikan University

● Members

[CP] Tatsuaki Oyabu [FA] Keiko Watanabe [MBR] Keta Togawa, Koji Okamoto, Naohisa Kuwabara, Tsuyoshi Aoyama, Junya Muto, Ryota Morimasa, Koshin Obayashi, Taiga Nishimura, Kei Tomie, Kuniaki Neshi, Daiki Tanaka, Ryoya Higashiyama

● Car Features and Team Aspirations

In this season, We completed RF-014 machine on the basis of our concept [Moving Emotion]. We will fight by our machine brushed up from last. We aim to win this competition.

● Team sponsors

Kawasaki Heavy Industries, NTN, KYOWA, Solid Works Japan, Daihatsu Moter, Z.A.M JAPAN, West Racing Cars, Misumi, Biwako Sport Land, Bike Koubou IWAKI, ISIHARA Radiator, ARAYA INDUSTRIAL, YAMAZAKI, Body Shop NAKAJIMA, TECHNOIL JAPON, Nissin Kogyo, KOBELCO, JIN, Chemitec, TAMADIC, IDAJ, Altair Engineering, FUKAI MFG, NMB, Works Bell, Puls μ , ENUMA CHAIN MFG, TAKATA, NHK SPRING, GANSAN, EWP-JAPAN, CAR KOUBOU YAMANAKA, ATSystem, OKANO BLAST, Kind Heat Technology, NKN, NOK, Heiwa Hatsujyo Industry, HOPEC, Ofa, DAINES Industrial Art Technology, Yamamoto Racing, BEAR, JRC, AVO/MoTeC JAPAN, Nihon Parkerizing, Sumitomo Wiring Systems, Nifco, CAST, Henkel Japan, SOLIZE Products, TOKUSHIMA CAM, HI-LEX CORPORATION, THE DOW CHEMICAL, Software Cradle, DAIKEN, UMEMURA GIKEN, ACCEL

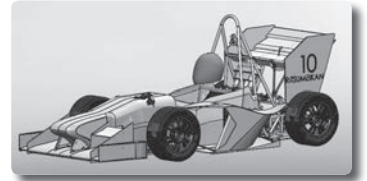

11 Nippon Institute of Technology

● Members

[CP] Minami Tadenuma [FA] Michio Nakano [FA] Toshiyuki Yasuhara [MBR] Motohiro Inage, Takanori Miyuchi, Tatsuya Sakai, Satoru Takazawa, Taiga Matsumoto, Takuma Fuse, Kosuke Monzen, Koichi Sonoda, Yuki Amemiya, Kaiga Honda, Fumiya Kawashima, Takumi Tomatsu, Shunichi Tsuchiya, kiichi Takano, Arata Sato, Shunsuke Suzuki, Taiki Maejima, Akihiro Tsuruta, Takumi Tojo, Akimasa Hamaguchi, masahiko Obana

● Car Features and Team Aspirations

● Team sponsors



12 Osaka University

● Members

[CP] Shogo Kajii [FA] Hisashi Ishihara [FA] Daigo Izumi [FA] Shoji Tsushima [MBR] Takuto Ishida, Hiroyuki Inoue, Shuhei Ikeda, Sena Harada, Yui Mitsuhashi, Syuhei Suzuki, Kentaro Okada, Yutaro Kitano, Yoshinori Kobayashi, Yikinobu Naya, Nodoka Nishimura, Taichi Matsui, Yusuke Matsuoka, Kazuki Imamura

● Car Features and Team Aspirations

In order to achieve the two goals of performance and reliability improvement this fiscal year, we have been actively working with V-shaped process for both vehicle design and management. We aim to win the tournament as a culmination of the process.

● Team sponsors

IDAJ, Altair Engineering, Aoikoki, Altechno, RS Components, Ibaraki Industrial, Ueda, F.C.C, NTN, FT Techno, Osaka University, FRC, Oxiso, KANAE, Keizer, KHI, KINOKUNI Enterprise, Kyowa UJ, Kubota, Keihin, KOBELKO, Kokuyo Alminum, Komatsu, Cybernetyssystem, Sanyo Chemical Industries, CKD, JVC KENWOOD, Signal, Nippon Steel & Sumitomo Metal, Sumitomo Electric Hardmetal, Sumitomo Wiring Systems, 3M Japan, Software Cradle, Solidworks Japan, Tiger Seisakusyo, Taiseiplas, Daito Radiator, Daihatsu Motor, THK, TOHNICHI, Tokyo R&D, Tohgenkyo, Nikkal, Nissin kogyo, Nippon Welding Rod, VI-Grade Japan, Nippon Oil Pump, NHK Spring, NGK SPARK PLUG, BNK Japan, FARO Japan, Fuji Seimitsu, Blenny Giken, HOPEC, MathWorks, Magna International Japan, Marubeni Information Systems, MISUMI, MITSUI KINZOKU ACT, MITSUYASU, Minebea, NMB, Mitate Kobo, MITSUBOSHI BELTING, Minatogawa, MUTHO ENGINEERING, UNI AUTO PLANNING, WAKO Chemical, WACHO, TSURUGA, DAIHEN, EVANS-JAPAN, Henkel Japan, KOTORI, ARTNER



13 Kyushu Institute of Technology

● Members

[CP] Shunsuke Yamaguchi [FA] Toru Kawabe [FA] Naoki Toyohashi [MBR] Mitsunori Miyazaki, Yuya Jinno, Yusaku Morii, Fumiki Ohno, Satoshi Kozuka, Keita Sonoda, Rika Inatsu, Hirohumi Nakane, Kunpei Nakao, Yuki Ueno, Sinsuke Otomo, Yurika Nakano, Tsuyoshi Konishi, Ryo Murotsu, Shuhei Ikeda, Masashi Shibata, Shotaro Tsutsui, Yukitaka Goto, Makoto Nakamura, Taichi Takasaki, Shougo Yamaguchi, Keisuke Sato, Koushi Manabe, Hiroyasu Murakami, Yuki Urano, Tomohiro Kuwano, Genki Hayashida, Shuhei Ishizaka, Tomohumi Abe

● Car Features and Team Aspirations

We have developed new machine and charenged new system. We would like to get single car number again so we will do our best.

● Team sponsors

IDAJ, ASAHI KASEI CONSTRUCTION MATERIALS, ARTNER, RAC, igus, Ishihara Radiator, WEST RACING CARS, Air Gases Kitakyushu, HPC Systems, NTN, F.C.C, Office K, Kawasaki, Kinokuni Enterprise, Kyushu Institute of Technology Practice Factory, KYOWA, Kobe Steel, CYAN, Sasakikogyo, Shinba Iron Works, Sumitomo Wiring Systems, Software Cradle, Taiseiplas, TAKADA, THK, DENSO, TONE, Trailbucks, NHK Spring, Nippon Light Metal Company, VI-grade Japan, Fukai, Fuji Seimitsu, PRIME Garage, PLOT, Henkel Japan, MACH FC, MISUMI, Minebea, Meisenkai, Yamato Industrial, Yamanaka Eng, RS-Watanabe, WAKO CHEMICAL

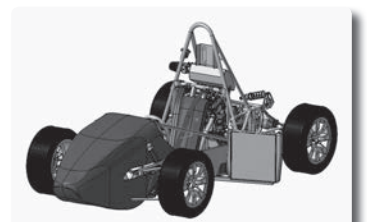

14 Ibaraki University

● Members

[CP] Shuntaro Nakaaki [FA] Souichro Nishino [MBR] Yuto Eguchi, Keita Maruyama, Daisuke Kurihara, Seiji Okita, Nobuaki Tsuboi, Hikaru Fushimi, Shunma Sasaki, Hiroto Tanaka, Ichihiro Hayashi, Shun Nikaido, Daiki Kudo, TUXUNBATE, Yuki Katsu, Kota Ohno, Yuki Oka, Daishi Takahashi

● Car Features and Team Aspirations

The concept of the machine is "fastest with ease"-for anyone who can drive it fast and easily. Along with regulation change, we are installing a new single cylinder engine from this year. We aim for victory!

● Team sponsors

ART, IDAJ, AIWA, Achilles, AsahiKASEI, ASIDA CORPORATION, enable, ARTNER, IBASEI, IBARAKI TOYOTA, Ibaraki Toyopet, Ibaraki plating Kogyo, IMAHASHI, IWAKI SEIKI, Iwate Factory, Wit, NOK, NTN, OETIKER, Oarai creative management, OKAWA, Autobacs Seven, KIKUCHI SEIKI, KIKUCHI, Kinokuni, GALLOP, KYOWA, Keisoku engineering, KONAN, COCO FACTORY, KOMINE, KONDO, Satte-spring, Something

Corporation, SANOH, SAWAHATA, SunTechno, SANWA, CD-adapco, Schaeffler Japan, JPC, JWAY, SHIGEMATSU, SHOEI, SUNAKAWA PLUS, SHINEI, SCOOTTECH JAPAN, SUKEGAWA, SUZUKI, SEIWA, Sensata, SOTETU, SOLID WORKS JAPAN, suzukikogyousyo, Daiji, Taiyo, TAMADIC, TAISEI PLUS, TAKATA, TAN-EI-SYA WHEEL SUPPLY, TSUJICON JAPAN, Turumachi, THK, Ties, TOTAL JAPAN, TEC, TOCALO, TOHO, Tokyo sokki, TOHNICHI, Topre, Joyo motors, Toyo, Nkamura, Hitachi minsyu Nishizaka Factory, Hitachidenki, Hiroki Factory, Mito Seiko, MITROY, MURATA Factory, Nishizaka Factory, Hitachidenki, Hiroki Factory, Mito Seiko, MITROY, MURATA Factory, TOYODENSO, Tomitamokuzai, TOYOURA Co., Ltd, NUTEC Japan Co., Ltd, Nikko Electric Co., Ltd, Nissho Co., Ltd, NISSHIN Kokan CO., LTD, Nissin Kogyo Co., Ltd, Nifco Inc. Husqvarna Motorcycles Japan, NDC, Hitachi Denki Inc., HITACHIKOH HOSPITAL, Hinomaru Sekiyu, VSN, FORM, FUKAI, Fukuda, Fuji Seimitsu, PLUS-MYU, PRO-TECTA, BEKAERT, Henkel Japan Ltd., HOTTA ELECTRIC, Honda Motor, Moriwaki, MISUMI Corporation, Minami Koya Medical Office, Yagisita giken, Yamaya Kigata Seisakusyo, UACJ, UGO Inc., Factory YUKI, Inc, UNICAST Inc., YOKOTA, Raycraft racing service,



15 Utsunomiya University

● Members

[CP] Satoshi Watanabe [FA] Hitoshi Sugiyama [FA] Naoto Kato [FA] Shin Hara [FA] Atsushi Tsukikawa [MBR] Seiya Ishihara, Kento Hashizume, Shotaro Kikuchi, Junpei Oota, Yasuaki Hochi, Akihiko Asahi, Juri Takayama

● Car Features and Team Aspirations

This year the vehicle UF-15 has developed "Multi Enjoyment" as a concept. We will do my best aiming for the 6th overall prize and Endurance final.

● Team sponsors



16 Waseda University

● Members

[CP] Takahiro Suzuki [FA] Izumi Ishii [FA] Tomoyuki Miyashita [FA] Makoto Sato [MBR] Hiroaki Ogawa, Takahiro Horigome, Yuto Fujii, Takahiro Arai, Takehiro Handa, Takuya Washio, Jun Onodera, Kodai Uchiyama, Daiki Suzuki, Tetsuhiro Katahara, Toshihito Tatsuoaka

● Car Features and Team Aspirations

WFP2017 is the successor to the concept of WFP2016, "Driving Pleasure." We have worked for the improvements in performance including re-designed suspension system, and achieved a 30kg reduction in GVM. We are aiming to complete all the events and finish within 10th place on the overall result.

● Team sponsors

NTN, KYB, JUNIOR MOTOR PARK Quick HANYU, SolidWorks Japan, SUZUKI, Nakagawa Sangyo, UD Trucks, LifeRing, Resinic Japan, ASAHI SPRING Manufacturing, TAMACHI INDUSTRIES, Cars Hatano, Rush Factory, REIMAX, RAC, Asso International, Ishihara Radiator, WEST RACING CARS, Ueda, F.C.C, nmb Hambai, OZ Japan, Auto Force, KINOKUNI Enterprize, KYO-EI Industrial, KYOSEI, KYOWA Industry, KOHSHIN CHEMICAL, KOTORA, XAM Japan, Shichifuku Kinzoku, Sumitomo Wiring System, 3M Japan, DAW, T.CRAFT NECTO, TECHNOIL JAPON, Nishimura Tire, Nissin Kogyo, FUKAI MFG, PRO-TECTA, PLOT, MISUMI Group, Moto Liberty, UACJ, Works Bell, Waseda University Kusaka Lab., Waseda University Miyashita Lab., Waseda Monozukuri-Koubou, Waseda University Automobile Club, Waseda Mechanical Engineers, Personal Sponsors



17 Tongji University

● Members

[CP] Li Xiaojie [FA] Zhang Xinfeng [FA] Liu Yongxiang [MBR] Huo Ran, Kang Jiajun, Li Mo, Li Yiming, Xu Xuejian, Ning Youbo, Wang Mengyue, Wei Yi, Xue Song, Yin Bin, Zhao Peng, Zhao Xinyu, Fang Peiyuan, Liu Jianan, Yang Tuwang, Zhang Wenhan, Wang Lidong

● Car Features and Team Aspirations

Car Features: pneumatic paddle shifting Full set of aerodynamic package Launch Control Monocoque Electronic Throttle

● Team sponsors

JTEKT, Continental AG, KSPG AG, BorgWarner, NSK, ZF Friedrichshafen AG, AVL, Axalta, Magneti Marelli, Shanghai Fuan Industrail, Shanghai Kartworld, Bosch, Shanghai Fuel Cell Vehicle Powertrain Co., LTD, Shanghai Xin'an, Lemo Connectors, ANSYS, MSC Software, Altair Engineering



Team Information (Members and Sponsors)

18 TOYOTA TECHNICAL COLLEGE NAGOYA

● Members

[CP] Shuhei Adachi [FA] Tetuya Hayakawa [FA] Kazunari Takahashi [FA] Kennichi Kubota [FA] Shiro Kaga [FA] Hidenobu Miwa [FA] Keisuke Yamasaki [FA] Masaharu Murakami [MBR] Ryota Yasita, Yusuke Kaneto, Yuichiro Urata, Hiroki Nakazono, Kannji Hoshiyama, Shoto Nakajima, Yuta Asaoka, Yuto Kuroki, Kazuki Tudoku, Kennji Nakae, Ryuki Tejima, Sekichi Matumoto, Seichiro Yamaguchi, Takahiro Sakai, Daichi Okano, Sinnsei Imayama, Akihiro Miyata, Yudai Wada, Daiki Tanaka, Taishi Ito, Toru Hatayama, Ryusei Fujikawa, Chihaya Ishiguro, Shinngo Sakai, Yusuke Moriya, Takahide Sasaki, Yuki Takemasa, Shihō Takeda, Takuma Goto, Kazuki Oshima, Koya Yamaguchi, Yuki Kawamura, Tukasa Kitagami, Tubasa Sakai, Toshiki Sakurai, Soya Suzuki, Kosuke Nakamura, Kenngo Hashimoto, Syoki Terakawa, Daisuke Sato, Renn Onishi, Kotaro Honnma, Tomohiko Akaya, Koya Motono, Yuma Shiga, Takashi Sasaki, Shinnya Simoo, Morishima Hiroo, Toyohiro Hayashi, Genndai Kawamura, Naoya Nisimura, Daichi Ito

● Car Features and Team Aspirations

The concept this year is, 'based on ergonomics, improvement of the operability.' We make a car is, first point easy to operation of the driver. Therefore we aim for inside of tenth.

● Team sponsors

YAMAHA Motor, TOYOTA GOSEI, GOODYEAR Japan, WAKO CHEMICAL, TACTI, SolidWorks Japan, F.C.C, DAD, FUKAI Seisakujo, Kyouwa Kougyou, WEST RACING CARS, AICHI, TOYOTA COROLLA AICHI, SHINMEI KOUGYOU, IWATAFUKUSO, Sekiya Syuzou, Daisen Sangyou, Vicor Japan, Okano Electronics, Nicole Racing Japan, Takagi Seisakujo, EV AICHI, Yazaki Sougyou, Sensata Technologies Japan, Kyouiku Sangyou, Kyoseikoku College, NOMURAMACHINE, FT TECHNO

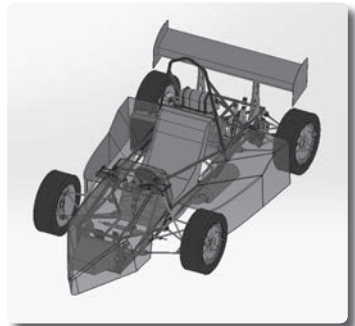

19 Tokyo University of Science, Yamaguchi

● Members

[CP] Naoto Kokura [FA] Takao Kijima [MBR] Gai Muranaka, Sugae Yuji, Nishi Teruhito, Taiga Uchida, oohashi yutaka, Ito Tanaka, Shougo Yamaguchi, Satoshi Kawasaki, Yuya Ohtani, Kazushi Murakami, Shinichiro Nagahama, uraokahiroshi, yutainagaki, Riku Takeda, Kotaro Sakai, Wataru Nagai, Takuma Fukura, Shinya Waseda, Takumi Negoro, Yuki Nakanishi, Ryota Nakanishi, Komei Matano, Masakazu Fujihara, Taiga Uemori, Kenta Takayama, Katsujin Kinjo, Yuya Namekawa

● Car Features and Team Aspirations

Our newest machine, built upon our past achievements, has been designed with the fundamental goal of reaching the ultimate in linear controllability. We thoroughly adjusted our machine's balance weight and appreciably lowered its center of gravity in order to attain the goal and achieve maximum success. We now feel confident that

we can accomplish a complete run of the whole course, becoming one of the outstanding leaders of the competition.

● Team sponsors

RAYS, SUNLIGHT, VSN, WAKO CHEMICAL, Fuji Seimitsu, DOW CHEMICAL, TAKATA, nest industry, Sumitomo Wiring Systems, Minebea, Honda Motor, MISUMI, SOLIDWORKS Japan, IKEYA FORMULA, Terada seisakusyo, Auto Exe, THK, NISSIN Kogyo, KINOKUNI Enterprise, F.C.C, Natura Circuit, Uchidakouki, NTN, Nisimuratekkosyo, Kasama Industry, Yamato Kogyo, amon Kogyo, WEST RACING CARS, X.A.M JAPAN, Tokyo University of Science Yamaguchi, Honda master club, KYOWA INDUSTRY, Prior Tec, Roadster Club of Japan, Sanyo Tool, KYO-EI, Shimada Kogyoimori-biomass, MZRacing, fukaisei sakusyo, kasama seisakusyo, Natura Circuit, cybernet, DID, DENSO, turu jidouyakyougou



20 Tokyo University of Science

● Members

[CP] Yuto Mori [FA] Yasuo Kawaguchi [FA] Ryosuke Matsuzaki [FA] Hiroshi Okada [MBR] Kanata Kawakami, Takumi hiraoka, Yoshito Otuka, Shigesato Okumura, Tatsuharu Kobayashi, Yusuke Koyama, Tomoki Sakata, Taisei Hayama, Sorachi Fujimoto, Sena Yanagisawa, Ei Takahashi, Mitsuki Narita, Akito Fukai, Moriaki Inamine, Takumi Otomo, Shingo Ochiai, Hiroki Saito, Mamoru Shoji, Taisei Tadachi, Fumito Taninaka, Kenji Nakamura, Ryotaro Namiki

● Car Features and Team Aspirations

Inheriting the foundation of TFR 12, we developed a vehicle that can maximize the potential of the driver. We will aim for the podium which we could not fulfill, with the car with the most sophisticated packaging layout in the history of TFR.

● Team sponsors

IDAJ, MF Matsumoto, Calsonic Kansei, Kinokuni enterprise, Keihin, Kondo Kagaku, Sankei Giken Kogyo, TECHNOIL JAPON, DENSO, TopLine product, Nicole Racing Japan, Nippon Oil Pump, Nippon Light Metal, Nippon Plate Seiko, Brave Auto, Honda Motor, MARUBENI INFORMATION SYSTEMS, RION, INOUE SPECIAL STEEL, SAKAE KOUKAN, syou-ritsu, NMB, O-Z JAPAN, oriflame, KYOWA KOGYO, GOODRIDGE, Continental Automotive, CYAN, Cosmo Seimitsu, ZF Japan, TOKYO R&D, Nissin Kogyo, NHK Spring, NSK, NIPPON THOMPSON, NHK SPRING, PLUS μ, YUTAKA, LEARS, Works Bell, ICHIKOH INDUSTRIES, AlmTech Srl, LDL TECHNOLOGY Japan, K.MECS, Sumitomo Wiring Systems, Sensata Technologies Japan Limited, Tyco Electronics Japan, ASahi KASEI CONSTRUCTION MATERIALS, KOHSHIN CHEMICAL, KOVAX, Cybernet Systems, D shop Asahi, Signal SHOW UP support center, Future Henkel Japan, Minaro, RAMPF Group Japan, Oxen AB, kvv, NTN, ENJUMA CHAIN MFG, X.A.M JAPAN, KYOWA LEATHER CLOTH, Sealed Air Japan, Takata, FUKAI, enable, ALTAIR ENGINEERING, igus, NOK, OILES, Kobe Steel, City Kart, JUNIOR MOTOR PARK Quick HANYU, JobTessio, SHINSEIKIKO, SOLIDWORKS Japan, DENTSU Scholarship Foundation, TOA, Tohnichi Manufacturing, Nippal Kinzoku, VI-grade Japan, Nifco, NATS, Nord-Lock Japan, HI-LEX CORPORATION, Fuji Seimitsu, Furuto Industrial, Horikoshi Seiki, Maruni-Seiki, Maxnet, MISUMI, MITOLOY, SANWA PLATING INDUSTRY, LOBTEX, EUROPORT, VSN



21 University of Yamanashi

● Members

[CP] Shogo Hakamata [FA] Hiroyuki Tunoda [FA] Tsutomu Tanzawa [MBR] Yoshihito Oagu, Kengo Nonomura, Sho Iwabuchi, Hironu Marukawa, Yuki Imai, Masanao Yanagisawa, Ryoki Miura, Ryota Komiya, Syoya Nagata, Takumi Watanabe, Syuto Hatano, Yoshinori hukuda, Tomomi Yoneyama, Toshiyuki Kawai, Rikuya Hiraoka, Haru Sakai, Toko Miyata

● Car Features and Team Aspirations

We aimed at "ZINSYA ITTAI" of the machine concept, optimized the suspension geometry, improved main frame rigidity, and created a handy car. We aim to further improve the ranking by improving the overall score.

● Team sponsors

SUZUKI MOTOR, MITSUI KINZOKU ACT, SOLIDWORKS Japan, CHUOGIKEN, NTN, MISUMI, Sankin, SHINBA IRON WORKS, WEST RACING CARS, F.C.C, NHK SPRING, T.M.WORKS, J.A.A



22 Gifu University

● Members

[CP] Yusuke Ochiai [FA] Satoshi Kikuchi [MBR] Airi Kuno, Kaoru Terashima, Masaaki Yagi, Shota Okuyama, Kaori Kimura, Shota Kunii, Tsuyoshi Kuroda, Kanako Sakakibara, Daichi Shimizu, Miyu Furuhashi, Koichi Ito, Waki Sasada, Tomoko Sugano, Shin Seido, Yuta Takahashi, Eito Horiyama, Tomo Yamada, Shogo Yoshikawa

● Car Features and Team Aspirations

Our concept is high cornering and acceleration performance. For this concept, we try two new things. First is putting defuser on the machine. And second is using longitudinal engine layout. We'll try to finish all races and move up our ranking.

● Team sponsors

Akechi Hiltop Circuit, ASAHI FORGE, ALTAIR ENGINEERING, NTN, OSCO Industries, Katano, IME, enable, Iwata Mfg, F.C.C., OGUMA MFG, KINOKUNI Enterprise, Shinba Iron Works, SUGIYAMA SEISAKUSYO, Sensata Technologies Japan, T.M.D, TRINITY, NABEYA, HIKARI MANUFACTURE, Fukai MFG, Makita, MISUMI, GIFUGEAR, Gifu Auto Body, Gifu Plastic Industry, Kondo Kagaku, CCI, Shimonoseki Packing, SUZUKI, SUZUHIRO FORKLIFT, Sumitomo Wiring Systems, SOLIDWORKS Japan, DAIDO KOGYO, Daido Die & Mold Steel Solutions, PACIFIC INDUSTRIAL, Chubukaken Industry, DIC Material, Nabeya Bi-tech, Nissin Kogyo, NIPPON THOMPSON, Hattori welding, Fukuda seiko, The Furukawa Battery, MITAHORA DRIVING SCHOOL, SHlb mold, Takahashi weldig, Tugepurasesu, HayanoKenko, Tenryuu composite, Wakazono seiki, Daukaku, Kaneko higuruma industry, Tohnichi mold, Nipponhatujyou

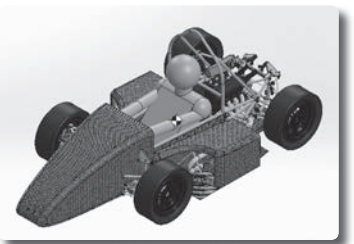

23 Kyoto University

● Members

[CP] Aoi Nakamura [FA] Iwao Yamaji [MBR] Shimpei Inoue, Masafumi Suzuki, Jun Nagao, Kentarou Hayakawa, Taito Matsumoto, Yuu Maruyama, Haruomi Noguchi, Yuuki Hamasaki, Tsunoda Jumpei, Syuntarou Kida, Masaki Fukao, Akihiro Togashi, Eri Itou

● Car Features and Team Aspirations

KZ-F15 has newly introduced Carbon Monocoque Body and Original Seamless Transmission. We promise to push on toward the victory.

● Team sponsors

DMG MORI, Yamaha Motor, Heishin Techno Werke, OXISO, JETKT, UACJ, NTN, Mitate, ASANO GEAR, Io, FUTAQ, Seisakusho, Sumitomo Wiring Systems, Sumitomo Electric Hardmetal, Sumitomo Electric Industries, SOLIDWORKS Japan K.K., Kondo Kagaku, Umihira, Henkel

Japan, NSK, ATS, Keishinkai, Denso, Aisin, THK, Biwako Sports Land, Yamagishi hompo, Ishida Seisakusho, Hirobe Kigata Engineering, Komatsu, AVO, Sanwa Mekki, Hayami Kyosei Shika, Misumi, Technoil JapanK.K., Works Bell, Kafael, Iwai Casting Pattern, Tire Box Evolve, ANSYS, Cybernet System, Tanaka Factory, Nihon Keikinzoku, Nissin, Asahikasei-Kenzai, Emu, Witt, Sunrise, Wai Enterprise, Future Technology, Next, IDAJ, CAST, Syouwa Hikouki, Mazda Aoiikai, Chubukaken Kogyo, Ikeda Kinzoku Kougyou, Yanmar, Meihan Sports Land, Plus u, Techserfu, Contec Labo, Tohnichi, Biseisya, Matsumoto Kinzoku, Techno Solutions, Keikikai, Advics, Kotoru, Landmark Technology, Miki Pulley, Cyuo Hatsujou, Weld One, Axson Japan, Sangu-do, Japan Insulation, Toray Carbon Magic CO., Ltd., Ikeya Formula, MNB, Neos



24 Universitas Gadjah Mada

● Members

[CP] Rifqi Taufik Alhakim [FA] Fauzun, S.T., M.T., Ph.D [FA] Akmal Irfan Majid, S.T., M.Eng. [MBR] Adrianus Prabowo Guritno, Alfian Wildan, Arinta Budhi Nugraha, Arviyan Dendi Mahendra, Dhiaurochman Airlangga, Endang Pertiwi, Erinda Septyaningrum, Fadhillah Aldi Ramadhan, Fajar Fitrahadi Danda, Farhan Wahyu Pratama, Febiola, Gilang Sandy Firdaus, Hafidz Miftah Rosyadi, Hanif Adyatma Herindra, Maitsaa Nur Sya'ban, Monika Sekar Melati Istanto, Moses Gregory Ginting, Muhammad Adlan Hawari, Muhammad Bhigar Wachid Puriyanto, Muhammad Ferdiawan Hananto, Muhammad Kamal Ardi Putra, Nadia Nur Amalina, Nabila Ridwan, Nyoman Arya Wiriyawan, Prastyastuti Ari Ratnasari, Rezki Eriyanto, Rian Achmad Wildan Anisanto, Rifqi Dwantara, Rizki Pujianto, Romario Muhammad Amri, Said Yanuar, Sarah Ifin Atsani, Thareq Akbar Arya Yudhistira, Wenmas Ardyu Iftihar, Zeffany Nehemia

● Car Features and Team Aspirations

As one of the delegation of Indonesia, we hope to achieve an independent

National Automotive Industry to further boost the country's economy. Lightweight, Swift, Ergonomic and Efficient. Those are the vehicle concept we hope to fulfill by introducing a new aerodynamic package, a new bodywork material, traction control, and other major features.

● Team sponsors

Pertamina, Telkomsel Indonesia, Poeser Indonesia, Kawasaki Motor Indonesia, PT Pelindo II, Keizer, Hoosier Tires, HRS Racing, Braille, Silk Air, Petrokimia Gresik, ISTW

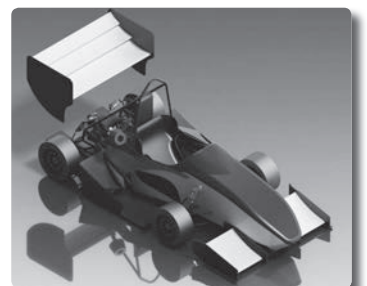

25 Institut Teknologi Sepuluh Nopember

● Members

[CP] Khalikul Haqqur Rahman [FA] Witantyo Witantyo [FA] Atok Setiyawan [MBR] Alfian Rafi Harsyawina, Lutfi Agus Salim, Joko Ade Nugroho, M. Khoiril Khuluk, Septiyen Abdullah, Annas Fauzy, Ricky Bramudia Kurniawan, Muhammad Fajar Auliya, Angga Eka Wahyu Ramadan, Kahfi Adhijatma Himawan, Sutrisno Birowo, Devi Maharani Kosa, Achmad Achsin Fathoni Syarief, Maulana Syarif Habibi, Nafi'an Zukhrufa, Bagus Widoto Aji

● Car Features and Team Aspirations

As one of the most prestigious event in the world, Formula Student Japan is our place to show our team's skill in creating a great formula car and achieving our goal which are being recognized by people around

the world and also winning the competition in order to bring Indonesia to the same level with other countries

● Team sponsors

Semen Indonesia, BNI, Lintech, FIM, IKA ITS, IKOMA ITS



Team Information (Members and Sponsors)

26 Kanazawa University

● Members

[CP] Kazuki Saito [FA] Noboru Hieda [MBR] Kunio Uenishi, Fumihiro Hanazato, Satoko katagiri, Koki Kosugi, Kensho Inaba, Sho Tsuzuki, Ryo Nakagawa, Hiroki Shinagawa, Ryuhei Oiwa, Kotaro Kushima, Kaname Kume, Yuki Sawamoto, Yoshitomo Shimeno, Naoya Higashi, Ryoichi Mochiduki, Yoshikazu Yokoyama, Gaku Shimoyama

● Car Features and Team Aspirations

This year, our concept of vehicle is "Fun to Run". We attached importance to weight saving and aerodynamic analysis, tried to produce lighter and more compact vehicle. We will give "The vehicle we can enjoy everything about it" at competition.

● Team sponsors

ALTECHNO, ANSYS, Ishigane Seiki, ISHIHARA-METAL MANUFACTURING, igus, Uno Sanso, NTN, ENUMA CHAIN MFG, MSC software, OHNO, OKAJIMA PIPE, Kanazawa Kogyokai, Kanazawa University Technical Support Center, KINOKUNI ENTERPRISE, kyowakougyou, KusajimaRadiatorWorks, Growth, KEINZ, KOMATSU NTC, KOMATSU KOKI, Cybernet Systems, SAWAMURA DENKI INDUSTRIAL, GAT, SUZUKI, SUZUKI AKITA AUTO PARTS MFG, Suzunaga Kougeisya, 3M Japan, SEKI, Central Glass, SolidWorks Japan, Dow Building Solutions, TAKASU CIRCUIT, TAKAMAZ MACHINERY, CHADANI TEKKO, TSUDAKOMA, THK, Techno-Clean, ToJiTsU, TOHNICHI, TODOROKI SANGYO, NAGAYAMA JIBI INKOUKA IIN, NAC KS, NISHIMURA JIGU, Kistler Japan, Niitigura, NGK SPARK PLUG, NISSIN RESIN, HAGA KIGATA KANAGATA SEISAKUSHO, BABA KAGAKU KOUGYO, Honeywell, HANSHIN NEJI, NISSIN, HIGASHIYAMA, HYUGA SEISAKUSYO, PFU, FUJIKOSHI, FUJISHAFT, Blenny Giken, PLASJ, PLOT, Hosoda Toryo, UACJ, THE HOKKOKU SHIMBUN, BOSCH, CRAFT MK, MISUMI, MITO KOGYO, MORITA KOGYO, LOCK FASTENER, V1-grade, WAKO CHEMICAL, Yamamoto, Yokoyama Shokai,

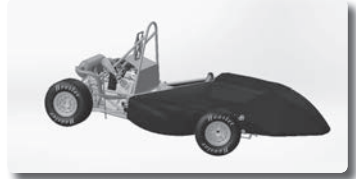

27 UNIVERSITAS NEGERI YOGYAKARTA

● Members

[CP] TEGUH ARIFIN [FA] Dr. Zainal Arifin, M.T. [FA] Prof. Dr. Sutrisna Wibawa, M.Pd [MBR] Deni Restu Widodo, Mustafit Septian, Robi Febrianto, Rizki Arumning Tyas, Een Juliani, Sultan Gunawan, Suratijo, Chahyo Handoko, Ardi Maulana Mubarak, Dwi Agung Yulianto, Agung Priyono, Erwin Hanari Subarno, Elga Fajar Kurniawan, Prabasta Berlian Putra, Rizzal Hardiyanto, Dicky Putra Kurniawan

● Car Features and Team Aspirations

Formula Garuda 17 (FG17) is the third generation of our Formula Student Car. We commit to use single cylinder 600 cc engine with integrated control system to reach our goals these are lighter than previous car, easy handling, ergonomic, cost efficiency, and have a great finish on

Top 20 overall. Telemetry and data acquisition used to improve Vehicle tuning. Ambition is a dream with Garuda UNY Racing Team. Bismillahirrohmanirrokhim.

● Team sponsors

KEMENRISTEKDIKTI, Motul Indonesia, Hossier, K2W Precision Inc. PT. Indonesia Steel Tube Works (ISTW), PT. Panatek, Riillon, IKATO, Manual Tech, Bies Injection, Bengkel Idek, PT. Yuasa Battery, PT. Igus Indonesia, PT. NSK Bearings Manufacturing Indonesia, Dasault System, Yamaha Motor Manufacturing Indonesia, Maguwoharjo International Stadium, PT. Citra Jogja Kreasi, C-Maxi Alloy Cast, Embrella, Fukai, Jogja Istimewa, U2i MGT, Shift Engineering, GNFI, Kedaulatan Rakyat

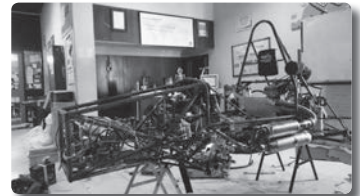

28 Toyohashi University of Technology

● Members

[CP] Takanori Kodera [FA] Hideki Yanada [FA] Toshiaki Yasui [FA] Akihiko Mitsuishi [MBR] Takeru Okano, Yuya Sugawara, Masaki Takamizawa, Takeshi Matsushashi, Shion Tachibana, Takahiro Miyachi, Kenta Tanaka, Yoshikazu Yamazaki, Yuto Hayakawa, Mitsuharu Hattori, Ryosei Tanaka, Ryoga Kishimoto, Keiya Oguri, Naoto Ayada, Kohei Nagao, Takuro Saeki, Yuto Naide, Takahiro Yamashita, Yoshihiro Yato, Tatsunari Miyama, Tetsuya Mizoguchi, Kento Kimura, Yuta Ueda, Souichirou Moriyama, Ryuhei Kobayashi, Takahisa Sasayama, Koki Tamekuni, Chiba Shogo, Masashi Masuda, Yuto Mochizuki, Nagamasa Kametani, Tasuku Miki, Takumi Yamahata, Tsubasa Nimura, Ryota Hamana, Mizuno Yuhi, Shoma Tanaka, Sato Takeru

● Car Features and Team Aspirations

Our vehicle for this season is developed under the concept of "Improvement of cornering

speed". We will achieve this concept by a complete overview of the vehicle, including the output characteristics of the engine and steering stability of our vehicle. Ultimately our aim is to secure a podium finish.

● Team sponsors

Musashi Seinitu Industry, MITSUBISHI CHEMICAL, OHBA SEIKEN, CDS, MITSUI KINZOKU ACT, MIYAGAWA KOKI, Meidoh, JAPAN INSULATION, IME, Daido Dai & Mold Steel Solutions, HONDA Motor, Henkel Japan, TOPY INDUSTRIES, TAKAGI KIGATA, WINKS, AXSIN JAPAN, NIPPON POP RIVETS AND FASTENERS, SOLID WORKS JAPAN, MISUMI, HOEI industry, Tsuge Plasess, ofa, NTN, WAKO CHEMICAL, AUTO STUDIO SKILL, DENSO, SHOWA AIRCRAFT INDUSTRY, TAMATSUURA PATTERN, Sumitomo Wiring Systems, OSG, DAYTONA, Enuma Chain, Fuji Seimitsu, CFC Design, TAKATA, Minebea, NHK SPRING, NEXT, YAMAHA SPORTS PLAZA South-Toyohashi, ISK, SATO MANUFACTURING, Toyohashi University of Technology CRFC, Toyohashi University of Technology Frontier Forming System Laboratory, SANKYO RADIATOR, Toyohashi University of Technology Information and Media Center



29 Sophia University

● Members

[CP] Yusaku Ohtsu [FA] Takashi Suzuki [MBR] Hironori Sasai, IkuroTanaka, Yuji Murata, Tomohiro Kubota, Yuta Aishima, Koki Okamoto, Yuuki Ito, Takafumi Endo, Hajime Sakai, Reo Saito, Naoki Takamura, Motoki Fukuda, Moe Matsui, Takumi Kimura, Alex Tsubasa Tanaka, Makoto Horie, Kento Kajiki, Haruki Matsuo, Narumi Aratake, Masayuki Osada, Huka Kato

● Car Features and Team Aspirations

Since Formula SAE kicked off in Japan, Sophia Racing has been participating in every single tournament. Throughout our career, we've had our golden ages, winning multiple titles back to back, and experienced dramatic turnarounds losing momentum. This year's model is packed with years of experience and support from our loyal sponsors; a renowned worldwide trend focused on: lightweight, compact, and a big aero package. Sophia Racing

aims at reclaiming the throne.

● Team sponsors

Yamaha Motor, VAMTEC HTS FORWARDING, TAGUCHI PATTERN WORKS, PTC Japan, OKITSURASEN, UD TRUCKS, HIRAGAKI SEISAKUJO, Aoshima Gear, Iwakura Welding Industry, FARO Japan, Resin readmodel, GAT, NTN, ACM, V1-grade Japan, Concurrent Computer Corporation, TANAKA Industry, Fuji WPC, Reseach Center of Computational Mechanics, MITO KOGYO, RK Japan, Miyaco Motor, MSC Software, Nissin Kogyo, F.C.C., AVO/MoTeC Japan, DOW Kakoh, CYBERNET SYSTEMS, Mathworks Japan, MISUMI, Mobarata twin circuit, IgoW, Quick Hanyu, IDAJ, IHI, Sanyo Chemical, Kondo Kagaku, RS Components, RAMPF Group Japan, Materialise Japan, SMC, Lasermax, Kondo Hatsudoki, FUKAI MFG, CYAN, NATS, NICOLE GROUP OF COMPANIES, Musasisakai Driving School, CITY KART, HAT, MARUBENI INFORMATION SYSTEMS, SH CONSULTING, Deif, TOKYO TANSO KOGYO, KOYO Seiki, Okugi Seisakujiyo, igus, OKUNO GLOBAL TEC, Fuji Seimitsu, TAKATA, RAC, MURATA Boring, NIPPON COATING INDUSTRY, TOKYO R&D, HOKUSHEN, KIMURA FOUNDRY, Magna International, Dai-ichi Orkyo, RACING SERVICES Watanabe, Tokyo Sokki Kenkyujo, Altair Engineering, TeXTreme, KYB, BOSCH, NP, TRADING, resonic Japan, TEIN, SUNOCO



30 Tokyo City University

● Members

[CP] Yusuke Matsumura [FA] Yuji Mihara [MBR] Koyo Kimura, Yuri Gomi, Takayuki Shiba, Shunsuke Soematsu, Akiya Nakayama, Masatoshi Horiguchi, Takahiro Yuhara, Kodai Sato, Tatsuya Yachi, Naoto Kawano, Daiki Hukuhara, Yuuki Hiruta, Yuusuke Sakamoto, Yuuki Hunase, Hikari Nagaami, Syouhei Wada, Keisuke Kodama, Syuuhei Kobayashi, Tatsunori Miura, Bunta Takase, Ryosuke Wada, Riki Chida

● Car Features and Team Aspirations

This year's vehicle M2017 inserted "The sharp movement" in a concept and we aim for the top.

● Team sponsors

AVO/MoTeC Japan, NTN Co., Ltd., OSCO Industries Co., Ltd., Iwamoto Co., Ltd., FCC Co., Ltd., KINOKUNI Enterprise Co., Ltd., KYOWA Co., Ltd., KUWAHARA International Co., Ltd., KOYAMA GARAGE Co., Ltd., Socket center Co., Ltd., TOKYO R&D Co., Ltd., PIOLAX Inc., HI-LEX CORPORATION Co., Ltd., Fuji Manufacturing Co., Ltd., Fuji Seimitsu Co.,

Ltd., MISUMI Corporation, Minoru INTERNATIONAL Inc, RACING SERVICE Watanabe Co., Ltd., KYOWA KOGYO Co., Ltd., Kohara Gear Industry Co., Ltd., Cybernet Systems Co., Ltd., Quick Hanyu, SUZUKI MOTOR CORPORATION, Sumitomo Wiring Systems, Ltd., SolidWorks Japan K.K., TEITO RUBBER LTD, TOYO DENGYO CO., LTD., Nikkeikin Aluminium Core Technology Company Ltd., NISSAN MOTOR CO., LTD., NISSIN KOGYO CO., LTD., Nippon Light Metal Company, Ltd., NHK SPRING Co., Ltd., The Furukawa Battery Co., Ltd., Honda Motor Co., Ltd., Meister club, Kitamura-Kogyo Corporation., Nikken Manufacturing Co., Ltd., BEAR inc., UD TRUCKS Co., Ltd., IDAJ Co., LTD., KEIYO BEND CO., LTD., TOHNICHI Mfg. CO.,

LTD., HIRAYAMA auto industry Ltd., Suzuki Engineering Co., Ltd., FUKAI MFG CO., LTD., MARUBENI INFORMATION SYSTEMS CO., LTD., TOYODENSO CO., LTD., Nakazato Gear Industry Co., Ltd., Maruyama-radiator Co., Ltd., JobTessio, Inc., MUSASHI CO., LTD., Tashiro Co., Ltd., Ito seimitsu kogyo Co., Ltd., Nakamura tekko Co., Ltd., PLUS-MYU Co., Ltd.

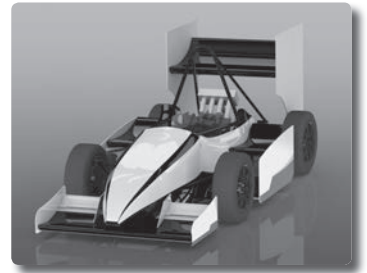

31 Shizuoka Institute of Science and Technology

● Members

[CP] Shun Makino [FA] Takashi Nozaki [FA] zhu ning [MBR] Ryuya Ikki, Kazuya Sakamoto, Maya Shinmura, Shota Sugiura, Masatomo Furuya, Taichi Shiraiwa, Naoki Ueguchi, Shogo Kimpara, Kento Kubota, Syun Saitou, Ryou Sakai, Hiroki Shizuhata, Eisuke Nakano, Tomotaka Nagai, Runa Yamada, Yuki Gotou, Ryou Tanizawa, Syunsuke Murotani, Yuta Asanoma, Rintarou Ashikawa, Ryouta Abe, Kouichi Arai, Keito Syukushima, Erika Fujita, Shiori Takada, Mayo Hatta, Zhang Haipeng

● Car Features and Team Aspirations

We planned this year's car what was lighter than last year's car, especially we consciously lightened that yaw inertia moment. And we got downforce from aeroparts. We gained enough power so we aim for within

sixth place.

● Team sponsors

SUZUKI, DAIKIN, Shinba Iron Works, SOLIDWORKS, TORII, UNIVANCE, NTN, DAYTONA, DAIDO KOGYO, SEKIMONODUKURI, THK, KYOWA KOGYO, Sensata Technologies, OETIKER, Tyco Electronics, YAZAKI, IRS, OGUSU INDUSTRY, SHOEI, Fukai MFG, Yutaka Giken, Minebea, PROTRAD, XAM JAPAN, igus, ISK, MISUMI, Sumitomo Wiring Systems, KYO-EI Industrial, WEST RACING CARS, FUJI COMMUNICATIONS, KOITO, Fuji Xerox, Belle Carriere, TOSHIBA, Suzuyo Shoji, Suzuyo System Technology, Suzuyo Kensetsu, Shizuoka Bill Service, chuhatsu, Tohnichi Manufacturing, MathWorks, ARTNER, NISSIN KOGYO, Fuji Seimitsu, KURE Engineering, IDAJ, LORD, KINOKUNI, NHK SPRING, SHIBATA

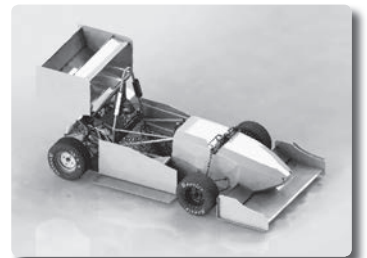

32 King Mongkut's University of Technology Thonburi

● Members

[CP] Tawan Thongmanogoon [FA] Surachate Chutima [FA] Asst. Prof. Anak Khantachawana [FA] Asst.Prof.Chawin Chantarasenawong [FA] Danai Phaoharuhansa [MBR] Supanat Mounpluan, Pattharawadee Nuchthapho, Thanaphon Phonlapanun, Chanatip Chairawan, Romeo Mahaduljan, Chayaphon Taisanakarn, Jirawit Putsrit, Thanaporn Sukjai, Teerut Krusri, Banjong Zonklin, Nattawat Seesai, Jirayu Auychai, Anawat Tien-ngam, Jirakit Chitaugorn, Pattarakit Jainom, Thaya Jangprajak, Apisit Thanee, Thanakrit Rattanamongkol, Nipitphon Wattananit, Itthipon Suesat, Peerapong Tangitsarapharp, Mekkaradkeeta Kalantananda, Anakorn Kanoksilp, Phunyawat Thongnual, Warunchit Chueprasert

● Car Features and Team Aspirations

The high performance racing car with the assistive driver We design and manufacture the racing car for every driver can be drive.

● Team sponsors

Tozzhin International Corporation Co., Ltd, Mazda, Jasic, Izusu, Nippon Cargo, Henkel, koh-kae, laemthong, ATP pylon, PCB-Bangkok, M1 Autowerk, White cloud, Injector shop, Power speed shop, EGAT, Quantumec, patkol, S9, Thai austro mold, Bangmod racing, vattana auto sales, Ltd., Maeklong Garage Co., Naspas Asia Co., Ltd, Valvoline, Pink Mobile, N-brake, SKF Thailand, Toray, Delcam, KTW, Phra Padaeng Steel Pipe, NTS, Shizuoka Bank, CHUTIMA, ASSAB Steels (Thailand) Ltd.Oxiso (Japan) Co., Ltd+, Exedy Friction and Materials(Thailand) Co., Ltd+, N.T.S Co., Ltd+, Cobra International Co., Ltd, SKF Thailand co. ltd, Michelin Siam Company

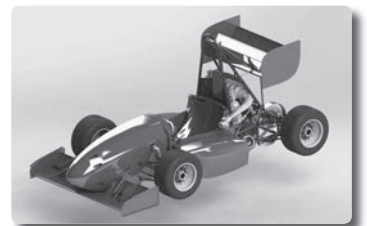

33 College of Industrial Technology, Nihon University

● Members

[CP] Issei Tsuino [FA] Susumu Takahashi [FA] Yoshihiko Obata [MBR] Kazuma Hiroya, Kouta Kawai, Tsubasa Komaki, Makoto Yoshida, Shota Waga, Kentaro Komuro, Naoto Hirai, Tomohiro Hoshi, Hiroki Iwabuchi, Hidekazu Koyake, Shiori Sawafuji, Akihisa Okuda, Kei Toyoda, kouhei takaoka, Hayato Aoki, Miyu Nakao, Kai Asamura, Taiga Kasahara, Soushi Obara

● Car Features and Team Aspirations

Our machine has good maintainability as a top priority, realizing improved drivability and low center of gravity. We aim to complete all kinds of events by making use of the lightness of adopting suport tire and single cylinder engine.

● Team sponsors

HONDA, NISSIN, Solid Works Japan, Sakata Designers, Tohoku Radiator, RAC, Keiyou Bend, AUTOLAND TECHNO, Sumitomo Rubber Industries, STAUBLI, Nippon Dry-Chemical, RS EMA, Vigrade, Hard Rock Industry, Ancar, NOK, NU-CAR, NMB Sales company, IPG Automotive, World Walk, DENSO, KOBELCO, Moty's

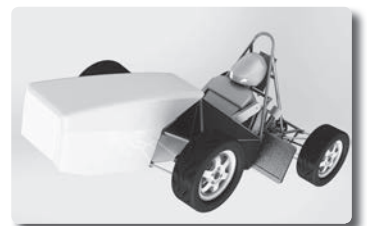

Team Information (Members and Sponsors)

34 Institute of Technologists

● Members

[CP] Yoshimichi Sato [FA] Kaoru Hara [FA] Minoru Mitsui [MBR] Takuya Hshimoto, Shohei Noguchi, Daigo Kasai, Takuma Yamabayashi, Kohei Takahashi, Soichi Narita, Kengo Miyazawa, Kosuke Yasunaga, Tomotaka Yoshizawa, Hiromu Ishizaki, Hiroto Shindo, Akitaka Imamura, Toru Kawai, Shohei Taninaga, Seiya Takada, Naoya Takahashi, Keiichi Sato, Ryoa Anashige, Kenichiro Kakizawa, Tomoaki Nishimura, Takuya Igarashi

● Car Features and Team Aspirations

We improved the problems of the last fiscal year with the goal of improving drivability. Aiming at the early completion of the vehicle, we also focused on learning of vehicles and drivers. We will strive to improve in-house production ratio and quality, and aim for within 15th overall

ranking.

● Team sponsors

Altair Engineering, NTN, Eharasanso, F.C.C., Okada Motors, Kinokuni enterprise, Gyokuryu, Junior motor park quick Hanyu, SACLAM, studio37, Sumitomo Wiring Systems, SOLIDWORKS Japan, Tire Select Hukiage, Toyota Leasing, Bike Staff ARIE, Honda Motor, MISUMI, Enshuichi



35 Tokai University

● Members

[CP] Ryota Asa [FA] Masashi Yoshinaga [FA] Takeshi Yamamoto [MBR] Yo Sugisaka, Takumi Oguri, Daisuke Hayashi, Nozomi Takano, Yusei Watari, Wataru Oike, Syunsuke Noduki, Kohei Sudou, Kaori Sato, Hayato Minami, Keisuke Oda, Shun Ito, Mizuki Nishiyama, Syuji Ootani, Yoshiyuki Honda, Tomohito Inoue, Kohei Sasage, Hiroki Nakamichi, Yuto Kubota, Taiga Kubomatsu, Kouta Yamamoto, Ryotaro Murata, Shouhei Simizu, Shinya Kasai, Shoon Toma, Toshiya Miura, Gouta Maeda, Yukiko Ooe, Ryo Suzuki, Jun Saito, Rirai Yamasita, Keisuke Kojima, Motoki Shimizu, Reo Sakata, Kohei Narikawa, Yuta Tsukimura, Hiroyuki Fujii, Kento Nishiyama, Nozomu Miura, Yuto Horii, Chaun Kei, Daiki Sato

● Car Features and Team Aspirations

Our goal is to win the overall victory at the 15th JSAE competition "to win all dynamic events". The concept of the vehicle is "Improvement of engine response and steering

stability", we tried less weight and improve production precision.

● Team sponsors

SUZUKI, DENSO, TOTAL JAPAN, MIKUNI, N.A.C.T., INOUE BORING, TAN-EI-SHA WHEEL SUPPLY, VIEWTEC JAPAN, Oikawa Seisakujyo, MUTO KOGYO, PLASTIC TOTAL PRODUCE, VOLCANO, KOYORAD, Hiratsuka Itohneji, braille BATTERY JAPAN, NISSIN KOGYO, cyan, Fukai MFG, MARUBENI INFORMATION SYSTEMS, AVO/MoTeC Japan, MISUMI, Tokaibane, SOLIDWORKS, NIFCO, TOKA SEIKI, SANFLECHE, KEIO Kanko, NE, HPC SYSTEMS, ooi-mazda racing kart Land, Takasago Sangyo, SUZUKI SEIKI, NTN, MARUYAMA RADIATOR, Fukuoka Tire Service, ISHIHARA-METAL MANUFACTURING, Shin Nippon Feather Core, WEST RACING CARS, RENT, suzumura seisakusyo, Henkel Japan, Bright Logic, CYBERNET, IDAJ, K2W PRECISION, automax, LANDMARK TECHNOLOGY, KANEKO GEAR MFG, VI-grade Japan, CAST, NTN, TOSHIBA MACHINE, VSN, Tokai University Challenge Center



36 University of Fukui

● Members

[CP] Reo Obara [FA] Masanori Shintani [FA] Takatoshi Kawasaki [MBR] Masahiro Hirata, Wataru Yagi, Gen Niimi, Takaaki Mabuchi, Hiroto Fujita, Shouhei Shimizu, Takeshi Ikemoto, Akifumi Otomo, Naoyuki Asai, Keimei Kuriki, Shinya Ishise, Takumi Sakata, Takumi Yamada, Ryo Takakura, Hiroki Sakakibara, Masaki Nanbu, Takuya Yamamoto, Tatsuya Imai, Katsuhiro Hayashi, Shintaro Yoshida, Yuki Harashim, Yasutomo Asakura

● Car Features and Team Aspirations

The concept of this this year is "pursuit of turning performance and drivability". We will approach turning performance from approach, steady turning, escape and weight saving and drivability from easy to work engine and cockpit.

● Team sponsors

SUZUKI, YOSHIOKA KOH, University of Fukui Advanced Science and Technology Development Center, MathWorks, AKIRAX, AVO/Motec JAPAN, DUKE FUKUI, igus, LinkMaker, NTN, TAD, TAYASU, TOP, enable, Altair Engineering, WEST RACING CARS, H&F, NMB Sales, F.C.C., AUTO STAFF, AUTOBACS SEVEN, Calsonic Kansei, Kinokuni PERFORMANCE PRODUCTS, Japan Polymark, Sensata Technologies Japan, SOLIDWORKS Japan K.K., Tsubokawa Industry, TMC, TECHNOIL-JAPON, DENSO, NAC K S, HI-LEX, BLenny Giken, Henkel Japan, HOKUSIN, MISUMI, RAYS, Uno Gear Industry, Marugo Rubber Industry, KYO-EI Industrial Corporation, Kyowa Industry, Enuma Chain, SANGO, SUMITOMODENSO, Fukai Works, Kobe Steel, AOYAMA SEISAKUSYO, Kusajima Radiator Industry, Daido DM solution, NAKAKENSYOU TEN, TOYODENSO, Nippon VI-GRADE, NISSIN, NIPPONHATUJO, Hino Electronics, Fuji Seimitsu, Fukui Prefecture Sakai High School, Fukui Chamber of Commerce and Industry



37 Okayama University of Science

● Members

[CP] Takumi Wakimoto [FA] Chihiro Kondo [FA] Toshiaki Kaneeda [MBR] Hirokuni Kojima, Keita Unagi, Kenta Inoue, Naoto Tsuchihata, Takayuki Yamamoto, Naoya Yoshida, Takeru Ishihara, Kazuaki Urata, Yuichiro Yasunobe, Ryo Katayama, Sakichi Kaihara, Syunpei Ueda, Kotaro Yamamoto, Ryota Kanamoto

● Car Features and Team Aspirations

This year's concept is "Shape Controls Performance". While utilizing past data, we will promote vehicle development focusing on all part. We will focus on all Dynamic Events and Static Events and aim to improve overall ranking.

● Team sponsors

Kawasaki Heavy Industries, Solidworks Japan, Four technos, Kyowa Finetech, Okayama harada pipe&tube, NTN, Nissin Kogyo, THK, F-C-C, NSK, Sumitomo Wiring Systems, ITANO KIKOU, KYOWA KOGYO, SOJA SENOO Electrical Construction, VSN, Okayama Lacermax, Sanyo Resin Industries, Kohge Racing Service, Sekiguchi cars, Okayama International circuit, FUJIX, DENSO, artner, Kitamura Builders



38 Kanazawa Institute of Technology

● Members

[CP] Motoki Watanabe [FA] Hajime Gontani [MBR] Akinori Iino, Yuya Hanamura, Takayoshi Matsumoto, Ryousuke Arimoto, Yuto Iguchi, Kosuke Kawano, Masahiro Kitamura, Hideki Nishikawa, Hiroshi Nishide, Yuta Nojima, Takahiro Matsusaka, Yosuke Mitsushishi, Takuya Mori, Hiroki Morita, Takefumi Amari, Naoko Arie, Masahiro Ikeda, Masaya Ozaki, Kenta Kakumoto, Hiroyuki Sakai, Kouichi Sakano, Takumi Sasagawa, Yoshimasa Takaku, Minoru Takahashi, Takumi Yamamoto, Kouki Abe, Koutarou Kokubun, Shigeki Takabatake, Yusuke Hasegawa, Tomohiko Hirose, Kiyohiro Fukuroi, Ryota Miyake, Toshiaki Wakabayashi, Naoki Akabayashi, Hiroyuki Asano, Yuta Kimura, Keita Nakahashi, Keita Niimi, Taichi Nishizumi, Yuma Yamamoto, Shiro Arakawa, Syuntaro Umeda, Masaki Endo, Fumitake Takaya, Taiga Nonaka, Yuki Hosokawa

● Car Features and Team Aspirations

This year, our team reviewed the geometry and weight reducing to fulfill the new KIT-17 model vehicle concept "Improvement of cornering ability". Our goal is to finish all events completely and win in the top 9 teams at overall ranking.

● Team sponsors

Kanazawa Institute of Technology Yumekobo, AKIRAX, Ueda, NTN, F.C.C., KYOWA KOGYO, Kusajima Radiator Works, SUZUKI, Sumitomo Wiring Systems, DAIDO KOGYO, TAN-EI-SYA, TAN-EI-SYA WHEEL SUPPLY, TOLAP, BAIKA, Maruso Rubber, Morita Shokai, MISUMI, Nissin Kogyo, FUKAI

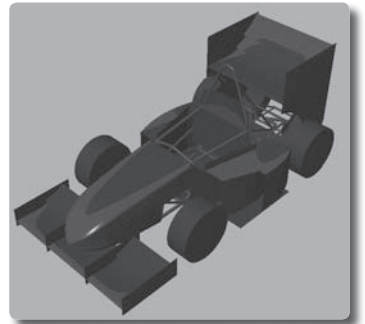

39 Meijo University

● Members

[CP] Kouta Morishima [FA] Hidetoshi Hayafuji [MBR] Fumihiko Isobe, Seigo Iwahara, Hiroaki Nakai, Naoki Tokudome, Kiiichi Arako, Kai Ito, Yasunori Onuki, Akio Shimizu, Yuuki Sonokawa, Hiroki Tsuda, Kohei Nakagomi, Yoichiro Nagatsu, Kazuki Murai, Minato Yokoyama, Yoshiki Iwasawa, Masatoshi Asaka, Hayate Asano, Koki Ikegami, Tomoki Kato, Takumi Kawamura, Tomoki Koike, Tatsuya Kouketsu, yuzuki gotou, Miki Sato, Mitsuki Shibata, Akira Suzuki, Yukiko Hikosaka, Keisuke Hozo, Akihiro Hosoda, Noritsugu Horikoshi, Takahiro Yasuda, Hikaru Yoshida

● Car Features and Team Aspirations

Last year, we finished the competition at 42th place. So we are sorry about this place. We aim the place of top 10 teams with our car that take over last year's package,

problem solving and new challenge.

● Team sponsors

ARRK, IME, Amaki Machine Works, ARTNER, ANSYS JAPAN, ISHIKAWA, ISHINO CIRCUIT, ISOWA, Wing Auto, AW engineering, EXCEED, NTN, OXISO, KAWAMOTO steel materials, Kinokuni enterprise, CAST, KOTA CIRCUIT YRP KIRIYAMA, KOYORAD, KYOWA KOGYO, Cybernet Systems, SAKAI OVEX, SANGO, GS YUASA, GAT, Jatoco, J-3D, SHORAI JAPAN, Sumitomo Wiring Systems, SOFTPREN INDUSTRY CORPORATION, SENSATA TECHNOLOGIES JAPAN, SOLIDWORKS JAPAN, DAD, D.I.D., Teshima Printing, Total Technical Solutions, TOTEC, NAGOYA metal plating industry, NISSINKOGYO, NGK, Japan U-pica, NEXT, PALM TOWN GARAGE, HITAP, FUKAI MFG, MAKINO JIDOSHA, MathWorks, MiSUMi, MIDORI PRECISIONS, yamato industrial, YAMAHA MOTOR, UNIONDENSHO, RAINBOW SPORTS, LASERTEC, WAKO CHEMICAL, WADA WELDING



40 Tokyo University of Agriculture and Technology

● Members

[CP] Yuta Hishinuma [FA] Kamada Takayoshi [FA] Keisuke Kazama [MBR] Asato Soyama, Masato Imai, Masanori Makino, Wataru Komatsu, Kiyotaka Takada, Hidetoshi Takemura, Buntaro Ueki, Hiroaki Ninuma, Junsei Nishimoto, Junnosuke Miyoshi, Daichi Asaoka, Riku Koyama, Haruto Ishikawa, Kento Sato, Masahiro Makino, Naofumi Kobayashi, Kenji Asakawa, Toru Yada, Ryo Inaba, Hiroto Endo, Yuta Koshimura, Kazuki Sekine, Ryohei Takahashi, Akihiro Terahara, Akihiro Miyazaki

● Car Features and Team Aspirations

We've developed our machine with better drivability based on the track character. We hope to complete the competition and get 15th place with enough effort and preparation.

● Team sponsors

NOK, NTN, F.C.C., FC Design, Kato Cam Giken, Kaneko Gear Mfg., KAMIJIMA HEAT TREATMENT, Calsonic Kansei, KINOKUNI ENTERPRISE, KYOWA KOGYO, KEIYO BEND, Kondo Kagaku, KOTORA, Sumitomo Rubber Industries, Sumitomo Wiring Systems, SOLIDWORKS Japan, Tire Fitting Service, Takata, T.RAD, THK, DMM.com, DMM.make, Nakai Inter Circuit, Niitakagiya-, Nihon Automobile College, NICHIRIN, Nissin Kogyo, Nippon Rent-A-Car Service, HARDLOCK INDUSTRY, hi-1000.com, Fukai MFG, Honda Motor, MISUMI, YUTAKA, WELDING SHOP RYUSEI, RAYS, Lenovo Japan, WAKO'S, Tokyo University of Agriculture and Technology Department of Mechanical Systems Engineering, Tokyo University of Agriculture and Technology Kiyukai



41 Osaka Institute of Technology

● Members

[CP] Mikiya Fujii [FA] Kazunari Kuwahara [FA] Yukitoshi Ihara [FA] Miki Kazutaka [MBR] Hitoshi Ueno, Akira Sato, Ryota Morimura, Hitoshi Imar, Hiroo Takuya, Katsuya Kubota, Takuya Kaneko, Eitaro Katayama, Yusuke Yamaguchi, Hitoshi Torisu, Shoma Tokunaga, Seiya Hatakenaka, Hiromu Mutakami, Yuko Takei, Wataru satake, Kanta Tani, Goki Tamura, Mitsuki Miura, Shinya Huruakaawa, Mutsuki Osuka, Koichiro Eguchi, Yuya Tanimori, Ryota Enomoto, Shoto Tsumori, Shotaro Kubo, Takateru Kawamura, Akihiro Kikuta, Takaya Uchiyama, Teruyuki Minato, Ryusei Yanagida, Renka Yasuda, Katsunari Ota, Koki Mimura, Ryo Shimizu, Koki Ando, Takuya Hamaguchi, Yuki Fujihata, Atsuya Yoshiga, Yuki Ijuhara, Naoki Ueda, Shota Miyoshi, Naoto Tada, Takauma Kawakami

● Car Features and Team Aspirations

This year, "Uplifting Car" was adopted as the vehicle concept, aiming for vehicle with improved performance based on the vehicle from last year. In addition to unachieved last year's goal of

autocross time in 59.999 seconds, we will aim to be a team that can always be named in the upper-ranking schools, with the team's goal to improve all events rankings.

● Team sponsors

SUZUKI, Solid Works Japan, Yamato, Ecott, ZION, Mishima Infinity Circuit, Nipponkako, Meihan Sports Land, Fu-se Vacuum Forming, MIZUTA SEISAKUSHO, EXEDY, LASER TECH, P's supply, Business Rental Lease, Tanigawa Electric Industry, OSAKA BANE, KOTORA, Honda Techno Fort, VSN, KUMONSIKIKOUGYOU, F.C.C., Sumitomo Wiring Systems, TAKATA, NANIWAYA, Project Mu, Carport Maluzen, U Workshop, Nissin Kogyo, KYOWA, Gruppe M, NTN, KOKEN, DENSO, OSG, Osaka Foming, Nifco, igus, IDAJ, Altar Engineering, VI-GRADE, GENETEC, CAST, FACE, OZ japan, Daito Radiator, WORKS BELL, OKUNO GLOBAL TEC, SIGNAL, FUKAI, NISSO KOGYO, MCS, North Hillz Welding Industry

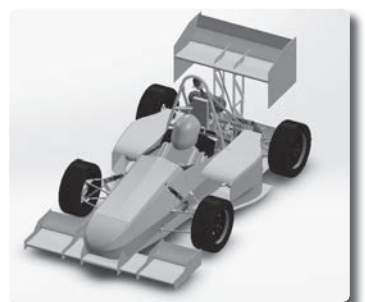

Team Information (Members and Sponsors)

42 Osaka Sangyou University

● Members

[CP] Yuuta Inoue [FA] Hiroyuki Ueda [MBR] Kazuya Inui, Reiya Fujioka, Ryouichi Wada, Masato Nakajima, Hiroaki Goto, Mana Murata, Shingo Sakurai, Ryo Isomura, Koichi Kawai

● Car Features and Team Aspirations

We refined the detail of our vehicle based on last year's specification to improve the vehicle performance. We also completed the manufacturing of the vehicle early by thorough schedule control and conducted running tests in order to secure reliability. We aim to achieve a good result in every event and overall ranking.

● Team sponsors

Osaka Sangyo University, Kawasaki inc., inc. RAYS, inc. EXEDY, Co., Ltd. Tani Iron Works, inc. F.C.C., inc. JRC, NTN inc., ShinNihon Feather inc. Daito Radiator Industrial Factory, TAKATA inc., Solid Works Japan inc., inc. Ueda, inc. MISUMI, inc. WAKO Chemical, Altair Engineering inc., WEST Racing Cars, MATSUDA inc., Co., Ltd. Plus μ , Sports land Ikoma, KYOWA Industry inc., inc. Sunayama Plant, NISSIN Industry inc., Miwa Plating Industry inc., Sumitomo Denso inc. inc. VI



43 Harbin Institute of Technology at Weihai

● Members

[CP] Azhun Zhu [FA] Jianfeng Wang [MBR] Jiadong Liu, Jingwei Yan, Jinmao Cui, Kairui Wang, Sixin Huang, Xue Li, Yang Liu, Lei Yin, Haoran Liu, Sha Li, Yuxiang Tang, Zihui Lang, Beihong Liao, Shengkai Gao, Peng He, Mingyu Huang, Bohan Yang, Tangmao Hui, Guoyi Zhang, Zijie Wang, Changbo Zhao

● Car Features and Team Aspirations

HRT was established in November 2009, and it is one of the national teams to participate in the first event of FSC. Based on domestic but look international, and three stations in SFJ and one in FSG showing the world Chinese FSAE style. Besides HRT is also the pioneer of the monocoque, carbon fiber axle, suspension, and one-piece full carbon

fiber rim.

● Team sponsors

Menshine, Guangwei, Wanfeng, MITSUBISHI MOTORS



44 Kasetsart University

● Members

[CP] Juggarin Chutikusol [FA] Prapot Kunthong, Ph.D [FA] Jay-Tawee Pukrushpan [MBR] Chokchai Jarunongkran, Chattarin Teerawattanasook, Patcharakorn Wattanapanom, Yasinthorn Sibuasod, Pongsakorn Sakulkaew, Kunat Lertrattananon, Kawin Limjanon, Kittapat Kaewprasit, Pattarapol Pattaraumpornchai, Nattawat Sunjitto

● Car Features and Team Aspirations

Unique suspension with six damper, full arero dynamic package, MOTeC M150, Real time long length telemetry data For this year we hopefully to finish all event completely and perfect.

● Team sponsors

BOSCH, SKF, Okuma, Toyota Motor Thailand, WELPRO, Thakita, AEROFLEX, LIQUI MOLY, POWeR LAB, COBRA International, Nippon Cargo Airline, Pearl Logistics, Morin Racing, EURO Racing, WURTH, D.I.D, SPSC, D Square, CC Auto parts, Dyno Revspec, Sticker GT Shop, BORN TO RACE, H&R, Dhawath Technology Systems

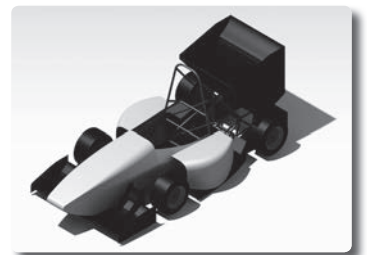

45 Shizuoka University

● Members

[CP] Takeo Kura [FA] Masaaki Motozawa [FA] Mitsuhiro Fukuta [MBR] Saki Isokawa, Hokuto Kurosawa, Kengo Shigetate, Naoki Tsunekawa, Nakanishi Yuto, Kazuma Nogi, Hiroya Irahara, Kenichiro Jinno, Kyosuke Nomura, Momoko Hasegawa, Tatsuya Hiyoshi, Tsubasa Ishii, Ryosuke Hatada, Tomoya Koga, Toshihumi Kojima, Atsuya Sasaki, Taiki Sekiguchi, Kentaro Takechi, Chisato Toyoda, Akira Fujii, Ryuki Masubara, Suzuna Momiyama, Yudai Yahara, Hiroya Tomita, Hayate Takahira, Tatsuaki Murakami, Norihiko Itaba, Itsuki Fukuta, Yuji Sasai, Hiroshi Suzuki, Daigo Ikke, Masanori Suzuki, Taro Yazawa

● Car Features and Team Aspirations

It was passed two years since we changed machine's layout. We aim to all

events finish with so sophisticated "HAMAKAZE" to use the experience obtained last year.

● Team sponsors

Kato Cam Giken, Shin Nippon Tokki, Shinba Iron Works, TRICK STAR, IDAJ, Wako Chemical, SUZUKI World Hamamatsu, SUZUKI, NRS, AKOYA high tech, NTN, Shimizu Material, Kaneko Gear, Hamamatsu Daiichi Tosou, NIFCO, CYBERNET, Fukai MFG, Toho Tenax, Umezawa Cyukou, KYOWA, Toyo Sokki, Nicole Marketing, NMB hanbai, RAYS, Maruichi, Goto Riken, Nakayama Seiki, Nissin Kogyo, TMC, Atsumi Kogyo, AVO/MoTeC Japan, OMRON, cyan, Tyco Electronics Japan, Sumitomo Wiring Systems, R's Racing Service, Asahi Kasei Construction Materials, Syowa Aircraft, Fujita, SolidWorks, MISUMI, Quick Hamana, Shizuoka University Faculty of Engineering Center for Creative Engineers, Shizuoka University, takayanagi, Hamamatsu Active Machine Industry Organization, Kobayashi Industrial, Sakurai, Kunimoto Industry, Hamani Kasei, FEC chain, Kozu seisakusho



46 Niigata University

● Members

[CP] Shunsuke Ohya [FA] Takeo Tamura [FA] Takuji Haneda [MBR] Daiki Takahashi, Yoshiki Maeda, Riku Kagaya, takumi shimizu, Sato Kazuhito, Takeru Kimura, Ryo yamanouchi, Yuki Yoshida, Kaiki Miyakawa, Koumei Kobayashi, Yuta Kasahara, Ryoma Suzuki, Mei Masutani, Kazuki Yamaga, Ryo mukainakano, Kazuki Ichikawa, hayato honda, Yuki Obara, Narumi Asakawa, Tasaki Katsuhiko, Yuta Hojo, Kazunori Yahata

● Car Features and Team Aspirations

The concept of our car NU-17 is "Reliability". We have solved some problems of NU-16. Our goals are completing the all events and better order than 20th.

● Team sponsors

SUZUKI, NIIGATA LOADING SYSTEMS, NISSIN KOGYO, SUMITOMO RUBBER INDUSTRIES, NTN, WAKO'S, MISUMI, RACING SERVICE Watanabe, F.C.C., SolidWorks Japan, AVO/MoTeC Japan, KUWAHARA BIKEWORKS JAPAN, KOHARA GEAR INDUSTRY, TAKAHASHI Machinery, Shin Nippon Feather Core, SHOWA DENKO, BLENNY, Altechno, KINOKUNI Enterprise, Sakamoto-engineering, Works Bell, Nikkei Niigata, MARUTO HASEGAWA KOSAKUJO, YAMAWA MFG., WATANABE Industrial, The Dow Chemical, RAC, S.T-Link, NANBA Seisakujo, NIPPON TALC, Tabata Radiator, TOP KOGYO, KUJIMA, SUNAYAMA SEISAKUSYO, SUNTECH, VSN, KYOSEI INTERNATIONAL, HUEKI WELDING, WEST RACING CARS, Tec Nagasawa, KITACO, Daines, KURIYAMA, The Furukawa Battery, ISIKAWA INK, Kyoei Sangyo, KANEKO Commercial Establishment, Cool Nuts, MG Corporation, OSG, KYOWA KOGYO, Naniwa iron works, DAIDO KOGYO, FUKAI Seisakujo, NIFCO, SUMITOMO DENSO, Altair Engineering, Sunright, TAKATA, HONDA YATABE, IRS, HARDLOCK Industry, Shindo, Okajima Pipe, Iigus, THK, OZ Japan, Nikkei Niigata, Kobayashi Seisakusho, Speed Park Niigata, Nihonkai Maze Circuit, Department of Mechanical and Production Engineering Niigata University, Alumni association of Niigata University

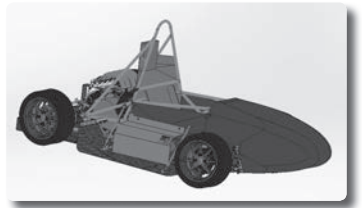

47 Okayama University

● Members

[CP] Saki Kotani [FA] Nobuyuki Kawahara [FA] Yoshihiko Tamura [FA] Hiroyuki Hiraoka [MBR] Nobuyoshi Genba, Keitaro Nakata, Akira Okumo, Koudai Nanba, Kazuma Okamoto, Takuya Hirai, Toshiki Kawai, Tsuyoshi Fukuchi, Akihiro Kawashima, Yutaka Hiruma, Yuka Takenaka, Yuto Higashide, Daiki Mitake, Kohe Miyake, Yu Miyazaki, Tsubasa Uehara, Masataka Tsuru, Koichiro Ikemizu

● Car Features and Team Aspirations

● Team sponsors

Uchiyama manufacturing, OKAYAMA International Circuit, Kawasaki Heavy Industries, RAC, IDAJ, Gamma Technologies, antlion, ALTAIR ENGINEERING, igus, Ishihara Radiator, AVO / MoTeC JAPAN, NSK, NTN, F.C.C., FC Design, OSG, OKAYAMA KAGISEN, Okudaira-pipe-kogyo, OptimumG, Lab-CAST, KYOWA KOGYO, KURASHIKI KAKO, K-MAX SPEED, Kobe Steel, SANPOH ENGINEERING, Sanyo Resin Industries, JX Nippon Oil & Energy, SHINSEI SANGYO, SUZUKI MOTOR, Sumitomo Wiring Systems, SOLIDWORKS Japan, DAIHATSU MOTOR, TAKE OFF, TOHNICHI Mfg., Tokyo Sokki Kenkyujo, TOYO CORK MANUFACTURING, TODA RACING, NAKASHIMA PROPELLER, NISSIN KIKAI, NISSIN KOGYO, HIRANO, VI-grade Japan, Fukushima Kako, FUJIX, plus-myu, PLOT, MIKUNI INDUSTRY, MISUMI, Mitsui Engineering & Shipbuilding, Mitsubishi Motors, MOTUL, YASDA PRECISION TOOLS, LIGHT DENGYO, RIDE ON OKAYAMA, La Strada, RAYS, ROCK PAINT, Works Bell, Okayama University Faculty of Engineering, Okayama University Engineering Work Center

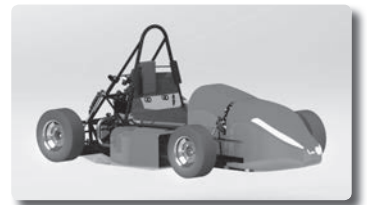

48 Kurume Institute of Technology

● Members

[CP] Atsushi Naito [FA] Daisuke Azuma [FA] Ikeda Shigeru [FA] Kouichi Kajiyama [MBR] Yuki Adachi, Yuki Oga, Takahiro Kihara, Akinari Sato, Fredericsaito Bekert, Taiki Miyamoto, Hiroyuki Yoko, Naoya Mada, Go Fukukawa, Ryosuke Hirakawa, Yuki Hattori, Takumi Nakai, Yusuke Kumegata, Takuma Ono, Tuyaoshi Okuda, Kiyoshi Tanaka, Yoshino Sato, Hiroto Tunashima, Yuto Tanaka

● Car Features and Team Aspirations

Our car powered by turbo in the single-cylinder engine and controled boost. This year's competition, We aiming all Examination Accomplishment and the lightest weight award, Acceleration First place.

● Team sponsors

SUZUKI, Dassault Systemes, NTN, HKS, Honda TechnoFort, General Engineering, takaki iron, Nishijima Sheet metal industry, VSN, WAKO'S, B-FACTORY, YASUNAGA, F.C.C., SUMITOMO Wiring Systems, MISUMI, Miyako, Fukai Factory, TOKYO R&D, RS Watanabe, Fuchigami Weld, Tsurusaki Factory, Japanese Hotel Tatamiya, Kurume driving school, WEST RACING CARS, Kamitsu car rental office, KIT alumni meeting, KIT-FP OB Association, KIT Manufacturing Center, KIT Processing Project



49 Seikei University

● Members

[CP] Kouta Mochinaga [FA] Junji Horiguchi [MBR] Youtarou Tsuchiya, Ohno Naoto, Okada Masatsugu, Ohba Seiya, Suzuki Nozomi, Suzuki Hayate, Tsukamoto Syouta, Nomura Kouki, Nomura Takuya, Fukada Kahori, Hori Hayato, Tsukamoto Kenzi, Ogino Hideki, Tamura Tomoya, Hashimoto Yukinori

● Car Features and Team Aspirations

In SFT 11, one word called "Gaku" was put in the concept. We design and production with pursuing three performances, motility, operability, maintenance. We will aim for the achievement+ of all events we could not fulfill last year. Thank you for your support.

● Team sponsors

AZUMA STEEL PIPE, ALTAIR ENGINEERING, HKS, NTN, F.C.C., KYOWA KOGYO, Kondo Mill, Kobayashi Kikou, SUZUKI, Sumitomo Wiring System, Dow Kakoh, THK, Tohoku Radiator, Niitaka Gear, Nissin Kogyo, Nippa Kinzoku, Nifco, BG Japan, Fukai Mill, Fuji Seimitsu, FUTURE TECHNOLOGY, Honda Motor, MISUMI Group, Motobamu, Yamanakagokin, Yutaka Giken, Seikei University department of science and engeneering class reunion

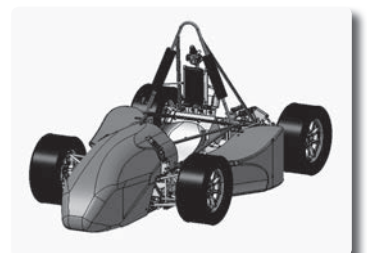

Team Information (Members and Sponsors)

50 Setsunan University

● Members

[CP] Yusuke Ima [FA] Masaaki Horie [FA] Kuwata Toshiki [FA] Hashimoto Masaharu [MBR] Yusuke Shibata, Yuto Kojima, Kensuke Kato, Tomoki Asada, Honoka Miyauchi, Wataru Ueno, Hiroki Morita, Suzuka Kimura, Shota Yamanaka, Minako Shimohira, Masaki Douno

● Car Features and Team Aspirations

This fiscal year I have been engaged in activities with the goal of completing all kinds of events for the second consecutive year. For that purpose, we reviewed each part from first in designing and processing, and tried to understand and improve the motor performance of the machine. We will achieve the target and aim for the top prize.

● Team sponsors

SUZUKI, NTN, Solid Works Japan, WAKO CHEMICAL, TAKATA, F.C.C., VSN, NISSIN, TOYODENSO, General Engineering, Fuji Seimitsu, DENSO, JBM, X.A.M JAPAN, Kinokuni PERFORMANCE PRODUCTS, NHK Spring, FUKAI Workshop, KOMATU YUKINAGA Store, PLOT, RECO SHUTER, Rays, Setsunan University Booster Club, KISETSUKAI

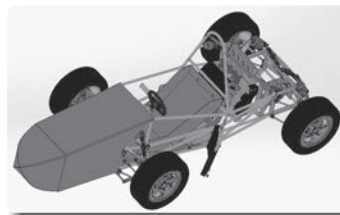

51 Hokkaido University/Hokkaido University of Science

● Members

[CP] Kazuya Ito [FA] Hideyuki Ogawa [FA] Takemi Chikahisa [FA] Yutaka Tabe [MBR] Takuya Kainuma, Naoki Iguchi, Ryoma Kinoshita, Takuya Imai, Ryohei Kukutsu, Seiji Saito, Takuma Matsuo, Hisayoshi Sasaki, Miu Kanno, Tomu Hirasawa, Bunta Kouda, Yuya Watanabe, Tomoya Tsukiyama, Yuta Tamura, Yusuke Ishimatsu, Akihide Takano, Haruki Morinaka, Shusei Ueda

● Car Features and Team Aspirations

We think this year as important year to recover our position. This year Students of Hokkaido University of Science have belonged to our team. We aim to get good results through speedy creating and drastic test run. Furthermore, We frequently upload our HP, so please access it.

● Team sponsors

Honda Motor, AIS Hokkaido, TBK, Hokuai Vets, Shinba Iron Works, NTN, DAIHEN Welding and Mechatronics System, IDAJ, SOLIDWORKS Japan, SoftwareCradle, ALTAIR ENGINEERING, Vi-grade Japan, MathWorks Japan, Minebea, ESKAuto, M-Cubic, TOYOTA Rent a Car SAPPORO, BUG DMG MORI, MSF, TaihoKogyo, Lasermex Hokkaido, Technoil Japon, Sankyo Radiator, Taihriyo Ferry, New Chitose Motorland, ZF, MISUMI, Nippon LightMetal, GAINAR, TOKYO R&D, Sugimoto Metal Manufacturing, ASPECT, F.C.C., HOKKAIDO SHEARING, Fuji Seimitsu, KYOWA KOGYO, Sarabetsu Village, NISSIN KOGYO, Fukai MFG, INGING, CUSCO, Sapporo Solid Data Service, Tyco Electronics Japan, ASSIST, Yutaka Giken, Ishikawa Metal Manufacturing, DENSO, Tokyo Hatsujyo Manufacturing, Works Bell, M-LINE, RAC, Soda's Factory, ImpexSapporo, TECHWORKS, TRIANGLE, TOYOTA Corolla Sapporo, La Foret Institute, Higuchi, ROBTEX, Kanemichi Camera, Ishihara Metal Industry, NHK spring, Hokkaido Polytechnic College, Hokkaido University Faculty of engineering Department of Mechanical and Intelligent System Engineering, FHT OB

NO DATA

52 Nihon University College of science and technology

● Members

[CP] Yuji Shibata [FA] Michihiko Hoshino [MBR] Sota Nakamura, Toshiki Kimura, Kazuya Okada, Ken Yamanoi, Tomohiro Tanaka, Takumi Numano, Syota Yamamoto, yoshihiro shirasu, Tatsuhiko Isikawa, Akiyoshi Nakamura, Sachio Mochizuki, Ryu Narusawa, Takahiro Baba, Shotaro Otani, Mutoh Mitsuru, Ryoga Ochiai, Ryo Ochiai, Tomohiro Naruse, Kazuya Okamura, Yuki Ueda, Izuki Naito, Tsubasa Ikenobe, Tomoki Takahashi, Yuki Tsushima, Yuji Okamura, ryoha ito, Koya Tatsuta, Hiroki Kikukawa

● Car Features and Team Aspirations

"Light and Response" is the concept of NU-CST/015. And we designed parts in setting them low center of gravity. This is the year that our car

receives the checkered flag.

● Team sponsors

Rsangyomaki, SPS UNBRAKO, KINOKUNI Enterprise, KOTORA, Kohara Gear Industry, koukendenka, sankyo material, SANWA PLATING INDUSTRY INCORPORATED COMPANY, SHIGEMATSU WORKS, JONAN-KEY, SUZUKI, General Engineering, Software Cradle, SolidWorks Japan, TAIYO PIPE BENDER, TAIYO OIL, Daido Metal, DECK, TOYODENSO, Nagase ChemteX, NISSAN, MECST, NHK SPRING, NEWREGISTON, Fukai MFG, FUTURE TECHNOLOGY, plus μ , PLOT, HONDA, Mitsubishi Materials, MiSUMI, Minebea, YAMAHA, RACING SERVICE Watanabe, WAKO CHEMICAL, braille BATTERY JAPAN., F.C.C., NOK, NTN, NTT DATA ENGINEERING SYSTEMS, SEVENTH NIGHT, VSN



53 Meisei University

● Members

[CP] Ogura Youhei [FA] Takahito Kawahara [FA] Nobuaki Kamei [FA] Masashi Koyama [MBR] Syunsuke Adachi, Kzato Osanai, Kousuke Sasaki, Yudai Dewa, Satoshi Naka, Hirofumi Ishiguro, Tatsunobu Yamada, Seiya Kamiyama, Hikaru Usunaga, Mai Harada, Masaki Izumi, Yutarou Ara, Sakura Koyamastu, Tomoki Negishi

● Car Features and Team Aspirations

My resolution is to completing dynamic events. Our vehicle's features are transverse mono shock absorber system: We have improved this system since 2011. This system has advantages for weight and component count.

● Team sponsors

Earth Engineering, Altechno, Ishikawaseisakusyo, West Racing Cars, Okamura Taiya, Kozimaseisakuzyo, Sakanishi Seiki, Sasakikogyo, G tech, Dassault Systemes, DriverstandFuchu2rinkan, Fukai MFG, Blenny Giken, Honda Motor, F.C.C., NTN, RAC, RAYZ, Woodfamily, YOKOHAMA, Ikusei-kai, Meisei University Alumni Association, Meisei University Mechanical Engineering



54 Aichi Institute of Technology

● Members

[CP] Shinya Aoki [FA] Toshio Fujimura [MBR] Kakeru Mizutani, Akira Jindo, Takahiro Hirata, Daiki Aoyama, Tomohide Ide, Naofumi Taki, Yuya Ota, Asuka Shimizu, Ruka Funazaki

● Car Features and Team Aspirations

Our team will eliminate the 500 cc 2 cylinder engine from this fiscal year and will challenge the competition with a machine equipped with a 450 cc single cylinder engine. It is a machine that takes advantage of the considerable weight saving of the power train and aims for a good result in the first year of single cylinder engine.

● Team sponsors

YAMAHA MOTOR CORPPRATION, FT Techno, MAEDA SHELL SERVICE/GIKEN, AI Tech, Maruhiro steel material, OSG, Sumitomo writing system, SUMITOMORUBBER INDUSTRIES, enable, toyokoshuha, SARD, FCC, NTN, O.Z Japan, Watanabe kougyou, Okajima pipe, ACCEL, nissin kogyo, nakada Craft, Solid Works Japan, THK, KYOWA, Mitsutoyo, sasano, AIT challenge project, suzuiro, TAKATA, Umeno Industry, D.I.D, Sunstar After Market Division, ACTIVE

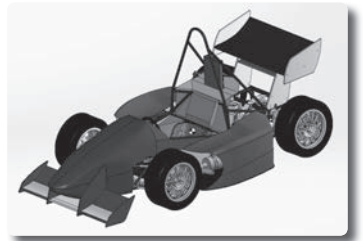

55 Honda Technical College Kanto

● Members

[CP] Shun Ito [FA] Mizuki Takenaka [MBR] Takumi Iijima, Akira Okawara, Takumi Ueki, Ryo Manabe, Tatsuki Fjisaki, HIroyuki Matsumoto, Daisuke Nakajima, Kenta Iinuma, Kohei Hattori, Takumi Tohata, Rikuo Tsuji, Hiroki Tai, Leon Sato, Ryo Watanabe, Hirofumi Kakehata, Atsuki Fujitani, Katuaki Yamaguchi, Taiki Irie, Souichi Ikeya, Akiyasu Kokubo, Sara Osone, Kanako Ishii, Mana Fujita, Masashi Kawahara, Kiyomitu Nakamura

● Car Features and Team Aspirations

This year, we have designed and manufactured our machine under the concept "FIT", setting our goal to improve the driving ability. We have also mounted a new engine which has solved the problem we had on our

ignition system last year. We are aiming for the top record in this tournament.

● Team sponsors

Idemitsu Kosan Co., Ltd, KYOWA KOGYO Co, SANNO TEC Co., Ltd, Sumitomo Wiring Systems, Ltd, Nissin Kogyo Co., Ltd, Formuland RA HANNO Co., Ltd, FARO Technologies Inc Co, Honda Motor Co., Ltd, Yachiyo Industry Co., Ltd, MISUMI Group Inc., Honda Techno Fort Co., Ltd.



56 National Tsing Hua University

● Members

[CP] WU, CHUNG-HSIN [FA] Lin, Chao An [MBR] Lin, Zhan Jun, Chen, Yu Ting, Kao, Chu Yu, Poe, Williams, Hsie, Sheng Han, Li, Yuan Chun, Liu, Yu Wei, Tsai, Tsung Ting, Lin, Yi Hsiang, Chen, Po Hsun, Lin, Zhi Da, Hsu, Cheng Huan, Chen, Sian Ying, Wu, Jie Ying, Liu, Yi Lin, Wang, Shao Yu, Hu, Ming Hsuan, Wu, Da Shan, Chang, Chun Hao, Lin, Wei Ting, Ma, Jie Yun, Luo, You Wen, Tsai, Nian Hsuan, Chen, Chun Ju, Chien, Cheng Chun, Cheng, Hsiang Ru, Chen, Ting Sheng Lin, Zhan Jun, Chen, Yu Ting, Kao, Chu Yu, Poe, Williams, Hsie, Sheng Han, Li, Yuan Chun, Liu, Yu Wei, Tsai, Tsung Ting, Lin, Yi Hsiang, Chen, Po Hsun, Lin, Zhi Da, Hsu, Cheng Huan, Chen, Sian Ying, Wu, Jie Ying, Liu, Yi Lin, Wang, Shao Yu, Hu, Ming Hsuan, Wu, Da Shan, Chang, Chun Hao, Lin, Wei Ting, Ma, Jie Yun, Luo, You Wen, Tsai, Nian Hsuan, Chen, Chun Ju, Chien, Cheng Chun, Cheng, Hsiang Ru, Chen, Ting Sheng

● Car Features and Team Aspirations

This year is the second year we attend to SFJ event. Comparing with last year car, 2017 edition had lots of improvement. In addition, the most significant improvement is weight-loss, we almost loss 30% weight by using carbon fiber, aluminum alloy and titanium instead of steel. Moreover, as result of the reducing of wheelbase and redesigned Ackerman geometry, 2017 car can have much more accurate steering directivity.

● Team sponsors

KYMCO, WEL & CUT Co, T&K Enterprise Co, TAIWAY, FCC(TAIWAN) Co., RacingBros international Inc., SGT瀚和賽車設計有限公司, Wah Lee Industrial Corp., aRacer SpeedTek, TRIONES, KS POWER 馳騰國際貿易有限公司, EIZAWA R&D Industrial Co., CFPHD 銘德實業有限公司, ENERGIUMEN 啟豐科技有限公司, Founder Land Co, Tokai, Reduce Carbon Energy Develop Co., 亞森烤漆, Red Wood Enterprise Co., DS SolidWorks Corp., 名將技研, MSC Software Taiwan, 1Mail 衣美兒



57 Tottori University

● Members

[CP] Yuta Ochiai [FA] Naoki Kawamura [FA] Takashi Muramatsu [MBR] Yusuke Kubota, Toshiki Ohdan, Shoya Ueda, Mahiro Yoshii, Makabe Kei, Jumpei Yamane, Tomohiro Itou, Moeto Oshima, Hidenori Okamoto, Asami Doi, Tomoya Naknishi

● Car Features and Team Aspirations

This year's machine aimed at a fighting machine by "optimization" various places by making full use of the know-how that has been done. We will do our best as a team with all members finishing the goal and completing the overall ranking of 30th and more.

● Team sponsors

Kawasaki Heavy Industries, F.C.C, NTN, NISSIN Industries, SOLIDWORKS Japan, THK, MISUMI, TIRESHOP T2, Rin Parts, M4H, HEARTILY, KOSEI ALUMINUM, WAKO CHEMICAL, KYOWA Industries, monocolle, Tottori University Manufacturing Education Practice Center, SEKI Manufacturing Laboratory, YAMANE Equipment, Bonito plus flying fish soap, TOHAKU Gas Industry

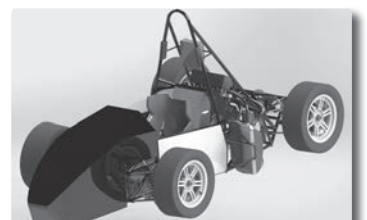

Team Information (Members and Sponsors)

58 Honda Technical college Kansai

● Members

[CP] Daichi Terashima [FA] Yasuyuki Kimura [FA] Kunihiko Jintsu [MBR] Wataru Isobe, Seiryu Eguchi, Ryunosuke Onishi, Toshiki Okamoto, Yugo Kanda, Yudai Kitagawa, Tepei Kuroda, Ryo Goya, Hironori Koshiishi, Tomohisa Kondo, Ryota Shigaki, Ikuo Suganuma, Tatsuya Sunda, Akira Takano, Ken Takahashi, Atsushi Takiuchi, Syuzo Tanaka, Tomohiro Tamura, Masaya Chiba, Naoki Nakatsuji, Hiroto Nokami, Masahiko Furuta, Kodai Maegawa, Yoshikazu Morishita, Ryohei Yamazaki, Kouki Yamada, Motochika Yamada

● Car Features and Team Aspirations

The concept of our team is "EASY FASTURN" We reduced the weight of the machine and lowered the center of gravity target user Beginner

racer to realize fast speed. The goal of the team is to aim for dynamic event completion, skit pad 5seconds, jump up prize.

● Team sponsors

Altea Engineering, Fukai Manufacturing, F.C.C, Hirrex Corpolation, Honda Techno Fort, NTN, Nissin Industry, Oires Industry, Kawakami Manufacturing, Sanno Tec

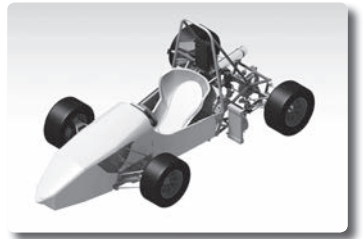

59 Sojo University

● Members

[CP] Katsuya Matsushita [FA] Kouji uchida [FA] Yukinori Ikuta [MBR] Mikihiro Masuda, Kohei Ito, Yuya Okubo, Hikaru Tsunoda, Kazuki Sakamoto, Nozomi Morioka, Ryohei Toshikawa, Tetsuro Minami, Shogo Morita, Keiichiro Yamashita, Daichi Yoshidome, Junpei Mitsuda, Yuma Akahoshi, Hiroto Nakayama, Shinosuke Takahashi

● Car Features and Team Aspirations

Our team, named SPF-14 determined a concept of promoting speed and improving drivability of our car, about the same as a last year. We tried to improve an accelerating, traveling, turning, and braking performance that a driver wants. Also, we tried to participate in an endurance event that we could not do because we did not fulfill a requirement to enter it.

● Team sponsors

Honda Motor, solid works, RAYS, VSN, KYOWA KOGYO, F.C.C, NTN, GS Yuasa Corporation, FUJI LIGHT METAL, Tobata seisakusyo, SAKAI BODY, Takata, Times Car Rental, Kumamoto IB sangyou, Honda Techno Fort, FUKAI MFG, General Engineering, Minamikakou, KINOKUNI Enterprise, CYBERNET SYSTEMS, Nissin Kogyo, Ishihara Radiator Kogyosyo, Sumitomo Wiring Systems, IKEMATU KIKOU, MISUMI,

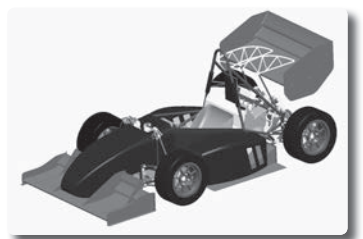

60 The University of Kitakyushu

● Members

[CP] Takehito Nishida [FA] Sadami Yoshiyama [FA] Hiroki Cho [MBR] Kazuki Uchiyama, Takashi Akamatsu, Keisuke Matsuo, Yusuke Awata, Naoya Inoshita, Hiroki Asano, Takuto Araki, Tomoya Ueda, Takehiro Ando, Mitsutoshi Yaeshima, Masaki Hokamoto, Yu Fujita, Ryota Fukunaga, Ren Shodai, Takahiro Isomoto, Atsushi Yamaji, Tomohiro Chuganji, Masatora Yamaguchi, Kazuki Sumi, Kazuki Watanabe, Tomoki Miyajima

● Car Features and Team Aspirations

Our concept is "Pursue the speed" Our car are designed to improvement driverbility and car performance. We aim for all events.

● Team sponsors

Kawasaki Heavy Industries, F.C.C, SolidWorks Japan, SUMITOMO RUBBER INDUSTRIES, Software Cradle, THK, TOYOTA Rent a Car Fukuoka Kyoritsudaimae, WEST RACING CARS, KINOKUNI Enterprise, digitalstage, THE DOW CHEMICAL, KYOWA KOGYO, FUKAI MFG, NTN, K's moto, MISUMI, WAKO CHEMICAL, ENUMA CHAIN MFG, NISSIN KOGYO, OZ Japan, Takata, Ishihara Radiator Works, Altair Engineering, TANAC, NICOLE RACING JAPAN, Brabio, Sumitomo Wiring Systems, Kitakyusyu Foundation for the Advancement of Industry Science and Technology, The University of Kitakyusyu Faculty of Environmental Engineering, The University of Kitakyusyu Faculty of Environmental Engineering Dept. of Mechanical Systems Engineering, The University of Kitakyusyu Faculty of Environmental Engineering Processing center, The University of Kitakyushu Alumni Association

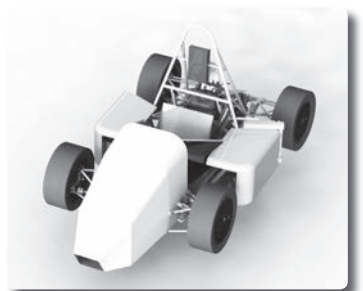

61 Kyushu University

● Members

[CP] Masashi Ikemi [FA] Osamu Moriue [MBR] Yuto Kajitani, Yudai Kato, Miwa Sueda, Takafumi Ota

● Car Features and Team Aspirations

Our team participate in this competition for the second time. Many parts are lighter than the last year's, so our car of this year is stylish. Our goal is all events completed.

● Team sponsors

AsahiKASEI, ATA! Design, Altair, igus, INTREPID JAPAN, West Racing Cars, NOK, NTN, FRP-KOUDA, FCC, KOTORA, KEIHIN, SHIGEMATSU, DENSO, FUKAI, MISUMI, MOBITEC, UACJ, YOSHIDA SANSO, La Strada, KYO-EI, KYOWA, KHK, DUNLOP, Sumitomo Wiring Systems, SOLIDWORKS, THK, D-GARAGE, MOTUL, NISIN, NSK, NHK SPRING, Fuji Seimitsu, HONDA, WORKS BELL, AUTOBACS SEVEN

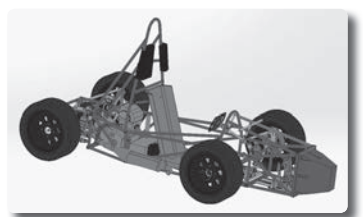

62 Chiba Institute of Technology

● Members

[CP] Kousuke Kawai [FA] Shigeru Murakoshi [MBR] Takuto Ito, Nobuyuki Sohmiya, Tatsuya Kaito, Junichi Wada, Yuma Takai, Tomohiro Tanaka, Honoka Atsuchi, Yudai Uesugi, Daiki Kamagata, Yuki Takada, Masataka Izaki, Shiori Ito, Chihiro Kai, Naoki Kitakaze, Tomorou Yazawa, Masayuki Nakayama, Ryota Kezuka, Yuto Suzuki, Mamoru Wada, Norihisa Wada, Kotaro Kawamura

● Car Features and Team Aspirations

The design concept of this car is "Easy for Drive". So the biggest responsibility of each team members is achieving designs for controllable and responsible car. We keep using CVT as we did last year. Also we use FEA more to optimize design and its material for weight saving. The

goal for this year is having more test to find out the errors and finishing the endurance event in competition.

● Team sponsors

NTN, TET'S RV CENTER, VSN

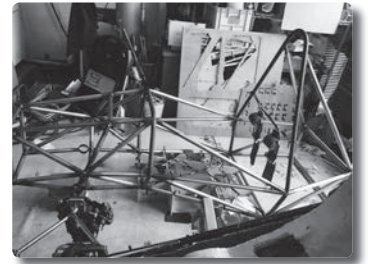

63 Kindai University

● Members

[CP] Tadamasa Fukuoka [FA] Shinji Kajiwara [FA] Atsutoshi Ikeda [MBR] Arisa Kono, Takashi Eguchi, Tasuku Tamaoka, Yuji Yoneshima, Yuta Iriguchi, Yota Uranishi, Dai Terakado, Yu Moriya, Hiroyo Watanabe, Sota Nakahara, Motoki Takebe, Ryoga Murakami, Taichi Fukumoto, Takafumi Shibuya

● Car Features and Team Aspirations

This fiscal year we installed a 2-cylinder 650 cc engine and made a full model change. In addition, we focused on aerodynamic development, we installed variable wing and side wing. We do not compromise on vehicle development, we aim to advance to the top.

● Team sponsors

Ishizue, NTN, AVO MoTeC Japn, amon, Kawasaki, Kinokuni Enterprise, Kondo Science Co., Ltd, Sports Land Ikoma, Sumitomo Wiring Systems, Solid Works Japan, Daito Corporation, Daito Radiator, DI.D, Toyo Electric Co., Ltd., Nisshin, Nifco, Nippori kako, Fukai, Misumi, Miyake kogyo, Meihan Sports Land, Yamato kogyo, Wako Chemica

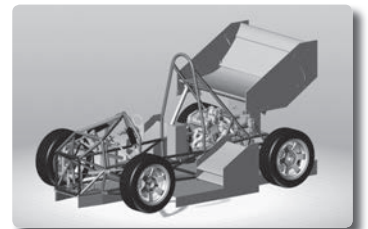

64 Sinhgad Technical Education Society

● Members

[CP] Asane Deoraj Nitin [FA] Dr. Amar P. Pandhare [MBR] Apoorva Nagarkar, Kerman Cooper, Rudresh Lonkar, Sahil Shah, Pranav Darade, Sanmitra Salunke, Rishabh Dara, Nikunj Choudhari, Shounak Deo, Piyush Biraje, Karan Chithore, Sumit Goski, Shumoil Ansari, Tushar Fariya, Rohan Nimbalkar, Himanshu Patil, Yash Gugaliya, Samihan Kulkarni, Neeraj Khandekar, Pathik Bokade, Gaurav Chide, Parth Jade, Vikas Patil, Akash Solanki, Jatan Shah, Suyash Basate, Saharsh Chandak, Dhanashri Gadekar, Aaditya Gunjal, Shahrukh Parwez, Aniruddha Talange

● Car Features and Team Aspirations

SR17 is a basic non-aero, IC type FS Car with sound vehicle handling

and above average performance in terms of Acceleration and Efficiency. Focus is more on the safety and elegance of the Car.

The team this year aspires to complete all the dynamic events successfully and to see ourselves in the top 15 overall rankings at the end of the competition.

● Team sponsors

Wilwood, Plascore, Kakade Laser, SolidWorks, Arun 3D Labs, Euro Hose India, Hoosier, OZ Racing, Killer Jeans, Stanley, ChassisSim, OptimumG

NO DATA

65 Aoyama Gakuin University

● Members

[CP] Hiroto Asano [FA] Hiroshi Sakuta [MBR] Harasawa Taichi, Masaki Yamada, Ryoga Otaki, Masataka Yamazaki, Takuya Arima, Shoma Ujiie

● Car Features and Team Aspirations

Our team aims towards a machine where the driver can drive with confidence.

● Team sponsors

YAMAHA, PTC Japan, Altech, HORIBA, NTN, Nissin Kogyo, Quick Hanyu, TAISHO, HANEDA PIPE WORKS, CYBERNET SYSTEMS, SHIGEMATSU WORKS, miro zokei, Fine Tech, Murata, UPSHIFT, FUKAI MFG



Team Information (Members and Sponsors)

67 Kokushikan university

● Members

[CP] Chihiro Matsui [FA] Tomoaki Kodama [MBR]

● Car Features and Team Aspirations

● Team sponsors

NO DATA

68 Aso College of Automotive Engineering and Technology

● Members

[CP] Takuya Okimura [FA] sakaguchi [MBR] Seiya Isibasi, Masahiro Sawata, Takahiro Katsuragi

● Car Features and Team Aspirations

This fiscal year we introduced a new power train and optimized the frame accordingly. Last year I cried in the engine trouble during the tournament, so this year I will try to make a ridiculous vehicle making, I will aim for the tournament final ranking and all the competition finish.

● Team sponsors

Suzuki, Umeda, You One Design, Wako Chemical, Technical Factory Braines, Fukai Manufacturing Co, COB-KART, Factory Gear Foreo Hakata Store, Advantage Kyushu, a-one Circuit, Raizansennyoji, Cockpit Jounann, Chikuho Manufacturing Co, Solid Works Japan,

F.C.C, MISUMI, Honda Dream Kyushu, Sumitomo Wiring Systems

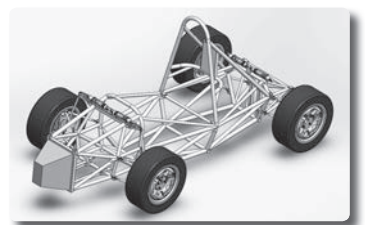

69 Shizuoka Professional College of Automobile Technology

● Members

[CP] Takuro Iwanabe [FA] Warabe Sugimoto [FA] Kazuhito Ishida [MBR] Kazuki Okada, Aoba Kurebayashi, Hiroki Yamada, Yuya Shimasa, Riku Nagata, Takumi Watanabe, Naoki Kubota, Ryo Ikeda

● Car Features and Team Aspirations

This year we challenged our first chain drive and pursued the appropriate reduction gear ratio. We will do my best for all dynamic examination finish.

● Team sponsors

SUZUKI, NTN, SOLIDWORKS, NISSIN, YUTAKA, RS TAICHI, F.C.C, KUMHO, THK, TOKUBEN, SANKIN, DAYTONA, KYOWA, UNIVANCE,

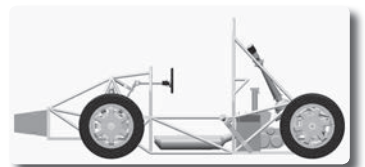

70 Southern Taiwan University of Science & Technology/Xiamen University of Technology

● Members

[CP] Huang, Shao Yu [FA] Wei-Chin Chang [MBR] Chen, Tai-You, CHEN, BO-SYUN, CHEN, ZONG-YOU

● Car Features and Team Aspirations

● Team sponsors

NO DATA

71 National Taipei University of Technology

● Members

[CP] PO-SIANG, CHANG [FA] JIA-SHIUN, CHEN [MBR] PO-SIANG, CHANG, ZONG-XUAN, WU, CHENG-TA, TSAI, KE-QUN, HSIEH, PO-HUA, WANG, MING-CHIEH, HSIEH, SYUAN-ZOU, CHOU, CHUAN-YU, YAN, YANG-CHU, HONG, CHUNG-CHIA, YANG, TZU-YI, CHUANG, ZHOU-EN, ZHENG, TING, MAI, BAI-CHEN, JIAN, CHENG-SHIAN, YANG, SHUN-WEI, HUNG, CHENG-YING, HSIEH

● Car Features and Team Aspirations

"Stable & Light" is this year new racing car's design target! We correct the suspension error, do more tests and correct before competition. "Racing for Dreams", our team's spirit. The past two years failure did not defeated us, we will bring our new racing car to Formula Student Japan and get

the honor, Top 30 overall!

● Team sponsors

SANYANG Motor, EPOLAB Chemical Industry, Formosa Taffeta, DNM Suspension Technology, RCE Power, Triones, FounderLand, Red Line Synthetic Oil, FCC Taiwan

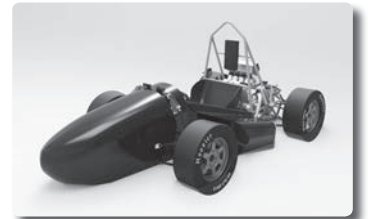

72 Hiroshima Institute of Technology

● Members

[CP] Shota Hiroi [FA] Hisanori Nakane [FA] Kenji Yoshida [MBR] Masakazu Hirota, Hiroki Onishi, Ikumi Yamamoto, Hisashi Yasunaga, Makoto Hiyake, Ki Keigo, Arata Yamada, Mashiro Takaki, Fuki Umayahara, Shiki Yoshimoto, Masatoshi Honda, Ryoha Huzioka

● Car Features and Team Aspirations

For our team, this year is the first year of the three year's program to win the competition. All team members are studying and working hard to grow up to be good engineer. Our vehicle of this year is developed focusing on the Skid pad event. The torsion bar suspension system is introduced to achieve the center of gravity lower. We are working very hard to get Completing all of the events!

● Team sponsors

Hiroshima Institute of Technology, igus, FC Design, UE KANAMONO, NTN, Kawasaki Heavy Industries, Sportsland TAMADA, SOLIDWORKS Japan, VSN, YAMABIKO, ABEBE dining room, LEAF GARDEN

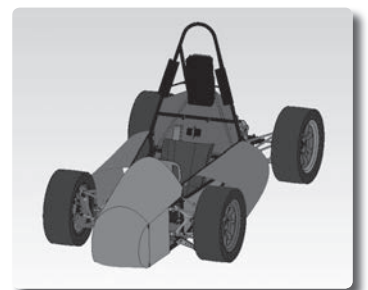

73 University of Toyama

● Members

[CP] Akinori Yamada [FA] Tetsuo Aida [MBR] Yoshinobu Miyabe, Yoshihiro Netsu, Yasuharu hobo, Ruiho Ikeda, Rio Ohashi, Yusuke Imai, Ryo Hiramiya, Hiroshi Kita, Takumi Hashigaya, Tetsuya Higashino, Ryota Tsuchida, Yuji Mori, Yoshinao Takahashi, Ryota Asano, Taira Yuge, Mitsumasa Teramoto, Mika Ashikawa, Katuya Yatukura, Seiryu Matuda, Tatuki Atumi, yudai Takado, Ryosuke Yokoyama

● Car Features and Team Aspirations

Last year We achieved the first car inspection pass of the team, but dynamic examination failed to leave what we expected. "TF-02" which made its weight a lot lighter due to its regret. We will do our best for end the endurance with this machine.

● Team sponsors

Honda, Solidworks-Japan, TAN-EI-SYA, DENSO, MISUMI, Fukai MFG, Okajima Pipe, NTN, NACHI-FUJIKOSHI, FC design, IOX-AROSA, Ishigane Seiki, F.C.C., Taisei, SKY, FINECS, TOYAMA SHIMBUN

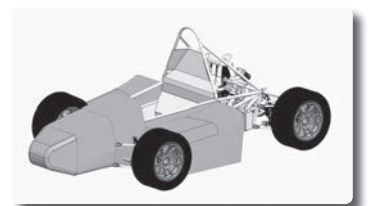

75 Tokyo Technical College Setagaya Campus

● Members

[CP] Yoshikazu Takahashi [FA] Motohiro Matsuda [FA] Keiichi Asai [FA] Takeshi Sibuya [FA] Akira Takeishi [FA] Makoto Tane [MBR] Hosen Oh, Ryota Shimizu, Go Fujimori, Tetsuto Hiyaoka, Syungo Yamazaki, Daiki Sato, Yuki Fukushima, Tomohiko Miyajima, Yuki Aoyama, Motoki Seida, Hiroyuki Saishu, Atsuhiko Wada, Shoichiro Nakatani, Kai Makabe, Oba Shoki, Kouki Kamizuru, Yosefu Shiraiishi, Motoki Takizawa, Masato Hada, Ryuichi Marutama, Hiroshi Minakata, Naoki Ohtsubo, Win Kanno, Kouhei Sahara, Daiki Mutou, Waseto Watanabe, Keichiro Yutani

● Car Features and Team Aspirations

The concept of the vehicle in 2017 is "easy-to-handle vehicles." Easy to handle, we are making cars considering easy-to-drive vehicles, easy-to-

maintain vehicles, etc. This year we are trying hard to complete the entire game I will.

● Team sponsors

Tokyo Subaru, Tokyo Mazda sales, Eye Tex, Tokyo Toyopet, Isuzu Tokyo metropolitan area, Nets Toyota Yokohama, Miyazono import car sales, Yokohama Hino Motors



Team Information (Members and Sponsors)

76 Sebelas Maret University

● Members

[CP] Bhre Wangsa Lenggana [FA] Sukmaji Indro Cahyono [FA] Ubaidillah, S.T., M. Sc., Ph.D. [FA] Agung Tri Wijayanta [MBR] Aji Masa'id, Fahmi Imanullah, Adhe Aji Wirawan, Murnanda Zaesy Saputra, Julian Wisnu Wirawan, Alan Firdaus, Bagus Aulia Saputra, Gabriel Setyohandoko, Arga Ahmadi Nugraha, Brillian Aqif Naufal, Dicky Agus Triono

● Car Features and Team Aspirations

This car uses an electrical shifter and failure mode (manual) shifter. It also uses a fuel adjuster to set the fuel debit, creating a convenient combustion. The air supply of this car uses a plenum chamber because it has a restriction in the intake manifold. We are aiming to acquire much

knowledge from this competition and looking forward to achieve at least one title.

● Team sponsors

Indonesia Steel Tube Works (ISTW), Hoosier Tire, Keizer, Prorock Engineering



77 Hubei University Of Automotive Technology

● Members

[CP] Jia Minghao [FA] Shi Zhen [MBR] Lin Chenli, Bai Kai, Wang Keke, Zhao Xinxin, Liu Qiang, Zhao Shiyuan, Wang Ruifeng, Ye Qinghua, Chen Zhen, Tao Li, Zhou Haoyin, Yue libi, Bai Yu, Zhang Zinan, Li Chang, Chen Xiaoli, Guo Yuqi, Chen Xiaowei, Liu Ningyuan, Cai Wei

● Car Features and Team Aspirations

1.DRS, pneumatic shift, adjustable parameters, intelligent operation; 2. Dongfeng HUAT racing team was established in March 2011. Has been adhering to the "strive to the upper reaches, create the future" purposes. Dongfeng HUAT fleet of oil vehicles have participated in the Fifth China and a German race, a Japanese race. For four consecutive years won the domestic top five, two championship.

● Team sponsors

Dongfeng Trucks



78 Graz Technical University

● Members

[CP] Stefan Rameseder [FA] Johannes Lassacher [MBR] Stefan Peter Jurecs

● Car Features and Team Aspirations

● Team sponsors

NO DATA

79 The University of Tokyo

● Members

[CP] Daichi Okazaki [FA] Kohei Kusaka [MBR] Toshiki Maeda, Asahi Ueda, Shungo Azuma, Yutaro Kofuji, Yoshihito Murakami, Takuya Miyachi, Kei Kato, Takahiro Inokuchi

● Car Features and Team Aspirations

This year's UTFF16 is our third machine with a compact 10-inch wheel, V-twin engine, shaft-driven package. With a completely new team consisting mainly of first and second year students, we will do our best to bring our machine to the finish line.

● Team sponsors

RK JAPAN, IDAJ, IHI, ALTECHNO, Ishikawa Special Express Binding, INOUE BORING, NTN, F.C.C., NOK, ENGINEER, Ofa, Kato Cam Giken, KANEKO GEAR, KINOKUNI Enterprise, KYOWA KOGYO, GRAZ, KOBE STEEL, KOTORA, CYBERNET SYSTEMS, Sankin, Sankei Industry, Sankyo Seisakusho, Showa Aircraft Industry, Silicon Sensing Systems Japan, SUZUKI MOTOR, ZF Japan, The Dow Chemical Company, Diamond Engineering, Takata, CHINO, THK, DKK-Toa, TOKO, NIPPON STEEL & SUMIKIN CHEMICAL, TOYO SOKKI, Toho Tenax, NAOX, Nissin Kogyo, Nitto Boseki, VIEWTEC JAPAN, Eutectic Japan, NIHON AUTOMOBILE HIGH TECHNICAL SCHOOL, HIOKI E.E., BASF Japan, First Molding, Fuji WPC, Fujikura, FUCHINO, Future Technology, BLITZ, BLENNY, UACJ, BOSCH, MARUICHI STEEL TUBE, MISUMI, Mitokogyo, Mimiu, MUTOH ENGINEERING, MEIRA, Yamate Kogyo, Yamaha Motor, UD Trucks, YOSHIMURA JAPAN, Yoda Rallying, LOCKFASTENER, WAKO CHEMICAL, AVO MoTeC Japan, ORIGINAL BOX, KANTO Industrial College, TECHNICAL PROSHOP TANSHAYA, The University of Tokyo Institute of Industrial Science

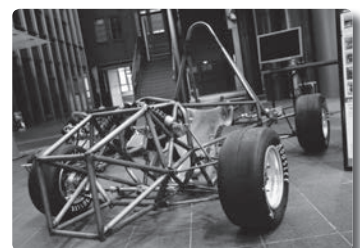

80 Saitama University

● Members

[CP] Yuta Kobayashi [FA] Hiroyuki Hirahara [FA] Kazuyuki Kojima [FA] Yohei Yamada [MBR] Koki Kubota, miyu inagaki, Tomotaka Uemura, Shota Akimoto, Atsuhiko Tmegai, Ryusei Homma, Keita Takahashi, Toru Kobayashi, Yuki Suzuki, Ryota Takahashi, Kaito Kobayashi, akimoto yuki, Taira Ishikawa, Hayato Takagi, Yusuke Ooseki, Taku Kojima, Koki Murakami, Chon Hyonu, Makoto Funada, Yuki Takanami

● Car Features and Team Aspirations

This year's machine, which will be our first appearance, has been designing and producing under the concept of a single car. There are many things that we do not understand for the first time in anything but everyone has solved it one by one. We will try hard so that I can run as hard as we can in the competition!

● Team sponsors

Honda Motor Co., Ltd., SOLIDWORKS Japan K.K., Calsonic Kasei Corporation, Origin Electric Co., Ltd., Matsushou Co., Ltd, Koganei Seiki Co., Ltd, NHK Spring Co., Ltd., NSK Ltd., NOK Corporation, F.C.C. Co., Ltd., FUKAI MFG.CO., LTD, THK CO., LTD., Circuit Akigase, MISUMI Group Inc., NTN Corporation, KYOWA KOGYO Co., LTD, Tokyo Titanium Co., LTD, Nippon Piston Ring Co., Ltd., X.A.M JAPAN, Inc, The Urawa car dismantling, UCHIDA Co., Ltd., Bridgestone Retail branch of Numazu Sawada, Yutaka Giken Co., Ltd, Kitami Mold Steel Co, LTD, firstmolding, YAGISHITA GIKEN. Co., LTD., Ishihara radiator Industries, Sumitomo Rubber Industries, Ltd., ASAH KASEI CONSTRUCTION MATERIALS CORPORATION, igus k.k., HI-LEX CORPORATION, Takata Corporation, WAKO CHEMICAL, LTD., Sumitomo Wiring Systems, Ltd., Porite Corporation, Kijima Rikuun, Central Jidosha Gkiken Corp, Inoue Tekkoujo, Simada ironworks corporation, Saitama Chamber of Commerce and Industry, ARAI HELMET LTD., DESSIN Co., Ltd., Tajima keikinzoku, Matsuda kigata seisakujo, Nissin Kogyo Co., Ltd., RAC RACING GEAR SHOP, SAITAMA Employers'Association, Saitama University - Comprehensive Open Innovation Center

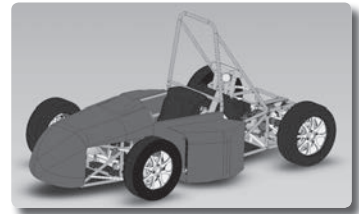

82 Teikyo University

● Members

[CP] Keita Sasaki [FA] Koji Sorimachi [FA] Masanori Takano [FA] Makoto Shinohara [FA] Yoshihisa Inoue [MBR] Yuki Yoshida, Masakage Sunouchi, Hoshino Kaito, Shunpei Takanashi, Kaito Otake, hiraishi daichi, Naoki Hayashi, kodai mitsuhashi

● Car Features and Team Aspirations

Our team tries to participation in competition, FSAE at first time. We hope to be running the race and to win rookie prize.

● Team sponsors

HONDA, TEIKYO, HondaTechnoFort, USAMI, Altair, FUKAI, NTN, RS★R, SEIWA INDUSTRY INCORPORATED, F.C.C., watanabe-kinzoku

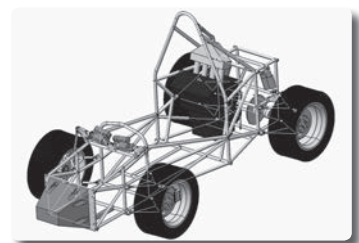

83 Nishinippon Institute of Technology

● Members

[CP] Shigemaru Hayashi [FA] Atushi Sanada [MBR] Masaoki Ogata, Ryoutaro Tateyama, Matsusita Akihiro, Mizuki Sakamoto, Koki Nakamura, Takumi Iwanaga

● Car Features and Team Aspirations

We are FSAE team of Nishinippon institute of Technology. This tournament will be the first participation. The car was made considering ease of production and playful design. I am eager to have fun with the first student formula competition, the whole team.

● Team sponsors

Driver's Cafe FOREST, Racing Garage ENOMOTO, FCC, Robtex, MISUMI, X.A.M JAPAN, FUKAI MFG, HONDA SHOP LIFE, MITSUWA Steel, TUNINGFACTORY BUDOYA

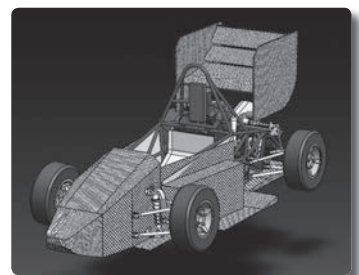

85 Osaka Prefecture University

● Members

[CP] Kosei Hatanaka [FA] Daisuke Segawa [FA] Nobuhiro Sugimura [FA] Hidefumi Kataoka [MBR] Ryo Omura, Tomoki Tani, Shin Kusuda, Masanao Fujimoto, Yuya Teraura, Kouki Tatebe, Takuya Yamaguchi, Akihiro shidara, Yuki Igarashi, Kou Bunchou, Fumiki Hayashi, Yuto Murata

● Car Features and Team Aspirations

We will participate in the Student Formula Japan for the first time in five years. Our vehicle concept is "Low Complexity Low Weight Low Risk". We designed and manufactured a simple structure vehicle. Because of the first experience of all the members, we aim to pass the technical inspection and complete all kinds of events.

● Team sponsors

Kawasaki Heavy Industries, Mitsubishi, FCC, Solidworks Japan, Nissin, Misumi, Motoliberty, Takata, Dow Chemical, West Racingcars, Sumitomo Wiring Systems, PLOT

NO DATA

Team Information (Members and Sponsors)

86 RAJSHAHI UNIVERSITY OF ENGINEERING & TECHNOLOGY

● Members

[CP] SUMIT KUMAR KARMOKER [FA] MD. SAIFUL ISLAM [FA] Prof. Md. Rokunuzzaman [MBR] MD ANIK KAMAL, SHAFIN MAHMUD JALAL, MD ABDULLAH AL MAMUN, MD. MUSA MAHMUD RANA, FARHAN KHALIL, Kh. Ferdous Wahid, Md. Roknuzzaman, Riziya Akter Keya, Md. Rafi Uddin, Md. Zahid Hasan, Tahrim Zaman Tila, Md. Mahmudul Hasan, Anika Fahmida, Md. Tenver Shahriar Utso, Shafi Md. Istiak, A T M Naser Nahedi Ador, Sourav Ghosh, Dipanzon Sarker, Md. Zahid Hasan, Razoan Mahmud, Md. Abu Saleh, Iftekhar Anam, Name: Md Fazley Rabbi

● Car Features and Team Aspirations

. Colour: Black with green and Red Wheelbase 1501.23mm Suspension is Double A-arm Pushrod both rear and front. Gross vehicle mass is 321.5kg. Seamless Steel

spaceframe is used. Our Team aspiration is to introduce technology to general people, Specially those who are deprived of technological advances. Also to acquire Knowledge and establishing communication between different cultural background people. Engine is Honda CBR600RR with Maxpower of 118 hp and top speed of 158.6 mph overlength 2566.56mm

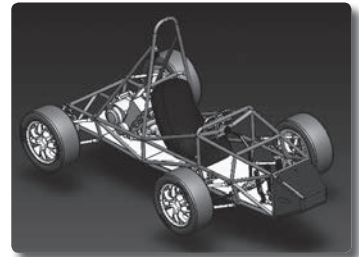

● Team sponsors

RUET, Keyshot, Runner Automobile limited

96 Universitas Indonesia

● Members

[CP] jordy angkawidjaja [FA] Dr.-Ing. Mohammad Adhitya B.Eng., M.Sc. [MBR] Aditya Hartawan, Miftah Shidqi, Fachreza Imam Prathama, Muhammad Denni Kesuma, Damian Nicolas Adisuwono, Bayu Amarta Zulkarnaen, Rayhan Ammarsyah Nasution, Rahadian Dwi Putra, Rachmat Rahardian, Filbert Nainggolan, Vinka Damianra Ayu Larasati, Felix Fujiana, Abram Dionisius Antory

● Car Features and Team Aspirations

Features: Aerodynamic body, Robust chassis and components for safety reason. This year is our first participation in Student Formula Japan (SFJ). We hope that we can participate this race successfully, get a good results and have a chance to participate again in the future.

● Team sponsors

N/A

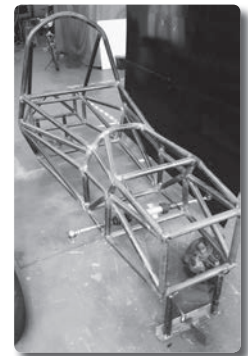

98 Prince of Songkla University

● Members

[CP] Iklas Yayusah [FA] Wacharin Kaewapichai [MBR] Chanon Wongpotipan, Natakorn Faharoon, Amnard vinyoocheroenkul, Noppadon Malisong, Kanokwan Phungkhliang, Jirarote Arwut, Jakkapong Sengchuay, Annob Puckdeewanich, Vitchapad Boonyod

● Car Features and Team Aspirations

Car Features: The car include a rigidity frame, gripping, electric shifter, and turbocharger. Our car was designed for suitable at all conditions and make a good performance. Team Aspirations: Our soul is for benefit of mankind

● Team sponsors

ENG. PSU ALUMNI TOZZHIN NSK HONDA ARDUINOTHAI



E1 National Institute of Technology, Ichinoskei College / Iwate University / Iwate Prefectural University

● Members

[CP] Sou Nakatsugawa [FA] Sho Inoue [FA] Yoshikazu Arai [FA] Nobuhito Yoshihara [FA] Takashi Tsuchiya [FA] Kazuya Itoh [FA] Shou Inoue [MBR] Daisuke Sasano, Akiyoshi Yamaoi, Takumi Abe, Toshiyuki Kikuchi, Hiromu Komai, Koki Saito, Kota Sato, Kazuya Roppongi, Arata Kusaka, Yuki Takizawa

● Car Features and Team Aspirations

It will participate in vehicles equipped with the world's first technology "2 motor torque difference amplification type TVD". The SkidPad first place, sixth overall, EV 2 consecutive championship is the goal of the team. We aim for our total goal of 700 points!

● Team sponsors

National Institute of Technology, Ichinoskei College/Iwate University/Iwate Prefectural University, ICHIKOH INDUSTRIES, Iwagin Jigyo Souzou Capital, Iwate Industrial Reseach Institute, IWATE AUTOMOBILE DEALER ASSOCIATION, South Iwate Research Center of Technology, Iwate Industry Promotion Center, Faculty of Science and Engineering, IwateUniversity, NKN, KYOWA KOGYO, Itoh lab.SAHARA, Sanko Gear Industries, Society of Automotive Engineers of Japan Tohoku Branch, Shinryo Auto(SHINRYO RACING TEAM), TOYOTA MOTOR EAST JAPAN, Nissin Kogyo, MIKUNI, MITSUBA, MODI, Lithium Energy Japan, Takumi, Chida Seimitsu Industry, Nagashima Plant, Iwafuji Industry, Hirose Electric, Prime Earth EV Energy, NPR, Sumitomo Electric, ELEViX, Fukai Works, MISUMI, EJ service



E2 TOYOTA TECHNICAL COLLEGE NAGOYA

● Members

[CP] Onishi Ren [FA] Tetsuya Hayakawa [FA] Kazunarin Takahashi [FA] Kennichi Kubota [FA] Shiro Kaga [FA] Hidenobu Miwa [FA] Keisuke Yamasaki [FA] Masaharu Murakami [MBR] Kotaro Honma, Tomohiko Akaya, Koya Motono, Yuma Shiga, Takashi Sasaki, Shinnya Simoo, Hiroo Morishima, Toyohiro Hayashi, Genndai Kawamura, Naoya Nishimura, Ito Daichi, Takahiro Skai, Daichi Okano, Shinnsei Imayama, Akihiro Miyata, Yudai Wada, Daiki Tanaka, Taishi Ito, Toru Hatayama, Ryusei Fujikawa, Chihaya Ishiguro, Shingo Sakai, Yusuke Moriya, Takahide Sasaki, Yuki Takemasa, Shiho Takeda, Takuma Goto, Kazuki Oshima, Yuki Kawamura, Tukasa Kitagami, Tubasa Sakai, Koya Yamaguchi, Toshiki Sakurai, Soya Suzuki, Kosuke Nakamura, Kenngo Hashimoto, Syoki Terakawa, Shuhei Adachi, Ryuta Yashita, Yusuke Kaneto, Daisuke Sato, Yuichiro Urata, Hiroki Nakazono, Kannji Hoshiyama, Shoto Nakajima, Yuta Asaoka, Yuto Kuroki, Kazuki Tuduki, Kennji Nakae, Ryuki Tejima, Seikiti Matumoto, Yamaguchi Seichiro

● Car Features and Team Aspirations

This year will maintain the reliability of the car last year, changed the shape and location of accumulator container. This improves athletic performance, all aiming at dynamic test finish its EV class winning.

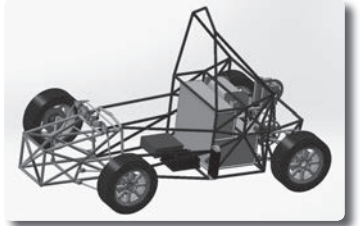

● Team sponsors

Yamaha Motor, TOYODA GOSEI, GOODYEAR Japan, WAKO CHEMICAL, TACTI, SOLIDWORKS Japan, F.C.C., DAD, FUKAI, KYOWA KOGYO, axona AICHI, TOYOTA COROLLA AICHI, SHINMEI INDUSTRY, IWATA FUKUSOU, Sekiya Brewery, DAISENSANGYO, Vicor Japan, OKANO ELECTRONICS, Nicole Group, Takagi Mfg, EV-AICHI, YAZAKI, Sensata Technologies, KYOIKU SANGYO, Kyosei Kotsu Daigaku, NOMURA MACHINE, FT TECHNO

E3 Tohoku University

● Members

[CP] Yutaro Ishikawa [FA] Kenji Nakamura [FA] Koichiro Kamata [MBR] Akira Matsui, Shota Sawasato, Naoki Tashiro, Mizuki Konishi, Ayano Yoshida, Haruka Kubota, Tomohiro Kondo, Hayato Nishimura, Taichi Nagasaki, Kenta Shishido, Hiroki Suzuki

● Car Features and Team Aspirations

Features of our cars (Series TF) consist of "Speed", "Lightness" and "Manageability". For design of our car for the competition, we mainly focused on reliability improvement without losing the features. This year, we are aiming to win the title of EV class and come in 6th or above in total.

● Team sponsors

Ichinokura, Nakamura and Goto Laboratory, Tohoku University, New Industry Creation Hatchery Center, Tohoku University, MotoGarage WINDS, Micro System Integration Center, Honda Motor, MODI, Toyota Motor East Japan, Miyagi Toyota, Boeing, Toyota Rent a Car Miyagi, TOHOKU STEEL, AUTOBACS SEVEN, MIYAGI DAIHATSU, Netz Toyota Miyagi, Netz Toyota Sendai, Sendai Toyopet, Toyota Rent a Car Sendai, KADAN Automotive Technical College Sendai, ZF Japan, KYOWA Engineering Laboratory, Nifco, Umezawa-musen, SOLIDWORKS Japan, MISUMI, Nissin Kogyo, KYOWA KOGYO, THK, NTN, VSN, NSK, Fukai MFG, Sensata Technologies, NHK SPRING, IZUMI Tech, Watabe Kogyo, Keihin, Protrad, Twinkle Pochet, Sumitomo Wiring Systems, National Instruments, JUJUCHIYA-BOLT, PLUSμ, SusProg, OZ JAPAN, Menter Automotive, Aoba Engineering, Toyota Home Tohoku, Toyota L&F Miyagi, Automotive Energy Supply, Electric Japan, RS Components, Ono Seiko, Sanko Gear, YAZAKI, NOK, GV Technologies, Onodera Iron, KUDO ELECTRIC, TONE, TUFT OB&OG

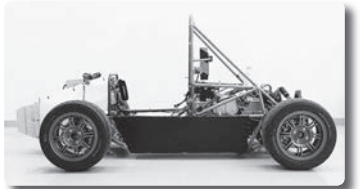

E4 Harbin Institute of Technology at Weihai

● Members

[CP] Xin Tan [FA] Jianfeng Wang [MBR] Zehua Qin

● Car Features and Team Aspirations

HIT Racing Team founded in 2013, our concept is 'Design to win, compete for victory', HRT-17E is based on innovation, lightweight and reliability. We design one piece CFRP monocoque, and we design our aerodynamic devices based on CFD. As for the powertrain, the PMSM motor and Lithium-Polymer battery is used to realise high power density and efficiency. Launch Control/Torque Control/EDS/Break Energy Regeneration System&data &logger system are available.

● Team sponsors

猛狮科技集团, 光威集团, 万丰镁业, 科列, 蔚来汽车, 易车, 华海科技, 长鹿工具, 贤泽电子, 中科恒泰, 山东荣和国际赛车场Melasta, Igus, IPG, Continental, Bender, Ansys, Henkel, Loctite, Mathworks, Altair, MSC, Chroma, TIFAN, Sensata, jettop



E5 Nagoya University

● Members

[CP] Teruki Shibayama [FA] Tatsuya Suzuki [FA] Hiroyuki Okuda [FA] Eiji Abe [MBR] Akira Mikubo, Kaito Nakao, Yuta Ito, Yoshihiro Toyoshima, Atsuno Tsuji, Naoki Kosugi, Naoki Nishimura, Hironori Nagata, Wakiya Hiroshi, Daichi Akaishi, Yuya Takeuchi, Ryu Miyaki, Haruna Taki, Yohei Yamada, Jumpei Mitsushita, Hina Takeoka, Soki Nakano, Kei Sugiura, Arata Takaki, Kaito Ogawa, Masaharu Miyajima, Tomotaka Nakaya, Yumi Tsukamoto, Takashi Suzuki, Ryuga Nishida, Taiki Yasuda, Naoki Ueno, Masaki Murakami, Ryota Takemura, Tatsuya Hamada, Seiya Tanaka, Tsuyoshi Kato, Ren Takagaki, Mao Watanabe, Shingo Nishimoto, Tomotaka Nagai, Takashige Satou, Wang Haoyu, Kaito Fujii, Shusuke Numata, Ryouosuke Kuno, Naohiro Kusunoki, Satoru Nakayasu, Koji Sadayuki, Yuki Yoshida, Wataru Sawada, Kazunori Yoneda, Fujikawa Chie, Moeka-Obuchi

● Car Features and Team Aspirations

"FEM-14" is the first EV machine that the team independently produced. Utilizing high power, high torque motor and chassis

excellent in vehicle movement aim at appearance of endurance finals with Auto Cross 6th place and more.

● Team sponsors

IME, AISIN AW, IDAJ, IPG Automotive, ARRK, ACTIVE, Asahi Kasei Construction Materials, Asahi Chiyoda Kogyo, ANSYS JAPAN, IGUS, ISHINO Circuit, Ishihara Radiator, ISOWA, Iwakura Welding Industry, AW Engineering, ATS, SS Mold, HKS, NTN, Enuma Chain MFG, OZ, Oyama ENG, Okajima Pipe, Kato Cam Giken, Gamagori Seisakusyo, Kawamuraoki Seisakusyo, GIFUGEAR, Lab-CAST, CALIO, Kyosei Kotsu Daigaku, Kyowa Kogyo, Kyowa Electronic Instruments, Kure ENG, Koken, Kota Circuit YRP Kiriya, Kobe Steel, ZEAL by TS-SUMIYAMA, CAS, COI, SWING, Sumitomo Wiring Systems, Three Bond, ZF, Sensata Technologies, SolidWorks Japan, Issoku, TE Connectivity, Taiho Kogyo, TAKATA, Chubu Industry, Tecwel, Technoil Group, Techno Solutions, DENSO, Denshi Tsusin, Toho Tenax, Tohnichi MFG, Topline Products, TOYOTA CARLUM, Nakazawa Chuzosyo, Nissan Motor, Nissin Kyogyo, VI GRADE, Nippon Lite Metal, Nihon Kenshi, Nippon Thompson, Nihon Parkerizing, NHK Spring, NEXT, Notoh Machine, HI-LEX, Hibiki Seiki, Fashion Mishimaya, Fuji Seimitsu, Fujita Rashi Kogyo, Fujimoto Service, Furuto Industrial, Brave Auto, PRO-TECTA, Protrad, Fujikin, Henkel Japan, BOEING Japan, HOT, Polyplastics, Hongkong Mingda Industrial, Honda Motor, LA MOTO KOHSAKA, Honda Meister Club, Makita, The MathWorks, Marubeni Information Systems, Maruwakikai, Misumi, Minoru International, Mutoh ENG, Meidoh, Mentor Graphics, Moriwaki ENG, YAZAKI, Yamashita Seisakusyo, RAMPF Group, Roland DG, Resonic Japan, World Walk, Okudaya Giken, Toyota Meidai Kai, Denso Higashiyama Kai, Aisin Seiki OB, Toyota Central R&D Labs OB, Nagoya University Alumni Association



Team Information (Members and Sponsors)

E6 Shizuoka Institute of Science and Technology

● Members

[CP] Shun Makino [FA] Takashi Nozaki [FA] zhu ning [MBR] Ryuya Ikki, Kazuya Sakamoto, Maya Shinmura, Shota Sugiura, Masatomo Furuya, Taichi Shiraiwa, Naoki Ueguchi, Shogo Kimpara, Kento Kubota, Syun Saitou, Ryou Sakai, Hiroki Shizuhata, Eisuke Nakano, Tomotaka Nagai, Runa Yamada, Yuki Gotou, Ryou Tanizawa, Syunsuke Murotani, Yuta Asanoma, Rintarou Ashikawa, Ryouta Abe, Kouichi Arai, Keito Syukushima, Erika Fujita, Shiori Takada, Mayo Hatta, Zhang Haipeng

● Car Features and Team Aspirations

We have aimed to enhance the vehicle dynamic performance by symmetrical layout. In addition, we intended to implement the vehicle control system which a driver could drive the machine safely. We have

never finished dynamic events until, but we will do our best and complete all of the dynamic events.

● Team sponsors

SUZUKI, DAIKIN, Shinba Iron Works, SOLIDWORKS, TORII, UNIVANCE, NTN, DAYTONA, DAIDO KOGYO, SEKIMONODUKURI, THK, KYOWA KOGYO, Sensata Technologies, OETIKER, Tyco Electronics, YAZAKI, IRS, OGUSU INDUSTRY, SHOEI, Fukai MFG, Yutaka Giken, Minebea, PROTRAD, XAM JAPAN, igus, ISK, MISUMI, Sumitomo Wiring Systems, KYO-EI Industrial, WEST RACING CARS, FUJI COMMUNICATIONS, KOITO, Fuji Xerox, Belle Carriere, TOSHIBA, Suzuyo Shoji, Suzuyo System Technology, Suzuyo Kensetsu, Shizuoka Bill Service, Toukai riki, kinokuniyashoten, chuhatsu, Tohnichi Manufacturing, MathWorks, ARTNER, NISSIN KOGYO, Fuji Seimitsu, KURE Engineering, IDAJ, LORD, KINOKUNI, NHK SPRING, SHIBATA, JST, HKS, FUJICO



E8 Kanagawa University

● Members

[CP] Kento Kawaguchi [FA] Hiroki Nakamura [FA] Mitsuhiro Yamaguchi [MBR] Kevin Carazas, Kensho Tamura, Yohei Miyazaki, Kanae Komatsu, Kousuke Nakanishi, Shin Kuroda, Rikiya Tanabe, Chihaya Nakamae, Hiroki Sugimoto, Takamasa Funaki, Ryo Ujima, Koudai Satoh, Daiki Enomoto, Tubasa Yazawa, Aoi Kimata, Masao Azechi, Msahro Sudou, Shingo Kishigami, Syoya Abe

● Car Features and Team Aspirations

We are team KURAFT from Kanagawa University. Last year, we were struggling against the weight of the car, the heat problem, the noise in the circuit and comprehending the regulations. This year, as we decided to deal with those problems, we designed the car based on the concept

of "Development". We will do our best to accomplish our objective which is to participate all the dynamic events.

● Team sponsors

KawasakiMunicipalIndustryFoundati on. MathuyamaIndustry. MathuiIndustry. OzCorporation. HinodeManufacturing. ThuthumiIndustry. SevconJapan. RikenOptec. WestRacingCars. Rays. JapanMolex. SaimaCorporation. JMC. SentanTechnicalResarchInstitute. ShiftUp. AutoshopFukui. NisshinIndustry. Misumi. XamJapan. DeepStage. NTN. NishikawaSeiki. NDC. HiroTec. Hiramiya. LinearTechnology. AutomotiveEnergySupply. Subaru. Plusmyu. FukaiManufacturing. Fcc. Puroto. Nichiatuogyo. Nifco. SatoParts. AmphenolJapan. YazakiSogyo. Djac. MinebeaMitsumi. kitaco. Hioki

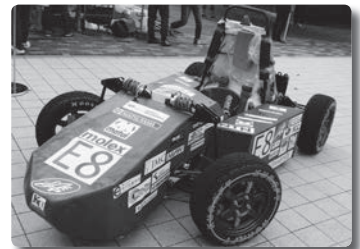

E9 R V College of Engineering

● Members

[CP] Ashad Farhan [FA] Dr. Shanmukha Nagaraj [MBR] Anoop Anand, Darshan Gadginmath, Ganne Sai Gokul, Karthik Sullia

● Car Features and Team Aspirations

Team Chimera is a Hybrid/Electric Research Project team in R. V. College of Engineering, Bangalore, with the purpose of advancing in "Hybrid/Electric Automotive Technology" in India. This year, we are going to build the cost effective Electric Race car with more powerful motor and advance features like Regenerative Braking, better suspension and power-train, LiFePO4 battery pack and interactive dashboard.

● Team sponsors

BEML, HP Coop Ltd, Toradex, Sensata, Mahindra Reva, Altium, MatLab, Accord Lasers, General Industries, JSW, Curtis

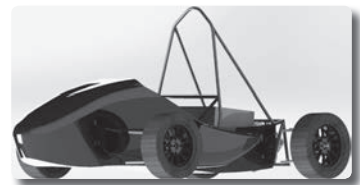

E10 Tongji University

● Members

[CP] Ma Ruisheng [FA] Dai Haifeng [MBR] Ma Jiajun, Shen Lvyu, Li Peizheng, Zeng Yikai, Li Yiming, Gu Mingkang, Gu Peng, Chen Haoxiang, Song Shiyao, Xiao Hongyu, Liu Mengxuan, Bao Zhengyu, Li Qianhao, Xue Feng, Zhang Qingyi, Yang Zhifei, Li Junxing, Wu Wei, Li Ziwen, Jiang Tao, Wu Jingpei, Yin Jun, Huang Luying, Ge Yixin, Sandro Busse, Yin Ding

● Car Features and Team Aspirations

DRe16 is our first 4WD car, and also the first car with full monocoque. We downsized to 10" rim and focused on lightweight. And for torque vectoring, traction control, we developed our own algorithm to improve the performance of DRe16. DIAN Racing is a passionate Formula

Student Electric team from Tongji University. Established in March 2013, the consists of 80 members.

● Team sponsors

VW China, Sunshine Laser, Chroma, SAGW, SHEFFLER, Huahai Technologies, LEMO, Shanghai E-Drive



E11 Liaoning University of Technology

● Members

[CP] Chengbiao Song [FA] Gang Li [MBR] Guoliang Wu, Chenhui Xu, Haobo Zhang, Yinghao Ma, Siyuan Tang, Zengjiang Guo, Yang Li, Liming Wang, Na Li, Hongshuang Lang, Sai Liu, Youfu Zhang, Mingzhong Liu, Hongchen Xu, Yunxiang Lv, Xiaohui Song, Zhicheng Chen, Yiming Chen

● Car Features and Team Aspirations

Features: Carbon fiber suspension & Independent development of vehicle controller Team Aspirations: We regard 'Respect, Gratitude, Solidarity, Creativity' as our principles. Respect team pay. Be active and innovative. Make full efforts to build a pure electric formula car with excellent performance and to be one of the top class teams.

● Team sponsors

Wonder Auto Group Limited; Yiche.com; NEXTEV; Auto Charity Foundation; Jinzhou Jinheng Auto Motive Safety System; Shenzhen Kiclear Technology Co., Ltd; Jiangsu LOPAL Tech.Co., Ltd; YATO; Shandong Changlu Tools Co., Ltd; Igus Energychain-Systems and Bearings and Warehousing and Trade (Shanghai) Co., Ltd; Shenzhen Lang Bowan Advanced Material Co., Ltd; Shenzhen City Hua Jiexin Circuit Technology Co. Ltd; Luffy Technology; BENDER; ANSYS; Altair; Mscsoftware; Ningbo Beilun AoMeiKe industry and Trade Co., Ltd; Suzhou CNP M&E Technology Co., Ltd; Sensata Technology Management (Shanghai) Co. Ltd; Xinya Electronics Co., Ltd; Luoyang Xinguang lithium battery technology Co. Ltd; Beijing Jiuzhou Huahai Technology Co., Ltd; Suzhou Borui extract fire protection science and Technology Co., Ltd



E12 King Mongkut's University of Technology Thonburi

● Members

[CP] Tawan Thongmanagoon [FA] Surachate Chutima [FA] Asst. Prof. Anak Khantachawana [FA] Asst.Prof.Chawin Chantarasenawong [FA] Danai Phaoharuhansa [MBR] Thanakrit Rattanamongkol, Supanat Mungpluan, Pattharawadee Nuchthapho, Thanaphon Phonlapanun, Chanatip Chaiorawan, Romeo Mahaduljan, Chayaphon Taisanakarn, Jirawit Putsri, Thanaporn Sukjai, Teerut Krusri, Banjong Zonklin, Nattawat Seesai, Jirayu Auychai, Anawat Tien-ngam, Jirakit Chitaungsorn, Pattarakit Jainom, Thaya Jangprajak, Apisit Thaneer, Warunchit Chueprasert, Mekkaradkeeta Kalantananda, Anakorn Kanoksilp, Phunyawat Thongnual

● Car Features and Team Aspirations

The Black Pearl EV is a first electric vehicle Formula SAE of KMUTT

Formula Student. Our main goal is to design the high performance vehicle with the highest power to achieve the Dynamics event especially in Autocross event.

● Team sponsors

KMUTT, VOLTH, Tozzhin, Pasho, CHUTIMA, COCARE, SMART lab, BENDER, EMRAX, UNITEK, OXISO, NTS, Excedy, CAC



E13 Universitas Gadjah Mada

● Members

[CP] luqman adi prasetya [FA] Muslim Mahardika [MBR] Farid Ibrahim

● Car Features and Team Aspirations

We are Arjuna UGM proudly present our first ever formula electric car from Indonesia, The Arjuna IPC. Our car adheres to the principle of zero incident and zero accident. The main purpose of our electric car is to create a formula car that is environmentally friendly and also safe to drive. Our main goal in 2017 Japan FSAE is to pass all the static test and become the best rookie

● Team sponsors

PT. Indonesia Kendaraan Terminal, PT. PJB, ISTW, PT. UNISEM, Bender



E15 Niigata Institute of Technology

● Members

[CP] Shouya Oofuchi [FA] Koji Kadomatsu [FA] Chikara Kanesaki [MBR] Kousuke Mimura, Ryuuya Sasaki, Takumi Watanabe, Yao Yi, Hirofumi Hashimoto

● Car Features and Team Aspirations

Our Veichle is AWD with in-wheel motors. We succeeded in maintaining the power as it is and reducing the weight of the car body. We effort to get a higher rank.

● Team sponsors

Shinagin, Limit, Corona, Sakai tec, KondoDenkiShoukai, Dainichi, Wako Chemical, Hokuetsu Industries, Todoroki Sangyo, Niko Sangyo, c, HakuyoKouki, Niigata Yokohama Tire, Koizumi Hajime, Arisawa Eiichi, Kondo Hitosi, Yazaki, Protrad, SolidWorksJapan, Sensata Technology Japan et cetera

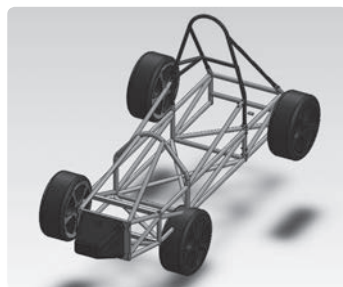

Team Information (Members and Sponsors)

E16 Toyota Technical College Tokyo

● Members

CP Tatsuki Saito **FA** Syuuiti Mori **FA** Yusuke Hishinuma **MBR**
Fumiki Iida, Daiki Yamasita, Ryota Tsujii, Koudai Kazurayama, Sho Ooki,
Naoki Tabata, Kenta Tazawa, MYEONG SEHOON, Atsuhito Otomo, Yuta
Asai, Syunji Yamamoto, Ryo Yamazaki, Shinya Onodera, Soushi Kikuchi

NO DATA

● Car Features and Team Aspirations

● Team sponsors

E17 Universitas Islam Indonesia

● Members

CP Kristamayu **FA** Yanuar Anaba Wahyuesa **MBR**

● Car Features and Team Aspirations

NO DATA

● Team sponsors

スポンサー企業一覧

Sクラススポンサー 4社

TOYOTA

NISSAN

MOTOR CORPORATION

HONDA

日立金属

Materials Mag!c

Aクラススポンサー 17社

 **SUBARU** **MAZDA**

MITSUBISHI MOTORS

TAMADIC
Change creation into power **IPG**
AUTOMOTIVE**NOK****VSN****AISIN****HKS****Kawasaki** **SUZUKI****DENSO**

MOTION & CONTROL™

NSK**HITACHI**
Inspire the Next
日立オートモティブシステムズ

HTFT
Honda TechnoFort

 **YAMAHA**
Revs your Heart

Bクラススポンサー 48社

HORIBA
Explore the future**YORUZZU**

UD TRUCKS

NIFCO **HINO** **BOSCH**
Invented for life**dSPACE**

KYB
Our Precision, Your Advantage

MAGNETI MARELLI**Mentor**
A Siemens Business

世界をなめらかにする仕事。

NTN**TBK**

AW
アイシン・エイ・ダブリュ

ADVICS **Altair****ANSYS****ETAS****ISUZU** **株式会社 インターテクノ**
Intertecno Co., Ltd.**AVL**



Cクラススポンサー 79社 他1社



Competition Site



ECOPA Guide Map

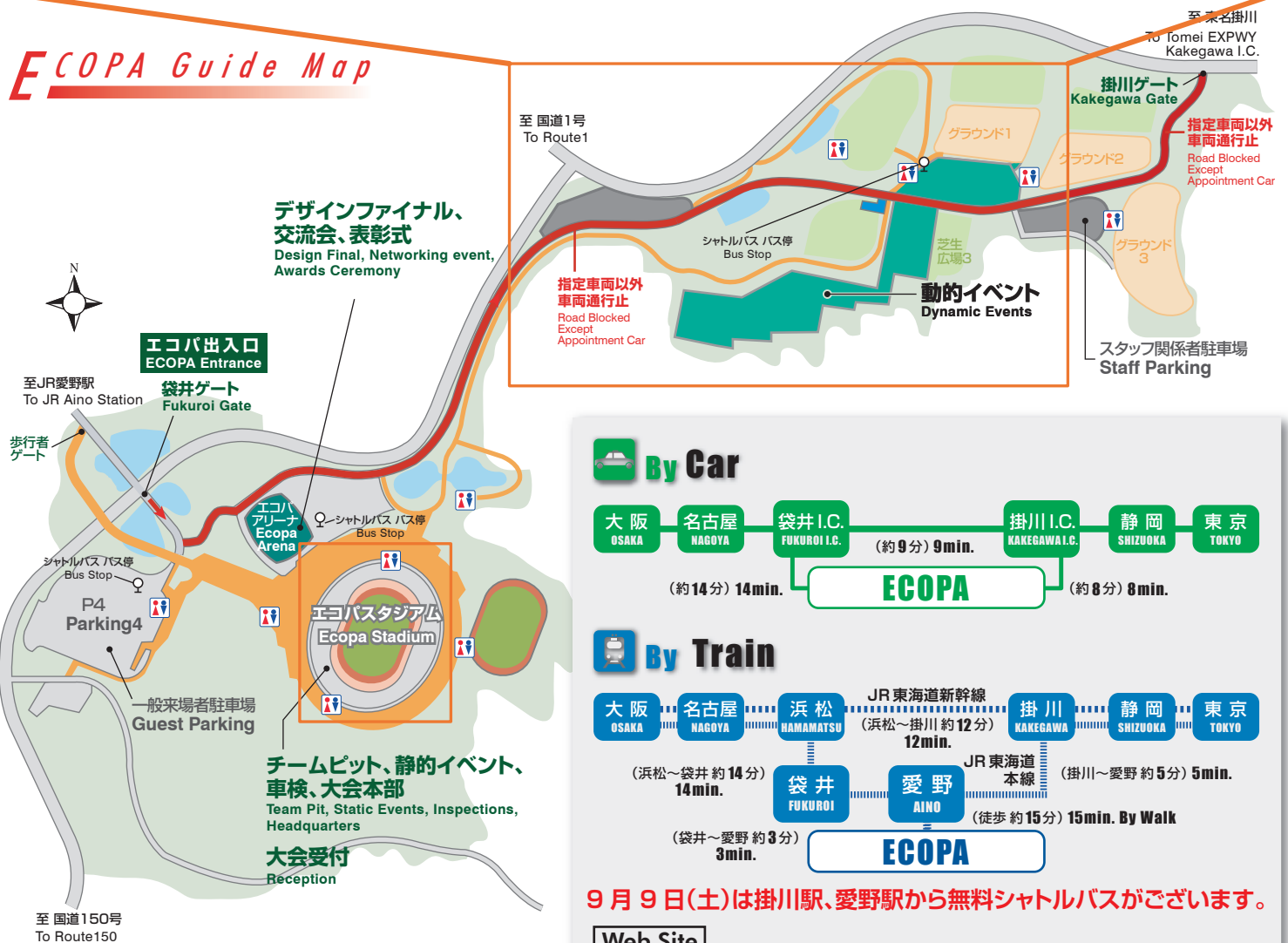

By Car



By Train

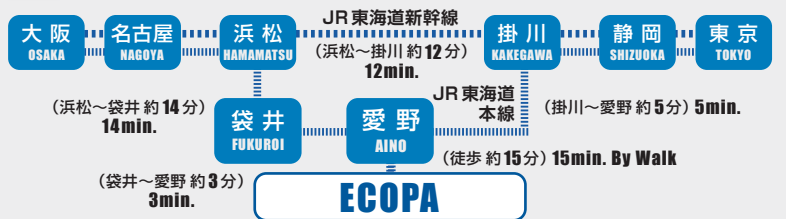

9月9日(土)は掛川駅、愛野駅から無料シャトルバスがございました。

Web Site

<http://www.jsae.or.jp/formula/jp/>