



**EMERGE™ SERIES**

# **SPECIFICATION GUIDE**

**AUGUST 2019**

An electronic version of this book will be kept updated with all revisions at

[www.mbc1touch.com](http://www.mbc1touch.com)

(ANY REVISIONS TO THIS DOCUMENT WILL NOT BE PRINTED.)

©2019 MasterBrand Cabinets, Inc. All rights reserved.

# KEMPER®

## EMERGE™ SERIES

Customer Service  
Phone: 800.730.0171  
Fax: 877.333.7122

Account Information

Account Code: \_\_\_\_\_

Designer ID: \_\_\_\_\_

Sales Rep Name: \_\_\_\_\_

Sales Rep Phone Number: \_\_\_\_\_

Sales Rep E-mail: \_\_\_\_\_

Sales Rep Fax: \_\_\_\_\_

General Customer Service Inquiries  
[emergecs@masterbrand.com](mailto:emergecs@masterbrand.com)

Order Submission  
[emergeorders@masterbrand.com](mailto:emergeorders@masterbrand.com)

*Notes*

# Table of Contents

Index	A•2-A•16
Design Checklist & NKBA Guidelines	B•1-B•3
Characteristics of Wood	C•1
Door Styles	D•1-D•15
Finishes	E•1-E•12
Specifications & Dimensions	F•1-F•19
Modifications	G•1-G•54
Specialty Doors	H•1-H•30
Storage Solutions Reference Chart	I•1-I•2
Wall Cabinets	J•1-J•104
Wood Hoods & Hearths	K•1-K•23
Base Cabinets	L•1-L•108
Tall Cabinets	M•1-M•37
Microwave & Oven Cabinets	N•1-N•53
Office & Furniture Cabinets	O•1-O•40
Vanity Cabinets	P•1-P•67
Fillers & Panels	Q•1-Q•33
Mouldings & Embellishments	R•1-R•66
Kits & Hardware	S•1-S•18
Lighting	T•1-T•3
Specialty Collections	U•1-U•10
Policies & Forms	V•1-V•9

# Description Index

## How to Use Kemper Emerge Product Codes

### Prefix letters:

Prefix letters are abbreviations for the type of cabinet or other unit being described. For example, **B** designates a **Base** cabinet (such as a **B12 L** or **R**) and **W** designates a **Wall** cabinet (as in a **W1230 L** or **R**).

### Product code numbers:

Numbers in a product code describe cabinet dimensions in inches.

For wall, oven, and tall cabinets, the first two digits indicate width, while the last two digits indicate height. That is, a **W1230 L** or **R** is 12" wide and 30" high.

For base and vanity cabinets, digits indicate width only. For instance, a **B12 L** or **R** is a base cabinet that is 12" wide.

### Suffix letters:

Suffix letters in a product code designate standard options. For example, a **B15BB L** or **R** indicates a **Bread Board** option.

See the Modifications section of this catalog for a complete list of Kemper Emerge option suffixes and their meanings.

## Contents By Description

Description	Code	Page Number	Description	Code	Page Number
135° Corner Inside Base	BFH..CIA	I●87	Arch Valance	AV	R●18
135° Corner Inside Wall	..W.CIA	J●88	Art Corbel	..CORBELART	R●25
135° Corner Outside Base	BFH..COA	I●86	Arts & Crafts Corbel	..CORBELART	R●25
135° Corner Outside Wall	..W.COA	J●87	Arts & Crafts Open Corbel	..CORBELARTO	R●25
30" SuperCabinet	BSC30PR, R, RP, RS, SR	I●20	Asymmetrical Base Easy Reach	BER	I●68
36" SuperCabinet	BSC36PRP, PRS, SRP, SRS	I●21	Asymmetrical Easy Reach Wall Corner	..ER	J●63-J●64
4 Zone Dimming Receiver	4ZONEDIMREC	T●1	Attach Toekick Modification	ATTK	G●29
4 Zone Wall Controller	4ZONECON	T●1	Authentic Flush End Modification	AUTH	G●25
Abbey Column Insert - Bar	ABBEYCOLINST	R●49	Authentic Panels	..DAAUTHENTIC	Q●27
Abbey Column Insert - Island	ABBEYCOLINS	R●49	Automatic Opening Mechanism Activation Switch	..AOMACTSWITCH	S●12
Abbey Corbel Insert - Large	ABBEYCORINSL	R●27	Automatic Opening Mechanism Cable Clip	..AOMCABLECLIP	S●12
Abbey Corbel Insert - Medium	ABBEYCORINSM	R●27	Automatic Opening Mechanism Cable Connector	..AOMCABLECONN	S●12
Abbey Corbel Insert - Small	ABBEYCORINSS	R●27	Automatic Opening Mechanism Cable End Protector	..AOMCABLEPROT	S●12
Abbey Crown Insert	ABBEYINS	R●6	Automatic Opening Mechanism for Lift Up Systems Modification	..AOMD	G●13
Abbey Light Rail Insert	ABBEYINSS	R●6	Automatic Opening Mechanism for Wastebaskets Modification	..AOMBWB	G●13
Acanthus Decorative Onlays/Overlays	..ACOVLY	R●20	Automatic Opening Mechanism Universal Cable	..AOMCABLE	S●12
Acanthus Decorative Ornaments	..ACO	R●20	Band All Edges Modification	..BND.ALL	G●8
Acanthus Foot	..ACANFOOT	R●29	Banding Location Modification	..BND.FRT	G●8
Acanthus Leg	..ACANTHUSLEG	R●41	Bar Leg	..SBARLEG	R●35
Acanthus Rosette	..ROSETTEACA	R●16	Bar Leg, Square	..SQBARLEG	R●35
Accessory Nail	..ACCNAIL	R●16	Baroque Bracket	..BRACKETBAROQUE	R●23
Add Drawer Below Wall Unit Modification	ADRW	G●19	Baroque Column	..BARISLCOLUMN	R●45
Add Exterior Cool Light to Bottom of Wall Cabinet	..EXT.BTM.LGTC	T●3	Baroque Valance	..BARV	R●18
Add Exterior Warm Light to Bottom of Wall Cabinet	..EXT.BTM.LGTW	T●3	Base	..B	I●3
Add Interior Light to All Openings of Cabinet	..INT.ALL.LGT	T●2	Base Angled Cabinet	..BAC	I●85
Add Interior Light to Bottom Opening of Cabinet	..INT.BTM.LGT	T●3	Base Bottle Storage Kit	..BBSKIT18	S●2
Add Interior Light to Middle and Bottom Openings of Cabinet	..INT.MID.BTM.LGT	T●3	Base Box Column Pull-out, Overlay	..BBCPO..OL	I●90
Add Interior Light to Middle Opening of Cabinet	..INT.MID.LGT	T●2	Base Box Column Pull-out, Plain	..BBCPO	I●89
Add Interior Light to Single Opening Wall Cabinet or Corner Base Cabinet	..INT.LGT	T●2	Base Buffet	..B..B	I●4
Add Interior Light to Top and Bottom Openings of Cabinet	..INT.TOP.BTM.LGT	T●3	Base Buffet w/Roll Trays	..B..RTB	I●20
Add Interior Light to Top and Middle Openings of Cabinet	..INT.TOP.MID.LGT	T●3	Base Built-in Microwave Cabinet w/Drawer	..BBMWD	N●13
Add Interior Light to Top Opening of Cabinet	..INT.TOP.LGT	T●2	Base Can Storage Kit	..BPPKIT.PG	S●2
Add Shelf Modification	..ADD..SHLF	G●36	Base Combination Drawer Cabinet	..BCD	I●36
Add Toekick Modification	..ADDTK	G●29	Base Container Organization Pantry	..BCOPP	I●93
Aluminum Door Modification	..AF	G●14	Base Cooking Center w/Bread Board	..BCC..BB	I●37
Angled Base End Panel	..BEP	Q●14	Base Corner	..BC	I●59
Angled Corner Sink Base	..ACS	I●53	Base Corner Full Width	..BCFW	I●60
Angled Corner Sink Base w/Tilt-out Tray	..ACS..ST	I●54	Base Corner Full Width Peninsula	..BCFW..P	I●66
Angled Corner Sink Front	..ACSF	I●55	Base Corner Full Width Pull-out	..BCFW..PO	I●62
Angled Corner Sink Front Bottom	..ACSF..B	I●52	Base Corner Full Width w/Arched Pull-out	..BCFW..CPO	I●63
Angled End Wall Cabinet Double Door	..AEW	J●79, J●83	Base Corner Full Width w/Roll Trays & Swing-out	..BCFW..SP	I●63
Angled End Wall Cabinet Double Door w/Face Frame & Door on End	..AEWFFD	J●80, J●84	Base Corner Peninsula	..BCP	I●81
Angled End Wall Cabinet Single Door	..AEW	J●77, J●81	Base Corner Pull-out	..BC..PO	I●61
Angled End Wall Cabinet Single Door w/Face Frame & Door on End	..AEWFFD	J●78, J●82	Base Dishwasher Cabinet	..BDW	I●51
Angled Fillers	..FB, FO, FU, FV, FW	Q●12	Base Double Door w/Four Split Drawers	..B4D	I●18-I●19
Angled Soffit Trim Moulding	..ASTM	R●4	Base Double Door w/Four Split Drawers & Roll Tray	..B4D..RT	I●18
Angled Tall End Panels	..TEP	Q●14	Base Double Door w/Four Split Drawers & Roll Trays	..B4D..RT	I●19
Angled Wall End Panel	..WEP	Q●14	Base, Drop-in Range	..B..DR	I●56
Apex Leg	..APEXLEG	R●41	Base Easy Access Storage	..BEAS	I●15
			Base Easy Reach	..BER	I●69

Description	Code	Page Number
Base Easy Reach w/Lazy Susan	.BER..S	1072
Base Easy Reach w/Reduced Shelf	.BER..RS	1070
Base End Cabinet	.BEC	1084
Base End Panel	.BEPF..WD, BEPWD	1013
Base Fillers	.FB	102
Base Fluted Fillers	.FFB	104
Base Half Round End Shelf	.BHRES	1101
Base Lazy Susan	.BLS	1067
Base Message Center	.BMC	1108
Base Microwave Cabinet w/Deep Drawer	.BMWD..DD	1014
Base Microwave Cabinet w/Drawer	.BMWD	1013
Base Microwave Cabinet w/Roll Tray(s)	.BMW..RT	1012
Base Open Basket Kits	.BASKET	102
Base Open Basket w/Arched Valance	.BOB..AV	1089
Base Open Cabinet w/Car Siding Back	.BOCB	1106
Base Open Cabinet w/Car Siding Back & Drawer	.BODB	1107
Base Open Cabinet w/Plain Back	.BOCP	1106
Base Open Cabinet w/Plain Back & Drawer	.BODP	1107
Base Oven Cabinet	.BO..AC	1016
Base Oven Cabinet w/Lower Drawer	.BO..LD	1017
Base Oven Trimmable Cabinet	.BO	
Base Overlay Fillers	.OFB	109
Base Pans Storage	.BPS..KIT	103
Base Pantry Can Storage	.BPCS	1037
Base Pantry Pull-out	.BPP	1090
Base Peninsula	.B..P	1079
Base Pots & Pans Pull-out	.BPPP	1035
Base Pots & Pans Storage	.BPS	1035
Base Quarter Round End Shelf	.BQRES	1101
Base Recycling Center	.TRBD	1099
Base Rotating Deep Bin	.BRDB	1076
Base Shoe Moulding	.BSM	109
Base Sliding Door Island Cabinet	.B..SDI	1078
Base Sliding Door Island Cabinet w/Sliding Desk	.B..SDIDSK	1078
Base Spice Drawer	.BSD	1100
Base Spice Pull-out	.BSP..PG	1091
Base SuperCabinet Gourmet	.BSCG	1122
Base Transition Cabinet	.BTC	1083
Base Tray Divider Pantry Pull-out	.BTDDP	1092
Base Utensil Pantry Pull-out	.BUPP	1091
Base Utensil Pantry Pull-out w/Knife Block	.BUPPKB	1092
Base Wastebasket	.BWB	1094
Base Wastebasket Full Height	.BWB..FH	1095
Base Wastebasket Full Height w/Roll Tray	.BWB..FHRT2	1096
Base Wastebasket Lid	.BWBFLID, BWBLID	1012
Base Wastebasket w/Bread Board	.BWB..BB	1096
Base Wastebasket w/Charging Drawer	.BWB..CHGDRW	1098
Base Wastebasket w/Wood Tiered Cutlery Divider	.BWB..WTCD	1097
Base Wastebasket w/Wood Tiered K-Cup Drawer	.BWB..KCUP	1097
Base Wine Cubby	.BWC	1099
Base w/Bottle Storage	.BBS	1100
Base w/Bread Board	.B..BB	104
Base w/Charging Drawer	.B..CHGDRW	105
Base w/Cutlery Insert Wood Dividers	.B..CIW	109
Base w/Cutlery Insert Wood Dividers & Roll Trays	.B..RTCIW	1010
Base w/Drawer & Lid Organizer & Roll Trays	.B..RTLO	1036
Base w/Food Storage Container Organizer	.B..FSCO	1011
Base w/Mixer Shelf	.B..FHMIXSC	1088
Base w/Plastic Storage Bins	.B..PSB	1088
Base w/Reduced Depth Roll Trays, Drop-in Range	.B..RTDR	1057
Base w/Roll Trays	.B..RT	106
Base w/Roll Trays & Charging Drawer	.B..CHGDRWRT	107
Base w/Roll Trays, Drop-in Range	.B..RTDR	1057
Base w/Roll-out Tray Divider	.B..TDRO	1083
Base w/Spice Drawer	.B..SD	1093
Base w/Tray Divider	.TD	1082
Base w/Two Split Drawers	.B2D	1016
Base w/Two Split Drawers & Roll Tray	.B2D..RT	1017
Base w/Wood Tiered Cutlery Divider	.B..WTCD	107
Base w/Wood Tiered Cutlery Divider & Roll Trays	.B..RTWTCD	108
Base w/Wood Tiered K-Cup Drawer	.B..KCUP	1010

Description	Code	Page Number
Base w/Wood Tiered K-Cup Drawer & Roll Trays	.B..KCUPRT	1011
Baseboard Moulding Sculpted	.BBMSC	109
Baseboard Moulding Shaker	.BBMSH	109
Basilica Column Insert - Bar	.BASILCOLINST	1049
Basilica Column Insert - Island	.BASILCOLINS	1049
Basilica Corbel Insert - Large	.BASILCORINSL	1027
Basilica Corbel Insert - Medium	.BASILCORINSM	1028
Basilica Corbel Insert - Small	.BASILCORINSS	1028
Basilica Crown Insert	.BASILINS	106
Basilica Light Rail Insert	.BASILINSS	107
Bath Base Cabinet	.BCB..NTK	1053
Bath Channel Wall Mirror	.BCCWM	1066
Bath Drawer Sink Base	.BCDB	1059
Bath Drawer Sink Vanity	.BCDRW	1060
Bath Drawer Sink Vanity Platform	.BCPLATFORM	1060
Bath Drop Tray Sink Base	.BCBDT..NTK	1060
Bath Feet	.FOOTMETAL	1067
Bath Framed Wall Mirror	.BCFWM	1066
Bath Glass Shelf	.GSK	107
Bath Grooming Pull-out Kit	.GPOKIT	1067
Bath Hamper Kit	.HAMPERKIT	1066
Bath Hamper Sink Base	.BCBH..D	1056
Bath Mirror Wall Pull-out	.VMP	1066
Bath Sink Base Cabinet w/Doors	.BCBCD	1055
Bath Sink Base Cabinet w/Shelf	.BCBCO	1054
Bath Sink Wall Tower	.BCWT	1053
Bath Storage Tower	.BCST	1061
Bath Storage Tower Double Drawer	.BCSTDWR	1064
Bath Storage Tower Single Drawer	.BCSTDWR	1062-1063
Bath Tank Topper	.BCTT	1065
Bath Tank Topper Open Shelf	.BCTTOS	1065
Bath Two Drawer Sink Base	.BC2DB	1059
Bath Wall Hung Sink Console	.BCWC	1052
Bath Wall Hung Sink Drawer Base	.BCWHDB	1056-1057
Bath Wall Hung Sink w/Grooming Pull-out	.BCWHDBPO..D	1058
Beaded Inset Door Modification	.BEADED	1012
Beveled Edge Moulding	.TCM	107
Bijou Bun Foot	.BIJBUNFOOT	1032
Bottom Valance Rail Modification	.BVR	1019
Box Column Fillers, Base	.B..BCFP	1011
Box Column Fillers, Office	.O..BCFP	1011
Box Column Fillers, Tall	.T..BCFP	1011
Box Column Fillers, Vanity	.V..BCFP	1011
Box Column Fillers, Wall	.W..BCFP	1010
Braided Moulding	.BRAIDM	105
Bread Board	.BBOARDKIT	103
Built-in Oven Microwave Cabinet	.OMC..AC	1023-1027
Built-in Double Oven Cabinet	.OCD..AC	1048-1051
Built-in Single Oven Cabinet	.OCS..AC	1040-1043
Built-in Single Oven Cabinet w/Drawers	.OCSD..AC	1032-1035
Bunn Foot	.RDBUNNFOOT	1028
Cabinet Box Only Modification	.CBO	1020
Cabinet Case Only Modification	.CCO	1020
Cabinet False Panel Modification	.CFP	1030
Cabinet Frame Only Modification	.CFRMO	1021
Cabinet Front Only Modification	.CFNTO	1021
Cabinet No Door Modification	.CND	1021
Cabinet Panel Edge	.CPE	109
CabMat	.CABMAT	1013
CabMat Modification	.CMAT	1036
CabMat Vanity	.CABMATV	1013
Cap Moulding	.CAPM	104
Car Siding	.CSDG	1021
Car Siding Back Modification	.CSDGBK	1036
Car Siding Flush Panel End Modification	.CSFPE	1025
Celtic Bracket	.BRACKETCELTIC	1023
Celtic Corbel	.CORBELCELTIC	1024, 1025
Celtic Foot	.CELTICFOOT	1030
Center Beaded Moulding	.CBADM	105
Charging Drawer	.CHGDRW	1056
Charging Drawer Modification	.CHGDRW	1037

# Description Index

Description	Code	Page Number
Charleston Bead Column w/Foot	WFOOTCHARLESTON	R•48
Charleston Bead Column, Double Square	DBLSQCHARLESTON	R•48
Charleston Pedestal	CHARLESSEPED	R•44
Chrome Hamper	HAMPERKIT	S•12
Classic Bun Foot	CLBUNNFOOT	R•28
Classic Revival Corbel	CORBELCLREV	R•24
Classic Tall Crown Moulding	CLTCROWN	R•2
Clipped Corner Modification	CLIP	G•21
Clipped Corner Wood Tops Modification	WTCLIP	G•34
Concave Light Rail Moulding	CNVLRAIL	R•5
Contemporary Cap	CONCAP	R•48
Contemporary Light Rail Moulding	JINSERTLRC	R•5
Cooking Utensil Divider	CUD	S•4
Cooking Utensil Divider	CUDD	S•3
Corner End Panels	BEP, TCEP, WEP	Q•23
Corner Sink Base without Shelf	CS	L•67
Corner Strap	APEXSTRP	R•23
Corner Tall Moulding	DCM	Q•23
Cornice Tall Crown Moulding	COTCROWN	R•2
Cosmo Foot	COSFOOT	R•30
Countertop Support	SBS	R•22
Country Sink Base Cabinet	CNTYSB	L•48
Country Sink Base w/CabMat	CNTYSB..CM	L•49
Cove Crown Moulding	COVECROWN	R•2
CPU Base	CPU	O•25
Craftsman Bun Foot	CRFTSMNBUNFOOT	R•31
Craftsman Corbel	CORBELCRAFT	R•23, R•24
Craftsman Corbel Open	CORBELCRAFTO	R•23
Craftsman Door Modification	CCG, CCP	G•14
Craftsman Foot	CRFTSMNFOOT	R•31
Craftsman Foot, Corner	CRFTSMNFOOTC	R•31
Craftsman Valance	CRFTSMNV	R•18
Create-A-Crown Insert	INSERTFRM	R•4
Criss Cross Wine Rack Material	WNRMAT	Q•20
Crown Moulding	SWCRM	R•2
Cut-for-glass Modification	CG	G•15
Cutlery Divider	CIW	S•5
Deco Baseboard Moulding	DECOBBM	R•9
Deco Bun Foot	DECOBUNFOOT	R•32
Deco Valance	DECOV	R•18
Decorative Baseboard Moulding	BBM	R•9
Decorative Pulls & Knobs	KNOB, PULL	S•17-S•18
Deep Roll Tray Kit	DDGK..FXSRTPG, DRT..SP	S•9
Deep Roll Trays Modification	DRT	G•31
Dentil Moulding	DE8	R•6
Desk Door Drawer Base	DDO	O•22
Desk Drawer Base	DDR	O•24
Desk File Drawer Base	DF3D	O•24
Desk File Drawer Base	DFD	L•101, L•102
Desk Office Base w/Full Height Doors	DO..FH	O•23
Diagonal Base w/Full Height Door & Lazy Susan	DAB..S	L•72
Diagonal Base w/Full Height Door & Super Lazy Susan	DAB..SLS	L•74
Diagonal Base w/Full Shelf	DAB..FS	L•69
Diagonal Corner Sink Base without Shelf	DAB	L•68
Diagonal Wall	DW, DW..D	J•65
Diagonal Wall Peninsula	DW..P	J•72
Diagonal Wall w/Appliance Garage & Lazy Susan Open Bottom	DW..DS	J•69
Diagonal Wall w/Appliance Garage Open Bottom	DW..D	J•68
Diagonal Wall w/Full Height Door	DW..FH	J•66
Diagonal Wall w/Lazy Susan	DW..DS, DW..S	J•69
Diagonal Wall w/Vertical-Lift	DW..AG	J•70
Diagonal Wall w/Vertical-Lift & Lazy Susan	DW..AGS	J•71
Dishwasher Panel	DWPWD	Q•19
Door Only	DOORONLY	H•1
Door Rail Material	CGRAIL, DRRAILCROSS, DRRRAILEND, DRWRAILCROSS, DRWRRAILEND, MUNTIN	Q•22
Double Hook Black	EEHDB	O•8
Double Hook Nickel	EEHDN	O•8
Double Outlet Cover	DOC	R•51
Double Oven Trimmable Cabinet	OCD	N•36-O•0

Description	Code	Page Number
Double Oven Trimmable Cabinet w/Deep Drawer	OCD..DD	N•52-N•53
Double Rocker Plate	DRP	R•50
Double Switch Plate	DSP	R•50
Double Vanity Sink Base	VSB	P•37
Double Vanity Sink Base w/Four Drawers	AVSD	P•37-P•38
Drawer Front Flat 5-piece Inset Modification	DF5PCINS	G•10
Drawer Front Flat 5-piece Modification	DF5PC	G•9
Drawer Front Flat 5-piece w/Slab Top Modification	DF5PCSLBT	G•10
Drawer Front Only	DRWFRONLY	H•1
Drawer Front Raised 5-piece Inset Modification	DFR5PCINS	G•11
Drawer Front Raised 5-piece Modification	DFR5PC	G•10
Drawer Front Raised 5-piece w/Slab Top Modification	DFR5PCSLBT	G•10
Drawer Front Slab Modification	DFSLB	G•11
Drawer Front Slab Top Modification	DFSLBT	G•11
Ductless Conversion Kit	CONVERSION, FILTER	K•12
Easy Reach Wall Corner	ER	J•63
Edgebanding	BANDVEN	S•14
End Extended Back Modification	EXBK	G•25
End Panels - Full Overlay	BEPOF..WD, TEP..OF3WD, WEPOF..WD	Q•15
English Country Car Siding Paneling	BP..VG	Q•19
English Country Car Siding Skins	BEPS..VG, TEPS..VG, WEPS..VG	Q•18
English Country Island Column	ENGISLCOLUMN	R•44
English Country Island Quartered Column	ENGISLQTRCOL	R•44
English Country Leg	ENGCNTYLEG	R•37
Entertainment Base	EB	O•12
Entertainment Base, No Toekick	EB..NTK	O•12
Entertainment Base w/Drawers	EBDB	O•14
Entertainment Box Column Filler	EBCF	O•15
Entertainment Open Drawer	EOD	O•12
Entertainment Platform	EP	O•16
Entertainment Stacked Wall	ESTW	O•13
Entertainment Topper	ET	O•15
Entertainment Wall	EW	O•13
Entertainment Wood Tops w/Beveled Edge	1TWT..BE, 2TWT..BE, 3TWT..BE	O•16
Entertainment Wood Tops w/Ogee Edge	1TWT..OG, 2TWT..OG, 3TWT..OG	O•17
Entertainment Wood Tops w/Round Over Edge	1TWT..RO, 2TWT..RO, 3TWT..RO	O•17
Entertainment Wood Tops w/Square Edge	1TWT..SE, 2TWT..SE, 3TWT..SE	O•18
Entry Ensemble Drawer Base	EEDB	O•3
Entry Ensemble Open Base	EEOB	O•4
Entry Ensemble Stacked Wall	EESTW	O•6
Entry Ensemble Stacked Wall Message	EESTWM	O•7
Entry Ensemble Stacked Wall Open	EESTWO	O•5
Entry Ensemble Tall	EET	O•3
Estate Leg	ESTATE	R•38
Estate Mullion Door Modification	ESMD	G•15
Extended Stile w/Overlay Modification	EXBOL, EXLOL, EXROL	G•21
Extended Stiles Modification	EX	G•22
Face Frame and Door on End Modification	FFD	G•26
Faux Hinge Strap	HINGEFH	S•16
Faux Hinges	HINGEFH	S•16
Finish Kit	FINKIT	E•12
Finished Blind Modification	FBF	G•22
Finished Bottom Modification	PFINBTMB	G•8
Finished Edges - All Modification	FALL	G•8
Finished Edges Modification	F.FRT	G•8
Finished Ends Modification	FL, FR	G•8
Floating Shelf	FS, SHELFIND	J•90, R•21
Flower Rosette	ROSETTEFLW	R•16
Flush Panel End Modification	FPE	G•26
Flush Toekick - Arch Modification	FTKAV	G•22
Flush Toekick Modification	FTK	G•22
Flute Leg	FLUTELEG	R•41
Fluted Island Leg	DISLEGFL	R•34
Fluting Modification	FLUT	G•37
Fluting on Fillers Modification	FLUT	G•37
Food Storage Container Organizer Kit	FSCO..KIT	S•2
Four Drawer Base	4DB	L•24
Four Drawer Base w/Bread Board	4DB..BB	L•25
Four Drawer Base w/Charging Drawer	4DB..CHGDRW	L•27
Four Drawer Base w/Cutlery Insert Wood Dividers	4DB..CIW	L•26
Four Drawer Base w/Wood Tiered Cutlery Divider	4DB..WTCD	L•25

Description	Code	Page Number
Four Drawer Base w/Wood Tiered K-Cup Drawer	4DB..KCUP	1026
Four Drawer Entertainment Base	4EDB	013
Four Drawer Entertainment Base, No Toekick	4EDB..NTK	014
Frame Rail Material	FFRAIL	022
French Country Foot	FRNCNTYFOOT	R30
French Country Leg	FRNCNTYLEG	R38, R39
French Country Reeded Leg	FRNCNTYRDLEG	R39
French Country Square Leg	FRNCNTYSQLEG	R39
Full Depth Shelf Modification	FD	G38
Full Extension Drawer & Roll Tray Slides	DGK..FXSPG	S14
Full Height Base	B..FH	L12, L13
Full Height Base Angled Cabinet	BAC..FH	L85
Full Height Base Corner Full Width w/Arched Pull-out	BCFWFH..CPO	L84
Full Height Base Corner Full Width w/Curve Pull-out	BCFWFH..CRVPO	L65
Full Height Base Peninsula	B..FHP	L80
Full Height Base w/Roll Trays	B..FHRT	L14, L15
Full Height Base w/Tray Divider	TD..FH	L82
Full Overlay Crown Moulding	FOLCROWN	R3
Furniture Drawer	FD	L102, L103
Furniture Drawer Window Bench	FDWB	L104
Gaelic Leg	GAELICLEG	R41
Gallery Mullion Door Modification	GAMD	G15
Glass Shelf Kits	GSK	S7
Glaze Pen	GLAZEPEN	F12
Grape Decorative Onlays/Overlays	GROVLY	R20
Grape Rosette	GRO	R16
Grommet	EEGRM	08
Hampton Pedestal Foot, Center	HAMPPEDFOOTCTR	R31
Hampton Pedestal Foot, Corner	HAMPPEDFOOTC	R30
Hampton Pedestal Foot, Left	HAMPPEDFOOTL	R30
Hampton Pedestal Foot, Right	HAMPPEDFOOTR	R30
Hearth Door Front Configurations	H..DF	K21, K22
Hearth Liner	HL	K23
Hearth Mantel	HM	K20
Hearth Overlay Fillers	HOF	K23
Hearth Pier	HP	K19
Hearth Pier Pull-out	HPP	K20
Hearth Shelf	HS	K22
Hearth Tower Pull-out Kit	HPPKIT	S8
Hinge Angle Restriction Clip	HINGERESCLIP	S15
Hinge Angle Restriction Clip Inset	HINGERESCLIPIN	S15
Hinge Plates	HINGEISCLPT	S15
Hinge Restriction Clip	WTH..CLIP	S15
Hinge Spacers	HNGSPACER	S14
Hinges	HINGE	S15
Horizon Door Modification	HCG, HCP	G15
Hutch Base	HB	L105
Hutch End Panel	HE	019
Increased Depths Modification	ID	G38
Increased Height Plus Drawer Modification	IH+DRW	G39
Increased Heights Modification	IH	G40
Increased Widths Modification	IW	G46, G48
Industrial Bracket, Loop	BRACKETIND	R22
Industrial Bracket, Straight	STBRACKETIND	R22
Industrial Foot	INDFOOT	R32
Industrial Leg	INDLEG	R43
Industrial Shelf	SHELFIND	R21
Insert Crown Moulding	SWVCRM	R3
Insert Panel Crown	INSCROWN	R4
Inset Appliance Panels	JAPPLIANCE	029
Inset Door Modification	NOBEAD	G12
Inset Finial Hinges Modification	IF	G12
Inset Magnetic Catches	MAGCATCHINSET	S14
Inset Panel Ends Modification	IPE	G27
Inside Corner Moulding	ICM	R8
Inside Corner Moulding (#2)	ICMA	R8
Installation Hardware Parts	BRKOFFSCREW, BUMPERPADS	S16
Integral End Modification	INTGE	G28
Integrated Panels	DAINTEGRATEDDF, DAINTEGRATEDDR	030
Inverted Frame Modification	INVFRM	G22
Island Leg	SISLLEG	R36

Description	Code	Page Number
Island Leg, Square	SQISLLEG	R36
Jumper Cables	BRIDGECABLE	T1
Kensington Foot	KENSFOOT	R31
Kensington Leg	KENSINGLEG	R39
Keyboard Tray	KBT	025
Kit Components for BCOPP	BCOPPKIT	S2
Kit Components for BTDPP	BTDPKKIT	S2
Kit Components for BUPP	BUPPKIT	S2
Kit Components for BUPPKB	BUPPKBKIT	S2
Kitchen Island Leg	DISLLEG	R34
Lacquer Spray Can	SSC	E12
Large Batten Moulding	SM..LG	R8
Large Bijou Corbel	CORBELBIJL	R26
Large Crown Moulding	SWLCRM	R3
Large Diamond Weaved Island Column	WEAVELEGL	R46
Large Grape Shelf Support	LGGRPSUPPORT	R21
Large Insert Crown	LRCROWN	R3
Large Outside Corner	LOSC	R9
Large Scribe Moulding	LSM	R7
Large Shaker Crown Moulding	LSHAKER	R3
Large Shelf Support	LGCORBEL	R21
Large Straight Angle Crown Moulding	LSACROWN	R3
Large Weaved Corbel	CORBELWEAVEL	R26
Lazy Susan Base Panel	BLSBEPWD	019
Lazy Susan Kit	BER..SKIT, BLSKIT, BRDB..KIT, DAB..KIT, DWLKIT, SLS..KIT, SLSKR..KIT	S8
Lazy Susan Pole Kit	LSPOLEKIT	S8
Lazy Susan Pull-out	LSP	L77
Leveler	LEVELER	R33
Lexington Island Pedestal Kit	LEXISLKIT	R43
Lexington Shelf Strap	LEXSHLFSTRP	R23
Lexington Table Pedestal Kit	LEXTBLKIT	R43
L-shaped Organizer	VLSO	G50
Lid Organizer	LO	S8
Lid Pull-out Kit	LH..KIT	S12
Light Baffle	LB	R5
Light Rail Moulding	LRM	R5
Lille Fluted Foot	LIFLUTFOOT	R28
Lille Foot	LIFOOT	R28
Linen Closet	LC	P50
Linen Closet w/Removable Hamper	LCRH	P51
Linen Storage Cabinet	LT	P51
Madeline Bun Foot	MADDEFoot	R30
Madeline Post, Large	MADLINEPOSTL	R37
Madison Foot	MADFOOT	R31
Matching Interior Modification	MIP	G9
Medium Straight Angle Crown Moulding	MSACROWN	R3
Metro Bar Column	METBARCOLUMN	R45
Metro Island Column	METISLCOLUMN	R45
Metropolitan Foot	METROFOOT	R31
Microwave & Single Oven Trimmable Cabinet	OMC	N28-N29
Microwave & Single Oven Trimmable Cabinet w/Deep Drawer	OMC..DD	N30-N31
Mid-Century Bracket	TRIBRKT	R22
Mid-Century Foot, Medium	MCFOOTM	R32
Mid-Century Foot, Short	MCFOOTS	R32
Mid-Century Foot, Tall	MCFOOTT	R32
Mid-Century Island Column	MCISLCOLUMN	R47
Mid-Century Leg	MCLEG	R43
Mid-Century Metal Foot	MCMFOOT	R33
Mid-Century Table Leg	MCLEG	R42
Mid-Century Vanity Column	MCVANCOLUMN	R48
Mission Corbel	CORBELMIS	K23, R27
Mission Door Modification	MCG, MCP	G16
Mission Leg	DLEGMISSION	R35
Mission Rosette	ROSETTEMIS	R16
Mixer Shelf w/Pop-Up Shelf	MIXKIT	S8
Modern Corner Shelf	MDCCRNSHLF	R20
Modern Floating Corner Shelf	MDFLCRNSHLF	R20
Modified Full Overlay Modification	MFO	G13
Moulding Location Modification	MLDG	G35
Mullion Door Clips	MDCLIPS	S14



# Description Index

Description	Code	Page Number
Mullion Doors Modification	.MD	.G●16
Natural Material	.NAT	.Q●20
Natural Veneer	.NATVEN	.Q●20
Nickel Towel Bar Modification	.TBN	.G●24
No Hinge Cut Modification	.NHC	.G●16
Notched Mid-Century Foot, Medium	.NMCFOOTM	.R●32
Notched Mid-Century Foot, Tall	.NMCFT	.R●32
Notched Mid-Century Island Column	.NMCILSCOLUMN	.R●47
Notched Mid-Century Vanity Column	.NMCVANCOLUMN	.R●48
Office & Vanity Fillers	.CFB, FBCO, FBCV	.Q●03
Office & Vanity Overlay Fillers	.OFO, OFV	.Q●09
Office Fillers	.FO	.Q●02
Office Fluted Fillers	.FFO	.Q●05
Ogee Moulding	.OGEEM	.R●06
Old World Bracket	.BRACKETOWD	.R●23
Old World Corbel	.CORBELOWD	.K●23, R●27
Old World Corbel w/Strap	.CORBELOWDSTR	.K●23, R●27
Open Bottom Rail Base Modification	.OBRB	.G●22
Outside 135° Corner Moulding	.OC	.R●08
Outside Corner Moulding	.OCM	.R●08
Oven Microwave Trimmable Cabinet	.TBMWB	.N●21-N●22
Overlay Fillers	.OFBC	.Q●10
Overlay Panels	.DAOVERLAY	.Q●32
Overlay Valance	.OSV	.R●19
Pacific Rim Create A Column	.PRCCOLUMN	.R●47
Pacific Rim Island Column	.PRISLCOLUMN	.R●47
Pacific Rim Leg	.PRLEG	.R●42
Palladian Corbel	.CORBELPALLA	.R●24
Paneling	.BP, WP	.Q●19
Pantry Unit	.PY	.M●25-M●26
Peaked Large Rosette	.ROSETTELGPK	.R●16
Peaked Small Rosette	.ROSETTESMPK	.R●16
Pedestal Foot - Corner	.PEDFOOTC	.R●29
Pedestal Foot - No Return Left	.PEDFOOTL	.R●29
Pedestal Foot - No Return Right	.PEDFOOTR	.R●29
Pedestal Foot - Return Left	.PEDFOOTREL	.R●29
Pedestal Foot - Return Right	.PEDFOOTRETR	.R●29
Pegged Dish Organizer	.PDO, PDOPOSTS	.S●08
Petite Acanthus Corbel	.CORBELACANS	.R●26
Pilasters	.PIL	.Q●23, Q●24
Pinnacle Corbel	.CORBELPINN	.R●25
Pinnacle Rosette	.ROSETTEPINN	.R●20
Pinnacle Valance	.PINNV	.R●18
Plain Nouveau Bar Column	.NOULEGT	.R●45
Plain Nouveau Island Column	.NOULEG	.R●45
Plain Nouveau Large Corbel	.CORBELNOUL	.R●26
Plain Nouveau Medium Corbel	.CORBELNOUM	.R●26
Plain Nouveau Small Corbel	.CORBELNOUS	.R●26
Plastic Shelf Clips	.SHELFPEGS	.S●14
Plastic Storage Bins	.PSBKIT	.S●08
Position Bridge on Bottom of Wall Cabinet	.BRIDGE.BTM	.T●2
Position Bridge on Top of Wall Cabinet	.BRIDGE.TOP	.T●2
Pots & Pans Pull-out Kit	.PPH.KIT, PPP.KIT	.S●09, S●13
Power Bridge	.3ZONEPWRBRDG	.T●1
Power Pod	.PWRPOD	.S●10
Power Strip	.EEPWR	.O●08
Prairie Mullion Doors Modification	.PRMD	.G●17
Premium Door Mechanism	.PDM	.S●15
Profile Edge Moulding	.SHAPE	.R●07
Profiled and Finished Edges - All Modification	.PRO.ALL	.G●09
Profiled and Finished Edges Modification	.PRO	.G●09
Push-to-Open Wastebasket Modification	.PTOWB	.G●13
Quart of Glaze	.GLAZEQUART	.E●12
Quart of Paint	.PAINTQUART	.E●12
Quart of Stain	.STAINQUART	.E●12
Quart of Toner	.TONERQUART	.E●12
Quarter Round Moulding	.QRM	.R●08
Queen Anne Buffet Column	.QALEGT	.R●46
Queen Anne Corner Acanthus Leg	.QACNRACALEG	.R●40
Queen Anne Corner Fluted Leg	.QACNRFLUTLEG	.R●40
Queen Anne Corner Leg	.QACNRLEG	.R●40

Description	Code	Page Number
Queen Anne Foot	.QAFOOT	.R●31
Queen Anne Leg	.FRNLG	.R●40
Queen Anne Scroll Foot	.QASCRULLFOOT	.R●32
Raised Panel Valance	.RPV	.R●18
Range Hood Stainless Steel Square	.RHSS	.K●10
Range Hood Stainless Steel Tapered	.RHST	.K●10
Range Panel	.DRP	.L●58
Range Platform w/Drawers	.R..PD	.L●58
Recessed Panel Valance	.RCPV	.R●18
Recessed Toe Kick Front Modification	.RECTKFRT	.G●23
Recessed Toe Kick Modification	.RECTK	.G●29
Recessed Vanity Wall Modification	.REC	.G●23
Reduced Depths Modification	.RD	.G●38
Reduced Heights Modification	.RH	.G●40
Reduced Widths Modification	.RW	.G●49
Reed Leg	.RDLEG	.R●34
Refrigerator Panel	.TEP	.Q●16-Q●17
Retainer Clips	.RETAINER	.S●14
Roll Tray Bottom w/Full Depth Shelf Modification	.FDSRTBTM	.G●31
Roll Tray Bumper Pads	.BUMPERTT	.S●14
Roll Tray Kit	.DGK..FXSRTPG, RT.SP	.S●09
Roll Trays Modification	.RT	.G●31
Rope Island Leg	.DISLEGRP	.R●35
Rope Leg	.ROPELEG	.R●40
Rope Moulding	.RPM	.R●06
Rose Fluting Modification	.ROSLFUT	.G●50
Rose Fluting on Fillers Modification	.ROSLFUT	.G●50
Round Base	.ROUNDBASE	.R●44
Round Countertop Moulding	.RTM	.R●07
Rustic Corner Shelf	.RSTCCRNSHLF	.R●20
Rustic Floating Corner Shelf	.RSTCFLTCRNSHLF	.R●20
Scooped Drawers Modification	.SCPDWR	.G●32
Scroll Corbel	.CORBELSCR6	.R●27
Shaker Corbel	.CORBELSHKR	.R●25, R●26
Shaker Crown Moulding	.SHKRCRM	.R●03
Shaker Mullion Door Modification	.SHMD	.G●17
Shelving Material	.SHELF	.Q●22
Shoe Convex Inside Corner Moulding	.SHM	.R●09
Simplicity Crown	.SIMCROWN	.R●02
Single Bead Edge	.SBE	.R●06
Single Bead Moulding	.SBM	.R●06
Single Hook Black	.EEHSB	.O●08
Single Hook Nickel	.EEHSN	.O●08
Single Outlet Cover	.SOC	.R●51
Single Oven Cabinet w/Drawers	.OCSD	.N●38-N●39
Single Oven Trimmable Cabinet	.OCS	.N●44-N●45
Single Oven Trimmable Cabinet w/Deep Drawer	.OCS.DD	.N●46-N●47
Single Oven Trimmable Cabinet w/Drawers	.OCSD	.N●38-N●39
Single Rocker Plate	.SRP	.R●50
Single Switch Plate	.SSP	.R●50
Sink Base	.SB	.L●38, L●43
Sink Base Cleaning Caddy	.SBCADDY, SBCADDYSM	.S●13
Sink Base Cleaning Caddy Modification	.SBCADDY	.G●51
Sink Base Cleaning Caddy Small Modification	.SBCADDYSM	.G●51
Sink Base Double Door w/CabMat	.SB..CM	.L●39
Sink Base Double Door w/Caddy	.SB..CDY	.L●39
Sink Base SuperCabinet	.SB..S	.L●45
Sink Base SuperCabinet w/CabMat	.SB..SCM	.L●46
Sink Base SuperCabinet w/Caddy	.SB..SCDY	.L●45
Sink Base SuperCabinet w/Tilt-out Tray	.SB..STS	.L●46
Sink Base SuperCabinet w/Tilt-out Tray & Caddy	.SB..STSCDY	.L●47
Sink Base SuperCabinet w/Tilt-out Trays & CabMat	.SB..STSCM	.L●47
Sink Base w/Drawer Below	.SB..D	.L●50
Sink Base w/Tilt-out Tray	.SB..ST	.L●40-L●41, L●44
Sink Base w/Tilt-out Tray & Caddy	.SB..STCDY	.L●42
Sink Base w/Tilt-out Trays & CabMat	.SB..STCM	.L●42
Sink Front	.SF	.L●51, L●52
Sink Front Bottom	.SFB	.L●52
Six Drawer Base	.6DB	.L●24
Six Drawer Entertainment Base, No Toe Kick	.6EDB	.O●14
Skins	.BEPS, TEPS, VEPS, WEPS	.Q●18

Description	Code	Page Number
Sliding Towel Bar	.STR	.S09
Small Acanthus Corbel	.CORBELACAN	.R026
Small Batten Moulding	.SM	.R08
Small Bijou Corbel	.CORBELBIJS	.R026
Small Cove Crown Moulding	.SMCOVECROWN	.R02
Small Gaelic Rosette	.ROSETTEGAE	.R016
Small Grape Shelf Support	.SMGRPSUPPORT	.R021
Small Light Rail Moulding	.SMLR	.R05
Small Scribe Moulding	.SSM	.R07
Small Shelf Support	.SMCORBEL	.R022
Small Weaved Corbel	.CORBELWEAVES	.R027
Soffit Filler Moulding	.SFM	.R02
Soffit Scribe Crown Moulding	.SCM	.R03
Soffit Trim Moulding	.STM, TSTM	.R04
Solid Wood	.SOLID	.Q021
Solid Wood Tall Crown Moulding	.SWTCRM	.R04
Spice Drawer	.SD	.S09
Spice Pull-out	.SPICE..PG	.S010
Split Doors Modification	.SPLITDR	.G014
Split Drawers Modification	.SPLITDRWS	.G014
Split Turning Acanthus	.3SPTRINGACA	.R017
Split Turning Block	.3SPTRINGBLK	.R017
Split Turning Capital	.3SPTRINGCAP	.R017
Split Turning Center	.3SPTRINGCTR	.R016
Split Turning Spindle	.3SPTRINGSPNDL	.R017
Split Turning Systems End	.SPTRINGEND	.R017
Split Turning Systems Reed	.SPTRINGREED	.R017
Split Turning Systems Rope	.SPTRINGROPE	.R017
Split Turning Systems Spool	.SPTRINGSPPOOL	.R017
Split Turning Weaved	.3SPTRINGWV	.R017
Spool Leg	.SPLEG	.R034
Square Foot	.SMSQFOOT	.Q015, R029
Square Island Leg	.DISLEGSQ	.R035
Square Leg w/ Sleeve	.SQLEG	.R042, R043
Stack Moulding Kits	.STRKMLD	.R010-R015
Stacked Wall	.STW	.J028-J035
Stacked Wall Cabinet Heights Modification	.STW	.G023
Stacked Wall End Cabinet Double Door	.STWEC..D	.J041
Stacked Wall End Cabinet Single Door	.STWEC	.J042
Stacked Wall Transition Cabinet	.STWTC	.J043, J044
Stacked Wall w/Appliance Garage	.STWDAG	.J024-J027
Stacked Wall w/Vertical Hift	.STWAG	.J036-J039
Stainless Hood Air Deviators	.RHSS-DEV, RHST-DEV	.K011
Stainless Hood Filter	.KF	.K011
Standard Drivers	.STAND	.T01
Starter Moulding	.STR	.R02
Starter Shaker Moulding	.STRS	.R02
Stem Bumper Pads	.BUMPERSTEM	.S014
Stem Glass Holder	.WGH	.S010
Storage Open Rail Base Modification	.STORB	.G023
Straight Angle Crown Moulding	.SACROWN	.R03
Straight Valance	.VV	.R019
Stretcher Material	.STRETCHERMAT	.Q022
Summit Foot	.SUMFOOT	.R030
Summit Mullion Door Modification	.SUMD	.G017
Sumter Island Column, Double Square	.DBLSQSUMTER	.R048
Sumter Table Column, Double Square	.DBLSQTBL	.R048
Super Lazy Susan	.SLSW	.L073
Super Lazy Susan w/Chrome Rail	.SLSCR	.L075
Super Lazy Susan w/Chrome Rail & Corner Drawer	.SLSCR..CD	.L076
Super Lazy Susan w/Chrome Rail & Reduced Shelf	.SLSCR..RS	.L071
Tablet Holder	.TABLETHLDR	.S011
Tall Bookcase w/Arched Valance	.T..BCAV	.Q029-Q031
Tall Bookcase w/Doors & Arched Valance	.TD..BCAV	.Q032-Q034
Tall Bookcase w/Office Height Doors & Arched Valance	.TDO..BCAV	.Q038-Q040
Tall Bookcase w/Vanity Height Doors & Arched Valance	.TDV..BCAV	.Q035-Q037
Tall Built-in Microwave Cabinet	.OCM..AC	.N018-N020
Tall Crown Moulding	.MTCROWN, TCROWN, TLCROWN	.R04
Tall Fluted Fillers	.FTF, TF	.Q05
Tall Pantry Pull-out	.TPP	.M022-M024
Tapered 4-Sided Leg	.T4SLEG	.R030

Description	Code	Page Number
Tapered Leg	.TAPLG, TLEG	.R030
Tapered Vanity End Panel	.VDL2130WD	.Q019
Tapered Wood Hood	.TWH	.K010
Three Corner Drawer Base	.3CDB	.L077
Three Drawer Base	.3DB	.L027-L028
Three Drawer Base Buffet	.3DBB	.L028
Three Drawer Base Buffet w/Deep Drawer	.3DBBDD	.L031
Three Drawer Base, Warming Drawer	.3DB..WD	.N011
Three Drawer Base w/Bread Board	.3DB..BB	.L030
Three Drawer Base w/Charging Drawer	.3DB..CHGDRW	.L031
Three Drawer Base w/Deep Drawer	.3DBDD	.L029
Three Drawer Base w/Wood Tiered Cutlery Divider	.3DB..WTC	.L029
Three Drawer Base w/Wood Tiered K-Cup Drawer	.3DB..KCUP	.L030
Tilt-out Tray(s) Stainless Steel	.TOTSSS	.S06
Toe Board Trim	.TB8WD	.Q018
Toekick Caps	.TKC	.Q019
Toekick Drawer Modification	.DRWTK	.G030
Toekick Pedestal Modification	.TKP	.G030
Toekick Tulip Foot	.TKTLFOOT	.R029
Top Valance Rail Modification	.TVR	.G024
Touch-up Kit	.TUK	.E012
Traditional Batten Moulding	.TBATM	.R08
Traditional Light Rail	.TLR	.R05
Traditional Light Rail Moulding	.JINSETRLT	.R05
Traditional Open Corbel	.CORBELTRADO	.R025
Traditional Rosette	.TROSETTE	.R016
Traditional Window Casing	.WCT	.R09
Transom Doors Modification	.TCG, TCP	.G018
Tray Divider	.TDKIT	.S010
Tray Divider Modification	.TD	.G052
Tray Divider Roll-out	.TDRO, TDROHDWONLY	.S010
Triad Corbel	.CORBELTRIAD	.R025
Triad Rosette	.ROSETTRIAD	.R020
Trim Moulding	.TM	.R04
Triple Bead Moulding	.TBEM	.R06
Tri-View Medicine Cabinet	.TV	.P06
Tudor Column Insert - Bar	.TUDORCOLINST	.R049
Tudor Column Insert - Island	.TUDORCOLINS	.R049
Tudor Corbel Insert - Large	.TUDORCORINSL	.R028
Tudor Corbel Insert - Medium	.TUDORCORINSM	.R028
Tudor Corbel Insert - Small	.TUDORCORINSS	.R028
Tudor Crown Insert	.TUDORINS	.R07
Tudor Light Rail Insert	.TUDORINSS	.R07
Tulip Foot	.TLFOOT	.R029
Tulip Foot Square	.FOOTTULIPSQ	.R029
Turnbuckles for False Drawer Fronts	.FALSEPANELCLIP	.S014
Two Drawer Base	.2DB	.L032, L034
Two Drawer Base Corner Full Width w/Curve Pull-out	.BCFV2D..CRVPO	.L065
Two Drawer Base w/Pegged Dish Organizer	.2DB..PDO	.L032
Two Drawer Base w/Reduced Drawers, Drop-in Range	.2DB..RDR	.L056
Two Drawer Base w/Roll Tray & Pegged Dish Organizer	.2DB..RTPDO	.L033
Two Drawer Base w/Roll Trays	.2DB..RT	.L033
Two Drawer Base, Drop-in Range	.2DB..DR	.L055
Under Counter Drawer	.UCD	.P046
Under Counter Drawer, Trimmable	.UCD..T	.P046
Urban Foot	.URBANFT	.R033
Urban Island Column	.URBISLCOLUMN	.R046, R047
Urban Leg	.URBANLEG	.R043
U-shaped Deep Roll Tray Kit	.UDRT..SP	.S07
U-shaped Drawer Box Modification	.UBDX	.G032
U-shaped Roll Tray Kit	.URT..SP	.S07
U-shaped Roll Tray Modification	.URT	.G033
Utility	.U	.M03-M011
Utility Fillers	.UF	.Q03
Utility Inverted	.UI	.M016-M017
Utility Organizer Cabinet	.UOC	.M027-M034
Utility Organizer Drop Zone Cabinet	.UOCDZ	.M035-M036
Utility Organizer Drop Zone Cabinet w/Authentic End	.UOCDZ..AE	.M037
Utility Overlay Fillers	.OL	.Q09
Utility w/Four Drawers	.U4D	.M014, M015
Utility w/Roll Trays	.U..RT	.M018-M021

# Description Index

Description	Code	Page Number	Description	Code	Page Number
Utility w/Three Drawers	.U3D	M•12, M•13	Wall Open Cabinet w/Plain Back	.WOCB	J•50
Valley Forge Moulding	.VFR	R•5	Wall Organizer	.WORG	J•90
Vanity Angled Corner Sink Front	.VACSF	P•45	Wall Organizer & Bookshelf	.WOBS	J•91
Vanity Base, Double Door w/Drawer	.VB	P•8	Wall Overlay Fillers	.OL	Q•8
Vanity Base Pull-out	.VBP	P•13	Wall Peninsula	.W.P	J•73-J•76
Vanity Base Pull-out Kit	.VBPKIT	S•10	Wall Quarter Round End Shelf	.WQRES	J•97-J•100
Vanity Base, Single Door w/Drawer	.VB	P•7	Wall Refrigerator	.W	J•45-J•48
Vanity Base Single Door w/Shelf	.V.S	P•9	Wall Refrigerator Pull-out Cabinet	.W.PO	J•49
Vanity Base Single Door without Shelf	.V	P•11	Wall Spice Drawer Horizontal	.WSD	J•96
Vanity Base w/Shelf	.V.S	P•10	Wall Spice Drawer Vertical	.WSDV	J•96
Vanity Base without Shelf	.MV, V	P•12, P•13	Wall Spice Pull-out Cabinet	.WSP	J•100
Vanity Combination Drawer Base w/Four Drawers	.4VCDB..D	P•29	Wall Spice Pull-out Kit	.WSPKIT	S•10
Vanity Combination Drawer Base w/Three Drawers	.VCDB..D	P•28	Wall Spice Rack Cabinet	.WSRC	J•101
Vanity Console Drawer Base w/Eight Drawers	.4-6VCDB	P•30, P•31	Wall Top Hinge w/Bifold	.WTH..BF	J•15
Vanity Console Drawer Base w/Six Drawers	.6VCDB	P•30, P•31	Wall Top Hinge w/Stay Lift	.WTH..SL	J•9
Vanity Console Drawer Base w/Six Drawers & Wood Tiered Vanity Drawer	.6VSDB..WTV	P•36	Wall Top Hinge w/Vertical-Lift & Stay Lift	.WVL	J•5-J•6
Vanity Fillers	.FV	Q•2	Wall Transition Cabinet	.WTC	J•40
Vanity Fluted Fillers	.FFV	Q•5	Wall Wine Rack	.WNR	J•92
Vanity Four Drawer Base	.4VDB	P•44-P•45	Wall Wine Storage Cabinet	.WSC	J•93
Vanity Hamper Base Cabinet	.VH..FH	P•38	Wall w/Three Drawers	.W3D	J•22-J•23
Vanity Mirror	.VM	P•5	Wall w/Two Drawers	.W2D	J•20-J•21
Vanity Recessed Cabinet	.VWR	P•4	Wastebasket Assembly	.BWB..FHKIT, BWB..KIT	S•11, S•11
Vanity Sink & Hamper Drawer Base	.VSHDB..D	P•39	Wastebasket Only	.WASTEBIN	S•11, S•12
Vanity Sink & Hamper Drawer Base w/Four Drawers	.4VSHDB..D	P•40	Water Closet	.WCT	P•6
Vanity Sink & Two Drawer Base w/Extended Stiles	.2VSD..FP	P•20	Weaved Bar Column	.WEAVELEGT	R•46
Vanity Sink Base SuperCabinet w/Tilt-out Trays	.VSSB..ST	P•18	Weaved Bun Foot	.WEAVEBUNFOOT	R•32
Vanity Sink Base w/False Panel	.VSB	P•14-P•17	Weaved Island Column	.WEAVELEG	R•46
Vanity Sink Base w/Three Drawers	.VS3D	P•25	Wide Scribe Moulding	.WSCRIBE	R•8
Vanity Sink Base w/U-shaped Roll Trays	.VSB..U	P•17	Wide Stiles Modification	.WS	G•24
Vanity Sink Drawer Base	.2VSD, 2VSD..FP	P•19	Wide Top Rail Modification	.WTR	G•24
Vanity Sink Drawer Base w/Eight Drawers & False Panel	.8VSD..FP	P•34-P•35	Wine Cube Horizontal	.W	J•95
Vanity Sink Drawer Base w/False Panel	.VSD..FP	P•21-P•22	Wine Cube Vertical	.WCV	J•95
Vanity Sink Drawer Base w/Four Drawers & False Panel	.4VSD..FPD	P•26-P•27	Wood Hood Arch	.WHA	K•3
Vanity Sink Drawer Base w/Six Drawers	.6VSD..FP	P•32-P•33	Wood Hood Artisan Straight	.WHAS	K•9
Vanity Sink Drawer Base w/Three Drawers & False Panel	.3VSD..FP	P•23-P•24	Wood Hood Blower	.BLOWER	K•11, K•12
Vanity Sink Front	.VSF	P•41	Wood Hood Blower Unit	.TWHBLOWER	K•12
Vanity Three Drawer Base	.VDB	P•42-P•43	Wood Hood Canopy Arched	.WHCA	K•4
Vanity Utility	.UV	P•47-P•49	Wood Hood Canopy Square	.WHCS	K•5
Vanity Utility w/Drawers	.VUD	P•50	Wood Hood Chimney	.WHC	K•3
Vanity Wall	.W	P•3, P•4	Wood Hood Island Arch	.JWHIA	K•8
Vanity Wall Recessed Cabinet	.VWR	P•5	Wood Hood Island Straight	.JWHIS	K•9
Vanity Wastebasket Container	.VWB	G•52	Wood Hood Linear	.JWHL	K•9
Veneer	.VEN	Q•21	Wood Hood Nantucket Arch	.JWHNA	K•6
Victorian Countertop Support	.VSBS	R•22	Wood Hood Nantucket Chimney	.JWHNC	K•6
Void Toe Kick Modification	.VTK	G•30	Wood Hood Nantucket Straight	.JWHNS	K•6
Wainscoting	.WAIN	Q•26	Wood Hood Shiplap Straight	.JWHSHIPSTR	K•7
Wall	.W	J•3-J•19	Wood Hood Shiplap Straight w/Corbel	.JWHSHIPSTRCB	K•7
Wall & Base Fillers	.FB, FW	Q•3	Wood Hood Shiplap Tapered	.JWHSHIPT	K•7
Wall Base	.WB	L•23	Wood Hood Shiplap Tapered Chimney	.JWHSHIPCH	K•8
Wall, Base, Office, & Vanity 135° Overlay Fillers	.135OF	Q•10	Wood Hood Shiplap Tapered w/Corbel	.JWHSHIPTCB	K•8
Wall Bookcase w/Arched Valance	.W.BCAV	Q•26-Q•28	Wood Hood Square	.WHS	K•3
Wall Box Column Pull-out w/K-Cup	.WBCPOKUP	J•104	Wood Tiered Cutlery Divider Drawer Modification	.WTCB	G•52
Wall Box Column Pull-out, Overlay	.WBCPO..OL	J•103	Wood Tiered Cutlery Divider Drawer w/Installation Hardware	.WTCB	S•5
Wall Box Column Pull-out, Plain	.WBCPO	J•102	Wood Tiered K-Cup Drawer Modification	.WTKCUP	G•53
Wall Built-in Microwave Double Door Cabinet	.WBMW, WBMW..AC	N•5-N•10	Wood Tiered K-Cup Drawer w/Installation Hardware	.KUCP	S•6
Wall Cabinet w/Wine Rack	.WWR	J•91	Wood Tiered Vanity Drawer Kit	.WTVD	S•6
Wall China Display	.WCD	J•94	Wood Top, Four Sided	.4TWT	Q•7
Wall Corner Double Door	.WC	J•54-J•62	Wood Top, One Sided	.1TWT	Q•6
Wall Corner Single Door	.WC	J•52-J•61	Wood Top, Three Sided	.3TWT	Q•6
Wall Easy Access Storage Cabinet	.WEAS	J•13	Wood Tops	.WOODTOP	Q•6
Wall End and Back Extended Down Modification	.EXDN	G•29	Wood Tops for Angled & Base End Cabinets - Beveled Edge	.WTOPBAC..BE	Q•7
Wall End Cabinet Double Door	.WEC..D	J•85	Wood Tops for Angled & Base End Cabinets - Ogee Edge	.WTOPBAC..OG	Q•7
Wall End Cabinet Single Door	.WEC	J•86	Wood Tops for Angled & Base End Cabinets - Round Over	.WTOPBAC..RO	Q•8
Wall End Panel	.WEPF	Q•13	Wood Tops for Angled & Base End Cabinets - Square Edge	.WTOPBAC..SE	Q•8
Wall Fillers	.F	Q•2	X-End Panel	.XEND	R•50
Wall Fluted Fillers	.FF	Q•4			
Wall Message Center	.WMC	J•89			
Wall Microwave Cabinet	.MW	N•3			
Wall Microwave Double Door Cabinet	.MW	N•4-N•8			
Wall Open Cabinet w/Car Siding Back	.WOCB	J•51			

## Contents By Code

Code	Description	Page Number	Code	Description	Page Number
1350F	Wall, Base, Office, & Vanity 135° Overlay Fillers	Q•10	ABBEYCORINSS	Abbey Corbel Insert - Small	R•27
1TWT	Wood Top, One Sided	Q•6	ABBEYINS	Abbey Crown Insert	R•6
1TWT.BE	Entertainment Wood Tops w/Beveled Edge	Q•16	ABBEYINSS	Abbey Light Rail Insert	R•6
1TWT.OG	Entertainment Wood Tops w/Ogee Edge	Q•17	ACANFOOT	Acanthus Foot	R•29
1TWT.RO	Entertainment Wood Tops w/Round Over Edge	Q•17	ACANTHUSLEG	Acanthus Leg	R•41
1TWT.SE	Entertainment Wood Tops w/Square Edge	Q•18	ACCNAIL	Accessory Nail	R•16
2DB	Two Drawer Base	L•32, L•34	ACO	Acanthus Decorative Ornaments	R•20
2DB.DR	Two Drawer Base, Drop-in Range	L•55	ACOVLY	Acanthus Decorative Onlays/Overlays	R•20
2DB.PDO	Two Drawer Base w/Pegged Dish Organizer	L•32	ACS	Angled Corner Sink Base	L•53
2DB.RDR	Two Drawer Base w/Reduced Drawers, Drop-in Range	L•56	ACS.ST	Angled Corner Sink Base w/Tilt-out Tray	L•54
2DB.RT	Two Drawer Base w/Roll Trays	L•33	ACSF	Angled Corner Sink Front	L•55
2DB.RTPDO	Two Drawer Base w/Roll Tray & Pegged Dish Organizer	L•33	ACSF.B	Angled Corner Sink Front Bottom	L•52
2TWT.BE	Entertainment Wood Tops w/Beveled Edge	Q•16	ADD.SHLF	Add Shelf Modification	G•36
2TWT.OG	Entertainment Wood Tops w/Ogee Edge	Q•17	ADDTK	Add Toekick Modification	G•29
2TWT.RO	Entertainment Wood Tops w/Round Over Edge	Q•17	ADRW	Add Drawer Below Wall Unit Modification	G•19
2TWT.SE	Entertainment Wood Tops w/Square Edge	Q•18	AEW	Angled End Wall Cabinet Double Door	J•79, J•83
2VSD	Vanity Sink Drawer Base	P•19	AEW	Angled End Wall Cabinet Single Door	J•77, J•81
2VSD.FP	Vanity Sink & Two Drawer Base w/Extended Stiles	P•20	AEWFFD	Angled End Wall Cabinet Double Door w/Face Frame & Door on End	J•80, J•84
2VSD.FP	Vanity Sink Drawer Base	P•19	AEWFFD	Angled End Wall Cabinet Single Door w/Face Frame & Door on End	J•78, J•82
3CDB	Three Corner Drawer Base	L•77	AF	Aluminum Door Modification	G•14
3DB	Three Drawer Base	L•27-L•28	AOMACTSWITCH	Automatic Opening Mechanism Activation Switch	S•12
3DB.BB	Three Drawer Base w/Bread Board	L•30	AOMBWB	Automatic Opening Mechanism for Wastebaskets Modification	G•13
3DB.CHGDRW	Three Drawer Base w/Charging Drawer	L•31	AOMCABLE	Automatic Opening Mechanism Universal Cable	S•12
3DB.KCUP	Three Drawer Base w/Wood Tiered K-Cup Drawer	L•30	AOMCABLECLIP	Automatic Opening Mechanism Cable Clip	S•12
3DB.WD	Three Drawer Base, Warming Drawer	N•11	AOMCABLECONN	Automatic Opening Mechanism Cable Connector	S•12
3DB.WTCD	Three Drawer Base w/Wood Tiered Cutlery Divider	L•29	AOMCABLEPROT	Automatic Opening Mechanism Cable End Protector	S•12
3DBB	Three Drawer Base Buffet	L•28	AOMD	Automatic Opening Mechanism for Lift Up Systems Modification	G•13
3DBBDD	Three Drawer Base Buffet w/Deep Drawer	L•31	APEXLEG	Apex Leg	R•41
3DBDD	Three Drawer Base w/Deep Drawer	L•29	APEXSTRP	Corner Strap	R•23
3SPTRINGACA	Split Turning Acanthus	R•17	ASTM	Angled Soffit Trim Moulding	R•4
3SPTRINGBLK	Split Turning Block	R•17	ATTK	Attach Toekick Modification	G•29
3SPTRINGCAP	Split Turning Capital	R•17	AUTH	Authentic Flush End Modification	G•25
3SPTRINGCTR	Split Turning Center	R•16	AV	Arch Valance	R•18
3SPTRINGSPNDL	Split Turning Spindle	R•17	B	Base	L•3
3SPTRINGWV	Split Turning Weaved	R•17	B.B	Base Buffet	L•4
3TWT	Wood Top, Three Sided	Q•6	B.BB	Base w/Bread Board	L•4
3TWT.BE	Entertainment Wood Tops w/Beveled Edge	Q•16	B.BCFP	Box Column Fillers, Base	Q•11
3TWT.OG	Entertainment Wood Tops w/Ogee Edge	Q•17	B.CHGDRW	Base w/Charging Drawer	L•5
3TWT.RO	Entertainment Wood Tops w/Round Over Edge	Q•17	B.CHGDRWRT	Base w/Roll Trays & Charging Drawer	L•7
3TWT.SE	Entertainment Wood Tops w/Square Edge	Q•18	B.CIW	Base w/Cutlery Insert Wood Dividers	L•9
3ZONEPWRBRDG	Power Bridge	T•1	B.DR	Base, Drop-in Range	L•56
4-6VCDB	Vanity Console Drawer Base w/Eight Drawers	P•30, P•31	B.FH	Full Height Base	L•12-L•13
4DB	Four Drawer Base	L•24	B.FHMIXSC	Base w/Mixer Shelf	L•88
4DB.BB	Four Drawer Base w/Bread Board	L•25	B.FHP	Full Height Base Peninsula	L•80
4DB.CHGDRW	Four Drawer Base w/Charging Drawer	L•27	B.FHRT	Full Height Base w/Roll Trays	L•4-L•15
4DB.CIW	Four Drawer Base w/Cutlery Insert Wood Dividers	L•26	B.FSCO	Base w/Food Storage Container Organizer	L•11
4DB.KCUP	Four Drawer Base w/Wood Tiered K-Cup Drawer	L•26	B.KCUP	Base w/Wood Tiered K-Cup Drawer	L•10
4DB.WTCD	Four Drawer Base w/Wood Tiered Cutlery Divider	L•25	B.KCUPRT	Base w/Wood Tiered K-Cup Drawer & Roll Trays	L•11
4EDB	Four Drawer Entertainment Base	Q•13	B.P	Base Peninsula	L•79
4EDB.NTK	Four Drawer Entertainment Base, No Toekick	Q•14	B.PSB	Base w/Plastic Storage Bins	L•88
4TWT	Wood Top, Four Sided	Q•7	B.RRTDR	Base w/Roll Trays, Drop-in Range	L•57
4VCDB.D	Vanity Combination Drawer Base w/Four Drawers	P•29	B.RT	Base w/Roll Trays	L•6
4VDB	Vanity Four Drawer Base	P•44-P•45	B.RTB	Base Buffet w/Roll Trays	L•20
4VSD	Double Vanity Sink Base w/Four Drawers	P•37-P•38	B.RTCIW	Base w/Cutlery Insert Wood Dividers & Roll Trays	L•10
4VSD.FPD	Vanity Sink Drawer Base w/Four Drawers & False Panel	P•26-P•27	B.RTDR	Base w/Reduced Depth Roll Trays, Drop-in Range	L•57
4VSHDB.D	Vanity Sink & Hamper Drawer Base w/Four Drawers	P•40	B.RTLO	Base w/Drawer & Lid Organizer & Roll Trays	L•36
4ZONECON	4 Zone Wall Controller	T•1	B.RTWCD	Base w/Wood Tiered Cutlery Divider & Roll Trays	L•8
4ZONEDIMREC	4 Zone Dimming Receiver	T•1	B.SD	Base w/Spice Drawer	L•93
6DB	Six Drawer Base	L•24	B.SDI	Base Sliding Door Island Cabinet	L•78
6EDB	Six Drawer Entertainment Base, No Toekick	Q•14	B.SDIDSK	Base Sliding Door Island Cabinet w/Sliding Desk	L•78
6VCDB	Vanity Console Drawer Base w/Six Drawers	P•30, P•31	B.TDRO	Base w/Roll-out Tray Divider	L•83
6VSD.FP	Vanity Sink Drawer Base w/Six Drawers	P•32-P•33	B.WTCD	Base w/Wood Tiered Cutlery Divider	L•7
6VSD.B.WTV	Vanity Console Drawer Base w/Six Drawers & Wood Tiered Vanity Drawer	P•36	B2D	Base w/Two Split Drawers	L•16
8VSD.FP	Vanity Sink Drawer Base w/Eight Drawers & False Panel	P•34-P•35	B2D.RT	Base w/Two Split Drawers & Roll Tray	L•17
ABBEYCOLINS	Abbey Column Insert - Island	R•49	B4D	Base Double Door w/Four Split Drawers	L•18-L•19
ABBEYCOLINST	Abbey Column Insert - Bar	R•49	B4D.RT	Base Double Door w/Four Split Drawers & Roll Tray	L•18
ABBEYCORINSL	Abbey Corbel Insert - Large	R•27	B4D.RT	Base Double Door w/Four Split Drawers & Roll Trays	L•19
ABBEYCORINSM	Abbey Corbel Insert - Medium	R•27	BAC	Base Angled Cabinet	L•85

# Code Index

Code	Description	Page Number
BAC..FH	Full Height Base Angled Cabinet	L●85
BANDVEN	Edgebanding	S●14
BARISLCOLUMN	Baroque Column	R●45
BARV	Baroque Valance	R●18
BASILCOLINS	Basilica Column Insert - Island	R●49
BASILCOLINST	Basilica Column Insert - Bar	R●49
BASILCORINSL	Basilica Corbel Insert - Large	R●27
BASILCORINSM	Basilica Corbel Insert - Medium	R●28
BASILCORINSS	Basilica Corbel Insert - Small	R●28
BASILINS	Basilica Crown Insert	R●6
BASILINSS	Basilica Light Rail Insert	R●7
BASKET	Base Open Basket Kits	S●2
BBCPO	Base Box Column Pull-out, Plain	L●89
BBCPO..OL	Base Box Column Pull-out, Overlay	L●90
BBM	Decorative Baseboard Moulding	R●9
BBMSC	Baseboard Moulding Sculpted	R●9
BBMSH	Baseboard Moulding Shaker	R●9
BBMWD	Base Built-in Microwave Cabinet w/Drawer	N●13
BBOARDKIT	Bread Board	S●3
BBS	Base w/Bottle Storage	L●100
BBSKIT18	Base Bottle Storage Kit	S●2
BC	Base Corner	L●59
BC..PO	Base Corner Pull-out	L●61
BC2DB	Bath Two Drawer Sink Base	P●59
BCB..NTK	Bath Base Cabinet	P●53
BCBCD	Bath Sink Base Cabinet w/Doors	P●55
BCBCO	Bath Sink Base Cabinet w/Shelf	P●54
BCBDT..NTK	Bath Drop Tray Sink Base	P●60
BCBH..D	Bath Hamper Sink Base	P●56
BCC..BB	Base Cooking Center w/Bread Board	L●37
BCCWM	Bath Channel Wall Mirror	P●66
BCD	Base Combination Drawer Cabinet	L●36
BCDB	Bath Drawer Sink Base	P●59
BCDRW	Bath Drawer Sink Vanity	P●60
BCFW	Base Corner Full Width	L●60
BCFW..CPO	Base Corner Full Width w/Arched Pull-out	L●63
BCFW..P	Base Corner Full Width Peninsula	L●66
BCFW..PO	Base Corner Full Width Pull-out	L●62
BCFW..SP	Base Corner Full Width w/Roll Trays & Swing-out	L●63
BCFW2D..CRVPO	Two Drawer Base Corner Full Width w/Curve Pull-out	L●65
BCFWFH..CPO	Full Height Base Corner Full Width w/Arched Pull-out	L●64
BCFWFH..CRVPO	Full Height Base Corner Full Width w/Curve Pull-out	L●65
BCFWM	Bath Framed Wall Mirror	P●66
BCOPP	Base Container Organization Pantry	L●93
BCOPPKIT	Kit Components for BCOPP	S●2
BCP	Base Corner Peninsula	L●81
BCPLATFORM	Bath Drawer Sink Vanity Platform	P●60
BCST	Bath Storage Tower	P●61
BCSTDRW	Bath Storage Tower Double Drawer	P●64
BCSTDRW	Bath Storage Tower Single Drawer	P●62-P●63
BCTT	Bath Tank Topper	P●65
BCTTOS	Bath Tank Topper Open Shelf	P●65
BCWHC	Bath Wall Hung Sink Console	P●52
BCWHDB	Bath Wall Hung Sink Drawer Base	P●56-P●57
BCWHDBPO..D	Bath Wall Hung Sink w/Grooming Pull-out	P●58
BCWT	Bath Sink Wall Tower	P●53
BDW	Base Dishwasher Cabinet	L●51
BEADED	Beaded Inset Door Modification	G●12
BEAS	Base Easy Access Storage	L●15
BEC	Base End Cabinet	L●84
BEP	Angled Base End Panel	Q●14
BEP	Corner End Panels	Q●23
BEPE..WD	Base End Panel	Q●13
BEPOF..WD	End Panels - Full Overlay	Q●15
BEPS	Skins	Q●18
BEPS..VG	English Country Car Siding Skins	Q●18
BEPWD	Base End Panel	Q●13
BER	Asymmetrical Base Easy Reach	L●68
BER	Base Easy Reach	L●69
BER..RS	Base Easy Reach w/Reduced Shelf	L●70
BER..S	Base Easy Reach w/Lazy Susan	L●72

Code	Description	Page Number
BER..SKIT	Lazy Susan Kit	S●8
BFH..CIA	135° Corner Inside Base	L●87
BFH..COA	135° Corner Outside Base	L●86
BHRES	Base Half Round End Shelf	L●101
BIJBUNFOOT	Bijou Bun Foot	R●32
BLOWER	Wood Hood Blower	K●11, K●12
BLS	Base Lazy Susan	L●67
BLSBEPWD	Lazy Susan Base Panel	Q●19
BLSKIT	Lazy Susan Kit	S●8
BMC	Base Message Center	L●108
BMW..RT	Base Microwave Cabinet w/Roll Tray(s)	N●12
BMWD	Base Microwave Cabinet w/Drawer	N●13
BMWD..DD	Base Microwave Cabinet w/Deep Drawer	N●14
BND.ALL	Band All Edges Modification	G●8
BND.FRT	Banding Location Modification	G●8
BO	Base Oven Trimmable Cabinet	
BO..AC	Base Oven Cabinet	N●16
BO..LD	Base Oven Cabinet w/Lower Drawer	N●17
BOB..AV	Base Open Basket w/Arched Valance	L●89
BOCB	Base Open Cabinet w/Car Siding Back	L●106
BOCP	Base Open Cabinet w/Plain Back	L●106
BODB	Base Open Cabinet w/Car Siding Back & Drawer	L●107
BODP	Base Open Cabinet w/Plain Back & Drawer	L●107
BP	Paneling	Q●19
BP..VG	English Country Car Siding Paneling	Q●19
BPCS	Base Pantry Can Storage	L●37
BPP	Base Pantry Pull-out	L●90
BPPKIT..PG	Base Can Storage Kit	S●2
BPPP	Base Pots & Pans Pull-out	L●35
BPS	Base Pots & Pans Storage	L●35
BPS..KIT	Base Pans Storage	S●3
BQRES	Base Quarter Round End Shelf	L●101
BRACKETBAROQUE	Baroque Bracket	R●23
BRACKETCELTIC	Celtic Bracket	R●23
BRACKETIND	Industrial Bracket, Loop	R●22
BRACKETOWD	Old World Bracket	R●23
BRAIDM	Braided Moulding	R●5
BRDB	Base Rotating Deep Bin	L●76
BRDB..KIT	Lazy Susan Kit	S●8
BRIDGE.BTM	Position Bridge on Bottom of Wall Cabinet	T●2
BRIDGE.TOP	Position Bridge on Top of Wall Cabinet	T●2
BRIDGECABLE	Jumper Cables	T●1
BRKOFFSCREW	Installation Hardware Parts	S●16
BSC3OPR, R, RP, RS, SR	30" SuperCabinet	L●20
BSC36PRP, PRS, SRP, SRS	36" SuperCabinet	L●21
BSCG	Base SuperCabinet Gourmet	L●22
BSD	Base Spice Drawer	L●100
BSM	Base Shoe Moulding	R●9
BSP..PG	Base Spice Pull-out	L●91
BTC	Base Transition Cabinet	L●83
BTDDP	Base Tray Divider Pantry Pull-out	L●92
BTDDPKIT	Kit Components for BTDDP	S●2
BUMPERPADS	Installation Hardware Parts	S●16
BUMPERRT	Roll Tray Bumper Pads	S●14
BUMPERSTEM	Stem Bumper Pads	S●14
BUPP	Base Utensil Pantry Pull-out	L●91
BUPPKB	Base Utensil Pantry Pull-out w/Knife Block	L●92
BUPPKBIT	Kit Components for BUPPKB	S●2
BUPPKIT	Kit Components for BUPP	S●2
BVR	Bottom Valance Rail Modification	G●19
BWB	Base Wastebasket	L●94
BWB..BB	Base Wastebasket w/Bread Board	L●96
BWB..CHGDRW	Base Wastebasket w/Charging Drawer	L●98
BWB..FH	Base Wastebasket Full Height	L●95
BWB..FHKIT	Wastebasket Assembly	S●11, S●11
BWB..FHRT2	Base Wastebasket Full Height w/Roll Tray	L●96
BWB..KCUUP	Base Wastebasket w/Wood Tiered K-Cup Drawer	L●97
BWB..KIT	Wastebasket Assembly	S●11, S●11
BWB..WTCU	Base Wastebasket w/Wood Tiered Cutlery Divider	L●97
BWBFHLID	Base Wastebasket Lid	S●12
BWBLLID	Base Wastebasket Lid	S●12

Code	Description	Page Number	Code	Description	Page Number
BWC	Base Wine Cubby	L●99	DAB	Diagonal Corner Sink Base without Shelf	L●68
CABMAT	CabMat	S●13	DAB_FS	Diagonal Base w/Full Shelf	L●69
CABMATV	CabMat Vanity	S●13	DAB_KIT	Lazy Susan Kit	S●8
CAPM	Cap Moulding	R●4	DAB_S	Diagonal Base w/Full Height Door & Lazy Susan	L●72
CBEADM	Center Beaded Moulding	R●5	DAB_SLS	Diagonal Base w/Full Height Door & Super Lazy Susan	L●74
CBO	Cabinet Box Only Modification	G●20	DAINTEGRATEDDF	Integrated Panels	Q●30
CCG	Craftsman Door Modification	G●14	DAINTEGRATEDDR	Integrated Panels	Q●30
CCO	Cabinet Case Only Modification	G●20	DAOVERLAY	Overlay Panels	Q●32
CCP	Craftsman Door Modification	G●14	DBLSQCHARLESTON	Charleston Bead Column, Double Square	R●48
CELTICFOOT	Celtic Foot	R●30	DBLSQSUMTER	Sumter Island Column, Double Square	R●48
CFB	Office & Vanity Fillers	Q●3	DBLSQTLB	Sumter Table Column, Double Square	R●48
CFNTO	Cabinet Front Only Modification	G●21	DCM	Corner Tall Moulding	Q●23
CFP	Cabinet False Panel Modification	G●30	DDGK_FXSRTPG	Deep Roll Tray Kit	S●9
CFRMO	Cabinet Frame Only Modification	G●21	DDO	Desk Door Drawer Base	Q●22
CG	Cut-for-glass Modification	G●15	DDR	Desk Drawer Base	Q●24
CGRAIL	Door Rail Material	Q●22	DE8	Dentil Moulding	R●6
CHARLESESPED	Charleston Pedestal	R●44	DECOBBM	Deco Baseboard Moulding	R●9
CHGDRW	Charging Drawer	S●6	DECOBUNFOOT	Deco Bun Foot	R●32
CHGDRW	Charging Drawer Modification	G●37	DECOV	Deco Valance	R●18
CIW	Cutlery Divider	S●5	DF3D	Desk File Drawer Base	Q●24
CLBUNNFOOT	Classic Bun Foot	R●28	DFD	Desk File Drawer Base	L●101, L●102
CLIP	Clipped Corner Modification	G●21	DFFSPC	Drawer Front Flat 5-piece Modification	G●9
CLTCROWN	Classic Tall Crown Moulding	R●2	DFFSPCINS	Drawer Front Flat 5-piece Inset Modification	G●10
CMAT	CabMat Modification	G●36	DFFSPCSLBT	Drawer Front Flat 5-piece w/Slab Top Modification	G●10
CND	Cabinet No Door Modification	G●21	DFRSPC	Drawer Front Raised 5-piece Modification	G●10
CNTYSB	Country Sink Base Cabinet	L●48	DFRSPCINS	Drawer Front Raised 5-piece Inset Modification	G●11
CNTYSB_CM	Country Sink Base w/CabMat	L●49	DFRSPCSLBT	Drawer Front Raised 5-piece w/Slab Top Modification	G●10
CNVLRAIL	Concave Light Rail Moulding	R●5	DFSLB	Drawer Front Slab Modification	G●11
CONCAP	Contemporary Cap	R●48	DFSLBT	Drawer Front Slab Top Modification	G●11
CONVERSION	Ductless Conversion Kit	K●12	DGK_FXSPG	Full Extension Drawer & Roll Tray Slides	S●14
CORBELACAN	Small Acanthus Corbel	R●26	DGK_FXSRTPG	Roll Tray Kit	S●9
CORBELACANS	Petite Acanthus Corbel	R●26	DISLEGFL	Fluted Island Leg	R●34
CORBELART	Art Corbel	R●25	DISLEGRP	Rope Island Leg	R●35
CORBELART	Arts & Crafts Corbel	R●25	DISLEGSQ	Square Island Leg	R●35
CORBELARTO	Arts & Crafts Open Corbel	R●25	DISLLEG	Kitchen Island Leg	R●34
CORBELBIJL	Large Bijou Corbel	R●26	DLEMISSION	Mission Leg	R●35
CORBELBIJS	Small Bijou Corbel	R●26	DO_FH	Desk Office Base w/Full Height Doors	Q●23
CORBELCELTIC	Celtic Corbel	R●24, R●25	DOC	Double Outlet Cover	R●51
CORBELCLREV	Classic Revival Corbel	R●24	DOORONLY	Door Only	H●1
CORBELCRAFT	Craftsman Corbel	R●23, R●24	DRP	Double Rocker Plate	R●50
CORBELCRAFTO	Craftsman Corbel Open	R●23	DRP	Range Panel	L●58
CORBELMIS	Mission Corbel	K●23, R●27	DRRAILCROSS	Door Rail Material	Q●22
CORBELNOUL	Plain Nouveau Large Corbel	R●26	DRRAILEND	Door Rail Material	Q●22
CORBELNOUM	Plain Nouveau Medium Corbel	R●26	DRT	Deep Roll Trays Modification	G●31
CORBELNOUS	Plain Nouveau Small Corbel	R●26	DRT_SP	Deep Roll Tray Kit	S●9
CORBELOWD	Old World Corbel	K●23, R●27	DRWFRONLY	Drawer Front Only	H●1
CORBELOWDSTR	Old World Corbel w/Strap	K●23, R●27	DRWRAILCROSS	Door Rail Material	Q●22
CORBELPALLA	Palladian Corbel	R●24	DRWRAILEND	Door Rail Material	Q●22
CORBELPINN	Pinnacle Corbel	R●25	DRWTK	Toekick Drawer Modification	G●30
CORBELSCR6	Scroll Corbel	R●27	DSP	Double Switch Plate	R●50
CORBELSHKR	Shaker Corbel	R●25, R●26	DW	Diagonal Wall	J●65
CORBELTRADO	Traditional Open Corbel	R●25	DW_AG	Diagonal Wall w/Vertical-Lift	J●70
CORBELTRIAD	Triad Corbel	R●25	DW_AGS	Diagonal Wall w/Vertical-Lift & Lazy Susan	J●71
CORBELWEAVEL	Large Weaved Corbel	R●26	DW_D	Diagonal Wall	J●65
CORBELWEAVES	Small Weaved Corbel	R●27	DW_D	Diagonal Wall w/Appliance Garage Open Bottom	J●68
COSFOOT	Cosmo Foot	R●30	DW_DS	Diagonal Wall w/Appliance Garage & Lazy Susan Open Bottom	J●69
COTCROWN	Cornice Tall Crown Moulding	R●2	DW_DS	Diagonal Wall w/Lazy Susan	J●69
COVECROWN	Cove Crown Moulding	R●2	DW_FH	Diagonal Wall w/Full Height Door	J●66
CPE	Cabinet Panel Edge	R●9	DW_FP	Diagonal Wall Peninsula	J●72
CPU	CPU Base	Q●25	DW_S	Diagonal Wall w/Lazy Susan	J●69
CRFTSMNBUNFOOT	Craftsman Bun Foot	R●31	DWLKIT	Lazy Susan Kit	S●8
CRFTSMNFOOT	Craftsman Foot	R●31	DWPWD	Dishwasher Panel	Q●19
CRFTSMNFOOTC	Craftsman Foot, Corner	R●31	EB	Entertainment Base	Q●12
CRFTSMNV	Craftsman Valance	R●18	EB_NTK	Entertainment Base, No Toekick	Q●12
CS	Corner Sink Base without Shelf	L●67	EBCF	Entertainment Box Column Filler	Q●15
CSDG	Car Siding	Q●21	EBDB	Entertainment Base w/Drawers	Q●14
CSDGBK	Car Siding Back Modification	G●36	EEDB	Entry Ensemble Drawer Base	Q●3
CSFPE	Car Siding Flush Panel End Modification	G●25	EGRM	Grommet	Q●8
CUD	Cooking Utensil Divider	S●4	EEHDB	Double Hook Black	Q●8
CUDD	Cooking Utensil Divider	S●3	EEHDN	Double Hook Nickel	Q●8
DAAUTHENTIC	Authentic Panels	Q●27	EEHSB	Single Hook Black	Q●8

# Code Index

Code	Description	Page Number
EEHSN	Single Hook Nickel	.Q08
EEOB	Entry Ensemble Open Base	.Q04
EEPWR	Power Strip	.Q08
EESTW	Entry Ensemble Stacked Wall	.Q06
EESTWM	Entry Ensemble Stacked Wall Message	.Q07
EESTWO	Entry Ensemble Stacked Wall Open	.Q05
EET	Entry Ensemble Tall	.Q03
ENGCONTYLEG	English Country Leg	R037
ENGISLCOLUMN	English Country Island Column	R044
ENGISLQTRCOL	English Country Island Quartered Column	R044
EOD	Entertainment Open Drawer	.Q12
EP	Entertainment Platform	.Q16
ER	Asymmetrical Easy Reach Wall Corner	J063-J064
ER	Easy Reach Wall Corner	J063
ESMD	Estate Mullion Door Modification	G015
ESTATE	Estate Leg	R038
ESTW	Entertainment Stacked Wall	.Q13
ET	Entertainment Topper	.Q15
EW	Entertainment Wall	.Q13
EX	Extended Stiles Modification	G022
EXBK	End Extended Back Modification	G025
EXBOL	Extended Stile w/Overlay Modification	G021
EXDN	Wall End and Back Extended Down Modification	G029
EXLOL	Extended Stile w/Overlay Modification	G021
EXROL	Extended Stile w/Overlay Modification	G021
EXT.BTM.LGT.C	Add Exterior Cool Light to Bottom of Wall Cabinet	T03
EXT.BTM.LGT.W	Add Exterior Warm Light to Bottom of Wall Cabinet	T03
F	Wall Fillers	.Q02
F.ALL	Finished Edges - All Modification	G08
F.FRT	Finished Edges Modification	G08
FALSEPANELCLIP	Turnbuckles for False Drawer Fronts	S014
FB	Angled Fillers	.Q12
FB	Base Fillers	.Q02
FB	Wall & Base Fillers	.Q03
FBCO	Office & Vanity Fillers	.Q03
FBCV	Office & Vanity Fillers	.Q03
FBF	Finished Blind Modification	G022
FD	Full Depth Shelf Modification	G038
FD	Furniture Drawer	L102, L103
FDSRTBTM	Roll Tray Bottom w/Full Depth Shelf Modification	G031
FDWB	Furniture Drawer Window Bench	L104
FF	Wall Fluted Fillers	.Q04
FFB	Base Fluted Fillers	.Q04
FFD	Face Frame and Door on End Modification	G026
FFO	Office Fluted Fillers	.Q05
FFRAIL	Frame Rail Material	Q022
FFV	Vanity Fluted Fillers	.Q05
FILTER	Ductless Conversion Kit	K012
FINKIT	Finish Kit	E012
FL	Finished Ends Modification	G08
FLUT	Fluting Modification	G037
FLUT	Fluting on Fillers Modification	G037
FLUTELEG	Flute Leg	R041
FO	Angled Fillers	.Q12
FO	Office Fillers	.Q02
FOLCROWN	Full Overlay Crown Moulding	R03
FOOTMETAL	Bath Feet	P067
FOOTULIPSQ	Tulip Foot Square	R029
FPE	Flush Panel End Modification	G026
FR	Finished Ends Modification	G08
FRNCNTYFOOT	French Country Foot	R030
FRNCNTYLEG	French Country Leg	R038, R039
FRNCNTYRDLEG	French Country Reeded Leg	R039
FRNCNTYSQLEG	French Country Square Leg	R039
FRNLG	Queen Anne Leg	R040
FS	Floating Shelf	J090, R021
FSCO..KIT	Food Storage Container Organizer Kit	S02
FTF	Tall Fluted Fillers	.Q05
FTK	Flush Toekick Modification	G022
FTKAV	Flush Toekick - Arch Modification	G022
FU	Angled Fillers	.Q12

Code	Description	Page Number
FV	Angled Fillers	.Q12
FV	Vanity Fillers	.Q02
FW	Angled Fillers	.Q12
FW	Wall & Base Fillers	.Q03
GAELICLEG	Gaelic Leg	R041
GAMD	Gallery Mullion Door Modification	G015
GLAZEPEN	Glaze Pen	E012
GLAZEQUART	Quart of Glaze	E012
GPOKIT	Bath Grooming Pull-out Kit	P067
GRO	Grape Rosette	R016
GROVLY	Grape Decorative Onlays/Overlays	R020
GSK	Bath Glass Shelf	S07
GSK	Glass Shelf Kits	S07
H..DF	Hearth Door Front Configurations	K021, K022
HAMPERKIT	Bath Hamper Kit	P066
HAMPERKIT	Chrome Hamper	S012
HAMPPEDFOOTC	Hampton Pedestal Foot, Corner	R030
HAMPPEDFOOTCTR	Hampton Pedestal Foot, Center	R031
HAMPPEDFOOTL	Hampton Pedestal Foot, Left	R030
HAMPPEDFOOTR	Hampton Pedestal Foot, Right	R030
HB	Hutch Base	L105
HCG	Horizon Door Modification	G015
HCP	Horizon Door Modification	G015
HE	Hutch End Panel	Q019
HINGE	Hinges	S015
HINGEFH	Faux Hinge Strap	S016
HINGEFH	Faux Hinges	S016
HINGEISCPIT	Hinge Plates	S015
HINGERESCLIP	Hinge Angle Restriction Clip	S015
HINGERESCLIPIN	Hinge Angle Restriction Clip Inset	S015
HL	Hearth Liner	K023
HM	Hearth Mantel	K020
HNGSPACER	Hinge Spacers	S014
HOF	Hearth Overlay Fillers	K023
HP	Hearth Pier	K019
HPP	Hearth Pier Pull-out	K020
HPPKIT	Hearth Tower Pull-out Kit	S08
HS	Hearth Shelf	K022
IAPPLIANCE	Inset Appliance Panels	Q029
ICM	Inside Corner Moulding	R08
ICMA	Inside Corner Moulding (#2)	R08
ID	Increased Depths Modification	G038
IF	Inset Finial Hinges Modification	G012
IH	Increased Heights Modification	G040
IH+DRW	Increased Height Plus Drawer Modification	G039
INDFOOT	Industrial Foot	R032
INDLEG	Industrial Leg	R043
INSCROWN	Inset Panel Crown	R04
INSERTFRM	Create-A-Crown Inset	R04
INT.ALL.LGT	Add Interior Light to All Openings of Cabinet	T02
INT.BTM.LGT	Add Interior Light to Bottom Opening of Cabinet	T03
INT.LGT	Add Interior Light to Single Opening Wall Cabinet or Corner Base Cabinet	T02
INT.MID.BTM.LGT	Add Interior Light to Middle and Bottom Openings of Cabinet	T03
INT.MID.LGT	Add Interior Light to Middle Opening of Cabinet	T02
INT.TOP.BTM.LGT	Add Interior Light to Top and Bottom Openings of Cabinet	T03
INT.TOP.LGT	Add Interior Light to Top Opening of Cabinet	T02
INT.TOP.MID.LGT	Add Interior Light to Top and Middle Openings of Cabinet	T03
INTGE	Integral End Modification	G028
INVERM	Inverted Frame Modification	G022
IPE	Inset Panel Ends Modification	G027
IW	Increased Widths Modification	G046, G048
JINSERTLRC	Contemporary Light Rail Moulding	R05
JINSERTLRT	Traditional Light Rail Moulding	R05
JWHIA	Wood Hood Island Arch	K08
JWHIS	Wood Hood Island Straight	K09
JWHL	Wood Hood Linear	K09
JWHSHPCH	Wood Hood Shiplap Tapered Chimney	K08
JWHSHPSTR	Wood Hood Shiplap Straight	K07
JWHSHPSTRCB	Wood Hood Shiplap Straight w/Corbel	K07
JWHSIPT	Wood Hood Shiplap Tapered	K07
JWHSIPTCB	Wood Hood Shiplap Tapered w/Corbel	K08

Code	Description	Page Number	Code	Description	Page Number
KBT	Keyboard Tray	.0●25	OC	Outside 135° Corner Moulding	.R●8
KCUP	Wood Tiered K-Cup Drawer w/Installation Hardware	.S●6	OCD	Double Oven Trimmable Cabinet	.N●36-●00
KENSFOOT	Kensington Foot	.R●31	OCD.AC	Built-in Double Oven Cabinet	.N●48-N●51
KENSINGLEG	Kensington Leg	.R●39	OCD.DD	Double Oven Trimmable Cabinet w/Deep Drawer	.N●52-N●53
KF	Stainless Hood Filter	.K●11	OCM	Outside Corner Moulding	.R●8
KNOB	Decorative Pulls & Knobs	.S●17-S●18	OCM.AC	Tall Built-in Microwave Cabinet	.N●18-N●20
LB	Light Baffle	.R●5	OCS	Single Oven Trimmable Cabinet	.N●44-N●45
LC	Linen Closet	.P●50	OCS.AC	Built-in Single Oven Cabinet	.N●40-N●43
LCRH	Linen Closet w/Removable Hamper	.P●51	OCS.DD	Single Oven Trimmable Cabinet w/Deep Drawer	.N●46-N●47
LEVELER	Leveler	.R●33	OCS.D	Single Oven Cabinet w/Drawers	.N●38-N●39
LEXISLKIT	Lexington Island Pedestal Kit	.R●43	OCS.D	Single Oven Trimmable Cabinet w/Drawers	.N●38-N●39
LEXSHLFSTRP	Lexington Shelf Strap	.R●23	OCS.D.AC	Built-in Single Oven Cabinet w/Drawers	.N●32-N●35
LEXTBLKIT	Lexington Table Pedestal Kit	.R●43	OFB	Base Overlay Fillers	.Q●9
LGCORBEL	Large Shelf Support	.R●21	OFBC	Overlay Fillers	.Q●10
LGGRRPSUPPORT	Large Grape Shelf Support	.R●21	OFO	Office & Vanity Overlay Fillers	.Q●9
LH..KIT	Lid Pull-out Kit	.S●12	OFV	Office & Vanity Overlay Fillers	.Q●9
LIFLUTFOOT	Lille Fluted Foot	.R●28	OGEM	Ogee Moulding	.R●6
LIFOOT	Lille Foot	.R●28	OL	Utility Overlay Fillers	.Q●9
LO	Lid Organizer	.S●8	OL	Wall Overlay Fillers	.Q●8
LOSC	Large Outside Corner	.R●9	OMC	Microwave & Single Oven Trimmable Cabinet	.N●28-N●29
LRCROWN	Large Insert Crown	.R●3	OMC.AC	Built-in Oven Microwave Cabinet	.N●23-N●27
LRM	Light Rail Moulding	.R●5	OMC.DD	Microwave & Single Oven Trimmable Cabinet w/Deep Drawer	.N●30-N●31
LSACROWN	Large Straight Angle Crown Moulding	.R●3	OSV	Overlay Valance	.R●19
LSHAKER	Large Shaker Crown Moulding	.R●3	PAINTQUART	Quart of Paint	.E●12
LSM	Large Scribe Moulding	.R●7	PDM	Premium Door Mechanism	.S●15
LSP	Lazy Susan Pull-out	.I●77	PDO	Pegged Dish Organizer	.S●8
LSPOLEKIT	Lazy Susan Pole Kit	.S●8	PDOPOSTS	Pegged Dish Organizer	.S●8
LT	Linen Storage Cabinet	.P●51	PEDFOOTC	Pedestal Foot - Corner	.R●29
MADEFOOT	Madeline Bun Foot	.R●30	PEDFOOTL	Pedestal Foot - No Return Left	.R●29
MADLINEPOSTL	Madeline Post, Large	.R●37	PEDFOOTR	Pedestal Foot - No Return Right	.R●29
MADFOOT	Madison Foot	.R●31	PEDFOOTRETL	Pedestal Foot - Return Left	.R●29
MAGCATCHINSET	Inset Magnetic Catches	.S●14	PEDFOOTRETR	Pedestal Foot - Return Right	.R●29
MCFOOTM	Mid-Century Foot, Medium	.R●32	PFINBTMB	Finished Bottom Modification	.G●8
MCFOOTS	Mid-Century Foot, Short	.R●32	PIL	Pilasters	.Q●23, Q●24
MCFOOTT	Mid-Century Foot, Tall	.R●32	PINNV	Pinnacle Valance	.R●18
MCG	Mission Door Modification	.G●16	PPH..KIT	Pots & Pans Pull-out Kit	.S●9, S●13
MCISLCOLUMN	Mid-Century Island Column	.R●47	PPP..KIT	Pots & Pans Pull-out Kit	.S●9, S●13
MCLEG	Mid-Century Leg	.R●43	PRCCOLUMN	Pacific Rim Create A Column	.R●47
MCLEG	Mid-Century Table Leg	.R●42	PRISLCOLUMN	Pacific Rim Island Column	.R●47
MCMFOOT	Mid-Century Metal Foot	.R●33	PRLEG	Pacific Rim Leg	.R●42
MCP	Mission Door Modification	.G●16	PRMD	Prairie Mullion Doors Modification	.G●17
MCVANCOLUMN	Mid-Century Vanity Column	.R●48	PRO	Profiled and Finished Edges Modification	.G●9
MD	Mullion Doors Modification	.G●16	PRO.ALL	Profiled and Finished Edges - All Modification	.G●9
MDCCRNSHLF	Modern Corner Shelf	.R●20	PSBKIT	Plastic Storage Bins	.S●8
MDCLIPS	Mullion Door Clips	.S●14	PTOWB	Push-to-Open Wastebasket Modification	.G●13
MDFLCRNSHLF	Modern Floating Corner Shelf	.R●20	PULL	Decorative Pulls & Knobs	.S●17-S●18
METBARCOLUMN	Metro Bar Column	.R●45	PWRPOD	Power Pod	.S●10
METISLCOLUMN	Metro Island Column	.R●45	PY	Pantry Unit	.M●25-M●26
METROFOOT	Metropolitan Foot	.R●31	QACRNRACALEG	Queen Anne Corner Acanthus Leg	.R●40
MFO	Modified Full Overlay Modification	.G●13	QACRNRFLUTLEG	Queen Anne Corner Fluted Leg	.R●40
MIP	Matching Interior Modification	.G●9	QACRNRLEG	Queen Anne Corner Leg	.R●40
MIXKIT	Mixer Shelf w/Pop-Up Shelf	.S●8	QAFOOT	Queen Anne Foot	.R●31
MLDG	Moulding Location Modification	.G●35	QALEGT	Queen Anne Buffet Column	.R●46
MSACROWN	Medium Straight Angle Crown Moulding	.R●3	QASCROLLFOOT	Queen Anne Scroll Foot	.R●32
MTCROWN	Tall Crown Moulding	.R●4	QRM	Quarter Round Moulding	.R●8
MUNTIN	Door Rail Material	.Q●22	R..PD	Range Platform w/Drawers	.I●58
MV	Vanity Base without Shelf	.P●13	RCPV	Recessed Panel Valance	.R●18
MW	Wall Microwave Cabinet	.N●3	RCTM	Round Countertop Moulding	.R●7
MW	Wall Microwave Double Door Cabinet	.N●4-N●8	RD	Reduced Depths Modification	.G●38
NAT	Natural Material	.Q●20	RDBUNNFOOT	Bunn Foot	.R●28
NATVEN	Natural Veneer	.Q●20	RDEG	Reed Leg	.R●34
NHC	No Hinge Cut Modification	.G●16	REC	Recessed Vanity Wall Modification	.G●23
NMCFOOTM	Notched Mid-Century Foot, Medium	.R●32	RECTK	Recessed Toekick Modification	.G●29
NMCF	Notched Mid-Century Foot, Tall	.R●32	RECTKFRT	Recessed Toekick Front Modification	.G●23
NMCISLCOLUMN	Notched Mid-Century Island Column	.R●47	RETAINER	Retainer Clips	.S●14
NMCVANCOLUMN	Notched Mid-Century Vanity Column	.R●48	RH	Reduced Heights Modification	.G●40
NOBEAD	Inset Door Modification	.G●12	RHSS	Range Hood Stainless Steel Square	.K●10
NOULEG	Plain Nouveau Island Column	.R●45	RHSS-DEV	Stainless Hood Air Deviators	.K●11
NOULEGT	Plain Nouveau Bar Column	.R●45	RHST	Range Hood Stainless Steel Tapered	.K●10
O..BCFP	Box Column Fillers, Office	.Q●11	RHST-DEV	Stainless Hood Air Deviators	.K●11
OBRB	Open Bottom Rail Base Modification	.G●22	ROPELEG	Rope Leg	.R●40



# Code Index

Code	Description	Page Number
ROSETTEACA	Acanthus Rosette	R•16
ROSETTEFLW	Flower Rosette	R•16
ROSETTEGAE	Small Gaelic Rosette	R•16
ROSETTELGPK	Peaked Large Rosette	R•16
ROSETTEMIS	Mission Rosette	R•16
ROSETTEPINN	Pinnacle Rosette	R•20
ROSETTESMPK	Peaked Small Rosette	R•16
ROSETTETRIAD	Triad Rosette	R•20
ROSFLUT	Rose Fluting Modification	G•50
ROSFLUT	Rose Fluting on Fillers Modification	G•50
ROUNDBASE	Round Base	R•44
RPM	Rope Moulding	R•6
RPV	Raised Panel Valance	R•18
RSTCCRNHLF	Rustic Corner Shelf	R•20
RSTCFLTRNHLF	Rustic Floating Corner Shelf	R•20
RT	Roll Trays Modification	G•31
RT.SP	Roll Tray Kit	S•9
RW	Reduced Widths Modification	G•49
SACROWN	Straight Angle Crown Moulding	R•3
SB	Sink Base	L•38, L•43
SB..CDY	Sink Base Double Door w/Caddy	L•39
SB..CM	Sink Base Double Door w/CabMat	L•39
SB..D	Sink Base w/Drawer Below	L•50
SB..S	Sink Base SuperCabinet	L•45
SB..SCDY	Sink Base SuperCabinet w/Caddy	L•45
SB..SCM	Sink Base SuperCabinet w/CabMat	L•46
SB..ST	Sink Base w/Tilt-out Tray	L•40-L•41, L•44
SB..STCDY	Sink Base w/Tilt-out Tray & Caddy	L•42
SB..STCM	Sink Base w/Tilt-out Trays & CabMat	L•42
SB..STS	Sink Base SuperCabinet w/Tilt-out Tray	L•46
SB..STSCDY	Sink Base SuperCabinet w/Tilt-out Tray & Caddy	L•47
SB..STSCM	Sink Base SuperCabinet w/Tilt-out Trays & CabMat	L•47
SBARLEG	Bar Leg	R•35
SBCADDY	Sink Base Cleaning Caddy	S•13
SBCADDY	Sink Base Cleaning Caddy Modification	G•51
SBCADDYSM	Sink Base Cleaning Caddy	S•13
SBCADDYSM	Sink Base Cleaning Caddy Small Modification	G•51
SBE	Single Bead Edge	R•6
SBM	Single Bead Moulding	R•6
SBS	Countertop Support	R•22
SCM	Soffit Scribe Crown Moulding	R•3
SCPDRW	Scooped Drawers Modification	G•32
SD	Spice Drawer	S•9
SF	Sink Front	L•51, L•52
SFB	Sink Front Bottom	L•52
SFM	Soffit Filler Moulding	R•2
SHAPE	Profile Edge Moulding	R•7
SHELF	Shelving Material	Q•22
SHELFIND	Floating Shelf	R•21
SHELFIND	Industrial Shelf	R•21
SHELFPEGS	Plastic Shelf Clips	S•14
SHKRCRM	Shaker Crown Moulding	R•3
SHM	Shoe Convex Inside Corner Moulding	R•9
SHMD	Shaker Mullion Door Modification	G•17
SIMCROWN	Simplicity Crown	R•2
SISLLEG	Island Leg	R•36
SLS..KIT	Lazy Susan Kit	S•8
SLSR	Super Lazy Susan w/Chrome Rail	L•75
SLSR..CD	Super Lazy Susan w/Chrome Rail & Corner Drawer	L•76
SLSR..KIT	Lazy Susan Kit	S•8
SLSR..RS	Super Lazy Susan w/Chrome Rail & Reduced Shelf	L•71
SLSW	Super Lazy Susan	L•73
SM	Small Batten Moulding	R•8
SM..LG	Large Batten Moulding	R•8
SMCORBEL	Small Shelf Support	R•22
SMCOVFCROWN	Small Cove Crown Moulding	R•2
SMGRPSUPPORT	Small Grape Shelf Support	R•21
SMLR	Small Light Rail Moulding	R•5
SMSQFOOT	Square Foot	Q•15, R•29
SOC	Single Outlet Cover	R•51
SOLID	Solid Wood	Q•21

Code	Description	Page Number
SPICE..PG	Spice Pull-out	S•10
SPLEG	Spool Leg	R•34
SPLITDR	Split Doors Modification	G•14
SPLITDRWS	Split Drawers Modification	G•14
SPTRINGEND	Split Turning Systems End	R•17
SPTRINGREED	Split Turning Systems Reed	R•17
SPTRINGROPE	Split Turning Systems Rope	R•17
SPTRINGSPOOL	Split Turning Systems Spool	R•17
SQBARLEG	Bar Leg, Square	R•35
SQISLLEG	Island Leg, Square	R•36
SQLEG	Square Leg w/Sleeve	R•42, R•43
SRP	Single Rocker Plate	R•50
SSC	Lacquer Spray Can	F•12
SSM	Small Scribe Moulding	R•7
SSP	Single Switch Plate	R•50
STAINQUART	Quart of Stain	F•12
STAND	Standard Drivers	T•1
STBRACKETIND	Industrial Bracket, Straight	R•22
STKMLD	Stack Moulding Kits	R•10-R•15
STM	Soffit Trim Moulding	R•4
STORB	Storage Open Rail Base Modification	G•23
STR	Sliding Towel Bar	S•9
STR	Starter Moulding	R•2
STRETCHERMAT	Stretcher Material	Q•22
STRS	Starter Shaker Moulding	R•2
STW	Stacked Wall	J•28-J•35
STW	Stacked Wall Cabinet Heights Modification	G•23
STWAG	Stacked Wall w/VerticalHift	J•36-J•39
STWDAG	Stacked Wall w/Appliance Garage	J•24-J•27
STWEC	Stacked Wall End Cabinet Single Door	J•42
STWEC..D	Stacked Wall End Cabinet Double Door	J•41
STWTC	Stacked Wall Transition Cabinet	J•43, J•44
SUMD	Summit Mullion Door Modification	G•17
SUMFOOT	Summit Foot	R•30
SWCRM	Crown Moulding	R•2
SWLCRM	Large Crown Moulding	R•3
SWTCRM	Solid Wood Tall Crown Moulding	R•4
SWVCRM	Insert Crown Moulding	R•3
T..BCAV	Tall Bookcase w/Arched Valance	Q•29-Q•31
T..BCFP	Box Column Fillers, Tall	Q•11
T4SLEG	Tapered 4-Sided Leg	R•30
TABLEHLDR	Tablet Holder	S•11
TAPLG	Tapered Leg	R•30
TB8WD	Toe Board Trim	Q•18
TBATM	Traditional Batten Moulding	R•8
TBEM	Triple Bead Moulding	R•6
TBMWB	Oven Microwave Trimmable Cabinet	N•21-N•22
TBN	Nickel Towel Bar Modification	G•24
TCEP	Corner End Panels	Q•23
TCG	Transom Doors Modification	G•18
TCM	Beveled Edge Moulding	R•7
TCP	Transom Doors Modification	G•18
TCROWN	Tall Crown Moulding	R•4
TD	Base w/Tray Divider	L•82
TD	Tray Divider Modification	G•52
TD..BCAV	Tall Bookcase w/Doors & Arched Valance	Q•32-Q•34
TD..FH	Full Height Base w/Tray Divider	L•82
TDKIT	Tray Divider	S•10
TD0..BCAV	Tall Bookcase w/Office Height Doors & Arched Valance	Q•38-Q•40
TDRO	Tray Divider Roll-out	S•10
TDROHDONLY	Tray Divider Roll-out	S•10
TDV..BCAV	Tall Bookcase w/Vanity Height Doors & Arched Valance	Q•35-Q•37
TEP	Angled Tall End Panels	Q•14
TEP	Refrigerator Panel	Q•16-Q•17
TEP..OF3WD	End Panels - Full Overlay	Q•15
TEPS	Skins	Q•18
TEPS..VG	English Country Car Siding Skins	Q•18
TF	Tall Fluted Fillers	Q•5
TF	Utility Fillers	Q•3
TKC	Toekick Caps	Q•19
TKP	Toekick Pedestal Modification	G•30

Code	Description	Page Number	Code	Description	Page Number
TKTLFOOT	Toekick Tulip Foot	R•29	VSF	Vanity Sink Front	P•41
TLCROWN	Tall Crown Moulding	R•4	VSHDB..D	Vanity Sink & Hamper Drawer Base	P•39
TLEG	Tapered Leg	R•30	VSSB..ST	Vanity Sink Base SuperCabinet w/Tilt-out Trays	P•18
TLFOOT	Tulip Foot	R•29	VTK	Void Toekick Modification	G•30
TLR	Traditional Light Rail	R•5	VUD	Vanity Utility w/Drawers	P•50
TM	Trim Moulding	R•4	VV	Straight Valance	R•19
TONERQUART	Quart of Toner	F•12	VWB	Vanity Wastebasket Container	G•52
TOTSSS	Tilt-out Tray(s) Stainless Steel	S•6	VWR	Vanity Recessed Cabinet	P•4
TPP	Tall Pantry Pull-out	M•22-M•24	VWR	Vanity Wall Recessed Cabinet	P•5
TRBD	Base Recycling Center	L•99	W	Vanity Wall	P•3, P•4
TRIBRKT	Mid-Century Bracket	R•22	W	Wall	J•3-J•19
TROSETTE	Traditional Rosette	R•16	W	Wall Refrigerator	J•45-J•48
TSTM	Soffit Trim Moulding	R•4	W	Wine Cube Horizontal	J•95
TUDORCOLINS	Tudor Column Insert - Island	R•49	W..BCAV	Wall Bookcase w/Arched Valance	O•26-O•28
TUDORCOLINST	Tudor Column Insert - Bar	R•49	W..BCFP	Box Column Fillers, Wall	Q•10
TUDORCORINS	Tudor Corbel Insert - Large	R•28	W..CIA	135° Corner Inside Wall	J•88
TUDORCORINSM	Tudor Corbel Insert - Medium	R•28	W..COA	135° Corner Outside Wall	J•87
TUDORCORINSS	Tudor Corbel Insert - Small	R•28	W..P	Wall Peninsula	J•73-J•76
TUDORINS	Tudor Crown Insert	R•7	W..PD	Wall Refrigerator Pull-out Cabinet	J•49
TUDORINSS	Tudor Light Rail Insert	R•7	W2D	Wall w/Two Drawers	J•20-J•21
TUK	Touch-Up Kit	F•12	W3D	Wall w/Three Drawers	J•22-J•23
TV	Tri-View Medicine Cabinet	P•6	WAIN	Wainscoting	Q•26
TVR	Top Valance Rail Modification	G•24	WASTEBIN	Wastebasket Only	S•11, S•12
TWH	Tapered Wood Hood	K•10	WB	Wall Base	L•23
TWHBLOWER	Wood Hood Blower Unit	K•12	WBCPO	Wall Box Column Pull-out, Plain	J•102
U	Utility	M•3-M•11	WBCPO..OL	Wall Box Column Pull-out, Overlay	J•103
U..RT	Utility w/Roll Trays	M•18-M•21	WBCPOKUP	Wall Box Column Pull-out w/K-Cup	J•104
U3D	Utility w/Three Drawers	M•12, M•13	WBMW	Wall Built-in Microwave Double Door Cabinet	N•5-N•10
U4D	Utility w/Four Drawers	M•14, M•15	WBMW..AC	Wall Built-in Microwave Double Door Cabinet	N•5-N•10
UCD	Under Counter Drawer	P•46	WC	Wall Corner Double Door	J•54-J•62
UCD..T	Under Counter Drawer, Trimmable	P•46	WC	Wall Corner Single Door	J•52-J•61
UDBX	U-shaped Drawer Box Modification	G•32	WCD	Wall China Display	J•94
UDRT..SP	U-shaped Deep Roll Tray Kit	S•7	WCT	Traditional Window Casing	R•9
UI	Utility Inverted	M•16-M•17	WCT	Water Closet	P•6
UOC	Utility Organizer Cabinet	M•27-M•34	WCV	Wine Cube Vertical	J•95
UOCDZ	Utility Organizer Drop Zone Cabinet	M•35-M•36	WEAS	Wall Easy Access Storage Cabinet	J•13
UOCDZ..AE	Utility Organizer Drop Zone Cabinet w/Authentic End	M•37	WEAVEBUNFOOT	Weaved Bun Foot	R•32
URBANFT	Urban Foot	R•33	WEAVELEG	Weaved Island Column	R•46
URBANLEG	Urban Leg	R•43	WEAVELEG..L	Large Diamond Weaved Island Column	R•46
URBISLCOLUMN	Urban Island Column	R•46, R•47	WEAVELEGT	Weaved Bar Column	R•46
URT	U-shaped Roll Tray Modification	G•33	WEC	Wall End Cabinet Single Door	J•86
URT..SP	U-shaped Roll Tray Kit	S•7	WEC..D	Wall End Cabinet Double Door	J•85
UV	Vanity Utility	P•47-P•49	WEP	Angled Wall End Panel	Q•14
V	Vanity Base Single Door without Shelf	P•11	WEP	Corner End Panels	Q•23
V	Vanity Base without Shelf	P•12	WEPF	Wall End Panel	Q•13
V..BCFP	Box Column Fillers, Vanity	Q•11	WEPOF..WD	End Panels - Full Overlay	Q•15
V..S	Vanity Base Single Door w/Shelf	P•9	WEPS	Skins	Q•18
V..S	Vanity Base w/Shelf	P•10	WEPS..VG	English Country Car Siding Skins	Q•18
VACSF	Vanity Angled Corner Sink Front	P•45	WFOOTCHARLESTON	Charleston Bead Column w/Foot	R•48
VB	Vanity Base, Double Door w/Drawer	P•8	WGH	Stem Glass Holder	S•10
VB	Vanity Base, Single Door w/Drawer	P•7	WHA	Wood Hood Arch	K•3
VBP	Vanity Base Pull-out	P•13	WHAS	Wood Hood Artisan Straight	K•9
VBPKIT	Vanity Base Pull-out Kit	S•10	WHC	Wood Hood Chimney	K•3
VCDB..D	Vanity Combination Drawer Base w/Three Drawers	P•28	WHCA	Wood Hood Canopy Arched	K•4
VCD..FP	Vanity Sink Drawer Base w/Three Drawers & False Panel	P•23-P•24	WHCS	Wood Hood Canopy Square	K•5
VDB	Vanity Three Drawer Base	P•42-P•43	WHNA	Wood Hood Nantucket Arch	K•6
VDL2130WD	Tapered Vanity End Panel	Q•19	WHNC	Wood Hood Nantucket Chimney	K•6
VEN	Veneer	Q•21	WHNS	Wood Hood Nantucket Straight	K•6
VEPS	Skins	Q•18	WHS	Wood Hood Square	K•3
VEPS..VG	English Country Car Siding Skins	Q•18	WMC	Wall Message Center	J•89
VFR	Valley Forge Moulding	R•5	WNR	Wall Wine Rack	J•92
VH..FH	Vanity Hamper Base Cabinet	P•38	WNRMAT	Criss Cross Wine Rack Material	Q•20
VLSO	L-shaped Organizer	G•50	WOB	Wall Organizer & Bookshelf	J•91
VM	Vanity Mirror	P•5	WOCB	Wall Open Cabinet w/Car Siding Back	J•51
VMP	Bath Mirror Wall Pull-out	P•66	WOC	Wall Open Cabinet w/Plain Back	J•50
VS3D	Vanity Sink Base w/Three Drawers	P•25	WOODTOP	Wood Tops	Q•6
VS	Vanity Sink Base w/False Panel	P•14-P•17	WORG	Wall Organizer	J•90
VS..U	Vanity Sink Base w/U-shaped Roll Trays	P•17	WP	Paneling	Q•19
VSBD	Double Vanity Sink Base	P•37	WQRES	Wall Quarter Round End Shelf	J•97-J•100
VSBS	Victorian Countertop Support	R•22	WS	Wide Shelves Modification	G•24
VSD..FP	Vanity Sink Drawer Base w/False Panel	P•21-P•22	WSC	Wall Wine Storage Cabinet	J•93

# Code Index

Code	Description	Page Number
WSCRIBE	.Wide Scribe Moulding	.R●8
WSD	.Wall Spice Drawer Horizontal	J●96
WSDV	.Wall Spice Drawer Vertical	J●96
WSP	.Wall Spice Pull-out Cabinet	J●100
WSPKIT	.Wall Spice Pull-out Kit	S●10
WSRC	.Wall Spice Rack Cabinet	J●101
WTC	.Wall Transition Cabinet	J●40
WTCB	.Wood Tiered Cutlery Divider Drawer Modification	G●52
WTCB	.Wood Tiered Cutlery Divider Drawer w/Installation Hardware	S●5
WTCUP	.Clipped Corner Wood Tops Modification	G●34
WTH.BF	.Wall Top Hinge w/Bifold	J●15
WTH.CLIP	.Hinge Restriction Clip	S●15
WTH.SL	.Wall Top Hinge w/Stay Lift	J●9
WTKCUP	.Wood Tiered K-Cup Drawer Modification	G●53
WTOPBAC.BE	.Wood Tops for Angled & Base End Cabinets - Beveled Edge	.Q●7
WTOPBAC.OG	.Wood Tops for Angled & Base End Cabinets - Ogee Edge	.Q●7
WTOPBAC.RO	.Wood Tops for Angled & Base End Cabinets - Round Over	.Q●8
WTOPBAC.SE	.Wood Tops for Angled & Base End Cabinets - Square Edge	.Q●8
WTR	.Wide Top Rail Modification	G●24
WTVB	.Wood Tiered Vanity Drawer Kit	S●6
WVL	.Wall Top Hinge w/Vertical-Lift & Stay Lift	J●5-J●6
WWR	.Wall Cabinet w/Wine Rack	J●91
XEND	.X-End Panel	R●50

## CONSTRUCTION OPTIONS

Consider exposed end options:

- Adding a veneer finished end (FL or FR) will age uniformly with the rest of the kitchen.
- Apply Flush End (FPEL/FPER). This will allow the ends to age uniformly with the rest of the kitchen and will make it flush.
- Upgrade exposed cabinet ends with Authentic Ends (AUTHL/AUTHR/AUTHB) Modification.

## WOOD AND FINISH CHARACTERISTICS

Review specific details with the customer:

- Mineral Streaks, Birdseye Dots, Grain Variations (especially Rustic Alder).
- Color Variations/Darkening (especially Natural/Light Cherry).
- Finish Variations (Glazes are "consistently inconsistent"), hairline cracks may develop at frame joints on painted frame.
- Underside of cabinets are Natural Maple. Use light rail or PFINBTMB to hide, especially when designing with peninsula wall cabinets. For cabinets that are bridged between taller adjacent cabinets, specify PFINBTMB modification. See page G•8 for more details.

## STORAGE SOLUTIONS

Review storage and usage needs with Customer. See chart on pages I•1-I•2 for more Storage Solutions.

- Storage Solutions:
  - SuperCabinet™
  - Base Rotating Deep Bin
  - Pegged Dish Organizer
  - Wall Message Center
- Clean-up Center:
  - Base Wastebasket

## CLEARANCES

- Add fillers or extended stiles between end cabinets and walls on full overlay door styles.
- Allow space between door/window trim and end cabinets for countertop and top moulding overhang.
- Include refrigerator door hinges in overall refrigerator height when placing cabinets above it.

Maintain a minimum clearance of 3" by pulling blind corners as follows:

- Full Overlay: 1 1/4", Standard Overlay 1/2". (More is needed in certain situations such as when adjacent to an appliance or when using oversized pulls or knobs.)
- Allow sufficient clearance (3") on each side of accessory cabinets (such as roll-out trays, swing-out units, etc.). Doors on these cabinets must open fully for accessories to be functional.
- Ensure the height between the cooktop and range hood is 24" to meet NKBA guidelines.

Qualify customer carefully on upper cabinet/microwave advantages/disadvantages as follows:

- Minimum of 18" from cooktop to upper cabinet/above the range microwave which allows for easy access to either, but less room over back burner.
- Minimum of 21" from cooktop to upper cabinet/microwave which allows for access to large pots on back burner of cooktop, but longer reach to microwave.

## FILLERS

- Place fillers toward end of run where least conspicuous if needed.
- Attach overlay fillers on top of the base, wall, or tall fillers when using full overlay door styles to maintain a consistent reveal. Don't forget to include blind corner fillers.
- Add a filler at least 6" wide to accommodate a decorative onlay when the filler is used as valance.

## VARYING HEIGHTS AND DEPTHS

- Also increase the depth of a wall cabinet run when you increase the height (so moulding on adjacent cabinet will fill into the side of the taller cabinet).
- Skin the sides of tall cabinets to keep adjacent base and wall cabinets out from reveal of tall cabinet.
- Add increased depth on tall end panels for a built-in look for deep refrigerators.
- Account for the additional support needed for wall cabinets with a depth of 18" or greater. This can be achieved by installing a soffit or end panels.

## MATCHING INTERIOR CABINETS/GLASS OPTIONS

- Verify cut-for-glass or mullion door option is available on desired cabinet size. (See pages H•4-H•14 for available cut-for-glass/mullion door sizes.)
- Verify glass insert option is available for desired cut-for-glass door size chosen.
- Verify matching interior option has been selected for all open or glass cabinets.
- Use light rail and PFINBTMB to hide color variation between bottom of cabinets with and without matching interior.
- Verify mullion door lite grid matches customer expectations.

## MOULDINGS

- Order rosettes in beaded or fluted styles to match fillers.
- Verify correct amount of crown moulding has been ordered.
- Order toekick caps.
- Order extra scribe.

## ISLANDS AND PENINSULAS

- Consider standard height bars are 34 1/2" tall and require 19" knee space. Raised bars are 42" tall.
- Consider base peninsula cabinets (B\_P) are 24 1/4" deep and require 12" of knee space. Use back panels/doors to flush non B\_P cabinets with B\_P cabinets.
- Use recess toe on sides and back or BBM8 when using multiple base cabinets to create an island.
- Use outside corner moulding if a skin is exposed on the back of the island.

## APPLIANCES

- Note for all consumers, appliances are not included with any cabinetry product.
- Do not place dishwashers next to diagonal front cabinet (interference) or next to a range (no countertop support).
- Verify refrigerator door has enough clearance to open beyond 90° so refrigerator drawers can be utilized. Refer to appliance manufacturer's specs.
- Order appliance panels.

## SPECIAL CONSIDERATIONS

- Consider V-groove skins and/or decorative doors on exposed cabinet sides in glazed kitchen.

## MISCELLANEOUS

- Order full size touch-up kit (mini touch-up kit included with standard sink base).

## TIPS TO THE INSTALLER

#10 x 2 1/2" installation screws are furnished and packaged inside all cabinets. Proper wall stud or ceiling joist installation is essential for Wall and Peninsula cabinets to support weight. Whenever possible, cabinets should be attached to each other for additional strength. Excessive weight should not be put on cabinets hung by themselves. Shimming may be required to ensure proper alignment. Wallboard alone is not strong enough to support the cabinets.

Our Warranty does not cover damage caused by improper installation. Please be sure to install cabinets properly. If you have questions, please contact your representative or customer service.

# NKBA Guidelines

## kitchen planning guidelines

### DOOR/ENTRY

- Door opening should be at least 32" wide, requiring a minimum 2' 10" wide door.

### DOOR INTERFERENCE

- Entry door should not interfere with safe appliance operation or appliance doors.

### DISTANCE BETWEEN WORK CENTERS

- With three work centers, the total distance traveled should not be more than 26' with no single leg of the triangle less than 4' or more than 9'.
- With more than three work centers, each additional travel distance to another work center should be no less than 4' or more than 9'. Each leg is measured from the center-front of the appliance/sink. No work triangle leg should intersect an island/peninsula by more than 12".

### SEPARATING WORK CENTERS

- A tall obstacle should not separate two primary work centers. A properly recessed tall corner unit is acceptable.

### WORK TRIANGLE TRAFFIC

- Major traffic patterns should not cross through the basic work triangle.

### WORK AISLE

- The work aisle should be at least 42" for one cook and at least 48" for multiple cooks.

### WALKWAY

- The walkway width should be at least 36".

### TRAFFIC CLEARANCE AT SEATING

- Allow 32" of clearance from the table to wall/obstacle if no traffic passes behind a seated diner. If traffic passes behind the diner, allow at least 36" to edge past or 44" to walk past.

### SEATING CLEARANCE

- 30" high tables/counters should allow a 24" wide by 18" deep space for each seated diner and at least 18" knee space.
- 36" high counters should allow a 24" wide by 15" deep space for each seated diner and at least 15" kneespace.
- 42" high counters should allow a 24" wide by 12" deep space for each seated diner and at least 12" kneespace.

### CLEAN-UP/PREP SINK PLACEMENT

- With only one sink, locate it adjacent to or across from the cooking surface and refrigerator.

### CLEAN-UP/PREP SINK LANDING AREA

- Include at least a 24" wide landing space on one side of the sink and 18" on the other.
- If all the countertop at the sink is not the same height, plan a 24" landing space on one side of the sink and 3" of countertop frontage on the other, both at the same height of the sink.

### PREPARATION/WORK AREA

- Include a section of countertop at least 36" wide x 24" deep next to the sink for a work area.

### DISHWASHER PLACEMENT

- Nearest edge of dishwasher should be within 36" of nearest edge of sink. Provide at least 21" of standing space between the edge of the dishwasher and countertop frontage/appliances/cabinets which are placed at a right angle to the dishwasher.

### WASTE RECEPTACLES

- Include at least 2 waste receptacles, one near the sink and the other nearby for recycling.

### AUXILIARY SINK

- Provide at least 3" of countertop frontage on one side of the auxiliary sink and 18" on the other side, both at the same height as the sink.

### REFRIGERATOR LANDING AREA

- Include at least 15" of landing area on the handle side of the refrigerator, 15" on either side of a side-by-side refrigerator, 15" of landing space which is no more than 48" across from the front of the refrigerator, and 15" above or adjacent to any under-counter style refrigerator.

### COOKING SURFACE LANDING AREA

- Include a minimum of 12" of landing area on one side of the cooking surface and 15" on the other.
- If cooking surface is at a different countertop height than the rest of the kitchen, then the 12" and 15" landing areas must be the same height as the cooking surface.
- For safety reasons, in an island or peninsula situation, the countertop should extend a minimum of 9" behind the cooking surface if the counter height is the same height as the cooking surface.

### COOKING SURFACE CLEARANCE

- Allow 24" between the cooking surface and a protected noncombustible surface above it.
- At least 30" of clearance is required between the cooking surface and an unprotected/combustible surface above it.
- If a microwave/hood combination is used, then the manufacturer's specifications should be followed.

### COOKING SURFACE VENTILATION

- A correctly sized, ducted ventilation system is recommended for all cooking surface appliances. The recommended minimum is 150 CFM.
- Code requires that the manufacturer's specifications be followed. Minimum exhaust rate for a ducted hood is 100 CFM and must be ducted to the outside.
- Make-up air may need to be provided. Refer to local codes.

### COOKING SURFACE SAFETY

- Do not locate cooking surface under an operable window.
- Window treatments above cooking surface should not use flammable materials.
- Place a fire extinguisher near the kitchen exit away from cooking equipment.

### MICROWAVE OVEN PLACEMENT

- The ideal location for the bottom of the microwave is 3" below the principle user's shoulder, but no more than 54" above the floor.

### MICROWAVE LANDING AREA

- Provide at least 15" above, below, or adjacent to the handle side of a microwave oven.

### OVEN LANDING AREA

- Include at least 15" next to or above the oven.
- A 15" landing area that is not more than 48" away is also acceptable as long as the oven does not open into a walkway.

### COMBINING LANDING AREAS

- If two landing areas are adjacent to one another, determine a new minimum for the two by taking the longer of the two and adding 12".

(cont'd)

## kitchen planning guidelines (cont'd)

### COUNTERTOP SPACE

- A total of 158" of countertop frontage, 24" deep, with at least 15" clearance above is needed to accommodate all landing, preparation, work, and storage areas.

### COUNTERTOP EDGES

- Clipped or round corners, rather than sharp edges, are recommended on all counters.

### STORAGE

- The recommended total shelf/drawer frontage for a small kitchen (less than 150 square feet) is 1400", for a medium kitchen (151 to 350 square feet) is 1700", and for a large kitchen (greater than 350 square feet) is 2000".

Sizes:	S	M	L
Wall	300"	360"	360"
Base	520"	615"	660"
Drawer	360"	400"	525"
Pantry	180"	230"	310"
Misc.	40"	95"	145"

- The totals for wall, base, drawer, and pantry shelf/drawer frontage can be adjusted upward or downward as long as the recommended total stays the same.

### STORAGE AT CLEAN-UP/PREP SINK

- The recommended total for a small kitchen is 400", a medium kitchen is 480", a large kitchen is 560", and should be located within 72" of the centerline of the main clean-up/prep sink.

### CORNER CABINET STORAGE

- At least one corner cabinet should include a functional storage device.

### ELECTRICAL RECEPTACLES

- GFCI (Ground-Fault-Circuit-Interrupter) protection is required on all receptacles servicing countertop surfaces within the kitchen.

### LIGHTING

- Every work surface should be well illuminated. At least one wall switch-controlled light must be placed at the entrance.
- Window/skylight area, equal to at least 8% of the total square footage of the kitchen, or a total living space which includes a kitchen, is required.

## bathroom planning guidelines

### DOOR/ENTRY

- Doorway opening should be at least 32", requiring a minimum 2' 10" wide door.

### DOOR INTERFERENCE

- The door area should include clear floor space for maneuvering which varies according to the type of door and the direction of the approach.

### CEILING HEIGHT

- Bathroom floor to ceiling minimum height is 80". A shower or tub with a shower head shall have a minimum floor to ceiling height of 80" above a minimum area 30" x 30" at the shower head.

### CLEAR SPACE

- Plan a clear space of 30" from the front edge of all fixtures to any opposite bath fixture, wall, or obstacle.
- A minimum space of at least 21" is required in front of a lavatory, toilet, bidet, and tub, with a 24" minimum space in front of a shower entry.

### SINGLE LAVATORY PLACEMENT

- The distance from the centerline of the lavatory to the sidewall/tall obstacle should be at least 20".
- The minimum distance required is 15". The minimum distance required between a wall and the edge of a lavatory is 4".

### DOUBLE LAVATORY PLACEMENT

- The distance between the centerlines of two lavatories should be at least 36".
- The minimum distance required is 30".
- The minimum distance required between the edges of two lavatories is 4".

### LAVATORY/VANITY HEIGHT

- The height for a lavatory varies from 32" to 43" to fit the user.

### COUNTERTOP EDGES

- Clipped or round corners, rather than sharp edges, are recommended on all counters.

### SHOWER SIZE

- The interior shower size should be at least 36" x 36". The minimum interior shower size required is 30" x 30".

### STORAGE

- Provide adequate, accessible storage for toiletries, bath linens, grooming and general bathroom supplies.
- Storage of frequently used items should be 15" to 48" above floor.

### ELECTRICAL RECEPTACLES

- All GFCI receptacles should be located at electrical appliance points of use.

**Load bearing floors and shelves meet KCMA standards of 15 lbs. per square foot. Warranty does not cover overloading beyond this point.**

To view a complete and updated list of the NKBA Guidelines, visit <http://www.nkba.org/guidelines/default.aspx>

© Copyright 2010 National Kitchen & Bath Association



## Wood Specifications

When choosing a finish, one needs to consider the substrate or material that is to be used in the cabinet construction. The substrate material is the first characteristic to affect finish. Since no two trees produce the same type of grain pattern or mineral characteristic, the wood grain is unique to a tree (i.e., fingerprints). The amount of allowable mineral and natural variation is outlined by the NHLA (National Hardwood Lumber Association). The type and color of mineral and grain are greatly dependent on the location of where the tree grew in the United States, type of soil and location in the forest. Kemper Emerge does not sort product for certain color, grain or mineral variation. Unique characteristics of wood enhance the beauty of every kitchen. As hardwood ages, it will darken when exposed to different types of light. Color differences or changes in wood can also be caused by exposure to harsh chemicals, extreme heat or other contributing external conditions. Additionally, wood species exhibit other defining characteristics, such as mineral deposits/streaks, knots, sap runs, pin holes and wormholes. These markings make the wood unique and contribute to its enduring beauty. Neither Kemper Emerge nor your Kemper Emerge dealer can be responsible for the type or degree of variations which may actually characterize your cabinetry.

- Alder has a straight fine textured grain similar to Cherry and Maple. Although classified as a hardwood, it is moderately light in weight and considerably softer than other species. Therefore, care must be taken as it will dent and mar easily. Alder may exhibit grain and color variations, sapwood can be distinguishable from the heartwood, tight pin knots are sometimes present.
- Rustic Alder is characterized by its light brown and reddish undertones and may contain a variety of pin holes, open and closed knots of various sizes and colors, small cracks, bird pecks, mineral streaks, and grain variation. Some knots may have small holes through the panel. Larger holes will not be filled. In addition, the wood will contain color difference caused by variations in minerals found in the soil, creating visible mineral tracks.



- A. Sound Closed Knot (not moveable) – Expected in Rustic Alder up to approximately 3” diameter.  
B. Sound Knot with Cracks – Expect sound knots with open cracks up to approximately 1” in length.  
C. Open Knot (through door) – Expected in Rustic Alder with open area up to approximately 3/4” diameter. Note: 3/4” diameter is about the size of a penny. Holes created by open knots pass completely through the door and are desirable for this rustic look.  
D. Unsound Knot (moveable core) – Not to be expected.  
E. Knot Cluster (cluster of tight sound knots) – To be expected in Rustic Alder.  
F. Worm Holes/Pin Holes (can go through door) – Can be expected on Rustic Alder up to approximately 1/4” diameter.  
G. Worm Tracks – Can be expected on Rustic Alder in sizes up to approximately 1/8” wide by 8” long.

**NOTE:** Certain components will be Alder species but will not feature Rustic characteristics.

✍️ Signed agreement required with Rustic Alder wood type; see page V●6.

- Cherry is characterized by its red undertones, but may vary in color from white to a deep, rich brown. This color variation can occur in a single door panel. Cherry is a close-grained wood with fairly uniform texture, revealing pin knots and curly graining. All wood will age with time and the finish will darken. This is especially true for Cherry. This is a sought-after quality in Cherry cabinetry, and those who select it expect this evolution.
- Maple is a close-grained hardwood that is predominately white to creamy-white in color, with occasional reddish-brown tones. While Maple typically features uniform graining as compared to other wood species, characteristic markings may include fine brown lines, wavy or curly graining, bird’s eye dots and mineral streaks. These traits are natural and serve to enhance Maple’s natural beauty.
- Quartersawn Oak features a tight grain or “comb grain”. This grain will reveal a fairly straight pattern that can range from very close together to quite far apart, displaying a slight curve in the grain on the verge of creating a cathedral pattern similar to that of flat cut Oak. Medullary rays, sometimes called “tiger striping” or “flecking” may occur. These rays are a common characteristic of Oak and are evident as shiny patches or scars which cut across the grain of the wood. They reflect light differently than the general grain, especially when finished. They are not usually seen in standard Oak. These medullary rays will occur at random and are not considered a defect.

No matter which species you choose for your new kitchen or bath cabinetry, please keep in mind that no two pieces of wood are exactly the same. Stains are likely to exaggerate the difference between open and closed grains and other markings in wood. Grain variation and color change should be expected. As hardwood ages, it will darken when exposed to different types of light. Color differences or changes in wood can also be caused by exposure to harsh chemicals, extreme heat or other contributing external conditions. Additionally, wood species exhibit other defining characteristics, such as mineral deposits/streaks, knots, sap runs, pin holes and wormholes. These markings make the wood unique and contribute to its enduring beauty.





## Profile Selection

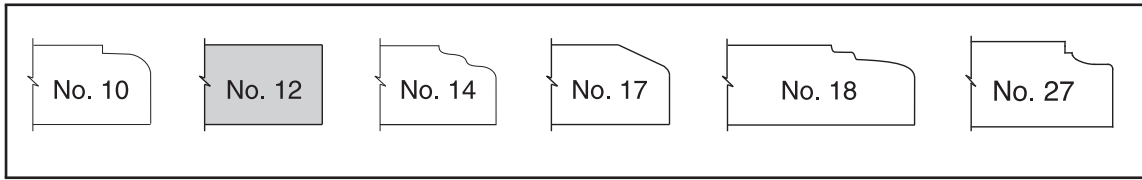

## #12 Profile Design Tip

It is not required to specify 1/8" EXL and/or EXR on cabinets with the #12 profile unless it meets the criteria as shown below.

For full function and access, always use 1/8" EXL and/or EXR in the following design applications:

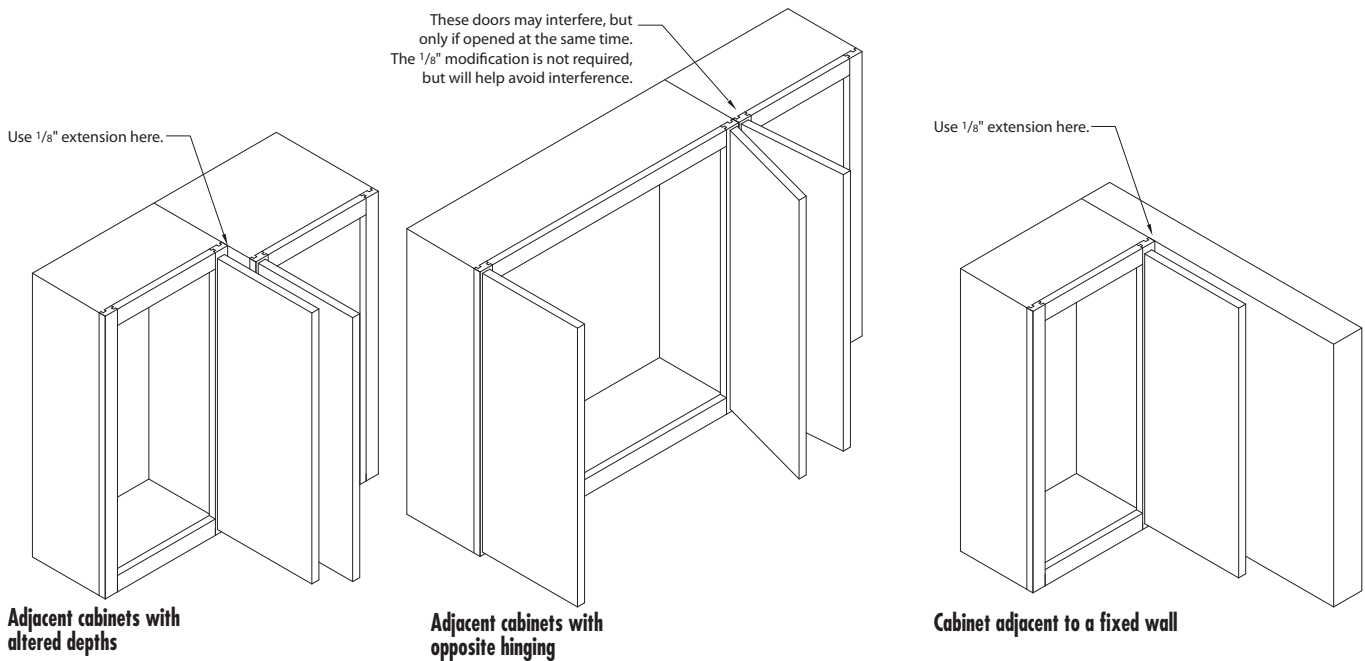

Other applications may require the 1/8" EXL/EXR modification. For example, when cabinets are installed adjacent to a wall.

Full Overlay Styles

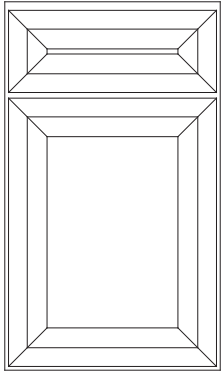

Burke

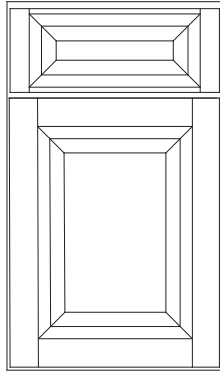

Decker

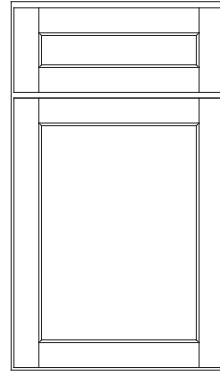

Gordon

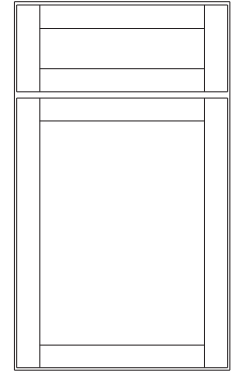

Kirby

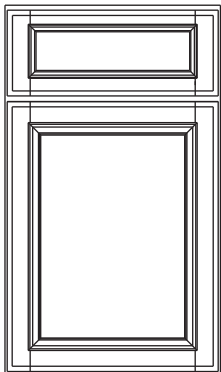

Landry

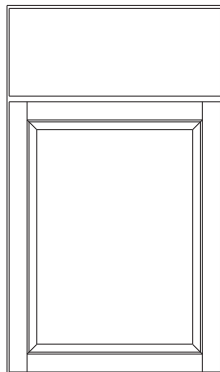

Shanley

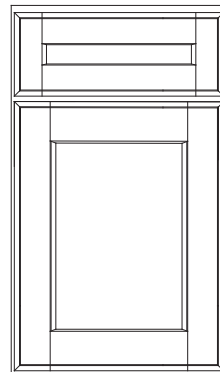

Tate

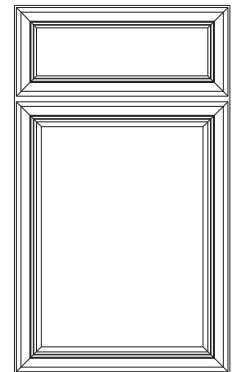

Vinson

## Burke Collection\*

Full Overlay Door Styles

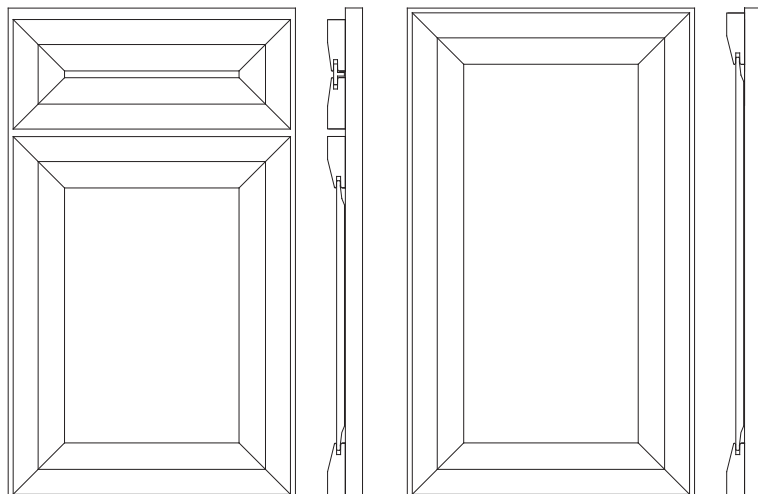

Square Base Cabinet

Square Wall Cabinet

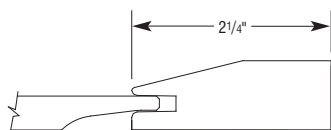

Door Rail/Center Panel Detail

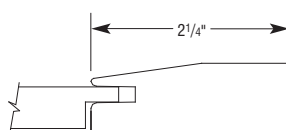

Drawer Rail/Center Panel Detail

### Wood Species

Alder  
Cherry  
Maple  
Quartersawn Oak  
Rustic Alder

### Outside Profile Selections

No. 12

### Special Notes

- 5-piece mitered drawer front with flat center panel
- Drawer fronts smaller than 5 3/4" high will have slab front
- 5-piece mitered solid reverse raised panel door

### Design Notes

- Solid slab drawer front (DFSLB) available. See page G•11.
- Solid slab drawer front top (DFSLBT) available. See page G•11.
- Mullion doors and Prairie Mullion doors not available.
- 1/8" EXL and/or EXR options may be required. See page D•1 for details.

## Decker Collection\*

Full Overlay Door Styles

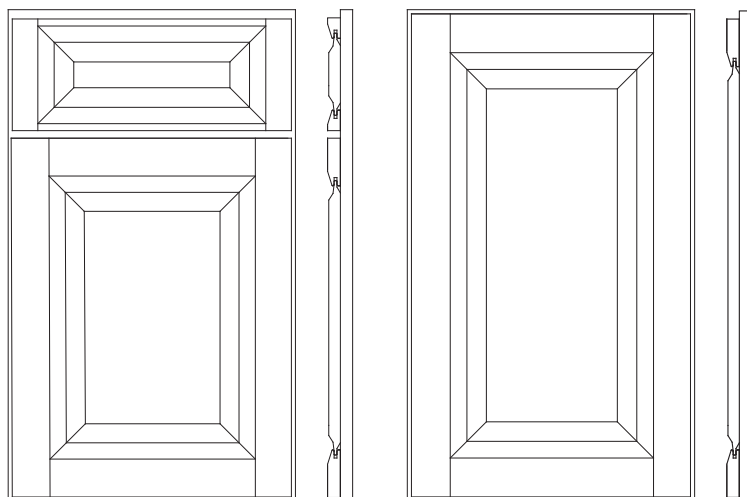

Square Base Cabinet

Square Wall Cabinet

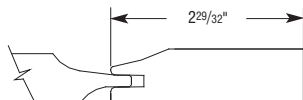

Door Rail/Center Panel Detail

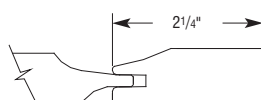

Drawer Side Rail/Center Panel Detail

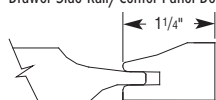

Drawer Top/Bottom Rail/Center Panel Detail

### Wood Species

Alder  
Cherry  
Maple  
Quartersawn Oak  
Rustic Alder

### Outside Profile Selections

No. 12

### Special Notes

- 5-piece raised center panel drawer front
- Drawer end rails are 2 1/4" and crossrails are 1 1/4" (finished width). This rule will apply on all 4 1/4" and 4 1/2" high drawer openings.
- Any drawer openings larger than 4 1/2" high will utilize 2 1/4" end rails and crossrails
- Drawer fronts smaller than 5 3/4" high will have slab front
- Solid double raised center panel door

### Design Notes

- Solid slab drawer front (DFSLB) available. See page G•11.
- Solid slab drawer front top (DFSLBT) available. See page G•11.
- Mullion doors and Prairie Mullion doors not available
- 1/8" EXL and/or EXR options may be required. See page D•1 for details.

\*When Painted finishes are specified, the door center panel may be constructed of Medium Density Fiberboard (MDF), except when Timeworn, Hewn, Extra Timeworn, Extra Hewn, or Brushed Finish techniques or Black paint are specified. MDF provides a smoother finish when painted, and is more resistant to warping, expansion, and contraction.

# Door Styles

## Gordon Collection\*

Full Overlay Door Styles

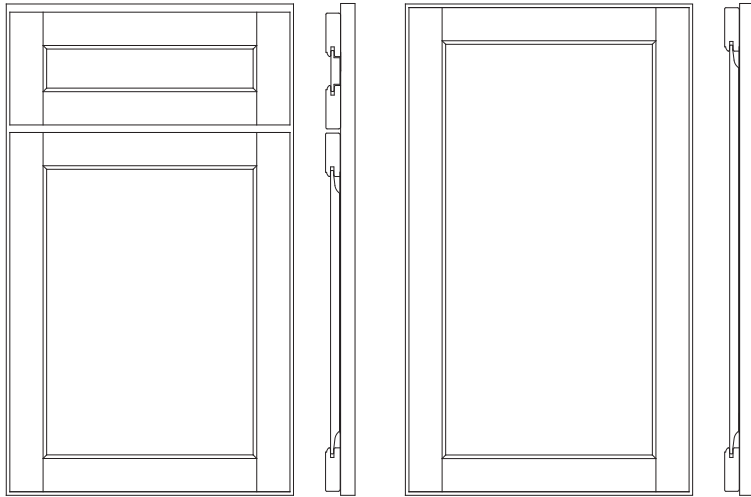

Square Base Cabinet

Square Wall Cabinet

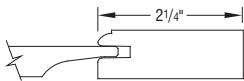

Door Rail/Center Panel Detail

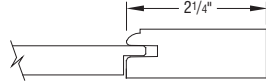

Drawer Rail/Center Panel Detail

### Wood Species

Alder  
Cherry  
Maple  
Quartersawn Oak  
Rustic Alder

### Outside Profile Selections\*

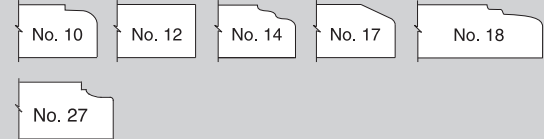

\*Profile No. 12 shown

### Special Notes

- 5-piece flat center panel drawer front
- Drawer fronts smaller than 5 3/4" high will have slab front
- 5-piece solid reverse raised panel door

### Design Notes

- Solid slab drawer front (DFS LB) available. See page G•11.
- Solid slab drawer front top (DFS LBT) available. See page G•11.
- 1/8" EXL and/or EXR options may be required. See page D•1 for details.

## Kirby Collection\*

Full Overlay Door Styles

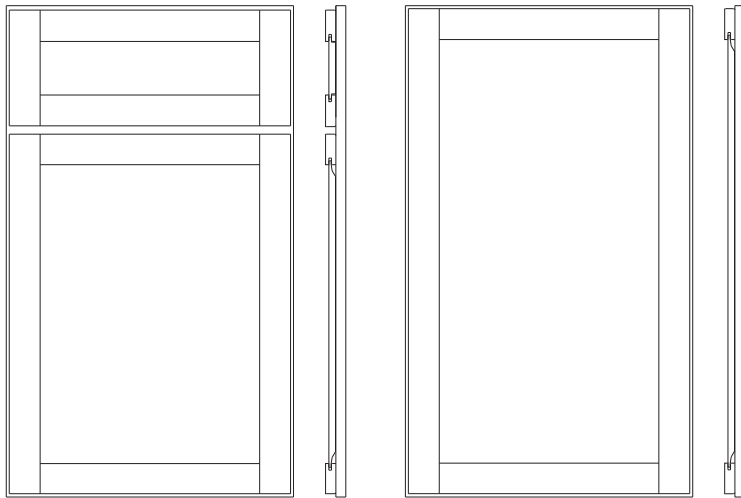

Square Base Cabinet

Square Wall Cabinet

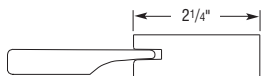

Door Rail/Center Panel Detail

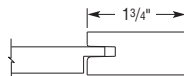

Drawer Top/Bottom Rail/  
Center Panel Detail

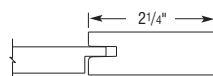

Drawer Side Rail/  
Center Panel Detail

### Wood Species

Alder  
Cherry  
Maple  
Quartersawn Oak  
Rustic Alder

### Outside Profile Selections\*

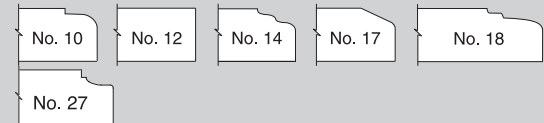

\*Profile No. 12 shown

### Special Notes

- Drawer fronts smaller than 4 1/2" high will have slab front
- 5-piece flat center panel drawer front
- 5-piece drawer front will utilize a 1 3/4" wide top and bottom rail
- Solid reverse raised panel door

### Design Notes

- Solid slab drawer front (DFS LB) available. See page G•11.
- Solid slab drawer front top (DFS LBT) available. See page G•11.
- 1/8" EXL and/or EXR options may be required. See page D•1 for details.

\*When Painted finishes are specified, the door center panel may be constructed of Medium Density Fiberboard (MDF), except when Timeworn, Hewn, Extra Timeworn, Extra Hewn, or Brushed Finish techniques or Black paint are specified. MDF provides a smoother finish when painted, and is more resistant to warping, expansion, and contraction.

## Landry Collection\*

Full Overlay Door Styles

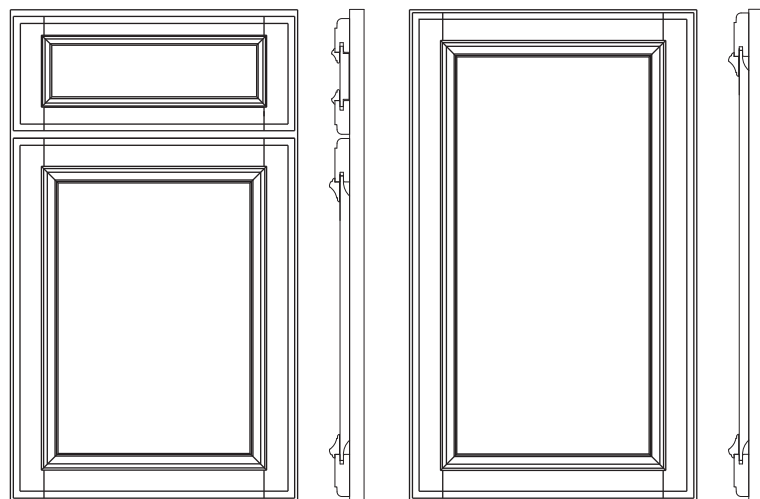

Square Base Cabinet

Square Wall Cabinet

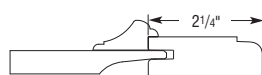

Door Rail/Center Panel Detail

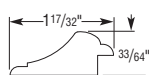

Door Onlay/Moulding Detail

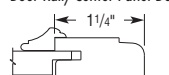

Drawer Top/Bottom Rail/Center Panel Detail

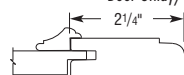

Drawer Side Rail/Center Panel Detail

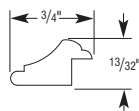

Drawer Onlay/Moulding Detail

## Wood Species

Alder  
Cherry  
Maple  
Quartersawn Oak  
Rustic Alder

## Outside Profile Selections\*

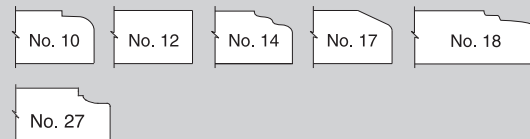

\*Profile No. 10 shown

## Special Notes

- Bold onlay moulding applied to door; larger than drawer
- 9-piece flat center panel drawer front with onlay moulding
- 9-piece solid reverse raised panel door
- Drawer fronts smaller than 5 3/4" high or drop front applications will have slab front

## Design Notes

- Solid slab drawer front (DFS LB) available. See page G•11.
- Solid slab drawer front top (DFS LBT) available. See page G•11.
- Mullion doors and Prairie Mullion doors not available
- 1/8" EXL and/or EXR options may be required. See page D•1 for details.

## Shanley Collection\*

Full Overlay Door Styles

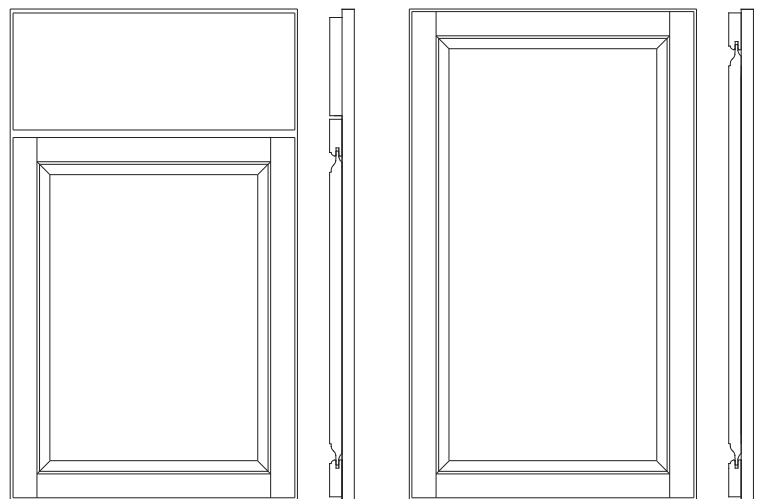

Square Base Cabinet

Square Wall Cabinet

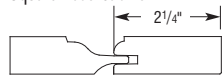

Door Side Rail/Center Panel Detail

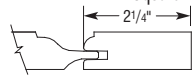

Option: DFR5PC Drawer Side Rail/Center Panel Detail

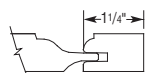

Option: DFR5PC Drawer Top/Bottom Rail/Center Panel Detail

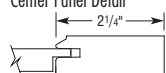

Option: DFF5PC Drawer Rail/Center Panel Detail

## Wood Species

Alder  
Cherry  
Maple  
Quartersawn Oak  
Rustic Alder

## Outside Profile Selections\*



\*Profile No. 12 shown

## Special Notes

- Solid slab drawer front
- 5-piece solid double raised panel door

## Design Notes

- 5-piece flat center panel drawer front (DFF5PC) available. Some exceptions may apply. See page G•9 for details.
- 5-piece flat center panel drawer front with slab top (DFF5PCSLBT) available. Some exceptions may apply. See page G•10 for details.
- 5-piece double raised panel drawer front (DFR5PC) available. Some exceptions may apply. See page G•10 for details.
- 5-piece double raised panel drawer front with slab top (DFR5PCSLBT) available. Some exceptions may apply. See page G•10 for details.
- 1/8" EXL and/or EXR options may be required. See page D•1 for details.

\*When Painted finishes are specified, the door center panel may be constructed of Medium Density Fiberboard (MDF), except when Timeworn, Hewn, Extra Timeworn, Extra Hewn, or Brushed Finish techniques or Black paint are specified. MDF provides a smoother finish when painted, and is more resistant to warping, expansion, and contraction.

# Door Styles

## Tate Collection\*

Full Overlay Door Styles

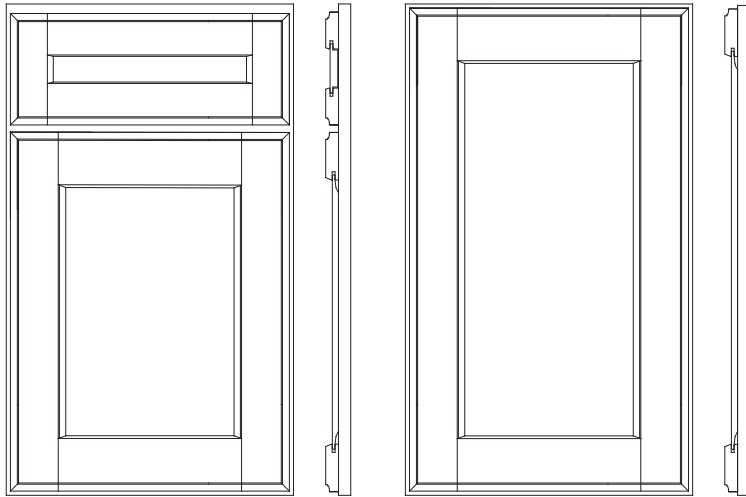

Square Base Cabinet

Square Wall Cabinet

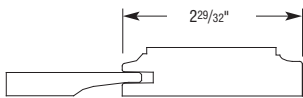

Door Side Rail/Center Panel Detail

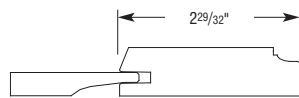

Door Top/Bottom Rail/Center Panel Detail

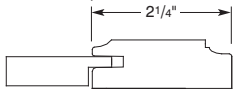

Drawer Side Rail/Center Panel Detail

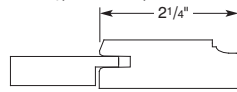

Drawer Top/Bottom Rail/Center Panel Detail

### Wood Species

- Alder
- Cherry
- Maple
- Quartersawn Oak
- Rustic Alder

### Outside Profile Selections\*

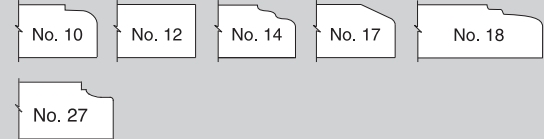

\*Profile No. 27 shown

### Special Notes

- 5-piece flat center panel drawer front
- Drawer fronts smaller than 5 3/4" high will have slab front
- 5-piece solid reverse raised panel door

### Design Notes

- Solid slab drawer front (DFS LB) available. See page G•11.
- Solid slab drawer front top (DFS LB T) available. See page G•11.
- Mullion doors and Prairie Mullion doors not available
- 1/8" EXL and/or EXR options may be required. See page D•1 for details.

## Vinson Collection\*

Full Overlay Door Styles

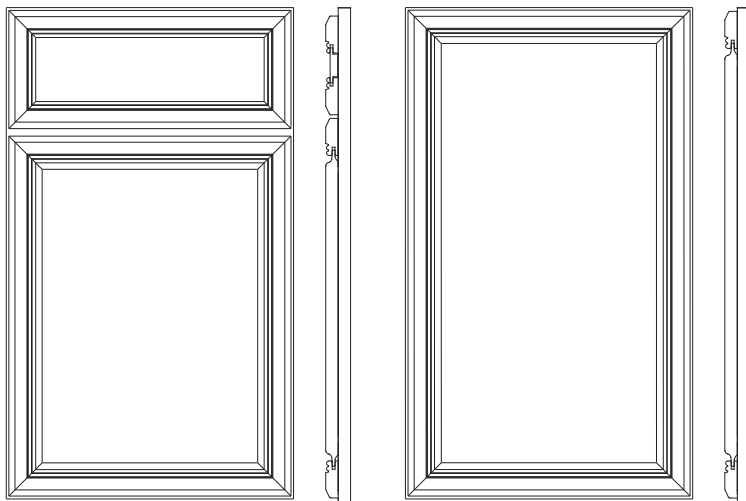

Square Base Cabinet

Square Wall Cabinet

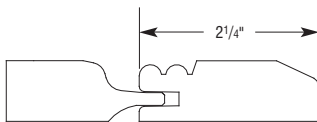

Door Rail/Center Panel Detail

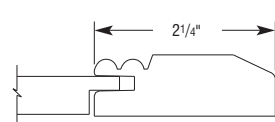

Drawer Rail/Center Panel Detail

### Wood Species

- Alder
- Cherry
- Maple
- Quartersawn Oak
- Rustic Alder

### Outside Profile Selections\*

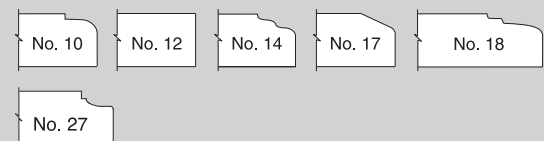

\*Profile No. 17 shown

### Special Notes

- Double bead door and drawer rails
- 5-piece mitered drawer front with flat center panel
- Drawer fronts smaller than 5 3/4" high will have slab front
- 5-piece mitered door with solid double raised center panel

### Design Notes

- Solid slab drawer front (DFS LB) available. See page G•11.
- Solid slab drawer front top (DFS LB T) available. See page G•11.
- 1/8" EXL and/or EXR options may be required. See page D•1 for details.

\*When Painted finishes are specified, the door center panel may be constructed of Medium Density Fiberboard (MDF), except when Timeworn, Hewn, Extra Timeworn, Extra Hewn, or Brushed Finish techniques or Black paint are specified. MDF provides a smoother finish when painted, and is more resistant to warping, expansion, and contraction.

Inset and Beaded Inset Door Styles

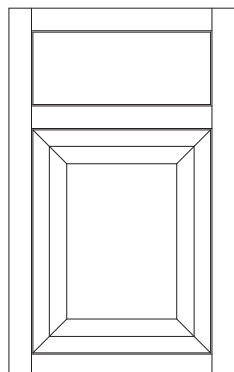

Burke  
Inset

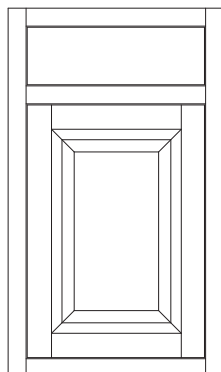

Decker  
Inset

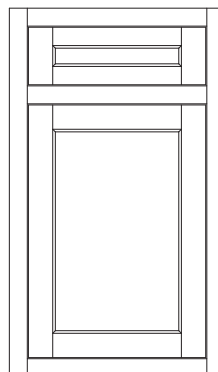

Gordon  
Inset

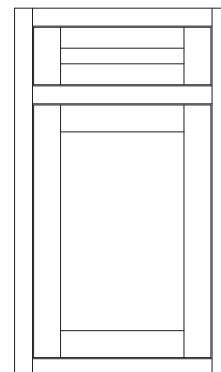

Kirby  
Inset

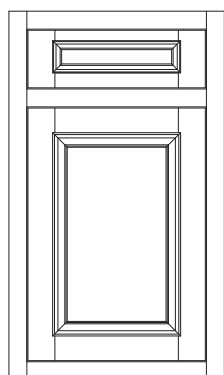

Landry  
Inset

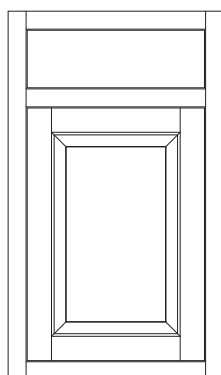

Shanley  
Inset

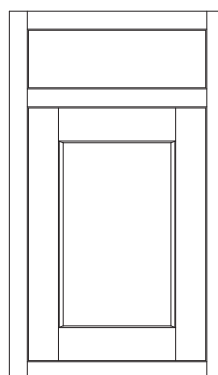

Tate  
Inset

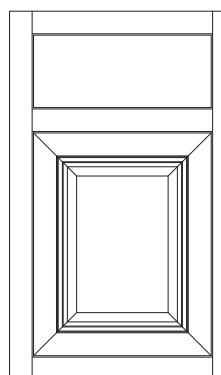

Vinson  
Inset

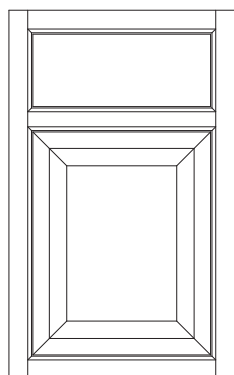

Burke  
Beaded Inset

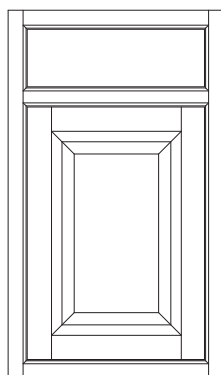

Decker  
Beaded Inset

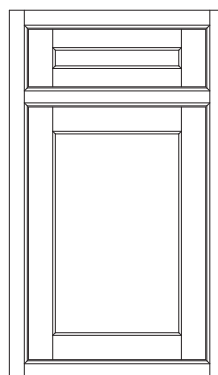

Gordon  
Beaded Inset

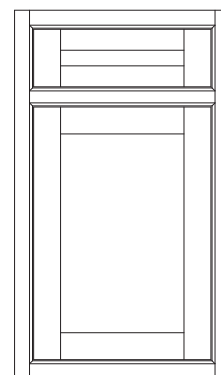

Kirby  
Beaded Inset

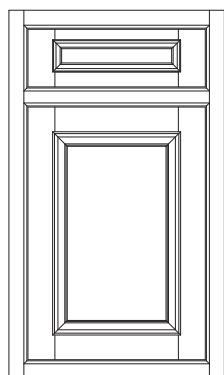

Landry  
Beaded Inset

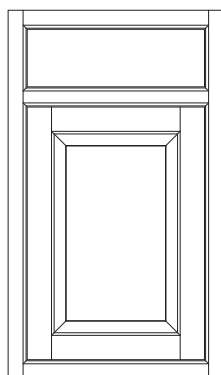

Shanley  
Beaded Inset

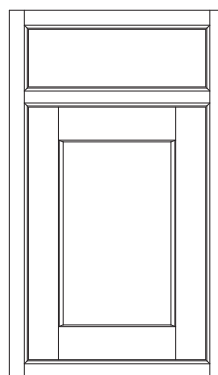

Tate  
Beaded Inset

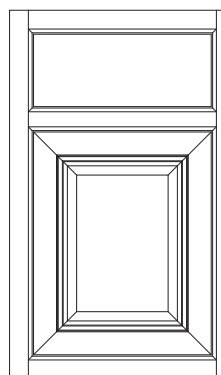

Vinson  
Beaded Inset



# Door Styles

## Burke Collection

Inset Door Styles\*

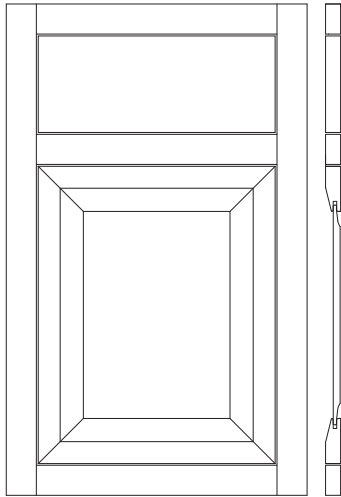

Square Base Cabinet

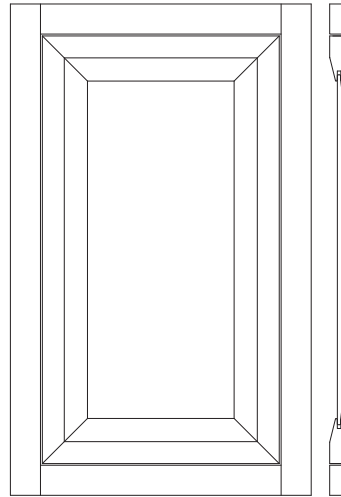

Square Wall Cabinet

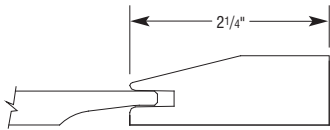

Door Rail/Center Panel Detail

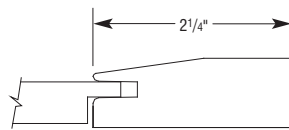

Option: DFF5PCINS Drawer Rail/Center Panel Detail

### Wood Species

Alder  
Cherry  
Maple  
Quartersawn Oak  
Rustic Alder

### Outside Profile Selections

No. 12

### Special Notes

- Solid slab drawer front
- Solid reverse raised center panel door

### Design Notes

- Mullion and Prairie Mullion doors not available.
- Finial Hinges (IFAB, IFBN, IFMB, IFORB) available on Profile #12 only. See page G•12 for details.
- Drawer Front Flat 5-piece Inset (DFF5PCINS) available. Some exceptions may apply. See page G•10 for details.

Beaded Inset Door Styles\*

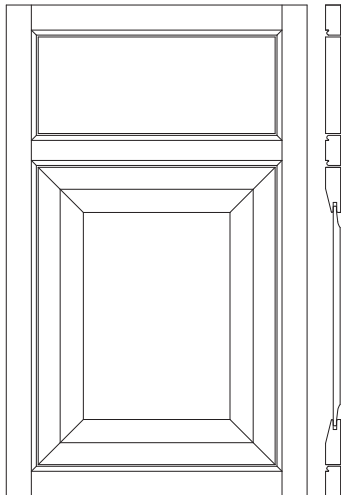

Square Base Cabinet

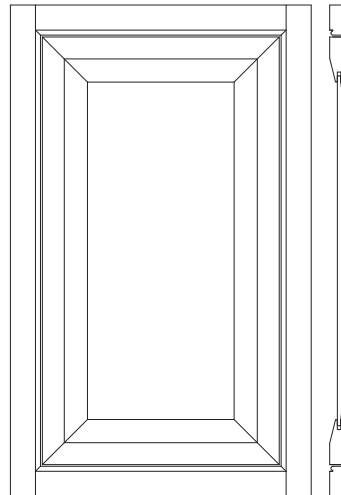

Square Wall Cabinet

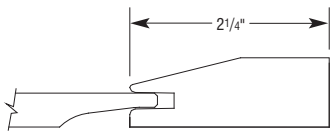

Door Rail/Center Panel Detail

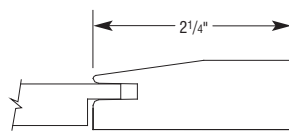

Option: DFF5PCINS Drawer Rail/Center Panel Detail

### Wood Species

Alder  
Cherry  
Maple  
Quartersawn Oak  
Rustic Alder

### Outside Profile Selections

No. 12

### Special Notes

- Solid slab drawer front
- Solid reverse raised center panel door

### Design Notes

- Mullion and Prairie Mullion doors not available.
- Finial Hinges (IFAB, IFBN, IFMB, IFORB) available on Profile #12 only. See page G•12 for details.
- Drawer Front Flat 5-piece Inset (DFF5PCINS) available. Some exceptions may apply. See page G•10 for details.

\*When Painted finishes are specified, the door center panel may be constructed of Medium Density Fiberboard (MDF), except when Timeworn, Hewn, Extra Timeworn, Extra Hewn, or Brushed Finish techniques or Black paint are specified. MDF provides a smoother finish when painted, and is more resistant to warping, expansion, and contraction.

## Decker Collection

Inset Door Styles\*

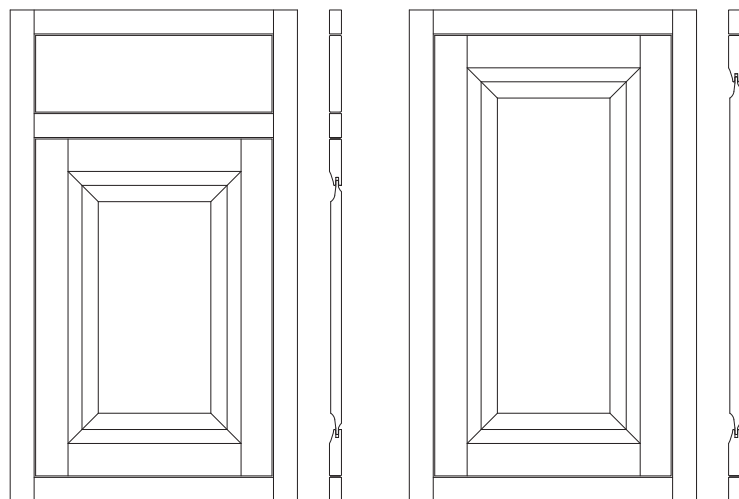

Square Base Cabinet

Square Wall Cabinet

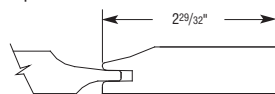

Door Rail/Center Panel Detail

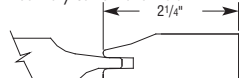

Option: DFR5PCINS Drawer Side Rail/Center Panel Detail



Option: DFR5PCINS Drawer Top/Bottom Rail/Center Panel Detail

### Wood Species

Alder  
Cherry  
Maple  
Quartersawn Oak  
Rustic Alder

### Outside Profile Selections

No. 12

### Special Notes

- Solid slab drawer front
- Solid double raised center panel door

### Design Notes

- Mullion and Prairie Mullion doors not available
- Finial Hinges (IFAB, IFBN, IFMB, IFORB) available on Profile #12 only. See page G•12 for details.
- Drawer Front Raised 5-piece Inset (DFR5PCINS) available. Some exceptions may apply. See page G•11 for details.

Beaded Inset Door Styles\*

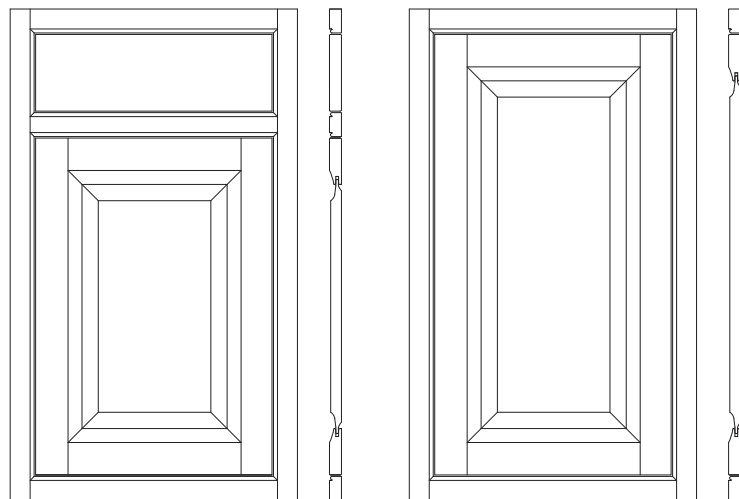

Square Base Cabinet

Square Wall Cabinet

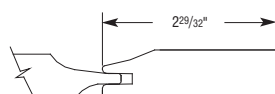

Door Rail/Center Panel Detail

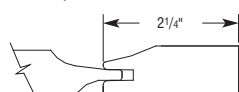

Option: DFR5PCINS Drawer Side Rail/Center Panel Detail

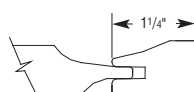

Option: DFR5PCINS Drawer Top/Bottom Rail/Center Panel Detail

### Wood Species

Alder  
Cherry  
Maple  
Quartersawn Oak  
Rustic Alder

### Outside Profile Selections

No. 12

### Special Notes

- Solid slab drawer front
- Solid double raised center panel door

### Design Notes

- Mullion and Prairie Mullion doors not available
- Finial Hinges (IFAB, IFBN, IFMB, IFORB) available on Profile #12 only. See page G•12 for details.
- Drawer Front Raised 5-piece Inset (DFR5PCINS) available. Some exceptions may apply. See page G•11 for details.

\*When Painted finishes are specified, the door center panel may be constructed of Medium Density Fiberboard (MDF), except when Timeworn, Hewn, Extra Timeworn, Extra Hewn, or Brushed Finish techniques or Black paint are specified. MDF provides a smoother finish when painted, and is more resistant to warping, expansion, and contraction.

# Door Styles

## Gordon Collection

Inset Door Styles\*

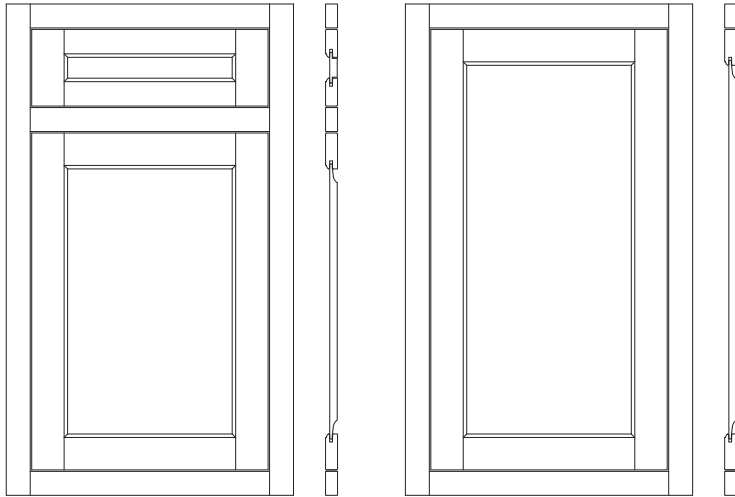

Square Base Cabinet

Square Wall Cabinet

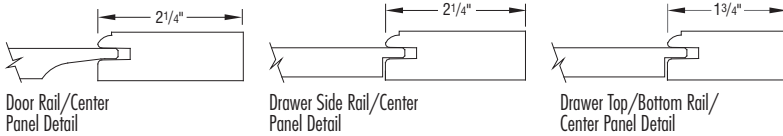

Door Rail/Center Panel Detail

Drawer Side Rail/Center Panel Detail

Drawer Top/Bottom Rail/Center Panel Detail

### Wood Species

Alder  
Cherry  
Maple  
Quartersawn Oak  
Rustic Alder

### Outside Profile Selections\*



\*Profile No. 12 shown

### Special Notes

- 5-piece flat center panel drawer front
- Drawer fronts smaller than 4 13/16" high will have slab front
- 5-piece solid reversed raised panel door
- 5-piece drawer front will utilize a 1 3/4" wide top and bottom rail

### Design Notes

- Solid slab drawer front (DFSLB) available. See page G•11.
- Solid slab drawer front top (DFSLBT) available. See page G•11.
- Finial Hinges (IFAB, IFBN, IFMB, IFORB) available on Profile #12 only. See page G•12 for details.

Beaded Inset Door Styles\*

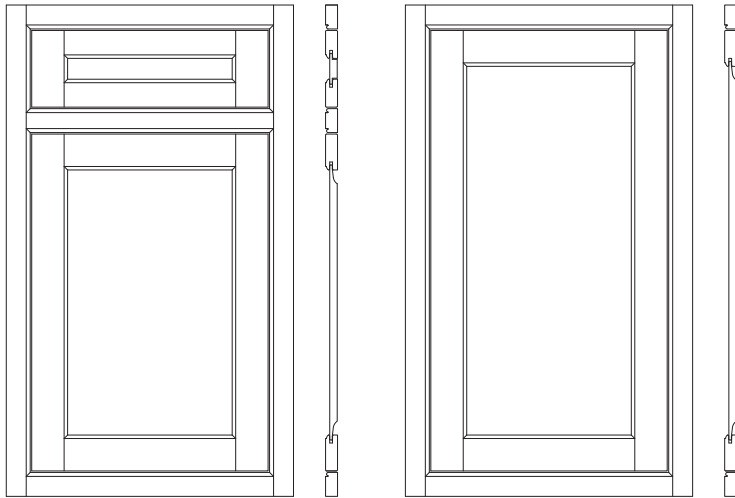

Square Base Cabinet

Square Wall Cabinet

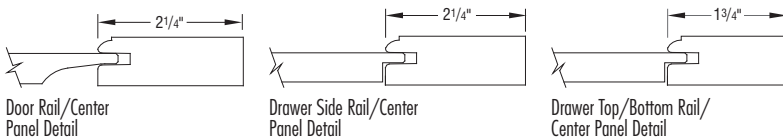

Door Rail/Center Panel Detail

Drawer Side Rail/Center Panel Detail

Drawer Top/Bottom Rail/Center Panel Detail

### Wood Species

Alder  
Cherry  
Maple  
Quartersawn Oak  
Rustic Alder

### Outside Profile Selections\*



\*Profile No. 12 shown

### Special Notes

- 5-piece flat center panel drawer front
- Drawer fronts smaller than 4 13/16" high will have slab front
- 5-piece solid reversed raised panel door
- 5-piece drawer front will utilize a 1 3/4" wide top and bottom rail

### Design Notes

- Solid slab drawer front (DFSLB) available. See page G•11.
- Solid slab drawer front top (DFSLBT) available. See page G•11.
- Finial Hinges (IFAB, IFBN, IFMB, IFORB) available on Profile #12 only. See page G•12 for details.

\*When Painted finishes are specified, the door center panel may be constructed of Medium Density Fiberboard (MDF), except when Timeworn, Hewn, Extra Timeworn, Extra Hewn, or Brushed Finish techniques or Black paint are specified. MDF provides a smoother finish when painted, and is more resistant to warping, expansion, and contraction.

## Kirby Collection

Inset Door Styles\*

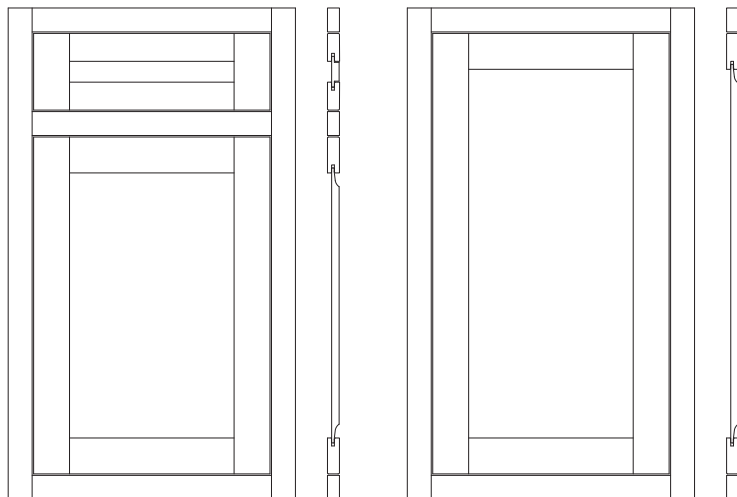

Square Base Cabinet

Square Wall Cabinet

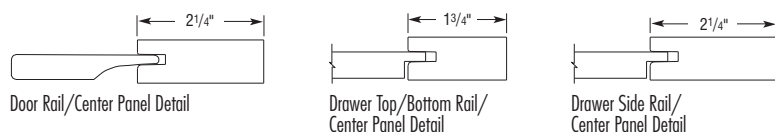

Door Rail/Center Panel Detail

Drawer Top/Bottom Rail/Center Panel Detail

Drawer Side Rail/Center Panel Detail

### Wood Species

Alder  
Cherry  
Maple  
Quartersawn Oak  
Rustic Alder

### Outside Profile Selections\*



\*Profile No. 12 shown

### Special Notes

- Drawer fronts smaller than 4 13/16" high will have slab front
- 5-piece flat center panel drawer front
- Solid reverse raised panel door

### Design Notes

- Solid slab drawer front (DFSLB) available. See page G•11.
- Solid slab drawer front top (DFSLBT) available. See page G•11.
- Finial Hinges (IFAB, IFBN, IFMB, IFORB) available on Profile #12 only. See page G•12 for details.

Beaded Inset Door Styles\*

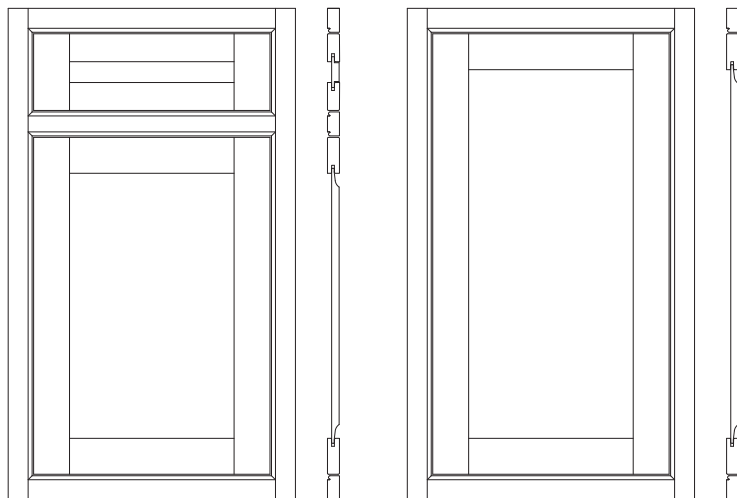

Square Base Cabinet

Square Wall Cabinet

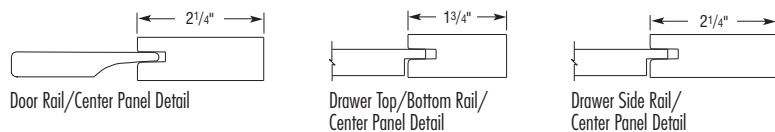

Door Rail/Center Panel Detail

Drawer Top/Bottom Rail/Center Panel Detail

Drawer Side Rail/Center Panel Detail

### Wood Species

Alder  
Cherry  
Maple  
Quartersawn Oak  
Rustic Alder

### Outside Profile Selections\*



\*Profile No. 12 shown

### Special Notes

- Drawer fronts smaller than 4 13/16" high will have slab front
- 5-piece flat center panel drawer front
- Solid reverse raised panel door

### Design Notes

- Solid slab drawer front (DFSLB) available. See page G•11.
- Solid slab drawer front top (DFSLBT) available. See page G•11.
- Finial Hinges (IFAB, IFBN, IFMB, IFORB) available on Profile #12 only. See page G•12 for details.

\*When Painted finishes are specified, the door center panel may be constructed of Medium Density Fiberboard (MDF), except when Timeworn, Hewn, Extra Timeworn, Extra Hewn, or Brushed Finish techniques or Black paint are specified. MDF provides a smoother finish when painted, and is more resistant to warping, expansion, and contraction.

# Door Styles

## Landry Collection

Inset Door Styles\*

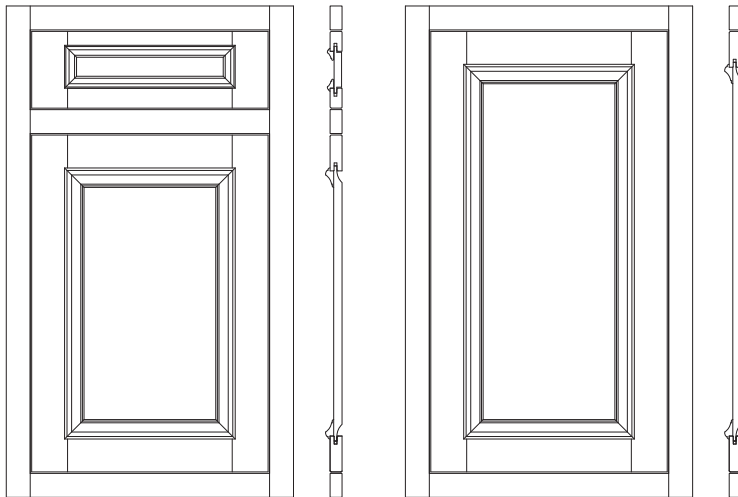

Square Base Cabinet

Square Wall Cabinet

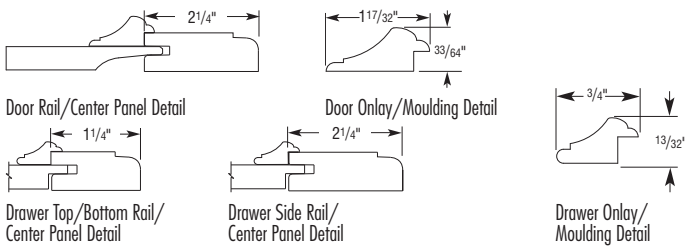

### Wood Species

Alder  
Cherry  
Maple  
Quartersawn Oak  
Rustic Alder

### Outside Profile Selections\*



\*Profile No. 12 shown

### Special Notes

- Bold onlay moulding applied to door; larger than drawer
- 9-piece flat center panel drawer front with onlay moulding
- 9-piece solid reverse raised panel door
- Drawer fronts smaller than 4 13/16" high will have slab front

### Design Notes

- Solid slab drawer front (DFSLB) available. See page G•11.
- Solid slab drawer front top (DFSLBT) available. See page G•11.
- Mullion doors and Prairie Mullion doors not available
- Finial Hinges (IFAB, IFBN, IFMB, IFORB) available on Profile #12 only. See page G•12 for details.

Beaded Inset Door Styles\*

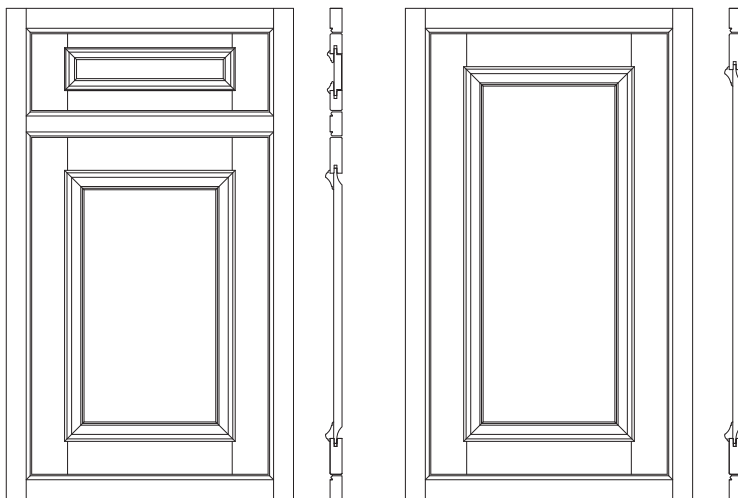

Square Base Cabinet

Square Wall Cabinet

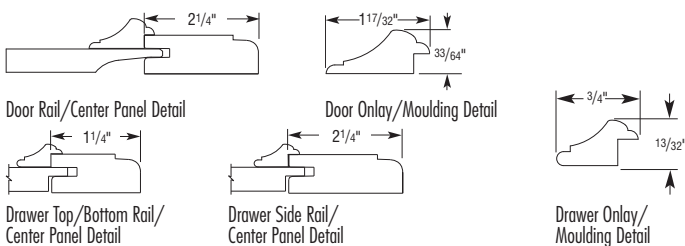

### Wood Species

Alder  
Cherry  
Maple  
Quartersawn Oak  
Rustic Alder

### Outside Profile Selections\*



\*Profile No. 12 shown

### Special Notes

- Bold onlay moulding applied to door; larger than drawer
- 9-piece flat center panel drawer front with onlay moulding
- 9-piece solid reverse raised panel door
- Drawer fronts smaller than 4 13/16" high will have slab front

### Design Notes

- Solid slab drawer front (DFSLB) available. See page G•11.
- Solid slab drawer front top (DFSLBT) available. See page G•11.
- Mullion doors and Prairie Mullion doors not available
- Finial Hinges (IFAB, IFBN, IFMB, IFORB) available on Profile #12 only. See page G•12 for details.

\*When Painted finishes are specified, the door center panel may be constructed of Medium Density Fiberboard (MDF), except when Timeworn, Hewn, Extra Timeworn, Extra Hewn, or Brushed Finish techniques or Black paint are specified. MDF provides a smoother finish when painted, and is more resistant to warping, expansion, and contraction.

## Shanley Collection

Inset Door Styles\*

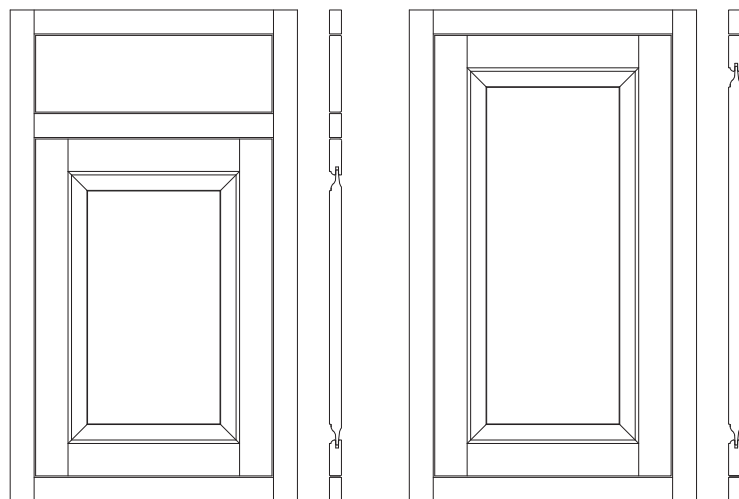

Square Base Cabinet

Square Wall Cabinet



Door Side Rail/Center Panel Detail

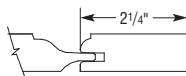

Option: DFR5PCINS Drawer Side Rail/Center Panel Detail

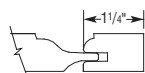

Option: DFR5PCINS Drawer Top/Bottom Rail/Center Panel Detail

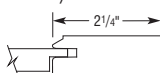

Option: DFF5PCINS Drawer Rail/Center Panel Detail

### Wood Species

Alder  
Cherry  
Maple  
Quartersawn Oak  
Rustic Alder

### Outside Profile Selections\*



\*Profile No. 12 shown

### Special Notes

- Solid slab drawer front
- 5-piece solid double raised panel door

### Design Notes

- Finial Hinges (IFAB, IFBN, IFMB, IFORB) available on Profile #12 only. See page G•12 for details.
- Drawer Front Flat 5-piece Inset (DFF5PCINS) available. Some exceptions may apply. See page G•10 for details.
- Drawer Front Raised 5-piece Inset (DFR5PCINS) available. Some exceptions may apply. See page G•11 for details.

Beaded Inset Door Styles\*

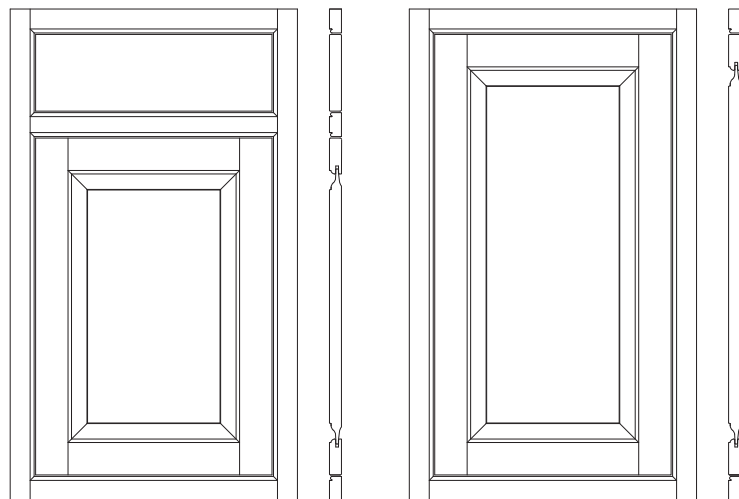

Square Base Cabinet

Square Wall Cabinet



Door Side Rail/Center Panel Detail

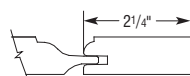

Option: DFR5PCINS Drawer Side Rail/Center Panel Detail



Option: DFR5PCINS Drawer Top/Bottom Rail/Center Panel Detail

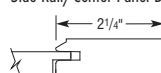

Option: DFF5PCINS Drawer Rail/Center Panel Detail

### Wood Species

Alder  
Cherry  
Maple  
Quartersawn Oak  
Rustic Alder

### Outside Profile Selections\*



\*Profile No. 12 shown

### Special Notes

- Solid slab drawer front
- 5-piece solid double raised panel door

### Design Notes

- Finial Hinges (IFAB, IFBN, IFMB, IFORB) available on Profile #12 only. See page G•12 for details.
- Drawer Front Flat 5-piece Inset (DFF5PCINS) available. Some exceptions may apply. See page G•10 for details.
- Drawer Front Raised 5-piece Inset (DFR5PCINS) available. Some exceptions may apply. See page G•11 for details.

\*When Painted finishes are specified, the door center panel may be constructed of Medium Density Fiberboard (MDF), except when Timeworn, Hewn, Extra Timeworn, Extra Hewn, or Brushed Finish techniques or Black paint are specified. MDF provides a smoother finish when painted, and is more resistant to warping, expansion, and contraction.

# Door Styles

## Tate Collection

Inset Door Styles\*

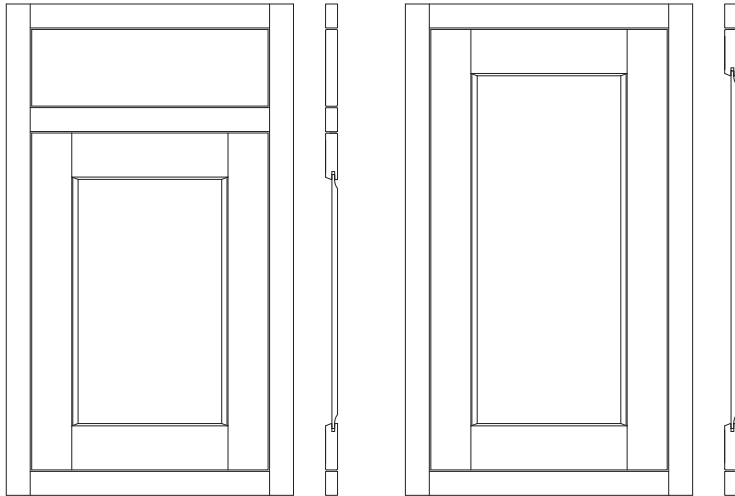

Square Base Cabinet

Square Wall Cabinet

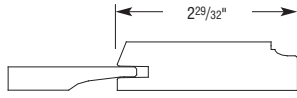
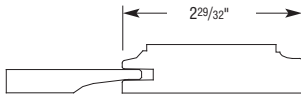

Door Side Rail/Center Panel Detail

Door Top/Bottom Rail/Center Panel Detail

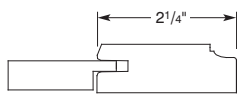
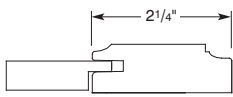

Option: DFF5PCINS Drawer Side Rail/Center Panel Detail

Option: DFF5PCINS Drawer Top/Bottom Rail/Center Panel Detail

### Wood Species

Alder  
Cherry  
Maple  
Quartersawn Oak  
Rustic Alder

### Outside Profile Selections\*



\*Profile No. 12 shown

### Special Notes

- Solid slab drawer front
- 5-piece solid reverse raised panel door

### Design Notes

- Mullion and Prairie Mullion doors not available
- Finial Hinges (IFAB, IFBN, IFMB, IFORB) available on Profile #12 only. See page G•12 for details.
- Drawer Front Flat 5-piece Inset (DFF5PCINS) available. Some exceptions may apply. See page G•10 for details.

Beaded Inset Door Styles\*

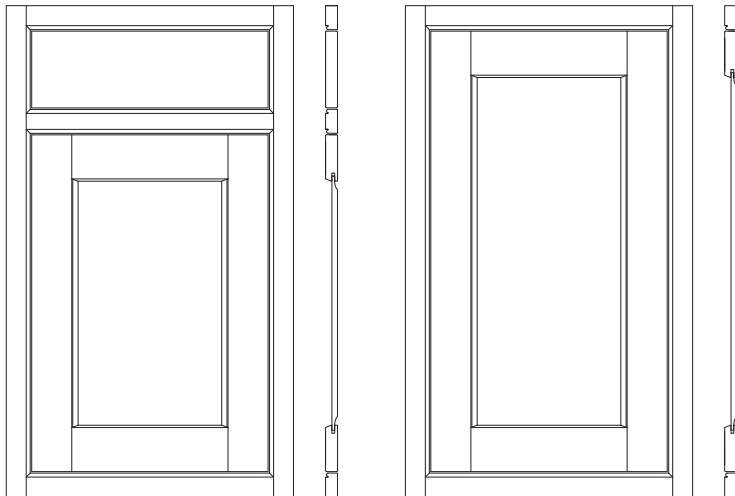

Square Base Cabinet

Square Wall Cabinet

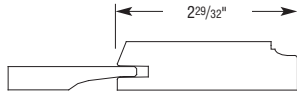
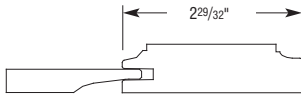

Door Side Rail/Center Panel Detail

Door Top/Bottom Rail/Center Panel Detail

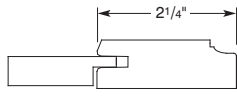
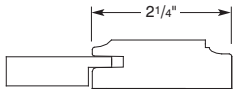

Option: DFF5PCINS Drawer Side Rail/Center Panel Detail

Option: DFF5PCINS Drawer Top/Bottom Rail/Center Panel Detail

### Wood Species

Alder  
Cherry  
Maple  
Quartersawn Oak  
Rustic Alder

### Outside Profile Selections\*



\*Profile No. 12 shown

### Special Notes

- Solid slab drawer front
- 5-piece solid reverse raised panel door

### Design Notes

- Mullion and Prairie Mullion doors not available
- Finial Hinges (IFAB, IFBN, IFMB, IFORB) available on Profile #12 only. See page G•12 for details.
- Drawer Front Flat 5-piece Inset (DFF5PCINS) available. Some exceptions may apply. See page G•10 for details.

\*When Painted finishes are specified, the door center panel may be constructed of Medium Density Fiberboard (MDF), except when Timeworn, Hewn, Extra Timeworn, Extra Hewn, or Brushed Finish techniques or Black paint are specified. MDF provides a smoother finish when painted, and is more resistant to warping, expansion, and contraction.

## Vinson Collection

Inset Door Styles\*

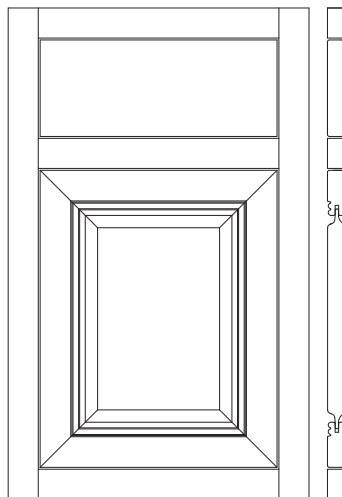

Square Base Cabinet

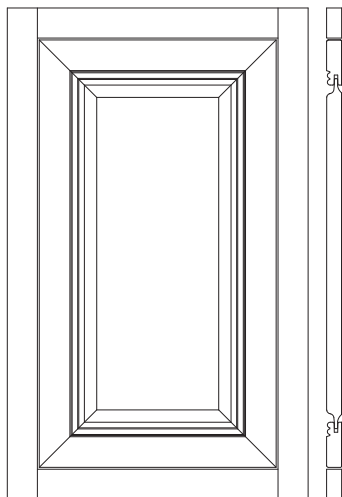

Square Wall Cabinet

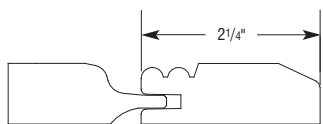

Door Rail/Center Panel Detail

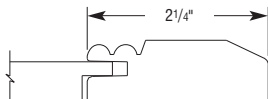

Option: DFF5PCINS Drawer Rail/Center Panel Detail

### Wood Species

Alder  
Cherry  
Maple  
Quartersawn Oak  
Rustic Alder

### Outside Profile Selections\*

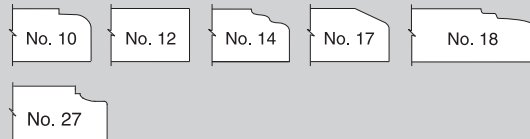

\*Profile No. 12 shown

### Special Notes

- Solid slab drawer front
- Solid double raised center panel door

### Design Notes

- Mullion and Prairie Mullion doors not available.
- Finial Hinges (IFAB, IFBN, IFMB, IFORB) available on Profile #12 only. See page G•12 for details.
- Drawer Front Flat 5-piece Inset (DFF5PCINS) available. Some exceptions may apply. See page G•10 for details.

Beaded Inset Door Styles\*

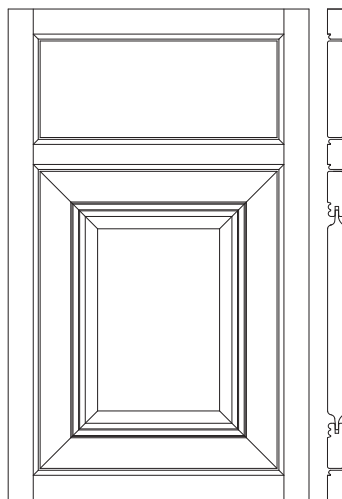

Square Base Cabinet

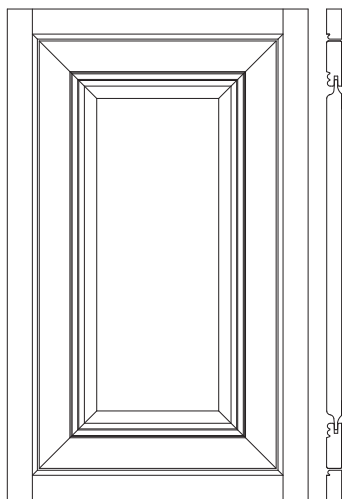

Square Wall Cabinet

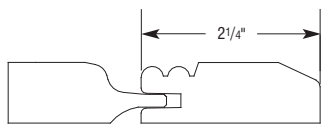

Door Rail/Center Panel Detail

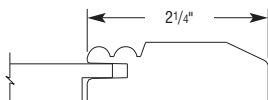

Option: DFF5PCINS Drawer Rail/Center Panel Detail

### Wood Species

Alder  
Cherry  
Maple  
Quartersawn Oak  
Rustic Alder

### Outside Profile Selections\*

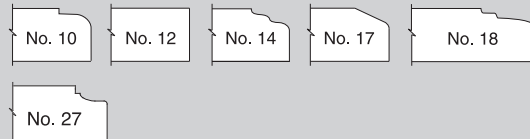

\*Profile No. 12 shown

### Special Notes

- Solid slab drawer front
- Solid double raised center panel door

### Design Notes

- Mullion and Prairie Mullion doors not available.
- Finial Hinges (IFAB, IFBN, IFMB, IFORB) available on Profile #12 only. See page G•12 for details.
- Drawer Front Flat 5-piece Inset (DFF5PCINS) available. Some exceptions may apply. See page G•10 for details.

\*When Painted finishes are specified, the door center panel may be constructed of Medium Density Fiberboard (MDF), except when Timeworn, Hewn, Extra Timeworn, Extra Hewn, or Brushed Finish techniques or Black paint are specified. MDF provides a smoother finish when painted, and is more resistant to warping, expansion, and contraction.





## Kemper Emerge's Door Applications

Kemper Emerge proudly offers multiple finishes and techniques to provide limitless looks for you and your customers.

### Finishes

- Stains
- Specialties
- Paints
- Brushed Finishes
- Cered Finishes

### Sheens

- Standard Sheen
- Matte Sheen Option

### Glazes

- Penned Glazes
- Flooded Glazes

### Techniques

- Hewn
- Extra Hewn
- Timeworn
- Extra Timeworn

## Finishes

### Stains

Stained finishes highlight the inherent qualities of genuine wood to create a truly beautiful product. Shadings of white, red, black and even green may be visible. Mineral streaks may also add to the distinctive appearance, reflecting the tree "life history" as it absorbed minerals differently in one region or another. Grain and apparent texture may range from even and consistent to varied and dramatic. The natural variations will be present throughout Kemper Emerge cabinetry, resulting in unique character marking on adjacent cabinets, on pairs of doors, and even within the same panel. These variations will also appear on edges of hardwood doors where solid lumber cores are exposed in certain Kemper Emerge styles (those featuring flush doors and drawer fronts). These unique characteristics of Natural finishes point out that each piece of wood is different; varied effect of finished cabinetry in a complete installation may be different from that represented by a smaller display or finish sample. The variations are broad, and that is where the beauty of wood lies. A stained finish uses both the toner and the wipe stain to achieve the final color. The toner is applied to the door and allowed to dry. A wipe stain is hand-applied to achieve the final color. All standard finishes will exhibit some degree of Natural characteristics.

## Specialty Finishes

### Alpaca

Developed to introduce a neutral color that works well with a wide variety of complements. The muted green tones were pulled into this finish to allow it to work as an accent color or a stand alone finish. The base color for Alpaca is an off white or creamy colored paint. This finish has a green glaze applied to the total product as a "Flooded Glaze" which allows the glaze to have an effect on the overall color. Some faint rag marks on the surface may be left to simulate the look of "brush strokes", but no heavy streaks.

### Balsamic and Cordial Ombres

A new look to an old style; Kemper Emerge is refreshing the classics by providing the Ombre collection, a dual toned sunburst effect of a golden amber or shadowed ruby, eclipsed by a dark chocolate hue. This finish seamlessly blends the characteristics of the lighter stains with a dark, semi-transparent toner. This is accomplished by a skilled spraying technique of two different toners with a wiped stain to help blend the two colors into one unique finish.

There may be a dark chocolate glazed effect left in some profiles and especially highlighted within the lighter tones of this finish. This will show grain patterns, as well as pick up the lighter and darker tones within the wood itself. The exact placement of the fade transition will vary from one door style to another. The Ombre effect is only applicable on doors, drawer fronts, overlays, authentic ends, inset panel ends, integral ends, and select accessories.

### Beachglass

Developed as a naturally worn accent color, complementary to the Kemper Emerge palette, the base color for Beachglass is a turquoise toner with the Toasted Almond glaze applied as a "Flooded Glaze". The glaze will be completely flooded on the product and wiped to leave hang up in profiles as well as allowing rag marks along the surface. This finish is not intended to be cleaned up with mineral, but rather, allowed to look very dirty so the glaze has an effect on the overall color. A brown "spattering" material is also applied to the overall product in varying sizes. This technique should allow for some clustering as well as a few, small blank areas. Inconsistencies should be expected.

### Black Canyon

This finish has a black surface finish with a brownish red undercoat. As the product is chemically distressed to achieve its weathered or well worn appearance, the red undercoat will be seen beneath the top Black toner to accentuate the two colors. The complement of the red and black expands the choices within the color palette and allows for a bold risk on a minimal scale. Canyon effect only applicable on doors, drawer fronts, overlays, authentic ends, inset panel ends, integral ends, and select accessories.

### Cigar Box

Refined finish. This hue incorporates deep rich reds, oranges and browns with a black glaze that shadows the profiles and helps define the grain and enhance the natural beauty of the wood tones. This multi-tonal finish has added definition with the introduction of speckling to the overall surface of the doors, face frames, accessories and panels. This is a transparent stain with all the depth of fine aged whiskey.

### Driftwood

A whisper of cloudy white translucence plays with natural wood tones in Kemper Emerge's Driftwood finish. This color was developed to introduce a neutral color that works well with a wide variety of complements. The black tones were pulled into this finish to allow it to work as an accent color or a stand alone finish, and the base color is an off white or creamy colored transparent toner. Minimal grain and minerals will be visible under the finish, which will allow wood characteristics to have play in the overall look. This finish has a black "flooded" glaze applied to the total product which allows the glaze to have an effect on the overall color creating a veiling effect. Some faint rag marks on the surface may be left to enhance the character of this finish.

### Poppyseed

This finish allows Kemper Emerge to incorporate the natural beauty of raw wood with the realistic hues of stone. This is a semi-transparent slate gray toner that is accented with a dark brown glaze which provides the overall look of a historic stone floor. The finish will show grain patterns, as well as pick up the light and dark tones in the wood color itself. By integrating stone and wood, Kemper Emerge has provided a beautiful complement to the existing finish palette.

### Worn Beachglass

Developed as a naturally worn accent color, complementary to the Kemper Emerge palette, the base color for Worn Beachglass is a turquoise toner with the Toasted Almond glaze applied as a "Flooded Glaze". The glaze will be completely flooded on the product and wiped to leave hang up in profiles as well as allowing rag marks along the surface. This finish is not intended to be cleaned up with mineral, but rather, allowed to look very dirty so the glaze has an effect on the overall color. A sand-through process is involved with a chemical wipe down of the toner to create bare wood areas that fade out to simulate natural wear. Most if not all corners should be hit in varying degrees, as well as "hit and miss" inside and outside profiles. A brown "spattering" material is also applied to the overall product in varying sizes. This technique should allow for some clustering as well as a few, small blank areas. Inconsistencies should be expected.

### Worn Black

This black finish combines the aged surface of a higher degree of distressing with the appealing imperfections of our Timeworn technique. Worn Black utilizes the same chemical distressing process of Black Canyon but will reveal the underlying wood color only.

# Finishes

## Paints

An interactive collection that is hand-picked and in step with today's most popular fashions and emerging trends, Kemper Emerge has a palette of 30 custom hues. This colorful collection is readily available without a color sample request, nor the requirement of a signed door, allowing for order placement and fulfillment within current lead times. You'll find a wealth of popular neutral tones from light to dark, as well as a chart-topping offering of gray pigmentations. Pops of trend-centric colors are also included, allowing the design statement your customer craves. While some colors may remain constant for several selling cycles, you'll find this collection to be carefully curated with colors that are relevant to homes today.

A painted finish is a full color hiding finish. When using a painted finish on a tight grain wood surface, the surface will be smooth and no wood grain should be seen.

With Maple painted finishes, the center panel will be constructed of Medium Density Fiberboard (MDF), except when Extra Hewn, Extra Timeworn, Hewn, or Timeworn finish techniques or Brushed Finishes or Black paint are specified. MDF provides a smoother finish when painted, and is more resistant to warping, expansion, and contraction.

## Brushed Finish

This program allows for flexibility to choose any painted finish and combine with one of three choices: Brushed Lakeshore, Brushed Nightfall or Brushed Timber, to create a one of a kind look. Available on Maple species only. The techniques of Extra Hewn, Extra Timeworn, Hewn, or Timeworn are not available in combination with brushed finish.

1. A sample is **required** before purchasing any product in a brushed finish option. A "Sample Door Order Form", found on [www.mbc1touch.com](http://www.mbc1touch.com), must be submitted. Please include the door style and profile selection.
2. Upon receiving the "Sample Door Order Form", a sample door in the finish, style and profile requested will be produced, labeled, and reference the order number. One half of the door will be sent to the customer for approval and the other half will be retained by Kemper Emerge for 180 days. If an order is placed after this time, a new custom color sample (CCSMPL) is required.

Code	Description
CCSMPL	Brushed Sample

3. The customer will review and approve the door sample. A Brushed Finish Agreement Form is required (received with the 1/2 CCSMPL from Kemper Emerge). Submit the cabinet order and include the following: "Brushed Finish Agreement" Form and Purchase Order Number (PO#).

### Brushed Lakeshore

Brushed Lakeshore is a soft gray, toned color applied to the selected base color.

### Brushed Nightfall

Brushed Nightfall is a rich, black toned color applied to the selected base color.

### Brushed Timber

Brushed Timber is a lush brown toned color applied to the selected base color.

The hand-brushed application is designed to give depth and movement to the base color. Depending on the combination selected, the finished look can range from an aged, weathered appearance to a modern contemporary look. Brushed Lakeshore, Nightfall and Timber are only available on painted finishes on Maple.

### Brushed Finish Application Details

	Front of Door	Back of Door	Face Frame	Ends	Fixed Door on End	Recessed/Raised Panel End	Interior of Open & Glass Door Cabinetry (if matching interior mod is specified)
Brushed Finish	YES	NO	YES	YES	YES	YES	YES

### Direction of brush stroke with Brushed Finishes.

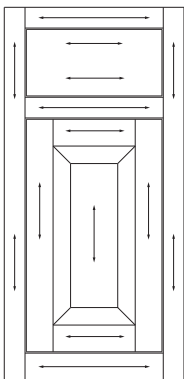

## Ceruse Finish

Ceruse, also known as "limed", is a pigmented grain filler that adds contrast against the open pores of the grain of stained Quartersawn Oak wood species. This creates an effect evoking a bygone era of craftsmanship and style that has made a comeback today. Ceruse is available on Buckskin, Morel and Quarry in two colorways.

### Brindle

The contrasting qualities of white ceruse against stained finishes offer an aesthetic that reads vintage just as easily as modern styling.

### Roan

Dark ceruse plays off of stained finishes, lending a moody vibe and a furniture feel that complements any style décor.

## Sheens

Kemper Emerge products are enhanced with a predetermined furniture sheen level, complementing the natural beauty of the selected wood and finish combination.

### Standard Sheen

Kemper Emerge's standard sheen, non-pigmented top coat accentuates the beauty of a variety of finishes, adding a soft patina to selected wood/finish combinations as well as all painted products.

### Matte Sheen Option

The Matte Sheen option is a low sheen, non-pigmented top coat available on all paints and stains except Ceruse finishes. The average degree of sheen is 5°.

## Glazes

Kemper Emerge has multiple door style selections that represent many of the trends and fashions found in today's kitchens and baths. Each door style will uniquely change the appearance of your kitchen. For example, a glaze product is not usually favored for door styles that have limited areas on the profile for glazes to hang up. Doors designed with greater detail will have a heavily shadowed appearance due to the increased amount of glaze hang up.

### Flooded Glaze

All flooded glazes will have a rustic appearance. This finish technique involves flooding the wood component with the glaze material and then hand-wiping the excess material into and off of the component. The glaze material is not completely wiped from the corners of the door and it is left to accumulate in the corners and along the profiles of the component. The uniqueness of the materials and the process of hand-wiping will cause a variation from door to door and within the same component. Depending on the color of glaze applied, the mineral or natural wood characteristics of the door may become more accentuated.

### Penned Glaze

After the product is finished, it is removed from the finish line and transferred to the penned operation. The penned glaze is hand-applied in areas of the door, drawer front, and select mouldings to highlight distinct profiles. Face frames, ends, matching interior, panels, and selected mouldings will not have penned glaze applied. The color on penned glaze is not dependent on the penned glaze to achieve the desired color, therefore the penned glaze is not applied or flooded on the entire part. The moulding and embellishment pieces that do not receive penned glaze do not have profiled areas for the penned glaze to be applied, and will match the base color of the doors.

## Techniques

As with normal aging, the distressed areas, worn edges, sanded edges, etc. will vary within individual doors and throughout the entire room. The affect and amount of sanding will vary based on the door or drawer front profile. Each combination of finish, species and door style will provide a unique look largely due to different finishing processes. The areas that are distressed may be enhanced with glazes or specialty finishes, while they may appear more muted with lighter colors, stains and finishes. It is recommended that a sample door and drawer front is ordered to illustrate these unique characteristics. Kemper Emerge does not warranty these finish and technique combinations.

## Hewn

Gently highlights the distinctive details of each cabinet; this technique creates a subtle, time worn look with the softness of natural wear. The finish is lightly sanded through in places to create the effect. Inset and Beaded Inset door styles will not feature any Hewn technique on the frame. Hewn is not available on Unfinished, Natural, Natural Amaretto Crème Penned, Natural Toasted Almond Penned, Alpaca, Black Canyon, Worn Beachglass, or Worn Black. Not available with the brushed finish technique.

## Extra Hewn

Aggressively burnished sand-through technique applied to corners and raised profiles, exposing the underlying wood for all species and colors in the Kemper Emerge line. As with normal aging, the worn edges will vary within individual doors and throughout the entire room. Inset and Beaded Inset door styles will not feature any Extra Hewn technique on the frame. Extra Hewn is not available on Unfinished, Natural, Natural Amaretto Crème Penned, Natural Toasted Almond Penned, Alpaca, Black Canyon, Worn Beachglass, or Worn Black. Not available with the brushed finish technique.

## Timeworn

A lightly distressed technique, featuring random worm holes, tiny dents and light signs of wear; the technique creates a look of unique and appealing imperfections, similar to those in time worn antiques. Veneer parts with furniture board core will not be distressed. Not available with the brushed finish technique.

## Extra Timeworn

A more aggressive, random appearance of rasped corners and edges, worm holes, mars, splits, gouges, small dings and dents for a true authentic look. Veneer parts with furniture board core will not be distressed. Inset and Beaded Inset door styles will not feature rasped corners and edges on the frame. Not available with the brushed finish technique.

Available combinations are Extra Timeworn with Extra Hewn and Timeworn with Hewn.

# Finish Process







## Stain Finish Process

1. Kemper Emerge's craftspeople carefully inspect each cabinet piece to ensure that the wood is in excellent condition and ready for finish application.
2. Multiple sanding processes prepare selected woods for a quality finish. Sanding steps include shaping, jitter sanding, wide belt sanding, and cross grain sanding.
3. Toner is applied. Toner is a base coat that provides initial color and helps to equalize the surface of the wood.
4. Skilled craftspeople carefully apply the selected stain.
5. The stain is hand-wiped into the wood's surface, highlighting the beauty of the grain patterns.
- 6.\* The wood enters the oven for the first time to seal the stain.
- 7.\* Sealer is applied, ensuring that the toner and stain are locked in, protecting the rich wood tones.
- 8.\* The wood enters the oven for the second time in the finish process, adding greater finish durability.
9. The sealer is sanded to ensure a completely smooth surface for the top coat application.
10. The wood is wiped down with a tack cloth to make sure that the wood surface is exceptionally clean.
11. The wood enters the oven for the third time in the finish process, adding greater finish durability.
12. After the third surface preparation, the final protective top coat of catalyzed conversion varnish is applied.
13. Finally, the piece is ready for the last step in the finish process, where it travels through the oven for the fourth time, ensuring years of carefree beauty.

An unfinished door receives the normal white wood sanding process, but is re-sanded in the field just prior to finish application. Kemper Emerge does not warranty finish on cabinets that have been finished by an outside source.

\*Does not apply for natural finish.

# Door Style & Finish Availability Chart

		Standard Sheen	Matte Sheen Option †	Alder Door Styles	Cherry Door Styles	Maple Door Styles  1	Quartersawn Oak Door Styles	Rustic Alder Door Styles  2
<b>Stains</b>	Boardwalk	15°	5°	✓^	✓^	✓^	✓	✓^
	Boulder	15°	5°	✓^	✓^	✓^	✓	✓^
	Buckskin	15°	5°	✓^	✓^	✓^	✓	✓^
	Caribou	35°	5°	✓^	✓^	✓^	✓	✓^
	Cattail 	15°	5°	✓^	✓^	✓^	✓	✓^
	Chocolate 	15°	5°	✓^	✓^	✓^	✓	✓^
	Flax	15°	5°	✓^	✓^	✓^	✓	✓^
	Havana 	15°	5°	✓^	✓^	✓^	✓	✓^
	Henna 	15°	5°	✓^	✓^	✓^	✓	✓^
	Marsala	35°	5°	✓^	✓^	✓^	✓	✓^
	Morel	15°	5°	✓^	✓^	✓^	✓	✓^
	Mustang	35°	5°	✓^	✓^	✓^	✓	✓^
	Natural	35°	5°	✓^	✓^	✓^	✓	✓^
	Quarry	15°	5°	✓^	✓^	✓^	✓	✓^
	Rodeo	15°	5°	✓^	✓^	✓^	✓	✓^
	Sandpiper	35°	5°	✓^	✓^	✓^	✓	✓^
	Satchel	15°	5°	✓^	✓^	✓^	✓	✓^
	Single Malt	35°	5°	✓^	✓^	✓^	✓	✓^
	Stout	35°	5°	✓^	✓^	✓^	✓	✓^
	Sun Tea	35°	5°	✓^	✓^	✓^	✓	✓^
Thatch 	15°	5°	✓^	✓^	✓^	✓	✓^	
Unfinished			✓	✓	✓	✓	✓	
<b>Flooded Glazes</b>	Marsala Amaretto Crème	35°	5°	✓	✓		✓	✓
	Mustang Amaretto Crème	35°	5°		✓			
	Natural Liqueur	35°	5°	✓	✓	✓	✓	✓
	Natural Toasted Almond	35°	5°	✓	✓	✓		✓
	Ruddy Toasted Almond	35°	5°	✓	✓			✓
	Rye Amaretto Crème	35°	5°		✓			
	Rye Toasted Almond	35°	5°	✓	✓	✓	✓	✓
	Sandpiper Amaretto Crème	35°	5°	✓	✓			✓
	Sandpiper Liqueur	35°	5°	✓	✓	✓	✓	✓
	Sun Tea Amaretto Crème	35°	5°	✓	✓			✓
Sun Tea Toasted Almond	35°	5°	✓	✓			✓	
<b>Paints</b>	Paints**	15°	5°			✓*		
<b>Specialties</b>	Alpaca	15°	5°			✓	✓	
	Balsamic Ombre	15°	5°	✓	✓			✓
	Beachglass	15°	5°			✓	✓	
	Black Canyon	15°	5°			✓		
	Cigar Box	15°	5°	✓	✓		✓	✓
	Cordial Ombre	15°	5°	✓	✓			✓
	Driftwood	15°	5°			✓	✓	
	Poppyseed	15°	5°			✓^		
	Worn Beachglass	15°	5°			✓	✓	
	Worn Black	15°	5°			✓		
<b>Cerused Finishes</b>	Buckskin Brindle	3°					✓	
	Buckskin Roan	3°					✓	
	Morel Brindle	3°					✓	
	Morel Roan	3°					✓	
	Quarry Brindle	3°					✓	
	Quarry Roan	3°					✓	

For Finish Descriptions and availability details, see pages E•1 through E•3.

\*Available with Amaretto Crème, Meringue, Nougat, Slate, Smoked Caviar, and Toasted Almond panned glazes.

\*\*Smoked Caviar panned glaze not available with Black.







†All 5° matte sheens are available.

^Available with Amaretto Crème or Toasted Almond panned glaze.

 1 Signed finish agreement required, see page V•5.

 2 Signed Rustic Alder agreement required, see page V•6.

# Paints Finish Chart

		Standard Sheen	Matte Sheen Option <sup>†</sup>	Alder Door Styles	Cherry Door Styles	Maple Door Styles 🔪 <sup>1</sup>	Quartersawn Oak Door Styles	Rustic Alder Door Styles 🔪 <sup>2</sup>
<b>Techniques</b>	Hewn			✓	✓	✓	✓	✓
	Extra Hewn			✓	✓	✓	✓	✓
	Timeworn			✓	✓	✓	✓	✓
	Extra Timeworn			✓	✓	✓	✓	✓
<b>Paints</b>	Abyss	15°	5°			✓*		
	Agreeable Gray	15°	5°			✓*		
	Black**	15°	5°			✓*		
	Cloud	15°	5°			✓*		
	Coastal Plain	15°	5°			✓*		
	Coconut	15°	5°			✓*		
	Distance 	15°	5°			✓*		
	Dover 	15°	5°			✓*		
	Eclipse	15°	5°			✓*		
	Egret	15°	5°			✓*		
	Escape Gray	15°	5°			✓*		
	Forest Floor	15°	5°			✓*		
	Icy Avalanche	15°	5°			✓*		
	Interesting Aqua	15°	5°			✓*		
	Jogging Path	15°	5°			✓*		
	Lambswool 	15°	5°			✓*		
	Limestone 	15°	5°			✓*		
	Living Greige	15°	5°			✓*		
	Maritime	15°	5°			✓*		
	Mindful Gray	15°	5°			✓*		
	Moonstone 	15°	5°			✓*		
	Naval 	15°	5°			✓*		
	North Star	15°	5°			✓*		
	Peppercorn	15°	5°			✓*		
	Pure Linen	15°	5°			✓*		
	Retreat	15°	5°			✓*		
	Sea Salt	15°	5°			✓*		
	Seaside 	15°	5°			✓*		
	Soft Glow	15°	5°			✓*		
	Sterling White	15°	5°			✓*		
Stone Trail	15°	5°			✓*			
Tawny Owl	15°	5°			✓*			
Urbane Bronze	15°	5°			✓*			
Waterbury Clay	15°	5°			✓*			
White	15°	5°			✓*			
<b>Brushed Finishes</b>	Brushed Lakeshore	15°	5°			✓‡		
	Brushed Nightfall	15°	5°			✓‡		
	Brushed Timber	15°	5°			✓‡		

For Finish Descriptions and availability details, see pages E•1 through E•3.

Signed Finish Agreement forms required for Maple paints and Brushed Finishes. Sample door sign off required for Brushed Finishes. See page V•5.

Brushed Finishes must be ordered along with a painted finish as the base color. Example: Coconut plus Brushed Nightfall.

\*Available with Amaretto Crème, Meringue, Nougat, Slate, Smoked Caviar, and Toasted Almond panned glazes.

\*\*Smoked Caviar panned glaze not available with Black.

†All 5° matte sheens are available.

‡NOT available with Amaretto Crème, Meringue, Nougat, Slate, Smoked Caviar, and Toasted Almond panned glazes.

🔪<sup>1</sup> Signed finish agreement required, see page V•5.

🔪<sup>2</sup> Signed Rustic Alder agreement required, see page V•6.

FINISH / GLAZE NAME	Toner	Stain	Glaze	Paint	Glaze Pen	Spray Can*	Touch-up Kit
<b>Stains</b>							
Boardwalk	(1) TONERQUART	(1) STAINQUART				(1) SSC15**	(1) TUK
Boardwalk Amaretto Crème	(1) TONERQUART	(1) STAINQUART			(1) GLAZEPEN	(1) SSC15**	(1) TUK
Boardwalk Toasted Almond	(1) TONERQUART	(1) STAINQUART			(1) GLAZEPEN	(1) SSC15**	(1) TUK
Boulder	(1) TONERQUART	(1) STAINQUART				(1) SSC15**	(1) TUK
Boulder Amaretto Crème	(1) TONERQUART	(1) STAINQUART			(1) GLAZEPEN	(1) SSC15**	(1) TUK
Boulder Toasted Almond	(1) TONERQUART	(1) STAINQUART			(1) GLAZEPEN	(1) SSC15**	(1) TUK
Buckskin	(1) TONERQUART	(1) STAINQUART				(1) SSC15**	(1) TUK
Buckskin Amaretto Crème	(1) TONERQUART	(1) STAINQUART			(1) GLAZEPEN	(1) SSC15**	(1) TUK
Buckskin Toasted Almond	(1) TONERQUART	(1) STAINQUART			(1) GLAZEPEN	(1) SSC15**	(1) TUK
Caribou	(1) TONERQUART	(1) STAINQUART				(1) SSC35**	(1) TUK
Caribou Amaretto Crème	(1) TONERQUART	(1) STAINQUART			(1) GLAZEPEN	(1) SSC35**	(1) TUK
Caribou Toasted Almond	(1) TONERQUART	(1) STAINQUART			(1) GLAZEPEN	(1) SSC35**	(1) TUK
Cattail	(1) TONERQUART	(1) STAINQUART				(1) SSC15**	(1) TUK
Cattail Amaretto Crème	(1) TONERQUART	(1) STAINQUART			(1) GLAZEPEN	(1) SSC15**	(1) TUK
Cattail Toasted Almond	(1) TONERQUART	(1) STAINQUART			(1) GLAZEPEN	(1) SSC15**	(1) TUK
Chocolate	(1) TONERQUART	(1) STAINQUART				(1) SSC15**	(1) TUK
Chocolate Amaretto Crème	(1) TONERQUART	(1) STAINQUART			(1) GLAZEPEN	(1) SSC15**	(1) TUK
Chocolate Toasted Almond	(1) TONERQUART	(1) STAINQUART			(1) GLAZEPEN	(1) SSC15**	(1) TUK
Flax	(1) TONERQUART	(1) STAINQUART				(1) SSC15**	(1) TUK
Flax Amaretto Crème	(1) TONERQUART	(1) STAINQUART			(1) GLAZEPEN	(1) SSC15**	(1) TUK
Flax Toasted Almond	(1) TONERQUART	(1) STAINQUART			(1) GLAZEPEN	(1) SSC15**	(1) TUK
Havana	(1) TONERQUART	(1) STAINQUART				(1) SSC15**	(1) TUK
Havana Amaretto Crème	(1) TONERQUART	(1) STAINQUART			(1) GLAZEPEN	(1) SSC15**	(1) TUK
Havana Toasted Almond	(1) TONERQUART	(1) STAINQUART			(1) GLAZEPEN	(1) SSC15**	(1) TUK
Henna	(1) TONERQUART	(1) STAINQUART				(1) SSC15**	(1) TUK
Henna Amaretto Crème	(1) TONERQUART	(1) STAINQUART			(1) GLAZEPEN	(1) SSC15**	(1) TUK
Henna Toasted Almond	(1) TONERQUART	(1) STAINQUART			(1) GLAZEPEN	(1) SSC15**	(1) TUK
Marsala	(1) TONERQUART	(1) STAINQUART				(1) SSC35**	(1) TUK
Marsala Amaretto Crème	(1) TONERQUART	(1) STAINQUART			(1) GLAZEPEN	(1) SSC35**	(1) TUK
Marsala Toasted Almond	(1) TONERQUART	(1) STAINQUART			(1) GLAZEPEN	(1) SSC35**	(1) TUK
Morel	(1) TONERQUART	(1) STAINQUART				(1) SSC15**	(1) TUK
Morel Amaretto Crème	(1) TONERQUART	(1) STAINQUART			(1) GLAZEPEN	(1) SSC15**	(1) TUK
Morel Toasted Almond	(1) TONERQUART	(1) STAINQUART			(1) GLAZEPEN	(1) SSC15**	(1) TUK
Mustang	(1) TONERQUART	(1) STAINQUART				(1) SSC35**	(1) TUK
Mustang Amaretto Crème	(1) TONERQUART	(1) STAINQUART			(1) GLAZEPEN	(1) SSC35**	(1) TUK
Mustang Toasted Almond	(1) TONERQUART	(1) STAINQUART			(1) GLAZEPEN	(1) SSC35**	(1) TUK
Natural						(1) SSC35**	(1) TUK
Natural Amaretto Crème					(1) GLAZEPEN	(1) SSC35**	(1) TUK
Natural Toasted Almond					(1) GLAZEPEN	(1) SSC35**	(1) TUK
Quarry	(1) TONERQUART	(1) STAINQUART				(1) SSC15**	(1) TUK
Quarry Amaretto Crème	(1) TONERQUART	(1) STAINQUART			(1) GLAZEPEN	(1) SSC15**	(1) TUK
Quarry Toasted Almond	(1) TONERQUART	(1) STAINQUART			(1) GLAZEPEN	(1) SSC15**	(1) TUK
Rodeo	(1) TONERQUART	(1) STAINQUART				(1) SSC15**	(1) TUK
Rodeo Amaretto Crème	(1) TONERQUART	(1) STAINQUART			(1) GLAZEPEN	(1) SSC15**	(1) TUK
Rodeo Toasted Almond	(1) TONERQUART	(1) STAINQUART			(1) GLAZEPEN	(1) SSC15**	(1) TUK
Sandpiper		(1) STAINQUART				(1) SSC35**	(1) TUK
Sandpiper Amaretto Crème		(1) STAINQUART			(1) GLAZEPEN	(1) SSC35**	(1) TUK
Sandpiper Toasted Almond		(1) STAINQUART			(1) GLAZEPEN	(1) SSC35**	(1) TUK
Satchel	(1) TONERQUART	(1) STAINQUART				(1) SSC15**	(1) TUK
Satchel Amaretto Crème	(1) TONERQUART	(1) STAINQUART			(1) GLAZEPEN	(1) SSC15**	(1) TUK
Satchel Toasted Almond	(1) TONERQUART	(1) STAINQUART			(1) GLAZEPEN	(1) SSC15**	(1) TUK
Single Malt	(1) TONERQUART	(1) STAINQUART				(1) SSC35**	(1) TUK
Single Malt Amaretto Crème	(1) TONERQUART	(1) STAINQUART			(1) GLAZEPEN	(1) SSC35**	(1) TUK
Single Malt Toasted Almond	(1) TONERQUART	(1) STAINQUART			(1) GLAZEPEN	(1) SSC35**	(1) TUK
Stout	(1) TONERQUART	(1) STAINQUART				(1) SSC35**	(1) TUK
Stout Amaretto Crème	(1) TONERQUART	(1) STAINQUART			(1) GLAZEPEN	(1) SSC35**	(1) TUK
Stout Toasted Almond	(1) TONERQUART	(1) STAINQUART			(1) GLAZEPEN	(1) SSC35**	(1) TUK
Sun Tea	(1) TONERQUART	(1) STAINQUART				(1) SSC35**	(1) TUK
Sun Tea Amaretto Crème	(1) TONERQUART	(1) STAINQUART			(1) GLAZEPEN	(1) SSC35**	(1) TUK
Sun Tea Toasted Almond	(1) TONERQUART	(1) STAINQUART			(1) GLAZEPEN	(1) SSC35**	(1) TUK
Thatch	(1) TONERQUART	(1) STAINQUART				(1) SSC15**	(1) TUK
Thatch Amaretto Crème	(1) TONERQUART	(1) STAINQUART			(1) GLAZEPEN	(1) SSC15**	(1) TUK
Thatch Toasted Almond	(1) TONERQUART	(1) STAINQUART			(1) GLAZEPEN	(1) SSC15**	(1) TUK

\*Spray Can accessory is a clear coat material.

\*\*If matte sheen option is selected, then spray can code SSC5 will need to be selected instead of the spray can code listed in chart.



# Finish Accessories

FINISH / GLAZE NAME	Toner	Stain	Glaze	Paint	Glaze Pen	Spray Can*	Touch-up Kit
<b>Flooded Glazes</b>							
Marsala Amaretto Crème	(1) TONERQUART		(1) GLAZEQUART			(1) SSC35**	(1) TUK
Mustang Amaretto Crème	(1) TONERQUART	(1) STAINQUART	(1) GLAZEQUART			(1) SSC35**	(1) TUK
Natural Liqueur	(1) TONERQUART		(1) GLAZEQUART			(1) SSC35**	(1) TUK
Natural Toasted Almond	(1) TONERQUART		(1) GLAZEQUART			(1) SSC35**	(1) TUK
Ruddy Toasted Almond	(1) TONERQUART		(1) GLAZEQUART			(1) SSC35**	(1) TUK
Rye Amaretto Crème	(1) TONERQUART		(1) GLAZEQUART			(1) SSC35**	(1) TUK
Rye Toasted Almond	(1) TONERQUART		(1) GLAZEQUART			(1) SSC35**	(1) TUK
Sandpiper Amaretto Crème	(1) TONERQUART		(1) GLAZEQUART			(1) SSC35**	(1) TUK
Sandpiper Liqueur	(1) TONERQUART		(1) GLAZEQUART			(1) SSC35**	(1) TUK
Sun Tea Amaretto Crème	(1) TONERQUART		(1) GLAZEQUART			(1) SSC35**	(1) TUK
Sun Tea Toasted Almond	(1) TONERQUART		(1) GLAZEQUART			(1) SSC35**	(1) TUK
<b>Paints</b>							
Abys				(1) PAINTQUART		(1) SSC15**	(1) TUK
Abys Amaretto Crème				(1) PAINTQUART	(1) GLAZEPEN	(1) SSC15**	(1) TUK
Abys Meringue				(1) PAINTQUART	(1) GLAZEPEN	(1) SSC15**	(1) TUK
Abys Nougat				(1) PAINTQUART	(1) GLAZEPEN	(1) SSC15**	(1) TUK
Abys Slate				(1) PAINTQUART	(1) GLAZEPEN	(1) SSC15**	(1) TUK
Abys Smoked Caviar				(1) PAINTQUART	(1) GLAZEPEN	(1) SSC15**	(1) TUK
Abys Toasted Almond				(1) PAINTQUART	(1) GLAZEPEN	(1) SSC15**	(1) TUK
Agreeable Gray				(1) PAINTQUART		(1) SSC15**	(1) TUK
Agreeable Gray Amaretto Crème				(1) PAINTQUART	(1) GLAZEPEN	(1) SSC15**	(1) TUK
Agreeable Gray Meringue				(1) PAINTQUART	(1) GLAZEPEN	(1) SSC15**	(1) TUK
Agreeable Gray Nougat				(1) PAINTQUART	(1) GLAZEPEN	(1) SSC15**	(1) TUK
Agreeable Gray Slate				(1) PAINTQUART	(1) GLAZEPEN	(1) SSC15**	(1) TUK
Agreeable Gray Smoked Caviar				(1) PAINTQUART	(1) GLAZEPEN	(1) SSC15**	(1) TUK
Agreeable Gray Toasted Almond				(1) PAINTQUART	(1) GLAZEPEN	(1) SSC15**	(1) TUK
Black	(1) TONERQUART					(1) SSC15**	(1) TUK
Black Amaretto Crème	(1) TONERQUART				(1) GLAZEPEN	(1) SSC15**	(1) TUK
Black Meringue	(1) TONERQUART				(1) GLAZEPEN	(1) SSC15**	(1) TUK
Black Nougat	(1) TONERQUART				(1) GLAZEPEN	(1) SSC15**	(1) TUK
Black Slate	(1) TONERQUART				(1) GLAZEPEN	(1) SSC15**	(1) TUK
Black Toasted Almond	(1) TONERQUART				(1) GLAZEPEN	(1) SSC15**	(1) TUK
Cloud				(1) PAINTQUART		(1) SSC15**	(1) TUK
Cloud Amaretto Crème				(1) PAINTQUART	(1) GLAZEPEN	(1) SSC15**	(1) TUK
Cloud Meringue				(1) PAINTQUART	(1) GLAZEPEN	(1) SSC15**	(1) TUK
Cloud Nougat				(1) PAINTQUART	(1) GLAZEPEN	(1) SSC15**	(1) TUK
Cloud Slate				(1) PAINTQUART	(1) GLAZEPEN	(1) SSC15**	(1) TUK
Cloud Smoked Caviar				(1) PAINTQUART	(1) GLAZEPEN	(1) SSC15**	(1) TUK
Cloud Toasted Almond				(1) PAINTQUART	(1) GLAZEPEN	(1) SSC15**	(1) TUK
Coastal Plain				(1) PAINTQUART		(1) SSC15**	(1) TUK
Coastal Plain Amaretto Crème				(1) PAINTQUART	(1) GLAZEPEN	(1) SSC15**	(1) TUK
Coastal Plain Meringue				(1) PAINTQUART	(1) GLAZEPEN	(1) SSC15**	(1) TUK
Coastal Plain Nougat				(1) PAINTQUART	(1) GLAZEPEN	(1) SSC15**	(1) TUK
Coastal Plain Slate				(1) PAINTQUART	(1) GLAZEPEN	(1) SSC15**	(1) TUK
Coastal Plain Smoked Caviar				(1) PAINTQUART	(1) GLAZEPEN	(1) SSC15**	(1) TUK
Coastal Plain Toasted Almond				(1) PAINTQUART	(1) GLAZEPEN	(1) SSC15**	(1) TUK
Coconut				(1) PAINTQUART		(1) SSC15**	(1) TUK
Coconut Amaretto Crème				(1) PAINTQUART	(1) GLAZEPEN	(1) SSC15**	(1) TUK
Coconut Meringue				(1) PAINTQUART	(1) GLAZEPEN	(1) SSC15**	(1) TUK
Coconut Nougat				(1) PAINTQUART	(1) GLAZEPEN	(1) SSC15**	(1) TUK
Coconut Slate				(1) PAINTQUART	(1) GLAZEPEN	(1) SSC15**	(1) TUK
Coconut Smoked Caviar				(1) PAINTQUART	(1) GLAZEPEN	(1) SSC15**	(1) TUK
Coconut Toasted Almond				(1) PAINTQUART	(1) GLAZEPEN	(1) SSC15**	(1) TUK
Distance				(1) PAINTQUART		(1) SSC15**	(1) TUK
Distance Amaretto Crème				(1) PAINTQUART	(1) GLAZEPEN	(1) SSC15**	(1) TUK
Distance Meringue				(1) PAINTQUART	(1) GLAZEPEN	(1) SSC15**	(1) TUK
Distance Nougat				(1) PAINTQUART	(1) GLAZEPEN	(1) SSC15**	(1) TUK
Distance Slate				(1) PAINTQUART	(1) GLAZEPEN	(1) SSC15**	(1) TUK
Distance Smoked Caviar				(1) PAINTQUART	(1) GLAZEPEN	(1) SSC15**	(1) TUK
Distance Toasted Almond				(1) PAINTQUART	(1) GLAZEPEN	(1) SSC15**	(1) TUK
Dover				(1) PAINTQUART		(1) SSC15**	(1) TUK
Dover Amaretto Crème				(1) PAINTQUART	(1) GLAZEPEN	(1) SSC15**	(1) TUK
Dover Meringue				(1) PAINTQUART	(1) GLAZEPEN	(1) SSC15**	(1) TUK

\*Spray Can accessory is a clear coat material.

\*\*If matte sheen option is selected, then spray can code SSC5 will need to be selected instead of the spray can code listed in chart.

FINISH / GLAZE NAME	Toner	Stain	Glaze	Paint	Glaze Pen	Spray Can*	Touch-up Kit
Dover Nougat				(1) PAINTQUART	(1) GLAZEPEN	(1) SSC15**	(1) TUK
Dover Slate				(1) PAINTQUART	(1) GLAZEPEN	(1) SSC15**	(1) TUK
Dover Smoked Caviar				(1) PAINTQUART	(1) GLAZEPEN	(1) SSC15**	(1) TUK
Dover Toasted Almond				(1) PAINTQUART	(1) GLAZEPEN	(1) SSC15**	(1) TUK
Eclipse				(1) PAINTQUART		(1) SSC15**	(1) TUK
Eclipse Amaretto Crème				(1) PAINTQUART	(1) GLAZEPEN	(1) SSC15**	(1) TUK
Eclipse Meringue				(1) PAINTQUART	(1) GLAZEPEN	(1) SSC15**	(1) TUK
Eclipse Nougat				(1) PAINTQUART	(1) GLAZEPEN	(1) SSC15**	(1) TUK
Eclipse Slate				(1) PAINTQUART	(1) GLAZEPEN	(1) SSC15**	(1) TUK
Eclipse Smoked Caviar				(1) PAINTQUART	(1) GLAZEPEN	(1) SSC15**	(1) TUK
Eclipse Toasted Almond				(1) PAINTQUART	(1) GLAZEPEN	(1) SSC15**	(1) TUK
Egret				(1) PAINTQUART		(1) SSC15**	(1) TUK
Egret Amaretto Crème				(1) PAINTQUART	(1) GLAZEPEN	(1) SSC15**	(1) TUK
Egret Meringue				(1) PAINTQUART	(1) GLAZEPEN	(1) SSC15**	(1) TUK
Egret Nougat				(1) PAINTQUART	(1) GLAZEPEN	(1) SSC15**	(1) TUK
Egret Slate				(1) PAINTQUART	(1) GLAZEPEN	(1) SSC15**	(1) TUK
Egret Smoked Caviar				(1) PAINTQUART	(1) GLAZEPEN	(1) SSC15**	(1) TUK
Egret Toasted Almond				(1) PAINTQUART	(1) GLAZEPEN	(1) SSC15**	(1) TUK
Escape Gray				(1) PAINTQUART		(1) SSC15**	(1) TUK
Escape Gray Amaretto Crème				(1) PAINTQUART	(1) GLAZEPEN	(1) SSC15**	(1) TUK
Escape Gray Meringue				(1) PAINTQUART	(1) GLAZEPEN	(1) SSC15**	(1) TUK
Escape Gray Nougat				(1) PAINTQUART	(1) GLAZEPEN	(1) SSC15**	(1) TUK
Escape Gray Slate				(1) PAINTQUART	(1) GLAZEPEN	(1) SSC15**	(1) TUK
Escape Gray Smoked Caviar				(1) PAINTQUART	(1) GLAZEPEN	(1) SSC15**	(1) TUK
Escape Gray Toasted Almond				(1) PAINTQUART	(1) GLAZEPEN	(1) SSC15**	(1) TUK
Forest Floor				(1) PAINTQUART		(1) SSC15**	(1) TUK
Forest Floor Amaretto Crème				(1) PAINTQUART	(1) GLAZEPEN	(1) SSC15**	(1) TUK
Forest Floor Meringue				(1) PAINTQUART	(1) GLAZEPEN	(1) SSC15**	(1) TUK
Forest Floor Nougat				(1) PAINTQUART	(1) GLAZEPEN	(1) SSC15**	(1) TUK
Forest Floor Slate				(1) PAINTQUART	(1) GLAZEPEN	(1) SSC15**	(1) TUK
Forest Floor Smoked Caviar				(1) PAINTQUART	(1) GLAZEPEN	(1) SSC15**	(1) TUK
Forest Floor Toasted Almond				(1) PAINTQUART	(1) GLAZEPEN	(1) SSC15**	(1) TUK
Icy Avalanche				(1) PAINTQUART		(1) SSC15**	(1) TUK
Icy Avalanche Amaretto Crème				(1) PAINTQUART	(1) GLAZEPEN	(1) SSC15**	(1) TUK
Icy Avalanche Meringue				(1) PAINTQUART	(1) GLAZEPEN	(1) SSC15**	(1) TUK
Icy Avalanche Nougat				(1) PAINTQUART	(1) GLAZEPEN	(1) SSC15**	(1) TUK
Icy Avalanche Slate				(1) PAINTQUART	(1) GLAZEPEN	(1) SSC15**	(1) TUK
Icy Avalanche Smoked Caviar				(1) PAINTQUART	(1) GLAZEPEN	(1) SSC15**	(1) TUK
Icy Avalanche Toasted Almond				(1) PAINTQUART	(1) GLAZEPEN	(1) SSC15**	(1) TUK
Interesting Aqua				(1) PAINTQUART		(1) SSC15**	(1) TUK
Interesting Aqua Amaretto Crème				(1) PAINTQUART	(1) GLAZEPEN	(1) SSC15**	(1) TUK
Interesting Aqua Meringue				(1) PAINTQUART	(1) GLAZEPEN	(1) SSC15**	(1) TUK
Interesting Aqua Nougat				(1) PAINTQUART	(1) GLAZEPEN	(1) SSC15**	(1) TUK
Interesting Aqua Slate				(1) PAINTQUART	(1) GLAZEPEN	(1) SSC15**	(1) TUK
Interesting Aqua Smoked Caviar				(1) PAINTQUART	(1) GLAZEPEN	(1) SSC15**	(1) TUK
Interesting Aqua Toasted Almond				(1) PAINTQUART	(1) GLAZEPEN	(1) SSC15**	(1) TUK
Jogging Path				(1) PAINTQUART		(1) SSC15**	(1) TUK
Jogging Path Amaretto Crème				(1) PAINTQUART	(1) GLAZEPEN	(1) SSC15**	(1) TUK
Jogging Path Meringue				(1) PAINTQUART	(1) GLAZEPEN	(1) SSC15**	(1) TUK
Jogging Path Nougat				(1) PAINTQUART	(1) GLAZEPEN	(1) SSC15**	(1) TUK
Jogging Path Slate				(1) PAINTQUART	(1) GLAZEPEN	(1) SSC15**	(1) TUK
Jogging Path Smoked Caviar				(1) PAINTQUART	(1) GLAZEPEN	(1) SSC15**	(1) TUK
Jogging Path Toasted Almond				(1) PAINTQUART	(1) GLAZEPEN	(1) SSC15**	(1) TUK
Lambswool				(1) PAINTQUART		(1) SSC15**	(1) TUK
Lambswool Amaretto Crème				(1) PAINTQUART	(1) GLAZEPEN	(1) SSC15**	(1) TUK
Lambswool Meringue				(1) PAINTQUART	(1) GLAZEPEN	(1) SSC15**	(1) TUK
Lambswool Nougat				(1) PAINTQUART	(1) GLAZEPEN	(1) SSC15**	(1) TUK
Lambswool Slate				(1) PAINTQUART	(1) GLAZEPEN	(1) SSC15**	(1) TUK
Lambswool Smoked Caviar				(1) PAINTQUART	(1) GLAZEPEN	(1) SSC15**	(1) TUK
Lambswool Toasted Almond				(1) PAINTQUART	(1) GLAZEPEN	(1) SSC15**	(1) TUK
Limestone				(1) PAINTQUART		(1) SSC15**	(1) TUK
Limestone Amaretto Crème				(1) PAINTQUART	(1) GLAZEPEN	(1) SSC15**	(1) TUK
Limestone Meringue				(1) PAINTQUART	(1) GLAZEPEN	(1) SSC15**	(1) TUK

\*Spray Can accessory is a clear coat material.

\*\*If matte sheen option is selected, then spray can code SSC5 will need to be selected instead of the spray can code listed in chart.

# Finish Accessories

FINISH / GLAZE NAME	Toner	Stain	Glaze	Paint	Glaze Pen	Spray Can*	Touch-up Kit
Limestone Nougat				(1) PAINTQUART	(1) GLAZEPEN	(1) SSC15**	(1) TUK
Limestone Slate				(1) PAINTQUART	(1) GLAZEPEN	(1) SSC15**	(1) TUK
Limestone Smoked Caviar				(1) PAINTQUART	(1) GLAZEPEN	(1) SSC15**	(1) TUK
Limestone Toasted Almond				(1) PAINTQUART	(1) GLAZEPEN	(1) SSC15**	(1) TUK
Living Greige				(1) PAINTQUART		(1) SSC15**	(1) TUK
Living Greige Amaretto Crème				(1) PAINTQUART	(1) GLAZEPEN	(1) SSC15**	(1) TUK
Living Greige Meringue				(1) PAINTQUART	(1) GLAZEPEN	(1) SSC15**	(1) TUK
Living Greige Nougat				(1) PAINTQUART	(1) GLAZEPEN	(1) SSC15**	(1) TUK
Living Greige Slate				(1) PAINTQUART	(1) GLAZEPEN	(1) SSC15**	(1) TUK
Living Greige Smoked Caviar				(1) PAINTQUART	(1) GLAZEPEN	(1) SSC15**	(1) TUK
Living Greige Toasted Almond				(1) PAINTQUART	(1) GLAZEPEN	(1) SSC15**	(1) TUK
Maritime				(1) PAINTQUART		(1) SSC15**	(1) TUK
Maritime Amaretto Crème				(1) PAINTQUART	(1) GLAZEPEN	(1) SSC15**	(1) TUK
Maritime Meringue				(1) PAINTQUART	(1) GLAZEPEN	(1) SSC15**	(1) TUK
Maritime Nougat				(1) PAINTQUART	(1) GLAZEPEN	(1) SSC15**	(1) TUK
Maritime Slate				(1) PAINTQUART	(1) GLAZEPEN	(1) SSC15**	(1) TUK
Maritime Smoked Caviar				(1) PAINTQUART	(1) GLAZEPEN	(1) SSC15**	(1) TUK
Maritime Toasted Almond				(1) PAINTQUART	(1) GLAZEPEN	(1) SSC15**	(1) TUK
Mindful Gray				(1) PAINTQUART		(1) SSC15**	(1) TUK
Mindful Gray Amaretto Crème				(1) PAINTQUART	(1) GLAZEPEN	(1) SSC15**	(1) TUK
Mindful Gray Meringue				(1) PAINTQUART	(1) GLAZEPEN	(1) SSC15**	(1) TUK
Mindful Gray Nougat				(1) PAINTQUART	(1) GLAZEPEN	(1) SSC15**	(1) TUK
Mindful Gray Slate				(1) PAINTQUART	(1) GLAZEPEN	(1) SSC15**	(1) TUK
Mindful Gray Smoked Caviar				(1) PAINTQUART	(1) GLAZEPEN	(1) SSC15**	(1) TUK
Mindful Gray Toasted Almond				(1) PAINTQUART	(1) GLAZEPEN	(1) SSC15**	(1) TUK
Moonstone				(1) PAINTQUART		(1) SSC15**	(1) TUK
Moonstone Amaretto Crème				(1) PAINTQUART	(1) GLAZEPEN	(1) SSC15**	(1) TUK
Moonstone Meringue				(1) PAINTQUART	(1) GLAZEPEN	(1) SSC15**	(1) TUK
Moonstone Nougat				(1) PAINTQUART	(1) GLAZEPEN	(1) SSC15**	(1) TUK
Moonstone Slate				(1) PAINTQUART	(1) GLAZEPEN	(1) SSC15**	(1) TUK
Moonstone Smoked Caviar				(1) PAINTQUART	(1) GLAZEPEN	(1) SSC15**	(1) TUK
Moonstone Toasted Almond				(1) PAINTQUART	(1) GLAZEPEN	(1) SSC15**	(1) TUK
Naval				(1) PAINTQUART		(1) SSC15**	(1) TUK
Naval Amaretto Crème				(1) PAINTQUART	(1) GLAZEPEN	(1) SSC15**	(1) TUK
Naval Meringue				(1) PAINTQUART	(1) GLAZEPEN	(1) SSC15**	(1) TUK
Naval Nougat				(1) PAINTQUART	(1) GLAZEPEN	(1) SSC15**	(1) TUK
Naval Slate				(1) PAINTQUART	(1) GLAZEPEN	(1) SSC15**	(1) TUK
Naval Smoked Caviar				(1) PAINTQUART	(1) GLAZEPEN	(1) SSC15**	(1) TUK
Naval Toasted Almond				(1) PAINTQUART	(1) GLAZEPEN	(1) SSC15**	(1) TUK
North Star				(1) PAINTQUART		(1) SSC15**	(1) TUK
North Star Amaretto Crème				(1) PAINTQUART	(1) GLAZEPEN	(1) SSC15**	(1) TUK
North Star Meringue				(1) PAINTQUART	(1) GLAZEPEN	(1) SSC15**	(1) TUK
North Star Nougat				(1) PAINTQUART	(1) GLAZEPEN	(1) SSC15**	(1) TUK
North Star Slate				(1) PAINTQUART	(1) GLAZEPEN	(1) SSC15**	(1) TUK
North Star Smoked Caviar				(1) PAINTQUART	(1) GLAZEPEN	(1) SSC15**	(1) TUK
North Star Toasted Almond				(1) PAINTQUART	(1) GLAZEPEN	(1) SSC15**	(1) TUK
Peppercorn				(1) PAINTQUART		(1) SSC15**	(1) TUK
Peppercorn Amaretto Crème				(1) PAINTQUART	(1) GLAZEPEN	(1) SSC15**	(1) TUK
Peppercorn Meringue				(1) PAINTQUART	(1) GLAZEPEN	(1) SSC15**	(1) TUK
Peppercorn Nougat				(1) PAINTQUART	(1) GLAZEPEN	(1) SSC15**	(1) TUK
Peppercorn Slate				(1) PAINTQUART	(1) GLAZEPEN	(1) SSC15**	(1) TUK
Peppercorn Smoked Caviar				(1) PAINTQUART	(1) GLAZEPEN	(1) SSC15**	(1) TUK
Peppercorn Toasted Almond				(1) PAINTQUART	(1) GLAZEPEN	(1) SSC15**	(1) TUK
Pure Linen				(1) PAINTQUART		(1) SSC15**	(1) TUK
Pure Linen Amaretto Crème				(1) PAINTQUART	(1) GLAZEPEN	(1) SSC15**	(1) TUK
Pure Linen Meringue				(1) PAINTQUART	(1) GLAZEPEN	(1) SSC15**	(1) TUK
Pure Linen Nougat				(1) PAINTQUART	(1) GLAZEPEN	(1) SSC15**	(1) TUK
Pure Linen Slate				(1) PAINTQUART	(1) GLAZEPEN	(1) SSC15**	(1) TUK
Pure Linen Smoked Caviar				(1) PAINTQUART	(1) GLAZEPEN	(1) SSC15**	(1) TUK
Pure Linen Toasted Almond				(1) PAINTQUART	(1) GLAZEPEN	(1) SSC15**	(1) TUK
Retreat				(1) PAINTQUART		(1) SSC15**	(1) TUK
Retreat Amaretto Crème				(1) PAINTQUART	(1) GLAZEPEN	(1) SSC15**	(1) TUK
Retreat Meringue				(1) PAINTQUART	(1) GLAZEPEN	(1) SSC15**	(1) TUK
Retreat Nougat				(1) PAINTQUART	(1) GLAZEPEN	(1) SSC15**	(1) TUK

\*Spray Can accessory is a clear coat material.

\*\*If matte sheen option is selected, then spray can code SSC5 will need to be selected instead of the spray can code listed in chart.

FINISH / GLAZE NAME	Toner	Stain	Glaze	Paint	Glaze Pen	Spray Can*	Touch-up Kit
Retreat Slate				(1) PAINTQUART	(1) GLAZEPEN	(1) SSC15**	(1) TUK
Retreat Smoked Caviar				(1) PAINTQUART	(1) GLAZEPEN	(1) SSC15**	(1) TUK
Retreat Toasted Almond				(1) PAINTQUART	(1) GLAZEPEN	(1) SSC15**	(1) TUK
Sea Salt				(1) PAINTQUART		(1) SSC15**	(1) TUK
Sea Salt Amaretto Crème				(1) PAINTQUART	(1) GLAZEPEN	(1) SSC15**	(1) TUK
Sea Salt Meringue				(1) PAINTQUART	(1) GLAZEPEN	(1) SSC15**	(1) TUK
Sea Salt Nougat				(1) PAINTQUART	(1) GLAZEPEN	(1) SSC15**	(1) TUK
Sea Salt Slate				(1) PAINTQUART	(1) GLAZEPEN	(1) SSC15**	(1) TUK
Sea Salt Smoked Caviar				(1) PAINTQUART	(1) GLAZEPEN	(1) SSC15**	(1) TUK
Sea Salt Toasted Almond				(1) PAINTQUART	(1) GLAZEPEN	(1) SSC15**	(1) TUK
Seaside				(1) PAINTQUART		(1) SSC15**	(1) TUK
Seaside Amaretto Crème				(1) PAINTQUART	(1) GLAZEPEN	(1) SSC15**	(1) TUK
Seaside Meringue				(1) PAINTQUART	(1) GLAZEPEN	(1) SSC15**	(1) TUK
Seaside Nougat				(1) PAINTQUART	(1) GLAZEPEN	(1) SSC15**	(1) TUK
Seaside Slate				(1) PAINTQUART	(1) GLAZEPEN	(1) SSC15**	(1) TUK
Seaside Smoked Caviar				(1) PAINTQUART	(1) GLAZEPEN	(1) SSC15**	(1) TUK
Seaside Toasted Almond				(1) PAINTQUART	(1) GLAZEPEN	(1) SSC15**	(1) TUK
Soft Glow				(1) PAINTQUART		(1) SSC15**	(1) TUK
Soft Glow Amaretto Crème				(1) PAINTQUART	(1) GLAZEPEN	(1) SSC15**	(1) TUK
Soft Glow Meringue				(1) PAINTQUART	(1) GLAZEPEN	(1) SSC15**	(1) TUK
Soft Glow Nougat				(1) PAINTQUART	(1) GLAZEPEN	(1) SSC15**	(1) TUK
Soft Glow Slate	(1) TONERQUART				(1) GLAZEPEN	(1) SSC15**	(1) TUK
Soft Glow Smoked Caviar				(1) PAINTQUART	(1) GLAZEPEN	(1) SSC15**	(1) TUK
Soft Glow Toasted Almond				(1) PAINTQUART	(1) GLAZEPEN	(1) SSC15**	(1) TUK
Sterling White				(1) PAINTQUART		(1) SSC15**	(1) TUK
Sterling White Amaretto Crème				(1) PAINTQUART	(1) GLAZEPEN	(1) SSC15**	(1) TUK
Sterling White Meringue				(1) PAINTQUART	(1) GLAZEPEN	(1) SSC15**	(1) TUK
Sterling White Nougat				(1) PAINTQUART	(1) GLAZEPEN	(1) SSC15**	(1) TUK
Sterling White Slate				(1) PAINTQUART	(1) GLAZEPEN	(1) SSC15**	(1) TUK
Sterling White Smoked Caviar				(1) PAINTQUART	(1) GLAZEPEN	(1) SSC15**	(1) TUK
Sterling White Toasted Almond				(1) PAINTQUART	(1) GLAZEPEN	(1) SSC15**	(1) TUK
Stone Trail				(1) PAINTQUART		(1) SSC15**	(1) TUK
Stone Trail Amaretto Crème				(1) PAINTQUART	(1) GLAZEPEN	(1) SSC15**	(1) TUK
Stone Trail Meringue				(1) PAINTQUART	(1) GLAZEPEN	(1) SSC15**	(1) TUK
Stone Trail Nougat				(1) PAINTQUART	(1) GLAZEPEN	(1) SSC15**	(1) TUK
Stone Trail Slate				(1) PAINTQUART	(1) GLAZEPEN	(1) SSC15**	(1) TUK
Stone Trail Smoked Caviar				(1) PAINTQUART	(1) GLAZEPEN	(1) SSC15**	(1) TUK
Stone Trail Toasted Almond				(1) PAINTQUART	(1) GLAZEPEN	(1) SSC15**	(1) TUK
Tawny Owl				(1) PAINTQUART		(1) SSC15**	(1) TUK
Tawny Owl Amaretto Crème				(1) PAINTQUART	(1) GLAZEPEN	(1) SSC15**	(1) TUK
Tawny Owl Meringue				(1) PAINTQUART	(1) GLAZEPEN	(1) SSC15**	(1) TUK
Tawny Owl Nougat				(1) PAINTQUART	(1) GLAZEPEN	(1) SSC15**	(1) TUK
Tawny Owl Slate	(1) TONERQUART				(1) GLAZEPEN	(1) SSC15**	(1) TUK
Tawny Owl Smoked Caviar				(1) PAINTQUART		(1) SSC15**	(1) TUK
Tawny Owl Toasted Almond				(1) PAINTQUART	(1) GLAZEPEN	(1) SSC15**	(1) TUK
Urbane Bronze				(1) PAINTQUART		(1) SSC15**	(1) TUK
Urbane Bronze Amaretto Crème				(1) PAINTQUART	(1) GLAZEPEN	(1) SSC15**	(1) TUK
Urbane Bronze Meringue				(1) PAINTQUART	(1) GLAZEPEN	(1) SSC15**	(1) TUK
Urbane Bronze Nougat				(1) PAINTQUART	(1) GLAZEPEN	(1) SSC15**	(1) TUK
Urbane Bronze Slate				(1) PAINTQUART	(1) GLAZEPEN	(1) SSC15**	(1) TUK
Urbane Bronze Smoked Caviar				(1) PAINTQUART	(1) GLAZEPEN	(1) SSC15**	(1) TUK
Urbane Bronze Toasted Almond				(1) PAINTQUART	(1) GLAZEPEN	(1) SSC15**	(1) TUK
Waterbury Clay				(1) PAINTQUART		(1) SSC15**	(1) TUK
Waterbury Clay Amaretto Crème				(1) PAINTQUART	(1) GLAZEPEN	(1) SSC15**	(1) TUK
Waterbury Clay Meringue				(1) PAINTQUART	(1) GLAZEPEN	(1) SSC15**	(1) TUK
Waterbury Clay Nougat				(1) PAINTQUART	(1) GLAZEPEN	(1) SSC15**	(1) TUK
Waterbury Clay Slate				(1) PAINTQUART	(1) GLAZEPEN	(1) SSC15**	(1) TUK
Waterbury Clay Smoked Caviar				(1) PAINTQUART	(1) GLAZEPEN	(1) SSC15**	(1) TUK
Waterbury Clay Toasted Almond				(1) PAINTQUART	(1) GLAZEPEN	(1) SSC15**	(1) TUK
White				(1) PAINTQUART		(1) SSC15**	(1) TUK
White Amaretto Crème				(1) PAINTQUART	(1) GLAZEPEN	(1) SSC15**	(1) TUK
White Meringue				(1) PAINTQUART	(1) GLAZEPEN	(1) SSC15**	(1) TUK
White Nougat				(1) PAINTQUART	(1) GLAZEPEN	(1) SSC15**	(1) TUK
White Slate				(1) PAINTQUART	(1) GLAZEPEN	(1) SSC15**	(1) TUK

\*Spray Can accessory is a clear coat material.

\*\*If matte sheen option is selected, then spray can code SSC5 will need to be selected instead of the spray can code listed in chart.

# Finish Accessories

FINISH / GLAZE NAME	Toner	Stain	Glaze	Paint	Glaze Pen	Spray Can*	Touch-up Kit
White Smoked Caviar				(1) PAINTQUART	(1) GLAZEPEN	(1) SSC15**	(1) TUK
White Toasted Almond				(1) PAINTQUART	(1) GLAZEPEN	(1) SSC15**	(1) TUK
<b>Specialties</b>							
Alpaca				(1) FINKIT		(1) SSC15**	(1) TUK
Balsamic Ombre	(2) TONERQUART		(1) GLAZEQUART			(1) SSC15**	(1) TUK
Beachglass	(1) TONERQUART	(1) STAINQUART				(1) SSC15**	(1) TUK
Black Canyon	(2) TONERQUART					(1) SSC15**	(1) TUK
Cigar Box	(1) TONERQUART		(1) GLAZEQUART			(1) SSC15**	(1) TUK
Cordial Ombre	(1) TONERQUART	(1) STAINQUART				(1) SSC15**	(1) TUK
Driftwood	(1) TONERQUART	(1) STAINQUART				(1) SSC15**	(1) TUK
Poppyseed	(1) TONERQUART		(1) GLAZEQUART			(1) SSC15**	(1) TUK
Poppyseed Amaretto Crème	(1) TONERQUART		(1) GLAZEQUART		(1) GLAZEPEN	(1) SSC15**	(1) TUK
Poppyseed Toasted Almond	(1) TONERQUART	(1) STAINQUART			(1) GLAZEPEN	(1) SSC15**	(1) TUK
Worn Beachglass	(1) TONERQUART	(1) STAINQUART				(1) SSC15**	(1) TUK
Worn Black	(1) TONERQUART					(1) SSC15**	(1) TUK
<b>Cerused Finishes</b>							
Buckskin Brindle	(1) TONERQUART	(1) STAINQUART				(1) SSC5	(1) TUK
Buckskin Roan	(1) TONERQUART	(1) STAINQUART				(1) SSC5	(1) TUK
Morel Brindle	(1) TONERQUART	(1) STAINQUART				(1) SSC5	(1) TUK
Morel Roan	(1) TONERQUART	(1) STAINQUART				(1) SSC5	(1) TUK
Quarry Brindle	(1) TONERQUART	(1) STAINQUART				(1) SSC5	(1) TUK
Quarry Roan	(1) TONERQUART	(1) STAINQUART				(1) SSC5	(1) TUK

\*Spray Can accessory is a clear coat material.

\*\*If matte sheen option is selected, then spray can code SSC5 will need to be selected instead of the spray can code listed in chart.

- To order stains, refer to above chart and specify material and color.
- For example, to order Cigar Box, specify (1) TONERQUART Cigar Box and (1) GLAZEQUART Cigar Box.
- All finishes intended for field repair. Not to be used for full cabinet application.
- FINKIT contains 1 pint paint, 1 pint glaze, 1 pint clear top coat and instructions for application.
- To order points, refer to above chart and specify material and color.
- For example, to order Sterling White, specify (1) PAINTQUART Sterling White.
- To order points with glaze, refer to above chart and specify material and color. For example, to order Sterling White Toasted Almond, specify (1) PAINTQUART Sterling White and (1) GLAZEPEN Toasted Almond.

DESCRIPTION	CODE
Quart of Toner	TONERQUART
Quart of Stain	STAINQUART
Quart of Glaze	GLAZEQUART
Quart of Paint	PAINTQUART
Finish Kit	FINKIT
Lacquer Spray Can - 5°	SSC5
Lacquer Spray Can - 15°	SSC15
Lacquer Spray Can - 35°	SSC35
Touch-up Kit	TUK
Glaze Pen	GLAZEPEN



## Cabinet Construction Specifications

### 1. Cabinet Interiors

Natural wood interior is durable interior and highly resistant to water and most common household chemicals. It's easy-care with a rich, attractive appearance.

### 2. Shelves

Standard shelves are 3/4" thick Natural plywood with edgebanding on all exposed edges matches the standard interior of the cabinet. All standard shelves are fully adjustable for added customer convenience. (Cabinets ordered with matching interiors feature 3/4" wood veneered shelves.)

### 3. End Panels

End panels are 1/2" thick Natural plywood. End panels fit into the 1/2" groove on the back side of the face frame and are secured with furniture staples. Flush ends optional.

### 4. Tops and Bottoms

Tops and bottoms of wall and base cabinets are 1/2" thick Natural plywood. Base bottoms and wall tops and bottoms are dadoed into the end panels and into a groove on the back side of the face frame and are secured with furniture staples.

### 5. Backs

Backs on all standard base and wall cabinets are 3/16" thick Natural plywood. The back is held securely in a partially-captive groove in the end panel, then furniture stapled and hot melt glued to provide an outstanding, durable joint. For ease of installation, wall cabinets include 3/8" plywood hanger rails, and base cabinets feature an 1 1/16" pine hanger rail at the top and a 3/8" plywood hanger rail at the bottom. The hanger rails and back are secured to the tops and bottoms with hot melt glue and furniture staples.

(Backs on special corner units and angled units, such as the AEW units, CS units, DW units, and ER units, are constructed of 3/8" furniture core. This material and construction technique adds structural stability to these special units.)

### 6. Toekicks

A 1/2" plywood sub-toekick is attached between the end panels in all units with a toekick space. The sub-toekick is secured in a 1/8" deep by 17/32" wide groove on the bottom and stapled to the bottom and end panels to hold in place. Toekick skins are available in 8-foot lengths for application to the toekick space after installation for a custom appearance.

### 7. Corner Blocks

Plywood corner blocks are glued into the grooves on base cabinet face frames and glued and stapled into the grooves in pine hanger rails and end panels. These supports help keep the cabinet square and sturdy and provide a method to attach countertops.

### 8. Face Frames

Face frames are constructed of 3/4" solid wood using the glue and screw joinery technique. The glue and screw method provides a more consistent joint and has been proven stronger in extensive testing. The "reveal" on the exterior back side of the face frame stile is 9/64", allowing the creation of a flush end when applying 3/32" finished panels for a custom look.

### 9. Door and Drawer Fronts

Depending upon the style selected, door and drawer fronts may be 3/4" thick solid double raised panels, solid flat panels or one-piece seamless MDF. When painted Maple 5-piece door styles are ordered, the door's center panel will be constructed of MDF material.

When painted Maple 5-piece door styles are ordered with Hewn, Extra Hewn, Timeworn, Extra Timeworn, or Brushed Finish techniques or Black paint the door's center panel will remain solid. All door styles include drilled stemmed bumper pads.

### 10. Hinges

All cabinets use standard concealed hinges, they will vary per door style. Full overlay door styles use a 110 degree 1 5/16" overlay Smart Stop concealed hinge and Inset and Beaded Inset door styles use an inset clip top 110 degree Smart Stop concealed hinge. For all corner type units (i.e. Corner Walls (ER), Base Rotating Deep Bin (BRDB), Lazy Susan Base Cabinets (BLS), Base SuperCabinets™ (BSC), Square Base Corner Cabinets (CS), Square Lazy Susan Base Cabinets (BER), Super Space Savers (SLS)), 170 degree hinges (non Smart Stop) are used in place of the standard hinge. For Inset and Beaded Inset door styles, there is an option to use finial hinges; see modification section for more details.

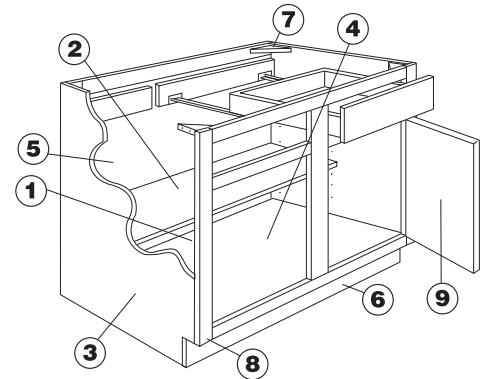

**NOTE:** Kemper Emerge is committed to offering solutions that meet or exceed air emissions rules and regulations. All-plywood used in the construction of our cabinets for end panels, shelves, tops, bottoms, backs, toekicks, and corner blocks is compliant to the California Air Resources Board (CARB) current requirements.

The door center panel may be constructed of Medium Density Fiberboard (MDF), except when Timeworn, Hewn, Extra Timeworn, Extra Hewn, or Brushed Finish techniques or Black paint is specified.

All-plywood components meet ANSI/HPVA HP-1 standards, and may contain MDF or particleboard.

Styles, product availability and construction may vary slightly from those shown in this book due to material availability and/or design evolution. Specifications are subject to change without notice. Customer Service is available if your design requires verification of product availability and specifications.

# Specifications & Dimensions

## Dovetailed Drawer & Roll Tray Construction Specifications

### Drawer and Roll Tray Construction

Drawer and roll tray box sides, backs and fronts are thick solid wood with dovetailed corner construction. Kemper Emerge's uses a four-sided drawer and dovetail joinery for superior stability and drawer box strength. Kemper Emerge applies an advanced synthetic-based glue to the tenons of all dovetails for even greater stability and box strength. The drawer bottom is 5.2mm veneer plywood and is fully captured within the four sides of the drawer box. Capturing the bottom on four sides provides "solid" drawers and roll trays for optimum load capacity.

Kemper Emerge drawer sides, backs and fronts, and bottoms receive a high quality appearance resulting from fine sanding, sealer application, sealer sanding, and top coat application. The result is a smooth, protective shield for the drawer box.

### Full Extension Drawer/Roll Tray Slides with Smart Stop™ Feature

Advanced, lifetime-guaranteed, zinc-coated steel drawer slides are manufactured of sturdy Class I cold rolled steel. Bottom mounting adds to strength, with the result being a drawer suspension system rated at 90 pounds capacity. Locking devices provide automatic latching, easy release for drawer removal and tool-free height adjustment. Quiet gliding permanently lubricated, synthetic rollers deliver a lifetime of smooth, trouble-free operation.

The drawer/roll tray system's Smart Stop feature adds an extra measure of convenience. The Smart Stop feature engages when the drawer/roll tray is 2" from closing. Resistance is applied to the self-closing mechanism, giving a gentle, controlled closing. Parallel-closing design ensures proper alignment.

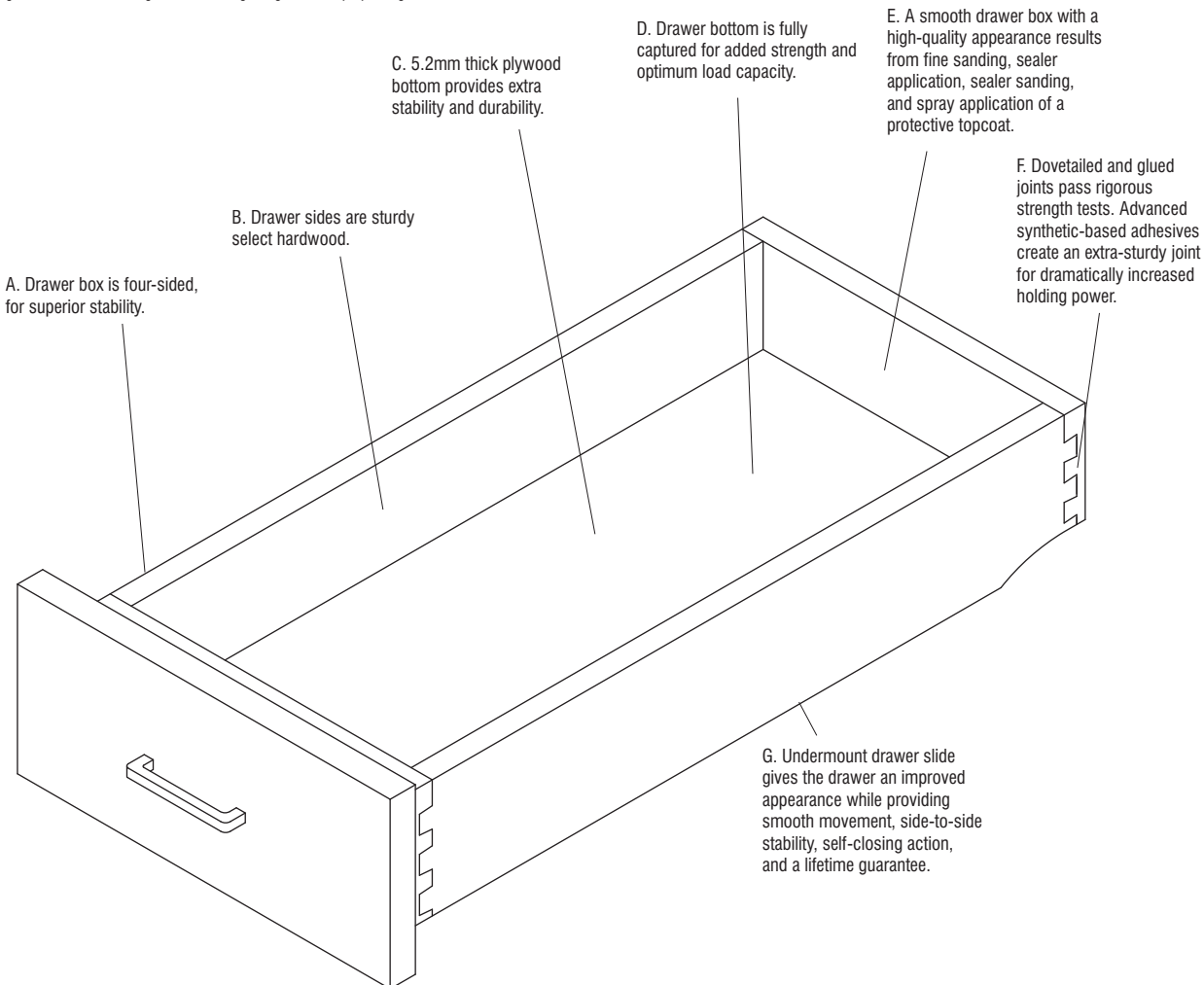

## Inset and Beaded Inset Specifications

- Customers should be aware that Inset cabinetry is very different than standard overlay cabinetry, as it is not as tolerant or forgiving. Since the doors and drawer fronts are made to fit inside the frame with tight tolerances, inset cabinets are much more vulnerable to dimensional changes and racking than standard overlay cabinetry.
- Dimensional changes primarily occur when environmental conditions, such as temperature and humidity, are not controlled at an acceptable level. This causes the wood to expand and contract. This is something that cannot be avoided. It is very important that inset cabinets are never stored or installed in an environment where temperature and humidity reach extreme levels. Humidity levels should be kept between 30 to 55% for optimal results. Customers living in areas where these extremes cannot be controlled should avoid inset cabinets.
  - Too much humidity will cause the wood to expand, potentially leading to binding and nonfunctional doors/ drawers.
  - Too little humidity will cause the wood to contract, which could lead to larger gaps around the perimeter.
  - Doors / drawers that have been impacted by exposure to extreme environmental changes will usually return to their normal size over time once acceptable environmental levels have been implemented.
- If the style selected is inset, all standard 12" deep Wall cabinets will be converted to 13" deep. This additional depth makes up for the interior space lost by placing the door inside the face frame opening.
- Inset doors and drawers are manufactured with an approximate reveal of 3/32" on all sides. Changes in temperature and humidity may cause this gap to fluctuate over time. This is normal when using inset cabinets and should be expected.
- Designers suggest working with cabinets 15" wide or wider to ensure aesthetic balance throughout the kitchen. In cases where this is not possible, customers should be aware that cabinets less than 12" wide (9" opening) will use slab doors.
- Designers also suggest using one large cabinet versus multiple smaller cabinets to reduce the amount of visible face frame rails and seams. For example, the preference would be to use a W4530 instead of three W1530 L or R cabinets.
- Inset cabinets are available with standard concealed hinges or optional finial hinges. There are some noticeable differences between the two hinge types:
  - Concealed hinges are six-way adjustable (in/out, left/right, up/down). These hinges include the standard Smart Stop feature found on Kemper Emerge's existing hinges. They allow for a 110-degree opening.
  - Finial hinges provide limited four-way adjustability (left/right, up/down), as they do not feature any in/out adjustment. These hinges do not include any type of Smart Stop feature (PDM add-ons are not available on Inset), therefore they swing freely when not held closed by the magnets. They offer a 180-degree opening. Finial hinges come in four colors: Antique Brass, Brushed Nickel, Matte Black, and Oil Rubbed Bronze.
- Finial hinges can only be used with Profile #12.
- When ordering Oven/Microwave cabinets in beaded inset, the cabinet should be ordered to the appropriate width using the 1/4" width modification instead of using piece-in or cut-out applications.
- Inset cabinets will use a standard 5" drawer opening height instead of the standard cabinetry opening of 4 1/2". There are some exceptions to this rule, all of which will require slab drawer fronts, regardless of the style selected. Exceptions are listed below:
  - These units will use 4 1/2" openings and slab drawer fronts at all times:
    - 30" high File Drawer Bases (DFD)
    - Office Desk File Base (DFD)
    - Any Wall cabinet w/ added drawers
  - These units will use 3 1/2" openings and slab drawer fronts at all times:
    - Desk Vanity Drawer (UCD)
    - Keyboard Tray (KBT)
- Racking can occur if a cabinet is not installed properly. If the cabinet is installed out of square, it is possible to make the unit nonfunctional, as the doors and drawers will bind. Inset cabinets should be installed by experienced and patient installers. Inset cabinets require additional time to install and adjust components to the correct positioning.



# Specifications & Dimensions

## Wall Cabinet Dimensions (without doors)

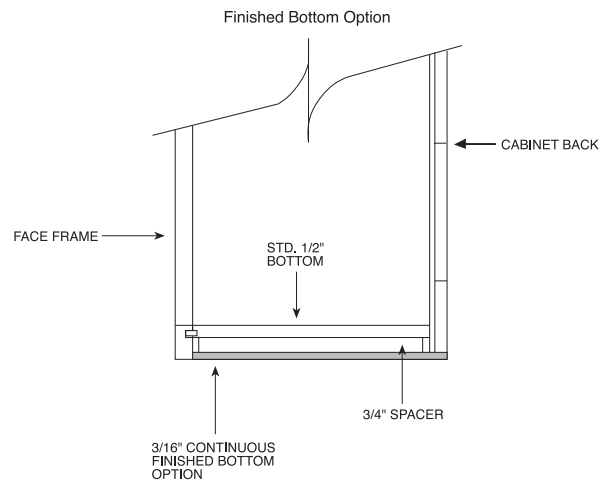
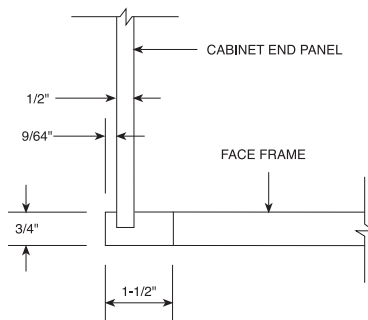
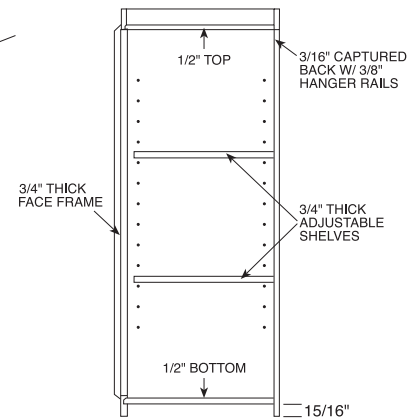
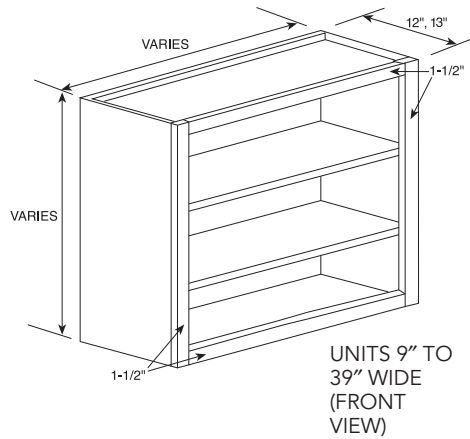
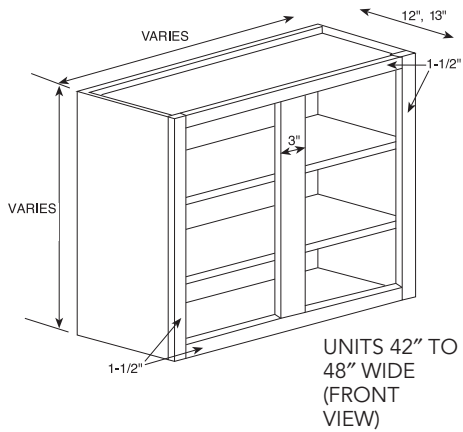

Base Cabinet Dimensions (without doors)

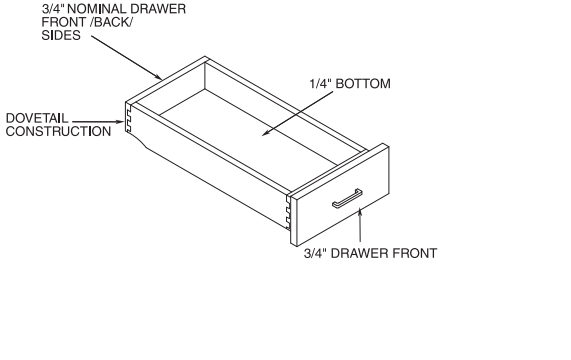
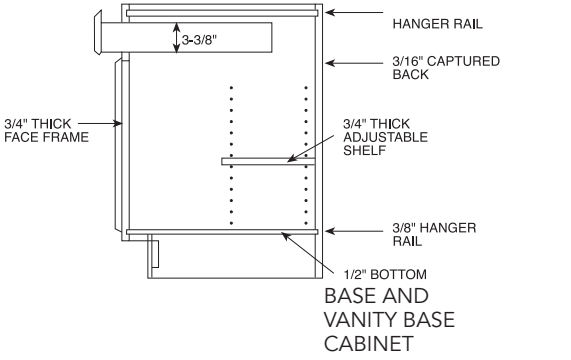
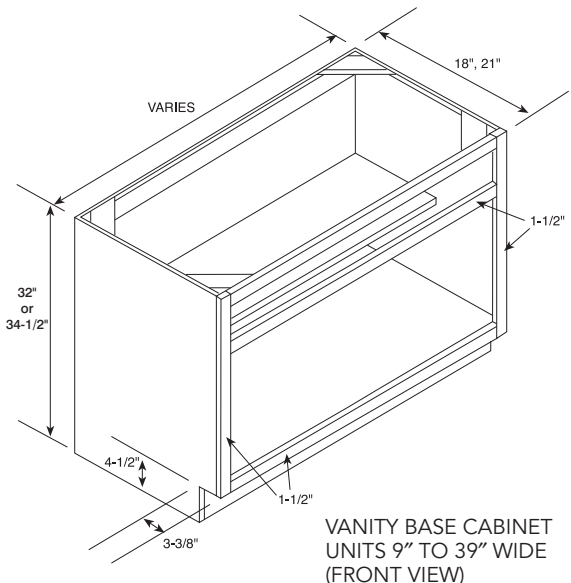
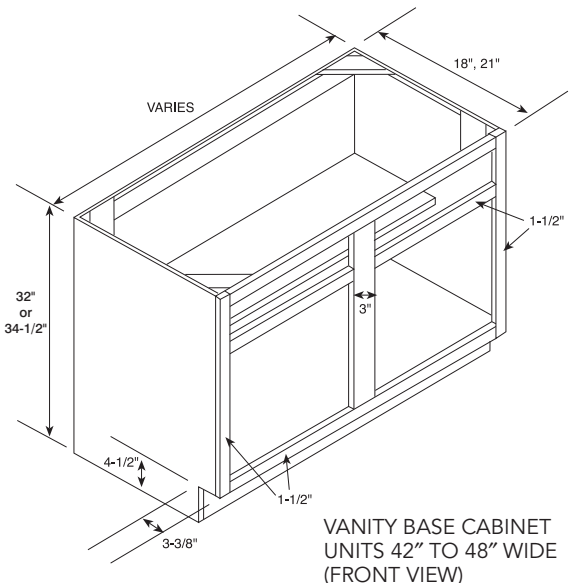
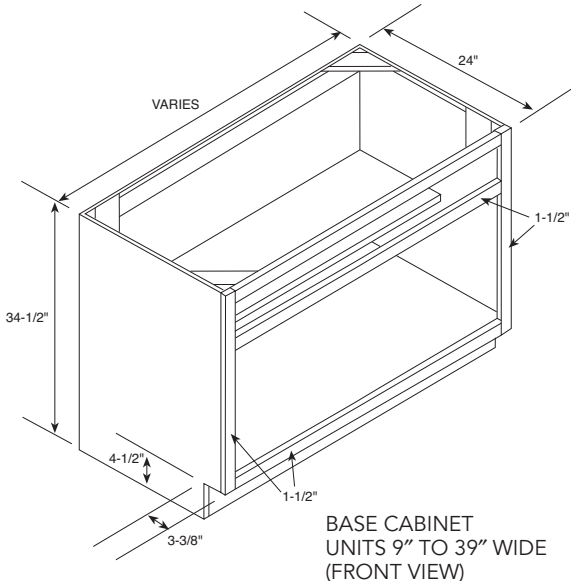
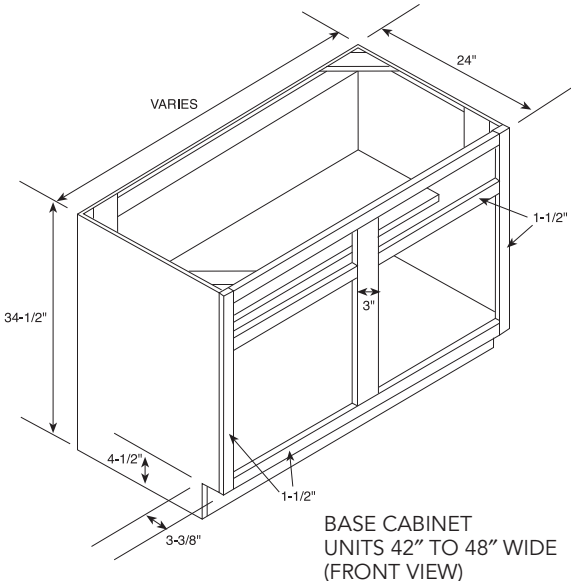

# Specifications & Dimensions

## Utility Cabinet Dimensions (without doors)

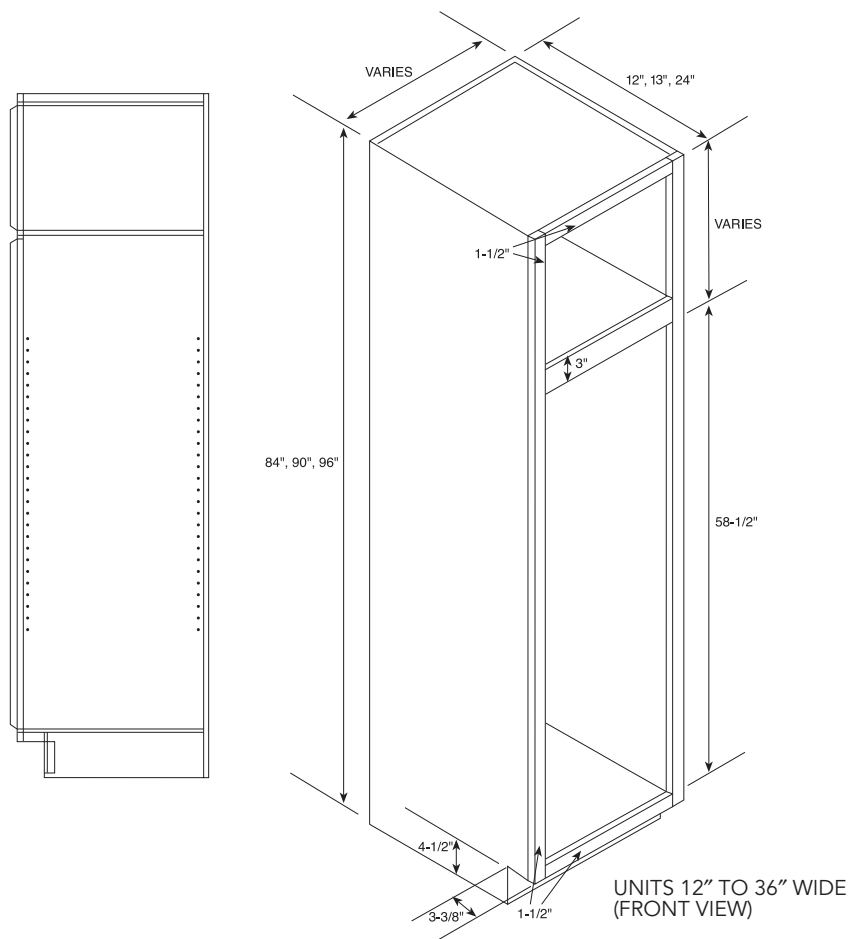

\*Includes adjustable shelves.

Cabinet Reveals

**Reveals for Full Overlay Door Styles**

Shown is the amount of face frame that is exposed (revealed) with full overlay door styling.

- Reveal between butt door cabinets is 1/8".

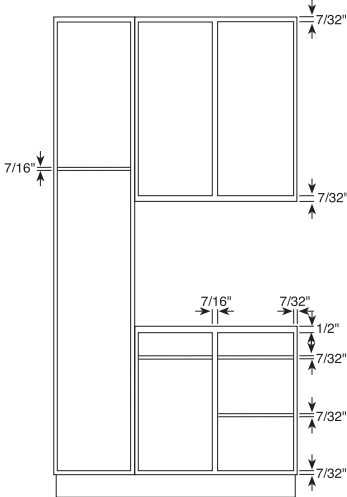

**Modified Full Overlay**

Shown is the amount of face frame that is exposed (revealed) with modified full overlay door styling.

- Reveal between butt door cabinets is 1/8".

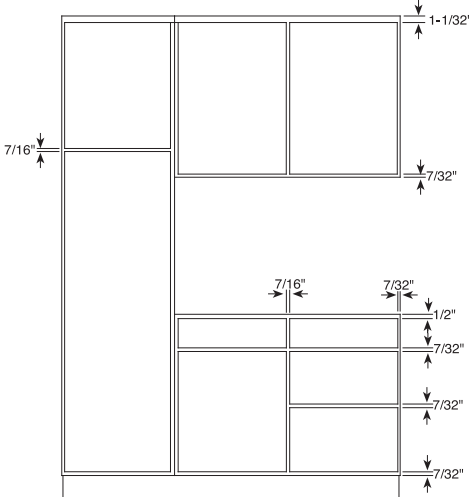

**Inset and Beaded Inset Doors**

Shown is the amount of face frame that is exposed (revealed) with Inset and Beaded Inset door styling.

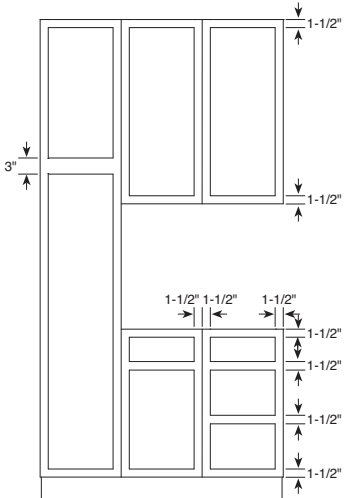

# Specifications & Dimensions

## Standard Full Overlay Styles Opening Sizes

### Wall Cabinets

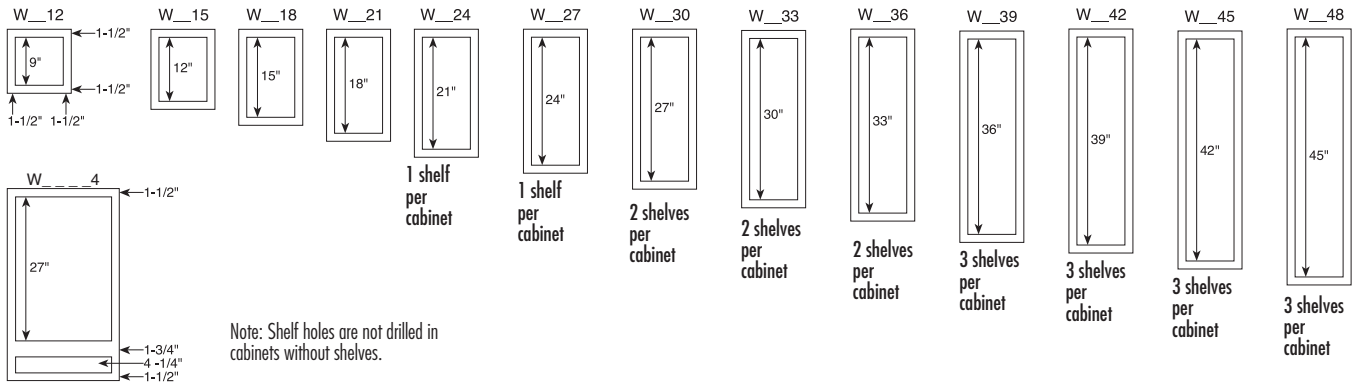

### Base Cabinets

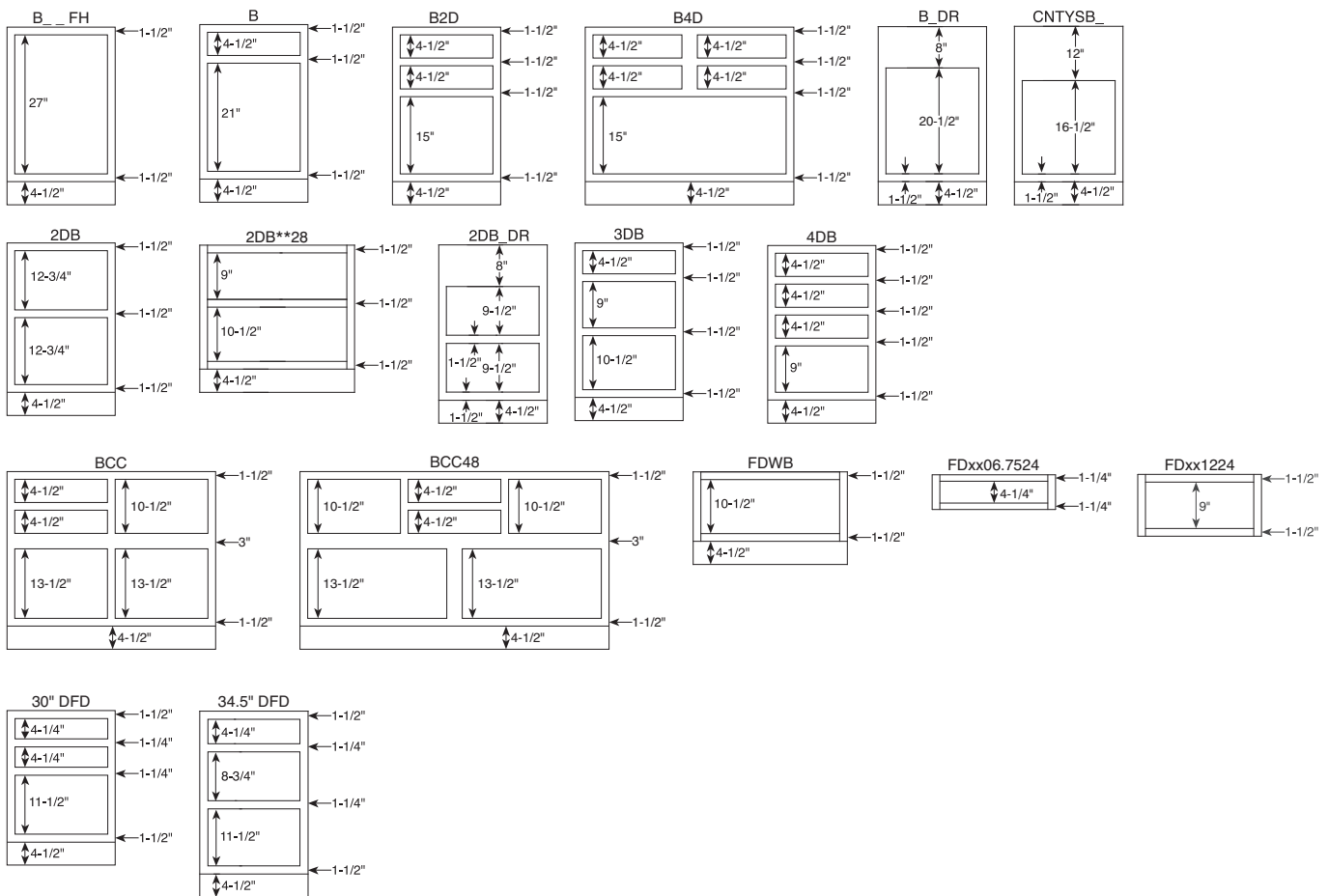

Standard Full Overlay Styles Opening Sizes

Vanity Base Cabinets

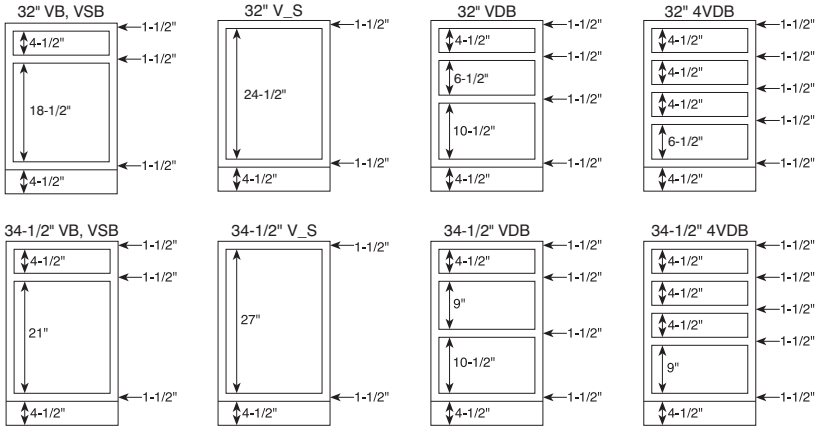

Bath Collection

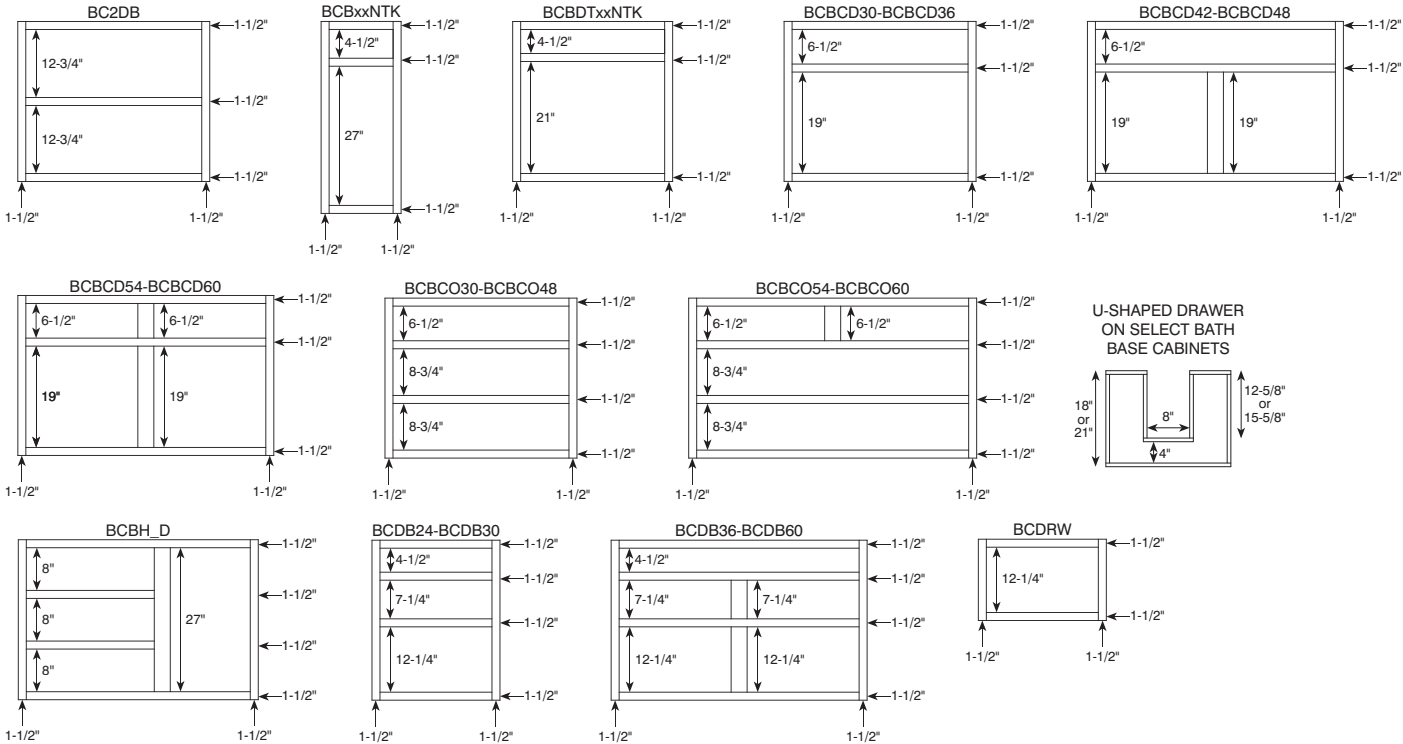

# Specifications & Dimensions

## Standard Full Overlay Styles Opening Sizes

### Bath Collection

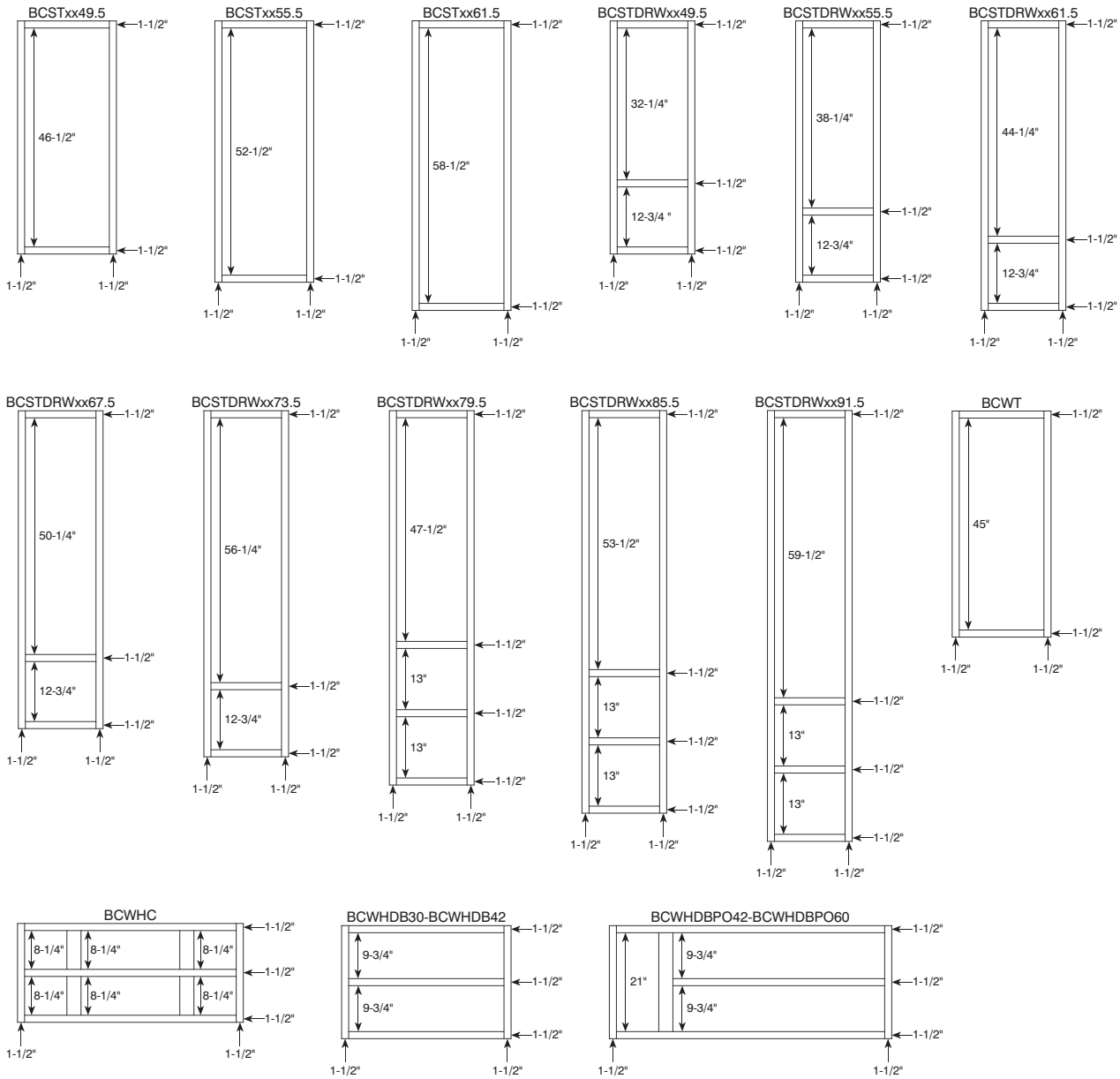

Standard Full Overlay Styles Opening Sizes

Utility Cabinets

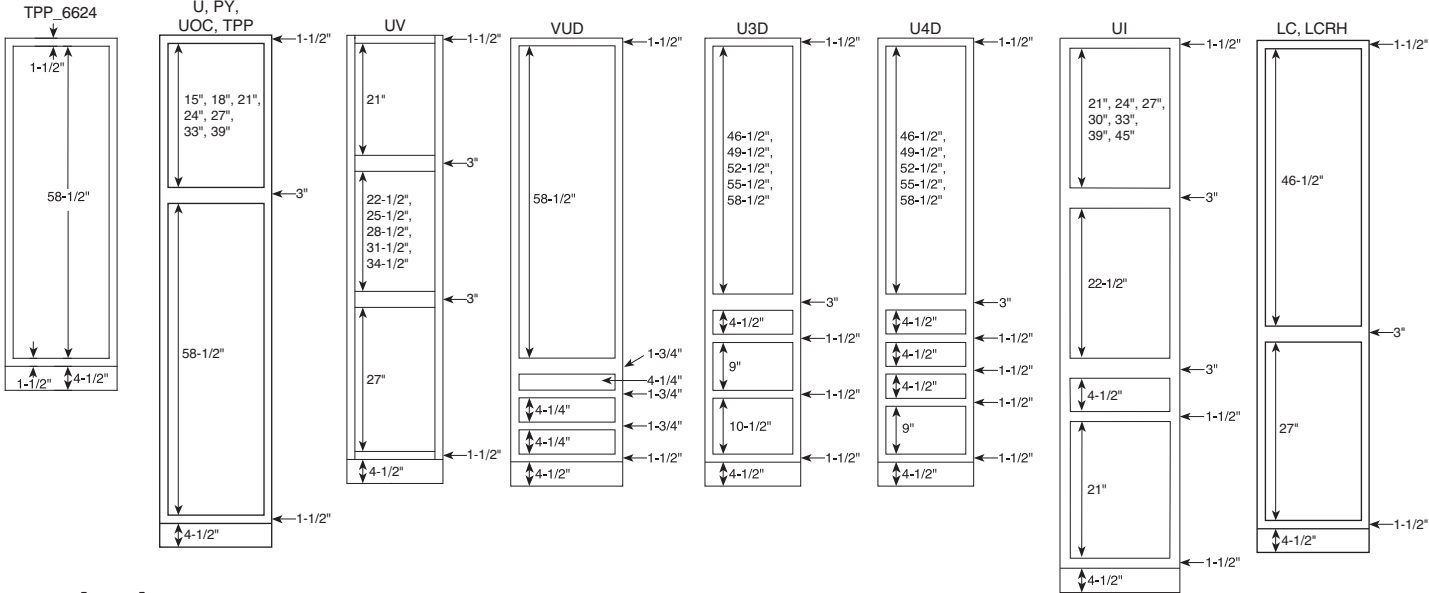

Hearth Cabinets

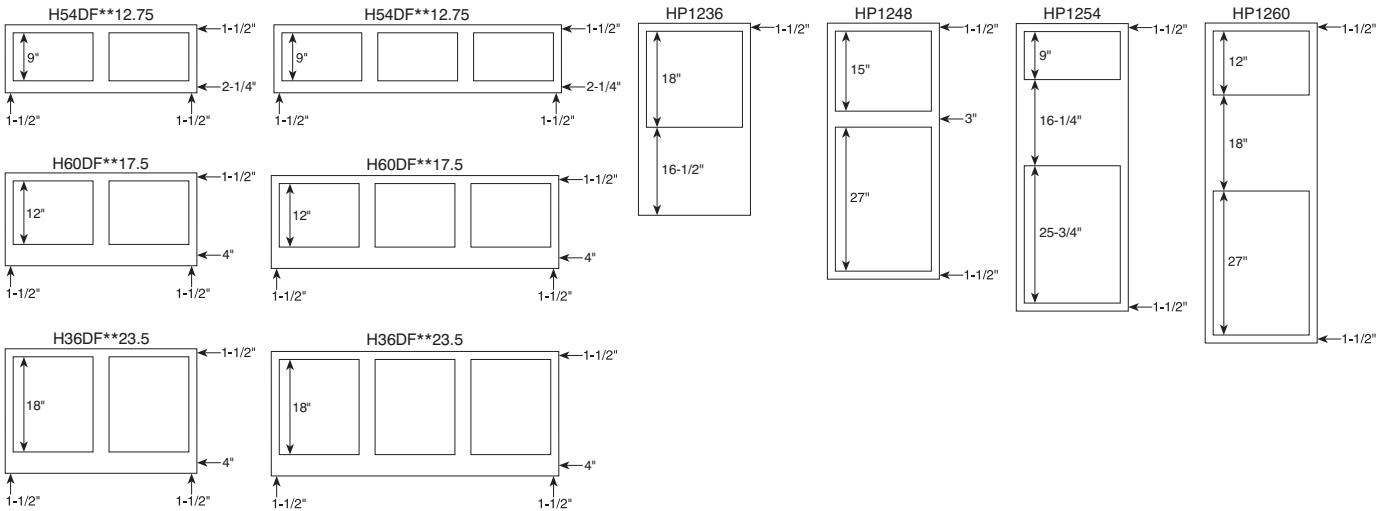



# Specifications & Dimensions

## Standard Full Overlay Styles Opening Sizes

### Entertainment Cabinets

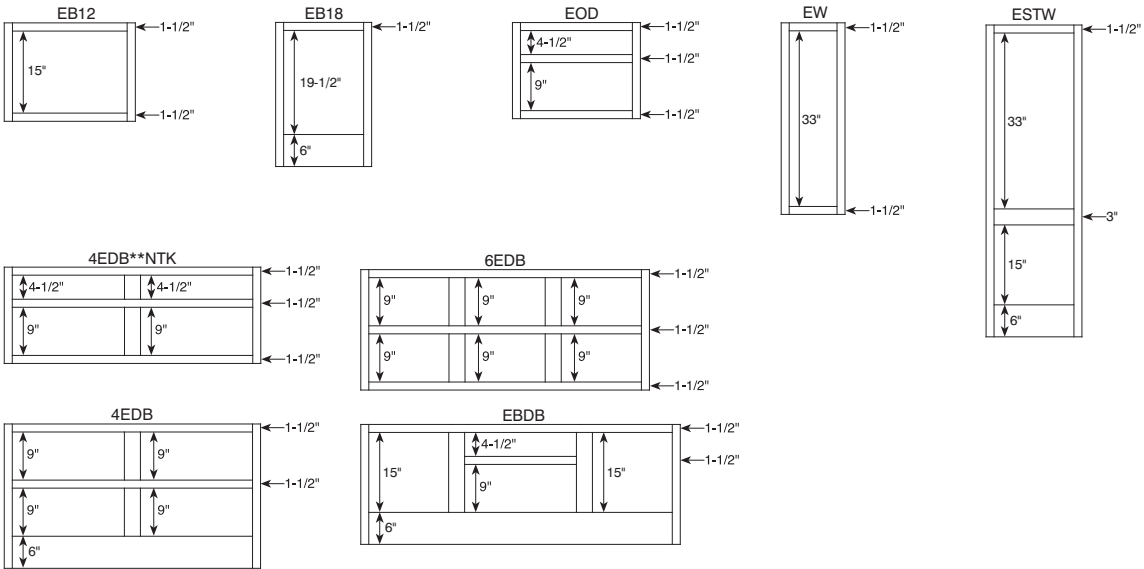

### Home Office Cabinets

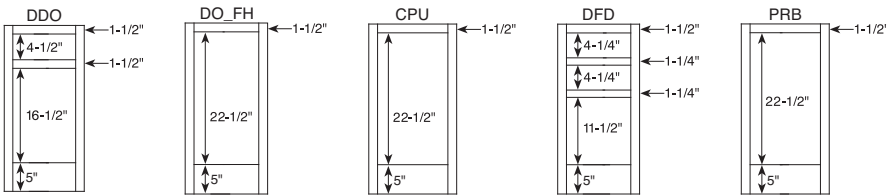

# Standard Full Overlay Styles Opening Sizes

## Entry Ensembles

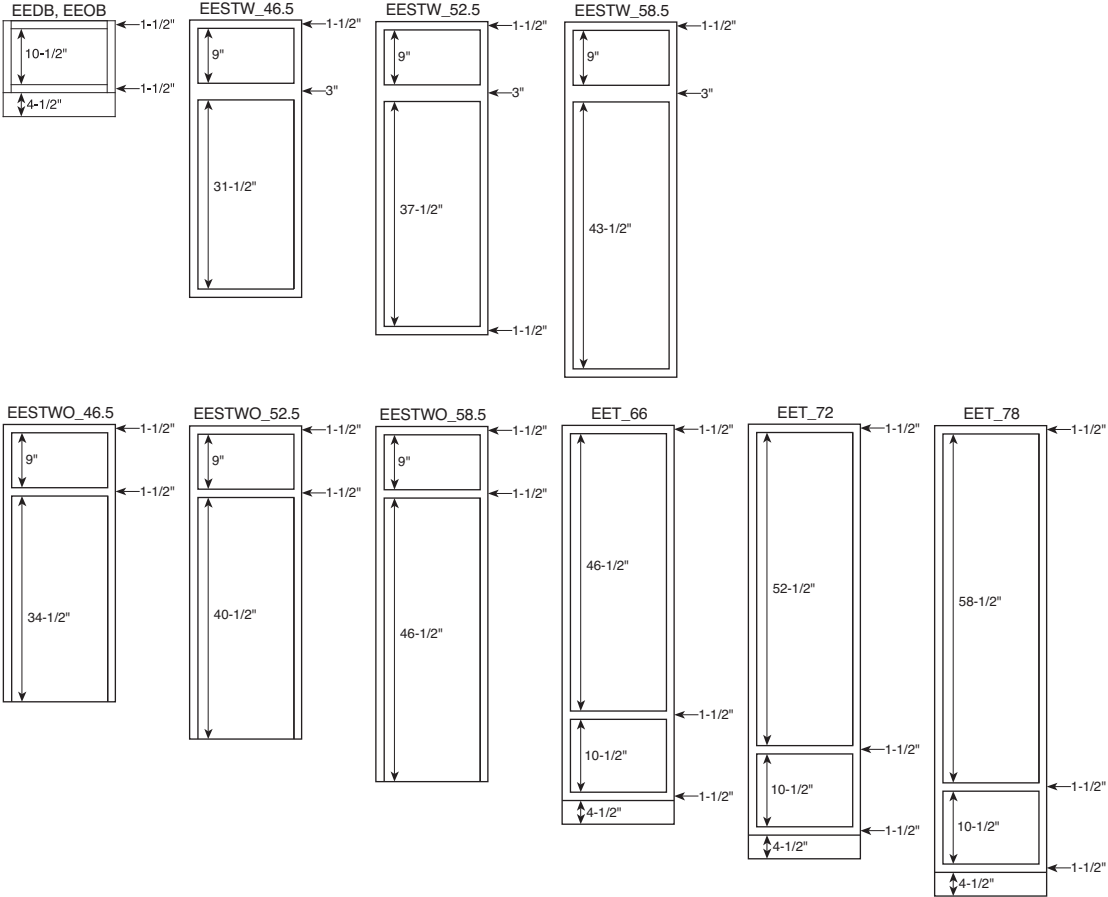

# Specifications & Dimensions

## Standard Inset and Beaded Inset Styles Opening Sizes

### Wall Cabinets

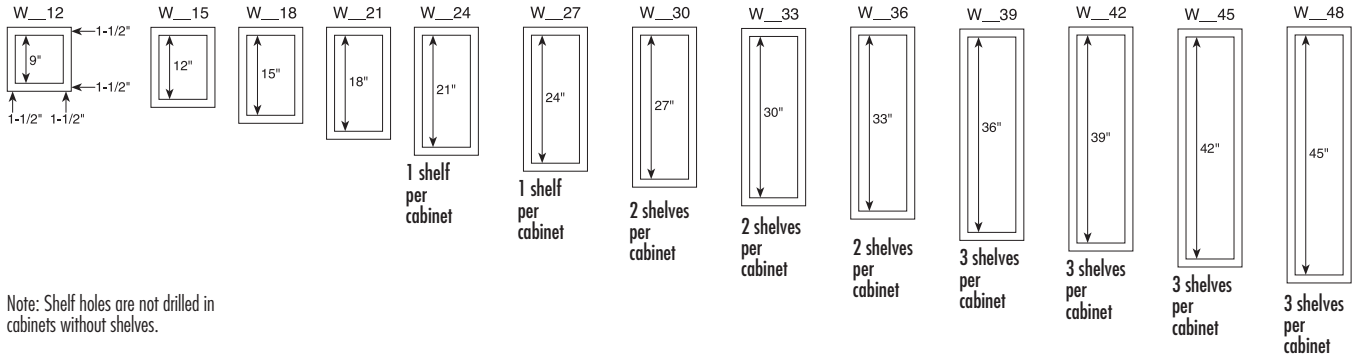

Note: Shelf holes are not drilled in cabinets without shelves.

### Base Cabinets

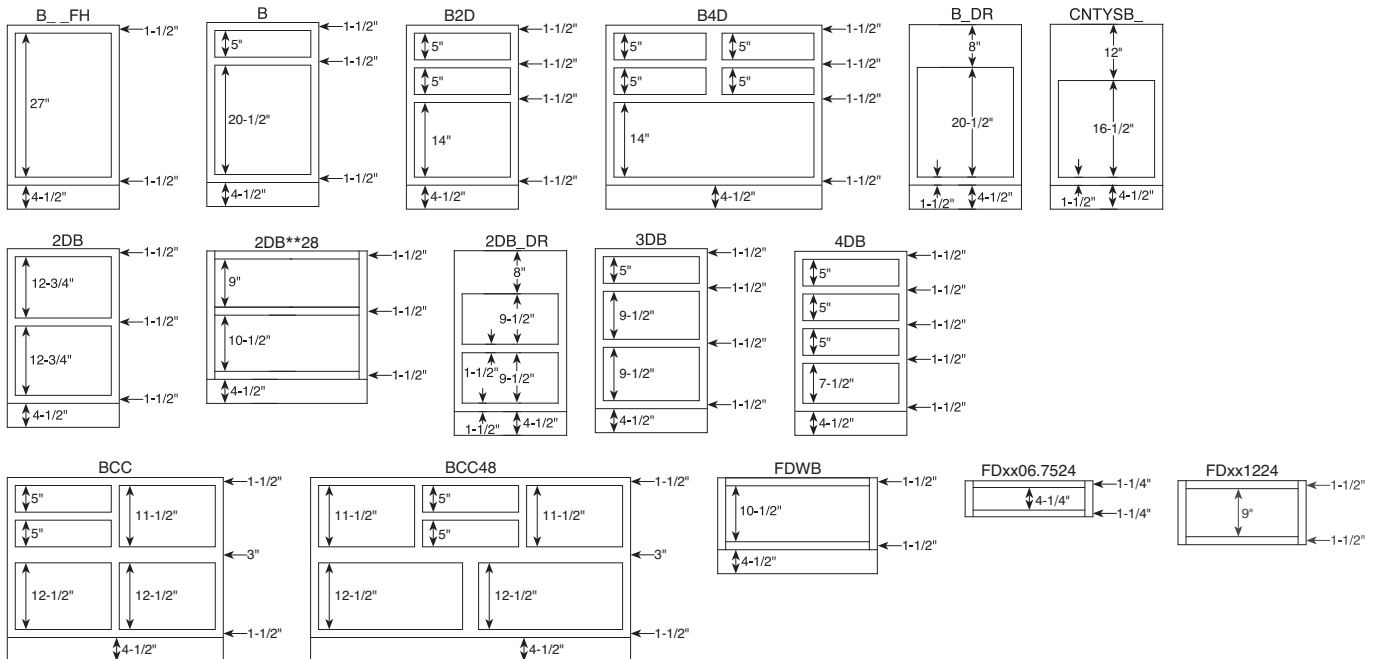

Standard Inset and Beaded Inset Styles Opening Sizes

Vanity Base Cabinets

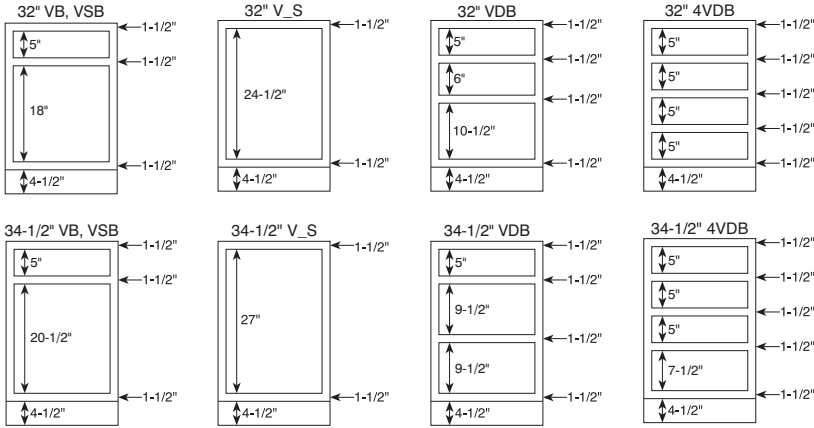

Bath Collection

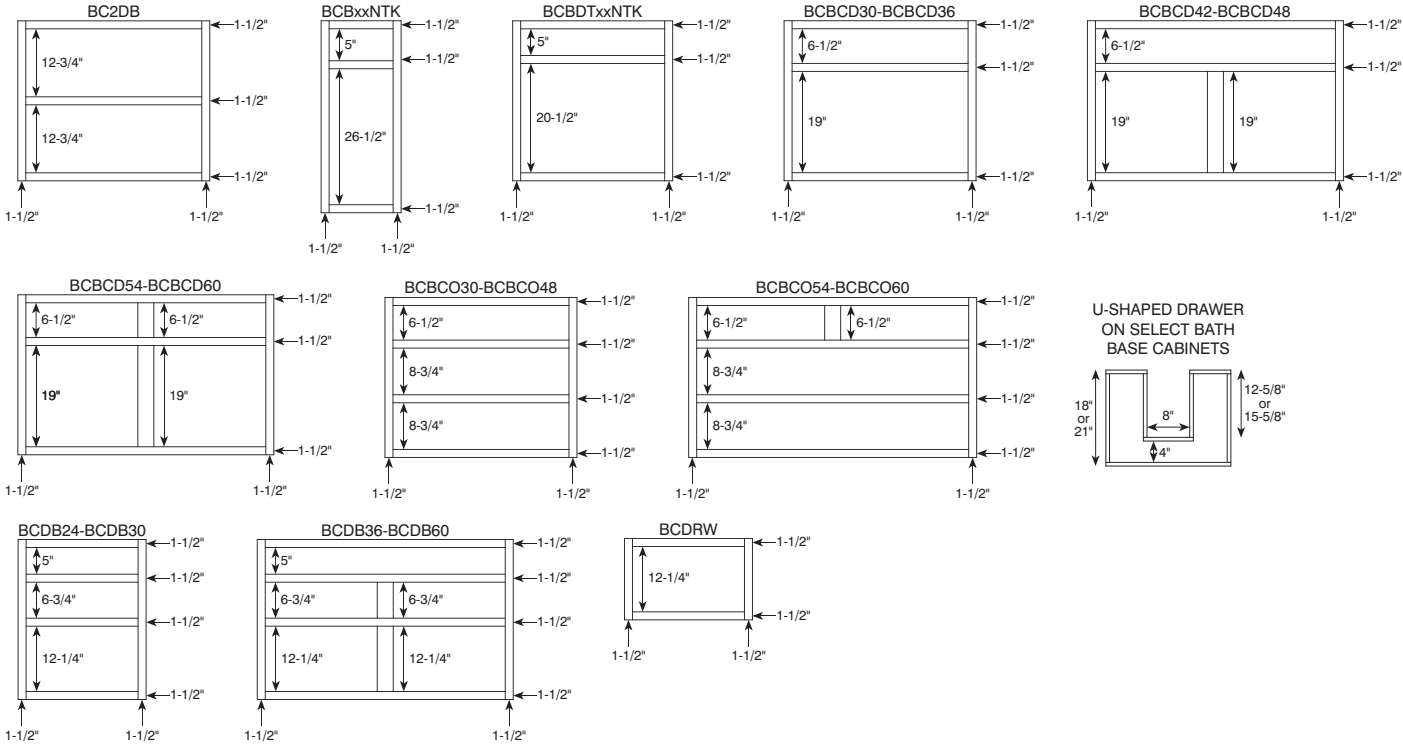

# Specifications & Dimensions

## Standard Inset and Beaded Inset Styles Opening Sizes

### Bath Collection

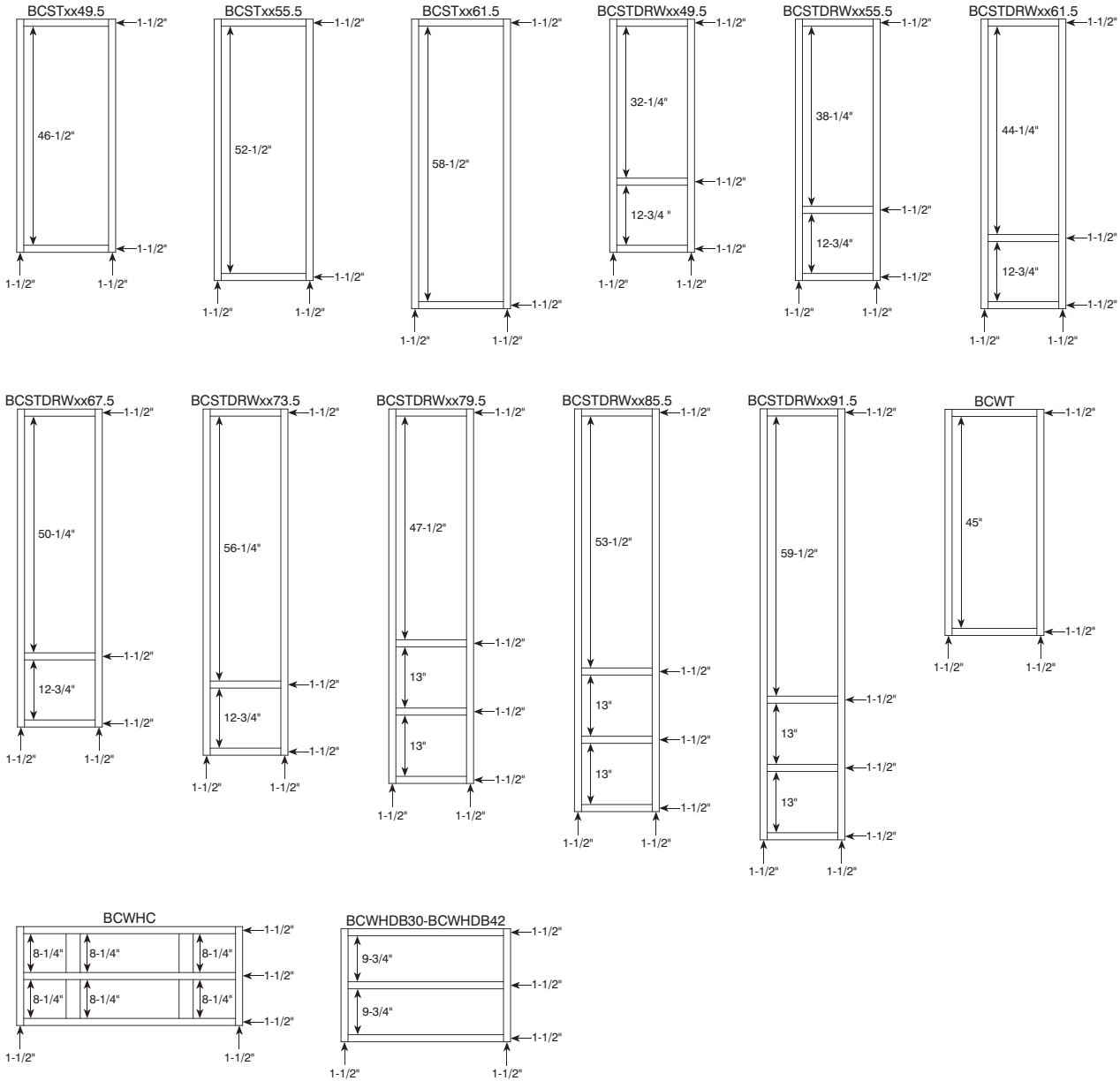

Standard Inset and Beaded Inset Styles Opening Sizes

Utility Cabinets

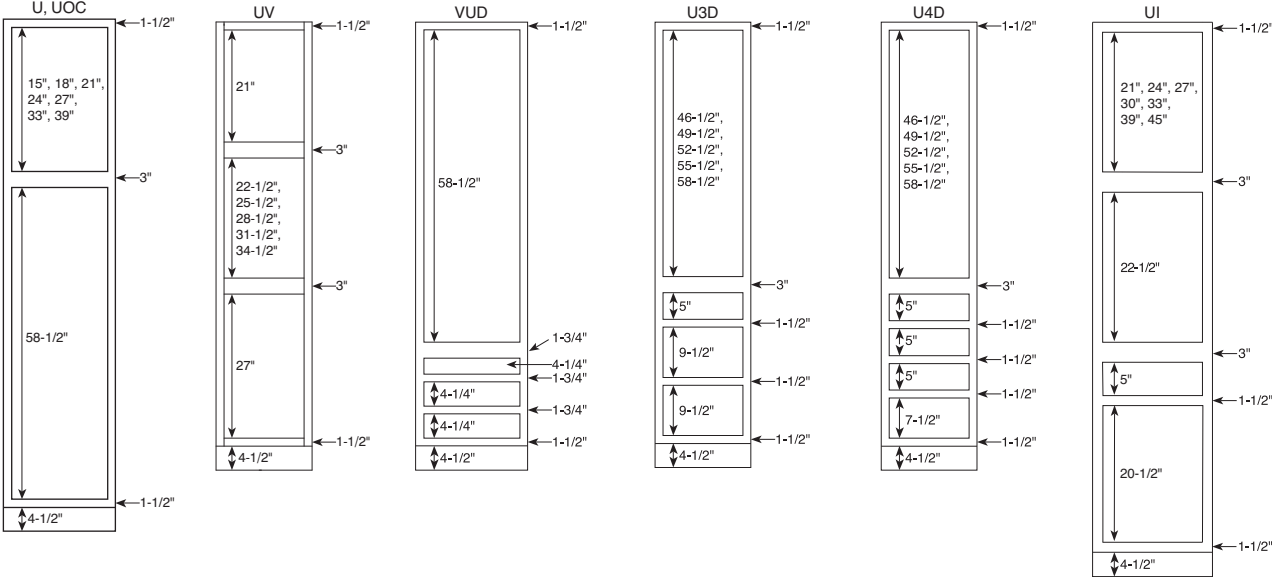

Hearth Cabinets

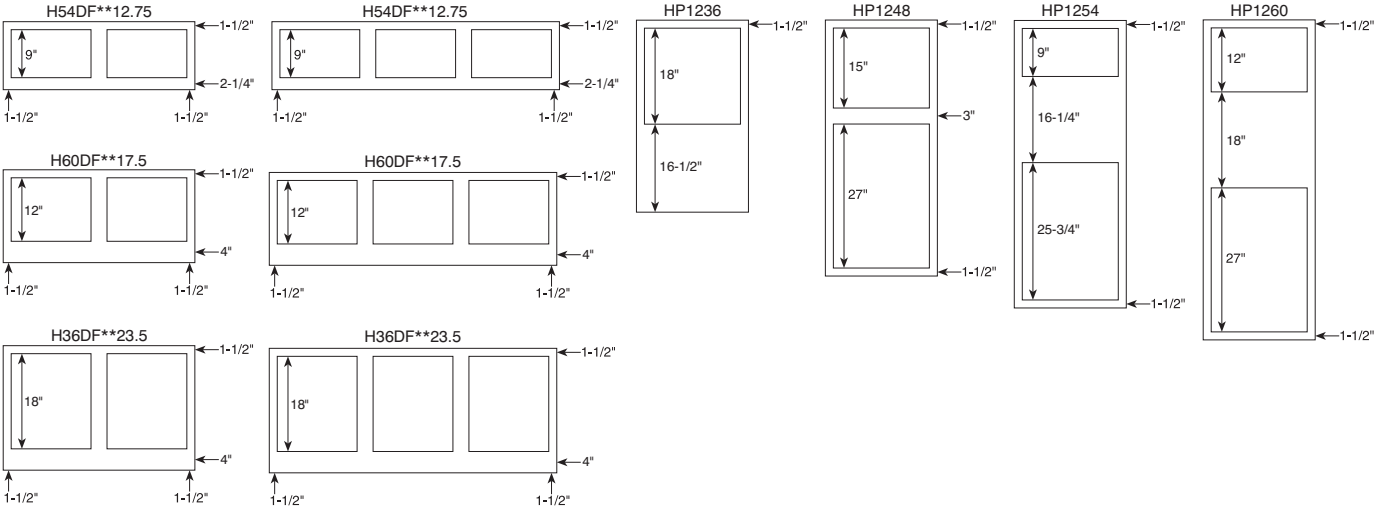

# Specifications & Dimensions

## Standard Inset and Beaded Inset Styles Opening Sizes

### Entertainment Cabinets

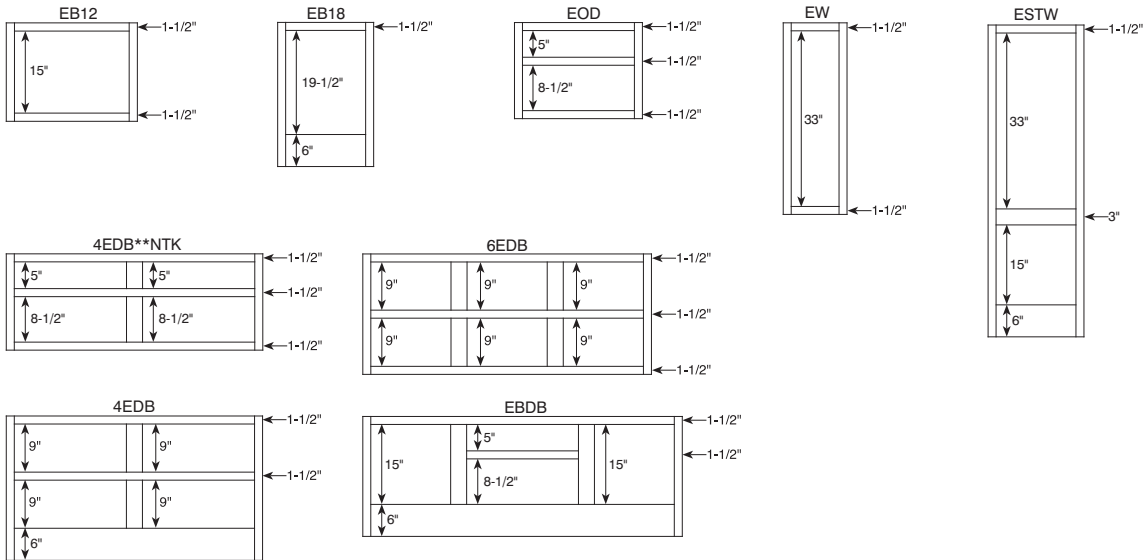

### Home Office Cabinets

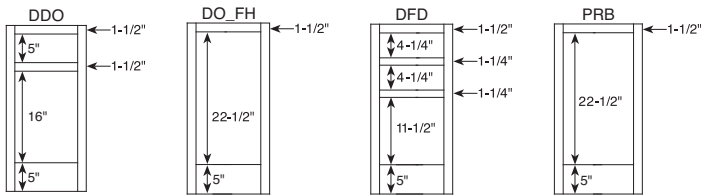

### Dimensions for Corner Installations (45° Diagonal)

#### Wall Cabinets

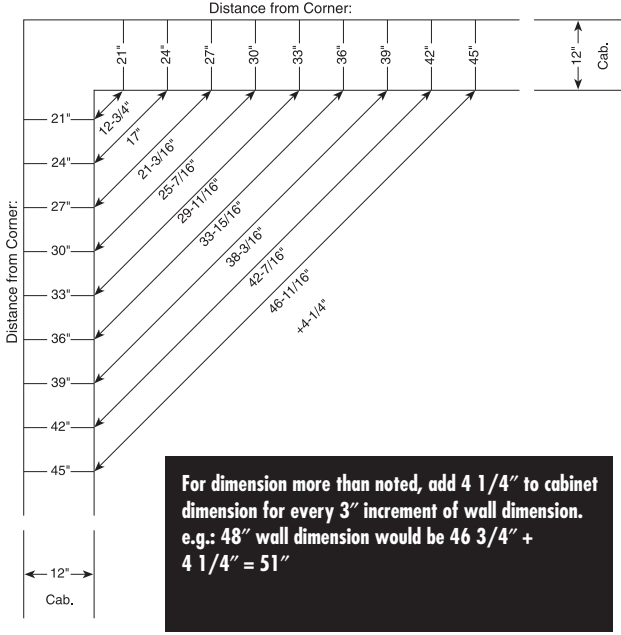
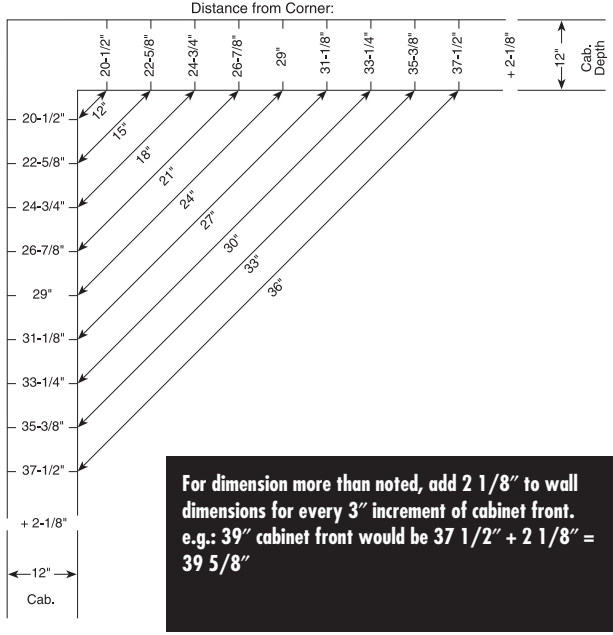

#### Base Cabinets

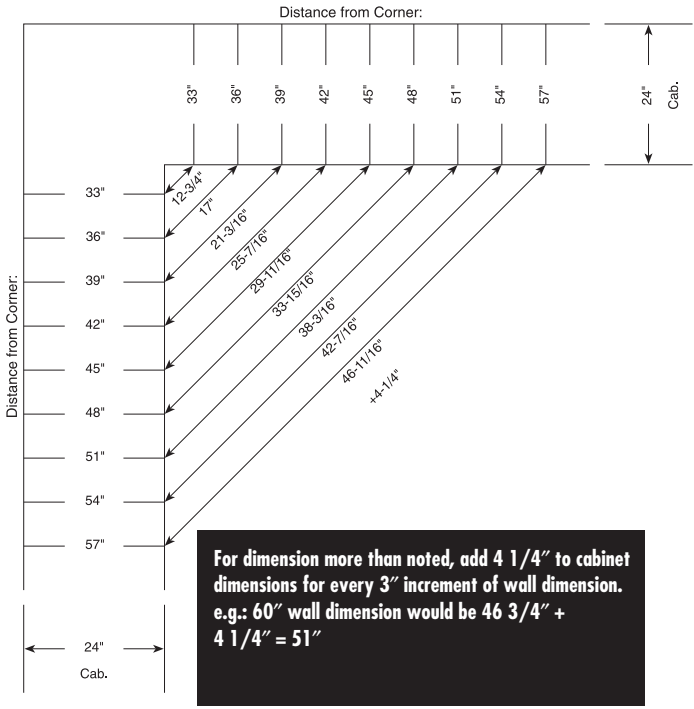
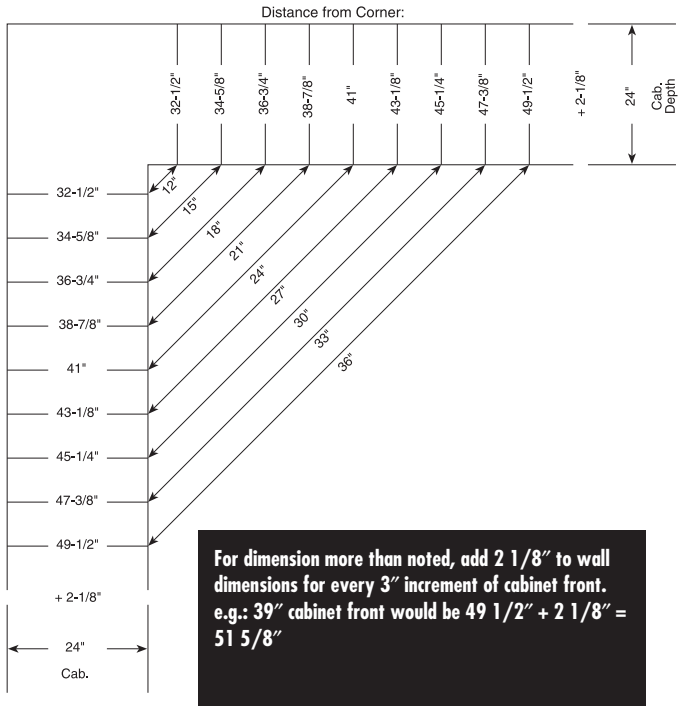





## Modifications Quick Reference Sheet

Modification	Page	Code
Add 1 Drawer Below Wall Unit	G•19	ADRW
Add 2 Drawers Below Wall Unit	G•19	A2DRW
Add 2 Drawers Below Wall Unit Increases Height by 18"	G•19	A2DRW18
Add 3 Drawers Below Wall Unit	G•19	A3DRW
Add Shelf	G•36	ADD_SHLF
Add Toekick	G•29	ADDTK
Aluminum Door	G•14	Profile AF003, Profile AF006, Profile AF007
Attach Toekick	G•29	ATTTK
Authentic Flush End	G•25	AUTHL, AUTHR, AUTHB
Automatic Opening Mechanism for Lift Up Systems	G•13	AOMD
Automatic Opening Mechanism for Wastebaskets	G•13	AOMBWB
Band All Edges	G•8	BND.ALL
Banding Location	G•8	BND.FRT, BND.FRT.L, BND.FRT.R, BND.FRT.L.R, BND.FRT.BK
Beaded Inset Door	G•12	BEADED
Bottom Valance Rail	G•19	BVR_
Cabinet Box Only	G•20	CBO
Cabinet Case Only	G•20	CCO
Cabinet False Panel	G•30	CFP, CFPL, CFPR, CFPB
Cabinet Frame Only	G•21	CFRMO
Cabinet Front Only	G•21	CFNTO
Cabinet No Door	G•21	CND, CND.TOP, CND.MID, CND.BTM, CND.P
CabMat™ (Base)	G•36	CMAT1
CabMat™ (Vanity)	G•36	CMAT2
Car Siding Back	G•36	CSDGBK
Car Siding Flush Panel End	G•25	CSFPEL, CSFPER
Charging Drawer	G•37	CHGDRW, CHGDRWL, CHGDRWR CHGDRWB
3" Clipped Corner	G•21	CLIP3L, CLIP3R, etc.
Craftsman Door	G•14	CCG, CCP, etc.
Cut-for-glass	G•15	CG
Deep Roll Trays	G•31	DRT
Drawer Front Flat 5-piece	G•9	DF5PC
Drawer Front Flat 5-piece Inset	G•10	DF5PCINS
Drawer Front Flat 5-piece with Slab Top	G•10	DF5PCSFLT
Drawer Front Raised 5-piece	G•10	DFR5PC
Drawer Front Raised 5-piece Inset	G•11	DFR5PCINS
Drawer Front Raised 5-piece with Slab Top	G•10	DFR5PCSFLT
Drawer Front Slab	G•11	DFSLB
Drawer Front Slab Top	G•11	DFSLBT
End Extended Back	G•25	EXBKL, EXBKR
Estate Mullion Door	G•15	ESMD, ESMD.TOP, ESMD.MID, ESMD.BTM, ESMD.P
Extended Stile with Overlay	G•21	EXLXL, EXROL, EXBOL, EXLXL.P, EXROL.P, EXBOL.P
Extended Stiles	G•22	EXL, EXR, EXR.P, EXL.P
Face Frame and Door on End	G•26	FFDL, FFDR, etc.
Finished Blind	G•22	FBFL, FBFR
Finished Bottom	G•8	PFINBTMB
Finished Edges	G•8	F.FRT, F.FRT.L, F.FRT.R, F.FRT.L.R, F.FRT.BK
Finished Edges -- All	G•8	F.ALL
Finished Ends	G•8	FL, FR
Flush Panel End	G•26	FPEL, FPER
Flush Toekick	G•22	FTK, FTK.P
Flush Toekick - Arch	G•22	FTKAV, FTKAV.P

# Custom Modifications

Modification	Page	Code
Fluting — 3" parts	G•37	FLUT3L, FLUT3R, FLUT3B, etc.
Fluting — 6" parts	G•37	FLUT6L, FLUT6R, FLUT6B, etc.
Fluting on Fillers — 3" parts	G•38	FLUT3
Fluting on Fillers — 6" parts	G•38	FLUT6, FLUT3CTR
Full Depth Shelf	G•38	FD
Gallery Mullion Door	G•15	GAMD, GAMD.TOP, GAMD.MID, GAMD.BTM, GAMD.P
Horizon Door	G•15	HCG, HCGCP, HCP, etc.
Increased Depths	G•38	ID
Increased Height Plus Drawer	G•39	IH+DRW
Increased Heights	G•40	IH
Increased Widths	G•48	IW
Increased Widths in 1/4" Increments	G•46	IW____.
Inset Door	G•12	NOBEAD
Inset Finial Hinges	G•12	IFAB, IFBN, IFMB, IFORB
Inset Panel Ends	G•27	IPEL, IPER
Integral End	G•28	INTGEL, INTGER
Inverted Frame	G•22	INVFRM
L-shaped Organizer	G•50	VLSOL, VLSOR VLSOB
Matching Interior	G•9	MIP
Mission Door	G•16	MCG, MCGCP, MCP, etc.
Modified Full Overlay	G•13	MFO
Moulding Location	G•35	MLDG
Mullion Doors	G•16	MD, MD.TOP, MD.MID, MD.BTM, MD.P
Nickel Towel Bar	G•24	TBN
No Hinge Cut	G•16	NHC
Open Bottom Rail Base	G•22	OBRB, OBRB.P
Prairie Mullion Doors	G•17	PRMD, PRMD.TOP, PRMD.MID, PRMD.BTM, PRMD.P
Profiled and Finished Edges	G•9	PRO.FRT, PRO.FRT.BK, PRO.FRT.L, PRO.FRT.R, PRO.FRT.L.R, PRO.FRT.L.BK, PRO.FRT.R.BK, PRO.L.R
Profiled and Finished Edges — All	G•9	PRO.ALL
Push-to-Open Wastebasket	G•13	PTOWB
Recessed Toekick	G•29	RECTKL, RECTKR, RECTKBK, etc.
Recessed Toekick Front	G•23	RECTKFRT
Recessed Vanity Wall	G•23	REC
Reduced Depths	G•38	RD
Reduced Heights	G•40	RH
Reduced Widths	G•49	RW
Roll Tray Bottom with Full Depth Shelf (12" to 36")	G•31	FDSRTBTM
Roll Tray Bottom with Full Depth Shelf (39" to 48")	G•31	FDSRTBTM
Roll Trays (12" to 24")	G•31	__RT, __RTL, __RTR, etc.
Roll Trays (27" to 36")	G•31	__RT, __RTL, __RTR, etc.
Rose Fluting — 3" parts	G•50	ROSLUT3L, ROSFLUT3R, ROSFLUT3B, etc.
Rose Fluting on Fillers — 3" parts	G•51	ROSLUT3
Rose Fluting on Fillers — 6" parts	G•51	ROSLUT3CTR
Scooped Drawer	G•32	SCPDRW, SCPDRWL, SCPDRWR SCPDRWB
Shaker Mullion Door	G•17	SHMD, SHMD.TOP, SHMD.MID, SHMD.BTM, SHMD.P
Sink Base Cleaning Caddy	G•51	SBCADDYL, SBCADDYR
Sink Base Cleaning Caddy Small	G•51	SBCADDYSML, SBCADDYSMR
Split Doors	G•14	SPLITDR, SPLITDR.LL, SPLITDR.RR, SPLITDR.P, SPLITDR.LL.P, SPLITDR.RR.P
Split Drawers	G•14	SPLITDRWS
Stacked Wall Cabinet Heights	G•23	STW.TOP_, STW.BTM_
Storage Open Rail Base	G•23	STORB

<b>Modification</b>	<b>Page</b>	<b>Code</b>
Summit Mullion Door	G•17	SUMD, SUMD.TOP, SUMD.MID, SUMD.BTM, SUMD.P
Toeckick Drawer	G•30	DRWTK
Toeckick Pedestal	G•30	TKP
Top Valance Rail – Arch	G•24	TVRAV, TVRAVBTM, TVRAVMID, TVRAVTOP, TVRAV.P
Top Valance Rail – Straight	G•24	TVRVV, TVRVVBTM, TVRVVMID, TVRVVTOP, TVRVV.P
Transom Doors – Center Panel	G•18	TCP, TCPG, TCP.TOP, TCPG.TOP, TCP.P, TCPG.P
Transom Doors – Cut-for-glass	G•18	TCG, TCGG, TCG.TOP, TCGG.TOP, TCG.P, TCGG.P
Tray Divider	G•52	_TD, etc.
U-shaped Drawer Box	G•32	UDBX, UDBXL, UDBXR, UDBXB, UDBX1, UDBX2, UDBX1L, UDBX2L, UDBX1R, UDBX2R, UDBX1B, UDBX2B, UDBX3, UDBX4
U-shaped Roll Tray	G•33	URT, URTL, URTR, URTB URT_
Vanity Wastebasket Container	G•52	VWBL, VWBR
Void Toeckick	G•30	VTK
Wall End and Back Extended Down	G•29	EXDNL, EXDNR, EXDNLRB
Wide Stiles	G•24	WSL1.5, WSR1.5, WSL3, WSR3, WSB1.5, WSB3
Wide Top Rail	G•24	WTR
Wood Tiered Cutlery Divider Drawer	G•52	WTCD, WTCDL, WTCDR WTCDB
Wood Tiered K-Cup Drawer	G•53	WTKCUP, WTKCUPL, WTKCUPR WTKCUPB
3" Wood Top Clipped Corner	G•34	WTCLIP3L, WTCLIP3R, WTCLIP3B, WTCLIP3LFRT.LBK, WTCLIP3RFRT.RBK
6" Wood Top Clipped Corner	G•34	WTCLIP6L, WTCLIP6R, WTCLIP6B, WTCLIP6LFRT.LBK, WTCLIP6RFRT.RBK











### Band All Edges

Specify BND.ALL (Band All Edges)

- Available on:
    - SHELFMI, SHELFNAT, 1/2NAT2S, 3/4NAT2S, 1/2NATVEN, 3/4VEN2S, and 1/2VEN2S. See filler and panel section for more detail.
- 

### Banding Location

Specify BND.FRT (Band Front), BND.FRT.L (Band Front & Left), BND.FRT.R (Band Front & Right), BND.FRT.L.R (Band Front, Left & Right), BND.FRT.BK (Band Front & Back)

- Available on:
    - SHELFMI and SHELFNAT. See filler and panel section for more detail.
- 

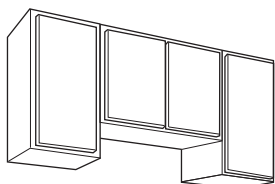

### Finished Bottom

Specify PFINBTMB (Finished Bottom)

Wall cabinets can be ordered with this option, which provides an attractive uniform appearance for the bottom of a run of wall cabinets. Cabinets are prepared with pre-installed spacer blocks.

- The designer must order a 3/16VEN1S to fit the run of the cabinets which will need to be attached by the installer.
  - The designer will need to add the correct number of panels required for all depths of Finished Bottom cabinets on the order.
  - Additional blocking in field may be required when ordered in conjunction with BVR\_ options.
  - For use with Diagonal Wall & Diagonal Wall Peninsula Wall Cabinets, Wall Refrigerator Cabinets, and straight cabinet runs (different depths can be ordered in a cabinet run, but a different 3/16VEN1S will need to be ordered for each depth).
    - Finished Bottom Diagonal Wall Dimensions: 24" W x 24" D
    - Finished Bottom Diagonal Wall Peninsula Dimensions: 27" W x 27" D
    - Finished Bottom Wall Refrigerator Dimensions: 23 1/4" W x 48" D
    - Straight Cabinet Run Finished Bottom Dimensions: W (Cabinet Depth - 3/4") x 96" D
  - Not available on:
    - Flush Toekick - Arch and Add Drawer.
- 

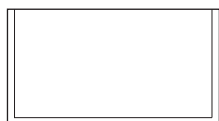

Finished Front, Left and Right Shown

### Finished Edges

Specify F.FRT (Finished Front), F.FRT.L (Finished Front and Left), F.FRT.R (Finished Front and Right), F.FRT.L.R (Finished Front, Left and Right), F.FRT.BK (Finished Front and Back), or F.ALL (Finished All Edges)

With this option, the finished edge selected on the order will be applied to the specified sides.

- Finished All Edges (F.ALL) is available on all mouldings but the two ends are not finished.
  - Available on:
    - 3/4SOLID and SHELFSLD material. See pages Q•21 and Q•22.
- 

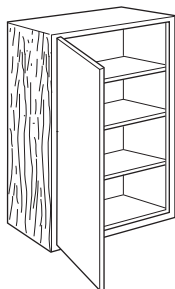

### Finished Ends

Specify FL (Finished End Left) or FR (Finished End Right)

Finished Ends should be specified on any cabinet end that will be exposed after installation.

- Finished Ends standard on:
    - Authentic End, Flush Panel End, Cor Siding Flush Panel End, or Face Frame and Door on End.
-

## Finish Modifications (cont'd)

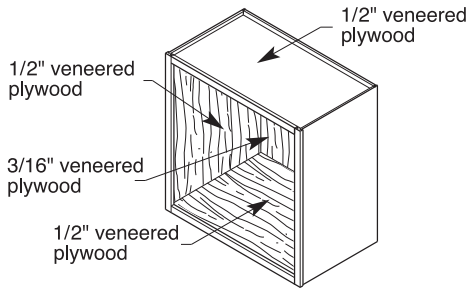

### Matching Interior

#### Specify MIP (Matching Interior)

With this option, the cabinet interior is stained to match the exterior of the cabinet. The cabinet shelf, top and bottom exteriors are also stained to match with this option.

- Pull-out options such as drawer boxes, roll trays, swing-outs, etc., remain in the Natural wood color.
- On all cabinets with a white painted finish, Matching Interior (MIP) option must be used if white interior finish is desired.
- See individual cabinets for details.
- When a decorative door option is chosen in 20/20, Matching Interior Plywood (MIP) is a preselected option. If MIP is not desired, it can be deselected by choosing NOTMIP.



Profiled and Finished Front, Left and Right Shown

### Profiled and Finished Edges

Specify PRO.FRT (Profiled and Finished Front), PRO.FRT.L (Profiled and Finished Front and Left), PRO.FRT.R (Profiled and Finished Front and Right), PRO.FRT.BK (Profiled and Finished Front and Back), PRO.FRT.L.R (Profiled and Finished Front, Left and Right), PRO.FRT.L.BK (Profiled and Finished Front, Left and Back), PRO.FRT.R.BK (Profiled and Finished Front, Right and Back), PRO.L.R (Profiled and Finished Left and Right), or PRO.ALL (Profiled and Finished All Edges)

With this option, finish will match the finish selected on the order. This will be applied to the specified sides.

- Material must follow specifications below to be available with this option:
  - Minimum length: 3", maximum length: 96".
  - Minimum width: 1 1/2", maximum width: 23 3/4".
  - Edge profile will match door profile selected (#10, #12, #14, #17, #18, #27).
- Available on:
  - 3/4SOLID, SHELFSLD, Hearth Shelf and Straight Valance.

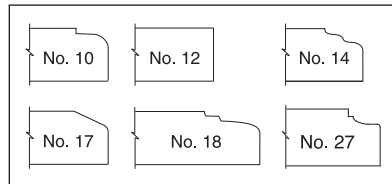

## Modifications to Doors and Drawer Fronts

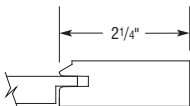
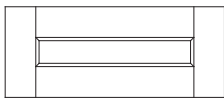

Shanley

### Drawer Front Flat 5-piece

#### Specify DFF5PC (Drawer Front Flat 5-piece)

Drawer Front Flat 5-piece (DFF5PC) includes a 5-piece flat panel drawer.

- Under Counter Drawers and Keyboard Trays will be slab.
- Drawer fronts smaller than 5 3/4" high will have slab front.
- Available on:
  - Most cabinets with drawers featuring Shanley.

# Custom Modifications

## Modifications to Doors and Drawer Fronts (cont'd)

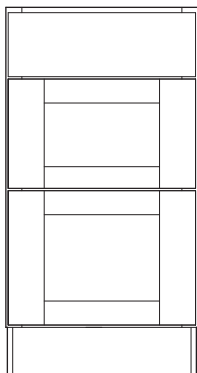

### Drawer Front Flat 5-piece with Slab Top

Specify DFF5PCSLBT (Drawer Front Flat 5-piece, Slab Top)

Drawer Front Flat 5-piece with Slab Top includes a 5-piece flat panel drawer front, with the exception of the top front of base and vanity cabinets when the opening is 4 1/2" or 4 1/4", which will remain slab. Talls with drawer fronts at base/vanity height level will maintain the slab drawer front also, example UI \_\_\_\_\_. Drawer fronts smaller than 5 3/4" high will have slab front which includes Under Counter Drawers and Keyboard Trays.

- Available on:
  - Shanley.

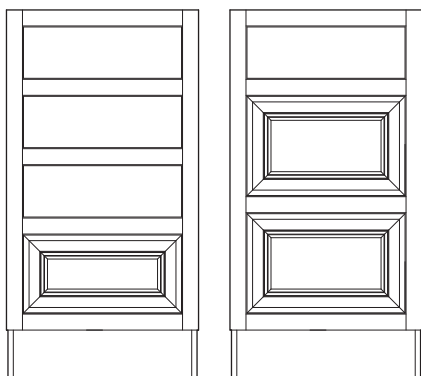

### Drawer Front Flat 5-piece Inset

Specify DFF5PCINS (Drawer Front Flat 5-piece Inset)

Drawer Front Flat 5-piece Inset (DFF5PCINS) includes a 5-piece flat panel drawer. Changes drawer fronts on openings 6" high and greater from a slab front to a 5-piece flat panel drawer front.

- Drawer fronts on openings less than 6" high will remain a slab front. For example, only the bottom drawer front will change to a 5-piece flat panel front on a four drawer 4DB. On a 3DB, the middle and bottom will change to a 5-piece flat panel front.
- Available on:
  - Most cabinets with drawers featuring Burke Beaded Inset, Burke Inset, Shanley Beaded Inset, Shanley Inset, Tate Beaded Inset, Tate Inset, Vinson Beaded Inset, and Vinson Inset.

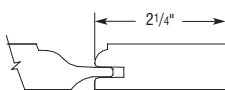
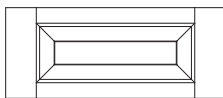

**Drawer Side Rail / Center Panel Detail – Used on Top/Bottom Rail, when Drawer Front is over 6 3/4" High**

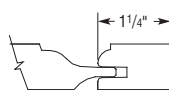

**Drawer Top / Bottom Rail / Center Panel Detail – Used on 6 3/4" High and Less Drawer Fronts**

### Drawer Front Raised 5-piece

Specify DFR5PC (Drawer Front Raised 5-piece)

Drawer Front Raised 5-piece (DFR5PC) includes a 5-piece double raised center panel drawer.

- End rails are 2 1/4" and crossrails are 1 1/4" (finished width). This rule will apply on all 4 1/4" and 4 1/2" high drawer openings.
- Any drawer openings larger than 4 1/2" high will utilize 2 1/4" end rails and crossrails.
- Under Counter Drawers, Drop Fronts (excluding Tilt-out Trays), and Keyboard Trays will be slab.
- Drawer fronts smaller than 5 3/4" high will have slab front.
- Available on:
  - Shanley.

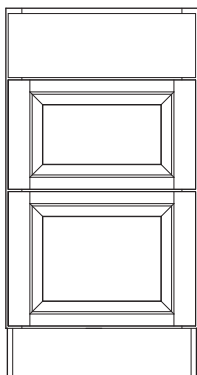

### Drawer Front Raised 5-piece with Slab Top

Specify DFR5PCSLBT (Drawer Front Raised 5-piece, Slab Top)

Drawer Front Raised 5-piece with Slab Top includes a 5-piece double raised center panel drawer front, with the exception of the top front of base and vanity cabinets when the opening is 4 1/2" or 4 1/4", which will remain slab. Talls with drawer fronts at base/vanity height level will maintain the slab drawer front also, example UI \_\_\_\_\_. End rails are 2 1/4" and crossrails are 1 1/4" (finished width). This rule will apply on all 4 1/4" and 4 1/2" high drawer openings, with the exception of top fronts. Any drawer openings larger than 4 1/2" high will utilize 2 1/4" end rails and crossrails. Drawer fronts smaller than 5 3/4" high will have slab front which includes Under Counter Drawers and Keyboard Trays.

- Available on:
  - Shanley.

## Modifications to Doors and Drawer Fronts (cont'd)

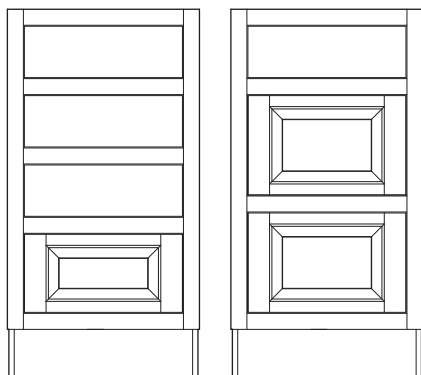

### Drawer Front Raised 5-piece Inset

Specify DFR5PCINS (Drawer Front Raised 5-piece Inset)

Drawer Front Raised 5-piece Inset (DFR5PCINS) includes a 5-piece double raised panel drawer. Changes drawer fronts on openings 6" high and greater from a slab front to a 5-piece raised panel drawer front.

- Drawer fronts on openings less than 6" high will remain a slab front. For example, only the bottom drawer front will change to a 5-piece raised panel front on a four drawer 4DB. On a 3DB, the middle and bottom will change to a 5-piece raised panel front.
- Available on:
  - Most cabinets with drawers featuring Decker Beaded Inset, Decker Inset, Shanley Beaded Inset and Shanley Inset.



### Drawer Front Slab

Specify DFSLB (Drawer Front Slab)

Drawer Front Slab (DFSLB) includes a solid slab drawer front.

- Available on:
  - Burke, Decker, Gordon, Gordon Beaded Inset, Gordon Inset, Kirby, Kirby Beaded Inset, Kirby Inset, Landry, Landry Beaded Inset, Landry Inset, Tate, and Vinson.

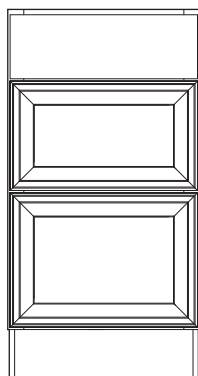

### Drawer Front Slab Top

Specify DFSLBT (Drawer Front Slab Top)

Drawer Front Slab Top (DFSLBT) includes a solid slab drawer front on the top front of base and vanity cabinets when the opening is 4 1/2" or 4 1/4". Tall with drawer fronts at base/vanity height level will also be changed to slab, example UI \_\_\_\_\_.

- Available on:
  - Burke, Decker, Gordon, Gordon Beaded Inset, Gordon Inset, Kirby, Kirby Beaded Inset, Kirby Inset, Landry, Landry Beaded Inset, Landry Inset, Tate, and Vinson.
- Not available on:
  - Add Drawer modification, W\_\_364 models, and VWR1536.

# Custom Modifications

## Modifications to Doors and Drawer Fronts (cont'd)

---

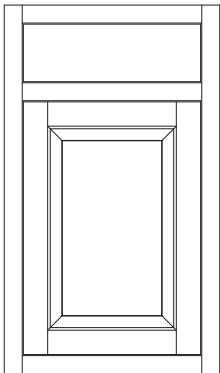

Shanley Inset

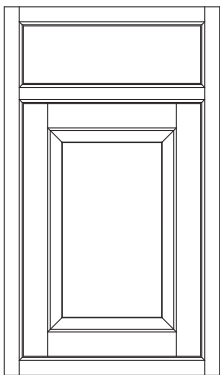

Shanley Beaded Inset

### Inset & Beaded Inset Doors

Specify NOBEAD (Inset Door Styles) or BEADED (Beaded Inset Door Styles)

With this option, the door style selected will follow the Inset and Beaded Inset style requirements.

- Wall Cabinets are a standard 13" deep.
- Standard hinge is a 6-way adjustable Smart Stop concealed hinge. Finial hinges (IFAB, IFBN, IFMB, IFORB) are available at no additional charge, see modification for details.
- Not available on Inset and Beaded Inset:
  - Authentic Ends (AUTHL, AUTHR, AUTHB), Drawer Front Flat 5-piece (DFF5PC), Drawer Front Raised 5-piece (DFR5PC), Extended Stile w/Overlay (EXLOL, EXROL), Face Frame and Door on End (FFD), Integral Ends (INTGEL, INTGER), Modified Full Overlay (MFO), and Wood Tops for Angled End Base Cabinets (WTOPBAC, WTOPBEC).
- Not available on Beaded Inset:
  - Top Valance Rail - Arch (TVRAV).
- Available styles include:
  - Decker, Gordon, Kirby, and Shanley. These styles are featured under the Door Style section. Please see pages D•9-D•13 for more details.
- See individual cabinets for availability.

---

### Inset Finial Hinges

Specify IFAB (Inset Finial Hinge - Antique Brass), IFBN (Inset Finial Hinge - Brushed Nickel), IFMB (Inset Finial Hinge - Matte Black), or IFORB (Inset Finial Hinge - Oil Rubbed Bronze)

With this option, finial hinges will be attached to the door.

- Special placement of finial hinges is not available.
- Hinge will not feature Smart Stop.
- 180 degree hinge.
- Four way adjustable hinge (left, right, up and down).
- Available on:
  - Inset and Beaded Inset door styles with #12 profile only.
- Not available on:
  - Aluminum Frame Doors, Faux Hinges, and Inset Panel Ends.

## Modifications to Doors and Drawer Fronts (cont'd)

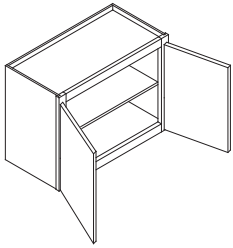

### Modified Full Overlay

#### Specify MFO (Modified Full Overlay)

Full Overlay Cabinets can be ordered with a modified full overlay. Modified Full Overlay will reduce the size of the top door by 13/16" allowing for a reveal of 1 1/32".

- When Modified Full Overlay is specified it will be applied to all Wall and Tall cabinets on order.
- When ordering two wall cabinets that will be field stacked, both cabinets will come with Modified Full Overlay unless otherwise specified.
- Modified Full Overlay adjustment will not occur on Wall Cabinets with Add Toe Kick modification.
- When Integral Ends are ordered in conjunction with Modified Full Overlay, the cross rail will not increase to match the change in reveal.
- When Fluting modifications are selected in conjunction with Modified Full Overlay, the Fluting dimensions do not change.
- When Transom modification is selected in conjunction with Modified Full Overlay, the bottom section of door will decrease in height by 13/16".
- Available on:
  - Most wall and tall cabinets, see individual cabinets for availability.
- Not available on:
  - Aluminum Frame Doors, Inset Doors, Beaded Inset Doors, Inset Finial Hinges, and Inset Panel Ends.

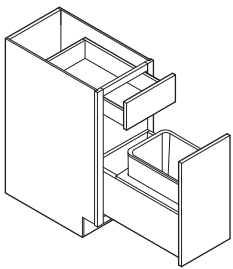

### Push-to-Open Wastebasket

#### Specify PTOWB (Push-to-Open Wastebasket)

- Available on:
  - BWB15, BWB18, BWB21, BWB15BB, BWB18BB, BWB21BB, BWB15FH, BWB18FH, BWB21FH, BWB15FHKIT, BWB18FHKIT, BWB21FHKIT, BWB18KCUP, BWB15KIT, BWB18KIT, BWB21KIT, BWB15WTCD, BWB18WTCD, BWB21WTCD.
- Changes the guide mechanism on wastebasket pull-outs to a mechanical push to open guide with Smart Stop.
- Available on 24" deep cabinets only.
- Does not change other drawer guides on the cabinet.

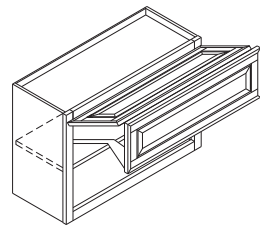

### Automatic Opening Mechanism for Lift Up System

#### Specify AOMD (Automatic Opening Mechanism for Lift Up Systems)

A light touch on the front using your hand or elbow is all that's required to open doors with Automatic Opening Mechanism.

- AOMD available on the following:
  - WTH\_BF, WTH\_SL, WTH\_VL, STWAG, and DW\_AG.
- Automatic Opening Mechanism is not available on WTH\_VL, STWAG and DW\_AG units when used with the following door styles:
  - Burke, Gordon, Kirby, Landry, Shanley, and Vinson.
- See page S•12 for Automatic Opening Mechanism accessories and parts.

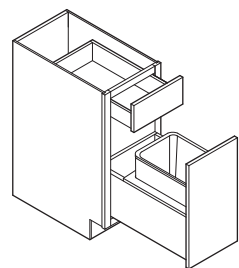

### Automatic Opening Mechanism for Wastebaskets

#### Specify AOMBWB (Automatic Opening Mechanism for Wastebaskets)

A light touch on the front using your hand or knee is all that's required to open doors with Automatic Opening Mechanism.

- AOMBWB available on the following:
  - BWB15, BWB18, BWB21, BWB24, BWB15BB, BWB18BB, BWB21BB, BWB24BB, BWB15FH, BWB18FH, BWB21FH, BWB24FH, BWB18KCUP, BWB15WTCD, BWB18WTCD, BWB21WTCD, BWB24WTCD.
- See page S•12 for Automatic Opening Mechanism accessories and parts.

# Custom Modifications

## Modifications to Doors and Drawer Fronts (cont'd)

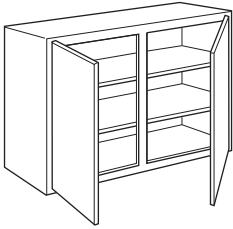

### Split Doors

Specify SPLITDR, SPLITDR.LL (Split Doors Left-Hinged), SPLITDR.RR (Split Doors Right-Hinged), SPLITDR.P (Split Doors - Peninsula), SPLITDR.LL.P (Split Doors Left - Hinged - Peninsula), or SPLITDR.RR.P (Split Doors Right - Hinged - Peninsula)

Butt Doors are standard on double door cabinets 24" to 39" wide. If a center face frame mullion is desired, specify the Split Doors option. If the unit includes a drawer, the drawer is one wide drawer unless the Split Drawers option is selected.

- Not available on:
  - Top Valance Rail.

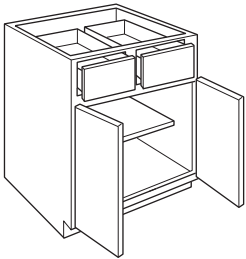

### Split Drawers

Specify SPLITDRWS (Split Drawers)

When a unit includes a drawer, one wide drawer configuration is standard. If two small, side-by-side drawers are desired, specify the Split Drawers option.

- Split Drawer front widths will not be aligned with the doors unless the Split Doors option is specified.
- When IH+DRW is ordered in conjunction with Split Drawers, only top drawers will be split.
- When Split Drawers are specified on a drawer base, only the top drawer will be split.
- Minimum cabinet width is 24". Maximum cabinet width is 39".

## Specialty Door Modifications

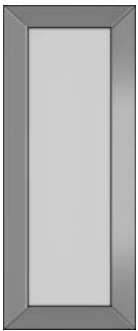

### Aluminum Door

Specify AF003 (Aluminum Frame profile 003), AF006 (Aluminum Frame profile 006), or AF007 (Aluminum Frame profile 007)

Specify Finish NA (Natural Aluminum), S (Brushed Stainless), RB (Rubbed Bronze), W (White), or B (Black)

Specify Insert, see page H●19 for selections.

Cabinets can be ordered with Aluminum Frame doors with insert.

- Must specify Matching Interior if desired. When a decorative door option is chosen in 20/20, Matching Interior Plywood (MIP) is a preselected option. If MIP is not desired, it can be deselected by choosing NOTMIP.
- Limited cabinet availability.
- Face Frame and Door on End option will always match the face.
- See Specialty doors for availability.

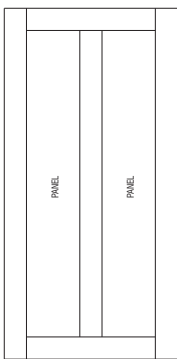

CCP  
(Two Center Panels)

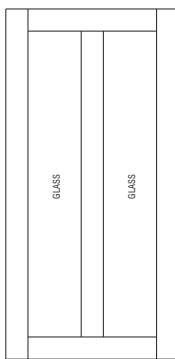

CCG  
(Two sections Cut-for-glass)

### Craftsman Door

Specify CCP (Two center panels), CCG (Two sections Cut-for-glass), CCG.TOP (Two sections Cut-for-glass - Top Door), CCG.BTM (Two sections Cut-for-glass - Bottom Door), CCG.P (Two sections Cut-for-glass - Peninsula), CCP.TOP (Two center panels - Top Door), CCP.BTM (Two center panels - Bottom Door), or CCP.P (Two center panels - Peninsula).

Cabinets can be ordered with Craftsman Door.

- Both sections will be equal size.
- Doors sections will be split with a vertical center door mullion.
- Due to the width and height size limitations for Craftsman Doors, the Authentic Flush End modification may not match the Craftsman Door configuration specified. The door configuration for Authentic Flush End modification will be the CCP option when achievable (Cut-for-glass is not available), otherwise the door configuration will match the door style of the order. Refer to page H●11 for minimum width and height by style.
- Due to the width and height size limitations for Craftsman Doors, the Face Frame and Door on End modification may not match the Craftsman Door configuration specified. The door configuration for Face Frame and Door on End modification will match the Craftsman option chosen when achievable, otherwise the door configuration will match the door style of the order. Refer to page H●11 for minimum width and height by style.
- If Craftsman option is selected in conjunction with IPEL or IPER option, the Inset Panel End doors will NOT match the front doors on the cabinet. They will remain standard doors on the Inset Panel End side.
- If Craftsman option is selected in conjunction with INTGEL or INTGER option, the INTEGRAL doors will NOT match the front doors on the cabinet. They will remain standard doors on the integral side.
- Glass is not included. When ordering glass, two equal sizes of glass will be required. Art Glass not available.
- Craftsman modification is available on Wall cabinets only.
- See Specialty doors for availability.
- When a decorative door option is chosen in 20/20 for CCG, Matching Interior Plywood (MIP) is a preselected option. If MIP is not desired, it can be deselected by choosing NOTMIP.

Specialty Door Modifications (cont'd)

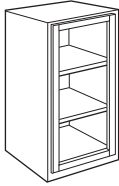

**Cut-for-glass**

Specify CG (Cut-for-glass), CG.TOP (Cut-for-glass Top), CG.MID (Cut-for-glass Middle), CG.BTM (Cut-for-glass Bottom), or CG.P (Cut-for-glass Peninsula)

Cabinets can be ordered with doors routed to accept glass inserts. Clips to attach glass are included.

- Doors more than 54" tall have two panels routed for glass, divided by a horizontal mullion.
- Glass is not included.
- Must specify Matching Interior if desired. When a decorative door option is chosen in 20/20, Matching Interior Plywood (MIP) is a preselected option. If MIP is not desired, it can be deselected by choosing NOTMIP.
- Not available on:
  - Cabinets with bifold doors.

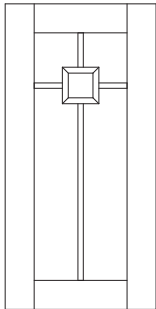

**Estate Mullion Door**

Specify ESMD (Estate Mullion Door) door location, ESMD.TOP (top door), ESMD.MID (middle door), ESMD.BTM (bottom door), or ESMD.P (peninsula door)

With this option, doors will feature a mullion cut-out. Clips to attach glass are included. All doors feature a square door style.

- Must specify Matching Interior if desired. When a decorative door option is chosen in 20/20, Matching Interior Plywood (MIP) is a preselected option. If MIP is not desired, it can be deselected by choosing NOTMIP.
- Glass is not included.
- See Specialty doors for availability.

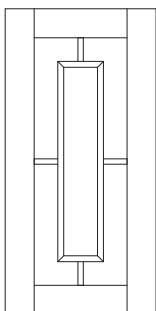

**Gallery Mullion Door**

Specify GAMD (Gallery Mullion Door) door location, GAMD.TOP (top door), GAMD.MID (middle door), GAMD.BTM (bottom door), or GAMD.P (peninsula door)

With this option, doors will feature a mullion cut-out. Clips to attach glass are included. All doors feature a square door style.

- Must specify Matching Interior if desired. When a decorative door option is chosen in 20/20, Matching Interior Plywood (MIP) is a preselected option. If MIP is not desired, it can be deselected by choosing NOTMIP.
- Glass is not included.
- See Specialty doors for availability.

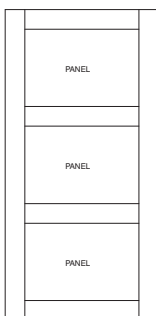

**HCP**  
(Center panels)

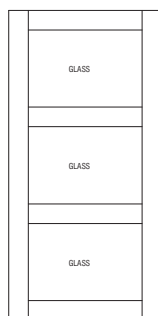

**HCG**  
(Cut-for-glass)

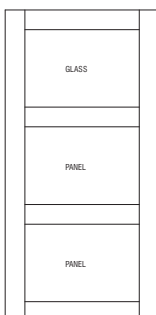

**HCGCP**  
(Cut-for-glass top and center panels)

**Horizon Door**

Specify HCP (Three equal panels), HCG (Three equal sections Cut-for-glass), HCGCP (Three equal sections. Top section is Cut-for-glass. Bottom two sections have panels), HCG.TOP (Three equal sections Cut-for-glass - Top Door), HCG.BTM (Three equal sections Cut-for-glass - Bottom Door), HCG.P (Three equal sections Cut-for-glass - Peninsula), HCGCP.TOP (Three equal sections. Top section is Cut-for-glass. Bottom two sections have panels - Top Door), HCGCP.BTM (Three equal sections. Top section is Cut-for-glass. Bottom two sections have panels - Bottom Door), HCGCP.P (Three equal sections. Top section is Cut-for-glass. Bottom two sections have panels - Peninsula), HCP.TOP (Three equal panels - Top Door), HCP.BTM (Three equal panels - Bottom Door), or HCP.P (Three equal panels - Peninsula).

Cabinets can be ordered with Horizon Door.

- All three sections will be equal size.
- Due to the width and height size limitations for Horizon Doors, the Authentic Flush End modification may not match the Horizon Door configuration specified. The door configuration for Authentic Flush End modification will be the HCP option when achievable (Cut-for-glass is not available), otherwise the door configuration will match the door style of the order. Refer to page H•12 for minimum width and height by style.
- Due to the width and height size limitations for Horizon Doors, the Face Frame and Door on End modification may not match the Horizon Door configuration specified. The door configuration for Face Frame and Door on End modification will match the Horizon option chosen when achievable, otherwise the door configuration will match the door style of the order. Refer to page H•12 for minimum width and height by style.
- If Horizon option is selected in conjunction with IPEL or IPER option, the Inset Panel End doors will NOT match the front doors on the cabinet. They will remain standard doors on the Inset Panel End side.
- If Horizon option is selected in conjunction with INTGEL or INTGER option, the INTEGRAL doors will NOT match the front doors on the cabinet. They will remain standard doors on the integral side.
- When Modified Full Overlay modification is selected in conjunction with Horizon, the three sections will remain equal.
- Glass is not included. When ordering glass, three equal sizes of glass will be required. Art Glass not available.
- Horizon modification is available on Wall cabinets only.
- See Specialty doors for availability.
- When a decorative door option is chosen in 20/20 for HCG or HCGCP, Matching Interior Plywood (MIP) is a preselected option. If MIP is not desired, it can be deselected by choosing NOTMIP.



# Custom Modifications

## Specialty Door Modifications (cont'd)

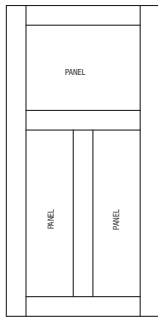

**MCP**  
(Center panels)

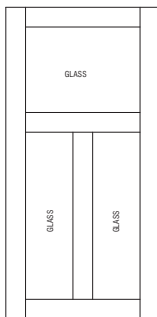

**MCG**  
(Cut-for-glass)

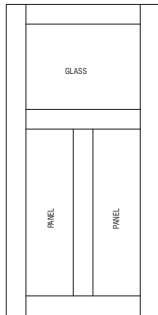

**MCGCP**  
(Cut-for-glass top and center panels)

### Mission Door

Specify MCP (Three center panels), MCG (Three sections Cut-for-glass), MCGCP (Three sections. Top section is Cut-for-glass. Bottom two sections have panels), MCG.TOP (Three sections Cut-for-glass - Top Door), MCG.BTM (Three sections Cut-for-glass - Bottom Door), MCG.P (Three sections Cut-for-glass - Peninsula), MCGCP.TOP (Three sections. Top section is Cut-for-glass. Bottom two sections have panels - Top Door), MCGCP.BTM (Three sections Cut-for-glass. Top section is Cut-for-glass. Bottom two sections have panels - Bottom Door), MCGCP.P (Three sections Cut-for-glass. Top section is Cut-for-glass. Bottom two sections have panels - Peninsula), MCP.TOP (Three center panels - Top Door), MCP.BTM (Three center panels - Bottom Door), or MCP.P (Three center panels - Peninsula).

Cabinets can be ordered with Mission Door.

- The upper section of the door will always have a 12" tall section, which includes the width of the upper crossrails and the upper opening.
- Due to the width and height size limitations for Mission Doors, the Authentic Flush End modification may not match the Mission Door configuration specified. The door configuration for Authentic Flush End modification will be the MCP option when achievable (Cut-for-glass is not available), otherwise the door configuration will match the door style of the order. Refer to page H•14 for minimum width and height by style.
- Due to the width and height size limitations for Mission Doors, the Face Frame and Door on End modification may not match the Mission Door configuration specified. The door configuration for Face Frame and Door on End modification will match the Mission option chosen when achievable, otherwise the door configuration will match the door style of the order. Refer to page H•14 for minimum width and height by style.
- If Mission option is selected in conjunction with IPEL or IPER option, the Inset Panel End doors will NOT match the front doors on the cabinet. They will remain standard doors on the Inset Panel End side.
- If Mission option is selected in conjunction with INTGEL or INTGER option, the INTEGRAL doors will NOT match the front doors on the cabinet. They will remain standard doors on the integral side.
- Glass is not included. When ordering glass, three separate pieces of glass in two sizes will be required. Art Glass not available.
- Mission modification is available on Wall cabinets only.
- See Specialty doors for availability.
- When a decorative door option is chosen in 20/20 for MCG or MCGCP, Matching Interior Plywood (MIP) is a preselected option. If MIP is not desired, it can be deselected by choosing NOTMIP.

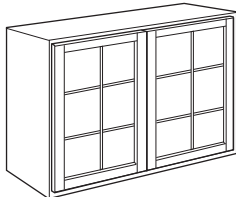

### Mullion Doors

Specify MD (Mullion Door), MD.TOP (Mullion Door Top), MD.MID (Mullion Door Middle), MD.BTM (Mullion Door Bottom), or MD.P (Mullion Door Peninsula)

With this option, doors will feature a mullion cut-out. Clips to attach glass are included. See the Specialty Doors section for style availability and complete ordering information and size limitations.

- Must specify Matching Interior if desired. When a decorative door option is chosen in 20/20, Matching Interior Plywood (MIP) is a preselected option. If MIP is not desired, it can be deselected by choosing NOTMIP.
- Glass is not included.
- Not available on:
  - Burke, Decker, Decker Beaded Inset, Decker Inset, Landry, Tate, Tate Beaded Inset, and Tate Inset.
  - Cabinets with bifold doors, 9" wide cabinets and cabinets less than 15" high or taller than 48" high.

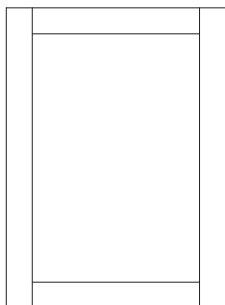

### No Hinge Cut

Specify NHC (No Hinge Cut)

- Available on:
  - DOORONLY.

Specialty Door Modifications (cont'd)

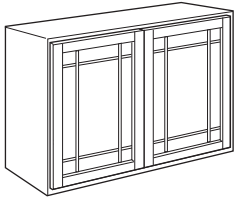

**Prairie Mullion Doors**

Specify PRMD (Prairie Mullion Door), PRMD.TOP (Prairie Mullion Door Top), PRMD.MID (Prairie Mullion Door Middle), PRMD.BTM (Prairie Mullion Door Bottom), or PRMD.P (Prairie Mullion Door Peninsula)

With this option, door will feature a prairie mullion cut-out. Clips to attach glass are included. All doors feature a square door style.

- Must specify Matching Interior if desired. When a decorative door option is chosen in 20/20, Matching Interior Plywood (MIP) is a preselected option. If MIP is not desired, it can be deselected by choosing NOTMIP.
- Glass is not included.
- Not available on:
  - Burke, Decker, Decker Beaded Inset, Decker Inset, Landry, Tate, Tate Beaded Inset, and Tate Inset.
  - Cabinets with bifold doors, 12" wide and 24" wide two door cabinets.

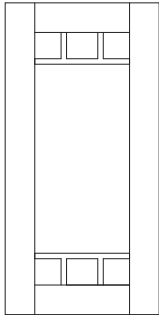

**Shaker Mullion Door**

Specify SHMD (Shaker Mullion Door) door location, SHMD.TOP (top door), SHMD.MID (middle door), SHMD.BTM (bottom door), or SHMD.P (peninsula door)

With this option, doors will feature a mullion cut-out. Clips to attach glass are included. All doors feature a square door style.

- Must specify Matching Interior if desired. When a decorative door option is chosen in 20/20, Matching Interior Plywood (MIP) is a preselected option. If MIP is not desired, it can be deselected by choosing NOTMIP.
- Glass is not included.
- See Specialty doors for availability.

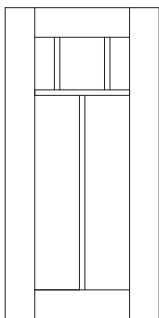

**Summit Mullion Door**

Specify SUMD (Summit Mullion Door) door location, SUMD.TOP (top door), SUMD.MID (middle door), SUMD.BTM (bottom door), or SUMD.P (peninsula door)

With this option, doors will feature a mullion cut-out. Clips to attach glass are included. All doors feature a square door style.

- Must specify Matching Interior if desired. When a decorative door option is chosen in 20/20, Matching Interior Plywood (MIP) is a preselected option. If MIP is not desired, it can be deselected by choosing NOTMIP.
- Glass is not included.
- See Specialty doors for availability.

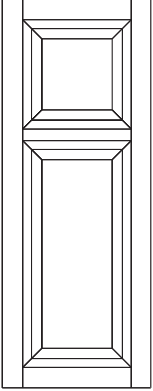

**TCP (Transom with both sections Center Panel)**

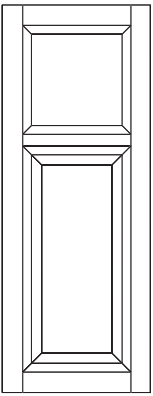

**TCG (Transom with Top Cut-for-glass and Bottom Center Panel)**

### Transom Doors

Specify TCP (Transom with both sections Center Panels),  
TCG (Transom with Top Cut-for-glass and Bottom Center Panel),  
TCPG (Transom with Top Center Panel and Bottom Cut-for-glass),  
TCGCG (Transom with both sections Cut-for-glass),  
TCP.TOP (Transom with both sections Center Panels - Top Door),  
TCG.TOP (Transom with Top Cut-for-glass and Bottom Center Panel - Top Door),  
TCPG.TOP (Transom with Top Center Panel and Bottom Cut-for-glass - Top Door),  
TCGCG.TOP (Transom with both sections Cut-for-glass - Top Door),  
TCP.P (Transom with both sections Center Panels - Peninsula),  
TCG.P (Transom with Top Cut-for-glass and Bottom Center Panel - Peninsula),  
TCPG.P (Transom with Top Center Panel and Bottom Cut-for-glass - Peninsula), or  
TCGCG.P (Transom with both sections Cut-for-glass - Peninsula)

Cabinets can be ordered with Transom Doors. Clips to attach glass are included.

- The upper section of the door will always have a 12" tall section, which includes the width of the upper crossrails and the upper opening.
- Authentic End will always be Transom with both sections Center Panel.
- Face Frame and Door on End option will always match the face.
- Center panel standard on lower section. Cut-for-glass Door option available on lower section.
- When Modified Full Overlay modification is selected in conjunction with Transom, the bottom section of door will decrease in height by 1 inch.
- Glass is not included.
- Available on:
  - Decker, Gordon, Kirby, and Tate.
  - 36", 39", 42", 45" and 48" high doors.
- Transom with Top for Glass and Bottom Center Panel (TCG) not available on:
  - Corner Walls and Wall Message Centers.
- Transom Doors are not available on stacked wall units.
- When a decorative door option is chosen in 20/20 for TCG, TCPG or TCGCG, Matching Interior Plywood (MIP) is a preselected option. If MIP is not desired, it can be deselected by choosing NOTMIP.

## Modifications to Cabinet Box Frame

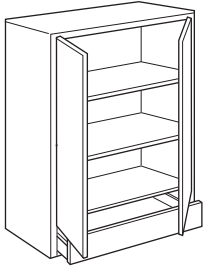

ADRW

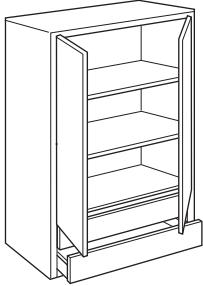

A2DRW

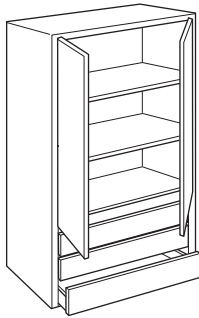

A3DRW

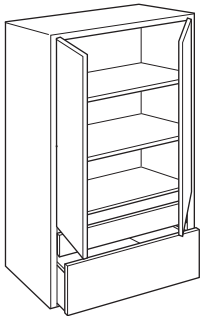

A2DRW18

### Add Drawer Below Wall Unit

Specify ADRW (Add One Drawer Below Wall Unit, increases height by 6"), A2DRW (Add Two Drawers below Wall Unit, increases height by 12"), A3DRW (Add Three Drawers below Wall Unit, increases height by 18"), or A2DRW18 (Add Two Drawers below Wall Unit, increases height by 18")

Most wall cabinets can have full width drawer(s) added below a wall unit. With this option the overall height of the cabinet increases.

- ADRW adds one full width drawer below wall unit, 4 1/4" drawer opening height. The height increases by 6". The maximum cabinet height is 60" before drawers are added. Maximum overall cabinet height is 66".
- A2DRW adds two full width drawers below wall unit, both at 4 1/4" drawer opening heights. The height increases by 12". The maximum cabinet height is 54" before drawers are added. Maximum overall cabinet height is 66".
- A3DRW adds three full width drawers below wall unit, all at 4 1/4" drawer opening heights. The height increases by 18". The maximum cabinet height is 48" before drawers are added. Maximum overall cabinet height is 66".
- A2DRW18 adds one full width drawer with a 4 1/4" drawer opening height and one full width drawer with a 10 1/4" drawer opening height. The height increases by 18". The maximum cabinet height is 48" before drawers are added. Maximum overall cabinet height is 66".
- Maximum cabinet width is 48".
- Inset and Beaded Inset will feature a slab drawer front on the 4 1/4" opening heights with this option.
- Increased or Reduced Depth available in 1/4" increments from 12" to 24".
- Not available on:
  - Peninsula cabinets or in conjunction with Finished Bottom.

### Bottom Valance Rail

Specify BVR (Bottom Valance Rail)\_\_\_\_ and fill in the added height dimension required

The standard 1 1/2" bottom rail on wall cabinets can be increased in 1/4" increments up to an additional 3 1/2".

- Ends and back are extended down with the frame. If desired, field modification is possible.
- The overall height of the cabinet increases by the amount of Bottom Valance Rail specified.
- When Finished Bottom option is selected, additional blocking in field may be required.
- When Bottom Valance Rail is specified in conjunction with Integral Ends, the cross rails on the End Panel will not increase to match the extension.

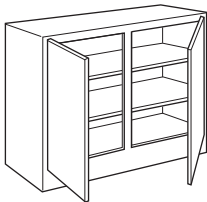

# Custom Modifications

## Modifications to Cabinet Box Frame (cont'd)

---

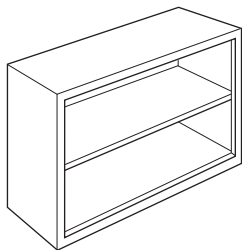

Cabinets less doors - Wall

### Cabinet Box Only

Specify CBO (Cabinet Box Only)

With this option, the doors and/or drawer fronts are removed (no hinge drilling on face frame).

- Complete drawer box and any interior components remain in cabinet.
- Contact Customer Service for more details.

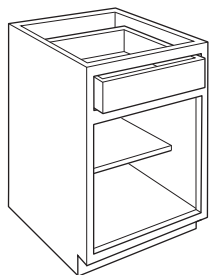

Cabinets less doors and drawers fronts - Base and Vanity

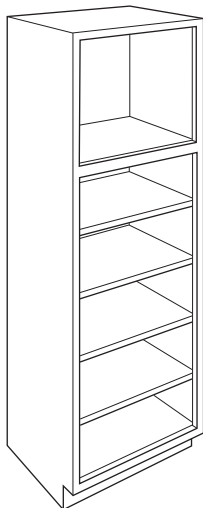

Cabinet less doors - Tall

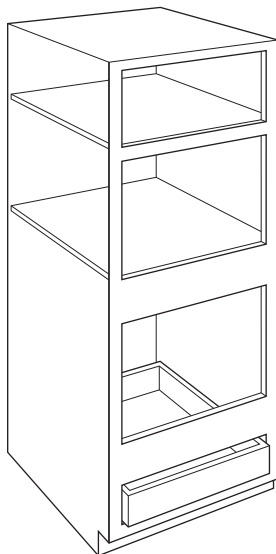

Cabinet less doors and drawer fronts - Tall

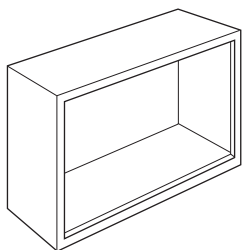

Cabinet case only - Wall

### Cabinet Case Only

Specify CCO (Cabinet Case Only)

With this option, the doors (no hinge drilling on face frame), drawer fronts, hardware and interior components are removed.

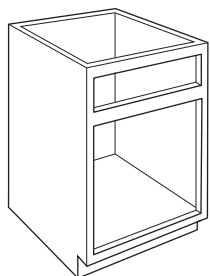

Cabinet case only - Base and Vanity

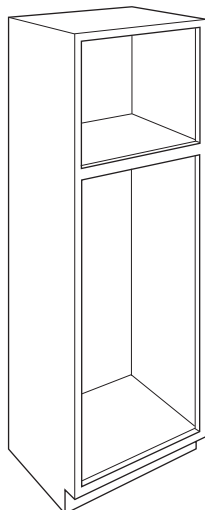

Cabinet case only - Tall

## Modifications to Cabinet Box Frame (cont'd)

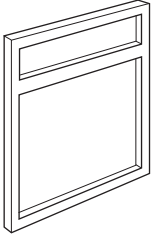

### Cabinet Frame Only

Specify CFRMO (Cabinet Frame Only)

With this option, the cabinet, doors, hinges, drawers, and drawer fronts are removed.

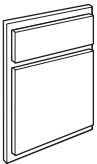

### Cabinet Front Only

Specify CFNTO (Cabinet Front Only)

The top and bottom edges of the frame are not available in finished quality. While the vertical edges are finished, the standard groove to accept the 1/2" end panel is on the back vertical edge of all Face Frames and Doors.

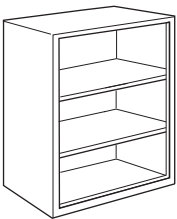

### Cabinet No Door

Specify CND (Cabinet No Door), CND.TOP (Cabinet No Door Top), CND.MID (Cabinet No Door Middle), CND.BTM (Cabinet No Door Bottom), or CND.P (Cabinet No Door Peninsula)

Cabinets can be ordered without doors (no hinge drilling on face frame). The interior of the cabinet is Natural unless a Matching Interior is specified.

- Complete drawer box and any interior components remain in cabinet.
- Hinges are not included.
- Openings larger than 36" wide will have center face frame mullion.

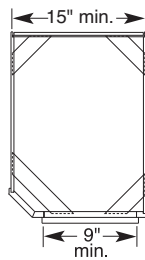
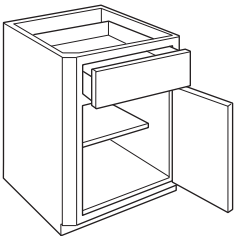

### 3" Clipped Corner

Specify CLIP3L (Clipped Left Corner), CLIP3R (Clipped Right Corner), CLIP3L.P (Clipped Left Corner Peninsula), or CLIP3R.P (Clipped Right Corner Peninsula)

Many cabinets can be ordered with either the left or right front corners of the face frame clipped at a 45° angle. The Clipped Corner side end panel is set back 3" by the clip. The size of the face frame opening is reduced by 3" with one clip. The overall width of the cabinet does not change.

- The Clipped Corners are available with fluting, but this must be specified.
- Minimum face frame opening is 9" after Clipped Corner option is applied.
- Minimum depth of cabinet is 9".
- When cabinet is clipped to 21" opening, specify one or two doors.
- Not available on:
  - Face Frame and Door on End, Extended Stiles, Inset Panel Ends, or Wide Stiles are not available on same side as the Clipped Corner.

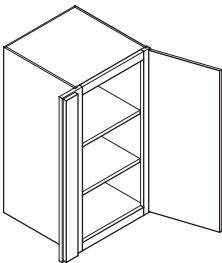

### Extended Stile with Overlay

Specify EXLLOL (Extended Left Stile with Overlay), EXROL (Extended Right Stile with Overlay), EXBOL (Extended Left and Right Stiles with Overlay), EXLLOL.P (Extended Left Stile with Overlay Peninsula Side), EXROL.P (Extended Right Stile with Overlay Peninsula Side), or EXBOL.P (Extended Left and Right Stiles with Overlay Peninsula Side)

Cabinets can be ordered with Extended Stiles of 3" that include a 2 9/16" profiled overlay. The overlay is sent loose for field trimming.

- Overlays cannot be fluted.
- When ordered with #18 profile, #14 profile will be used.
- Not available:
  - Inset and Beaded Inset Door styles.

# Custom Modifications

## Modifications to Cabinet Box Frame (cont'd)

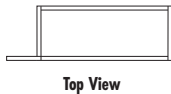
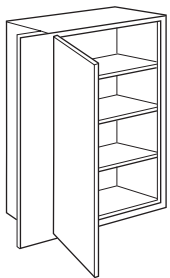

### Extended Stiles

Specify EXL (Extended Left Stile), EXR (Extended Right Stile), EXR.P (Extended Right Stile Peninsula Side), or EXL.P (Extended Left Stile Peninsula Side) and fill in the added dimension required

To eliminate the need for fillers, cabinets can be ordered with Extended Stiles. Two options are available when ordering Extended Stiles: 1/8" only or 1/4" increments up to an additional 3".

- When the cabinet has doors, Flute option available on 3" Extended Stiles only.
- 1/8" EXL and/or EXR options recommended on cabinets with #12 profile selected when the adjacent cabinets are ordered with altered depths or next to a fixed wall. See page D•1 for details. Applies to Full Overlay only.
- Not available on:
  - The angled end of any angled frame cabinet or clipped corner ends.

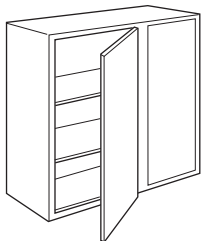

### Finished Blind

Specify FBFL (Finished Blind Left) or FBFR (Finished Blind Right)

The blind section of a square corner wall or blind corner base can be filled in to appear as a solid section.

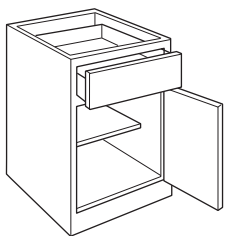

FTK

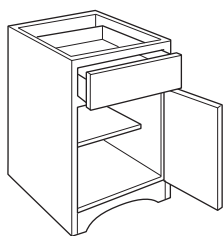

FTKAV

### Flush Toekick

Specify FTK (Flush Toekick), FTKAV (Flush Toekick - Arch), FTK.P (Flush Toekick - Peninsula), or FTKAV.P (Flush Toekick - Arch Peninsula)

The recessed toe space on base cabinets can be eliminated by extending the face frame down with the end panels.

- When Flush Toekick is selected for wall cabinets, it increases the overall height of the wall cabinet by 4 1/2". It is not necessary to pick both Add Toekick and Flush Toekick to get this look on walls. All doors feature a square door style to match other base cabinets on order.
- Frame opening width on Flush Toekick - Arch: minimum: 12", maximum: 57".

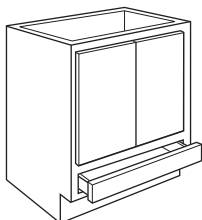

### Inverted Frame

Specify INVFRM (Inverted Frame)

Base and 48" to 60" Diagonal Wall cabinets can be ordered with the face frame openings inverted. The Inverted Frame option applies only to an actual exchanging of opening locations, not a re-sizing of any opening. Drawer openings relocated to the bottom of a base must always be a working drawer.

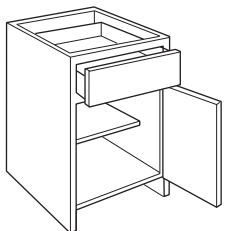

### Open Bottom Rail Base

Specify OBRB (Open Bottom Rail Base)

With this option, the sub-toekick on base and tall cabinets is eliminated and the stiles are extended down 4 1/2", which is the standard toekick height.

- When Open Bottom Rail Base is selected for wall cabinets, it increases the overall height of the wall cabinet by 4 1/2".
- Available in place of Flush Toekick on office units with the open area remaining 3 1/2".
- Maximum frame opening width is 57".

## Modifications to Cabinet Box Frame (cont'd)

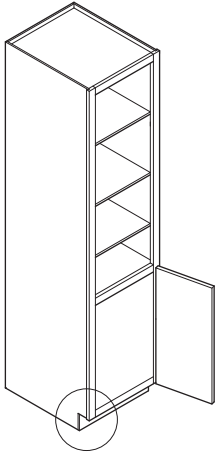

### Recessed Toe Kick Front

Specify RECTKFRT (Recess Toe Kick Front)

With this option, the toe kick area is recessed in the front only.

- Available on:
  - Tall Bookcases (T\_BCAV, TD\_BCAV, and TDV\_BCAV). See pages 0•29-0•40.

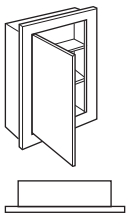

Top View

### Recessed Vanity Wall

Specify REC (Recessed Vanity Wall)

With this option, the standard vanity wall cabinet construction will change to match the construction of the Recessed Vanity Wall cabinets.

- Available on:
  - Vanity Wall Cabinets (W\_ \_ \_ \_ 4) only. See pages P•3-P•4.

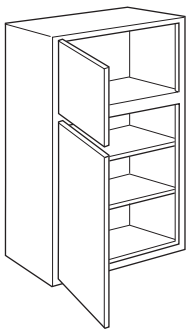

### Stacked Wall Cabinet Heights

Specify STW.TOP\_ (Stacked Wall Top) or STW.BTM\_ (Stacked Wall Bottom)

Stacked wall cabinets can be ordered with different top and bottom “cabinet” heights as long as the total height of the cabinet remains constant. For example, an STW2748 has a top cabinet height of 18” and a bottom cabinet height of 30”, stacked as one cabinet. This option will allow flexibility by specifying STW.TOP 12” and STW.BTM 36”, where the total height still adds up to 48”.

When used in conjunction with the increased/reduced height modification, the specified increase/reduction in height will be applied to the bottom cabinet, in addition to, or as a reduction of, the height specified by the STW.BTM modification. The top cabinet height will remain as specified by the STW.TOP modification.

- The minimum height of the top/bottom cabinet is 12”.

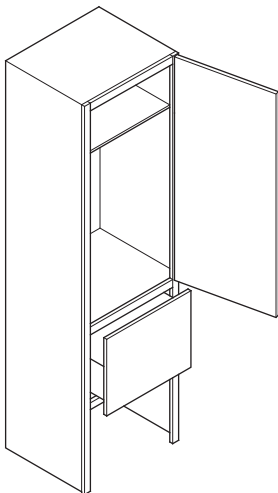

### Storage Open Rail Base

Specify STORB (Storage Open Rail Base)

With this option, the 4 1/2” sub-toe kick on base and tall cabinets is eliminated and the face frame stiles, end panels, and back are extended down the amount specified.

- This option is available in 1/4” increments from 4 3/4” to 18”.
  - Example: When selecting an EET1878 L or R with the STORB modification of 18”, the overall cabinet height will be 91.5”. (i.e. 78-4.5+18=91.5)
- See individual cabinets in the Office and Furniture Cabinets section for availability.



# Custom Modifications

## Modifications to Cabinet Box Frame (cont'd)

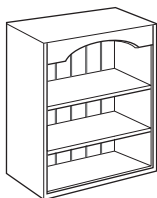

### Top Valance Rail

Specify TVRAV (Top Valance Rail - Arch), TVRAVTOP (Top Valance Rail - Arch - Top), TVRAVMID (Top Valance Rail - Arch - Middle), TVRAVBTM (Top Valance Rail - Arch - Bottom), TVRAV.P (Top Valance Rail - Arch - Peninsula), TVRVV (Top Valance Rail - Straight), TVRVVTOP (Top Valance Rail - Straight - Top), TVRVVMID (Top Valance Rail - Straight - Middle), TVRVVBTM (Top Valance Rail - Straight - Bottom), TVRVV.P (Top Valance Rail - Straight - Peninsula)

Cabinets with frame openings of 12" or more can be ordered with an Arch valance in place of the standard top rail when the Cabinet No Door option is chosen. The Straight top valance rail is available on most cabinets regardless of the width of the frame opening.

- Must specify Matching Interior, if desired.
- Arch not available in Beaded Inset Styles.
- Not available on:
  - Cabinets over 39" wide or units with the Split Doors option.

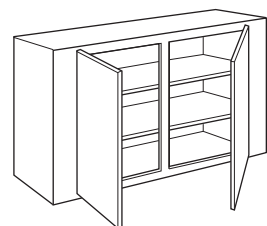

### Wide Stiles

Specify WSL1.5 (Wide Stile Left 1.5"), WSR1.5 (Wide Stile Right 1.5"), WSB1.5 (Wide Stile Left & Right 1.5"), WSL1.5.P (Wide Stile Left Peninsula 1.5"), WSR1.5.P (Wide Stile Right Peninsula 1.5"), WSB1.5.P (Wide Stile Left & Right Peninsula 1.5"), WSL3 (Wide Stile Left 3"), WSR3 (Wide Stile Right 3"), WSB3 (Wide Stile Left & Right 3"), WSL3.P (Wide Stile Left Peninsula 3"), WSR3.P (Wide Stile Right Peninsula 3"), or WSB3.P (Wide Stile Left & Right Peninsula 3")

Wide Stiles can be ordered in 1 1/2" and 3" increments. The Wide Stile 1 1/2" option increases the stile size to 3" overall. The Wide Stile 3" option increases the stile to a total of 4 1/2" wide. The overall back width of the cabinet does not change with this option. The face frame opening is reduced.

- On units with doors and/or drawers, only the Wide Stile 3" can be fluted. On units without doors, the Wide Stile 1 1/2" can be fluted utilizing the standard 1 1/2" end rail as part of the fluting location.
- Not available on:
  - Clipped Corner.

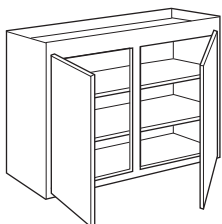

### Wide Top Rail

Specify WTR (Wide Top Rail)\_\_\_\_ and fill in the added height dimension required

Most cabinets can have the standard 1 1/2" top rail increased in 1/4" increments up to an additional 3 1/2". Cabinet height increases by the dimension given.

- Ends and backs are extended up with frame. If desired, field modification is possible.
- When Wide Top Rail is specified in conjunction with Integral Ends, the cross rails on the End Panel will not increase to match the extension.
- Authentic Ends are recommended, door size will not increase when Wide Top Rail (WTR) is specified.
- Not available on:
  - 96" high cabinets with Flush Toekick.

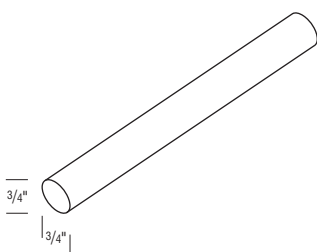

### Nickel Towel Bar

TBN

For use with BCTOS and BCTT units only.

## Modifications to Ends

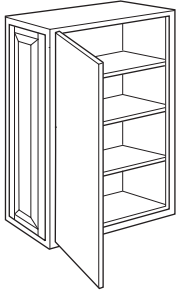

### Authentic Flush End

Specify AUTHL (Authentic Flush Left), AUTHR (Authentic Flush Right), or AUTHB (Authentic Flush Left and Right)

Authentic Flush Ends are available on most cabinets where the look of a working door on the end is desired. The fixed door panel is applied to a finished flush end. Base cabinets have a full height door applied over a finished flush end.

- Finished Flush Ends (5/8" thick) standard on Authentic Ends.
- On base or tall cabinets, Recessed Toekick must be specified if desired.
- If cabinet is over 24" deep, two doors will be applied to end.
- See individual cabinets for availability.
- Not available on:
  - Inset and Beaded Inset Door Styles.
  - Cabinet backs, and on same side as an Extended Stile.

Minimum Cabinet Depth for Authentic Ends	Non-Peninsula	Peninsula
Gordon, Kirby, Landry, Shanley	8"	8"
Burke, Decker, Tate, Vinson	8 1/2"	8 1/2"

Minimum Cabinet Depth for 3" Clipped Corners	Non-Peninsula	Peninsula	Front & Back
Gordon, Kirby, Landry, Shanley	11"	11"	14"
Burke, Decker, Tate, Vinson	11 1/2"	11 1/2"	14 1/2"

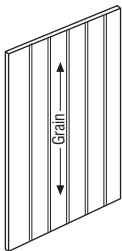

### Car Siding Flush Panel End

Specify CSFPEL (Car Siding Flush Panel Left End) or CSFPER (Car Siding Flush Panel Right End)

Cabinets can be ordered with a 5/8" finished veneer end panel to achieve a car siding flush panel end appearance.

- Finished End standard on Car Siding Flush Panel End.
- See individual cabinets for availability.

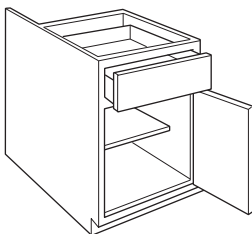
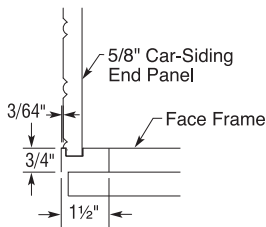

### End Extended Back

Specify EXBKL (End Extended Back Left) or EXBKR (End Extended Back Right) and fill in the amount to be extended

The end panel can be extended back in 1/4" increments up to an additional 12". Finished End must be specified if desired.

- End treatment must be specified (i.e. FL, AUTHL, etc.).
- See individual cabinets for availability.

# Custom Modifications

## Modifications to Ends (cont'd)

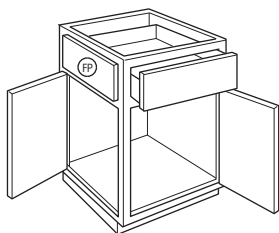

FP False Panel

### Face Frame and Door on End

Specify FFDR.HL (Face Frame and Door on Right End – Hinge Left),  
FFDR.HR (Face Frame and Door on Right End – Hinge Right),  
FFDR.HL.FH (Full Height Face Frame and Door on Right End – Hinge Left),  
FFDR.HR.FH (Full Height Face Frame and Door on Right End – Hinge Right),  
FFDL.HL (Face Frame and Door on Left End – Hinge Left),  
FFDL.HR (Face Frame and Door on Left End – Hinge Right),  
FFDL.HL.FH (Full Height Face Frame and Door on Left End – Hinge Left), or  
FFDL.HR.FH (Full Height Face Frame and Door on Left End – Hinge Right)

When a working door is desired on the end of a cabinet, specify Face Frame and Door on End.

- When Face Frame and Door on End is selected on base and tall cabinets, Recessed Toekick is standard.
- If the Flush Toekick option is selected, then all sides of cabinet will be Flush Toekick.
- Not available on:
  - Inset and Beaded Inset Door Styles.
  - Both cabinet ends or cabinets with End Extended Back.
  - Peninsula cabinets.
- See individual cabinets for availability.

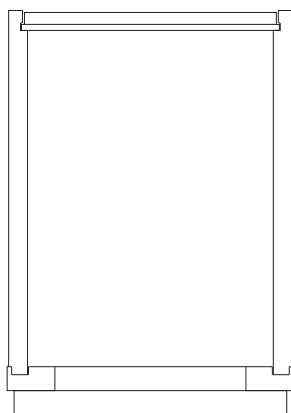

Top View

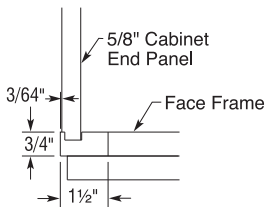

### Flush Panel End

Specify FPFL (Flush Left End) or FPER (Flush Right End)

- Cabinets can be ordered with a 5/8" finished veneer end panel to achieve a Flush Panel End appearance.
- Finished End standard on Flush Panel End. The other side is unfinished unless a finished end is specified.
  - See individual cabinets for availability.

Modifications to Ends (cont'd)

**Inset Panel Ends**

Specify IPEL (Inset Panel End Left) or IPER (Inset Panel End Right)

With this option, the current end panel is replaced with a frame and door that is then applied to a 3/8" end panel.

- Cabinets deeper than 24" will have two butt doors.
- Minimum cabinet depth is 9". Maximum cabinet depth is 30".
- Minimum cabinet height is 12". Maximum cabinet height is 96".
- Cabinets less than 12" deep will utilize a slab door.
- Cabinets with a toekick (Base, Vanity, Office, and Tall Cabinets, as well as Wall Cabinets with ADDTK) will include a Flush Toekick with a notch on the inset panel end frame.
- When Wide Top Rail (WTR) and Bottom Valance Rail (BVR\_) is selected the frame on the inset panel end will also have the modification applied.
- Available on:
  - Inset and Beaded Inset door styles only.
- Not available with:
  - Aluminum Frame Doors, Modified Full Overlay, End Extended Back, Face Frame and Door on End, Glass Shelf Kits, Wall End & Back Extended Down, or 3" Clipped Corners.

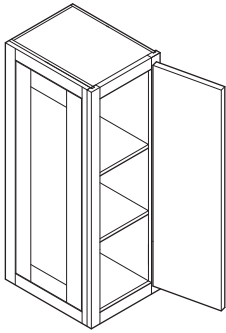

Wall

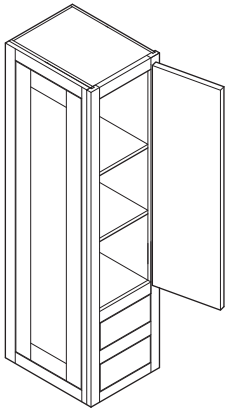

Wall with Added Drawer

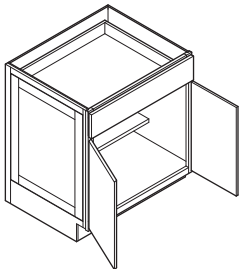

Base

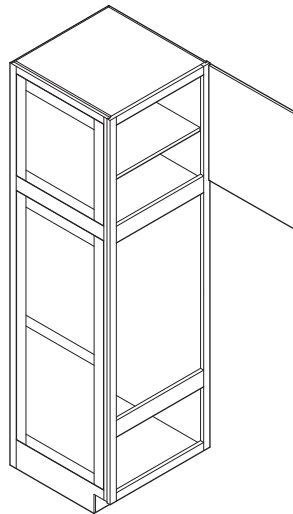

Tall Oven

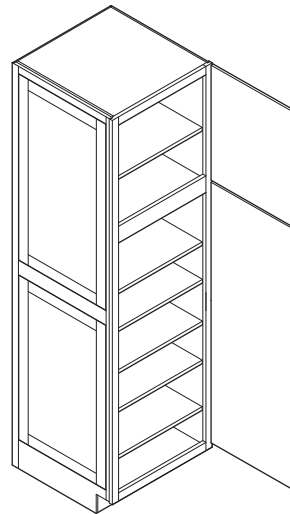

Utility

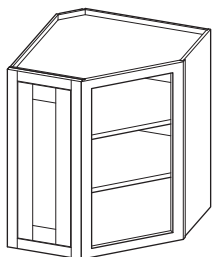
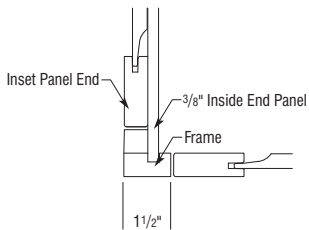

Diagonal

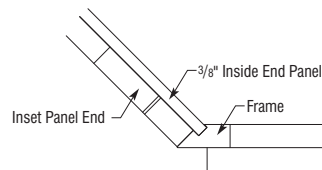

# Custom Modifications

## Modifications to Ends (cont'd)

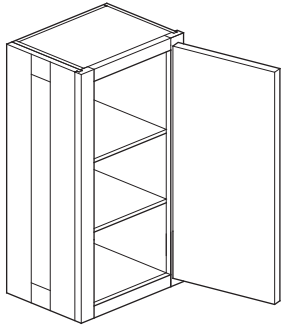

Wall

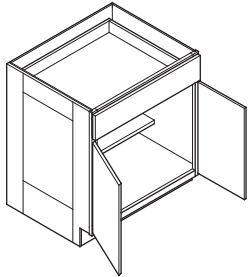

Base

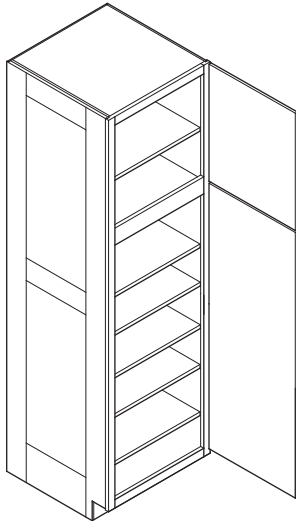

Tall

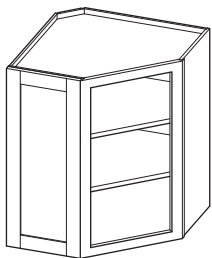
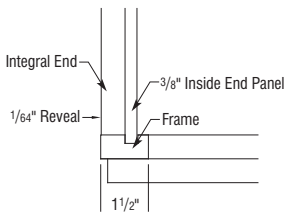

Diagonal

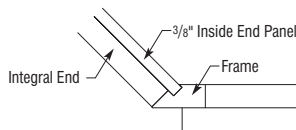

### Integral End

Specify INTGEL (Integral End Left) or INTGER (Integral End Right)

Integral Ends are available on most cabinets where the look of a furniture end is desired. Integral Ends will closely match the door style specified on the order.

- Outside profile will be #12 regardless of door profile.
- On wall cabinets, all rails and stiles are sized to match the selected door styles.
- On base, vanity, and tall cabinets, the bottom rail is always 7" high. Gordon, Kirby, Landry, and Shanley utilize 3 1/2" rails and stiles. Decker utilizes 4" rails and stiles.
- Cabinets over 48" will always have 2 equally sized panels in height.
- Cabinets deeper than 24" will have double wide panels.
- Minimum wall cabinet depth is 9".
- Minimum base cabinet depth is 12".
- Minimum cabinet height is 18".
- Not available in conjunction with: Face Frame and Door on End, Glass Shelf Kits, Add Toekick, Toekick Drawer, Toekick Pedestal and Clipped Corner.
- 96" tall cabinets will have Attached Toekick standard. 96" tall cabinets not available with Wide Top Rail.
- When Bottom Valance Rail, Modified Full Overlay or Wide Top Rail is selected in conjunction with Integral End, the cross rail on the Integral End will not increase to match the extension.
- The maximum cut-out for oven cabinets is 3" less than the cabinet width.
- Only available on the following Full Overlay styles:
  - Decker, Gordon, Kirby, Landry, and Shanley.

## Modifications to Ends (cont'd)

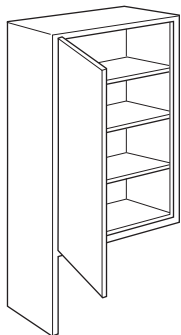

### Wall End and Back Extended Down

Specify EXDNL\_\_ (Wall End Extended Down Left) or EXDNR\_\_ (Wall End Extended Down Right) and fill in the amount to be extended  
Specify EXDNLRB\_\_ (Back Extended Down) when both right and left ends are extended down and fill in the amount to be extended

The end panel and attached face frame rail can be extended down in 1/4" increments up to an additional 24". When one or both ends are extended down, the interior of the extended ends is skinned to match the cabinet exterior.

- If both the ends and the back are extended down, the cabinet must be Matching Interior.
- When ordering a cabinet with Bottom Valance Rail in conjunction with End Extended Down, overall cabinet height is standard height plus Bottom Valance Rail plus Extended Down.
- Not available on:
  - Cabinets with Face Frame and Door on End and Inset Panel Ends.

## Modifications to Toekicks

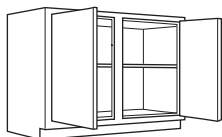

### Add Toekick

Specify ADDTK (Add Toekick)

Wall cabinets can be ordered with a 4 1/2" high recessed toekick added. The overall height of the cabinet increases by 4 1/2". All doors feature a square door style to match other base cabinets on order.

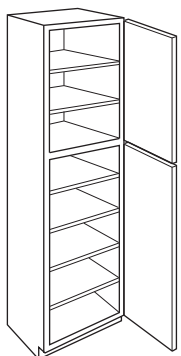

### Attach Toekick

Specify ATTTK (Attach Toekick)

For 96" cabinets only, specify Attach Toekick if toekick is desired.

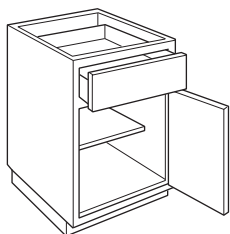

### Recessed Toekick

Specify RECTKL (Recessed Left End), RECTKR (Recessed Right End), RECTKBK (Recessed Back), RECTKL.R (Recessed Left and Right Ends), RECTL.BK (Recessed Left and Back Ends), RECTKR.BK (Recessed Right and Back Ends), RECTKL.R.BK (Recessed Left, Right and Back Ends), or RECTKALL (Recessed All Ends)

Cabinets with a toekick are available with recessed toekick on ends and/or back.

- Recessed Toekick standard when Face Frame and Door on End is ordered.
- Not available when:
  - Units with Flush Toekick, Open Bottom Rail Base or Toekick Drawer is specified.

# Custom Modifications

## Modifications to Toekicks (cont'd)

---

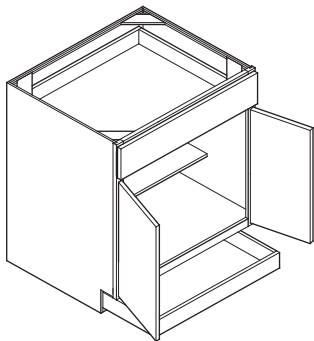

### Toekick Drawer

Specify DRWTK (Toekick Drawer)

Cabinets with toekicks are available with a toekick drawer.

- Toekick drawer is push to open.
- Front is unfinished, allow enough toe skin to cover front.
- Available in:
  - 1/4" widths from 12" to 36"
  - 21" and 24" deep
  - Cabinets less than 15" wide
- Not available on:
  - Units with Clipped Corners, Increased or Reduced Depths, Modified Bottom Rails, Modified Toekick, and Inset Panel Ends.
  - Smart Stop is standard.

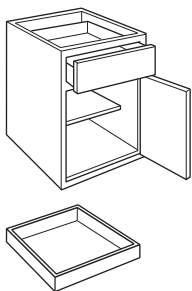

### Toekick Pedestal

Specify TKP (Toekick Pedestal)

Specify Toekick Pedestal if toekick unattached from cabinet is desired.

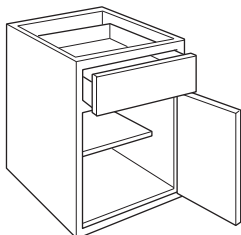

### Void Toekick

Specify VTK (Void Toekick)

To reduce the height of the cabinet by 4 1/2" and remove the Recessed Toekick.

## Modifications to Drawers and Roll Trays

---

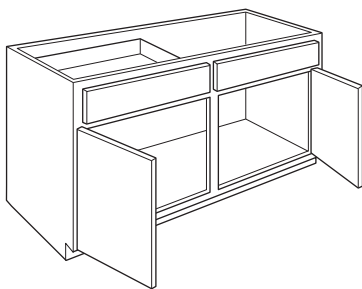

### Cabinet False Panel

Specify CFP (Cabinet False Panel), CFPL (Cabinet False Panel Left), CFPR (Cabinet False Panel Right), or CFPB (Cabinet False Panel Both)

Base and vanity cabinets with two side-by-side working drawers can be ordered with cabinet false panels in place of the working drawers.

- Available on:
  - 24" to 39" wide two drawer cabinets

## Modifications to Drawers and Roll Trays (cont'd)

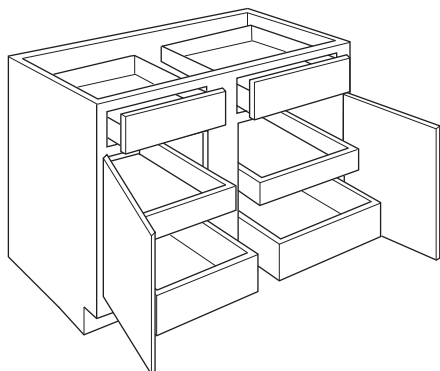

### Deep Roll Trays

#### Specify DRT (Deep Roll Tray)

Modification upgrades bottom roll tray only on base cabinets and bottom 2 roll trays on utility cabinets.

- Modification available on standard roll tray cabinets only.
- Largest single full width roll tray is available on a 36" wide cabinet with increased width up to 38 3/4".
- Available on:
  - 12" to 24" deep cabinets in 3" increments
  - 12" to 48" wide cabinets in 1/4" increments
- Not available on:
  - Units with Face Frame and Door on End.
  - Peninsula cabinets.

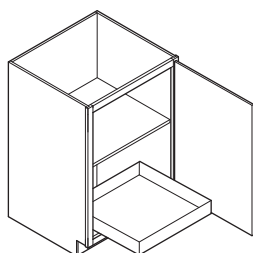

### Roll Tray Bottom with Full Depth Shelf

#### Specify FDSRTBTM (Installed Roll Tray Bottom with Full Depth Shelf)

With this option, a Roll Tray is installed in the bottom of cabinet with a full depth shelf in base cabinets.

- Available on Base Cabinets with Full Height Doors which have a standard full depth shelf.
- Available on Base Cabinets, Base Cabinets with Bread Board, and Base Cabinets with Wood Tiered Cutlery Divider which have a standard half depth shelf that will be replaced with an adjustable full depth shelf.
- Largest single full width roll tray is available on a 39" wide cabinet. 39 1/4" or wider cabinet width will include split doors and a roll tray on both the left and right side of the cabinet.
- Available on:
  - 12" to 24" deep cabinets - roll tray will be in 3" increments
  - 12" to 48" wide cabinets - roll tray will be in 1/4" increments
- Roll Tray width will adjust with cabinet width.
- Not available on:
  - Units with Face Frame and Door on End or Peninsula Cabinets.

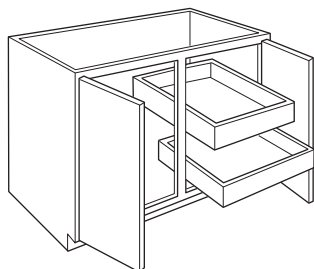

### Roll Trays

Specify \_RT (Installed Roll Tray), \_RTBTM (Installed Roll Tray - Bottom), \_RTLBTM (Installed Roll Tray - Left - Bottom), \_RTRBTM (Installed Roll Tray - Right - Bottom), \_RTL (Installed Roll Tray - Left), \_RTMID (Installed Roll Tray - Middle), \_RTLMID (Installed Roll Tray - Left - Middle), \_RTRMID (Installed Roll Tray - Right - Middle), \_RTR (Installed Roll Tray - Right), \_RTTOP (Installed Roll Tray - Top), \_RTLTOP (Installed Roll Tray - Left - Top), or \_RTRTOP (Installed Roll Tray - Right - Top)

With this option, Roll Trays are installed in the cabinet.

- Roll tray width will adjust with cabinet width.
- Roll Tray option substitutes pull-out for standard shelf.
- Largest single full width roll tray is available on a 36" wide cabinet with increased or reduced width up to 38 3/4".
- Specify the number of roll trays between 1 and 5.
- Available on:
  - 12" to 24" deep cabinets - roll tray will be in 3" increments
  - 12" to 48" wide cabinets - roll tray will be in 1/4" increments
- Not available on:
  - Units with Face Frame and Door on End.
  - Peninsula cabinets.



# Custom Modifications

## Modifications to Drawers and Roll Trays (cont'd)

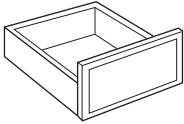

### Scooped Drawer

Specify SCPDRW, SCPDRWL (Scooped Drawer Left), SCPDRWR (Scooped Drawer Right), or SCPDRWB (Scooped Drawer Both)

Cabinets with drawers can be ordered with the top drawer box height reduced to 2" to allow for clearance of cooktops, etc.

- Only top drawer is modified when specified on drawer base units.

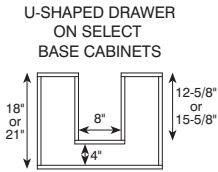

### U-shaped Drawer Box

Specify UDBX

- Available on cabinet depths of 21" to 24" in 1/4" increments (18" or 21" box depth).
- Minimum opening width is 21".
- Maximum opening width is 45".
- 8" and 4" dimensions of U-shape stays constant for all drawer box sizes, the legs of U-shape are either 12 5/8" or 15 5/8".
- Available in conjunction with Scooped Drawer.
- Not available with: Any drawer insert or pull-out (CIW, BB, WTCD, etc.).
- Available on the following models:
  - The 1, 2, 3, 4 in the modification code refer to the location of drawer box in cabinet and all drawers above that location will be affected.
  - On a 4DB model, if the request is to have to top be a dummy and a U-shape in the #2, order CPP plus UDBX2.

Model Description	Model Names	Modification Code	Modification Meaning
Base/vanity models with full width drawer at top	B24 L or R - B39 B24RT L or R - B36RT B24P L or R - B39P VB243221 L or R - VB393221 VB243421 L or R - VB393421	UDBX	U-shaped drawer box
Base models with two side by side top drawers, specify left, right or both	B48, B48RT, B48P VB483221 VB483421	UDBXL UDBXR UDBXB	U-shaped drawer box left U-shaped drawer box right U-shaped drawer box left & right
Base models with two drawers, specify top only or both	B2D24 L or R - B2D36 B2D24RT - B2D36RT	UDBX1 UDBX2	U-shaped drawer box #1 location U-shaped drawer box #1 and #2 location
Base models with four split drawers, specify top left, top & 2nd left, top right, top & 2nd right, top left & top right, all	B4D48 B4D48RT	UDBX1L UDBX2L UDBX1R UDBX2R UDBX1B UDBX2B	U-shaped drawer box #1 location left U-shaped drawer box #1 and #2 location left U-shaped drawer box #1 location right U-shaped drawer box #1 and #2 location right U-shaped drawer box #1 location left & right U-shaped drawer box #1 and #2 location left & right
3DB models, specify top drawer only, top & 2nd only, all	3DB24 - 3DB42 VDB243221 - VDB363221 VDB243421 - VDB363421	UDBX1 UDBX2 UDBX3	U-shaped drawer box #1 location U-shaped drawer box #1 and #2 location U-shaped drawer box #1, #2 and #3 location
4DB models, specify top drawer only, top & 2nd only, top, 2nd & third only, all	4DB24 - 4DB42 4VDB123221 - 4VDB363221 4VDB123421 - 4VDB363421	UDBX1 UDBX2 UDBX3 UDBX4	U-shaped drawer box #1 location U-shaped drawer box #1 and #2 location U-shaped drawer box #1, #2 and #3 location U-shaped drawer box #1, #2, #3 and #4 location
2DB 28.5" high, specify top only or both	2DB2428 - 2DB3628	UDBX1 UDBX2	U-shaped drawer box #1 location U-shaped drawer box #1 and #2 location
Base Pots & Pans	BPPP24 L or R, BPPP24, BPPP30	UDBX	U-shaped drawer box
Base Pots & Pans Storage	B24PS, B30PS, B36PS	UDBX	U-shaped drawer box
Base Lid Organizer	B30RTLO - B36RTLO	UDBX	U-shaped drawer box
Base w/Food Storage Container Organizer	B24FSCO L or R	UDBX	U-shaped drawer box
2 Drawer Drop-in Range Base, specify top only, both	2DB30DR, 2DB36DR	UDBX1 UDBX2	U-shaped drawer box #1 location U-shaped drawer box #1 and #2 location

Modifications to Drawers and Roll Trays (cont'd)

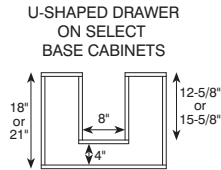

U-shaped Roll Tray

Specify URT

- Available on cabinet depths of 21" to 24" in 1/4" increments (18" or 21" box depth).
- Minimum opening width is 21". Minimum opening width on inset cabinet is 24".
- Maximum opening width is 33".
- Dimensions of U-shape stays constant for all roll tray sizes.
- Available in conjunction with Deep Roll Tray option.
- Modification will upgrade all roll trays in cabinet.

Model Description	Model Names	Modification Code	Modification Meaning
Base models w/roll trays	B24RT L or R - B36RT	URT	Both roll trays U-shape
Base models w/roll trays and with two side by side top drawers	B48RT	URTL URTR URTB	Both roll trays on left U-shape Both roll trays on right U-shape Both roll trays on left & right U-shape
Base models w/roll tray and with two drawers	B2D24RT L or R - B2D36RT	URT	Roll tray U-shape
Base models w/roll tray and with four split drawers	B4D48RT	URTL URTR URTB	Roll tray on left U-shape Roll tray on right U-shape Roll tray on left & right U-shape

- Available on roll trays added as an accessory to the following cabinets. Specify the number of U-shaped roll tray between 1 to 5.

Model Description	Model Names	Modification Code	Modification Meaning
Base Cabinet w/Full Height Doors	B24FH L or R - B36FH, B24FH	URT_	# of U-shaped roll trays added
Sink and Range Base Cabinet	SB24 L or R - SB36, SB24	URT_	# of U-shaped roll trays added
Sink and Range Base Cabinet w/Tilt-out Tray	SB24ST L or R - SB36ST, SB24ST	URT_	# of U-shaped roll trays added
Country Sink Base Cabinet	CNTYSB30 - CNTYSB36	URT_	# of U-shaped roll trays added
Vanity Base Cabinet	VB243221 L or R - VB363221, VB243221 VB243421 L or R - VB363421, VB243421	URT_	# of U-shaped roll trays added
Vanity Base Cabinet w/Full Height Door	V243221S L or R - V363221S, V243221S V243421S L or R - V363421S, V243421S	URT_	# of U-shaped roll trays added
Vanity Sink Base Cabinet	VSB243221 L or R - VSB363221, VSB243221 VSB243421 L or R - VSB363421, VSB243421	URT_	# of U-shaped roll trays added

# Custom Modifications

## Modifications to Wood Tops

---

### Ordering Information

To clip **ONE** corner, please specify:

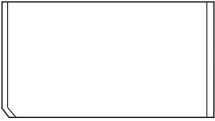

Clip Left WTCLIP3L or WTCLIP6L

**OR**



Clip Right WTCLIP3R or WTCLIP6R

To clip **TWO** corners, please specify:



Clip Left and Right WTCLIP3B or WTCLIP6B

**OR**



Clip Left Sides WTCLIP3LFRT.LBK or WTCLIP6LFRT.LBK

**OR**



Clip Right Sides WTCLIP3RFRT.RBK or WTCLIP6RFRT.RBK

### Clipped Corner Wood Tops

Specify WTCLIP3L (Wood Top Clipped Corner Left), WTCLIP3R (Wood Top Clipped Corner Right), WTCLIP3B (Wood Top Clipped Corner Left & Right), WTCLIP3LFRT.LBK (Wood Top Clipped Corner Left Front & Left Back), WTCLIP3RFRT.RBK (Wood Top Clipped Corner Right Front & Right Back), WTCLIP6L (Wood Top Clipped Corner 6" Left), WTCLIP6R (Wood Top Clipped Corner 6" Right), WTCLIP6B (Wood Top Clipped Corner 6" Left & Right), WTCLIP6LFRT.LBK (Wood Top Clipped Corner 6" Left Front & Left Back), or WTCLIP6RFRT.RBK (Wood Top Clipped Corner 6" Right Front & Right Back)

Wood tops may be ordered with up to two corners "clipped" at a 45° angle. The clipped corner on wood tops will match the clipped corners offered as a cabinet frame modification available in a 3" x 3" clip and 6" x 6" clip. When ordering a Clipped Corner Wood Top, all information as listed under wood top section must be specified, as well as the location of the clipped corners (see ordering information). The wood top is limited to a maximum depth of 48" and maximum length of 96", including the length of the clipped corners.

- All available clipped options shown in drawings.

## Modifications to Wood Tops (cont'd)



**MLDG.FRT (Moulding Front)**



**MLDG.FRT.BK (Moulding Front & Back)**



**MLDG.FRT.L (Moulding Front & Left)**



**MLDG.FRT.L.BK (Moulding Front, Left & Back)**



**MLDG.FRT.L.R (Moulding Front, Left & Right)**



**MLDG.FRT.R (Moulding Front & Right)**



**MLDG.FRT.R.BK (Moulding Front, Right & Back)**



**MLDG.L.R (Moulding Left & Right)**



**MLDG.ALL (Moulding All)**

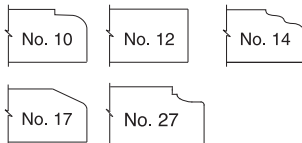

### Moulding Location

Specify MLDG.FRT (Moulding Front), MLDG.FRT.BK (Moulding Front & Back), MLDG.FRT.L (Moulding Front & Left), MLDG.FRT.L.BK (Moulding Front, Left & Back), MLDG.FRT.L.R (Moulding Front, Left & Right), MLDG.FRT.R (Moulding Front & Right), MLDG.FRT.R.BK (Moulding Front, Right & Back), MLDG.L.R (Moulding Left & Right), MLDG.ALL (Moulding All), or NOMLDG (No Moulding)

With this option, moulding is added to specified location.

- Edge profile will match door profile selected (#10, #12, #14, #17, #27).
- Glazes and/or Techniques available: F, HW, XHW.

#### Glazes and Techniques

**F** = Flooded (see page E•3.)  
**P** = Penned (see page E•3.)  
**TW** = Timeworn (see page E•3.)  
**XTW** = Extra Timeworn (see page E•3.)  
**HW** = Hewn (see page E•3.)  
**XHW** = Extra Hewn (see page E•3.)

# Custom Modifications

## General Cabinet Modifications

---

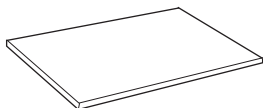

### Add Shelf

Specify ADD1SHLF (Add Shelf) or ADD2SHLF (Add Two Shelves)

To add a standard shelf in cabinets.

- Wall cabinets must have minimum 21" high opening.

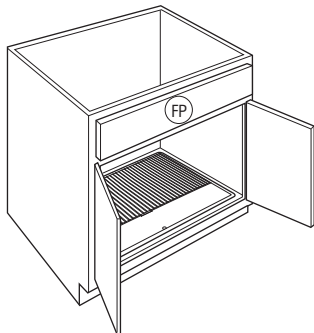

Base cabinets (CMAT1)

### CabMat™

Specify CMAT1 (Base Cabinets) or CMAT2 (Vanity Cabinets with Double Bowl)

This option installs removable CabMat™.

- Size is determined by face frame opening width and cabinet depth.
- CMAT1 is available on most 30", 33" and 36" sink base and vanity cabinets.
- CMAT2 is only available on vanity cabinets designed for double bowl applications.
- Not available with Reduced Depth modification.
- When ordered with Increased Depth modification, CabMat™ size does not change.
- Vanity cabinets with face frame openings of 24" and 30" will utilize CabMat™ sized for 21" and 27" openings.
- CabMat™ features a gray sloped mat to capture spills and is removable for cleaning.
- CabMat™ not available on inset vanity cabinets.

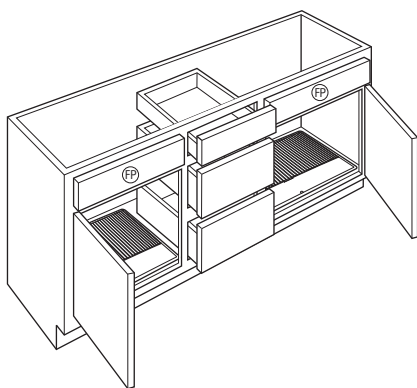

Vanity cabinets with double bowl (CMAT2)

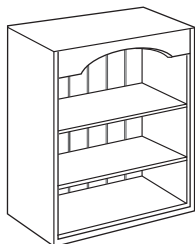

### Car Siding Back

Specify CSDGBK (Car Siding Back)

Cabinets that are available as Matching Interior cabinets are available with an installed 3/16" Car Siding Back in the same color as the exterior.

- If the Matching Interior option is not standard on the cabinet, the Matching Interior option must be added to your order.
- If Car Siding interior sides are desired, Car Siding panel must be ordered separately and field installed.
- See individual cabinets for availability.

General Cabinet Modifications (cont'd)

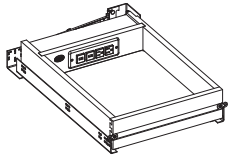

**Charging Drawer** 

Specify CHGDRW (Charging Drawer),  
CHGDRWL (Charging Drawer Left),  
CHGDRWR (Charging Drawer Right), CHGDRWB (Charging Drawer Both)

Select base cabinets can be ordered with the standard top drawer (4 1/2" high frame opening) replaced with the CHGDRW.

- Designed for 18" base cabinet drawers.
- Full extension, concealed Smart Stop slides.
- 110 lb. rated.
- 120V outlet must be installed in rear of cabinet within 10" of bottom of drawer, in rear of cabinet.
- CUL US listed power strip with two 120V plugs and two 2.1 amp USB ports.
- Max Current: AC 15 amps @ 120VAC; USB 2.1 amp and 5 VDC each.
- Tamper resistant outlets.
- Power cord with NEMA 5-15 plug.
- Integrated cord guide mounts to cabinet side to ensure safe operation.
- Black, shock absorbing mat included.
- Special sizes not available.
- Only available in 24" deep.
- Available in top drawer(s) only.
- Not available on Inset or Beaded Inset Styles.

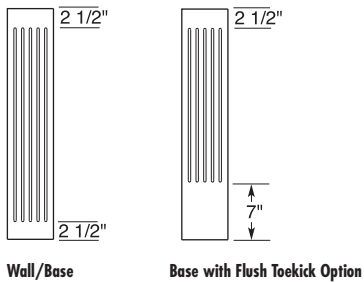

**Fluting**

Specify FLUT3L (3" Flute Left), FLUT3R (3" Flute Right),  
FLUT3B (3" Flute Both), FLUT3L.P (3" Flute Left - Peninsula), FLUT3R.P (3" Flute Right - Peninsula), FLUT3B.P (3" Flute Both - Peninsula),  
FLUT6L (6" Flute Left), FLUT6R (6" Flute Right), FLUT6B (6" Flute Both), FLUT6L.P (6" Flute Left - Peninsula),  
FLUT6R.P (6" Flute Right - Peninsula), or FLUT6B.P (6" Flute Both - Peninsula)

With this option, fluting detail is added. Clipped Corners, 3" Extended Stiles, and Wide Stiles may have the Fluting option added.

- Any option that extends the stiles (Bottom Valance Rail, Flush Toekick, Open Bottom Rail Base, Top Valance Rail, and Wide Top Rail) do not extend the Flute dimensions.
- Special spacing between flutes not available.
- See individual cabinets for availability.

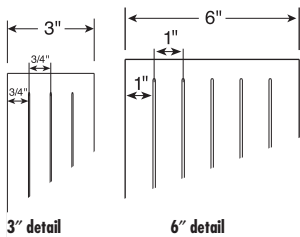
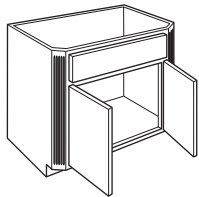

# Custom Modifications

## General Cabinet Modifications (cont'd)

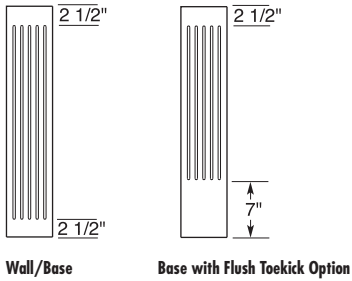

### Fluting on Fillers

Specify FLUT3 (3" Fluting on Filler), FLUT6 (6" Fluting on Filler), or FLUT3CTR (6" Filler Fluted 3" on Center)

With this option, fluting detail is added to 3" and 6" fillers.

- Base and Tall End panels with 3" or 6" frame rail return are available with Fluting. Specify Left or Right.
- Special spacing between flutes not available.
- The options Wide Top Rail and Flush Toekick do not extend the flute dimensions.
- See individual fillers and panels for availability.

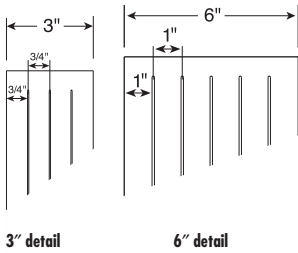

### Full Depth Shelf

Specify FD (Full Depth Shelf)

To replace the standard half depth shelf in base cabinets with an adjustable full depth shelf.

- Standard on Base Full, Peninsula Base, Peninsula Base Full, and Vanity Base Full units.

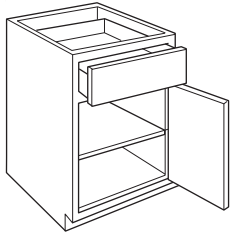

### Increased or Reduced Depths

Specify ID\_ (Increase Depth) or RD\_ (Reduce Depth) and fill in the total required depth of the unit

Increased or Reduced Depths available in 1/4" increments. Limitations are identified throughout the catalog.

- Minimum depth 6", maximum depth 30" on units without drawers or roll trays.
- Minimum depth 12", maximum depth 24" on most units with drawers or roll trays.

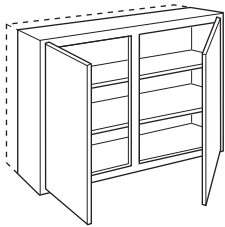

## General Cabinet Modifications (cont'd)

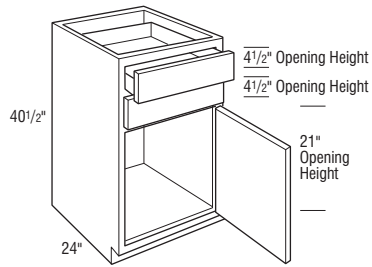

### Increased Height Plus Drawer

#### Specify IH+DRW (Increased Height Plus Drawer)

Base Cabinets will have a full width drawer above the existing drawer. The option increases the overall height of the cabinet by 6". For example, a B18 L or R with the IH+DRW option applied will have an overall cabinet height of 40 1/2".

- Increased or Reduced Depths available in 1/4" increments from 12" to 24".
- When IH+DRW option is selected other Increased or Reduced Height options are not available.
- Not available on:
  - Inset and Beaded Inset styles.
- Available on:
  - Base, page L•3
  - Base Corner Full Width, page L•60
  - Base Corner Full Width Pull-out, page L•62
  - Base Pots and Pans Pull-out, page L•35
  - Base Pots and Pans Storage, page L•35
  - Base Recycling Center, page L•99
  - Base Wastebasket, page L•94
  - Base Wastebasket with Wood Tiered Cutlery Divider, page L•97
  - Base with Bottle Storage, page L•100
  - Base with Food Storage Container Organizer, page L•11
  - Base with Plastic Storage Bins, page L•88
  - Base with Roll-out Tray Divider, page L•83
  - Base with Roll Trays, page L•6
  - Base with Spice Drawer, page L•93
  - Base with Tray Divider, page L•82
  - Base with Wood Tiered Cutlery Divider, page L•7
  - Base with Wood Tiered Cutlery Divider and Roll Trays, page L•8
  - Base with Wood Tiered K-Cup Drawer, page L•10
  - Base with Wood Tiered K-Cup Drawer and Roll Trays, page L•11
  - Four Drawer Base, page L•24
  - Four Drawer Base with Wood Tiered Cutlery Divider, page L•25
  - Six Drawer Base, page L•24
  - Three Drawer Base, page L•27
  - Three Drawer Base with Wood Tiered Cutlery Divider, page L•29



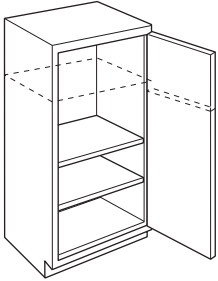

### Increased or Reduced Heights

Specify IH\_ (Increased Height) or RH\_ (Reduce Height)

Select cabinets can be ordered with Increased or Reduced Height. Limitations are identified throughout the catalog.

- To achieve desired heights, select the existing cabinet and specify RH or IH along with the new height. For example, to achieve a wall cabinet 18" wide and 18" high, specify W1824 L or R RH18.
- Increased or Reduced Height will increase or decrease the door opening height to achieve the overall desired cabinet height.
- For Wall Cabinets:
  - Increased Heights available in 1/4" increments on select wall cabinets, see the chart below for availability.
  - Reduced Heights available in 1/4" increments on select wall cabinets, see the chart below for availability.
  - For additional information on wall height modifications, please call Customer Service.
- For Base Cabinets:
  - Increased Heights available in 1/4" increments on select base cabinets, see the chart below for availability.
  - Reduced Heights available in 1/4" increments on select base cabinets, see the chart below for availability.
  - For additional information on base height modifications, please call Customer Service.
- For Tall and Oven Cabinets:
  - Increased Heights available in 1/4" increments on select tall and oven cabinets, see the chart below for availability.
  - For additional information on tall and oven cabinet height modifications, please call Customer Service.
- When Increased Height is applied, the B\*\* door opening will be modified, the 3DB\*\* will have height adjustments equally applied to the bottom two drawer openings, the 4DB\*\* will have height adjustments to the bottom drawer, and the 2DB\*\* will have height adjustments added equally to both the drawer openings.

Increased or Reduced Heights		
Model	Increased Height Range	Reduced Height Range
2DB18, 2DB21, 2DB24, 2DB27, 2DB30, 2DB33, 2DB36, 2DB39, 2DB42, 2DB45, 2DB48	46 1/2"	30"
2DB18RT, 2DB21RT, 2DB24RT, 2DB27RT, 2DB30RT, 2DB33RT, 2DB36RT	46 1/2"	
2DB30DR, 2DB36DR	46 1/2"	30"
2DB30RDR, 2DB36RDR	46 1/2"	30"
2DB36RTPDO	46 1/2"	
3DB12, 3DB15, 3DB18, 3DB21, 3DB24	46 1/2"	30"
3DB12BB, 3DB15BB, 3DB18BB, 3DB21BB, 3DB24BB	46 1/2"	30"
3DB15WTCD, 3DB18WTCD, 3DB21WTCD, 3DB24WTCD, 3DB30WTCD, 3DB36WTCD	46 1/2"	30"
3DB18KCLP	46 1/2"	30"
3DB27, 3DB30, 3DB33, 3DB36, 3DB39, 3DB42	46 1/2"	30"
4DB12, 4DB15, 4DB18, 4DB21, 4DB24, 4DB27, 4DB30, 4DB33, 4DB36, 4DB39, 4DB42	46 1/2"	30"
4DB12BB, 4DB15BB, 4DB18BB, 4DB21BB, 4DB24BB	46 1/2"	30"
4DB15WTCD, 4DB18WTCD, 4DB21WTCD, 4DB24WTCD, 4DB30WTCD, 4DB36WTCD	46 1/2"	30"
4DB18KCLP	46 1/2"	30"
6DB30, 6DB33, 6DB36, 6DB42	46 1/2"	30"
ACS36 L or R, ACS39 L or R, ACS42	46 1/2"	30"
ACS36ST L or R, ACS39ST L or R, ACS42ST	46 1/2"	30"
ACSF36 L or R, ACSF39 L or R, ACSF42	46 1/2"	30"
AEW2430-45L, AEWFFD2430-45LL, AEW3630-45L, AEWFFD3630-45LL	30 1/4" to 32 3/4"	
AEW2430LL, AEWFFD2430LL, AEW3630 L or R, AEWFFD3630 L or R	30 1/4" to 32 3/4"	
AEW2433-45L, AEWFFD2433-45LL, AEW3633-45L, AEWFFD3633-45LL	33 1/4" to 35 3/4"	
AEW2433LL, AEWFFD2433LL, AEW3633 L or R, AEWFFD3633 L or R	33 1/4" to 35 3/4"	
AEW2436-45L, AEWFFD2436-45LL, AEW3636-45L, AEWFFD3636-45LL	36 1/4" to 38 3/4"	
AEW2436LL, AEWFFD2436LL, AEW3636 L or R, AEWFFD3636 L or R	36 1/4" to 38 3/4"	
AEW2439-45L, AEWFFD2439-45LL, AEW3639-45L, AEWFFD3639-45LL	39 1/4" to 41 3/4"	
AEW2439LL, AEWFFD2439LL, AEW3639 L or R, AEWFFD3639 L or R	39 1/4" to 41 3/4"	
AEW2442-45L, AEWFFD2442-45LL, AEW3642-45L, AEWFFD3642-45LL	42 1/4" to 48"	
AEW2442LL, AEWFFD2442LL, AEW3642 L or R, AEWFFD3642 L or R	42 1/4" to 48"	
B2D9 L or R, B2D12 L or R, B2D15 L or R, B2D18 L or R, B2D21 L or R, B2D24 L or R, B2D24, B2D27, B2D30, B2D33, B2D36	46 1/2"	30"
B2D12RT L or R, B2D15RT L or R, B2D18RT L or R, B2D21RT L or R, B2D24RT L or R, B2D24RT, B2D27RT, B2D30RT, B2D33RT, B2D36RT	46 1/2"	30"
B4D24, B4D27, B4D30, B4D33, B4D36, B4D39, B4D42, B4D45, B4D48	46 1/2"	30"
B4D24RT, B4D27RT, B4D30RT, B4D33RT, B4D36RT	46 1/2"	30"
B4D39RT, B4D42RT, B4D45RT, B4D48RT	46 1/2"	30"
B6FH L or R, B9FH L or R, B12FH L or R, B15FH L or R, B18FH L or R, B21FH L or R, B24FH L or R, B24FH, BF27, B30FH, B33FH, B36FH, B39FH, B42FH, B45FH, B48FH	46 1/2"	30"
B9 L or R, B12 L or R, B15 L or R, B18 L or R, B21 L or R, B24 L or R, B24, B27, B30, B33, B36, B39, B42, B45, B48	46 1/2"	30"
B9FHP L or R, B12FHP L or R, B15FHP L or R, B18FHP L or R, B21FHP L or R, B24FHP L or R, B24FHP, B27FHP, B30FHP, B33FHP, B36FHP, B39FHP, B42FHP, B45FHP, B48FHP	46 1/2"	30"
B9P L or R, B12P L or R, B15P L or R, B18P L or R, B21P L or R, B24P L or R, B24P, B27P, B30P, B33P, B36P, B39P, B42P, B45P, B48P	46 1/2"	30"
B12BB L or R, B15BB L or R, B18BB L or R, B21BB L or R, B24BB L or R, B24BB, B30BB L or R, B36BB L or R, B42BB L or R, B48BB L or R	46 1/2"	30"
B12RT L or R, B15RT L or R, B18RT L or R, B21RT L or R, B24RT L or R, B24RT, B27RT, B30RT, B33RT, B36RT, B39RT, B42RT, B45RT, B48RT	46 1/2"	30"
B12DRO L or R, B15DRO L or R	46 1/2"	30"
B15PSB L or R, B18PSB L or R	46 1/2"	

General Cabinet Modifications (cont'd)

Increased or Reduced Heights		
Model	Increased Height Range	Reduced Height Range
B15RTWTC L or R, B18RTWTC L or R, B21RTWTC L or R, B24RTWTC L or R, B24RTWTC, B30RTWTC, B36RTWTC	46 1/2"	30"
B15WTC L or R, B18WTC L or R, B21WTC L or R, B24WTC L or R, B24WTC, B30WTC, B36WTC	46 1/2"	30"
B18FSCO L or R, B24FSCO L or R	46 1/2"	
B18KCUP L or R	46 1/2"	30"
B18KCUPRT L or R	46 1/2"	30"
B18SD L or R, B24SD L or R	46 1/2"	30"
B24PS, B30PS, B36PS	46 1/2"	
B30DR, B36DR	46 1/2"	30"
B30RRTDR, B36RRTDR	46 1/2"	30"
B30RTDR, B36RTDR	46 1/2"	30"
B30RTL0, B33RTL0, B36RTL0	46 1/2"	30"
B72SDI	34 3/4" to 46 1/2"	32" to 34 1/4"
B72SDIDSK	34 3/4" to 46 1/2"	32" to 34 1/4"
BAC24	46 1/2"	30"
BAC24FH	46 1/2"	30"
BBS18 L or R	46 1/2"	30"
BC36 L or R, BC39 L or R, BC42 L or R, BC45 L or R, BC48 L or R	34 3/4" to 46 1/2"	30" to 34 1/4"
BC45PO L or R, BC48PO L or R	34 3/4" to 46 1/2"	
BCC30BB L or R, BCC36BB L or R, BCC42BB L or R, BCC48BB	46 1/2"	30"
BCD30 L or R, BCD36 L or R, BCD42 L or R, BCD48 L or R	46 1/2"	30"
BCFW2D48CRVPO L or R	46 1/2"	
BCFW36 L or R, BCFW39 L or R, BCFW42 L or R, BCFW45 L or R, BCFW48 L or R	46 1/2"	30"
BCFW39P L or R, BCFW42P L or R, BCFW48P L or R	46 1/2"	30"
BCFW45CPO L or R, BCFW48CPO L or R	46 1/2"	
BCFW45PO L or R, BCFW48PO L or R	46 1/2"	
BCFW48SP L or R	34 3/4" to 46 1/2"	
BCFWFH45CPO L or R, BCFWFH48CPO L or R	46 1/2"	
BCFWFH48CRVPO L or R	46 1/2"	
BCP27	46 1/2"	30"
BEC24	46 1/2"	30"
BEC24FP	46 1/2"	30"
BER3336 L or R	46 1/2"	30"
BER36RS L or R	46 1/2"	30"
BFH6COA, BFH9COA, BFH12COA	46 1/2"	30"
BFH21CIA, BFH24CIA, BFH27CIA	46 1/2"	30"
BPPP24 L or R, BPPP24, BPPP30	46 1/2"	
BRDB36 L or R	46 1/2"	30"
BTC12LL	46 1/2"	30"
BWB15, BWB18, BWB21, BWB24	46 1/2"	
BWB152	34 3/4" to 46 1/2"	
BWB15BB, BWB18BB, BWB21BB, BWB24BB	46 1/2"	
BWB15FH, BWB18FH, BWB21FH, BWB24FH	46 1/2"	
BWB15FH2, BWB18FH2	34 3/4" to 46 1/2"	
BWB15FHRT2, BWB18FHRT2	34 3/4" to 46 1/2"	
BWB15WTC, BWB18WTC, BWB21WTC, BWB24WTC	46 1/2"	
BWB18KCUP	46 1/2"	
CNTYSB30, CNTYSB33, CNTYSB36, CNTYSB39, CNTYSB42, CNTYSB25, CNTYSB48	46 1/2"	30"
CS36 L or R	46 1/2"	30"
DAB33FS L or R, DAB36FS L or R	46 1/2"	30"
DAB33SLS L or R, DAB36SLS L or R	46 1/2"	30"
DAB36 L or R	46 1/2"	30"
DFD153021, DFD183021, DFD213021, DFD243021	34 1/4"	30"
DFD153421, DFD183421, DFD213421, DFD243421	46 1/2"	
DW182424 L or R, DW182727 L or R	18 1/4" to 23 3/4"	12" to 17 3/4"
DW242424 L or R, DW242727 L or R	24 1/4" to 29 3/4"	
DW302424 L or R, DW302727 L or R	30 1/4" to 32 3/4"	
DW332424 L or R, DW332727 L or R	33 1/4" to 35 3/4"	
DW362424 L or R, DW362727 L or R	36 1/4" to 38 3/4"	
DW392424 L or R, DW392727 L or R	39 1/4" to 41 3/4"	
DW422424 L or R, DW422727 L or R	42 1/4" to 44 3/4"	
DW452424 L or R, DW452727 L or R	45 1/4" to 47 3/4"	
DW302424AG L or R, DW302727AG L or R	48 1/4" to 50 3/4"	

## General Cabinet Modifications (cont'd)

Increased or Reduced Heights		
Model	Increased Height Range	Reduced Height Range
DW332424AG L or R, DW332727AG L or R	51 1/4" to 53 3/4"	
DW362424AG L or R, DW362727AG L or R	54 1/4" to 56 3/4"	
DW392424AG L or R, DW392727AG L or R	57 1/4" to 59 3/4"	
DW422424AG L or R, DW422727AG L or R	60 1/4" to 66"	
DW302424D L or R, DW302727D L or R	48 1/4" to 53 3/4"	
DW362424D L or R, DW362727D L or R	54 1/4" to 59 3/4"	
DW422424D L or R, DW422727D L or R	60 1/4" to 66"	
DW482424FH L or R, DW482727FH L or R	48 1/4" to 54"	
DW302424PLL	30 1/4" to 32 3/4"	24" to 29 3/4"
DW332424PLL	33 1/4" to 35 3/4"	
DW362424PLL	36 1/4" to 38 3/4"	
DW392424PLL	39 1/4" to 41 3/4"	
DW422424PLL	42 1/4" to 44 3/4"	
DW452424PLL	45 1/4" to 47 3/4"	
DW482424PLL	48 1/4" to 54"	
ER302121 L or R, ER302124 L or R, ER302421 L or R	30 1/4" to 32 3/4"	18" to 29 3/4"
ER33 L or R	30 1/4" to 32 3/4"	
ER332121 L or R, ER332124 L or R, ER332421 L or R	33 1/4" to 35 3/4"	
ER362121 L or R, ER362124 L or R, ER362421 L or R	36 1/4" to 38 3/4"	
ER392121 L or R, ER392124 L or R, ER392421 L or R	39 1/4" to 41 3/4"	
ER422121 L or R, ER422124 L or R, ER422421 L or R	42 1/4" to 48"	
FD1506.7524, FD1806.7524, FD2106.7524, FD2406.7524, FD2706.7524, FD3006.7524, FD3306.7524, FD3606.7524, FD3906.7524, FD4206.7524, FD4506.7524, FD4806.7524	7" to 11 3/4"	
FD151224, FD181224, FD211224, FD241224, FD271224, FD301224, FD331224, FD361224, FD391224, FD421224, FD451224, FD481224	12 1/4" to 18"	
FDWB151824, FDWB181824, FDWB211824, FDWB241824, FDWB271824, FDWB301824, FDWB331824, FDWB361824, FDWB391824, FDWB421824, FDWB451824, FDWB481824	18 1/4" to 22 1/2"	12" to 17 3/4"
HB30, HB36, HB42, HB48	46 1/2"	30"
LSP36 L or R	46 1/2"	30"
MW2718, MW3018	18 1/4" to 20 3/4"	
OCD278424, OCD308424, OCD338424, OCD368424, OCD398424	84" to 86 3/4"	
OCD278724, OCD308724, OCD338724, OCD368724, OCD398724	87" to 89 3/4"	
OCD279024, OCD309024, OCD339024, OCD369024, OCD399024	90" to 92 3/4"	
OCD279324, OCD309324, OCD339324, OCD369324, OCD399324	93" to 95 3/4"	
OCD2710224AC, OCD3010224AC, OCD3310224AC, OCD3610224AC, OCD3910224AC	102 1/4" to 107 3/4"	96 1/4" to 101 3/4"
OCD278424DD, OCD308424DD, OCD338424DD, OCD368424DD, OCD398424DD	84 1/4" to 86 3/4"	
OCD278724DD, OCD308724DD, OCD338724DD, OCD368724DD, OCD398724DD	87 1/4" to 89 3/4"	
OCD279024DD, OCD309024DD, OCD339024DD, OCD369024DD, OCD399024DD	90 1/4" to 92 3/4"	
OCD279324DDAH, OCD309324DDAH, OCD339324DDAH, OCD369324DDAH, OCD399324DDAH	93 1/4" to 95 3/4"	
OCM278424, OCM308424, OCM338424, OCM368424, OCM398424	84" to 86 3/4"	
OCM278724, OCM308724, OCM338724, OCM368724, OCM398724	87" to 89 3/4"	
OCM279024, OCM309024, OCM339024, OCM369024, OCM399024	90" to 92 3/4"	
OCM279324, OCM309324, OCM339324, OCM369324, OCM399324	93" to 95 3/4"	
OCM2710224AC, OCM3010224AC, OCM3310224AC, OCM3610224AC, OCM3910224AC	102 1/4" to 107 3/4"	96 1/4" to 101 3/4"
OCS278424, OCS308424, OCS338424, OCS368424, OCS398424	84" to 86 3/4"	
OCS278724, OCS308724, OCS338724, OCS368724, OCS398724	87" to 89 3/4"	
OCS279024, OCS309024, OCS339024, OCS369024, OCS399024	90" to 92 3/4"	
OCS279324, OCS309324, OCS339324, OCS369324, OCS399324	93" to 95 3/4"	
OCS2710224AC, OCS3010224AC, OCS3310224AC, OCS3610224AC, OCS3910224AC	102 1/4" to 107 3/4"	96 1/4" to 101 3/4"
OCS278424DD, OCS308424DD, OCS338424DD, OCS368424DD, OCS398424DD	84 1/4" to 86 3/4"	
OCS278724DD, OCS308724DD, OCS338724DD, OCS368724DD, OCS398724DD	87 1/4" to 89 3/4"	
OCS279024DDAH, OCS309024DDAH, OCS339024DDAH, OCS369024DDAH, OCS399024DDAH	90 1/4" to 92 3/4"	
OCS279324DDAH, OCS309324DDAH, OCS339324DDAH, OCS369324DDAH, OCS399324DDAH	93 1/4" to 95 3/4"	
OCSD278424, OCSD308424, OCSD338424, OCSD368424, OCSD398424	84" to 86 3/4"	
OCSD278724, OCSD308724, OCSD338724, OCSD368724, OCSD398724	87" to 89 3/4"	
OCSD279024, OCSD309024, OCSD339024, OCSD369024, OCSD399024	90" to 92 3/4"	
OCSD279324, OCSD309324, OCSD339324, OCSD369324, OCSD399324	93" to 95 3/4"	
OCSD2710224AC, OCSD3010224AC, OCSD3310224AC, OCSD3610224AC, OCSD3910224AC	102 1/4" to 107 3/4"	96 1/4" to 101 3/4"
OMC278424, OMC308424, OMC338424, OMC368424, OMC398424	84" to 86 3/4"	
OMC278724, OMC308724, OMC338724, OMC368724, OMC398724	87" to 89 3/4"	

General Cabinet Modifications (cont'd)

Increased or Reduced Heights		
Model	Increased Height Range	Reduced Height Range
OMC279024, OMC309024, OMC339024, OMC369024, OMC399024	90" to 92 3/4"	
OMC279324, OMC309324, OMC339324, OMC369324, OMC399324	93" to 95 3/4"	
OMC2710224AC, OMC3010224AC, OMC3310224AC, OMC3610224AC, OMC3910224AC	102 1/4" to 107 3/4"	96 1/4" to 101 3/4"
OMC278424DD, OMC308424DD, OMC338424DD, OMC368424DD, OMC398424DD	84 1/4" to 86 3/4"	
OMC278724DD, OMC308724DD, OMC338724DD, OMC368724DD, OMC398724DD	87 1/4" to 89 3/4"	
OMC279024DD, OMC309024DD, OMC339024DD, OMC369024DD, OMC399024DD	90 1/4" to 92 3/4"	
OMC279324DDAH, OMC309324DDAH, OMC339324DDAH, OMC369324DDAH, OMC399324DDAH	93 1/4" to 95 3/4"	
PY368424	84" to 86 3/4"	
PY368724	87" to 89 3/4"	
PY369024	90" to 92 3/4"	
PY369324	93" to 95 3/4"	
PY3610224	102 1/4" to 107 3/4"	96 1/4" to 101 3/4"
SB18 L or R, SB21 L or R, SB24 L or R, SB24, SB27, SB30, SB33, SB36, SB39, SB42, SB45, SB48	46 1/2"	30"
SB18ST L or R, SB21ST L or R, SB24ST L or R	46 1/2"	30"
SB24ST, SB27ST, SB30ST, SB33ST, SB36ST, SB39ST, SB42ST, SB45ST, SB48ST	46 1/2"	30"
SF18 L or R	46 1/2"	30"
SF24, SF30, SF36	46 1/2"	30"
SLS3336 L or R, SLS36 L or R	46 1/2"	30"
SLS3R3336 L or R, SLS3R36 L or R	46 1/2"	30"
SLS3R33RS L or R, SLS3R36RS L or R	46 1/2"	30"
SLS3R36CD L or R	46 1/2"	30"
STW_36 L or R, STW2436	36 1/4" to 38 3/4"	
STW_39 L or R, STW2439	39 1/4" to 41 3/4"	
STW_42 L or R, STW2442	42 1/4" to 44 3/4"	
STW_45 L or R, STW2445	45 1/4" to 47 3/4"	
STW_48 L or R, STW2448	48 1/4" to 50 3/4"	
STW_51 L or R, STW2451	51 1/4" to 53 3/4"	
STW_54 L or R, STW2454	54 1/4" to 56 3/4"	
STW_57 L or R, STW2457	57 1/4" to 59 3/4"	
STW_60 L or R, STW2460	60 1/4" to 66"	
STWAG_36 L or R, STWAG2436, STWDAG_36 L or R, STWDAG2436	36 1/4" to 38 3/4"	
STWAG_39 L or R, STWAG2439, STWDAG_39 L or R, STWDAG2439	39 1/4" to 41 3/4"	
STWAG_42 L or R, STWAG2442, STWDAG_42 L or R, STWDAG2442	42 1/4" to 44 3/4"	
STWAG_45 L or R, STWAG2445, STWDAG_45 L or R, STWDAG2445	45 1/4" to 47 3/4"	
STWAG_48 L or R, STWAG2448, STWDAG_48 L or R, STWDAG2448	48 1/4" to 50 3/4"	
STWAG_51 L or R, STWAG2451, STWDAG_51 L or R, STWDAG2451	51 1/4" to 53 3/4"	
STWAG_54 L or R, STWAG2454, STWDAG_54 L or R, STWDAG2454	54 1/4" to 56 3/4"	
STWAG_57 L or R, STWAG2457, STWDAG_57 L or R, STWDAG2457	57 1/4" to 59 3/4"	
STWAG_60 L or R, STWAG2460, STWDAG_60 L or R, STWDAG2460	60 1/4" to 66"	
STWEC1236D, STWEC1236 L or R, STWTC1236LL	36 1/4" to 38 3/4"	
STWEC1239D, STWEC1239 L or R, STWTC1239LL	39 1/4" to 41 3/4"	
STWEC1242D, STWEC1242 L or R, STWTC1242LL	42 1/4" to 44 3/4"	
STWEC1245D, STWEC1245 L or R, STWTC1245LL	45 1/4" to 47 3/4"	
STWEC1248D, STWEC1248 L or R, STWTC1248LL	48 1/4" to 50 3/4"	
STWEC1251D, STWEC1251 L or R, STWTC1251LL	51 1/4" to 53 3/4"	
STWEC1254D, STWEC1254 L or R, STWTC1254LL	54 1/4" to 56 3/4"	
STWEC1257D, STWEC1257 L or R, STWTC1257LL	57 1/4" to 59 3/4"	
STWEC1260D, STWEC1260 L or R, STWTC1260LL	60 1/4" to 66"	
TD6FH L or R, TD9FH L or R, TD12FH L or R, TD15FH L or R, TD18FH L or R	46 1/2"	30"
TD9 L or R, TD12 L or R	46 1/2"	30"
TPP128424 L or R, TPP158424 L or R, TPP188424 L or R	84" to 86 3/4"	
TPP128724 L or R, TPP158724 L or R, TPP188724 L or R	87" to 89 3/4"	
TPP129024 L or R, TPP159024 L or R, TPP189024 L or R	90" to 92 3/4"	
TPP129324 L or R, TPP159324 L or R, TPP189324 L or R	93" to 95 3/4"	
TPP910224 L or R, TPP1210224 L or R, TPP1510224 L or R, TPP1810224 L or R	102 1/4" to 107 3/4"	96 1/4" to 101 3/4"
TRBD27	46 1/2"	
U3D128424 L or R, U3D158424 L or R, U3D188424 L or R, U3D218424 L or R, U3D248424 L or R	84" to 86 3/4"	
U3D128724 L or R, U3D158724 L or R, U3D188724 L or R, U3D218724 L or R, U3D248724 L or R	87" to 89 3/4"	
U3D129024 L or R, U3D159024 L or R, U3D189024 L or R, U3D219024 L or R, U3D249024 L or R	90" to 92 3/4"	
U3D129324 L or R, U3D159324 L or R, U3D189324 L or R, U3D219324 L or R, U3D249324 L or R	93" to 95 3/4"	

# Custom Modifications

## General Cabinet Modifications (cont'd)

Increased or Reduced Heights		
Model	Increased Height Range	Reduced Height Range
U3D248424, U3D278424, U3D308424, U3D338424, U3D368424	84" to 86 3/4"	
U3D248724, U3D278724, U3D308724, U3D338724, U3D368724	87" to 89 3/4"	
U3D249024, U3D279024, U3D309024, U3D339024, U3D369024	90" to 92 3/4"	
U3D249324, U3D279324, U3D309324, U3D339324, U3D369324	93" to 95 3/4"	
U4D128424 L or R, U4D158424 L or R, U4D188424 L or R, U4D218424 L or R, U4D248424 L or R	84" to 86 3/4"	
U4D128724 L or R, U4D158724 L or R, U4D188724 L or R, U4D218724 L or R, U4D248724 L or R	87" to 89 3/4"	
U4D129024 L or R, U4D159024 L or R, U4D189024 L or R, U4D219024 L or R, U4D249024 L or R	90" to 92 3/4"	
U4D129324 L or R, U4D159324 L or R, U4D189324 L or R, U4D219324 L or R, U4D249324 L or R	93" to 95 3/4"	
U4D248424, U4D278424, U4D308424, U4D338424, U4D368424	84" to 86 3/4"	
U4D248724, U4D278724, U4D308724, U4D338724, U4D368724	87" to 89 3/4"	
U4D249024, U4D279024, U4D309024, U4D339024, U4D369024	90" to 92 3/4"	
U4D249324, U4D279324, U4D309324, U4D339324, U4D369324	93" to 95 3/4"	
U128412 L or R, U158412 L or R, U188412 L or R, U218412 L or R, U248412 L or R	84" to 86 3/4"	
U128712 L or R, U158712 L or R, U188712 L or R, U218712 L or R, U248712 L or R	87" to 89 3/4"	
U129012 L or R, U159012 L or R, U189012 L or R, U219012 L or R, U249012 L or R	90" to 92 3/4"	
U129312 L or R, U159312 L or R, U189312 L or R, U219312 L or R, U249312 L or R	93" to 95 3/4"	
U1210212 L or R, U1510212 L or R, U1810212 L or R, U2110212 L or R, U2410212 L or R	102 1/4" to 107 3/4"	96 1/4" to 101 3/4"
U128424 L or R, U158424 L or R, U188424 L or R, U218424 L or R, U248424 L or R	84" to 86 3/4"	
U128724 L or R, U158724 L or R, U188724 L or R, U218724 L or R, U248724 L or R	87" to 89 3/4"	
U129024 L or R, U159024 L or R, U189024 L or R, U219024 L or R, U249024 L or R	90" to 92 3/4"	
U129324 L or R, U159324 L or R, U189324 L or R, U219324 L or R, U249324 L or R	93" to 95 3/4"	
U1210224 L or R, U1510224 L or R, U1810224 L or R, U2110224 L or R, U2410224 L or R	102 1/4" to 107 3/4"	96 1/4" to 101 3/4"
U248412, U278412, U308412, U338412, U368412	84" to 86 3/4"	
U248712, U278712, U308712, U338712, U368712	87" to 89 3/4"	
U249012, U279012, U309012, U339012, U369012	90" to 92 3/4"	
U249312, U279312, U309312, U339312, U369312	93" to 95 3/4"	
U2410212, U2710212, U3010212, U3310212, U3610212	102 1/4" to 107 3/4"	96 1/4" to 101 3/4"
U248424, U278424, U308424, U338424, U368424	84" to 86 3/4"	
U248724, U278724, U308724, U338724, U368724	87" to 89 3/4"	
U249024, U279024, U309024, U339024, U369024	90" to 92 3/4"	
U249324, U279324, U309324, U339324, U369324	93" to 95 3/4"	
U2410224, U2710224, U3010224, U3310224, U3610224	102 1/4" to 107 3/4"	96 1/4" to 101 3/4"
U158424RT L or R, U188424RT L or R, U218424RT L or R, U248424RT L or R	84" to 86 3/4"	
U158724RT L or R, U188724RT L or R, U218724RT L or R, U248724RT L or R	87" to 89 3/4"	
U159024RT L or R, U189024RT L or R, U219024RT L or R, U249024RT L or R	90" to 92 3/4"	
U159324RT L or R, U189324RT L or R, U219324RT L or R, U249324RT L or R	93" to 95 3/4"	
U1510224RT L or R, U1810224RT L or R, U2110224RT L or R, U2410224RT L or R	102 1/4" to 107 3/4"	96 1/4" to 101 3/4"
U248424RT, U278424RT, U308424RT, U338424RT, U368424RT	84" to 86 3/4"	
U248724RT, U278724RT, U308724RT, U338724RT, U368724RT	87" to 89 3/4"	
U249024RT, U279024RT, U309024RT, U339024RT, U369024RT	90" to 92 3/4"	
U249324RT, U279324RT, U309324RT, U339324RT, U369324RT	93" to 95 3/4"	
U2410224RT, U2710224RT, U3010224RT, U3310224RT, U3610224RT	102 1/4" to 107 3/4"	96 1/4" to 101 3/4"
UCD1521, UCD1821, UCD2121, UCD2421, UCD2721, UCD3021, UCD3321, UCD3621	5 1/4" to 6 1/2"	
U1128424 L or R, U1158424 L or R, U1188424 L or R, U1218424 L or R, U1248424 L or R	84" to 86 3/4"	
U1128724 L or R, U1158724 L or R, U1188724 L or R, U1218724 L or R, U1248724 L or R	87" to 89 3/4"	
U1129024 L or R, U1159024 L or R, U1189024 L or R, U1219024 L or R, U1249024 L or R	90" to 92 3/4"	
U1129324 L or R, U1159324 L or R, U1189324 L or R, U1219324 L or R, U1249324 L or R	93" to 95 3/4"	
U11210224 L or R, U11510224 L or R, U11810224 L or R, U12110224 L or R, U12410224 L or R	102 1/4" to 107 3/4"	96 1/4" to 101 3/4"
UOC24846 L or R	84" to 86 3/4"	
UOC24876 L or R	87" to 89 3/4"	
UOC24906 L or R	90" to 92 3/4"	
UOC24936 L or R	93" to 95 3/4"	
UOC241026 L or R	102 1/4" to 107 3/4"	96 1/4" to 101 3/4"
UOC24846	84" to 86 3/4"	
UOC24876	87" to 89 3/4"	
UOC24906	90" to 92 3/4"	
UOC24936	93" to 95 3/4"	
UOC241026	102 1/4" to 107 3/4"	96 1/4" to 101 3/4"
UOC24849 L or R	84" to 86 3/4"	
UOC24879 L or R	87" to 89 3/4"	
UOC24909 L or R	90" to 92 3/4"	
UOC24939 L or R	93" to 95 3/4"	

General Cabinet Modifications (cont'd)

Increased or Reduced Heights		
Model	Increased Height Range	Reduced Height Range
UOC241029 L or R	102 1/4" to 107 3/4"	96 1/4" to 101 3/4"
UOC24849	84" to 86 3/4"	
UOC24879	87" to 89 3/4"	
UOC24909	90" to 92 3/4"	
UOC24939	93" to 95 3/4"	
UOC241029	102 1/4" to 107 3/4"	96 1/4" to 101 3/4"
UOCDZ24849	84" to 86 3/4"	
UOCDZ24879	87" to 89 3/4"	
UOCDZ24909	90" to 92 3/4"	
UOCDZ24939	93" to 95 3/4"	
UOCDZ241029	102 1/4" to 107 3/4"	96 1/4" to 101 3/4"
W_12, W2412	12 1/4" to 14 3/4"	
W_15, W2415	15 1/4" to 17 3/4"	
W_18, W2418	18 1/4" to 20 3/4"	
W_27, W2427	27 1/4" to 29 3/4"	
W_30, W2430	30 1/4" to 32 3/4"	
W_33, W2433	33 1/4" to 35 3/4"	
W_36, W2436	36 1/4" to 38 3/4"	
W_39, W2439	39 1/4" to 41 3/4"	
W_42, W2442	42 1/4" to 44 3/4"	
W_45, W2445	45 1/4" to 47 3/4"	
W_48, W2448	48 1/4" to 54"	
W_18P L or R, W2418P	18 1/4" to 23 3/4"	12" to 17 3/4"
W_24P L or R, W2424P	24 1/4" to 29 3/4"	
W_30P L or R, W2430P	30 1/4" to 35 3/4"	
W_36P L or R, W2436P	36 1/4" to 42"	
W921 L or R, W2421	21 1/4" to 23 3/4"	
W924 L or R, W2424	24 1/4" to 26 3/4"	
W361824PO L or R, W361824PO, W371824PO L or R, W371824PO, W391824PO L or R, W391824PO	18 1/4" to 20 3/4"	
W362124PO L or R, W362124PO, W372124PO L or R, W372124PO, W392124PO L or R, W392124PO	21 1/4" to 23 3/4"	
WB12 L or R, WB15 L or R, WB18 L or R, WB21 L or R, WB24 L or R, WB24, WB27, WB30, WB33, WB36, WB39, WB42, WB45, WB48	46 1/2"	30"
WC_30BL, WC_30BR	30 1/4" to 32 3/4"	12" to 29 3/4"
WC_33BL, WC_33BR	33 1/4" to 35 3/4"	
WC_36BL, WC_36BR	36 1/4" to 38 3/4"	
WC_39BL, WC_39BR	39 1/4" to 41 3/4"	
WC_42BL, WC_42BR	42 1/4" to 48"	
WEC1230D, WEC1230 L or R	30 1/4" to 32 3/4"	12" to 29 3/4"
WEC1233D, WEC1233 L or R	33 1/4" to 35 3/4"	
WEC1236D, WEC1236 L or R	36 1/4" to 38 3/4"	
WEC1239D, WEC1239 L or R	39 1/4" to 41 3/4"	
WEC1242D, WEC1242 L or R	42 1/4" to 48"	
WEC1245D, WEC1245 L or R	45 1/4" to 47 3/4"	
WEC1248D, WEC1248 L or R	48 1/4" to 54"	
WOB52436, WOB53036, WOB53636	36 1/4" to 48"	
WTCT1230LL	30 1/4" to 32 3/4"	12" to 29 3/4"
WTCT1233LL	33 1/4" to 35 3/4"	
WTCT1236LL	36 1/4" to 38 3/4"	
WTCT1239LL	39 1/4" to 41 3/4"	
WTCT1242LL	42 1/4" to 44 3/4"	
WTCT1245LL	45 1/4" to 47 3/4"	
WTCT1248LL	48 1/4" to 54"	
WTH_30BF	30 1/4" to 32 3/4"	
WTH_33BF	33 1/4" to 35 3/4"	
WTH_15VL	15 1/4" to 17 3/4"	
WTH_18VL	18 1/4" to 20 3/4"	
WTH2415SL, WTH2715SL, WTH3015SL, WTH3315SL, WTH3615SL	15 1/4" to 17 3/4"	
WTH2418SL, WTH2718SL, WTH3018SL, WTH3318SL, WTH3618SL	18 1/4" to 20 3/4"	
WTH2421SL, WTH2721SL, WTH3021SL, WTH3321SL, WTH3621SL	21 1/4" to 23 3/4"	

### Increased Widths in 1/4" Increments

Specify IW \_\_\_\_\_. (Increased Widths in 1/4" Increments)

Modification is restricted to starting with the smaller standard cabinet width and then increasing the width.

For example, to achieve a Wall Cabinet 13 1/4" wide by 12" high, order a W1212 L or R IW13.25.

Many cabinets are available with the Increased Widths 1/4" Increments modification. See chart below for included cabinets and width availabilities.

- Not available in conjunction with some modifications including: Clipped Corner, Split Doors, Wide Stiles, and Split Drawers.
- The following configurations will apply to cabinets with doors and/or drawers:

9" - 23 3/4" - 1 door

24 1/4" - 38 3/4" - 2 door, 1 drawer

39 1/4" - 47 3/4" - 2 door, 2 drawer (will have a mullion between the doors and drawers)

\*will not have mullion

Increased Width 1/4" Increments				
Cabinet	Description	Page #	Cabinet Widths	
			Minimum	Maximum
<b>Wall Cabinets</b>				
MW_18	Wall Microwave Cabinet, 18" High	N•3	27 1/4"	32 3/4"
MW_21	Wall Microwave Cabinet, 21" High	N•3	27 1/4"	32 3/4"
STW	Stacked Wall	J•28	12"	48"
STWAG	Stacked Wall w/Vertical-lift	J•36	15"	36"
STWDAG	Stacked Wall w/Appliance Garage	J•24	15"	36"
W	Wall	J•3	9"	48"
W_P	Wall Peninsula	J•73	9"	48"
W_24PO	Refrigerator Wall Pull-out Cabinet	J•49	36"	39"
W_24PO L or R	Refrigerator Wall Pull-out Cabinet	J•49	36"	39"
WBMW	Wall Built-in Microwave Double Door Cabinet	N•9	27 1/4"	32 3/4"
WTH_BF	Wall Top Hinge w/Bifold	J•15	24"	36"
WTH_SL	Wall Top Hinge w/Stay Lift	J•9	24"	36"
WVL	Wall Top Hinge w/Vertical-lift & Stay Lift	J•5	24"	36"
<b>Base Cabinets</b>				
2DB	Two Drawer Base	L•32	24"	38 3/4"
2DB_RT	Two Drawer Base w/Roll Trays	L•33	18"	36"
3DB*	Three Drawer Base	L•27	12"	42"
3DBBDD_	Three Drawer Base Buffet w/Deep Drawer	L•31	30 1/4"	35 3/4"
3DBDD_	Three Drawer Base w/Deep Drawer	L•29	24 1/4"	35 3/4"
4DB*	Four Drawer Base	L•24	12"	42"
B	Base	L•3	9"	48"
B_FH	Full Height Base	L•12	6"	48"
B_FHP	Full Height Base Peninsula	L•80	9"	48"
B_P	Base Peninsula	L•79	9"	48"
B_RT	Base w/Roll Tray	L•6	12"	48"
B2D	Base w/Two Split Drawers	L•16	9"	36"
B2D_RT	Base w/Two Split Drawers & Roll Tray	L•17	12"	36"
B4D	Base Double Door w/Four Split Drawers	L•18	24"	48"
B4D_RT	Base Double Door w/Four Split Drawers & Roll Tray	L•18	24"	48"
CNTYSB	Country Sink Base Cabinet	L•48	30"	48"
SB	Sink Base	L•38	18"	48"
TD_FH	Full Height Base w/Tray Divider	L•82	6"	18"
WB	Wall Base	L•23	12"	48"
<b>Tall Cabinets</b>				
U	Utility	M•3	12"	36"
U	Utility	M•8	12"	36"
U_RT	Utility w/Roll Trays	M•18	15"	36"
U3D	Utility w/Three Drawers	M•12	12"	36"
U4D	Utility w/Four Drawers	M•14	12"	36"
UV	Vanity Utility	P•47	15"	24"
<b>Oven &amp; Microwave Cabinets</b>				
3DBWD	Three Drawer Base, Warming Drawer	N•11	24"	36"
BBMWD_	Base Built-in Microwave Cabinet w/Drawer	N•13	24 1/4"	32 3/4"
BO	Base Oven Cabinet	N•16	27"	36"
BO_	Base Oven Trimmable Cabinet	N•15	27 1/4"	35 3/4"
BO_LD	Base Oven Cabinet w/Lower Drawer	N•17	27"	36"
BMW_RT	Base Microwave Cabinet w/Roll Tray	N•12	24"	36"
BMWD	Base Microwave Cabinet w/Drawer	N•13	24"	36"
BMWD_DD	Base Microwave Cabinet w/Deep Drawer	N•14	24 1/4"	32 3/4"

General Cabinet Modifications (cont'd)

Increased Width 1/4" Increments				
Cabinet	Description	Page #	Cabinet Widths	
			Minimum	Maximum
<b>Oven &amp; Microwave Cabinets, (cont'd)</b>				
MW	Wall Microwave Double Door Cabinet	N#4	24"	36"
OCD	Double Oven Trimmable Cabinet	N#36	27"	39"
OCD_____DD	Double Oven Trimmable Cabinet w/Deep Drawer	N#52	27 1/4"	35 3/4"
OCD_____DDAH	Double Oven Trimmable Cabinet w/Deep Drawer	N#53	27 1/4"	35 3/4"
OCM	Tall Built-in Microwave Cabinet	N#18	27"	39"
OCS	Single Oven Trimmable Cabinet	N#44	27"	39"
OCS_____DD	Single Oven Trimmable Cabinet w/Deep Drawer	N#46	27 1/4"	35 3/4"
OCS_____DDAH	Single Oven Trimmable Cabinet w/Deep Drawer	N#46	27 1/4"	35 3/4"
OCS_D	Single Oven Trimmable Cabinet w/Drawers	N#38	27"	39"
OMC	Microwave & Single Oven Trimmable Cabinet	N#28	27"	39"
OMC_____DD	Microwave & Single Oven Trimmable Cabinet w/Deep Drawer	N#30	27 1/4"	35 3/4"
OMC_____DDAH	Microwave & Single Oven Trimmable Cabinet w/Deep Drawer	N#31	27 1/4"	35 3/4"
<b>Vanity Cabinets</b>				
4VDB	Vanity Four Drawer Base	P#44	12"	36"
BCST	Bath Storage Tower	P#61	12"	30"
BCSTDRW_	Base Storage Tower Single Drawer	P#62	12"	30"
V_S	Vanity Base w/Shelf	P#9	12"	48"
VB	Vanity Base	P#7	12"	48"
VDB	Vanity Three Drawer Base	P#42	12"	36"
VSB	Vanity Sink Base w/False Panel	P#14	18"	48"
<b>Office &amp; Furniture Cabinets</b>				
DDR_____	Desk Drawer Base	O#24	12 1/4"	35 3/4"
T_BCAV	Tall Bookcase w/Arched Valance	O#29	18"	36"
TD_BCAV	Tall Bookcase w/Doors & Arched Valance	O#32	18"	36"
TDO_BCAV	Tall Bookcase w/Office Height Doors & Arched Valance	O#38	18"	36"
TDV_BCAV	Tall Bookcase w/Vanity Height Doors & Arched Valance	O#35	18"	36"
W_BCAV	Wall Bookcase w/Arched Valance	O#26	15"	39"
<b>Panels</b>				
TEP_WD	Refrigerator Panel 24" Deep	Q#17	1 1/2"	6"
TEP_WD	Refrigerator Panel 12" or 13" Deep	Q#16	1 1/2"	6"
_3_BCFP	Box Column Filler 3" Wide	Q#10	3 1/4"	5 3/4"
_6_BCFP	Box Column Filler 6" Wide	Q#10	6 1/4"	12"
BEP_	Base End Panel 24" Deep, 34 1/2" High	Q#13	1 1/2"	6"
BEPOF3WD	End Panels – Full Overlay Styles Only	Q#15	3"	5 3/4"
WEPOF3_WD	End Panels – Full Overlay Styles Only	Q#15	3"	5 3/4"
TEP_OF3WD	End Panels – Full Overlay Styles Only	Q#15	3"	5 3/4"
WEPF3_WD	Wall End Panel 12" or 13" Deep, 30" High	Q#13	1.5"	6"
<b>Kits &amp; Hardware</b>				
CIW	Cutlery Divider	S#5	12"	36"
CUD	Cooking Utensil Divider	S#4	5"	36"
DRT_SP	Deep Roll Tray Kit	S#9	12"	36"
RT_SP	Roll Tray Kit	S#9	12"	36"
<b>Furniture Drawers</b>				
FDWB	Furniture Drawer Window Bench	L#104	15"	48"
<b>Desk Drawers</b>				
UCD_	Under Counter Drawer 5" High, 21" Deep	P#46	15 1/4"	35 3/4"



# Custom Modifications

## General Cabinet Modifications (cont'd)

### Increased Widths in 3" increments

Specify IW \_\_ (Increased Width)

Some cabinets are available with the Increased Width option. See chart below for cabinets with this option along with available sizes.

- To achieve desired widths, select the existing cabinet from below and specify IW along with the new width. For example, to achieve a B036, order a B033 IW36.
- For Wall Quarter Round End Shelf (WQRES), Increased Widths available in 9" and 12". See page J•97 for WQRES cabinets.
- Increased widths available in 3" increments from 15" to 45".

Increased Width in 3" Increments													
Cabinet	Description	Page #	Cabinet Widths										
			15"	18"	21"	24"	27"	30"	33"	36"	39"	42"	45"
<b>Wall Cabinets</b>													
WOBS3636	Wall Organizer & Bookshelf 36" W	J•91										✓	
<b>Range Hoods</b>													
HP-12	Hearth Pier 12" W	K•19	✓										
<b>Base Cabinets</b>													
2DB36DR	Two Drawer Base, Drop-in Range 36" W	L•55										✓	
2DB36RDR	Two Drawer Base w/Reduced Drawers, Drop-in Range 36" W	L•56										✓	
B36DR	Base, Drop-in Range 36" W	L•56										✓	
BQRES L or R	Base Quarter Round End Shelf	L•101	✓										
<b>Office &amp; Furniture Cabinets</b>													
CPU152924	CPU Base	O•25		✓									
EB12NTK L or R	Entertainment Base w/No Toekick	O•12	✓	✓									
EB18 L or R	Entertainment Base	O•12			✓	✓							
ESTW1858.5 L or R	Entertainment Stacked Wall	O•13			✓	✓							
EW1236 L or R	Entertainment Wall	O•13	✓	✓									

General Cabinet Modifications (cont'd)

Reduced Widths in 3" increments

Specify RW\_\_ (Reduced Width)

Some cabinets are available with the special width option. See chart below for cabinets with this option along with sizes available.

- To achieve desired widths, select the existing cabinet from below and specify RW along with the new width. For example, to achieve a B36DR, order a B36DR RW33.
- Reduced widths available in 3" increments from 9" to 33".

\*For Wall Quarter Round End Shelf (WQRES) Reduced Widths available in 5". See page J•97 for WQRES cabinets.

Reduced Width in 3" Increments																	
Cabinet	Description	Page #	Cabinet Widths														
			9"	12"	15"	18"	21"	24"	27"	30"	33"	36"	39"	42"			
<b>Wall Cabinets</b>																	
W618	Wine Cube Horizontal 18" W	J•95		✓													
WCD3015	Wall China Display 30" W	J•94								✓							
WCD3615	Wall China Display 36" W	J•94											✓				
WOB53036	Wall Organizer & Bookshelf 30" W	J•91								✓							
WOB53636	Wall Organizer & Bookshelf 36" W	J•91											✓				
WSD18	Wall Spice Drawer Horizontal 18" W	J•96		✓													
<b>Range Hoods</b>																	
HP-12	Hearth Pier 12" W	K•19	✓														
<b>Base Cabinets</b>																	
2DB18RT	Two Drawer Base w/Roll Trays 18" W	L•33		✓	✓												
2DB24RT	Two Drawer Base w/Roll Trays 24" W	L•33						✓									
2DB36DR	Two Drawer Base, Drop-in Range 36" W	L•55												✓			
2DB36RDR	Two Drawer Base w/Reduced Drawers, Drop-in Range 36" W	L•56												✓			
B36DR	Base, Drop-in Range 36" W	L•56												✓			
B36RRTDR	Base w/Roll Trays, Drop-in Range 36" W	L•57												✓			
B36RTDR	Base w/Reduced Depth Roll Trays, Drop-in Range 36" W	L•57												✓			
BQRES L or R	Base Quarter Round End Shelf	L•101	✓														
<b>Office &amp; Furniture Cabinets</b>																	
4EDB48NTK	Four Drawer Entertainment Base, No Toekick 48" W	0•14								✓		✓		✓		✓	✓
4EDB48	Four Drawer Entertainment Base 48" W	0•13								✓		✓		✓		✓	✓
DF3D182924	Desk File Drawer Base	0•24				✓											
EB18 L or R	Entertainment Base	0•12	✓	✓	✓												
EEDB	Entry Ensemble Drawer Base	0•3		✓	✓												
EEOB	Entry Ensemble Open Base	0•4		✓	✓												
EOD24	Entertainment Open Drawer	0•12	✓	✓	✓	✓	✓	✓									
EESTW	Entry Ensemble Stacked Wall	0•6		✓	✓												
ESTW1858.5 L or R	Entertainment Stacked Wall	0•13	✓	✓	✓												
EESTWO	Entry Ensemble Stacked Wall Open	0•5		✓	✓												
EESTWO	Entry Ensemble Stacked Wall Open	0•5								✓							
EET	Entry Ensemble Tall	0•3		✓	✓												
EW1236 L or R	Entertainment Wall	0•13	✓														
TT8-BCAV	Tall Bookcase w/Arched Valance	0•29			✓												
TD18-BCAV	Tall Bookcase w/Doors & Arched Valance	0•32			✓												
TD018-BCAV	Tall Bookcase w/Office Height Doors & Arched Valance	0•38			✓												
TDV18-BCAV	Tall Bookcase w/Vanity Height Doors & Arched Valance	0•35			✓												

# Custom Modifications

## General Cabinet Modifications (cont'd)

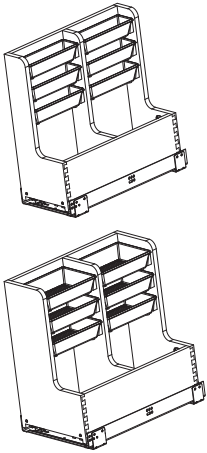

### L-shaped Organizer NEW

Specify VLSOL (L-shaped Organizer Left), VLSOR (L-shaped Organizer Right), and VLSOB (L-shaped Organizer Both)

This option installs an L-shaped Organizer.

- L or R designates installed side.
- Includes 6 acrylic bins in upper section.
- Bottom mounted full extension, Smart Stop slides.
- Pull-out dimensions for 12" wide model are 8 3/4" W x 18 3/4" D x 18 13/16" H.
- Pull-out dimensions for 15" wide model are 11 5/8" W x 18 3/4" D x 18 13/16" H.
- Only available as a modification in select 2VSD, VSB, VCSD, VCDB and 6VSD skus.

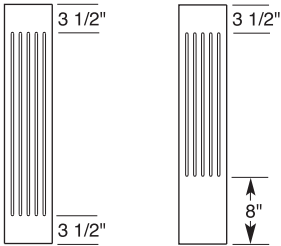

Wall/Base

Base with Flush Toe Kick Option

### Rose Fluting

Specify ROSFLUT3L (3" Rose Flute Left), ROSFLUT3R (3" Rose Flute Right), ROSFLUT3B (3" Rose Flute Both), ROSFLUT3L.P (3" Rose Flute Left - Peninsula), ROSFLUT3R.P (3" Rose Flute Right - Peninsula), or ROSFLUT3B.P (3" Rose Flute Both - Peninsula)

When Rosettes are selected to be used with Fluting, Rosette Fluting (ROSFLUT) must be specified. This option reduces Fluting length 1" on the top and bottom to provide enough space to attach the Rosettes.

- Any option that extends the stiles (Bottom Valance Rail, Flush Toe Kick, Open Bottom Rail Base, Top Valance Rail, and Wide Top Rail) do not extend the Flute dimensions.
- Special spacing between flutes not available.
- See individual cabinets for availability.

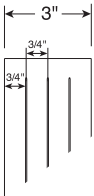
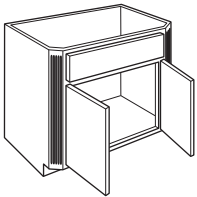

3" detail

## General Cabinet Modifications (cont'd)

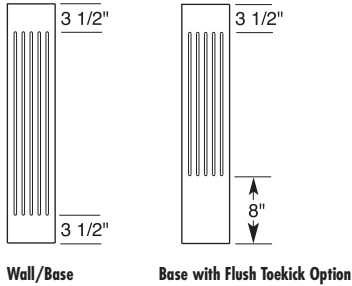

### Rose Fluting on Fillers

Specify ROSFLUT3 (3" Rose Fluting on Filler) or ROSFLUT3CTR (6" Filler Rose Fluted 3" on Center)

When Rosettes are selected to be used with Fluting, Rosette Fluting (ROSFLUT) must be specified. This option reduces Fluting length 1" on the top and bottom to provide enough space to attach the Rosettes.

- Base and Tall End panels with 3" or 6" frame rail return are available with Fluting. Specify Left or Right.
- Special spacing between flute is not available.
- Available in 3" or 6".
- The options Wide Bottom Rail, Wide Top Rail and Flush Toekick do not extend the flute dimensions.
- See individual fillers and panels for availability.

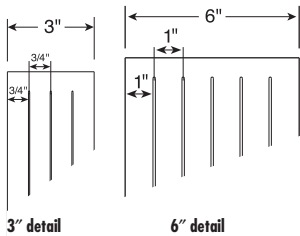

### Sink Base Cleaning Caddy

Specify SBCADDYL (Sink Base Cleaning Caddy Left) or SBCADDYR (Sink Base Cleaning Caddy Right)

- L or R designates installed side.
- Includes one removable basket with handle, one basket without handle, swivel basket and 8 dividers.
- Bottom mounted full extension, Smart Stop slides.
- Caddy dimensions are 11" wide x 20" high x 18 1/2" deep.
- Caddy fits in cabinets with a minimum: 12" wide (15" for inset) x 20 1/2" high (frame opening) x 21" deep.

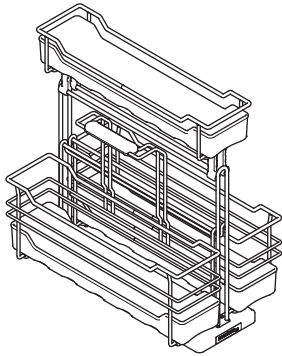

### Sink Base Cleaning Caddy Small

Specify SBCADDYSML (Sink Base Cleaning Caddy Small Left) or SBCADDYSMR (Sink Base Cleaning Caddy Small Right)

- L or R designates installed side.
- Includes one removable basket with handle and four dividers.
- Bottom mounted full extension, Smart Stop slides.
- Caddy dimensions are 6 3/8" wide x 15 3/4" high x 18 1/2" deep.
- Caddy fits in cabinets with a minimum: 9" wide x 16" high (frame opening) x 21" deep.

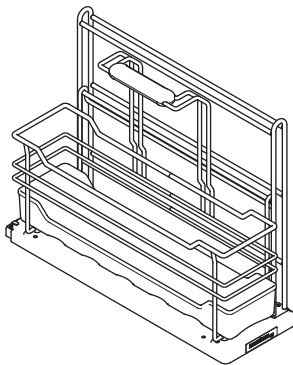

# Custom Modifications

## General Cabinet Modifications (cont'd)

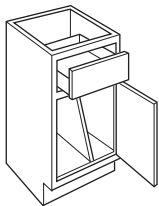

Opening	TD
3	0
6	1
9	1
10 1/2	1
12	2
13 1/2	2
15	2
16 1/2	2
18	3
19 1/2	3
21	3
22 1/2	3
24	4
27	4
30	5
33	5
36	5

### Tray Divider

Specify **\_TD** (Installed Tray Divider), **\_TDBTM** (Installed Tray Divider - Bottom), **\_TDLBTM** (Installed Tray Divider - Left - Bottom), **\_TDRBTM** (Installed Tray Divider - Right - Bottom), **\_TDL** (Installed Tray Divider - Left), **\_TDMID** (Installed Tray Divider - Middle), **\_TDLMID** (Installed Tray Divider - Left - Middle), **\_TDRMID** (Installed Tray Divider - Right - Middle), **\_TDR** (Installed Tray Divider - Right), **\_TDTOP** (Installed Tray Divider - Top), **\_TDLTOP** (Installed Tray Divider - Left - Top), or **\_TDRTOP** (Installed Tray Divider - Right - Top)

Removable Tray Dividers are available installed in cabinets. The Tray Dividers are Natural regardless of the color of the interior of the cabinet. Opening heights of 9" to 39" can have installed Tray Dividers. Tray Dividers can be installed in cabinets with reduced depths (9" minimum), but may not be installed in units over 30" deep.

- Tray Dividers will be evenly spaced unless specified otherwise. When special spacing is requested, 6" minimum between dividers is required.
- See chart for maximum number of dividers per face frame opening.
- When the Tray Divider (TD) option is chosen, shelf holes will not be drilled in cabinet. Shelves will not ship with cabinet.
- Specify the number of tray dividers between 1 and 5.
- See individual cabinets for availability.

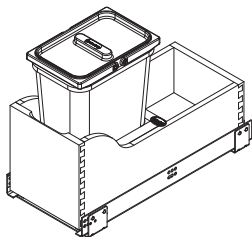

### Vanity Wastebasket Container NEW

Specify **VWBL** (Vanity Wastebasket Container Left) or **VWBR** (Vanity Wastebasket Container Right)

This option installs a Vanity Wastebasket Container.

- L or R designates installed side.
- Includes 8 qt. wastebin.
- Bottom mounted full extension, Smart Stop slides.
- Pull-out dimensions: 8 5/8" W x 18 9/16" D x 13 15/16" H.

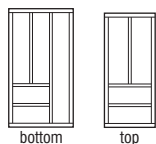
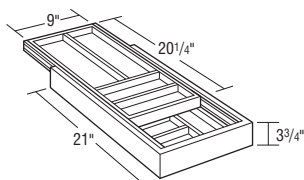

WTCD15

### Wood Tiered Cutlery Divider Drawer

Specify **WTCD** (Installed Wood Tiered Cutlery Divider Drawer), **WTCDL** (Installed Wood Tiered Cutlery Divider Drawer Left), **WTCDR** (Installed Wood Tiered Cutlery Divider Drawer Right), or **WTCDDB** (Installed Wood Tiered Cutlery Divider Drawer Both)

Many base cabinets can be ordered with the standard top drawer (4 1/2" high frame opening) replaced with the WTCD.

- The WTCD is available in six sizes, see chart for availability.
- Available on 24" deep cabinets only.
- Reference page S•5 for detailed dimensions.
- Special sizes not available.

Cabinet Width	Frame Opening Width
15"	12"
18"	15"
21"	18"
24"	21"
30"	27"
36"	33"

General Cabinet Modifications (cont'd)

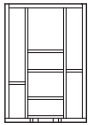
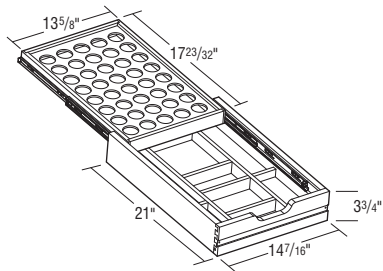

bottom

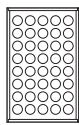

top

### Wood Tiered K-Cup\* Drawer

Specify WTKCUP (Installed Wood Tiered K-Cup Drawer), WTKCUPL (Installed Wood Tiered K-Cup Drawer Left), WTKCUPR (Installed Wood Tiered K-Cup Drawer Right), or WTKCUPB (Installed Wood Tiered K-Cup Drawer Both)

Many base cabinets can be ordered with the standard top drawer (4 1/2" high frame opening) replaced with the WTKCUP.

- The WTKCUP is available in 15" frame opening width.
- Holds 40 K-Cups.
- The Wood Tiered K-Cup Drawer is compatible with K-Cup pods only.
- Available on 24" deep cabinets only.
- Reference page S•6 for detailed dimensions.
- Special sizes not available.

\*K-Cup is a registered trademark of Keurig Green Mountain, Inc.

# Custom Modifications

## Recommendations for Fully Accessible/Barrier-Free Design

---

Many Kemper Emerge modifications may be utilized to increase cabinet accessibility and convenience for the elderly, the physically challenged, and other individuals with special needs.

For your reference when designing for wheelchair access, the most commonly accepted industry standard for toe-kick space is between 8" and 9" high with a 6" set-back. This may be achieved with Kemper Emerge cabinetry by ordering an 8 1/2" high, 6" deep toe space.

The most commonly accepted height for tables and work surfaces is 30" to 33". Ordering 32 1/2" high Kemper Emerge base and vanity base cabinets achieves this standard; call customer service for details.

The addition of roll trays in cabinet interiors is recommended. Utilize the Roll Trays option listed in this "Modifications" section.

The use of easily-gripped cabinet handles and/or knobs is recommended. Choose from several selections in the "Hardware" section of the Kemper Emerge Product Catalog.

The following information from the U.S. Government Publication American National Standards and other sources may also be helpful:

Wheelchair dimensions: length – 42"; open width – 25"; collapsed width – 11"; seat to floor – 19 1/2"; armrest to floor – 29".

Wheelchair access: Minimum turn space for 360° turn – 60"; minimum turn space for 180° turn – 36"; side reach limits – 9" to 54"; safest ramp slope – 1:12; table height – 30" to 33".

Model

**DOORONLY**

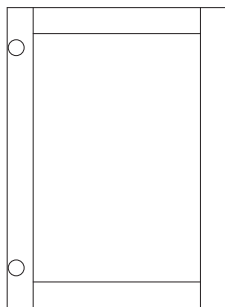

## Door Only

With this option, you can order a special size door with or without hinging.

- Full Overlay Styles:
  - Specify width in  $1/32''$  increments from  $8\ 9/16''$  to  $24''$ .
  - Specify height in  $1/32''$  increments from  $11\ 9/16''$  to  $61\ 1/16''$ .
- Inset & Beaded Inset Styles:
  - Specify width in  $1/32''$  increments from  $5\ 13/16''$  to  $24''$ .
  - Specify height in  $1/32''$  increments from  $8\ 13/16''$  to  $58\ 5/16''$ .
  - No Hinge Cut modification available, see page 6•16 for details.

**DRWFRONLY**

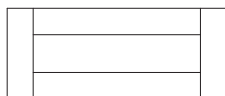

## Drawer Front Only

With this option, you can order a special size drawer front.

- Full Overlay Styles:
  - Specify width in  $1/32''$  increments from  $7\ 1/2''$  to  $47\ 9/16''$ .
  - Specify height in  $1/32''$  increments from  $4\ 1/4''$  to  $14\ 23/32''$ .
- Inset & Beaded Inset Styles:
  - Specify width in  $1/32''$  increments from  $5\ 13/16''$  to  $47\ 9/16''$ .
  - Specify height in  $1/32''$  increments from  $3\ 13/32''$  to  $14\ 23/32''$ .



# Door Size Chart

## Kemper Emerge Standard Door Size Chart

**NOTE:** Using a combination of width and height on this chart must also coincide with standard cabinet size offering. Example: A W912 L or R is not a standard size cabinet offering, therefore an 8 9/16" W x 11 9/16" H door cannot be ordered as a standard door.

Width			
Cabinet Width Where Used	FOL Door Style	Miter Door Style	Inset & Beaded Inset Door Style
BLS33 L or R	7 7/8	7 7/8	7 11/32
9	8 9/16	8 9/16	5 13/16
ER's, BLS36 L or R, etc.	10 7/8	10 7/8	10 11/32
DAB335LS L or R	11 1/4	11 1/4	9 1/16
12	11 9/16	11 9/16	8 13/16
B24	11 3/4	11 3/4	10 11/32
27 Split DR	13 1/16	13 1/16	10 5/16
27 Butt DR	13 1/4	13 1/4	11 27/32
15, 30 Split DR	14 9/16	14 9/16	11 13/16
30 Butt DR	14 3/4	14 3/4	13 11/32
Diagonal	15	15	11 7/8
33 Split DR	16 1/16	16 1/16	13 5/16
33 Butt DR	16 1/4	16 1/4	14 27/32
18, 36 Split DR	17 9/16	17 9/16	14 13/16
36 Butt DR	17 3/4	17 3/4	16 11/32
ACS39 L or R	18 1/4	18 1/4	16 5/16
39 Split DR	19 1/16	19 1/16	16 5/16
39 Butt DR	19 1/4	19 1/4	17 27/32
21, 42	20 9/16	20 9/16	17 13/16
45	22 1/16	22 1/16	19 5/16
24, 48	23 9/16	23 9/16	20 13/16

Height			
Cabinet Height Where Used	FOL Door Style	Miter Door Style	Inset & Beaded Inset Door Style
W_12	11 9/16	11 9/16	8 13/16
W_15	14 9/16	14 9/16	11 13/16
W_18	17 9/16	17 9/16	14 13/16
W_21	20 9/16	20 9/16	17 13/16
W_24	23 9/16	23 9/16	20 13/16
W_27	26 9/16	26 9/16	23 13/16
W_30	29 9/16	29 9/16	26 13/16
W_33	32 9/16	32 9/16	29 13/16
W_36	35 9/16	35 9/16	32 13/16
W_39	38 9/16	38 9/16	35 13/16
W_42	41 9/16	41 9/16	38 13/16
W_45	44 9/16	44 9/16	41 13/16
W_48	47 9/16	47 9/16	44 13/16
STWDAG, DW_DOB - BOTTOM DOOR	17 9/16	17 9/16	16 5/16
STWAG, DW_AG - BOTTOM DOOR	17 13/16	17 13/16	N/A
HP1254 L or R, HPP1254 L or R - BOTTOM DOOR	28 5/16	28 5/16	25 9/16
H36DF_23.5	20 9/16	20 9/16	17 13/16
H54DF_12.75	11 9/16	11 9/16	8 13/16
H60DF_17.5	14 9/16	14 9/16	11 13/16
B	23 1/16	23 1/16	20 5/16
B2D, B4D	17 3/32	17 3/32	13 13/16
B_FH	29 9/32	29 9/32	26 13/16
BCC	17 3/32	17 3/32	13 13/16
CNTYSB	19 1/16	19 1/16	16 5/16
B_DR, B_RTDR, B_RRTDR	23 1/16	23 1/16	20 5/16
HB	17 3/32	17 3/32	13 13/16
U3D, U4D 84" tall	49 1/16	49 1/16	46 5/16
U3D, U4D 87" tall	52 1/16	52 1/16	49 5/16
U3D, U4D 90" tall	55 1/16	55 1/16	52 5/16
U3D, U4D 93" tall	58 1/16	58 1/16	55 5/16
U3D, U4D 96" tall	61 1/16	61 1/16	58 5/16
U - BOTTOM DOOR	61 1/16	61 1/16	58 5/16
UI - MIDDLE DOOR	24 25/32	24 25/32	22 5/16
TPP - BOTTOM DOOR	61 1/16	61 1/16	N/A
VB (32"H)	20 9/16	20 9/16	17 13/16
VB (34.5"H)	23 1/16	23 1/16	20 5/16
V_S (32"H)	26 25/32	26 25/32	24 5/16
V_S (34.5"H)	29 9/32	29 9/32	26 13/16
LC - UPPER DOOR	49 11/32	49 11/32	N/A
BCBCD	21 1/16	21 1/16	18 13/16
BCBH_D	29 9/32	29 9/32	26 13/16
BCWHDBPO_D	23 9/32	23 9/32	20 13/16
BCSTDRW_49.5	34 5/16	34 5/16	32 1/16
BCSTDRW_55.5	40 5/16	40 5/16	38 1/16
BCSTDRW_61.5	46 5/16	46 5/16	44 1/16
BCSTDRW_67.5	52 5/16	52 5/16	50 1/16
BCSTDRW_73.5	58 5/16	58 5/16	56 1/16
BCSTDRW_79.5	49 9/16	49 9/16	47 5/16
BCSTDRW_85.5	55 9/16	55 9/16	53 5/16
BCSTDRW_91.5	61 9/16	61 9/16	59 5/16

Refer to pages F-8-F-18 for standard opening heights of cabinets listed in the Width chart above.

Doors ordered as Authentic will have an unfinished back.

Doors in 1/32" increments will need to be ordered through the parts list.

## Kemper Emerge Standard Drawer Front Size Chart

**NOTE:** Using a combination of width and height on this chart must also coincide with standard cabinet size offering. Example: A 4DB09 is not a standard size cabinet offering, therefore an 8 9/16" W x 6" H drawer front cannot be ordered as a standard drawer front.

Width			
Cabinet Width Where Used	FOL Door Style	Miter Door Style	Inset & Beaded Inset Door Style
9	8 9/16	8 9/16	5 13/16
12	11 9/16	11 9/16	8 13/16
24	23 9/16	23 9/16	20 13/16
27	26 9/16	26 9/16	23 13/16
27 Split DRW	13 1/16	13 1/16	10 5/16
30	29 9/16	29 9/16	26 13/16
15, 30 Split DRW	14 9/16	14 9/16	11 13/16
33	32 9/16	32 9/16	29 13/16
33 Split DRW	16 1/16	16 1/16	13 5/16
18, 36 Split DRW	17 9/16	17 9/16	14 13/16
36	35 9/16	35 9/16	32 13/16
39	38 9/16	38 9/16	35 13/16
39 Split DRW	19 1/16	19 1/16	16 5/16
21, 42 Split DRW	20 9/16	20 9/16	17 13/16
45 Split DRW	22 1/16	22 1/16	19 5/16
48 Split DRW	23 9/16	23 9/16	20 13/16

Height			
Cabinet Height Where Used	FOL Door Style	Miter Door Style	Inset & Beaded Inset Door Style
ADRW	5 3/4	5 3/4	4 1/16
A2DRW	5 3/4	5 3/4	4 1/16
A2DRW18 - 1st	5 3/4	5 3/4	4 1/16
A2DRW18 - 2nd	11 3/4	11 3/4	10 1/16
A3DRW	5 3/4	5 3/4	4 1/16
Base	6	6	4 13/16
B2D & B4D - 1st	6	6	4 13/16
B2D & B4D - 2nd	5 3/4	5 3/4	4 13/16
2DB_RT - 1st	14 17/32	14 17/32	12 9/16
2DB_RT - 2nd	14 17/32	14 17/32	12 9/16
2DB_28 - 1st	10 15/32	10 15/32	8 13/16
2DB_28 - 2nd	12 19/32	12 19/32	10 13/16
2DB_DR - 1st	11 1/8	11 1/8	9 5/16
2DB_DR - 2nd	11 23/32	11 23/32	9 5/16
4 Drawer Base - 1st (30"H)	6	6	4 5/16
4 Drawer Base - 2nd (30"H)	5 3/4	5 3/4	4 5/16
4 Drawer Base - 3rd (30"H)	5 3/4	5 3/4	4 5/16
4 Drawer Base - 4th (30"H)	6 5/8	6 5/8	4 5/16
4 Drawer Base - 1st (32"H)	6	6	4 13/16
4 Drawer Base - 2nd (32"H)	5 3/4	5 3/4	4 13/16
4 Drawer Base - 3rd (32"H)	5 3/4	5 3/4	4 13/16
4 Drawer Base - 4th (32"H)	8 5/8	8 5/8	4 13/16
4 Drawer Base - 1st (34.5"H)	6	6	4 13/16
4 Drawer Base - 2nd (34.5"H)	5 3/4	5 3/4	4 13/16
4 Drawer Base - 3rd (34.5"H)	5 3/4	5 3/4	4 13/16
4 Drawer Base - 4th (34.5"H)	11 1/8	11 1/8	7 5/16

Height			
Cabinet Height Where Used	FOL Door Style	Miter Door Style	Inset & Beaded Inset Door Style
3 Drawer Base - 1st (30"H)	6	6	4 13/16
3 Drawer Base - 2nd (30"H)	5 3/4	5 3/4	4 13/16
3 Drawer Base - 3rd (30"H)	12 19/32	12 19/32	9 5/16
3 Drawer Base - 1st (32"H)	6	6	4 13/16
3 Drawer Base - 2nd (32"H)	7 3/4	7 3/4	5 13/16
3 Drawer Base - 3rd (32"H)	12 19/32	12 19/32	10 5/16
3 Drawer Base - 1st (34.5"H)	6	6	4 13/16
3 Drawer Base - 2nd (34.5"H)	10 1/4	10 1/4	9 5/16
3 Drawer Base - 3rd (34.5"H)	12 19/32	12 19/32	9 5/16
File Drawer Base - 1st (30")	5 3/4	5 3/4	4 1/16
File Drawer Base - 2nd (30")	5 3/4	5 3/4	4 1/16
File Drawer Base - 3rd (30")	12 27/32	12 27/32	11 5/16
File Drawer Base - 1st (34.5")	6	6	4 13/16
File Drawer Base - 2nd (34.5")	10	10	7 13/16
File Drawer Base - 3rd (34.5")	12 27/32	12 27/32	11 5/16
BCC - large front	11 31/32	11 31/32	11 5/16
UCD	4 1/2	4 1/2	3 13/32
BCWHC	10 1/32	10 1/32	8 1/16
BCBCO	8	8	6 5/16
BCBCD	8	8	6 5/16
BCBH_D - 1st	9 5/8	9 5/8	N/A
BCBH_D - 2nd	9 5/8	9 5/8	N/A
BCBH_D - 3rd	9 5/8	9 5/8	N/A
BCWHDB - 1st	11 17/32	11 17/32	9 9/16
BCWHDB - 2nd	11 17/32	11 17/32	9 9/16
BCDB - 1st	6	6	4 13/16
BCDB - 2nd	8 5/16	8 5/16	6 9/16
BCDB - 3rd	14 17/32	14 17/32	12 1/16
BC2DB - 1st	14 17/32	14 17/32	12 9/16
BC2DB - 2nd	14 17/32	14 17/32	12 9/16
BCDRW	14 17/32	14 17/32	12 1/16
BCSTDRW_49.5, 55.5, 61.5, 67.5, 73.5	14 17/32	14 17/32	12 9/16
BCSTDRW_79.5, 85.5, 91.5 - 1st	14 17/32	14 17/32	12 13/16
BCSTDRW_79.5, 85.5, 91.5 - 2nd	14 17/32	14 17/32	12 13/16
EET	12 25/32	12 25/32	10 5/16
EEDB	12 25/32	12 25/32	10 5/16
EOD	11 1/8	11 1/8	8 5/16
4EDB - 1st	10 25/32	10 25/32	8 13/16
4EDB - 2nd	10 25/32	10 25/32	8 13/16
4EDB - 1st	6	6	4 13/16
4EDB - 2nd	11 1/16	11 1/16	8 5/16
6EDB - 1st	10 25/32	10 25/32	8 13/16
6EDB - 2nd	10 25/32	10 25/32	8 13/16
EBDB - 1st	6	6	4 13/16
EBDB - 2nd	11 1/16	11 1/16	8 5/16
DFD - 1st	5 3/4	5 3/4	4 1/16
DFD - 2nd	5 3/4	5 3/4	4 1/16
DFD - 3rd	12 27/32	12 27/32	11 5/16

Refer to pages F•8-F•18 for standard opening heights of cabinets listed in the Width chart above.

Drawer Fronts ordered as Authentic will have an unfinished back.

# Specialty Doors

## Estate Mullion Doors Ordering Procedures

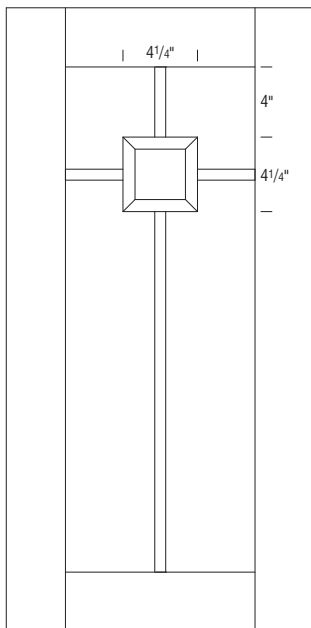

### Muntin Profiles



Gordon  
Gordon Beaded Inset  
Gordon Inset  
Kirby  
Kirby Beaded Inset  
Kirby Inset



Shanley  
Shanley Beaded Inset  
Shanley Inset



Vinson

- When ordering glass mullion doors, use Kemper Emerge's standard cabinet item number (W3030, W2430 L or R, DW302424 L or R, etc.) and then designate the corresponding option name (see below) in the description portion of the purchase order.
- All glass mullion doors ordered will be of the same wood species, finish, door style, hinge selection, and profile as the other cabinets specified on the original kitchen order unless instructed otherwise.
- Door is prepared for glass insert; dealer must supply glass. Designed to utilize one piece of glass per door — not separate panes. Clips for inserting glass included in installation package. Doors are pre-drilled for clips.
- Door styles not available include: Burke, Burke Beaded Inset, Burke Inset, Decker, Decker Beaded Inset, Decker Inset, Landry, Landry Beaded Inset, Landry Inset, Tate, Tate Beaded Inset, and Tate Inset.
- Must specify Matching Interior if desired. When a decorative door option is chosen in 20/20, Matching Interior Plywood (MIP) is a preselected option. If MIP is not desired, it can be deselected by choosing NOTMIP.
- Mullion doors are not available on cabinets that are taller than 48".
  - This includes any cabinet that is modified to be taller than 48".

Option Name	Cabinet Height
ESMD15	15"
ESMD18	18"
ESMD21	21"
ESMD24	24"
ESMD27	27"
ESMD30	30"
ESMD33	33"
ESMD36	36"
ESMD39	39"
ESMD42	42"
ESMD45	45"
ESMD48	48"

Door Style	Min. Door Width	Min. Door Height	Min. Cabinet Width	Min. Cabinet Height
Gordon	14 9/16"	17 9/16"	15"	18"
Gordon Inset	14 13/16"	17 13/16"	18"	21"
Kirby	14 9/16"	17 9/16"	15"	18"
Kirby Inset	14 13/16"	17 13/16"	18"	21"
Shanley	14 9/16"	17 9/16"	15"	18"
Shanley Inset	14 13/16"	17 13/16"	18"	21"
Vinson	14 9/16"	17 9/16"	15"	18"

## Gallery Mullion Doors Ordering Procedures

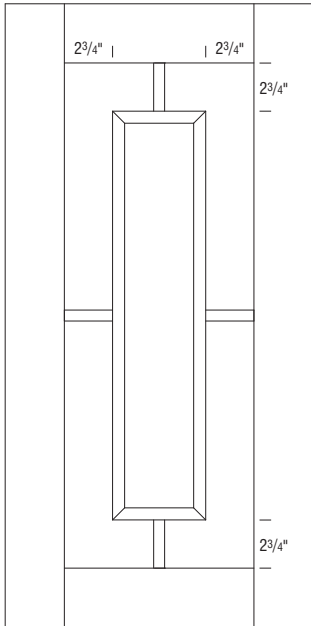

### Muntin Profiles



- Gordon
- Gordon Beaded Inset
- Gordon Inset
- Kirby
- Kirby Beaded Inset
- Kirby Inset

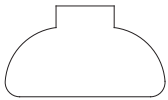

- Shanley
- Shanley Beaded Inset
- Shanley Inset



- Vinson

- When ordering glass mullion doors, use Kemper Emerge’s standard cabinet item number (W3030, W2430 L or R, DW302424 L or R, etc.) and then designate the corresponding option name (see below) in the description portion of the purchase order.
- All glass mullion doors ordered will be of the same wood species, finish, door style, hinge selection, and profile as the other cabinets specified on the original kitchen order unless instructed otherwise.
- Door is prepared for glass insert; dealer must supply glass. Designed to utilize one piece of glass per door — not separate panes. Clips for inserting glass included in installation package. Doors are pre-drilled for clips.
- Door styles not available include: Burke, Decker, Decker Beaded Inset, Decker Inset, Landry, Landry Beaded Inset, Landry Inset, Tate, Tate Beaded Inset, Tate Inset.
- Must specify Matching Interior if desired. When a decorative door option is chosen in 20/20, Matching Interior Plywood (MIP) is a preselected option. If MIP is not desired, it can be deselected by choosing NOTMIP.
- Mullion doors are not available on cabinets that are taller than 48”.
  - This includes any cabinet that is modified to be taller than 48”.

Option Name	Cabinet Height
GAMD15	15”
GAMD18	18”
GAMD21	21”
GAMD24	24”
GAMD27	27”
GAMD30	30”
GAMD33	33”
GAMD36	36”
GAMD39	39”
GAMD42	42”
GAMD45	45”
GAMD48	48”

Door Style	Min. Door Width	Min. Door Height	Min. Cabinet Width	Min. Cabinet Height
Gordon	13 1/4”	14 9/16”	15”	15”
Gordon Inset	14 13/16”	14 13/16”	18”	18”
Kirby	13 1/4”	14 9/16”	15”	15”
Kirby Inset	14 13/16”	14 13/16”	18”	18”
Shanley	13 1/4”	14 9/16”	15”	15”
Shanley Inset	14 13/16”	14 13/16”	18”	18”
Vinson	13 1/4”	14 9/16”	15”	15”

# Specialty Doors

## Mullion Doors Ordering Procedures

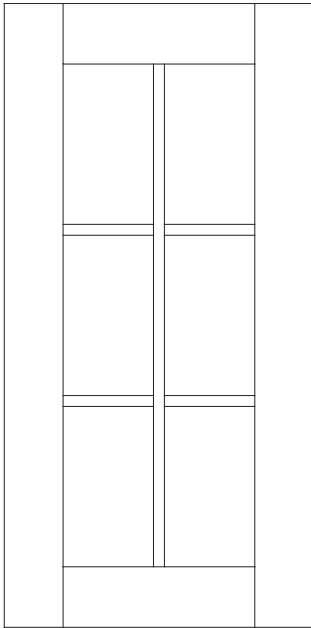

### Muntin Profiles



Gordon  
Gordon Beaded Inset  
Gordon Inset  
Kirby  
Kirby Beaded Inset  
Kirby Inset

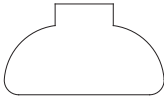

Shanley  
Shanley Beaded Inset  
Shanley Inset



Vinson

- When ordering glass mullion doors, use Kemper Emerge's standard cabinet item number (W3030, W2430 L or R, DW302424 L or R, etc.) and then designate the corresponding option name (see below) in the description portion of the purchase order.
- All glass mullion doors ordered will be of the same wood species, finish, door style, hinge selection, and profile as the other cabinets specified on the original kitchen order unless instructed otherwise.
- Door is prepared for glass insert; dealer must supply glass. Designed to utilize one piece of glass per door — not separate panes. Clips for inserting glass included in installation package. Doors are pre-drilled for clips.
- Door styles not available include: Burke, Decker, Decker Beaded Inset, Decker Inset, Landry, Landry Beaded Inset, Landry Inset, Tate, Tate Beaded Inset, and Tate Inset.
- Full Overlay:
  - Not available on cabinets with bifold doors, cabinets less than 15" high or more than 48" high and cabinets less than 12" wide.
- Inset and Beaded Inset:
  - Not available on cabinets with bifold doors, cabinets less than 18" high or more than 48" high and cabinets less than 15" wide.
- Must specify Matching Interior if desired. When a decorative door option is chosen in 20/20, Matching Interior Plywood (MIP) is a preselected option. If MIP is not desired, it can be deselected by choosing NOTMIP.

Option Name	Cabinet Height	Number of Lites per Door
MD15	15"	4
MD18	18"	4
MD21	21"	4
MD24	24"	4
MD27	27"	4
MD30	30"	6
MD33	33"	6
MD36	36"	6
MD39	39"	8
MD42	42"	8
MD45	45"	8
MD48	48"	8

# Prairie Mullion Doors Ordering Procedures

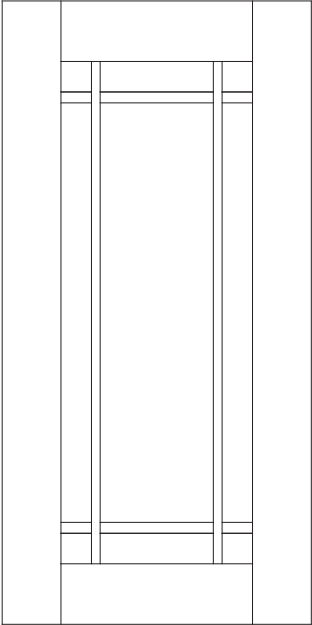

**Muntin Profiles**



- Gordon
- Gordon Beaded Inset
- Gordon Inset
- Kirby
- Kirby Beaded Inset
- Kirby Inset

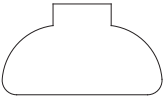

- Shanley
- Shanley Beaded Inset
- Shanley Inset

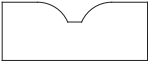

- Vinson

- When ordering Prairie glass mullion doors, use Kemper Emerge’s standard cabinet item number (W3030, W2430 L or R, DW302424 L or R, etc.) and then designate the corresponding option name (see below) in the description portion of the purchase order.
- All glass mullion doors ordered will be of the same wood species, finish, door style, hinge selection, and profile as the other cabinets specified on the original kitchen order unless instructed otherwise.
- Door is prepared for glass inset; dealer must supply glass. Designed to utilize one piece of glass per door — not separate panes. Clips for inserting glass included in installation package. Doors are pre-drilled for clips.
- Doors more than 48” tall have two panels routed for glass, divided by a horizontal mullion.
- Door styles not available include: Burke, Decker, Decker Beaded Inset, Decker Inset, Landry, Landry Beaded Inset, Landry Inset, Tate, Tate Beaded Inset, and Tate Inset.
- Full Overlay and 3/4” Overlay:
  - Not available on cabinets with bifold doors, cabinet less than 18” high or more than 48” high, cabinets less than 12” wide, and 24” wide two door cabinets.
- Inset and Beaded Inset:
  - Not available on cabinets with bifold doors, cabinets less than 21” high or more than 48” high and cabinets less than 15” wide.
- Must specify Matching Interior if desired. When a decorative door option is chosen in 20/20, Matching Interior Plywood (MIP) is a preselected option. If MIP is not desired, it can be deselected by choosing NOTMIP.

Option Name	Cabinet Height
PRMD18	18”
PRMD21	21”
PRMD24	24”
PRMD27	27”
PRMD30	30”
PRMD33	33”
PRMD36	36”
PRMD39	39”
PRMD42	42”
PRMD45	45”
PRMD48	48”

# Specialty Doors

## Shaker Mullion Doors Ordering Procedures

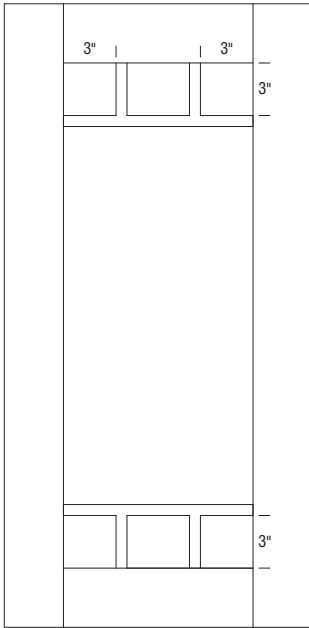

### Muntin Profiles



Gordon  
Gordon Beaded Inset  
Gordon Inset  
Kirby  
Kirby Beaded Inset  
Kirby Inset

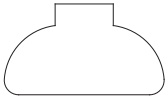

Shanley  
Shanley Beaded Inset  
Shanley Inset



Vinson

- When ordering glass mullion doors, use Kemper Emerge's standard cabinet item number (W3030, W2430 L or R, DW302424 L or R, etc.) and then designate the corresponding option name (see below) in the description portion of the purchase order.
- All glass mullion doors ordered will be of the same wood species, finish, door style, hinge selection, and profile as the other cabinets specified on the original kitchen order unless instructed otherwise.
- Door is prepared for glass insert; dealer must supply glass. Designed to utilize one piece of glass per door — not separate panes. Clips for inserting glass included in installation package. Doors are pre-drilled for clips.
- Door styles not available include: Burke, Decker, Decker Beaded Inset, Decker Inset, Landry, Landry Beaded Inset, Landry Inset, Tate, Tate Beaded Inset, and Tate Inset.
- Must specify Matching Interior if desired. When a decorative door option is chosen in 20/20, Matching Interior Plywood (MIP) is a preselected option. If MIP is not desired, it can be deselected by choosing NOTMIP.
- Mullion doors are not available on cabinets that are taller than 48".
  - This includes any cabinet that is modified to be taller than 48".

Option Name	Cabinet Height
SHMD15	15"
SHMD18	18"
SHMD21	21"
SHMD24	24"
SHMD27	27"
SHMD30	30"
SHMD33	33"
SHMD36	36"
SHMD39	39"
SHMD42	42"
SHMD45	45"
SHMD48	48"

Door Style	Min. Door Width	Min. Door Height	Min. Cabinet Width	Min. Cabinet Height	Door Size Range for Single Vertical Muntin	Door Size Range for Double Vertical Muntin
Gordon	11 9/16"	17 9/16"	12"	18"	11 9/16" to 14 1/2"	14 9/16" to 23 9/16"
Gordon Inset	11 13/16"	17 13/16"	15"	21"	11 13/16" to 14 1/2"	14 9/16" to 23 9/16"
Kirby	11 9/16"	17 9/16"	12"	18"	11 9/16" to 14 1/2"	14 9/16" to 23 9/16"
Kirby Inset	11 13/16"	17 13/16"	15"	21"	11 13/16" to 14 1/2"	14 9/16" to 23 9/16"
Shanley	11 9/16"	17 9/16"	12"	18"	11 9/16" to 14 1/2"	14 9/16" to 23 9/16"
Shanley Inset	11 13/16"	17 13/16"	15"	21"	11 13/16" to 14 1/2"	14 9/16" to 23 9/16"
Vinson	11 9/16"	17 9/16"	12"	18"	11 9/16" to 14 1/2"	14 9/16" to 23 9/16"

## Summit Mullion Doors Ordering Procedures

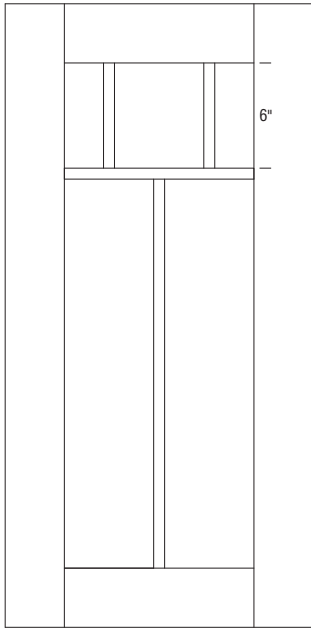

- When ordering glass mullion doors, use Kemper Emerge’s standard cabinet item number (W3030, W2430 L or R, DW302424 L or R, etc.) and then designate the corresponding option name (see below) in the description portion of the purchase order.
- All glass mullion doors ordered will be of the same wood species, finish, door style, hinge selection, and profile as the other cabinets specified on the original kitchen order unless instructed otherwise.
- Door is prepared for glass insert; dealer must supply glass. Designed to utilize one piece of glass per door — not separate panes. Clips for inserting glass included in installation package. Doors are pre-drilled for clips.
- Door styles not available include: Burke, Decker, Decker Beaded Inset, Decker Inset, Landry, Landry Beaded Inset, Landry Inset, Tate, Tate Beaded Inset, and Tate Inset.
- Must specify Matching Interior if desired. When a decorative door option is chosen in 20/20, Matching Interior Plywood (MIP) is a preselected option. If MIP is not desired, it can be deselected by choosing NOTMIP.
- Mullion doors are not available on cabinets that are taller than 48”.
  - This includes any cabinet that is modified to be taller than 48”.

Option Name	Cabinet Height
SUMD15	15”
SUMD18	18”
SUMD21	21”
SUMD24	24”
SUMD27	27”
SUMD30	30”
SUMD33	33”
SUMD36	36”
SUMD39	39”
SUMD42	42”
SUMD45	45”
SUMD48	48”

### Muntin Profiles



- Gordon
- Gordon Beaded Inset
- Gordon Inset
- Kirby
- Kirby Beaded Inset
- Kirby Inset

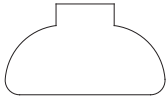

- Shanley
- Shanley Beaded Inset
- Shanley Inset



- Vinson

Door Style	Min. Door Width	Min. Door Height	Min. Cabinet Width	Min. Cabinet Height	Door Size Range for Single Vertical Muntin	Door Size Range for Double Vertical Muntin
Gordon	11 9/16”	17 9/16”	12”	18”	11 9/16” to 13 3/16”	13 1/4” to 23 9/16”
Gordon Inset	11 13/16”	17 13/16”	15”	21”	11 13/16” to 14 1/2”	14 9/16” to 23 9/16”
Kirby	11 9/16”	17 9/16”	12”	18”	11 9/16” to 13 3/16”	13 1/4” to 23 9/16”
Kirby Inset	11 13/16”	17 13/16”	15”	21”	11 13/16” to 14 1/2”	14 9/16” to 23 9/16”
Shanley	11 9/16”	17 9/16”	12”	18”	11 9/16” to 13 3/16”	13 1/4” to 23 9/16”
Shanley Inset	11 13/16”	17 13/16”	15”	21”	11 13/16” to 14 1/2”	14 9/16” to 23 9/16”
Vinson	11 9/16”	17 9/16”	12”	18”	11 9/16” to 13 3/16”	13 1/4” to 23 9/16”



# Specialty Doors

## Craftsman Doors Ordering Procedures

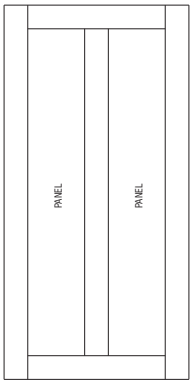

CCP (Craftsman with Center Panels)

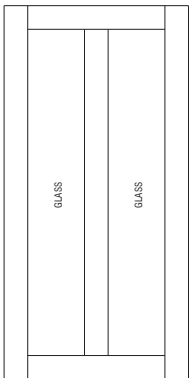

CCG (Craftsman with Cut-for-glass)

- When ordering Craftsman Door, use Kemper Emerge's standard cabinet item number (W2430 L or R, W4830, etc.) and then designate the corresponding option name (see below) in the description portion of the purchase order.
- All Craftsman Doors ordered will be of the same wood species, finish, door style, hinge selection, and profile as the other cabinets specified on the original kitchen order unless instructed otherwise.
- Craftsman Doors available on wall cabinets only starting at 12" height through 48" height cabinets.
- Both sections will be equal size.
- Due to the width and height size limitations for Craftsman Doors, the Authentic Flush End modification may not match the Craftsman Door configuration specified. The door configuration for Authentic Flush End modification will be the CCP option when achievable (Cut-for-glass is not available), otherwise the door configuration will match the door style of the order. Refer to page H•11 for minimum width and height by style.
- Due to the width and height size limitations for Craftsman Doors, the Face Frame and Door on End modification may not match the Craftsman Door configuration specified. The door configuration for Face Frame and Door on End modification will match the Craftsman option chosen when achievable, otherwise the door configuration will match the door style of the order. Refer to page H•11 for minimum width and height by style.
- If Craftsman option is selected in conjunction with IPEL or IPER option, the IPE doors will NOT match the front doors on the cabinet. They will remain standard doors on the IPE side. The door widths are too small to produce in Craftsman Door type.
- If Craftsman option is selected in conjunction with INTGEL or INTGER option, the INTEGRAL doors will NOT match the front doors on the cabinet. They will remain standard doors on the integral side. The door widths are too small to produce in Craftsman Door type.
- Door styles not available include: Tate.
- Matching Interior must be specified on CCG if desired. When a decorative door option is chosen in 20/20 for CCG, Matching Interior Plywood (MIP) is a preselected option. If MIP is not desired, it can be deselected by choosing NOTMIP.
- See chart on page H•11 for minimum width and height availability by style.
- For CCG modification, the door is prepared for glass. Two separate, equal sizes of glass will be required. Clips for inserting glass included in cabinet.
- Glass is not included.
- Art Glass is not available.
- See chart below for minimum width and height per door style for glass availability through Kemper Emerge.

Craftsman Door Minimums for Kemper Emerge to Supply Glass		
Door Style	Min. Door Width	Min. Door Height
Burke	16 1/4"	11 9/16"
Decker	18 1/4"	11 9/16"
Decker Inset	18 1/4"	11 9/16"
Gordon	16 1/4"	11 9/16"
Gordon Inset	16 1/4"	11 9/16"
Kirby	16 1/4"	11 9/16"
Kirby Inset	16 1/4"	11 9/16"
Landry	16 1/4"	11 9/16"
Landry Inset	16 1/4"	11 9/16"
Shanley	16 1/4"	11 9/16"
Shanley Inset	16 1/4"	11 9/16"
Tate	N/A	N/A
Tate Inset	N/A	N/A
Vinson	16 1/4"	11 9/16"

Craftsman Doors Ordering Procedures (cont'd)

Door Style	Min. Door Width	Min. Door Height	Min. Cabinet Width	Min. Cabinet Height
Burke	11 9/16"	11 9/16"	12"	12"
Decker	14 1/4"	11 9/16"	14 3/4"	12"
Decker Inset	14 1/4"	11 9/16"	17 1/2"	14 3/4"
Gordon	11 9/16"	11 9/16"	12"	12"
Gordon Inset	11 9/16"	11 9/16"	14 3/4"	14 3/4"
Kirby	11 9/16"	11 9/16"	12"	12"
Kirby Inset	11 9/16"	11 9/16"	14 3/4"	14 3/4"
Landry	13 1/2"	11 9/16"	14"	12"
Landry Inset	13 1/2"	11 9/16"	16 3/4"	14 3/4"
Shanley	11 3/4"	11 9/16"	12 1/4"	12"
Shanley Inset	11 13/16"	11 9/16"	15"	14 3/4"
Tate	N/A	N/A	N/A	N/A
Tate Inset	N/A	N/A	N/A	N/A
Vinson	11 9/16"	11 9/16"	12"	12"

# Specialty Doors

## Horizon Doors Ordering Procedures

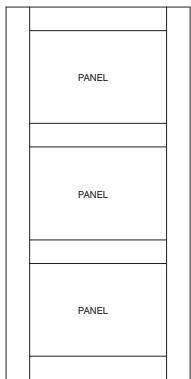

HCP (Horizon with Center Panels)

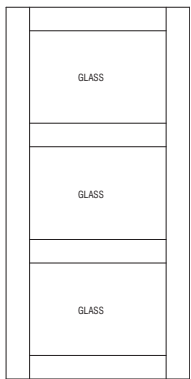

HCG (Horizon with Cut-for-glass)

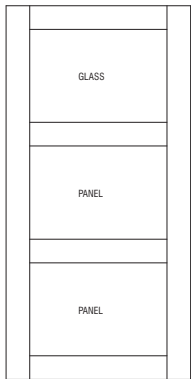

HCGCP (Horizon with Cut-for-glass Top and Center Panels)

- When ordering Horizon Door, use Kemper Emerge's standard cabinet item number (W2430 L or R, W4830, etc.) and then designate the corresponding option name (see below) in the description portion of the purchase order.
- All Horizon Doors ordered will be of the same wood species, finish, door style, hinge selection, and profile as the other cabinets specified on the original kitchen order unless instructed otherwise.
- Horizon Doors available on wall cabinets only starting at 30" height through 48" height cabinets.
- For HCG modification, the door is prepared for glass. Three separate, equal sizes of glass will be required. Clips for inserting glass included in cabinet.
- For HCGCP modification, the top section only is prepared for glass. Clips for inserting glass included in cabinet.
- All three sections will be equal size.
- Due to the width and height size limitations for Horizon Doors, the Authentic Flush End modification may not match the Horizon Door configuration specified. The door configuration for Authentic Flush End modification will be the HCP option when achievable (Cut-for-glass is not available), otherwise the door configuration will match the door style of the order. Refer to page H•12 for minimum width and height by style.
- Due to the width and height size limitations for Horizon Doors, the Face Frame and Door on End modification may not match the Horizon Door configuration specified. The door configuration for Face Frame and Door on End modification will match the Horizon option chosen when achievable, otherwise the door configuration will match the door style of the order. Refer to page H•12 for minimum width and height by style.
- If Horizon option is selected in conjunction with IPEL or IPER option, the IPE doors will NOT match the front doors on the cabinet. They will remain standard doors on the IPE side. The door widths are too small to produce in Horizon Door type.
- If Horizon option is selected in conjunction with INTGEL or INTGER option, the INTEGRAL doors will NOT match the front doors on the cabinet. They will remain standard doors on the integral side. The door widths are too small to produce in Horizon Door type.
- When Modified Full Overlay modification is selected in conjunction with Horizon, the three sections will remain equal.
- Matching Interior must be specified on HCG and HCGCP if desired. When a decorative door option is chosen in 20/20 for HCG and HCGCP, Matching Interior Plywood (MIP) is a preselected option. If MIP is not desired, it can be deselected by choosing NOTMIP.
- See chart on page H•12 for minimum width and height availability by style.

Door Style	Min. Door Width	Min. Door Height	Min. Cabinet Width	Min. Cabinet Height
Burke	11 9/16"	29 9/16"	12"	30"
Decker	11 9/16"	29 9/16"	12"	30"
Decker Inset	11 13/16"	26 13/16"	15"	30"
Gordon	11 9/16"	29 9/16"	12"	30"
Gordon Inset	11 13/16"	26 13/16"	15"	30"
Kirby	11 9/16"	29 9/16"	12"	30"
Kirby Inset	11 13/16"	26 13/16"	15"	30"
Landry	11 9/16"	29 9/16"	12"	30"
Landry Inset	11 13/16"	26 13/16"	15"	30"
Shanley	11 9/16"	29 9/16"	12"	30"
Shanley Inset	11 13/16"	26 13/16"	15"	30"
Tate	11 9/16"	29 9/16"	12"	30"
Tate Inset	11 13/16"	26 13/16"	15"	30"
Vinson	11 9/16"	29 9/16"	12"	30"

## Mission Doors Ordering Procedures

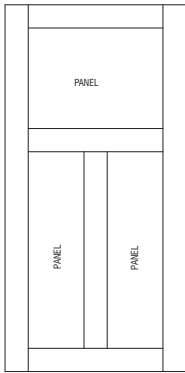

MCP (Mission with Center Panels)

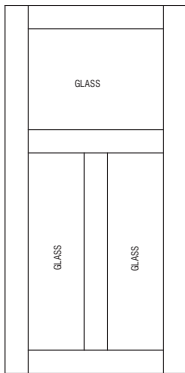

MCG (Mission with Cut-for-glass)

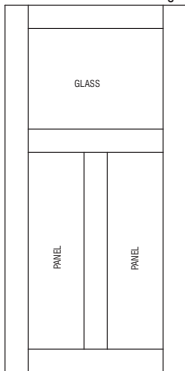

MCGCP (Mission with Cut-for-glass Top and Center Panels)

- When ordering Mission Door, use Kemper Emerge's standard cabinet item number (W2430 L or R, W4830, etc.) and then designate the corresponding option name (see below) in the description portion of the purchase order.
- All Mission Doors ordered will be of the same wood species, finish, door style, hinge selection, and profile as the other cabinets specified on the original kitchen order unless instructed otherwise.
- Mission Doors available on wall cabinets only starting at 30" height through 48" height cabinets.
- For MCG modification, the door is prepared for glass. Three separate pieces of glass in two sizes will be required. Clips for inserting glass included in cabinet.
- For MCGCP modification, the top section only is prepared for glass. Clips for inserting glass included in cabinet.
- The upper section of the door will always have a 12" tall section, which includes the width of the upper crossrails and the upper opening.
- Bottom section is two equal sections.
- Due to the width and height size limitations for Mission Doors, the Authentic Flush End modification may not match the Mission Door configuration specified. The door configuration for Authentic Flush End modification will be the MCP option when achievable (Cut-for-glass is not available), otherwise the door configuration will match the door style of the order. Refer to page H•14 for minimum width and height by style.
- Due to the width and height size limitations for Mission Doors, the Face Frame and Door on End modification may not match the Mission Door configuration specified. The door configuration for Face Frame and Door on End modification will match the Mission option chosen when achievable, otherwise the door configuration will match the door style of the order. Refer to page H•14 for minimum width and height by style.
- If Mission option is selected in conjunction with IPEL or IPER option, the IPE doors will NOT match the front doors on the cabinet. They will remain standard doors on the IPE side. The door widths are too small to produce in Mission Door type.
- If Mission option is selected in conjunction with INTGEL or INTGER option, the INTEGRAL doors will NOT match the front doors on the cabinet. They will remain standard doors on the integral side. The door widths are too small to produce in Mission Door type.
- Door styles not available include: Tate.
- Matching Interior must be specified on MCG and MCGCP if desired. When a decorative door option is chosen in 20/20 for MCG and MCGCP, Matching Interior Plywood (MIP) is a preselected option. If MIP is not desired, it can be deselected by choosing NOTMIP.
- See chart on page H•14 for minimum width and height availability by style.
- For MCG modification, the door is prepared for glass; dealer must supply glass. Each opening will require a separate piece of glass. Clips for inserting glass included in installation package.
- Glass is not included. When ordering glass, three separate pieces of glass in two sizes will be required. Art Glass is not available.
- See chart below for minimum width and height per door style for glass availability through Kemper Emerge.

Mission Door Minimums for Kemper Emerge to Supply Glass		
Door Style	Min. Door Width	Min. Door Height
Burke	16 1/4"	29 9/16"
Decker	18 1/4"	29 9/16"
Decker Inset	18 1/4"	26 13/16"
Gordon	16 1/4"	29 9/16"
Gordon Inset	16 1/4"	26 13/16"
Kirby	16 1/4"	29 9/16"
Kirby Inset	16 1/4"	26 13/16"
Landry	16 1/4"	29 9/16"
Landry Inset	16 1/4"	26 13/16"
Shanley	16 1/4"	29 9/16"
Shanley Inset	16 1/4"	26 13/16"
Tate	N/A	N/A
Tate Inset	N/A	N/A
Vinson	16 1/4"	29 9/16"

# Specialty Doors

## Mission Doors Ordering Procedures (cont'd)

Door Style	Min. Door Width	Min. Door Height	Min. Cabinet Width	Min. Cabinet Height
Burke	11 9/16"	29 9/16"	12"	30"
Decker	14 1/4"	29 9/16"	14 3/4"	30"
Decker Inset	14 1/4"	26 13/16"	17 1/2"	30"
Gordon	11 9/16"	29 9/16"	12"	30"
Gordon Inset	11 9/16"	26 13/16"	14 3/4"	30"
Kirby	11 9/16"	29 9/16"	12"	30"
Kirby Inset	11 9/16"	26 13/16"	14 3/4"	30"
Landry	13 1/2"	29 9/16"	14"	30"
Landry Inset	13 1/2"	29 13/16"	16 3/4"	30"
Shanley	11 3/4"	29 9/16"	12 1/4"	30"
Shanley Inset	11 13/16"	26 13/16"	15"	30"
Tate	N/A	N/A	N/A	N/A
Tate Inset	N/A	N/A	N/A	N/A
Vinson	11 9/16"	29 9/16"	12"	30"

## Transom Doors Ordering Procedures

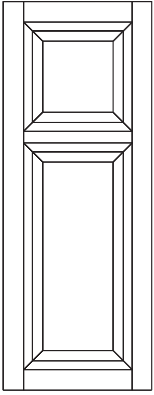

TCP (Transom with both sections Center Panel)

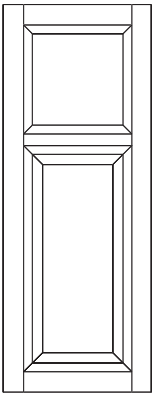

TCG (Transom with Top Cut-for-glass and Bottom Center Panel)

- Cabinets can be ordered with Transom Doors. Clips to attach glass are included.
- The upper section of the door will always have a 12" tall section, which includes the width of the upper crossrails and the upper opening.
- Authentic End will always be Transom with both sections Center Panel.
- Face Frame and Door on End option will always match the face.
- Center panel standard on lower section. Cut-for-glass Door option available on lower section.
- When Modified Full Overlay modification is selected in conjunction with Transom, the bottom section of door will decrease in height by 1 inch.
- Glass is not included.
- Available on:
  - Decker, Gordon, Kirby, and Tate.
  - 36", 39", 42", 45" and 48" high doors
- Transom with Top for Glass and Bottom Center Panel (TCG) not available on:
  - Corner Walls and Wall Message Centers.
- When a decorative door option is chosen in 20/20 for TCG, TCPCG or TCGCG, Matching Interior Plywood (MIP) is a preselected option. If MIP is not desired, it can be deselected by choosing NOTMIP.

Option Name	Cabinet Height
TCG / TCP	36"
TCG / TCP	39"
TCG / TCP	42"
TCG / TCP	45"
TCG / TCP	48"

# Specialty Doors

## Aluminum Doors

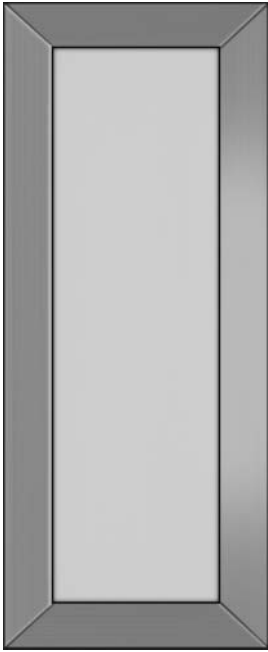

- Available in full overlay and inset styles.
- Inset finial hinges not available on aluminum doors.
- Limited cabinet availability, see chart below for details.
- Must specify Matching Interior if desired. When a decorative door option is chosen in 20/20, Matching Interior Plywood (MIP) is a preselected option. If MIP is not desired, it can be deselected by choosing NOTMIP.
- Specify profile in desired finish and insert. Reference pages H●17-H●19 for profile, finish and insert availability.
- Use of decorative hardware with profile AFO06 and Glass or Backpainted Glass insert must be pre-drilled. Refer to Aluminum Frame Door Order Form, page V●8.

Aluminum Doors Availability
B9FH L or R - B48FH
DW_AGS (top door only)
DW, DW_S (top, bottom, or both)
DW_P
EET, EESTWO, EESTW
HP (excluding the pull-out section)
MW
STW12__-STW48__ (top, bottom or both)
STWAG_ (top door only)
U (upper)
U3D
U4D
UOC (upper)
WOBS
W_P
W_24
W9__-W48__
WB
WC
WEC, AEW, AEWFFD, AEW-45, AEWFFD-45
WWR

## Aluminum Door Profiles

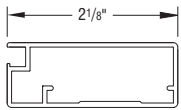

### Profile AF003

- Available in the following anodized finishes:
  - Natural Aluminum and Brushed Stainless.
- Available in the following powder coated finishes:
  - Black, White and Oil Rubbed Bronze.
- Specify door to be modified. See order form for details.

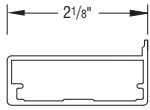

### Profile AF006

- Available with backpainted glass insert only.
- Available in the following anodized finishes:
  - Natural Aluminum and Brushed Stainless.
- Available in the following powder coated finishes:
  - Black, White and Oil Rubbed Bronze.
- Specify door to be modified. See order form for details.
- If Decorative hardware drilling is required it must be specified on Glass and Backpainted Glass inserts. Refer to Aluminum Frame Door Order Form, page V●8. Glass inserts are tempered and cannot be drilled after this process.

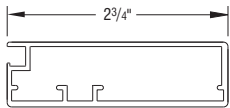

### Profile AF007

- Available in the following anodized finishes:
  - Natural Aluminum and Brushed Stainless.
- Available in the following powder coated finishes:
  - Black, White and Oil Rubbed Bronze.
- Specify door to be modified. See order form for details.



# Specialty Doors

## Aluminum Door Profiles

Profile and Finish	
Profile	Natural Aluminum
AF003	AF003NA
AF006	AF006NA
AF007	AF007NA

Profile and Finish	
Profile	Brushed Stainless
AF003	AF003S
AF006	AF006S
AF007	AF007S

Profile and Finish	
Profile	Rubbed Bronze
AF003	AF003RB
AF006	AF006RB
AF007	AF007RB

Profile and Finish		
Profile	White	Black
AF003	AF003W	AF003B
AF006	AF006W	AF006B
AF007	AF007W	AF007B

## Inserts for Aluminum Doors

Inserts are required for the preceding aluminum door profiles

Glass	Modification
Clear Glass	AF_CLEAR
Satin Glass	AF_SATIN

Backpainted Glass Finish	Modification
White Gloss	AF_WHITE_GLO
White Matte	AF_WHITE_MAT
Bronze Gloss	AF_BRONZE_GLO
Bronze Matte	AF_BRONZE_MAT

Metallic Inserts	Modification
Aluminum Lam	AF_ALUMINUM
Brushed Stainless Lam	AF_STAINLESS
Platinum Ice Ac	AF_PLATINUM

Insert Finish
Clear glass
Satin glass
Backpainted glass - gloss
Backpainted glass - matte
Metallic Inserts

# Specialty Doors

## Decorative Glass Insert

### Art Glass Inserts

Style	Panel Thickness	Coming Material	Modification Code
Anson	1/4"	Zinc Black Patina	ANSO__
Avalon	1/4"	Zinc	AVAL__
Ballard	1/4"	Zinc	BALL__
Beckett	1/4"	Zinc Black Patina	BECK__
Bennington Brass	1/4"	Brass	BENB__
Bennington Patina	1/4"	Zinc Black Patina	BENP__
Delray	1/4"	Zinc	DELR__
Emery*	1/4"	Copper	EMER__
Fenton	1/4"	Zinc	FENT__
Foster	1/4"	Zinc	FOST__
Merrimack	1/4"	Zinc Black Patina	MERR__
Serafina	1/4"	Brass	SERA__
Stratton	1/4"	Brass	STRA__
Waterbury	1/4"	Zinc Black Patina	WATE__
Westerly	1/4"	Zinc	WEST__
Wickford	1/4"	Zinc	WICK__
Winslet	1/4"	Zinc Black Patina	WISL__
Wright	1/4"	Zinc Black Patina	WRIG__

\*Not available in 9", 12", 27", or W24 wide cabinets.

Art Glass not available on: Base Rotating Deep Bin, Transom Door Cabinets, Corner Wall Cabinets, 9" wide cabinets, Wall Top Hinge with Stay Lift Cabinets, Lazy Susan Base Cabinets, Square Base Corner Cabinets, Super Space Saver Cabinets, Super Lazy Susan Base Cabinets, Diagonal Square Base Corner 33" Cabinets, and Diagonal Super Space Saver 33" Cabinets. Glass will be shipped directly to the order destination from the glass manufacturing facility within standard lead times. Cut-for-glass (CG) door must be ordered separately.

### Textured Glass Inserts

Style	Panel Thickness	Modification Code
Antique <sup>†</sup>	1/8"	ANTQ__
Beveled <sup>†</sup>	1/4"	BEVE__
Beveled Fog <sup>†</sup>	1/4"	BEVF__
Bronze Fabric	3/16"	MBRF__
Centurian	1/8"	CENT__
Clear <sup>†</sup>	1/8"	CLEA__
Diamond Lattice <sup>†</sup>	1/8"	DIAL__
Frost <sup>†</sup>	5/32"	FROS__
Hammered	5/32"	HAMM__
Kinetic <sup>†</sup>	1/4"	KINE__
Morisco <sup>†</sup>	1/8"	MORS__
Reeded <sup>†</sup>	5/32"	REED__
Ridge <sup>†</sup>	1/8"	RIDG__
Seeded	9/32"	SEED__
Silhouette	1/8"	SILH__

<sup>†</sup>Not available in W912 L or R, W1212 L or R, W2412 and W2712.

The following glass inserts are not available on 12" wide Transom Door Cabinets: Seeded and Metallic Bronze Fabric.

Textured Glass not available on: Base Rotating Deep Bin, 9" wide cabinets, Corner Wall Cabinets, Lazy Susan Base Cabinets, Square Base Corner Cabinets, Super Space Saver Cabinets, Super Lazy Susan Base Cabinets, Diagonal Square Base Corner 33" Cabinet, and Diagonal Super Space Saver 33" Cabinet.

Glass will be shipped directly to the order destination from the glass manufacturing facility within standard lead times.

Cut-for-glass (CG) door must be ordered separately.

## Decorative Art Glass Doors\*



**Anson**



**Avalon**



**Ballard**

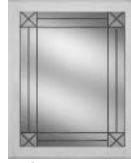

**Beckett**



**Bennington Brass**



**Bennington Patina**



**Delray**



**Emery**



**Fenton**

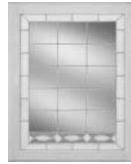

**Foster**



**Merrimack**



**Serafina**



**Stratton**



**Waterbury**



**Westerly**

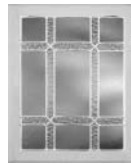

**Wickford**



**Winslet**



**Wright**

\*Suggested for use with Square door styles

## Decorative Textured Glass Doors



**Antique**

Clear glass with surface striations simulating the texture and appearance of popular mouthblown antique glass. Uniform thickness, color, texture, highly transparent.



**Beveled\***

1/4" clear glass with a 1 1/4" bevel. Transparent in appearance.



**Beveled Fog**

1/4" gray tinted tempered glass with a 1" beveled edge.



**Centurian**

1/8" frost etched glass. Not recommended for use with Mullion Doors.



**Clear**

Clear glass.



**Diamond Lattice**

Laminated clear glass with a diamond wire pattern interlayer. Transparent in appearance.



**Frost**

Clear glass with one surface "acid etched" to create a frosted appearance. Translucent in appearance.



**Hammered**

5/32" hammered glass.



**Kinetic**

5/32" obscure tempered glass with a random, vertical pattern resembling small twigs.



**Bronze Fabric**

Laminated clear glass with a metallic bronze fabric interlayer. Translucent in appearance.



**Morisco**

5/32" obscure tempered glass with a unique, raised, repetitive pattern.



**Reeded**

Clear glass with 1/2" flutes or reeds. Transparent in appearance.



**Ridge Glass**

5/32" tempered glass with 1/8" vertical reeds—obscure in appearance.



**Seeded**

Clear textured 9/32" glass with "seeds," small air bubbles trapped in the glass at random. Transparent in appearance.



**Silhouette**

1/8" frost etched glass. Suggested to use with square doors. Not recommended for use with Mullion Doors. Transparent in appearance.

\*Suggested for use with Square door styles. Not suggested for use with Landry.

# Specialty Doors

## Anson

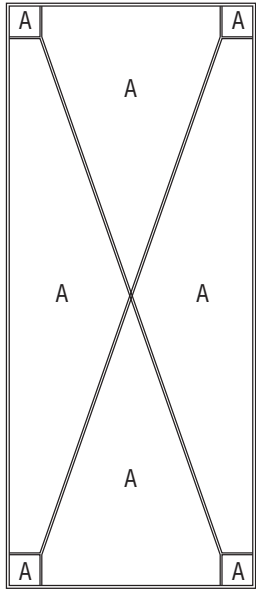

1 3/8  
1 3/8

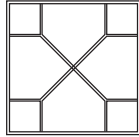

Glass Types:

A) Clear Seedy 100SDY

Metal Types:

3/16" H-Ch Zinc Proglaze2 (all) Black Patina Finish

Minimum Width 6"  
Minimum Height 6"

## Avalon

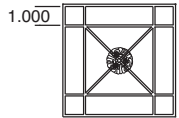
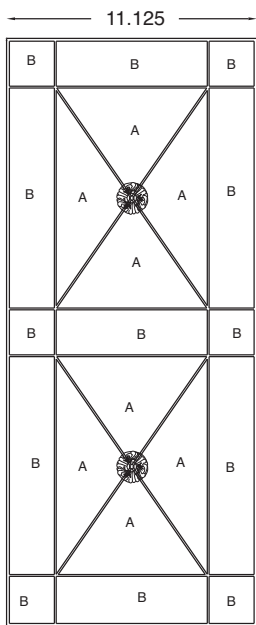

WIDTHS < 8"  
1" BORDERS

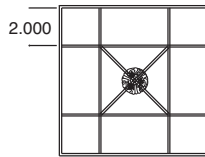

WIDTHS >= 8"  
2" BORDERS

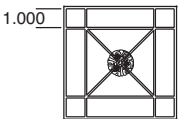

HEIGHTS < 8"  
1" BORDERS

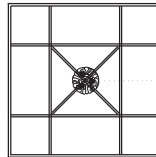

HEIGHTS < 15"  
1 INTERSECTION

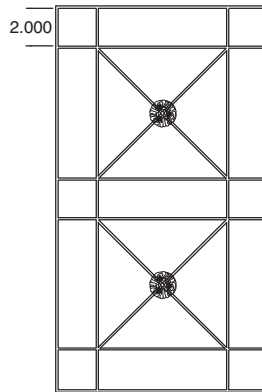

HEIGHTS > 15"  
2 INTERSECTIONS



METAL ROSETTE APPLICATION

Glass Types:

A) Clear Waterglass 100W

B) 1/8" Clear

Metal Types:

3/16" H-CH Zinc PROGLAZE2 (All)

Minimum Width 5 1/2"  
Minimum Height 5 1/2"

### Ballard

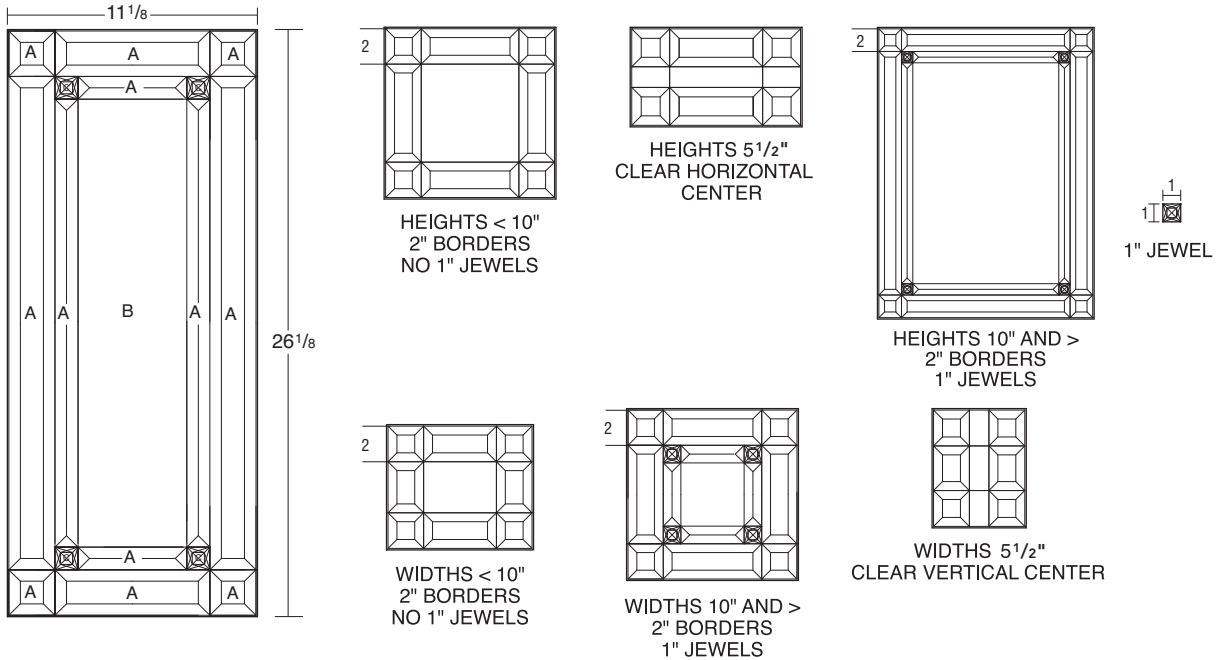

**Glass Types:**

- A) 3/16" Clear W/1/2" Bevel
- B) 1/8" Clear
- C) 3/16" Clear Jewel

Minimum Width 5 1/2"  
Minimum Height 5 1/2"

**Metal Types:**

3/16" H-CH Zinc PROGLAZE2 (All)

### Beckett

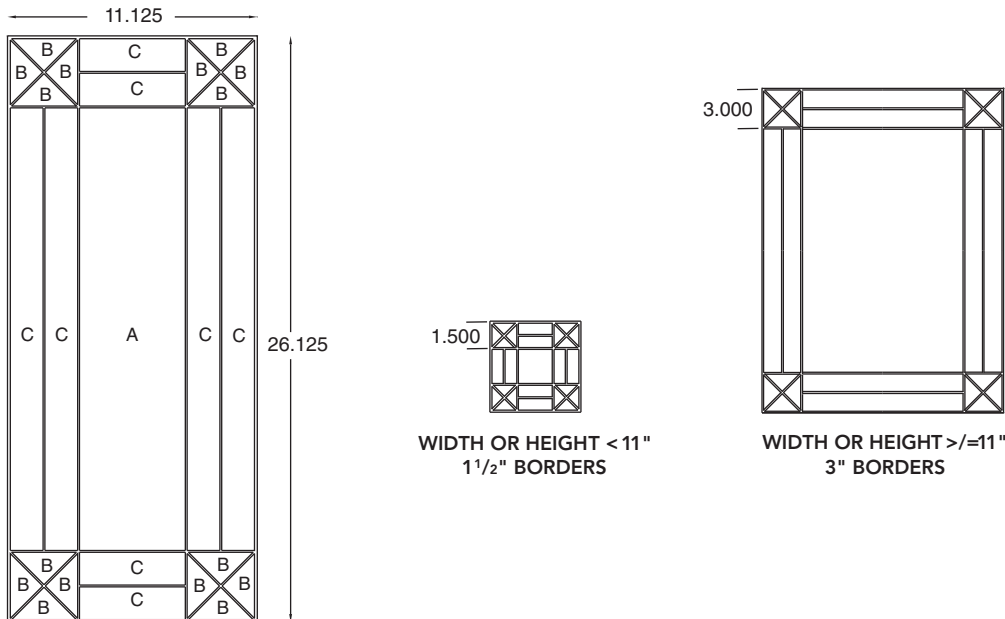

**Glass Types:**

- A) 3/16" Clear
- B) Frost ETCH 100
- C) Seedy Clear 100SDY

Minimum Width 5 1/2"  
Minimum Height 5 1/2"

**Metal Types:**

3/16" H-CH ZINC PROGLAZE2 (All) Patina

# Specialty Doors

## Bennington Brass

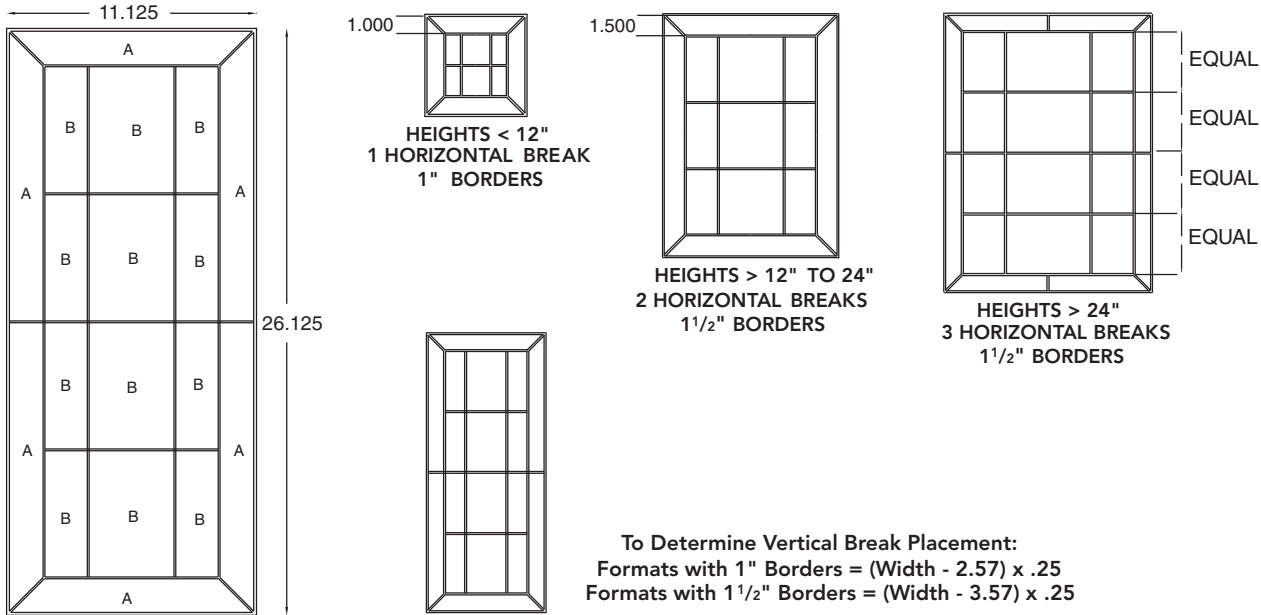

**Glass Types:**

- A) 1/8" Clear
- B) Clear Artique 100A

**Metal Types:**

3/16" H-CH Zinc PROGLAZE2 (All)

Minimum Width 5 1/2"  
 Minimum Height 5 1/2"  
 Widths < 12" = 1" Borders

## Bennington Patina

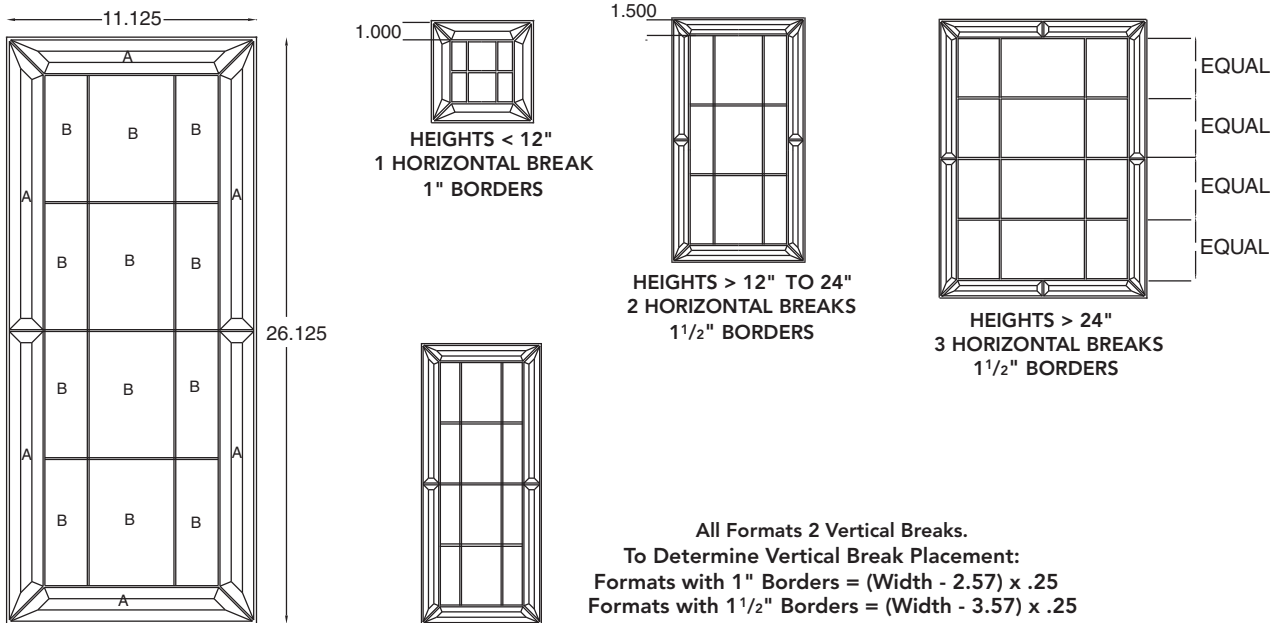

**Glass Types:**

- A) 3/16" Clear W/1/2" Bevel
- B) Clear Artique 100A

**Metal Types:**

3/16" H-CH Zinc PROGLAZE2 (All) Patina

Minimum Width 5 1/2"  
 Minimum Height 5 1/2"  
 Widths < 12" = 1" Borders

### Delray

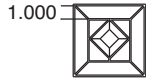
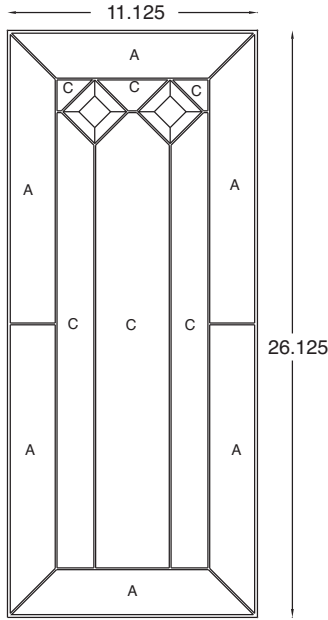

WIDTHS OR HEIGHTS < 8"  
1" BORDERS



WIDTHS 5 1/2" TO 10"  
1 COLUMN

WIDTHS 10" TO 13"  
2 COLUMNS

WIDTHS > 13"  
3 COLUMNS

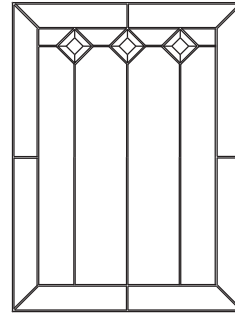
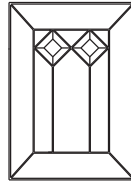
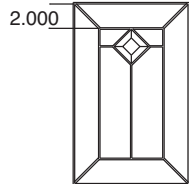

WIDTHS OR HEIGHTS > 8"  
2" BORDERS

**Glass Types:**

- A) Clear Sparkolite
- B) 3/16" Clear W/1/2" Bevel
- C) 1/8" Clear

**Metal Types:**

3/16" H-CH Zinc PROGLAZE2 (All)

Minimum Width 5 1/2"  
Minimum Height 5 1/2"

### Emery

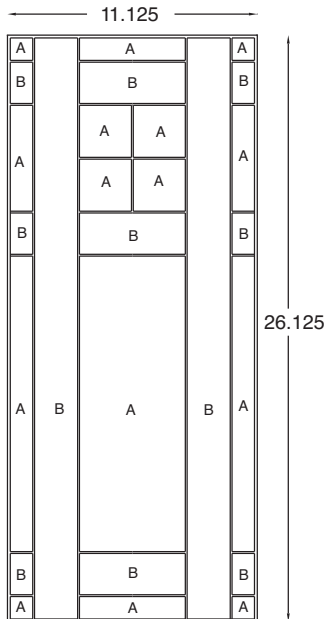

**HEIGHT ADJUSTMENT**

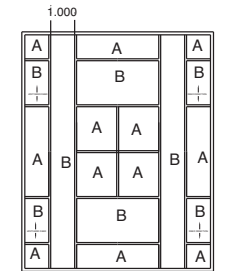
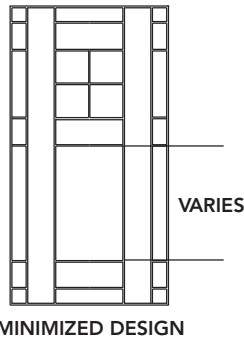

WIDTHS > 8"-11"  
1" VERTICAL COLUMNS

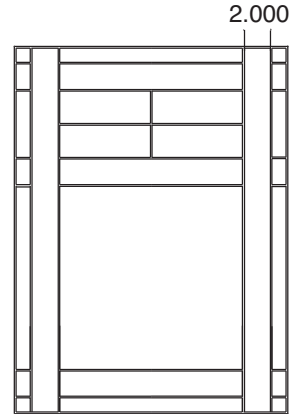

WIDTHS > 11"  
2" VERTICAL COLUMNS  
FULL DESIGN

**Glass Types:**

- A) Clear Artique 100A
- B) Thin Reeded Clear 1/8" Reeds # 4034

**Metal Types:**

3/16" H-CH Copper PROGLAZE2

Minimum Width 8"  
Minimum Height 10"  
(N/A in 9", 12", 15" Wide)  
(N/A in 12" & 15" High)



# Specialty Doors

## Fenton

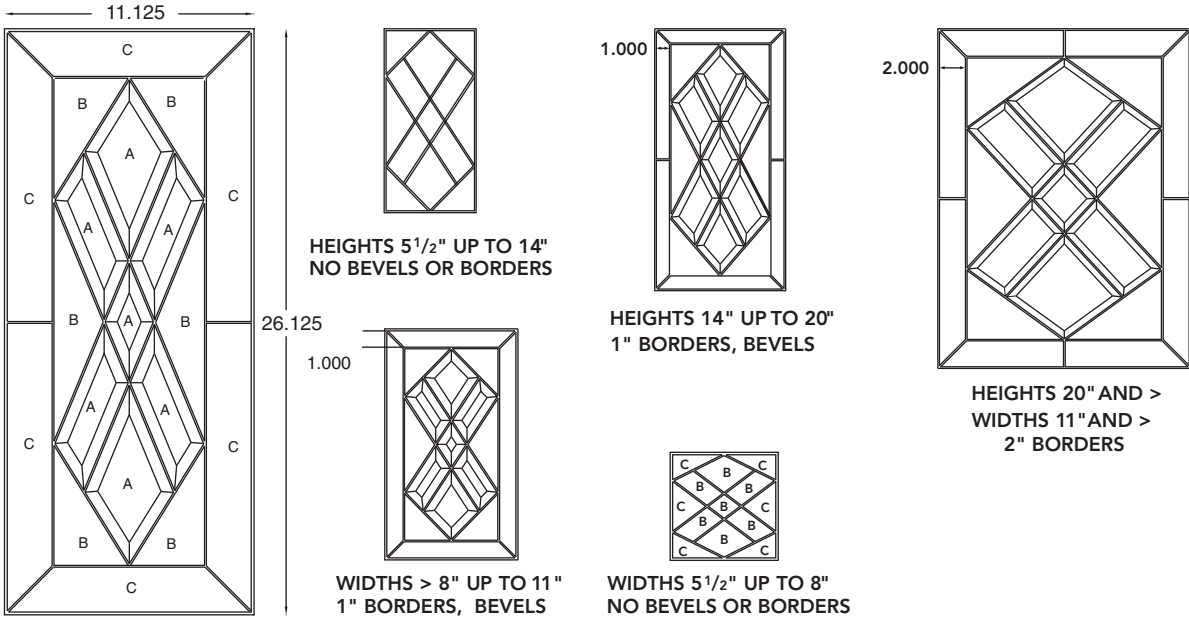

Glass Types:  
 A) 3/16" Clear W/1/2" BEVEL  
 B) 1/8" Clear  
 C) Clear Waterglass 100W

Metal Types:  
 3/16" H-CH ZINC PROGLAZE2 (ALL)

Minimum Width 5 1/2"  
 Minimum Height 5 1/2"

## Foster

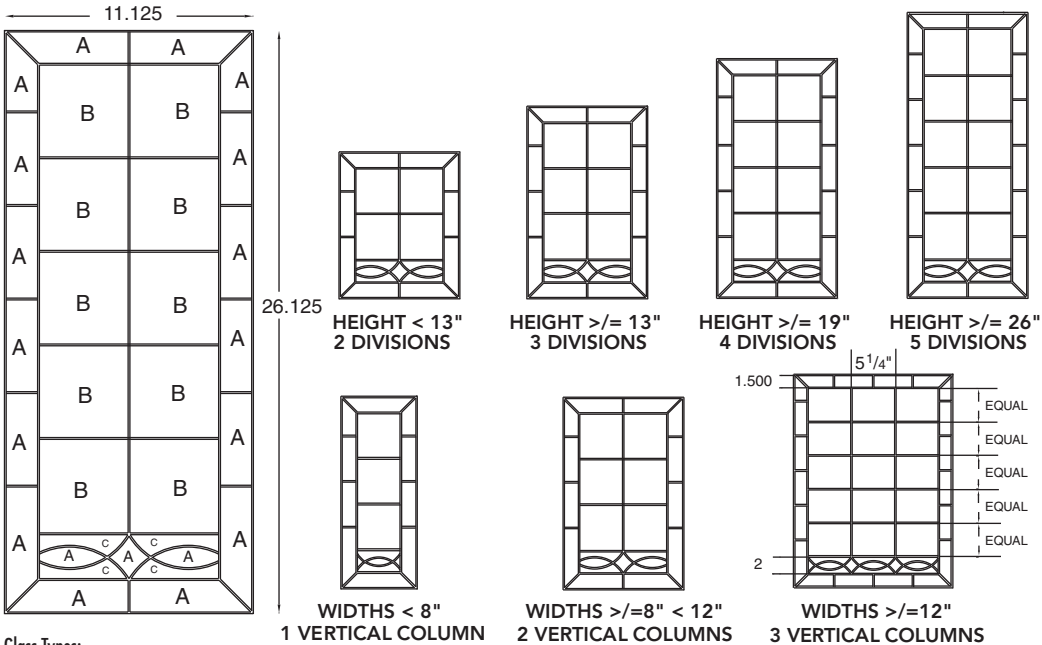

Glass Types:  
 A) Clear & White, Translucent "Feather" 3075  
 B) Clear Rough Rolled 100 RR  
 C) Frost Etch 100W

Metal Types:  
 3/16" H-CH Zinc PROGLAZE2 (All)

Minimum Width 5 1/2"  
 Minimum Height 9"  
 (N/A In 12"-15" High)

### Merrimack

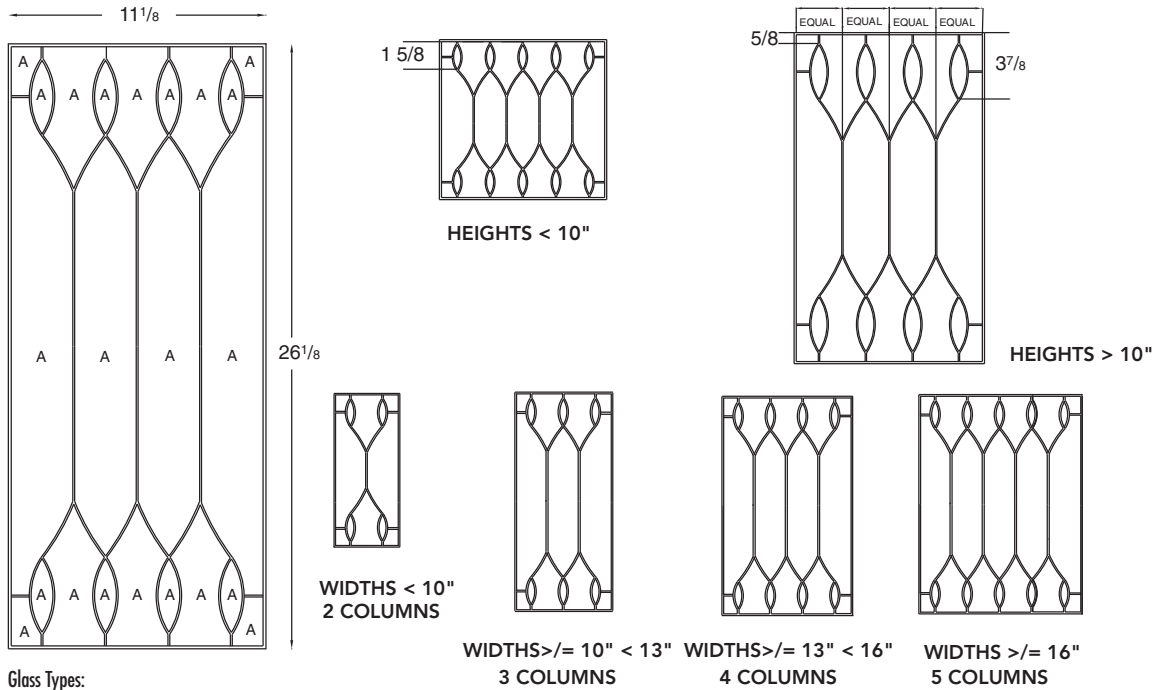

Glass Types:  
 A) Clear Baroque BR/CLR  
 Metal Types:  
 3/16" H-CH Zinc PROGLAZE2 (Patina)

Minimum Width 5 1/2"  
 Minimum Height 7"

### Serafina

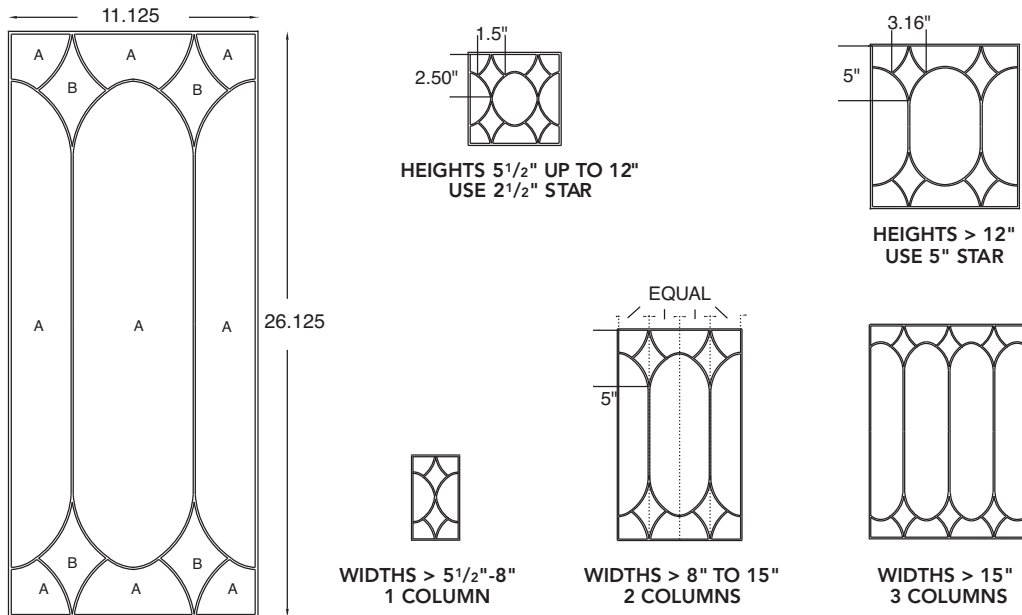

Glass Types:  
 A) Clear Artique 100-A  
 B) Clear Granite 100G  
 Metal Types:  
 3/16" H-CH Brass PROGLAZE2 (All)

Minimum Width 5 1/2"  
 Minimum Height 5 1/2"

# Specialty Doors

## Stratton

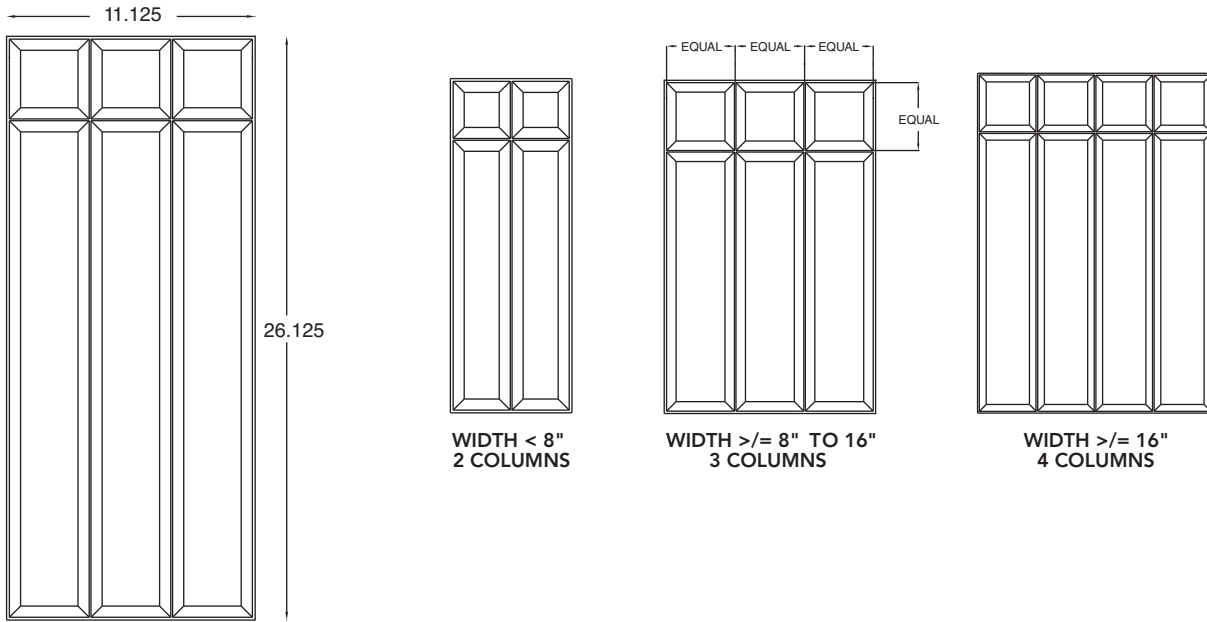

Glass Types:  
A) 3/16" Clear W/1/2" Bevel (All)

Metal Types:  
3/16" HC-H Brass PROGLAZE2 (All)

Minimum Width 5 1/2"  
Minimum Height 5 1/2"

## Waterbury

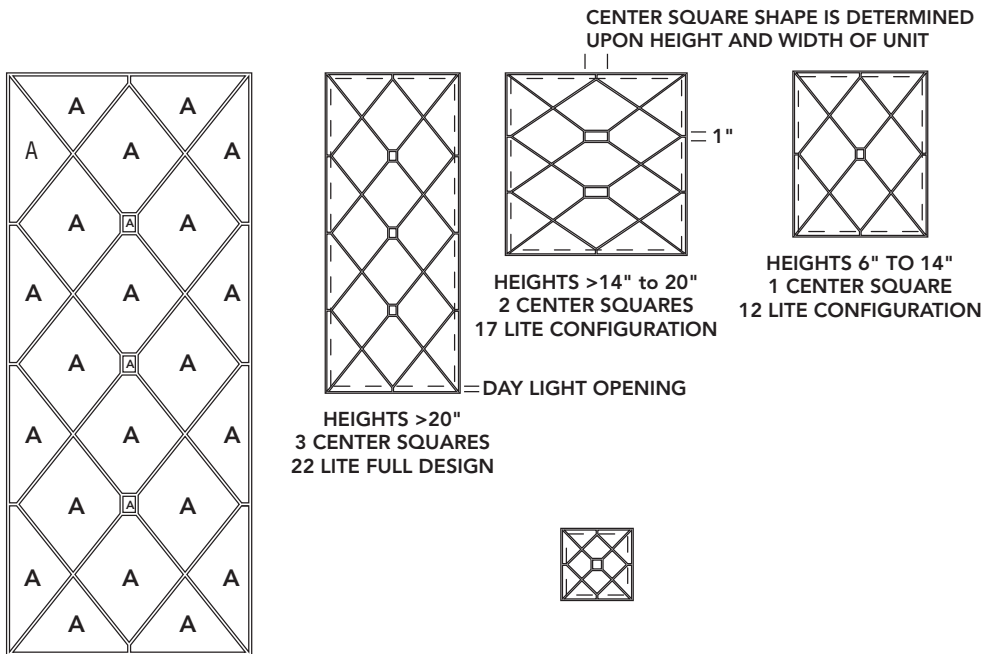

Glass Types:  
A) Clear Waterglass 100W

Metal Types:  
3/16" H-Ch Zinc Proglaze2 (all)  
Black Patina Finish

Minimum Width 6"  
Minimum Height 6"

### Westerly

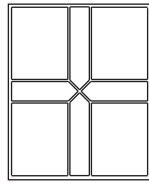
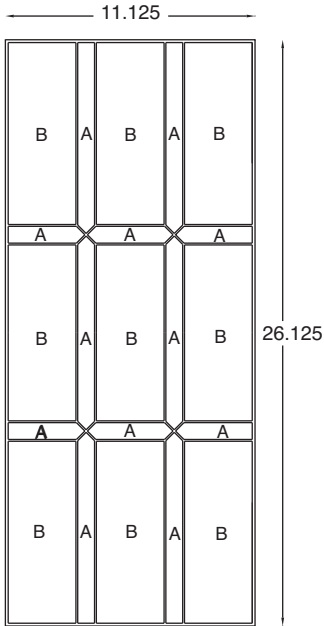

HEIGHT 5 1/2" TO 9"  
1 HORIZONTAL COLUMN CENTERED

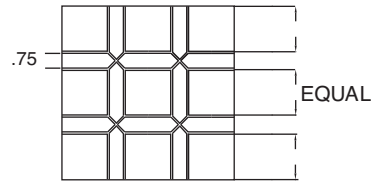

HEIGHT >= 15"  
2 HORIZONTAL COLUMNS EQUALLY SPACED

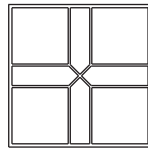

WIDTH 5 1/2" TO 9"  
1 VERTICAL COLUMN CENTERED

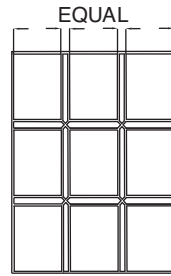

WIDTHS > 9"  
2 VERTICAL COLUMNS EQUALLY SPACED

Glass Types:

- A) Clear Glue Chip
- B) 1/8" Clear

Metal Types:

- 3/16" H-CH Zinc PROGLAZE2 (All)

Minimum Width 5 1/2"  
Minimum Height 5 1/2"

### Wickford

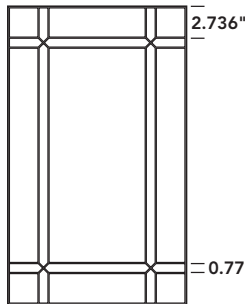
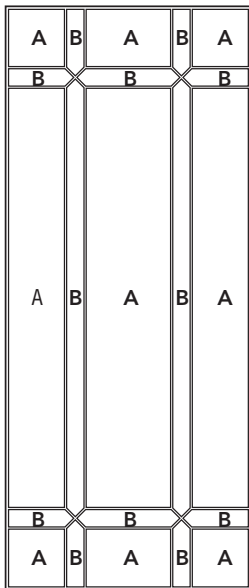

WIDTHS > 9"  
2 VERTICAL COLUMNS



WIDTHS 6 1/2" TO 9"  
1 VERTICAL COLUMN CENTERED

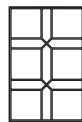

Glass Types:

- A) Clear Artique 100A
- B) Clear Granite 100G

Metal Types:

- 3/16" H-Ch Round Zinc Proglaze2 (all)

Minimum Width 6 1/2"  
Minimum Height 10"

# Specialty Doors

## Winslet

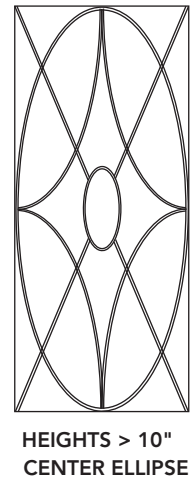
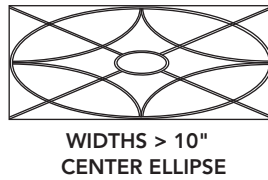
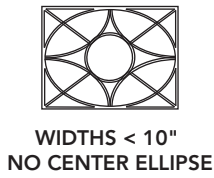
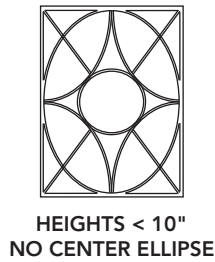
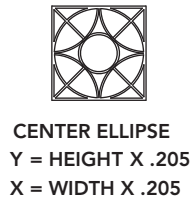
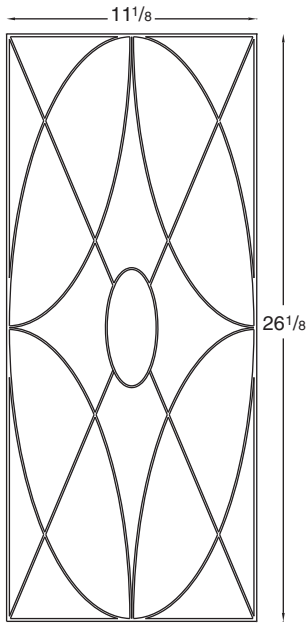

Glass Types:  
 A) 1/8" Clear Artique 100A (All)  
 Metal Types:  
 3/16" H-CH Zinc PROGLAZE2 (All) Patina

Minimum Width 5 1/2"  
 Minimum Height 5 1/2"

## Wright

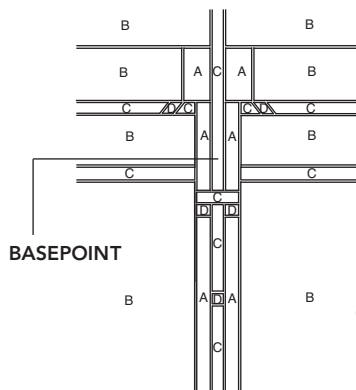
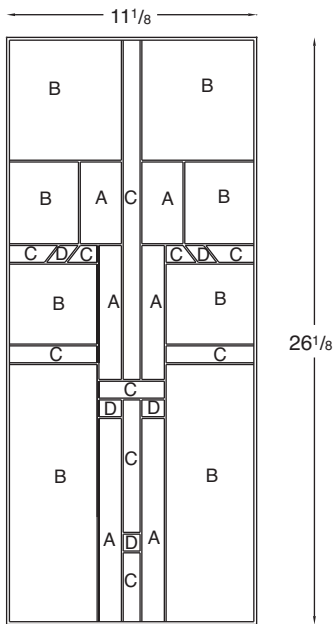

COMPONENT A  
 WIDTHS 9" >  
 HEIGHTS 10" >

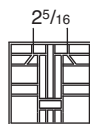

COMPONENTS PLACED ON  
 FORMAT MIDPOINT

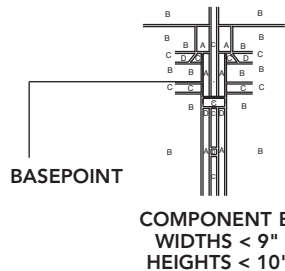

COMPONENT B  
 WIDTHS < 9"  
 HEIGHTS < 10"

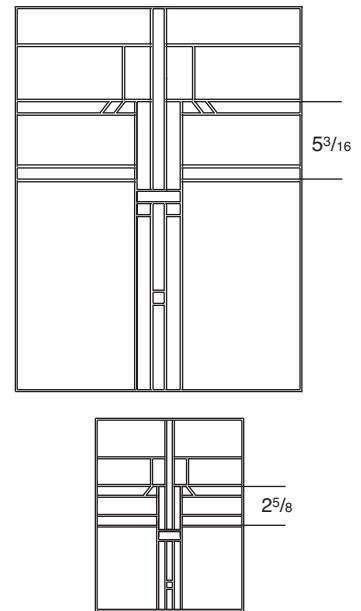

Glass Types:  
 A) Sparkolite (Crystal Ice)  
 B) Clear Rough Rolled 100RR  
 Clear Artique  
 D) Light Amber and White Translucent 317-1S  
 Metal Types:  
 3/16" H-CH Zinc PROGLAZE2 (All) Patina

Minimum Width 5 1/2"  
 Minimum Height 5 1/2"

STORAGE SOLUTIONS REFERENCE CHART

Wall Cabinets	Description	3"	6"	9"	12"	15"	18"	19"	21"	24"	27"	30"	33"	36"	37"	39"	42"	45"	48"	54"	60"	72"	Page
W____24PO L or R, W____24PO	Wall Refrigerator Pull-out Cabinet													•	•	•							J•49
WBCPO____, OL	Wall Box Column Pull-out (Plain, Overlay)	•	•																				J•102
WBCPOKCU	Wall Box Column Pull-out w/K-Cup	•																					J•104
WEAS__30 L or R, WEAS__30	Wall Easy Access Storage Cabinet					•	•					•		•									J•13
WMC____ L or R	Wall Message Center	•																					J•89
WOBS__36	Wall Organizer & Bookshelf									•		•		•									J•91
WSP_____	Wall Spice Pull-out Cabinet			•	•																		J•100
WSRC21__ L or R	Wall Spice Rack Cabinet								•														J•101
WWR__30	Wall Cabinet w/Wine Rack									•		•		•									J•91
<b>Hearths</b>																							
HPP12__ L or R	Hearth Pier Pull-out				•																		K•20
<b>Base Cabinets</b>																							
2DB__RT	Two Drawer Base w/Roll Trays						•		•	•	•	•	•	•									L•33
2DB36PDO	Two Drawer Base with Pegged Dish Organizer													•									L•32
2DB36RTPDO	Two Drawer Base w/Roll Tray & Pegged Dish Organizer													•									L•33
3CDB36	Three Corner Drawer Base													•									L•77
3DB__WTCD	Three Drawer Base w/Wood Tiered Cutlery Divider					•	•		•	•		•		•									L•29
3DB18CHGDRW	Three Drawer Base w/Charging Drawer						•																L•31
3DB18KCUP	Three Drawer Base w/Wood Tiered K-Cup Drawer						•																L•30
4DB__CIW	Four Drawer Base w/Cutlery Insert Wood Dividers					•	•		•	•													L•26
4DB__WTCD	Four Drawer Base w/Wood Tiered Cutlery Divider					•	•		•	•		•		•									L•25
4DB18CHGDRW	Four Drawer Base w/Charging Drawer						•																L•27
4DB18KCUP	Four Drawer Base w/Wood Tiered K-Cup Drawer						•																L•26
B__CIW L or R, B24CIW	Base w/Cutlery Insert Wood Dividers					•	•		•	•													L•9
B__FHMIXSC L or R	Base w/Mixer Shelf						•		•	•													L•88
B__FSCO L or R	Base w/Food Storage Container Organizer						•			•													L•11
B__PS	Base Pot & Pans Storage									•	•		•										L•35
B__PSB L or R	Base w/Plastic Storage Bins					•	•																L•88
B__RTCIW L or R, B24RTCIW	Base w/Cutlery Insert Wood Dividers & Roll Trays					•	•		•	•													L•10
B__RTLO	Base w/Drawer & Lid Organizer & Roll Trays											•	•	•									L•36
B__RTWTCD L or R, B__RTWTCD	Base w/Wood Tiered Cutlery Divider & Roll Trays					•	•		•	•		•		•									L•8
B__SD L or R	Base w/Spice Drawer						•			•													L•93
B__TDRO L or R	Base w/Roll-out Tray Divider				•	•																	L•83
B__WTCD L or R, B__WTCD	Base w/Wood Tiered Cutlery Divider					•	•		•	•		•		•									L•7
B18CHGDRW L or R	Base w/Charging Drawer						•																L•5
B18CHGDRWRT L or R	Base w/Roll Trays & Charging Drawer						•																L•7
B18KCUP L or R	Base w/Wood Tiered K-Cup Drawer						•																L•10
B18KCUPRT L or R	Base w/Wood Tiered K-Cup Drawer & Roll Trays						•																L•11
B72SDIDSK	Base Sliding Door Island Cabinet w/Sliding Desk																					•	L•78
BBCPO__OL	Base Box Column Pull-out (Plain, Overlay)	•	•																				L•89
BBS18 L or R	Base w/Bottle Storage						•																L•100
BC__PO L or R	Base Corner Pull-out																		•	•			L•61
BCC__BB	Base Cooking Center w/Bread Board											•		•			•		•				L•37
BCFW__PO L or R	Base Corner Full Width Pull-out																			•	•		L•62
BCFW2D48CRVPO L or R	Two Drawer Base Corner Full Width w/Curve Pull-out																				•		L•65
BCFW48SP L or R	Base Corner Full Width w/Roll Trays & Swing-out																				•		L•63
BCFWFH48CRVPO L or R	Full Height Base Corner Full Width w/Curve Pull-out																				•		L•65
BCOPP12	Base Container Organization Pantry					•																	L•93
BMC24 L or R	Base Message Center	•																					L•108
BPCS36	Base Pantry Can Storage														•								L•37
BPP__	Base Pantry Pull-out			•	•	•	•																L•90
BPPP24 L or R, BPPP__	Base Pots & Pans Pull-out									•		•											L•35
BRDB36 L or R	Base Rotating Deep Bin													•									L•76

•Available widths

# Storage Solutions

Base Cabinets (cont'd)	Description	3"	6"	9"	12"	15"	18"	19"	21"	24"	27"	30"	33"	36"	37"	39"	42"	45"	48"	54"	60"	72"	Page	
BSC30 PR, R, RP, RS, SR	Base SuperCabinet™											•											L•20	
BSC36 PRP, PRS, SRP, SRS	Base SuperCabinet™													•										L•21
BSP__PG	Base Spice Pull-out				•	•																		L•91
BTDPP__	Base Tray Divider Pantry Pull-out				•	•																		L•92
BUPP__	Base Utensil Pantry Pull-out				•	•																		L•91
BUPPKB__	Base Utensil Pantry Pull-out w/Knife Block				•	•																		L•92
BWB__	Base Wastebasket					•	•		•	•														L•94
BWB__BB	Base Wastebasket w/Bread Board					•	•		•	•														L•96
BWB__FH	Base Wastebasket Full Height					•	•		•	•														L•95
BWB__FHRT2	Base Wastebasket Full Height w/Roll Tray					•	•		•	•														L•96
BWB__WTC	Base Wastebasket w/Wood Tiered Cutlery Divider					•	•		•	•														L•97
BWB18CHGDRW	Base Wastebasket w/Charging Drawer						•																	L•98
BWB18KUCUP	Base Wastebasket w/Wood Tiered K-Cup Drawer						•																	L•97
CNTYSB__CM	Country Sink Base w/CabMat™											•	•	•										L•49
SB__CM	Sink Base Double Door w/CabMat™											•	•	•										L•39
SB__S	Sink Base SuperCabinet™											•	•	•										L•45
SB__SCM	Sink Base SuperCabinet™ w/CabMat™											•	•	•										L•46
SB__STCM	Sink Base w/Tilt-out Trays & CabMat™											•	•	•										L•42
SB__STS	Sink Base SuperCabinet™ w/Tilt-out Tray											•	•	•										L•46
SB__STSCM	Sink Base SuperCabinet™ w/Tilt-out Trays & CabMat™											•	•	•										L•47
SB36CDY L or R	Sink Base Double Door w/Caddy													•										L•39
SB36SCDY L or R	Sink Base SuperCabinet™ w/Caddy													•										L•45
SB36STCDY L or R	Sink Base w/Tilt-out Tray & Caddy													•										L•42
SB36STSCDY L or R	Sink Base SuperCabinet™ w/Tilt-out Tray & Caddy													•										L•47
SLSR____L or R	Super Lazy Susan w/Chrome Rail													•	•									L•75
SLSR__RS L or R	Super Lazy Susan w/Chrome Rail & Reduced Shelf													•	•									L•71
SLSR36CD L or R	Super Lazy Susan w/Chrome Rail & Corner Drawer													•										L•76
TRBD27	Base Recycling Center										•													L•99
<b>Tall Cabinets</b>																								
PY36__24	Pantry Unit																							M•25
TPP____24, TPP____24 L or R	Tall Pantry Pull-out				•	•	•	•																M•22
UOC24____L or R, UOC24____	Utility Organizer Cabinet										•													M•27
UOCDZ24__9	Utility Organizer Drop Zone Cabinet										•													M•35
<b>Vanity Cabinets</b>																								
6VSDB____21WTV L or R, 6VSDB____21WTV	Vanity Console Drawer Base w/Six Drawers & Wood Tiered Vanity Drawer																	•		•	•	•		P•36
LCRH188421 L or R	Linen Closet w/Removable Hamper																							P•51
VBP1234.5	Vanity Base Pull-out					•																		P•13
<b>Modifications</b>																								
CMAT1	CabMat™											•	•	•										G•36
CMAT2	CabMat™											•	•	•	•									G•36
DRWTK	Toekick Drawer				•	•	•		•	•	•	•	•	•										G•30

•Available widths

# Kemper Emerge Modification Option Descriptions

Your Kemper Emerge specification guide contains charts with modification option codes for each applicable cabinetry product. Reference the listing below to identify the modification description.

## Door & Drawer Options

Option	Description
AF	Aluminum Door
AOMD	Automatic Opening Mechanism for Lift Up System
CC	Craftsman Door
CG	Cut-for-glass
ESMD	Estate Mullion Door
GAMD	Gallery Mullion Door
HC	Horizon Door
IFHG	Inset Finial Hinges
MC	Mission Door
MD	Mullion Door
MFO	Modified Full Overlay
PRMD	Prairie Mullion Door
SHMD	Shaker Mullion Door
SPLITDR	Split Doors
SPLITDRWS	Split Drawers
SUMD	Summit Mullion Door
TCG	Transom w/Top Cut-for-glass and Bottom Center Panel
TCP	Transom w/both sections Center Panels

## End Panel Options

Option	Description
AUTH	Authentic Flush End
CSFPE	Car Siding Flush Panel End
EXBK	End Extended Back
EXDN	Wall End and Back Extended Down
FFD	Face Frame and Door on End
FPE	Flush Panel End
INTGE	Integral End
IPE	Inset Panel Ends

## Custom Modification Options

Option	Description
ADD_SHLF	Add Shelf
ADDTK	Add Toekick
ADRW	Add Drawer Below Wall Unit
BVR	Bottom Valance Rail
CBO	Cabinet Box Only
CCO	Cabinet Case Only
CFNTO	Cabinet Front Only
CFRMO	Cabinet Frame Only
CLIP	Clipped Corner
CND	Cabinet No Door
CSDGBK	Car Siding Back
EF	Finished Ends
EX	Extended Stile
EX_OL	Extended Stile with Overlay
F.ALL	Finished All
FBFL	Finished Blind
FLUT	Fluting
FTK	Flush Toekick
ID	Increased Depth
IH	Increased Height
INVERM	Inverted Frame
IW	Increased Width
LIGHT	Lighting
MIP	Matching Interior
OBRB	Open Bottom Rail Base
PFINBTMB	Finished Bottom
RD	Reduced Depth
RECTK	Recessed Toekick
RH	Reduced Height
ROSLUT	Rose Fluting
RT	Roll Trays
RW	Reduced Width
STW	Stacked Wall Cabinet Heights
TD	Tray Divider
TKP	Toekick Pedestal
TVR	Top Valance Rail
WS	Wide Stiles
WTR	Wide Top Rail





## Description

### WALL, 12" HIGH

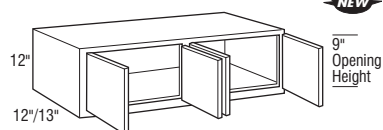
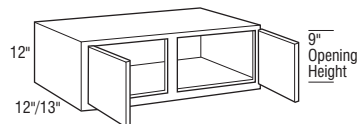
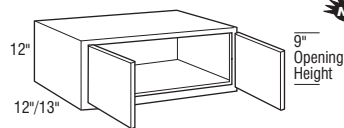

## Model

W912 L or R

W1212 L or R

W1512 L or R

W1812 L or R

W2112 L or R

W2412 L or R



W2112

W2412

W2712

W3012

W3312



W3412

W3612



W3712

W3912

W4212CS

W4512CS



W4212



W4512

W4812

Notes below apply to all products in section above:

- Inset and Beaded Inset Door Styles are a standard 13" deep.
- Full Overlay Styles:
  - Increased Depths available in 1/4" increments from 12 1/4" to 30"
  - Reduced Depths available in 1/4" increments from 6" to 11 3/4".
- Inset and Beaded Inset Styles:
  - Increased Depths available in 1/4" increments from 13 1/4" to 30"
  - Reduced Depths available in 1/4" increments from 6" to 12 3/4".

#### Door & Drawer Options

AF	AOMD	CC <sup>1</sup>	CG	ESMD	GAMD	HC	IFHG	MC	MD	MFO	PRMD	SHMD <sup>2</sup>	SPLITDR <sup>3</sup>	SPLITDRWS	SUMD	TCG	TCP
		✓					✓			✓		✓	✓				

#### End Panel Options

AUTH	CSFPE	EXBK	EXDN	FFD	FPE	INTGE	IPE
✓	✓	✓	✓	✓	✓	✓	✓

#### Custom Modification Options

ADD	SHLF	ADDTK	ADRW	BVR	CBO	CCO	CFNTO	CFRMO	CLIP <sup>4</sup>	CND	CSDGBK	EF	EX	EX_OL	FALL	FBFL	FLUT <sup>5</sup>	FTK <sup>6</sup>	ID	IH
			✓	✓	✓	✓	✓	✓	✓	✓	✓	✓	✓	✓	✓		✓	✓	✓	✓

INVFRM	IW <sup>7</sup>	LIGHT <sup>8</sup>	MIP	OBRB	PFINBTMB	RD	RECTK	RH	ROSFLUT	RT <sup>9</sup>	RW	STW	TD	TKP	TVR <sup>10</sup>	WS	WTR
	✓	✓	✓	✓	✓	✓			✓	✓	✓				✓	✓	✓

<sup>1</sup>Not available on 9" or 12" wide.

<sup>2</sup>Not available on 9" wide.

<sup>3</sup>Only available on 24" (2 doors)-39" wide.

<sup>4</sup>Not available on 9", 12" or 24" (2 doors) wide.

<sup>5</sup>Not available with 6" fluting.

<sup>6</sup>FTKAV not available on 9" or 12" wide.

<sup>7</sup>Not available on 24" (1 door) or 48" wide.

<sup>8</sup>Not available on 24" (2 doors) wide.

<sup>9</sup>Not available on 9" or 39" wide.

<sup>10</sup>Not available on 42"-48" wide and TVRAV not available on 9" or 12" wide.

# Wall Cabinets

## Description

## Model

### WALL, 15" HIGH

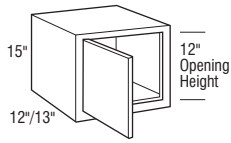

W915 L or R  
W1215 L or R  
W1515 L or R  
W1815 L or R  
W2115 L or R  
W2415 L or R

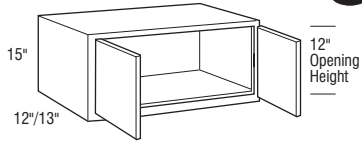

W2115  
W2415  
W2715  
W3015  
W3315



W3415  
W3615



W3715  
W3915

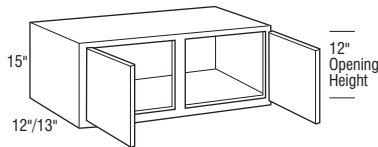

W4215CS  
W4515CS  
W4815CS



W4215



W4515



W4815

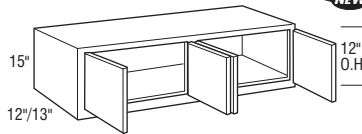

Notes below apply to all products in section above:

- Inset and Beaded Inset Door Styles are a standard 13" deep.
- Full Overlay Styles:
  - Increased Depths available in 1/4" increments from 12 1/4" to 30".
  - Reduced Depths available in 1/4" increments from 6" to 11 3/4".
- Inset and Beaded Inset Styles:
  - Increased Depths available in 1/4" increments from 13 1/4" to 30".
  - Reduced Depths available in 1/4" increments from 6" to 12 3/4".

### Door & Drawer Options

AF	AOMD	CC <sup>1</sup>	CG	ESMD <sup>2</sup>	GAMD <sup>2</sup>	HC	IFHG	MC	MD	MFO	PRMD	SHMD <sup>1</sup>	SPLITDR <sup>3</sup>	SPLITDRWS	SUMD <sup>2</sup>	TCG	TCP
		✓	✓	✓	✓	✓	✓	✓	✓	✓	✓	✓	✓	✓	✓	✓	✓

### End Panel Options

AUTH	CSFPE	EXBK	EXDN	FFD	FPE	INTGE	IPE
✓	✓	✓	✓	✓	✓	✓	✓

### Custom Modification Options

ADD_SHLF	ADDTK	ADRW	BVR	CBO	CCO	CFNTO	CFRMO	CLIP <sup>4</sup>	CND	CSDGBK	EF	EX	EX_OL	F.ALL	FBFL	FLUT <sup>5</sup>	FTK <sup>6</sup>	ID	IH
		✓	✓	✓	✓	✓	✓	✓	✓	✓	✓	✓	✓	✓	✓	✓	✓	✓	✓

INVFRM	IW <sup>7</sup>	LIGHT <sup>8</sup>	MIP	OBRB	PFINBTMB	RD	RECTK	RH	ROSLUT	RT <sup>9</sup>	RW	STW	TD	TKP	TVR <sup>10</sup>	WS	WTR
	✓	✓	✓	✓	✓	✓	✓	✓	✓	✓	✓	✓	✓	✓	✓	✓	✓

<sup>1</sup>Not available on 9" wide.  
<sup>2</sup>Not available on 9" or 12" wide.  
<sup>3</sup>Only available on 24" (2 doors)-39" wide.  
<sup>4</sup>Not available on 9", 12" or 24" (2 doors) wide.  
<sup>5</sup>Not available with 6" fluting.  
<sup>6</sup>FTKAV not available on 9" or 12" wide.  
<sup>7</sup>Not available on 24" (1 door) or 48" wide.  
<sup>8</sup>Not available on 24" (2 doors) wide.  
<sup>9</sup>Not available on 9" or 39" wide.  
<sup>10</sup>Not available on 42"-48" wide and TVRAV not available on 9" or 12" wide.

IH/RH availability charts starting on page G•40.  
IW/RW availability charts starting on page G•46.

## Description

### WALL TOP HINGE with VERTICAL-LIFT and STAY LIFT, 15", 18", or 21" HIGH

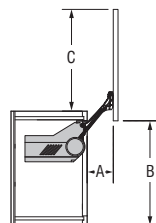
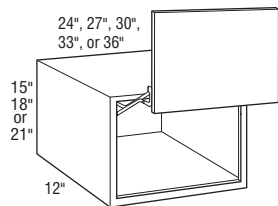

## Model

WVL2415

WVL2715

WVL3015

WVL3315

WVL3615

WVL2418

WVL2718

WVL3018

WVL3318

WVL3618

WVL2421

WVL2721

WVL3021

WVL3321

WVL3621

- Not available on Inset and Beaded Inset door styles.
- Grain on center panels and slab doors will run horizontally and door rail configuration on non-miter doors will be unique from adjacent cabinet doors.
- AOMD option is not available when used with the following door styles:
  - Burke, Gordon, Kirby, Landry, Shanley, or Vinson.
- AOMD option not available with Aluminum Door profiles AF003 and AF006.
- Additional accessories available for Automatic Opening Mechanism option, refer to page S•12.

	Cabinet Height	A	B	C
Full Overlay	15"	5 3/4"	13 13/16"	13 3/8"
	18"	8 1/4"	20 13/16"	20 3/8"
	21"	7"	17 5/16"	16 7/8"

#### Door & Drawer Options

AF	AOMD	CC	CG	ESMD	GAMD	HC	IFHG	MC	MD	MFO	PRMD	SHMD	SPLITDR	SPLITDRWS	SUMD	TCG	TCP
✓	✓	✓	✓	✓	✓	✓	✓	✓	✓	✓	✓	✓	✓	✓	✓	✓	✓

#### End Panel Options

AUTH	CSFPE	EXBK	EXDN	FFD	FPE	INTGE	IPE
✓	✓	✓	✓	✓	✓	✓	✓

#### Custom Modification Options

ADD	SHLF	ADDTK	ADRW	BVR	CBO	CCO	CFNTO	CFRMO	CLIP	CND	CSDGBK	EF	EX	EX_OL	FALL	FBFL	FLUT <sup>1</sup>	FTK	ID	IH <sup>2</sup>
✓	✓	✓	✓	✓	✓	✓	✓	✓	✓	✓	✓	✓	✓	✓	✓	✓	✓	✓	✓	✓

INVERM	IW <sup>3</sup>	LIGHT	MIP	OBRB	PFINBTMB	RD	RECTK	RH	ROSFLUT	RT	RW	STW	TD	TKP	TVR	WS <sup>4</sup>	WTR
✓	✓	✓	✓	✓	✓	✓	✓	✓	✓	✓	✓	✓	✓	✓	✓	✓	✓

<sup>1</sup>Not available with 6" fluting.

<sup>2</sup>Not available on 21" high.

<sup>3</sup>Not available on 36" wide.

<sup>4</sup>18" high only available with wide stile both.

# Wall Cabinets

## Description



**WALL TOP HINGE with VERTICAL-LIFT and STAY LIFT, 18" or 21" HIGH**

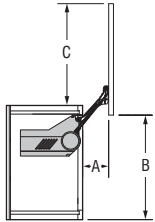
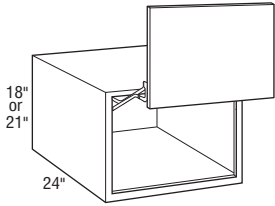

## Model

**WVL301824**

**WVL361824**

**WVL302124**

**WVL362124**

- Not available on Inset and Beaded Inset door styles.
- Grain on center panels and slab doors will run horizontally and door rail configuration on non-miter doors will be unique from adjacent cabinet doors.
- AOMD option is not available when used with the following door styles:
  - Burke, Gordon, Kirby, Landry, Shanley, or Vinson.
- AOMD option not available with Aluminum Door profiles AF003 and AF006.
- Additional accessories available for Automatic Opening Mechanism option, refer to page S•12.

	Cabinet Height	A	B	C
Full Overlay	18"	8 1/4"	20 13/16"	20 3/8"
	21"	7"	17 5/16"	16 7/8"

### Door & Drawer Options

AF	AOMD	CC	CG	ESMD	GAMD	HC	IFHG	MC	MD	MFO	PRMD	SHMD	SPLITDR	SPLITDRWS	SUMD	TCG	TCP
✓			✓							✓							

### End Panel Options

AUTH	CSFPE	EXBK	EXDN	FFD	FPE	INTGE	IPE
✓	✓	✓	✓	✓	✓		

### Custom Modification Options

ADD	SHLF	ADDTK	ADRW	BVR	CBO	CCO	CFNTO	CFRMO	CLIP	CND	CSDGBK	EF	EX	EX_OL	FALL	FBFL	FLUT <sup>1</sup>	FTK	ID	IH <sup>2</sup>
✓	✓	✓	✓	✓	✓	✓	✓	✓	✓	✓	✓	✓	✓	✓	✓	✓	✓	✓	✓	✓

INVERM	IW <sup>3</sup>	LIGHT	MIP	OBRB	PFINBTMB	RD	RECTK	RH	ROSFLUT	RT	RW	STW	TD	TKP	TVR	WS	WTR
✓	✓	✓	✓	✓	✓	✓	✓	✓	✓	✓	✓	✓	✓	✓	✓	✓	✓

<sup>1</sup>Not available with 6" fluting.

<sup>2</sup>Not available on 21" high.

<sup>3</sup>Not available on 36" wide.

IH/RH availability charts starting on page G•40.  
IW/RW availability charts starting on page G•46.

## Description

### WALL, 18" or 21" HIGH

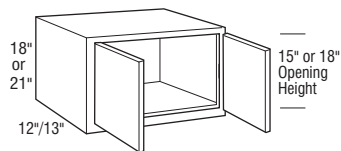
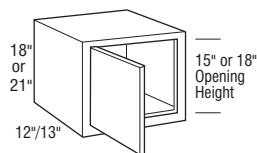

## Model

W918 L or R

W1218 L or R

W1518 L or R

W1818 L or R

W2118 L or R

W2418 L or R

W921 L or R

W1221 L or R

W1521 L or R

W1821 L or R

W2121 L or R

W2421 L or R

W2418

W2718

W3018

W3318



W3418

W3618



W3718

W3918

W2421

W2721

W3021

W3321



W3421

W3621



W3721

W3921

Notes below apply to all products in section above:

- Inset and Beaded Inset Door Styles are a standard 13" deep.
- Full Overlay Styles:
  - Increased Depths available in 1/4" increments from 12 1/4" to 30".
  - Reduced Depths available in 1/4" increments from 6" to 11 3/4".
- Inset and Beaded Inset Styles:
  - Increased Depths available in 1/4" increments from 13 1/4" to 30".
  - Reduced Depths available in 1/4" increments from 6" to 12 3/4".

#### Door & Drawer Options

AF	AOMD	CC <sup>1</sup>	CG	ESMD <sup>1</sup>	GAMD <sup>1</sup>	HC	IFHG	JMC	MD <sup>1</sup>	MFO	PRMD <sup>2</sup>	SHMD <sup>1</sup>	SPLITDR <sup>3</sup>	SPLITDRWS	SJMD <sup>1</sup>	TCG	TCP	
		✓	✓	✓	✓		✓		✓	✓	✓	✓	✓	✓		✓		

#### End Panel Options

AUTH	CSFPE	EXBK	EXDN	FFD	FPE	INTGE	IPE
✓	✓	✓	✓	✓	✓	✓	✓

#### Custom Modification Options

ADD_SHLF	ADDTK	ADRW	BVR	CBO	CCO	CFNTD	CFRMO	CLIP <sup>4</sup>	CND	CSDGBK	EF	EX	EX_OL	FALL	FBFL	FLUT <sup>5</sup>	FTK <sup>6</sup>	ID	IH	
			✓	✓	✓	✓	✓	✓	✓	✓	✓	✓	✓	✓	✓	✓	✓	✓	✓	✓

INVFRM	IW <sup>7</sup>	LIGHT <sup>8</sup>	MIP	OBRB	PFINBTMB	RD	RECTK	RH	ROSFLUT	RT <sup>9</sup>	RW	STW	TD	TKP	TVR <sup>10</sup>	WS	WTR
	✓	✓	✓	✓	✓	✓			✓	✓			✓	✓	✓	✓	✓

<sup>1</sup>Not available on 9" wide.

<sup>2</sup>Not available on 9", 12" or 24" (2 doors) wide.

<sup>3</sup>Only available on 24" (2 doors)-39" wide.

<sup>4</sup>Not available on the 9", 12" or 24" (2 doors) wide.

<sup>5</sup>Not available with 6" fluting.

<sup>6</sup>FTKAV not available on 9" or 12" wide.

<sup>7</sup>Not available on 24" (1 door) or 48" wide.

<sup>8</sup>Not available on the 24" (2 doors) wide.

<sup>9</sup>Not available on the 9" or 39" wide.

<sup>10</sup>Not available on 42"-48" wide and TVRAV not available on 9" or 12" wide.

# Wall Cabinets

## Description

**WALL, 18" or 21" HIGH  
(cont'd)**

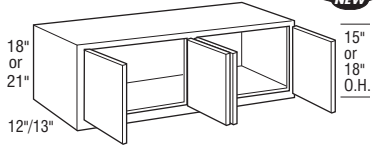
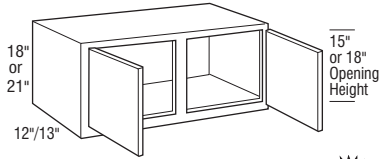

## Model

**W4218**

**W4518**

**W4818CS**

**W4221**

**W4521**

**W4821CS**

**W4818**

**W4821**

- Inset and Beaded Inset Door Styles are a standard 13" deep.
- Full Overlay Styles:
  - Increased Depths available in 1/4" increments from 12 1/4" to 30".
  - Reduced Depths available in 1/4" increments from 6" to 11 3/4".
- Inset and Beaded Inset Styles:
  - Increased Depths available in 1/4" increments from 13 1/4" to 30".
  - Reduced Depths available in 1/4" increments from 6" to 12 3/4".

### Door & Drawer Options

AF	AOMD	CC <sup>1</sup>	CG	ESMD <sup>1</sup>	GAMD <sup>1</sup>	HC	IFHG	MC	MD <sup>1</sup>	MFO	PRMD <sup>2</sup>	SHMD <sup>1</sup>	SPLITDR <sup>3</sup>	SPLITDRWS	SUMD <sup>1</sup>	TCG	TCP
		✓	✓	✓	✓	✓	✓	✓	✓	✓	✓	✓	✓	✓	✓	✓	✓

### End Panel Options

AUTH	CSFPE	EXBK	EXDN	FFD	FPE	INTGE	IPE
✓	✓	✓	✓	✓	✓	✓	✓

### Custom Modification Options

ADD	SHLF	ADDTK	ADRW	BVR	CBO	CCO	CFNTD	CFRMO	CLIP <sup>4</sup>	CND	CSDGBK	EF	EX	EX_OL	F.ALL	FBFL	FLUT <sup>5</sup>	FTK <sup>6</sup>	ID	IH
			✓	✓	✓	✓	✓	✓	✓	✓	✓	✓	✓	✓	✓		✓	✓	✓	✓

INVRM	IW <sup>7</sup>	LIGHT <sup>8</sup>	MIP	OBRB	PFINBTMB	RD	RECTK	RH	ROSFLUT	RT <sup>9</sup>	RW	STW	TD	TKP	TVR <sup>10</sup>	WS	WTR
✓	✓	✓	✓	✓	✓	✓	✓	✓	✓	✓	✓	✓	✓	✓	✓	✓	✓

<sup>1</sup>Not available on 9" wide.  
<sup>2</sup>Not available on 9", 12" or 24" (2 doors) wide.  
<sup>3</sup>Only available on 24" (2 doors)-39" wide.  
<sup>4</sup>Not available on the 9", 12" or 24" (2 doors) wide.  
<sup>5</sup>Not available with 6" fluting.  
<sup>6</sup>FTKAN not available on 9" or 12" wide.  
<sup>7</sup>Not available on 24" (1 door) or 48" wide.  
<sup>8</sup>Not available on the 24" (2 doors) wide.  
<sup>9</sup>Not available on the 9" or 39" wide.  
<sup>10</sup>Not available on 42"-48" wide and TVRAV not available on 9" or 12" wide.

IH/RH availability charts starting on page G•40.  
 IW/RW availability charts starting on page G•46.

## Description

### WALL TOP HINGE with STAY LIFT, 15", 18", 21", or 24" HIGH

24", 27", 30", 33", or 36"

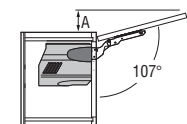
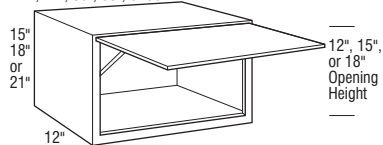

24", 27", 30", 33", or 36"

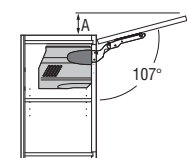
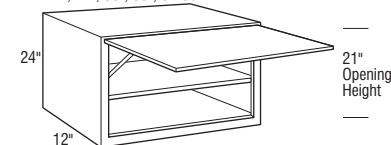

## Model

WTH2415SL

WTH2715SL

WTH3015SL

WTH3315SL

WTH3615SL

WTH2418SL

WTH2718SL

WTH3018SL

WTH3318SL

WTH3618SL

WTH2421SL

WTH2721SL

WTH3021SL

WTH3321SL

WTH3621SL

WTH2424SL

WTH2724SL

WTH3024SL

WTH3324SL

WTH3624SL

- One adjustable shelf.

Notes below apply to all products in section above:

- Heavy duty Stay Lift mechanism.
- Mechanism is not sold separately.
- Grain on center panels and slab doors will run horizontally and door rail configuration on non-miter doors will be unique from adjacent cabinet doors.
- Increased Depths available in 1/4" increments from 12 1/4" to 30".
- Door opens to 107°. Angle restriction clips available, see page S•15.
- Additional accessories available for Automatic Opening Mechanism option, refer to page S•12.

	A Dimension			
Cabinet Height	15"	18"	21"	24"
Full Overlay	3 11/16"	4 1/2"	5 3/8"	6 1/4"

### Door & Drawer Options

AF	AOMD	CC	CG	ESMD	GAMD	HC	IFHG	JMC	MD	MFO	PRMD	SHMD	SPLITDR	SPLITDRWS	SUMD	TCG	TCP
✓	✓	✓					✓			✓				✓			

### End Panel Options

AUTH	CSFPE	EXBK	EXDN	FFD	FPE	INTGE	IPE
✓	✓	✓	✓	✓	✓	✓	✓

### Custom Modification Options

ADD_SHLF	ADDTK	ADRW	BVR	CBO	CCO	CFNTO	CFRMO	CLIP	CND	CSDGBK	EF	EX	EX_OL	FALL	FBFL	FLUT <sup>1</sup>	FTK	ID	IH <sup>2</sup>
			✓	✓				✓		✓	✓	✓	✓	✓		✓	✓	✓	✓

INVRM	IW <sup>3</sup>	LIGHT	MIP	OBRB	PFINBTMB	RD	RECTK	RH	ROSLUT	RT	RW	STW	TD	TKP	TVR	WS <sup>4</sup>	WTR
	✓	✓	✓	✓	✓				✓							✓	✓

<sup>1</sup>Not available with 6" fluting.

<sup>2</sup>Not available on 24" high.

<sup>3</sup>Not available on 36" wide.

<sup>4</sup>18" and 24" high only available with wide stile both.



# Wall Cabinets

## Description

### WALL, 24" or 27" HIGH

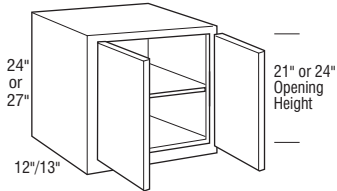
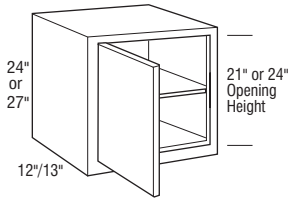

## Model

W924 L or R

W1224 L or R

W1524 L or R

W1824 L or R

W2124 L or R

W2424 L or R

W927 L or R

W1227 L or R

W1527 L or R

W1827 L or R

W2127 L or R

W2427 L or R

W2424

W2724

W3024

W3324



W3424

W3624



W3724

W3924

W2427

W2727

W3027

W3327



W3427

W3627



W3727

W3927

Notes below apply to all products in section above:

- One adjustable shelf.
- Inset and Beaded Inset Door Styles are a standard 13" deep.
- Full Overlay Styles:
  - Increased Depths available in 1/4" increments from 12 1/4" to 30".
  - Reduced Depths available in 1/4" increments from 6" to 11 3/4".
- Inset and Beaded Inset Styles:
  - Increased Depths available in 1/4" increments from 13 1/4" to 30".
  - Reduced Depths available in 1/4" increments from 6" to 12 3/4".

### Door & Drawer Options

AF	AOMD	CC <sup>1</sup>	CG	ESMD <sup>1</sup>	GAMD <sup>1</sup>	HC	IFHG	MC	MD <sup>1</sup>	MFO	PRMD <sup>2</sup>	SHMD <sup>1</sup>	SPLITDR <sup>3</sup>	SPLITDRWS	SUMD <sup>1</sup>	TCG	TCP	
		✓	✓	✓	✓	✓	✓	✓	✓	✓	✓	✓	✓	✓	✓	✓	✓	✓

### End Panel Options

AUTH	CSFPE	EXBK	EXDN	FFD	FPE	INTGE	IPE
✓	✓	✓	✓	✓	✓	✓	✓

### Custom Modification Options

ADD_SHLF	ADDTK	ADRW	BVR	CBO	CCO	CFNTO	CFRMO	CLIP <sup>4</sup>	CND	CSDGBK	EF	EX	EX_OL	F.ALL	FBFL	FLUT <sup>5</sup>	FTK <sup>6</sup>	ID	IH	
✓	✓	✓	✓	✓	✓	✓	✓	✓	✓	✓	✓	✓	✓	✓	✓	✓	✓	✓	✓	✓

INVRM	IW <sup>7</sup>	LIGHT <sup>8</sup>	MIP	OBRB	PFINBTMB	RD	RECTK	RH	ROSFLUT	RT <sup>9</sup>	RW	STW	TD	TKP	TVR <sup>10</sup>	WS	WTR			
✓	✓	✓	✓	✓	✓	✓	✓	✓	✓	✓	✓	✓	✓	✓	✓	✓	✓	✓	✓	✓

<sup>1</sup>Not available on 9" wide.

<sup>2</sup>Not available on 9", 12" or 24" (2 doors) wide.

<sup>3</sup>Only available on 24" (2 doors)-39" wide.

<sup>4</sup>Not available on 9", 12" or 24" (2 doors) wide.

<sup>5</sup>Not available with 6" fluting.

<sup>6</sup>FTKAV not available on 9" or 12" wide.

<sup>7</sup>Not available on 24" (1 door), 36" or 48" wide.

<sup>8</sup>Not available on 24" (2 doors) wide.

<sup>9</sup>Not available on 9" or 39" wide.

<sup>10</sup>Not available on 42"-48" wide and TVRAV not available on 9" or 12" wide.

IH/RH availability charts starting on page G•40.  
IW/RW availability charts starting on page G•46.

## Description

### WALL, 24" or 27" HIGH (cont'd)

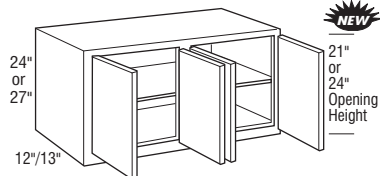
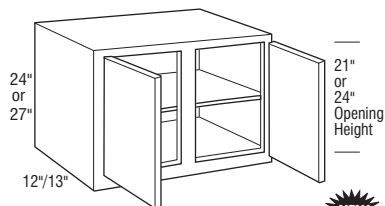

## Model

W4224

W4524

W4824CS

W4227

W4527

W4827CS

**NEW** W4824

**NEW** W4827

- One adjustable shelf.
- Inset and Beaded Inset Door Styles are a standard 13" deep.
- Full Overlay Styles:
  - Increased Depths available in 1/4" increments from 12 1/4" to 30".
  - Reduced Depths available in 1/4" increments from 6" to 11 3/4".
- Inset and Beaded Inset Styles:
  - Increased Depths available in 1/4" increments from 13 1/4" to 30".
  - Reduced Depths available in 1/4" increments from 6" to 12 3/4".

#### Door & Drawer Options

AF	AOMD	CC <sup>1</sup>	CG	ESMD <sup>1</sup>	GAMD <sup>1</sup>	HC	IFHG	MC	MD <sup>1</sup>	MFO	PRMD <sup>2</sup>	SHMD <sup>1</sup>	SPLITDR <sup>3</sup>	SPLITDRWS	SJMD <sup>1</sup>	TCG	TCP	
		✓	✓	✓	✓		✓		✓	✓	✓	✓	✓	✓		✓		

#### End Panel Options

AUTH	CSPE	EXBK	EXDN	FFD	FPE	INTGE	IPE
✓	✓	✓	✓	✓	✓	✓	✓

#### Custom Modification Options

ADD_SHLF	ADDTK	ADRW	BVR	CBO	CCO	CFNTD	CFRMO	CLIP <sup>4</sup>	CND	CSDGBK	EF	EX	EX_OL	FALL	FBFL	FLUT <sup>5</sup>	FTK <sup>6</sup>	ID	IH	
✓	✓	✓	✓	✓	✓	✓	✓	✓	✓	✓	✓	✓	✓	✓	✓	✓	✓	✓	✓	
INVFRM	IW <sup>7</sup>	LIGHT <sup>8</sup>	MIP	OBRB	PFINBTMB	RD	RECTK	RH	ROSFLUT	RT <sup>9</sup>	RW	STW	TD	TKP	TVR <sup>10</sup>	WS	WTR			
✓	✓	✓	✓	✓	✓	✓	✓	✓	✓	✓	✓	✓	✓	✓	✓	✓	✓	✓	✓	✓

<sup>1</sup>Not available on 9" wide.  
<sup>2</sup>Not available on 9", 12" or 24" (2 doors) wide.  
<sup>3</sup>Only available on 24" (2 doors)-39" wide.  
<sup>4</sup>Not available on 9", 12" or 24" (2 doors) wide.  
<sup>5</sup>Not available with 6" fluting.  
<sup>6</sup>FTKAV not available on 9" or 12" wide.  
<sup>7</sup>Not available on 24" (1 door), 36" or 48" wide.  
<sup>8</sup>Not available on 24" (2 doors) wide.  
<sup>9</sup>Not available on 9" or 39" wide.  
<sup>10</sup>Not available on 42"-48" wide and TVRAV not available on 9" or 12" wide.

# Wall Cabinets

## Description

### WALL, 30" or 33" HIGH

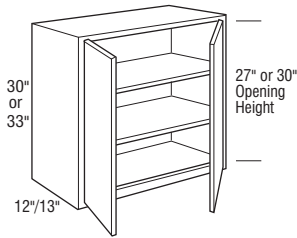
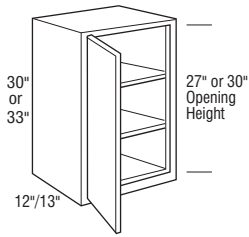

## Model

W930 L or R

W1230 L or R

W1530 L or R

W1830 L or R

W2130 L or R

W2430 L or R

W933 L or R

W1233 L or R

W1533 L or R

W1833 L or R

W2133 L or R

W2433 L or R

W2430

W2730

W3030

W3330

W3630

W3930

W2433

W2733

W3033

W3333

W3633

W3933

Notes below apply to all products in section above:

- Two adjustable shelves.
- Inset and Beaded Inset Door Styles are a standard 13" deep.
- Full Overlay Styles:
  - Increased Depths available in 1/4" increments from 12 1/4" to 30".
  - Reduced Depths available in 1/4" increments from 6" to 11 3/4".
- Inset and Beaded Inset Styles:
  - Increased Depths available in 1/4" increments from 13 1/4" to 30".
  - Reduced Depths available in 1/4" increments from 6" to 12 3/4".

### Door & Drawer Options

AF	AOMD	CC <sup>1</sup>	CG	ESMD <sup>1</sup>	GAMD <sup>1</sup>	HC <sup>1</sup>	IFHG	MC <sup>1</sup>	MD <sup>1</sup>	MFO	PRMD <sup>2</sup>	SHMD <sup>1</sup>	SPLITDR <sup>3</sup>	SPLITDRWS	SUMD <sup>1</sup>	TCG	TCP	
		✓	✓	✓	✓	✓	✓	✓	✓	✓	✓	✓	✓	✓	✓	✓	✓	✓

### End Panel Options

AUTH	CSFPE	EXBK	EXDN	FFD	FPE	INTGE	IPE
✓	✓	✓	✓	✓	✓	✓	✓

### Custom Modification Options

ADD_SHLF	ADDTK	ADRW	BVR	CBO	CCO	CFNTO	CFRMO	CLIP <sup>4</sup>	CND	CSDGBK	EF	EX	EX_OL	F.ALL	FBFL	FLUT <sup>5</sup>	FTK <sup>6</sup>	ID	IH
✓	✓	✓	✓	✓	✓	✓	✓	✓	✓	✓	✓	✓	✓	✓	✓	✓	✓	✓	✓

INVFRM	IW <sup>7</sup>	LIGHT <sup>8</sup>	MIP	OBRB	PFINBTMB	RD	RECTK	RH	ROSFLUT	RT <sup>9</sup>	RW	STW	TD	TKP	TVR <sup>10</sup>	WS	WTR
	✓	✓	✓	✓	✓	✓	✓	✓	✓	✓	✓	✓	✓	✓	✓	✓	✓

<sup>1</sup>Not available on 9" wide.

<sup>2</sup>Not available on 9", 12" or 24" (2 doors) wide.

<sup>3</sup>Only available on 24" (2 doors)-39" wide.

<sup>4</sup>Not available on 9", 12" or 24" (2 doors) wide.

<sup>5</sup>Not available with 6" fluting.

<sup>6</sup>FTKAV not available on 9" or 12" wide.

<sup>7</sup>Not available on 24" (1 door), 36" or 48" wide.

<sup>8</sup>Not available on 24" (2 doors) wide.

<sup>9</sup>Not available on 9" or 39" wide.

<sup>10</sup>Not available on 42"-48" wide and TVRAV not available on 9" or 12" wide.

IH/RH availability charts starting on page G-40.  
IW/RW availability charts starting on page G-46.

## Description

### WALL, 30" or 33" HIGH (cont'd)

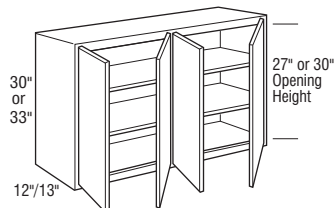
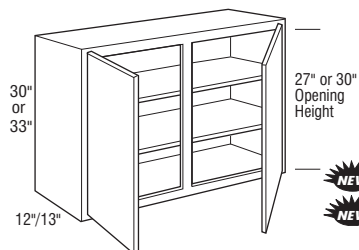

## Model

W4230

W4530

W4830CS

W4233

W4533

W4833CS

W4830

W4833

- Two adjustable shelves.
- Inset and Beaded Inset Door Styles are a standard 13" deep.
- Full Overlay Styles:
  - Increased Depths available in 1/4" increments from 12 1/4" to 30".
  - Reduced Depths available in 1/4" increments from 6" to 11 3/4".
- Inset and Beaded Inset Styles:
  - Increased Depths available in 1/4" increments from 13 1/4" to 30".
  - Reduced Depths available in 1/4" increments from 6" to 12 3/4".

#### Door & Drawer Options

AF	AOMD	CC <sup>1</sup>	CG	ESMD <sup>1</sup>	GAMD <sup>1</sup>	HC <sup>1</sup>	IFHG	MC <sup>1</sup>	MD <sup>1</sup>	MFO	PRMD <sup>2</sup>	SHMD <sup>1</sup>	SPLITDR <sup>3</sup>	SPLITDRWS	SUMD <sup>1</sup>	TCG	TCP	
		✓	✓	✓	✓	✓	✓	✓	✓	✓	✓	✓	✓	✓	✓	✓	✓	✓

#### End Panel Options

AUTH	CSFPE	EXBK	EXDN	FFD	FPE	INTGE	IPE
✓	✓	✓	✓	✓	✓	✓	✓

#### Custom Modification Options

ADD	SHLF	ADDTK	ADRW	BVR	CBO	CCO	CFNTO	CFRMO	CLIP <sup>4</sup>	CND	CSDGBK	EF	EX	EX_OL	FALL	FBFL	FLUT <sup>5</sup>	FTK <sup>6</sup>	ID	IH	
✓			✓	✓	✓	✓	✓	✓	✓	✓	✓	✓	✓	✓	✓	✓	✓	✓	✓	✓	✓

INVRM	IW <sup>7</sup>	LIGHT <sup>8</sup>	MIP	OBRB	PFINBTMB	RD	RECTK	RH	ROSLUT	RT <sup>9</sup>	RW	STW	TD	TKP	TVR <sup>10</sup>	WS	WTR
✓	✓	✓	✓	✓	✓	✓	✓	✓	✓	✓	✓	✓	✓	✓	✓	✓	✓

- <sup>1</sup>Not available on 9" wide.  
<sup>2</sup>Not available on 9", 12" or 24" (2 doors) wide.  
<sup>3</sup>Only available on 24" (2 doors)-39" wide.  
<sup>4</sup>Not available on 9", 12" or 24" (2 doors) wide.  
<sup>5</sup>Not available with 6" fluting.  
<sup>6</sup>FTKAV not available on 9" or 12" wide.  
<sup>7</sup>Not available on 24" (1 door), 36" or 48" wide.  
<sup>8</sup>Not available on 24" (2 doors) wide.  
<sup>9</sup>Not available on 9" or 39" wide.  
<sup>10</sup>Not available on 42"-48" wide and TVRAV not available on 9" or 12" wide.

### WALL EASY ACCESS STORAGE CABINET, 30" HIGH storage SOLUTIONS

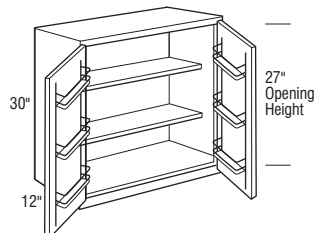
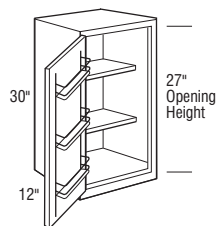

WEAS1530 L or R

WEAS1830 L or R

WEAS3030

WEAS3630

#### Notes below apply to all products in section above:

- Adjustable shelves are 7 1/4" deep.
- Racks on doors are 3 1/4" deep
- Reduced Depths available in 1/4" increments from 9" to 11 3/4".
- Increased Depths available in 1/4" increments from 12 1/4" to 30".
- Not available on Inset and Beaded Inset styles.

#### Door & Drawer Options

AF	AOMD	CC	CG	ESMD	GAMD	HC	IFHG	MC	MD	MFO	PRMD	SHMD	SPLITDR	SPLITDRWS	SUMD	TCG	TCP
							✓			✓							

#### End Panel Options

AUTH	CSFPE	EXBK	EXDN	FFD	FPE	INTGE	IPE
✓	✓	✓	✓	✓	✓	✓	✓

#### Custom Modification Options

ADD	SHLF	ADDTK	ADRW	BVR	CBO	CCO	CFNTO	CFRMO	CLIP <sup>1</sup>	CND	CSDGBK	EF	EX	EX_OL	FALL	FBFL	FLUT <sup>2</sup>	FTK	ID	IH	
✓			✓	✓	✓	✓	✓	✓	✓	✓	✓	✓	✓	✓	✓	✓	✓	✓	✓	✓	✓

INVRM	IW	LIGHT	MIP	OBRB	PFINBTMB	RD	RECTK	RH	ROSLUT	RT	RW	STW	TD	TKP	TVR	WS	WTR
✓	✓	✓	✓	✓	✓	✓	✓	✓	✓	✓	✓	✓	✓	✓	✓	✓	✓

- <sup>1</sup>Not available on 15" wide.  
<sup>2</sup>Not available with 6" fluting.

# Wall Cabinets

## Description

## Model

### WALL, 36" HIGH

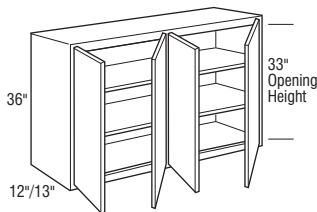
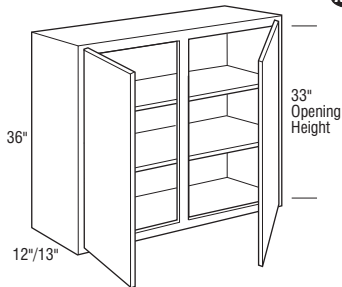
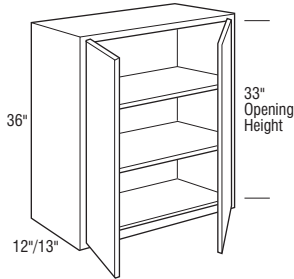
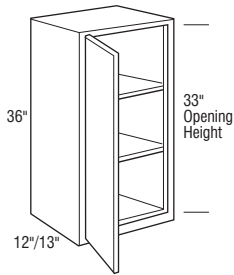

**W936 L or R**

**W1236 L or R**

**W1536 L or R**

**W1836 L or R**

**W2136 L or R**

**W2436 L or R**

**W2436**

**W2736**

**W3036**

**W3336**

**W3636**

**W3936**

**W4236**

**W4536**

**W4836CS**

**W4836**



Notes below apply to all products in section above:

- Two adjustable shelves.
- Inset and Beaded Inset Door Styles are a standard 13" deep.
- Full Overlay Styles:
  - Increased Depths available in 1/4" increments from 12 1/4" to 30".
  - Reduced Depths available in 1/4" increments from 6" to 11 3/4".
- Inset and Beaded Inset Styles:
  - Increased Depths available in 1/4" increments from 13 1/4" to 30".
  - Reduced Depths available in 1/4" increments from 6" to 12 3/4".

#### Door & Drawer Options

AF	AOMD	CC <sup>1</sup>	CG	ESMD <sup>1</sup>	GAMD <sup>1</sup>	HC	IFHG	MC	MD <sup>1</sup>	MFO	PRMD <sup>2</sup>	SHMD <sup>1</sup>	SPLITDR <sup>3</sup>	SPLITDRWS	SUMD <sup>1</sup>	TCG	TCP	
		✓	✓	✓	✓	✓	✓	✓	✓	✓	✓	✓	✓	✓	✓	✓	✓	✓

#### End Panel Options

AUTH	CSFPE	EXBK	EXDN	FFD	FPE	INTGE	IPE
✓	✓	✓	✓	✓	✓	✓	✓

#### Custom Modification Options

ADD	SHLF	ADDTK	ADRW	BVR	CBO	CCO	CFNTO	CFRMO	CLIP <sup>4</sup>	CND	CSDGBK	EF	EX	EX_OL	F.ALL	FBFL	FLUT <sup>5</sup>	FTK <sup>6</sup>	ID	IH	
✓	✓	✓	✓	✓	✓	✓	✓	✓	✓	✓	✓	✓	✓	✓	✓	✓	✓	✓	✓	✓	✓

INVRM	IW <sup>7</sup>	LIGHT <sup>8</sup>	MIP	OBRB	PFINBTMB	RD	RECTK	RH	ROSFLUT	RT <sup>9</sup>	RW	STW	TD <sup>10</sup>	TKP	TVR <sup>11</sup>	WS	WTR
	✓	✓	✓	✓	✓	✓	✓	✓	✓	✓	✓	✓	✓	✓	✓	✓	✓

<sup>1</sup>Not available on 9" wide.

<sup>2</sup>Not available on 9", 12" or 24" (2 doors) wide.

<sup>3</sup>Only available on 24" (2 doors); 39" wide.

<sup>4</sup>Not available on 9", 12" or 24" (2 doors) wide.

<sup>5</sup>Not available with 6" fluting.

<sup>6</sup>FTKAV not available on 9" or 12" wide.

<sup>7</sup>Not available on 24" (1 door), 36" or 48" wide.

<sup>8</sup>Not available on 24" (2 doors) wide.

<sup>9</sup>Not available on 9" or 39" wide.

<sup>10</sup>Not available on 9" or 24" (2 doors) wide.

<sup>11</sup>Not available on 42"-48" wide and TVRAV not available on 9" or 12" wide.

IH/RH availability charts starting on page G•40.  
IW/RW availability charts starting on page G•46.

## Description

**WALL TOP HINGE with BIFOLD,  
30", 33", or 36" HIGH**

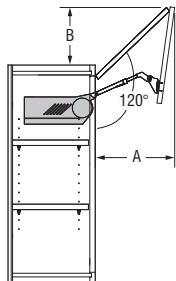
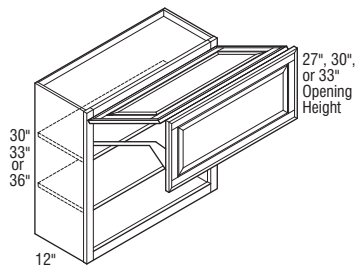

## Model

**WTH2430BF**

**WTH2730BF**

**WTH3030BF**

**WTH3330BF**

**WTH3630BF**

**WTH2433BF**

**WTH2733BF**

**WTH3033BF**

**WTH3333BF**

**WTH3633BF**

**WTH2436BF**

**WTH2736BF**

**WTH3036BF**

**WTH3336BF**

**WTH3636BF**

- Not available on Inset and Beaded Inset styles.
- Grain on center panels and slab doors will run horizontally and door rail configuration on non-miter doors will be unique from adjacent cabinet doors.
- Door opens to 120°. Angle restriction clips available; see page S•15.
- Additional accessories available for Automatic Opening Mechanism option, refer to page S•12.

	Cabinet Height	A	B
Full Overlay	30"	14 3/8"	7 3/8"
	33"	15 3/4"	8 1/16"
	36"	17 1/16"	8 3/4"

### Door & Drawer Options

AF	AOMD	CC	CG	ESMD	GAMD	HC	IFHG	MC	MD	MFO	PRMD	SHMD	SPLITDR	SPLITDRWS	SUMD	TCG	TCP
✓	✓	✓					✓			✓				✓			

### End Panel Options

AUTH	CSFPE	EXBK	EXDN	FFD	FPE	INTGE	IPE
✓	✓	✓	✓	✓	✓	✓	

### Custom Modification Options

ADD_SHLF	ADDTK	ADRW	BVR	CBO	CCO	CFNTO	CFRMO	CLIP	CND	CSDGBK	EF	EX	EX_OL	FALL	FBFL	FLUT <sup>1</sup>	FTK	ID	IH <sup>2</sup>
		✓	✓					✓		✓	✓	✓	✓			✓	✓	✓	✓

INVERM	IW <sup>3</sup>	LIGHT	MIP	OBRB	PFINBTMB	RD	RECTK	RH	ROSFLUT	RT	RW	STW	TD	TKP	TVR	WS	WTR
	✓	✓	✓	✓	✓				✓							✓	✓

<sup>1</sup>Not available with 6" fluting.

<sup>2</sup>Not available on 36" high.

<sup>3</sup>Not available on 36" wide.

# Wall Cabinets

## Description

### WALL, 39" or 42" HIGH

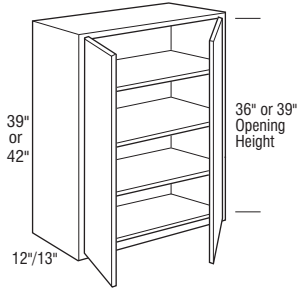
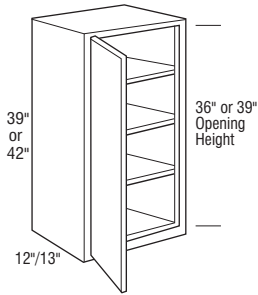

## Model

**W939 L or R**  
**W1239 L or R**  
**W1539 L or R**  
**W1839 L or R**  
**W2139 L or R**  
**W2439 L or R**  
**W942 L or R**  
**W1242 L or R**  
**W1542 L or R**  
**W1842 L or R**  
**W2142 L or R**  
**W2442 L or R**

**W2439**  
**W2739**  
**W3039**  
**W3339**  
**W3639**  
**W3939**  
**W2442**  
**W2742**  
**W3042**  
**W3342**  
**W3642**  
**W3942**

Notes below apply to all products in section above:

- Three adjustable shelves.
- Inset and Beaded Inset Door Styles are a standard 13" deep.
- Full Overlay Styles:
  - Increased Depths available in 1/4" increments from 12 1/4" to 30".
  - Reduced Depths available in 1/4" increments from 6" to 11 3/4".
- Inset and Beaded Inset Styles:
  - Increased Depths available in 1/4" increments from 13 1/4" to 30".
  - Reduced Depths available in 1/4" increments from 6" to 12 3/4".

### Door & Drawer Options

AF	AOMD	CC <sup>1</sup>	CG	ESMD <sup>1</sup>	GAMD <sup>1</sup>	HC	IFHG	MC	MD <sup>1</sup>	MFO	PRMD <sup>2</sup>	SHMD <sup>1</sup>	SPLITDR <sup>3</sup>	SPLITDRWS	SUMD <sup>1</sup>	TCG	TCP	
		✓	✓	✓	✓	✓	✓	✓	✓	✓	✓	✓	✓	✓	✓	✓	✓	✓

### End Panel Options

AUTH	CSFPE	EXBK	EXDN	FFD	FPE	INTGE	IPE
✓	✓	✓	✓	✓	✓	✓	✓

### Custom Modification Options

ADD_SHLF	ADDTK	ADRW	BVR	CBO	CCO	CFNTO	CFRMO	CLIP <sup>4</sup>	CND	CSDGBK	EF	EX	EX_OL	F.ALL	FBFL	FLUT <sup>5</sup>	FTK <sup>6</sup>	ID	IH
✓		✓	✓	✓	✓	✓	✓	✓	✓	✓	✓	✓	✓	✓	✓	✓	✓	✓	✓

INVERM	IW <sup>7</sup>	LIGHT <sup>8</sup>	MIP	OBRB	PFINBTMB	RD	RECTK	RH	ROSFLUT	RT <sup>9</sup>	RW	STW	TD <sup>10</sup>	TKP	TVR <sup>11</sup>	WS	WTR
	✓	✓	✓	✓	✓	✓			✓	✓			✓	✓	✓	✓	✓

<sup>1</sup>Not available on 9" wide.  
<sup>2</sup>Not available on 9", 12", or 24" (2 doors) wide.  
<sup>3</sup>Only available on 24" (2 doors)-39" wide.  
<sup>4</sup>Not available on 9", 12" or 24" (2 doors) wide.  
<sup>5</sup>Not available with 6" fluting.  
<sup>6</sup>FTKAV not available on 9" or 12" wide.  
<sup>7</sup>Not available on 24" (1 door), 36" or 48" wide.  
<sup>8</sup>Not available on 24" (2 doors) wide.  
<sup>9</sup>Not available on 9" or 39" wide.  
<sup>10</sup>Not available on 9" or 24" (2 doors) wide.  
<sup>11</sup>Not available on 42"-48" wide and TVRAV not available on 9" or 12" wide.

IH/RH availability charts starting on page G•40.  
IW/RW availability charts starting on page G•46.

## Description

**WALL, 39" or 42" HIGH (cont'd)**

## Model

**W4239**

**W4539**

**W4839CS**

**W4242**

**W4542**

**W4842CS**

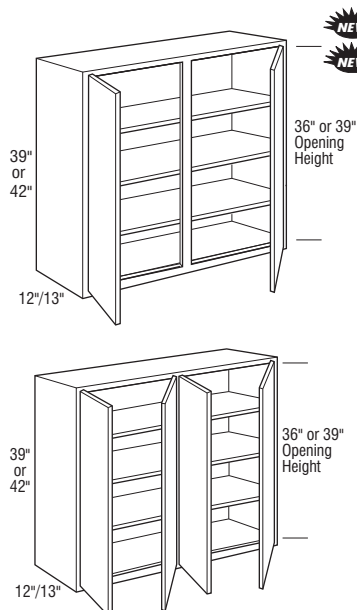

**NEW**  
**NEW**

**W4839**

**W4842**

- Three adjustable shelves.
- Inset and Beaded Inset Door Styles are a standard 13" deep.
- Full Overlay Styles:
  - Increased Depths available in 1/4" increments from 12 1/4" to 30".
  - Reduced Depths available in 1/4" increments from 6" to 11 3/4".
- Inset and Beaded Inset Styles:
  - Increased Depths available in 1/4" increments from 13 1/4" to 30".
  - Reduced Depths available in 1/4" increments from 6" to 12 3/4".

### Door & Drawer Options

AF	AOMD	CC <sup>1</sup>	CG	ESMD <sup>1</sup>	GAMD <sup>1</sup>	HC	IFHG	MC	MD <sup>1</sup>	MFO	PRMD <sup>2</sup>	SHMD <sup>1</sup>	SPLITDR <sup>3</sup>	SPLITDRWS	SUMD <sup>1</sup>	TCG	TCP	
		✓	✓	✓	✓	✓	✓	✓	✓	✓	✓	✓	✓	✓	✓	✓	✓	✓

### End Panel Options

AUTH	CSFPE	EXBK	EXDN	FFD	FPE	INTGE	IPE
✓	✓	✓	✓	✓	✓	✓	✓

### Custom Modification Options

ADD	SHLF	ADDTK	ADRW	BVR	CBO	CCO	CFNTO	CFRMO	CLIP <sup>4</sup>	CND	CSDGBK	EF	EX	EX_OL	FALL	FBFL	FLUT <sup>5</sup>	FTK <sup>6</sup>	ID	IH	
✓			✓	✓	✓	✓	✓	✓	✓	✓	✓	✓	✓	✓	✓	✓	✓	✓	✓	✓	✓

INVRM	IW <sup>7</sup>	LIGHT <sup>8</sup>	MIP	OBRB	PFINBTMB	RD	RECTK	RH	ROSFLUT	RT <sup>9</sup>	RW	STW	TD <sup>10</sup>	TKP	TVR <sup>11</sup>	WS	WTR
✓	✓	✓	✓	✓	✓	✓	✓	✓	✓	✓	✓	✓	✓	✓	✓	✓	✓

<sup>1</sup>Not available on 9" wide.

<sup>2</sup>Not available on 9", 12", or 24" (2 doors) wide.

<sup>3</sup>Only available on 24" (2 doors)-39" wide.

<sup>4</sup>Not available on 9", 12" or 24" (2 doors) wide.

<sup>5</sup>Not available with 6" fluting.

<sup>6</sup>FTKAV not available on 9" or 12" wide.

<sup>7</sup>Not available on 24" (1 door), 36" or 48" wide.

<sup>8</sup>Not available on 24" (2 doors) wide.

<sup>9</sup>Not available on 9" or 39" wide.

<sup>10</sup>Not available on 9" or 24" (2 doors) wide.

<sup>11</sup>Not available on 42"-48" wide and TVRAV not available on 9" or 12" wide.



# Wall Cabinets

## Description

### WALL, 45" or 48" HIGH

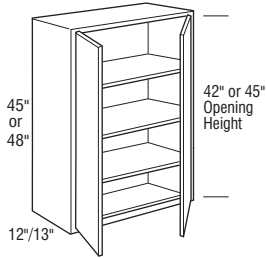
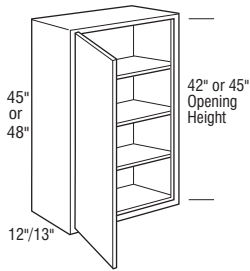

## Model

**W945 L or R**  
**W1245 L or R**  
**W1545 L or R**  
**W1845 L or R**  
**W2145 L or R**  
**W2445 L or R**  
**W948 L or R**  
**W1248 L or R**  
**W1548 L or R**  
**W1848 L or R**  
**W2148 L or R**  
**W2448 L or R**

**W2445**  
**W2745**  
**W3045**  
**W3345**  
**W3645**  
**W3945**  
**W2448**  
**W2748**  
**W3048**  
**W3348**  
**W3648**  
**W3948**

Notes below apply to all products in section above:

- Three adjustable shelves.
- Inset and Beaded Inset Door Styles are a standard 13" deep.
- Full Overlay Styles:
  - Increased Depths available in 1/4" increments from 12 1/4" to 30".
  - Reduced Depths available in 1/4" increments from 6" to 11 3/4".
- Inset and Beaded Inset Styles:
  - Increased Depths available in 1/4" increments from 13 1/4" to 30".
  - Reduced Depths available in 1/4" increments from 6" to 12 3/4".

### Door & Drawer Options

AF	AOMD	CC <sup>1</sup>	CG	ESMD <sup>1</sup>	GAMD <sup>1</sup>	HC	IFHG	MC	MD <sup>1</sup>	MFO	PRMD <sup>2</sup>	SHMD <sup>1</sup>	SPLITDR <sup>3</sup>	SPLITDRWS	SUMD <sup>1</sup>	TCG	TCP	
		✓	✓	✓	✓	✓	✓	✓	✓	✓	✓	✓	✓	✓	✓	✓	✓	✓

### End Panel Options

AUTH	CSFPE	EXBK	EXDN	FFD	FPE	INTGE	IPE
✓	✓	✓	✓	✓	✓	✓	✓

### Custom Modification Options

ADD_SHLF	ADDTK	ADRW	BVR	CBO	CCO	CFNTO	CFRMO	CLIP <sup>4</sup>	CND	CSDGBK	EF	EX	EX_OL	F.ALL	FBFL	FLUT <sup>5</sup>	FTK <sup>6</sup>	ID	IH
✓	✓	✓	✓	✓	✓	✓	✓	✓	✓	✓	✓	✓	✓	✓	✓	✓	✓	✓	✓

INVRM	IW <sup>7</sup>	LIGHT <sup>8</sup>	MIP	OBRB	PFINBTMB	RD	RECTK	RH	ROSFLUT	RT <sup>9</sup>	RW	STW	TD	TKP	TVR <sup>10</sup>	WS	WTR
✓	✓	✓	✓	✓	✓	✓	✓	✓	✓	✓	✓	✓	✓	✓	✓	✓	✓

<sup>1</sup>Not available on 9" wide.  
<sup>2</sup>Not available on 9", 12", or 24" (2 doors) wide.  
<sup>3</sup>Only available on 24" (2 doors)-39" wide.  
<sup>4</sup>Not available on 9", 12" or 24" (2 doors) wide.  
<sup>5</sup>Not available with 6" fluting.  
<sup>6</sup>FTKAV not available on 9" or 12" wide.  
<sup>7</sup>Not available on 24" (1 door), 36" or 48" wide.  
<sup>8</sup>Not available on 24" (2 doors) wide.  
<sup>9</sup>Not available on 9" or 39" wide.  
<sup>10</sup>Not available on 42"-48" wide and TVRAV not available on 9" or 12" wide.

IH/RH availability charts starting on page G•40.  
IW/RW availability charts starting on page G•46.

## Description

### WALL, 45" or 48" HIGH (cont'd)

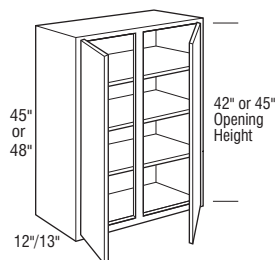

## Model

W4245

W4545

W4845

W4248

W4548

W4848

- Three adjustable shelves.
- Inset and Beaded Inset Door Styles are a standard 13" deep.
- Full Overlay Styles:
  - Increased Depths available in 1/4" increments from 12 1/4" to 30".
  - Reduced Depths available in 1/4" increments from 6" to 11 3/4".
- Inset and Beaded Inset Styles:
  - Increased Depths available in 1/4" increments from 13 1/4" to 30".
  - Reduced Depths available in 1/4" increments from 6" to 12 3/4".

### Door & Drawer Options

AF	AOMD	CC <sup>1</sup>	CG	ESMD <sup>1</sup>	GAMD <sup>1</sup>	HC	IFHG	JMC	MD <sup>1</sup>	MFO	PRMD <sup>2</sup>	SHMD <sup>1</sup>	SPLITDR <sup>3</sup>	SPLITDRWS	SUMD <sup>1</sup>	TCG	TCP	
		✓	✓	✓	✓	✓	✓	✓	✓	✓	✓	✓	✓	✓	✓	✓	✓	✓

### End Panel Options

AUTH	CSFPE	EXBK	EXDN	FFD	FPE	INTGE	IPE
✓	✓	✓	✓	✓	✓	✓	✓

### Custom Modification Options

ADD_SHLF	ADDTK	ADRW	BVR	CBO	CCO	CFNTO	CFRMO	CLIP <sup>4</sup>	CND	CSDGBK	EF	EX	EX_OL	FALL	FBFL	FLUT <sup>5</sup>	FTK <sup>6</sup>	ID	IH	
✓		✓	✓	✓	✓	✓	✓	✓	✓	✓	✓	✓	✓	✓	✓	✓	✓	✓	✓	✓
INVFRM	IW <sup>7</sup>	LIGHT <sup>8</sup>	MIP	OBRB	PFINBTMB	RD	RECTK	RH	ROSFLUT	RT <sup>9</sup>	RW	STW	TD	TKP	TVR <sup>10</sup>	WS	WTR			
✓	✓	✓	✓	✓	✓	✓			✓	✓					✓	✓	✓			

<sup>1</sup>Not available on 9" wide.

<sup>2</sup>Not available on 9", 12", or 24" (2 doors) wide.

<sup>3</sup>Only available on 24" (2 doors)-39" wide.

<sup>4</sup>Not available on 9", 12" or 24" (2 doors) wide.

<sup>5</sup>Not available with 6" fluting.

<sup>6</sup>FTKAV not available on 9" or 12" wide.

<sup>7</sup>Not available on 24" (1 door), 36" or 48" wide.

<sup>8</sup>Not available on 24" (2 doors) wide.

<sup>9</sup>Not available on 9" or 39" wide.

<sup>10</sup>Not available on 42"-48" wide and TVRAV not available on 9" or 12" wide.

# Wall Cabinets

## Description

**NEW** WALL with TWO DRAWERS,  
48", 51", 54", 57", or 60" HIGH

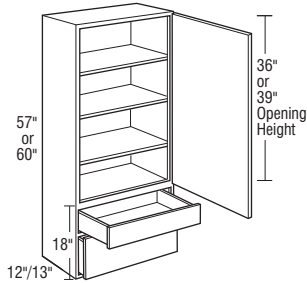
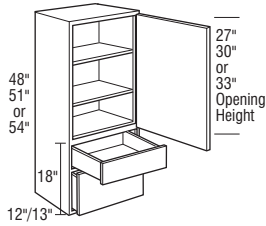

## Model

W2D1548 L or R

W2D1848 L or R

W2D2448 L or R

W2D1551 L or R

W2D1851 L or R

W2D2451 L or R

W2D1554 L or R

W2D1854 L or R

W2D2454 L or R

W2D1557 L or R

W2D1857 L or R

W2D2457 L or R

W2D1560 L or R

W2D1860 L or R

W2D2460 L or R

- 48"-54" high includes two adjustable shelves. 57"-60" high includes three adjustable shelves.
- Countertop backsplash must stop to set cabinet against wall.
- Inset and Beaded Inset Door Styles are a standard 13" deep.
- When Inset and Beaded Inset Door Styles are selected, the top drawer will be slab.
- Full Overlay Styles:
  - Increased Depths available in 1/4" increments from 12 1/4" to 30".
  - Reduced Depths available in 1/4" increments from 6" to 11 3/4".
- Inset and Beaded Inset Styles:
  - Increased Depths available in 1/4" increments from 13 1/4" to 30".
  - Reduced Depths available in 1/4" increments from 6" to 12 3/4".

### Door & Drawer Options

AF	AOMD	CC	CG	ESMD	GAMD	HC	IFHG	MC	MD	MFO	PRMD	SHMD	SPLITDR	SPLITDRWS	SUMD	TCG <sup>1</sup>	TCP <sup>1</sup>	

### End Panel Options

AUTH	CSFPE	EXBK	EXDN	FFD	FPE	INTGE	IPE

### Custom Modification Options

ADD	SHLF	ADDTK	ADRW	BVR	CBO	CCO	CFNTO	CFRMO	CLIP	CND	CSDGBK	EF	EX	EX_OL	FALL	FBFL	FLUT <sup>2</sup>	FTK	ID <sup>3</sup>	IH	
INVERM	IW <sup>4</sup>	LIGHT	MIP	OBRB	PFINBTMB	RD	RECTK	RH	ROSLUT	RT <sup>4</sup>	RW	STW	TD <sup>5</sup>	TKP	TVR	WS	WTR				

<sup>1</sup>Not available on 48" or 51" high.

<sup>2</sup>Not available with 6" fluting.

<sup>3</sup>Not available on W2D2448 L or R and W2D2451 L or R.

<sup>4</sup>Not available on 24" wide.

<sup>5</sup>Only available on 48" high and W2D2454 L or R.

IH/RH availability charts starting on page G•40.  
IW/RW availability charts starting on page G•46.

## Description



**WALL with TWO DRAWERS,  
48", 51", 54", 57", or 60" HIGH**

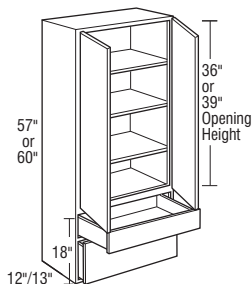
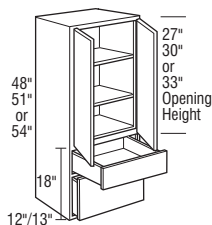

## Model

W2D2448
W2D2748
W2D3048
W2D3348
W2D3648
W2D2451
W2D2751
W2D3051
W2D3351
W2D3651
W2D2454
W2D2754
W2D3054
W2D3354
W2D3654
W2D2457
W2D2757
W2D3057
W2D3357
W2D3657
W2D2460
W2D2760
W2D3060
W2D3360
W2D3660

- 48"-54" high includes two adjustable shelves. 57"-60" high includes three adjustable shelves.
- Countertop backsplash must stop to set cabinet against wall.
- Inset and Beaded Inset Door Styles are a standard 13" deep.
- When Inset and Beaded Inset Door Styles are selected, the top drawer will be slab.
- Full Overlay Styles:
  - Increased Depths available in 1/4" increments from 12 1/4" to 30".
  - Reduced Depths available in 1/4" increments from 6" to 11 3/4".
- Inset and Beaded Inset Styles:
  - Increased Depths available in 1/4" increments from 13 1/4" to 30".
  - Reduced Depths available in 1/4" increments from 6" to 12 3/4".

### Door & Drawer Options

AF	AOMD	CC	CG	ESMD	GAMD	HC	IFHG	MC	MD	MFO	PRMD	SHMD	SPLITDR	SPLITDRWS	SUMD	TCG <sup>1</sup>	TCP <sup>1</sup>

### End Panel Options

AUTH	CSFPE	EXBK	EXDN	FFD	FPE	INTGE	IPE

### Custom Modification Options

ADD_SHLF	ADDTK	ADRW	BVR	CBO	CCO	CFNTD	CFRMO	CLIP <sup>2</sup>	CND	CSDGBK	EF	EX	EX_OL	FALL	FBFL	FLUT <sup>3</sup>	FTK	ID <sup>4</sup>	IH	
INVERM	IW	LIGHT	MIP	OBRB	PFINBTMB	RD	RECTK	RH	ROSLUT	RT	RW	STW	TD <sup>5</sup>	TKP	TVR	WS	WTR			

<sup>1</sup>Not available on 48" or 54" high.

<sup>2</sup>Not available on 24" wide.

<sup>3</sup>Not available with 6" fluting.

<sup>4</sup>Not available on W2D2451 and W2D2454.

<sup>5</sup>Not available on 48" high.

# Wall Cabinets

## Description

**NEW** WALL with THREE DRAWERS,  
48", 51", 54", 57", or 60" HIGH

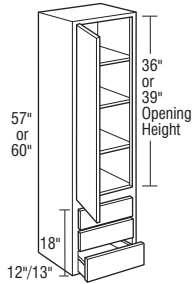
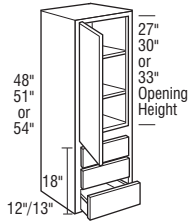

## Model

W3D1548 L or R

W3D1848 L or R

W3D2448 L or R

W3D1551 L or R

W3D1851 L or R

W3D2451 L or R

W3D1554 L or R

W3D1854 L or R

W3D2454 L or R

W3D1557 L or R

W3D1857 L or R

W3D2457 L or R

W3D1560 L or R

W3D1860 L or R

W3D2460 L or R

- 48"-54" high includes two adjustable shelves. 57"-60" high includes three adjustable shelves.
- Includes three standard drawers.
- Countertop backsplash must stop to set cabinet against wall.
- Inset and Beaded Inset Door Styles are a standard 13" deep.
- When Inset and Beaded Inset Door Styles are selected, drawers will be slab.
- Full Overlay Styles:
  - Increased Depths available in 1/4" increments from 12 1/4" to 30".
  - Reduced Depths available in 1/4" increments from 6" to 11 3/4".
- Inset and Beaded Inset Styles:
  - Increased Depths available in 1/4" increments from 13 1/4" to 30".
  - Reduced Depths available in 1/4" increments from 6" to 12 3/4".

### Door & Drawer Options

AF	AOMD	CC	CG	ESMD	GAMD	HC	IFHG	MC	MD	MFO	PRMD	SHMD	SPLITDR	SPLITDRWS	SUMD	TCG <sup>1</sup>	TCP <sup>1</sup>	
			✓							✓	✓	✓					✓	✓

### End Panel Options

AUTH	CSFPE	EXBK	EXDN	FFD	FPE	INTGE	IPE
✓	✓	✓	✓	✓	✓	✓	✓

### Custom Modification Options

ADD	SHLF	ADTK	ADRW	BVR	CBO	CCO	CFNTO	CFRMO	CLIP	CND	CSDGBK	EF	EX	EX_OL	FALL	FBFL	FLUT <sup>2</sup>	FTK	ID <sup>3</sup>	IH	
	✓			✓	✓	✓	✓	✓	✓	✓	✓	✓	✓	✓	✓	✓	✓	✓	✓	✓	✓

INVFRM	IW <sup>4</sup>	LIGHT	MIP	OBRB	PFINBTMB	RD	RECTK	RH	ROSFLUT	RT <sup>4</sup>	RW	STW	TD <sup>5</sup>	TKP	TVR	WS	WTR
	✓	✓	✓	✓	✓	✓	✓	✓	✓	✓	✓	✓	✓	✓	✓	✓	✓

<sup>1</sup>Not available on 48" or 51" high.

<sup>2</sup>Not available with 6" fluting.

<sup>3</sup>Not available on W3D2448 L or R and W3D2451 L or R.

<sup>4</sup>Not available on 24" wide.

<sup>5</sup>Only available on 48" high and W3D2454 L or R.

IH/RH availability charts starting on page G•40.  
IW/RW availability charts starting on page G•46.

## Description



**WALL with THREE DRAWERS,  
48", 51", 54", 57", or 60" HIGH**

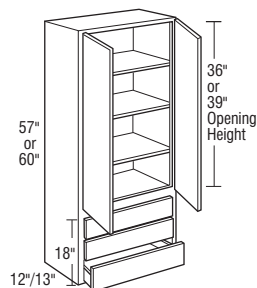
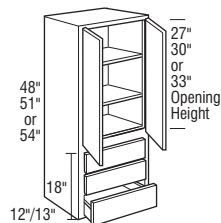

## Model

**W3D2448**

**W3D2451**

**W3D2454**

**W3D2457**

**W3D2460**

- 48"-54" high includes two adjustable shelves. 57"-60" high includes three adjustable shelves.
- Includes three standard drawers.
- Countertop backsplash must stop to set cabinet against wall.
- Inset and Beaded Inset Door Styles are a standard 13" deep.
- When Inset and Beaded Inset Door Styles are selected, drawers will be slab.
- Full Overlay Styles:
  - Increased Depths available in 1/4" increments from 12 1/4" to 30".
  - Reduced Depths available in 1/4" increments from 6" to 11 3/4".
- Inset and Beaded Inset Styles:
  - Increased Depths available in 1/4" increments from 13 1/4" to 30".
  - Reduced Depths available in 1/4" increments from 6" to 12 3/4".

### Door & Drawer Options

AF	AOMD	CC	CG	ESMD	GAMD	HC	IFHG	MC	MD	MFO	PRMD	SHMD	SPLITDR	SPLITDRWS	SUMD	TCG <sup>1</sup>	TCP <sup>1</sup>
			✓							✓	✓	✓	✓	✓		✓	✓

### End Panel Options

AUTH	CSFPE	EXBK	EXDN	FFD	FPE	INTGE	IPE
✓	✓	✓	✓	✓	✓	✓	✓

### Custom Modification Options

ADD_SHLF	ADDTK	ADRW	BVR	CBO	CCO	CFNTO	CFRMO	CLIP	CND	CSDGBK	EF	EX	EX_OL	F.ALL	FBFL	FLUT <sup>2</sup>	FTK	ID <sup>3</sup>	IH
	✓		✓	✓	✓	✓	✓	✓	✓	✓	✓	✓	✓	✓	✓	✓	✓	✓	✓

INVFRM	IW	LIGHT	MIP	OBRB	PFINBTMB	RD	RECTK	RH	ROSLUT	RT	RW	STW	TD <sup>4</sup>	TKP	TVR	WS	WTR
✓	✓	✓	✓	✓	✓	✓	✓	✓	✓	✓	✓	✓	✓	✓	✓	✓	✓

<sup>1</sup>Not available on 48" or 54" high.

<sup>2</sup>Not available with 6" fluting.

<sup>3</sup>Not available on W3D2451 and W3D2454.

<sup>4</sup>Only available on 48" high

# Stacked Wall Cabinets

## Description

## Model

**STACKED WALL with APPLIANCE GARAGE,  
36" or 39" HIGH**

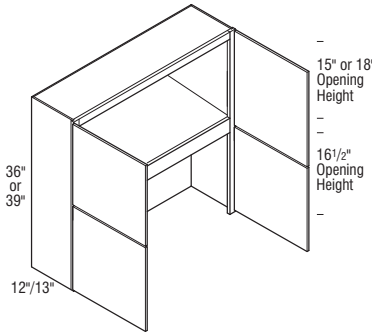
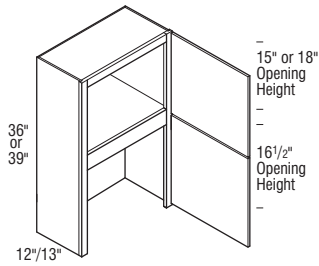

STWDAG1536 L or R

STWDAG1836 L or R

STWDAG2136 L or R

STWDAG2436 L or R

STWDAG1539 L or R

STWDAG1839 L or R

STWDAG2139 L or R

STWDAG2439 L or R

STWDAG2436

STWDAG2736

STWDAG3036

STWDAG3336

STWDAG3636

STWDAG2439

STWDAG2739

STWDAG3039

STWDAG3339

STWDAG3639

Notes below apply to all products in section above:

- Appliance garage opening is 16 1/2".
- Increased Heights modification will increase the height of the upper cabinet section. The bottom section will retain its original height.
- Bottom section does not include floor.
- Full Overlay Styles:
  - Increased Depths available in 1/4" increments from 12 1/4" to 30".
  - Reduced Depths available in 1/4" increments from 6" to 11 3/4".
- Inset and Beaded Inset Styles:
  - Increased Depths available in 1/4" increments from 13 1/4" to 30".
  - Reduced Depths available in 1/4" increments from 6" to 12 3/4".

### Door & Drawer Options

AF	AQMD	CC	CG	ESMD <sup>1</sup>	GAMD	HC	IFHG	MC	MD	MFO	PRMD <sup>1</sup>	SHMD	SPLITDR	SPLITDRWS	SUMD	TCG	TCP
✓			✓	✓	✓		✓			✓	✓	✓				✓	

### End Panel Options

AUTH	CSFPE	EXBK	EXDN	FFD	FPE	INTGE	IPE
✓	✓	✓				✓	✓

### Custom Modification Options

ADD	SHLF	ADTK	ADRW	BVR	CBO	CCO	CFNTO	CFRMO	CLIP <sup>1</sup>	CND	CSDGBK	EF	EX	EX_OL	F.ALL	FBFL	FLUT <sup>2</sup>	FTK	ID	IH
					✓	✓	✓	✓	✓	✓	✓	✓	✓	✓	✓		✓		✓	✓

INVERM	IW <sup>3</sup>	LIGHT	MIP	OBRB	PFINBTMB	RD	RECTK	RH	ROSFLUT	RT	RW	STW	TD	TKP	TVR	WS <sup>4</sup>	WTR
	✓		✓		✓	✓			✓							✓	✓

<sup>1</sup>Not available on 24" (2 doors) wide.

<sup>2</sup>Not available with 6" fluting.

<sup>3</sup>Not available on 24" (1 door) or 36" wide.

<sup>4</sup>Wide stile both 3" not available on 24" (2 doors) wide.

IH/RH availability charts starting on page G•40.  
IW/RW availability charts starting on page G•46.

## Description

### STACKED WALL with APPLIANCE GARAGE, 42" or 45" HIGH

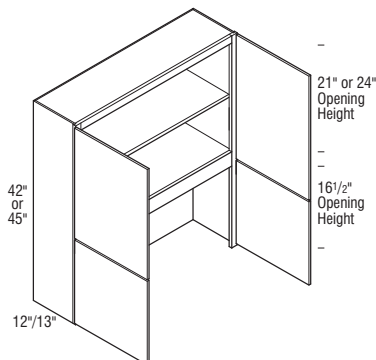
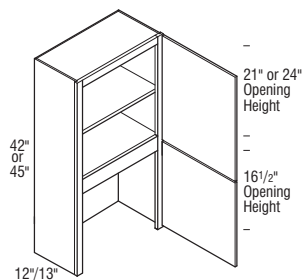

## Model

STWDAG1542 L or R

STWDAG1842 L or R

STWDAG2142 L or R

STWDAG2442 L or R

STWDAG1545 L or R

STWDAG1845 L or R

STWDAG2145 L or R

STWDAG2445 L or R

STWDAG2442

STWDAG2742

STWDAG3042

STWDAG3342

STWDAG3642

STWDAG2445

STWDAG2745

STWDAG3045

STWDAG3345

STWDAG3645

Notes below apply to all products in section above:

- One adjustable shelf.
- Appliance garage opening is 16 1/2".
- Increased Heights modification will increase the height of the upper cabinet section. The bottom section will retain its original height.
- Bottom section does not include floor.
- Full Overlay Styles:
  - Increased Depths available in 1/4" increments from 12 1/4" to 30".
  - Reduced Depths available in 1/4" increments from 6" to 11 3/4".
- Inset and Beaded Inset Styles:
  - Increased Depths available in 1/4" increments from 13 1/4" to 30".
  - Reduced Depths available in 1/4" increments from 6" to 12 3/4".

#### Door & Drawer Options

AF	AOMD	CC	CG	ESMD <sup>1</sup>	GAMD	HC	IFHG	MC	MD	MFO	PRMD <sup>1</sup>	SHMD	SPLITDR	SPLITDRWS	SUMD	TCG	TCP
✓		✓	✓	✓	✓	✓	✓	✓	✓	✓	✓	✓				✓	

#### End Panel Options

AUTH	CSFPE	EXBK	EXDN	FFD	FPE	INTGE	IPE
✓	✓	✓			✓	✓	✓

#### Custom Modification Options

ADD_SHLF	ADDTK	ADRW	BVR	CBO	CCO	CFNTO	CFRMO	CLIP <sup>1</sup>	CND	CSDGBK	EF	EX	EX_OL	FALL	FBFL	FLUT <sup>2</sup>	FTK	ID	IH
✓				✓	✓	✓	✓	✓	✓	✓	✓	✓	✓	✓			✓	✓	✓

INVERM	IW <sup>3</sup>	LIGHT	MIP	OBRB	PFINBTMB	RD	RECTK	RH	ROSLUT	RT	RW	STW	TD	TKP	TVR	WS <sup>4</sup>	WTR	
	✓		✓		✓	✓			✓							✓	✓	✓

<sup>1</sup>Not available on 24" (2 doors) wide.

<sup>2</sup>Not available with 6" fluting.

<sup>3</sup>Not available on 24" (1 door) or 36" wide.

<sup>4</sup>Wide stile both 3" not available on 24" (2 doors) wide.



# Stacked Wall Cabinets

## Description

## Model

**STACKED WALL with APPLIANCE GARAGE, 48", 51", or 54" HIGH**

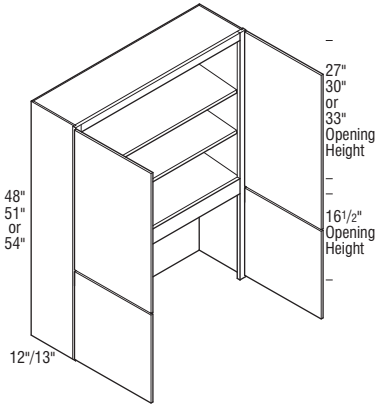
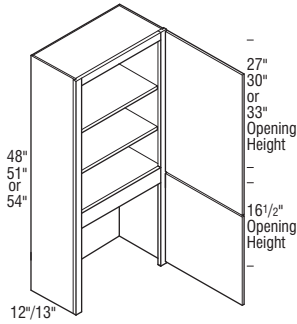

STWDAG1548 L or R
STWDAG1848 L or R
STWDAG2148 L or R
STWDAG2448 L or R
STWDAG1551 L or R
STWDAG1851 L or R
STWDAG2151 L or R
STWDAG2451 L or R
STWDAG1554 L or R
STWDAG1854 L or R
STWDAG2154 L or R
STWDAG2454 L or R
STWDAG2448
STWDAG2748
STWDAG3048
STWDAG3348
STWDAG3648
STWDAG2451
STWDAG2751
STWDAG3051
STWDAG3351
STWDAG3651
STWDAG2454
STWDAG2754
STWDAG3054
STWDAG3354
STWDAG3654

Notes below apply to all products in section above:

- One fixed and two adjustable shelves.
- Appliance garage opening is 16 1/2".
- Increased Heights modification will increase the height of the upper cabinet section. The bottom section will retain its original height.
- Bottom section does not include floor.
- Full Overlay Styles:
  - Increased Depths available in 1/4" increments from 12 1/4" to 30".
  - Reduced Depths available in 1/4" increments from 6" to 11 3/4".
- Inset and Beaded Inset Styles:
  - Increased Depths available in 1/4" increments from 13 1/4" to 30".
  - Reduced Depths available in 1/4" increments from 6" to 12 3/4".

### Door & Drawer Options

AF	AOMD	CC	CG	ESMD	GAMD	HC	IFHG	MC	MD	MFO	PRMD	SHMD	SPLITDR	SPLITDRWS	SUMD	TCG	TCP
✓		✓	✓	✓	✓	✓	✓	✓	✓	✓	✓	✓				✓	

### End Panel Options

AUTH	CSFPE	EXBK	EXDN	FFD	FPE	INTGE <sup>1</sup>	IPE
✓	✓	✓			✓	✓	✓

### Custom Modification Options

ADD	SHLF	ADTK	ADRW	BVR	CBO <sup>1</sup>	CCO <sup>1</sup>	CFNTO <sup>1</sup>	CFRMO <sup>1</sup>	CLIP	CND	CSDBGK	EF	EX	EX_OL	FALL	FBFL	FLUT <sup>2</sup>	FTK	ID	IH	
✓		✓	✓	✓	✓	✓	✓	✓	✓	✓	✓	✓	✓	✓	✓	✓	✓	✓	✓	✓	✓

INVERM	IW	LIGHT <sup>1</sup>	MIP	OBRB	PFINBTMB	RD	RECTK	RH	ROSLUT	RT	RW	STW	TD	TKP	TVR	WS	WTR
		✓	✓	✓	✓	✓	✓	✓	✓	✓	✓	✓	✓	✓	✓	✓	✓

<sup>1</sup>Not available on 24" (2 doors) wide.

<sup>2</sup>Not available with 6" fluting.

IH/RH availability charts starting on page G•40.  
IW/RW availability charts starting on page G•46.

## Description

### STACKED WALL with APPLIANCE GARAGE, 57" or 60" HIGH

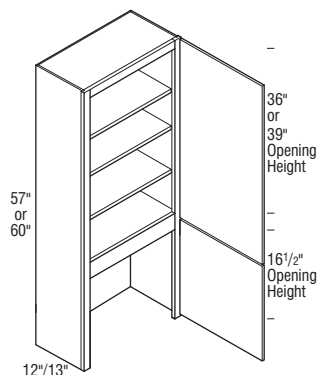

## Model

STWDAG1557 L or R

STWDAG1857 L or R

STWDAG2157 L or R

STWDAG2457 L or R

STWDAG1560 L or R

STWDAG1860 L or R

STWDAG2160 L or R

STWDAG2460 L or R

STWDAG2457

STWDAG2757

STWDAG3057

STWDAG3357

STWDAG3657

STWDAG2460

STWDAG2760

STWDAG3060

STWDAG3360

STWDAG3660

Notes below apply to all products in section above:

- One fixed and three adjustable shelves.
- Appliance garage opening is 16 1/2".
- Increased Heights modification will increase the height of the upper cabinet section. The bottom section will retain its original height.
- Bottom section does not include floor.
- Full Overlay Styles:
  - Increased Depths available in 1/4" increments from 12 1/4" to 30".
  - Reduced Depths available in 1/4" increments from 6" to 11 3/4".
- Inset and Beaded Inset Styles:
  - Increased Depths available in 1/4" increments from 13 1/4" to 30".
  - Reduced Depths available in 1/4" increments from 6" to 12 3/4".

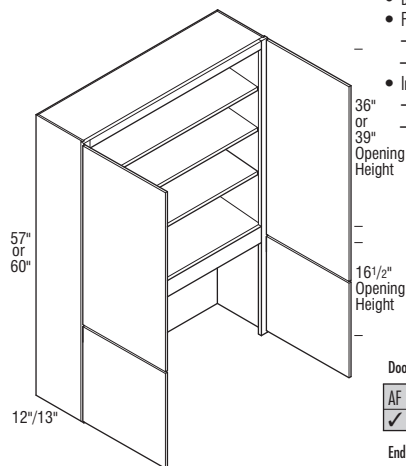

#### Door & Drawer Options

AF	AOMD	CC	CG	ESMD	GAMD	HC	IFHG	JMC	MD	MFO	PRMD	SHMD	SPLITDR	SPLITDRWS	SUMD	TGC	TCP
✓		✓	✓	✓	✓	✓	✓	✓	✓	✓	✓	✓				✓	

#### End Panel Options

AUTH	CSFPE	EXBK	EXDN	FFD	FPE	INTGE <sup>1</sup>	IPE
✓	✓	✓			✓	✓	✓

#### Custom Modification Options

ADD	SHLF	ADTK	ADRW	BVR	CBO <sup>1</sup>	CCO <sup>1</sup>	CFNTO <sup>1</sup>	CFRMO <sup>1</sup>	CLIP	CND	CSDGBK	EF	EX	EX_OL	FALL	FBFL	FLUT <sup>2</sup>	FTK	ID	IH	
✓					✓	✓	✓	✓	✓	✓	✓	✓	✓	✓	✓	✓	✓	✓	✓	✓	✓

INVRM	IW	LIGHT <sup>1</sup>	MIP	OBRB	PFINBTMB	RD	RECTK	RH	ROSEFLUT	RT	RW	STW	TD	TKP	TVR	WS	WTR
		✓	✓	✓	✓	✓	✓		✓						✓	✓	✓

<sup>1</sup>Not available on 24" (2 doors) wide.

<sup>2</sup>Not available with 6" fluting.

# Stacked Wall Cabinets

## Description

### STACKED WALL, 36" or 39" HIGH

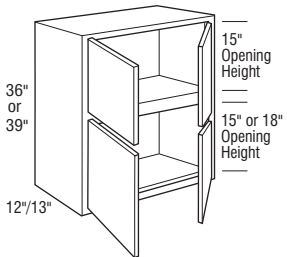
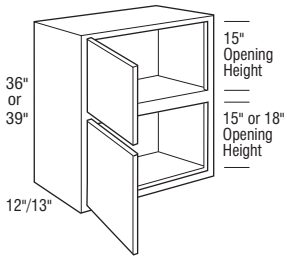

## Model

STW1236 L or R

STW1536 L or R

STW1836 L or R

STW2136 L or R

STW2436 L or R

STW1239 L or R

STW1539 L or R

STW1839 L or R

STW2139 L or R

STW2439 L or R

STW2436

STW2736

STW3036

STW3336

STW3636

STW3936

STW2439

STW2739

STW3039

STW3339

STW3639

STW3939

#### Notes below apply to all products in section above:

- Inset and Beaded Inset Door Styles are a standard 13" deep.
- Full Overlay Styles:
  - Increased Depths available in 1/4" increments from 12 1/4" to 30".
  - Reduced Depths available in 1/4" increments from 6" to 11 3/4".
- Inset and Beaded Inset Styles:
  - Increased Depths available in 1/4" increments from 13 1/4" to 30".
  - Reduced Depths available in 1/4" increments from 6" to 12 3/4".
- Increased Heights modification will increase the height of the lower cabinet section. The upper cabinet section will retain its original height.

#### Door & Drawer Options

AF	AOMD	CC	CG	ESMD <sup>1</sup>	GAMD <sup>1</sup>	HC	IFHG	MC	MD	MFO	PRMD <sup>1</sup>	SHMD	SPLITDR <sup>2</sup>	SPLITDRWS	SUMD	TCG	TCP	
✓		✓	✓	✓	✓	✓	✓	✓	✓	✓	✓	✓	✓	✓	✓	✓	✓	✓

#### End Panel Options

AUTH	CSFPE	EXBK	EXDN	FFD	FPE	INTGE	IPE
✓	✓	✓	✓	✓	✓	✓	✓

#### Custom Modification Options

ADD	SHLF	ADDTK	ADRW	BVR	CBO	CCO	CFNTD	CFRMO	CLIP <sup>3</sup>	CND	CSDGBK	EF	EX	EX_OL	F.ALL	FBFL	FLUT <sup>4</sup>	FTK <sup>5</sup>	ID	IH	
✓	✓	✓	✓	✓	✓	✓	✓	✓	✓	✓	✓	✓	✓	✓	✓	✓	✓	✓	✓	✓	✓

INVERM	IW <sup>6</sup>	LIGHT	MIP	OBRB	PFINBTMB	RD	RECTK	RH	ROSLUT	RT	RW	STW	TD	TKP	TVR <sup>7</sup>	WS <sup>8</sup>	WTR
✓	✓	✓	✓	✓	✓	✓	✓	✓	✓	✓	✓	✓	✓	✓	✓	✓	✓

<sup>1</sup>Not available on 12" or 24" (2 doors) wide.

<sup>2</sup>Not available on 12"-24" (1 door) wide.

<sup>3</sup>Not available on 12" wide.

<sup>4</sup>Not available with 6" fluting.

<sup>5</sup>FTKAV not available on 12" wide.

<sup>6</sup>Not available on 24" (1 door), 36" or 48" wide.

<sup>7</sup>TVRAV not available on 12" wide.

<sup>8</sup>Wide stile both 3" not available on 12" or 24" (2 doors) wide.

IH/RH availability charts starting on page G•40.  
IW/RW availability charts starting on page G•46.

## Description

### STACKED WALL, 36" or 39" HIGH (cont'd)

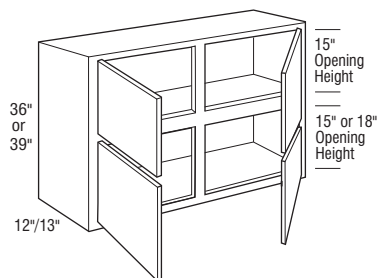

## Model

STW4236

STW4536

STW4836

STW4239

STW4539

STW4839

#### Notes below apply to all products in section above:

- Inset and Beaded Inset Door Styles are a standard 13" deep.
- Full Overlay Styles:
  - Increased Depths available in 1/4" increments from 12 1/4" to 30".
  - Reduced Depths available in 1/4" increments from 6" to 11 3/4".
- Inset and Beaded Inset Styles:
  - Increased Depths available in 1/4" increments from 13 1/4" to 30".
  - Reduced Depths available in 1/4" increments from 6" to 12 3/4".
- Increased Heights modification will increase the height of the lower cabinet section. The upper cabinet section will retain its original height.

#### Door & Drawer Options

AF	AOMD	CC	CG	ESMD <sup>1</sup>	GAMD <sup>1</sup>	HC	IFHG	MC	MD	MFO	PRMD <sup>1</sup>	SHMD	SPLITDR <sup>2</sup>	SPLITDRWS	SJMD	TCG	TCP
✓	✓	✓	✓	✓	✓	✓	✓	✓	✓	✓	✓	✓	✓	✓	✓	✓	✓

#### End Panel Options

AUTH	CSFPE	EXBK	EXDN	FFD	FPE	INTGE	IPE
✓	✓	✓	✓	✓	✓	✓	✓

#### Custom Modification Options

ADD	SHLF	ADDTK	ADRW	BVR	CBO	CCO	CFNTO	CFRMO	CLIP <sup>3</sup>	CND	CSDGBK	EF	EX	EX_OL	FALL	FBFL	FLUT <sup>4</sup>	FTK <sup>5</sup>	ID	IH	
✓	✓	✓	✓	✓	✓	✓	✓	✓	✓	✓	✓	✓	✓	✓	✓	✓	✓	✓	✓	✓	✓

INVFRM	IW <sup>6</sup>	LIGHT	MIP	OBRB	PFINBTMB	RD	RECTK	RH	ROSEFLUT	RT	RW	STW	TD	TKP	TVR <sup>7</sup>	WS <sup>8</sup>	WTR
✓	✓	✓	✓	✓	✓	✓	✓	✓	✓	✓	✓	✓	✓	✓	✓	✓	✓

<sup>1</sup>Not available on 12" or 24" (2 doors) wide.

<sup>2</sup>Not available on 12"×24" (1 door) wide.

<sup>3</sup>Not available on 12" wide.

<sup>4</sup>Not available with 6" fluting.

<sup>5</sup>FTKAV not available on 12" wide.

<sup>6</sup>Not available on 24" (1 door), 36" or 48" wide.

<sup>7</sup>TVRAV not available on 12" wide.

<sup>8</sup>Wide stile both 3" not available on 12" or 24" (2 doors) wide.

# Stacked Wall Cabinets

## Description

### STACKED WALL, 42" or 45" HIGH

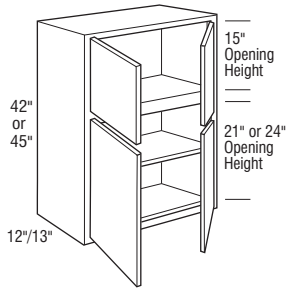
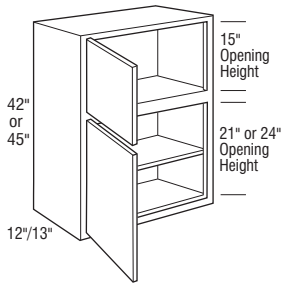

## Model

STW1242 L or R

STW1542 L or R

STW1842 L or R

STW2142 L or R

STW2442 L or R

STW1245 L or R

STW1545 L or R

STW1845 L or R

STW2145 L or R

STW2445 L or R

STW2442

STW2742

STW3042

STW3342

STW3642

STW3942

STW2445

STW2745

STW3045

STW3345

STW3645

STW3945

#### Notes below apply to all products in section above:

- One adjustable shelf.
- Inset and Beaded Inset Door Styles are a standard 13" deep.
- Full Overlay Styles:
  - Increased Depths available in 1/4" increments from 12 1/4" to 30".
  - Reduced Depths available in 1/4" increments from 6" to 11 3/4".
- Inset and Beaded Inset Styles:
  - Increased Depths available in 1/4" increments from 13 1/4" to 30".
  - Reduced Depths available in 1/4" increments from 6" to 12 3/4".
- Increased Heights modification will increase the height of the lower cabinet section. The upper cabinet section will retain its original height.

#### Door & Drawer Options

AF	AQMD	CC	CG	ESMD <sup>1</sup>	GAMD <sup>1</sup>	HC	IFHG	MC	MD	MFO	PRMD <sup>1</sup>	SHMD	SPLITDR <sup>2</sup>	SPLITDRWS	SUMD	TCG	TCP	
✓		✓	✓	✓	✓	✓	✓	✓	✓	✓	✓	✓	✓	✓	✓	✓	✓	✓

#### End Panel Options

AUTH	CSFPE	EXBK	EXDN	FFD	FPE	INTGE	IPE
✓	✓	✓	✓	✓	✓	✓	✓

#### Custom Modification Options

ADD_SHLF	ADDTK	ADRW	BVR	CBO	CCO	CFNTO	CFRMO	CLIP <sup>3</sup>	CND	CSDGBK	EF	EX	EX_OL	F.ALL	FBFL	FLUT <sup>4</sup>	FTK <sup>5</sup>	ID	IH	
✓	✓	✓	✓	✓	✓	✓	✓	✓	✓	✓	✓	✓	✓	✓	✓	✓	✓	✓	✓	✓

INVFRM	IW <sup>6</sup>	LIGHT <sup>7</sup>	MIP	OBRB	PFINBTMB	RD	RECTK	RH	ROSFLUT	RT	RW	STW	TD	TKP	TVR <sup>8</sup>	WS <sup>9</sup>	WTR
✓	✓	✓	✓	✓	✓	✓	✓	✓	✓	✓	✓	✓	✓	✓	✓	✓	✓

<sup>1</sup>Not available on 12" or 24" (2 doors) wide.

<sup>2</sup>Not available on 12"-24" (1 door) wide.

<sup>3</sup>Not available on 12" wide.

<sup>4</sup>Not available with 6" fluting.

<sup>5</sup>FTKAN not available on 12" wide.

<sup>6</sup>Not available on 24" (1 door), 36" or 48" wide.

<sup>7</sup>Only available on 24" (2 doors) wide.

<sup>8</sup>TVRAV not available on 12" wide.

<sup>9</sup>Wide stile both 3" not available on 12" or 24" (2 doors) wide.

IH/RH availability charts starting on page G•40.  
IW/RW availability charts starting on page G•46.

## Description

### STACKED WALL, 42" or 45" HIGH (cont'd)

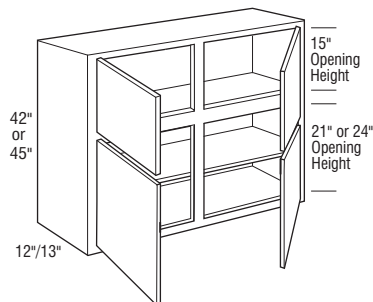

## Model

STW4242

STW4542

STW4842

STW4245

STW4545

STW4845

- One adjustable shelf.
- Inset and Beaded Inset Door Styles are a standard 13" deep.
- Full Overlay Styles:
  - Increased Depths available in 1/4" increments from 12 1/4" to 30".
  - Reduced Depths available in 1/4" increments from 6" to 11 3/4".
- Inset and Beaded Inset Styles:
  - Increased Depths available in 1/4" increments from 13 1/4" to 30".
  - Reduced Depths available in 1/4" increments from 6" to 12 3/4".
- Increased Heights modification will increase the height of the lower cabinet section. The upper cabinet section will retain its original height.

#### Door & Drawer Options

AF	AOMD	CC	CG	ESMD <sup>1</sup>	GAMD <sup>1</sup>	HC	IFHG	MC	MD	MFO	PRMD <sup>1</sup>	SHMD	SPLITDR <sup>2</sup>	SPLITDRWS	SJMD	TCG	TCP
✓			✓	✓	✓		✓		✓	✓	✓	✓	✓	✓		✓	

#### End Panel Options

AUTH	CSFPE	EXBK	EXDN	FFD	FPE	INTGE	IPE
✓	✓	✓	✓	✓	✓	✓	✓

#### Custom Modification Options

ADD	SHLF	ADDTK	ADRW	BVR	CBO	CCO	CFNTO	CFRMO	CLIP <sup>3</sup>	CND	CSDGBK	EF	EX	EX_OL	FALL	FBFL	FLUT <sup>4</sup>	FTK <sup>5</sup>	ID	IH	
✓	✓	✓	✓	✓	✓	✓	✓	✓	✓	✓	✓	✓	✓	✓	✓	✓	✓	✓	✓	✓	✓

INVRM	IW <sup>6</sup>	LIGHT <sup>7</sup>	MIP	OBRB	PFINBTMB	RD	RECTK	RH	ROSFLUT	RT	RW	STW	TD	TKP	TVR <sup>8</sup>	WS <sup>9</sup>	WTR
✓	✓	✓	✓	✓	✓	✓	✓	✓	✓	✓	✓	✓	✓	✓	✓	✓	✓

<sup>1</sup>Not available on 12" or 24" (2 doors) wide.

<sup>2</sup>Not available on 12":24" (1 door) wide.

<sup>3</sup>Not available on 12" wide.

<sup>4</sup>Not available with 6" fluting.

<sup>5</sup>FTKAV not available on 12" wide.

<sup>6</sup>Not available on 24" (1 door), 36" or 48" wide.

<sup>7</sup>Only available on 24" (2 doors) wide.

<sup>8</sup>TVRAV not available on 12" wide.

<sup>9</sup>Wide stile both 3" not available on 12" or 24" (2 doors) wide.

# Stacked Wall Cabinets

## Description

### STACKED WALL, 48" or 51" HIGH

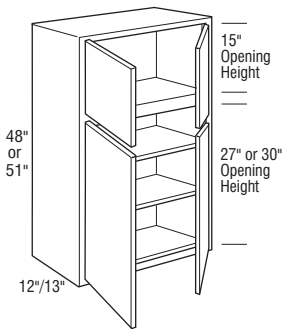
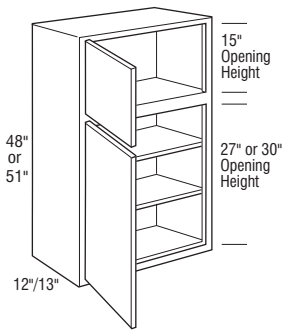

## Model

STW1248 L or R

STW1548 L or R

STW1848 L or R

STW2148 L or R

STW2448 L or R

STW1251 L or R

STW1551 L or R

STW1851 L or R

STW2151 L or R

STW2451 L or R

STW2448

STW2748

STW3048

STW3348

STW3648

STW3948

STW2451

STW2751

STW3051

STW3351

STW3651

STW3951

Notes below apply to all products in section above:

- Two adjustable shelves.
- Inset and Beaded Inset Door Styles are a standard 13" deep.
- Full Overlay Styles:
  - Increased Depths available in 1/4" increments from 12 1/4" to 30".
  - Reduced Depths available in 1/4" increments from 6" to 11 3/4".
- Inset and Beaded Inset Styles:
  - Increased Depths available in 1/4" increments from 13 1/4" to 30".
  - Reduced Depths available in 1/4" increments from 6" to 12 3/4".
- Increased Heights modification will increase the height of the lower cabinet section. The upper cabinet section will retain its original height.

#### Door & Drawer Options

AF	AOMD	CC	CG	ESMD	GAMD	HC	IFHG	MC	MD	MFO	PRMD <sup>1</sup>	SHMD	SPLITDR <sup>2</sup>	SPLITDRWS	SUMD	TCG	TCP
✓		✓	✓	✓	✓	✓	✓	✓	✓	✓	✓	✓	✓			✓	

#### End Panel Options

AUTH	CSFPE	EXBK	EXDN	FFD	FPE	INTGE	IPE
✓	✓	✓	✓	✓	✓	✓	✓

#### Custom Modification Options

ADD_SHLF	ADDTK	ADRW	BVR	CBO	CCO	CFNTO	CFRMO	CLIP <sup>1</sup>	CND	CSDGBK	EF	EX	EX_OL	F.ALL	FBFL	FLUT <sup>3</sup>	FTK <sup>4</sup>	ID	IH
	✓	✓	✓	✓	✓	✓	✓	✓	✓	✓	✓	✓	✓	✓		✓	✓	✓	✓
INVFRM	IW <sup>5</sup>	LIGHT	MIP	OBRB	PFINBTMB	RD	RECTK	RH	ROSLUT	RT	RW	STW	TD	TKP	TVR <sup>6</sup>	WS <sup>7</sup>	WTR		
	✓	✓	✓	✓	✓	✓	✓	✓	✓	✓	✓	✓	✓	✓	✓	✓	✓		

<sup>1</sup>Not available on 12" or 24" (2 doors) wide.

<sup>2</sup>Only available on 24" (2 doors)-39" wide.

<sup>3</sup>Not available with 6" fluting.

<sup>4</sup>FTKAV not available on 12" wide.

<sup>5</sup>Not available on 24" (1 door), 36" or 48" wide.

<sup>6</sup>Not available on 42"-48" wide and TVRAV not available on 12" wide.

<sup>7</sup>Not available on 24" (2 doors) wide and wide stile both 3" not available on 12" wide.

IH/RH availability charts starting on page G•40.  
IW/RW availability charts starting on page G•46.

## Description

### STACKED WALL, 48" or 51" HIGH (cont'd)

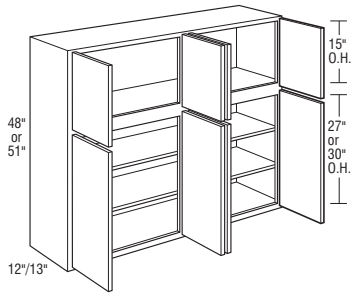
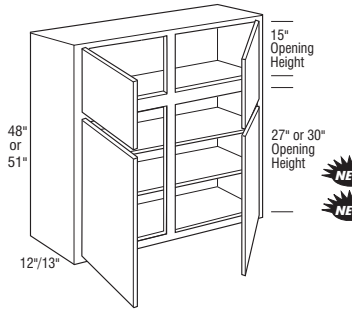

## Model

STW4248

STW4548

STW4848CS

STW4251

STW4551

STW4851CS

STW4848

STW4851

- Two adjustable shelves.
- Inset and Beaded Inset Door Styles are a standard 13" deep.
- Full Overlay Styles:
  - Increased Depths available in 1/4" increments from 12 1/4" to 30".
  - Reduced Depths available in 1/4" increments from 6" to 11 3/4".
- Inset and Beaded Inset Styles:
  - Increased Depths available in 1/4" increments from 13 1/4" to 30".
  - Reduced Depths available in 1/4" increments from 6" to 12 3/4".
- Increased Heights modification will increase the height of the lower cabinet section. The upper cabinet section will retain its original height.

#### Door & Drawer Options

AF	AOMD	CC	CG	ESMD	GAMD	HC	IFHG	MC	MD	MFO	PRMD <sup>1</sup>	SHMD	SPLITDR <sup>2</sup>	SPLITDRWS	SUMD	TCG	TCP
✓	✓	✓	✓	✓	✓	✓	✓	✓	✓	✓	✓	✓	✓	✓	✓	✓	✓

#### End Panel Options

AUTH	CSFPE	EXBK	EXDN	FFD	FPE	INTGE	IPE
✓	✓	✓	✓	✓	✓	✓	✓

#### Custom Modification Options

ADD_SHLF	ADDTK	ADRW	BVR	CBO	CCO	CFNTO	CFRMO	CLIP <sup>1</sup>	CND	CSDGBK	EF	EX	EX_OL	FALL	FBFL	FLUT <sup>3</sup>	FTK <sup>4</sup>	ID	IH
✓	✓	✓	✓	✓	✓	✓	✓	✓	✓	✓	✓	✓	✓	✓	✓	✓	✓	✓	✓

INVERM	IW <sup>5</sup>	LIGHT	MIP	OBRB	PFINBTMB	RD	RECTK	RH	ROSLUT	RT	RW	STW	TD	TKP	TVR <sup>6</sup>	WS <sup>7</sup>	WTR
✓	✓	✓	✓	✓	✓	✓	✓	✓	✓	✓	✓	✓	✓	✓	✓	✓	✓

<sup>1</sup>Not available on 12" or 24" (2 doors) wide.

<sup>2</sup>Only available on 24" (2 doors)-39" wide.

<sup>3</sup>Not available with 6" fluting.

<sup>4</sup>FTKAV not available on 12" wide.

<sup>5</sup>Not available on 24" (1 door), 36" or 48" wide.

<sup>6</sup>Not available on 42"-48" wide and TVRAV not available on 12" wide.

<sup>7</sup>Not available on 24" (2 doors) wide and wide stile both 3" not available on 12" wide.



# Stacked Wall Cabinets

## Description

**STACKED WALL, 54", 57", or 60" HIGH**

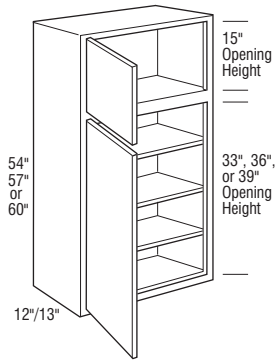

## Model

- STW1254 L or R
- STW1554 L or R
- STW1854 L or R
- STW2154 L or R
- STW2454 L or R
- STW1257 L or R
- STW1557 L or R
- STW1857 L or R
- STW2157 L or R
- STW2457 L or R
- STW1260 L or R
- STW1560 L or R
- STW1860 L or R
- STW2160 L or R
- STW2460 L or R

- Three adjustable shelves.
- Inset and Beaded Inset Door Styles are a standard 13" deep.
- Full Overlay Styles:
  - Increased Depths available in 1/4" increments from 12 1/4" to 30".
  - Reduced Depths available in 1/4" increments from 6" to 11 3/4".
- Inset and Beaded Inset Styles:
  - Increased Depths available in 1/4" increments from 13 1/4" to 30".
  - Reduced Depths available in 1/4" increments from 6" to 12 3/4".
- Increased Heights modification will increase the height of the lower cabinet section. The upper cabinet section will retain its original height.

### Door & Drawer Options

AF	AOMD	CC	CG	ESMD	GAMD	HC	IFHG	MC	MD	MFO	PRMD <sup>1</sup>	SHMD	SPLITDR	SPLITDRWS	SUMD	TCG	TCP
✓	✓	✓	✓	✓	✓	✓	✓	✓	✓	✓	✓	✓	✓	✓	✓	✓	✓

### End Panel Options

AUTH	CSFPE	EXBK	EXDN	FFD	FPE	INTGE	IPE
✓	✓	✓	✓	✓	✓	✓	✓

### Custom Modification Options

ADD_SHLF	ADDTK	ADRW	BVR	CBO	CCO	CFNTO	CFRMO	CLIP <sup>1</sup>	CND	CSDGBK	EF	EX	EX_OL	FALL	FBFL	FLUT <sup>2</sup>	FTK <sup>3</sup>	ID	IH
✓	✓	✓	✓	✓	✓	✓	✓	✓	✓	✓	✓	✓	✓	✓	✓	✓	✓	✓	✓
INVFRM	IW <sup>4</sup>	LIGHT	MIP	OBRB	PFINBTMB	RD	RECTK	RH	ROSLUT	RT	RW	STW	TD	TKP	TVR <sup>5</sup>	WS <sup>6</sup>	WTR		
✓	✓	✓	✓	✓	✓	✓	✓	✓	✓	✓	✓	✓	✓	✓	✓	✓	✓		

<sup>1</sup>Not available on 12" wide.  
<sup>2</sup>Not available with 6" fluting.  
<sup>3</sup>FTKAV not available on 12" wide.  
<sup>4</sup>Not available on 24" wide.  
<sup>5</sup>TVRAV not available on 12" wide.  
<sup>6</sup>Wide stile both 3" not available on 12" wide.

IH/RH availability charts starting on page G•40.  
 IW/RW availability charts starting on page G•46.

## Description

**STACKED WALL, 54", 57", or 60" HIGH (cont'd)**

## Model

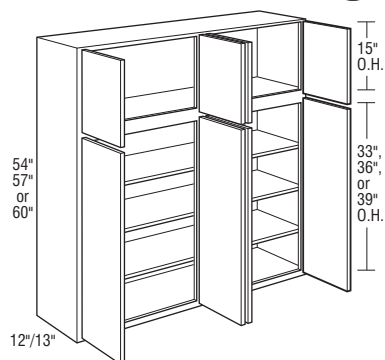
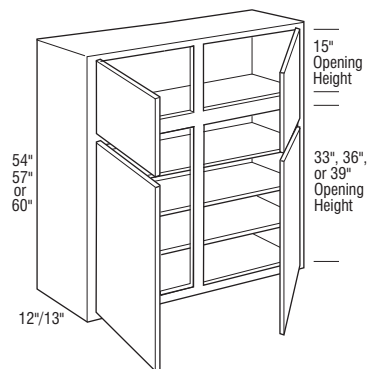
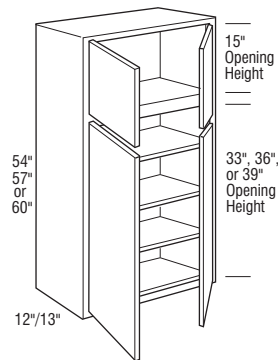

- STW2454
- STW2754
- STW3054
- STW3354
- STW3654
- STW3954
- STW2457
- STW2757
- STW3057
- STW3357
- STW3657
- STW3957
- STW2460
- STW2760
- STW3060
- STW3360
- STW3660
- STW3960
- STW4254
- STW4554
- STW4854CS
- STW4257
- STW4557
- STW4857CS
- STW4260
- STW4560
- STW4860CS
- STW4854
- STW4857
- STW4860



- Three adjustable shelves.
- Inset and Beaded Inset Door Styles are a standard 13" deep.
- Full Overlay Styles:
  - Increased Depths available in 1/4" increments from 12 1/4" to 30"
  - Reduced Depths available in 1/4" increments from 6" to 11 3/4"
- Inset and Beaded Inset Styles:
  - Increased Depths available in 1/4" increments from 13 1/4" to 30"
  - Reduced Depths available in 1/4" increments from 6" to 12 3/4"
- Increased Heights modification will increase the height of the lower cabinet section. The upper cabinet section will retain its original height.

### Door & Drawer Options

AF	AOMD	CC	CG	ESWD	GAMD	HC	IFHG	MC	MD	MFO	PRMD <sup>1</sup>	SHMD	SPLITDR <sup>2</sup>	SPLITDRWS	SUMD	TCG	TCP
✓	✓	✓	✓	✓	✓	✓	✓	✓	✓	✓	✓	✓	✓	✓	✓	✓	✓

### End Panel Options

AUTH	CSFPE	EXBK	EXDN	FFD	FPE	INTGE	IPE
✓	✓	✓	✓	✓	✓	✓	✓

### Custom Modification Options

ADD_SHLF	ADDTK	ADRW	BVR	CBO	CCO	CFNTO	CFRMO	CLIP <sup>1</sup>	CND	CSDGBK	EF	EX	EX_OL	FALL	FBFL	FLUT <sup>3</sup>	FTK	ID	IH
✓	✓	✓	✓	✓	✓	✓	✓	✓	✓	✓	✓	✓	✓	✓	✓	✓	✓	✓	✓

INVFRM	IW <sup>4</sup>	LIGHT	MIP	OBRB	PFINBTMB	RD	RECTK	RH	ROSFLUT	RT	RW	STW	TD	TKP	TVR <sup>2</sup>	WS <sup>1</sup>	WTR
✓	✓	✓	✓	✓	✓	✓	✓	✓	✓	✓	✓	✓	✓	✓	✓	✓	✓

<sup>1</sup>Not available on 24" wide.  
<sup>2</sup>Not available on 42"-48" wide.  
<sup>3</sup>Not available with 6" fluting.  
<sup>4</sup>Not available on 36" or 48" wide.

# Stacked Wall Cabinets

## Description

**STACKED WALL with VERTICAL-LIFT,  
36", 39", 42" or 45" HIGH**

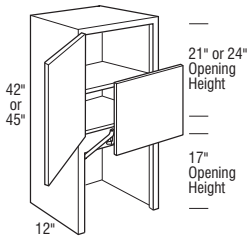
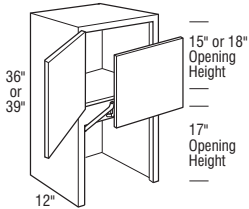

## Model

**STWAG1536 L or R**

**STWAG1836 L or R**

**STWAG2136 L or R**

**STWAG2436 L or R**

**STWAG1539 L or R**

**STWAG1839 L or R**

**STWAG2139 L or R**

**STWAG2439 L or R**

**STWAG1542 L or R**

**STWAG1842 L or R**

**STWAG2142 L or R**

**STWAG2442 L or R**

**STWAG1545 L or R**

**STWAG1845 L or R**

**STWAG2145 L or R**

**STWAG2445 L or R**

- Heavy duty Vertical-lift mechanism.
- 36" and 39" high have no shelves. 42" and 45" high have one adjustable shelf.
- Appliance garage opening is 17" high, dimension from cabinet base to bottom of mechanism is 15 3/4".
- Increased Heights modification will increase the height of the upper cabinet section. The bottom section will retain its original height.
- Increased Depths available in 1/4" increments from 12 1/4" to 30".
- Not available on Inset and Beaded Inset styles.
- Automatic Opening Mechanism is available except when used with the following door styles:
  - Burke, Gordon, Kirby, Landry, Shanley, or Vinson.

### Door & Drawer Options

AF	AOMD	CC	CG	ESMD	GAMD	HC	IFHG	MC	MD	MFO	PRMD	SHMD	SPLITDR	SPLITDRWS	SJMD	TCG	TCP	
✓	✓	✓	✓	✓	✓	✓	✓	✓	✓	✓	✓	✓	✓	✓	✓	✓	✓	✓

### End Panel Options

AUTH	CSFPE	EXBK	EXDN	FFD	FPE	INTGE	IPE
✓	✓	✓	✓	✓	✓	✓	✓

### Custom Modification Options

ADD	SHLF <sup>1</sup>	ADDTK	ADRW	BVR	CBO	CCO	CFNTD	CFRMO	CLJP	CND	CSDGBK	EF	EX	EX_OL	F-ALL	FBFL	FLUT <sup>2</sup>	FTK	ID	IH	
✓	✓	✓	✓	✓	✓	✓	✓	✓	✓	✓	✓	✓	✓	✓	✓	✓	✓	✓	✓	✓	✓

INVFRM	IW <sup>3</sup>	LIGHT	MIP	OBRB	PFINBTMB	RD	RECTK	RH	ROSLUT	RT	RW	STW	TD	TKP	TVR	WS	WTR
✓	✓	✓	✓	✓	✓	✓	✓	✓	✓	✓	✓	✓	✓	✓	✓	✓	✓

<sup>1</sup>Not available on 36" or 39" high.

<sup>2</sup>Not available with 6" fluting.

<sup>3</sup>Not available on 24" wide.

IH/RH availability charts starting on page G•40.  
IW/RW availability charts starting on page G•46.

## Description

### STACKED WALL with VERTICAL-LIFT, 36", 39", 42" or 45" HIGH (cont'd)

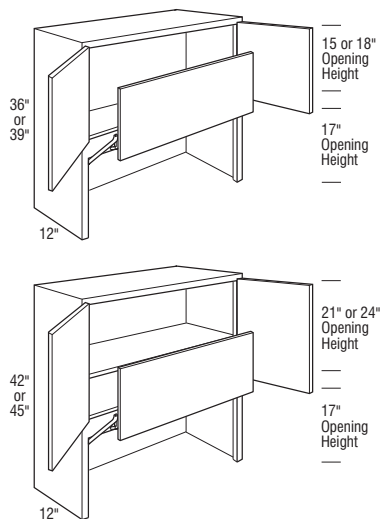

## Model

STWAG2436

STWAG2736

STWAG3036

STWAG3336

STWAG3636

STWAG2439

STWAG2739

STWAG3039

STWAG3339

STWAG3639

STWAG2442

STWAG2742

STWAG3042

STWAG3342

STWAG3642

STWAG2445

STWAG2745

STWAG3045

STWAG3345

STWAG3645

- Heavy duty Vertical-lift mechanism.
- 36" and 39" high have no shelves. 42" and 45" high have one adjustable shelf.
- Appliance garage opening is 17" high, dimension from cabinet base to bottom of mechanism is 15 3/4".
- Increased Heights modification will increase the height of the upper cabinet section. The bottom section will retain its original height.
- Increased Depths available in 1/4" increments from 12 1/4" to 30".
- Not available on Inset and Beaded Inset styles.
- Automatic Opening Mechanism is available except when used with the following door styles:
  - Burke, Gordon, Kirby, Landry, Shanley, or Vinson.

#### Door & Drawer Options

AF	AOMD	CC	CG	ESMD <sup>1</sup>	GAMD <sup>1</sup>	HC	IFHG	MC	MD	MFO	PRMD <sup>1</sup>	SHMD	SPLITDR	SPLITDRWS	SUMD	TCG	TCP
✓	✓	✓	✓	✓	✓	✓	✓	✓	✓	✓	✓	✓				✓	✓

#### End Panel Options

AUTH	CSFPE	EXBK	EXDN	FFD	FPE	INTGE	IPE
✓	✓	✓				✓	

#### Custom Modification Options

ADD	SHLF <sup>2</sup>	ADDTK	ADRW	BVR	CBO	CCO	CFNTO	CFRMO	CLIP <sup>1</sup>	CND	CSDGBK	EF	EX	EX	OL	F.FALL	FBFL	FLUT <sup>3</sup>	FTK	ID	IH
✓									✓	✓	✓	✓	✓	✓	✓			✓	✓	✓	✓
INVFRM	IW <sup>4</sup>	LIGHT	MIP	OBRB	PFINBTMB	RD	RECTK	RH	ROSLUT	RT	RW	STW	TD	TKP	TVR	WS <sup>1</sup>	WTR				
✓	✓		✓						✓						✓	✓	✓				

<sup>1</sup>Not available on 24" wide.

<sup>2</sup>Not available on 36" or 39" high.

<sup>3</sup>Not available with 6" fluting.

<sup>4</sup>Not available on 36" wide.

# Stacked Wall Cabinets

## Description

**STACKED WALL with VERTICAL-LIFT,  
48", 51", 54", 57", or 60" HIGH**

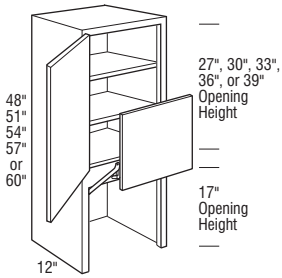

## Model

STWAG1548 L or R  
 STWAG1848 L or R  
 STWAG2148 L or R  
 STWAG2448 L or R  
 STWAG1551 L or R  
 STWAG1851 L or R  
 STWAG2151 L or R  
 STWAG2451 L or R  
 STWAG1554 L or R  
 STWAG1854 L or R  
 STWAG2154 L or R  
 STWAG2454 L or R  
 STWAG1557 L or R  
 STWAG1857 L or R  
 STWAG2157 L or R  
 STWAG2457 L or R  
 STWAG1560 L or R  
 STWAG1860 L or R  
 STWAG2160 L or R  
 STWAG2460 L or R

- Heavy duty Vertical-Lift mechanism.
- 48", 51" and 54" high have one fixed and two adjustable shelves. 57" and 60" high have one fixed and three adjustable shelves.
- Appliance garage opening is 17" high, dimension from cabinet base to bottom of mechanism is 15 3/4".
- Increased Heights modification will increase the height of the upper cabinet section. The bottom section will retain its original height.
- Increased Depths available in 1/4" increments from 12 1/4" to 30".
- Not available on Inset and Beaded Inset styles.
- Automatic Opening Mechanism is available except when used with the following door styles:
  - Burke, Gordon, Kirby, Landry, Shanley, or Vinson.

### Door & Drawer Options

AF	AOMD	CC	CG	ESMD	GAMD	HC	IFHG	MC	MD	MFO	PRMD	SHMD	SPLITDR	SPLITDRWS	SJMD	TCG	TCP
✓	✓	✓	✓	✓	✓	✓	✓	✓	✓	✓	✓	✓				✓	✓

### End Panel Options

AUTH	CSFPE	EXBK	EXDN	FFD	FPE	INTGE	IPE
✓	✓	✓			✓		

### Custom Modification Options

ADD_SHLF	ADDTK	ADRW	BVR	CBO	CCO	CFNTO	CFRMO	CLIP	CND	CSDGBK	EF	EX	EX_OL	FALL	FBFL	FLUT <sup>1</sup>	FTK	ID	IH
								✓	✓	✓	✓	✓	✓			✓			✓
INVFRM	IW <sup>2</sup>	LIGHT	MIP	OBRB	PFINBTMB	RD	RECTK	RH	ROSLUT	RT	RW	STW	TD	TKP	TVR	WS	WTR		
	✓	✓	✓						✓	✓	✓				✓	✓	✓		

<sup>1</sup>Not available with 6" fluting.

<sup>2</sup>Not available on 24" wide.

IH/RH availability charts starting on page G•40.  
 IW/RW availability charts starting on page G•46.

## Description

**STACKED WALL with VERTICAL-LIFT,  
48", 51", 54", 57", or 60" HIGH (cont'd)**

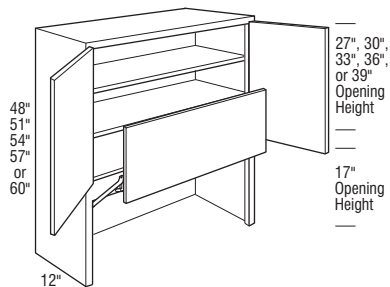

## Model

STWAG2448

STWAG2748

STWAG3048

STWAG3348

STWAG3648

STWAG2451

STWAG2751

STWAG3051

STWAG3351

STWAG3651

STWAG2454

STWAG2754

STWAG3054

STWAG3354

STWAG3654

STWAG2457

STWAG2757

STWAG3057

STWAG3357

STWAG3657

STWAG2460

STWAG2760

STWAG3060

STWAG3360

STWAG3660

- Heavy duty Vertical-lift mechanism.
- 48", 51" and 54" high have one fixed and two adjustable shelves. 57" and 60" high have one fixed and three adjustable shelves.
- Appliance garage opening is 17" high, dimension from cabinet base to bottom of mechanism is 15 3/4".
- Increased Heights modification will increase the height of the upper cabinet section. The bottom section will retain its original height.
- Increased Depths available in 1/4" increments from 12 1/4" to 30".
- Not available on Inset and Beaded Inset styles.
- Automatic Opening Mechanism is available except when used with the following door styles:
  - Burke, Gordon, Kirby, Landry, Shanley, or Vinson.

### Door & Drawer Options

AF	AOMD	CC	CG	ESMD	GAMD	HC	IFHG	MC	MD	MFO	PRMD	SHMD	SPLITDR	SPLITDRWS	SUMD	TCG	TCP
✓	✓	✓	✓	✓	✓	✓	✓	✓	✓	✓	✓	✓	✓	✓	✓	✓	✓

### End Panel Options

AUTH	CSFPE	EXBK	EXDN	FFD	FPE	INTGE	IPE
✓	✓	✓	✓	✓	✓	✓	✓

### Custom Modification Options

ADD_SHLF	ADDTK	ADRW	BVR	CBO	CCO	CFNTO	CFRMO	CLIP	CND	CSDGBK	EF	EX	EX_OL	FALL	FBFL	FLUT <sup>1</sup>	FTK	ID	IH
✓	✓	✓	✓	✓	✓	✓	✓	✓	✓	✓	✓	✓	✓	✓	✓	✓	✓	✓	✓

INVERM	IW <sup>2</sup>	LIGHT <sup>3</sup>	MIP	OBRB	PFINBTMB	RD	RECTK	RH	ROSFLUT	RT	RW	STW	TD	TKP	TVR	WS <sup>3</sup>	WTR
✓	✓	✓	✓	✓	✓	✓	✓	✓	✓	✓	✓	✓	✓	✓	✓	✓	✓

<sup>1</sup>Not available with 6" fluting.

<sup>2</sup>Not available on 36" wide.

<sup>3</sup>Not available on 24" wide.

# Wall Transition Cabinets

## Description

**WALL TRANSITION CABINET, 30", 33", 36", 39", 42", 45", or 48" HIGH**

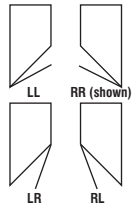
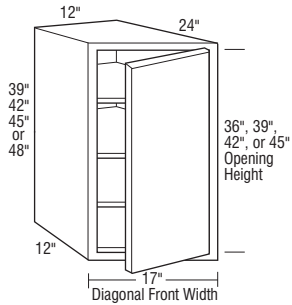
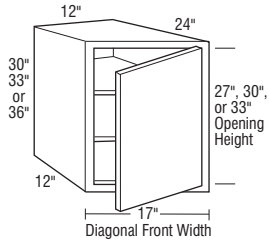

Hinging Options

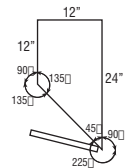

Top View

## Model

WTC1 230LL
WTC1 230RR
WTC1 230LR
WTC1 230RL
WTC1 233LL
WTC1 233RR
WTC1 233LR
WTC1 233RL
WTC1 236LL
WTC1 236RR
WTC1 236LR
WTC1 236RL
• Two adjustable shelves.
WTC1 239LL
WTC1 239RR
WTC1 239LR
WTC1 239RL
WTC1 242LL
WTC1 242RR
WTC1 242LR
WTC1 242RL
WTC1 245LL
WTC1 245RR
WTC1 245LR
WTC1 245RL
WTC1 248LL
WTC1 248RR
WTC1 248LR
WTC1 248RL

- Three adjustable shelves.

Notes below apply to all products in section above:

- Flushed Ends and FFD on End available on angled side only.
- Increased Depths available in 1/4" increments from 24 1/4" to 30".
- Reduced Depths available in 1/4" increments from 18" to 23 3/4".
- Not available on Inset and Beaded Inset styles.

### Door & Drawer Options

AF	AOAMD	CC	CG	ESMD	GAMD	HC	IFHG	MC	MD	MFO	PRMD	SHMD	SPLITDR	SPLITDRWS	SUMD	TCG	TCP
✓		✓	✓	✓	✓	✓	✓	✓	✓	✓	✓	✓			✓		

### End Panel Options

AUTH <sup>1</sup>	CSFPE	EXBK	EXDN	FFD	FPE	INTGE	IPE
✓	✓	✓	✓	✓	✓	✓	

### Custom Modification Options

ADD	SHLF	ADTK	ADRW	BVR	CBO	CCO	CFNTO	CFRMO	CLIP	CND	CSDGBK	EF	EX	EX_OL	FALL	FBFL	FLUT	FTK	ID	IH	
✓				✓	✓	✓	✓	✓	✓	✓	✓	✓	✓						✓	✓	✓

INVFRM	IW	LIGHT	MIP	OBRB	PFINBTMB	RD	RECTK	RH <sup>2</sup>	ROSFLUT	RT	RW	STW	TD	TKP	TVR	WS	WTR
	✓		✓	✓	✓	✓	✓	✓								✓	✓

<sup>1</sup>Not available with authentic flush end both.

<sup>2</sup>Only available on 30" high.

IH/RH availability charts starting on page G•40.  
IW/RW availability charts starting on page G•46.

## Description

### STACKED WALL END CABINET DOUBLE DOOR, 36", 39", 42", 45", 48", 51", 54", 57", or 60" HIGH

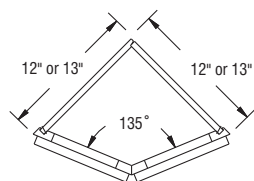
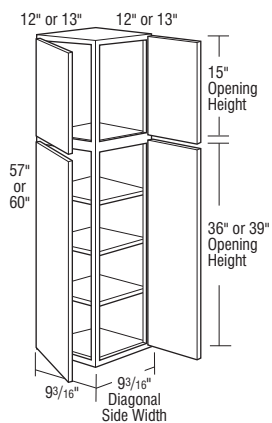
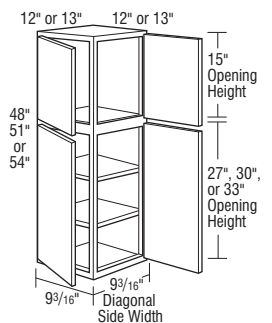
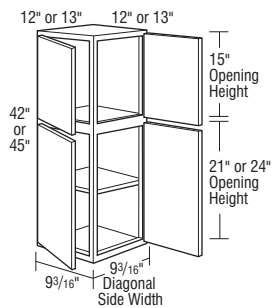
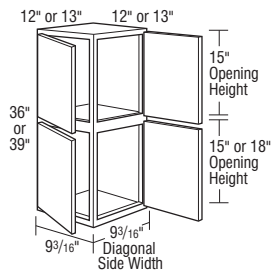

Top View

## Model

STWEC1236D

STWEC1239D

- No shelves.

STWEC1242D

STWEC1245D

- One adjustable shelf.

STWEC1248D

STWEC1251D

STWEC1254D

- Two adjustable shelves.

STWEC1257D

STWEC1260D

- Three adjustable shelves.

Notes below apply to all products in section above:

- Decorative Glass Door designs limited on this unit. See page H●20 for details.
- One 12" end/back may be ordered as Finished End. See page G●8 for details.
- Increased Heights modification will increase the height of the lower cabinet section. The upper section will retain its original height.
- Increased Depths available in 3" increments from 15" to 24".
- When ordering Inset or Beaded Inset styles, the doors must be hinged to the center face frame stiles.

#### Door & Drawer Options

AF	AOMD	CC	CG	ESMD	GAMD	HC	IFHG	MC	MD	MFO	PRMD	SHMD	SPLITDR	SPLITDRWS	SUMD	TCG	TCP
✓		✓					✓			✓		✓					

#### End Panel Options

AUTH	CSFPE	EXBK	EXDN <sup>1</sup>	FFD	FPE	INTGE	IPE
			✓				

#### Custom Modification Options

ADD_SHLF	ADDTK	ADRW	BVR	CBO	CCO	CFNTO	CFRMO	CLIP	CND	CSDGBK	EF	EX	EX_OL	FALL	FBFL	FLUT	FTK <sup>2</sup>	ID	IH
✓				✓	✓	✓	✓	✓	✓	✓	✓	✓	✓	✓	✓	✓	✓	✓	✓

INVFRM	IW	LIGHT <sup>3</sup>	MIP	OBRB	PFINBTMB	RD	RECTK	RH	ROSLUT	RT	RW	STW	TD	TKP	TVR	WS	WTR
		✓	✓	✓	✓	✓	✓	✓	✓	✓	✓	✓	✓	✓	✓	✓	✓

<sup>1</sup>Not available with EXDNLRB.

<sup>2</sup>Not available on FTKAV.

<sup>3</sup>Not available on 36"-45" high.



# Wall End Cabinets

## Description

**STACKED WALL END CABINET SINGLE DOOR, 36", 39", 42", 45", 48", 51", 54", 57", or 60" HIGH**

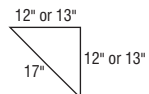
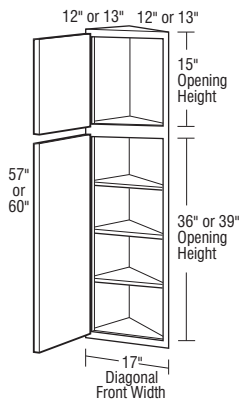
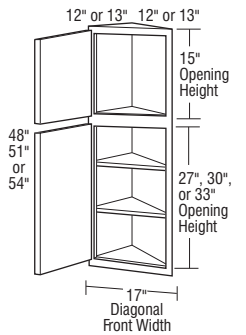
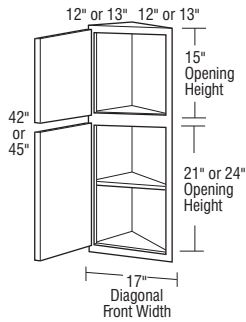
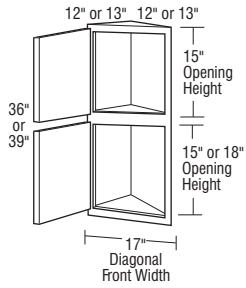

Top View

## Model

**STWEC1236 L or R**

**STWEC1239 L or R**

- No shelves.

**STWEC1242 L or R**

**STWEC1245 L or R**

- One adjustable shelf.

**STWEC1248 L or R**

**STWEC1251 L or R**

**STWEC1254 L or R**

- Two adjustable shelves.

**STWEC1257 L or R**

**STWEC1260 L or R**

- Three adjustable shelves.

Notes below apply to all products in section above:

- One 12" end/back may be ordered as Finished End. See page G•8 for details.
- Increased Heights modification will increase the height of the lower cabinet section. The upper section will retain its original height.
- Increased Depths available in 3" increments from 15" to 24".
- Only available in Inset and Beaded Inset when used in conjunction with a finial hinge.

### Door & Drawer Options

AF	AQMD	CC	CG	ESMD	GAMD	HC	IFHG	MC	MD	MFO	PRMD	SHMD	SPLITDR	SPLITDRWS	SJMD	TCG	TCP
✓			✓	✓	✓	✓	✓	✓	✓	✓	✓	✓				✓	

### End Panel Options

AUTH	CSFPE	EXBK	EXDN <sup>1</sup>	FFD	FPE	INTGE	IPE
			✓				

### Custom Modification Options

ADD	SHLF	ADDTK	ADRW	BVR	CBO	CCO	CFNTO	CFRMO	CLIP	CND	CSDGBK	EF	EX	EX_OL	FALL	FBFL	FLUT	FTK	ID	IH	
✓				✓	✓	✓	✓	✓	✓	✓	✓	✓	✓						✓	✓	✓

INVERM	IW	LIGHT	MIP	OBRB	PFINBTMB	RD	RECTK	RH	ROSFLUT	RT	RW	STW	TD	TKP	TVR	WS	WTR
			✓	✓	✓	✓						✓			✓	✓	✓

<sup>1</sup>Not available with EXDNLRB.

IH/RH availability charts starting on page G•40.  
IW/RW availability charts starting on page G•46.

## Description

**STACKED WALL TRANSITION CABINET, 36", 39", 42", 45", 48", 51", or 54" HIGH**

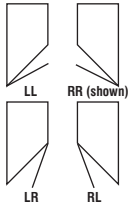
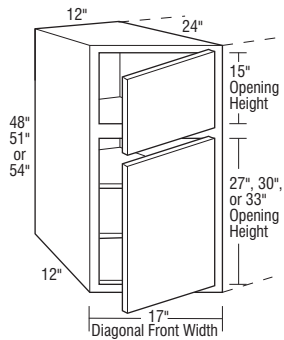
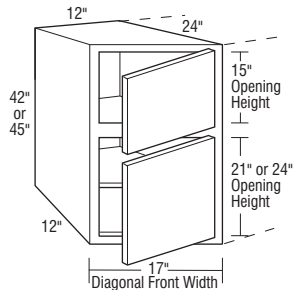
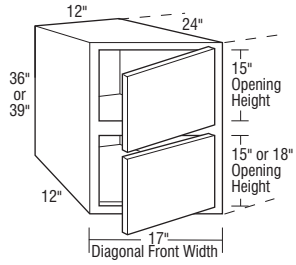

### Hinging Options

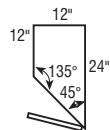

### Top View

## Model

STWTC1236LL
STWTC1236RR
STWTC1236LR
STWTC1236RL
STWTC1239LL
STWTC1239RR
STWTC1239LR
STWTC1239RL
• No shelves.
STWTC1242LL
STWTC1242RR
STWTC1242LR
STWTC1242RL
STWTC1245LL
STWTC1245RR
STWTC1245LR
STWTC1245RL
• One adjustable shelf.
STWTC1248LL
STWTC1248RR
STWTC1248LR
STWTC1248RL
STWTC1251LL
STWTC1251RR
STWTC1251LR
STWTC1251RL
STWTC1254LL
STWTC1254RR
STWTC1254LR
STWTC1254RL

• Two adjustable shelves.

### Notes below apply to all products in section above:

- Flushed Ends and FFD on End available on angled side only.
- Increased Depths available in 1/4" increments from 24 1/4" to 30".
- Reduced Depths available in 1/4" increments from 18" to 23 3/4".
- Increased Heights modification will increase the height of the lower cabinet section. The upper section will retain its original height.
- Not available on Inset and Beaded Inset styles.

### Door & Drawer Options

AF	AOMD	CC	CG	ESMD	GAMD	HC	IFHG	MC	MD	MFO	PRMD	SHMD	SPLITDR	SPLITDRWS	SUMD	TCG	TCP
✓	✓	✓	✓	✓	✓	✓	✓	✓	✓	✓	✓	✓	✓	✓	✓	✓	✓

### End Panel Options

AUTH <sup>1</sup>	CSFPE	EXBK	EXDN	FFD	FPE	INTGE	IPE
✓	✓	✓	✓	✓	✓	✓	✓

### Custom Modification Options

ADD_SHLF	ADDTK	ADRW	BVR	CBO	CCO	CFNTD	CFRMO	CLIP	CND	CSDGBK	EF	EX	EX_OL	FALL	FBFL	FLUT	FTK	ID	IH
✓	✓	✓	✓	✓	✓	✓	✓	✓	✓	✓	✓	✓	✓	✓	✓	✓	✓	✓	✓
INVERM	IW	LIGHT <sup>2</sup>	MIP	OBRB	PFINBTMB	RD	RECTK	RH	ROSFLUT	RT	RW	STW	TD	TKP <sup>2</sup>	TVR	WS	WTR		
✓	✓	✓	✓	✓	✓	✓	✓	✓	✓	✓	✓	✓	✓	✓	✓	✓	✓		

<sup>1</sup>Not available with authentic flush ends both.

<sup>2</sup>Not available on 36"-45" high.

# Wall Transition Cabinets

## Description

### STACKED WALL TRANSITION CABINET, 57" or 60" HIGH

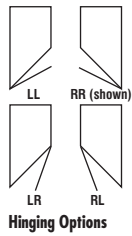
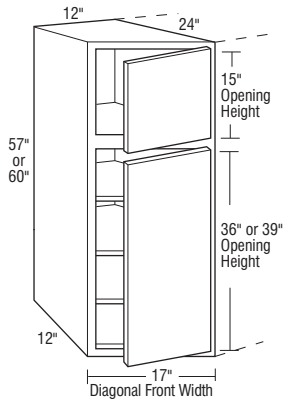

Hinging Options

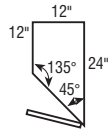

Top View

## Model

STWTC1257LL

STWTC1257RR

STWTC1257LR

STWTC1257RL

STWTC1260LL

STWTC1260RR

STWTC1260LR

STWTC1260RL

- Three adjustable shelves.

Notes below apply to all products in section above:

- Flushed Ends and FFD on End available on angled side only.
- Increased Depths available in 1/4" increments from 24 1/4" to 30".
- Reduced Depths available in 1/4" increments from 18" to 23 3/4".
- Increased Heights modification will increase the height of the lower cabinet section. The upper section will retain its original height.
- Not available on Inset and Beaded Inset styles.

### Door & Drawer Options

AF	AOMD	CC	CG	ESMD	GAMD	HC	IFHG	MC	MD	MFO	PRMD	SHMD	SPLITDR	SPLITDRWS	SJMD	TCG	TCP
✓			✓	✓	✓	✓	✓	✓	✓	✓	✓	✓				✓	

### End Panel Options

AUTH <sup>1</sup>	CSFPE	EXBK	EXDN	FFD	FPE	INTGE	IPE
✓	✓	✓	✓	✓	✓	✓	✓

### Custom Modification Options

ADD_SHLF	ADDTK	ADRW	BVR	CBO	CCO	CFNTO	CFRMO	CLIP	CND	CSDGBK	EF	EX	EX_OL	FALL	FBFL	FLUT	FTK	ID	IH
✓	✓		✓	✓	✓	✓	✓	✓	✓	✓	✓							✓	✓

INVFRM	IW	LIGHT	MIP	OBRB	PFINBTMB	RD	RECTK	RH	ROSLUT	RT	RW	STW	TD	TKP	TVR	WS	WTR
	✓	✓	✓	✓	✓	✓	✓	✓				✓		✓	✓		✓

<sup>1</sup>Not available with authentic flush ends both.

IH/RH availability charts starting on page G•40.  
IW/RW availability charts starting on page G•46.

## Description



**WALL REFRIGERATOR, 18", 21", 24", or 27" HIGH, 24" DEEP**

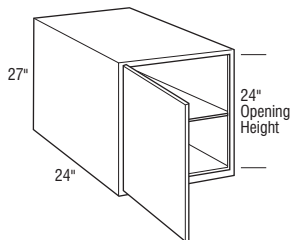
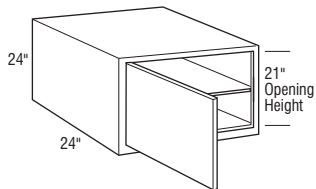
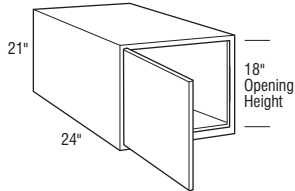
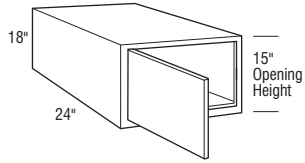

## Model

**W241824 L or R**

**W242124 L or R**

**W242424 L or R**

- Includes one adjustable shelf.

**W242724 L or R**

- Includes one adjustable shelf.

**Notes below apply to all products in section above:**

- 24" deep cabinets must be fully supported by screws installed in a structural member in the ceiling or soffit, and into adjacent cabinets.
- Load limit is 15 lbs. per square foot of load bearing surface.
- Increased Depths available in 1/4" increments from 24 1/4" to 30".
- Reduced Depths available in 1/4" increments from 6" to 23 3/4".

### Door & Drawer Options

AF	AOMD	CC	CG	ESMD	GAMD	HC	IFHG	MC	MD	MFO	PRMD	SHMD	SPLITDR	SPLITDRWS	SUMD	TCG	TCP
			✓						✓	✓	✓						

### End Panel Options

AUTH	CSFPE	EXBK	EXDN	FFD	FPE	INTGE	IPE
✓	✓	✓	✓	✓	✓	✓	✓

### Custom Modification Options

ADD	SHLF	ADDTK	ADRW	BVR	CBO	CCO	CFNTO	CFRMO	CLIP	CND	CSDGBK	EF	EX	EX_OL	F.ALL	FBFL	FLUT <sup>1</sup>	FTK	ID	IH
		✓	✓	✓	✓	✓	✓	✓	✓	✓	✓	✓	✓	✓	✓		✓	✓	✓	✓

INVFRM	IW	LIGHT	MIP	OBRB	PFINBTMB	RD	RECTK	RH	ROSELUT	RT	RW	STW	TD	TKP	TVR	WS	WTR
			✓	✓		✓	✓	✓	✓	✓				✓	✓	✓	✓

<sup>1</sup>Not available with 6" fluting.

# Wall Refrigerator Cabinets

## Description

**WALL REFRIGERATOR, 12", 15", 18", 21", 24", or 27" HIGH, 24" DEEP**

## Model



W241224



W271224

W301224

W331224



W341224

W361224



W371224

W391224



W421224



W451224

W481224

• Two sets of butt doors.



W241524



W271524

W301524

W331524



W341524

W361524



W371524

W391524



W241824



W271824

W301824

W331824



W341824

W361824



W371824

W391824

• One adjustable shelf.

Notes below apply to all products in section above:

- 24" deep cabinets must be fully supported by screws installed in a structural member in the ceiling or soffit, and into adjacent cabinets.
- Load limit is 15 lbs. per square foot of load bearing surface.
- Increased Depths available in 1/4" increments from 24 1/4" to 30".
- Reduced Depths available in 1/4" increments from 6" to 23 3/4".

### Door & Drawer Options

AF	AOMD	CC	CG	ESMD <sup>1</sup>	GAMD <sup>1</sup>	HC	IFHG	MC	MD <sup>1</sup>	MFO	PRMD <sup>2</sup>	SHMD	SPLITDR	SPLITDRWS	SUMD <sup>1</sup>	TCG	TCP	
✓	✓	✓	✓	✓	✓	✓	✓	✓	✓	✓	✓	✓	✓	✓	✓	✓	✓	✓

### End Panel Options

AUTH	CSFPE	EXBK	EXDN	FFD	FPE	INTGE <sup>2</sup>	IPE
✓	✓	✓	✓	✓	✓	✓	✓

### Custom Modification Options

ADD_SHLF	ADDTK	ADRW	BVR	CBO	CCO	CFNTO	CFRMO	CLIP	CND	CSDGBK	EF	EX	EX_OL	FALL	FBFL	FLUT <sup>3</sup>	FTK	ID	IH	
✓	✓	✓	✓	✓	✓	✓	✓	✓	✓	✓	✓	✓	✓	✓	✓	✓	✓	✓	✓	✓

INVFRM	IW	LIGHT	MIP	OBRB	PFINBTMB	RD	RECTK	RH	ROSLUT	RT <sup>4</sup>	RW	STW	TD	TKP	TVR	WS	WTR
✓	✓	✓	✓	✓	✓	✓	✓	✓	✓	✓	✓	✓	✓	✓	✓	✓	✓

<sup>1</sup>Not available on 12" high.

<sup>2</sup>Not available on 12" or 15" high.

<sup>3</sup>Not available with 6" fluting.

<sup>4</sup>Not available on 39" wide.

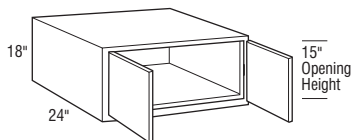
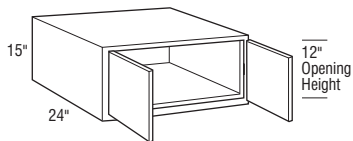
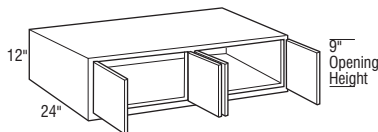
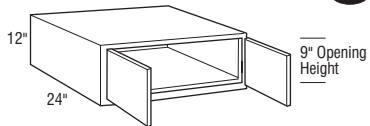

IH/RH availability charts starting on page G•40.  
IW/RW availability charts starting on page G•46.

## Description

**WALL REFRIGERATOR, 12", 15", 18", 21", 24", or 27" HIGH, 24" DEEP (cont'd)**

## Model



W242124



W272124

W302124

W332124



W342124

W362124



W372124

W392124



W242424



W272424

W302424

W332424



W342424

W362424



W372424

W392424

• One adjustable shelf.



W242724



W272724

W302724

W332724



W342724

W362724



W372724

W392724

• One adjustable shelf.

Notes below apply to all products in section above:

• 24" deep cabinets must be fully supported by screws installed in a structural member in the ceiling or soffit, and into adjacent cabinets.

• Load limit is 15 lbs. per square foot of load bearing surface.

• Increased Depths available in 1/4" increments from 24 1/4" to 30".

• Reduced Depths available in 1/4" increments from 6" to 23 3/4".

### Door & Drawer Options

AF	AOMD	CC	CG	ESMD	GAMD	HC	IFHG	MC	MD	MFO	PRMD	SHMD	SPLITDR	SPLITDRWS	SUMD	TCG	TCP
✓	✓	✓	✓	✓	✓	✓	✓	✓	✓	✓	✓	✓	✓	✓	✓	✓	✓

### End Panel Options

AUTH	CSFPE	EXBK	EXDN	FFD	FPE	INTGE	IPE
✓	✓	✓	✓	✓	✓	✓	✓

### Custom Modification Options

ADD_SHLF <sup>1</sup>	ADDTK	ADRW	BVR	CBO	CCO	CFNTO	CFRMO	CLIP	CND	CSDGBK	EF	EX	EX_OL	F.ALL	FBFL	FLUT <sup>2</sup>	FTK	ID	IH
✓	✓	✓	✓	✓	✓	✓	✓	✓	✓	✓	✓	✓	✓	✓	✓	✓	✓	✓	✓

INVRM	IW	LIGHT	MIP	OBRB	PFINBTMB	RD	RECTK	RH	ROSLUT	RT <sup>3</sup>	RW	STW	TD	TKP	TVR	WS	WTR
✓	✓	✓	✓	✓	✓	✓	✓	✓	✓	✓	✓	✓	✓	✓	✓	✓	✓

<sup>1</sup>Only available on 24" and 27" high.

<sup>2</sup>Not available with 6" fluting.

<sup>3</sup>Not available on 39" wide.

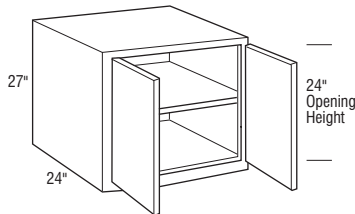
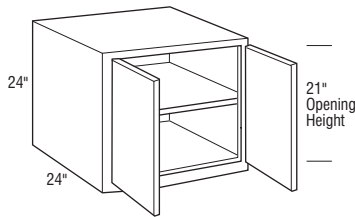
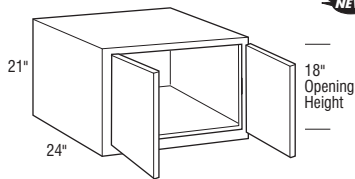

# Wall Refrigerator Cabinets

## Description

## Model

**NEW** WALL REFRIGERATOR, 15", 18", 21", 24", or 27" HIGH, 24" DEEP

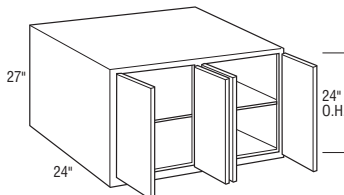
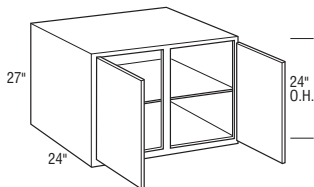
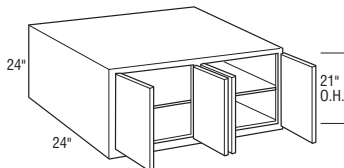
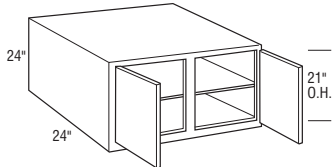
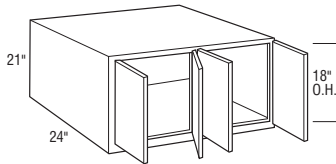
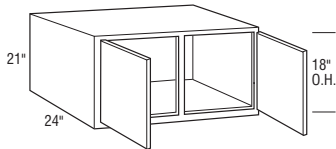
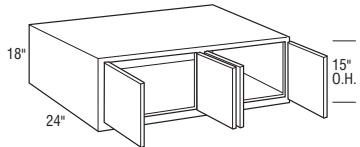
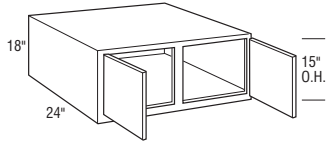
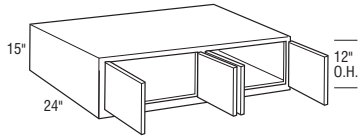

**W421524**

**W451524**

**W481524**

**W421824**

**W451824**

**W481824CS**

**W481824**

- Two sets of butt doors.

**W422124**

**W452124**

**W482124CS**

**W482124**

- Two sets of butt doors.

**W422424**

**W452424**

**W482424CS**

- Includes one adjustable shelf.

**W482424**

- Two sets of butt doors.
- Includes one adjustable shelf.

**W422724**

**W452724**

**W482724CS**

- Includes one adjustable shelf.

**W482724**

- Two sets of butt doors.
- Includes one adjustable shelf.

### Notes below apply to all products in section above:

- 24" deep cabinets must be fully supported by screws installed in a structural member in the ceiling or soffit, and into adjacent cabinets.
- Load limit is 15 lbs. per square foot of load bearing surface.
- Increased Depths available in 1/4" increments from 24 1/4" to 30".
- Reduced Depths available in 1/4" increments from 6" to 23 3/4".

### Door & Drawer Options

AF	AOMD	CC	CG	ESMD	GAMD	HC	IFHG	MC	MD	MFO	PRMD <sup>1</sup>	SHMD	SPLITDR	SPLITDRWS	SUMD	TCG	TCP
✓	✓	✓	✓	✓	✓	✓	✓	✓	✓	✓	✓	✓	✓	✓	✓	✓	✓

### End Panel Options

AUTH	CSFPE	EXBK	EXDN	FFD	FPE	INTGE <sup>1</sup>	IPE
✓	✓	✓	✓	✓	✓	✓	✓

### Custom Modification Options

ADD	SHLF <sup>2</sup>	ADDTK	ADRW	BVR	CBO	CCO	CFNTO	CFRMO	CLIP	CND	CSDGBK	EF	EX	EX_OL	F.ALL	FBFL	FLUT <sup>3</sup>	FTK	ID	IH
✓	✓	✓	✓	✓	✓	✓	✓	✓	✓	✓	✓	✓	✓	✓	✓	✓	✓	✓	✓	✓

INVFRM	IW	LIGHT	MIP	OBRB	PFINBTMB	RD	RECTK	RH	ROSLUT	RT <sup>4</sup>	RW	STW	TD	TKP	TVR	WS	WTR
✓	✓	✓	✓	✓	✓	✓	✓	✓	✓	✓	✓	✓	✓	✓	✓	✓	✓

<sup>1</sup>Not available on 15" high.

<sup>2</sup>Only available on 24" and 27" high.

<sup>3</sup>Not available with 6" fluting.

<sup>4</sup>Not available on 39" wide.

IH/RH availability charts starting on page G•40.  
IW/RW availability charts starting on page G•46.

## Description



**WALL REFRIGERATOR PULL-OUT CABINET, 18", 21", or 24" HIGH, 24" DEEP**

storage  
SOLUTIONS

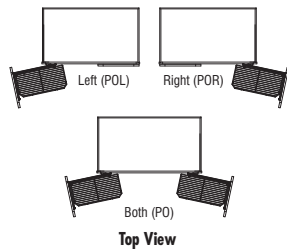
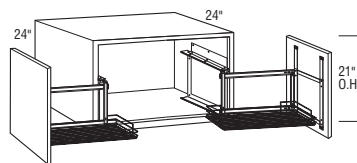
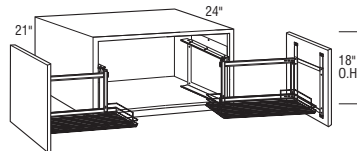
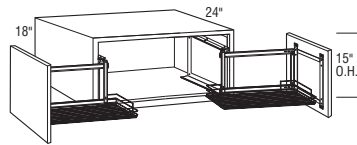

## Model

W361824PO L or R

W371824PO L or R

W391824PO L or R

W361824PO

W371824PO

W391824PO

W362124PO L or R

W372124PO L or R

W392124PO L or R

W362124PO

W372124PO

W392124PO

W362424PO L or R

W372424PO L or R

W392424PO L or R

W362424PO

W372424PO

W392424PO

- Door mounted pull-out with a chrome wire rack that extends fully to the front of the cabinet then opens to the side for easy accessibility to contents.
- Designed for use above refrigerator or other high applications.
- Smart Stop feature not available on pull-out.
- Available installed in either the left side, right side or both sides.
- For sufficient pull-out clearance, 13 1/8" of adjacent space is required for door to open fully when installed near a wall or corner.
- Chrome rack is 10" wide and 20 13/16" deep.
- 24" deep cabinets must be fully supported by screws installed in a structural member in the ceiling or soffit, and into adjacent cabinets.
- Load limit is 15 lbs. per square foot of load bearing surface.
- Not available on Inset and Beaded Inset styles.

### Door & Drawer Options

AF	AOMD	CC	CG	ESMD	GAMD	HC	IFHG	MC	MD	MFO	PRMD	SHMD	SPLITDR	SPLITDRWS	SUMD	TCG	TCP
										✓							

### End Panel Options

AUTH	CSFPE	EXBK	EXDN	FFD	FPE	INTGE	IPE
✓	✓	✓	✓	✓	✓		

### Custom Modification Options

ADD_SHLF	ADDTK	ADRW	BVR	CBO	CCO	CFNTO	CFRMO	CLIP	CND	CSDGBK	EF	EX	EX_OL	F.ALL	FBFL	FLUT	FTK	ID	IH <sup>1</sup>
	✓	✓	✓							✓	✓	✓	✓			✓	✓	✓	✓
INVERM	IW	LIGHT	MIP	OBRB	PFINBTMB	RD	RECTK	RH	ROSLUT <sup>2</sup>	RT	RW	STW	TD	TKP	TVR	WS	WTR		✓
							✓		✓					✓					

<sup>1</sup>Not available on 24" high.

<sup>2</sup>Not available with 6" fluting.



# Wall Open Cabinets

## Description

**NEW** WALL OPEN CABINET with PLAIN BACK, 30", 33", 36", 39", or 42" HIGH

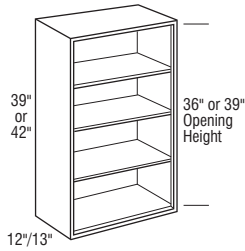
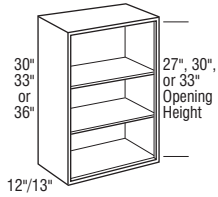

## Model

WACP2430

WACP3030

WACP3630

WACP2433

WACP3033

WACP3633

WACP2436

WACP3036

WACP3636

WACP2439

WACP3039

WACP3639

WACP2442

WACP3042

WACP3642

- 30"/33"/36" high includes two adjustable shelves, and 39"/42" high includes three adjustable shelves.
- If ordered with Hewn Technique, will not feature sand-through characteristics.
- To change the top rail valance, specify one of the following modifications: Arch (TVRAV) or Straight Valance (TVRW).
- Straight Valance is standard on Beaded Inset styles.
- Minimum cabinet width with Arch Valance is 15".
- Inset and Beaded Inset Door Styles are a standard 13" deep.
- Full Overlay Styles:
  - Increased Depths available in 1/4" increments from 12 1/4" to 30".
  - Reduced Depths available in 1/4" increments from 6" to 11 3/4".
- Inset and Beaded Inset Styles:
  - Increased Depths available in 1/4" increments from 13 1/4" to 30".
  - Reduced Depths available in 1/4" increments from 6" to 12 3/4".

### Door & Drawer Options

AF	AOMD	CC	CG	ESMD	GAMD	HC	IFHG	MC	MD	MFO	PRMD	SHMD	SPLITDR	SPLITDRWS	SUMD	TCG	TCP

### End Panel Options

AUTH	CSFPE	EXBK	EXDN	FFD	FPE	INTGE	IPE
✓	✓	✓	✓	✓	✓	✓	✓

### Custom Modification Options

ADD	SHLF	ADTK	ADRW	BVR	CBO	CCO	CFNTO	CFRMO	CLIP <sup>1</sup>	CND	CSDGBK	EF	EX	EX_OL	F.ALL	FBFL	FLUT <sup>2</sup>	FTK	ID <sup>3</sup>	IH
	✓			✓	✓	✓	✓	✓	✓	✓	✓	✓	✓	✓	✓	✓	✓	✓	✓	✓

INVRM	IW	LIGHT	MIP	OBRB	PFINBTMB	RD <sup>3</sup>	RECTK	RH	ROSLUT	RT <sup>4</sup>	RW	STW	TD <sup>5</sup>	TKP	TVR	WS <sup>1</sup>	WTR
	✓		✓	✓	✓	✓	✓	✓	✓	✓	✓	✓	✓	✓	✓	✓	✓

<sup>1</sup>Not available on 24" wide.

<sup>2</sup>Not available with 6" fluting.

<sup>3</sup>Not available on WACP2433 and WACP2436.

<sup>4</sup>Not available on 39" wide.

<sup>5</sup>Not available on 33"-42" high.

IH/RH availability charts starting on page G-40.  
IW/RW availability charts starting on page G-46.

## Description



**WALL OPEN CABINET with CAR SIDING BACK, 30", 33", 36", 39", or 42" HIGH**

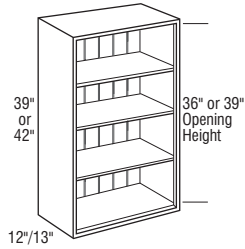
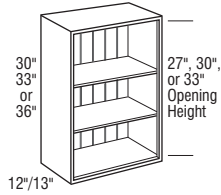

## Model

WOCB2430

WOCB3030

WOCB3630

WOCB2433

WOCB3033

WOCB3633

WOCB2436

WOCB3036

WOCB3636

WOCB2439

WOCB3039

WOCB3639

WOCB2442

WOCB3042

WOCB3642

- 30"/33"/36" high includes two adjustable shelves, and 39"/42" high includes three adjustable shelves.
- If ordered with Hewn Technique, will not feature sand-through characteristics.
- To change the top rail valance, specify one of the following modifications: Arch (TVRAV) or Straight Valance (TVRVV).
- Straight Valance is standard on Beaded Inset styles.
- Minimum cabinet width with Arch Valance is 15".
- Inset and Beaded Inset Door Styles are a standard 13" deep.
- Full Overlay Styles:
  - Increased Depths available in 1/4" increments from 12 1/4" to 30".
  - Reduced Depths available in 1/4" increments from 6" to 11 3/4".
- Inset and Beaded Inset Styles:
  - Increased Depths available in 1/4" increments from 13 1/4" to 30".
  - Reduced Depths available in 1/4" increments from 6" to 12 3/4".

### Door & Drawer Options

AF	AOMD	CC	CG	ESMD	GAMD	HC	IFHG	MC	MD	MFO	PRMD	SHMD	SPLITDR	SPLITDRWS	SUMD	TCG	TCB	

### End Panel Options

AUTH	CSFPE	EXBK	EXDN	FFD	FPE	INTGE	IPE
✓	✓	✓	✓	✓	✓	✓	✓

### Custom Modification Options

ADD_SHLF	ADDTK	ADRW	BVR	CBO	CCO	CFNTO	CFRMO	CLIP <sup>1</sup>	CND	CSDGBK	EF	EX	EX_OL	F.ALL	FBFL	FLUT <sup>2</sup>	FTK	ID <sup>3</sup>	IH
	✓			✓	✓	✓	✓	✓	✓	✓	✓	✓	✓	✓	✓	✓	✓	✓	✓

INVRM	IW	LIGHT	MIP	OBRB	PFINBTMB	RD <sup>3</sup>	RECTK	RH	ROSFLUT	RT <sup>4</sup>	RW	STW	TD <sup>5</sup>	TKP	TVR	WS <sup>1</sup>	WTR
	✓		✓	✓	✓	✓	✓	✓	✓	✓	✓	✓	✓	✓	✓	✓	✓

<sup>1</sup>Not available on 24" wide.

<sup>2</sup>Not available with 6" fluting.

<sup>3</sup>Not available on WOCB2433 and WOCB2436.

<sup>4</sup>Not available on 39" wide.

<sup>5</sup>Not available on 33"-42" high.

# Wall Corner Cabinets

## Description

### **NEW** WALL CORNER SINGLE DOOR, 24" HIGH

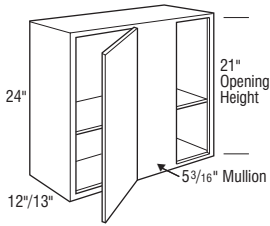

## Model

**WC2424 L or R**

**WC2724 L or R**

**WC3024 L or R**

- Door will be hinged on same side as blind section unless specified otherwise.
- L or R denotes blind.
- One adjustable shelf.
- Can be pulled 3".
- When ordering cabinet in a full overlay door style, unit must be pulled at least 1 1/2" to 3" from wall.
- Filler is recommended on adjacent cabinet.
- Inset and Beaded Inset Door Styles are a standard 13" deep.
- Full Overlay Styles:
  - Increased Depths available in 1/4" increments from 12 1/4" to 30".
  - Reduced Depths available in 1/4" increments from 6" to 11 3/4".
- Inset and Beaded Inset Styles:
  - Increased Depths available in 1/4" increments from 13 1/4" to 30".
  - Reduced Depths available in 1/4" increments from 6" to 12 3/4".

### Door & Drawer Options

AF	AOMD	CC	CG	ESMD	GAMD	HC	IFHG	MC	MD	MFO	PRMD <sup>1</sup>	SHMD	SPLITDR	SPLITDRWS	SUMD	TCG	TCP	

### End Panel Options

AUTH	CSFPE	EXBK	EXDN	FFD	FPE	INTGE	IPE

### Custom Modification Options

ADD	SHLF	ADTK	ADRW	BVR	CBO	CCO	CFNT0	CFRMO	CLIP <sup>1</sup>	CND	CSDGBK	EF	EX	OL	FALL	FBFL	FLUT <sup>2</sup>	FTK	ID	IH	

INVFRM	IW	LIGHT	MIP	OBRB	PFINBTMB	RD	RECTK	RH	ROSLUT	RT	RW	STW	TD	TKP <sup>1</sup>	TVR	WS	WTR	

<sup>1</sup>Not available on 24" wide.

<sup>2</sup>Not available with 6" fluting.

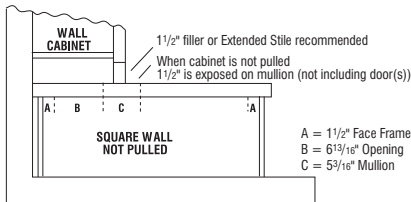

**Top View Full Overlay Styles**

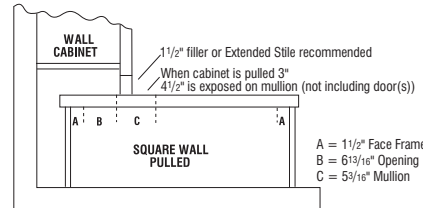

**Top View, Pulled 3"**

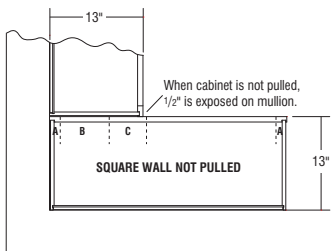

**Top View Inset Styles**

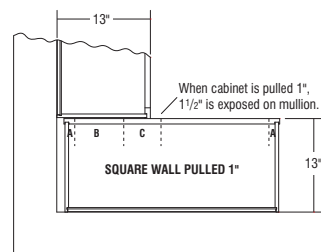

**Top View, Pulled 1"**

IH/RH availability charts starting on page G•40.  
IW/RW availability charts starting on page G•46.

## Description

### WALL CORNER SINGLE DOOR, 30" HIGH

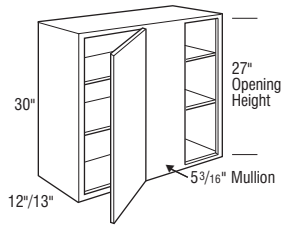

## Model

WC2430 L or R

WC2730 L or R

WC3030 L or R

WC3330 L or R

WC3630 L or R

- Door will be hinged on same side as blind section unless specified otherwise.
- L or R denotes blind.
- Two adjustable shelves.
- Can be pulled 3".
- When ordering cabinet in a full overlay door style, unit must be pulled at least 1 1/2" to 3" from wall.
- Filler is recommended on adjacent cabinet.
- Inset and Beaded Inset Door Styles are a standard 13" deep.
- Full Overlay Styles:
  - Increased Depths available in 1/4" increments from 12 1/4" to 30".
  - Reduced Depths available in 1/4" increments from 6" to 11 3/4".
- Inset and Beaded Inset Styles:
  - Increased Depths available in 1/4" increments from 13 1/4" to 30".
  - Reduced Depths available in 1/4" increments from 6" to 12 3/4".

#### Door & Drawer Options

AF	AOMD	CC	CG	ES/MD	GAMD	HC	IFHG	MC	MD	MFO	PRMD <sup>1</sup>	SHMD	SPLITDR	SPLITDRWS	SUMD	TCG	TCP
✓	✓	✓	✓	✓	✓	✓	✓	✓	✓	✓	✓	✓	✓	✓	✓	✓	✓

#### End Panel Options

AUTH	CSFPE	EXBK	EXDN	FFD	FPE	INTGE	IPE
✓	✓	✓	✓	✓	✓	✓	✓

#### Custom Modification Options

ADD_SHLF	ADDTK	ADRW	BVR	CBO	CCO	CFNTO	CFRMO	CLIP <sup>2</sup>	CND	CSDGBK	EF	EX	EX_OL	FALL	FBFL	FLUT <sup>3</sup>	FTK	ID	IH
✓	✓	✓	✓	✓	✓	✓	✓	✓	✓	✓	✓	✓	✓	✓	✓	✓	✓	✓	✓

INVFRM	IW	LIGHT	MIP	OBRB	PFINBTMB	RD	RECTK	RH	ROSLUT	RT	RW	STW	TD	TKP	TVR	WS	WTR
✓	✓	✓	✓	✓	✓	✓	✓	✓	✓	✓	✓	✓	✓	✓	✓	✓	✓

<sup>1</sup>Not available on 24" wide.

<sup>2</sup>Not available on 24" wide, with clipped left.

<sup>3</sup>Not available with 6" fluting.

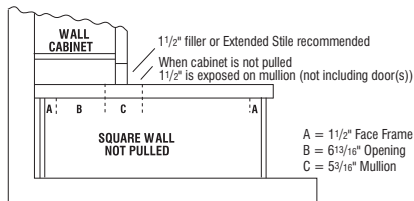

Top View  
Full Overlay Styles

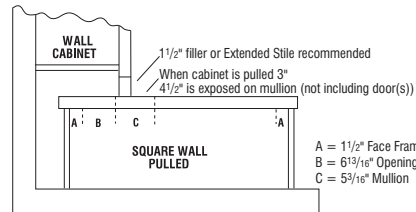

Top View, Pulled 3"

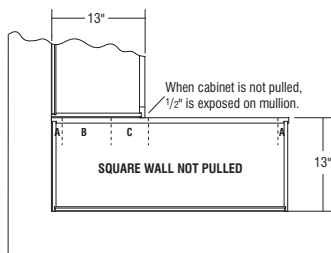

Top View  
Inset Styles

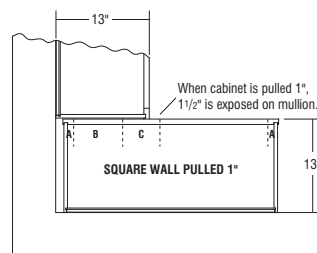

Top View, Pulled 1"

# Wall Corner Cabinets

## Description

### WALL CORNER DOUBLE DOOR, 30" HIGH

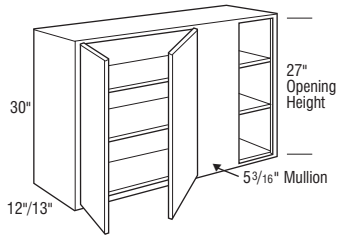

## Model

WC3930 L or R

WC4230 L or R

WC4530 L or R

WC4830 L or R

- L or R denotes blind.
- Two adjustable shelves.
- Can be pulled 3".
- When ordering cabinet in a full overlay door style, unit must be pulled at least 1 1/2" to 3" from wall.
- Filler is recommended on adjacent cabinet.
- Inset and Beaded Inset Door Styles are a standard 13" deep.
- Full Overlay Styles:
  - Increased Depths available in 1/4" increments from 12 1/4" to 30".
  - Reduced Depths available in 1/4" increments from 6" to 11 3/4".
- Inset and Beaded Inset Styles:
  - Increased Depths available in 1/4" increments from 13 1/4" to 30".
  - Reduced Depths available in 1/4" increments from 6" to 12 3/4".

### Door & Drawer Options

AF	AOMD	CC	CG	ESMD	GAMD	HC	IFHG	MC	MD	MFO	PRMD	SHMD	SPLITDR <sup>1</sup>	SPLITDRWS	SUMD	TCG	TCP	
✓	✓	✓	✓	✓	✓	✓	✓	✓	✓	✓	✓	✓	✓	✓	✓	✓	✓	✓

### End Panel Options

AUTH	CSFPE	EXBK	EXDN	FFD	FPE	INTGE	IPE
✓	✓	✓	✓	✓	✓	✓	✓

### Custom Modification Options

ADD_SHLF	ADDTK	ADRW	BVR	CBO	CCO	CFNTD	CFRMO	CLIP <sup>2</sup>	CND	CSDGBK	EF	EX	EX_OL	F.ALL	FBFL	FLUT <sup>3</sup>	FTK	ID	IH	
✓	✓	✓	✓	✓	✓	✓	✓	✓	✓	✓	✓	✓	✓	✓	✓	✓	✓	✓	✓	✓

INVRM	IW	LIGHT	MIP	OBRB	PFINBTMB	RD	RECTK	RH	ROSLUT	RT	RW	STW	TD	TKP	TVR	WS	WTR
✓	✓	✓	✓	✓	✓	✓	✓	✓	✓	✓	✓	✓	✓	✓	✓	✓	✓

<sup>1</sup>Not available on 39" or 42" wide.

<sup>2</sup>Not available with clipped left.

<sup>3</sup>Not available with 6" fluting.

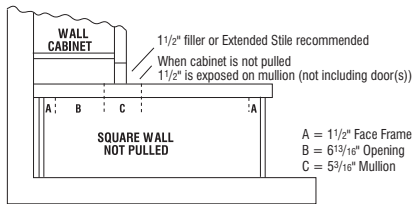

Top View  
Full Overlay Styles

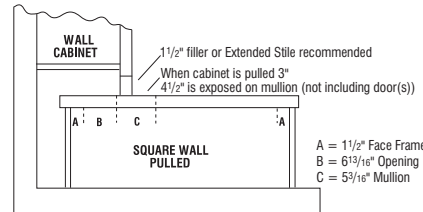

Top View, Pulled 3"

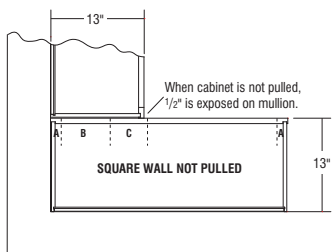

Top View  
Inset Styles

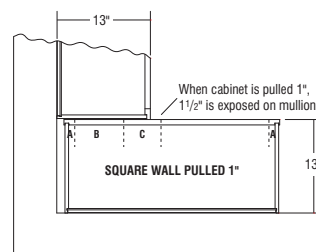

Top View, Pulled 1"

IH/RH availability charts starting on page G•40.  
IW/RW availability charts starting on page G•46.

## Description

### WALL CORNER SINGLE DOOR, 33" HIGH

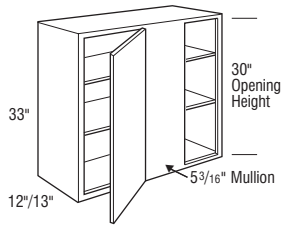

## Model

WC2433 L or R

WC2733 L or R

WC3033 L or R

WC3333 L or R

WC3633 L or R

- Door will be hinged on same side as blind section unless specified otherwise.
- L or R denotes blind.
- Two adjustable shelves.
- Can be pulled 3".
- When ordering cabinet in a full overlay door style, unit must be pulled at least 1 1/2" to 3" from wall.
- 3" filler must be ordered separately.
- Inset and Beaded Inset Door Styles are a standard 13" deep.
- Full Overlay Styles:
  - Increased Depths available in 1/4" increments from 12 1/4" to 30".
  - Reduced Depths available in 1/4" increments from 6" to 11 3/4".
- Inset and Beaded Inset Styles:
  - Increased Depths available in 1/4" increments from 13 1/4" to 30".
  - Reduced Depths available in 1/4" increments from 6" to 12 3/4".

### Door & Drawer Options

AF	AOMD	CC	CG	ES/MD	GAMD	HC	IFHG	MC	MD	MFO	PRMD <sup>1</sup>	SHMD	SPLITDR	SPLITDRWS	SUMD	TCG	TCP	
✓	✓	✓	✓	✓	✓	✓	✓	✓	✓	✓	✓	✓	✓	✓	✓	✓	✓	✓

### End Panel Options

AUTH	CSFPE	EXBK	EXDN	FFD	FPE	INTGE	IPE
✓	✓	✓	✓	✓	✓	✓	✓

### Custom Modification Options

ADD_SHLF	ADDTK	ADRW	BVR	CBO	CCO	CFNTD	CFRMO	CLIP <sup>2</sup>	CND	CSDGBK	EF	EX	EX_OL	FALL	FBFL	FLUT <sup>3</sup>	FTK	ID	IH	
✓	✓	✓	✓	✓	✓	✓	✓	✓	✓	✓	✓	✓	✓	✓	✓	✓	✓	✓	✓	✓

INVERM	IW	LIGHT	MIP	OBRB	PFINBTMB	RD	RECTK	RH	ROSLUT	RT	RW	STW	TD	TKP	TVR	WS	WTR
✓	✓	✓	✓	✓	✓	✓	✓	✓	✓	✓	✓	✓	✓	✓	✓	✓	✓

<sup>1</sup>Not available for 24" wide.

<sup>2</sup>Not available on 24" wide, with clipped left.

<sup>3</sup>Not available with 6" fluting.

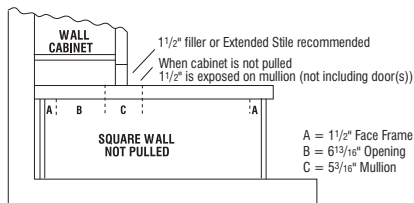

Top View  
Full Overlay Styles

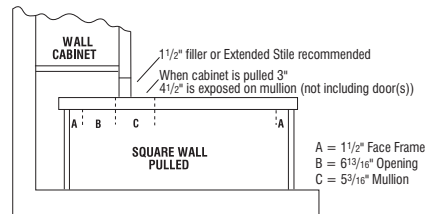

Top View, Pulled 3"

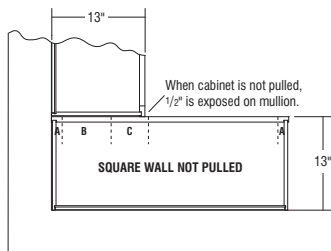

Top View  
Inset Styles

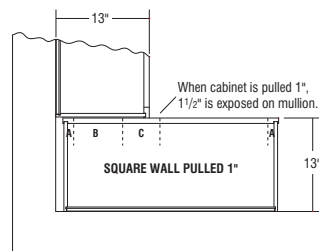

Top View, Pulled 1"

# Wall Corner Cabinets

## Description

### WALL CORNER DOUBLE DOOR, 33" HIGH

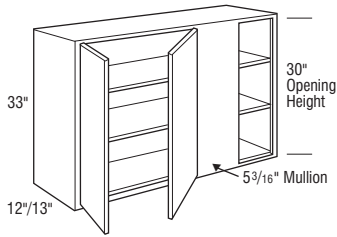

## Model

WC3933 L or R

WC4233 L or R

WC4533 L or R

WC4833 L or R

- L or R denotes blind.
- Two adjustable shelves.
- Can be pulled 3".
- When ordering cabinet in a full overlay door style, unit must be pulled at least 1 1/2" to 3" from wall.
- 3" filler must be ordered separately.
- Inset and Beaded Inset Door Styles are a standard 13" deep.
- Full Overlay Styles:
  - Increased Depths available in 1/4" increments from 12 1/4" to 30".
  - Reduced Depths available in 1/4" increments from 6" to 11 3/4".
- Inset and Beaded Inset Styles:
  - Increased Depths available in 1/4" increments from 13 1/4" to 30".
  - Reduced Depths available in 1/4" increments from 6" to 12 3/4".

### Door & Drawer Options

AF	AOMD	CC	CG	ESMD	GAMD	HC	IFHG	MC	MD	MFO	PRMD	SHMD	SPLITDR <sup>1</sup>	SPLITDRWS	SUMD	TCG	TCP	
✓	✓	✓	✓	✓	✓	✓	✓	✓	✓	✓	✓	✓	✓	✓	✓	✓	✓	✓

### End Panel Options

AUTH	CSFPE	EXBK	EXDN	FFD	FPE	INTGE	IPE
✓	✓	✓	✓	✓	✓	✓	✓

### Custom Modification Options

ADD	SHLF	ADDTK	ADRW	BVR	CBO	CCO	CFNTD	CFRMO	CLIP <sup>2</sup>	CND	CSDGBK	EF	EX	EX_OL	F.ALL	FBFL	FLUT <sup>3</sup>	FTK	ID	IH	
✓	✓	✓	✓	✓	✓	✓	✓	✓	✓	✓	✓	✓	✓	✓	✓	✓	✓	✓	✓	✓	✓

INVFRM	IW	LIGHT	MIP	OBRB	PFINBTMB	RD	RECTK	RH	ROSLUT	RT	RW	STW	TD	TKP	TVR	WS	WTR
✓	✓	✓	✓	✓	✓	✓	✓	✓	✓	✓	✓	✓	✓	✓	✓	✓	✓

<sup>1</sup>Not available on 39" or 42" wide.

<sup>2</sup>Not available with clipped left.

<sup>3</sup>Not available with 6" fluting.

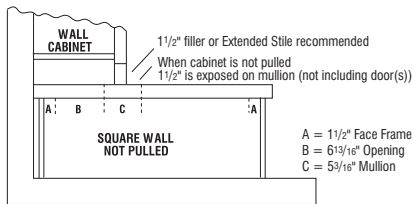

Top View  
Full Overlay Styles

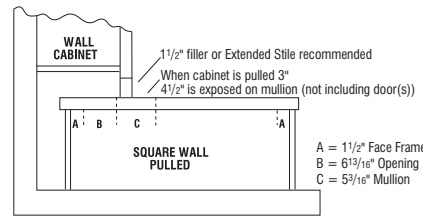

Top View, Pulled 3"

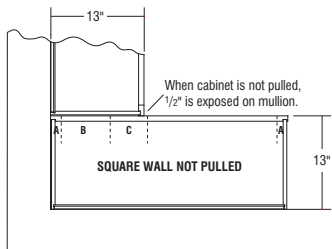

Top View  
Inset Styles

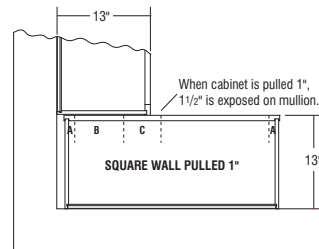

Top View, Pulled 1"

IH/RH availability charts starting on page G•40.  
IW/RW availability charts starting on page G•46.

## Description

### WALL CORNER SINGLE DOOR, 36" HIGH

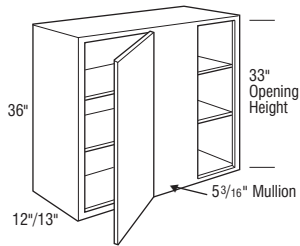

## Model

WC2436 L or R

WC2736 L or R

WC3036 L or R

WC3336 L or R

WC3636 L or R

- Door will be hinged on same side as blind section unless specified otherwise.
- L or R denotes blind.
- Two adjustable shelves.
- Can be pulled 3".
- When ordering cabinet in a full overlay door style, unit must be pulled at least 1 1/2" to 3" from wall.
- 3" filler must be ordered separately.
- Inset and Beaded Inset Door Styles are a standard 13" deep.
- Full Overlay Styles:
  - Increased Depths available in 1/4" increments from 12 1/4" to 30".
  - Reduced Depths available in 1/4" increments from 6" to 11 3/4".
- Inset and Beaded Inset Styles:
  - Increased Depths available in 1/4" increments from 13 1/4" to 30".
  - Reduced Depths available in 1/4" increments from 6" to 12 3/4".

### Door & Drawer Options

AF	AOMD	CC	CG	ES/MD	GAMD	HC	IFHG	MC	MD	MFO	PRMD	SHMD	SPLITDR	SPLITDRWS	SUMD	TCG	TCP	
✓	✓	✓	✓	✓	✓	✓	✓	✓	✓	✓	✓	✓	✓	✓	✓	✓	✓	✓

### End Panel Options

AUTH	CSFPE	EXBK	EXDN	FFD	FPE	INTGE	IPE
✓	✓	✓	✓	✓	✓	✓	✓

### Custom Modification Options

ADD_SHLF	ADDTK	ADRW	BVR	CBO	CCO	CFNTO	CFRMO	CLIP <sup>1</sup>	CND	CSDGBK	EF	EX	EX_OL	FALL	FBFL	FLUT <sup>2</sup>	FTK	ID	IH	
✓	✓	✓	✓	✓	✓	✓	✓	✓	✓	✓	✓	✓	✓	✓	✓	✓	✓	✓	✓	✓

INVERM	IW	LIGHT	MIP	OBRB	PFINBTMB	RD	RECTK	RH	ROSLUT	RT	RW	STW	TD	TKP	TVR	WS	WTR
✓	✓	✓	✓	✓	✓	✓	✓	✓	✓	✓	✓	✓	✓	✓	✓	✓	✓

<sup>1</sup>Not available on 24" wide, with clipped left.

<sup>2</sup>Not available with 6" fluting.

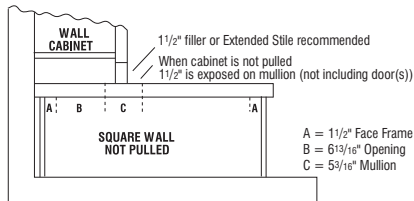

Top View  
Full Overlay Styles

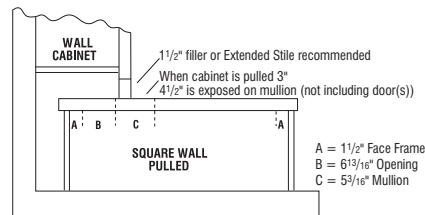

Top View, Pulled 3"

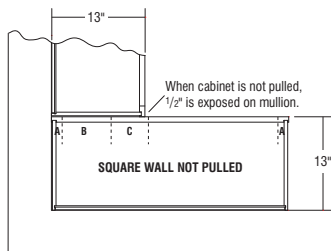

Top View  
Inset Styles

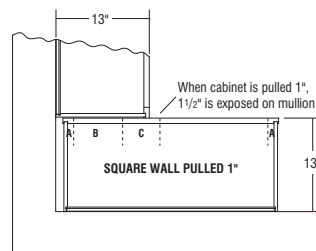

Top View, Pulled 1"



# Wall Corner Cabinets

## Description

### WALL CORNER DOUBLE DOOR, 36" HIGH

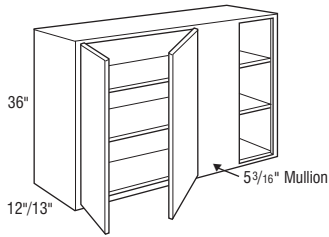

## Model

WC3936 L or R

WC4236 L or R

WC4536 L or R

WC4836 L or R

- L or R denotes blind.
- Two adjustable shelves.
- Can be pulled 3".
- When ordering cabinet in a full overlay door style, unit must be pulled at least 1 1/2" to 3" from wall.
- 3" filler must be ordered separately.
- Inset and Beaded Inset Door Styles are a standard 13" deep.
- Full Overlay Styles:
  - Increased Depths available in 1/4" increments from 12 1/4" to 30".
  - Reduced Depths available in 1/4" increments from 6" to 11 3/4".
- Inset and Beaded Inset Styles:
  - Increased Depths available in 1/4" increments from 13 1/4" to 30".
  - Reduced Depths available in 1/4" increments from 6" to 12 3/4".

#### Door & Drawer Options

AF	AOMD	CC	CG	ESMD	GAMD	HC	IFHG	MC	MD	MFO	PRMD	SHMD	SPLITDR <sup>1</sup>	SPLITDRWS	SUMD	TCG	TCP	
✓	✓	✓	✓	✓	✓	✓	✓	✓	✓	✓	✓	✓	✓	✓	✓	✓	✓	✓

#### End Panel Options

AUTH	CSFPE	EXBK	EXDN	FFD	FPE	INTGE	IPE
✓	✓	✓	✓	✓	✓	✓	✓

#### Custom Modification Options

ADD	SHLF	ADDTK	ADRW	BVR	CBO	CCO	CFNTD	CFRMO	CLIP <sup>2</sup>	CND	CSDGBK	EF	EX	EX_OL	F.ALL	FBFL	FLUT <sup>3</sup>	FTK	ID	IH	
✓	✓	✓	✓	✓	✓	✓	✓	✓	✓	✓	✓	✓	✓	✓	✓	✓	✓	✓	✓	✓	✓

INVRM	IW	LIGHT	MIP	OBRB	PFINBTMB	RD	RECTK	RH	ROSLUT	RT	RW	STW	TD	TKP	TVR	WS	WTR
✓	✓	✓	✓	✓	✓	✓	✓	✓	✓	✓	✓	✓	✓	✓	✓	✓	✓

<sup>1</sup>Not available on 39" or 42" wide.

<sup>2</sup>Not available with clipped left.

<sup>3</sup>Not available with 6" fluting.

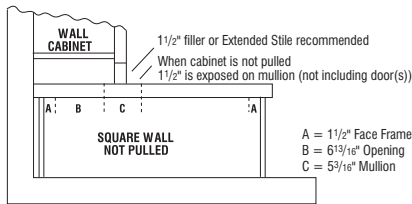

Top View  
Full Overlay Styles

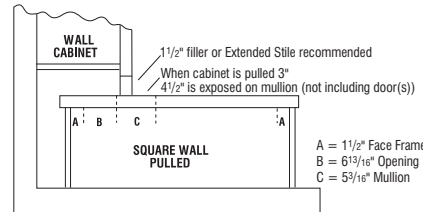

Top View, Pulled 3"

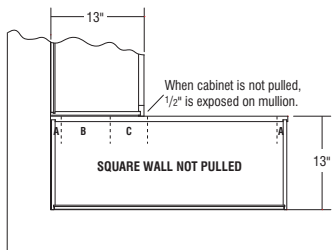

Top View  
Inset Styles

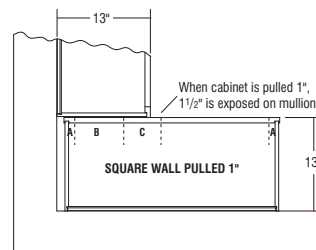

Top View, Pulled 1"

IH/RH availability charts starting on page G•40.  
IW/RW availability charts starting on page G•46.

## Description

### WALL CORNER SINGLE DOOR, 39" HIGH

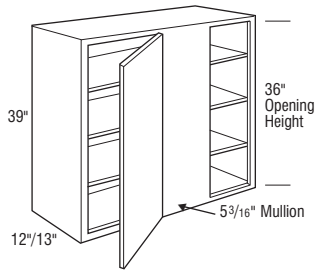

## Model

WC2439 L or R

WC2739 L or R

WC3039 L or R

WC3339 L or R

WC3639 L or R

- Door will be hinged on same side as blind section unless specified otherwise.
- L or R denotes blind.
- Three adjustable shelves.
- Can be pulled 3".
- When ordering cabinet in a full overlay door style, unit must be pulled at least 1 1/2" to 3" from wall.
- 3" filler must be ordered separately.
- Inset and Beaded Inset Door Styles are a standard 13" deep.
- Full Overlay Styles:
  - Increased Depths available in 1/4" increments from 12 1/4" to 30".
  - Reduced Depths available in 1/4" increments from 6" to 11 3/4".
- Inset and Beaded Inset Styles:
  - Increased Depths available in 1/4" increments from 13 1/4" to 30".
  - Reduced Depths available in 1/4" increments from 6" to 12 3/4".

### Door & Drawer Options

AF	AOMD	CC	CG	ES/MD	GAMD	HC	IFHG	MC	MD	MFO	PRMD <sup>1</sup>	SHMD	SPLITDR	SPLITDRWS	SUMD	TCG	TCP
✓	✓	✓	✓	✓	✓	✓	✓	✓	✓	✓	✓	✓	✓	✓	✓	✓	✓

### End Panel Options

AUTH	CSFPE	EXBK	EXDN	FFD	FPE	INTGE	IPE
✓	✓	✓	✓	✓	✓	✓	✓

### Custom Modification Options

ADD_SHLF	ADDTK	ADRW	BVR	CBO	CCO	CFNTO	CFRMO	CLIP <sup>2</sup>	CND	CSDGBK	EF	EX	EX_OL	FALL	FBFL	FLUT <sup>3</sup>	FTK	ID	IH
✓	✓	✓	✓	✓	✓	✓	✓	✓	✓	✓	✓	✓	✓	✓	✓	✓	✓	✓	✓

INVFRM	IW	LIGHT	MIP	OBRB	PFINBTMB	RD	RECTK	RH	ROSLUT	RT	RW	STW	TD	TKP	TVR	WS	WTR
✓	✓	✓	✓	✓	✓	✓	✓	✓	✓	✓	✓	✓	✓	✓	✓	✓	✓

<sup>1</sup>Not available on 24" wide.

<sup>2</sup>Not available on 24" wide, with clipped left.

<sup>3</sup>Not available with 6" fluting.

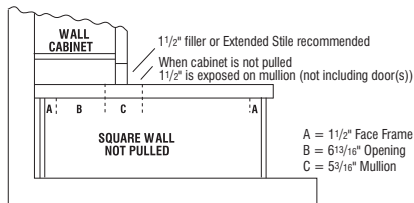

Top View  
Full Overlay Styles

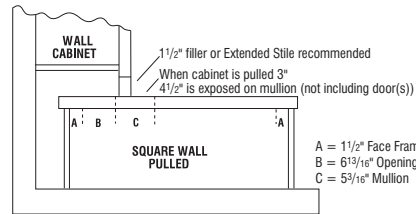

Top View, Pulled 3"

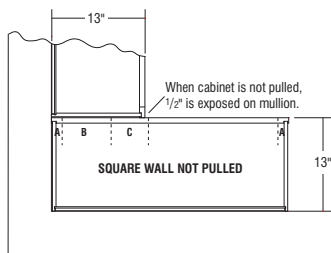

Top View  
Inset Styles

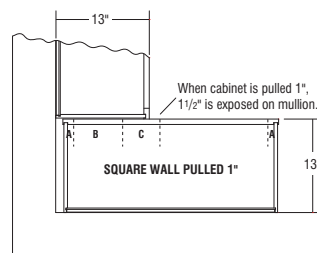

Top View, Pulled 1"

# Wall Corner Cabinets

## Description

## Model

### WALL CORNER DOUBLE DOOR, 39" HIGH

WC3939 L or R

WC4239 L or R

WC4539 L or R

WC4839 L or R

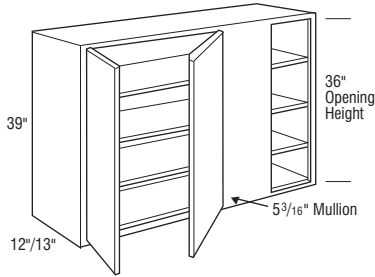

- L or R denotes blind.
- Three adjustable shelves.
- Can be pulled 3".
- When ordering cabinet in a full overlay door style, unit must be pulled at least 1 1/2" to 3" from wall.
- 3" filler must be ordered separately.
- Inset and Beaded Inset Door Styles are a standard 13" deep.
- Full Overlay Styles:
  - Increased Depths available in 1/4" increments from 12 1/4" to 30".
  - Reduced Depths available in 1/4" increments from 6" to 11 3/4".
- Inset and Beaded Inset Styles:
  - Increased Depths available in 1/4" increments from 13 1/4" to 30".
  - Reduced Depths available in 1/4" increments from 6" to 12 3/4".

#### Door & Drawer Options

AF	AOMD	CC	CG	ESMD	GAMD	HC	IFHG	MC	MD	MFO	PRMD	SHMD	SPLITDR <sup>1</sup>	SPLITDRWS	SUMD	TCG	TCP
✓	✓	✓	✓	✓	✓	✓	✓	✓	✓	✓	✓	✓	✓	✓	✓	✓	✓

#### End Panel Options

AUTH	CSFPE	EXBK	EXDN	FFD	FPE	INTGE	IPE
✓	✓	✓	✓	✓	✓	✓	✓

#### Custom Modification Options

ADD	SHLF	ADDTK	ADRW	BVR	CBO	CCO	CFNTD	CFRMO	CLIP <sup>2</sup>	CND	CSDGBK	EF	EX	EX_OL	F.ALL	FBFL	FLUT <sup>3</sup>	FTK	ID	IH	
✓	✓	✓	✓	✓	✓	✓	✓	✓	✓	✓	✓	✓	✓	✓	✓	✓	✓	✓	✓	✓	✓

INVFRM	IW	LIGHT	MIP	OBRB	PFINBTMB	RD	RECTK	RH	ROSLUT	RT	RW	STW	TD	TKP	TVR	WS	WTR
✓	✓	✓	✓	✓	✓	✓	✓	✓	✓	✓	✓	✓	✓	✓	✓	✓	✓

<sup>1</sup>Not available on 39" or 42" wide.

<sup>2</sup>Not available with clipped left.

<sup>3</sup>Not available with 6" fluting.

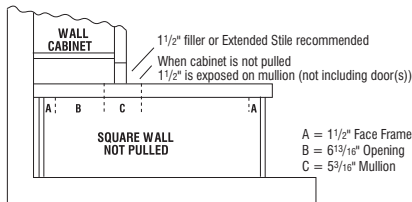

Top View  
Full Overlay Styles

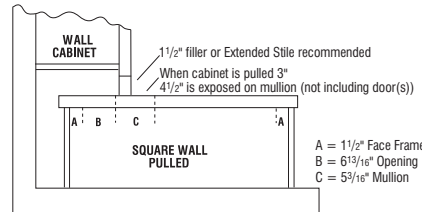

Top View, Pulled 3"

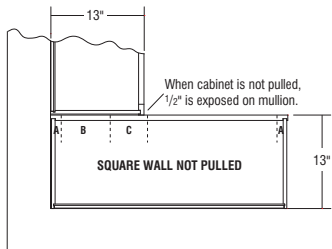

Top View  
Inset Styles

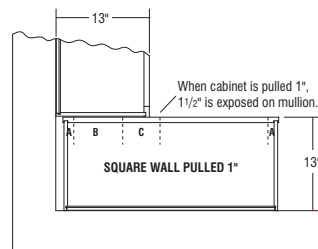

Top View, Pulled 1"

IH/RH availability charts starting on page G•40.  
IW/RW availability charts starting on page G•46.

## Description

### WALL CORNER SINGLE DOOR, 42" HIGH

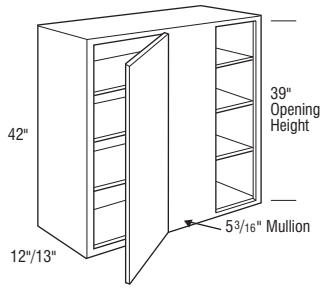

## Model

WC2442 L or R

WC2742 L or R

WC3042 L or R

WC3342 L or R

WC3642 L or R

- Door will be hinged on same side as blind section unless specified otherwise.
- L or R denotes blind.
- Three adjustable shelves.
- Can be pulled 3".
- When ordering cabinet in a full overlay door style, unit must be pulled at least 1 1/2" to 3" from wall.
- 3" filler must be ordered separately.
- Inset and Beaded Inset Door Styles are a standard 13" deep.
- Full Overlay Styles:
  - Increased Depths available in 1/4" increments from 12 1/4" to 30".
  - Reduced Depths available in 1/4" increments from 6" to 11 3/4".
- Inset and Beaded Inset Styles:
  - Increased Depths available in 1/4" increments from 13 1/4" to 30".
  - Reduced Depths available in 1/4" increments from 6" to 12 3/4".

### Door & Drawer Options

AF	AOMD	CC	CG	ES/MD	GAMD	HC	IFHG	MC	MD	MFO	PRMD <sup>1</sup>	SHMD	SPLITDR	SPLITDRWS	SUMD	TCG	TCP
✓	✓	✓	✓	✓	✓	✓	✓	✓	✓	✓	✓	✓	✓	✓	✓	✓	✓

### End Panel Options

AUTH	CSFPE	EXBK	EXDN	FFD	FPE	INTGE	IPE
✓	✓	✓	✓	✓	✓	✓	✓

### Custom Modification Options

ADD_SHLF	ADDTK	ADRW	BVR	CBO	CCO	CFNTO	CFRMO	CLIP <sup>2</sup>	CND	CSDGBK	EF	EX	EX_OL	FALL	FBFL	FLUT <sup>3</sup>	FTK	ID	IH
✓			✓	✓	✓	✓	✓	✓	✓	✓	✓	✓	✓	✓	✓	✓	✓	✓	✓

INVFRM	IW	LIGHT	MIP	OBRB	PFINBTMB	RD	RECTK	RH	ROSLUT	RT	RW	STW	TD	TKP	TVR	WS	WTR
	✓	✓	✓	✓	✓	✓	✓	✓	✓	✓	✓	✓	✓	✓	✓	✓	✓

<sup>1</sup>Not available on 24" wide.

<sup>2</sup>Not available on 24" wide, with clipped left.

<sup>3</sup>Not available with 6" fluting.

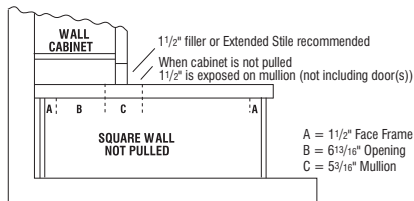

Top View  
Full Overlay Styles

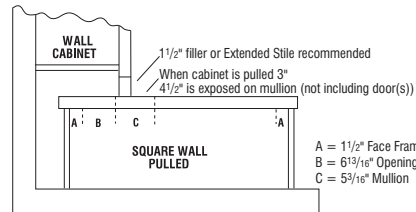

Top View, Pulled 3"

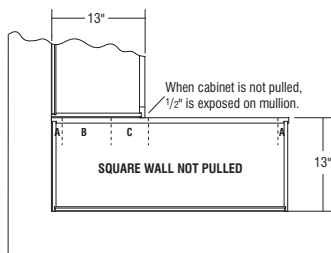

Top View  
Inset Styles

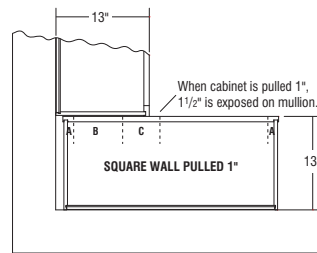

Top View, Pulled 1"

# Wall Corner Cabinets

## Description

## Model

### WALL CORNER DOUBLE DOOR, 42" HIGH

WC3942 L or R

WC4242 L or R

WC4542 L or R

WC4842 L or R

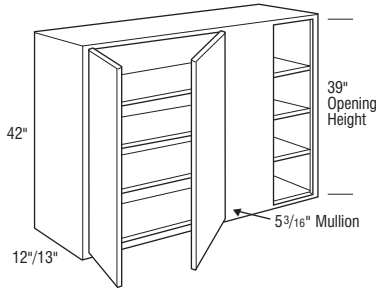

- L or R denotes blind.
- Three adjustable shelves.
- Can be pulled 3".
- When ordering cabinet in a full overlay door style, unit must be pulled at least 1 1/2" to 3" from wall.
- 3" filler must be ordered separately.
- Inset and Beaded Inset Door Styles are a standard 13" deep.
- Full Overlay Styles:
  - Increased Depths available in 1/4" increments from 12 1/4" to 30".
  - Reduced Depths available in 1/4" increments from 6" to 11 3/4".
- Inset and Beaded Inset Styles:
  - Increased Depths available in 1/4" increments from 13 1/4" to 30".
  - Reduced Depths available in 1/4" increments from 6" to 12 3/4".

#### Door & Drawer Options

AF	AOMD	CC	CG	ESMD	GAMD	HC	IFHG	MC	MD	MFO	PRMD	SHMD	SPLITDR <sup>1</sup>	SPLITDRWS	SUMD	TCG	TCP
✓	✓	✓	✓	✓	✓	✓	✓	✓	✓	✓	✓	✓	✓	✓	✓	✓	✓

#### End Panel Options

AUTH	CSFPE	EXBK	EXDN	FFD	FPE	INTGE	IPE
✓	✓	✓	✓	✓	✓	✓	✓

#### Custom Modification Options

ADD	SHLF	ADDTK	ADRW	BVR	CBO	CCO	CFNTD	CFRMO	CLIP <sup>2</sup>	CND	CSDGBK	EF	EX	EX_OL	F.ALL	FBFL	FLUT <sup>3</sup>	FTK	ID	IH
✓	✓	✓	✓	✓	✓	✓	✓	✓	✓	✓	✓	✓	✓	✓	✓	✓	✓	✓	✓	✓

INVFRM	IW	LIGHT	MIP	OBRB	PFINBTMB	RD	RECTK	RH	ROSLUT	RT	RW	STW	TD	TKP	TVR	WS	WTR
✓	✓	✓	✓	✓	✓	✓	✓	✓	✓	✓	✓	✓	✓	✓	✓	✓	✓

<sup>1</sup>Not available on 39" or 42" wide.

<sup>2</sup>Not available with clipped left.

<sup>3</sup>Not available with 6" fluting.

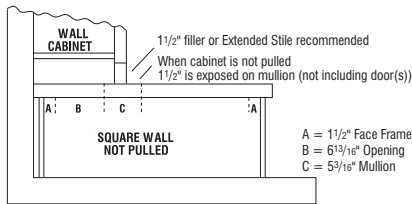

Top View  
Full Overlay Styles

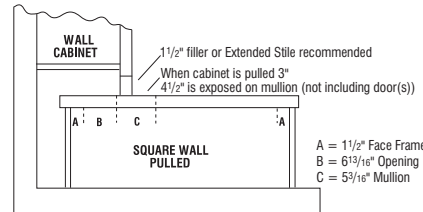

Top View, Pulled 3"

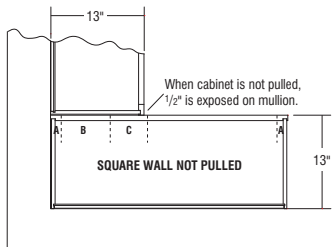

Top View  
Inset Styles

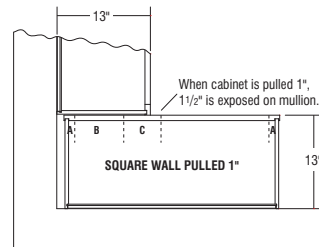

Top View, Pulled 1"

IH/RH availability charts starting on page G-40.  
IW/RW availability charts starting on page G-46.

## Description

### EASY REACH WALL CORNER, 30", 33", 36", 39", or 42" HIGH

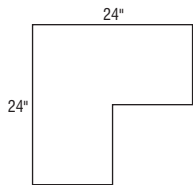
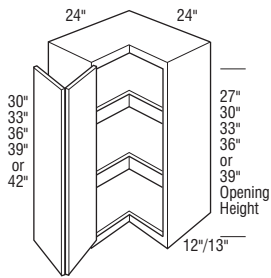

Top View

## Model

ER30 L or R

ER33 L or R

ER36 L or R

- Includes two shelves.

ER39 L or R

ER42 L or R

- Includes three shelves.

Notes below apply to all products in section above:

- Doors are connected with bifold hinge.
- End panels must be equal in size.
- Inset and Beaded Inset Door Styles are a standard 13" deep.
- Increased Depths available in 3" increments to 15".
- Reduced Depths available in 3" increments to 9".

#### Door & Drawer Options

AF	AOMD	CC	CG	ESMD	GAMD	HC	IFHG	MC	MD	MFO	PRMD	SHMD	SPLITDR	SPLITDRWS	SUMD	TCG	TCP
							✓			✓							

#### End Panel Options

AUTH	CSFPE	EXBK	EXDN	FFD	FPE	INTGE	IPE
✓	✓		✓	✓	✓	✓	✓

#### Custom Modification Options

ADD_SHLF	ADDTK	ADRW	BVR	CBO	CCO	CFNTO	CFRMO	CLIP	CND	CSDGBK	EF	EX	EX_OL	F.ALL	FBFL	FLUT <sup>1</sup>	FTK	ID	IH
	✓		✓	✓	✓				✓	✓	✓	✓	✓	✓		✓	✓	✓	

INVFRM	IW	LIGHT	MIP	OBRB	PFINBTMB	RD	RECTK	RH <sup>2</sup>	ROSLUT	RT	RW	STW	TD	TKP	TVR	WS	WTR
	✓	✓	✓	✓	✓	✓	✓	✓	✓	✓	✓	✓	✓	✓	✓	✓	✓

<sup>1</sup>Not available with 6" fluting.  
<sup>2</sup>Only available on 30" high.

### ASYMMETRICAL EASY REACH WALL CORNER, 30", 33", or 36" HIGH



ER302121 L or R

ER302124 L or R

ER302421 L or R



ER332121 L or R



ER332124 L or R



ER332421 L or R



ER362121 L or R

ER362124 L or R

ER362421 L or R

- Includes two adjustable shelves.
- Hinged door opens to 170°.
- Legs at the front frames are 9" on 21" leg and 12" on 24" leg.
- ER \_\_ 2124 L shown.

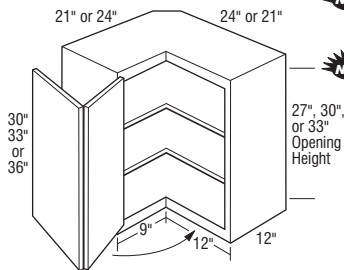

#### Door & Drawer Options

AF	AOMD	CC	CG	ESMD	GAMD	HC	IFHG	MC	MD	MFO	PRMD	SHMD	SPLITDR	SPLITDRWS	SUMD	TCG	TCP
										✓							

#### End Panel Options

AUTH	CSFPE	EXBK	EXDN	FFD	FPE	INTGE	IPE
✓	✓		✓	✓	✓	✓	✓

#### Custom Modification Options

ADD_SHLF	ADDTK	ADRW	BVR	CBO	CCO	CFNTO	CFRMO	CLIP	CND	CSDGBK	EF	EX	EX_OL	F.ALL	FBFL	FLUT <sup>1</sup>	FTK	ID	IH
	✓		✓	✓	✓	✓	✓		✓	✓	✓	✓	✓	✓		✓	✓	✓	

INVFRM	IW	LIGHT	MIP	OBRB	PFINBTMB	RD	RECTK	RH <sup>2</sup>	ROSLUT	RT	RW	STW	TD	TKP	TVR	WS	WTR
	✓	✓	✓	✓	✓	✓	✓	✓	✓	✓	✓	✓	✓	✓	✓	✓	✓

<sup>1</sup>Not available with 6" fluting.  
<sup>2</sup>Only available on 30" high.

# Wall Corner Cabinets

## Description

### ASYMMETRICAL EASY REACH WALL CORNER, 39" or 42" HIGH

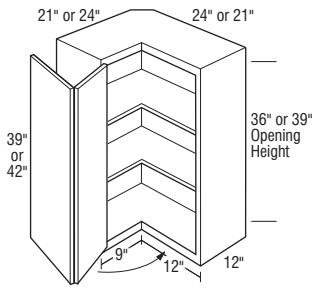

## Model

**ER392121 L or R**

**ER392124 L or R**

**ER392421 L or R**

**ER422121 L or R**

**ER422124 L or R**

**ER422421 L or R**

- Includes two adjustable shelves.
- Hinged door opens to 170°.
- Legs at the front frames are 9" on 21" leg and 12" on 24" leg.
- ER\_\_2124 L shown.

#### Door & Drawer Options

AF	AOMD	CC	CG	ESMD	GAMD	HC	IFHG	MC	MD	MFO	PRMD	SHMD	SPLITDR	SPLITDRWS	SUMD	TCG	TCP
										✓							

#### End Panel Options

AUTH	CSFPE	EXBK	EXDN	FFD	FPE	INTGE	IPE
✓	✓	✓	✓	✓	✓	✓	✓

#### Custom Modification Options

ADD_SHLF	ADDTK	ADRW	BVR	CBO	CCO	CFNTO	CFRMO	CLIP	CND	CSDGBK	EF	EX	EX_OL	FALL	FBFL	FLUT <sup>1</sup>	FTK	ID	IH
	✓		✓	✓	✓	✓	✓		✓	✓	✓	✓	✓			✓	✓	✓	✓

INVFRM	IW	LIGHT <sup>2</sup>	MIP	OBRB	PFINBTMB	RD	RECTK	RH	ROSLUT	RT	RW	STW	TD	TKP	TVR	WS	WTR
	✓		✓	✓	✓	✓	✓	✓	✓					✓	✓	✓	✓

<sup>1</sup>Not available with 6" fluting.

<sup>2</sup>INT.LGT not available on 39" high.

IH/RH availability charts starting on page G•40.  
IW/RW availability charts starting on page G•46.

## Description

### DIAGONAL WALL, 12", 13", or 15" DEEP

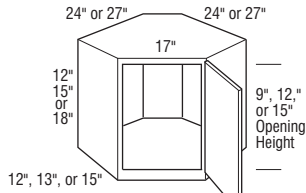

DW122424 L or R - DW182727 L or R

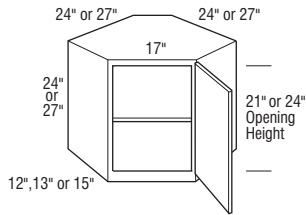

DW242424 L or R - DW272727 L or R

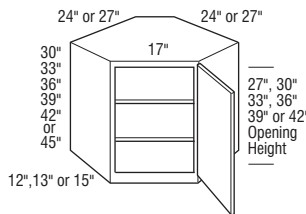

DW302424 L or R - DW452727 L or R

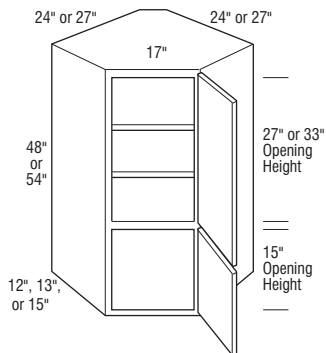

DW302424D L or R - DW362727D L or R

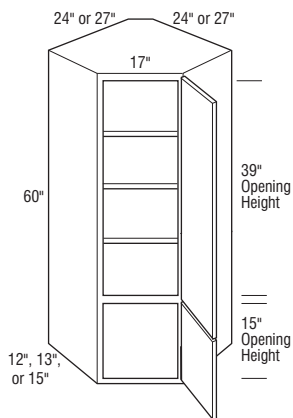

DW422424D L or R - DW422727D L or R

## Model



DW122424 L or R



DW152424 L or R



DW182424 L or R



DW122727 L or R



DW152727 L or R

DW182727 L or R

DW242424 L or R



DW272424 L or R

DW242727 L or R



DW272727 L or R

- One adjustable shelf.

DW302424 L or R

DW332424 L or R

DW362424 L or R

DW302727 L or R

DW332727 L or R

DW362727 L or R

- Two adjustable shelves.

DW392424 L or R

DW422424 L or R

DW392727 L or R

DW422727 L or R

DW452727 L or R

- Three adjustable shelves.

DW302424DWB L or R

DW362424DWB L or R

DW302727DWB L or R

DW362727DWB L or R

- Two adjustable shelves.

- Increased Heights modification will increase the height of the upper cabinet section. The bottom section will retain its original height.

DW422424DWB L or R

DW422727DWB L or R

- Three adjustable shelves.

- Increased Heights modification will increase the height of the upper cabinet section. The bottom section will retain its original height.

#### Notes below apply to all products in section above:

- All Full Overlay doors have a 3/4" overlay hinge standard.
- EXL or EXR not required on opposing cabinets.
- Inset and Beaded Inset Door Styles are a standard 13" deep.
- Adjustable shelf cannot be removed/retrofitted.

#### Door & Drawer Options

AF	AOMD	CC	CG	ESMD <sup>1</sup>	GAMD <sup>1</sup>	HC	IFHG	MC	MD <sup>1</sup>	MFO	PRMD	SHMD	SPLITDR	SPLITDRWS	SUMD <sup>1</sup>	TCG <sup>2</sup>	TCP <sup>2</sup>
✓			✓	✓	✓	✓	✓	✓	✓	✓	✓	✓			✓	✓	✓

#### End Panel Options

AUTH	CSFPE	EXBK	EXDN	FFD	FPE	INTGE	IPE
✓	✓	✓	✓	✓	✓	✓	✓

#### Custom Modification Options

ADD_SHLF	ADDTK	ADRW	BVR	CBO	CCO	CFNTO	CFRMO	CLIP	CND	CSDGBK	EF	EX	EX_OL	F.ALL	FBFL	FLUT	FTK	ID	IH
✓	✓	✓	✓	✓	✓	✓	✓	✓	✓	✓	✓	✓	✓	✓	✓	✓	✓	✓	✓

INVERM <sup>3</sup>	IW	LIGHT	MIP	OBRB	PFINBTMB	RD	RECTK	RH <sup>4</sup>	ROSFLUT	RT	RW	STW	TD	TKP	TVR	WS	WTR
✓	✓	✓	✓	✓	✓	✓	✓	✓	✓	✓	✓	✓	✓	✓	✓	✓	✓

<sup>1</sup>Not available on 48", 54" or 60" high.

<sup>2</sup>Only available on 36", 39", 42", 45", 54", and 60" high.

<sup>3</sup>Only available on 48", 54" and 60" high.

<sup>4</sup>Only available on 15"-24" high.



# Diagonal Wall Cabinets

## Description

### DIAGONAL WALL with FULL HEIGHT DOOR, 48" HIGH

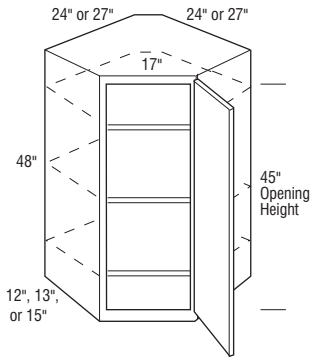

## Model

DW482424FH L or R

DW482727FH L or R

- Three adjustable shelves.
- All Full Overlay doors have a 3/4" overlay hinge standard.
- EXL or EXR not required on opposing cabinets.
- Inset and Beaded Inset Door Styles are a standard 13" deep.

#### Door & Drawer Options

AF	AOMD	CC	CG	ESMD	GAMD	HC	IFHG	MC	MD	MFO	PRMD	SHMD	SPLITDR	SPLITDRWS	SUMD	TCG	TCP
✓		✓		✓	✓	✓	✓	✓	✓	✓	✓	✓			✓	✓	✓

#### End Panel Options

AUTH	CSFPE	EXBK	EXDN	FFD	FPE	INTGE	IPE
✓	✓		✓	✓	✓	✓	✓

#### Custom Modification Options

ADD_SHLF	ADDTK	ADRW	BVR	CBO	CCO	CFNTO	CFRMO	CLIP	CND	CSDGBK	EF	EX	EX_OL	FALL	FBFL	FLUT	FTK	ID	IH
	✓	✓	✓	✓	✓	✓	✓	✓	✓	✓	✓						✓	✓	✓

INVERM	IW	LIGHT	MIP	OBRB	PFINBTMB	RD	RECTK	RH	ROSFLUT	RT	RW	STW	TD	TKP	TVR	WS	WTR
		✓	✓	✓	✓		✓							✓	✓	✓	✓

IH/RH availability charts starting on page G•40.  
IW/RW availability charts starting on page G•46.

## Description

### DIAGONAL WALL with LAZY SUSAN, 30", 36", 39", 42", 48", or 60" HIGH

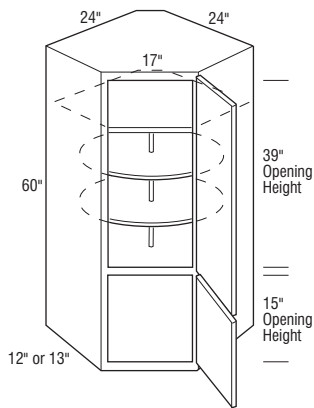
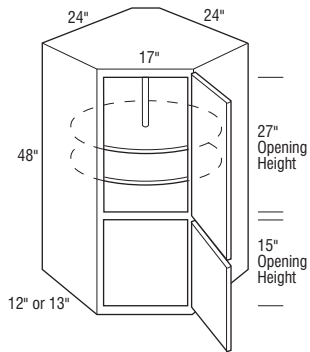
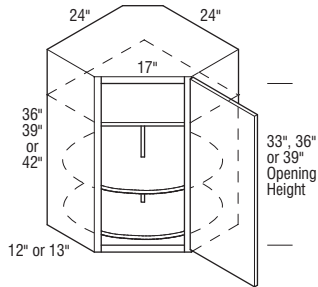
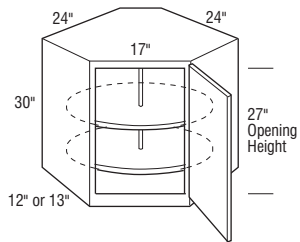

## Model

DW302424S L or R

DW362424S L or R

DW392424S L or R

DW422424S L or R

- One fixed shelf.

DW302424DSWB L or R

- One fixed shelf.

DW422424DSWB L or R

- One fixed shelf.

Notes below apply to all products in section above:

- Wood Pan diameter 18".
- All Full Overlay doors have a 3/4" overlay hinge standard.
- EXL or EXR not required on opposing cabinets.
- Inset and Beaded Inset Door Styles are a standard 13" deep.

#### Door & Drawer Options

AF	AOMD	CC	CG	ESMD	GAMD	HC	IFHG	MC	MD	MFO	PRMD	SHMD	SPLITDR	SPLITDRWS	SUMD	TCG <sup>1</sup>	TCP <sup>1</sup>
✓	✓	✓	✓	✓	✓	✓	✓	✓	✓	✓	✓	✓	✓	✓	✓	✓	✓

#### End Panel Options

AUTH	CSFPE	EXBK	EXDN	FFD <sup>2</sup>	FPE	INTGE	IPE
✓	✓	✓	✓	✓	✓	✓	✓

#### Custom Modification Options

ADD_SHLF	ADDTK	ADRW	BVR	CBO	CCO <sup>3</sup>	CFNTO	CFRMO <sup>3</sup>	CLIP	CND	CSDGBK	EF	EX	EX_OL	F.ALL	FBFL	FLUT	FTK	ID	IH
✓	✓	✓	✓	✓	✓	✓	✓	✓	✓	✓	✓	✓	✓	✓	✓	✓	✓	✓	✓

INVERM <sup>4</sup>	IW	LIGHT	MIP	OBRB	PFINBTMB	RD	RECTK	RH	ROSLUT	RT	RW	STW	TD	TKP	TVR	WS	WTR
✓	✓	✓	✓	✓	✓	✓	✓	✓	✓	✓	✓	✓	✓	✓	✓	✓	✓

<sup>1</sup>Not available on 30" or 48" high.

<sup>2</sup>Only available on 30" and 48" high.

<sup>3</sup>Not available on 48" high.

<sup>4</sup>Only available on 48" and 60" high.

# Diagonal Wall Cabinets

## Description

**DIAGONAL WALL with APPLIANCE GARAGE OPEN BOTTOM, 48", 51", 54", 57", or 60" HIGH**

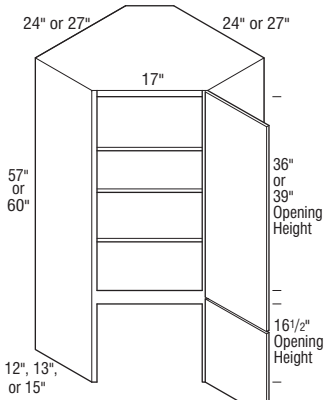
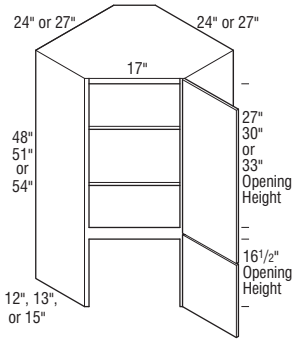

## Model

DW302424D L or R

DW332424D L or R

DW362424D L or R

DW302727D L or R

DW332727D L or R

DW362727D L or R

DW392424D L or R

DW422424D L or R

DW392727D L or R

DW422727D L or R

- One fixed and two adjustable shelves.

- One fixed and three adjustable shelves.

Notes below apply to all products in section above:

- All Full Overlay doors have a 3/4" overlay hinge standard.
- EXL or EXR not required on opposing cabinets.
- Increased Heights modification will increase the height of the upper cabinet section. The bottom section will retain its original height.
- Bottom section does not include floor.

### Door & Drawer Options

AF	AOMD	CC	CG	ESMD	GAMD	HC	IFHG	MC	MD	MFO	PRMD	SHMD	SPLITDR	SPLITDRWS	SJMD	TCG	TCP
✓			✓	✓	✓	✓	✓	✓	✓	✓	✓	✓	✓			✓	

### End Panel Options

AUTH	CSFPE	EXBK	EXDN	FFD	FPE	INTGE	IPE
✓	✓		✓		✓	✓	✓

### Custom Modification Options

ADD	SHLF	ADDTK	ADRW	BVR	CBO	CCO	CFNTD	CFRMO	CLIP	CND	CSDGBK	EF	EX	EX_OL	FALL	FBFL	FLUT	FTK	ID	IH	
					✓	✓	✓	✓	✓	✓	✓	✓	✓							✓	✓

INVFRM	IW	LIGHT	MIP	OBRB	PFINBTMB	RD	RECTK	RH	ROSLUT	RT	RW	STW	TD	TKP	TVR	WS	WTR
		✓	✓													✓	✓

IH/RH availability charts starting on page G•40.  
IW/RW availability charts starting on page G•46.

## Description

**DIAGONAL WALL with APPLIANCE GARAGE and LAZY SUSAN OPEN BOTTOM, 48", 51", 54", 57", or 60" HIGH**

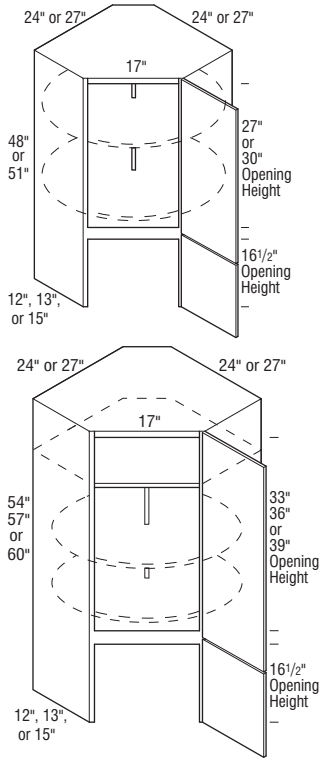

## Model

**DW302424DS L or R**

**DW332424DS L or R**

- One fixed shelf.

**DW362424DS L or R**

**DW392424DS L or R**

**DW422424DS L or R**

- Two fixed shelves.

Notes below apply to all products in section above:

- Wood Pan diameter 18".
- All Full Overlay doors have a 3/4" overlay hinge standard.
- EXL or EXR not required on opposing cabinets.
- Bottom section does not include floor.

### Door & Drawer Options

AF	AOMD	CC	CG	ESMD	GAMD	HC	IFHG	MC	MD	MFO	PRMD	SHMD	SPLITDR	SPLITDRWS	SUMD	TCG	TCP
✓		✓	✓	✓	✓	✓	✓	✓	✓	✓	✓	✓			✓		

### End Panel Options

AUTH	CSFPE	EXBK	EXDN	FFD	FPE	INTGE	IPE
✓	✓				✓	✓	✓

### Custom Modification Options

ADD_SHLF	ADDTK	ADRW	BVR	CBO	CCO	CFNTD	CFRMO	CLIP	CND	CSDGBK	EF	EX	EX_OL	FALL	FBFL	FLUT	FTK	ID	IH	
				✓	✓	✓	✓	✓	✓	✓	✓								✓	
INVERM	IW	LIGHT	MIP	OBRB	PFINBTMB	RD	RECTK	RH	ROSLUT	RT	RW	STW	TD	TKP	TVR	WS	WTR			
			✓	✓												✓	✓	✓		

# Diagonal Wall Cabinets

## Description

**DIAGONAL WALL with VERTICAL-LIFT, 48", 51", 54", 57", or 60" HIGH, 12" or 15" DEEP**

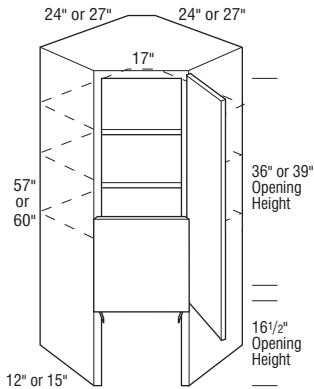
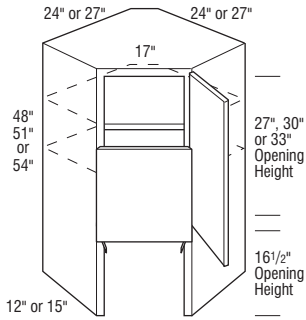

## Model

DW302424AG L or R

DW332424AG L or R

DW362424AG L or R

DW392424AG L or R

DW422424AG L or R

- One fixed and two adjustable shelves.

DW302727AG L or R

DW332727AG L or R

DW362727AG L or R

DW392727AG L or R

DW422727AG L or R

- One fixed and three adjustable shelves.

Notes below apply to all products in section above:

- Heavy duty Vertical-Lift mechanism.
- All Full Overlay doors have a 3/4" overlay hinge standard.
- EXL or EXR not required on opposing cabinets.
- Not available on Inset and Beaded Inset styles.
- Increased Heights modification will increase the height of the upper cabinet section. The bottom section will retain its original height.
- Automatic Opening Mechanism is available except when used with the following door styles:
  - Burke, Gordon, Kirby, Landry, Shanley, or Vinson.

### Door & Drawer Options

AF	AOMD	CC	CG	ESMD	GAMD	HC	IFHG	MC	MD	MFO	PRMD	SHMD	SPLITDR	SPLITDRWS	SJMD	TCG <sup>1</sup>	TCP <sup>1</sup>
✓	✓	✓	✓	✓	✓	✓	✓	✓	✓	✓	✓	✓	✓	✓	✓	✓	✓

### End Panel Options

AUTH	CSFPE	EXBK	EXDN	FFD	FPE	INTGE	IPE
✓	✓	✓	✓	✓	✓	✓	✓

### Custom Modification Options

ADD_SHLF	ADDTK	ADRW	BVR	CBO	CCO	CFNTO	CFRMO	CLIP	CND	CSDGBK	EF	EX	EX_OL	FALL	FBFL	FLUT	FTK	ID	IH
✓	✓	✓	✓	✓	✓	✓	✓	✓	✓	✓	✓	✓	✓	✓	✓	✓	✓	✓	✓

INVFRM	IW	LIGHT	MIP	OBRB	PFINBTMB	RD	RECTK	RH	ROSLUT	RT	RW	STW	TD	TKP	TVR	WS	WTR
✓	✓	✓	✓	✓	✓	✓	✓	✓	✓	✓	✓	✓	✓	✓	✓	✓	✓

<sup>1</sup>Not available on 48" or 51" high.

IH/RH availability charts starting on page G•40.  
IW/RW availability charts starting on page G•46.

## Description

### DIAGONAL WALL with VERTICAL-LIFT and LAZY SUSAN, 48", 54", or 60" HIGH

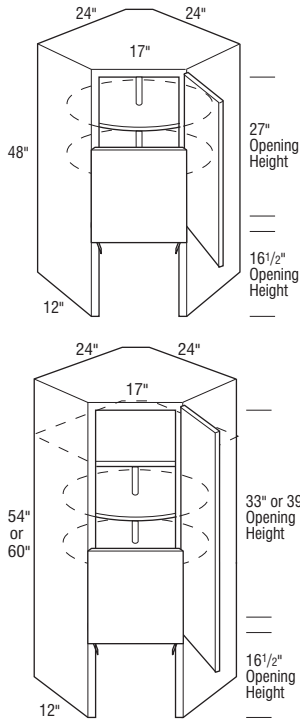

## Model

### DW302424AGS L or R

- One fixed shelf.

### DW362424AGS L or R

### DW422424AGS L or R

- Two fixed shelves.

Notes below apply to all products in section above:

- Heavy duty Vertical-lift mechanism.
- Wood Pan diameter 18".
- All Full Overlay doors have a 3/4" overlay hinge standard.
- EXL or EXR not required on opposing cabinets.
- Not available on Inset and Beaded Inset styles.
- Automatic Opening Mechanism is available except when used with the following door styles:
  - Burke, Gordon, Kirby, Landry, Shanley, or Vinson.

#### Door & Drawer Options

AF	AOMD	CC	CG	ESMD	GAMD	HC	IFHG	MC	MD	MFO	PRMD	SHMD	SPLITDR	SPLITDRWS	SUMD	TCG	TCP
✓		✓	✓	✓	✓	✓	✓	✓	✓	✓	✓	✓	✓	✓	✓	✓	✓

#### End Panel Options

AUTH	CSFPE	EXBK	EXDN	FFD	FPE	INTGE	IPE
✓	✓				✓	✓	✓

#### Custom Modification Options

ADD_SHLF	ADDTK	ADRW	BVR	CBO	CCO	CFNTO	CFRMO	CLIP	CND	CSDGBK	EF	EX	EX_OL	F.ALL	FBFL	FLUT	FTK	ID	IH
				✓					✓	✓	✓								
INVERM	IW	LIGHT	MIP	OBRB	PFINBTMB	RD	RECTK	RH	ROSLUT	RT	RW	STW	TD	TKP	TVR	WS	WTR		
		✓	✓														✓		

### **NEW** STACKED DIAGONAL WALL, 48", 51", 54", 57", or 60" HIGH

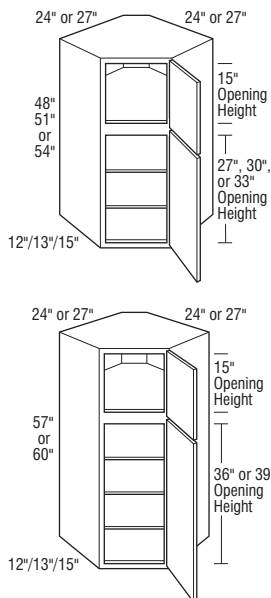

### STDW482424 L or R

### STDW512424 L or R

### STDW542424 L or R

### STDW482727 L or R

### STDW512727 L or R

### STDW542727 L or R

- Two adjustable shelves.

### STDW572424 L or R

### STDW602424 L or R

### STDW572727 L or R

### STDW602727 L or R

- Three adjustable shelves.

Notes below apply to all products in section above:

- All Full Overlay doors have a 3/4" overlay hinge standard.
- EXL or EXR not required on opposing cabinets.
- Inset and Beaded Inset Door Styles are a standard 13" deep.
- Increased Heights modification will increase the height of the upper cabinet section. The bottom section will retain its original height.

#### Door & Drawer Options

AF	AOMD	CC	CG	ESMD	GAMD	HC	IFHG	MC	MD	MFO	PRMD	SHMD	SPLITDR	SPLITDRWS	SUMD	TCG	TCP
				✓					✓	✓	✓						

#### End Panel Options

AUTH	CSFPE	EXBK	EXDN	FFD	FPE	INTGE	IPE
✓	✓				✓	✓	✓

#### Custom Modification Options

ADD_SHLF	ADDTK	ADRW	BVR	CBO	CCO	CFNTO	CFRMO	CLIP	CND	CSDGBK	EF	EX	EX_OL	F.ALL	FBFL	FLUT	FTK	ID	IH
				✓					✓	✓	✓								
INVERM	IW	LIGHT	MIP	OBRB	PFINBTMB	RD	RECTK	RH	ROSLUT	RT	RW	STW	TD	TKP	TVR	WS	WTR		
		✓	✓														✓		

# Diagonal Wall Peninsula Cabinets

## Description

**DIAGONAL WALL PENINSULA, 30", 33", 36", 39", 42", 45", or 48" HIGH**

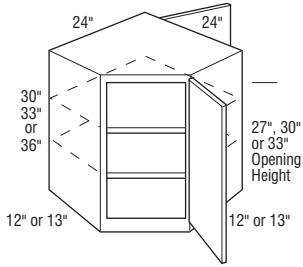

DW\*PRR shown

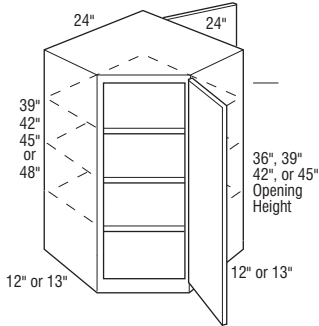

DW\*PRR shown

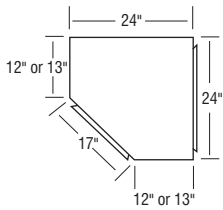

DW\*PRR shown

## Model

DW302424PLL

DW302424PRR

DW302424PLR

DW302424PRL

• Reduced Heights available in 1/4" increments. See page G•40 for details.

DW332424PLL

DW332424PRR

DW332424PLR

DW332424PRL

DW362424PLL

DW362424PRR

DW362424PLR

DW362424PRL

• Two adjustable shelves.

DW392424PLL

DW392424PRR

DW392424PLR

DW392424PRL

DW422424PLL

DW422424PRR

DW422424PLR

DW422424PRL

DW452424PLL

DW452424PRR

DW452424PLR

DW452424PRL

DW482424PLL

DW482424PRR

DW482424PLR

DW482424PRL

• Three adjustable shelves.

Notes below apply to all products in section above:

- First letter is hinging of front door. Second letter is side of cabinet the Peninsula will be on and the hinging of that door.
- Peninsula one side only.
- All Full Overlay doors have a 3/4" overlay hinge standard.
- EXL or EXR not required on opposing cabinets.
- Inset and Beaded Inset Door Styles are a standard 13" deep.

### Door & Drawer Options

AF	AOMD	CC	CG	ESMD	GAMD	HC	IFHG	MC	MD	MFO	PRMD	SHMD	SPLITDR	SPLITDRWS	SJMD	TCG <sup>1</sup>	TCP <sup>1</sup>
✓	✓	✓	✓	✓	✓	✓	✓	✓	✓	✓	✓	✓	✓	✓	✓	✓	✓

### End Panel Options

AUTH	CSFPE	EXBK	EXDN <sup>2</sup>	FFD	FPE	INTGE	IPE
✓	✓	✓	✓	✓	✓	✓	✓

### Custom Modification Options

ADD	SHLF	ADDTK	ADRW	BVR	CBO	CCO	CFNTO	CFRMO	CLIP	CND	CSDGBK	EF	EX	EX_OL	FALL	FBFL	FLUT <sup>3</sup>	FTK	ID	IH
✓	✓	✓	✓	✓	✓	✓	✓	✓	✓	✓	✓	✓	✓	✓	✓	✓	✓	✓	✓	✓
INVERM	IW	LIGHT	MIP	OBRB	PFINBTMB	RD	RECTK <sup>4</sup>	RH <sup>5</sup>	ROSLUT	RT	RW	STW	TD	TKP	TVR	WS	WTR			
✓	✓	✓	✓	✓	✓	✓	✓	✓	✓	✓	✓	✓	✓	✓	✓	✓	✓			

<sup>1</sup>Not available on 30" or 33" high.

<sup>2</sup>Not available on EXDNLRB.

<sup>3</sup>Not available with 6" fluting.

<sup>4</sup>Not available on 48" high.

<sup>5</sup>Only available on 30" high.

IH/RH availability charts starting on page G•40.  
IW/RW availability charts starting on page G•46.

## Description

### WALL PENINSULA, 18" HIGH

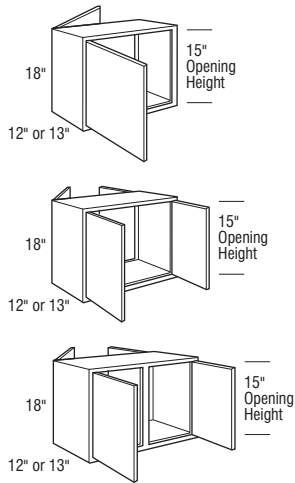

## Model

W918P L or R

W1218P L or R

W1518P L or R

W1818P L or R

W2118P L or R

W2418P L or R

W2418P

W2718P

W3018P

W3318P

W3618P

W3918P

W4218P

W4518P

W4818P

#### Notes below apply to all products in section above:

- Specify location of modification for front or peninsula side.
- Inset and Beaded Inset Door Styles are a standard 13" deep.
- Full Overlay Styles:
  - Increased Depths available in 1/4" increments from 12 1/4" to 30".
  - Reduced Depths available in 1/4" increments from 6" to 11 3/4".
- Inset and Beaded Inset Styles:
  - Increased Depths available in 1/4" increments from 13 1/4" to 30".
  - Reduced Depths available in 1/4" increments from 6" to 12 3/4".

#### Door & Drawer Options

AF	AOMD	CC	CG	ESMD <sup>1</sup>	GAMD <sup>1</sup>	HC	IFHG	MC	MD <sup>1</sup>	MFO	PRMD <sup>3</sup>	SHMD	SPLITDR <sup>2</sup>	SPLITDRWS	SUMD <sup>1</sup>	TCG	TCP	
✓	✓	✓	✓	✓	✓	✓	✓	✓	✓	✓	✓	✓	✓	✓	✓	✓	✓	✓

#### End Panel Options

AUTH	CSFPE	EXBK	EXDN <sup>4</sup>	FFD	FPE	INTGE	IPE
✓	✓	✓	✓	✓	✓	✓	✓

#### Custom Modification Options

ADD_SHLF	ADDTK	ADRW	BVR	CBO	CCO	CFNTO	CFRMO	CLIP <sup>5</sup>	CND	CSDGBK	EF	EX	EX_OL	FALL	FBFL	FLUT <sup>6</sup>	FTK <sup>8</sup>	ID	IH	
✓	✓	✓	✓	✓	✓	✓	✓	✓	✓	✓	✓	✓	✓	✓	✓	✓	✓	✓	✓	✓
INVRM	IW <sup>9</sup>	LIGHT	MIP	OBRB	PFINBTMB	RD	RECTK	RH	ROSFLUT <sup>7</sup>	RT	RW	STW	TD	TKP	TVR <sup>10</sup>	WS	WTR			
✓	✓	✓	✓	✓	✓	✓	✓	✓	✓	✓	✓	✓	✓	✓	✓	✓	✓	✓	✓	✓

<sup>1</sup>Not available on 9" wide.

<sup>2</sup>Not available on 9" or 24" (2 doors) wide.

<sup>3</sup>Only available on 24" (2 doors)-39" wide.

<sup>4</sup>Not available with EXDNLRB.

<sup>5</sup>Not available on 9" or 24" (2 doors) wide.

<sup>6</sup>Not available on 9" or 24" (2 doors) wide and fluting both not available on 27"-36", 42" or 48" wide. Not available with 6" fluting.

<sup>7</sup>Not available on 9" and 24" (2 doors) wide except on fluting both peninsula. Fluting both 3" not available on 27"-36", 42" or 48" wide except on fluting both peninsula.

<sup>8</sup>FTKAV not available on 9" or 12" wide.

<sup>9</sup>Not available on 24" (1 door), 36" or 48" wide.

<sup>10</sup>Not available on 45" or 48" wide and TVRAV not available on 9"-15".



# Wall Peninsula Cabinets

## Description

### WALL PENINSULA, 24" HIGH

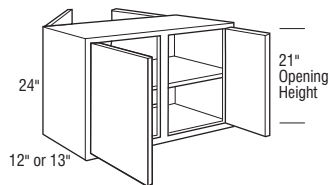
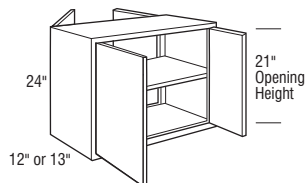
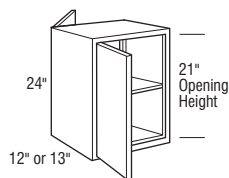

## Model

W924P L or R

W1224P L or R

W1524P L or R

W1824P L or R

W2124P L or R

W2424P L or R

W2424P

W2724P

W3024P

W3324P

W3624P

W3924P

W4224P

W4524P

W4824P

#### Notes below apply to all products in section above:

- One adjustable shelf.
- Specify location of modification for front or peninsula side.
- Inset and Beaded Inset Door Styles are a standard 13" deep.
- Full Overlay Styles:
  - Increased Depths available in 1/4" increments from 12 1/4" to 30".
  - Reduced Depths available in 1/4" increments from 6" to 11 3/4".
- Inset and Beaded Inset Styles:
  - Increased Depths available in 1/4" increments from 13 1/4" to 30".
  - Reduced Depths available in 1/4" increments from 6" to 12 3/4".

#### Door & Drawer Options

AF	AOMD	CC	CG	ESMD <sup>1</sup>	GAMD <sup>1</sup>	HC	IFHG	MC	MD <sup>1</sup>	MFO	PRMD <sup>2</sup>	SHMD	SPLITDR <sup>3</sup>	SPLITDRWS	SUMD <sup>1</sup>	TCG	TCP
✓	✓	✓	✓	✓	✓	✓	✓	✓	✓	✓	✓	✓	✓	✓	✓	✓	✓

#### End Panel Options

AUTH	CSFPE	EXBK <sup>4</sup>	EXDN <sup>5</sup>	FFD	FPE	INTGE	IPE
✓	✓	✓	✓	✓	✓	✓	✓

#### Custom Modification Options

ADD_SHLF	ADDTK	ADRW	BVR	CBO	CCO	CFNTO <sup>6</sup>	CFRMO <sup>6</sup>	CLIP <sup>2</sup>	CND	CSDGBK	EF	EX	EX_OL	F.ALL	FBFL	FLUT <sup>7</sup>	FTK <sup>8</sup>	ID	IH
✓	✓	✓	✓	✓	✓	✓	✓	✓	✓	✓	✓	✓	✓	✓	✓	✓	✓	✓	✓
INVFRM	IW <sup>9</sup>	LIGHT	MIP	OBRB	PFINBTMB	RD	RECTK	RH <sup>10</sup>	ROSFLUT <sup>11</sup>	RT	RW	STW	TD	TKP	TVR <sup>12</sup>	WS	WTR		
✓	✓	✓	✓	✓	✓	✓	✓	✓	✓	✓	✓	✓	✓	✓	✓	✓	✓		

<sup>1</sup>Not available on 9" wide.

<sup>2</sup>Not available on 9", 12" or 24" (2 doors) wide.

<sup>3</sup>Only available on 24" (2 doors)-39" wide.

<sup>4</sup>Not available with end extended back left.

<sup>5</sup>Not available on EXDNLRB.

<sup>6</sup>Only available on 9" wide.

<sup>7</sup>Not available on 24" (2 doors) wide and fluting both not available on 27"-48" wide. Not available with 6" fluting.

<sup>8</sup>FTKAV not available on 9" or 12" wide.

<sup>9</sup>Not available on 24" (1 door), 36" or 48" wide.

<sup>10</sup>Not available on 36"-48" wide.

<sup>11</sup>Not available on 24" (2 doors) wide and fluting both not available on 27"-48" wide except on fluting both peninsula.

<sup>12</sup>Not available on 42"-48" wide and TVRAV not available on 9" or 12" wide.

IH/RH availability charts starting on page G•40.  
IW/RW availability charts starting on page G•46.

## Description

### WALL PENINSULA, 30" HIGH

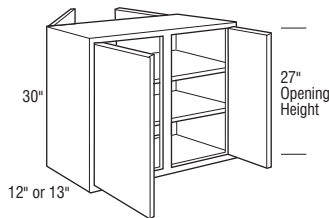
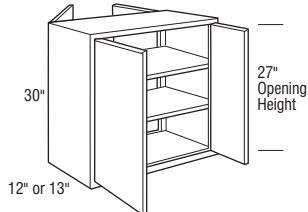
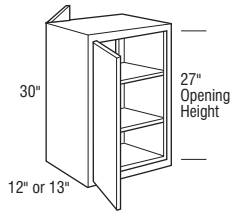

## Model

W930P L or R

W1230P L or R

W1530P L or R

W1830P L or R

W2130P L or R

W2430P L or R

W2430P

W2730P

W3030P

W3330P

W3630P

W3930P

W4230P

W4530P

W4830P

#### Notes below apply to all products in section above:

- Two adjustable shelves.
- Specify location of modification for front or peninsula side.
- Inset and Beaded Inset Door Styles are a standard 13" deep.
- Full Overlay Styles:
  - Increased Depths available in 1/4" increments from 12 1/4" to 30".
  - Reduced Depths available in 1/4" increments from 6" to 11 3/4".
- Inset and Beaded Inset Styles:
  - Increased Depths available in 1/4" increments from 13 1/4" to 30".
  - Reduced Depths available in 1/4" increments from 6" to 12 3/4".

#### Door & Drawer Options

AF	AOMD	CC	CG	ESMD <sup>1</sup>	GAMD <sup>1</sup>	HC <sup>1</sup>	IFHG	MC <sup>1</sup>	MD <sup>1</sup>	MFO	PRMD <sup>2</sup>	SHMD	SPLITDR <sup>3</sup>	SPLITDRWS	SUMD <sup>1</sup>	TCG	TCP	
✓	✓	✓	✓	✓	✓	✓	✓	✓	✓	✓	✓	✓	✓	✓	✓	✓	✓	✓

#### End Panel Options

AUTH	CSFPE	EXBK <sup>4</sup>	EXDN <sup>5</sup>	FFD	FPE	INTGE	IPE
✓	✓	✓	✓	✓	✓	✓	✓

#### Custom Modification Options

ADD_SHLF	ADDTK	ADRW	BVR	CBO	CCO	CFNTO	CFRMO	CLIP <sup>2</sup>	CND	CSDGBK	EF	EX	EX_OL	FALL	FBFL	FLUT <sup>6</sup>	FTK <sup>7</sup>	ID	IH	
✓	✓	✓	✓	✓	✓	✓	✓	✓	✓	✓	✓	✓	✓	✓	✓	✓	✓	✓	✓	✓
INVERM	IW <sup>8</sup>	LIGHT	MIP	OBRB	PFINBTMB	RD	RECTK	RH	ROSLUT <sup>9</sup>	RT	RW	STW	TD	TKP	TVR <sup>10</sup>	WS	WTR			
✓	✓	✓	✓	✓	✓	✓	✓	✓	✓	✓	✓	✓	✓	✓	✓	✓	✓	✓	✓	✓

<sup>1</sup>Not available on 9" wide.

<sup>2</sup>Not available on 9" or 24" (2 doors) wide.

<sup>3</sup>Only available on 24" (2 doors)-39" wide.

<sup>4</sup>Not available on 9" or 12" wide and not available with end extended back left.

<sup>5</sup>Not available on EXDNLRB.

<sup>6</sup>Not available on 9" or 24" (2 doors) wide and fluting both not available on 27"-48" wide. Not available with 6" fluting.

<sup>7</sup>FTKAV not available on 9" or 12" wide.

<sup>8</sup>Not available on 24" (1 door), 36" or 48" wide.

<sup>9</sup>Not available on 9" or 24" (2 doors) wide and fluting both not available on 27"-48" wide except with fluting both peninsula.

<sup>10</sup>Not available on 42"-48" wide and TVRAV not available on 9" or 12" wide.

# Wall Peninsula Cabinets

## Description

## Model

### WALL PENINSULA, 36" HIGH

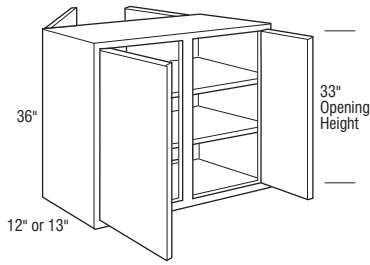
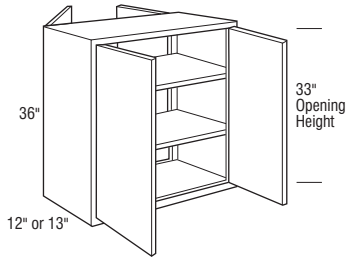
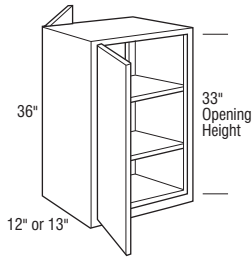

**W936P L or R**

**W1236P L or R**

**W1536P L or R**

**W1836P L or R**

**W2136P L or R**

**W2436P L or R**

**W2436P**

**W2736P**

**W3036P**

**W3336P**

**W3636P**

**W3936P**

**W4236P**

**W4536P**

**W4836P**

#### Notes below apply to all products in section above:

- Two adjustable shelves.
- Specify location of modification for front or peninsula side.
- Inset and Beaded Inset Door Styles are a standard 13" deep.
- Full Overlay Styles:
  - Increased Depths available in 1/4" increments from 12 1/4" to 30".
  - Reduced Depths available in 1/4" increments from 6" to 11 3/4".
- Inset and Beaded Inset Styles:
  - Increased Depths available in 1/4" increments from 13 1/4" to 30".
  - Reduced Depths available in 1/4" increments from 6" to 12 3/4".

#### Door & Drawer Options

AF	AOMD	CC	CG	ESMD <sup>1</sup>	GAMD <sup>1</sup>	HC <sup>1</sup>	IFHG	MC <sup>1</sup>	MD <sup>1</sup>	MFO	PRMD <sup>2</sup>	SHMD	SPLITDR <sup>3</sup>	SPLITDRWS	SUMD <sup>1</sup>	TCC <sup>4</sup>	TCP <sup>4</sup>	
✓	✓	✓	✓	✓	✓	✓	✓	✓	✓	✓	✓	✓	✓	✓	✓	✓	✓	✓

#### End Panel Options

AUTH	CSFPE	EXBK <sup>5</sup>	EXDN <sup>6</sup>	FFD	FPE	INTGE	IPE
✓	✓	✓	✓	✓	✓	✓	✓

#### Custom Modification Options

ADD_SHLF	ADDTK	ADRW	BVR	CBO	CCO	CFNTO	CFRMO	CLIP <sup>2</sup>	CND	CSDGBK	EF	EX	EX_OL	F.ALL	FBFL	FLUT <sup>7</sup>	FTK <sup>8</sup>	ID	IH
✓	✓	✓	✓	✓	✓	✓	✓	✓	✓	✓	✓	✓	✓	✓	✓	✓	✓	✓	✓
INVFRM	IW <sup>9</sup>	LIGHT	MIP	OBRB	PFINBTMB	RD	RECTK	RH	ROSLUT <sup>10</sup>	RT	RW	STW	TD	TKP	TVR <sup>11</sup>	WS	WTR		
✓	✓	✓	✓	✓	✓	✓	✓	✓	✓	✓	✓	✓	✓	✓	✓	✓	✓		

<sup>1</sup>Not available on 9" wide.

<sup>2</sup>Not available on 9" or 24" (2 doors) wide.

<sup>3</sup>Only available on 24" (2 doors) - 39" wide.

<sup>4</sup>Not available on 9" or 12" wide.

<sup>5</sup>Not available on 9", 12" or 39-48" wide and not available with end extended back left.

<sup>6</sup>Not available on EXDNLRB.

<sup>7</sup>Not available on 9" or 24" (2 doors) wide and fluting both not available on 27"-36" wide. Not available with 6" fluting.

<sup>8</sup>FTKAV not available on 9" or 12" wide.

<sup>9</sup>Not available on 24" (1 door), 36" or 48" wide.

<sup>10</sup>Not available on 9" or 24" (2 doors) wide and fluting both not available on 27"-36" wide except with fluting both peninsula.

<sup>11</sup>TVRAV not available on 9" or 12" wide.

IH/RH availability charts starting on page G•40.  
IW/RW availability charts starting on page G•46.

## Description

### ANGLED END WALL CABINET SINGLE DOOR – 22 1/2° ANGLE

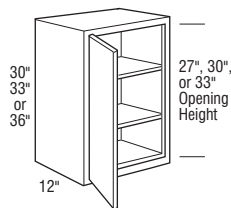

LL Shown

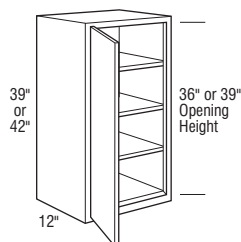

## Model

AEW2430LL

AEW2430RR

AEW2430LR

AEW2430RL

AEW2433LL

AEW2433RR

AEW2433LR

AEW2433RL

AEW2436LL

AEW2436RR

AEW2436LR

AEW2436RL

- Two adjustable shelves.

AEW2439LL

AEW2439RR

AEW2439LR

AEW2439RL

AEW2442LL

AEW2442RR

AEW2442LR

AEW2442RL

- Three adjustable shelves.

Notes below apply to all products in section above:

- First letter denotes side of angle. Second letter denotes hinging of door.
- For use at the end of a run of wall cabinets.
- Front frame size is 5" (for 22 1/2°) less than overall width.
- Angle available on one side only.
- For AEW angled end, must specify end treatment of Finished End or Authentic End.
- Integral Ends, and Flush Panel Ends not available on Angled End.
- Increased Depths available in 3" increments to 15".
- Reduced Depths available in 3" increments to 9".

### AEW-Angled End Wall Cabinets

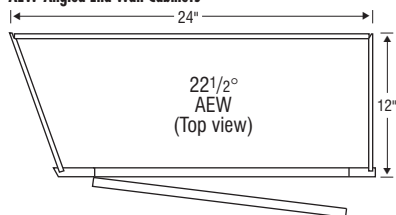

### Door & Drawer Options

AF	AOMD	CC	CG	ESMD	GAMD	HC	IFHG	JMC	MD	MFO	PRMD	SHMD	SPLITDR	SPLITDRWS	SUMD	TCG <sup>1</sup>	TCP <sup>1</sup>
✓	✓	✓	✓	✓	✓	✓	✓	✓	✓	✓	✓	✓			✓	✓	✓

### End Panel Options

AUTH <sup>2</sup>	CSFPE	EXBK	EXDN	FFD	FPE	INTGE	IPE
✓	✓	✓	✓	✓	✓	✓	✓

### Custom Modification Options

ADD_SHLF	ADDTK	ADRW	BVR	CBO	CCO	CFNTO	CFRMO	CLIP	CND	CSDGBK	EF	EX <sup>3</sup>	EX_OL <sup>4</sup>	F.ALL	FBFL	FLUT <sup>5</sup>	FTK	ID	IH
	✓		✓	✓	✓	✓			✓	✓	✓	✓	✓			✓	✓	✓	✓
INVFRM	IW	LIGHT	MIP	OBRB	PFINBTMB	RD	RECTK	RH	ROSLUT <sup>6</sup>	RT	RW	STW	TD	TKP	TVR	WS	WTR		
	✓	✓	✓	✓	✓	✓	✓	✓	✓	✓	✓	✓	✓	✓	✓	✓	✓		

<sup>1</sup>Not available on 30" or 33" high.

<sup>2</sup>Not available with authentic flush ends both.

<sup>3</sup>Extended stile left not available on 36" or 39" wide.

<sup>4</sup>Extended stile left not available on 36" or 39" wide. Not available with extended stile both.

<sup>5</sup>Not available with fluting both or 6" fluting.

<sup>6</sup>Not available with fluting both.

# Angled End Wall Cabinets

## Description

## Model

**ANGLED END WALL CABINET SINGLE DOOR**  
with FACE FRAME and DOOR on END –  
22 1/2° ANGLE

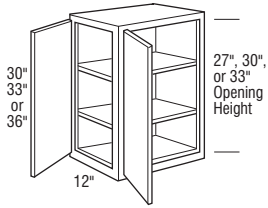

LL Shown

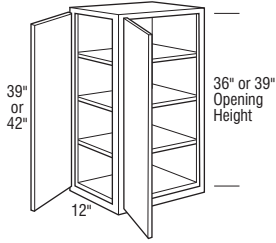

AEWFFD2430LL

AEWFFD2430RR

AEWFFD2430LR

AEWFFD2430RL

AEWFFD2433LL

AEWFFD2433RR

AEWFFD2433LR

AEWFFD2433RL

AEWFFD2436LL

AEWFFD2436RR

AEWFFD2436LR

AEWFFD2436RL

• Two adjustable shelves.

AEWFFD2439LL

AEWFFD2439RR

AEWFFD2439LR

AEWFFD2439RL

AEWFFD2442LL

AEWFFD2442RR

AEWFFD2442LR

AEWFFD2442RL

• Three adjustable shelves.

Notes below apply to all products in section above:

- First letter denotes side of angle. Second letter denotes hinging of door.
- FFD door will be hinged same side as angle unless otherwise specified.
- For use at the end of a run of wall cabinets.
- Front frame size is 5" (for 22 1/2°) less than overall width.
- Angle available on one side only.
- Integral Ends, and Flush Panel Ends not available on Angled End.
- Increased Depths available in 3" increments to 15".
- Reduced Depths available in 3" increments to 9".
- When Inset or Beaded Inset is specified, the FFD door will be hinged on the back side.

### AEW-Angled End Wall Cabinets with Frame

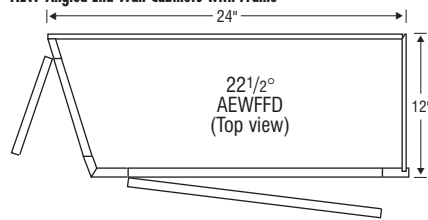

### Door & Drawer Options

AF	AOMD	CC	CG	ESMD	GAJD	HC	IFHG	MC	MD	MFO	PRMD	SHMD	SPLITDR	SPLITDRWS	SUMD	TCG <sup>1</sup>	TCP <sup>1</sup>	
✓		✓	✓	✓	✓	✓	✓	✓	✓	✓	✓	✓	✓	✓	✓	✓	✓	✓

### End Panel Options

AUTH <sup>2</sup>	CSFPE	EXBK	EXDN	FFD	FPE	INTGE	IPE
✓	✓	✓	✓	✓	✓	✓	✓

### Custom Modification Options

ADD_SHLF	ADDTK	ADRW	BVR	CBO	CCO	CFNTO	CFRMO	CLIP	CND	CSDGBK	EF	EX	EX_OL <sup>3</sup>	F.ALL	FBFL	FLUT <sup>4</sup>	FTK	ID	IH
	✓		✓	✓	✓	✓	✓	✓	✓	✓	✓	✓	✓	✓		✓	✓	✓	✓

INVFRM	IW	LIGHT	MIP	OBRB	PFINBTMB	RD	RECTK	RH	ROSLUT <sup>5</sup>	RT	RW	STW	TD	TKP	TVR	WS	WTR
			✓	✓	✓	✓	✓	✓	✓	✓	✓	✓	✓	✓	✓	✓	✓

<sup>1</sup>Not available with 30" or 33" high.

<sup>2</sup>Not available with authentic flush ends both.

<sup>3</sup>Not available with extended stile both.

<sup>4</sup>Not available with fluting both or 6" fluting.

<sup>5</sup>Not available with fluting both.

IH/RH availability charts starting on page G•40.  
IW/RW availability charts starting on page G•46.

## Description

### ANGLED END WALL CABINET DOUBLE DOOR – 22 1/2° ANGLE

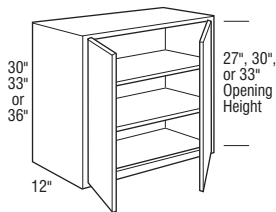

Left Angle Shown

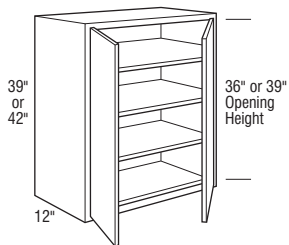

## Model

**AEW3630 L or R**

**AEW3633 L or R**

**AEW3636 L or R**

- Two adjustable shelves.

**AEW3639 L or R**

**AEW3642 L or R**

- Three adjustable shelves.

Notes below apply to all products in section above:

- Must specify L or R to designate a left or right angle.
- For use at the end of a run of wall cabinets.
- Front frame size is 5" (for 22 1/2°) less than overall width.
- Angle available on one side only.
- For AEW angled end, must specify end treatment of Finished End or Authentic End.
- Integral Ends, and Flush Panel Ends not available on Angled End.
- Increased Depths available in 3" increments to 15".
- Reduced Depths available in 3" increments to 9".

### AEW-Angled End Wall Cabinets

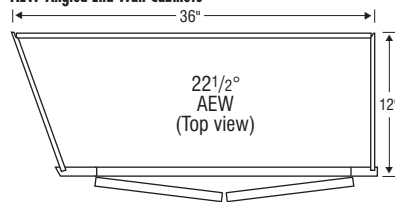

### Door & Drawer Options

AF	AOMD	CC	CG	ESMD	GAMD	HC	IFHG	MC	MD	MFO	PRMD	SHMD	SPLITDR	SPLITDRWS	SUMD	TCG <sup>1</sup>	TCP <sup>1</sup>
✓	✓	✓	✓	✓	✓	✓	✓	✓	✓	✓	✓	✓	✓	✓	✓	✓	✓

### End Panel Options

AUTH <sup>2</sup>	CSFPE	EXBK	EXDN	FFD	FPE	INTGE	IPE
✓	✓	✓	✓	✓	✓	✓	✓

### Custom Modification Options

ADD_SHLF	ADDTK	ADRW	BVR	CBO	CCO	CFNTO	CFRMO	CLIP	CND	CSDGBK	EF	EX	EX_OL <sup>3</sup>	FALL	FBFL	FLUT <sup>4</sup>	FTK	ID	IH
	✓		✓	✓	✓	✓			✓	✓	✓	✓	✓			✓	✓	✓	✓
INVERM	IW	LIGHT	MIP	OBRB	PFINBTMB	RD	RECTK	RH	ROSEFLUT <sup>5</sup>	RT	RW	STW	TD	TKP	TVR	WS	WTR		
			✓	✓	✓	✓	✓	✓	✓					✓	✓	✓	✓		

<sup>1</sup>Not available on 30" or 33" high.

<sup>2</sup>Not available with authentic flush ends both.

<sup>3</sup>Not available with extended stile both.

<sup>4</sup>Not available with fluting both or 6" fluting.

<sup>5</sup>Not available with fluting both.

# Angled End Wall Cabinets

## Description

### ANGLED END WALL CABINET DOUBLE DOOR with FACE FRAME and DOOR on END – 22 1/2° ANGLE

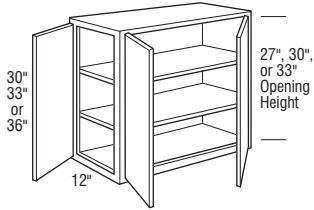

Left Angle Shown

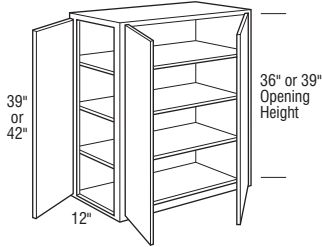

## Model

AEWFFD3630 L or R

AEWFFD3633 L or R

AEWFFD3636 L or R

- Two adjustable shelves.

AEWFFD3639 L or R

AEWFFD3642 L or R

- Three adjustable shelves.

#### Notes below apply to all products in section above:

- Must specify L or R to designate a left or right angle.
- FFD door will be hinged same side as angle unless otherwise specified.
- For use at the end of a run of wall cabinets.
- Front frame size is 5" (for 22 1/2°) less than overall width.
- Angle available on one side only.
- Integral Ends, and Flush Panel Ends not available on Angled End.
- Increased Depths available in 3" increments to 15".
- Reduced Depths available in 3" increments to 9".
- When Inset or Beaded Inset is specified, the FFD door will be hinged on the back side.

#### AEW-Angled End Wall Cabinets with Frame

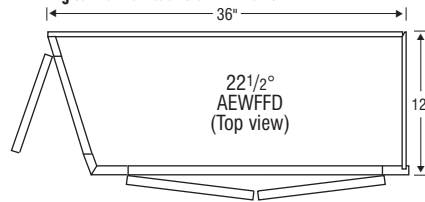

#### Door & Drawer Options

AF	AOMD	CC	CG	ESMD	GAMD	HC	IFHG	MC	MD	MFO	PRMD	SHMD	SPLITDR	SPLITDRWS	SJMD	TCG <sup>1</sup>	TCP <sup>1</sup>	
✓		✓	✓	✓	✓	✓	✓	✓	✓	✓	✓	✓	✓	✓	✓	✓	✓	✓

#### End Panel Options

AUTH <sup>2</sup>	CSFPE	EXBK	EXDN	FFD	FPE	INTGE	IPE
✓	✓				✓	✓	✓

#### Custom Modification Options

ADD	SHLF	ADDTK	ADRW	BVR	CBO	CCO	CFNTD	CFRMO	CLIP	CND	CSDGBK	EF	EX	EX	OL <sup>3</sup>	FALL	FBFL	FLUT <sup>4</sup>	FTK	ID	IH
	✓			✓	✓	✓	✓	✓		✓	✓	✓	✓	✓	✓			✓	✓	✓	✓

INVERM	IW	LIGHT	MIP	OBRB	PFINBTMB	RD	RECTK	RH	ROSLUT <sup>5</sup>	RT	RW	STW	TD	TKP	TVR	WS	WTR
	✓	✓	✓	✓	✓	✓	✓	✓	✓	✓	✓	✓	✓	✓	✓	✓	✓

<sup>1</sup>Not available on 30" or 33" high.

<sup>2</sup>Not available with authentic flush ends both.

<sup>3</sup>Extended stile left not available on 42" high. Not available with extended stile both.

<sup>4</sup>Not available with fluting both or 6" fluting.

<sup>5</sup>Not available with fluting both.

IH/RH availability charts starting on page G•40.  
IW/RW availability charts starting on page G•46.

## Description

### ANGLED END WALL CABINET SINGLE DOOR – 45° ANGLE

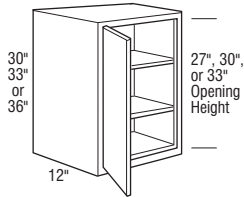

LL Shown

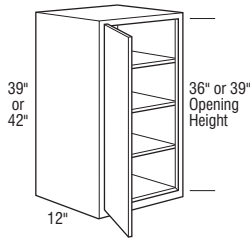

## Model

AEW2430-45LL

AEW2430-45RR

AEW2430-45LR

AEW2430-45RL

AEW2433-45LL

AEW2433-45RR

AEW2433-45LR

AEW2433-45RL

AEW2436-45LL

AEW2436-45RR

AEW2436-45LR

AEW2436-45RL

- Two adjustable shelves.

AEW2439-45LL

AEW2439-45RR

AEW2439-45LR

AEW2439-45RL

AEW2442-45LL

AEW2442-45RR

AEW2442-45LR

AEW2442-45RL

- Three adjustable shelves.

Notes below apply to all products in section above:

- First letter denotes side of angle. Second letter denotes hinging of door.
- For use at the end of a run of wall cabinets.
- Front frame size is 12" (for 45°) less than overall width.
- Angle available on one side only.
- For AEW angled end, must specify end treatment of Finished End or Authentic End.
- Integral Ends, and Flush Panel Ends not available on Angled End.
- Increased Depths available in 3" increments to 15".
- Reduced Depths available in 3" increments to 9".

### AEW-Angled End Wall Cabinets

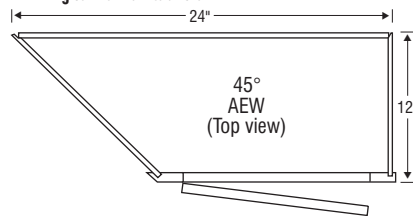

### Door & Drawer Options

AF	AOMD	CC	CG	ESMD	GAMD	HC	IFHG	JMC	MD	MFO	PRMD	SHMD	SPLITDR	SPLITDRWS	SUMD	TCG <sup>1</sup>	TCP <sup>1</sup>	
✓	✓	✓	✓	✓	✓	✓	✓	✓	✓	✓	✓	✓	✓	✓	✓	✓	✓	✓

### End Panel Options

AUTH <sup>2</sup>	CSFPE	EXBK	EXDN	FFD	FPE	INTGE	IPE
✓	✓	✓	✓	✓	✓	✓	✓

### Custom Modification Options

ADD_SHLF	ADDTK	ADRW	BVR	CBO	CCO	CFNTO	CFRMO	CLIP	CND	CSDGBK	EF	EX	EX_OL <sup>3</sup>	FALL	FBFL	FLUT <sup>4</sup>	FTK	ID	IH
✓	✓	✓	✓	✓	✓	✓	✓	✓	✓	✓	✓	✓	✓	✓	✓	✓	✓	✓	✓
INVFRM	IW	LIGHT	MIP	OBRB	PFINBTMB	RD	RECTK	RH	ROSLUT <sup>5</sup>	RT	RW	STW	TD	TKP	TVR	WS	WTR		
✓	✓	✓	✓	✓	✓	✓	✓	✓	✓	✓	✓	✓	✓	✓	✓	✓	✓		

<sup>1</sup>Not available on 30" or 33" high.

<sup>2</sup>Not available with authentic flush ends both.

<sup>3</sup>Not available with extended stiles both.

<sup>4</sup>Not available with fluting both or 6" fluting.

<sup>5</sup>Not available with fluting both.



# Angled End Wall Cabinets

## Description

## Model

**ANGLED END WALL CABINET SINGLE DOOR**  
with FACE FRAME and DOOR on END –  
45° ANGLE

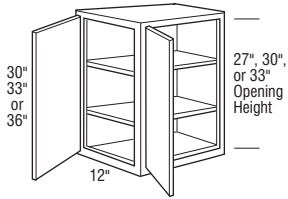

LL Shown

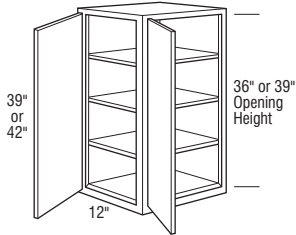

AEWFFD2430-45LL

AEWFFD2430-45RR

AEWFFD2430-45LR

AEWFFD2430-45RL

AEWFFD2433-45LL

AEWFFD2433-45RR

AEWFFD2433-45LR

AEWFFD2433-45RL

AEWFFD2436-45LL

AEWFFD2436-45RR

AEWFFD2436-45LR

AEWFFD2436-45RL

• Two adjustable shelves.

AEWFFD2439-45LL

AEWFFD2439-45RR

AEWFFD2439-45LR

AEWFFD2439-45RL

AEWFFD2442-45LL

AEWFFD2442-45RR

AEWFFD2442-45LR

AEWFFD2442-45RL

• Three adjustable shelves.

Notes below apply to all products in section above:

- First letter denotes side of angle. Second letter denotes hinging of door.
- FFD door will be hinged same side as angle unless otherwise specified.
- For use at the end of a run of wall cabinets.
- Front frame size is 12" (for 45°) less than overall width.
- Angle available on one side only.
- Integral Ends, and Flush Panel Ends not available on Angled End.
- Increased Depths available in 3" increments to 15".
- Reduced Depths available in 3" increments to 9".
- When Inset or Beaded Inset is specified, the FFD door will be hinged on the back side.

### AEW-Angled End Wall Cabinets with Frame

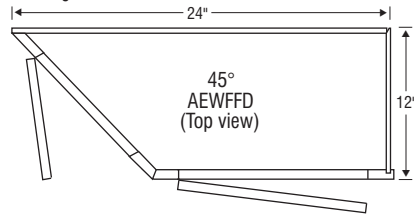

### Door & Drawer Options

AF	AOMD	CC	CG	ESMD	GAJD	HC	IFHG	MC	MD	MFO	PRMD	SHMD	SPLITDR	SPLITDRWS	SUMD	TCG <sup>1</sup>	TCP <sup>1</sup>	
✓			✓	✓	✓	✓	✓	✓	✓	✓	✓	✓				✓	✓	✓

### End Panel Options

AUTH <sup>2</sup>	CSFPE	EXBK	EXDN	FFD	FPE	INTGE	IPE
✓	✓	✓		✓	✓	✓	✓

### Custom Modification Options

ADD_SHLF	ADDTK	ADRW	BVR	CBO	CCO	CFNTO	CFRMO	CLIP	CND	CSDGBK	EF	EX	EX_OL <sup>3</sup>	F.ALL	FBFL	FLUT <sup>4</sup>	FTK	ID	IH
	✓		✓	✓	✓	✓	✓	✓	✓	✓	✓	✓	✓	✓		✓	✓	✓	✓

INVFRM	IW	LIGHT	MIP	OBRB	PFINBTMB	RD	RECTK	RH	ROSLUT <sup>5</sup>	RT	RW	STW	TD	TKP	TVR	WS	WTR
	✓		✓	✓	✓	✓	✓	✓	✓					✓	✓	✓	✓

<sup>1</sup>Not available on 30" or 33" high.

<sup>2</sup>Not available with authentic flush ends both.

<sup>3</sup>Not available with extended stiles both.

<sup>4</sup>Not available with fluting both or 6" fluting.

<sup>5</sup>Not available with fluting both.

IH/RH availability charts starting on page G•40.  
IW/RW availability charts starting on page G•46.

## Description

### ANGLED END WALL CABINET DOUBLE DOOR – 45° ANGLE

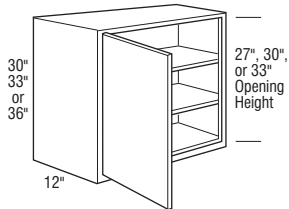

LL Shown

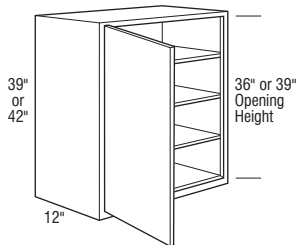

## Model

AEW3630-45LL

AEW3630-45RR

AEW3630-45LR

AEW3630-45RL

AEW3633-45LL

AEW3633-45RR

AEW3633-45LR

AEW3633-45RL

AEW3636-45LL

AEW3636-45RR

AEW3636-45LR

AEW3636-45RL

- Two adjustable shelves.

AEW3639-45LL

AEW3639-45RR

AEW3639-45LR

AEW3639-45RL

AEW3642-45LL

AEW3642-45RR

AEW3642-45LR

AEW3642-45RL

- Three adjustable shelves.

Notes below apply to all products in section above:

- First letter denotes side of angle. Second letter denotes hinging of door.
- For use at the end of a run of wall cabinets.
- Front frame size is 12" (for 45°) less than overall width.
- Angle available on one side only.
- For AEW angled end, must specify end treatment of Finished End or Authentic End.
- Integral Ends, and Flush Panel Ends not available on Angled End.
- Increased Depths available in 3" increments to 15".
- Reduced Depths available in 3" increments to 9".

### AEW-Angled End Wall Cabinets

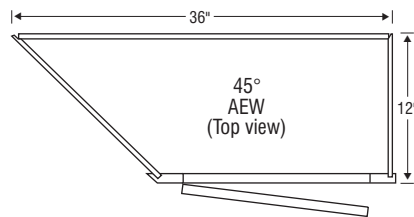

#### Door & Drawer Options

AF	AOMD	CC	CG	ESMD	GAMD	HC	IFHG	JMC	MD	MFO	PRMD <sup>1</sup>	SHMD	SPLITDR	SPLITDRWS	SUMD	TCG <sup>3</sup>	TCP <sup>3</sup>	
✓	✓	✓	✓	✓	✓	✓	✓	✓	✓	✓	✓	✓	✓	✓	✓	✓	✓	✓

#### End Panel Options

AUTH <sup>2</sup>	CSFPE	EXBK	EXDN	FFD	FPE	INTGE	IPE
✓	✓	✓	✓	✓	✓	✓	✓

#### Custom Modification Options

ADD_SHLF	ADDTK	ADRW	BVR	CBO	CCO	CFNTO	CFRMO	CLIP	CND	CSDGBK	EF	EX	EX_OL <sup>4</sup>	FALL	FBFL	FLUT <sup>5</sup>	FTK	ID	IH	
✓	✓	✓	✓	✓	✓	✓	✓	✓	✓	✓	✓	✓	✓	✓	✓	✓	✓	✓	✓	✓

INVFRM	IW	LIGHT	MIP	OBRB	PFINBTMB	RD	RECTK	RH	ROSLUT <sup>6</sup>	RT	RW	STW	TD	TKP	TVR	WS	WTR
✓	✓	✓	✓	✓	✓	✓	✓	✓	✓	✓	✓	✓	✓	✓	✓	✓	✓

<sup>1</sup>Not available on 33" or 39" high.

<sup>2</sup>Not available with authentic flush ends both.

<sup>3</sup>Not available on 30" or 33" high.

<sup>4</sup>Not available with extended stiles both.

<sup>5</sup>Not available with fluting both or 6" fluting.

<sup>6</sup>Not available with fluting both.

# Angled End Wall Cabinets

## Description

**ANGLED END WALL CABINET DOUBLE DOOR with FACE FRAME and DOOR on END – 45° ANGLE**

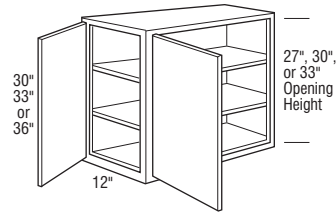

LL Shown

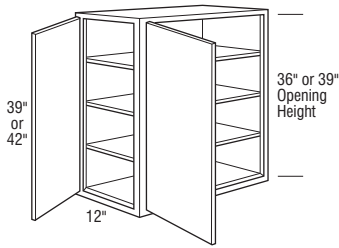

## Model

**AEWFFD3630-45LL**

**AEWFFD3630-45RR**

**AEWFFD3630-45LR**

**AEWFFD3630-45RL**

**AEWFFD3633-45LL**

**AEWFFD3633-45RR**

**AEWFFD3633-45LR**

**AEWFFD3633-45RL**

**AEWFFD3636-45LL**

**AEWFFD3636-45RR**

**AEWFFD3636-45LR**

**AEWFFD3636-45RL**

• Two adjustable shelves.

**AEWFFD3639-45LL**

**AEWFFD3639-45RR**

**AEWFFD3639-45LR**

**AEWFFD3639-45RL**

**AEWFFD3642-45LL**

**AEWFFD3642-45RR**

**AEWFFD3642-45LR**

**AEWFFD3642-45RL**

• Three adjustable shelves.

Notes below apply to all products in section above:

- First letter denotes side of angle. Second letter denotes hinging of door.
- FFD door will be hinged same side as angle unless otherwise specified.
- For use at the end of a run of wall cabinets.
- Front frame size is 12" (for 45°) less than overall width.
- Angle available on one side only.
- Integral Ends, and Flush Panel Ends not available on Angled End.
- Increased Depths available in 3" increments to 15".
- Reduced Depths available in 3" increments to 9".
- When Inset or Beaded Inset is specified, the FFD door will be hinged on the back side.

### AEW-Angled End Wall Cabinets with Frame

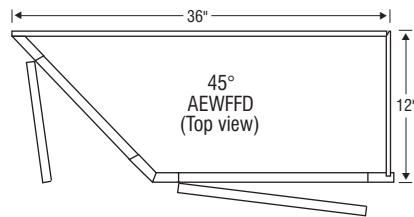

#### Door & Drawer Options

AF	AO	MD	CC	CG	ES	MD	GAM	HC	IF	HG	MC	MD	MFO	PR	MD	SH	MD	SPL	ITDR	SPL	ITDRWS	SU	MD	TCG	TCP
✓			✓	✓	✓	✓	✓	✓	✓	✓	✓	✓	✓	✓	✓	✓	✓					✓	✓	✓	

#### End Panel Options

AUTH	CS	FPE	EX	BK	EX	DN	FF	FPE	INT	GE	IPE
✓	✓							✓	✓	✓	

#### Custom Modification Options

ADD	SH	LFL	ADD	TK	ADR	BVR	CBO	CCO	CF	NTO	CF	RM	CL	IP	CND	CSD	GBK	EF	EX	OL	F	ALL	FB	FL	FLUT	FTK	ID	IH	
			✓			✓	✓	✓	✓	✓	✓	✓	✓	✓	✓	✓	✓	✓	✓	✓	✓	✓	✓	✓	✓	✓	✓	✓	✓

INV	FR	M	LIGHT	MIP	OBR	B	PF	IN	B	T	A	M	B	RD	RECT	RH	ROS	FLUT	RT	RW	STW	TD	TKP	TVR	WS	WTR	
			✓	✓	✓	✓	✓	✓	✓	✓	✓	✓	✓	✓	✓	✓	✓	✓	✓	✓	✓	✓	✓	✓	✓	✓	✓

<sup>1</sup>Not available on 30" or 33" high.

<sup>2</sup>Not available with authentic flush ends both.

<sup>3</sup>Not available on 33" high.

<sup>4</sup>Not available with extended stiles both.

<sup>5</sup>Not available with fluting both or 6" fluting.

<sup>6</sup>Recessed all ends not available on 33" high.

<sup>7</sup>Not available with fluting both.

<sup>8</sup>Only available on 33" high.

IH/RH availability charts starting on page G•40.  
IW/RW availability charts starting on page G•46.

## Description

### WALL END CABINET DOUBLE DOOR, 30", 33", 36", 39", 42", 45", or 48" HIGH

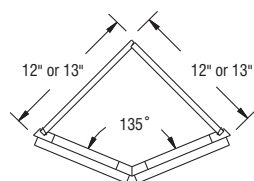
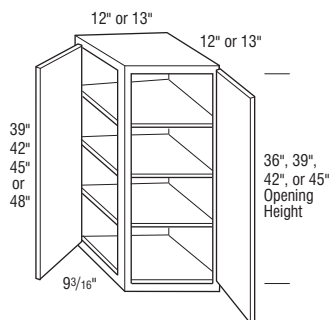
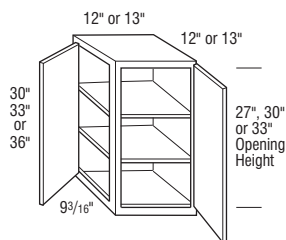

Top View

## Model

### WEC1230D

- Reduced Heights available in 1/4" increments. See page G•40 for details.

### WEC1233D

### WEC1236D

- Two adjustable shelves.

### WEC1239D

### WEC1242D

### WEC1245D

### WEC1248D

- Three adjustable shelves

#### Notes below apply to all products in section above:

- Decorative Glass Door designs limited on this unit. See page H•20 for details.
- One 12" end/back may be ordered as finished.
- Finished End modification available on one side only. See page G•8 for details.
- Increased Depths available in 3" increments from 15" to 24".
- When used in conjunction with Inset or Beaded Inset, the hinge location will be changed on both doors to the center mullion.

#### Door & Drawer Options

AF	AOMD	CC	CG	ESMD	GAMD	HC <sup>1</sup>	IFHG	MC <sup>1</sup>	MD	MFO	PRMD	SHMD	SPLITDR	SPLITDRWS	SUMD	TCG <sup>2</sup>	TCP <sup>2</sup>	
✓						✓	✓	✓		✓		✓					✓	✓

#### End Panel Options

AUTH <sup>3</sup>	CSFPE	EXBK <sup>4</sup>	EXDN <sup>5</sup>	FFD	FPE	INTGE	IPE
✓		✓	✓				

#### Custom Modification Options

ADD	SHLF	ADDTK	ADRW	BVR	CBO	CCO	CFNTO	CFRMO	CLIP	CND	CSDGBK	EF	EX	EX_OL	FALL	FBFL	FLUT	FTK	ID	IH	
					✓	✓	✓	✓	✓	✓	✓	✓							✓	✓	✓

INVFRM	IW	LIGHT	MIP	OBRB	PFINBTMB	RD	RECTK	RH <sup>6</sup>	ROSLUT	RT	RW	STW	TD	TKP	TVR <sup>7</sup>	WS	WTR
			✓	✓	✓			✓							✓	✓	✓

<sup>1</sup>Only available on 36"-42" high.

<sup>2</sup>Not available on 30" or 33" high.

<sup>3</sup>Not available with authentic flush ends both.

<sup>4</sup>Not available on end extended back left.

<sup>5</sup>Not available on EXDNLRB.

<sup>6</sup>Only available on 30" high.

<sup>7</sup>Only available on TVRVV.

# Wall End Cabinets

## Description

### WALL END CABINET SINGLE DOOR, 30", 33", 36", 39", 42", 45", or 48" HIGH

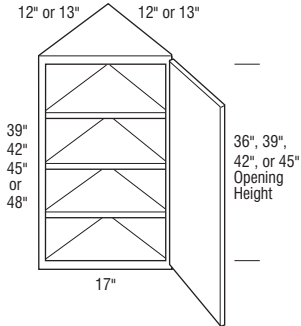
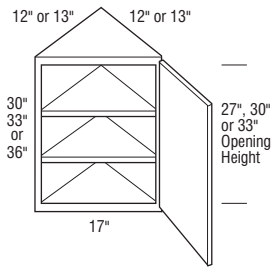

## Model

### WEC1230 L or R

- Reduced Heights available in 1/4" increments. See page G•40 for details.

### WEC1233 L or R

### WEC1236 L or R

- Two adjustable shelves.

### WEC1239 L or R

### WEC1242 L or R

### WEC1245 L or R

### WEC1248 L or R

- Three adjustable shelves

#### Notes below apply to all products in section above:

- One 12" end/back may be ordered as finished.
- Finished End modification available on one side only. See page G•8 for details.
- Increased Depths available in 3" increments from 15" to 24".
- Only available in Inset and Beaded Inset when used in conjunction with a finial hinge.

#### Door & Drawer Options

AF	AOMD	CC	CG	ESMD	GAMD	HC <sup>1</sup>	IFHG	MC <sup>1</sup>	MD	MFO	PRMD	SHMD	SPLITDR	SPLITDRWS	SUMD	TCG <sup>2</sup>	TCP <sup>2</sup>	
✓		✓	✓	✓	✓	✓	✓	✓	✓	✓	✓	✓				✓	✓	✓

#### End Panel Options

AUTH	CSFPE	EXBK <sup>3</sup>	EXDN <sup>4</sup>	FFD	FPE	INTGE	IPE
		✓	✓				

#### Custom Modification Options

ADD_SHLF	ADDTK	ADRW	BVR	CBO	CCO	CFNTO	CFRMO	CLIP	CND	CSDGBK	EF	EX	EX_OL	F.ALL	FBFL	FLUT	FTK	ID	IH	
			✓	✓	✓	✓	✓		✓	✓	✓							✓	✓	✓

INVFRM	IW	LIGHT	MIP	OBRB	PFINBTMB	RD	RECTK	RH <sup>5</sup>	ROSLUT	RT	RW	STW	TD	TKP	TVR	WS	WTR	
			✓	✓	✓			✓								✓	✓	✓

<sup>1</sup>Only available on 36"-42" high.

<sup>2</sup>Not available on 30" or 33" high.

<sup>3</sup>Not available on end extended back left.

<sup>4</sup>Not available on EXDNLRB.

<sup>5</sup>Only available on 30" high.

IH/RH availability charts starting on page G•40.  
IW/RW availability charts starting on page G•46.

## Description

**135° CORNER OUTSIDE WALL, 30", 33", 36", 39", or 42" HIGH**

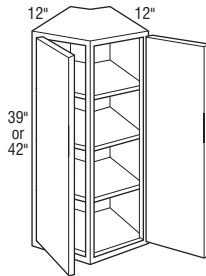
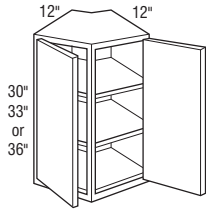

## Model

W630COA

W930COA

W1230COA

W633COA

W933COA

W1233COA

W636COA

W936COA

W1236COA

W639COA

W939COA

W1239COA

W642COA

W942COA

W1242COA

Notes below apply to all products in section above:

- Doors are hinged on outside of frame.
- Adjustable shelf cannot be removed from cabinet.
- No leg changes allowed.
- Reduced depths available in 3" increments to 9".
- Increased depths available in 13" deep, 15" deep, 18" deep, 21" deep, and 24" deep.

Model	A Dimension	B Dimension
W6(*)COA	6"	10 31/32"
W9(*)COA	9"	13 31/32"
W12(*)COA	12"	16 31/32"

A indicates back width of cabinet and wall space

B indicates face frame width

(\*) indicates height of cabinet

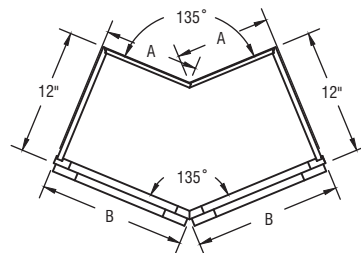

## Top View

### Door & Drawer Options

AF	AOMD	CC	CG	ESMD	GAMD	HC	IFHG	MC	MD	MFO	PRMD	SHMD	SPLITDR	SPLITDRWS	SUMD	TCG	TCP
			✓				✓		✓	✓	✓	✓					

### End Panel Options

AUTH	CSFPE	EXBK	EXDN	FFD	FPE	INTGE	IPE
✓	✓		✓			✓	

### Custom Modification Options

ADD_SHLF	ADDTK	ADRW	BVR	CBO	CCO	CFNTO	CFRMO	CLIP	CND	CSDGBK	EF	EX	EX_OL <sup>1</sup>	FALL	FBFL	FLUT	FTK	ID	IH
				✓	✓	✓				✓	✓	✓	✓						✓

INVERM	IW	LIGHT	MIP	OBRB	PFINBTMB	RD	RECTK	RH	ROSFLUT	RT	RW	STW	TD	TKP	TVR	WS	WTR
		✓	✓			✓	✓									✓	✓

<sup>1</sup>Not available with extended stiles both.

# 135° Corner Wall Cabinets

## Description

**135° CORNER INSIDE WALL, 30", 33", 36", 39", or 42" HIGH**

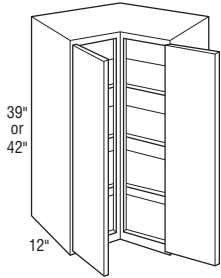
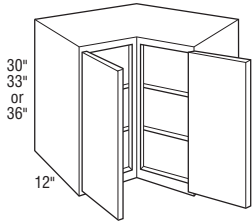

## Model

W2130CIA

W2430CIA

W2730CIA

W2133CIA

W2433CIA

W2733CIA

W2136CIA

W2436CIA

W2736CIA

W2139CIA

W2439CIA

W2739CIA

W2142CIA

W2442CIA

W2742CIA

Notes below apply to all products in section above:

- Doors are hinged on outside of frame.
- Adjustable shelf cannot be removed from cabinet.
- No leg changes allowed.
- Reduced depths available in 3" increments to 9".
- Increased depths available in 13" deep, 15" deep, 18" deep, 21" deep, and 24" deep.

Model	A Dimension	B Dimension
W21(*)CIA	21"	16 1/16"
W24(*)CIA	24"	19 1/16"
W27(*)CIA	27"	22 1/16"

A indicates back width of cabinet and wall space

B indicates face frame width

(\*) indicates height of cabinet

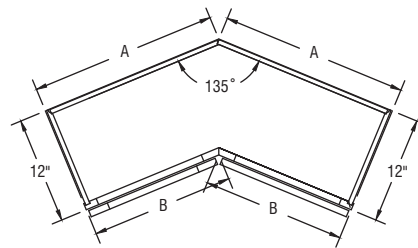

Top View

### Door & Drawer Options

AF	AOMD	CC	CG	ESMD	GAMD	HC	IFHG	MC	MD	MFO	PRMD	SHMD	SPLITDR	SPLITDRWS	SUMD	TCG	TCP
			✓					✓	✓	✓	✓	✓					

### End Panel Options

AUTH	CSFPE	EXBK	EXDN	FFD	FPE	INTGE	IPE
✓	✓					✓	

### Custom Modification Options

ADD_SHLF	ADDTK	ADRW	BVR	CBO	CCO	CFNTO	CFRMO	CLIP	CND	CSDGBK	EF	EX	EX_OL <sup>1</sup>	F.ALL	FBFL	FLUT <sup>2</sup>	FTK	ID	IH
					✓	✓	✓			✓	✓	✓	✓			✓			✓

INVFRM	IW	LIGHT	MIP	OBRB	PFINBTMB	RD	RECTK	RH	ROSLUT	RT	RW	STW	TD	TKP	TVR	WS	WTR
		✓	✓		✓	✓			✓							✓	✓

<sup>1</sup>Not available with extended stiles both.

<sup>2</sup>Not available with 6" fluting.

IH/RH availability charts starting on page G•40.  
IW/RW availability charts starting on page G•46.

## Description

### WALL MESSAGE CENTER, 12" WIDE, 30", 33", or 36" HIGH, 3" DEEP storage SOLUTIONS

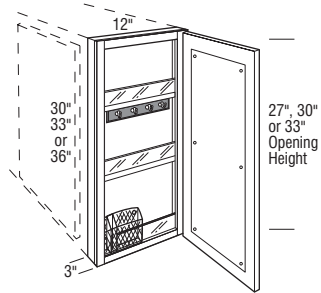

## Model

**WMC1230 L or R**

**WMC1233 L or R**

**WMC1236 L or R**

- Finished Flush Panel Ends standard.
- Two fixed shelves.
- Includes magnetic whiteboard on back of door, key hooks, pencil holder, and fixed plexi-glass fronted shelves.
- Door will open 90° without decorative hardware.
- Cabinet recommended to be hinged on wall side.
- For proper installation, adjacent cabinet must have flush ends or 3/32" skin applied.
- Embellishments or overlay fillers can be used on side of cabinet to add a decorative touch.
- Some modifications will require a Special Increased Depth option to be selected.
- Increased Depths available in 1/4" increments from 3 1/4" to 30".
- Not available on Inset and Beaded Inset styles.

#### Door & Drawer Options

AF	AOMD	CC	CG	ESMD	GAMD	HC	IFHG	MC	MD	MFO	PRMD	SHMD	SPLITDR	SPLITDRWS	SUMD	TCG	TCP	
							✓			✓								

#### End Panel Options

AUTH <sup>1</sup>	CSFPE	EXBK	EXDN	FFD	FPE	INTGE	IPE
✓	✓	✓	✓				

#### Custom Modification Options

ADD_SHLF	ADDTK	ADRW	BVR	CBO	CCO	CFNTO	CFRMO	CLIP	CND	CSDGBK	EF	EX	EX_OL	F.ALL	FBFL	FLUT <sup>2</sup>	FTK <sup>3</sup>	ID	IH
			✓	✓	✓	✓	✓		✓	✓	✓	✓	✓			✓	✓	✓	

INVERM	IW	LIGHT	MIP	OBRB	PFINBTMB	RD	RECTK	RH	ROSLUT	RT	RW	STW	TD	TKP	TVR	WS	WTR
			✓	✓	✓				✓							✓	✓

<sup>1</sup>Not available with authentic flush ends both.

<sup>2</sup>Not available with 6" fluting.

<sup>3</sup>Not available with FTKAV.

### WALL MESSAGE CENTER, 12" WIDE, 39" or 42" HIGH, 3" DEEP storage SOLUTIONS

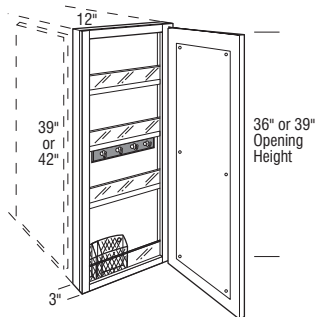

**WMC1239 L or R**

**WMC1242 L or R**

- Finished Flush Ends standard.
- Three fixed shelves.
- Includes magnetic whiteboard on back of door, key hooks, pencil holder, and fixed plexi-glass fronted shelves.
- Door will open 90° without decorative hardware.
- Cabinet recommended to be hinged on wall side.
- For proper installation, adjacent cabinet must have flush ends or 3/32" skin applied.
- Embellishments or overlay fillers can be used on side of cabinet to add a decorative touch.
- Some modifications will require a Special Increased Depth option to be selected.
- Increased Depths available in 1/4" increments from 3 1/4" to 30".
- Not available on Inset and Beaded Inset styles.

#### Door & Drawer Options

AF	AOMD	CC	CG	ESMD	GAMD	HC	IFHG	MC	MD	MFO	PRMD	SHMD	SPLITDR	SPLITDRWS	SUMD	TCG	TCP		
							✓			✓									

#### End Panel Options

AUTH <sup>1</sup>	CSFPE	EXBK	EXDN	FFD	FPE	INTGE	IPE
✓	✓	✓	✓				

#### Custom Modification Options

ADD_SHLF	ADDTK	ADRW	BVR	CBO	CCO	CFNTO	CFRMO	CLIP	CND	CSDGBK	EF	EX	EX_OL	F.ALL	FBFL	FLUT <sup>2</sup>	FTK <sup>3</sup>	ID	IH
			✓	✓	✓	✓	✓		✓	✓	✓	✓	✓			✓	✓	✓	

INVERM	IW	LIGHT	MIP	OBRB	PFINBTMB	RD	RECTK	RH	ROSLUT <sup>4</sup>	RT	RW	STW	TD	TKP	TVR	WS	WTR
			✓	✓	✓				✓							✓	✓

<sup>1</sup>Not available with authentic flush ends both.

<sup>2</sup>Not available on 42" high or with 6" fluting.

<sup>3</sup>Not available with FTKAV.

<sup>4</sup>Not available on 42" high.



# Wall Organizer & Floating Shelves

## Description

**WALL ORGANIZER, 30", 33", or 36" WIDE, 9" HIGH**

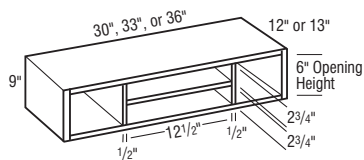

## Model

**WORG30**

**WORG33**

**WORG36**

- Matching Interior standard.
- Inset and Beaded Inset Door Styles are a standard 13" deep.
- Increased Depths available in 3" increments from 15" to 24".
- Reduced Depths available in 3" increments from 6" to 9".

### Door & Drawer Options

AF	AOMD	CC	CG	ESMD	GAMD	HC	IFHG	MC	MD	MFO	PRMD	SHMD	SPLITDR	SPLITDRWS	SUMD	TCG	TCP
----	------	----	----	------	------	----	------	----	----	-----	------	------	---------	-----------	------	-----	-----

### End Panel Options

AUTH	CSFPE	EXBK	EXDN	FFD	FPE	INTGE	IPE
	✓	✓	✓	✓			

### Custom Modification Options

ADD_SHLF	ADDTK	ADRW	BVR	CBO	CCO	CFNTO	CFRMO	CLIP	CND	CSDGBK	EF	EX	EX_OL <sup>1</sup>	FALL	FBFL	FLUT <sup>2</sup>	FTK	ID	IH
			✓	✓		✓				✓		✓	✓			✓		✓	✓

INVERM	IW	LIGHT	MIP	OBRB	PFINBTMB	RD	RECTK	RH	ROSFLUT	RT	RW	STW	TD	TKP	TVR	WS	WTR
						✓			✓							✓	✓

<sup>1</sup>Not available with extended stiles both.

<sup>2</sup>Not available with 6" fluting.

## FLOATING SHELF, 2 1/2" HIGH, 10" DEEP

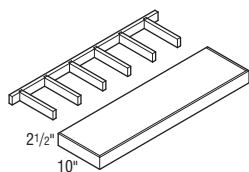

**FS24**

**FS30**

**FS36**

**FS42**

**FS48**

**FS54**

**FS60**

- Installation instructions included.
- Weight capacity is 15 lbs. per linear foot of width.
- Edge will be a #12 profile.

### Door & Drawer Options

AF	AOMD	CC	CG	ESMD	GAMD	HC	IFHG	MC	MD	MFO	PRMD	SHMD	SPLITDR	SPLITDRWS	SUMD	TCG	TCP
----	------	----	----	------	------	----	------	----	----	-----	------	------	---------	-----------	------	-----	-----

### End Panel Options

AUTH	CSFPE	EXBK	EXDN	FFD	FPE	INTGE	IPE

### Custom Modification Options

ADD_SHLF	ADDTK	ADRW	BVR	CBO	CCO	CFNTO	CFRMO	CLIP	CND	CSDGBK	EF	EX	EX_OL	FALL	FBFL	FLUT	FTK	ID	IH
														✓				✓	✓

INVERM	IW <sup>1</sup>	LIGHT	MIP	OBRB	PFINBTMB	RD	RECTK	RH	ROSFLUT	RT	RW	STW	TD	TKP	TVR	WS	WTR
	✓					✓										✓	✓

<sup>1</sup>Not available on 60" wide.

IH/RH availability charts starting on page G•40.  
IW/RW availability charts starting on page G•46.

# Wall Organizer and Bookshelf & Wall Cabinet with Wine Rack

## Description

### WALL ORGANIZER and BOOKSHELF, 36" HIGH storage SOLUTIONS

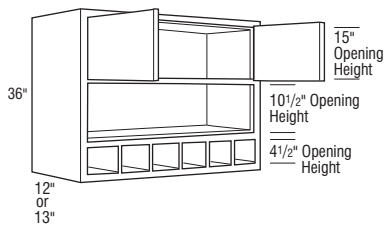

## Model

**WOBS2436** (4 openings)

**WOBS3036** (5 openings)

**WOBS3636** (6 openings)

- Matching Interior standard.
- Change of configuration in organizer section not available.
- Inset and Beaded Inset Door Styles are a standard 13" deep.
- Full Overlay Styles:
  - Increased Depths available in 1/4" increments from 12 1/4" to 30".
  - Reduced Depths available in 1/4" increments from 6" to 11 3/4".
- Inset and Beaded Inset Styles:
  - Increased Depths available in 1/4" increments from 13 1/4" to 30".
  - Reduced Depths available in 1/4" increments from 6" to 12 3/4".
- Increased Heights modification will increase the height of the upper cabinet section. The bottom section will retain its original height.

#### Door & Drawer Options

AF	AOMD	CC	CG	ESMD	GAMD	HC	IFHG	JMC	MD	MFO	PRMD <sup>1</sup>	SHMD	SPLITDR	SPLITDRWS	SUMD	TCG	TCP
✓			✓	✓	✓		✓		✓	✓	✓		✓				

#### End Panel Options

AUTH	CSFPE	EXBK	EXDN	FFD	FPE	INTGE	IPE
✓	✓	✓	✓	✓	✓		

#### Custom Modification Options

ADD_SHLF	ADDTK	ADRW	BVR	CBO	CCO	CFNTO	CFRMO	CLIP	CND	CSDGBK	EF	EX	EX_OL	F.ALL	FBFL	FLUT <sup>2</sup>	FTK	ID	IH
✓			✓	✓	✓	✓			✓	✓	✓	✓	✓	✓		✓	✓	✓	✓
INVFRM	IW	LIGHT	MIP	OBRB	PFINBTMB	RD	RECTK	RH	ROSLUT	RT	RW <sup>1</sup>	STW	TD	TKP	TVR	WS	WTR		
	✓			✓	✓	✓			✓	✓	✓	✓	✓	✓	✓	✓	✓		

<sup>1</sup>Not available on 24" wide.

<sup>2</sup>Not available with 6" fluting.

<sup>3</sup>Not available on 24" or 36" wide.

### WALL CABINET with WINE RACK, 30" HIGH storage SOLUTIONS

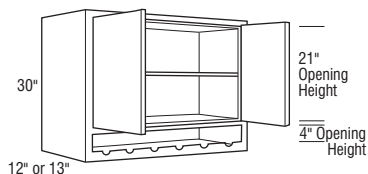

**WWR2430** (4 openings)

**WWR3030** (5 openings)

**WWR3630** (6 openings)

- Matching Interior and Flush Bottom standard.
- One adjustable and one fixed shelf.
- Reveal under these models is less than the standard wall cabinet reveal. This may interfere with installation of cabinets/accessories to the bottom of the cabinet.
- Inset and Beaded Inset Door Styles are a standard 13" deep.
- Full Overlay Styles:
  - Increased Depths available in 1/4" increments from 12 1/4" to 30".
  - Reduced Depths available in 1/4" increments from 6" to 11 3/4".
- Inset and Beaded Inset Styles:
  - Increased Depths available in 1/4" increments from 13 1/4" to 30".
  - Reduced Depths available in 1/4" increments from 6" to 12 3/4".
- Increased Heights modification will increase the height of the upper cabinet section. The bottom section will retain its original height.

#### Door & Drawer Options

AF	AOMD	CC	CG	ESMD	GAMD	HC	IFHG	JMC	MD	MFO	PRMD <sup>1</sup>	SHMD	SPLITDR	SPLITDRWS	SUMD	TCG	TCP
✓			✓	✓	✓		✓		✓	✓	✓		✓				

#### End Panel Options

AUTH	CSFPE	EXBK	EXDN	FFD	FPE	INTGE	IPE
✓	✓	✓	✓	✓	✓		

#### Custom Modification Options

ADD_SHLF	ADDTK	ADRW	BVR	CBO	CCO	CFNTO	CFRMO	CLIP	CND	CSDGBK	EF	EX	EX_OL	F.ALL	FBFL	FLUT <sup>2</sup>	FTK	ID	IH
✓			✓	✓	✓	✓			✓	✓	✓	✓	✓	✓		✓	✓	✓	✓
INVFRM	IW	LIGHT	MIP	OBRB	PFINBTMB	RD	RECTK	RH	ROSLUT <sup>3</sup>	RT	RW	STW	TD	TKP	TVR	WS	WTR		
	✓			✓	✓	✓			✓	✓	✓	✓	✓	✓	✓	✓	✓		

<sup>1</sup>Not available on 24" wide.

<sup>2</sup>Not available with fluting both or 6" fluting.

<sup>3</sup>Not available with fluting both.

# Wall Wine Racks

## Description

**WALL WINE RACK, 15", 18", 30", or 36" HIGH**

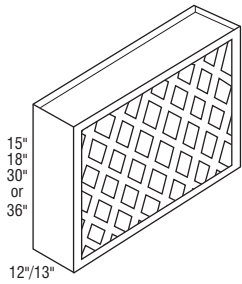

## Model

WNR3015

WNR3315

WNR3615

WNR3018

WNR3318

WNR3618



WNR1530

WNR1830



WNR2130

WNR2430

WNR3630

WNR1836

WNR2436

- Matching Interior standard.
- Size of openings is 4"W x 4"H; number of openings varies with size of unit.
- Inset and Beaded Inset Door Styles are a standard 13" deep.
- If ordered with Hewn Technique, will not feature sand-through characteristics.

Model	Sections
WNR3015	10
WNR3315	14
WNR3615	14
WNR3018	10
WNR3318	14
WNR3618	14
WNR1530	10
WNR1830	10
WNR2130	18
WNR2430	18
WNR3630	32
WNR1836	14
WNR2436	22

### Door & Drawer Options

AF	AOMD	CC	CG	ESMD	GAMD	HC	IFHG	MC	MD	MFO	PRMD	SHMD	SPLITDR	SPLITDRWS	SUMD	TCG	TCP

### End Panel Options

AUTH	CSFPE	EXBK	EXDN	FFD	FPE	INTGE	IPE
✓	✓	✓	✓	✓	✓		

### Custom Modification Options

ADD	SHLF	ADTK	ADRW	BVR	CBO	CCO	CFNTO	CFRMO	CLIP	CND	CSDGBK	EF	EX	EX_OL	FALL	FBFL	FLUT <sup>1</sup>	FTK	ID	IH
			✓	✓								✓	✓	✓			✓	✓		

INVERM	IW	LIGHT	MIP	OBRB	PFINBTMB	RD	RECTK	RH	ROSEFLUT	RT	RW	STW	TD	TKP	TVR	WS	WTR
			✓			✓			✓							✓	✓

<sup>1</sup>Not available with 6" fluting.

IH/RH availability charts starting on page G•40.  
IW/RW availability charts starting on page G•46.

## Description

**WALL WINE STORAGE CABINET, 12", 15", 18", 21", or 24" HIGH**

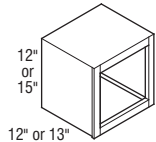

12" or 15"  
(Left Shown)

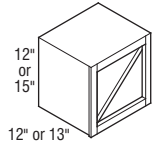

12" or 15"  
(Right Shown)

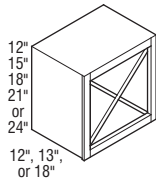

12", 15", 18", 21", or 24"  
12", 13", or 18"

## Model

**WSC121212 L or R**

**WSC151512 L or R**

- Specify L or R angle.



**WSC121212**



**WSC151512**

**WSC181812**

**WSC212112**

**WSC242412**



**WSC181818**

Notes below apply to all products in section above:

- Matching Interior standard.
- Wine bottle quantities based on a wine bottle diameter of 3 1/2".
- Inset and Beaded Inset Door Styles are a standard 13" deep.
- "X" shelf configuration cannot be removed.
- If ordered with Heirloom Technique, will not feature sand-through characteristics.
- Full Overlay Styles:
  - Increased Depths available in 1/4" increments from 12 1/4" to 18".
- Inset and Beaded Inset Styles:
  - Increased Depths available in 1/4" increments from 13 1/4" to 18".
  - Reduced Depths available in 1/4" increments from 12" to 12 3/4".

Model	# Openings	# Wine Bottles
WSC121212 L or R	2	4
WSC151512 L or R	2	9
WSC121212	4	4
WSC151512	4	6
WSC181812	4	12
WSC212112	4	16
WSC242412	4	24
WSC181818	4	12

### Door & Drawer Options

AF	AOMD	CC	CG	ESMD	GAMD	HC	IFHG	MC	MD	MFO	PRMD	SHMD	SPLITDR	SPLITDRWS	SUMD	TCG	TCP
----	------	----	----	------	------	----	------	----	----	-----	------	------	---------	-----------	------	-----	-----

### End Panel Options

AUTH	CSFPE	EXBK	EXDN	FFD	FPE	INTGE	IPE
✓	✓	✓	✓	✓	✓	✓	✓

### Custom Modification Options

ADD	SHLF	ADDTK	ADRW	BVR	CBO	CCO	CFNTO	CFRMO	CLIP	CND	CSDGBK	EF	EX	EX_OL	F.ALL	FBFL	FLUT <sup>1</sup>	FTK	ID <sup>2</sup>	IH
				✓							✓	✓	✓	✓			✓	✓	✓	✓
INVFRM	IW	LIGHT	MIP	OBRB	PFINBTMB	RD	RECTK	RH	ROSLUT <sup>3</sup>	RT	RW	STW	TD	TKP	TVR	WS	WTR			
				✓	✓				✓							✓	✓			

<sup>1</sup>Not available with fluting both or 6" fluting.

<sup>2</sup>Not available on 18" deep.

<sup>3</sup>Not available with fluting both.

# Wall China Displays

## Description

### WALL CHINA DISPLAY, 15" HIGH

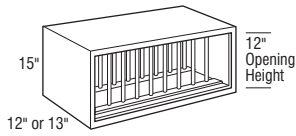

Model	# of Plates
WCD2415	8
WCD3015	10
WCD3615	12

## Model

WCD2415

WCD3015

WCD3615

- Matching Interior standard.
- Not available built as one unit with other wall cabinets.
- Inset and Beaded Inset Door Styles are a standard 13" deep.
- Full Overlay Styles:
  - Increased Depths available in 1/4" increments from 12 1/4" to 30".
  - Reduced Depths available in 1/4" increments from 6" to 11 3/4".
- Inset and Beaded Inset Styles:
  - Increased Depths available in 1/4" increments from 13 1/4" to 30".
  - Reduced Depths available in 1/4" increments from 6" to 12 3/4".

#### Door & Drawer Options

AF	AOMD	CC	CG	ESMD	GAMD	HC	IFHG	MC	MD	MFO	PRMD	SHMD	SPLITDR	SPLITDRWS	SUMD	TCG	TCP
							✓										

#### End Panel Options

AUTH	CSFPE	EXBK	EXDN	FFD	FPE	INTGE	IPE
✓	✓	✓	✓	✓	✓		

#### Custom Modification Options

ADD_SHLF	ADDTK	ADRW	BVR	CBO	CCO	CFNTO	CFRMO	CLIP	CND	CSDGBK	EF	EX	EX_OL	FALL	FBFL	FLUT <sup>1</sup>	FTK	ID	IH
		✓	✓							✓	✓	✓	✓			✓	✓	✓	

INVERM	IW	LIGHT	MIP	OBRB	PFINBTMB	RD	RECTK	RH	ROSLUT	RT	RW <sup>2</sup>	STW	TD	TKP	TVR	WS	WTR
				✓	✓	✓			✓		✓					✓	✓

<sup>1</sup>Not available with 6" fluting.

<sup>2</sup>Not available on 24" wide.

IH/RH availability charts starting on page G•40.  
IW/RW availability charts starting on page G•46.

## Description

### WINE CUBE HORIZONTAL, 6" HIGH

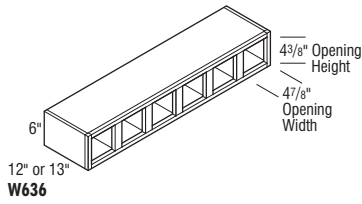

## Model

**W618** (3 openings)

**W624** (4 openings)

**W630** (5 openings)

**W636** (6 openings)

**W642** (7 openings)

- Available as separate unit only.
- Inset Door Styles are standard 13" deep. Beaded Inset not available.
- Increased Depths available in 1/4" increments from 12 1/4" to 24".
- Matching Interior, Finished Ends, and Flush Panel Ends are standard.

#### Door & Drawer Options

AF	AOMD	CC	CG	ESMD	GAMD	HC	IFHG	MC	MD	MFO	PRMD	SHMD	SPLITDR	SPLITDRWS	SUMD	TCG	TCP
----	------	----	----	------	------	----	------	----	----	-----	------	------	---------	-----------	------	-----	-----

#### End Panel Options

AUTH	CSFPE	EXBK	EXDN	FFD	FPE	INTGE	IPE
------	-------	------	------	-----	-----	-------	-----

#### Custom Modification Options

ADD_SHLF	ADDTK	ADRW	BVR	CBO	CCO	CFNTO	CFRMO	CLIP	CND	CSDGBK	EF	EX	EX_OL	F.ALL	FBFL	FLUT	FTK	ID	IH
----------	-------	------	-----	-----	-----	-------	-------	------	-----	--------	----	----	-------	-------	------	------	-----	----	----

INVERM	IW	LIGHT	MIP	OBRB	PFINBTMB	RD	RECTK	RH	ROSLUT	RT	RW	STW	TD	TKP	TVR	WS	WTR
--------	----	-------	-----	------	----------	----	-------	----	--------	----	----	-----	----	-----	-----	----	-----

### WINE CUBE VERTICAL, 6" WIDE

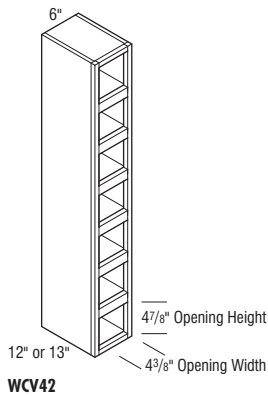

**WCV18** (3 openings)

- Reduced Heights available in 6" increments to 12".

**WCV24** (4 openings)

**WCV30** (5 openings)

**WCV36** (6 openings)

**WCV42** (7 openings)

#### Notes below apply to all products in section above:

- Available as separate unit only.
- Inset Door Styles are standard 13" deep. Beaded Inset not available.
- Matching Interior standard.
- Finished or Flush Panel Ends must be specified if required.

#### Door & Drawer Options

AF	AOMD	CC	CG	ESMD	GAMD	HC	IFHG	MC	MD	MFO	PRMD	SHMD	SPLITDR	SPLITDRWS	SUMD	TCG	TCP
----	------	----	----	------	------	----	------	----	----	-----	------	------	---------	-----------	------	-----	-----

#### End Panel Options

AUTH	CSFPE	EXBK	EXDN	FFD	FPE	INTGE	IPE
------	-------	------	------	-----	-----	-------	-----

#### Custom Modification Options

ADD_SHLF	ADDTK	ADRW	BVR	CBO	CCO	CFNTO	CFRMO	CLIP	CND	CSDGBK	EF	EX	EX_OL	F.ALL	FBFL	FLUT	FTK	ID	IH
----------	-------	------	-----	-----	-----	-------	-------	------	-----	--------	----	----	-------	-------	------	------	-----	----	----

INVERM	IW	LIGHT	MIP	OBRB	PFINBTMB	RD	RECTK	RH	ROSLUT	RT	RW	STW	TD	TKP	TVR	WS	WTR
--------	----	-------	-----	------	----------	----	-------	----	--------	----	----	-----	----	-----	-----	----	-----

# Wall Spice Drawers

## Description

### WALL SPICE DRAWER HORIZONTAL, 6" HIGH

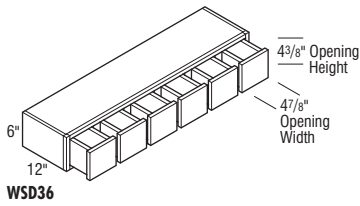

WSD36

## Model

WSD18 (3 drawers)

WSD24 (4 drawers)

WSD30 (5 drawers)

WSD36 (6 drawers)

WSD42 (7 drawers)

- Matching Interior, Finished Ends, and Flush Panel Ends are standard.
- Not available on Inset and Beaded Inset styles.

#### Door & Drawer Options

AF	AOMD	CC	CG	ESMD	GAMD	HC	IFHG	MC	MD	MFO	PRMD	SHMD	SPLITDR	SPLITDRWS	SUMD	TCG	TCP
----	------	----	----	------	------	----	------	----	----	-----	------	------	---------	-----------	------	-----	-----

#### End Panel Options

AUTH	CSFPE	EXBK <sup>1</sup>	EXDN	FFD	FPE	INTGE	IPE
------	-------	-------------------	------	-----	-----	-------	-----

#### Custom Modification Options

ADD	SHLF	ADTK	ADRW	BVR	CBO	CCO	CFNTD	CFRMO	CLIP	CND	CSDGBK	EF	EX	EX_OL	FALL	FBFL	FLUT	FTK	ID	IH
-----	------	------	------	-----	-----	-----	-------	-------	------	-----	--------	----	----	-------	------	------	------	-----	----	----

INVERM	IW	LIGHT	MIP	OBRB	PFINBTMB	RD	RECTK	RH	ROSFLUT	RT	RW <sup>2</sup>	STW	TD	TKP	TVR	WS	WTR
--------	----	-------	-----	------	----------	----	-------	----	---------	----	-----------------	-----	----	-----	-----	----	-----

<sup>1</sup>Not available on end extended back left.

<sup>2</sup>Only available on 18" wide.

### WALL SPICE DRAWER VERTICAL, 6" WIDE

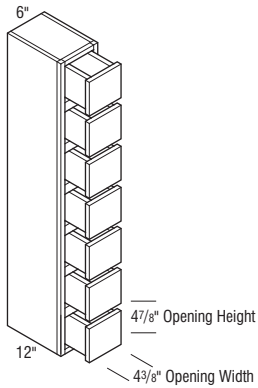

WSDV42

WSDV18 (3 drawers)

- Reduced Heights available in 6" increments to 12".

WSDV24 (4 drawers)

WSDV30 (5 drawers)

WSDV36 (6 drawers)

WSDV42 (7 drawers)

#### Notes below apply to all products in section above:

- Not available on Inset and Beaded Inset styles.
- Matching Interior standard.
- Finished or Flush Panel Ends must be specified if required.

#### Door & Drawer Options

AF	AOMD	CC	CG	ESMD	GAMD	HC	IFHG	MC	MD	MFO	PRMD	SHMD	SPLITDR	SPLITDRWS	SUMD	TCG	TCP
----	------	----	----	------	------	----	------	----	----	-----	------	------	---------	-----------	------	-----	-----

#### End Panel Options

AUTH	CSFPE	EXBK <sup>1</sup>	EXDN	FFD	FPE	INTGE	IPE
------	-------	-------------------	------	-----	-----	-------	-----

#### Custom Modification Options

ADD	SHLF	ADTK	ADRW	BVR	CBO	CCO	CFNTD	CFRMO	CLIP	CND	CSDGBK	EF	EX	EX_OL	FALL	FBFL	FLUT	FTK	ID	IH
-----	------	------	------	-----	-----	-----	-------	-------	------	-----	--------	----	----	-------	------	------	------	-----	----	----

INVERM	IW	LIGHT	MIP	OBRB	PFINBTMB	RD	RECTK	RH	ROSFLUT	RT	RW	STW	TD	TKP	TVR	WS	WTR
--------	----	-------	-----	------	----------	----	-------	----	---------	----	----	-----	----	-----	-----	----	-----

<sup>1</sup>Not available on end extended back left.

IH/RH availability charts starting on page G•40.  
IW/RW availability charts starting on page G•46.

## Description

### WALL QUARTER ROUND END SHELF, 30", 33", 36", 39", 42", 45", or 48" HIGH

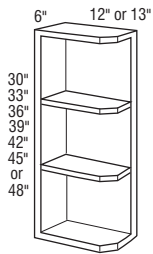

**WQRES630RT**  
(Left angle shown)

## Model

### WQRES630RT

- Four fixed shelves including top/bottom.
- Reduced Heights available in 1/4" increments from 18" to 29 3/4".
- Increased Heights available in 1/4" increments from 30 1/4" to 32 3/4".

### WQRES633RT

- Four fixed shelves including top/bottom.
- Increased Heights available in 1/4" increments from 33 1/4" to 35 3/4".

### WQRES636RT

- Four fixed shelves including top/bottom.
- Increased Heights available in 1/4" increments from 36 1/4" to 38 3/4".

### WQRES639RT

- Four fixed shelves including top/bottom.
- Increased Heights available in 1/4" increments from 39 1/4" to 44 3/4".

### WQRES642RT

- Five fixed shelves including top/bottom.
- Increased Heights available in 1/4" increments from 42 1/4" to 47 3/4".

### WQRES645RT

- Five fixed shelves including top/bottom.
- Increased Heights available in 1/4" increments from 45 1/4" to 47 3/4".

### WQRES648RT

- Five fixed shelves including top/bottom.

#### Notes below apply to all products in section above:

- 3/4" thick back and side.
- Inset and Beaded Inset Door Styles are a standard 13" deep.
- Increased Depths available in 1/4" increments to 18".
- Reduced Depths available in 1/4" increments to 9".

#### Door & Drawer Options

AF	AOMD	CC	CG	ESMD	GAMD	HC	IFHG	MC	MD	MFO	PRMD	SHMD	SPLITDR	SPLITDRWS	SUMD	TCG	TCP
----	------	----	----	------	------	----	------	----	----	-----	------	------	---------	-----------	------	-----	-----

#### End Panel Options

AUTH	CSFPE	EXBK	EXDN	FFD	FPE	INTGE	IPE
------	-------	------	------	-----	-----	-------	-----

#### Custom Modification Options

ADD_SHLF	ADDTK	ADRW	BVR	CBO	CCO	CFNTO	CFRMO	CLIP	CND	CSDGBK	EF	EX	EX_OL	FALL	FBFL	FLUT	FTK	ID	IH <sup>1</sup>
----------	-------	------	-----	-----	-----	-------	-------	------	-----	--------	----	----	-------	------	------	------	-----	----	-----------------

INVFRM	IW	LIGHT	MIP	OBRB	PFINBTMB	RD	RECTK	RH <sup>2</sup>	ROSLUT	RT	RW	STW	TD	TKP	TVR	WS	WTR
--------	----	-------	-----	------	----------	----	-------	-----------------	--------	----	----	-----	----	-----	-----	----	-----

<sup>1</sup>Not available on 48" high.

<sup>2</sup>Only available on 30" high.



# Wall Quarter Round End Shelves

## Description

**WALL QUARTER ROUND END SHELF, SQUARE TOP and CLIPPED BOTTOM SHELVES, 30", 33", 36", 39", 42", 45", or 48" HIGH**

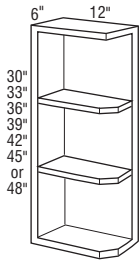

## Model

**WQRES630ST L or R**

**WQRES633ST L or R**

**WQRES636ST L or R**

**WQRES639ST L or R**

**WQRES642ST L or R**

**WQRES645ST L or R**

**WQRES648ST L or R**

- L or R denotes square top placement.
- 30", 33", and 36" high have four fixed shelves including top/bottom.
- 39", 42", 45", and 48" high have five fixed shelves including top/bottom.
- 3/4" thick back and side.
- Solid-wood construction.

### Door & Drawer Options

AF	AOMD	CC	CG	ESMD	GAMD	HC	IFHG	MC	MD	MFO	PRMD	SHMD	SPLITDR	SPLITDRWS	SUMD	TCG	TCP
----	------	----	----	------	------	----	------	----	----	-----	------	------	---------	-----------	------	-----	-----

### End Panel Options

AUTH	CSFPE	EXBK	EXDN	FFD	FPE	INTGE	IPE
------	-------	------	------	-----	-----	-------	-----

### Custom Modification Options

ADD_SHLF	ADDTK	ADRW	BVR	CBO	CCO	CFNTO	CFRMO	CLIP	CND	CSDGBK	EF	EX	EX_OL	FALL	FBFL	FLUT	FTK	ID	IH <sup>1</sup>
----------	-------	------	-----	-----	-----	-------	-------	------	-----	--------	----	----	-------	------	------	------	-----	----	-----------------

INVFRM	IW	LIGHT	MIP	OBRB	PFINBTMB	RD	RECTK	RH <sup>2</sup>	ROSFLUT	RT	RW	STW	TD	TKP	TVR	WS	WTR
--------	----	-------	-----	------	----------	----	-------	-----------------	---------	----	----	-----	----	-----	-----	----	-----

<sup>1</sup>Not available on 48" high.

<sup>2</sup>Only available on 30" high.

**WALL QUARTER ROUND END SHELF, SQUARE SHELVES, 30", 33", 36", 39", 42", 45", or 48" HIGH**

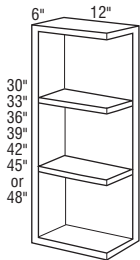

**WQRES630STSB**

**WQRES633STSB**

**WQRES636STSB**

**WQRES639STSB**

**WQRES642STSB**

**WQRES645STSB**

**WQRES648STSB**

- 30", 33", and 36" high have four fixed shelves including top/bottom.
- 39", 42", 45", and 48" high have five fixed shelves including top/bottom.
- 3/4" thick back and side.
- Solid-wood construction.
- All shelves are square.

### Door & Drawer Options

AF	AOMD	CC	CG	ESMD	GAMD	HC	IFHG	MC	MD	MFO	PRMD	SHMD	SPLITDR	SPLITDRWS	SUMD	TCG	TCP
----	------	----	----	------	------	----	------	----	----	-----	------	------	---------	-----------	------	-----	-----

### End Panel Options

AUTH	CSFPE	EXBK	EXDN	FFD	FPE	INTGE	IPE
------	-------	------	------	-----	-----	-------	-----

### Custom Modification Options

ADD_SHLF	ADDTK	ADRW	BVR	CBO	CCO	CFNTO	CFRMO	CLIP	CND	CSDGBK	EF	EX	EX_OL	FALL	FBFL	FLUT	FTK	ID	IH <sup>1</sup>
----------	-------	------	-----	-----	-----	-------	-------	------	-----	--------	----	----	-------	------	------	------	-----	----	-----------------

INVFRM	IW	LIGHT	MIP	OBRB	PFINBTMB	RD	RECTK	RH <sup>2</sup>	ROSFLUT	RT	RW	STW	TD	TKP	TVR	WS	WTR
--------	----	-------	-----	------	----------	----	-------	-----------------	---------	----	----	-----	----	-----	-----	----	-----

<sup>1</sup>Not available on 48" high.

<sup>2</sup>Only available on 30" high.

IH/RH availability charts starting on page G•40.  
IW/RW availability charts starting on page G•46.

## Description

**WALL QUARTER ROUND END SHELF, 12" RADIUS, CLIPPED SHELVES, 30", 33", 36", 39", 42", 45", or 48" HIGH**

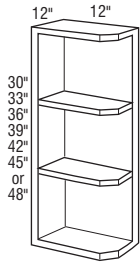

## Model

WQRES1230RT

WQRES1233RT

WQRES1236RT

WQRES1239RT

WQRES1242RT

WQRES1245RT

WQRES1248RT

- 30", 33", and 36" high have four fixed shelves including top/bottom.
- 39", 42", 45", and 48" high have five fixed shelves including top/bottom.
- 3/4" thick back and side.
- Solid-wood construction.

### Door & Drawer Options

AF	AOMD	CC	CG	ESMD	GAMD	HC	IFHG	MC	MD	MFO	PRMD	SHMD	SPLITDR	SPLITDRWS	SUMD	TCG	TCP
----	------	----	----	------	------	----	------	----	----	-----	------	------	---------	-----------	------	-----	-----

### End Panel Options

AUTH	CSFPE	EXBK	EXDN	FFD	FPE	INTGE	IPE
------	-------	------	------	-----	-----	-------	-----

### Custom Modification Options

ADD_SHLF	ADDTK	ADRW	BVR	CBO	CCO	CFNTO	CFRMO	CLIP	CND	CSDGBK	EF	EX	EX_OL	F.ALL	FBFL	FLUT	FTK	ID	IH <sup>1</sup>
----------	-------	------	-----	-----	-----	-------	-------	------	-----	--------	----	----	-------	-------	------	------	-----	----	-----------------

INVERM	IW	LIGHT	MIP	OBRB	PFINBTMB	RD	RECTK	RH <sup>2</sup>	ROSLUT	RT	RW	RTW	TD	TKP	TVR	WS	WTR
--------	----	-------	-----	------	----------	----	-------	-----------------	--------	----	----	-----	----	-----	-----	----	-----

<sup>1</sup>Not available on 48" high.

<sup>2</sup>Only available on 30" high.

**WALL QUARTER ROUND END SHELF, 12" RADIUS, SQUARE TOP and CLIPPED BOTTOM SHELVES, 30", 33", 36", 39", 42", 45", or 48" HIGH**

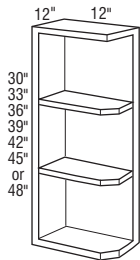

WQRES1230ST L or R

WQRES1233ST L or R

WQRES1236ST L or R

WQRES1239ST L or R

WQRES1242ST L or R

WQRES1245ST L or R

WQRES1248ST L or R

- L or R denotes square top placement.
- 30", 33", and 36" high have four fixed shelves including top/bottom.
- 39", 42", 45", and 48" high have five fixed shelves including top/bottom.
- 3/4" thick back and side.
- Solid-wood construction.

### Door & Drawer Options

AF	AOMD	CC	CG	ESMD	GAMD	HC	IFHG	MC	MD	MFO	PRMD	SHMD	SPLITDR	SPLITDRWS	SUMD	TCG	TCP
----	------	----	----	------	------	----	------	----	----	-----	------	------	---------	-----------	------	-----	-----

### End Panel Options

AUTH	CSFPE	EXBK	EXDN	FFD	FPE	INTGE	IPE
------	-------	------	------	-----	-----	-------	-----

### Custom Modification Options

ADD_SHLF	ADDTK	ADRW	BVR	CBO	CCO	CFNTO	CFRMO	CLIP	CND	CSDGBK	EF	EX	EX_OL	F.ALL	FBFL	FLUT	FTK	ID	IH <sup>1</sup>
----------	-------	------	-----	-----	-----	-------	-------	------	-----	--------	----	----	-------	-------	------	------	-----	----	-----------------

INVERM	IW	LIGHT	MIP	OBRB	PFINBTMB	RD	RECTK	RH <sup>2</sup>	ROSLUT	RT	RW	STW	TD	TKP	TVR	WS	WTR
--------	----	-------	-----	------	----------	----	-------	-----------------	--------	----	----	-----	----	-----	-----	----	-----

<sup>1</sup>Not available on 48" high.

<sup>2</sup>Only available on 30" high.

# Wall Quarter Round End Shelves & Wall Spice Pull-out Cabinets

## Description

**WALL QUARTER ROUND END SHELF,  
12", SQUARE SHELVES, 30",  
33", 36", 39", 42", 45", or 48" HIGH**

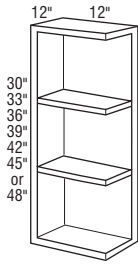

## Model

**WQRES1230STSB**  
**WQRES1233STSB**  
**WQRES1236STSB**  
**WQRES1239STSB**  
**WQRES1242STSB**  
**WQRES1245STSB**  
**WQRES1248STSB**

- 30", 33", and 36" high have four fixed shelves including top/bottom.
- 39", 42", 45", and 48" high have five fixed shelves including top/bottom.
- 3/4" thick back and side.
- Solid-wood construction.

### Door & Drawer Options

AF	AOMD	CC	CG	ESMD	GAMD	HC	IFHG	MC	MD	MFO	PRMD	SHMD	SPLITDR	SPLITDRWS	SUMD	TCG	TCP

### End Panel Options

AUTH	CSFPE	EXBK	EXDN	FFD	FPE	INTGE	IPE
		✓					

### Custom Modification Options

ADD_SHLF	ADDTK	ADRW	BVR	CBO	CCO	CFNTO	CFRMO	CLIP	CND	CSDGBK	EF	EX	EX_OL	F.ALL	FBFL	FLUT	FTK	ID	IH <sup>1</sup>	
																			✓	✓

INVERM	IW	LIGHT	MIP	OBRB	PFINBTMB	RD	RECTK	RH <sup>2</sup>	ROSLUT	RT	RW	RTW	TD	TKP	TVR	WS	WTR
							✓	✓									

<sup>1</sup>Not available on 48" high.

<sup>2</sup>Only available on 30" high.

**WALL SPICE PULL-OUT CABINET, 30", 33",  
36", 39", or 42" HIGH**

storage  
SOLUTIONS

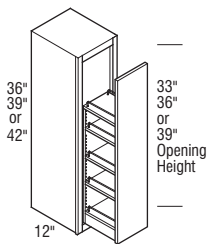
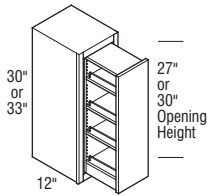

**WSP930**

**WSP1230**

**WSP933**

**WSP1233**

**WSP936**

**WSP1236**

**WSP939**

**WSP1239**

**WSP942**

**WSP1242**

Notes below apply to all products in section above:

- Pull-out features Smart Stop.

### Door & Drawer Options

AF	AOMD	CC	CG	ESMD	GAMD	HC	IFHG	MC	MD	MFO	PRMD	SHMD	SPLITDR	SPLITDRWS	SUMD	TCG	TCP
							✓			✓							

### End Panel Options

AUTH	CSFPE	EXBK	EXDN	FFD	FPE	INTGE	IPE
✓	✓	✓	✓	✓	✓	✓	✓

### Custom Modification Options

ADD_SHLF	ADDTK	ADRW	BVR	CBO <sup>1</sup>	CCO <sup>2</sup>	CFNTO	CFRMO	CLIP	CND	CSDGBK	EF	EX	EX_OL	F.ALL	FBFL	FLUT <sup>3</sup>	FTK <sup>4</sup>	ID	IH
				✓	✓	✓	✓	✓	✓	✓	✓	✓	✓	✓	✓	✓	✓	✓	✓

INVERM	IW	LIGHT	MIP	OBRB	PFINBTMB	RD	RECTK	RH	ROSLUT <sup>5</sup>	RT	RW	STW	TD	TKP	TVR	WS	WTR
				✓	✓	✓	✓	✓	✓							✓	✓

<sup>1</sup>Not available on 33" or 39" high.

<sup>2</sup>Not available on 30", 36" or 42" high.

<sup>3</sup>Not available on 30", 36" or 42" high and not available with fluting both or 6" fluting.

<sup>4</sup>Not available on FTKAV.

<sup>5</sup>Not available on 30", 36" or 42" high and not available with fluting both.

IH/RH availability charts starting on page G•40.  
IW/RW availability charts starting on page G•46.

## Description

**WALL SPICE RACK CABINET, 30", 33", 36", 39", or 42" HIGH**  
storage  
SOLUTIONS

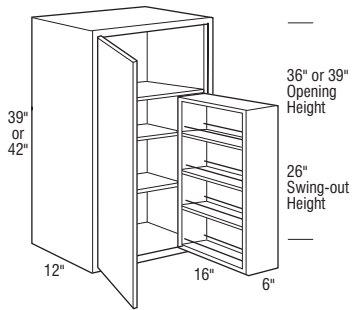
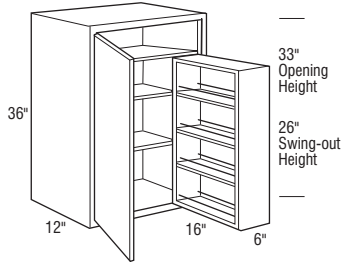
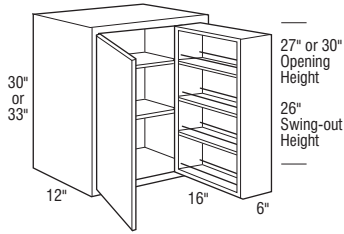

## Model

**WSRC2130 L or R**

**WSRC2133 L or R**

- Two 4 1/4" deep shelves are included behind swing-out spice rack.

**WSRC2136 L or R**

- Two 4 1/4" deep shelves are included behind swing-out spice rack; one fixed shelf above swing-out.

**WSRC2139 L or R**

**WSRC2142 L or R**

Notes below apply to all products in section above:

- Hinged opposite cabinet door.
- Two 4 1/4" deep shelves are included behind swing-out spice rack; one fixed shelf above swing-out.
- Increased Depths available in 1/4" increments from 12 1/4" to 30".
- Not available on Inset and Beaded Inset styles.

### Door & Drawer Options

AF	AOMD	CC	CG	ESMD	GAMD	HC	IFHG	MC	MD	MFO	PRMD	SHMD	SPLITDR	SPLITDRWS	SUMD	TCCG <sup>1</sup>	TCP <sup>1</sup>	
				✓	✓	✓	✓	✓	✓	✓	✓	✓				✓	✓	✓

### End Panel Options

AUTH	CSFPE	EXBK	EXDN	FFD	FPE	INTGE	IPE
✓	✓	✓	✓	✓	✓		

### Custom Modification Options

ADD	SHLF	ADDTK	ADRB	BVR	CBO	CCO	CFNTO	CFRMO	CLIP	CND <sup>2</sup>	CSDGBK	EF	EX	EX_OL	FALL	FBFL	FLUT <sup>3</sup>	FTK	ID	IH	
✓				✓	✓	✓					✓	✓	✓	✓			✓	✓	✓	✓	✓

INVFRM	IW	LIGHT	MIP	OBRB	PFINBTMB	RD <sup>4</sup>	RECTK	RH	ROSLUT <sup>5</sup>	RT	RW	STW	TD	TKP	TVR	WS	WTR
			✓	✓	✓	✓			✓							✓	✓

<sup>1</sup>Not available on 30" or 33" high.

<sup>2</sup>Not available on 36" or 42" high.

<sup>3</sup>Not available with fluting both or 6" fluting.

<sup>4</sup>Not available on 33" or 39" high.

<sup>5</sup>Not available with fluting both.

# Wall Box Column Pull-outs

## Description

**WALL BOX COLUMN PULL-OUT, PLAIN,  
30", 33", 36", 39", or 42" HIGH,  
12" DEEP**  
storage  
SOLUTIONS

## Model

WBCPO330

WBCPO630



WBCPO333



WBCPO633



WBCPO336



WBCPO636



WBCPO339



WBCPO639



WBCPO342



WBCPO642

- Includes adjustable shelves.
- Standard face application includes filler with overlay.
- Finger pull routed on bottom edge of wall unit. Hardware optional.
- Bottom of unit is always Natural Maple.
- Pull-out features Smart Stop.

### Door & Drawer Options

AF	AOMD	CC	CG	ESMD	GAMD	HC	IFHG	MC	MD	MFO	PRMD	SHMD	SPLITDR	SPLITDRWS	SUMD	TCG	TCP	

### End Panel Options

AUTH	CSFPE	EXBK	EXDN	FFD	FPE	INTGE	IPE

### Custom Modification Options

ADD_SHLF	ADDTK	ADRW	BVR	CBO	CCO	CFNTO	CFRMO	CLIP	CND	CSDGBK	EF	EX	EX_OL	FALL	FBFL	FLUT	FTK	ID	IH	

INVERM	IW	LIGHT	MIP	OBRB	PFINBTMB	RD	RECTK	RH	ROSLUT	RT	RW	RTW	TD	TKP	TVR	WS	WTR

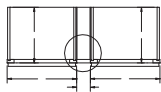
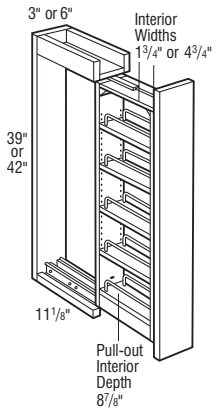
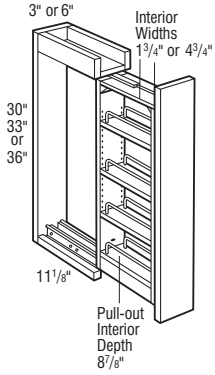

Top View Installation



Top View

IH/RH availability charts starting on page G•40.  
IW/RW availability charts starting on page G•46.

**Description**

**WALL BOX COLUMN PULL-OUT, OVERLAY, 30", 33", 36", 39", or 42" HIGH, 12" DEEP storage SOLUTIONS**

**Model**

- WBCP0330OL
- WBCP0630OL
- NEW** WBCP0333OL
- NEW** WBCP0633OL
- NEW** WBCP0336OL
- NEW** WBCP0636OL
- WBCP0339OL
- NEW** WBCP0639OL
- NEW** WBCP0342OL
- NEW** WBCP0642OL

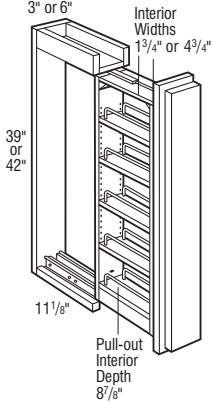
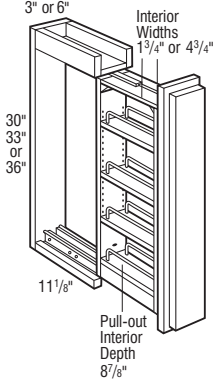

- Overlay standard.
- Edge profile will match door profile selected (#10, #12, #14, #17, #27).
- Finger pull routed on bottom edge of wall unit. Hardware optional.
- Pull-out features Smart Stop.
- Available on end of run.
- Three adjustable shelves.
- Fluting modification available when the No Overlay modification is selected.
- Bottom of unit is always Natural Maple.
- Not available on Inset and Beaded Inset styles.

**Door & Drawer Options**

AF	AOMD	CC	CG	ESMD	GAMD	HC	IFHG	MC	MD	MFO	PRMD	SHMD	SPLITDR	SPLITDRWS	SUMD	TCG	TCP
										✓							

**End Panel Options**

AUTH	CSFPE	EXBK <sup>1</sup>	EXDN	FFD	FPE	INTGE	IPE
		✓					

**Custom Modification Options**

ADD_SHLF	ADDTK	ADRW	BVR	CBO	CCO	CFNTO	CFRMO	CLIP	CND	CSDGBK	EF	EX	EX_OL	F.ALL	FBFL	FLUT	FTK	ID	IH
																✓			
INVFRM	IW	LIGHT	MIP	OBRB	PFINBTMB	RD	RECTK	RH	ROSELUT	RT	RW	STW	TD	TKP	TVR	WS	WTR		
			✓						✓							✓			

<sup>1</sup>Not available with end extended back left.

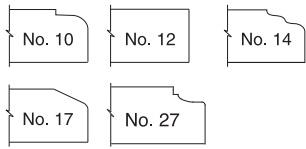
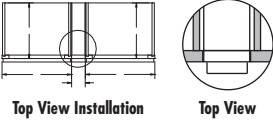

# Wall Box Column Pull-outs

## Description

**WALL BOX COLUMN PULL-OUT with K-CUP\*, 30" HIGH, 12" DEEP storage**  
SOLUTIONS

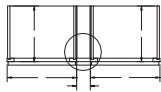
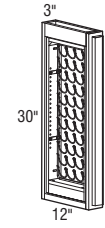

Top View Installation



Top View



## Model

### WBCPOKCUP330

- Holds 44 K-Cups.
- The K-Cup pull-out is compatible with K-Cup pods only.
- Overlay standard.
- Edge profile will match door profile selected (#10, #12, #14, #17, #27).
- Finger pull routed on bottom edge of wall unit. Hardware optional.
- Wire rack comes factory installed on the left side and can be reversed in the field.
- Smart Stop feature not available on pull-out.
- Available on end of run.
- Fluting modification available when the No Overlay modification is selected.
- Bottom of unit is always Natural Maple.
- Not available on Inset and Beaded Inset styles.

\*K-Cup is a registered trademark of Keurig Green Mountain, Inc.

#### Door & Drawer Options

AF	AOMD	CC	CG	ESMD	GAMD	HC	IFHG	MC	MD	MFO	PRMD	SHMD	SPLITDR	SPLITDRWS	SUMD	TCG	TCP
----	------	----	----	------	------	----	------	----	----	-----	------	------	---------	-----------	------	-----	-----

#### End Panel Options

AUTH	CSFPE	EXBK	EXDN	FFD	FPE	INTGE	IPE
------	-------	------	------	-----	-----	-------	-----

#### Custom Modification Options

ADD_SHLF	ADDTK	ADRW	BVR	CBO	CCO	CFNTO	CFRMO	CLIP	CND	CSDGBK	EF	EX	EX_OL	FALL	FBFL	FLUT	FTK	ID	IH
----------	-------	------	-----	-----	-----	-------	-------	------	-----	--------	----	----	-------	------	------	------	-----	----	----

INVERM	IW	LIGHT	MIP	OBRB	PFINBTMB	RD	RECTK	RH	ROSLUT	RT	RW	STW	TD	TKP	TVR	WLC	WS	WTR
--------	----	-------	-----	------	----------	----	-------	----	--------	----	----	-----	----	-----	-----	-----	----	-----

IH/RH availability charts starting on page G•40.  
IW/RW availability charts starting on page G•46.

# Kemper Emerge Modification Option Descriptions

Your Kemper Emerge specification guide contains charts with modification option codes for each applicable cabinetry product. Reference the listing below to identify the modification description.

## Door & Drawer Options

Option	Description
AF	Aluminum Door
CC	Craftsman Door
CG	Cut-for-glass
ESMD	Estate Mullion Door
GAMD	Gallery Mullion Door
IFHG	Inset Finial Hinges
MD	Mullion Door
MFO	Modified Full Overlay
PRMD	Prairie Mullion Door
SHMD	Shaker Mullion Door
SUMD	Summit Mullion Door

## End Panel Options

Option	Description
AUTH	Authentic Flush End
CSFPE	Car Siding Flush Panel End
EXBK	End Extended Back
EXDN	Wall End and Back Extended Down
FPE	Flush Panel End
INTGE	Integral End
IPE	Inset Panel Ends

## Custom Modification Options

Option	Description
ADD_SHLF	Add Shelf
ADDTK	Add Toekick
ADRW	Add Drawer Below Wall Unit
BVR	Bottom Valance Rail
CBO	Cabinet Box Only
CCO	Cabinet Case Only
CFNTO	Cabinet Front Only
CFRMO	Cabinet Frame Only
CND	Cabinet No Door
CSDGBK	Car Siding Back
EX	Extended Stile
EX_OL	Extended Stile with Overlay
FLUT	Fluting
FTK	Flush Toekick
ID	Increased Depth
IW	Increased Width
MIP	Matching Interior
OBRB	Open Bottom Rail Base
PFINBTMB	Finished Bottom
RD	Reduced Depth
RECTK	Recessed Toekick
ROSFLOT	Rose Fluting
RW	Reduced Width
TKP	Toekick Pedestal
WS	Wide Stiles
WTR	Wide Top Rail



*Notes*

## Description

### WOOD HOOD ARCH, 36", 42", or 48" WIDE, 24 7/8" HIGH

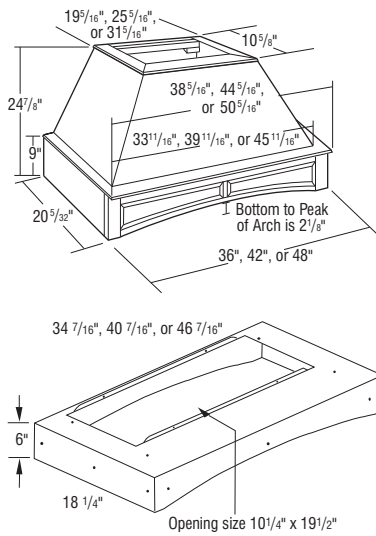

## Model

**WHA36**

**WHA42**

**WHA48**

- Freestanding unit. (Must be properly secured to wall and cannot be attached to adjacent cabinets.)
- Silver Metallic liner included. Assembly required.
- Arched raised panel valance front.
- Exhaust system not included.
- Installation instructions and hardware included.
- Alder substituted for Rustic Alder.
- Compatible with all blowers offered by Kemper Emerge.
- Chimney available (WHC).
- Check your local building code for installation heights above the range.

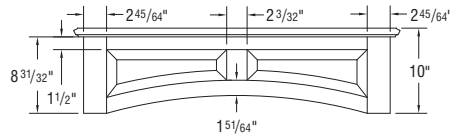

Modifications  
Are Not  
Available

### WOOD HOOD SQUARE, 36", 42", or 48" WIDE, 22 7/8" HIGH

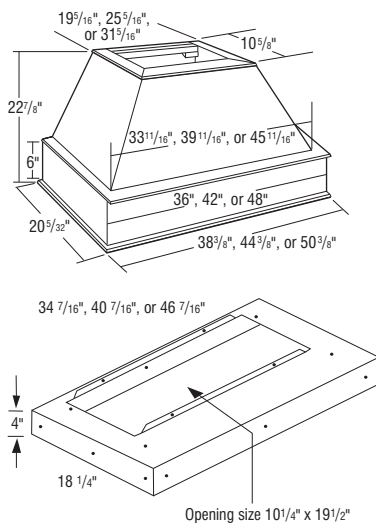

**WHS36**

**WHS42**

**WHS48**

- Freestanding unit. (Must be properly secured to wall and cannot be attached to adjacent cabinets.)
- Silver Metallic liner included. Assembly required.
- Exhaust system not included.
- Installation instructions and hardware included.
- Alder substituted for Rustic Alder.
- Compatible with all blowers offered by Kemper Emerge.
- Chimney available (WHC).
- Check your local building code for installation heights above the range.

Modifications  
Are Not  
Available

### WOOD HOOD CHIMNEY, 24" HIGH

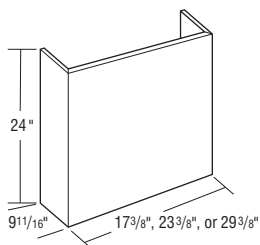

**WHC36**

**WHC42**

**WHC48**

- Height trimmable up to 23".
- Optional accessory for Wood Hood Square and Arch.
- 3/4" plywood.
- Alder substituted for Rustic Alder.

Modifications  
Are Not  
Available

# Wood Hoods

## Description

**WOOD HOOD CANOPY ARCHED, 30", 36", or 42" WIDE, 24", 30", or 36" HIGH**

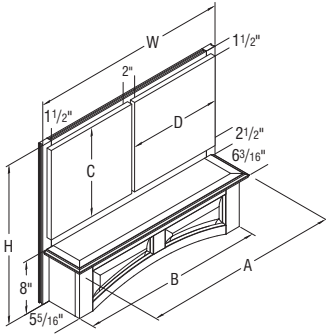

## Model

**WHCA30**

**WHCA36**

**WHCA42**

**JWHCA3030**

**JWHCA3630**

**JWHCA4230**

**WHCA3036**

**WHCA3636**

**WHCA4236**

- Area above mantel will match selected door style.
- Range hoods are ordered on an "as required" basis. No changes or cancellations will be accepted after 24 hours from acknowledgment of order.
- Install wood hood between 2 adjacent cabinets.
- Exhaust system not included.
- Compatible with all blowers offered by Kemper Emerge.
- Installation instructions and hardware included.
- Liner opening size: 10 1/4" deep x 19 1/2" wide.
- Alder substituted for Rustic Alder.
- Square silver metallic liner included. Assembly required.
- Beaded Inset is not available.
- Modifications available on applied doors only, including: Inset and Beaded Inset, Inset Finial Hinges, Modified Full Overlay, Mullion Doors, and Prairie Mullion Doors.

	Width (W)	Height (H)	Max. Width (A)	Min. Width (B)	Opening Height (C)	Opening Width (D)
WHCA30	30"	24"	29 9/16"	27 13/16"	12"	12 1/2"
WHCA36	36"	24"	35 9/16"	33 13/16"	12"	15 1/2"
WHCA42	42"	24"	41 9/16"	39 13/16"	12"	18 1/2"
JWHCA3030	30"	30"	29 9/16"	27 13/16"	18"	12 1/2"
JWHCA3630	36"	30"	35 9/16"	33 13/16"	18"	15 1/2"
JWHCA4230	42"	30"	41 9/16"	39 13/16"	18"	18 1/2"
WHCA3036	30"	36"	29 9/16"	27 13/16"	24"	12 1/2"
WHCA3636	36"	36"	35 9/16"	33 13/16"	24"	15 1/2"
WHCA4236	42"	36"	41 9/16"	39 13/16"	24"	18 1/2"

### Door & Drawer Options

AF	CC	CG	ESMD	GAMD	IFHG	MD	MFO	PRMD	SHMD	SUMD
			✓	✓	✓	✓	✓	✓	✓	✓

### End Panel Options

AUTH	CSFPE	EXBK	EXDN	FPE	INTGE	IPE

### Custom Modification Options

ADD_SHLF	ADDTK	ADRW	BVR	CBO	CCO	CFNTO	CFRMO	CND	CSDGBK	EX	EX_OL	FLUT	FTK	ID	IW	MIP	OBRB	PFINBTMB
								✓										

RD	RECTK	ROSEFLUT	RW	TKP	WS	WTR

IH/RH availability charts starting on page G•40.  
IW/RW availability charts starting on page G•46.

## Description

**WOOD HOOD CANOPY SQUARE, 30", 36", or 42" WIDE, 24", 30", or 36" HIGH**

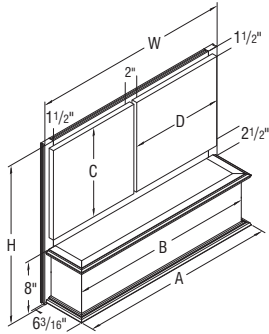

## Model

WHCS30

WHCS36

WHCS42

JWHCS3030

JWHCS3630

JWHCS4230

WHCS3036

WHCS3636

WHCS4236

- Area above mantel will match selected door style.
- Range hoods are ordered on an "as required" basis. No changes or cancellations will be accepted after 24 hours from acknowledgment of order.
- Install wood hood between 2 adjacent cabinets.
- Exhaust system not included.
- Compatible with all blowers offered by Kemper Emerge.
- Installation instructions and hardware included.
- Liner opening size: 10 1/4" deep x 19 1/2" wide.
- Alder substituted for Rustic Alder.
- Square silver metallic liner included. Assembly required.
- Beaded Inset is not available.
- Modifications available on applied doors only, including: Inset Finition Hinges, Modified Full Overlay, Mullion Doors, and Prairie Mullion Doors.

	Width (W)	Height (H)	Max. Width (A)	Min. Width (B)	Opening Height (C)	Opening Width (D)
WHCS30	30"	24"	29 9/16"	27 13/16"	12"	12 1/2"
WHCS36	36"	24"	35 9/16"	33 13/16"	12"	15 1/2"
WHCS42	42"	24"	41 9/16"	39 13/16"	12"	18 1/2"
JWHCS3030	30"	30"	29 9/16"	27 13/16"	18"	12 1/2"
JWHCS3630	36"	30"	35 9/16"	33 13/16"	18"	15 1/2"
JWHCS4230	42"	30"	41 9/16"	39 13/16"	18"	18 1/2"
WHCS3036	30"	36"	29 9/16"	27 13/16"	24"	12 1/2"
WHCS3636	36"	36"	35 9/16"	33 13/16"	24"	15 1/2"
WHCS4236	42"	36"	41 9/16"	39 13/16"	24"	18 1/2"

### Door & Drawer Options

AF	CC	CG	ESMD	GAMD	IFHG	MD	MFO	PRMD	SHMD	SUMD
		✓	✓	✓	✓	✓	✓	✓	✓	✓

### End Panel Options

AUTH	CSFPE	EXBK	EXDN	FPE	INTGE	IPE

### Custom Modification Options

ADD	SHLF	ADDTK	ADRW	BVR	CBO	CCO	CFNTO	CFRMO	CND	CSDGBK	EX	EX_OL	FLUT	FTK	ID	IW	MIP	OBRB	PFINBTMB
									✓										

RD	RECTK	ROSLUT	RW	TKP	WS	WTR

# Wood Hoods

## Description

### WOOD HOOD NANTUCKET ARCH, 36", 42", or 48" WIDE, 24 7/8" HIGH

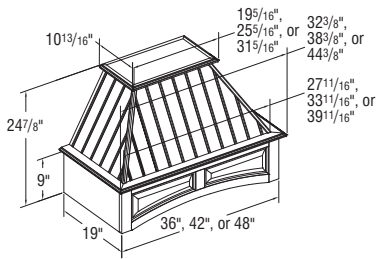

## Model

WHNA36

WHNA42

WHNA48

- Range hoods are ordered on an "as required" basis. No changes or cancellations will be accepted after 24 hours from acknowledgment of order.
- Exhaust system not included.
- Compatible with all blowers offered by Kemper Emerge .
- Chimney available (WHNC).
- Beading spacing 3" on center.
- Arched raised panel valance front.
- Installation instructions and hardware included.
- Silver metallic liner included. Assembly required.
- Liner opening size: 10 1/4" deep x 19 1/2" wide.
- Alder substituted for Rustic Alder.
- Check your local building code for installation heights above the range.

Modifications  
Are Not  
Available

### WOOD HOOD NANTUCKET STRAIGHT, 36", 42", or 48" WIDE, 22 7/8" HIGH

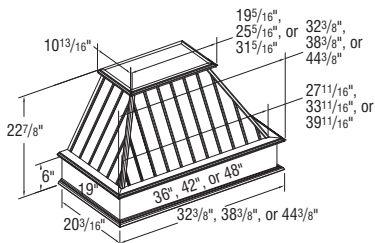

WHNS36

WHNS42

WHNS48

- Range hoods are ordered on an "as required" basis. No changes or cancellations will be accepted after 24 hours from acknowledgment of order.
- Exhaust system not included.
- Compatible with all blowers offered by Kemper Emerge .
- Chimney available (WHNC).
- Beading spacing 3" on center.
- Installation instructions and hardware included.
- Silver metallic liner included. Assembly required.
- Liner opening size: 10 1/4" deep x 19 1/2" wide.
- Alder substituted for Rustic Alder.
- Check your local building code for installation heights above the range.

Modifications  
Are Not  
Available

### WOOD HOOD NANTUCKET CHIMNEY, 31" HIGH

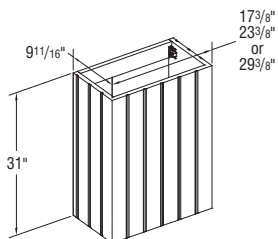

WHNC36

WHNC42

WHNC48

- Chimneys are ordered on an "as required" basis. No changes or cancellations will be accepted after 24 hours from acknowledgment of order.
- Optional accessory for Wood Hood Nantucket (WHNA & WHNS).
- Alder substituted for Rustic Alder.
- Height trimmable up to 23 1/2".
- 3/4" plywood.

Modifications  
Are Not  
Available

IH/RH availability charts starting on page G•40.  
IW/RW availability charts starting on page G•46.

## Description

### WOOD HOOD SHIPLAP STRAIGHT, 36", 42", or 48" WIDE, 42" HIGH

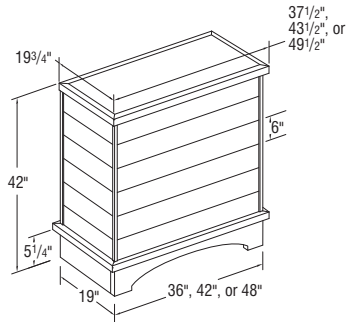

## Model

**JWHSHPSTR36**

**JWHSHPSTR42**

**JWHSHPSTR48**

- Freestanding unit. (Must be properly secured to wall and cannot be attached to adjacent cabinets).
- Range hoods are ordered on an "as required" basis. No changes or cancellations will be accepted after 24 hours from acknowledgment of order.
- Exhaust system not included.
- Square silver metallic liner included. Assembly required.
- Compatible with all blowers offered by Kemper Emerge.
- Liner opening size: 10 1/4" deep x 19 1/2" wide.
- Alder substituted for Rustic Alder.
- Check local building code and appliance installation specifications for clearance requirements and installation heights above the range.

Modifications  
Are Not  
Available

### WOOD HOOD SHIPLAP STRAIGHT with CORBEL, 36", 42", or 48" WIDE, 42" HIGH

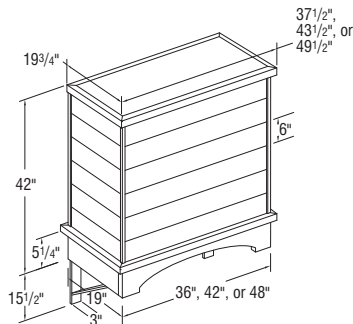

**JWHSHPSTRCB36**

**JWHSHPSTRCB42**

**JWHSHPSTRCB48**

- Freestanding unit. (Must be properly secured to wall and cannot be attached to adjacent cabinets).
- Includes a pair of decorative corbels.
- Range hoods are ordered on an "as required" basis. No changes or cancellations will be accepted after 24 hours from acknowledgment of order.
- Exhaust system not included.
- Square silver metallic liner included. Assembly required.
- Compatible with all blowers offered by Kemper Emerge.
- Liner opening size: 10 1/4" deep x 19 1/2" wide.
- Alder substituted for Rustic Alder.
- Check local building code and appliance installation specifications for clearance requirements (including corbels) and installation heights above the range.

Modifications  
Are Not  
Available

### WOOD HOOD SHIPLAP TAPERED, 36", 42", or 48" WIDE, 31 1/4" HIGH

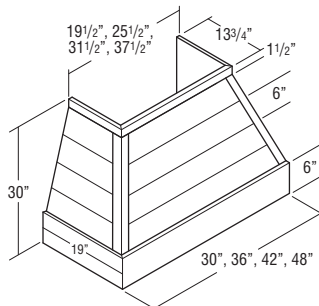

**JWHSHIPT30**

**JWHSHIPT36**

**JWHSHIPT42**

**JWHSHIPT48**

- Freestanding unit. (Must be properly secured to wall and cannot be attached to adjacent cabinets).
- Range hoods are ordered on an "as required" basis. No changes or cancellations will be accepted after 24 hours from acknowledgment of order.
- Exhaust system not included.
- Square silver metallic liner included. Assembly required.
- Compatible with all blowers offered by Kemper Emerge.
- Liner opening size: 10 1/4" deep x 19 1/2" wide.
- Alder substituted for Rustic Alder.
- Check local building code and appliance installation specifications for clearance requirements and installation heights above the range.

Modifications  
Are Not  
Available

# Wood Hoods

## Description

**WOOD HOOD SHIPLAP TAPERED with CORBEL, 36", 42", or 48" WIDE, 31 1/4" HIGH**

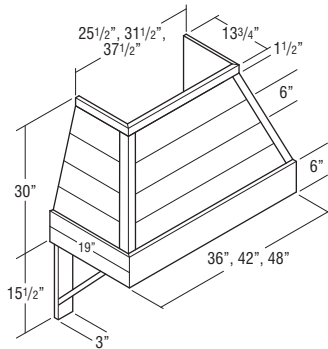

## Model

**JWHSHIPTCB36**

**JWHSHIPTCB42**

**JWHSHIPTCB48**

- Freestanding unit. (Must be properly secured to wall and cannot be attached to adjacent cabinets).
- Includes a pair of decorative corbels.
- Range hoods are ordered on an "as required" basis. No changes or cancellations will be accepted after 24 hours from acknowledgment of order.
- Exhaust system not included.
- Square silver metallic liner included. Assembly required.
- Compatible with all blowers offered by Kemper Emerge.
- Liner opening size: 10 1/4" deep x 19 1/2" wide.
- Alder substituted for Rustic Alder.
- Check local building code and appliance installation specifications for clearance requirements (including corbels) and installation heights above the range.

Modifications  
Are Not  
Available

**WOOD HOOD SHIPLAP TAPERED CHIMNEY, 30", 36", 42", or 48" WIDE, 23 1/2" HIGH**

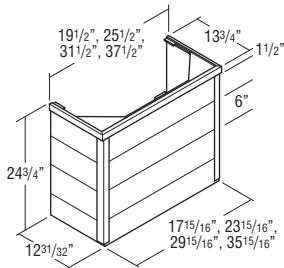

**JWHSIPCH30**

**JWHSIPCH36**

**JWHSIPCH42**

**JWHSIPCH48**

- Constructed of 3/4" thick grooved plywood creating a shiplap appearance.
- Trimable. If trimmed, moulding is recommended to conceal any cut marks.
- Optional accessory for Wood Hood Shiplap Tapered (JWHSIPT and JWHSIPTCB skus) for an installed height of 54".
- Alder substituted for Rustic Alder.
- No changes or cancellations will be accepted after 24 hours from acknowledgment of order.

Modifications  
Are Not  
Available

**WOOD HOOD ISLAND ARCH, 36", 42", or 48" WIDE, 54 9/16" HIGH**

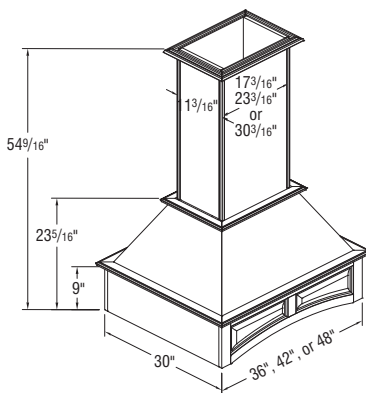

**JWHIA36**

**JWHIA42**

**JWHIA48**

- Freestanding unit. (Must be properly secured to ceiling and cannot be attached to adjacent cabinets).
- Range hoods are ordered on an "as required" basis. No changes or cancellations will be accepted after 24 hours from acknowledgment of order.
- Exhaust system not included.
- Compatible with all blowers offered by Kemper Emerge.
- Arched raised panel valance front.
- Installation instructions and hardware included.
- Silver metallic liner included. Assembly required.
- Liner opening size: 10 1/4" deep x 19 1/2" wide.
- Chimney height is trimmable up to 38".
- Alder substituted for Rustic Alder.
- Check your local building code for installation heights above the range.

Modifications  
Are Not  
Available

IH/RH availability charts starting on page G•40.  
IW/RW availability charts starting on page G•46.

## Description

### WOOD HOOD ISLAND STRAIGHT, 36", 42", or 48" WIDE, 52 9/16" HIGH

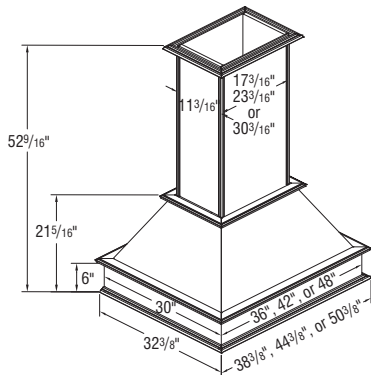

## Model

JWHIS36

JWHIS42

JWHIS48

- Freestanding unit. (Must be properly secured to ceiling and cannot be attached to adjacent cabinets).
- Range hoods are ordered on an "as required" basis. No changes or cancellations will be accepted after 24 hours from acknowledgment of order.
- Exhaust system not included.
- Compatible with all blowers offered by Kemper Emerge.
- Installation instructions and hardware included.
- Silver metallic liner included. Assembly required.
- Liner opening size: 10 1/4" deep x 19 1/2" wide.
- Chimney height trimmable up to 36".
- Alder substituted for Rustic Alder.
- Check your local building code for installation heights above the range.

Modifications  
Are Not  
Available

### WOOD HOOD ARTISAN STRAIGHT, 36", 42", or 48" WIDE, 46" HIGH

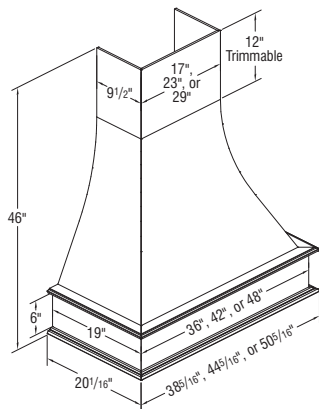

WHAS36

WHAS42

WHAS48

- Range hoods are ordered on an "as required" basis. No changes or cancellations will be accepted after 24 hours from acknowledgment of order.
- Exhaust system not included.
- Compatible with all blowers offered by Kemper Emerge.
- Installation instructions and hardware included.
- Silver metallic liner included. Assembly required.
- Liner opening size: 10 1/4" deep x 19 1/2" wide.
- Chimney height trimmable up to 36".
- Alder substituted for Rustic Alder.
- Check your local building code for installation heights above the range.

Modifications  
Are Not  
Available

### WOOD HOOD LINEAR, 30", 36", or 42" WIDE, 40 5/16" HIGH

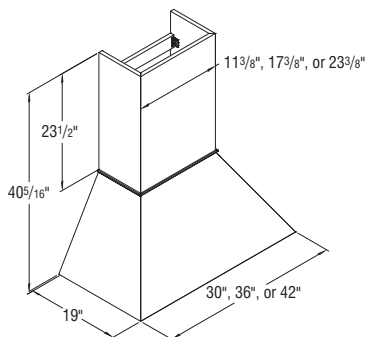

JWHL30

JWHL36

JWHL42

- Range hoods are ordered on an "as required" basis. No changes or cancellations will be accepted after 24 hours from acknowledgment of order.
- Exhaust system not included.
- Compatible with all blowers offered by Kemper Emerge.
- Installation instructions and hardware included.
- Silver metallic liner included. Assembly required.
- Liner opening size: 10 1/4" deep x 19 1/2" wide.
- Alder substituted for Rustic Alder.
- Check your local building code for installation heights above the range.

Modifications  
Are Not  
Available



# Range Hoods

## Description

## Model

### TAPERED WOOD HOOD, 30" or 36" WIDE, 24" HIGH

### TWH30

### TWH36

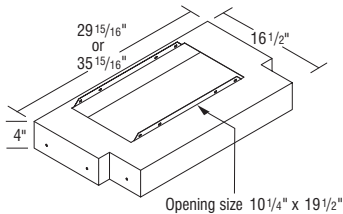
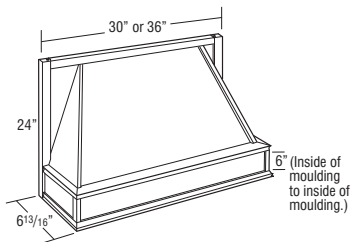

Metal Liner for TWH \_ \_ Range Hood

- Install TWH between adjoining cabinets.
- Exhaust system not included.
- Metal liner included.
- Wood hoods are designed for use with decorative overlays.
- Compatible with all blowers offered by Kemper Emerge.
- Check your local building code for installation heights above the range.

Modifications  
Are Not  
Available

### RANGE HOOD STAINLESS STEEL SQUARE, 30" or 36" WIDE

### RHSS30

### RHSS36

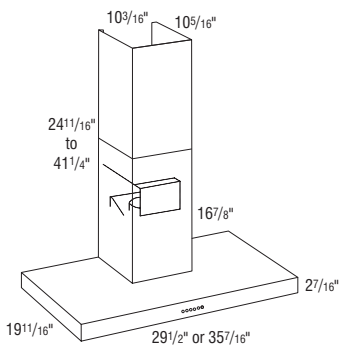

- Range hoods are ordered on an "as required" basis. No changes or cancellations will be accepted after 24 hours from acknowledgment of order.
- Compatible with all blowers offered by Kemper Emerge.
- Fan included.
- Installation instructions and hardware included.
- Metal liner not required.
- Includes a 4-speed 600 CFM blower.
- Check your local building codes for installation heights above the range.
- Includes two 20 watt halogen lights.

Modifications  
Are Not  
Available

### RANGE HOOD STAINLESS STEEL TAPERED, 30" or 36" WIDE

### RHST30

### RHST36

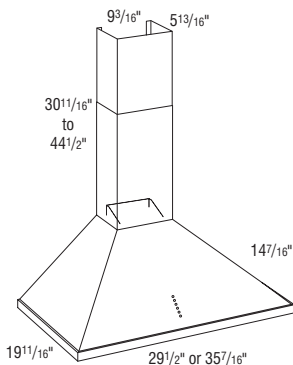

- Range hoods are ordered on an "as required" basis. No changes or cancellations will be accepted after 24 hours from acknowledgment of order.
- Compatible with all blowers offered by Kemper Emerge.
- Fan included.
- Installation instructions and hardware included.
- Metal liner not required.
- Includes a 4-speed 600 CFM blower.
- Check your local building codes for installation heights above the range.
- Includes two 20 watt halogen lights.

Modifications  
Are Not  
Available

IH/RH availability charts starting on page G•40.  
IW/RW availability charts starting on page G•46.

## Description

### STAINLESS HOOD AIR DEVIATORS

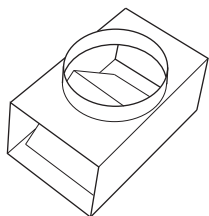

## Model

### RHSS-DEV

- For use with RHSS models.

### RHST-DEV

- For use with RHST models.

Notes below apply to all products in section above:

- For use with Range Hood Stainless Steel.
- Air deviators are ordered on an "as required" basis. No changes or cancellations will be accepted after 24 hours from acknowledgment of order.
- Installation instructions and hardware included.

Modifications  
Are Not  
Available

### STAINLESS HOOD FILTER

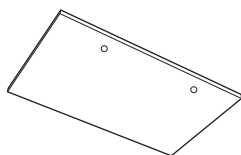

### KF2

- Installation instructions and hardware included.
- For use with RHST and RHSS models.
- Hood Filters are ordered on an "as required" basis. No changes or cancellations will be accepted after 24 hours from acknowledgment of order.

Modifications  
Are Not  
Available

### WOOD HOOD BLOWER, 1100 CFM

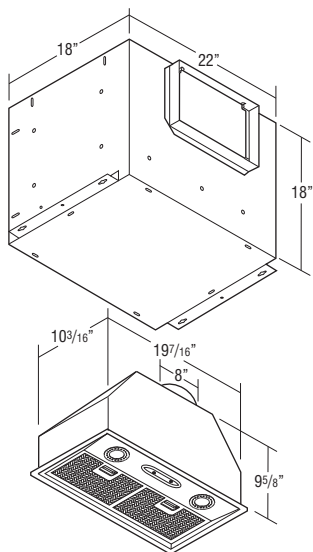

### BLOWER 1100

- 1100 CFM.
- Ventilator housing unit features stainless steel finish.
- Two 50 watt (120 volt) halogen lamps included.
- Satellite blower installs remotely in the interior of the home (i.e. unfinished attic area).
- Designed to work independently from internal blowers.
- Installation instructions, warranty, and repair information included.
- External ventilation required.
- Professional installation required.
- Compatible with all Wood Hoods and Hearths.
- Includes 2 inline transition 8"x12" to 10" round.
- Three speed control.
- Includes 2 removable dishwasher safe grease filters.
- Liner sold separately.

Modifications  
Are Not  
Available

# Range Hoods

## Description

### WOOD HOOD BLOWER, 500 CFM

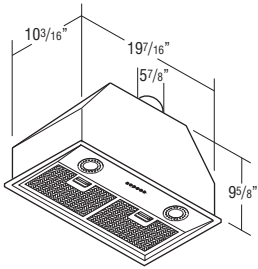

## Model

### BLOWER500

- 500 CFM.
- Two 20 watt (12 volt, G4 base) halogen lamps included.
- Installation instructions, warranty and repair information included.
- Compatible with all Wood Hoods and Hearths.
- Stainless steel finish.
- Three speed push button control.
- Includes two removable dishwasher safe grease filters.
- Liner sold separately.

Modifications  
Are Not  
Available

### WOOD HOOD BLOWER UNIT

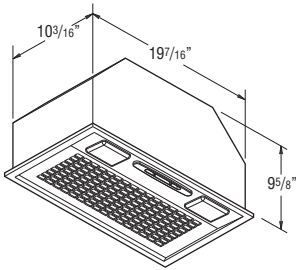

### TWHBLOWER390

- 390 CFM.
- Range Hood Component Package has 3-speed centrifugal fan and lighted filter control.
- 6" diameter vent.
- 1 year warranty.
- Two 40 watt candelabra lights required, but not included.
- Vented unit. To use as a ventless unit, conversion kit (CONVERSION) must be ordered.
- Installation instructions, warranty and repair info included.
- Compatible with all Wood Hoods and Hearths.
- Sound rating is 6 sones.
- Uses 3.2 amps.
- Metallic gray exterior finish.
- Includes removable dishwasher safe grease filter.
- Liner sold separately.

Modifications  
Are Not  
Available

### DUCTLESS CONVERSION KIT

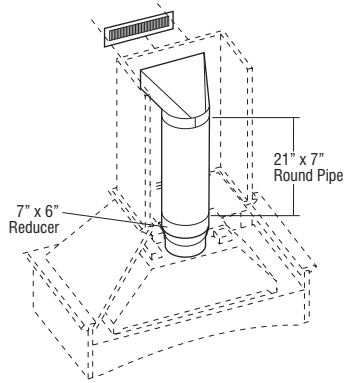

### CONVERSION

#### FILTER500

#### FILTER250/390

- Kit includes: 1-21" x 7" round pipe, 1 adjustable collar, 1 White metal soffit grille, 1 adjustable boot, 1-7" x 6" reducer.
- Charcoal filter required (FILTER250/390 or FILTER500).
- Installation instructions included.
- For use with all blowers.

Modifications  
Are Not  
Available

IH/RH availability charts starting on page G•40.  
IW/RW availability charts starting on page G•46.

## Hearth SKU Collection – 36" High, 21" Deep

### Hearth, 66" Wide

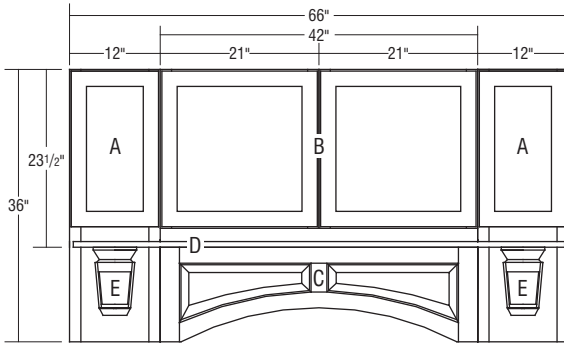

Parts Required	Page Number	Quantity	Size
(A) HP1236 L or R	K•19	2	12 x 36 x 21
(B) H36DF4223.5	K•21	1	42 x 23 1/2 x 1 1/2
(C) JRPV42	R•18	1	3/4 x 12 1/2 x 42
(D) HS66	K•22	1	3/4 x 4 1/2 x 65 1/2
(E) CORBELS	R•27	2	Refer to selection

### Hearth, 72" Wide

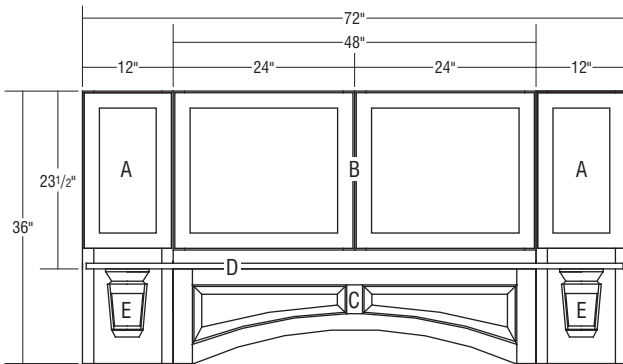

Parts Required	Page Number	Quantity	Size
(A) HP1236 L or R	K•19	2	12 x 36 x 21
(B) H36DF4823.5	K•21	1	48 x 23 1/2 x 1 1/2
(C) RPV48	R•18	1	3/4 x 12 1/2 x 48
(D) HS72	K•22	1	3/4 x 4 1/2 x 71 1/2
(E) CORBELS	R•27	2	Refer to selection

### Hearth, 78" Wide

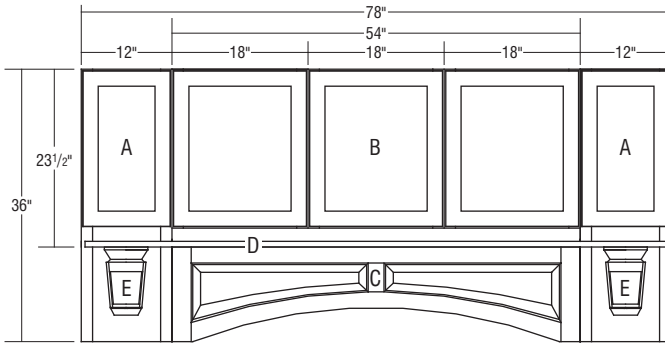

Parts Required	Page Number	Quantity	Size
(A) HP1236 L or R	K•19	2	12 x 36 x 21
(B) H36DF5423.5	K•21	1	54 x 23 1/2 x 1 1/2
(C) RPV54	R•18	1	3/4 x 12 1/2 x 54
(D) HS78	K•22	1	3/4 x 4 1/2 x 77 1/2
(E) CORBELS	R•27	2	Refer to selection

### Hearth, 84" Wide

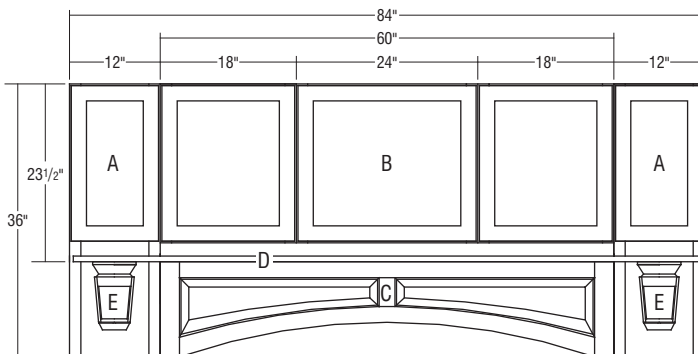

Parts Required	Page Number	Quantity	Size
(A) HP1236 L or R	K•19	2	12 x 36 x 21
(B) H36DF6023.5	K•21	1	60 x 23 1/2 x 1 1/2
(C) RPV60	R•18	1	3/4 x 12 1/2 x 54
(D) HS84	K•22	1	3/4 x 4 1/2 x 83 1/2
(E) CORBELS	R•27	2	Refer to selection

# Hearths

## Hearth SKU Collection – 48” High, 21” Deep

### Hearth, 66” Wide

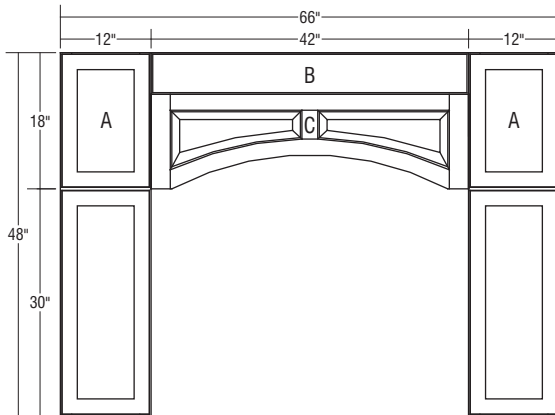

Parts Required	Page Number	Quantity	Size
(A) HP1248 L or R	K•19	2	12 x 48 x 21
(B) HOF42	K•23	1	1 1/2 x 5 1/2 x 42
(C) JRPV42	R•18	1	3/4 x 12 1/2 x 42

### Hearth, 72” Wide

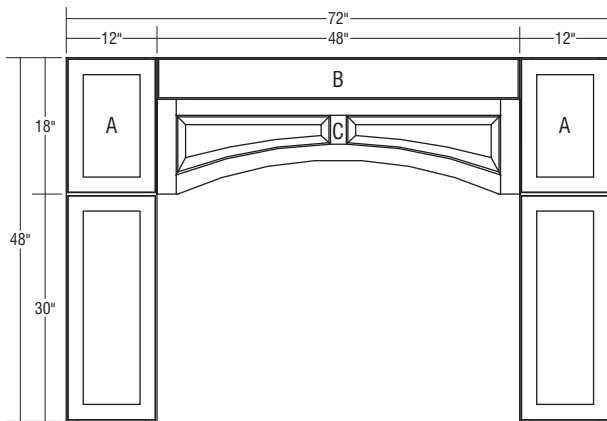

Parts Required	Page Number	Quantity	Size
(A) HP1248 L or R	K•19	2	12 x 48 x 21
(B) HOF48	K•23	1	1 1/2 x 5 1/2 x 48
(C) RPV48	R•18	1	3/4 x 12 1/2 x 48

### Hearth, 78” Wide

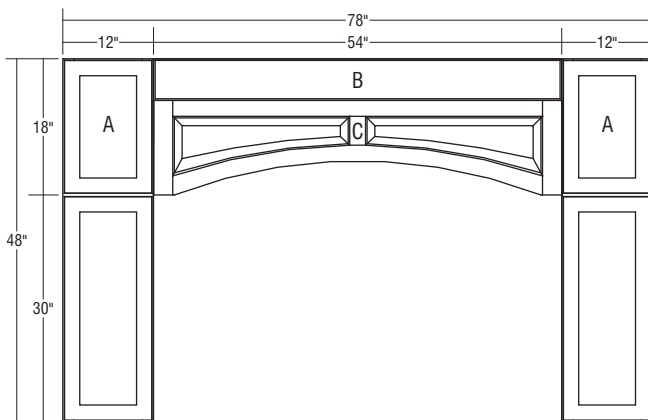

Parts Required	Page Number	Quantity	Size
(A) HP1248 L or R	K•19	2	12 x 48 x 21
(B) HOF54	K•23	1	1 1/2 x 5 1/2 x 54
(C) RPV54	R•18	1	3/4 x 12 1/2 x 54

Kemper Emerge recommends a clearance of 7” - 12” on each side of a gas burner to a combustible surface, 3” - 6” from non-combustible surfaces including the backsplash surface, and 30” from the vent. Kemper Emerge also suggests you reference local codes before installation.

**Hearth, 84" Wide**

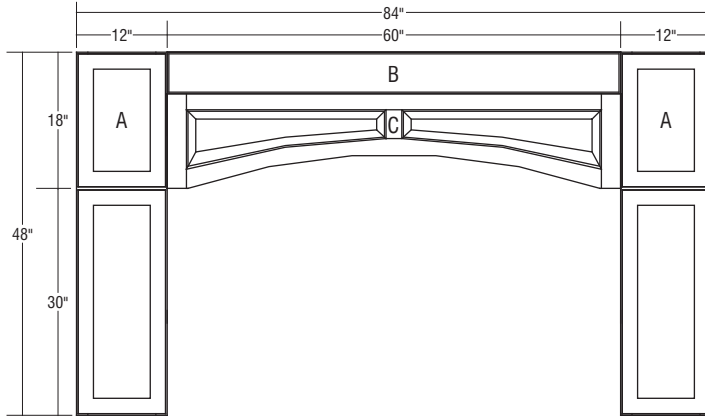

Parts Required	Page Number	Quantity	Size
(A) HP1248 L or R	K•19	2	12 x 48 x 21
(B) HOF60	K•23	1	1 1/2 x 5 1/2 x 60
(C) RPV60	R•18	1	3/4 x 12 1/2 x 60

**Hearth SKU Collection – 54" High, 21" Deep**

**Hearth, 66" Wide**

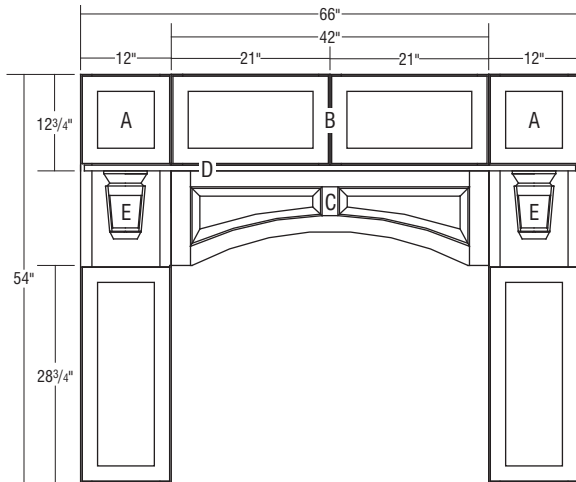

Parts Required	Page Number	Quantity	Size
(A) HP1254 L or R/ HPP1254 L or R	K•19	2	12 x 54 x 21
(B) H54DF4212.75	K•21	1	42 x 12 3/4 x 1 1/2
(C) JRPV42	R•18	1	3/4 x 12 1/2 x 42
(D) HS66	K•22	1	3/4 x 4 1/2 x 65 1/2
(E) CORBELS	R•27	2	Refer to selection

**Hearth, 72" Wide**

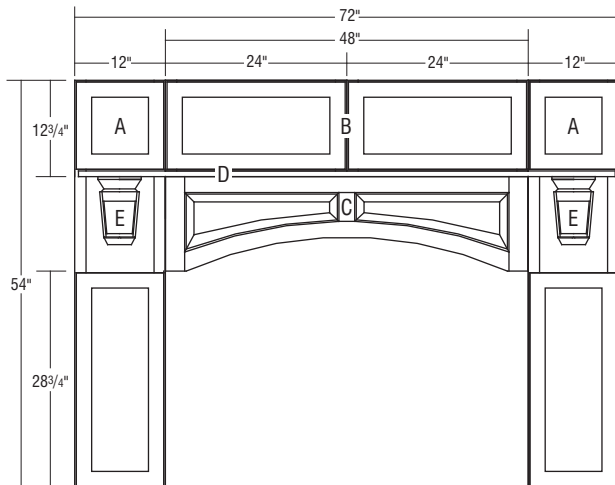

Parts Required	Page Number	Quantity	Size
(A) HP1254 L or R/ HPP1254 L or R	K•19	2	12 x 54 x 21
(B) H54DF4812.75	K•21	1	48 x 12 3/4 x 1 1/2
(C) RPV48	R•18	1	3/4 x 12 1/2 x 48
(D) HS72	K•22	1	3/4 x 4 1/2 x 71 1/2
(E) CORBELS	R•27	2	Refer to selection

Kemper Emerge recommends a clearance of 7" - 12" on each side of a gas burner to a combustible surface, 3" - 6" from non-combustible surfaces including the backslash surface, and 30" from the vent. Kemper Emerge also suggests you reference local codes before installation.

# Hearths

## Hearth, 78" Wide

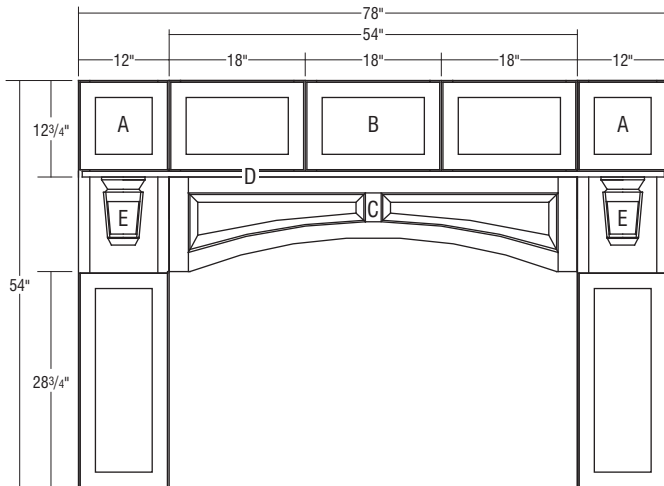

Parts Required	Page Number	Quantity	Size
(A) HP1254 L or R/ HPP1254 L or R	K•19	2	12 x 54 x 21
(B) H54DF5412.75	K•21	1	54 x 12 3/4 x 1 1/2
(C) RPV54	R•18	1	3/4 x 12 1/2 x 54
(D) HS78	K•22	1	3/4 x 4 1/2 x 77 1/2
(E) CORBELS	R•27	2	Refer to selection

## Hearth, 84" Wide

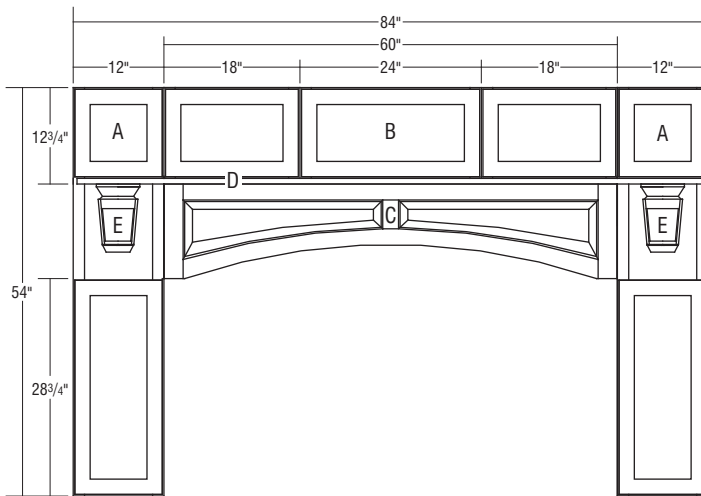

Parts Required	Page Number	Quantity	Size
(A) HP1254 L or R/ HPP1254 L or R	K•19	2	12 x 54 x 21
(B) H54DF6012.75	K•21	1	60 x 12 3/4 x 1 1/2
(C) RPV60	R•18	1	3/4 x 12 1/2 x 60
(D) HS84	K•22	1	3/4 x 4 1/2 x 83 1/2
(E) CORBELS	R•27	2	Refer to selection

## Hearth SKU Collection – 60" High, 21" Deep

### Hearth, 66" Wide

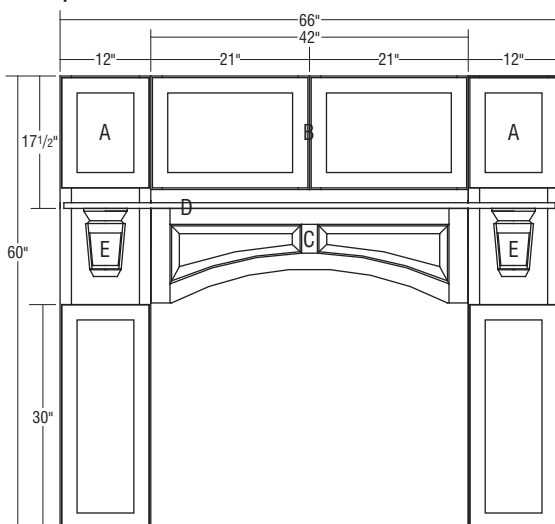

Parts Required	Page Number	Quantity	Size
(A) HP1260 L or R/ HPP1260 L or R	K•19	2	12 x 60 x 21
(B) H60DF4217.5	K•22	1	42 x 17 1/2 x 1 1/2
(C) JRPV42	R•18	1	3/4 x 12 1/2 x 42
(D) HS66	K•22	1	3/4 x 4 1/2 x 65 1/2
(E) CORBELS	R•27	2	Refer to selection

Kemper Emerge recommends a clearance of 7" - 12" on each side of a gas burner to a combustible surface, 3" - 6" from non-combustible surfaces including the backsplash surface, and 30" from the vent. Kemper Emerge also suggests you reference local codes before installation.

## Hearth, 72" Wide

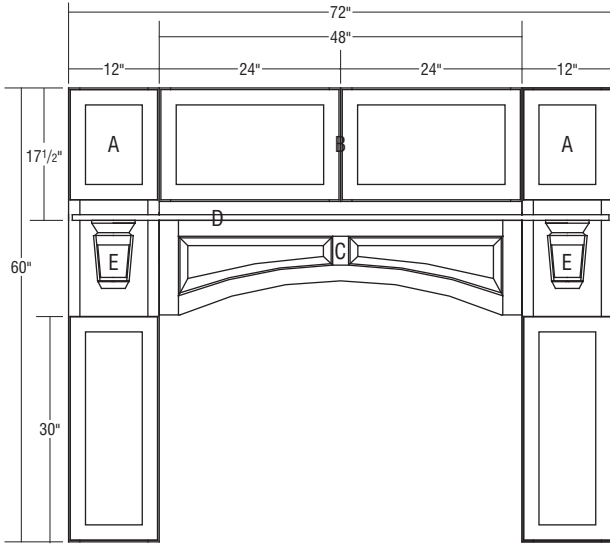

Parts Required	Page Number	Quantity	Size
(A) HP1260 L or R/ HPP1260 L or R	K•19	2	12 x 60 x 21
(B) H60DF4817.5	K•22	1	48 x 17 1/2 x 1 1/2
(C) RPV48	R•18	1	3/4 x 12 1/2 x 48
(D) HS72	K•22	1	3/4 x 4 1/2 x 71 1/2
(E) CORBELS	R•27	2	Refer to selection

## Hearth, 78" Wide

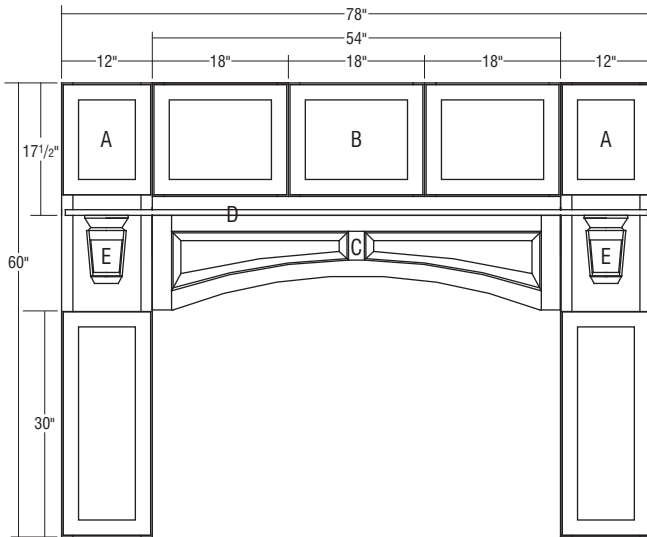

Parts Required	Page Number	Quantity	Size
(A) HP1260 L or R/ HPP1260 L or R	K•19	2	12 x 60 x 21
(B) H60DF5417.5	K•22	1	54 x 17 1/2 x 1 1/2
(C) RPV54	R•18	1	3/4 x 12 1/2 x 54
(D) HS78	K•22	1	3/4 x 4 1/2 x 77 1/2
(E) CORBELS	R•27	2	Refer to selection

Kemper Emerge recommends a clearance of 7" - 12" on each side of a gas burner to a combustible surface, 3" - 6" from non-combustible surfaces including the backsplash surface, and 30" from the vent. Kemper Emerge also suggests you reference local codes before installation.



# Hearths

## Hearth, 84" Wide

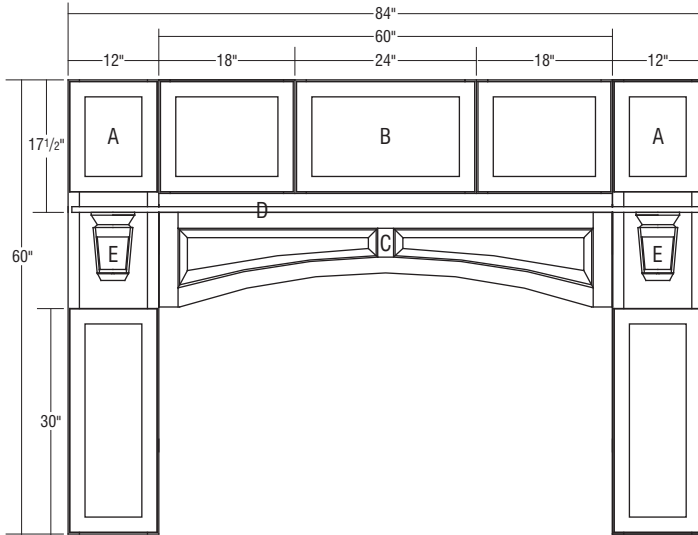

Parts Required	Page Number	Quantity	Size
(A) HP1260 L or R / HPP1260 L or R	K•19	2	12 x 60 x 21
(B) H60DF6017.5	K•22	1	60 x 17 1/2 x 1 1/2
(C) RPV60	R•18	1	3/4 x 12 1/2 x 60
(D) HS84	K•22	1	3/4 x 4 1/2 x 83 1/2
(E) CORBELS	R•27	2	Refer to selection

Kemper Emerge recommends a clearance of 7" - 12" on each side of a gas burner to a combustible surface, 3" - 6" from non-combustible surfaces including the backsplash surface, and 30" from the vent. Kemper Emerge also suggests you reference local codes before installation.

**Description**

**HEARTH PIER, 12" WIDE, 36", 48", 54", or 60" HIGH, 21" DEEP**

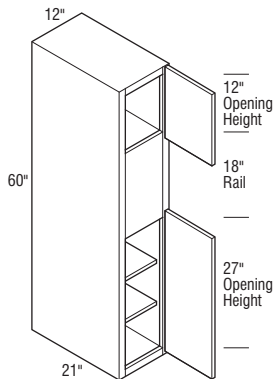
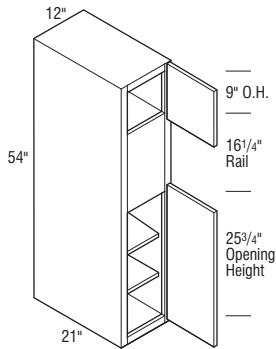
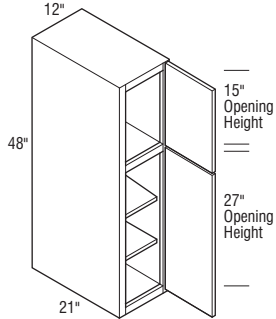
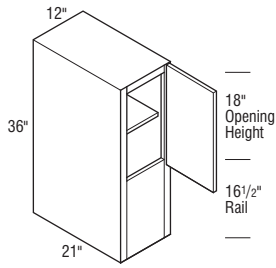

**Model**

**HP1236 L or R (12 x 36 x 21)**

- Matching Interior standard.
- Cabinets constructed with:  
Top, bottom, one adjustable shelf. No fixed floor under door opening.

**HP1248 L or R (12 x 48 x 21)**

- Cabinets constructed with:  
Top, bottom, fixed floor between doors, and two adjustable shelves in bottom opening.

**HP1254 L or R (12 x 54 x 21)**

- Cabinets constructed with:  
Top, bottom, fixed floor under top door opening, and two adjustable shelves in bottom opening.

**HP1260 L or R (12 x 60 x 21)**

- Cabinets constructed with:  
Top, bottom, fixed floor under top door opening, and two adjustable shelves in bottom opening.

**Notes below apply to all products in section above:**

- Finished Ends standard.
- For opening sizes and cabinet dimensions, see pages F•11 and F•17.
- Increased Depths available in 1/4" increments from 21 1/4" to 30".
- Reduced Depths available in 1/4" increments from 6" to 20 3/4".
- Increased or Reduced Widths available in 3" increments. See pages G•48-G•49 for details.
- Not available with Art Glass.

**Door & Drawer Options**

AF	CC	CG	ESMD	GAMD	IFHG	MD	MFO	PRMD	SHMD	SUMD
✓	✓	✓	✓	✓	✓	✓	✓	✓	✓	✓

**End Panel Options**

AUTH <sup>1</sup>	CSFPE	EXBK	EXDN	FPE	INTGE	IPE
✓	✓	✓	✓	✓	✓	✓

**Custom Modification Options**

ADD	SHLF <sup>2</sup>	ADTK	ADRW <sup>3</sup>	BVR	CBO	CCO	CFNTO	CFRMO	CND	CSDGBK	EX	EX_OL	FLUT <sup>4</sup>	FTK <sup>5</sup>	ID	IW	MIP <sup>6</sup>	OBRB	PFINBTMB	
✓	✓	✓	✓	✓	✓	✓	✓	✓	✓	✓	✓	✓	✓	✓	✓	✓	✓	✓	✓	✓

RD	RECTK	ROSLUT	RW	TKP	WS	WTR
✓	✓	✓	✓	✓	✓	✓

<sup>1</sup>Not available on authentic flush ends both.

<sup>2</sup>Only available on 36" high.

<sup>3</sup>Not available on 60" high.

<sup>4</sup>Not available with 6" fluting.

<sup>5</sup>Not available with FTKAV.

<sup>6</sup>Not available on 36" high.

# Hearths

## Description

**HEARTH PIER PULL-OUT, 12" WIDE, 54" or 60" HIGH, 21" DEEP storage SOLUTIONS**

## Model

**HPP1254 L or R**

**HPP1260 L or R**

- Finished Ends standard.
- Pull-out features three adjustable shelves with chrome rail sides.
- For opening sizes and cabinet dimensions, see pages F•11 and F•17.
- Not available with Art Glass.

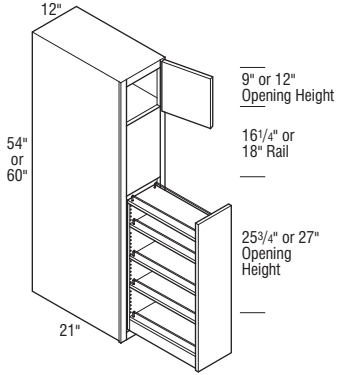

### Door & Drawer Options

AF	CC	CG	ESMD <sup>1</sup>	GAMD <sup>1</sup>	IFHG	MD	MFO	PRMD	SHMD	SUMD <sup>1</sup>
✓	✓	✓	✓	✓	✓	✓	✓	✓	✓	✓

### End Panel Options

AUTH <sup>2</sup>	CSFPE	EXBK	EXDN	FPE	INTGE	IPE
✓	✓	✓	✓	✓	✓	✓

### Custom Modification Options

ADD_SHLF	ADDTK	ADRW <sup>3</sup>	BVR	CBO	CCO	CFNTD	CFRMO	CND	CSDGBK	EX	EX_OL	FLUT <sup>4</sup>	FTK <sup>5</sup>	ID	IW	MIP	OBRB	PFINBTMB
✓	✓	✓	✓	✓	✓	✓	✓	✓	✓	✓	✓	✓	✓	✓	✓	✓	✓	✓

RD	RECTK	ROSLUT	RW	TKP	WS	WTR
✓	✓	✓	✓	✓	✓	✓

- <sup>1</sup>Not available on 54" high.  
<sup>2</sup>Not available with authentic flush ends both.  
<sup>3</sup>Not available on 60" high.  
<sup>4</sup>Not available with 6" fluting.  
<sup>5</sup>Not available with FTKAV.

## **NEW** HEARTH MANTEL, 6" or 9" HIGH

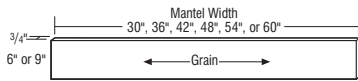

**HM306**

**HM366**

**HM426**

**HM486**

**HM546**

**HM606**

**HM309**

**HM369**

**HM429**

**HM489**

**HM549**

**HM609**

- Recommended for use with 48" high Hearth Piers and same width Arched Valance (see page R•18).

Modifications  
Are Not  
Available

IH/RH availability charts starting on page G•40.  
IW/RW availability charts starting on page G•46.

## Description

## Model

### HEARTH DOOR FRONT CONFIGURATIONS, 12 3/4", 23 1/2" HIGH

H36DF4223.5

H36DF4823.5

H36DF5423.5

H36DF6023.5

H54DF4212.75

H54DF4812.75

H54DF5412.75

H54DF6012.75

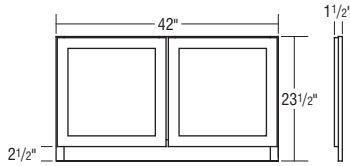

H36DF4223.5

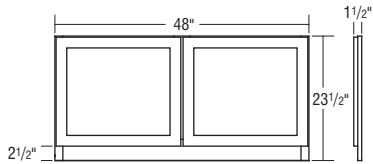

H36DF4823.5

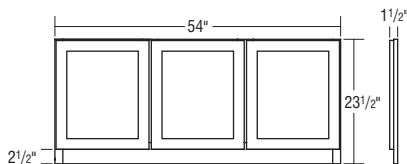

H36DF5423.5

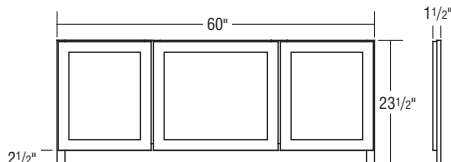

H36DF6023.5

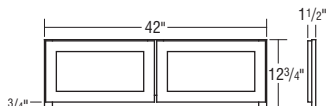

H54DF4212.75

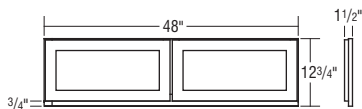

H54DF4812.75

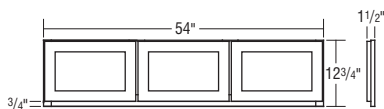

H54DF5412.75

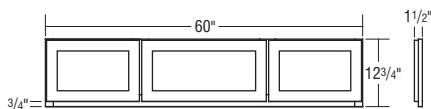

H54DF6012.75

- Wide Bottom Rail standard.
- Unit is Face Frame and Doors Only. 1 1/2" depth.
- Doors are working doors.
- Three door applications will have middle door hinged left unless otherwise specified.
- Some modifications not available, including Increased or Reduced Depths, Increased or Reduced Heights, Increased or Reduced Widths, Split Doors, Wide Stiles, etc.; for more detail contact customer service.

#### Door & Drawer Options

AF	CC	CG	ESMD	GAMD	IFHG	MD	MFO	PRMD <sup>1</sup>	SHMD	SUMD
<input checked="" type="checkbox"/>	<input checked="" type="checkbox"/>	<input checked="" type="checkbox"/>	<input checked="" type="checkbox"/>	<input checked="" type="checkbox"/>	<input checked="" type="checkbox"/>	<input checked="" type="checkbox"/>	<input checked="" type="checkbox"/>	<input checked="" type="checkbox"/>	<input checked="" type="checkbox"/>	<input checked="" type="checkbox"/>

#### End Panel Options

AUTH	CSFPE	EXBK	EXDN	FPE	INTGE	IPE
<input checked="" type="checkbox"/>	<input checked="" type="checkbox"/>	<input checked="" type="checkbox"/>	<input checked="" type="checkbox"/>	<input checked="" type="checkbox"/>	<input checked="" type="checkbox"/>	<input checked="" type="checkbox"/>

#### Custom Modification Options

ADD	SHLF	ADDTK	ADRW	BVR	CBO	CCO	CFNTO	CFRMO	CND	CSDGBK	EX	EX_OL	FLUT <sup>2</sup>	FTK	ID	IW	MIP	OBRB	PFINBTMB
<input checked="" type="checkbox"/>	<input checked="" type="checkbox"/>	<input checked="" type="checkbox"/>	<input checked="" type="checkbox"/>	<input checked="" type="checkbox"/>	<input checked="" type="checkbox"/>	<input checked="" type="checkbox"/>	<input checked="" type="checkbox"/>	<input checked="" type="checkbox"/>	<input checked="" type="checkbox"/>	<input checked="" type="checkbox"/>	<input checked="" type="checkbox"/>	<input checked="" type="checkbox"/>	<input checked="" type="checkbox"/>	<input checked="" type="checkbox"/>	<input checked="" type="checkbox"/>	<input checked="" type="checkbox"/>	<input checked="" type="checkbox"/>	<input checked="" type="checkbox"/>	<input checked="" type="checkbox"/>

RD	RECTK	ROSFLOT	RW	TKP	WS	WTR
<input checked="" type="checkbox"/>	<input checked="" type="checkbox"/>	<input checked="" type="checkbox"/>	<input checked="" type="checkbox"/>	<input checked="" type="checkbox"/>	<input checked="" type="checkbox"/>	<input checked="" type="checkbox"/>

<sup>1</sup>Not available on 12 3/4" high.

<sup>2</sup>Not available with 6" fluting.

# Hearths

## Description

## Model

### HEARTH DOOR FRONT CONFIGURATIONS, 17 1/2" HIGH

**H60DF4217.5**

**H60DF4817.5**

**H60DF5417.5**

**H60DF6017.5**

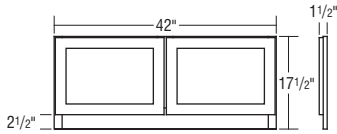

**H60DF4217.5**

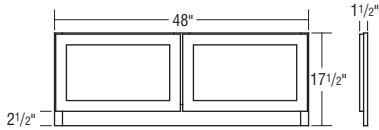

**H60DF4817.5**

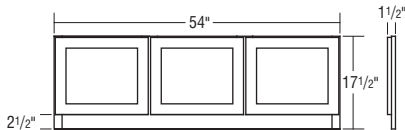

**H60DF5417.5**

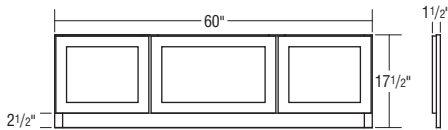

**H60DF6017.5**

- Wide Bottom Rail standard.
- Unit is Face Frame and Doors Only. 1 1/2" depth.
- Doors are working doors.
- Three door applications will have middle door hinged left unless otherwise specified.
- Some modifications not available, including Increased or Reduced Depths, Increased or Reduced Heights, Increased or Reduced Widths, Split Doors, Wide Stiles, etc.; for more detail contact customer service.

#### Door & Drawer Options

AF	CC	CG	ESMD	GAMD	IFHG	MD	MFO	PRMD	SHMD	SUMD
	✓	✓	✓	✓	✓	✓	✓		✓	✓

#### End Panel Options

AUTH	CSFPE	EXBK	EXDN	FPE	INTGE	IPE

#### Custom Modification Options

ADD	SHLF	ADDTK	ADRW	BVR	CBO	CCO	CFNTO	CFRMO	CND	CSDGBK	EX	EX_OL	FLUT <sup>1</sup>	FTK	ID	IW	MIP	OBRB	PFINBTMB
									✓		✓	✓	✓						

RD	RECTK	ROSLUT	RW	TKP	WS	WTR
		✓				✓

<sup>1</sup>Not available with 6" fluting.



### HEARTH SHELF, 4 1/2" DEEP

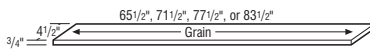

**HS66**

**HS72**

**HS78**

**HS84**

- Shelf is solid wood finished on both sides, one long edge, and two short edges.
- Available with edge profile. Specify desired profile. No. 12 profile standard. Profiles available: 10, 14, 17, 18, 27. See page D•1 for details.
- Shelves will install on top of corbels (4 1/2" deep) and will slightly overlay the Arched Valance.
- Shelf width should match the overall hearth width (pier width + mantel/valance width).
- Actual shelf width is 1/2" shorter than the dimension in the product code.

#### Door & Drawer Options

AF	CC	CG	ESMD	GAMD	IFHG	MD	MFO	PRMD	SHMD	SUMD
								✓		

#### End Panel Options

AUTH	CSFPE	EXBK	EXDN	FPE	INTGE	IPE

#### Custom Modification Options

ADD	SHLF	ADDTK	ADRW	BVR	CBO	CCO	CFNTO	CFRMO	CND	CSDGBK	EX	EX_OL	FLUT	FTK	ID	IW	MIP	OBRB	PFINBTMB

RD	RECTK	ROSLUT	RW	TKP	WS	WTR

IH/RH availability charts starting on page G•40.  
IW/RW availability charts starting on page G•46.

**Description**

**HEARTH OVERLAY FILLERS, 5 1/2" DEEP**

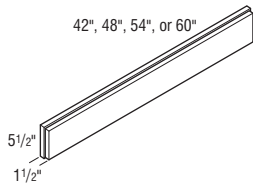

**Model**

**HOF42**

**HOF48**

**HOF54**

**HOF60**

- Size adjusted to door style overlay.
- Shipped loose.
- Profiled on all 4 sides.

**Door & Drawer Options**

AF	CC	CG	ESMD	GAMD	IFHG	MD	MFO	PRMD	SHMD	SUMD
					✓		✓			

**End Panel Options**

AUTH	CSFPE	EXBK	EXDN	FPE	INTGE	IPE

**Custom Modification Options**

ADD_SHLF	ADDTK	ADRW	BVR	CBO	CCO	CFNTO	CFRMO	CND	CSDGBK	EX	EX_OL	FLUT	FTK	ID	IW	MIP	OBRB	PFINBTMB

RD	RECTK	ROSLUT	RW	TKP	WS	WTR

**CORBEL SELECTIONS**

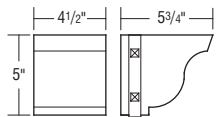
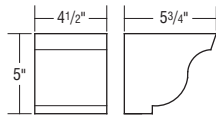
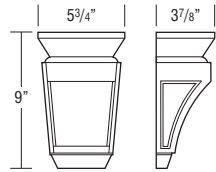

**CORBELMIS9**

**CORBELOWD5**

**CORBELOWDSTR5**

- Oak will be used for Quartersawn Oak on CORBELMIS9.
- Glazes and/or Techniques available: TW, XTW.

Modifications  
Are Not  
Available

**Glazes and Techniques**  
**F** = Flooded (see page E•3.)  
**P** = Penned (see page E•3.)  
**TW** = Timeworn (see page E•3.)  
**XTW** = Extra Timeworn (see page E•3.)  
**HW** = Hewn (see page E•3.)  
**XHW** = Extra Hewn (see page E•3.)

**HEARTH LINER**

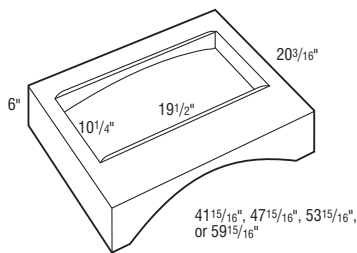

**HL42**

**HL48**

**HL54**

**HL60**

- Liner is Metallic Silver.
- Compatible with all blowers offered by Kemper Emerge.

Modifications  
Are Not  
Available



# Kemper Emerge Modification Option Descriptions

Your Kemper Emerge specification guide contains charts with modification option codes for each applicable cabinetry product. Reference the listing below to identify the modification description.

Door & Drawer Options	
Option	Description
AF	Aluminum Door
AOMBWB	Automatic Opening Mechanism for Wastebaskets
CC	Craftsman Door
CG	Cut-for-glass
ESMD	Estate Mullion Door
GAMD	Gallery Mullion Door
IFHG	Inset Finial Hinges
MD	Mullion Door
PRMD	Prairie Mullion Door
PTOWB	Push-to-Open Wastebasket
SHMD	Shaker Mullion Door
SPLITDR	Split Doors
SPLITDRWS	Split Drawers
SUMD	Summit Mullion Door
TCP	Transom w/both sections Center Panels

End Panel Options	
Option	Description
AUTH	Authentic Flush End
CSFPE	Car Siding Flush Panel End
EXBK	End Extended Back
FFD	Face Frame and Door on End
FPE	Flush Panel End
INTGE	Integral End
IPE	Inset Panel Ends

Custom Modification Options	
Option	Description
ADD_SHLF	Add Shelf
ADDTK	Add Toekick
CBO	Cabinet Box Only
CCO	Cabinet Case Only
CFNTO	Cabinet Front Only
CFP	Cabinet False Panel
CFRMO	Cabinet Frame Only
CHGDRW	Charging Drawer
CLIP	Clipped Corner
CMAT	CabMat™
CND	Cabinet No Door
CSDGBK	Car Siding Back
DRT	Deep Roll Trays
DRWTK	Toekick Drawer
EF	Finished Ends
EX	Extended Stile
EX_OL	Extended Stile with Overlay
FBFL	Finished Blind
FD	Full Depth Shelf
FDSRTBTM	Roll Tray Bottom with Full Depth Shelf
FLUT	Fluting
FTK	Flush Toekick
ID	Increased Depth
IH	Increased Height
IH+DRW	Increased Height Plus Drawer
INVFRM	Inverted Frame
IW	Increased Width
LIGHT	Lighting
MIP	Matching Interior
OBRB	Open Bottom Rail Base
PFINBTMB	Finished Bottom
RD	Reduced Depth
RECTK	Recessed Toekick
RH	Reduced Height
ROSLUT	Rose Fluting
RT	Roll Trays
RW	Reduced Width
SBCADDY	Sink Base Cleaning Caddy
SBCADDYSM	Sink Base Cleaning Caddy Small
SCPDRW	Scooped Drawer
STW	Stacked Wall Cabinet Heights
TD	Tray Divider
TKP	Toekick Pedestal
TVR	Top Valance Rail
UDBX	U-shaped Drawer Box
URT	U-shaped Roll Tray
VTK	Void Toekick
WS	Wide Stiles
WTCB	Wood Tiered Cutlery Divider Drawer
WTKCUP	Wood Tiered K-Cup Drawer
WTR	Wide Top Rail





## Description

### BASE, 34 1/2" HIGH, 24" DEEP

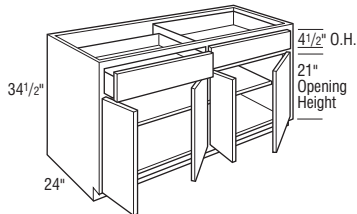
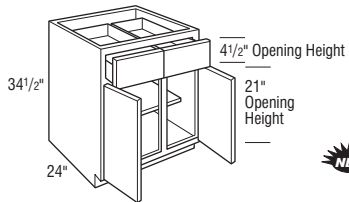
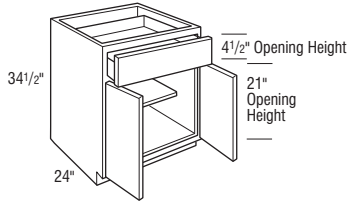
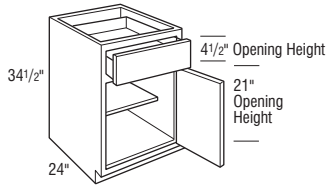

## Model

B9 L or R

B12 L or R

B15 L or R

B18 L or R

B21 L or R

B24 L or R

B24

B27

B30

B33

B36

B39

B42

B45

B48CS

B48

- Two sets of butt doors.

Notes below apply to all products in section above:

- One adjustable half shelf.
- Reduced Depths available in 1/4" increments from 12" to 23 3/4".

#### Door & Drawer Options

AF	AOMBWB	CC	CG	ESMD	GAMD	IFHG	MD	PRMD <sup>1</sup>	PTOWB	SHMD <sup>2</sup>	SPLITDR <sup>3</sup>	SPLITDRWS <sup>4</sup>	SJMD	TCP
		✓	✓	✓	✓	✓	✓	✓		✓	✓	✓	✓	

#### End Panel Options

AUTH	CSFPE	EXBK	FFD	FPE	INTGE	IPE
✓	✓	✓	✓	✓	✓	✓

#### Custom Modification Options

ADD_SHLF	ADDTK	CBO	CCO	CFNTO	CFP	CFRMO	CHGDRW <sup>5</sup>	CLIP <sup>6</sup>	CMAT	CND	CSDGBK	DRT	DRWTK <sup>7</sup>	EF	EX	EX_OL	FBFL	FD	
		✓	✓	✓	✓	✓	✓	✓	✓	✓	✓	✓	✓	✓	✓	✓	✓	✓	✓

FDSRTBTM <sup>2</sup>	FLUT <sup>8</sup>	FTK <sup>9</sup>	ID	IH	IH+DRW	INVERM	IW <sup>10</sup>	LIGHT	MIP	OBRB	PFINBTMB	RD	RECTK	RH	ROSLUT	RT <sup>2</sup>
✓	✓	✓	✓	✓	✓	✓	✓	✓	✓	✓	✓	✓	✓	✓	✓	✓

RW	SBCADDY <sup>2</sup>	SBCADDYSM <sup>1</sup>	SCPRDW	STW	TD	TKP	TVR <sup>11</sup>	UDBX <sup>12</sup>	URT	VTK	WS <sup>13</sup>	WTCD <sup>14</sup>	WTKCUP <sup>15</sup>	WTR <sup>16</sup>
✓	✓	✓	✓	✓	✓	✓	✓	✓	✓	✓	✓	✓	✓	✓

<sup>1</sup>Not available on 9" or 12" wide.

<sup>2</sup>Not available on 9" wide.

<sup>3</sup>Only available on 24" (2 doors)-39" wide.

<sup>4</sup>Only available on 24" (1 and 2 doors)-39" wide.

<sup>5</sup>Only available with 36" wide. 36" wide only available in conjunction with SPLITDRWS modification.

<sup>6</sup>Not available on 9", 12" or 24" (2 doors) wide.

<sup>7</sup>Only available on 24" (1 and 2 doors), 30" and 36" wide.

<sup>8</sup>6" fluting not available on 9", 12", 15", or 24" (2 doors) wide. 6" fluting both not available on 18" or 21" wide.

<sup>9</sup>FTKAV not available on 9" or 12" wide.

<sup>10</sup>Not available on 24" (1 door) or 48" wide.

<sup>11</sup>Not available on 18", 21", 24" (2 doors), or 27" wide. TVRAV not available on 12", 42" or 45" wide.

<sup>12</sup>Only available on 24" (1 and 2 doors)-39" and 48" wide.

<sup>13</sup>Not available on 9" or 24" (2 doors) wide. Wide stile 3" both not available on 12" wide.

<sup>14</sup>Only available on 30", 36", 42", and 48" wide.

<sup>15</sup>Only available on 21", 24" (1 door and 2 doors) and 36" wide.

<sup>16</sup>Only available on 36" wide.

# Base Cabinets

## Description

### **NEW** BASE BUFFET, 34 1/2" HIGH, 24" DEEP

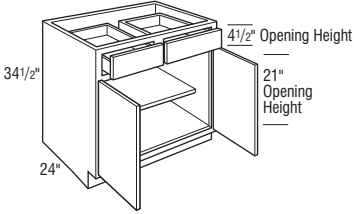

## Model

**B30B**

**B33B**

**B36B**

- One adjustable half shelf.
- Reduced Depths available in 1/4" increments from 12" to 23 3/4".
- Reveal between drawers will not align with doors below.

#### Door & Drawer Options

AF	AOMBWB	CC	CG	ESMD	GAMD	IFHG	MD	PRMD	PTOWB	SHMD	SPLITDR	SPLITDRWS	SUMD	TCP

#### End Panel Options

AUTH	CSFPE	EXBK	FFD	FPE	INTGE	IPE

#### Custom Modification Options

ADD_SHLF	ADDTK	CBO	CCO	CFNTO	CFP	CFRMO	CHGDRW <sup>1</sup>	CLIP	CMAT	CND	CSDGBK	DRT	DRWTK	EF	EX	EX_OL	FBFL	FD	

FDSRTBTM	FLUT	FTK	ID	IH	IH+DRW	INVERM	IW	LIGHT	MIP	OBRB	PFINBTMB	RD	RECTK	RH	ROSFLUT	RT

RW	SBCADDY	SBCADDYSM	SCPDRW	STW	TD	TKP	TVR	UDBX	URT	VTK	WS	WTCDD <sup>2</sup>	WTKCUP <sup>1</sup>	WTR

<sup>1</sup>Only available on 36" wide.

<sup>2</sup>Only available on 30" and 36" wide.

### BASE with BREAD BOARD, 34 1/2" HIGH, 24" DEEP

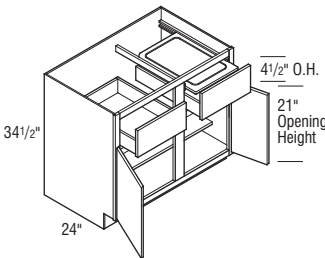
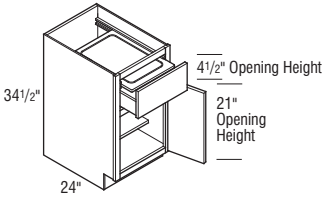

**B12BB L or R**

**B15BB L or R**

**B18BB L or R**

**B21BB L or R**

**B24BB L or R**

**B24BB\***

**B30BB L or R**

**B36BB L or R**

**B42BB L or R**

**B48BB L or R**

- L or R must be specified to denote Bread Board location.

#### Notes below apply to all products in section above:

- One adjustable half shelf.
- \*One drawer - two doors; butt doors standard.

#### Door & Drawer Options

AF	AOMBWB	CC	CG	ESMD	GAMD	IFHG	MD	PRMD	PTOWB	SHMD	SPLITDR	SPLITDRWS	SUMD	TCP

#### End Panel Options

AUTH	CSFPE	EXBK	FFD <sup>2</sup>	FPE	INTGE	IPE

#### Custom Modification Options

ADD_SHLF	ADDTK	CBO	CCO	CFNTO	CFP <sup>3</sup>	CFRMO	CHGDRW	CLIP <sup>3</sup>	CMAT	CND	CSDGBK	DRT	DRWTK <sup>4</sup>	EF	EX	EX_OL	FBFL	FD	

FDSRTBTM	FLUT <sup>5</sup>	FTK <sup>6</sup>	ID	IH	IH+DRW <sup>7</sup>	INVERM	IW	LIGHT	MIP	OBRB	PFINBTMB	RD	RECTK	RH	ROSFLUT	RT

RW	SBCADDY	SBCADDYSM <sup>1</sup>	SCPDRW <sup>8</sup>	STW	TD	TKP <sup>1</sup>	TVR <sup>3</sup>	UDBX	URT	VTK	WS <sup>10</sup>	WTCDD <sup>2</sup>	WTKCUP <sup>11</sup>	WTR <sup>12</sup>

<sup>1</sup>Not available on 12" wide.

<sup>2</sup>Not available on 12"-24" (1 door and 2 doors) wide.

<sup>3</sup>3" clipped corners available on 15"-24" (1 door) wide.

<sup>4</sup>Only available on 24" (1 door and 2 doors)-36" wide.

<sup>5</sup>6" fluting not available on 12", 15" or 24" (2 doors) and fluting both 6" not available on 12"-36" wide.

<sup>6</sup>FTKAV not available on 12" wide.

<sup>7</sup>Not available on 18"-24" (1 door) wide.

<sup>8</sup>Not available on 12"-24" (1 door) wide.

<sup>9</sup>Not available on 18"-21" or 24" (2 doors) wide. TVRAV not available on 36" or 42" wide.

<sup>10</sup>Not available on 12" or 30" wide. Not available on wide stile 1.5" except on the wide stile both 1.5". 36"-48" wide only available on wide stile both 3".

<sup>11</sup>Only available on 36" wide.

<sup>12</sup>Not available on 18", 21", or 24" (2 doors) wide.

IH/RH availability charts starting on page G-40.  
IW/RW availability charts starting on page G-46.

## Description



### BASE with CHARGING DRAWER, 34 1/2" HIGH, 24" DEEP

storage  
SOLUTIONS

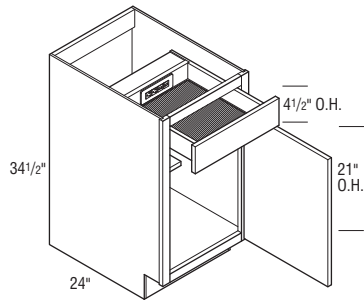

## Model

### B18CHGDRW L or R

- One adjustable half shelf.
- Charging drawer has full extension, concealed Smart Stop slides.
- 110 lb. rated.
- 120V outlet must be installed in rear of cabinet within 10" of bottom of drawer, in rear of cabinet.
- CUL US listed power strip with two 120V plugs and two 2.1 amp USB ports.
- Max Current: AC 15 amps @ 120VAC; USB 2.1 amp and 5 VDC each.
- Tamper resistant outlets.
- Power cord with NEMA 5-15 plug.
- Integrated cord guide mounts to cabinet side to ensure safe operation.
- Black, shock absorbing mat included.
- Special sizes not available.
- Only available in 24" deep.
- Not available on Inset or Beaded Inset Styles.

#### Door & Drawer Options

AF	AOMBWB	CC	CG	ESMD	GAMD	IFHG	MD	PRMD	PTOWB	SHMD	SPLITDR	SPLITDRWS	SUMD	TCP
			✓	✓	✓	✓	✓	✓	✓	✓				✓

#### End Panel Options

AUTH	CSFPE	EXBK	FFD	FPE	INTGE	IPE
✓	✓		✓	✓	✓	✓

#### Custom Modification Options

ADD_SHLF	ADDTK	CBO	CCO	CFNTO	CFP	CFRMO	CHGDRW	CLIP	CMAT	CND	CSDGBK	DRT	DRWTK	EF	EX	EX_OL	FBFL	FD
			✓	✓	✓	✓	✓			✓	✓		✓	✓	✓	✓	✓	

FDSRTBTM	FLUT	FTK	ID	IH	IH+DRW	INVFRM	IW	LIGHT	MIP	OBRB	PFINBTMB	RD	RECTK	RH	ROSLUT	RT
		✓							✓	✓						

RW	SBCADDY	SBCADDYSM	SCPDRW	STW	TD	TKP	TVR	UDBX	URT	VTK	WS	WTCD	WTKCUP	WTR
						✓	✓			✓				

# Base Cabinets

## Description

**BASE with ROLL TRAYS, 34 1/2" HIGH, 24" DEEP**

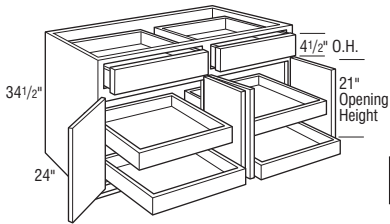
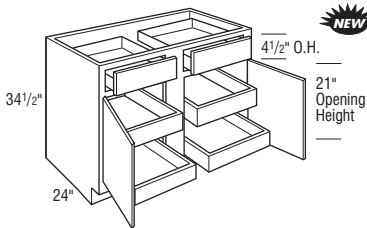
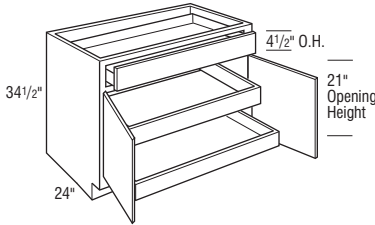
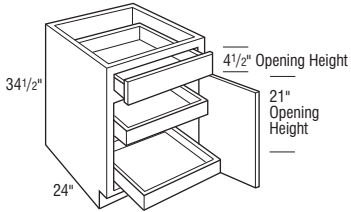

## Model

**B12RT L or R**

**B15RT L or R**

**B18RT L or R**

**B21RT L or R**

**B24RT L or R**

- Contains two easily adjustable roll trays.

**B24RT**

**B27RT**

**B30RT**

**B33RT**

**B36RT**

- Contains two easily adjustable roll trays.

**B39RT**

**B42RT**

**B45RT**

**B48CSRT**

- Includes four easily adjustable roll trays and center mullion.
- 39" wide and wider will receive two easily adjustable roll trays in the width.

**B48RT**

- Two sets of butt doors.
- Includes four easily adjustable roll trays and center mullion.

Notes below apply to all products in section above:

- Reduced Depths available in 1/4" increments from 12" to 23 3/4".

### Door & Drawer Options

AF	AOMBWB	CC	CG	ESMD	GAMD	IFHG	MD	PRMD <sup>1</sup>	PTOWB	SHMD	SPLITDR	SPLITDRWS <sup>2</sup>	SUMD	TCP
			✓	✓	✓	✓	✓	✓		✓		✓	✓	

### End Panel Options

AUTH	CSFPE	EXBK	FFD	FPE	INTGE	IPE
✓	✓	✓	✓	✓	✓	✓

### Custom Modification Options

ADD	SHLF	ADDTK	CBO	CCO <sup>3</sup>	CFNT0	CFP	CFRMO	CHGDRW <sup>4</sup>	CLIP <sup>5</sup>	CMAT	CND	CSDGBK	DRT	DRWTK <sup>6</sup>	EF	EX	EX_OL	FBFL	FD	
				✓	✓	✓	✓	✓	✓	✓	✓	✓	✓	✓	✓	✓	✓	✓	✓	

FDSRTBTM	FLUT <sup>7</sup>	FTK <sup>8</sup>	ID	IH	IH+DRW	INVFRM	IW <sup>9</sup>	LIGHT	MIP	OBRB	PFINBTMB	RD	RECTK	RH	ROSLUT	RT <sup>10</sup>
	✓	✓	✓	✓	✓	✓	✓	✓	✓	✓		✓	✓	✓	✓	✓

RW	SBCADDY	SBCADDYSM	SCPDRW	STW	TD	TKP	TVR <sup>11</sup>	UDBX <sup>12</sup>	URT <sup>12</sup>	VTK	WS <sup>13</sup>	WTCO <sup>14</sup>	WTKCUP <sup>15</sup>	WTR
							✓	✓	✓	✓	✓	✓	✓	✓

<sup>1</sup>Not available on 12" wide.

<sup>2</sup>Only available on 24" (1 door) and 27"-36" wide.

<sup>3</sup>Not available on 30"-48" wide.

<sup>4</sup>Only available with 36" wide. 36" wide only available in conjunction with SPLITDRWS modification.

<sup>5</sup>Not available on 9" or 24" (2 doors) wide.

<sup>6</sup>Only available on 24" (1 door), 30" and 36" wide.

<sup>7</sup>6" fluting not available on 12", 15", 42", or 48" wide. 6" fluting both not available on 18"-24" (1 door and 2 doors) wide.

<sup>8</sup>FTKAV not available on 12" wide.

<sup>9</sup>Not available on 24" (1 door and 2 doors) wide.

<sup>10</sup>Not available on 39" or 45" wide.

<sup>11</sup>Not available on 39"-48" wide and TVRAV not available on 12" wide.

<sup>12</sup>Not available on 12"-21" or 39"-45" wide.

<sup>13</sup>Only available on 30", 36", 42", and 48" wide.

<sup>14</sup>Not available on 12", 27", 33", 36", 39", or 45" wide.

<sup>15</sup>Only available on 36" wide.

IH/RH availability charts starting on page G-40.  
IW/RW availability charts starting on page G-46.

## Description



### BASE with ROLL TRAYS and CHARGING DRAWER, 34 1/2" HIGH, 24" DEEP

storage SOLUTIONS

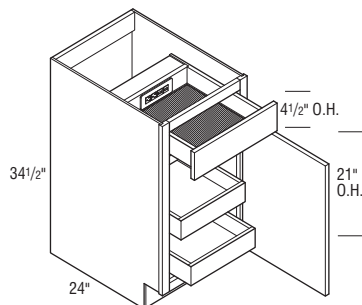

## Model

### B18CHGDRWT L or R

- Contains two easily adjustable roll trays.
- Charging drawer has full extension, concealed Smart Stop slides.
- 110 lb. rated.
- 120V outlet must be installed in rear of cabinet within 10" of bottom of drawer, in rear of cabinet.
- CUL US listed power strip with two 120V plugs and two 2.1 amp USB ports.
- Max Current: AC 15 amps @ 120VAC; USB 2.1 amp and 5 VDC each.
- Tamper resistant outlets.
- Power cord with NEMA 5-15 plug.
- Integrated cord guide mounts to cabinet side to ensure safe operation.
- Black, shock absorbing mat included.
- Special sizes not available.
- Only available in 24" deep.
- Not available on Inset or Beaded Inset Styles.

#### Door & Drawer Options

AF	AOMBWB	CC	CG	ESMD	GAMD	IFHG	MD	PRMD	PTOWB	SHMD	SPLITDR	SPLITDRWS	SUMD	TCP
			✓	✓	✓	✓	✓	✓	✓	✓				✓

#### End Panel Options

AUTH	CSFPE	EXBK	FFD	FPE	INTGE	IPE
✓	✓			✓	✓	✓

#### Custom Modification Options

ADD_SHLF	ADDTK	CBO	CCO	CFNTD	CFP	CFRMO	CHGDRW	CLIP <sup>1</sup>	CMAT	CND	CSDGBK	DRT	DRWTK	EF	EX	EX_OL	FBFL	FD	
			✓	✓	✓	✓	✓	✓	✓	✓	✓	✓	✓	✓	✓	✓	✓	✓	✓

FDSRTBTM	FLUT <sup>2</sup>	FTK	ID	IH	IH+DRW	INVERM	IW	LIGHT	MIP	OBRB	PFINBTMB	RD	RECTK	RH	ROSFLUT	RT
	✓			✓	✓	✓	✓	✓	✓	✓	✓	✓	✓	✓	✓	✓

RW	SBCADDY	SBCADDYSM	SCPDRW	STW	TD	TKP	TVR	UDBX	URT	VTK	WS <sup>3</sup>	WTC	WTKCUP	WTR
		✓	✓	✓	✓	✓	✓	✓	✓	✓	✓	✓	✓	✓

<sup>1</sup>Not available with clipped both.

<sup>2</sup>Not available with 6" fluting or fluting both.

<sup>3</sup>Not available with WSR1.5, WSL1.5, WSL&R3.

## BASE with WOOD TIERED CUTLERY DIVIDER, 34 1/2" HIGH, 24" DEEP

storage SOLUTIONS

### B15WTCD L or R

### B18WTCD L or R

### B21WTCD L or R

### B24WTCD L or R

### B24WTCD

### B30WTCD

### B36WTCD



Notes below apply to all products in section above:

- One adjustable half shelf.
- Exterior Wood Tiered Cutlery Divider drawer box height is 3 3/4", interior height of top tier is 1 5/8", and interior height of bottom tier is 1 3/8".

#### Door & Drawer Options

AF	AOMBWB	CC	CG	ESMD	GAMD	IFHG	MD	PRMD	PTOWB	SHMD	SPLITDR	SPLITDRWS	SUMD	TCP
			✓	✓	✓	✓	✓	✓	✓	✓				✓

#### End Panel Options

AUTH	CSFPE	EXBK	FFD	FPE	INTGE	IPE
✓	✓	✓	✓	✓	✓	✓

#### Custom Modification Options

ADD_SHLF	ADDTK	CBO	CCO	CFNTD	CFP	CFRMO	CHGDRW	CLIP <sup>1</sup>	CMAT	CND	CSDGBK	DRT	DRWTK <sup>2</sup>	EF	EX	EX_OL	FBFL	FD	
			✓	✓	✓	✓	✓	✓	✓	✓	✓	✓	✓	✓	✓	✓	✓	✓	✓

FDSRTBTM	FLUT <sup>3</sup>	FTK	ID	IH	IH+DRW	INVERM	IW	LIGHT	MIP	OBRB	PFINBTMB	RD	RECTK	RH	ROSFLUT	RT
	✓			✓	✓	✓	✓	✓	✓	✓	✓	✓	✓	✓	✓	✓

RW	SBCADDY	SBCADDYSM	SCPDRW	STW	TD	TKP	TVR	UDBX	URT	VTK	WS <sup>4</sup>	WTC	WTKCUP	WTR
		✓	✓	✓	✓	✓	✓	✓	✓	✓	✓	✓	✓	✓

<sup>1</sup>Not available on 15" or 24" (2 doors) wide.

<sup>2</sup>Not available on 15"-21" wide.

<sup>3</sup>6" fluting not available on 15", 18" or 24" (2 doors) wide and not available with 6" fluting both.

<sup>4</sup>Not available on 15" or 24" (2 doors) wide. Not available with wide stiles 1.5" except wide stile both 1.5". Wide stile both 3" only available on 24" (1 door) wide.

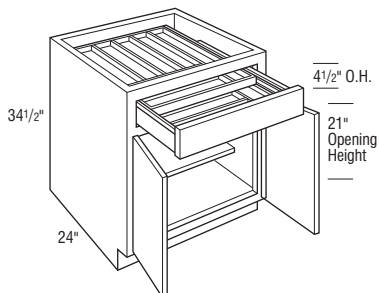
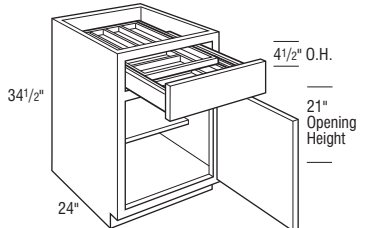

# Base Cabinets

## Description

**NEW** BASE with WOOD TIERED CUTLERY DIVIDER and ROLL TRAYS, 34 1/2" HIGH, 24" DEEP storage SOLUTIONS

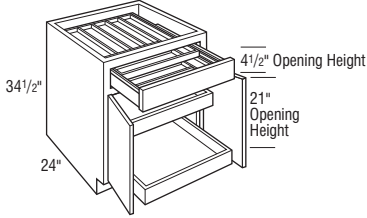
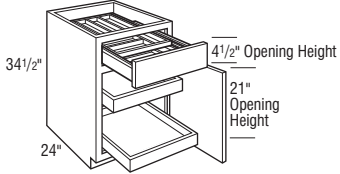

## Model

B15RTWTC D L or R  
 B18RTWTC D L or R  
 B21RTWTC D L or R  
 B24RTWTC D L or R

B24RTWTC D  
 B30RTWTC D  
 B36RTWTC D

Notes below apply to all products in section above:

- Two roll trays standard.
- Includes Wood Tiered Cutlery Divider Drawer.
- Exterior Wood Tiered Cutlery Divider drawer box height is 3 3/4", interior height of top tier is 1 5/8", and interior height of bottom tier is 1 3/8".
- Cabinet may accommodate up to four roll trays, which may be purchased separately for field installation. See page S•9.
- Wood Tiered Cutlery Divider Drawer is also available as an accessory for field installation. See page S•5.
- For Inset and Beaded Inset styles opening sizes, see pages F•14-F•18.

### Door & Drawer Options

AF	AOMBWB	CC	CG	ESMD	GAMD	IFHG	MD	PRMD	PTOWB	SHMD	SPLITDR	SPLITDRWS	SJMD	TCP
			✓	✓	✓	✓	✓	✓		✓				✓

### End Panel Options

AUTH	CSFPE	EXBK	FFD <sup>1</sup>	FPE	INTGE	IPE
✓	✓		✓	✓	✓	✓

### Custom Modification Options

ADD	SHLF	ADTK	CBO	CCO	CFNTD	CFP	CFRMO	CHGDRW	CLIP <sup>2</sup>	CMAT	CND	CSDGBK	DRT	DRWTK	EF	EX	EX_OL	FBFL	FD
			✓	✓	✓		✓		✓		✓	✓	✓	✓	✓	✓	✓	✓	✓

FDSRTBTM	FLUT <sup>3</sup>	FTK <sup>1</sup>	ID	IH	IH+DRW	INVFRM	IW	LIGHT	MIP	OBRB	PFINBTMB	RD	RECTK	RH	ROSFLUT <sup>1</sup>	RT
	✓	✓			✓				✓	✓			✓		✓	✓

RW	SBCADDY	SBCADDYSM	SCPDRW	STW	TD	TKP	TVR	UDBX	URT	VTK	WS <sup>4</sup>	WTCD	WTKCUP	WTR
							✓	✓		✓	✓			

<sup>1</sup>Only available on 30" and 36" wide.

<sup>2</sup>Clipped both and Clipped 6" not available on 15" or 18" wide. Clipped both 6" only available on 30" and 36" wide. Not available on CLIPL and CLIPR not available on 30" or 36" wide.

<sup>3</sup>Fluting both and 6" fluting not available on 15" or 18" wide. Fluting both 6" only available on 30" and 36" wide. Not available on FLUT3L and FLUT3R not available on 30" or 36" wide.

<sup>4</sup>Not available on 15" wide. WSL&R3 not available on 15" or 18" wide.

IH/RH availability charts starting on page G•40.  
 IW/RW availability charts starting on page G•46.

## Description

**NEW** BASE with CUTLERY INSERT  
WOOD DIVIDERS, 34 1/2" HIGH,  
24" DEEP

## storage SOLUTIONS

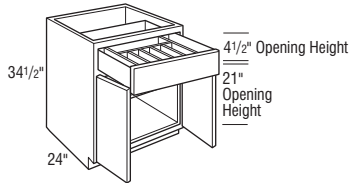
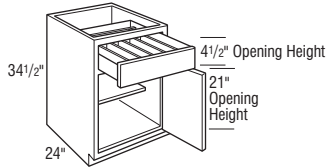

## Model

**B15CIW L or R**

**B18CIW L or R**

**B21CIW L or R**

**B24CIW L or R**

## B24CIW

Notes below apply to all products in section above:

- Includes one adjustable half shelf.
- Includes Cutlery Insert Wood Divider.
- Features hard wood.
- Cutlery Insert Wood Divider is also available as an accessory for field installation. See page S•5.
- For Inset and Beaded Inset styles opening sizes, see pages F•14-F•18.

### Door & Drawer Options

AF	AOMBWB	CC	CG	ESMD	GAMD	IFHG	MD <sup>1</sup>	PRMD <sup>1</sup>	PTOWB	SHMD	SPLITDR	SPLITDRWS <sup>2</sup>	SJMD	TCP
		✓					✓	✓				✓		

### End Panel Options

AUTH	CSFPE	EXBK	FFD	FPE	INTGE	IPE
✓	✓	✓	✓	✓	✓	✓

### Custom Modification Options

ADD_SHLF	ADDTK	CBO	CCO	CFNTO	CFP	CFRMO	CHGDRW	CLIP <sup>1</sup>	CMAT	CND	CSDGBK	DRT	DRWTK	EF	EX	EX_OL	FBFL	FD	
		✓	✓	✓	✓	✓	✓	✓		✓	✓	✓	✓	✓	✓	✓	✓	✓	✓

FDSRTBTM	FLUT <sup>3</sup>	FTK	ID	IH	IH+DRW	INVERM	IW <sup>4</sup>	LIGHT	MIP	OBRB	PFINBTMB	RD	RECTK	RH	ROSFLUT	RT
✓	✓	✓				✓	✓	✓	✓	✓		✓	✓	✓	✓	✓

RW	SBCADDY <sup>1</sup>	SBCADDYSM	SCPDWR	STW	TD	TKP	TVR <sup>5</sup>	UDBX	URT	VTK	WS <sup>1</sup>	WTCD	WTKCUP <sup>1</sup>	WTR
	✓	✓	✓	✓	✓	✓	✓	✓	✓	✓	✓	✓	✓	✓

<sup>1</sup>Not available on 24" (2 doors) wide.

<sup>2</sup>Only available on 24" (1 door) wide.

<sup>3</sup>6" fluting not available on 15" or 24" (2 doors) wide, and FLUT6B is only available on 24" (1 door) wide.

<sup>4</sup>Not available on 24" wide.

<sup>5</sup>Not available on 18", 21" or 24" (2 doors) wide.



# Base Cabinets

## Description

**NEW** BASE with CUTLERY INSERT WOOD DIVIDERS and ROLL TRAYS, 34 1/2" HIGH, 24" DEEP

## storage SOLUTIONS

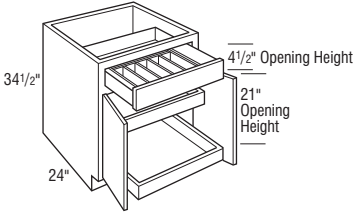
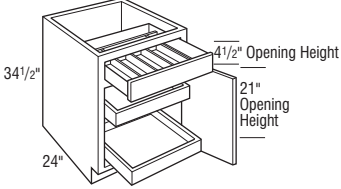

## Model

**B15RTCIW L or R**

**B18RTCIW L or R**

**B21RTCIW L or R**

**B24RTCIW L or R**

## B24RTCIW

Notes below apply to all products in section above:

- Two roll trays standard.
- Includes Cutlery Insert Wood Divider.
- Features hard wood.
- Cabinet may accommodate up to four roll trays, which may be purchased separately for field installation. See page S•9.
- Cutlery Insert Wood Divider is also available as an accessory for field installation. See page S•5.
- For Inset and Beaded Inset styles opening sizes, see pages F•14-F•18.

### Door & Drawer Options

AF	AOMBWB	CC	CG	ESMD	GAMD	IFHG	MD	PRMD	PTOWB	SHMD	SPLITDR	SPLITDRWS <sup>1</sup>	SUMD	TCP
			✓				✓	✓				✓		

### End Panel Options

AUTH	CSFPE	EXBK	FFD	FPE	INTGE	IPE
✓	✓	✓	✓	✓	✓	✓

### Custom Modification Options

ADD	SHLF	ADDTK	CBO	CCO	CFNTO	CFP	CFRMO	CHGDRW	CLIP <sup>2</sup>	CMAT	CND	CSDGBK	DRT	DRWTK	EF	EX	EX_OL	FBFL	FD	
			✓	✓	✓	✓	✓		✓		✓	✓	✓	✓	✓	✓	✓	✓	✓	✓

FDSRTBTM	FLUT <sup>3</sup>	FTK	ID <sup>2</sup>	IH	IH+DRW	INVFRM	IW <sup>4</sup>	LIGHT	MIP	OBRB	PFINBTMB	RD	RECTK	RH	ROSLUT	RT
	✓	✓	✓	✓	✓	✓	✓	✓	✓	✓	✓	✓	✓	✓	✓	✓

RW	SBCADDY	SBCADDYSM	SCPDRW	STW	TD	TKP	TVR	UDBX <sup>5</sup>	URT	VTK	WS <sup>6</sup>	WTCD	WTKCUP	WTR
			✓				✓	✓	✓	✓	✓	✓	✓	✓

<sup>1</sup>Only available on 24" (1 door) wide.

<sup>2</sup>Not available on 24" (2 doors) wide.

<sup>3</sup>6" fluting not available on 15" wide and FLUT6B not available.

<sup>4</sup>Not available on 24" (1 door) wide.

<sup>5</sup>Only available on 24" (2 doors) wide.

<sup>6</sup>WSB3 not available on 15" wide and WSR1.5 and WSL1.5 not available on 24" (1 door) wide. Not available on 24" (1 door) wide.

BASE with WOOD TIERED K-CUP\* DRAWER, 34 1/2" HIGH, 24" DEEP

## storage SOLUTIONS

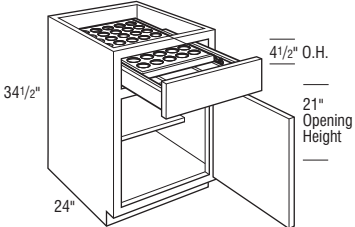

## B18KCUP L or R

- One adjustable half shelf.
- Holds 40 K-Cups.
- The Wood Tiered K-Cup Drawer is compatible with K-Cup pods only.
- Exterior Wood Tiered K-Cup drawer box height is 3 3/4", interior height of top tier is 1 5/8", and interior height of bottom tier is 1 3/8".

\*K-Cup is a registered trademark of Keurig Green Mountain, Inc.

### Door & Drawer Options

AF	AOMBWB	CC	CG	ESMD	GAMD	IFHG	MD	PRMD	PTOWB	SHMD	SPLITDR	SPLITDRWS	SUMD	TCP
			✓				✓			✓				

### End Panel Options

AUTH	CSFPE	EXBK	FFD	FPE	INTGE	IPE
✓	✓	✓	✓	✓	✓	✓

### Custom Modification Options

ADD	SHLF	ADDTK	CBO	CCO	CFNTO	CFP	CFRMO	CHGDRW	CLIP	CMAT	CND	CSDGBK	DRT	DRWTK	EF	EX	EX_OL	FBFL	FD
			✓	✓	✓	✓	✓				✓	✓	✓	✓	✓	✓	✓	✓	✓

FDSRTBTM	FLUT <sup>1</sup>	FTK	ID	IH	IH+DRW	INVFRM	IW	LIGHT	MIP	OBRB	PFINBTMB	RD	RECTK	RH	ROSLUT	RT
	✓	✓	✓	✓	✓	✓	✓	✓	✓	✓	✓	✓	✓	✓	✓	✓

RW	SBCADDY	SBCADDYSM	SCPDRW	STW	TD	TKP	TVR	UDBX	URT	VTK	WSWCDWTKCUPWTR
			✓				✓	✓	✓	✓	✓

<sup>1</sup>Not available with 6" fluting.

IH/RH availability charts starting on page G•40.  
IW/RW availability charts starting on page G•46.

## Description



### BASE with WOOD TIERED K-CUP\* DRAWER and ROLL TRAYS, 34 1/2" HIGH, 24" DEEP

#### storage SOLUTIONS

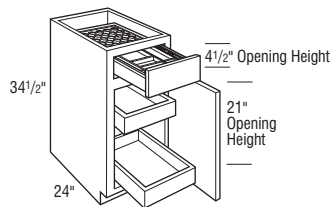

## Model

### B18KUPRT L or R

- Two roll trays standard.
- Cabinet may accommodate up to four roll trays, which may be purchased separately for field installation. See page S●9.
- Holds 40 K-Cups.
- The Wood Tiered K-Cup Drawer is compatible with K-Cup pods only.
- Exterior Wood Tiered K-Cup drawer box height is 3 3/4", interior height of top tier is 1 5/8", and interior height of bottom tier is 1 3/8".
- For Inset and Beaded Inset styles opening sizes, see pages F●14-F●18.

\*K-Cup is a registered trademark of Keurig Green Mountain, Inc.

#### Door & Drawer Options

AF	AOMBWB	CC	CG	ESMD	GAMD	IFHG	MD	PRMD	PTOWB	SHMD	SPLITDR	SPLITDRWS	SUMD	TCP
		✓	✓	✓	✓	✓	✓	✓		✓				✓

#### End Panel Options

AUTH	CSFPE	EXBK	FFD	FPE	INTGE	IPE
✓	✓			✓	✓	✓

#### Custom Modification Options

ADD_SHLF	ADDTK	CBO	CCO	CFNTD	CFP	CFRMO	CHGDRW	CLIP <sup>1</sup>	CMAT	CND	CSDGBK	DRT	DRWTK	EF	EX	EX_OL	FBFL	FD
		✓	✓	✓				✓		✓	✓	✓	✓	✓	✓	✓	✓	

FDSRTBTM	FLUT <sup>2</sup>	FTK	ID	IH	IH+DRW	INVERM	IW	LIGHT	MIP	OBRB	PFINBTMB	RD	RECTK	RH	ROSLUT	RT
	✓				✓				✓	✓						

RW	SBCADDY	SBCADDYSM	SCPDWR	STW	TD	TKP	TVR	UDBX	URT	VTK	WS	WTCD	WTKCUP	WTR
						✓	✓			✓	✓			

<sup>1</sup>Not available with 6" clipped corners.

<sup>2</sup>Not available with fluting both or 6" fluting.



### BASE with FOOD STORAGE CONTAINER ORGANIZER, 34 1/2" HIGH, 24" DEEP

#### storage SOLUTIONS

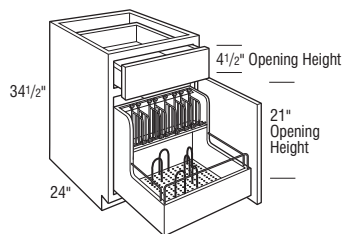

### B18FSCO L or R

### B24FSCO L or R

- Pull-out features natural finished hardwood dovetailed box with chrome rails on lower section with undermount Smart Stop guides.
- Includes seven chrome "U" pegs to use on the pegboard bottom to customize the fit to container sizes.
- Adjustable clip-on lid dividers included to fit with a variety of lid shapes. 18" wide includes five dividers, 24" wide includes eight dividers.
- Front of pull-out is routed for easy access.
- 18" wide cabinet pull-out dimensions: 14 1/2" W x 21 1/2" D x 18" H.
- 24" wide cabinet pull-out dimensions: 20 1/2" W x 21 1/2" D x 18" H.
- Not available on Inset and Beaded Inset styles.

#### Door & Drawer Options

AF	AOMBWB	CC	CG	ESMD	GAMD	IFHG	MD	PRMD	PTOWB	SHMD	SPLITDR	SPLITDRWS	SUMD	TCP
		✓	✓	✓	✓	✓	✓	✓		✓				✓

#### End Panel Options

AUTH	CSFPE	EXBK	FFD	FPE	INTGE	IPE
✓	✓			✓	✓	✓

#### Custom Modification Options

ADD_SHLF	ADDTK	CBO	CCO	CFNTD	CFP	CFRMO	CHGDRW <sup>1</sup>	CLIP	CMAT	CND	CSDGBK	DRT	DRWTK	EF	EX	EX_OL	FBFL	FD
		✓	✓	✓			✓			✓	✓	✓	✓	✓	✓	✓	✓	

FDSRTBTM	FLUT	FTK	ID	IH	IH+DRW	INVERM	IW	LIGHT	MIP	OBRB	PFINBTMB	RD	RECTK	RH	ROSLUT	RT
					✓				✓	✓						

RW	SBCADDY	SBCADDYSM	SCPDWR	STW	TD	TKP	TVR	UDBX	URT	VTK	WS	WTCD	WTKCUP	WTR
						✓	✓			✓	✓			

<sup>1</sup>Only available on 18" wide.

# Base Cabinets

## Description

**FULL HEIGHT BASE, 34 1/2" HIGH,  
24" DEEP**

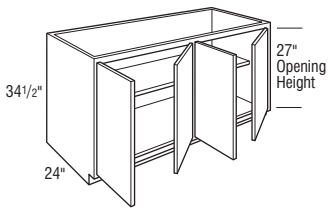
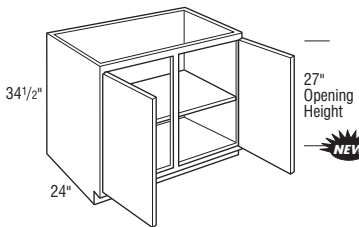
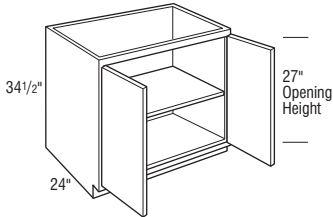
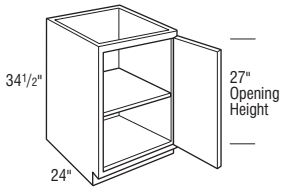

## Model

**B6FH L or R**  
**B9FH L or R**  
**B12FH L or R**  
**B15FH L or R**  
**B18FH L or R**  
**B21FH L or R**  
**B24FH L or R**

**B24FH**  
**B27FH**  
**B30FH**  
**B33FH**  
**B36FH**  
**B39FH**

**B42FH**  
**B45FH**  
**B48FHCS**

### **B48FH**

- Two sets of butt doors.

Notes below apply to all products in section above:

- One adjustable Full Depth Shelf.
- Reduced Depths available in 1/4" increments from 6" to 23 3/4".
- Increased Depths available in 1/4" increments from 24 1/4" to 30".
- 6" not available with Insert or Beaded Inset styles.
- Utilizes a slab door on cabinets up to 9" wide.

### Door & Drawer Options

AE <sup>1</sup>	AOMBWB	CC	CG <sup>1</sup>	ESMD <sup>2</sup>	GAMD <sup>2</sup>	IFHG	MD <sup>2</sup>	PRMD <sup>3</sup>	PTOWB	SHMD <sup>2</sup>	SPLITDR <sup>4</sup>	SPLITDRWS	SUMD <sup>2</sup>	TCP
✓	✓	✓	✓	✓	✓	✓	✓	✓	✓	✓	✓	✓	✓	✓

### End Panel Options

AUTH	CSFPE	EXBK	FFD	FPE	INTGE <sup>1</sup>	IPE <sup>1</sup>
✓	✓	✓	✓	✓	✓	✓

### Custom Modification Options

ADD	SHLF	ADDTK	CBO	CCO	CFNTO	CFP	CFRMO	CHGDRW	CLIP <sup>5</sup>	CMAT	CND	CSDGBK <sup>1</sup>	DRT	DRWTK <sup>6</sup>	EF	EX	EX	OL	FBFL	FD
✓	✓	✓	✓	✓	✓	✓	✓	✓	✓	✓	✓	✓	✓	✓	✓	✓	✓	✓	✓	✓

FDSRTBTM <sup>2</sup>	FLUT <sup>7</sup>	FTK <sup>8</sup>	ID	IH	IH+DRW	INVFRM	IW <sup>9</sup>	LIGHT	MIP	OBRB	PFINBTMB	RD	RECTK <sup>10</sup>	RH	ROSLUT <sup>11</sup>	RT <sup>1</sup>
✓	✓	✓	✓	✓	✓	✓	✓	✓	✓	✓	✓	✓	✓	✓	✓	✓

RW	SBCADDY <sup>12</sup>	SBCADDYSM <sup>13</sup>	SCPDWR	STW	TD <sup>1</sup>	TKP	TVR <sup>10</sup>	UBBX	URT <sup>14</sup>	VTK	WS <sup>15</sup>	WTCB	WTKCUP	WTR
✓	✓	✓	✓	✓	✓	✓	✓	✓	✓	✓	✓	✓	✓	✓

<sup>1</sup>Not available on 6" wide.

<sup>2</sup>Not available on 6" or 9" wide.

<sup>3</sup>Not available on 6", 9", 12", or 24" (2 doors) wide.

<sup>4</sup>Only available on 30"-39" wide.

<sup>5</sup>Not available on 6", 9", 12", or 24" (2 doors) wide.

<sup>6</sup>Only available on 24" (1 door), 30" and 36" wide.

<sup>7</sup>Not available on 24" (2 doors) or 27" wide. Fluting both 3" only available on 15"-21" wide. 6" fluting not available on 6"-21" wide and fluting both 6" not available.

<sup>8</sup>FTKAV not available on 6", 9" or 12" wide.

<sup>9</sup>Not available on 48" wide.

<sup>10</sup>Not available on 9", 42", 45", or 48" wide. TVRAV not available on 6" or 12" wide.

<sup>11</sup>Not available on 24" (2 doors) or 27" wide. Fluting both only available on 15"-21" wide.

<sup>12</sup>Not available on 6", 9", 12", or 45" wide.

<sup>13</sup>Not available on 6", 9" or 45" wide.

<sup>14</sup>Only available on 24" (1 door and 2 doors)-36" wide.

<sup>15</sup>Not available on 6"-9" wide and wide stile both 3" not available on 12" wide.

IH/RH availability charts starting on page G•40.  
 IW/RW availability charts starting on page G•46.

## Description



**FULL HEIGHT BASE, 40 1/2" HIGH, 24" DEEP**

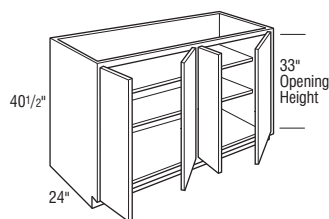
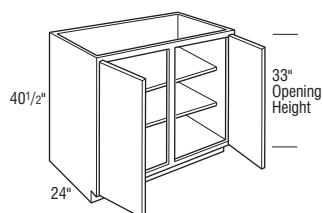
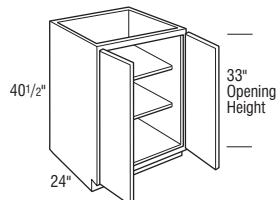
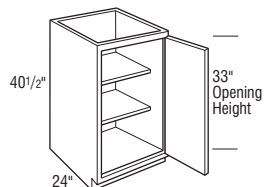

## Model

**B940FH L or R**

**B1240FH L or R**

**B1540FH L or R**

**B1840FH L or R**

**B2140FH L or R**

**B2440FH L or R**

**B2440FH**

**B2740FH**

**B3040FH**

**B3340FH**

**B3640FH**

**B3940FH**

**B4240FH**

**B4540FH**

**B4840FHCS**

**B4840FH**

- Two sets of butt doors.

Notes below apply to all products in section above:

- Two adjustable shelves.
- Reduced Depths available in 1/4" increments from 6" to 23 3/4".
- Increased Depths available in 1/4" increments from 24 1/4" to 30".

### Door & Drawer Options

AF	AOMBWB	CC	CG	ESMD	GAMD	IFHG	MD <sup>1</sup>	PRMD <sup>1</sup>	PTOWB	SHMD	SPLITDR	SPLITDRWS	SUMD	TCP

### End Panel Options

AUTH	CSFPE	EXBK	FFD	FPE	INTGE	IPE

### Custom Modification Options

ADD	SHLF	ADDTK	CBO	CCO	CFNTO	CFP	CFRMO	CHGDRW	CLIP <sup>2</sup>	CMAT	CND	CSDGBK	DRT	DRWTK <sup>3</sup>	EF	EX	EX_OL	FBFL	FD	

FDSRTBTM <sup>1</sup>	FLUT <sup>4</sup>	FTK <sup>5</sup>	ID	IH	IH+DRW	INVFRM	IW <sup>6</sup>	LIGHT	MIP	OBRB	PFINBTMB	RD	RECTK	RH	ROSFLUT <sup>7</sup>	RT <sup>1</sup>

RW	SBCADDY <sup>8</sup>	SBCADDYSM <sup>1</sup>	SCPDRW	STW	TD	TKP	TVR <sup>9</sup>	UDBX	URT <sup>10</sup>	VTK	WS <sup>11</sup>	WTCB	WTKCUP	WTR

<sup>1</sup>Not available on 9" wide.

<sup>2</sup>Not available on 9"-12" wide or 24" (2 doors) wide.

<sup>3</sup>Not available on 9", 39"-48" wide.

<sup>4</sup>6" fluting only available on 24" (1 door) wide. Not available on 24" (2 doors) or 27" wide.

<sup>5</sup>FTKAV not available on 9"-12" wide.

<sup>6</sup>Not available on 48" wide.

<sup>7</sup>Not available on 24" (2 doors) or 27" wide.

<sup>8</sup>Not available on 9"-12" wide.

<sup>9</sup>Not available on 9" wide or 42"-48" wide and TVRAV not available on 9"-12".

<sup>10</sup>Only available on 24"-36" wide.

<sup>11</sup>Not available on 9" wide and WS83 not available on 9"-12" wide.

# Base Cabinets

## Description

**NEW** FULL HEIGHT BASE with ROLL TRAYS, 34 1/2" HIGH, 24" DEEP

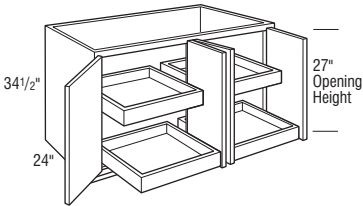
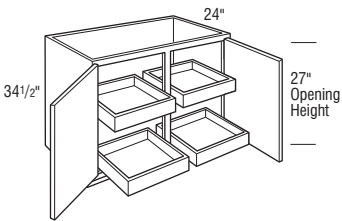
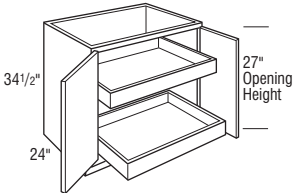
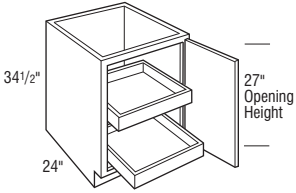

## Model

B12FHRT L or R

B15FHRT L or R

B18FHRT L or R

B21FHRT L or R

B24FHRT L or R

B24FHRT

B27FHRT

B30FHRT

B33FHRT

B36FHRT

B39FHRT

B42FHRT

B45FHRT

B48FHCSRT

B48FHRT

- Two sets of butt doors.

Notes below apply to all products in section above:

- Two roll trays standard.
- Cabinet may accommodate up to five roll trays, which may be purchased separately for field installation. See page S•9.
- Reduced Depths available in 1/4" increments from 12" to 23 3/4".

### Door & Drawer Options

AF	AOMBWB	CC	CG	ESMD	GAMD	IFHG	MD	PRMD	PTOWB	SHMD	SPLITDR	SPLITDRWS	SUMD	TCP
			✓				✓	✓						

### End Panel Options

AUTH	CSFPE	EXBK	FFD	FPE	INTGE	IPE
✓	✓	✓	✓	✓	✓	✓

### Custom Modification Options

ADD	SHLF	ADDTK	CBO	CCO	CFNTD	CFP	CFRMO	CHGDRW	CLIP <sup>1</sup>	CMAT	CND	CSDGBK	DRT	DRWTK	EF	EX	EX_OL	FBFL	FD
			✓	✓	✓	✓	✓	✓	✓	✓	✓	✓	✓	✓	✓	✓	✓	✓	✓

FDSRTBTM	FLUT <sup>2</sup>	FTK <sup>3</sup>	ID	IH	IH+DRW	INVFRM	IW <sup>4</sup>	LIGHT	MIP	OBRB	PFINBTMB	RD	RECTK	RH	ROSFLOT <sup>5</sup>	RT
	✓	✓					✓	✓	✓	✓	✓	✓	✓	✓	✓	✓

RW	SBCADDY	SBCADDYSM	SCPDRW	STW	TD	TKP	TVR <sup>6</sup>	UDBX	URT <sup>7</sup>	VTK	WS <sup>8</sup>	WTCD	WTKCUP	WTR
							✓	✓	✓	✓	✓			✓

<sup>1</sup>Not available on 12" or 24" (2 doors) wide.

<sup>2</sup>6" fluting only available on 24" wide. Not available on 24" (2 doors) or 27" wide.

<sup>3</sup>FTKAV not available on 12" wide.

<sup>4</sup>Not available on 48" wide.

<sup>5</sup>Not available on 24" (2 doors) or 27" wide.

<sup>6</sup>TVRAV not available on 12". Not available on 39"-42" wide.

<sup>7</sup>Only available on 24"-36" wide.

<sup>8</sup>WSB3 not available on 12" wide.

IH/RH availability charts starting on page G•40.  
IW/RW availability charts starting on page G•46.

## Description



**FULL HEIGHT BASE with ROLL TRAYS, 40 1/2" HIGH, 24" DEEP**

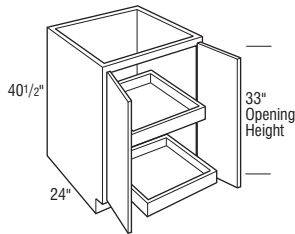
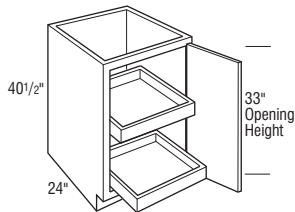

## Model

**B1540FHRT L or R**

**B1840FHRT L or R**

**B2140FHRT L or R**

**B2440FHRT L or R**

**B2440FHRT**

**B2740FHRT**

Notes below apply to all products in section above:

- Two roll trays standard.
- Cabinet may accommodate up to five roll trays, which may be purchased separately for field installation. See page S99.
- Reduced Depths available in 1/4" increments from 12" to 23 3/4".

### Door & Drawer Options

AF	AOMBWB	CC	CG	ESMD	GAMD	IFHG	MD	PRMD	PTOWB	SHMD	SPLITDR	SPLITDRWS	SUMD	TCP
			✓				✓	✓						

### End Panel Options

AUTH	CSFPE	EXBK	FFD	FPE	INTGE	IPE
✓	✓	✓	✓	✓	✓	✓

### Custom Modification Options

ADD	SHLF	ADDTK	CBO	CCO	CFNTD	CFP	CFRMO	CHGDRW	CLIP <sup>1</sup>	CMAT	CND	CSDGBK	DRT	DRWTK	EF	EX	EX_OL	FBFL	FD
			✓	✓	✓		✓		✓		✓	✓	✓	✓	✓	✓	✓	✓	✓

FDSRTBTM	FLUT <sup>2</sup>	FTK	ID	IH	IH+DRW	INVFRM	IW	LIGHT	MIP	OBRB	PFINBTMB	RD	RECTK	RH	ROSFLOT <sup>3</sup>	RT
	✓	✓					✓		✓	✓		✓	✓	✓	✓	

RW	SBCADDY	SBCADDYSM	SCPDRW	STW	TD	TKP	TVR	UDBX	URT <sup>4</sup>	VTK	WS	WTCD	WTKCUP	WTR
							✓	✓	✓	✓	✓		✓	✓

<sup>1</sup>Not available on 24" (2 doors) wide.

<sup>2</sup>6" fluting only available on 24" (1 door) wide. Not available on 24" (2 doors) or 27" wide.

<sup>3</sup>Not available on 24" (2 doors) or 27" wide.

<sup>4</sup>Only available on 24"-27" wide.

## BASE EASY ACCESS STORAGE, 34 1/2" HIGH, 24" DEEP

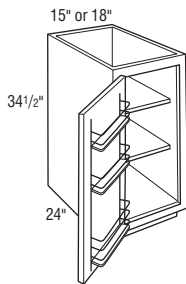

**BEAS15 L or R**

**BEAS18 L or R**

- Two adjustable 19 1/4" deep shelves.
- Door includes a three-tiered chrome rack with wood bottoms.
- Not available on Inset and Beaded Inset styles.

### Door & Drawer Options

AF	AOMBWB	CC	CG	ESMD	GAMD	IFHG	MD	PRMD	PTOWB	SHMD	SPLITDR	SPLITDRWS	SUMD	TCP
						✓				✓				

### End Panel Options

AUTH	CSFPE	EXBK	FFD	FPE	INTGE	IPE
✓	✓	✓	✓	✓	✓	✓

### Custom Modification Options

ADD	SHLF	ADDTK	CBO	CCO	CFNTD	CFP	CFRMO	CHGDRW	CLIP	CMAT	CND	CSDGBK	DRT	DRWTK	EF	EX	EX_OL	FBFL	FD
			✓	✓	✓		✓				✓	✓	✓	✓	✓	✓	✓	✓	✓

FDSRTBTM	FLUT <sup>1</sup>	FTK	ID	IH	IH+DRW	INVFRM	IW	LIGHT	MIP	OBRB	PFINBTMB	RD	RECTK	RH	ROSFLOT	RT
	✓	✓	✓						✓	✓		✓	✓	✓	✓	

RW	SBCADDY	SBCADDYSM	SCPDRW	STW	TD	TKP	TVR	UDBX	URT	VTK	WS	WTCD	WTKCUP	WTR
											✓		✓	✓

<sup>1</sup>Not available with 6" fluting.

# Base Cabinets

## Description

**BASE with TWO SPLIT DRAWERS,  
34 1/2" HIGH, 24" DEEP**

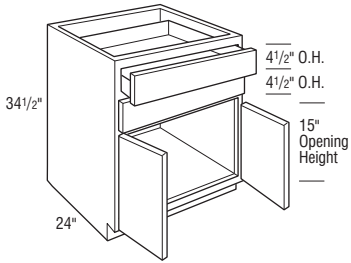
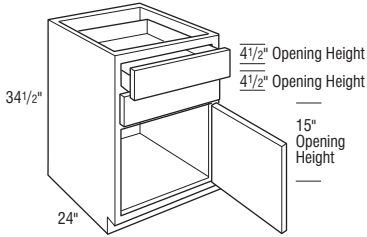

## Model

**B2D9 L or R**

**B2D12 L or R**

**B2D15 L or R**

**B2D18 L or R**

**B2D21 L or R**

**B2D24 L or R**

**B2D24**

**B2D27**

**B2D30**

**B2D33**

**B2D36**

Notes below apply to all products in section above:

- No shelving in door section.
- Reduced Depths available in 1/4" increments from 12" to 23 3/4".

### Door & Drawer Options

AF	AOMBWB	CC	CG	ESMD <sup>1</sup>	GAMD <sup>1</sup>	IFHG	MD <sup>1</sup>	PRMD <sup>2</sup>	PTOWB	SHMD <sup>1</sup>	SPLITDR <sup>3</sup>	SPLITDRWS	SUMD <sup>1</sup>	TCP	

### End Panel Options

AUTH	CSFPE	EXBK	FFD	FPE	INTGE	IPE

### Custom Modification Options

ADD	SHLF	ADDTK	CBO	CCO	CFNTO	CFP	CFRMO	CHGDRW <sup>4</sup>	CLIP <sup>5</sup>	CMAT	CND	CSDGBK	DRT	DRWTK <sup>6</sup>	EF	EX	EX_OL	FBFL	FD	

FDSRTBTM	FLUT <sup>7</sup>	FTK <sup>8</sup>	ID	IH	IH+DRW	INVFRM	IW <sup>9</sup>	LIGHT	MIP	OBRB	PFINBTMB	RD	RECTK	RH	ROSFLUT	RT

RW	SBCADDY	SBCADDYSM	SCPDRW	STW	TD	TKP	TVR	UDBX <sup>10</sup>	URT	VTK	WS <sup>11</sup>	WTC <sup>12</sup>	WTKCUP <sup>4</sup>	WTR

<sup>1</sup>Not available on 9" wide.

<sup>2</sup>Not available on 9", 12" or 24" (2 doors) wide.

<sup>3</sup>Not available on 9" x 24" (1 door) wide.

<sup>4</sup>Only available on 18" wide.

<sup>5</sup>Not available on 9", 12" or 24" (2 doors) wide.

<sup>6</sup>Only available on 24" (1 door and 2 doors), 30" and 36" wide.

<sup>7</sup>6" fluting not available on 9", 12", 15", or 24" (2 doors) wide. Fluting both 6" not available on 18" or 21" wide.

<sup>8</sup>FTKAV not available on 9" or 12" wide.

<sup>9</sup>Not available on 24" (1 door) wide.

<sup>10</sup>Not available on 9" x 21" wide.

<sup>11</sup>Not available on 9" wide and wide stile both 3" not available on 12" wide.

<sup>12</sup>Only available on 15", 18", 21", 24", 30", and 36" wide.

IH/RH availability charts starting on page G-40.  
IW/RW availability charts starting on page G-46.

## Description

**BASE with TWO SPLIT DRAWERS and ROLL TRAY, 34 1/2" HIGH, 24" DEEP**

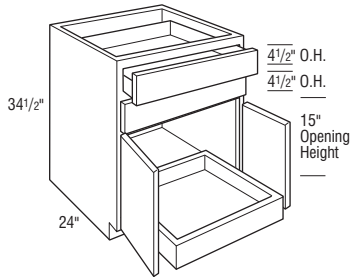
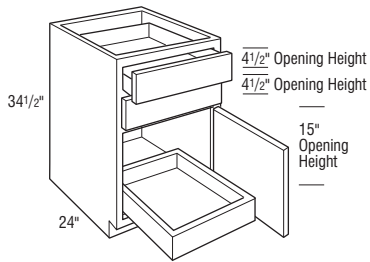

## Model

**B2D12RT L or R**

**B2D15RT L or R**

**B2D18RT L or R**

**B2D21RT L or R**

**B2D24RT L or R**

**B2D24RT**

**B2D27RT**

**B2D30RT**

**B2D33RT**

**B2D36RT**

Notes below apply to all products in section above:

- No shelving in door section.
- Contains one easily adjustable roll tray.
- Reduced Depths available in 1/4" increments from 12 1/4" to 23 3/4".

### Door & Drawer Options

AF	AOMBWB	CC	CG	ESMD	GAMD	IFHG	MD	PRMD <sup>1</sup>	PTOWB	SHMD	SPLITDR <sup>2</sup>	SPLITDRWS	SUMD	TCP
			✓	✓	✓	✓	✓	✓		✓	✓		✓	

### End Panel Options

AUTH	CSFPE	EXBK	FFD	FPE	INTGE	IPE
✓	✓	✓	✓	✓	✓	✓

### Custom Modification Options

ADD_SHLF	ADDTK	CBO	CCO	CFNTO	CFP	CFRMO	CHGDRW <sup>3</sup>	CLIP <sup>4</sup>	CMAT	CND	CSDGBK	DRT	DRWTK <sup>5</sup>	EF	EX	EX_OL	FBFL	FD	
				✓	✓	✓	✓	✓	✓	✓	✓	✓	✓	✓	✓	✓	✓	✓	✓

FDSRTBTM	FLUT <sup>6</sup>	FTK <sup>7</sup>	ID	IH	IH+DRW	INVERM	IW <sup>8</sup>	LIGHT	MIP	OBRB	PFINBTMB	RD	RECTK	RH	ROSFLUT	RT
	✓	✓					✓	✓	✓	✓		✓	✓	✓	✓	✓

RW	SBCADDY	SBCADDYSM	SCPDRW	STW	TD	TKP	TVR	UDBX <sup>9</sup>	URT <sup>9</sup>	VTK	WS <sup>10</sup>	WTC <sup>11</sup>	WTKCUP <sup>3</sup>	WTR
			✓				✓	✓	✓	✓	✓	✓	✓	✓

<sup>1</sup>Not available on 12" or 24" (2 doors) wide.

<sup>2</sup>Not available on 12"-24" (1 door and 2 doors) wide.

<sup>3</sup>Only available on 18" wide.

<sup>4</sup>Not available on 12" or 24" (2 doors) wide.

<sup>5</sup>Not available on 12"-21", 27" or 33" wide.

<sup>6</sup>6" fluting not available on 12", 15" or 24" (2 doors) wide. Fluting both 6" not available on 18" or 21" wide.

<sup>7</sup>FTKAV not available on 12" wide.

<sup>8</sup>Not available on 24" (1 door) wide.

<sup>9</sup>Not available on 12"-21" wide.

<sup>10</sup>Not available on 12" wide and wide stile both 1.5" not available on 15" wide.

<sup>11</sup>Only available on 15", 18", 21", 24", 30", and 36" wide.



# Base Cabinets

## Description

### BASE DOUBLE DOOR with FOUR SPLIT DRAWERS, 34 1/2" HIGH, 24" DEEP

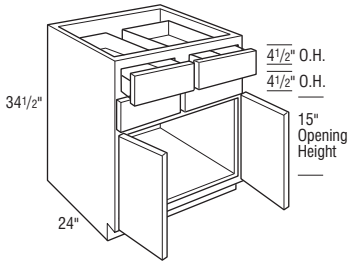

## Model

**B4D24**

**B4D27**

**B4D30**

**B4D33**

**B4D36**

**B4D39**

- No shelving in door section.
- Reduced Depths available in 1/4" increments from 12" to 23 3/4".

#### Door & Drawer Options

AF	AOMBWB	CC	CG	ESMD	GAMD	IFHG	MD	PRMD <sup>1</sup>	PTOWB	SHMD	SPLITDR <sup>1</sup>	SPLITDRWS	SUMD	TCP

#### End Panel Options

AUTH	CSFPE	EXBK	FFD	FPE	INTGE	IPE

#### Custom Modification Options

ADD_SHLF	ADDTK	CBO	CCO	CFNTO	CFP	CFRMO	CHGDRW <sup>2</sup>	CLIP <sup>3</sup>	CMAT	CND	CSDGBK	DRT	DRWTK <sup>4</sup>	EF	EX	EX_OL	FBFL	FD	

FDSRTBTM	FLUT <sup>5</sup>	FTK	ID	IH	IH+DRW	INVFRM	IW	LIGHT	MIP	OBRB	PFINBTMB	RD	RECTK	RH	ROSLUT	RT

RW	SBCADDY	SBCADDYSM	SCPDRW	STW	TD	TKP	TVR	UDBX	URT	VTK	WS	WTC <sup>6</sup>	WTKCUP <sup>2</sup>	WTR

<sup>1</sup>Not available on 24" wide.

<sup>2</sup>Only available on 36" wide.

<sup>3</sup>Not available on 24" wide.

<sup>4</sup>Not available on 27" or 33" wide.

<sup>5</sup>6" fluting not available on 24" or 27" wide and not available with fluting both 6".

<sup>6</sup>Not available on 24", 27" or 33" wide.

### BASE DOUBLE DOOR with FOUR SPLIT DRAWERS and ROLL TRAY, 34 1/2" HIGH, 24" DEEP

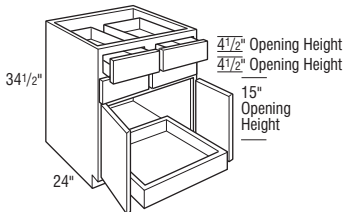

**B4D24RT**

**B4D27RT**

**B4D30RT**

**B4D33RT**

**B4D36RT**

- No shelving in door section.
- Contains one easily adjustable roll tray.
- Reduced Depths available in 1/4" increments from 12" to 23 3/4".

#### Door & Drawer Options

AF	AOMBWB	CC	CG	ESMD	GAMD	IFHG	MD	PRMD <sup>1</sup>	PTOWB	SHMD	SPLITDR <sup>1</sup>	SPLITDRWS	SUMD	TCP

#### End Panel Options

AUTH	CSFPE	EXBK	FFD	FPE	INTGE	IPE

#### Custom Modification Options

ADD_SHLF	ADDTK	CBO	CCO	CFNTO	CFP	CFRMO	CHGDRW <sup>2</sup>	CLIP <sup>3</sup>	CMAT	CND	CSDGBK	DRT	DRWTK <sup>4</sup>	EF	EX	EX_OL	FBFL	FD	

FDSRTBTM	FLUT <sup>5</sup>	FTK	ID	IH	IH+DRW	INVFRM	IW	LIGHT	MIP	OBRB	PFINBTMB	RD	RECTK	RH	ROSLUT	RT

RW	SBCADDY	SBCADDYSM	SCPDRW	STW	TD	TKP	TVR	UDBX	URT	VTK	WS	WTC <sup>6</sup>	WTKCUP <sup>7</sup>	WTR

<sup>1</sup>Not available on 24" wide.

<sup>2</sup>Only available with 36" wide. 36" wide only available in conjunction with SPLITDRWS modification.

<sup>3</sup>Not available on 24" wide.

<sup>4</sup>Not available on 27" or 33" wide.

<sup>5</sup>6" fluting not available on 24" or 27" wide and not available with fluting both 6".

<sup>6</sup>Not available on 24", 27" or 33" wide.

<sup>7</sup>Only available on 36" wide.

IH/RH availability charts starting on page G•40.  
IW/RW availability charts starting on page G•46.

## Description

### BASE DOUBLE DOOR with FOUR SPLIT DRAWERS, 34 1/2" HIGH, 24" DEEP

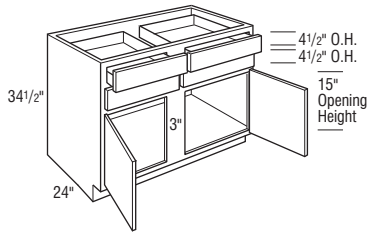

## Model

**B4D42**

**B4D45**

**B4D48**

- No shelving in door section.
- Reduced Depths available in 1/4" increments from 12" to 23 3/4".

#### Door & Drawer Options

AF	AOMBWB	CC	CG	ESMD	GAMD	IFHG	MD	PRMD	PTOWB	SHMD	SPLITDR	SPLITDRWS	SUMD	TCP
			✓	✓	✓	✓	✓	✓		✓				✓

#### End Panel Options

AUTH	CSFPE	EXBK	FFD	FPE	INTGE	IPE
✓	✓	✓	✓	✓	✓	✓

#### Custom Modification Options

ADD_SHLF	ADDTK	CBO	CCO	CFNTD	CFP	CFRMO	CHGDRW	CLIP	CMAT	CND	CSDGBK	DRT	DRWTK	EF	EX	EX_OL	FBFL	FD
			✓	✓	✓	✓			✓		✓	✓	✓	✓	✓	✓	✓	✓

FDSRTBTM	FLUT	FTK	ID	IH	IH+DRW	INVFRM	IW <sup>1</sup>	LIGHT	MIP	OBRB	PFINBTMB	RD	RECTK	RH	ROSLUT	RT
	✓	✓	✓	✓			✓	✓	✓	✓	✓	✓	✓	✓	✓	✓

RW	SBCADDY	SBCADDYSM	SCPDRW	STW	TD	TKP	TVR	UDBX <sup>2</sup>	URT	VTK	WS	WTC <sup>3</sup>	WTKCUP	WTR
			✓		✓	✓	✓	✓	✓	✓	✓	✓	✓	✓

<sup>1</sup>Not available on 48" wide.

<sup>2</sup>Only available on 48" wide.

<sup>3</sup>Not available on 45" wide.

### BASE DOUBLE DOOR with FOUR SPLIT DRAWERS and ROLL TRAYS, 34 1/2" HIGH, 24" DEEP

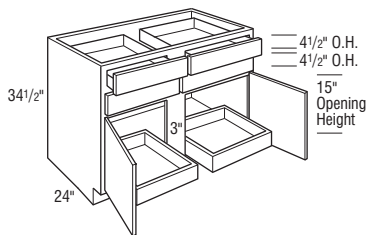

**B4D39RT**

**B4D42RT**

**B4D45RT**

**B4D48RT**

- No shelving in door section.
- Contains two easily adjustable roll trays.
- Reduced Depths available in 1/4" increments from 12" to 23 3/4".

#### Door & Drawer Options

AF	AOMBWB	CC	CG	ESMD	GAMD	IFHG	MD	PRMD	PTOWB	SHMD	SPLITDR	SPLITDRWS	SUMD	TCP
			✓	✓	✓	✓	✓	✓		✓				✓

#### End Panel Options

AUTH	CSFPE	EXBK	FFD	FPE	INTGE	IPE
✓	✓	✓	✓	✓	✓	✓

#### Custom Modification Options

ADD_SHLF	ADDTK	CBO	CCO	CFNTD	CFP	CFRMO	CHGDRW	CLIP	CMAT	CND	CSDGBK	DRT	DRWTK	EF	EX	EX_OL	FBFL	FD
			✓	✓	✓	✓			✓		✓	✓	✓	✓	✓	✓	✓	✓

FDSRTBTM	FLUT <sup>1</sup>	FTK	ID	IH	IH+DRW	INVFRM	IW <sup>2</sup>	LIGHT	MIP	OBRB	PFINBTMB	RD	RECTK	RH	ROSLUT	RT
	✓	✓	✓	✓			✓	✓	✓	✓	✓	✓	✓	✓	✓	✓

RW	SBCADDY	SBCADDYSM	SCPDRW	STW	TD	TKP	TVR	UDBX <sup>3</sup>	URT <sup>3</sup>	VTK	WS	WTC <sup>4</sup>	WTKCUP	WTR
			✓		✓	✓	✓	✓	✓	✓	✓	✓	✓	✓

<sup>1</sup>Not available with fluting both 6".

<sup>2</sup>Not available on 48" wide.

<sup>3</sup>Only available on 48" wide.

<sup>4</sup>Not available on 39" or 45" wide.

# Base Cabinets & Base SuperCabinets™

## Description

### **NEW** BASE BUFFET with ROLL TRAYS, 34 1/2" HIGH, 24" DEEP

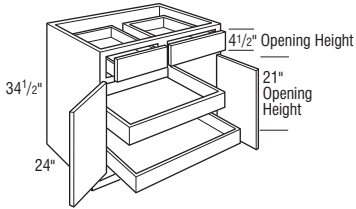

## Model

**B30RTB**

**B33RTB**

**B36RTB**

- Two roll trays standard.
- Reveal between drawers will not align with doors below.
- Cabinet may accommodate up to four roll trays, which may be purchased separately for field installation. See page S•9.

#### Door & Drawer Options

AF	AOMBWB	CC	CG	ESMD	GAMD	IFHG	MD	PRMD	PTOWB	SHMD	SPLITDR	SPLITDRWS	SUMD	TCP
			✓				✓	✓						

#### End Panel Options

AUTH	CSFPE	EXBK	FFD	FPE	INTGE	IPE
✓	✓	✓	✓	✓	✓	✓

#### Custom Modification Options

ADD	SHLF	ADDTK	CBO	CCO	CFNTD	CFP	CFRMO	CHGDRW <sup>1</sup>	CLIP	CMAT	CND	CSDGBK	DRT	DRWTK	EF	EX	EX_OL	FBFL	FD	
						✓	✓	✓	✓	✓	✓	✓	✓	✓	✓	✓	✓	✓	✓	✓

FDSRTBTM	FLUT	FTK	ID	IH	IH+DRW	INVFRM	IW	LIGHT	MIP	OBRB	PFINBTMB	RD	RECTK	RH	ROSFLUT	RT
	✓	✓	✓	✓	✓	✓	✓	✓	✓	✓	✓	✓	✓	✓	✓	✓

RW	SBCADDY	SBCADDYSM	SCPDRW	STW	TD	TKP	TVR	UDBX	URT	VTK	WS	WTC <sup>2</sup>	WTKCUP <sup>1</sup>	WTR
							✓	✓		✓	✓	✓	✓	✓

<sup>1</sup>Only available on 36" wide.

<sup>2</sup>Not available on 33" wide.

### 30" SUPERCABINET™, 34 1/2" HIGH, 24" DEEP storage SOLUTIONS

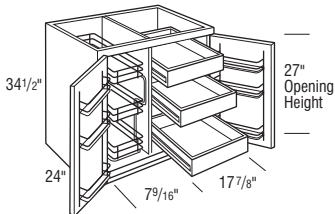

Right Shown

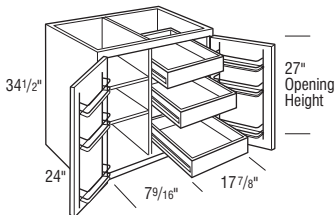

Right Shown

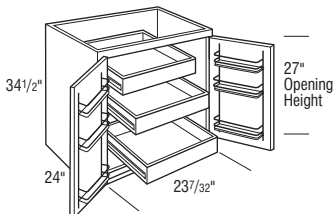

**BSC30R**

**BSC30RP**

**BSC30PR**

**BSC30RS**

**BSC30SR**

**BSC30R**

#### Notes below apply to all products in section above:

- Cabinets with full overlay style utilize 170° hinge. For sufficient pull-out clearance, 12" of adjacent space is required for door to open 170° when installed near a wall or corner.
- Shelves are adjustable and 20" deep.
- Roll trays are Full Extension side-mounted.
- Pull-out side door has to open 170°.
- Smart Stop feature not available.
- Door includes a three-tiered chrome rack with wood bottoms.
- Not available on Inset and Beaded Inset styles.

#### Door & Drawer Options

AF	AOMBWB	CC	CG	ESMD	GAMD	IFHG	MD	PRMD	PTOWB	SHMD	SPLITDR	SPLITDRWS	SUMD	TCP

#### End Panel Options

AUTH	CSFPE	EXBK	FFD	FPE	INTGE	IPE
✓	✓	✓	✓	✓	✓	✓

#### Custom Modification Options

ADD	SHLF	ADDTK	CBO	CCO	CFNTD	CFP	CFRMO	CHGDRW	CLIP	CMAT	CND	CSDGBK	DRT	DRWTK	EF	EX <sup>1</sup>	EX_OL <sup>1</sup>	FBFL	FD
															✓	✓	✓	✓	✓

FDSRTBTM	FLUT <sup>2</sup>	FTK	ID	IH	IH+DRW	INVFRM	IW	LIGHT	MIP	OBRB	PFINBTMB	RD	RECTK	RH	ROSFLUT	RT
	✓	✓	✓	✓	✓	✓	✓	✓	✓	✓	✓	✓	✓	✓	✓	✓

RW	SBCADDY	SBCADDYSM	SCPDRW	STW	TD	TKP	TVR	UDBX	URT	VTK	WS	WTC <sup>2</sup>	WTKCUP	WTR
								✓			✓			✓

<sup>1</sup>Not available on BSC30SR.

<sup>2</sup>Not available with 6" fluting.

IH/RH availability charts starting on page G•40.  
IW/RW availability charts starting on page G•46.

## Description

**36" SUPERCABINET™, 34 1/2" HIGH,  
24" DEEP**  
storage  
SOLUTIONS

## Model

**BSC36PRP**

**BSC36PRS**

**BSC36SRP**

**BSC36SRS**

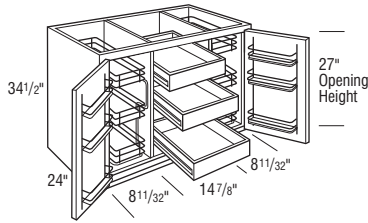

**BSC36PRP**

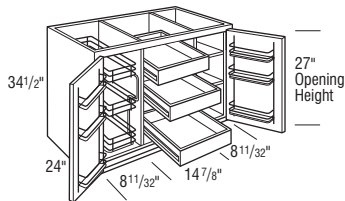

**BSC36PRS**

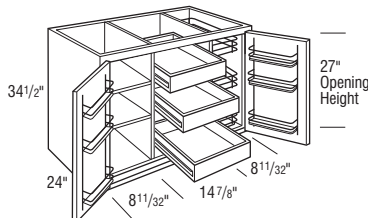

**BSC36SRP**

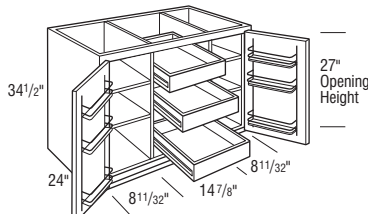

**BSC36SRS**

### Notes below apply to all products in section above:

- Cabinets with full overlay style utilize 170° hinge. For sufficient pull-out clearance, 12" of adjacent space is required for door to open 170° when installed near a wall or corner.
- Shelves are adjustable and 20" deep.
- Roll trays are Full Extension side-mounted.
- Pull-out side door has to open 170°.
- Smart Stop feature not available.
- Door includes a three-tiered chrome rack with wood bottoms.
- Not available on Inset and Beaded Inset styles.

### Door & Drawer Options

AF	AOMBWB	CC	CG	ESMD	GAMD	IFHG	MD	PRMD	PTOWB	SHMD	SPLITDR	SPLITDRWS	SUMD	TCP
----	--------	----	----	------	------	------	----	------	-------	------	---------	-----------	------	-----

### End Panel Options

AUTH	CSFPE	EXBK	FFD	FPE	INTGE	IPE
✓	✓	✓	✓	✓	✓	✓

### Custom Modification Options

ADD_SHLF	ADDTK	CBO	CCO	CFNTO	CFP	CFRMO	CHGDRW	CLIP	CMAT	CND	CSDGBK	DRT	DRWTK	EF	EX	EX_OL	FBFL	FD	
													✓	✓	✓	✓			

FDSRTBTM	FLUT <sup>1</sup>	FTK	ID	IH	IH+DRW	INFRM	IW	LIGHT	MIP	OBRB	PFINBTMB	RD	RECTK	RH	ROSFLUT	RT
	✓	✓								✓			✓	✓	✓	✓

RW	SBCADDY	SBCADDYSM	SCPDRW	STW	TD	TKP	TVR	UDBX	URT	VTK	WS	WTCD	WTKCUP	WTR
						✓				✓				✓

<sup>1</sup>Not available with 6" fluting.

# Base SuperCabinets™

## Description

### BASE SUPERCABINET™ GOURMET, 34 1/2" HIGH, 24" DEEP

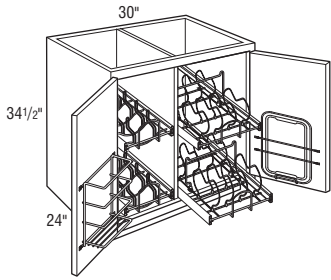

BSCG30 L or R

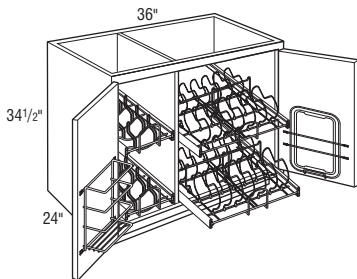

BSCG36 L or R

## Model

### BSCG30 L or R

- Pots and Pans pull-out includes 8 dividers per tray for adjustable storage.

### BSCG36 L or R

- Pots and Pans pull-out includes 16 dividers per tray for adjustable storage.

#### Notes below apply to all products in section above:

- L or R designates lid holder side.
- Cabinets with full overlay style utilize 170° hinge. For sufficient pull-out clearance, 12" of adjacent space is required for door to open 170° when installed near a wall or corner.
- Left door features wrap/foil rack.
- Right door features cutting board and cutting board storage rack.
- Lid pull-out will hold 6 lids per tray. Maximum lid diameter is 8 1/2" on bottom tray and 9 3/4" on top tray.
- Not available on Inset and Beaded Inset.
- Smart Stop feature not available.

#### Door & Drawer Options

AF	AOMBWB	CC	CG	ESMD	GAMD	IFHG	MD	PRMD	PTOWB	SHMD	SPLITDR	SPLITDRWS	SUMD	TCP
----	--------	----	----	------	------	------	----	------	-------	------	---------	-----------	------	-----

#### End Panel Options

AUTH	CSFPE	EXBK	FFD	FPE	INTGE	IPE
✓	✓	✓		✓		

#### Custom Modification Options

ADD	SHLF	ADDTK	CBO	CCO	CFNTD	CFP	CFRMO	CHGDRW	CLIP	CMAT	CND	CSDGBK	DRT	DRWTK	EF	EX	EX_OL	FBFL	FD	
															✓					

FDSRTBTM	FLUT <sup>1</sup>	FTK	ID	IH	IH+DRW	INVERM	IW	LIGHT	MIP	OBRB	PFINBTMB	RD	RECTK	RH	ROSFLUT	RT
	✓	✓									✓					✓

RW	SBCADDY	SBCADDYSM	SCPDRW	STW	TD	TKP	TVR	UDBX	URT	VTK	WS	WTCB	WTKCUP	WTR
											✓			✓

<sup>1</sup>Not available with 6" fluting.

IH/RH availability charts starting on page G•40.  
IW/RW availability charts starting on page G•46.

## Description

### WALL BASE, 34 1/2" HIGH, 12" DEEP

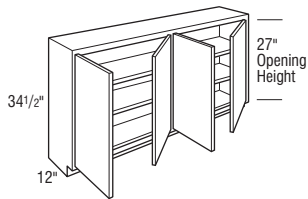
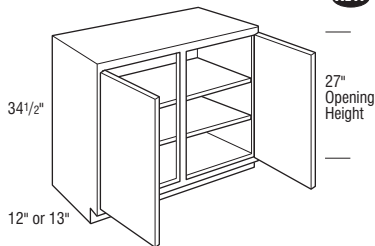
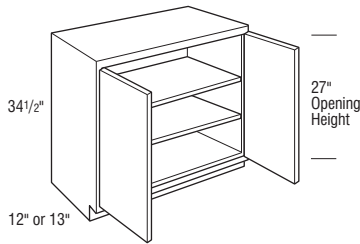
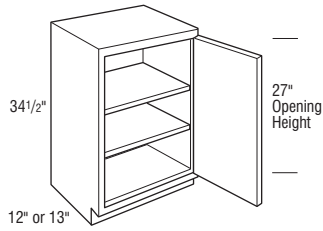

## Model

WB12 L or R

WB15 L or R

WB18 L or R

WB21 L or R

WB24 L or R

WB24

WB27

WB30

WB33

WB36

WB39

WB42

WB45

WB48CS

**WB48**

- Two sets of butt doors.

Notes below apply to all products in section above:

- Two adjustable shelves.
- Unit is constructed with toekick and full wall-type top.
- Inset and Beaded Inset Door Styles are a standard 13" deep.
- Full Overlay Styles:
  - Increased Depths available in 1/4" increments from 12 1/4" to 30".
  - Reduced Depths available in 1/4" increments from 6" to 11 3/4".
- Inset and Beaded Inset Styles:
  - Increased Depths available in 1/4" increments from 13 1/4" to 30".
  - Reduced Depths available in 1/4" increments from 6" to 12 3/4".

#### Door & Drawer Options

AF	AOMBWB	CC	CG	ESMD	GAMD	IFHG	MD	PRMD <sup>1</sup>	PTOWB	SHMD	SPLITDR <sup>2</sup>	SPLITDRWS	SUMD	TCP
✓	✓	✓	✓	✓	✓	✓	✓	✓	✓	✓	✓	✓	✓	✓

#### End Panel Options

AUTH	CSFPE	EXBK	FFD	FPE	INTGE	IPE
✓	✓	✓	✓	✓	✓	✓

#### Custom Modification Options

ADD	SHLF	ADDTK	CBO	CCO	CFNT0	CFP	CFRMO	CHGDRW	CLIP <sup>3</sup>	CMAT	CND	CSDGBK	DRT	DRWTK	EF	EX	EX_OL	FBFL	FD	
✓	✓	✓	✓	✓	✓	✓	✓	✓	✓	✓	✓	✓	✓	✓	✓	✓	✓	✓	✓	✓

FDSRTBTM <sup>4</sup>	FLUT <sup>5</sup>	FTK <sup>6</sup>	ID	IH	IH+DRW	INVFRM	IW	LIGHT	MIP	OBRB	PFINBTMB	RD	RECTK	RH	ROSFLUT	RT
✓	✓	✓	✓	✓	✓	✓	✓	✓	✓	✓	✓	✓	✓	✓	✓	✓

RW	SBCADDY	SBCADDYSM	SCPDRW	STW	TD	TKP	TVR <sup>7</sup>	UDBX	URT	VTK	WS	WTCO	WTKCUP	WTR
✓	✓	✓	✓	✓	✓	✓	✓	✓	✓	✓	✓	✓	✓	✓

<sup>1</sup>Not available on 12" or 24" (2 doors) wide.

<sup>2</sup>Only available on 24" (2 doors)-39" wide.

<sup>3</sup>Not available on 24" (2 doors).

<sup>4</sup>Only available on 12" wide.

<sup>5</sup>Not available with 6" fluting.

<sup>6</sup>FTKAV not available on 12" wide.

<sup>7</sup>Not available on 42"-48" wide.

# Drawer Base Cabinets

## Description

**FOUR DRAWER BASE, 34 1/2" HIGH, 24" DEEP**

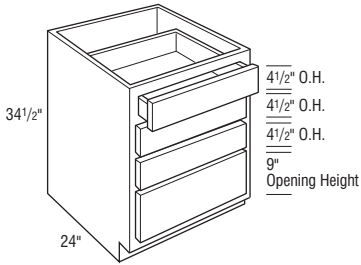

## Model

- 4DB12
- 4DB15
- 4DB18
- 4DB21
- 4DB24
- 4DB27
- 4DB30
- 4DB33
- 4DB36
- 4DB39
- 4DB42

• Reduced Depths available in 1/4" increments from 12" to 23 3/4".

### Door & Drawer Options

AF	AOMBWB	CC	CG	ESMD	GAMD	IFHG	MD	PRMD	PTOWB	SHMD	SPLITDR	SPLITDRWS <sup>1</sup>	SUMD	TCP
						✓						✓		

### End Panel Options

AUTH	CSFPE	EXBK	FFD	FPE	INTGE	IPE
✓	✓	✓	✓	✓	✓	✓

### Custom Modification Options

ADD	SHLF	ADDTK	CBO	CCO	CFNTD	CFP	CFRMO	CHGDRW <sup>2</sup>	CLIP <sup>3</sup>	CMAT	CND	CSDGBK	DRT	DRWTK <sup>4</sup>	EF	EX	EX_OL	FBFL	FD	
				✓	✓	✓	✓	✓	✓	✓	✓	✓	✓	✓	✓	✓	✓	✓	✓	✓

FDSRTBTM	FLUT <sup>5</sup>	FTK <sup>6</sup>	ID	IH	IH+DRW	INVFRM	IW <sup>7</sup>	LIGHT	MIP	OBRB	PFINBTMB	RD	RECTK	RH	ROSLUT	RT
	✓	✓	✓	✓	✓	✓	✓	✓	✓	✓	✓	✓	✓	✓	✓	✓

RW	SBCADDY	SBCADDYSM	SCPDRW	STW	TD	TKP	TVR	UDBX <sup>1</sup>	URT	VTK	WS <sup>8</sup>	WTCD <sup>9</sup>	WTKCUP <sup>10</sup>	WTR
			✓					✓	✓	✓	✓	✓	✓	✓

<sup>1</sup>Not available on 12"-21" wide.  
<sup>2</sup>Only available with 36" wide. 36" wide only available in conjunction with SPLITDRWS modification.  
<sup>3</sup>Not available on 12" wide.  
<sup>4</sup>Only available on 24", 30" and 36" wide.  
<sup>5</sup>6" fluting not available on 12"-15" wide and fluting both 6" not available on 18" or 21" wide.  
<sup>6</sup>FTKAV not available on 12" wide.  
<sup>7</sup>Not available on 42" wide.  
<sup>8</sup>Not available on 12" wide.  
<sup>9</sup>Only available on 30" and 36" wide.  
<sup>10</sup>Only available on 36" wide.

**SIX DRAWER BASE, 34 1/2" HIGH, 24" DEEP**

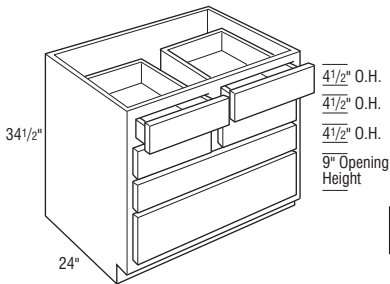

- 6DB30
- 6DB33
- 6DB36
- 6DB42

• Reduced Depths available in 1/4" increments from 12" to 23 3/4".

### Door & Drawer Options

AF	AOMBWB	CC	CG	ESMD	GAMD	IFHG	MD	PRMD	PTOWB	SHMD	SPLITDR	SPLITDRWS	SUMD	TCP
						✓								

### End Panel Options

AUTH	CSFPE	EXBK	FFD	FPE	INTGE	IPE
✓	✓	✓	✓	✓	✓	✓

### Custom Modification Options

ADD	SHLF	ADDTK	CBO	CCO	CFNTD	CFP	CFRMO	CHGDRW <sup>1</sup>	CLIP	CMAT	CND	CSDGBK	DRT	DRWTK <sup>2</sup>	EF	EX	EX_OL	FBFL	FD	
				✓	✓	✓	✓	✓	✓	✓	✓	✓	✓	✓	✓	✓	✓	✓	✓	✓

FDSRTBTM	FLUT <sup>3</sup>	FTK	ID	IH	IH+DRW	INVFRM	IW	LIGHT	MIP	OBRB	PFINBTMB	RD	RECTK	RH	ROSLUT	RT
	✓	✓	✓	✓	✓	✓	✓	✓	✓	✓	✓	✓	✓	✓	✓	✓

RW	SBCADDY	SBCADDYSM	SCPDRW	STW	TD	TKP	TVR <sup>4</sup>	UDBX	URT	VTK	WS	WTCD	WTKCUP <sup>1</sup>	WTR
			✓				✓	✓	✓	✓	✓	✓	✓	✓

<sup>1</sup>Only available on 36" wide.  
<sup>2</sup>Not available on 33" or 42" wide.  
<sup>3</sup>Fluting both 6" not available on 30" or 33" wide.  
<sup>4</sup>Not available on 30" or 36" wide.

IH/RH availability charts starting on page G-40.  
 IW/RW availability charts starting on page G-46.

## Description

### FOUR DRAWER BASE with BREAD BOARD, 34 1/2" HIGH, 24" DEEP

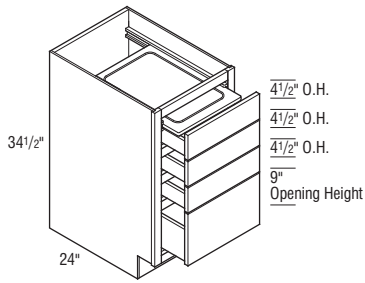

## Model

4DB12BB

4DB15BB

4DB18BB

4DB21BB

4DB24BB

#### Door & Drawer Options

AF	AOMBWB	CC	CG	ESMD	GAMD	IFHG	MD	PRMD	PTOWB	SHMD	SPLITDR	SPLITDRWS	SUMD	TCP
						✓								

#### End Panel Options

AUTH	CSFPE	EXBK	FFD	FPE	INTGE	IPE
✓	✓	✓	✓	✓	✓	✓

#### Custom Modification Options

ADD_SHLF	ADDTK	CBO	CCO	CFNTD	CFP	CFRMO	CHGDRW	CLIP <sup>1</sup>	CMAT	CND	CSDGBK	DRT	DRWTK <sup>2</sup>	EF	EX	EX_OL	FBFL	FD
			✓	✓	✓	✓	✓	✓			✓		✓	✓	✓	✓	✓	✓

FDSRTBTM	FLUT <sup>3</sup>	FTK <sup>4</sup>	ID	IH	IH+DRW	INVERM	IW	LIGHT	MIP	OBRB	PFINBTMB	RD	RECTK	RH	ROSLUT	RT
	✓	✓	✓	✓				✓	✓	✓	✓	✓	✓	✓	✓	✓

RW	SBCADDY	SBCADDYSM	SCPDRW	STW	TD	TKP	TVR	UDBX	URT	VTK	WS <sup>5</sup>	WTCB	WTKCUP	WTR
						✓				✓	✓			✓

<sup>1</sup>Not available on 12" wide.

<sup>2</sup>Only available on 24" wide.

<sup>3</sup>6" fluting not available on 12", 15" or 18" wide and fluting both 6" not available on 21" wide.

<sup>4</sup>FTKAV not available on 12" wide.

<sup>5</sup>Not available on 12" wide. Not available on wide stile 1.5" version except wide stile both 1.5" is available on 15"-24" wide.



### FOUR DRAWER BASE with WOOD TIERED CUTLERY DIVIDER, 34 1/2" HIGH, 24" DEEP

## storage SOLUTIONS

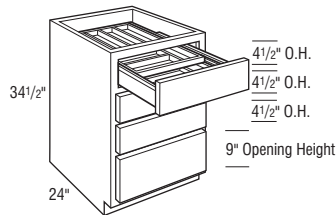

4DB15WTCB

4DB18WTCB

4DB21WTCB

4DB24WTCB

4DB30WTCB

4DB36WTCB

- Includes Wood Tiered Cutlery Divider Drawer.
- Exterior Wood Tiered Cutlery Divider drawer box height is 3 3/4", interior height of top tier is 1 5/8", and interior height of bottom tier is 1 3/8".
- Wood Tiered Cutlery Divider Drawer is also available as an accessory for field installation. See page S•5.

#### Door & Drawer Options

AF	AOMBWB	CC	CG	ESMD	GAMD	IFHG	MD	PRMD	PTOWB	SHMD	SPLITDR	SPLITDRWS	SUMD	TCP

#### End Panel Options

AUTH	CSFPE	EXBK	FFD	FPE	INTGE	IPE
✓	✓	✓	✓	✓	✓	✓

#### Custom Modification Options

ADD_SHLF	ADDTK	CBO	CCO	CFNTD	CFP	CFRMO	CHGDRW	CLIP <sup>1</sup>	CMAT	CND	CSDGBK	DRT	DRWTK	EF	EX	EX_OL	FBFL	FD
			✓	✓	✓	✓	✓	✓			✓		✓	✓	✓	✓	✓	✓

FDSRTBTM	FLUT <sup>2</sup>	FTK	ID	IH	IH+DRW <sup>3</sup>	INVERM	IW	LIGHT	MIP	OBRB	PFINBTMB	RD	RECTK	RH	ROSLUT <sup>2</sup>	RT
	✓	✓	✓	✓	✓			✓	✓	✓	✓	✓	✓	✓	✓	✓

RW	SBCADDY	SBCADDYSM	SCPDRW	STW	TD	TKP	TVR	UDBX	URT	VTK	WS <sup>4</sup>	WTCB	WTKCUP	WTR
						✓				✓	✓			✓

<sup>1</sup>Not available on 15" wide. CLIP1&R and 6" clipped not available on 15" or 18" wide. CLIP6L&R only available on 30" and 36" wide. CLIP1 and CLIPR not available on 30" and 36" wide.

<sup>2</sup>Not available on 15" wide. FLUT3B and 6" fluting not available on 15" or 18" wide. FLUT6B only available on 30" and 36" wide. FLUT3L and FLUT3R not available on 30" and 36" wide.

<sup>3</sup>Only available on 30" and 36" wide.

<sup>4</sup>Not available on 15" wide. Wide Stile both only available on 30" and 36" wide. WSL&R3 only available on 30" and 36" wide.



# Drawer Base Cabinets

## Description

### FOUR DRAWER BASE with WOOD TIERED K-CUP\* DRAWER, 34 1/2" HIGH, 24" DEEP

storage SOLUTIONS

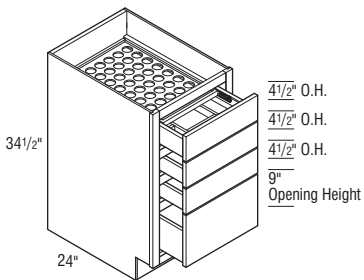

## Model

### 4DB18KCUP

- Holds 40 K-Cups.
- The Wood Tiered K-Cup Drawer is compatible with K-Cup pods only.
- Wood Tiered K-Cup Drawer available in 18" wide units.
- The K-Cup drawer will be positioned in the top drawer.

\*K-Cup is a registered trademark of Keurig Green Mountain, Inc.

#### Door & Drawer Options

AF	AOMBWB	CC	CG	ESMD	GAMD	IFHG	MD	PRMD	PTOWB	SHMD	SPLITDR	SPLITDRWS	SUMD	TCP
			✓			✓								

#### End Panel Options

AUTH	CSFPE	EXBK	FFD	FPE	INTGE	IPE
✓	✓	✓	✓	✓	✓	✓

#### Custom Modification Options

ADD	SHLF	ADDTK	CBO	CCO	CFNTD	CFP	CFRMO	CHGDRW	CLIP	CMAT	CND	CSDGBK	DRT	DRWTK	EF	EX	EX_OL	FBFL	FD
			✓								✓					✓	✓	✓	

FDSRTBTM	FLUT <sup>1</sup>	FTK	ID	IH	IH+DRW	INVERM	IW	LIGHT	MIP	OBRB	PFINBTMB	RD	RECTK	RH	ROSLUT	RT
	✓	✓	✓	✓	✓			✓	✓	✓			✓	✓	✓	✓

RW	SBCADDY	SBCADDYSM	SCPDRW	STW	TD	TKP	TVR	UDBX	URT	VTK	WS	WTCB	WTKCUP	WTR
							✓			✓		✓	✓	✓

<sup>1</sup>Not available with 6" fluting.

### NEW FOUR DRAWER BASE with CUTLERY INSERT WOOD DIVIDERS, 34 1/2" HIGH, 24" DEEP

storage SOLUTIONS

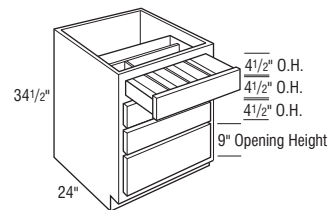

### 4DB15CIW

### 4DB18CIW

### 4DB21CIW

### 4DB24CIW

- Includes Cutlery Insert Wood Divider.
- Features hard wood.
- Exterior height for bottom drawer box is 6 3/8".
- Cutlery Insert Wood Divider is also available as an accessory for field installation. See page S•5.

#### Door & Drawer Options

AF	AOMBWB	CC	CG	ESMD	GAMD	IFHG	MD	PRMD	PTOWB	SHMD	SPLITDR	SPLITDRWS <sup>1</sup>	SUMD	TCP
												✓		

#### End Panel Options

AUTH	CSFPE	EXBK	FFD	FPE	INTGE	IPE
✓	✓	✓	✓	✓	✓	✓

#### Custom Modification Options

ADD	SHLF	ADDTK	CBO	CCO	CFNTD	CFP	CFRMO	CHGDRW	CLIP	CMAT	CND	CSDGBK	DRT	DRWTK	EF	EX	EX_OL	FBFL	FD
			✓	✓	✓	✓	✓	✓	✓	✓	✓	✓	✓	✓	✓	✓	✓	✓	

FDSRTBTM	FLUT <sup>2</sup>	FTK	ID	IH	IH+DRW	INVERM	IW	LIGHT	MIP	OBRB	PFINBTMB	RD	RECTK	RH	ROSLUT	RT
	✓	✓	✓	✓	✓			✓	✓	✓			✓	✓	✓	✓

RW	SBCADDY	SBCADDYSM	SCPDRW	STW	TD	TKP	TVR	UDBX <sup>1</sup>	URT	VTK	WS	WTCB	WTKCUP	WTR
							✓	✓	✓	✓	✓	✓	✓	✓

<sup>1</sup>Not available on 15", 18", or 21" wide.

<sup>2</sup>Not available on 15" wide and FLUT6B not available on 18" or 21" wide.

IH/RH availability charts starting on page G•40.  
IW/RW availability charts starting on page G•46.

**Description**



**FOUR DRAWER BASE with CHARGING DRAWER, 34 1/2" HIGH, 24" DEEP**

**storage SOLUTIONS**

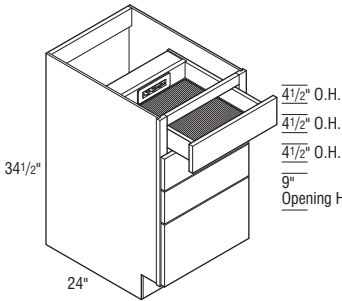

**Model**

**4DB18CHGDRW**

- The charging drawer will be positioned in the top drawer.
- Charging drawer has full extension, concealed Smart Stop slides.
- 110 lb. rated.
- 120V outlet must be installed in rear of cabinet within 10" of bottom of drawer, in rear of cabinet.
- CUL US listed power strip with two 120V plugs and two 2.1 amp USB ports.
- Max Current: AC 15 amps @ 120VAC; USB 2.1 amp and 5 VDC each.
- Tamper resistant outlets.
- Power cord with NEMA 5-15 plug.
- Integrated cord guide mounts to cabinet side to ensure safe operation.
- Black, shock absorbing mat included.
- Special sizes not available.
- Only available in 24" deep.
- Not available on Inset or Beaded Inset Styles.

**Door & Drawer Options**

AF	AOMBWB	CC	CG	ESMD	GAMD	IFHG	MD	PRMD	PTOWB	SHMD	SPLITDR	SPLITDRWS	SUMD	TCP
----	--------	----	----	------	------	------	----	------	-------	------	---------	-----------	------	-----

**End Panel Options**

AUTH	CSFPE	EXBK	FFD	FPE	INTGE	IPE
✓	✓	✓	✓	✓	✓	✓

**Custom Modification Options**

ADD_SHLF	ADDTK	CBO	CCO	CFNTO	CFP	CFRMO	CHGDRW	CLIP	CMAT	CND	CSDGBK	DRT	DRWTK	EF	EX	EX_OL	FBFL	FD	
	✓	✓	✓	✓	✓	✓	✓	✓	✓	✓	✓	✓	✓	✓	✓	✓	✓	✓	✓
FDSRTBTM	FLUT	FTK	ID	IH	IH+DRW	INVFRM	IW	LIGHT	MIP	OBRB	PFINBTMB	RD	RECTK	RH	ROSLUT	RT			
	✓	✓	✓	✓	✓	✓	✓	✓	✓	✓	✓	✓	✓	✓	✓	✓			
RW	SBCADDY	SBCADDYSM	SCPDRW	STW	TD	TKP	TVR	UDBX	URT	VTK	WS	WTCO	WTKCUP	WTR					
			✓			✓				✓				✓					

**THREE DRAWER BASE, 34 1/2" HIGH, 24" DEEP**

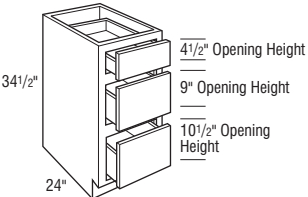

**3DB12**

**3DB15**

**3DB18**

**3DB21**

**3DB24**

- Reduced Depths available in 1/4" increments from 12" to 23 3/4".

**Door & Drawer Options**

AF	AOMBWB	CC	CG	ESMD	GAMD	IFHG	MD	PRMD	PTOWB	SHMD	SPLITDR	SPLITDRWS	SUMD	TCP
						✓								

**End Panel Options**

AUTH	CSFPE	EXBK	FFD	FPE	INTGE	IPE
✓	✓	✓	✓	✓	✓	✓

**Custom Modification Options**

ADD_SHLF	ADDTK	CBO	CCO	CFNTO	CFP	CFRMO	CHGDRW	CLIP <sup>1</sup>	CMAT	CND	CSDGBK	DRT	DRWTK <sup>2</sup>	EF	EX	EX_OL	FBFL	FD	
	✓	✓	✓	✓	✓	✓	✓	✓	✓	✓	✓	✓	✓	✓	✓	✓	✓	✓	✓
FDSRTBTM	FLUT <sup>3</sup>	FTK <sup>4</sup>	ID	IH	IH+DRW	INVFRM	IW	LIGHT	MIP	OBRB	PFINBTMB	RD	RECTK	RH	ROSLUT	RT			
	✓	✓	✓	✓	✓	✓	✓	✓	✓	✓	✓	✓	✓	✓	✓	✓			
RW	SBCADDY	SBCADDYSM	SCPDRW	STW	TD	TKP	TVR	UDBX	URT	VTK	WS <sup>5</sup>	WTCO	WTKCUP	WTR					
			✓			✓				✓	✓			✓					

<sup>1</sup>Not available on 12" wide.

<sup>2</sup>Only available on 24" wide.

<sup>3</sup>6" fluting not available on 12" or 15" wide and 6" fluting both not available on 18" or 21" wide.

<sup>4</sup>FTKAV not available on 12" wide.

<sup>5</sup>Not available on 12" wide.

# Drawer Base Cabinets

## Description

**THREE DRAWER BASE, 34 1/2" HIGH, 24" DEEP**

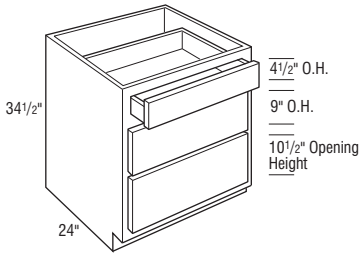

## Model

**3DB27**

**3DB30**

**3DB33**

**3DB36**

**3DB39**

**3DB42**

- Reduced Depths available in 1/4" increments from 12" to 23 3/4"

### Door & Drawer Options

AF	AOMBWB	CC	CG	ESMD	GAMD	IFHG	MD	PRMD	PTOWB	SHMD	SPLITDR	SPLITDRWS	SUMD	TCP

### End Panel Options

AUTH	CSFPE	EXBK	FFD	FPE	INTGE	IPE

### Custom Modification Options

ADD_SHLF	ADDTK	CBO	CCO	CFNTO	CFP	CFRMO	CHGDRW <sup>1</sup>	CLIP	CMAT	CND	CSDGBK	DRT	DRWTK <sup>2</sup>	EF	EX	EX_OL	FBFL	FD	

FDSRTBTM	FLUT	FTK	ID	IH	IH+DRW	INVFRM	IW <sup>3</sup>	LIGHT	MIP	OBRB	PFINBTMB	RD	RECTK	RH	ROSLUT	RT

RW	SBCADDY	SBCADDYSM	SCPDRW	STW	TD	TKP	TVR	UDBX	URT	VTK	WS	WTC <sup>2</sup>	WTKCUP <sup>4</sup>	WTR

<sup>1</sup>Only available with 36" wide. 36" wide only available in conjunction with SPLITDRWS modification.

<sup>2</sup>Not available on 27", 33", 39", or 42" wide.

<sup>3</sup>Not available on 42" wide.

<sup>4</sup>Only available on 36" wide.

## **NEW** THREE DRAWER BASE BUFFET, 34 1/2" HIGH, 24" DEEP

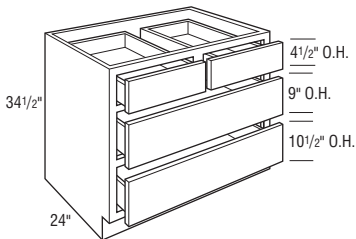

**3DBB30**

**3DBB33**

**3DBB36**

- Scoop drawer option available in top drawer only.

### Door & Drawer Options

AF	AOMBWB	CC	CG	ESMD	GAMD	IFHG	MD	PRMD	PTOWB	SHMD	SPLITDR	SPLITDRWS	SUMD	TCP

### End Panel Options

AUTH	CSFPE	EXBK	FFD	FPE	INTGE	IPE

### Custom Modification Options

ADD_SHLF	ADDTK	CBO	CCO	CFNTO	CFP	CFRMO	CHGDRW <sup>1</sup>	CLIP	CMAT	CND	CSDGBK	DRT	DRWTK	EF	EX	EX_OL	FBFL	FD	

FDSRTBTM	FLUT	FTK	ID	IH	IH+DRW	INVFRM	IW	LIGHT	MIP	OBRB	PFINBTMB	RD	RECTK	RH	ROSLUT	RT

RW	SBCADDY	SBCADDYSM	SCPDRW	STW	TD	TKP	TVR	UDBX	URT	VTK	WS	WTC <sup>2</sup>	WTKCUP <sup>1</sup>	WTR

<sup>1</sup>Only available on 36" wide.

<sup>2</sup>Only available on 30" or 36" wide.

IH/RH availability charts starting on page G-40.  
IW/RW availability charts starting on page G-46.

**Description**

**Model**



**THREE DRAWER BASE with DEEP DRAWER, 34 1/2" HIGH, 24" DEEP**

**3DBDD24**

**3DBDD27**

**3DBDD30**

**3DBDD33**

**3DBDD36**

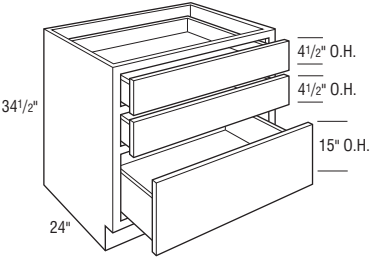

- Exterior height for bottom drawer box is 10".
- Scoop drawer option available in top drawer only.
- Reduced Depths available in 1/4" increments from 12" to 23 3/4".

**Door & Drawer Options**

AF	AOMBWB	CC	CG	ESMD	GAMD	IFHG	MD	PRMD	PTOWB	SHMD	SPLITDR	SPLITDRWS	SUMD	TCP

**End Panel Options**

AUTH	CSFPE	EXBK	FFD	FPE	INTGE	IPE
✓	✓	✓	✓	✓	✓	✓

**Custom Modification Options**

ADD	SHLF	ADDTK	CBO	CCO	CFNTO	CFP	CFRMO	CHGDRW	CLIP	CMAT	CND	CSDGBK	DRT	DRWTK	EF	EX	EX_OL	FBFL	FD	

FDSRTBTM	FLUT <sup>1</sup>	FTK	ID	IH	IH+DRW	INVERM	IW <sup>2</sup>	LIGHT	MIP	OBRB	PFINBTMB	RD	RECTK	RH	ROSFLUT	RT
	✓	✓					✓		✓	✓			✓	✓		✓

RW	SBCADDY	SBCADDYSM	SCPDRW	STW	TD	TKP	TVR	UDBX	URT	VTK	WS	WTCDD <sup>3</sup>	WTKCUP	WTR

<sup>1</sup>Not available with 6" fluting.

<sup>2</sup>Not available on 36" wide.

<sup>3</sup>Only available on 24" wide.



**THREE DRAWER BASE with WOOD TIERED CUTLERY DIVIDER, 34 1/2" HIGH, 24" DEEP**

**3DB15WTCDD**

**3DB18WTCDD**

**3DB21WTCDD**

**3DB24WTCDD**

**3DB30WTCDD**

**3DB36WTCDD**

storage SOLUTIONS

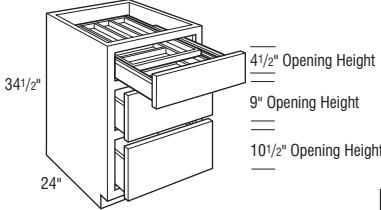

- Includes Wood Tiered Cutlery Divider Drawer.
- Exterior Wood Tiered Cutlery Divider drawer box height is 3 3/4", interior height of top tier is 1 5/8", and interior height of bottom tier is 1 3/8".
- Wood Tiered Cutlery Divider Drawer is also available as an accessory for field installation. See page S•5.
- For Inset and Beaded Inset styles opening sizes, see pages F•14-F•18.

**Door & Drawer Options**

AF	AOMBWB	CC	CG	ESMD	GAMD	IFHG	MD	PRMD	PTOWB	SHMD	SPLITDR	SPLITDRWS	SUMD	TCP

**End Panel Options**

AUTH	CSFPE	EXBK	FFD	FPE	INTGE	IPE
✓	✓	✓	✓	✓	✓	✓

**Custom Modification Options**

ADD	SHLF	ADDTK	CBO	CCO	CFNTO	CFP	CFRMO	CHGDRW	CLIP <sup>1</sup>	CMAT	CND	CSDGBK	DRT	DRWTK	EF	EX	EX_OL	FBFL	FD	

FDSRTBTM	FLUT <sup>2</sup>	FTK	ID	IH	IH+DRW <sup>3</sup>	INVERM	IW	LIGHT	MIP	OBRB	PFINBTMB	RD	RECTK	RH	ROSFLUT <sup>2</sup>	RT
	✓	✓							✓	✓			✓	✓		✓

RW	SBCADDY	SBCADDYSM	SCPDRW	STW	TD	TKP	TVR	UDBX	URT	VTK	WS <sup>4</sup>	WTCDD	WTKCUP	WTR

<sup>1</sup>Not available on 15" wide. CLIPL&R and 6" clipped not available on 15" or 18" wide. CLIP6L&R only available on 30" and 36" wide. CLIPL and CLIPR not available on 30" and 36" wide.

<sup>2</sup>Not available on 15" wide. FLUT3B and 6" fluting not available on 15" or 18" wide. FLUT6B only available on 30" and 36" wide. FLUT3L and FLUT3R not available on 30" and 36" wide.

<sup>3</sup>Only available on 30" and 36" wide.

<sup>4</sup>Not available on 15" wide. Wide Sstile both only available on 30" and 36" wide. WSL&R3 only available on 30" and 36" wide.

# Drawer Base Cabinets

## Description

**THREE DRAWER BASE with WOOD TIERED K-CUP\* DRAWER, 34 1/2" HIGH, 24" DEEP storage SOLUTIONS**

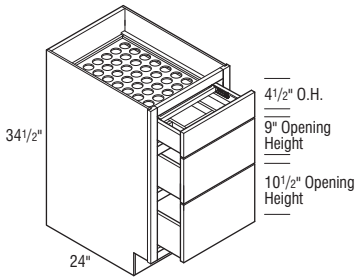

## Model

### 3DB18KCUP

- Holds 40 K-Cups.
- The Wood Tiered K-Cup Drawer is compatible with K-Cup pods only.
- Wood Tiered K-Cup Drawer available in 18" wide units.
- The K-Cup drawer will be positioned in the top drawer.

\*K-Cup is a registered trademark of Keurig Green Mountain, Inc.

#### Door & Drawer Options

AF	AOMBWB	CC	CG	ESMD	GAMD	IFHG	MD	PRMD	PTOWB	SHMD	SPLITDR	SPLITDRWS	SJMD	TCP
			✓			✓								

#### End Panel Options

AUTH	CSFPE	EXBK	FFD	FPE	INTGE	IPE
✓	✓	✓	✓	✓	✓	✓

#### Custom Modification Options

ADD_SHLF	ADDTK	CBO	CCO	CFNTO	CFP	CFRMO	CHGDRW	CLIP	CMAT	CND	CSDGBK	DRT	DRWTK	EF	EX	EX_OL	FBFL	FD	
		✓								✓					✓	✓	✓		

FDSRTBTM	FLUT <sup>1</sup>	FTK	ID	IH	IH+DRW	INVERM	IW	LIGHT	MIP	OBRB	PFINBTMB	RD	RECTK	RH	ROSLUT	RT
	✓	✓	✓	✓	✓				✓	✓			✓		✓	

RW	SBCADDY	SBCADDYSM	SCPDRW	STW	TD	TKP	TVR	UDBX	URT	VTK	WS	WTCD	WTKCUP	WTR
											✓		✓	✓

<sup>1</sup>Not available with 6" fluting.

**THREE DRAWER BASE with BREAD BOARD, 34 1/2" HIGH, 24" DEEP**

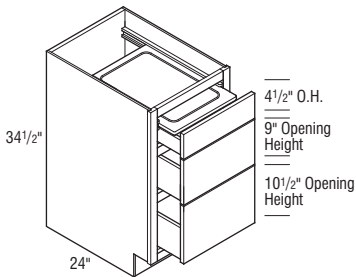

### 3DB12BB

### 3DB15BB

### 3DB18BB

### 3DB21BB

### 3DB24BB

#### Door & Drawer Options

AF	AOMBWB	CC	CG	ESMD	GAMD	IFHG	MD	PRMD	PTOWB	SHMD	SPLITDR	SPLITDRWS	SJMD	TCP
						✓								

#### End Panel Options

AUTH	CSFPE	EXBK	FFD	FPE	INTGE	IPE
✓	✓	✓	✓	✓	✓	✓

#### Custom Modification Options

ADD_SHLF	ADDTK	CBO	CCO	CFNTO	CFP	CFRMO	CHGDRW	CLIP <sup>1</sup>	CMAT	CND	CSDGBK	DRT	DRWTK <sup>2</sup>	EF	EX	EX_OL	FBFL	FD	
		✓	✓	✓	✓	✓		✓			✓		✓	✓	✓	✓	✓		

FDSRTBTM	FLUT <sup>3</sup>	FTK <sup>4</sup>	ID	IH	IH+DRW	INVERM	IW	LIGHT	MIP	OBRB	PFINBTMB	RD	RECTK	RH	ROSLUT	RT
	✓	✓	✓	✓	✓				✓	✓			✓		✓	

RW	SBCADDY	SBCADDYSM	SCPDRW	STW	TD	TKP	TVR	UDBX	URT	VTK	WS <sup>5</sup>	WTCD	WTKCUP	WTR <sup>6</sup>
											✓		✓	✓

<sup>1</sup>Not available on 12" wide.

<sup>2</sup>Only available on 24" wide.

<sup>3</sup>6" fluting not available on 12" or 15" and fluting both 6" not available on 18" or 21" wide.

<sup>4</sup>FTKAV not available on 12" wide.

<sup>5</sup>Not available on 12" wide. Not available on 1.5" except wide stile both 1.5".

<sup>6</sup>Not available on 18" or 24" wide.

IH/RH availability charts starting on page G•40.  
IW/RW availability charts starting on page G•46.

**Description**

**NEW** **THREE DRAWER BASE with CHARGING DRAWER, 34 1/2" HIGH, 24" DEEP**  
storage SOLUTIONS

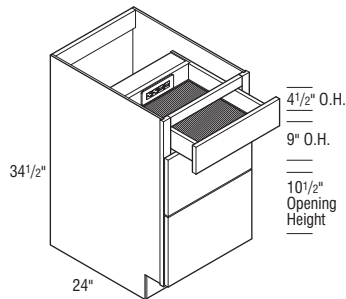

**Model**

**3DB18CHGDRW**

- The charging drawer will be positioned in the top drawer.
- Charging drawer has full extension, concealed Smart Stop slides.
- 110 lb. rated.
- 120V outlet must be installed in rear of cabinet within 10" of bottom of drawer, in rear of cabinet.
- CUL US listed power strip with two 120V plugs and two 2.1 amp USB ports.
- Max Current: AC 15 amps @ 120VAC; USB 2.1 amp and 5 VDC each.
- Tamper resistant outlets.
- Power cord with NEMA 5-15 plug.
- Integrated cord guide mounts to cabinet side to ensure safe operation.
- Black, shock absorbing mat included.
- Special sizes not available.
- Only available in 24" deep.
- Not available on Inset or Beaded Inset Styles.

**Door & Drawer Options**

AF	AOMBWB	CC	CG	ESMD	GAMD	IFHG	MD	PRMD	PTOWB	SHMD	SPLITDR	SPLITDRWS	SUMD	TCP
----	--------	----	----	------	------	------	----	------	-------	------	---------	-----------	------	-----

**End Panel Options**

AUTH	CSFPE	EXBK	FFD	FPE	INTGE	IPE
✓	✓	✓	✓	✓	✓	✓

**Custom Modification Options**

ADD_SHLF	ADDTK	CBO	CCO	CFNTO	CFP	CFRMO	CHGDRW	CLIP	CMAT	CND	CSDGBK	DRT	DRWTK	EF	EX	EX_OL	FBFL	FD
			✓	✓	✓								✓	✓		✓		
FDSRTBTM	FLUT	FTK	ID	IH	IH+DRW	INVERM	IW	LIGHT	MIP	OBRB	PFINBTMB	RD	RECTK	RH	ROSLUT	RT		
		✓							✓	✓			✓					
RW	SBCADDY	SBCADDYSM	SCPDRW	STW	TD	TKP	TVR	UDBX	URT	VTK	WS	WTCD	WTKCUP	WTR				
			✓					✓		✓				✓				

**NEW** **THREE DRAWER BASE BUFFET with DEEP DRAWER, 34 1/2" HIGH, 24" DEEP**

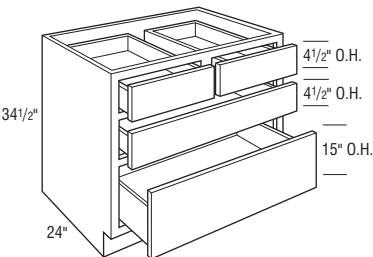

**3DBBDD30**

**3DBBDD33**

**3DBBDD36**

- Exterior height for bottom drawer box is 10".
- Scoop drawer option available in top drawer only.
- Reduced Depths available in 1/4" increments from 12" to 23 3/4".

**Door & Drawer Options**

AF	AOMBWB	CC	CG	ESMD	GAMD	IFHG	MD	PRMD	PTOWB	SHMD	SPLITDR	SPLITDRWS	SUMD	TCP
----	--------	----	----	------	------	------	----	------	-------	------	---------	-----------	------	-----

**End Panel Options**

AUTH	CSFPE	EXBK	FFD	FPE	INTGE	IPE
✓	✓	✓	✓	✓	✓	✓

**Custom Modification Options**

ADD_SHLF	ADDTK	CBO	CCO	CFNTO	CFP	CFRMO	CHGDRW	CLIP	CMAT	CND	CSDGBK	DRT	DRWTK	EF	EX	EX_OL	FBFL	FD
			✓	✓	✓	✓							✓	✓		✓		
FDSRTBTM	FLUT	FTK	ID	IH	IH+DRW	INVERM	IW	LIGHT	MIP	OBRB	PFINBTMB	RD	RECTK	RH	ROSLUT	RT		
		✓							✓	✓			✓	✓	✓	✓		
RW	SBCADDY	SBCADDYSM	SCPDRW	STW	TD	TKP	TVR	UDBX	URT	VTK	WS	WTCD	WTKCUP	WTR				
			✓					✓		✓				✓				

<sup>1</sup>Not available with 6" fluting.

<sup>2</sup>Not available on 36" wide.

# Drawer Base Cabinets

## Description

**TWO DRAWER BASE, 34 1/2" HIGH, 24" DEEP**

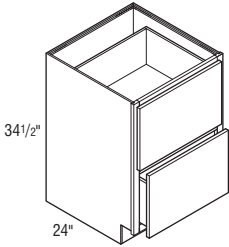

## Model

<b>2DB18</b>
<b>2DB21</b>
<b>2DB24</b>
<b>2DB27</b>
<b>2DB30</b>
<b>2DB33</b>
<b>2DB36</b>
<b>2DB39</b>
<b>2DB42</b>
<b>2DB45</b>
<b>2DB48</b>

- Utilizes 10" high drawer box height.
- Reduced Depths available in 1/4" increments from 12" to 23 3/4".

### Door & Drawer Options

AF	AOMBWB	CC	CG	ESMD	GAMD	IFHG	MD	PRMD	PTOWB	SHMD	SPLITDR	SPLITDRWS	SJMD	TCP
						✓								

### End Panel Options

AUTH	CSFPE	EXBK	FFD	FPE	INTGE	IPE
✓	✓	✓	✓	✓	✓	✓

### Custom Modification Options

ADD_SHLF	ADDTK	CBO	CCO	CFNTO	CFP	CFRMO	CHGDRW	CLIP	CMAT	CND	CSDGBK	DRT	DRWTK	EF	EX	EX_OL	FBFL	FD
		✓	✓	✓	✓	✓		✓			✓			✓	✓	✓	✓	✓

FDSRTBTM	FLUT	FTK	ID	IH	IH+DRW	INVFRM	IW <sup>1</sup>	LIGHT	MIP	OBRB	PFINBTMB	RD	RECTK	RH	ROSFLUT	RT
	✓	✓		✓			✓		✓	✓			✓		✓	

RW	SBCADDY	SBCADDYSM	SCPRW	STW	TD	TKP	TVR	UDBX	URT	VTK	WS	WTCO	WTKCUP	WTR
							✓					✓		✓

<sup>1</sup>Not available on 36" or 48" wide.

## **NEW** TWO DRAWER BASE with PEGGED DISH ORGANIZER, 34 1/2" HIGH, 24" DEEP

storage SOLUTIONS

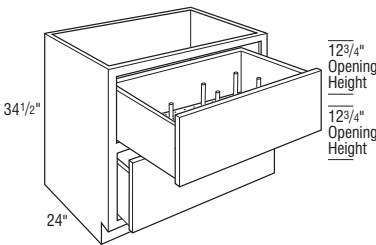

## 2DB36PDO

- Utilizes 10" high drawer box height.
- Cabinet not applicable for stove top installation.
- Includes 8 wooden posts and 19/32" thick removable pegged board in top drawer, shipped loose.
- Pegged board dimensions: 29 15/16" W x 19 1/2" D.

### Door & Drawer Options

AF	AOMBWB	CC	CG	ESMD	GAMD	IFHG	MD	PRMD	PTOWB	SHMD	SPLITDR	SPLITDRWS	SJMD	TCP

### End Panel Options

AUTH	CSFPE	EXBK	FFD	FPE	INTGE	IPE
✓	✓	✓	✓	✓	✓	✓

### Custom Modification Options

ADD_SHLF	ADDTK	CBO	CCO	CFNTO	CFP	CFRMO	CHGDRW	CLIP	CMAT	CND	CSDGBK	DRT	DRWTK	EF	EX	EX_OL	FBFL	FD
			✓	✓	✓	✓					✓	✓		✓	✓	✓	✓	✓

FDSRTBTM	FLUT <sup>1</sup>	FTK	ID	IH	IH+DRW	INVFRM	IW	LIGHT	MIP	OBRB	PFINBTMB	RD	RECTK	RH	ROSFLUT	RT
	✓	✓							✓	✓			✓		✓	

RW	SBCADDY	SBCADDYSM	SCPRW	STW	TD	TKP	TVR	UDBX	URT	VTK	WS	WTCO	WTKCUP	WTR
							✓					✓		✓

<sup>1</sup>Not available with 6" fluting.

IH/RH availability charts starting on page G•40.  
IW/RW availability charts starting on page G•46.

**Description**

**TWO DRAWER BASE with ROLL TRAYS,  
34 1/2" HIGH, 24" DEEP**  
storage  
SOLUTIONS

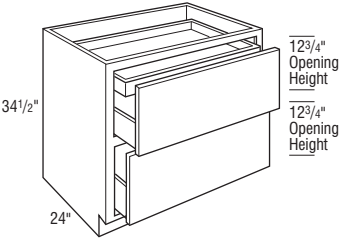

**Model**

- 2DB18RT
- 2DB21RT
- 2DB24RT
- 2DB27RT
- 2DB30RT
- 2DB33RT
- 2DB36RT

- Cabinet not applicable for stove top installation.
- Roll tray can be removed and installed above lower drawers.
- Reduced Depths available in 1/4" increments from 12" to 23 3/4".

**Door & Drawer Options**

AF	AOMBWB	CC	CG	ESMD	GAMD	IFHG	MD	PRMD	PTOWB	SHMD	SPLITDR	SPLITDRWS	SUMD	TCP
						✓								

**End Panel Options**

AUTH	CSFPE	EXBK	FFD	FPE	INTGE	IPE
✓	✓	✓	✓	✓	✓	✓

**Custom Modification Options**

ADD_SHLF	ADDTK	CBO	CCO	CFNTD	CFP	CFRMO	CHGDRW	CLIP	CMAT	CND	CSDGBK	DRT	DRWTK <sup>1</sup>	EF	EX	EX_OL	FBFL	FD
	✓		✓		✓			✓			✓		✓	✓	✓	✓	✓	✓

FDSRTBTM	FLUT <sup>2</sup>	FTK	ID	IH	IH+DRW	INVFRM	IW	LIGHT	MIP	OBRB	PFINBTMB	RD	RECTK	RH	ROSLUT	RT
	✓	✓	✓	✓	✓		✓		✓	✓		✓	✓	✓	✓	✓

RW <sup>3</sup>	SBCADDY	SBCADDYSM	SCPDRW	STW	TD	TKP	TVR	UDBX	URT	VTK	WS	WTCD	WTKCUP	WTR
✓						✓				✓	✓			✓

<sup>1</sup>Only available on 24", 30" and 36" wide.  
<sup>2</sup>6" fluting not available on 18"-27" wide.  
<sup>3</sup>Only available on 18" and 24" wide.

**TWO DRAWER BASE with ROLL TRAY  
and PEGGED DISH ORGANIZER,  
34 1/2" HIGH, 24" DEEP**  
storage  
SOLUTIONS

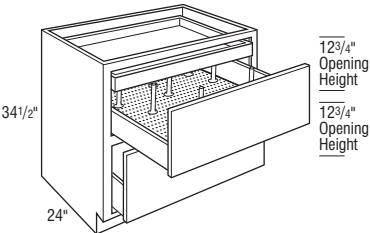

**2DB36RTPDO**

- Cabinet not applicable for stove top installation.
- Roll tray can be removed and installed above lower drawers.
- Includes eight wooden posts and 19/32" thick removable pegged board in top drawer, shipped loose.
- Pegged board dimensions: 29 15/16" W x 19 1/2" D.

**Door & Drawer Options**

AF	AOMBWB	CC	CG	ESMD	GAMD	IFHG	MD	PRMD	PTOWB	SHMD	SPLITDR	SPLITDRWS	SUMD	TCP
						✓								

**End Panel Options**

AUTH	CSFPE	EXBK	FFD	FPE	INTGE	IPE
✓	✓	✓	✓	✓	✓	✓

**Custom Modification Options**

ADD_SHLF	ADDTK	CBO	CCO	CFNTD	CFP	CFRMO	CHGDRW	CLIP	CMAT	CND	CSDGBK	DRT	DRWTK	EF	EX	EX_OL	FBFL	FD
	✓		✓		✓			✓			✓		✓	✓	✓	✓	✓	✓

FDSRTBTM	FLUT <sup>1</sup>	FTK	ID	IH	IH+DRW	INVFRM	IW	LIGHT	MIP	OBRB	PFINBTMB	RD	RECTK	RH	ROSLUT	RT
	✓	✓	✓	✓	✓		✓		✓	✓		✓	✓	✓	✓	✓

RW	SBCADDY	SBCADDYSM	SCPDRW	STW	TD	TKP	TVR	UDBX	URT	VTK	WS	WTCD	WTKCUP	WTR
						✓				✓	✓			✓

<sup>1</sup>Not available with 6" fluting.



# Drawer Base Cabinets

## Description

**TWO DRAWER BASE, 28 1/2" HIGH,  
24" DEEP**

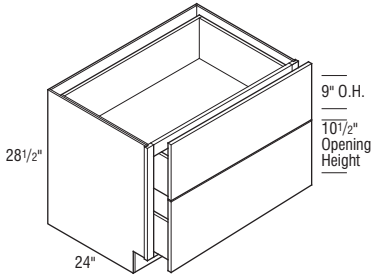

## Model

**2DB2428**

**2DB2728**

**2DB3028**

**2DB3328**

**2DB3628**

- Reduced Depths available in 1/4" increments from 12" to 23 3/4".

### Door & Drawer Options

AF	AOMBWB	CC	CG	ESMD	GAMD	IFHG	MD	PRMD	PTOWB	SHMD	SPLITDR	SPLITDRWS	SUMD	TCP
						✓								

### End Panel Options

AUTH	CSFPE	EXBK	FFD	FPE	INTGE	IPE
✓	✓	✓	✓	✓	✓	✓

### Custom Modification Options

ADD_SHLF	ADDTK	CBO	CCO	CFNTD	CFP	CFRMO	CHGDRW	CLIP	CMAT	CND	CSDGBK	DRT	DRWTK <sup>1</sup>	EF	EX	EX_OL	FBFL	FD
		✓	✓	✓	✓	✓		✓			✓		✓	✓	✓	✓	✓	

FDSRTBTM	FLUT	FTK	ID	IH	IH+DRW	INVFRM	IW	LIGHT	MIP	OBRB	PFINBTMB	RD	RECTK	RH	ROSFLUT	RT
	✓	✓					✓		✓	✓			✓	✓	✓	

RW <sup>2</sup>	SBCADDY	SBCADDYSM	SCPDRW	STW	TD	TKP	TVR	UDBX	URT	VTK	WS	WTCD	WTKCUP	WTR
✓								✓	✓	✓	✓			✓

<sup>1</sup>Not available on 27" or 33" wide.

<sup>2</sup>Only available on 24" wide.

IH/RH availability charts starting on page G•40.  
IW/RW availability charts starting on page G•46.

# Base Pots & Pans Pull-out & Storage Cabinets

## Description

### BASE POTS and PANS PULL-OUT, 34 1/2" HIGH, 24" DEEP storage SOLUTIONS

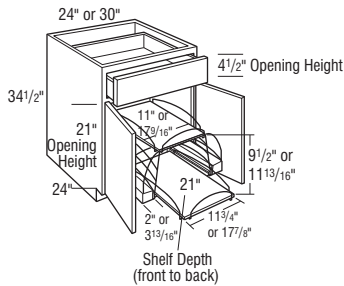
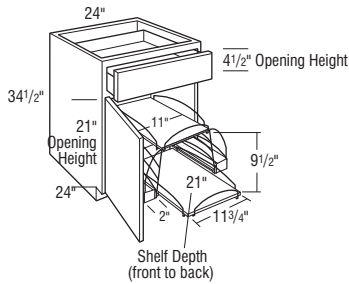

## Model

### BPPP24 L or R

- Pull-out dimensions: 19 3/4" W x 22 1/4" D x 14 1/2" H.
- Inset and Beaded Inset only available with Finial Hinge.

### BPPP24

- Pull-out dimensions: 19 3/4" W x 22 1/4" D x 14 1/2" H.
- Inset and Beaded Inset only available with Finial Hinge.

### BPPP30

- Pull-out dimensions: 25 1/2" W x 22 1/4" D x 14 13/16" H.
- Full Extension slide-out shelves pull out independently.
- Inset and Beaded Inset styles will use the 24" pull-out shown above.

Notes below apply to all products in section above:

- Smart Stop feature not available on pull-out.

#### Door & Drawer Options

AF	AOMBWB	CC	CG	ESMD	GAMD	IFHG	MD	PRMD	PTOWB	SHMD	SPLITDR	SPLITDRWS	SUMD	TCP

#### End Panel Options

AUTH	CSFPE	EXBK	FFD	FPE	INTGE	IPE

#### Custom Modification Options

ADD_SHLF	ADDTK	CBO	CCO	CFNTD	CFP	CFRMO	CHGDRW	CLIP	CMAT	CND	CSDGBK	DRT	DRWTK	EF	EX	EX_OL	FBFL	FD	

FDSRTBTM	FLUT <sup>1</sup>	FTK	ID	IH	IH+DRW	INVERM	IW	LIGHT	MIP	OBRB	PFINBTMB	RD	RECTK	RH	ROSFLUT	RT

RW	SBCADDY	SBCADDYSM	SCPDRW	STW	TD	TKP	TVR	UDBX	URT	VTK	WS	WTCD	WTKCUP	WTR

<sup>1</sup>Not available with 6" fluting.

### BASE POTS and PANS STORAGE, 34 1/2" HIGH, 24" DEEP storage SOLUTIONS

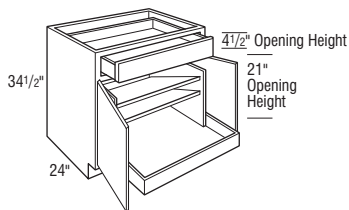

### B24PS

### B30PS

### B36PS

- Reduced Depths available in 3" increments from 15" to 21".
- Not available on Inset and Beaded Inset styles.

#### Door & Drawer Options

AF	AOMBWB	CC	CG	ESMD	GAMD	IFHG	MD	PRMD	PTOWB	SHMD	SPLITDR	SPLITDRWS	SUMD	TCP

#### End Panel Options

AUTH	CSFPE	EXBK	FFD	FPE	INTGE	IPE

#### Custom Modification Options

ADD_SHLF	ADDTK	CBO	CCO	CFNTD	CFP	CFRMO	CHGDRW <sup>1</sup>	CLIP	CMAT	CND	CSDGBK	DRT	DRWTK	EF	EX	EX_OL	FBFL	FD	

FDSRTBTM	FLUT <sup>2</sup>	FTK	ID	IH	IH+DRW	INVERM	IW	LIGHT	MIP	OBRB	PFINBTMB	RD	RECTK	RH	ROSFLUT	RT

RW	SBCADDY	SBCADDYSM	SCPDRW	STW	TD	TKP	TVR <sup>3</sup>	UDBX	URT	VTK	WS <sup>4</sup>	WTCD	WTKCUP <sup>5</sup>	WTR <sup>6</sup>

<sup>1</sup>Only available with 36" wide. 36" wide only available in conjunction with SPLITDRWS modification.

<sup>2</sup>Not available with 6" fluting.

<sup>3</sup>Not available on 24" wide. TVR not available on 36" wide.

<sup>4</sup>Only available on 30" and 36" wide with wide stile both 3".

<sup>5</sup>Only available on 36" wide.

<sup>6</sup>Not available on 24" wide.

# Base Lid Organizer & Base Combination Drawer Cabinets

## Description

## Model

**BASE with DRAWER and LID ORGANIZER and ROLL TRAYS, 34 1/2" HIGH, 24" DEEP storage solutions**

**B30RTLO**  
**B33RTLO**  
**B36RTLO**

- Lid Organizer dimensions: 7" W x 19" D x 4 3/8" H.

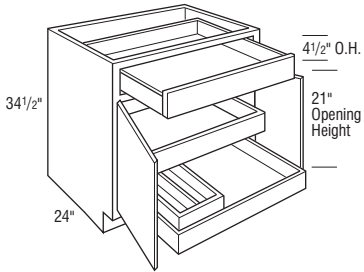

### Door & Drawer Options

AF	AOMBWB	CC	CG	ESMD	GAMD	IFHG	MD	PRMD	PTOWB	SHMD	SPLITDR	SPLITDRWS <sup>1</sup>	SUMD	TCP
		✓	✓	✓	✓	✓	✓	✓	✓	✓	✓	✓	✓	✓

### End Panel Options

AUTH	CSFPE	EXBK	FFD	FPE	INTGE	IPE
✓	✓	✓	✓	✓	✓	✓

### Custom Modification Options

ADD	SHLF	ADDTK	CBO	CCO	CFNTO	CFP	CFRMO	CHGDRW <sup>2</sup>	CLIP	CMAT	CND	CSDGBK	DRT	DRWTK <sup>3</sup>	EF	EX	EX_OL	FBFL	FD	
			✓			✓		✓	✓	✓	✓	✓	✓	✓	✓	✓	✓	✓	✓	✓

FDSRTBTM	FLUT	FTK	ID	IH	IH+DRW	INVFRM	IW	LIGHT	MIP	OBRB	PFINBTMB	RD	RECTK	RH	ROSFLUT	RT
✓	✓	✓	✓	✓	✓	✓	✓	✓	✓	✓	✓	✓	✓	✓	✓	✓

RW	SBCADDY	SBCADDYSM	SCPDRW <sup>1</sup>	STW	TD	TKP	TVR	UDBX	URT	VTK	WS	WTC <sup>2</sup>	WTKCUP <sup>4</sup>	WTR
			✓				✓	✓	✓	✓	✓	✓	✓	✓

<sup>1</sup>Not available on 36" wide.

<sup>2</sup>Only available with 36" wide. 36" wide only available in conjunction with SPLITDRWS modification.

<sup>3</sup>Not available on 33" wide.

<sup>4</sup>Only available on 36" wide.

## BASE COMBINATION DRAWER CABINET, 34 1/2" HIGH, 24" DEEP

**BCD30 L or R**

**BCD36 L or R**

**BCD42 L or R**

**BCD48 L or R**

- Door will be hinged opposite drawer stack.
- Includes one easily adjustable roll tray.
- Reduced Depths available in 1/4" increments from 12" to 23 3/4".

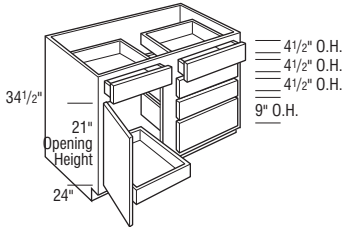

### Door & Drawer Options

AF	AOMBWB	CC	CG	ESMD	GAMD	IFHG	MD	PRMD	PTOWB	SHMD	SPLITDR	SPLITDRWS	SUMD	TCP
		✓	✓	✓	✓	✓	✓	✓	✓	✓	✓	✓	✓	✓

### End Panel Options

AUTH	CSFPE	EXBK	FFD	FPE	INTGE	IPE
✓	✓	✓	✓	✓	✓	✓

### Custom Modification Options

ADD	SHLF	ADDTK	CBO	CCO	CFNTO	CFP	CFRMO	CHGDRW <sup>1</sup>	CLIP	CMAT	CND	CSDGBK	DRT	DRWTK <sup>2</sup>	EF	EX	EX_OL	FBFL	FD	
			✓			✓		✓	✓	✓	✓	✓	✓	✓	✓	✓	✓	✓	✓	✓

FDSRTBTM	FLUT <sup>3</sup>	FTK	ID	IH	IH+DRW	INVFRM	IW	LIGHT	MIP	OBRB	PFINBTMB	RD	RECTK	RH	ROSFLUT	RT
✓	✓	✓	✓	✓	✓	✓	✓	✓	✓	✓	✓	✓	✓	✓	✓	✓

RW	SBCADDY	SBCADDYSM	SCPDRW	STW	TD	TKP	TVR	UDBX	URT	VTK	WS <sup>4</sup>	WTC <sup>2</sup>	WTKCUP <sup>1</sup>	WTR
			✓				✓	✓	✓	✓	✓	✓	✓	✓

<sup>1</sup>Only available on 36" wide.

<sup>2</sup>Not available on 42" or 48" wide.

<sup>3</sup>Not available with fluting both 6".

<sup>4</sup>Only available on wide stile 3", but not available on wide stile both 3".

IH/RH availability charts starting on page G-40.  
IW/RW availability charts starting on page G-46.

# Base Cooking Center & Base Pantry Can Storage Cabinets

## Description

### BASE COOKING CENTER with BREAD BOARD, 34 1/2" HIGH, 24" DEEP storage SOLUTIONS

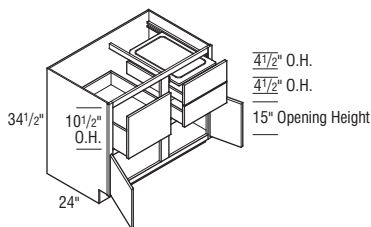

Right Shown

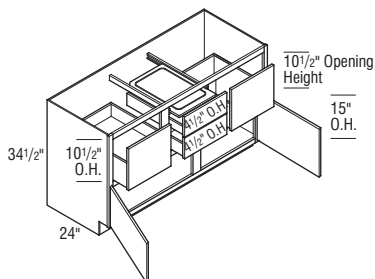

## Model

**BCC30BB L or R**

**BCC36BB L or R**

**BCC42BB L or R**

**BCC48BB**

Notes below apply to all products in section above:

- One cutlery divider included.

#### Door & Drawer Options

AF	AOMBWB	CC	CG	ESMD	GAMD	IFHG	MD	PRMD	PTOWB	SHMD	SPLITDR	SPLITDRWS	SUMD	TCP
			✓	✓	✓	✓	✓	✓		✓				✓

#### End Panel Options

AUTH	CSFPE	EXBK	FFD	FPE	INTGE	IPE
✓	✓	✓	✓	✓	✓	✓

#### Custom Modification Options

ADD_SHLF	ADDTK	CBO	CCO	CFNTO	CFP	CFRMO	CHGDRW	CLIP	CMAT	CND	CSDGBK	DRT	DRWTK <sup>1</sup>	EF	EX	EX_OL	FBFL	FD
						✓					✓		✓	✓	✓	✓		

FDSRTBTM	FLUT <sup>2</sup>	FTK	ID	IH	IH+DRW	INVFRM	IW	LIGHT	MIP	OBRB	PFINBTMB	RD	RECTK	RH	ROSFLUT	RT
	✓	✓		✓					✓	✓			✓	✓	✓	

RW	SBCADDY	SBCADDYSM	SCPDRW	STW	TD	TKP	TVR	UDBX	URT	VTK	WS <sup>3</sup>	WTCD	WTKCUP	WTR
							✓	✓		✓	✓			✓

<sup>1</sup>Not available on 42" or 48" wide.

<sup>2</sup>Not available with 6" fluting.

<sup>3</sup>Only available on 48" wide.

### BASE PANTRY CAN STORAGE, 34 1/2" HIGH, 24" DEEP storage SOLUTIONS

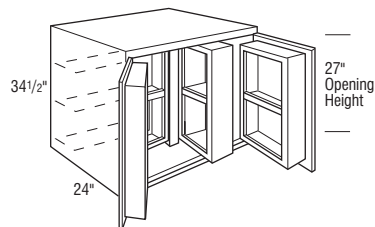

## BPCS36

- Six adjustable shelves behind swing-out.
- Swing-out section includes two fixed shelves.
- Unit can be used next to wall without use of a filler.
- Not available on Inset and Beaded Inset styles.

#### Door & Drawer Options

AF	AOMBWB	CC	CG	ESMD	GAMD	IFHG	MD	PRMD	PTOWB	SHMD	SPLITDR	SPLITDRWS	SUMD	TCP
														✓

#### End Panel Options

AUTH	CSFPE	EXBK	FFD	FPE	INTGE	IPE
✓	✓	✓	✓	✓	✓	✓

#### Custom Modification Options

ADD_SHLF	ADDTK	CBO	CCO	CFNTO	CFP	CFRMO	CHGDRW	CLIP	CMAT	CND	CSDGBK	DRT	DRWTK	EF	EX	EX_OL	FBFL	FD
														✓	✓	✓	✓	

FDSRTBTM	FLUT <sup>1</sup>	FTK	ID	IH	IH+DRW	INVFRM	IW	LIGHT	MIP	OBRB	PFINBTMB	RD	RECTK	RH	ROSFLUT	RT
	✓	✓							✓	✓			✓	✓	✓	

RW	SBCADDYSM	SBCADDY	SCPDRW	STW	TD	TKP	TVR	UDBX	URT	VTK	WS	WTCD	WTKCUP	WTR
								✓		✓				✓

<sup>1</sup>Not available with 6" fluting.

# Sink Base Cabinets

## Description

**SINK BASE, 34 1/2" HIGH, 24" DEEP**

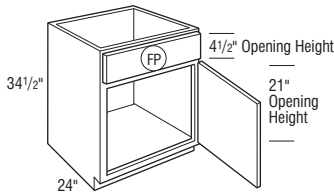

**FP** False Panel

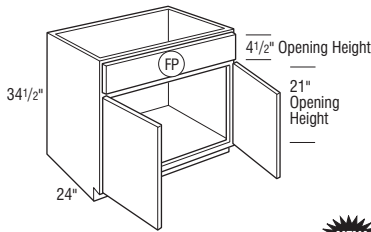

**FP** False Panel

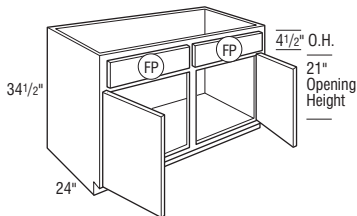

**FP** False Panel

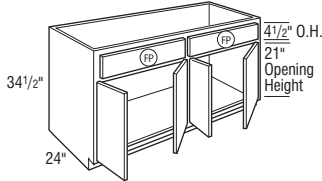

**FP** False Panel

## Model

**SB18 L or R**

**SB21 L or R**

**SB24 L or R**

**SB24**

**SB27**

**SB30**

**SB33**

**SB36**

**SB39**

**SB42**

**SB45**

**SB48CS**

**SB48**

- Two sets of butt doors.

Notes below apply to all products in section above:

- Touch-up kit (TUK) and Owner's Guide included.
- Increased Depths available in 1/4" increments from 24 1/4" to 30".
- Reduced Depths available in 1/4" increments from 6" to 23 3/4".

### Door & Drawer Options

AF	AOMBWB	CC	CG	ESMD	GAMD	IFHG	MD	PRMD	PTOWB	SHMD	SPLITDR <sup>1</sup>	SPLITDRWS <sup>2</sup>	SUMD	TCP

### End Panel Options

AUTH	CSFPE	EXBK	FFD	FPE	INTGE	IPE

### Custom Modification Options

ADD	SHLF	ADTK	CBO	CCO <sup>3</sup>	CFNT0	CFP	CFRMO	CHGDRW	CLIP	CMAT <sup>4</sup>	CND	CSDGBK	DRT	DRWTK <sup>5</sup>	EF	EX	EX	OL	FBFL	FD

FDSRTBTM	FLUT <sup>6</sup>	FTK	ID	IH	IH+DRW	INVFRM	IW <sup>7</sup>	LIGHT	MIP	OBRB	PFINBTMB	RD	RECTK	RH	ROSLUT <sup>8</sup>	RT

RW	SBCADDY	SBCADDYSM	SCPDRW	STW	TD	TKP	TVR	UDBX	URT <sup>9</sup>	VTK	WS <sup>10</sup>	WTCD	WTKCUP	WTR

<sup>1</sup>Only available on 24" (2 doors)-39" wide.

<sup>2</sup>Not available on 18", 21" or 48" wide.

<sup>3</sup>Only available on 18"-24" (1 door) wide.

<sup>4</sup>Only available on 30", 33" and 36" wide.

<sup>5</sup>Only available on 24" (1 door and 2 doors), 30" and 36" wide.

<sup>6</sup>Fluting both 3" not available on 24" (2 doors) wide. 6" fluting not available with 18"-21" or 24" (2 doors) wide.

<sup>7</sup>Not available on 18"-24" (1 door), 27", 36", or 48" wide.

<sup>8</sup>Fluting both not available on 24" (2 doors) wide.

<sup>9</sup>Only available on 24" (1 door and 2 doors)-36" wide.

<sup>10</sup>Not available on 24" (2 doors) wide.

IH/RH availability charts starting on page G•40.  
IW/RW availability charts starting on page G•46.

## Description

**SINK BASE DOUBLE DOOR with CABMAT™, 34 1/2" HIGH, 24" DEEP storage SOLUTIONS**

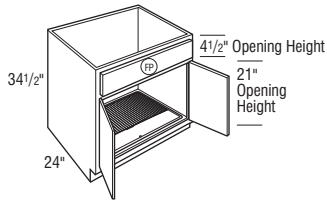

**FP False Panel**

## Model

**SB30CM**  
**SB33CM**  
**SB36CM**

- Touch-up kit (TUK) and Owner's Guide included.
- CabMat™ features a gray sloped mat to capture spills.
- CabMat™ is removable for cleaning.

	Liquid Capacity		Cabinet Size	
	Quarts	Liters	Width	Depth
SB30CM	4.2	3.9	30"	24"
SB33CM	4.6	4.3	33"	24"
SB36CM	5.0	4.7	36"	24"

### Door & Drawer Options

AF	AOMBWB	CC	CG	ESMD	GAMD	IFHG	MD	PRMD	PTOWB	SHMD	SPLITDR	SPLITDRWS	SUMD	TCP
			✓	✓	✓	✓	✓	✓		✓	✓		✓	

### End Panel Options

AUTH	CSFPE	EXBK	FFD	FPE	INTGE	IPE
✓	✓	✓	✓	✓	✓	✓

### Custom Modification Options

ADD_SHLF	ADDTK	CBO	CCO	CFNTO	CFP	CFRMO	CHGDRW	CLIP	CMAT	CND	CSDGBK	DRT	DRWTK	EF	EX	EX_OL	FBFL	FD
				✓		✓				✓	✓		✓	✓	✓	✓	✓	

FDSRTBTM	FLUT <sup>1</sup>	FTK	ID	IH	IH+DRW	INVERM	IW	LIGHT	MIP	OBRB	PFINBTMB	RD	RECTK	RH	ROSFLUT	RT <sup>2</sup>
	✓	✓	✓	✓			✓		✓	✓			✓	✓	✓	✓

RW	SBCADDY	SBCADDYSM	SCPDRW	STW	TD <sup>2</sup>	TKP	TVR	UDBX	URT	VTK	WS	WTCD	WTKCUP	WTR
						✓	✓			✓	✓			✓

<sup>1</sup>Not available with 6" fluting.  
<sup>2</sup>Only available on 30" wide.

**NEW** **SINK BASE DOUBLE DOOR with CADDY, 34 1/2" HIGH, 24" DEEP storage SOLUTIONS**

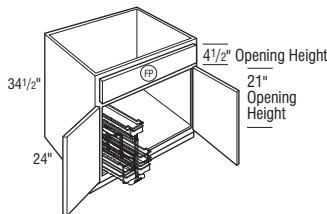

## Model

**SB36CDY L or R**

- Touch-up kit (TUK) and Owner's Guide included.
- L or R designates caddy installed side.
- Caddy includes one removable basket with handle, one basket without handle, swivel basket and 8 dividers.
- Bottom mounted full extension, Smart Stop slides.
- Caddy dimensions are 11" wide x 20" high x 18 1/2" deep.
- Caddy is removable and portable.
- Caddy also available for field installation. See page S•13.

### Door & Drawer Options

AF	AOMBWB	CC	CG	ESMD	GAMD	IFHG	MD	PRMD	PTOWB	SHMD	SPLITDR	SPLITDRWS	SUMD	TCP
			✓				✓	✓			✓	✓		

### End Panel Options

AUTH	CSFPE	EXBK	FFD	FPE	INTGE	IPE
✓	✓	✓	✓	✓	✓	✓

### Custom Modification Options

ADD_SHLF	ADDTK	CBO	CCO	CFNTO	CFP	CFRMO	CHGDRW	CLIP	CMAT	CND	CSDGBK	DRT	DRWTK	EF	EX	EX_OL	FBFL	FD
				✓		✓				✓	✓		✓	✓	✓	✓	✓	

FDSRTBTM	FLUT	FTK	ID	IH	IH+DRW	INVERM	IW	LIGHT	MIP	OBRB	PFINBTMB	RD	RECTK	RH	ROSFLUT	RT
	✓	✓	✓	✓			✓		✓	✓			✓	✓	✓	✓

RW	SBCADDY	SBCADDYSM	SCPDRW	STW	TD	TKP	TVR	UDBX	URT	VTK	WS	WTCD	WTKCUP	WTR
						✓	✓	✓		✓	✓			✓

# Sink Base Cabinets

## Description

**SINK BASE with TILT-OUT TRAY,  
34 1/2" HIGH, 24" DEEP**

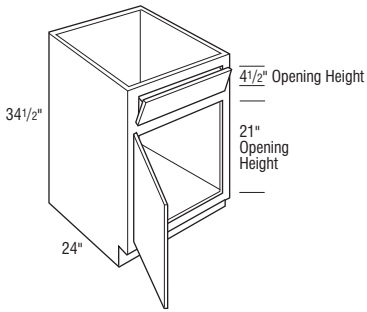

## Model

**SB18ST L or R**

**SB21ST L or R**

**SB24ST L or R**

- Touch-up kit (TUK) and Owner's Guide included.
- Increased Depths available in 1/4" increments from 24 1/4" to 30".
- Reduced Depths available in 1/4" increments from 6" to 23 3/4".
- One drawer front with one 1 1/16" deep stainless steel Tilt-out Tray attached.

### Door & Drawer Options

AF	AOMBWB	CC	CG	ESMD	GAMD	IFHG	MD	PRMD	PTOWB	SHMD	SPLITDR	SPLITDRWS <sup>1</sup>	SUMD	TCP

### End Panel Options

AUTH	CSFPE	EXBK	FFD	FPE	INTGE	IPE

### Custom Modification Options

ADD	SHLF	ADDTK	CBO	CCO	CFNTO	CFP	CFRMO	CHGDRW	CLIP	CMAT	CND	CSDGBK	DRT	DRWTK <sup>1</sup>	EF	EX	EX_OL	FBFL	FD	

FDSRTBTM	FLUT <sup>2</sup>	FTK	ID	IH	IH+DRW	INVERM	IW	LIGHT	MIP	OBRB	PFINBTMB	RD	RECTK	RH	ROSLUT	RT

RW	SBCADDY	SBCADDYSM	SCPDRW	STW	TD	TKP	TVR	UDBX	URT <sup>1</sup>	VTK	WS	WTCD	WTKCUP	WTR

<sup>1</sup>Only available on 24" wide.

<sup>2</sup>6" fluting not available on 18" or 21" wide.

IH/RH availability charts starting on page G•40.  
IW/RW availability charts starting on page G•46.

## Description

### SINK BASE with TILT-OUT TRAY, 34 1/2" HIGH, 24" DEEP

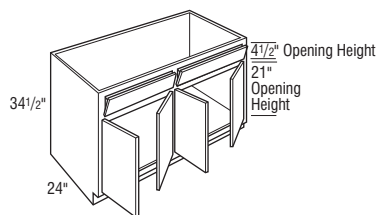
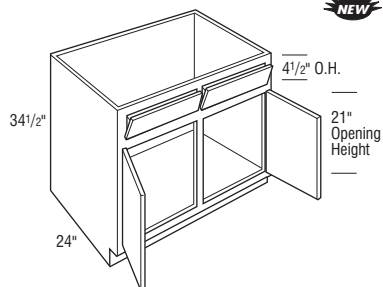
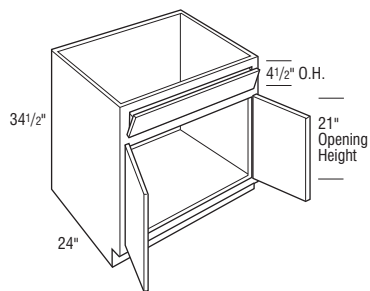

## Model

SB24ST

SB27ST

SB30ST

SB33ST

SB36ST

SB39ST

- One drawer front with one 1 11/16" deep stainless steel Tilt-out Tray attached.

SB42ST

SB45ST

SB48CSST

- Two drawer fronts with two 1 11/16" deep stainless steel Tilt-out Trays attached.

**NEW** SB48ST

- Two sets of butt doors.
- Two drawer fronts with two 1 11/16" deep stainless steel Tilt-out Trays attached.

#### Notes below apply to all products in section above:

- Touch-up kit (TUK) and Owner's Guide included.
- Increased Depths available in 1/4" increments from 24 1/4" to 30".
- Reduced Depths available in 1/4" increments from 6" to 23 3/4".

#### Door & Drawer Options

AF	AOMBWB	CC	CG	ESMD	GAMD	IFHG	MD	PRMD <sup>1</sup>	PTOWB	SHMD	SPLITDR <sup>2</sup>	SPLITDRWS <sup>3</sup>	SUMD	TCP
			✓	✓	✓	✓	✓	✓	✓	✓	✓	✓	✓	✓

#### End Panel Options

AUTH	CSFPE	EXBK	FFD	FPE	INTGE	IPE
✓	✓	✓	✓	✓	✓	✓

#### Custom Modification Options

ADD	SHLF	ADDTK	CBO	CCO	CFNTD	CFP	CFRMO	CHGDRW	CLIP <sup>4</sup>	CMT <sup>5</sup>	CND	CSDGBK	DRT	DRWTK <sup>6</sup>	EF	EX	EX_OL	FBFL	FD	
			✓	✓	✓	✓	✓	✓	✓	✓	✓	✓	✓	✓	✓	✓	✓	✓	✓	✓

FDSRTBTM	FLUT <sup>7</sup>	FTK	ID	IH	IH+DRW	INVERM	IW	LIGHT	MIP	OBRB	PFINBTMB	RD	RECTK	RH	ROSFLUT	RT
	✓	✓	✓	✓	✓	✓	✓	✓	✓	✓	✓	✓	✓	✓	✓	✓

RW	SBCADDY	SBCADDYSM	SCPDRW	STW	TD	TKP	TVR	UDBX	URT <sup>8</sup>	VTK	WS <sup>1</sup>	WTCD	WTKCUP	WTR
	✓	✓	✓	✓	✓	✓	✓	✓	✓	✓	✓	✓	✓	✓

<sup>1</sup>Not available on 24" wide.

<sup>2</sup>Not available on 42"-48" wide.

<sup>3</sup>Not available on 24" or 48" wide.

<sup>4</sup>Not available on 24" wide.

<sup>5</sup>Only available on 30"-36" wide.

<sup>6</sup>Only available on 24", 30" and 36" wide.

<sup>7</sup>6" fluting not available on 24" wide.

<sup>8</sup>Not available on 39"-48" wide.



# Sink Base Cabinets

## Description

**NEW** SINK BASE with TILT-OUT TRAY and CADDY, 34 1/2" HIGH, 24" DEEP

### storage SOLUTIONS

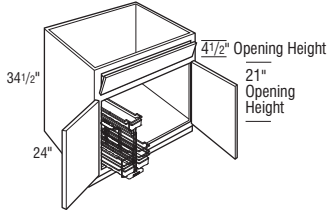

## Model

### SB36STCDY L or R

- One drawer front with one 1 11/16" deep stainless steel Tilt-out Tray attached.
- Touch-up kit (TUK) and Owner's Guide included.
- L or R designates caddy installed side.
- Caddy includes one removable basket with handle, one basket without handle, swivel basket and 8 dividers.
- Bottom mounted full extension, Smart Stop slides.
- Caddy dimensions are 11" wide x 20" high x 18 1/2" deep.
- Caddy is removable and portable.
- Caddy also available for field installation. See page S•13.

#### Door & Drawer Options

AF	AOMBWB	CC	CG	ESMD	GAMD	IFHG	MD	PRMD	PTOWB	SHMD	SPLITDR	SPLITDRWS	SUMD	TCP
			✓				✓	✓			✓	✓		

#### End Panel Options

AUTH	CSFPE	EXBK	FFD	FPE	INTGE	IPE
✓	✓	✓	✓	✓	✓	✓

#### Custom Modification Options

ADD	SHLF	ADDTK	CBO	CCO	CFNTD	CFP	CFRMO	CHGDRW	CLIP	CMAT	CND	CSDGBK	DRT	DRWTK	EF	EX	EX_OL	FBFL	FD
					✓					✓		✓		✓	✓	✓	✓	✓	✓

FDSRTBTM	FLUT	FTK	ID	IH	IH+DRW	INVFRM	IW	LIGHT	MIP	OBRB	PFINBTMB	RD	RECTK	RH	ROSFLUT	RT
	✓	✓	✓	✓				✓	✓			✓	✓	✓	✓	✓

RW	SBCADDY	SBCADDYSM	SCPDRW	STW	TD	TKP	TVR	UDBX	URT	VTK	WS	WTCDD	WTKCUP	WTR
							✓	✓	✓	✓	✓			✓

## SINK BASE with TILT-OUT TRAYS and CABMAT™, 34 1/2" HIGH, 24" DEEP

### storage SOLUTIONS

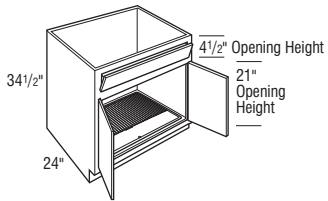

### SB30STCM

### SB33STCM

### SB36STCM

- Touch-up kit (TUK) and Owner's Guide included.
- CabMat™ features a gray sloped mat to capture spills.
- CabMat™ is removable for cleaning.
- One drawer front with one 1 11/16" deep stainless steel Tilt-out Tray attached.

	Liquid Capacity		Cabinet Size	
	Quarts	Liters	Width	Depth
SB30STCM	4.2	3.9	30"	24"
SB33STCM	4.6	4.3	33"	24"
SB36STCM	5.0	4.7	36"	24"

#### Door & Drawer Options

AF	AOMBWB	CC	CG	ESMD	GAMD	IFHG	MD	PRMD	PTOWB	SHMD	SPLITDR	SPLITDRWS	SUMD	TCP
			✓	✓	✓	✓	✓	✓		✓	✓			✓

#### End Panel Options

AUTH	CSFPE	EXBK	FFD	FPE	INTGE	IPE
✓	✓	✓	✓	✓	✓	✓

#### Custom Modification Options

ADD	SHLF	ADDTK	CBO	CCO	CFNTD	CFP	CFRMO	CHGDRW	CLIP	CMAT	CND	CSDGBK	DRT	DRWTK	EF	EX	EX_OL	FBFL	FD
					✓						✓			✓	✓	✓	✓	✓	✓

FDSRTBTM	FLUT <sup>1</sup>	FTK	ID	IH	IH+DRW	INVFRM	IW	LIGHT	MIP	OBRB	PFINBTMB	RD	RECTK	RH	ROSFLUT	RT <sup>2</sup>
	✓	✓	✓	✓				✓	✓			✓	✓	✓	✓	✓

RW	SBCADDY	SBCADDYSM	SCPDRW	STW	TD <sup>2</sup>	TKP	TVR	UDBX	URT	VTK	WS	WTCDD	WTKCUP	WTR
							✓	✓		✓	✓			✓

<sup>1</sup>Not available with 6" fluting.

<sup>2</sup>Only available on 30" wide.

IH/RH availability charts starting on page G•40.  
IW/RW availability charts starting on page G•46.

## Description

**NEW** SINK BASE, 34 1/2" HIGH, 27" DEEP

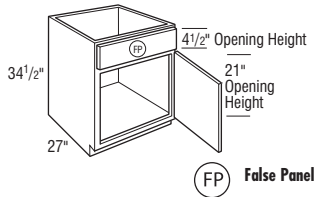

FP False Panel

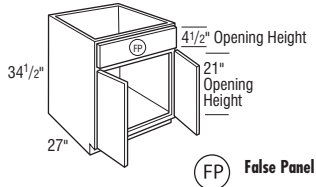

FP False Panel

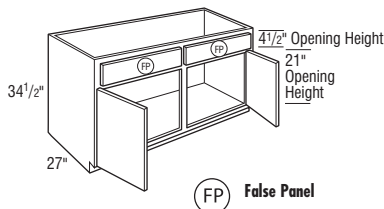

FP False Panel

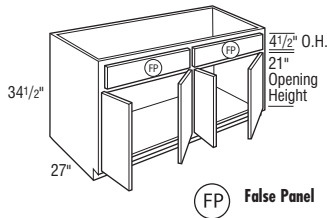

FP False Panel

## Model

SB243427 L or R

SB243427

SB273427

SB303427

SB333427

SB363427

SB393427

SB423427

SB453427

SB483427CS

SB483427

- Two sets of butt doors.

Notes below apply to all products in section above:

- Touch-up kit (TUK) and Owner's Guide included.
- Increased Depths available in 1/4" increments from 27 1/4" to 30".
- Reduced Depths available in 1/4" increments from 6" to 26 3/4".

### Door & Drawer Options

AF	AOMBWB	CC	CG	ESMD	GAMD	IFHG	MD	PRMD	PTOWB	SHMD	SPLITDR <sup>1</sup>	SPLITDRWS <sup>2</sup>	SUMD	TCP

### End Panel Options

AUTH	CSFPE	EXBK	FFD	FPE	INTGE	IPE

### Custom Modification Options

ADD_SHLF	ADDTK	CBO	CCO <sup>3</sup>	CFNTD	CFP	CFRMO	CHGDRW	CLIP	CMAT	CND	CSDGBK	DRT	DRWTK <sup>4</sup>	EF	EX	EX_OL	FBFL	FD

FDSRTBTM	FLUT <sup>5</sup>	FTK	ID	IH	IH+DRW	INVFRM	IW <sup>2</sup>	LIGHT	MIP	OBRB	PFINBTMB	RD	RECTK	RH	ROSFLUT <sup>6</sup>	RT

RW	SBCADDY	SBCADDYSM	SCPDRW	STW	TD	TKP	TVR	UDBX	URT	VTK	WS <sup>7</sup>	WTCO	WTKCUP	WTR

<sup>1</sup>Not available on 42"-48" wide.

<sup>2</sup>Not available on 48" wide.

<sup>3</sup>Not available on 24" (1 door) wide.

<sup>4</sup>Not available on 24" (1 door) or 39"-48" wide.

<sup>5</sup>6" fluting and FLUT3B not available on 24" wide.

<sup>6</sup>ROSFLUT3B not available on 24" wide.

<sup>7</sup>Not available on 24" wide.

# Sink Base Cabinets

## Description

**NEW** SINK BASE with TILT-OUT TRAY,  
34 1/2" HIGH, 27" DEEP

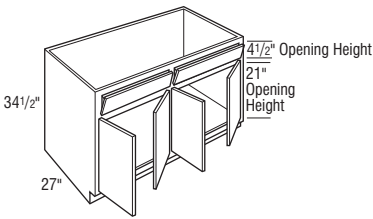
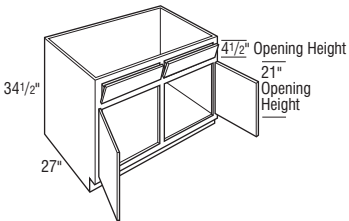
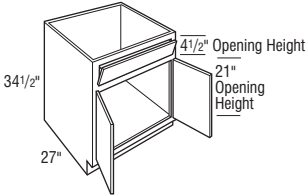
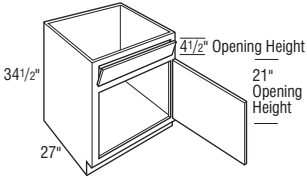

## Model

### SB243427ST L or R

- One drawer front with one 1 11/16" deep stainless steel Tilt-out Tray attached.

### SB243427ST

### SB273427ST

### SB303427ST

### SB333427ST

### SB363427ST

### SB393427ST

- One drawer front with one 1 11/16" deep stainless steel Tilt-out Tray attached.

### SB423427ST

### SB453427ST

### SB483427CSST

- Two drawer fronts with two 1 11/16" deep stainless steel Tilt-out Trays attached.

### SB483427ST

- Two sets of butt doors.
- Two drawer fronts with two 1 11/16" deep stainless steel Tilt-out Trays attached.

#### Notes below apply to all products in section above:

- Touch-up kit (TUK) and Owner's Guide included.
- Increased Depths available in 1/4" increments from 27 1/4" to 30".
- Reduced Depths available in 1/4" increments from 6" to 26 3/4".

#### Door & Drawer Options

AF	AOMBWB	CC	CG	ESMD	GAMD	IFHG	MD	PRMD	PTOWB	SHMD	SPLITDR <sup>1</sup>	SPLITDRWS <sup>2</sup>	SUMD	TCP
			✓					✓	✓		✓	✓		

#### End Panel Options

AUTH	CSFPE	EXBK	FFD	FPE	INTGE	IPE
✓	✓	✓	✓	✓	✓	✓

#### Custom Modification Options

ADD	SHLF	ADDTK	CBD	CCO <sup>3</sup>	CFNT0	CFP	CFRMO	CHGDRW	CLIP <sup>4</sup>	CMAT	CND	CSDGBK	DRT	DRWTK <sup>5</sup>	EF	EX	EX_OL	FBFL	FD	
			✓	✓	✓	✓	✓	✓	✓	✓	✓	✓	✓	✓	✓	✓	✓	✓	✓	✓

FDSRTBTM	FLUT <sup>6</sup>	FTK	ID	IH	IH+DRW	INFRM	IW	LIGHT	MIP	OBRB	PFINBTMB	RD	RECTK	RH	ROSFLUT	RT
	✓	✓	✓	✓	✓				✓	✓		✓	✓	✓	✓	✓

RW	SBCADDY	SBCADDYSM	SCPDRW	STW	TD	TKP	TVR	UDBX	URT	VTK	WS <sup>4</sup>	WTCD	WTKCUP	WTR
	✓	✓				✓	✓	✓		✓	✓			✓

<sup>1</sup>Not available on 24" (1 door) or 42"-48" wide.

<sup>2</sup>Not available on 24" (2 doors) or 48" wide.

<sup>3</sup>Only available on 24" (1 door) wide.

<sup>4</sup>Not available on 24" (2 doors) wide.

<sup>5</sup>Not available on 39"-48" wide.

<sup>6</sup>6" fluting not available with 30"-39" wide.

IH/RH availability charts starting on page G•40.  
IW/RW availability charts starting on page G•46.

## Description

### SINK BASE SUPERCABINET™, 34 1/2" HIGH, 24" DEEP storage SOLUTIONS

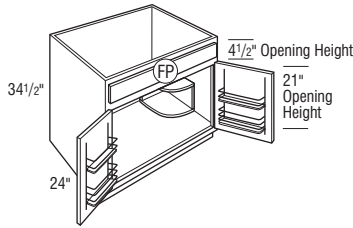

FP False Panel

## Model

SB30S

SB33S

SB36S

- Quarter Round Reversible Shelf for left or right applications included.
- Basket size on 30" and 33" door is 11 1/2" W x 20 1/2" H x 3 1/2" D.
- Basket size on 36" door is 14 1/2" W x 20 1/2" H x 3 1/2" D.
- Touch-up kit (TUK) and Owner's Guide included.
- Door includes a two-tiered non-adjustable chrome rack with wood bottoms.
- Increased Depths available in 1/4" increments from 24 1/4" to 30".
- Not available on Inset and Beaded Inset styles.

#### Door & Drawer Options

AF	AOMBWB	CC	CG	ESMD	GAMD	IFHG	MD	PRMD	PTOWB	SHMD	SPLITDR	SPLITDRWS	SUMD	TCP
						✓						✓		

#### End Panel Options

AUTH	CSFPE	EXBK	FFD	FPE	INTGE	IPE
✓	✓	✓	✓	✓	✓	✓

#### Custom Modification Options

ADD_SHLF	ADDTK	CBO	CCO	CFNTO	CFP	CFRMO	CHGDRW	CLIP <sup>1</sup>	CMAT	CND	CSDGBK	DRT	DRWTK <sup>2</sup>	EF	EX	EX_OL	FBFL	FD
								✓	✓	✓	✓		✓	✓	✓	✓		

FDSRTBTM	FLUT <sup>3</sup>	FTK	ID	IH <sup>2</sup>	IH+DRW	INVERM	IW	LIGHT	MIP	OBRB	PFINBTMB	RD	RECTK	RH <sup>4</sup>	ROSFLUT	RT
	✓	✓	✓	✓					✓	✓		✓	✓	✓	✓	

RW	SBCADDY	SBCADDYSM	SCPDRW	STW	TD	TKP	TVR	UDBX	URT	VTK	WS <sup>5</sup>	WTCD	WTKCUP	WTR
						✓	✓			✓	✓			✓

<sup>1</sup>Not available on 30" wide.

<sup>2</sup>Not available on 33" wide.

<sup>3</sup>6" fluting not available on 30" wide.

<sup>4</sup>Only available on 30" wide.

<sup>5</sup>Not available on 30" wide. Not available on wide stile 1.5" except wide stile both 1.5".

### NEW SINK BASE SUPERCABINET™ with CADDY, 34 1/2" HIGH, 24" DEEP storage SOLUTIONS

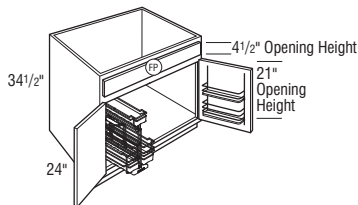

## SB36SCDY L or R

- Touch-up kit (TUK) and Owner's Guide included.
- L or R designates caddy installed side.
- Caddy includes one removable basket with handle, one basket without handle, swivel basket and 8 dividers.
- Bottom mounted full extension, Smart Stop slides.
- Caddy dimensions are 11" wide x 20" high x 18 1/2" deep.
- Caddy is removable and portable.
- Caddy also available for field installation. See page S•13.
- Door without caddy features a two-tiered non-adjustable chrome rack with wood bottoms.
- Basket size on door is 14 1/2" W x 20 1/2" H x 3 1/2" D.
- Not available on Inset and Beaded Inset styles.

#### Door & Drawer Options

AF	AOMBWB	CC	CG	ESMD	GAMD	IFHG	MD	PRMD	PTOWB	SHMD	SPLITDR	SPLITDRWS	SUMD	TCP
													✓	

#### End Panel Options

AUTH	CSFPE	EXBK	FFD	FPE	INTGE	IPE
✓	✓	✓	✓	✓	✓	✓

#### Custom Modification Options

ADD_SHLF	ADDTK	CBO	CCO	CFNTO	CFP	CFRMO	CHGDRW	CLIP	CMAT	CND	CSDGBK	DRT	DRWTK	EF	EX	EX_OL	FBFL	FD
									✓	✓	✓		✓	✓	✓	✓		

FDSRTBTM	FLUT	FTK	ID	IH	IH+DRW	INVERM	IW	LIGHT	MIP	OBRB	PFINBTMB	RD	RECTK	RH	ROSFLUT	RT
	✓	✓	✓	✓					✓	✓		✓	✓	✓	✓	

RW	SBCADDY	SBCADDYSM	SCPDRW	STW	TD	TKP	TVR	UDBX	URT	VTK	WS	WTCD	WTKCUP	WTR
						✓	✓			✓	✓			✓

# Sink Base Supercabinets™

## Description

### SINK BASE SUPERCABINET™ with CABMAT™, 34 1/2" HIGH, 24" DEEP storage SOLUTIONS

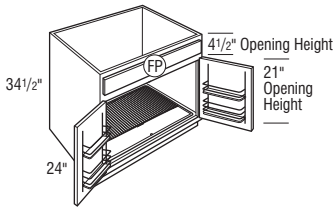

FP False Panel

## Model

SB30SCM

SB33SCM

SB36SCM

- Both doors will have a chrome and wood two-tiered rack.
- Basket size on 30" and 33" door is 11 1/2" W x 20 1/2" H x 3 1/2" D.
- Basket size on 36" door is 14 1/2" W x 20 1/2" H x 3 1/2" D.
- CabMat™ features a gray sloped mat to capture spills.
- CabMat™ is removable for cleaning.
- Touch-up kit (TUK) and Owner's Guide included.

	Liquid Capacity		Cabinet Size	
	Quarts	Liters	Width	Depth
SB30SCM	4.2	3.9	30"	24"
SB33SCM	4.6	4.3	33"	24"
SB36SCM	5.0	4.7	36"	24"

#### Door & Drawer Options

AF	AOMBWB	CC	CG	ESMD	GAMD	IFHG	MD	PRMD	PTOWB	SHMD	SPLITDR	SPLITDRWS	SUMD	TCP
						✓						✓		

#### End Panel Options

AUTH	CSFPE	EXBK	FFD	FPE	INTGE	IPE
✓	✓	✓	✓	✓	✓	✓

#### Custom Modification Options

ADD	SHLF	ADDTK	CBO	CCO	CFNTO	CFP	CFRMO	CHGDRW	CLIP	CMAT	CND	CSDGBK	DRT	DRWTK	EF	EX	EX_OL	FBFL	FD
											✓	✓	✓	✓	✓	✓	✓	✓	✓

FDSRTBTM	FLUT <sup>1</sup>	FTK	ID	IH	IH+DRW	INVERM	IW	LIGHT	MIP	OBRB	PFINBTMB	RD	RECTK	RH <sup>2</sup>	ROSLUT	RT
	✓	✓	✓	✓	✓			✓	✓	✓	✓	✓	✓	✓	✓	✓

RW	SBCADDY	SBCADDYSM	SCPDWR	STW	TD	TKP	TVR	UDBX	URT	VTK	WS	WTCD	WTKCUP	WTR
							✓			✓				✓

<sup>1</sup>Not available with 6" fluting.

<sup>2</sup>Only available on 30" wide.

### SINK BASE SUPERCABINET™ with TILT-OUT TRAY, 34 1/2" HIGH, 24" DEEP storage SOLUTIONS

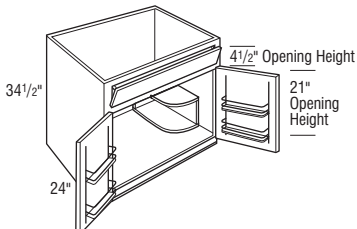

SB30STS

SB33STS

SB36STS

- Quarter Round Reversible Shelf for left or right applications included.
- Basket size on 36" door is 14 1/2" W x 20 1/2" H x 3 1/2" D.
- Basket size on 30" and 33" door is 11 1/2" W x 20 1/2" H x 3 1/2" D.
- Touch-up kit (TUK) and Owner's Guide included.
- Door includes a two-tiered non-adjustable chrome rack with wood bottoms.
- Increased Depths available in 1/4" increments from 24 1/4" to 30".
- Not available on Inset and Beaded Inset styles.
- One drawer front with one 1 1/16" deep stainless steel Tilt-out Tray attached.

#### Door & Drawer Options

AF	AOMBWB	CC	CG	ESMD	GAMD	IFHG	MD	PRMD	PTOWB	SHMD	SPLITDR	SPLITDRWS	SUMD	TCP
						✓								

#### End Panel Options

AUTH	CSFPE	EXBK	FFD	FPE	INTGE	IPE
✓	✓	✓	✓	✓	✓	✓

#### Custom Modification Options

ADD	SHLF	ADDTK	CBO	CCO	CFNTO	CFP	CFRMO	CHGDRW	CLIP <sup>1</sup>	CMAT	CND	CSDGBK	DRT	DRWTK <sup>2</sup>	EF	EX	EX_OL	FBFL	FD
											✓	✓	✓	✓	✓	✓	✓	✓	✓

FDSRTBTM	FLUT <sup>3</sup>	FTK	ID	IH <sup>2</sup>	IH+DRW	INVERM	IW	LIGHT	MIP	OBRB	PFINBTMB	RD	RECTK	RH <sup>4</sup>	ROSLUT	RW
	✓	✓	✓	✓	✓			✓	✓	✓	✓	✓	✓	✓	✓	✓

RW	SBCADDY	SBCADDYSM	SCPDWR	STW	TD	TKP	TVR	UDBX	URT	VTK	WS <sup>5</sup>	WTCD	WTKCUP	WTR
							✓	✓	✓	✓	✓	✓	✓	✓

<sup>1</sup>Not available on 30" wide.

<sup>2</sup>Not available on 33" wide.

<sup>3</sup>6" fluting not available on 30" or 33" wide.

<sup>4</sup>Only available on 30" wide.

<sup>5</sup>Not available on 30" wide. Not available on wide stile 1.5" except wide stile both 1.5".

IH/RH availability charts starting on page G•40.  
IW/RW availability charts starting on page G•46.

## Description

**NEW** **SINK BASE SUPERCABINET™ with TILT-OUT TRAY and CADDY, 34 1/2" HIGH, 24" DEEP**  
storage SOLUTIONS

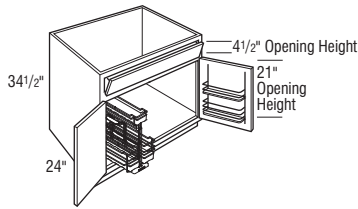

## Model

### SB36STSCDY L or R

- Touch-up kit (TUK) and Owner's Guide included.
- One drawer front with one 1 11/16" deep stainless steel Tilt-out Tray attached.
- L or R designates caddy installed side.
- Caddy includes one removable basket with handle, one basket without handle, swivel basket and 8 dividers.
- Bottom mounted full extension, Smart Stop slides.
- Caddy dimensions are 11" wide x 20" high x 18 1/2" deep.
- Caddy is removable and portable.
- Caddy also available for field installation. See page S-13.
- Door without caddy features a two-tiered non-adjustable chrome rack with wood bottoms.
- Basket size on door is 14 1/2" W x 20 1/2" H x 3 1/2" D.
- Not available on Inset and Beaded Inset styles.

#### Door & Drawer Options

AF	AOMBWB	CC	CG	ESMD	GAMD	IFHG	MD	PRMD	PTOWB	SHMD	SPLITDR	SPLITDRWS	SUMD	TCP
----	--------	----	----	------	------	------	----	------	-------	------	---------	-----------	------	-----

#### End Panel Options

AUTH	CSFPE	EXBK	FFD	FPE	INTGE	IPE
------	-------	------	-----	-----	-------	-----

#### Custom Modification Options

ADD	SHLF	ADDTK	CBO	CCO	CFNTD	CFP	CFRMO	CHGDRW	CLIP	CMAT	CND	CSDGBK	DRT	DRWTK	EF	EX	EX_OL	FBFL	FD
-----	------	-------	-----	-----	-------	-----	-------	--------	------	------	-----	--------	-----	-------	----	----	-------	------	----

FDSRTBTM	FLUT <sup>1</sup>	FTK	ID	IH	IH+DRW	INVERM	IW	LIGHT	MIP	OBRB	PFINBTMB	RD	RECTK	RH	ROSFLUT	RT
----------	-------------------	-----	----	----	--------	--------	----	-------	-----	------	----------	----	-------	----	---------	----

RW	SBCADDY	SBCADDYSM	SCPDRW	STW	TD	TKP	TVR	UDBX	URT	VTK	WS	WTCD	WTKCUP	WTR
----	---------	-----------	--------	-----	----	-----	-----	------	-----	-----	----	------	--------	-----

<sup>1</sup>6" fluting not available.

**SINK BASE SUPERCABINET™ with TILT-OUT TRAYS and CABMAT™, 34 1/2" HIGH, 24" DEEP**  
storage SOLUTIONS

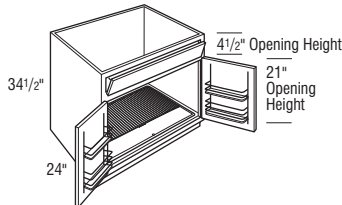

### SB30STSCM

### SB33STSCM

### SB36STSCM

- Both doors will have a chrome and wood two-tiered rack.
- Basket size on 30" and 33" door is 11 1/2" W x 20 1/2" H x 3 1/2" D.
- Basket size on 36" door is 14 1/2" W x 20 1/2" H x 3 1/2" D.
- CabMat™ features a gray sloped mat to capture spills.
- CabMat™ is removable for cleaning.
- Touch-up kit (TUK) and Owner's Guide included.
- One drawer front with one 1 11/16" deep stainless steel Tilt-out Tray attached.

	Liquid Capacity		Cabinet Size	
	Quarts	Liters	Width	Depth
SB30STSCM	4.2	3.9	30"	24"
SB33STSCM	4.6	4.3	33"	24"
SB36STSCM	5.0	4.7	36"	24"

#### Door & Drawer Options

AF	AOMBWB	CC	CG	ESMD	GAMD	IFHG	MD	PRMD	PTOWB	SHMD	SPLITDR	SPLITDRWS	SUMD	TCP
----	--------	----	----	------	------	------	----	------	-------	------	---------	-----------	------	-----

#### End Panel Options

AUTH	CSFPE	EXBK	FFD	FPE	INTGE	IPE
------	-------	------	-----	-----	-------	-----

#### Custom Modification Options

ADD	SHLF	ADDTK	CBO	CCO	CFNTD	CFP	CFRMO	CHGDRW	CLIP	CMAT	CND	CSDGBK	DRT	DRWTK	EF	EX	EX_OL	FBFL	FD
-----	------	-------	-----	-----	-------	-----	-------	--------	------	------	-----	--------	-----	-------	----	----	-------	------	----

FDSRTBTM	FLUT <sup>1</sup>	FTK	ID	IH	IH+DRW	INVERM	IW	LIGHT	MIP	OBRB	PFINBTMB	RD	RECTK	RH	ROSFLUT	RT
----------	-------------------	-----	----	----	--------	--------	----	-------	-----	------	----------	----	-------	----	---------	----

RW	SBCADDY	SBCADDYSM	SCPDRW	STW	TD	TKP	TVR	UDBX	URT	VTK	WS	WTCD	WTKCUP	WTR
----	---------	-----------	--------	-----	----	-----	-----	------	-----	-----	----	------	--------	-----

<sup>1</sup>Not available with 6" fluting.

# Country Sink Base Cabinets

## Description

**COUNTRY SINK BASE CABINET,  
34 1/2" HIGH, 24" DEEP**

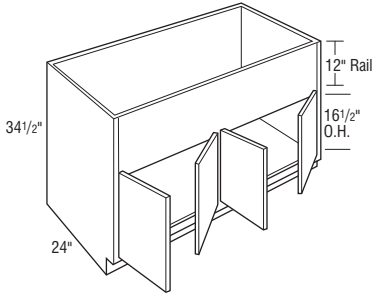
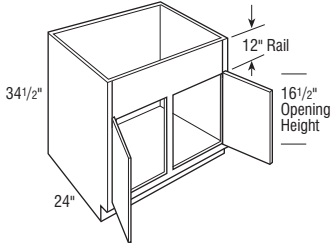
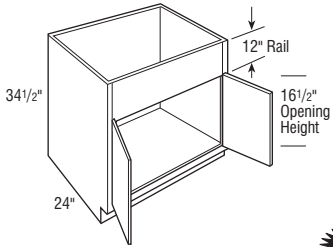

## Model

CNTYSB30

CNTYSB33

CNTYSB36

CNTYSB39

CNTYSB42

CNTYSB45

CNTYSB48CS



CNTYSB48

- Two sets of butt doors.

Notes below apply to all products in section above:

- Top rail can be trimmed up to 10 1/2".
- Touch-up kit (TUK) and Owner's Guide Included.
- Top rail dimension can be specified from 3" to 11 3/4" in 1/4" increments.
- Increased Depths available in 1/4" increments from 24 1/4" to 30".
- Reduced Depths available in 1/4" increments from 6" to 23 3/4".

### Door & Drawer Options

AF	AOMBWB	CC	CG	ESMD	GAMD	IFHG	MD	PRMD	PTOWB	SHMD	SPLITDR <sup>1</sup>	SPLITDRWS	SUMD	TCP
		✓	✓	✓	✓	✓	✓	✓		✓	✓		✓	

### End Panel Options

AUTH	CSFPE	EXBK	FFD	FPE	INTGE	IPE
✓	✓	✓	✓	✓	✓	✓

### Custom Modification Options

ADD	SHLF	ADDTK	CBO	CCO	CFNTO	CFP	CFRMO	CHGDRW	CLIP	CMTAT <sup>2</sup>	CND	CSDGBK	DRT	DRWTK <sup>3</sup>	EF	EX	EX_OL	FBFL	FD	
		✓			✓		✓	✓	✓	✓	✓	✓	✓	✓	✓	✓	✓	✓	✓	✓

FDSRTBTM	FLUT	FTK	ID	IH	IH+DRW	INVERM	IW <sup>4</sup>	LIGHT	MIP	OBRB	PFINBTMB	RD	RECTK	RH	ROSFLUT	RT <sup>5</sup>
✓	✓	✓	✓				✓	✓	✓			✓	✓	✓	✓	✓

RW	SBCADDY	SBCADDYSM	SCPDRW	STW	TD	TKP	TVR	UDBX	URT <sup>2</sup>	VTK	WS	WTCD	WTKCUP	WTR
✓	✓					✓	✓		✓	✓	✓			

<sup>1</sup>Not available on 42"-48" wide.

<sup>2</sup>Not available on 39"-48" wide.

<sup>3</sup>Only available on 30" and 36" wide.

<sup>4</sup>Not available on 48" wide.

<sup>5</sup>Not available on 45" wide.

IH/RH availability charts starting on page G•40.  
IW/RW availability charts starting on page G•46.

## Description

**COUNTRY SINK BASE with CABMAT™, 34 1/2" HIGH, 24" DEEP storage SOLUTIONS**

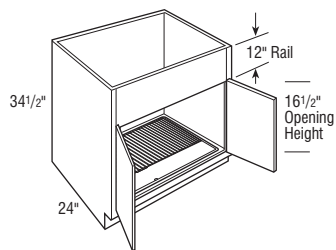

## Model

**CNTYSB30CM**

**CNTYSB33CM**

**CNTYSB36CM**

- 12" top rail can be trimmed up to 10 1/2".
- Touch-up kit (TUK) and Owner's Guide included.
- CabMat™ features a gray sloped mat to capture spills.
- CabMat™ is removable for cleaning.

	Liquid Capacity		Cabinet Size	
	Quarts	Liters	Width	Depth
CNTYSB30CM	4.2	3.9	30"	24"
CNTYSB33CM	4.6	4.3	33"	24"
CNTYSB36CM	5.0	4.7	36"	24"

### Door & Drawer Options

AF	AOMBWB	CC	CG	ESMD	GAMD	IFHG	MD	PRMD	PTOWB	SHMD	SPLITDR	SPLITDRWS	SUMD	TCP
			✓	✓	✓	✓	✓	✓		✓	✓		✓	

### End Panel Options

AUTH	CSFPE	EXBK	FFD	FPE	INTGE	IPE
✓	✓	✓	✓	✓	✓	✓

### Custom Modification Options

ADD_SHLF	ADDTK	CBO	CCO	CFNTO	CFP	CFRMO	CHGDRW	CLIP	CMAT	CND	CSDGBK	DRT	DRWTK	EF	EX	EX_OL	FBFL	FD
		✓	✓	✓		✓				✓	✓		✓	✓	✓	✓	✓	

FDSRTBTM	FLUT <sup>1</sup>	FTK	ID	IH	IH+DRW	INVFRM	IW	LIGHT	MIP	OBRB	PFINBTMB	RD	RECTK	RH	ROSFLUT	RT
	✓	✓	✓	✓			✓		✓	✓			✓	✓	✓	

RW	SBCADDY	SBCADDYSM	SCPDRW	STW	TD	TKP	TVR	UDBX	URT	VTK	WS	WTCD	WTKCUP	WTR
								✓			✓	✓		

<sup>1</sup>Not available with 6" fluting.



# Sink Base Cabinets with Drawer Below

## Description

## Model



**SINK BASE with DRAWER BELOW,  
34 1/2" HIGH, 24" DEEP**

**SB24D L or R**

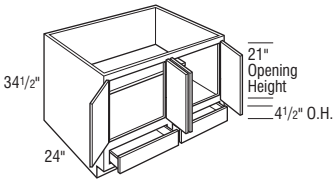
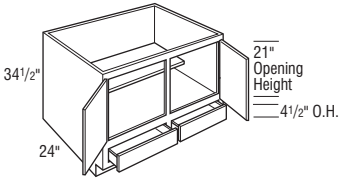
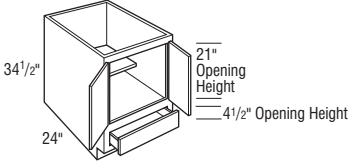
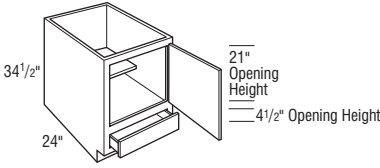

**SB24D**

**SB27D**

**SB30D**

**SB33D**

**SB36D**

**SB39D**

**SB42D**

**SB45D**

**SB48DCS**

**SB48D**

- Two sets of butt doors.

Notes below apply to all products in section above:

- Touch-up kit (TUK) and Owner's Guide included.
- Face frame opening height is 21".
- Face frame opening height for drawer is 4 1/2".
- Includes one adjustable half shelf.
- Drawer is below full cabinet floor.
- Verify that sink, garbage disposal, and plumbing fit opening.
- Plumbing going through floor will interfere with drawer operation, 2 1/8" clearance from back of drawer to interior back of cabinet.

### Door & Drawer Options

AF	AOMBWB	CC	CG	ESMD	GAMD	IFHG	MD	PRMD	PTOWB	SHMD	SPLITDR <sup>1</sup>	SPLITDRWS <sup>2</sup>	SUMD	TCP
	✓						✓	✓			✓	✓		

### End Panel Options

AUTH	CSFPE	EXBK	FFD	FPE	INTGE	IPE
✓	✓	✓	✓	✓	✓	✓

### Custom Modification Options

ADD	SHLF	ADDTK	CBO	CCO	CFNTO	CFP	CFRMO	CHGDRW	CLIP <sup>3</sup>	CMAT <sup>4</sup>	CND	CSDGBK	DRT	DRWTK <sup>5</sup>	EF	EX	EX_OL	FBFL	FD	
			✓	✓	✓	✓	✓		✓	✓	✓	✓	✓	✓	✓	✓	✓	✓	✓	✓

FDSRTBTM	FLUT <sup>6</sup>	FTK	ID	IH	IH+DRW	INVFRM	IW <sup>7</sup>	LIGHT	MIP	OBRB	PFINBTMB	RD	RECTK	RH	ROSLUT	RT
✓	✓	✓	✓	✓	✓	✓	✓	✓	✓	✓	✓	✓	✓	✓	✓	✓

RW	SBCADDY	SBCADDYSM	SCPDRW	STW	TD	TKP	TVR <sup>8</sup>	UDBX <sup>2</sup>	URT	VTK	WS <sup>3</sup>	WTC <sup>9</sup>	WTKCUP <sup>10</sup>	WTR
	✓	✓	✓	✓	✓	✓	✓	✓	✓	✓	✓	✓	✓	✓

<sup>1</sup>Not available on 24" (1 door) or 42"-48" wide.

<sup>2</sup>Not available on 42"-48" wide.

<sup>3</sup>Not available on 24" (2 doors) wide.

<sup>4</sup>Only available on 30"-36" wide.

<sup>5</sup>Not available on 39"-48" wide.

<sup>6</sup>Fluting not available on 24" (2 doors) wide.

<sup>7</sup>Not available on 24" or 48" wide.

<sup>8</sup>Not available on 24" (2 doors) or 27" wide. TVRAV not available on 42" or 45" wide.

<sup>9</sup>Only available on 30" and 36" wide.

<sup>10</sup>Only available on 24" (1 door) and 36" wide.

IH/RH availability charts starting on page G•40.  
IW/RW availability charts starting on page G•46.

# Base Dishwasher Cabinets & Sink Fronts

## Description

**BASE DISHWASHER CABINET, 40 1/2" or 46 1/2" HIGH, 24" DEEP**

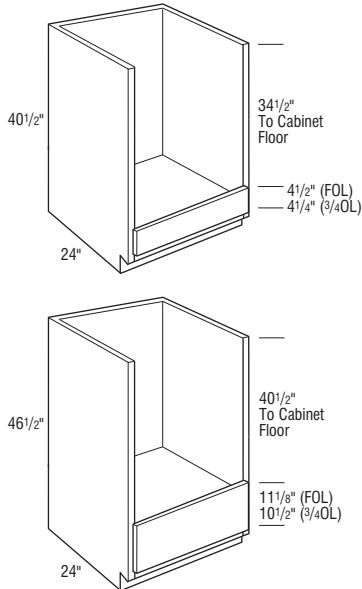

## Model

**BDW2740**

**BDW2748**

Notes below apply to all products in section above:

- Drawer front is a false front.
- Increased Depths available in 1/4" increments from 24 1/4" to 30".
- Reduced Depths available in 1/4" increments from 6" to 23 3/4".

### Door & Drawer Options

AF	AOMBWB	CC	CG	ESMD	GAMD	IFHG	MD	PRMD	PTOWB	SHMD	SPLITDR	SPLITDRWS	SUMD	TCP
----	--------	----	----	------	------	------	----	------	-------	------	---------	-----------	------	-----

### End Panel Options

AUTH	CSFPE	EXBK	FFD	FPE	INTGE	IPE
✓	✓			✓	✓	✓

### Custom Modification Options

ADD_SHLF	ADDTK	CBO	CCO	CFNTD	CFP	CFRMO	CHGDRW	CLIP	CMAT	CND	CSDGBK	DRT	DRWTK	EF	EX	EX_OL	FBFL	FD
								✓			✓			✓	✓	✓		

FDSRTBTM	FLUT	FTK	ID	IH	IH+DRW	INVFRM	IW	LIGHT	MIP	OBRB	PFINBTMB	RD	RECTK	RH	ROSLUT	RW
	✓	✓	✓						✓	✓		✓			✓	✓

RW	SBCADDY	SBCADDYSM	SCPDRW	STW	TD	TKP	TVR	UDBX	URT	VTK	WS	WTCD	WTKCUP	WTR
								✓		✓	✓	✓		✓

## SINK FRONT, 34 1/2" HIGH

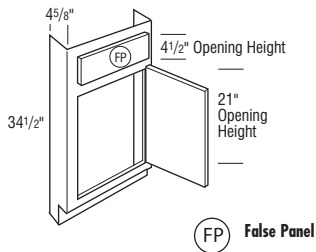

## SF18 L or R

- Floor included.

### Door & Drawer Options

AF	AOMBWB	CC	CG	ESMD	GAMD	IFHG	MD	PRMD	PTOWB	SHMD	SPLITDR	SPLITDRWS	SUMD	TCP
		✓	✓	✓	✓	✓	✓	✓		✓			✓	

### End Panel Options

AUTH	CSFPE	EXBK	FFD	FPE	INTGE	IPE

### Custom Modification Options

ADD_SHLF	ADDTK	CBO	CCO	CFNTD	CFP	CFRMO	CHGDRW	CLIP	CMAT	CND	CSDGBK	DRT	DRWTK	EF	EX	EX_OL	FBFL	FD
																✓	✓	

FDSRTBTM	FLUT <sup>1</sup>	FTK	ID	IH	IH+DRW	INVFRM	IW	LIGHT	MIP	OBRB	PFINBTMB	RD	RECTK	RH	ROSLUT	RT
	✓	✓	✓						✓	✓			✓		✓	✓

RW	SBCADDY	SBCADDYSM	SCPDRW	STW	TD	TKP	TVR	UDBX	URT	VTK	WS	WTCD	WTKCUP	WTR
								✓		✓	✓	✓		✓

<sup>1</sup>Not available with 6" fluting.

# Sink Fronts

## Description

### SINK FRONT, 34 1/2" HIGH

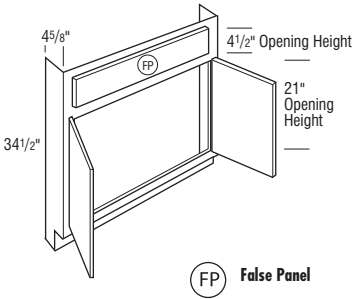

## Model

**SF24**

**SF30**

**SF36**

- Floor included.

#### Door & Drawer Options

AF	AOMBWB	CC	CG	ESMD	GAMD	IFHG	MD	PRMD <sup>1</sup>	PTOWB	SHMD	SPLITDR <sup>1</sup>	SPLITDRWS <sup>1</sup>	SJMD	TCP

#### End Panel Options

AUTH	CSFPE	EXBK	FFD	FPE	INTGE	IPE

#### Custom Modification Options

ADD	SHLF	ADTK	CBO	CCO	CFNT0	CFP	CFRMO	CHGDRW	CLIP	CMAT	CND	CSDGBK	DRT	DRWTK	EF	EX	EX_OL	FBFL	FD	

FDSRTBTM	FLUT <sup>2</sup>	FTK	ID	IH	IH+DRW	INVFRM	IW	LIGHT	MIP	OBRB	PFINBTMB	RD	RECTK	RH	ROSLUT	RT

RW	SBCADDY	SBCADDYSM	SCPDRW	STW	TD	TKP	TVR	UDBX	URT	VTK	WS	WTCO	WTKCUP	WTR

<sup>1</sup>Not available on 24" wide.  
<sup>2</sup>Not available with 6" fluting.

### **NEW** SINK FRONT BOTTOM, 23 1/16" DEEP, 48" WIDE

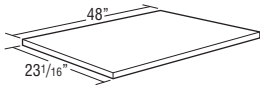

**SFB48**

- 1/2" thick.
- Trimmable.
- Sink Front Bottoms are designed for use with Sink Bases ordered with CFNT0 modification.

Modifications  
Are Not  
Available

### **NEW** ANGLED CORNER SINK FRONT BOTTOM, 36", 39", or 42" DEEP

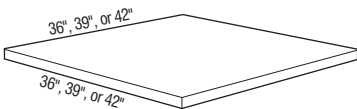

**ACSF36**

**ACSF39**

**ACSF42**

- 1/2" thick.
- Angled Corner Sink Front Bottoms are designed for use with Angled Corner Sink Fronts.

Modifications  
Are Not  
Available

IH/RH availability charts starting on page G•40.  
 IW/RW availability charts starting on page G•46.

**Description**

**ANGLED CORNER SINK BASE,  
34 1/2" HIGH**

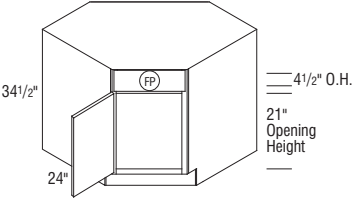

**FP False Panel**

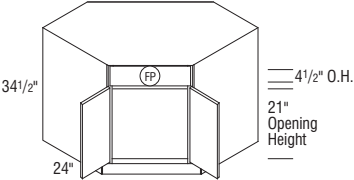

**FP False Panel**

**Model**

**ACS36 L or R**

**ACS39 L or R**

**ACS42**

Notes below apply to all products in section above:

- Touch-up kit (TUK) and Owner's Guide included.

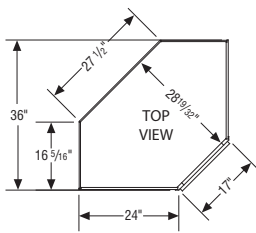

**36" Shown**

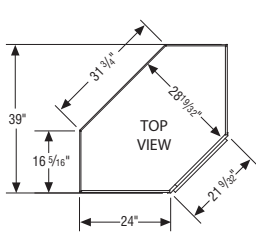

**39" Shown**

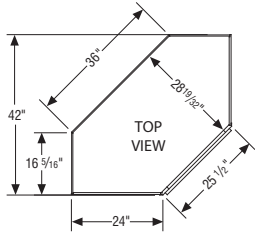

**42" Shown**

**Door & Drawer Options**

AF	AOMBWB	CC	CG	ESMD	GAMD	IFHG	MD	PRMD	PTOWB	SHMD	SPLITDR	SPLITDRWS	SUMD	TCP
			✓	✓	✓	✓	✓	✓	✓	✓				✓

**End Panel Options**

AUTH <sup>1</sup>	CSFPE	EXBK	FFD	FPE	INTGE	IPE
✓	✓				✓	

**Custom Modification Options**

ADD_SHLF	ADDTK	CBO	CCO	CFNTD	CFP	CFRMO	CHGDRW	CLIP	CMAT	CND	CSDGBK	DRT	DRWTK	EF	EX	EX_OL	FBFL	FD	
			✓		✓	✓				✓					✓				

FDSRTBTM	FLUT	FTK	ID	IH	IH+DRW	INVFRM	IW	LIGHT	MIP	OBRB	PFINBTMB	RD	RECTK	RH	ROSFLUT	RT
		✓		✓					✓	✓			✓	✓		

RW	SBCADDY	SBCADDYSM	SCPDRW	STW	TD	TKP	TVR	UDBX	URT	VTK	WS	WTCD	WTKCUP	WTR
								✓		✓				✓

<sup>1</sup>Not available on authentic flush ends both.

# Angled Corner Sink Base Cabinets

## Description

**ANGLED CORNER SINK BASE with  
TILT-OUT TRAY, 34 1/2" HIGH, 24" DEEP**

## Model

**ACS36ST L or R**

**ACS39ST L or R**

## ACS42ST

Notes below apply to all products in section above:

- Touch-up kit (TUK) and Owner's Guide included.
- One drawer front with one 1 11/16" deep stainless steel Tilt-out Tray attached.

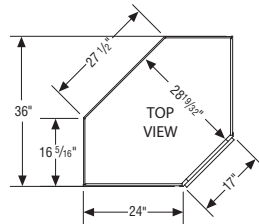
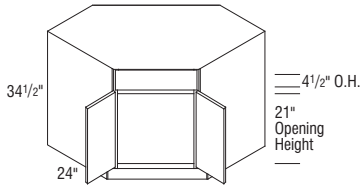
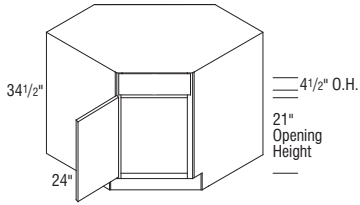

36" Shown

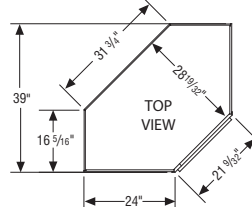

39" Shown

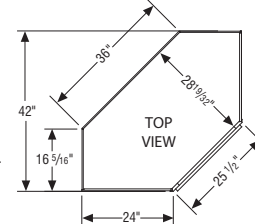

42" Shown

### Door & Drawer Options

AF	AOMBWB	CC	CG	ESMD	GAMD	IFHG	MD	PRMD	PTOWB	SHMD	SPLITDR	SPLITDRWS	SJMD	TCP
	✓	✓	✓	✓	✓	✓	✓	✓	✓	✓	✓	✓	✓	✓

### End Panel Options

AUTH <sup>1</sup>	CSFPE	EXBK	FFD	FPE	INTGE	IPE
✓	✓	✓	✓	✓	✓	✓

### Custom Modification Options

ADD	SHLF	ADDTK	CBO	CCO	CFNTO	CFP	CFRMO	CHGDRW	CLIP	CMAT	CND	CSDGBK	DRT	DRWTK	EF	EX	EX	OL	FBFL	FD	
			✓	✓	✓	✓	✓	✓	✓	✓	✓	✓	✓	✓	✓	✓	✓	✓	✓	✓	✓

FDSRTBTM	FLUT	FTK	ID	IH	IH+DRW	INVERM	IW	LIGHT	MIP	OBRB	PFINBTMB	RD	RECTK	RH	ROSFLUT	RT
	✓	✓	✓	✓	✓	✓	✓	✓	✓	✓	✓	✓	✓	✓	✓	✓

RW	SBCADDY	SBCADDYSM	SCPDRW	STW	TD	TKP	TVR	UDBX	URT	VTK	WS	WTCD	WTKCUP	WTR
						✓	✓	✓	✓	✓	✓	✓	✓	✓

<sup>1</sup>Not available on authentic flush ends both.

IH/RH availability charts starting on page G•40.  
IW/RW availability charts starting on page G•46.

# Angled Corner Sink Fronts & Drop-in Range Bases

## Description

### ANGLED CORNER SINK FRONT, 34 1/2" HIGH

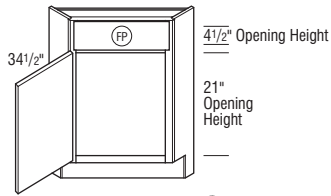

FP False Panel

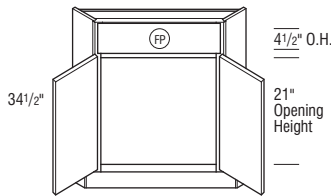

FP False Panel

## Model

ACSF36 L or R

ACSF39 L or R

## ACSF42

Notes below apply to all products in section above:

- Floor included and packed separately.
- Touch-up kit (TUK) and Owner's Guide included.

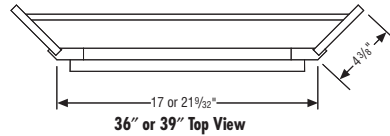

36" or 39" Top View

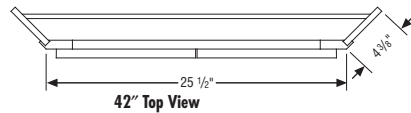

42" Top View

### Door & Drawer Options

AF	AOMBWB	CC	CG	ESMD	GAMD	IFHG	MD	PRMD	PTOWB	SHMD	SPLITDR <sup>1</sup>	SPLITDRWS <sup>1</sup>	SUMD	TCP
			✓	✓	✓	✓	✓	✓		✓	✓	✓	✓	✓

### End Panel Options

AUTH	CSFPE	EXBK	FFD	FPE	INTGE	IPE
	✓	✓	✓	✓	✓	✓

### Custom Modification Options

ADD_SHLF	ADDTK	CBO	CCO	CFNTD	CFP	CFRMO	CHGDRW	CLIP	CMAT	CND	CSDGBK	DRT	DRWTK	EF	EX	EX_OL	FBFL	FD	
											✓								

FDSRTBTM	FLUT	FTK	ID	IH	IH+DRW	INVERM	IW	LIGHT	MIP	OBRB	PFINBTMB	RD	RECTK	RH	ROSLUT	RT
	✓	✓	✓	✓					✓	✓			✓	✓	✓	✓

RW	SBCADDY	SBCADDYSM	SCPDWR	STW	TD	TKP	TVR	UDBX	URT	VTK	WS	WTCB	WTKCUP	WTR
										✓				✓

<sup>1</sup>Only available on 42" wide.

### TWO DRAWER BASE, DROP-IN RANGE, 34 1/2" HIGH, 24" DEEP

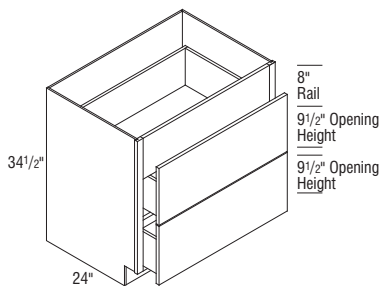

## 2DB30DR

## 2DB36DR

- 8" panel can be trimmed up to 6 1/2".
- Reduced Depths available in 1/4" increments from 12" to 23 3/4".

### Door & Drawer Options

AF	AOMBWB	CC	CG	ESMD	GAMD	IFHG	MD	PRMD	PTOWB	SHMD	SPLITDR	SPLITDRWS	SUMD	TCP
						✓								

### End Panel Options

AUTH	CSFPE	EXBK	FFD	FPE	INTGE	IPE
	✓	✓	✓	✓	✓	✓

### Custom Modification Options

ADD_SHLF	ADDTK	CBO	CCO	CFNTD	CFP	CFRMO	CHGDRW	CLIP	CMAT	CND	CSDGBK	DRT	DRWTK	EF	EX	EX_OL	FBFL	FD	
											✓								

FDSRTBTM	FLUT <sup>1</sup>	FTK	ID	IH	IH+DRW	INVERM	IW <sup>2</sup>	LIGHT	MIP	OBRB	PFINBTMB	RD	RECTK	RH	ROSLUT	RT
	✓	✓	✓	✓					✓	✓			✓	✓	✓	✓

RW <sup>2</sup>	SBCADDY	SBCADDYSM	SCPDWR	STW	TD	TKP	TVR	UDBX	URT	VTK	WS	WTCB	WTKCUP	WTR
✓										✓				✓

<sup>1</sup>6" fluting both not available on 30" wide.

<sup>2</sup>Only available on 36" wide.

# Drop-in Range Bases

## Description

**TWO DRAWER BASE with REDUCED DRAWERS, DROP-IN RANGE, 34 1/2" HIGH, 24" DEEP**

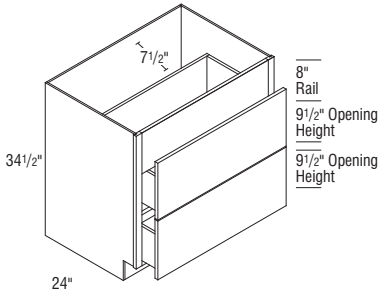

## Model

**2DB30RDR**

**2DB36RDR**

- 8" panel can be trimmed up to 6 1/2".
- Drawers are reduced 6" to allow for proper range installation. Clearance dimension is 7 1/2".

### Door & Drawer Options

AF	AOMBWB	CC	CG	ESMD	GAMD	IFHG	MD	PRMD	PTOWB	SHMD	SPLITDR	SPLITDRWS	SUMD	TCP
						✓								

### End Panel Options

AUTH	CSFPE	EXBK	FFD	FPE	INTGE	IPE
✓	✓	✓	✓	✓	✓	✓

### Custom Modification Options

ADD	SHLF	ADDTK	CBO	CCO	CFNTD	CFP	CFRMO	CHGDRW	CLIP	CMAT	CND	CSDGBK	DRT	DRWTK	EF	EX	EX_OL	FBFL	FD

FDSRTBTM	FLUT <sup>1</sup>	FTK	ID	IH	IH+DRW	INVERM	IW <sup>2</sup>	LIGHT	MIP	OBRB	PFINBTMB	RD	RECTK	RH	ROSFLUT <sup>3</sup>	RT
	✓	✓	✓	✓	✓	✓	✓	✓	✓	✓	✓	✓	✓	✓	✓	✓

RW <sup>2</sup>	SBCADDY	SBCADDYSM	SCPDRW	STW	TD	TKP	TVR	UDBX	URT	VTK	WS	WTCD	WTKCUP	WTR
✓														

<sup>1</sup>Fluting both 3" not available on 36" wide. Not available with 6" fluting.

<sup>2</sup>Only available on 36" wide.

<sup>3</sup>Fluting both not available on 36" wide.

**BASE, DROP-IN RANGE, 34 1/2" HIGH, 24" DEEP**

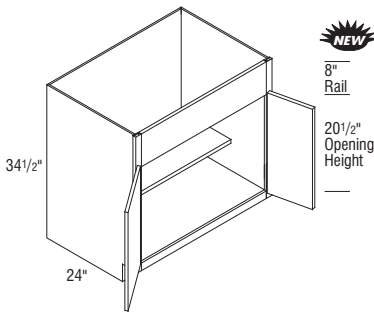

**B30DR**

**B33DR**

**B36DR**

**B39DR**

- 8" panel can be trimmed up to 6 1/2".
- Increased Depths available in 1/4" increments from 24 1/4" to 30".
- Reduced Depths available in 1/4" increments from 6" to 23 3/4".

### Door & Drawer Options

AF	AOMBWB	CC	CG	ESMD	GAMD	IFHG	MD	PRMD	PTOWB	SHMD	SPLITDR	SPLITDRWS	SUMD	TCP
						✓	✓	✓	✓	✓	✓	✓	✓	✓

### End Panel Options

AUTH	CSFPE	EXBK	FFD	FPE	INTGE	IPE
✓	✓	✓	✓	✓	✓	✓

### Custom Modification Options

ADD	SHLF	ADDTK	CBO	CCO	CFNTD	CFP	CFRMO	CHGDRW	CLIP	CMAT	CND	CSDGBK	DRT	DRWTK	EF	EX	EX_OL	FBFL	FD

FDSRTBTM	FLUT	FTK	ID	IH	IH+DRW	INVERM	IW <sup>1</sup>	LIGHT	MIP	OBRB	PFINBTMB	RD	RECTK	RH	ROSFLUT	RT
	✓	✓	✓	✓	✓	✓	✓	✓	✓	✓	✓	✓	✓	✓	✓	✓

RW <sup>1</sup>	SBCADDY	SBCADDYSM	SCPDRW	STW	TD	TKP	TVR	UDBX	URT	VTK	WS	WTCD	WTKCUP	WTR
✓														

<sup>1</sup>Only available on 36" wide.

IH/RH availability charts starting on page G•40.  
IW/RW availability charts starting on page G•46.

## Description

**BASE with REDUCED DEPTH ROLL TRAYS, DROP-IN RANGE, 34 1/2" HIGH, 24" DEEP**

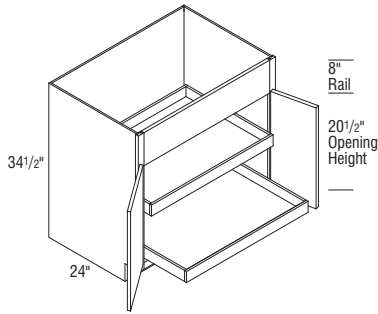

## Model

**B30RTDR**

**B36RTDR**

- 8" panel can be trimmed up to 6 1/2".
- Contains two easily adjustable roll trays.
- Reduced Depths available in 1/4" increments from 12" to 23 3/4".

### Door & Drawer Options

AF	AOMBWB	CC	CG	ESMD	GAMD	IFHG	MD	PRMD	PTOWB	SHMD	SPLITDR	SPLITDRWS	SUMD	TCP
		✓	✓	✓	✓	✓	✓	✓	✓	✓			✓	

### End Panel Options

AUTH	CSFPE	EXBK	FFD	FPE	INTGE	IPE
✓	✓	✓	✓	✓	✓	✓

### Custom Modification Options

ADD_SHLF	ADDTK	CBO	CCO	CFNTD	CFP	CFRMO	CHGDRW	CLIP	CMAT	CND	CSDGBK	DRT	DRWTK	EF	EX	EX_OL	FBFL	FD
		✓		✓		✓		✓		✓	✓		✓	✓	✓	✓	✓	

FDSRTBTM	FLUT	FTK	ID	IH	IH+DRW	INVFRM	IW	LIGHT	MIP	OBRB	PFINBTMB	RD	RECTK	RH	ROSFLUT	RT
	✓	✓		✓					✓	✓			✓	✓		✓

RW <sup>1</sup>	SBCADDY	SBCADDYSM	SCPDRW	STW	TD	TKP	TVR <sup>2</sup>	UDBX	URT	VTK	WS	WTCB	WTKCUP	WTR
✓							✓	✓		✓	✓			✓

<sup>1</sup>Not available on 30" wide.

<sup>2</sup>TVRAV not available on 36" wide.

**BASE with ROLL TRAYS, DROP-IN RANGE, 34 1/2" HIGH, 24" DEEP**

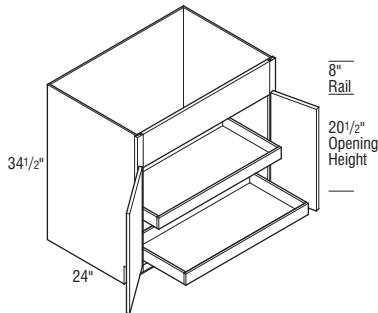

**B30RRDR**

**B36RRDR**

- 8" panel can be trimmed up to 6 1/2".
- Roll trays are reduced 6" to allow for proper range installation. Clearance dimension is 5 1/4".
- Contains two easily adjustable roll trays.

### Door & Drawer Options

AF	AOMBWB	CC	CG	ESMD	GAMD	IFHG	MD	PRMD	PTOWB	SHMD	SPLITDR	SPLITDRWS	SUMD	TCP
		✓	✓	✓	✓	✓	✓	✓	✓	✓			✓	

### End Panel Options

AUTH	CSFPE	EXBK	FFD	FPE	INTGE	IPE
✓	✓	✓	✓	✓	✓	✓

### Custom Modification Options

ADD_SHLF	ADDTK	CBO	CCO	CFNTD	CFP	CFRMO	CHGDRW	CLIP	CMAT	CND	CSDGBK	DRT	DRWTK	EF	EX	EX_OL	FBFL	FD
		✓		✓		✓		✓		✓	✓		✓	✓	✓	✓	✓	

FDSRTBTM	FLUT <sup>1</sup>	FTK	ID	IH	IH+DRW	INVFRM	IW	LIGHT	MIP	OBRB	PFINBTMB	RD	RECTK	RH	ROSFLUT	RT
	✓	✓		✓					✓	✓			✓	✓		✓

RW <sup>2</sup>	SBCADDY	SBCADDYSM	SCPDRW	STW	TD	TKP	TVR <sup>3</sup>	UDBX	URT	VTK	WS	WTCB	WTKCUP	WTR
✓							✓	✓		✓	✓			✓

<sup>1</sup>Not available with 6" fluting.

<sup>2</sup>Not available on 30" wide.

<sup>3</sup>TVRAV not available on 36" wide.



# Range Platform & Range Panel

## Description

**RANGE PLATFORM with DRAWERS,  
13 1/2" HIGH, 24" DEEP**

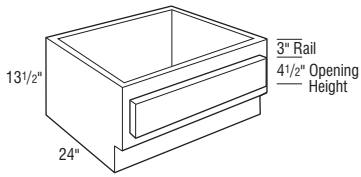

## Model

**R21PD**

**R24PD**

**R27PD**

**R30PD**

**R33PD**

**R36PD**

- Overall cabinet height must be specified: 13 1/4", 13 1/2", 15 1/2", 18", 19 1/2", 20 1/2" and 21 3/4".
- Maintain 3" rail above drawer for full overlay clearance.
- Reduced Depths available in 1/4" increments is from 12" to 23 3/4".
- Drawer opening height must be specified: 4 1/2", 6 1/2", 9", 10 1/2", 11 1/2", and 12 3/4".

### Door & Drawer Options

AF	AOMBWB	CC	CG	ESMD	GAMD	IFHG	MD	PRMD	PTOWB	SHMD	SPLITDR	SPLITDRWS <sup>1</sup>	SUMD	TCP

### End Panel Options

AUTH <sup>2</sup>	CSFPE	EXBK	FFD	FPE	INTGE	IPE

### Custom Modification Options

ADD_SHLF	ADDTK	CBO	CCO	CFNTO	CFP	CFRMO	CHGDRW	CLIP	CMAT	CND	CSDGBK	DRT	DRWTK	EF	EX	EX_OL	FBFL	FD	

FDSRTBTM	FLUT <sup>3</sup>	FTK	ID	IH	IH+DRW	INVFRM	IW	LIGHT	MIP	OBRB	PFINBTMB	RD	RECTK	RH	ROSLUT	RW

RW	SBCADDY	SBCADDYSM	SCPDRW	STW	TD	TKP	TVR <sup>4</sup>	UDBX	URT	VTK	WS	WTCD	WTKCUP	WTR <sup>4</sup>

<sup>1</sup>Not available on 21" wide.

<sup>2</sup>Not available on authentic flush ends both.

<sup>3</sup>Fluting both 6" not available on 21" wide.

<sup>4</sup>Not available on 21"-27" wide.

## RANGE PANEL

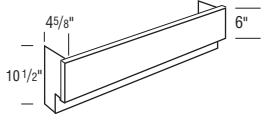

## DRP30

- Panel height must be specified between 6" to 12" in 1/4" increments.

### Door & Drawer Options

AF	AOMBWB	CC	CG	ESMD	GAMD	IFHG	MD	PRMD	PTOWB	SHMD	SPLITDR	SPLITDRWS	SUMD	TCP

### End Panel Options

AUTH	CSFPE	EXBK	FFD	FPE	INTGE	IPE

### Custom Modification Options

ADD_SHLF	ADDTK	CBO	CCO	CFNTO	CFP	CFRMO	CHGDRW	CLIP	CMAT	CND	CSDGBK	DRT	DRWTK	EF	EX	EX_OL	FBFL	FD	

FDSRTBTM	FLUT <sup>1</sup>	FTK	ID	IH	IH+DRW	INVFRM	IW	LIGHT	MIP	OBRB	PFINBTMB	RD	RECTK <sup>2</sup>	RH	ROSLUT	RW

RW	SBCADDY	SBCADDYSM	SCPDRW	STW	TD	TKP	TVR	UDBX	URT	VTK	WS	WTCD	WTKCUP	WTR

<sup>1</sup>Not available with 6" fluting.

<sup>2</sup>Only available on RECTKALL.

IH/RH availability charts starting on page G•40.  
IW/RW availability charts starting on page G•46.

## Description



**BASE CORNER, 34 1/2" HIGH,  
24" DEEP**

## Model

**BC36 L or R**

**BC39 L or R**

**BC42 L or R**

**BC45 L or R**

**BC48 L or R**

- Includes one 3" filler, shipped unattached.
- L or R denotes blind.
- Includes one adjustable half shelf.
- Not recommended for use next to an appliance deeper than standard cabinet depth.
- Door will be hinged on same side as blind section.
- Reduced Heights available in 1/4" increments from 12 1/4" to 23 3/4".

SKU	A	B	C	D	E	F
BC36	7 1/2"	9"	27"	36"	9"	3"
BC39	9"	9"	30"	39"	9"	4 1/2"
BC42	13 1/2"	9"	39"	42"	3"	3"
BC45	15"	9"	42"	45"	3"	4 1/2"
BC48	16 1/2"	9"	45"	48"	3"	6"

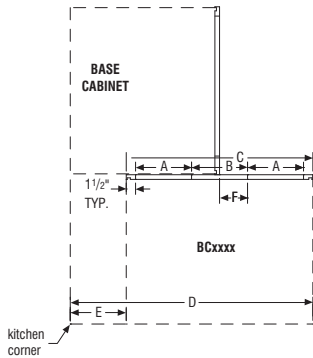
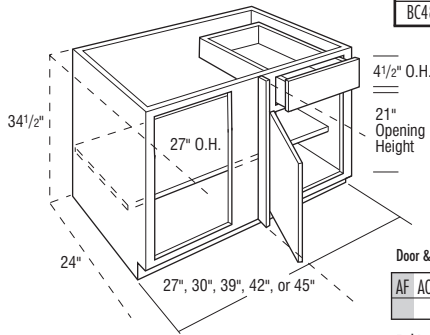

### Door & Drawer Options

AF	AOMBWB	CC	CG	ESMD	GAMD	IFHG	MD	PRMD	PTOWB	SHMD	SPLITDR	SPLITDRWS	SUMD	TCP

### End Panel Options

AUTH	CSFPE	EXBK	FFD	FPE	INTGE	IPE

### Custom Modification Options

ADD_SHLF	ADDTK	CBO	CCO	CFNT0	CFP	CFRMO	CHGDRW	CLIP <sup>1</sup>	CMAT	CND	CSDGBK	DRT	DRWTK	EF	EX	EX_OL	FBFL	FD
FDSRTBTM	FLUT <sup>2</sup>	FTK	ID	IH	IH+DRW	INVERM	IW	LIGHT	MIP	OBRB	PFINBTMB	RD	RECTK	RH	ROSFLUT	RT		
RW	SBCADDY	SBCADDYSM	SCPDRW	STW	TD	TKP	TVR	UDBX	URT	VTK	WS	WTCO <sup>3</sup>	WTKCUP <sup>3</sup>	WTR				

<sup>1</sup>Not available on BC36 L or R.

<sup>2</sup>Not available with 6" fluting.

<sup>3</sup>Only available on BC45 L or R.

# Base Corner Cabinets

## Description

**BASE CORNER FULL WIDTH,  
34 1/2" HIGH, 24" DEEP**

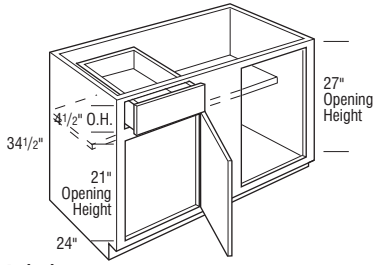

Right shown

## Model

**BCFW36 L or R**

**BCFW39 L or R**

**BCFW42 L or R**

**BCFW45 L or R**

**BCFW48 L or R**

- Door will be hinged on same side as blind section.
- One adjustable half shelf.
- Can be pulled 3".
- Should not be used next to appliances.
- Filler is recommended on adjacent cabinets.
- When ordering cabinet in a full overlay door style, unit must be pulled at least 1 1/2" to 3" from wall.
- Reduced Depths available in 1/4" increments from 12" to 23 3/4".

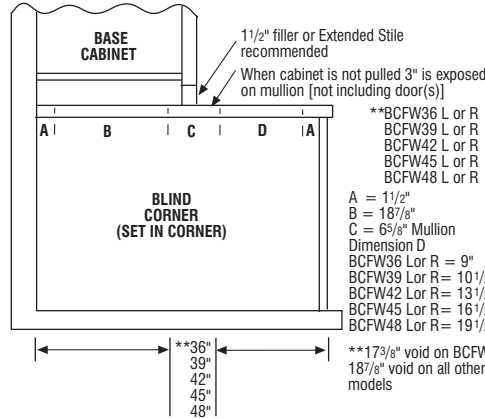

Top View

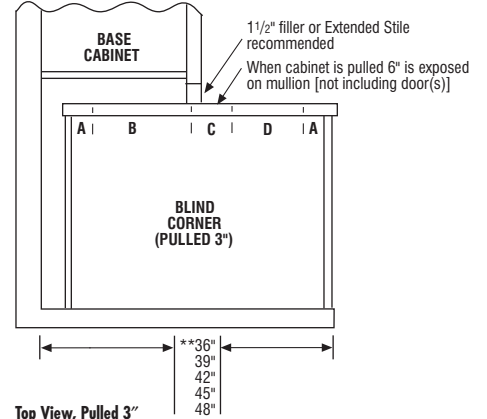

Top View, Pulled 3"

### Door & Drawer Options

AF	AOMBWB	CC	CG	ESMD	GAMD	IFHG	MD	PRMD	PTOWB	SHMD	SPLITDR	SPLITDRWS	SJMD	TCP
		✓	✓	✓	✓	✓	✓	✓	✓	✓	✓	✓	✓	✓

### End Panel Options

AUTH	CSFPE	EXBK	FFD	FPE	INTGE	IPE
✓	✓	✓	✓	✓	✓	✓

### Custom Modification Options

ADD_SHLF	ADDTK	CBO	CCO	CFNTD	CFP	CFRMO	CHGDRW	CLIP	CMAT	CND	CSDGBK	DRT	DRWTK	EF	EX	EX_OL	FBFL	FD
✓	✓	✓	✓	✓	✓	✓	✓	✓	✓	✓	✓	✓	✓	✓	✓	✓	✓	✓
FDSRTBTM	FLUT <sup>1</sup>	FTK	ID	IH	IH+DRW	INVFRM	IW	LIGHT	MIP	OBRB	PFINBTMB	RD	RECTK	RH	ROSLUT	RT		
✓	✓	✓	✓	✓	✓	✓	✓	✓	✓	✓	✓	✓	✓	✓	✓	✓		
RW	SBCADDY	SBCADDYSM	SCPDRW	STW	TD	TKP	TVR	UDBX	URT	VTK	WS <sup>2</sup>	WTCD	WTKCUP	WTR				
✓	✓	✓	✓	✓	✓	✓	✓	✓	✓	✓	✓	✓	✓	✓				

<sup>1</sup>6" fluting not available on 36"-42" wide. Fluting both 6" not available.

<sup>2</sup>Not available on 36" wide or with wide stile both.

IH/RH availability charts starting on page G•40.  
IW/RW availability charts starting on page G•46.

## Description

**NEW** **BASE CORNER PULL-OUT, 34 1/2" HIGH, 24" DEEP**  
storage SOLUTIONS

## Model

**BC45PO L or R**

**BC48PO L or R**

- Includes one 3" filler, shipped unattached.
- L or R denotes blind.
- Pull-out features four adjustable wood shelves with chrome surrounds.
- Wire pull-out dimensions: 10 3/4" wide x 17 1/4" deep x 2 11/16" high.
- Door will be hinged on same side as blind section.
- Smart Stop feature not available on pull-out.
- Not recommended for use next to an appliance deeper than standard cabinet depth and cannot be installed next to a wall. Adjacent cabinet hardware may interfere with adjustable shelf position on pull-out.
- For pull-out to function properly, 10" of adjacent space is required with no obstruction beyond 1 3/4" in front of the cabinet face frame.
- Only available in Inset and Beaded Inset when used in conjunction with a finial hinge.

SKU	A	B	C	D	E	F
BC45PO	15"	9"	42"	45"	3"	4 1/2"
BC48PO	16 1/2"	9"	45"	48"	3"	6"

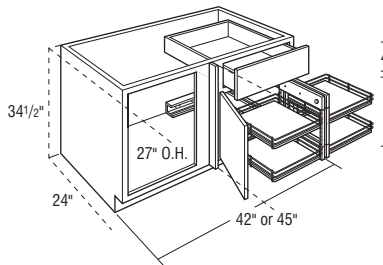

4 1/2" O.H.

21" Opening Height

Door & Drawer Options

AF	AOMBWB	CC	CG	ESMD	GAMD	IFHG	MD	PRMD	PTOWB	SHMD	SPLITDR	SPLITDRWS	SUMD	TCP
			✓				✓	✓						

End Panel Options

AUTH	CSFPE	EXBK	FFD	FPE	INTGE	IPE
✓	✓	✓	✓	✓	✓	✓

Custom Modification Options

ADD_SHLF	ADDTK	CBO	CCO	CFNTO	CFP	CFRMO	CHGDRW	CLIP	CMAT	CND	CSDGBK	DRT	DRWTK	EF	EX	EX_OL	FBFL	FD	
				✓	✓	✓	✓	✓	✓	✓	✓	✓	✓	✓	✓	✓	✓	✓	✓

FDSRTBTM	FLUT <sup>1</sup>	FTK	ID	IH	IH+DRW	INVERM	IW	LIGHT	MIP	OBRB	PFINBTMB	RD	RECTK	RH	ROSLUT	RT
	✓			✓		✓			✓	✓			✓	✓	✓	✓

RW	SBCADDY	SBCADDYSM	SCPDRW	STW	TD	TKP	TVR	UDBX	URT	VTK	WS	WTCDD <sup>2</sup>	WTKCUP <sup>2</sup>	WTR
			✓				✓			✓		✓	✓	✓

<sup>1</sup>Not available with 6" fluting.

<sup>2</sup>Only available on 45" wide.

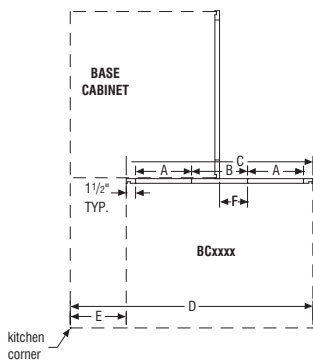

kitchen corner

# Base Corner Cabinets

## Description

**BASE CORNER FULL WIDTH PULL-OUT,  
34 1/2" HIGH, 24" DEEP  
storage  
SOLUTIONS**

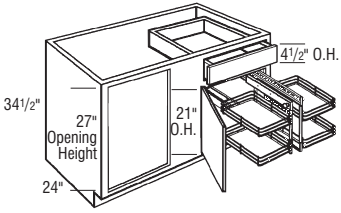

Left shown

## Model

**BCFW45PO L or R**

**BCFW48PO L or R**

- Door will be hinged on same side as blind section.
- Can be pulled 3".
- Smart Stop feature not available on pull-out.
- Not recommended for use next to a range.
- Interior pull-out drawer is 10 3/4" W by 17 1/4" D by 2 11/16" H.
- When ordering cabinet in a full overlay door style, unit must be pulled at least 1 1/2" to 3" from wall.
- Only available in Inset and Beaded Inset when used in conjunction with a finial hinge.

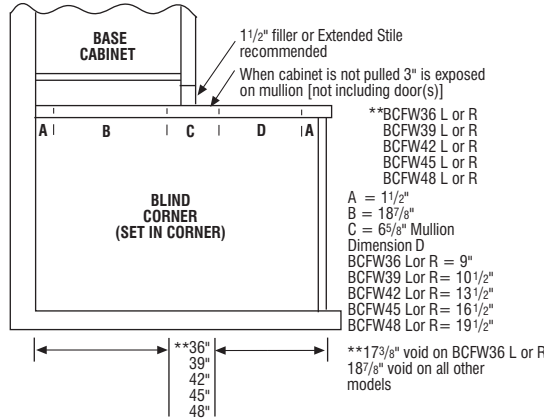

Top View

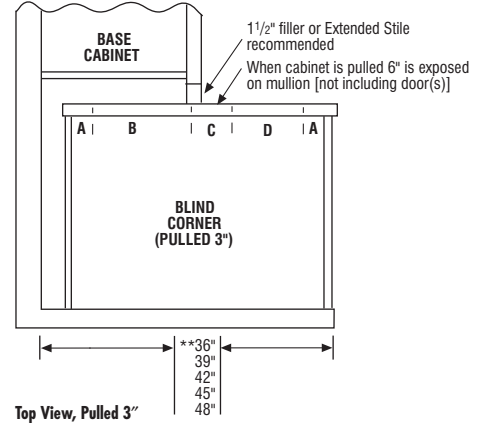

Top View, Pulled 3"

### Door & Drawer Options

AF	AOMBWB	CC	CG	ESMD	GAMD	IFHG	MD	PRMD	PTOWB	SHMD	SPLITDR	SPLITDRWS	SJMD	TCP
		✓	✓	✓	✓	✓	✓	✓	✓	✓	✓	✓	✓	✓

### End Panel Options

AUTH	CSFPE	EXBK	FFD	FPE	INTGE	IPE
✓	✓	✓	✓	✓	✓	✓

### Custom Modification Options

ADD	SHLF	ADDTK	CBO	CCO	CFNTO	CFP	CFRMO	CHGDRW	CLIP	CMAT	CND	CSDGBK	DRT	DRWTK	EF	EX	EX_OL	FBFL	FD	
						✓					✓	✓				✓	✓	✓	✓	✓

FDSRTBTM	FLUT <sup>1</sup>	FTK	ID	IH	IH+DRW	INVFRM	IW	LIGHT	MIP	OBRB	PFINBTMB	RD	RECTK	RH	ROSFLUT	RT
	✓	✓	✓	✓					✓	✓			✓		✓	✓

RW	SBCADDY	SBCADDYSM	SCPDRW	STW	TD	TKP	TVR	UDBX	URT	VTK	WS	WTCD	WTKCUP	WTR
			✓				✓				✓			✓

<sup>1</sup>Not available with 6" fluting.

IH/RH availability charts starting on page G•40.  
IW/RW availability charts starting on page G•46.

## Description

**NEW** **BASE CORNER FULL WIDTH with ROLL TRAYS and SWING-OUT, 34 1/2" HIGH, 24" DEEP**  
storage SOLUTIONS

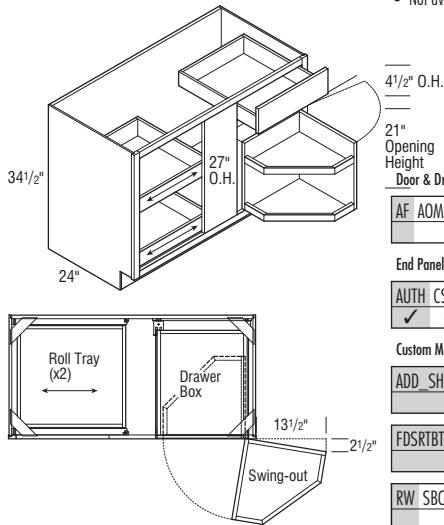

## Model

### BCFW48SP L or R

- Includes one 3" filler, shipped unattached.
- L or R denotes blind.
- Swing-out hinged opposite door.
- Door will be hinged on same side as blind section.
- Two roll trays and swing-out installed.
- Swing-out is 3/4" natural plywood.
- Should not be used next to appliances, cabinets deeper than standard depth, or next to a wall.
- Smart Stop feature not available on pull-out.
- Not available with Inset and Beaded Inset.

4 1/2" O.H.

21" Opening Height

#### Door & Drawer Options

AF	AOMBWB	CC	CG	ESMD	GAMD	IFHG	MD	PRMD	PTOWB	SHMD	SPLITDR	SPLITDRWS	SUMD	TCP
			✓				✓	✓						

#### End Panel Options

AUTH	CSFPE	EXBK	FFD	FPE	INTGE	IPE
✓	✓	✓	✓	✓	✓	✓

#### Custom Modification Options

ADD_SHLF	ADDTK	CBO	CCO	CFNTO	CFP	CFRMO	CHGDRW	CLIP	CMAT	CND	CSDGBK	DRT	DRWTK	EF	EX	EX_OL	FBFL	FD
		✓	✓	✓	✓	✓		✓		✓	✓				✓	✓	✓	✓
FDSRTBTM	FLUT <sup>1</sup>	FTK	ID	IH	IH+DRW	INVFRM	IW	LIGHT	MIP	OBRB	PFINBTMB	RD	RECTK	RH	ROSLUT	RT		
	✓		✓			✓			✓	✓			✓		✓			
RW	SBCADDY	SBCADDYSM	SCPDRW	STW	TD	TKP	TVR	UDBX	URT	VTK	WS	WTCD	WTKCUP	WTR				
			✓			✓		✓		✓		✓	✓	✓				

<sup>1</sup>Not available with 6" fluting.

## BASE CORNER FULL WIDTH with ARCHED PULL-OUT, 34 1/2" HIGH, 24" DEEP

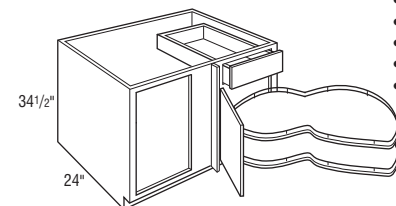

Left shown

### BCFW45CPO L or R

### BCFW48CPO L or R

- Pull-out features two chrome and wood adjustable kidney shaped shelves.
- Not recommended for use next to an appliance deeper than standard cabinet depth and cannot be installed next to a wall.
- Adjacent cabinet hardware may interfere with adjustable shelf position on pull-out.
- 55 lb. weight capacity per shelf.
- For pull-out to function properly, 9 3/4" of adjacent space is required with no obstruction beyond 1 1/8" in front of the cabinet face frame.
- Door must be hinged on same side as blind section.
- Can be pulled 3".
- Pull-out features Smart Stop.
- Only available in Inset and Beaded Inset when used in conjunction with a finial hinge.

#### Door & Drawer Options

AF	AOMBWB	CC	CG	ESMD	GAMD	IFHG	MD	PRMD	PTOWB	SHMD	SPLITDR	SPLITDRWS	SUMD	TCP
			✓	✓	✓	✓	✓	✓		✓			✓	

#### End Panel Options

AUTH	CSFPE	EXBK	FFD	FPE	INTGE	IPE
✓	✓	✓	✓	✓	✓	✓

#### Custom Modification Options

ADD_SHLF	ADDTK	CBO	CCO	CFNTO	CFP	CFRMO	CHGDRW	CLIP	CMAT	CND	CSDGBK	DRT	DRWTK	EF	EX	EX_OL	FBFL	FD
		✓	✓	✓	✓	✓		✓		✓	✓				✓	✓	✓	✓
FDSRTBTM	FLUT <sup>1</sup>	FTK	ID	IH	IH+DRW	INVFRM	IW	LIGHT	MIP	OBRB	PFINBTMB	RD	RECTK	RH	ROSLUT	RT		
	✓		✓			✓			✓	✓			✓		✓			
RW	SBCADDY	SBCADDYSM	SCPDRW	STW	TD	TKP	TVR	UDBX	URT	VTK	WS	WTCD	WTKCUP	WTR				
											✓			✓				

<sup>1</sup>Not available with 6" fluting.

# Base Corner Cabinets

## Description

**FULL HEIGHT BASE CORNER FULL WIDTH with ARCHED PULL-OUT, 34 1/2" HIGH, 24" DEEP**

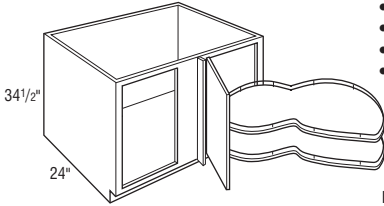

## Model

**BCFWFH45CPO L or R**

**BCFWFH48CPO L or R**

- Pull-out features two chrome and wood adjustable kidney shaped shelves.
- Not recommended for use next to an appliance deeper than standard cabinet depth and cannot be installed next to a wall.
- Adjacent cabinet hardware may interfere with adjustable shelf position on pull-out.
- 55 lb. weight capacity per shelf.
- For pull-out to function properly, 9 3/4" of adjacent space is required with no obstruction beyond 1 1/8" in front of the cabinet face frame.
- Door must be hinged on same side as blind section.
- Can be pulled 3".
- Pull-out features Smart Stop.
- Only available in Inset and Beaded Inset when used in conjunction with a finial hinge.

### Door & Drawer Options

AF	AOMBWB	CC	CG	ESMD	GAMD	IFHG	MD	PRMD	PTOWB	SHMD	SPLITDR	SPLITDRWS	SJMD	TCP
		✓	✓	✓	✓	✓	✓	✓		✓			✓	

### End Panel Options

AUTH	CSFPE	EXBK	FFD	FPE	INTGE	IPE
✓	✓	✓	✓	✓	✓	✓

### Custom Modification Options

ADD	SHLF	ADDTK	CBO	CCO	CFNTO	CFP	CFRMO	CHGDRW	CLIP	CMAT	CND	CSDGBK	DRT	DRWTK	EF	EX	EX	OL	FBFL	FD
			✓	✓	✓	✓	✓	✓			✓	✓	✓	✓	✓	✓	✓	✓	✓	✓

FDSRTBTM	FLUT <sup>1</sup>	FTK	ID	IH	IH+DRW	INVFRM	IW	LIGHT	MIP	OBRB	PFINBTMB	RD	RECTK	RH	ROSLUT	RT
	✓	✓	✓	✓					✓	✓					✓	

RW	SBCADDY	SBCADDYSM	SCPDRW	STW	TD	TKP	TVR	UDBX	URT	VTK	WS	WTCD	WTKCUP	WTR
											✓			✓

<sup>1</sup>Not available with 6" fluting.

IH/RH availability charts starting on page G•40.  
IW/RW availability charts starting on page G•46.

## Description



### FULL HEIGHT BASE CORNER FULL WIDTH with CURVE PULL-OUT, 34 1/2" HIGH, 24" DEEP

storage SOLUTIONS

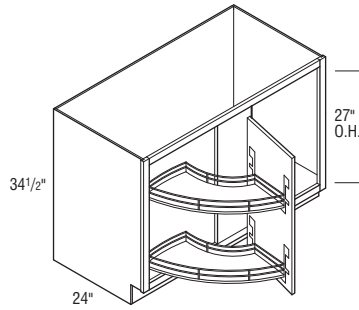

## Model

### BCFWFH48CRVPO L or R

- Pull-out features two chrome and wood curve shaped shelves.
- 60 lb. weight capacity per shelf.
- Door is attached to top and bottom shelves of pull-out.
- Can be pulled 3".
- Pull-out features Smart Stop slides.
- Not available on Inset or Beaded Inset Styles.

#### Door & Drawer Options

AF	AOMBWB	CC	CG	ESMD	GAMD	IFHG	MD	PRMD	PTOWB	SHMD	SPLITDR	SPLITDRWS	SUMD	TCP
			✓	✓	✓	✓	✓	✓		✓				✓

#### End Panel Options

AUTH	CSFPE	EXBK	FFD	FPE	INTGE	IPE
✓	✓	✓	✓	✓	✓	✓

#### Custom Modification Options

ADD_SHLF	ADDTK	CBO	CCO	CFNTD	CFP	CFRMO	CHGDRW	CLIP	CMAT	CND	CSDGBK	DRT	DRWTK	EF	EX	EX_OL	FBFL	FD
			✓	✓	✓	✓				✓	✓			✓	✓	✓	✓	✓
FDSRTBTM	FLUT	FTK	ID	IH	IH+DRW	INVFRM	IW	LIGHT	MIP	OBRB	PFINBTMB	RD	RECTK	RH	ROSFLUT	RT		
	✓	✓							✓	✓			✓		✓			
RW	SBCADDY	SBCADDYSM	SCPDRW	STW	TD	TKP	TVR	UDBX	URT	VTK	WS	WTCD	WTKCUP	WTR				
											✓			✓				



### TWO DRAWER BASE CORNER FULL WIDTH with CURVE PULL-OUT, 34 1/2" HIGH, 24" DEEP

storage SOLUTIONS

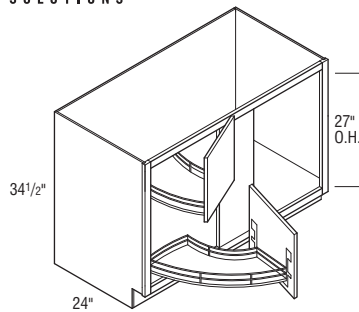

### BCFW2D48CRVPO L or R

- Pull-out features two chrome and wood curve shaped shelves.
- 60 lb. weight capacity per shelf.
- Pull-out shelves are attached to the drawer fronts. Each drawer front opens independently.
- Can be pulled 3".
- Pull-out features Smart Stop slides.
- Not available on Inset or Beaded Inset Styles.

#### Door & Drawer Options

AF	AOMBWB	CC	CG	ESMD	GAMD	IFHG	MD	PRMD	PTOWB	SHMD	SPLITDR	SPLITDRWS	SUMD	TCP
			✓	✓	✓	✓	✓	✓		✓				✓

#### End Panel Options

AUTH	CSFPE	EXBK	FFD	FPE	INTGE	IPE
✓	✓	✓	✓	✓	✓	✓

#### Custom Modification Options

ADD_SHLF	ADDTK	CBO	CCO	CFNTD	CFP	CFRMO	CHGDRW	CLIP	CMAT	CND	CSDGBK	DRT	DRWTK	EF	EX	EX_OL	FBFL	FD
			✓	✓	✓	✓				✓	✓			✓	✓	✓	✓	✓
FDSRTBTM	FLUT	FTK	ID	IH	IH+DRW	INVFRM	IW	LIGHT	MIP	OBRB	PFINBTMB	RD	RECTK	RH	ROSFLUT	RT		
	✓	✓	✓						✓	✓			✓		✓			
RW	SBCADDY	SBCADDYSM	SCPDRW	STW	TD	TKP	TVR	UDBX	URT	VTK	WS	WTCD	WTKCUP	WTR				
											✓			✓				



# Base Corner Cabinets

## Description

**BASE CORNER FULL WIDTH PENINSULA,  
34 1/2" HIGH, 24" DEEP**

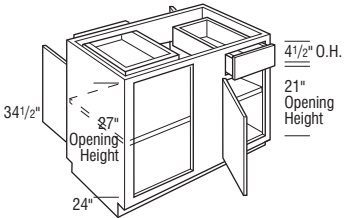

Left Shown

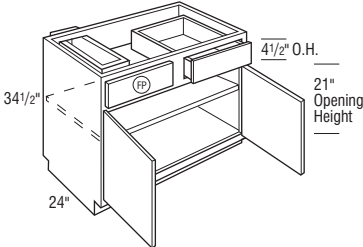

Peninsula Side Shown

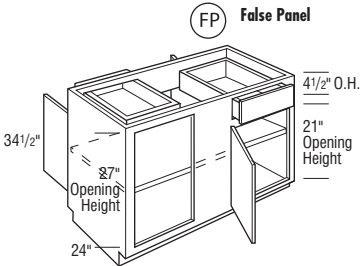

BCFW48P L or R  
Left Shown

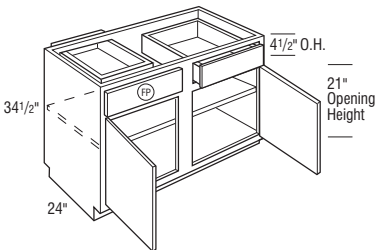

BCFW48P L or R  
Peninsula Side Shown

(FP) False Panel

## Model

**BCFW39P L or R**

**BCFW42P L or R**

**BCFW48P L or R**

Notes below apply to all products in section above:

- Specify location of modification for front or peninsula side.
- One adjustable Full Depth Shelf.
- Door will be hinged on same side as blind.
- Peninsula side with one cabinet false panel and one drawer.
- When ordering cabinet in a full overlay door style, unit must be pulled at least 1 1/2" to 3" from wall.
- Reduced Depths available in 1/4" increments from 12" to 23 3/4".

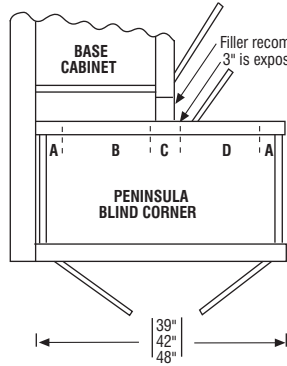

Top View

**KITCHEN**

A = 1 1/2"  
B = 18 7/8"  
C = 6 5/8"  
Dimension D = BCFW39P 10 1/2"  
BCFW42P 13 1/2"  
BCFW48P 19 1/2"

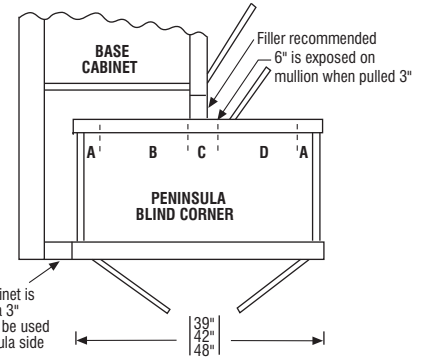

Dining Room

Top View, Pulled 3"

When cabinet is pulled 3" a 3" filler must be used on peninsula side

### Door & Drawer Options

AF	AOMBWB	CC	CG	ESMD	GAMD	IFHG	MD	PRMD	PTOWB	SHMD	SPLITDR	SPLITDRWS	SJMD	TCP
	✓	✓	✓	✓	✓	✓	✓	✓	✓	✓	✓	✓	✓	✓

### End Panel Options

AUTH	CSFPE	EXBK	FFD	FPE	INTGE	IPE
✓	✓	✓	✓	✓	✓	✓

### Custom Modification Options

ADD	SHLF	ADTK	CBO	CCO	CFNT0	CFP	CFRMO	CHGDRW	CLIP	CMAT	CND	CSDGBK	DRT	DRWTK	EF	EX	EX_OL	FBFL	FD	
✓	✓	✓	✓	✓	✓	✓	✓	✓	✓	✓	✓	✓	✓	✓	✓	✓	✓	✓	✓	✓

FDSRTBTM	FLUT <sup>1</sup>	FTK	ID	IH	IH+DRW	INFRM	IW	LIGHT	MIP	OBRB	PFINBTMB	RD	RECTK	RH	ROSLUT	RT
✓	✓	✓	✓	✓	✓	✓	✓	✓	✓	✓	✓	✓	✓	✓	✓	✓

RW	SBCADDY	SBCADDYSM	SCPRW	STW	TD	TKP	TVR	UDBX	URT	VTK	WS <sup>2</sup>	WTCD	WTKCUP	WTR
✓	✓	✓	✓	✓	✓	✓	✓	✓	✓	✓	✓	✓	✓	✓

<sup>1</sup>1/4" fluting not available on 39" or 42" wide.

<sup>2</sup>Not available with wide stile both.

IH/RH availability charts starting on page G•40.  
IW/RW availability charts starting on page G•46.

# Base Lazy Susan & Corner Sink Base Cabinets

## Description

### BASE LAZY SUSAN, 34 1/2" HIGH

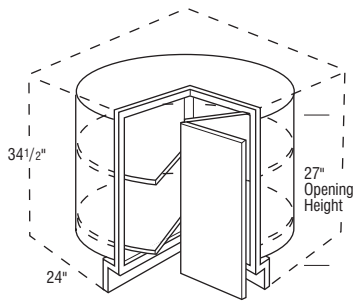

## Model

### BLS33 L or R

- Wood pan size is 18".

### BLS36 L or R

- Wood Pan size is 24".

Notes below apply to all products in section above:

- Not available on Inset and Beaded Inset styles.
- Use Lazy Susan Base End Panel panel for end application.
- Doors are connected with bifold hinge.

#### Door & Drawer Options

AF	AOMBWB	CC	CG	ESMD	GAMD	IFHG	MD	PRMD	PTOWB	SHMD	SPLITDR	SPLITDRWS	SUMD	TCP
						✓								

#### End Panel Options

AUTH	CSFPE	EXBK	FFD	FPE	INTGE	IPE
✓	✓	✓	✓	✓	✓	✓

#### Custom Modification Options

ADD_SHLF	ADDTK	CBO	CCO	CFNTD	CFP	CFRMO	CHGDRW	CLIP	CMAT	CND	CSDGBK	DRT	DRWTK	EF	EX	EX_OL	FBFL	FD
		✓	✓							✓					✓	✓	✓	

FDSRTBTM	FLUT <sup>1</sup>	FTK <sup>2</sup>	ID	IH	IH+DRW	INVFRM	IW	LIGHT	MIP	OBRB	PFINBTMB	RD	RECTK	RH	ROSFLUT	RT
	✓	✓													✓	

RW	SBCADDY	SBCADDYSM	SCPDRW	STW	TD	TKP	TVR	UDBX	URT	VTK	WS	WTCD	WTKCUP	WTR
										✓				✓

<sup>1</sup>Not available with 6" fluting.

<sup>2</sup>Not available with FTKAV.

### CORNER SINK BASE without SHELF, 34 1/2" HIGH, 24" DEEP

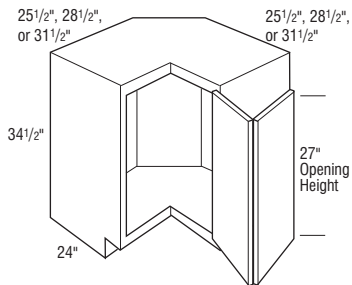

### CS36 L or R

### CS39 L or R

### CS42 L or R

- Doors are connected with a bifold hinge.

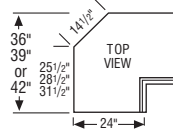

#### Door & Drawer Options

AF	AOMBWB	CC	CG	ESMD	GAMD	IFHG	MD	PRMD	PTOWB	SHMD	SPLITDR	SPLITDRWS	SUMD	TCP
						✓								

#### End Panel Options

AUTH	CSFPE	EXBK	FFD	FPE	INTGE	IPE
✓	✓	✓	✓	✓	✓	✓

#### Custom Modification Options

ADD_SHLF	ADDTK	CBO	CCO	CFNTD	CFP	CFRMO	CHGDRW	CLIP	CMAT	CND	CSDGBK	DRT	DRWTK	EF	EX	EX_OL	FBFL	FD
										✓					✓	✓	✓	

FDSRTBTM	FLUT <sup>1</sup>	FTK <sup>2</sup>	ID	IH	IH+DRW	INVFRM	IW	LIGHT	MIP	OBRB	PFINBTMB	RD	RECTK	RH	ROSFLUT	RT		
	✓	✓	✓	✓	✓										✓	✓	✓	

RW	SBCADDY	SBCADDYSM	SCPDRW	STW	TD	TKP	TVR	UDBX	URT	VTK	WS	WTCD	WTKCUP	WTR
						✓				✓				✓

<sup>1</sup>Not available with 6" fluting.

<sup>2</sup>Not available with FTKAV.

# Square Base Corner Cabinets

## Description

### ASYMMETRICAL BASE EASY REACH, 34 1/2" HIGH

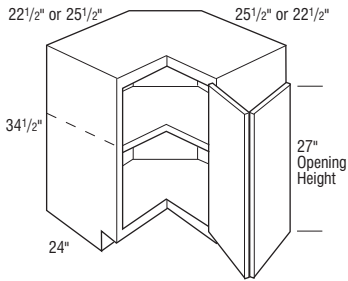

## Model

**BER3336 L or R**

**BER3633 L or R**

- Units include one fixed shelf.
- Doors are connected with a bifold hinge.

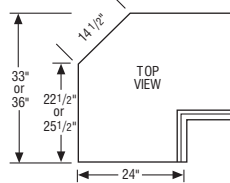

#### Door & Drawer Options

AF	AOMBWB	CC	CG	ESMD	GAMD	IFHG	MD	PRMD	PTOWB	SHMD	SPLITDR	SPLITDRWS	SJMD	TCP
						✓								

#### End Panel Options

AUTH	CSFPE	EXBK	FFD	FPE	INTGE	IPE
✓	✓	✓	✓	✓	✓	

#### Custom Modification Options

ADD	SHLF	ADTK	CBO	CCO	CFNTD	CFP	CFRMO	CHGDRW	CLIP	CMAT	CND	CSDGBK	DRT	DRWTK	EF	EX	EX_OL	FBFL	FD
			✓	✓							✓					✓	✓	✓	

FDSRTBTM	FLUT <sup>1</sup>	FTK <sup>2</sup>	ID	IH	IH+DRW	INVERM	IW	LIGHT	MIP	OBRB	PFINBTMB	RD	RECTK	RH	ROSLUT	RT
	✓	✓	✓	✓				✓	✓				✓	✓	✓	

RW	SBCADDY	SBCADDYSM	SCPDRW	STW	TD	TKP	TVR	UDBX	URT	VTK	WS	WTCDD	WTKCUP	WTR
							✓	✓		✓				✓

<sup>1</sup>Not available with 6" fluting.

<sup>2</sup>Not available with FTKAV.

### DIAGONAL CORNER SINK BASE without SHELF, 34 1/2" HIGH, 24" DEEP

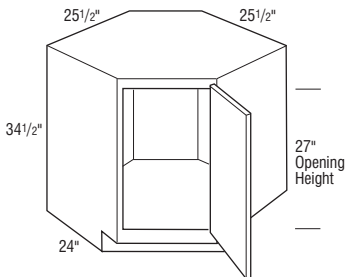

## DAB36 L or R

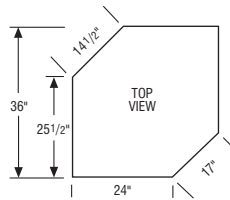

#### Door & Drawer Options

AF	AOMBWB	CC	CG	ESMD	GAMD	IFHG	MD	PRMD	PTOWB	SHMD	SPLITDR	SPLITDRWS	SJMD	TCP
				✓	✓	✓	✓	✓	✓	✓				✓

#### End Panel Options

AUTH	CSFPE	EXBK	FFD	FPE	INTGE	IPE
✓	✓	✓	✓	✓	✓	✓

#### Custom Modification Options

ADD	SHLF	ADTK	CBO	CCO	CFNTD	CFP	CFRMO	CHGDRW	CLIP	CMAT	CND	CSDGBK	DRT	DRWTK	EF	EX	EX_OL <sup>1</sup>	FBFL	FD
											✓					✓	✓		

FDSRTBTM	FLUT	FTK	ID	IH	IH+DRW	INVERM	IW	LIGHT	MIP	OBRB	PFINBTMB	RD	RECTK	RH	ROSLUT	RT
	✓	✓	✓	✓				✓	✓				✓	✓		

RW	SBCADDY	SBCADDYSM	SCPDRW	STW	TD	TKP	TVR	UDBX	URT	VTK	WS	WTCDD	WTKCUP	WTR
							✓	✓		✓				✓

<sup>1</sup>Only available on extended stile both.

IH/RH availability charts starting on page G•40.  
IW/RW availability charts starting on page G•46.

# Diagonal Base & Base Easy Reach Cabinets

## Description

### DIAGONAL BASE with FULL SHELF, 34 1/2" HIGH, 24" DEEP

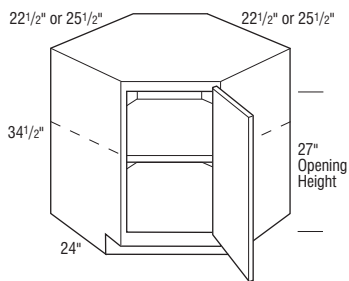

## Model

**DAB33FS L or R**

**DAB36FS L or R**

- Units include one fixed shelf.

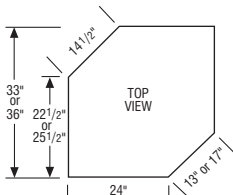

#### Door & Drawer Options

AF	AOMBWB	CC	CG	ESMD	GAMD	IFHG	MD	PRMD <sup>1</sup>	PTOWB	SHMD	SPLITDR	SPLITDRWS	SUMD	TCP

#### End Panel Options

AUTH	CSFPE	EXBK	FFD	FPE	INTGE	IPE

#### Custom Modification Options

ADD_SHLF	ADDTK	CBO	CCO	CFNTO	CFP	CFRMO	CHGDRW	CLIP	CMAT	CND	CSDGBK	DRT	DRWTK	EF	EX	EX_OL <sup>2</sup>	FBFL	FD	

FDSRTBTM	FLUT	FTK	ID	IH	IH+DRW	INVFRM	IW	LIGHT	MIP	OBRB	PFINBTMB	RD	RECTK	RH	ROSLUT	RT

RW	SBCADDY	SBCADDYSM	SCPDRW	STW	TD	TKP	TVR <sup>3</sup>	UDBX	URT	VTK	WS	WTCB	WTKCUP	WTR

<sup>1</sup>Not available on 33" wide.

<sup>2</sup>Only available on extended stile both.

<sup>3</sup>TVRAV not available on 33" wide.

### BASE EASY REACH, 34 1/2" HIGH, 24" DEEP

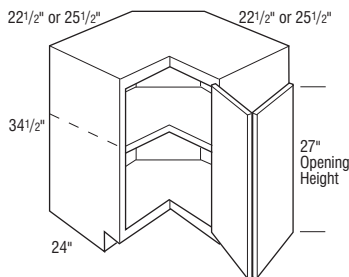

**BER33 L or R**

**BER36 L or R**

- Includes one fixed shelf.
- Doors are connected with bifold hinge.

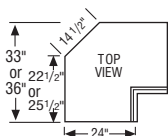

#### Door & Drawer Options

AF	AOMBWB	CC	CG	ESMD	GAMD	IFHG	MD	PRMD	PTOWB	SHMD	SPLITDR	SPLITDRWS	SUMD	TCP

#### End Panel Options

AUTH	CSFPE	EXBK	FFD	FPE	INTGE	IPE

#### Custom Modification Options

ADD_SHLF	ADDTK	CBO	CCO	CFNTO	CFP	CFRMO	CHGDRW	CLIP	CMAT	CND	CSDGBK	DRT	DRWTK	EF	EX	EX_OL	FBFL	FD	

FDSRTBTM	FLUT	FTK	ID	IH	IH+DRW	INVFRM	IW	LIGHT	MIP	OBRB	PFINBTMB	RD	RECTK	RH	ROSLUT	RT

RW	SBCADDY	SBCADDYSM	SCPDRW	STW	TD	TKP	TVR	UDBX	URT	VTK	WS	WTCB	WTKCUP	WTR

# Base Easy Reach Cabinets

## Description

**BASE EASY REACH with REDUCED SHELF,  
34 1/2" HIGH, 24" DEEP**

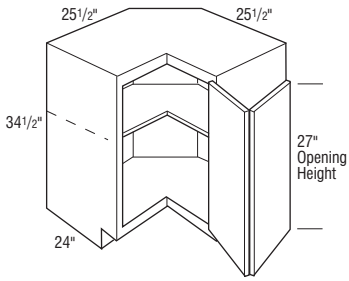

## Model

**BER36RS L or R**

- Doors are connected with a bifold hinge.
- Unit includes one fixed shelf.
- Fixed shelf reduced 3".

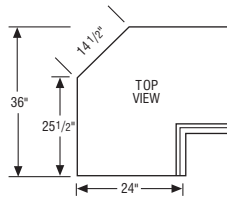

### Door & Drawer Options

AF	AOMBWB	CC	CG	ESMD	GAMD	IFHG	MD	PRMD	PTOWB	SHMD	SPLITDR	SPLITDRWS	SJMD	TCP
						✓								

### End Panel Options

AUTH	CSFPE	EXBK	FFD	FPE	INTGE	IPE
✓	✓	✓		✓		

### Custom Modification Options

ADD	SHLF	ADDTK	CBO	CCO	CFNTD	CFP	CFRMO	CHGDRW	CLIP	CMAT	CND	CSDGBK	DRT	DRWTK	EF	EX	EX_OL	FBFL	FD	
			✓	✓							✓					✓	✓	✓		

FDSRTBTM	FLUT <sup>1</sup>	FTK <sup>2</sup>	ID	IH	IH+DRW	INVERM	IW	LIGHT	MIP	OBRB	PFINBTMB	RD	RECTK	RH	ROSLUT	RT
	✓	✓	✓					✓	✓				✓	✓	✓	

RW	SBCADDY	SBCADDYSM	SCPDRW	STW	TD	TKP	TVR	UDBX	URT	VTK	WS	WTCD	WTKCUP	WTR
						✓				✓				✓

<sup>1</sup>Not available with 6" fluting.

<sup>2</sup>Not available with FTKAV.

IH/RH availability charts starting on page G•40.  
IW/RW availability charts starting on page G•46.

## Description

### SUPER LAZY SUSAN with CHROME RAIL and REDUCED SHELF, 34 1/2" HIGH storage SOLUTIONS

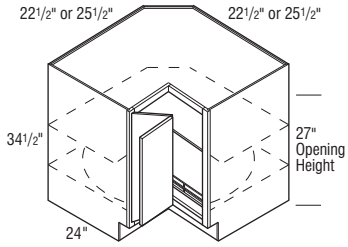

## Model

### SLSCR33RS L or R

- Tray diameter is 28".
- Not available on Inset and Beaded Inset styles.

### SLSCR36RS L or R

- Tray diameter is 32".

Notes below apply to all products in section above:

- Doors are connected with a bifold hinge.
- Unit includes chrome rail Lazy Susan on bottom and a reduced fixed shelf on top.
- Fixed shelf is reduced 3".

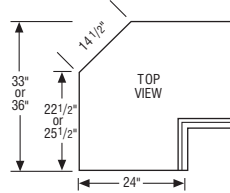

#### Door & Drawer Options

AF	AOMBWB	CC	CG	ESMD	GAMD	IFHG	MD	PRMD	PTOWB	SHMD	SPLITDR	SPLITDRWS	SUMD	TCP
						✓								

#### End Panel Options

AUTH	CSFPE	EXBK	FFD	FPE	INTGE	IPE
✓	✓	✓		✓	✓	

#### Custom Modification Options

ADD_SHLF	ADDTK	CBO	CCO	CFNTO	CFP	CFRMO	CHGDRW	CLIP	CMAT	CND	CSDGBK	DRT	DRWTK	EF	EX	EX_OL	FBFL	FD
			✓							✓				✓	✓	✓		

FDSRTBTM	FLUT <sup>2</sup>	FTK <sup>3</sup>	ID	IH	IH+DRW	INVERM	IW	LIGHT	MIP	OBRB	PFINBTMB	RD	RECTK	RH	ROSFLOT	RT
	✓	✓		✓					✓				✓	✓	✓	

RW	SBCADDY	SBCADDYSM	SCPDRW	STW	TD	TKP	TVR	UDBX	URT	VTK	WS	WTCD	WTKCUP	WTR
							✓			✓				✓

<sup>1</sup>Not available on 33" wide.

<sup>2</sup>Not available with 6" fluting.

<sup>3</sup>Not available with FTKAV.

# Super Space Saver Cabinets

## Description

**BASE EASY REACH with LAZY SUSAN and DIAGONAL BASE with FULL HEIGHT DOOR and LAZY SUSAN, 34 1/2" HIGH, 24" DEEP**

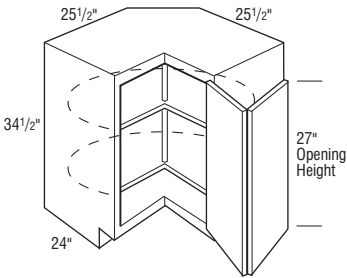

**BER36S L or R**

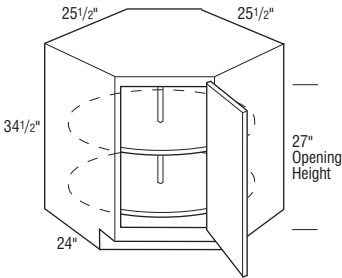

**DAB36S L or R**

## Model

### BER36S L or R

- Doors are connected with a bifold hinge.
- Pan diameter is 28".

### DAB36S L or R

- Wood pans are adjustable and rotate individually.
- Pan diameter is 28".

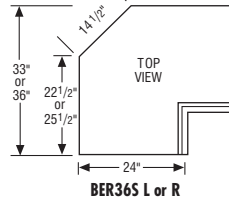

**BER36S L or R**

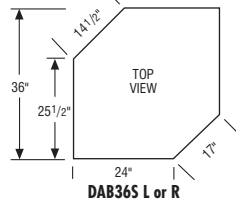

**DAB36S L or R**

### Door & Drawer Options

AF	AOMBWB	CC	CG <sup>1</sup>	ESMD <sup>1</sup>	GAMD <sup>1</sup>	IFHG	MD <sup>1</sup>	PRMD <sup>1</sup>	PTOWB	SHMD <sup>1</sup>	SPLITDR	SPLITDRWS	SUMD <sup>1</sup>	TCP
			✓	✓	✓	✓	✓	✓	✓	✓	✓	✓	✓	✓

### End Panel Options

AUTH	CSFPE	EXBK	FFD <sup>1</sup>	FPE	INTGE <sup>1</sup>	IPE
✓	✓	✓	✓	✓	✓	✓

### Custom Modification Options

ADD	SHLF	ADDTK	CBO	CCO	CFNT0 <sup>1</sup>	CFP	CFRMO <sup>1</sup>	CHGDRW	CLIP	CMAT	CND	CSDGBK	DRT	DRWTK	EF	EX <sup>2</sup>	EX_OL <sup>2</sup>	FBFL	FD
			✓	✓	✓	✓	✓	✓	✓	✓	✓	✓	✓	✓	✓	✓	✓	✓	✓

FDSRTBTM	FLUT <sup>3</sup>	FTK <sup>4</sup>	ID	IH	IH+DRW	INVERM	IW	LIGHT <sup>1</sup>	MIP	OBRB	PFINBTMB	RD	RECTK	RH	ROSFLUT <sup>5</sup>	RT
	✓	✓						✓	✓	✓	✓	✓	✓	✓	✓	✓

RW	SBCADDY	SBCADDYSM	SCPDRW	STW	TD	TKP	TVR <sup>1</sup>	UDBX	URT	VTK	WS	WTCD	WTKCUP	WTR
							✓	✓	✓	✓	✓	✓	✓	✓

<sup>1</sup>Not available on BER36S L or R version.

<sup>2</sup>Not available on DAB36S L or R version.

<sup>3</sup>Not available on DAB36S L or R version. Not available with 6" fluting.

<sup>4</sup>FTKAV not available with BER36S L or R version.

<sup>5</sup>Not available on DAB36S L or R version.

IH/RH availability charts starting on page G•40.  
IW/RW availability charts starting on page G•46.

## Description

### SUPER LAZY SUSAN, 34 1/2" HIGH

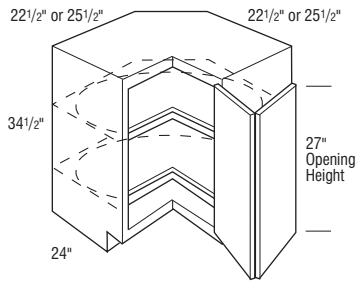

## Model

**SLSW3336 L or R**

**SLSW3633 L or R**

- Pan diameter is 28".
- Not available on Inset and Beaded Inset styles.

**SLSW33 L or R**

**SLSW36 L or R**

- Pan diameter is 32".

Notes below apply to all products in section above:

- Doors are connected with a bifold hinge.

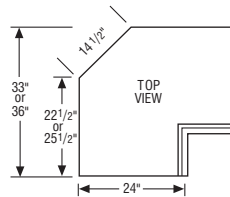

#### Door & Drawer Options

AF	AOMBWB	CC	CG	ESMD	GAMD	IFHG	MD	PRMD	PTOWB	SHMD	SPLITDR	SPLITDRWS	SUMD	TCP
						✓								

#### End Panel Options

AUTH	CSFPE	EXBK <sup>1</sup>	FFD	FPE	INTGE	IPE
✓	✓	✓		✓		

#### Custom Modification Options

ADD_SHLF	ADDTK	CBO	CCO	CFNTO	CFP	CFRMO	CHGDRW	CLIP	CMAT	CND	CSDGBK	DRT	DRWTK	EF	EX	EX_OL	FBFL	FD
										✓				✓	✓	✓		

FDSRTBTM	FLUT <sup>2</sup>	FTK <sup>3</sup>	ID	IH	IH+DRW	INVFRM	IW	LIGHT	MIP	OBRB	PFINBTMB	RD	RECTK	RH	ROSLUT	RT
	✓	✓	✓						✓				✓	✓	✓	

RW	SBCADDY	SBCADDYSM	SCPDRW	STW	TD	TKP	TVR	UDBX	URT	VTK	WS	WTCD	WTKCUP	WTR
						✓				✓				✓

<sup>1</sup>Not available on 36" wide.

<sup>2</sup>Not available with 6" fluting.

<sup>3</sup>Not available with FTKAV.



**Description**

**DIAGONAL BASE with FULL HEIGHT DOOR and SUPER LAZY SUSAN, 34 1/2" HIGH, 24" DEEP**

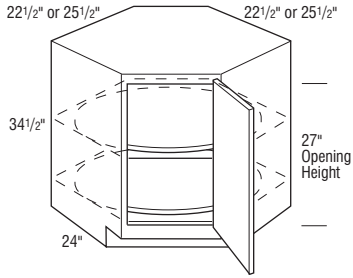

**Model**

**DAB33SLS L or R**

- Tray diameter is 28".

**DAB36SLS L or R**

- Tray diameter is 32".

Notes below apply to all products in section above:

- Wood Pans attached to fixed shelf, do rotate individually.
- Recommend hinging on the larger side on bifold units.

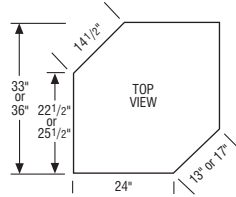

**Door & Drawer Options**

AF	AOMBWB	CC	CG	ESMD	GAMD	IFHG	MD	PRMD	PTOWB	SHMD	SPLITDR	SPLITDRWS	SJMD	TCP
			✓	✓	✓	✓	✓	✓		✓				✓

**End Panel Options**

AUTH	CSFPE	EXBK	FFD	FPE	INTGE	IPE
✓	✓	✓	✓	✓	✓	✓

**Custom Modification Options**

ADD_SHLF	ADDTK	CBO	CCO	CFNT0	CFP	CFRMO	CHGDRW	CLIP	CMAT	CND	CSDGBK	DRT	DRWTK	EF	EX	EX_OL <sup>2</sup>	FBFL	FD
			✓	✓	✓	✓				✓					✓	✓		

FDSRTBTM	FLUT	FTK <sup>3</sup>	ID	IH	IH+DRW	INVFRM	IW	LIGHT	MIP	OBRB	PFINBTMB	RD	RECTK	RH	ROSLUT	RT
		✓	✓		✓			✓	✓				✓	✓		

RW	SBCADDY	SBCADDYSM	SCPDRW	STW	TD	TKP	TVR	UDBX	URT	VTK	WS	WTCD	WTKCUP	WTR
						✓	✓			✓				✓

<sup>1</sup>Not available on 33" wide.

<sup>2</sup>Only available on extended stile both.

<sup>3</sup>FTKAV not available on 33" wide.

IH/RH availability charts starting on page G•40.  
IW/RW availability charts starting on page G•46.

## Description

**SUPER LAZY SUSAN with CHROME RAIL, 34 1/2" HIGH storage SOLUTIONS**

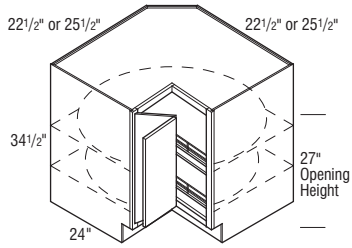

## Model

**SLSCR3336 L or R**

**SLSCR3633 L or R**

- Tray diameter is 28".
- Not available on Inset and Beaded Inset styles.

**SLSCR33 L or R**

**SLSCR36 L or R**

- Tray diameter is 32".

Notes below apply to all products in section above:

- Doors are connected with a bifold hinge.
- Wood Pans attached to fixed shelf, do rotate individually.

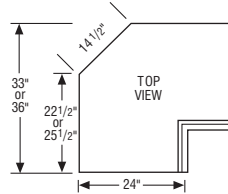

### Door & Drawer Options

AF	AOMBWB	CC	CG	ESMD	GAMD	IFHG	MD	PRMD	PTOWB	SHMD	SPLITDR	SPLITDRWS	SUMD	TCP
						✓								

### End Panel Options

AUTH	CSFPE	EXBK	FFD	FPE	INTGE	IPE
✓	✓	✓		✓		

### Custom Modification Options

ADD_SHLF	ADDTK	CBO	CCO	CFNTO	CFP	CFRMO	CHGDRW	CLIP	CMAT	CND	CSDGBK	DRT	DRWTK	EF	EX	EX_OL	FBFL	FD
			✓							✓					✓	✓	✓	

FDSRTBTM	FLUT <sup>2</sup>	FTK <sup>3</sup>	ID	IH	IH+DRW	INVERM	IW	LIGHT	MIP	OBRB	PFINBTMB	RD	RECTK	RH	ROSLUT	RT
	✓	✓		✓					✓				✓	✓	✓	

RW	SBCADDY	SBCADDYSM	SCPDRW	STW	TD	TKP	TVR	UDBX	URT	VTK	WS	WTCD	WTKCUP	WTR
								✓		✓				✓

<sup>1</sup>Not available on 33" wide.

<sup>2</sup>Not available with 6" fluting.

<sup>3</sup>Not available with FTKAV.

# Super Lazy Susan & Base Rotating Deep Bin Cabinets

## Description

### SUPER LAZY SUSAN with CHROME RAIL and CORNER DRAWER, 34 1/2" HIGH storage SOLUTIONS

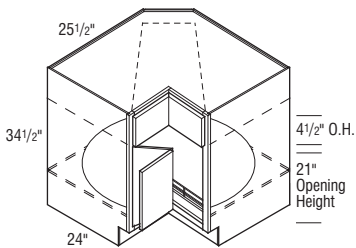

## Model

### SLSR36CD L or R

- Doors are connected with a bifold hinge.
- Tray diameter is 32".
- Allow for proper clearance of drawer head when specifying corner drawer cabinets next to appliances.
- Will have 1" of exposed frame rail so drawer fronts will clear doors and drawer front of adjacent cabinets.
- Not available on Inset and Beaded Inset styles.

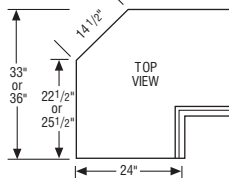

#### Door & Drawer Options

AF	AOMBWB	CC	CG	ESMD	GAMD	IFHG	MD	PRMD	PTOWB	SHMD	SPLITDR	SPLITDRWS	SUMD	TCP
						✓								

#### End Panel Options

AUTH	CSFPE	EXBK	FFD	FPE	INTGE	IPE
✓	✓	✓	✓		✓	

#### Custom Modification Options

ADD	SHLF	ADTK	CBO	CCO	CFNTO	CFP	CFRMO	CHGDRW	CLIP	CMAT	CND	CSDGBK	DRT	DRWTK	EF	EX	EX_OL	FBFL	FD
			✓								✓				✓	✓	✓		

FDSRTBTM	FLUT <sup>1</sup>	FTK <sup>2</sup>	ID	IH	IH+DRW	INVERM	IW	LIGHT	MIP	OBRB	PFINBTMB	RD	RECTK	RH	ROSLUT	RT
	✓	✓		✓					✓				✓	✓	✓	

RW	SBCADDY	SBCADDYSM	SCPDRW	STW	TD	TKP	TVR	UDBX	URT	VTK	WS	WTCED	WTKCUP	WTR
							✓			✓				✓

<sup>1</sup>Not available with 6" fluting.  
<sup>2</sup>Not available with FTKAV.

## BASE ROTATING DEEP BIN, 36" WIDE storage SOLUTIONS

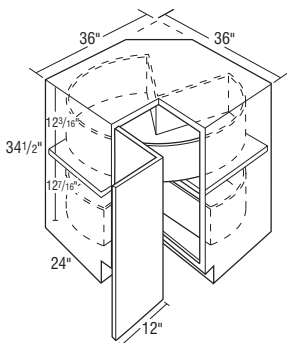

### BRDB36 L or R

- Doors are connected with a bifold hinge.
- BRDB36 L or R shelves are 30" diameter. Bins are 6" tall.
- Decorative hardware screws must be countersunk to prevent scratching of adjacent cabinets and face frame of BRDB.
- Integrated Smart Stop hinge not included.
- Inside bottom of lower deep susan to the fixed shelf is 12 7/16" high.
- Inside bottom of upper deep susan to the bottom of face frame cross rail is 12 3/16" high.

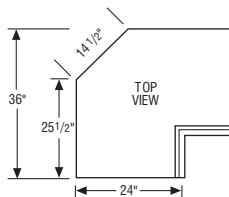

#### Door & Drawer Options

AF	AOMBWB	CC	CG	ESMD	GAMD	IFHG	MD	PRMD	PTOWB	SHMD	SPLITDR	SPLITDRWS	SUMD	TCP
						✓								

#### End Panel Options

AUTH	CSFPE	EXBK	FFD	FPE	INTGE	IPE
✓	✓	✓	✓		✓	

#### Custom Modification Options

ADD	SHLF	ADTK	CBO	CCO	CFNTO	CFP	CFRMO	CHGDRW	CLIP	CMAT	CND	CSDGBK	DRT	DRWTK	EF	EX	EX_OL	FBFL	FD
			✓								✓				✓	✓	✓		

FDSRTBTM	FLUT <sup>1</sup>	FTK <sup>2</sup>	ID	IH	IH+DRW	INVERM	IW	LIGHT	MIP	OBRB	PFINBTMB	RD	RECTK	RH	ROSLUT	RT
	✓	✓		✓					✓				✓	✓	✓	

RW	SBCADDY	SBCADDYSM	SCPDRW	STW	TD	TKP	TVR	UDBX	URT	VTK	WS	WTCED	WTKCUP	WTR
							✓			✓				✓

<sup>1</sup>Not available with 6" fluting.  
<sup>2</sup>Not available with FTKAV.

IH/RH availability charts starting on page G•40.  
 IW/RW availability charts starting on page G•46.

# Lazy Susan Pull-out & Three Corner Drawer Base Cabinets

## Description

### LAZY SUSAN PULL-OUT, 34 1/2" HIGH, 36" WIDE

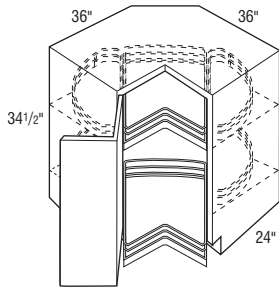

## Model

### LSP36 L or R

- Doors are connected with a bifold hinge.
- Roto diameter is 30".
- Rotos attached to fixed shelf and rotate individually.
- Each roto features two half-moon bins (8 3/8" x 25 1/2") with plywood shelves and chrome rail sides.
- Center pull-outs have Smart Stop guides and operate independently.

#### Door & Drawer Options

AF	AOMBWB	CC	CG	ESMD	GAMD	IFHG	MD	PRMD	PTOWB	SHMD	SPLITDR	SPLITDRWS	SUMD	TCP
						✓								

#### End Panel Options

AUTH	CSFPE	EXBK	FFD	FPE	INTGE	IPE
✓	✓	✓	✓	✓	✓	✓

#### Custom Modification Options

ADD_SHLF	ADDTK	CBO	CCO	CFNTD	CFP	CFRMO	CHGDRW	CLIP	CMAT	CND	CSDGBK	DRT	DRWTK	EF	EX	EX_OL	FBFL	FD
			✓	✓						✓					✓	✓	✓	

FDSRTBTM	FLUT <sup>1</sup>	FTK <sup>2</sup>	ID	IH	IH+DRW	INVFRM	IW	LIGHT	MIP	OBRB	PFINBTMB	RD	RECTK	RH	ROSFLUT	RT
	✓	✓	✓	✓	✓			✓						✓	✓	

RW	SBCADDY	SBCADDYSM	SCPDRW	STW	TD	TKP	TVR	UDBX	URT	VTK	WS	WTCD	WTKCUP	WTR
											✓			✓

<sup>1</sup>Not available with 6" fluting.

<sup>2</sup>Not available with FTKAV.

### THREE CORNER DRAWER BASE, 34 1/2" HIGH storage SOLUTIONS

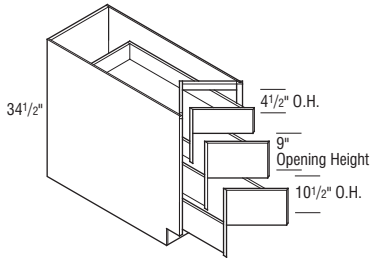

### 3CDB36

- Must be installed between two cabinets.
- Allow for proper clearance of drawer head when specifying corner drawer cabinets next to appliances.
- Will have less than 3/4" overlay side reveal for clearance purposes.
- Not available on Inset and Beaded Inset styles.

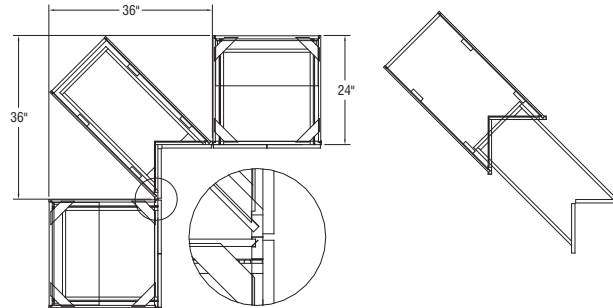

#### Door & Drawer Options

AF	AOMBWB	CC	CG	ESMD	GAMD	IFHG	MD	PRMD	PTOWB	SHMD	SPLITDR	SPLITDRWS	SUMD	TCP
						✓								

#### End Panel Options

AUTH	CSFPE	EXBK	FFD	FPE	INTGE	IPE

#### Custom Modification Options

ADD_SHLF	ADDTK	CBO	CCO	CFNTD	CFP	CFRMO	CHGDRW	CLIP	CMAT	CND	CSDGBK	DRT	DRWTK	EF	EX	EX_OL <sup>1</sup>	FBFL	FD
																	✓	

FDSRTBTM	FLUT	FTK <sup>2</sup>	ID	IH	IH+DRW	INVFRM	IW	LIGHT	MIP	OBRB	PFINBTMB	RD	RECTK	RH	ROSFLUT	RT
		✓							✓	✓						

RW	SBCADDY	SBCADDYSM	SCPDRW	STW	TD	TKP	TVR	UDBX	URT	VTK	WS	WTCD	WTKCUP	WTR
								✓		✓				✓

<sup>1</sup>Only available on extended stile both.

<sup>2</sup>Not available with FTKAV.

# Base Sliding Door Island Cabinets

## Description

### BASE SLIDING DOOR ISLAND CABINET, 34 1/2" HIGH, 24" DEEP

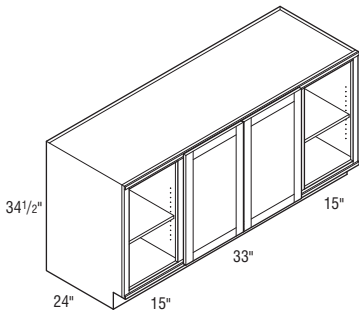
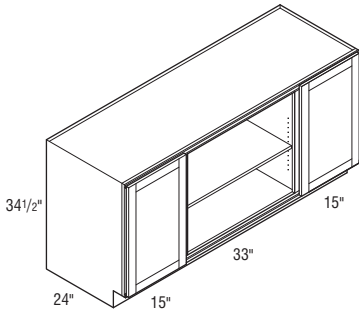

## Model

### B72SDI

- Cabinet has two Smart Stop Sliding Doors.
- Cabinet has one adjustable full depth shelf in each opening.
- Not available on Inset and Beaded Inset styles.
- Increased depth in 1/4" increments to 30".
- Reduced depth in 1/4" increments to 12".
- Outside openings 15" wide. Middle opening is 33" wide.
- Matching Interior is standard.
- Cabinet is not finished on the back, and would require a skin or panel to finish the back side if used for an island application.

#### Door & Drawer Options

AF	AOMBWB	CC	CG	ESMD	GAMD	IFHG	MD	PRMD	PTOWB	SHMD	SPLITDR	SPLITDRWS	SUMD	TCP
						✓								

#### End Panel Options

AUTH	CSFPE	EXBK	FFD	FPE	INTGE	IPE
✓	✓	✓	✓	✓	✓	✓

#### Custom Modification Options

ADD	SHLF	ADDTK	CBO	CCO	CFNTO	CFP	CFRMO	CHGDRW	CLIP	CMAT	CND	CSDGBK	DRT	DRWTK	EF	EX	EX_OL	FBFL	FD	
✓																			✓	
FDSRTBTM	FLUT	FTK	ID	IH	IH+DRW	INVFRM	IW	LIGHT	MIP	OBRB	PFINBTMB	RD	RECTK	RH	ROSFLUT	RT				
		✓	✓	✓						✓		✓	✓	✓		✓				
RW	SBCADDY	SBCADDYSM	SCPDRW	STW	TD	TKP	TVR	UDBX	URT	VTK	WS	WTCD	WTKCUP	WTR						
							✓			✓										

### BASE SLIDING DOOR ISLAND CABINET with SLIDING DESK, 34 1/2" HIGH, 24" DEEP storage SOLUTIONS

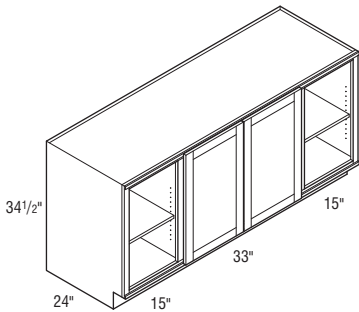
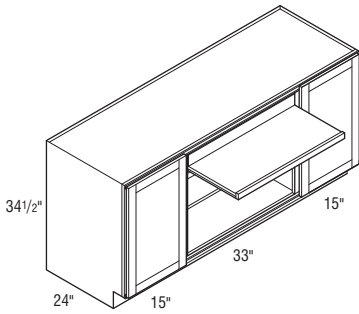

### B72SDIDSK

- Cabinet has two Smart Stop Sliding Doors.
- Cabinet has one adjustable full depth shelf in each opening.
- Center section will include a sliding desk with Smart Stop slides.
- Not available on Inset and Beaded Inset styles.
- Increased depth in 1/4" increments to 30".
- Outside openings 15" wide. Middle opening is 33" wide.
- Matching Interior is standard.
- Cabinet is not finished on the back, and would require a skin or panel to finish the back side if used for an island application.

#### Door & Drawer Options

AF	AOMBWB	CC	CG	ESMD	GAMD	IFHG	MD	PRMD	PTOWB	SHMD	SPLITDR	SPLITDRWS	SUMD	TCP
						✓								

#### End Panel Options

AUTH	CSFPE	EXBK	FFD	FPE	INTGE	IPE
✓	✓	✓	✓	✓	✓	✓

#### Custom Modification Options

ADD	SHLF	ADDTK	CBO	CCO	CFNTO	CFP	CFRMO	CHGDRW	CLIP	CMAT	CND	CSDGBK	DRT	DRWTK	EF	EX	EX_OL	FBFL	FD	
✓																			✓	
FDSRTBTM	FLUT	FTK	ID	IH	IH+DRW	INVFRM	IW	LIGHT	MIP	OBRB	PFINBTMB	RD	RECTK	RH	ROSFLUT	RT				
		✓	✓	✓						✓		✓	✓	✓		✓				
RW	SBCADDY	SBCADDYSM	SCPDRW	STW	TD	TKP	TVR	UDBX	URT	VTK	WS	WTCD	WTKCUP	WTR						
							✓			✓										

IH/RH availability charts starting on page G•40.  
IW/RW availability charts starting on page G•46.

## Description

**BASE PENINSULA, 34 1/2" HIGH, 24" DEEP**

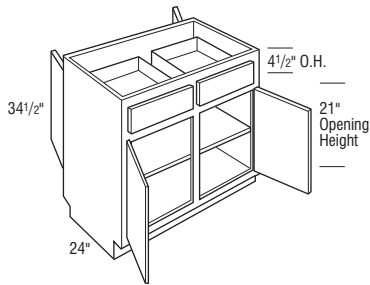
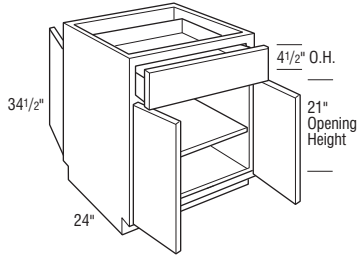
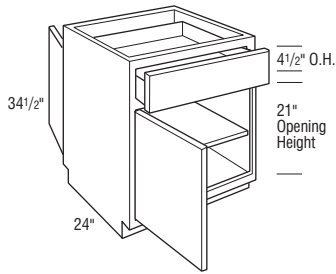

## Model

**B9P L or R**

**B12P L or R**

**B15P L or R**

**B18P L or R**

**B21P L or R**

**B24P L or R**

**B24P**

**B27P**

**B30P**

**B33P**

**B36P**

**B39P**

**B42P**

**B45P**

**B48P**

Notes below apply to all products in section above:

- One adjustable Full Depth Shelf.
- Peninsula back includes false drawer front and functional doors.
- Specify location of modification for front or peninsula side.
- Reduced Depths available in 1/4" increments from 12" to 23 3/4".

### Door & Drawer Options

AF	AOMBWB	CC	CG	ESMD	GAMD	IFHG	MD	PRMD <sup>1</sup>	PTOWB	SHMD <sup>2</sup>	SPLITDR <sup>3</sup>	SPLITDRWS <sup>4</sup>	SUMD	TCP
				✓	✓	✓	✓	✓		✓	✓	✓	✓	✓

### End Panel Options

AUTH	CSFPE	EXBK	FFD	FPE	INTGE	IPE
✓	✓			✓	✓	✓

### Custom Modification Options

ADD_SHLF	ADDTK	CBO	CCO	CFNTO	CFP	CFRMO	CHGDRW	CLIP <sup>5</sup>	CMAT	CND	CSDGBK	DRT	DRWTK	EF <sup>2</sup>	EX	EX_OL	FBFL	FD <sup>6</sup>	
		✓	✓	✓	✓	✓	✓	✓	✓	✓	✓	✓	✓	✓	✓	✓	✓	✓	✓

FDSRTBTM	FLUT <sup>7</sup>	FTK <sup>8</sup>	ID	IH	IH+DRW	INVFRM <sup>9</sup>	IW <sup>10</sup>	LIGHT	MIP	OBRB	PFINBTMB	RD	RECTK	RH	ROSLUT	RT	RW
	✓	✓	✓	✓	✓	✓	✓	✓	✓	✓	✓	✓	✓	✓	✓	✓	✓

RW	SBCADDY	SBCADDYSM	SCPDRW	STW	TD <sup>11</sup>	TKP	TVR <sup>12</sup>	UDBX <sup>4</sup>	URT	VTK	WS <sup>13</sup>	WTC <sup>14</sup>	WTKCUP <sup>15</sup>	WTR
			✓	✓	✓	✓	✓	✓	✓	✓	✓	✓	✓	✓

<sup>1</sup>Not available on 9", 12" or 24" (2 doors) wide.

<sup>2</sup>Not available on 9" wide.

<sup>3</sup>Only available on 24" (2 doors)-39" wide.

<sup>4</sup>Only available on 24" (1 door and 2 doors)-39" wide.

<sup>5</sup>Not available on 9", 12" or 24" (2 doors) wide.

<sup>6</sup>Only available on 30" and 36" wide.

<sup>7</sup>6" fluting not available on 9", 12", 15", or 24" (2 doors) wide. Fluting both 6" also not available on 18-24" (1 door) wide.

<sup>8</sup>FTKAV not available on 9" or 12" wide.

<sup>9</sup>Not available on 21" wide.

<sup>10</sup>Not available on 24" (1 door) or 48" wide.

<sup>11</sup>Only available on 24" (2 doors) wide.

<sup>12</sup>Not available on 18", 21", 24" (2 doors), or 27" wide. TVRAV also not available on 12" or 42" wide.

<sup>13</sup>Not available on 9" or 24" (2 doors) wide.

<sup>14</sup>Only available on 15", 18", 21", 24", 30", 36", 42", and 48" wide.

<sup>15</sup>Only available on 18" and 36" wide.

# Base Peninsula Cabinets

## Description

**FULL HEIGHT BASE PENINSULA,  
34 1/2" HIGH, 24" DEEP**

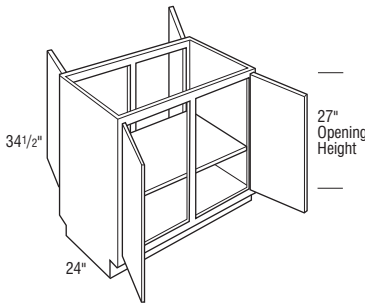
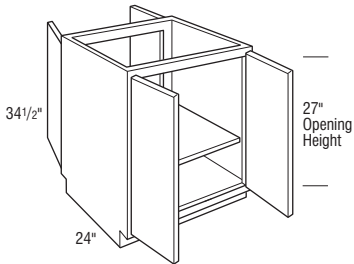
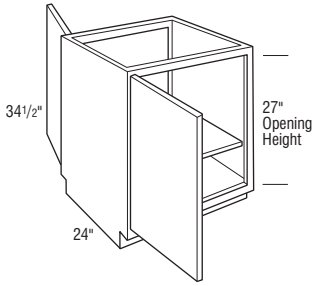

## Model

**B9FHP L or R**

**B12FHP L or R**

**B15FHP L or R**

**B18FHP L or R**

**B21FHP L or R**

**B24FHP L or R**

**B24FHP**

**B27FHP**

**B30FHP**

**B33FHP**

**B36FHP**

**B39FHP**

**B42FHP**

**B45FHP**

**B48FHP**

Notes below apply to all products in section above:

- One adjustable Full Depth Shelf.
- Specify location of modification for front or peninsula side.
- Increased Depths available in 1/4" increments from 24 1/4" to 30".
- Reduced Depths available in 1/4" increments from 6" to 23 3/4".

### Door & Drawer Options

AF	AOMBWB	CC	CG	ESMD <sup>1</sup>	GAMD <sup>1</sup>	IFHG	MD <sup>1</sup>	PRMD <sup>2</sup>	PTOWB	SHMD <sup>1</sup>	SPLITDR <sup>3</sup>	SPLITDRWS	SUMD <sup>1</sup>	TCP
				✓	✓	✓	✓	✓		✓	✓		✓	✓

### End Panel Options

AUTH	CSFPE	EXBK	FFD	FPE	INTGE	IPE
✓	✓			✓	✓	✓

### Custom Modification Options

ADD	SHLF	ADDTK	CBO	CCO	CFNTO	CFP	CFRMO	CHGDRW	CLIP <sup>4</sup>	CMAT	CND	CSDGBK	DRT	DRWTK	EF	EX	EX_OL	FBFL	FD	
									✓		✓									

FDSRTBTM	FLUT <sup>5</sup>	FTK <sup>6</sup>	ID	IH	IH+DRW	INVFRM	IW <sup>7</sup>	LIGHT	MIP	OBRB	PFINBTMB	RD	RECTK	RH	ROSLUT <sup>8</sup>	RT
	✓	✓	✓	✓			✓		✓	✓		✓	✓	✓	✓	✓

RW	SBCADDY	SBCADDYSM	SCPDRW	STW	TD <sup>9</sup>	TKP	TVR <sup>10</sup>	UDBX	URT	VTK	WS <sup>11</sup>	WTC	WTKCUP	WTR
						✓	✓	✓		✓	✓			✓

<sup>1</sup>Not available on 9" wide.

<sup>2</sup>Not available on 9", 12" or 24" (2 doors) wide.

<sup>3</sup>Only available on 30"-39" wide.

<sup>4</sup>Not available on 9", 12" or 24" (2 doors) wide.

<sup>5</sup>Not available on 24" (2 doors) or 27" wide. Fluting both 3" not available on 9" wide. 6" fluting not available on 9"-21" wide.

<sup>6</sup>FTKAV not available on 9" or 12" wide.

<sup>7</sup>Not available on 48" wide.

<sup>8</sup>Not available on 24" (2 doors) or 27" wide. Fluting both not available on 9" or 30"-48" wide.

<sup>9</sup>Only available on 24" (2 doors) wide.

<sup>10</sup>Not available on 9" or 42"-48" wide. TVRAV also not available on 12" wide.

<sup>11</sup>Not available on 9" wide and wide stile 3" also not available on 12" wide.

IH/RH availability charts starting on page G-40.  
IW/RW availability charts starting on page G-46.

# Base Corner Peninsula Cabinets

## Description

### BASE CORNER PENINSULA, 34 1/2" HIGH

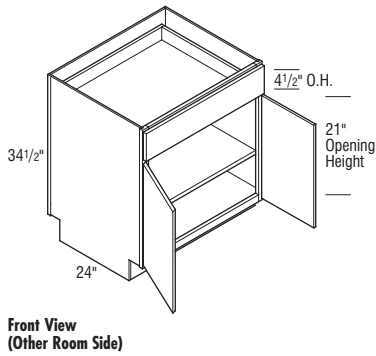

## Model

### BCP27

- Specify location of modification for front or peninsula side.
- One adjustable Full Depth Shelf.
- Reduced Depths available in 1/4" increments from 12" to 23 3/4".

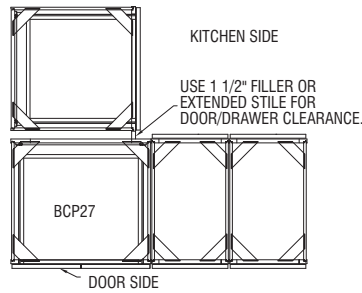

OTHER ROOM SIDE  
**Top View**

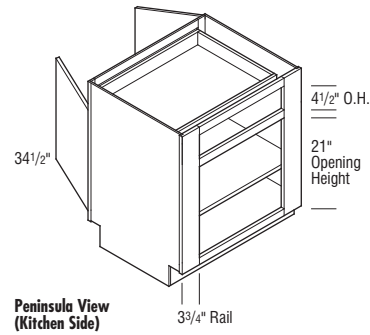

#### Door & Drawer Options

AF	AOMBWB	CC	CG	ESMD	GAMD	IFHG	MD	PRMD	PTOWB	SHMD	SPLITDR	SPLITDRWS	SUMD	TCP
----	--------	----	----	------	------	------	----	------	-------	------	---------	-----------	------	-----

#### End Panel Options

AUTH	CSFPE	EXBK	FFD	FPE	INTGE	IPE
✓	✓			✓	✓	✓

#### Custom Modification Options

ADD_SHLF	ADDTK	CBO	CCO	CFNTO	CFP	CFRMO	CHGDRW	CLJP	CMAT	CND	CSDGBK	DRT	DRWTK	EF	EX	EX_OL	FBFL	FD	
								✓											

FDSRTBTM	FLUT <sup>1</sup>	FTK	ID	IH	IH+DRW	INVFRM	IW	LIGHT	MIP	OBRB	PFINBTMB	RD	RECTK	RH	ROSFLOT <sup>2</sup>	RT
	✓			✓					✓				✓		✓	✓

RW	SBCADDY	SBCADDYSM	SCPDRW	STW	TD	TKP	TVR	UDBX	URT	VTK	WS	WTCD	WTKCUP	WTR
											✓			

<sup>1</sup>Only available with FLUT3B.P.

<sup>2</sup>Only available with ROSFLUT3B.P.



# Base with Tray Divider Cabinets

## Description

### FULL HEIGHT BASE with TRAY DIVIDER, 34 1/2" HIGH, 24" DEEP

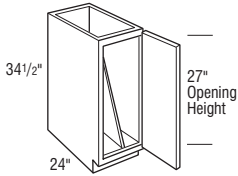

## Model

### TD6FH L or R

- Utilizes a slab door on cabinets up to 9" wide.
- Not available on Inset and Beaded Inset styles.
- Does not include dividers or tracks. Increased width models 7 1/2" or wider include divider and tracks.

### TD9FH L or R

### TD12FH L or R

### TD15FH L or R

### TD18FH L or R

#### Door & Drawer Options

AF	AOMBWB	CC	CG <sup>1</sup>	ESMD <sup>2</sup>	GAMD <sup>2</sup>	IFHG	MD <sup>1</sup>	PRMD <sup>4</sup>	PTOWB	SHMD <sup>2</sup>	SPLITDR	SPLITDRWS	SUMD <sup>2</sup>	TCP
			✓	✓	✓	✓	✓	✓		✓				✓

#### End Panel Options

AUTH	CSFPE	EXBK	FFD <sup>1</sup>	FPE	INTGE	IPE
✓	✓	✓	✓	✓	✓	✓

#### Custom Modification Options

ADD	SHLF	ADDTK	CBO	CCO <sup>3</sup>	CFNTO	CFP <sup>1</sup>	CFRMO	CHGDRW	CLIP <sup>5</sup>	CMAT	CND	CSDGBK	DRT	DRWTK	EF	EX	EX_OL	FBFL	FD
				✓	✓	✓	✓		✓			✓				✓	✓	✓	

FDSRTBTM	FLUT <sup>6</sup>	FTK <sup>7</sup>	ID	IH	IH+DRW	INVFRM	IW <sup>8</sup>	LIGHT	MIP	OBRB	PFINBTMB	RD	RECTK	RH	ROSFLUT <sup>9</sup>	RT
	✓	✓			✓		✓		✓	✓			✓	✓	✓	✓

RW	SBCADDY	SBCADDYSM	SCPDRW	STW	TD	TKP	TVR <sup>10</sup>	UDBX	URT	VTK	WS	WTCO	WTKCUP	WTR
							✓				✓			✓

<sup>1</sup>Not available on 6" wide.

<sup>2</sup>Not available on 6" or 9" wide.

<sup>3</sup>Only available on 6" wide.

<sup>4</sup>Only available on 15" wide.

<sup>5</sup>Not available on 6" or 12" wide.

<sup>6</sup>Fluting both 3" not available on 9"-12" wide. 6" fluting not available.

<sup>7</sup>FTKAV not available on 6"-12" wide.

<sup>8</sup>Not available on 18" wide.

<sup>9</sup>Fluting both not available on 9"-12" wide.

<sup>10</sup>Not available on 6" wide. TVRAV also not available on 9" or 12" wide.

### BASE with TRAY DIVIDER, 34 1/2" HIGH, 24" DEEP

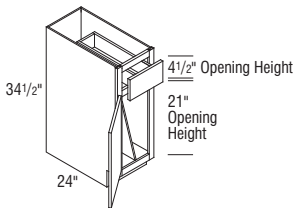

### TD9 L or R

### TD12 L or R

- Reduced Depths available in 1/4" increments from 12" to 23 3/4".

#### Door & Drawer Options

AF	AOMBWB	CC	CG	ESMD <sup>1</sup>	GAMD <sup>1</sup>	IFHG	MD <sup>1</sup>	PRMD	PTOWB	SHMD <sup>1</sup>	SPLITDR	SPLITDRWS	SUMD <sup>1</sup>	TCP
				✓	✓	✓	✓			✓				✓

#### End Panel Options

AUTH	CSFPE	EXBK	FFD	FPE	INTGE	IPE
✓	✓	✓	✓	✓	✓	✓

#### Custom Modification Options

ADD	SHLF	ADDTK	CBO	CCO	CFNTO	CFP	CFRMO	CHGDRW	CLIP	CMAT	CND	CSDGBK	DRT	DRWTK	EF	EX	EX_OL	FBFL	FD
				✓	✓	✓	✓					✓	✓			✓	✓	✓	

FDSRTBTM	FLUT <sup>2</sup>	FTK <sup>3</sup>	ID	IH	IH+DRW	INVFRM <sup>1</sup>	IW	LIGHT	MIP	OBRB	PFINBTMB	RD	RECTK	RH	ROSFLUT	RT
	✓	✓			✓	✓			✓	✓			✓	✓	✓	✓

RW	SBCADDY	SBCADDYSM	SCPDRW	STW	TD	TKP	TVR <sup>4</sup>	UDBX	URT	VTK	WS	WTCO	WTKCUP	WTR
							✓				✓			✓

<sup>1</sup>Not available on 9" wide.

<sup>2</sup>Not available with 6" fluting.

<sup>3</sup>Not available with FTKAV.

<sup>4</sup>TVRAV not available on 9" wide.

IH/RH availability charts starting on page G-40.  
IW/RW availability charts starting on page G-46.

# Base with Roll-out Tray Divider & Base Transition Cabinets

## Description

**BASE with ROLL-OUT TRAY DIVIDER,**  
**34 1/2" HIGH, 24" DEEP**  
**storage**  
**SOLUTIONS**

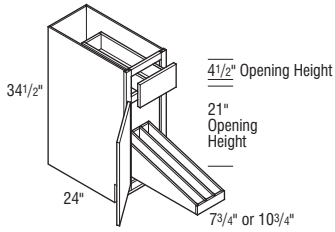

## Model

### B12TDRO L or R

- Pull-out has three compartments.

### B15TDRO L or R

- Pull-out has four compartments.

Notes below apply to all products in section above:

- Dividers are removable.
- Not available on Inset and Beaded Inset styles.

#### Door & Drawer Options

AF	AOMBWB	CC	CG	ESMD	GAMD	IFHG	MD	PRMD <sup>1</sup>	PTOWB	SHMD	SPLITDR	SPLITDRWS	SUMD	TCP
			✓	✓	✓	✓	✓	✓		✓				✓

#### End Panel Options

AUTH	CSFPE	EXBK	FFD	FPE	INTGE	IPE
✓	✓	✓	✓	✓	✓	

#### Custom Modification Options

ADD_SHLF	ADDTK	CBO	CCO	CFNTD	CFP	CFRMO	CHGDRW	CLIP	CMAT	CND	CSDGBK	DRT	DRWTK	EF	EX	EX_OL	FBFL	FD	
											✓	✓					✓	✓	

FDSRTBMT	FLUT <sup>2</sup>	FTK <sup>3</sup>	ID	IH	IH+DRW	INVFRM	IW	LIGHT	MIP	OBRB	PFINBTMB	RD	RECTK	RH	ROSFLUT	RT
		✓	✓	✓						✓	✓		✓		✓	✓

RW	SBCADDY	SBCADDYSM	SCPDRW	STW	TD	TKP	TVR <sup>4</sup>	UDBX	URT	VTK	WS	WTC <sup>1</sup>	WTKCUP	WTR
							✓	✓		✓		✓		✓

<sup>1</sup>Not available on 12" wide.

<sup>2</sup>Not available with 6" fluting.

<sup>3</sup>FTKAV not available on 12" wide.

<sup>4</sup>TVRAV not available on 12" wide.

## BASE TRANSITION CABINET, 34 1/2" HIGH

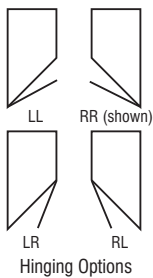
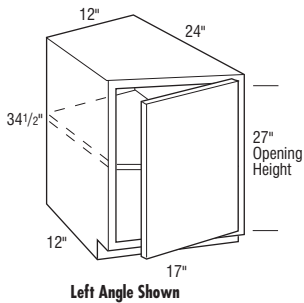

### BTC12LL

### BTC12RR

### BTC12LR

### BTC12RL

- One adjustable Full Depth Shelf.
- Flushed Ends, FFD on End, Inset Panel Ends, and Integral Ends available on angled side only.
- Increased Depths available in 1/4" increments from 24 1/4" to 30".
- Reduced Depths available in 1/4" increments from 18" to 23 3/4".
- When Inset or Beaded Inset styles are specified, the door must be hinged on the same side as the angle side.

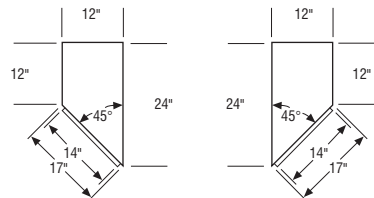

#### Door & Drawer Options

AF	AOMBWB	CC	CG	ESMD	GAMD	IFHG	MD	PRMD	PTOWB	SHMD	SPLITDR	SPLITDRWS	SUMD	TCP
			✓	✓	✓	✓	✓	✓		✓				✓

#### End Panel Options

AUTH <sup>1</sup>	CSFPE <sup>2</sup>	EXBK	FFD	FPE	INTGE	IPE
✓	✓	✓	✓	✓	✓	

#### Custom Modification Options

ADD_SHLF	ADDTK	CBO	CCO	CFNTD	CFP	CFRMO	CHGDRW	CLIP	CMAT	CND	CSDGBK	DRT	DRWTK	EF	EX	EX_OL	FBFL	FD	
											✓	✓					✓	✓	

FDSRTBMT	FLUT	FTK	ID	IH	IH+DRW	INVFRM	IW	LIGHT	MIP	OBRB	PFINBTMB	RD	RECTK	RH	ROSFLUT	RT
		✓	✓	✓						✓	✓		✓		✓	✓

RW	SBCADDY	SBCADDYSM	SCPDRW	STW	TD	TKP	TVR	UDBX	URT	VTK	WS	WTC <sup>1</sup>	WTKCUP	WTR
							✓	✓		✓		✓		✓

<sup>1</sup>Not available on authentic flush ends both.

<sup>2</sup>Not available with car siding flush panel ends left.

# Base End Cabinets

## Description

### BASE END CABINET, 34 1/2" HIGH, 24" DEEP

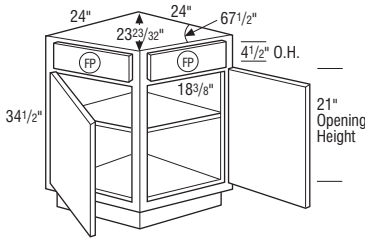

FP False Panel

## Model

### BEC24FP

- One adjustable Full Depth Shelf.
- Includes top support panel for stability, 3/8" thick.
- Wood Top with dimensions to match this unit is available for field installation. See page Q•7.
- Finished Ends available on one end only.
- When Inset or Beaded Inset styles are specified, the doors must be hinged to the center face frame stiles.

#### Door & Drawer Options

AF	AOMBWB	CC	CG	ESMD	GAMD	IFHG	MD	PRMD	PTOWB	SHMD	SPLITDR	SPLITDRWS	SJMD	TCP
		✓	✓	✓	✓	✓	✓	✓	✓	✓	✓	✓	✓	✓

#### End Panel Options

AUTH <sup>1</sup>	CSFPE	EXBK	FFD	FPE	INTGE	IPE
✓						

#### Custom Modification Options

ADD	SHLF	ADDTK	CBO	CCO	CFNTD	CFP	CFRMO	CHGDRW	CLIP	CMAT	CND	CSDGBK	DRT	DRWTK	EF	EX	EX_OL	FBFL	FD	
			✓	✓	✓	✓	✓	✓	✓	✓	✓	✓	✓	✓	✓	✓	✓	✓	✓	✓

FDSRTBTM	FLUT	FTK	ID	IH	IH+DRW	INVFRM	IW	LIGHT	MIP	OBRB	PFINBTMB	RD	RECTK	RH	ROSLUT	RT
	✓	✓	✓	✓	✓	✓	✓	✓	✓	✓	✓	✓	✓	✓	✓	✓

RW	SBCADDY	SBCADDYSM	SCPDRW	STW	TD	TKP	TVR	UDBX	URT	VTK	WS	WTCDD	WTKCUP	WTR
						✓	✓	✓	✓	✓	✓	✓	✓	✓

<sup>1</sup>Not available with authentic flush ends both.

### BASE END CABINET, 34 1/2" HIGH, 24" DEEP

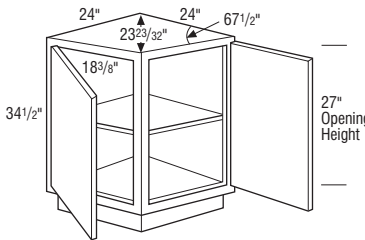

## Model

### BEC24

- One adjustable Full Depth Shelf.
- Wood Top with dimensions to match this unit is available for field installation. See page Q•7.
- Finished Ends available on one end only.
- When Inset or Beaded Inset styles are specified, the doors must be hinged to the center face frame stiles.

#### Door & Drawer Options

AF	AOMBWB	CC	CG	ESMD	GAMD	IFHG	MD	PRMD	PTOWB	SHMD	SPLITDR	SPLITDRWS	SJMD	TCP
		✓	✓	✓	✓	✓	✓	✓	✓	✓	✓	✓	✓	✓

#### End Panel Options

AUTH <sup>1</sup>	CSFPE	EXBK	FFD	FPE	INTGE	IPE
✓						

#### Custom Modification Options

ADD	SHLF	ADDTK	CBO	CCO	CFNTD	CFP	CFRMO	CHGDRW	CLIP	CMAT	CND	CSDGBK	DRT	DRWTK	EF	EX	EX_OL	FBFL	FD	
			✓	✓	✓	✓	✓	✓	✓	✓	✓	✓	✓	✓	✓	✓	✓	✓	✓	✓

FDSRTBTM	FLUT	FTK	ID	IH	IH+DRW	INVFRM	IW	LIGHT	MIP	OBRB	PFINBTMB	RD	RECTK	RH	ROSLUT	RW
	✓	✓	✓	✓	✓	✓	✓	✓	✓	✓	✓	✓	✓	✓	✓	✓

RW	SBCADDY	SBCADDYSM	SCPDRW	STW	TD	TKP	TVR	UDBX	URT	VTK	WS	WTCDD	WTKCUP	WTR
						✓	✓	✓	✓	✓	✓	✓	✓	✓

<sup>1</sup>Not available with authentic flush ends both.

IH/RH availability charts starting on page G•40.  
IW/RW availability charts starting on page G•46.

## Description

### BASE ANGLED CABINET and FULL HEIGHT BASE ANGLED CABINET, 34 1/2" HIGH – 45° ANGLE

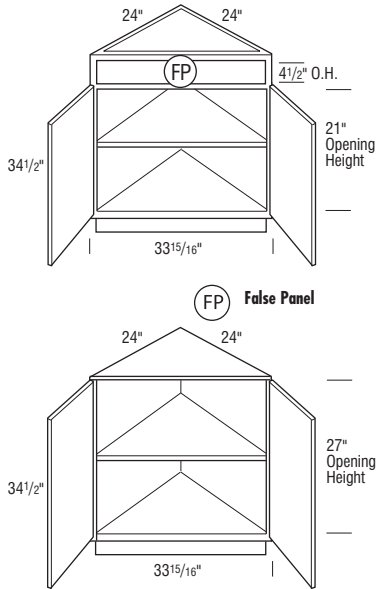

## Model

BAC24

BAC24FH

Notes below apply to all products in section above:

- One adjustable Full Depth Shelf.
- Wood Top with dimensions to match this unit is available for field installation. See page Q•7.
- Finished Ends available on one end only.
- Only available in Inset and Beaded Inset when used in conjunction with a finial hinge.

#### Door & Drawer Options

AF	AOMBWB	CC	CG	ESMD	GAMD	IFHG	MD	PRMD	PTOWB	SHMD	SPLITDR	SPLITDRWS <sup>1</sup>	SUMD	TCP
			✓	✓	✓	✓	✓	✓		✓	✓	✓	✓	

#### End Panel Options

AUTH <sup>2</sup>	CSFPE	EXBK	FFD	FPE	INTGE	IPE
✓						

#### Custom Modification Options

ADD_SHLF	ADDTK	CBO	CCO	CFNTO	CFP	CFRMO	CHGDRW	CLIP	CMAT	CND	CSDGBK	DRT	DRWTK	EF	EX	EX_OL	FBFL	FD	
		✓	✓	✓		✓				✓									

FDSRTBTM	FLUT	FTK	ID	IH	IH+DRW	INVFRM	IW	LIGHT	MIP	OBRB	PFINBTMB	RD	RECTK <sup>1</sup>	RH	ROSLUT	RT
		✓	✓	✓					✓	✓			✓	✓		

RW	SBCADDY	SBCADDYSM	SCPDRW	STW	TD	TKP	TVR	UDBX	URT	VTK	WS	WTCD	WTKCUP	WTR
								✓		✓				✓

<sup>1</sup>Not available on BAC24FH version.

<sup>2</sup>Not available with authentic flush ends both.

# 135° Corner Base Cabinets

## Description

**135° CORNER OUTSIDE BASE,  
34 1/2" HIGH, 24" DEEP**

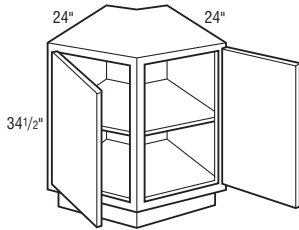

## Model

**BFH6COA**

**BFH9COA**

**BFH12COA**

- Doors are hinged on outside of frame.
- Adjustable shelf cannot be removed from cabinet.
- No leg changes allowed.
- Reduced depths available in 3" increments from 12" to 21".

Model	A Dimension	B Dimension
BFH6COA	6"	15 15/16"
BFH9COA	9"	18 15/16"
BFH12COA	12"	21 15/16"

A indicates back width of cabinet and wall space  
B indicates face frame width

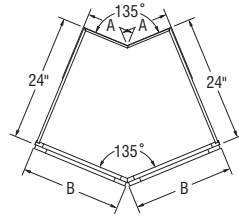

## Top View

### Door & Drawer Options

AF	AOMBWB	CC	CG	ESMD	GAMD	IFHG	MD	PRMD	PTOWB	SHMD	SPLITDR	SPLITDRWS	SUMD	TCP
			✓			✓	✓	✓		✓				

### End Panel Options

AUTH	CSFPE	EXBK	FFD	FPE	INTGE	IPE
✓	✓			✓		

### Custom Modification Options

ADD	SHLF	ADDTK	CBO	CCO	CFNTO	CFP	CFRMO	CHGDRW	CLIP	CMAT	CND	CSDGBK	DRT	DRWTK	EF	EX	EX_OL <sup>1</sup>	FBFL	FD
				✓	✓							✓	✓			✓	✓	✓	

FDSRTBTM	FLUT	FTK	ID	IH	IH+DRW	INVERM	IW	LIGHT	MIP	OBRB	PFINBTMB	RD	RECTK	RH	ROSFLUT	RT
				✓					✓			✓	✓			

RW	SBCADDY	SBCADDYSM	SCPDRW	STW	TD	TKP	TVR	UDBX	URT	VTK	WS	WTCO	WTKCUP	WTR
												✓		✓

<sup>1</sup>Not available with extended stile both.

IH/RH availability charts starting on page G•40.  
IW/RW availability charts starting on page G•46.

## Description

**135° CORNER INSIDE BASE,  
34 1/2" HIGH, 24" DEEP**

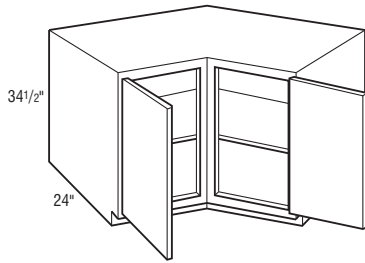

## Model

**BFH21CIA**

**BFH24CIA**

**BFH27CIA**

- Doors are hinged on outside of frame.
- Adjustable shelf cannot be removed from cabinet.
- No leg changes allowed.
- Reduced depths available in 3" increments from 12" to 21".

Model	A Dimension	B Dimension
BFH21CIA	21"	11 3/32"
BFH24CIA	24"	14 3/32"
BFH27CIA	27"	17 3/32"

A indicates back width of cabinet and wall space  
B indicates face frame width

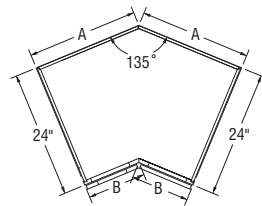

## Top View

### Door & Drawer Options

AF	AOMBWB	CC	CG	ESMD	GAMD	IFHG	MD	PRMD	PTOWB	SHMD	SPLITDR	SPLITDRWS	SUMD	TCP
			✓			✓	✓	✓		✓				

### End Panel Options

AUTH	CSFPE	EXBK	FFD	FPE	INTGE	IPE
✓	✓			✓		

### Custom Modification Options

ADD_SHLF	ADDTK	CBO	CCO	CFNTO	CFP	CFRMO	CHGDRW	CLIP	CMAT	CND	CSDGBK	DRT	DRWTK	EF	EX	EX_OL	FBFL	FD
				✓	✓					✓	✓			✓	✓	✓		

FDSRTBTM	FLUT <sup>1</sup>	FTK	ID	IH	IH+DRW	INVERM	IW	LIGHT	MIP	OBRB	PFINBTMB	RD	RECTK	RH	ROSLUT	RT
	✓			✓					✓		✓	✓				✓

RW	SBCADDY	SBCADDYSM	SCPDRW	STW	TD	TKP	TVR	UDBX	URT	VTK	WS	WTCD	WTKCUP	WTR
											✓			✓

<sup>1</sup>Not available with 6" fluting.

# Base Specialty Cabinets

## Description

**BASE with MIXER SHELF, 34 1/2" HIGH, 24" DEEP**  
storage SOLUTIONS

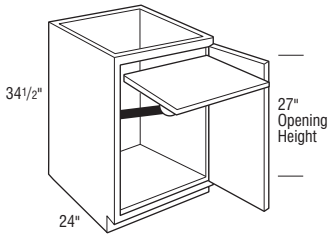

## Model

**B18FHMIXSC L or R**  
**B21FHMIXSC L or R**  
**B24FHMIXSC L or R**

- Weight capacity of mixer shelf is 26 pounds.
- Appliance height clearance for swing-out mixer shelf is 20".
- Mixer Shelf features Smart Stop.

### Door & Drawer Options

AF	AOMBWB	CC	CG	ESMD	GAMD	IFHG	MD	PRMD	PTOWB	SHMD	SPLITDR	SPLITDRWS	SUMD	TCP
		✓	✓	✓	✓	✓	✓	✓		✓			✓	

### End Panel Options

AUTH	CSFPE	EXBK	FFD	FPE	INTGE	IPE
✓	✓	✓	✓	✓	✓	✓

### Custom Modification Options

ADD	SHLF	ADDTK	CBO	CCO	CFNTO	CFP	CFRMO	CHGDRW	CLIP	CMAT	CND	CSDGBK	DRT	DRWTK <sup>1</sup>	EF	EX	EX_OL	FBFL	FD	
			✓	✓	✓	✓	✓	✓			✓	✓	✓	✓	✓	✓	✓	✓	✓	✓

FDSRTBTM	FLUT <sup>2</sup>	FTK	ID	IH	IH+DRW	INVERM	IW	LIGHT	MIP	OBRB	PFINBTMB	RD	RECTK	RH	ROSLUT	RT
	✓	✓			✓				✓				✓	✓	✓	✓

RW	SBCADDY	SBCADDYSM	SCPDRW	STW	TD	TKP	TVR	UDBX	URT	VTK	WS	WTCD	WTKCUP	WTR
						✓				✓			✓	✓

<sup>1</sup>Only available on 24" wide.

<sup>2</sup>Not available with 6" fluting.

**BASE with PLASTIC STORAGE BINS, 34 1/2" HIGH, 24" DEEP**  
storage SOLUTIONS

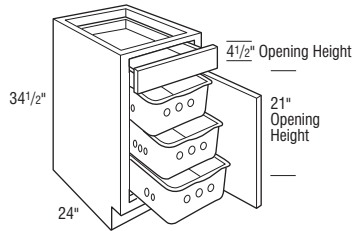

**B15PSB L or R**

**B18PSB L or R**

- Three plastic pull-out storage bins, 10" W x 5" H x 13 1/2" D.
- Unit is 11 1/2" W x 21" H x 17 3/4" D.
- Reduced Depth of 21" available.
- Only available in Inset and Beaded Inset when used in conjunction with a finial hinge.
- B15PSB L or R not available in Inset.

### Door & Drawer Options

AF	AOMBWB	CC	CG	ESMD	GAMD	IFHG	MD	PRMD	PTOWB	SHMD	SPLITDR	SPLITDRWS	SUMD	TCP
		✓	✓	✓	✓	✓	✓	✓		✓			✓	

### End Panel Options

AUTH	CSFPE	EXBK	FFD	FPE	INTGE	IPE
✓	✓	✓	✓	✓	✓	✓

### Custom Modification Options

ADD	SHLF	ADDTK	CBO	CCO	CFNTO	CFP	CFRMO	CHGDRW	CLIP	CMAT	CND	CSDGBK	DRT	DRWTK	EF	EX	EX_OL	FBFL	FD	
			✓	✓	✓	✓	✓	✓			✓	✓	✓	✓	✓	✓	✓	✓	✓	✓

FDSRTBTM	FLUT <sup>1</sup>	FTK	ID	IH	IH+DRW	INVERM	IW	LIGHT	MIP	OBRB	PFINBTMB	RD	RECTK	RH	ROSLUT	RT
	✓	✓			✓				✓				✓	✓	✓	✓

RW	SBCADDY	SBCADDYSM	SCPDRW	STW	TD	TKP	TVR <sup>2</sup>	UDBX	URT	VTK	WS	WTCD	WTKCUP <sup>3</sup>	WTR <sup>2</sup>
						✓	✓			✓			✓	✓

<sup>1</sup>Not available with 6" fluting.

<sup>2</sup>Not available on 18" wide.

<sup>3</sup>Not available on 15" wide.

IH/RH availability charts starting on page G•40.  
IW/RW availability charts starting on page G•46.

# Base Open Basket & Base Box Column Pull-out Cabinets

## Description

### BASE OPEN BASKET with ARCHED VALANCE, 34 1/2" HIGH, 24" DEEP

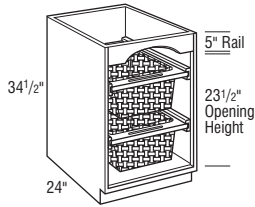

## Model

### BOB15AV

- Basket size 11 5/16" W x 7 7/8" H x 21 1/4" D.

### BOB18AV

- Basket size 14 5/16" W x 7 7/8" H x 21 1/4" D.

Notes below apply to all products in section above:

- Matching Interior standard.
- Two wicker baskets.
- Handles and Rails are natural finish.
- Finish of wicker baskets will be the same regardless of cabinet finish/door style.
- Arched Top Valance Rail standard.
- Not available on Inset and Beaded Inset styles.

#### Door & Drawer Options

AF	AOMBWB	CC	CG	ESMD	GAMD	IFHG	MD	PRMD	PTOWB	SHMD	SPLITDR	SPLITDRWS	SUMD	TCP
----	--------	----	----	------	------	------	----	------	-------	------	---------	-----------	------	-----

#### End Panel Options

AUTH	CSFPE	EXBK	FFD	FPE	INTGE	IPE
------	-------	------	-----	-----	-------	-----

#### Custom Modification Options

ADD_SHLF	ADDTK	CBO	CCO	CFNTO	CFP	CFRMO	CHGDRW	CLIP	CMAT	CND	CSDGBK	DRT	DRWTK	EF	EX	EX_OL	FBFL	FD
----------	-------	-----	-----	-------	-----	-------	--------	------	------	-----	--------	-----	-------	----	----	-------	------	----

FDSRTBTM	FLUT <sup>1</sup>	FTK	ID	IH	IH+DRW	INVERM	IW	LIGHT	MIP	OBRB	PFINBTMB	RD	RECTK	RH	ROSLUT	RT
----------	-------------------	-----	----	----	--------	--------	----	-------	-----	------	----------	----	-------	----	--------	----

RW	SBCADDY	SBCADDYSM	SCPDRW	STW	TD	TKP	TVR <sup>2</sup>	UDBX	URT	VTK	WS	WTCD	WTKCUP	WTR
----	---------	-----------	--------	-----	----	-----	------------------	------	-----	-----	----	------	--------	-----

<sup>1</sup>Not available with 6" fluting.

<sup>2</sup>Not available on TVRAV.

### BASE BOX COLUMN PULL-OUT, PLAIN, 30" HIGH, 3" or 6" WIDE storage SOLUTIONS

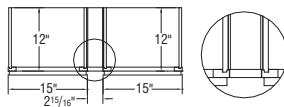
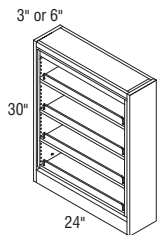

Top View Installation

### BBCP03

### BBCP06

- Fluting modification available, when no overlay filler is specified.
- Hardware required on base units.
- Matching interior not available.

#### Door & Drawer Options

AF	AOMBWB	CC	CG	ESMD	GAMD	IFHG	MD	PRMD	PTOWB	SHMD	SPLITDR	SPLITDRWS	SUMD	TCP
----	--------	----	----	------	------	------	----	------	-------	------	---------	-----------	------	-----

#### End Panel Options

AUTH	CSFPE	EXBK	FFD	FPE	INTGE	IPE
------	-------	------	-----	-----	-------	-----

#### Custom Modification Options

ADD_SHLF	ADDTK	CBO	CCO	CFNTO	CFP	CFRMO	CHGDRW	CLIP	CMAT	CND	CSDGBK	DRT	DRWTK	EF	EX	EX_OL	FBFL	FD
----------	-------	-----	-----	-------	-----	-------	--------	------	------	-----	--------	-----	-------	----	----	-------	------	----

FDSRTBTM	FLUT	FTK	ID	IH	IH+DRW	INVERM	IW	LIGHT	MIP	OBRB	PFINBTMB	RD	RECTK	RH	ROSLUT	RT
----------	------	-----	----	----	--------	--------	----	-------	-----	------	----------	----	-------	----	--------	----

RW	SBCADDY	SBCADDYSM	SCPDRW	STW	TD	TKP	TVR	UDBX	URT	VTK	WS	WTCD	WTKCUP	WTR
----	---------	-----------	--------	-----	----	-----	-----	------	-----	-----	----	------	--------	-----



# Base Box Column & Base Pantry Pull-outs

## Description

## Model

### BASE BOX COLUMN PULL-OUT, OVERLAY, 3" or 6" WIDE, 30" HIGH

**BBCP03OL**

**BBCP06OL**

### storage SOLUTIONS

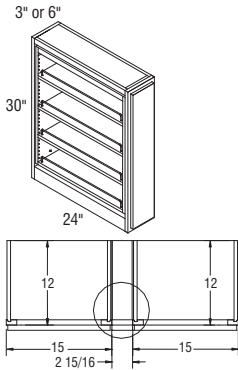

#### Top View Installation

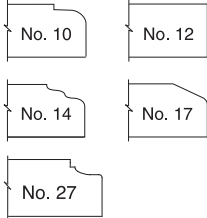

- Features adjustable shelves.
- Standard face application includes profiled full overlay filler.
- Edge profile will match door profile selected (#10, #12, #14, #17, #27).
- Pull or knob hardware required on base units.
- Top and bottom of unit are always Natural Maple.
- Not available on end of run.
- 2 1/8" clearance between chrome rails on shelves of 3" wide unit.
- 5 1/8" clearance between chrome rails on shelves of 6" wide unit.
- Fluting modification available when No Overlay modification is specified. See page G•37 for details.

#### Door & Drawer Options

AF AOMBWB CC CG ESMD GAMD IFHG MD PRMD PTOWB SHMD<sup>1</sup> SPLITDR SPLITDRWS SUMD<sup>2</sup> TCP

#### End Panel Options

AUTH CSFPE EXBK<sup>3</sup> FFD FPE INTGE IPE

#### Custom Modification Options

ADD\_SHLF ADDTK CBO CCO CFNTO CFP CFRMO CHGDRW CLIP CMAT CND CSDGBK DRT DRWTK EF EX EX\_OL FBFL FD

FDSRTBTM FLUT FTK ID IH IH+DRW INVFRM IW LIGHT MIP OBRB PFINBTMB RD RECTK RH ROSFLUT RT

RW SBCADDY SBCADDYSM SCPDRW STW TD TKP TVR UDBX URT VTK WS WTC D WTKCUP WTR

<sup>1</sup>Not available with end extended back left.

### BASE PANTRY PULL-OUT, 34 1/2" HIGH, 24" DEEP

**BPP9**

**BPP12**

**BPP15**

**BPP18**

### storage SOLUTIONS

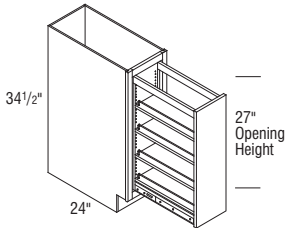

- Features adjustable shelves.

#### Door & Drawer Options

AF AOMBWB CC CG ESMD GAMD IFHG MD PRMD PTOWB SHMD<sup>1</sup> SPLITDR SPLITDRWS SUMD<sup>2</sup> TCP

#### End Panel Options

AUTH CSFPE EXBK<sup>3</sup> FFD FPE INTGE IPE

#### Custom Modification Options

ADD\_SHLF ADDTK CBO CCO CFNTO CFP CFRMO CHGDRW CLIP CMAT CND CSDGBK DRT DRWTK EF EX EX\_OL FBFL FD

FDSRTBTM FLUT<sup>3</sup> FTK<sup>4</sup> ID IH IH+DRW INVFRM IW LIGHT MIP OBRB PFINBTMB RD RECTK RH ROSFLUT RW

RW SBCADDY SBCADDYSM SCPDRW STW TD TKP TVR UDBX URT VTK WS WTC D WTKCUP WTR

<sup>1</sup>Not available on 9" wide.

<sup>2</sup>Only available on 15" wide.

<sup>3</sup>Not available with 6" fluting.

<sup>4</sup>FTKAV not available on 9" or 12" wide.

IH/RH availability charts starting on page G•40.  
IW/RW availability charts starting on page G•46.

# Base Spice & Base Utensil Pantry Pull-outs

## Description

**BASE SPICE PULL-OUT, 34 1/2" HIGH, 24" DEEP**  
storage  
SOLUTIONS

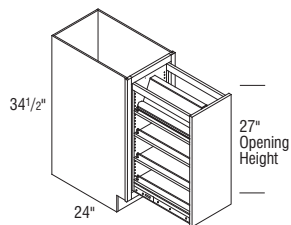

34 1/2"  
27"  
Opening  
Height  
24"  
3 13/16"  
Spice Insert Top Shelf

## Model

**BSP12PG**  
**BSP15PG**

- Features adjustable shelves.

### Door & Drawer Options

AF	AOMBWB	CC	CG	ESMD	GAMD	IFHG	MD	PRMD	PTOWB	SHMD	SPLITDR	SPLITDRWS	SUMD	TCP
----	--------	----	----	------	------	------	----	------	-------	------	---------	-----------	------	-----

### End Panel Options

AUTH	CSFPE	EXBK	FFD	FPE	INTGE	IPE
------	-------	------	-----	-----	-------	-----

### Custom Modification Options

ADD_SHLF	ADDTK	CBO	CCO	CFNTO	CFP	CFRMO	CHGDRW	CLIP	CMAT	CND	CSDGBK	DRT	DRWTK	EF	EX	EX_OL	FBFL	FD
----------	-------	-----	-----	-------	-----	-------	--------	------	------	-----	--------	-----	-------	----	----	-------	------	----

FDSRTBTM	FLUT <sup>1</sup>	FTK <sup>2</sup>	ID	IH	IH+DRW	INVERM	IW	LIGHT	MIP	OBRB	PFINBTMB	RD	RECTK	RH	ROSFLUT	RT
----------	-------------------	------------------	----	----	--------	--------	----	-------	-----	------	----------	----	-------	----	---------	----

RW	SBCADDY	SBCADDYSM	SCPDRW	STW	TD	TKP	TVR	UDBX	URT	VTK	WS	WTCD	WTKCUP	WTR
----	---------	-----------	--------	-----	----	-----	-----	------	-----	-----	----	------	--------	-----

<sup>1</sup>Not available with 6" fluting.  
<sup>2</sup>FTKAV not available on 12" wide.

**BASE UTENSIL PANTRY PULL-OUT, 34 1/2" HIGH, 24" DEEP**  
storage  
SOLUTIONS

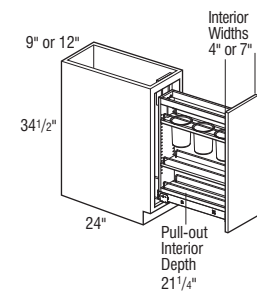

## Model

**BUPP9**  
**BUPP12**

- Features Smart Stop pull-out with two adjustable shelves (including canister shelf) and one fixed shelf with chrome rails.
- Top shelf features three stainless steel (removable) canisters for utensils.
- BUPP9 canisters are 5.85" tall and have an inside diameter of 4.3". BUPP12 canisters are 6.7" tall and have an inside diameter of 5".

### Door & Drawer Options

AF	AOMBWB	CC	CG	ESMD	GAMD	IFHG	MD	PRMD	PTOWB	SHMD <sup>1</sup>	SPLITDR	SPLITDRWS	SUMD	TCP
----	--------	----	----	------	------	------	----	------	-------	-------------------	---------	-----------	------	-----

### End Panel Options

AUTH	CSFPE	EXBK	FFD	FPE	INTGE	IPE
------	-------	------	-----	-----	-------	-----

### Custom Modification Options

ADD_SHLF	ADDTK	CBO	CCO	CFNTO	CFP	CFRMO	CHGDRW	CLIP	CMAT	CND	CSDGBK	DRT	DRWTK	EF	EX	EX_OL	FBFL	FD
----------	-------	-----	-----	-------	-----	-------	--------	------	------	-----	--------	-----	-------	----	----	-------	------	----

FDSRTBTM	FLUT <sup>2</sup>	FTK <sup>3</sup>	ID	IH	IH+DRW	INVERM	IW	LIGHT	MIP	OBRB	PFINBTMB	RD	RECTK	RH	ROSFLUT	RT
----------	-------------------	------------------	----	----	--------	--------	----	-------	-----	------	----------	----	-------	----	---------	----

RW	SBCADDY	SBCADDYSM	SCPDRW	STW	TD	TKP	TVR	UDBX	URT	VTK	WS	WTCD	WTKCUP	WTR
----	---------	-----------	--------	-----	----	-----	-----	------	-----	-----	----	------	--------	-----

<sup>1</sup>Only available on 12" wide.  
<sup>2</sup>Not available with 6" fluting.  
<sup>3</sup>Not available with FTKAV.

# Base Utensil Pantry & Base Tray Divider Pantry Pull-out

## Description

### BASE UTENSIL PANTRY PULL-OUT with KNIFE BLOCK, 34 1/2" HIGH, 24" DEEP storage

SOLUTIONS

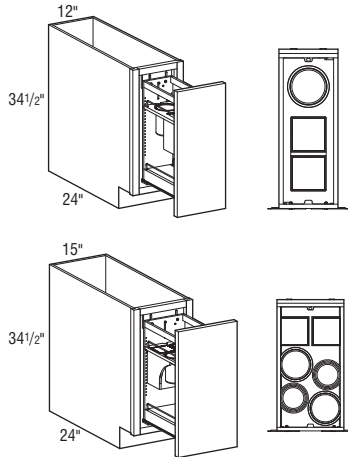

## Model

### BUPPKB12

### BUPPKB15

- Features Smart Stop pull-out with adjustable knife and canister shelf and one fixed shelf with chrome rails.
- BUPPKB12 includes one stainless steel canister, 6.7" tall and has an inside diameter of 5".
- BUPPKB15 includes two stainless steel canisters 5.85" tall with an inside diameter of 4.3", and two stainless steel canisters 6.7" tall with an inside diameter of 5".
- Knife block features movable flex rods that adjust to hold a multitude of knives.

#### Door & Drawer Options

AF	AOMBWB	CC	CG	ESMD	GAMD	IFHG	MD	PRMD	PTOWB	SHMD	SPLITDR	SPLITDRWS	SUMD	TCP
						✓				✓				

#### End Panel Options

AUTH	CSFPE	EXBK	FFD	FPE	INTGE	IPE
✓	✓	✓	✓	✓	✓	✓

#### Custom Modification Options

ADD_SHLF	ADDTK	CBO	CCO	CFNTO	CFP	CFRMO	CHGDRW	CLIP	CMAT	CND	CSDGBK	DRT	DRWTK	EF	EX	EX_OL	FBFL	FD	
											✓				✓	✓	✓		

FDSRTBTM	FLUT <sup>1</sup>	FTK <sup>2</sup>	ID	IH	IH+DRW	INVFRM	IW	LIGHT	MIP	OBRB	PFINBTMB	RD	RECTK	RH	ROSFLUT	RT
	✓	✓							✓	✓					✓	

RW	SBCADDY	SBCADDYSM	SCPDRW	STW	TD	TKP	TVR	UDBX	URT	VTK	WS	WTC	WTKCUP	WTR
											✓			✓

<sup>1</sup>Not available with 6" fluting.

<sup>2</sup>Not available with FTKAV.

### BASE TRAY DIVIDER PANTRY PULL-OUT, 34 1/2" HIGH, 24" DEEP storage

SOLUTIONS

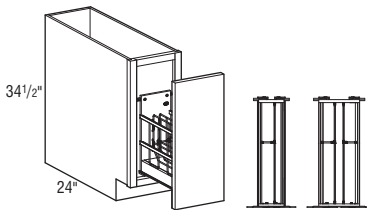

### BTDPP9

### BTDPP12

- Features Smart Stop slides.
- BTDPP9 includes one removable center divider and one snap on T-bar.
- BTDPP12 includes two removable center dividers and two snap on T-bars.
- Tray dividers are chrome plated steel.

#### Door & Drawer Options

AF	AOMBWB	CC	CG	ESMD	GAMD	IFHG	MD	PRMD	PTOWB	SHMD	SPLITDR	SPLITDRWS	SUMD	TCP
							✓			✓				

#### End Panel Options

AUTH	CSFPE	EXBK	FFD	FPE	INTGE	IPE
✓	✓	✓	✓	✓	✓	✓

#### Custom Modification Options

ADD_SHLF	ADDTK	CBO	CCO	CFNTO	CFP	CFRMO	CHGDRW	CLIP	CMAT	CND	CSDGBK	DRT	DRWTK	EF	EX	EX_OL	FBFL	FD	
															✓	✓	✓		

FDSRTBTM	FLUT <sup>2</sup>	FTK <sup>3</sup>	ID	IH	IH+DRW	INVFRM	IW	LIGHT	MIP	OBRB	PFINBTMB	RD	RECTK	RH	ROSFLUT	RT
	✓	✓							✓	✓					✓	

RW	SBCADDY	SBCADDYSM	SCPDRW	STW	TD	TKP	TVR	UDBX	URT	VTK	WS	WTC	WTKCUP	WTR
											✓			✓

<sup>1</sup>Not available on 9" wide.

<sup>2</sup>Not available with 6" fluting.

<sup>3</sup>Not available with FTKAV.

IH/RH availability charts starting on page G•40.  
IW/RW availability charts starting on page G•46.

## Description

### BASE CONTAINER ORGANIZATION PANTRY, 34 1/2" HIGH, 24" DEEP storage SOLUTIONS

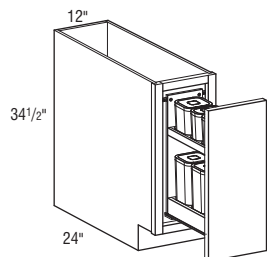

## Model

### BCOPP12

- Features Smart Stop slides.
- Includes 7 OXO Good Grips® POP containers, BPA Free: (3) 1.7 quart, (1) 2.6 quart, (3) 4.3 quart.
- Fixed shelf.

#### Door & Drawer Options

AF	AOMBWB	CC	CG	ESMD	GAMD	IFHG	MD	PRMD	PTOWB	SHMD	SPLITDR	SPLITDRWS	SUMD	TCP
						✓				✓				

#### End Panel Options

AUTH	CSFPE	EXBK	FFD	FPE	INTGE	IPE
✓	✓	✓	✓	✓	✓	✓

#### Custom Modification Options

ADD_SHLF	ADDTK	CBO	CCO	CFNTO	CFP	CFRMO	CHGDRW	CLIP	CMAT	CND	CSDGBK	DRT	DRWTK	EF	EX	EX_OL	FBFL	FD
														✓	✓	✓		

FDSRTBTM	FLUT <sup>1</sup>	FTK	ID	IH	IH+DRW	INVFRM	IW	LIGHT	MIP	OBRB	PFINBTMB	RD	RECTK	RH	ROSFLUT	RT
	✓	✓						✓	✓						✓	

RW	SBCADDY	SBCADDYSM	SCPDRW	STW	TD	TKP	TVR	UDBX	URT	VTK	WS	WTCD	WTKCUP	WTR
											✓			✓

<sup>1</sup>Not available with 6" fluting.

### BASE with SPICE DRAWER, 34 1/2" HIGH, 24" DEEP storage SOLUTIONS

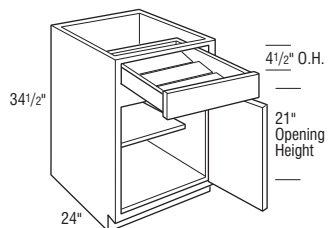

### B18SD L or R

### B24SD L or R

- Spice Drawer Insert not trimmable.

#### Door & Drawer Options

AF	AOMBWB	CC	CG	ESMD	GAMD	IFHG	MD	PRMD	PTOWB	SHMD	SPLITDR	SPLITDRWS	SUMD	TCP
			✓	✓	✓	✓	✓	✓		✓				✓

#### End Panel Options

AUTH	CSFPE	EXBK	FFD	FPE	INTGE	IPE
✓	✓	✓	✓	✓	✓	✓

#### Custom Modification Options

ADD_SHLF	ADDTK	CBO	CCO	CFNTO	CFP	CFRMO	CHGDRW	CLIP	CMAT	CND	CSDGBK	DRT	DRWTK <sup>1</sup>	EF	EX	EX_OL	FBFL	FD
											✓	✓	✓	✓	✓	✓		✓

FDSRTBTM	FLUT <sup>2</sup>	FTK	ID	IH	IH+DRW	INVFRM <sup>3</sup>	IW	LIGHT	MIP	OBRB	PFINBTMB	RD	RECTK	RH	ROSFLUT	RT
	✓	✓						✓	✓						✓	

RW	SBCADDY	SBCADDYSM	SCPDRW	STW	TD	TKP	TVR <sup>3</sup>	UDBX	URT	VTK	WS	WTCD	WTKCUP	WTR <sup>3</sup>
							✓	✓			✓			✓

<sup>1</sup>Not available on 18" wide.

<sup>2</sup>Not available with 6" fluting.

<sup>3</sup>Not available on 24" wide.

# Base Wastebasket Cabinets

## Description

**BASE WASTEBASKET, 34 1/2" HIGH,  
24" DEEP**  
storage  
SOLUTIONS

## Model

### BWB15

- One 35 quart wastebasket included.
- Will have a 10" high wastebasket pull-out box.



### BWB152

- Includes two 27 quart wastebaskets.
- Will have a 6 3/8" high wastebasket pull-out box.

### BWB18

### BWB21

### BWB24

- Two 35 quart wastebaskets and one lid included. Wastebasket lid is operational on front wastebasket only.
- Will have a 10" high wastebasket pull-out box.

#### Notes below apply to all products in section above:

- Features Smart Stop slides.
- Wastebasket is metallic gray.
- Panel inserted under drawer.
- It is recommended that the front wastebasket be removed for easier removal of the back wastebasket.

#### Door & Drawer Options

AF	AOMBWB	CC	CG	ESMD	GAMD	IFHG	MD	PRMD	PTOWB <sup>1</sup>	SHMD	SPLITDR	SPLITDRWS	SUMD	TCP
	✓								✓					

#### End Panel Options

AUTH	CSFPE	EXBK	FFD	FPE	INTGE	IPE
✓	✓	✓	✓	✓	✓	✓

#### Custom Modification Options

ADD_SHLF	ADDTK	CBO	CCO	CFNTD	CFP	CFRMO	CHGDRW	CLIP <sup>2</sup>	CMAT	CND	CSDGBK	DRT	DRWTK	EF	EX	EX_OL	FBFL	FD	
			✓					✓			✓				✓	✓	✓		

FDSRTBTM <sup>3</sup>	FLUT <sup>4</sup>	FTK	ID	IH	IH+DRW	INVFRM	IW	LIGHT	MIP	OBRB	PFINBTMB	RD	RECTK	RH	ROSFLUT <sup>5</sup>	RT
✓	✓	✓	✓	✓	✓	✓	✓	✓	✓	✓	✓	✓	✓	✓	✓	✓

RW	SBCADDY	SBCADDYSM	SCPDRW	STW	TD	TKP	TVR	UDBX	URT	VTK	WS	WTCD	WTKCUP	WTR
			✓									✓		✓

<sup>1</sup>Not available on 24" wide.

<sup>2</sup>Not available on 15" wide.

<sup>3</sup>Only available on 18" wide.

<sup>4</sup>Fluting both 3" not available on 15"-21" wide. Not available with 6" fluting.

<sup>5</sup>Fluting both not available on 15"-21" wide.

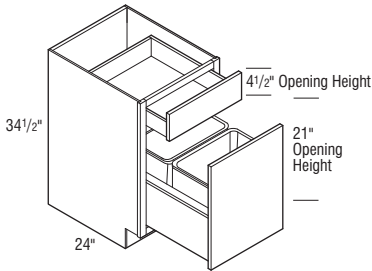
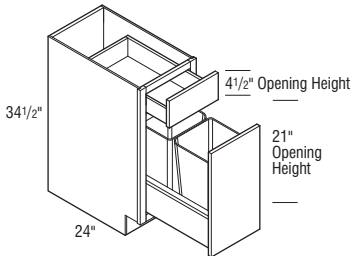
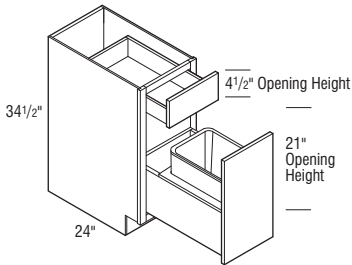

IH/RH availability charts starting on page G•40.  
IW/RW availability charts starting on page G•46.

## Description

**BASE WASTEBASKET FULL HEIGHT,  
34 1/2" HIGH, 24" DEEP**  
storage  
SOLUTIONS

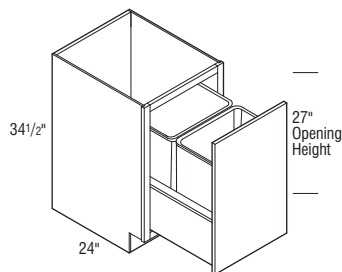
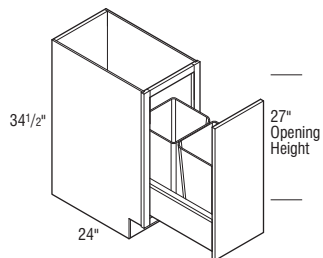
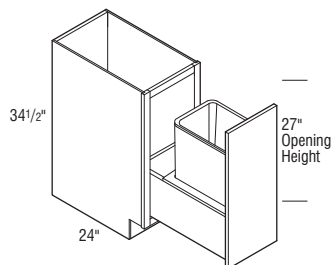

## Model

### BWB15FH

### BWB18FH

- One 50 quart wastebasket included.
- Will have a 10" high wastebasket pull-out box.

### BWB15FH2

### BWB18FH2

- BWB15FH2 includes two 27 quart wastebaskets. Wastebasket pull-out box will be 6 3/8" high.
- BWB18FH2 includes two 35 quart wastebaskets and one lid included. Wastebasket lid is operational on front wastebasket only. Wastebasket pull-out box will be 10" high.

### BWB21FH

### BWB24FH

- Two 50 quart wastebaskets and one lid included. Wastebasket lid is operational on front wastebasket only.
- Will have a 10" high wastebasket pull-out box.

Notes below apply to all products in section above:

- Features Smart Stop slides.
- Wastebasket is metallic gray.
- It is recommended that the front wastebasket be removed for easier removal of the back wastebasket.

#### Door & Drawer Options

AF	AOMBWB	CC	CG	ESMD	GAMD	IFHG	MD	PRMD	PTOWB <sup>1</sup>	SHMD	SPLITDR	SPLITDRWS	SUMD	TCP
	✓								✓					

#### End Panel Options

AUTH	CSFPE	EXBK	FFD	FPE	INTGE	IPE
✓	✓	✓	✓	✓	✓	✓

#### Custom Modification Options

ADD	SHLF	ADDTK	CBO	CCO	CFNTO	CFP	CFRMO	CHGDRW	CLIP	CMAT	CND	CSDGBK	DRT	DRWTK	EF	EX	EX_OL	FBFL	FD
		✓							✓			✓			✓	✓	✓		

FDSRTBTM	FLUT <sup>2</sup>	FTK	ID	IH	IH+DRW	INVFRM	IW	LIGHT	MIP	OBRB	PFINBTMB	RD	RECTK	RH	ROSFLUT <sup>3</sup>	RT
	✓	✓	✓	✓					✓	✓					✓	

RW	SBCADDY	SBCADDYSM	SCPDRW	STW	TD	TKP	TVR	UDBX	URT	VTK	WS	WTCD	WTKCUP	WTR
			✓								✓			✓

<sup>1</sup>Not available on 24" wide.

<sup>2</sup>Fluting both 3" not available on 15"-21" wide. Not available with 6" fluting.

<sup>3</sup>Fluting both not available on 15"-21" wide.

# Base Wastebasket Cabinets

## Description

### **NEW** BASE WASTEBASKET FULL HEIGHT with ROLL TRAY, 34 1/2" HIGH, 24" DEEP

#### storage SOLUTIONS

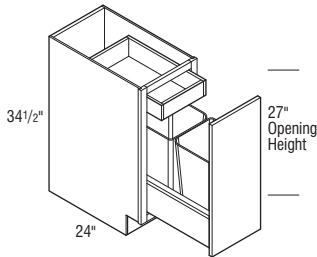

## Model

**BWB15FHRT2**

**BWB18FHRT2**

- BWB15FHRT2 includes two 27 quart wastebaskets.
- BWB18FHRT2 includes two 35 quart wastebaskets.
- Features Smart Stop slides.
- Wastebasket is metallic gray.
- It is recommended that the front wastebasket be removed for easier removal of the back wastebasket.
- On the BWB18FHRT2, one lid will be included. Wastebasket lid is operational on front wastebasket only.
- 15" wide will have a 6 3/8" high wastebasket pull-out box.
- 18" wide will have a 10" high wastebasket pull-out box.

#### Door & Drawer Options

AF	AOMBWB	CC	CG	ESMD	GAMD	IFHG	MD	PRMD	PTOWB	SHMD	SPLITDR	SPLITDRWS	SUMD	TCP
										✓				

#### End Panel Options

AUTH	CSFPE	EXBK	FFD	FPE	INTGE	IPE
✓	✓	✓	✓	✓	✓	✓

#### Custom Modification Options

ADD	SHLF	ADDTK	CBO	CCO	CFNT0	CFP	CFRMO	CHGDRW	CLIP	CMAT	CND	CSDGBK	DRT	DRWTK	EF	EX	EX_OL	FBFL	FD	

FDSRTBTM	FLUT <sup>1</sup>	FTK	ID	IH	IH+DRW	INVFRM	IW	LIGHT	MIP	OBRB	PFINBTMB	RD	RECTK	RH	ROSLUT	RT
	✓	✓	✓	✓					✓	✓			✓		✓	✓

RW	SBCADDY	SBCADDYSM	SCPDRW	STW	TD	TKP	TVR	UDBX	URT	VTK	WS	WTC	WTKCUP	WTR
								✓			✓			✓

<sup>1</sup>Not available with 6" fluting.

### BASE WASTEBASKET with BREAD BOARD, 34 1/2" HIGH, 24" DEEP

#### storage SOLUTIONS

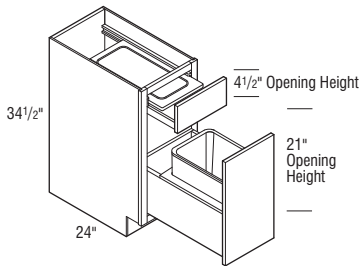

**BWB15BB**

- One 35 quart wastebasket included.

**BWB18BB**

**BWB21BB**

**BWB24BB**

- Two 35 quart wastebaskets and one lid included. Wastebasket lid is operational on front wastebasket only.

#### Notes below apply to all products in section above:

- Features Smart Stop slides.
- Wastebasket is metallic gray.
- Panel inserted under drawer.
- It is recommended that the front wastebasket be removed for easier removal of the back wastebasket.
- Wastebasket pull-out box will be 10" high.

#### Door & Drawer Options

AF	AOMBWB	CC	CG	ESMD	GAMD	IFHG	MD	PRMD	PTOWB <sup>1</sup>	SHMD	SPLITDR	SPLITDRWS	SUMD	TCP
										✓				

#### End Panel Options

AUTH	CSFPE	EXBK	FFD	FPE	INTGE	IPE
✓	✓	✓	✓	✓	✓	✓

#### Custom Modification Options

ADD	SHLF	ADDTK	CBO	CCO	CFNT0	CFP	CFRMO	CHGDRW	CLIP <sup>2</sup>	CMAT	CND	CSDGBK	DRT	DRWTK	EF	EX	EX_OL	FBFL	FD	

FDSRTBTM	FLUT <sup>3</sup>	FTK	ID	IH	IH+DRW	INVFRM	IW	LIGHT	MIP	OBRB	PFINBTMB	RD	RECTK	RH	ROSLUT <sup>4</sup>	RT
	✓	✓	✓	✓					✓	✓			✓		✓	✓

RW	SBCADDY	SBCADDYSM	SCPDRW	STW	TD	TKP	TVR	UDBX	URT	VTK	WS	WTC	WTKCUP	WTR
								✓			✓			✓

<sup>1</sup>Not available on 24" wide.

<sup>2</sup>Not available on 15" wide.

<sup>3</sup>Fluting both 3" not available on 15"-18" wide. Not available with 6" fluting.

<sup>4</sup>Fluting both not available on 15"-18" wide.

IH/RH availability charts starting on page G•40.  
IW/RW availability charts starting on page G•46.

## Description



### BASE WASTEBASKET with WOOD TIERED CUTLERY DIVIDER, 34 1/2" HIGH, 24" DEEP

storage SOLUTIONS

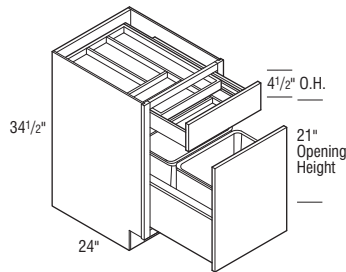
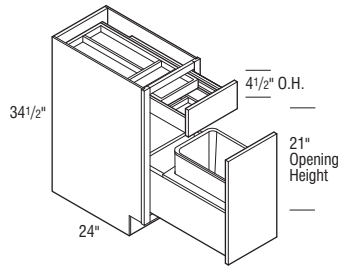

## Model

### BWB15WTC

- One 35 quart wastebasket included.

### BWB18WTC

### BWB21WTC

### BWB24WTC

- Two 35 quart wastebaskets and one lid included. Wastebasket lid is operational on front wastebasket only.

Notes below apply to all products in section above:

- Features Smart Stop slides.
- Includes Wood Tiered Cutlery Divider.
- Exterior Wood Tiered Cutlery Divider drawer box height is 3 3/4", interior height of top tier is 1 5/8", and interior height of bottom tier is 1 3/8".
- Wood Tiered Cutlery Divider Drawer is also available as an accessory for field installation. See page S•5.
- For Inset and Beaded Inset styles opening sizes, see pages F•14-F•18.
- Wastebasket is metallic gray.
- Panel inserted under drawer.
- It is recommended that the front wastebasket be removed for easier removal of the back wastebasket.
- Wastebasket pull-out box will be 10" high.

#### Door & Drawer Options

AF	AOMBWB	CC	CG	ESMD	GAMD	IFHG	MD	PRMD	PTOWB <sup>1</sup>	SHMD	SPLITDR	SPLITDRWS	SUMD	TCP
	✓								✓					

#### End Panel Options

AUTH	CSFPE	EXBK	FFD	FPE	INTGE	IPE
✓	✓	✓	✓	✓	✓	✓

#### Custom Modification Options

ADD_SHLF	ADDTK	CBO	CCO	CFNTO	CFP	CFRMO	CHGDRW	CLIP	CMAT	CND	CSDGBK	DRT	DRWTK	EF	EX	EX_OL	FBFL	FD
	✓	✓	✓							✓	✓		✓	✓	✓	✓	✓	✓

FDSRTBTM	FLUT <sup>2</sup>	FTK	ID	IH	IH+DRW	INVFRM	IW	LIGHT	MIP	OBRB	PFINBTMB	RD	RECTK	RH	ROSFLOT <sup>2</sup>	RT
	✓	✓	✓	✓	✓				✓	✓			✓	✓	✓	✓

RW	SBCADDY	SBCADDYSM	SCPDRW	STW	TD	TKP	TVR	UDBX	URT	VTK	WS	WTCD	WTKCUP	WTR
							✓				✓			✓

<sup>1</sup>Not available on 24" wide.

<sup>2</sup>Fluting both 3" not available on 15"-18" wide. Not available with 6" fluting.

### BASE WASTEBASKET with WOOD TIERED K-CUP\* DRAWER, 34 1/2" HIGH, 24" DEEP

storage SOLUTIONS

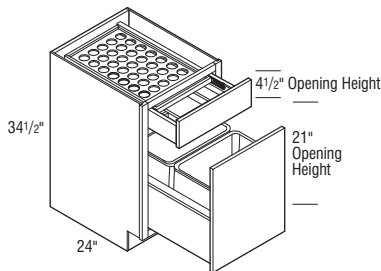

### BWB18KUCP

- Features Smart Stop slides.
- Holds 40 K-Cups.
- The Wood Tiered K-Cup Drawer is compatible with K-Cup pods only.
- Two 35 quart wastebaskets and one lid included. Wastebasket lid is operational on front wastebasket only.
- Wastebasket is metallic gray.
- Panel inserted under drawer.
- It is recommended that the front wastebasket be removed for easier removal of the back wastebasket.
- Wastebasket pull-out box will be 10" high.

\*K-Cup is a registered trademark of Keurig Green Mountain, Inc.

#### Door & Drawer Options

AF	AOMBWB	CC	CG	ESMD	GAMD	IFHG	MD	PRMD	PTOWB	SHMD	SPLITDR	SPLITDRWS	SUMD	TCP
	✓		✓			✓			✓					

#### End Panel Options

AUTH	CSFPE	EXBK	FFD	FPE	INTGE	IPE
✓	✓	✓	✓	✓	✓	✓

#### Custom Modification Options

ADD_SHLF	ADDTK	CBO	CCO	CFNTO	CFP	CFRMO	CHGDRW	CLIP	CMAT	CND	CSDGBK	DRT	DRWTK	EF	EX	EX_OL	FBFL	FD
	✓									✓			✓	✓	✓	✓	✓	✓

FDSRTBTM	FLUT <sup>1</sup>	FTK	ID	IH	IH+DRW	INVFRM	IW	LIGHT	MIP	OBRB	PFINBTMB	RD	RECTK	RH	ROSFLOT	RT
	✓	✓	✓	✓	✓				✓	✓			✓	✓	✓	✓

RW	SBCADDY	SBCADDYSM	SCPDRW	STW	TD	TKP	TVR	UDBX	URT	VTK	WS	WTCD	WTKCUP	WTR
											✓			✓

<sup>1</sup>Not available with 6" fluting.



# Base Wastebasket Cabinets

## Description

**NEW** BASE WASTEBASKET with CHARGING DRAWER, 34 1/2" HIGH, 24" DEEP storage SOLUTIONS

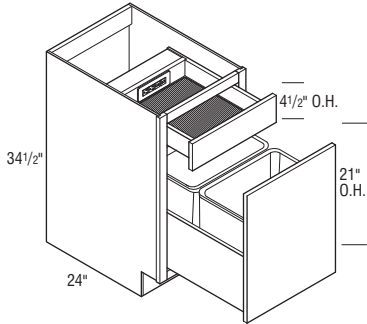

## Model

### BWB18CHGDRW

- Two 35 quart wastebaskets and one lid included. Wastebasket lid is operational on front wastebasket only.
- Features Smart Stop slides.
- Wastebasket is metallic gray.
- Panel inserted under drawer.
- It is recommended that the front wastebasket be removed for easier removal of the back wastebasket.
- Charging drawer has full extension, concealed Smart Stop slides.
- 110 lb. rated.
- 120V outlet must be installed in rear of cabinet within 10" of bottom of drawer, in rear of cabinet.
- CUL US listed power strip with two 120V plugs and two 2.1 amp USB ports.
- Max Current: AC 15 amps @ 120VAC; USB 2.1 amp and 5 VDC each.
- Tamper resistant outlets.
- Power cord with NEMA 5-15 plug.
- Integrated cord guide mounts to cabinet side to ensure safe operation.
- Black, shock absorbing mat included.
- Special sizes not available.
- Only available in 24" deep.
- Not available on Inset or Beaded Inset Styles.

#### Door & Drawer Options

AF	AOMBWB	CC	CG	ESMD	GAMD	IFHG	MD	PRMD	PTOWB	SHMD	SPLITDR	SPLITDRWS	SJMD	TCP
	✓								✓					

#### End Panel Options

AUTH	CSFPE	EXBK	FFD	FPE	INTGE	IPE
✓	✓			✓	✓	✓

#### Custom Modification Options

ADD	SHLF	ADDTK	CBO	CCO	CFNTO	CFP	CFRMO	CHGDRW	CLIP	CMAT	CND	CSDGBK	DRT	DRWTK	EF	EX	EX_OL	FBFL	FD
			✓	✓	✓		✓				✓	✓	✓	✓	✓	✓	✓	✓	✓
FDSRTBTM	FLUT	FTK	ID	IH	IH+DRW	INVERM	IW	LIGHT	MIP	OBRB	PFINBTMB	RD	RECTK	RH	ROSFLUT	RT			
									✓	✓			✓						
RW	SBCADDY	SBCADDYSM	SCPDRW	STW	TD	TKP	TVR	UDBX	URT	VTK	WS	WTCB	WTKCUP	WTR					
							✓			✓									

IH/RH availability charts starting on page G•40.  
IW/RW availability charts starting on page G•46.

## Description

### BASE RECYCLING CENTER, 34 1/2" HIGH, 24" DEEP storage SOLUTIONS

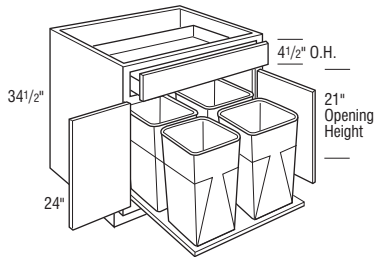

## Model

### TRBD27

- Each bin has a 27 quart capacity. Total capacity equals 108 quarts.
- Wastebasket dimensions: 11 3/8" W x 17 3/4" H x 11 3/8" D.
- Wastebaskets are white.
- Smart Stop feature not available on pull-out.
- Only available in Inset and Beaded Inset when used in conjunction with a finial hinge.

#### Door & Drawer Options

AF	AOMBWB	CC	CG	ESMD	GAMD	IFHG	MD	PRMD	PTOWB	SHMD	SPLITDR	SPLITDRWS	SUMD	TCP
			✓	✓	✓	✓	✓	✓				✓	✓	

#### End Panel Options

AUTH	CSFPE	EXBK	FFD	FPE	INTGE	IPE
✓	✓	✓	✓	✓	✓	✓

#### Custom Modification Options

ADD	SHLF	ADDTK	CBO	CCO	CFNTO	CFP	CFRMO	CHGDRW	CLIP	CMAT	CND	CSDGBK	DRT	DRWTK	EF	EX	EX_OL	FBFL	FD
			✓				✓									✓	✓	✓	

FDSRTBTM	FLUT <sup>1</sup>	FTK	ID	IH	IH+DRW	INVFRM	IW	LIGHT	MIP	OBRB	PFINBTMB	RD	RECTK	RH	ROSLUT <sup>2</sup>	RW
		✓	✓	✓	✓	✓			✓	✓						✓

RW	SBCADDY	SBCADDYSM	SCPDRW	STW	TD	TKP	TVR	UDBX	URT	VTK	WS	WTCD	WTKCUP	WTR
			✓								✓			✓

<sup>1</sup>Not available with fluting both or with 6" fluting.

<sup>2</sup>Not available with fluting both.

### BASE WINE CUBBY, 34 1/2" HIGH, 24" DEEP

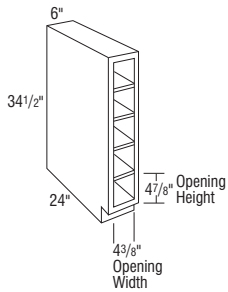

### BWC6

- Five openings.

### BWC640.5

- Six openings.

### BWC646.5

- Seven openings.

#### Notes below apply to all products in section above:

- Matching Interior standard.
- Finished or Flush Panel Ends must be specified if required.
- Available as separate unit only.
- Reduced Depths available in 1/4" increments from 12" to 23 3/4".

#### Door & Drawer Options

AF	AOMBWB	CC	CG	ESMD	GAMD	IFHG	MD	PRMD	PTOWB	SHMD	SPLITDR	SPLITDRWS	SUMD	TCP

#### End Panel Options

AUTH	CSFPE	EXBK	FFD	FPE	INTGE	IPE
✓	✓			✓		

#### Custom Modification Options

ADD	SHLF	ADDTK	CBO	CCO	CFNTO	CFP	CFRMO	CHGDRW	CLIP	CMAT	CND	CSDGBK	DRT	DRWTK	EF	EX	EX_OL	FBFL	FD

FDSRTBTM	FLUT	FTK	ID	IH	IH+DRW	INVFRM	IW	LIGHT	MIP	OBRB	PFINBTMB	RD	RECTK	RH	ROSLUT	RT
			✓						✓				✓			

RW	SBCADDY	SBCADDYSM	SCPDRW	STW	TD	TKP	TVR	UDBX	URT	VTK	WS	WTCD	WTKCUP	WTR
											✓			

# Base Spice & Bottle Storage Cabinets

## Description

### BASE SPICE DRAWER, 34 1/2" HIGH, 24" DEEP

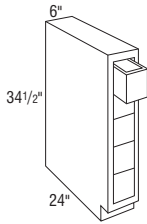

## Model

### BSD6

- Five drawers.

### BSD640.5

- Six drawers.

### BSD646.5

- Seven drawers.

Notes below apply to all products in section above:

- Matching Interior standard.
- Finished or Flush Panel Ends must be specified if required.
- Not available on Inset or Beaded Inset Styles.
- Reduced Depths available in 3" increments from 12" to 24".

#### Door & Drawer Options

AF	AOMBWB	CC	CG	ESMD	GAMD	IFHG	MD	PRMD	PTOWB	SHMD	SPLITDR	SPLITDRWS	SUMD	TCP
----	--------	----	----	------	------	------	----	------	-------	------	---------	-----------	------	-----

#### End Panel Options

AUTH	CSFPE	EXBK <sup>1</sup>	FFD	FPE	INTGE	IPE
------	-------	-------------------	-----	-----	-------	-----

#### Custom Modification Options

ADD	SHLF	ADDTK	CBO	CCO	CFNTD	CFP	CFRMO	CHGDRW	CLIP	CMAT	CND	CSDGBK	DRT	DRWTK	EF	EX	EX_OL	FBFL	FD
-----	------	-------	-----	-----	-------	-----	-------	--------	------	------	-----	--------	-----	-------	----	----	-------	------	----

FDSRTBTM	FLUT	FTK	ID	IH	IH+DRW	INVFRM	IW	LIGHT	MIP	OBRB	PFINBTMB	RD	RECTK	RH	ROSLUT	RT
----------	------	-----	----	----	--------	--------	----	-------	-----	------	----------	----	-------	----	--------	----

RW	SBCADDY	SBCADDYSM	SCPDRW	STW	TD	TKP	TVR	UDBX	URT	VTK	WS	WTCB	WTKCUP	WTR
----	---------	-----------	--------	-----	----	-----	-----	------	-----	-----	----	------	--------	-----

<sup>1</sup>Not available on end extended back left.

### BASE with BOTTLE STORAGE, 34 1/2" HIGH, 24" DEEP storage SOLUTIONS

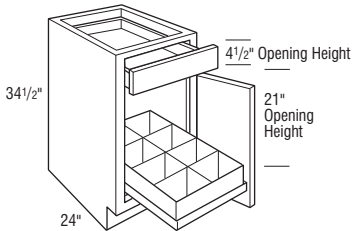

### BBS18 L or R

- Pull-out includes eight storage compartments, each compartment is 5 1/4" x 4 3/8".
- Not available on Inset and Beaded Inset styles.

#### Door & Drawer Options

AF	AOMBWB	CC	CG	ESMD	GAMD	IFHG	MD	PRMD	PTOWB	SHMD	SPLITDR	SPLITDRWS	SUMD	TCP
----	--------	----	----	------	------	------	----	------	-------	------	---------	-----------	------	-----

#### End Panel Options

AUTH	CSFPE	EXBK	FFD	FPE	INTGE	IPE
------	-------	------	-----	-----	-------	-----

#### Custom Modification Options

ADD	SHLF	ADDTK	CBO	CCO	CFNTD	CFP	CFRMO	CHGDRW	CLIP	CMAT	CND	CSDGBK	DRT	DRWTK	EF	EX	EX_OL <sup>1</sup>	FBFL	FD
-----	------	-------	-----	-----	-------	-----	-------	--------	------	------	-----	--------	-----	-------	----	----	--------------------	------	----

FDSRTBTM	FLUT <sup>2</sup>	FTK	ID	IH	IH+DRW	INVFRM	IW	LIGHT	MIP	OBRB	PFINBTMB	RD	RECTK	RH	ROSLUT <sup>2</sup>	RT
----------	-------------------	-----	----	----	--------	--------	----	-------	-----	------	----------	----	-------	----	---------------------	----

RW	SBCADDY	SBCADDYSM	SCPDRW	STW	TD	TKP	TVR	UDBX	URT	VTK	WS	WTCB	WTKCUP	WTR
----	---------	-----------	--------	-----	----	-----	-----	------	-----	-----	----	------	--------	-----

<sup>1</sup>Not available with extended stile both.

<sup>2</sup>Not available with 6" fluting.

IH/RH availability charts starting on page G•40.  
IW/RW availability charts starting on page G•46.

# Base Shelves & Desk File Drawer Base Cabinets

## Description

### BASE QUARTER ROUND END SHELF

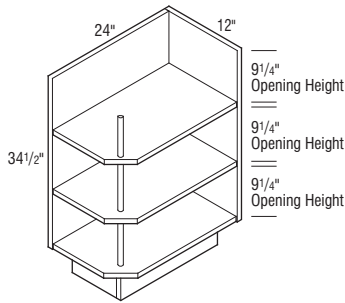

45° Angle (Right Angle Shown)

## Model

### BQRES L or R

- L or R must be specified.
- 3/4" thick back and sides.
- Reduced Depths available in 1/4" increments from 9" to 23 3/4".
- Increased Depths available in 1/4" increments from 24 1/4" to 30".

#### Door & Drawer Options

AF	AOMBWB	CC	CG	ESMD	GAMD	IFHG	MD	PRMD	PTOWB	SHMD	SPLITDR	SPLITDRWS	SUMD	TCP
----	--------	----	----	------	------	------	----	------	-------	------	---------	-----------	------	-----

#### End Panel Options

AUTH	CSFPE	EXBK	FFD	FPE	INTGE	IPE
------	-------	------	-----	-----	-------	-----

#### Custom Modification Options

ADD_SHLF	ADDTK	CBO	CCO	CFNTO	CFP	CFRMO	CHGDRW	CLIP	CMAT	CND	CSDGBK	DRT	DRWTK	EF	EX	EX_OL	FBFL	FD
----------	-------	-----	-----	-------	-----	-------	--------	------	------	-----	--------	-----	-------	----	----	-------	------	----

FDSRTBTM	FLUT	FTK	ID	IH	IH+DRW	INVFRM	IW	LIGHT	MIP	OBRB	PFINBTMB	RD	RECTK	RH	ROSLUT	RT
----------	------	-----	----	----	--------	--------	----	-------	-----	------	----------	----	-------	----	--------	----

RW	SBCADDY	SBCADDYSM	SCPDRW	STW	TD	TKP	TVR	UDBX	URT	VTK	WS	WTCD	WTKCUP	WTR
----	---------	-----------	--------	-----	----	-----	-----	------	-----	-----	----	------	--------	-----

### BASE HALF ROUND END SHELF

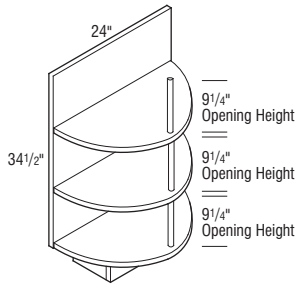

12" Radius

### BHRES

- 3/4" thick back.
- Designed for use with Peninsula Base Cabinets.

Modifications  
Are Not  
Available

### DESK FILE DRAWER BASE, 30" HIGH, 21" DEEP

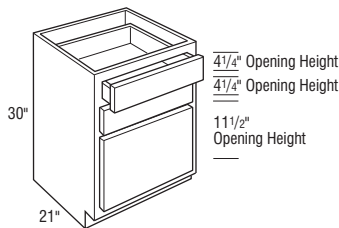

### DFD153021

### DFD183021

### DFD213021

### DFD243021

- Lateral (side-to-side) Filing system installed.
- Increased Depth of 24" available.
- When an Inset or Beaded Inset style is selected, drawer fronts will be slab.

#### Door & Drawer Options

AF	AOMBWB	CC	CG	ESMD	GAMD	IFHG	MD	PRMD	PTOWB	SHMD	SPLITDR	SPLITDRWS	SUMD	TCP
----	--------	----	----	------	------	------	----	------	-------	------	---------	-----------	------	-----

#### End Panel Options

AUTH	CSFPE	EXBK	FFD	FPE	INTGE	IPE
------	-------	------	-----	-----	-------	-----

#### Custom Modification Options

ADD_SHLF	ADDTK	CBO	CCO	CFNTO	CFP	CFRMO	CHGDRW	CLIP	CMAT	CND	CSDGBK	DRT	DRWTK	EF	EX	EX_OL	FBFL	FD
----------	-------	-----	-----	-------	-----	-------	--------	------	------	-----	--------	-----	-------	----	----	-------	------	----

FDSRTBTM	FLUT <sup>2</sup>	FTK	ID	IH	IH+DRW	INVFRM	IW	LIGHT	MIP	OBRB	PFINBTMB	RD	RECTK	RH	ROSLUT	RT
----------	-------------------	-----	----	----	--------	--------	----	-------	-----	------	----------	----	-------	----	--------	----

RW	SBCADDY	SBCADDYSM	SCPDRW	STW	TD	TKP	TVR	UDBX	URT	VTK	WS	WTCD	WTKCUP	WTR
----	---------	-----------	--------	-----	----	-----	-----	------	-----	-----	----	------	--------	-----

<sup>1</sup>Only available on 15" wide.

<sup>2</sup>Not available with 6" fluting.

# Desk File Drawer Base Cabinets & Furniture Drawers

## Description

## Model

**DESK FILE DRAWER BASE, 34 1/2" HIGH, 21" DEEP**

**DFD153421**

**DFD183421**

**DFD213421**

**DFD243421**

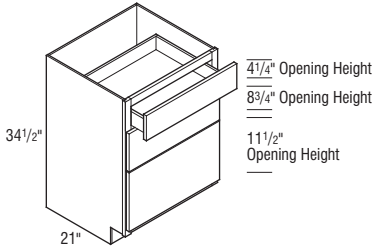

4 1/4" Opening Height

8 3/4" Opening Height

11 1/2" Opening Height

- Lateral (side-to-side) Filing system installed.
- Increased Depths available in 3" increments from 24".

### Door & Drawer Options

AF	AOMBWB	CC	CG	ESMD	GAMD	IFHG	MD	PRMD	PTOWB	SHMD	SPLITDR	SPLITDRWS	SUMD	TCP
						✓								

### End Panel Options

AUTH	CSFPE	EXBK	FFD	FPE	INTGE	IPE
✓	✓	✓	✓	✓	✓	✓

### Custom Modification Options

ADD_SHLF	ADDTK	CBO	CCO	CFNTD	CFP	CFRMO	CHGDRW	CLIP	CMAT	CND	CSDGBK	DRT	DRWTK	EF	EX	EX_OL	FBFL	FD	
		✓	✓	✓	✓	✓	✓	✓	✓	✓	✓	✓	✓	✓	✓	✓	✓	✓	✓

FDSRTBTM	FLUT <sup>2</sup>	FTK	ID	IH	IH+DRW	INVERM	IW	LIGHT	MIP	OBRB	PFINBTMB	RD	RECTK	RH	ROSFLUT	RT
	✓	✓	✓	✓	✓	✓	✓	✓	✓	✓	✓	✓	✓	✓	✓	✓

RW	SBCADDY	SBCADDYSM	SCPDRW	STW	TD	TKP	TVR	UDBX	URT	VTK	WS	WTCB	WTKCUP	WTR
						✓				✓	✓			✓

<sup>1</sup>Only available on 15" wide.

<sup>2</sup>Not available with 6" fluting.

**FURNITURE DRAWER, 6 3/4" HIGH, 24" DEEP**

**FD1506.7524**

**FD1806.7524**

**FD2106.7524**

**FD2406.7524**

**FD2706.7524**

**FD3006.7524**

**FD3306.7524**

**FD3606.7524**

**FD3906.7524**

**FD4206.7524**

**FD4506.7524**

**FD4806.7524**

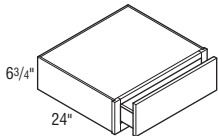

- Reduced Depths available in 1/4" increments from 12" to 23 3/4".
- Increased Heights will not add a toekick.

### Door & Drawer Options

AF	AOMBWB	CC	CG	ESMD	GAMD	IFHG	MD	PRMD	PTOWB	SHMD	SPLITDR	SPLITDRWS	SUMD	TCP
						✓						✓		

### End Panel Options

AUTH	CSFPE	EXBK	FFD	FPE	INTGE	IPE
✓		✓				

### Custom Modification Options

ADD_SHLF	ADDTK	CBO	CCO	CFNTD	CFP	CFRMO	CHGDRW	CLIP	CMAT	CND	CSDGBK	DRT	DRWTK	EF	EX	EX_OL	FBFL	FD	
		✓	✓	✓	✓	✓	✓	✓	✓	✓	✓	✓	✓	✓	✓	✓	✓	✓	✓

FDSRTBTM	FLUT	FTK	ID	IH	IH+DRW	INVERM	IW	LIGHT	MIP	OBRB	PFINBTMB	RD	RECTK	RH	ROSFLUT	RT
	✓	✓	✓	✓	✓	✓	✓	✓	✓	✓	✓	✓	✓	✓	✓	✓

RW	SBCADDY	SBCADDYSM	SCPDRW	STW	TD	TKP	TVR	UDBX	URT	VTK	WS	WTCB	WTKCUP	WTR
										✓	✓			✓

IH/RH availability charts starting on page G•40.  
IW/RW availability charts starting on page G•46.

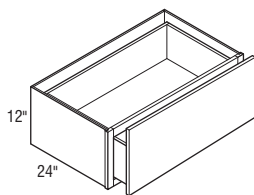
**Description**
**FURNITURE DRAWER, 12" HIGH, 24" DEEP**

**Model**
**FD151224**
**FD181224**
**FD211224**
**FD241224**
**FD271224**
**FD301224**
**FD331224**
**FD361224**
**FD391224**
**FD421224**
**FD451224**
**FD481224**

- Reduced Depths available in 1/4" increments from 12" to 23 3/4".
- Increased Heights will not add a toekick.

**Door & Drawer Options**

AF	AOMBWB	CC	CG	ESMD	GAMD	IFHG	MD	PRMD	PTOWB	SHMD	SPLITDR	SPLITDRWS	SUMD	TCP
						✓						✓		

**End Panel Options**

AUTH	CSFPE	EXBK	FFD	FPE	INTGE	IPE
✓		✓				

**Custom Modification Options**

ADD_SHLF	ADDTK	CBO	CCO	CFNTO	CFP	CFRMO	CHGDRW	CLIP	CMAT	CND	CSDGBK	DRT	DRWTK	EF	EX	EX_OL	FBFL	FD
		✓	✓	✓		✓		✓			✓			✓	✓	✓	✓	

FDSRTBTM	FLUT	FTK	ID	IH	IH+DRW	INVFRM	IW	LIGHT	MIP	OBRB	PFINBTMB	RD	RECTK	RH	ROSFLUT	RT
	✓		✓	✓			✓		✓			✓				

RW	SBCADDY	SBCADDYSM	SCPDRW	STW	TD	TKP	TVR	UDBX	URT	VTK	WS	WTCD	WTKCUP	WTR
											✓			✓

# Furniture Drawers

## Description

**FURNITURE DRAWER WINDOW BENCH,  
18" HIGH, 24" DEEP**

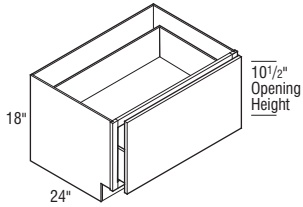

## Model

FDWB151824  
FDWB181824  
FDWB211824  
FDWB241824  
FDWB271824  
FDWB301824  
FDWB331824  
FDWB361824  
FDWB391824  
FDWB421824  
FDWB451824  
FDWB481824

- Reduced Depths available in 1/4" increments from 12" to 23 3/4".
- Toekick will remain when increasing or reducing heights.

### Door & Drawer Options

AF	AOMBWB	CC	CG	ESMD	GAMD	IFHG	MD	PRMD	PTOWB	SHMD	SPLITDR	SPLITDRWS <sup>1</sup>	SUMD	TCP
						✓						✓		

### End Panel Options

AUTH	CSFPE	EXBK	FFD	FPE	INTGE	IPE
	✓	✓		✓	✓	✓

### Custom Modification Options

ADD	SHLF	ADDTK	CBO	CCO	CFNTD	CFP	CFRMO	CHGDRW	CLIP	CMAT	CND	CSDGBK	DRT	DRWTK	EF	EX	EX_OL	FBFL	FD	
			✓	✓	✓		✓		✓			✓				✓	✓	✓		

FDSRTBTM	FLUT <sup>2</sup>	FTK	ID	IH	IH+DRW	INVERM	IW <sup>3</sup>	LIGHT	MIP	OBRB	PFINBTMB	RD	RECTK	RH	ROSFLUT <sup>4</sup>	RT
	✓	✓	✓				✓		✓	✓		✓	✓	✓	✓	

RW	SBCADDY	SBCADDYSM	SCPDRW	STW	TD	TKP	TVR	UDBX	URT	VTK	WS	WTCB	WTKCUP	WTR
							✓				✓	✓		

<sup>1</sup>Not available on 15"-21" wide.

<sup>2</sup>6" fluting not available on 15" or 18" wide. Fluting both 6" also not available on 21" wide.

<sup>3</sup>Not available on 36" or 48" wide.

<sup>4</sup>Fluting both not available on 15" or 18" wide.

IH/RH availability charts starting on page G•40.  
IW/RW availability charts starting on page G•46.

## Description

**HUTCH BASE, 34 1/2" HIGH, 24" DEEP**

## Model

**HB30**

**HB36**

**HB42**

**HB48**

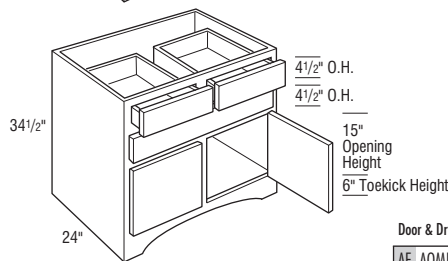
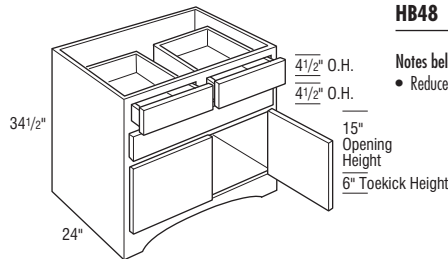

Notes below apply to all products in section above:

- Reduced Depths available in 1/4" increments from 12" to 23 3/4".

### Door & Drawer Options

AF	AOMBWB	CC	CG	ESMD	GAMD	IFHG	MD	PRMD	PTOWB	SHMD	SPLITDR <sup>1</sup>	SPLITDRWS	SUMD	TCP
			✓	✓	✓	✓	✓	✓		✓	✓		✓	

### End Panel Options

AUTH	CSFPE	EXBK	FFD	FPE	INTGE	IPE
✓	✓	✓	✓	✓	✓	✓

### Custom Modification Options

ADD_SHLF	ADDTK	CBO	CCO	CFNTO	CFP	CFRMO	CHGDRW	CLIP	CMAT	CND	CSDGBK	DRT	DRWTK <sup>1</sup>	EF	EX	EX_OL	FBFL	FD	
		✓	✓	✓	✓	✓	✓	✓	✓	✓	✓	✓	✓	✓	✓	✓	✓	✓	✓
FDSRTBTM	FLUT <sup>2</sup>	FTK <sup>3</sup>	ID	IH	IH+DRW	INVFRM	IW	LIGHT	MIP	OBRB	PFINBTMB	RD	RECTK	RH	ROSLUT	RT			
	✓	✓	✓						✓	✓		✓			✓	✓			
RW	SBCADDY	SBCADDYSM	SCPDWR	STW	TD	TKP	TVR	UDBX	URT	VTK	WS	WTCD	WTKCUP	WTR					
			✓		✓		✓	✓		✓	✓	✓	✓	✓					

<sup>1</sup>Not available on 42" or 48" wide.

<sup>2</sup>Fluting both 6" not available on 30" wide.

<sup>3</sup>Not available on FTKAV.



# Base Open Cabinets

## Description

**NEW** BASE OPEN CABINET with PLAIN BACK, 34 1/2" HIGH, 24" DEEP

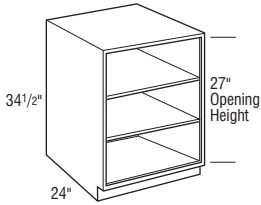

## Model

BOCP15

BOCP18

BOCP24

BOCP30

BOCP36

Notes below apply to all products in section above:

- Matching Interior Plywood (MIP) standard.
- If ordered with Hewn Technique, will not feature sand-through characteristics.
- To change the top rail valance, specify one of the following modifications: Arch (TVRAV) or Straight Valance (TVRVV).
- Includes two adjustable shelves.
- Reduced Depths available in 1/4" increments from 6" to 23 3/4".
- Increased Depths available in 1/4" increments from 24 1/4" to 30".

### Door & Drawer Options

AF	AOMBWB	CC	CG	ESMD	GAMD	IFHG	MD	PRMD	PTOWB	SHMD	SPLITDR	SPLITDRWS	SUMD	TCP

### End Panel Options

AUTH	CSFPE	EXBK	FFD	FPE	INTGE	IPE
✓	✓	✓	✓	✓	✓	✓

### Custom Modification Options

ADD	SHLF	ADDTK	CBO	CCO	CFNTO	CFP	CFRMO	CHGDRW	CLIP	CMAT	CND	CSDGBK	DRT	DRWTK	EF	EX	EX_OL	FBFL	FD
			✓	✓			✓		✓			✓				✓	✓		

FDSRTBTM	FLUT <sup>1</sup>	FTK	ID	IH	IH+DRW	INVFRM	IW	LIGHT	MIP	OBRB	PFINBTMB	RD	RECTK	RH	ROSFLUT	RT
	✓	✓	✓	✓						✓			✓	✓	✓	✓

RW	SBCADDY	SBCADDYSM	SCPDRW	STW	TD	TKP	TVR	UDBX	URT	VTK	WS	WTCB	WTKCUP	WTR
							✓	✓	✓		✓	✓		✓

<sup>1</sup>Not available with 6" fluting.

**NEW** BASE OPEN CABINET with CAR SIDING BACK, 34 1/2" HIGH, 24" DEEP

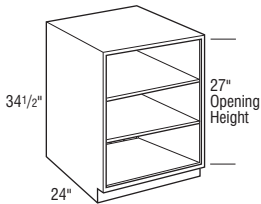

BOCB15

BOCB18

BOCB24

BOCB30

BOCB36

Notes below apply to all products in section above:

- Matching Interior Plywood (MIP) standard.
- The interior back of cabinet will be car siding back.
- If ordered with Hewn Technique, will not feature sand-through characteristics.
- To change the top rail valance, specify one of the following modifications: Arch (TVRAV) or Straight Valance (TVRVV).
- Includes two adjustable shelves.
- Reduced Depths available in 1/4" increments from 6" to 23 3/4".
- Increased Depths available in 1/4" increments from 24 1/4" to 30".

### Door & Drawer Options

AF	AOMBWB	CC	CG	ESMD	GAMD	IFHG	MD	PRMD	PTOWB	SHMD	SPLITDR	SPLITDRWS	SUMD	TCP

### End Panel Options

AUTH	CSFPE	EXBK	FFD	FPE	INTGE	IPE
✓	✓	✓	✓	✓	✓	✓

### Custom Modification Options

ADD	SHLF	ADDTK	CBO	CCO	CFNTO	CFP	CFRMO	CHGDRW	CLIP	CMAT	CND	CSDGBK	DRT	DRWTK	EF	EX	EX_OL	FBFL	FD
			✓	✓			✓		✓			✓				✓	✓		

FDSRTBTM	FLUT <sup>1</sup>	FTK	ID	IH	IH+DRW	INVFRM	IW	LIGHT	MIP	OBRB	PFINBTMB	RD	RECTK	RH	ROSFLUT	RT
	✓	✓	✓	✓						✓			✓	✓	✓	✓

RW	SBCADDY	SBCADDYSM	SCPDRW	STW	TD	TKP	TVR	UDBX	URT	VTK	WS	WTCB	WTKCUP	WTR
							✓	✓	✓		✓	✓		✓

<sup>1</sup>Not available with 6" fluting.

IH/RH availability charts starting on page G•40.  
IW/RW availability charts starting on page G•46.

## Description



### BASE OPEN CABINET with PLAIN BACK and DRAWER, 34 1/2" HIGH, 24" DEEP

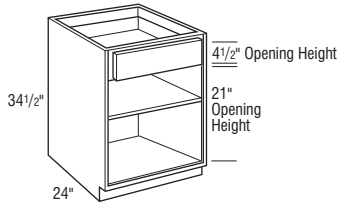

## Model

BODP15

BODP18

BODP24

BODP30

BODP36

Notes below apply to all products in section above:

- Includes one adjustable shelf.
- Matching Interior Plywood (MIP) standard.
- If ordered with Hewn Technique, will not feature sand-through characteristics.
- To change the top rail valance, specify one of the following modifications: Arch (TVRAV) or Straight Valance (TVRVV).

#### Door & Drawer Options

AF	AOMBWB	CC	CG	ESMD	GAMD	IFHG	MD	PRMD	PTOWB	SHMD	SPLITDR	SPLITDRWS <sup>1</sup>	SUMD	TCP
												✓		

#### End Panel Options

AUTH	CSFPE	EXBK	FFD	FPE	INTGE	IPE
✓	✓	✓	✓	✓	✓	✓

#### Custom Modification Options

ADD	SHLF	ADDTK	CBO	CCO	CFNTO	CFP	CFRMO	CHGDRW	CLIP	CMAT	CND	CSDGBK	DRT	DRWTK	EF	EX	EX_OL	FBFL	FD	
		✓	✓	✓	✓	✓	✓	✓	✓	✓	✓	✓	✓	✓	✓	✓	✓	✓	✓	✓

FDSRTBTM	FLUT <sup>2</sup>	FTK	ID	IH	IH+DRW	INVFRM	IW <sup>3</sup>	LIGHT	MIP	OBRB	PFINBTMB	RD	RECTK	RH	ROSFLUT	RT
✓	✓	✓	✓	✓	✓	✓	✓	✓	✓	✓	✓	✓	✓	✓	✓	✓

RW	SBCADDY	SBCADDYSM	SCPDRW	STW	TD	TKP	TVR <sup>4</sup>	UDBX <sup>1</sup>	URT	VTK	WS	WTCB	WTKCUP	WTR
	✓	✓	✓	✓	✓	✓	✓	✓	✓	✓	✓	✓	✓	✓

<sup>1</sup>Only available on 24" wide.

<sup>2</sup>6" fluting not available on 15" wide and FLUT6B is only available on 24" wide.

<sup>3</sup>Not available on 24" wide.

<sup>4</sup>Not available on 18" wide.



### BASE OPEN CABINET with CAR SIDING BACK and DRAWER, 34 1/2" HIGH, 24" DEEP

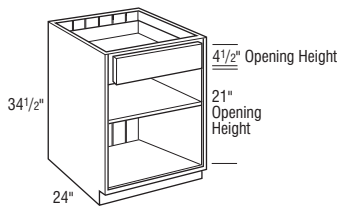

BODB15

BODB18

BODB24

BODB30

BODB36

Notes below apply to all products in section above:

- Includes one adjustable shelf.
- Matching Interior Plywood (MIP) standard.
- The interior back of cabinet will be car siding back.
- If ordered with Hewn Technique, will not feature sand-through characteristics.
- To change the top rail valance, specify one of the following modifications: Arch (TVRAV) or Straight Valance (TVRVV).

#### Door & Drawer Options

AF	AOMBWB	CC	CG	ESMD	GAMD	IFHG	MD	PRMD	PTOWB	SHMD	SPLITDR	SPLITDRWS <sup>1</sup>	SUMD	TCP
												✓		

#### End Panel Options

AUTH	CSFPE	EXBK	FFD	FPE	INTGE	IPE
✓	✓	✓	✓	✓	✓	✓

#### Custom Modification Options

ADD	SHLF	ADDTK	CBO	CCO	CFNTO	CFP	CFRMO	CHGDRW	CLIP	CMAT	CND	CSDGBK	DRT	DRWTK	EF	EX	EX_OL	FBFL	FD	
		✓	✓	✓	✓	✓	✓	✓	✓	✓	✓	✓	✓	✓	✓	✓	✓	✓	✓	✓

FDSRTBTM	FLUT <sup>2</sup>	FTK	ID	IH	IH+DRW	INVFRM	IW <sup>3</sup>	LIGHT	MIP	OBRB	PFINBTMB	RD	RECTK	RH	ROSFLUT	RT
✓	✓	✓	✓	✓	✓	✓	✓	✓	✓	✓	✓	✓	✓	✓	✓	✓

RW	SBCADDY	SBCADDYSM	SCPDRW	STW	TD	TKP	TVR <sup>4</sup>	UDBX <sup>1</sup>	URT	VTK	WS	WTCB	WTKCUP	WTR
	✓	✓	✓	✓	✓	✓	✓	✓	✓	✓	✓	✓	✓	✓

<sup>1</sup>Only available on 24" wide.

<sup>2</sup>6" fluting not available on 15" wide and FLUT6B is only available on 24" wide.

<sup>3</sup>Not available on 24" wide.

<sup>4</sup>Not available on 18" wide.

# Base Message Center Cabinets

## Description

**BASE MESSAGE CENTER, 30" HIGH,  
3" DEEP**  
storage  
SOLUTIONS

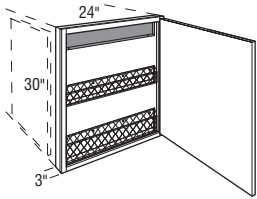

## Model

### BMC24 L or R

- Finished Flush Ends standard.
- Includes magazine holder, bulletin board and mail holder.
- Cabinet recommended to be hinged on wall side.
- Door will open 90° without decorative hardware.
- For proper installation, adjacent cabinet must have flush ends or 3/32" skin applied.
- Embellishments or overlay fillers can be used on side of cabinet to add a decorative touch.
- Increased Depths available in 1/4" increments from 3 1/4" to 30".
- Not available on Inset and Beaded Inset styles.

#### Door & Drawer Options

AF	AOMBWB	CC	CG	ESMD	GAMD	IFHG	MD	PRMD	PTOWB	SHMD	SPLITDR	SPLITDRWS	SJMD	TCP
		✓	✓	✓	✓	✓	✓	✓		✓			✓	✓

#### End Panel Options

AUTH	CSFPE	EXBK	FFD	FPE	INTGE	IPE
		✓				

#### Custom Modification Options

ADD	SHLF	ADDTK	CBO	CCO	CFNTD	CFP	CFRMO	CHGDRW	CLIP	CMAT	CND	CSDGBK	DRT	DRWTK	EF	EX	EX_OL	FBFL	FD	
			✓	✓	✓		✓				✓						✓	✓		

FDSRTBTM	FLUT	FTK	ID	IH	IH+DRW	INVERM	IW	LIGHT	MIP	OBRB	PFINBTMB	RD	RECTK	RH	ROSLUT	RT
		✓	✓						✓	✓						

RW	SBCADDY	SBCADDYSM	SCPDRW	STW	TD	TKP	TVR	UDBX	URT	VTK	WS	WTCD	WTKCUP	WTR
											✓			✓

IH/RH availability charts starting on page G•40.  
IW/RW availability charts starting on page G•46.

# Kemper Emerge Modification Option Descriptions

Your Kemper Emerge specification guide contains charts with modification option codes for each applicable cabinetry product. Reference the listing below to identify the modification description.

## Door & Drawer Options

Option	Description
AF	Aluminum Door
CC	Craftsman Door
CG	Cut-for-glass
ESMD	Estate Mullion Door
GAMD	Gallery Mullion Door
IFHG	Inset Finial Hinges
MD	Mullion Door
MFO	Modified Full Overlay
PRMD	Prairie Mullion Door
SHMD	Shaker Mullion Door
SPLITDR	Split Doors
SUMD	Summit Mullion Door

## End Panel Options

Option	Description
AUTH	Authentic Flush End
CSFPE	Car Siding Flush Panel End
EXBK	End Extended Back
FFD	Face Frame and Door on End
FPE	Flush Panel End
INTGE	Integral End
IPE	Inset Panel Ends

## Custom Modification Options

Option	Description
ATTK	Attach Toekick
CBO	Cabinet Box Only
CCO	Cabinet Case Only
CFNTO	Cabinet Front Only
CFRMO	Cabinet Frame Only
CLIP	Clipped Corner
CND	Cabinet No Door
CSDGBK	Car Siding Back
DRT	Deep Roll Trays
DRWTK	Toekick Drawer
EF	Finished Ends
EX	Extended Stile
EX_OL	Extended Stile with Overlay
FLUT	Fluting
FTK	Flush Toekick
ID	Increased Depth
IH	Increased Height
IW	Increased Width
LIGHT	Lighting
MIP	Matching Interior
OBRB	Open Bottom Rail Base
RD	Reduced Depth
RECTK	Recessed Toekick
RH	Reduced Height
ROSFLOT	Rose Fluting
RT	Roll Trays
TD	Tray Divider
TKP	Toekick Pedestal
TVR	Top Valance Rail
VTK	Void Toekick
WS	Wide Stiles
WTR	Wide Top Rail



## Description

**UTILITY, 84", 87", 90", 93", or 96" HIGH, 12" DEEP**

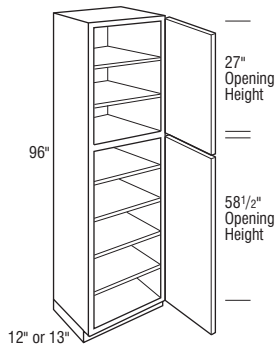
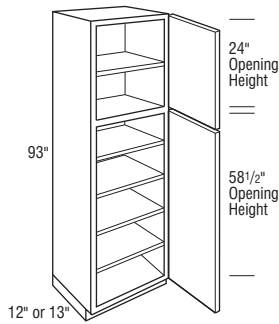
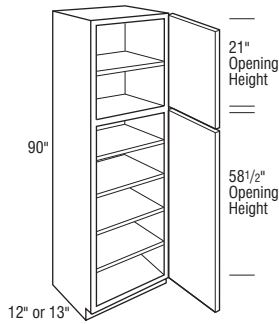
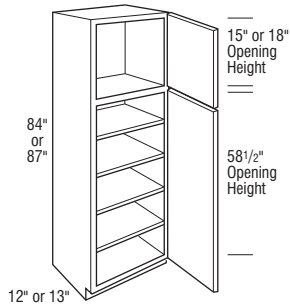

## Model

**U128412 L or R**

**U158412 L or R**

**U188412 L or R**

**U218412 L or R**

**U248412 L or R**

**U128712 L or R**

**U158712 L or R**

**U188712 L or R**

**U218712 L or R**

**U248712 L or R**

- Includes four adjustable shelves.

**U129012AH L or R**

**U159012AH L or R**

**U189012AH L or R**

**U219012AH L or R**

**U249012AH L or R**

- AH represents upper section alignment with doors on 24" or 27" high cabinets.
- Includes five adjustable shelves.
- Toekick shipped attached unless otherwise specified.

**U129312AH L or R**

**U159312AH L or R**

**U189312AH L or R**

**U219312AH L or R**

**U249312AH L or R**

- AH represents upper section alignment with doors on 24" or 27" high cabinets.
- Includes five adjustable shelves.
- Shipped with loose toe space unless Attach Toekick or Flush Toekick is specified.

**U129612 L or R**

**U159612 L or R**

**U189612 L or R**

**U219612 L or R**

**U249612 L or R**

- Includes six adjustable shelves.
- Shipped with loose toe space unless Attach Toekick or Flush Toekick is specified.
- Flush Toekick option not available in conjunction with Wide Top Rail unless loose Flush Toekick is specified.

### Notes below apply to all products in section above:

- Large opening on tall doors will include two panels.
- Inset and Beaded Inset Door Styles are a standard 13" deep.
- Full Overlay Styles:
  - Increased Depths available in 1/4" increments from 12 1/4" to 30".
  - Reduced Depths available in 1/4" increments from 6" to 11 3/4".
- Inset and Beaded Inset Styles:
  - Increased Depths available in 1/4" increments from 13 1/4" to 30".
  - Reduced Depths available in 1/4" increments from 6" to 12 3/4".
- Recessed Toekick on ends must be specified if required.

### Door & Drawer Options

AF	CC	CG	ESMD <sup>1</sup>	GAMD <sup>1</sup>	IFHG	MD <sup>1</sup>	MFO	PRMD <sup>2</sup>	SHMD <sup>1</sup>	SPLITDR	SUMD <sup>1</sup>
✓	✓	✓	✓	✓	✓	✓	✓	✓	✓	✓	✓

### End Panel Options

AUTH	CSFPE	EXBK	FFD	FPE	INTGE	IPE
✓	✓	✓	✓	✓	✓	✓

### Custom Modification Options

ATTK <sup>3</sup>	CBO	CCO	CFNTO	CFRMO	CLIP <sup>4</sup>	CND	CSDGBK	DRT	DRWTK	EF	EX	EX_OL	FLUT <sup>5</sup>	FTK <sup>6</sup>	ID	IH <sup>7</sup>	IW <sup>8</sup>	LIGHT	MIP	OBRB	
✓	✓	✓	✓	✓	✓	✓	✓	✓	✓	✓	✓	✓	✓	✓	✓	✓	✓	✓	✓	✓	✓

RD	RECTK <sup>9</sup>	RH	ROSFLUT	RT	TD <sup>1</sup>	TKP <sup>10</sup>	TVR <sup>11</sup>	VTK	WS	WTR
✓	✓	✓	✓	✓	✓	✓	✓	✓	✓	✓

<sup>1</sup>Only available on top section.  
<sup>2</sup>Not available on 12" wide. Only available on top section.  
<sup>3</sup>Only available on 93"-96" high.  
<sup>4</sup>Not available on 12" wide.  
<sup>5</sup>Not available with 6" fluting.  
<sup>6</sup>FTKAV not available on 12" wide.  
<sup>7</sup>Not available on 96" high.  
<sup>8</sup>Not available on 24" wide.  
<sup>9</sup>Only available on RECTKL.R.BK.  
<sup>10</sup>Not available on 93"-96" high.  
<sup>11</sup>Not available on 12" wide.

# Utility Cabinets

## Description



**UTILITY, 102" or 108" HIGH,  
12" DEEP**

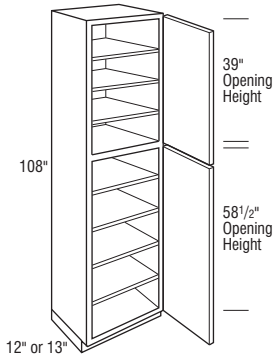
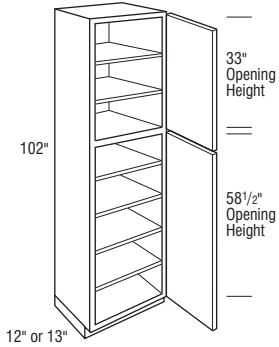

## Model

**U1210212 L or R**

**U1510212 L or R**

**U1810212 L or R**

**U2110212 L or R**

**U2410212 L or R**

- Includes six adjustable shelves.

**U1210812 L or R**

**U1510812 L or R**

**U1810812 L or R**

**U2110812 L or R**

**U2410812 L or R**

- Includes seven adjustable shelves.

### Notes below apply to all products in section above:

- Shipped with loose toe space unless Attach Toekick or Flush Toekick is specified.
- Large opening on tall doors will include two panels.
- Inset and Beaded Inset Door Styles are a standard 13" deep.
- Full Overlay Styles:
  - Increased Depths available in 1/4" increments from 12 1/4" to 26".
  - Reduced Depths available in 1/4" increments from 6" to 11 3/4".
- Inset and Beaded Inset Styles:
  - Increased Depths available in 1/4" increments from 13 1/4" to 26".
  - Reduced Depths available in 1/4" increments from 6" to 12 3/4".
- Recessed Toekick on ends must be specified if required.
- Finish Flushed Ends standard.
- Available in Cherry and Maple only.

### Door & Drawer Options

AF	CC	CG	ESMD <sup>1</sup>	GAMD <sup>1</sup>	IFHG	MD <sup>1</sup>	MFO	PRMD <sup>2</sup>	SHMD <sup>1</sup>	SPLITDR	SUMD <sup>1</sup>
✓	✓	✓	✓	✓	✓	✓	✓	✓	✓	✓	✓

### End Panel Options

AUTH	CSFPE	EXBK <sup>3</sup>	FFD	FPE	INTGE	IPE
✓	✓	✓	✓	✓	✓	✓

### Custom Modification Options

ATTK	CBO	CCO	CFNTO	CFRMO	CLIP	CND	CSDGBK	DRT	DRWTK <sup>4</sup>	EF	EX	EX_OL	FLUT <sup>5</sup>	FTK <sup>6</sup>	ID	IH <sup>7</sup>	IW <sup>8</sup>	LIGHT	MIP	OBRB
✓	✓	✓	✓	✓	✓	✓	✓	✓	✓	✓	✓	✓	✓	✓	✓	✓	✓	✓	✓	✓

RD	RECTK	RH <sup>7</sup>	ROSELLUT <sup>5</sup>	RT	TD <sup>1</sup>	TKP	TVR <sup>9</sup>	VTK	WS	WTR
✓	✓	✓	✓	✓	✓	✓	✓	✓	✓	✓

<sup>1</sup>Only available on top section.

<sup>2</sup>Not available on 12" wide. Only available on top section.

<sup>3</sup>This modification will allow the end to extend back to a maximum of 30" deep.

<sup>4</sup>Only available when used in conjunction with attach toekick modification.

<sup>5</sup>Not available with 6" fluting.

<sup>6</sup>FTKAN not available on 12" wide.

<sup>7</sup>Not available on 108" high.

<sup>8</sup>Not available on 24" wide.

<sup>9</sup>Not available on 12" wide.

IH/RH availability charts starting on page G•40.  
IW/RW availability charts starting on page G•46.

## Description

**UTILITY, 84", 87", 90", or 93" HIGH, 12" DEEP**

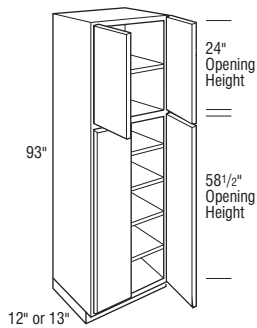
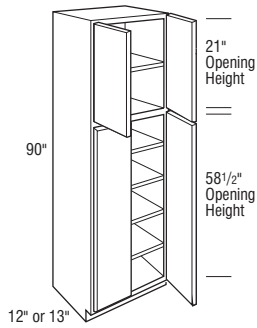
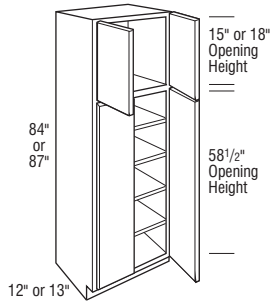

## Model

**U248412**

**U278412**

**U308412**

**U338412**

**U368412**

**U248712**

**U278712**

**U308712**

**U338712**

**U368712**

- Includes four adjustable shelves.

**U249012AH**

**U279012AH**

**U309012AH**

**U339012AH**

**U369012AH**

- AH represents upper section alignment with doors on 24" or 27" high cabinets.
- Includes five adjustable shelves.
- Toekick shipped attached unless otherwise specified.

**U249312AH**

**U279312AH**

**U309312AH**

**U339312AH**

**U369312AH**

- AH represents upper section alignment with doors on 24" or 27" high cabinets.
- Includes five adjustable shelves.
- Shipped with loose toe space unless Attach Toekick or Flush Toekick is specified.

### Notes below apply to all products in section above:

- Large opening on tall doors will include two panels.
- Inset and Beaded Inset Door Styles are a standard 13" deep.
- Full Overlay Styles:
  - Increased Depths available in 1/4" increments from 12 1/4" to 30".
  - Reduced Depths available in 1/4" increments from 6" to 11 3/4".
- Inset and Beaded Inset Styles:
  - Increased Depths available in 1/4" increments from 13 1/4" to 30".
  - Reduced Depths available in 1/4" increments from 6" to 12 3/4".
- Recessed Toekick on ends must be specified if required.

### Door & Drawer Options

AF <sup>1</sup>	CC	CG	ESMD <sup>2</sup>	GAMD <sup>2</sup>	IFHG	MD <sup>2</sup>	MFO	PRMD <sup>2</sup>	SHMD <sup>2</sup>	SPLITDR	SUMD <sup>2</sup>
✓	✓	✓	✓	✓	✓	✓	✓	✓	✓	✓	✓

### End Panel Options

AUTH	CSFPE	EXBK	FFD <sup>3</sup>	FPE	INTGE	IPE
✓	✓	✓	✓	✓	✓	✓

### Custom Modification Options

ATTK <sup>4</sup>	CBO	CCO	CFNT0	CFRMO	CLIP <sup>1</sup>	CND	CSDGBK	DRT	DRWTK	EF	EX	EX	OL	FLUT <sup>5</sup>	FTK	ID	IH	IW <sup>6</sup>	LIGHT <sup>8</sup>	MIP	OBRB
✓	✓	✓	✓	✓	✓	✓	✓	✓	✓	✓	✓	✓	✓	✓	✓	✓	✓	✓	✓	✓	✓

RD	RECTK <sup>7</sup>	RH	ROSLUT	RT	TD <sup>2</sup>	TKP <sup>8</sup>	TVR	VTK	WS	WTR
✓	✓	✓	✓	✓	✓	✓	✓	✓	✓	✓

<sup>1</sup>Not available on 24" wide.

<sup>2</sup>Only available on top section.

<sup>3</sup>Not available on 2484 version.

<sup>4</sup>Only available on 93" high.

<sup>5</sup>Not available with 6" fluting.

<sup>6</sup>Not available on 36" wide.

<sup>7</sup>Only available on RECTKL.R.BK.

<sup>8</sup>Not available on 93" high.



# Utility Cabinets

## Description

### UTILITY, 96" HIGH, 12" DEEP

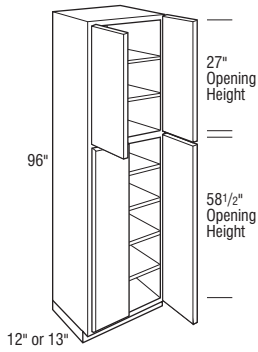

## Model

U249612

U279612

U309612

U339612

U369612

- Includes six adjustable shelves.
- Shipped with loose toe space unless Attach Toekick or Flush Toekick is specified.
- Flush Toekick option not available in conjunction with Wide Top Rail unless loose Flush Toekick is specified.
- Large opening on tall doors will include two panels.
- Inset and Beaded Inset Door Styles are a standard 13" deep.
- Full Overlay Styles:
  - Increased Depths available in 1/4" increments from 12 1/4" to 30".
  - Reduced Depths available in 1/4" increments from 6" to 11 3/4".
- Inset and Beaded Inset Styles:
  - Increased Depths available in 1/4" increments from 13 1/4" to 30".
  - Reduced Depths available in 1/4" increments from 6" to 12 3/4".
- Recessed Toekick on ends must be specified if required.

#### Door & Drawer Options

AF <sup>1</sup>	CC	CG	ESMD <sup>2</sup>	GAMD <sup>2</sup>	IFHG	MD <sup>2</sup>	MFO	PRMD <sup>2</sup>	SHMD <sup>2</sup>	SPLITDR	SJMD <sup>2</sup>
✓	✓	✓	✓	✓	✓	✓	✓	✓	✓	✓	✓

#### End Panel Options

AUTH	CSFPE	EXBK	FFD	FPE	INTGE	IPE
✓	✓	✓	✓	✓	✓	✓

#### Custom Modification Options

ATTK	CBO	CCO	CFNTO	CFRMO <sup>1</sup>	CLIP <sup>1</sup>	CND	CSDGBK	DRT	DRWTK	EF	EX	EX_OL	FLUT <sup>3</sup>	FTK	ID	IH	IW <sup>4</sup>	LIGHT <sup>1</sup>	MIP	OBRB	
✓	✓	✓	✓	✓	✓	✓	✓	✓	✓	✓	✓	✓	✓	✓	✓	✓	✓	✓	✓	✓	✓

RD	RECTK <sup>5</sup>	RH	ROSLUT	RT	TD <sup>2</sup>	TKP	TVR	VTK	WS	WTR
✓	✓	✓	✓	✓	✓	✓	✓	✓	✓	✓

<sup>1</sup>Not available on 24" wide.

<sup>2</sup>Only available on top section.

<sup>3</sup>Not available with 6" fluting.

<sup>4</sup>Not available on 36" wide.

<sup>5</sup>Only available on RECTCLR.BK.

IH/RH availability charts starting on page G•40.  
IW/RW availability charts starting on page G•46.

## Description

**NEW** UTILITY, 102" or 108" HIGH, 12" DEEP

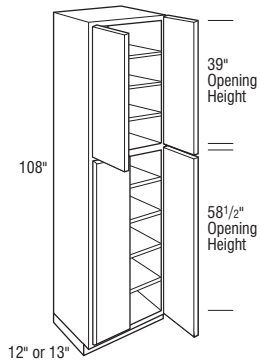
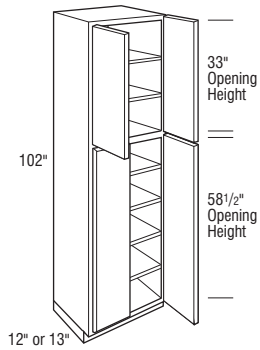

## Model

U2410212

U2710212

U3010212

U3310212

U3610212

- Includes six adjustable shelves.

U2410812

U2710812

U3010812

U3310812

U3610812

- Includes seven adjustable shelves.

### Notes below apply to all products in section above:

- Shipped with loose toe space unless Attach Toekick or Flush Toekick is specified.
- Large opening on tall doors will include two panels.
- Inset and Beaded Inset Door Styles are a standard 13" deep.
- Full Overlay Styles:
  - Increased Depths available in 1/4" increments from 12 1/4" to 26"
  - Reduced Depths available in 1/4" increments from 6" to 11 3/4"
- Inset and Beaded Inset Styles:
  - Increased Depths available in 1/4" increments from 13 1/4" to 26"
  - Reduced Depths available in 1/4" increments from 6" to 12 3/4"
- Recessed Toekick on ends must be specified if required.
- Finish Flushed Ends standard.
- Available in Cherry and Maple only.

### Door & Drawer Options

AF <sup>1</sup>	CC	CG	ESMD <sup>2</sup>	GAMD <sup>3</sup>	IFHG	MD <sup>2</sup>	MFO	PRMD <sup>2</sup>	SHMD <sup>2</sup>	SPLITDR	SUMD <sup>2</sup>
✓	✓	✓	✓	✓	✓	✓	✓	✓	✓	✓	✓

### End Panel Options

AUTH	CSFPE	EXBK <sup>3</sup>	FFD	FPE	INTGE	IPE
✓	✓	✓	✓	✓	✓	✓

### Custom Modification Options

ATTK	CBO	CCO	CFNT0	CFRMO	CLIP	CND	CSDGBK	DRT	DRWTK <sup>4</sup>	EF	EX	EX_OL	FLUT <sup>5</sup>	FTK	ID	IH <sup>6</sup>	IW <sup>7</sup>	LIGHT	MIP	OBRB	
✓	✓	✓	✓	✓	✓	✓	✓	✓	✓	✓	✓	✓	✓	✓	✓	✓	✓	✓	✓	✓	✓

RD	RECTK	RH <sup>6</sup>	ROSLUT <sup>5</sup>	RT	TD <sup>2</sup>	TKP	TVR	VTK	WS	WTR
✓	✓	✓	✓	✓	✓	✓	✓	✓	✓	✓

<sup>1</sup>Not available on 24" wide.

<sup>2</sup>Only available on top section.

<sup>3</sup>This modification will allow the end to extend back to a maximum of 30" deep.

<sup>4</sup>Only available when used in conjunction with attach toekick modification.

<sup>5</sup>Not available with 6" fluting.

<sup>6</sup>Not available on 108" high.

<sup>7</sup>Not available on 36" wide.

# Utility Cabinets

## Description

## Model

**UTILITY, 84", 87", 90", 93, or 96" HIGH, 24" DEEP**

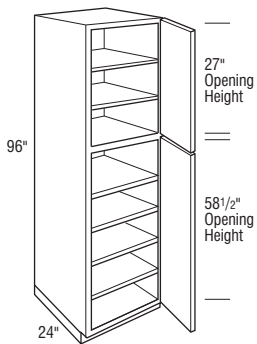
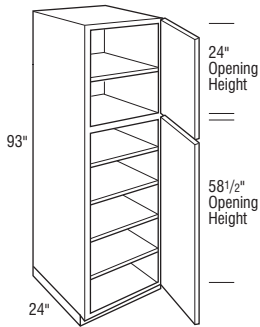
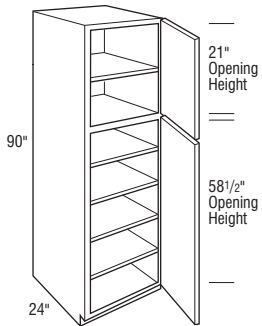
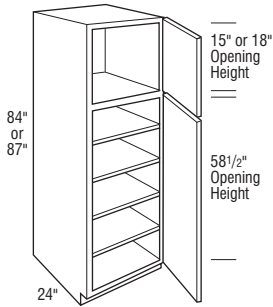

**U128424 L or R**

**U158424 L or R**

**U188424 L or R**

**U218424 L or R**

**U248424 L or R**

**U128724 L or R**

**U158724 L or R**

**U188724 L or R**

**U218724 L or R**

**U248724 L or R**

- Includes four adjustable shelves.

**U129024AH L or R**

**U159024AH L or R**

**U189024AH L or R**

**U219024AH L or R**

**U249024AH L or R**

- AH represents upper section alignment with doors on 24" or 27" high cabinets.
- Includes five adjustable shelves.
- Toekick shipped attached unless otherwise specified.

**U129324AH L or R**

**U159324AH L or R**

**U189324AH L or R**

**U219324AH L or R**

**U249324AH L or R**

- AH represents upper section alignment with doors on 24" or 27" high cabinets.
- Includes five adjustable shelves.
- Shipped with loose toe space unless Attach Toekick or Flush Toekick is specified.

**U129624 L or R**

**U159624 L or R**

**U189624 L or R**

**U219624 L or R**

**U249624 L or R**

- Includes six adjustable shelves.
- Shipped with loose toe space unless Attach Toekick or Flush Toekick is specified.
- Flush Toekick option not available in conjunction with Wide Top Rail unless loose Flush Toekick is specified.

### Notes below apply to all products in section above:

- Large opening on tall doors will include two panels.
- Increased Depths available in 1/4" increments from 24 1/4" to 30".
- Reduced Depths available in 1/4" increments from 6" to 23 3/4".

### Door & Drawer Options

AF	CC	CG	ESMD <sup>1</sup>	GAMD <sup>1</sup>	IFHG	MD <sup>1</sup>	MFO	PRMD <sup>2</sup>	SHMD <sup>1</sup>	SPLITDR	SUMD <sup>1</sup>
✓	✓	✓	✓	✓	✓	✓	✓	✓	✓	✓	✓

### End Panel Options

AUTH	CSFPE	EXBK	FFD <sup>3</sup>	FPE	INTGE	IPE
✓	✓	✓	✓	✓	✓	✓

### Custom Modification Options

ATTK <sup>4</sup>	CBO <sup>5</sup>	CCO	CFNT0	CFRMO	CLIP <sup>6</sup>	CND	CSDGBK	DRT	DRWTK	EF	EX	EX_OL	FLUT <sup>7</sup>	FTK <sup>8</sup>	ID	IH <sup>9</sup>	IW <sup>10</sup>	LIGHT	MIP	OBRB	
✓	✓	✓	✓	✓	✓	✓	✓	✓	✓	✓	✓	✓	✓	✓	✓	✓	✓	✓	✓	✓	✓

RD	RECTK <sup>11</sup>	RH	ROSFLUT	RT	TD <sup>1</sup>	TKP <sup>12</sup>	TVR <sup>13</sup>	VTK	WS	WTR
✓	✓	✓	✓	✓	✓	✓	✓	✓	✓	✓

<sup>1</sup>Only available on top section.

<sup>2</sup>Not available on 12" wide. Only available on top section.

<sup>3</sup>Not available on 1284 version.

<sup>4</sup>Only available on 93"-96" high.

<sup>5</sup>Not available on 12" wide or on 1584 version.

<sup>6</sup>Not available on 12" wide.

<sup>7</sup>Not available with 6" fluting.

<sup>8</sup>FTKAV not available on 12" wide.

<sup>9</sup>Not available on 96" high.

<sup>10</sup>Not available on 24" wide.

<sup>11</sup>Only available on RECTKL.R.BK.

<sup>12</sup>Not available on 93"-96" high.

<sup>13</sup>Not available on 12" wide.

IH/RH availability charts starting on page G•40.  
IW/RW availability charts starting on page G•46.

## Description

**NEW** UTILITY, 102" or 108" HIGH, 24" DEEP

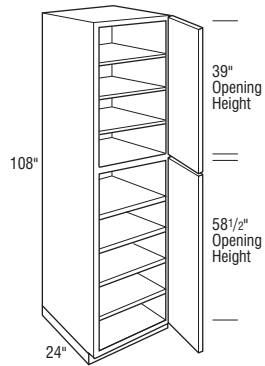
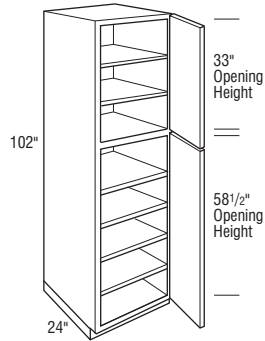

## Model

U1210224 L or R

U1510224 L or R

U1810224 L or R

U2110224 L or R

U2410224 L or R

- Includes six adjustable shelves.

U1210824 L or R

U1510824 L or R

U1810824 L or R

U2110824 L or R

U2410824 L or R

- Includes seven adjustable shelves.

Notes below apply to all products in section above:

- Shipped with loose toe space unless Attach Toekick or Flush Toekick is specified.
- Large opening on tall doors will include two panels.
- Increased Depths available in 1/4" increments from 24 1/4" to 26".
- Reduced Depths available in 1/4" increments from 6" to 23 3/4".
- Finish Flushed Ends standard.
- Available in Cherry and Maple only.

### Door & Drawer Options

AF	CC	CG	ESMD <sup>1</sup>	GAMD <sup>1</sup>	IFHG	MD <sup>1</sup>	MFO	PRMD <sup>2</sup>	SHMD <sup>1</sup>	SPLITDR	SUMD <sup>1</sup>
✓	✓	✓	✓	✓	✓	✓	✓	✓	✓	✓	✓

### End Panel Options

AUTH	CSFPE	EXBK <sup>3</sup>	FFD	FPE	INTGE	IPE
✓	✓	✓	✓	✓	✓	✓

### Custom Modification Options

ATTK	CBO	CCO	CFNT0	CFRMO	CLIP	CND	CSDGBK	DRT	DRWTK <sup>4</sup>	EF	EX	EX_OL	FLUT <sup>5</sup>	FTK <sup>6</sup>	ID	IH <sup>7</sup>	IW <sup>8</sup>	LIGHT	MIP	OBRB	
✓	✓	✓	✓	✓	✓	✓	✓	✓	✓	✓	✓	✓	✓	✓	✓	✓	✓	✓	✓	✓	✓

RD	RECTK	RH <sup>7</sup>	ROSFLUT <sup>5</sup>	RT	TD <sup>1</sup>	TKP	TVR <sup>9</sup>	VTK	WS	WTR
✓	✓	✓	✓	✓	✓	✓	✓	✓	✓	✓

<sup>1</sup>Only available on top section.  
<sup>2</sup>Not available on 12" wide. Only available on top section.  
<sup>3</sup>This modification will allow the end to extend back to a maximum of 30" deep.  
<sup>4</sup>Only available when used in conjunction with attach toekick modification.  
<sup>5</sup>Not available with 6" fluting.  
<sup>6</sup>FTKAV not available on 12" wide.  
<sup>7</sup>Not available on 108" high.  
<sup>8</sup>Not available on 24" wide.  
<sup>9</sup>Not available on 12" wide.

# Utility Cabinets

## Description

## Model

**UTILITY, 84", 87", 90", 93, or 96" HIGH,  
24" DEEP**

**U248424**

**U278424**

**U308424**

**U338424**

**U368424**

**U248724**

**U278724**

**U308724**

**U338724**

**U368724**

- Includes four adjustable shelves.

**U249024AH**

**U279024AH**

**U309024AH**

**U339024AH**

**U369024AH**

- AH represents upper section alignment with doors on 24" or 27" high cabinets.
- Includes five adjustable shelves.
- Toekick shipped attached unless otherwise specified.

**U249324AH**

**U279324AH**

**U309324AH**

**U339324AH**

**U369324AH**

- AH represents upper section alignment with doors on 24" or 27" high cabinets.
- Includes five adjustable shelves.
- Shipped with loose toe space unless Attach Toekick or Flush Toekick is specified.

**U249624**

**U279624**

**U309624**

**U339624**

**U369624**

- Includes six adjustable shelves.
- Shipped with loose toe space unless Attach Toekick or Flush Toekick is specified.
- Flush Toekick option not available in conjunction with Wide Top Rail unless loose Flush Toekick is specified.

Notes below apply to all products in section above:

- Large opening on tall doors will include two panels.
- Increased Depths available in 1/4" increments from 24 1/4" to 30".
- Reduced Depths available in 1/4" increments from 6" to 23 3/4".

### Door & Drawer Options

AF	CC	CG	ESMD <sup>1</sup>	GAMD <sup>1</sup>	IFHG	MD <sup>1</sup>	MFO	PRMD <sup>1</sup>	SHMD <sup>1</sup>	SPLITDR	SUMD <sup>1</sup>
✓	✓	✓	✓	✓	✓	✓	✓	✓	✓	✓	✓

### End Panel Options

AUTH	CSFPE	EXBK	FFD	FPE	INTGE	IPE
✓	✓	✓	✓	✓	✓	✓

### Custom Modification Options

ATTK <sup>2</sup>	CBO <sup>3</sup>	CCO	CFNTO	CFRMO <sup>4</sup>	CLIP <sup>5</sup>	CND	CSDGBK	DRT	DRWTK	EF	EX	EX	OL	FLUT <sup>6</sup>	FTK	ID	IH <sup>7</sup>	IW <sup>8</sup>	LIGHT <sup>9</sup>	MIP	OBRB	
✓	✓	✓	✓	✓	✓	✓	✓	✓	✓	✓	✓	✓	✓	✓	✓	✓	✓	✓	✓	✓	✓	✓

RD	RECTK <sup>10</sup>	RH	ROSFLUT	RT	TD <sup>1</sup>	TKP <sup>11</sup>	TVR	VTK	WS	WTR
✓	✓	✓	✓	✓	✓	✓	✓	✓	✓	✓

<sup>1</sup>Only available on top section.

<sup>2</sup>Only available on 93"-96" high.

<sup>3</sup>Only available on 24" wide.

<sup>4</sup>Not available on 2496 version.

<sup>5</sup>Not available on 24" wide.

<sup>6</sup>Not available with 6" fluting.

<sup>7</sup>Not available on 96" high.

<sup>8</sup>Not available on 36" wide.

<sup>9</sup>Not available on 24" wide.

<sup>10</sup>Only available on RECTKL.R.BK.

<sup>11</sup>Not available on 93"-96" high.

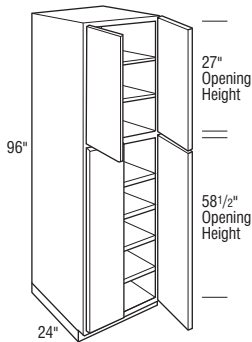
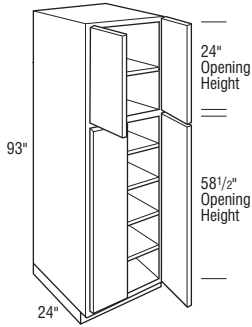
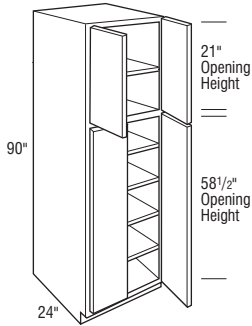
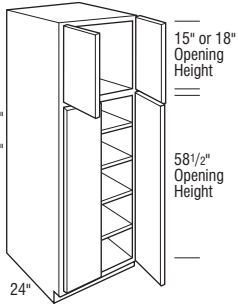

IH/RH availability charts starting on page G•40.  
IW/RW availability charts starting on page G•46.

## Description

**NEW** UTILITY, 102" or 108" HIGH,  
24" DEEP

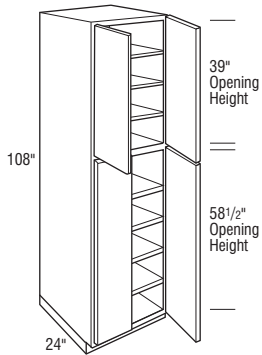
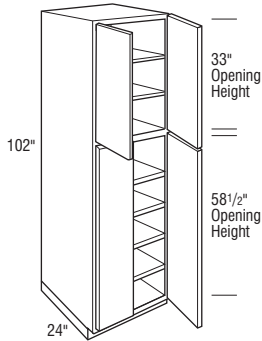

## Model

U2410224

U2710224

U3010224

U3310224

U3610224

- Includes six adjustable shelves.

U2410824

U2710824

U3010824

U3310824

U3610824

- Includes seven adjustable shelves.

### Notes below apply to all products in section above:

- Shipped with loose toe space unless Attach Toekick or Flush Toekick is specified.
- Large opening on tall doors will include two panels.
- Increased Depths available in 1/4" increments from 24 1/4" to 26".
- Reduced Depths available in 1/4" increments from 6" to 23 3/4".
- Finish Flushed Ends standard.
- Available in Cherry and Maple only.

### Door & Drawer Options

AF	CC	CG	ESMD <sup>1</sup>	GAMD <sup>1</sup>	IFHG	MD <sup>1</sup>	MFO	PRMD <sup>1</sup>	SHMD <sup>1</sup>	SPLITDR	SUMD <sup>1</sup>
✓	✓	✓	✓	✓	✓	✓	✓	✓	✓	✓	✓

### End Panel Options

AUTH	CSFPE	EXBK <sup>2</sup>	FFD	FPE	INTGE	IPE
✓	✓	✓	✓	✓	✓	✓

### Custom Modification Options

ATTK	CBO	CCO	CFNT0	CFRMO	CLIP	CND	CSDGBK	DRT	DRWTK <sup>3</sup>	EF	EX	EX_OL	FLUT <sup>4</sup>	FTK	ID	IH <sup>5</sup>	IW <sup>6</sup>	LIGHT <sup>7</sup>	MIP	OBRB	
✓	✓	✓	✓	✓	✓	✓	✓	✓	✓	✓	✓	✓	✓	✓	✓	✓	✓	✓	✓	✓	✓

RD	RECTK	RH <sup>5</sup>	ROSLUT <sup>4</sup>	RT	TD <sup>1</sup>	TKP	TVR	VTK	WS	WTR
✓	✓	✓	✓	✓	✓	✓	✓	✓	✓	✓

<sup>1</sup>Only available on top section.  
<sup>2</sup>This modification will allow the end to extend back to a maximum of 30" deep.  
<sup>3</sup>Only available when used in conjunction with attach toekick modification.  
<sup>4</sup>Not available with 6" fluting.  
<sup>5</sup>Not available on 108" high.  
<sup>6</sup>Not available on 36" wide.  
<sup>7</sup>Not available on 24" wide.

# Utility Drawer Cabinets

## Description

**UTILITY with THREE DRAWERS, 84", 87", 90", 93", or 96" HIGH, 24" DEEP**

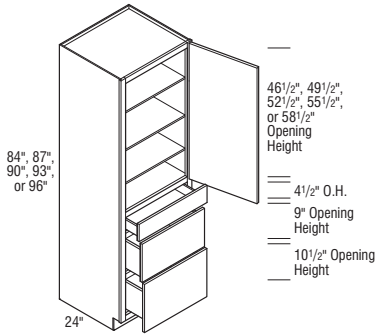

## Model

**U3D128424 L or R**

**U3D158424 L or R**

**U3D188424 L or R**

**U3D218424 L or R**

**U3D248424 L or R**

**U3D128724 L or R**

**U3D158724 L or R**

**U3D188724 L or R**

**U3D218724 L or R**

**U3D248724 L or R**

**U3D129024 L or R**

**U3D159024 L or R**

**U3D189024 L or R**

**U3D219024 L or R**

**U3D249024 L or R**

- Includes three adjustable shelves in upper section.

**U3D129324 L or R**

**U3D159324 L or R**

**U3D189324 L or R**

**U3D219324 L or R**

**U3D249324 L or R**

- Includes four adjustable shelves in upper section.
- Shipped with loose toe space unless Attach Toekick or Flush Toekick is specified.

**U3D129624 L or R**

**U3D159624 L or R**

**U3D189624 L or R**

**U3D219624 L or R**

**U3D249624 L or R**

- Includes four adjustable shelves in upper section.
- Shipped with loose toe space unless Attach Toekick or Flush Toekick is specified.
- Flush Toekick option not available in conjunction with Wide Top Rail unless loose Flush Toekick is specified.

### Notes below apply to all products in section above:

- Large opening on tall doors will include two panels.
- Drawers are the same size as on a standard 34 1/2" high three drawer base.
- Reduced Depths available in 1/4" increments from 12" to 23 3/4".
- For Inset and Beaded Inset styles opening sizes, see pages F•14-F•18.

### Door & Drawer Options

AF	CC	CG	ESMD	GAMD	IFHG	MD	MFO	PRMD	SHMD	SPLITDR	SUMD
✓	✓				✓		✓				

### End Panel Options

AUTH	CSFPE	EXBK	FFD	FPE	INTGE	IPE
✓	✓	✓	✓	✓	✓	✓

### Custom Modification Options

ATTK <sup>1</sup>	CBO	CCO	CFNTO	CFRMO	CLIP <sup>2</sup>	CND	CSDGBK	DRT	DRWTK	EF	EX	EX_OL	FLUT	FTK <sup>3</sup>	ID	IH <sup>4</sup>	IW <sup>5</sup>	LIGHT	MIP	OBRB	
✓	✓	✓	✓	✓	✓	✓	✓	✓	✓	✓	✓	✓	✓	✓	✓	✓	✓	✓	✓	✓	✓

RD	RECTK	RH	ROSLUT	RT	TD	TKP <sup>6</sup>	TVR <sup>7</sup>	VTK	WS	WTR
✓	✓	✓	✓	✓	✓	✓	✓	✓	✓	✓

<sup>1</sup>Only available on 93" or 96" high.

<sup>2</sup>Not available on 12" wide.

<sup>3</sup>FTKAV not available on 12" wide.

<sup>4</sup>Not available on 96" high.

<sup>5</sup>Not available on 24" wide.

<sup>6</sup>Not available on 93" or 96" high.

<sup>7</sup>TVRAV not available on 12" wide.

IH/RH availability charts starting on page G•40.  
IW/RW availability charts starting on page G•46.

## Description

**UTILITY with THREE DRAWERS, 84", 87", 90", 93", or 96" HIGH, 24" DEEP**

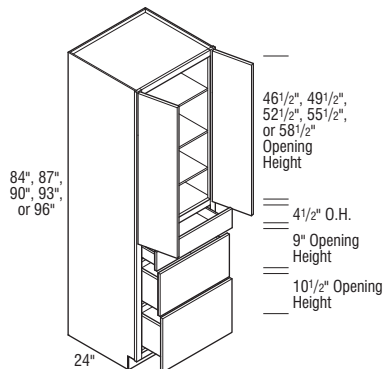

## Model

**U3D248424**

**U3D278424**

**U3D308424**

**U3D338424**

**U3D368424**

**U3D248724**

**U3D278724**

**U3D308724**

**U3D338724**

**U3D368724**

**U3D249024**

**U3D279024**

**U3D309024**

**U3D339024**

**U3D369024**

- Includes three adjustable shelves in upper section.

**U3D249324**

**U3D279324**

**U3D309324**

**U3D339324**

**U3D369324**

- Includes four adjustable shelves in upper section.
- Shipped with loose toe space unless Attach Toekick or Flush Toekick is specified.

**U3D249624**

**U3D279624**

**U3D309624**

**U3D339624**

**U3D369624**

- Includes four adjustable shelves in upper section.
- Shipped with loose toe space unless Attach Toekick or Flush Toekick is specified.
- Flush Toekick option not available in conjunction with Wide Top Rail unless loose Flush Toekick is specified.

### Notes below apply to all products in section above:

- Large opening on tall doors will include two panels.
- Drawers are the same size as on a standard 34 1/2" high three drawer base.
- Reduced Depths available in 1/4" increments from 12" to 23 3/4".
- For Inset and Beaded Inset styles opening sizes, see pages F•14-F•18.

### Door & Drawer Options

AF	CC	CG	ESMD	GAMD	IFHG	MD	MFO	PRMD	SHMD	SPLITDR	SUMD
✓	✓	✓			✓		✓			✓	

### End Panel Options

AUTH	CSFPE	EXBK	FFD	FPE	INTGE	IPE
✓	✓	✓	✓	✓	✓	✓

### Custom Modification Options

ATTK <sup>1</sup>	CBO	CCO	CFNTD	CFRMO	CLIP	CND	CSDGBK	DRT	DRWTK	EF	EX	EX_OL	FLUT	FTK	ID	IH <sup>2</sup>	IW <sup>3</sup>	LIGHT	MIP	OBRB	
✓	✓	✓	✓	✓	✓	✓	✓	✓	✓	✓	✓	✓	✓	✓	✓	✓	✓	✓	✓	✓	✓

RD	RECTK	RH	ROSLUT	RT	TD	TKP <sup>4</sup>	TVR	VTK	WS <sup>5</sup>	WTR
✓	✓	✓	✓	✓	✓	✓	✓	✓	✓	✓

<sup>1</sup>Only available on 93" or 96" high.

<sup>2</sup>Not available on 96" high.

<sup>3</sup>Not available on 36" wide.

<sup>4</sup>Not available on 93"-96" high.

<sup>5</sup>Not available on 24" wide.



# Utility Drawer Cabinets

## Description

**UTILITY with FOUR DRAWERS, 84", 87", 90", 93", or 96" HIGH, 24" DEEP**

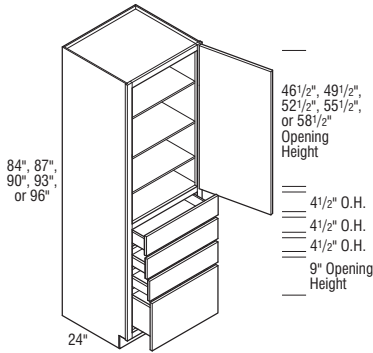

## Model

**U4D128424 L or R**

**U4D158424 L or R**

**U4D188424 L or R**

**U4D218424 L or R**

**U4D248424 L or R**

**U4D128724 L or R**

**U4D158724 L or R**

**U4D188724 L or R**

**U4D218724 L or R**

**U4D248724 L or R**

**U4D129024 L or R**

**U4D159024 L or R**

**U4D189024 L or R**

**U4D219024 L or R**

**U4D249024 L or R**

- Includes three adjustable shelves in upper section.

**U4D129324 L or R**

**U4D159324 L or R**

**U4D189324 L or R**

**U4D219324 L or R**

**U4D249324 L or R**

- Includes four adjustable shelves in upper section.
- Shipped with loose toe space unless Attach Toekick or Flush Toekick is specified.

**U4D129624 L or R**

**U4D159624 L or R**

**U4D189624 L or R**

**U4D219624 L or R**

**U4D249624 L or R**

- Includes four adjustable shelves in upper section.
- Shipped with loose toe space unless Attach Toekick or Flush Toekick is specified.
- Flush Toekick option not available in conjunction with Wide Top Rail unless loose Flush Toekick is specified.

### Notes below apply to all products in section above:

- Large opening on tall doors will include two panels.
- Drawers are the same size as on a standard 34 1/2" high four drawer base.
- Reduced Depths available in 1/4" increments from 12" to 23 3/4".
- For Inset and Beaded Inset styles opening sizes, see pages F•14-F•18.

### Door & Drawer Options

AF	CC	CG	ESMD	GAMD	IFHG	MD	MFO	PRMD	SHMD	SPLITDR	SUMD
✓	✓				✓		✓				

### End Panel Options

AUTH	CSFPE	EXBK	FFD	FPE	INTGE	IPE
✓	✓	✓	✓	✓	✓	✓

### Custom Modification Options

ATTK <sup>1</sup>	CBO	CCO	CFNTO	CFRMO	CLIP <sup>2</sup>	CND	CSDGBK	DRT	DRWTK	EF	EX	EX_OL	FLUT	FTK <sup>3</sup>	ID	IH <sup>4</sup>	IW <sup>5</sup>	LIGHT	MIP	OBRB	
✓	✓	✓	✓	✓	✓	✓	✓	✓	✓	✓	✓	✓	✓	✓	✓	✓	✓	✓	✓	✓	✓

RD	RECTK	RH	ROSLUT	RT	TD	TKP <sup>6</sup>	TVR <sup>7</sup>	VTK	WS <sup>8</sup>	WTR
✓	✓	✓	✓	✓	✓	✓	✓	✓	✓	✓

<sup>1</sup>Only available on 93" or 96" high.  
<sup>2</sup>Not available on 12" wide.  
<sup>3</sup>FTKAV not available on 12" wide.  
<sup>4</sup>Not available on 96" high.  
<sup>5</sup>Not available on 24" wide.  
<sup>6</sup>Not available on 93"-96" high.  
<sup>7</sup>TVRAV not available on 12" wide.  
<sup>8</sup>Wide stile both 3" not available on 12" wide.

IH/RH availability charts starting on page G•40.  
 IW/RW availability charts starting on page G•46.

## Description

**UTILITY with FOUR DRAWERS, 84", 87", 90", 93", or 96" HIGH, 24" DEEP**

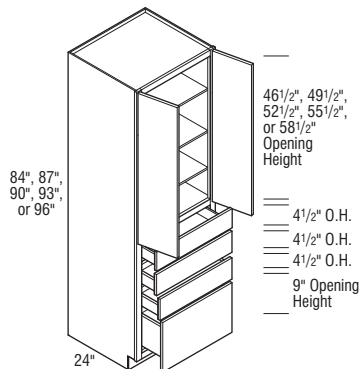

## Model

**U4D248424**

**U4D278424**

**U4D308424**

**U4D338424**

**U4D368424**

**U4D248724**

**U4D278724**

**U4D308724**

**U4D338724**

**U4D368724**

**U4D249024**

**U4D279024**

**U4D309024**

**U4D339024**

**U4D369024**

- Includes three adjustable shelves in upper section.

**U4D249324**

**U4D279324**

**U4D309324**

**U4D339324**

**U4D369324**

- Includes four adjustable shelves in upper section.
- Shipped with loose toe space unless Attach Toekick or Flush Toekick is specified.

**U4D249624**

**U4D279624**

**U4D309624**

**U4D339624**

**U4D369624**

- Includes four adjustable shelves in upper section.
- Shipped with loose toe space unless Attach Toekick or Flush Toekick is specified.
- Flush Toekick option not available in conjunction with Wide Top Rail unless loose Flush Toekick is specified.

### Notes below apply to all products in section above:

- Large opening on tall doors will include two panels.
- Drawers are the same size as on a standard 34 1/2" high four drawer base.
- Reduced Depths available in 1/4" increments from 12" to 23 3/4".
- For Inset and Beaded Inset styles opening sizes, see pages F•14-F•18.

### Door & Drawer Options

AF	CC	CG	ESMD	GAMD	IFHG	MD	MFO	PRMD	SHMD	SPLITDR	SUMD
✓	✓	✓			✓		✓			✓	

### End Panel Options

AUTH	CSFPE	EXBK	FFD	FPE	INTGE	IPE
✓	✓	✓	✓	✓	✓	✓

### Custom Modification Options

ATTK <sup>1</sup>	CBO	CCO	CFNTD	CFRMO	CLIP	CND	CSDGBK	DRT	DRWTK	EF	EX	EX_OL	FLUT	FTK	ID	IW <sup>2</sup>	LIGHT	MIP	OBRB
✓	✓	✓	✓	✓	✓	✓	✓	✓	✓	✓	✓	✓	✓	✓	✓	✓	✓	✓	✓

RD	RECTK	RH	ROSLUT	RT	TD	TKP <sup>3</sup>	TVR	VTK	WS <sup>4</sup>	WTR
✓	✓	✓	✓	✓	✓	✓	✓	✓	✓	✓

<sup>1</sup>Only available on 93" or 96" high.

<sup>2</sup>Not available on 36" wide.

<sup>3</sup>Not available on 93"-96" high.

<sup>4</sup>Not available on 24" wide.

# Utility Inverted Cabinets

## Description

## Model

**UTILITY INVERTED, 84", 87", 90", 93", or 96" HIGH, 24" DEEP**

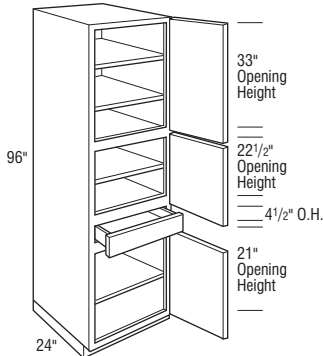
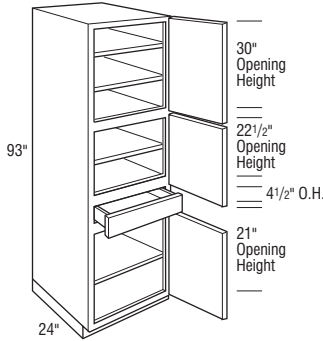
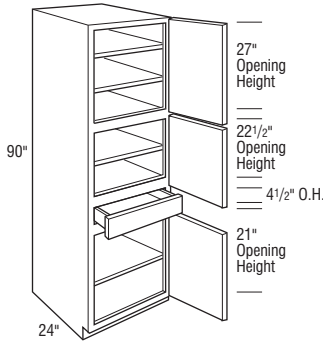
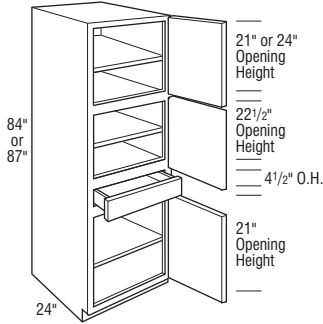

**UI128424 L or R**

**UI158424 L or R**

**UI188424 L or R**

**UI218424 L or R**

**UI248424 L or R**

**UI128724 L or R**

**UI158724 L or R**

**UI188724 L or R**

**UI218724 L or R**

**UI248724 L or R**

- Includes three adjustable shelves.

**UI129024 L or R**

**UI159024 L or R**

**UI189024 L or R**

**UI219024 L or R**

**UI249024 L or R**

- Includes four adjustable shelves.
- Toekick shipped attached unless otherwise specified.

**UI129324 L or R**

**UI159324 L or R**

**UI189324 L or R**

**UI219324 L or R**

**UI249324 L or R**

- Includes four adjustable shelves.
- Shipped with loose toe space unless Attach Toekick or Flush Toekick is specified.

**UI129624 L or R**

**UI159624 L or R**

**UI189624 L or R**

**UI219624 L or R**

**UI249624 L or R**

- Includes four adjustable shelves.
- Shipped with loose toe space unless Attach Toekick or Flush Toekick is specified.
- Flush Toekick option not available in conjunction with Wide Top Rail unless loose Flush Toekick is specified.

Notes below apply to all products in section above:

- Reduced Depths available in 1/4" increments from 12" to 23 3/4".
- For Inset and Beaded Inset styles opening sizes, see pages F-14-F-18.

### Door & Drawer Options

AF	CC	CG	ESMD	GAMD	IFHG	MD	MFO	PRMD <sup>1</sup>	SHMD <sup>2</sup>	SPLITDR	SUMD
✓	✓	✓	✓	✓	✓	✓	✓	✓	✓	✓	✓

### End Panel Options

AUTH	CSFPE	EXBK	FFD	FPE	INTGE	IPE
✓	✓	✓	✓	✓	✓	✓

### Custom Modification Options

ATTK <sup>3</sup>	CBO	CCO	CFNTO	CFRMO	CLIP <sup>4</sup>	CND	CSDGBK	DRT	DRWTK	EF	EX	EX_OL	FLUT <sup>5</sup>	FTK <sup>6</sup>	ID	IH	IW	LIGHT	MIP	OBRB	
✓	✓	✓	✓	✓	✓	✓	✓	✓	✓	✓	✓	✓	✓	✓	✓	✓	✓	✓	✓	✓	✓

RD	RECTK <sup>7</sup>	RH	ROSFLUT	RT	TD	TKP <sup>8</sup>	TVR <sup>1</sup>	VTK	WS	WTR
✓	✓	✓	✓	✓	✓	✓	✓	✓	✓	✓

<sup>1</sup>Not available on 12" wide.

<sup>2</sup>Only available on top section.

<sup>3</sup>Only available on 93"-96" high.

<sup>4</sup>Not available on 12" wide.

<sup>5</sup>Not available with 6" fluting.

<sup>6</sup>FTKAV not available on 12" wide.

<sup>7</sup>Only available on RECTKL.R.BK.

<sup>8</sup>Not available on 93"-96" high.

IH/RH availability charts starting on page G-40.  
IW/RW availability charts starting on page G-46.

## Description

**NEW** UTILITY INVERTED, 102" or 108" HIGH, 24" DEEP

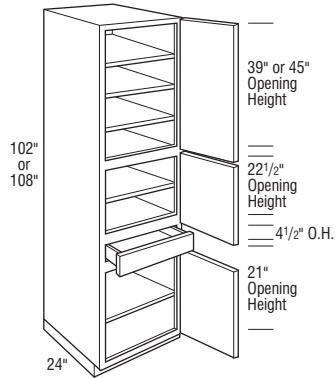

## Model

UI1210224 L or R

UI1510224 L or R

UI1810224 L or R

UI2110224 L or R

UI2410224 L or R

UI1210824 L or R

UI1510824 L or R

UI1810824 L or R

UI2110824 L or R

UI2410824 L or R

- Includes five adjustable shelves.
- Shipped with loose toe space unless Attach Toekick or Flush Toekick is specified.
- Reduced Depths available in 1/4" increments from 12" to 23 3/4".
- Finish Flushed Ends standard.
- Available in Cherry and Maple only.
- For Inset and Beaded Inset styles opening sizes, see pages F•14-F•18.

### Door & Drawer Options

AF	CC	CG	ESMD	GAMD	IFHG	MD	MFO	PRMD <sup>1</sup>	SHMD <sup>2</sup>	SPLITDR	SUMD
✓	✓	✓	✓	✓	✓	✓	✓	✓	✓	✓	✓

### End Panel Options

AUTH	CSFPE	EXBK <sup>3</sup>	FFD	FPE	INTGE	IPE
✓	✓	✓	✓	✓	✓	✓

### Custom Modification Options

ATTK	CBO	CCO	CFNT0	CFRMO	CLIP	CND	CSDGBK	DRT	DRWTK <sup>4</sup>	EF	EX	EX_OL	FLUT <sup>5</sup>	FTK <sup>6</sup>	ID	IH <sup>7</sup>	IW	LIGHT	MIP	OBRB	
✓	✓	✓	✓	✓	✓	✓	✓	✓	✓	✓	✓	✓	✓	✓	✓	✓	✓	✓	✓	✓	✓

RD	RECTK	RH <sup>7</sup>	ROSLUT <sup>5</sup>	RT	TD	TKP	TVR <sup>1</sup>	VTK	WS	WTR
✓	✓	✓	✓	✓	✓	✓	✓	✓	✓	✓

- <sup>1</sup>Not available on 12" wide.  
<sup>2</sup>Only available on top section.  
<sup>3</sup>This modification will allow the end to extend back to a maximum of 30" deep.  
<sup>4</sup>Only available when used in conjunction with attach toekick modification.  
<sup>5</sup>Not available with 6" fluting.  
<sup>6</sup>FTKAV not available on 12" wide.  
<sup>7</sup>Not available on 108" high.

# Utility with Roll Trays Cabinets

## Description

## Model

**UTILITY with ROLL TRAYS, 84", 87", 90", 93", or 96" HIGH, 24" DEEP**

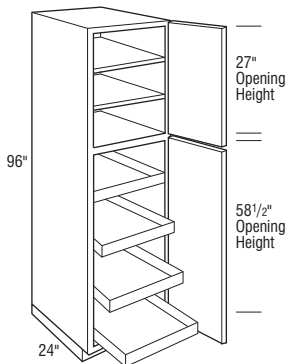
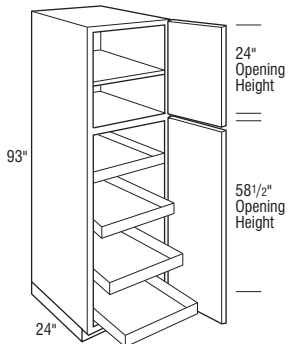
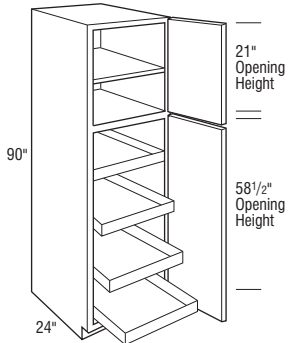
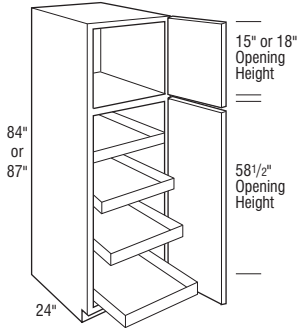

**U158424RT L or R**

**U188424RT L or R**

**U218424RT L or R**

**U248424RT L or R**

**U158724RT L or R**

**U188724RT L or R**

**U218724RT L or R**

**U248724RT L or R**

**U159024RTAH L or R**

**U189024RTAH L or R**

**U219024RTAH L or R**

**U249024RTAH L or R**

- AH represents upper section alignment with doors on 24" or 27" high cabinets.
- Includes one adjustable shelf in upper section.
- Toekick shipped attached unless otherwise specified.

**U159324RTAH L or R**

**U189324RTAH L or R**

**U219324RTAH L or R**

**U249324RTAH L or R**

- AH represents upper section alignment with doors on 24" or 27" high cabinets.
- Includes one adjustable shelf in upper section.
- Shipped with loose toe space unless Attach Toekick or Flush Toekick is specified.

**U159624RT L or R**

**U189624RT L or R**

**U219624RT L or R**

**U249624RT L or R**

- Includes two adjustable shelves in upper section.
- Shipped with loose toe space unless Attach Toekick or Flush Toekick is specified.
- Flush Toekick option not available in conjunction with Wide Top Rail unless loose Flush Toekick is specified.

Notes below apply to all products in section above:

- Large opening on tall doors will include two panels.
- Contains four easily adjustable roll trays.
- Reduced Depths available in 1/4" increments from 12" to 23 3/4".

### Door & Drawer Options

AF	CC	CG	ESMD <sup>1</sup>	GAMD <sup>1</sup>	IFHG	MD <sup>1</sup>	MFO	PRMD <sup>1</sup>	SHMD <sup>1</sup>	SPLITDR	SUMD <sup>1</sup>
✓	✓	✓	✓	✓	✓	✓	✓	✓	✓	✓	✓

### End Panel Options

AUTH	CSFPE	EXBK	FFD	FPE	INTGE	IPE
✓	✓	✓	✓	✓	✓	✓

### Custom Modification Options

ATTK <sup>2</sup>	CBO	CCO	CFNTO	CFRMO	CLIP	CND	CSDGBK	DRT	DRWTK	EF	EX	EX_OL	FLUT <sup>3</sup>	FTK	ID	IH <sup>4</sup>	IW <sup>5</sup>	LIGHT	MIP	OBRB	
✓	✓	✓	✓	✓	✓	✓	✓	✓	✓	✓	✓	✓	✓	✓	✓	✓	✓	✓	✓	✓	✓

RD	RECTK	RH	ROSLUT	RT <sup>1</sup>	TD <sup>1</sup>	TKP <sup>6</sup>	TVR	VTK	WS	WTR
✓	✓	✓	✓	✓	✓	✓	✓	✓	✓	✓

<sup>1</sup>Only available on top section.

<sup>2</sup>Only available 93"-96" high.

<sup>3</sup>Not available with 6" fluting.

<sup>4</sup>Not available on 96" high.

<sup>5</sup>Not available on 24" wide.

<sup>6</sup>Not available on 93"-96" high.

IH/RH availability charts starting on page G•40.  
IW/RW availability charts starting on page G•46.

## Description

**NEW** UTILITY with ROLL TRAYS,  
102" or 108" HIGH, 24" DEEP

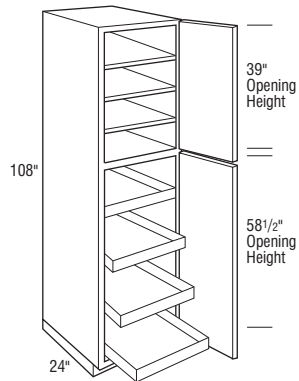
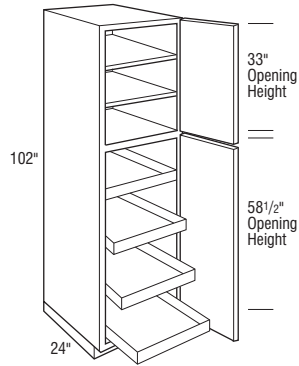

## Model

**U1510224RT L or R**

**U1810224RT L or R**

**U2110224RT L or R**

**U2410224RT L or R**

- Includes two adjustable shelves in upper section.

**U1510824RT L or R**

**U1810824RT L or R**

**U2110824RT L or R**

**U2410824RT L or R**

- Includes three adjustable shelves in upper section.

Notes below apply to all products in section above:

- Shipped with loose toe space unless Attach Toekick or Flush Toekick is specified.
- Large opening on tall doors will include two panels.
- Contains four easily adjustable roll trays.
- Reduced Depths available in 1/4" increments from 12" to 23 3/4".
- Finish Flushed Ends standard.
- Available in Cherry and Maple only.

### Door & Drawer Options

AF	CC	CG	ESMD <sup>1</sup>	GAMD <sup>1</sup>	IFHG	MD <sup>1</sup>	MFO	PRMD <sup>1</sup>	SHMD <sup>1</sup>	SPLITDR	SUMD <sup>1</sup>
✓	✓	✓	✓	✓	✓	✓	✓	✓	✓	✓	✓

### End Panel Options

AUTH	CSFPE	EXBK <sup>2</sup>	FFD	FPE	INTGE	IPE
✓	✓	✓	✓	✓	✓	✓

### Custom Modification Options

ATTK	CBO	CCO	CFNT0	CFRMO	CLIP	CND	CSDGBK	DRT	DRWTK <sup>3</sup>	EF	EX	EX_OL	FLUT <sup>4</sup>	FTK	ID	IH <sup>5</sup>	IW <sup>6</sup>	LIGHT	MIP	OBRB
✓	✓	✓	✓	✓	✓	✓	✓	✓	✓	✓	✓	✓	✓	✓	✓	✓	✓	✓	✓	✓
RD	RECTK	RH <sup>5</sup>	ROSLUT <sup>4</sup>	RT <sup>1</sup>	TD <sup>1</sup>	TKP	TVR	VTK	WS	WTR										
✓	✓	✓	✓	✓	✓	✓	✓	✓	✓	✓										

<sup>1</sup>Only available on top section.

<sup>2</sup>This modification will allow the end to extend back to a maximum of 30" deep.

<sup>3</sup>Only available when used in conjunction with attach toekick modification.

<sup>4</sup>Not available with 6" fluting.

<sup>5</sup>Not available on 108" high.

<sup>6</sup>Not available on 24" wide.

# Utility with Roll Trays Cabinets

## Description

## Model

**UTILITY with ROLL TRAYS, 84", 87", 90", 93", or 96" HIGH, 24" DEEP**

**U248424RT**

**U278424RT**

**U308424RT**

**U338424RT**

**U368424RT**

**U248724RT**

**U278724RT**

**U308724RT**

**U338724RT**

**U368724RT**

**U249024RTAH**

**U279024RTAH**

**U309024RTAH**

**U339024RTAH**

**U369024RTAH**

- AH represents upper section alignment with doors on 24" or 27" high cabinets.
- Includes one adjustable shelf in upper section.
- Toekick shipped attached unless otherwise specified.

**U249324RTAH**

**U279324RTAH**

**U309324RTAH**

**U339324RTAH**

**U369324RTAH**

- AH represents upper section alignment with doors on 24" or 27" high cabinets.
- Includes one adjustable shelf in upper section.
- Shipped with loose toe space unless Attach Toekick or Flush Toekick is specified.

**U249624RT**

**U279624RT**

**U309624RT**

**U339624RT**

**U369624RT**

- Includes two adjustable shelves in upper section.
- Shipped with loose toe space unless Attach Toekick or Flush Toekick is specified.
- Flush Toekick option not available in conjunction with Wide Top Rail unless loose Flush Toekick is specified.

### Notes below apply to all products in section above:

- Large opening on tall doors will include two panels.
- Contains four easily adjustable roll trays.
- Reduced Depths available in 1/4" increments from 12" to 23 3/4".

### Door & Drawer Options

AF	CC	CG	ESMD <sup>1</sup>	GAMD <sup>1</sup>	IFHG	MD <sup>1</sup>	MFO	PRMD <sup>1</sup>	SHMD <sup>1</sup>	SPLITDR	SUMD <sup>1</sup>
✓	✓	✓	✓	✓	✓	✓	✓	✓	✓	✓	✓

### End Panel Options

AUTH	CSFPE	EXBK	FFD	FPE	INTGE	IPE
✓	✓	✓	✓	✓	✓	✓

### Custom Modification Options

ATTK <sup>2</sup>	CBO <sup>3</sup>	CCO	CFNTQ <sup>4</sup>	CFRMO <sup>4</sup>	CLIP <sup>5</sup>	CND	CSDGBK	DRT	DRWTK	EF	EX	EX_OL	FLUT <sup>6</sup>	FTK	ID	IH <sup>7</sup>	IW <sup>8</sup>	LIGHT	MIP	OBRB
✓	✓	✓	✓	✓	✓	✓	✓	✓	✓	✓	✓	✓	✓	✓	✓	✓	✓	✓	✓	✓

RD	RECTK <sup>9</sup>	RH	ROSLUT	RT <sup>1</sup>	TD <sup>1</sup>	TKP <sup>10</sup>	TVR	VTK	WS	WTR
✓	✓	✓	✓	✓	✓	✓	✓	✓	✓	✓

<sup>1</sup>Only available on top section.

<sup>2</sup>Only available on 93"-96" high.

<sup>3</sup>Only available on 24" wide.

<sup>4</sup>Not available on 24" wide.

<sup>5</sup>Not available on 24" wide. Not available with 6" clipped corners.

<sup>6</sup>Not available with 6" fluting.

<sup>7</sup>Not available on 96" high.

<sup>8</sup>Not available on 36" wide.

<sup>9</sup>Only available on RECTKL.R.BK.

<sup>10</sup>Not available on 93"-96" high.

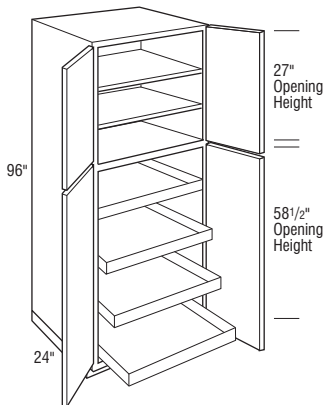
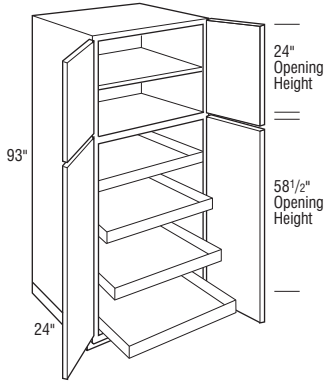
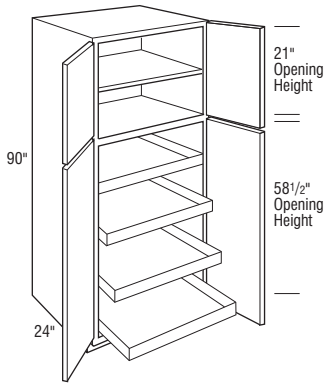
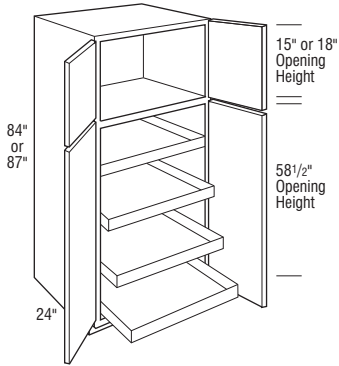

IH/RH availability charts starting on page G-40.  
IW/RW availability charts starting on page G-46.

## Description



**UTILITY with ROLL TRAYS,  
102" or 108" HIGH, 24" DEEP**

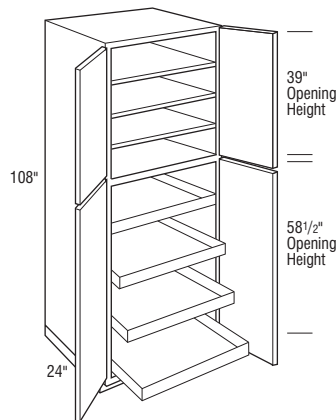
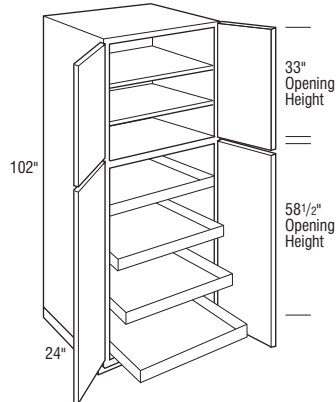

## Model

**U2410224RT**

**U2710224RT**

**U3010224RT**

**U3310224RT**

**U3610224RT**

- Includes two adjustable shelves in upper section.

**U2410824RT**

**U2710824RT**

**U3010824RT**

**U3310824RT**

**U3610824RT**

- Includes three adjustable shelves in upper section.

Notes below apply to all products in section above:

- Shipped with loose toe space unless Attach Toekick or Flush Toekick is specified.
- Large opening on tall doors will include two panels.
- Contains four easily adjustable roll trays.
- Reduced Depths available in 1/4" increments from 12" to 23 3/4".
- Finish Flushed Ends standard.
- Available in Cherry and Maple only.

### Door & Drawer Options

AF	CC	CG	ESMD <sup>1</sup>	GAMD <sup>1</sup>	IFHG	MD <sup>1</sup>	MFO	PRMD <sup>1</sup>	SHMD <sup>1</sup>	SPLITDR	SUMD <sup>1</sup>
✓	✓	✓	✓	✓	✓	✓	✓	✓	✓	✓	✓

### End Panel Options

AUTH	CSFPE	EXBK <sup>2</sup>	FFD	FPE	INTGE	IPE
✓	✓	✓	✓	✓	✓	✓

### Custom Modification Options

ATTK	CBO	CCO	CFNT0	CFRMO	CLIP	CND	CSDGBK	DRT	DRWTK <sup>3</sup>	EF	EX	EX_OL	FLUT <sup>4</sup>	FTK	ID	IH <sup>5</sup>	IW <sup>6</sup>	LIGHT	MIP	OBRB	
✓	✓	✓	✓	✓	✓	✓	✓	✓	✓	✓	✓	✓	✓	✓	✓	✓	✓	✓	✓	✓	✓

RD	RECTK	RH <sup>5</sup>	ROSFLUT <sup>4</sup>	RT <sup>1</sup>	TD <sup>1</sup>	TKP	TVR	VTK	WS	WTR
✓	✓	✓	✓	✓	✓	✓	✓	✓	✓	✓

<sup>1</sup>Only available on top section.

<sup>2</sup>This modification will allow the end to extend back to a maximum of 30" deep.

<sup>3</sup>Only available when used in conjunction with attach toekick modification.

<sup>4</sup>Not available with 6" fluting.

<sup>5</sup>Not available on 108" high.

<sup>6</sup>Not available on 36" wide.



# Tall Pantry Pull-outs

## Description

**TALL PANTRY PULL-OUT, 66", 84", 87", 90", 93", or 96" HIGH, 24" DEEP storage solutions**

## Model

TPP96624  
 TPP126624  
 TPP156624  
 TPP186624

- This unit is not designed to be freestanding. It must be bolted or screwed to the wall. Failure to do so will result in the unit tipping forward and will invalidate the product warranty.

TPP98424 L or R

TPP128424 L or R

TPP158424 L or R

TPP188424 L or R

TPP98724 L or R

TPP128724 L or R

TPP158724 L or R

TPP188724 L or R

TPP99024AH L or R

TPP129024AH L or R

TPP159024AH L or R

TPP189024AH L or R

- AH represents upper section alignment with doors on 24" or 27" high cabinets.
- Toekick shipped attached unless otherwise specified.

Notes below apply to all products in section above:

- Pull-outs include adjustable wood/chrome shelves.
- Large opening on tall doors will include two panels.
- Not available on Inset and Beaded Inset styles.

### Door & Drawer Options

AF	CC	CG <sup>1</sup>	ESMD <sup>2</sup>	GAMD <sup>2</sup>	IFHG	MD <sup>2</sup>	MFO	PRMD <sup>3</sup>	SHMD <sup>2</sup>	SPLITDR	SJMD <sup>2</sup>
		✓	✓	✓	✓	✓	✓	✓	✓	✓	✓

### End Panel Options

AUTH	CSFPE	EXBK	FFD	FPE	INTGE	IPE
✓	✓	✓	✓	✓	✓	✓

### Custom Modification Options

AITTK	CBO	CCO	CFNTO	CFRMO	CLIP	CND <sup>1</sup>	CSDGBK	DRT	DRWTK	EF	EX	EX_OL	FLUT <sup>4</sup>	FTK <sup>5</sup>	ID	IH <sup>6</sup>	IW	LIGHT	MIP	OBRB
						✓	✓			✓	✓	✓	✓	✓	✓	✓	✓		✓	✓

RD	RECTK <sup>7</sup>	RH	ROSLUT	RT <sup>2</sup>	TD <sup>1</sup>	TKP	TVR <sup>3</sup>	VTK	WS <sup>8</sup>	WTR
	✓		✓	✓	✓	✓	✓	✓	✓	✓

<sup>1</sup>Not available on 66" high and only available on top section.

<sup>2</sup>Not available on 66" high and only available on top section and not available with 9" wide.

<sup>3</sup>Only available on 15"-18" wide. Not available on 66" high. Only available on top section.

<sup>4</sup>Not available with 6" fluting.

<sup>5</sup>FTKAV not available on 12" wide.

<sup>6</sup>Not available on 96" high, 9" wide, or 66" high.

<sup>7</sup>Only available on RECTKL.R.BK.

<sup>8</sup>Not available on 9" wide.

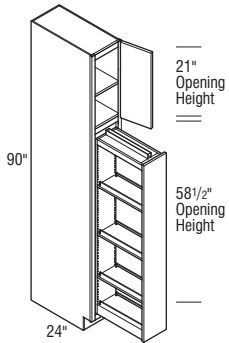
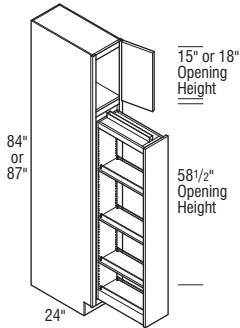
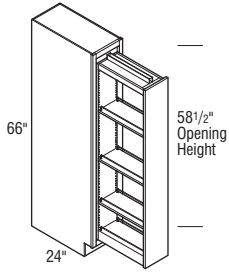

IH/RH availability charts starting on page G•40.  
 IW/RW availability charts starting on page G•46.

## Description

**TALL PANTRY PULL-OUT, 66", 84", 87", 90", 93", or 96" HIGH, 24" DEEP (cont'd) storage SOLUTIONS**

## Model

**TPP99324AH L or R**

**TPP129324AH L or R**

**TPP159324AH L or R**

**TPP189324AH L or R**

- AH represents upper section alignment with doors on 24" or 27" high cabinets.
- Shipped with loose toe space unless Attach Toekick or Flush Toekick is specified.

**TPP99624 L or R**

**TPP129624 L or R**

**TPP159624 L or R**

**TPP189624 L or R**

- Shipped with loose toe space unless Attach Toekick or Flush Toekick is specified.
- Flush Toekick option not available in conjunction with Wide Top Rail unless loose Flush Toekick is specified.

Notes below apply to all products in section above:

- Pull-outs include adjustable wood/chrome shelves.
- Large opening on tall doors will include two panels.
- Not available on Inset and Beaded Inset styles.

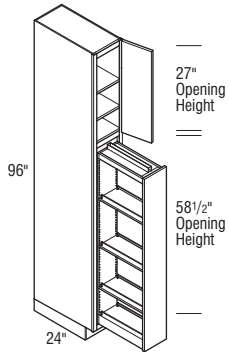
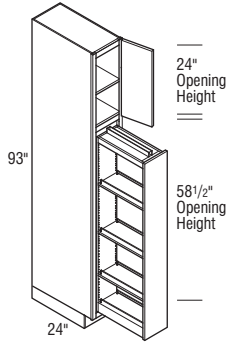

### Door & Drawer Options

AF	CC	CG <sup>1</sup>	ESMD <sup>2</sup>	GAMD <sup>2</sup>	IFHG	MD <sup>2</sup>	MFO	PRMD <sup>3</sup>	SHMD <sup>2</sup>	SPLITDR	SUMD <sup>2</sup>
		✓	✓	✓	✓	✓	✓	✓	✓	✓	✓

### End Panel Options

AUTH	CSFPE	EXBK	FFD	FPE	INTGE	IPE
✓	✓	✓	✓	✓	✓	✓

### Custom Modification Options

ATTK	CBO	CCO	CFNTO	CFRMO	CLIP	CND <sup>3</sup>	CSDGBK	DRT	DRWTK	EF	EX	EX_OL	FLUT <sup>4</sup>	FTK <sup>5</sup>	ID	IH <sup>6</sup>	IW	LIGHT	MIP	OBRB
✓						✓	✓			✓	✓	✓	✓	✓	✓	✓			✓	✓

RD	RECTK <sup>7</sup>	RH	ROSFLUT	RT <sup>2</sup>	TD <sup>1</sup>	TKP	TVR <sup>3</sup>	VTK	WS <sup>8</sup>	WTR
	✓		✓	✓	✓	✓	✓	✓	✓	✓

<sup>1</sup>Not available on 66" high and only available on top section.

<sup>2</sup>Not available on 66" high and only available on top section and not available with 9" wide.

<sup>3</sup>Only available on 15"-18" wide. Not available on 66" high. Only available on top section.

<sup>4</sup>Not available with 6" fluting.

<sup>5</sup>FTKAV not available on 12" wide.

<sup>6</sup>Not available on 96" high, 9" wide, or 66" high.

<sup>7</sup>Only available on RECTKL.R.BK.

<sup>8</sup>Not available on 9" wide.

# Tall Pantry Pull-outs

## Description

**NEW** TALL PANTRY PULL-OUT,  
102" or 108" HIGH, 24" DEEP  
storage  
SOLUTIONS

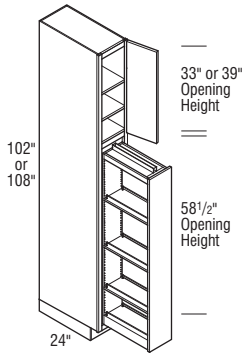

## Model

TPP910224 L or R

TPP1210224 L or R

TPP1510224 L or R

TPP1810224 L or R

TPP910824 L or R

TPP1210824 L or R

TPP1510824 L or R

TPP1810824 L or R

- Shipped with loose toe space unless Attach Toekick or Flush Toekick is specified.
- Pull-outs include adjustable wood/chrome shelves.
- Large opening on tall doors will include two panels.
- Not available on Inset and Beaded Inset styles.
- Finish Flushed Ends standard.
- Available in Cherry and Maple only.

### Door & Drawer Options

AF	CC	CG <sup>1</sup>	ESMD <sup>2</sup>	GAMD <sup>2</sup>	IFHG	MD <sup>2</sup>	MFO	PRMD <sup>3</sup>	SHMD <sup>2</sup>	SPLITDR	SUMD <sup>2</sup>
		✓	✓	✓		✓	✓	✓	✓		✓

### End Panel Options

AUTH	CSFPE	EXBK <sup>4</sup>	FFD	FPE	INTGE	IPE
✓		✓				

### Custom Modification Options

ATTK	CBO	CCO	CFNTO	CFRMO	CLIP	CND <sup>1</sup>	CSDGBK	DRT	DRWTK <sup>5</sup>	EF	EX	EX_OL	FLUT <sup>6</sup>	FTK <sup>7</sup>	ID	IH <sup>8</sup>	IW	LIGHT	MIP	OBRB	
✓						✓			✓	✓	✓	✓	✓	✓	✓	✓					✓

RD	RECTK	RH <sup>9</sup>	ROSLUT <sup>6</sup>	RT <sup>2</sup>	TD <sup>1</sup>	TKP	TVR <sup>9</sup>	VTK	WS	WTR
	✓	✓	✓	✓	✓		✓	✓		✓

<sup>1</sup>Only available on top section.

<sup>2</sup>Only available on top section and not available on 9" wide.

<sup>3</sup>Only available on top section and not available on 9" or 12" wide.

<sup>4</sup>This modification will allow the end to extend back to a maximum of 30" deep.

<sup>5</sup>Only available when used in conjunction with attach toekick modification. Not available on 9" wide.

<sup>6</sup>Not available with 6" fluting.

<sup>7</sup>FTKAV not available on 9" or 12" wide.

<sup>8</sup>Not available on 108" high.

<sup>9</sup>Only available on top section. TVRAVTOP not available on 9" or 12" wide.

IH/RH availability charts starting on page G•40.  
IW/RW availability charts starting on page G•46.

## Description

**PANTRY UNIT, 84", 87", 90", 93", or 96" HIGH, 24" DEEP storage SOLUTIONS**

## Model

**PY368424**

**PY368724**

**PY369024AH**

- AH represents upper section alignment with doors on 24" or 27" high cabinets.
- Includes one adjustable shelf in upper section.
- Toekick shipped attached unless otherwise specified.

**PY369324AH**

- Includes one adjustable shelf in upper section.
- Shipped with loose toe space unless Attach Toekick or Flush Toekick is specified.

**PY369624**

- Includes two adjustable shelves in upper section.
- Shipped with loose toe space unless Attach Toekick or Flush Toekick is specified.
- Flush Toekick option not available in conjunction with Wide Top Rail unless loose Flush Toekick is specified.

Notes below apply to all products in section above:

- Large opening on tall doors will include two panels.
- Door mounted racks include six adjustable shelves and one fixed shelf.
- Ten 6 1/4" deep adjustable shelves located behind pull-out.
- Swing-outs include four adjustable shelves and three fixed shelves.
- Swing-outs and door mounted racks have 4 1/2" deep adjustable shelves that are a natural finished wood with metallic finish wire rail fronts.
- Unit can be used next to wall without use of a filler.
- Not available on Inset and Beaded Inset styles.

### Door & Drawer Options

AF	CC	CG <sup>1</sup>	ESMD <sup>1</sup>	GAMD <sup>1</sup>	IFHG	MD <sup>1</sup>	MFO	PRMD <sup>1</sup>	SHMD <sup>1</sup>	SPLITDR	SUMD <sup>1</sup>
		✓	✓	✓	✓	✓	✓	✓	✓	✓	✓

### End Panel Options

AUTH	CSFPE	EXBK	FFD	FPE	INTGE	IPE
✓	✓	✓	✓	✓	✓	✓

### Custom Modification Options

ATTK <sup>2</sup>	CBO	CCO	CFNTO	CFRMO	CLIP	CND <sup>1</sup>	CSDGBK	DRT	DRWTK <sup>3</sup>	EF	EX	EX_OL	FLUT <sup>4</sup>	FTK	ID	IH <sup>5</sup>	IW	LIGHT	MIP	OBRB	
✓	✓	✓	✓	✓	✓	✓	✓	✓	✓	✓	✓	✓	✓	✓	✓	✓	✓	✓	✓	✓	✓

RD	RECTK	RH	ROSLUT	RT <sup>1</sup>	TD <sup>1</sup>	TKP <sup>6</sup>	TVR	VTK	WS	WTR
✓	✓	✓	✓	✓	✓	✓	✓	✓	✓	✓

<sup>1</sup>Only available on top section.  
<sup>2</sup>Only available on 93" or 96" high.  
<sup>3</sup>93" and 96" high are not available except when used in conjunction with attach toekick modification.  
<sup>4</sup>Not available with 6" fluting.  
<sup>5</sup>Not available on 96" high.  
<sup>6</sup>Not available on 93"-96" high.

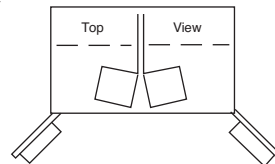
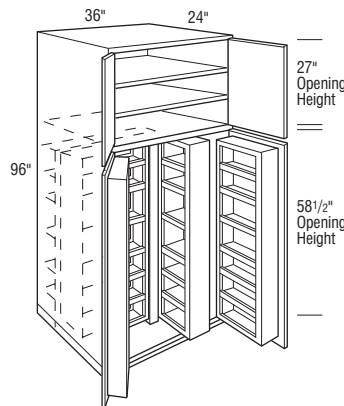
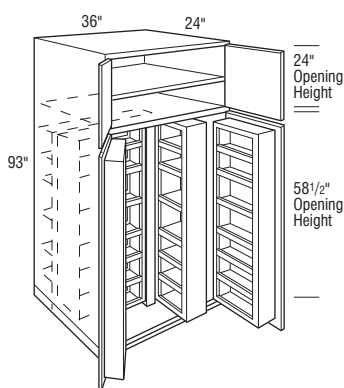
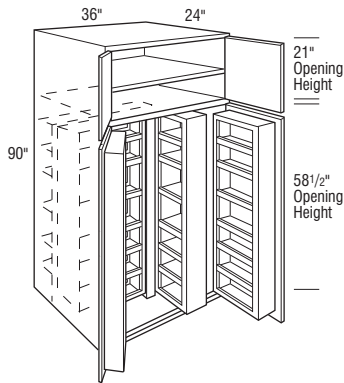
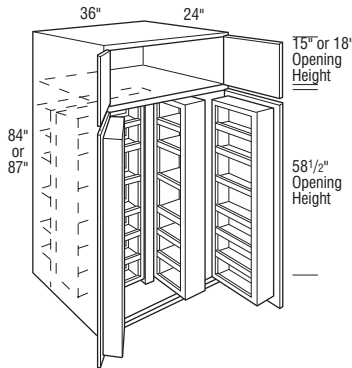

# Pantry Cabinets

## Description

**NEW** PANTRY UNIT, 102" or 108" HIGH, 24" DEEP storage SOLUTIONS

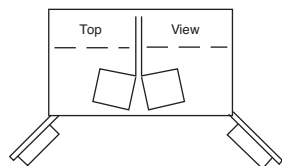
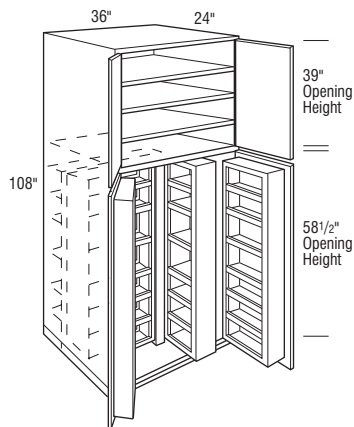
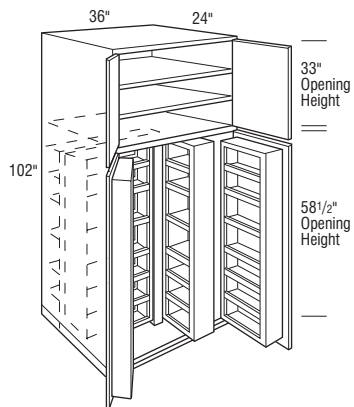

## Model

### PY3610224

- Includes two adjustable shelves in upper section.

### PY3610824

- Includes three adjustable shelves in upper section.

#### Notes below apply to all products in section above:

- Shipped with loose toe space unless Attach Toekick or Flush Toekick is specified.
- Large opening on tall doors will include two panels.
- Door mounted racks include six adjustable shelves and one fixed shelf.
- Ten 6 1/4" deep adjustable shelves located behind pull-out.
- Swing-outs include four adjustable shelves and three fixed shelves.
- Swing-outs and door mounted racks have 4 1/2" deep adjustable shelves that are a natural finished wood with metallic finish wire rail fronts.
- Unit can be used next to wall without use of a filler.
- Not available on Inset and Beaded Inset styles.
- Finish Flushed Ends standard.
- Available in Cherry and Maple only.

#### Door & Drawer Options

AF	CC	CG	ESMD <sup>1</sup>	GAMD <sup>1</sup>	IFHG	MD <sup>1</sup>	MFO	PRMD <sup>1</sup>	SHMD <sup>1</sup>	SPLITDR	SUMD <sup>1</sup>
✓	✓	✓	✓	✓	✓	✓	✓	✓	✓	✓	✓

#### End Panel Options

AUTH	CSFPE	EXBK <sup>2</sup>	FFD	FPE	INTGE	IPE
✓	✓	✓	✓	✓	✓	✓

#### Custom Modification Options

ATTK	CBO	CCO	CFNTO	CFRMO	CLIP	CND <sup>1</sup>	CSDGBK	DRT	DRWTK <sup>3</sup>	EF	EX	EX	OL	FLUT <sup>4</sup>	FTK	ID	IH <sup>5</sup>	IW	LIGHT	MIP	OBRB	
✓	✓	✓	✓	✓	✓	✓	✓	✓	✓	✓	✓	✓	✓	✓	✓	✓	✓	✓	✓	✓	✓	✓
RD	RECTK	RH <sup>5</sup>	ROSEFLUT <sup>4</sup>	RT <sup>1</sup>	TD <sup>1</sup>	TKP	TVR	VTK	WS	WTR												
✓	✓	✓	✓	✓	✓	✓	✓	✓	✓	✓												

<sup>1</sup>Only available on top section.

<sup>2</sup>This modification will allow the end to extend back to a maximum of 30" deep.

<sup>3</sup>Only available when used in conjunction with attach toekick modification.

<sup>4</sup>Not available with 6" fluting.

<sup>5</sup>Not available on 108" high.

IH/RH availability charts starting on page G•40.  
IW/RW availability charts starting on page G•46.

## Description

**UTILITY ORGANIZER CABINET, 84", 87", 90", 93", or 96" HIGH, 6" DEEP storage SOLUTIONS**

## Model

**UOC24846 L or R**

**UOC24876 L or R**

- Includes four adjustable shelves.

**UOC24906 L or R**

**UOC24936 L or R**

- Includes five adjustable shelves.

**UOC24966 L or R**

- Includes six adjustable shelves.

Notes below apply to all products in section above:

- Finish Flushed Ends standard.
- Door for large opening will include 2 panels.
- Void toekick standard.
- Field installs on side of 24" deep tall cabinet.
- Cabinet includes a broom clip (included in cabinet un-installed) that can be used instead of shelves in lower section.
- Broom clip installation instructions included.

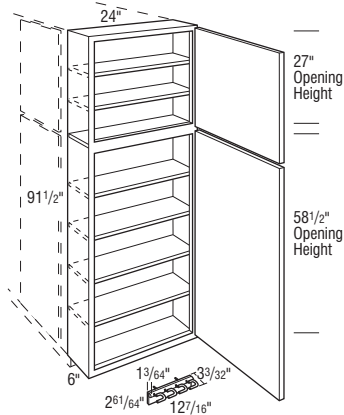
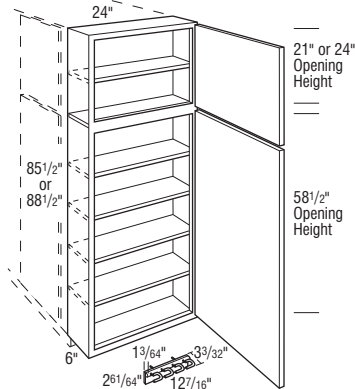
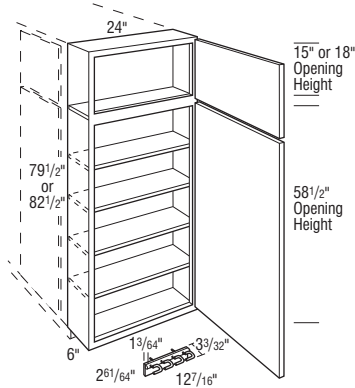

### Door & Drawer Options

AF	CC	CG	ESMD <sup>1</sup>	GAMD <sup>1</sup>	IFHG	MD <sup>1</sup>	MFO	PRMD <sup>1</sup>	SHMD <sup>1</sup>	SPLITDR	SUMD <sup>1</sup>
✓	✓	✓	✓	✓	✓	✓	✓	✓	✓	✓	✓

### End Panel Options

AUTH	CSFPE	EXBK	FFD	FPE	INTGE	IPE
✓						

### Custom Modification Options

ATTK	CBO	CCO	CFNT0	CFRMO	CLIP	CND	CSDGBK	DRT	DRWTK	EF	EX	EX_OL	FLUT <sup>2</sup>	FTK	ID	IH <sup>3</sup>	IW	LIGHT	MIP	OBRB	
✓	✓	✓	✓	✓	✓	✓	✓	✓	✓	✓	✓	✓	✓	✓	✓	✓	✓	✓	✓	✓	✓

RD	RECTK	RH	ROSLUT	RT	TD	TKP	TVR	VTK	WS	WTR
			✓				✓		✓	✓

<sup>1</sup>Only available on top section.

<sup>2</sup>Not available with 6" fluting.

<sup>3</sup>Not available on 96" high.

# Utility Organizer Cabinets

## Description

**NEW** UTILITY ORGANIZER CABINET,  
102" or 108" HIGH, 6" DEEP  
storage  
SOLUTIONS

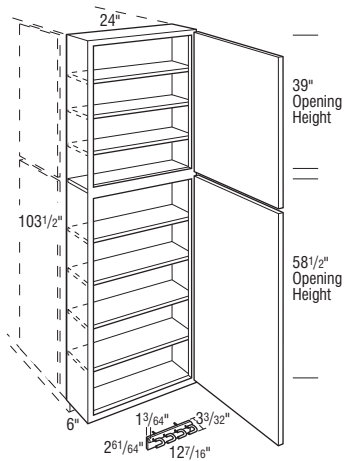
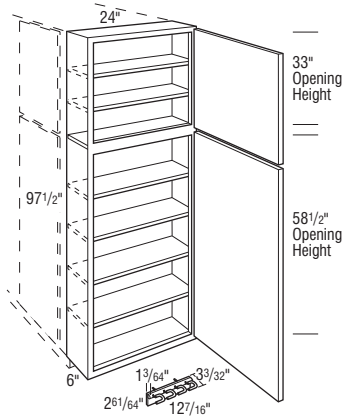

## Model

### UOC241026 L or R

- Includes six adjustable shelves.

### UOC241086 L or R

- Includes seven adjustable shelves.

#### Notes below apply to all products in section above:

- Finish Flushed Ends standard.
- Door for large opening will include 2 panels.
- Void toekick standard.
- Field installs on side of 24" deep tall cabinet.
- Cabinet includes a broom clip (included in cabinet un-installed) that can be used instead of shelves in lower section.
- Broom clip installation instructions included.
- Available in Cherry and Maple only.

#### Door & Drawer Options

AF	CC	CG	ESMD <sup>1</sup>	GAMD <sup>1</sup>	IFHG	MD <sup>1</sup>	MFO	PRMD <sup>1</sup>	SHMD <sup>1</sup>	SPLITDR	SUMD <sup>1</sup>
✓	✓	✓	✓	✓	✓	✓	✓	✓	✓	✓	✓

#### End Panel Options

AUTH	CSFPE	EXBK	FFD	FPE	INTGE	IPE
✓	✓	✓	✓	✓	✓	✓

#### Custom Modification Options

ATTK	CBO	CCO	CFNTO	CFRMO	CLIP	CND	CSDGBK	DRT	DRWTK <sup>2</sup>	EF	EX	EX_OL	FLUT <sup>3</sup>	FTK	ID	IH <sup>4</sup>	IW	LIGHT	MIP	OBRB	
✓	✓	✓	✓	✓	✓	✓	✓	✓	✓	✓	✓	✓	✓	✓	✓	✓	✓	✓	✓	✓	✓

RD	RECTK	RH <sup>4</sup>	ROSLUT <sup>3</sup>	RT	TD	TKP	TVR	VTK	WS	WTR
✓	✓	✓	✓	✓	✓	✓	✓	✓	✓	✓

- <sup>1</sup>Only available on top section.  
<sup>2</sup>Only available when used in conjunction with attach toekick modification.  
<sup>3</sup>Not available with 6" fluting.  
<sup>4</sup>Not available on 108" high.

IH/RH availability charts starting on page G•40.  
IW/RW availability charts starting on page G•46.

## Description

**UTILITY ORGANIZER CABINET, 84", 87", 90", 93", or 96" HIGH, 6" DEEP storage SOLUTIONS**

## Model

**UOC24846**

**UOC24876**

**UOC24906AH**

**UOC24936AH**

- Includes four adjustable shelves.
- AH represents upper section alignment with doors on 24" or 27" high cabinets.
- Includes five adjustable shelves.

**UOC24966**

- Includes six adjustable shelves.

### Notes below apply to all products in section above:

- Finish Flushed Ends standard.
- Door for large opening will include 2 panels.
- Void toekick standard.
- Field installs on side of 24" deep tall cabinet.
- Cabinet includes a broom clip (included in cabinet un-installed) that can be used instead of shelves in lower section.
- Broom clip installation instructions included.

### Door & Drawer Options

AF	CC	CG	ESMD <sup>1</sup>	GAMD <sup>1</sup>	IFHG	MD <sup>1</sup>	MFO	PRMD <sup>1</sup>	SHMD <sup>1</sup>	SPLITDR	SUMD <sup>1</sup>
✓	✓	✓	✓	✓	✓	✓	✓	✓	✓	✓	✓

### End Panel Options

AUTH	CSFPE	EXBK	FFD	FPE	INTGE	IPE
✓	✓	✓	✓	✓	✓	✓

### Custom Modification Options

ATTK	CBO	CCO	CFNT0	CFRMO	CLIP	CND	CSDGBK	DRT	DRWTK	EF	EX	EX_OL	FLUT <sup>2</sup>	FTK	ID	IH <sup>3</sup>	IW	LIGHT	MIP	OBRB	
✓	✓	✓	✓	✓	✓	✓	✓	✓	✓	✓	✓	✓	✓	✓	✓	✓	✓	✓	✓	✓	✓

RD	RECTK	RH	ROSLUT	RT	TD	TKP	TVR	VTK	WS	WTR
✓	✓	✓	✓	✓	✓	✓	✓	✓	✓	✓

<sup>1</sup>Only available on top section.

<sup>2</sup>Not available with 6" fluting.

<sup>3</sup>Not available on 96" high.

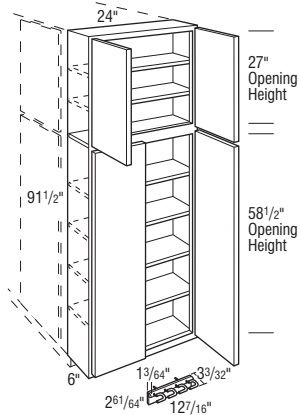
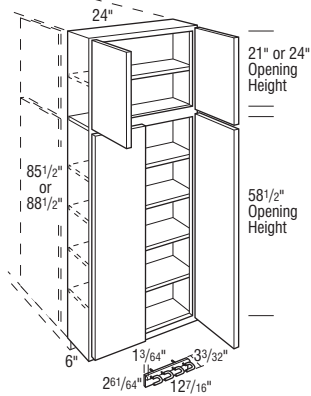
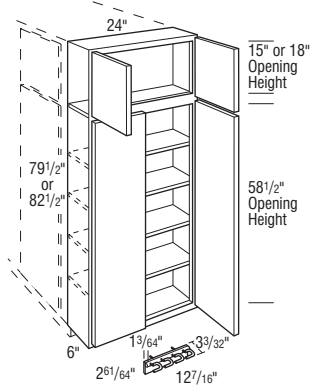



# Utility Organizer Cabinets

## Description

**NEW** UTILITY ORGANIZER CABINET,  
102" or 108" HIGH, 6" DEEP  
storage  
SOLUTIONS

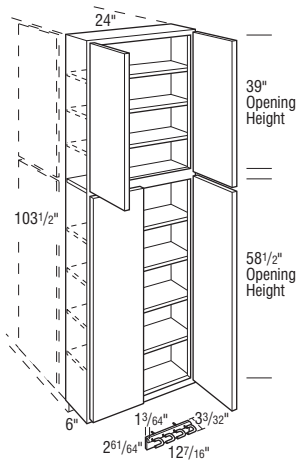
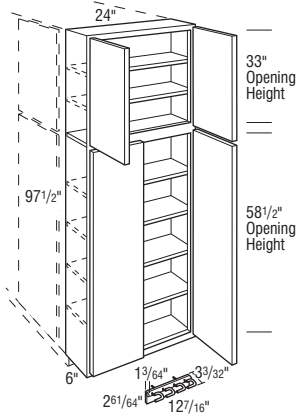

## Model

### UOC241026

- Includes six adjustable shelves.

### UOC241086

- Includes seven adjustable shelves.

Notes below apply to all products in section above:

- Finish Flushed Ends standard.
- Door for large opening will include 2 panels.
- Void toekick standard.
- Field installs on side of 24" deep tall cabinet.
- Cabinet includes a broom clip (included in cabinet un-installed) that can be used instead of shelves in lower section.
- Broom clip installation instructions included.
- Available in Cherry and Maple only.

#### Door & Drawer Options

AF	CC	CG	ESMD <sup>1</sup>	GAMD <sup>1</sup>	IFHG	MD <sup>1</sup>	MFO	PRMD <sup>1</sup>	SHMD <sup>1</sup>	SPLITDR	SUMD <sup>1</sup>
✓	✓	✓	✓	✓	✓	✓	✓	✓	✓	✓	✓

#### End Panel Options

AUTH	CSFPE	EXBK	FFD	FPE	INTGE	IPE
✓	✓	✓	✓	✓	✓	✓

#### Custom Modification Options

ATTK	CBO	CCO	CFNTO	CFRMO	CLIP	CND	CSDGBK	DRT	DRWTK <sup>2</sup>	EF	EX	EX_OL	FLUT <sup>3</sup>	FTK	ID	IH <sup>4</sup>	IW	LIGHT	MIP	OBRB	
✓	✓	✓	✓	✓	✓	✓	✓	✓	✓	✓	✓	✓	✓	✓	✓	✓	✓	✓	✓	✓	✓

RD	RECTK	RH <sup>4</sup>	ROSLUT <sup>3</sup>	RT	TD	TKP	TVR	VTK	WS	WTR
✓	✓	✓	✓	✓	✓	✓	✓	✓	✓	✓

- <sup>1</sup>Only available on top section.  
<sup>2</sup>Only available when used in conjunction with attach toekick modification.  
<sup>3</sup>Not available with 6" fluting.  
<sup>4</sup>Not available on 108" high.

IH/RH availability charts starting on page G•40.  
IW/RW availability charts starting on page G•46.

## Description

**UTILITY ORGANIZER CABINET, 84", 87", 90", 93", or 96" HIGH, 9" DEEP storage SOLUTIONS**

## Model

**UOC24849 L or R**

**UOC24879 L or R**

- Includes four adjustable shelves.

**UOC24909 L or R**

- Includes five adjustable shelves.

**UOC24939 L or R**

- Includes five adjustable shelves.
- Shipped with loose toe space unless Attach Toekick or Flush Toekick is specified.

**UOC24969 L or R**

- Includes six adjustable shelves.
- Shipped with loose toe space unless Attach Toekick or Flush Toekick is specified.
- Flush Toekick option not available in conjunction with Wide Top Rail unless a Flush Toekick Loose is specified.

Notes below apply to all products in section above:

- Finish Flushed Ends standard.
- Door for large opening will include 2 panels.
- Field installs on side of 24" deep tall cabinet.
- Cabinet includes a broom clip (included in cabinet un-installed) that can be used instead of shelves in lower section.
- Broom clip installation instructions included.
- Increased Depths available in 1/4" increments from 9 1/4" to 30".

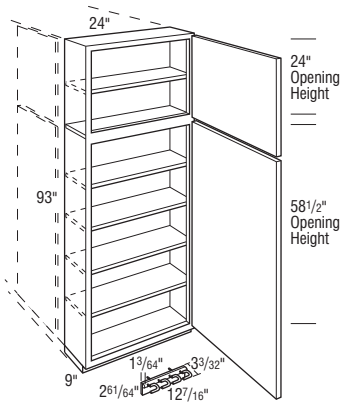
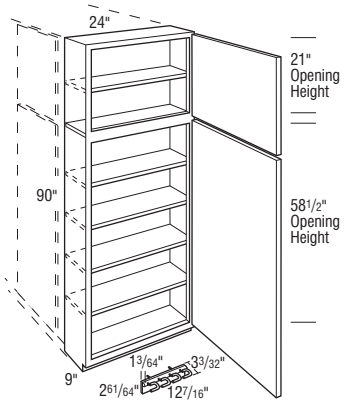
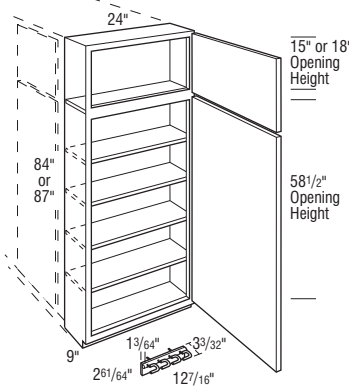

### Door & Drawer Options

AF	CC	CG	ESMD <sup>1</sup>	GAMD <sup>1</sup>	IFHG	MD <sup>1</sup>	MFO	PRMD <sup>1</sup>	SHMD <sup>1</sup>	SPLITDR	SUMD <sup>1</sup>
✓	✓	✓	✓	✓	✓	✓	✓	✓	✓	✓	✓

### End Panel Options

AUTH	CSFPE	EXBK	FFD	FPE	INTGE	IPE
✓	✓	✓	✓	✓	✓	✓

### Custom Modification Options

ATTK <sup>2</sup>	CBO	CCO	CFNTO	CFRMO	CLIP	CND	CSDGBK	DRT	DRWTK	EF	EX	EX	OL	FLUT <sup>3</sup>	FTK	ID	IH <sup>4</sup>	IW	LIGHT	MIP	OBRB	
✓	✓	✓	✓	✓	✓	✓	✓	✓	✓	✓	✓	✓	✓	✓	✓	✓	✓	✓	✓	✓	✓	✓

RD	RECTK	RH	ROSLUT	RT	TD	TKP <sup>5</sup>	TVR	VTK	WS	WTR
✓	✓	✓	✓	✓	✓	✓	✓	✓	✓	✓

- <sup>1</sup>Only available on top section.  
<sup>2</sup>Only available on 93"-96" high.  
<sup>3</sup>Not available with 6" fluting.  
<sup>4</sup>Not available on 96" high.  
<sup>5</sup>Not available on 93"-96" high.

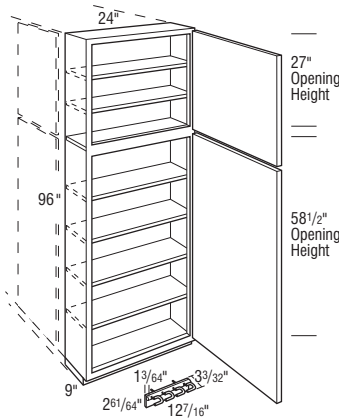

# Utility Organizer Cabinets

## Description

**NEW** UTILITY ORGANIZER CABINET,  
102" or 108" HIGH, 9" DEEP  
storage  
SOLUTIONS

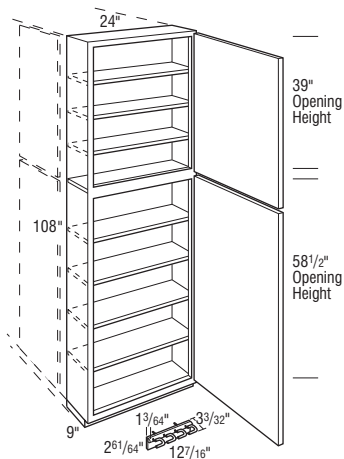
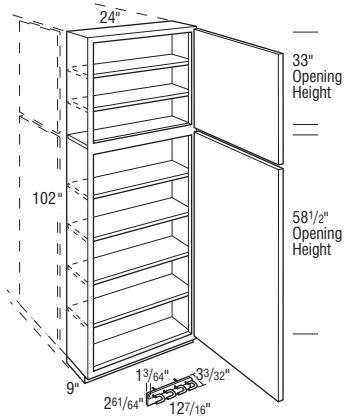

## Model

### UOC241029 L or R

- Includes six adjustable shelves.

### UOC241089 L or R

- Includes seven adjustable shelves.

#### Notes below apply to all products in section above:

- Finish Flushed Ends standard.
- Shipped with loose toe space unless Attach Toekick or Flush Toekick is specified.
- Door for large opening will include 2 panels.
- Field installs on side of 24" deep tall cabinet.
- Cabinet includes a broom clip (included in cabinet un-installed) that can be used instead of shelves in lower section.
- Broom clip installation instructions included.
- Increased Depths available in 1/4" increments from 9 1/4" to 26".
- Available in Cherry and Maple only.

#### Door & Drawer Options

AF	CC	CG	ESMD <sup>1</sup>	GAMD <sup>1</sup>	IFHG	MD <sup>1</sup>	MFO	PRMD <sup>1</sup>	SHMD <sup>1</sup>	SPLITDR	SUMD <sup>1</sup>
✓	✓	✓	✓	✓	✓	✓	✓	✓	✓	✓	✓

#### End Panel Options

AUTH	CSFPE	EXBK	FFD	FPE	INTGE	IPE
✓	✓	✓	✓	✓	✓	✓

#### Custom Modification Options

ATTK	CBO	CCO	CFNTO	CFRMO	CLIP	CND	CSDGBK	DRT	DRWTK <sup>2</sup>	EF	EX	EX_OL	FLUT <sup>3</sup>	FTK	ID	IH <sup>4</sup>	IW	LIGHT	MIP	OBRB	
✓	✓	✓	✓	✓	✓	✓	✓	✓	✓	✓	✓	✓	✓	✓	✓	✓	✓	✓	✓	✓	✓

RD	RECTK	RH <sup>4</sup>	ROSFLUT <sup>3</sup>	RT	TD	TKP	TVR	VTK	WS	WTR
✓	✓	✓	✓	✓	✓	✓	✓	✓	✓	✓

<sup>1</sup>Only available on top section.

<sup>2</sup>Only available when used in conjunction with attach toekick modification.

<sup>3</sup>Not available with 6" fluting.

<sup>4</sup>Not available on 108" high.

IH/RH availability charts starting on page G•40.  
IW/RW availability charts starting on page G•46.

## Description

**UTILITY ORGANIZER CABINET, 84", 87", 90", 93", or 96" HIGH, 9" DEEP storage SOLUTIONS**

## Model

**UOC24849**

**UOC24879**

**UOC24909**

• Includes five adjustable shelves.

**UOC24939**

• Includes five adjustable shelves.  
• Shipped with loose toe space unless Attach Toekick or Flush Toekick is specified.

**UOC24969**

• Includes six adjustable shelves.  
• Shipped with loose toe space unless Attach Toekick or Flush Toekick is specified.  
• Flush Toekick option not available in conjunction with Wide Top Rail unless a Flush Toekick Loose is specified.

Notes below apply to all products in section above:

- Finish Flushed Ends standard.
- Door for large opening will include 2 panels.
- Field installs on side of 24" deep tall cabinet.
- Cabinet includes a broom clip (included in cabinet un-installed) that can be used instead of shelves in lower section.
- Broom clip installation instructions included.
- Increased Depths available in 1/4" increments from 9 1/4" to 30".

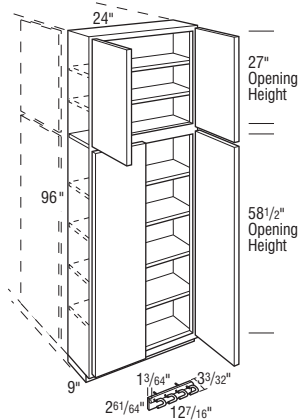
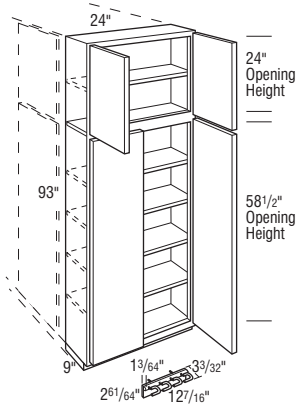
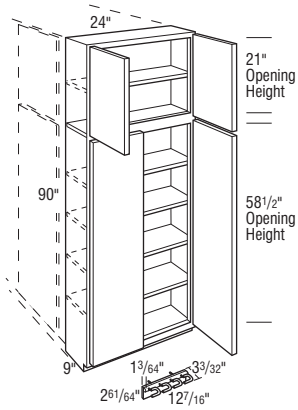
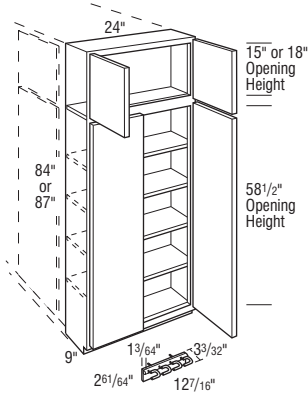

### Door & Drawer Options

AF	CC	CG	ESMD <sup>1</sup>	GAMD <sup>1</sup>	IFHG	MD <sup>1</sup>	MFO	PRMD <sup>1</sup>	SHMD <sup>1</sup>	SPLITDR	SUMD <sup>1</sup>
✓	✓	✓	✓	✓	✓	✓	✓	✓	✓	✓	✓

### End Panel Options

AUTH	CSFPE	EXBK	FFD	FPE	INTGE	IPE
✓	✓	✓	✓	✓	✓	✓

### Custom Modification Options

ATTK <sup>2</sup>	CBO	CCO	CFNTD	CFRMD	CLIP	CND	CSDGBK	DRT	DRWTK	EF	EX	EX_OL	FLUT <sup>3</sup>	FTK	ID	IH <sup>4</sup>	IW	LIGHT	MIP	OBRB	
✓	✓	✓	✓	✓	✓	✓	✓	✓	✓	✓	✓	✓	✓	✓	✓	✓	✓	✓	✓	✓	✓

RD	RECTK	RH	ROSFLUT	RT	TD	TKP <sup>5</sup>	TVR	VTK	WS	WTR
✓	✓	✓	✓	✓	✓	✓	✓	✓	✓	✓

<sup>1</sup>Only available on top section.

<sup>2</sup>Only available on 93"-96" high.

<sup>3</sup>Not available with 6" fluting.

<sup>4</sup>Not available on 96" high.

<sup>5</sup>Not available on 93"-96" high.

# Utility Organizer Cabinets

## Description

**NEW** UTILITY ORGANIZER CABINET,  
102" or 108" HIGH, 9" DEEP  
storage  
SOLUTIONS

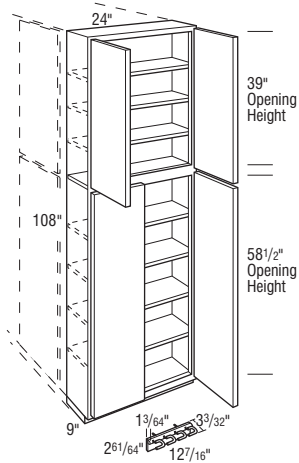
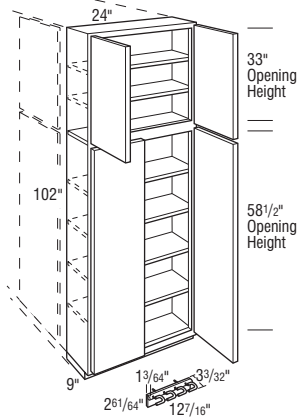

## Model

### UOC241029

- Includes six adjustable shelves.

### UOC241089

- Includes seven adjustable shelves.

Notes below apply to all products in section above:

- Finish Flushed Ends standard.
- Shipped with loose toe space unless Attach Toekick or Flush Toekick is specified.
- Door for large opening will include 2 panels.
- Field installs on side of 24" deep tall cabinet.
- Cabinet includes a broom clip (included in cabinet un-installed) that can be used instead of shelves in lower section.
- Broom clip installation instructions included.
- Increased Depths available in 1/4" increments from 9 1/4" to 26".
- Available in Cherry and Maple only.

#### Door & Drawer Options

AF	CC	CG	ESMD <sup>1</sup>	GAMD <sup>1</sup>	IFHG	MD <sup>1</sup>	MFO	PRMD <sup>1</sup>	SHMD <sup>1</sup>	SPLITDR	SUMD <sup>1</sup>
✓	✓	✓	✓	✓	✓	✓	✓	✓	✓	✓	✓

#### End Panel Options

AUTH	CSFPE	EXBK	FFD	FPE	INTGE	IPE
✓						

#### Custom Modification Options

ATTK	CBO	CCO	CFNTO	CFRMO	CLIP	CND	CSDGBK	DRT	DRWTK <sup>2</sup>	EF	EX	EX_OL	FLUT <sup>3</sup>	FTK	ID	IH <sup>4</sup>	IW	LIGHT	MIP	OBRB	
✓	✓	✓	✓	✓	✓	✓	✓	✓	✓	✓	✓	✓	✓	✓	✓	✓	✓	✓	✓	✓	✓

RD	RECTK	RH <sup>4</sup>	ROSFLUT <sup>3</sup>	RT	TD	TKP	TVR	VTK	WS	WTR
✓	✓	✓	✓	✓	✓	✓	✓	✓	✓	✓

<sup>1</sup>Only available on top section.

<sup>2</sup>Only available when used in conjunction with attach toekick modification.

<sup>3</sup>Not available with 6" fluting.

<sup>4</sup>Not available on 108" high.

IH/RH availability charts starting on page G•40.  
IW/RW availability charts starting on page G•46.

## Description

**UTILITY ORGANIZER DROP ZONE CABINET,**  
**84", 87", 93", or 96" HIGH, 9" DEEP**  
**storage**  
**SOLUTIONS**

## Model

**UOCDZ24849**

**UOCDZ24879**

- Includes three adjustable shelves.

**UOCDZ24909**

- Includes four adjustable shelves.

**UOCDZ24939**

- Includes four adjustable shelves.
- Shipped with loose toe space unless Attach Toekick or Flush Toekick is specified.

**UOCDZ24969**

- Includes five adjustable shelves.
- Shipped with loose toe space unless Attach Toekick or Flush Toekick is specified.
- Flush Toekick option not available in conjunction with Wide Top Rail unless a Flush Toekick Loose is specified.

Notes below apply to all products in section above:

- Finish Flushed Ends standard.
- Features magnetic whiteboards on back of lower doors, one magnetic black mesh pencil holder, charging station shelf, power strip, black plastic grommet for power cord, key hooks, and coat hooks.
- Charging station shelf is adjustable, features four cord cut-out areas.
- Power strip is UL listed with three standard 110-volt plug-ins and one USB charging port.
- Field installs on side of 24" deep tall cabinet.
- Door for large opening will include two panels.
- Increased Depths available in 1/4" increments from 9 1/4" to 30".
- Not available on Inset and Beaded Inset styles.

### Door & Drawer Options

AF	CC	CG	ESMD	GAMD	IFHG	MD <sup>1</sup>	MFO	PRMD	SHMD <sup>1</sup>	SPLITDR	SUMD

### End Panel Options

AUTH	CSFPE	EXBK	FFD	FPE	INTGE	IPE

### Custom Modification Options

ATTK <sup>2</sup>	CBO	CCO	CFNT0	CFRMO	CLIP	CND	CSDGBK	DRT	DRWTK	EF	EX	EX_OL	FLUT <sup>3</sup>	FTK	ID	IH <sup>4</sup>	IW	LIGHT	MIP	OBRB	

RD	RECTK	RH	ROSLUT	RT	TD <sup>1</sup>	TKP <sup>5</sup>	TVR	VTK	WS	WTR

- <sup>1</sup>Only available on top section.  
<sup>2</sup>Only available on 93"-96" high.  
<sup>3</sup>Not available with 6" fluting.  
<sup>4</sup>Not available on 96" high.  
<sup>5</sup>Not available 93"-96" high.

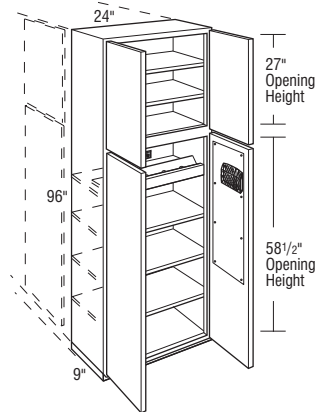
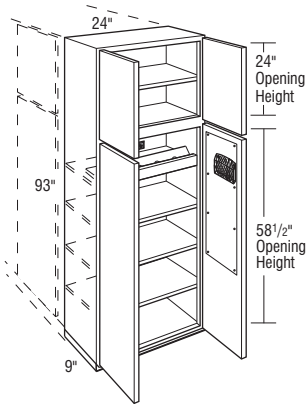
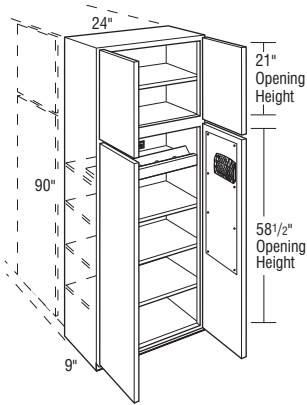
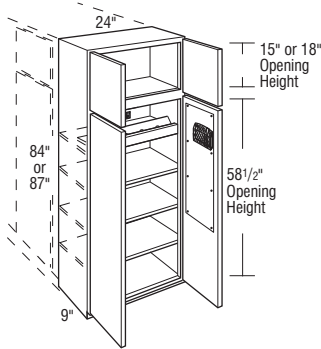

# Utility Organizer Cabinets

## Description



### UTILITY ORGANIZER DROP ZONE CABINET, 102" or 108" HIGH, 9" DEEP

### storage SOLUTIONS

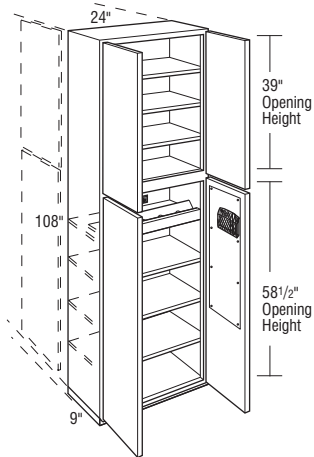
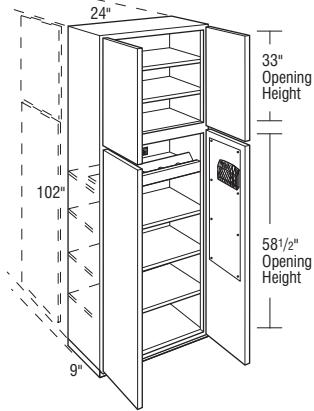

## Model

### UOCDZ241029

- Includes five adjustable shelves.

### UOCDZ241089

- Includes six adjustable shelves.

#### Notes below apply to all products in section above:

- Shipped with loose toe space unless Attach Toekick or Flush Toekick is specified.
- Finish Flushed Ends standard.
- Features magnetic whiteboards on back of lower doors, one magnetic black mesh pencil holder, charging station shelf, power strip, black plastic grommet for power cord, key hooks and coat hooks.
- Charging station shelf is adjustable, features four cord cut-out areas.
- Power strip is UL listed with three standard 110-volt plug-ins and one USB charging port.
- Field installs on side of 24" deep tall cabinet.
- Door for large opening will include two panels.
- Increased Depths available in 1/4" increments from 9 1/4" to 26".
- Not available on Inset and Beaded Inset styles.
- Available in Cherry and Maple only.

#### Door & Drawer Options

AF	CC	CG	ESMD	GAMD	IFHG	MD <sup>1</sup>	MFO	PRMD <sup>1</sup>	SHMD <sup>1</sup>	SPLITDR	SUMD

#### End Panel Options

AUTH	CSFPE	EXBK	FFD	FPE	INTGE	IPE

#### Custom Modification Options

ATTK	CBO	CCO	CFNTO	CFRMO	CLIP	CND	CSDGBK	DRT	DRWTK <sup>2</sup>	EF	EX	EX_OL	FLUT <sup>3</sup>	FTK	ID	IH <sup>4</sup>	IW	LIGHT	MIP	OBRB

RD	RECTK	RH <sup>4</sup>	ROSFLUT <sup>3</sup>	RT	TD <sup>1</sup>	TKP	TVR	VTK	WS	WTR

<sup>1</sup>Only available on top section.

<sup>2</sup>Only available when used in conjunction with attach toekick modification.

<sup>3</sup>Not available with 6" fluting.

<sup>4</sup>Not available on 108" high.

IH/RH availability charts starting on page G•40.  
IW/RW availability charts starting on page G•46.

## Description



**UTILITY ORGANIZER DROP ZONE CABINET with AUTHENTIC END, 84", 87", 90", 93", or 96" HIGH, 9" DEEP**

## Model

**UOCDZ24849AE L or R**

**UOCDZ24879AE L or R**

- Three full depth adjustable shelves in lower section are included, but packaged separately.

**UOCDZ24909AHA L or R**

**UOCDZ24939AHA L or R**

- AH represents upper section alignment with doors on 24" or 27" high cabinets.
- One full depth adjustable shelf in upper section, and three full depth adjustable shelves in lower section are included, but packaged separately.

**UOCDZ24969AE L or R**

- Two full depth adjustable shelves in upper section, and three full depth adjustable shelves in lower section are included, but packaged separately.

### Notes below apply to all products in section above:

- Features magnetic whiteboards on back of lower doors, one magnetic black mesh pencil holder, charging station with power strip, black plastic grommet for power cord, key hooks, and coat hooks. Accessories are field installed.
- Charging station shelf is adjustable, features four cord cut-out areas.
- Power strip is UL listed with three standard 110-volt plug-ins and one USB charging port.
- Authentic Ends are standard on one side. Specify AEL model for installation on the right side of a tall cabinet. Specify AER model for installation on the left side of a tall cabinet.
- Designed to be installed onto an adjacent 24" deep tall cabinet.
- Utility cabinets with depths of 12" or less must be installed to wall studs or onto the end of another tall cabinet.
- Does not include toeboard or pedestal.
- Consult local electrical/building codes for proper installation.
- For proper installation, adjacent cabinet must have FPEB or 3/32" skin applied.
- Finish Flushed Ends standard.
- Door for large opening will include two panels.
- Increased Depths available in 1/4" increments from 9 1/4" to 30".
- Not available on Inset and Beaded Inset styles.

### Door & Drawer Options

AF	CC	CG	ESMD	GAMD	IFHG	MD	MFO	PRMD	SHMD	SPLITDR	SUMD
		✓				✓	✓	✓			

### End Panel Options

AUTH	CSFPE	EXBK	FFD	FPE	INTGE	IPE
✓	✓					

### Custom Modification Options

ATTK	CBO	CCO	CFNTO	CFRMO	CLIP	CND	CSDGBK	DRT	DRWTK	EF	EX	EX_OL	FLUT	FTK	ID	IH	IW	LIGHT	MIP	OBRB	
✓	✓	✓	✓	✓	✓	✓	✓	✓	✓	✓	✓	✓	✓	✓	✓	✓	✓	✓	✓	✓	✓
RD	RECTK	RH	ROSFLUT	RT	TD	TKP	TVR	VTK	WS	WTR											
✓	✓	✓	✓	✓	✓	✓	✓	✓	✓	✓											

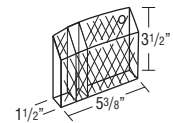
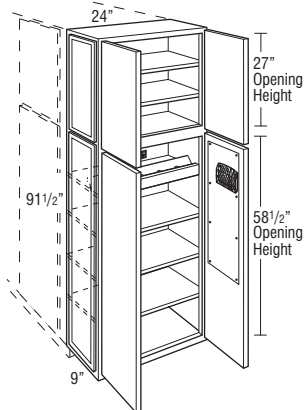
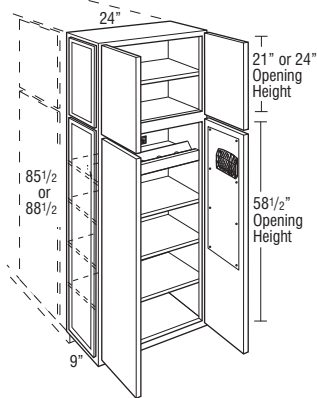
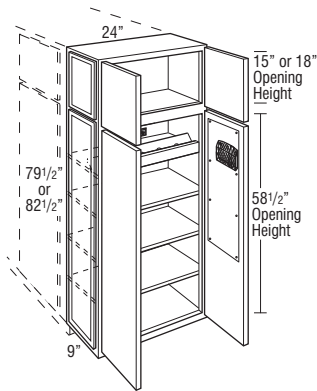

Pencil Holder

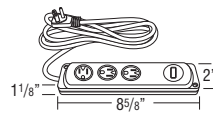

Power Strip



Grommet



Key Hooks



Coat Hooks





# Kemper Emerge Modification Option Descriptions

Your Kemper Emerge specification guide contains charts with modification option codes for each applicable cabinetry product. Reference the listing below to identify the modification description.

## Door & Drawer Options

Option	Description
AF	Aluminum Door
CC	Craftsman Door
CG	Cut-for-glass
ESMD	Estate Mullion Door
GAMD	Gallery Mullion Door
HC	Horizon Door
IFHG	Inset Finial Hinges
MC	Mission Door
MD	Mullion Door
MFO	Modified Full Overlay
PRMD	Prairie Mullion Door
SHMD	Shaker Mullion Door
SPLITDR	Split Doors
SPLITDRWS	Split Drawers
SUMD	Summit Mullion Door

## End Panel Options

Option	Description
AUTH	Authentic Flush End
CSFPE	Car Siding Flush Panel End
EXBK	End Extended Back
EXDN	Wall End and Back Extended Down
FPE	Flush Panel End
INTGE	Integral End
IPE	Inset Panel Ends

## Custom Modification Options

Option	Description
ADD_SHLF	Add Shelf
ADDTK	Add Toekick
ADRW	Add Drawer Below Wall Unit
ATTK	Attach Toekick
BVR	Bottom Valance Rail
CBO	Cabinet Box Only
CCO	Cabinet Case Only
CFNTO	Cabinet Front Only
CFP	Cabinet False Panel
CFRMO	Cabinet Frame Only
CLIP	Clipped Corner
CND	Cabinet No Door
CSDGBK	Car Siding Back
DRWTK	Toekick Drawer
EF	Finished Ends
EX	Extended Stile
EX_OL	Extended Stile with Overlay
FLUT	Fluting
FTK	Flush Toekick
ID	Increased Depth
IH	Increased Height
IW	Increased Width
MIP	Matching Interior
OBRB	Open Bottom Rail Base
PFINBTMB	Finished Bottom
RD	Reduced Depth
RECTK	Recessed Toekick
RH	Reduced Height
ROSLUT	Rose Fluting
RT	Roll Trays
SCPDRW	Scooped Drawer
TD	Tray Divider
TKP	Toekick Pedestal
TVR	Top Valance Rail
VTK	Void Toekick
WS	Wide Stiles
WTCD	Wood Tiered Cutlery Divider Drawer
WTKCUP	Wood Tiered K-Cup Drawer
WTR	Wide Top Rail



## Description



### WALL MICROWAVE CABINET, 18" or 21" HIGH

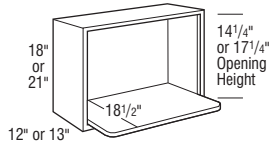

	Opening		Cabinet	
	Width	Height	Width	Height
MW2718	24"	14 1/4"	27"	18"
MW3018	27"	14 1/4"	30"	18"
MW2721	24"	17 1/4"	27"	21"
MW3021	27"	17 1/4"	30"	21"

## Model

**MW2718**

**MW3018**

**MW2721**

**MW3021**

- Matching Interior standard.
- Solid-wood microwave shelf shipped unattached.
- Full Overlay Styles:
  - Increased Depths available in 1/4" increments from 12 1/4" to 30".
- Inset and Beaded Inset Styles:
  - Increased Depths available in 1/4" increments from 13 1/4" to 30".
- Inset and Beaded Inset Door Styles are a standard 13" deep.

### Door & Drawer Options

AF	CC	CG	ESMD	GAMD	HC	IFHG	MC	MD	MFO	PRMD	SHMD	SPLITDR	SPLITDRWS	SUMD
----	----	----	------	------	----	------	----	----	-----	------	------	---------	-----------	------

### End Panel Options

AUTH	CSFPE	EXBK	EXDN	FPE	INTGE	IPE
✓	✓	✓	✓	✓	✓	✓

### Custom Modification Options

ADD_SHLF	ADDTK	ADRW	ATTK	BVR	CBO	CCO	CFNTD	CFP	CFRMO	CLIP <sup>1</sup>	CND	CSDGBK	DRWTK	EF	EX	EX_OL	FLUT <sup>2</sup>	FTK	ID
	✓	✓		✓	✓	✓	✓		✓	✓		✓			✓	✓	✓	✓	✓

IH <sup>3</sup>	IW	MIP	OBRB	PFINBTMB	RD	RECTK	RH	ROSLUT <sup>2</sup>	RT	SCPDRW	TD	TKP	TVR	VTK	WS	WTCB	WTKCUP	WTR
✓	✓	✓	✓	✓	✓	✓	✓	✓				✓	✓	✓	✓			✓

<sup>1</sup>Not available with clipped both.

<sup>2</sup>Not available with fluting both or 6" fluting.

<sup>3</sup>Not available on 21" high.

# Wall Microwave Cabinets

## Description

### WALL MICROWAVE DOUBLE DOOR CABINET, 30" or 33" HIGH

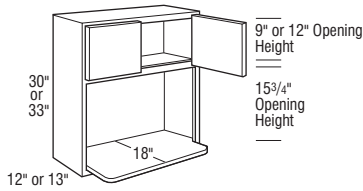

Specify appliance opening dimensions:

#### MW \_ \_ Microwave Wall with Shelf

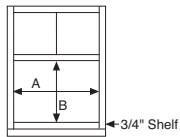

Appliance Opening Dimensions:

A \_\_\_\_\_  
B \_\_\_\_\_

#### NOTE:

See chart for specific model appliance opening limitations.

Cabinet appliance openings may vary with modifications (i.e. clipped corner modification reduces maximum cut-out width by 3" per clipped corner).

## Model

MW2430  
MW2730  
MW3030  
MW3330  
MW3630  
MW2433  
MW2733  
MW3033  
MW3333  
MW3633

- Matching Interior standard.
- Specify cut-out size.
- When Beaded Inset is ordered, the cabinet should be ordered to the appropriate width using the 1/4" width modification instead of using the piece-in or cut-out applications.
- The maximum cut-out width is 2" less than the overall width of the cabinet. The maximum cut-out height varies depending on the cabinet.
- Shelf shipped unattached.
- Microwave shelf depth may be decreased; specify depth required.
- Microwave shelf is solid wood.
- Inset and Beaded Inset Door Styles are a standard 13" deep.
- Full Overlay Styles:
  - Reduced Depths available in 1/4" increments from 6" to 11 3/4".
- Inset and Beaded Inset Styles:
  - Reduced Depths available in 1/4" increments from 6" to 12 3/4".

	Standard Appliance Opening		Decreased Appliance Opening Width*		Increased Appliance Opening Width**		Appliance Opening Height***	
	Width (A)	Height (B)	Min. Width (A)	Max. Width (A)	Min. Width (A)	Max. Width (A)	Min. Height (B)	Max. Height (B)
MW2430	21"	15 3/4"	9"	20 1/2"	21 1/16"	22"	14"	15 3/4"
MW2730	24"	15 3/4"	12"	23 1/2"	24 1/16"	25"	14"	15 3/4"
MW3030	27"	15 3/4"	15"	26 1/2"	27 1/16"	28"	14"	15 3/4"
MW3330	30"	15 3/4"	18"	29 1/2"	30 1/16"	31"	14"	15 3/4"
MW3630	33"	15 3/4"	21"	32 1/2"	33 1/16"	34"	14"	15 3/4"
MW2433	21"	15 3/4"	9"	20 1/2"	21 1/16"	22"	14"	18 3/4"
MW2733	24"	15 3/4"	12"	23 1/2"	24 1/16"	25"	14"	18 3/4"
MW3033	27"	15 3/4"	15"	26 1/2"	27 1/16"	28"	14"	18 3/4"
MW3333	30"	15 3/4"	18"	29 1/2"	30 1/16"	31"	14"	18 3/4"
MW3633	33"	15 3/4"	21"	32 1/2"	33 1/16"	34"	14"	18 3/4"

\*Decreased Appliance Opening Width can vary in 1/16" increments by piecing in frame material.

\*\*Increased Appliance Opening Width can vary in 1/16" increments by cutting out the frame stiles.

\*\*\*Appliance Opening Height could have a variance of 1/16". By changing openings, it may require the door/drawer openings to change.

#### Door & Drawer Options

AF	CC	CG	ESMD	GAMD	HC	IFHG	MC	MD <sup>1</sup>	MFO	PRMD <sup>1</sup>	SHMD	SPLITDR	SPLITDRWS	SJMD
✓	✓	✓	✓	✓	✓	✓	✓	✓	✓	✓	✓	✓	✓	✓

#### End Panel Options

AUTH	CSFPE	EXBK	EXDN	FPE	INTGE	IPE
✓	✓	✓	✓	✓	✓	✓

#### Custom Modification Options

ADD	SHLF	ADTK <sup>2</sup>	ADRW	ATTK	BVR	CBO	CCO	CFNTO	CFP	CFRMO	CLIP	CND	CSDGBK	DRWTK	EF	EX	EX_OL	FLUT <sup>3</sup>	FTK	ID	
✓	✓	✓	✓	✓	✓	✓	✓	✓	✓	✓	✓	✓	✓	✓	✓	✓	✓	✓	✓	✓	✓

IH	IW <sup>4</sup>	MIP	OBRB	PFINBTMB	RD	RECTK <sup>5</sup>	RH <sup>5</sup>	ROSLUT <sup>6</sup>	RT	SCPDWR	TD <sup>7</sup>	TKP <sup>2</sup>	TVR	VTK	WS	WTC	WTKCUP	WTR		
✓	✓	✓	✓	✓	✓	✓	✓	✓	✓	✓	✓	✓	✓	✓	✓	✓	✓	✓	✓	✓

<sup>1</sup>Only available on 33" high except not available on 24" wide.

<sup>2</sup>Not available on 24" or 33" wide.

<sup>3</sup>Not available with fluting both or with 6" fluting.

<sup>4</sup>Not available on 36" wide.

<sup>5</sup>Only available on 33" wide.

<sup>6</sup>Not available with fluting both.

<sup>7</sup>Not available on 24" wide.

IH/RH availability charts starting on page G•40.  
IW/RW availability charts starting on page G•46.

## Description

**WALL BUILT-IN MICROWAVE DOUBLE DOOR CABINET, 30" or 33" HIGH, 18" DEEP**

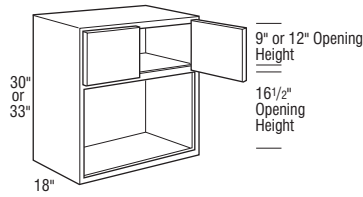

Specify appliance opening dimensions:

**WBMW\_ \_ \_ 18AC**  
Microwave Wall  
18" Deep

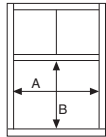

Appliance Opening Dimensions:

A \_\_\_\_\_  
B \_\_\_\_\_

### NOTE:

See chart for specific model appliance opening limitations.

Cabinet appliance openings may vary with modifications (i.e. clipped corner modification reduces maximum cut-out width by 3" per clipped corner).

## Model

**WBMW243018AC**

**WBMW273018AC**

**WBMW303018AC**

**WBMW333018AC**

**WBMW363018AC**

**WBMW243318AC**

**WBMW273318AC**

**WBMW303318AC**

**WBMW333318AC**

**WBMW363318AC**

- Matching Interior standard.
- Specify cut-out size.
- When Beaded Inset is ordered, the cabinet should be ordered to the appropriate width using the 1/4" width modification instead of using the piece-in or cut-out applications.
- The maximum cut-out width is 1 1/2" less than the overall width of the cabinet. The maximum cut-out height varies depending on the cabinet.
- Reduced Depths available in 1/4" increments from 6" to 17 3/4".
- Ordering Maximum Width Cut-out on cabinet will change end panel thickness from 1/2" to 3/8" for non-flush ends, and from 5/8" to 1/2" for flush ends.

	Standard Appliance Opening		Decreased Appliance Opening Width*		Increased Appliance Opening Width**		Appliance Opening Height***	
	Width (A)	Height (B)	Min. Width (A)	Max. Width (A)	Min. Width (A)	Max. Width (A)	Min. Height (B)	Max. Height (B)
WBMW243018AC	21"	16 1/2"	9"	20 1/2"	21 1/16"	22 1/2"	14"	16 1/2"
WBMW273018AC	24"	16 1/2"	12"	23 1/2"	24 1/16"	25 1/2"	14"	16 1/2"
WBMW303018AC	27"	16 1/2"	15"	26 1/2"	27 1/16"	28 1/2"	14"	16 1/2"
WBMW333018AC	30"	16 1/2"	18"	29 1/2"	30 1/16"	31 1/2"	14"	16 1/2"
WBMW363018AC	33"	16 1/2"	21"	32 1/2"	33 1/16"	34 1/2"	14"	16 1/2"
WBMW243318AC	21"	16 1/2"	9"	20 1/2"	21 1/16"	22 1/2"	14"	19 1/2"
WBMW273318AC	24"	16 1/2"	12"	23 1/2"	24 1/16"	25 1/2"	14"	19 1/2"
WBMW303318AC	27"	16 1/2"	15"	26 1/2"	27 1/16"	28 1/2"	14"	19 1/2"
WBMW333318AC	30"	16 1/2"	18"	29 1/2"	30 1/16"	31 1/2"	14"	19 1/2"
WBMW363318AC	33"	16 1/2"	21"	32 1/2"	33 1/16"	34 1/2"	14"	19 1/2"

\*Decreased Appliance Opening Width can vary in 1/16" increments by piecing in frame material.

\*\*Increased Appliance Opening Width can vary in 1/16" increments by cutting out the frame stiles.

\*\*\*Appliance Opening Height could have a variance of 1/16". By changing openings, it may require the door/drawer openings to change.

### Door & Drawer Options

AF	CC	CG	ESMD <sup>1</sup>	GAMD <sup>1</sup>	HC	IFHG	MC	MD <sup>2</sup>	MFO	PRMD <sup>3</sup>	SHMD	SPLITDR	SPLITDRWS	SUMD <sup>1</sup>
✓	✓	✓	✓	✓	✓	✓	✓	✓	✓	✓	✓	✓	✓	✓

### End Panel Options

AUTH	CSFPE <sup>4</sup>	EXBK	EXDN	FPE	INTGE <sup>4</sup>	IPE <sup>4</sup>
✓	✓	✓	✓	✓	✓	✓

### Custom Modification Options

ADD	SHLF	ADTK	ADRW	ATTK	BVR	CBO	CCO	CFNTO	CFP	CFRMO	CLIP	CND	CSDGBK	DRWTK	EF	EX	EX	OL	FLUT <sup>5</sup>	FTK	ID	
✓	✓	✓	✓	✓	✓	✓	✓	✓	✓	✓	✓	✓	✓	✓	✓	✓	✓	✓	✓	✓	✓	✓

IH	IW <sup>6</sup>	MIP	OBRB	PFINBTMB	RD	RECTK	RH	ROSLUT	RT	SCPRDW	TD <sup>7</sup>	TKP	TVR	VTK	WS	WTKCUP	WTR
✓	✓	✓	✓	✓	✓	✓	✓	✓	✓	✓	✓	✓	✓	✓	✓	✓	✓

<sup>1</sup>Only available on 273318, 303318 and 363318 versions.

<sup>2</sup>Only available on 33" high.

<sup>3</sup>Only available on 33" high except not available on 24" wide.

<sup>4</sup>Not available when cut-out width is greater than standard.

<sup>5</sup>Not available with 6" fluting.

<sup>6</sup>Not available on 36" wide.

<sup>7</sup>Not available on 24" wide.

# Wall Microwave Cabinets

## Description

### WALL MICROWAVE DOUBLE DOOR CABINET, 36" or 39" HIGH

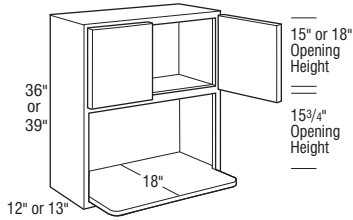

Specify appliance opening dimensions:

#### MW \_ Microwave Wall with Shelf

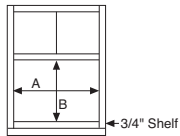

Appliance Opening Dimensions:

A \_\_\_\_\_  
B \_\_\_\_\_

#### NOTE:

See chart for specific model appliance opening limitations.

Cabinet appliance openings may vary with modifications (i.e. clipped corner modification reduces maximum cut-out width by 3" per clipped corner).

## Model

MW2436  
MW2736  
MW3036  
MW3336  
MW3636  
MW2439  
MW2739  
MW3039  
MW3339  
MW3639

- Matching Interior standard.
- Specify cut-out size.
- When Beaded Inset is ordered, the cabinet should be ordered to the appropriate width using the 1/4" width modification instead of using the piece-in or cut-out applications.
- The maximum cut-out width is 2" less than the overall width of the cabinet. The maximum cut-out height varies depending on the cabinet.
- Shelf shipped unattached.
- Microwave shelf depth may be decreased; specify depth required.
- Microwave shelf is solid wood.
- Inset and Beaded Inset Door Styles are a standard 13" deep.
- Full Overlay Styles:
  - Reduced Depths available in 1/4" increments from 6" to 11 3/4".
- Inset and Beaded Inset Styles:
  - Reduced Depths available in 1/4" increments from 6" to 12 3/4".

	Standard Appliance Opening		Decreased Appliance Opening Width*		Increased Appliance Opening Width**		Appliance Opening Height***	
	Width (A)	Height (B)	Min. Width (A)	Max. Width (A)	Min. Width (A)	Max. Width (A)	Min. Height (B)	Max. Height (B)
MW2436	21"	15 3/4"	9"	20 1/2"	21 1/16"	22"	14"	18 3/4"
MW2736	24"	15 3/4"	12"	23 1/2"	24 1/16"	25"	14"	18 3/4"
MW3036	27"	15 3/4"	15"	26 1/2"	27 1/16"	28"	14"	18 3/4"
MW3336	30"	15 3/4"	18"	29 1/2"	30 1/16"	31"	14"	18 3/4"
MW3636	33"	15 3/4"	21"	32 1/2"	33 1/16"	34"	14"	18 3/4"
MW2439	21"	15 3/4"	9"	20 1/2"	21 1/16"	22"	14"	18 3/4"
MW2739	24"	15 3/4"	12"	23 1/2"	24 1/16"	25"	14"	18 3/4"
MW3039	27"	15 3/4"	15"	26 1/2"	27 1/16"	28"	14"	18 3/4"
MW3339	30"	15 3/4"	18"	29 1/2"	30 1/16"	31"	14"	18 3/4"
MW3639	33"	15 3/4"	21"	32 1/2"	33 1/16"	34"	14"	18 3/4"

\*Decreased Appliance Opening Width can vary in 1/16" increments by piecing in frame material.

\*\*Increased Appliance Opening Width can vary in 1/16" increments by cutting out the frame stiles.

\*\*\*Appliance Opening Height could have a variance of 1/16". By changing openings, it may require the door/drawer openings to change.

#### Door & Drawer Options

AF	CC	CG	ESMD	GAMD	HC	IFHG	MC	MD	MFO	PRMD <sup>1</sup>	SHMD	SPLITDR	SPLITDRWS	SUMD
<input checked="" type="checkbox"/>	<input checked="" type="checkbox"/>	<input checked="" type="checkbox"/>	<input checked="" type="checkbox"/>	<input checked="" type="checkbox"/>	<input checked="" type="checkbox"/>	<input checked="" type="checkbox"/>	<input checked="" type="checkbox"/>	<input checked="" type="checkbox"/>	<input checked="" type="checkbox"/>	<input checked="" type="checkbox"/>	<input checked="" type="checkbox"/>	<input checked="" type="checkbox"/>	<input checked="" type="checkbox"/>	<input checked="" type="checkbox"/>

#### End Panel Options

AUTH	CSFPE	EXBK	EXDN	FPE	INTGE	IPE
<input checked="" type="checkbox"/>	<input checked="" type="checkbox"/>	<input checked="" type="checkbox"/>	<input checked="" type="checkbox"/>	<input checked="" type="checkbox"/>	<input checked="" type="checkbox"/>	<input checked="" type="checkbox"/>

#### Custom Modification Options

ADD	SHLF	ADTK <sup>1</sup>	ADRW	ATTK	BVR	CBO	CCO	CFNT0	CFP	CFRMO	CLIP	CND	CSDGBK	DRWTK	EF <sup>2</sup>	EX	EX_OL	FLUT <sup>3</sup>	FTK	ID
<input checked="" type="checkbox"/>	<input checked="" type="checkbox"/>	<input checked="" type="checkbox"/>	<input checked="" type="checkbox"/>	<input checked="" type="checkbox"/>	<input checked="" type="checkbox"/>	<input checked="" type="checkbox"/>	<input checked="" type="checkbox"/>	<input checked="" type="checkbox"/>	<input checked="" type="checkbox"/>	<input checked="" type="checkbox"/>	<input checked="" type="checkbox"/>	<input checked="" type="checkbox"/>	<input checked="" type="checkbox"/>	<input checked="" type="checkbox"/>	<input checked="" type="checkbox"/>	<input checked="" type="checkbox"/>	<input checked="" type="checkbox"/>	<input checked="" type="checkbox"/>	<input checked="" type="checkbox"/>	<input checked="" type="checkbox"/>

IH	IW <sup>4</sup>	MIP	OBRB	PFINBTMB	RD	RECTK <sup>1</sup>	RH <sup>5</sup>	ROSFLUT <sup>6</sup>	RT	SCPDRW	TD <sup>1</sup>	TKP <sup>1</sup>	TVR	VTK	WS	WTCD	WTKCUP	WTR
<input checked="" type="checkbox"/>	<input checked="" type="checkbox"/>	<input checked="" type="checkbox"/>	<input checked="" type="checkbox"/>	<input checked="" type="checkbox"/>	<input checked="" type="checkbox"/>	<input checked="" type="checkbox"/>	<input checked="" type="checkbox"/>	<input checked="" type="checkbox"/>	<input checked="" type="checkbox"/>	<input checked="" type="checkbox"/>	<input checked="" type="checkbox"/>	<input checked="" type="checkbox"/>	<input checked="" type="checkbox"/>	<input checked="" type="checkbox"/>	<input checked="" type="checkbox"/>	<input checked="" type="checkbox"/>	<input checked="" type="checkbox"/>	<input checked="" type="checkbox"/>

<sup>1</sup>Not available on 24" wide.

<sup>2</sup>Not available on 3639 version.

<sup>3</sup>Not available with fluting both or with 6" fluting.

<sup>4</sup>Not available on 36" wide.

<sup>5</sup>Only available on 3336 version.

<sup>6</sup>Not available with fluting both.

IH/RH availability charts starting on page G•40.  
IW/RW availability charts starting on page G•46.

## Description

### WALL BUILT-IN MICROWAVE DOUBLE DOOR CABINET, 36" or 39" HIGH, 18" DEEP

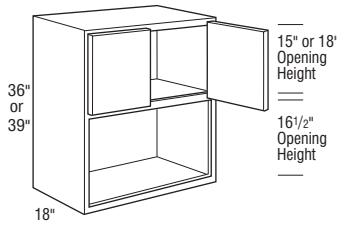

Specify appliance opening dimensions:

#### WBMW\_\_18AC

Microwave Wall  
18" Deep

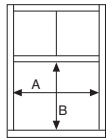

Appliance Opening Dimensions:

A \_\_\_\_\_  
B \_\_\_\_\_

#### NOTE:

See chart for specific model appliance opening limitations.

Cabinet appliance openings may vary with modifications (i.e. clipped corner modification reduces maximum cut-out width by 3" per clipped corner).

## Model

WBMW243618AC

WBMW273618AC

WBMW303618AC

WBMW333618AC

WBMW363618AC

WBMW243918AC

WBMW273918AC

WBMW303918AC

WBMW333918AC

WBMW363918AC

- Matching Interior standard.
- Specify cut-out size.
- When Beaded Inset is ordered, the cabinet should be ordered to the appropriate width using the 1/4" width modification instead of using the piece-in or cut-out applications.
- The maximum cut-out width is 1 1/2" less than the overall width of the cabinet. The maximum cut-out height varies depending on the cabinet.
- Reduced Depths available in 1/4" increments from 6" to 17 3/4".
- Ordering Maximum Width Cut-out on cabinet will change end panel thickness from 1/2" to 3/8" for non-flush ends, and from 5/8" to 1/2" for flush ends.

	Standard Appliance Opening		Decreased Appliance Opening Width*		Increased Appliance Opening Width**		Appliance Opening Height***	
	Width (A)	Height (B)	Min. Width (A)	Max. Width (A)	Min. Width (A)	Max. Width (A)	Min. Height (B)	Max. Height (B)
WBMW243618AC	21"	16 1/2"	9"	20 1/2"	21 1/16"	22 1/2"	14"	19 1/2"
WBMW273618AC	24"	16 1/2"	12"	23 1/2"	24 1/16"	25 1/2"	14"	19 1/2"
WBMW303618AC	27"	16 1/2"	15"	26 1/2"	27 1/16"	28 1/2"	14"	19 1/2"
WBMW333618AC	30"	16 1/2"	18"	29 1/2"	30 1/16"	31 1/2"	14"	19 1/2"
WBMW363618AC	33"	16 1/2"	21"	32 1/2"	33 1/16"	34 1/2"	14"	19 1/2"
WBMW243918AC	21"	16 1/2"	9"	20 1/2"	21 1/16"	22 1/2"	14"	19 1/2"
WBMW273918AC	24"	16 1/2"	12"	23 1/2"	24 1/16"	25 1/2"	14"	19 1/2"
WBMW303918AC	27"	16 1/2"	15"	26 1/2"	27 1/16"	28 1/2"	14"	19 1/2"
WBMW333918AC	30"	16 1/2"	18"	29 1/2"	30 1/16"	31 1/2"	14"	19 1/2"
WBMW363918AC	33"	16 1/2"	21"	32 1/2"	33 1/16"	34 1/2"	14"	19 1/2"

\*Decreased Appliance Opening Width can vary in 1/16" increments by piecing in frame material.

\*\*Increased Appliance Opening Width can vary in 1/16" increments by cutting out the frame stiles.

\*\*\*Appliance Opening Height could have a variance of 1/16". By changing openings, it may require the door/drawer openings to change.

#### Door & Drawer Options

AF	CC	CG	ESMD <sup>1</sup>	GAMD <sup>1</sup>	HC	IFHG	MC	MD	MFO	PRMD <sup>1</sup>	SHMD	SPLITDR	SPLITDRWS	SUMD <sup>1</sup>
✓	✓	✓	✓	✓	✓	✓	✓	✓	✓	✓	✓	✓	✓	✓

#### End Panel Options

AUTH	CSFPE <sup>2</sup>	EXBK	EXDN	FPE	INTGE <sup>2</sup>	IPE <sup>2</sup>
✓	✓	✓	✓	✓	✓	✓

#### Custom Modification Options

ADD_SHLF	ADDTK	ADRW	ATTK	BVR	CBO	CCO	CFNTO	CFP	CFRMO	CLIP	CND	CSDGBK	DRWTK	EF	EX	EX_OL	FLUT <sup>3</sup>	FTK	ID
✓	✓	✓	✓	✓	✓	✓	✓	✓	✓	✓	✓	✓	✓	✓	✓	✓	✓	✓	✓

IH	IW <sup>4</sup>	MIP	OBRB	PFINBTMB	RD	RECTK	RH	ROSLUT	RT	SCDRW	TD <sup>1</sup>	TKP	TVR	VTK	WS	WTC	WTKCUP	WTR
✓	✓	✓	✓	✓	✓	✓	✓	✓	✓	✓	✓	✓	✓	✓	✓	✓	✓	✓

<sup>1</sup>Not available on 24" wide.

<sup>2</sup>Not available when cut-out width is greater than standard.

<sup>3</sup>Not available with 6" fluting.

<sup>4</sup>Not available on 36" wide.



# Wall Microwave Cabinets

## Description

### WALL MICROWAVE DOUBLE DOOR CABINET, 42", 45", or 48" HIGH

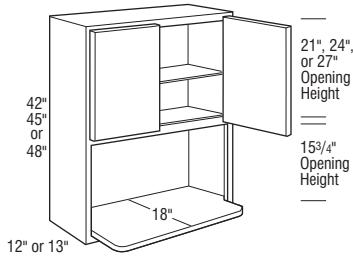

Specify appliance opening dimensions:

MW\_\_  
Microwave Wall  
with Shelf

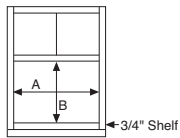

Appliance Opening Dimensions:

A \_\_\_\_\_  
B \_\_\_\_\_

#### NOTE:

See chart for specific model appliance opening limitations.

Cabinet appliance openings may vary with modifications (i.e. clipped corner modification reduces maximum cut-out width by 3" per clipped corner).

## Model

- MW2442
- MW2742
- MW3042
- MW3342
- MW3642
- MW2445
- MW2745
- MW3045
- MW3345
- MW3645
- MW2448
- MW2748
- MW3048
- MW3348
- MW3648

- Matching Interior standard.
- Specify cut-out size.
- When Beaded Inset is ordered, the cabinet should be ordered to the appropriate width using the 1/4" width modification instead of using the piece-in or cut-out applications.
- The maximum cut-out width is 2" less than the overall width of the cabinet. The maximum cut-out height varies depending on the cabinet.
- 48" high has two adjustable shelves. Varies with modifications.
- Shelf shipped unattached.
- Microwave shelf depth may be decreased; specify depth required.
- Microwave shelf is solid wood.
- Inset and Beaded Inset Door Styles are a standard 13" deep.
- Full Overlay Styles:
  - Reduced Depths available in 1/4" increments from 6" to 11 3/4".
- Inset and Beaded Inset Styles:
  - Reduced Depths available in 1/4" increments from 6" to 12 3/4".

	Standard Appliance Opening		Decreased Appliance Opening Width*		Increased Appliance Opening Width**		Appliance Opening Height***	
	Width (A)	Height (B)	Min. Width (A)	Max. Width (A)	Min. Width (A)	Max. Width (A)	Min. Height (B)	Max. Height (B)
MW2442	21"	15 3/4"	9"	20 1/2"	21 1/16"	22"	14"	18 3/4"
MW2742	24"	15 3/4"	12"	23 1/2"	24 1/16"	25"	14"	18 3/4"
MW3042	27"	15 3/4"	15"	26 1/2"	27 1/16"	28"	14"	18 3/4"
MW3342	30"	15 3/4"	18"	29 1/2"	30 1/16"	31"	14"	18 3/4"
MW3642	33"	15 3/4"	21"	32 1/2"	33 1/16"	34"	14"	18 3/4"
MW2445	21"	15 3/4"	9"	20 1/2"	21 1/16"	22"	14"	18 3/4"
MW2745	24"	15 3/4"	12"	23 1/2"	24 1/16"	25"	14"	18 3/4"
MW3045	27"	15 3/4"	15"	26 1/2"	27 1/16"	28"	14"	18 3/4"
MW3345	30"	15 3/4"	18"	29 1/2"	30 1/16"	31"	14"	18 3/4"
MW3645	33"	15 3/4"	21"	32 1/2"	33 1/16"	34"	14"	18 3/4"
MW2448	21"	15 3/4"	9"	20 1/2"	21 1/16"	22"	14"	18 3/4"
MW2748	24"	15 3/4"	12"	23 1/2"	24 1/16"	25"	14"	18 3/4"
MW3048	27"	15 3/4"	15"	26 1/2"	27 1/16"	28"	14"	18 3/4"
MW3348	30"	15 3/4"	18"	29 1/2"	30 1/16"	31"	14"	18 3/4"
MW3648	33"	15 3/4"	21"	32 1/2"	33 1/16"	34"	14"	18 3/4"

\*Decreased Appliance Opening Width can vary in 1/16" increments by piecing in frame material.

\*\*Increased Appliance Opening Width can vary in 1/16" increments by cutting out the frame stiles.

\*\*\*Appliance Opening Height could have a variance of 1/16". By changing openings, it may require the door/drawer openings to change.

#### Door & Drawer Options

AF	CC	CG	ESMD	GAMD	HC	IFHG	MC	MD	MFO	PRMD <sup>1</sup>	SHMD	SPLITDR	SPLITDRWS	SUMD
✓	✓	✓	✓	✓	✓	✓	✓	✓	✓	✓	✓	✓	✓	✓

#### End Panel Options

AUTH	CSFPE	EXBK	EXDN	FPE	INTGE	IPE
✓	✓	✓	✓	✓	✓	✓

#### Custom Modification Options

ADD_SHLF	ADDTK <sup>2</sup>	ADRW	ATTK	BVR	CBO	CCO	CFNTO	CFP	CFRMO	CLIP	CND	CSDGBK	DRWTK	EF	EX	EX_OL	FLUT <sup>3</sup>	FTK	ID	
✓	✓	✓	✓	✓	✓	✓	✓	✓	✓	✓	✓	✓	✓	✓	✓	✓	✓	✓	✓	✓

IH	IW <sup>4</sup>	MIP	OBRB	PFINBTMB	RD	RECTK <sup>2</sup>	RH <sup>5</sup>	ROSFLUT <sup>6</sup>	RT	SCPDWR	TD <sup>1</sup>	TKP <sup>2</sup>	TVR	VTK	WS	WTCD	WTKCUP	WTR	
✓	✓	✓	✓	✓	✓	✓	✓	✓	✓	✓	✓	✓	✓	✓	✓	✓	✓	✓	✓

<sup>1</sup>Not available on 24" wide.

<sup>2</sup>Only available on 27" and 30" wide.

<sup>3</sup>Not available with fluting both or with 6" fluting.

<sup>4</sup>Not available on 36" wide.

<sup>5</sup>Only available on 33" wide.

<sup>6</sup>Not available with fluting both.

IH/RH availability charts starting on page G•40.  
IW/RW availability charts starting on page G•46.

## Description



**WALL BUILT-IN MICROWAVE  
DOUBLE DOOR CABINET, 36", 39",  
or 42" HIGH, 18" or 21" DEEP**

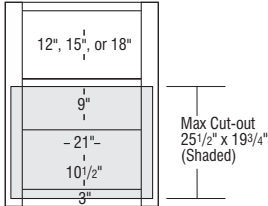
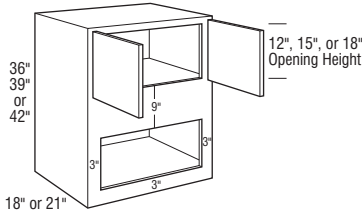

WBMW273618, WBMW273918, WBMW274218  
WBMW273621, WBMW273921, WBMW274221

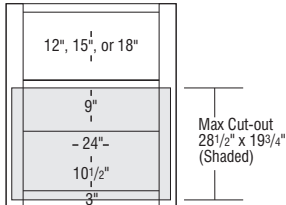

WBMW303618, WBMW303918, WBMW304218  
WBMW303621, WBMW303921, WBMW304221

## Model

WBMW273618

WBMW303618

WBMW273621

WBMW303621

WBMW273918

WBMW303918

WBMW273921

WBMW303921

WBMW274218

WBMW304218

WBMW274221

WBMW304221

- 42" high includes one adjustable shelf.
- See chart for specific model appliance opening limitations.
- Designed for built-in microwaves.
- Increased Depths available in 1/4" increments from 18 1/4" to 30".
- Reduced Depths available in 1/4" increments from 6" to 17 3/4".

	Factory Opening		Maximum Cut-out	
	Width	Height	Width	Height
WBMW273618	21"	10 1/2"	25 1/2"	19 3/4"
WBMW303618	24"	10 1/2"	28 1/2"	19 3/4"
WBMW273621	21"	10 1/2"	25 1/2"	19 3/4"
WBMW303621	24"	10 1/2"	28 1/2"	19 3/4"
WBMW273918	21"	10 1/2"	25 1/2"	19 3/4"
WBMW303918	24"	10 1/2"	28 1/2"	19 3/4"
WBMW273921	21"	10 1/2"	25 1/2"	19 3/4"
WBMW303921	24"	10 1/2"	28 1/2"	19 3/4"
WBMW274218	21"	10 1/2"	25 1/2"	19 3/4"
WBMW304218	24"	10 1/2"	28 1/2"	19 3/4"
WBMW274221	21"	10 1/2"	25 1/2"	19 3/4"
WBMW304221	24"	10 1/2"	28 1/2"	19 3/4"

### Door & Drawer Options

AF	CC	CG	ESMD <sup>1</sup>	GAMD <sup>1</sup>	HC	IFHG	MC	MD	MFO	PRMD <sup>1</sup>	SHMD	SPLITDR	SPLITDRWS	SJMD <sup>1</sup>
✓	✓	✓	✓	✓	✓	✓	✓	✓	✓	✓	✓	✓	✓	✓

### End Panel Options

AUTH	CSFPE	EXBK	EXDN	FPE	INTGE	IPE
✓	✓	✓	✓	✓	✓	✓

### Custom Modification Options

ADD	SHLF	ADTK	ADRW	ATTK	BVR	CBO	CCO	CFNTO	CFP	CFRMO	CLIP	CND	CSDGBK	DRWTK	EF	EX	EX_OL	FLUT <sup>2</sup>	FTK	ID
✓	✓	✓	✓	✓	✓	✓	✓	✓	✓	✓	✓	✓	✓	✓	✓	✓	✓	✓	✓	✓

IH	IW <sup>3</sup>	MIP	OBRB	PFINBTMB	RD	RECTK	RH	ROSLUT	RT	SCPRW	TD <sup>1</sup>	TKP	TVR	VTK	WS	WTCD	WTKCUP	WTR
✓	✓	✓	✓	✓	✓	✓	✓	✓	✓	✓	✓	✓	✓	✓	✓	✓	✓	✓

<sup>1</sup>Not available on 24" wide.

<sup>2</sup>Not available with 6" fluting.

<sup>3</sup>Not available on 36" wide.

# Wall Microwave Cabinets

## Description

**WALL BUILT-IN MICROWAVE DOUBLE DOOR CABINET, 42", 45", or 48" HIGH, 18" DEEP**

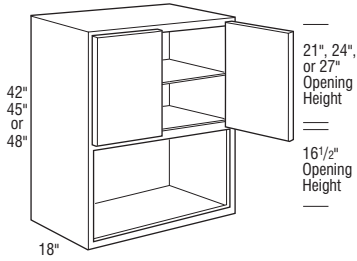

Specify appliance opening dimensions:

**WBMW** \_\_\_ **18**  
Microwave Wall  
18" Deep

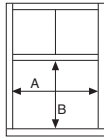

Appliance Opening Dimensions:

A \_\_\_\_\_  
B \_\_\_\_\_

### NOTE:

See chart for specific model appliance opening limitations.

Cabinet appliance openings may vary with modifications (i.e. clipped corner modification reduces maximum cut-out width by 3" per clipped corner).

## Model

**WBMW244218AC**

**WBMW274218AC**

**WBMW304218AC**

**WBMW334218AC**

**WBMW364218AC**

**WBMW244518AC**

**WBMW274518AC**

**WBMW304518AC**

**WBMW334518AC**

**WBMW364518AC**

**WBMW244818AC**

**WBMW274818AC**

**WBMW304818AC**

**WBMW334818AC**

**WBMW364818AC**

- Matching Interior standard.
- Specify cut-out size.
- When Beaded Inset is ordered, the cabinet should be ordered to the appropriate width using the 1/4" width modification instead of using the piece-in or cut-out applications.
- The maximum cut-out width is 1 1/2" less than the overall width of the cabinet. The maximum cut-out height varies depending on the cabinet.
- 48" high has two adjustable shelves. Varies with modifications.
- Reduced Depths available in 1/4" increments from 6" to 17 3/4".
- Ordering Maximum Width Cut-out on cabinet will change end panel thickness from 1/2" to 3/8" for non-flush ends, and from 5/8" to 1/2" for flush ends.

	Standard Appliance Opening		Decreased Appliance Opening Width*		Increased Appliance Opening Width**		Appliance Opening Height***	
	Width (A)	Height (B)	Min. Width (A)	Max. Width (A)	Min. Width (A)	Max. Width (A)	Min. Height (B)	Max. Height (B)
WBMW244218AC	21"	16 1/2"	9"	20 1/2"	21 1/16"	22 1/2"	14"	19 1/2"
WBMW274218AC	24"	16 1/2"	12"	23 1/2"	24 1/16"	25 1/2"	14"	19 1/2"
WBMW304218AC	27"	16 1/2"	15"	26 1/2"	27 1/16"	28 1/2"	14"	19 1/2"
WBMW334218AC	30"	16 1/2"	18"	29 1/2"	30 1/16"	31 1/2"	14"	19 1/2"
WBMW364218AC	33"	16 1/2"	21"	32 1/2"	33 1/16"	34 1/2"	14"	19 1/2"
WBMW244518AC	21"	16 1/2"	9"	20 1/2"	21 1/16"	22 1/2"	14"	19 1/2"
WBMW274518AC	24"	16 1/2"	12"	23 1/2"	24 1/16"	25 1/2"	14"	19 1/2"
WBMW304518AC	27"	16 1/2"	15"	26 1/2"	27 1/16"	28 1/2"	14"	19 1/2"
WBMW334518AC	30"	16 1/2"	18"	29 1/2"	30 1/16"	31 1/2"	14"	19 1/2"
WBMW364518AC	33"	16 1/2"	21"	32 1/2"	33 1/16"	34 1/2"	14"	19 1/2"
WBMW244818AC	21"	16 1/2"	9"	20 1/2"	21 1/16"	22 1/2"	14"	19 1/2"
WBMW274818AC	24"	16 1/2"	12"	23 1/2"	24 1/16"	25 1/2"	14"	19 1/2"
WBMW304818AC	27"	16 1/2"	15"	26 1/2"	27 1/16"	28 1/2"	14"	19 1/2"
WBMW334818AC	30"	16 1/2"	18"	29 1/2"	30 1/16"	31 1/2"	14"	19 1/2"
WBMW364818AC	33"	16 1/2"	21"	32 1/2"	33 1/16"	34 1/2"	14"	19 1/2"

\*Decreased Appliance Opening Width can vary in 1/16" increments by piecing in frame material.

\*\*Increased Appliance Opening Width can vary in 1/16" increments by cutting out the frame stiles.

\*\*\*Appliance Opening Height could have a variance of 1/16". By changing openings, it may require the door/drawer openings to change.

### Door & Drawer Options

AF	CC	CG	ESMD <sup>1</sup>	GAMD <sup>1</sup>	HC	IFHG	MC	MD	MFO	PRMD <sup>2</sup>	SHMD	SPLITDR	SPLITDRWS	SUMD <sup>1</sup>
✓	✓	✓	✓	✓	✓	✓	✓	✓	✓	✓	✓	✓	✓	✓

### End Panel Options

AUTH	CSFPE <sup>3</sup>	EXBK	EXDN	FPE	INTGE <sup>3</sup>	IPE <sup>3</sup>
✓	✓	✓	✓	✓	✓	✓

### Custom Modification Options

ADD	SHLF	ADTK	ADRW	ATTK	BVR	CBO	CCO	CFNTO	CFP	CFRMO	CLIP	CND	CSDGBK	DRWTK	EF	EX	EX_OL	FLUT <sup>4</sup>	FTK	ID	
✓	✓	✓	✓	✓	✓	✓	✓	✓	✓	✓	✓	✓	✓	✓	✓	✓	✓	✓	✓	✓	✓

IH	IW <sup>5</sup>	MIP	OBRB	PFINBTMB	RD	RECTK	RH	ROSLUT	RT	SCPDRW	TD <sup>2</sup>	TKP	TVR	VTK	WS	WTCD	WTKCUP	WTR		
✓	✓	✓	✓	✓	✓	✓	✓	✓	✓	✓	✓	✓	✓	✓	✓	✓	✓	✓	✓	✓

<sup>1</sup>Only available on 27" and 30" wide.

<sup>2</sup>Not available on 24" wide.

<sup>3</sup>Not available when cut-out width is greater than standard.

<sup>4</sup>Not available with 6" fluting.

<sup>5</sup>Not available on 36" wide.

IH/RH availability charts starting on page G•40.  
IW/RW availability charts starting on page G•46.

## Description

### THREE DRAWER BASE, WARMING DRAWER, 34 1/2" HIGH, 24" DEEP

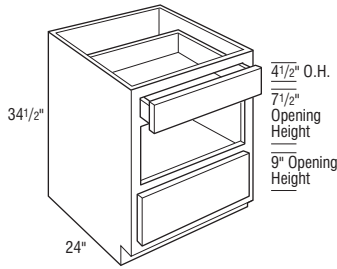

Specify appliance opening dimensions:

#### 3DB \_WD

3 Drawer Base, Warming Drawer

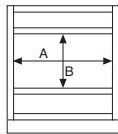

Appliance Opening Dimensions:

A \_\_\_\_\_  
B \_\_\_\_\_

#### NOTE:

See chart for specific model appliance opening limitations.

Cabinet appliance openings may vary with modifications (i.e. clipped corner modification reduces maximum cut-out width by 3" per clipped corner).

## Model

3DB24WD

3DB27WD

3DB30WD

3DB33WD

3DB36WD

- When Beaded Inset is ordered, the cabinet should be ordered to the appropriate width using the 1/4" width modification instead of using the piece-in or cut-out applications.
- Ordering Maximum Width Cut-out on cabinet will change end panel thickness from 1/2" to 3/8" for non-flush ends, and from 5/8" to 1/2" for flush ends.

	Standard Appliance Opening		Decreased Appliance Opening Width*		Increased Appliance Opening Width**		Appliance Opening Height***	
	Width (A)	Height (B)	Min. Width (A)	Max. Width (A)	Min. Width (A)	Max. Width (A)	Min. Height (B)	Max. Height (B)
3DB24WD	21"	7 1/2"	9"	20 1/2"	21 1/16"	22 1/2"	7 1/2"	10 1/2"
3DB27WD	24"	7 1/2"	12"	23 1/2"	24 1/16"	25 1/2"	7 1/2"	10 1/2"
3DB30WD	27"	7 1/2"	15"	26 1/2"	27 1/16"	28 1/2"	7 1/2"	10 1/2"
3DB33WD	30"	7 1/2"	18"	29 1/2"	30 1/16"	31 1/2"	7 1/2"	10 1/2"
3DB36WD	33"	7 1/2"	21"	32 1/2"	33 1/16"	34 1/2"	7 1/2"	10 1/2"

\*Decreased Appliance Opening Width can vary in 1/16" increments by piecing in frame material.

\*\*Increased Appliance Opening Width can vary in 1/16" increments by cutting out the frame stiles.

\*\*\*Appliance Opening Height could have a variance of 1/16". By changing openings, it may require the door/drawer openings to change.

#### Door & Drawer Options

AF	CC	CG	ESMD	GAMD	HC	IFHG	MC	MD	MFO	PRMD	SHMD	SPLITDR	SPLITDRWS	SUMD
						✓							✓	

#### End Panel Options

AUTH	CSFPE <sup>1</sup>	EXBK	EXDN	FPE	INTGE <sup>1</sup>	IPE <sup>1</sup>
✓	✓	✓	✓	✓	✓	✓

#### Custom Modification Options

ADD	SHLF	ADDTK	ADRW	ATTK	BVR	CBO	CCO	CFNTO	CFP	CFRMO	CLIP	CND	CSDBGK	DRWTK <sup>2</sup>	EF	EX	EX_OL	FLUT	FTK	ID	
						✓	✓	✓	✓	✓	✓	✓	✓	✓	✓	✓	✓	✓	✓	✓	✓

IH	IW <sup>3</sup>	MIP	OBRB	PFINBTMB	RD	RECTK <sup>4</sup>	RH	ROSLUT	RT	SCPDRW	TD	TKP <sup>4</sup>	TVR <sup>5</sup>	VTK <sup>4</sup>	WS	WTCO <sup>6</sup>	WTKCUP	WTR
✓	✓	✓	✓	✓	✓	✓	✓	✓	✓	✓	✓	✓	✓	✓	✓	✓	✓	✓

<sup>1</sup>Not available when cut-out width is greater than standard.

<sup>2</sup>Only available on 27" and 30" wide.

<sup>3</sup>Not available on 36" wide.

<sup>4</sup>Not available on 33" or 36" wide.

<sup>5</sup>Not available on 24" or 27" wide.

<sup>6</sup>Not available on 27" or 33" wide.

# Base Microwave Cabinets

## Description

**BASE MICROWAVE CABINET with ROLL TRAY(S), 34 1/2" or 40 1/2" HIGH, 24" DEEP**

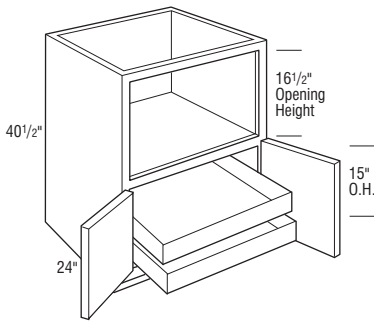
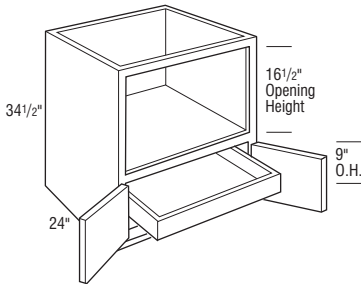

Specify appliance opening dimensions:

**BMW** \_ \_  
Base Microwave with Drawer

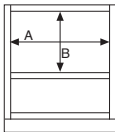

Appliance Opening Dimensions:

A \_\_\_\_\_  
B \_\_\_\_\_

### NOTE:

See chart for specific model appliance opening limitations.

Cabinet appliance openings may vary with modifications (i.e. clipped corner modification reduces maximum cut-out width by 3" per clipped corner).

## Model

**BMW24RT**

**BMW27RT**

**BMW30RT**

**BMW33RT**

**BMW36RT**

• Includes one roll-out tray.

**BMW2440RT**

**BMW2740RT**

**BMW3040RT**

**BMW3340RT**

**BMW3640RT**

• Includes two roll-out trays.

Notes below apply to all products in section above:

- Matching Interior standard.
- Specify cut-out or use standard cut-out.
- When Beaded Inset is ordered, the cabinet should be ordered to the appropriate width using the 1/4" width modification instead of using the piece-in or cut-out applications.
- The maximum cut-out width is 1 1/2" less than the overall width of the cabinet.
- Reduced Depths available in 1/4" increments from 12" to 23 3/4".
- Ordering Maximum Width Cut-out on cabinet will change end panel thickness from 1/2" to 3/8" for non-flush ends, and from 5/8" to 1/2" for flush ends.

	Standard Appliance Opening		Decreased Appliance Opening Width*		Increased Appliance Opening Width**		Appliance Opening Height***	
	Width (A)	Height (B)	Min. Width (A)	Max. Width (A)	Min. Width (A)	Max. Width (A)	Min. Height (B)	Max. Height (B)
BMW24RT	21"	16 1/2"	9"	20 1/2"	21 1/16"	22 1/2"	11 1/2"	16 1/2"
BMW27RT	24"	16 1/2"	12"	23 1/2"	24 1/16"	25 1/2"	11 1/2"	16 1/2"
BMW30RT	27"	16 1/2"	15"	26 1/2"	27 1/16"	28 1/2"	11 1/2"	16 1/2"
BMW33RT	30"	16 1/2"	18"	29 1/2"	30 1/16"	31 1/2"	11 1/2"	16 1/2"
BMW36RT	33"	16 1/2"	21"	32 1/2"	33 1/16"	34 1/2"	11 1/2"	16 1/2"
BMW2440RT	21"	16 1/2"	9"	20 1/2"	21 1/16"	22 1/2"	11 1/2"	19 1/2"
BMW2740RT	24"	16 1/2"	12"	23 1/2"	24 1/16"	25 1/2"	11 1/2"	19 1/2"
BMW3040RT	27"	16 1/2"	15"	26 1/2"	27 1/16"	28 1/2"	11 1/2"	19 1/2"
BMW3340RT	30"	16 1/2"	18"	29 1/2"	30 1/16"	31 1/2"	11 1/2"	19 1/2"
BMW3640RT	33"	16 1/2"	21"	32 1/2"	33 1/16"	34 1/2"	11 1/2"	19 1/2"

\*Decreased Appliance Opening Width can vary in 1/16" increments by piecing in frame material.

\*\*Increased Appliance Opening Width can vary in 1/16" increments by cutting out the frame stiles.

\*\*\*Appliance Opening Height could have a variance of 1/16". By changing openings, it may require the door/drawer openings to change.

### Door & Drawer Options

AF	CC	CG <sup>1</sup>	ESMD <sup>2</sup>	GAMD <sup>2</sup>	HC	IFHG <sup>3</sup>	MC	MD <sup>1</sup>	MFO	PRMD <sup>4</sup>	SHMD	SPLITDR	SPLITDRWS	SUMD <sup>2</sup>
		✓	✓	✓	✓	✓	✓	✓	✓	✓				✓

### End Panel Options

AUTH	CSFPE <sup>5</sup>	EXBK <sup>6</sup>	EXDN	FPE	INTGE <sup>5</sup>	IPE <sup>5</sup>
✓	✓	✓	✓	✓	✓	✓

### Custom Modification Options

ADD	SHLF	ADTK	ADRW	ATTK	BVR	CBO <sup>6</sup>	CCO	CFNTO <sup>6</sup>	CFP	CFRMO <sup>6</sup>	CLJP	CND <sup>6</sup>	CSDGBK	DRWTR <sup>7</sup>	EF	EX	EX	OL	FLUT <sup>8</sup>	FTK	ID	
						✓		✓		✓	✓	✓	✓	✓	✓	✓	✓	✓	✓	✓	✓	✓

IH	IW <sup>9</sup>	MIP	OBRB <sup>4</sup>	PFINBTMB	RD	RECTK <sup>10</sup>	RH	ROSLUT	RT	SCPDRW	TD	TKP <sup>10</sup>	TVR	VTK <sup>10</sup>	WS	WTCD	WTKCUP	WTR	
	✓		✓		✓	✓		✓				✓		✓	✓				✓

<sup>1</sup>Only available on 40.5" high.

<sup>2</sup>Not available on 24" or 27" wide.

<sup>3</sup>Not available on 27" wide.

<sup>4</sup>Only available on the 40.5" high except on the 24" and 27" wide.

<sup>5</sup>Not available when cut-out width is greater than standard.

<sup>6</sup>Not available on 24" or 27" wide on the 34.5" high. Not available on 27" wide on the 40.5" high.

<sup>7</sup>Only available on the 30" wide on the 34.5" high.

<sup>8</sup>6" fluting not available on 24" or 27" wide. Not available with 6" fluting both.

<sup>9</sup>Not available on 36" wide.

<sup>10</sup>Only available on 27" and 30" wide.

IH/RH availability charts starting on page G•40.  
IW/RW availability charts starting on page G•46.

## Description



### BASE MICROWAVE CABINET with DRAWER, 34 1/2" HIGH, 24" DEEP

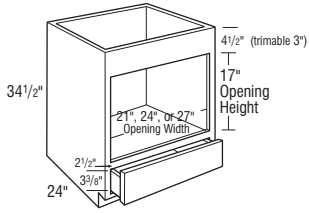

Specify appliance opening dimensions:

**BMWD** \_ \_

Base Microwave with Drawer

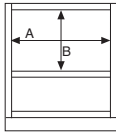

Appliance Opening Dimensions:

A \_\_\_\_\_  
B \_\_\_\_\_

#### NOTE:

See chart for specific model appliance opening limitations.

Cabinet appliance openings may vary with modifications (i.e. clipped corner modification reduces maximum cut-out width by 3" per clipped corner).

## Model

**BMWD24**

**BMWD27**

**BMWD30**

- The usable cabinet face height between top of drawer front and top of cabinet is 23 1/2". Be sure to verify overall appliance height, gap requirements, and cut-out dimensions with cabinet specifications.
- Includes one drawer.
- Reduced Depths available in 1/4" increments from 12" to 23 3/4".

Model	Opening Width (A)	Maximum Width (A)	Opening Height (B)	Maximum Height (B)
BMWD24	21"	22 1/2"	17"	20"
BMWD27	24"	25 1/2"	17"	20"
BMWD30	27"	28 1/2"	17"	20"

#### Door & Drawer Options

AF	CC	CG	ESMD	GAMD	HC	IFHG	MC	MD	MFO	PRMD	SHMD	SPLITDR	SPLITDRWS	SUMD
						✓								

#### End Panel Options

AUTH	CSFPE	EXBK	EXDN	FPE	INTGE	IPE
✓	✓	✓	✓	✓	✓	✓

#### Custom Modification Options

ADD	SHLF	ADDTK	ADRW	ATTK	BVR	CBO	CCO	CFNTO	CFP	CFRMO	CLIP	CND	CSDGBK	DRWTK <sup>1</sup>	EF	EX	EX_OL	FLUT <sup>2</sup>	FTK	ID	
								✓	✓	✓	✓	✓	✓	✓	✓	✓	✓	✓	✓	✓	✓

IH	IW <sup>3</sup>	MIP	OBRB	PFINBTMB	RD	RECTK <sup>4</sup>	RH	ROSFLUT	RT	SCPDRW	TD	TKP <sup>4</sup>	TVR	VTK <sup>4</sup>	WS	WTCD	WTKCUP	WTR		
✓	✓	✓	✓	✓	✓	✓	✓	✓	✓	✓	✓	✓	✓	✓	✓	✓	✓	✓	✓	✓

<sup>1</sup>Only available on 24" and 30" wide.

<sup>2</sup>6" fluting not available on 24" or 27" wide. Not available with 6" fluting both.

<sup>3</sup>Not available on 36" wide.

<sup>4</sup>Not available on 33" or 36" wide.



### BASE BUILT-IN MICROWAVE CABINET with DRAWER, 34 1/2" HIGH, 24" DEEP

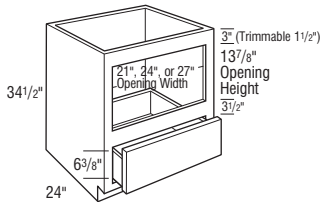

Specify appliance opening dimensions:

**BBMWD** \_ \_

Base Microwave with Drawer

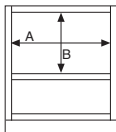

Appliance Opening Dimensions:

A \_\_\_\_\_  
B \_\_\_\_\_

#### NOTE:

See chart for specific model appliance opening limitations.

Cabinet appliance openings may vary with modifications (i.e. clipped corner modification reduces maximum cut-out width by 3" per clipped corner).

**BBMWD24**

**BBMWD27**

**BBMWD30**

- The usable cabinet face height between top of drawer front and top of cabinet is 19 3/4". Be sure to verify overall appliance height, gap requirements, and cut-out dimensions with cabinet specifications.
- Includes one drawer.
- Reduced Depths available in 1/4" increments from 12" to 23 3/4".
- For built-in appliance support, OCINSTALLKIT is included in 24" deep cabinets, but will not be included when depth is modified.

Model	Opening Width (A)	Maximum Width (A)	Opening Height (B)	Maximum Height (B)
BBMWD24	21"	22 1/2"	13 7/8"	16 7/8"
BBMWD27	24"	25 1/2"	13 7/8"	16 7/8"
BBMWD30	27"	28 1/2"	13 7/8"	16 7/8"

#### Door & Drawer Options

AF	CC	CG	ESMD	GAMD	HC	IFHG	MC	MD	MFO	PRMD	SHMD	SPLITDR	SPLITDRWS	SUMD
						✓								

#### End Panel Options

AUTH	CSFPE	EXBK	EXDN	FPE	INTGE	IPE
✓	✓	✓	✓	✓	✓	✓

#### Custom Modification Options

ADD	SHLF	ADDTK	ADRW	ATTK	BVR	CBO	CCO	CFNTO	CFP	CFRMO	CLIP	CND	CSDGBK	DRWTK <sup>1</sup>	EF	EX	EX_OL	FLUT <sup>2</sup>	FTK	ID	
								✓	✓	✓	✓	✓	✓	✓	✓	✓	✓	✓	✓	✓	✓

IH	IW <sup>3</sup>	MIP	OBRB	PFINBTMB	RD	RECTK <sup>4</sup>	RH	ROSFLUT	RT	SCPDRW	TD	TKP <sup>4</sup>	TVR	VTK <sup>4</sup>	WS	WTCD	WTKCUP	WTR			
✓	✓	✓	✓	✓	✓	✓	✓	✓	✓	✓	✓	✓	✓	✓	✓	✓	✓	✓	✓	✓	✓

<sup>1</sup>Only available on 24" and 30" wide.

<sup>2</sup>6" fluting not available on 24" or 27" wide. Not available with 6" fluting both.

<sup>3</sup>Not available on 36" wide.

<sup>4</sup>Not available on 33" or 36" wide.

# Base Microwave Cabinets

## Description

### BASE MICROWAVE CABINET with DEEP DRAWER, 34 1/2" HIGH, 24" DEEP

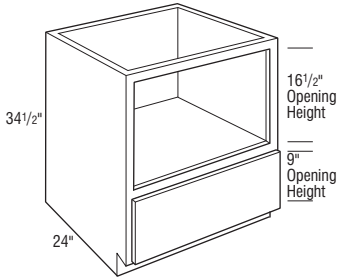

Specify appliance opening dimensions:

#### BMWDD - DD

Base Microwave with Drawer

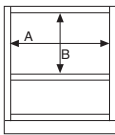

Appliance Opening Dimensions:

A \_\_\_\_\_

B \_\_\_\_\_

#### NOTE:

See chart for specific model appliance opening limitations.

Cabinet appliance openings may vary with modifications (i.e. clipped corner modification reduces maximum cut-out width by 3" per clipped corner).

## Model

**BMWWD24DD**

**BMWWD27DD**

**BMWWD30DD**

**BMWWD33DD**

**BMWWD36DD**

- Matching Interior standard.
- If opening height increases, drawer opening decreases to 6 1/2" or 4 1/2".
- Reduced Depths available in 1/4" increments from 12" to 23 3/4".
- When Beaded Inset is ordered, the cabinet should be ordered to the appropriate width using the 1/4" width modification instead of using the piece-in or cut-out applications.
- Ordering Maximum Width Cut-out on cabinet will change end panel thickness from 1/2" to 3/8" for non-flush ends, and from 5/8" to 1/2" for flush ends.

	Standard Appliance Opening		Decreased Appliance Opening Width*		Increased Appliance Opening Width**		Appliance Opening Height***	
	Width (A)	Height (B)	Min. Width (A)	Max. Width (A)	Min. Width (A)	Max. Width (A)	Min. Height (B)	Max. Height (B)
BMWWD24DD	21"	16 1/2"	9"	20 1/2"	21 1/16"	22 1/2"	11 1/2"	21"
BMWWD27DD	24"	16 1/2"	12"	23 1/2"	24 1/16"	25 1/2"	11 1/2"	21"
BMWWD30DD	27"	16 1/2"	15"	26 1/2"	27 1/16"	28 1/2"	11 1/2"	21"
BMWWD33DD	30"	16 1/2"	18"	29 1/2"	30 1/16"	31 1/2"	11 1/2"	21"
BMWWD36DD	33"	16 1/2"	21"	32 1/2"	33 1/16"	34 1/2"	11 1/2"	21"

\*Decreased Appliance Opening Width can vary in 1/16" increments by piecing in frame material.

\*\*Increased Appliance Opening Width can vary in 1/16" increments by cutting out the frame stiles.

\*\*\*Appliance Opening Height could have a variance of 1/16". By changing openings, it may require the door/drawer openings to change.

#### Door & Drawer Options

AF	CC	CG	ESMD	GAMD	HC	IFHG	MC	MD	MFO	PRMD	SHMD	SPLITDR	SPLITDRWS	SUMD
						✓								

#### End Panel Options

AUTH	CSFPE <sup>1</sup>	EXBK	EXDN	FPE	INTGE <sup>1</sup>	IPE <sup>1</sup>
✓	✓	✓		✓	✓	✓

#### Custom Modification Options

ADD	SHLF	ADDTK	ADRW	ATTK	BVR	CBO	CCO	CFNTO	CFP	CFRMO	CLIP	CND	CSDGBK	DRWTK <sup>2</sup>	EF	EX	EX_OL	FLUT <sup>3</sup>	FTK	ID	
						✓		✓		✓	✓	✓	✓	✓	✓	✓	✓	✓	✓	✓	✓

IH	IW <sup>4</sup>	MIP	OBRB	PFINBTMB	RD	RECTK <sup>5</sup>	RH	ROSFLUT	RT	SCPDRW	TD	TKP <sup>5</sup>	TVR	VTK <sup>5</sup>	WS	WTCD	WTKCUP	WTR
	✓		✓		✓	✓		✓			✓	✓	✓	✓	✓			✓

<sup>1</sup>Not available when cut-out width is greater than standard.

<sup>2</sup>Only available on 24" and 30" wide.

<sup>3</sup>6" fluting not available on 24" or 27" wide. Not available with 6" fluting both.

<sup>4</sup>Not available on 36" wide.

<sup>5</sup>Not available on 33" or 36" wide.

IH/RH availability charts starting on page G•40.  
IW/RW availability charts starting on page G•46.

## Description



### BASE OVEN TRIMMABLE CABINET, 34 1/2" HIGH, 24" DEEP

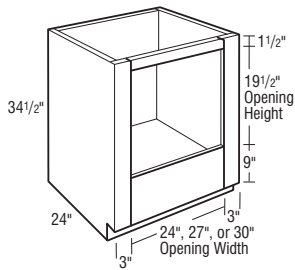

## Model

**BO27**

**BO30**

**BO33**

**BO36**

- See chart for specific model appliance opening limitations.
- Increased Depths available in 1/4" increments from 24 1/4" to 30".
- Reduced Depths available in 1/4" increments from 6" to 23 3/4".
- For built-in appliance support, OCINSTALLKIT is included in 24" deep cabinets, but will not be included when depth is modified.

Model	Opening Width	Maximum Width	Opening Height	Maximum Height*
BO27	21"	25 1/2"	19 1/2"	27 1/2"
BO30	24"	28 1/2"	19 1/2"	27 1/2"
BO33	27"	31 1/2"	19 1/2"	27 1/2"
BO36	30"	34 1/2"	19 1/2"	27 1/2"

\*Top frame cross rail can be removed during field installation if cabinet is properly installed between two adjacent cabinets, increasing the maximum height to 28 1/4".

### Door & Drawer Options

AF	CC	CG	ESMD	GAMD	HC	IFHG	MC	MD	MFO	PRMD	SHMD	SPLITDR	SPLITDRWS	SUMD
----	----	----	------	------	----	------	----	----	-----	------	------	---------	-----------	------

### End Panel Options

AUTH	CSFPE	EXBK	EXDN	FPE	INTGE	IPE
✓	✓	✓		✓	✓	✓

### Custom Modification Options

ADD_SHLF	ADDTK	ADRW	ATTK	BVR	CBO	CCO	CFNT0	CFP	CFRMO	CLIP	CND	CSDGBK	DRWTK	EF	EX	EX_OL	FLUT <sup>1</sup>	FTK	ID
										✓		✓	✓	✓	✓	✓	✓	✓	✓
IH	IW <sup>2</sup>	MIP	OBRB	PFINBTMB	RD	RECTK <sup>2</sup>	RH	ROSLUT	RT	SCPDWR	TD	TKP <sup>2</sup>	TVR	VTK <sup>2</sup>	WS	WTCD	WTKCUP	WTR	
✓	✓	✓	✓		✓	✓		✓				✓	✓	✓	✓	✓	✓	✓	

<sup>1</sup>6" fluting not available on 27" wide. 6" fluting both only available on 36" wide.

<sup>2</sup>Not available on 36" wide.



# Base Oven Cabinets

## Description

**BASE OVEN CABINET, 34 1/2" HIGH, 24" DEEP**

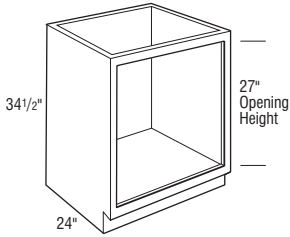

Specify appliance opening dimensions:

**BO\_\_AC**

Base Oven Cabinet

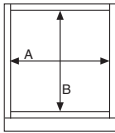

Appliance Opening Dimensions:

A \_\_\_\_\_

B \_\_\_\_\_

### NOTE:

See chart for specific model appliance opening limitations.

Cabinet appliance openings may vary with modifications (i.e. clipped corner modification reduces maximum cut-out width by 3" per clipped corner).

## Model

**BO27AC**

**BO30AC**

**BO33AC**

**BO36AC**

- Includes floor under oven section.
- Specify cut-out size.
- When Beaded Inset is ordered, the cabinet should be ordered to the appropriate width using the 1/4" width modification instead of using the piece-in or cut-out applications.
- Reduced Depths available in 1/4" increments from 6" to 23 3/4".
- Ordering Maximum Width Cut-out on cabinet will change end panel thickness from 1/2" to 3/8" for non-flush ends, and from 5/8" to 1/2" for flush ends.

	Standard Appliance Opening		Decreased Appliance Opening Width*		Increased Appliance Opening Width**		Appliance Opening Height***	
	Width (A)	Height (B)	Min. Width (A)	Max. Width (A)	Min. Width (A)	Max. Width (A)	Min. Height (B)	Max. Height (B)
BO27AC	24"	27"	12"	23 1/2"	24 1/16"	25 1/2"	22"	27 1/2"
BO30AC	27"	27"	15"	26 1/2"	27 1/16"	28 1/2"	22"	27 1/2"
BO33AC	30"	27"	18"	29 1/2"	30 1/16"	31 1/2"	22"	27 1/2"
BO36AC	33"	27"	21"	32 1/2"	33 1/16"	34 1/2"	22"	27 1/2"

\*Decreased Appliance Opening Width can vary in 1/16" increments by piecing in frame material.

\*\*Increased Appliance Opening Width can vary in 1/16" increments by cutting out the frame stiles.

\*\*\*Appliance Opening Height could have a variance of 1/16". By changing openings, it may require the door/drawer openings to change.

### Door & Drawer Options

AF	CC	CG	ESMD	GAMD	HC	IFHG	MC	MD	MFO	PRMD	SHMD	SPLITDR	SPLITDRWS	SUMD
----	----	----	------	------	----	------	----	----	-----	------	------	---------	-----------	------

### End Panel Options

AUTH	CSFPE <sup>1</sup>	EXBK	EXDN	FPE	INTGE <sup>1</sup>	IPE <sup>1</sup>
✓	✓	✓	✓	✓	✓	✓

### Custom Modification Options

ADD	SHLF	ADDTK	ADRW	ATTK	BVR	CBO	CCO	CFNTO	CFP	CFRMO	CLIP	CND	CSDGBK	DRWTK <sup>2</sup>	EF	EX	EX_OL	FLUT <sup>3</sup>	FTK	ID	
✓	✓	✓	✓	✓	✓	✓	✓	✓	✓	✓	✓	✓	✓	✓	✓	✓	✓	✓	✓	✓	✓
IH	IW <sup>4</sup>	MIP	OBRB	PFINBTMB	RD	RECTK <sup>4</sup>	RH	ROSFLUT	RT	SCPDRW	TD	TKP <sup>4</sup>	TVR	VTK <sup>4</sup>	WS	WTCD	WTKCUP	WTR			
✓	✓	✓	✓	✓	✓	✓	✓	✓	✓	✓	✓	✓	✓	✓	✓	✓	✓	✓	✓	✓	

<sup>1</sup>Not available when cut-out width is greater than standard.

<sup>2</sup>Not available on 36" wide.

<sup>3</sup>6" fluting not available on 27" wide. 6" fluting both only available on 36" wide.

<sup>4</sup>Not available on 36" wide.

IH/RH availability charts starting on page G•40.  
IW/RW availability charts starting on page G•46.

## Description

### BASE OVEN CABINET with LOWER DRAWER, 34 1/2" HIGH, 24" DEEP

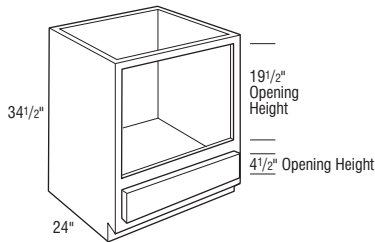

Specify appliance opening dimensions:

#### BO\_ID

Base Oven Cabinet with Lower Drawer

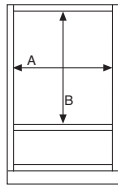

Appliance Opening Dimensions:

A \_\_\_\_\_  
B \_\_\_\_\_

#### NOTE:

See chart for specific model appliance opening limitations.

Cabinet appliance openings may vary with modifications (i.e. clipped corner modification reduces maximum cut-out width by 3" per clipped corner).

## Model

**BO27LD**

**BO30LD**

**BO33LD**

**BO36LD**

- Includes floor between oven and drawer section.
- Maintain 3" rail above drawer for full overlay clearance.
- Specify cut-out size.
- When Beaded Inset is ordered, the cabinet should be ordered to the appropriate width using the 1/4" width modification instead of using the piece-in or cut-out applications.
- Reduced Depths available in 1/4" increments from 12" to 23 3/4".
- Ordering Maximum Width Cut-out on cabinet will change end panel thickness from 1/2" to 3/8" for non-flush ends, and from 5/8" to 1/2" for flush ends.

	Standard Appliance Opening		Decreased Appliance Opening Width*		Increased Appliance Opening Width**		Appliance Opening Height***	
	Width (A)	Height (B)	Min. Width (A)	Max. Width (A)	Min. Width (A)	Max. Width (A)	Min. Height (B)	Max. Height (B)
BO27LD	24"	19 1/2"	12"	23 1/2"	24 1/16"	25 1/2"	16"	21"
BO30LD	27"	19 1/2"	15"	26 1/2"	27 1/16"	28 1/2"	16"	21"
BO33LD	30"	19 1/2"	18"	29 1/2"	30 1/16"	31 1/2"	16"	21"
BO36LD	33"	19 1/2"	21"	32 1/2"	33 1/16"	34 1/2"	16"	21"

\*Decreased Appliance Opening Width can vary in 1/16" increments by piecing in frame material.

\*\*Increased Appliance Opening Width can vary in 1/16" increments by cutting out the frame stiles.

\*\*\*Appliance Opening Height could have a variance of 1/16". By changing openings, it may require the door/drawer openings to change.

#### Door & Drawer Options

AF	CC	CG	ESMD	GAMD	HC	IFHG	MC	MD	MFO	PRMD	SHMD	SPLITDR	SPLITDRWS	SUMD
							✓							

#### End Panel Options

AUTH	CSFPE <sup>1</sup>	EXBK	EXDN	FPE	INTGE <sup>1</sup>	IPE <sup>1</sup>
✓	✓	✓	✓	✓	✓	✓

#### Custom Modification Options

ADD_SHLF	ADDTK	ADRW	ATTK	BVR	CBO	CCO	CFNTO	CFP	CFRMO	CLIP	CND	CSDGBK	DRWTK <sup>2</sup>	EF	EX	EX_OL	FLUT	FTK	ID	
						✓	✓	✓	✓	✓	✓	✓	✓	✓	✓	✓	✓	✓	✓	✓

IH	IW <sup>3</sup>	MIP	OBRB	PFINBTMB	RD	RECTK <sup>3</sup>	RH	ROSFLUT	RT	SCPDRW	TD	TKP <sup>3</sup>	TVR <sup>4</sup>	VTK <sup>3</sup>	WS	WTKD	WTKCUP	WTR <sup>4</sup>	
✓	✓	✓	✓	✓	✓	✓	✓	✓	✓	✓	✓	✓	✓	✓	✓	✓	✓	✓	✓

<sup>1</sup>Not available when cut-out width is greater than standard.

<sup>2</sup>Only available on 30" wide.

<sup>3</sup>Not available on 36" wide.

<sup>4</sup>Not available on 27" wide.

# Tall Microwave Cabinets

## Description

**TALL BUILT-IN MICROWAVE CABINET,  
84", 87", or 90" HIGH, 24" DEEP**

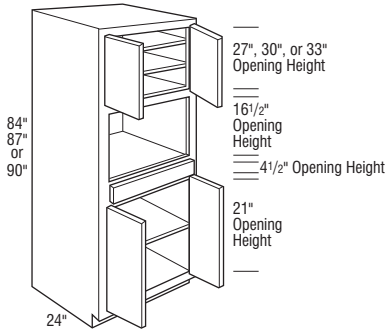

Specify appliance opening dimensions:

**OCM \_ AC**

Microwave

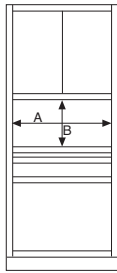

Appliance Opening Dimensions:

A \_\_\_\_\_

B \_\_\_\_\_

### NOTE:

See chart for specific model appliance opening limitations.

Cabinet appliance openings may vary with modifications (i.e. clipped corner modification reduces maximum cut-out width by 3" per clipped corner).

## Model

**OCM278424AC**

**OCM308424AC**

**OCM338424AC**

**OCM368424AC**

**OCM398424AC**

**OCM278724AC**

**OCM308724AC**

**OCM338724AC**

**OCM368724AC**

**OCM398724AC**

**OCM279024AC**

**OCM309024AC**

**OCM339024AC**

**OCM369024AC**

**OCM399024AC**

- Specify cut-out size.
- When Beaded Inset is ordered, the cabinet should be ordered to the appropriate width using the 1/4" width modification instead of using the piece-in or cut-out applications.
- Cabinet openings are subject to change based on the cut-out. Please review the acknowledged drawing.
- Two adjustable shelves in upper section and one adjustable shelf on the bottom.
- Increased Depths available in 1/4" increments from 24 1/4" to 30".
- Reduced Depths available in 1/4" increments from 12" to 23 3/4".
- Ordering Maximum Width Cut-out on cabinet will change end panel thickness from 1/2" to 3/8" for non-flush ends, and from 5/8" to 1/2" for flush ends.

	Standard Appliance Opening		Decreased Appliance Opening Width*		Increased Appliance Opening Width**		Appliance Opening Height***	
	Width (A)	Height (B)	Min. Width (A)	Max. Width (A)	Min. Width (A)	Max. Width (A)	Min. Height (B)	Max. Height (B)
OCM278424AC	24"	16 1/2"	12"	23 1/2"	24 1/16"	25 1/2"	12"	23 1/2"
OCM308424AC	27"	16 1/2"	15"	26 1/2"	27 1/16"	28 1/2"	12"	23 1/2"
OCM338424AC	30"	16 1/2"	18"	29 1/2"	30 1/16"	31 1/2"	12"	23 1/2"
OCM368424AC	33"	16 1/2"	21"	32 1/2"	33 1/16"	34 1/2"	12"	23 1/2"
OCM398424AC	36"	16 1/2"	24"	35 1/2"	36 1/16"	37 1/2"	12"	23 1/2"
OCM278724AC	24"	16 1/2"	12"	23 1/2"	24 1/16"	25 1/2"	12"	23 1/2"
OCM308724AC	27"	16 1/2"	15"	26 1/2"	27 1/16"	28 1/2"	12"	23 1/2"
OCM338724AC	30"	16 1/2"	18"	29 1/2"	30 1/16"	31 1/2"	12"	23 1/2"
OCM368724AC	33"	16 1/2"	21"	32 1/2"	33 1/16"	34 1/2"	12"	23 1/2"
OCM398724AC	36"	16 1/2"	24"	35 1/2"	36 1/16"	37 1/2"	12"	23 1/2"
OCM279024AC	24"	16 1/2"	12"	23 1/2"	24 1/16"	25 1/2"	12"	23 1/2"
OCM309024AC	27"	16 1/2"	15"	26 1/2"	27 1/16"	28 1/2"	12"	23 1/2"
OCM339024AC	30"	16 1/2"	18"	29 1/2"	30 1/16"	31 1/2"	12"	23 1/2"
OCM369024AC	33"	16 1/2"	21"	32 1/2"	33 1/16"	34 1/2"	12"	23 1/2"
OCM399024AC	36"	16 1/2"	24"	35 1/2"	36 1/16"	37 1/2"	12"	23 1/2"

\*Decreased Appliance Opening Width can vary in 1/16" increments by piecing in frame material.

\*\*Increased Appliance Opening Width can vary in 1/16" increments by cutting out the frame stiles.

\*\*\*Appliance Opening Height could have a variance of 1/16". By changing openings, it may require the door/drawer openings to change.

### Door & Drawer Options

AF	CC	CG	ESMD	GAMD	HC	IFHG	MC	MD	MFO	PRMD	SHMD <sup>1</sup>	SPLITDR	SPLITDRWS	SUMD
<input checked="" type="checkbox"/>	<input checked="" type="checkbox"/>	<input checked="" type="checkbox"/>	<input checked="" type="checkbox"/>	<input checked="" type="checkbox"/>	<input checked="" type="checkbox"/>	<input checked="" type="checkbox"/>	<input checked="" type="checkbox"/>	<input checked="" type="checkbox"/>	<input checked="" type="checkbox"/>	<input checked="" type="checkbox"/>	<input checked="" type="checkbox"/>	<input checked="" type="checkbox"/>	<input checked="" type="checkbox"/>	<input checked="" type="checkbox"/>

### End Panel Options

AUTH	CSFPE <sup>2</sup>	EXBK	EXDN	FPE	INTGE <sup>2</sup>	IPE <sup>2</sup>
<input checked="" type="checkbox"/>	<input checked="" type="checkbox"/>	<input checked="" type="checkbox"/>	<input checked="" type="checkbox"/>	<input checked="" type="checkbox"/>	<input checked="" type="checkbox"/>	<input checked="" type="checkbox"/>

### Custom Modification Options

ADD	SHLF	ADTK	ADRW	ATTK	BVR	CBO	CCO	CFNTO	CFP	CFRMO	CLIP	CND	CSDGBK	DRWTK <sup>3</sup>	EF	EX	EX_OL	FLUT <sup>4</sup>	FTK	ID
<input checked="" type="checkbox"/>	<input checked="" type="checkbox"/>	<input checked="" type="checkbox"/>	<input checked="" type="checkbox"/>	<input checked="" type="checkbox"/>	<input checked="" type="checkbox"/>	<input checked="" type="checkbox"/>	<input checked="" type="checkbox"/>	<input checked="" type="checkbox"/>	<input checked="" type="checkbox"/>	<input checked="" type="checkbox"/>	<input checked="" type="checkbox"/>	<input checked="" type="checkbox"/>	<input checked="" type="checkbox"/>	<input checked="" type="checkbox"/>	<input checked="" type="checkbox"/>	<input checked="" type="checkbox"/>	<input checked="" type="checkbox"/>	<input checked="" type="checkbox"/>	<input checked="" type="checkbox"/>	<input checked="" type="checkbox"/>

IH	IW <sup>5</sup>	MIP	OBRB	PFINBTMB	RD	RECTK	RH	ROSLUT	RT	SCPDWR	TD	TKP	TVR	VTK	WS	WTCD	WTKCUP	WTR
<input checked="" type="checkbox"/>	<input checked="" type="checkbox"/>	<input checked="" type="checkbox"/>	<input checked="" type="checkbox"/>	<input checked="" type="checkbox"/>	<input checked="" type="checkbox"/>	<input checked="" type="checkbox"/>	<input checked="" type="checkbox"/>	<input checked="" type="checkbox"/>	<input checked="" type="checkbox"/>	<input checked="" type="checkbox"/>	<input checked="" type="checkbox"/>	<input checked="" type="checkbox"/>	<input checked="" type="checkbox"/>	<input checked="" type="checkbox"/>	<input checked="" type="checkbox"/>	<input checked="" type="checkbox"/>	<input checked="" type="checkbox"/>	<input checked="" type="checkbox"/>

<sup>1</sup>Only available on top section.

<sup>2</sup>Not available when cut-out width is greater than standard.

<sup>3</sup>Not available on units over 36" wide.

<sup>4</sup>Not available with 6" fluting.

<sup>5</sup>Not available on 39" wide.

IH/RH availability charts starting on page G-40.  
IW/RW availability charts starting on page G-46.

## Description

### TALL BUILT-IN MICROWAVE CABINET, 93" or 96" HIGH, 24" DEEP

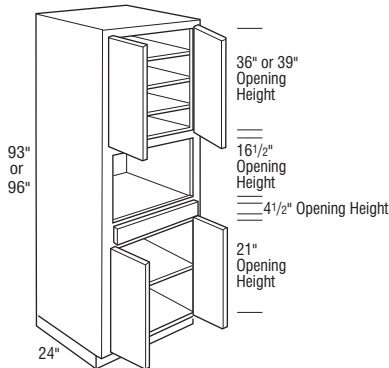

Specify appliance opening dimensions:

### OCM\_AC

#### Microwave

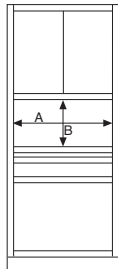

Appliance Opening Dimensions:

A \_\_\_\_\_  
B \_\_\_\_\_

#### NOTE:

See chart for specific model appliance opening limitations.

Cabinet appliance openings may vary with modifications (i.e. clipped corner modification reduces maximum cut-out width by 3" per clipped corner).

## Model

OCM279324AC

OCM309324AC

OCM339324AC

OCM369324AC

OCM399324AC

- Includes two adjustable shelves in upper section and one adjustable shelf on the bottom.

OCM279624AC

OCM309624AC

OCM339624AC

OCM369624AC

OCM399624AC

- Includes three adjustable shelves in upper section and one adjustable shelf on the bottom.
- Flush Toekick modification not available in conjunction with Wide Top Rail unless loose Flush Toekick is specified.

Notes below apply to all products in section above:

- Specify cut-out size.
- When Beaded Inset is ordered, the cabinet should be ordered to the appropriate width using the 1/4" width modification instead of using the piece-in or cut-out applications.
- Cabinet openings are subject to change based on the cut-out. Please review the acknowledged drawing.
- Shipped with loose toe space unless Attach Toekick or Flush Toekick is specified.
- Increased Depths available in 1/4" increments from 24 1/4" to 30".
- Reduced Depths available in 1/4" increments from 12" to 23 3/4".
- Ordering Maximum Width Cut-out on cabinet will change end panel thickness from 1/2" to 3/8" for non-flush ends, and from 5/8" to 1/2" for flush ends.

	Standard Appliance Opening		Decreased Appliance Opening Width*		Increased Appliance Opening Width**		Appliance Opening Height***	
	Width (A)	Height (B)	Min. Width (A)	Max. Width (A)	Min. Width (A)	Max. Width (A)	Min. Height (B)	Max. Height (B)
OCM279324AC	24"	16 1/2"	12"	23 1/2"	24 1/16"	25 1/2"	12"	23 1/2"
OCM309324AC	27"	16 1/2"	15"	26 1/2"	27 1/16"	28 1/2"	12"	23 1/2"
OCM339324AC	30"	16 1/2"	18"	29 1/2"	30 1/16"	31 1/2"	12"	23 1/2"
OCM369324AC	33"	16 1/2"	21"	32 1/2"	33 1/16"	34 1/2"	12"	23 1/2"
OCM399324AC	36"	16 1/2"	24"	35 1/2"	36 1/16"	37 1/2"	12"	23 1/2"
OCM279624AC	24"	16 1/2"	12"	23 1/2"	24 1/16"	25 1/2"	12"	23 1/2"
OCM309624AC	27"	16 1/2"	15"	26 1/2"	27 1/16"	28 1/2"	12"	23 1/2"
OCM339624AC	30"	16 1/2"	18"	29 1/2"	30 1/16"	31 1/2"	12"	23 1/2"
OCM369624AC	33"	16 1/2"	21"	32 1/2"	33 1/16"	34 1/2"	12"	23 1/2"
OCM399624AC	36"	16 1/2"	24"	35 1/2"	36 1/16"	37 1/2"	12"	23 1/2"

\*Decreased Appliance Opening Width can vary in 1/16" increments by piecing in frame material.

\*\*Increased Appliance Opening Width can vary in 1/16" increments by cutting out the frame stiles.

\*\*\*Appliance Opening Height could have a variance of 1/16". By changing openings, it may require the door/drawer openings to change.

#### Door & Drawer Options

AF	CC	CG	ESMD	GAMD	HC	IFHG	MC	MD	MFO	PRMD	SHMD <sup>1</sup>	SPLITDR	SPLITDRWS	SUMD
	✓	✓	✓	✓	✓	✓	✓	✓	✓	✓	✓	✓	✓	✓

#### End Panel Options

AUTH	CSFPE <sup>2</sup>	EXBK	EXDN	FPE	INTGE <sup>2</sup>	IPE <sup>2</sup>
✓	✓	✓	✓	✓	✓	✓

#### Custom Modification Options

ADD_SHLF	ADDTK	ADRW	ATTK	BVR	CBO	CCO	CFNT0	CFP	CFRMO	CLIP	CND	CSDGBK	DRWTK <sup>3</sup>	EF	EX	EX_OL	FLUT <sup>4</sup>	FTK	ID	
	✓	✓	✓	✓	✓	✓	✓	✓	✓	✓	✓	✓	✓	✓	✓	✓	✓	✓	✓	✓

IH	IW <sup>5</sup>	MIP	OBRB	PFINBTMB	RD	RECTK	RH	ROSLUT	RT	SCPDWR	TD	TKP	TVR	VTK	WS	WTCD	WTKCUP	WTR	
✓	✓	✓	✓	✓	✓	✓	✓	✓	✓	✓	✓	✓	✓	✓	✓	✓	✓	✓	✓

<sup>1</sup>Only available on top section.

<sup>2</sup>Not available when cut-out width is greater than standard.

<sup>3</sup>Not available on units over 36" wide and only available when used in conjunction with attach toekick modification.

<sup>4</sup>Not available with 6" fluting.

<sup>5</sup>Not available on 39" wide.

# Tall Microwave Cabinets

## Description



**TALL BUILT-IN MICROWAVE CABINET, 102" or 108" HIGH, 24" DEEP**

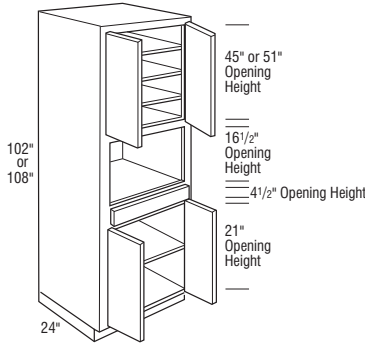

Specify appliance opening dimensions:

**OCM \_ AC**

Microwave

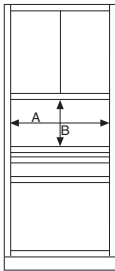

Appliance Opening Dimensions:

A \_\_\_\_\_  
B \_\_\_\_\_

### NOTE:

See chart for specific model appliance opening limitations.

Cabinet appliance openings may vary with modifications (i.e. clipped corner modification reduces maximum cut-out width by 3" per clipped corner).

## Model

**OCM2710224AC**

**OCM3010224AC**

**OCM3310224AC**

**OCM3610224AC**

**OCM3910224AC**

**OCM2710824AC**

**OCM3010824AC**

**OCM3310824AC**

**OCM3610824AC**

**OCM3910824AC**

- Specify cut-out size.
- When Beaded Inset is ordered, the cabinet should be ordered to the appropriate width using the 1/4" width modification instead of using the piece-in or cut-out applications.
- Cabinet openings are subject to change based on the cut-out. Please review the acknowledged drawing.
- Shipped with loose toe space unless Attach Toekick or Flush Toekick is specified.
- Units include three adjustable shelves in upper section and one adjustable shelf on the bottom.
- Increased Depths available in 1/4" increments from 24 1/4" to 26".
- Reduced Depths available in 1/4" increments from 12" to 23 3/4".
- Finish Flushed Ends standard.
- Available in Cherry and Maple only.

	Standard Appliance Opening		Decreased Appliance Opening Width*		Increased Appliance Opening Width**		Appliance Opening Height***	
	Width (A)	Height (B)	Min. Width (A)	Max. Width (A)	Min. Width (A)	Max. Width (A)	Min. Height (B)	Max. Height (B)
OCM2710224AC	24"	16 1/2"	12"	23 1/2"	24 1/16"	25"	12"	23 1/2"
OCM3010224AC	27"	16 1/2"	15"	26 1/2"	27 1/16"	28"	12"	23 1/2"
OCM3310224AC	30"	16 1/2"	18"	29 1/2"	30 1/16"	31"	12"	23 1/2"
OCM3610224AC	33"	16 1/2"	21"	32 1/2"	33 1/16"	34"	12"	23 1/2"
OCM3910224AC	36"	16 1/2"	24"	35 1/2"	36 1/16"	37"	12"	23 1/2"
OCM2710824AC	24"	16 1/2"	12"	23 1/2"	24 1/16"	25"	12"	23 1/2"
OCM3010824AC	27"	16 1/2"	15"	26 1/2"	27 1/16"	28"	12"	23 1/2"
OCM3310824AC	30"	16 1/2"	18"	29 1/2"	30 1/16"	31"	12"	23 1/2"
OCM3610824AC	33"	16 1/2"	21"	32 1/2"	33 1/16"	34"	12"	23 1/2"
OCM3910824AC	36"	16 1/2"	24"	35 1/2"	36 1/16"	37"	12"	23 1/2"

\*Decreased Appliance Opening Width can vary in 1/16" increments by piecing in frame material.

\*\*Increased Appliance Opening Width can vary in 1/16" increments by cutting out the frame stiles.

\*\*\*Appliance Opening Height could have a variance of 1/16". By changing openings, it may require the door/drawer openings to change.

### Door & Drawer Options

AF	CC	CG	ESMD	GAMD	HC	IFHG	MC	MD	MFO	PRMD	SHMD <sup>1</sup>	SPLITDR	SPLITDRWS	SUMD
		✓	✓	✓		✓		✓	✓	✓	✓	✓	✓	✓

### End Panel Options

AUTH	CSFPE	EXBK <sup>2</sup>	EXDN	FPE	INTGE	IPE
✓		✓				✓

### Custom Modification Options

ADD	SHLF	ADTK	ADRW	ATTK	BVR	CBO	CCO	CFNT0	CFP	CFRMO	CLIP	CND	CSDGBK	DRWTK <sup>3</sup>	EF	EX	EX_OL	FLUT <sup>4</sup>	FTK	ID	
						✓	✓	✓	✓	✓	✓	✓	✓	✓	✓	✓	✓	✓	✓	✓	✓

IH <sup>5</sup>	IW <sup>6</sup>	MIP	OBRB	PFINBTMB	RD	RECTK	RH <sup>5</sup>	ROSLUT <sup>4</sup>	RT	SCPDWR	TD <sup>7</sup>	TKP	TVR	VTK	WS	WTCD	WTKCUP	WTR	
✓	✓					✓	✓	✓	✓	✓	✓	✓	✓	✓	✓	✓	✓	✓	✓

<sup>1</sup>Only available on top section.

<sup>2</sup>This modification will allow the end to extend back to a maximum of 30" deep.

<sup>3</sup>Not available on units over 36" wide and only available when used in conjunction with attach toekick modification.

<sup>4</sup>Not available with 6" fluting.

<sup>5</sup>Not available on 108" high.

<sup>6</sup>Not available on 39" wide.

<sup>7</sup>Only available on bottom section.

IH/RH availability charts starting on page G•40.  
IW/RW availability charts starting on page G•46.

## Description



**OVEN MICROWAVE TRIMMABLE CABINET, 84", 87", or 90" HIGH, 24" DEEP**

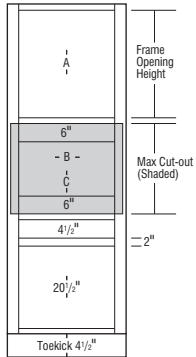
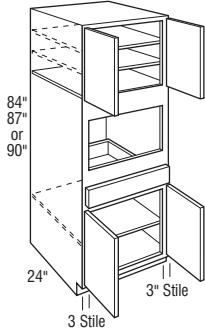

## Model

- TBMWB278424AH
- TBMWB308424AH
- TBMWB338424AH
- TBMWB368424AH
- TBMWB398424AH
- TBMWB278724
- TBMWB308724
- TBMWB338724
- TBMWB368724
- TBMWB398724
- TBMWB279024
- TBMWB309024
- TBMWB339024
- TBMWB369024
- TBMWB399024

- AH represents upper section alignment with doors on 24" or 27" high cabinets.
- All top and bottom cross rails are 1 1/2" wide.
- Includes two adjustable shelves in upper section and one adjustable shelf on the bottom.
- Cabinet installation kit will not be included when depth is modified.
- A cabinet installation kit will be provided.
- Oven cabinet cut-out is shaded in gray and is cut out on job site.
- Increased Heights modification will increase the height of the upper cabinet section. The bottom section will retain its original height.

	A Frame Opening Height	B Cut-out Width		C Cut-out Height		Door Height (Upper Section)
		Min.	Max.	Min.	Max.	Full Overlay
TBMWB278424AH	24"	21"	25 1/2"	13 1/2"	22 1/2"	26 1/2"
TBMWB308424AH	24"	24"	28 1/2"	13 1/2"	22 1/2"	26 1/2"
TBMWB338424AH	24"	27"	31 1/2"	13 1/2"	22 1/2"	26 1/2"
TBMWB368424AH	24"	30"	34 1/2"	13 1/2"	22 1/2"	26 1/2"
TBMWB398424AH	24"	33"	37 1/2"	13 1/2"	22 1/2"	26 1/2"
TBMWB278724	27"	21"	25 1/2"	13 1/2"	22 1/2"	29 1/2"
TBMWB308724	27"	24"	28 1/2"	13 1/2"	22 1/2"	29 1/2"
TBMWB338724	27"	27"	31 1/2"	13 1/2"	22 1/2"	29 1/2"
TBMWB368724	27"	30"	34 1/2"	13 1/2"	22 1/2"	29 1/2"
TBMWB398724	27"	33"	37 1/2"	13 1/2"	22 1/2"	29 1/2"
TBMWB279024	30"	21"	25 1/2"	13 1/2"	22 1/2"	32 1/2"
TBMWB309024	30"	24"	28 1/2"	13 1/2"	22 1/2"	32 1/2"
TBMWB339024	30"	27"	31 1/2"	13 1/2"	22 1/2"	32 1/2"
TBMWB369024	30"	30"	34 1/2"	13 1/2"	22 1/2"	32 1/2"
TBMWB399024	30"	33"	37 1/2"	13 1/2"	22 1/2"	32 1/2"

Maximum cut-out dimension will allow 1/4" reveal for doors and drawer fronts on full overlay for trim kit face clearance.

### Door & Drawer Options

AF	CC	CG	ESMD	GAMD	HC	IFHG	MC	MD	MFO	PRMD	SHMD	SPLITDR	SPLITDRWS	SUMD
	✓	✓	✓					✓	✓	✓	✓	✓	✓	✓

### End Panel Options

AUTH	CSFPE	EXBK	EXDN	FPE	INTGE	IPE
✓	✓	✓		✓	✓	

### Custom Modification Options

ADD_SHLF	ADDTK	ADRW	ATTCK	BVR	CBO	CCO	CFNTO	CFP	CFRMO	CLIP	CND	CSDGBK	DRWTK <sup>1</sup>	EF	EX	EX_OL	FLUT <sup>2</sup>	FTK	ID	
				✓	✓	✓	✓	✓	✓	✓	✓	✓	✓	✓	✓	✓	✓	✓	✓	✓
IH	IW <sup>3</sup>	MIP	ORBR	PFINBTMB	RD	RECTK	RH	ROSLUT	RT	SCPDRW	TD	TKP	TVR	VTK	WS	WTCO	WTKCUP	WTR		
✓	✓	✓	✓	✓	✓	✓	✓	✓	✓	✓	✓	✓	✓	✓	✓	✓	✓	✓	✓	

<sup>1</sup>Not available on units over 36" wide.

<sup>2</sup>Not available with 6" fluting.

<sup>3</sup>Not available on 39" wide.

# Oven Microwave Cabinets

## Description



**OVEN MICROWAVE TRIMMABLE CABINET, 93" or 96" HIGH, 24" DEEP**

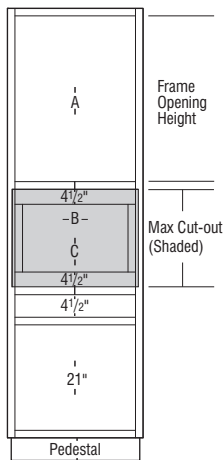
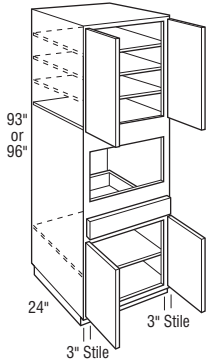

## Model

**TBMWB279324**

**TBMWB309324**

**TBMWB339324**

**TBMWB369324**

**TBMWB399324**

**TBMWB279624**

**TBMWB309624**

**TBMWB339624**

**TBMWB369624**

**TBMWB399624**

- Includes two adjustable shelves in upper section and one adjustable shelf on the bottom.

- Includes three adjustable shelves in upper section and one adjustable shelf on the bottom.
- Flush toekick option not available in conjunction with Wide Top Rail unless loose Flush ToeKick is specified.

### Notes below apply to all products in section above:

- Shipped with loose toekick unless ATTK or Flush ToeKick is specified.
- Cabinet installation kit will not be included when depth is modified.
- A cabinet installation kit will be provided.
- Oven cabinet cut-out is shaded in gray and is cut out on job site.
- Increased Heights modification will increase the height of the upper cabinet section. The bottom section will retain its original height.

	A Frame Opening Height	B Cut-out Width		C Cut-out Height		Door Height (Upper Section)
		Min.	Max.	Min.	Max.	Full Overlay
TBMWB279324	33"	21"	25 1/2"	13 1/2"	22 1/2"	35 1/2"
TBMWB309324	33"	24"	28 1/2"	13 1/2"	22 1/2"	35 1/2"
TBMWB339324	33"	27"	31 1/2"	13 1/2"	22 1/2"	35 1/2"
TBMWB369324	33"	30"	34 1/2"	13 1/2"	22 1/2"	35 1/2"
TBMWB399324	33"	33"	37 1/2"	13 1/2"	22 1/2"	35 1/2"
TBMWB279624	36"	21"	25 1/2"	13 1/2"	22 1/2"	38 1/2"
TBMWB309624	36"	24"	28 1/2"	13 1/2"	22 1/2"	38 1/2"
TBMWB339624	36"	27"	31 1/2"	13 1/2"	22 1/2"	38 1/2"
TBMWB369624	36"	30"	34 1/2"	13 1/2"	22 1/2"	38 1/2"
TBMWB399624	36"	33"	37 1/2"	13 1/2"	22 1/2"	38 1/2"

Maximum cut-out dimension will allow 1/4" reveal for doors and drawer fronts on full overlay for trim kit face clearance.

### Door & Drawer Options

AF	CC	CG	ESMD	GAMD	HC	IFHG	MC	MD	MFO	PRMD	SHMD	SPLITDR	SPLITDRWS	SUMD
✓	✓	✓	✓	✓	✓	✓	✓	✓	✓	✓	✓	✓	✓	✓

### End Panel Options

AUTH	CSFPE	EXBK	EXDN	FPE	INTGE	IPE
✓	✓	✓	✓	✓	✓	✓

### Custom Modification Options

ADD	SHLF	ADTK	ADRW	ATTK	BVR	CBO	CCO	CFNTO	CFP	CFRMO	CLIP	CND	CSDGBK	DRWTK <sup>1</sup>	EF	EX	EX_OL	FLUT <sup>2</sup>	FTK	ID	
✓	✓	✓	✓	✓	✓	✓	✓	✓	✓	✓	✓	✓	✓	✓	✓	✓	✓	✓	✓	✓	✓

IH <sup>3</sup>	IW <sup>4</sup>	MIP	OBRB	PFINBTMB	RD	RECTK	RH	ROSLUT	RT	SCPDRW	TD	TKP	TVR	VTK	WS	WTCD	WTKCUP	WTR
✓	✓	✓	✓	✓	✓	✓	✓	✓	✓	✓	✓	✓	✓	✓	✓	✓	✓	✓

<sup>1</sup>Not available on units over 36" wide and only available when used in conjunction with attach toeKick modification.

<sup>2</sup>Not available with 6" fluting.

<sup>3</sup>Not available on 96" high.

<sup>4</sup>Not available on 39" wide.

IH/RH availability charts starting on page G•40.  
IW/RW availability charts starting on page G•46.

## Description

### BUILT-IN OVEN MICROWAVE CABINET, 84" or 87" HIGH, 24" DEEP

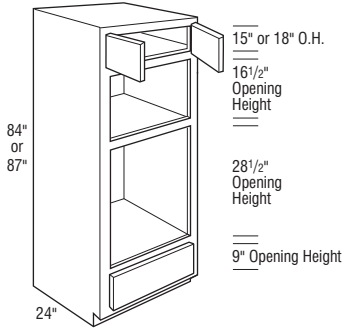

Specify appliance opening dimensions:

#### OMC\_AC

Microwave/Single Oven

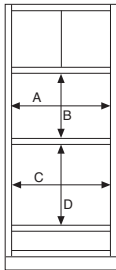

Appliance Opening Dimensions:

A \_\_\_\_\_  
 B \_\_\_\_\_  
 C \_\_\_\_\_  
 D \_\_\_\_\_

#### NOTE:

See chart for specific model appliance opening limitations.

Cabinet appliance openings may vary with modifications (i.e. clipped corner modification reduces maximum cut-out width by 3" per clipped corner).

## Model

OMC278424AC

OMC308424AC

OMC338424AC

OMC368424AC

OMC398424AC

OMC278724AC

OMC308724AC

OMC338724AC

OMC368724AC

OMC398724AC

- Specify cut-out size.
- When Beaded Inset is ordered, the cabinet should be ordered to the appropriate width using the 1/4" width modification instead of using the piece-in or cut-out applications.
- Cabinet openings are subject to change based on the cut-out. Please review the acknowledged drawing.
- Increased Depths available in 1/4" increments from 24 1/4" to 30".
- Reduced Depths available in 1/4" increments from 12" to 23 3/4".
- Ordering Maximum Width Cut-out on cabinet will change end panel thickness from 1/2" to 3/8" for non-flush ends, and from 5/8" to 1/2" for flush ends.

Microwave	Standard Appliance Opening		Decreased Appliance Opening Width*		Increased Appliance Opening Width**		Appliance Opening Height***	
	Width (A)	Height (B)	Min. Width (A)	Max. Width (A)	Min. Width (A)	Max. Width (A)	Min. Height (B)	Max. Height (B)
OMC278424AC	24"	16 1/2"	12"	23 1/2"	24 1/16"	25 1/2"	14"	19 1/2"
OMC308424AC	27"	16 1/2"	15"	26 1/2"	27 1/16"	28 1/2"	14"	19 1/2"
OMC338424AC	30"	16 1/2"	18"	29 1/2"	30 1/16"	31 1/2"	14"	19 1/2"
OMC368424AC	33"	16 1/2"	21"	32 1/2"	33 1/16"	34 1/2"	14"	19 1/2"
OMC398424AC	36"	16 1/2"	24"	35 1/2"	36 1/16"	37 1/2"	14"	19 1/2"
OMC278724AC	24"	16 1/2"	12"	23 1/2"	24 1/16"	25 1/2"	14"	19 1/2"
OMC308724AC	27"	16 1/2"	15"	26 1/2"	27 1/16"	28 1/2"	14"	19 1/2"
OMC338724AC	30"	16 1/2"	18"	29 1/2"	30 1/16"	31 1/2"	14"	19 1/2"
OMC368724AC	33"	16 1/2"	21"	32 1/2"	33 1/16"	34 1/2"	14"	19 1/2"
OMC398724AC	36"	16 1/2"	24"	35 1/2"	36 1/16"	37 1/2"	14"	19 1/2"

\*Decreased Appliance Opening Width can vary in 1/16" increments by piecing in frame material.

\*\*Increased Appliance Opening Width can vary in 1/16" increments by cutting out the frame stiles.

\*\*\*Appliance Opening Height could have a variance of 1/16". By changing openings, it may require the door/drawer openings to change.

Oven	Standard Appliance Opening		Decreased Appliance Opening Width*		Increased Appliance Opening Width**		Appliance Opening Height***	
	Width (C)	Height (D)	Min. Width (C)	Max. Width (C)	Min. Width (C)	Max. Width (C)	Min. Height (D)	Max. Height (D)
OMC278424AC	24"	28 1/2"	12"	23 1/2"	24 1/16"	25 1/2"	25 1/2"	32 1/2"
OMC308424AC	27"	28 1/2"	15"	26 1/2"	27 1/16"	28 1/2"	25 1/2"	32 1/2"
OMC338424AC	30"	28 1/2"	18"	29 1/2"	30 1/16"	31 1/2"	25 1/2"	32 1/2"
OMC368424AC	33"	28 1/2"	21"	32 1/2"	33 1/16"	34 1/2"	25 1/2"	32 1/2"
OMC398424AC	36"	28 1/2"	24"	35 1/2"	36 1/16"	37 1/2"	25 1/2"	32 1/2"
OMC278724AC	24"	28 1/2"	12"	23 1/2"	24 1/16"	25 1/2"	25 1/2"	32 1/2"
OMC308724AC	27"	28 1/2"	15"	26 1/2"	27 1/16"	28 1/2"	25 1/2"	32 1/2"
OMC338724AC	30"	28 1/2"	18"	29 1/2"	30 1/16"	31 1/2"	25 1/2"	32 1/2"
OMC368724AC	33"	28 1/2"	21"	32 1/2"	33 1/16"	34 1/2"	25 1/2"	32 1/2"
OMC398724AC	36"	28 1/2"	24"	35 1/2"	36 1/16"	37 1/2"	25 1/2"	32 1/2"

#### Door & Drawer Options

AF	CC	CG	ESMD	GAMD	HC	IFHG	MC	MD	MFO	PRMD	SHMD	SPLITDR	SPLITDRWS	SUMD
✓	✓	✓	✓	✓	✓	✓	✓	✓	✓	✓	✓	✓	✓	✓

#### End Panel Options

AUTH	CSFPE <sup>1</sup>	EXBK	EXDN	FPE	INTGE <sup>1</sup>	IPE <sup>1</sup>
✓	✓	✓	✓	✓	✓	✓

#### Custom Modification Options

ADD	SHLF	ADDTK	ADRW	ATTK	BVR	CBO	CCO	CFNT0	CFP	CFRMO	CLIP	CND	CSDGBK	DRWTK <sup>2</sup>	EF	EX	EX_OL	FLUT <sup>3</sup>	FTK	ID	
✓	✓	✓	✓	✓	✓	✓	✓	✓	✓	✓	✓	✓	✓	✓	✓	✓	✓	✓	✓	✓	✓

IH	IW <sup>4</sup>	MIP	OBRB	PFINBTMB	RD	RECTK	RH	ROSLUT	RT	SCPDRW	TD	TKP	TVR	VTK	WS	WTCD	WTKCUP	WTR	
✓	✓	✓	✓	✓	✓	✓	✓	✓	✓	✓	✓	✓	✓	✓	✓	✓	✓	✓	✓

<sup>1</sup>Not available when cut-out width is greater than standard.

<sup>2</sup>Not available on units over 36" wide.

<sup>3</sup>Not available with 6" fluting.

<sup>4</sup>Not available on 39" wide.



# Oven Microwave Cabinets

## Description

### BUILT-IN OVEN MICROWAVE CABINET, 90" HIGH, 24" DEEP

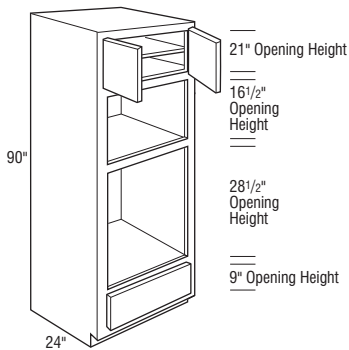

Specify appliance opening dimensions:

#### OMC \_AC Microwave/Single Oven

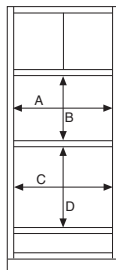

Appliance Opening Dimensions:

A \_\_\_\_\_  
 B \_\_\_\_\_  
 C \_\_\_\_\_  
 D \_\_\_\_\_

#### NOTE:

See chart for specific model appliance opening limitations.

Cabinet appliance openings may vary with modifications (i.e. clipped corner modification reduces maximum cut-out width by 3" per clipped corner).

## Model

OMC279024AC

OMC309024AC

OMC339024AC

OMC369024AC

OMC399024AC

- Specify cut-out size.
- When Beaded Inset is ordered, the cabinet should be ordered to the appropriate width using the 1/4" width modification instead of using the piece-in or cut-out applications.
- Cabinet openings are subject to change based on the cut-out. Please review the acknowledged drawing.
- 90" high includes one adjustable shelf in upper section.
- Increased Depths available in 1/4" increments from 24 1/4" to 30".
- Reduced Depths available in 1/4" increments from 12" to 23 3/4".
- Ordering Maximum Width Cut-out on cabinet will change end panel thickness from 1/2" to 3/8" for non-flush ends, and from 5/8" to 1/2" for flush ends.

Microwave	Standard Appliance Opening		Decreased Appliance Opening Width*		Increased Appliance Opening Width**		Appliance Opening Height***	
	Width (A)	Height (B)	Min. Width (A)	Max. Width (A)	Min. Width (A)	Max. Width (A)	Min. Height (B)	Max. Height (B)
OMC279024AC	24"	16 1/2"	12"	23 1/2"	24 1/16"	25 1/2"	14"	19 1/2"
OMC309024AC	27"	16 1/2"	15"	26 1/2"	27 1/16"	28 1/2"	14"	19 1/2"
OMC339024AC	30"	16 1/2"	18"	29 1/2"	30 1/16"	31 1/2"	14"	19 1/2"
OMC369024AC	33"	16 1/2"	21"	32 1/2"	33 1/16"	34 1/2"	14"	19 1/2"
OMC399024AC	36"	16 1/2"	24"	35 1/2"	36 1/16"	37 1/2"	14"	19 1/2"

\*Decreased Appliance Opening Width can vary in 1/16" increments by piecing in frame material.

\*\*Increased Appliance Opening Width can vary in 1/16" increments by cutting out the frame stiles.

\*\*\*Appliance Opening Height could have a variance of 1/16". By changing openings, it may require the door/drawer openings to change.

Oven	Standard Appliance Opening		Decreased Appliance Opening Width*		Increased Appliance Opening Width**		Appliance Opening Height***	
	Width (C)	Height (D)	Min. Width (C)	Max. Width (C)	Min. Width (C)	Max. Width (C)	Min. Height (D)	Max. Height (D)
OMC279024AC	24"	28 1/2"	12"	23 1/2"	24 1/16"	25 1/2"	25 1/2"	32 1/2"
OMC309024AC	27"	28 1/2"	15"	26 1/2"	27 1/16"	28 1/2"	25 1/2"	32 1/2"
OMC339024AC	30"	28 1/2"	18"	29 1/2"	30 1/16"	31 1/2"	25 1/2"	32 1/2"
OMC369024AC	33"	28 1/2"	21"	32 1/2"	33 1/16"	34 1/2"	25 1/2"	32 1/2"
OMC399024AC	36"	28 1/2"	24"	35 1/2"	36 1/16"	37 1/2"	25 1/2"	32 1/2"

#### Door & Drawer Options

AF	CC	CG	ESMD	GAMD	HC	IFHG	MC	MD	MFO	PRMD	SHMD	SPLITDR	SPLITDRWS	SUMD
✓	✓	✓	✓	✓	✓	✓	✓	✓	✓	✓	✓	✓	✓	✓

#### End Panel Options

AUTH	CSFPE <sup>1</sup>	EXBK	EXDN	FPE	INTGE <sup>1</sup>	IPE <sup>1</sup>
✓	✓	✓	✓	✓	✓	✓

#### Custom Modification Options

ADD_SHLF	ADDTK	ADRW	ATTK	BVR	CBO	CCO	CFNTD	CFP	CFRMO	CLIP	CND	CSDGBK	DRWTK <sup>2</sup>	EF	EX	EX_OL	FLUT <sup>3</sup>	FTK	ID	
✓	✓	✓	✓	✓	✓	✓	✓	✓	✓	✓	✓	✓	✓	✓	✓	✓	✓	✓	✓	✓

IH	IW <sup>4</sup>	MIP	OBRB	PFINBTMB	RD	RECTK	RH	ROSFLUT	RT	SCPDRAW	TD	TKP	TVR	VTK	WS	WTCD	WTKCUP	WTR	
✓	✓	✓	✓	✓	✓	✓	✓	✓	✓	✓	✓	✓	✓	✓	✓	✓	✓	✓	✓

<sup>1</sup>Not available when cut-out width is greater than standard.

<sup>2</sup>Not available on units over 36" wide.

<sup>3</sup>Not available with 6" fluting.

<sup>4</sup>Not available on 39" wide.

IH/RH availability charts starting on page G•40.  
 IW/RW availability charts starting on page G•46.

## Description

### BUILT-IN OVEN MICROWAVE CABINET, 93" or 96" HIGH, 24" DEEP

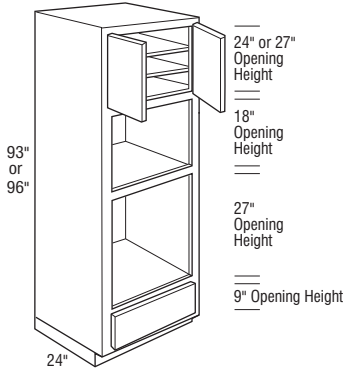

Specify appliance opening dimensions:

#### OMC\_ \_AC

Microwave/Single Oven

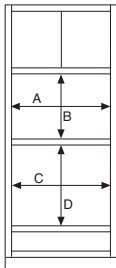

Appliance Opening Dimensions:

A \_\_\_\_\_  
 B \_\_\_\_\_  
 C \_\_\_\_\_  
 D \_\_\_\_\_

#### NOTE:

See chart for specific model appliance opening limitations.

Cabinet appliance openings may vary with modifications (i.e. clipped corner modification reduces maximum cut-out width by 3" per clipped corner).

## Model

OMC279324AC

OMC309324AC

OMC339324AC

OMC369324AC

OMC399324AC

OMC279624AC

OMC309624AC

OMC339624AC

OMC369624AC

OMC399624AC

- Includes one adjustable shelf in upper section.

- Includes two adjustable shelves in upper section.
- Flush Toekick modification not available in conjunction with Wide Top Rail unless loose Flush Toekick is specified.

Notes below apply to all products in section above:

- Specify cut-out size.
- When Beaded Inset is ordered, the cabinet should be ordered to the appropriate width using the 1/4" width modification instead of using the piece-in or cut-out applications.
- Cabinet openings are subject to change based on the cut-out. Please review the acknowledged drawing.
- Shipped with loose toe space unless Attach Toekick or Flush Toekick is specified.
- Increased Depths available in 1/4" increments from 24 1/4" to 30".
- Reduced Depths available in 1/4" increments from 12" to 23 3/4".
- Ordering Maximum Width Cut-out on cabinet will change end panel thickness from 1/2" to 3/8" for non-flush ends, and from 5/8" to 1/2" for flush ends.

Microwave	Standard Appliance Opening		Decreased Appliance Opening Width*		Increased Appliance Opening Width**		Appliance Opening Height***	
	Width (A)	Height (B)	Min. Width (A)	Max. Width (A)	Min. Width (A)	Max. Width (A)	Min. Height (B)	Max. Height (B)
OMC279324AC	24"	18"	12"	23 1/2"	24 1/16"	25 1/2"	14"	19 1/2"
OMC309324AC	27"	18"	15"	26 1/2"	27 1/16"	28 1/2"	14"	19 1/2"
OMC339324AC	30"	18"	18"	29 1/2"	30 1/16"	31 1/2"	14"	19 1/2"
OMC369324AC	33"	18"	21"	32 1/2"	33 1/16"	34 1/2"	14"	19 1/2"
OMC399324AC	36"	18"	24"	35 1/2"	36 1/16"	37 1/2"	14"	19 1/2"
OMC279624AC	24"	18"	12"	23 1/2"	24 1/16"	25 1/2"	14"	19 1/2"
OMC309624AC	27"	18"	15"	26 1/2"	27 1/16"	28 1/2"	14"	19 1/2"
OMC339624AC	30"	18"	18"	29 1/2"	30 1/16"	31 1/2"	14"	19 1/2"
OMC369624AC	33"	18"	21"	32 1/2"	33 1/16"	34 1/2"	14"	19 1/2"
OMC399624AC	36"	18"	24"	35 1/2"	36 1/16"	37 1/2"	14"	19 1/2"

\*Decreased Appliance Opening Width can vary in 1/16" increments by piecing in frame material.

\*\*Increased Appliance Opening Width can vary in 1/16" increments by cutting out the frame stiles.

\*\*\*Appliance Opening Height could have a variance of 1/16". By changing openings, it may require the door/drawer openings to change.

Oven	Standard Appliance Opening		Decreased Appliance Opening Width*		Increased Appliance Opening Width**		Appliance Opening Height***	
	Width (C)	Height (D)	Min. Width (C)	Max. Width (C)	Min. Width (C)	Max. Width (C)	Min. Height (D)	Max. Height (D)
OMC279324AC	24"	27"	12"	23 1/2"	24 1/16"	25 1/2"	25 1/2"	32 1/2"
OMC309324AC	27"	27"	15"	26 1/2"	27 1/16"	28 1/2"	25 1/2"	32 1/2"
OMC339324AC	30"	27"	18"	29 1/2"	30 1/16"	31 1/2"	25 1/2"	32 1/2"
OMC369324AC	33"	27"	21"	32 1/2"	33 1/16"	34 1/2"	25 1/2"	32 1/2"
OMC399324AC	36"	27"	24"	35 1/2"	36 1/16"	37 1/2"	25 1/2"	32 1/2"
OMC279624AC	24"	27"	12"	23 1/2"	24 1/16"	25 1/2"	25 1/2"	32 1/2"
OMC309624AC	27"	27"	15"	26 1/2"	27 1/16"	28 1/2"	25 1/2"	32 1/2"
OMC339624AC	30"	27"	18"	29 1/2"	30 1/16"	31 1/2"	25 1/2"	32 1/2"
OMC369624AC	33"	27"	21"	32 1/2"	33 1/16"	34 1/2"	25 1/2"	32 1/2"
OMC399624AC	36"	27"	24"	35 1/2"	36 1/16"	37 1/2"	25 1/2"	32 1/2"

#### Door & Drawer Options

AF	CC	CG	ESMD	GAMD	HC	IFHG	MC	MD	MFO	PRMD	SHMD	SPLITDR	SPLITDRWS	SUMD
✓	✓	✓	✓	✓	✓	✓	✓	✓	✓	✓	✓	✓	✓	✓

#### End Panel Options

AUTH	CSFPE <sup>1</sup>	EXBK	EXDN	FPE	INTGE <sup>1</sup>	IPE <sup>1</sup>
✓	✓	✓	✓	✓	✓	✓

#### Custom Modification Options

ADD_SHLF	ADDTK	ADRW	ATTK	BVR	CBO	CCO	CFNTO	CFP	CFRMO	CLIP	CND	CSDGBK	DRWTK <sup>2</sup>	EF	EX	EX_OL	FLUT <sup>3</sup>	FTK	ID	
✓	✓	✓	✓	✓	✓	✓	✓	✓	✓	✓	✓	✓	✓	✓	✓	✓	✓	✓	✓	✓

IH	IW <sup>4</sup>	MIP	OBRB	PFINBTMB	RD	RECTK	RH	ROSLUT	RT	SCPRDW	TD	TKP	TVR	VTK	WS	WTCD	WTKCUP	WTR	
✓	✓	✓	✓	✓	✓	✓	✓	✓	✓	✓	✓	✓	✓	✓	✓	✓	✓	✓	✓

<sup>1</sup>Not available when cut-out width is greater than standard.

<sup>2</sup>Not available on units over 36" wide and only available when used in conjunction with attach toekick modification.

<sup>3</sup>Not available with 6" fluting.

<sup>4</sup>Not available on 39" wide.

# Oven Microwave Cabinets

## Description

**NEW** BUILT-IN OVEN MICROWAVE CABINET, 102" HIGH, 24" DEEP

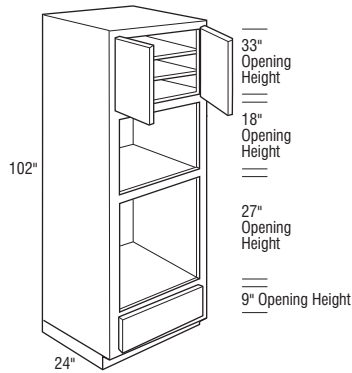

Specify appliance opening dimensions:

**OMC\_\_AC**  
Microwave/Single Oven

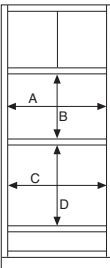

Appliance Opening Dimensions:

A \_\_\_\_\_  
B \_\_\_\_\_  
C \_\_\_\_\_  
D \_\_\_\_\_

### NOTE:

See chart for specific model appliance opening limitations.

Cabinet appliance openings may vary with modifications (i.e. clipped corner modification reduces maximum cut-out width by 3" per clipped corner).

## Model

**OMC2710224AC**

**OMC3010224AC**

**OMC3310224AC**

**OMC3610224AC**

**OMC3910224AC**

- Specify cut-out size.
- When Beaded Inset is ordered, the cabinet should be ordered to the appropriate width using the 1/4" width modification instead of using the piece-in or cut-out applications.
- Cabinet openings are subject to change based on the cut-out. Please review the acknowledged drawing.
- Two adjustable shelves in upper section.
- Shipped with loose toe space unless Attach Toekick or Flush Toekick is specified.
- Increased Depths available in 1/4" increments from 24 1/4" to 26".
- Reduced Depths available in 1/4" increments from 12" to 23 3/4".
- Finish Flushed Ends standard.
- Available in Cherry and Maple only.

Microwave	Standard Appliance Opening		Decreased Appliance Opening Width*		Increased Appliance Opening Width**		Appliance Opening Height***	
	Width (A)	Height (B)	Min. Width (A)	Max. Width (A)	Min. Width (A)	Max. Width (A)	Min. Height (B)	Max. Height (B)
OMC2710224AC	24"	18"	12"	23 1/2"	24 1/16"	25"	14"	19 1/2"
OMC3010224AC	27"	18"	15"	26 1/2"	27 1/16"	28"	14"	19 1/2"
OMC3310224AC	30"	18"	18"	29 1/2"	30 1/16"	31"	14"	19 1/2"
OMC3610224AC	33"	18"	21"	32 1/2"	33 1/16"	34"	14"	19 1/2"
OMC3910224AC	36"	18"	24"	35 1/2"	36 1/16"	37"	14"	19 1/2"

\*Decreased Appliance Opening Width can vary in 1/16" increments by piecing in frame material.

\*\*Increased Appliance Opening Width can vary in 1/16" increments by cutting out the frame stiles.

\*\*\*Appliance Opening Height could have a variance of 1/16". By changing openings, it may require the door/drawer openings to change.

Oven	Standard Appliance Opening		Decreased Appliance Opening Width*		Increased Appliance Opening Width**		Appliance Opening Height***	
	Width (C)	Height (D)	Min. Width (C)	Max. Width (C)	Min. Width (C)	Max. Width (C)	Min. Height (D)	Max. Height (D)
OMC2710224AC	24"	27"	12"	23 1/2"	24 1/16"	25"	25 1/2"	32 1/2"
OMC3010224AC	27"	27"	15"	26 1/2"	27 1/16"	28"	25 1/2"	32 1/2"
OMC3310224AC	30"	27"	18"	29 1/2"	30 1/16"	31"	25 1/2"	32 1/2"
OMC3610224AC	33"	27"	21"	32 1/2"	33 1/16"	34"	25 1/2"	32 1/2"
OMC3910224AC	36"	27"	24"	35 1/2"	36 1/16"	37"	25 1/2"	32 1/2"

### Door & Drawer Options

AF	CC	CG	ESMD	GAMD	HC	IFHG	MC	MD	MFO	PRMD	SHMD <sup>1</sup>	SPLITDR	SPLITDRWS	SUMD
	✓	✓	✓	✓		✓	✓	✓	✓	✓	✓	✓	✓	✓

### End Panel Options

AUTH	CSFPE	EXBK <sup>2</sup>	EXDN	FPE	INTGE	IPE
✓	✓	✓				✓

### Custom Modification Options

ADD	SHLF	ADTK	ADRW	ATTK	BVR	CBO	CCO	CFNTD	CFP	CFRMO	CLIP	CND	CSDGBK	DRWTK <sup>3</sup>	EF	EX	EX_OL	FLUT <sup>4</sup>	FTK	ID	
			✓	✓	✓	✓	✓	✓	✓	✓	✓	✓	✓	✓	✓	✓	✓	✓	✓	✓	✓

IH	IW <sup>5</sup>	MIP	OBRB	PFINBTMB	RD	RECTK	RH	ROSLUT <sup>4</sup>	RT	SCPDWR	TD	TKP	TVR	VTK	WS	WTCD	WTKCUP	WTR		
✓	✓	✓	✓	✓	✓	✓	✓	✓	✓	✓	✓	✓	✓	✓	✓	✓	✓	✓	✓	✓

<sup>1</sup>Only available on top section.

<sup>2</sup>This modification will allow the end to extend back to a maximum of 30" deep.

<sup>3</sup>Not available on units over 36" wide and only available when used in conjunction with attach toekick modification.

<sup>4</sup>Not available with 6" fluting.

<sup>5</sup>Not available on 39" wide.

IH/RH availability charts starting on page G•40.  
IW/RW availability charts starting on page G•46.

## Description



### BUILT-IN OVEN MICROWAVE CABINET, 108" HIGH, 24" DEEP

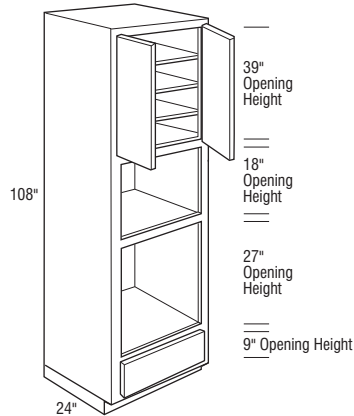

Specify appliance opening dimensions:

#### OMC\_AC Microwave/Single Oven

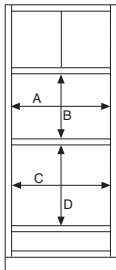

Appliance Opening Dimensions:

A \_\_\_\_\_  
 B \_\_\_\_\_  
 C \_\_\_\_\_  
 D \_\_\_\_\_

#### NOTE:

See chart for specific model appliance opening limitations.

Cabinet appliance openings may vary with modifications (i.e. clipped corner modification reduces maximum cut-out width by 3" per clipped corner).

## Model

OMC2710824AC

OMC3010824AC

OMC3310824AC

OMC3610824AC

OMC3910824AC

- Specify cut-out size.
- When Beaded Inset is ordered, the cabinet should be ordered to the appropriate width using the 1/4" width modification instead of using the piece-in or cut-out applications.
- Cabinet openings are subject to change based on the cut-out. Please review the acknowledged drawing.
- Three adjustable shelves in upper section.
- Shipped with loose toe space unless Attach Toekick or Flush Toekick is specified.
- Increased Depths available in 1/4" increments from 24 1/4" to 26".
- Reduced Depths available in 1/4" increments from 12" to 23 3/4".
- Finish Flushed Ends standard.
- Available in Cherry and Maple only.

Microwave	Standard Appliance Opening		Decreased Appliance Opening Width*		Increased Appliance Opening Width**		Appliance Opening Height***	
	Width (A)	Height (B)	Min. Width (A)	Max. Width (A)	Min. Width (A)	Max. Width (A)	Min. Height (B)	Max. Height (B)
OMC2710824AC	24"	18"	12"	23 1/2"	24 1/16"	25"	14"	19 1/2"
OMC3010824AC	27"	18"	15"	26 1/2"	27 1/16"	28"	14"	19 1/2"
OMC3310824AC	30"	18"	18"	29 1/2"	30 1/16"	31"	14"	19 1/2"
OMC3610824AC	33"	18"	21"	32 1/2"	33 1/16"	34"	14"	19 1/2"
OMC3910824AC	36"	18"	24"	35 1/2"	36 1/16"	37"	14"	19 1/2"

\*Decreased Appliance Opening Width can vary in 1/16" increments by piecing in frame material.

\*\*Increased Appliance Opening Width can vary in 1/16" increments by cutting out the frame stiles.

\*\*\*Appliance Opening Height could have a variance of 1/16". By changing openings, it may require the door/drawer openings to change.

Oven	Standard Appliance Opening		Decreased Appliance Opening Width*		Increased Appliance Opening Width**		Appliance Opening Height***	
	Width (C)	Height (D)	Min. Width (C)	Max. Width (C)	Min. Width (C)	Max. Width (C)	Min. Height (D)	Max. Height (D)
OMC2710824AC	24"	27"	12"	23 1/2"	24 1/16"	25"	25 1/2"	32 1/2"
OMC3010824AC	27"	27"	15"	26 1/2"	27 1/16"	28"	25 1/2"	32 1/2"
OMC3310824AC	30"	27"	18"	29 1/2"	30 1/16"	31"	25 1/2"	32 1/2"
OMC3610824AC	33"	27"	21"	32 1/2"	33 1/16"	34"	25 1/2"	32 1/2"
OMC3910824AC	36"	27"	24"	35 1/2"	36 1/16"	37"	25 1/2"	32 1/2"

#### Door & Drawer Options

AF	CC	CG	ESMD	GAMD	HC	IFHG	MC	MD	MFO	PRMD	SHMD	SPLITDR	SPLITDRWS	SUMD
	✓		✓	✓		✓		✓	✓	✓	✓	✓	✓	✓

#### End Panel Options

AUTH	CSFPE	EXBK <sup>1</sup>	EXDN	FPE	INTGE	IPE
✓	✓	✓				✓

#### Custom Modification Options

ADD_SHLF	ADDTK	ADRW	ATTK	BVR	CBO	CCO	CFNTD	CFP	CFRMO	CLIP	CND	CSDGBK	DRWTK <sup>2</sup>	EF	EX	EX_OL	FLUT <sup>3</sup>	FTK	ID	
	✓			✓	✓	✓	✓	✓	✓	✓	✓	✓	✓	✓	✓	✓	✓	✓	✓	✓

IH	IW <sup>4</sup>	MIP	OBRB	PFINBTMB	RD	RECTK	RH	ROSLUT <sup>3</sup>	RT	SCPDRW	TD	TKP	TVR	VTK	WS	WTC	WTKCUP	WTR	
✓	✓		✓		✓	✓		✓	✓	✓	✓	✓	✓	✓	✓	✓	✓	✓	✓

<sup>1</sup>This modification will allow the end to extend back to a maximum of 30" deep.

<sup>2</sup>Not available on units over 36" wide and only available when used in conjunction with attach toekick modification.

<sup>3</sup>Not available with 6" fluting.

<sup>4</sup>Not available on 39" wide.

# Oven Microwave Cabinets

## Description



**MICROWAVE and SINGLE OVEN TRIMMABLE CABINET, 84", 87", or 90" HIGH, 24" DEEP**

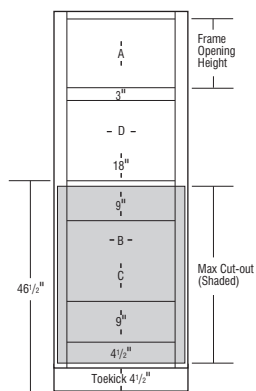
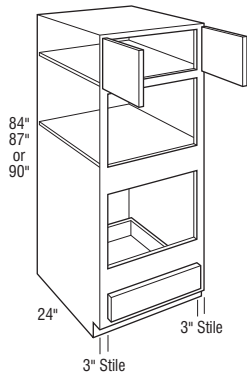

## Model

OMC278424
OMC308424
OMC338424
OMC368424
OMC398424
OMC278724
OMC308724
OMC338724
OMC368724
OMC398724
OMC279024AH
OMC309024AH
OMC339024AH
OMC369024AH
OMC399024AH

- AH represents upper section alignment with doors on 24" or 27" high cabinets.
- Includes one adjustable shelf in upper section.

### Notes below apply to all products in section above:

- All top and bottom cross rails are 1 1/2" wide.
- Cabinet installation kit will not be included when depth is modified.
- A cabinet installation kit will be provided.
- Oven cabinet cut-out is shaded in gray and is cut out on job site.
- Designed for use with separate built-in microwave above, built-in oven below.
- For built-in double ovens, see OCD cabinets.
- Increased Heights modification will increase the height of the upper cabinet section. The bottom section will retain its original height.

	A Frame Opening Height	B Cut-out Width		C Cut-out Height		D Frame Opening Width	Door Height (Upper Section) Full Overlay
		Min.	Max.	Min.	Max.		
OMC278424	15"	21"	25 1/2"	18"	39"	21"	17 1/2"
OMC308424	15"	24"	28 1/2"	18"	39"	24"	17 1/2"
OMC338424	15"	27"	31 1/2"	18"	39"	27"	17 1/2"
OMC368424	15"	30"	34 1/2"	18"	39"	30"	17 1/2"
OMC398424	15"	33"	37 1/2"	18"	39"	33"	17 1/2"
OMC278724	18"	21"	25 1/2"	18"	39"	21"	20 1/2"
OMC308724	18"	24"	28 1/2"	18"	39"	24"	20 1/2"
OMC338724	18"	27"	31 1/2"	18"	39"	27"	20 1/2"
OMC368724	18"	30"	34 1/2"	18"	39"	30"	20 1/2"
OMC398724	18"	33"	37 1/2"	18"	39"	33"	20 1/2"
OMC279024AH	21"	21"	25 1/2"	18"	39"	21"	23 1/2"
OMC309024AH	21"	24"	28 1/2"	18"	39"	24"	23 1/2"
OMC339024AH	21"	27"	31 1/2"	18"	39"	27"	23 1/2"
OMC369024AH	21"	30"	34 1/2"	18"	39"	30"	23 1/2"
OMC399024AH	21"	33"	37 1/2"	18"	39"	33"	23 1/2"

Maximum cut-out dimension will allow 1/4" reveal for doors and drawer fronts on full overlay for trim kit face clearance.

### Door & Drawer Options

AF	CC	CG	ESMD	GAMD	HC	IFHG	MC	MD	MFO	PRMD	SHMD	SPLITDR	SPLITDRWS	SUMD
	✓	✓	✓	✓				✓	✓	✓	✓	✓	✓	✓

### End Panel Options

AUTH	CSFPE	EXBK	EXDN	FPE	INTGE	IPE
✓	✓	✓	✓	✓	✓	✓

### Custom Modification Options

ADD	SHLF	ADDTK	ADRW	ATTK	BVR	CBO	CCO	CFNT0	CFP	CFRMO	CLIP	CND	CSDGBK	DRWTK <sup>1</sup>	EF	EX	EX_OL	FLUT <sup>2</sup>	FTK	ID	
								✓	✓	✓	✓	✓	✓	✓	✓	✓	✓	✓	✓	✓	✓

IH	IW <sup>3</sup>	MIP	OBRB	PFINBTMB	RD	RECTK	RH	ROSLUT	RT	SCPDWR	TD	TKP	TVR	VTK	WS	WTCD	WTKCUP	WTR		
✓	✓	✓	✓	✓	✓	✓	✓	✓	✓	✓	✓	✓	✓	✓	✓	✓	✓	✓	✓	✓

<sup>1</sup>Not available on units over 36" wide.

<sup>2</sup>Not available with 6" fluting.

<sup>3</sup>Not available on 39" wide.

IH/RH availability charts starting on page G•40.  
IW/RW availability charts starting on page G•46.

## Description



**MICROWAVE and SINGLE OVEN TRIMMABLE CABINET, 93" or 96" HIGH, 24" DEEP**

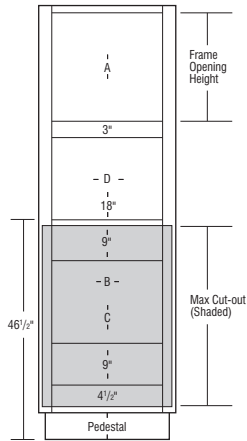
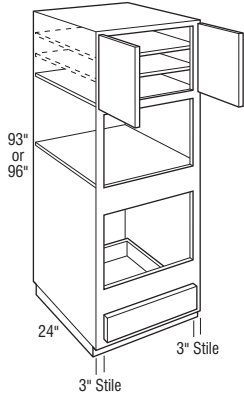

## Model

OMC279324AH

OMC309324AH

OMC339324AH

OMC369324AH

OMC399324AH

- AH represents upper section alignment with doors on 24" or 27" high cabinets.
- Includes one adjustable shelf in upper section.

OMC279624

OMC309624

OMC339624

OMC369624

OMC399624

- Includes two adjustable shelves in upper section.
- Flush toekick option not available in conjunction with Wide Top Rail unless loose Flush ToeKick is specified.

### Notes below apply to all products in section above:

- Shipped with loose toekick unless ATTK or Flush ToeKick is specified.
- All top and bottom cross rails are 1 1/2" wide.
- Cabinet installation kit will not be included when depth is modified.
- A cabinet installation kit will be provided.
- Oven cabinet cut-out is shaded in gray and is cut out on job site.
- Designed for use with separate built-in microwave above, built-in oven below.
- For built-in double ovens, see OCD cabinets.
- Increased Heights modification will increase the height of the upper cabinet section. The bottom section will retain its original height.

	A Frame Opening Height	B Cut-out Width		C Cut-out Height		D Frame Opening Width	Door Height (Upper Section)
		Min.	Max.	Min.	Max.		Full Overlay
OMC279324AH	24"	21"	25 1/2"	18"	39"	21"	26 1/2"
OMC309324AH	24"	24"	28 1/2"	18"	39"	24"	26 1/2"
OMC339324AH	24"	27"	31 1/2"	18"	39"	27"	26 1/2"
OMC369324AH	24"	30"	34 1/2"	18"	39"	30"	26 1/2"
OMC399324AH	24"	33"	37 1/2"	18"	39"	33"	26 1/2"
OMC279624	27"	21"	25 1/2"	18"	39"	21"	29 1/2"
OMC309624	27"	24"	28 1/2"	18"	39"	24"	29 1/2"
OMC339624	27"	27"	31 1/2"	18"	39"	27"	29 1/2"
OMC369624	27"	30"	34 1/2"	18"	39"	30"	29 1/2"
OMC399624	27"	33"	37 1/2"	18"	39"	33"	29 1/2"

Maximum cut-out dimension will allow 1/4" reveal for doors and drawer fronts on full overlay for trim kit face clearance.

### Door & Drawer Options

AF	CC	CG	ESMD	GAMD	HC	IFHG	MC	MD	MFO	PRMD	SHMD	SPLITDR	SPLITDRWS	SUMD
✓	✓	✓	✓	✓	✓	✓	✓	✓	✓	✓	✓	✓	✓	✓

### End Panel Options

AUTH	CSFPE	EXBK	EXDN	FPE	INTGE	IPE
✓	✓	✓	✓	✓	✓	✓

### Custom Modification Options

ADD	SHLF	ADTK	ADRW	ATTK	BVR	CBO	CCO	CFNT0	CFP	CFRMO	CLIP	CND	CSDGBK	DRWTK <sup>1</sup>	EF	EX	EX_OL	FLUT <sup>2</sup>	FTK	ID	
✓	✓	✓	✓	✓	✓	✓	✓	✓	✓	✓	✓	✓	✓	✓	✓	✓	✓	✓	✓	✓	✓
IH <sup>3</sup>	IW <sup>4</sup>	MIP	OBRB	PFINBTMB	RD	RECTK	RH	ROSFLUT	RT	SCPDRW	TD	TKP	TVR	VTK	WS	WTCD	WTKCUP	WTR			
✓	✓	✓	✓	✓	✓	✓	✓	✓	✓	✓	✓	✓	✓	✓	✓	✓	✓	✓	✓	✓	✓

<sup>1</sup>Not available on units over 36" wide and only available when used in conjunction with attach toekick modification.

<sup>2</sup>Not available with 6" fluting.

<sup>3</sup>Not available on 96" high.

<sup>4</sup>Not available on 39" wide.

# Oven Microwave Cabinets

## Description



**MICROWAVE and SINGLE OVEN TRIMMABLE CABINET with DEEP DRAWER, 84", 87", or 90" HIGH, 24" DEEP**

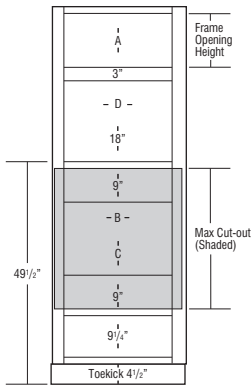
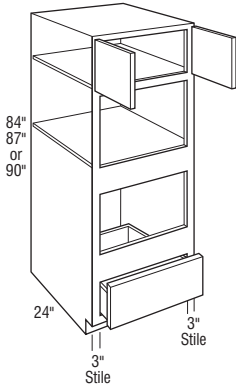

## Model

- OMC278424DD
- OMC308424DD
- OMC338424DD
- OMC368424DD
- OMC398424DD
- OMC278724DD
- OMC308724DD
- OMC338724DD
- OMC368724DD
- OMC398724DD
- OMC279024DD
- OMC309024DD
- OMC339024DD
- OMC369024DD
- OMC399024DD

- All top and bottom cross rails are 1 1/2" wide.
- For built-in appliance support, OCINSTALLKIT is included in 24" deep oven cabinets.
- Oven cabinet cut-out is shaded in gray and is cut out on job site.
- Designed for use with separate built-in microwave above, built-in oven below.
- For built-in double ovens, see OCD cabinets.
- Cabinet installation kit will not be included when depth is modified.
- A cabinet installation kit will be provided.
- Increased Heights modification will increase the height of the upper cabinet section. The bottom section will retain its original height.
- Reduced Depths available in 1/4" increments from 12" to 23 3/4".

	A Frame Opening Height	B Cut-out Width		C Cut-out Height		D Frame Opening Width	Door Height (Upper Section) Full Overlay
		Min.	Max.	Min.	Max.		
OMC278424DD	12"	21"	25 1/2"	16 1/4"	31 1/4"	21"	14 1/2"
OMC308424DD	12"	24"	28 1/2"	16 1/4"	31 1/4"	24"	14 1/2"
OMC338424DD	12"	27"	31 1/2"	16 1/4"	31 1/4"	27"	14 1/2"
OMC368424DD	12"	30"	34 1/2"	16 1/4"	31 1/4"	30"	14 1/2"
OMC398424DD	12"	33"	37 1/2"	16 1/4"	31 1/4"	33"	14 1/2"
OMC278724DD	15"	21"	25 1/2"	16 1/4"	31 1/4"	21"	17 1/2"
OMC308724DD	15"	24"	28 1/2"	16 1/4"	31 1/4"	24"	17 1/2"
OMC338724DD	15"	27"	31 1/2"	16 1/4"	31 1/4"	27"	17 1/2"
OMC368724DD	15"	30"	34 1/2"	16 1/4"	31 1/4"	30"	17 1/2"
OMC398724DD	15"	33"	37 1/2"	16 1/4"	31 1/4"	33"	17 1/2"
OMC279024DD	18"	21"	25 1/2"	16 1/4"	31 1/4"	21"	20 1/2"
OMC309024DD	18"	24"	28 1/2"	16 1/4"	31 1/4"	24"	20 1/2"
OMC339024DD	18"	27"	31 1/2"	16 1/4"	31 1/4"	27"	20 1/2"
OMC369024DD	18"	30"	34 1/2"	16 1/4"	31 1/4"	30"	20 1/2"
OMC399024DD	18"	33"	37 1/2"	16 1/4"	31 1/4"	33"	20 1/2"

Maximum cut-out dimension will allow 1/4" reveal for doors and drawer fronts for trim kit face clearance.

### Door & Drawer Options

AF	CC	CG	ESMD	GAMD	HC	IFHG	MC	MD	MFO	PRMD	SHMD	SPLITDR	SPLITDRWS	SUMD
	✓	✓	✓	✓				✓	✓	✓	✓	✓	✓	✓

### End Panel Options

AUTH	CSFPE	EXBK	EXDN	FPE	INTGE	IPE
✓	✓	✓	✓	✓	✓	✓

### Custom Modification Options

ADD	SHLF	ADDTK	ADRW	ATTK	BVR	CBO	CCO	CFNTO	CFP	CFRMO	CLIP	CND	CSDGBK	DRWTK <sup>1</sup>	EF	EX	EX_OL	FLUT <sup>2</sup>	FTK	ID	
						✓	✓	✓	✓	✓	✓	✓	✓	✓	✓	✓	✓	✓	✓	✓	✓
IH	IW <sup>3</sup>	MIP	OBRB	PFINBTMB	RD	RECTK	RH	ROSLUT	RT	SCPDRW	TD	TKP	TVR	VTK	WS	WTCD	WTKCUP	WTR			
✓	✓	✓	✓	✓	✓	✓	✓	✓	✓	✓	✓	✓	✓	✓	✓	✓	✓	✓			

<sup>1</sup>Not available on units over 36" wide.

<sup>2</sup>Not available with 6" fluting.

<sup>3</sup>Not available on 39" wide.

IH/RH availability charts starting on page G•40.  
IW/RW availability charts starting on page G•46.

## Description



**MICROWAVE and SINGLE OVEN TRIMMABLE CABINET with DEEP DRAWER, 93" or 96" HIGH, 24" DEEP**

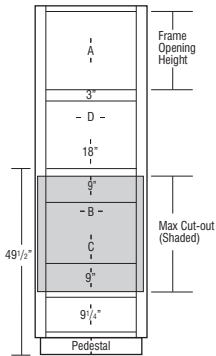
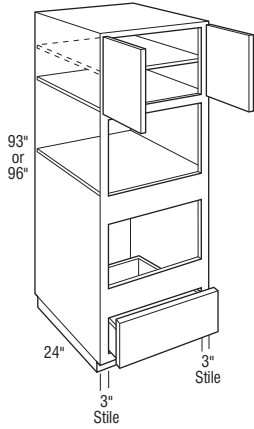

## Model

- OMC279324DDAH
- OMC309324DDAH
- OMC339324DDAH
- OMC369324DDAH
- OMC399324DDAH
- OMC279624DDAH
- OMC309624DDAH
- OMC339624DDAH
- OMC369624DDAH
- OMC399624DDAH

- AH represents upper section alignment with doors on 24" or 27" high cabinets.
- Includes one adjustable shelf in upper section.
- Shipped with loose toe kick unless ATTK or Flush Toe kick is specified.
- On the 96" high, flush toe kick option not available in conjunction with Wide Top Rail unless loose Flush Toe kick is specified.
- All top and bottom cross rails are 1 1/2" wide.
- For built-in appliance support, OCINSTALLKIT is included in 24" deep oven cabinets.
- Oven cabinet cut-out is shaded in gray and is cut out on job site.
- Designed for use with separate built-in microwave above, built-in oven below.
- For built-in double ovens, see OCD cabinets.
- Cabinet installation kit will not be included when depth is modified.
- A cabinet installation kit will be provided.
- Increased Heights modification will increase the height of the upper cabinet section. The bottom section will retain its original height.
- Reduced Depths available in 1/4" increments from 12" to 23 3/4".

	A Frame Opening Height	B Cut-out Width		C Cut-out Height		D Frame Opening Width	Door Height (Upper Section) Full Overlay
		Min.	Max.	Min.	Max.		
OMC279324DDAH	21"	21"	25 1/2"	16 1/4"	31 1/4"	21"	23 1/2"
OMC309324DDAH	21"	24"	28 1/2"	16 1/4"	31 1/4"	24"	23 1/2"
OMC339324DDAH	21"	27"	31 1/2"	16 1/4"	31 1/4"	27"	23 1/2"
OMC369324DDAH	21"	30"	34 1/2"	16 1/4"	31 1/4"	30"	23 1/2"
OMC399324DDAH	21"	33"	37 1/2"	16 1/4"	31 1/4"	33"	23 1/2"
OMC279624DDAH	24"	21"	25 1/2"	16 1/4"	31 1/4"	21"	26 1/2"
OMC309624DDAH	24"	24"	28 1/2"	16 1/4"	31 1/4"	24"	26 1/2"
OMC339624DDAH	24"	27"	31 1/2"	16 1/4"	31 1/4"	27"	26 1/2"
OMC369624DDAH	24"	30"	34 1/2"	16 1/4"	31 1/4"	30"	26 1/2"
OMC399624DDAH	24"	33"	37 1/2"	16 1/4"	31 1/4"	33"	26 1/2"

Maximum cut-out dimension will allow 1/4" reveal for doors and drawer fronts for trim kit face clearance.

### Door & Drawer Options

AF	CC	CG	ESMD	GAMD	HC	IFHG	MC	MD	MFO	PRMD	SHMD	SPLITDR	SPLITDRWS	SUMD
✓	✓	✓	✓	✓	✓	✓	✓	✓	✓	✓	✓	✓	✓	✓

### End Panel Options

AUTH	CSFPE	EXBK	EXDN	FPE	INTGE	IPE
✓	✓	✓	✓	✓	✓	✓

### Custom Modification Options

ADD_SHLF	ADDTK	ADRW	ATTK	BVR	CBO	CCO	CFNTO	CFP	CFRMO	CLIP	CND	CSDGBK	DRWTK <sup>1</sup>	EF	EX	EX_OL	FLUT <sup>2</sup>	FTK	ID	
✓	✓	✓	✓	✓	✓	✓	✓	✓	✓	✓	✓	✓	✓	✓	✓	✓	✓	✓	✓	✓

IH <sup>3</sup>	IW <sup>4</sup>	MIP	OBRB	PFINBTMB	RD	RECTK	RH	ROSFLUT	RT	SCPDRW	TD	TKP	TVR	VTK	WS	WTCD	WTKCUP	WTR	
✓	✓	✓	✓	✓	✓	✓	✓	✓	✓	✓	✓	✓	✓	✓	✓	✓	✓	✓	✓

<sup>1</sup>Not available on units over 36" wide and only available when used in conjunction with attach toe kick modification.

<sup>2</sup>Not available with 6" fluting.

<sup>3</sup>Not available on 96" high.

<sup>4</sup>Not available on 39" wide.



# Oven Cabinets

## Description

**BUILT-IN SINGLE OVEN CABINET with DRAWERS, 84", 87", or 90" HIGH, 24" DEEP**

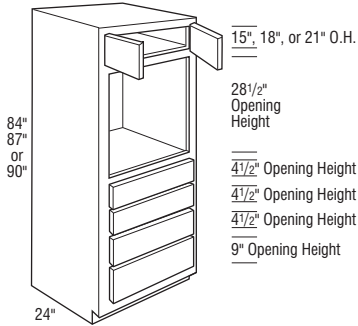

Specify appliance opening dimensions:

### OCSD \_ AC

Single Oven with Drawers

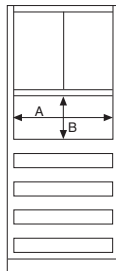

Appliance Opening Dimensions:

A \_\_\_\_\_  
B \_\_\_\_\_

### NOTE:

See chart for specific model appliance opening limitations.

Cabinet appliance openings may vary with modifications (i.e. clipped corner modification reduces maximum cut-out width by 3" per clipped corner).

## Model

OCSD278424AC

OCSD308424AC

OCSD338424AC

OCSD368424AC

OCSD398424AC

OCSD278724AC

OCSD308724AC

OCSD338724AC

OCSD368724AC

OCSD398724AC

OCSD279024AC

OCSD309024AC

OCSD339024AC

OCSD369024AC

OCSD399024AC

- Specify cut-out size.
- When Beaded Inset is ordered, the cabinet should be ordered to the appropriate width using the 1/4" width modification instead of using the piece-in or cut-out applications.
- Cabinet openings are subject to change based on the cut-out. Please review the acknowledged drawing.
- 90" high includes one adjustable shelf in upper section.
- Increased Depths available in 1/4" increments from 24 1/4" to 30".
- Reduced Depths available in 1/4" increments from 12" to 23 3/4".
- Ordering Maximum Width Cut-out on cabinet will change end panel thickness from 1/2" to 3/8" for non-flush ends, and from 5/8" to 1/2" for flush ends.

	Standard Appliance Opening		Decreased Appliance Opening Width*		Increased Appliance Opening Width**		Appliance Opening Height***	
	Width (A)	Height (B)	Min. Width (A)	Max. Width (A)	Min. Width (A)	Max. Width (A)	Min. Height (B)	Max. Height (B)
OCSD278424AC	24"	28 1/2"	12"	23 1/2"	24 1/16"	25 1/2"	27"	32 1/2"
OCSD308424AC	27"	28 1/2"	15"	26 1/2"	27 1/16"	28 1/2"	27"	32 1/2"
OCSD338424AC	30"	28 1/2"	18"	29 1/2"	30 1/16"	31 1/2"	27"	32 1/2"
OCSD368424AC	33"	28 1/2"	21"	32 1/2"	33 1/16"	34 1/2"	27"	32 1/2"
OCSD398424AC	36"	28 1/2"	24"	35 1/2"	36 1/16"	37 1/2"	27"	32 1/2"
OCSD278724AC	24"	28 1/2"	12"	23 1/2"	24 1/16"	25 1/2"	27"	32 1/2"
OCSD308724AC	27"	28 1/2"	15"	26 1/2"	27 1/16"	28 1/2"	27"	32 1/2"
OCSD338724AC	30"	28 1/2"	18"	29 1/2"	30 1/16"	31 1/2"	27"	32 1/2"
OCSD368724AC	33"	28 1/2"	21"	32 1/2"	33 1/16"	34 1/2"	27"	32 1/2"
OCSD398724AC	36"	28 1/2"	24"	35 1/2"	36 1/16"	37 1/2"	27"	32 1/2"
OCSD279024AC	24"	28 1/2"	12"	23 1/2"	24 1/16"	25 1/2"	27"	32 1/2"
OCSD309024AC	27"	28 1/2"	15"	26 1/2"	27 1/16"	28 1/2"	27"	32 1/2"
OCSD339024AC	30"	28 1/2"	18"	29 1/2"	30 1/16"	31 1/2"	27"	32 1/2"
OCSD369024AC	33"	28 1/2"	21"	32 1/2"	33 1/16"	34 1/2"	27"	32 1/2"
OCSD399024AC	36"	28 1/2"	24"	35 1/2"	36 1/16"	37 1/2"	27"	32 1/2"

\*Decreased Appliance Opening Width can vary in 1/16" increments by piecing in frame material.

\*\*Increased Appliance Opening Width can vary in 1/16" increments by cutting out the frame stiles.

\*\*\*Appliance Opening Height could have a variance of 1/16". By changing openings, it may require the door/drawer openings to change.

### Door & Drawer Options

AF	CC	CG	ESMD	GAMD	HC	IFHG	MC	MD	MFO	PRMD	SHMD	SPLITDR	SPLITDRWS	SUMD
<input checked="" type="checkbox"/>	<input checked="" type="checkbox"/>	<input checked="" type="checkbox"/>	<input checked="" type="checkbox"/>	<input checked="" type="checkbox"/>	<input checked="" type="checkbox"/>	<input checked="" type="checkbox"/>	<input checked="" type="checkbox"/>	<input checked="" type="checkbox"/>	<input checked="" type="checkbox"/>	<input checked="" type="checkbox"/>	<input checked="" type="checkbox"/>	<input checked="" type="checkbox"/>	<input checked="" type="checkbox"/>	<input checked="" type="checkbox"/>

### End Panel Options

AUTH	CSFPE <sup>1</sup>	EXBK	EXDN	FPE	INTGE <sup>1</sup>	IPE <sup>1</sup>
<input checked="" type="checkbox"/>	<input checked="" type="checkbox"/>	<input checked="" type="checkbox"/>	<input checked="" type="checkbox"/>	<input checked="" type="checkbox"/>	<input checked="" type="checkbox"/>	<input checked="" type="checkbox"/>

### Custom Modification Options

ADD	SHLF	ADDTK	ADRW	ATTK	BVR	CBO	CCO	CFNTD	CFP	CFRMO	CLIP	CND	CSDGBK	DRWTK <sup>2</sup>	EF	EX	EX_OL	FLUT <sup>3</sup>	FTK	ID
<input checked="" type="checkbox"/>	<input checked="" type="checkbox"/>	<input checked="" type="checkbox"/>	<input checked="" type="checkbox"/>	<input checked="" type="checkbox"/>	<input checked="" type="checkbox"/>	<input checked="" type="checkbox"/>	<input checked="" type="checkbox"/>	<input checked="" type="checkbox"/>	<input checked="" type="checkbox"/>	<input checked="" type="checkbox"/>	<input checked="" type="checkbox"/>	<input checked="" type="checkbox"/>	<input checked="" type="checkbox"/>	<input checked="" type="checkbox"/>	<input checked="" type="checkbox"/>	<input checked="" type="checkbox"/>	<input checked="" type="checkbox"/>	<input checked="" type="checkbox"/>	<input checked="" type="checkbox"/>	<input checked="" type="checkbox"/>

IH	IW <sup>4</sup>	IMP	OBRB	PFINBTMB	RD	RECTK	RH	ROSFLUT	RT	SCPDRW	TD	TKP	TVR	VTK	WS	WTCD	WTKCUP	WTR
<input checked="" type="checkbox"/>	<input checked="" type="checkbox"/>	<input checked="" type="checkbox"/>	<input checked="" type="checkbox"/>	<input checked="" type="checkbox"/>	<input checked="" type="checkbox"/>	<input checked="" type="checkbox"/>	<input checked="" type="checkbox"/>	<input checked="" type="checkbox"/>	<input checked="" type="checkbox"/>	<input checked="" type="checkbox"/>	<input checked="" type="checkbox"/>	<input checked="" type="checkbox"/>	<input checked="" type="checkbox"/>	<input checked="" type="checkbox"/>	<input checked="" type="checkbox"/>	<input checked="" type="checkbox"/>	<input checked="" type="checkbox"/>	<input checked="" type="checkbox"/>

<sup>1</sup>Not available when cut-out width is greater than standard.

<sup>2</sup>Not available on units over 36" wide.

<sup>3</sup>Not available with 6" fluting.

<sup>4</sup>Not available on 39" wide.

IH/RH availability charts starting on page G•40.  
IW/RW availability charts starting on page G•46.

## Description

### BUILT-IN SINGLE OVEN CABINET with DRAWERS, 93" or 96" HIGH, 24" DEEP

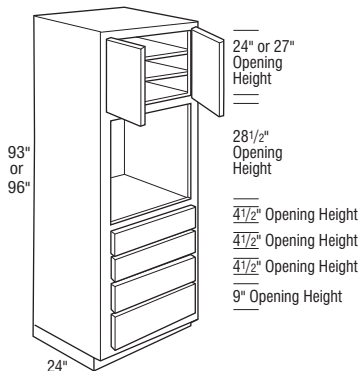

Specify appliance opening dimensions:

#### OCS\_D\_AC

Single Oven with Drawers

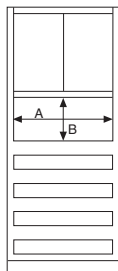

Appliance Opening Dimensions:

A \_\_\_\_\_  
B \_\_\_\_\_

#### NOTE:

See chart for specific model appliance opening limitations.

Cabinet appliance openings may vary with modifications (i.e. clipped corner modification reduces maximum cut-out width by 3" per clipped corner).

## Model

OCS279324AC

OCS2309324AC

OCS2339324AC

OCS2369324AC

OCS2399324AC

- Includes one adjustable shelf in upper section.

OCS2279624AC

OCS2309624AC

OCS2339624AC

OCS2369624AC

OCS2399624AC

- Includes two adjustable shelves in upper section.

- Flush ToeKick modification not available in conjunction with Wide Top Rail, unless loose Flush ToeKick is specified.

Notes below apply to all products in section above:

- Specify cut-out size.
- When Beaded Inset is ordered, the cabinet should be ordered to the appropriate width using the 1/4" width modification instead of using the piece-in or cut-out applications.
- Cabinet openings are subject to change based on the cut-out. Please review the acknowledged drawing.
- Shipped with loose toe space unless Attach ToeKick or Flush ToeKick is specified.
- Increased Depths available in 1/4" increments from 24 1/4" to 30".
- Reduced Depths available in 1/4" increments from 12" to 23 3/4".
- Ordering Maximum Width Cut-out on cabinet will change end panel thickness from 1/2" to 3/8" for non-flush ends, and from 5/8" to 1/2" for flush ends.

	Standard Appliance Opening		Decreased Appliance Opening Width*		Increased Appliance Opening Width**		Appliance Opening Height***	
	Width (A)	Height (B)	Min. Width (A)	Max. Width (A)	Min. Width (A)	Max. Width (A)	Min. Height (B)	Max. Height (B)
OCS279324AC	24"	28 1/2"	12"	23 1/2"	24 1/16"	25 1/2"	27"	32 1/2"
OCS2309324AC	27"	28 1/2"	15"	26 1/2"	27 1/16"	28 1/2"	27"	32 1/2"
OCS2339324AC	30"	28 1/2"	18"	29 1/2"	30 1/16"	31 1/2"	27"	32 1/2"
OCS2369324AC	33"	28 1/2"	21"	32 1/2"	33 1/16"	34 1/2"	27"	32 1/2"
OCS2399324AC	36"	28 1/2"	24"	35 1/2"	36 1/16"	37 1/2"	27"	32 1/2"
OCS2279624AC	24"	28 1/2"	12"	23 1/2"	24 1/16"	25 1/2"	27"	32 1/2"
OCS2309624AC	27"	28 1/2"	15"	26 1/2"	27 1/16"	28 1/2"	27"	32 1/2"
OCS2339624AC	30"	28 1/2"	18"	29 1/2"	30 1/16"	31 1/2"	27"	32 1/2"
OCS2369624AC	33"	28 1/2"	21"	32 1/2"	33 1/16"	34 1/2"	27"	32 1/2"
OCS2399624AC	36"	28 1/2"	24"	35 1/2"	36 1/16"	37 1/2"	27"	32 1/2"

\*Decreased Appliance Opening Width can vary in 1/16" increments by piecing in frame material.

\*\*Increased Appliance Opening Width can vary in 1/16" increments by cutting out the frame stiles.

\*\*\*Appliance Opening Height could have a variance of 1/16". By changing openings, it may require the door/drawer openings to change.

#### Door & Drawer Options

AF	CC	CG	ESMD	GAMD	HC	IFHG	MC	MD	MFO	PRMD	SHMD	SPLITDR	SPLITDRWS	SUMD
✓	✓	✓	✓	✓	✓	✓	✓	✓	✓	✓	✓	✓	✓	✓

#### End Panel Options

AUTH	CSFPE <sup>1</sup>	EXBK	EXDN	FPE	INTGE <sup>1</sup>	IPE <sup>1</sup>
✓	✓	✓	✓	✓	✓	✓

#### Custom Modification Options

ADD_SHLF	ADDTK	ADRW	ATTK	BVR	CBO	CCO	CFNTD	CFP	CFRMO	CLIP	CND	CSDGBK	DRWTK <sup>2</sup>	EF	EX	EX_OL	FLUT <sup>3</sup>	FTK	ID
✓	✓	✓	✓	✓	✓	✓	✓	✓	✓	✓	✓	✓	✓	✓	✓	✓	✓	✓	✓

IH	IW <sup>4</sup>	MIP	OBRB	PFINBTMB	RD	RECTK	RH	ROSLUT	RT	SCPDWR	TD	TKP	TVR	VTK	WS	WTCD	WTKCUP	WTR
✓	✓	✓	✓	✓	✓	✓	✓	✓	✓	✓	✓	✓	✓	✓	✓	✓	✓	✓

<sup>1</sup>Not available when cut-out width is greater than standard.

<sup>2</sup>Not available on units over 36" wide when used in conjunction with attach toeKick modification.

<sup>3</sup>Not available with 6" fluting.

<sup>4</sup>Not available on 39" wide.

# Oven Cabinets

## Description

**NEW** **BUILT-IN SINGLE OVEN CABINET**  
with **DRAWERS, 102" HIGH,**  
**24" DEEP**

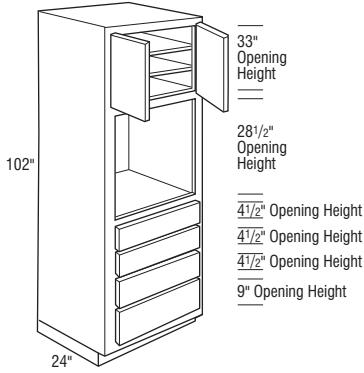

Specify appliance opening dimensions:

**OCSD\_\_AC**  
Single Oven with Drawers

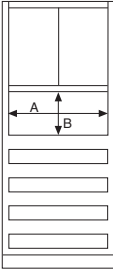

Appliance Opening Dimensions:

A \_\_\_\_\_  
B \_\_\_\_\_

### NOTE:

See chart for specific model appliance opening limitations.

Cabinet appliance openings may vary with modifications (i.e. clipped corner modification reduces maximum cut-out width by 3" per clipped corner).

## Model

**OCSD2710224AC**

**OCSD3010224AC**

**OCSD3310224AC**

**OCSD3610224AC**

**OCSD3910224AC**

- Specify cut-out size.
- When Beaded Inset is ordered, the cabinet should be ordered to the appropriate width using the 1/4" width modification instead of using the piece-in or cut-out applications.
- Cabinet openings are subject to change based on the cut-out. Please review the acknowledged drawing.
- Two adjustable shelves in upper section.
- Shipped with loose toe space unless Attach Toekick or Flush Toekick is specified.
- Increased Depths available in 1/4" increments from 24 1/4" to 26".
- Reduced Depths available in 1/4" increments from 12" to 23 3/4".
- Finish Flushed Ends standard.
- Available in Cherry and Maple only.

	Standard Appliance Opening		Decreased Appliance Opening Width*		Increased Appliance Opening Width**		Appliance Opening Height***	
	Width (A)	Height (B)	Min. Width (A)	Max. Width (A)	Min. Width (A)	Max. Width (A)	Min. Height (B)	Max. Height (B)
OCSD2710224AC	24"	28 1/2"	12"	23 1/2"	24 1/16"	25"	27"	32 1/2"
OCSD3010224AC	27"	28 1/2"	15"	26 1/2"	27 1/16"	28"	27"	32 1/2"
OCSD3310224AC	30"	28 1/2"	18"	29 1/2"	30 1/16"	31"	27"	32 1/2"
OCSD3610224AC	33"	28 1/2"	21"	32 1/2"	33 1/16"	34"	27"	32 1/2"
OCSD3910224AC	36"	28 1/2"	24"	35 1/2"	36 1/16"	37"	27"	32 1/2"

\*Decreased Appliance Opening Width can vary in 1/16" increments by piecing in frame material.

\*\*Increased Appliance Opening Width can vary in 1/16" increments by cutting out the frame stiles.

\*\*\*Appliance Opening Height could have a variance of 1/16". By changing openings, it may require the door/drawer openings to change.

### Door & Drawer Options

AF	CC	CG	ESMD	GAMD	HC	IFHG	MC	MD	MFO	PRMD	SHMD	SPLITDR	SPLITDRWS	SUMD
	✓	✓	✓	✓		✓	✓	✓	✓	✓	✓			✓

### End Panel Options

AUTH	CSFPE	EXBK <sup>1</sup>	EXDN	FPE	INTGE	IPE
✓		✓				✓

### Custom Modification Options

ADD_SHLF	ADDTK	ADRW	ATTK	BVR	CBO	CCO	CFNTO	CFP	CFRMO	CLIP	CND	CSDGBK	DRWTK <sup>2</sup>	EF	EX	EX_OL	FLUT <sup>3</sup>	FTK	ID	
			✓		✓	✓	✓	✓	✓	✓	✓	✓	✓	✓	✓	✓	✓	✓	✓	✓
IH	IW <sup>4</sup>	IMP	OBRB	PFINBTMB	RD	RECTK	RH	ROSFLUT <sup>3</sup>	RT	SCDRW	TD	TKP	TVR	VTK	WS	WTCO	WTKCUP	WTR		
✓	✓		✓		✓	✓	✓	✓	✓	✓	✓	✓	✓	✓	✓	✓	✓	✓		✓

<sup>1</sup>This modification will allow the end to extend back to a maximum of 30" deep.

<sup>2</sup>Not available on units over 36" wide and only available when used in conjunction with attach toekick modification.

<sup>3</sup>Not available with 6" fluting.

<sup>4</sup>Not available on 39" wide.

IH/RH availability charts starting on page G•40.  
IW/RW availability charts starting on page G•46.

## Description



**BUILT-IN SINGLE OVEN CABINET**  
with DRAWERS, 108" HIGH,  
24" DEEP

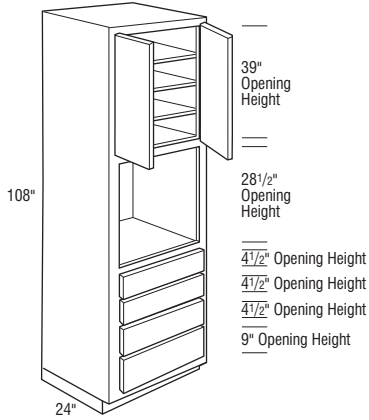

Specify appliance opening dimensions:

**OCS\_D\_AC**  
Single Oven with Drawers

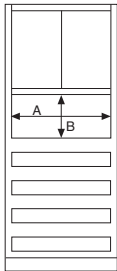

Appliance Opening Dimensions:

A \_\_\_\_\_  
B \_\_\_\_\_

### NOTE:

See chart for specific model appliance opening limitations.

Cabinet appliance openings may vary with modifications (i.e. clipped corner modification reduces maximum cut-out width by 3" per clipped corner).

## Model

OCS2710824AC

OCS3010824AC

OCS3310824AC

OCS3610824AC

OCS3910824AC

- Specify cut-out size.
- When Beaded Inset is ordered, the cabinet should be ordered to the appropriate width using the 1/4" width modification instead of using the piece-in or cut-out applications.
- Cabinet openings are subject to change based on the cut-out. Please review the acknowledged drawing.
- Three adjustable shelves in upper section.
- Shipped with loose toe space unless Attach Toekick or Flush Toekick is specified.
- Increased Depths available in 1/4" increments from 24 1/4" to 26".
- Reduced Depths available in 1/4" increments from 12" to 23 3/4".
- Finish Flushed Ends standard.
- Available in Cherry and Maple only.

	Standard Appliance Opening		Decreased Appliance Opening Width*		Increased Appliance Opening Width**		Appliance Opening Height***	
	Width (A)	Height (B)	Min. Width (A)	Max. Width (A)	Min. Width (A)	Max. Width (A)	Min. Height (B)	Max. Height (B)
OCS2710824AC	24"	28 1/2"	12"	23 1/2"	24 1/16"	25"	27"	32 1/2"
OCS3010824AC	27"	28 1/2"	15"	26 1/2"	27 1/16"	28"	27"	32 1/2"
OCS3310824AC	30"	28 1/2"	18"	29 1/2"	30 1/16"	31"	27"	32 1/2"
OCS3610824AC	33"	28 1/2"	21"	32 1/2"	33 1/16"	34"	27"	32 1/2"
OCS3910824AC	36"	28 1/2"	24"	35 1/2"	36 1/16"	37"	27"	32 1/2"

\*Decreased Appliance Opening Width can vary in 1/16" increments by piecing in frame material.

\*\*Increased Appliance Opening Width can vary in 1/16" increments by cutting out the frame stiles.

\*\*\*Appliance Opening Height could have a variance of 1/16". By changing openings, it may require the door/drawer openings to change.

### Door & Drawer Options

AF	CC	CG	ESMD	GAMD	HC	IFHG	MC	MD	MFO	PRMD	SHMD	SPLITDR	SPLITDRWS	SUMD
	✓		✓	✓		✓		✓	✓	✓	✓			✓

### End Panel Options

AUTH	CSFPE	EXBK <sup>1</sup>	EXDN	FPE	INTGE	IPE
✓		✓				✓

### Custom Modification Options

ADD	SHLF	ADDTK	ADRW	ATTK	BVR	CBO	CCO	CFNTO	CFP	CFRMO	CLIP	CND	CSDGBK	DRWTK <sup>2</sup>	EF	EX	EX_OL	FLUT <sup>3</sup>	FTK	ID	
						✓	✓	✓	✓	✓	✓	✓	✓	✓	✓	✓	✓	✓	✓	✓	✓

IH	IW <sup>4</sup>	MIP	OBRB	PFINBTMB	RD	RECTK	RH	ROSFLUT <sup>3</sup>	RT	SCPDRW	TD	TKP	TVR	VTK	WS	WTCD	WTKCUP	WTR
✓	✓	✓	✓	✓	✓	✓	✓	✓	✓	✓	✓	✓	✓	✓	✓	✓	✓	✓

<sup>1</sup>This modification will allow the end to extend back to a maximum of 30" deep.

<sup>2</sup>Not available on units over 36" wide and only available when used in conjunction with attach toekick modification.

<sup>3</sup>Not available with 6" fluting.

<sup>4</sup>Not available on 39" wide.

# Oven Cabinets

## Description

**NEW** **DOUBLE OVEN TRIMMABLE CABINET, 84", 87", or 90" HIGH, 24" DEEP**

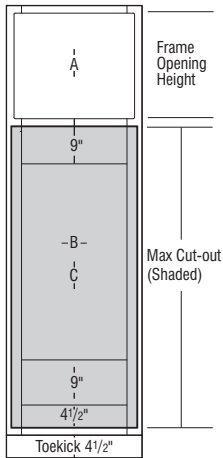
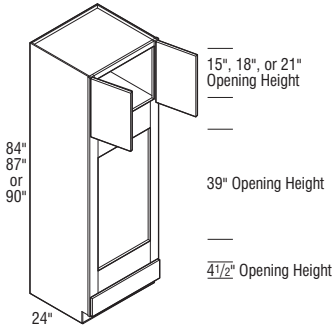

## Model

<b>OCD278424</b>
<b>OCD308424</b>
<b>OCD338424</b>
<b>OCD368424</b>
<b>OCD398424</b>
<b>OCD278724</b>
<b>OCD308724</b>
<b>OCD338724</b>
<b>OCD368724</b>
<b>OCD398724</b>
<b>OCD279024AH</b>
<b>OCD309024AH</b>
<b>OCD339024AH</b>
<b>OCD369024AH</b>
<b>OCD399024AH</b>

- AH represents upper section alignment with doors on 24" or 27" high cabinets.
- 90" high includes one adjustable shelf in upper section.
- For built-in double oven applications, remove drawer as needed.
- All top and bottom cross rails are 1 1/2" wide.
- Cabinet installation kit will not be included when depth is modified.
- A cabinet installation kit will be provided.
- Oven cabinet cut-out is shaded in gray and is cut out on job site.
- Increased Heights modification will increase the height of the upper cabinet section. The bottom section will retain its original height.

	A Frame Opening Height	B Cut-out Width		C Cut-out Height		Door Height (Upper Section) Full Overlay
		Min.	Max.	Min.	Max.	
OCD278424	15"	21"	25 1/2"	39"	60"	17 9/16"
OCD308424	15"	24"	28 1/2"	39"	60"	17 9/16"
OCD338424	15"	27"	31 1/2"	39"	60"	17 9/16"
OCD368424	15"	30"	34 1/2"	39"	60"	17 9/16"
OCD398424	15"	33"	37 1/2"	39"	60"	17 9/16"
OCD278724	18"	21"	25 1/2"	39"	60"	20 9/16"
OCD308724	18"	24"	28 1/2"	39"	60"	20 9/16"
OCD338724	18"	27"	31 1/2"	39"	60"	20 9/16"
OCD368724	18"	30"	34 1/2"	39"	60"	20 9/16"
OCD398724	18"	33"	37 1/2"	39"	60"	20 9/16"
OCD279024AH	21"	21"	25 1/2"	39"	60"	23 9/16"
OCD309024AH	21"	24"	28 1/2"	39"	60"	23 9/16"
OCD339024AH	21"	27"	31 1/2"	39"	60"	23 9/16"
OCD369024AH	21"	30"	34 1/2"	39"	60"	23 9/16"
OCD399024AH	21"	33"	37 1/2"	39"	60"	23 9/16"

Maximum cut-out dimension will allow 1/4" reveal for doors and drawer fronts on full overlay for trim kit face clearance.

### Door & Drawer Options

AF	CC	CG	ESMD	GAMD	HC	IFHG	MC	MD	MFO	PRMD	SHMD	SPLITDR	SPLITDRWS	SUMD
	✓	✓	✓	✓				✓	✓	✓	✓	✓	✓	✓

### End Panel Options

AUTH	CSFPE	EXBK	EXDN	FPE	INTGE	IPE
✓	✓	✓	✓	✓	✓	✓

### Custom Modification Options

ADD	SHLF	ADDTK	ADRW	ATTK	BVR	CBO	CCO	CFNTO	CFP	CFRMO	CLIP	CND	CSDGBK	DRWTK <sup>1</sup>	EF	EX	EX_OL	FLUT <sup>2</sup>	FTK	ID	
							✓	✓	✓	✓	✓	✓	✓	✓	✓	✓	✓	✓	✓	✓	✓

IH	IW <sup>3</sup>	MIP	OBRB	PFINBTMB	RD	RECTK	RH	ROSFLUT	RT	SCPDRW	TD	TKP	TVR	VTK	WS	WTCD	WTKCUP	WTR		
✓	✓	✓	✓	✓	✓	✓	✓	✓	✓	✓	✓	✓	✓	✓	✓	✓	✓	✓	✓	✓

<sup>1</sup>Not available on units over 36" wide.

<sup>2</sup>Not available with 6" fluting.

<sup>3</sup>Only available on 39" wide.

IH/RH availability charts starting on page G•40.  
IW/RW availability charts starting on page G•46.

## Description



**DOUBLE OVEN TRIMMABLE CABINET, 93" or 96" HIGH, 24" DEEP**

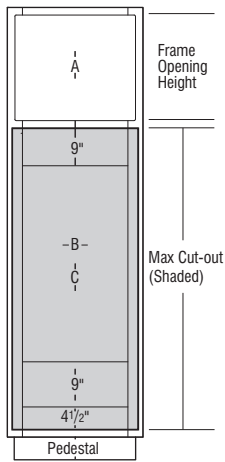
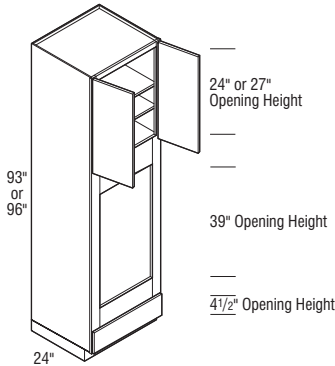

## Model

**OCD279324AH**

**OCD309324AH**

**OCD339324AH**

**OCD369324AH**

**OCD399324AH**

- AH represents upper section alignment with doors on 24" or 27" high cabinets.
- Upper section has one full depth adjustable shelf.

**OCD279624**

**OCD309624**

**OCD339624**

**OCD369624**

**OCD399624**

- Includes two adjustable shelves in upper section.
- Flush toeckick option not available in conjunction with Wide Top Rail unless loose Flush Toeckick is specified.

### Notes below apply to all products in section above:

- Shipped with loose toeckick unless ATTK or Flush Toeckick is specified.
- For built-in double oven applications, remove drawers as needed.
- All top and bottom cross rails are 1 1/2" wide.
- Cabinet installation kit will not be included when depth is modified.
- A cabinet installation kit will be provided.
- Oven cabinet cut-out is shaded in gray and is cut out on job site.
- Increased Heights modification will increase the height of the upper cabinet section. The bottom section will retain its original height.

	A Frame Opening Height	B Cut-out Width		C Cut-out Height		Door Height (Upper Section)
		Min.	Max.	Min.	Max.	Full Overlay
OCD279324AH	24"	21"	25 1/2"	39"	60"	26 9/16"
OCD309324AH	24"	24"	28 1/2"	39"	60"	26 9/16"
OCD339324AH	24"	27"	31 1/2"	39"	60"	26 9/16"
OCD369324AH	24"	30"	34 1/2"	39"	60"	26 9/16"
OCD399324AH	24"	33"	37 1/2"	39"	60"	26 9/16"
OCD279624	27"	21"	25 1/2"	39"	60"	29 9/16"
OCD309624	27"	24"	28 1/2"	39"	60"	29 9/16"
OCD339624	27"	27"	31 1/2"	39"	60"	29 9/16"
OCD369624	27"	30"	34 1/2"	39"	60"	29 9/16"
OCD399624	27"	33"	37 1/2"	39"	60"	29 9/16"

Maximum cut-out dimension will allow 1/4" reveal for doors and drawer fronts on full overlay for trim kit face clearance.

### Door & Drawer Options

AF	CC	CG	ESMD	GAMD	HC	IFHG	MC	MD	MFO	PRMD	SHMD	SPLITDR	SPLITDRWS	SUMD
	✓	✓	✓	✓				✓	✓	✓	✓	✓	✓	✓

### End Panel Options

AUTH	CSFPE	EXBK	EXDN	FPE	INTGE	IPE
✓	✓	✓	✓	✓	✓	✓

### Custom Modification Options

ADD	SHLF	ADDTK	ADRW	ATTK	BVR	CBO	CCO	CFNTO	CFP	CFRMO	CLIP	CND	CSDGBK	DRWTK <sup>1</sup>	EF	EX	EX_OL	FLUT <sup>2</sup>	FTK	ID	
				✓		✓	✓	✓	✓	✓	✓	✓	✓	✓	✓	✓	✓	✓	✓	✓	✓
IH <sup>3</sup>	IW <sup>4</sup>	MIP	OBRB	PFINBTMB	RD	RECTK	RH	ROSFLUT	RT	SCPDRW	TD	TKP	TVR	VTK	WS	WTC4	WTKCUP	WTR			
✓	✓	✓	✓	✓	✓	✓	✓	✓	✓	✓	✓	✓	✓	✓	✓	✓	✓	✓	✓	✓	

<sup>1</sup>Not available on units over 36" wide and only available when used in conjunction with attach toeckick modification.

<sup>2</sup>Not available with 6" fluting.

<sup>3</sup>Not available on 96" high.

<sup>4</sup>Not available on 39" wide.

# Oven Cabinets

## Description

**SINGLE OVEN TRIMMABLE CABINET with DRAWERS, 84", 87", or 90" HIGH, 24" DEEP**

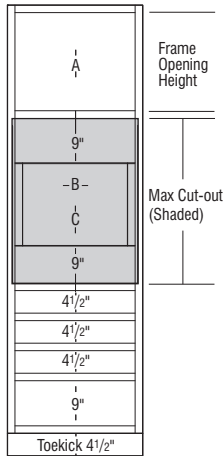
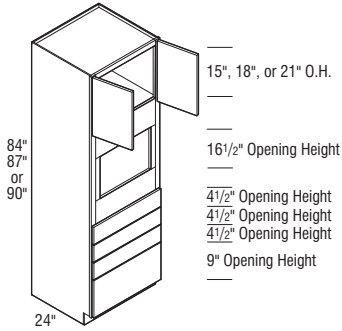

## Model

OCSD278424  
 OCSD308424  
 OCSD338424  
 OCSD368424  
 OCSD398424  
 OCSD278724  
 OCSD308724  
 OCSD338724  
 OCSD368724  
 OCSD398724  
 OCSD279024  
 OCSD309024  
 OCSD339024  
 OCSD369024  
 OCSD399024

- 90" high includes one full depth adjustable shelf in upper section.
- All top and bottom cross rails are 1 1/2" wide.
- Cabinet installation kit will not be included when depth is modified.

	A Frame Opening Height	B Cut-out Width		C Cut-out Height		Door Height (Upper Section)
		Min.	Max.	Min.	Max.	Full Overlay
OCSD278424	15"	21"	25"	16 1/2"	31 1/2"	17 9/16"
OCSD308424	15"	24"	28"	16 1/2"	31 1/2"	17 9/16"
OCSD338424	15"	27"	31"	16 1/2"	31 1/2"	17 9/16"
OCSD368424	15"	30"	34"	16 1/2"	31 1/2"	17 9/16"
OCSD398424	15"	33"	37"	16 1/2"	31 1/2"	17 9/16"
OCSD278724	18"	21"	25"	16 1/2"	31 1/2"	20 9/16"
OCSD308724	18"	24"	28"	16 1/2"	31 1/2"	20 9/16"
OCSD338724	18"	27"	31"	16 1/2"	31 1/2"	20 9/16"
OCSD368724	18"	30"	34"	16 1/2"	31 1/2"	20 9/16"
OCSD398724	18"	33"	37"	16 1/2"	31 1/2"	20 9/16"
OCSD279024	21"	21"	25"	16 1/2"	31 1/2"	23 9/16"
OCSD309024	21"	24"	28"	16 1/2"	31 1/2"	23 9/16"
OCSD339024	21"	27"	31"	16 1/2"	31 1/2"	23 9/16"
OCSD369024	21"	30"	34"	16 1/2"	31 1/2"	23 9/16"
OCSD399024	21"	33"	37"	16 1/2"	31 1/2"	23 9/16"

Maximum cut-out dimension will allow 1/4" reveal for doors and drawer fronts on full overlay for trim kit face clearance.

### Door & Drawer Options

AF	CC	CG	ESMD	GAMD	HC	IFHG	MC	MD	MFO	PRMD	SHMD	SPLITDR	SPLITDRWS	SUMD

### End Panel Options

AUTH	CSFPE	EXBK	EXDN	FPE	INTGE	IPE

### Custom Modification Options

ADD	SHLF	ADDTK	ADRW	ATTK	BVR	CBO	CCO	CFNT0	CFP	CFRMO	CLIP	CND	CSDGBK	DRWTK <sup>1</sup>	EF	EX	EX_OL	FLUT <sup>2</sup>	FTK	ID	
IH	IW <sup>3</sup>	MIP	OBRB	PFINBTMB	RD	RECTK	RH	ROSEFLUT	RT	SCPDRW	TD	TKP	TVR	VTK	WS	WD	WTKCUP	WTR			

<sup>1</sup>Not available on units over 36" wide.

<sup>2</sup>Not available with 6" fluting.

<sup>3</sup>Not available on 39" wide.

IH/RH availability charts starting on page G•40.  
 IW/RW availability charts starting on page G•46.

## Description

### SINGLE OVEN TRIMMABLE CABINET with DRAWERS, 93" or 96" HIGH, 24" DEEP

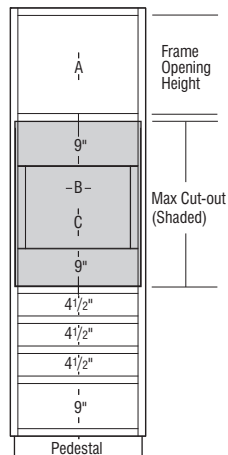
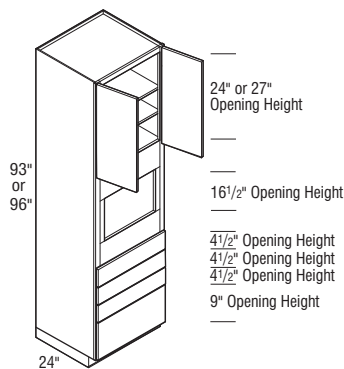

## Model

OCSD279324

OCSD309324

OCSD339324

OCSD369324

OCSD399324

OCSD279624

OCSD309624

OCSD339624

OCSD369624

OCSD399624

- Includes one adjustable shelf in upper section.

- Includes two adjustable shelves in upper section.
- Flush toekick option not available in conjunction with Wide Top Rail unless loose Flush Toekick is specified.

#### Notes below apply to all products in section above:

- Shipped with loose toekick unless ATTK or Flush Toekick is specified.
- All top and bottom cross rails are 1 1/2" wide.
- Cabinet installation kit will not be included when depth is modified.

	A Frame Opening Height	B Cut-out Width		C Cut-out Height		Door Height (Upper Section)
		Min.	Max.	Min.	Max.	Full Overlay
OCSD279324	24"	21"	25"	16 1/2"	31 1/2"	26 9/16"
OCSD309324	24"	24"	28"	16 1/2"	31 1/2"	26 9/16"
OCSD339324	24"	27"	31"	16 1/2"	31 1/2"	26 9/16"
OCSD369324	24"	30"	34"	16 1/2"	31 1/2"	26 9/16"
OCSD399324	24"	33"	37"	16 1/2"	31 1/2"	26 9/16"
OCSD279624	27"	21"	25"	16 1/2"	31 1/2"	29 9/16"
OCSD309624	27"	24"	28"	16 1/2"	31 1/2"	29 9/16"
OCSD339624	27"	27"	31"	16 1/2"	31 1/2"	29 9/16"
OCSD369624	27"	30"	34"	16 1/2"	31 1/2"	29 9/16"
OCSD399624	27"	33"	37"	16 1/2"	31 1/2"	29 9/16"

Maximum cut-out dimension will allow 1/4" reveal for doors and drawer fronts on full overlay for trim kit face clearance.

#### Door & Drawer Options

AF	CC	CG	ESMD	GAMD	HC	IFHG	MC	MD	MFO	PRMD	SHMD	SPLITDR	SPLITDRWS	SUMD
	✓	✓	✓					✓	✓	✓	✓			✓

#### End Panel Options

AUTH	CSFPE	EXBK	EXDN	FPE	INTGE	IPE
✓	✓	✓		✓	✓	

#### Custom Modification Options

ADD_SHLF	ADDTK	ADRW	ATTK	BVR	CBO	CCO	CFNT0	CFP	CFRMO	CLIP	CND	CSDG8K	DRWTK <sup>1</sup>	EF	EX	EX_OL	FLUT <sup>2</sup>	FTK	ID	
	✓	✓	✓	✓	✓	✓	✓	✓	✓	✓	✓	✓	✓	✓	✓	✓	✓	✓	✓	✓

IH	IW	JMP	OBRB	PFINBTMB	RD	RECTK	RH	ROSLUT	RT	SCPDRW	TD	TKP	TVR	VTK	WS	WD	WTKCUP	WTR	
✓	✓	✓	✓	✓	✓	✓	✓	✓	✓	✓	✓	✓	✓	✓	✓	✓	✓	✓	✓

<sup>1</sup>Not available on units over 36" wide and only available when used in conjunction with attach toekick modification.

<sup>2</sup>Not available with 6" fluting.



# Oven Cabinets

## Description

## Model

**BUILT-IN SINGLE OVEN CABINET, 84", 87", or 90" HIGH, 24" DEEP**

**OCS278424AC**

**OCS308424AC**

**OCS338424AC**

**OCS368424AC**

**OCS398424AC**

**OCS278724AC**

**OCS308724AC**

**OCS338724AC**

**OCS368724AC**

**OCS398724AC**

**OCS279024AC**

**OCS309024AC**

**OCS339024AC**

**OCS369024AC**

**OCS399024AC**

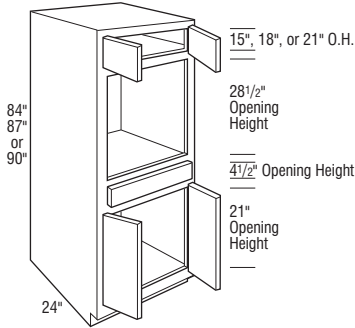

Specify appliance opening dimensions:

**OCS\_AC**  
Single Oven

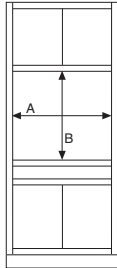

Appliance Opening Dimensions:

A \_\_\_\_\_  
B \_\_\_\_\_

### NOTE:

See chart for specific model appliance opening limitations.

Cabinet appliance openings may vary with modifications (i.e. clipped corner modification reduces maximum cut-out width by 3" per clipped corner).

- Specify cut-out size.
- When Beaded Inset is ordered, the cabinet should be ordered to the appropriate width using the 1/4" width modification instead of using the piece-in or cut-out applications.
- Cabinet openings are subject to change based on the cut-out. Please review the acknowledged drawing.
- 90" high includes one adjustable shelf in upper section.
- Increased Depths available in 1/4" increments from 24 1/4" to 30".
- Reduced Depths available in 1/4" increments from 12" to 23 3/4".
- Ordering Maximum Width Cut-out on cabinet will change end panel thickness from 1/2" to 3/8" for non-flush ends, and from 5/8" to 1/2" for flush ends.

	Standard Appliance Opening		Decreased Appliance Opening Width*		Increased Appliance Opening Width**		Appliance Opening Height***	
	Width (A)	Height (B)	Min. Width (A)	Max. Width (A)	Min. Width (A)	Max. Width (A)	Min. Height (B)	Max. Height (B)
OCS278424AC	24"	28 1/2"	12"	23 1/2"	24 1/16"	25 1/2"	27"	32 1/2"
OCS308424AC	27"	28 1/2"	15"	26 1/2"	27 1/16"	28 1/2"	27"	32 1/2"
OCS338424AC	30"	28 1/2"	18"	29 1/2"	30 1/16"	31 1/2"	27"	32 1/2"
OCS368424AC	33"	28 1/2"	21"	32 1/2"	33 1/16"	34 1/2"	27"	32 1/2"
OCS398424AC	36"	28 1/2"	24"	35 1/2"	36 1/16"	37 1/2"	27"	32 1/2"
OCS278724AC	24"	28 1/2"	12"	23 1/2"	24 1/16"	25 1/2"	27"	32 1/2"
OCS308724AC	27"	28 1/2"	15"	26 1/2"	27 1/16"	28 1/2"	27"	32 1/2"
OCS338724AC	30"	28 1/2"	18"	29 1/2"	30 1/16"	31 1/2"	27"	32 1/2"
OCS368724AC	33"	28 1/2"	21"	32 1/2"	33 1/16"	34 1/2"	27"	32 1/2"
OCS398724AC	36"	28 1/2"	24"	35 1/2"	36 1/16"	37 1/2"	27"	32 1/2"
OCS279024AC	24"	28 1/2"	12"	23 1/2"	24 1/16"	25 1/2"	27"	32 1/2"
OCS309024AC	27"	28 1/2"	15"	26 1/2"	27 1/16"	28 1/2"	27"	32 1/2"
OCS339024AC	30"	28 1/2"	18"	29 1/2"	30 1/16"	31 1/2"	27"	32 1/2"
OCS369024AC	33"	28 1/2"	21"	32 1/2"	33 1/16"	34 1/2"	27"	32 1/2"
OCS399024AC	36"	28 1/2"	24"	35 1/2"	36 1/16"	37 1/2"	27"	32 1/2"

\*Decreased Appliance Opening Width can vary in 1/16" increments by piecing in frame material.

\*\*Increased Appliance Opening Width can vary in 1/16" increments by cutting out the frame stiles.

\*\*\*Appliance Opening Height could have a variance of 1/16". By changing openings, it may require the door/drawer openings to change.

### Door & Drawer Options

AF	CC	CG	ESMD	GAMD	HC	IFHG	MC	MD	MFO	PRMD	SHMD <sup>1</sup>	SPLITDR	SPLITDRWS	SUMD
<input checked="" type="checkbox"/>	<input checked="" type="checkbox"/>	<input checked="" type="checkbox"/>	<input checked="" type="checkbox"/>	<input checked="" type="checkbox"/>	<input checked="" type="checkbox"/>	<input checked="" type="checkbox"/>	<input checked="" type="checkbox"/>	<input checked="" type="checkbox"/>	<input checked="" type="checkbox"/>	<input checked="" type="checkbox"/>	<input checked="" type="checkbox"/>	<input checked="" type="checkbox"/>	<input checked="" type="checkbox"/>	<input checked="" type="checkbox"/>

### End Panel Options

AUTH	CSFPE <sup>2</sup>	EXBK	EXDN	FPE	INTGE <sup>2</sup>	IPE <sup>2</sup>
<input checked="" type="checkbox"/>	<input checked="" type="checkbox"/>	<input checked="" type="checkbox"/>	<input checked="" type="checkbox"/>	<input checked="" type="checkbox"/>	<input checked="" type="checkbox"/>	<input checked="" type="checkbox"/>

### Custom Modification Options

ADD	SHLF	ADDTK	ADRW	ATTK	BVR	CBO	CCO	CFNT0	CFP	CFRMO	CLIP	CND	CSDGBK	DRWTK <sup>3</sup>	EF	EX	EX_OL	FLUT <sup>4</sup>	FTK	ID
<input checked="" type="checkbox"/>	<input checked="" type="checkbox"/>	<input checked="" type="checkbox"/>	<input checked="" type="checkbox"/>	<input checked="" type="checkbox"/>	<input checked="" type="checkbox"/>	<input checked="" type="checkbox"/>	<input checked="" type="checkbox"/>	<input checked="" type="checkbox"/>	<input checked="" type="checkbox"/>	<input checked="" type="checkbox"/>	<input checked="" type="checkbox"/>	<input checked="" type="checkbox"/>	<input checked="" type="checkbox"/>	<input checked="" type="checkbox"/>	<input checked="" type="checkbox"/>	<input checked="" type="checkbox"/>	<input checked="" type="checkbox"/>	<input checked="" type="checkbox"/>	<input checked="" type="checkbox"/>	<input checked="" type="checkbox"/>

IH	IW <sup>5</sup>	IMP	OBRB	PFINBTMB	RD	RECTK	RH	ROSFLUT	RT	SCPDWR	TD	TKP	TVR	VTK	WS	WTCD	WTKCUP	WTR
<input checked="" type="checkbox"/>	<input checked="" type="checkbox"/>	<input checked="" type="checkbox"/>	<input checked="" type="checkbox"/>	<input checked="" type="checkbox"/>	<input checked="" type="checkbox"/>	<input checked="" type="checkbox"/>	<input checked="" type="checkbox"/>	<input checked="" type="checkbox"/>	<input checked="" type="checkbox"/>	<input checked="" type="checkbox"/>	<input checked="" type="checkbox"/>	<input checked="" type="checkbox"/>	<input checked="" type="checkbox"/>	<input checked="" type="checkbox"/>	<input checked="" type="checkbox"/>	<input checked="" type="checkbox"/>	<input checked="" type="checkbox"/>	<input checked="" type="checkbox"/>

<sup>1</sup>Only available on top section.

<sup>2</sup>Not available when cut-out width is greater than standard.

<sup>3</sup>Not available on units over 36" wide.

<sup>4</sup>Not available with 6" fluting.

<sup>5</sup>Not available on 39" wide.

IH/RH availability charts starting on page G-40.  
IW/RW availability charts starting on page G-46.

## Description

### BUILT-IN SINGLE OVEN CABINET, 93" or 96" HIGH, 24" DEEP

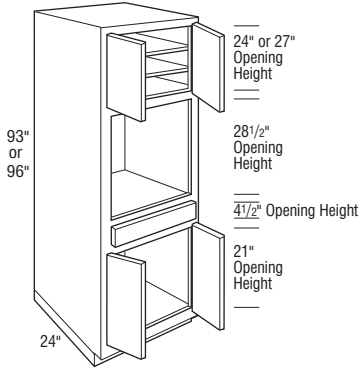

Specify appliance opening dimensions:

### OCS\_ \_AC Single Oven

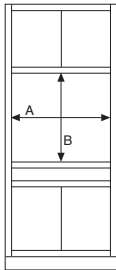

Appliance Opening Dimensions:

A \_\_\_\_\_  
B \_\_\_\_\_

### NOTE:

See chart for specific model appliance opening limitations.

Cabinet appliance openings may vary with modifications (i.e. clipped corner modification reduces maximum cut-out width by 3" per clipped corner).

## Model

OCS279324AC

OCS309324AC

OCS339324AC

OCS369324AC

OCS399324AC

- Includes one adjustable shelf in upper section.

OCS279624AC

OCS309624AC

OCS339624AC

OCS369624AC

OCS399624AC

- Includes two adjustable shelves in upper section.
- Flush ToeKick modification not available in conjunction with Wide Top Rail unless loose Flush ToeKick is specified.

Notes below apply to all products in section above:

- Specify cut-out size.
- When Beaded Inset is ordered, the cabinet should be ordered to the appropriate width using the 1/4" width modification instead of using the piece-in or cut-out applications.
- Cabinet openings are subject to change based on the cut-out. Please review the acknowledged drawing.
- Shipped with loose toe space unless Attach ToeKick or Flush ToeKick is specified.
- Increased Depths available in 1/4" increments from 24 1/4" to 30".
- Reduced Depths available in 1/4" increments from 12" to 23 3/4".
- Ordering Maximum Width Cut-out on cabinet will change end panel thickness from 1/2" to 3/8" for non-flush ends, and from 5/8" to 1/2" for flush ends.

	Standard Appliance Opening		Decreased Appliance Opening Width*		Increased Appliance Opening Width**		Appliance Opening Height***	
	Width (A)	Height (B)	Min. Width (A)	Max. Width (A)	Min. Width (A)	Max. Width (A)	Min. Height (B)	Max. Height (B)
OCS279324AC	24"	28 1/2"	12"	23 1/2"	24 1/16"	25 1/2"	27"	32 1/2"
OCS309324AC	27"	28 1/2"	15"	26 1/2"	27 1/16"	28 1/2"	27"	32 1/2"
OCS339324AC	30"	28 1/2"	18"	29 1/2"	30 1/16"	31 1/2"	27"	32 1/2"
OCS369324AC	33"	28 1/2"	21"	32 1/2"	33 1/16"	34 1/2"	27"	32 1/2"
OCS399324AC	36"	28 1/2"	24"	35 1/2"	36 1/16"	37 1/2"	27"	32 1/2"
OCS279624AC	24"	28 1/2"	12"	23 1/2"	24 1/16"	25 1/2"	27"	32 1/2"
OCS309624AC	27"	28 1/2"	15"	26 1/2"	27 1/16"	28 1/2"	27"	32 1/2"
OCS339624AC	30"	28 1/2"	18"	29 1/2"	30 1/16"	31 1/2"	27"	32 1/2"
OCS369624AC	33"	28 1/2"	21"	32 1/2"	33 1/16"	34 1/2"	27"	32 1/2"
OCS399624AC	36"	28 1/2"	24"	35 1/2"	36 1/16"	37 1/2"	27"	32 1/2"

\*Decreased Appliance Opening Width can vary in 1/16" increments by piecing in frame material.

\*\*Increased Appliance Opening Width can vary in 1/16" increments by cutting out the frame stiles.

\*\*\*Appliance Opening Height could have a variance of 1/16". By changing openings, it may require the door/drawer openings to change.

### Door & Drawer Options

AF	CC	CG	ESMD	GAMD	HC	IFHG	MC	MD	MFO	PRMD	SHMD <sup>1</sup>	SPLITDR	SPLITDRWS	SUMD

### End Panel Options

AUTH	CSFPE <sup>2</sup>	EXBK	EXDN	FPE	INTGE <sup>2</sup>	IPE <sup>2</sup>

### Custom Modification Options

ADD_SHLF	ADTK	ADRW	ATTK	BVR	CBO	CCO	CFNTD	CFP	CFRMO	CLIP	CND	CSDGBK	DRWTK <sup>3</sup>	EF	EX	EX_OL	FLUT <sup>4</sup>	FTK	ID

IH	IW <sup>5</sup>	MIP	OBRB	PFINBTMB	RD	RECTK	RH	ROSLUT	RT	SCPRDW	TD	TKP	TVR	VTK	WS	WTCD	WTKCUP	WTR

<sup>1</sup>Only available on top section.

<sup>2</sup>Not available when cut-out width is greater than standard.

<sup>3</sup>Not available on units over 36" wide and only available when used in conjunction with attach toeKick modification.

<sup>4</sup>Not available with 6" fluting.

<sup>5</sup>Not available on 39" wide.

# Oven Cabinets

## Description

**NEW** BUILT-IN SINGLE OVEN CABINET,  
102" HIGH, 24" DEEP

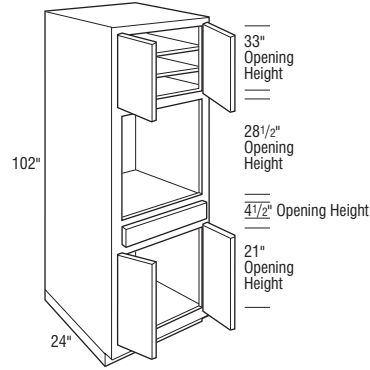

Specify appliance opening dimensions:

**OCS\_AC**  
Single Oven

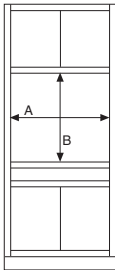

Appliance Opening Dimensions:

A \_\_\_\_\_  
B \_\_\_\_\_

### NOTE:

See chart for specific model appliance opening limitations.

Cabinet appliance openings may vary with modifications (i.e. clipped corner modification reduces maximum cut-out width by 3" per clipped corner).

## Model

OCS2710224AC

OCS3010224AC

OCS3310224AC

OCS3610224AC

OCS3910224AC

- Specify cut-out size.
- When Beaded Inset is ordered, the cabinet should be ordered to the appropriate width using the 1/4" width modification instead of using the piece-in or cut-out applications.
- Cabinet openings are subject to change based on the cut-out. Please review the acknowledged drawing.
- Two adjustable shelves in upper section.
- Shipped with loose toe space unless Attach Toekick or Flush Toekick is specified.
- Increased Depths available in 1/4" increments from 24 1/4" to 26".
- Reduced Depths available in 1/4" increments from 12" to 23 3/4".
- Finish Flushed Ends standard.
- Available in Cherry and Maple only.

	Standard Appliance Opening		Decreased Appliance Opening Width*		Increased Appliance Opening Width**		Appliance Opening Height***	
	Width (A)	Height (B)	Min. Width (A)	Max. Width (A)	Min. Width (A)	Max. Width (A)	Min. Height (B)	Max. Height (B)
OCS2710224AC	24"	28 1/2"	12"	23 1/2"	24 1/16"	25"	27"	32 1/2"
OCS3010224AC	27"	28 1/2"	15"	26 1/2"	27 1/16"	28"	27"	32 1/2"
OCS3310224AC	30"	28 1/2"	18"	29 1/2"	30 1/16"	31"	27"	32 1/2"
OCS3610224AC	33"	28 1/2"	21"	32 1/2"	33 1/16"	34"	27"	32 1/2"
OCS3910224AC	36"	28 1/2"	24"	35 1/2"	36 1/16"	37"	27"	32 1/2"

\*Decreased Appliance Opening Width can vary in 1/16" increments by piecing in frame material.

\*\*Increased Appliance Opening Width can vary in 1/16" increments by cutting out the frame stiles.

\*\*\*Appliance Opening Height could have a variance of 1/16". By changing openings, it may require the door/drawer openings to change.

### Door & Drawer Options

AF	CC	CG	ESMD	GAMD	HC	IFHG	MC	MD	MFO	PRMD	SHMD <sup>1</sup>	SPLITDR	SPLITDRWS	SUMD
<input checked="" type="checkbox"/>	<input checked="" type="checkbox"/>	<input checked="" type="checkbox"/>	<input checked="" type="checkbox"/>	<input checked="" type="checkbox"/>	<input checked="" type="checkbox"/>	<input checked="" type="checkbox"/>	<input checked="" type="checkbox"/>	<input checked="" type="checkbox"/>	<input checked="" type="checkbox"/>	<input checked="" type="checkbox"/>	<input checked="" type="checkbox"/>	<input checked="" type="checkbox"/>	<input checked="" type="checkbox"/>	<input checked="" type="checkbox"/>

### End Panel Options

AUTH	CSFPE	EXBK <sup>2</sup>	EXDN	FPE	INTGE	IPE
<input checked="" type="checkbox"/>	<input checked="" type="checkbox"/>	<input checked="" type="checkbox"/>	<input checked="" type="checkbox"/>	<input checked="" type="checkbox"/>	<input checked="" type="checkbox"/>	<input checked="" type="checkbox"/>

### Custom Modification Options

ADD_SHLF	ADDTK	ADRW	ATTK	BVR	CBO	CCO	CFNT0	CFP	CFRMO	CLIP	CND	CSDGBK	DRWTK <sup>3</sup>	EF	EX	EX_OL	FLUT <sup>4</sup>	FTK	ID
<input checked="" type="checkbox"/>	<input checked="" type="checkbox"/>	<input checked="" type="checkbox"/>	<input checked="" type="checkbox"/>	<input checked="" type="checkbox"/>	<input checked="" type="checkbox"/>	<input checked="" type="checkbox"/>	<input checked="" type="checkbox"/>	<input checked="" type="checkbox"/>	<input checked="" type="checkbox"/>	<input checked="" type="checkbox"/>	<input checked="" type="checkbox"/>	<input checked="" type="checkbox"/>	<input checked="" type="checkbox"/>	<input checked="" type="checkbox"/>	<input checked="" type="checkbox"/>	<input checked="" type="checkbox"/>	<input checked="" type="checkbox"/>	<input checked="" type="checkbox"/>	<input checked="" type="checkbox"/>

IH	IW <sup>5</sup>	MIP	OBRB	PFINBTMB	RD	RECTK	RH	ROSFLUT <sup>4</sup>	RT	SCPDRW	TD	TKP	TVR	VTK	WS	WTCD	WTKCUP	WTR
<input checked="" type="checkbox"/>	<input checked="" type="checkbox"/>	<input checked="" type="checkbox"/>	<input checked="" type="checkbox"/>	<input checked="" type="checkbox"/>	<input checked="" type="checkbox"/>	<input checked="" type="checkbox"/>	<input checked="" type="checkbox"/>	<input checked="" type="checkbox"/>	<input checked="" type="checkbox"/>	<input checked="" type="checkbox"/>	<input checked="" type="checkbox"/>	<input checked="" type="checkbox"/>	<input checked="" type="checkbox"/>	<input checked="" type="checkbox"/>	<input checked="" type="checkbox"/>	<input checked="" type="checkbox"/>	<input checked="" type="checkbox"/>	<input checked="" type="checkbox"/>

<sup>1</sup>Only available on top section.

<sup>2</sup>This modification will allow the end to extend back to a maximum of 30" deep.

<sup>3</sup>Not available on units over 36" wide and only available when used in conjunction with attach toekick modification.

<sup>4</sup>Not available with 6" fluting.

<sup>5</sup>Not available on 39" wide.

IH/RH availability charts starting on page G•40.  
IW/RW availability charts starting on page G•46.

## Description



### BUILT-IN SINGLE OVEN CABINET, 108" HIGH, 24" DEEP

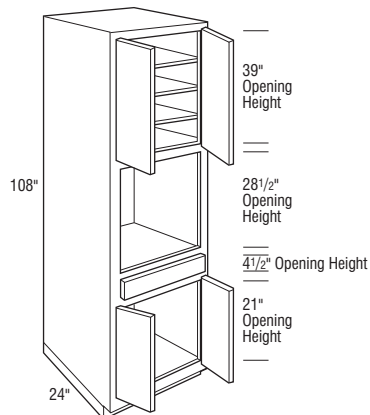

Specify appliance opening dimensions:

### OCS\_\_AC Single Oven

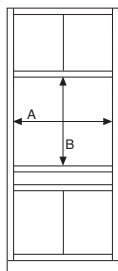

Appliance Opening Dimensions:

A \_\_\_\_\_  
B \_\_\_\_\_

### NOTE:

See chart for specific model appliance opening limitations.

Cabinet appliance openings may vary with modifications (i.e. clipped corner modification reduces maximum cut-out width by 3" per clipped corner).

## Model

OCS2710824AC

OCS3010824AC

OCS3310824AC

OCS3610824AC

OCS3910824AC

- Specify cut-out size.
- When Beaded Inset is ordered, the cabinet should be ordered to the appropriate width using the 1/4" width modification instead of using the piece-in or cut-out applications.
- Cabinet openings are subject to change based on the cut-out. Please review the acknowledged drawing.
- Three adjustable shelves in upper section.
- Shipped with loose toe space unless Attach Toekick or Flush Toekick is specified.
- Increased Depths available in 1/4" increments from 24 1/4" to 26".
- Reduced Depths available in 1/4" increments from 12" to 23 3/4".
- Finish Flushed Ends standard.
- Available in Cherry and Maple only.

	Standard Appliance Opening		Decreased Appliance Opening Width*		Increased Appliance Opening Width**		Appliance Opening Height***	
	Width (A)	Height (B)	Min. Width (A)	Max. Width (A)	Min. Width (A)	Max. Width (A)	Min. Height (B)	Max. Height (B)
OCS2710824AC	24"	28 1/2"	12"	23 1/2"	24 1/16"	25"	27"	32 1/2"
OCS3010824AC	27"	28 1/2"	15"	26 1/2"	27 1/16"	28"	27"	32 1/2"
OCS3310824AC	30"	28 1/2"	18"	29 1/2"	30 1/16"	31"	27"	32 1/2"
OCS3610824AC	33"	28 1/2"	21"	32 1/2"	33 1/16"	34"	27"	32 1/2"
OCS3910824AC	36"	28 1/2"	24"	35 1/2"	36 1/16"	37"	27"	32 1/2"

\*Decreased Appliance Opening Width can vary in 1/16" increments by piecing in frame material.

\*\*Increased Appliance Opening Width can vary in 1/16" increments by cutting out the frame stiles.

\*\*\*Appliance Opening Height could have a variance of 1/16". By changing openings, it may require the door/drawer openings to change.

### Door & Drawer Options

AF	CC	CG	ESMD	GAMD	HC	IFHG	MC	MD	MFO	PRMD	SHMD <sup>1</sup>	SPLITDR	SPLITDRWS	SUMD
<input checked="" type="checkbox"/>	<input checked="" type="checkbox"/>	<input checked="" type="checkbox"/>	<input checked="" type="checkbox"/>	<input checked="" type="checkbox"/>	<input checked="" type="checkbox"/>	<input checked="" type="checkbox"/>	<input checked="" type="checkbox"/>	<input checked="" type="checkbox"/>	<input checked="" type="checkbox"/>	<input checked="" type="checkbox"/>	<input checked="" type="checkbox"/>	<input checked="" type="checkbox"/>	<input checked="" type="checkbox"/>	<input checked="" type="checkbox"/>

### End Panel Options

AUTH	CSFPE	EXBK <sup>2</sup>	EXDN	FPE	INTGE	IPE
<input checked="" type="checkbox"/>	<input checked="" type="checkbox"/>	<input checked="" type="checkbox"/>	<input checked="" type="checkbox"/>	<input checked="" type="checkbox"/>	<input checked="" type="checkbox"/>	<input checked="" type="checkbox"/>

### Custom Modification Options

ADD	SHLF	ADDTK	ADRW	ATTK	BVR	CBO	CCO	CFNTO	CFP	CFRMO	CLUP	CND	CSDGBK	DRWTK <sup>3</sup>	EF	EX	EX_OL	FLUT <sup>4</sup>	FTK	ID
<input checked="" type="checkbox"/>	<input checked="" type="checkbox"/>	<input checked="" type="checkbox"/>	<input checked="" type="checkbox"/>	<input checked="" type="checkbox"/>	<input checked="" type="checkbox"/>	<input checked="" type="checkbox"/>	<input checked="" type="checkbox"/>	<input checked="" type="checkbox"/>	<input checked="" type="checkbox"/>	<input checked="" type="checkbox"/>	<input checked="" type="checkbox"/>	<input checked="" type="checkbox"/>	<input checked="" type="checkbox"/>	<input checked="" type="checkbox"/>	<input checked="" type="checkbox"/>	<input checked="" type="checkbox"/>	<input checked="" type="checkbox"/>	<input checked="" type="checkbox"/>	<input checked="" type="checkbox"/>	<input checked="" type="checkbox"/>

IH	IW <sup>5</sup>	MIP	OBRB	PFINBTMB	RD	RECTK	RH	ROSLUT <sup>4</sup>	RT	SCPDRW	TD	TKP	TVR	VTK	WS	WTCD	WTKCUP	WTR
<input checked="" type="checkbox"/>	<input checked="" type="checkbox"/>	<input checked="" type="checkbox"/>	<input checked="" type="checkbox"/>	<input checked="" type="checkbox"/>	<input checked="" type="checkbox"/>	<input checked="" type="checkbox"/>	<input checked="" type="checkbox"/>	<input checked="" type="checkbox"/>	<input checked="" type="checkbox"/>	<input checked="" type="checkbox"/>	<input checked="" type="checkbox"/>	<input checked="" type="checkbox"/>	<input checked="" type="checkbox"/>	<input checked="" type="checkbox"/>	<input checked="" type="checkbox"/>	<input checked="" type="checkbox"/>	<input checked="" type="checkbox"/>	<input checked="" type="checkbox"/>

<sup>1</sup>Only available on top section.

<sup>2</sup>This modification will allow the end to extend back to a maximum of 30" deep.

<sup>3</sup>Not available on units over 36" wide and only available when used in conjunction with attach toekick modification.

<sup>4</sup>Not available with 6" fluting.

<sup>5</sup>Not available on 39" wide.

# Oven Cabinets

## Description



**SINGLE OVEN TRIMMABLE CABINET, 84", 87", or 90" HIGH, 24" DEEP**

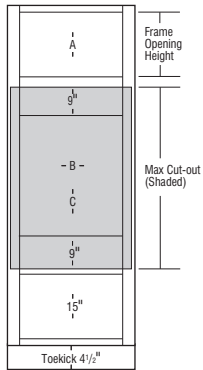
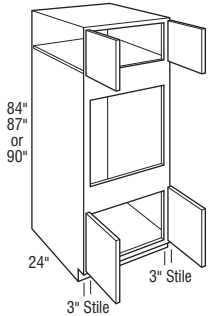

## Model

<b>OCS278424</b>
<b>OCS308424</b>
<b>OCS338424</b>
<b>OCS368424</b>
<b>OCS398424</b>
<b>OCS278724</b>
<b>OCS308724</b>
<b>OCS338724</b>
<b>OCS368724</b>
<b>OCS398724</b>
<b>OCS279024AH</b>
<b>OCS309024AH</b>
<b>OCS339024AH</b>
<b>OCS369024AH</b>
<b>OCS399024AH</b>

- AH represents upper section alignment with doors on 24" or 27" high cabinets.
- 90" high includes one adjustable shelf in upper section.
- All top and bottom cross rails are 1 1/2" wide.
- Cabinet installation kit will not be included when depth is modified.
- A cabinet installation kit will be provided.
- Oven cabinet cut-out is shaded in gray and is cut out on job site.
- Increased Heights modification will increase the height of the upper cabinet section. The bottom section will retain its original height.

	A Frame Opening Height	B Cut-out Width		C Cut-out Height		Door Height (Upper Section) Full Overlay
		Min.	Max.	Min.	Max.	
OCS278424	15"	21"	25 1/2"	28 1/2"	43 1/2"	17 1/2"
OCS308424	15"	24"	28 1/2"	28 1/2"	43 1/2"	17 1/2"
OCS338424	15"	27"	31 1/2"	28 1/2"	43 1/2"	17 1/2"
OCS368424	15"	30"	34 1/2"	28 1/2"	43 1/2"	17 1/2"
OCS398424	15"	33"	37 1/2"	28 1/2"	43 1/2"	17 1/2"
OCS278724	18"	21"	25 1/2"	28 1/2"	43 1/2"	20 1/2"
OCS308724	18"	24"	28 1/2"	28 1/2"	43 1/2"	20 1/2"
OCS338724	18"	27"	31 1/2"	28 1/2"	43 1/2"	20 1/2"
OCS368724	18"	30"	34 1/2"	28 1/2"	43 1/2"	20 1/2"
OCS398724	18"	33"	37 1/2"	28 1/2"	43 1/2"	20 1/2"
OCS279024AH	21"	21"	25 1/2"	28 1/2"	43 1/2"	23 1/2"
OCS309024AH	21"	24"	28 1/2"	28 1/2"	43 1/2"	23 1/2"
OCS339024AH	21"	27"	31 1/2"	28 1/2"	43 1/2"	23 1/2"
OCS369024AH	21"	30"	34 1/2"	28 1/2"	43 1/2"	23 1/2"
OCS399024AH	21"	33"	37 1/2"	28 1/2"	43 1/2"	23 1/2"

Maximum cut-out dimension will allow 1/4" reveal for doors and drawer fronts on full overlay for trim kit face clearance.

### Door & Drawer Options

AF	CC	CG	ESMD	GAMD	HC	IFHG	MC	MD	MFO	PRMD	SHMD	SPLITDR	SPLITDRWS	SUMD
✓	✓	✓	✓	✓	✓	✓	✓	✓	✓	✓	✓	✓	✓	✓

### End Panel Options

AUTH	CSFPE	EXBK	EXDN	FPE	INTGE	IPE
✓	✓	✓	✓	✓	✓	✓

### Custom Modification Options

ADD	SHLF	ADTK	ADRW	ATTK	BVR	CBO	CCO	CFNTD	CFP	CFRMO	CLIP	CND	CSDGBK	DRWK <sup>1</sup>	EF	EX	EX_OL	FLUT <sup>2</sup>	FTK	ID	
✓	✓	✓	✓	✓	✓	✓	✓	✓	✓	✓	✓	✓	✓	✓	✓	✓	✓	✓	✓	✓	✓

IH	IW <sup>3</sup>	MIP	OBRB	PFINBTMB	RD	RECTK	RH	ROSFLUT	RT	SCPDRW	TD	TKP	TVR	VTK	WS	WTCD	WTKCUP	WTR	
✓	✓	✓	✓	✓	✓	✓	✓	✓	✓	✓	✓	✓	✓	✓	✓	✓	✓	✓	✓

<sup>1</sup>Not available on units over 36" wide.

<sup>2</sup>Not available with 6" fluting.

<sup>3</sup>Not available on 39" wide.

IH/RH availability charts starting on page G•40.  
IW/RW availability charts starting on page G•46.

## Description



**SINGLE OVEN TRIMMABLE CABINET, 93" or 96" HIGH, 24" DEEP**

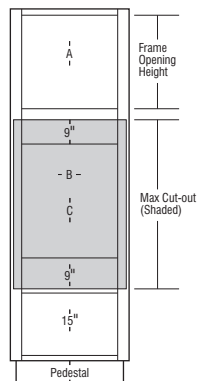
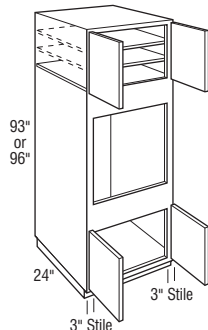

## Model

OCS279324AH

OCS309324AH

OCS339324AH

OCS369324AH

OCS399324AH

- AH represents upper section alignment with doors on 24" or 27" high cabinets.
- Includes one adjustable shelf in upper section.

OCS279624

OCS309624

OCS339624

OCS369624

OCS399624

- Includes two adjustable shelves in upper section.
- Flush toeckick option not available in conjunction with Wide Top Rail unless loose Flush Toeckick is specified.

### Notes below apply to all products in section above:

- Shipped with loose toeckick unless ATTK or Flush Toeckick is specified.
- All top and bottom cross rails are 1 1/2" wide.
- Cabinet installation kit will not be included when depth is modified.
- A cabinet installation kit will be provided.
- Oven cabinet cut-out is shaded in gray and is cut out on job site.
- Increased Heights modification will increase the height of the upper cabinet section. The bottom section will retain its original height.

	A Frame Opening Height	B Cut-out Width		C Cut-out Height		Door Height (Upper Section) Full Overlay
		Min.	Max.	Min.	Max.	
OCS279324AH	24"	21"	25 1/2"	28 1/2"	43 1/2"	26 1/2"
OCS309324AH	24"	24"	28 1/2"	28 1/2"	43 1/2"	26 1/2"
OCS339324AH	24"	27"	31 1/2"	28 1/2"	43 1/2"	26 1/2"
OCS369324AH	24"	30"	34 1/2"	28 1/2"	43 1/2"	26 1/2"
OCS399324AH	24"	33"	37 1/2"	28 1/2"	43 1/2"	26 1/2"
OCS279624	27"	21"	25 1/2"	28 1/2"	43 1/2"	29 1/2"
OCS309624	27"	24"	28 1/2"	28 1/2"	43 1/2"	29 1/2"
OCS339624	27"	27"	31 1/2"	28 1/2"	43 1/2"	29 1/2"
OCS369624	27"	30"	34 1/2"	28 1/2"	43 1/2"	29 1/2"
OCS399624	27"	33"	37 1/2"	28 1/2"	43 1/2"	29 1/2"

Maximum cut-out dimension will allow 1/4" reveal for doors and drawer fronts on full overlay for trim kit face clearance.

### Door & Drawer Options

AF	CC	CG	ESMD	GAMD	HC	IFHG	MC	MD	MFO	PRMD	SHMD	SPLITDR	SPLITDRWS	SUMD
	✓	✓	✓	✓				✓	✓	✓	✓	✓	✓	✓

### End Panel Options

AUTH	CSFPE	EXBK	EXDN	FPE	INTGE	IPE
✓	✓	✓	✓	✓	✓	✓

### Custom Modification Options

ADD_SHLF	ADDTK	ADRW	ATTK	BVR	CBO	CCO	CFNTO	CFP	CFRMO	CLIP	CND	CSDGBK	DRWTK <sup>1</sup>	EF	EX	EX_OL	FLUT <sup>2</sup>	FTK	ID	
			✓	✓	✓	✓	✓	✓	✓	✓	✓	✓	✓	✓	✓	✓	✓	✓	✓	✓

IH <sup>3</sup>	IW <sup>4</sup>	MIP	OBRB	PFINBTMB	RD	RECTK	RH	ROSFLUT	RT	SCPDRW	TD	TKP	TVR	VTK	WS	WTCD	WTKCUP	WTR	
✓	✓	✓	✓	✓	✓	✓	✓	✓	✓	✓	✓	✓	✓	✓	✓	✓	✓	✓	✓

<sup>1</sup>Not available on units over 36" wide and only used in conjunction with attach toeckick modification.

<sup>2</sup>Not available with 6" fluting.

<sup>3</sup>Not available on 96" high.

<sup>4</sup>Not available on 39" wide.

# Oven Cabinets

## Description



**SINGLE OVEN TRIMMABLE CABINET with DEEP DRAWER, 84", 87", or 90" HIGH, 24" DEEP**

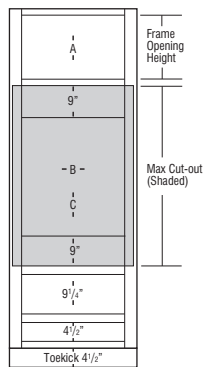
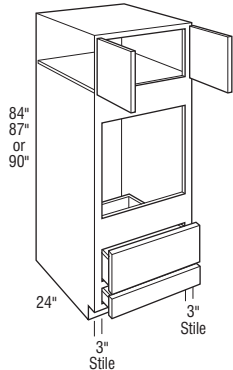

## Model

OCS278424DD

OCS308424DD

OCS338424DD

OCS368424DD

OCS398424DD

OCS278724DD

OCS308724DD

OCS338724DD

OCS368724DD

OCS398724DD

OCS279024DDAH

OCS309024DDAH

OCS339024DDAH

OCS369024DDAH

OCS399024DDAH

- AH represents upper section alignment with doors on 24" or 27" high cabinets.
- 90" high includes one adjustable shelf in upper section.
- All top and bottom cross rails are 1 1/2" wide.
- For built-in appliance support, OCINSTALLKIT is included in 24" deep oven cabinets.
- Oven cabinet cut-out is shaded in gray and is cut out on job site.
- Cabinet installation kit will not be included when depth is modified.
- A cabinet installation kit will be provided.
- Increased Heights modification will increase the height of the upper cabinet section. The bottom section will retain its original height.
- Reduced Depths available in 1/4" increments from 12" to 23 3/4".

	A Frame Opening Height	B Cut-out Width		C Cut-out Height		Door Height (Upper Section)
		Min.	Max.	Min.	Max.	Full Overlay
OCS278424DD	15"	21"	25 1/2"	27 3/4"	42 3/4"	17 1/2"
OCS308424DD	15"	24"	28 1/2"	27 3/4"	42 3/4"	17 1/2"
OCS338424DD	15"	27"	31 1/2"	27 3/4"	42 3/4"	17 1/2"
OCS368424DD	15"	30"	34 1/2"	27 3/4"	42 3/4"	17 1/2"
OCS398424DD	15"	33"	37 1/2"	27 3/4"	42 3/4"	17 1/2"
OCS278724DD	18"	21"	25 1/2"	27 3/4"	42 3/4"	20 1/2"
OCS308724DD	18"	24"	28 1/2"	27 3/4"	42 3/4"	20 1/2"
OCS338724DD	18"	27"	31 1/2"	27 3/4"	42 3/4"	20 1/2"
OCS368724DD	18"	30"	34 1/2"	27 3/4"	42 3/4"	20 1/2"
OCS398724DD	18"	33"	37 1/2"	27 3/4"	42 3/4"	20 1/2"
OCS279024DDAH	21"	21"	25 1/2"	27 3/4"	42 3/4"	23 1/2"
OCS309024DDAH	21"	24"	28 1/2"	27 3/4"	42 3/4"	23 1/2"
OCS339024DDAH	21"	27"	31 1/2"	27 3/4"	42 3/4"	23 1/2"
OCS369024DDAH	21"	30"	34 1/2"	27 3/4"	42 3/4"	23 1/2"
OCS399024DDAH	21"	33"	37 1/2"	27 3/4"	42 3/4"	23 1/2"

Maximum cut-out dimension will allow 1/4" reveal for doors and drawer fronts for trim kit face clearance.

### Door & Drawer Options

AF	CC	CG	ESMD	GAMD	HC	IFHG	MC	MD	MFO	PRMD	SHMD	SPLITDR	SPLITDRWS	SUMD
	✓	✓	✓	✓				✓	✓	✓	✓	✓	✓	✓

### End Panel Options

AUTH	CSFPE	EXBK	EXDN	FPE	INTGE	IPE
✓	✓	✓	✓	✓	✓	✓

### Custom Modification Options

ADD	SHLF	ADDTK	ADRW	ATTK	BVR	CBO	CCO	CFNTD	CFP	CFRMO	CLIP	CND	CSDGBK	DRWTK <sup>1</sup>	EF	EX	EX_OL	FLUT <sup>2</sup>	FTK	ID	

IH	IW <sup>3</sup>	MIP	OBRB	PFINBTMB	RD	RECTK <sup>4</sup>	RH	ROSLUT	RT	SCPDRW	TD	TKP <sup>4</sup>	TVR	VTK <sup>4</sup>	WS	WTCD	WTKCUP	WTR		
✓	✓	✓	✓	✓	✓	✓	✓	✓	✓	✓	✓	✓	✓	✓	✓	✓	✓	✓	✓	✓

<sup>1</sup>Not available on units over 36" wide.

<sup>2</sup>6" Fluting not available on 24" or 27" wide. Not available with 6" fluting both.

<sup>3</sup>Not available on 39" wide.

<sup>4</sup>Not available on 33" or 36" wide.

IH/RH availability charts starting on page G•40.  
IW/RW availability charts starting on page G•46.

## Description



**SINGLE OVEN TRIMMABLE CABINET with DEEP DRAWER, 93" or 96" HIGH, 24" DEEP**

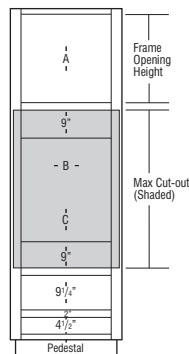
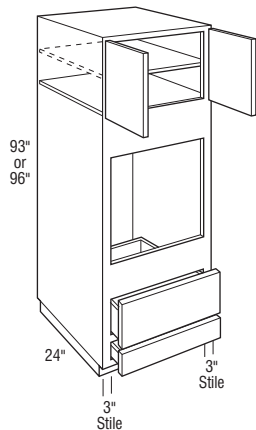

## Model

OCS279324DDAH

OCS309324DDAH

OCS339324DDAH

OCS369324DDAH

OCS399324DDAH

- AH represents upper section alignment with doors on 24" or 27" high cabinets.
- Includes one adjustable shelf in upper section.

OCS279624DD

OCS309624DD

OCS339624DD

OCS369624DD

OCS399624DD

- Includes two adjustable shelves in upper section.
- Flush toekick option not available in conjunction with Wide Top Rail unless loose Flush Toekick is specified.

### Notes below apply to all products in section above:

- Shipped with loose toekick unless ATTK or Flush Toekick is specified.
- All top and bottom cross rails are 1 1/2" wide.
- For built-in appliance support, OCINSTALLKIT is included in 24" deep oven cabinets.
- Oven cabinet cut-out is shaded in gray and is cut out on job site.
- Cabinet installation kit will not be included when depth is modified.
- A cabinet installation kit will be provided.
- Increased Heights modification will increase the height of the upper cabinet section. The bottom section will retain its original height.
- Reduced Depths available in 1/4" increments from 12" to 23 3/4".

	A Frame Opening Height	B Cut-out Width		C Cut-out Height		Door Height (Upper Section)
		Min.	Max.	Min.	Max.	Full Overlay
OCS279324DDAH	24"	21"	25 1/2"	27 3/4"	42 3/4"	26 1/2"
OCS309324DDAH	24"	24"	28 1/2"	27 3/4"	42 3/4"	26 1/2"
OCS339324DDAH	24"	27"	31 1/2"	27 3/4"	42 3/4"	26 1/2"
OCS369324DDAH	24"	30"	34 1/2"	27 3/4"	42 3/4"	26 1/2"
OCS399324DDAH	24"	33"	37 1/2"	27 3/4"	42 3/4"	26 1/2"
OCS279624DD	27"	21"	25 1/2"	27 3/4"	42 3/4"	29 1/2"
OCS309624DD	27"	24"	28 1/2"	27 3/4"	42 3/4"	29 1/2"
OCS339624DD	27"	27"	31 1/2"	27 3/4"	42 3/4"	29 1/2"
OCS369624DD	27"	30"	34 1/2"	27 3/4"	42 3/4"	29 1/2"
OCS399624DD	27"	33"	37 1/2"	27 3/4"	42 3/4"	29 1/2"

Maximum cut-out dimension will allow 1/4" reveal for doors and drawer fronts for trim kit face clearance.

### Door & Drawer Options

AF	CC	CG	ESMD	GAMD	HC	IFHG	MC	MD	MFO	PRMD	SHMD	SPLITDR	SPLITDRWS	SUMD
	✓	✓	✓	✓					✓	✓	✓	✓	✓	✓

### End Panel Options

AUTH	CSFPE	EXBK	EXDN	FPE	INTGE	IPE
✓	✓	✓	✓	✓	✓	✓

### Custom Modification Options

ADD_SHLF	ADDTK	ADRW	ATTK	BVR	CBO	CCO	CFNTO	CFP	CFRMO	CLIP	CND	CSDGBK	DRWTK <sup>1</sup>	EF	EX	EX_OL	FLUT <sup>2</sup>	FTK	ID	
			✓		✓	✓	✓	✓	✓	✓	✓	✓	✓	✓	✓	✓	✓	✓	✓	✓

IH <sup>3</sup>	IW <sup>4</sup>	MIP	OBRB	PFINBTMB	RD	RECTK	RH	ROSFLUT	RT	SCDRW	TD	TKP	TVR	VTK	WS	WTCD	WTKCUP	WTR	
✓	✓	✓	✓	✓	✓	✓	✓	✓	✓	✓	✓	✓	✓	✓	✓	✓	✓	✓	✓

<sup>1</sup>Not available on units over 36" wide and only available when used in conjunction with the attach toekick modification.

<sup>2</sup>Not available with 6" fluting.

<sup>3</sup>Not available on 96" high.

<sup>4</sup>Not available on 39" wide.



# Oven Cabinets

## Description

**BUILT-IN DOUBLE OVEN CABINET, 84", 87", or 90" HIGH, 24" DEEP**

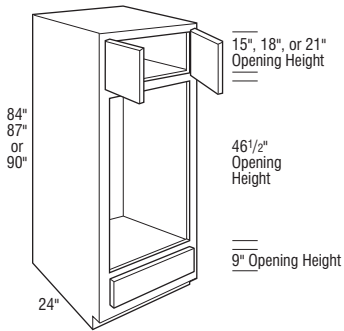

Specify appliance opening dimensions:

**OCD \_ AC**   
Double Oven

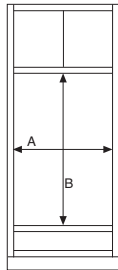

Appliance Opening Dimensions:

A \_\_\_\_\_  
B \_\_\_\_\_

### NOTE:

See chart for specific model appliance opening limitations.

Cabinet appliance openings may vary with modifications (i.e. clipped corner modification reduces maximum cut-out width by 3" per clipped corner).

## Model

<b>OCD278424AC</b>
<b>OCD308424AC</b>
<b>OCD338424AC</b>
<b>OCD368424AC</b>
<b>OCD398424AC</b>
<b>OCD278724AC</b>
<b>OCD308724AC</b>
<b>OCD338724AC</b>
<b>OCD368724AC</b>
<b>OCD398724AC</b>
<b>OCD279024AC</b>
<b>OCD309024AC</b>
<b>OCD339024AC</b>
<b>OCD369024AC</b>
<b>OCD399024AC</b>

- Specify cut-out size.
- When Beaded Inset is ordered, the cabinet should be ordered to the appropriate width using the 1/4" width modification instead of using the piece-in or cut-out applications.
- Cabinet openings are subject to change based on the cut-out. Please review the acknowledged drawing.
- 90" high includes one adjustable shelf in upper section.
- Increased Depths available in 1/4" increments from 24 1/4" to 30".
- Reduced Depths available in 1/4" increments from 12" to 23 3/4".
- Ordering Maximum Width Cut-out on cabinet will change end panel thickness from 1/2" to 3/8" for non-flush ends, and from 5/8" to 1/2" for flush ends.

	Standard Appliance Opening		Decreased Appliance Opening Width*		Increased Appliance Opening Width**		Appliance Opening Height***	
	Width (A)	Height (B)	Min. Width (A)	Max. Width (A)	Min. Width (A)	Max. Width (A)	Min. Height (B)	Max. Height (B)
OCD278424AC	24"	46 1/2"	12"	23 1/2"	24 1/16"	25 1/2"	40"	52"
OCD308424AC	27"	46 1/2"	15"	26 1/2"	27 1/16"	28 1/2"	40"	52"
OCD338424AC	30"	46 1/2"	18"	29 1/2"	30 1/16"	31 1/2"	40"	52"
OCD368424AC	33"	46 1/2"	21"	32 1/2"	33 1/16"	34 1/2"	40"	52"
OCD398424AC	36"	46 1/2"	24"	35 1/2"	36 1/16"	37 1/2"	40"	52"
OCD278724AC	24"	46 1/2"	12"	23 1/2"	24 1/16"	25 1/2"	40"	52"
OCD308724AC	27"	46 1/2"	15"	26 1/2"	27 1/16"	28 1/2"	40"	52"
OCD338724AC	30"	46 1/2"	18"	29 1/2"	30 1/16"	31 1/2"	40"	52"
OCD368724AC	33"	46 1/2"	21"	32 1/2"	33 1/16"	34 1/2"	40"	52"
OCD398724AC	36"	46 1/2"	24"	35 1/2"	36 1/16"	37 1/2"	40"	52"
OCD279024AC	24"	46 1/2"	12"	23 1/2"	24 1/16"	25 1/2"	40"	52"
OCD309024AC	27"	46 1/2"	15"	26 1/2"	27 1/16"	28 1/2"	40"	52"
OCD339024AC	30"	46 1/2"	18"	29 1/2"	30 1/16"	31 1/2"	40"	52"
OCD369024AC	33"	46 1/2"	21"	32 1/2"	33 1/16"	34 1/2"	40"	52"
OCD399024AC	36"	46 1/2"	24"	35 1/2"	36 1/16"	37 1/2"	40"	52"

\*Decreased Appliance Opening Width can vary in 1/16" increments by piecing in frame material.

\*\*Increased Appliance Opening Width can vary in 1/16" increments by cutting out the frame stiles.

\*\*\*Appliance Opening Height could have a variance of 1/16". By changing openings, it may require the door/drawer openings to change.

### Door & Drawer Options

AF	CC	CG	ESMD	GAMD	HC	IFHG	MC	MD	MFO	PRMD	SHMD	SPLITDR	SPLITDRWS	SUMD
<input checked="" type="checkbox"/>	<input checked="" type="checkbox"/>	<input checked="" type="checkbox"/>	<input checked="" type="checkbox"/>	<input checked="" type="checkbox"/>	<input checked="" type="checkbox"/>	<input checked="" type="checkbox"/>	<input checked="" type="checkbox"/>	<input checked="" type="checkbox"/>	<input checked="" type="checkbox"/>	<input checked="" type="checkbox"/>	<input checked="" type="checkbox"/>	<input checked="" type="checkbox"/>	<input checked="" type="checkbox"/>	<input checked="" type="checkbox"/>

### End Panel Options

AUTH	CSFPE <sup>1</sup>	EXBK	EXDN	FPE	INTGE <sup>1</sup>	IPE <sup>1</sup>
<input checked="" type="checkbox"/>	<input checked="" type="checkbox"/>	<input checked="" type="checkbox"/>	<input checked="" type="checkbox"/>	<input checked="" type="checkbox"/>	<input checked="" type="checkbox"/>	<input checked="" type="checkbox"/>

### Custom Modification Options

ADD	SHLF	ADDTK	ADRW	ATTK	BVR	CBO	CCO	CFNTD	CFP	CFRMO	CLIP	CND	CSDGBK	DRWTK <sup>2</sup>	EF	EX	EX_OL	FLUT <sup>3</sup>	FTK	ID
<input checked="" type="checkbox"/>	<input checked="" type="checkbox"/>	<input checked="" type="checkbox"/>	<input checked="" type="checkbox"/>	<input checked="" type="checkbox"/>	<input checked="" type="checkbox"/>	<input checked="" type="checkbox"/>	<input checked="" type="checkbox"/>	<input checked="" type="checkbox"/>	<input checked="" type="checkbox"/>	<input checked="" type="checkbox"/>	<input checked="" type="checkbox"/>	<input checked="" type="checkbox"/>	<input checked="" type="checkbox"/>	<input checked="" type="checkbox"/>	<input checked="" type="checkbox"/>	<input checked="" type="checkbox"/>	<input checked="" type="checkbox"/>	<input checked="" type="checkbox"/>	<input checked="" type="checkbox"/>	<input checked="" type="checkbox"/>

IH	IW <sup>4</sup>	MIP	OBRB	PFINBTMB	RD	RECTK	RH	ROSFLUT	RT	SCPDWR	TD	TKP	TVR	VTK	WS	WTCD	WTKCUP	WTR
<input checked="" type="checkbox"/>	<input checked="" type="checkbox"/>	<input checked="" type="checkbox"/>	<input checked="" type="checkbox"/>	<input checked="" type="checkbox"/>	<input checked="" type="checkbox"/>	<input checked="" type="checkbox"/>	<input checked="" type="checkbox"/>	<input checked="" type="checkbox"/>	<input checked="" type="checkbox"/>	<input checked="" type="checkbox"/>	<input checked="" type="checkbox"/>	<input checked="" type="checkbox"/>	<input checked="" type="checkbox"/>	<input checked="" type="checkbox"/>	<input checked="" type="checkbox"/>	<input checked="" type="checkbox"/>	<input checked="" type="checkbox"/>	<input checked="" type="checkbox"/>

<sup>1</sup>Not available when cut-out width is greater than standard.

<sup>2</sup>Not available on units over 36" wide.

<sup>3</sup>Not available with 6" fluting.

<sup>4</sup>Not available on 39" wide.

IH/RH availability charts starting on page G•40.  
IW/RW availability charts starting on page G•46.

## Description

### BUILT-IN DOUBLE OVEN CABINET, 93" or 96" HIGH, 24" DEEP

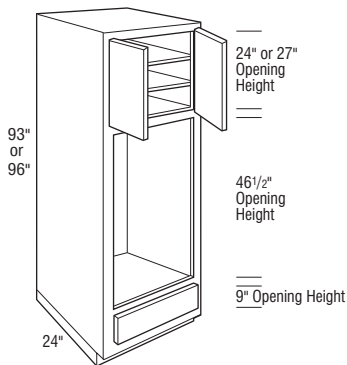

Specify appliance opening dimensions:

#### OCD \_ AC Double Oven

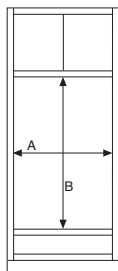

Appliance Opening Dimensions:

A \_\_\_\_\_  
B \_\_\_\_\_

#### NOTE:

See chart for specific model appliance opening limitations.

Cabinet appliance openings may vary with modifications (i.e. clipped corner modification reduces maximum cut-out width by 3" per clipped corner).

## Model

OCD279324AC

OCD309324AC

OCD339324AC

OCD369324AC

OCD399324AC

- Includes one adjustable shelf in upper section.

OCD279624AC

OCD309624AC

OCD339624AC

OCD369624AC

OCD399624AC

- Includes two adjustable shelves in upper section.
- Flush Toekick option not available in conjunction with Wide Top Rail unless loose Flush Toekick is specified.

Notes below apply to all products in section above:

- Specify cut-out size.
- When Beaded Inset is ordered, the cabinet should be ordered to the appropriate width using the 1/4" width modification instead of using the piece-in or cut-out applications.
- Cabinet openings are subject to change based on the cut-out. Please review the acknowledged drawing.
- Shipped with loose toe space unless Attach Toekick or Flush Toekick is specified.
- Increased Depths available in 1/4" increments from 24 1/4" to 30".
- Reduced Depths available in 1/4" increments from 12" to 23 3/4".
- Ordering Maximum Width Cut-out on cabinet will change end panel thickness from 1/2" to 3/8" for non-flush ends, and from 5/8" to 1/2" for flush ends.

	Standard Appliance Opening		Decreased Appliance Opening Width*		Increased Appliance Opening Width**		Appliance Opening Height***	
	Width (A)	Height (B)	Min. Width (A)	Max. Width (A)	Min. Width (A)	Max. Width (A)	Min. Height (B)	Max. Height (B)
OCD279324AC	24"	46 1/2"	12"	23 1/2"	24 1/16"	25 1/2"	40"	52"
OCD309324AC	27"	46 1/2"	15"	26 1/2"	27 1/16"	28 1/2"	40"	52"
OCD339324AC	30"	46 1/2"	18"	29 1/2"	30 1/16"	31 1/2"	40"	52"
OCD369324AC	33"	46 1/2"	21"	32 1/2"	33 1/16"	34 1/2"	40"	52"
OCD399324AC	36"	46 1/2"	24"	35 1/2"	36 1/16"	37 1/2"	40"	52"
OCD279624AC	24"	46 1/2"	12"	23 1/2"	24 1/16"	25 1/2"	40"	52"
OCD309624AC	27"	46 1/2"	15"	26 1/2"	27 1/16"	28 1/2"	40"	52"
OCD339624AC	30"	46 1/2"	18"	29 1/2"	30 1/16"	31 1/2"	40"	52"
OCD369624AC	33"	46 1/2"	21"	32 1/2"	33 1/16"	34 1/2"	40"	52"
OCD399624AC	36"	46 1/2"	24"	35 1/2"	36 1/16"	37 1/2"	40"	52"

\*Decreased Appliance Opening Width can vary in 1/16" increments by piecing in frame material.

\*\*Increased Appliance Opening Width can vary in 1/16" increments by cutting out the frame stiles.

\*\*\*Appliance Opening Height could have a variance of 1/16". By changing openings, it may require the door/drawer openings to change.

#### Door & Drawer Options

AF	CC	CG	ESMD	GAMD	HC	IFHG	MC	MD	MFO	PRMD	SHMD	SPLITDR	SPLITDRWS	SUMD
✓	✓	✓	✓	✓	✓	✓	✓	✓	✓	✓	✓	✓	✓	✓

#### End Panel Options

AUTH	CSFPE <sup>1</sup>	EXBK	EXDN	FPE	INTGE <sup>1</sup>	IPE <sup>1</sup>
✓	✓	✓	✓	✓	✓	✓

#### Custom Modification Options

ADD_SHLF	ADDTK	ADRW	ATTIK	BVR	CBO	CCO	CFNTO	CFP	CFRMO	CLIP	CND	CSDGBK	DRWTK <sup>2</sup>	EF	EX	EX_OL	FLUT <sup>3</sup>	FTK	ID	
✓	✓	✓	✓	✓	✓	✓	✓	✓	✓	✓	✓	✓	✓	✓	✓	✓	✓	✓	✓	✓
IH	IW <sup>4</sup>	MIP	OBRB	PFINBTMB	RD	RECTK	RH	ROSLUT	RT	SCPDRW	TD	TKP	TVR	VTK	WS	WTCD	WTKCUP	WTR		
✓	✓	✓	✓	✓	✓	✓	✓	✓	✓	✓	✓	✓	✓	✓	✓	✓	✓	✓	✓	

<sup>1</sup>Not available when cut-out width is greater than standard.

<sup>2</sup>Not available on units over 36" wide and only available when used in conjunction with attach toekick modification.

<sup>3</sup>Not available with 6" fluting.

<sup>4</sup>Not available on 39" wide.

# Oven Cabinets

## Description

**NEW** BUILT-IN DOUBLE OVEN CABINET,  
102" HIGH, 24" DEEP

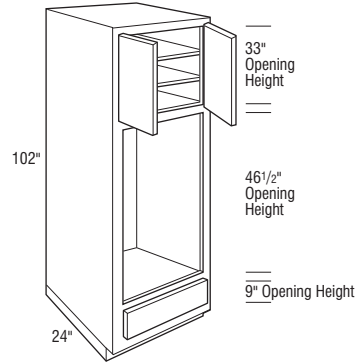

Specify appliance opening dimensions:

**OCD \_ \_ AC**  
Double Oven

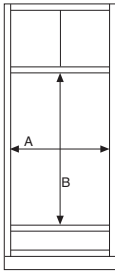

Appliance Opening Dimensions:

A \_\_\_\_\_  
B \_\_\_\_\_

### NOTE:

See chart for specific model appliance opening limitations.

Cabinet appliance openings may vary with modifications (i.e. clipped corner modification reduces maximum cut-out width by 3" per clipped corner).

## Model

OCD2710224AC

OCD3010224AC

OCD3310224AC

OCD3610224AC

OCD3910224AC

- Specify cut-out size.
- When Beaded Inset is ordered, the cabinet should be ordered to the appropriate width using the 1/4" width modification instead of using the piece-in or cut-out applications.
- Cabinet openings are subject to change based on the cut-out. Please review the acknowledged drawing.
- Two adjustable shelves in upper section.
- Shipped with loose toe space unless Attach Toekick or Flush Toekick is specified.
- Increased Depths available in 1/4" increments from 24 1/4" to 26".
- Reduced Depths available in 1/4" increments from 12" to 23 3/4".
- Finish Flushed Ends standard.
- Available in Cherry and Maple only.

	Standard Appliance Opening		Decreased Appliance Opening Width*		Increased Appliance Opening Width**		Appliance Opening Height***	
	Width (A)	Height (B)	Min. Width (A)	Max. Width (A)	Min. Width (A)	Max. Width (A)	Min. Height (B)	Max. Height (B)
OCD2710224AC	24"	46 1/2"	12"	23 1/2"	24 1/16"	25"	40"	52"
OCD3010224AC	27"	46 1/2"	15"	26 1/2"	27 1/16"	28"	40"	52"
OCD3310224AC	30"	46 1/2"	18"	29 1/2"	30 1/16"	31"	40"	52"
OCD3610224AC	33"	46 1/2"	21"	32 1/2"	33 1/16"	34"	40"	52"
OCD3910224AC	36"	46 1/2"	24"	35 1/2"	36 1/16"	37"	40"	52"

\*Decreased Appliance Opening Width can vary in 1/16" increments by piecing in frame material.

\*\*Increased Appliance Opening Width can vary in 1/16" increments by cutting out the frame stiles.

\*\*\*Appliance Opening Height could have a variance of 1/16". By changing openings, it may require the door/drawer openings to change.

### Door & Drawer Options

AF	CC	CG	ESMD	GAMD	HC	IFHG	MC	MD	MFO	PRMD	SHMD	SPLITDR	SPLITDRWS	SUMD
	✓	✓	✓	✓	✓	✓	✓	✓	✓	✓	✓	✓	✓	✓

### End Panel Options

AUTH	CSFPE	EXBK <sup>1</sup>	EXDN	FPE	INTGE	IPE
✓	✓	✓	✓	✓	✓	✓

### Custom Modification Options

ADD_SHLF	ADDTK	ADRW	ATTK	BVR	CBO	CCO	CFNT0	CFP	CFRMO	CLIP	CND	CSDGBK	DRWTK <sup>2</sup>	EF	EX	EX_OL	FLUT <sup>3</sup>	FTK	ID	
				✓		✓	✓	✓	✓	✓	✓	✓	✓	✓	✓	✓	✓	✓	✓	✓

IH	IW <sup>4</sup>	MIP	OBRB	PFINBTMB	RD	RECTK	RH	ROSFLUT <sup>3</sup>	RT	SCPDRW	TD	TKP	TVR	VTK	WS	WTC0	WTKCUP	WTR	
✓	✓	✓	✓	✓	✓	✓	✓	✓	✓	✓	✓	✓	✓	✓	✓	✓	✓	✓	✓

<sup>1</sup>This modification will allow the end to extend back to a maximum of 30" deep.

<sup>2</sup>Not available on units over 36" wide and only available when used in conjunction with attach toekick modification.

<sup>3</sup>Not available with 6" fluting.

<sup>4</sup>Not available on 39" wide.

IH/RH availability charts starting on page G•40.  
IW/RW availability charts starting on page G•46.

## Description



**BUILT-IN DOUBLE OVEN CABINET,  
108" HIGH, 24" DEEP**

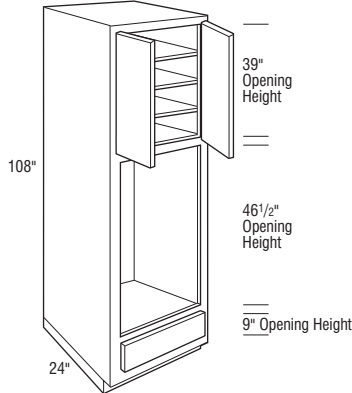

Specify appliance opening dimensions:

**OCD\_ \_AC**  
Double Oven

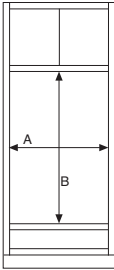

Appliance Opening Dimensions:

A \_\_\_\_\_  
B \_\_\_\_\_

### NOTE:

See chart for specific model appliance opening limitations.

Cabinet appliance openings may vary with modifications (i.e. clipped corner modification reduces maximum cut-out width by 3" per clipped corner).

## Model

**OCD2710824AC**

**OCD3010824AC**

**OCD3310824AC**

**OCD3610824AC**

**OCD3910824AC**

- Specify cut-out size.
- When Beaded Inset is ordered, the cabinet should be ordered to the appropriate width using the 1/4" width modification instead of using the piece-in or cut-out applications.
- Cabinet openings are subject to change based on the cut-out. Please review the acknowledged drawing.
- Three adjustable shelves in upper section.
- Shipped with loose toe space unless Attach Toekick or Flush Toekick is specified.
- Increased Depths available in 1/4" increments from 24 1/4" to 26".
- Reduced Depths available in 1/4" increments from 12" to 23 3/4".
- Finish Flushed Ends standard.
- Available in Cherry and Maple only.

	Standard Appliance Opening		Decreased Appliance Opening Width*		Increased Appliance Opening Width**		Appliance Opening Height***	
	Width (A)	Height (B)	Min. Width (A)	Max. Width (A)	Min. Width (A)	Max. Width (A)	Min. Height (B)	Max. Height (B)
OCD2710824AC	24"	46 1/2"	12"	23 1/2"	24 1/16"	25"	40"	52"
OCD3010824AC	27"	46 1/2"	15"	26 1/2"	27 1/16"	28"	40"	52"
OCD3310824AC	30"	46 1/2"	18"	29 1/2"	30 1/16"	31"	40"	52"
OCD3610824AC	33"	46 1/2"	21"	32 1/2"	33 1/16"	34"	40"	52"
OCD3910824AC	36"	46 1/2"	24"	35 1/2"	36 1/16"	37"	40"	52"

\*Decreased Appliance Opening Width can vary in 1/16" increments by piecing in frame material.

\*\*Increased Appliance Opening Width can vary in 1/16" increments by cutting out the frame stiles.

\*\*\*Appliance Opening Height could have a variance of 1/16". By changing openings, it may require the door/drawer openings to change.

### Door & Drawer Options

AF	CC	CG	ESMD	GAMD	HC	IFHG	MC	MD	MFO	PRMD	SHMD	SPLITDR	SPLITDRWS	SUMD
			✓	✓		✓		✓	✓	✓	✓	✓	✓	✓

### End Panel Options

AUTH	CSFPE	EXBK <sup>1</sup>	EXDN	FPE	INTGE	IPE
✓		✓				✓

### Custom Modification Options

ADD_SHLF	ADDTK	ADRW	ATTK	BVR	CBO	CCO	CFNT0	CFP	CFRMO	CLIP	CND	CSDGBK	DRWTK <sup>2</sup>	EF	EX	EX_OL	FLUT <sup>3</sup>	FTK	ID	

IH	IW <sup>4</sup>	MIP	OBRB	PFINBTMB	RD	RECTK	RH	ROSLUT <sup>3</sup>	RT	SCPDRW	TD	TKP	TVR	VTK	WS	WTCD	WTKCUP	WTR	
✓	✓	✓	✓	✓	✓	✓	✓	✓	✓	✓	✓	✓	✓	✓	✓	✓	✓	✓	✓

<sup>1</sup>This modification will allow the end to extend back to a maximum of 30" deep.

<sup>2</sup>Not available on units over 36" wide and only available in conjunction with attach toekick modification.

<sup>3</sup>Not available with 6" fluting.

<sup>4</sup>Not available on 39" wide.

# Oven Cabinets

## Description



**DOUBLE OVEN TRIMMABLE CABINET with DEEP DRAWER, 84", 87", or 90" HIGH, 24" DEEP**

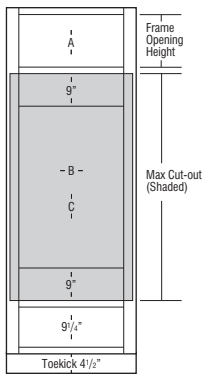
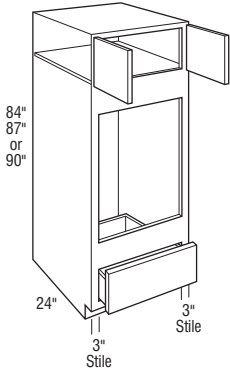

## Model

<b>OCD278424DD</b>
<b>OCD308424DD</b>
<b>OCD338424DD</b>
<b>OCD368424DD</b>
<b>OCD398424DD</b>
<b>OCD278724DD</b>
<b>OCD308724DD</b>
<b>OCD338724DD</b>
<b>OCD368724DD</b>
<b>OCD398724DD</b>
<b>OCD279024DD</b>
<b>OCD309024DD</b>
<b>OCD339024DD</b>
<b>OCD369024DD</b>
<b>OCD399024DD</b>

- All top and bottom cross rails are 1 1/2" wide.
- For built-in appliance support, OCINSTALLKIT is included in 24" deep oven cabinets.
- Oven cabinet cut-out is shaded in gray and is cut out on job site.
- Reduced Depths available in 1/4" increments from 12" to 23 3/4".
- Cabinet installation kit will not be included when depth is modified.
- A cabinet installation kit will be provided.
- Increased Heights modification will increase the height of the upper cabinet section. The bottom section will retain its original height.

	A Frame Opening Height	B Cut-out Width		C Cut-out Height		Door Height (Upper Section) Full Overlay
		Min.	Max.	Min.	Max.	
OCD278424DD	12"	21"	25 1/2"	37 1/4"	52 1/4"	14 1/2"
OCD308424DD	12"	24"	28 1/2"	37 1/4"	52 1/4"	14 1/2"
OCD338424DD	12"	27"	31 1/2"	37 1/4"	52 1/4"	14 1/2"
OCD368424DD	12"	30"	34 1/2"	37 1/4"	52 1/4"	14 1/2"
OCD398424DD	12"	33"	37 1/2"	37 1/4"	52 1/4"	14 1/2"
OCD278724DD	15"	21"	25 1/2"	37 1/4"	52 1/4"	17 1/2"
OCD308724DD	15"	24"	28 1/2"	37 1/4"	52 1/4"	17 1/2"
OCD338724DD	15"	27"	31 1/2"	37 1/4"	52 1/4"	17 1/2"
OCD368724DD	15"	30"	34 1/2"	37 1/4"	52 1/4"	17 1/2"
OCD398724DD	15"	33"	37 1/2"	37 1/4"	52 1/4"	17 1/2"
OCD279024DD	18"	21"	25 1/2"	37 1/4"	52 1/4"	20 1/2"
OCD309024DD	18"	24"	28 1/2"	37 1/4"	52 1/4"	20 1/2"
OCD339024DD	18"	27"	31 1/2"	37 1/4"	52 1/4"	20 1/2"
OCD369024DD	18"	30"	34 1/2"	37 1/4"	52 1/4"	20 1/2"
OCD399024DD	18"	33"	37 1/2"	37 1/4"	52 1/4"	20 1/2"

Maximum cut-out dimension will allow 1/4" reveal for doors and drawer fronts for trim kit face clearance.

### Door & Drawer Options

AF	CC	CG	ESMD	GAMD	HC	IFHG	MC	MD	MFO	PRMD	SHMD	SPLITDR	SPLITDRWS	SUMD
✓	✓	✓	✓	✓	✓	✓	✓	✓	✓	✓	✓	✓	✓	✓

### End Panel Options

AUTH	CSFPE	EXBK	EXDN	FPE	INTGE	IPE
✓	✓	✓	✓	✓	✓	✓

### Custom Modification Options

ADD	SHLF	ADTK	ADRW	ATTK	BVR	CBO	CCO	CFNTO	CFP	CFRMO	CLIP	CND	CSDGBK	DRWK <sup>1</sup>	EF	EX	EX_OL	FLUT <sup>2</sup>	FTK	ID	
✓	✓	✓	✓	✓	✓	✓	✓	✓	✓	✓	✓	✓	✓	✓	✓	✓	✓	✓	✓	✓	✓

IH	IW <sup>3</sup>	MIP	OBRB	PFINBTMB	RD	RECTK	RH	ROSFLUT	RT	SCPDWR	TD	TKP	TVR	VTK	WS	WTCD	WTKCUP	WTR
✓	✓	✓	✓	✓	✓	✓	✓	✓	✓	✓	✓	✓	✓	✓	✓	✓	✓	✓

<sup>1</sup>Not available on units over 36" wide.

<sup>2</sup>Not available with 6" fluting.

<sup>3</sup>Not available on 39" wide.

IH/RH availability charts starting on page G•40.  
IW/RW availability charts starting on page G•46.

## Description



**DOUBLE OVEN TRIMMABLE CABINET with DEEP DRAWER, 93" or 96" HIGH, 24" DEEP**

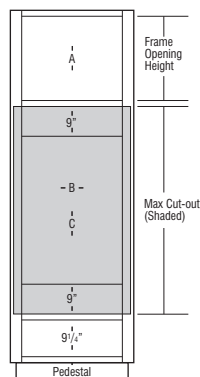
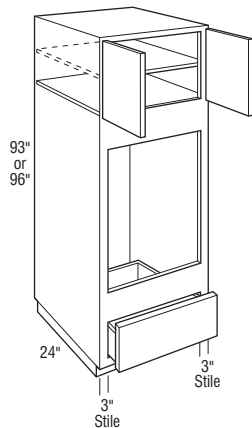

## Model

OCD279324DDAH

OCD309324DDAH

OCD339324DDAH

OCD369324DDAH

OCD399324DDAH

OCD279624DDAH

OCD309624DDAH

OCD339624DDAH

OCD369624DDAH

OCD399624DDAH

- AH represents upper section alignment with doors on 24" or 27" high cabinets.
- Upper section has one full depth adjustable shelf.
- Shipped with loose toekick unless ATTK or Flush ToeKick is specified.
- On the 96" high, flush toeKick option not available in conjunction with Wide Top Rail unless loose Flush ToeKick is specified.
- All top and bottom cross rails are 1 1/2" wide.
- For built-in appliance support, OCINSTALLKIT is included in 24" deep oven cabinets.
- Oven cabinet cut-out is shaded in gray and is cut out on job site.
- For built-in double oven applications, remove drawers as needed.
- Cabinet installation kit will not be included when depth is modified.
- A cabinet installation kit will be provided.
- Increased Heights modification will increase the height of the upper cabinet section. The bottom section will retain its original height.
- Reduced Depths available in 1/4" increments from 12" to 23 3/4".

	A Frame Opening Height	B Cut-out Width		C Cut-out Height		Door Height (Upper Section) Full Overlay
		Min.	Max.	Min.	Max.	
OCD279324DDAH	21"	21"	25 1/2"	37 1/4"	52 1/4"	23 1/2"
OCD309324DDAH	21"	24"	28 1/2"	37 1/4"	52 1/4"	23 1/2"
OCD339324DDAH	21"	27"	31 1/2"	37 1/4"	52 1/4"	23 1/2"
OCD369324DDAH	21"	30"	34 1/2"	37 1/4"	52 1/4"	23 1/2"
OCD399324DDAH	21"	33"	37 1/2"	37 1/4"	52 1/4"	23 1/2"
OCD279624DDAH	24"	21"	25 1/2"	37 1/4"	52 1/4"	26 1/2"
OCD309624DDAH	24"	24"	28 1/2"	37 1/4"	52 1/4"	26 1/2"
OCD339624DDAH	24"	27"	31 1/2"	37 1/4"	52 1/4"	26 1/2"
OCD369624DDAH	24"	30"	34 1/2"	37 1/4"	52 1/4"	26 1/2"
OCD399624DDAH	24"	33"	37 1/2"	37 1/4"	52 1/4"	26 1/2"

Maximum cut-out dimension will allow 1/4" reveal for doors and drawer fronts for trim kit face clearance.

### Door & Drawer Options

AF	CC	CG	ESMD	GAMD	HC	IFHG	MC	MD	MFO	PRMD	SHMD	SPLITDR	SPLITDRWS	SUMD
	✓	✓	✓	✓				✓	✓	✓	✓	✓	✓	✓

### End Panel Options

AUTH	CSFPE	EXBK	EXDN	FPE	INTGE	IPE
✓	✓	✓	✓	✓	✓	✓

### Custom Modification Options

ADD_SHLF	ADDTK	ADRW	ATTK	BVR	CBO	CCO	CFNTD	CFP	CFRMO	CLIP	CND	CSDGBK	DRWTK <sup>1</sup>	EF	EX	EX_OL	FLUT <sup>2</sup>	FTK	ID	
			✓			✓	✓	✓	✓	✓	✓	✓	✓	✓	✓	✓	✓	✓	✓	✓

IH <sup>3</sup>	IW <sup>4</sup>	MIP	OBRB	PFINBTMB	RD	RECTK	RH	ROSFLUT	RT	SCPDRW	TD	TKP	TVR	VTK	WS	WTCB	WTKCUP	WTR	
✓	✓	✓	✓			✓	✓	✓	✓	✓	✓	✓	✓	✓	✓	✓	✓	✓	✓

<sup>1</sup>Not available on units over 36" wide and only available when used in conjunction with attach toeKick modification.

<sup>2</sup>Not available with 6" fluting.

<sup>3</sup>Not available on 96" high.

<sup>4</sup>Only available on 39" wide.



# Kemper Emerge Modification Option Descriptions

Your Kemper Emerge specification guide contains charts with modification option codes for each applicable cabinetry product. Reference the listing below to identify the modification description.

Door & Drawer Options	
Option	Description
AF	Aluminum Door
CC	Craftsman Door
CG	Cut-for-glass
ESMD	Estate Mullion Door
GAMD	Gallery Mullion Door
IFHG	Inset Finial Hinges
MD	Mullion Door
MFO	Modified Full Overlay
PRMD	Prairie Mullion Door
SHMD	Shaker Mullion Door
SPLITDR	Split Doors
SUMD	Summit Mullion Door

End Panel Options	
Option	Description
AUTH	Authentic Flush End
CSFPE	Car Siding Flush Panel End
EXBK	End Extended Back
EXDN	Wall End and Back Extended Down
FFD	Face Frame and Door on End
FPE	Flush Panel End
INTGE	Integral End
IPE	Inset Panel Ends

Custom Modification Options	
Option	Description
ADDTK	Add Toekick
ADRW	Add Drawer Below Wall Unit
BVR	Bottom Valance Rail
CBO	Cabinet Box Only
CCO	Cabinet Case Only
CFNTO	Cabinet Front Only
CFP	Cabinet False Panel
CFRMO	Cabinet Frame Only
CLIP	Clipped Corner
CND	Cabinet No Door
CSDGBK	Car Siding Back
EF	Finished Ends
EX	Extended Stile
EX_OL	Extended Stile with Overlay
FD	Full Depth Shelf
FLUT	Fluting
FTK	Flush Toekick
ID	Increased Depth
IH	Increased Height
INVERM	Inverted Frame
IW	Increased Width
MIP	Matching Interior
OBRB	Open Bottom Rail Base
PFINBTMB	Finished Bottom
RD	Reduced Depth
RECTK	Recessed Toekick
RECTKFRT	Recessed Toekick Front
RH	Reduced Height
ROSLUT	Rose Fluting
RT	Roll Trays
RW	Reduced Width
STORB	Storage Open Rail Base
TD	Tray Divider
TKP	Toekick Pedestal
TVR	Top Valance Rail
VTK	Void Toekick
WS	Wide Stiles
WTR	Wide Top Rail





## Description

### ENTRY ENSEMBLE TALL, 66", 72", or 78" HIGH, 21" DEEP

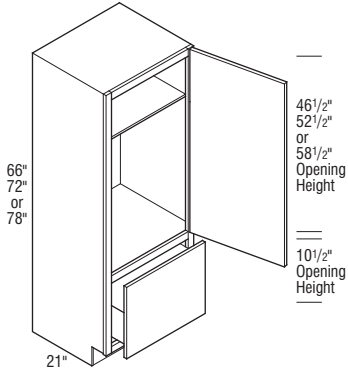

## Model

EET1866 L or R

EET2166 L or R

EET2466 L or R

EET1872 L or R

EET2172 L or R

EET2472 L or R

EET1878 L or R

EET2178 L or R

EET2478 L or R

- Includes one fixed shelf.
- Matching Interior and Finished Ends standard.
- Large opening on tall doors will include two panels.
- Increased Depths available in 1/4" increments from 21 1/4" to 24".
- Reduced Depths available in 1/4" increments from 12" to 20 3/4".

#### Door & Drawer Options

AF	CC	CG	ESMD	GAMD	IFHG	MD	MFO	PRMD	SHMD	SPLITDR	SUMD
✓	✓	✓	✓	✓	✓	✓	✓	✓	✓	✓	✓

#### End Panel Options

AUTH	CSFPE	EXBK	EXDN	FFD	FPE	INTGE	IPE
✓	✓	✓	✓	✓	✓	✓	✓

#### Custom Modification Options

ADDTK	ADRW	BVR	CBO	CCO	CFNTD	CFP	CFRMO	CLIP	CND	CSDGBK	EF	EX	EX_OL	FD	FLUT <sup>1</sup>	FTK	ID	IH	INVERM	
✓	✓	✓	✓	✓	✓	✓	✓	✓	✓	✓	✓	✓	✓	✓	✓	✓	✓	✓	✓	✓

IW	MIP	OBRB	PFINBTMB	RD	RECTK	RECTKFRT	RH	ROSFLUT	RT	RW <sup>2</sup>	STORB	TD	TKP	TVR	VTK	WS	WTR
✓	✓	✓	✓	✓	✓	✓	✓	✓	✓	✓	✓	✓	✓	✓	✓	✓	✓

<sup>1</sup>Not available with 6" fluting.

<sup>2</sup>Only available on 18" wide.

### ENTRY ENSEMBLE DRAWER BASE, 18" HIGH, 21" DEEP

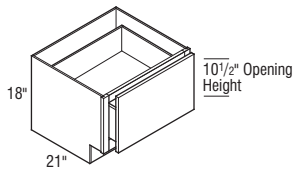

EEDB18

EEDB21

EEDB24

EEDB36

- Matching Interior and Finished Ends standard.
- Increased Depths available in 1/4" increments from 21 1/4" to 24".
- Reduced Depths available in 1/4" increments from 12" to 20 3/4".

#### Door & Drawer Options

AF	CC	CG	ESMD	GAMD	IFHG	MD	MFO	PRMD	SHMD	SPLITDR	SUMD
✓	✓	✓	✓	✓	✓	✓	✓	✓	✓	✓	✓

#### End Panel Options

AUTH	CSFPE	EXBK	EXDN	FFD	FPE	INTGE	IPE
✓	✓	✓	✓	✓	✓	✓	✓

#### Custom Modification Options

ADDTK	ADRW	BVR	CBO	CCO	CFNTD	CFP	CFRMO	CLIP	CND	CSDGBK	EF	EX	EX_OL	FD	FLUT <sup>1</sup>	FTK	ID	IH	INVERM	
✓	✓	✓	✓	✓	✓	✓	✓	✓	✓	✓	✓	✓	✓	✓	✓	✓	✓	✓	✓	✓

IW	MIP	OBRB	PFINBTMB	RD	RECTK	RECTKFRT	RH	ROSFLUT	RT	RW <sup>2</sup>	STORB	TD	TKP	TVR	VTK	WS	WTR
✓	✓	✓	✓	✓	✓	✓	✓	✓	✓	✓	✓	✓	✓	✓	✓	✓	✓

<sup>1</sup>6" fluting not available with 18" wide. Fluting both 6" also not available on 21" wide.

<sup>2</sup>Only available on 18" wide.

# Entry Ensembles

## Description

**ENTRY ENSEMBLE OPEN BASE, 18" HIGH, 21" DEEP**

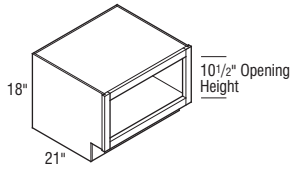

## Model

**EEOB18**

**EEOB21**

**EEOB24**

**EEOB36**

- Matching Interior and Finished Ends standard.
- Increased Depths available in 1/4" increments from 21 1/4" to 30".
- Reduced Depths available in 1/4" increments from 6" to 20 3/4".

### Door & Drawer Options

AF	CC	CG	ESMD	GAMD	IFHG	MD	MFO	PRMD	SHMD	SPLITDR	SUMD

### End Panel Options

AUTH	CSFPE	EXBK	EXDN	FFD	FPE	INTGE	IPE
✓	✓	✓			✓	✓	✓

### Custom Modification Options

ADDTK	ADRW	BVR	CBO	CCO	CFNT0	CFP	CFRMO	CLIP	CND	CSDGBK	EF	EX	EX_OL	FD	FLUT <sup>1</sup>	FTK	ID	IH	INVRM	
				✓	✓	✓		✓	✓		✓		✓	✓	✓	✓	✓	✓	✓	

IW	MIP	OBRB	PFINBTMB	RD	RECTK	RECTKERT	RH	ROSLUT	RT	RW <sup>2</sup>	STORB	TD	TKP	TVR	VTK	WS	WTR	
		✓			✓	✓		✓		✓	✓	✓	✓	✓	✓	✓	✓	

<sup>1</sup>Fluting both 6" not available on 18" or 21" wide.

<sup>2</sup>Only available on 18" wide.

IH/RH availability charts starting on page G•40.  
IW/RW availability charts starting on page G•46.

## Description

### ENTRY ENSEMBLE STACKED WALL OPEN, 46 1/2", 52" 1/2", or 58 1/2" HIGH

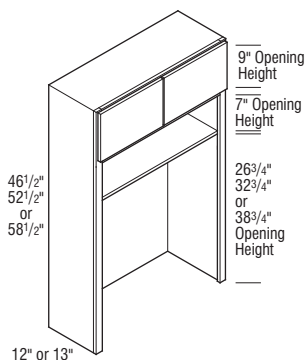
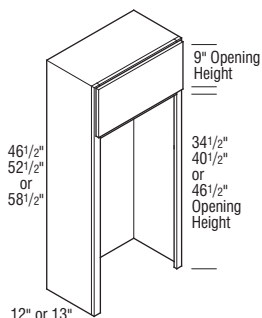

## Model

EESTWO1846.5 L or R

EESTWO2146.5 L or R

EESTWO2446.5 L or R

EESTWO1852.5 L or R

EESTWO2152.5 L or R

EESTWO2452.5 L or R

EESTWO1858.5 L or R

EESTWO2158.5 L or R

EESTWO2458.5 L or R

EESTWO2446.5

EESTWO3646.5

- Includes one fixed shelf.

EESTWO2452.5

EESTWO3652.5

- Includes one fixed shelf.

EESTWO2458.5

EESTWO3658.5

- Includes one fixed shelf.

Notes below apply to all products in section above:

- Matching Interior and Finished Ends standard.
- Inset and Beaded Inset styles are a standard 13" deep.
- Full Overlay Styles:
  - Increased Depths available in 1/4" increments from 12 1/4" to 24".
  - Reduced Depths available in 1/4" increments from 6" to 11 3/4".

#### Door & Drawer Options

AF	CC	CG	ESMD	GAMD	IFHG	MD	MFO	PRMD	SHMD	SPLITDR <sup>1</sup>	SUMD
✓	✓				✓		✓		✓	✓	

#### End Panel Options

AUTH	CSFPE	EXBK	EXDN	FFD	FPE	INTGE	IPE
✓	✓	✓		✓	✓	✓	✓

#### Custom Modification Options

ADDTK	ADRW	BVR	CBO	CCO	CFNT0	CFP	CFRMO	CLIP	CND	CSDGBK	EF	EX	EX_OL	FD	FLUT <sup>2</sup>	FTK	ID	IH	INVFRM
					✓	✓	✓	✓	✓	✓	✓	✓	✓	✓	✓	✓	✓	✓	✓

IW	MIP	OBRB	PFINBTMB	RD	RECTK <sup>3</sup>	RECTKFRT	RH	ROSLUT	RT	RW <sup>4</sup>	STORB	TD	TKP	TVR	VTK	WS <sup>5</sup>	WTR
					✓	✓		✓		✓				✓	✓	✓	✓

<sup>1</sup>Not available on 18" or 21" wide.

<sup>2</sup>Not available with 6" fluting.

<sup>3</sup>Only available with RECTLR.BK.

<sup>4</sup>Only available on 18" and 36" wide.

<sup>5</sup>Not available on 24" (2 doors) wide.

# Entry Ensembles

## Description

**ENTRY ENSEMBLE STACKED WALL,  
46 1/2", 52 1/2", or 58 1/2" HIGH**

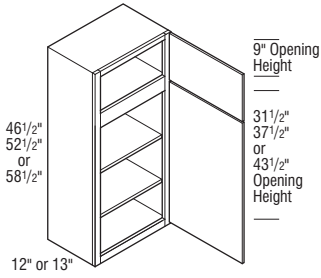

## Model

**EESTW1846.5 L or R**

**EESTW2146.5 L or R**

**EESTW2446.5 L or R**

- Includes two adjustable shelves.

**EESTW1852.5 L or R**

**EESTW2152.5 L or R**

**EESTW2452.5 L or R**

- Includes three adjustable shelves.

**EESTW1858.5 L or R**

**EESTW2158.5 L or R**

**EESTW2458.5 L or R**

- Includes three adjustable shelves.

Notes below apply to all products in section above:

- Matching Interior and Finished Ends standard.
- Inset and Beaded Inset styles are a standard 13" deep.
- Full Overlay Styles:
  - Increased Depths available in 1/4" increments from 12 1/4" to 30".
  - Reduced Depths available in 1/4" increments from 6" to 11 3/4".
- Inset and Beaded Inset Styles:
  - Increased Depths available in 1/4" increments from 13 1/4" to 24".
  - Reduced Depths available in 1/4" increments from 6" to 12 3/4".

### Door & Drawer Options

AF	CC	CG	ESMD	GAMD	IFHG	MD	MFO	PRMD	SHMD	SPLITDR	SUMD
✓	✓	✓	✓	✓	✓	✓	✓	✓	✓	✓	✓

### End Panel Options

AUTH	CSFPE	EXBK	EXDN	FFD	FPE	INTGE	IPE
✓	✓	✓	✓	✓	✓	✓	✓

### Custom Modification Options

ADDTK	ADRW	BVR	CBO	CCO	CFNT0	CFP	CFRMO	CLIP	CND	CSDGBK	EF	EX	EX_OL	FD	FLUT <sup>1</sup>	FTK	ID	IH	INVFRM	
✓	✓	✓	✓	✓	✓	✓	✓	✓	✓	✓	✓	✓	✓	✓	✓	✓	✓	✓	✓	✓

IW	MIP	OBRB	PFINBTMB	RD	RECTK	RECTKFRT	RH	ROSLUT	RT	RW <sup>2</sup>	STORB	TD	TKP	TVR	VTK	WS	WTR
✓	✓	✓	✓	✓	✓	✓	✓	✓	✓	✓	✓	✓	✓	✓	✓	✓	✓

<sup>1</sup>Not available with 6" fluting.

<sup>2</sup>Only available on 18" wide.

IH/RH availability charts starting on page G•40.  
IW/RW availability charts starting on page G•46.

## Description

### ENTRY ENSEMBLE STACKED WALL MESSAGE, 46 1/2", 52 1/2", or 58 1/2" HIGH

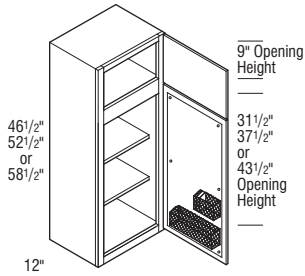

## Model

**EESTWM1846.5 L or R**

**EESTWM2146.5 L or R**

- Includes two adjustable shelves.

**EESTWM1852.5 L or R**

**EESTWM2152.5 L or R**

- Includes three adjustable shelves.

**EESTWM1858.5 L or R**

**EESTWM2158.5 L or R**

- Includes three adjustable shelves.

Notes below apply to all products in section above:

- Matching Interior and Finished Ends standard.
- Includes whiteboard, pencil holder, and mail holder.
- Full Overlay Styles:
  - Increased Depths available in 1/4" increments from 12 1/4" to 30".
  - Reduced Depths available in 1/4" increments from 9" to 11 3/4".
- Not available on Inset and Beaded Inset styles.

#### Door & Drawer Options

AF	CC	CG	ESMD	GAMD	IFHG	MD	MFO	PRMD	SHMD	SPLITDR	SUMD
✓	✓	✓			✓		✓		✓		

#### End Panel Options

AUTH	CSPE	EXBK	EXDN	FFD	FPE	INTGE	IPE
✓	✓	✓	✓	✓	✓	✓	✓











#### Custom Modification Options

ADDTK	ADRW	BVR	CBO	CCO	CFNTO	CFP	CFRMO	CLIP	CND	CSDGBK	EF	EX	EX_OL	FD	FLUT <sup>1</sup>	FTK	ID	IH	INVFRM	
✓	✓	✓								✓	✓	✓	✓	✓	✓	✓	✓	✓	✓	✓

IW	MIP	OBRB	PFINBTMB	RD	RECTK	RECTKFRT	RH	ROSLUT	RT	RW	STORB	TD	TKP	TVR	VTK	WS	WTR
	✓	✓	✓	✓	✓	✓		✓					✓	✓	✓	✓	✓

<sup>1</sup>Not available with 6" fluting.

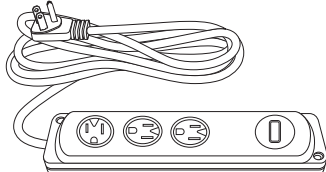
# Entry Ensemble Accessories

Description	Model
<p><b>SINGLE HOOK NICKEL</b></p>  	<p><b>EEHSN</b></p> <p>Modifications Are Not Available</p>
<p><b>DOUBLE HOOK NICKEL</b></p>  	<p><b>EEHDN</b></p> <p>Modifications Are Not Available</p>
<p><b>SINGLE HOOK BLACK</b></p>  	<p><b>EEHSB</b></p> <p>Modifications Are Not Available</p>
<p><b>DOUBLE HOOK BLACK</b></p>  	<p><b>EEHDB</b></p> <p>Modifications Are Not Available</p>
<p><b>POWER STRIP</b></p>  	<p><b>EEPWR</b></p> <ul style="list-style-type: none"> <li>• Power strip is black.</li> </ul> <p>Modifications Are Not Available</p>
<p><b>GROMMET</b></p>  	<p><b>EEGRM</b></p> <ul style="list-style-type: none"> <li>• Grommet is black.</li> </ul> <p>Modifications Are Not Available</p>

IH/RH availability charts starting on page G•40.  
IW/RW availability charts starting on page G•46.

## ENTRY ENSEMBLE 1, 66" WIDE x 78" HIGH x 21" DEEP

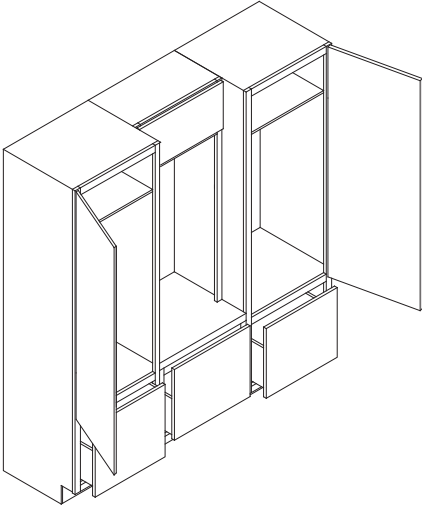

Parts Required	Quantity
(1) EET_----	1
(2) EESTWO_----	1
(3) EEDB_--	1
(4) EET_----	1
(5) WOODTOP	1

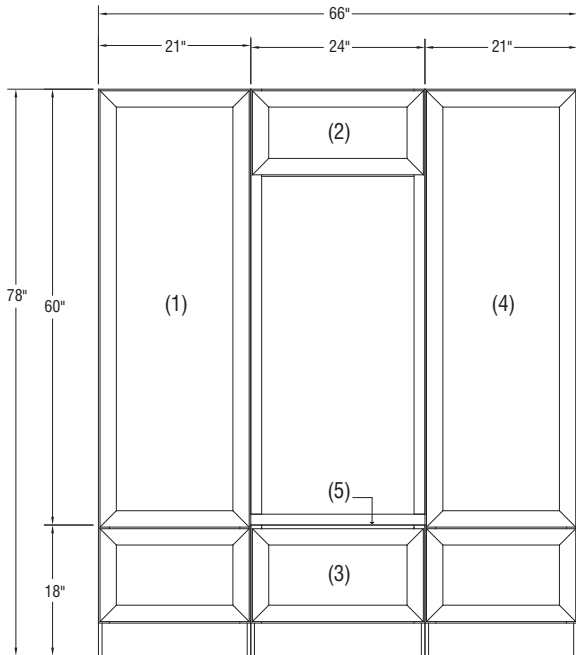



# Entry Ensembles

## ENTRY ENSEMBLE 2, 72" WIDE x 72" HIGH x 21" DEEP

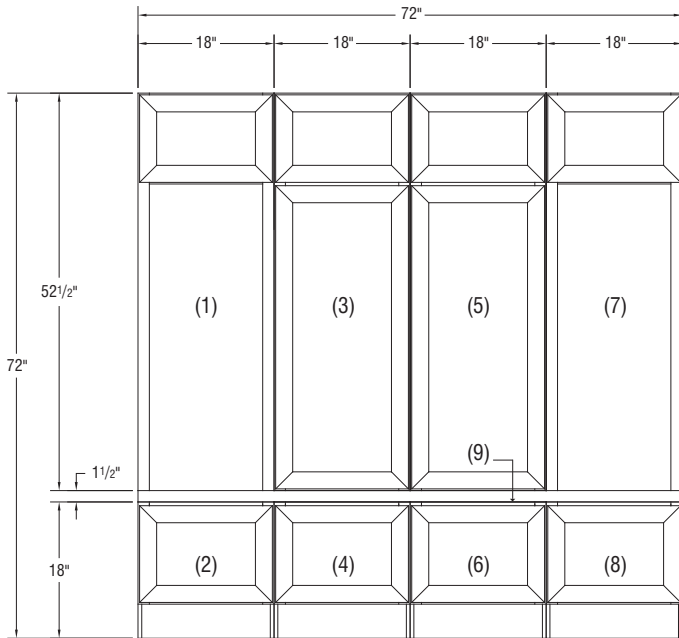
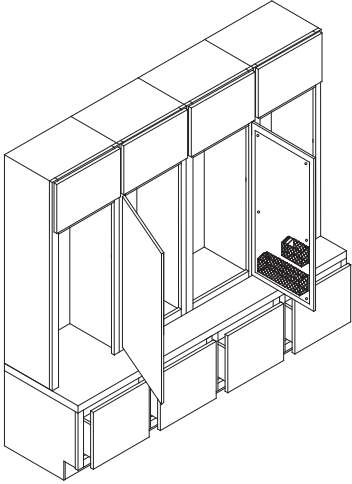

Parts Required	Quantity
(1) EESTWO_-----	1
(2) EEDB_--	1
(3) EESTWM_-----	1
(4) EEDB_--	1
(5) EESTW_-----	1
(6) EEDB_--	1
(7) EESTWO_-----	1
(8) EEDB_--	1
(9) WOODTOP	1

## ENTRY ENSEMBLE 3, 72" WIDE x 78" HIGH x 21" DEEP

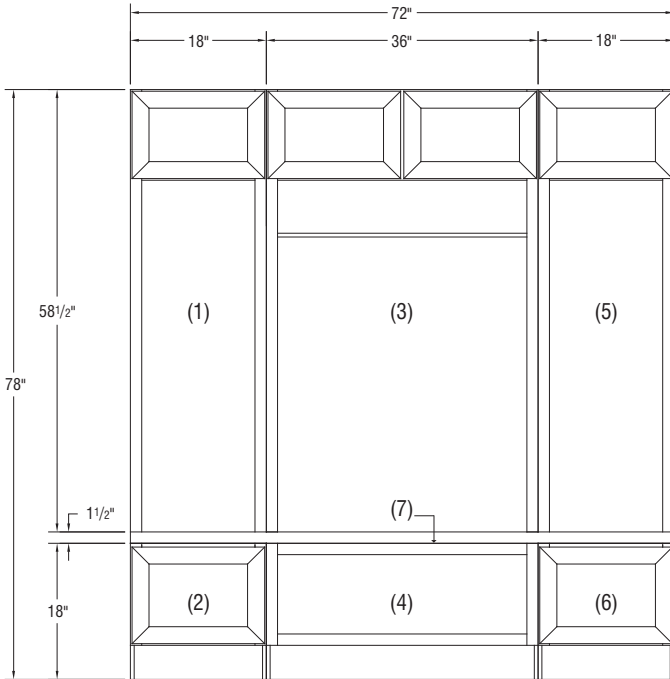
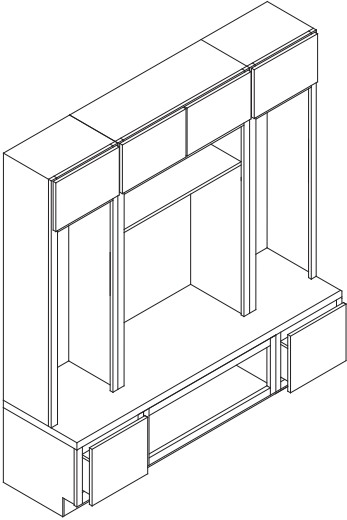

Parts Required	Quantity
(1) EESTWO_	1
(2) EEDB_	1
(3) EESTWO_	1
(4) EEOB_	1
(5) EESTWO_	1
(6) EEDB_	1
(7) WOODTOP	1

# Entertainment Centers

## Description

### ENTERTAINMENT OPEN DRAWER, 18" HIGH, 21" DEEP

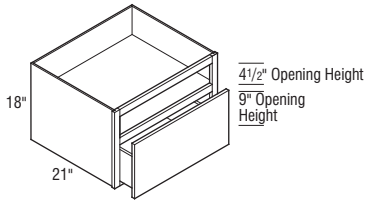

## Model

### EOD24

- Finished Ends and Matching Interior standard.
- Void toekick standard.
- Increased Depths available in 1/4" increments from 21 1/4" to 24".
- Reduced Depths available in 1/4" increments from 12" to 20 3/4".

#### Door & Drawer Options

AF	CC	CG	ESMD	GAMD	IFHG	MD	MFO	PRMD	SHMD	SPLITDR	SUMD

#### End Panel Options

AUTH	CSFPE	EXBK	EXDN	FFD	FPE	INTGE	IPE

#### Custom Modification Options

ADDTK	ADRW	BVR	CBO	CCO	CFNTD	CFP	CFRMO	CLIP	CND	CSDGBK	EF	EX	EX_OL	FD	FLUT	FTK	ID	IH	INVFRM	

IW	MIP	OBRB	PFINBTMB	RD	RECTK	RECTKFRT	RH	ROSFLUT	RT	RW	STORB	TD	TKP	TVR	VTK	WS	WTR

### ENTERTAINMENT BASE, NO TOEKICK, 18" HIGH, 21" DEEP

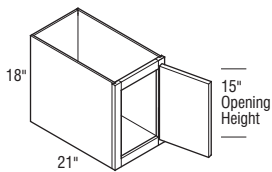

### EB12NTK L or R

- Finished Ends and Matching Interior standard.
- Increased Depths available in 1/4" increments from 21 1/4" to 30".
- Reduced Depths available in 1/4" increments from 6" to 20 3/4".

#### Door & Drawer Options

AF	CC	CG	ESMD	GAMD	IFHG	MD	MFO	PRMD	SHMD	SPLITDR	SUMD

#### End Panel Options

AUTH	CSFPE	EXBK	EXDN	FFD	FPE	INTGE	IPE

#### Custom Modification Options

ADDTK	ADRW	BVR	CBO	CCO	CFNTD	CFP	CFRMO	CLIP	CND	CSDGBK	EF	EX	EX_OL	FD	FLUT	FTK	ID	IH	INVFRM	

IW	MIP	OBRB	PFINBTMB	RD	RECTK	RECTKFRT	RH	ROSFLUT	RT	RW	STORB	TD	TKP	TVR	VTK	WS <sup>3</sup>	WTR

<sup>1</sup>Not available with 6" fluting.

<sup>2</sup>Not available with FTKAV.

<sup>3</sup>Not available with wide stile both 3".

### ENTERTAINMENT BASE, 27" HIGH, 18" DEEP

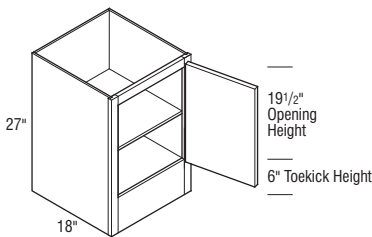

### EB18 L or R

- Finished Ends, Matching Interior, Flush Toekick, and Full Depth Shelf standard.
- Increased Depths available in 1/4" increments from 18 1/4" to 30".
- Reduced Depths available in 1/4" increments from 6" to 17 3/4".

#### Door & Drawer Options

AF	CC	CG	ESMD	GAMD	IFHG	MD	MFO	PRMD	SHMD	SPLITDR	SUMD

#### End Panel Options

AUTH	CSFPE	EXBK	EXDN	FFD	FPE	INTGE	IPE

#### Custom Modification Options

ADDTK	ADRW	BVR	CBO	CCO	CFNTD	CFP	CFRMO	CLIP	CND	CSDGBK	EF	EX	EX_OL	FD	FLUT <sup>1</sup>	FTK <sup>2</sup>	ID	IH	INVFRM	

IW	MIP	OBRB	PFINBTMB	RD	RECTK	RECTKFRT	RH	ROSFLUT	RT	RW	STORB	TD	TKP	TVR	VTK	WS	WTR

<sup>1</sup>Not available with fluting both 6".

<sup>2</sup>Only available on FTKAV.

## Description

### ENTERTAINMENT WALL, 36" HIGH, 9" DEEP

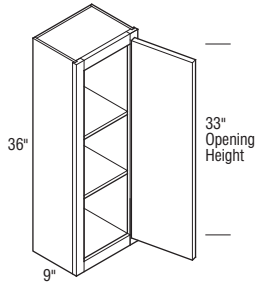

## Model

### EW1236 L or R

- Finished Ends and Matching Interior standard.
- Increased Depths available in 1/4" increments from 9 1/4" to 30".
- Reduced Depths available in 1/4" increments from 6" to 8 3/4".

#### Door & Drawer Options

AF	CC	CG	ESMD	GAMD	IFHG	MD	MFO	PRMD	SHMD	SPLITDR	SUMD
	✓	✓	✓	✓	✓	✓	✓	✓	✓	✓	✓

#### End Panel Options

AUTH	CSFPE	EXBK	EXDN	FFD	FPE	INTGE	IPE
✓	✓	✓	✓	✓	✓	✓	✓

#### Custom Modification Options

ADDTK	ADRW	BVR	CBO	CCO	CFNTD	CFP	CFRMO	CLIP	CND	CSDGBK	EF	EX	EX_OL	FD	FLUT <sup>1</sup>	FTK <sup>2</sup>	ID	IH	INVFRM	
			✓	✓	✓	✓	✓	✓	✓	✓	✓	✓	✓	✓	✓	✓	✓	✓	✓	✓

IW	MIP	OBRB	PFINBTMB	RD	RECTK	RECTKFRT	RH	ROSLUT	RT	RW	STORB	TD	TKP	TVR	VTK	WS <sup>3</sup>	WTR
✓	✓	✓	✓	✓	✓	✓	✓	✓	✓	✓	✓	✓	✓	✓	✓	✓	✓

<sup>1</sup>Not available with 6" fluting.

<sup>2</sup>Not available with FTKAV.

<sup>3</sup>Not available with wide stile both 3".

### ENTERTAINMENT STACKED WALL, 58 1/2" HIGH, 18" DEEP

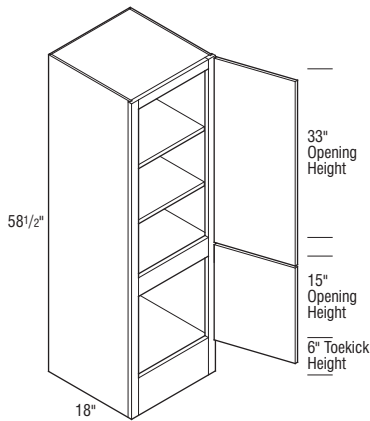

### ESTW1858.5 L or R

- Finished Ends, Matching Interior, and Flush Toekick standard.
- Increased Depths available in 1/4" increments from 18 1/4" to 30".
- Reduced Depths available in 1/4" increments from 6" to 17 3/4".

#### Door & Drawer Options

AF	CC	CG	ESMD	GAMD	IFHG	MD	MFO	PRMD	SHMD	SPLITDR	SUMD
	✓	✓	✓	✓	✓	✓	✓	✓	✓	✓	✓

#### End Panel Options

AUTH	CSFPE	EXBK	EXDN	FFD	FPE	INTGE	IPE
✓	✓	✓	✓	✓	✓	✓	✓

#### Custom Modification Options

ADDTK	ADRW	BVR	CBO	CCO	CFNTD	CFP	CFRMO	CLIP	CND	CSDGBK	EF	EX	EX_OL	FD	FLUT <sup>1</sup>	FTK <sup>2</sup>	ID	IH	INVFRM	
			✓	✓	✓	✓	✓	✓	✓	✓	✓	✓	✓	✓	✓	✓	✓	✓	✓	✓

IW	MIP	OBRB	PFINBTMB	RD	RECTK	RECTKFRT	RH	ROSLUT	RT	RW	STORB	TD	TKP	TVR	VTK	WS	WTR
✓	✓	✓	✓	✓	✓	✓	✓	✓	✓	✓	✓	✓	✓	✓	✓	✓	✓

<sup>1</sup>Not available with 6" fluting.

<sup>2</sup>Only available with FTKAV.

### FOUR DRAWER ENTERTAINMENT BASE, 27" HIGH, 18" DEEP

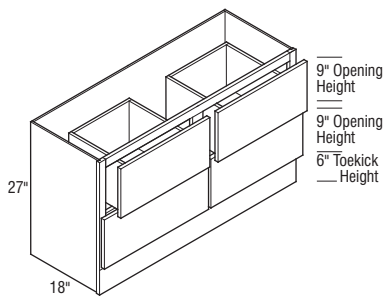

### 4EDB48

- Finished Ends, Matching Interior, and Flush Toekick standard.
- Increased Depths available in 1/4" increments from 18 1/4" to 24".
- Reduced Depths available in 1/4" increments from 12" to 17 3/4".

#### Door & Drawer Options

AF	CC	CG	ESMD	GAMD	IFHG	MD	MFO	PRMD	SHMD	SPLITDR	SUMD
					✓						

#### End Panel Options

AUTH	CSFPE	EXBK	EXDN	FFD	FPE	INTGE	IPE
✓	✓	✓	✓	✓	✓	✓	✓

#### Custom Modification Options

ADDTK	ADRW	BVR	CBO	CCO	CFNTD	CFP	CFRMO	CLIP	CND	CSDGBK	EF	EX	EX_OL	FD	FLUT <sup>1</sup>	FTK <sup>2</sup>	ID	IH	INVFRM	
			✓	✓	✓	✓	✓	✓	✓	✓	✓	✓	✓	✓	✓	✓	✓	✓	✓	✓

IW	MIP	OBRB	PFINBTMB	RD	RECTK	RECTKFRT	RH	ROSLUT	RT	RW	STORB	TD	TKP	TVR	VTK	WS	WTR
✓	✓	✓	✓	✓	✓	✓	✓	✓	✓	✓	✓	✓	✓	✓	✓	✓	✓

<sup>1</sup>Not available with 6" fluting.

<sup>2</sup>Only available with FTKAV.

# Entertainment Centers

## Description

### FOUR DRAWER ENTERTAINMENT BASE, NO TOEKICK, 18" HIGH, 15" DEEP

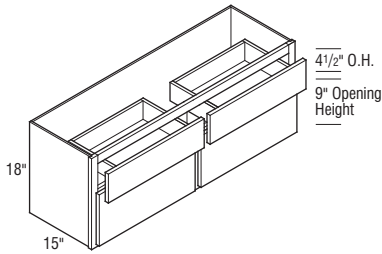

## Model

### 4EDB48NTK

- Finished Ends and Matching Interior standard.
- Increased Depths available in 1/4" increments from 15 1/4" to 24".
- Reduced Depths available in 1/4" increments from 12" to 14 3/4".

#### Door & Drawer Options

AF	CC	CG	ESMD	GAMD	IFHG	MD	MFO	PRMD	SHMD	SPLITDR	SUMD
					✓						

#### End Panel Options

AUTH	CSFPE	EXBK	EXDN	FFD	FPE	INTGE	IPE
✓	✓	✓			✓	✓	✓

#### Custom Modification Options

ADDTK	ADRW	BVR	CBO	CCO	CFNT0	CFP	CFRMO	CLIP	CND	CSDGBK	EF	EX	EX_OL	FD	FLUT <sup>1</sup>	FTK	ID	IH	INVFRM	
			✓	✓	✓		✓			✓			✓	✓	✓	✓			✓	

IW	MIP	OBRB	PFINBTMB	RD	RECTK	RECTKFRT	RH	ROSFLUT	RT	RW	STORB	TD	TKP	TVR	VTK	WS	WTR		
				✓				✓		✓						✓	✓		

<sup>1</sup>Not available with 6" fluting.

### SIX DRAWER ENTERTAINMENT BASE, NO TOEKICK, 22 1/2" HIGH, 18" DEEP

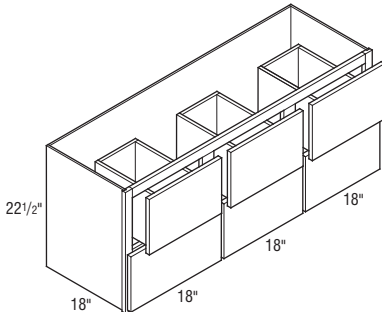

### 6EDB54

- Finished Ends and Matching Interior standard.
- Increased Depths available in 1/4" increments from 15 1/4" to 24".
- Reduced Depths available in 1/4" increments from 12" to 17 3/4".

#### Door & Drawer Options

AF	CC	CG	ESMD	GAMD	IFHG	MD	MFO	PRMD	SHMD	SPLITDR	SUMD
					✓						

#### End Panel Options

AUTH	CSFPE	EXBK	EXDN	FFD	FPE	INTGE	IPE
✓	✓	✓			✓	✓	✓

#### Custom Modification Options

ADDTK	ADRW	BVR	CBO	CCO	CFNT0	CFP	CFRMO	CLIP	CND	CSDGBK	EF	EX	EX_OL	FD	FLUT <sup>1</sup>	FTK	ID	IH	INVFRM	
			✓	✓	✓		✓			✓			✓	✓	✓	✓			✓	

IW	MIP	OBRB	PFINBTMB	RD	RECTK	RECTKFRT	RH	ROSFLUT	RT	RW	STORB	TD	TKP	TVR	VTK	WS	WTR		
				✓				✓		✓						✓	✓		

<sup>1</sup>Not available with 6" fluting.

### ENTERTAINMENT BASE with DRAWERS, 22 1/2" HIGH, 18" DEEP

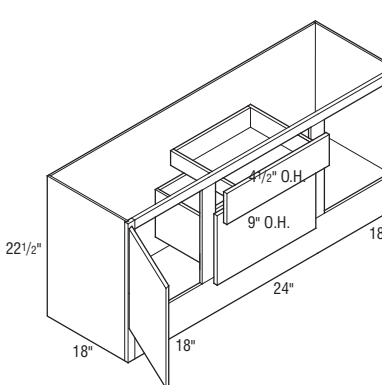

### EBDB60

- Finished Ends, Matching Interior, and Flush Toekick standard.
- Increased Depths available in 1/4" increments from 18 1/4" to 24".
- Reduced Depths available in 1/4" increments from 12" to 17 3/4".

#### Door & Drawer Options

AF	CC	CG	ESMD	GAMD	IFHG	MD	MFO	PRMD	SHMD	SPLITDR	SUMD
			✓	✓	✓	✓	✓	✓			✓

#### End Panel Options

AUTH	CSFPE	EXBK	EXDN	FFD	FPE	INTGE	IPE
✓	✓	✓			✓	✓	✓

#### Custom Modification Options

ADDTK	ADRW	BVR	CBO	CCO	CFNT0	CFP	CFRMO	CLIP	CND	CSDGBK	EF	EX	EX_OL	FD	FLUT <sup>1</sup>	FTK	ID	IH	INVFRM	
			✓	✓	✓		✓			✓			✓	✓	✓	✓			✓	

IW	MIP	OBRB	PFINBTMB	RD	RECTK	RECTKFRT	RH	ROSFLUT	RT	RW	STORB	TD	TKP	TVR	VTK	WS	WTR		
				✓				✓		✓						✓	✓		

<sup>1</sup>Not available with 6" fluting.

<sup>2</sup>Only available with FTKAV.

IH/RH availability charts starting on page G•40.  
IW/RW availability charts starting on page G•46.

**Description**

**ENTERTAINMENT BOX COLUMN FILLER,  
22 1/2" HIGH, 15" DEEP**

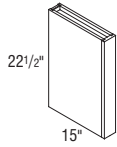

**Model**

**EBCF322.5**

- Flush Toekick and Flush Panel Ends standard.
- Reversible, may be used on either left or right end.
- Front and both sides finished, back is unfinished.
- Enclosed top and bottom.
- Increased Depths available in 1/4" increments from 15 1/4" to 30".
- Reduced Depths available in 1/4" increments from 9" to 14 3/4".

**Door & Drawer Options**

AF	CC	CG	ESMD	GAMD	IFHG	MD	MFO	PRMD	SHMD	SPLITDR	SUMD

**End Panel Options**

AUTH	CSFPE	EXBK	EXDN	FFD	FPE	INTGE	IPE

**Custom Modification Options**

ADDTK	ADRW	BVR	CBO	CCO	CFNTD	CFP	CFRMO	CLIP	CND	CSDGBK	EF	EX	EX_OL	FD	FLUT <sup>1</sup>	FTK	ID	IH	INVERM	

IW	MIP	OBRB	PFINBTMB	RD	RECTK	RECTKFRT	RH	ROSFLUT	RT	RW	STORB	TD	TKP	TVR	VTK	WS	WTR

<sup>1</sup>Not available with 6" fluting.

**ENTERTAINMENT BOX COLUMN FILLER,  
27" HIGH, 18" DEEP**

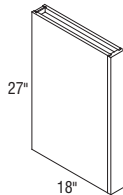

**EBCF327**

- Flush Toekick and Flush Panel Ends standard.
- Reversible, may be used on either left or right end.
- Front and both sides finished, back is unfinished.
- Enclosed top and bottom.
- Increased Depths available in 1/4" increments from 18 1/4" to 30".
- Reduced Depths available in 1/4" increments from 9" to 17 3/4".

**Door & Drawer Options**

AF	CC	CG	ESMD	GAMD	IFHG	MD	MFO	PRMD	SHMD	SPLITDR	SUMD

**End Panel Options**

AUTH	CSFPE	EXBK	EXDN	FFD	FPE	INTGE	IPE

**Custom Modification Options**

ADDTK	ADRW	BVR	CBO	CCO	CFNTD	CFP	CFRMO	CLIP	CND	CSDGBK	EF	EX	EX_OL	FD	FLUT <sup>1</sup>	FTK	ID	IH	INVERM	

IW	MIP	OBRB	PFINBTMB	RD	RECTK	RECTKFRT	RH	ROSFLUT	RT	RW	STORB	TD	TKP	TVR	VTK	WS	WTR

<sup>1</sup>Not available with 6" fluting.

**SQUARE FOOT,  
3 3/4" x 3 3/4" x 4" HIGH**

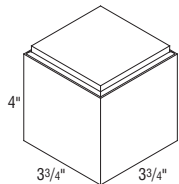

**SMSQFOOT**

- 3 3/4" W x 4" H x 3 3/4" D.
- Glazes and/or Techniques available: F, P, HW, XHW.

Modifications  
Are Not  
Available

**Glazes and Techniques**

- F** = Flooded (see page E-3.)
- P** = Penned (see page E-3.)
- TW** = Timeworn (see page E-3.)
- XTW** = Extra Timeworn (see page E-3.)
- HW** = Hewn (see page E-3.)
- XHW** = Extra Hewn (see page E-3.)

**ENTERTAINMENT TOPPER, 3/4" THICK,  
10" DEEP**

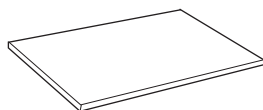

**ET13**

- If special sizing is required, order 3/4VEN2S.
- Top and bottom finished standard.
- All edges banded.

Modifications  
Are Not  
Available

# Entertainment Centers

## Description

### ENTERTAINMENT TOPPER, 3/4" THICK, 19" DEEP

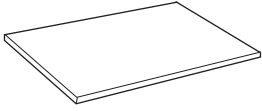

## Model

### ET19

- If special sizing is required, order 3/4VEN2S.
- Top and bottom finished standard.
- All edges banded.

Modifications  
Are Not  
Available

### ENTERTAINMENT PLATFORM, 3/4" THICK, 22" DEEP

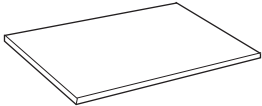

### EP49

### EP73

- If special sizing is required, order 3/4VEN2S.
- Top and bottom finished standard.
- All edges banded.

Modifications  
Are Not  
Available

### ENTERTAINMENT WOOD TOPS with BEVELED EDGE, 1 1/2" THICK

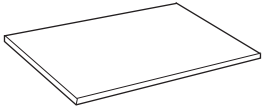

Beveled

### 3TWT4922BE

### 1TWT5416BE

### 2TWT54.516BE

### 3TWT5516BE

### 3TWT6119BE

### 3TWT7322BE

### 3TWT8519BE

- Profiled on 3 sides except 1TWT5416BE and 2TWT54.516BE. See chart below.
- If Increased or Reduced Width or Increased or Reduced Depth is required, order WOODTOPBE.

Code	Profiled Sides	Side Details	Dimensions
3TWT4922BE	3 sides	Front, Left, Right	1 1/2" x 49" x 22"
1TWT5416BE	1 side	Front	1 1/2" x 54" x 16"
2TWT54.516BE	2 sides: 1 long, 1 short	Front, Left	1 1/2" x 54 1/2" x 16"
3TWT5516BE	3 sides	Front, Left, Right	1 1/2" x 55" x 16"
3TWT6119BE	3 sides	Front, Left, Right	1 1/2" x 61" x 19"
3TWT7322BE	3 sides	Front, Left, Right	1 1/2" x 73" x 22"
3TWT8519BE	3 sides	Front, Left, Right	1 1/2" x 85" x 19"

Modifications  
Are Not  
Available

IH/RH availability charts starting on page G•40.  
IW/RW availability charts starting on page G•46.

## Description

### ENTERTAINMENT WOOD TOPS with OGEE EDGE, 1 1/2" THICK

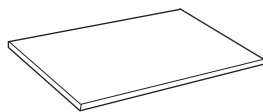

Ogee

## Model

3TWT4922OG

1TWT5416OG

2TWT54.516OG

3TWT5516OG

3TWT6119OG

3TWT7322OG

3TWT8519OG

- Profiled on 3 sides except 1TWT5416OG and 2TWT54.516OG. See chart below.
- If Increased or Reduced Width or Increased or Reduced Depth is required, order WOODTOPOG.

Code	Profiled Sides	Side Details	Dimensions
3TWT4922OG	3 sides	Front, Left, Right	1 1/2" x 49" x 22"
1TWT5416OG	1 side	Front	1 1/2" x 54" x 16"
2TWT54.516OG	2 sides: 1 long, 1 short	Front, Left	1 1/2" x 54 1/2" x 16"
3TWT5516OG	3 sides	Front, Left, Right	1 1/2" x 55" x 16"
3TWT6119OG	3 sides	Front, Left, Right	1 1/2" x 61" x 19"
3TWT7322OG	3 sides	Front, Left, Right	1 1/2" x 73" x 22"
3TWT8519OG	3 sides	Front, Left, Right	1 1/2" x 85" x 19"

Modifications  
Are Not  
Available

### ENTERTAINMENT WOOD TOPS with ROUND OVER EDGE, 1 1/2" THICK

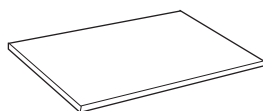

Round Over

3TWT4922RO

1TWT5416RO

2TWT54.516RO

3TWT5516RO

3TWT6119RO

3TWT7322RO

3TWT8519RO

- Profiled on 3 sides except 1TWT5416RO and 2TWT54.516RO. See chart below.
- If Increased or Reduced Width or Increased or Reduced Depth is required, order WOODTOPRO.

Code	Profiled Sides	Side Details	Dimensions
3TWT4922RO	3 sides	Front, Left, Right	1 1/2" x 49" x 22"
1TWT5416RO	1 side	Front	1 1/2" x 54" x 16"
2TWT54.516RO	2 sides: 1 long, 1 short	Front, Left	1 1/2" x 54 1/2" x 16"
3TWT5516RO	3 sides	Front, Left, Right	1 1/2" x 55" x 16"
3TWT6119RO	3 sides	Front, Left, Right	1 1/2" x 61" x 19"
3TWT7322RO	3 sides	Front, Left, Right	1 1/2" x 73" x 22"
3TWT8519RO	3 sides	Front, Left, Right	1 1/2" x 85" x 19"

Modifications  
Are Not  
Available



# Entertainment Centers

## Description

**ENTERTAINMENT WOOD TOPS with SQUARE EDGE, 1 1/2" THICK**

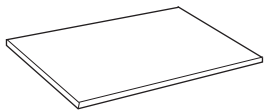

Square

## Model

**3TWT4922SE**

**1TWT5416SE**

**2TWT54.516SE**

**3TWT5516SE**

**3TWT6119SE**

**3TWT7322SE**

**3TWT8519SE**

- Profiled on 3 sides except 1TWT5416SE and 2TWT54.516SE. See chart below.
- If Increased or Reduced Width or Increased or Reduced Depth is required, order WOODTOPSE.

Code	Profiled Sides	Side Details	Dimensions
3TWT4922SE	3 sides	Front, Left, Right	1 1/2" x 49" x 22"
1TWT5416SE	1 side	Front	1 1/2" x 54" x 16"
2TWT54.516SE	2 sides: 1 long, 1 short	Front, Left	1 1/2" x 54 1/2" x 16"
3TWT5516SE	3 sides	Front, Left, Right	1 1/2" x 55" x 16"
3TWT6119SE	3 sides	Front, Left, Right	1 1/2" x 61" x 19"
3TWT7322SE	3 sides	Front, Left, Right	1 1/2" x 73" x 22"
3TWT8519SE	3 sides	Front, Left, Right	1 1/2" x 85" x 19"

Modifications  
Are Not  
Available

IH/RH availability charts starting on page G•40.  
IW/RW availability charts starting on page G•46.

## DAVIS COLLECTION A, 49" x 24 1/4" x 22"

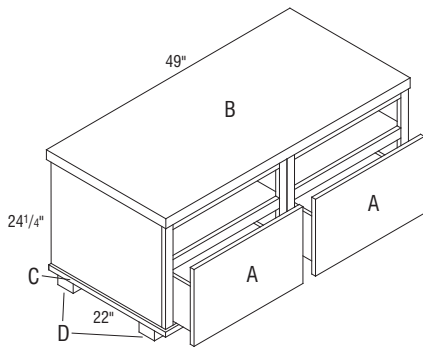

Parts Required	Quantity	Size
(A) EOD24	2	24" x 18" x 21"
(B) 3TWT4922	1	1 1/2" x 49" x 22"
(C) EP49	1	3/4" x 49" x 22"
(D) SMSQFOOT	4	3 3/4" x 3 3/4" x 4"

## DAVIS COLLECTION B, 73" x 24 1/4" x 22"

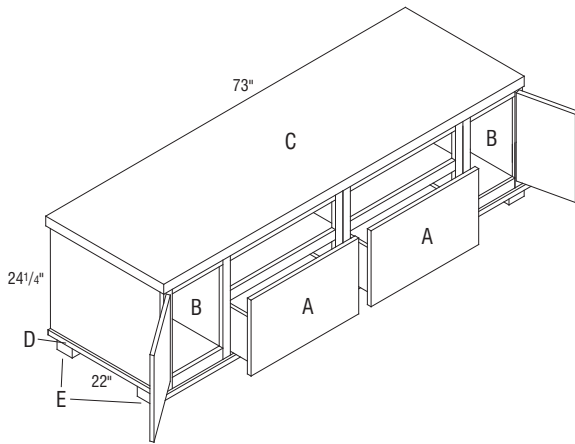

Parts Required	Quantity	Size
(A) EOD24	2	24" x 18" x 21"
(B) EB12NTK L or R	2	12" x 18" x 21"
(C) 3TWT7322	1	1 1/2" x 73" x 22"
(D) EP73	1	3/4" x 73" x 22"
(E) SMSQFOOT	6	3 3/4" x 3 3/4" x 4"

## DAVIS COLLECTION C, 73" x 61" x 22"

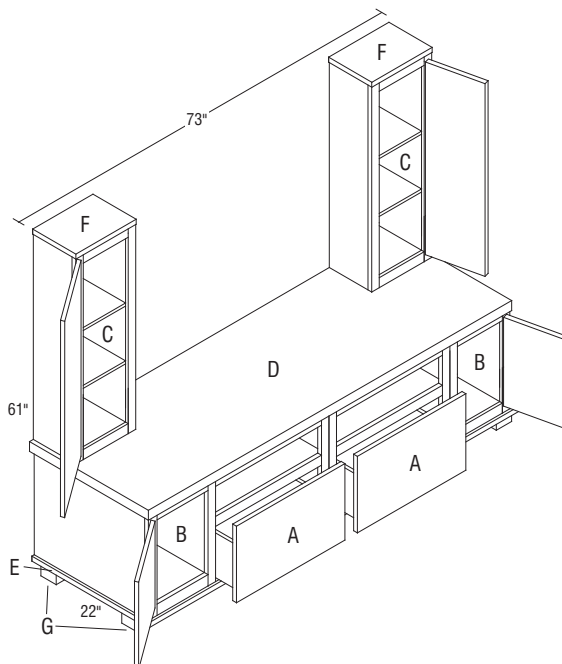

Parts Required	Quantity	Size
(A) EOD24	2	24" x 18" x 21"
(B) EB12NTK L or R	2	12" x 18" x 21"
(C) EW1236 L or R	2	12" x 36" x 9"
(D) 3TWT7322	1	1 1/2" x 73" x 22"
(E) EP73	1	3/4" x 73" x 22"
(F) ET13	2	3/4" x 13" x 10"
(G) SMSQFOOT	6	3 3/4" x 3 3/4" x 4"

# Entertainment Centers

## HUDSON COLLECTION A, 55" x 24" x 16"

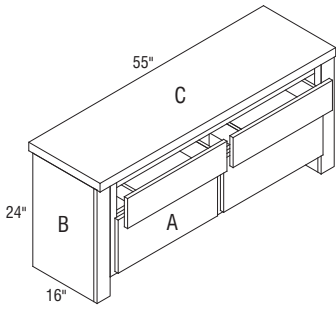

Parts Required	Quantity	Size
(A) 4EDB48NTK	1	48" x 18" x 15"
(B) EBCF322.5	2	3" x 22 1/2" x 15"
(C) 3TWT5516	1	1 1/2" x 55" x 16"

## HUDSON COLLECTION B, 73" x 59 1/4" x 19"

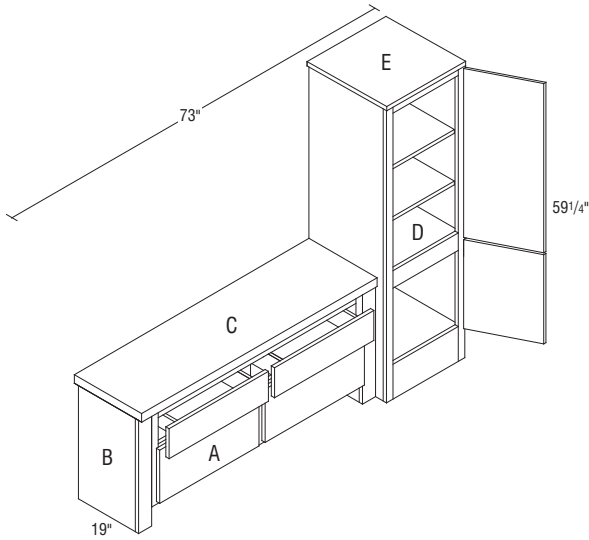

Parts Required	Quantity	Size
(A) 4EDB48NTK	1	48" x 18" x 15"
(B) EBCF322.5	2	3" x 22 1/2" x 15"
(C) 2TWT54.516	1	1 1/2" x 54 1/2" x 16"
(D) ESTW1858.5 L or R	1	18" x 58 1/2" x 18"
(E) ET19	1	3/4" x 19" x 19"

## HUDSON COLLECTION C, 91" x 59 1/4" x 19"

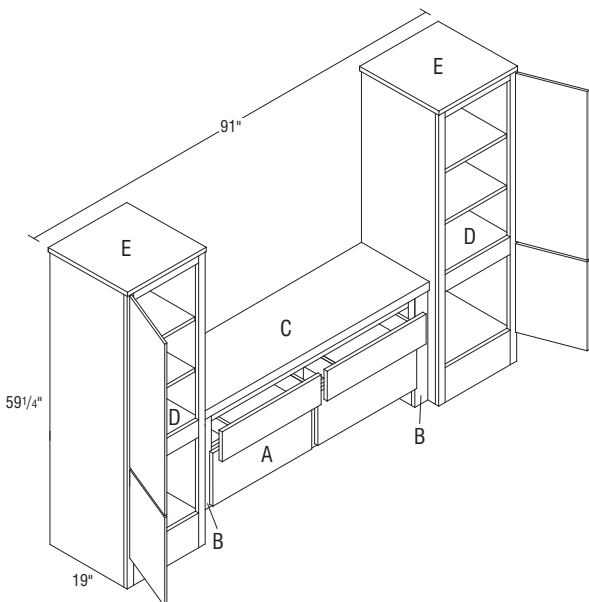

Parts Required	Quantity	Size
(A) 4EDB48NTK	1	48" x 18" x 15"
(B) EBCF322.5	2	3" x 22 1/2" x 15"
(C) 1TWT5416	1	1 1/2" x 54" x 16"
(D) ESTW1858.5 L or R	2	18" x 58 1/2" x 18"
(E) ET19	2	3/4" x 19" x 19"

## HUDSON COLLECTION D, 61" x 28 1/2" x 19"

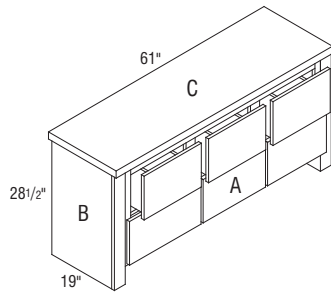

Parts Required	Quantity	Size
(A) 6EDB54	1	54" x 22 1/2" x 18"
(B) EBCF327	2	3" x 27" x 18"
(C) 3TWT6119	1	1 1/2" x 61" x 19"

## BENNETT COLLECTION A, 61" x 24" x 19"

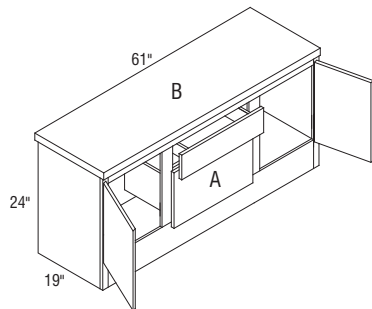

Parts Required	Quantity	Size
(A) EBDB60	1	60" x 22 1/2" x 18"
(B) 3TWT6119	1	1 1/2" x 61" x 19"

## BENNETT COLLECTION B, 85" x 28 1/2" x 19"

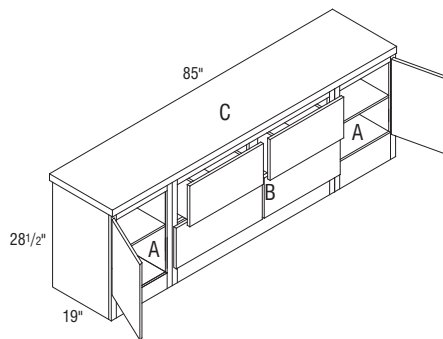

Parts Required	Quantity	Size
(A) EB18 L or R	2	18" x 27" x 18"
(B) 4EDB48	1	48" x 27" x 18"
(C) 3TWT8519	1	1 1/2" x 85" x 19"

## Description

**NEW** DESK DOOR DRAWER BASE,  
29" HIGH, 21" or 24" DEEP

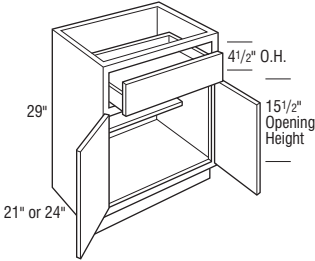
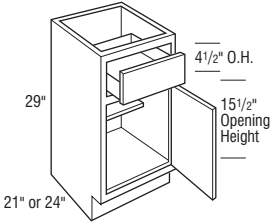

## Model

DDO122921 L or R

DDO152921 L or R

DDO182921 L or R

DDO212921 L or R

DDO242921 L or R

DDO122924 L or R

DDO152924 L or R

DDO182924 L or R

DDO212924 L or R

DDO242924 L or R

DDO242921

DDO272921

DDO302921

DDO332921

DDO362921

DDO242924

DDO272924

DDO302924

DDO332924

DDO362924

- Reduced Depths available in 1/4" increments from 12" to 23 3/4".
- Includes one adjustable half shelf.
- Fronts will not align with the 5" flush toekick Desk Cabinets.
- Base Shoe Moulding (BSM, BBM8) is not recommended.

### Door & Drawer Options

AF	CC	CG	ESMD	GAMD	IFHG	MD	MFO	PRMD <sup>1</sup>	SHMD	SPLITDR	SJMD
	✓	✓	✓	✓	✓	✓	✓	✓	✓	✓	✓

### End Panel Options

AUTH	CSFPE	EXBK	EXDN	FFD	FPE	INTGE	IPE
✓	✓	✓	✓	✓	✓	✓	✓

### Custom Modification Options

ADDTK	ADRW	BVR	CBO	CCO	CFNT0	CFP	CFRMO	CLIP <sup>2</sup>	CND	CSDGBK	EF	EX	EX_OL	FD	FLUT <sup>3</sup>	FTK	ID	IH	INVFRM	
	✓	✓	✓	✓	✓	✓	✓	✓	✓	✓	✓	✓	✓	✓	✓	✓	✓	✓	✓	✓

IW	MIP	OBRB	PFINBTMB	RD	RECTK	RECTKFRT	RH	ROSFLUT	RT	RW	STORB	TD	TKP	TVR	VTK	WS <sup>4</sup>	WTR
✓	✓	✓	✓	✓	✓	✓	✓	✓	✓	✓	✓	✓	✓	✓	✓	✓	✓

<sup>1</sup>Not available on 12" wide.

<sup>2</sup>Not available on 12" wide.

<sup>3</sup>6" Fluting not available on 12" or 15" wide. Fluting both 6" also not available on 18" or 21" wide.

<sup>4</sup>Wide stile both 3" not available on 12" wide.

## Description

### DESK OFFICE BASE with FULL HEIGHT DOORS, 29" HIGH, 24" DEEP

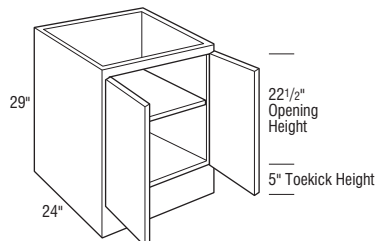
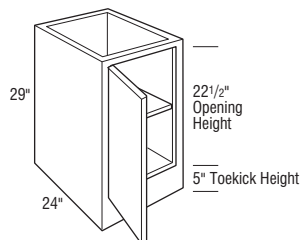

## Model

DO122924FH L or R

DO152924FH L or R

DO182924FH L or R

DO212924FH L or R

DO242924FH L or R

DO242924FH

DO272924FH

DO302924FH

DO332924FH

DO362924FH

Notes below apply to all products in section above:

- Flush Toekick standard.
- Increased Depths available in 1/4" increments from 24 1/4" to 30".
- Reduced Depths available from 1/4" increments from 6" to 23 3/4".
- The cabinet's toekick will not align with standard base and vanity cabinets.
- Base Shoe Moulding (BSM, BBM8) is not recommended.

#### Door & Drawer Options

AF	CC	CG	ESMD	GAMD	IFHG	MD	MFO	PRMD <sup>1</sup>	SHMD	SPLITDR <sup>2</sup>	SJMD
			✓	✓	✓	✓	✓	✓	✓	✓	✓

#### End Panel Options

AUTH	CSFPE	EXBK	EXDN	FFD	FPE	INTGE	IPE
✓	✓	✓		✓	✓	✓	✓

#### Custom Modification Options

ADDTK	ADRW	BVR	CBO	CCO	CFNTO	CFP	CFRMO	CLIP <sup>3</sup>	CND	CSDGBK	EF	EX	EX_OL	FD	FLUT <sup>4</sup>	FTK	ID	IH	INVFRM
			✓	✓	✓	✓	✓	✓	✓	✓	✓	✓	✓	✓	✓	✓	✓	✓	✓

IW	MIP	OBRB	PFINBTMB	RD	RECTK	RECTKFR	RH	ROSFLUT	RT	RW	STORB	TD	TKP	TVR	VTK	WS <sup>5</sup>	WTR
✓	✓			✓				✓	✓							✓	✓

<sup>1</sup>Not available on 12" wide.

<sup>2</sup>Not available on 12" to 24" (1 door) wide.

<sup>3</sup>Not available on 12" or 24" (2 doors) wide.

<sup>4</sup>6" fluting not available on 12", 15" or 24" (2 doors) wide. Fluting both 6" also not available with 18" or 21" wide.

<sup>5</sup>Not available on 24" (2 doors) wide. Wide stile both 3" also not available on 12" wide.

## Description

**NEW** DESK DRAWER BASE, 29" HIGH,  
21" or 24" DEEP

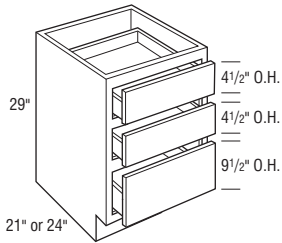

## Model

DDR122921
DDR152921
DDR182921
DDR212921
DDR242921
DDR272921
DDR302921
DDR332921
DDR362921
DDR122924
DDR152924
DDR182924
DDR212924
DDR242924
DDR272924
DDR302924
DDR332924
DDR362924

- Reduced Depths available in 1/4" increments from 12" to 23 3/4".
- Fronts will not align with the 5" flush toe-kick Desk Cabinets.

### Door & Drawer Options

AF	CC	CG	ESMD	GAMD	IFHG	MD	MFO	PRMD	SHMD	SPLITDR	SUMD
							✓				

### End Panel Options

AUTH	CSFPE	EXBK	EXDN	FFD	FPE	INTGE	IPE
✓	✓	✓		✓	✓	✓	

### Custom Modification Options

ADDTK	ADRW	BVR	CBO	CCO	CFNTD	CFP	CFRMO	CLIP	CND	CSDGBK	EF	EX	EX_OL	FD	FLUT <sup>1</sup>	FTK <sup>2</sup>	ID	IH	INVFRM	
			✓	✓	✓	✓	✓	✓	✓	✓	✓	✓	✓	✓	✓	✓	✓			

IW <sup>3</sup>	MIP	OBRB	PFINBTMB	RD	RECTK	RECTKFRT	RH	ROSFLUT	RT	RW	STORB	TD	TKP	TVR	VTK	WS	WTR
✓	✓	✓		✓	✓			✓					✓	✓	✓	✓	✓

<sup>1</sup>Not available with 6" fluting.

<sup>2</sup>Not available on 12" wide.

<sup>3</sup>Not available on 36" wide.

## DESK FILE DRAWER BASE, 29" HIGH, 24" DEEP

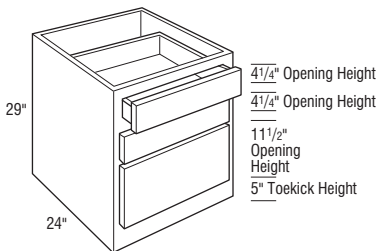

## DF3D182924

## DF3D212924

## DF3D242924

- Flush Toe-kick standard.
- Lateral Filing (Left-to-Right) system installed.
- When an Inset or Beaded Inset style is selected, drawer fronts will be slab.
- Reduced Depths available in 1/4" increments from 16" to 23 3/4".
- The cabinet's toe-kick will not align with standard base and vanity cabinets.
- Base Shoe Moulding (BSM, BBM8) is not recommended.

### Door & Drawer Options

AF	CC	CG	ESMD	GAMD	IFHG	MD	MFO	PRMD	SHMD	SPLITDR	SUMD
							✓				

### End Panel Options

AUTH	CSFPE	EXBK	EXDN	FFD	FPE	INTGE	IPE
✓	✓	✓		✓	✓	✓	✓

### Custom Modification Options

ADDTK	ADRW	BVR	CBO	CCO	CFNTD	CFP	CFRMO	CLIP	CND	CSDGBK	EF	EX	EX_OL	FD	FLUT <sup>1</sup>	FTK	ID	IH	INVFRM	
			✓	✓	✓	✓	✓	✓	✓	✓	✓	✓	✓	✓	✓	✓	✓			

IW	MIP	OBRB	PFINBTMB	RD	RECTK	RECTKFRT	RH	ROSFLUT	RT	RW <sup>2</sup>	STORB	TD	TKP	TVR	VTK	WS	WTR
✓	✓	✓		✓	✓			✓		✓			✓	✓	✓	✓	✓

<sup>1</sup>Not available with 6" fluting.

<sup>2</sup>Only available on 18" wide

IH/RH availability charts starting on page G•40.  
IW/RW availability charts starting on page G•46.

## Description

**NEW** CPU BASE, 29" HIGH, 21" or 24" DEEP

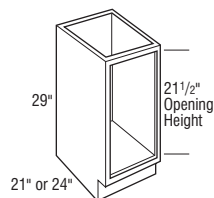

## Model

CPU122921

CPU152921

CPU122924

CPU152924

- FOL shelf width is 10 9/16".
- Inset shelf width is 8 7/16".
- Fronts will not align with the 5" flush toekick Desk Cabinets.
- Grommets required for proper ventilation.
- Reduced Depths available in 3" increments to 21".
- Base Shoe Moulding (BSM, BMB8) is not recommended.

### Door & Drawer Options

AF	CC	CG	ESMD	GAMD	IFHG	MD	MFO	PRMD	SHMD	SPLITDR	SUMD
		✓	✓	✓	✓	✓		✓	✓		✓

### End Panel Options

AUTH <sup>1</sup>	CSFPE	EXBK	EXDN	FFD	FPE	INTGE	IPE
✓	✓	✓			✓		

### Custom Modification Options

ADDTK	ADRW	BVR	CBO	CCO	CFNTD	CFP	CFRMO	CLIP	CND	CSDGBK	EF	EX	EX_OL	FD	FLUT <sup>2</sup>	FTK	ID	IH	INVFRM	
			✓	✓	✓		✓		✓		✓	✓	✓	✓	✓	✓				

IW	MIP	OBRB	PFINBTMB	RD	RECTK	RECTKFRT	RH	ROSFLUT	RT	RW	STORB	TD	TKP	TVR	VTK	WS	WTR
✓	✓	✓		✓				✓						✓	✓	✓	✓

<sup>1</sup>Only available on authentic flush ends both.

<sup>2</sup>Not available with 6" fluting.

## KEYBOARD TRAY, 5" HIGH, 21" DEEP

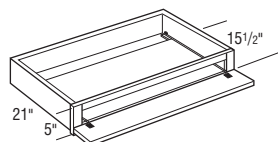
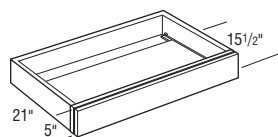

(Front tilts down, tray slides out.)

KBT2421

KBT2721

KBT3021

- Kirby will utilize a 5-piece drawer front, all other styles will be slab.
- Tray is 1/2" veneer MDF stained to match exterior finish.
- Tray slides out 15 1/2" and is 15 1/2" deep.
- Smart Stop feature not available.
- Not available on Inset or Beaded Inset door styles.

### Door & Drawer Options

AF	CC	CG	ESMD	GAMD	IFHG	MD	MFO	PRMD	SHMD	SPLITDR	SUMD
					✓						

### End Panel Options

AUTH <sup>1</sup>	CSFPE	EXBK	EXDN	FFD	FPE	INTGE	IPE
	✓	✓			✓		

### Custom Modification Options

ADDTK	ADRW	BVR	CBO	CCO	CFNTD	CFP	CFRMO	CLIP	CND	CSDGBK	EF	EX	EX_OL <sup>1</sup>	FD	FLUT <sup>2</sup>	FTK	ID	IH	INVFRM	
											✓	✓	✓		✓					

IW	MIP	OBRB	PFINBTMB	RD	RECTK	RECTKFRT	RH	ROSFLUT	RT	RW	STORB	TD	TKP	TVR	VTK	WS	WTR
	✓							✓							✓	✓	✓

<sup>1</sup>Not available with extended stile both.

<sup>2</sup>Not available with 6" fluting.



# Bookcases

## Description

### WALL BOOKCASE with ARCHED VALANCE, 48" HIGH

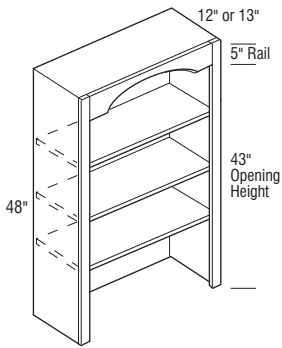

## Model

W2448BCAV

W2748BCAV

W3048BCAV

W3348BCAV

W3648BCAV

W3948BCAV

- Matching Interior standard.
- Three adjustable shelves.
- Straight Valance is standard on Beaded Inset styles.
- Arch Valance is standard; specify Straight if desired.
- Minimum cabinet width with Arch Valance is 15".
- Inset and Beaded Inset styles are a standard 13" deep.
- Full Overlay Styles:
  - Increased Depths available in 1/4" increments from 12 1/4" to 24".
  - Reduced Depths available in 1/4" increments from 6" to 11 3/4".
- Inset and Beaded Inset Styles:
  - Increased Depths available in 1/4" increments from 13 1/4" to 30".
  - Reduced Depths available in 1/4" increments from 6" to 12 3/4".

#### Door & Drawer Options

AF	CC	CG	ESMD	GAMD	IFHG	MD	MFO	PRMD	SHMD	SPLITDR	SUMD
----	----	----	------	------	------	----	-----	------	------	---------	------

#### End Panel Options

AUTH	CSFPE	EXBK	EXDN	FFD	FPE	INTGE	IPE
✓	✓	✓				✓	✓

#### Custom Modification Options

ADDTK	ADRW	BVR	CBO	CCO	CFNT0	CFP	CFRMO	CLIP	CND	CSDGBK	EF	EX	EX_OL	FD	FLUT <sup>1</sup>	FTK	ID	IH	INVERM
									✓	✓	✓	✓	✓	✓	✓	✓	✓	✓	✓

IW <sup>2</sup>	MIP	OBRB	PFINBTMB	RD	RECTK	RECTKFRT	RH <sup>3</sup>	ROSEFLUT <sup>4</sup>	RT	RW <sup>5</sup>	STORB	TD	TKP	TVR <sup>6</sup>	VTK	WS	WTR
✓				✓			✓	✓		✓				✓	✓	✓	✓

<sup>1</sup>Not available with fluting both or 6" fluting.

<sup>2</sup>Not available on 36" and 39" wide.

<sup>3</sup>Not available on 24" wide.

<sup>4</sup>Not available with fluting both.

<sup>5</sup>Only available on 24" wide.

<sup>6</sup>Not available on TVRAV

IH/RH availability charts starting on page G•40.  
IW/RW availability charts starting on page G•46.

## Description

### WALL BOOKCASE with ARCHED VALANCE, 52 1/2" HIGH

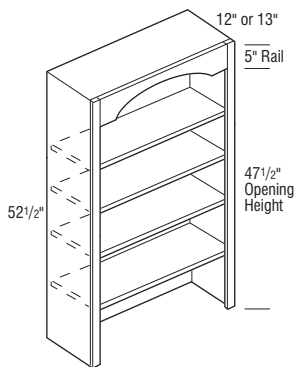

## Model

W2452BCAV

W2752BCAV

W3052BCAV

W3352BCAV

W3652BCAV

W3952BCAV

- Matching Interior standard.
- Four adjustable shelves.
- Straight Valance is standard on Beaded Inset styles.
- Arch Valance is standard; specify Straight if desired.
- Minimum cabinet width with Arch Valance is 15".
- Inset and Beaded Inset styles are a standard 13" deep.
- Full Overlay Styles:
  - Increased Depths available in 1/4" increments from 12 1/4" to 30".
  - Reduced Depths available in 1/4" increments from 6" to 11 3/4".
- Inset and Beaded Inset Styles:
  - Increased Depths available in 1/4" increments from 13 1/4" to 30".
  - Reduced Depths available in 1/4" increments from 6" to 12 3/4".

#### Door & Drawer Options

AF	CC	CG	ESMD	GAMD	IFHG	MD	MFO	PRMD	SHMD	SPLITDR	SUMD

#### End Panel Options

AUTH	CSFPE	EXBK	EXDN	FFD	FPE	INTGE	IPE
✓	✓	✓				✓	✓

#### Custom Modification Options

ADDTK	ADRW	BVR	CBO	CCO	CEN TO	CFP	CFRMO	CLIP	CND	CSDGBK	EF	EX	EX_OL	FD	FLUT <sup>1</sup>	FTK	ID	IH	INVFRM	
						✓			✓	✓	✓	✓	✓	✓	✓	✓	✓	✓	✓	

IW <sup>2</sup>	MIP	OBRB	PFINBTMB	RD	RECTK	RECTKFRT	RH <sup>3</sup>	ROSLUT <sup>4</sup>	RT	RW <sup>5</sup>	STORB	TD	TKP	TVR <sup>6</sup>	VTK	WS	WTR
✓				✓			✓	✓		✓				✓	✓	✓	✓

<sup>1</sup>Not available with fluting both or 6" fluting.

<sup>2</sup>Not available on 36" or 39" wide.

<sup>3</sup>Not available on 24" wide.

<sup>4</sup>Not available with fluting both.

<sup>5</sup>Only available on 24" wide.

<sup>6</sup>Not available on TVRAV.

# Bookcases

## Description

### WALL BOOKCASE with ARCHED VALANCE, 60" HIGH

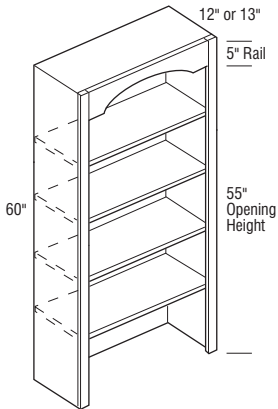

## Model

W2460BCAV

W2760BCAV

W3060BCAV

W3360BCAV

W3660BCAV

W3960BCAV

- Matching Interior standard.
- Four adjustable shelves.
- Straight Valance is standard on Beaded Inset styles.
- Arch Valance is standard; specify Straight if desired.
- Minimum cabinet width with Arch Valance is 15".
- Inset and Beaded Inset styles are a standard 13" deep.
- Full Overlay Styles:
  - Increased Depths available in 1/4" increments from 12 1/4" to 30".
  - Reduced Depths available in 1/4" increments from 6" to 11 3/4".
- Inset and Beaded Inset Styles:
  - Increased Depths available in 1/4" increments from 13 1/4" to 30".
  - Reduced Depths available in 1/4" increments from 6" to 12 3/4".

#### Door & Drawer Options

AF	CC	CG	ESMD	GAMD	IFHG	MD	MFO	PRMD	SHMD	SPLITDR	SUMD

#### End Panel Options

AUTH	CSFPE	EXBK	EXDN	FFD	FPE	INTGE	IPE
✓	✓	✓			✓	✓	✓

#### Custom Modification Options

ADDTK	ADRW	BVR	CBO	CCO	CFNT0	CFP	CFRMO	CLIP	CND	CSDGBK	EF	EX	EX_OL	FD	FLUT <sup>1</sup>	FTK	ID	IH	INVERM	
					✓			✓	✓	✓	✓	✓	✓	✓	✓	✓	✓	✓	✓	

IW <sup>2</sup>	MIP	OBRB	PFINBTMB	RD	RECTK	RECTKFRT	RH	ROSLUT <sup>3</sup>	RT	RW <sup>4</sup>	STORB	TD	TKP	TVR <sup>5</sup>	VTK	WS	WTR
✓				✓			✓	✓		✓				✓	✓	✓	✓

<sup>1</sup>Not available with fluting both or 6" fluting.

<sup>2</sup>Not available on 36" or 39" wide.

<sup>3</sup>Not available with fluting both.

<sup>4</sup>Only available on 24" wide.

<sup>5</sup>Not available on TVRAV.

IH/RH availability charts starting on page G•40.  
IW/RW availability charts starting on page G•46.

## Description

### TALL BOOKCASE with ARCHED VALANCE, 84" HIGH

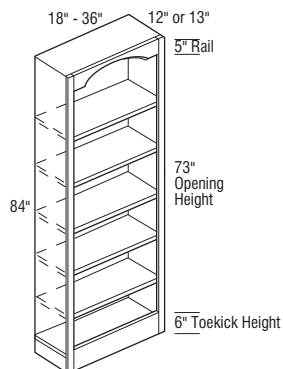

## Model

T188412BCAV

T218412BCAV

T248412BCAV

T278412BCAV

T308412BCAV

T338412BCAV

T368412BCAV

- Matching Interior and Flush Toekick standard.
- Five adjustable shelves.
- Straight Valance is standard on Beaded Inset styles.
- Arch Valance is standard; specify Straight if desired.
- Inset and Beaded Inset styles are a standard 13" deep.
- Full Overlay Styles:
  - Increased Depths available in 1/4" increments from 12 1/4" to 30".
  - Reduced Depths available in 1/4" increments from 6" to 11 3/4".
- Inset and Beaded Inset Styles:
  - Increased Depths available in 1/4" increments from 13 1/4" to 30".
  - Reduced Depths available in 1/4" increments from 6" to 12 3/4".

#### Door & Drawer Options

AF	CC	CG	ESMD	GAMD	IFHG	MD	MFO	PRMD	SHMD	SPLITDR	SUMD
----	----	----	------	------	------	----	-----	------	------	---------	------

#### End Panel Options

AUTH	CSFPE	EXBK	EXDN	FFD	FPE	INTGE	IPE
✓	✓	✓			✓	✓	✓

#### Custom Modification Options

ADDTK	ADRW	BVR	CBO	CCO	CFNT0	CFP	CFRMO	CLIP	CND	CSDGBK	EF	EX	EX_OL	FD	FLUT <sup>1</sup>	FTK <sup>2</sup>	ID	IH	INVFRM	
						✓	✓		✓		✓	✓	✓	✓	✓	✓	✓	✓	✓	

IW <sup>3</sup>	MIP	OBRB	PFINBTMB	RD	RECTK	RECTKFRT	RH	ROSFLUT <sup>4</sup>	RT	RW <sup>5</sup>	STORB	TD	TKP	TVR <sup>6</sup>	VTK	WS	WTR
✓		✓		✓	✓	✓	✓	✓	✓	✓				✓	✓	✓	✓

<sup>1</sup>Not available with fluting both or 6" fluting.

<sup>2</sup>Only available on FTKAV.

<sup>3</sup>Not available on 36" wide.

<sup>4</sup>Not available with fluting both.

<sup>5</sup>Only available on 18" wide.

<sup>6</sup>Not available on TVRAV.

# Bookcases

## Description

### TALL BOOKCASE with ARCHED VALANCE, 90" HIGH

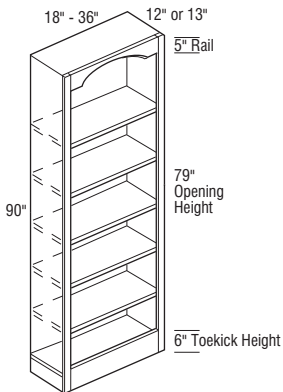

## Model

T189012BCAV

T219012BCAV

T249012BCAV

T279012BCAV

T309012BCAV

T339012BCAV

T369012BCAV

- Matching Interior and Flush ToeKick standard.
- Five adjustable shelves.
- Straight Valance is standard on Beaded Inset styles.
- Arch Valance is standard; specify Straight if desired.
- Inset and Beaded Inset styles are a standard 13" deep.
- Full Overlay Styles:
  - Increased Depths available in 1/4" increments from 12 1/4" to 30".
  - Reduced Depths available in 1/4" increments from 6" to 11 3/4".
- Inset and Beaded Inset Styles:
  - Increased Depths available in 1/4" increments from 13 1/4" to 30".
  - Reduced Depths available in 1/4" increments from 6" to 12 3/4".

#### Door & Drawer Options

AF	CC	CG	ESMD	GAMD	IFHG	MD	MFO	PRMD	SHMD	SPLITDR	SUMD
----	----	----	------	------	------	----	-----	------	------	---------	------

#### End Panel Options

AUTH	CSFPE	EXBK	EXDN	FFD	FPE	INTGE	IPE
✓	✓	✓			✓	✓	✓

#### Custom Modification Options

ADDTK	ADRW	BVR	CBO	CCO	CFNTO	CFP	CFRMO	CLIP	CND	CSDGBK	EF	EX	EX_OL	FD	FLUT <sup>1</sup>	FTK <sup>2</sup>	ID	IH	INVFRM	
					✓	✓		✓		✓	✓	✓	✓		✓	✓	✓			

IW <sup>3</sup>	MIP	OBRB	PFINBTMB	RD	RECTK	RECTKFRT	RH	ROSLUT <sup>4</sup>	RT	RW <sup>5</sup>	STORB	TD	TKP	TVR <sup>6</sup>	VTK	WS	WTR
✓		✓		✓		✓	✓	✓	✓	✓				✓	✓	✓	✓

<sup>1</sup>Not available with fluting both or 6" fluting.

<sup>2</sup>Only available on FTKAV.

<sup>3</sup>Not available on 36" wide.

<sup>4</sup>Not available with fluting both.

<sup>5</sup>Only available on 18" wide.

<sup>6</sup>Not available on TVRAV.

IH/RH availability charts starting on page G•40.  
IW/RW availability charts starting on page G•46.

## Description

### TALL BOOKCASE with ARCHED VALANCE, 96" HIGH

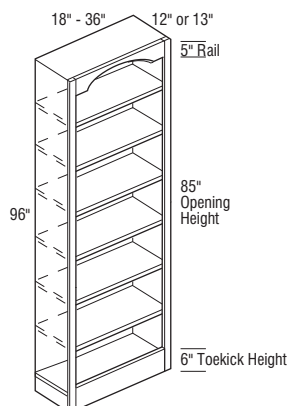

## Model

T189612BCAV

T219612BCAV

T249612BCAV

T279612BCAV

T309612BCAV

T339612BCAV

T369612BCAV

- Matching Interior and Flush Toekick standard.
- Six adjustable shelves.
- Straight Valance is standard on Beaded Inset styles.
- Arch Valance is standard; specify Straight if desired.
- Inset and Beaded Inset styles are a standard 13" deep.
- Full Overlay Styles:
  - Increased Depths available in 1/4" increments from 12 1/4" to 30".
  - Reduced Depths available in 1/4" increments from 6" to 11 3/4".
- Inset and Beaded Inset Styles:
  - Increased Depths available in 1/4" increments from 13 1/4" to 30".
  - Reduced Depths available in 1/4" increments from 6" to 12 3/4".

#### Door & Drawer Options

AF	CC	CG	ESMD	GAMD	IFHG	MD	MFO	PRMD	SHMD	SPLITDR	SUMD
----	----	----	------	------	------	----	-----	------	------	---------	------

#### End Panel Options

AUTH	CSFPE	EXBK	EXDN	FFD	FPE	INTGE	IPE
✓	✓	✓			✓	✓	✓

#### Custom Modification Options

ADDTK	ADRW	BVR	CBO	CCO	CFNT0	CFP	CFRMO	CLIP	CND	CSDGBK	EF	EX	EX_OL	FD	FLUT <sup>1</sup>	FTK <sup>2</sup>	ID	IH	INVFRM	
						✓	✓		✓		✓	✓	✓	✓	✓	✓	✓	✓	✓	

IW <sup>3</sup>	MIP	OBRB	PFINBTMB	RD	RECTK	RECTKFRT	RH	ROSFLUT <sup>4</sup>	RT	RW <sup>5</sup>	STORB	TD	TKP	TVR <sup>6</sup>	VTK	WS	WTR
✓	✓	✓		✓	✓	✓	✓	✓	✓	✓				✓	✓	✓	✓

<sup>1</sup>Not available with fluting both or 6" fluting.

<sup>2</sup>Only available on FTKAV.

<sup>3</sup>Not available on 36" wide.

<sup>4</sup>Not available with fluting both.

<sup>5</sup>Only available on 18" wide.

<sup>6</sup>Not available on TVRAV.

# Bookcases

## Description

## Model

### TALL BOOKCASE with DOORS and ARCHED VALANCE, 84" HIGH

TD188412BCAV L or R

TD218412BCAV L or R

TD248412BCAV L or R

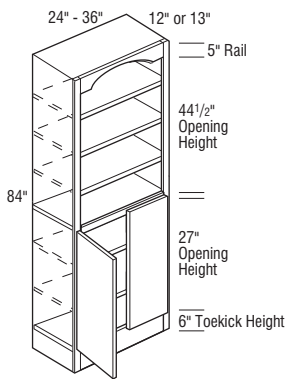
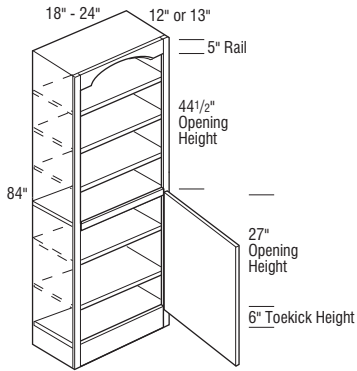

TD248412BCAV

TD278412BCAV

TD308412BCAV

TD338412BCAV

TD368412BCAV

Notes below apply to all products in section above:

- Matching Interior and Flush Toe Kick standard.
- Five adjustable shelves.
- Straight Valance is standard on Beaded Inset styles.
- Arch Valance is standard; specify Straight if desired.
- Inset and Beaded Inset styles are a standard 13" deep.
- Full Overlay Styles:
  - Increased Depths available in 1/4" increments from 12 1/4" to 30".
  - Reduced Depths available in 1/4" increments from 6" to 11 3/4".
- Inset and Beaded Inset Styles:
  - Increased Depths available in 1/4" increments from 13 1/4" to 30".
  - Reduced Depths available in 1/4" increments from 6" to 12 3/4".

#### Door & Drawer Options

AF	CC	CG	ESMD	GAMD	IFHG	MD	MFO <sup>1</sup>	PRMD	SHMD	SPLITDR <sup>2</sup>	SUMD
					✓		✓		✓	✓	

#### End Panel Options

AUTH	CSFPE	EXBK	EXDN	FFD	FPE	INTGE	IPE
✓	✓	✓				✓	✓

#### Custom Modification Options

ADDTK	ADRW	BVR	CBO	CCO <sup>3</sup>	CFNT0	CFP <sup>4</sup>	CFRMO <sup>1</sup>	CLIP	CND <sup>5</sup>	CSDGBK	EF	EX	EX_OL	FD	FLUT <sup>6</sup>	FTK <sup>7</sup>	ID	IH	INVFRM	
✓	✓	✓	✓	✓	✓	✓	✓	✓	✓	✓	✓	✓	✓	✓	✓	✓	✓	✓	✓	✓

IW <sup>8</sup>	MIP	OBRB	PFINBTMB	RD	RECTK	RECTKFRT	RH	ROSELUT <sup>9</sup>	RT	RW <sup>10</sup>	STORB	TD <sup>11</sup>	TKP	TVR <sup>12</sup>	VTK	WS	WTR	
✓	✓	✓	✓	✓	✓	✓	✓	✓	✓	✓	✓	✓	✓	✓	✓	✓	✓	✓

<sup>1</sup>Only available on 24" (1 door) wide.

<sup>2</sup>Not available on 18"-24" (1 door) wide.

<sup>3</sup>Only available on 24" (1 door and 2 doors) wide.

<sup>4</sup>Only available on 27"-36" wide.

<sup>5</sup>Not available on 24" (1 door) wide.

<sup>6</sup>Not available with fluting both or 6" fluting.

<sup>7</sup>Only available on FIKAV.

<sup>8</sup>Not available on 24" (1 door) or 36" wide.

<sup>9</sup>Not available with fluting both.

<sup>10</sup>Only available on 18" wide.

<sup>11</sup>Not available on 24" (2 doors) wide.

<sup>12</sup>Not available on TVRAV.

IH/RH availability charts starting on page G•40.  
IW/RW availability charts starting on page G•46.

## Description

### TALL BOOKCASE with DOORS and ARCHED VALANCE, 90" HIGH

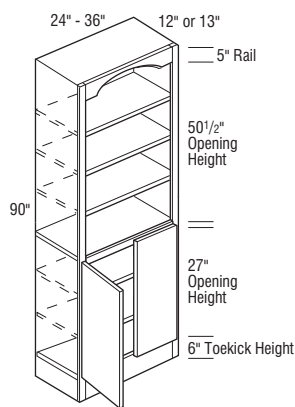
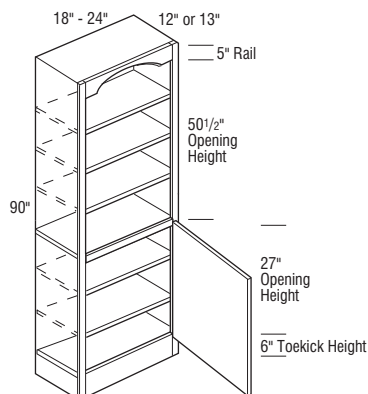

## Model

TD189012BCAV L or R

TD219012BCAV L or R

TD249012BCAV L or R

TD249012BCAV

TD279012BCAV

TD309012BCAV

TD339012BCAV

TD369012BCAV

Notes below apply to all products in section above:

- Matching Interior and Flush Toe Kick standard.
- Five adjustable shelves.
- Straight Valance is standard on Beaded Inset styles.
- Arch Valance is standard; specify Straight if desired.
- Inset and Beaded Inset styles are a standard 13" deep.
- Full Overlay Styles:
  - Increased Depths available in 1/4" increments from 12 1/4" to 30".
  - Reduced Depths available in 1/4" increments from 6" to 11 3/4".
- Inset and Beaded Inset Styles:
  - Increased Depths available in 1/4" increments from 13 1/4" to 30".
  - Reduced Depths available in 1/4" increments from 6" to 12 3/4".

#### Door & Drawer Options

AF	CC	CG	ESMD	GAMD	IFHG	MD	MFO <sup>1</sup>	PRMD	SHMD	SPLITDR <sup>2</sup>	SJMD
					✓		✓		✓	✓	

#### End Panel Options

AUTH	CSPE	EXBK	EXDN	FFD	FPE	INTGE	IPE
✓	✓	✓		✓	✓	✓	✓

#### Custom Modification Options

ADDTK	ADRW	BVR	CBO	CCO <sup>3</sup>	CFNT0	CFP <sup>4</sup>	CFRMO <sup>1</sup>	CLIP	CND <sup>5</sup>	CSDGBK	EF	EX	EX_OL	FLUT <sup>6</sup>	FLUT <sup>6</sup>	FTK <sup>7</sup>	ID	IH	INVERM	
				✓	✓	✓	✓	✓	✓	✓	✓	✓	✓	✓	✓	✓	✓	✓	✓	✓

IW <sup>8</sup>	MIP	OBRB	PFINBTMB	RD	RECTK	RECTKFRT	RH	ROSFLUT <sup>9</sup>	RT	RW <sup>10</sup>	STORB	TD <sup>11</sup>	TKP	TVR <sup>12</sup>	VTK	WS	WTR
✓		✓		✓		✓	✓	✓	✓	✓	✓	✓	✓	✓	✓	✓	✓

<sup>1</sup>Only available on 24" (1 door) wide.

<sup>2</sup>Not available on 18"-24" (1 door) wide.

<sup>3</sup>Only available on 24" (1 door and 2 doors) wide.

<sup>4</sup>Only available on 27"-36" wide.

<sup>5</sup>Not available on 24" (1 door) wide.

<sup>6</sup>Not available with fluting both or 6" fluting.

<sup>7</sup>Only available on FTKAV.

<sup>8</sup>Not available on 24" (1 door) or 36" wide.

<sup>9</sup>Not available with fluting both.

<sup>10</sup>Only available on 18" wide.

<sup>11</sup>Not available on 24" (2 doors) wide.

<sup>12</sup>Not available on TVRAV.



# Bookcases

## Description

## Model

**TALL BOOKCASE with DOORS and ARCHED VALANCE, 96" HIGH**

**TD189612BCAV L or R**

**TD219612BCAV L or R**

**TD249612BCAV L or R**

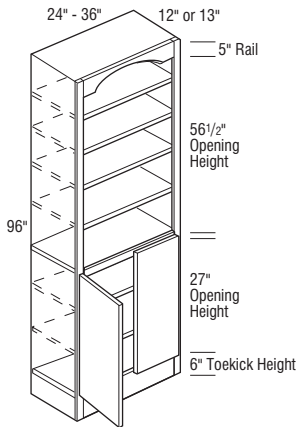
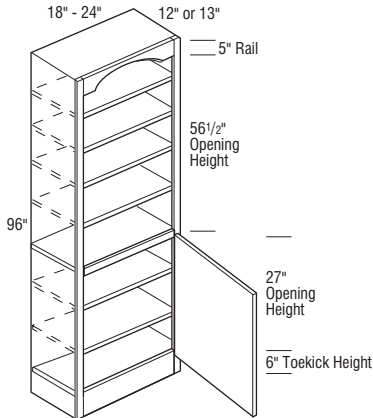

**TD249612BCAV**

**TD279612BCAV**

**TD309612BCAV**

**TD339612BCAV**

**TD369612BCAV**

Notes below apply to all products in section above:

- Matching Interior and Flush Toekick standard.
- Six adjustable shelves.
- Straight Valance is standard on Beaded Inset styles.
- Arch Valance is standard; specify Straight if desired.
- Inset and Beaded Inset styles are a standard 13" deep.
- Full Overlay Styles:
  - Increased Depths available in 1/4" increments from 12 1/4" to 30".
  - Reduced Depths available in 1/4" increments from 6" to 11 3/4".
- Inset and Beaded Inset Styles:
  - Increased Depths available in 1/4" increments from 13 1/4" to 30".
  - Reduced Depths available in 1/4" increments from 6" to 12 3/4".

### Door & Drawer Options

AF	CC	CG	ESMD	GAMD	IFHG	MD	MFO <sup>1</sup>	PRMD	SHMD	SPLITDR <sup>2</sup>	SUMD
					✓		✓		✓	✓	

### End Panel Options

AUTH	CSFPE	EXBK	EXDN	FFD	FPE	INTGE	IPE
✓	✓	✓				✓	✓

### Custom Modification Options

ADDTK	ADRW	BVR	CBO	CCO <sup>3</sup>	CFNT0	CFP <sup>4</sup>	CFRMO <sup>1</sup>	CLIP	CND <sup>5</sup>	CSDGBK	EF	EX	EX_OL	FD	FLUT <sup>6</sup>	FTK <sup>7</sup>	ID	IH	INVFRM	
											✓	✓	✓	✓	✓	✓	✓	✓	✓	✓

IW <sup>8</sup>	MIP	OBRB	PFINBTMB	RD	RECTK	RECTKFRT	RH	ROSELUT <sup>9</sup>	RT	RW <sup>10</sup>	STORB	TD <sup>11</sup>	TKP	TVR <sup>12</sup>	VTK	WS	WTR
✓		✓		✓		✓	✓	✓	✓	✓		✓		✓	✓	✓	✓

<sup>1</sup>Only available on 24" (1 door) wide.

<sup>2</sup>Not available on 18"-24" (1 door) wide.

<sup>3</sup>Only available on 24" (1 door and 2 doors) wide.

<sup>4</sup>Only available on 27"-36" wide.

<sup>5</sup>Not available on 24" (1 door) wide.

<sup>6</sup>Not available with fluting both or 6" fluting.

<sup>7</sup>Only available on FIKAV.

<sup>8</sup>Not available on 24" (1 door) or 36" wide.

<sup>9</sup>Not available with fluting both.

<sup>10</sup>Only available on 18" wide.

<sup>11</sup>Not available on 24" (2 doors) wide.

<sup>12</sup>Not available on TVRAV.

IH/RH availability charts starting on page G•40.  
IW/RW availability charts starting on page G•46.

## Description

### TALL BOOKCASE with VANITY HEIGHT DOORS and ARCHED VALANCE, 84" HIGH

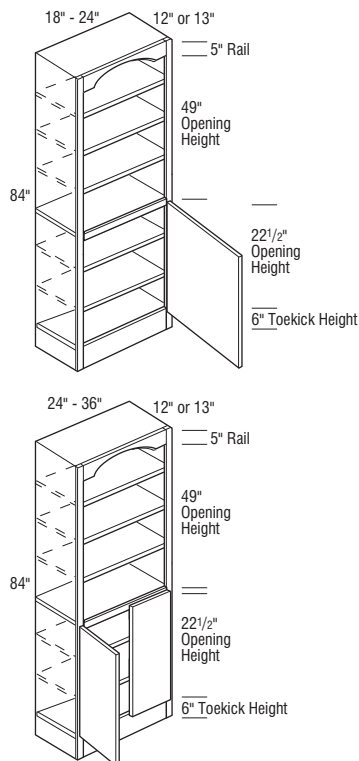

## Model

TDV188412BCAV L or R

TDV218412BCAV L or R

TDV248412BCAV L or R

TDV248412BCAV

TDV278412BCAV

TDV308412BCAV

TDV338412BCAV

TDV368412BCAV

#### Notes below apply to all products in section above:

- Matching Interior and Flush Toekick standard.
- Five adjustable shelves.
- Straight Valance is standard on Beaded Inset styles.
- Arch Valance is standard; specify Straight if desired.
- Inset and Beaded Inset styles are a standard 13" deep.
- Full Overlay Styles:
  - Increased Depths available in 1/4" increments from 12 1/4" to 30".
  - Reduced Depths available in 1/4" increments from 6" to 11 3/4".
- Inset and Beaded Inset Styles:
  - Increased Depths available in 1/4" increments from 13 1/4" to 30".
  - Reduced Depths available in 1/4" increments from 6" to 12 3/4".

#### Door & Drawer Options

AF	CC	CG	ESMD	GAMD	IFHG	MD	MFO <sup>1</sup>	PRMD	SHMD	SPLITDR <sup>2</sup>	SJMD
					✓		✓		✓	✓	

#### End Panel Options

AUTH	CSFPE	EXBK	EXDN	FFD	FPE	INTGE	IPE
✓	✓	✓		✓	✓	✓	✓

#### Custom Modification Options

ADDTK	ADRW	BVR	CBO	CCO <sup>3</sup>	CFNT0	CFP <sup>4</sup>	CFRMO <sup>1</sup>	CLIP	CND <sup>4</sup>	CSDGBK	EF	EX	EX_OL	FD	FLUT <sup>5</sup>	FTK <sup>6</sup>	ID	IH	INVERM		
✓			✓	✓	✓	✓	✓	✓	✓	✓	✓	✓	✓	✓	✓	✓	✓	✓	✓	✓	
IW <sup>7</sup>	MIP	OBRB	PFINBTMB	RD	RECTK	RECTKFRT	RH	ROSFLUT <sup>8</sup>	RT	RW <sup>9</sup>	STORB	TD <sup>10</sup>	TKP	TVR <sup>11</sup>	VTK	WS	WTR				
✓		✓		✓	✓	✓	✓	✓	✓	✓	✓	✓	✓	✓	✓	✓	✓	✓			

<sup>1</sup>Only available on 24" (1 door) wide.

<sup>2</sup>Only available on 27"-36" wide.

<sup>3</sup>Only available on 24" (1 door and 2 doors) wide.

<sup>4</sup>Not available on 24" (1 door) wide.

<sup>5</sup>Not available with fluting both or 6" fluting.

<sup>6</sup>Only available on FTKAV.

<sup>7</sup>Not available on 24" (1 door) or 36" wide.

<sup>8</sup>Not available with fluting both.

<sup>9</sup>Only available on 18" wide.

<sup>10</sup>Not available on 24" (2 doors) wide.

<sup>11</sup>Not available on TVRAV.

# Bookcases

## Description

### TALL BOOKCASE with VANITY HEIGHT DOORS and ARCHED VALANCE, 90" HIGH

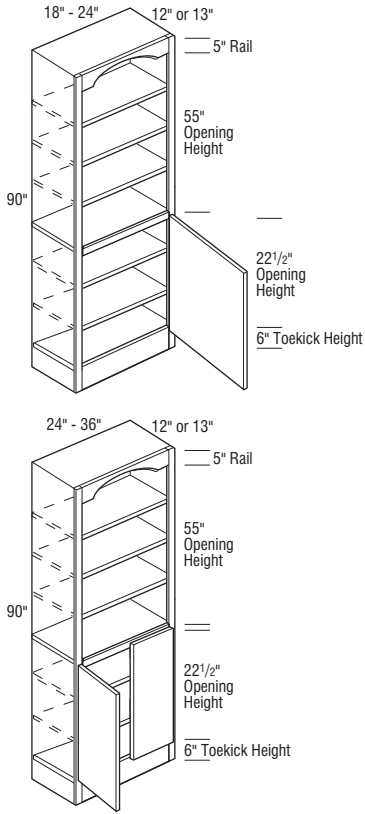

## Model

**TDV189012BCAV L or R**

**TDV219012BCAV L or R**

**TDV249012BCAV L or R**

**TDV249012BCAV**

**TDV279012BCAV**

**TDV309012BCAV**

**TDV339012BCAV**

**TDV369012BCAV**

Notes below apply to all products in section above:

- Matching Interior and Flush Toekick standard.
- Five adjustable shelves.
- Straight Valance is standard on Beaded Inset styles.
- Arch Valance is standard; specify Straight if desired.
- Inset and Beaded Inset styles are a standard 13" deep.
- Full Overlay Styles:
  - Increased Depths available in 1/4" increments from 12 1/4" to 30".
  - Reduced Depths available in 1/4" increments from 6" to 11 3/4".
- Inset and Beaded Inset Styles:
  - Increased Depths available in 1/4" increments from 13 1/4" to 30".
  - Reduced Depths available in 1/4" increments from 6" to 12 3/4".

#### Door & Drawer Options

AF	CC	CG	ESMD	GAMD	IFHG	MD	MFO <sup>1</sup>	PRMD	SHMD	SPLITDR <sup>2</sup>	SUMD
					✓		✓		✓	✓	

#### End Panel Options

AUTH	CSFPE	EXBK	EXDN	FFD	FPE	INTGE	IPE
✓	✓	✓				✓	✓

#### Custom Modification Options

ADDTK	ADRW	BVR	CBO	CCO <sup>3</sup>	CFNT0	CFP <sup>4</sup>	CFRMO <sup>1</sup>	CLIP	CND <sup>4</sup>	CSDGBK	EF	EX	EX_OL	FD	FLUT <sup>5</sup>	FTK <sup>6</sup>	ID	IH	INVRM	
✓	✓	✓	✓	✓	✓	✓	✓	✓	✓	✓	✓	✓	✓	✓	✓	✓	✓	✓	✓	✓

IW <sup>7</sup>	MIP	OBRB	PFINBTMB	RD	RECTK	RECTKFT	RH	ROSELUT <sup>8</sup>	RT	RW <sup>9</sup>	STORB	TD <sup>10</sup>	TKP	TVR <sup>11</sup>	VTK	WS	WTR
✓	✓	✓	✓	✓	✓	✓	✓	✓	✓	✓	✓	✓	✓	✓	✓	✓	✓

<sup>1</sup>Only available on 24" (1 door) wide.

<sup>2</sup>Only available on 27"-36" wide.

<sup>3</sup>Only available on 24" (1 door and 2 doors) wide.

<sup>4</sup>Not available on 24" (1 door) wide.

<sup>5</sup>Not available with fluting both or 6" fluting.

<sup>6</sup>Only available on FTKAV.

<sup>7</sup>Not available on 24" (1 door) or 36" wide.

<sup>8</sup>Not available with fluting both.

<sup>9</sup>Only available on 18" wide.

<sup>10</sup>Not available on 24" (2 doors) wide.

<sup>11</sup>Not available on TVRAV.

IH/RH availability charts starting on page G•40.  
IW/RW availability charts starting on page G•46.

## Description

### TALL BOOKCASE with VANITY HEIGHT DOORS and ARCHED VALANCE, 96" HIGH

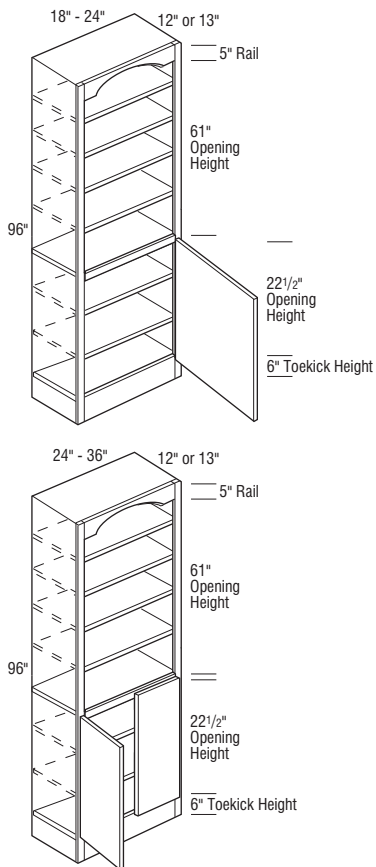

## Model

**TDV189612BCAV L or R**

**TDV219612BCAV L or R**

**TDV249612BCAV L or R**

**TDV249612BCAV**

**TDV279612BCAV**

**TDV309612BCAV**

**TDV339612BCAV**

**TDV369612BCAV**

Notes below apply to all products in section above:

- Matching Interior and Flush Toe kick standard.
- Six adjustable shelves.
- Straight Valance is standard on Beaded Inset styles.
- Arch Valance is standard; specify Straight if desired.
- Inset and Beaded Inset styles are a standard 13" deep.
- Full Overlay Styles:
  - Increased Depths available in 1/4" increments from 12 1/4" to 30".
  - Reduced Depths available in 1/4" increments from 6" to 11 3/4".
- Inset and Beaded Inset Styles:
  - Increased Depths available in 1/4" increments from 13 1/4" to 30".
  - Reduced Depths available in 1/4" increments from 6" to 12 3/4".

#### Door & Drawer Options

AF	CC	CG	ESMD	GAMD	IFHG	MD	MFO <sup>1</sup>	PRMD	SHMD	SPLITDR	SUMD
					✓		✓		✓		

#### End Panel Options

AUTH	CSPE	EXBK	EXDN	FFD	FPE	INTGE	IPE
✓	✓	✓		✓	✓	✓	✓

#### Custom Modification Options

ADDTK	ADRW	BVR	CBO	CCO <sup>2</sup>	CFNT0	CFP <sup>3</sup>	CFRMO <sup>1</sup>	CLIP	CND <sup>3</sup>	CSDGBK	EF	EX	EX_OL	FD	FLUT <sup>4</sup>	FTK <sup>5</sup>	ID	IH	INVERM	
				✓	✓	✓	✓	✓	✓	✓	✓	✓	✓	✓	✓	✓	✓	✓	✓	✓

IW <sup>6</sup>	MIP	OBRB	PFINBTMB	RD	RECTK	RECTKFRT	RH	ROSFLUT <sup>7</sup>	RT	RW <sup>8</sup>	STORB	TD <sup>9</sup>	TKP	TVR <sup>10</sup>	VTK	WS	WTR
✓		✓		✓		✓	✓	✓	✓	✓	✓	✓	✓	✓	✓	✓	✓

<sup>1</sup>Only available on 24" (1 door) wide.

<sup>2</sup>Only available on 24" (1 door and 2 doors) wide.

<sup>3</sup>Not available on 24" (1 door) wide.

<sup>4</sup>Not available with fluting both or 6" fluting.

<sup>5</sup>Only available on FTKAV.

<sup>6</sup>Not available on 24" (1 door) or 36" wide.

<sup>7</sup>Not available with fluting both.

<sup>8</sup>Only available on 18" wide.

<sup>9</sup>Not available on 24" (2 doors) wide.

<sup>10</sup>Not available on TVRAV.

# Bookcases

## Description

### TALL BOOKCASE with OFFICE HEIGHT DOORS and ARCHED VALANCE, 84" HIGH

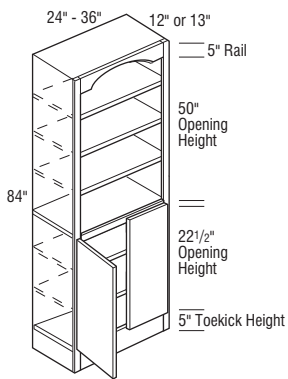
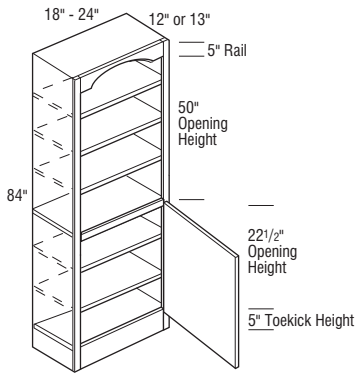

## Model

TDO188412BCAV L or R

TDO218412BCAV L or R

TDO248412BCAV L or R

TDO248412BCAV

TDO278412BCAV

TDO308412BCAV

TDO338412BCAV

TDO368412BCAV

#### Notes below apply to all products in section above:

- Matching Interior and Flush Toe kick standard.
- Five adjustable shelves.
- Straight Valance is standard on Beaded Inset styles.
- Arch Valance is standard; specify Straight if desired.
- Inset and Beaded Inset styles are a standard 13" deep.
- Full Overlay Styles:
  - Increased Depths available in 1/4" increments from 12 1/4" to 30".
  - Reduced Depths available in 1/4" increments from 6" to 11 3/4".
- Inset and Beaded Inset Styles:
  - Increased Depths available in 1/4" increments from 13 1/4" to 30".
  - Reduced Depths available in 1/4" increments from 6" to 12 3/4".

#### Door & Drawer Options

AF	CC	CG	ESMD	GAMD	IFHG	MD	MFO <sup>1</sup>	PRMD	SHMD	SPLITDR <sup>2</sup>	SUMD
					✓		✓		✓	✓	

#### End Panel Options

AUTH	CSFPE	EXBK	EXDN	FFD	FPE	INTGE	IPE
✓	✓	✓				✓	✓

#### Custom Modification Options

ADDTK	ADRW	BVR	CBO	CCO <sup>3</sup>	CFNT0	CFP <sup>4</sup>	CFRMO <sup>1</sup>	CLIP	CND <sup>4</sup>	CSDGBK	EF	EX	EX_OL	FD	FLUT <sup>5</sup>	FTK <sup>6</sup>	ID	IH	INVFRM
✓	✓										✓	✓	✓	✓	✓	✓	✓	✓	✓

IW <sup>7</sup>	MIP	OBRB	PFINBTMB	RD	RECTK	RECTKFRT	RH	ROSELUT <sup>8</sup>	RT	RW <sup>9</sup>	STORB	TD <sup>10</sup>	TKP	TVR <sup>11</sup>	VTK	WS	WTR
✓		✓						✓	✓	✓	✓	✓	✓	✓	✓	✓	✓

<sup>1</sup>Only available on 24" (1 door) wide.  
<sup>2</sup>Only available on 24" (2 doors)-36" wide.  
<sup>3</sup>Only available on 24" (1 door and 2 doors) wide.  
<sup>4</sup>Not available on 24" (1 door) wide.  
<sup>5</sup>Not available with fluting both or 6" fluting.  
<sup>6</sup>Only available on FTKAV.  
<sup>7</sup>Not available on 24" (1 door) or 36" wide.  
<sup>8</sup>Not available with fluting both.  
<sup>9</sup>Only available on 18" wide.  
<sup>10</sup>Not available on 24" (2 doors) wide.  
<sup>11</sup>Not available on TVRAV.

IH/RH availability charts starting on page G•40.  
 IW/RW availability charts starting on page G•46.

## Description

### TALL BOOKCASE with OFFICE HEIGHT DOORS and ARCHED VALANCE, 90" HIGH

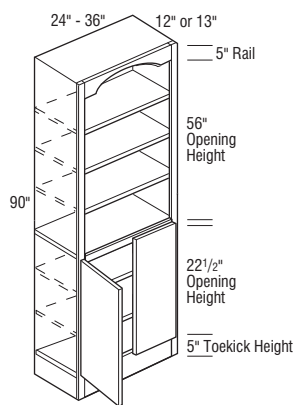
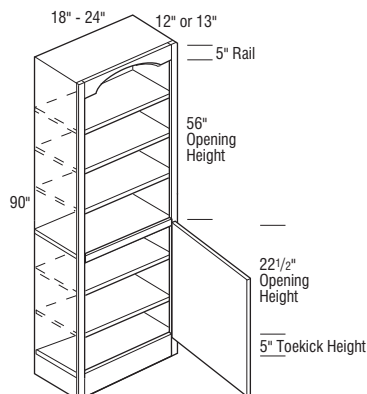

## Model

TDO189012BCAV L or R

TDO219012BCAV L or R

TDO249012BCAV L or R

TDO249012BCAV

TDO279012BCAV

TDO309012BCAV

TDO339012BCAV

TDO369012BCAV

#### Notes below apply to all products in section above:

- Matching Interior and Flush Toe-kick standard.
- Five adjustable shelves.
- Straight Valance is standard on Beaded Inset styles.
- Arch Valance is standard; specify Straight if desired.
- Inset and Beaded Inset styles are a standard 13" deep.
- Full Overlay Styles:
  - Increased Depths available in 1/4" increments from 12 1/4" to 30".
  - Reduced Depths available in 1/4" increments from 6" to 11 3/4".
- Inset and Beaded Inset Styles:
  - Increased Depths available in 1/4" increments from 13 1/4" to 30".
  - Reduced Depths available in 1/4" increments from 6" to 12 3/4".

#### Door & Drawer Options

AF	CC	CG	ESMD	GAMD	IFHG	MD	MFO <sup>1</sup>	PRMD	SHMD	SPLITDR <sup>2</sup>	SJMD
					✓		✓		✓	✓	

#### End Panel Options

AUTH	CSFPE	EXBK	EXDN	FFD	FPE	INTGE	IPE
✓	✓	✓		✓	✓	✓	✓

#### Custom Modification Options

ADDTK	ADRW	BVR	CBO	CCO <sup>3</sup>	CFNT0	CFP <sup>4</sup>	CFRMO <sup>1</sup>	CLIP	CND <sup>4</sup>	CSDGBK	EF	EX	EX_OL	FD	FLUT <sup>5</sup>	FTK <sup>6</sup>	ID	IH	INVERM	
✓		✓		✓	✓	✓	✓	✓	✓	✓	✓	✓	✓	✓	✓	✓	✓	✓	✓	✓
IW <sup>7</sup>	MIP	OBRB	PFINBTMB	RD	RECTK	RECTKFRT	RH	ROSFLUT <sup>8</sup>	RT	RW <sup>9</sup>	STORB	TD <sup>10</sup>	TKP	TVR <sup>11</sup>	VTK	WS	WTR			
✓		✓		✓			✓	✓	✓	✓	✓	✓	✓	✓	✓	✓	✓			

<sup>1</sup>Only available on 24" (1 door) wide.

<sup>2</sup>Only available on 24" (2 doors)-36" wide.

<sup>3</sup>Only available on 24" (1 door and 2 doors) wide.

<sup>4</sup>Not available on 24" (1 door) wide.

<sup>5</sup>Not available with fluting both or 6" fluting.

<sup>6</sup>Only available on FTKAV.

<sup>7</sup>Not available on 24" (1 door) or 36" wide.

<sup>8</sup>Not available with fluting both.

<sup>9</sup>Only available on 18" wide.

<sup>10</sup>Not available on 24" (2 doors) wide.

<sup>11</sup>Not available on TVRAV.

# Bookcases

## Description

**TALL BOOKCASE with OFFICE HEIGHT DOORS and ARCHED VALANCE, 96" HIGH**

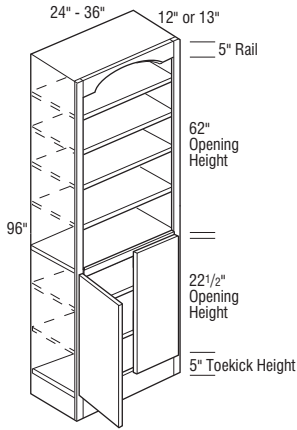
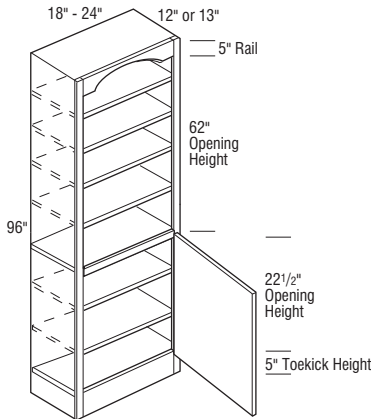

## Model

**TDO189612BCAV L or R**

**TDO219612BCAV L or R**

**TDO249612BCAV L or R**

**TDO249612BCAV**

**TDO279612BCAV**

**TDO309612BCAV**

**TDO339612BCAV**

**TDO369612BCAV**

Notes below apply to all products in section above:

- Matching Interior and Flush Toe Kick standard.
- Six adjustable shelves.
- Straight Valance is standard on Beaded Inset styles.
- Arch Valance is standard; specify Straight if desired.
- Inset and Beaded Inset styles are a standard 13" deep.
- Full Overlay Styles:
  - Increased Depths available in 1/4" increments from 12 1/4" to 30".
  - Reduced Depths available in 1/4" increments from 6" to 11 3/4".
- Inset and Beaded Inset Styles:
  - Increased Depths available in 1/4" increments from 13 1/4" to 30".
  - Reduced Depths available in 1/4" increments from 6" to 12 3/4".

### Door & Drawer Options

AF	CC	CG	ESMD	GAMD	IFHG	MD	MFO <sup>1</sup>	PRMD	SHMD	SPLITDR <sup>2</sup>	SUMD
					✓		✓		✓	✓	

### End Panel Options

AUTH	CSFPE	EXBK	EXDN	FFD	FPE	INTGE	IPE
✓	✓	✓				✓	✓

### Custom Modification Options

ADDTK	ADRW	BVR	CBO	CCO <sup>3</sup>	CFNT0	CFP <sup>4</sup>	CFRMO <sup>1</sup>	CLIP	CND <sup>4</sup>	CSDGBK	EF	EX	EX_OL	FD	FLUT <sup>5</sup>	FTK <sup>6</sup>	ID	IH	INVRM	
✓	✓	✓	✓	✓	✓	✓	✓	✓	✓	✓	✓	✓	✓	✓	✓	✓	✓	✓	✓	✓

IW <sup>7</sup>	MIP	OBRB	PFINBTMB	RD	RECTK	RECTKFRT	RH	ROSELUT <sup>8</sup>	RT	RW <sup>9</sup>	STORB	TD <sup>10</sup>	TKP	TVR <sup>11</sup>	VTK	WS	WTR
✓	✓	✓	✓	✓	✓	✓	✓	✓	✓	✓	✓	✓	✓	✓	✓	✓	✓

<sup>1</sup>Only available on 24" (1 door) wide.  
<sup>2</sup>Only available on 24" (2 doors)-36" wide.  
<sup>3</sup>Only available on 24" (1 door and 2 doors) wide.  
<sup>4</sup>Not available on 24" (1 door) wide.  
<sup>5</sup>Not available with fluting both or 6" fluting.  
<sup>6</sup>Only available on FTKAV.  
<sup>7</sup>Not available on 24" (1 door) or 36" wide.  
<sup>8</sup>Not available with fluting both.  
<sup>9</sup>Only available on 18" wide.  
<sup>10</sup>Not available on 24" (2 doors) wide.  
<sup>11</sup>Not available on TVRAV.

IH/RH availability charts starting on page G•40.  
 IW/RW availability charts starting on page G•46.

# Kemper Emerge Modification Option Descriptions

Your Kemper Emerge specification guide contains charts with modification option codes for each applicable cabinetry product. Reference the listing below to identify the modification description.

Door & Drawer Options	
Option	Description
CC	Craftsman Door
CG	Cut-for-glass
ESMD	Estate Mullion Door
GAMD	Gallery Mullion Door
HC	Horizon Door
IFHG	Inset Finial Hinges
MC	Mission Door
MD	Mullion Door
MFO	Modified Full Overlay
PRMD	Prairie Mullion Door
SHMD	Shaker Mullion Door
SPLITDR	Split Doors
SPLITDRWS	Split Drawers
SUMD	Summit Mullion Door
TCG	Transom w/Top Cut-for-glass and Bottom Center Panel
TCP	Transom w/both sections Center Panels

End Panel Options	
Option	Description
AUTH	Authentic Flush End
CSFPE	Car Siding Flush Panel End
EXBK	End Extended Back
EXDN	Wall End and Back Extended Down
FFD	Face Frame and Door on End
FPE	Flush Panel End
INTGE	Integral End
IPE	Inset Panel Ends

Custom Modification Options	
Option	Description
ADD_SHLF	Add Shelf
ADRW	Add Drawer Below Wall Unit
BVR	Bottom Valance Rail
CBO	Cabinet Box Only
CCO	Cabinet Case Only
CFNTO	Cabinet Front Only
CFP	Cabinet False Panel
CFRMO	Cabinet Frame Only
CLIP	Clipped Corner
CMAT	CabMat™
CND	Cabinet No Door
CSDGBK	Car Siding Back
DRWTK	Toekick Drawer
EF	Finished Ends
EX	Extended Stile
EX_OL	Extended Stile with Overlay
FD	Full Depth Shelf
FLUT	Fluting
FTK	Flush Toekick
ID	Increased Depth
IH	Increased Height
INVFRM	Inverted Frame
IW	Increased Width
MIP	Matching Interior
OBRB	Open Bottom Rail Base
PFINBTMB	Finished Bottom
RD	Reduced Depth
REC	Recessed Vanity Wall
RECTK	Recessed Toekick
RH	Reduced Height
ROSFLOT	Rose Fluting
RT	Roll Trays
SBCADDY	Sink Base Cleaning Caddy
SBCADDYSM	Sink Base Cleaning Caddy Small
SCPDRW	Scooped Drawer
TBN	Nickel Towel Bar
TD	Tray Divider
TKP	Toekick Pedestal
TVR	Top Valance Rail
UDBX	U-shaped Drawer Box
URT	U-shaped Roll Tray
VLSO	L-shaped Organizer
VTK	Void Toekick
VWB	Vanity Wastebasket Container
WS	Wide Stiles
WTR	Wide Top Rail





## Description

**VANITY WALL, 30" HIGH, 4 5/8" DEEP**

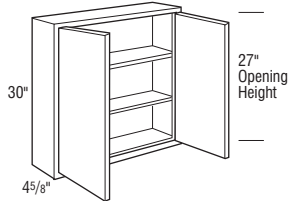
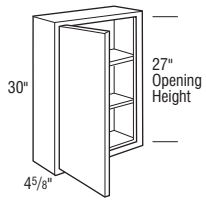

## Model

**W12304 L or R**

**W15304 L or R**

**W18304 L or R**

**W21304 L or R**

**W24304 L or R**

**W24304**

**W30304**

Notes below apply to all products in section above:

- Two adjustable shelves.
- Regular doors, not mirrored.

### Door & Drawer Options

CC	CG	ESMD	GAMD	HC	IFHG <sup>1</sup>	MC	MD	MFO	PRMD <sup>2</sup>	SHMD	SPLITDR <sup>3</sup>	SPLITDRWS	SUMD	TCG	TCP
✓	✓	✓	✓	✓	✓	✓	✓	✓	✓	✓	✓	✓	✓	✓	✓

### End Panel Options

AUTH	CSFPE	EXBK	EXDN	FFD	FPE	INTGE	IPE
✓	✓	✓	✓	✓	✓	✓	✓

### Custom Modification Options

ADD	SHLF	ADRW	BVR <sup>4</sup>	CBO	CCO	CFNTO	CFP	CFRMO	CLIP	CMAT	CND	CSDGBK	DRWTK	EF	EX	EX_OL	FD	FLUT <sup>5</sup>	FTK <sup>6</sup>	ID	IH	INVERM	IW	
✓	✓	✓	✓	✓	✓	✓	✓	✓	✓	✓	✓	✓	✓	✓	✓	✓	✓	✓	✓	✓	✓	✓	✓	✓

MIP	OBRB <sup>7</sup>	PFINBTMB <sup>8</sup>	RD	REC	RECTK	RH	ROSLUT <sup>9</sup>	RT	SBCADDY	SBCADDYSM	SCPDRW	TBN	TD	TKP	TVR <sup>10</sup>	UDBX	URT	VLSO	VTK	VWB	WS	WTR	
✓	✓	✓	✓	✓	✓	✓	✓	✓	✓	✓	✓	✓	✓	✓	✓	✓	✓	✓	✓	✓	✓	✓	✓

<sup>1</sup>Not available on 24" (2 doors) wide.

<sup>2</sup>Not available on 12" or 24" (2 doors) wide.

<sup>3</sup>Not available on 12"-24" (1 door) wide.

<sup>4</sup>Only available on 24" (1 door) wide.

<sup>5</sup>Fluting both 3" not available on 12" wide. Not available with 6" fluting.

<sup>6</sup>Not available on 24" (1 door) wide. FTKAV also not available on 12" wide.

<sup>7</sup>Not available on 24" (1 door) wide.

<sup>8</sup>Only available on 24" (2 doors) wide.

<sup>9</sup>Fluting both not available on 12" wide.

<sup>10</sup>TVRAV not available on 12" wide.

# Vanity Wall Cabinets

## Description

### VANITY WALL, 36" HIGH, 4 5/8" DEEP

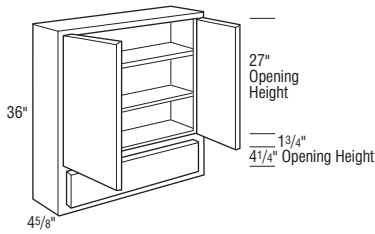
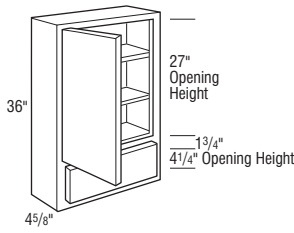

## Model

W12364 L or R

W15364 L or R

W18364 L or R

W21364 L or R

W24364 L or R

W24364

W30364

W36364

Notes below apply to all products in section above:

- One fixed and two adjustable shelves.
- Regular door(s), not mirrored.
- Includes drop front. Decker, Landry, and DFR5PC incorporate slab front.
- Not available on Inset and Beaded Inset styles.

#### Door & Drawer Options

CC	CG	ESMD <sup>1</sup>	GAMD <sup>1</sup>	HC	IFHG <sup>2</sup>	MC	MD	MFO	PRMD	SHMD	SPLITDR <sup>3</sup>	SPLITDRWS	SUMD	TCG <sup>4</sup>	TCP <sup>4</sup>
✓	✓	✓	✓	✓	✓	✓	✓	✓	✓	✓	✓	✓	✓	✓	✓

#### End Panel Options

AUTH	CSFPE	EXBK	EXDN	FFD	FPE	INTGE	IPE
	✓	✓	✓	✓	✓	✓	✓

#### Custom Modification Options

ADD	SHLF	ADRW	BVR <sup>4</sup>	CBO	CCO	CFNT0	CFP	CFRMO	CLIP	CMAT	CND	CSDGBK	DRWTK	EF	EX	EX_OL	FD	FLUT <sup>5</sup>	FTK <sup>6</sup>	ID	IH	INFRM	IW	
			✓	✓	✓	✓	✓	✓	✓	✓	✓	✓	✓	✓	✓	✓	✓	✓	✓	✓	✓	✓	✓	✓
MIP	OBRB <sup>7</sup>	PFINBTMB <sup>8</sup>	RD	REC	RECTK	RH	ROSFLUT <sup>9</sup>	RT	SBCADDY	SBCADDYSM	SCPDRW	TBN	TD	TKP	TVR <sup>10</sup>	UDBX	URT	VLSO	VTK	VWB	WS	WTR		
✓	✓	✓	✓	✓	✓	✓	✓	✓	✓	✓	✓	✓	✓	✓	✓	✓	✓	✓	✓	✓	✓	✓	✓	

<sup>1</sup>Not available on 12" or 24" (2 doors) wide.

<sup>2</sup>Not available on 24" (2 doors) wide.

<sup>3</sup>Not available on 12"-24" (1 door) wide.

<sup>4</sup>Only available on 24" (1 door) wide.

<sup>5</sup>Fluting both 3" not available on 12" wide. Not available with 6" fluting.

<sup>6</sup>Not available on 24" (1 door) wide. FTKAV also not available on 12" wide.

<sup>7</sup>Not available on 24" (1 door) wide.

<sup>8</sup>Only available on 24" (2 doors) wide.

<sup>9</sup>Fluting both not available on 12" wide.

<sup>10</sup>TVRAV not available on 12" wide.

### VANITY RECESSED CABINET, 24" HIGH, 4 5/8" DEEP

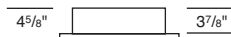
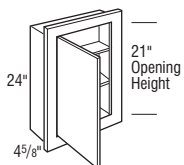

Top View

## Model

- Two adjustable shelves.
- Regular door, not mirrored.
- To recess use opening 1 1/2" less than overall dimension.
- Cut-out size is 13 1/2" W x 22 1/2" H x 4" D.

#### Door & Drawer Options

CC	CG	ESMD	GAMD	HC	IFHG	MC	MD	MFO	PRMD	SHMD	SPLITDR	SPLITDRWS	SUMD	TCG	TCP
✓	✓	✓	✓	✓	✓	✓	✓	✓	✓	✓	✓	✓	✓	✓	✓

#### End Panel Options

AUTH	CSFPE	EXBK	EXDN	FFD	FPE	INTGE	IPE
		✓					

#### Custom Modification Options

ADD	SHLF	ADRW	BVR	CBO	CCO	CFNT0	CFP	CFRMO	CLIP	CMAT	CND	CSDGBK	DRWTK	EF	EX	EX_OL	FD	FLUT <sup>2</sup>	FTK	ID	IH	INFRM	IW	
			✓	✓	✓	✓	✓	✓	✓	✓	✓	✓	✓	✓	✓	✓	✓	✓	✓	✓	✓	✓	✓	✓
MIP	OBRB	PFINBTMB	RD	REC	RECTK	RH	ROSFLUT	RT	SBCADDY	SBCADDYSM	SCPDRW	TBN	TD	TKP	TVR	UDBX	URT	VLSO	VTK	VWB	WS	WTR		
✓	✓	✓	✓	✓	✓	✓	✓	✓	✓	✓	✓	✓	✓	✓	✓	✓	✓	✓	✓	✓	✓	✓	✓	

<sup>1</sup>Not available on end extended back left.

<sup>2</sup>Not available with 6" fluting.

IH/RH availability charts starting on page G•40.  
IW/RW availability charts starting on page G•46.

## Description

### VANITY WALL RECESSED CABINET, 36" HIGH, 4 5/8" DEEP

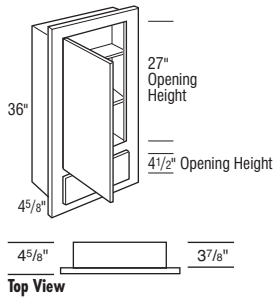

Top View

## Model

### VWR1536 L or R

- To recess use opening 1 1/2" less than overall dimension.
- One fixed and two adjustable shelves.
- Cut-out size is 13 1/2" W x 34 1/2" H x 4" D.
- Regular door, not mirrored.
- Includes drop front.
- Not available on Inset and Beaded Inset styles.

#### Door & Drawer Options

CC	CG	ESMD	GAMD	HC	IFHG	MC	MD	MFO	PRMD	SHMD	SPLITDR	SPLITDRWS	SUMD	TCG	TCP
✓	✓	✓	✓	✓	✓	✓	✓	✓	✓	✓	✓	✓	✓	✓	✓

#### End Panel Options

AUTH	CSFPE	EXBK <sup>1</sup>	EXDN	FFD	FPE	INTGE	IPE
		✓					

#### Custom Modification Options

ADD_SHLF	ADRW	BVR	CBO	CCO	CFNTO	CFP	CFRMO	CLIP	CMAT	CND	CSDGBK	DRWTK	EF	EX	EX_OL	FD	FLUT <sup>2</sup>	FTK	ID	IH	INVERM	IW	
			✓	✓	✓		✓				✓	✓			✓	✓		✓					
MIP	OBRB	PFINBTMB	RD	REC	RECTK	RH	ROSLUT	RT	SBCADDY	SBCADDYSM	SCPDRW	TBN	TD	TKP	TVR	UDBX	URT	VLSO	VTK	VWB	WS	WTR	
✓							✓									✓						✓	✓

<sup>1</sup>Not available on end extended back left.

<sup>2</sup>Not available with 6" fluting.



### VANITY MIRROR, 35" HIGH, 21", 27", or 33" WIDE

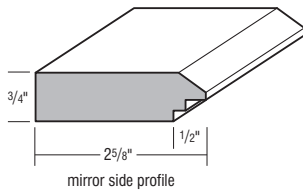
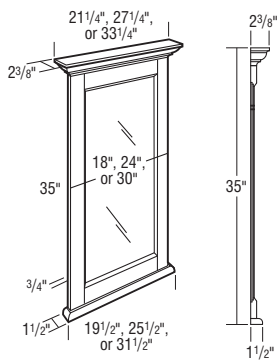

### VM2135

### VM2735

### VM3335

- Installed mirror has beveled edge.
- Includes two installed metal hanging hooks on back.
- Only available in Cherry and Maple

	Overall Dimensions		Mirror - Visible Dimensions	
	Width	Height	Width	Height
VM2135	21 1/4"	35"	12 15/16"	26 15/16"
VM2735	27 1/4"	35"	18 15/16"	26 15/16"
VM3335	33 1/4"	35"	24 15/16"	26 15/16"

Modifications  
Are Not  
Available

# Vanity Wall & Medicine Cabinets

## Description

### WATER CLOSET, 36" HIGH, 9" DEEP

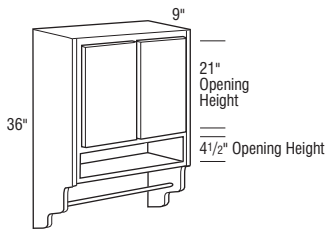

## Model

### WCT24

### WCT27

- Finished Ends and Matching Interior standard.
- Open shelf standard.
- One fixed and two adjustable shelves.
- Regular doors, not mirrored.

#### Door & Drawer Options

CC	CG	ESMD	GAMD	HC	IFHG	MC	MD	MFO	PRMD	SHMD	SPLITDR	SPLITDRWS	SUMD	TCG	TCP
✓	✓	✓	✓	✓	✓	✓	✓	✓	✓	✓			✓		

#### End Panel Options

AUTH	CSFPE	EXBK <sup>1</sup>	EXDN	FFD	FPE	INTGE	IPE
		✓					

#### Custom Modification Options

ADD	SHLF	ADRW	BVR	CBO	CCO	CFNTD	CFP	CFRMO	CLIP	CMAT	CND	CSDGBK	DRWRW	EF	EX	EX_OL	FD	FLUT	FTK	ID	IH	INVFRM	IW	
											✓	✓												

MIP	OBRB	PFINBTMB	RD	REC	RECTK	RH	ROSFLUT	RT	SBCADDY	SBCADDYSM	SCPDRW	TBN	TD	TKP	TVR	UDBX	URT	VLSO	VTK	VWB	WS	WTR	
																✓							✓

<sup>1</sup>Not available on end extended back left.

### TRI-VIEW MEDICINE CABINET, 32" HIGH, 4 5/8" DEEP

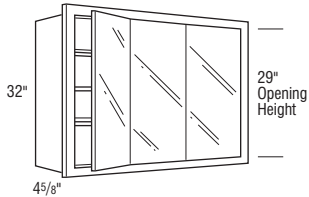

### TV24

### TV30

### TV36

### TV48

- Standard hinging from left to right: HR, HL, HL.
- To recess tri-view use an opening 1 1/2" less than overall dimension.
- Finished Ends are standard.
- Three adjustable shelves.
- Door edge profile required when ordering.
- Not available on Inset and Beaded Inset styles.
- Hardware used is Chrome.

#### Door & Drawer Options

CC	CG	ESMD	GAMD	HC	IFHG	MC	MD	MFO	PRMD	SHMD	SPLITDR	SPLITDRWS	SUMD	TCG	TCP

#### End Panel Options

AUTH	CSFPE	EXBK	EXDN	FFD	FPE	INTGE	IPE

#### Custom Modification Options

ADD	SHLF	ADRW	BVR	CBO	CCO	CFNTD	CFP	CFRMO	CLIP	CMAT	CND	CSDGBK	DRWRW	EF	EX	EX_OL	FD	FLUT <sup>1</sup>	FTK	ID	IH	INVFRM	IW
												✓				✓	✓	✓					

MIP	OBRB	PFINBTMB	RD	REC	RECTK	RH	ROSFLUT	RT	SBCADDY	SBCADDYSM	SCPDRW	TBN	TD	TKP	TVR	UDBX	URT	VLSO	VTK	VWB	WS	WTR	
✓								✓															✓

<sup>1</sup>Not available with 6" fluting.

IH/RH availability charts starting on page G•40.  
IW/RW availability charts starting on page G•46.

## Description

**VANITY BASE, SINGLE DOOR with DRAWER, 32" or 34 1/2" HIGH, 18" or 21" DEEP**

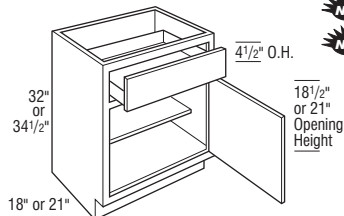

## Model



**VB123218 L or R**



**VB153218 L or R**



**VB183218 L or R**



**VB213218 L or R**



**VB243218 L or R**

**VB123221 L or R**

**VB153221 L or R**

**VB183221 L or R**

**VB213221 L or R**

**VB243221 L or R**



**VB123418 L or R**



**VB153418 L or R**



**VB183418 L or R**



**VB213418 L or R**



**VB243418 L or R**

**VB123421 L or R**

**VB153421 L or R**

**VB183421 L or R**

**VB213421 L or R**

**VB243421 L or R**

- Adjustable half shelf.
- Increased Depths available in 1/4" increments from 21 1/4" to 24".
- Reduced Depths available in 1/4" increments from 12" to 20 3/4".

### Door & Drawer Options

CC	CG	ESMD	GAMD	HC	IFHG	MC	MD	MFO	PRMD <sup>1</sup>	SHMD	SPLITDR	SPLITDRWS	SUMD	TCG	TCP
✓	✓	✓	✓	✓	✓	✓	✓	✓	✓	✓	✓	✓	✓	✓	✓

### End Panel Options

AUTH	CSFPE	EXBK	EXDN	FFD	FPE	INTGE	IPE
✓	✓	✓	✓	✓	✓	✓	✓

### Custom Modification Options

ADD	SHLF	ADRW	BVR	CBO	CCO	CFNTO	CFP	CFRMO	CLIP <sup>2</sup>	CMAT	CND	CSDGBK	DRWTX <sup>3</sup>	EF	EX	EX_OL	FD	FLUT <sup>4</sup>	FTK <sup>5</sup>	ID	IH	INVFRM	IW	
✓	✓	✓	✓	✓	✓	✓	✓	✓	✓	✓	✓	✓	✓	✓	✓	✓	✓	✓	✓	✓	✓	✓	✓	✓
MIP	OBRB	PFINBTMB	RD	REC	RECTK	RH	ROSFLUT	RT	SBCADDY	SBCADDYSM <sup>1</sup>	SCPDRW	TBN	TD	TKP	TVR <sup>6</sup>	UDBX <sup>3</sup>	URT <sup>3</sup>	VLSO	VTK	VWB	WS	WTR		
✓	✓	✓	✓	✓	✓	✓	✓	✓	✓	✓	✓	✓	✓	✓	✓	✓	✓	✓	✓	✓	✓	✓	✓	

<sup>1</sup>Not available on 12" wide.

<sup>2</sup>Not available on 12" wide.

<sup>3</sup>Only available on 24" wide.

<sup>4</sup>6" fluting not available on 12" or 15" wide. Fluting both 6" not available.

<sup>5</sup>FTKAV not available on 12" wide.

<sup>6</sup>TVRAV not available on 12" wide.

# Vanity Base Cabinets

## Description

## Model

**VANITY BASE, DOUBLE DOOR with DRAWER, 32" or 34 1/2" HIGH, 18" or 21" DEEP**

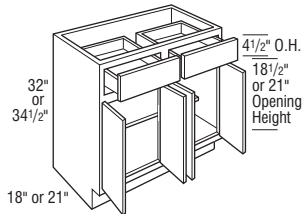
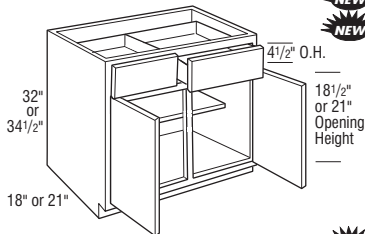
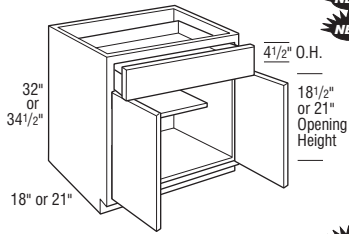

<b>NEW</b>	<b>VB243218</b>
<b>NEW</b>	<b>VB273218</b>
<b>NEW</b>	<b>VB303218</b>
<b>NEW</b>	<b>VB333218</b>
<b>NEW</b>	<b>VB363218</b>
<b>NEW</b>	<b>VB393218</b>
	<b>VB243221</b>
	<b>VB273221</b>
	<b>VB303221</b>
	<b>VB333221</b>
	<b>VB363221</b>
	<b>VB393221</b>
<b>NEW</b>	<b>VB243418</b>
<b>NEW</b>	<b>VB273418</b>
<b>NEW</b>	<b>VB303418</b>
<b>NEW</b>	<b>VB333418</b>
<b>NEW</b>	<b>VB363418</b>
<b>NEW</b>	<b>VB393418</b>
	<b>VB243421</b>
	<b>VB273421</b>
	<b>VB303421</b>
	<b>VB333421</b>
	<b>VB363421</b>
	<b>VB393421</b>
<b>NEW</b>	<b>VB423218</b>
<b>NEW</b>	<b>VB453218</b>
<b>NEW</b>	<b>VB483218CS</b>
	<b>VB423221</b>
	<b>VB453221</b>
	<b>VB483221CS</b>
<b>NEW</b>	<b>VB423418</b>
<b>NEW</b>	<b>VB453418</b>
<b>NEW</b>	<b>VB483418CS</b>
	<b>VB423421</b>
	<b>VB453421</b>
	<b>VB483421CS</b>
<b>NEW</b>	<b>VB483218</b>
<b>NEW</b>	<b>VB483221</b>
<b>NEW</b>	<b>VB483418</b>
<b>NEW</b>	<b>VB483421</b>

- Adjustable half shelf.
- Increased Depths available in 1/4" increments from 21 1/4" to 24".
- Reduced Depths available in 1/4" increments from 12" to 20 3/4".

### Door & Drawer Options

CC	CG	ESMD	GAMD	HC	IFHG	MC	MD	MFO	PRMD	SHMD	SPLITDR <sup>1</sup>	SPLITDRWS <sup>2</sup>	SUMD	TCG	TCP
✓	✓	✓	✓	✓	✓	✓	✓	✓	✓	✓	✓	✓	✓	✓	✓

### End Panel Options

AUTH	CSFPE	EXBK	EXDN	FFD	FPE	INTGE	IPE
✓	✓	✓	✓	✓	✓	✓	✓

### Custom Modification Options

ADD	SHLF	ADRW	BVR	CBO	CCO	CFNT0	CFP <sup>1</sup>	CFRMO	CLIP	CMAT	CND	CSDGBK	DRWTK <sup>3</sup>	EF	EX	EX_OL	FD	FLUT <sup>4</sup>	FTK	ID	IH	INVFRM	IW <sup>5</sup>	
✓	✓	✓	✓	✓	✓	✓	✓	✓	✓	✓	✓	✓	✓	✓	✓	✓	✓	✓	✓	✓	✓	✓	✓	✓

MIP	OBRB	PFINBTMB	RD	REC	RECTK	RH	ROSFLUT	RT	SBCADDY <sup>6</sup>	SBCADDYSM <sup>6</sup>	SCPRDW	TBN	TD	TKP	TVR <sup>1</sup>	UDBX <sup>7</sup>	URT <sup>4</sup>	VLSO	VTK	VWB	WS	WTR	
✓	✓	✓	✓	✓	✓	✓	✓	✓	✓	✓	✓	✓	✓	✓	✓	✓	✓	✓	✓	✓	✓	✓	✓

<sup>1</sup>Not available on 42"-48" wide.

<sup>2</sup>Not available on 24" or 48" wide.

<sup>3</sup>Not available on 39"-48" wide.

<sup>4</sup>6" fluting not available on 24" wide.

<sup>5</sup>Not available on 36" or 48" wide.

<sup>6</sup>Not available on 24" wide.

<sup>7</sup>Not available on 42" or 45" wide.

IH/RH availability charts starting on page G•40.  
IW/RW availability charts starting on page G•46.

## Description

**VANITY BASE SINGLE DOOR with SHELF, 32" or 34 1/2" HIGH, 21" DEEP**

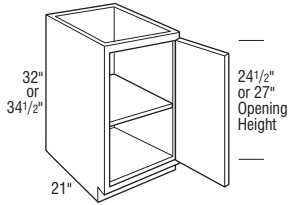

## Model

**V123221S L or R**  
**V153221S L or R**  
**V183221S L or R**  
**V213221S L or R**  
**V243221S L or R**  
**V123421S L or R**  
**V153421S L or R**  
**V183421S L or R**  
**V213421S L or R**  
**V243421S L or R**

- Adjustable Full Depth Shelf.
- Increased Depths available in 1/4" increments from 21 1/4" to 24".
- Reduced Depths available in 1/4" increments from 12" to 20 3/4".

### Door & Drawer Options

CC	CG	ESMD	GAMD	HC	IFHG	MC	MD	MFO	PRMD <sup>1</sup>	SHMD	SPLITDR	SPLITDRWS	SUMD	TCG	TCP
✓	✓	✓	✓	✓	✓	✓	✓	✓	✓	✓				✓	

### End Panel Options

AUTH	CSFPE	EXBK	EXDN	FFD	FPE	INTGE	IPE
✓	✓	✓	✓	✓	✓	✓	✓

### Custom Modification Options

ADD_SHLF	ADRW	BVR	CBO	CCO	CFNTO	CFP	CFRMO	CLIP <sup>2</sup>	CMAT	CND	CSDGBK	DRWTK	EF	EX	EX_OL	FD	FLUT <sup>3</sup>	FTK <sup>4</sup>	ID	IH	INVERM	IW	
✓	✓	✓	✓	✓	✓	✓	✓	✓	✓	✓	✓	✓	✓	✓	✓	✓	✓	✓	✓	✓	✓	✓	✓
MIP	OBRB	PFINBTMB	RD	REC	RECTK	RH	ROSLUT	RT	SBCADDY	SBCADDYSM <sup>1</sup>	SCPDRW	TBN	TD	TKP	TVR <sup>5</sup>	UDBX	URT <sup>6</sup>	VLSO	VTK	VWB	WS	WTR	
✓	✓	✓	✓	✓	✓	✓	✓	✓	✓	✓	✓	✓	✓	✓	✓	✓	✓	✓	✓	✓	✓	✓	✓

<sup>1</sup>Not available on 12" wide.

<sup>2</sup>Not available on 12" wide.

<sup>3</sup>6" fluting not available on 12" or 15" wide. Fluting both 6" not available.

<sup>4</sup>FTKAV not available on 12" wide.

<sup>5</sup>TVRAV not available on 12" wide.

<sup>6</sup>Only available on 24" wide.



# Vanity Base Cabinets

## Description

**VANITY BASE with SHELF, 32" or 34 1/2" HIGH, 21" DEEP**

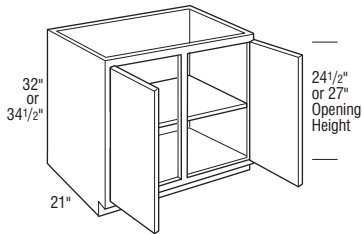
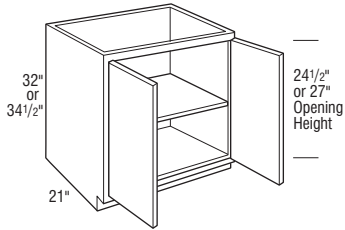

## Model

V243221S

V273221S

V303221S

V333221S

V363221S

V393221S

V243421S

V273421S

V303421S

V333421S

V363421S

V393421S

V423221S

V453221S

V483221S

V423421S

V453421S

V483421S

- Adjustable Full Depth Shelf.
- Increased Depths available in 1/4" increments from 21 1/4" to 24".
- Reduced Depths available in 1/4" increments from 12" to 20 3/4".

### Door & Drawer Options

CC	CG	ESMD	GAMD	HC	IFHG	MC	MD	MFO	PRMD	SHMD	SPLITDR <sup>1</sup>	SPLITDRWS	SUMD	TCG	TCP
✓	✓	✓	✓	✓	✓	✓	✓	✓	✓	✓	✓	✓	✓	✓	✓

### End Panel Options

AUTH	CSFPE	EXBK	EXDN	FFD	FPE	INTGE	IPE
✓	✓	✓	✓	✓	✓	✓	✓

### Custom Modification Options

ADD	SHLF	ADRW	BVR	CBO	CCO	CFNTO	CFP	CFRMO	CLIP	CMAT	CND	CSDGBK	DRWTK	EF	EX	EX_OL	FD	FLUT <sup>2</sup>	FTK	ID	IH	INVFRM	IW <sup>3</sup>	
✓	✓	✓	✓	✓	✓	✓	✓	✓	✓	✓	✓	✓	✓	✓	✓	✓	✓	✓	✓	✓	✓	✓	✓	✓
MIP	OBRB	PFINBTMB	RD	REC	RECTK	RH	ROSFLUT	RT	SBCADDY <sup>4</sup>	SBCADDYSM <sup>4</sup>	SCPDRW	TBN	TD	TKP	TVR <sup>1</sup>	UDBX	URT <sup>5</sup>	VLSO	VTK	VWB	WS	WTR		
✓	✓	✓	✓	✓	✓	✓	✓	✓	✓	✓	✓	✓	✓	✓	✓	✓	✓	✓	✓	✓	✓	✓	✓	

<sup>1</sup>Not available on 42"-48" wide.

<sup>2</sup>6" fluting not available on 24" wide.

<sup>3</sup>Not available on 36" or 48" wide.

<sup>4</sup>Not available on 24" wide.

<sup>5</sup>Not available on 39"-48" wide.

IH/RH availability charts starting on page G•40.  
IW/RW availability charts starting on page G•46.

## Description



**VANITY BASE SINGLE DOOR**  
without SHELF, 32" or 34 1/2"  
HIGH, 18" or 21" DEEP

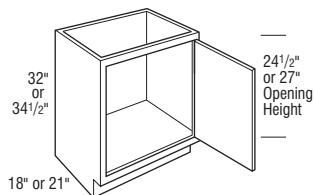

## Model

V123218 L or R

V153218 L or R

V183218 L or R

V213218 L or R

V243218 L or R

V123221 L or R

V153221 L or R

V183221 L or R

V213221 L or R

V243221 L or R

V123418 L or R

V153418 L or R

V183418 L or R

V213418 L or R

V243418 L or R

V123421 L or R

V153421 L or R

V183421 L or R

V213421 L or R

V243421 L or R

- Increased Depths available in 1/4" increments from 21 1/4" to 24".
- Reduced Depths available in 1/4" increments from 12" to 20 3/4".

### Door & Drawer Options

CC	CG	ESMD	GAMD	HC	IFHG	MC	MD <sup>1</sup>	MFO	PRMD <sup>1</sup>	SHMD	SPLITDR	SPLITDRWS	SUMD	TCG	TCP
✓							✓		✓						

### End Panel Options

AUTH	CSFPE	EXBK	EXDN	FFD	FPE	INTGE	IPE
✓	✓	✓		✓	✓	✓	

### Custom Modification Options

ADD_SHLF	ADRW	BVR	CBO	CCO	CFNTO	CFP	CFRMO	CLIP <sup>1</sup>	CMAT	CND	CSDGBK	DRWTK	EF	EX	EX_OL	FD	FLUT <sup>2</sup>	FTK <sup>3</sup>	ID	IH	INVFRM	IW <sup>4</sup>
			✓	✓	✓		✓	✓		✓	✓	✓	✓	✓	✓	✓	✓	✓	✓	✓		✓

MIP	OBRB	PFINBTMB	RD	REC	RECTK	RH	ROSLUT <sup>5</sup>	RT	SBCADDY <sup>6</sup>	SBCADDYSM <sup>6</sup>	SCPDRW	TBN	TD	TKP	TVR <sup>7</sup>	UDBX	URT <sup>8</sup>	VLSO	VTK	VWB	WS <sup>9</sup>	WTR
✓	✓		✓	✓	✓	✓	✓	✓	✓	✓				✓	✓	✓	✓	✓	✓	✓	✓	✓

<sup>1</sup>Not available on 12" wide.

<sup>2</sup>6" fluting not available on 12" or 15" wide and FLUT6B not available.

<sup>3</sup>FTKAV not available on 12" wide.

<sup>4</sup>Not available on 24" wide.

<sup>5</sup>ROSLUT3B not available on 12" or 15" wide.

<sup>6</sup>Not available on depths less than 21" and SBCADDY also not available on 12" wide.

<sup>7</sup>TVRAV not available on 12" wide.

<sup>8</sup>Not available on 18" deep and only available on 24" wide.

<sup>9</sup>WSB3 not available on 12" wide.

# Vanity Base Cabinets

## Description



**VANITY BASE without SHELF,  
32" or 34 1/2" HIGH, 18" or  
21" DEEP**

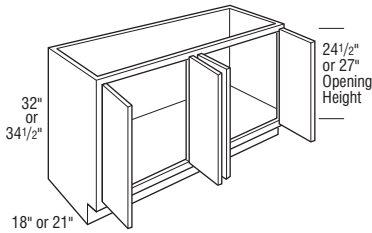
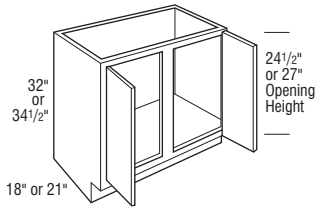
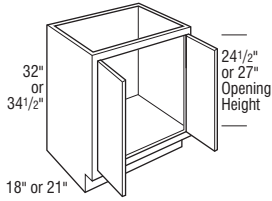

## Model

V243218
V273218
V303218
V333218
V363218
V393218
V243221
V273221
V303221
V333221
V363221
V393221
V243418
V273418
V303418
V333418
V363418
V393418
V243421
V273421
V303421
V333421
V363421
V393421
V423218
V453218
V483218CS
V423221
V453221
V483221CS
V423418
V453418
V483418CS
V423421
V453421
V483421CS
V483218
V483221
V483418
V483421

- Increased Depths available in 1/4" increments from 21 1/4" to 24".
- Reduced Depths available in 1/4" increments from 12" to 20 3/4".

### Door & Drawer Options

CC	CG	ESMD	GAMD	HC	IFHG	MC	MD	MFO	PRMD	SHMD	SPLITDR <sup>1</sup>	SPLITDRWS	SUMD	TCG	TCP
✓							✓		✓		✓				

### End Panel Options

AUTH	CSFPE	EXBK	EXDN	FFD	FPE	INTGE	IPE
✓	✓	✓		✓	✓	✓	

### Custom Modification Options

ADD	SHLF	ADRW	BVR	CBO	CCO	CFNTO	CFP	CFRMO	CLIP	CMAT	CND	CSDGBK	DRWTK <sup>2</sup>	EF	EX	EX_OL	FD	FLUT <sup>3</sup>	FTK	ID	IH	INVERM	IW <sup>4</sup>
				✓	✓	✓	✓	✓	✓	✓	✓	✓	✓	✓	✓	✓	✓	✓	✓	✓	✓	✓	✓
MIP <sup>5</sup>	OBRR	PFINBTMB	RD	REC	RECTK	RH	ROSFLUT	RT	SBCADDY <sup>3</sup>	SBCADDYSM <sup>3</sup>	SCPDRW	TBN	TD	TKP	TVR <sup>1</sup>	UBBX	URT <sup>6</sup>	VLSO	VTK	VWB	WS <sup>7</sup>	WTR	
✓	✓			✓	✓	✓	✓	✓	✓	✓	✓	✓	✓	✓	✓	✓	✓	✓	✓	✓	✓	✓	

<sup>1</sup>Not available on 42"-48" wide.

<sup>2</sup>Not available on 39"-48" wide.

<sup>3</sup>FLUT6B not available on 24" wide.

<sup>4</sup>Not available on 48" wide.

<sup>5</sup>Not available on depths less than 21".

<sup>6</sup>18" deep not available, and also not available on 39"-48" wide.

<sup>7</sup>Not available on 24" wide.

IH/RH availability charts starting on page G•40.  
IW/RW availability charts starting on page G•46.

## Description

### VANITY BASE PULL-OUT, 34 1/2" HIGH, 21" DEEP storage SOLUTIONS

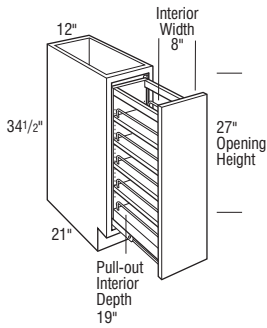

## Model

### VBP1234.5

- Pull-out features three adjustable shelves with chrome rail sides.

#### Door & Drawer Options

CC	CG	ESMD	GAMD	HC	IFHG	MC	MD	MFO	PRMD	SHMD	SPLITDR	SPLITDRWS	SUMD	TCG	TCP
					✓										

#### End Panel Options

AUTH	CSFPE	EXBK	EXDN	FFD	FPE	INTGE	IPE
✓	✓	✓			✓	✓	✓

#### Custom Modification Options

ADD_SHLF	ADRW	BVR	CBO	CCO	CFNTO	CFP	CFRMO	CLIP	CMAT	CND	CSDGBK	DRWTK	EF	EX	EX_OL	FD	FLUT <sup>1</sup>	FTK	ID	IH	INVFRM	IW	
											✓			✓	✓	✓		✓	✓				
MIP	OBRB	PFINBTMB	RD	REC	RECTK	RH	ROSFLUT	RT	SBCADDY	SBCADDYSM	SCPDWR	TBN	TD	TKP	TVR	UDBX	URT	VLSO	VTK	VWB	WS	WTR	
✓	✓			✓	✓	✓	✓	✓								✓	✓			✓	✓	✓	✓

<sup>1</sup>Not available with 6" fluting.



### VANITY BASE without SHELF, 32" or 34 1/2" HIGH,

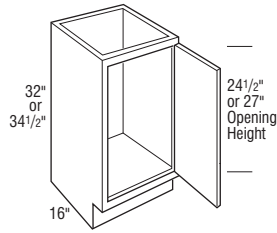

### MV183216 L or R

### MV183416 L or R

- MV = Mini Vanity.

#### Door & Drawer Options

CC	CG	ESMD	GAMD	HC	IFHG	MC	MD	MFO	PRMD	SHMD	SPLITDR	SPLITDRWS	SUMD	TCG	TCP
	✓						✓		✓						

#### End Panel Options

AUTH	CSFPE	EXBK	EXDN	FFD	FPE	INTGE	IPE
✓	✓	✓			✓	✓	✓

#### Custom Modification Options

ADD_SHLF	ADRW	BVR	CBO	CCO	CFNTO	CFP	CFRMO	CLIP	CMAT	CND	CSDGBK	DRWTK	EF	EX	EX_OL	FD	FLUT <sup>1</sup>	FTK	ID	IH	INVFRM	IW	
											✓			✓	✓	✓		✓	✓				
MIP	OBRB	PFINBTMB	RD	REC	RECTK	RH	ROSFLUT	RT	SBCADDY	SBCADDYSM	SCPDWR	TBN	TD	TKP	TVR	UDBX	URT	VLSO	VTK	VWB	WS	WTR	
✓	✓			✓	✓	✓	✓	✓								✓	✓			✓	✓	✓	✓

<sup>1</sup>6" fluting not available.

# Vanity Sink Base Cabinets

## Description

**VANITY SINK BASE with FALSE PANEL, 32" or 34 1/2" HIGH, 18" or 21" DEEP**

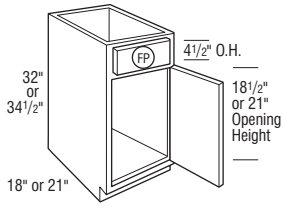

## Model



VSB183218 L or R



VSB213218 L or R



VSB243218 L or R

VSB183221 L or R

VSB213221 L or R

VSB243221 L or R



VSB183418 L or R



VSB213418 L or R



VSB243418 L or R

VSB183421 L or R

VSB213421 L or R

VSB243421 L or R

Notes below apply to all products in section above:

- Touch-up kit (TUK) and Owner's Guide included.
- Increased Depths available in 1/4" increments from 21 1/4" to 30".
- Reduced Depths available in 1/4" increments from 6" to 20 3/4".

**FP** False Panel

### Door & Drawer Options

CC	CG	ESMD	GAMD	HC	IFHG	MC	MD	MFO	PRMD	SHMD	SPLITDR <sup>1</sup>	SPLITDRWS <sup>2</sup>	SUMD	TCG	TCP
✓	✓	✓	✓	✓	✓	✓	✓	✓	✓	✓	✓	✓	✓	✓	✓

### End Panel Options

AUTH	CSFPE	EXBK	EXDN	FFD	FPE	INTGE	IPE
✓	✓	✓	✓	✓	✓	✓	✓

### Custom Modification Options

ADD	SHLF	ADRW	BVR	CBO	CCO	CFNTO	CFP	CFRMO	CLIP	CMAT <sup>3</sup>	CND	CSDGBK	DRWTK <sup>4</sup>	EF	EX	EX	OL	FD	FLUT <sup>5</sup>	FTK	ID	IH	INVERM	IW <sup>6</sup>
✓	✓	✓	✓	✓	✓	✓	✓	✓	✓	✓	✓	✓	✓	✓	✓	✓	✓	✓	✓	✓	✓	✓	✓	✓

MIP	OBRB	PFINBTMB	RD	REC	RECTK	RH	ROSLUT	RT	SBCADDY	SBCADDYSM	SCPDRW	TBN	TD	TKP	TVR	UBBX	URT <sup>4</sup>	VLSO <sup>7</sup>	VTK	VWB <sup>8</sup>	WS	WTR	
✓	✓	✓	✓	✓	✓	✓	✓	✓	✓	✓	✓	✓	✓	✓	✓	✓	✓	✓	✓	✓	✓	✓	✓

<sup>1</sup>Not available on 18"-24" (1 door) wide.

<sup>2</sup>Not available on 18"-24" (1 door and 2 doors) wide.

<sup>3</sup>Not available on 18" or 21" wide.

<sup>4</sup>Not available on 18", 21" or 39" wide.

<sup>5</sup>Fluting both 6" not available on 18" or 21" wide.

<sup>6</sup>Not available on 36" wide.

<sup>7</sup>Only available on 34 1/2" high. Not available on depths less than 21". VLSOB only available on 24" wide.

<sup>8</sup>Not available on depths less than 21".

IH/RH availability charts starting on page G•40.  
IW/RW availability charts starting on page G•46.

## Description

**VANITY SINK BASE with FALSE PANEL, 32" or 34 1/2" HIGH, 18" or 21" DEEP (cont'd)**

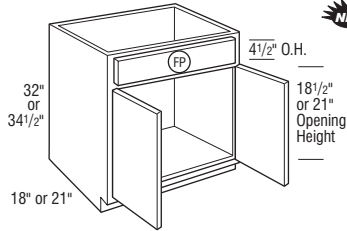

## Model



VSB243218

VSB273218

VSB303218

VSB333218

VSB363218

VSB393218

VSB243221

VSB273221

VSB303221

VSB333221

VSB363221

VSB393221



VSB243418

VSB273418

VSB303418

VSB333418

VSB363418

VSB393418

VSB243421

VSB273421

VSB303421

VSB333421

VSB363421

VSB393421

Notes below apply to all products in section above:

- Touch-up kit (TUK) and Owner's Guide included.
- Increased Depths available in 1/4" increments from 21 1/4" to 30".
- Reduced Depths available in 1/4" increments from 6" to 20 3/4".

**(FP) False Panel**

### Door & Drawer Options

CC	CG	ESMD	GAMD	HC	IFHG	JMC	MD	MF0	PRMD	SHMD	SPLITDR <sup>1</sup>	SPLITDRWS <sup>2</sup>	SUMD	TCG	TCP
✓	✓	✓	✓	✓	✓	✓	✓	✓	✓	✓	✓	✓	✓	✓	✓

### End Panel Options

AUTH	CSFPE	EXBK	EXDN	FFD	FPE	INTGE	IPE
✓	✓	✓	✓	✓	✓	✓	✓

### Custom Modification Options

ADD	SHLF	ADRW	BVR	CBO	CCO	CFNTO	CFP	CFRMO	CLIP	CMAT <sup>3</sup>	CND	CSDGBK	DRWTK <sup>4</sup>	EF	EX	EX_OL	FD	FLUT <sup>5</sup>	FTK	ID	IH	INVERM	IW <sup>6</sup>	
✓	✓	✓	✓	✓	✓	✓	✓	✓	✓	✓	✓	✓	✓	✓	✓	✓	✓	✓	✓	✓	✓	✓	✓	✓
MIP	OBRB	PFINBTMB	RD	REC	RECTK	RH	ROSFLUT	RT	SBCADDY	SBCADDYSM	SCPDWR	TBN	TD	TKP	TVR	UDBX	URT <sup>7</sup>	VLSO <sup>8</sup>	VTK	VWB <sup>9</sup>	WS	WTR		
✓	✓	✓	✓	✓	✓	✓	✓	✓	✓	✓	✓	✓	✓	✓	✓	✓	✓	✓	✓	✓	✓	✓	✓	

<sup>1</sup>Not available on 18":24" (1 door) wide.

<sup>2</sup>Not available on 18":24" (1 door and 2 doors) wide.

<sup>3</sup>Not available on 18" or 21" wide.

<sup>4</sup>Not available on 18", 21" or 39" wide.

<sup>5</sup>Fluting both 6" not available on 18" or 21" wide.

<sup>6</sup>Not available on 36" wide.

<sup>7</sup>Only available on 34 1/2" high. Not available on depths less than 21".

<sup>9</sup>Not available on depths less than 21".

# Vanity Sink Base Cabinets

## Description

**VANITY SINK BASE with FALSE PANEL, 32" or 34 1/2" HIGH, 18" or 21" DEEP**

## Model



VSB423218

VSB453218

VSB483218CS

VSB423221

VSB453221

VSB483221CS



VSB423418

VSB453418

VSB483418CS

VSB423421

VSB453421

VSB483421CS



VSB483218

VSB483221

VSB483418

VSB483421

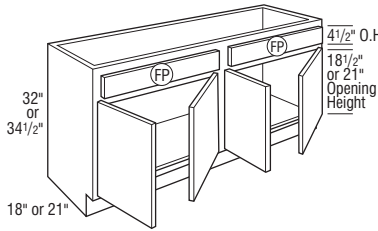
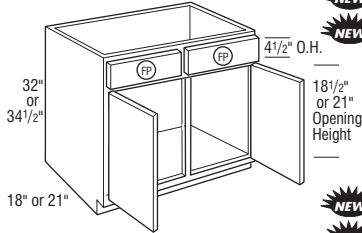

- Touch-up kit (TUK) and Owner's Guide included.
- Increased Depths available in 1/4" increments from 21 1/4" to 30".
- Reduced Depths available in 1/4" increments from 6" to 20 3/4".

**FP** False Panel

### Door & Drawer Options

CC	CG	ESMD	GAMD	HC	IFHG	MC	MD	MFO	PRMD	SHMD	SPLITDR <sup>1</sup>	SPLITDRWS <sup>1</sup>	SUMD	TCG	TCP
✓	✓	✓	✓	✓	✓	✓	✓	✓	✓	✓	✓	✓	✓	✓	✓

### End Panel Options

AUTH	CSFPE	EXBK	EXDN	FFD	FPE	INTGE	IPE
✓	✓	✓	✓	✓	✓	✓	✓

### Custom Modification Options

ADD	SHLF	ADRW	BVR	CBO	CCO	CFNTD	CFP	CFRMO	CLIP	CMAT	CND	CSDGBK	DRWTK	EF	EX	EX_OL	FD	FLUT	FTK	ID	IH	INVFRM	IW <sup>1</sup>	
✓	✓	✓	✓	✓	✓	✓	✓	✓	✓	✓	✓	✓	✓	✓	✓	✓	✓	✓	✓	✓	✓	✓	✓	✓

MIP	OBRB	PFINBTMB	RD	REC	RECTK	RH	ROSFLUT	RT	SBCADDY	SBCADDYSM	SCPDRW	TBN	TD	TKP	TVR	UDBX	URT	VLSO <sup>2</sup>	VTK	VWB <sup>3</sup>	WS	WTR	
✓	✓	✓	✓	✓	✓	✓	✓	✓	✓	✓	✓	✓	✓	✓	✓	✓	✓	✓	✓	✓	✓	✓	✓

<sup>1</sup>Not available on 48" wide.

<sup>2</sup>Only available on 34 1/2" high. Not available on depths less than 21".

<sup>3</sup>Not available on depths less than 21".

IH/RH availability charts starting on page G•40.  
IW/RW availability charts starting on page G•46.

## Description

**VANITY SINK BASE with FALSE PANEL, 32" or 34 1/2" HIGH, 18" or 21" DEEP**

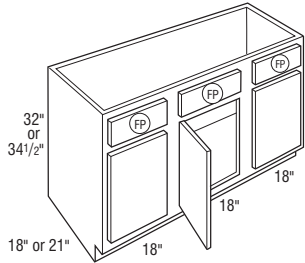

## Model

**VSB543218**

**VSB543418**

**VSB543221**

**VSB543421**

- Middle door will be hinged left unless specified otherwise.



**VSB603218**

**VSB603418**

**VSB603221**

**VSB603421**

Notes below apply to all products in section above:

- Touch-up kit (TUK) and Owner's Guide included.
- All false drawer fronts.
- Increased Depths available in 1/4" increments from 21 1/4" to 30".
- Reduced Depths available in 1/4" increments from 6" to 20 3/4".

**FP False Panel**

### Door & Drawer Options

CC	CG	ESMD	GAMD	HC	IFHG	MC	MD	MFO	PRMD	SHMD	SPLITDR	SPLITDRWS	SUMD	TCG	TCP
✓	✓	✓	✓	✓	✓	✓	✓	✓	✓	✓	✓	✓	✓	✓	✓

### End Panel Options

AUTH	CSFPE	EXBK	EXDN	FFD	FPE	INTGE	IPE
✓	✓	✓	✓	✓	✓	✓	✓

### Custom Modification Options

ADD_SHLF	ADRW	BVR	CBO	CCO	CFNTD	CFP	CFRMO	CLIP	CMAT <sup>1</sup>	CND	CSDGBK	DRWTK	EF	EX	EX_OL	FD	FLUT	FTK	ID	IH	INVFRM	IW	
✓	✓	✓	✓	✓	✓	✓	✓	✓	✓	✓	✓	✓	✓	✓	✓	✓	✓	✓	✓	✓	✓	✓	✓

MIP	OBRB	PFINBTMB	RD	REC	RECTK	RH	ROSFLUT	RT	SBCADDY	SBCADDYSM	SCPRDW	TBN	TD	TKP	TVR	UDBX	URT	VLSO	VTK	VWB	WS	WTR	
✓	✓	✓	✓	✓	✓	✓	✓	✓	✓	✓	✓	✓	✓	✓	✓	✓	✓	✓	✓	✓	✓	✓	✓

<sup>1</sup>Not available on 54" wide.

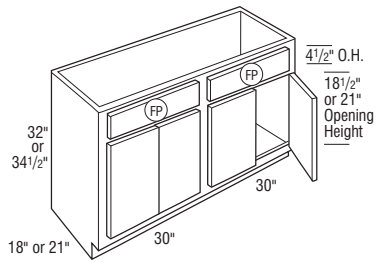

**VANITY SINK BASE with U-SHAPED ROLL TRAYS, 34 1/2" HIGH, 21" DEEP**

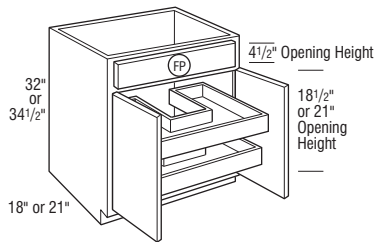

**VSB303221U**

**VSB303421U**

- Includes two wooden U-shaped Smart Stop roll trays.
- Touch-up kit (TUK) and Owner's Guide included.

**FP False Panel**

### Door & Drawer Options

CC	CG	ESMD	GAMD	HC	IFHG	MC	MD	MFO	PRMD	SHMD	SPLITDR	SPLITDRWS	SUMD	TCG	TCP
✓	✓	✓	✓	✓	✓	✓	✓	✓	✓	✓	✓	✓	✓	✓	✓

### End Panel Options

AUTH	CSFPE	EXBK	EXDN	FFD	FPE	INTGE	IPE
✓	✓	✓	✓	✓	✓	✓	✓

### Custom Modification Options

ADD_SHLF	ADRW	BVR	CBO	CCO	CFNTD	CFP	CFRMO	CLIP	CMAT	CND	CSDGBK	DRWTK	EF	EX	EX_OL	FD	FLUT	FTK	ID	IH	INVFRM	IW	
✓	✓	✓	✓	✓	✓	✓	✓	✓	✓	✓	✓	✓	✓	✓	✓	✓	✓	✓	✓	✓	✓	✓	✓

MIP	OBRB	PFINBTMB	RD	REC	RECTK	RH	ROSFLUT	RT	SBCADDY	SBCADDYSM	SCPRDW	TBN	TD	TKP	TVR	UDBX	URT	VLSO	VTK	VWB	WS	WTR	
✓	✓	✓	✓	✓	✓	✓	✓	✓	✓	✓	✓	✓	✓	✓	✓	✓	✓	✓	✓	✓	✓	✓	✓

U-SHAPED DRAWER ON SELECT BATH BASE CABINETS

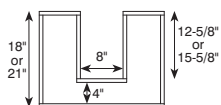



# Vanity Sink Base Cabinets

## Description

**NEW** VANITY SINK BASE  
**SUPERCABINET™** with TILT-OUT  
 TRAYS, 34 1/2" HIGH, 21" DEEP

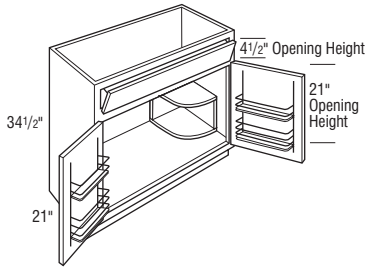

## Model

VSSB303421ST

VSSB333421ST

VSSB363421ST

- Quarter Round Reversible Shelf for left or right applications included.
- Basket size on 36" door is 14 1/2" W x 20 1/2" H x 3 1/2" D.
- Basket size on 30" and 33" door is 11 1/2" W x 20 1/2" H x 3 1/2" D.
- Touch-up kit (TUK) and Owner's Guide included.
- Door includes a two-tiered non-adjustable chrome rack with wood bottoms.
- Increased Depths available in 1/4" increments from 21 1/4" to 30".
- Not available on Inset and Beaded Inset styles.
- One drawer front with one 1 11/16" deep stainless steel Tilt-out Tray attached.

### Door & Drawer Options

CC	CG	ESMD	GAMD	HC	IFHG	MC	MD	MFO	PRMD	SHMD	SPLITDR	SPLITDRWS	SUMD	TCG	TCP
----	----	------	------	----	------	----	----	-----	------	------	---------	-----------	------	-----	-----

### End Panel Options

AUTH	CSFPE	EXBK	EXDN	FFD	FPE	INTGE	IPE
✓	✓	✓		✓	✓	✓	

### Custom Modification Options

ADD	SHLF	ADRW	BVR	CBO	CCO	CFNTD	CFP	CFRMO	CLIP <sup>1</sup>	CMAT	CND	CSDGBK	DRWTK	EF	EX	EX_OL	FD	FLUT <sup>2</sup>	FTK	ID	IH <sup>3</sup>	INVFRM	IW	
					✓				✓		✓	✓	✓	✓	✓	✓	✓	✓	✓	✓	✓	✓	✓	✓

MIP	OBRB	PFINBTMB	RD	REC	RECTK	RH	ROSFLUT	RT	SBCADDY	SBCADDYSM	SCPDRW	TBN	TD	TKP	TVR	UDBX	URT	VLSO	VTK	VWB	WS <sup>4</sup>	WTR	
✓	✓				✓		✓	✓						✓	✓	✓			✓	✓	✓	✓	✓

<sup>1</sup>Not available on 30" wide.

<sup>2</sup>6" fluting not available on 36" wide.

<sup>3</sup>Only available on 36" wide.

<sup>4</sup>Not available on 30" wide or WSR1.5 and WSL1.5.

IH/RH availability charts starting on page G•40.  
 IW/RW availability charts starting on page G•46.

# Vanity Sink Drawer Base Cabinets

## Description

**VANITY SINK DRAWER BASE, 32" or 34 1/2" HIGH, 18" or 21" DEEP**

## Model

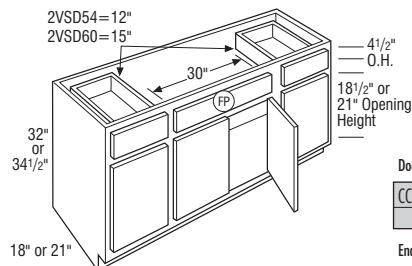
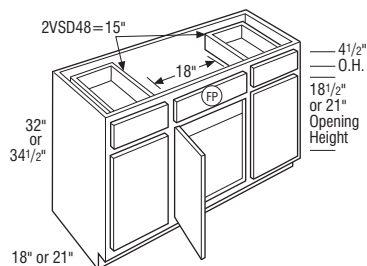
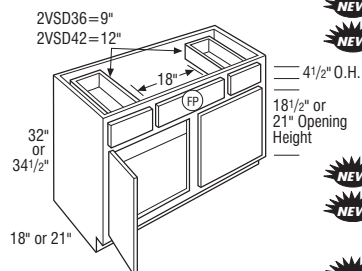

**NEW** 2VSD363218†

**NEW** 2VSD423218

2VSD363221†

2VSD423221

**NEW** 2VSD363418†

**NEW** 2VSD423418

2VSD363421†

2VSD423421

†Butt doors standard.

**NEW** 2VSD483221 L or R

**NEW** 2VSD483421 L or R

• Middle door will be hinged left unless specified otherwise.

**NEW** 2VSD543218FP

**NEW** 2VSD603218FP

**NEW** 2VSD543418FP

**NEW** 2VSD603418FP

**NEW** 2VSD543221FP

2VSD603221FP

**NEW** 2VSD543421FP

2VSD603421FP

Notes below apply to all products in section above:

- Touch-up kit (TUK) and Owner's Guide included.
- Two drawers, one false drawer front, center doors butt doors.
- Increased Depths available in 1/4" increments from 21 1/4" to 24".
- Reduced Depths available in 1/4" increments from 12" to 20 3/4".

(FP) False Panel

### Door & Drawer Options

CC	CG	ESMD	GAMD	HC	IFHG	MC	MD	MFO	PRMD	SHMD	SPLITDR <sup>1</sup>	SPLITDRWS	SUMD	TCG	TCP
✓	✓	✓	✓	✓	✓	✓	✓	✓	✓	✓	✓	✓	✓	✓	✓

### End Panel Options

AUTH	CSFPE	EXBK	EXDN	FFD	FPE	INTGE	IPE
✓	✓	✓	✓	✓	✓	✓	✓

### Custom Modification Options

ADD	SHLF	ADRW	BVR	CBO	CCO	CFNTO	CFP	CFRMO	CLIP	CMAT <sup>2</sup>	CND	CSDGBK <sup>3</sup>	DRWTK <sup>1</sup>	EF	EX	EX_OL	FD	FLUT <sup>4</sup>	FTK	ID	IH	INVFRM	IW	
✓	✓	✓	✓	✓	✓	✓	✓	✓	✓	✓	✓	✓	✓	✓	✓	✓	✓	✓	✓	✓	✓	✓	✓	✓

MIP	OBRB	PFINBTMB	RD	REC	RECTK	RH	ROSFLUT	RT	SBCADDY <sup>5</sup>	SBCADDYSM <sup>5</sup>	SCPDWR	TBN	TD <sup>3</sup>	TKP	TVR <sup>1</sup>	UDBX	URT	VLSO <sup>2</sup>	VTK	VWB <sup>6</sup>	WS <sup>6</sup>	WTR	
✓	✓	✓	✓	✓	✓	✓	✓	✓	✓	✓	✓	✓	✓	✓	✓	✓	✓	✓	✓	✓	✓	✓	✓

<sup>1</sup>Only available on 36" wide.

<sup>2</sup>Only available on 36" and 60" wide.

<sup>3</sup>Not available on 54" or 60" wide.

<sup>4</sup>Not available with 6" fluting.

<sup>5</sup>Only available on 36" and 42" wide.

<sup>6</sup>Not available on 36" wide. Wide stile both 1.5" also not available on 42" wide.

<sup>7</sup>Only available on 34 1/2" high. Not available on depths less than 21". Not available with 2VSD483421 L or R. 54" wide not available with VLSO8.

<sup>8</sup>Not available on depths less than 21".

# Vanity Sink Drawer Base Cabinets

## Description



**VANITY SINK and TWO DRAWER BASE with EXTENDED STILES, 32" or 34 1/2" HIGH, 18" or 21" DEEP**

## Model

2VSD57/603218FP

2VSD57/603418FP

2VSD57/603221FP

2VSD57/603421FP

- Stiles may be trimmed 1 1/2" per side.
- Touch-up kit (TUK) and Owner's Guide included.
- Two drawers, one false drawer front, center doors butt doors.
- Increased Depths available in 1/4" increments from 21 1/4" to 24".
- Reduced Depths available in 1/4" increments from 12" to 20 3/4".

**FP False Panel**

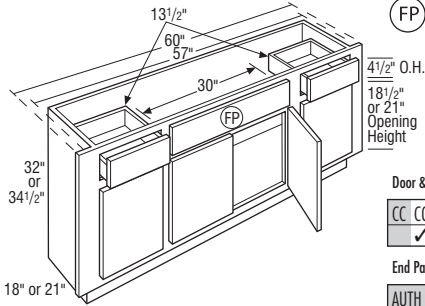

### Door & Drawer Options

CC	CG	ESMD	GAMD	HC	IFHG	MC	MD	MFO	PRMD	SHMD	SPLITDR	SPLITDRWS	SUMD	TCG	TCP
	✓						✓		✓						

### End Panel Options

AUTH	CSFPE	EXBK	EXDN	FFD	FPE	INTGE	IPE
		✓					

### Custom Modification Options

ADD_SHLF	ADRW	BVR	CBO	CCO	CFNTD	CFP	CFRMO	CLIP	CMAT	CND	CSDGBK	DRWTK	EF	EX	EX_OL	FD	FLUT	FTK	ID	IH	INVFRM	IW
			✓	✓	✓	✓	✓			✓									✓	✓		

MIP	OBRB	PFINBTMB	RD	REC	RECTK	RH	ROSFLUT	RT	SBCADDY	SBCADDYSM	SCPDRW	TBN	TD	TKP	TVR	UDBX	URT	VLSO	VTK	VWB	WS	WTR
✓	✓		✓		✓		✓	✓							✓				✓			✓

IH/RH availability charts starting on page G•40.  
IW/RW availability charts starting on page G•46.

# Vanity Sink Drawer Base Cabinets

**Description**

**Model**



**VANITY SINK DRAWER BASE with FALSE PANEL, 32" HIGH, 18" or 21" DEEP**

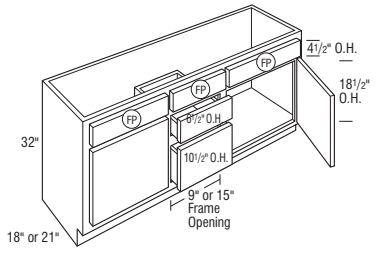
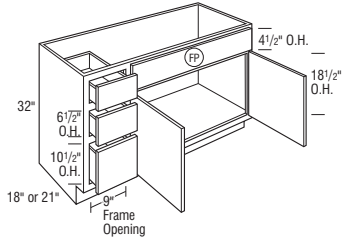
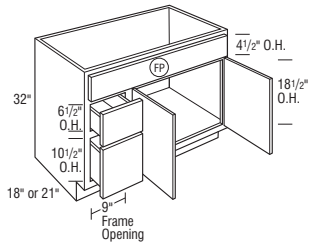
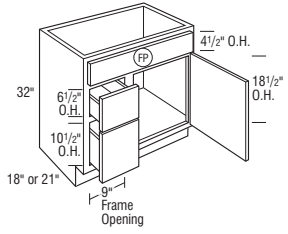

- VSD243218FP DL or DR
- VSD273218FP DL or DR
- VSD303218FP DL or DR
- VSD333218FP DL or DR
- VSD243221FP DL or DR
- VSD273221FP DL or DR
- VSD303221FP DL or DR
- VSD333221FP DL or DR
- Door hinges on opposite side of drawer stack.
- DL or DR indicates drawer location.
- VSD363218FP DL or DR
- VSD363221FP DL or DR
- DL or DR indicates drawer location.
- VSD423218FP DL or DR
- VSD453218FP DL or DR
- VSD483218FP DL or DR
- VSD423221FP DL or DR
- VSD453221FP DL or DR
- VSD483221FP DL or DR
- DL or DR indicates drawer location.
- VSD543218FP
- VSD603218FP
- VSD543221FP
- VSD603221FP
- Door hinges on opposite side of drawer stack.

Notes below apply to all products in section above:

- Touch-up kit (TUK) and Owner's Guide included.
- Increased Depths available in 1/4" increments from 21 1/4" to 24".
- Reduced Depths available in 1/4" increments from 12" to 20 3/4".

**(FP) False Panel**

**Door & Drawer Options**

CC	CG	ESMD	GAMD	HC	IFHG	MC	MD	MFO	PRMD	SHMD	SPLITDR	SPLITDRWS	SUMD	TCG	TCP
✓							✓		✓						

**End Panel Options**

AUTH	CSFPE	EXBK	EXDN	FFD	FPE	INTGE	IPE
✓	✓	✓	✓	✓	✓	✓	✓

**Custom Modification Options**

ADD	SHLF	ADRW	BVR	CBO	CCO	CFNTD	CFP	CFRMO	CLIP	CMAT	CND	CSDGBX	DRWTK	EF	EX	EX_OL	FD	FLUT <sup>1</sup>	FTK	ID <sup>2</sup>	IH	INVFRM	IW	
✓	✓	✓	✓	✓	✓	✓	✓	✓	✓	✓	✓	✓	✓	✓	✓	✓	✓	✓	✓	✓	✓	✓	✓	✓
MIP	OBRB	PFINBTMB	RD	REC	RECTK	RH	ROSLUT <sup>3</sup>	RT	SBCADDY	SBCADDYSM	SCPDRW	TBN	TD	TKP	TVR	UDBX	URT	VLSO	VTK	VWB	WS <sup>4</sup>	WTR		
✓	✓	✓	✓	✓	✓	✓	✓	✓	✓	✓	✓	✓	✓	✓	✓	✓	✓	✓	✓	✓	✓	✓	✓	

<sup>1</sup>Not available with fluting both or 6" fluting.  
<sup>2</sup>Not available on 18" deep.  
<sup>3</sup>Not available on 24" wide. Not available with 6" fluting or fluting both.  
<sup>4</sup>Not available on wide stile 3" or wide stile both.

# Vanity Sink Drawer Base Cabinets

## Description



**VANITY SINK DRAWER BASE with FALSE PANEL, 34 1/2" HIGH, 18" or 21" DEEP**

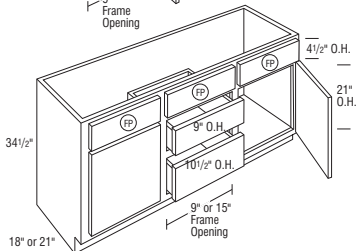
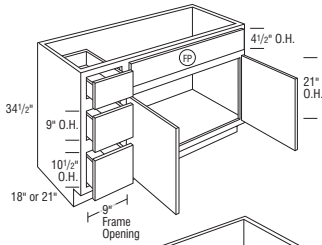
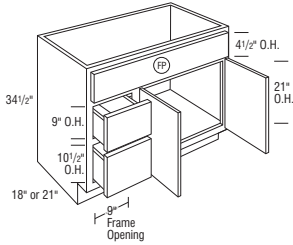
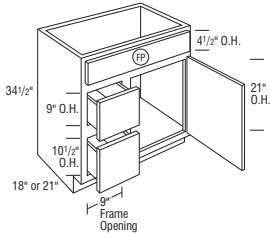

## Model

VSD243418FP DL or DR

VSD273418FP DL or DR

VSD303418FP DL or DR

VSD333418FP DL or DR

VSD243421FP DL or DR

VSD273421FP DL or DR

VSD303421FP DL or DR

VSD333421FP DL or DR

- Door hinges on opposite side of drawer stack.
- DL or DR indicates drawer location.

VSD363418FP DL or DR

VSD363421FP DL or DR

- DL or DR indicates drawer location.

VSD423418FP DL or DR

VSD453418FP DL or DR

VSD483418FP DL or DR

VSD423421FP DL or DR

VSD453421FP DL or DR

VSD483421FP DL or DR

- DL or DR indicates drawer location.

VSD543418FP

VSD603418FP

VSD543421FP

VSD603421FP

- Door hinges on opposite side of drawer stack.

Notes below apply to all products in section above:

- Touch-up kit (TUK) and Owner's Guide included.
- Increased Depths available in 1/4" increments from 21 1/4" to 24".
- Reduced Depths available in 1/4" increments from 12" to 20 3/4".

**FP** False Panel

### Door & Drawer Options

CC	CG	ESMD	GAMD	HC	IFHG	MC	MD	MFO	PRMD	SHMD	SPLITDR	SPLITDRWS	SUMD	TCG	TCP
✓							✓		✓						

### End Panel Options

AUTH	CSFPE	EXBK	EXDN	FFD	FPE	INTGE	IPE
✓	✓	✓		✓	✓	✓	✓

### Custom Modification Options

ADD	SHLF	ADRW	BVR	CBO	CCO	CFNTD	CFP	CFRMO	CLIP	CMAT	CND	CSDGBK	DRWTK	EF	EX	EX_OL	FD	FLUT <sup>1</sup>	FTK	ID <sup>2</sup>	IH	INVFRM	IW	
				✓	✓	✓		✓	✓	✓	✓	✓	✓	✓	✓	✓	✓	✓	✓	✓	✓	✓	✓	✓

MIP	OBRB	PFINBTMB	RD	REC	RECTK	RH	ROSFLUT <sup>1</sup>	RT	SBCADDY	SBCADDYSM	SCPDRW	TBN	TD	TKP	TVR	UDBX	URT	VLSO	VTK	VWB	WS <sup>3</sup>	WTR	
✓	✓		✓	✓	✓	✓	✓	✓	✓	✓	✓	✓	✓	✓	✓	✓	✓	✓	✓	✓	✓	✓	✓

<sup>1</sup>Not available with fluting both or 6" fluting.

<sup>2</sup>Not available on 18" deep.

<sup>3</sup>Not available on wide stile 3" or wide stile both.

IH/RH availability charts starting on page G•40.  
IW/RW availability charts starting on page G•46.

## Description

**VANITY SINK DRAWER BASE with THREE DRAWERS and FALSE PANEL, 32" HIGH, 18" or 21" DEEP**

## Model



VCSD243218FP DL or DR



VCSD273218FP DL or DR



VCSD303218FP DL or DR



VCSD333218FP DL or DR



VCSD363218FP DL or DR

VCSD243221FP DL or DR

VCSD273221FP DL or DR

VCSD303221FP DL or DR

VCSD333221FP DL or DR

VCSD363221FP DL or DR



VCSD423218FP DL or DR



VCSD453218FP DL or DR



VCSD483218FP DL or DR

VCSD423221FP DL or DR

VCSD453221FP DL or DR

VCSD483221FP DL or DR



VCSD543218FP DL or DR



VCSD603218FP DL or DR

VCSD543221FP DL or DR

VCSD603221FP DL or DR

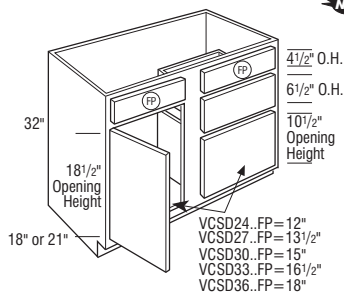

Notes below apply to all products in section above:

- DL or DR indicates drawer location.
- Touch-up kit (TUK) and Owner's Guide included.
- Increased Depths available in 1/4" increments from 21 1/4" to 24".
- Reduced Depths available in 1/4" increments from 12" to 20 3/4".

**(FP) False Panel**

### Door & Drawer Options

CC	CG	ESMD	GAMD	HC	IFHG	MC	MD	MFO	PRMD	SHMD	SPLITDR	SPLITDRWS	SUMD	TCG	TCP
✓	✓	✓	✓	✓	✓	✓	✓	✓	✓	✓	✓	✓	✓	✓	✓

### End Panel Options

AUTH	CSFPE	EXBK	EXDN	FFD	FPE	INTGE	IPE
✓	✓	✓	✓	✓	✓	✓	✓

### Custom Modification Options

ADD_SHLF	ADRW	BVR	CBO	CCO	CFNTO	CFP <sup>1</sup>	CFRMO	CLIP	CMAF <sup>2</sup>	CND	CSDGBK	DRWTK <sup>3</sup>	EF	EX	EX_OL	FD	FLUT <sup>4</sup>	FTK	ID	IH	INVFRM	IW	
✓	✓	✓	✓	✓	✓	✓	✓	✓	✓	✓	✓	✓	✓	✓	✓	✓	✓	✓	✓	✓	✓	✓	✓

MIP	OBRB	PFINBTMB	RD	REC	RECTK	RH	ROSFLUT	RT	SBCADDY	SBCADDYSM	SCPRW <sup>1</sup>	TBN	TD	TKP	TVR	UDBX	URT	VLSO	VTK	VWB <sup>5</sup>	WS <sup>6</sup>	WTR
✓	✓	✓	✓	✓	✓	✓	✓	✓	✓	✓	✓	✓	✓	✓	✓	✓	✓	✓	✓	✓	✓	✓

<sup>1</sup>Only available on 42"-60" wide.

<sup>2</sup>Only available on 48" (1 door and 2 doors)-60" wide.

<sup>3</sup>Only available on 24"-36" wide.

<sup>4</sup>Not available with 6" fluting.

<sup>5</sup>Not available on depths less than 21".

<sup>6</sup>Not available on 24" wide.

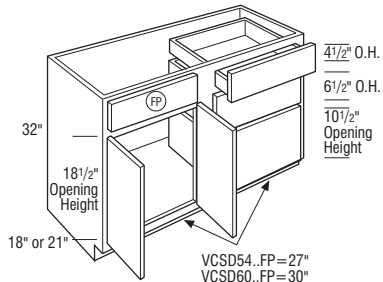
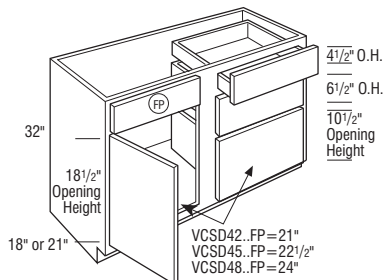

# Vanity Sink Drawer Base Cabinets

## Description

**VANITY SINK DRAWER BASE with THREE DRAWERS and FALSE PANEL, 34 1/2" HIGH, 18" or 21" DEEP**

## Model



VCSD243418FP DL or DR  
 VCSD273418FP DL or DR  
 VCSD303418FP DL or DR  
 VCSD333418FP DL or DR  
 VCSD363418FP DL or DR  
 VCSD243421FP DL or DR  
 VCSD273421FP DL or DR  
 VCSD303421FP DL or DR  
 VCSD333421FP DL or DR  
 VCSD363421FP DL or DR



VCSD423418FP DL or DR  
 VCSD453418FP DL or DR  
 VCSD483418FP DL or DR  
 VCSD423421FP DL or DR  
 VCSD453421FP DL or DR  
 VCSD483421FP DL or DR



VCSD543418FP DL or DR  
 VCSD603418FP DL or DR  
 VCSD543421FP DL or DR  
 VCSD603421FP DL or DR

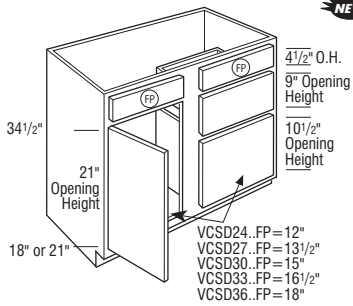

Notes below apply to all products in section above:

- DL or DR indicates drawer location.
- Touch-up kit (TUK) and Owner's Guide included.
- Increased Depths available in 1/4" increments from 21 1/4" to 24".
- Reduced Depths available in 1/4" increments from 12" to 20 3/4".

**FP** False Panel

### Door & Drawer Options

CC	CG	ESMD	GAMD	HC	IFHG	MC	MD	MFO	PRMD	SHMD	SPLITDR	SPLITDRWS	SUMD	TCG	TCP
✓	✓	✓	✓	✓	✓	✓	✓	✓	✓	✓	✓	✓	✓	✓	✓

### End Panel Options

AUTH	CSFPE	EXBK	EXDN	FFD	FPE	INTGE	IPE
✓	✓	✓	✓	✓	✓	✓	✓

### Custom Modification Options

ADD	SHLF	ADRW	BVR	CBO	CCO	CFNT0	CFP <sup>1</sup>	CFRMO	CLIP	CMAT <sup>2</sup>	CND	CSDGBK	DRWTK <sup>3</sup>	EF	EX	EX_OL	FD	FLUT <sup>4</sup>	FTK	ID	IH	INVFRM	IW	
✓	✓	✓	✓	✓	✓	✓	✓	✓	✓	✓	✓	✓	✓	✓	✓	✓	✓	✓	✓	✓	✓	✓	✓	✓
MIP	OBRB	PFINBTMB	RD	REC	RECTK	RH	ROSFLUT	RT	SBCADDY	SBCADDYSM	SCPDRW <sup>1</sup>	TBN	TD	TKP	TVR	UDBX	URT	VLSO <sup>5</sup>	VTK	VWB <sup>6</sup>	WS <sup>7</sup>	WTR		
✓	✓	✓	✓	✓	✓	✓	✓	✓	✓	✓	✓	✓	✓	✓	✓	✓	✓	✓	✓	✓	✓	✓	✓	

<sup>1</sup>Only available on 42"-60" wide.

<sup>2</sup>Only available on 48" (1 door and 2 doors)-60" wide.

<sup>3</sup>Only available on 24"-36" wide.

<sup>4</sup>Not available with 6" fluting.

<sup>5</sup>Not available on depths less than 21". VLSOB not available on 24"-45" wide. 24"-27" wide not available.

<sup>6</sup>Not available on depths less than 21".

<sup>7</sup>Not available on 24" wide.

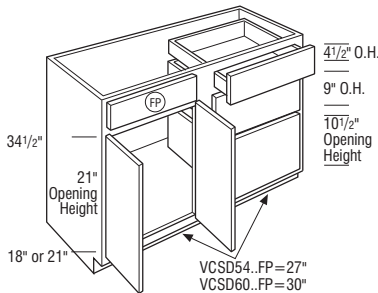
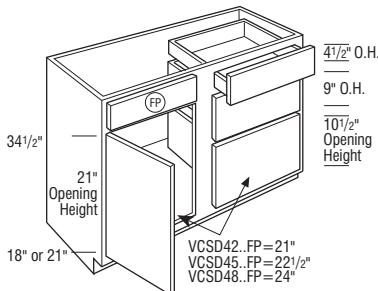

IH/RH availability charts starting on page G•40.  
 IW/RW availability charts starting on page G•46.

# Vanity Sink Drawer Base Cabinets

**Description**

**NEW** VANITY SINK BASE with THREE DRAWERS, 32" HIGH, 18" or 21" DEEP

**Model**

- VS3D543218
- VS3D603218
- VS3D543221
- VS3D603221

Notes below apply to all products in section above:

- Door hinges on opposite side of drawer stack.
- Touch-up kit (TUK) and Owner's Guide included.
- Increased Depths available in 1/4" increments from 21 1/4" to 24".
- Reduced Depths available in 1/4" increments from 12" to 20 3/4".

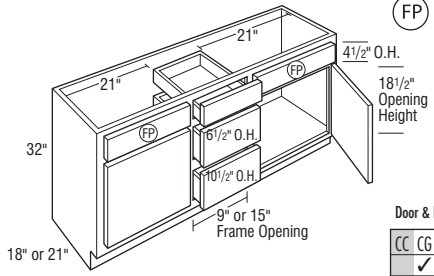

**(FP) False Panel**

**Door & Drawer Options**

CC	CG	ESMD	GAMD	HC	IFHG	MC	MD	MFO	PRMD	SHMD	SPLITDR	SPLITDRWS	SUMD	TCG	TCP
✓						✓			✓						

**End Panel Options**

AUTH	CSFPE	EXBK	EXDN	FFD	FPE	INTGE	IPE
✓	✓	✓		✓	✓	✓	

**Custom Modification Options**

ADD_SHLF	ADRW	BVR	CBO	CCO	CFNTD	CFP	CFRMO	CLIP	CMAT	CND	CSDGBK	DRWTK	EF	EX	EX_OL	FD	FLUT <sup>1</sup>	FTK	ID <sup>2</sup>	IH	INVFRM	IW	
			✓	✓	✓		✓	✓	✓	✓	✓	✓	✓	✓	✓	✓	✓	✓	✓	✓	✓	✓	✓
MIP	OBRB	PFINBTMB	RD	REC	RECTK	RH	ROSFLUT <sup>1</sup>	RT	SBCADDY	SBCADDYSM	SCPDRW	TBN	TD	TKP	TVR	UDBX	URT	VLSO	VTK	VWB	WS <sup>3</sup>	WTR	
✓	✓		✓	✓	✓	✓	✓	✓	✓	✓	✓	✓	✓	✓	✓	✓	✓	✓	✓	✓	✓	✓	

<sup>1</sup>Not available with fluting both or 6" fluting.  
<sup>2</sup>Not available on 18" deep.  
<sup>3</sup>Only available with wide stile 1.5".

**NEW** VANITY SINK BASE with THREE DRAWERS, 34 1/2" HIGH, 18" or 21" DEEP

- VS3D543418
- VS3D603418
- VS3D543421
- VS3D603421

Notes below apply to all products in section above:

- Door hinges on opposite side of drawer stack.
- Touch-up kit (TUK) and Owner's Guide included.
- Increased Depths available in 1/4" increments from 21 1/4" to 24".
- Reduced Depths available in 1/4" increments from 12" to 20 3/4".

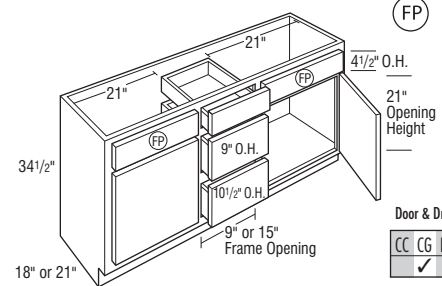

**(FP) False Panel**

**Door & Drawer Options**

CC	CG	ESMD	GAMD	HC	IFHG	MC	MD	MFO	PRMD	SHMD	SPLITDR	SPLITDRWS	SUMD	TCG	TCP
✓						✓			✓						

**End Panel Options**

AUTH	CSFPE	EXBK	EXDN	FFD	FPE	INTGE	IPE
✓	✓	✓		✓	✓	✓	

**Custom Modification Options**

ADD_SHLF	ADRW	BVR	CBO	CCO	CFNTD	CFP	CFRMO	CLIP	CMAT	CND	CSDGBK	DRWTK	EF	EX	EX_OL	FD	FLUT <sup>1</sup>	FTK	ID <sup>2</sup>	IH	INVFRM	IW	
			✓	✓	✓		✓	✓	✓	✓	✓	✓	✓	✓	✓	✓	✓	✓	✓	✓	✓	✓	✓
MIP	OBRB	PFINBTMB	RD	REC	RECTK	RH	ROSFLUT <sup>1</sup>	RT	SBCADDY	SBCADDYSM	SCPDRW	TBN	TD	TKP	TVR	UDBX	URT	VLSO	VTK	VWB	WS <sup>3</sup>	WTR	
✓	✓		✓	✓	✓	✓	✓	✓	✓	✓	✓	✓	✓	✓	✓	✓	✓	✓	✓	✓	✓	✓	✓

<sup>1</sup>Not available with fluting both or 6" fluting.  
<sup>2</sup>Not available on 18" deep.  
<sup>3</sup>Only available with wide stile 1.5".



# Vanity Sink Drawer Base Cabinets

## Description

**VANITY SINK DRAWER BASE with FOUR DRAWERS and FALSE PANEL, 32" HIGH, 21" DEEP**

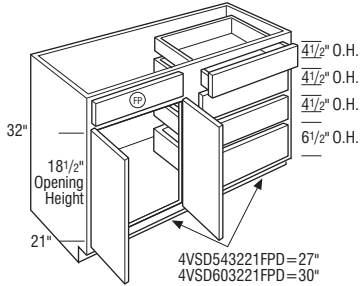
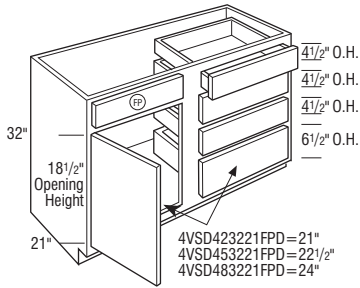
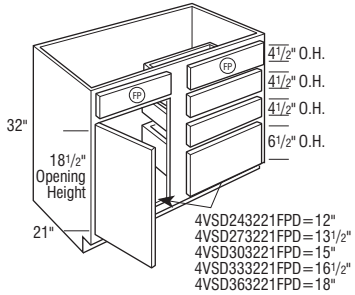

## Model

4VSD243221FPD L or R

4VSD273221FPD L or R

4VSD303221FPD L or R

4VSD333221FPD L or R

4VSD363221FPD L or R

4VSD423221FPD L or R

4VSD453221FPD L or R

4VSD483221FPD L or R

4VSD543221FPD L or R

4VSD603221FPD L or R

Notes below apply to all products in section above:

- Door will be hinged on the opposite side of the drawer stack unless specified otherwise.
- Touch-up kit (TUK) and Owner's Guide included.
- Increased Depths available in 1/4" increments from 21 1/4" to 24".
- Reduced Depths available in 1/4" increments from 12" to 20 3/4".

**FP** False Panel

### Door & Drawer Options

CC	CG	ESMD	GAMD	HC	IFHG	MC	MD	MFO	PRMD	SHMD	SPLITDR	SPLITDRWS	SUMD	TCG	TCP
✓	✓	✓	✓	✓	✓	✓	✓	✓	✓	✓			✓		

### End Panel Options

AUTH	CSFPE	EXBK	EXDN	FFD	FPE	INTGE	IPE
✓	✓	✓	✓	✓	✓	✓	✓

### Custom Modification Options

ADD	SHLF	ADRW	BVR	CBO	CCO	CFNT0	CFP <sup>1</sup>	CFRMO	CLIP <sup>2</sup>	CMAT <sup>3</sup>	CND	CSDGBK	DRWTK <sup>4</sup>	EF	EX	EX_OL	FD	FLUT <sup>5</sup>	FTK	ID	IH	INVFRM	IW	
							✓	✓	✓	✓	✓	✓	✓	✓	✓	✓	✓	✓	✓	✓	✓	✓	✓	✓
MIP <sup>6</sup>	OBRB	PFINBTMB	RD	REC	RECTK	RH	ROSFLUT <sup>6</sup>	RT	SBCADDY	SBCADDYSM	SCPDWR <sup>1</sup>	TBN	TD	TKP	TVR	UDBX	URT	VLSO	VTK	VWB	WS	WTR		
✓	✓	✓	✓	✓	✓	✓	✓	✓	✓	✓	✓	✓	✓	✓	✓	✓	✓	✓	✓	✓	✓	✓	✓	

<sup>1</sup>Only available on 42"-60" wide.

<sup>2</sup>Not available on 24"-27" wide.

<sup>3</sup>Only available on 48" (1 door and 2 doors)-60" wide.

<sup>4</sup>Only available on 24"-36" wide.

<sup>5</sup>Not available on 24"-27" wide. 6" fluting not available on 30" wide.

<sup>6</sup>Not available on 24"-27" wide.

IH/RH availability charts starting on page G•40.  
IW/RW availability charts starting on page G•46.

**Description**

**VANITY SINK DRAWER BASE with FOUR DRAWERS and FALSE PANEL, 34 1/2" HIGH, 21" DEEP**

**Model**

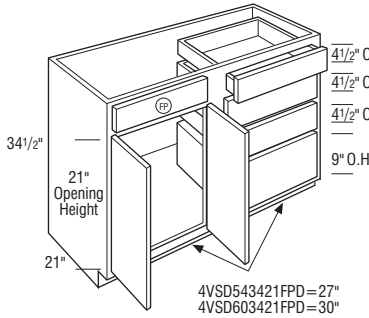
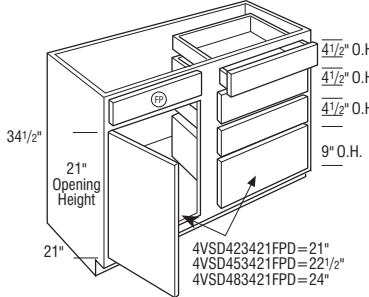
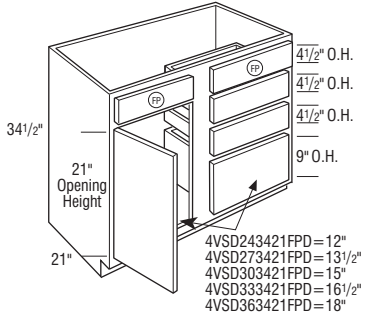

- 4VSD243421FPD L or R
- 4VSD273421FPD L or R
- 4VSD303421FPD L or R
- 4VSD333421FPD L or R
- 4VSD363421FPD L or R
- 4VSD423421FPD L or R
- 4VSD453421FPD L or R
- 4VSD483421FPD L or R
- 4VSD543421FPD L or R
- 4VSD603421FPD L or R

Notes below apply to all products in section above:

- Door will be hinged on the opposite side of the drawer stack unless specified otherwise.
- Touch-up kit (TUK) and Owner's Guide included.
- Increased Depths available in 1/4" increments from 21 1/4" to 24".
- Reduced Depths available in 1/4" increments from 12" to 20 3/4".

**FP** False Panel

**Door & Drawer Options**

CC	CG	ESMD	GAMD	HC	IFHG	MC	MD	MFO	PRMD	SHMD	SPLITDR	SPLITDRWS	SUMD	TCG	TCP
✓	✓	✓	✓	✓	✓	✓	✓	✓	✓	✓			✓		

**End Panel Options**

AUTH	CSFPE	EXBK	EXDN	FFD	FPE	INTGE	IPE
✓	✓	✓	✓	✓	✓	✓	✓

**Custom Modification Options**

ADD_SHLF	ADRW	BVR	CBO	CCO	CFNT0	CFP <sup>1</sup>	CFRMO	CLIP <sup>2</sup>	CMA <sup>3</sup>	CND	CSDGBK	DRWTK <sup>4</sup>	EF	EX	EX_OL	FD	FLUT <sup>5</sup>	FTK	ID	IH	INVERM	IW	
						✓	✓	✓	✓	✓	✓	✓	✓	✓	✓	✓	✓	✓	✓	✓	✓	✓	✓

MIP	OBRB	PFINBTMB	RD	REC	RECTK	RH	ROSLUT <sup>6</sup>	RT	SBCADDY	SBCADDYSM	SCPDRW <sup>1</sup>	TBN	TD	TKP	TVR	UBX	URT	VLSO	VTK	VWB	WS	WTR
✓	✓		✓				✓	✓	✓	✓	✓	✓	✓	✓	✓	✓	✓	✓	✓	✓	✓	✓

<sup>1</sup>Only available on 42"-60" wide.  
<sup>2</sup>Not available on 24"-27" wide.  
<sup>3</sup>Only available on 48" (1 door and 2 doors)-60" wide.  
<sup>4</sup>Only available on 24"-36" wide.  
<sup>5</sup>Not available on 24"-27" wide. 6" fluting not available on 30" wide.  
<sup>6</sup>Not available on 24"-27" wide.

# Vanity Combination Drawer Base Cabinets

## Description

### VANITY COMBINATION DRAWER BASE with THREE DRAWERS, 32" HIGH, 21" DEEP

VCDB423221D=12"  
VCDB483221D=15"  
VCDB543221D=18"  
VCDB603221D=21"

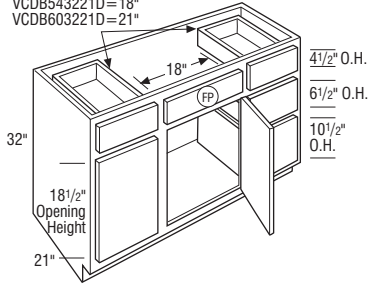

## Model

VCDB423221D L or R

VCDB483221D L or R

VCDB543221D L or R

VCDB603221D L or R

- Middle door hinged same side as drawer stack unless specified otherwise.
- Touch-up kit (TUK) and Owner's Guide included.
- Increased Depths available in 1/4" increments from 21 1/4" to 24".
- Reduced Depths available in 1/4" increments from 12" to 20 3/4".

**FP** False Panel

#### Door & Drawer Options

CC	CG	ESMD	GAMD	HC	IFHG	MC	MD	MFO	PRMD	SHMD	SPLITDR	SPLITDRWS	SUMD	TCG	TCP
✓	✓	✓	✓	✓	✓	✓	✓	✓	✓	✓	✓	✓	✓	✓	✓

#### End Panel Options

AUTH	CSFPE	EXBK	EXDN	FFD	FPE	INTGE	IPE
✓	✓	✓	✓	✓	✓	✓	✓

#### Custom Modification Options

ADD	SHLF	ADRW	BVR	CBO	CCO	CFNTD	CFP	CFRMO	CLIP	CMAT	CND	CSDGBK <sup>1</sup>	DRWTK	EF	EX	EX_OL	FD	FLUT <sup>2</sup>	FTK	ID	IH	INVFRM	IW
				✓	✓	✓	✓	✓			✓	✓		✓	✓	✓	✓	✓	✓	✓	✓	✓	✓

MIP	OBRB	PFINBTMB	RD	REC	RECTK	RH	ROSFLUT	RT	SBCADDY	SBCADDYSM	SCPDRW	TBN	TD	TKP	TVR	UBBX	URT	VLSO	VTK	VWB	WS <sup>3</sup>	WTR
✓	✓	✓	✓	✓	✓	✓	✓	✓			✓	✓	✓	✓	✓	✓	✓	✓	✓	✓	✓	✓

<sup>1</sup>Only available on 42" and 48" wide.

<sup>2</sup>Not available with 6" fluting.

<sup>3</sup>Wide stile both 1.5" not available on 42" wide.

### VANITY COMBINATION DRAWER BASE with THREE DRAWERS, 34 1/2" HIGH, 21" DEEP

VCDB423421D=12"  
VCDB483421D=15"  
VCDB543421D=18"  
VCDB603421D=21"

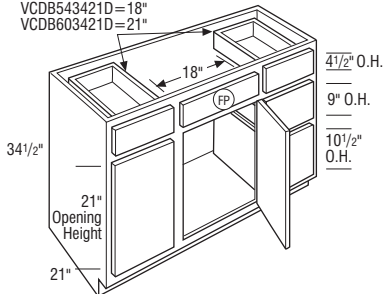

VCDB423421D L or R

VCDB483421D L or R

VCDB543421D L or R

VCDB603421D L or R

- Middle door hinged same side as drawer stack unless specified otherwise.
- Touch-up kit (TUK) and Owner's Guide included.
- Increased Depths available in 1/4" increments from 21 1/4" to 24".
- Reduced Depths available in 1/4" increments from 12" to 20 3/4".

**FP** False Panel

#### Door & Drawer Options

CC	CG	ESMD	GAMD	HC	IFHG	MC	MD	MFO	PRMD	SHMD	SPLITDR	SPLITDRWS	SUMD	TCG	TCP
✓	✓	✓	✓	✓	✓	✓	✓	✓	✓	✓	✓	✓	✓	✓	✓

#### End Panel Options

AUTH	CSFPE	EXBK	EXDN	FFD	FPE	INTGE	IPE
✓	✓	✓	✓	✓	✓	✓	✓

#### Custom Modification Options

ADD	SHLF	ADRW	BVR	CBO	CCO	CFNTD	CFP	CFRMO	CLIP	CMAT	CND	CSDGBK <sup>1</sup>	DRWTK	EF	EX	EX_OL	FD	FLUT <sup>2</sup>	FTK	ID	IH	INVFRM	IW
				✓	✓	✓	✓	✓			✓	✓		✓	✓	✓	✓	✓	✓	✓	✓	✓	✓

MIP	OBRB	PFINBTMB	RD	REC	RECTK	RH	ROSFLUT	RT	SBCADDY	SBCADDYSM	SCPDRW	TBN	TD	TKP	TVR	UBBX	URT	VLSO <sup>3</sup>	VTK	VWB	WS <sup>3</sup>	WTR	
✓	✓	✓	✓	✓	✓	✓	✓	✓			✓	✓	✓	✓	✓	✓	✓	✓	✓	✓	✓	✓	✓

<sup>1</sup>Only available on 42" and 48" wide.

<sup>2</sup>Not available with 6" fluting.

<sup>3</sup>VLSO<sup>3</sup> not available.

IH/RH availability charts starting on page G•40.  
IW/RW availability charts starting on page G•46.

# Vanity Combination Drawer Base Cabinets

## Description

**VANITY COMBINATION DRAWER BASE  
with FOUR DRAWERS, 32" HIGH,  
21" DEEP**

4VCDB423221D=12"  
4VCDB483221D=15"  
4VCDB543221D=18"  
4VCDB603221D=21"

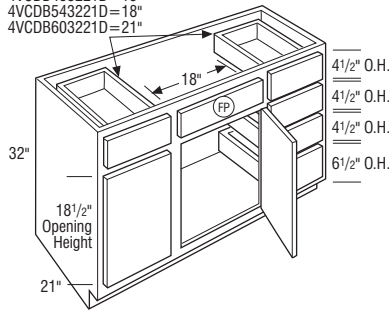

**(FP) False Panel**

### Door & Drawer Options

CC	CG	ESMD	GAMD	HC	IFHG	MC	MD	MFO	PRMD	SHMD	SPLITDR	SPLITDRWS	SUMD	TCG	TCP
✓	✓	✓	✓	✓	✓	✓	✓	✓	✓	✓	✓	✓	✓	✓	✓

### End Panel Options

AUTH	CSFPE	EXBK	EXDN	FFD	FPE	INTGE	IPE
✓	✓	✓	✓	✓	✓	✓	✓

### Custom Modification Options

ADD_SHLF	ADRW	BVR	CBO	CCO	CFNTO	CFP	CFRMO	CLIP	CMAT	CND	CSDGBX	DRWTK	EF	EX	EX_OL	FD	FLUT <sup>1</sup>	FTK	ID	IH	INVFRM	IW	
✓	✓	✓	✓	✓	✓	✓	✓	✓	✓	✓	✓	✓	✓	✓	✓	✓	✓	✓	✓	✓	✓	✓	✓
MIP	OBRB	PFINBTMB	RD	REC	RECTK	RH	ROSFLUT	RT	SBCADDY	SBCADDYSM	SCPRDW	TBN	TD	TKP	TVR	UDBX	URT	VLSO	VTK	VWB	WS	WTR	
✓	✓	✓	✓	✓	✓	✓	✓	✓	✓	✓	✓	✓	✓	✓	✓	✓	✓	✓	✓	✓	✓	✓	✓

<sup>1</sup>Not available with 6" fluting.

**VANITY COMBINATION DRAWER BASE  
with FOUR DRAWERS, 34 1/2" HIGH,  
21" DEEP**

4VCDB423421D=12"  
4VCDB483421D=15"  
4VCDB543421D=18"  
4VCDB603421D=21"

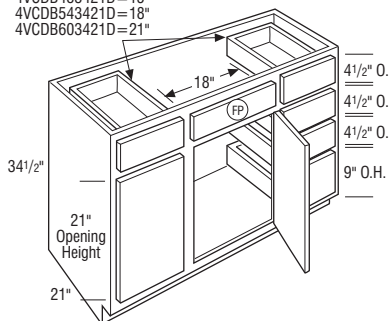

**(FP) False Panel**

### Door & Drawer Options

CC	CG	ESMD	GAMD	HC	IFHG	MC	MD	MFO	PRMD	SHMD	SPLITDR	SPLITDRWS	SUMD	TCG	TCP
✓	✓	✓	✓	✓	✓	✓	✓	✓	✓	✓	✓	✓	✓	✓	✓

### End Panel Options

AUTH	CSFPE	EXBK	EXDN	FFD	FPE	INTGE	IPE
✓	✓	✓	✓	✓	✓	✓	✓

### Custom Modification Options

ADD_SHLF	ADRW	BVR	CBO	CCO	CFNTO	CFP	CFRMO	CLIP	CMAT	CND	CSDGBX	DRWTK	EF	EX	EX_OL	FD	FLUT <sup>1</sup>	FTK	ID	IH	INVFRM	IW	
✓	✓	✓	✓	✓	✓	✓	✓	✓	✓	✓	✓	✓	✓	✓	✓	✓	✓	✓	✓	✓	✓	✓	✓
MIP	OBRB	PFINBTMB	RD	REC	RECTK	RH	ROSFLUT	RT	SBCADDY	SBCADDYSM	SCPRDW	TBN	TD	TKP	TVR	UDBX	URT	VLSO	VTK	VWB	WS	WTR	
✓	✓	✓	✓	✓	✓	✓	✓	✓	✓	✓	✓	✓	✓	✓	✓	✓	✓	✓	✓	✓	✓	✓	✓

<sup>1</sup>Not available with 6" fluting.

# Vanity Console Drawer Base Cabinets

## Description

**VANITY CONSOLE DRAWER BASE with SIX DRAWERS, 32" HIGH, 21" DEEP**

## Model

**6VCDB423221 L or R**

**6VCDB483221 L or R**

**6VCDB543221 L or R**

**6VCDB603221 L or R**

- Specify L or R hinge for center door.

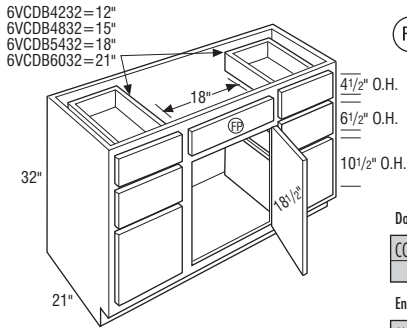

**FP** False Panel

### Door & Drawer Options

CC	CG	ESMD	GAMD	HC	IFHG	MC	MD	MFO	PRMD	SHMD	SPLITDR	SPLITDRWS	SUMD	TCG	TCP
✓	✓	✓	✓	✓	✓	✓	✓	✓	✓	✓	✓	✓	✓	✓	✓

### End Panel Options

AUTH	CSFPE	EXBK	EXDN	FFD	FPE	INTGE	IPE
✓	✓	✓	✓	✓	✓	✓	✓

### Custom Modification Options

ADD	SHLF	ADRW	BVR	CBO	CCO	CFNTD	CFP	CFRMO	CLIP	CMAT	CND	CSDGBK	DRWTK	EF	EX	EX_OL	FD	FLUT <sup>1</sup>	FTK	ID	IH	INVFRM	IW	
✓	✓	✓	✓	✓	✓	✓	✓	✓	✓	✓	✓	✓	✓	✓	✓	✓	✓	✓	✓	✓	✓	✓	✓	✓

MIP	OBRB	PFINBTMB	RD	REC	RECTK	RH	ROSFLUT	RT	SBCADDY	SBCADDYSM	SCPDRW <sup>2</sup>	TBN	TD	TKP	TVR	UDBX	URT	VLSO	VTK	VWB	WS <sup>3</sup>	WTR	
✓	✓	✓	✓	✓	✓	✓	✓	✓	✓	✓	✓	✓	✓	✓	✓	✓	✓	✓	✓	✓	✓	✓	✓

<sup>1</sup>Not available with 6" fluting.

<sup>2</sup>Only available on 42" and 48" wide.

<sup>3</sup>Only available with wide stile 3".

**VANITY CONSOLE DRAWER BASE with EIGHT DRAWERS, 32" HIGH, 21" DEEP**

**4-6VCDB423221 L or R**

**4-6VCDB483221 L or R**

**4-6VCDB543221 L or R**

**4-6VCDB603221 L or R**

- Specify L or R hinge for center door.
- Includes touch-up kit and owner's guide.

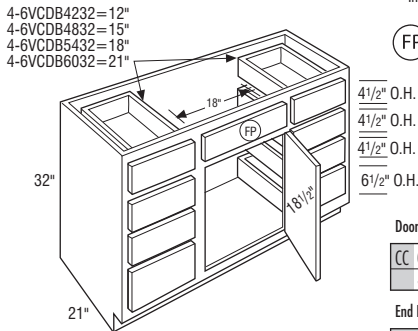

**FP** False Panel

### Door & Drawer Options

CC	CG	ESMD	GAMD	HC	IFHG	MC	MD	MFO	PRMD	SHMD	SPLITDR	SPLITDRWS	SUMD	TCG	TCP
✓	✓	✓	✓	✓	✓	✓	✓	✓	✓	✓	✓	✓	✓	✓	✓

### End Panel Options

AUTH	CSFPE	EXBK	EXDN	FFD	FPE	INTGE	IPE
✓	✓	✓	✓	✓	✓	✓	✓

### Custom Modification Options

ADD	SHLF	ADRW	BVR	CBO	CCO	CFNTD	CFP	CFRMO	CLIP	CMAT	CND	CSDGBK	DRWTK	EF	EX	EX_OL	FD	FLUT <sup>1</sup>	FTK	ID	IH	INVFRM	IW
✓	✓	✓	✓	✓	✓	✓	✓	✓	✓	✓	✓	✓	✓	✓	✓	✓	✓	✓	✓	✓	✓	✓	✓

MIP	OBRB	PFINBTMB	RD	REC	RECTK	RH	ROSFLUT	RT	SBCADDY	SBCADDYSM	SCPDRW <sup>2</sup>	TBN	TD	TKP	TVR	UDBX	URT	VLSO	VTK	VWB	WS <sup>3</sup>	WTR	
✓	✓	✓	✓	✓	✓	✓	✓	✓	✓	✓	✓	✓	✓	✓	✓	✓	✓	✓	✓	✓	✓	✓	✓

<sup>1</sup>Not available with 6" fluting.

<sup>2</sup>Only available on 42" and 48" wide.

<sup>3</sup>Only available with wide stile 3".

IH/RH availability charts starting on page G•40.  
IW/RW availability charts starting on page G•46.

## Description

### VANITY CONSOLE DRAWER BASE with SIX DRAWERS, 34 1/2" HIGH, 21" DEEP

6VCDB4234=12"  
6VCDB4834=15"  
6VCDB5434=18"  
6VCDB6034=21"

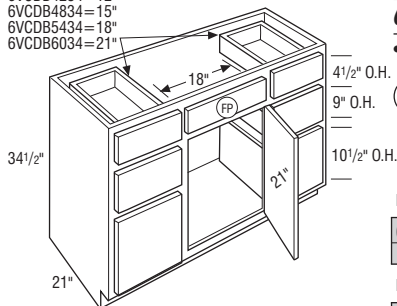

## Model

6VCDB423421 L or R

6VCDB483421 L or R

6VCDB543421 L or R

6VCDB603421 L or R

- Specify L or R hinge for center door.

**FP** False Panel

#### Door & Drawer Options

CC	CG	ESMD	GAMD	HC	IFHG	MC	MD	MFO	PRMD	SHMD	SPLITDR	SPLITDRWS	SUMD	TCG	TCP
✓	✓	✓	✓	✓	✓	✓	✓	✓	✓	✓	✓	✓	✓	✓	✓

#### End Panel Options

AUTH	CSFPE	EXBK	EXDN	FFD	FPE	INTGE	IPE
✓	✓	✓	✓	✓	✓	✓	✓

#### Custom Modification Options

ADD_SHLF	ADRW	BVR	CBO	CCO	CFNTO	CFP	CFRMO	CLIP	CMAT	CND	CSDGBK <sup>1</sup>	DRWTK	EF	EX	EX_OL	FD	FLUT <sup>2</sup>	FTK	ID	IH	INVERM	IW	
			✓	✓	✓	✓	✓			✓	✓		✓	✓	✓	✓	✓	✓	✓	✓	✓	✓	✓

MIP	OBRB	PFINBTMB	RD	REC	RECTK	RH	ROSLUT	RT	SBCADDY	SBCADDYSM	SCPDWR	TBN	TD	TKP	TVR	UDBX	URT	VLSO	VTK	VWB	WS <sup>3</sup>	WTR	
✓	✓	✓	✓	✓	✓	✓	✓	✓			✓	✓	✓	✓	✓	✓	✓	✓	✓	✓	✓	✓	✓

<sup>1</sup>Only available on 42" and 48" wide.

<sup>2</sup>Not available with 6" fluting.

<sup>3</sup>Only available with wide stile 3".

### VANITY CONSOLE DRAWER BASE with EIGHT DRAWERS, 34 1/2" HIGH, 21" DEEP

4-6VCDB4234=12"  
4-6VCDB4834=15"  
4-6VCDB5434=18"  
4-6VCDB6034=21"

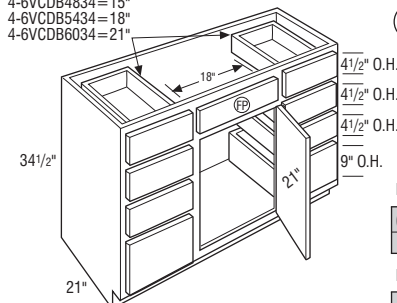

4-6VCDB423421 L or R

4-6VCDB483421 L or R

4-6VCDB543421 L or R

4-6VCDB603421 L or R

- Specify L or R hinge for center door.
- Includes touch-up kit and owner's guide.

**FP** False Panel

#### Door & Drawer Options

CC	CG	ESMD	GAMD	HC	IFHG	MC	MD	MFO	PRMD	SHMD	SPLITDR	SPLITDRWS	SUMD	TCG	TCP
✓	✓	✓	✓	✓	✓	✓	✓	✓	✓	✓	✓	✓	✓	✓	✓

#### End Panel Options

AUTH	CSFPE	EXBK	EXDN	FFD	FPE	INTGE	IPE
✓	✓	✓	✓	✓	✓	✓	✓

#### Custom Modification Options

ADD_SHLF	ADRW	BVR	CBO	CCO	CFNTO	CFP	CFRMO	CLIP	CMAT	CND	CSDGBK <sup>1</sup>	DRWTK	EF	EX	EX_OL	FD	FLUT <sup>2</sup>	FTK	ID	IH	INVERM	IW
			✓	✓	✓	✓	✓			✓	✓		✓	✓	✓	✓	✓	✓	✓	✓	✓	✓

MIP	OBRB	PFINBTMB	RD	REC	RECTK	RH	ROSLUT	RT	SBCADDY	SBCADDYSM	SCPDWR	TBN	TD	TKP	TVR	UDBX	URT	VLSO	VTK	VWB	WS <sup>3</sup>	WTR	
✓	✓	✓	✓	✓	✓	✓	✓	✓			✓	✓	✓	✓	✓	✓	✓	✓	✓	✓	✓	✓	✓

<sup>1</sup>Only available on 42" and 48" wide.

<sup>2</sup>Not available with 6" fluting.

<sup>3</sup>Only available with wide stile 3".

# Vanity Sink Drawer Base Cabinets

## Description

**VANITY SINK DRAWER BASE with SIX DRAWERS, 32" HIGH, 18" or 21" DEEP**

## Model



6VSD423218FP L or R



6VSD483218FP L or R

6VSD423221FP L or R

6VSD483221FP L or R

• Middle door will be hinged left unless specified otherwise.



6VSD483218FP



6VSD543218FP



6VSD603218FP



6VSD483221FP

6VSD543221FP

6VSD603221FP

- Touch-up kit (TUK) and Owner's Guide included.
- Six total drawers.
- Increased Depths available in 1/4" increments from 21 1/4" to 24".
- Reduced Depths available in 1/4" increments from 12" to 20 3/4".

**FP False Panel**

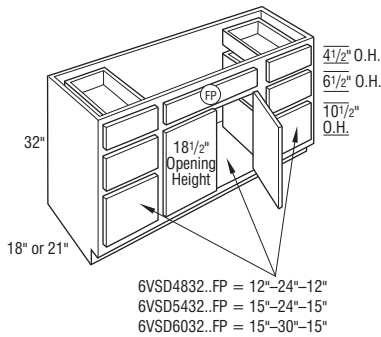
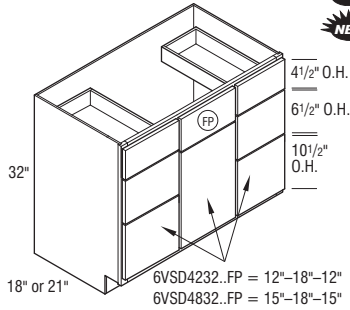

### Door & Drawer Options

CC	CG	ESMD	GAMD	HC	IFHG	MC	MD	MFO	PRMD	SHMD	SPLITDR	SPLITDRWS	SUMD	TCG	TCP
✓	✓	✓	✓	✓	✓	✓	✓	✓	✓	✓	✓	✓	✓	✓	✓

### End Panel Options

AUTH	CSFPE	EXBK	EXDN	FFD	FPE	INTGE	IPE
✓	✓	✓	✓	✓	✓	✓	✓

### Custom Modification Options

ADD	SHLF	ADRW	BVR	CBO	CCO	CFNTO	CFP	CFRMO	CLIP	CMAT <sup>1</sup>	CND	CSDGBK	DRWTK	EF	EX	EX_OL	FD	FLUT <sup>2</sup>	FTK	ID	IH	INFRM	IW	
✓	✓	✓	✓	✓	✓	✓	✓	✓	✓	✓	✓	✓	✓	✓	✓	✓	✓	✓	✓	✓	✓	✓	✓	✓

MIP	OBRB	PFINBTMB	RD	REC	RECTK <sup>3</sup>	RH	ROSLUT	RT	SBCADDY	SBCADDYSM	SCPDWR	TBN	TD	TKP <sup>3</sup>	TVR	UDBX	URT	VLSO	VTK <sup>3</sup>	VWB <sup>4</sup>	WS <sup>5</sup>	WTR	
✓	✓	✓	✓	✓	✓	✓	✓	✓	✓	✓	✓	✓	✓	✓	✓	✓	✓	✓	✓	✓	✓	✓	✓

<sup>1</sup>Not available with 42" or 48" wide.

<sup>2</sup>Not available with 6" fluting.

<sup>3</sup>Only available on 60" wide.

<sup>4</sup>Not available on depths less than 21".

<sup>5</sup>Wide stile 1.5" versions not available on 60" wide.

IH/RH availability charts starting on page G•40.  
IW/RW availability charts starting on page G•46.

# Vanity Sink Drawer Base Cabinets

**Description**

**VANITY SINK DRAWER BASE with SIX DRAWERS, 34 1/2" HIGH, 18" or 21" DEEP**

**Model**



- 6VSD423418FP L or R
- 6VSD483418FP L or R
- 6VSD423421FP L or R
- 6VSD483421FP L or R

• Middle door will be hinged left unless specified otherwise.



- 6VSD483418FP
- 6VSD543418FP
- 6VSD603418FP
- 6VSD483421FP

- 6VSD543421FP
- 6VSD603421FP

- Touch-up kit (TUK) and Owner's Guide included.
- Six total drawers.
- Increased Depths available in 1/4" increments from 21 1/4" to 24".
- Reduced Depths available in 1/4" increments from 12" to 20 3/4".

**(FP) False Panel**

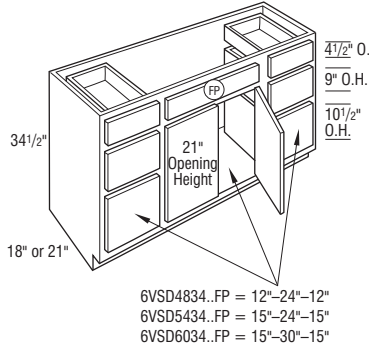
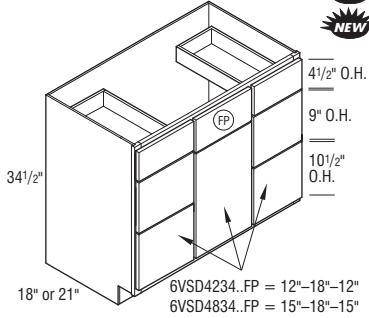

**Door & Drawer Options**

CC	CG	ESMD	GAMD	HC	IFHG	MC	MD	MFO	PRMD	SHMD	SPLITDR	SPLITDRWS	SUMD	TCG	TCP
✓	✓	✓	✓	✓	✓	✓	✓	✓	✓	✓	✓	✓	✓	✓	✓

**End Panel Options**

AUTH	CSFPE	EXBK	EXDN	FFD	FPE	INTGE	IPE
✓	✓	✓	✓	✓	✓	✓	✓

**Custom Modification Options**

ADD	SHLF	ADRW	BVR	CBO	CCO	CFNTO	CFP	CFRMO	CLIP	CMAT <sup>1</sup>	CND	CSDGBK	DRWTK	EF	EX	EX_OL	FD	FLUT <sup>2</sup>	FTK <sup>3</sup>	ID	IH	INVERM	IW	
✓	✓	✓	✓	✓	✓	✓	✓	✓	✓	✓	✓	✓	✓	✓	✓	✓	✓	✓	✓	✓	✓	✓	✓	✓
MIP	OBRB	PFINBTMB	RD	REC	RECTK	RH	ROSLUT	RT	SBCADDY	SBCADDYSM	SCPDRW	TBN	TD	TKP	TVR	UDBX	URT	VLSO <sup>4</sup>	VTK	VWB <sup>5</sup>	WS <sup>6</sup>	WTR		
✓	✓	✓	✓	✓	✓	✓	✓	✓	✓	✓	✓	✓	✓	✓	✓	✓	✓	✓	✓	✓	✓	✓	✓	

<sup>1</sup>Not available with 42" or 48" wide.  
<sup>2</sup>Not available with 6" fluting.  
<sup>3</sup>FTKAV not available on 60" wide.  
<sup>4</sup>Not available on depths less than 21". VLSOB not available on 1 door version. Not available on 48" wide.  
<sup>5</sup>Not available on depths less than 21".  
<sup>6</sup>Wide stile 1.5" versions not available on 60" wide.



# Vanity Sink Drawer Base Cabinets

## Description

**VANITY SINK DRAWER BASE with EIGHT DRAWERS and FALSE PANEL, 32" HIGH, 18" or 21" DEEP**

## Model



**8VSD423218FP L or R**



**8VSD483218FP L or R**

**8VSD423221FP L or R**

**8VSD483221FP L or R**

- Middle door will be hinged left unless specified otherwise.



**8VSD543218FP**



**8VSD603218FP**

**8VSD543221FP**

**8VSD603221FP**

- Touch-up kit (TUK) and Owner's Guide included.
- Eight total drawers.
- Increased Depths available in 1/4" increments from 21 1/4" to 24".
- Reduced Depths available in 1/4" increments from 12" to 20 3/4".

8VSD423221FP=12"  
8VSD483221FP=15"

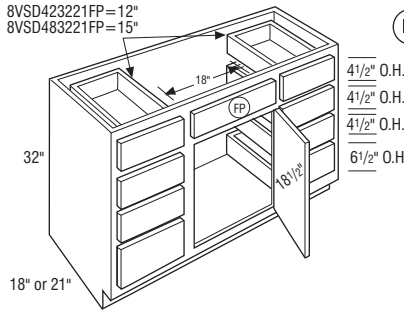

**FP False Panel**

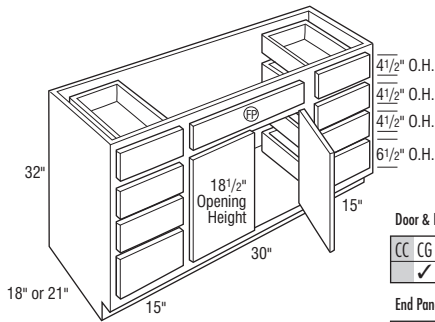

### Door & Drawer Options

CC	CG	ESMD	GAMD	HC	IFHG	MC	MD	MFO	PRMD	SHMD	SPLITDR	SPLITDRWS	SUMD	TCG	TCP
✓	✓	✓	✓	✓	✓	✓	✓	✓	✓	✓				✓	

### End Panel Options

AUTH	CSFPE	EXBK	EXDN	FFD	FPE	INTGE	IPE
✓	✓	✓	✓	✓	✓	✓	✓

### Custom Modification Options

ADD	SHLF	ADRW	BVR	CBO	CCO	CFNTO	CFP	CFRMO	CLIP	CMAT <sup>1</sup>	CND	CSDGBK	DRWTK	EF	EX	EX_OL	FD	FLUT	FTK	ID	IH	INVFRM	IW	

MIP	OBRB	PFINBTMB	RD	REC	RECTK	RH	ROSFLUT	RT	SBCADDY	SBCADDYSM	SCPDRW	TBN	TD	TKP	TVR	UDBX	URT	VLSO	VTK	VWB <sup>2</sup>	WS	WTR	
✓	✓		✓					✓	✓	✓	✓				✓					✓	✓		

<sup>1</sup>Not available on 42"-48" wide.

<sup>2</sup>Not available on depths less than 21".

IH/RH availability charts starting on page G•40.  
IW/RW availability charts starting on page G•46.

# Vanity Sink Drawer Base Cabinets

**Description**

**VANITY SINK DRAWER BASE with EIGHT DRAWERS and FALSE PANEL, 34 1/2" HIGH, 18" or 21" DEEP**

**Model**



**8VSD423418FP L or R**



**8VSD483418FP L or R**

**8VSD423421FP L or R**

**8VSD483421FP L or R**

- Middle door will be hinged left unless specified otherwise.



**8VSD543418FP**



**8VSD603418FP**

**8VSD543421FP**

**8VSD603421FP**

- Touch-up kit (TUK) and Owner's Guide included.
- Eight total drawers.
- Increased Depths available in 1/4" increments from 21 1/4" to 24".
- Reduced Depths available in 1/4" increments from 12" to 20 3/4".

**(FP) False Panel**

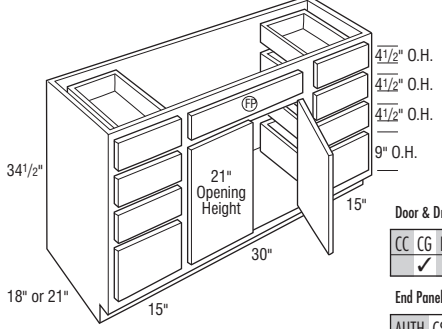
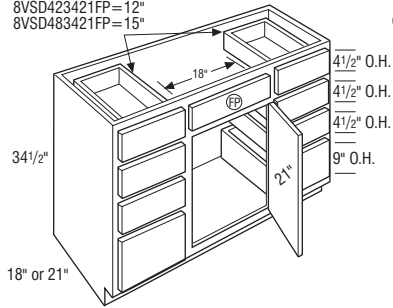

**Door & Drawer Options**

CC	CG	ESMD	GAMD	HC	IFHG	JMC	MD	MFO	PRMD	SHMD	SPLITDR	SPLITDRWS	SUMD	TCG	TCP
✓	✓	✓	✓	✓	✓	✓	✓	✓	✓	✓	✓	✓	✓	✓	✓

**End Panel Options**

AUTH	CSFPE	EXBK	EXDN	FFD	FPE	INTGE	IPE
✓	✓	✓	✓	✓	✓	✓	✓

**Custom Modification Options**

ADD	SHLF	ADRW	BVR	CBO	CCO	CFNTO	CFP	CFRMO	CLIP	CMAT <sup>1</sup>	CND	CSDGBK	DRWTK	EF	EX	EX_OL	FD	FLUT	FTK	ID	IH	INVERM	IW	
✓	✓	✓	✓	✓	✓	✓	✓	✓	✓	✓	✓	✓	✓	✓	✓	✓	✓	✓	✓	✓	✓	✓	✓	✓

MIP	OBRB	PFINBTMB	RD	REC	RECTK	RH	ROSLUT	RT	SBCADDY	SBCADDYSM	SCPDWR	TBN	TD	TKP	TVR	UDBX	URT	VLSO	VTK	VWB <sup>2</sup>	WS	WTR	
✓	✓	✓	✓	✓	✓	✓	✓	✓	✓	✓	✓	✓	✓	✓	✓	✓	✓	✓	✓	✓	✓	✓	✓

<sup>1</sup>Not available on 42"-48" wide.  
<sup>2</sup>Not available on depths less than 21".

# Vanity Console Drawer Base Cabinets

## Description



**VANITY CONSOLE DRAWER BASE with SIX DRAWERS and WOOD TIERED VANITY DRAWER, 32" HIGH, 21" DEEP**

storage  
SOLUTIONS

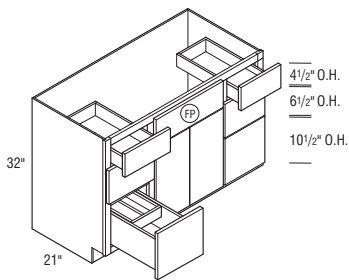
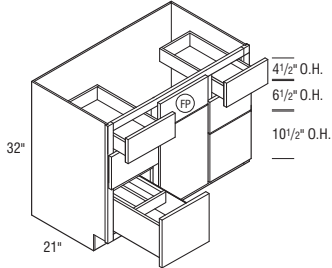

## Model

**6VSDB423221WTV L or R**

**6VSDB483221WTV L or R**

**6VSDB543221WTV**

**6VSDB603221WTV**

- Middle door will be hinged left unless specified otherwise.

- For Inset and Beaded Inset styles opening sizes, see pages F•14-F•18.
- Touch-up kit (TUK) and Owner's Guide included.
- Six total drawers.
- Includes Wood Tiered Vanity Drawer.
- Wood Tiered Vanity Drawer will be installed in the left side of the cabinet.
- Wood Tiered Vanity Drawer is also available as an accessory for field installation. See page S•5.
- Exterior Wood Tiered Vanity drawer box height is 7 1/2", interior height of top tier is 2 1/4", and interior height of bottom tier is 4 1/4".

**FP** False Panel

### Door & Drawer Options

CC	CG	ESMD	GAMD	HC	IFHG	MC	MD	MFO	PRMD	SHMD	SPLITDR	SPLITDRWS	SUMD	TCG	TCP
✓	✓	✓	✓	✓	✓	✓	✓	✓	✓	✓	✓	✓	✓	✓	✓

### End Panel Options

AUTH	CSFPE	EXBK	EXDN	FFD	FPE	INTGE	IPE
✓	✓	✓	✓	✓	✓	✓	✓

### Custom Modification Options

ADD	SHLF	ADRW	BVR	CBO	CCO	CFNTD	CFP	CFRMO	CLIP	CMAT <sup>1</sup>	CND	CSDGBK	DRWTK	EF	EX	EX_OL	FD	FLUT <sup>2</sup>	FTK <sup>3</sup>	ID	IH	INVFRM	IW	
✓	✓	✓	✓	✓	✓	✓	✓	✓	✓	✓	✓	✓	✓	✓	✓	✓	✓	✓	✓	✓	✓	✓	✓	✓
MIP	OBRB	PFINBTMB	RD	REC	RECTK	RH	ROSFLUT <sup>2</sup>	RT	SBCADDY	SBCADDYSM	SCPDWR	TBN	TD	TKP	TVR	UDBX	URT	VLSO	VTK	VWB	WS <sup>4</sup>	WTR		
✓	✓	✓	✓	✓	✓	✓	✓	✓	✓	✓	✓	✓	✓	✓	✓	✓	✓	✓	✓	✓	✓	✓	✓	

- <sup>1</sup>Only available on 54" and 60" wide.
- <sup>2</sup>Not available with 6" fluting.
- <sup>3</sup>FTKAV not available on 60" wide.
- <sup>4</sup>Wide stile 1.5 not available on 60" wide.



**VANITY CONSOLE DRAWER BASE with SIX DRAWERS and WOOD TIERED VANITY DRAWER, 34 1/2" HIGH, 21" DEEP**

storage  
SOLUTIONS

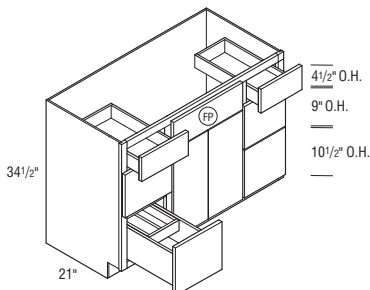
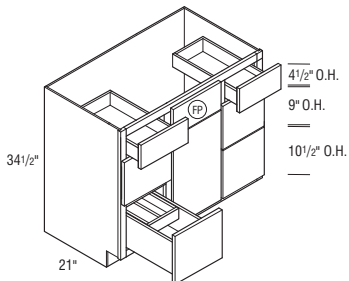

**6VSDB423421WTV L or R**

**6VSDB483421WTV L or R**

**6VSDB543421WTV**

**6VSDB603421WTV**

- Middle door will be hinged left unless specified otherwise.

- For Inset and Beaded Inset styles opening sizes, see pages F•14-F•18.
- Touch-up kit (TUK) and Owner's Guide included.
- Six total drawers.
- Includes Wood Tiered Vanity Drawer.
- Wood Tiered Vanity Drawer will be installed in the left side of the cabinet.
- Wood Tiered Vanity Drawer is also available as an accessory for field installation. See page S•5.
- Exterior Wood Tiered Vanity drawer box height is 7 1/2", interior height of top tier is 2 1/4", and interior height of bottom tier is 4 1/4".

**FP** False Panel

### Door & Drawer Options

CC	CG	ESMD	GAMD	HC	IFHG	MC	MD	MFO	PRMD	SHMD	SPLITDR	SPLITDRWS	SUMD	TCG	TCP
✓	✓	✓	✓	✓	✓	✓	✓	✓	✓	✓	✓	✓	✓	✓	✓

### End Panel Options

AUTH	CSFPE	EXBK	EXDN	FFD	FPE	INTGE	IPE
✓	✓	✓	✓	✓	✓	✓	✓

### Custom Modification Options

ADD	SHLF	ADRW	BVR	CBO	CCO	CFNTD	CFP	CFRMO	CLIP	CMAT <sup>1</sup>	CND	CSDGBK	DRWTK	EF	EX	EX_OL	FD	FLUT <sup>2</sup>	FTK <sup>3</sup>	ID	IH	INVFRM	IW
✓	✓	✓	✓	✓	✓	✓	✓	✓	✓	✓	✓	✓	✓	✓	✓	✓	✓	✓	✓	✓	✓	✓	✓
MIP	OBRB	PFINBTMB	RD	REC	RECTK	RH	ROSFLUT <sup>2</sup>	RT	SBCADDY	SBCADDYSM	SCPDWR	TBN	TD	TKP	TVR	UDBX	URT	VLSO	VTK	VWB	WS <sup>3</sup>	WTR	
✓	✓	✓	✓	✓	✓	✓	✓	✓	✓	✓	✓	✓	✓	✓	✓	✓	✓	✓	✓	✓	✓	✓	✓

- <sup>1</sup>Only available on 54" and 60" wide.
- <sup>2</sup>Not available with 6" fluting.
- <sup>3</sup>Wide stile 1.5 not available on 60" wide.

IH/RH availability charts starting on page G•40.  
IW/RW availability charts starting on page G•46.

## Description

### DOUBLE VANITY SINK BASE, 32" HIGH, 21" DEEP

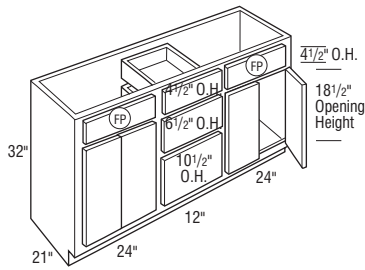

## Model

### VSBD603221

- Touch-up kit (TUK) and Owner's Guide included.
- Increased Depths available in 1/4" increments from 21 1/4" to 24".
- Reduced Depths available in 1/4" increments from 12" to 20 3/4".

#### FP False Panel

#### Door & Drawer Options

CC	CG	ESMD	GAMD	HC	IFHG	MC	MD	MFO	PRMD	SHMD	SPLITDR	SPLITDRWS	SUMD	TCG	TCP
✓	✓	✓	✓	✓	✓	✓	✓	✓	✓	✓	✓	✓	✓	✓	✓

#### End Panel Options

AUTH	CSFPE	EXBK	EXDN	FFD	FPE	INTGE	IPE
✓	✓	✓	✓	✓	✓	✓	✓

#### Custom Modification Options

ADD_SHLF	ADRW	BVR	CBO	CCO	CFNTO	CFP	CFRMO	CLIP	CMAT	CND	CSDGBK	DRWTK	EF	EX	EX_OL	FD	FLUT <sup>1</sup>	FTK	ID	IH	INVFRM	IW	
			✓	✓	✓	✓	✓	✓	✓	✓	✓	✓	✓	✓	✓	✓	✓	✓	✓	✓	✓	✓	✓
MIP	OBRB	PFINBTMB	RD	REC	RECTK	RH	ROSLUT	RT	SBCADDY	SBCADDYSM	SCPDWR	TBN	TD	TKP	TVR	UDBX	URT	VLSO	VTK	VWB	WS	WTR	
✓	✓	✓	✓	✓	✓	✓	✓	✓	✓	✓	✓	✓	✓	✓	✓	✓	✓	✓	✓	✓	✓	✓	✓

<sup>1</sup>Not available with 6" fluting.

### DOUBLE VANITY SINK BASE, 34 1/2" HIGH, 21" DEEP

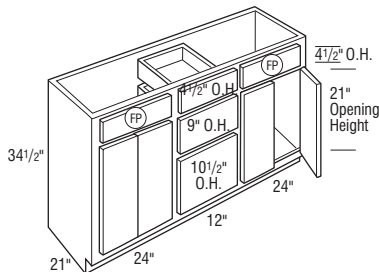

### VSBD603421

- Touch-up kit (TUK) and Owner's Guide included.
- Increased Depths available in 1/4" increments from 21 1/4" to 24".
- Reduced Depths available in 1/4" increments from 12" to 20 3/4".

#### FP False Panel

#### Door & Drawer Options

CC	CG	ESMD	GAMD	HC	IFHG	MC	MD	MFO	PRMD	SHMD	SPLITDR	SPLITDRWS	SUMD	TCG	TCP
✓	✓	✓	✓	✓	✓	✓	✓	✓	✓	✓	✓	✓	✓	✓	✓

#### End Panel Options

AUTH	CSFPE	EXBK	EXDN	FFD	FPE	INTGE	IPE
✓	✓	✓	✓	✓	✓	✓	✓

#### Custom Modification Options

ADD_SHLF	ADRW	BVR	CBO	CCO	CFNTO	CFP	CFRMO	CLIP	CMAT	CND	CSDGBK	DRWTK	EF	EX	EX_OL	FD	FLUT <sup>1</sup>	FTK	ID	IH	INVFRM	IW	
			✓	✓	✓	✓	✓	✓	✓	✓	✓	✓	✓	✓	✓	✓	✓	✓	✓	✓	✓	✓	✓
MIP	OBRB	PFINBTMB	RD	REC	RECTK	RH	ROSLUT	RT	SBCADDY	SBCADDYSM	SCPDWR	TBN	TD	TKP	TVR	UDBX	URT	VLSO	VTK	VWB	WS	WTR	
✓	✓	✓	✓	✓	✓	✓	✓	✓	✓	✓	✓	✓	✓	✓	✓	✓	✓	✓	✓	✓	✓	✓	✓

<sup>1</sup>Not available with 6" fluting.

### DOUBLE VANITY SINK BASE with FOUR DRAWERS, 32" HIGH, 21" DEEP

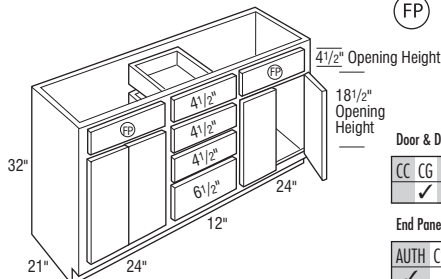

### 4VSD603221

- Touch-up kit (TUK) and Owner's Guide included.
- Increased Depths available in 1/4" increments from 21 1/4" to 24".
- Reduced Depths available in 1/4" increments from 12" to 20 3/4".

#### FP False Panel

#### Door & Drawer Options

CC	CG	ESMD	GAMD	HC	IFHG	MC	MD	MFO	PRMD	SHMD	SPLITDR	SPLITDRWS	SUMD	TCG	TCP
✓	✓	✓	✓	✓	✓	✓	✓	✓	✓	✓	✓	✓	✓	✓	✓

#### End Panel Options

AUTH	CSFPE	EXBK	EXDN	FFD	FPE	INTGE	IPE
✓	✓	✓	✓	✓	✓	✓	✓

#### Custom Modification Options

ADD_SHLF	ADRW	BVR	CBO	CCO	CFNTO	CFP	CFRMO	CLIP	CMAT	CND	CSDGBK	DRWTK	EF	EX	EX_OL	FD	FLUT <sup>1</sup>	FTK	ID	IH	INVFRM	IW	
			✓	✓	✓	✓	✓	✓	✓	✓	✓	✓	✓	✓	✓	✓	✓	✓	✓	✓	✓	✓	✓
MIP	OBRB	PFINBTMB	RD	REC	RECTK	RH	ROSLUT	RT	SBCADDY	SBCADDYSM	SCPDWR	TBN	TD	TKP	TVR	UDBX	URT	VLSO	VTK	VWB	WS	WTR	
✓	✓	✓	✓	✓	✓	✓	✓	✓	✓	✓	✓	✓	✓	✓	✓	✓	✓	✓	✓	✓	✓	✓	✓

# Double Vanity Sink Base & Vanity Hamper Base Cabinets

## Description

### DOUBLE VANITY SINK BASE with FOUR DRAWERS, 34 1/2" HIGH, 21" DEEP

## Model

### 4VSD603421

- Touch-up kit (TUK) and Owner's Guide included.
- Increased Depths available in 1/4" increments from 21 1/4" to 24".
- Reduced Depths available in 1/4" increments from 12" to 20 3/4".

**(FP) False Panel**

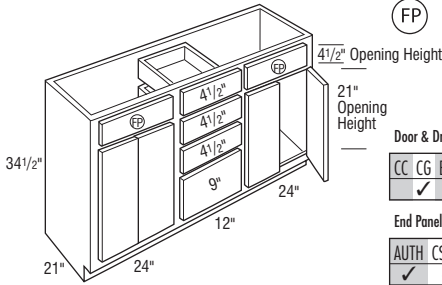

#### Door & Drawer Options

CC	CG	ESMD	GAMD	HC	IFHG	MC	MD	MFO	PRMD	SHMD	SPLITDR	SPLITDRWS	SUMD	TCG	TCP
✓	✓	✓	✓	✓	✓	✓	✓	✓	✓	✓	✓	✓	✓	✓	✓

#### End Panel Options

AUTH	CSFPE	EXBK	EXDN	FFD	FPE	INTGE	IPE
✓	✓	✓	✓	✓	✓	✓	✓

#### Custom Modification Options

ADD_SHLF	ADRW	BVR	CBO	CCO	CFNTD	CFP	CFRMO	CLIP	CMAT	CND	CSDGBK	DRWTK	EF	EX	EX_OL	FD	FLUT	FTK	ID	IH	INVFRM	IW	
			✓	✓	✓	✓	✓	✓	✓	✓	✓	✓	✓	✓	✓	✓	✓	✓	✓	✓	✓	✓	✓

MIP	OBRB	PFINBTMB	RD	REC	RECTK	RH	ROSFLUT	RT	SBCADDY	SBCADDYSM	SCPDRW	TBN	TD	TKP	TVR	UDBX	URT	VLSD	VTK	VWB	WS	WTR	
✓	✓	✓	✓	✓	✓	✓	✓	✓	✓	✓	✓	✓	✓	✓	✓	✓	✓	✓	✓	✓	✓	✓	✓

### VANITY HAMPER BASE CABINET, 32" or 34 1/2" HIGH, 21" DEEP

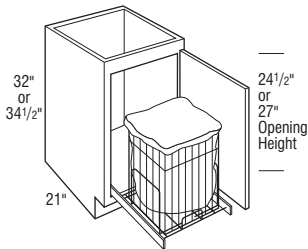

### VH183221FH L or R

### VH183421FH L or R

- Hamper utilizes floor mounted glides.
- Hamper size is 14 9/16" W x 18 15/16" H x 17 23/32" D.
- Chrome basket with creme linen liner.
- Increased Depths available in 1/4" increments from 21 1/4" to 30".
- Only available in Inset and Beaded Inset when used in conjunction with a finial hinge.

#### Door & Drawer Options

CC	CG	ESMD	GAMD	HC	IFHG	MC	MD	MFO	PRMD	SHMD	SPLITDR	SPLITDRWS	SUMD	TCG	TCP
✓	✓	✓	✓	✓	✓	✓	✓	✓	✓	✓	✓	✓	✓	✓	✓

#### End Panel Options

AUTH	CSFPE	EXBK	EXDN	FFD	FPE	INTGE	IPE
✓	✓	✓	✓	✓	✓	✓	✓

#### Custom Modification Options

ADD_SHLF	ADRW	BVR	CBO	CCO	CFNTD	CFP	CFRMO	CLIP	CMAT	CND	CSDGBK	DRWTK	EF	EX	EX_OL	FD	FLUT <sup>1</sup>	FTK	ID	IH	INVFRM	IW
			✓	✓	✓	✓	✓	✓	✓	✓	✓	✓	✓	✓	✓	✓	✓	✓	✓	✓	✓	✓

MIP	OBRB	PFINBTMB	RD	REC	RECTK	RH	ROSFLUT	RT	SBCADDY	SBCADDYSM	SCPDRW	TBN	TD	TKP	TVR	UDBX	URT	VLSD	VTK	VWB	WS	WTR	
✓	✓	✓	✓	✓	✓	✓	✓	✓	✓	✓	✓	✓	✓	✓	✓	✓	✓	✓	✓	✓	✓	✓	✓

<sup>1</sup>Not available with 6" fluting.

IH/RH availability charts starting on page G•40.  
IW/RW availability charts starting on page G•46.

# Vanity Sink and Hamper Drawer Base Cabinets

## Description

### VANITY SINK and HAMPER DRAWER BASE, 32" HIGH, 21" DEEP

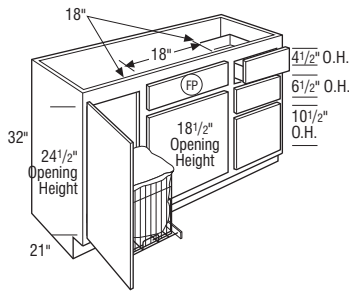

## Model

### VSHDB543221D L or R

- Middle door hinged same side as drawer stack unless specified otherwise.
- Hamper utilizes floor mounted glides.
- Hamper size is 14 9/16" W x 18 15/16" H x 17 23/32" D.
- Chrome basket with creme linen liner.
- Touch-up kit (TUK) and Owner's Guide included.
- Increased Depths available in 1/4" increments from 21 1/4" to 24".
- Only available in Inset and Beaded Inset when used in conjunction with a finial hinge.

(FP) False Panel

#### Door & Drawer Options

CC	CG	ESMD	GAMD	HC	IFHG	MC	MD	MFO	PRMD	SHMD	SPLITDR	SPLITDRWS	SUMD	TCG	TCP
✓	✓	✓	✓	✓	✓	✓	✓	✓	✓	✓	✓	✓	✓	✓	✓

#### End Panel Options

AUTH	CSFPE	EXBK	EXDN	FFD	FPE	INTGE	IPE
✓	✓	✓	✓	✓	✓	✓	✓

#### Custom Modification Options

ADD_SHLF	ADRW	BVR	CBO	CCO	CFNTD	CFP	CFRMO	CLIP	CMAT	CND	CSDGBK	DRWTK	EF	EX	EX_OL	FD	FLUT <sup>1</sup>	FTK	ID	IH	INVFRM	IW	
✓	✓	✓	✓	✓	✓	✓	✓	✓	✓	✓	✓	✓	✓	✓	✓	✓	✓	✓	✓	✓	✓	✓	✓

MIP	OBRB	PFINBTMB	RD	REC	RECTK	RH	ROSLUT	RT	SBCADDY	SBCADDYSM	SCPDWR	TBN	TD	TKP	TVR	UDBX	URT	VLSO	VTK	VWB	WS <sup>2</sup>	WTR	
✓	✓	✓	✓	✓	✓	✓	✓	✓	✓	✓	✓	✓	✓	✓	✓	✓	✓	✓	✓	✓	✓	✓	✓

<sup>1</sup>Not available with 6" fluting.

<sup>2</sup>Not available with wide stile both.

### VANITY SINK and HAMPER DRAWER BASE, 34 1/2" HIGH, 21" DEEP

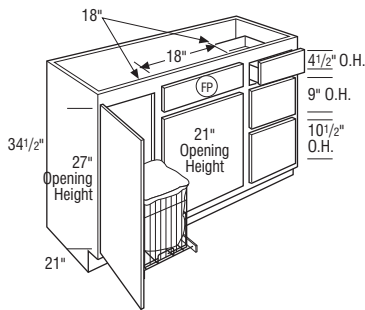

### VSHDB543421D L or R

- Middle door hinged same side as drawer stack unless specified otherwise.
- Hamper utilizes floor mounted glides.
- Hamper size is 14 9/16" W x 18 15/16" H x 17 23/32" D.
- Chrome basket with creme linen liner.
- Touch-up kit (TUK) and Owner's Guide included.
- Increased Depths available in 1/4" increments from 21 1/4" to 24".
- Only available in Inset and Beaded Inset when used in conjunction with a finial hinge.

(FP) False Panel

#### Door & Drawer Options

CC	CG	ESMD	GAMD	HC	IFHG	MC	MD	MFO	PRMD	SHMD	SPLITDR	SPLITDRWS	SUMD	TCG	TCP
✓	✓	✓	✓	✓	✓	✓	✓	✓	✓	✓	✓	✓	✓	✓	✓

#### End Panel Options

AUTH	CSFPE	EXBK	EXDN	FFD	FPE	INTGE	IPE
✓	✓	✓	✓	✓	✓	✓	✓

#### Custom Modification Options

ADD_SHLF	ADRW	BVR	CBO	CCO	CFNTD	CFP	CFRMO	CLIP	CMAT	CND	CSDGBK	DRWTK	EF	EX	EX_OL	FD	FLUT <sup>1</sup>	FTK	ID	IH	INVFRM	IW	
✓	✓	✓	✓	✓	✓	✓	✓	✓	✓	✓	✓	✓	✓	✓	✓	✓	✓	✓	✓	✓	✓	✓	✓

MIP	OBRB	PFINBTMB	RD	REC	RECTK	RH	ROSLUT	RT	SBCADDY	SBCADDYSM	SCPDWR	TBN	TD	TKP	TVR	UDBX	URT	VLSO	VTK	VWB	WS <sup>2</sup>	WTR	
✓	✓	✓	✓	✓	✓	✓	✓	✓	✓	✓	✓	✓	✓	✓	✓	✓	✓	✓	✓	✓	✓	✓	✓

<sup>1</sup>Not available with 6" fluting.

<sup>2</sup>Not available with wide stile both.

# Vanity Sink and Hamper Drawer Base Cabinets

## Description

## Model

### VANITY SINK and HAMPER DRAWER BASE with FOUR DRAWERS, 32" HIGH, 21" DEEP

### 4VSHDB543221D L or R

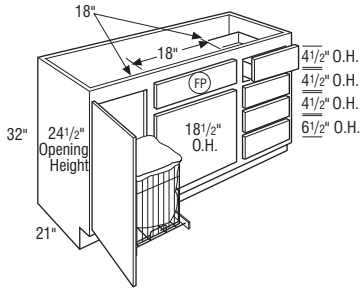

- Middle door hinged same side as drawer stack unless specified otherwise.
- Hamper utilizes floor mounted glides.
- Hamper size is 14 9/16" W x 18 15/16" H x 17 23/32" D.
- Chrome basket with creme linen liner.
- Touch-up kit (TUK) and Owner's Guide included.
- Increased Depths available in 1/4" increments from 21 1/4" to 24".
- Only available in Inset and Beaded Inset when used in conjunction with a finial hinge.

**(FP) False Panel**

#### Door & Drawer Options

CC	CG	ESMD	GAMD	HC	IFHG	MC	MD	MFO	PRMD	SHMD	SPLITDR	SPLITDRWS	SUMD	TCG	TCP
✓	✓	✓	✓	✓	✓	✓	✓	✓	✓	✓	✓	✓	✓	✓	✓

#### End Panel Options

AUTH	CSFPE	EXBK	EXDN	FFD	FPE	INTGE	IPE
✓	✓	✓	✓	✓	✓	✓	✓

#### Custom Modification Options

ADD_SHLF	ADRW	BVR	CBO	CCO	CFNTD	CFP	CFRMO	CLIP	CMAT	CND	CSDGBK	DRWTK	EF	EX	EX_OL	FD	FLUT <sup>1</sup>	FTK	ID	IH	INVFRM	IW	
✓	✓	✓	✓	✓	✓	✓	✓	✓	✓	✓	✓	✓	✓	✓	✓	✓	✓	✓	✓	✓	✓	✓	✓

MIP	OBRB	PFINBTMB	RD	REC	RECTK	RH	ROSFLUT	RT	SBCADDY	SBCADDYSM	SCPDRW	TBN	TD	TKP	TVR	UDBX	URT	VLSO	VTK	VWB	WS <sup>2</sup>	WTR	
✓	✓	✓	✓	✓	✓	✓	✓	✓	✓	✓	✓	✓	✓	✓	✓	✓	✓	✓	✓	✓	✓	✓	✓

<sup>1</sup>Not available with 6" fluting.

<sup>2</sup>Not available with wide stile both.

### VANITY SINK and HAMPER DRAWER BASE with FOUR DRAWERS, 34 1/2" HIGH, 21" DEEP

### 4VSHDB543421D L or R

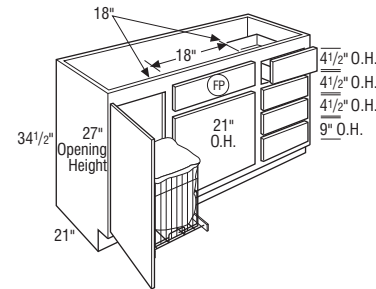

- Middle door hinged same side as drawer stack unless specified otherwise.
- Hamper utilizes floor mounted glides.
- Hamper size is 14 9/16" W x 18 15/16" H x 17 23/32" D.
- Chrome basket with creme linen liner.
- Touch-up kit (TUK) and Owner's Guide included.
- Increased Depths available in 1/4" increments from 21 1/4" to 24".
- Only available in Inset and Beaded Inset when used in conjunction with a finial hinge.

**(FP) False Panel**

#### Door & Drawer Options

CC	CG	ESMD	GAMD	HC	IFHG	MC	MD	MFO	PRMD	SHMD	SPLITDR	SPLITDRWS	SUMD	TCG	TCP
✓	✓	✓	✓	✓	✓	✓	✓	✓	✓	✓	✓	✓	✓	✓	✓

#### End Panel Options

AUTH	CSFPE	EXBK	EXDN	FFD	FPE	INTGE	IPE
✓	✓	✓	✓	✓	✓	✓	✓

#### Custom Modification Options

ADD_SHLF	ADRW	BVR	CBO	CCO	CFNTD	CFP	CFRMO	CLIP	CMAT	CND	CSDGBK	DRWTK	EF	EX	EX_OL	FD	FLUT <sup>1</sup>	FTK	ID	IH	INVFRM	IW	
✓	✓	✓	✓	✓	✓	✓	✓	✓	✓	✓	✓	✓	✓	✓	✓	✓	✓	✓	✓	✓	✓	✓	✓

MIP	OBRB	PFINBTMB	RD	REC	RECTK	RH	ROSFLUT	RT	SBCADDY	SBCADDYSM	SCPDRW	TBN	TD	TKP	TVR	UDBX	URT	VLSO	VTK	VWB	WS <sup>2</sup>	WTR	
✓	✓	✓	✓	✓	✓	✓	✓	✓	✓	✓	✓	✓	✓	✓	✓	✓	✓	✓	✓	✓	✓	✓	✓

<sup>1</sup>Not available with 6" fluting.

<sup>2</sup>Not available with wide stile both.

IH/RH availability charts starting on page G•40.  
IW/RW availability charts starting on page G•46.

## Description

**VANITY SINK FRONT, 32" or 34 1/2" HIGH, 4 5/8" DEEP**

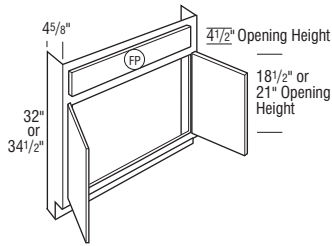
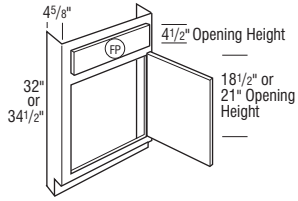

## Model

VSF2432 L or R

VSF2434 L or R

VSF3032

VSF3632

VSF3034

VSF3634

Notes below apply to all products in section above:

- Bottom included.

**(FP) False Panel**

### Door & Drawer Options

CC	CG	ESMD	GAMD	HC	IFHG	MC	MD	MFO	PRMD	SHMD	SPLITDR <sup>1</sup>	SPLITDRWS	SUMD	TCG	TCP
✓	✓	✓	✓	✓	✓	✓	✓	✓	✓	✓	✓	✓	✓	✓	✓

### End Panel Options

AUTH	CSFPE	EXBK	EXDN	FFD	FPE	INTGE	IPE
✓	✓	✓	✓	✓	✓	✓	✓

### Custom Modification Options

ADD_SHLF	ADRW	BVR	CBO <sup>1</sup>	CCO <sup>1</sup>	CFNTD	CFP	CFRMO	CLIP	CMAT	CND	CSDGBK	DRWTK	EF	EX	EX_OL	FD	FLUT <sup>2</sup>	FTK	ID	IH	INVERM <sup>1</sup>	IW
✓	✓	✓	✓	✓	✓	✓	✓	✓	✓	✓	✓	✓	✓	✓	✓	✓	✓	✓	✓	✓	✓	✓
MIP	OBRB	PFINBTMB	RD	REC	RECTK	RH	ROSFLUT	RT	SBCADDY	SBCADDYSM	SCPDRAW	TBN	TD	TKP	TVR	UDBX	URT	VLSO	VTK	VWB	WS	WTR
✓	✓	✓	✓	✓	✓	✓	✓	✓	✓	✓	✓	✓	✓	✓	✓	✓	✓	✓	✓	✓	✓	✓

<sup>1</sup>Not available on 24" wide.

<sup>2</sup>Not available with 6" fluting.



# Vanity Drawer Base Cabinets

## Description

**VANITY THREE DRAWER BASE,  
32" HIGH, 18" or 21" DEEP**

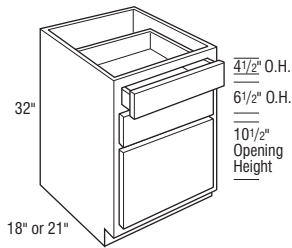

## Model

<b>NEW</b>	<b>VDB123218</b>
<b>NEW</b>	<b>VDB153218</b>
<b>NEW</b>	<b>VDB183218</b>
<b>NEW</b>	<b>VDB213218</b>
<b>NEW</b>	<b>VDB243218</b>
<b>NEW</b>	<b>VDB273218</b>
<b>NEW</b>	<b>VDB303218</b>
<b>NEW</b>	<b>VDB333218</b>
<b>NEW</b>	<b>VDB363218</b>
	<b>VDB123221</b>
	<b>VDB153221</b>
	<b>VDB183221</b>
	<b>VDB213221</b>
	<b>VDB243221</b>
	<b>VDB273221</b>
	<b>VDB303221</b>
	<b>VDB333221</b>
	<b>VDB363221</b>

- Increased Depths available in 1/4" increments from 21 1/4" to 24".
- Reduced Depths available in 1/4" increments from 12" to 20 3/4".

### Door & Drawer Options

CC	CG	ESMD	GAMD	HC	IFHG	MC	MD	MFO	PRMD	SHMD	SPLITDR	SPLITDRWS <sup>1</sup>	SUMD	TCG	TCP

### End Panel Options

AUTH	CSFPE	EXBK	EXDN	FFD	FPE	INTGE	IPE

### Custom Modification Options

ADD_SHLF	ADRW	BVR	CBO	CCO	CFNTO	CFP	CFRMO	CLIP	CMAT	CND	CSDGBK	DRWTK <sup>1</sup>	EF	EX	EX_OL	FD	FLUT <sup>3</sup>	FTK <sup>4</sup>	ID	IH	INVFRM	IW <sup>5</sup>	
MIP	OBRB	PFINBTMB	RD	REC	RECTK	RH	ROSFLUT	RT	SBCADDY	SBCADDYSM	SCPDRW	TBN	TD	TKP	TVR	UDBX <sup>1</sup>	URT	VLSO	VTK	VWB	WS	WTR	

<sup>1</sup>Not available on 12"-21" wide.

<sup>2</sup>Not available on 12" wide.

<sup>3</sup>6" fluting not available on 12" or 15" wide. Fluting both 6" only available on 24"-36" wide.

<sup>4</sup>FTKAV not available on 12" wide.

<sup>5</sup>Not available on 36" wide.

IH/RH availability charts starting on page G•40.  
IW/RW availability charts starting on page G•46.

## Description

**VANITY THREE DRAWER BASE,  
34 1/2" HIGH, 18" or 21" DEEP**

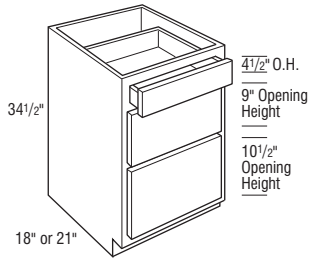

## Model



VDB123418

VDB153418

VDB183418

VDB213418

VDB243418

VDB273418

VDB303418

VDB333418

VDB363418

VDB123421

VDB153421

VDB183421

VDB213421

VDB243421

VDB273421

VDB303421

VDB333421

VDB363421

- Increased Depths available in 1/4" increments from 21 1/4" to 24".
- Reduced Depths available in 1/4" increments from 12" to 20 3/4".

### Door & Drawer Options

CC	CG	ESMD	GAMD	HC	IFHG	MC	MD	MFO	PRMD	SHMD	SPLITDR	SPLITDRWS <sup>1</sup>	SUMD	TCG	TCP

### End Panel Options

AUTH	CSFPE	EXBK	EXDN	FFD	FPE	INTGE	IPE

### Custom Modification Options

ADD_SHLF	ADRW	BVR	CBO	CCO	CFNTD	CFP	CFRMO	CLIP <sup>2</sup>	CMAT	CND	CSDGBK	DRWTK <sup>1</sup>	EF	EX	EX_OL	FD	FLUT <sup>3</sup>	FTK <sup>4</sup>	ID	IH	INVFRM	IW <sup>5</sup>	
MIP	OBRB	PFINBTMB	RD	REC	RECTK	RH	ROSFLUT	RT	SBCADDY	SBCADDYSM	SCPDWR	TBN	TD	TKP	TVR	UDBX <sup>1</sup>	URT	VLSO	VTK	VWB	WS	WTR	

<sup>1</sup>Not available on 12"-21" wide.

<sup>2</sup>Not available on 12" wide.

<sup>3</sup>6" fluting not available on 12" or 15" wide. Fluting both 6" only available on 24"-36" wide.

<sup>4</sup>FTKAV not available on 12" wide.

<sup>5</sup>Not available on 36" wide.

# Vanity Drawer Base Cabinets

## Description

**VANITY FOUR DRAWER BASE,  
32" HIGH, 18" or 21" DEEP**

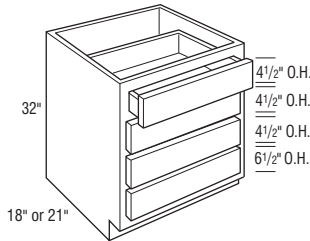

## Model

<b>NEW</b>	<b>4VDB123218</b>
<b>NEW</b>	<b>4VDB153218</b>
<b>NEW</b>	<b>4VDB183218</b>
<b>NEW</b>	<b>4VDB213218</b>
<b>NEW</b>	<b>4VDB243218</b>
<b>NEW</b>	<b>4VDB273218</b>
<b>NEW</b>	<b>4VDB303218</b>
<b>NEW</b>	<b>4VDB333218</b>
<b>NEW</b>	<b>4VDB363218</b>
	<b>4VDB123221</b>
	<b>4VDB153221</b>
	<b>4VDB183221</b>
	<b>4VDB213221</b>
	<b>4VDB243221</b>
	<b>4VDB273221</b>
	<b>4VDB303221</b>
	<b>4VDB333221</b>
	<b>4VDB363221</b>

- When an Inset or Beaded Inset style is selected, please refer to individual door style sections for drawer front heights that will convert to slab on pages D•8 through D•15.
- Increased Depths available in 1/4" increments from 21 1/4" to 24".
- Reduced Depths available in 1/4" increments from 12" to 20 3/4".

### Door & Drawer Options

CC	CG	ESMD	GAMD	HC	IFHG	MC	MD	MFO	PRMD	SHMD	SPLITDR	SPLITDRWS	SUMD	TCG	TCP
						✓									

### End Panel Options

AUTH	CSFPE	EXBK	EXDN	FFD	FPE	INTGE	IPE
✓	✓	✓		✓	✓	✓	✓

### Custom Modification Options

ADD	SHLF	ADRW	BVR	CBO	CCO	CFNTO	CFP	CFRMO	CLIP <sup>1</sup>	CMAT	CND	CSDGBK	DRWTK <sup>2</sup>	EF	EX	EX	OL	FD	FLUT <sup>3</sup>	FTK	ID	IH	INVFRM	IW
					✓	✓	✓	✓	✓				✓	✓	✓	✓	✓	✓	✓	✓	✓	✓	✓	✓
MIP	OBRB	PFINBTMB	RD	REC	RECTK	RH	ROSFLUT	RT	SBCADDY	SBCADDYSM	SCPDRW	TBN	TD	TKP	TVR	UDBX	URT	VLSO	VTK	VWB	WS <sup>4</sup>	WTR		
✓	✓		✓				✓	✓			✓			✓		✓				✓		✓	✓	

<sup>1</sup>Not available on 12" wide.

<sup>2</sup>Not available on 12"-21" wide.

<sup>3</sup>6" fluting not available on 12" or 15" wide. Fluting both 6" also not available on 18" or 21" wide.

<sup>4</sup>Not available on 12" wide.

IH/RH availability charts starting on page G•40.  
IW/RW availability charts starting on page G•46.

# Vanity Drawer Base Cabinets & Sink Fronts

## Description

**VANITY FOUR DRAWER BASE,  
34 1/2" HIGH, 18" or 21" DEEP**

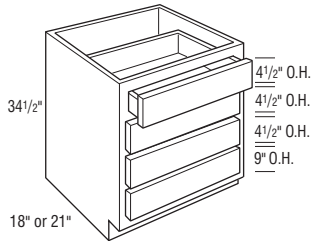

## Model



4VDB123418  
4VDB153418  
4VDB183418  
4VDB213418  
4VDB243418  
4VDB273418  
4VDB303418  
4VDB333418  
4VDB363418  
4VDB123421  
4VDB153421  
4VDB183421  
4VDB213421  
4VDB243421  
4VDB273421  
4VDB303421  
4VDB333421  
4VDB363421

- When an Inset or Beaded Inset style is selected, please refer to individual door style sections for drawer front heights that will convert to slab on pages D•8 through D•15.
- Increased Depths available in 1/4" increments from 21 1/4" to 24".
- Reduced Depths available in 1/4" increments from 12" to 20 3/4".

### Door & Drawer Options

CC	CG	ESMD	GAMD	HC	IFHG	MC	MD	MFO	PRMD	SHMD	SPLITDR	SPLITDRWS	SUMD	TCG	TCP
						✓									

### End Panel Options

AUTH	CSFPE	EXBK	EXDN	FFD	FPE	INTGE	IPE
✓	✓	✓	✓	✓	✓	✓	✓

### Custom Modification Options

ADD	SHLF	ADRW	BVR	CBO	CCO	CFNTD	CFP	CFRMO	CLIP <sup>1</sup>	CMAT	CND	CSDGBK	DRWTK <sup>2</sup>	EF	EX	EX_OL	FD	FLUT <sup>3</sup>	FTK	ID	IH	INVERM	IW	
														✓	✓	✓	✓	✓	✓	✓	✓	✓	✓	✓
MIP	OBRB	PFINBTMB	RD	REC	RECTK	RH	ROSFLUT	RT	SBCADDY	SBCADDYSM	SCPDWR	TBN	TD	TKP	TVR	UDBX	URT	VLSO	VTK	VWB	WS <sup>4</sup>	WTR		
✓	✓			✓				✓				✓			✓					✓		✓	✓	

<sup>1</sup>Not available on 12" wide.

<sup>2</sup>Not available on 12"-21" wide.

<sup>3</sup>6" fluting not available on 12" or 15" wide. Fluting both 6" also not available on 18" or 21" wide.

<sup>4</sup>Not available on 12" wide.



## VANITY ANGLED CORNER SINK FRONT, 32" HIGH

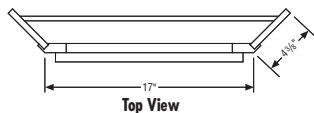
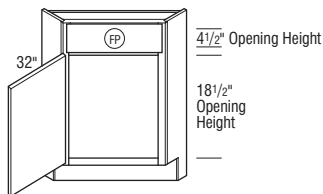

## VACSF L or R

- Floor included and packed separately.
- Tilt-out tray available as an accessory.
- Touch-up kit (TUK) and Owner's Guide included.

(FP) **False Panel**

### Door & Drawer Options

CC	CG	ESMD	GAMD	HC	IFHG	MC	MD	MFO	PRMD	SHMD	SPLITDR	SPLITDRWS	SUMD	TCG	TCP
							✓			✓					

### End Panel Options

AUTH	CSFPE	EXBK	EXDN	FFD	FPE	INTGE	IPE

### Custom Modification Options

ADD	SHLF	ADRW	BVR	CBO	CCO	CFNTD	CFP	CFRMO	CLIP	CMAT	CND	CSDGBK	DRWTK	EF	EX	EX_OL	FD	FLUT	FTK	ID	IH	INVERM	IW
														✓	✓	✓	✓	✓	✓	✓	✓	✓	✓
MIP	OBRB	PFINBTMB	RD	REC	RECTK	RH	ROSFLUT	RT	SBCADDY	SBCADDYSM	SCPDWR	TBN	TD	TKP	TVR	UDBX	URT	VLSO	VTK	VWB	WS	WTR	
✓	✓					✓									✓					✓		✓	✓

# Under Counter Drawers

## Description

**UNDER COUNTER DRAWER, 5" HIGH, 18" or 21" DEEP**

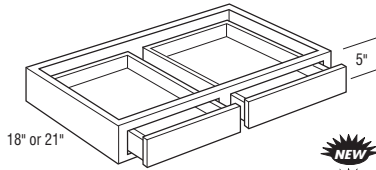
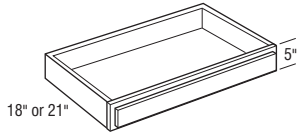

## Model



UCD1518



UCD1818



UCD2118



UCD2418



UCD2718

UCD1521

UCD1821

UCD2121

UCD2421

UCD2721



UCD3018



UCD3318



UCD3618



UCD3021



UCD3321



UCD3621

- Kirby will utilize a 5-piece drawer front, all other styles will be slab.
- When an Inset or Beaded Inset style is selected, drawer fronts will be slab.
- Increased Depths available in 1/4" increments from 21 1/4" to 24".
- Reduced Depths available in 1/4" increments from 12" to 20 3/4".

### Door & Drawer Options

CC	CG	ESMD	GAMD	HC	IFHG	MC	MD	MFO	PRMD	SHMD	SPLITDR	SPLITDRWS	SUMD	TCG	TCP
----	----	------	------	----	------	----	----	-----	------	------	---------	-----------	------	-----	-----

### End Panel Options

AUTH	CSFPE	EXBK	EXDN	FFD	FPE	INTGE	IPE
	✓	✓			✓		

### Custom Modification Options

ADD	SHLF	ADRW	BVR	CBO	CCO	CFNTD	CFP	CFRMO	CLIP	CMAT	CND	CSDGBK	DRWTK	EF	EX	EX_OL	FD	FLUT	FTK	ID	IH	INVERM	IW <sup>1</sup>	
									✓					✓	✓						✓	✓		✓

MIP	OBRB	PFINBTMB	RD	REC	RECTK	RH	ROSFLUT	RT	SBCADDY	SBCADDYSM	SCPDRW	TBN	TD	TKP	TVR	UDBX	URT	VLSO	VTK	VWB	WS	WTR	
✓			✓																			✓	✓

<sup>1</sup>Not available on 36" wide.

**UNDER COUNTER DRAWER, TRIMMABLE, 5" HIGH, 21" DEEP**

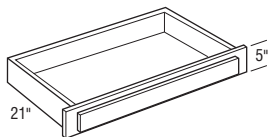

UCD2418T

UCD2721T

UCD3024T

UCD3630T

UCD4236T

- Trimmable up to 6".
- When an Inset or Beaded Inset style is selected, drawer fronts will be slab.
- Kirby will utilize a 5-piece drawer front, all other styles will be slab.
- Increased Depths available in 1/4" increments from 21 1/4" to 24".
- Reduced Depths available in 1/4" increments from 12" to 20 3/4".

### Door & Drawer Options

CC	CG	ESMD	GAMD	HC	IFHG	MC	MD	MFO	PRMD	SHMD	SPLITDR	SPLITDRWS	SUMD	TCG	TCP
----	----	------	------	----	------	----	----	-----	------	------	---------	-----------	------	-----	-----

### End Panel Options

AUTH	CSFPE	EXBK	EXDN	FFD	FPE	INTGE	IPE
	✓	✓			✓		

### Custom Modification Options

ADD	SHLF	ADRW	BVR	CBO	CCO	CFNTD	CFP	CFRMO	CLIP	CMAT	CND	CSDGBK	DRWTK	EF	EX <sup>1</sup>	EX_OL	FD	FLUT	FTK	ID	IH	INVERM	IW <sup>2</sup>
									✓					✓	✓						✓	✓	✓

MIP	OBRB	PFINBTMB	RD	REC	RECTK	RH	ROSFLUT	RT	SBCADDY	SBCADDYSM	SCPDRW	TBN	TD	TKP	TVR	UDBX	URT	VLSO	VTK	VWB	WS	WTR	
✓			✓																			✓	✓

<sup>1</sup>Only available on 24" wide.

<sup>2</sup>Not available on 36" or 42" wide.

IH/RH availability charts starting on page G•40.  
IW/RW availability charts starting on page G•46.

## Description

### VANITY UTILITY, 84" or 87" HIGH, 21" DEEP

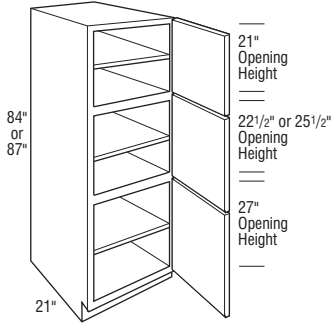

## Model

UV158421 L or R

UV188421 L or R

UV218421 L or R

UV248421 L or R

UV158721 L or R

UV188721 L or R

UV218721 L or R 27.1

UV248721 L or R 30.7

- Includes three adjustable shelves.
- Increased Depths available in 1/4" increments from 21 1/4" to 30".
- Reduced Depths available in 1/4" increments from 6" to 20 3/4".

#### Door & Drawer Options

CC	CG	ESMD	GAMD	HC	IFHG	MC	MD	MFO	PRMD	SHMD	SPLITDR	SPLITDRWS	SUMD	TCG	TCP
✓	✓	✓	✓	✓	✓	✓	✓	✓	✓	✓	✓	✓	✓	✓	✓

#### End Panel Options

AUTH	CSFPE	EXBK	EXDN	FFD	FPE	INTGE	IPE
✓	✓	✓	✓	✓	✓	✓	✓

#### Custom Modification Options

ADD_SHLF	ADRW	BVR	CBO	CCO	CFNTO	CFP	CFRMO	CLIP	CMAT	CND	CSDGBK	DRWTK <sup>1</sup>	EF	EX	EX_OL	FD	FLUT <sup>2</sup>	FTK	ID	IH	INVERM	IW <sup>3</sup>	
✓	✓	✓	✓	✓	✓	✓	✓	✓	✓	✓	✓	✓	✓	✓	✓	✓	✓	✓	✓	✓	✓	✓	✓
MIP	OBRB	PFINBTMB	RD	REC	RECTK	RH	ROSFLUT <sup>4</sup>	RT	SBCADDY	SBCADDYSM	SCPDRW	TBN	TD	TKP	TVR <sup>5</sup>	UDBX	URT	VLSO	VTK	VWB	WS	WTR	
✓	✓	✓	✓	✓	✓	✓	✓	✓	✓	✓	✓	✓	✓	✓	✓	✓	✓	✓	✓	✓	✓	✓	✓

<sup>1</sup>Only available on 24" wide.

<sup>2</sup>Fluting both 3" not available on 1584 version. Not available with 6" fluting.

<sup>3</sup>Not available on 24" wide.

<sup>4</sup>Fluting both not available on 1584 version.

<sup>5</sup>Not available on 2484 version.

### VANITY UTILITY, 90" or 93" HIGH, 21" DEEP

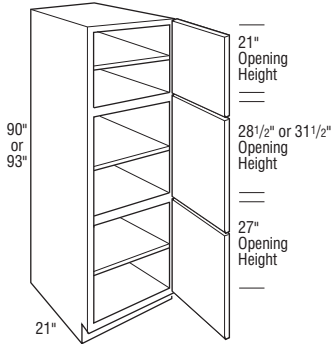

UV159021 L or R

UV189021 L or R

UV219021 L or R

UV249021 L or R

UV159321 L or R

UV189321 L or R

UV219321 L or R

UV249321 L or R

- Includes three adjustable shelves.
- 90" high toeckick shipped attached.
- 93" high is shipped with loose toeckick unless ATTK or Flush Toeckick is specified.
- Increased Depths available in 1/4" increments from 21 1/4" to 30".
- Reduced Depths available in 1/4" increments from 6" to 20 3/4".

#### Door & Drawer Options

CC	CG	ESMD	GAMD	HC	IFHG	MC	MD	MFO	PRMD	SHMD	SPLITDR	SPLITDRWS	SUMD	TCG	TCP
✓	✓	✓	✓	✓	✓	✓	✓	✓	✓	✓	✓	✓	✓	✓	✓

#### End Panel Options

AUTH	CSFPE	EXBK	EXDN	FFD	FPE	INTGE	IPE
✓	✓	✓	✓	✓	✓	✓	✓

#### Custom Modification Options

ADD_SHLF	ADRW	BVR	CBO	CCO	CFNTO	CFP	CFRMO	CLIP	CMAT	CND	CSDGBK	DRWTK <sup>1</sup>	EF	EX	EX_OL	FD	FLUT <sup>2</sup>	FTK	ID	IH	INVERM	IW <sup>3</sup>	
✓	✓	✓	✓	✓	✓	✓	✓	✓	✓	✓	✓	✓	✓	✓	✓	✓	✓	✓	✓	✓	✓	✓	✓
MIP	OBRB	PFINBTMB	RD	REC	RECTK	RH	ROSFLUT <sup>4</sup>	RT	SBCADDY	SBCADDYSM	SCPDRW	TBN	TD	TKP	TVR <sup>5</sup>	UDBX	URT	VLSO	VTK	VWB	WS	WTR	
✓	✓	✓	✓	✓	✓	✓	✓	✓	✓	✓	✓	✓	✓	✓	✓	✓	✓	✓	✓	✓	✓	✓	✓

<sup>1</sup>Only available on 24" wide.

<sup>2</sup>Fluting both 3" not available on 1590 version. Not available with 6" fluting.

<sup>3</sup>Not available on 24" wide.

<sup>4</sup>Fluting both not available on 1590 version.

<sup>5</sup>Not available on 2490 version.

# Vanity Utility Cabinets

## Description

### VANITY UTILITY, 96" HIGH, 21" DEEP

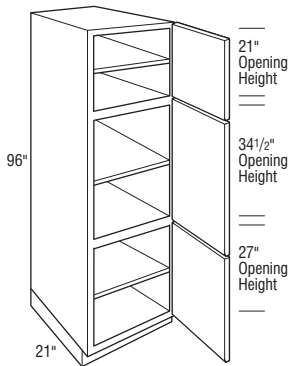

## Model

**UV159621 L or R**

**UV189621 L or R**

**UV219621 L or R**

**UV249621 L or R**

- Includes three adjustable shelves.
- Increased Depths available in 1/4" increments from 21 1/4" to 30".
- Reduced Depths available in 1/4" increments from 6" to 20 3/4".

#### Door & Drawer Options

CC	CG	ESMD	GAMD	HC	IFHG	MC	MD	MFO	PRMD	SHMD	SPLITDR	SPLITDRWS	SUMD	TCG	TCP
✓	✓	✓	✓	✓	✓	✓	✓	✓	✓	✓			✓		

#### End Panel Options

AUTH	CSFPE	EXBK	EXDN	FFD	FPE	INTGE	IPE
✓	✓	✓	✓	✓	✓	✓	✓

#### Custom Modification Options

ADD	SHLF	ADRW	BVR	CBO	CCO	CFNTD	CFP	CFRMO	CLIP	CMAT	CND	CSDGBK	DRWTK <sup>1</sup>	EF	EX	EX_OL	FD	FLUT <sup>2</sup>	FTK	ID	IH	INVFRM	IW <sup>3</sup>
				✓	✓	✓	✓	✓	✓	✓	✓	✓	✓	✓	✓	✓	✓	✓	✓	✓	✓	✓	✓
MIP	OBRB	PFINBTMB	RD	REC	RECTK	RH	ROSFLUT <sup>4</sup>	RT	SBCADDY	SBCADDYSM	SCPDRW	TBN	TD	TKP	TVR <sup>4</sup>	UDBX	URT	VLSO	VTK	VWB	WS	WTR	
✓	✓		✓				✓	✓						✓	✓							✓	✓

<sup>1</sup>Only available on 24" wide.

<sup>2</sup>Not available on 24" wide. Fluting both 3" not available on 15" wide. Not available with 6" fluting.

<sup>3</sup>Not available on 24" wide.

<sup>4</sup>Not available on 24" wide. Fluting both not available on 15" wide.

### VANITY UTILITY, 84" or 87" HIGH, 21" DEEP

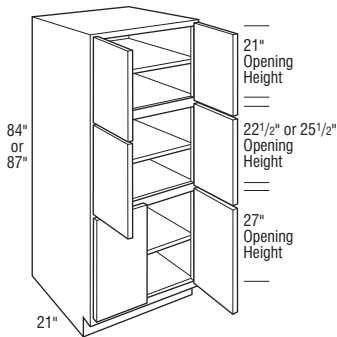

**UV248421**

**UV248721**

- Includes three adjustable shelves.
- Increased Depths available in 1/4" increments from 21 1/4" to 30".
- Reduced Depths available in 1/4" increments from 6" to 20 3/4".

#### Door & Drawer Options

CC	CG	ESMD	GAMD	HC	IFHG	MC	MD	MFO	PRMD	SHMD	SPLITDR <sup>1</sup>	SPLITDRWS	SUMD	TCG	TCP
✓	✓	✓	✓	✓	✓	✓	✓	✓	✓	✓	✓		✓		

#### End Panel Options

AUTH	CSFPE	EXBK	EXDN	FFD	FPE	INTGE	IPE
✓	✓	✓	✓	✓	✓	✓	✓

#### Custom Modification Options

ADD	SHLF	ADRW	BVR	CBO	CCO	CFNTD	CFP	CFRMO	CLIP	CMAT	CND	CSDGBK	DRWTK	EF	EX	EX_OL	FD	FLUT <sup>2</sup>	FTK	ID	IH	INVFRM	IW
				✓	✓	✓	✓	✓	✓	✓	✓	✓	✓	✓	✓	✓	✓	✓	✓	✓	✓	✓	✓
MIP	OBRB	PFINBTMB	RD	REC	RECTK	RH	ROSFLUT <sup>3</sup>	RT	SBCADDY	SBCADDYSM	SCPDRW	TBN	TD	TKP	TVR	UDBX	URT	VLSO	VTK	VWB	WS	WTR	
✓	✓		✓				✓	✓						✓	✓							✓	✓

<sup>1</sup>Not available on 84" high.

<sup>2</sup>Not available on 87" high. Not available with 6" fluting.

<sup>3</sup>Not available on 87" high.

IH/RH availability charts starting on page G•40.  
IW/RW availability charts starting on page G•46.

## Description

### VANITY UTILITY, 90" or 93" HIGH, 21" DEEP

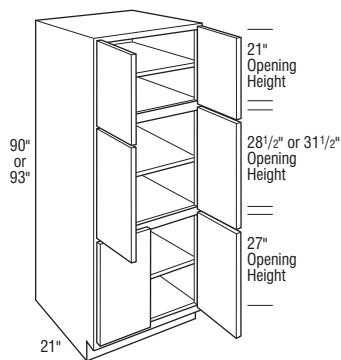

## Model

**UV249021**

**UV249321**

- Includes three adjustable shelves.
- 90" high toe kick shipped attached.
- 93" high is shipped with loose toe kick unless ATTK or Flush Toe kick is specified.
- Increased Depths available in 1/4" increments from 21 1/4" to 30".
- Reduced Depths available in 1/4" increments from 6" to 20 3/4".

#### Door & Drawer Options

CC	CG	ESMD	GAMD	HC	IFHG	MC	MD	MFO	PRMD	SHMD	SPLITDR <sup>1</sup>	SPLITDRWS	SUMD	TCG	TCP
✓	✓	✓	✓	✓	✓	✓	✓	✓	✓	✓	✓	✓	✓	✓	✓

#### End Panel Options

AUTH	CSFPE	EXBK	EXDN	FFD	FPE	INTGE	IPE
✓	✓	✓	✓	✓	✓	✓	✓

#### Custom Modification Options

ADD_SHLF	ADRW	BVR	CBO	CCO	CFNTD	CFP	CFRMO	CLIP	CMAT	CND	CSDGBK	DRWTK	EF	EX	EX_OL	FD	FLUT <sup>2</sup>	FTK	ID	IH	INVFRM	IW	
✓	✓	✓	✓	✓	✓	✓	✓	✓	✓	✓	✓	✓	✓	✓	✓	✓	✓	✓	✓	✓	✓	✓	✓

MIP	OBRB	PFINBTMB	RD	REC	RECTK	RH	ROSFLUT <sup>3</sup>	RT	SBCADDY	SBCADDYSM	SCPDRW	TBN	TD	TKP	TVR	UDBX	URT	VLSD	VTK	VWB	WS	WTR	
✓	✓	✓	✓	✓	✓	✓	✓	✓	✓	✓	✓	✓	✓	✓	✓	✓	✓	✓	✓	✓	✓	✓	✓

<sup>1</sup>Not available on 90" high.

<sup>2</sup>Not available on 93" high. Not available with 6" fluting.

<sup>3</sup>Not available on 93" high.

### VANITY UTILITY, 96" HIGH, 21" DEEP

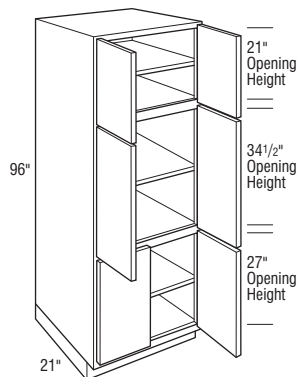

**UV249621**

- Includes three adjustable shelves.
- Increased Depths available in 1/4" increments from 21 1/4" to 30".
- Reduced Depths available in 1/4" increments from 6" to 20 3/4".

#### Door & Drawer Options

CC	CG	ESMD	GAMD	HC	IFHG	MC	MD	MFO	PRMD	SHMD	SPLITDR	SPLITDRWS	SUMD	TCG	TCP
✓	✓	✓	✓	✓	✓	✓	✓	✓	✓	✓	✓	✓	✓	✓	✓

#### End Panel Options

AUTH	CSFPE	EXBK	EXDN	FFD	FPE	INTGE	IPE
✓	✓	✓	✓	✓	✓	✓	✓

#### Custom Modification Options

ADD_SHLF	ADRW	BVR	CBO	CCO	CFNTD	CFP	CFRMO	CLIP	CMAT	CND	CSDGBK	DRWTK	EF	EX	EX_OL	FD	FLUT <sup>1</sup>	FTK	ID	IH	INVFRM	IW	
✓	✓	✓	✓	✓	✓	✓	✓	✓	✓	✓	✓	✓	✓	✓	✓	✓	✓	✓	✓	✓	✓	✓	✓

MIP	OBRB	PFINBTMB	RD	REC	RECTK	RH	ROSFLUT	RT	SBCADDY	SBCADDYSM	SCPDRW	TBN	TD	TKP	TVR	UDBX	URT	VLSD	VTK	VWB	WS	WTR	
✓	✓	✓	✓	✓	✓	✓	✓	✓	✓	✓	✓	✓	✓	✓	✓	✓	✓	✓	✓	✓	✓	✓	✓

<sup>1</sup>Not available with 6" fluting.



# Vanity Utility & Linen Closet Cabinets

## Description

**VANITY UTILITY with DRAWERS,  
84" HIGH, 21" DEEP**

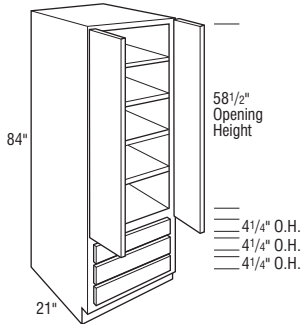
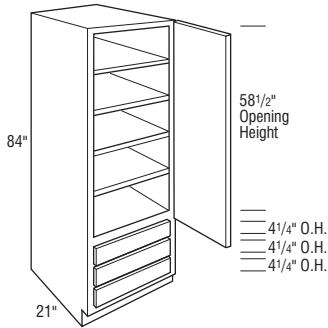

## Model

**VUD188421 L or R**

**VUD248421 L or R**

## VUD248421

Notes below apply to all products in section above:

- Includes four adjustable shelves.
- When an Inset or Beaded Inset style is selected, drawer fronts will be slab.
- Bottom section of drawers does not match vanity base height.
- Large opening on tall doors will include two panels.
- Increased Depths available in 1/4" increments from 21 1/4" to 24".
- Reduced Depths available in 1/4" increments from 12" to 20 3/4".

### Door & Drawer Options

CC	CG	ESMD	GAMD	HC	IFHG	MC	MD	MFO	PRMD	SHMD	SPLITDR	SPLITDRWS	SUMD	TCG	TCP
✓					✓			✓							

### End Panel Options

AUTH	CSFPE	EXBK	EXDN	FFD	FPE	INTGE	IPE
✓	✓	✓		✓	✓	✓	✓

### Custom Modification Options

ADD_SHLF	ADRW	BVR	CBO	CCO	CFNTD	CFP	CFRMO	CLIP <sup>1</sup>	CMAT	CND	CSDGBK	DRWTK <sup>1</sup>	EF	EX	EX_OL	FD	FLUT <sup>2</sup>	FTK	ID	IH	INVERM	IW	
			✓	✓	✓		✓	✓		✓	✓	✓	✓	✓	✓	✓	✓	✓	✓	✓	✓	✓	✓

MIP	OBRB	PFINBTMB	RD	REC	RECTK	RH	ROSFLUT	RT	SBCADDY	SBCADDYSM	SCPDRW	TBN	TD	TKP	TVR	UDBX	URT	VLSO	VTK	VWB	WS	WTR	
✓	✓			✓	✓	✓	✓	✓							✓	✓				✓	✓	✓	✓

<sup>1</sup>Not available on 24" (2 doors) wide.

<sup>2</sup>Not available on 18" wide.

<sup>3</sup>Not available with 6" fluting.

## LINEN CLOSET, 84" HIGH, 21" DEEP

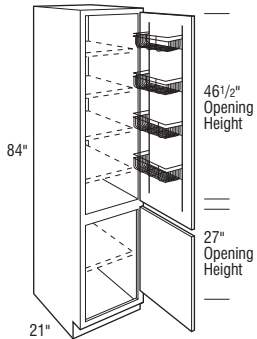

## LC188421 L or R

- Upper section includes a 5" deep chrome door rack.
- Upper section includes four adjustable shelves that are 13 1/4" deep.
- Lower section includes one adjustable shelf that is 19 1/4" deep.
- Increased Depths available in 3" increments to 24".
- Reduced Depths available in 3" increments from 15" to 18".
- Not available on Inset and Beaded Inset styles.

### Door & Drawer Options

CC	CG	ESMD	GAMD	HC	IFHG	MC	MD	MFO	PRMD	SHMD	SPLITDR	SPLITDRWS	SUMD	TCG	TCP
					✓										

### End Panel Options

AUTH	CSFPE	EXBK	EXDN	FFD	FPE	INTGE	IPE
✓	✓	✓		✓	✓	✓	✓

### Custom Modification Options

ADD_SHLF	ADRW	BVR	CBO	CCO	CFNTD	CFP	CFRMO	CLIP	CMAT	CND	CSDGBK	DRWTK	EF	EX	EX_OL	FD	FLUT <sup>1</sup>	FTK	ID	IH	INVERM	IW
			✓	✓	✓		✓						✓	✓	✓	✓	✓	✓	✓	✓	✓	✓

MIP	OBRB	PFINBTMB	RD	REC	RECTK	RH	ROSFLUT	RT <sup>2</sup>	SBCADDY	SBCADDYSM	SCPDRW	TBN	TD	TKP	TVR	UDBX	URT	VLSO	VTK	VWB	WS	WTR	
✓	✓			✓	✓	✓	✓	✓							✓	✓				✓	✓	✓	✓

<sup>1</sup>Not available with 6" fluting.

<sup>2</sup>Only available on lower section.

IH/RH availability charts starting on page G•40.  
IW/RW availability charts starting on page G•46.

## Description

### LINEN CLOSET with REMOVABLE HAMPER, 84" HIGH, 21" DEEP storage SOLUTIONS

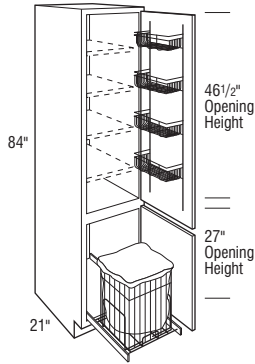

## Model

### LCRH188421 L or R

- Upper section includes a 5" deep chrome door rack.
- Includes four adjustable shelves that are 13 1/4" deep.
- Hamper utilizes floor mounted glides.
- Hamper size is 14 9/16" W x 18 15/16" H x 17 23/32" D.
- Chrome basket with creme linen liner.
- Increased Depths available in 1/4" increments from 21 1/4" to 30".
- Not available on Inset and Beaded Inset styles.

#### Door & Drawer Options

CC	CG	ESMD	GAMD	HC	IFHG	MC	MD	MFO	PRMD	SHMD	SPLITDR	SPLITDRWS	SUMD	TCG	TCP
						✓									

#### End Panel Options

AUTH	CSFPE	EXBK	EXDN	FFD	FPE	INTGE	IPE
✓	✓	✓			✓	✓	

#### Custom Modification Options

ADD_SHLF	ADRW	BVR	CBO	CCO	CFNTO	CFP	CFRMO	CLIP	CMAT	CND	CSDGBK	DRWTK	EF	EX	EX_OL	FD	FLUT <sup>1</sup>	FTK	ID	IH	INVFRM	IW	
				✓	✓	✓	✓						✓	✓	✓	✓	✓	✓	✓	✓	✓	✓	✓
MIP	OBRB	PFINBTMB	RD	REC	RECTK	RH	ROSFLUT	RT	SBCADDY	SBCADDYSM	SCPDWR	TBN	TD	TKP	TVR	UDBX	URT	VLSO	VTK	VWB	WS	WTR	
✓	✓			✓	✓	✓	✓								✓	✓				✓	✓	✓	✓

<sup>1</sup>Not available with 6" fluting.



### LINEN STORAGE CABINET, 84" HIGH, 18" or 21" DEEP

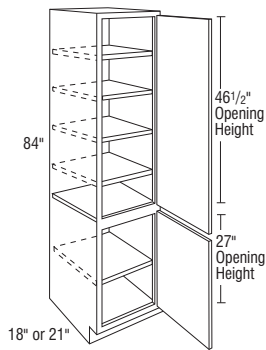

### LT188418 L or R

### LT218418 L or R

### LT188421 L or R

### LT218421 L or R

- Shelves indicated by light dotted lines are included, but packaged separately.
- Shelf indicated by solid line is fixed.
- Recommended for use with 34 1/2" high cabinets (bottom door will align with top of drawer front or top of full height door).
- Increased Depths available in 1/4" increments from 21 1/4" to 30".
- Reduced Depths available in 1/4" increments from 12" to 20 3/4".

#### Door & Drawer Options

CC	CG	ESMD	GAMD	HC	IFHG	MC	MD <sup>1</sup>	MFO	PRMD <sup>1</sup>	SHMD	SPLITDR	SPLITDRWS	SUMD	TCG	TCP
							✓	✓	✓						

#### End Panel Options

AUTH	CSFPE	EXBK	EXDN	FFD	FPE	INTGE	IPE
✓	✓	✓			✓	✓	

#### Custom Modification Options

ADD_SHLF	ADRW	BVR	CBO	CCO	CFNTO	CFP	CFRMO	CLIP	CMAT	CND	CSDGBK	DRWTK	EF	EX	EX_OL	FD	FLUT <sup>2</sup>	FTK	ID <sup>3</sup>	IH	INVFRM	IW	
				✓	✓	✓		✓			✓	✓	✓	✓	✓	✓	✓	✓	✓	✓	✓	✓	✓
MIP	OBRB	PFINBTMB	RD	REC	RECTK	RH	ROSFLUT	RT	SBCADDY	SBCADDYSM	SCPDWR	TBN	TD	TKP	TVR	UDBX	URT	VLSO	VTK	VWB	WS	WTR	
				✓	✓	✓	✓														✓	✓	✓

<sup>1</sup>Only available on top section.

<sup>2</sup>Not available with 6" fluting.

<sup>3</sup>Not available on 18" deep.

# Bath and Vanity Cabinets

## Description

### BATH WALL HUNG SINK CONSOLE, 21" HIGH, 21" DEEP

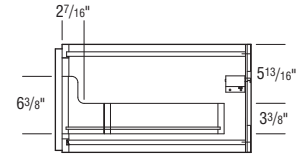
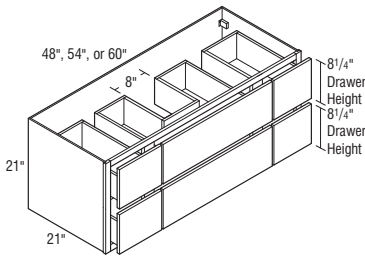

Top U-shaped drawer box has cascading side drawer feature.

## Model

BCWHC4821

BCWHC5421

BCWHC6021

- Six drawers.
- Top middle drawer is U-shaped.
- Includes hanging hardware.
- Flush Finished Ends standard.
- Sink bowl clearance to top of drawer box is 5 13/16".
- Touch-up kit (TUK) and Owner's Guide included.
- Unit must be securely fastened with sufficient type, quantity, and size of screws to all available wall studs and internal structural wall blocking placed between wall studs.
- Do not exceed loading of 25 lbs. / SF for countertop and sink.
- Do not exceed loading of 15 lbs. / SF for contents on shelves and/or in drawers.
- Avoid use of concrete or other heavy masonry countertops.
- Installation to be performed by qualified professionals only.

#### Door & Drawer Options

CC	CG	ESMD	GAMD	HC	IFHG	MC	MD	MFO	PRMD	SHMD	SPLITDR	SPLITDRWS	SUMD	TCG	TCP
				✓											

#### End Panel Options

AUTH	CSFPE	EXBK	EXDN	FFD	FPE	INTGE	IPE
✓	✓						✓

#### Custom Modification Options

ADD	SHLF	ADRW	BVR	CBO	CCO	CFNTO	CFP	CFRMO	CLIP	CMAT	CND	CSDGBK	DRWTK	EF	EX	EX_OL	FD	FLUT	FTK	ID	IH	INVERM	IW <sup>1</sup>	
				✓	✓	✓	✓	✓				✓					✓	✓	✓	✓	✓	✓	✓	✓

MIP	OBRB	PFINBTMB	RD	REC	RECTK	RH	ROSFLUT	RT	SBCADDY	SBCADDYSM	SCPDRW	TBN	TD	TKP	TVR	UDBX	URT	VLSO	VTK	VWB	WS	WTR	
✓								✓														✓	✓

<sup>1</sup>Not available on 60" wide.

#### U-SHAPED DRAWER ON SELECT BATH BASE CABINETS

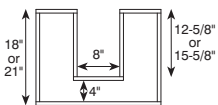

IH/RH availability charts starting on page G•40.  
IW/RW availability charts starting on page G•46.

**Description**

**BATH SINK WALL TOWER, 48" HIGH, 21" DEEP**

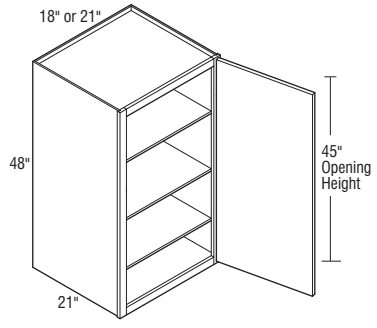

**Model**

**BCWT1848 L or R**  
**BCWT2148 L or R**

- Three adjustable shelves.
- Finished ends standard.
- No toekick.
- See page P-67 for optional legs.
- Blocking for use with legs pre-installed.

**Door & Drawer Options**

CC	CG	ESMD	GAMD	HC	IFHG	MC	MD	MFO	PRMD	SHMD	SPLITDR	SPLITDRWS	SUMD	TCG	TCP
✓	✓	✓	✓	✓	✓	✓	✓	✓	✓	✓	✓	✓	✓	✓	✓

**End Panel Options**

AUTH	CSFPE	EXBK	EXDN	FFD	FPE	INTGE	IPE
✓	✓	✓	✓	✓	✓	✓	✓

**Custom Modification Options**

ADD_SHLF	ADRW	BVR	CBO	CCO	CFNTD	CFP	CFRMO	CLIP	CMAT	CND	CSDGBX	DRWTK	EF	EX	EX_OL	FD	FLUT <sup>1</sup>	FTK	ID	IH	INVRM	IW	
✓	✓	✓	✓	✓	✓	✓	✓	✓	✓	✓	✓	✓	✓	✓	✓	✓	✓	✓	✓	✓	✓	✓	✓
MIP	OBRB	PFINBTMB	RD	REC	RECTK	RH	ROSLUT	RT	SBCADDY	SBCADDYSM	SCPDRW	TBN	TD	TKP	TVR	UDBX	URT	VLSO	VTK	VWB	WS	WTR	
✓	✓	✓	✓	✓	✓	✓	✓	✓	✓	✓	✓	✓	✓	✓	✓	✓	✓	✓	✓	✓	✓	✓	✓

<sup>1</sup>Not available with 6" fluting.

**BATH BASE CABINET, 36" HIGH, 21" DEEP**

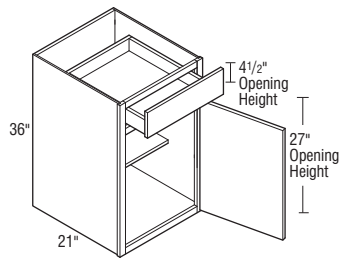

**BCB15NTK L or R**

**BCB18NTK L or R**

**BCB21NTK L or R**

- One adjustable shelf.
- Finished Ends standard.
- No toekick.
- See page P-67 for optional legs.
- Blocking for use with legs pre-installed.

**Door & Drawer Options**

CC	CG	ESMD	GAMD	HC	IFHG	MC	MD	MFO	PRMD	SHMD	SPLITDR	SPLITDRWS	SUMD	TCG	TCP
✓	✓	✓	✓	✓	✓	✓	✓	✓	✓	✓	✓	✓	✓	✓	✓

**End Panel Options**

AUTH	CSFPE	EXBK	EXDN	FFD	FPE	INTGE	IPE
✓	✓	✓	✓	✓	✓	✓	✓

**Custom Modification Options**

ADD_SHLF	ADRW	BVR	CBO	CCO	CFNTD	CFP	CFRMO	CLIP	CMAT	CND	CSDGBX	DRWTK	EF	EX	EX_OL	FD	FLUT <sup>1</sup>	FTK	ID	IH	INVRM	IW	
✓	✓	✓	✓	✓	✓	✓	✓	✓	✓	✓	✓	✓	✓	✓	✓	✓	✓	✓	✓	✓	✓	✓	✓
MIP	OBRB	PFINBTMB	RD	REC	RECTK	RH	ROSLUT	RT	SBCADDY	SBCADDYSM	SCPDRW	TBN	TD	TKP	TVR	UDBX	URT	VLSO	VTK	VWB	WS	WTR	
✓	✓	✓	✓	✓	✓	✓	✓	✓	✓	✓	✓	✓	✓	✓	✓	✓	✓	✓	✓	✓	✓	✓	✓

<sup>1</sup>Not available with 6" fluting.

# Bath and Vanity Cabinets

## Description

### BATH SINK BASE CABINET with SHELF, 30" HIGH, 21" DEEP

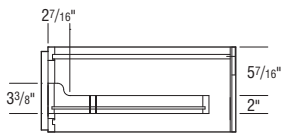
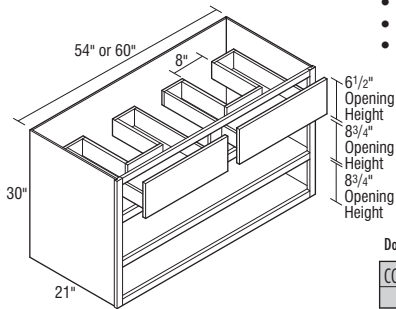
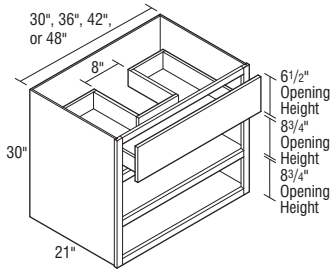

Top U-shaped drawer box has cascading side drawer feature.

## Model

BCBC030

BCBC036

BCBC042

BCBC048

BCBC054

BCBC060

Notes below apply to all products in section above:

- Matching interior standard.
- No toekick standard.
- U-shaped drawer(s).
- Finished Ends standard.
- Fixed shelf behind 1 1/2" horizontal frame rail.
- Feet are optional, see page P•67 for more information.
- Sink bowl clearance to top of drawer box is 5 1/2".
- Touch-up kit (TUK) and Owner's Guide included.
- Blocking for use with legs pre-installed.

#### Door & Drawer Options

CC	CG	ESMD	GAMD	HC	IFHG	MC	MD	MFO	PRMD	SHMD	SPLITDR	SPLITDRWS	SUMD	TCG	TCP
						✓									

#### End Panel Options

AUTH	CSFPE	EXBK	EXDN	FFD	FPE	INTGE	IPE
✓	✓	✓		✓	✓	✓	✓

#### Custom Modification Options

ADD	SHLF	ADRW	BVR	CBO	CCO	CFNTD	CFP	CFRMO	CLIP	CMAT	CND	CSDGBK	DRWTK	EF	EX	EX_OL	FD	FLUT	FTK	ID	IH	INVFRM	IW	
✓	✓	✓	✓	✓	✓	✓	✓	✓	✓	✓	✓	✓	✓	✓	✓	✓	✓	✓	✓	✓	✓	✓	✓	✓
MIP	OBRB	PFINBTMB	RD	REC	RECTK	RH	ROSFLUT	RT	SBCADDY	SBCADDYSM	SCPDRW	TBN	TD	TKP	TVR	UDBX	URT	VLSO	VTK	VWB	WS	WTR		
✓	✓							✓															✓	✓

#### U-SHAPED DRAWER ON SELECT BATH BASE CABINETS

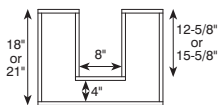

IH/RH availability charts starting on page G•40.  
IW/RW availability charts starting on page G•46.

**Description**

**BATH SINK BASE CABINET with DOORS,  
30" HIGH, 21" DEEP**

**Model**

- BCBCD30
- BCBCD36
- BCBCD42
- BCBCD48
- BCBCD54
- BCBCD60

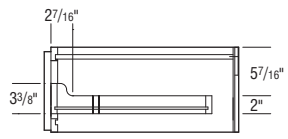
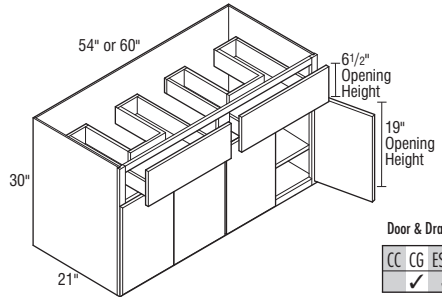
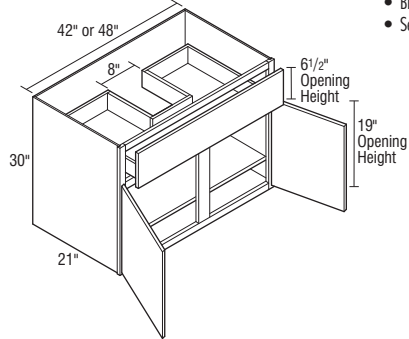
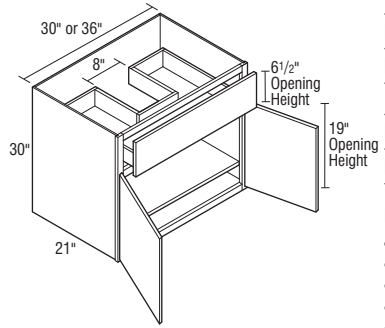

**Top U-shaped drawer box has cascading side drawer feature.**

Notes below apply to all products in section above:

- No toe-kick standard.
- U-shaped drawer(s).
- Finished Ends standard.
- Sink bowl clearance to top of drawer box is 5 1/2".
- Touch-up kit (TUK) and Owner's Guide included.
- Blocking for use with legs pre-installed.
- See page P-67 for optional legs.

**Door & Drawer Options**

CC	CG	ESMD	GAMD	HC	IFHG	MC	MD	MFO	PRMD	SHMD	SPLITDR	SPLITDRWS	SUMD	TCG	TCP
✓	✓	✓	✓	✓	✓	✓	✓	✓	✓	✓	✓	✓	✓	✓	✓

**End Panel Options**

AUTH	CSPE	EXBK	EXDN	FFD	FPE	INTGE	IPE
✓	✓	✓	✓	✓	✓	✓	✓

**Custom Modification Options**

ADD	SHLF	ADRW	BVR	CBO	CCO	CFNTD	CFP	CFRMO	CLIP	CMAT	CND	CSDGBK	DRWTK	EF	EX	EX_OL	FD	FLUT <sup>1</sup>	FTK	ID	IH	INVRM	IW	
✓	✓	✓	✓	✓	✓	✓	✓	✓	✓	✓	✓	✓	✓	✓	✓	✓	✓	✓	✓	✓	✓	✓	✓	✓

MIP	OBRB	PFINBTMB	RD	REC	RECTK	RH	ROSLUT	RT	SBCADDY	SBCADDYSM	SCPDWR	TBN	TD	TKP	TVR	UDBX	URT	VLSO	VTK	VWB	WS	WTR	
✓	✓	✓	✓	✓	✓	✓	✓	✓	✓	✓	✓	✓	✓	✓	✓	✓	✓	✓	✓	✓	✓	✓	✓

<sup>1</sup>Not available with 6" fluting.

**U-SHAPED DRAWER  
ON SELECT BATH  
BASE CABINETS**

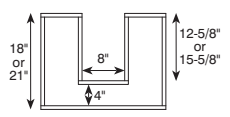

# Bath and Vanity Cabinets

## Description

### BATH HAMPER SINK BASE, 30" HIGH, 21" DEEP

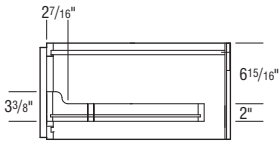
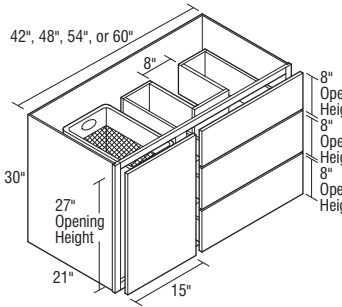

Top U-shaped drawer box has cascading side drawer feature.

## Model

BCBH42D L or R

BCBH48D L or R

BCBH54D L or R

BCBH60D L or R

- Not available on Inset or Beaded Inset styles.
- Pull-out Hamper section has a constant 15" wide opening.
- Top two drawers are U-shaped.
- Finished Ends standard.
- Sink bowl clearance to top of drawer box is 7 3/32".
- Touch-up kit (TUK) and Owner's Guide included.
- Blocking for use with legs pre-installed.
- See page P•67 for optional legs.

#### Door & Drawer Options

CC	CG	ESMD	GAMD	HC	IFHG	MC	MD	MFO	PRMD	SHMD	SPLITDR	SPLITDRWS	SUMD	TCG	TCP
						✓									

#### End Panel Options

AUTH	CSFPE	EXBK	EXDN	FFD	FPE	INTGE	IPE
✓	✓	✓			✓	✓	

#### Custom Modification Options

ADD_SHLF	ADRW	BVR	CBO	CCO	CFNTD	CFP	CFRMO	CLIP	CMAT	CND	CSDGBK	DRWTK	EF	EX	EX_OL	FD	FLUT <sup>1</sup>	FTK	ID	IH	INFRM	IW	

MIP	OBRB	PFINBTMB	RD	REC	RECTK	RH	ROSFLUT	RT	SBCADDY	SBCADDYSM	SCPDWR	TBN	TD	TKP	TVR	UDBX	URT	VLSO	VTK	VWB	WS	WTR	
✓	✓								✓													✓	✓

<sup>1</sup>Not available with 6" fluting.

### BATH WALL HUNG SINK DRAWER BASE, 18" HIGH, 21" DEEP

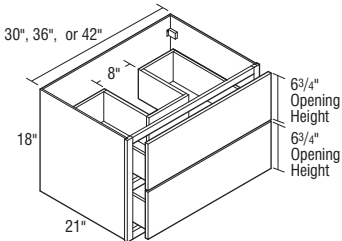

BCWHDB3018

BCWHDB3618

BCWHDB4218

- Top drawer is U-shaped.
- Flush Finished Ends standard.
- Increased Depth to 24" is available.
- Wall hanging hardware included.
- Sink bowl clearance to top of drawer box is 5 11/16".
- Touch-up kit (TUK) and Owner's Guide included.
- Unit comes with an attached top for stability and a hole for the sink must be cut in the field.
- Unit must be securely fastened with sufficient type, quantity, and size of screws to all available wall studs and internal structural wall blocking placed between wall studs.
- Do not exceed loading of 25 lbs. / SF for countertop and sink.
- Do not exceed loading of 15 lbs. / SF for contents on shelves and/or in drawers.
- Avoid use of concrete or other heavy masonry countertops.
- Installation to be performed by qualified professionals only.

#### Door & Drawer Options

CC	CG	ESMD	GAMD	HC	IFHG	MC	MD	MFO	PRMD	SHMD	SPLITDR	SPLITDRWS	SUMD	TCG	TCP
						✓									

#### End Panel Options

AUTH	CSFPE	EXBK	EXDN	FFD	FPE	INTGE	IPE
✓	✓					✓	✓

#### Custom Modification Options

ADD_SHLF	ADRW	BVR	CBO	CCO	CFNTD	CFP	CFRMO	CLIP	CMAT	CND	CSDGBK	DRWTK	EF	EX	EX_OL	FD	FLUT	FTK	ID	IH	INFRM	IW	

MIP	OBRB	PFINBTMB	RD	REC	RECTK	RH	ROSFLUT	RT	SBCADDY	SBCADDYSM	SCPDWR	TBN	TD	TKP	TVR	UDBX	URT	VLSO	VTK	VWB	WS	WTR	
✓									✓													✓	✓

#### U-SHAPED DRAWER ON SELECT BATH BASE CABINETS

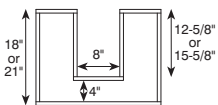

IH/RH availability charts starting on page G•40.  
IW/RW availability charts starting on page G•46.

## Description

### BATH WALL HUNG SINK DRAWER BASE, 21" HIGH, 21" DEEP

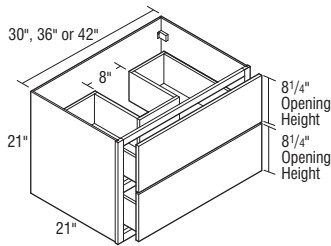

## Model

**BCWHDB3021**

**BCWHDB3621**

**BCWHDB4221**

- Top drawer is U-shaped.
- Flush Finished Ends standard.
- Increased Depth to 24" is available.
- Wall hanging hardware included.
- Sink bowl clearance to top of drawer box is 5 13/16".
- Touch-up kit (TUK) and Owner's Guide included.
- Unit comes with an attached top for stability and a hole for the sink must be cut in the field.
- Unit must be securely fastened with sufficient type, quantity, and size of screws to all available wall studs and internal structural wall blocking placed between wall studs.
- Do not exceed loading of 25 lbs. / SF for countertop and sink.
- Do not exceed loading of 15 lbs. / SF for contents on shelves and/or in drawers.
- Avoid use of concrete or other heavy masonry countertops.
- Installation to be performed by qualified professionals only.

#### Door & Drawer Options

CC	CG	ESMD	GAMD	HC	IFHG	MC	MD	MFO	PRMD	SHMD	SPLITDR	SPLITDRWS	SUMD	TCG	TCP
					✓										

#### End Panel Options

AUTH	CSFPE	EXBK	EXDN	FFD	FPE	INTGE	IPE
✓	✓					✓	✓

#### Custom Modification Options

ADD_SHLF	ADRW	BVR	CBO	CCO	CFNTO	CFP	CFRMO	CLIP	CMAT	CND	CSDGBK	DRWTK	EF	EX	EX_OL	FD	FLUT <sup>1</sup>	FTK	ID	IH	INVRM	IW	
				✓	✓	✓	✓	✓	✓		✓			✓	✓	✓	✓	✓	✓	✓			
MIP	OBRB	PFINBTMB	RD	REC	RECTK	RH	ROSFLUT	RT	SBCADDY	SBCADDYSM	SCPDWR	TBN	TD	TKP	TVR	UDBX	URT	VLSO	VTK	VWB	WS	WTR	
✓							✓									✓						✓	✓

<sup>1</sup>Not available with 6" fluting.

### BATH WALL HUNG SINK DRAWER BASE, 24" HIGH, 21" DEEP

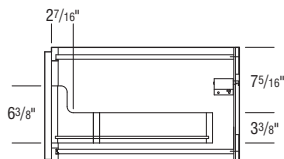
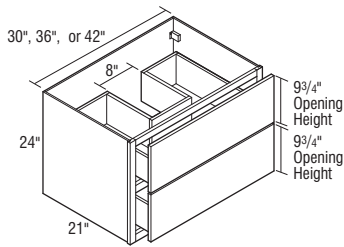

Top U-shaped drawer box has cascading side drawer feature.

**BCWHDB3024**

**BCWHDB3624**

**BCWHDB4224**

- Top drawer is U-shaped.
- Flush Finished Ends standard.
- Increased Depth to 24" is available.
- Wall hanging hardware included.
- Sink bowl clearance to top of drawer box is 7 5/16".
- Touch-up kit (TUK) and Owner's Guide included.
- Unit comes with an attached top for stability and a hole for the sink must be cut in the field.
- Unit must be securely fastened with sufficient type, quantity, and size of screws to all available wall studs and internal structural wall blocking placed between wall studs.
- Do not exceed loading of 25 lbs. / SF for countertop and sink.
- Do not exceed loading of 15 lbs. / SF for contents on shelves and/or in drawers.
- Avoid use of concrete or other heavy masonry countertops.
- Installation to be performed by qualified professionals only.

#### Door & Drawer Options

CC	CG	ESMD	GAMD	HC	IFHG	MC	MD	MFO	PRMD	SHMD	SPLITDR	SPLITDRWS	SUMD	TCG	TCP
					✓										

#### End Panel Options

AUTH	CSFPE	EXBK	EXDN	FFD	FPE	INTGE	IPE
✓	✓					✓	✓

#### Custom Modification Options

ADD_SHLF	ADRW	BVR	CBO	CCO	CFNTO	CFP	CFRMO	CLIP	CMAT	CND	CSDGBK	DRWTK	EF	EX	EX_OL	FD	FLUT	FTK	ID	IH	INVRM	IW	
				✓	✓	✓	✓	✓	✓		✓			✓	✓	✓	✓	✓	✓	✓			
MIP	OBRB	PFINBTMB	RD	REC	RECTK	RH	ROSFLUT	RT	SBCADDY	SBCADDYSM	SCPDWR	TBN	TD	TKP	TVR	UDBX	URT	VLSO	VTK	VWB	WS	WTR	
✓							✓									✓						✓	✓

#### U-SHAPED DRAWER ON SELECT BATH BASE CABINETS

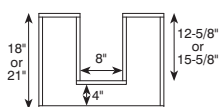



# Bath and Vanity Cabinets

## Description

## Model

**BATH WALL HUNG SINK with GROOMING PULL-OUT, 24" HIGH, 21" DEEP**

**BCWHDBPO42D L or R**

**BCWHDBPO48D L or R**

**BCWHDBPO54D L or R**

**BCWHDBPO60D L or R**

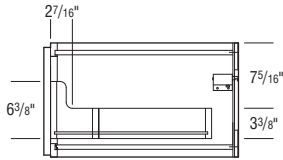
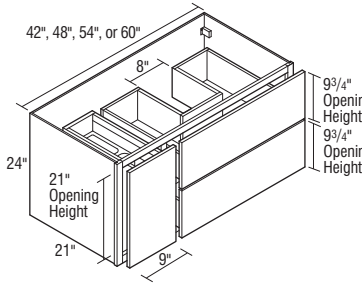

**Top U-shaped drawer box has cascading side drawer feature.**

- Touch-up kit (TUK) and Owner's Guide included.
- Top drawer is U-shaped.
- Pull-out features two stainless steel bins, one round and one rectangular.
- Pull-out opening width remains a constant 9".
- Increased Depth to 24" is available.
- Flush Finished Ends standard.
- Wall hanging hardware included.
- Sink bowl clearance to top of drawer box is 7 5/16".
- Pull-out features Smart Stop.
- Unit must be securely fastened with sufficient type, quantity, and size of screws to all available wall studs and internal structural wall blocking placed between wall studs.
- Do not exceed loading of 25 lbs. / SF for countertop and sink.
- Do not exceed loading of 15 lbs. / SF for contents on shelves and/or in drawers.
- Avoid use of concrete or other heavy masonry countertops.
- Installation to be performed by qualified professionals only.

### Door & Drawer Options

CC	CG	ESMD	GAMD	HC	IFHG	MC	MD	MFO	PRMD	SHMD	SPLITDR	SPLITDRWS	SUMD	TCG	TCP
						✓									

### End Panel Options

AUTH	CSFPE	EXBK	EXDN	FFD	FPE	INTGE	IPE
✓	✓					✓	✓

### Custom Modification Options

ADD_SHLF	ADRW	BVR	CBO	CCO	CFNTD	CFP	CFRMO	CLIP	CMAT	CND	CSDGBK	DRWTK	EF	EX	EX_OL	FD	FLUT	FTK	ID	IH	INVFRM	IW	
MIP	OBRB	PFINBTMB	RD	REC	RECTK	RH	ROSFLUT	RT	SBCADDY	SBCADDYSM	SCDRW	TBN	TD	TKP	TVR	UDBX	URT	VLSO	VTK	VWB	WS	WTR	
✓																							

### U-SHAPED DRAWER ON SELECT BATH BASE CABINETS

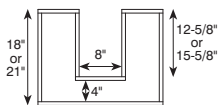

IH/RH availability charts starting on page G•40.  
IW/RW availability charts starting on page G•46.

## Description

### BATH DRAWER SINK BASE, 30" HIGH, 21" DEEP

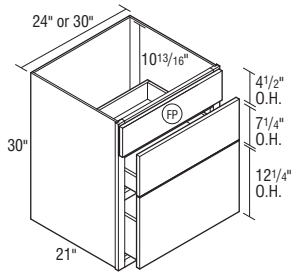

#### FP False Panel

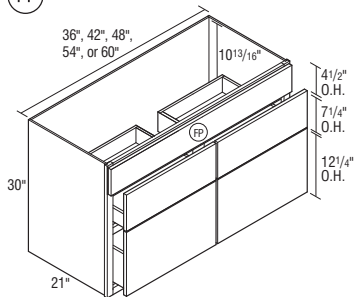

#### FP False Panel

## Model

BCDB24

BCDB30

BCDB36

BCDB42

BCDB48

BCDB54

BCDB60

Notes below apply to all products in section above:

- Top drawer is a false front.
- Finished Ends standard.
- Sink bowl clearance to top of drawer box is 10 13/16".
- Touch-up kit (TUK) and Owner's Guide included.
- Blocking for use with legs pre-installed.
- See page P-67 for optional legs.
- U-shaped drawers are not utilized in this cabinet.

#### Door & Drawer Options

CC	CG	ESMD	GAMD	HC	IFHG	MC	MD	MFO	PRMD	SHMD	SPLITDR	SPLITDRWS	SUMD	TCG	TCP
						✓									

#### End Panel Options

AUTH	CSFPE	EXBK	EXDN	FFD	FPE	INTGE	IPE
✓	✓	✓		✓	✓	✓	✓

#### Custom Modification Options

ADD_SHLF	ADRW	BVR	CBO	CCO	CFNTO	CFP	CFRMO	CLIP	CMAT	CND	CSDGBK	DRWTK	EF	EX	EX_OL	FD	FLUT	FTK	ID	IH	INVFRM	IW	

MIP	OBRB	PFINBTMB	RD	REC	RECTK	RH	ROSLUT	RT	SBCADDY	SBCADDYSM	SCPDWR	TBN	TD	TKP	TVR	UDBX	URT	VLSO	VTK	VWB	WS	WTR	
✓	✓																						

### BATH TWO DRAWER SINK BASE, 30" HIGH, 21" DEEP

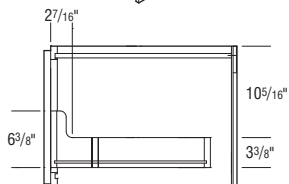
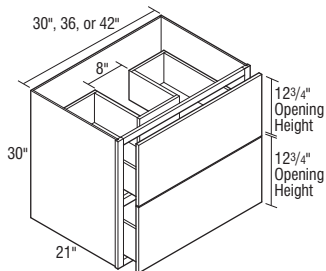

Top U-shaped drawer box has cascading side drawer feature.

#### U-SHAPED DRAWER ON SELECT BATH BASE CABINETS

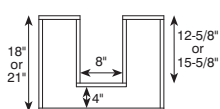

BC2DB30

BC2DB36

BC2DB42

- Top drawer is U-shaped.
- Finished Ends standard.
- No toe-kick standard.
- Increased depth to 24" is available.
- Sink bowl clearance to top of drawer box is 10 5/16".
- Touch-up kit (TUK) and Owner's Guide included.
- Blocking for use with legs pre-installed.
- See page P-67 for optional legs.

#### Door & Drawer Options

CC	CG	ESMD	GAMD	HC	IFHG	MC	MD	MFO	PRMD	SHMD	SPLITDR	SPLITDRWS	SUMD	TCG	TCP
						✓									

#### End Panel Options

AUTH	CSFPE	EXBK	EXDN	FFD	FPE	INTGE	IPE
✓	✓	✓		✓	✓	✓	✓

#### Custom Modification Options

ADD_SHLF	ADRW	BVR	CBO	CCO	CFNTO	CFP	CFRMO	CLIP	CMAT	CND	CSDGBK	DRWTK	EF	EX	EX_OL	FD	FLUT	FTK	ID	IH	INVFRM	IW	

MIP	OBRB	PFINBTMB	RD	REC	RECTK	RH	ROSLUT	RT	SBCADDY	SBCADDYSM	SCPDWR	TBN	TD	TKP	TVR	UDBX	URT	VLSO	VTK	VWB	WS	WTR	
✓	✓																						

# Bath and Vanity Cabinets

## Description

### BATH DRAWER SINK VANITY, 15 1/2" HIGH, 21" DEEP

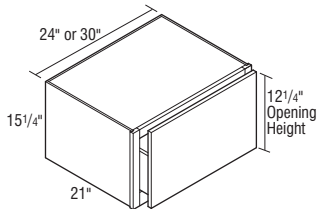

## Model

### BCDRW24

### BCDRW30

- Finished Ends standard.
- No toekick standard.
- Blocking for use with legs pre-installed.
- See page P•67 for optional legs.

#### Door & Drawer Options

CC	CG	ESMD	GAMD	HC	IFHG	MC	MD	MFO	PRMD	SHMD	SPLITDR	SPLITDRWS	SUMD	TCG	TCP

#### End Panel Options

AUTH	CSFPE	EXBK	EXDN	FFD	FPE	INTGE	IPE

#### Custom Modification Options

ADD_SHLF	ADRW	BVR	CBO	CCO	CFNTD	CFP	CFRMO	CLIP	CMAT	CND	CSDGBK	DRWTK	EF	EX	EX_OL	FD	FLUT	FTK	ID	IH	INFRM	IW	

MIP	OBRB	PFINBTMB	RD	REC	RECTK	RH	ROSFLUT	RT	SBCADDY	SBCADDYSM	SCPDRW	TBN	TD	TKP	TVR	UDBX	URT	VLSO	VTK	VWB	WS	WTR	

### BATH DRAWER SINK VANITY PLATFORM

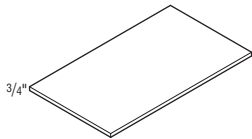

### BCPLATFORM

- Specify depth and length.
- 3/4" thick.
- Front, left, and right edges banded.

Modifications  
Are Not  
Available

### BATH DROP TRAY SINK BASE, 30" HIGH, 21" DEEP

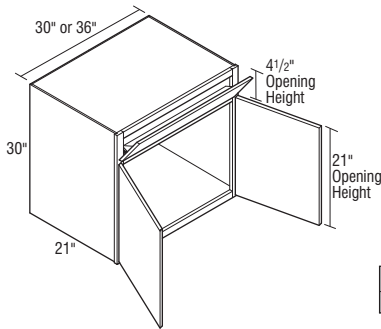

### BCBDT30NTK

### BCBDT36NTK

- No shelf included.
- Finished Ends standard.
- Blocking for use with legs pre-installed.
- See page P•67 for optional legs.
- One drawer front with one 1 11/16" deep stainless steel Tilt-out Tray attached.

#### Door & Drawer Options

CC	CG	ESMD	GAMD	HC	IFHG	MC	MD	MFO	PRMD	SHMD	SPLITDR	SPLITDRWS	SUMD	TCG	TCP

#### End Panel Options

AUTH	CSFPE	EXBK	EXDN	FFD	FPE	INTGE	IPE

#### Custom Modification Options

ADD_SHLF	ADRW	BVR	CBO	CCO	CFNTD	CFP	CFRMO	CLIP	CMAT	CND	CSDGBK	DRWTK	EF	EX	EX_OL	FD	FLUT	FTK	ID	IH	INFRM	IW	

MIP	OBRB	PFINBTMB	RD	REC	RECTK	RH	ROSFLUT	RT	SBCADDY	SBCADDYSM	SCPDRW	TBN	TD	TKP	TVR	UDBX	URT	VLSO	VTK	VWB	WS	WTR	

IH/RH availability charts starting on page G•40.  
IW/RW availability charts starting on page G•46.

## Description

**BATH STORAGE TOWER, 49 1/2", 55 1/2", or 61 1/2" HIGH, 21" DEEP**

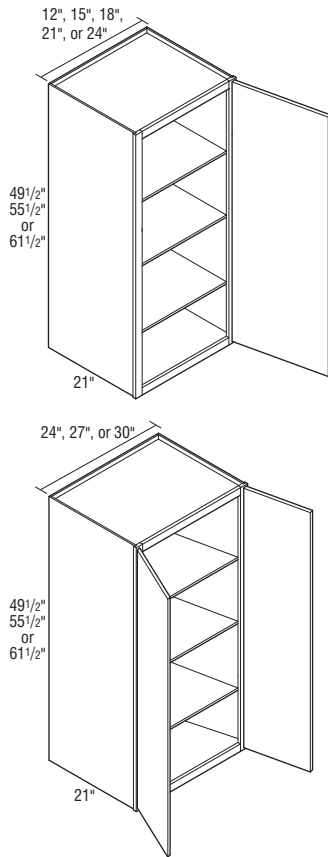

## Model

BCST1249.5 L or R

BCST1549.5 L or R

BCST1849.5 L or R

BCST2149.5 L or R

BCST2449.5 L or R

BCST2449.5

BCST2749.5

BCST3049.5

• Three adjustable shelves

BCST1255.5 L or R

BCST1555.5 L or R

BCST1855.5 L or R

BCST2155.5 L or R

BCST2455.5 L or R

BCST2455.5

BCST2755.5

BCST3055.5

BCST1261.5 L or R

BCST1561.5 L or R

BCST1861.5 L or R

BCST2161.5 L or R

BCST2461.5 L or R

BCST2461.5

BCST2761.5

BCST3061.5

• Four adjustable shelves.

Notes below apply to all products in section above:

- No toe-kick standard.
- Finished Ends standard.
- Glass shelf kit available, see page S-7.
- Legs sold separately, see page P-67 for options.
- Cabinets use standard wall cabinet construction. Additional materials may be required for field installation if top of cabinet will be visible.
- Blocking for use with legs pre-installed.

### Door & Drawer Options

CC	CG	ESMD	GAMD	HC	IFHG	MC	MD	MFO	PRMD	SHMD	SPLITDR <sup>1</sup>	SPLITDRWS	SUMD	TCG <sup>2</sup>	TCP <sup>2</sup>
✓	✓	✓	✓	✓	✓	✓	✓	✓	✓	✓	✓	✓	✓	✓	✓

### End Panel Options

AUTH	CSFPE	EXBK	EXDN	FFD	FPE	INTGE	IPE
✓	✓	✓	✓	✓	✓	✓	✓

### Custom Modification Options

ADD_SHLF	ADRW	BVR	CBO	CCO	CFNTD	CFP	CFRMO	CLIP	CMAT	CND	CSDGBK	DRWTK	EF	EX	EX_OL	FD	FLUT <sup>3</sup>	FTK	ID	IH	INVFRM	IW	
✓	✓	✓	✓	✓	✓	✓	✓	✓	✓	✓	✓	✓	✓	✓	✓	✓	✓	✓	✓	✓	✓	✓	✓
MIP	OBRB	PFINBTMB	RD	REC	RECTK	RH	ROSFLUT	RT	SBCADDY	SBCADDYSM	SCPRDW	TBN	TD	TKP	TVR <sup>4</sup>	UDBX	URT	VLISO	VTK	VWB	WS	WTR	
✓	✓	✓	✓	✓	✓	✓	✓	✓	✓	✓	✓	✓	✓	✓	✓	✓	✓	✓	✓	✓	✓	✓	✓

<sup>1</sup>Only available on 24" (2 doors)-30" wide.

<sup>2</sup>Only available on 24" (2 doors wide) wide except not available on 61 1/2" high.

<sup>3</sup>Not available with 6" fluting.

<sup>4</sup>Only available on TVRVV.

# Bath and Vanity Cabinets

## Description

**BATH STORAGE TOWER SINGLE DRAWER,**  
**49 1/2", 55 1/2", or 61 1/2" HIGH,**  
**21" DEEP**

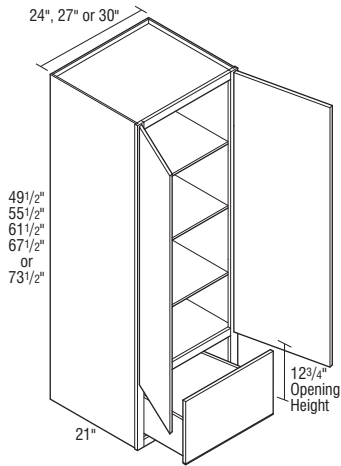
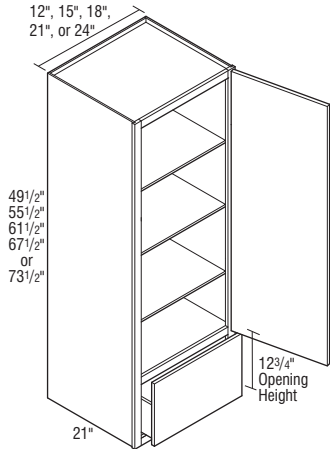

## Model

BCSTDRW1249.5 L or R

BCSTDRW1549.5 L or R

BCSTDRW1849.5 L or R

BCSTDRW2149.5 L or R

BCSTDRW2449.5 L or R

- Two adjustable shelves.

BCSTDRW2449.5

BCSTDRW2749.5

BCSTDRW3049.5

- Two adjustable shelves.

BCSTDRW1255.5 L or R

BCSTDRW1555.5 L or R

BCSTDRW1855.5 L or R

BCSTDRW2155.5 L or R

BCSTDRW2455.5 L or R

- Three adjustable shelves.

BCSTDRW2455.5

BCSTDRW2755.5

BCSTDRW3055.5

- Three adjustable shelves.

BCSTDRW1261.5 L or R

BCSTDRW1561.5 L or R

BCSTDRW1861.5 L or R

BCSTDRW2161.5 L or R

BCSTDRW2461.5 L or R

- Three adjustable shelves.

BCSTDRW2461.5

BCSTDRW2761.5

BCSTDRW3061.5

- Three adjustable shelves.

Notes below apply to all products in section above:

- Finished Ends standard.
- No toekick standard.
- Glass shelf kit available, see page S•7.
- Legs sold separately; see page P•67 for options.
- Cabinets use standard wall cabinet construction. Additional materials may be required for field installation if top of cabinet will be visible.
- Blocking for use with legs pre-installed.

### Door & Drawer Options

CC	CG	ESMD	GAMD	HC	IFHG	MC	MD	MFO	PRMD	SHMD	SPLITDR	SPLITDRWS	SUMD	TCG	TCP
✓	✓	✓	✓	✓	✓	✓	✓	✓	✓	✓	✓	✓	✓	✓	✓

### End Panel Options

AUTH	CSFPE	EXBK	EXDN	FFD	FPE	INTGE	IPE
✓	✓	✓	✓	✓	✓	✓	✓

### Custom Modification Options

ADD_SHLF	ADRW	BVR	CBO	CCO	CFNTO	CFP	CFRMO	CLIP <sup>1</sup>	CMAT	CND	CSDGBK	DRWTK	EF	EX	EX_OL	FD	FLUT <sup>2</sup>	FTK	ID	IH	INVRM	IW
✓	✓	✓	✓	✓	✓	✓	✓	✓	✓	✓	✓	✓	✓	✓	✓	✓	✓	✓	✓	✓	✓	✓
MIP	OBRB	PFINBTMB	RD	REC	RECTK	RH	ROSFLUT	RT	SBCADDY	SBCADDYSM	SCPDRW	TBN	TD	TKP	TVP <sup>3</sup>	UDBX	URT	VISO	VTK	VWB	WS	WTR
✓	✓	✓	✓	✓	✓	✓	✓	✓	✓	✓	✓	✓	✓	✓	✓	✓	✓	✓	✓	✓	✓	✓

<sup>1</sup>Not available on 12" wide.

<sup>2</sup>Not available with 6" fluting.

<sup>3</sup>TVP not available on 12" wide.

IH/RH availability charts starting on page G•40.  
 IW/RW availability charts starting on page G•46.

**Description**

**BATH STORAGE TOWER SINGLE DRAWER, 67 1/2" or 73 1/2" HIGH, 21" DEEP**

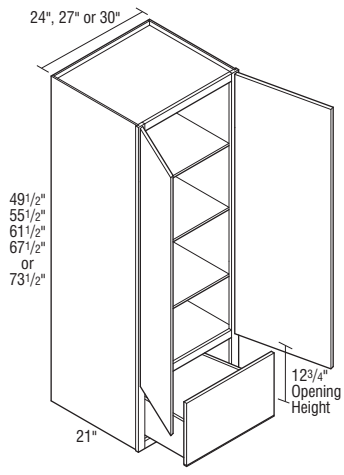
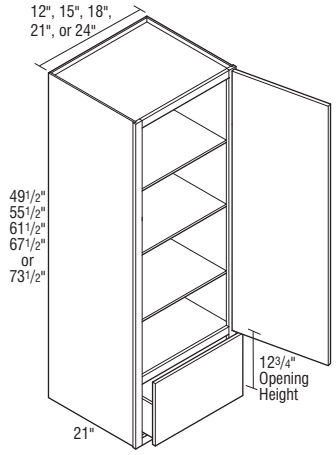

**Model**

- BCSTDRW1267.5 L or R
- BCSTDRW1567.5 L or R
- BCSTDRW1867.5 L or R
- BCSTDRW2167.5 L or R
- BCSTDRW2467.5 L or R
- Four adjustable shelves.
- BCSTDRW2467.5
- BCSTDRW2767.5
- BCSTDRW3067.5
- Four adjustable shelves.
- BCSTDRW1273.5 L or R
- BCSTDRW1573.5 L or R
- BCSTDRW1873.5 L or R
- BCSTDRW2173.5 L or R
- BCSTDRW2473.5 L or R
- Four adjustable shelves.
- BCSTDRW2473.5
- BCSTDRW2773.5
- BCSTDRW3073.5
- Four adjustable shelves.

**Notes below apply to all products in section above:**

- Finished Ends standard.
- No toe-kick standard.
- Glass shelf kit available, see page S-7.
- Legs sold separately; see page P-67 for options.
- Cabinets use standard wall cabinet construction. Additional materials may be required for field installation if top of cabinet will be visible.
- Blocking for use with legs pre-installed.

**Door & Drawer Options**

CC	CG	ESMD	GAMD	HC	IFHG	MC	MD <sup>1</sup>	MFO	PRMD	SHMD	SPLITDR	SPLITDRWS	SUMD	TCG	TCP
✓					✓		✓	✓							

**End Panel Options**

AUTH	CSFPE	EXBK	EXDN	FFD	FPE	INTGE	IPE
✓	✓	✓		✓	✓	✓	✓

**Custom Modification Options**

ADD_SHLF	ADRW	BVR	CBO	CCO	CFNTO	CFP	CFRMO	CLIP <sup>2</sup>	CMAT	CND	CSDGBK	DRWTK	EF	EX	EX_OL	FD	FLUT <sup>3</sup>	FTK	ID	IH	INVERM	IW	
			✓	✓	✓		✓	✓		✓	✓			✓	✓	✓	✓	✓	✓	✓	✓	✓	✓

MIP	OBRB	PFINBTMB	RD	REC	RECTK	RH	ROSFLUT	RT	SBCADDY	SBCADDYSM	SCPDRW	TBN	TD	TKP	TVR <sup>4</sup>	UDBX	URT	VLSO	VTK	VWB	WS	WTR	
✓	✓			✓			✓	✓	✓						✓	✓			✓	✓	✓	✓	✓

<sup>1</sup>Only available on 12"-21" wide on the 67 1/2" high.  
<sup>2</sup>Not available on 12" wide.  
<sup>3</sup>Not available with 6" fluting.  
<sup>4</sup>TVRAW not available on 12" wide.

# Bath and Vanity Cabinets

## Description

**BATH STORAGE TOWER DOUBLE DRAWER, 79 1/2", 85 1/2", or 91 1/2" HIGH, 21" DEEP**

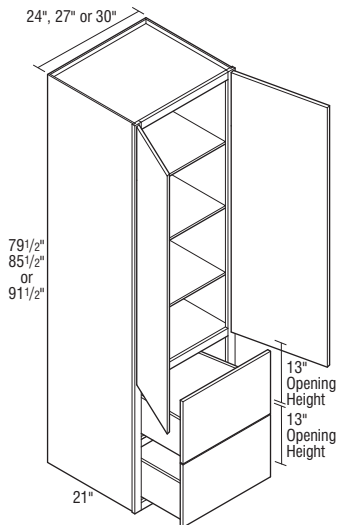
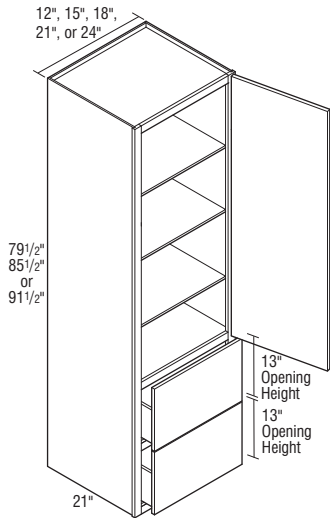

## Model

- BCSTDRW1279.5 L or R
- BCSTDRW1579.5 L or R
- BCSTDRW1879.5 L or R
- BCSTDRW2179.5 L or R
- BCSTDRW2479.5 L or R
- BCSTDRW2479.5
- BCSTDRW2779.5
- BCSTDRW3079.5
- BCSTDRW1285.5 L or R
- BCSTDRW1585.5 L or R
- BCSTDRW1885.5 L or R
- BCSTDRW2185.5 L or R
- BCSTDRW2485.5 L or R
- BCSTDRW2485.5
- BCSTDRW2785.5
- BCSTDRW3085.5
- BCSTDRW1291.5 L or R
- BCSTDRW1591.5 L or R
- BCSTDRW1891.5 L or R
- BCSTDRW2191.5 L or R
- BCSTDRW2491.5 L or R
- BCSTDRW2491.5
- BCSTDRW2791.5
- BCSTDRW3091.5

- Four adjustable shelves.
- Finished Ends standard.
- No toekick standard.
- Glass shelf kit available, see page S•7.
- Legs sold separately; see page P•67 for options.
- Cabinets use standard wall cabinet construction. Additional materials may be required for field installation if top of cabinet will be visible.
- Blocking for use with legs pre-installed.

### Door & Drawer Options

CC	CG	ESMD	GAMD	HC	IFHG	MC	MD	MFO	PRMD	SHMD	SPLITDR	SPLITDRWS	SUMD	TCG	TCP
✓				✓				✓							

### End Panel Options

AUTH	CSFPE	EXBK	EXDN	FFD	FPE	INTGE	IPE
✓	✓	✓		✓	✓	✓	✓

### Custom Modification Options

ADD_SHLF	ADRW	BVR	CBO	CCO	CFNT0	CFP	CFRMO	CLIP <sup>1</sup>	CMAT	CND	CSDGBK	DRWTK	EF	EX	EX_OL	FD	FLUT <sup>2</sup>	FTK	ID	IH	INVERM	IW	
✓	✓			✓	✓	✓	✓	✓		✓	✓		✓	✓	✓	✓	✓	✓	✓	✓	✓	✓	
MIP	OBRB	PFINBTMB	RD	REC	RECTK	RH	ROSFLUT <sup>3</sup>	RT	SBCADDY	SBCADDYSM	SCPDRW	TBN	TD	TKP	TVR <sup>4</sup>	UDBX	URT	VLSO	VTK	VWB	WS	WTR	
✓	✓			✓			✓	✓							✓							✓	✓

<sup>1</sup>Not available on 12" wide.

<sup>2</sup>Not available with 3091.5 version or with 6" fluting.

<sup>3</sup>Not available with 3091.5 version.

<sup>4</sup>TVRAV not available on 12" wide.

IH/RH availability charts starting on page G•40.  
IW/RW availability charts starting on page G•46.

## Description

### BATH TANK TOPPER OPEN SHELF, 30" or 36" HIGH, 8" DEEP

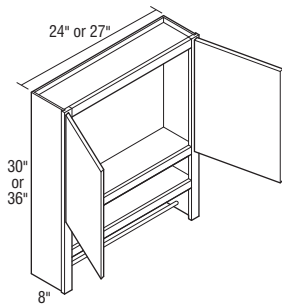

## Model

**BCTTOS2430**

**BCTTOS2436**

**BCTTOS2730**

**BCTTOS2736**

- Includes one shelf.
- Flush Panel Ends standard.
- Matching Interior standard.
- Wooden Towel Bar standard. Option to select Nickel, see modification TBN for more information.

#### Door & Drawer Options

CC	CG	ESMD	GAMD	HC	IFHG	MC	MD	MFO	PRMD	SHMD	SPLITDR	SPLITDRWS	SUMD	TCG	TCP
✓				✓			✓								

#### End Panel Options

AUTH	CSFPE	EXBK	EXDN	FFD	FPE	INTGE	IPE
		✓	✓				

#### Custom Modification Options

ADD_SHLF	ADRW	BVR	CBO	CCO	CFNTD	CFP	CFRMO	CLIP	CMAT	CND	CSDGBK	DRWTK	EF	EX	EX_OL	FD	FLUT	FTK	ID	IH	INVFRM	IW	
			✓	✓	✓		✓				✓		✓	✓	✓								

MIP	OBRB	PFINBTMB	RD	REC	RECTK	RH	ROSLUT	RT	SBCADDY	SBCADDYSM	SCPDWR	TBN	TD	TKP	TVR	UDBX	URT	VLSO	VTK	VWB	WS	WTR	
✓												✓										✓	✓

### BATH TANK TOPPER, 30" or 36" HIGH, 8" DEEP

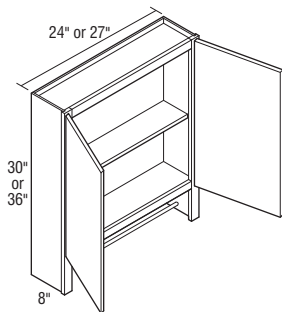

**BCTT2430**

**BCTT2436**

**BCTT2730**

**BCTT2736**

- Two adjustable shelves.
- Flush Panel Ends standard.
- Matching Interior standard.
- Wooden Towel Bar standard. Option to select Nickel Aluminum, see modification TBN for more information.

#### Door & Drawer Options

CC	CG	ESMD	GAMD	HC	IFHG	MC	MD	MFO	PRMD	SHMD	SPLITDR	SPLITDRWS	SUMD	TCG	TCP
✓				✓											

#### End Panel Options

AUTH	CSFPE	EXBK	EXDN	FFD	FPE	INTGE	IPE
		✓	✓				

#### Custom Modification Options

ADD_SHLF	ADRW	BVR	CBO	CCO	CFNTD	CFP	CFRMO	CLIP	CMAT	CND	CSDGBK	DRWTK	EF	EX	EX_OL	FD	FLUT	FTK	ID	IH	INVFRM	IW	
			✓	✓	✓		✓				✓		✓	✓	✓								

MIP	OBRB	PFINBTMB	RD	REC	RECTK	RH	ROSLUT	RT	SBCADDY	SBCADDYSM	SCPDWR	TBN	TD	TKP	TVR	UDBX	URT	VLSO	VTK	VWB	WS	WTR	
✓												✓										✓	✓

### BATH TANK TOPPER OPEN SHELF, 30" or 36" HIGH, 8" DEEP

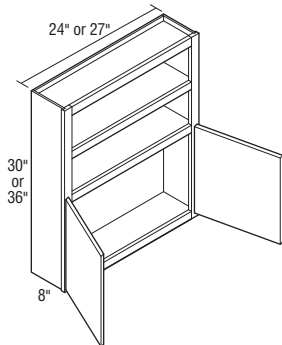

**BCTTOSM2430**

**BCTTOSM2436**

**BCTTOSM2730**

**BCTTOSM2736**

- 36" high units will include one adjustable shelf.
- Matching Interior standard.
- Flush Panel Ends standard.

#### Door & Drawer Options

CC	CG	ESMD	GAMD	HC	IFHG	MC	MD	MFO	PRMD	SHMD	SPLITDR	SPLITDRWS	SUMD	TCG	TCP
✓				✓			✓								

#### End Panel Options

AUTH	CSFPE	EXBK	EXDN	FFD	FPE	INTGE	IPE
		✓	✓				

#### Custom Modification Options

ADD_SHLF	ADRW	BVR	CBO	CCO	CFNTD	CFP	CFRMO	CLIP	CMAT	CND	CSDGBK	DRWTK	EF	EX	EX_OL	FD	FLUT	FTK	ID	IH	INVFRM	IW	
			✓	✓	✓		✓				✓		✓	✓	✓								

MIP	OBRB	PFINBTMB	RD	REC	RECTK	RH	ROSLUT	RT	SBCADDY	SBCADDYSM	SCPDWR	TBN	TD	TKP	TVR	UDBX	URT	VLSO	VTK	VWB	WS	WTR	
✓												✓										✓	✓



# Kits and Hardware

## Description

## Model

### BATH FRAMED WALL MIRROR, 3/4" DEEP

### BCFWM

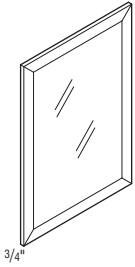

- 1/8" thick mirror.
- Mirror to be dropped shipped separately from mirror frame.
- Specify width x height.
- Maximum width is 60".
- Maximum height is 60".
- Maximum width or height is 36" when opposite width or height exceeds 36".

Modifications  
Are Not  
Available

### BATH CHANNEL WALL MIRROR, 1 1/2" DEEP

### BCCWM

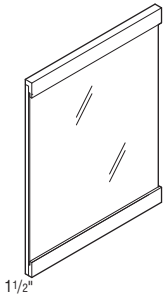

- 1/4" thick mirror.
- Mirror to be dropped shipped separately from mirror frame.
- Installation instructions included.
- Specify width x height.
- Maximum width is 96".
- Maximum height is 96".
- Maximum width or height is 48" when opposite width or height exceeds 48".

Modifications  
Are Not  
Available

### BATH MIRROR WALL PULL-OUT, 32 3/4" HIGH, 4 1/2" DEEP

### VMP2432.5

### VMP3032.5

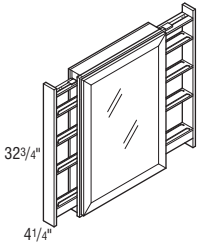

- Three adjustable shelves in each pull-out section.
- Installation instructions included.
- Mirror to be dropped shipped separately from mirror frame.
- Mirror frame will match door style.
- Pull-outs extend 10 3/8" on each side. VMP2432.5 open width is 44 3/4". VMP3032.5 open width is 50 3/4".
- Not available with Inset and Beaded Inset.

Modifications  
Are Not  
Available

### BATH HAMPER KIT, 21" HIGH, 19 3/4" DEEP



### HAMPERKIT15

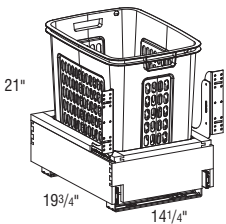

- For 18" wide base cabinet, 15" wide opening.
- Not available on Inset or Beaded Inset 21" deep cabinets.
- Available for installation in 21" or 24" deep cabinets.

Modifications  
Are Not  
Available

IH/RH availability charts starting on page G•40.  
IW/RW availability charts starting on page G•46.

**Description**

**BATH GROOMING PULL-OUT KIT, 20 1/2" HIGH, 19" DEEP**

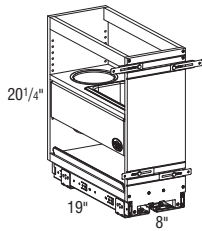

**Model**

**GPOKIT**

- For 12" wide base cabinet, 9" wide opening.
- Available for installation in 21" or 24" deep cabinets.
- Pull-out features two stainless steel bins, one round and one rectangular.
- Pull-out features Smart Stop.

Modifications  
Are Not  
Available

**BATH FEET**

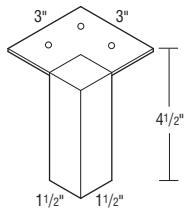

**FOOTMETALSQ**

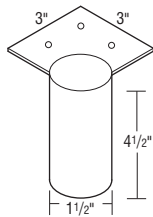

**FOOTMETALRD**

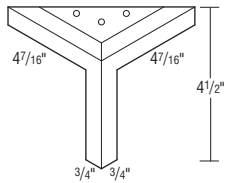

**FOOTMETALANG**

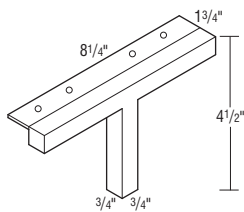

**FOOTMETALANGT**

**FOOTMETALSQPS**

**FOOTMETALRDPBS**

**FOOTMETALANGPC**

**FOOTMETALANGTPC**

**FOOTMETALSQBS**

**FOOTMETALRDBS**

**FOOTMETALANGBN**

**FOOTMETALANGTBN**

- PC = Polished Chrome
- BN = Brushed Nickel
- PS = Polished Stainless
- BS = Brushed Stainless

Modifications  
Are Not  
Available



# Kemper Emerge Modification Option Descriptions

Your Kemper Emerge specification guide contains charts with modification option codes for each applicable cabinetry product. Reference the listing below to identify the modification description.

End Panel Options	
Option	Description
AUTH	Authentic Flush End
CSFPE	Car Siding Flush Panel End
FPE	Flush Panel End
INTGE	Integral End
IPE	Inset Panel Ends

Custom Modification Options	
Option	Description
BAND	Band All Edges
BND	Banding Location
BVR	Bottom Valance Rail
EF	Finished Ends
EX	Extended Stile
EX_OL	Extended Stile with Overlay
F.ALL	Finished All
F.FRT	Finished Edges
FLUT	Fluting
FTK	Flush Toekick
ID	Increased Depth
IH	Increased Height
IW	Increased Width
MLDG	Moulding Location
MLDG.ALL	Moulding All
NOMLDG	No Moulding
PRO	Profiled and Finished Edges
RD	Reduced Depth
RH	Reduced Height
ROSFLUT	Rose Fluting
WTCLIP	Clipped Corner Wood Tops
WTR	Wide Top Rail

# Fillers & Panels

Description	Model	Height	Height w/FTK Option
<b>FILLERS (SPECIFY STYLE and STAIN)</b>			

## WALL FILLERS

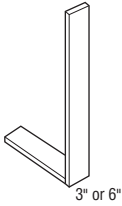

<b>F330</b>	30"	34.5"
<b>F333</b>	33"	37.5"
<b>F336</b>	36"	40.5"
<b>F339</b>	39"	43.5"
<b>F342</b>	42"	46.5"
<b>F345</b>	45"	49.5"
<b>F348</b>	48"	52.5"
<b>F630</b>	30"	34.5"
<b>F633</b>	33"	37.5"
<b>F636</b>	36"	40.5"
<b>F639</b>	39"	43.5"
<b>F642</b>	42"	46.5"
<b>F645</b>	45"	49.5"
<b>F648</b>	48"	52.5"

- Solid wood.
- Glazes and/or Techniques available: F, P, TW, XTW, HW, XHW.
- Increased or Reduced Heights available in 1/4" increments from 12" to 75".
- Height of filler excludes toekick height of 4 1/2", with the exception of Office fillers that have FTK standard.

### Custom Modification Options

BVR	F.ALL	FLUT	FTK	IH <sup>1</sup>	RH	ROSLUT	WTR
✓		✓	✓	✓	✓	✓	✓

<sup>1</sup>Only available on 348 and 648 versions.

## BASE FILLERS



<b>FB330</b>	30"	34.5"
<b>FB630</b>	30"	34.5"

- Solid wood.
- If Full Height is required, a Flush Toekick must be specified.
- Glazes and/or Techniques available: F, P, TW, XTW, HW, XHW.
- Increased or Reduced Heights available in 1/4" increments from 12" to 48".
- Height of filler excludes toekick height of 4 1/2", with the exception of Office fillers that have FTK standard.

### Custom Modification Options

BVR	F.ALL	FLUT	FTK	IH	RH	ROSLUT	WTR
		✓	✓	✓	✓	✓	✓

### Glazes and Techniques

- F** = Flooded (see page E•3.)
- P** = Penned (see page E•3.)
- TW** = Timeworn (see page E•3.)
- XTW** = Extra Timeworn (see page E•3.)
- HW** = Hewn (see page E•3.)
- XHW** = Extra Hewn (see page E•3.)

Description	Model	Height	Height w/FTK Option
<b>OFFICE FILLERS</b>			
	<b>F0329</b>	29"	Included
	<b>F0629</b>	29"	Included



- Solid wood.
- Glazes and/or Techniques available: F, P, TW, XTW, HW, XHW.
- Height of filler excludes toekick height of 4 1/2", with the exception of Office fillers that have FTK standard.

### Custom Modification Options

BVR	F.ALL	FLUT <sup>1</sup>	FTK	IH	RH	ROSLUT	WTR
		✓				✓	✓

<sup>1</sup>Not available with 6" fluting.

## VANITY FILLERS



<b>FV325.5</b>	25.5"	30"
<b>FV332</b>	27.5"	32"
<b>FV625.5</b>	25.5"	30"
<b>FV632</b>	27.5"	32"

- Solid wood.
- If Full Height is required, a Flush Toekick must be specified.
- Glazes and/or Techniques available: F, P, TW, XTW, HW, XHW.
- Increased or Reduced Heights available in 1/4" increments from 12" to 48".
- Height of filler excludes toekick height of 4 1/2", with the exception of Office fillers that have FTK standard.

### Custom Modification Options

BVR	F.ALL	FLUT <sup>1</sup>	FTK	IH	RH	ROSLUT <sup>1</sup>	WTR
		✓	✓	✓	✓	✓	✓

<sup>1</sup>Not available on 632 version.

Description	Model	Height	Height w/FTK Option
<b>UTILITY FILLERS</b>			
	<b>TF384</b>	79.5"	84"
	<b>TF387</b>	82.5"	87"
	<b>TF390</b>	85.5"	90"
	<b>TF393</b>	88.5"	93"
	<b>TF396</b>	91.5"	96"
	<b>TF396FH</b>	96"	96"
	<b>TF684</b>	79.5"	84"
	<b>TF687</b>	82.5"	87"
	<b>TF690</b>	85.5"	90"
	<b>TF693</b>	88.5"	93"
	<b>TF696</b>	91.5"	96"
	<b>TF696FH</b>	96"	96"
	<ul style="list-style-type: none"> <li>Reduced Heights available in 1/4" increments from 66" to 95 3/4".</li> </ul>		
	<b>TF3102</b>	97.5"	102"
	<b>TF6102</b>	97.5"	102"
	<b>TF3108</b>	103.5"	108"
	<b>TF6108</b>	103.5"	108"
	<b>TF3120</b>	115.5"	120"
	<b>TF3120FH</b>	115.5"	120"
	<b>TF6120</b>	115.5"	120"



- Alder will be substituted for Rustic Alder.
- Reduced Heights available in 1/4" increments from 96 1/4" to 119 3/4".

Notes below apply to all products in section above:

- Solid wood.
- If Full Height is required, a Flush Toekick must be specified.
- Glazes and/or Techniques available: F, P, TW, XTW, HW, XHW.
- Height of filler excludes toekick height of 4 1/2", with the exception of Office fillers that have FTK standard.

Custom Modification Options

BVR	F.ALL	FLUT	FTK	IH	RH <sup>1</sup>	ROSFLUT	WTR <sup>2</sup>
✓	✓	✓	✓	✓	✓	✓	✓

<sup>1</sup>Not available on 102" high versions.  
<sup>2</sup>Not available in 396 version.

Description	Model	Height	Height w/FTK Option					
<b>WALL and BASE FILLERS</b>								
	<b>135FW</b>	30"	34.5"					
	<b>135FW42</b>	42"	46.5"					
	<b>135FB</b>	30"	34.5"					
	<ul style="list-style-type: none"> <li>Solid wood.</li> <li>If Full Height is required on a Base Filler, Flush Toekick must be specified.</li> <li>Glazes and/or Techniques available: F, P, TW, XTW, HW, XHW.</li> <li>Increased or Reduced Heights available in 1/4" increments from 12" to 48".</li> <li>Height of filler excludes toekick height of 4 1/2", with the exception of Office fillers that have FTK standard.</li> </ul>							
	Custom Modification Options							
	BVR <sup>1</sup>	F.ALL	FLUT <sup>2</sup>	FTK	IH <sup>3</sup>	RH	ROSFLUT	WTR
	✓	✓	✓	✓	✓	✓	✓	✓
	<sup>1</sup> Not available on FB version. <sup>2</sup> Not available with 6" fluting. <sup>3</sup> Not available on FW version.							

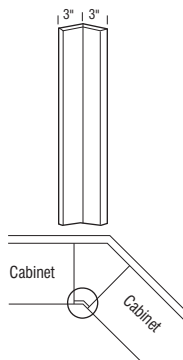

Installation of 135FW, 135FW42, and 135FB (overhead view)

Description	Model	Height	Height w/FTK Option
<b>OFFICE and VANITY FILLERS</b>			
	<b>FBCV3</b>	26.5"	30"
	<b>FBCV332</b>	27.5"	32"
	<b>FBCO329</b>	29"	Included
	<b>CFB330</b>	30"	34.5"



- Solid wood.
- If Full Height is required on a Vanity Filler, Flush Toekick must be specified.
- Glazes and/or Techniques available: F, P, TW, XTW, HW, XHW.
- Increased or Reduced Heights available in 1/4" increments from 12" to 48".
- Height of filler excludes toekick height of 4 1/2", with the exception of Office fillers that have FTK standard.

Custom Modification Options

BVR	F.ALL	FLUT <sup>1</sup>	FTK <sup>2</sup>	IH <sup>3</sup>	RH <sup>3</sup>	ROSFLUT	WTR <sup>2</sup>
✓	✓	✓	✓	✓	✓	✓	✓

<sup>1</sup>Not available with 6" fluting.  
<sup>2</sup>Not available on 329 version.  
<sup>3</sup>Only available on CFB330.

**Glazes and Techniques**

- F = Flooded (see page E•3.)
- P = Penned (see page E•3.)
- TW = Timeworn (see page E•3.)
- XTW = Extra Timeworn (see page E•3.)
- HW = Hewn (see page E•3.)
- XHW = Extra Hewn (see page E•3.)

# Fillers & Panels

Description	Model	Height	Height w/FTK Option
<b>FILLERS (SPECIFY STYLE and STAIN)</b>			

## WALL FLUTED FILLERS

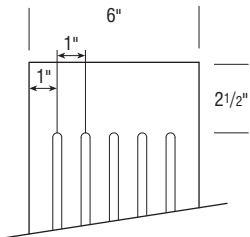
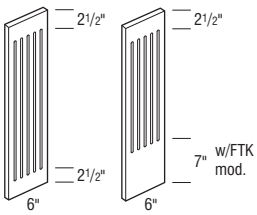
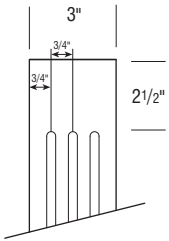
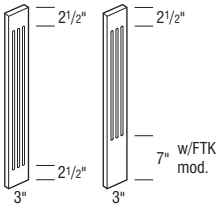

<b>FF330</b>	30"	34.5"
<b>FF333</b>	33"	37.5"
<b>FF336</b>	36"	40.5"
<b>FF339</b>	39"	43.5"
<b>FF342</b>	42"	46.5"
<b>FF345</b>	45"	49.5"
<b>FF348</b>	48"	52.5"
<b>FF630</b>	30"	34.5"
<b>FF633</b>	33"	37.5"
<b>FF636</b>	36"	40.5"
<b>FF639</b>	39"	43.5"
<b>FF642</b>	42"	46.5"
<b>FF645</b>	45"	49.5"
<b>FF648</b>	48"	52.5"

- Solid wood.
- 3/4" thick.
- Cleat included, but shipped loose.
- If full height is required with Flush Toe Kick modification, then flute changes to 7" from bottom of filler, but flute still remains 2 1/2" from top.
- Glazes and/or Techniques available: F, P, TW, XTW, HW, XHW.

### Custom Modification Options

BVR	F.ALL	FLUT	FTK	IH <sup>1</sup>	RH	ROSLUT	WTR
✓	✓	✓	✓	✓	✓	✓	✓

<sup>1</sup>Only available on 48" high.

Description	Model	Height	Height w/FTK Option
<b>BASE FLUTED FILLERS</b>			
<b>FFB330</b>	30"	34.5"	
<b>FFB630</b>	30"	34.5"	

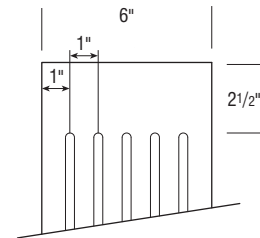
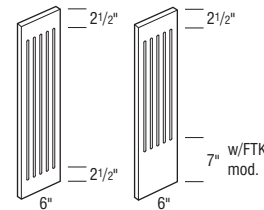
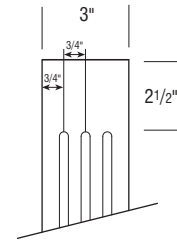
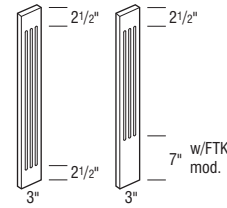

- Solid wood.
- 3/4" thick.
- If full height is required with Flush Toe Kick modification, then flute changes to 7" from bottom of filler, but flute still remains 2 1/2" from top.
- Glazes and/or Techniques available: F, P, TW, XTW, HW, XHW.

### Custom Modification Options

BVR	F.ALL	FLUT	FTK	IH	RH	ROSLUT	WTR
✓	✓	✓	✓	✓	✓	✓	✓

## Glazes and Techniques

- F** = Flooded (see page E•3.)
- P** = Penned (see page E•3.)
- TW** = Timeworn (see page E•3.)
- XTW** = Extra Timeworn (see page E•3.)
- HW** = Hewn (see page E•3.)
- XHW** = Extra Hewn (see page E•3.)

Description	Model	Height	Height w/FTK Option
-------------	-------	--------	---------------------

## VANITY FLUTED FILLERS

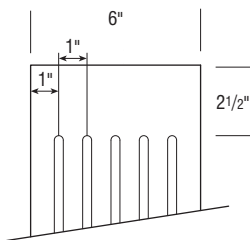
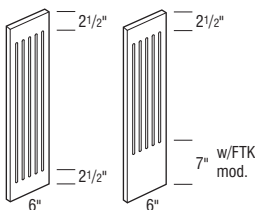
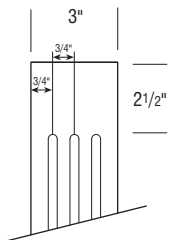
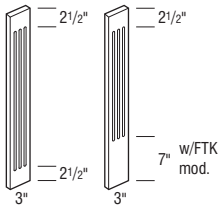

<b>FFV325.5</b>	25.5"	30"
<b>FFV332</b>	27.5"	32"
<b>FFV625.5</b>	25.5"	30"
<b>FFV632</b>	27.5"	32"

- Solid wood.
- 3/4" thick.
- If full height is required with Flush Toekick modification, then flute changes to 7" from bottom of filler, but flute still remains 2 1/2" from top.
- Glazes and/or Techniques available:  
F, P, TW, XTW, HW, XHW.

### Custom Modification Options

BVR	F.ALL	FLUT	FTK	IH	RH	ROSFLUT	WTR
<input checked="" type="checkbox"/>	<input type="checkbox"/>	<input type="checkbox"/>	<input checked="" type="checkbox"/>	<input checked="" type="checkbox"/>	<input checked="" type="checkbox"/>	<input type="checkbox"/>	<input checked="" type="checkbox"/>

Description	Model	Height	Height w/FTK Option
-------------	-------	--------	---------------------

## TALL FLUTED FILLERS

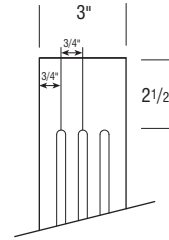
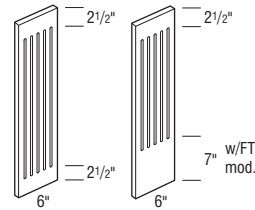
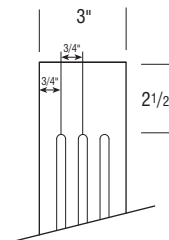
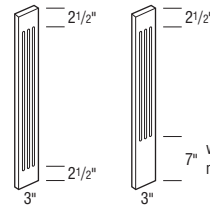

<b>FTF384</b>	79.5"	84"
<b>FTF387</b>	82.5"	87"
<b>FTF390</b>	85.5"	90"
<b>FTF393</b>	88.5"	93"
<b>FTF396</b>	91.5"	96"
<b>FTF396FH</b>	96"	96"
<b>FTF3102</b>	97.5"	102"
<b>FTF3108</b>	103.5"	108"
<b>FTF3120</b>	115.5"	120"
<b>FTF684</b>	79.5"	84"
<b>FTF687</b>	82.5"	87"
<b>FTF690</b>	85.5"	90"
<b>FTF693</b>	88.5"	93"
<b>FTF696</b>	91.5"	96"
<b>FTF696FH</b>	96"	96"
<b>FTF6102</b>	97.5"	102"
<b>FTF6108</b>	103.5"	108"
<b>FTF6120</b>	115.5"	120"

**NEW**

**NEW**

- Solid wood.
- 3/4" thick.
- If full height is required with Flush Toekick modification, then flute changes to 7" from bottom of filler, but flute still remains 2 1/2" from top.
- Glazes and/or Techniques available:  
F, P, TW, XTW, HW, XHW.

### Custom Modification Options

BVR	F.ALL	FLUT <sup>1</sup>	FTK <sup>2</sup>	IH	RH <sup>2</sup>	ROSFLUT <sup>1</sup>	WTR
<input checked="" type="checkbox"/>	<input checked="" type="checkbox"/>	<input checked="" type="checkbox"/>	<input checked="" type="checkbox"/>	<input checked="" type="checkbox"/>	<input checked="" type="checkbox"/>	<input checked="" type="checkbox"/>	<input checked="" type="checkbox"/>

<sup>1</sup>Only available on TF687.

<sup>2</sup>Not available on FH versions.

## OFFICE FLUTED FILLERS

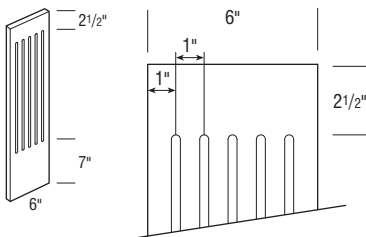
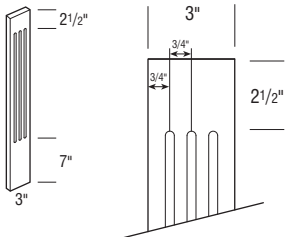

<b>FFO329</b>	29"	Included
<b>FFO629</b>	29"	Included

- Solid wood.
- 3/4" thick.
- Glazes and/or Techniques available:  
F, P, TW, XTW, HW, XHW.

### Custom Modification Options

BVR	F.ALL	FLUT	FTK	IH	RH	ROSFLUT	WTR
<input checked="" type="checkbox"/>	<input type="checkbox"/>	<input type="checkbox"/>	<input checked="" type="checkbox"/>	<input type="checkbox"/>	<input type="checkbox"/>	<input type="checkbox"/>	<input checked="" type="checkbox"/>

### Glazes and Techniques

- F** = Flooded (see page E•3.)
- P** = Penned (see page E•3.)
- TW** = Timeworn (see page E•3.)
- XTW** = Extra Timeworn (see page E•3.)
- HW** = Hewn (see page E•3.)
- XHW** = Extra Hewn (see page E•3.)



# Wood Tops

Description **WOOD TOPS** Model

## WOOD TOPS

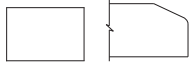

No Moulding Beveled edge

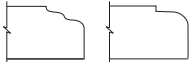

Ogee edge Round Over edge



Square edge

**WOODTOPNOMLD** (No moulding)

**WOODTOPBE** (Beveled edge)

**WOODTOPOG** (Ogee edge)

**WOODTOPRO** (Round over edge)

**WOODTOPSE** (Square edge)

- 1 1/2" thick.
- Alder will be substituted for Rustic Alder.

Custom Modification Options

MLDG	MLDG.ALL	NOMLDG <sup>1</sup>	WTCLIP	WTR
✓	✓	✓	✓	✓

<sup>1</sup>Only available on WOODTOPNOMLD.

Description **WOOD TOP, THREE SIDED** Model

- 3TWT1821
  - 3TWT2421
  - 3TWT3021
  - 3TWT3621
  - 3TWT4821
  - 3TWT5421
  - 3TWT6021
  - 3TWT6621
  - 3TWT7221
- 
- 3TWT1824
  - 3TWT2424
  - 3TWT3024
  - 3TWT3624
  - 3TWT4824
  - 3TWT5424
  - 3TWT6024
  - 3TWT6624
  - 3TWT7224

- 1/2" thick.
- Nomenclature refers to width and depth of cabinetry being used. See actual dimension of wood top in chart.
- Alder will be substituted for Rustic Alder.

**NEW** WOOD TOP, ONE SIDED

1TWT7221

1TWT7224

- 1/2" thick.
- Nomenclature refers to width and depth of cabinetry being used. See actual dimension of wood top in chart.
- Alder will be substituted for Rustic Alder.

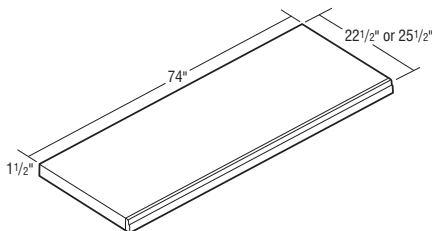

22 1/2" Deep	Overall Width	Overall Depth
1TWT7221	74"	22 1/2"

25 1/2" Deep	Overall Width	Overall Depth
1TWT7224	74"	25 1/2"

Custom Modification Options

MLDG	MLDG.ALL	NOMLDG <sup>1</sup>	WTCLIP	WTR
✓	✓	✓	✓	✓

<sup>1</sup>Only available on NOMLDG version.

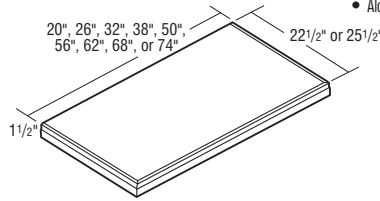
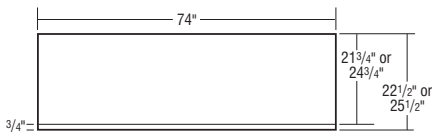

22 1/2" Deep	Overall Width	Overall Depth
3TWT1821	20"	22 1/2"
3TWT2421	26"	22 1/2"
3TWT3021	32"	22 1/2"
3TWT3621	38"	22 1/2"
3TWT4821	50"	22 1/2"
3TWT5421	56"	22 1/2"
3TWT6021	62"	22 1/2"
3TWT6621	68"	22 1/2"
3TWT7221	74"	22 1/2"

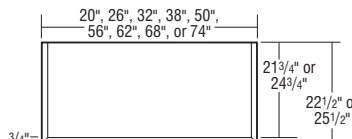

25 1/2" Deep	Overall Width	Overall Depth
3TWT1824	20"	25 1/2"
3TWT2424	26"	25 1/2"
3TWT3024	32"	25 1/2"
3TWT3624	38"	25 1/2"
3TWT4824	50"	25 1/2"
3TWT5424	56"	25 1/2"
3TWT6024	62"	25 1/2"
3TWT6624	68"	25 1/2"
3TWT7224	74"	25 1/2"

Custom Modification Options

MLDG	MLDG.ALL	NOMLDG <sup>1</sup>	WTCLIP	WTR
✓	✓	✓	✓	✓

<sup>1</sup>Only available on NOMLDG version.

### Glazes and Techniques

- F = Flooded (see page E•3.)
- P = Penned (see page E•3.)
- TW = Timeworn (see page E•3.)
- XTW = Extra Timeworn (see page E•3.)
- HW = Hewn (see page E•3.)
- XHW = Extra Hewn (see page E•3.)

Description	Model
 <b>WOOD TOP, FOUR SIDED</b>	4TWT4827
	4TWT5427
	4TWT6027
	4TWT6627
	4TWT7227
	4TWT4833
	4TWT5433
	4TWT6033
	4TWT6633
	4TWT7233

- 1/2" thick.
- Nomenclature refers to width and depth of cabinetry being used. See actual dimension of wood top in chart.
- Alder will be substituted for Rustic Alder.

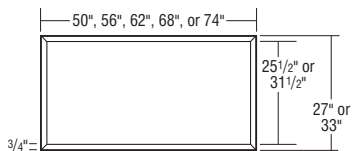
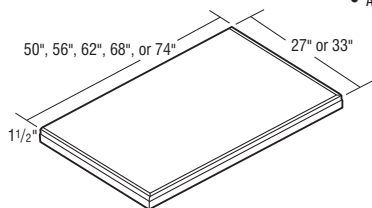

27" Deep	Overall Width	Overall Depth
4TWT4827	50"	27"
4TWT5427	56"	27"
4TWT6027	62"	27"
4TWT6627	68"	27"
4TWT7227	74"	27"

33" Deep	Overall Width	Overall Depth
4TWT4833	50"	33"
4TWT5433	56"	33"
4TWT6033	62"	33"
4TWT6633	68"	33"
4TWT7233	74"	33"

Custom Modification Options

MLDG	MLDG.ALL	NOMLDG <sup>1</sup>	WTCLIP	WTR
<input checked="" type="checkbox"/>	<input checked="" type="checkbox"/>	<input checked="" type="checkbox"/>	<input checked="" type="checkbox"/>	<input checked="" type="checkbox"/>

<sup>1</sup>Only available on NOMLDG version.

Description	Model
<b>WOOD TOPS for ANGLED and BASE END CABINETS — BEVELED EDGE</b>	WTOPBAC2412BE
	WTOPBAC2415BE
	WTOPBAC2418BE
	WTOPBAC2421BE
	WTOPBAC24BE
	WTOPBEC2412BE
	WTOPBEC2415BE
	WTOPBEC2418BE
	WTOPBEC2421BE
	WTOPBEC24BE

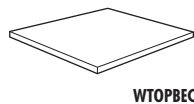

- Available on all BAC, BAC\_FH, BEC, and BEC\_FH cabinets.
- Not available on BTC12.
- Glazes and/or Techniques available: F, HW, XHW
- Alder will be substituted for Rustic Alder.

Custom Modification Options

MLDG	MLDG.ALL	NOMLDG	WTCLIP	WTR
<input type="checkbox"/>	<input type="checkbox"/>	<input type="checkbox"/>	<input checked="" type="checkbox"/>	<input type="checkbox"/>

<b>WOOD TOPS for ANGLED and BASE END CABINETS — OGEE EDGE</b>	WTOPBAC2412OG
	WTOPBAC2415OG
	WTOPBAC2418OG
	WTOPBAC2421OG
	WTOPBAC24OG
	WTOPBEC2412OG
	WTOPBEC2415OG
	WTOPBEC2418OG
	WTOPBEC2421OG
	WTOPBEC24OG

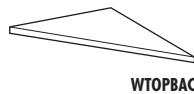

- Available on all BAC, BAC\_FH, BEC, and BEC\_FH cabinets.
- Not available on BTC12.
- Glazes and/or Techniques available: F, HW, XHW.
- Alder will be substituted for Rustic Alder.



Custom Modification Options



MLDG	MLDG.ALL	NOMLDG	WTCLIP	WTR
<input type="checkbox"/>	<input type="checkbox"/>	<input type="checkbox"/>	<input checked="" type="checkbox"/>	<input type="checkbox"/>

### Glazes and Techniques

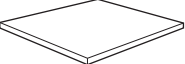
- F = Flooded (see page E•3.)
- P = Penned (see page E•3.)
- TW = Timeworn (see page E•3.)
- XTW = Extra Timeworn (see page E•3.)
- HW = Hewn (see page E•3.)
- XHW = Extra Hewn (see page E•3.)

# Fillers & Panels

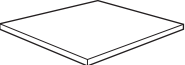
Description	Model										
<b>WOOD TOPS for ANGLED and BASE END CABINETS — ROUND OVER</b>	WTOPBAC2412RO										
	WTOPBAC2415RO										
	WTOPBAC2418RO										
	WTOPBAC2421RO										
	WTOPBAC24RO										
											
WTOPBAC											
											
WTOPBEC											
											
Beveled edge											
<ul style="list-style-type: none"> <li>Available on all BAC, BAC_FH, BEC, and BEC_FH cabinets.</li> <li>Not available on BTC12.</li> <li>Glazes and/or Techniques available: F, HW, XHW.</li> <li>Alder will be substituted for Rustic Alder.</li> </ul>											
Custom Modification Options											
<table border="1"> <tr> <td>MLDG</td> <td>MLDG.ALL</td> <td>NOMLDG</td> <td>WTCLIP</td> <td>WTR</td> </tr> <tr> <td></td> <td></td> <td></td> <td><input checked="" type="checkbox"/></td> <td></td> </tr> </table>	MLDG	MLDG.ALL	NOMLDG	WTCLIP	WTR				<input checked="" type="checkbox"/>		
MLDG	MLDG.ALL	NOMLDG	WTCLIP	WTR							
			<input checked="" type="checkbox"/>								

<b>WOOD TOPS for ANGLED and BASE END CABINETS — SQUARE EDGE</b>	WTOPBAC2412SE										
	WTOPBAC2415SE										
	WTOPBAC2418SE										
	WTOPBAC2421SE										
	WTOPBAC24SE										
											
WTOPBAC											
											
WTOPBEC											
											
Beveled edge											
<ul style="list-style-type: none"> <li>Available on all BAC, BAC_FH, BEC, and BEC_FH cabinets.</li> <li>Not available on BTC12.</li> <li>Glazes and/or Techniques available: F, HW, XHW.</li> <li>Alder will be substituted for Rustic Alder.</li> </ul>											
Custom Modification Options											
<table border="1"> <tr> <td>MLDG</td> <td>MLDG.ALL</td> <td>NOMLDG</td> <td>WTCLIP</td> <td>WTR</td> </tr> <tr> <td></td> <td></td> <td></td> <td><input checked="" type="checkbox"/></td> <td></td> </tr> </table>	MLDG	MLDG.ALL	NOMLDG	WTCLIP	WTR				<input checked="" type="checkbox"/>		
MLDG	MLDG.ALL	NOMLDG	WTCLIP	WTR							
			<input checked="" type="checkbox"/>								

**Glazes and Techniques**  
 F = Flooded (see page E•3.)  
 P = Penned (see page E•3.)  
 TW = Timeworn (see page E•3.)  
 XTW = Extra Timeworn (see page E•3.)  
 HW = Hewn (see page E•3.)  
 XHW = Extra Hewn (see page E•3.)

Description	Model	Height	Height w/FTK Option
<b>OVERLAY FILLERS for FULL OVERLAY STYLES (SPECIFY STYLE, STAIN and PROFILE)</b>			

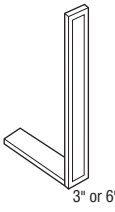
<b>WALL OVERLAY FILLERS</b>		Height	Height w/FTK Option
	OL330	30"	34.5"
	OL333	33"	37.5"
	OL336	36"	49.5"
	OL339	39"	43.5"
	OL342	42"	46.5"
	OL345	45"	49.5"
	OL348	48"	52.5"
	OL354	54"	58.5"
	OL630	30"	34.5"
	OL633	33"	37.5"
	OL636	36"	40.5"
	OL639	39"	43.5"
	OL642	42"	46.5"
	OL645	45"	49.5"
	OL648	48"	52.5"
OL654	54"	58.5"	

- 3" Wide Overlays with #18 profile will have overlay sent with #14 profile.
- Overlays profiled on all four sides.
- Glazes and/or Techniques available: F, P, TW, XTW, HW, XHW.
- Increased or Reduced Heights available in 1/4" increments from 12" to 75".
- Height of filler excludes toekick height of 4 1/2", with the exception of Office fillers that have FTK standard.

**Overlay width dimensions:**  
 2 9/16" overlay for 3" fillers  
 5 9/16" overlay for 6" fillers

Custom Modification Options

BVR	FTK	IH <sup>1</sup>	OOONLY	RH	WTR
<input checked="" type="checkbox"/>	<input checked="" type="checkbox"/>	<input checked="" type="checkbox"/>	<input checked="" type="checkbox"/>	<input checked="" type="checkbox"/>	<input checked="" type="checkbox"/>

<sup>1</sup>Only available on 354 and 654 versions.

Description	Model	Height	Height w/FTK Option
<b>BASE OVERLAY FILLERS</b>	<b>OFB330</b>	30"	34.5"
	<b>OFB630</b>	30"	34.5"

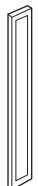

3" or 6"

- 3" Wide Overlays with #18 profile will have overlay sent with #14 profile.
- Overlays profiled on all four sides.
- If Full Height is required, a Flush Toekick must be specified.
- Glazes and/or Techniques available:  
F, P, TW, XTW, HW, XHW.
- Increased or Reduced Heights available in 1/4" increments from 12" to 48".
- Height of filler excludes toekick height of 4 1/2", with the exception of Office fillers that have FTK standard.

**Overlay width dimensions:**  
2 9/16" overlay for 3" fillers  
5 9/16" overlay for 6" fillers

Custom Modification Options

BVR	FTK	IH	OONLY	RH	WTR
✓	✓	✓	✓	✓	✓

## OFFICE and VANITY OVERLAY FILLERS

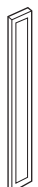

3" or 6"

<b>OFO329</b>	29"	Included
<b>OFO629</b>	29"	Included
<b>OFV325.5</b>	25.5"	30"
<b>OFV332</b>	27.5"	32"
<b>OFV625.5</b>	25.5"	30"
<b>OFV632</b>	27.5"	32"

- 3" Wide Overlays with #18 profile will have overlay sent with #14 profile.
- Overlays profiled on all four sides.
- If Full Height is required on a Vanity Filler, Flush Toekick must be specified.
- Glazes and/or Techniques available:  
F, P, TW, XTW, HW, XHW.
- Increased or Reduced Heights available in 1/4" increments from 12" to 48".
- Height of filler excludes toekick height of 4 1/2", with the exception of Office fillers that have FTK standard.

**Overlay width dimensions:**  
2 9/16" overlay for 3" fillers  
5 9/16" overlay for 6" fillers

Custom Modification Options

BVR	FTK <sup>1</sup>	IH <sup>1</sup>	OONLY	RH <sup>1</sup>	WTR
✓	✓	✓	✓	✓	✓

<sup>1</sup>Not available on 329 and 629 versions.

Description	Model	Height	Height w/FTK Option
<b>UTILITY OVERLAY FILLERS</b>	<b>OL384</b>	79.5"	84"
	<b>OL387</b>	82.5"	87"
	<b>OL390</b>	85.5"	90"
	<b>OL393</b>	88.5"	93"
	<b>OL396</b>	91.5"	96"
	<b>OL684</b>	79.5"	84"
	<b>OL687</b>	82.5"	87"
	<b>OL690</b>	85.5"	90"
	<b>OL693</b>	88.5"	93"
	<b>OL696</b>	91.5"	96"
	<b>OL3102</b>	97.5"	102"
	<b>OL6102</b>	97.5"	102"
	<b>OL3108</b>	103.5"	108"
	<b>OL6108</b>	103.5"	108"
	<b>OL3120</b>	115.5"	120"
<b>OL6120</b>	115.5"	120"	

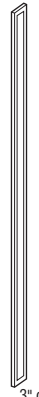

3" or 6"

- Reduced Heights available in 1/4" increments from 66" to 95 3/4".



<b>OL3102</b>	97.5"	102"
<b>OL6102</b>	97.5"	102"
<b>OL3108</b>	103.5"	108"
<b>OL6108</b>	103.5"	108"
<b>OL3120</b>	115.5"	120"
<b>OL6120</b>	115.5"	120"

- Alder will be substituted for Rustic Alder.
- Reduced Heights available in 1/4" increments from 96 1/4" to 119 3/4".
- All fillers over 96" high will get three equal overlays.

Notes below apply to all products in section above:

- 3" Wide Overlays with #18 profile will have overlay sent with #14 profile.
- Overlays profiled on all four sides.
- If Full Height is required, a Flush Toekick must be specified.
- Glazes and/or Techniques available:  
F, P, TW, XTW, HW, XHW.
- Height of filler excludes toekick height of 4 1/2", with the exception of Office fillers that have FTK standard.

**Overlay width dimensions:**  
2 9/16" overlay for 3" fillers  
5 9/16" overlay for 6" fillers

Custom Modification Options

BVR	FTK	IH	OONLY <sup>1</sup>	RH <sup>1</sup>	WTR
✓	✓	✓	✓	✓	✓

<sup>1</sup>Not available on 102" high.

### Glazes and Techniques

- F** = Flooded (see page E•3.)
- P** = Penned (see page E•3.)
- TW** = Timeworn (see page E•3.)
- XTW** = Extra Timeworn (see page E•3.)
- HW** = Hewn (see page E•3.)
- XHW** = Extra Hewn (see page E•3.)

# Fillers & Panels

## Description

### WALL, BASE, OFFICE, and VANITY 135° OVERLAY FILLERS

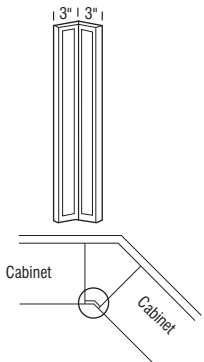

Installation of 1350FW \_\_\_, 1350F029 and 1350FB (overhead view)

Model	Height	Height w/FTK Option
1350FW	30"	34.5"
1350FW33	33"	37.5"
1350FW36	36"	40.5"
1350FW39	39"	43.5"
1350FW42	42"	46.5"
1350FW45	45"	49.5"
1350FW48	48"	52.5"
1350FW54	54"	58.5"
1350FV	25.5"	30"
1350FV32	27.5"	32"
1350F029	29"	Included
1350FB	30"	34.5"

- 3" Wide Overlays with #18 profile will have overlay sent with #14 profile.
- Overlays profiled on all four sides.
- If Full Height is required on a Base or Vanity Filler, Flush Toekick must be specified.
- Glazes and/or Techniques available:  
F, P, TW, XTW, HW, XHW.
- Increased or Reduced Heights available in 1/4" increments from 12" to 48".
- Height of filler excludes toekick height of 4 1/2", with the exception of Office fillers that have FTK standard.

**Overlay width dimensions:**  
2 9/16" overlay for 3" fillers  
5 9/16" overlay for 6" fillers

#### Custom Modification Options

BVR <sup>1</sup>	FTK <sup>2</sup>	IH <sup>3</sup>	OONLY	RH	WTR
<input checked="" type="checkbox"/>	<input checked="" type="checkbox"/>	<input checked="" type="checkbox"/>	<input checked="" type="checkbox"/>	<input checked="" type="checkbox"/>	<input checked="" type="checkbox"/>

- <sup>1</sup>Only available on OFW versions.
- <sup>2</sup>Not available on 1350F029.
- <sup>3</sup>Not available on OFW versions except OFW54.

## OVERLAY FILLERS

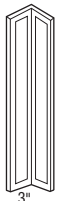

Model	Height	Height w/FTK Option
OFBC330	30"	34.5"

- 3" Wide Overlays with #18 profile will have overlay sent with #14 profile.
- Overlays profiled on all four sides.
- If Full Height is required, a Flush Toekick must be specified.
- Glazes and/or Techniques available:  
F, P, TW, XTW, HW, XHW.
- Increased or Reduced Heights available in 1/4" increments from 12" to 48".
- Height of filler excludes toekick height of 4 1/2", with the exception of Office fillers that have FTK standard.

**Overlay width dimensions:**  
2 9/16" overlay for 3" fillers

#### Custom Modification Options

BVR	FTK	IH	OONLY	RH	WTR
<input checked="" type="checkbox"/>	<input checked="" type="checkbox"/>	<input checked="" type="checkbox"/>	<input checked="" type="checkbox"/>	<input checked="" type="checkbox"/>	<input checked="" type="checkbox"/>

### Glazes and Techniques

- F = Flooded (see page E\*3.)
- P = Penned (see page E\*3.)
- TW = Timeworn (see page E\*3.)
- XTW = Extra Timeworn (see page E\*3.)
- HW = Hewn (see page E\*3.)
- XHW = Extra Hewn (see page E\*3.)

## Description

## Model

### BOX COLUMN FILLERS

#### WALL – PLAIN, 3" WIDE, 15" DEEP

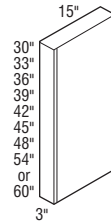

- W330BCFP
- W333BCFP
- W336BCFP
- W339BCFP
- W342BCFP
- W345BCFP
- W348BCFP
- W354BCFP
- W360BCFP

- Flush Panel Ends standard.
- Reversible, may be used on either left or right end.
- Front and both sides finished, back is unfinished.
- Enclosed top and bottom.
- Unit is field trimmable to any required depth.
- Increased Depths available in 1/4" increments from 15 1/4" to 30".
- Reduced Depths available in 1/4" increments from 9" to 14 3/4".
- Increased Heights available in 1/4" increments from 60 1/4" to 70".
- Reduced Heights available in 1/4" increments from 12" to 59 3/4".
- Increased Widths available in 1/4" increments. See page G\*46 for details.
- Glazes and/or Techniques available:  
F, P, TW, XTW, HW, XHW.

#### End Panel Options

CSFPE	<input checked="" type="checkbox"/>
-------	-------------------------------------

#### Custom Modification Options

FLUT	ID	IH <sup>1</sup>	IW	RD	RH	ROSFLUT
<input checked="" type="checkbox"/>	<input checked="" type="checkbox"/>	<input checked="" type="checkbox"/>	<input checked="" type="checkbox"/>	<input checked="" type="checkbox"/>	<input checked="" type="checkbox"/>	<input checked="" type="checkbox"/>

<sup>1</sup>Only available on 360 version.

#### WALL – PLAIN, 6" WIDE, 15" DEEP

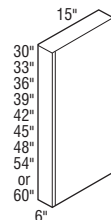

- W630BCFP
- W633BCFP
- W636BCFP
- W639BCFP
- W642BCFP
- W645BCFP
- W648BCFP
- W654BCFP
- W660BCFP

- Flush Panel Ends standard.
- Reversible, may be used on either left or right end.
- Front and both sides finished, back is unfinished.
- Enclosed top and bottom.
- Unit is field trimmable to any required depth.
- Increased Depths available in 1/4" increments from 15 1/4" to 30".
- Reduced Depths available in 1/4" increments from 9" to 14 3/4".
- Increased Heights available in 1/4" increments from 60 1/4" to 70".
- Reduced Heights available in 1/4" increments from 12" to 59 3/4".
- Increased Widths available in 1/4" increments. See page G\*46 for details.
- Glazes and/or Techniques available:  
F, P, TW, XTW, HW, XHW.

#### End Panel Options

CSFPE	<input checked="" type="checkbox"/>
-------	-------------------------------------

#### Custom Modification Options

FLUT	ID	IH <sup>1</sup>	IW	RD	RH	ROSFLUT
<input checked="" type="checkbox"/>	<input checked="" type="checkbox"/>	<input checked="" type="checkbox"/>	<input checked="" type="checkbox"/>	<input checked="" type="checkbox"/>	<input checked="" type="checkbox"/>	<input checked="" type="checkbox"/>

<sup>1</sup>Only available on 660 version.

## Description

### BASE – PLAIN, 27" DEEP

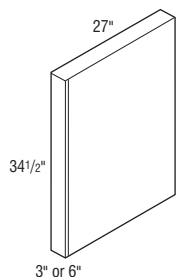

## Model

**B334.527BCFP**

**B634.527BCFP**

- Flush Toekick and Flush Panel Ends standard.
- Reversible, may be used on either left or right end.
- Front and both sides finished, back is unfinished.
- Enclosed top and bottom.
- Unit is field trimmable to any required depth.
- Increased Depths available in 1/4" increments from 27 1/4" to 30".
- Reduced Depths available in 1/4" increments from 9" to 26 3/4".
- Increased Heights available in 1/4" increments from 34 3/4" to 46 1/2".
- Reduced Heights available in 1/4" increments from 12" to 34 1/4".
- Increased Widths available in 1/4" increments. See page G•46 for details.
- Glazes and/or Techniques available:  
F, P, TW, XTW, HW, XHW.

#### End Panel Options

CSFPE
✓

#### Custom Modification Options

FLUT <sup>1</sup>	ID	IH	IW	RD	RH	ROSLUT
✓	✓	✓	✓	✓	✓	✓

<sup>1</sup>Only available with 3" fluting.

### OFFICE – PLAIN, 27" DEEP

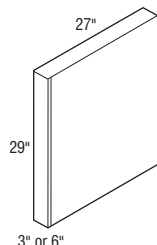

**O32927BCFP**

**O62927BCFP**

- Flush Toekick and Flush Panel Ends standard.
- Reversible, may be used on either left or right end.
- Front and both sides finished, back is unfinished.
- Enclosed top and bottom.
- Unit is field trimmable to any required depth.
- Increased Depths available in 1/4" increments from 27 1/4" to 30".
- Reduced Depths available in 1/4" increments from 9" to 26 3/4".
- Increased Heights available in 1/4" increments from 29 1/4" to 46 1/2".
- Reduced Heights available in 1/4" increments from 12" to 28 3/4".
- Glazes and/or Techniques available:  
F, P, TW, XTW, HW, XHW.

#### End Panel Options

CSFPE
✓

#### Custom Modification Options

FLUT	ID	IH	IW	RD	RH	ROSLUT
✓	✓	✓	✓	✓	✓	✓

## Description

### VANITY – PLAIN, 24" DEEP

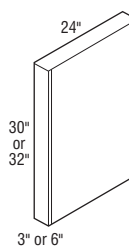

## Model

**V33024BCFP**

**V33224BCFP**

**V63024BCFP**

**V63224BCFP**

- Flush Toekick and Flush Panel Ends standard.
- Reversible, may be used on either left or right end.
- Front and both sides finished, back is unfinished.
- Enclosed top and bottom.
- Unit is field trimmable to any required depth.
- Increased Depths available in 1/4" increments from 24 1/4" to 30".
- Reduced Depths available in 1/4" increments from 9" to 23 3/4".
- Increased Heights available in 1/4" increments from 32 1/4" to 46 1/2".
- Reduced Heights available in 1/4" increments from 12" to 29 3/4".
- Increased Widths available in 1/4" increments. See page G•46 for details.
- Glazes and/or Techniques available:  
F, P, TW, XTW, HW, XHW.

#### End Panel Options

CSFPE
✓

#### Custom Modification Options

FLUT	ID	IH	IW	RD	RH	ROSLUT
✓	✓	✓	✓	✓	✓	✓

### TALL – PLAIN, 15" DEEP

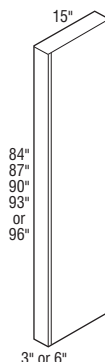

**T38415BCFP**

**T38715BCFP**

**T39015BCFP**

**T39315BCFP**

**T39615BCFP**

**T68415BCFP**

**T68715BCFP**

**T69015BCFP**

**T69315BCFP**

**T69615BCFP**

- Flush Toekick and Flush Panel Ends standard.
- Reversible, may be used on either left or right end.
- Front and both sides finished.
- Enclosed top and bottom.
- Unit is field trimmable to any required depth.
- Increased Depths available in 1/4" increments from 15 1/4" to 30".
- Reduced Depths available in 1/4" increments from 9" to 14 3/4".
- Reduced Heights available in 1/4" increments from 60" to 95 3/4".
- Glazes and/or Techniques available:  
F, P, TW, XTW, HW, XHW.

#### End Panel Options

CSFPE
✓

#### Custom Modification Options

FLUT	ID	IH	IW	RD	RH	ROSLUT
✓	✓	✓	✓	✓	✓	✓

#### Glazes and Techniques

- F** = Flooded (see page E•3.)
- P** = Penned (see page E•3.)
- TW** = Timeworn (see page E•3.)
- XTW** = Extra Timeworn (see page E•3.)
- HW** = Hewn (see page E•3.)
- XHW** = Extra Hewn (see page E•3.)

# Fillers & Panels

Description  
**TALL – PLAIN, 27" DEEP**

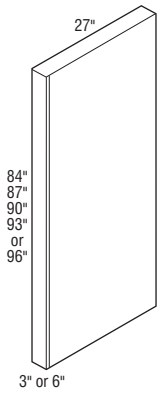

Model	
T38427BCFP	
T38727BCFP	
T39027BCFP	
T39327BCFP	
T39627BCFP	
T68427BCFP	
T68727BCFP	
T69027BCFP	
T69327BCFP	
T69627BCFP	

- Flush Toekick and Flush Panel Ends standard.
- Reversible, may be used on either left or right end.
- Front and both sides finished.
- Enclosed top and bottom.
- Unit is field trimmable to any required depth.
- Increased Depths available in 1/4" increments from 27 1/4" to 30".
- Reduced Depths available in 1/4" increments from 9" to 26 3/4".
- Reduced Heights available in 1/4" increments from 60" to 95 3/4".
- Glazes and/or Techniques available: F, P, TW, XTW, HW, XHW.

End Panel Options

CSFPE
✓

Custom Modification Options

FLUT	ID	IH	IW	RD	RH	ROSLUT
✓	✓			✓	✓	✓

### Glazes and Techniques

- F = Flooded (see page E•3.)
- P = Penned (see page E•3.)
- TW = Timeworn (see page E•3.)
- XTW = Extra Timeworn (see page E•3.)
- HW = Hewn (see page E•3.)
- XHW = Extra Hewn (see page E•3.)

Description Model Height Option  
**ANGLED FILLERS (SPECIFY STYLE and STAIN)**

### ANGLED FILLERS, 3"

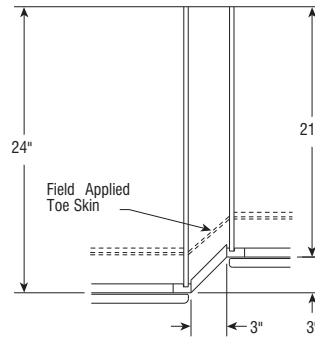
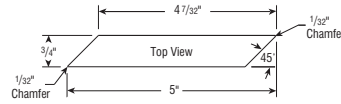

Top View of Installation  
Angled Filler Change in Depth  
Right Shown

Model	Height	Option
45FW30	30"	34.5"
45FW33	33"	37.5"
45FW36	36"	40.5"
45FW39	39"	43.5"
45FW42	42"	46.5"
45FW45	45"	49.5"
45FW48	48"	52.5"

- Glazes and/or Techniques available: F, P, TW, XTW, HW, XHW.
- Reduced Heights available in 1/4" increments from 12" to 75".

45FB	30"	34.5"
45FV32	27.5"	32"
45FO29	29"	Included
45FV	25.5"	30"

- Reduced Heights available in 1/4" increments from 12" to 48".

45FU84	79.5"	84"
45FU87	82.5"	87"
45FU90	85.5"	90"
45FU93	88.5"	93"
45FU96	91.5"	96"

- Toekick and return not available.
- Reduced Heights available in 1/4" increments from 66" to 95 3/4".
- Height of filler excludes toekick height of 4 1/2", with the exception of Office fillers that have FTK standard.

Custom Modification Options

BVR <sup>1</sup>	FLUT <sup>2</sup>	FTK <sup>3</sup>	IH <sup>4</sup>	RH <sup>5</sup>	WTR <sup>6</sup>
✓	✓	✓	✓	✓	✓

<sup>1</sup>Only available on FW versions.

<sup>2</sup>Not available with fluting both or 6" fluting.

<sup>3</sup>Not available on 45FO29.

<sup>4</sup>Not available on FW versions except FW48 and not available on FU versions.

<sup>5</sup>Not available on FU96 version.

<sup>6</sup>Not available on 45FB or 45FO29.

**Description** **Model**

**PANELS (SPECIFY STYLE and STAIN)**

**WALL END PANEL, 12" or 13" DEEP, 30" HIGH**

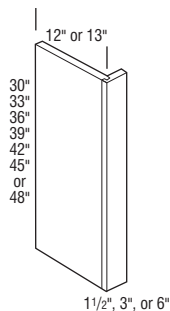

<b>WEPF1.5WD</b>
<b>WEPF1.533WD</b>
<b>WEPF1.536WD</b>
<b>WEPF1.539WD</b>
<b>WEPF1.542WD</b>
<b>WEPF1.545WD</b>
<b>WEPF1.548WD</b>
• Fluting and Rose Fluting not available.
<b>WEPF3WD</b>
<b>WEPF333WD</b>
<b>WEPF336WD</b>
<b>WEPF339WD</b>
<b>WEPF342WD</b>
<b>WEPF345WD</b>
<b>WEPF348WD</b>
<b>WEPF6WD</b>
<b>WEPF633WD</b>
<b>WEPF636WD</b>
<b>WEPF639WD</b>
<b>WEPF642WD</b>
<b>WEPF645WD</b>
<b>WEPF648WD</b>

Notes below apply to all products in section above:

- 1/2" wood veneer with face frame attached.
- Inset and Beaded Inset styles are a standard 13" deep.
- Full Overlay Styles:
  - Increased Depths available in 1/4" increments from 12 1/4" to 36".
  - Reduced Depths available in 1/4" increments from 6" to 11 3/4".
- Inset and Beaded Inset Styles:
  - Increased Depths available in 1/4" increments from 13 1/4" to 24".
  - Reduced Depths available in 1/4" increments from 6" to 12 3/4".
- Reduced Heights available in 1/4" increments from 12" to 47 3/4".
- Increased Widths available in 1/4" increments. See page G•46 for details.
- Glazes and/or Techniques available: F, P, TW, XTW, HW, XHW.

**End Panel Options**

AUTH <sup>1</sup>	CSFPE <sup>2</sup>	FPE <sup>2</sup>	INTGE <sup>2</sup>	IPE <sup>2</sup>
✓	✓	✓	✓	✓

**Custom Modification Options**

BVR <sup>2</sup>	EF	EX <sup>3</sup>	FLUT <sup>4</sup>	ID	IH <sup>5</sup>	IW <sup>3</sup>	RD	RH	ROSLUT <sup>4</sup>	WTR <sup>2</sup>
✓	✓	✓	✓	✓	✓	✓	✓	✓	✓	✓

- <sup>1</sup>Not available with authentic flush ends both.
- <sup>2</sup>Not available on 1.5" wide.
- <sup>3</sup>Not available on 6" wide.
- <sup>4</sup>Not available on 1.5" wide or with fluting both.
- <sup>5</sup>Only available on 48 versions.

**Description** **Model**

**BASE END PANEL, 24" DEEP, 34 1/2" HIGH**

**BEPF1.5WD**

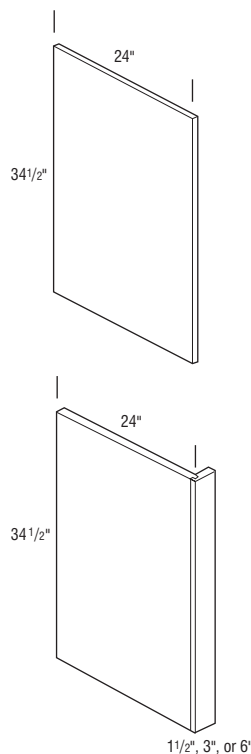

- 3/4" two-sided veneer panel with front edgebanded.

<b>BEPF1.5WD</b>
<b>BEPF3WD</b>
<b>BEPF6WD</b>

- 1/2" wood veneer with face frame attached.
- Notes below apply to all products in section above:
- Increased Depths available in 1/4" increments from 24 1/4" to 48".
- Reduced Depths available in 1/4" increments from 12 1/4" to 23 3/4".
- Increased Heights available in 1/4" increments from 34 3/4" to 48".
- Reduced Heights available in 1/4" increments from 12" to 34 1/4".
- Increased Widths available in 1/4" increments. See page G•46 for details.
- Glazes and/or Techniques available: F, P, TW, XTW, HW, XHW.

**End Panel Options**

AUTH <sup>1</sup>	CSFPE <sup>2</sup>	FPE <sup>2</sup>	INTGE <sup>2</sup>	IPE <sup>2</sup>
✓	✓	✓	✓	✓

**Custom Modification Options**

BVR	EF	EX	FLUT <sup>3</sup>	ID	IH	IW <sup>4</sup>	RD	RH	ROSLUT <sup>3</sup>	WTR <sup>2</sup>
✓	✓	✓	✓	✓	✓	✓	✓	✓	✓	✓

- <sup>1</sup>Not available with authentic flush ends both.
- <sup>2</sup>Not available on BEPWD.
- <sup>3</sup>Not available on BEPWD or BEPF1.5WD with fluting both.
- <sup>4</sup>Only available in BEPF1.5WD and BEPF3WD.

**Glazes and Techniques**

- F** = Flooded (see page E•3.)
- P** = Penned (see page E•3.)
- TW** = Timeworn (see page E•3.)
- XTW** = Extra Timeworn (see page E•3.)
- HW** = Hewn (see page E•3.)
- XHW** = Extra Hewn (see page E•3.)



# Fillers & Panels

## Description

### ANGLED WALL END PANELS, 3"

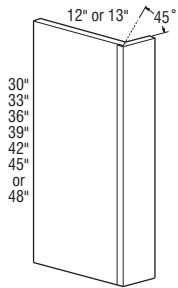

Left Shown

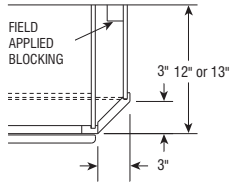

Right Shown

## Model

- 45WEP330
- 45WEP333
- 45WEP336
- 45WEP339
- 45WEP342
- 45WEP345
- 45WEP348

- Finished Ends standard.
- 1/2" wood veneer with face frame attached.
- Return not available.
- Inset and Beaded Inset styles are a standard 13" deep.
- Full Overlay Styles:
  - Increased Depths available in 1/4" increments from 12 1/4" to 36".
  - Reduced Depths available in 1/4" increments from 6" to 11 3/4".
- Inset and Beaded Inset Styles:
  - Increased Depths available in 1/4" increments from 13 1/4" to 24".
  - Reduced Depths available in 1/4" increments from 6" to 12 3/4".
- Glazes and/or Techniques available: F, P, TW, XTW, HW, XHW.

#### End Panel Options

AUTH	CSFPE	FPE	INTGE	IPE
✓	✓	✓		

#### Custom Modification Options

BVR	EF	EX	FLUT <sup>1</sup>	ID	IH	IW	RD	RH	ROSLFLUT <sup>2</sup>	WTR
	✓	✓	✓	✓	✓	✓	✓	✓	✓	✓

<sup>1</sup>Not available with 6" fluting or fluting both.  
<sup>2</sup>Only available on ROSLFLUT3CTR.

## Description

### ANGLED BASE END PANEL

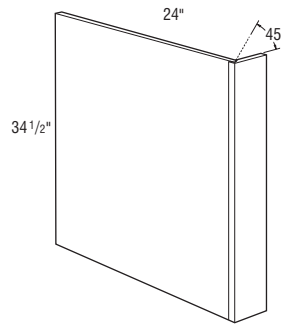

Left Shown

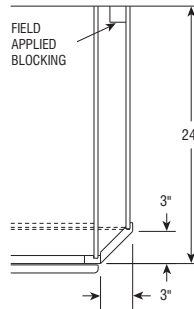

Right Shown

## Model

### 45BEP

- Finished Ends standard.
- Toekick not available.
- Increased Depths available in 1/4" increments from 24 1/4" to 48".
- Reduced Depths available in 1/4" increments from 12 1/4" to 23 3/4".
- Increased Heights available in 1/4" increments from 34 3/4" to 48".
- Reduced Heights available in 1/4" increments from 12" to 34 1/4".
- Glazes and/or Techniques available: F, P, TW, XTW, HW, XHW.

#### End Panel Options

AUTH	CSFPE	FPE	INTGE	IPE
✓	✓	✓		

#### Custom Modification Options

BVR	EF	EX	FLUT <sup>2</sup>	ID	IH	IW	RD	RH	ROSLFLUT	WTR
	✓	✓	✓	✓	✓	✓	✓	✓	✓	✓

<sup>1</sup>Not available with authentic flush ends both.  
<sup>2</sup>Not available with fluting both or 6" fluting.

## ANGLED TALL END PANELS

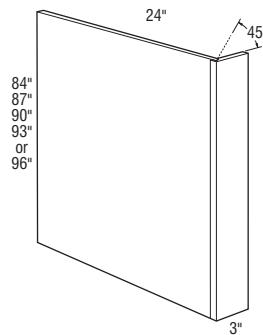

Left Shown

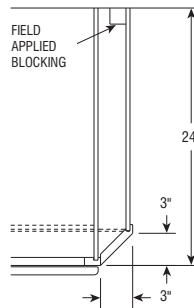

Right Shown

### 45STEP384

### 45STEP387

### 45STEP390

### 45STEP393

### 45STEP396

- 1/2" wood veneer with face frame attached.
- Toekick not available.
- Increased Depths available in 1/4" increments from 24 1/4" to 29 1/4".
- Reduced Depths available in 1/4" increments from 6" to 23 3/4".
- Glazes and/or Techniques available: F, P, TW, XTW, HW, XHW.

#### End Panel Options

AUTH	CSFPE	FPE	INTGE	IPE
✓	✓	✓		

#### Custom Modification Options

BVR	EF	EX	FLUT <sup>2</sup>	ID	IH	IW	RD	RH	ROSLFLUT	WTR
	✓	✓	✓	✓	✓	✓	✓	✓	✓	✓

<sup>1</sup>Not available with authentic flush ends both.  
<sup>2</sup>Not available with fluting both or 6" fluting.

### Glazes and Techniques

- F = Flooded (see page E•3.)
- P = Penned (see page E•3.)
- TW = Timeworn (see page E•3.)
- XTW = Extra Timeworn (see page E•3.)
- HW = Hewn (see page E•3.)
- XHW = Extra Hewn (see page E•3.)

## Description

### END PANELS – FULL OVERLAY STYLES ONLY

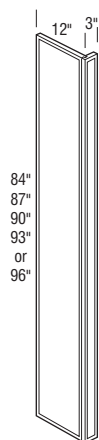
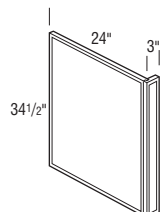
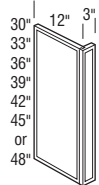

## Model

### WEPOF3WD

- Return not available.

### WEPOF333WD

### WEPOF336WD

### WEPOF339WD

### WEPOF342WD

### WEPOF345WD

### WEPOF348WD

- Must specify a profile.
- Full overlay styles with #18 profile will be sent with #14 profile.
- Increased Depths available in 1/4" increments from 12 1/4" to 36".
- Reduced Depths available in 1/4" increments from 6" to 11 3/4".
- Reduced Heights available in 1/4" increments from 12" to 47 3/4".
- Increased Widths available in 1/4" increments. See page G•46 for details.

### BEPOF3WD

- Must specify a profile.
- Full overlay styles with #18 profile will be sent with #14 profile.
- Toekick not included with BEPOF3WD.
- Increased Depths available in 1/4" increments from 24 1/4" to 48".
- Reduced Depths available in 1/4" increments from 12 1/4" to 23 3/4".
- Increased Heights available in 1/4" increments from 34 3/4" to 48".
- Reduced Heights available in 1/4" increments from 12" to 34 1/4".
- Increased Widths available in 1/4" increments. See page G•46 for details.

### TEP1284OF3WD

### TEP1287OF3WD

### TEP1290OF3WD

### TEP1293OF3WD

### TEP1296OF3WD

- Must specify a profile.
- Full overlay styles with #18 profile will be sent with #14 profile.
- Toekick not included with TEP1284OF3WD.
- Increased Depths available in 1/4" increments from 12 1/4" to 36".
- Reduced Depths available in 1/4" increments from 6" to 11 3/4".
- Reduced Heights available in 1/4" increments from 60" to 95 3/4".
- Increased Widths available in 1/4" increments. See page G•46 for details.

#### End Panel Options

AUTH <sup>1</sup>	CSFPE	FPE	INTGE	IPE
✓	✓	✓	✓	✓

#### Custom Modification Options

BVR	EF	EX	FLUT	ID <sup>2</sup>	IH <sup>3</sup>	IW	RD	RH	ROSFLUT	WTR
				✓	✓	✓	✓	✓		✓

<sup>1</sup>Not available with authentic flush ends both.

<sup>2</sup>Not available with TEP versions.

<sup>3</sup>Only available on WEPOF348WD and BEPOF3WD.

## Description

### END PANELS – FULL OVERLAY STYLES ONLY

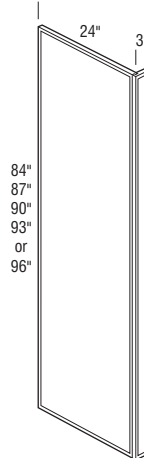

## Model

### TEP2484OF3WD

### TEP2487OF3WD

### TEP2490OF3WD

### TEP2493OF3WD

### TEP2496OF3WD

- 1/2" wood veneer with face frame attached.
- Must specify a profile.
- Full Overlay styles with #18 profile will have overlay sent with #14 profile.
- Overlays profiled on all four sides.
- Toekick not included with TEP2484OF3WD.
- Increased Depths available in 1/4" increments from 24 1/4" to 48".
- Reduced Depths available in 1/4" increments from 12 1/4" to 23 3/4".
- Reduced Heights available in 1/4" increments from 60" to 95 3/4".
- Increased Widths available in 1/4" increments. See page G•46 for details.

#### End Panel Options

AUTH <sup>1</sup>	CSFPE	FPE	INTGE	IPE
✓	✓	✓	✓	✓

#### Custom Modification Options

BVR	EF	EX	FLUT	ID	IH	IW	RD	RH	ROSFLUT	WTR
				✓	✓	✓	✓			✓

<sup>1</sup>Not available with authentic flush ends both.

## REFRIGERATOR PANEL, 12" DEEP

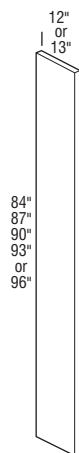

### TEP1284WD

### TEP1287WD

### TEP1290WD

### TEP1293WD

### TEP1296WD

- 3/4" double-sided veneer panel with front edgebanded.
- Reduced Heights available in 1/4" increments from 60" to 95 3/4".
- Inset and Beaded Inset styles are a standard 13" deep.
- Full Overlay Styles:
  - Reduced Depths available in 1/4" increments from 6" to 11 3/4".
- Inset and Beaded Inset Styles:
  - Reduced Depths available in 1/4" increments from 6" to 12 3/4".

#### End Panel Options

AUTH <sup>1</sup>	CSFPE	FPE	INTGE	IPE
✓				

#### Custom Modification Options

BVR	EF	EX	FLUT	ID	IH	IW	RD	RH	ROSFLUT	WTR
									✓	

<sup>1</sup>Not available with authentic flush ends both.

# Fillers & Panels

## Description

### REFRIGERATOR PANEL, 12" or 13" DEEP

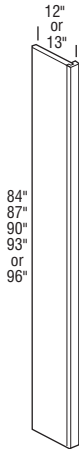

## Model

TEP1284F1.5WD  
TEP1284F3WD  
TEP1284F6WD

TEP1287F1.5WD  
TEP1287F3WD  
TEP1287F6WD

TEP1290F1.5WD  
TEP1290F3WD  
TEP1290F6WD

TEP1293F1.5WD  
TEP1293F3WD  
TEP1293F6WD

TEP1296F1.5WD  
TEP1296F3WD  
TEP1296F6WD

- 1/2" wood veneer with face frame attached.
- Reduced Heights available in 1/4" increments from 60" to 95 3/4".
- Increased Widths available in 1/4" increments. See page G-46 for details.
- Inset and Beaded Inset styles are a standard 13" deep.
- Full Overlay Styles:
  - Reduced Depths available in 1/4" increments from 6" to 11 3/4".
- Inset and Beaded Inset Styles:
  - Reduced Depths available in 1/4" increments from 6" to 12 3/4".

#### End Panel Options

AUTH <sup>1</sup>	CSFPE	FPE	INTGE	IPE
✓	✓	✓	✓	✓

#### Custom Modification Options

BVR	EF	EX	FLUT <sup>2</sup>	ID	IH	IW <sup>3</sup>	RD	RH	ROSFLUT <sup>2</sup>	WTR
✓	✓	✓	✓	✓	✓	✓	✓	✓	✓	✓

- <sup>1</sup>Not available with authentic flush ends both.  
<sup>2</sup>Not available on 1.5" wide or with fluting both.  
<sup>3</sup>Not available on 6" wide.

## Description

### REFRIGERATOR PANEL, 12" or 13" DEEP



## Model



TEP12102WD  
TEP12108WD  
TEP12120WD

- 3/4" double-sided veneer panel with front edgebanded.
- Inset and Beaded Inset styles are a standard 13" deep.
- Full Overlay Styles:
  - Reduced Depths available in 1/4" increments from 6" to 11 3/4".
- Inset and Beaded Inset Styles:
  - Reduced Depths available in 1/4" increments from 6" to 12 3/4".
- Not available in Quartersawn Oak.
- Alder will be substituted for Rustic Alder.
- Reduced Heights available in 1/4" increments from 96 1/4" to 119 3/4".
- All panels over 96" high will get three equal height authentic doors when authentic is ordered.



TEP12102F1.5WD  
TEP12102F3WD

TEP12108F1.5WD  
TEP12108F3WD

TEP12120F1.5WD  
TEP12120F3WD

- 5/8" standard finished flushed ends. Wood veneer with face frame attached.
- Inset and Beaded Inset styles are a standard 13" deep.
- Full Overlay Styles:
  - Reduced Depths available in 1/4" increments from 6" to 11 3/4".
- Increased Widths available in 1/4" increments. See page G-46 for details.
- Inset and Beaded Inset Styles:
  - Reduced Depths available in 1/4" increments from 6" to 12 3/4".
- Not available in Quartersawn Oak.
- Alder will be substituted for Rustic Alder.
- Reduced Heights available in 1/4" increments from 96 1/4" to 119 3/4".

#### End Panel Options

AUTH <sup>1</sup>	CSFPE	FPE	INTGE	IPE <sup>2</sup>
✓	✓	✓	✓	✓

#### Custom Modification Options

BVR	EF	EX	FLUT <sup>3</sup>	ID	IH	IW <sup>4</sup>	RD	RH	ROSFLUT <sup>5</sup>	WTR <sup>6</sup>
✓	✓	✓	✓	✓	✓	✓	✓	✓	✓	✓

- <sup>1</sup>Not available with authentic flush ends both.  
<sup>2</sup>Only available on 1.5 and 3 versions and only available on Cherry and Maple.  
<sup>3</sup>Only available with 3" wide. Not available with 6" fluting or fluting both.  
<sup>4</sup>Not available on TEP12108WD or TEP121208WD.  
<sup>5</sup>Only available with 3" wide. Not available with fluting both.  
<sup>6</sup>Only available in TEP12108F1.5WD and TEP12108F3WD.

**Description** **Model**

**REFRIGERATOR PANEL, 24" DEEP**

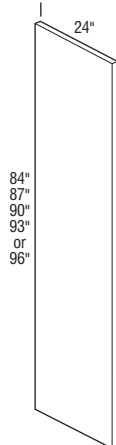

84"  
87"  
90"  
93"  
or  
96"

**TEP2484WD**  
**TEP2487WD**  
**TEP2490WD**  
**TEP2493WD**  
**TEP2496WD**

- 3/4" double-sided veneer panel with front edgebanded.
- Increased Depths available in 1/4" increments from 24 1/4" to 48".
- Reduced Depths available in 1/4" increments from 12 1/4" to 23 3/4".
- Reduced Height available in 1/4" increments from 60" to 95 3/4".

End Panel Options

AUTH <sup>1</sup>	CSFPE	FPE	INTGE	IPE
✓				

Custom Modification Options

BVR	EF	EX	FLUT	ID	IH	IW	RD	RH	ROSFLUT	WTR
				✓			✓	✓		✓

<sup>1</sup>Not available with authentic flush ends both.

**Description** **Model**

**REFRIGERATOR PANEL, 24" DEEP**

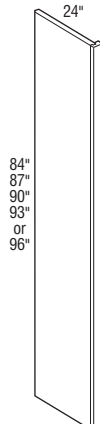

84"  
87"  
90"  
93"  
or  
96"

**TEP2484F1.5WD**  
**TEP2484F3WD**  
**TEP2484F6WD**

**TEP2487F1.5WD**  
**TEP2487F3WD**  
**TEP2487F6WD**

**TEP2490F1.5WD**  
**TEP2490F3WD**  
**TEP2490F6WD**

**TEP2493F1.5WD**  
**TEP2493F3WD**  
**TEP2493F6WD**

**TEP2496F1.5WD**  
**TEP2496F3WD**  
**TEP2496F6WD**

- 1/2" wood veneer with face frame attached.
- Increased Depths available in 1/4" increments from 24 1/4" to 48".
- Reduced Depths available in 1/4" increments from 12 1/4" to 23 3/4".
- Reduced Height available in 1/4" increments from 60" to 95 3/4".
- Increased Widths available in 1/4" increments. See page G•46 for details.

End Panel Options

AUTH <sup>1</sup>	CSFPE	FPE	INTGE	IPE
✓				

Custom Modification Options

BVR	EF	EX	FLUT <sup>2</sup>	ID	IH	IW <sup>3</sup>	RD	RH	ROSFLUT <sup>2</sup>	WTR
			✓	✓		✓	✓	✓	✓	✓

<sup>1</sup>Not available with authentic flush ends both.  
<sup>2</sup>Not available on 1.5" wide or with fluting both.  
<sup>3</sup>Not available on 6" wide.

**Description** **Model**

**REFRIGERATOR PANEL, 24" DEEP**

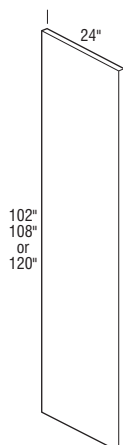

102"  
108"  
or  
120"

**NEW** **TEP24102WD**  
**TEP24108WD**  
**TEP24120WD**

- 3/4" double-sided veneer panel with front edgebanded.
- Increased Depths available in 1/4" increments from 24 1/4" to 30".
- Reduced Depths available in 1/4" increments from 12 1/4" to 23 3/4".
- Not available in Quartersawn Oak.
- Alder will be substituted for Rustic Alder.
- Reduced Heights available in 1/4" increments from 96 1/4" to 119 3/4".
- All panels over 96" high will get three equal height authentic doors when authentic is ordered.

**NEW** **TEP24102F1.5WD**  
**TEP24102F3WD**

**TEP24108F1.5WD**  
**TEP24108F3WD**

**TEP24120F1.5WD**  
**TEP24120F3WD**

- 5/8" standard finished flushed ends. Wood veneer with face frame attached.
- Increased Depths available in 1/4" increments from 24 1/4" to 30".
- Reduced Depths available in 1/4" increments from 12 1/4" to 23 3/4".
- Not available in Quartersawn Oak.
- Alder will be substituted for Rustic Alder.
- Reduced Heights available in 1/4" increments from 96 1/4" to 119 3/4".
- Increased Widths available in 1/4" increments. See page G•46 for details.

End Panel Options

AUTH <sup>1</sup>	CSFPE	FPE <sup>2</sup>	INTGE	IPE <sup>3</sup>
✓		✓		✓

Custom Modification Options

BVR	EF	EX	FLUT <sup>4</sup>	ID	IH	IW <sup>5</sup>	RD	RH	ROSFLUT <sup>6</sup>	WTR <sup>7</sup>
			✓	✓		✓	✓	✓	✓	✓

**Description** **Model**

**REFRIGERATOR PANEL, 24" DEEP**

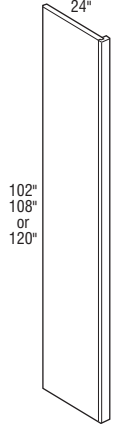

102"  
108"  
or  
120"

**NEW** **TEP24102F1.5WD**  
**TEP24102F3WD**

**TEP24108F1.5WD**  
**TEP24108F3WD**

**TEP24120F1.5WD**  
**TEP24120F3WD**

- 5/8" standard finished flushed ends. Wood veneer with face frame attached.
- Increased Depths available in 1/4" increments from 24 1/4" to 30".
- Reduced Depths available in 1/4" increments from 12 1/4" to 23 3/4".
- Not available in Quartersawn Oak.
- Alder will be substituted for Rustic Alder.
- Reduced Heights available in 1/4" increments from 96 1/4" to 119 3/4".
- Increased Widths available in 1/4" increments. See page G•46 for details.

End Panel Options

AUTH <sup>1</sup>	CSFPE	FPE <sup>2</sup>	INTGE	IPE <sup>3</sup>
✓		✓		✓

Custom Modification Options

BVR	EF	EX	FLUT <sup>4</sup>	ID	IH	IW <sup>5</sup>	RD	RH	ROSFLUT <sup>6</sup>	WTR <sup>7</sup>
			✓	✓		✓	✓	✓	✓	✓

<sup>1</sup>Not available with authentic flush ends both.  
<sup>2</sup>Only available on TEP24108F1.5WD and TEP24108F3WD.  
<sup>3</sup>Only available on 1.5 and 3 versions and only available on Cherry and Maple.  
<sup>4</sup>Only available with 3" wide. Not available with 6" fluting or fluting both.  
<sup>5</sup>Not available on TEP24108WD or TEP24120WD.  
<sup>6</sup>Only available with 3" wide. Not available with fluting both.  
<sup>7</sup>Only available on TEP24108WD, TEP24108F1.5WD and TEP24108F3WD.

# Fillers & Panels

## Description

### 3/32" SKINS

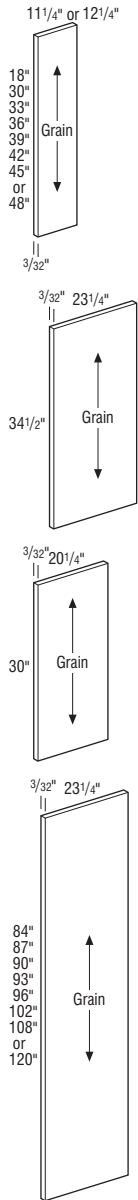

## Model

- WEPS18**
- WEPS30**
- WEPS33**
- WEPS36**
- WEPS39**
- WEPS42**
- WEPS45**
- WEPS48**

- 3/32" thick.
- Inset and Beaded Inset will have a standard depth of 12 1/4".
- Full Overlay Styles:
  - Increased Depths available in 1/4" increments from 11 1/2" to 47 3/4".
  - Reduced Depths available in 1/4" increments from 6" to 11".
- Inset and Beaded Inset Styles:
  - Increased Depths available in 1/4" increments from 12 1/2" to 47 3/4".
  - Reduced Depths available in 1/4" increments from 6" to 12".

### BEPS34.5

- 3/32" thick.
- Increased Depths available in 1/4" increments from 23 1/2" to 48".
- Reduced Depths available in 1/4" increments from 12 1/4" to 23".

### VEPS30

- 3/32" thick.
- Increased Depths available in 1/4" increments from 20 1/2" to 48".
- Reduced Depths available in 1/4" increments from 12 1/4" to 20".

### TEPS84

### TEPS87

### TEPS90

### TEPS93

### TEPS96



### TEPS102

### TEPS108

### TEPS120

- 3/32" thick.
- Increased Depths available in 1/4" increments from 23 1/2" to 29 1/4".
- Reduced Depths available in 1/4" increments from 6" to 23".

#### End Panel Options

AUTH <sup>1</sup>	CSFPE	FPE	INTGE	IPE
<input checked="" type="checkbox"/>	<input type="checkbox"/>	<input type="checkbox"/>	<input type="checkbox"/>	<input type="checkbox"/>

#### Custom Modification Options

BVR	EF	EX	FLUT	ID <sup>2</sup>	IH <sup>3</sup>	IW	RD <sup>2</sup>	RH <sup>4</sup>	ROSLUT	WTR
<input type="checkbox"/>	<input type="checkbox"/>	<input type="checkbox"/>	<input type="checkbox"/>	<input checked="" type="checkbox"/>	<input checked="" type="checkbox"/>	<input type="checkbox"/>	<input checked="" type="checkbox"/>	<input checked="" type="checkbox"/>	<input type="checkbox"/>	<input type="checkbox"/>

<sup>1</sup>Not available with authentic flush ends both. Not available on WEPS or BEPS34.5.

<sup>2</sup>Not available on WEPS45 or WEPS48.

<sup>3</sup>Only available on WEPS42.

<sup>4</sup>Only available on WEPS30-42 and TEPS84-TEPS96.

## Description

### ENGLISH COUNTRY CAR SIDING SKINS

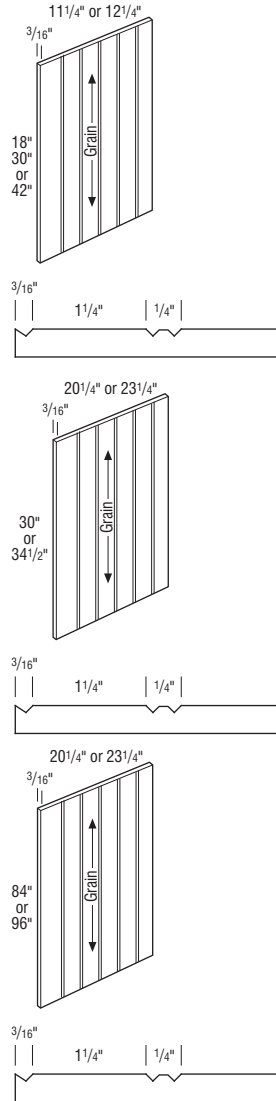

## Model

### WEPS18VG

Wall Cabinet Paneling

### WEPS30VG

Wall Cabinet Paneling

### WEPS42VG

Wall Cabinet Paneling

- 3/16" thick.

### VEPS30VG

Vanity Cabinet Paneling

### BEPS34.5VG

Base Cabinet Paneling

- 3/16" thick.

### TEPS2484VG

Utility Paneling

### TEPS2496VG

Utility Paneling

- 3/16" thick.

#### End Panel Options

AUTH <sup>1</sup>	CSFPE	FPE	INTGE	IPE
<input checked="" type="checkbox"/>	<input type="checkbox"/>	<input type="checkbox"/>	<input type="checkbox"/>	<input type="checkbox"/>

#### Custom Modification Options

BVR	EF	EX	FLUT	ID <sup>2</sup>	IH	IW	RD <sup>2</sup>	RH <sup>3</sup>	ROSLUT	WTR
<input type="checkbox"/>	<input type="checkbox"/>	<input type="checkbox"/>	<input type="checkbox"/>	<input checked="" type="checkbox"/>	<input type="checkbox"/>	<input type="checkbox"/>	<input checked="" type="checkbox"/>	<input checked="" type="checkbox"/>	<input type="checkbox"/>	<input type="checkbox"/>

<sup>1</sup>Only available in VEPS and TEPS versions. Not available with authentic flush ends both.

<sup>2</sup>Only available on WEPS18VG and WEPS30VG.

<sup>3</sup>Only available on WEPS30VG.

## TOE BOARD TRIM

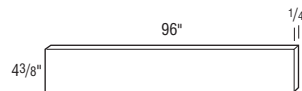

### TB8WD14

- 1/4" thick.

Modifications  
Are Not  
Available

## Description

### TOEKICK CAPS

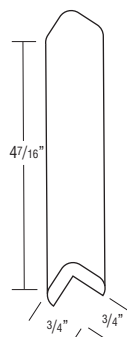

## Model

### TKC

- Available in Alder and Maple.
- Cherry finishes available on Maple.

Modifications  
Are Not  
Available

## PANELING

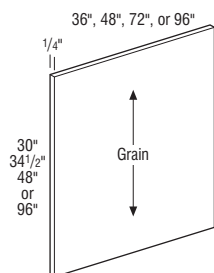

### WP9630WD

- 1/4" x 96" x 30"

### BP3634.5WD

- 1/4" x 36" x 34 1/2"

### BP4834.5WD

- 1/4" x 48" x 34 1/2"

### BP7234.5WD

- 1/4" x 72" x 34 1/2"

### BP9634.5WD

- 1/4" x 96" x 34 1/2"

### BP9648CRSGR

- 1/4" x 96" x 48"

### BP4896WD

- 1/4" x 48" x 96"

- 1/4" thick.

Modifications  
Are Not  
Available

## ENGLISH COUNTRY CAR SIDING PANELING

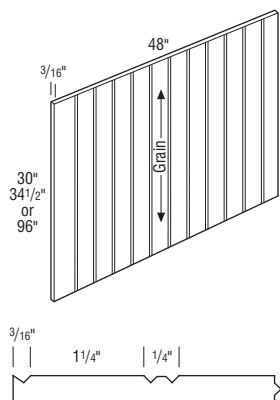

### WEP4830VG

Wall Cabinet Paneling

### BP4834.5VG

Base Cabinet Paneling

### BP4896VG

Tall Cabinet Paneling

Modifications  
Are Not  
Available

## Description

### DISHWASHER PANEL

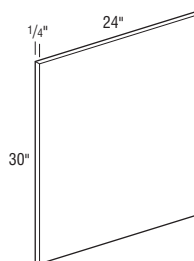

## Model

### DWPWD

- Dimensions: 1/4" x 24" x 30"

Modifications  
Are Not  
Available

## LAZY SUSAN BASE PANEL

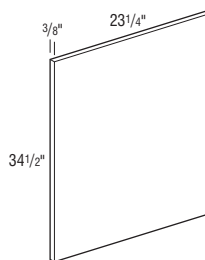

## BLSBEPWD

- Dimensions: 3/8" x 23 1/4" x 34 1/2"

Modifications  
Are Not  
Available

## TAPERED VANITY END PANEL, 21" DEEP

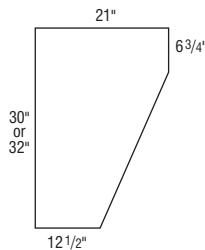

### VDL2130WD

### VDL2132WD

- 3/4" double sided veneer panel with front edgebanded.
- Increased Depths available in 3" increments to 24".
- Reduced Depths available in 3" increments to 18".
- Increased Height available in 1/4" increments from 30 1/4" to 46 1/2" .

End Panel Options

AUTH	CSFPE	FPE	INTGE	IPE
------	-------	-----	-------	-----

Custom Modification Options

BVR	EF	EX	FLUT	ID	IH	IW	RD	RH	ROSLUT	WTR
					✓	✓	✓			

## HUTCH END PANEL

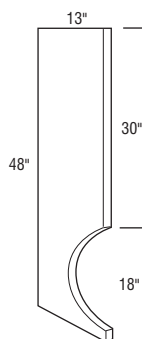

### HE48

- 3/4" thick.
- Increased Heights available in 1/4" increments from 48 1/4" to 60" .
- Reduced Heights available in 1/4" increments from 36" to 47 3/4" .

End Panel Options

AUTH	CSFPE	FPE	INTGE	IPE
------	-------	-----	-------	-----

Custom Modification Options

BVR	EF	EX	FLUT	ID	IH	IW	RD	RH	ROSLUT	WTR
					✓	✓	✓			

# Fillers & Panels

Description

Model

## MATERIAL (SPECIFY STAIN and STYLE)

### CRISS CROSS WINE RACK MATERIAL

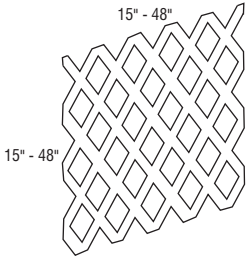

### WNRMAT

- Includes front and back grid.
- Specify width and height.
- Maximum width/height is 30" when the width/height exceeds 30".
- Minimum width is 15". Maximum width is 48".
- Minimum height is 15". Maximum height is 48".

End Panel Options

AUTH
------

Custom Modification Options

BAND	BND	F.ALL	F.FRT	PRO
			✓	

### 1/2" NATURAL MATERIAL – 2-SIDED

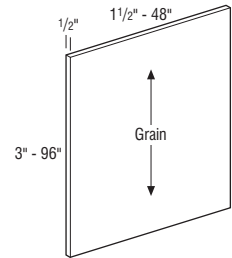

### 1/2NAT2S

- Cabinet top and bottom material.
- Specify width and height.
- Minimum width is 1 1/2". Maximum width is 48".
- Minimum height is 3". Maximum height is 96".

End Panel Options

AUTH
------

Custom Modification Options

BAND	BND	F.ALL	F.FRT	PRO
✓				

### 3/4" NATURAL MATERIAL – 2-SIDED

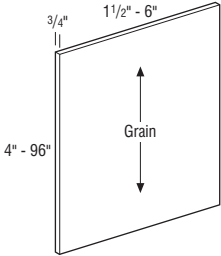

### 3/4NAT2S

- Specify width and height.
- Shelving material.
- Minimum width is 1 1/2". Maximum width is 48".
- Minimum height is 3". Maximum height is 96".

End Panel Options

AUTH
------

Custom Modification Options

BAND	BND	F.ALL	F.FRT	PRO
✓				

### 3/16" NATURAL MATERIAL – 1-SIDED

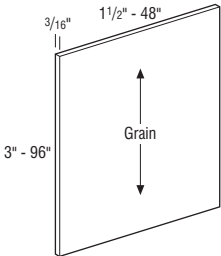

### 3/16NAT1S

- Specify width and height.
- Minimum width is 1 1/2". Maximum width is 48".
- Minimum height is 3". Maximum height is 96".

Modifications Are Not Available

Description

Model

### 1/2" NATURAL – 1 SIDE, VENEER – 1 SIDE

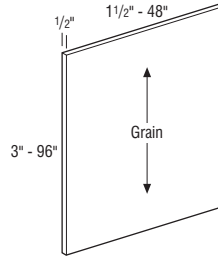

### 1/2NATVEN

- Specify width and height.
- Minimum width is 1 1/2". Maximum width is 48".
- Minimum height is 3". Maximum height is 96".

End Panel Options

AUTH
------

Custom Modification Options

BAND	BND	F.ALL	F.FRT	PRO
✓				

### 1/4" VENEER – 1-SIDED

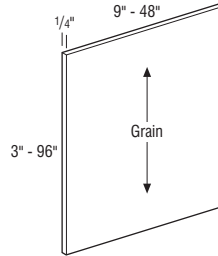

### 1/4VEN1S

- Specify width and height.
- Minimum width is 9". Maximum width is 48".
- Minimum height is 3". Maximum height is 96".
- 48" W x 96" H or 96" W x 48" H

Modifications Are Not Available

### 3/32" VENEER – 1-SIDED

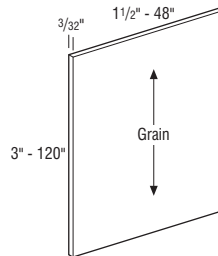

### 3/32VEN1S

- Specify width and height.
- Minimum width is 1 1/2". Maximum width is 48".
- Minimum height is 3". Maximum height is 120".
- 48" W x 48" H or 29 1/4" W x 120" H

Modifications Are Not Available

### 3/4" VENEER – 2-SIDED

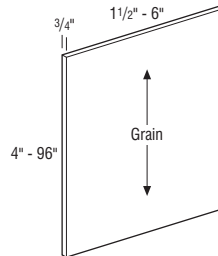

### 3/4VEN2S

- Specify width and height.
- Minimum width is 1 1/2". Maximum width is 48".
- Minimum height is 3". Maximum height is 96".

End Panel Options

AUTH
------

Custom Modification Options

BAND	BND	F.ALL	F.FRT	PRO
✓				

## Description

### 3/16" VENEER – 1-SIDED

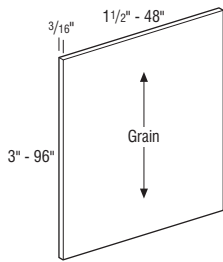

## Model

### 3/16VEN1S

- Specify width and height.
- Minimum width is 1 1/2". Maximum width is 48".
- Minimum height is 3". Maximum height is 96".

Modifications  
Are Not  
Available

### 1/2" VENEER – 2-SIDED

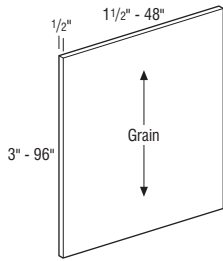

### 1/2VEN2S

- Specify width and height.
- Minimum width is 1 1/2". Maximum width is 48".
- Minimum height is 3". Maximum height is 96".

End Panel Options

AUTH

Custom Modification Options

BAND	BND	F.ALL	F.FRT	PRO
<input checked="" type="checkbox"/>	<input type="checkbox"/>	<input type="checkbox"/>	<input type="checkbox"/>	<input type="checkbox"/>

### 3/16" CAR SIDING – 1-SIDED

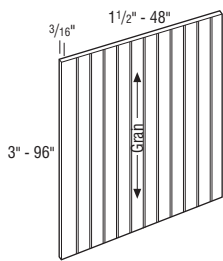

### 3/16CSDG1S

- Specify width and height.
- Minimum width is 1 1/2". Maximum width is 48".
- Minimum height is 3". Maximum height is 96".

Modifications  
Are Not  
Available

## Description

### 3/4" SOLID WOOD

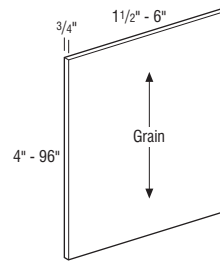

## Model

### 3/4SOLID 3/4" SOLID WOOD

- Specify width and height.
- Must be minimum of 2 9/16" wide to profile both long edges (height) for all profiles except #18. Must be minimum of 4 1/4" wide to profile both long edges (height) for profile #18.
- Alder will be substituted for Rustic Alder.

Species	Part Widths	Max. Height
Alder	1 1/2" to 6"	120"
	6 1/4" to 12"	60"
Cherry	1 1/2" to 6"	120"
	6 1/4" to 23 3/4"	61 1/4"
Maple	1 1/2" to 6"	120"
	6 1/4" to 23 3/4"	61 1/4"
Quartersawn Oak	1 1/2" to 6"	120"
	6 1/4" to 12"	60"
Rustic Alder	1 1/2" to 6"	120"
	6 1/4" to 12"	60"

All Species

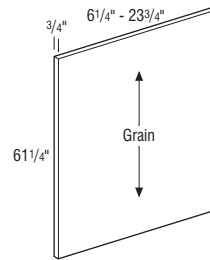

Cherry & Maple Species

End Panel Options

AUTH

Custom Modification Options

BAND	BND	F.ALL	F.FRT	PRO
<input type="checkbox"/>	<input type="checkbox"/>	<input checked="" type="checkbox"/>	<input checked="" type="checkbox"/>	<input checked="" type="checkbox"/>

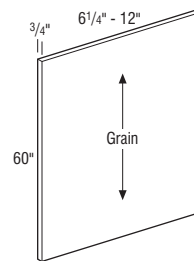

Alder, Quartersawn Oak & Rustic Alder Species

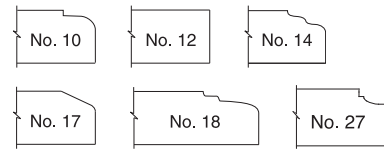

Profiles



# Fillers & Panels

**Description**  
**STRETCHER MATERIAL**

**Model**  
**STRETCHERMAT**

- 3/8" thick.
- Specify width and height.
- Minimum height is 6". Maximum height is 96".

Modifications Are Not Available

**3/4" SHELVING MATERIAL**

**Model**  
**SHELFLSD** 3/4" SOLID WOOD

- Specify width and height.
- Can be used for moulding applications.
- Alder will be substituted for Rustic Alder.

Species	Part Widths	Max. Height
Alder	1 1/2" to 6"	120"
	6 1/4" to 12"	61 1/4"
Cherry	1 1/2" to 6"	120"
	6 1/4" to 23 3/4"	61 1/4"
Maple	1 1/2" to 6"	120"
	6 1/4" to 23 3/4"	61 1/4"
Quartersawn Oak	1 1/2" to 6"	120"
	6 1/4" to 11"	61 1/4"
Rustic Alder	1 1/2" to 6"	120"
	6 1/4" to 12"	61 1/4"

Modifications Are Not Available

**3/4" SHELVING MATERIAL**

**Model**  
**SHELFNAT** 3/4" Natural Plywood 48" W x 96" H  
**SHELFMI** 3/4" Veneer Plywood 48" W x 96" H

- Specify width and height.
- Minimum width is 1 1/2". Maximum width is 48".
- Minimum height is 4". Maximum height is 96".

End Panel Options  
AUTH

Custom Modification Options  
BAND BND F.ALL F.FRT PRO

**Description**  
**DOOR RAIL MATERIAL**

**Model**  
**CGRAIL** Door Rail Material  
**DRWRAILEND** Drawer Rail  
**DRWRAILCROSS** Drawer  
**DRRAILEND** Door Rail  
**DRRAILCROSS** Door Rail

**Kirby Door Rail**

- Specify door style and length.
- CGRAIL, DRWRAILEND, DRRAILEND: Minimum height is 6". Maximum height is 72".
- DRWRAILCROSS, DRRAILCROSS: Minimum height is 6". Maximum height is 36".

**MUNTIN** Mullion door material

- Specify door style and length.
- Not available with the following door styles: Decker, Decker Beaded Inset, Decker Inset, Burke, Tate, Tate Beaded Inset, Tate Inset, Landry, Landry Beaded Inset, and Landry Inset.

End Panel Options  
AUTH

Custom Modification Options  
BAND BND F.ALL F.FRT PRO

<sup>1</sup>Not available on MUNTIN.

**FRAME RAIL MATERIAL**

**Model**  
**FFRAIL**

- Specify length.
- Minimum width is 1 1/2". Maximum width is 6".
- Minimum height is 6". For rails 1 1/2" up to 3" wide, the maximum height is 120". For rails greater than 3" to 6" wide, the maximum height is 96".

End Panel Options  
AUTH

Custom Modification Options  
BAND BND F.ALL F.FRT PRO

Description	Model
<b>CORNER TALL MOULDING</b>	<b>DCM7</b>
	<b>DCM8</b>
	<b>DCM10</b>

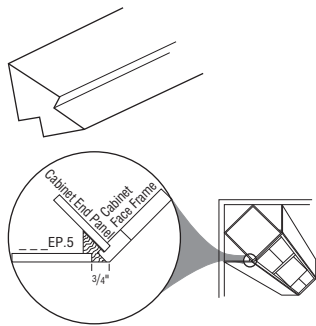

Section enlarged to show detail.

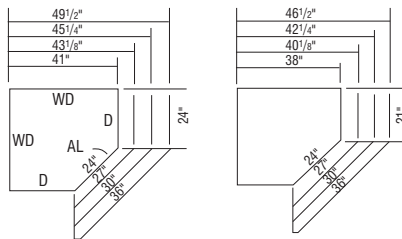

AL = Angle Length  
D = Depth  
AL = WD - D

AL = WD - D  
.7071

.7071

## CORNER END PANELS

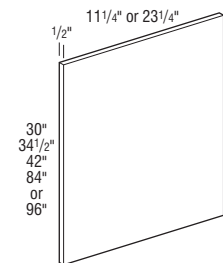

<b>30WEP.5</b>
<b>42WEP.5</b>
• Wall Corner End Panel
<b>BEP.5WD</b>
• Base Corner End Panel
<b>84TCEP.5</b>
<b>96TCEP.5</b>

- Tall Corner End Panel

Notes below apply to all products in section above:

- 1/2" veneer.
- For use with DCM7 and DCM8 in 45° diagonal installation. See diagram under Corner Tall Moulding section for DCM usage.

End Panel Options

AUTH <sup>1</sup>
<input checked="" type="checkbox"/>

Custom Modification Options

BAND	BND	F.FALL <sup>1</sup>	F.FRT	PRO
<input type="checkbox"/>	<input type="checkbox"/>	<input checked="" type="checkbox"/>	<input type="checkbox"/>	<input type="checkbox"/>

<sup>1</sup>Not available on WEP versions.

Description	Model
<b>PILASTERS (SPECIFY STYLE and STAIN)</b>	

## PILASTERS, 5" DEEP – INSTALLATION as a DIVIDER BETWEEN CABINETS

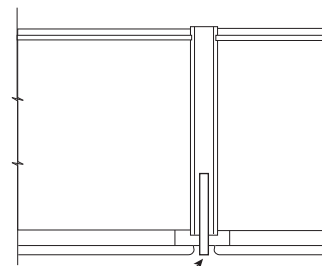

Example of 5" deep pilaster installed as a divider between cabinets

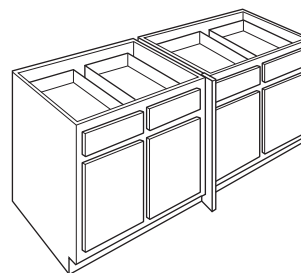

Divider between base cabinets

PIL530SBE
PIL530TBE
PIL530ROP
PIL530BAT
PIL534.5SBE
PIL534.5TBE
PIL534.5ROP
PIL534.5BAT
PIL548SBE
PIL548TBE
PIL548ROP
PIL548BAT
PIL584SBE
PIL584TBE
PIL584ROP
PIL584BAT
PIL596SBE
PIL596TBE
PIL596ROP
PIL596BAT

- Specify moulding to apply to one edge: SBE8, TBEM, RPM8, or TBATM.
- Pilasters with TBEM will be 4 13/16" deep.
- Pilasters are designed to function as dividers between cabinets and as an end of the run panel treatment. Pilasters are constructed of 3/4" thick MDF (veneered or painted) material.
- Reduced Heights available in 1/4" increments from 12" to 95 3/4".

Custom Modification Options

ID	IH <sup>1</sup>	RD	RH
<input type="checkbox"/>	<input checked="" type="checkbox"/>	<input type="checkbox"/>	<input checked="" type="checkbox"/>

<sup>1</sup>Only available on 548 version.

## Edging Options

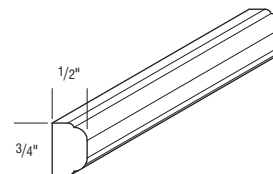

SBE8

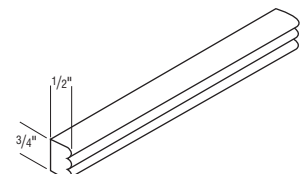

TBEM

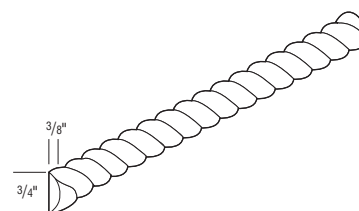

RPM8

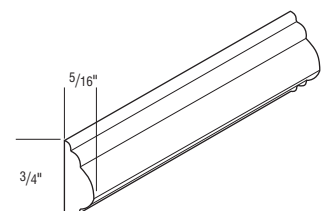

TBATM

# Fillers & Panels

## Description

### PILASTERS, 12 3/4" DEEP – INSTALLATION as WALL END TREATMENT

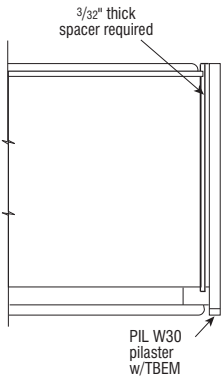

Example of 12 3/4" deep pilaster installed at the end of a run

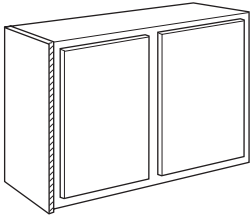

## Model

PILW30SBE  
PILW30TBE  
PILW30ROP  
PILW30BAT  
PILW34.5SBE  
PILW34.5TBE  
PILW34.5ROP  
PILW34.5BAT  
PILW48SBE  
PILW48TBE  
PILW48ROP  
PILW48BAT  
PILW84SBE  
PILW84TBE  
PILW84ROP  
PILW84BAT  
PILW96SBE  
PILW96TBE  
PILW96ROP  
PILW96BAT

- Specify moulding to apply to one edge: SBE8, TBEM, RPM8, or TBATM.
- Pilasters with TBEM will be 12 15/16" deep.
- Pilasters are designed to function as dividers between cabinets and as an end of the run panel treatment. Pilasters are constructed of 3/4" thick MDF (veneered or painted) material.
- Inset and Beaded Inset styles are a standard 13" deep.
- Full Overlay Styles:
  - Reduced Depths available in 1/4" increments from 5 1/4" to 12 1/2".
- Inset and Beaded Inset Styles:
  - Reduced Depths available in 1/4" increments from 5 1/4" to 13 1/2".
- Reduced Heights available in 1/4" increments from 12" to 95 3/4".

#### Custom Modification Options

ID	IH <sup>1</sup>	RD	RH
<input checked="" type="checkbox"/>	<input checked="" type="checkbox"/>	<input checked="" type="checkbox"/>	<input checked="" type="checkbox"/>

<sup>1</sup>Only available on 48 version.

### Edging Options

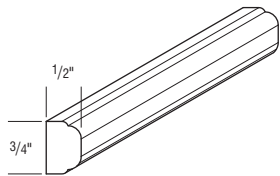

SBE8

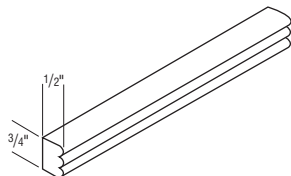

TBEM

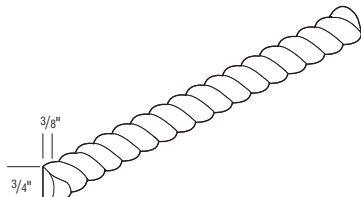

RPM8

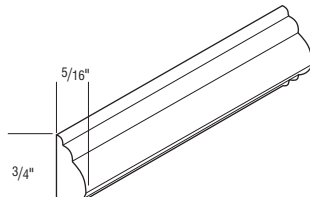

TBATM

## Description

### PILASTERS, 24 3/4" DEEP – INSTALLATION as BASE END TREATMENT

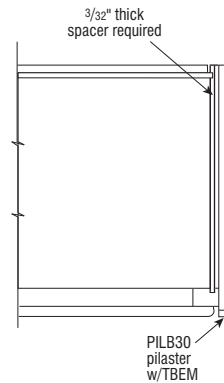

Example of 24 3/4" deep pilaster installed at the end of a run

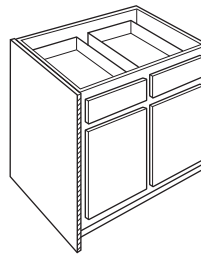

## Model

PILB30SBE  
PILB30TBE  
PILB30ROP  
PILB30BAT  
PILB34.5SBE  
PILB34.5TBE  
PILB34.5ROP  
PILB34.5BAT  
PILB48SBE  
PILB48TBE  
PILB48ROP  
PILB48BAT  
PILB84SBE  
PILB84TBE  
PILB84ROP  
PILB84BAT  
PILB96SBE  
PILB96TBE  
PILB96ROP  
PILB96BAT

- Specify moulding to apply to one edge: SBE8, TBEM, RPM8, or TBATM.
- Pilasters with TBEM will be 24 15/16" deep.
- Pilasters are designed to function as dividers between cabinets and as an end of the run panel treatment. Pilasters are constructed of 3/4" thick MDF (veneered or painted) material.
- Reduced Heights available in 1/4" increments from 12" to 95 3/4".
- Increased Depths available in 1/4" increments from 25" to 31".
- Reduced Depths available in 1/4" increments from 13" to 24 1/2".

#### Custom Modification Options

ID	IH <sup>1</sup>	RD	RH
<input checked="" type="checkbox"/>	<input checked="" type="checkbox"/>	<input checked="" type="checkbox"/>	<input checked="" type="checkbox"/>

<sup>1</sup>Only available on 48 version.

### Edging Options

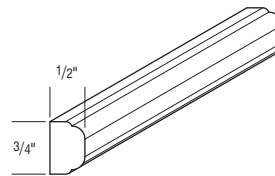

SBE8

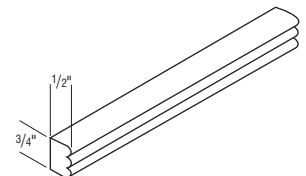

TBEM

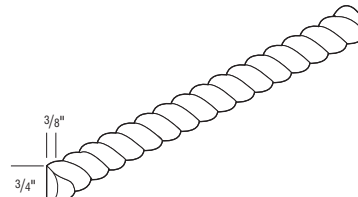

RPM8

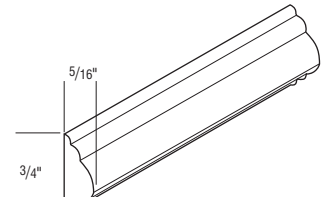

TBATM

Title Description	Availability	Page
Wainscoting	All Styles	Q•26
Authentic Panels	Full Overlay	Q•27
Authentic Drawer Front Limitations		
Authentic Door Size Limitations		
Authentic Appliance Panel Ordering Information		
Authentic Panel Order Forms ( <a href="http://www.mbcil1touch.com">www.mbcil1touch.com</a> )		
Inset Appliance Panels	Inset & Beaded Inset	Q•29
Inset Appliance Drawer Front Limitations		
Inset Appliance Door Size Limitations		
Inset Appliance Panel Order Forms ( <a href="http://www.mbcil1touch.com">www.mbcil1touch.com</a> )		
Integrated Panels	Full Overlay	Q•30
Integrated Drawer Front Limitations		
Integrated Door Size Limitations		
Integrated Appliance Panel Order Form ( <a href="http://www.mbcil1touch.com">www.mbcil1touch.com</a> )		
Overlay Panels	Full Overlay	Q•32
Overlay Drawer Front Limitations		
Overlay Door Size Limitations		
Integrated and Overlay Appliance Panel Ordering Information		
Overlay Appliance Panel Order Form ( <a href="http://www.mbcil1touch.com">www.mbcil1touch.com</a> )		

# Wainscoting

## Description

## Model

### WAINSCOTING, 34 1/2" or 40 1/2" HIGH

GROUP A – Full Overlay Doors 14 9/16" Wide; Inset & Beaded Inset Doors 11 13/16" Wide

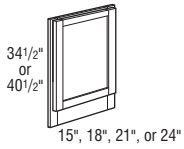

**WAIN1534.5**

**WAIN3034.5**

**WAIN4534.5**

**WAIN6034.5**

**WAIN7534.5**

**WAIN9034.5**

**WAIN1540.5**

**WAIN3040.5**

**WAIN4540.5**

**WAIN6040.5**

**WAIN7540.5**

**WAIN9040.5**

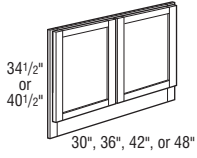

GROUP B – Full Overlay Doors 17 9/16" Wide; Inset & Beaded Inset Doors 14 13/16" Wide

**WAIN1834.5**

**WAIN3634.5**

**WAIN5434.5**

**WAIN1840.5**

**WAIN3640.5**

**WAIN5440.5**

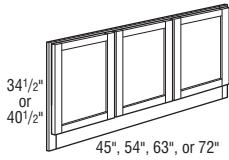

GROUP C – Full Overlay Doors 20 9/16" Wide; Inset & Beaded Inset Doors 17 13/16" Wide

**WAIN2134.5**

**WAIN4234.5**

**WAIN6334.5**

**WAIN8434.5**

**WAIN2140.5**

**WAIN4240.5**

**WAIN6340.5**

**WAIN8440.5**

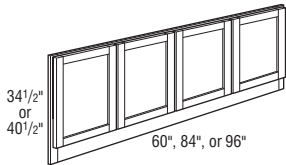

GROUP D – Full Overlay Doors 23 9/16" Wide; Inset & Beaded Inset Doors 20 13/16" Wide

**WAIN2434.5**

**WAIN4834.5**

**WAIN7234.5**

**WAIN9634.5**

**WAIN2440.5**

**WAIN4840.5**

**WAIN7240.5**

**WAIN9640.5**

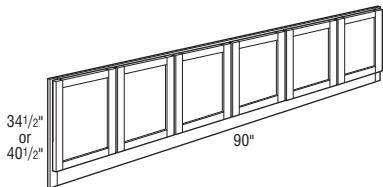
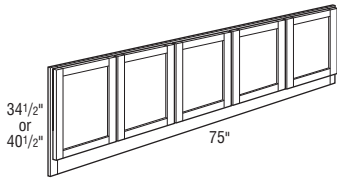

- Number of doors determined by width of panel.
- Flush Toekick standard.
- Split Doors standard on all units with more than one door.
- For widths not listed above, Extended Left and/or Extended Right options are available on all sizes except 96" wide.
- Full Overlay Styles:
  - Wainscoting panel backs are not finished, but they are sealed to prevent warping and cracking.
- Inset and Beaded Inset Styles:
  - Face frame and door construction, doors applied to frame with screws.
- All doors are square.
- Increased or Reduced Heights available: 34.5"-19.5", 22.5", 25.5", 28.5", 31.5", 40.5"-37.5", 43.5", 46.5", 49.5".

#### Custom Modification Options

EX	EX_OL	FLUT <sup>1</sup>	IH <sup>2</sup>	RH	ROSEFLUT <sup>3</sup>	WTR
<input checked="" type="checkbox"/>	<input checked="" type="checkbox"/>	<input checked="" type="checkbox"/>	<input checked="" type="checkbox"/>	<input checked="" type="checkbox"/>	<input checked="" type="checkbox"/>	<input checked="" type="checkbox"/>

<sup>1</sup>Not available with fluting both or 6" fluting.

<sup>2</sup>Only available on 40.5 versions.

<sup>3</sup>Not available with fluting both.

IH/RH availability charts starting on page G•40.  
IW/RW availability charts starting on page G•46.

## Authentic Panels

Model

**DAAUTHENTIC**

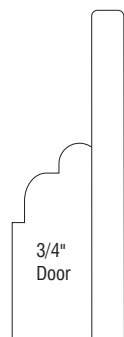

Authentic panels are used for appliance applications, backs of islands and peninsulas.

For the appliance application, the back panel will fit into the trim kit provided by the appliance manufacturer. Often called out on appliance specification sheets as framed panels. Specify the thickness and overall size of the back panel.

**Complete the Appliance/Authentic Panel Specification Forms ([www.mbc1touch.com](http://www.mbc1touch.com)).**

**Reference page Q•28 for additional appliance panel ordering information.**

Modifications  
Are Not  
Available

## Authentic Drawer Front Limitations

### Slab Drawer Fronts

Available Heights: 4 1/2" – 24"; Available Widths: 7 1/2" – 47 9/16"

### 5-piece Drawer Fronts: (Kirby)

Available Heights: 4 1/2" – 21 3/4"; Available Widths: 8 9/16" – 47 9/16"

### 5-piece Drawer Fronts: (All styles w/5-piece drawer fronts or 5-piece drawer front option (DFF5PC))

Available Heights: 5 3/4" – 21 3/4"; Available Widths: 8 9/16" – 47 9/16"

## Authentic Door Size Limitations

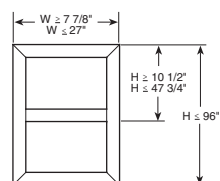

### Mitered Styles (Burke and Vinson)

- Minimum Width = 7 7/8"; Maximum Width = 27"
- Minimum Height = 10 1/2"; Maximum Height = 96"
- Arched doors are not available in mitered styles.

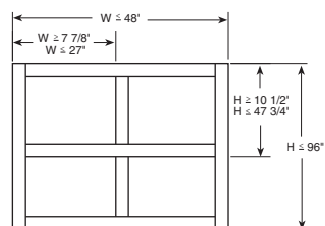

### Rustic Styles with Wide Rails (Decker)

- Minimum Width = 7 7/8"; Maximum Width = 48"
- Minimum Height = 10 1/2"; Maximum Height = 96"
- Heights over 47 3/4" will include two center panels, unless over 27", then they will consist of four center panels - refer to drawing chart.
- Widths up to 27" will include one center panel.
- Widths over 27" will include two center panels.

# Authentic Panels

## Authentic Door Size Limitations (cont'd)

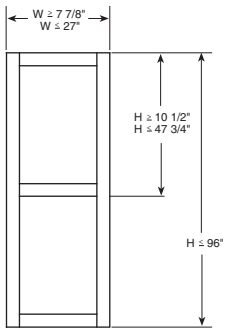

### Rustic Styles (Tate)

- Minimum Width = 7 7/8"; Maximum Width = 27"
- Minimum Height = 10 1/2"; Maximum Height = 96"
- Double wide panels not available.
- Heights over 47 3/4" will include two center panels, unless over 27", then they will consist of four center panels - refer to drawing chart.

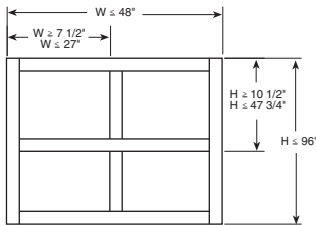

### Full Overlay, Shaker, and Onlay Styles (Gordon, Kirby, Landry, and Shanley)

- Minimum Width = 7 1/2"; Maximum Width = 48"
- Minimum Width Arch = 8 9/16"; Maximum Width Arch = 27"
- Minimum Height = 10 1/2"; Maximum Height = 96"
- Heights over 47 3/4" will include two center panels, unless over 27", then they will consist of four center panels - refer to drawing chart.
- Widths up to 27" will include one center panel.
- Widths over 27" will include two center panels.
- 7 1/2" wide shaped like a drawer front.
- Door side stiles in Landry may be narrower due to sizing limitations and may not match the width of side stiles within the kitchen.

## Authentic Appliance Panel Ordering Information

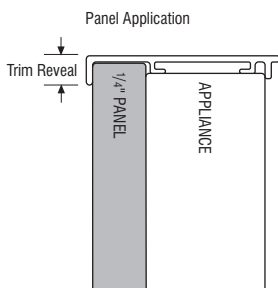

The model number from the appliance manufacturer will determine which panel type is required. Below are illustrations of authentic panels and ordering guidelines to help you place your order.

Order product 1/4VENTS for panel application.

Specify Width x Height for each panel required for appliance.

Panel is finished plywood veneer.

Edges cannot be banded or finished. Panel cut-outs not available.

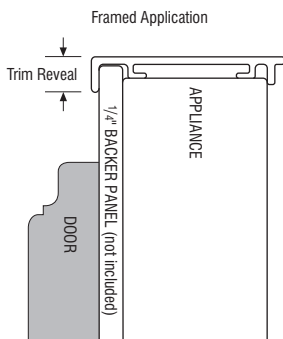

Order DAAUTHENTIC Panels for framed application.

DAAUTHENTIC is a 1/4" back panel with door applied to a panel.

Reveal is visible from front of panel.

Reference door and drawer front size limitations by style and species on pages Q•27-Q•28.

For the appliance application, the back panel will fit into the trim kit provided by the appliance manufacturer often called out on appliance specification sheets as framed panels.

1/4" back panel limitations:

48"W x 96"H (grain runs with height)

96"W x 48"H (grain runs with height)

**Use the Appliance/Authentic Panel Specification Forms ([www.mbcitouch.com](http://www.mbcitouch.com)) for ordering.**

Available in 1/16" increments.

## Inset Appliance Panels

Model

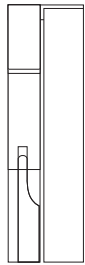

IAPPLIANCE is used for appliance applications, backs of islands and peninsulas.

**IAPPLIANCE**

Complete the Inset Appliance Panel Specification Forms ([www.mbc1touch.com](http://www.mbc1touch.com)) and fax to Kemper Emerge when placing your order.

Reference [www.mbc1touch.com](http://www.mbc1touch.com) for additional inset appliance panel ordering information.

Custom Modification Options

BVR	EX	FTK	WTR
✓	✓	✓	✓

## Inset Appliance Drawer Front Limitations

### Slab Drawer Fronts

Available Heights: 4 1/2" – 24"; Available Widths: 7 1/2" – 47 9/16"

### 5-piece Drawer Fronts: (Gordon, Kirby, and Landry)

Available Heights: 4 1/2" – 21 3/4"; Available Widths: 8 9/16" – 47 9/16"

## Inset Appliance Door Size Limitations

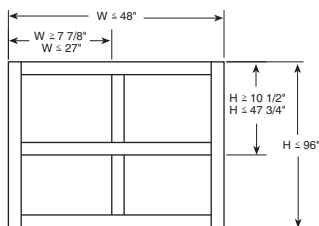

### Inset and Beaded Inset Rustic Styles with Wide Rails (Decker Beaded Inset and Decker Inset)

- Minimum Width = 7 7/8"; Maximum Width = 48"
- Minimum Height = 10 1/2"; Maximum Height = 96"
- Heights over 47 3/4" will include two center panels, unless over 27", then they will consist of four center panels - refer to drawing chart.
- Widths up to 27" will include one center panel.
- Widths over 27" will include two center panels.

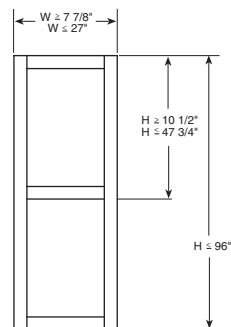

### Inset and Beaded Inset Rustic Styles (Tate Beaded Inset and Tate Inset)

- Minimum Width = 7 7/8"; Maximum Width = 27"
- Minimum Height = 10 1/2"; Maximum Height = 96"
- Double wide panels not available.
- Heights over 47 3/4" will include two center panels, unless over 27", then they will consist of four center panels - refer to drawing chart.

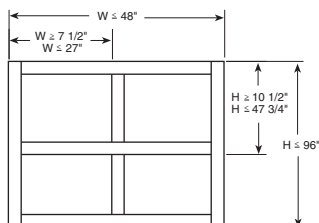

### Inset and Beaded Inset Styles (Gordon Beaded Inset, Gordon Inset, Kirby Beaded Inset, Kirby Inset, Landry Beaded Inset, Landry Inset, Shanley Beaded Inset, and Shanley Inset)

- Minimum Width = 7 1/2"; Maximum Width = 48"
- Minimum Height = 10 1/2"; Maximum Height = 96"
- Heights over 47 3/4" will include two center panels, unless over 27", then they will consist of four center panels - refer to drawing chart.
- Widths up to 27" will include one center panel.
- Widths over 27" will include two center panels.
- 7 1/2" wide shaped like a drawer front.



# Integrated Panels

## Integrated Panels

Model

**DAINTEGRATEDDF**  
**DAINTEGRATEDDR**

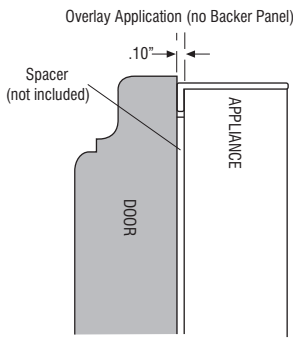

- Order product DAINTEGRATEDDR (door front)/ DAINTEGRATEDDF (drawer front) for overlay application without backer panel.
- Reference door and drawer front size limitations by style on pages Q•30-Q•31.
- Spacer panel is not available.
- If appliance specifications require sizes larger than the maximums stated (see size limitations on pages Q•30-Q•31, multiple doors will be shipped to total the overall size.
- Use the Appliance/Authentic Panel Specification Forms ([www.mbcitouch.com](http://www.mbcitouch.com)) for ordering.

## Integrated Drawer Front Limitations

### Slab Drawer Fronts

Available Heights: 4 1/2" – 24"; Available Widths: 7 1/2" – 47 9/16"

### 5-piece Drawer Fronts: (Kirby)

Available Heights: 4 1/2" – 21 3/4"; Available Widths: 8 9/16" – 47 9/16"

### 5-piece Drawer Fronts: (All styles w/5-piece drawer fronts or 5-piece drawer front option (DFF5PC))

Available Heights: 5 3/4" – 21 3/4"; Available Widths: 8 9/16" – 47 9/16"

## Integrated Door Size Limitations

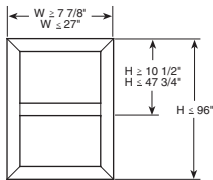

### Mitered Styles (Burke and Vinson)

- Minimum Width = 7 7/8"; Maximum Width = 27"
- Minimum Height = 10 1/2"; Maximum Height = 96"
- Arched doors are not available in mitered styles.

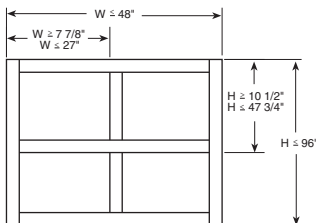

### Rustic Styles with Wide Rails (Decker)

- Minimum Width = 7 7/8"; Maximum Width = 48"
- Minimum Height = 10 1/2"; Maximum Height = 96"
- Heights over 47 3/4" will include two center panels, unless over 27", then they will consist of four center panels - refer to drawing chart.
- Widths up to 27" will include one center panel.
- Widths over 27" will include two center panels.

## Integrated Door Size Limitations (cont'd)

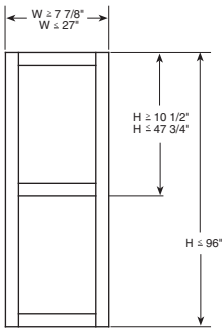

### Rustic Styles (Tate)

- Minimum Width =  $7 \frac{7}{8}''$ ; Maximum Width =  $27''$
- Minimum Height =  $10 \frac{1}{2}''$ ; Maximum Height =  $96''$
- Double wide panels not available.
- Heights over  $47 \frac{3}{4}''$  will include two center panels, unless over  $27''$ , then they will consist of four center panels - refer to drawing chart.

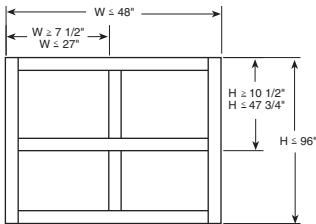

### Full Overlay, Shaker, and Onlay Styles (Gordon, Kirby, Landry, and Shanley)

- Minimum Width =  $7 \frac{1}{2}''$ ; Maximum Width =  $48''$
- Minimum Width Arch =  $8 \frac{9}{16}''$ , Maximum Width Arch =  $27''$
- Minimum Height =  $10 \frac{1}{2}''$ ; Maximum Height =  $96''$
- Heights over  $47 \frac{3}{4}''$  will include two center panels, unless over  $27''$ , then they will consist of four center panels - refer to drawing chart.
- Widths up to  $27''$  will include one center panel.
- Widths over  $27''$  will include two center panels.
- $7 \frac{1}{2}''$  wide shaped like a drawer front.
- Door side stiles in Landry may be narrower due to sizing limitations and may not match the width of side stiles within the kitchen.

# Overlay Panels

## Overlay Panels

Model

Overlay Application (with Backer Panel)

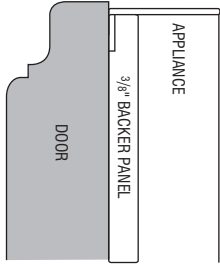

- Order product DAOVERLAY for overlay application with backer panel.
- DAOVERLAY is a 3/4" door/drawer front applied to a 3/8" backer panel rabbeted to accept a trim kit. The overlay design allows the 3/4" door/drawer front panel to cover the door trim for a more seamless appearance that blends with the design of the cabinets. (Arch doors available on sizes up to 24" wide, must specify.)
- If appliance specifications require sizes larger than the maximums stated (see size limitations on page Q•32), multiple doors will be sent to total the overall size and field work will be required to attach the doors together.
- The back of the door is unfinished, Finish All modification available when required.
- Available in 1/16" increments.

**DAOVERLAY**

## Overlay Drawer Front Limitations

### **Slab Drawer Fronts**

Available Heights: 4 1/2" – 24"; Available Widths: 7 1/2" – 47 9/16"

### **5-piece Drawer Fronts: (Kirby)**

Available Heights: 4 1/2" – 21 3/4"; Available Widths: 8 9/16" – 47 9/16"

### **5-piece Drawer Fronts: (All styles w/5-piece drawer fronts or 5-piece drawer front option (DFF5PC))**

Available Heights: 5 3/4" – 21 3/4"; Available Widths: 8 9/16" – 47 9/16"

## Overlay Door Size Limitations

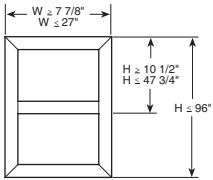

### **Mitered Styles (Burke and Vinson)**

- Minimum Width = 7 7/8"; Maximum Width = 27"
- Minimum Height = 10 1/2"; Maximum Height = 96"
- Arched doors are not available in mitered styles.

# Integrated and Overlay Appliance Panel Ordering Information

## Integrated and Overlay Appliance Panel Ordering Information

The model number from the appliance manufacturer will determine which panel type is required. Below are illustrations and ordering guidelines to help you place your order.

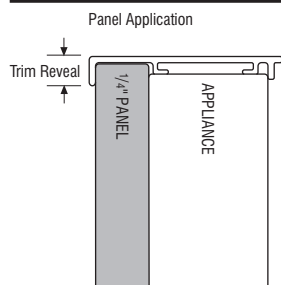

Order product 1/4VENTS for panel application.  
Specify Width x Height for each panel required for appliance.  
Panel is finished plywood veneer.  
Edges cannot be banded or finished. Panel cut-outs not available.

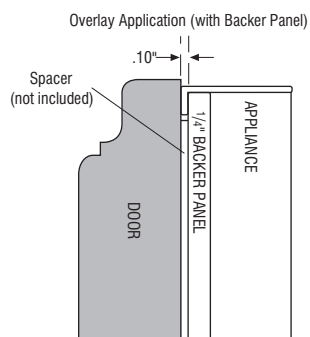

Order products 1/4VENTS and DAINTEGRATEDDR (door front)/DAINTEGRATEDDF (drawer front) for overlay application with backer panel.  
Doors and panels shipped unassembled.  
Spacer panel is not available.  
Specify Width x Height for each backer panel required for appliance.  
Order DAINTEGRATEDDR (door front)/DAINTEGRATEDDF (drawer front) required, reference door and drawer front size limitations by style and species on pages Q•30-Q•31.  
Use the Appliance Panel Specification Form ([www.mbc1touch.com](http://www.mbc1touch.com)) for ordering.

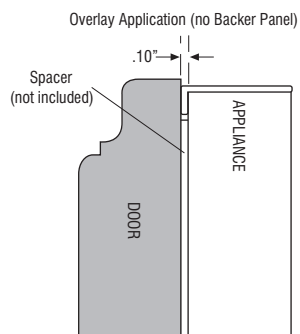

Order products DAINTEGRATEDDR (door front)/DAINTEGRATEDDF (drawer front) for overlay application without backer panel.  
Specify Width x Height for each door and/or drawer required for appliance.  
Reference door and drawer front size limitations by style and species on pages Q•30-Q•31.  
Spacer panel is not available.  
Use the Appliance Panel Specification Form ([www.mbc1touch.com](http://www.mbc1touch.com)) for ordering.

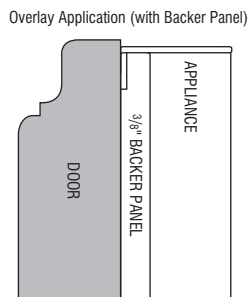

Order product DAOVERLAY for overlay application with backer panel.  
Specify Width x Height for each door and/or drawer required for appliance.  
Reference door and drawer front size limitations by style and species on page Q•32.  
Use the Appliance Panel Specification Form ([www.mbc1touch.com](http://www.mbc1touch.com)) for ordering.



# *Kemper Emerge Modification Option Descriptions*

Your Kemper Emerge specification guide contains charts with modification option codes for each applicable cabinetry product. Reference the listing below to identify the modification description.

<b>Custom Modification Options</b>	
<b>Option</b>	<b>Description</b>
F.ALL	Finished All
IH	Increased Height
IW	Increased Width
RH	Reduced Height
RW	Reduced Width

# Mouldings & Embellishments

Description	Model
-------------	-------

## MOULDINGS

### SOFFIT FILLER MOULDING

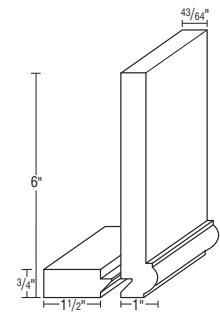

Model
SFM8
SFM10

- SFM8: 2 1/2" x 6" x 96".
- SFM10: 2 1/2" x 6" x 120".
- Alder will be used for Rustic Alder.
- Glazes and/or Techniques available: F, P, TW, XTW, HW, XHW.

Custom Modification Options

F.ALL <sup>1</sup>
✓

<sup>1</sup>Only available on 10'.

### STARTER MOULDING

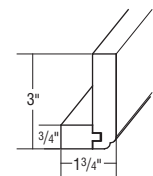

Model
STR8
STR10

- STR8: 1 3/4" x 3" x 96".
- STR10: 1 3/4" x 3" x 120".
- Alder will be used for Rustic Alder.
- Glazes and/or Techniques available: F, P, TW, XTW, HW, XHW.

Custom Modification Options

F.ALL <sup>1</sup>
✓

<sup>1</sup>Only available on 10'.

### STARTER SHAKER MOULDING

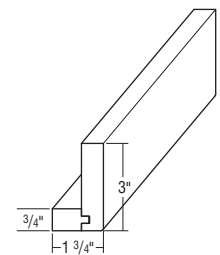

Model
STRS8
STRS10

- STRS8: 1 3/4" x 3" x 96".
- STRS10: 1 3/4" x 3" x 120".
- Not available in Alder or Rustic Alder.
- Glazes and/or Techniques available: F, P, TW, XTW, HW, XHW.

Custom Modification Options

F.ALL <sup>1</sup>
✓

<sup>1</sup>Only available on 10'.

### CLASSIC TALL CROWN MOULDING

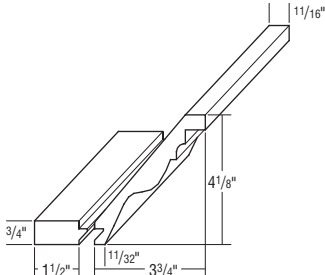

Model
CLTCROWN
CLTCROWN10

- CLTCROWN: 5 1/4" x 4 3/32" x 96".
- CLTCROWN10: 5 1/4" x 4 3/32" x 120".
- Ships in two pieces.
- Glazes and/or Techniques available: F, P, TW, XTW, HW, XHW.

Custom Modification Options

F.ALL <sup>1</sup>
✓

<sup>1</sup>Only available on 10'.

8' mouldings will have 93"-99" of useable length.  
10' mouldings will have 117"-123" useable length.

**Glazes and Techniques**

**F** = Flooded (see page E•3.)  
**P** = Penned (see page E•3.)  
**TW** = Timeworn (see page E•3.)  
**XTW** = Extra Timeworn (see page E•3.)  
**HW** = Hewn (see page E•3.)  
**XHW** = Extra Hewn (see page E•3.)

Description	Model
-------------	-------

## CORNICE TALL CROWN MOULDING

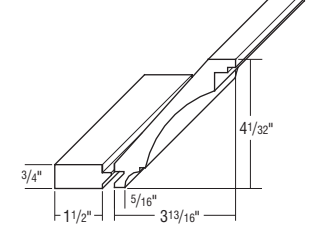

Model
COTCROWN
COTCROWN10

- COTCROWN: 5 5/16" x 4 1/32" x 96".
- COTCROWN10: 5 5/16" x 4 1/32" x 120".
- Ships in two pieces.
- Glazes and/or Techniques available: F, P, TW, XTW, HW, XHW.

Custom Modification Options

F.ALL <sup>1</sup>
✓

<sup>1</sup>Only available on 10'.

### COVE CROWN MOULDING

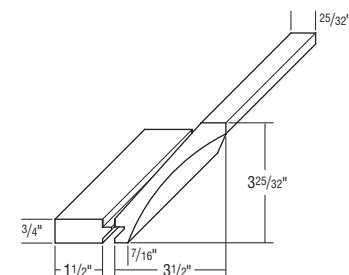

Model
COVECROWN
COVECROWN10

- COVECROWN: 5" x 3 25/32" x 96".
- COVECROWN10: 5" x 3 25/32" x 120".
- Ships in two pieces.
- Glazes and/or Techniques available: F, TW, XTW, HW, XHW.

Custom Modification Options

F.ALL <sup>1</sup>
✓

<sup>1</sup>Only available on 10'.

### SMALL COVE CROWN MOULDING

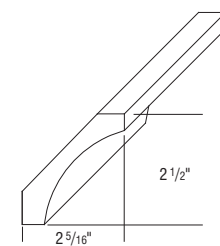

Model
SMCOVECROWN
SMCOVECROWN10

- SMCOVECROWN: 2 5/16" x 2 1/2" x 96".
- SMCOVECROWN10: 2 5/16" x 2 1/2" x 120".
- Glazes and/or Techniques available: F, TW, XTW, HW, XHW.

Custom Modification Options

F.ALL <sup>1</sup>
✓

<sup>1</sup>Only available on 10'.

### SIMPLICITY CROWN

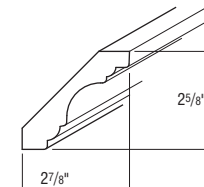

Model
SIMCROWN

- 3 29/32" x 2 7/32" x 96".
- Alder will be used for Rustic Alder.
- Not available in Quartersawn Oak.

Custom Modification Options

F.ALL
✓

### CROWN MOULDING

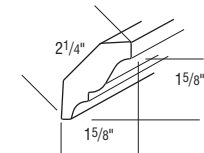

Model
SWCRM8
SWCRM10

- SWCRM8: 1 5/8" x 1 5/8" x 96".
- SWCRM10: 1 5/8" x 1 5/8" x 120".
- Glazes and/or Techniques available: F, P, TW, XTW, HW, XHW.

Custom Modification Options

F.ALL <sup>1</sup>
✓

<sup>1</sup>Only available on 10'.

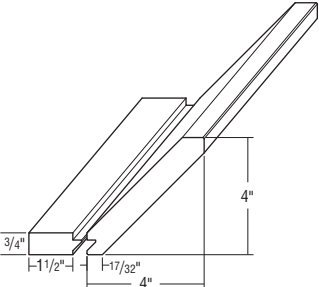
Description	Model		
<b>LARGE STRAIGHT ANGLE CROWN MOULDING</b>	<b>LSACROWN8</b> <b>LSACROWN10</b>		
	<ul style="list-style-type: none"> <li>• LSACROWN8: 5 1/2" x 4" x 96".</li> <li>• LSACROWN10: 5 1/2" x 4" x 120".</li> <li>• Ships in two pieces.</li> <li>• Includes Soffit Filler Moulding Cleat.</li> <li>• Not available in Alder or Rustic Alder.</li> <li>• Glazes and/or Techniques available: F, TW, XTW, HW, XHW.</li> </ul>		
	<p>Custom Modification Options</p> <table border="1"> <tr> <td>F.ALL<sup>1</sup></td> <td><input checked="" type="checkbox"/></td> </tr> </table> <p><sup>1</sup>Only available on 10'.</p>	F.ALL <sup>1</sup>	<input checked="" type="checkbox"/>
F.ALL <sup>1</sup>	<input checked="" type="checkbox"/>		

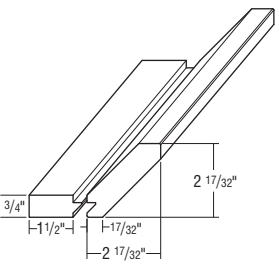
Description	Model		
<b>MEDIUM STRAIGHT ANGLE CROWN MOULDING</b>	<b>MSACROWN8</b> <b>MSACROWN10</b>		
	<ul style="list-style-type: none"> <li>• MSACROWN8: 4 1/32" x 2 17/32" x 96".</li> <li>• MSACROWN10: 4 1/32" x 2 17/32" x 120".</li> <li>• Ships in two pieces.</li> <li>• For use with mouldings specified in this section.</li> <li>• Includes Soffit Filler Moulding Cleat.</li> <li>• Not available in Alder or Rustic Alder.</li> <li>• Glazes and/or Techniques available: F, TW, XTW, HW, XHW.</li> </ul>		
	<p>Custom Modification Options</p> <table border="1"> <tr> <td>F.ALL<sup>1</sup></td> <td><input checked="" type="checkbox"/></td> </tr> </table> <p><sup>1</sup>Only available on 10'.</p>	F.ALL <sup>1</sup>	<input checked="" type="checkbox"/>
F.ALL <sup>1</sup>	<input checked="" type="checkbox"/>		

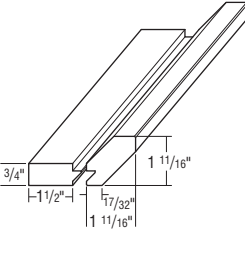
Description	Model		
<b>STRAIGHT ANGLE CROWN MOULDING</b>	<b>SACROWN8</b> <b>SACROWN10</b>		
	<ul style="list-style-type: none"> <li>• SACROWN8: 3 3/16" x 1 11/16" x 96".</li> <li>• SACROWN10: 3 3/16" x 1 11/16" x 120".</li> <li>• Ships in two pieces.</li> <li>• For use with mouldings specified in this section.</li> <li>• Includes Soffit Filler Moulding Cleat.</li> <li>• Not available in Alder or Rustic Alder.</li> <li>• Glazes and/or Techniques available: F, TW, XTW, HW, XHW.</li> </ul>		
	<p>Custom Modification Options</p> <table border="1"> <tr> <td>F.ALL<sup>1</sup></td> <td><input checked="" type="checkbox"/></td> </tr> </table> <p><sup>1</sup>Only available on 10'.</p>	F.ALL <sup>1</sup>	<input checked="" type="checkbox"/>
F.ALL <sup>1</sup>	<input checked="" type="checkbox"/>		

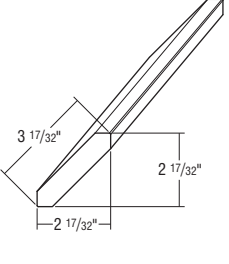
Description	Model		
<b>LARGE SHAKER CROWN MOULDING</b>	<b>LSHAKER8</b> <b>LSHAKER10</b>		
	<ul style="list-style-type: none"> <li>• LSHAKER8: 2 17/32" x 2 17/32" x 96".</li> <li>• LSHAKER10: 2 17/32" x 2 17/32" x 120".</li> <li>• For use with mouldings specified in this section.</li> <li>• Not available in Alder or Rustic Alder.</li> <li>• Glazes and/or Techniques available: F, TW, XTW, HW, XHW.</li> </ul>		
	<p>Custom Modification Options</p> <table border="1"> <tr> <td>F.ALL<sup>1</sup></td> <td><input checked="" type="checkbox"/></td> </tr> </table> <p><sup>1</sup>Only available on 10'.</p>	F.ALL <sup>1</sup>	<input checked="" type="checkbox"/>
F.ALL <sup>1</sup>	<input checked="" type="checkbox"/>		

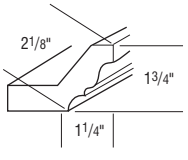
Description	Model		
<b>FULL OVERLAY CROWN MOULDING</b>	<b>FOLCROWN</b> <b>FOLCROWN10</b>		
	<ul style="list-style-type: none"> <li>• FOLCROWN: 1 1/4" x 2 1/8" x 96".</li> <li>• FOLCROWN10: 1 1/4" x 2 1/8" x 120".</li> <li>• Glazes and/or Techniques available: F, P, TW, XTW, HW, XHW.</li> </ul>		
	<p>Custom Modification Options</p> <table border="1"> <tr> <td>F.ALL<sup>1</sup></td> <td><input checked="" type="checkbox"/></td> </tr> </table> <p><sup>1</sup>Only available on 10'.</p>	F.ALL <sup>1</sup>	<input checked="" type="checkbox"/>
F.ALL <sup>1</sup>	<input checked="" type="checkbox"/>		

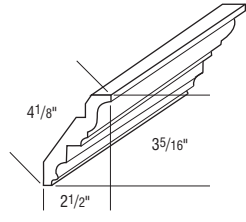
Description	Model		
<b>INSERT CROWN MOULDING</b>	<b>SWVCRM8</b> <b>SWVCRM10</b>		
	<ul style="list-style-type: none"> <li>• SWVCRM8: 2 1/2" x 3 5/16" x 96".</li> <li>• SWVCRM10: 2 1/2" x 3 5/16" x 120".</li> <li>• Glazes and/or Techniques available: F, P, TW, XTW, HW, XHW.</li> </ul>		
	<p>Custom Modification Options</p> <table border="1"> <tr> <td>F.ALL<sup>1</sup></td> <td><input checked="" type="checkbox"/></td> </tr> </table> <p><sup>1</sup>Only available on 10'.</p>	F.ALL <sup>1</sup>	<input checked="" type="checkbox"/>
F.ALL <sup>1</sup>	<input checked="" type="checkbox"/>		

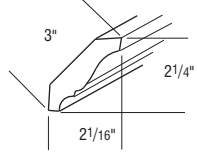
Description	Model		
<b>LARGE CROWN MOULDING</b>	<b>SWLCRM8</b> <b>SWLCRM10</b>		
	<ul style="list-style-type: none"> <li>• SWLCRM8: 2 1/16" x 2 1/4" x 96".</li> <li>• SWLCRM10: 2 1/16" x 2 1/4" x 120".</li> <li>• Glazes and/or Techniques available: F, P, TW, XTW, HW, XHW.</li> </ul>		
	<p>Custom Modification Options</p> <table border="1"> <tr> <td>F.ALL<sup>1</sup></td> <td><input checked="" type="checkbox"/></td> </tr> </table> <p><sup>1</sup>Only available on 10'.</p>	F.ALL <sup>1</sup>	<input checked="" type="checkbox"/>
F.ALL <sup>1</sup>	<input checked="" type="checkbox"/>		

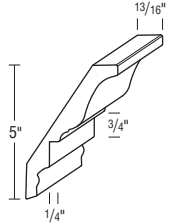
Description	Model		
<b>LARGE INSERT CROWN</b>	<b>LRCROWN</b>		
	<ul style="list-style-type: none"> <li>• 13/16" x 5" x 96".</li> <li>• For use with Light Rail Mouldings specified in Inserts section.</li> <li>• Oak will be used for Quartersawn Oak.</li> <li>• Glazes and/or Techniques available: F, P, TW, XTW, HW, XHW.</li> </ul>		
	<p>Custom Modification Options</p> <table border="1"> <tr> <td>F.ALL</td> <td><input checked="" type="checkbox"/></td> </tr> </table>	F.ALL	<input checked="" type="checkbox"/>
F.ALL	<input checked="" type="checkbox"/>		

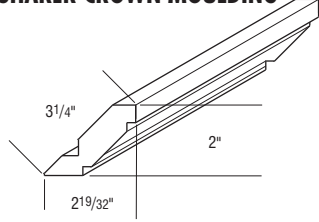
Description	Model		
<b>SHAKER CROWN MOULDING</b>	<b>SHKCRM8</b> <b>SHKCRM10</b>		
	<ul style="list-style-type: none"> <li>• SHKCRM8: 2 19/32" x 2" x 96".</li> <li>• SHKCRM10: 2 19/32" x 2" x 120".</li> <li>• Glazes and/or Techniques available: F, P, TW, XTW, HW, XHW.</li> </ul>		
	<p>Custom Modification Options</p> <table border="1"> <tr> <td>F.ALL<sup>1</sup></td> <td><input checked="" type="checkbox"/></td> </tr> </table> <p><sup>1</sup>Only available on 10'.</p>	F.ALL <sup>1</sup>	<input checked="" type="checkbox"/>
F.ALL <sup>1</sup>	<input checked="" type="checkbox"/>		

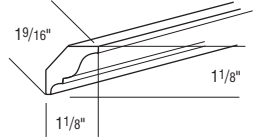
Description	Model		
<b>SOFFIT SCRIBE CROWN MOULDING</b>	<b>SCM8</b> <b>SCM10</b>		
	<ul style="list-style-type: none"> <li>• SCM8: 1 1/8" x 1 1/8" x 96".</li> <li>• SCM10: 1 1/8" x 1 1/8" x 120".</li> <li>• Glazes and/or Techniques available: F, P, TW, XTW, HW, XHW.</li> </ul>		
	<p>Custom Modification Options</p> <table border="1"> <tr> <td>F.ALL<sup>1</sup></td> <td><input checked="" type="checkbox"/></td> </tr> </table> <p><sup>1</sup>Only available on 10'.</p>	F.ALL <sup>1</sup>	<input checked="" type="checkbox"/>
F.ALL <sup>1</sup>	<input checked="" type="checkbox"/>		

8' mouldings will have 93"-99" of useable length.  
10' mouldings will have 117"-123" useable length.

Glazes and Techniques
F = Flooded (see page E•3.)
P = Penned (see page E•3.)
TW = Timeworn (see page E•3.)
XTW = Extra Timeworn (see page E•3.)
HW = Hewn (see page E•3.)
XHW = Extra Hewn (see page E•3.)



# Mouldings & Embellishments

Description	Model
<b>TALL CROWN MOULDING</b>	<b>MTCROWN8</b>
	<b>TCROWN10</b>
	<ul style="list-style-type: none"> <li>MTCROWN8: 2 3/8" x 3 17/32" x 96".</li> <li>TCROWN10: 2 3/8" x 3 17/32" x 120".</li> <li>Glazes and/or Techniques available: F, P, TW, XTW, HW, XHW.</li> </ul> <p>Custom Modification Options</p> <p>FALL<sup>1</sup></p> <p><sup>1</sup>Only available on 10'.</p>
	<b>TLCROWN</b>
	<ul style="list-style-type: none"> <li>TLCROWN: 4 13/32" x 5 5/16" x 96".</li> <li>TLCROWN10: 4 13/32" x 5 5/16" x 120".</li> <li>Glazes and/or Techniques available: F, P, TW, XTW, HW, XHW.</li> </ul> <p>Custom Modification Options</p> <p>FALL<sup>1</sup></p> <p><sup>1</sup>Only available on 10'.</p>

Description	Model
<b>NEW SOLID WOOD TALL CROWN MOULDING</b>	<b>SWTCRM8</b>
	<b>SWTCRM10</b>
	<ul style="list-style-type: none"> <li>SWTCRM8: 2 13/16" x 2 1/16" x 96".</li> <li>SWTCRM10: 2 13/16" x 2 1/16" x 120".</li> <li>Glazes and/or Techniques available: F, P, TW, XTW, HW, XHW.</li> <li>SWTCRM10 only available in Cherry and Maple.</li> </ul> <p>Custom Modification Options</p> <p>FALL</p> <p><input checked="" type="checkbox"/></p>

Description	Model
<b>INSERT PANEL CROWN</b>	<b>INSCROWN</b>
	<ul style="list-style-type: none"> <li>13/16" x 3 1/2" x 96".</li> <li>For use with mouldings specified in this section.</li> <li>Alder will be used for Rustic Alder.</li> <li>Oak will be used for Quartersawn Oak.</li> <li>Abbey, Basilica and Tudor Column Inserts available. See page R-49.</li> <li>Glazes and/or Techniques available: F, P.</li> </ul> <p>Custom Modification Options</p> <p>FALL</p> <p><input checked="" type="checkbox"/></p>

Description	Model
<b>CREATE-A-CROWN INSERT</b>	<b>INSERTFRM</b>
	<ul style="list-style-type: none"> <li>13/16" x 3 1/2" x 96".</li> <li>For use with mouldings specified in this section.</li> <li>Alder will be used for Rustic Alder.</li> <li>Oak will be used for Quartersawn Oak.</li> <li>Abbey, Basilica and Tudor Column Inserts available. See page R-49.</li> <li>Glazes and/or Techniques available: F, P.</li> </ul> <p>Custom Modification Options</p> <p>FALL</p> <p><input checked="" type="checkbox"/></p>

8' mouldings will have 93"-99" of useable length.  
10' mouldings will have 117"-123" useable length.

**Glazes and Techniques**  
**F** = Flooded (see page E-3.)  
**P** = Penned (see page E-3.)  
**TW** = Timeworn (see page E-3.)  
**XTW** = Extra Timeworn (see page E-3.)  
**HW** = Hewn (see page E-3.)  
**XHW** = Extra Hewn (see page E-3.)

Description	Model
<b>TRIM MOULDING</b>	<b>TM</b>
	<b>TM10</b>
	<ul style="list-style-type: none"> <li>TM: 3/4" x 3/4" x 96".</li> <li>TM10: 3/4" x 3/4" x 120".</li> <li>Alder will be used for Rustic Alder.</li> <li>Glazes and/or Techniques available: F, P, TW, XTW, HW, XHW.</li> </ul> <p>Custom Modification Options</p> <p>FALL<sup>1</sup></p> <p><input checked="" type="checkbox"/></p> <p><sup>1</sup>Only available on 10'.</p>

Description	Model
<b>CAP MOULDING</b>	<b>CAPM</b>
	<b>CAPM10</b>
	<ul style="list-style-type: none"> <li>CAPM: 3/4" x 1" x 96".</li> <li>CAPM10: 3/4" x 1" x 120".</li> <li>Alder will be used for Rustic Alder.</li> <li>Glazes and/or Techniques available: F, P, TW, XTW, HW, XHW.</li> </ul> <p>Custom Modification Options</p> <p>FALL<sup>1</sup></p> <p><input checked="" type="checkbox"/></p> <p><sup>1</sup>Only available on 10'.</p>

Description	Model
<b>SOFFIT TRIM MOULDING</b>	<b>TSTM</b>
	<b>TSTM10</b>
	<ul style="list-style-type: none"> <li>TSTM: 3/4" x 2 1/2" x 96".</li> <li>TSTM10: 3/4" x 2 1/2" x 120".</li> <li>Alder will be used for Rustic Alder.</li> <li>1/2" wide groove.</li> <li>Glazes and/or Techniques available: F, P, TW, XTW, HW, XHW.</li> <li>TSTM10 is not available in Quartersawn Oak.</li> </ul> <p>Custom Modification Options</p> <p>FALL<sup>1</sup></p> <p><input checked="" type="checkbox"/></p> <p><sup>1</sup>Only available on 10'.</p>

Description	Model
<b>SOFFIT TRIM MOULDING</b>	<b>STM8</b>
	<b>STM10</b>
	<ul style="list-style-type: none"> <li>STM8: 1 1/2" x 3/4" x 96".</li> <li>STM10: 1 1/2" x 3/4" x 120".</li> <li>1/2" wide groove.</li> <li>Not available in Alder or Rustic Alder.</li> <li>Glazes and/or Techniques available: F, P, TW, XTW, HW, XHW.</li> </ul> <p>Custom Modification Options</p> <p>FALL<sup>1</sup></p> <p><input checked="" type="checkbox"/></p> <p><sup>1</sup>Only available on 10'.</p>

Description	Model
<b>ANGLED SOFFIT TRIM MOULDING</b>	<b>ASTM8</b>
	<b>ASTM10</b>
	<ul style="list-style-type: none"> <li>ASTM8: 1 3/4" x 3/4" x 96".</li> <li>ASTM10: 1 3/4" x 3/4" x 120".</li> <li>1/2" wide groove.</li> <li>Not available in Alder or Rustic Alder.</li> <li>Glazes and/or Techniques available: F, P, TW, XTW, HW, XHW.</li> </ul> <p>Custom Modification Options</p> <p>FALL<sup>1</sup></p> <p><input checked="" type="checkbox"/></p> <p><sup>1</sup>Only available on 10'.</p>

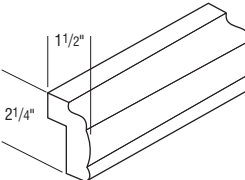
Description	Model		
<b>LIGHT RAIL MOULDING</b>	<b>LRM</b>		
	<b>LRM10</b>		
<ul style="list-style-type: none"> <li>• LRM: 1 1/2" x 2 1/4" x 96".</li> <li>• LRM10: 1 1/2" x 2 1/4" x 120".</li> <li>• Alder will be used for Rustic Alder.</li> <li>• Glazes and/or Techniques available: F, P, TW, XTW, HW, XHW.</li> </ul>	<p>Custom Modification Options</p> <table border="1"> <tr> <td>FALL<sup>1</sup></td> </tr> <tr> <td style="text-align: center;">✓</td> </tr> </table> <p><sup>1</sup>Only available on 10'.</p>	FALL <sup>1</sup>	✓
FALL <sup>1</sup>			
✓			

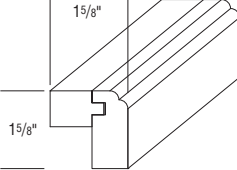
Description	Model		
<b>TRADITIONAL LIGHT RAIL</b>	<b>TLR8</b>		
	<b>TLR10</b>		
<ul style="list-style-type: none"> <li>• TLR8: 1 5/8" x 1 5/8" x 96".</li> <li>• TLR10: 1 5/8" x 1 5/8" x 120".</li> <li>• Alder will be used for Rustic Alder.</li> <li>• Glazes and/or Techniques available: F, P, TW, XTW, HW, XHW.</li> </ul>	<p>Custom Modification Options</p> <table border="1"> <tr> <td>FALL<sup>1</sup></td> </tr> <tr> <td style="text-align: center;">✓</td> </tr> </table> <p><sup>1</sup>Only available on 10'.</p>	FALL <sup>1</sup>	✓
FALL <sup>1</sup>			
✓			

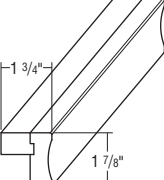
Description	Model		
<b>CONCAVE LIGHT RAIL MOULDING</b>	<b>CNVLRAIL8</b>		
	<b>CNVLRAIL10</b>		
<ul style="list-style-type: none"> <li>• CNVLRAIL8: 1 3/4" x 1 7/8" x 96".</li> <li>• CNVLRAIL10: 1 3/4" x 1 7/8" x 120".</li> <li>• Not available in Alder or Rustic Alder.</li> <li>• Glazes and/or Techniques available: F, P, TW, XTW, HW, XHW.</li> </ul>	<p>Custom Modification Options</p> <table border="1"> <tr> <td>FALL<sup>1</sup></td> </tr> <tr> <td style="text-align: center;">✓</td> </tr> </table> <p><sup>1</sup>Only available on 10'.</p>	FALL <sup>1</sup>	✓
FALL <sup>1</sup>			
✓			

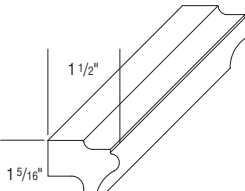
Description	Model		
<b>SMALL LIGHT RAIL MOULDING</b>	<b>SMLR</b>		
	<b>SMLR10</b>		
<ul style="list-style-type: none"> <li>• SMLR: 1 1/2" x 1 5/16" x 96".</li> <li>• SMLR10: 1 1/2" x 1 5/16" x 120".</li> <li>• Alder will be used for Rustic Alder.</li> <li>• Glazes and/or Techniques available: F, P, TW, XTW, HW, XHW.</li> </ul>	<p>Custom Modification Options</p> <table border="1"> <tr> <td>FALL<sup>1</sup></td> </tr> <tr> <td style="text-align: center;">✓</td> </tr> </table> <p><sup>1</sup>Only available on 10'.</p>	FALL <sup>1</sup>	✓
FALL <sup>1</sup>			
✓			

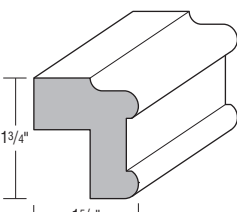
Description	Model		
<b>TRADITIONAL LIGHT RAIL MOULDING</b>	<b>JINSERTLRT</b>		
			
<ul style="list-style-type: none"> <li>• 1 5/8" x 1 3/4" x 96".</li> <li>• For use with Light Rail Mouldings specified in this section.</li> <li>• Oak will be used for Quartersawn Oak.</li> <li>• Glazes and/or Techniques available: F, P, TW, XTW, HW, XHW.</li> </ul>	<p>Custom Modification Options</p> <table border="1"> <tr> <td>FALL</td> </tr> <tr> <td style="text-align: center;">✓</td> </tr> </table>	FALL	✓
FALL			
✓			

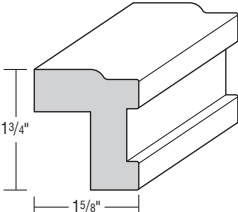
Description	Model		
<b>CONTEMPORARY LIGHT RAIL MOULDING</b>	<b>JINSERTLRC</b>		
			
<ul style="list-style-type: none"> <li>• 1 5/8" x 1 3/4" x 96".</li> <li>• For use with Light Rail Mouldings specified in this section.</li> <li>• Alder will be used for Rustic Alder.</li> <li>• Oak will be used for Quartersawn Oak.</li> <li>• Glazes and/or Techniques available: F, P, TW, XTW, HW, XHW.</li> </ul>	<p>Custom Modification Options</p> <table border="1"> <tr> <td>FALL</td> </tr> <tr> <td style="text-align: center;">✓</td> </tr> </table>	FALL	✓
FALL			
✓			

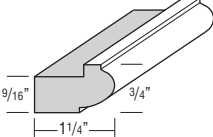
Description	Model		
<b>NEW VALLEY FORGE MOULDING</b>	<b>VFR8</b>		
			
<ul style="list-style-type: none"> <li>• VFR8: 1 1/4" x 3/4" x 96".</li> <li>• Glazes and/or Techniques available: F, P, TW, XTW, HW, XHW.</li> <li>• Alder will be used for Rustic Alder.</li> </ul>	<p>Custom Modification Options</p> <table border="1"> <tr> <td>FALL</td> </tr> <tr> <td style="text-align: center;">✓</td> </tr> </table>	FALL	✓
FALL			
✓			

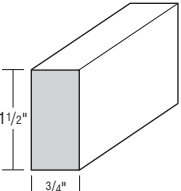
Description	Model		
<b>NEW LIGHT BAFFLE</b>	<b>LB2</b>		
			
<ul style="list-style-type: none"> <li>• LB2: 3/4" x 1 1/2" x 96".</li> <li>• Glazes and/or Techniques available: F, TW, XTW, HW, XHW.</li> <li>• Alder will be used for Rustic Alder.</li> </ul>	<p>Custom Modification Options</p> <table border="1"> <tr> <td>FALL</td> </tr> <tr> <td style="text-align: center;">✓</td> </tr> </table>	FALL	✓
FALL			
✓			

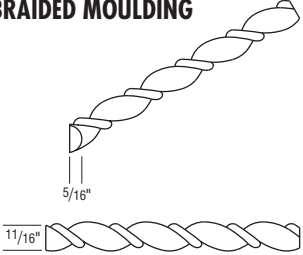
Description	Model		
<b>BRAIDED MOULDING</b>	<b>BRAIDM</b>		
			
<ul style="list-style-type: none"> <li>• 1 1/16" x 5/16" x 96".</li> <li>• Alder will be used for Rustic Alder.</li> <li>• Glazes and/or Techniques available: F, P.</li> </ul>	<p>Custom Modification Options</p> <table border="1"> <tr> <td>FALL</td> </tr> <tr> <td style="text-align: center;">✓</td> </tr> </table>	FALL	✓
FALL			
✓			

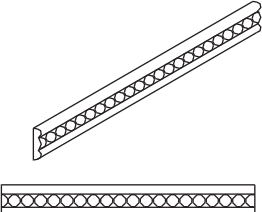
Description	Model		
<b>CENTER BEADED MOULDING</b>	<b>CBEADM</b>		
	<b>CBEADM10</b>		
<ul style="list-style-type: none"> <li>• CBEADM: 3/4" x 9/32" x 96".</li> <li>• CBEADM10: 3/4" x 9/32" x 120".</li> <li>• Alder will be used for Rustic Alder.</li> <li>• Glazes and/or Techniques available: F, P.</li> </ul>	<p>Custom Modification Options</p> <table border="1"> <tr> <td>FALL<sup>1</sup></td> </tr> <tr> <td style="text-align: center;">✓</td> </tr> </table> <p><sup>1</sup>Only available on 10'.</p>	FALL <sup>1</sup>	✓
FALL <sup>1</sup>			
✓			

8' mouldings will have 93"-99" of useable length.  
10' mouldings will have 117"-123" useable length.

**Glazes and Techniques**  
**F** = Flooded (see page E•3.)  
**P** = Penned (see page E•3.)  
**TW** = Timeworn (see page E•3.)  
**XTW** = Extra Timeworn (see page E•3.)  
**HW** = Hewn (see page E•3.)  
**XHW** = Extra Hewn (see page E•3.)

# Mouldings & Embellishments

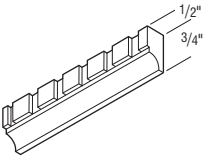
Description	Model
<b>DENTIL MOULDING</b>	<b>DE8</b>
	<ul style="list-style-type: none"> <li>• 1/2" x 3/4" x 96".</li> <li>• Alder will be used for Rustic Alder.</li> <li>• Glazes and/or Techniques available: F, P.</li> </ul>
	<div style="border: 1px solid black; padding: 5px; width: fit-content; margin-left: auto; margin-right: auto;">                     Modifications Are Not Available                 </div>

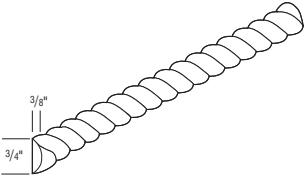
Description	Model
<b>ROPE MOULDING</b>	<b>RPM8</b>
	<ul style="list-style-type: none"> <li>• 3/8" x 3/4" x 96".</li> <li>• Alder will be used for Rustic Alder.</li> <li>• Can be used as an insert for insert crown moulding.</li> <li>• Glazes and/or Techniques available: F, P, HW, XHW.</li> </ul>
	<div style="text-align: right;">Custom Modification Options</div> <div style="border: 1px solid black; padding: 2px; width: fit-content; margin-left: auto;">                     FALL ✓                 </div>

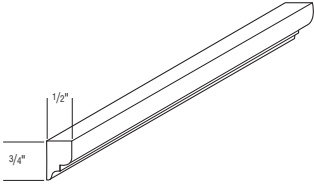
Description	Model
<b>OGEE MOULDING</b>	<b>OGEEM</b> <b>OGEEM10</b>
	<ul style="list-style-type: none"> <li>• OGEEM: 1/2" x 3/4" x 96".</li> <li>• OGEEM10: 1/2" x 3/4" x 120".</li> <li>• Alder will be used for Rustic Alder.</li> <li>• Can be used as an insert for insert crown moulding.</li> <li>• Glazes and/or Techniques available: F, P, TW, XTW, HW, XHW.</li> <li>• OGEEM10 is not available in Quartersawn Oak.</li> </ul>
	<div style="text-align: right;">Custom Modification Options</div> <div style="border: 1px solid black; padding: 2px; width: fit-content; margin-left: auto;">                     FALL<sup>1</sup> ✓                 </div> <p style="font-size: small; margin-left: 100px;"><sup>1</sup>Only available on 10'.</p>

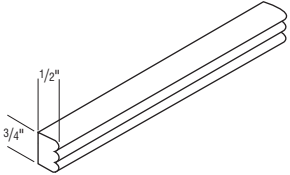
Description	Model
<b>TRIPLE BEAD MOULDING</b>	<b>TBEM</b> <b>TBEM10</b>
	<ul style="list-style-type: none"> <li>• TBEM: 1/2" x 3/4" x 96".</li> <li>• TBEM10: 1/2" x 3/4" x 120".</li> <li>• Alder will be used for Rustic Alder.</li> <li>• Can be used as an insert for insert crown moulding.</li> <li>• Glazes and/or Techniques available: F, P, TW, XTW, HW, XHW.</li> </ul>
	<div style="text-align: right;">Custom Modification Options</div> <div style="border: 1px solid black; padding: 2px; width: fit-content; margin-left: auto;">                     FALL<sup>1</sup> ✓                 </div> <p style="font-size: small; margin-left: 100px;"><sup>1</sup>Only available on 10'.</p>

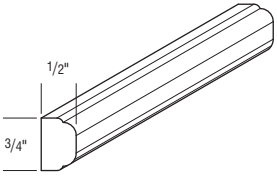
Description	Model
<b>SINGLE BEAD EDGE</b>	<b>SBE8</b> <b>SBE10</b>
	<ul style="list-style-type: none"> <li>• SBE8: 3/4" x 1/2" x 96".</li> <li>• SBE10: 3/4" x 1/2" x 120".</li> <li>• Alder will be used for Rustic Alder.</li> <li>• Glazes and/or Techniques available: F, P, TW, XTW.</li> </ul>
	<div style="text-align: right;">Custom Modification Options</div> <div style="border: 1px solid black; padding: 2px; width: fit-content; margin-left: auto;">                     FALL<sup>1</sup> ✓                 </div> <p style="font-size: small; margin-left: 100px;"><sup>1</sup>Only available on 10'.</p>

8' mouldings will have 93"-99" of useable length.  
10' mouldings will have 117"-123" useable length.

**Glazes and Techniques**

**F** = Flooded (see page E•3.)  
**P** = Penned (see page E•3.)  
**TW** = Timeworn (see page E•3.)  
**XTW** = Extra Timeworn (see page E•3.)  
**HW** = Hewn (see page E•3.)  
**XHW** = Extra Hewn (see page E•3.)

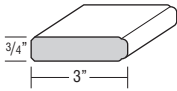
Description	Model
<b>SINGLE BEAD MOULDING</b>	<b>SBM8</b>
	<ul style="list-style-type: none"> <li>• SBM8: 3" x 3/4" x 96".</li> <li>• Glazes and/or Techniques available: F, P, TW, XTW, HW, XHW.</li> <li>• Alder will be used for Rustic Alder.</li> </ul>
	<div style="text-align: right;">Custom Modification Options</div> <div style="border: 1px solid black; padding: 2px; width: fit-content; margin-left: auto;">                     FALL ✓                 </div>

Description	Model
<b>ABBEY CROWN INSERT</b>	<b>ABBEYINSBR</b> <b>ABBEYINSSN</b> <b>ABBEYINSWI</b>
	<ul style="list-style-type: none"> <li>• Refined Bronze</li> <li>• Satin Nickel</li> <li>• Wrought Iron</li> </ul>
	<ul style="list-style-type: none"> <li>• 2 1/4" x 1/8" x 96".</li> <li>• 32" repeat.</li> <li>• Must be used as an insert for Insert Panel Crown (INSCROWN) or Create-A-Crown (INSERTFRM).</li> </ul>
	<div style="text-align: right;">Custom Modification Options</div> <div style="border: 1px solid black; padding: 2px; width: fit-content; margin-left: auto;">                     FALL ✓                 </div>

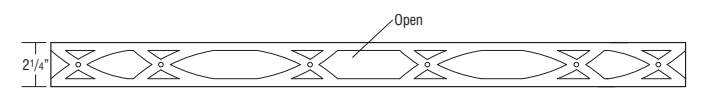

Description	Model
<b>ABBEY LIGHT RAIL INSERT</b>	<b>ABBEYINSBR</b> <b>ABBEYINSSN</b> <b>ABBEYINSWI</b>
	<ul style="list-style-type: none"> <li>• Refined Bronze</li> <li>• Satin Nickel</li> <li>• Wrought Iron</li> </ul>
	<ul style="list-style-type: none"> <li>• 3/4" x 1/8" x 96".</li> <li>• 8" repeat.</li> <li>• Must be used as an insert for Traditional Light Rail Moulding (JINSERTLRT) or Contemporary Light Rail Moulding (JINSERTLRC).</li> </ul>
	<div style="text-align: right;">Custom Modification Options</div> <div style="border: 1px solid black; padding: 2px; width: fit-content; margin-left: auto;">                     FALL ✓                 </div>

Description	Model
<b>BASILICA CROWN INSERT</b>	<b>BASILINSBR</b> <b>BASILINSSN</b> <b>BASILINSWI</b>
	<ul style="list-style-type: none"> <li>• Refined Bronze</li> <li>• Satin Nickel</li> <li>• Wrought Iron</li> </ul>
	<ul style="list-style-type: none"> <li>• 2 1/4" x 1/8" x 96".</li> <li>• 24" repeat.</li> <li>• Must be used as an insert for Insert Panel Crown (INSCROWN) or Create-A-Crown (INSERTFRM).</li> </ul>
	<div style="text-align: right;">Custom Modification Options</div> <div style="border: 1px solid black; padding: 2px; width: fit-content; margin-left: auto;">                     FALL ✓                 </div>

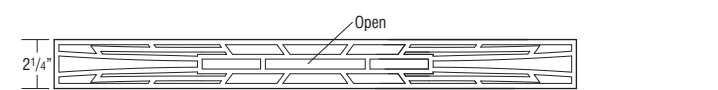

Description	Model
<b>BASILICA LIGHT RAIL INSERT</b> 	<b>BASILINSSBR</b> • Refined Bronze
	<b>BASILINSSN</b> • Satin Nickel
	<b>BASILINSSWI</b> • Wrought Iron  • 3/4" x 1/8" x 96" • 12" repeat. • Must be used as an insert for Traditional Light Rail Moulding (JINSERTLRT) or Contemporary Light Rail Moulding (JINSERTLRC).

Custom Modification Options

F.ALL
✓

Description	Model
<b>TUDOR CROWN INSERT</b> 	<b>TUDORINSBR</b> • Refined Bronze
	<b>TUDORINSSN</b> • Satin Nickel
	<b>TUDORINSWI</b> • Wrought Iron  • 2 1/4" x 1/8" x 96" • 24" repeat. • Must be used as an insert for Insert Panel Crown (INSCROWN) or Create-A-Crown (INSERTFRM).

Custom Modification Options

F.ALL
✓

Description	Model
<b>TUDOR LIGHT RAIL INSERT</b> 	<b>TUDORINSSBR</b> • Refined Bronze
	<b>TUDORINSSN</b> • Satin Nickel
	<b>TUDORINSSWI</b> • Wrought Iron  • 3/4" x 1/8" x 96" • 13 3/4" repeat. • Must be used as an insert for Traditional Light Rail Moulding (JINSERTLRT) or Contemporary Light Rail Moulding (JINSERTLRC).

Custom Modification Options

F.ALL
✓

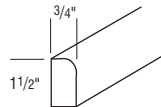
Description	Model
<b>ROUND COUNTERTOP MOULDING</b> 	<b>RCTM</b>
	<b>RCTM10</b>  • RCTM: 3/4" x 1 1/2" x 96" • RCTM10: 3/4" x 1 1/2" x 120" • Alder will be used for Rustic Alder. • Glazes and/or Techniques available: F, TW, XTW.

Custom Modification Options

F.ALL <sup>1</sup>
✓

<sup>1</sup>Only available on 10'.

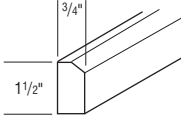
Description	Model
<b>BEVELED EDGE MOULDING</b> 	<b>TCM8</b>
	<b>TCM10</b>  • TCM8: 3/4" x 1 1/2" x 96" • TCM10: 3/4" x 1 1/2" x 120" • Alder will be used for Rustic Alder. • Glazes and/or Techniques available: F, TW, XTW, HW, XHW.

Custom Modification Options

F.ALL <sup>1</sup>
✓

<sup>1</sup>Only available on 10'.

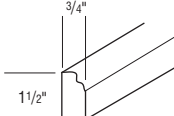
Description	Model
<b>PROFILE EDGE MOULDING</b> 	<b>SHAPE10</b>
	<b>SHAPE12</b>
	<b>SHAPE14</b>
	<b>SHAPE15</b>
	<b>SHAPE17</b> <b>SHAPE27</b>

Shape14 Shown

- Countertop Moulding 3/4" x 1 1/2" x 96"
- Alder will be used for Rustic Alder.
- Glazes and/or Techniques available: F, TW, XTW, HW, XHW.

Modifications Are Not Available

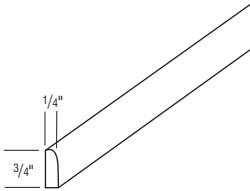
Description	Model
<b>SMALL SCRIBE MOULDING</b> 	<b>SSM</b>
	<b>SSM10</b>  • SSM: 1/4" x 3/4" x 96" • SSM10: 1/4" x 3/4" x 120" • Alder will be used for Rustic Alder. • Glazes and/or Techniques available: F, TW, XTW.

Custom Modification Options

F.ALL <sup>1</sup>
✓

<sup>1</sup>Only available on 10'.

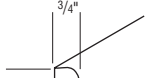
Description	Model
<b>LARGE SCRIBE MOULDING</b> 	<b>LSM</b>
	• 3/4" x 2" x 96" • Alder will be used for Rustic Alder. • Glazes and/or Techniques available: F, TW, XTW.

Modifications Are Not Available

8' mouldings will have 93"-99" of useable length.  
 10' mouldings will have 117"-123" useable length.

**Glazes and Techniques**  
**F** = Flooded (see page E•3.)  
**P** = Penned (see page E•3.)  
**TW** = Timeworn (see page E•3.)  
**XTW** = Extra Timeworn (see page E•3.)  
**HW** = Hewn (see page E•3.)  
**XHW** = Extra Hewn (see page E•3.)

# Mouldings & Embellishments

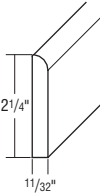
Description	Model
<b>WIDE SCRIBE MOULDING</b>	<b>WSCRIBE</b> <b>WSCRIBE10</b>
	<ul style="list-style-type: none"> <li>• WSCRIBE: 1 1/32" x 2 1/4" x 96"</li> <li>• WSCRIBE10: 1 1/32" x 2 1/4" x 120"</li> <li>• Alder will be used for Rustic Alder.</li> <li>• Glazes and/or Techniques available: F, TW, XTW, HW, XHW.</li> </ul>
	<p>Custom Modification Options</p> <p>F.A.L.L.<sup>1</sup></p> <p>✓</p> <p><sup>1</sup>Only available on 10'.</p>

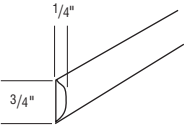
Description	Model
<b>SMALL BATTEN MOULDING</b>	<b>SM8</b> <b>SM10</b>
	<ul style="list-style-type: none"> <li>• SM8: 1/4" x 3/4" x 96"</li> <li>• SM10: 1/4" x 3/4" x 120"</li> <li>• Alder will be used for Rustic Alder.</li> <li>• Glazes and/or Techniques available: F, TW, XTW.</li> </ul>
	<p>Custom Modification Options</p> <p>F.A.L.L.<sup>1</sup></p> <p>✓</p> <p><sup>1</sup>Only available on 10'.</p>

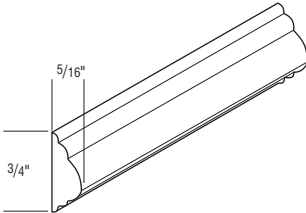
Description	Model
<b>TRADITIONAL BATTEN MOULDING</b>	<b>TBATM</b> <b>TBATM10</b>
	<ul style="list-style-type: none"> <li>• TBATM: 5/16" x 3/4" x 96"</li> <li>• TBATM10: 5/16" x 3/4" x 120"</li> <li>• Alder will be used for Rustic Alder.</li> <li>• Glazes and/or Techniques available: F, P, TW, XTW, HW, XHW.</li> </ul>
	<p>Custom Modification Options</p> <p>F.A.L.L.<sup>1</sup></p> <p>✓</p> <p><sup>1</sup>Only available on 10'.</p>

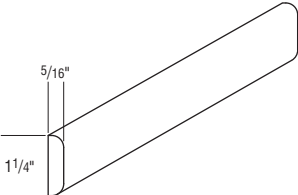
Description	Model
<b>LARGE BATTEN MOULDING</b>	<b>SM8LG</b> <b>SM10LG</b>
	<ul style="list-style-type: none"> <li>• SM8LG: 5/16" x 1 1/4" x 96"</li> <li>• SM10LG: 5/16" x 1 1/4" x 120"</li> <li>• Alder will be used for Rustic Alder.</li> <li>• Glazes and/or Techniques available: F, TW, XTW.</li> </ul>
	<p>Custom Modification Options</p> <p>F.A.L.L.<sup>1</sup></p> <p>✓</p> <p><sup>1</sup>Only available on 10'.</p>

8' mouldings will have 93"-99" of useable length.  
10' mouldings will have 117"-123" useable length.

**Glazes and Techniques**  
**F** = Flooded (see page E•3.)  
**P** = Penned (see page E•3.)  
**TW** = Timeworn (see page E•3.)  
**XTW** = Extra Timeworn (see page E•3.)  
**HW** = Hewn (see page E•3.)  
**XHW** = Extra Hewn (see page E•3.)

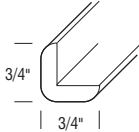
Description	Model
<b>OUTSIDE CORNER MOULDING</b>	<b>OCM3</b> (Outside corner 36") <b>OCM8</b> (Outside corner 8") <b>OCM10</b> (Outside corner 10")
	<ul style="list-style-type: none"> <li>• OCM3: 3/4" x 3/4" x 36"</li> <li>• OCM8: 3/4" x 3/4" x 96"</li> <li>• OCM10: 3/4" x 3/4" x 120"</li> <li>• Alder will be used for Rustic Alder.</li> <li>• Glazes and/or Techniques available: F, TW, XTW.</li> </ul>
	<p>Custom Modification Options</p> <p>F.A.L.L.<sup>1</sup></p> <p>✓</p> <p><sup>1</sup>Only available on 10'.</p>

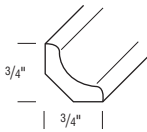
Description	Model
<b>INSIDE CORNER MOULDING</b>	<b>ICM8</b> <b>ICM10</b>
	<ul style="list-style-type: none"> <li>• ICM8: 3/4" x 3/4" x 96"</li> <li>• ICM10: 3/4" x 3/4" x 120"</li> <li>• Alder will be used for Rustic Alder.</li> <li>• Glazes and/or Techniques available: F, TW, XTW, HW, XHW.</li> </ul>
	<p>Custom Modification Options</p> <p>F.A.L.L.<sup>1</sup></p> <p>✓</p> <p><sup>1</sup>Only available on 10'.</p>

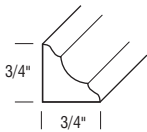
Description	Model
<b>INSIDE CORNER MOULDING (#2)</b>	<b>ICMA8</b> <b>ICMA10</b>
	<ul style="list-style-type: none"> <li>• ICMA8: 3/4" x 3/4" x 96"</li> <li>• ICMA10: 3/4" x 3/4" x 120"</li> <li>• Alder will be used for Rustic Alder.</li> <li>• Glazes and/or Techniques available: F, P, TW, XTW, HW, XHW.</li> </ul>
	<p>Custom Modification Options</p> <p>F.A.L.L.<sup>1</sup></p> <p>✓</p> <p><sup>1</sup>Only available on 10'.</p>

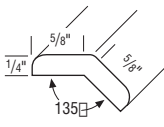
Description	Model
<b>OUTSIDE 135° CORNER MOULDING</b>	<b>OC135</b> <b>OC13510</b>
	<ul style="list-style-type: none"> <li>• OC135: 5/8" x 1/4" x 96"</li> <li>• OC13510: 5/8" x 1/4" x 120"</li> <li>• Alder will be used for Rustic Alder.</li> <li>• Glazes and/or Techniques available: F, TW, XTW.</li> </ul>
	<p>Custom Modification Options</p> <p>F.A.L.L.<sup>1</sup></p> <p>✓</p> <p><sup>1</sup>Only available on 10'.</p>

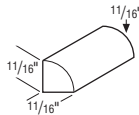
Description	Model
<b>QUARTER ROUND MOULDING</b>	<b>QRM</b> <b>QRM10</b>
	<ul style="list-style-type: none"> <li>• QRM: 1 1/16" x 1 1/16" x 96"</li> <li>• QRM10: 1 1/16" x 1 1/16" x 120"</li> <li>• Alder will be used for Rustic Alder.</li> <li>• Glazes and/or Techniques available: F, TW, XTW.</li> </ul>
	<p>Custom Modification Options</p> <p>F.A.L.L.<sup>1</sup></p> <p>✓</p> <p><sup>1</sup>Only available on 10'.</p>

**Description** **Model**

**NEW SHOE CONVEX INSIDE CORNER MOULDING** **SHM8**

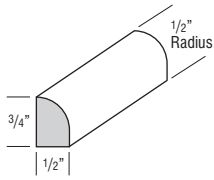

- SHM8: 1/2" x 3/4" x 96".
- Glazes and/or Techniques available: F, TW, XTW.
- Alder will be used for Rustic Alder.

Custom Modification Options

F.A.L.L. <sup>1</sup>
✓

**LARGE OUTSIDE CORNER** **LOSC8**

**LOSC10**

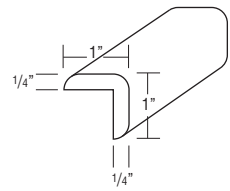

- LOSC8: 1" x 1" x 96".
- LOSC10: 1" x 1" x 120".
- Alder will be used for Rustic Alder.
- Glazes and/or Techniques available: F, TW, XTW.

Custom Modification Options

F.A.L.L. <sup>1</sup>
✓

<sup>1</sup>Only available on 10'.

**TRADITIONAL WINDOW CASING** **WCT8**

**WCT10**

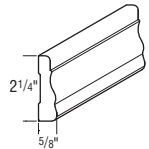

- WCT8: 2 1/4" x 5/8" x 96".
- WCT10: 2 1/4" x 5/8" x 120".
- Alder will be used for Rustic Alder.
- Glazes and/or Techniques available: F, P, TW, XTW, HW, XHW.
- WCT10 is not available in Quartersawn Oak.

Custom Modification Options

F.A.L.L. <sup>1</sup>
✓

<sup>1</sup>Only available on 10'.

**CABINET PANEL EDGE** **CPE8**

**CPE10**

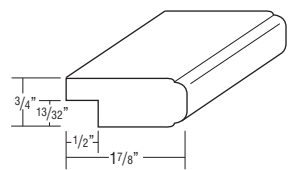

- CPE8: 1 7/8" x 3/4" x 96".
- CPE10: 1 7/8" x 3/4" x 120".
- Alder will be used for Rustic Alder.
- Glazes and/or Techniques available: F, P, TW, XTW.

Custom Modification Options

F.A.L.L. <sup>1</sup>
✓

<sup>1</sup>Only available on 10'.

**BASE SHOE MOULDING** **BSM** (Base Shoe 8')

**BSM10** (Base Shoe 10')

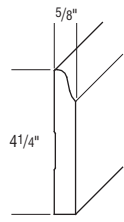

- BSM: 5/8" x 4 1/4" x 96".
- BSM10: 5/8" x 4 1/4" x 120".
- Designed for use only with Flush Toe Kick.
- Glazes and/or Techniques available: F, TW, XTW, HW, XHW.

Custom Modification Options

F.A.L.L. <sup>1</sup>
✓

<sup>1</sup>Only available on 10'.

**Description** **Model**

**DECORATIVE BASEBOARD MOULDING** **BBM8**

**BBM10**

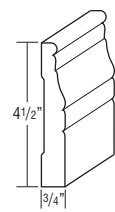

- BBM8: 3/4" x 4 1/2" x 96".
- BBM10: 3/4" x 4 1/2" x 120".
- Glazes and/or Techniques available: F, P, TW, XTW.

Custom Modification Options

F.A.L.L. <sup>1</sup>
✓

<sup>1</sup>Only available on 10'.

**NEW BASEBOARD MOULDING SHAKER** **BBMSH8**

**BBMSH10**

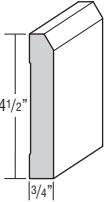

- BBMSH8: 3/4" x 4 1/2" x 96".
- BBMSH10: 3/4" x 4 1/2" x 120".
- Glazes and/or Techniques available: F, TW, XTW, HW, XHW.
- BBMSH10 only available in Cherry and Maple.

Custom Modification Options

F.A.L.L.
✓

**NEW BASEBOARD MOULDING SCULPTED** **BBMSC**

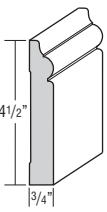

- BBMSC: 3/4" x 4 1/2" x 96".
- Glazes and/or Techniques available: F, P, TW, XTW, HW, XHW.

Custom Modification Options

F.A.L.L.
✓

**DECO BASEBOARD MOULDING** **DECOBBM**

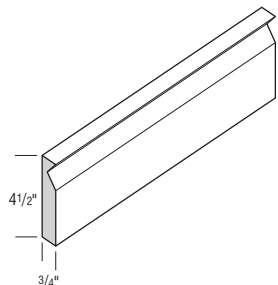

- 4 1/2" x 3/4" x 96".
- Alder will be used for Rustic Alder.
- Not available in Quartersawn Oak.

Custom Modification Options

F.A.L.L.
✓

8' mouldings will have 93"-99" of useable length.  
10' mouldings will have 117"-123" useable length.

**Glazes and Techniques**  
**F** = Flooded (see page E•3.)  
**P** = Penned (see page E•3.)  
**TW** = Timeworn (see page E•3.)  
**XTW** = Extra Timeworn (see page E•3.)  
**HW** = Hewn (see page E•3.)  
**XHW** = Extra Hewn (see page E•3.)

# Stack Moulding Kits

## Description

## Model

- Moulding stacks do not ship assembled; field assembly is required. Assembly instructions can be viewed in 20/20 spec pages and will also ship with moulding kits.
- When ordered as a kit, only one finish can be specified. To order with more than one finish, moulding pieces must be ordered separately.
- How to place a stack moulding in 20/20:

- Moulding
- Top Mouldings or Bottom Mouldings
- Stacked Mouldings
- Drag and drop desired moulding stack onto wall cabinets

### MOULDING STACK 5

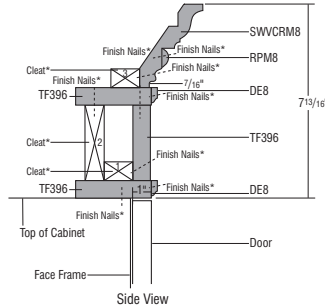
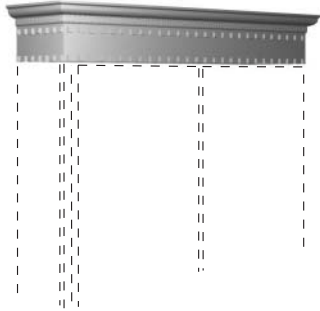

### STKMLD5D

- Includes:
  - 1 SWVCRM8
  - 1 RPM8
  - 2 DE8
  - 3 TF396
- Assembly instructions available upon request.
- \*Cleats and finish nails not included.

### MOULDING STACK 6

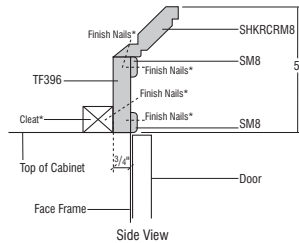
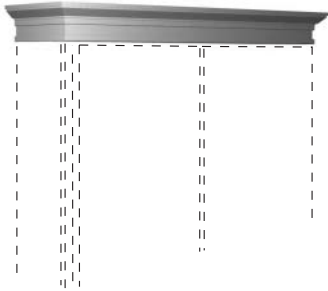

### STKMLD6D

- Includes:
  - 1 SHKRCRM8
  - 2 SM8
  - 1 TF396
- Assembly instructions available upon request.
- \*Cleats and finish nails not included.
- Not recommended for use when taking application to the ceiling.

### MOULDING STACK 7

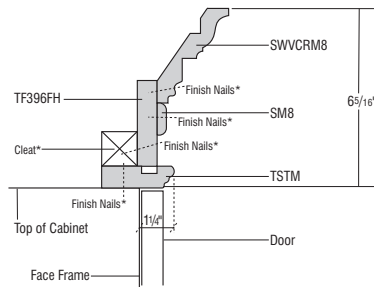
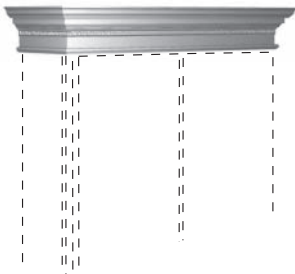

### STKMLD7D

- Includes:
  - 1 SWVCRM8
  - 1 SM8
  - 1 TF396
  - 1 TSTM
- Assembly instructions available upon request.
- \*Cleats and finish nails not included.

### MOULDING STACK 11

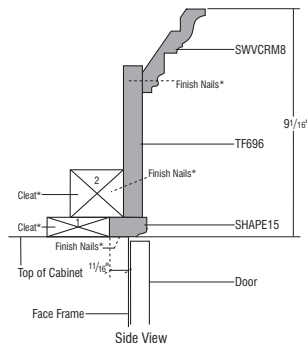

### STKMLD11D

- Includes:
  - 1 SWVCRM8
  - 1 TF696
  - 1 SHAPE15
- Assembly instructions available upon request.
- \*Cleats and finish nails not included.

## Description

## Model

- Moulding stacks do not ship assembled; field assembly is required. Assembly instructions can be viewed in 20/20 spec pages and will also ship with moulding kits.
- When ordered as a kit, only one finish can be specified. To order with more than one finish, moulding pieces must be ordered separately.
- How to place a stack moulding in 20/20:

- Moulding
- Top Mouldings or Bottom Mouldings
- Stacked Mouldings
- Drag and drop desired moulding stack onto wall cabinets

### MOULDING STACK 19

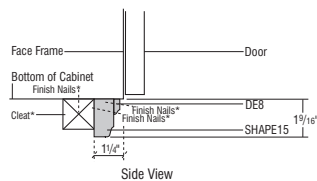
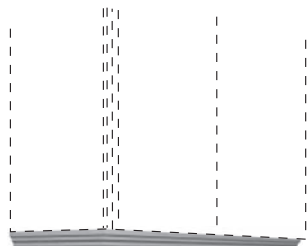

### STKMLD19D

- Includes:
  - 1 DE8
  - 1 SHAPE15
- Assembly instructions available upon request.
- \*Cleats and finish nails not included.

### MOULDING STACK 22

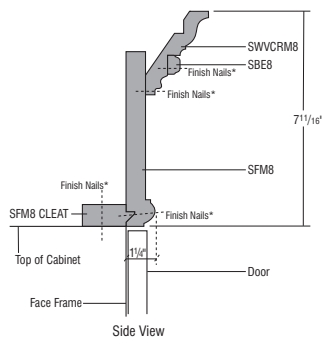
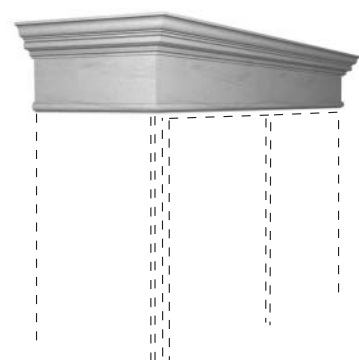

### STKMLD22D

- Includes:
  - 1 SWVCRM8
  - 1 SBE8
  - 1 SFM8
- Assembly instructions available upon request.
- \*Cleats and finish nails not included.

### MOULDING STACK 23

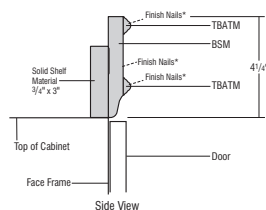
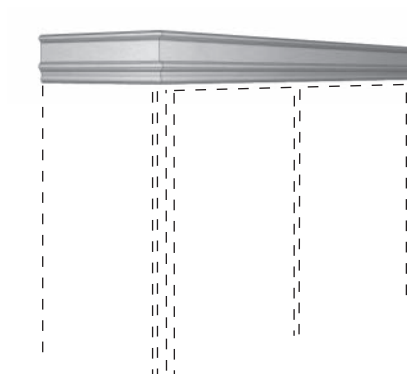

### STKMLD23D

- Includes:
  - 2 TBATM
  - 1 SHELSLD
  - 1 BSM
- Assembly instructions available upon request.
- \*Cleats and finish nails not included.



# Stack Moulding Kits

## Description

## Model

- Moulding stacks do not ship assembled; field assembly is required. Assembly instructions can be viewed in 20/20 spec pages and will also ship with moulding kits.
- When ordered as a kit, only one finish can be specified. To order with more than one finish, moulding pieces must be ordered separately.
- How to place a stack moulding in 20/20:

- Moulding
- Top Mouldings or Bottom Mouldings
- Stacked Mouldings
- Drag and drop desired moulding stack onto wall cabinets

### MOULDING STACK 25

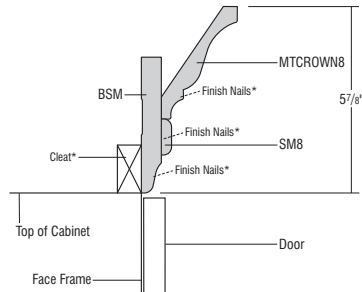
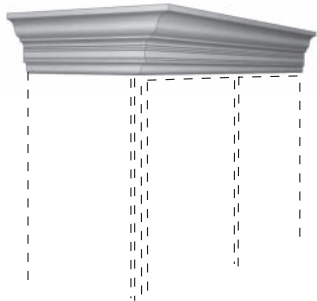

### STKMLD25D

- Includes:
  - 1 MTCROWN8
  - 1 SM8
  - 1 BSM
- Assembly instructions available upon request.
- \*Cleats and finish nails not included.

### MOULDING STACK 26

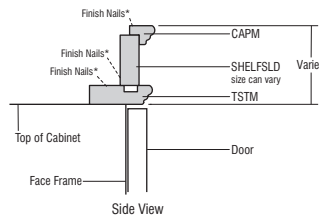
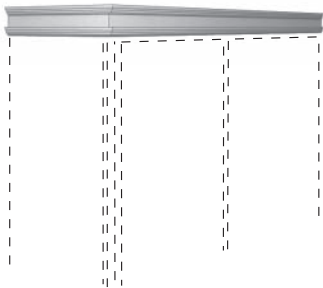

### STKMLD26D

- Includes:
  - 1 CAPM
  - 1 SHELFSLD
  - 1 TSTM
- Assembly instructions available upon request.
- \*Cleats and finish nails not included.
- Not recommended for use when taking application to the ceiling.

### MOULDING STACK 27

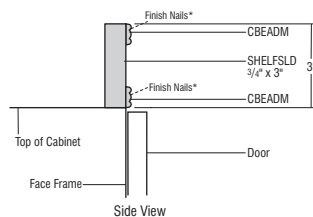
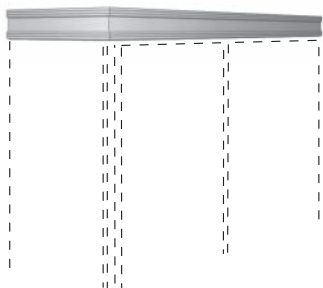

### STKMLD27D

- Includes:
  - 2 CBEADM
  - 1 SHELFSLD
- Assembly instructions available upon request.
- \*Cleats and finish nails not included.

### MOULDING STACK 28

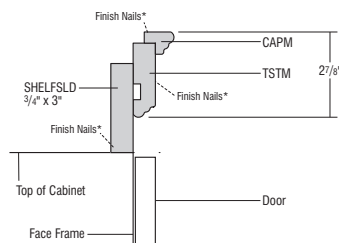
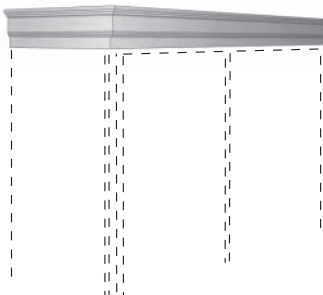

### STKMLD28D

- Includes:
  - 1 CAPM
  - 1 TSTM
  - 1 SHELFSLD
- Assembly instructions available upon request.
- \*Cleats and finish nails not included.
- Not recommended for use when taking application to the ceiling.

## Description

## Model

- Moulding stacks do not ship assembled; field assembly is required. Assembly instructions can be viewed in 20/20 spec pages and will also ship with moulding kits.
- When ordered as a kit, only one finish can be specified. To order with more than one finish, moulding pieces must be ordered separately.
- How to place a stack moulding in 20/20:

- Moulding
- Top Mouldings or Bottom Mouldings
- Stacked Mouldings
- Drag and drop desired moulding stack onto wall cabinets

### MOULDING STACK 31

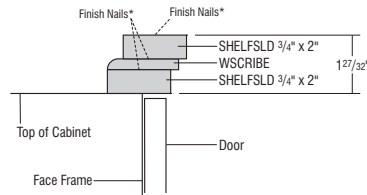
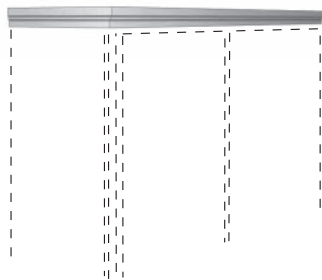

### STKMLD31D

- Includes:
  - 2 SHELFSLD
  - 1 WSCRIBE
- Assembly instructions available upon request.
- \*Cleats and finish nails not included.
- Not recommended for use when taking application to the ceiling.

### MOULDING STACK 32

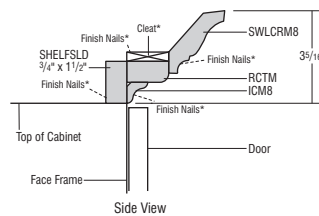
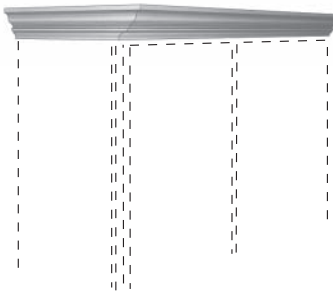

### STKMLD32D

- Includes:
  - 1 SWLCRM8
  - 1 SHELFSLD
  - 1 RCTM
  - 1 ICM8
- Assembly instructions available upon request.
- \*Cleats and finish nails not included.

### MOULDING STACK 33

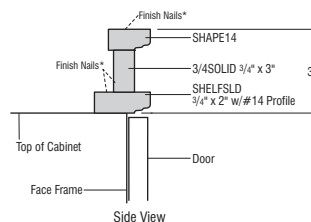
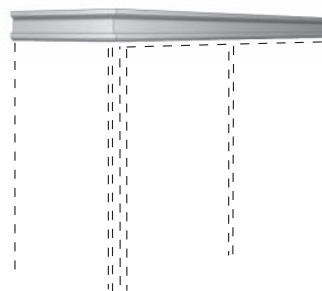

### STKMLD33D

- Includes:
  - 1 SHAPET4
  - 1 SHELFSLD
  - 1 3/4SOLID
- Assembly instructions available upon request.
- \*Cleats and finish nails not included.

### MOULDING STACK 36

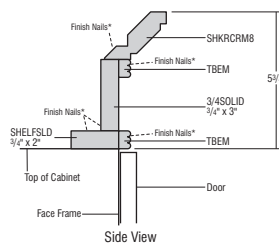
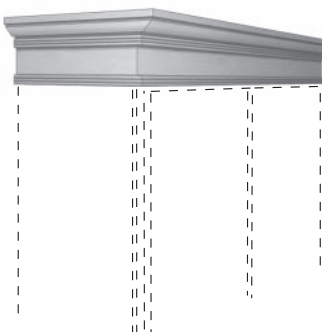

### STKMLD36D

- Includes:
  - 1 SHKRCRM8
  - 2 TBEM
  - 1 SHELFSLD
  - 1 3/4SOLID
- Assembly instructions available upon request.
- \*Cleats and finish nails not included.
- Not recommended for use when taking application to the ceiling.

# Stack Moulding Kits

## Description

## Model

- Moulding stacks do not ship assembled; field assembly is required. Assembly instructions can be viewed in 20/20 spec pages and will also ship with moulding kits.
- When ordered as a kit, only one finish can be specified. To order with more than one finish, moulding pieces must be ordered separately.
- How to place a stack moulding in 20/20:

- Moulding
- Top Mouldings or Bottom Mouldings
- Stacked Mouldings
- Drag and drop desired moulding stack onto wall cabinets

### MOULDING STACK 37

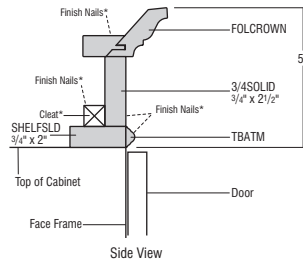

### STKMLD37D

- Includes:
  - 1 FOLCROWN
  - 1 SHELFSLD
  - 1 3/4SOLID
  - 1 TBATM
- Assembly instructions available upon request.
- \*Cleats and finish nails not included.
- Not recommended for use when taking application to the ceiling.

### MOULDING STACK 38

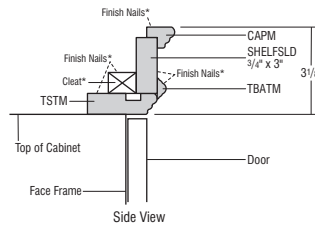
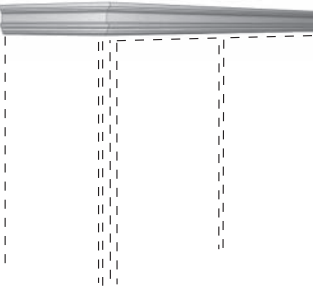

### STKMLD38D

- Includes:
  - 1 CAPM
  - 1 SHELFSLD
  - 1 TBATM
  - 1 TSTM
- Assembly instructions available upon request.
- \*Cleats and finish nails not included.
- Not recommended for use when taking application to the ceiling.

### MOULDING STACK 39

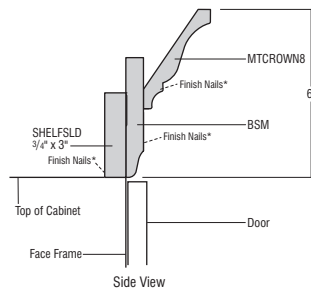
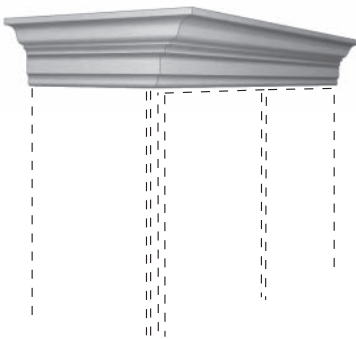

### STKMLD39D

- Includes:
  - 1 MTCROWN8
  - 1 BSM
  - 1 SHELFSLD
- Assembly instructions available upon request.
- \*Cleats and finish nails not included.

### MOULDING STACK 40

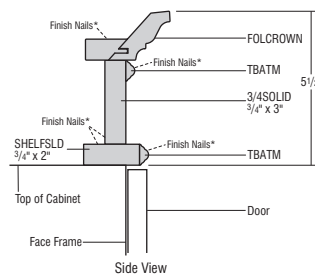

### STKMLD40D

- Includes:
  - 1 FOLCROWN
  - 1 SHELFSLD
  - 1 3/4SOLID
  - 2 TBATM
- Assembly instructions available upon request.
- \*Cleats and finish nails not included.
- Not recommended for use when taking application to the ceiling.

## Description

## Model

- Moulding stacks do not ship assembled; field assembly is required. Assembly instructions can be viewed in 20/20 spec pages and will also ship with moulding kits.
- When ordered as a kit, only one finish can be specified. To order with more than one finish, moulding pieces must be ordered separately.
- How to place a stack moulding in 20/20:

- Moulding
- Top Mouldings or Bottom Mouldings
- Stacked Mouldings
- Drag and drop desired moulding stack onto wall cabinets

### MOULDING STACK 41

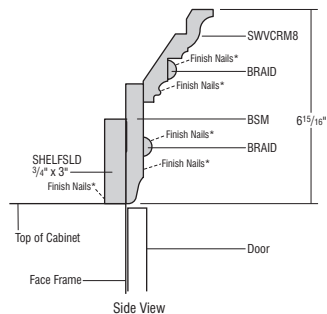
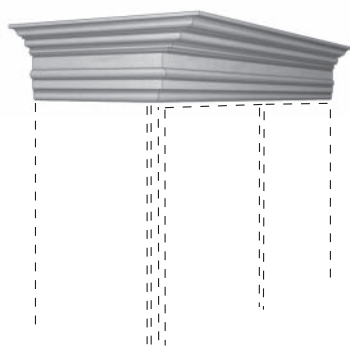

### STKMLD41D

- Includes:
  - 1 SWVCRM8
  - 2 BRAIDM
  - 1 BSM
  - 1 SHELFSLD
- Assembly instructions available upon request.
- \*Cleats and finish nails not included.

### MOULDING STACK 42

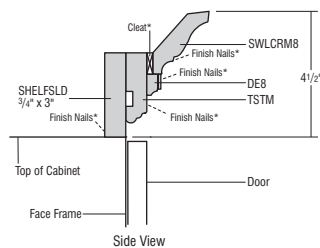
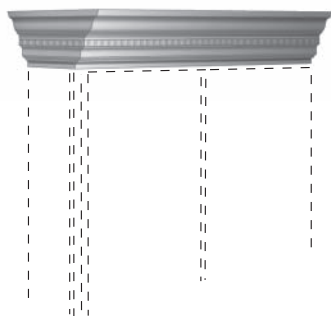

### STKMLD42D

- Includes:
  - 1 SWLCRM8
  - 1 DE8
  - 1 TSTM
  - 1 SHELFSLD
- Assembly instructions available upon request.
- \*Cleats and finish nails not included.

### MOULDING STACK 43

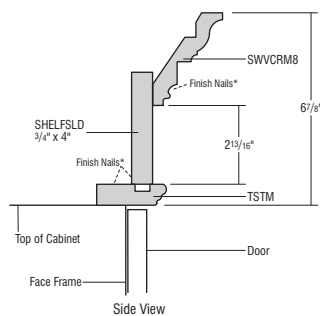
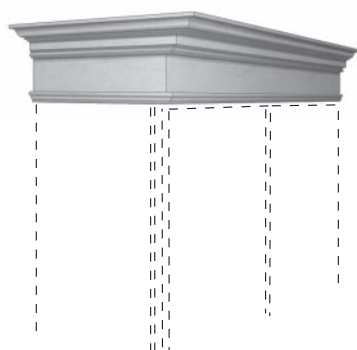

### STKMLD43D

- Includes:
  - 1 SWVCRM8
  - 1 SHELFSLD
  - 1 TSTM
- Assembly instructions available upon request.
- \*Cleats and finish nails not included.

### MOULDING STACK 44

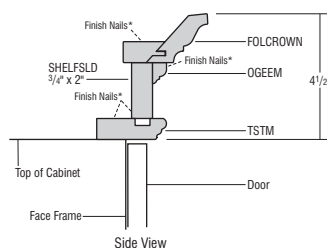

### STKMLD44D

- Includes:
  - 1 FOLCROWN
  - 1 OGEEM
  - 1 SHELFSLD
  - 1 TSTM
- Assembly instructions available upon request.
- \*Cleats and finish nails not included.
- Not recommended for use when taking application to the ceiling.

# Mouldings & Embellishments

Description	Model
<b>ROSETTES</b>	

## TRADITIONAL ROSETTE

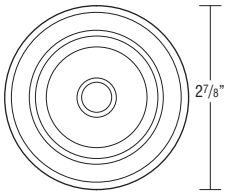

## TROSETTE

- 2 7/8" diameter x 3/8" thick.
- Alder will be used for Rustic Alder.
- Beech will be used for Quartersawn Oak.
- Glazes and/or Techniques available: F, P, HW, XHW.

Custom Modification Options

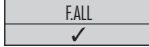

## FLOWER ROSETTE

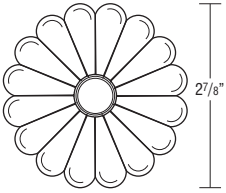

## ROSETTEFLW

- 2 7/8" diameter x 3/8" thick.
- Beech will be used for Quartersawn Oak.
- Not available in Alder or Rustic Alder.
- Glazes and/or Techniques available: F, P, HW, XHW.

Custom Modification Options



## GRAPE ROSETTE

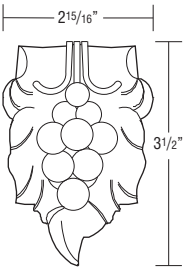

## GRO

- 2 5/16" wide x 3 1/2" high x 5/8" thick.
- Alder will be used for Rustic Alder.
- Beech will be used for Quartersawn Oak.
- Glazes and/or Techniques available: F, P, HW, XHW.

Custom Modification Options



## ACANTHUS ROSETTE

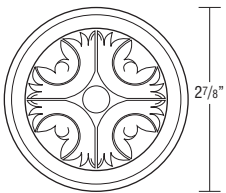

## ROSETTEACA

- 2 7/8" diameter x 3/8" thick.
- Beech will be used for Quartersawn Oak.
- Not available in Alder or Rustic Alder.
- Glazes and/or Techniques available: F, P, HW, XHW.

Custom Modification Options



## MISSION ROSETTE

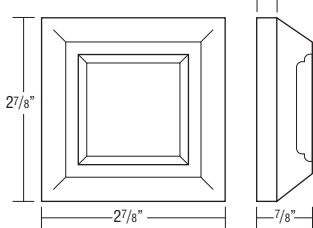

## ROSETTEMIS

- 2 7/8" wide x 2 7/8" high.
- Alder will be used for Rustic Alder.
- Oak will be used for Quartersawn Oak.
- Hand-carved.
- Glazes and/or Techniques available: F, P, HW, XHW.

Custom Modification Options



Description	Model
<b>SMALL GAELIC ROSETTE</b>	<b>ROSETTEGAE</b>

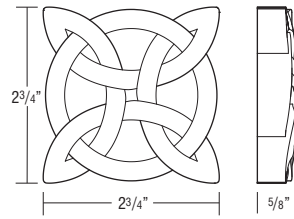

- 2 3/4" x 5/8" x 2 3/4".
- Alder will be used for Rustic Alder.
- Not available in Quartersawn Oak.

Custom Modification Options



## PEAKED SMALL ROSETTE

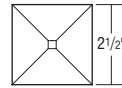

## ROSETTESMPK

- 2 1/2" wide x 2 1/2" high.
- Rustic hammered iron finish.
- 7/32" x 1/2" deep installation socket.

Modifications Are Not Available

## PEAKED LARGE ROSETTE

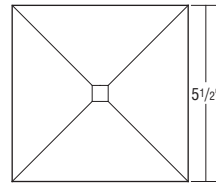

## ROSETTELGPK

- 5 1/2" wide x 5 1/2" high.
- Rustic hammered iron finish.
- 7/32" x 1/2" deep installation socket.

Modifications Are Not Available

## ACCESSORY NAILS

### ACCESSORY NAIL

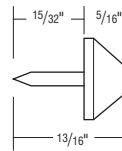

### ACCNAIL

- Rustic hammered iron finish.
- Sold in sets of ten.

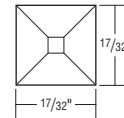

Modifications Are Not Available

## SPLIT TURN END/CAP

### 3" SPLIT TURNING CENTER

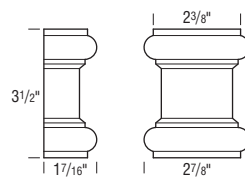

### 3SPRINGCTR

- 2 7/8" x 1 13/32" x 3 1/2".
- Alder will be used for Rustic Alder.
- Not available in Quartersawn Oak.

Custom Modification Options



### Glazes and Techniques

- F = Flooded (see page E•3.)
- P = Penned (see page E•3.)
- TW = Timeworn (see page E•3.)
- XTW = Extra Timeworn (see page E•3.)
- HW = Hewn (see page E•3.)
- XHW = Extra Hewn (see page E•3.)

**Description** **3" SPLIT TURNING ACANTHUS**

**Model** **3SPRINGACA**

- 2 7/8" x 1 3/8" x 4 3/4"
- Alder will be used for Rustic Alder.
- Not available in Quartersawn Oak.

Custom Modification Options

F.ALL ✓

**Description** **3" SPLIT TURNING WEAVED**

**Model** **3SPRINGWV**

- 3" x 1 7/16" x 3 1/2"
- Alder will be used for Rustic Alder.
- Not available in Quartersawn Oak.

Custom Modification Options

F.ALL ✓

**Description** **3" SPLIT TURNING BLOCK**

**Model** **3SPRINGBLK**

- 3" x 1 7/16" x 5 3/4"
- Alder will be used for Rustic Alder.
- Not available in Quartersawn Oak.

Custom Modification Options

F.ALL ✓

**Description** **3" SPLIT TURNING CAPITOL**

**Model** **3SPRINGCAP**

- 3" x 1 7/16" x 1 1/4"
- Alder will be used for Rustic Alder.
- Not available in Quartersawn Oak.

Custom Modification Options

F.ALL ✓

**Description** **3" SPLIT TURNING SPINDLE**

**Model** **3SPRINGSPNDL**

- 2 7/8" x 1 7/16" x 1 3/4"
- Alder will be used for Rustic Alder.
- Not available in Quartersawn Oak.

Custom Modification Options

F.ALL ✓

## SPLIT TURNING SYSTEMS

**END** **SPRINGEND**

**Front View** **Side View**

- Alder will be used for Rustic Alder.
- Oak will be used for Quartersawn Oak.
- Sold in pairs.
- Glazes and/or Techniques available: F, P, TW, XTW, HW, XHW.

Modifications Are Not Available

**Description** **REED**

**Model** **SPRINGREED30**  
**SPRINGREED60**  
**SPRINGREED96**

- Alder will be used for Rustic Alder.
- Oak will be used for Quartersawn Oak.
- Sold in 30", 60", or 96" lengths.
- Ends (SPRINGEND) sold separately.
- Glazes and/or Techniques available: F, P, TW, XTW.

Modifications Are Not Available

**Description** **ROPE**

**Model** **SPRINGROPE30**  
**SPRINGROPE60**  
**SPRINGROPE96**

- Alder will be used for Rustic Alder.
- Oak will be used for Quartersawn Oak.
- Sold in 30", 60", or 96" lengths.
- Ends (SPRINGEND) sold separately.
- Glazes and/or Techniques available: F, P, TW, XTW, HW, XHW.

Modifications Are Not Available

**Description** **SPOOL**

**Model** **SPRINGSPPOOL30**  
**SPRINGSPPOOL60**  
**SPRINGSPPOOL96**

- Alder will be used for Rustic Alder.
- Oak will be used for Quartersawn Oak.
- Sold in 30", 60", or 96" lengths.
- Ends (SPRINGEND) sold separately.
- Glazes and/or Techniques available: F, TW, XTW.

Modifications Are Not Available

**Glazes and Techniques**

F = Flooded (see page E•3.)  
P = Penned (see page E•3.)  
TW = Timeworn (see page E•3.)  
XTW = Extra Timeworn (see page E•3.)  
HW = Hewn (see page E•3.)  
XHW = Extra Hewn (see page E•3.)

# Mouldings & Embellishments

Description Model

---

## VALANCES

### 30" CRAFTSMAN VALANCE

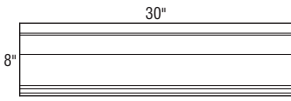

#### CRTSMNV30

- 8" x 3/4" x 30"
- Alder will be used for Rustic Alder.
- Not available in Quartersawn Oak.

Custom Modification Options

F.ALL	IH	IW	RH	RW
<input checked="" type="checkbox"/>	<input type="checkbox"/>	<input type="checkbox"/>	<input type="checkbox"/>	<input type="checkbox"/>

### 30" DECO VALANCE

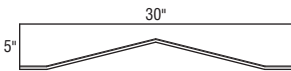

#### DECOV30

- 30" x 3/4" x 5"
- Alder will be used for Rustic Alder.
- Not available in Quartersawn Oak.

Custom Modification Options

F.ALL	IH	IW	OONLY	RH	RW
<input checked="" type="checkbox"/>	<input type="checkbox"/>	<input type="checkbox"/>	<input type="checkbox"/>	<input type="checkbox"/>	<input type="checkbox"/>

### 30" PINNACLE VALANCE

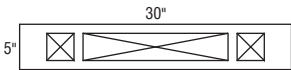

#### PINNV30

- 5" x 3/4" x 30"
- Alder will be used for Rustic Alder.
- Not available in Quartersawn Oak.

Custom Modification Options

F.ALL	IH	IW	OONLY	RH	RW
<input checked="" type="checkbox"/>	<input type="checkbox"/>	<input type="checkbox"/>	<input type="checkbox"/>	<input type="checkbox"/>	<input type="checkbox"/>

### BAROQUE VALANCE



#### BARV38

- 6" x 5/8" x 38"
- Alder will be used for Rustic Alder.
- Not available in Quartersawn Oak.

Custom Modification Options

F.ALL	IH	IW	OONLY	RH	RW
<input checked="" type="checkbox"/>	<input type="checkbox"/>	<input type="checkbox"/>	<input type="checkbox"/>	<input type="checkbox"/>	<input type="checkbox"/>

#### Glazes and Techniques

- F = Flooded (see page E•3.)
- P = Penned (see page E•3.)
- TW = Timeworn (see page E•3.)
- XTW = Extra Timeworn (see page E•3.)
- HW = Hewn (see page E•3.)
- XHW = Extra Hewn (see page E•3.)

Description Model

---

## RAISED PANEL VALANCE

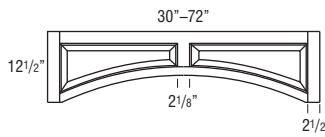

#### RPV30

#### JRPV36

#### JRPV42

#### RPV48

#### RPV54

#### RPV60

#### RPV72

- There is 8" from the top edge to the center of the arch. There is 4 1/2" from the center of the arch to the bottom of the part.
- Sides trimmable up to 1 3/4".
- Glazes and/or Techniques available: F, P, TW, XTW, HW, XHW.

Modifications  
Are Not  
Available

## RECESSED PANEL VALANCE

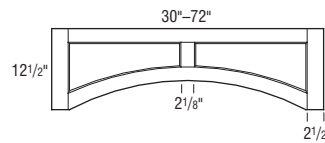

#### RCPV30

#### RCPV36

#### RCPV42

#### RCPV48

#### RCPV54

#### RCPV60

#### RCPV72

- There is 8" from the top edge to the center of the arch. There is 4 1/2" from the center of the arch to the bottom of the part.
- Sides trimmable up to 1 3/4".
- Glazes and/or Techniques available: F, P, TW, XTW, HW, XHW.

Modifications  
Are Not  
Available

## ARCH VALANCE

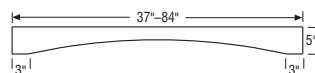

#### AV37

#### AV43

#### AV49

#### AV55

#### AV61

#### AV67

#### AV73

#### AV79

#### AV84

- Alder will be used for Rustic Alder.
- There is 2 5/16" from the top edge to the center of the arch.
- Increased Heights available in 1/4" increments from 5 1/4" to 12".
- Reduced Heights available in 1/4" increments from 4 1/2" to 4 3/4".
- Height must be less than or equal to 6" if width is more than 60".
- Increased Widths available in 1/4" increments. See page G•46 for details.
- Glazes and/or Techniques available: TW, XTW.

Custom Modification Options

F.ALL	IH	IW <sup>1</sup>	OONLY	RH	RW
<input checked="" type="checkbox"/>	<input checked="" type="checkbox"/>	<input checked="" type="checkbox"/>	<input checked="" type="checkbox"/>	<input checked="" type="checkbox"/>	<input checked="" type="checkbox"/>

<sup>1</sup>Only available on 84" wide.

Description	Model
<b>STRAIGHT VALANCE</b> 	<b>VV37</b>
	<b>VV43</b>
	<b>VV49</b>
	<b>VV55</b>
	<b>VV61</b>
	<b>VV67</b>
	<b>VV73</b>
	<b>VV79</b>
	<b>VV84</b>

- Alder will be used for Rustic Alder.
- Increased Heights available in 1/4" increments from 5 1/4" to 12".
- Reduced Heights available in 1/4" increments from 4 1/2" to 4 3/4".
- Height must be less than or equal to 6" if width is more than 60".
- Increased Widths available in 1/4" increments. See page G•46 for details.
- All edges finished excluding the back.
- Glazes and/or Techniques available: TW, XTW.

Custom Modification Options

F	ALL	IH	IW <sup>1</sup>	RH	RW
		✓	✓	✓	✓

<sup>1</sup>Only available on 84" wide.

<b>OVERLAY VALANCE (FULL OVERLAY STYLES ONLY)</b> 	<b>OSV37</b>
	<b>OSV43</b>
	<b>OSV49</b>
	<b>OSV55</b>
	<b>OSV61</b>
	<b>OSV67</b>
	<b>OSV73</b>
	<b>OSV79</b>
	<b>OSV84</b>

- Alder will be used for Rustic Alder.
- Increased Heights available in 1/4" increments from 5 1/4" to 12".
- Reduced Heights available in 1/4" increments from 4 1/2" to 4 3/4".
- Height must be less than 12" if width of 60" is required.
- Increased Widths available in 1/4" increments. See page G•46 for details.
- All edges finished excluding the back.
- Glazes and/or Techniques available: F, TW, XTW, HW, XHW.

Custom Modification Options

F	ALL	IH	IW <sup>1</sup>	RH	RW
✓		✓	✓	✓	✓

<sup>1</sup>Only available on 84" wide.

### Glazes and Techniques

F = Flooded (see page E•3.)  
P = Penned (see page E•3.)  
TW = Timeworn (see page E•3.)  
XTW = Extra Timeworn (see page E•3.)  
HW = Hewn (see page E•3.)  
XHW = Extra Hewn (see page E•3.)



# Mouldings & Embellishments

Description Model  
**DECORATIVE ONLAYS/OVERLAYS**

**GRAPE** **GROVLY**

- 20" wide x 4 1/2" high x 5/8" deep.
- Alder will be used for Rustic Alder.
- Beech will be used for Quartersawn Oak.
- Glazes and/or Techniques available: F, P, HW, XHW.

Modifications Are Not Available

**ACANTHUS** **ACOVLV**

- 20" wide x 4 1/2" high x 5/8" deep.
- Alder will be used for Rustic Alder.
- Beech will be used for Quartersawn Oak.
- Glazes and/or Techniques available: F, P, HW, XHW.

Modifications Are Not Available

**DECORATIVE ORNAMENTS**

**ACANTHUS** **ACO**

- 2 7/8" wide x 5" high x 1 1/2" deep.
- Not available in Alder or Rustic Alder.
- Beech will be used for Quartersawn Oak.
- Glazes and/or Techniques available: F, P, HW, XHW.

Modifications Are Not Available

**Glazes and Techniques**  
 F = Flooded (see page E•3.)  
 P = Penned (see page E•3.)  
 TW = Timeworn (see page E•3.)  
 XTW = Extra Timeworn (see page E•3.)  
 HW = Hewn (see page E•3.)  
 XHW = Extra Hewn (see page E•3.)

Description Model  
**TILE**

**TRIAD ROSETTE** **ROSETTETRIAD**

- 2 15/16" x 7/8".
- Alder will be used for Rustic Alder.
- Not available in Quartersawn Oak.

Custom Modification Options

F.ALL  
✓

**PINNACLE ROSETTE** **ROSETTEPINN**

- 5 15/16" x 3/4" x 2 15/16".
- Alder will be used for Rustic Alder.
- Not available in Quartersawn Oak.

Custom Modification Options

F.ALL  
✓

**SHELVING**

**30" x 30" RUSTIC CORNER SHELF** **RSTCCRNHLF**

- 30" x 30" x 3/4".
- Brackets sold separately; see Bracket section.
- Alder will be used for Rustic Alder.
- Not available in Quartersawn Oak.
- Top and bottom are finished and 4 sides are finished except the back 2 sides. To get all sides finished, please select the Finished All Modification (F.ALL).

Custom Modification Options

F.ALL  
✓

**30" x 30" MODERN CORNER SHELF** **MDCCRNHLF**

- 30" x 30" x 3/4".
- Brackets sold separately; see Bracket section.
- Alder will be used for Rustic Alder.
- Not available in Quartersawn Oak.
- Top and bottom are finished and 4 sides are finished except the back 2 sides. To get all sides finished, please select the Finished All Modification (F.ALL).

Custom Modification Options

F.ALL  
✓

**30" x 30" RUSTIC FLOATING CORNER SHELF** **RSTFLTCRNHLF**

- 30" x 30" x 2 5/8".
- Installation kit included with shelf.
- Alder will be used for Rustic Alder.
- Not available in Quartersawn Oak.

Custom Modification Options

F.ALL  
✓

**30" x 30" MODERN FLOATING CORNER SHELF** **MDFLCRNHLF**

- 30" x 30" x 2 5/8".
- Installation kit included with shelf.
- Alder will be used for Rustic Alder.
- Not available in Quartersawn Oak.

Custom Modification Options

F.ALL  
✓

**Description**  
**36" x 8" INDUSTRIAL SHELF**

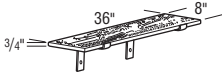

**Shown with brackets**

**Model**  
**SHELFIND3681**

- 36" x 8" x 3/4".
- Brackets sold separately; see Corbels and Brackets section.
- Alder will be used for Rustic Alder.
- Oak will be used for Quartersawn Oak.
- Shelf has a rough hewn appearance.
- Top and bottom are finished and 3 sides are finished except the back side. To get all sides finished, please select the Finished All Modification (F.ALL).

Custom Modification Options

F.ALL
✓

**Description**  
**36" x 12" INDUSTRIAL SHELF**

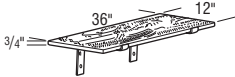

**Shown with brackets**

**Model**  
**SHELFIND36121**

- 36" x 12" x 3/4".
- Brackets sold separately; see Corbels and Brackets section.
- Alder will be used for Rustic Alder.
- Oak will be used for Quartersawn Oak.
- Shelf has a rough hewn appearance.
- Top and bottom are finished and 3 sides are finished except the back side. To get all sides finished, please select the Finished All Modification (F.ALL).

Custom Modification Options

F.ALL
✓

**Description**  
**60" x 8" INDUSTRIAL SHELF**

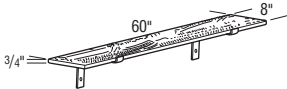

**Shown with brackets**

**Model**  
**SHELFIND6081**

- 60" x 8" x 3/4".
- Brackets sold separately; see Corbels and Brackets section.
- Alder will be used for Rustic Alder.
- Oak will be used for Quartersawn Oak.
- Shelf has a rough hewn appearance.
- Top and bottom are finished and 3 sides are finished except the back side. To get all sides finished, please select the Finished All Modification (F.ALL).

Custom Modification Options

F.ALL
✓

**Description**  
**60" x 12" INDUSTRIAL SHELF**

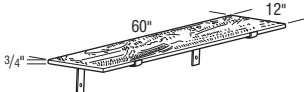

**Shown with brackets**

**Model**  
**SHELFIND60121**

- 60" x 12" x 3/4".
- Brackets sold separately; see Corbels and Brackets section.
- Alder will be used for Rustic Alder.
- Oak will be used for Quartersawn Oak.
- Shelf has a rough hewn appearance.
- Top and bottom are finished and 3 sides are finished except the back side. To get all sides finished, please select the Finished All Modification (F.ALL).

Custom Modification Options

F.ALL
✓

**Description**  
**24" x 10" FLOATING SHELF**



**Model**  
**SHELFIND24103**

- 24" x 10" x 2 5/8".
- Installation kit included with shelf.
- Alder will be used for Rustic Alder.
- Oak will be used for Quartersawn Oak.
- Shelf has a rough hewn appearance.

Custom Modification Options

F.ALL
✓

**Description**  
**36" x 10" FLOATING SHELF**



**Model**  
**SHELFIND36103**

- 36" x 10" x 2 5/8".
- Installation kit included with shelf.
- Alder will be used for Rustic Alder.
- Oak will be used for Quartersawn Oak.
- Shelf has a rough hewn appearance.

Custom Modification Options

F.ALL
✓

**Description**  
**FLOATING SHELF, 2 1/2" HIGH, 10" DEEP**

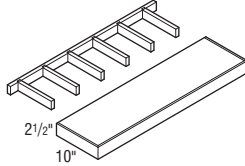

**Model**  
**FS24**  
**FS30**  
**FS36**  
**FS42**  
**FS48**  
**FS54**  
**FS60**

- Installation instructions included.
- Weight capacity is 15 lbs. per linear foot of width.
- Edge will be a #12 profile.

Custom Modification Options

F.ALL
✓

## SHELF SUPPORTS

**LARGE GRAPE SHELF SUPPORT**

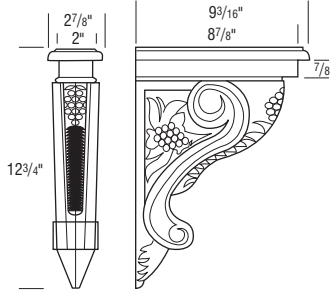

**LGGRPSUPPORT**

- 2 7/8" wide x 12 3/4" high.
- Not available in Alder or Rustic Alder.
- Oak will be used for Quartersawn Oak.
- Glazes and/or Techniques available: F, P, TW, XTW, HW, XHW.

Modifications Are Not Available

**SMALL GRAPE SHELF SUPPORT**

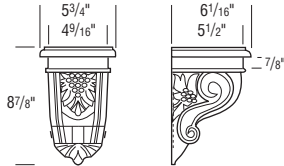

**SMGRPSUPPORT**

- 5 3/4" wide x 8 7/8" high.
- Not available in Alder or Rustic Alder.
- Oak will be used for Quartersawn Oak.
- Glazes and/or Techniques available: F, P, TW, XTW, HW, XHW.

Modifications Are Not Available

**LARGE SHELF SUPPORT**

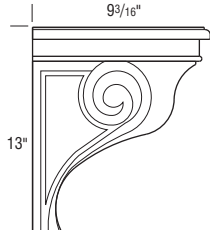

**LGCORBEL**

- 2 7/8" wide x 13" high.
- Alder will be used for Rustic Alder.
- Oak will be used for Quartersawn Oak.
- Glazes and/or Techniques available: F, P, TW, XTW, HW, XHW.

Modifications Are Not Available

**Glazes and Techniques**  
**F** = Flooded (see page E•3.)  
**P** = Penned (see page E•3.)  
**TW** = Timeworn (see page E•3.)  
**XTW** = Extra Timeworn (see page E•3.)  
**HW** = Hewn (see page E•3.)  
**XHW** = Extra Hewn (see page E•3.)

# Mouldings & Embellishments

## Description

### SMALL SHELF SUPPORT

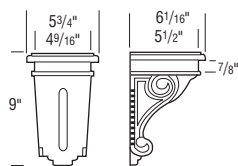

## Model

### SMCORBEL

- 5 3/4" wide x 9" high.
- Alder will be used for Rustic Alder.
- Oak will be used for Quartersawn Oak.
- Glazes and/or Techniques available: F, P, TW, XTW, HW, XHW.

Modifications  
Are Not  
Available

### COUNTERTOP SUPPORT

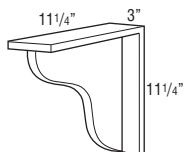

## SBS

- 3" wide x 11 1/4" high.
- Alder will be used for Rustic Alder.
- Glazes and/or Techniques available: F, P, TW, XTW, HW, XHW.

Modifications  
Are Not  
Available

### VICTORIAN COUNTERTOP SUPPORT VSBS

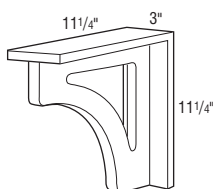

- 3" wide x 11 1/4" high.
- Alder will be used for Rustic Alder.
- Glazes and/or Techniques available: F, P, TW, XTW, HW, XHW.

Modifications  
Are Not  
Available

## CORBELS & BRACKETS

### 12" MID-CENTURY BRACKET

## TRIBRKT12GMG

## TRIBRKT12SN

## TRIBRKT12WI

## TRIBRKT12SS

- 12 5/8" x 3 3/4" x 6 7/8".
- Finishes available: Gun Metal Gray (GMG), Satin Nickel (SN), Wrought Iron (WI), and Stainless Steel (SS).
- Includes matching hardware.

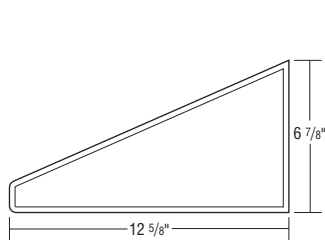

Modifications  
Are Not  
Available

#### Glazes and Techniques

- F = Flooded (see page E•3.)
- P = Penned (see page E•3.)
- TW = Timeworn (see page E•3.)
- XTW = Extra Timeworn (see page E•3.)
- HW = Hewn (see page E•3.)
- XHW = Extra Hewn (see page E•3.)

## Description

### 8 3/4" INDUSTRIAL BRACKET, LOOP

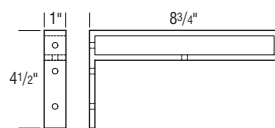

## Model

### BRACKETIND9SS

### BRACKETIND9GMG

### BRACKETIND9WI

- 1" x 8 3/4" x 4 1/2".
- On the stainless steel versions, the screws are countersunk.
- Finishes available: Stainless Steel (SS), Gun Metal Gray (GMG), and Wrought Iron (WI).

Modifications  
Are Not  
Available

### 12 3/4" INDUSTRIAL BRACKET, LOOP

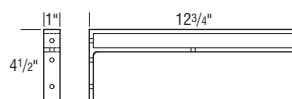

### BRACKETIND13SS

### BRACKETIND13GMG

### BRACKETIND13WI

- 1" x 12 3/4" x 4 1/2".
- On the stainless steel versions, the screws are countersunk.
- Finishes available: Stainless Steel (SS), Gun Metal Gray (GMG), and Wrought Iron (WI).

Modifications  
Are Not  
Available

### 8 1/2" INDUSTRIAL BRACKET, STRAIGHT

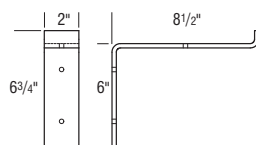

### STBRACKETIND9SS

### STBRACKETIND9G

### STBRACKETIND9WI

- 2" x 8 1/2" x 6".
- On the stainless steel versions, the screws are countersunk.
- Finishes available: Stainless Steel (SS), Gun Metal Gray (G), and Wrought Iron (WI).

Modifications  
Are Not  
Available

### 12 1/2" INDUSTRIAL BRACKET, STRAIGHT

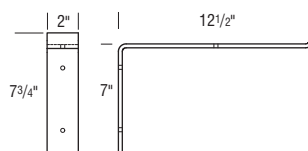

### STBRACKETIND13S

### STBRACKETIND13G

### STBRACKETIND13W

- 2" x 12 1/2" x 7".
- On the stainless steel versions, the screws are countersunk.
- Finishes available: Stainless Steel (S), Gun Metal Gray (G), and Wrought Iron (W).

Modifications  
Are Not  
Available

Description	Model
<b>10" LEXINGTON SHELF STRAP</b>	<b>LEXSHLFSTRP1OWI</b>
	<b>LEXSHLFSTRP1OGM</b>
	<b>LEXSHLFSTRP1OSN</b>

- 10 1/8" x 3" x 12 1/4".
- Finishes available: Gun Metal Gray (GM), Satin Nickel (SN), and Wrought Iron (WI).
- Includes matching hardware.

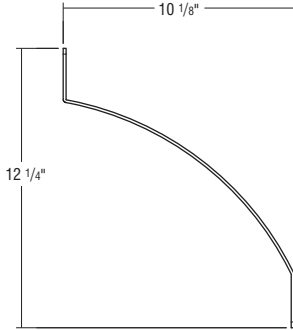

Modifications  
Are Not  
Available

Description	Model
<b>2" CORNER STRAP</b>	<b>APEXSTRP2GMG</b>
	<b>APEXSTRP2WI</b>
	<b>APEXSTRP2SN</b>

- 1/8" x 2" x 1".
- Decorative only.
- Square Lag Bolts included.
- Finishes available: Gun Metal Gray (GMG), Satin Nickel (SN), and Wrought Iron (WI).
- To be used with floating shelves.

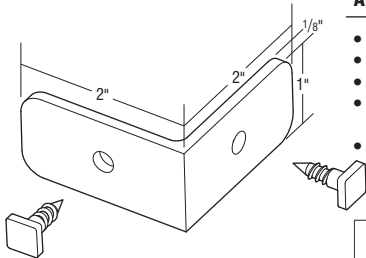

Modifications  
Are Not  
Available

Description	Model
<b>BAROQUE BRACKET</b>	<b>BRACKETBAROQUE</b>

- 5/8" x 5 7/8" x 10".
- Alder will be used for Rustic Alder.
- Not available in Quartersawn Oak.

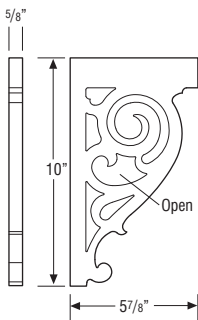

Modifications  
Are Not  
Available

Description	Model
<b>CELTIC BRACKET</b>	<b>BRACKETCELTIC</b>

- 5/8" x 7" x 7".
- Alder will be used for Rustic Alder.
- Not available in Quartersawn Oak.

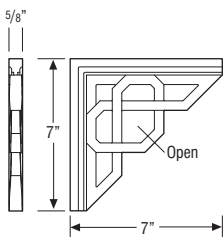

Modifications  
Are Not  
Available

Description	Model
<b>OLD WORLD BRACKET</b>	<b>BRACKETOWD</b>

- 2 7/8" wide x 9 3/8" high.
- Alder will be used for Rustic Alder.
- Glazes and/or Techniques available: F, P, TW, XTW, HW, XHW.

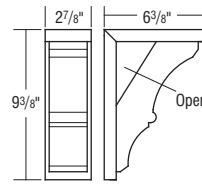

Custom Modification Options  
FALL  
✓

Description	Model
<b>CRAFTSMAN CORBEL OPEN</b>	<b>CORBELCRAFTO</b>

- 3 1/2" x 8" x 12".
- Alder will be used for Rustic Alder.

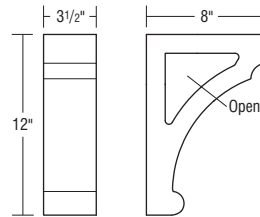

Custom Modification Options  
FALL  
✓

Description	Model
<b>CRAFTSMAN CORBEL</b>	<b>CORBELCRAFT</b>

- 1 1/2" x 8" x 12".
- Alder will be used for Rustic Alder.

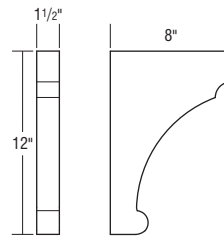

Custom Modification Options  
FALL  
✓

Description	Model
<b>10" CRAFTSMAN CORBEL</b>	<b>CORBELCRAFT10</b>

- 2 3/4" x 6" x 10".
- Alder will be used for Rustic Alder.

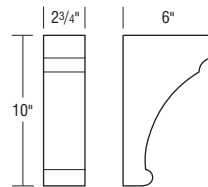

Custom Modification Options  
FALL  
✓

Description	Model
<b>12" CRAFTSMAN CORBEL</b>	<b>CORBELCRAFT12</b>

- 3 1/2" x 8" x 12".
- Alder will be used for Rustic Alder.

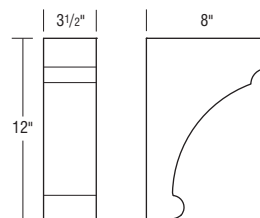

Custom Modification Options  
FALL  
✓

**Glazes and Techniques**  
**F** = Flooded (see page E•3.)  
**P** = Penned (see page E•3.)  
**TW** = Timeworn (see page E•3.)  
**XTW** = Extra Timeworn (see page E•3.)  
**HW** = Hewn (see page E•3.)  
**XHW** = Extra Hewn (see page E•3.)

# Mouldings & Embellishments

**Description**  
**18" CRAFTSMAN CORBEL**

**Model**  
**CORBELCRAFT18**

- 1 1/4" x 2 3/4" x 18"
- Alder will be used for Rustic Alder.
- Not available in Quartersawn Oak.

Custom Modification Options  
 F.A.L.L.

**Description**  
**34" CRAFTSMAN CORBEL**

**Model**  
**CORBELCRAFT34**

- 7" x 10" x 34"
- Alder will be used for Rustic Alder.
- Not available in Quartersawn Oak.

Custom Modification Options  
 F.A.L.L.

**Description**  
**7" PALLADIAN CORBEL**

**Model**  
**CORBELPALLA7**

- 3" x 3 7/8" x 7"
- Alder will be used for Rustic Alder.
- Not available in Quartersawn Oak.

Custom Modification Options  
 F.A.L.L.

**Description**  
**9" PALLADIAN CORBEL**

**Model**  
**CORBELPALLA9**

- 3 7/8" x 5" x 8 7/8"
- Alder will be used for Rustic Alder.
- Not available in Quartersawn Oak.

Custom Modification Options  
 F.A.L.L.

**Description**  
**14" PALLADIAN CORBEL**

**Model**  
**CORBELPALLA14**

- 6" x 8" x 14"
- Alder will be used for Rustic Alder.
- Not available in Quartersawn Oak.

Custom Modification Options  
 F.A.L.L.

**Description**  
**5" CLASSIC REVIVAL CORBEL**

**Model**  
**CORBELCLEV5**

- 1 1/4" x 5" x 5"
- Alder will be used for Rustic Alder.
- Not available in Quartersawn Oak.

Custom Modification Options  
 F.A.L.L.

**Description**  
**9" CLASSIC REVIVAL CORBEL**

**Model**  
**CORBELCLEV9**

- 3 3/4" x 9" x 9"
- Alder will be used for Rustic Alder.
- Not available in Quartersawn Oak.

Custom Modification Options  
 F.A.L.L.

**Description**  
**14" CLASSIC REVIVAL CORBEL**

**Model**  
**CORBELCLEV14**

- 3 3/4" x 9" x 14"
- Alder will be used for Rustic Alder.
- Not available in Quartersawn Oak.

Custom Modification Options  
 F.A.L.L.

**Description**  
**7" CELTIC CORBEL**

**Model**  
**CORBELCELTIC7**

- 3 1/2" x 3 7/8" x 6 5/8"
- Alder will be used for Rustic Alder.
- Not available in Quartersawn Oak.

Custom Modification Options  
 F.A.L.L.

**Description**  
**10" CELTIC CORBEL**

**Model**  
**CORBELCELTIC10**

- 4 3/4" x 5 3/4" x 9 1/2"
- Alder will be used for Rustic Alder.
- Not available in Quartersawn Oak.

Custom Modification Options  
 F.A.L.L.

**Description**  
**14" CELTIC CORBEL**

**Model**  
**CORBELCELTIC14**

- 5 1/2" x 7 1/8" x 14".
- Alder will be used for Rustic Alder.
- Not available in Quartersawn Oak.

Custom Modification Options  
F.ALL  
✓

**Description**  
**6" TRIAD CORBEL**

**Model**  
**CORBELTRIAD6**

- 3 3/4" x 4" x 5 1/2".
- Alder will be used for Rustic Alder.
- Not available in Quartersawn Oak.

Custom Modification Options  
F.ALL  
✓

**Description**  
**9" TRIAD CORBEL**

**Model**  
**CORBELTRIAD9**

- 7 1/2" x 6" x 8 1/4".
- Alder will be used for Rustic Alder.
- Not available in Quartersawn Oak.

Custom Modification Options  
F.ALL  
✓

**Description**  
**9" ART CORBEL**

**Model**  
**CORBELART9**

- 3 3/4" wide x 9" high.
- Alder will be used for Rustic Alder.
- Not available in Quartersawn Oak.
- Glazes and/or Techniques available: F, P, TW, XTW, HW, XHW.

Custom Modification Options  
F.ALL  
✓

**Description**  
**14" ARTS & CRAFTS CORBEL**

**Model**  
**CORBELART14**

- 4 1/2" x 7 1/2" x 14".
- Alder will be used for Rustic Alder.
- Not available in Quartersawn Oak.

Custom Modification Options  
F.ALL  
✓

**Description**  
**ARTS & CRAFTS OPEN CORBEL**

**Model**  
**CORBELARTO**

- 4 1/2" x 7 1/2" x 14".
- Alder will be used for Rustic Alder.
- Not available in Quartersawn Oak.

Custom Modification Options  
F.ALL  
✓

**Description**  
**7" PINNACLE CORBEL**

**Model**  
**CORBELPINN7**

- 3 7/8" x 3 1/2" x 6 11/16".
- Alder will be used for Rustic Alder.
- Not available in Quartersawn Oak.

Custom Modification Options  
F.ALL  
✓

**Description**  
**8" PINNACLE CORBEL**

**Model**  
**CORBELPINN8**

- 5 1/2" x 5" x 8".
- Alder will be used for Rustic Alder.
- Not available in Quartersawn Oak.

Custom Modification Options  
F.ALL  
✓

**Description**  
**12" PINNACLE CORBEL**

**Model**  
**CORBELPINN12**

- 9" x 7 1/4" x 12".
- Alder will be used for Rustic Alder.
- Not available in Quartersawn Oak.

Custom Modification Options  
F.ALL  
✓

**Description**  
**TRADITIONAL OPEN CORBEL**

**Model**  
**CORBELTRADO**

- 3 1/2" x 7" x 14".
- Alder will be used for Rustic Alder.
- Not available in Quartersawn Oak.

Custom Modification Options  
F.ALL  
✓

**Description**  
**3" SHAKER CORBEL**

**Model**  
**CORBELSHKR3**

- 1 1/4" x 1 1/2" x 3".
- Alder will be used for Rustic Alder.
- Not available in Quartersawn Oak.

Custom Modification Options  
F.ALL  
✓

**Description**  
**7" SHAKER CORBEL**

**Model**  
**CORBELSHKR7**

- 3 7/8" x 3 1/2" x 6 3/4".
- Alder will be used for Rustic Alder.

Custom Modification Options  
F.ALL  
✓

**Glazes and Techniques**  
**F** = Flooded (see page E•3.)  
**P** = Penned (see page E•3.)  
**TW** = Timeworn (see page E•3.)  
**XTW** = Extra Timeworn (see page E•3.)  
**HW** = Hewn (see page E•3.)  
**XHW** = Extra Hewn (see page E•3.)

# Mouldings & Embellishments

**Description**  
**14" SHAKER CORBEL**

**Model**  
**CORBELSHKR14**

- 5 5/8" x 6 3/4" x 13 3/8".
- Alder will be used for Rustic Alder.

Custom Modification Options  
F.A.L.L. ✓

**Description**  
**16" SHAKER CORBEL**

**Model**  
**CORBELSHKR16**

- 6 5/8" x 7 1/2" x 16".
- Alder will be used for Rustic Alder.

Custom Modification Options  
F.A.L.L. ✓

**Description**  
**5" PETITE ACANTHUS CORBEL**

**Model**  
**CORBELACAN5**

- 3" x 2" x 5".
- Alder will be used for Rustic Alder.
- Not available in Quartersawn Oak.

Custom Modification Options  
F.A.L.L. ✓

**Description**  
**10" SMALL ACANTHUS CORBEL**

**Model**  
**CORBELACAN10**

- 3 1/2" x 3 1/2" x 10".
- Alder will be used for Rustic Alder.
- Not available in Quartersawn Oak.

Custom Modification Options  
F.A.L.L. ✓

**Description**  
**14" SMALL ACANTHUS CORBEL**

**Model**  
**CORBELACAN14**

- 6" x 4 7/8" x 14".
- Alder will be used for Rustic Alder.
- Not available in Quartersawn Oak.

Custom Modification Options  
F.A.L.L. ✓

**Description**  
**LARGE BIJOU CORBEL**

**Model**  
**CORBELBIJL**

- 5 1/2" x 7" x 14 1/8".
- Alder will be used for Rustic Alder.
- Not available in Quartersawn Oak.

Custom Modification Options  
F.A.L.L. ✓

**Description**  
**SMALL BIJOU CORBEL**

**Model**  
**CORBELBIJS**

- 4 3/4" x 5 1/2" x 9 5/8".
- Alder will be used for Rustic Alder.
- Not available in Quartersawn Oak.

Custom Modification Options  
F.A.L.L. ✓

**Description**  
**PLAIN NOUVEAU LARGE CORBEL**

**Model**  
**CORBELNOUL**

- 5 1/2" x 9" x 13".
- Alder will be used for Rustic Alder.
- Not available in Quartersawn Oak.
- Abbey, Basilica and Tudor Column Inserts available. See page R-49.

Custom Modification Options  
F.A.L.L. ✓

**Description**  
**PLAIN NOUVEAU MEDIUM CORBEL**

**Model**  
**CORBELNOUM**

- 5 1/2" x 2 3/4" x 13".
- Alder will be used for Rustic Alder.
- Not available in Quartersawn Oak.
- Abbey, Basilica and Tudor Column Inserts available. See page R-49.

Custom Modification Options  
F.A.L.L. ✓

**Description**  
**PLAIN NOUVEAU SMALL CORBEL**

**Model**  
**CORBELNOUS**

- 3 1/2" x 3 7/8" x 6 13/16".
- Alder will be used for Rustic Alder.
- Not available in Quartersawn Oak.
- Abbey, Basilica and Tudor Column Inserts available. See page R-49.

Custom Modification Options  
F.A.L.L. ✓

**Description**  
**LARGE WEAVED CORBEL**

**Model**  
**CORBELWEAVL**

- 5 1/2" x 7" x 14".
- Alder will be used for Rustic Alder.
- Not available in Quartersawn Oak.

Custom Modification Options  
F.A.L.L. ✓

**Description** **Model**

**SMALL WEAVED CORBEL**

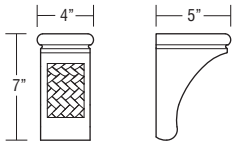

**CORBELWEAVES**

- 4" x 5" x 7".
- Alder will be used for Rustic Alder.
- Not available in Quartersawn Oak.

Custom Modification Options

F.ALL
✓

**6" SCROLL CORBEL**

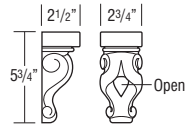

**CORBELSCR6**

- 2 3/4" wide x 5 3/4" high.
- Alder will be used for Rustic Alder.
- Oak will be used for Quartersawn Oak.
- Hand-carved.
- Glazes and/or Techniques available: F, P, TW, XTW, HW, XHW.

Custom Modification Options

F.ALL
✓

**6" MISSION CORBEL**

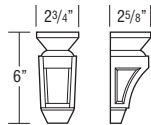

**CORBELMIS6**

- 2 3/4" wide x 6" high.
- Alder will be used for Rustic Alder.
- Oak will be used for Quartersawn Oak.
- Hand-carved.
- Glazes and/or Techniques available: F, P, TW, XTW, HW, XHW.

Custom Modification Options

F.ALL
✓

**9" MISSION CORBEL**

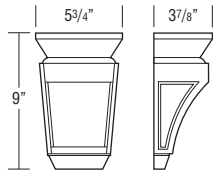

**CORBELMIS9**

- 5 3/4" wide x 9" high.
- Alder will be used for Rustic Alder.
- Oak will be used for Quartersawn Oak.
- Hand-carved.
- Glazes and/or Techniques available: F, P, TW, XTW, HW, XHW.

Custom Modification Options

F.ALL
✓

**OLD WORLD CORBEL**

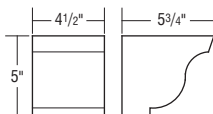

**CORBELOWD5**

- 4 1/2" wide x 5" high.
- Alder will be used for Rustic Alder.
- Glazes and/or Techniques available: F, P, TW, XTW, HW, XHW.

Custom Modification Options

F.ALL
✓

**OLD WORLD CORBEL with STRAP**

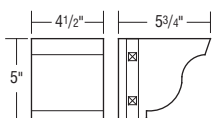

**CORBELOWDSTRS**

- 4 1/2" wide x 5" high.
- Alder will be used for Rustic Alder.
- Hammered iron finish strap.
- Glazes and/or Techniques available: F, P, TW, XTW, HW, XHW.

Custom Modification Options

F.ALL
✓

**Description**

**ABBEY CORBEL INSERT - LARGE**

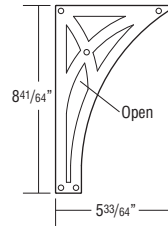

**Model**

**ABBEYCORINSLBR**

- Refined Bronze

**ABBEYCORINSLSN**

- Satin Nickel

**ABBEYCORINSLWI**

- Wrought Iron

- 1/8" x 5 33/64" x 8 41/64".
- Must be used as an insert for Plain Nouveau Large Corbel (CORBELNOUL).

Custom Modification Options

F.ALL
✓

**ABBEY CORBEL INSERT - MEDIUM**

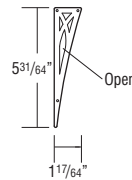

**ABBEYCORINSMBR**

- Refined Bronze

**ABBEYCORINSMSN**

- Satin Nickel

**ABBEYCORINSMWI**

- Wrought Iron

- 1/8" x 1 17/64" x 5 31/64".
- Must be used as an insert for Plain Nouveau Medium Corbel (CORBELNOUM).

Custom Modification Options

F.ALL
✓

**ABBEY CORBEL INSERT - SMALL**

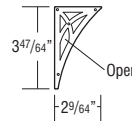

**ABBEYCORINSSBR**

- Refined Bronze

**ABBEYCORINSSSN**

- Satin Nickel

**ABBEYCORINSSWI**

- Wrought Iron

- 1/8" x 2 9/64" x 3 47/64".
- Must be used as an insert for Plain Nouveau Small Corbel (CORBELNOUS).

Custom Modification Options

F.ALL
✓

**BASILICA CORBEL INSERT - LARGE**

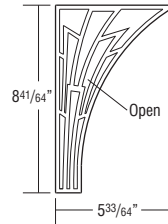

**BASILCORINSLBR**

- Refined Bronze

**BASILCORINSLSN**

- Satin Nickel

**BASILCORINSLWI**

- Wrought Iron

- 1/8" x 5 33/64" x 8 41/64".
- Must be used as an insert for Plain Nouveau Large Corbel (CORBELNOUL).

Custom Modification Options

F.ALL
✓

**Glazes and Techniques**  
**F** = Flooded (see page E•3.)  
**P** = Penned (see page E•3.)  
**TW** = Timeworn (see page E•3.)  
**XTW** = Extra Timeworn (see page E•3.)  
**HW** = Hewn (see page E•3.)  
**XHW** = Extra Hewn (see page E•3.)

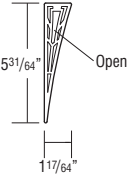

# Mouldings & Embellishments

Description	Model
<b>BASILICA CORBEL INSERT - MEDIUM</b> 	<b>BASILCORINSMBR</b> • Refined Bronze
	<b>BASILCORINSMSN</b> • Satin Nickel
	<b>BASILCORINSMWI</b> • Wrought Iron
	• 1/8" x 1 17/64" x 5 31/64" • Must be used as an insert for Plain Nouveau Medium Corbel (CORBELNOUM).
Custom Modification Options	
<input type="checkbox"/> FALL <input checked="" type="checkbox"/>	

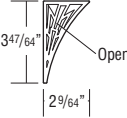
Description	Model
<b>BASILICA CORBEL INSERT - SMALL</b> 	<b>BASILCORINSSBR</b> • Refined Bronze
	<b>BASILCORINSSSN</b> • Satin Nickel
	<b>BASILCORINSSWI</b> • Wrought Iron
	• 1/8" x 2 9/64" x 3 47/64" • Must be used as an insert for Plain Nouveau Small Corbel (CORBELNOUS).
Custom Modification Options	
<input type="checkbox"/> FALL <input checked="" type="checkbox"/>	

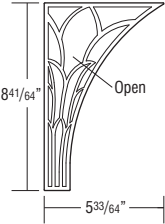
Description	Model
<b>TUDOR CORBEL INSERT - LARGE</b> 	<b>TUDORCORINSLBR</b> • Refined Bronze
	<b>TUDORCORINSLSN</b> • Satin Nickel
	<b>TUDORCORINSLWI</b> • Wrought Iron
	• 1/8" x 5 33/64" x 8 41/64" • Must be used as an insert for Plain Nouveau Large Corbel (CORBELNOUL).
Custom Modification Options	
<input type="checkbox"/> FALL <input checked="" type="checkbox"/>	

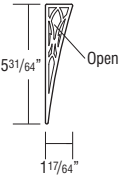
Description	Model
<b>TUDOR CORBEL INSERT - MEDIUM</b> 	<b>TUDORCORINSMBR</b> • Refined Bronze
	<b>TUDORCORINSMSN</b> • Satin Nickel
	<b>TUDORCORINSMWI</b> • Wrought Iron
	• 1/8" x 1 17/64" x 5 31/64" • Must be used as an insert for Plain Nouveau Medium Corbel (CORBELNOUM).
Custom Modification Options	
<input type="checkbox"/> FALL <input checked="" type="checkbox"/>	

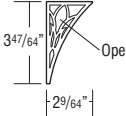
Description	Model
<b>TUDOR CORBEL INSERT - SMALL</b> 	<b>TUDORCORINSSBR</b> • Refined Bronze
	<b>TUDORCORINSSSN</b> • Satin Nickel
	<b>TUDORCORINSSWI</b> • Wrought Iron
	• 1/8" x 2 9/64" x 3 47/64" • Must be used as an insert for Plain Nouveau Small Corbel (CORBELNOUS).
Custom Modification Options	
<input type="checkbox"/> FALL <input checked="" type="checkbox"/>	

## FEET

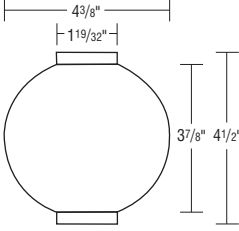
Description	Model
<b>BUNN FOOT</b> 	<b>RDBUNNFOOT</b>
	• 4 3/8" wide x 4 1/2" high. • Alder will be used for Rustic Alder. • Not available in Quartersawn Oak. • Glazes and/or Techniques available: F, P, HW, XHW.
Custom Modification Options	
<input type="checkbox"/> FALL <input checked="" type="checkbox"/>	

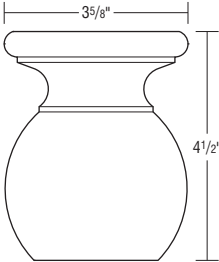
Description	Model
<b>CLASSIC BUN FOOT</b> 	<b>CLBUNNFOOT</b>
	• 3 5/8" x 3 5/8" x 4 1/2". • Alder will be used for Rustic Alder. • Not available in Quartersawn Oak.
Custom Modification Options	
<input type="checkbox"/> FALL <input checked="" type="checkbox"/>	

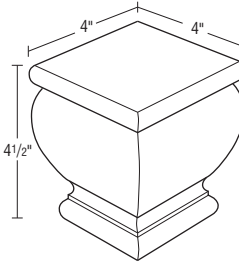
Description	Model
<b>LILLE FOOT</b> 	<b>LIFOOT</b>
	• 4" wide x 4 1/2" high. • Alder will be used for Rustic Alder. • Not available in Quartersawn Oak. • Glazes and/or Techniques available: F, P, TW, XTW, HW, XHW.
Custom Modification Options	
<input type="checkbox"/> FALL <input checked="" type="checkbox"/>	

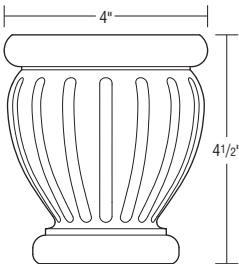
Description	Model
<b>LILLE FLUTED FOOT</b> 	<b>LIFLUTFOOT</b>
	• 4" x 4 1/2" x 4 1/2". • Alder will be used for Rustic Alder. • Not available in Quartersawn Oak.
Custom Modification Options	
<input type="checkbox"/> FALL <input checked="" type="checkbox"/>	

**Glazes and Techniques**  
**F** = Flooded (see page E•3.)  
**P** = Penned (see page E•3.)  
**TW** = Timeworn (see page E•3.)  
**XTW** = Extra Timeworn (see page E•3.)  
**HW** = Hewn (see page E•3.)  
**XHW** = Extra Hewn (see page E•3.)

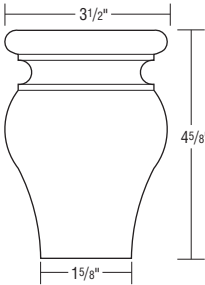
Description	Model		
<b>TULIP FOOT</b>	<b>TLFOOT</b>		
	<ul style="list-style-type: none"> <li>• 3 1/2" wide x 4 5/8" high.</li> <li>• Alder will be used for Rustic Alder.</li> <li>• Not available in Quartersawn Oak.</li> <li>• Glazes and/or Techniques available: F, P, HW, XHW.</li> </ul> <p>Custom Modification Options</p> <table border="1"> <tr><td>F.ALL</td></tr> <tr><td>✓</td></tr> </table>	F.ALL	✓
F.ALL			
✓			

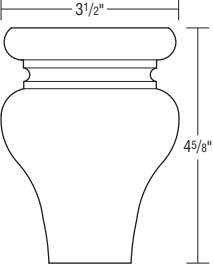
Description	Model		
<b>TULIP FOOT SQUARE</b>	<b>FOOTTULPSQ</b>		
	<ul style="list-style-type: none"> <li>• 3 1/2" x 3 1/2" x 4 1/2".</li> <li>• Alder will be used for Rustic Alder.</li> <li>• Not available in Quartersawn Oak.</li> </ul> <p>Custom Modification Options</p> <table border="1"> <tr><td>F.ALL</td></tr> <tr><td>✓</td></tr> </table>	F.ALL	✓
F.ALL			
✓			

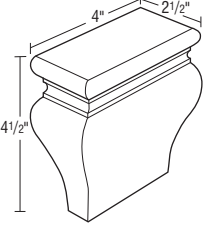
Description	Model		
<b>TOEKICK TULIP FOOT</b>	<b>TKTLFOOT</b>		
	<ul style="list-style-type: none"> <li>• 4" wide x 4 1/2" high.</li> <li>• Alder will be used for Rustic Alder.</li> <li>• Not available in Quartersawn Oak.</li> <li>• Glazes and/or Techniques available: F, P, TW, XTW, HW, XHW.</li> </ul> <p>Custom Modification Options</p> <table border="1"> <tr><td>F.ALL</td></tr> <tr><td>✓</td></tr> </table>	F.ALL	✓
F.ALL			
✓			

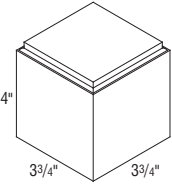
Description	Model		
<b>SQUARE FOOT</b>	<b>SMSQFOOT</b>		
	<ul style="list-style-type: none"> <li>• 3 3/4" wide x 4" high x 3 3/4" deep.</li> <li>• Alder will be used for Rustic Alder.</li> <li>• Glazes and/or Techniques available: F, P, HW, XHW.</li> </ul> <p>Custom Modification Options</p> <table border="1"> <tr><td>F.ALL</td></tr> <tr><td>✓</td></tr> </table>	F.ALL	✓
F.ALL			
✓			

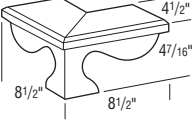
Description	Model		
<b>PEDESTAL FOOT - CORNER</b>	<b>PEDFOOTC</b>		
	<ul style="list-style-type: none"> <li>• 4 1/2" wide x 4 7/16" high.</li> <li>• Alder will be used for Rustic Alder.</li> <li>• Glazes and/or Techniques available: F, P, TW, XTW, HW, XHW.</li> </ul> <p>Custom Modification Options</p> <table border="1"> <tr><td>F.ALL</td></tr> <tr><td>✓</td></tr> </table>	F.ALL	✓
F.ALL			
✓			

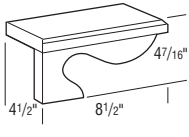
Description	Model		
<b>PEDESTAL FOOT - NO RETURN LEFT</b>	<b>PEDFOOTL</b>		
	<ul style="list-style-type: none"> <li>• 4 1/2" wide x 4 7/16" high.</li> <li>• Alder will be used for Rustic Alder.</li> <li>• Glazes and/or Techniques available: F, P, TW, XTW, HW, XHW.</li> </ul> <p>Custom Modification Options</p> <table border="1"> <tr><td>F.ALL</td></tr> <tr><td>✓</td></tr> </table>	F.ALL	✓
F.ALL			
✓			

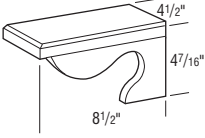
Description	Model		
<b>PEDESTAL FOOT - NO RETURN RIGHT</b>	<b>PEDFOOTR</b>		
	<ul style="list-style-type: none"> <li>• 4 1/2" wide x 4 7/16" high.</li> <li>• Alder will be used for Rustic Alder.</li> <li>• Glazes and/or Techniques available: F, P, TW, XTW, HW, XHW.</li> </ul> <p>Custom Modification Options</p> <table border="1"> <tr><td>F.ALL</td></tr> <tr><td>✓</td></tr> </table>	F.ALL	✓
F.ALL			
✓			

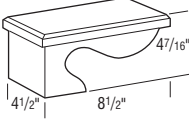
Description	Model		
<b>PEDESTAL FOOT - RETURN LEFT</b>	<b>PEDFOOTRETL</b>		
	<ul style="list-style-type: none"> <li>• 4 1/2" wide x 4 7/16" high.</li> <li>• Alder will be used for Rustic Alder.</li> <li>• Glazes and/or Techniques available: F, P, TW, XTW, HW, XHW.</li> </ul> <p>Custom Modification Options</p> <table border="1"> <tr><td>F.ALL</td></tr> <tr><td>✓</td></tr> </table>	F.ALL	✓
F.ALL			
✓			

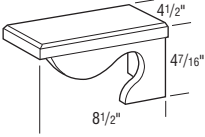
Description	Model		
<b>PEDESTAL FOOT - RETURN RIGHT</b>	<b>PEDFOOTRETR</b>		
	<ul style="list-style-type: none"> <li>• 4 1/2" wide x 4 7/16" high.</li> <li>• Alder will be used for Rustic Alder.</li> <li>• Glazes and/or Techniques available: F, P, TW, XTW, HW, XHW.</li> </ul> <p>Custom Modification Options</p> <table border="1"> <tr><td>F.ALL</td></tr> <tr><td>✓</td></tr> </table>	F.ALL	✓
F.ALL			
✓			

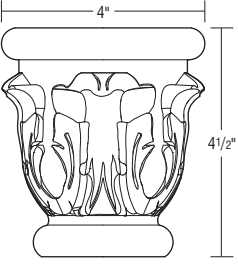
Description	Model		
<b>ACANTHUS FOOT</b>	<b>ACANFOOT</b>		
	<ul style="list-style-type: none"> <li>• 4" x 4" x 4 1/2".</li> <li>• Alder will be used for Rustic Alder.</li> <li>• Not available in Quartersawn Oak.</li> </ul> <p>Custom Modification Options</p> <table border="1"> <tr><td>F.ALL</td></tr> <tr><td>✓</td></tr> </table>	F.ALL	✓
F.ALL			
✓			

**Glazes and Techniques**  
 F = Flooded (see page E•3.)  
 P = Penned (see page E•3.)  
 TW = Timeworn (see page E•3.)  
 XTW = Extra Timeworn (see page E•3.)  
 HW = Hewn (see page E•3.)  
 XHW = Extra Hewn (see page E•3.)

# Mouldings & Embellishments

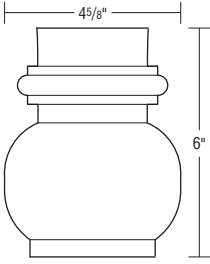
Description	Model
<b>CELTIC FOOT</b>	<b>CELTICFOOT</b>
	<ul style="list-style-type: none"> <li>• 4 5/8" x 4 5/8" x 6" high.</li> <li>• Alder will be used for Rustic Alder.</li> <li>• Not available in Quartersawn Oak.</li> </ul> <p>Custom Modification Options</p> <p>F.A.L.L. ✓</p>

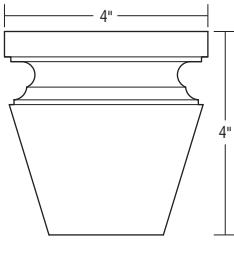
Description	Model
<b>COSMO FOOT</b>	<b>COSFOOT</b>
	<ul style="list-style-type: none"> <li>• 4" x 4" x 4".</li> <li>• Alder will be used for Rustic Alder.</li> <li>• Not available in Quartersawn Oak.</li> </ul> <p>Custom Modification Options</p> <p>F.A.L.L. ✓</p>

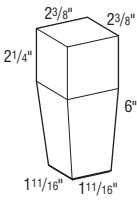
Description	Model
<b>TAPERED LEG</b>	<b>TLEG2</b>
	<ul style="list-style-type: none"> <li>• 2 3/8" x 2 3/8" x 6".</li> <li>• Alder will be used for Rustic Alder.</li> <li>• Not available in Quartersawn Oak.</li> </ul> <p>Custom Modification Options</p> <p>F.A.L.L. ✓</p>

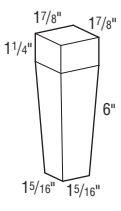
Description	Model
<b>TAPERED 4-SIDED LEG</b>	<b>T4SLEG</b>
	<ul style="list-style-type: none"> <li>• 1 7/8" x 1 7/8" x 6".</li> <li>• Alder will be used for Rustic Alder.</li> <li>• Not available in Quartersawn Oak.</li> </ul> <p>Custom Modification Options</p> <p>F.A.L.L. ✓</p>

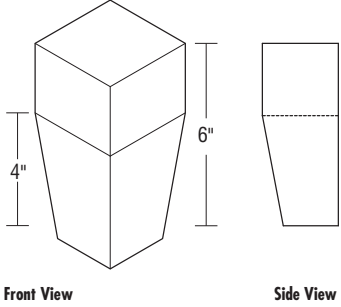
Description	Model
<b>TAPERED LEG</b>	<b>TAPLG</b>
 <p>Front View      Side View</p>	<ul style="list-style-type: none"> <li>• 2 1/2" wide x 6" high.</li> <li>• Alder will be used for Rustic Alder.</li> <li>• Not available in Quartersawn Oak.</li> <li>• Glazes and/or Techniques available: F, HW, XHW.</li> </ul> <p>Custom Modification Options</p> <p>F.A.L.L. ✓</p>

**Glazes and Techniques**  
**F** = Flooded (see page E•3.)  
**P** = Penned (see page E•3.)  
**TW** = Timeworn (see page E•3.)  
**XTW** = Extra Timeworn (see page E•3.)  
**HW** = Hewn (see page E•3.)  
**XHW** = Extra Hewn (see page E•3.)

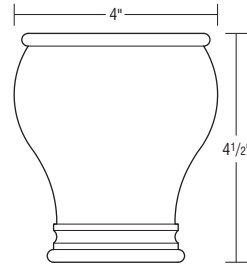
Description	Model
<b>SUMMIT FOOT</b>	<b>SUMFOOT</b>
	<ul style="list-style-type: none"> <li>• 4" x 4" x 4 1/2".</li> <li>• Alder will be used for Rustic Alder.</li> <li>• Not available in Quartersawn Oak.</li> </ul> <p>Custom Modification Options</p> <p>F.A.L.L. ✓</p>

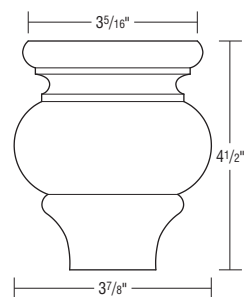
Description	Model
<b>MADLINE BUN FOOT</b>	<b>MADEFOOT</b>
	<ul style="list-style-type: none"> <li>• 3 7/8" x 3 5/16" x 4 1/2".</li> <li>• Alder will be used for Rustic Alder.</li> <li>• Not available in Quartersawn Oak.</li> </ul> <p>Custom Modification Options</p> <p>F.A.L.L. ✓</p>

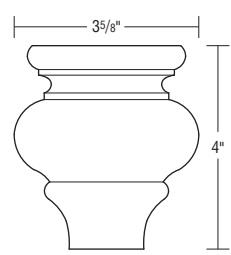
Description	Model
<b>FRENCH COUNTRY FOOT</b>	<b>FRNCNTYFOOT</b>
	<ul style="list-style-type: none"> <li>• 3 5/8" x 3 5/8" x 4".</li> <li>• Alder will be used for Rustic Alder.</li> <li>• Not available in Quartersawn Oak.</li> </ul> <p>Custom Modification Options</p> <p>F.A.L.L. ✓</p>

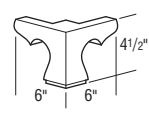
Description	Model
<b>HAMPTON PEDESTAL FOOT, CORNER</b>	<b>HAMPPEDFOOT</b>
	<ul style="list-style-type: none"> <li>• 4 1/2" x 6" x 6".</li> <li>• Alder will be used for Rustic Alder.</li> <li>• Not available in Quartersawn Oak.</li> </ul> <p>Custom Modification Options</p> <p>F.A.L.L. ✓</p>

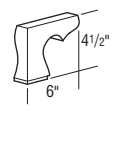
Description	Model
<b>HAMPTON PEDESTAL FOOT, LEFT</b>	<b>HAMPPEDFOOTL</b>
	<ul style="list-style-type: none"> <li>• 4 1/2" x 1 1/2" x 6".</li> <li>• Alder will be used for Rustic Alder.</li> <li>• Not available in Quartersawn Oak.</li> </ul> <p>Custom Modification Options</p> <p>F.A.L.L. ✓</p>

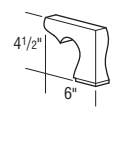
Description	Model
<b>HAMPTON PEDESTAL FOOT, RIGHT</b>	<b>HAMPPEDFOOTR</b>
	<ul style="list-style-type: none"> <li>• 4 1/2" x 1 1/2" x 6".</li> <li>• Alder will be used for Rustic Alder.</li> <li>• Not available in Quartersawn Oak.</li> </ul> <p>Custom Modification Options</p> <p>F.A.L.L. ✓</p>

Description	Model		
<b>HAMPTON PEDESTAL FOOT, CENTER</b>	<b>HAMPPEEFOOTCTR</b>		
	<ul style="list-style-type: none"> <li>• 2" x 1 1/2" x 10"</li> <li>• Alder will be used for Rustic Alder.</li> <li>• Not available in Quartersawn Oak.</li> </ul>		
<p>Custom Modification Options</p> <table border="1"> <tr> <td>F.A.L.L.</td> </tr> <tr> <td>✓</td> </tr> </table>		F.A.L.L.	✓
F.A.L.L.			
✓			

Description	Model		
<b>KENSINGTON FOOT</b>	<b>KENSFOOT</b>		
	<ul style="list-style-type: none"> <li>• 3" x 3" x 4 1/2"</li> <li>• Alder will be used for Rustic Alder.</li> <li>• Not available in Quartersawn Oak.</li> </ul>		
<p>Custom Modification Options</p> <table border="1"> <tr> <td>F.A.L.L.</td> </tr> <tr> <td>✓</td> </tr> </table>		F.A.L.L.	✓
F.A.L.L.			
✓			

Description	Model		
<b>MADISON FOOT</b>	<b>MADFOOT</b>		
	<ul style="list-style-type: none"> <li>• 3" x 6 1/8"</li> <li>• Alder will be used for Rustic Alder.</li> <li>• Not available in Quartersawn Oak.</li> </ul>		
<p>Custom Modification Options</p> <table border="1"> <tr> <td>F.A.L.L.</td> </tr> <tr> <td>✓</td> </tr> </table>		F.A.L.L.	✓
F.A.L.L.			
✓			

Description	Model		
<b>CRAFTSMAN FOOT</b>	<b>CRFTSMNFOOT</b>		
	<ul style="list-style-type: none"> <li>• 3" x 3" x 6"</li> <li>• Alder will be used for Rustic Alder.</li> <li>• Not available in Quartersawn Oak.</li> <li>• Four-sided Tapered Craftsman Foot.</li> </ul>		
<p>Custom Modification Options</p> <table border="1"> <tr> <td>F.A.L.L.</td> </tr> <tr> <td>✓</td> </tr> </table>		F.A.L.L.	✓
F.A.L.L.			
✓			

Description	Model		
<b>CRAFTSMAN FOOT, CORNER</b>	<b>CRFTSMNFOOTC</b>		
	<ul style="list-style-type: none"> <li>• 3 3/4" x 3 3/4" x 6"</li> <li>• Alder will be used for Rustic Alder.</li> <li>• Not available in Quartersawn Oak.</li> </ul>		
<p>Custom Modification Options</p> <table border="1"> <tr> <td>F.A.L.L.</td> </tr> <tr> <td>✓</td> </tr> </table>		F.A.L.L.	✓
F.A.L.L.			
✓			

Description	Model		
<b>CRAFTSMAN BUN FOOT</b>	<b>CRFTSMNBUNFOOT</b>		
	<ul style="list-style-type: none"> <li>• 3 3/8" x 4 1/2"</li> <li>• Alder will be used for Rustic Alder.</li> <li>• Not available in Quartersawn Oak.</li> </ul>		
<p>Custom Modification Options</p> <table border="1"> <tr> <td>F.A.L.L.</td> </tr> <tr> <td>✓</td> </tr> </table>		F.A.L.L.	✓
F.A.L.L.			
✓			

Description	Model		
<b>METROPOLITAN FOOT</b>	<b>METROFOOT</b>		
	<ul style="list-style-type: none"> <li>• 4" x 4" x 4 1/2"</li> <li>• Alder will be used for Rustic Alder.</li> <li>• Not available in Quartersawn Oak.</li> </ul>		
<p>Custom Modification Options</p> <table border="1"> <tr> <td>F.A.L.L.</td> </tr> <tr> <td>✓</td> </tr> </table>		F.A.L.L.	✓
F.A.L.L.			
✓			

Description	Model		
<b>QUEEN ANNE FOOT</b>	<b>QAFOOT</b>		
	<ul style="list-style-type: none"> <li>• 2 3/4" x 2 3/4" x 8"</li> <li>• Available in Maple and Cherry only.</li> </ul>		
<p>Custom Modification Options</p> <table border="1"> <tr> <td>F.A.L.L.</td> </tr> <tr> <td>✓</td> </tr> </table>		F.A.L.L.	✓
F.A.L.L.			
✓			

# Mouldings & Embellishments

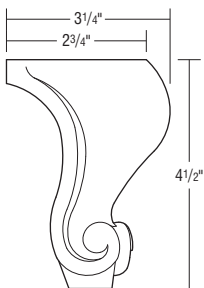
Description	Model
<b>QUEEN ANNE SCROLL FOOT</b>	<b>QASCROLLFOOT</b>
 <p>3 1/4" 2 3/4" 4 1/2"</p>	<ul style="list-style-type: none"> <li>• 3 1/4" x 3 1/4" x 4 1/2".</li> <li>• Available in Maple and Cherry only.</li> </ul> <p>Custom Modification Options</p> <p>F.A.L.L. ✓</p>

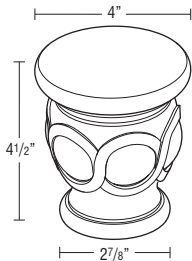
Description	Model
<b>BIJOU BUN FOOT</b>	<b>BIJBUNFOOT</b>
 <p>4" 4 1/2" 2 7/8"</p>	<ul style="list-style-type: none"> <li>• 4" x 4 1/2".</li> <li>• Alder will be used for Rustic Alder.</li> <li>• Not available in Quartersawn Oak.</li> </ul> <p>Custom Modification Options</p> <p>F.A.L.L. ✓</p>

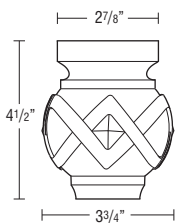
Description	Model
<b>DECO BUN FOOT</b>	<b>DECOBUNFOOT</b>
 <p>2 7/8" 4 1/2" 3 3/4"</p>	<ul style="list-style-type: none"> <li>• 3 3/4" x 3 3/4" x 4 1/2".</li> <li>• Alder will be used for Rustic Alder.</li> <li>• Not available in Quartersawn Oak.</li> </ul> <p>Custom Modification Options</p> <p>F.A.L.L. ✓</p>

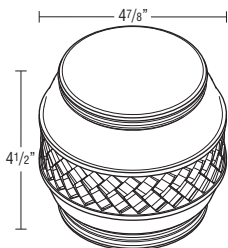
Description	Model
<b>WEAVED BUN FOOT</b>	<b>WEAVEBUNFOOT</b>
 <p>4 7/8" 4 1/2"</p>	<ul style="list-style-type: none"> <li>• 4 7/8" x 4 1/2".</li> <li>• Alder will be used for Rustic Alder.</li> <li>• Not available in Quartersawn Oak.</li> </ul> <p>Custom Modification Options</p> <p>F.A.L.L. ✓</p>

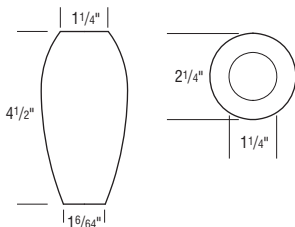
Description	Model
<b>MID-CENTURY FOOT, SHORT</b>	<b>MCFOOTS</b>
 <p>1 1/4" 4 1/2" 1 5/8" 2 1/4" 1 1/4"</p>	<ul style="list-style-type: none"> <li>• 2 1/4" x 4 1/2".</li> <li>• Alder will be used for Rustic Alder.</li> <li>• Oak will be used for Quartersawn Oak.</li> </ul> <p>Custom Modification Options</p> <p>F.A.L.L. ✓</p>

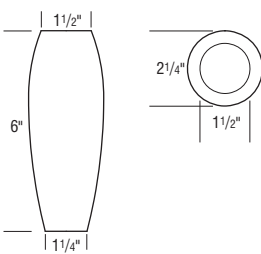
Description	Model
<b>MID-CENTURY FOOT, MEDIUM</b>	<b>MCFOOTM</b>
 <p>1 1/2" 6" 1 1/4" 2 1/4" 1 1/2"</p>	<ul style="list-style-type: none"> <li>• 2 1/4" x 6".</li> <li>• Alder will be used for Rustic Alder.</li> <li>• Oak will be used for Quartersawn Oak.</li> </ul> <p>Custom Modification Options</p> <p>F.A.L.L. ✓</p>

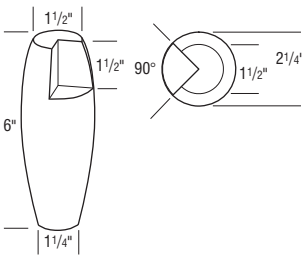
Description	Model
<b>NOTCHED MID-CENTURY FOOT, MEDIUM</b>	<b>NMCFEOTM</b>
 <p>1 1/2" 6" 1 1/4" 1 1/2" 90° 1 1/2" 2 1/4"</p>	<ul style="list-style-type: none"> <li>• 2 1/4" x 6".</li> <li>• Alder will be used for Rustic Alder.</li> <li>• Oak will be used for Quartersawn Oak.</li> </ul> <p>Custom Modification Options</p> <p>F.A.L.L. ✓</p>

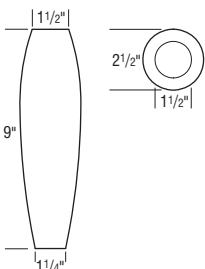
Description	Model
<b>MID-CENTURY FOOT, TALL</b>	<b>MCFOOTT</b>
 <p>1 1/2" 9" 1 1/4" 2 1/2" 1 1/2"</p>	<ul style="list-style-type: none"> <li>• 2 1/2" x 9".</li> <li>• Alder will be used for Rustic Alder.</li> <li>• Oak will be used for Quartersawn Oak.</li> </ul> <p>Custom Modification Options</p> <p>F.A.L.L. ✓</p>

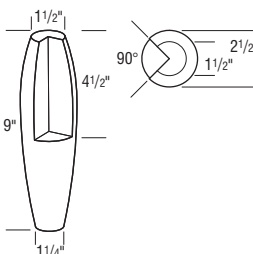
Description	Model
<b>NOTCHED MID-CENTURY FOOT, TALL</b>	<b>NMCFTE</b>
 <p>1 1/2" 9" 1 1/4" 1 1/2" 90° 2 1/2" 4 1/2"</p>	<ul style="list-style-type: none"> <li>• 2 1/2" x 9".</li> <li>• Alder will be used for Rustic Alder.</li> <li>• Oak will be used for Quartersawn Oak.</li> </ul> <p>Custom Modification Options</p> <p>F.A.L.L. ✓</p>

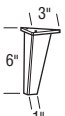
Description	Model
<b>6" INDUSTRIAL FOOT</b>	<b>INDFOOT6GMG</b> <b>INDFOOT6WI</b>
 <p>3" 6" 1"</p>	<ul style="list-style-type: none"> <li>• 3" x 3" x 6".</li> <li>• Finishes available: Gun Metal Gray (GMG) and Wrought Iron (WI).</li> </ul> <p>Modifications Are Not Available</p>

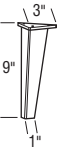
Description	Model
<b>9" INDUSTRIAL FOOT</b>	<b>INDFOOT9GMG</b>
	<b>INDFOOT9WI</b>
	<ul style="list-style-type: none"> <li>• 3" x 3" x 9".</li> <li>• Finishes available: Gun Metal Gray (GMG) and Wrought Iron (WI).</li> </ul>
	<div style="border: 1px solid black; padding: 5px; width: fit-content; margin: 0 auto;">                     Modifications Are Not Available                 </div>

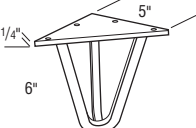
<b>MID-CENTURY METAL FOOT, SHORT</b>	<b>MCMFOOTSGMG</b>
	<b>MCMFOOTSWI</b>
	<ul style="list-style-type: none"> <li>• 5" x 5" x 6".</li> <li>• Finishes available: Gun Metal Gray (GMG) and Wrought Iron (WI).</li> </ul>
	<div style="border: 1px solid black; padding: 5px; width: fit-content; margin: 0 auto;">                     Modifications Are Not Available                 </div>

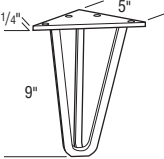
<b>MID-CENTURY METAL FOOT, TALL</b>	<b>MCMFOOTTGMG</b>
	<b>MCMFOOTTWI</b>
	<ul style="list-style-type: none"> <li>• 5" x 5" x 9".</li> <li>• Finishes available: Gun Metal Gray (GMG) and Wrought Iron (WI).</li> </ul>
	<div style="border: 1px solid black; padding: 5px; width: fit-content; margin: 0 auto;">                     Modifications Are Not Available                 </div>

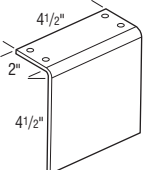
<b>4 1/2" x 4 1/2" URBAN FOOT</b>	<b>URBANFT5</b>
	<ul style="list-style-type: none"> <li>• 4 1/2" x 4 1/2" x 4 1/2".</li> <li>• Stainless Steel finish.</li> </ul>
	<div style="border: 1px solid black; padding: 5px; width: fit-content; margin: 0 auto;">                     Modifications Are Not Available                 </div>

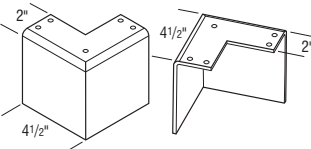
<b>4 1/2" x 2" URBAN FOOT</b>	<b>URBANFT2</b>
	<ul style="list-style-type: none"> <li>• 4 1/2" x 2" x 4 1/2".</li> <li>• Stainless Steel finish.</li> <li>• For use on metal or wood legs.</li> </ul>
	<div style="border: 1px solid black; padding: 5px; width: fit-content; margin: 0 auto;">                     Modifications Are Not Available                 </div>

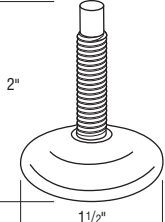
Description	Model
<b>ACCESSORIES</b>	
<b>LEVELER</b>	<b>LEVELER</b>
	<ul style="list-style-type: none"> <li>• 1 1/2" black guide/leveler.</li> <li>• 2 pack.</li> </ul>
	<div style="border: 1px solid black; padding: 5px; width: fit-content; margin: 0 auto;">                     Modifications Are Not Available                 </div>

# Mouldings & Embellishments

Description	Model
<b>LEGS</b>	

## REED LEG

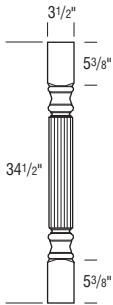

## RDLEG

- 3 1/2" diameter x 34 1/2" high.
- Alder will be used for Rustic Alder.
- Oak will be used for Quartersawn Oak.
- Glazes and/or Techniques available: F, P, TW, XTW, HW, XHW.

Custom Modification Options



## 40.5" HIGH REED LEG

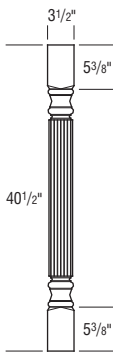

## RDLEG40

- 3 1/2" diameter x 40 1/2" high.
- Alder will be used for Rustic Alder.
- Not available in Quartersawn Oak.
- Glazes and/or Techniques available: F, P, TW, XTW, HW, XHW.

Custom Modification Options



## SPOOL LEG, SMALL

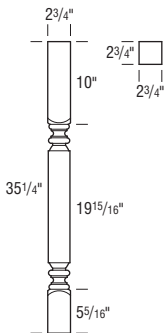

## SPLEGS

- 2 3/4" x 2 3/4" x 35 1/4".
- Alder will be used for Rustic Alder.
- Not available in Quartersawn Oak.

Custom Modification Options



Description	Model
<b>SPOOL LEG</b>	<b>SPLEG</b>

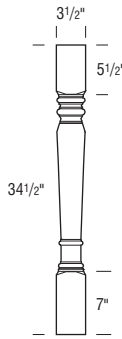

- 3 1/2" wide x 34 1/2" high.
- Alder will be used for Rustic Alder.
- Oak will be used for Quartersawn Oak.
- Glazes and/or Techniques available: F, P, TW, XTW, HW, XHW.

Custom Modification Options



## 40.5" HIGH SPOOL LEG

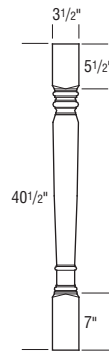

## SPLEG40

- 3 1/2" diameter x 40 1/2" high.
- Alder will be used for Rustic Alder.
- Not available in Quartersawn Oak.
- Glazes and/or Techniques available: F, P, TW, XTW, HW, XHW.

Custom Modification Options



## KITCHEN ISLAND LEG

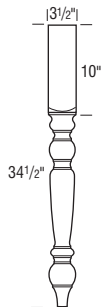

## DISLEG

- 3 1/2" wide x 34 1/2" high.
- Alder will be used for Rustic Alder.
- Oak will be used for Quartersawn Oak.
- Glazes and/or Techniques available: F, P, TW, XTW, HW, XHW.

Custom Modification Options



## FLUTED ISLAND LEG

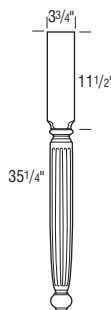

## DISLEGFL

- 3 3/4" wide x 35 1/4" high.
- Alder will be used for Rustic Alder.
- Oak will be used for Quartersawn Oak.
- Glazes and/or Techniques available: F, P, TW, XTW, HW, XHW.

Custom Modification Options



**Glazes and Techniques**  
**F** = Flooded (see page E•3.)  
**P** = Penned (see page E•3.)  
**TW** = Timeworn (see page E•3.)  
**XTW** = Extra Timeworn (see page E•3.)  
**HW** = Hewn (see page E•3.)  
**XHW** = Extra Hewn (see page E•3.)

Description	Model		
<b>SQUARE ISLAND LEG</b>	<b>DISLEGSQ</b>		
	<ul style="list-style-type: none"> <li>• 3 3/4" wide x 35 1/4" high.</li> <li>• Alder will be used for Rustic Alder.</li> <li>• Glazes and/or Techniques available: F, P, TW, XTW, HW, XHW.</li> </ul> <p>Custom Modification Options</p> <table border="1"> <tr><td>F.ALL</td></tr> <tr><td>✓</td></tr> </table>	F.ALL	✓
F.ALL			
✓			

Description	Model		
<b>ROPE ISLAND LEG</b>	<b>DISLEGRP</b>		
	<ul style="list-style-type: none"> <li>• 3 3/4" wide x 35 1/4" high.</li> <li>• Alder will be used for Rustic Alder.</li> <li>• Oak will be used for Quartersawn Oak.</li> <li>• Glazes and/or Techniques available: F, P, TW, XTW, HW, XHW.</li> </ul> <p>Custom Modification Options</p> <table border="1"> <tr><td>F.ALL</td></tr> <tr><td>✓</td></tr> </table>	F.ALL	✓
F.ALL			
✓			

Description	Model		
<b>MISSION LEG</b>	<b>DLEGMSSION</b>		
	<ul style="list-style-type: none"> <li>• 3" wide x 34 1/2" high.</li> <li>• Alder will be used for Rustic Alder.</li> <li>• Oak will be used for Quartersawn Oak.</li> <li>• Hand-carved.</li> <li>• Glazes and/or Techniques available: F, P, TW, XTW, HW, XHW.</li> </ul> <p>Custom Modification Options</p> <table border="1"> <tr><td>F.ALL</td></tr> <tr><td>✓</td></tr> </table>	F.ALL	✓
F.ALL			
✓			

Description	Model		
<b>BAR LEG, 2-SIDED</b>	<b>2SBARLEG</b>		
	<ul style="list-style-type: none"> <li>• 3 3/4" wide x 42 1/4" high.</li> <li>• Alder will be used for Rustic Alder.</li> <li>• Not available in Quartersawn Oak.</li> <li>• Glazes and/or Techniques available: F, TW, XTW, HW, XHW.</li> </ul> <p>Custom Modification Options</p> <table border="1"> <tr><td>F.ALL</td></tr> <tr><td>✓</td></tr> </table>	F.ALL	✓
F.ALL			
✓			

Description	Model		
<b>BAR LEG, 4-SIDED</b>	<b>4SBARLEG</b>		
	<ul style="list-style-type: none"> <li>• 3 3/4" wide x 42 1/4" high.</li> <li>• Alder will be used for Rustic Alder.</li> <li>• Not available in Quartersawn Oak.</li> <li>• Glazes and/or Techniques available: F, TW, XTW, HW, XHW.</li> </ul> <p>Custom Modification Options</p> <table border="1"> <tr><td>F.ALL</td></tr> <tr><td>✓</td></tr> </table>	F.ALL	✓
F.ALL			
✓			

Description	Model		
<b>BAR LEG, SQUARE, 2x2</b>	<b>SQBARLEG2</b>		
	<ul style="list-style-type: none"> <li>• 2" x 2" x 42 1/4".</li> <li>• Alder will be used for Rustic Alder.</li> <li>• Not available in Quartersawn Oak.</li> </ul> <p>Custom Modification Options</p> <table border="1"> <tr><td>F.ALL</td></tr> <tr><td>✓</td></tr> </table>	F.ALL	✓
F.ALL			
✓			

Description	Model		
<b>BAR LEG, SQUARE, 3x3</b>	<b>SQBARLEG3</b>		
	<ul style="list-style-type: none"> <li>• 3" wide x 3" deep x 42 1/4" high.</li> <li>• Alder will be used for Rustic Alder.</li> <li>• Glazes and/or Techniques available: F, TW, XTW, HW, XHW.</li> </ul> <p>Custom Modification Options</p> <table border="1"> <tr><td>F.ALL</td></tr> <tr><td>✓</td></tr> </table>	F.ALL	✓
F.ALL			
✓			

**Glazes and Techniques**  
**F** = Flooded (see page E•3.)  
**P** = Penned (see page E•3.)  
**TW** = Timeworn (see page E•3.)  
**XTW** = Extra Timeworn (see page E•3.)  
**HW** = Hewn (see page E•3.)  
**XHW** = Extra Hewn (see page E•3.)



# Mouldings & Embellishments

Description	Model
<b>BAR LEG, SQUARE, 4x4</b>	<b>SQBARLEG4</b>
	<ul style="list-style-type: none"> <li>4" wide x 4" deep x 42 1/4" high.</li> <li>Alder will be used for Rustic Alder.</li> <li>Glazes and/or Techniques available: F, TW, XTW, HW, XHW.</li> </ul>
	<p>Custom Modification Options</p> <p>F.ALL <input checked="" type="checkbox"/></p>

Description	Model
<b>BAR LEG, SQUARE, 5x5</b>	<b>SQBARLEG5</b>
	<ul style="list-style-type: none"> <li>5" x 5" x 42 1/4".</li> <li>Alder will be used for Rustic Alder.</li> <li>Not available in Quartersawn Oak.</li> </ul>
	<p>Custom Modification Options</p> <p>F.ALL <input checked="" type="checkbox"/></p>

Description	Model
<b>BAR LEG, SQUARE, 6x6</b>	<b>SQBARLEG6</b>
	<ul style="list-style-type: none"> <li>6" wide x 6" deep x 42 1/4" high.</li> <li>Alder will be used for Rustic Alder.</li> <li>Glazes and/or Techniques available: F, TW, XTW, HW, XHW.</li> </ul>
	<p>Custom Modification Options</p> <p>F.ALL <input checked="" type="checkbox"/></p>

**Glazes and Techniques**  
 F = Flooded (see page E•3.)  
 P = Penned (see page E•3.)  
 TW = Timeworn (see page E•3.)  
 XTW = Extra Timeworn (see page E•3.)  
 HW = Hewn (see page E•3.)  
 XHW = Extra Hewn (see page E•3.)

Description	Model
<b>ISLAND LEG, 2-SIDED</b>	<b>2SISLEG</b>
	<ul style="list-style-type: none"> <li>3 3/4" wide x 35 1/4" high.</li> <li>Alder will be used for Rustic Alder.</li> <li>Not available in Quartersawn Oak.</li> <li>Glazes and/or Techniques available: F, TW, XTW, HW, XHW.</li> </ul>
	<p>Custom Modification Options</p> <p>F.ALL <input checked="" type="checkbox"/></p>

Description	Model
<b>ISLAND LEG, 4-SIDED</b>	<b>4SISLEG</b>
	<ul style="list-style-type: none"> <li>3 3/4" wide x 35 1/4" high.</li> <li>Alder will be used for Rustic Alder.</li> <li>Not available in Quartersawn Oak.</li> <li>Glazes and/or Techniques available: F, TW, XTW, HW, XHW.</li> </ul>
	<p>Custom Modification Options</p> <p>F.ALL <input checked="" type="checkbox"/></p>

Description	Model
<b>ISLAND LEG, SQUARE, 2x2</b>	<b>SQISLEG2</b>
	<ul style="list-style-type: none"> <li>2" x 2" x 35 1/4".</li> <li>Alder will be used for Rustic Alder.</li> <li>Not available in Quartersawn Oak.</li> </ul>
	<p>Custom Modification Options</p> <p>F.ALL <input checked="" type="checkbox"/></p>

Description	Model
<b>ISLAND LEG, SQUARE, 3x3</b>	<b>SQISLEG3</b>
	<ul style="list-style-type: none"> <li>3" wide x 3" deep x 35 1/4" high.</li> <li>Alder will be used for Rustic Alder.</li> <li>Glazes and/or Techniques available: F, TW, XTW, HW, XHW.</li> </ul>
	<p>Custom Modification Options</p> <p>F.ALL <input checked="" type="checkbox"/></p>

Description	Model		
<b>ISLAND LEG, SQUARE, 4x4</b>	<b>JSQISLEG4</b>		
	<ul style="list-style-type: none"> <li>• 4" wide x 4" deep x 35 1/4" high.</li> <li>• Alder will be used for Rustic Alder.</li> <li>• Glazes and/or Techniques available: F, TW, XTW, HW, XHW.</li> </ul> <p>Custom Modification Options</p> <table border="1"> <tr> <td>F.ALL</td> </tr> <tr> <td>✓</td> </tr> </table>	F.ALL	✓
F.ALL			
✓			

Description	Model		
<b>ISLAND LEG, SQUARE, 5x5</b>	<b>SQISLEG5</b>		
	<ul style="list-style-type: none"> <li>• 5" x 5" x 35 1/4".</li> <li>• Alder will be used for Rustic Alder.</li> <li>• Not available in Quartersawn Oak.</li> </ul> <p>Custom Modification Options</p> <table border="1"> <tr> <td>F.ALL</td> </tr> <tr> <td>✓</td> </tr> </table>	F.ALL	✓
F.ALL			
✓			

Description	Model		
<b>ISLAND LEG, SQUARE, 6x6</b>	<b>JSQISLEG6</b>		
	<ul style="list-style-type: none"> <li>• 6" wide x 6" deep x 35 1/4" high.</li> <li>• Alder will be used for Rustic Alder.</li> <li>• Glazes and/or Techniques available: F, TW, XTW, HW, XHW.</li> </ul> <p>Custom Modification Options</p> <table border="1"> <tr> <td>F.ALL</td> </tr> <tr> <td>✓</td> </tr> </table>	F.ALL	✓
F.ALL			
✓			

Description	Model		
<b>MADLINE POST, LARGE</b>	<b>MADLINEPOSTL</b>		
	<ul style="list-style-type: none"> <li>• 6" x 6" x 35 1/2".</li> <li>• Alder will be used for Rustic Alder.</li> <li>• Not available in Quartersawn Oak.</li> </ul> <p>Custom Modification Options</p> <table border="1"> <tr> <td>F.ALL</td> </tr> <tr> <td>✓</td> </tr> </table>	F.ALL	✓
F.ALL			
✓			

Description	Model		
<b>ENGLISH COUNTRY LEG</b>	<b>ENGNTYLEG</b>		
	<ul style="list-style-type: none"> <li>• 3 3/4" x 3 3/4" x 35 1/4".</li> <li>• Alder will be used for Rustic Alder.</li> <li>• Not available in Quartersawn Oak.</li> </ul> <p>Custom Modification Options</p> <table border="1"> <tr> <td>F.ALL</td> </tr> <tr> <td>✓</td> </tr> </table>	F.ALL	✓
F.ALL			
✓			

Description	Model		
<b>ENGLISH COUNTRY LEG, TALL</b>	<b>ENGNTYLEGT</b>		
	<ul style="list-style-type: none"> <li>• 3 3/4" x 3 3/4" x 42 1/4".</li> <li>• Alder will be used for Rustic Alder.</li> <li>• Not available in Quartersawn Oak.</li> </ul> <p>Custom Modification Options</p> <table border="1"> <tr> <td>F.ALL</td> </tr> <tr> <td>✓</td> </tr> </table>	F.ALL	✓
F.ALL			
✓			

Description	Model		
<b>ENGLISH COUNTRY LEG, ISLAND</b>	<b>ENGNTYLEGISL</b>		
	<ul style="list-style-type: none"> <li>• 3 3/4" x 3 3/4" x 35 1/4".</li> <li>• Alder will be used for Rustic Alder.</li> <li>• Not available in Quartersawn Oak.</li> </ul> <p>Custom Modification Options</p> <table border="1"> <tr> <td>F.ALL</td> </tr> <tr> <td>✓</td> </tr> </table>	F.ALL	✓
F.ALL			
✓			

**Glazes and Techniques**  
 F = Flooded (see page E•3.)  
 P = Penned (see page E•3.)  
 TW = Timeworn (see page E•3.)  
 XTW = Extra Timeworn (see page E•3.)  
 HW = Hewn (see page E•3.)  
 XHW = Extra Hewn (see page E•3.)

# Mouldings & Embellishments

Description	Model
<b>ESTATE LEG</b>	<b>ESTATELEG</b>
	<ul style="list-style-type: none"> <li>• 3 3/4" x 3 3/4" x 35 1/4".</li> <li>• Alder will be used for Rustic Alder.</li> <li>• Not available in Quartersawn Oak.</li> </ul> <p>Custom Modification Options</p> <p>F.A.L.L. ✓</p>

Description	Model
<b>ESTATE LEG, LARGE</b>	<b>ESTATELEGL</b>
	<ul style="list-style-type: none"> <li>• 5" x 5" x 35 1/4".</li> <li>• Alder will be used for Rustic Alder.</li> <li>• Not available in Quartersawn Oak.</li> </ul> <p>Custom Modification Options</p> <p>F.A.L.L. ✓</p>

Description	Model
<b>ESTATE LEG, TALL</b>	<b>ESTATELEGT</b>
	<ul style="list-style-type: none"> <li>• 3 3/4" x 3 3/4" x 42 1/4".</li> <li>• Alder will be used for Rustic Alder.</li> <li>• Not available in Quartersawn Oak.</li> </ul> <p>Custom Modification Options</p> <p>F.A.L.L. ✓</p>

Description	Model
<b>ESTATE FLUTE LEG, TALL</b>	<b>ESTATEFLUTELEGT</b>
	<ul style="list-style-type: none"> <li>• 3 3/4" x 3 3/4" x 42 1/4".</li> <li>• Alder will be used for Rustic Alder.</li> <li>• Not available in Quartersawn Oak.</li> </ul> <p>Custom Modification Options</p> <p>F.A.L.L. ✓</p>

Description	Model
<b>ESTATE LEG, SQUARE</b>	<b>ESTATELEGS</b>
	<ul style="list-style-type: none"> <li>• 2 3/4" x 2 3/4" x 35 1/4".</li> <li>• Alder will be used for Rustic Alder.</li> <li>• Not available in Quartersawn Oak.</li> </ul> <p>Custom Modification Options</p> <p>F.A.L.L. ✓</p>

Description	Model
<b>FRENCH COUNTRY LEG, DOUBLE SQUARE</b>	<b>FRNCNTYLEG</b>
	<ul style="list-style-type: none"> <li>• 3 3/4" x 3 3/4" x 35 1/4".</li> <li>• Alder will be used for Rustic Alder.</li> <li>• Not available in Quartersawn Oak.</li> </ul> <p>Custom Modification Options</p> <p>F.A.L.L. ✓</p>

Description	Model
<b>FRENCH COUNTRY LEG, LARGE, DOUBLE SQUARE</b>	<b>FRNCNTYLEGL</b>
	<ul style="list-style-type: none"> <li>• 5" x 5" x 35 1/4".</li> <li>• Alder will be used for Rustic Alder.</li> <li>• Not available in Quartersawn Oak.</li> </ul> <p>Custom Modification Options</p> <p>F.A.L.L. ✓</p>

Description	Model
<b>FRENCH COUNTRY LEG, TALL, DOUBLE SQUARE</b>	<b>FRNCNTYLEGT</b>
	<ul style="list-style-type: none"> <li>• 3 3/4" x 3 3/4" x 42 1/4".</li> <li>• Alder will be used for Rustic Alder.</li> <li>• Not available in Quartersawn Oak.</li> </ul> <p>Custom Modification Options</p> <p>F.A.L.L. ✓</p>

**Description**  
**FRENCH COUNTRY LEG, SINGLE SQUARE**

**Model**  
**FRNCNTYLEG2**

- 3 3/4" x 3 3/4" x 35 1/4".
- Alder will be used for Rustic Alder.
- Not available in Quartersawn Oak.

Custom Modification Options

F.ALL
✓

**Description**  
**FRENCH COUNTRY SQUARE LEG, ROUTED**

**Model**  
**FRNCNTYSQLEG**

- 3 3/4" x 3 3/4" x 35 1/4".
- Alder will be used for Rustic Alder.
- Not available in Quartersawn Oak.

Custom Modification Options

F.ALL
✓

**Description**  
**FRENCH COUNTRY LEG, LARGE, SINGLE SQUARE**

**Model**  
**FRNCNTYLEG12**

- 5" x 5" x 35 1/4".
- Alder will be used for Rustic Alder.
- Not available in Quartersawn Oak.

Custom Modification Options

F.ALL
✓

**Description**  
**FRENCH COUNTRY LEG, TALL, SINGLE SQUARE**

**Model**  
**FRNCNTYLEG2T**

- 3 3/4" x 3 3/4" x 42 1/4".
- Alder will be used for Rustic Alder.
- Not available in Quartersawn Oak.

Custom Modification Options

F.ALL
✓

**Description**  
**FRENCH COUNTRY REEDED LEG, SINGLE SQUARE**

**Model**  
**FRNCNTYRDLEG2**

- 3 3/4" x 3 3/4" x 35 1/4".
- Alder will be used for Rustic Alder.
- Not available in Quartersawn Oak.

Custom Modification Options

F.ALL
✓

**Description**  
**FRENCH COUNTRY REEDED LEG, TALL, SINGLE SQUARE**

**Model**  
**FRNCNTYRDLEG2T**

- 3 3/4" x 3 3/4" x 42 1/4".
- Alder will be used for Rustic Alder.
- Not available in Quartersawn Oak.

Custom Modification Options

F.ALL
✓

**Description**  
**FRENCH COUNTRY SQUARE LEG**

**Model**  
**FRNCNTYSQLEG**

- 3 3/4" x 3 3/4" x 35 1/4".
- Alder will be used for Rustic Alder.
- Not available in Quartersawn Oak.

Custom Modification Options

F.ALL
✓

**Description**  
**KENSINGTON LEG**

**Model**  
**KENSINGLEG**

- 1 15/32" x 3" x 35 1/4".
- Alder will be used for Rustic Alder.
- Not available in Quartersawn Oak.

Custom Modification Options

F.ALL
✓

# Mouldings & Embellishments

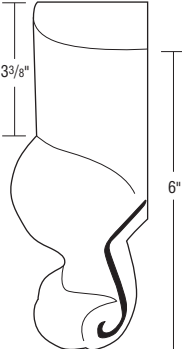
Description	Model		
<b>QUEEN ANNE LEG</b>	<b>FRNLG</b>		
	<ul style="list-style-type: none"> <li>• 2" wide x 6" high.</li> <li>• Alder will be used for Rustic Alder.</li> <li>• Not available in Quartersawn Oak.</li> <li>• Glazes and/or Techniques available: F, P, HW, XHW.</li> </ul> <p>Custom Modification Options</p> <table border="1"> <tr><td>F.ALL</td></tr> <tr><td>✓</td></tr> </table>	F.ALL	✓
F.ALL			
✓			

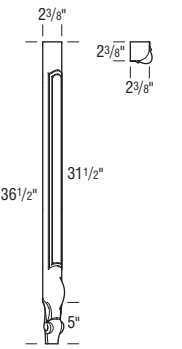
Description	Model		
<b>QUEEN ANNE CORNER LEG</b>	<b>QACRNLG</b>		
	<ul style="list-style-type: none"> <li>• 2 3/8" x 2 3/8" x 36 1/2".</li> <li>• Alder will be used for Rustic Alder.</li> <li>• Not available in Quartersawn Oak.</li> </ul> <p>Custom Modification Options</p> <table border="1"> <tr><td>F.ALL</td></tr> <tr><td>✓</td></tr> </table>	F.ALL	✓
F.ALL			
✓			

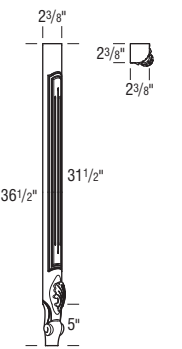
Description	Model		
<b>QUEEN ANNE CORNER ACANTHUS LEG</b>	<b>QACRNLG</b>		
	<ul style="list-style-type: none"> <li>• 2 3/8" x 2 3/8" x 36 1/2".</li> <li>• Alder will be used for Rustic Alder.</li> <li>• Not available in Quartersawn Oak.</li> </ul> <p>Custom Modification Options</p> <table border="1"> <tr><td>F.ALL</td></tr> <tr><td>✓</td></tr> </table>	F.ALL	✓
F.ALL			
✓			

**Glazes and Techniques**  
**F** = Flooded (see page E•3.)  
**P** = Penned (see page E•3.)  
**TW** = Timeworn (see page E•3.)  
**XTW** = Extra Timeworn (see page E•3.)  
**HW** = Hewn (see page E•3.)  
**XHW** = Extra Hewn (see page E•3.)

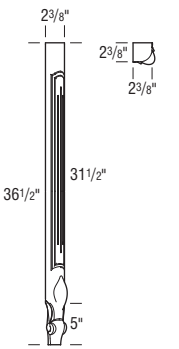
Description	Model		
<b>QUEEN ANNE CORNER FLUTED LEG</b>	<b>QACRNLFLUTLEG</b>		
	<ul style="list-style-type: none"> <li>• 2 3/8" x 2 3/8" x 36 1/2".</li> <li>• Alder will be used for Rustic Alder.</li> <li>• Not available in Quartersawn Oak.</li> </ul> <p>Custom Modification Options</p> <table border="1"> <tr><td>F.ALL</td></tr> <tr><td>✓</td></tr> </table>	F.ALL	✓
F.ALL			
✓			

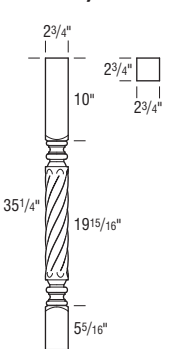
Description	Model		
<b>ROPE LEG, SMALL</b>	<b>ROPELEGS</b>		
	<ul style="list-style-type: none"> <li>• 2 3/4" x 2 3/4" x 35 1/4".</li> <li>• Alder will be used for Rustic Alder.</li> <li>• Not available in Quartersawn Oak.</li> </ul> <p>Custom Modification Options</p> <table border="1"> <tr><td>F.ALL</td></tr> <tr><td>✓</td></tr> </table>	F.ALL	✓
F.ALL			
✓			

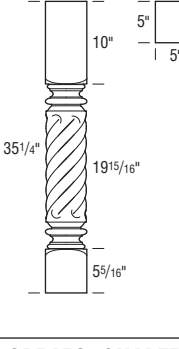
Description	Model		
<b>ROPE LEG, LARGE</b>	<b>ROPELEGL</b>		
	<ul style="list-style-type: none"> <li>• 5" x 5" x 35 1/4".</li> <li>• Alder will be used for Rustic Alder.</li> <li>• Not available in Quartersawn Oak.</li> </ul> <p>Custom Modification Options</p> <table border="1"> <tr><td>F.ALL</td></tr> <tr><td>✓</td></tr> </table>	F.ALL	✓
F.ALL			
✓			

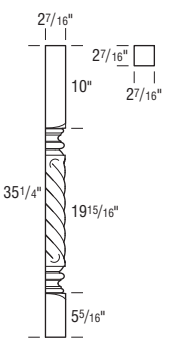
Description	Model		
<b>ROPE LEG, QUARTERED</b>	<b>ROPELEGQTR</b>		
	<ul style="list-style-type: none"> <li>• 2 7/16" x 2 7/16" x 35 1/4".</li> <li>• Alder will be used for Rustic Alder.</li> <li>• Not available in Quartersawn Oak.</li> </ul> <p>Custom Modification Options</p> <table border="1"> <tr><td>F.ALL</td></tr> <tr><td>✓</td></tr> </table>	F.ALL	✓
F.ALL			
✓			

Description	Model		
<b>FLUTE LEG, SMALL</b>	<b>FLUTELEGS</b>		
	<ul style="list-style-type: none"> <li>• 2 3/4" x 2 3/4" x 35 1/4".</li> <li>• Alder will be used for Rustic Alder.</li> <li>• Not available in Quartersawn Oak.</li> </ul> <p>Custom Modification Options</p> <table border="1"> <tr> <td>F.ALL</td> </tr> <tr> <td>✓</td> </tr> </table>	F.ALL	✓
F.ALL			
✓			

Description	Model		
<b>FLUTE LEG, LARGE</b>	<b>FLUTELEGL</b>		
	<ul style="list-style-type: none"> <li>• 5" x 5" x 35 1/4".</li> <li>• Alder will be used for Rustic Alder.</li> <li>• Not available in Quartersawn Oak.</li> </ul> <p>Custom Modification Options</p> <table border="1"> <tr> <td>F.ALL</td> </tr> <tr> <td>✓</td> </tr> </table>	F.ALL	✓
F.ALL			
✓			

Description	Model		
<b>FLUTE LEG, QUARTERED</b>	<b>FLUTELEGQTR</b>		
	<ul style="list-style-type: none"> <li>• 2 1/2" x 2 1/2" x 35 1/4".</li> <li>• Alder will be used for Rustic Alder.</li> <li>• Not available in Quartersawn Oak.</li> </ul> <p>Custom Modification Options</p> <table border="1"> <tr> <td>F.ALL</td> </tr> <tr> <td>✓</td> </tr> </table>	F.ALL	✓
F.ALL			
✓			

Description	Model		
<b>ACANTHUS LEG, LARGE</b>	<b>ACANTHUSLEGL</b>		
	<ul style="list-style-type: none"> <li>• 6" x 6" x 35 1/2".</li> <li>• Alder will be used for Rustic Alder.</li> <li>• Not available in Quartersawn Oak.</li> </ul> <p>Custom Modification Options</p> <table border="1"> <tr> <td>F.ALL</td> </tr> <tr> <td>✓</td> </tr> </table>	F.ALL	✓
F.ALL			
✓			

Description	Model		
<b>ACANTHUS LEG</b>	<b>ACANTHUSLEG</b>		
	<ul style="list-style-type: none"> <li>• 3 3/4" x 3 3/4" x 35 1/4".</li> <li>• Alder will be used for Rustic Alder.</li> <li>• Not available in Quartersawn Oak.</li> </ul> <p>Custom Modification Options</p> <table border="1"> <tr> <td>F.ALL</td> </tr> <tr> <td>✓</td> </tr> </table>	F.ALL	✓
F.ALL			
✓			

Description	Model		
<b>GAELIC LEG, LARGE</b>	<b>GAEICLEGL</b>		
	<ul style="list-style-type: none"> <li>• 6" x 6" x 35 1/2".</li> <li>• Alder will be used for Rustic Alder.</li> <li>• Not available in Quartersawn Oak.</li> </ul> <p>Custom Modification Options</p> <table border="1"> <tr> <td>F.ALL</td> </tr> <tr> <td>✓</td> </tr> </table>	F.ALL	✓
F.ALL			
✓			

Description	Model		
<b>GAELIC LEG, LARGE, ROUTED</b>	<b>GAEICLEGLR</b>		
	<ul style="list-style-type: none"> <li>• 6" x 6" x 35 1/2".</li> <li>• Alder will be used for Rustic Alder.</li> <li>• Not available in Quartersawn Oak.</li> </ul> <p>Custom Modification Options</p> <table border="1"> <tr> <td>F.ALL</td> </tr> <tr> <td>✓</td> </tr> </table>	F.ALL	✓
F.ALL			
✓			

Description	Model		
<b>APEX LEG</b>	<b>APEXLEG</b>		
	<ul style="list-style-type: none"> <li>• 3 1/2" x 3 1/2" x 34 1/2".</li> <li>• Alder will be used for Rustic Alder.</li> <li>• Not available in Quartersawn Oak.</li> </ul> <p>Custom Modification Options</p> <table border="1"> <tr> <td>F.ALL</td> </tr> <tr> <td>✓</td> </tr> </table>	F.ALL	✓
F.ALL			
✓			

# Mouldings & Embellishments

Description	Model		
<b>APEX LEG, TALL</b>	<b>APEXLEGT</b>		
	<ul style="list-style-type: none"> <li>• 3 1/2" x 3 1/2" x 40 1/2"</li> <li>• Alder will be used for Rustic Alder.</li> <li>• Not available in Quartersawn Oak.</li> </ul> <p>Custom Modification Options</p> <table border="1"> <tr> <td>F.A.L.L.</td> </tr> <tr> <td>✓</td> </tr> </table>	F.A.L.L.	✓
F.A.L.L.			
✓			

Description	Model		
<b>PACIFIC RIM LEG</b>	<b>PRLEG</b>		
	<ul style="list-style-type: none"> <li>• 4 7/8" x 29"</li> <li>• Alder will be used for Rustic Alder.</li> <li>• Oak will be used for Quartersawn Oak.</li> </ul> <p>Custom Modification Options</p> <table border="1"> <tr> <td>F.A.L.L.</td> </tr> <tr> <td>✓</td> </tr> </table>	F.A.L.L.	✓
F.A.L.L.			
✓			

Description	Model		
<b>MID-CENTURY TABLE LEG</b>	<b>MCLEG</b>		
	<ul style="list-style-type: none"> <li>• 6 1/4" x 29"</li> <li>• Alder will be used for Rustic Alder.</li> <li>• Oak will be used for Quartersawn Oak.</li> </ul> <p>Custom Modification Options</p> <table border="1"> <tr> <td>F.A.L.L.</td> </tr> <tr> <td>✓</td> </tr> </table>	F.A.L.L.	✓
F.A.L.L.			
✓			

Description	Model		
<b>3" x 35 1/4" SQUARE LEG with SLEEVE</b>	<b>3SQLEGALS-35 3SQLEGWIS-35</b>		
	<ul style="list-style-type: none"> <li>• 3" x 3" x 35 1/4"</li> <li>• Alder will be used for Rustic Alder.</li> <li>• Oak will be used for Quartersawn Oak.</li> <li>• Finishes available: Brushed Aluminum Sleeve (ALS) and Wrought Iron Sleeve (WIS).</li> </ul> <p>Custom Modification Options</p> <table border="1"> <tr> <td>F.A.L.L.</td> </tr> <tr> <td>✓</td> </tr> </table>	F.A.L.L.	✓
F.A.L.L.			
✓			

Description	Model		
<b>3" x 42 1/2" SQUARE LEG with SLEEVE</b>	<b>3SQLEGALS-42 3SQLEGWIS-42</b>		
	<ul style="list-style-type: none"> <li>• 3" x 3" x 42 1/2"</li> <li>• Alder will be used for Rustic Alder.</li> <li>• Oak will be used for Quartersawn Oak.</li> <li>• Finishes available: Brushed Aluminum Sleeve (ALS) and Wrought Iron Sleeve (WIS).</li> </ul> <p>Custom Modification Options</p> <table border="1"> <tr> <td>F.A.L.L.</td> </tr> <tr> <td>✓</td> </tr> </table>	F.A.L.L.	✓
F.A.L.L.			
✓			

Description	Model		
<b>4" x 35 1/4" SQUARE LEG with SLEEVE</b>	<b>4SQLEGALS-35 4SQLEGWIS-35</b>		
	<ul style="list-style-type: none"> <li>• 4" x 4" x 35 1/4"</li> <li>• Alder will be used for Rustic Alder.</li> <li>• Oak will be used for Quartersawn Oak.</li> <li>• Finishes available: Brushed Aluminum Sleeve (ALS) and Wrought Iron Sleeve (WIS).</li> </ul> <p>Custom Modification Options</p> <table border="1"> <tr> <td>F.A.L.L.</td> </tr> <tr> <td>✓</td> </tr> </table>	F.A.L.L.	✓
F.A.L.L.			
✓			

Description	Model		
<b>4" x 42 1/2" SQUARE LEG with SLEEVE</b>	<b>4SQLEGALS-42 4SQLEGWIS-42</b>		
	<ul style="list-style-type: none"> <li>• 4" x 4" x 42 1/2"</li> <li>• Alder will be used for Rustic Alder.</li> <li>• Oak will be used for Quartersawn Oak.</li> <li>• Finishes available: Brushed Aluminum Sleeve (ALS) and Wrought Iron Sleeve (WIS).</li> </ul> <p>Custom Modification Options</p> <table border="1"> <tr> <td>F.A.L.L.</td> </tr> <tr> <td>✓</td> </tr> </table>	F.A.L.L.	✓
F.A.L.L.			
✓			

**Description**  
**5" x 35 1/4" SQUARE LEG with SLEEVE**

**Model**  
**5SQLEGALS-35**  
**5SQLEGWIS-35**

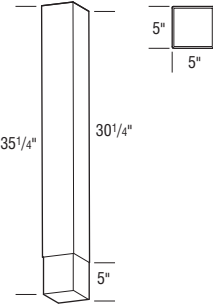

- 5" x 5" x 35 1/4".
- Alder will be used for Rustic Alder.
- Oak will be used for Quartersawn Oak.
- Finishes available: Brushed Aluminum Sleeve (ALS) and Wrought Iron Sleeve (WIS).

Custom Modification Options

F.A.L.L.
✓

**Description**  
**5" x 42 1/2" SQUARE LEG with SLEEVE**

**Model**  
**5SQLEGALS-42**  
**5SQLEGWIS-42**

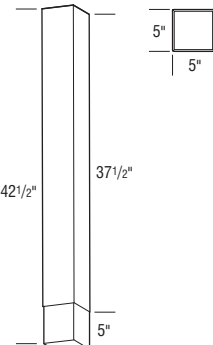

- 5" x 5" x 42 1/2".
- Alder will be used for Rustic Alder.
- Oak will be used for Quartersawn Oak.
- Finishes available: Brushed Aluminum Sleeve (ALS) and Wrought Iron Sleeve (WIS).

Custom Modification Options

F.A.L.L.
✓

**Description**  
**MID-CENTURY LEG**

**Model**  
**MCLEGGMG**  
**MCLEGWI**

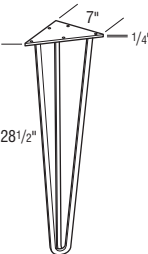

- 7" x 7" x 28 1/2".
- Finishes available: Gun Metal Gray (GMG) and Wrought Iron (WI).

Modifications Are Not Available

**Description**  
**INDUSTRIAL LEG, SMALL**

**Model**  
**INLEGGMG**  
**INLEGSWI**

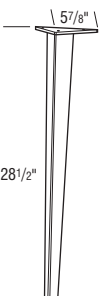

- 5 7/8" x 5 7/8" x 28 1/2".
- Finishes available: Gun Metal Gray (GMG) and Wrought Iron (WI).

Modifications Are Not Available

**Description**  
**INDUSTRIAL LEG, LARGE**

**Model**  
**INLEGLGMG**  
**INLEGLWI**

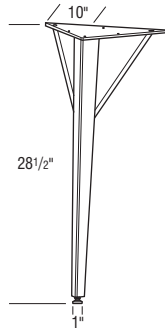

- 10" x 10" x 28 1/2".
- Finishes available: Gun Metal Gray (GMG) and Wrought Iron (WI).

Modifications Are Not Available

**Description**  
**URBAN LEG**

**Model**  
**URBANLEG**

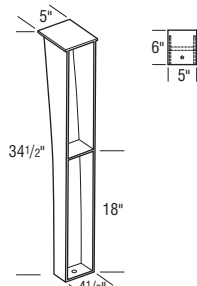

- 6" x 5" x 34 1/2".
- Stainless Steel finish.

Modifications Are Not Available

## PEDESTALS & BASES

**Description**  
**4" LEXINGTON TABLE PEDESTAL KIT**

**Model**  
**LEXTBLKIT4**

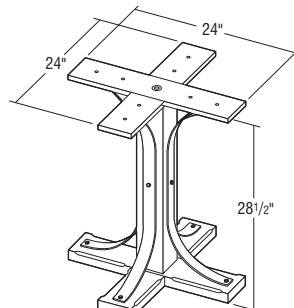

- 24" x 28 1/2".
- Alder will be used for Rustic Alder.
- Not available in Quartersawn Oak.
- Kit comes unassembled.
- Metal components are black matte sheen with matching hardware.

Custom Modification Options

F.A.L.L.
✓

**Description**  
**4" LEXINGTON ISLAND PEDESTAL KIT**

**Model**  
**LEXISLKIT4**

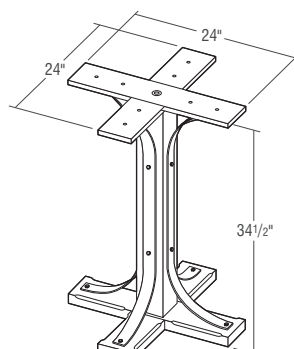

- 24" x 34 1/2".
- Alder will be used for Rustic Alder.
- Not available in Quartersawn Oak.
- Kit comes unassembled.
- Metal components are black matte sheen with matching hardware.

Custom Modification Options

F.A.L.L.
✓



# Mouldings & Embellishments

**Description**  
**CHARLESTON PEDESTAL, 29 1/2"**

**Model**  
**CHARLESESPED29**

- 12" x 29 1/2".
- Alder will be used for Rustic Alder.
- Not available in Quartersawn Oak.

Custom Modification Options

F.A.L.L.
✓

**Description**  
**CHARLESTON PEDESTAL, 33 1/2"**

**Model**  
**CHARLESESPED33**

- 12" x 33 1/2".
- Alder will be used for Rustic Alder.
- Not available in Quartersawn Oak.

Custom Modification Options

F.A.L.L.
✓

**Description**  
**ROUND BASE, 12" DIAMETER**

**Model**  
**ROUNDBASE12**

- 1" x 12".
- Alder will be used for Rustic Alder.
- Not available in Quartersawn Oak.

Custom Modification Options

F.A.L.L.
✓

**Description**  
**ROUND BASE, 24" DIAMETER**

**Model**  
**ROUNDBASE24**

- 1" x 24".
- Alder will be used for Rustic Alder.
- Not available in Quartersawn Oak.

Custom Modification Options

F.A.L.L.
✓

**Description**  
**COLUMNS**

**Model**  
**ENGLISCOLUMN**

**ENGLISH COUNTRY ISLAND COLUMN**

**ENGLISCOLUMN**

- 5" x 5" x 35 1/4".
- Alder will be used for Rustic Alder.
- Not available in Quartersawn Oak.

Custom Modification Options

F.A.L.L.
✓

**Description**  
**ENGLISH COUNTRY ISLAND QUARTERED COLUMN**

**Model**  
**ENGLISQTRCOL**

- 2 7/16" x 2 7/16" x 35 1/4".
- Alder will be used for Rustic Alder.
- Not available in Quartersawn Oak.

Custom Modification Options

F.A.L.L.
✓

**Description**  
**ENGLISH COUNTRY ISLAND COLUMN, DOUBLE SQUARE**

**Model**  
**ENGLISCOLUMN2**

- 5" x 5" x 35 1/4".
- Alder will be used for Rustic Alder.
- Not available in Quartersawn Oak.

Custom Modification Options

F.A.L.L.
✓

**Description**

**ENGLISH COUNTRY ISLAND QUARTERED COLUMN, DOUBLE SQUARE**

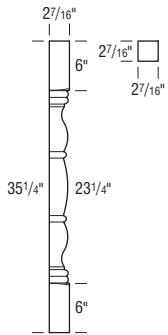

**Model**

**ENGLISLQTRCOL2**

- 2 7/16" x 2 7/16" x 35 1/4".
- Alder will be used for Rustic Alder.
- Not available in Quartersawn Oak.

Custom Modification Options

F.A.L.L.
✓

**METRO ISLAND COLUMN**

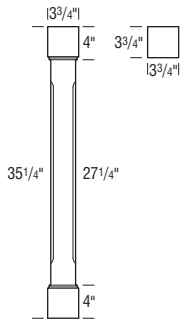

**METISLCOLUMN**

- 3 3/4" x 3 3/4" x 35 1/4".
- Alder will be used for Rustic Alder.
- Not available in Quartersawn Oak.

Custom Modification Options

F.A.L.L.
✓

**METRO ISLAND COLUMN, SMALL**

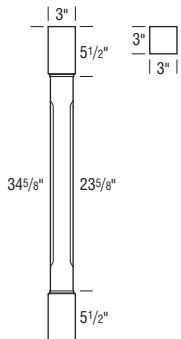

**METISLCOLUMNS**

- 3" x 3" x 34 5/8".
- Alder will be used for Rustic Alder.

Custom Modification Options

F.A.L.L.
✓

**METRO BAR COLUMN**

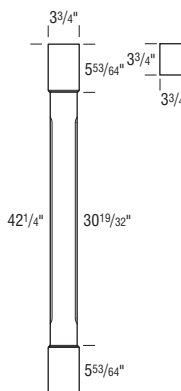

**METBARCOLUMN**

- 3 3/4" x 3 3/4" x 42 1/4".
- Alder will be used for Rustic Alder.

Custom Modification Options

F.A.L.L.
✓

**Description**

**BAROQUE COLUMN**

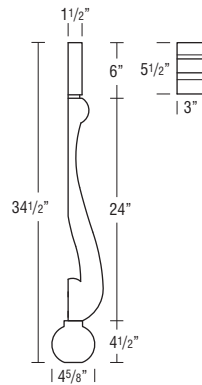

**Model**

**BARISLCOLUMN**

- 3" x 5 1/2" x 34 1/2".
- Alder will be used for Rustic Alder.
- Not available in Quartersawn Oak.

Custom Modification Options

F.A.L.L.
✓

**PLAIN NOUVEAU ISLAND COLUMN**

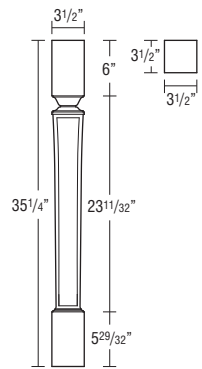

**NOULEG**

- 3 1/2" x 3 1/2" x 35 1/4".
- Alder will be used for Rustic Alder.
- Not available in Quartersawn Oak.
- Abbey, Basilica and Tudor Column Inserts available. See page R-49.

Custom Modification Options

F.A.L.L.
✓

**PLAIN NOUVEAU BAR COLUMN**

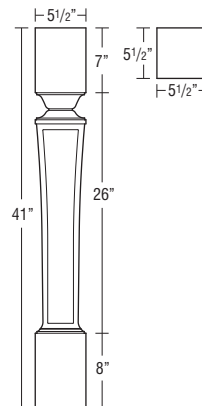

**NOULEGT**

- 5 1/2" x 5 1/2" x 41".
- Alder will be used for Rustic Alder.
- Not available in Quartersawn Oak.
- Abbey, Basilica and Tudor Column Inserts available. See page R-49.

Custom Modification Options

F.A.L.L.
✓

# Mouldings & Embellishments

**Description** **Model**

---

**QUEEN ANNE BUFFET COLUMN** **QALEGT**

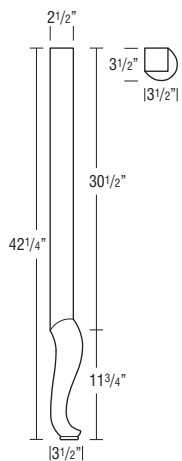

- 3 1/2" x 3 1/2" x 42 1/4".
- Alder will be used for Rustic Alder.
- Not available in Quartersawn Oak.

Custom Modification Options

F.A.L.L.
✓

**WEAVED ISLAND COLUMN** **WEAVELEG**

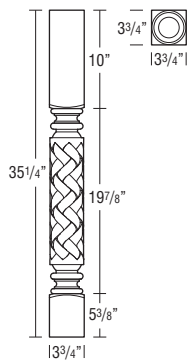

- 3 3/4" x 3 3/4" x 35 1/4".
- Alder will be used for Rustic Alder.
- Not available in Quartersawn Oak.

Modifications  
Are Not  
Available

**LARGE DIAMOND WEAVED ISLAND COLUMN** **WEAVELEGL**

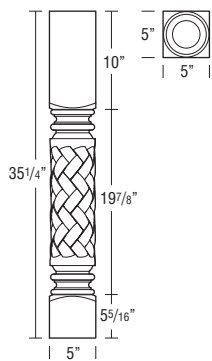

- 5" x 5" x 35 1/4".
- Alder will be used for Rustic Alder.
- Not available in Quartersawn Oak.

Modifications  
Are Not  
Available

**Description** **Model**

---

**WEAVED BAR COLUMN** **WEAVELEGT**

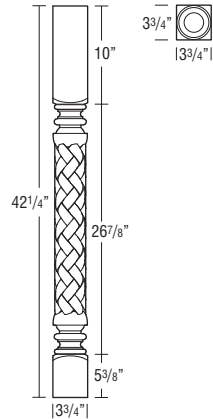

- 3 3/4" x 3 3/4" x 42 1/4".
- Alder will be used for Rustic Alder.
- Not available in Quartersawn Oak.

Modifications  
Are Not  
Available

**URBAN ISLAND COLUMN, COUNTER** **URBISLCOLUMNCC**

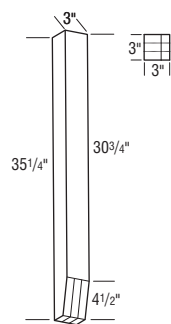

- 3" x 35 1/4".
- Alder will be used for Rustic Alder.
- Oak will be used for Quartersawn Oak.

Custom Modification Options

F.A.L.L.
✓

**URBAN ISLAND COLUMN, BAR** **URBISLCOLUMNBC**

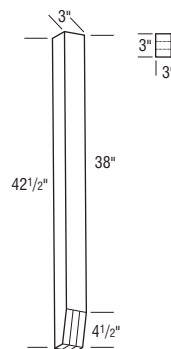

- 3" x 42 1/2".
- Alder will be used for Rustic Alder.
- Oak will be used for Quartersawn Oak.

Custom Modification Options

F.A.L.L.
✓

**URBAN ISLAND COLUMN, DOUBLE BEVEL, COUNTER** **URBISLCOLUMNDC**

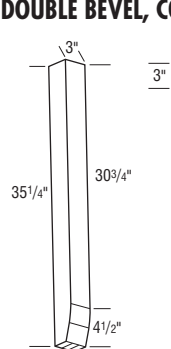

- 3" x 35 1/4".
- Alder will be used for Rustic Alder.
- Oak will be used for Quartersawn Oak.

Custom Modification Options

F.A.L.L.
✓

**Description**  
**URBAN ISLAND COLUMN, DOUBLE BEVEL, BAR**

**Model**  
**URBISLCOLUMNBD**

- 3" x 42 1/2".
- Alder will be used for Rustic Alder.
- Oak will be used for Quartersawn Oak.

Custom Modification Options

F.ALL
✓

**Description**  
**2 1/2" PACIFIC RIM ISLAND COLUMN**

**Model**  
**PRISLCOLUMN3**

- 2 1/2" x 35 1/4".
- Alder will be used for Rustic Alder.
- Oak will be used for Quartersawn Oak.

Custom Modification Options

F.ALL
✓

**Description**  
**3 3/4" PACIFIC RIM ISLAND COLUMN**

**Model**  
**PRISLCOLUMN4**

- 3 3/4" x 35 1/4".
- Alder will be used for Rustic Alder.
- Oak will be used for Quartersawn Oak.

Custom Modification Options

F.ALL
✓

**Description**  
**PACIFIC RIM ISLAND COLUMN**

**Model**  
**PRISLCOLUMN**

- 3 5/8" x 34 1/2".
- Alder will be used for Rustic Alder.
- Oak will be used for Quartersawn Oak.

Custom Modification Options

F.ALL
✓

**Description**  
**96" PACIFIC RIM CREATE A COLUMN**

**Model**  
**PRCCOLUMN96**

- 2" x 6 1/64" x 96".
- Alder will be used for Rustic Alder.
- Oak will be used for Quartersawn Oak.

Custom Modification Options

F.ALL
✓

**Description**  
**34 1/2" PACIFIC RIM CREATE A COLUMN**

**Model**  
**PRCCOLUMN35**

- 3 1/2" x 34 1/2".
- Alder will be used for Rustic Alder.
- Oak will be used for Quartersawn Oak.

Custom Modification Options

F.ALL
✓

**Description**  
**MID-CENTURY ISLAND COLUMN**

**Model**  
**MCISLCOLUMN**

- 2 5/8" x 34 1/2".
- Alder will be used for Rustic Alder.
- Oak will be used for Quartersawn Oak.

Custom Modification Options

F.ALL
✓

**Description**  
**NOTCHED MID-CENTURY ISLAND COLUMN**

**Model**  
**NMCISLCOLUMN**

- 2 5/8" x 34 1/2".
- Alder will be used for Rustic Alder.
- Oak will be used for Quartersawn Oak.

Custom Modification Options

F.ALL
✓

# Mouldings & Embellishments

**Description** **Model**

**MID-CENTURY VANITY COLUMN** **MCVANCOLUMN**

- 2 1/4" x 34 1/2".
- Alder will be used for Rustic Alder.
- Oak will be used for Quartersawn Oak.

Custom Modification Options

F.A.L.L. ✓

**NOTCHED MID-CENTURY VANITY COLUMN** **NMCVANCOLUMN**

- 2 1/4" x 34 1/2".
- Alder will be used for Rustic Alder.
- Oak will be used for Quartersawn Oak.

Custom Modification Options

F.A.L.L. ✓

**CHARLESTON BEAD COLUMN with FOOT** **WFOOTCHARLESTON**

- 3" x 3" x 35 1/4".
- Alder will be used for Rustic Alder.
- Not available in Quartersawn Oak.

Custom Modification Options

F.A.L.L. ✓

**CHARLESTON BEAD COLUMN, DOUBLE SQUARE** **DBLSQCHARLESTON**

- 3" x 3" x 35 1/4".
- Alder will be used for Rustic Alder.
- Not available in Quartersawn Oak.

Custom Modification Options

F.A.L.L. ✓

**Description** **Model**

**SUMTER ISLAND COLUMN, DOUBLE SQUARE** **DBLSQSUMTER5**

- 5" x 5" x 35 1/4".
- Alder will be used for Rustic Alder.
- Not available in Quartersawn Oak.

Custom Modification Options

F.A.L.L. ✓

**SUMTER TABLE COLUMN, DOUBLE SQUARE** **DBLSQTBLS**

- 5" x 5" x 30 1/4".
- Alder will be used for Rustic Alder.
- Not available in Quartersawn Oak.

Custom Modification Options

F.A.L.L. ✓

**CONTEMPORARY CAP for 3" COLUMN** **CONCAP-3**

- 2 1/2" x 4 5/8" x 4 5/8".
- Alder will be used for Rustic Alder.
- Oak will be used for Quartersawn Oak.

Custom Modification Options

F.A.L.L. ✓

**CONTEMPORARY CAP for 4" COLUMN** **CONCAP-4**

- 2 1/2" x 5 5/8" x 5 5/8".
- Alder will be used for Rustic Alder.
- Oak will be used for Quartersawn Oak.

Custom Modification Options

F.A.L.L. ✓

**CONTEMPORARY CAP for 5" COLUMN** **CONCAP-5**

- 2 1/2" x 6 5/8" x 6 5/8".
- Alder will be used for Rustic Alder.
- Oak will be used for Quartersawn Oak.

Custom Modification Options

F.A.L.L. ✓

**CONTEMPORARY CAP for 6" COLUMN** **CONCAP-6**

- 2 1/2" x 7 5/8" x 7 5/8".
- Alder will be used for Rustic Alder.
- Oak will be used for Quartersawn Oak.

Custom Modification Options

F.A.L.L. ✓

**Description**

**ABBAY COLUMN INSERT - ISLAND**

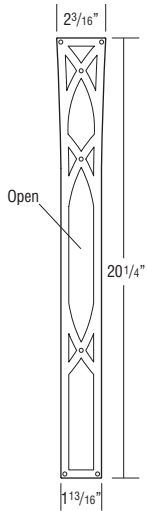

**Model**

**ABBAYCOLINSBR**

- Refined Bronze

**ABBAYCOLINSN**

- Satin Nickel

**ABBAYCOLINSWI**

- Wrought Iron

- 1/8" x 2 3/16" x 20 1/4"
- Must be used as an insert for Plain Nouveau Island Column (NOULEG).
- No Finish Techniques available.

Custom Modification Options

F.ALL
✓

**Description**

**BASILICA COLUMN INSERT - BAR**

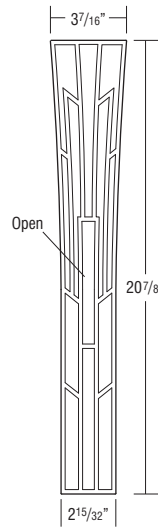

**Model**

**BASILCOLINSTBR**

- Refined Bronze

**BASILCOLINSTN**

- Satin Nickel

**BASILCOLINSTWI**

- Wrought Iron

- 1/8" x 3 7/16" x 20 7/8"
- Must be used as an insert for Plain Nouveau Bar Column (NOULEGT).

Custom Modification Options

F.ALL
✓

**ABBAY COLUMN INSERT - BAR**

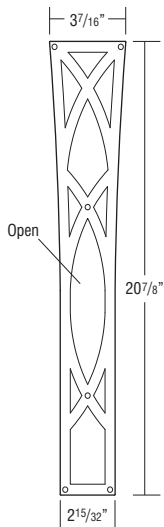

**ABBAYCOLINSTBR**

- Refined Bronze

**ABBAYCOLINSTN**

- Satin Nickel

**ABBAYCOLINSTWI**

- Wrought Iron

- 1/8" x 3 7/16" x 20 7/8"
- Must be used as an insert for Plain Nouveau Bar Column (NOULEGT).

Custom Modification Options

F.ALL
✓

**TUDOR COLUMN INSERT - ISLAND**

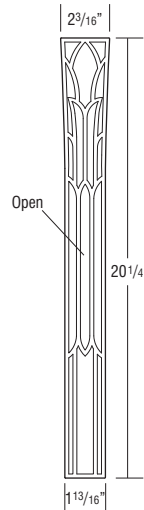

**TUDORCOLINSBR**

- Refined Bronze

**TUDORCOLINSN**

- Satin Nickel

**TUDORCOLINSWI**

- Wrought Iron

- 1/8" x 2 3/16" x 20 1/4"
- Must be used as an insert for Plain Nouveau Island Column (NOULEG).
- No Finish Techniques available.

Custom Modification Options

F.ALL
✓

**BASILICA COLUMN INSERT - ISLAND**

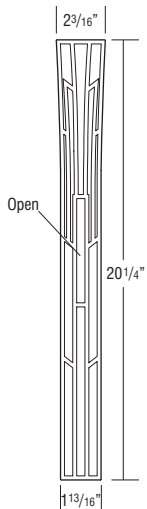

**BASILCOLINSBR**

- Refined Bronze

**BASILCOLINSN**

- Satin Nickel

**BASILCOLINSWI**

- Wrought Iron

- 1/8" x 2 3/16" x 20 1/4"
- Must be used as an insert for Plain Nouveau Island Column (NOULEG).
- No Finish Techniques available.

Custom Modification Options

F.ALL
✓

**TUDOR COLUMN INSERT - BAR**

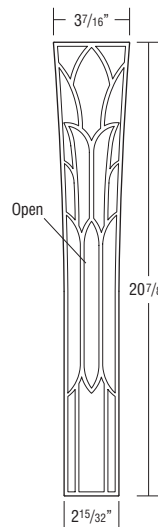

**TUDORCOLINSTBR**

- Refined Bronze

**TUDORCOLINSTN**

- Satin Nickel

**TUDORCOLINSTWI**

- Wrought Iron

- 1/8" x 3 7/16" x 20 7/8"
- Must be used as an insert for Plain Nouveau Bar Column (NOULEGT).

Custom Modification Options

F.ALL
✓

# Mouldings & Embellishments

Description	Model
-------------	-------

## X-END PANELS

### 3" x 25" X-END PANEL

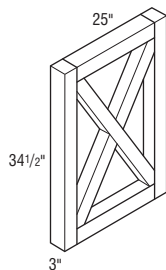

#### XEND325

- 3" x 25" x 34 1/2".
- Alder will be used for Rustic Alder.
- Not available in Quartersawn Oak.
- When applying the X-end panel to the side of a cabinet, you will want to make sure that you either skin the side of the cabinet or order as a flush finished side as the panel has openings in it.
- The panel is designed to sit out flush with the door on an adjacent cabinet.
- If using a square outside profile on a door cabinet next to the panel, you may want to consider modifying the cabinet to have a wide or extended stile to prevent binding.
- Panel is finished on both sides.

Custom Modification Options

FALL
✓

### 3" x 36" X-END PANEL

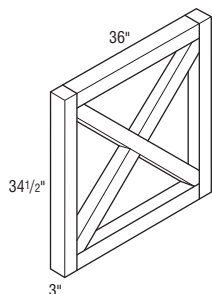

#### XEND336

- 3" x 36" x 34 1/2".
- Alder will be used for Rustic Alder.
- Not available in Quartersawn Oak.
- When applying the X-end panel to the side of a cabinet, you will want to make sure that you either skin the side of the cabinet or order as a flush finished side as the panel has openings in it.
- The panel is designed to sit out flush with the door on an adjacent cabinet.
- If using a square outside profile on a door cabinet next to the panel, you may want to consider modifying the cabinet to have a wide or extended stile to prevent binding.
- Panel is finished on both sides.

Custom Modification Options

FALL
✓

### 1 1/2" x 25" X-END PANEL

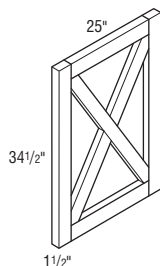

#### XEND125

- 1 1/2" x 25" x 34 1/2".
- Alder will be used for Rustic Alder.
- Not available in Quartersawn Oak.
- When applying the X-end panel to the side of a cabinet, you will want to make sure that you either skin the side of the cabinet or order as a flush finished side as the panel has openings in it.
- The panel is designed to sit out flush with the door on an adjacent cabinet.
- If using a square outside profile on a door cabinet next to the panel, you may want to consider modifying the cabinet to have a wide or extended stile to prevent binding.
- Panel is finished on both sides.

Custom Modification Options

FALL
✓

#### Glazes and Techniques

- F = Flooded (see page E•3.)
- P = Penned (see page E•3.)
- TW = Timeworn (see page E•3.)
- XTW = Extra Timeworn (see page E•3.)
- HW = Hewn (see page E•3.)
- XHW = Extra Hewn (see page E•3.)

Description	Model
-------------	-------

### 1 1/2" x 36" X-END PANEL

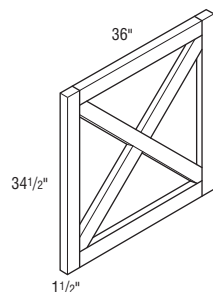

#### XEND136

- 1 1/2" x 36" x 34 1/2".
- Alder will be used for Rustic Alder.
- Not available in Quartersawn Oak.
- When applying the X-end panel to the side of a cabinet, you will want to make sure that you either skin the side of the cabinet or order as a flush finished side as the panel has openings in it.
- The panel is designed to sit out flush with the door on an adjacent cabinet.
- If using a square outside profile on a door cabinet next to the panel, you may want to consider modifying the cabinet to have a wide or extended stile to prevent binding.
- Panel is finished on both sides.

Custom Modification Options

FALL
✓

## SWITCH PLATE COVERS

### SINGLE SWITCH PLATE

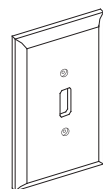

#### SSP

- Alder will be used for Rustic Alder.
- Oak will be used for Quartersawn Oak.
- Glazes and/or Techniques available: F, TW, XTW, HW, XHW.

Modifications  
Are Not  
Available

### DOUBLE SWITCH PLATE

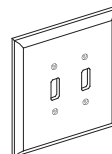

#### DSP

- Alder will be used for Rustic Alder.
- Oak will be used for Quartersawn Oak.
- Glazes and/or Techniques available: F, TW, XTW, HW, XHW.

Modifications  
Are Not  
Available

## ROCKER SWITCH PLATE

### SINGLE ROCKER PLATE

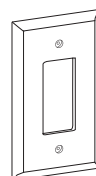

#### SRP

- Alder will be used for Rustic Alder.
- Glazes and/or Techniques available: F, TW, XTW, HW, XHW.

Modifications  
Are Not  
Available

### DOUBLE ROCKER PLATE

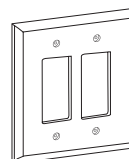

#### DRP

- Alder will be used for Rustic Alder.
- Glazes and/or Techniques available: F, TW, XTW, HW, XHW.

Modifications  
Are Not  
Available

Description	Model
<b>OUTLET COVERS</b>	

**SINGLE OUTLET COVER**

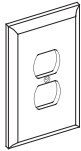

**SOC**

- Alder will be used for Rustic Alder.
- Oak will be used for Quartersawn Oak.
- Glazes and/or Techniques available:  
F, TW, XTW, HW, XHW.

Modifications  
Are Not  
Available

**DOUBLE OUTLET COVER**

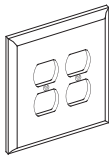

**DOC**

- Alder will be used for Rustic Alder.
- Oak will be used for Quartersawn Oak.
- Glazes and/or Techniques available:  
F, TW, XTW, HW, XHW.

Modifications  
Are Not  
Available

**Glazes and Techniques**  
**F** = Flooded (see page E•3.)  
**P** = Penned (see page E•3.)  
**TW** = Timeworn (see page E•3.)  
**XTW** = Extra Timeworn (see page E•3.)  
**HW** = Hewn (see page E•3.)  
**XHW** = Extra Hewn (see page E•3.)



# Mouldings & Embellishments

## ABBEY COLLECTION

**ABBEY COLUMN INSERT - ISLAND**  
R•49

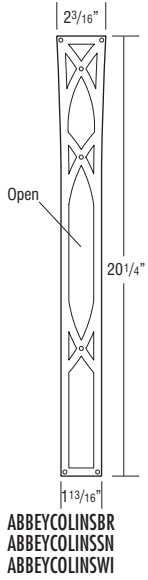

**ABBEY COLUMN INSERT - BAR**  
R•49

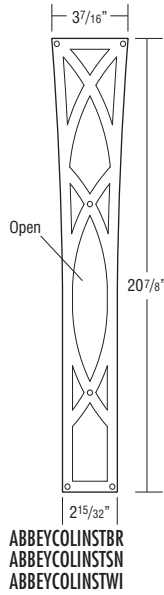

**ABBEY CORBEL INSERT - LARGE**  
R•27

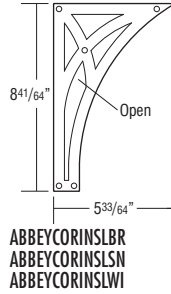

**ABBEY CORBEL INSERT - MEDIUM**  
R•27

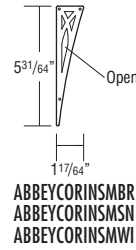

**ABBEY CORBEL INSERT - SMALL**  
R•27

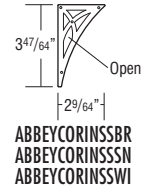

**ABBEY CROWN INSERT**  
R•6

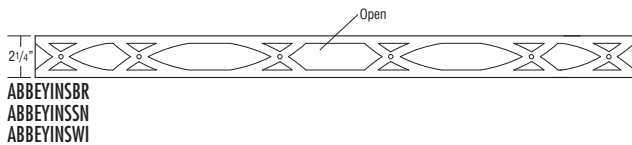

**ABBEY LIGHT RAIL INSERT**  
R•6

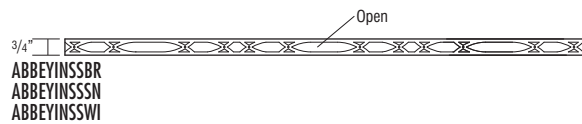

**PLAIN NOUVEAU ISLAND COLUMN**  
R•45

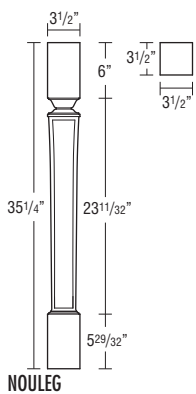

**PLAIN NOUVEAU BAR COLUMN**  
R•45

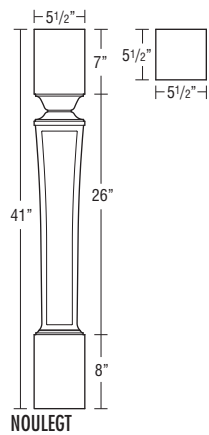

**PLAIN NOUVEAU LARGE CORBEL**  
R•26

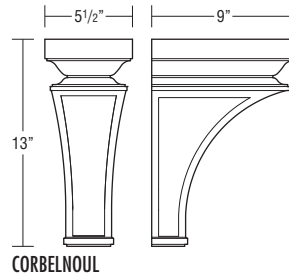

**PLAIN NOUVEAU MEDIUM CORBEL**  
R•26

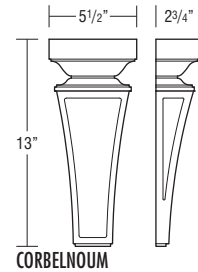

**PLAIN NOUVEAU SMALL CORBEL**  
R•26

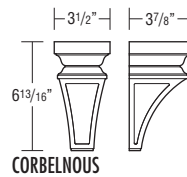

## ACANTHUS COLLECTION

**ACANTHUS LEG, LARGE**  
R•41

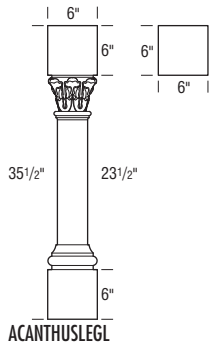

**ACANTHUS LEG**  
R•41

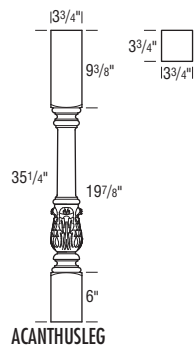

**10" SMALL ACANTHUS CORBEL**  
R•26

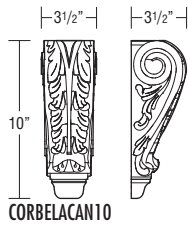

**14" SMALL ACANTHUS CORBEL**  
R•26

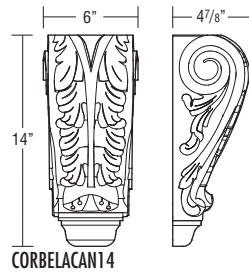

**5" PETITE ACANTHUS CORBEL**  
R•26

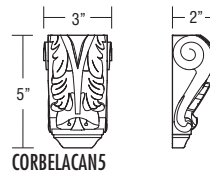

**ACANTHUS FOOT**  
R•29

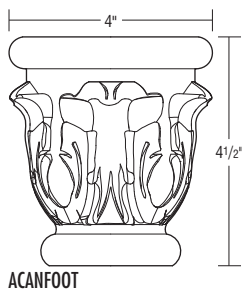

**ACANTHUS ROSETTE**  
R•16

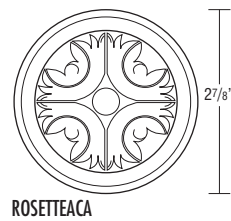

**3" SPLIT TURNING ACANTHUS**  
R•17

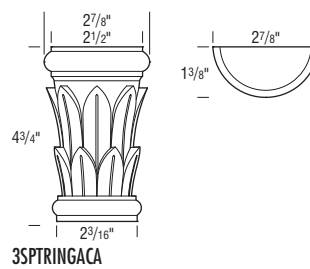

# Mouldings & Embellishments

## BASILICA COLLECTION

**PLAIN NOUVEAU  
ISLAND COLUMN  
R•45**

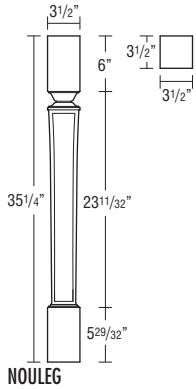

**PLAIN NOUVEAU  
BAR COLUMN  
R•45**

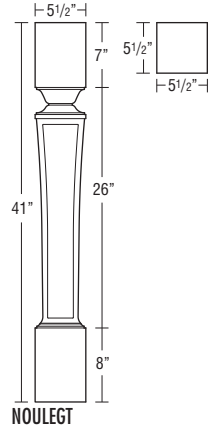

**PLAIN NOUVEAU  
LARGE CORBEL  
R•26**

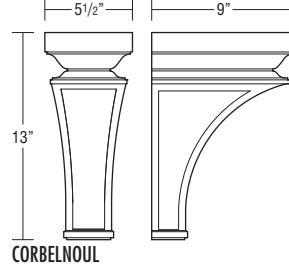

**PLAIN NOUVEAU  
MEDIUM CORBEL  
R•26**

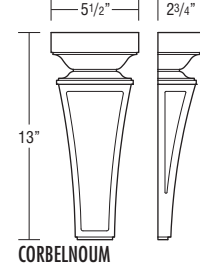

**PLAIN NOUVEAU  
SMALL CORBEL  
R•26**

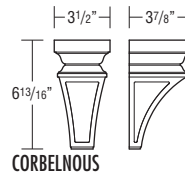

**BASILICA COLUMN INSERT -  
ISLAND  
R•49**

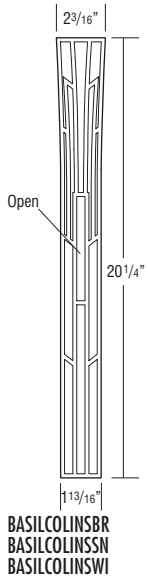

**BASILICA COLUMN INSERT -  
BAR  
R•49**

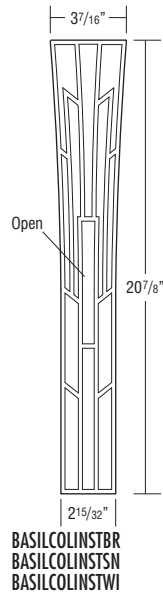

**BASILICA CORBEL INSERT -  
LARGE  
R•27**

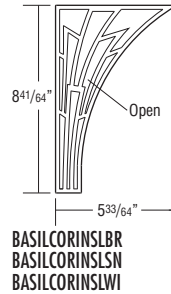

**BASILICA CORBEL INSERT -  
MEDIUM  
R•28**

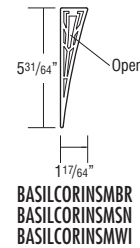

**BASILICA CORBEL INSERT -  
SMALL  
R•28**

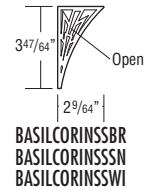

**BASILICA CROWN INSERT  
R•6**

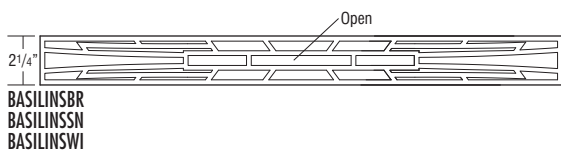

**BASILICA LIGHT RAIL INSERT  
R•7**

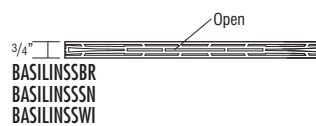

**CELTIC COLLECTION**

**CELTIC BRACKET**  
R•23

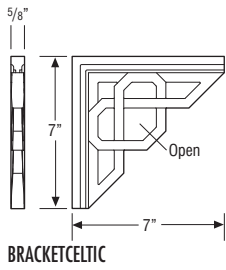

**7" CELTIC CORBEL**  
R•24

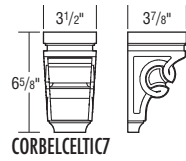

**10" CELTIC CORBEL**  
R•24

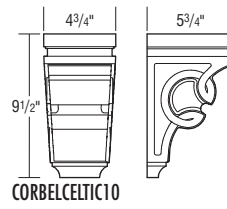

**14" CELTIC CORBEL**  
R•25

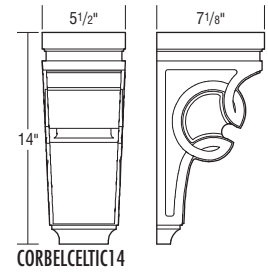

**CELTIC FOOT**  
R•30

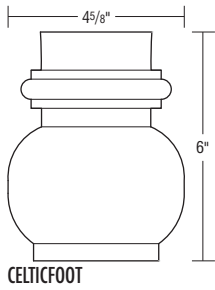

# Mouldings & Embellishments

## CRAFTSMAN COLLECTION

5" CLASSIC REVIVAL CORBEL  
R•24

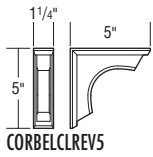

9" CLASSIC REVIVAL CORBEL  
R•24

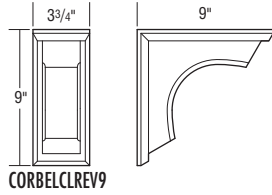

14" CLASSIC REVIVAL CORBEL  
R•24

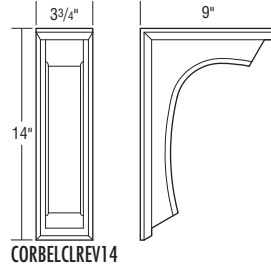

3" SHAKER CORBEL  
R•25

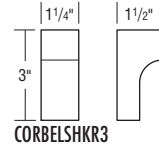

CRAFTSMAN CORBEL  
R•23

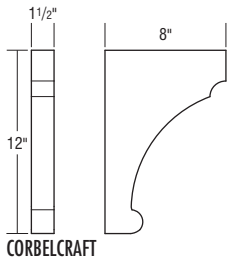

CRAFTSMAN CORBEL OPEN  
R•23

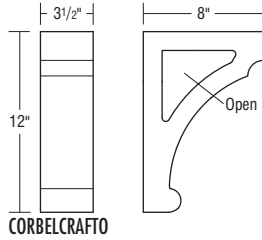

10" CRAFTSMAN CORBEL  
R•23

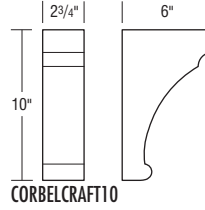

12" CRAFTSMAN CORBEL  
R•23

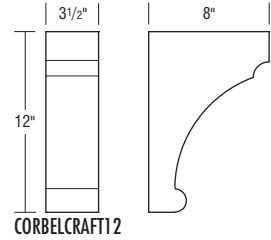

## CRAFTSMAN COLLECTION (cont'd)

**18" CRAFTSMAN CORBEL**  
R•24

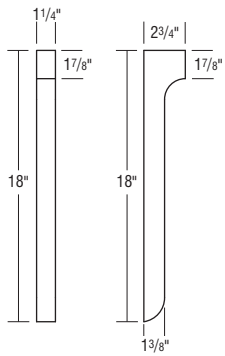

CORBELCRAFT18

**34" CRAFTSMAN CORBEL**  
R•24

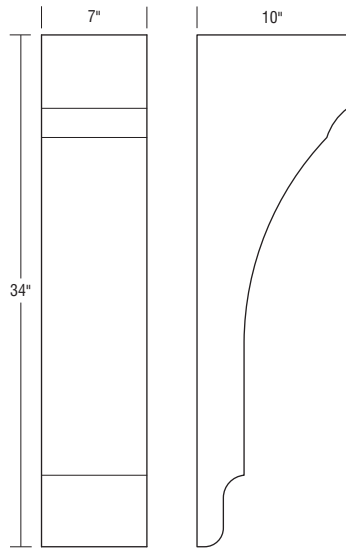

CORBELCRAFT34

**CRAFTSMAN FOOT**  
R•31

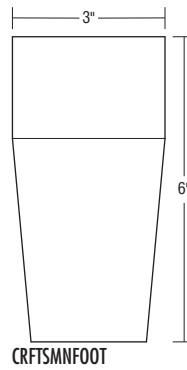

CRFTSMNFOOT

**CRAFTSMAN FOOT, CORNER**  
R•31

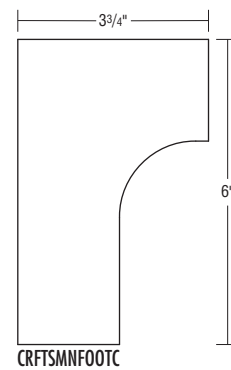

CRFTSMNFOOTC

**CRAFTSMAN BUN FOOT**  
R•31

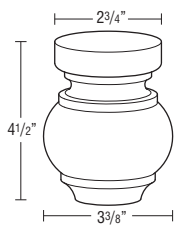

CRFTSMNBUNFOOT

**30" CRAFTSMAN VALANCE**  
R•18

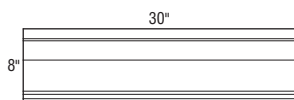

CRFTSMNV30

# Mouldings & Embellishments

## DECO COLLECTION

7" PALLADIAN CORBEL  
R•24

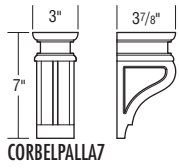

9" PALLADIAN CORBEL  
R•24

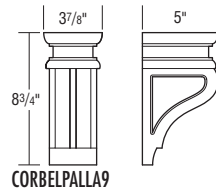

14" PALLADIAN CORBEL  
R•24

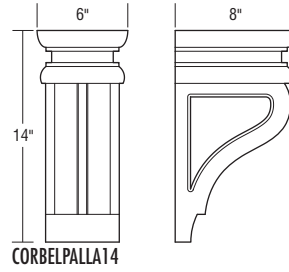

DECO BUN FOOT  
R•32

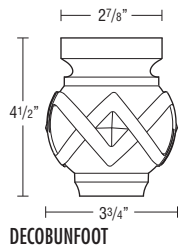

DECO BASEBOARD MOULDING  
R•9

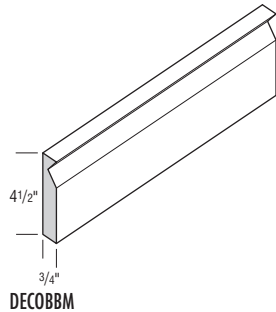

30" DECO VALANCE  
R•18

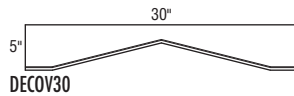

**GAELIC COLLECTION**

**GAELIC LEG, LARGE, ROUTED**  
R•41

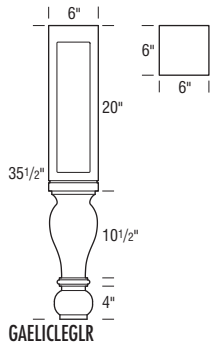

**GAELIC LEG, LARGE**  
R•41

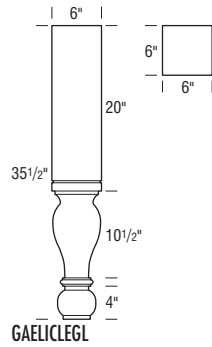

**SMALL GAELIC ROSETTE**  
R•16

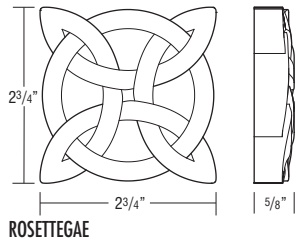



# Mouldings & Embellishments

## METRO COLLECTION

**METRO ISLAND COLUMN**

R•45

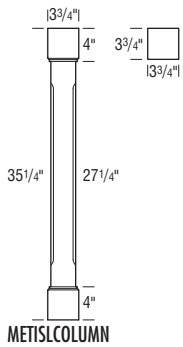

METISLCOLUMN

**METRO ISLAND COLUMN, SMALL**

R•45

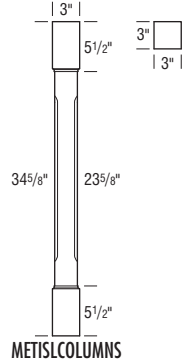

METISLCOLUMNS

**METRO BAR COLUMN**

R•45

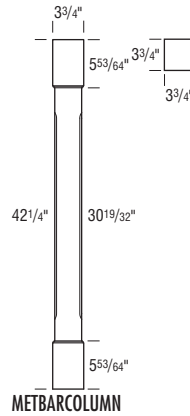

METBARCOLUMN

**9" TRIAD CORBEL**

R•25

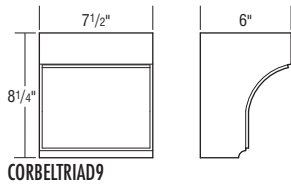

CORBELTRIAD9

**6" TRIAD CORBEL**

R•25

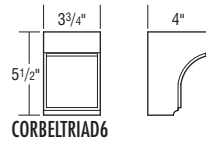

CORBELTRIAD6

**14" ARTS & CRAFTS CORBEL**

R•25

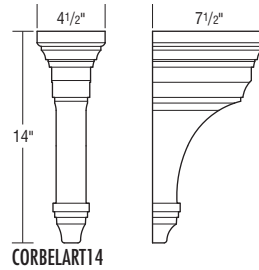

CORBELART14

**ARTS & CRAFTS OPEN CORBEL**

R•25

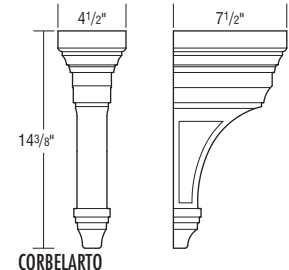

CORBELARTO

**COSMO FOOT**

R•30

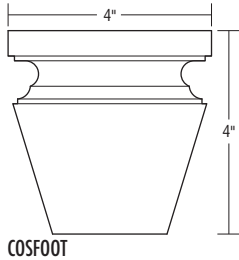

COSFOOT

**TAPERED LEG**

R•30

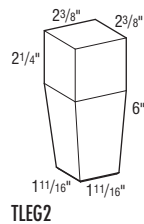

TLEG2

**TAPERED 4-SIDED LEG**

R•30

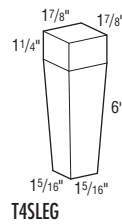

T4SLEG

**METRO COLLECTION (cont'd)**

**MADLINE POST, LARGE**

R•37

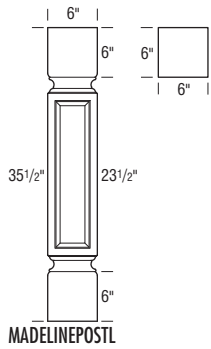

**TRIAD ROSETTE**

R•20

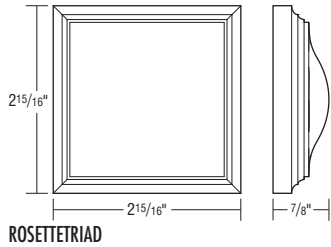

# Mouldings & Embellishments

## SUMMIT COLLECTION

**APEX LEG**  
R•41

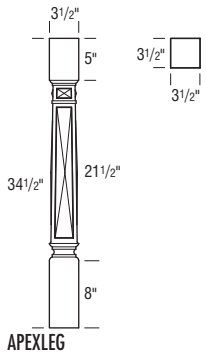

**APEX LEG, TALL**  
R•42

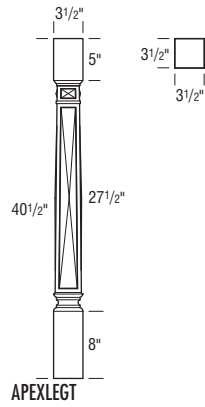

**7" PINNACLE CORBEL**  
R•25

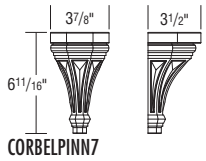

**8" PINNACLE CORBEL**  
R•25

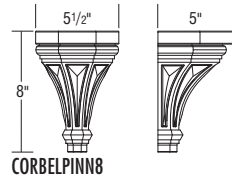

**12" PINNACLE CORBEL**  
R•25

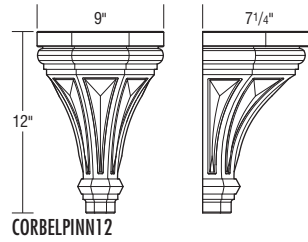

**SUMMIT FOOT**  
R•30

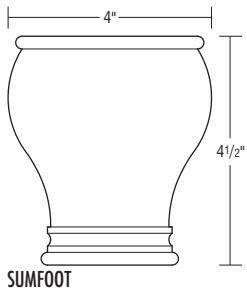

**SUMMIT COLLECTION (cont'd)**

**PINNACLE ROSETTE**

R•20

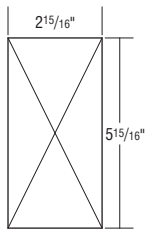

ROSETTEPINN

**30" PINNACLE VALANCE**

R•18

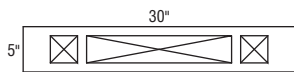

PINNV30

# Mouldings & Embellishments

## TUDOR COLLECTION

**PLAIN NOUVEAU  
ISLAND COLUMN  
R•45**

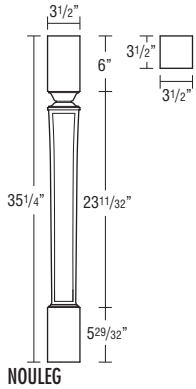

**PLAIN NOUVEAU  
BAR COLUMN  
R•45**

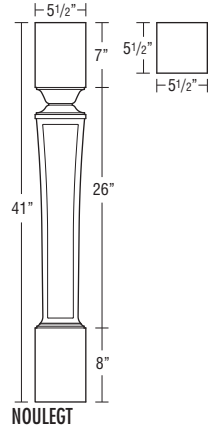

**TUDOR COLUMN INSERT -  
ISLAND  
R•49**

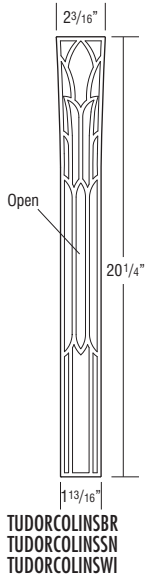

**TUDOR COLUMN INSERT -  
BAR  
R•49**

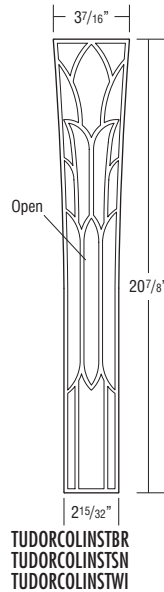

**TUDOR CORBEL INSERT -  
LARGE  
R•28**

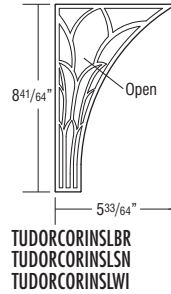

**TUDOR CORBEL INSERT -  
MEDIUM  
R•28**

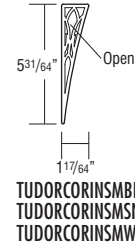

**TUDOR CORBEL INSERT -  
SMALL  
R•28**

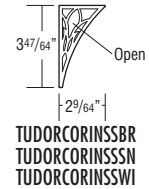

**PLAIN NOUVEAU  
LARGE CORBEL  
R•26**

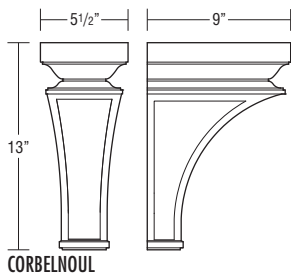

**PLAIN NOUVEAU  
MEDIUM CORBEL  
R•26**

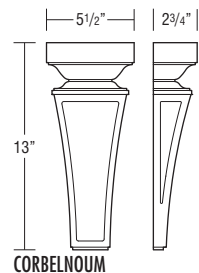

**PLAIN NOUVEAU  
SMALL CORBEL  
R•26**

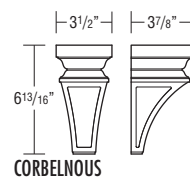

**TUDOR COLLECTION (cont'd)**

**TUDOR CROWN INSERT**  
R•7

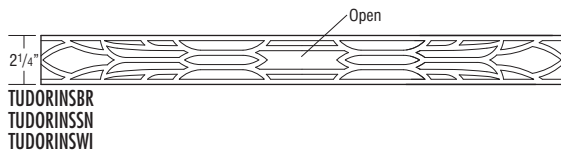

**TUDOR LIGHT RAIL INSERT**  
R•7

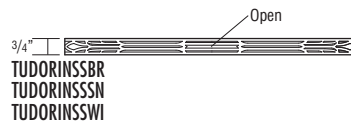

# Mouldings & Embellishments

## WEAVED COLLECTION

**WEAVED ISLAND COLUMN**

R•46

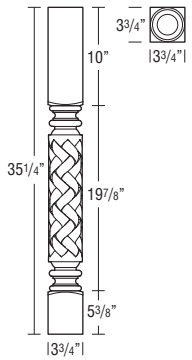

WEAVELEG

**LARGE DIAMOND WEAVED ISLAND COLUMN**

R•46

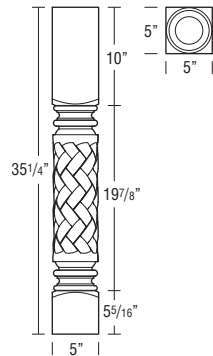

WEAVELEGL

**WEAVED BAR COLUMN**

R•46

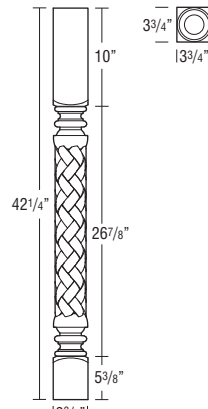

WEAVELEGT

**LARGE WEAVED CORBEL**

R•26

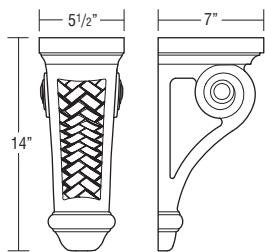

CORBELWEAVE

**SMALL WEAVED CORBEL**

R•27

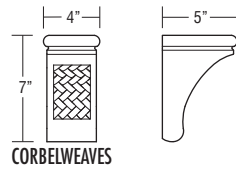

CORBELWEAVES

**WEAVED BUN FOOT**

R•32

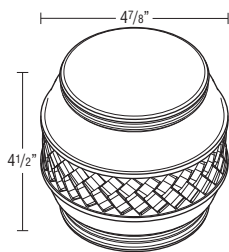

WEAVEBUNFOOT

# Kemper Emerge Modification Option Descriptions

Your Kemper Emerge specification guide contains charts with modification option codes for each applicable cabinetry product. Reference the listing below to identify the modification description.

End Panel Options	
Option	Description
INTGE	Integral End
IPE	Inset Panel Ends

Custom Modification Options	
Option	Description
IW	Increased Width
PTOWB	Push-to-Open Wastebasket
RD	Reduced Depth
SCPDRW	Scooped Drawer



# Kits & Hardware

Description

Model

## INTERIOR ACCESSORY KITS

### **NEW** FOOD STORAGE CONTAINER ORGANIZER KIT



#### FSCO18KIT

- For 18" wide base cabinet.

#### FSCO24KIT

- For 24" wide base cabinet.

- Pull-out features natural finished hardwood dovetailed box with chrome rails on lower section with undermount Smart Stop guides.
- Includes seven chrome "U" pegs to use on the pegboard bottom to customize the fit to container sizes.
- Adjustable clip-on lid dividers included to fit with a variety of lid shapes. 18" wide includes five dividers, 24" wide includes eight dividers.
- Front of pull-out is routed for easy access.
- FSCO18KIT Pull-out dimensions: 14 1/2" W x 21 1/2" D x 18" H.
- FSCO24KIT Pull-out dimensions: 20 1/2" W x 21 1/2" D x 18" H.
- Not available on Inset or Beaded Inset styles.

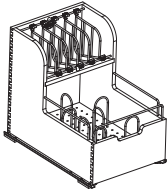

FSCO18KIT

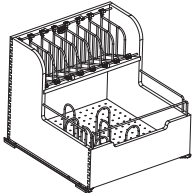

FSCO24KIT

Modifications  
Are Not  
Available

### BASE BOTTLE STORAGE KIT with INSTALLATION HARDWARE

#### BBSKIT18

- For 18" wide base cabinet.

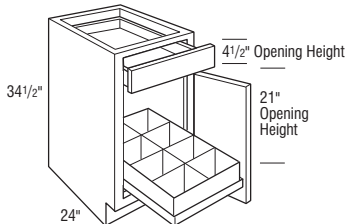

Modifications  
Are Not  
Available

### BASE CAN STORAGE KIT for BPP



#### BPPKIT9PG

- For 9" wide base cabinet.

#### BPPKIT12PG

- For 12" wide base cabinet.

#### BPPKIT15PG

- For 15" wide base cabinet.

#### BPPKIT18PG

- For 18" wide base cabinet.



Modifications  
Are Not  
Available

### KIT COMPONENTS for BUPP

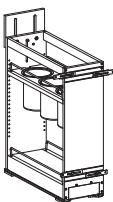

#### BUPPKIT9

- For 9" wide base cabinet.
- Canisters are 5.85" tall and have an inside diameter of 4.3".

#### BUPPKIT12

- For 12" wide base cabinet.
- Canisters are 6.7" tall and have an inside diameter of 5".

- Top shelf features three stainless steel (removable) canisters for utensils.
- Features Smart Stop pull-out with two adjustable shelves (including canister shelf) and one fixed shelf with chrome rails.

Modifications  
Are Not  
Available

To calculate the inside drawer box width to determine organization units and/or parts to order, utilize the following formula: Frame Opening Width - 1 5/8" = Interior Drawer Box Width

Description

Model

## KIT COMPONENTS for BUPPKB

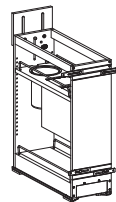

BUPPKBIT2

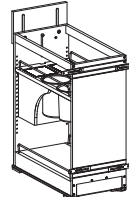

BUPPKBIT5

#### BUPPKBIT2

- For 12" wide base cabinet.
- Includes one stainless steel canister 6.7" tall with an inside diameter of 5", and knife block.

#### BUPPKBIT5

- For 15" wide base cabinet.
- Includes two stainless steel canisters 5.85" tall with an inside diameter of 4.3", and two stainless steel canisters 6.7" tall with an inside diameter of 5".

- Features Smart Stop pull-out with adjustable knife and canister shelf and one fixed shelf with chrome rails.
- Knife block features movable flex rods that adjust to hold a multitude of knives.

Modifications  
Are Not  
Available

## KIT COMPONENTS for BTDPP

#### BTDPPKIT9

- For 9" wide base cabinet.
- Includes one removable center divider and one snap on T-bar.

#### BTDPPKIT12

- For 12" wide base cabinet.
- Includes two removable center dividers and two snap on T-bars.

- Tray dividers are chrome plated steel.

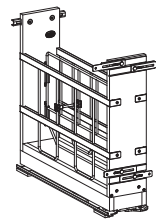

BTDPPKIT9

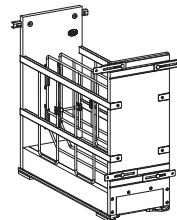

BTDPPKIT12

Modifications  
Are Not  
Available

## KIT COMPONENTS for BCOPP

#### BCOPPKIT12

- Features Smart Stop slides.
- Includes 7 OXO Good Grips® POP containers, BPA Free: (3) 1.7 quart, (1) 2.6 quart, (3) 4.3 quart.
- Fixed shelf.

Modifications  
Are Not  
Available



## BASE OPEN BASKET KITS



#### BASKET15

#### BASKET18

- Includes single basket and pair of rails.



Modifications  
Are Not  
Available

**Description**

**BASE PANS STORAGE**

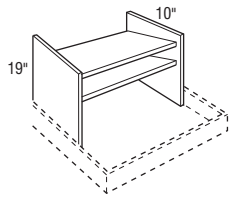

**Model**

- BPS24KIT**
- BPS30KIT**
- BPS36KIT**

- Not available for 12" deep cabinets.
- Kit is designed to be used with roll trays.

Modifications  
Are Not  
Available

**BREAD BOARD with  
INSTALLATION HARDWARE**

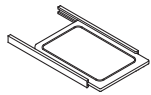

**WIDTH**

<b>BBOARDKIT12</b>	12"
<b>BBOARDKIT15</b>	15"
<b>BBOARDKIT18</b>	18"
<b>BBOARDKIT21</b>	21"
<b>BBOARDKIT24</b>	24"

- Bread Boards are 21/32" thick.

Kit Size	Cabinet Width
12"	12" Base
15"	15" Base
18"	18" Base
21"	21" Base
24"	24" Base

Modifications  
Are Not  
Available

**Description**

**NEW COOKING UTENSIL  
DIVIDER**

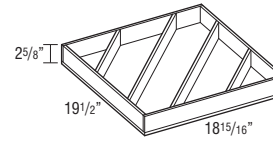

**CUDD24**

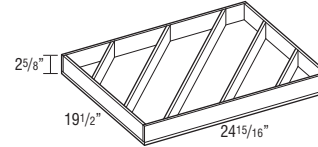

**CUDD30**

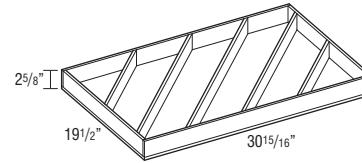

**CUDD36**

**Model**

- CUDD24**
- CUDD30**
- CUDD36**

- Pre-assembled natural wood drawer insert (does not fit roll trays).
- CUDD24 for use in 24" wide base cabinets.
- CUDD30 for use in 30" wide base cabinets.
- CUDD36 for use in 36" wide base cabinets.

Modifications  
Are Not  
Available

# Kits & Hardware

## Description

### COOKING UTENSIL DIVIDER

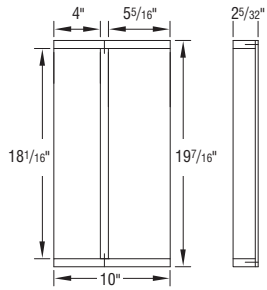

CUD15

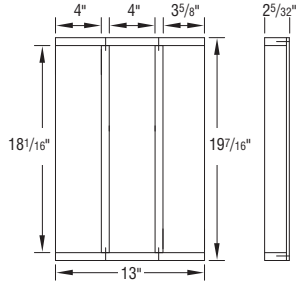

CUD18

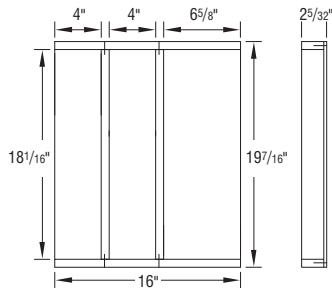

CUD21

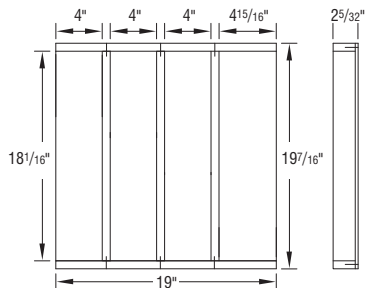

CUD24

## Model

- CUD15
- CUD18
- CUD21
- CUD24
- CUD27
- CUD30
- CUD33
- CUD36

- Available in 24" deep cabinets.
- Increased Heights not available.
- Increased Widths available in 1/4" increments. See page G-46 for details.
- CUD is not trimmable.

Model	No. of Vertical Dividers
CUD15	1
CUD18	2
CUD21	2
CUD24	3
CUD27	4
CUD30	4
CUD33	5
CUD36	5

#### End Panel Options

INTGE
  IPE

#### Custom Modification Options

IW<sup>1</sup>
 PTOWB
  RD
  SCPDRW

<sup>1</sup>Not available in 36 version.

## Description

## Model

### COOKING UTENSIL DIVIDER (cont'd)

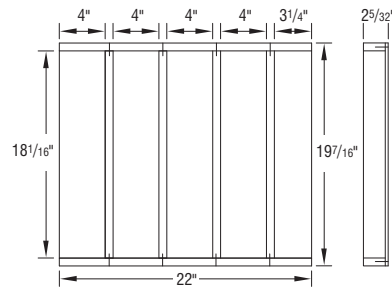

CUD27

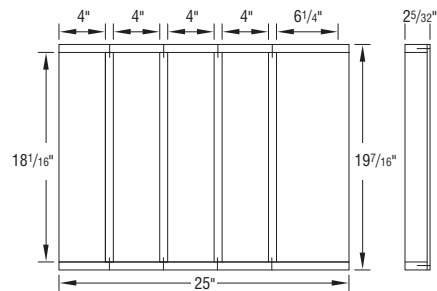

CUD30

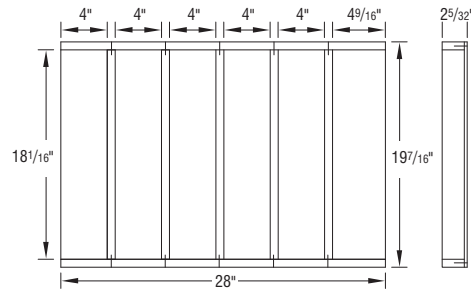

CUD33

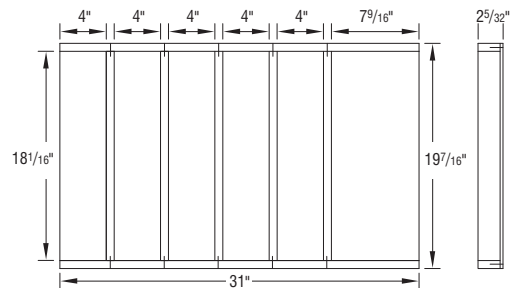

CUD36

To calculate the inside drawer box width to determine organization units and/or parts to order, utilize the following formula:  $\text{Frame Opening Width} - 1 \frac{5}{8}'' = \text{Interior Drawer Box Width}$

**Description**

**CUTLERY DIVIDER**

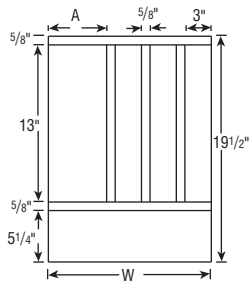

**Model**

- CIW1221
- CIW1224
- CIW13.521
- CIW13.524
- CIW1521
- CIW1524
- CIW16.521
- CIW16.524
- CIW1821
- CIW1824
- CIW19.521
- CIW19.524
- CIW2121
- CIW2124
- CIW22.521
- CIW22.524
- CIW2421
- CIW2424
- CIW2721
- CIW2724
- CIW3021
- CIW3024
- CIW3321
- CIW3324
- CIW3621
- CIW3624

- Features Maple wood.
- Cutlery dividers are only available in 24" or 21" deep cabinets.
- Specify size.
- 2 5/32" high.

Model	W Dim.	A Dim.	No. of Vertical Dividers
CIW1221	7"	3 3/8"	1
CIW1224	7"	3 3/8"	1
CIW13.521	8 1/2"	4 7/8"	1
CIW13.524	8 1/2"	4 7/8"	1
CIW1521	10"	2 3/4"	2
CIW1524	10"	2 3/4"	2
CIW16.521	11 1/2"	4 1/4"	2
CIW16.524	11 1/2"	4 1/4"	2
CIW1821	13"	6 3/4"	2
CIW1824	13"	6 3/4"	2
CIW19.521	14 1/2"	3 5/16"	3
CIW19.524	14 1/2"	3 5/16"	3
CIW2121	16"	6 1/8"	3
CIW2124	16"	6 1/8"	3
CIW22.521	17 1/2"	3"	4
CIW22.524	17 1/2"	3"	4
CIW2421	19"	4 1/2"	4
CIW2424	19"	4 1/2"	4
CIW2721	22"	3 7/8"	5
CIW2724	22"	3 7/8"	5
CIW3021	25"	3 1/4"	6
CIW3024	25"	3 1/4"	6
CIW3321	28"	2 5/8"	7
CIW3324	28"	2 5/8"	7
CIW3621	31"	6 3/8"	7
CIW3624	31"	6 3/8"	7

Modifications  
Are Not  
Available

**Description**

**WOOD TIERED CUTLERY DIVIDER DRAWER with INSTALLATION HARDWARE**



**Model**

- WTC15
- WTC18
- WTC21
- WTC24
- WTC30
- WTC36

- Replaces standard drawer (4 1/2" high frame opening).
- Requires field installation of drawer front.
- For use with 24" deep cabinets only.
- Exterior Wood Tiered Cutlery Divider drawer box height is 3 3/4", interior height of top tier is 1 5/8", and interior height of bottom tier is 1 3/8".
- Includes Drawer Guides.

Modifications  
Are Not  
Available

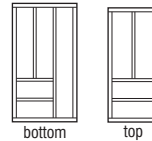
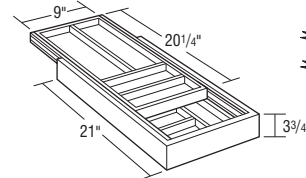

WTC15

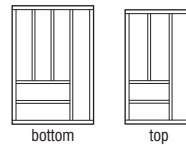
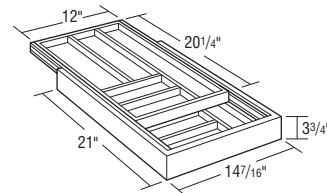

WTC18

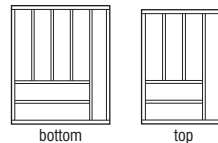
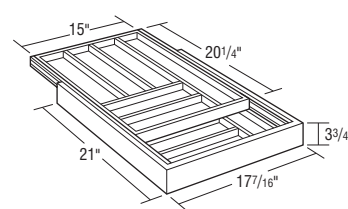

WTC21

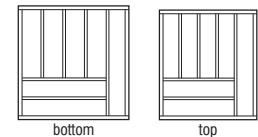
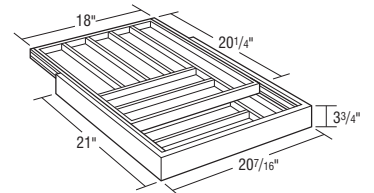

WTC18

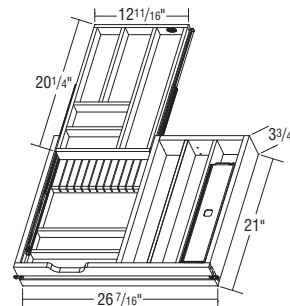

WTC30

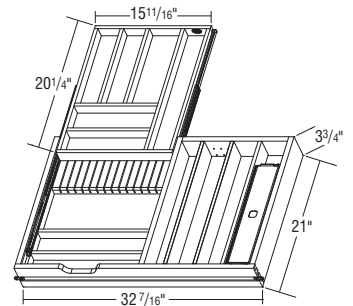

WTC36

# Kits & Hardware

## Description

### WOOD TIERED K-CUP\* DRAWER with INSTALLATION HARDWARE

## Model

KCUPI8

- Replaces standard drawer (4 1/2" high frame opening).
- Requires field installation of drawer front.
- Holds 40 K-Cups.
- The Wood Tiered K-Cup Drawer is compatible with K-Cup pods only.
- For use with 24" deep cabinets only.
- Exterior Wood Tiered K-Cup drawer box height is 3 3/4", interior height of top tier is 1 5/8", and interior height of bottom tier is 1 3/8".
- Includes Drawer Guides.

\*K-Cup is a registered trademark of Keurig Green Mountain, Inc.

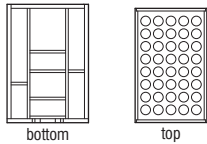
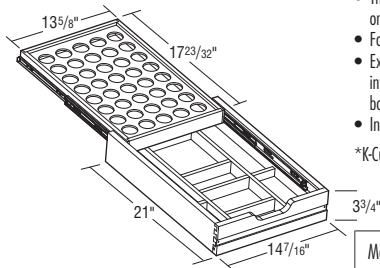

Modifications Are Not Available

### NEW CHARGING DRAWER



CHGDRW18

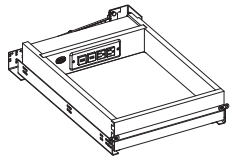

- Replaces standard drawer (4 1/2" high frame opening).
- Requires field installation of drawer front.
- Designed for 18" base cabinet drawers.
- Full extension, concealed Smart Stop slides.
- 110 lb. rated.
- 120V outlet must be installed in rear of cabinet within 10" of bottom of drawer, in rear of cabinet.
- CUL US listed power strip with two 120V plugs and two 2.1 amp USB ports.
- Max Current: AC 15 amps @ 120VAC; USB 2.1 amp and 5 VDC each.
- Tamper resistant outlets.
- Power cord with NEMA 5-15 plug.
- Integrated cord guide mounts to cabinet side to ensure safe operation.
- Black, shock absorbing mat included.
- Special sizes not available.
- For use with 24" deep cabinets only.
- Not available on Inset or Beaded Inset Styles.

Modifications Are Not Available

## Description

### NEW WOOD TIERED VANITY DRAWER KIT



## Model

WTVD12

WTVD15

WTVD18

- Replaces deep drawer and slides.
- Requires field installation of drawer front.
- For use with 21" deep cabinets only.
- Exterior Wood Tiered Vanity drawer box height is 7 1/2", interior height of top tier is 2 1/4", and interior height of bottom tier is 4 1/4".

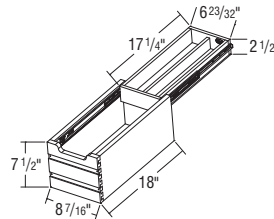

WTVD12

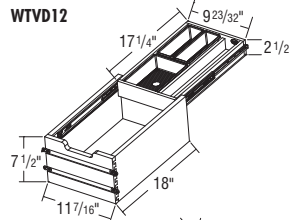

WTVD15

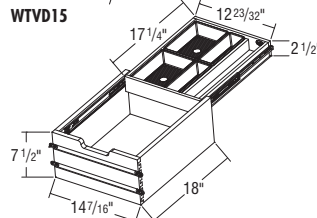

WTVD18

Modifications Are Not Available

### NEW TILT-OUT TRAY(S) STAINLESS STEEL for USE BEHIND FALSE DRAWER FRONT



TOTSSS10

TOTSSS13

TOTSSS16

TOTSSS19

TOTSSS25

TOTSSS31

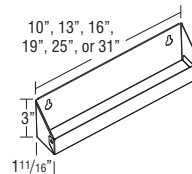

- Tilt-out trays protrude 3/4" into the cabinet on Full Overlay Styles and 1 11/16" into Inset and Beaded Inset styles.
- Two tilt-out scissor hinges per tray.

For field installation behind drawer fronts on SB and VSB units.

Cabinet Width	No. of Cabinet False Panels on Cabinet	Tilt-out Tray to Order	No. of Tilt-out Trays Needed
18"	1	TOTSSS13	1
21"	1	TOTSSS16	1
24"	1	TOTSSS19	1
27"	1	TOTSSS19	1
30"	1	TOTSSS25	1
33"	1	TOTSSS25	1
33"	2	TOTSSS10	2
36"	1	TOTSSS31	1
36"	2	TOTSSS13	2
39"	1	TOTSSS31	1
39"	2	TOTSSS13	2
42"	2	TOTSSS16	2
45"	2	TOTSSS16	2
48"	2	TOTSSS19	2

Modifications Are Not Available

## Description

### U-SHAPED ROLL TRAY KIT

U-SHAPED DRAWER  
ON SELECT BATH  
BASE CABINETS

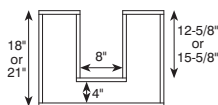

## Model

### URT24SP

- Available in 1/4" increments from 24" to 26 3/4" wide

### URT27SP

- Available in 1/4" increments from 27 1/4" to 29 3/4" wide

### URT30SP

- Available in 1/4" increments from 30 1/4" to 32 3/4" wide

### URT33SP

- Available in 1/4" increments from 33 1/4" to 35 3/4" wide

### URT36SP

Notes below apply to all products in section above:

- 8" and 4" dimensions of U-shape stays constant for all drawer box sizes, the legs of U-shape are either 12 5/8" or 15 5/8".
- Available in conjunction with Scooped Drawer.
- Not available with: Any drawer insert or pull-out (CD, BB, WTC, etc.).

End Panel Options



Custom Modification Options



### U-SHAPED DEEP ROLL TRAY KIT

U-SHAPED DRAWER  
ON SELECT BATH  
BASE CABINETS

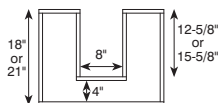

### UDRT24SP

- Available in 1/4" increments from 24" to 26 3/4" wide

### UDRT27SP

- Available in 1/4" increments from 27 1/4" to 29 3/4" wide

### UDRT30SP

- Available in 1/4" increments from 30 1/4" to 32 3/4" wide

### UDRT33SP

- Available in 1/4" increments from 33 1/4" to 35 3/4" wide

### UDRT36SP

Notes below apply to all products in section above:

- 8" and 4" dimensions of U-shape stays constant for all drawer box sizes, the legs of U-shape are either 12 5/8" or 15 5/8".
- Available in conjunction with Scooped Drawer.
- Not available with: Any drawer insert or pull-out (CD, BB, WTC, etc.).

End Panel Options



Custom Modification Options



### BATH GLASS SHELF

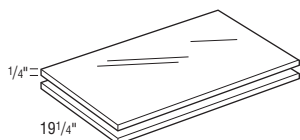

### GSK1221

### GSK1521

### GSK1821

### GSK2121

### GSK2421

### GSK2721

### GSK3021

- Kit includes two 1/4" tempered glass shelves.
- Glass shelves sized to fit standard cabinet with no modifications that affect the size of the shelf. Integral End, Inset Panel End, Clipped Corner modification not available in conjunction with glass shelf kit.

Modifications  
Are Not  
Available

## Description

### GLASS SHELF KITS

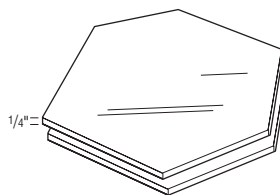
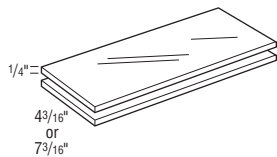
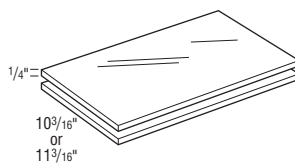

### GSKDW27

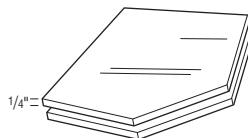

### GSKDW24

## Model

### GSK912

### GSK1206

### GSK1209

### GSK1212

### GSK1506

### GSK1509

### GSK1512

### GSK1806

### GSK1809

### GSK1812

### GSK2106

### GSK2109

### GSK2112

### GSK2406

### GSK2409

### GSK2412

### GSK2706

### GSK2709

### GSK2712

### GSK3006

### GSK3009

### GSK3012

### GSK3306

### GSK3309

### GSK3606

### GSK3609

### GSK3612

### GSKDW24\*

### GSKDW24P

### GSKDW27

\* Glass Shelves not available for DW182424 L or R, DW242424 L or R, and DW242727 L or R.

- Kit includes two 1/4" tempered glass shelves.
- Glass shelves sized to fit standard cabinet with no modifications that affect the size of the shelf. Integral End, Inset Panel End, Clipped Corner modification not available in conjunction with glass shelf kit.

Modifications  
Are Not  
Available

# Kits & Hardware

## Description

### HEARTH TOWER PULL-OUT KIT

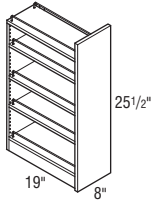

## Model

### HPPKIT12

- Smart Stop feature not available.

Modifications  
Are Not  
Available

### LAZY SUSAN KIT

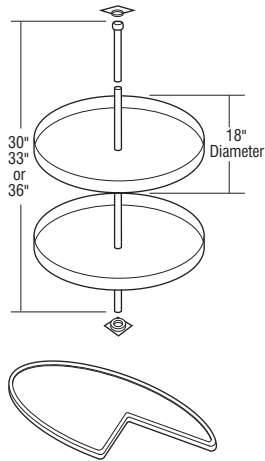

### DWLKIT24

- For DW Diagonal Wall 30" Opening

### BLSKIT33

- For BLS33 L or R Lazy Susan Base 33

### BLSKIT36

- For BLS36 L or R Lazy Susan Base 36

### BER36SKIT

- For SLSB36 Square Lazy Susan Base 36

### DAB36KIT

- For DAB36S L or R Diagonal Square Lazy Susan Base 36

Notes below apply to all products in section above:

- Includes 2 roto trays; pole and hardware included.

### BRDB36KIT

- For BRDB36 L or R Base Rotating Deep Bin 36

### SLS33KIT

- For SSS33 Super Space Saver 33

### SLS36KIT

- For SSS36 Super Space Saver 36

### SLS36KIT

- For SLS36 L or R and SLS36RS L or R

### SLS36KIT

- For SLS36 L or R and SLS36RS L or R

Notes below apply to all products in section above:

- Includes 1 roto tray; shelf not included.
- Mounts to shelf or floor, no pole or hardware required.

Modifications  
Are Not  
Available

### LAZY SUSAN POLE KIT

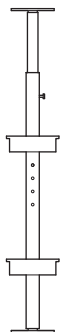

### LSPOLEKIT

- Required for DWLKIT24, BLSKIT33, BLSKIT36, BER36SKIT and DAB36KIT.
- Includes pole and required hardware.

Modifications  
Are Not  
Available

## Description

### LID ORGANIZER

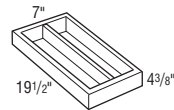

## Model

### LO

- Available only for 24" deep cabinets with roll tray.
- 7" W x 19 1/2" D x 4 3/8" H.
- Each opening is 2 3/4".

Modifications  
Are Not  
Available

### MIXER SHELF with POP-UP SHELF and INSTALLATION HARDWARE



### MIXKIT18

- For 18" wide base cabinet

### MIXKIT21

- For 21" wide base cabinet

### MIXKIT24

- For 24" wide base cabinet

- Mixer Shelf features Smart Stop.
- For use in cabinet with full height door only.

Modifications  
Are Not  
Available

### PEGGED DISH ORGANIZER

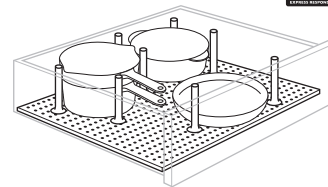

### PDO

- 8 posts and board

### PDOPOSTS

- 4 posts

- For use in 36" wide Base Cabinets.
- Pegged board is 19/32" thick.
- 29 15/16" x 19 1/2".

Modifications  
Are Not  
Available

### PLASTIC STORAGE BINS for BPSB

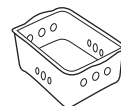

### PSBKIT15

- For 15" wide base cabinet

### PSBKIT18

- For 18" wide base cabinet

- Kit includes 3 storage bins.

Modifications  
Are Not  
Available

## Description

### POTS and PANS PULL-OUT KITS



## Model

PPP24KIT  
PPP30KIT

- Smart Stop feature not available on pull-out.
- Pull-out mounts to floor of cabinet.
- 24" pull-out dimensions: 19 3/4" W x 14 1/2" H x 22 1/4" D
- 30" pull-out dimensions: 25 1/2" W x 14 13/16" H x 22 1/4" D

Modifications  
Are Not  
Available

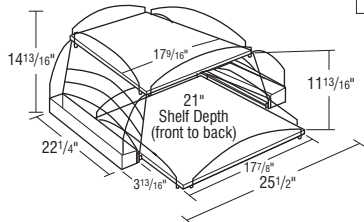
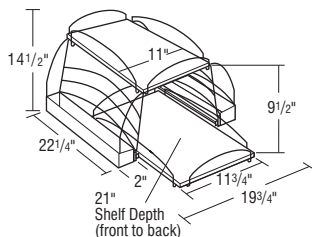

### ROLL TRAY KIT – ONE ROLL TRAY PER KIT

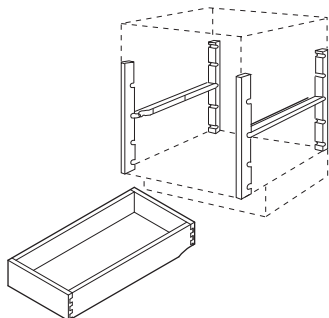

ROLL TRAY QUANTITY	MINIMUM OPENING HEIGHT
1	9
2	9
3	13.5
4	17.5
5	21

RT12SP

RT13.5SP

RT15SP

RT16.5SP

RT18SP

RT19.5SP

RT21SP

RT22.5SP

RT24SP

RT27SP

RT30SP

RT33SP

RT36SP

DGK12FXSRTPG\*

DGK15FXSRTPG\*

DGK18FXSRTPG\*

DGK21FXSRTPG\*

DGK24FXSRTPG\*

- \*Includes slides, uprights, and cross-members.
- Wooden trays with wood mounting brackets and mounting slides.
  - If cabinet has FFD on end, roll trays will not install properly.
  - Widths 39" and over will require two roll trays.
  - Reduced Depths available in 1/4" increments from 12" to 23 3/4".
  - Increased Widths available in 1/4" increments. See page G•46 for details.
  - All available modifications include: Increased Widths and Reduced Depths.
  - Not available on peninsula cabinets.

End Panel Options

INTGE <sup>1</sup>	IPE <sup>1</sup>
<input checked="" type="checkbox"/>	<input checked="" type="checkbox"/>

Custom Modification Options

IW <sup>2</sup>	PTOWB	RD <sup>1</sup>	SCPDRW <sup>3</sup>
<input checked="" type="checkbox"/>	<input checked="" type="checkbox"/>	<input checked="" type="checkbox"/>	<input checked="" type="checkbox"/>

<sup>1</sup>Not available on DGK versions.

<sup>2</sup>Not available on DGK versions or RT36SP.

<sup>3</sup>Only available on DGK versions.

## Description

### DEEP ROLL TRAY KIT – ONE ROLL TRAY PER KIT

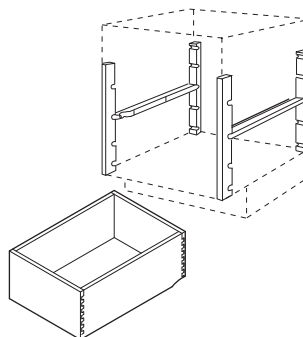

ROLL TRAY QUANTITY	MINIMUM OPENING HEIGHT
1	9
2	20
3	30
4	41
5	51

## Model

DRT12SP  
DRT13.5SP  
DRT15SP  
DRT16.5SP  
DRT18SP  
DRT19.5SP  
DRT21SP  
DRT22.5SP  
DRT24SP  
DRT27SP  
DRT30SP  
DRT33SP  
DRT36SP  
DDGK12FXSRTPG\*  
DDGK15FXSRTPG\*  
DDGK18FXSRTPG\*  
DDGK21FXSRTPG\*  
DDGK24FXSRTPG\*

\*Includes slides, uprights, and cross-members.

- Wooden trays with wood mounting brackets and mounting slides.
- If cabinet has FFD on end, roll trays will not install properly.
- Widths 39" and over will require two roll trays.
- Reduced Depths available in 1/4" increments from 12" to 23 3/4".
- Increased Widths available in 1/4" increments. See page G•46 for details.
- All available modifications include: Increased Widths and Reduced Depths.
- Not available on peninsula cabinets.

End Panel Options

INTGE <sup>1</sup>	IPE <sup>1</sup>
<input checked="" type="checkbox"/>	<input checked="" type="checkbox"/>

Custom Modification Options

IW <sup>1</sup>	PTOWB	RD <sup>1</sup>	SCPDRW
<input checked="" type="checkbox"/>	<input checked="" type="checkbox"/>	<input checked="" type="checkbox"/>	<input checked="" type="checkbox"/>

<sup>1</sup>Not available on DDGK versions.

### SLIDING TOWEL BAR

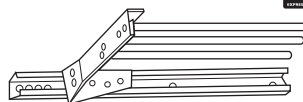

### STR

- Minimum opening width is 9".
- Not available in conjunction with Clipped Corner or Wide Siles.
- Minimum cabinet depth of 21".

Modifications  
Are Not  
Available

### SPICE DRAWER

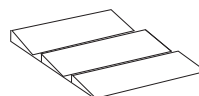

SD18  
SD24

- Available in 24" depth only.
- Not trimmable.

Modifications  
Are Not  
Available



# Kits & Hardware

**Description**  
**SPICE PULL-OUT**

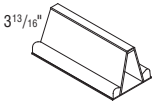

3 13/16"

**Model**  
**SPICE12PG**  
**SPICE15PG**

- Available in 24" depth only.
- For BSP & BCS only.

Modifications Are Not Available

**STEM GLASS HOLDER**

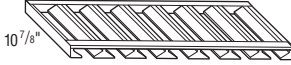

10 7/8"

**Model**  
**WGH15**  
**WGH18**  
**WGH21**  
**WGH24**  
**WGH27**  
**WGH30**  
**WGH33**  
**WGH36**

MODEL	DIM.	SLOTS
WGH15	12 1/8"	3
WGH18	16"	4
WGH21	19 13/16"	5
WGH24	19 7/8"	5
WGH27	23 21/32"	6
WGH30	27 17/32"	7
WGH33	31 7/16"	8
WGH36	34 7/16"	9

Modifications Are Not Available

**TRAY DIVIDER**

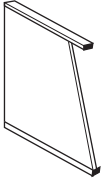

**Model**  
**TDKIT21**  
**TDKIT27**

- Divider sent loose; use Modifications section for installed option.
- Two-sided with natural maple standard.

Modifications Are Not Available

**TRAY DIVIDER ROLL-OUT**

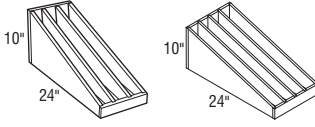

10"  
24"

**Model**  
**TDRO12**  
**TDRO15**  
**TDROHDWONLY\***

\*Slides, cross-members, and uprights must be ordered for installation of the Tray Divider Roll-out.

- For 12" and 15" wide Base cabinets.
- 12" dimensions – 7 9/16" W x 21" D x 10" H.
- 15" dimensions – 10 9/16" W x 21" D x 10" H.

Modifications Are Not Available

**Description**  
**VANITY BASE PULL-OUT KIT for VBP**

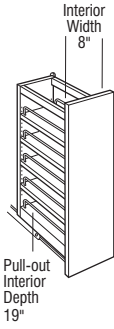

Interior Width 8"  
Pull-out Interior Depth 19"

**Model**  
**VBPKIT12**

- Smart Stop feature not available.

Modifications Are Not Available

**WALL SPICE PULL-OUT KIT for WSP**

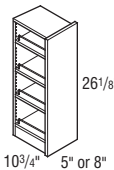

26 1/8"  
10 3/4" 5" or 8"

**Model**  
**WSPKIT09**  
**WSPKIT12**

- Pull-out features Smart Stop.

Modifications Are Not Available

**POWER POD storage SOLUTIONS**

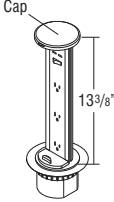

Cap  
13 3/8"

**Model**  
**PWRPODBK**  
**PWRPODGM**  
**PWRPODSS**

- Sensio Power Pod - Black
- Sensio Power Pod - Gun Metal
- Sensio Power Pod - Stainless

- Includes independent power switch, three electrical sockets, and two USB ports (located above power switch).
- 18" of clearance required below surface mount location and 3 1/2" diameter hole is required in countertop to install.
- This item requires field installation. This accessory can not be installed above drawers.
- Safe for countertop installation; rated IP54-splash proof from splashing water and water jets per IPX waterproof specifications; ETL approved-compliant for electrical and other safety standards to North American safety including: UL, ANSI, CSA, ASTM, and NFPA standards.
- When installed, top lip of strip sits on top of countertop with a pivoting handle. Handle is pulled up to bring bottom of power strip to countertop.

Modifications Are Not Available

**Description**

**TABLET HOLDER**

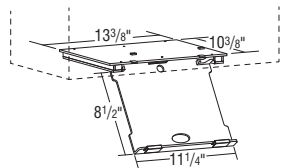

**Model**

**TABLEHLDR**

- Mounts under 15" cabinet or wider.
- Designed for cabinets 12" deep or deeper.
- Features an acrylic mounting base and pull-down tablet holder tray.
- Tray is movable forward and backward with a slight side to side rotation, and can be utilized at any position.
- Tray has side cut-outs for a charging cord and can be used to store most tablets when closed, depending on overall thickness, width, height, and weight of the tablet.
- Maximum dimensions for tablet: 11 1/4" x 8 1/2" x 1 1/8" thick. Maximum tablet weight is 3 1/2 lbs.
- Tablet Holder has an overall height of 1 17/32" when installed and in closed position (measured from the bottom panel of the cabinet), 0.78" visible from front of cabinet when closed.
- Installation instructions included.

Modifications  
Are Not  
Available

**WASTEBASKET ASSEMBLY with INSTALLATION HARDWARE for BWB CABINET with DRAWER (35 QUART)**

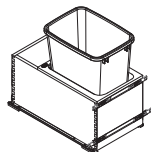

**BWB15KIT**

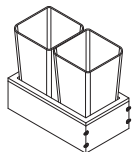

**BWB15KIT2**



**BWB18KIT**

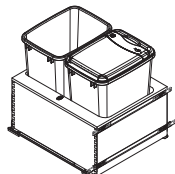

**BWB21KIT-BWB24KIT**

**BWB15KIT**

- For 15" wide base cabinet



**BWB15KIT2**

- For 15" wide base cabinet

**BWB18KIT**

- For 18" wide base cabinet

**BWB21KIT**

- For 21" wide base cabinet

**BWB24KIT**

- For 24" wide base cabinet

- Wastebasket dimensions for BWB\*\*KIT – 14 3/8" W x 18" H x 10 1/2" D.
- Wastebasket dimensions for BWB15KIT2 – 10 5/8" W x 17 3/4" H x 10 5/8" D.
- BWB15KIT includes one 35 quart wastebasket.
- BWB15KIT2 has two 27 quart wastebaskets.
- BWB18KIT, BWB21KIT, and BWB24KIT hold two 35 quart wastebaskets. One wastebasket includes lid.
- Wastebasket is a metallic gray.
- Full height door recommended for 21" and 24" dual wastebaskets on inset cabinets. For non-full height door styles, it is recommended that the front wastebasket be removed for easier removal of the back wastebasket.
- BWB15KIT2 will have a 6 3/8" high wastebasket pull-out box.
- BWB\*\*KIT will have a 10" high wastebasket pull-out box.

End Panel Options



Custom Modification Options



<sup>1</sup>Not available on 24" wide.

**Description**

**WASTEBASKET ASSEMBLY with INSTALLATION HARDWARE for BWB CABINET with FULL HEIGHT DOOR (50 QUART)**

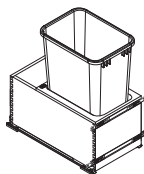

**BWB15FHKIT-BWB18FHKIT**

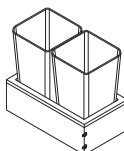

**BWB15FHKIT2-BWB18FHKIT2**

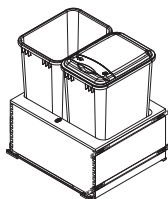

**BWB21FHKIT-BWB24FHKIT**

**Model**

**BWB15FHKIT**

- For 15" wide base cabinet

**BWB15FHKIT2**

- For 15" wide base cabinet

**BWB18FHKIT**

- For 18" wide base cabinet



**BWB18FHKIT2**

- For 18" wide base cabinet

**BWB21FHKIT**

- For 21" wide base cabinet

**BWB24FHKIT**

- For 24" wide base cabinet

- Wastebasket dimensions for BWB\*\*FHKIT – 14 3/4" W x 21 3/4" H x 10 11/16" D.
- Wastebasket dimensions for BWB15FHKIT2 – 10 5/8" W x 17 3/4" H x 10 5/8" D.
- Wastebasket dimensions for BWB18FHKIT2 – 10 1/2" W x 18" H x 14 3/8" D
- BWB15FHKIT and BWB18FHKIT hold one wastebasket.
- BWB15FHKIT2 has two 27 quart wastebaskets.
- BWB18KITFH2 has two 35 quart wastebaskets and one lid.
- BWB21FHKIT and BWB24FHKIT hold two wastebaskets. One wastebasket includes lid.
- Wastebasket is a metallic gray.
- BWB15FHKIT2 will have a 6 3/8" high wastebasket pull-out box.
- BWB\*\*FHKIT and BWB18FHKIT2 will have a 10" high wastebasket pull-out box.

End Panel Options



Custom Modification Options



<sup>1</sup>Not available on 24" wide.



**WASTEBASKET ONLY for BWB (27 QUART)**

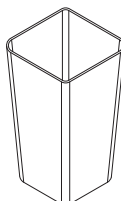

**WASTEBIN27**

- For 15" wide base cabinets.
- For 6 3/8" high wastebasket pull-out box.
- 2 wastebaskets required.
- Wastebasket dimensions – 10 5/8" W x 10 5/8" D x 17 3/4" H.
- Wastebasket is a metallic gray.

Modifications  
Are Not  
Available

**WASTEBASKET ONLY for BWB (35 QUART)**

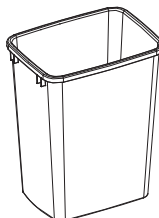

**WASTEBIN35**

- For 15", 18", 21" and 24" wide base cabinets.
- 2 wastebaskets required for 18", 21", or 24" wide base cabinets.
- Wastebasket dimensions – 14 1/4" W x 17 7/8" H x 10 7/16" D.
- Wastebasket is a metallic gray.
- For 10" high wastebasket pull-out box.

Modifications  
Are Not  
Available

# Kits & Hardware

**Description**

**WASTEBASKET ONLY  
for BWB (50 QUART)**

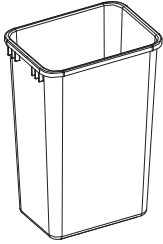

**Model**

**WASTEBIN50**

- For 18" and 21" wide base cabinets.
- One 50 quart wastebasket for 18" application.
- Two 50 quart wastebaskets for 21" application.
- Wastebasket dimensions –  
14 3/4" W x 21 3/4" H x 10 11/16" D.
- Wastebasket is a metallic gray.
- For 10" high wastebasket pull-out box.

Modifications  
Are Not  
Available

**Description**

**AUTOMATIC OPENING MECHANISM PARTS**

**AUTOMATIC OPENING  
MECHANISM ACTIVATION  
SWITCH**

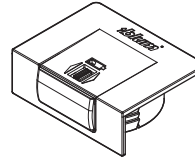

**AOMACTSWITCH**

Modifications  
Are Not  
Available

**AUTOMATIC OPENING  
MECHANISM CABLE  
CONNECTOR**

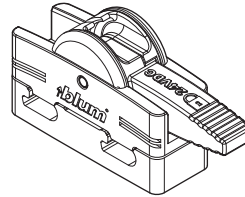

**AOMCABLECONN**

Modifications  
Are Not  
Available

**AUTOMATIC OPENING  
MECHANISM CABLE END  
PROTECTOR**

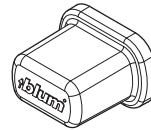

**AOMCABLEPROT**

Modifications  
Are Not  
Available

**AUTOMATIC OPENING  
MECHANISM UNIVERSAL  
CABLE, 26'**

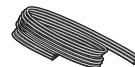

**AOMCABLE**

Modifications  
Are Not  
Available

**AUTOMATIC OPENING  
MECHANISM CABLE CLIP**

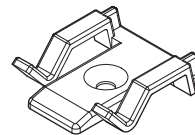

**AOMCABLECLIP**

Modifications  
Are Not  
Available

**LID PULL-OUT KIT**

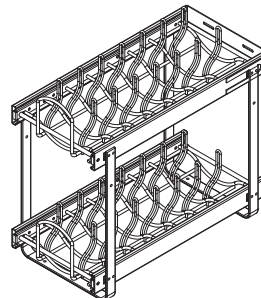

**LH12KIT**

- Lid pull-out will hold 6 lids per tray.
- Maximum lid diameter is 8 1/2" on bottom tray and 9 3/4" on top tray.
- Requires a minimum opening of 12" wide x 24 1/2" high x 21" deep.
- Installation to bottom and back, may require block out on side for extra support.

Modifications  
Are Not  
Available

**NEW BASE WASTEBASKET  
LID**

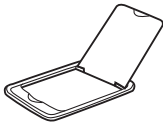

**BWBLID**

- Designed to be used with the BWB trash units.
- Fits 35 quart wastebaskets.
- Sold individually.

Modifications  
Are Not  
Available

**NEW BASE WASTEBASKET  
LID**

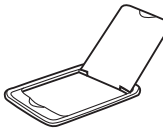

**BWBFHLD**

- Designed to be used with the BWB \_\_FH trash units.
- Fits 50 quart wastebaskets.
- Sold individually.

Modifications  
Are Not  
Available

**CHROME HAMPER with  
CREME LINEN LINER ONLY for  
VBH/VSHDB/4DVSHDB/LCRH**

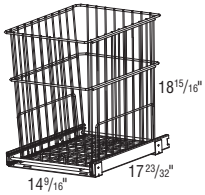

**HAMPERKIT18**

- For 18" wide base cabinet
- Hamper size is 14 9/16" W x 17 23/32" D x 18 15/16" H.

Modifications  
Are Not  
Available

## Description

### POTS and PANS PULL-OUT KIT

## Model

### PPH15KIT PPH21KIT



- PPH15KIT Pots and Pans pull-out includes 8 dividers per tray for adjustable storage.
- PPH15KIT requires a minimum opening of 15" wide x 24 1/2" high x 21" deep.
- PPH21KIT Pots and Pans pull-out includes 16 dividers per tray for adjustable storage.
- PPH21KIT requires a minimum opening of 21" wide x 24 1/2" high x 21" deep.
- Installation to bottom and back, may require block out on side for extra support.

Modifications  
Are Not  
Available

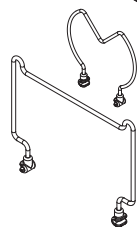
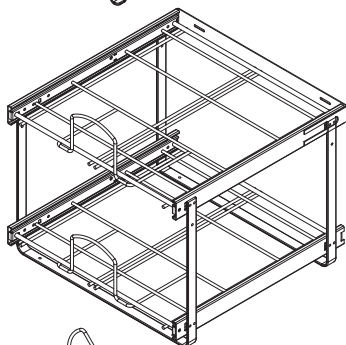
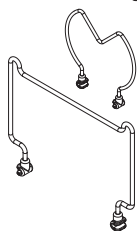
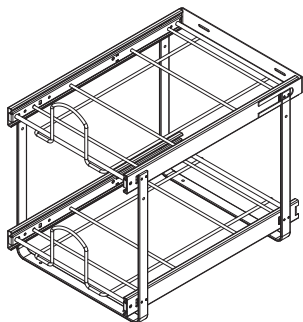

## CABMAT™



### CABMAT30 CABMAT33 CABMAT36

- CabMat™ features a gray sloped mat to capture spills and is removable for cleaning.
- Not trimmable. Can also be used in wider cabinets but will create a small void of unprotected area along the end panels.
- CabMat™ is also available installed as a modification for easy size selection by cabinet, see CMAT on page G-36.
- Inset on sink base cabinets will utilize the vanity CabMat™ size.

	Liquid Capacity		Cabinet Size	
	Quarts	Liters	Width	Depth
CABMAT30	4.2	3.9	30"	24"
CABMAT33	4.6	4.3	33"	24"
CABMAT36	5.0	4.7	36"	24"

Modifications  
Are Not  
Available

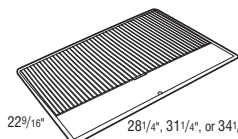

## Description

### CABMAT™ VANITY



## Model

### CABMATV24 CABMATV30 CABMATV36

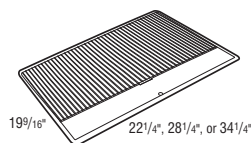

- CabMat™ features a gray sloped mat to capture spills and is removable for cleaning.
- Not trimmable. Can also be used in wider cabinets but will create a small void of unprotected area along the end panels.
- CabMat™ is also available installed as a modification for easy size selection by cabinet, see CMAT on page G-36.
- CabMat™ not available on inset vanity cabinets.

	Liquid Capacity		Cabinet Size	
	Quarts	Liters	Face Frame Opening	Depth
CABMATV24	2.5	2.4	21"-24"	21"
CABMATV30	3.3	3.1	27"-30"	21"
CABMATV36	3.9	3.7	33"	21"

Modifications  
Are Not  
Available

## SINK BASE CLEANING CADDY

### SBCADDYSM

- Includes one removable basket with handle and four dividers.
- Bottom mounted full extension, Smart Stop slides.
- Caddy dimensions are 6 3/8" wide x 15 3/4" high x 18 1/2" deep.
- Caddy fits in cabinets with a minimum: 9" wide x 16" high (frame opening) x 21" deep.

Modifications  
Are Not  
Available

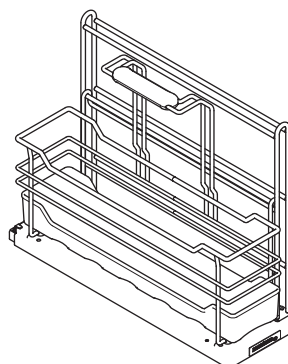

## SINK BASE CLEANING CADDY



### SBCADDY

- L or R designates installed side.
- Includes one removable basket with handle, one basket without handle, swivel basket and 8 dividers.
- Bottom mounted full extension, Smart Stop slides.
- Caddy dimensions are 11" wide x 20" high x 18 1/2" deep.
- Caddy fits in cabinets with a minimum: 12" wide (15" for inset) x 20 1/2" high (frame opening) x 21" deep.

Modifications  
Are Not  
Available

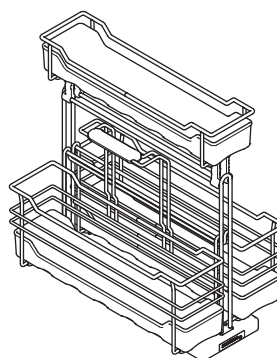

# Kits & Hardware

Description	Model
<b>MISCELLANEOUS ITEMS</b>	

## PLASTIC SHELF CLIPS – STANDARD

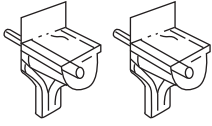

### SHELFPEGS

- Includes 6 plastic shelf clips and 3mm steel pin with clear plastic shoulder.

Modifications Are Not Available

## MULLION DOOR CLIPS



### MDCLIPS

- Package of 6 includes clear plastic retainer clips, screws, and PVC inserts.
- For use when inserting glass for Kemper Emerge Mullion Doors and Cut-for-glass Doors.
- Five styles of PVC inserts are included for varying glass thickness and/or door styles.

Modifications Are Not Available

## RETAINER CLIPS

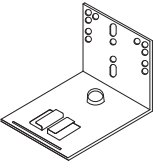

### RETAINER

- Sold in pairs.

Modifications Are Not Available

## STEM BUMPER PADS



### BUMPERSTEM

- Sold in quantities of 10.

Modifications Are Not Available

## HINGE SPACERS

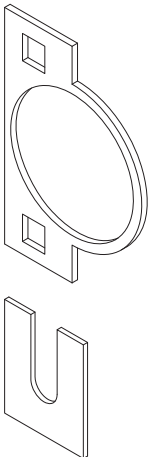

### HNGSPACER

- Specify round or U-shaped.
- Round spacer fits behind hinge on door. U-shaped spacer fits behind hinge plate on face frame.

Modifications Are Not Available

Description	Model
<b>ROLL TRAY BUMPER PADS</b>	<b>BUMPERTT</b>

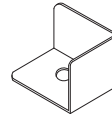

- Sold in quantities of 4.

Modifications Are Not Available

## INSET MAGNETIC CATCHES

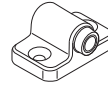

### MAGCATCHINSET

- Sold individually.
- Includes strike plate.

Modifications Are Not Available

## TURNBUCKLES for FALSE DRAWER FRONTS



### FALSEPANELCLIP

Modifications Are Not Available

## FULL EXTENSION DRAWER and ROLL TRAY SLIDES



**DGK12FXSPG**  
(Undermount with Smart Stop)

**DGK15FXSPG**  
(Undermount with Smart Stop)

**DGK18FXSPG**  
(Undermount with Smart Stop)

**DGK21FXSPG**  
(Undermount with Smart Stop)

**DGK24FXSPG**  
(Undermount with Smart Stop)

Modifications Are Not Available

## EDGEBANDING

### BANDVEN

- Veneer is unfinished.
- Minimum: 1".
- Maximum: 10".

Modifications Are Not Available

## Description

### HINGES

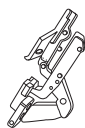

942HINGE



3/4HINGESC



32049HINGE



33657HINGE

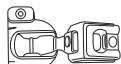

FOSHINGE

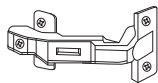

HINGEI170

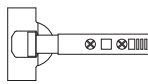

HINGEISC

### HINGE ANGLE RESTRICTION CLIP



### HINGE ANGLE RESTRICTION CLIP INSET



## Model



942HINGE 3/4" 170°

3/4HINGESC 3/4"

32049HINGE Bifold

33657HINGE Full Overlay 170°

FOSHINGE Full Overlay Smart Stop

HINGEI170

HINGEISC

SCISSORHINGE

Code	Hinge	Where Used
942HINGE	3/4" Overlay Concealed	All 3/4" overlay units requiring a 170° hinge (requires a hinge and plate #)
3/4HINGESC	3/4" Overlay Concealed	All 3/4" overlay units that do not require a 170° hinge
32049HINGE	Bifold	All corner units (requires a hinge and plate #) 60°
33657HINGE	1 3/8" Overlay FOL Concealed	All FOL units requiring a 170° hinge (i.e., corner units)
FOSHINGE	1 5/16" Overlay FOL Concealed Smart Stop	All FOL units except those requiring a 170° hinge
HINGEI170	Inset 170° Concealed	All Inset Units requiring a 170° inset hinge
HINGEISC	Inset Concealed Smart Stop	All Inset Units except those requiring a 170° inset hinge
SCISSORHINGE	Scissor Hinge	Used in Tilt-out Applications

Modifications  
Are Not  
Available

### HINGERESCLIP

- Sold in pairs.
- Restricts hinges to 86° opening capability.
- Works only with 3/4HINGESC and FOSHINGE.
- Not for use with bifold hinges or 170° corner hinges.
- Not recommended for cabinets with roll trays.

Modifications  
Are Not  
Available

### HINGERESCLIPIN

- Sold in pairs.
- Restricts hinges to 87° opening capability.
- Works only with HINGEISC. Will not work with finial hinges.
- Not for use with bifold hinges or 170° corner hinges.
- Not recommended for cabinets with roll trays.

Modifications  
Are Not  
Available

## Description

### HINGE RESTRICTION CLIP for WTH-BF and WTF-SL



WTHBF104CLIP



WTHBF83CLIP

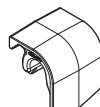

WTHSL100CLIP

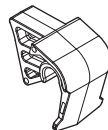

WTHSL75CLIP



## Model

WTHBF104CLIP

WTHBF83CLIP

WTHSL100CLIP

WTHSL75CLIP

- Sold in pairs.
- WTH-BF restricts hinges to 104° or 83° opening.
- WTH-SL restricts hinges to 100° or 75° opening.

Modifications  
Are Not  
Available

### HINGE PLATES

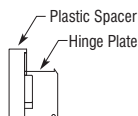
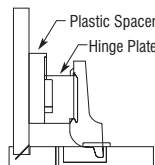

HINGEISCLPT1

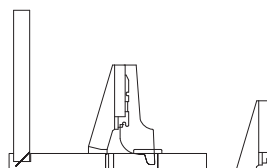

HINGEISCLPT2



### HINGEISCLPT1

- Plate attaches to the end panel.
- Plastic spacer included.
- Available on Inset and Beaded Inset Styles only.

### HINGEISCLPT2

- Plate attaches to the back side of the face frame.
- Used where Hinge Plate cannot be attached to the End Panel (i.e. Wide Slides, Clipped Corners, etc.).
- Available on Inset and Beaded Inset Styles only.

Modifications  
Are Not  
Available

### PREMIUM DOOR MECHANISM

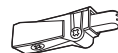

### PDM

- Includes all installation hardware.
- Creates a smooth and silent self-closing motion.
- Recommended PDMs per cabinet: 1 per door on any door with 2 hinges and 2 per door on any door with 3 or more hinges.
- Additional PDMs may be required when an accessory item is attached to the cabinet door.
- Not recommended for use on bifold doors.
- Not available with finial hinges.

Modifications  
Are Not  
Available

# Kits & Hardware

Description

Model

## FAUX HINGES

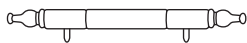

### HINGEFH1

- Antique Bronze

### HINGEFH4

- Matte Black

### HINGEFH2

- Pewter

- Sold in pairs.

Modifications  
Are Not  
Available

## FAUX HINGE STRAP



### HINGEFH3

- Matte black.

Modifications  
Are Not  
Available

## INSTALLATION HARDWARE PARTS

### BUMPERPADS\*

### BRKOFFSCREW8/32

- Sold in quantities of 25.















\*Rubber bumper pads.

Modifications  
Are Not  
Available

Description Model

**HARDWARE**



















**DECORATIVE PULLS and KNOBS**

	<b>PULLT001</b> • Pull - Brushed Satin Nickel • C/C: 7" L: 8" W: 3/8" P: 1 1/2"
	<b>KNOBT002</b> • Knob - Brushed Satin Nickel • C/C: 1 1/4" L: 2" W: 3/8" P: 1 1/2"
	<b>KNOBT013</b> • Knob - Tuscan Bronze • D: 1 1/4" P: 1 1/16"
	<b>PULLRH21</b> • C/C: 3"
	<b>PULLH50</b> • Pull - Satin Nickel • C/C: 5" L: 5" W: 5/16" P: 1 1/4"
	<b>PULLH63</b> • Pull - Satin Nickel • C/C: 96mm L: 4 1/8" W: 1/2" P: 1 1/16"
	<b>KNOBH100</b> • Acrylic Knob with Satin Nickel base • D: 1 3/8" P: 1 3/8" B: 3/4"
	<b>PULLH105</b> • 1.75" Tab Pull - Satin Nickel • C/C: 1" L: 1 3/4" W: 1" P: 1 3/4"
	<b>PULLH106</b> • 7" Tab Pull - Satin Nickel • C/C: 160mm L: 7" W: 1" P: 1 3/4"
	<b>PULLH107</b> • 12" Tab Pull - Satin Nickel • C/C: 12" L: 13" W: 1" P: 1 13/16"
	<b>KNOBH108</b> • Contemporary Knob - Iced Tea Nickel • L: 1 7/16" W: 1 1/16" P: 1" B: 1/2"
	<b>PULLH115</b> • 128mm SP Pull - Black Mist • C/C: 128mm L: 6 3/8" W: 1/2" P: 1"
	<b>KNOBH116</b> • SP Square Knob - Black Mist • L: 1 5/16" W: 1 1/4" P: 1 1/8" B: 3/8"
	<b>KNOBH117</b> • 1.32" Knob - Refined Bronze • L: 1 5/16" W: 1 5/16" P: 1 3/16" B: 7/8"

D = Diameter  
P = Projection (Hardware Depth)  
L = Length  
W = Width  
B = Base  
C/C = Center to Center

Description Model

**DECORATIVE PULLS and KNOBS** 









	<b>KNOBH118</b> • 1.32" Knob - Satin Nickel • L: 1 5/16" W: 1 5/16" P: 1 3/16" B: 7/8"
	<b>PULLH119</b> • 160mm Pull - Refined Bronze • C/C: 160mm L: 7 1/8" W: 3/4" P: 1"
	<b>PULLH120</b> • 160 Pull - Satin Nickel • C/C: 160mm L: 7 1/8" W: 3/4" P: 1"
	<b>PULLH122</b> • Pull - Satin Nickel • C/C: 12" L: 12 3/4" W: 7/8" P: 1 3/16"
	<b>KNOBH127</b> • 1.5" Round Knob - Silver Stone • D: 1 1/2" P: 1" B: 7/8"
	<b>PULLH128</b> • 160mm Pull - Silver Stone • C/C: 160mm L: 7 1/2" W: 3/4" P: 1 1/16"
	<b>PULLH129</b> • Pull - Stainless Steel • C/C: 128mm L: 6 3/8" W: 7/16" P: 1 1/8"
	<b>PULLH130</b> • Pull - Oil-Rubbed Bronze • C/C: 128mm L: 6 3/8" W: 7/16" P: 1 1/8"
	<b>PULLH131</b> • Pull - Stainless Steel • C/C: 224mm L: 10" W: 1/2" P: 1 3/8"
	<b>PULLH132</b> • Pull - Oil-Rubbed Bronze • C/C: 224mm L: 10" W: 1/2" P: 1 3/8"
	<b>KNOBH135</b> • Knob - Stainless Steel • L: 1 3/4" W: 1/2" P: 1 1/8" B: 1/2"
	<b>KNOBH136</b> • Knob - Oil-Rubbed Bronze • L: 1 3/4" W: 1/2" P: 1 1/8" B: 1/2"
	<b>PULLH141</b> • Pull - Stainless Steel • C/C: 128mm L: 7 3/8" W: 1/2" P: 1 1/4"
	<b>PULLH142</b> • Pull - Stainless Steel • C/C: 192mm L: 9 15/16" W: 1/2" P: 1 1/4"
	<b>PULLH143</b> • Pull - Stainless Steel • C/C: 384mm L: 17 1/2" W: 1/2" P: 1 1/4"
	<b>PULLH144</b> • 160 mm Pull - Iced Tea Nickel • C/C: 160mm L: 6 5/16" W: 9/16" P: 1 1/16"
	<b>KNOBM148</b> • Knob - Antique Pewter • L: 2 5/8" W: 5/8" P: 1 1/4"
	<b>KNOBM206</b> • Knob - Antique Pewter • D: 1 1/4" P: 1 1/16"



# Kits & Hardware

Description	Model
<b>DECORATIVE PULLS and KNOBS (cont'd)</b>	
	<b>NEW</b> <b>KNOBM207</b> • Knob - Rust • D: 1 1/4" P: 1 1/16"
	<b>NEW</b> <b>PULLM364</b> • Pull - Antique Pewter • C/C: 3" L: 4 5/8" W: 1 7/16" P: 15/16"
	<b>NEW</b> <b>PULLM366</b> • Pull - Rust • C/C: 3" L: 4 5/8" W: 1 7/16" P: 15/16"
	<b>NEW</b> <b>PULLM381</b> • Pull - Brushed Satin Nickel • C/C: 5 1/16" L: 6" W: 1/2" P: 1 1/16"
	<b>NEW</b> <b>PULLM383</b> • Pull - Brushed Matte Black • C/C: 5 1/16" L: 6" W: 1/2" P: 1 1/16"
	<b>NEW</b> <b>PULLM430</b> • Pull - Satin Nickel • C/C: 5 1/16" L: 7" W: 15/32" P: 1 7/16"
	<b>NEW</b> <b>PULLM475</b> • Pull - Antique Pewter • C/C: 3 3/4" L: 5" W: 9/16" P: 1"
	<b>NEW</b> <b>PULLM476</b> • Pull - Rust • C/C: 3 3/4" L: 5" W: 9/16" P: 1"
	<b>NEW</b> <b>KNOBM549</b> • Knob - Brushed Satin Nickel • D: 7/8" P: 1"
	<b>NEW</b> <b>PULLM570</b> • Pull - Brushed Satin Nickel • C/C: 5 1/16" L: 5 7/8" W: 1/2" P: 1 3/16"
	<b>PULLH911</b> • Pull - Hammered Blackened Bronze • C/C: 3" L: 5-5/8" W: 1" P: 1 1/4"
	<b>KNOBH913</b> • Knob - Blackened Bronze • 1 3/8"
	<b>KNOBH951</b> • Knob - Blackened Bronze • L: 1 3/4" W: 1" P: 1" B: 1 1/16" x 1/2"
	<b>PULLH952</b> • Labeled Secretary Pull - Blackened Bronze • C/C: 3" L: 4 1/4" W: 1 1/2" P: 11/16"
	<b>PULLH957</b> • Labeled Secretary Pull - Satin Nickel • C/C: 3" L: 4 1/4" W: 1 1/2" P: 11/16"

D = Diameter  
P = Projection (Hardware Depth)  
L = Length  
W = Width  
B = Base  
C/C = Center to Center

Description	Model
<b>DECORATIVE PULLS and KNOBS (cont'd)</b>	
	<b>NEW</b> <b>PULLT1015</b> • Pull - Black • C/C: 7" L: 8" W: 11/16" P: 1 1/2"
	<b>NEW</b> <b>KNOBT1017</b> • Knob - Black • C/C: 1 1/4" L: 2" W: 11/16" P: 1 1/4"
	<b>NEW</b> <b>PULLT1018</b> • Pull - Tuscan Bronze • C/C: 5 1/16" L: 6" W: 1/2" P: 1 1/16"
	<b>NEW</b> <b>KNOB1420</b> • Knob - Satin Nickel • D: 1 1/4" P: 1 1/8"
	<b>NEW</b> <b>KNOB1432</b> • Knob - Tuscan Bronze • D: 1 1/4" P: 1 1/8"
	<b>NEW</b> <b>PULLM1674</b> • Pull - Tuscan Bronze • C/C: 3" L: 4 5/8" W: 1 7/16" P: 15/16"
	<b>NEW</b> <b>KNOBM1820</b> • Knob - Cast Iron • L: 1 5/16" W: 1 5/16" P: 1"
	<b>NEW</b> <b>PULLM1823</b> • Pull - Cast Iron • C/C: 5 1/16" L: 7 3/8" W: 1" P: 1 1/4"

Description **FACTORY INSTALLED LIGHTING** Model

### STANDARD DRIVERS

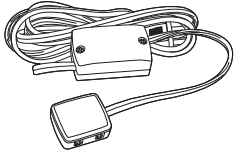

STAND1264

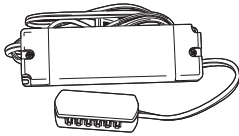

STAND123012  
STAND126012

STAND1264

STAND123012

STAND126012

- Minimum of one driver is required for each continuous cabinet run with lighting.
- To determine driver requirements, calculate the total wattage of each cabinet run and select the appropriate size driver(s).
- Driver plugs into a standard 110 volt outlet and converts down to 12 volts to power all LED lighting components installed in cabinets.

Code	Voltage	Wattage (Max Load)	Connector Ports
STAND1264	12	6	4
STAND123012	12	30	12
STAND126012	12	60	12

Modifications  
Are Not  
Available

### POWER BRIDGE

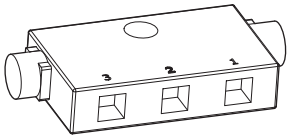

3ZONEPWRBRDG

- Allows for a non-controlled application and zoned application.
- Non-controlled: connects the Driver and Cabinet Bridge.
- Zoned: connects the Cabinet Bridge, Receiver, and Driver.

Modifications  
Are Not  
Available

### 4 ZONE DIMMING RECEIVER

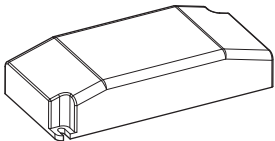

4ZONEDIMREC

- Allows the installed LED lighting to be controlled via wireless remote (not included).
- Connects the Driver and Power Bridge.
- Controls up to four zones.

Modifications  
Are Not  
Available

Description **4 ZONE WALL CONTROLLER** Model **4ZONECON**

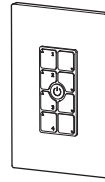

- Allows for wireless control of zoned lighting.

Modifications  
Are Not  
Available

### JUMPER CABLES

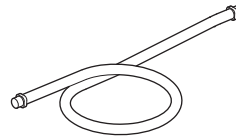

BRIDGECABLE18

BRIDGECABLE36

BRIDGECABLE72

- Transfers power between Cabinet Bridges.
- Cable plugs into end of each Bridge.
- Available in 18", 36" and 72" lengths.
- Can be combined for longer lengths.

Modifications  
Are Not  
Available

# Lighting

## Modifications for Factory Installed Lighting

---

### Position Bridge on Top of Wall Cabinet

**Specify BRIDGE.TOP**

On any wall cabinet with a lighting modification attached, the bridge will be factory installed on top of the cabinet.

---

### Position Bridge on Bottom of Wall Cabinet

**Specify BRIDGE.BTM**

On any wall cabinet with a lighting modification attached, the bridge will be factory installed on bottom of the cabinet.

---

### Add Interior Light to Single Opening Wall Cabinet or Corner Base Cabinet

**Specify INT.LGT (Single Opening Wall Cabinet) or INT.LGT.BC (Corner Base Cabinet)**

- Bridge unit comes installed on wall cabinets. Select appropriate modification for top or bottom installation.
  - Battery Pack included with corner base cabinets.
  - All wiring is connected to the bridge from each light strip.
- 

### Add Interior Light to All Openings of Cabinet

**Specify INT.ALL.LGT**

- Includes stacked wall cabinets and utility cabinets.
  - Bridge unit comes installed on cabinets. Select appropriate modification for top or bottom installation.
  - All wiring is connected to the bridge from each light strip.
- 

### Add Interior Light to Top Opening of Cabinet

**Specify INT.TOP.LGT**

- Includes stacked wall cabinets and utility cabinets.
  - Bridge unit comes installed on cabinets. Select appropriate modification for top or bottom installation.
  - All wiring is connected to the bridge from each light strip.
- 

### Add Interior Light to Middle Opening of Cabinet

**Specify INT.MID.LGT**

- Includes stacked wall cabinets and utility cabinets.
- Bridge unit comes installed on cabinets. Select appropriate modification for top or bottom installation.
- All wiring is connected to the bridge from each light strip.

\*Interior lighting is 5000K cool white hue. Interior lighting and exterior cool lighting are not available in California.

## Modifications for Factory Installed Lighting (cont'd)

---

### Add Interior Light to Bottom Opening of Cabinet

**Specify INT.BTM.LGT**

- Bridge unit comes installed on wall cabinets. Select appropriate modification for top or bottom installation.
  - All wiring is connected to the bridge from each light strip.
- 

### Add Interior Light to Top and Middle Openings of Cabinet

**Specify INT.TOP.MID.LGT**

- Bridge unit comes installed on wall cabinets. Select appropriate modification for top or bottom installation.
  - All wiring is connected to the bridge from each light strip.
- 

### Add Interior Light to Top and Bottom Openings of Cabinet

**Specify INT.TOP.BTM.LGT**

- Bridge unit comes installed on wall cabinets. Select appropriate modification for top or bottom installation.
  - All wiring is connected to the bridge from each light strip.
- 

### Add Interior Light to Middle and Bottom Openings of Cabinet

**Specify INT.MID.BTM.LGT**

- Bridge unit comes installed on wall cabinets. Select appropriate modification for top or bottom installation.
  - All wiring is connected to the bridge from each light strip.
- 

### Add Exterior Cool Light to Bottom of Wall Cabinet

**Specify EXT.BTM.LGT.C**

- LED light strip housed in a rigid aluminum extrusion.
  - 5000K cool white hue.
  - Installed 9" from back of cabinet.
- 

### Add Exterior Warm Light to Bottom of Wall Cabinet

**Specify EXT.BTM.LGT.W**

- LED light strip housed in a rigid aluminum extrusion.
- 3000K warm white hue.
- Installed 9" from back of cabinet.

\*Interior lighting is 5000K cool white hue. Interior lighting and exterior cool lighting are not available in California.



HEARTH1

HE01	Parts List
✓	(1) 2-WSP930, EXBKL & R6", FTK, FPEL, FPER
✓	(2) 1-BBM8
✓	(3) 1-RPV48
✓	(4) 1-SHELFMI 19" x 67", trim front with 2-CBEADM
✓	(5) 2-SWVCRM8
✓	(6) 1-SHELFMI 22" x 73", trim front with 2-CBEADM
✓	(7) 1-W3321, ID21
✓	(8) 1-W3321, ID21, Half Width 16.5R, FPEL
✓	(9) 1-W3321, ID21, Half Width 16.5L, FPER
✓	(10) 2-SM8

**NOTE:** Moulding needs to be ordered to match kitchen. See appliance specs for clearance requirements. Vent installation behind valance recommended.  
Use single design code HE01 to locate template in 20/20 catalog. You may edit these designs to accommodate actual dimensions in your projects.

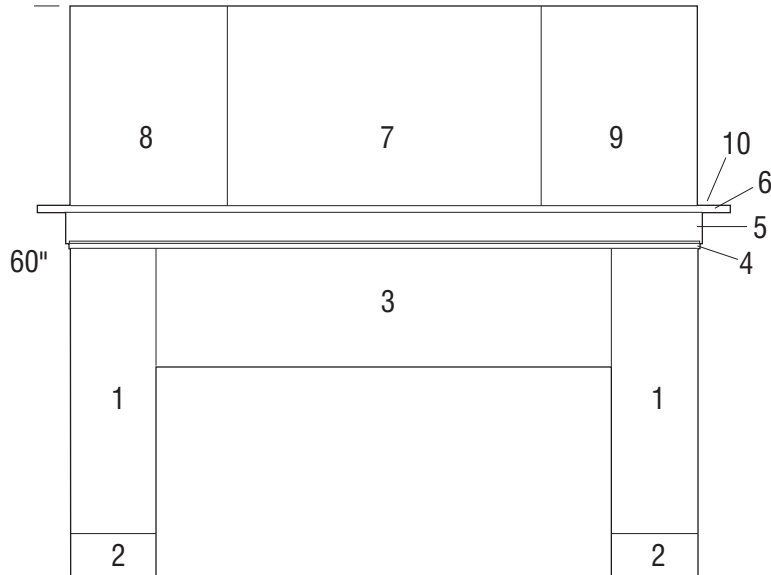
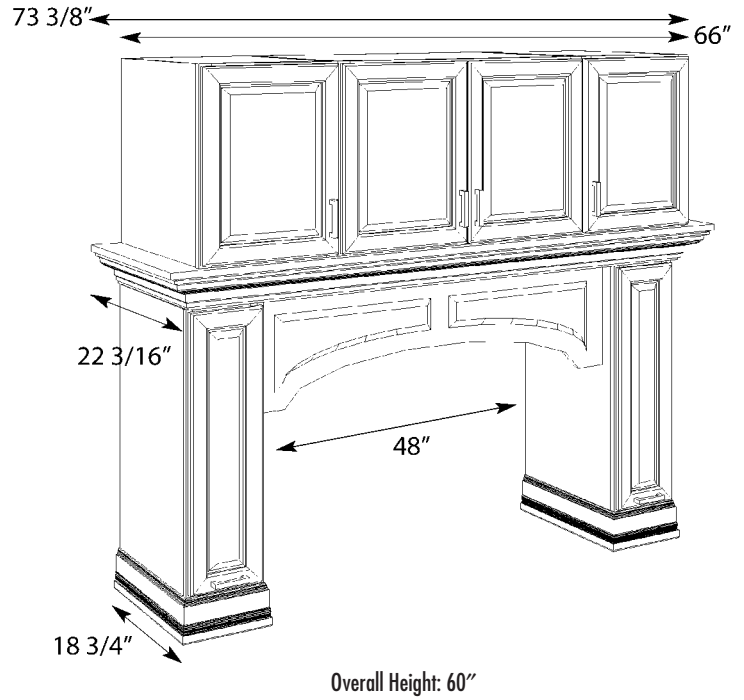

Parts Key  
(Aerial View)

# Distinctions

## HEARTH2

HE02	Parts List
✓	(1) 2-PILB84BAT w/TBATM Moulding (trim to 15 3/4" x 60" H)
✓	(2) 1-WSP936, EXBKR3", FPER
✓	(3) 1-WSP936, EXBKL3", FPEL
✓	(4) 1-RPV48
✓	(5) 1-W3318, ID15
✓	(6) 1-W3318, Half Width 16.5"R, ID15
✓	(7) 1-W3318, Half Width 16.5"L, ID15

**NOTE:** Moulding needs to be ordered to match kitchen. See appliance specs for clearance requirements.

Use single design code HE02 to locate template in 20/20 catalog. You may edit these designs to accommodate actual dimensions in your projects.

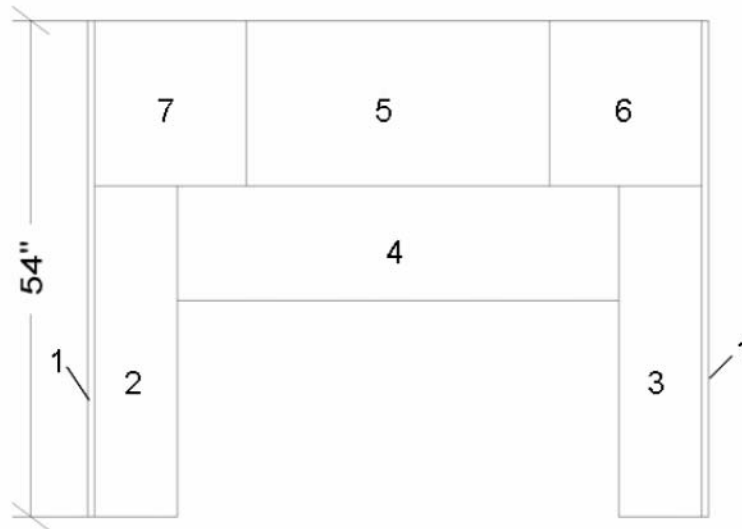
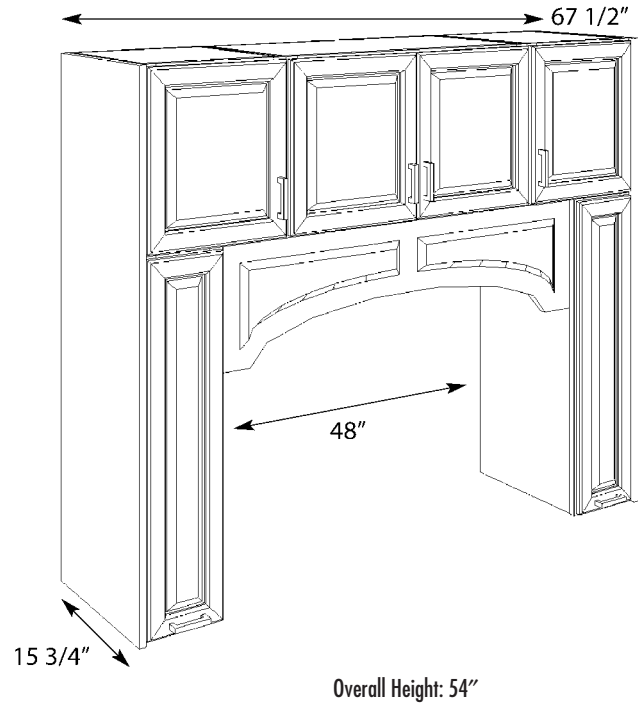

Parts Key  
(Aerial View)

ARMOIRE1

ARO1FO Full Overlay	Parts List
✓	(1) V33024BCFP FLUT3
✓	(2) VB363021 – 18" Deep EXL1/4", EXR1/4", FTK, MIP
✓	(3) V33024BCFP FLUT3
✓	(4) W360BCFP 27" Deep, FLUT3
✓	(5) W3618 ID18", EXL1/4", EXR1/4", MIP
✓	(6) W3636 MD36, MIP*, ID18", EXL1/4", EXR1/4"
✓	(7) 3/4SOLID 3/4" x 6" x 36 1/2"
✓	(8) W360BCFP 27" Deep, FLUT3
✓	(9) WOODTOP – 1 1/2" x 19 1/2" Deep x 43 1/2" #17 F, L, R
✓	(10) 2-ACO
✓	(11) ACOVLY
✓	(12) 2-TF396 FTK
✓	(13) 2-TSTM
✓	(14) 2-MTCROWN8
✓	(15) 2-BSM

ARO1FO

Mount W3636 on top of W3618. Place 3/4SOLID 3/4" x 6" x 36 1/2" on top of W3636. Attach ACOVLY to center of filler. Use W360BCFP cut to 19" deep on each side of stacked wall cabinets. Attach ACO to tops of columns. Use woodtop as countertop. Attach V33024BCFP cut to fit on each side of VB363021. Wrap BSM around entire unit. Construct top trim with TF396 FTK between TSTM and MTCROWN8.

**NOTE:** Glass not included. Not available in Burke, Decker, Landry, and Tate.

\*When a decorative door option is chosen in 20/20, Matching Interior Plywood (MIP) is a preselected option. If MIP is not desired, it can be deselected by choosing NOTMIP.

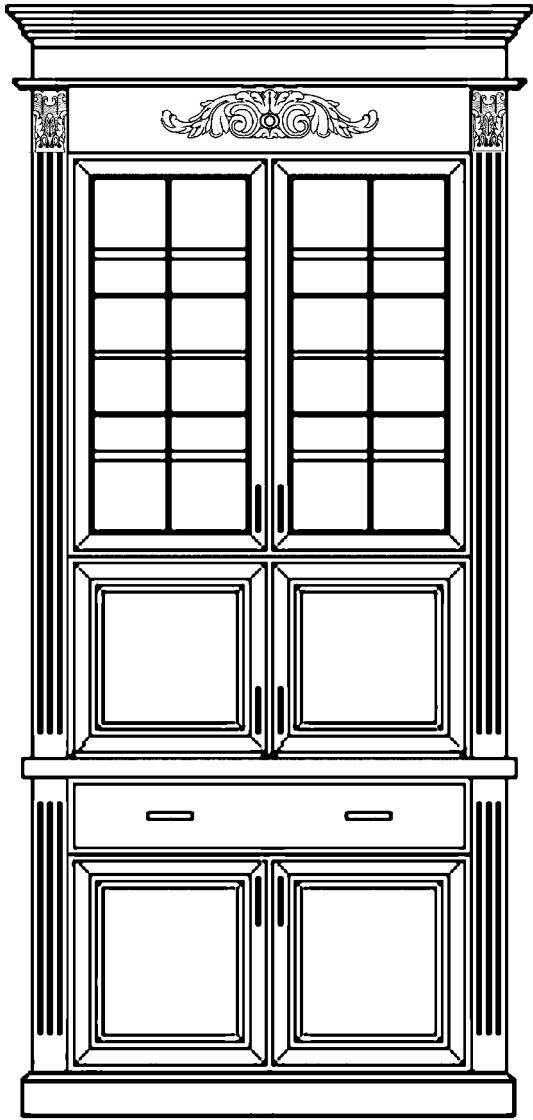

Overall Height: 97 1/8"  
(including moulding shown)

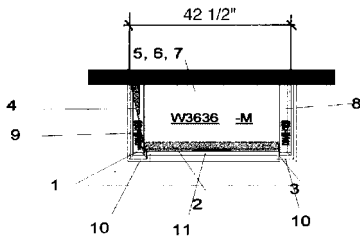

Full Overlay Parts Key  
(Aerial View)

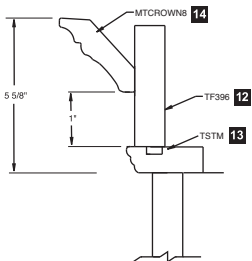

Top Trim



# Distinctions

## ARMOIRE3

AR03FO Full Overlay	Parts List
✓	<sup>(1)</sup> W2730, A2DRW, FPEL, FPER, AUTHB, FTKAV, 2WSL1.5, F, TW, XTW, HW, XHW2WSR1.5, ID18", MIP
✓	<sup>(2)</sup> W2718 ID18", ADRW, AUTHB, FPEL, FPER, 2WSL1.5, F, TW, XTW, HW, XHW2WSR1.5, MIP
✓	<sup>(3)</sup> WOODTOP 1 1/2"H x 19 1/4"D x 29"W #17 F, L, R
✓	<sup>(4)</sup> WOODTOP 1 1/2"H x 19 1/4"D x 29"W #17 F, L, R
✓	<sup>(5)</sup> 2-CBEADM

### AR03FO

Place 1 - WOODTOP on top of each cabinet. Place upper woodtop finished side down. Attach CBEADM moulding vertically on exposed face frame of both cabinets.

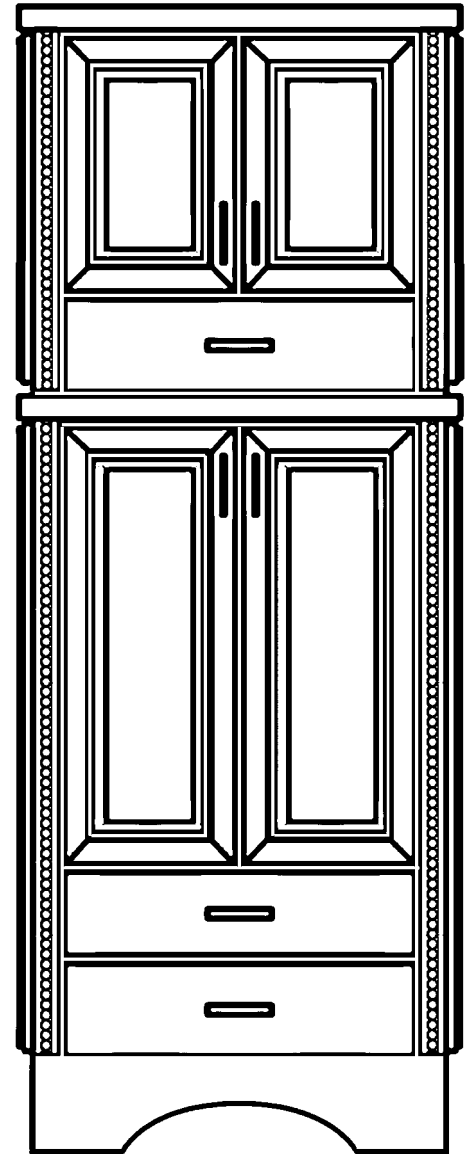

Overall Height: 73 1/2"

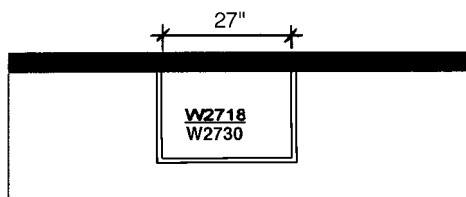

Parts Key  
(Aerial View)

ARMOIRE4

ARO4FO Full Overlay	Parts List
✓	(1) 6DB42 OBRB, EXL1/4", EXR1/4"
✓	(2) WOODTOP 1 1/2"H x 25 1/4"D x 45"W #17 F, L, R
✓	(3) AD42
✓	(4) AD42
✓	(5) W4236 ID18", MIP*, 2-PRMD36, EXL1/4", EXR1/4"
✓	(6) W4212 ID18", EXL1/4", EXR1/4", MIP
✓	(7) PILB34.5BAT, w/TBEM
✓	(8) PILB34.5BAT, w/TBEM
✓	(9) PILB84BAT, w/TBEM
✓	(10) PILB84BAT w/TBEM
✓	(11) 2-SHKRCRM8
✓	(12) 1-PIL584BAT w/TBEM
✓	(13) 1-FF330

ARO4FO

Attach pilasters to sides of all cabinets. Cut to fit. Pull AD42s out 6". Top trim is SHKRCRM8 cleated to PIL584BAT w/TBEM. Trim filler to 1/4" and install on each side of AD42s.

**NOTE:** Glass not included. Not available in Burke, Decker, Landry, and Tate.

\*When a decorative door option is chosen in 20/20, Matching Interior Plywood (MIP) is a preselected option. If MIP is not desired, it can be deselected by choosing NOTMIP.

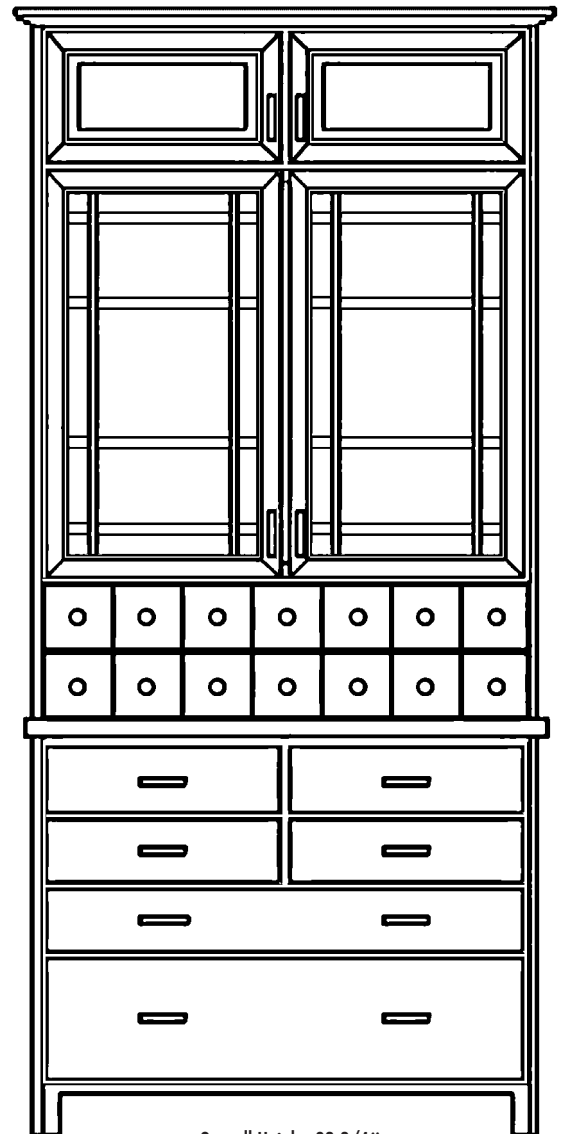

Overall Height: 98 3/4"  
(including moulding shown)

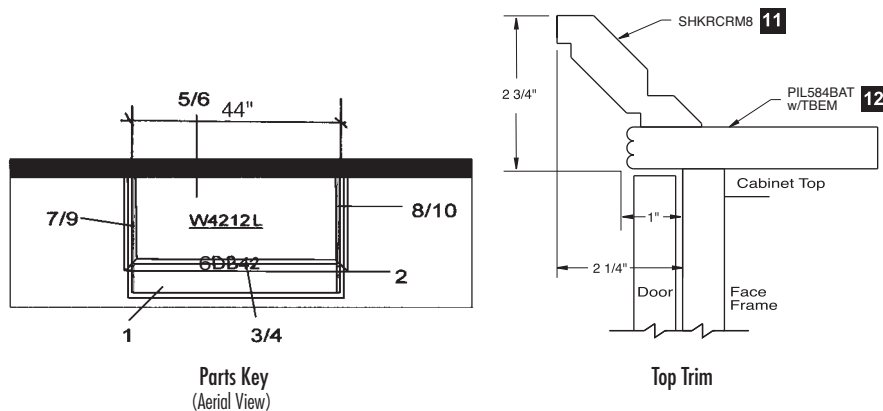

# Distinctions

## ARMOIRE5

ARO5FO Full Overlay	Parts List
✓	(1) B334.527BCFP ROSFLUT
✓	(2) BOB18AV EXL1/4"
✓	(3) BOB18AV EXR1/4"
✓	(4) B334.527BCFP ROSFLUT
✓	(5) W360BCFP 24"D, ROSFLUT
✓	(6) W3624 ID18", CND, MIP, A2DRW, EXL1/4", EXR1/4"
✓	(7) W3624 ID18", EXL1/4", EXR1/4", MIP
✓	(8) W360BCFP 24"D, ROSFLUT
✓	(9) WOODTOP 1 1/2"H x 25 1/2"D x 43 1/2" #17 F, L, R
✓	(10) 8-ROSETTEFLW
✓	(11) 1-TF396 FTK
✓	(12) 1-TSTM
✓	(13) 1-SWVCRM8
✓	(15) 1-TB8WD14

### ARO5FO

Attach ROSETTEFLW to top and bottom of box columns. Cut wall box columns (W360BCFP) to 19" depth. Cut base box columns (B334.527BCFP) to 25" depth.

Top Trim — TF396 FTK between TSTM and SWVCRM8.

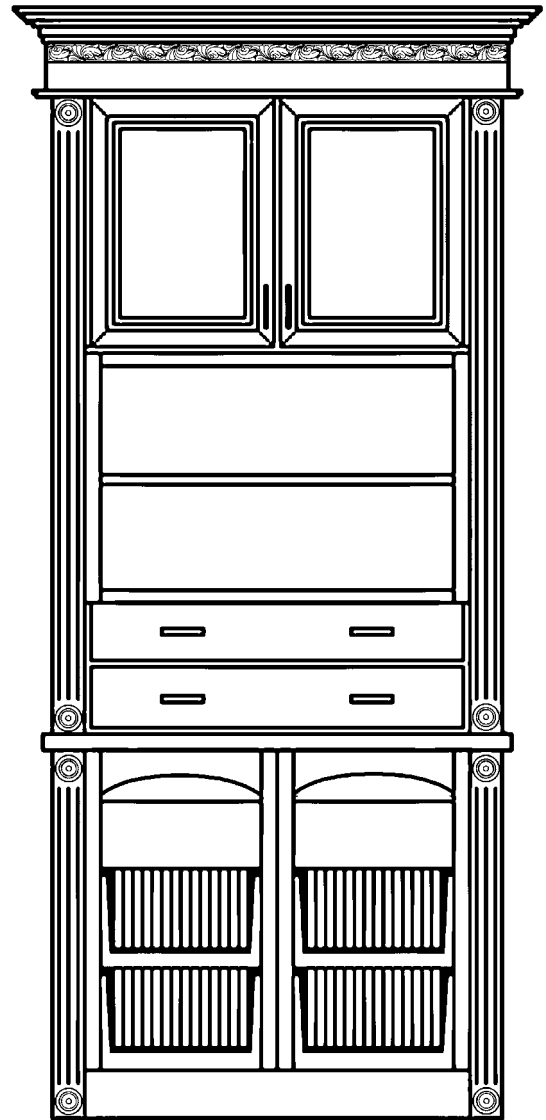

Overall Height: 101 9/16"  
(including moulding shown)

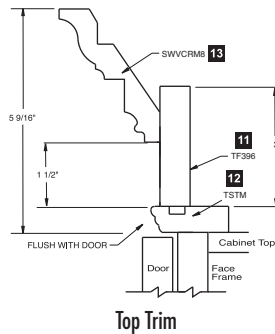
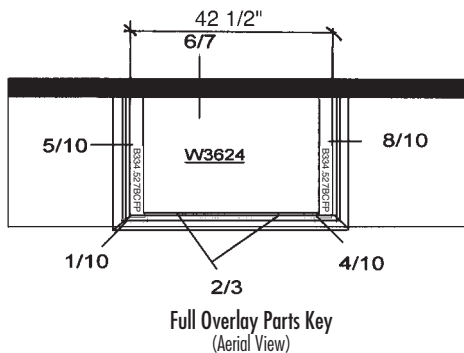

**ISLAND1**

ISO1FO Full Overlay	Parts List
✓	(1) DISLEGSQ
✓	(2) BWB18 FPER
✓	(3) B30FH RD18" w/2-RT30, EXL1/4", EXR1/4"
✓	(4) B18-R FPEL, FPER
✓	(5) DISLEGSQ
✓	(6) WB36 RD6", FPEL, FPER, FTKAV
✓	(7) DISLEGSQ
✓	(8) TD18FH-L FPEL
✓	(9) B30FH EXL1/4", EXR1/4"
✓	(10) 3DB18BB FPEL, FPER
✓	(11) DISLEGSQ
✓	(12) WB36 RD6", FPEL, FPER, FTKAV, CND, MIP
✓	(13) 3-TB8WD14

**ISO1FO**

Silicone legs in place under countertop, centered in available space.

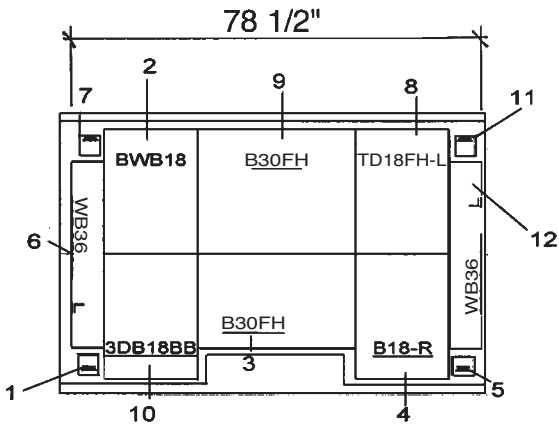
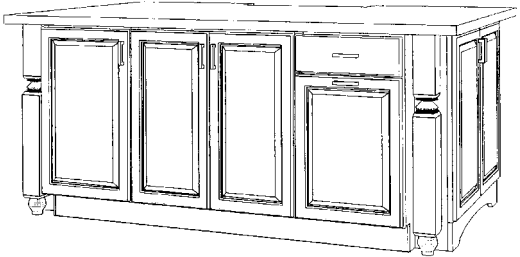
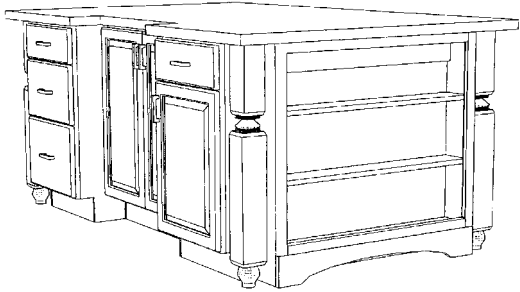
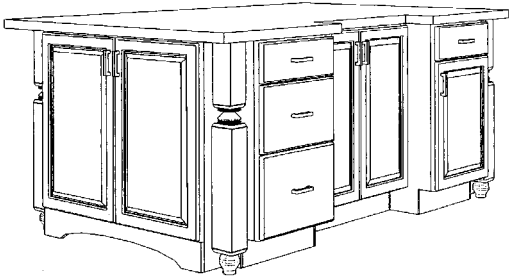

Full Overlay Parts Key  
(Aerial View)

# Distinctions

## ENTERTAINMENT CENTER 1

EC01FO Full Overlay	Parts List
✓	(1) T68427BCFP FLUT3
✓	(2) B18-L FTK, EXL1/4", MIP
✓	(3) 3DB36 FTK
✓	(4) B18-R FTK, EXR1/4", MIP
✓	(5) W1836-L, CG ID24", MIP*, FPER, A2DRW, EXL1/4"
✓	(6) W3612 ID24", PFINBTMB, MIP
✓	(7) W1836-R, CG ID24", MI, FPEL, A2DRW, EXR1/4"
✓	(8) T68427BCFP FLUT3
✓	(9) WOODTOP – 1 1/2"H x 25 1/4"D x 72 1/2"W #17 F, L, R
✓	(10) 2-TF396 FTK
✓	(11) 2-SWVCRM8
✓	(12) 2-BRAIDM
✓	(13) 2-BSM

### EC01FO

Top Trim – SWVCRM8 with BRAIDM in insert (cleat to TF396).

Baseboard – BSM (return into wall). 1/4" panel sent separately to be applied to W3612 for finished bottom.

**NOTE:** Glass not included. Open space for television: 36"W x 36"H x 22 1/2"D.

\*When a decorative door option is chosen in 20/20, Matching Interior Plywood (MIP) is a preselected option. If MIP is not desired, it can be deselected by choosing NOTMIP.

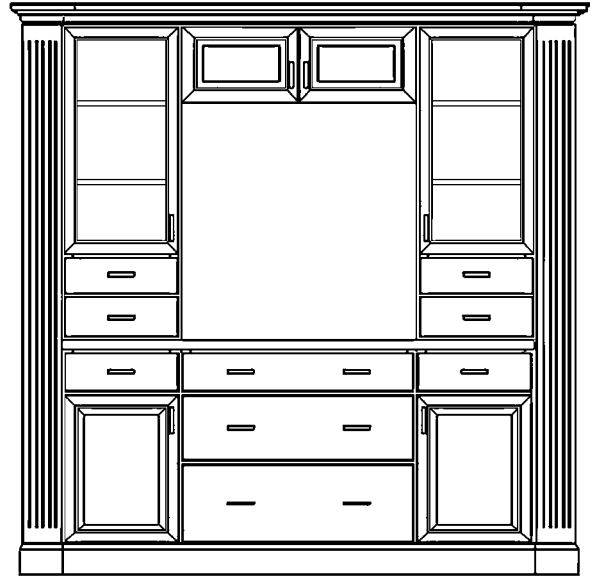

**Overall Height: 87 5/16"**  
(including moulding shown)

Not available in Landry.

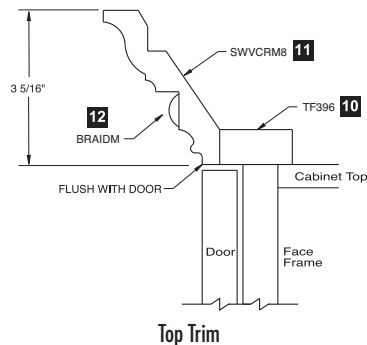
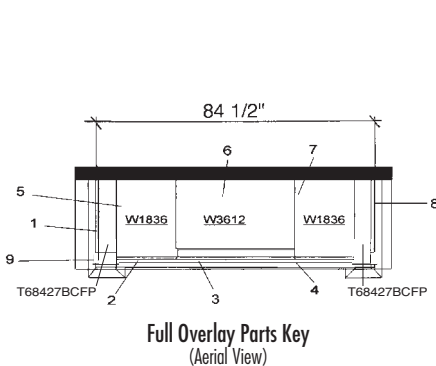

ENTERTAINMENT CENTER 2

ECO2FO Full Overlay	Parts List
✓	(1) UB1596RT-L FPEL, AUTHL, FTK, MIP
✓	(2) T39627BCFP
✓	(3) SHELVEN 3/4"H x 24"D x 60 1/2"W
✓	(4) SHELVEN 3/4"H x 24"D x 60 1/2"W
✓	(5) W301524 PFINBTMB, EXL1/4", MIP
✓	(6) W301524 PFINBTMB, EXR1/4", MIP
✓	(7) T39627BCFP
✓	(8) UB1596-R FPER, AUTHR, FTK, MIP
✓	(9) SV61
✓	(10) TF684 Finish 1 long edge
✓	(11) 2-SPRINGEND
✓	(12) 2-SPTRINGROPE96
✓	(16) 3-TF396 FTK
✓	(17) 3-TSTM
✓	(18) 3-SWLCRM8
✓	(19) 3-DE8
✓	(20) 1-BP7234.5WD
✓	(21) 1-BSM
✓	(22) 1-ICM8

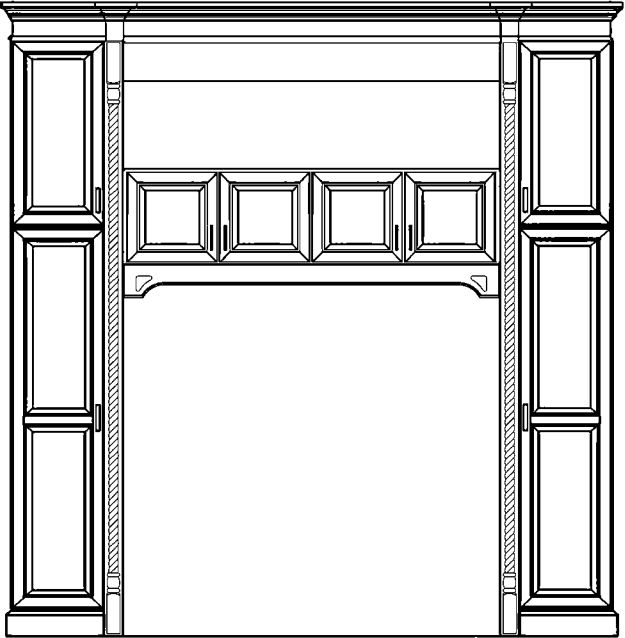

Overall Height: 100 1/16"  
(including moulding shown)  
Not available in Landry.

ECO2FO

Attach SPTRINGEND and SPTRINGROPE96 to T39627BCFP. Panel back of open shelf area with BP7234.5WD. Use ICM8 at corners of panel if needed. Cut SV61 to 60 1/2".

Top Trim – TF396 FTK between TSTM and SWLCRM8. Place DE8 under SWLCRM8. Wrap BSM around utility base. 1/4" panel sent separately to be applied to W301524 for finished bottom.

**NOTE:** Glass not included. Open Space for Television: 54 7/8"W x 60 1/2"H x 22 1/2"D.

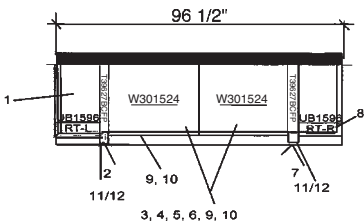

Full Overlay Parts Key  
(Aerial View)

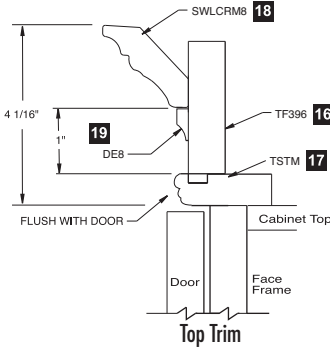

# Distinctions

## ENTERTAINMENT CENTER 3

ECO3FO Full Overlay	Parts List
✓	(1) T248412BCAV ID18", TVRVV, FPEL
✓	(2) B36RT FTK, EXL1/4", EXR1/4", MIP
✓	(3) T248412BCAV ID18", TVRVV, FPER
✓	(4) W3636 ID24", MIP, CND, EXL1/4", EXR1/4"
✓	(5) W362124 EXL1/4", EXR1/4", MIP
✓	(6) PILB96BAT w/MROPE
✓	(7) PILB96BAT w/MROPE
✓	(8) 3-TF396 FTK
✓	(9) 3-TLCROWN
✓	(10) 2-BSM

### ECO3FO

Construct top trim from TLCROWN cleated to TF396. Use BSM trim at baseboard.

**NOTE:** Glass not included. Open Space for Television: 33"W x 33"H x 22 1/2"D. Shelves will not support television.

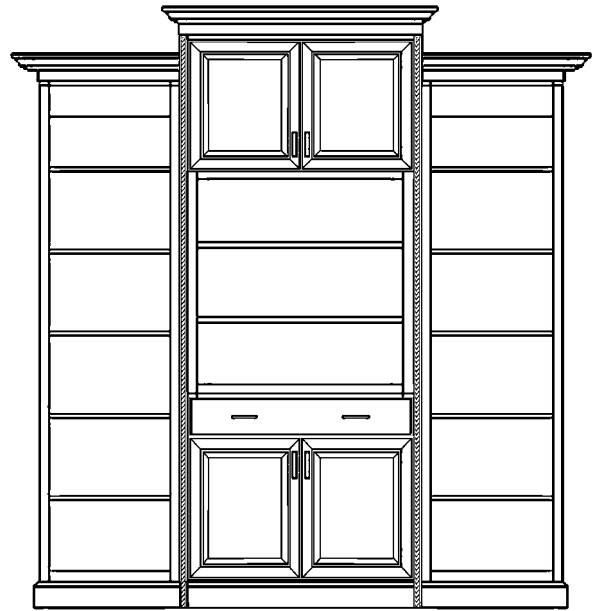

Overall Height: 101 5/16"  
(including moulding shown)

Not available in Landry.

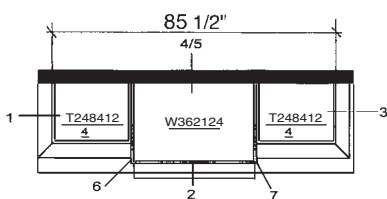

Parts Key  
(Aerial View)

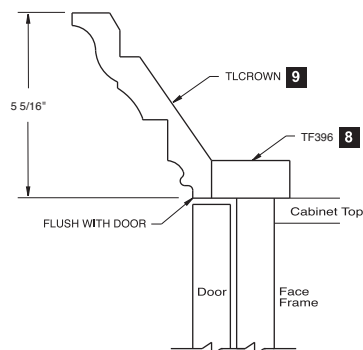

Top Trim

# Express Response Program **EXPRESS** RESPONSE

## Our Commitment to Channel Partners, Designers and Customers

Kemper Emerge's Express Response program is designed to expedite orders when customers need product faster than normal lead times to correct problems with an existing order. Below is an overview of the program and what you can expect from Kemper Emerge's commitment to superior service.

### Guidelines

- Order must be associated with a previous order number.
- All orders received by 12 NOON E.T. Monday-Friday will be automatically scheduled for Express Response that same day. Orders received after the cutoff time will be processed on the next business day.
- Lead time calculation is based on receipt of a clean order on a credit-worthy account. Clean orders are orders in which all information is provided and accurate.
- There are no cancellations or returns once order is received.
- Due to the special nature of the products listed, they are excluded from the Express Response program and will be processed as a standard lead time order.
  - Specials, Appliance Panels, Wood Hoods, and Element Design® Aluminum Frame Doors/Inserts. Contact customer service to help process these requests as standard lead time orders.
- Express Response is available within the continental United States. Should Alaska, Hawaii or international shipments be required, customer service representatives are ready to assist by providing shipping information and determining lead times.

### Lead times

12 WORKING DAYS OR LESS FROM ORDER TO DELIVERY (channel partner or home delivery agent):

- Items shipped via LTL (via SuperPAC™) or truckload
- Includes all catalog items except those that can be expedited through the 5-day program listed below.

20 WORKING DAYS OR LESS FROM ORDER TO DELIVERY (channel partner or home delivery agent):

- Items shipped via LTL (via SuperPAC™) or truckload

5 WORKING DAYS FROM ORDER TO DELIVERY:

- Qualified items are designated in the Specification Guide with an icon 
- Items will ship via parcel ground
  - Lead time calculation allows for 2 days parcel ground shipping time. Some geographic areas may require additional shipping time.
- For orders containing both 12 day and 5 day items, the longer lead time applies.

QUESTIONS? If you have questions that aren't answered here, contact your Customer Service team.



## Kemper Emerge Warped Door

Kemper Emerge's line of framed cabinetry is constructed to strict specifications, including the moisture content present in wood. When the moisture content is maintained at a constant level, Kemper Emerge is able to minimize the amount of expansion and contraction associated with natural wood. When a great amount of expansion and contraction occur, the result can be a warped door. By strictly controlling the amount of humidity present during manufacturing, Kemper Emerge is helping to ensure you receive a quality product.

Because wood is a natural product, each piece of wood exhibits its own unique color and grain variations. These differences give wood its genuine beauty. The wood's natural properties also determine how each individual piece will react to changing weather conditions. Therefore, eliminating warped doors is virtually impossible.

If you feel that you have a warped door, Kemper Emerge requires that you perform initial testing to determine the extent of the problem.

1. Remove the door from the cabinet and remove all decorative surface knobs or pulls and hinges.
2. Place the door on a completely flat surface, as determined by using a level, and alternately press on opposite corners to observe if the door "rocks" or pulls away from the flat surface.
3. If you observe a gap between the door and the flat surface, measure the distance to determine the amount of warpage.
  - A door must be warped at least 1/4" before it can be considered for replacement. When ordering a replacement by using Kemper Emerge Part/Replacement Order Form, be sure to fill in the "Reason for Replacement" section by identifying the applicable warping classification illustrated below.
  - If a door is warped less than 1/4", we recommend you allow a complete heating and cooling cycle (summer to winter season change) to allow the door to reach a moisture equilibrium. Adding magnetic catches or roller catches will often correct minor problems.
4. If the door does not pull away from the flat surface, it is not warped. Most likely, there is a problem with the cabinet installation. When cabinets are not installed in a level or plumb position, they become racked and will cause the door to appear warped. To check for a racked cabinet, place a level on one end rail. The bubble in the level will appear centered if the cabinet was properly installed in a level position. Now place the level on the other end rail.

Again, if the bubble appears centered, the cabinet is properly installed in a level position. Any variations in the location of the bubble will indicate the cabinet was not properly installed. (A plumb bob will reveal the same information.)

Another proper installation check is to place the level on the top, and then bottom, of the installed cabinet's face frame. Identify the bubble's position in both, top and bottom, locations of the face frame. The bubble's position will indicate if the cabinet was properly installed.

## Glossary

- LEVEL: (v) A term used to describe a true horizontal line.  
(n) A device for establishing a horizontal line or plane by means of a bubble in liquid that shows adjustment to the horizontal by movement to the center of a slightly bowed glass tube.
- PLUMB: (v) A term used to describe a true vertical line. If something is "out of plumb," it is not exactly straight up and down.
- RACK: (v) The action of straining or wrenching through improper installation.
- WARP: (v) The action of twisting or bending out of a true flat or level surface.

# Kemper Emerge Warped Door (cont'd)

## Classification of Warping

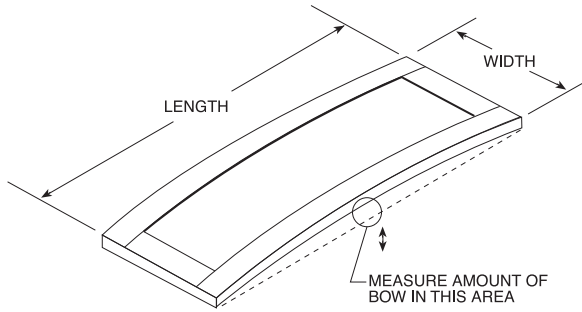

**BOW** – VERTICAL DEVIATION (UP OR DOWN) FROM A TRUE FLAT PLANE. A BOW IS USUALLY ASSOCIATED WITH THE LENGTH.

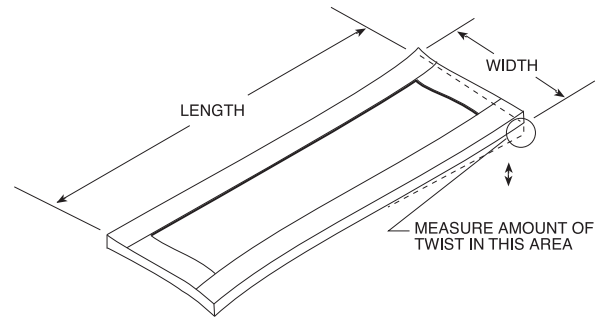

**TWIST** – VERTICAL DEVIATION (UP AND DOWN) FROM A TRUE FLAT PLANE. TWIST USUALLY OCCURS TO JUST THE CORNER(S) OR END.

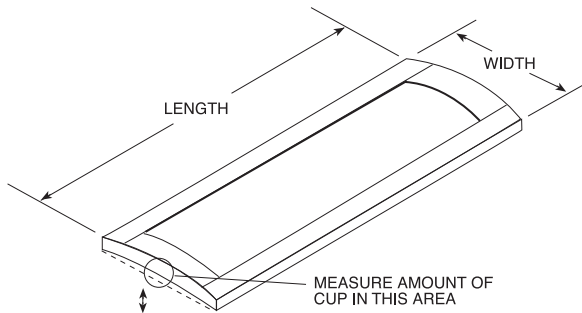

**CUP** – VERTICAL DEVIATION (UP OR DOWN) FROM A TRUE FLAT PLANE. A CUP IS USUALLY ASSOCIATED WITH THE WIDTH.

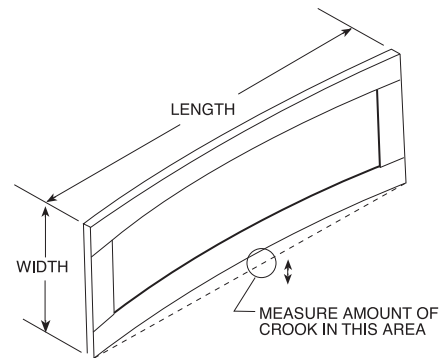

**CROOK** – HORIZONTAL DEVIATION (SIDE TO SIDE) FROM A TRUE EDGE. A CROOK IS USUALLY ASSOCIATED WITH THE LENGTH.



# KEMPER®

## EMERGE™ SERIES

### Painted Finish Agreement

Fax: 877.333.7122

Email: [emergeorders@masterbrand.com](mailto:emergeorders@masterbrand.com)

#### Alpaca, Paint, and Paint with Penned Cabinetry Agreement. Applies to Maple Door Styles.

Dear Kemper Emerge Customer,

**Congratulations on your selection of Kemper Emerge cabinetry.** Because of their unique characteristics, these finishes are quite different from other cabinetry finishes you may be familiar with. Your satisfaction is important to Kemper Emerge, and we want you to fully understand the characteristics that make painted finishes so distinctive.

In addition, as the wood naturally expands and contracts with varying weather conditions, slight joint separations may occur; these may become visible as small cracks in the finish, particularly in joint areas. When ordering painted Maple 5-piece styles, the door's center panel will be constructed of MDF material, except when Timeworn, Hewn, Extra Timeworn, Extra Hewn, or Brushed Finish techniques or Black paint is specified. **Joint separation may be more apparent on mitered doors; therefore, the finishes listed above are not recommended for use in environments with extremely high or low humidity levels.** Also, over time, there may be a slight color shift in these finishes due to continued exposure to natural and artificial light sources. We mention these characteristics because neither Kemper Emerge nor your Kemper Emerge dealer can be responsible for these conditions and variations.

Accordingly, Kemper Emerge orders for cabinetry with the above listed finishes must be accompanied by this letter of agreement bearing the customer's signature.

---

I have read the foregoing and find that the characteristic variations of wood are desirable. As such, I agree not to hold Kemper Emerge and/or the Kemper Emerge dealer listed below responsible in the event that these characteristics are later found by me to be less desirable than I had expected.

---

Customer Signature/Date

---

Dealer Signature/Date

---

Customer Name (please print)

---

Dealer Name (please print)

---

Dealer Purchase Order Number

# Rustic Alder Description Agreement

## KEMPER® EMERGE™ SERIES

### Rustic Alder Agreement

Fax: 877.333.7122

Email: [emergeorders@masterbrand.com](mailto:emergeorders@masterbrand.com)

Dear Kemper Emerge Customer,

**Congratulations on your selection of Kemper Emerge cabinetry in Rustic Alder.** Because of its unique characteristics, Rustic Alder is quite different from other wood types you may be familiar with. Your satisfaction is important to Kemper Emerge, and we want you to fully understand the characteristics that make Rustic Alder so distinctive.

It is important to realize that the beauty of wood cabinetry really comes from the natural qualities of wood itself. Rustic Alder is characterized by its light brown and reddish undertones and may contain a variety of pin holes, open and closed knots of various sizes and colors, small cracks, bird pecks, mineral streaks, and grain variation. Some knots may have small holes through the panel. Larger holes will not be filled. In addition, the wood will contain color difference caused by variations in minerals found in the soil, creating visible mineral tracks. However, those characteristics that might compromise the structural integrity of the door will not be included.

Sound Closed Knot (not moveable) – Expected in Rustic Alder up to approximately 3” diameter.

Sound Knot with Cracks – Expect sound knots with open cracks up to approximately 1” in length.

Open Knot (through door) – Expected in Rustic Alder with open area up to approximately 3/4” diameter.

Note: 3/4” diameter is about the size of a penny. Holes created by open knots pass completely through the door and are desirable for this rustic look.

Unsound Knot (moveable core) – Not to be expected.

Knot Cluster (cluster of tight sound knots) – To be expected in Rustic Alder.

Worm Holes/Pin Holes (can go through door) – Can be expected on Rustic Alder up to approximately 1/4” diameter.

Worm Tracks – Can be expected on Rustic Alder in sizes up to approximately 1/8” wide by 8” long.

Rustic Alder as described is featured for doors, drawer fronts, and selected mouldings. Other areas of the product will utilize Alder. Customers should expect a much lower occurrence of rustic characteristics in these other areas. The natural characteristics mentioned occur randomly in Rustic Alder. All doors, drawer fronts, and selected mouldings will contain some combination of the common Rustic Alder markings; however, it will be uncommon to find all markings on any single piece. We mention these characteristics because neither Kemper Emerge nor your Kemper Emerge dealer can be responsible for these conditions and variations.

Accordingly, Kemper Emerge orders with Rustic Alder must be accompanied by this letter of agreement bearing the customer’s signature.

---

I have read the foregoing and find that the characteristic variations of wood are desirable. As such, I agree not to hold Kemper Emerge and/or the Kemper Emerge dealer listed below responsible in the event that these characteristics are later found by me to be less desirable than I had expected.

\_\_\_\_\_  
Customer Signature/Date

\_\_\_\_\_  
Dealer Signature/Date

\_\_\_\_\_  
Customer Name (please print)

\_\_\_\_\_  
Dealer Name (please print)

\_\_\_\_\_  
Dealer Purchase Order Number

# KEMPER®

## EMERGE™ SERIES

### Inset Cabinetry Agreement

Fax: 877.333.7122

Email: [emergeorders@masterbrand.com](mailto:emergeorders@masterbrand.com)

Dear Kemper Emerge Customer,

**Congratulations on your selection of Kemper Emerge Inset cabinetry.** Because of the design and construction, inset cabinetry is quite different than a traditional overlay construction. Proper environmental, storage, and installation procedures are critical to the ultimate satisfaction of inset cabinetry. Your satisfaction is important to Kemper Emerge and we want you to fully understand the procedures for inset cabinetry.

Inset doors and drawer fronts are made to fit inside the frame with tight tolerances. Inset cabinets are much more vulnerable to dimensional changes and racking caused by incorrect environmental conditions or improper installation.

#### **Important Procedures**

- Inset cabinetry that is delivered and stored prior to installation must be stored in a climate controlled environment. Inset cabinetry should be allowed to acclimate in the install location(s) for 48 hours prior to installation. Relative humidity levels should be kept between 30% to 55%.
- Inset cabinets must never be installed in an environment where temperature and humidity reach extreme levels. Relative humidity levels should be kept between 30% to 55%.
- Racking can occur if a cabinet is not installed properly. If the cabinet is installed and forced out of square, it is possible to make the unit nonfunctional, as the doors and drawers will bind. The use of shims will be required to maintain proper level and plumb dimension.
- Inset cabinets should be installed by experienced and patient installers. Inset cabinets require additional time to install and adjust components to the correct positioning and function.
- Doors and drawers removed during installation must be re-installed to their original location within the specific cabinet in which they shipped from the factory.

The inset cabinetry experience and satisfaction is highly dependent upon following proper procedures as described above. Improper adherence to these procedures will void the Kemper Emerge warranty.

Accordingly, Kemper Emerge orders with inset construction must be accompanied by this letter of agreement bearing the customer's signature.

---

I have read the foregoing text and understand the importance of proper environmental, storage, and installation procedures for inset cabinetry. As such, I agree not to hold Kemper Emerge responsible in the event that these procedures are not followed.

---

Customer Signature/Date

---

Dealer Signature/Date

---

Customer Name (please print)

---

Dealer Name (please print)

---

Dealer Purchase Order Number

# Aluminum Frame Door Order Form

Customer Name _____	PO _____
Customer Account # _____	Pg ____ of ____

Fax: 877.333.7122  
 Email: [emergeorders@masterbrand.com](mailto:emergeorders@masterbrand.com)

Item	Model	Profile	Finish	Choose door to be modified if there is an upper and lower door.	Decorative Hardware Drilling
<input type="checkbox"/>	<input type="checkbox"/>	<input type="checkbox"/> AF003 <input type="checkbox"/> AF006 <input type="checkbox"/> AF007	<input type="checkbox"/> Black <input type="checkbox"/> Brushed Stainless Steel <input type="checkbox"/> Natural Aluminum <input type="checkbox"/> Oil Rubbed Bronze <input type="checkbox"/> White	<input type="checkbox"/> .TOP <input type="checkbox"/> .BTM	<input type="checkbox"/> No Drilling <input type="checkbox"/> Knob Drilling – specify K1 & K2 <input type="checkbox"/> Pull Drilling – specify K1, K2 & KC  K1 _____ (knob or pull) (Std = centered on frame)  K2 _____ (knob or pull) (min = 2 1/4", Std = 2 1/2")  KC _____ (pull only) (center to center)

Glass	
<input type="checkbox"/> Clear Glass	AF_CLEAR
<input type="checkbox"/> Satin Glass	AF_SATIN

Backpainted Glass Finish	
<input type="checkbox"/> White Gloss	AF_WHITE_GLO
<input type="checkbox"/> White Matte	AF_WHITE_MAT
<input type="checkbox"/> Bronze Gloss	AF_BRONZE_GLO
<input type="checkbox"/> Bronze Matte	AF_BRONZE_MAT

Metallic Inserts	
<input type="checkbox"/> Aluminum Lam	AF_ALUMINUM
<input type="checkbox"/> Brushed Stainless Lam	AF_STAINLESS
<input type="checkbox"/> Platinum Ice Ac	AF_PLATINUM

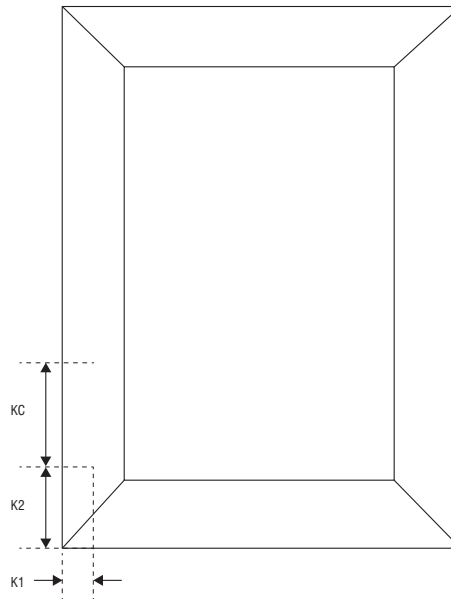

# Decorative Appliance Panel Request Form

Fax: 877.333.7122  
Email: [emergeorders@masterbrand.com](mailto:emergeorders@masterbrand.com)  
Use one form per appliance.

## STEP 1: Provide Order Information

DEALER ACCOUNT #: \_\_\_\_\_ DESIGNER NAME \_\_\_\_\_  
CUSTOMER NAME: \_\_\_\_\_ PHONE #: \_\_\_\_\_  
DEALER EMAIL: \_\_\_\_\_ FAX: \_\_\_\_\_  
DOOR STYLE: \_\_\_\_\_ WOOD: \_\_\_\_\_ FINISH: \_\_\_\_\_  
DRAWER FRONT OPTION (STD, DFF5PC, DFR5PC, or DFSLB): \_\_\_\_\_  
FULL OVERLAY, NON-BEAD INSET, or BEAD INSET: \_\_\_\_\_ PROFILE #: \_\_\_\_\_

## STEP 2: Select Appliance Panel to be Quoted (Check one per worksheet)

Refrigerator / Freezer Panel       Undercounter Refrigerator / Freezer Panel       Ice Maker Panel  
 Trash Compactor Panel       Dishwasher Panel       Warming Drawer Panel

Manufacturer: \_\_\_\_\_ Model #: \_\_\_\_\_  
(i.e. GE, Sub-zero, U-line, etc.) (List full model #)

● Handle Type:  J-Handle       Tubular Handle       Aftermarket Handle

## STEP 3: Provide Additional Appliance Information

- What type of appliance panel is preferred for the appliance?
  - Installation Type
    - Standard
    - Flush Inset
  - Panel Application
    - 1/4" finished plywood veneer panel.
  - Framed
    - Framed panels are a 1/4" plywood panel with a decorative door applied.
    - Framed panels will typically use J-style handles and require a reveal on all sides.
  - Overlay
    - Overlay panels will typically have a backer panel and overlay panel.
    - Overlay panels will use a handle applied to the front of the decorative door.
  - Integrated
    - Integrated panels are a cabinet door or drawer front only with no backer panel.
    - Maximum single panel door width is 27".
- Planned finish height for refrigerator: \_\_\_\_\_
- Is a decorative panel needed for the compressor grill area?
  - Yes (Note: If ice dispenser, field cut-out is required.)  No
- Does appliance have an external ice dispenser in the door?
  - Yes       No
- Is an additional panel trim kit from the appliance manufacturer required?
  - Yes. Trim kit model #: \_\_\_\_\_  No       Unknown
- If ordering warming drawer, warming drawer will be installed into: \_\_\_\_\_

## STEP 4: Include Special Instructions

● Special instructions/requests: \_\_\_\_\_  
\_\_\_\_\_  
\_\_\_\_\_

## STEP 5:

- Email completed form along with panel specification sheets from appliance manufacturer to Customer Service.
- Quote will be returned within 2 business days (excluding weekends).

**NOTE:** If appliance panel is not quoted prior to placing kitchen order, entire order will be delayed.

## STEP 6: Place and Order via 20/20

Refer to page H-2 for door style size guidelines.



*Notes*