

# S93070xB Modulation Distortion Application for the PNA-X

- EVM, NPR and ACPR measurements on the PNA-X for complete device characterization
- VNA calibration and de-embedding applied to modulation analysis
- Isolates the distortion and additive noise contributions while removing contributions from the input signal
- Very wide measurement bandwidth limited only by the signal generator
- High dynamic range and lowest residual EVM
- Simplifies high power setups and switch matrices for EVM, NPR and ACPR measurements



# Modulation Distortion – Fast and Accurate EVM, ACPR or NPR Measurements

The S93070xB Modulation Distortion Application combined with the PNA-X Vector Network Analyzer and a Vector Signal Generator, VSG, enables users to measure the nonlinear behavior of power amplifiers under the wideband modulated stimulus conditions. The new frequency-domain measurement method delivers lower residual EVM and faster EVM measurement speed. The VNA-based vector calibration accurately extends the reference planes of the signal generator and the analyzer to the DUT planes. As a result, users can achieve an excellent signal fidelity and accurate modulated measurement at RF and mmWave frequencies.

The PNA-X X microwave network analyzer with the new Modulation Distortion application allows complete characterization of an amplifier that would have taken two separate test stations or the use of a complex and expensive switching matrix which degrades performance. This helps speed device test through R&D, DVT by reducing design cycle times, as well as, speed manufacturing throughput.

For example, when wafer probing devices only a single-touch is needed which improves overall throughput or enables testing that was difficult in the past. The single touch to the device also eliminates unnecessary wear to bonding pads which ultimately improves device quality.

The modulation distortion application delivers faster, more accurate, and repeatable EVM, NPR and ACPR measurements than conventional signal analyzers.

- Lowest residual EVM
- Fast and accurate measurement
- Simple and intuitive setup
- Cost-effective solution

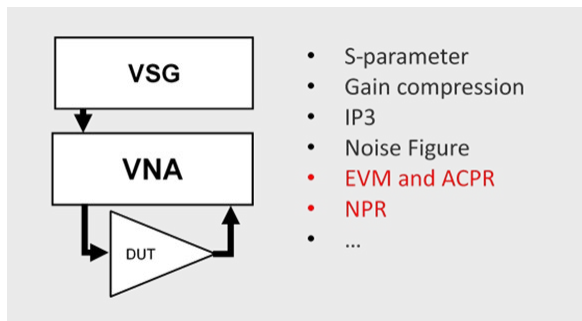

Single Connection/Single Touch

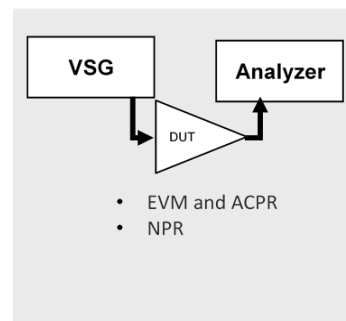

Traditional approach requiring two test stations or complex switch matrix

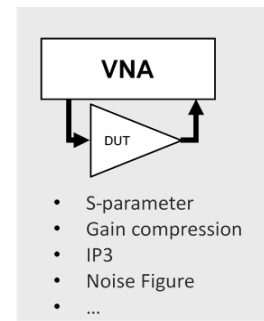

# Modulation Distortion Analysis Theory

The Modulation Distortion Analysis application uses the PNA-X's measurements of the input and the output spectrum, as well as, their complex ratio across the complete in-channel and out-of-channel bandwidth.

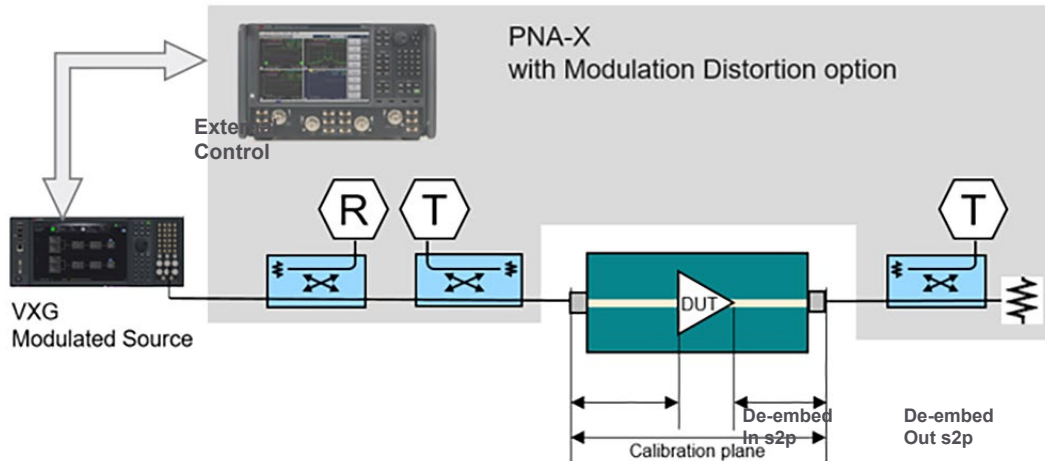

Simplified configuration example with VXG and PNA-X

A Vector Signal Generator is used to generate a repetitive signal with a given CCDF (Complementary-Cumulative-Distribution-Function) and PSD (Power Spectral Density). The VNA then measures the amplitude of the input spectrum  $|X(f)|$ , the amplitude of the output spectrum  $|Y(f)|$ , and the phase relationship of the tones relative to each other,  $\phi(Y(f))-\phi(X(f))$ .

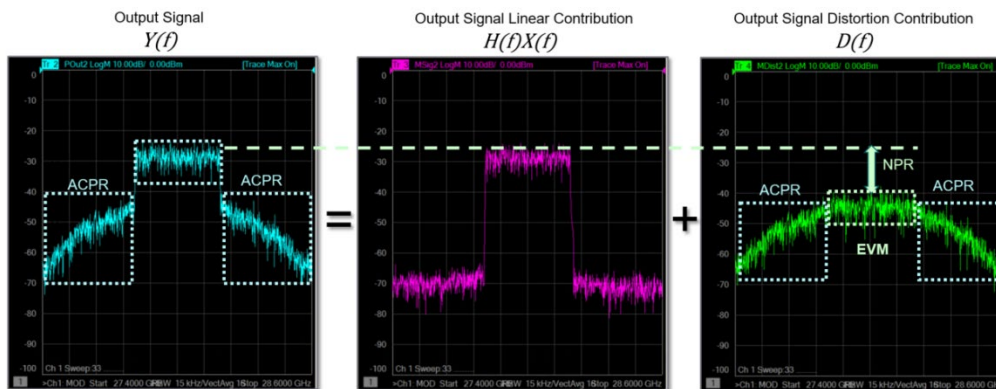

Calculation of the spectral correlation between the input and output enables decomposition the output spectrum into linearly correlated and non-linear spectrum and analysis of the distortion product EVM, ACPR and NPR

- The spectral correlation enables to determination of the linear and nonlinear distortion solely introduced by the DUT, eliminating contributions from the signal generator.
- Repetitive test signals are designed to faithfully represent the amplitude statistics as well as the power spectral density of the modulation format of choice.
- The total amount of distortion measured in the frequency domain is equal to the total amount of distortion in the time domain as measured using the existing EVM method.

# Modulation Distortion Measurements

The measured data is available for the input signal, output signal and calculated contribution of the DUT. For example, it is possible to measure the NPR into the device, the output NPR and the distortion NPR that is added by the device only.

The modulation distortion application performs the following measurements (see PNA-X help file for complete list of measurement parameters):

- EVM
  - Equalized EVM of the DUT (non-linear contribution)
  - Un-equalized EVM of the DUT (Includes non-linear and linear distortion due to frequency dispersion)
- ACP
  - Upper and lower side bands of the input signal
  - Upper and lower side bands of the output signal
  - Upper and lower side bands contribution of the DUT
- NPR
  - Input NPR
  - Output NPR
  - NPR contribution of the DUT
- Band Power
  - Input Band Power
  - Output Band Power
  - Band Power Gain of the DUT (magnitude and phase)

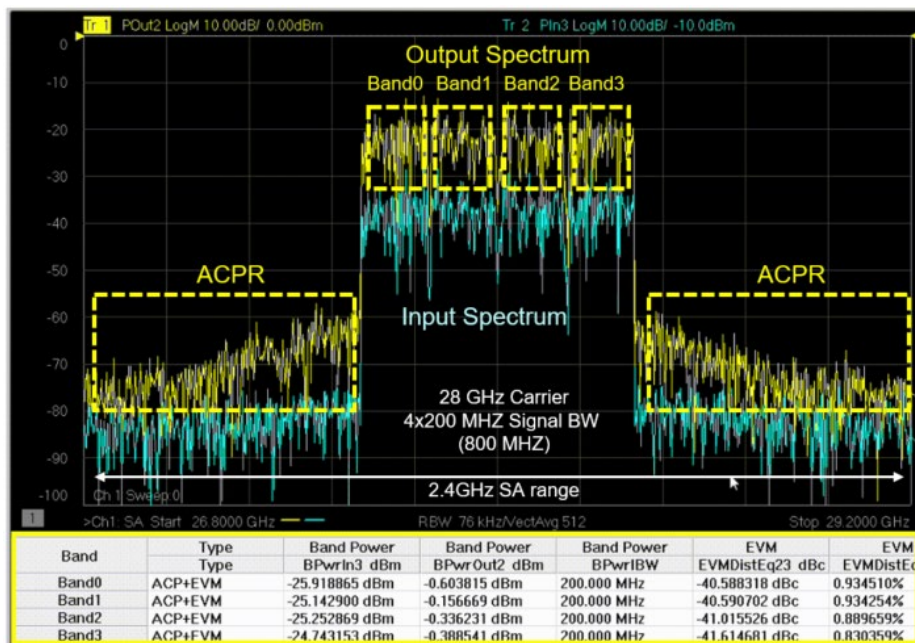

Measurements and results on a 200 MHz x 4CC (800 MHz) at carrier frequency of 28 GHz

# Simple Setup and Control

## Signal generator and external amplifier setup and control

Modulation Distortion application sets everything required for the measurement

- Creates compact test signal (CTS) based on standard compliant waveforms or user generated waveforms
- Creates NPR signals
- Sets proper paths and controls the external generator
- Measures the signal and corrects waveform to the DUT.
- Calibrates the power to the DUT including any booster amplifier needed before the DUT.

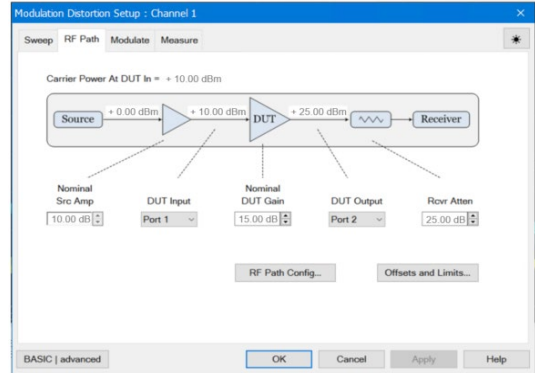

A typical external hardware setup using a M9383/84B VXG with the signal connected externally. Other supported signal generators include the M8190A with E8267D PSG, N5182B MXG, N5192A and the M9383A (see PNA-X help file for more supported configurations).

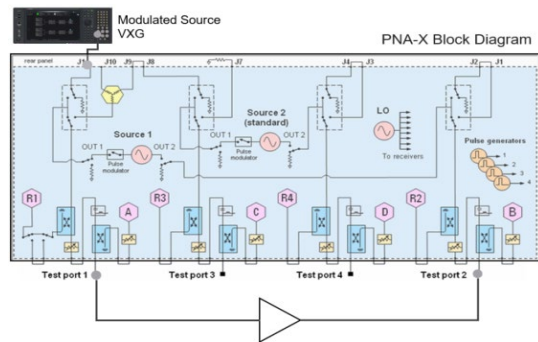

A simple setup for high power configurations uses the setup dialogs in the modulation distortion application and offers a variety of power and port settings.

For this example, the approximate gain of the external amplifier of 10 dB is input into the *Nominal Src Amp* of the Modulation Distortion Setup.

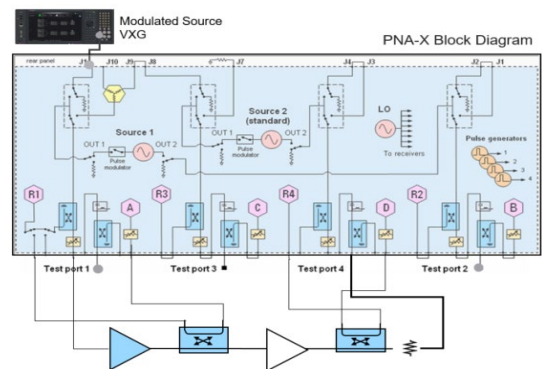

# Compact test signal generation

The Compact Test Signal (CTS) generation is automatic and the input waveforms can be Signal Studio or IQ files in \*.csv format. The resultant CTS version of the waveform matches the CCDF and PSD of the “parent-IQ waveform”.

The CTS waveform makes measurements faster while maintaining proper spectral and power statistics.

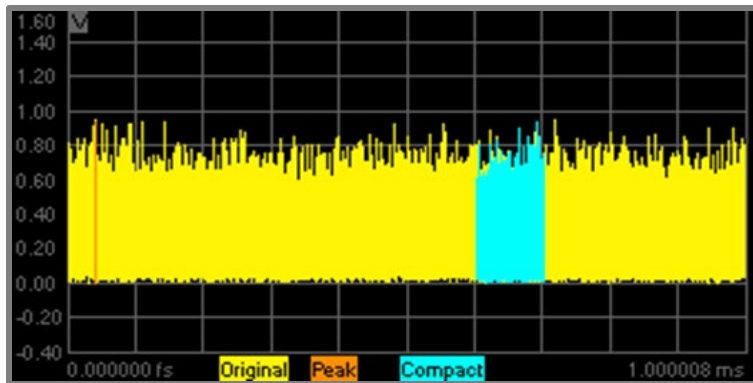
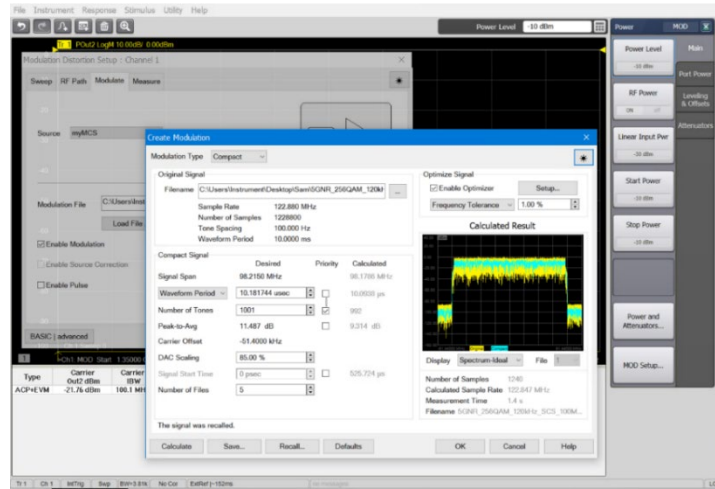

Example of a 5G NR 100 MHz parent-IQ waveform and Compact Test Signal (CTS) time slice

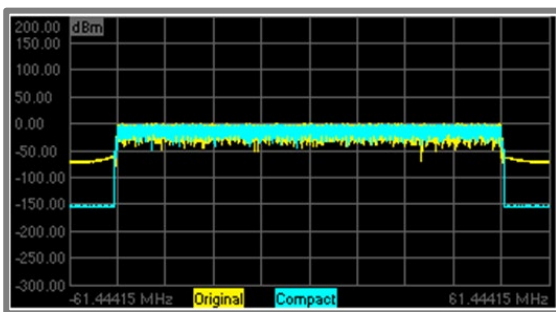

PSD

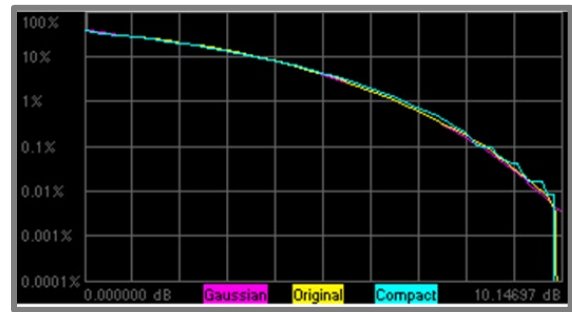

CCDF

Comparison of the original 5G NR 100 MHz signal vs. compact test signal consisting of 10,001 tones. Share the same Power Spectral Density (PSD) and Complementary Cumulative Density Function (CCDF)

# Correlation of Time and Frequency Domain EVM Measurements

It's important to note the total amount of distortion in spectral correlation frequency domain (the method used in the Modulation Distortion calculations) is equivalent to the distortion measured in time domain used by time domain demodulation methods of the VSA

Correlation has been shown in simulations and through measurement comparisons of actual devices.

## 5G NR 400 MHz amplifier measurement comparison

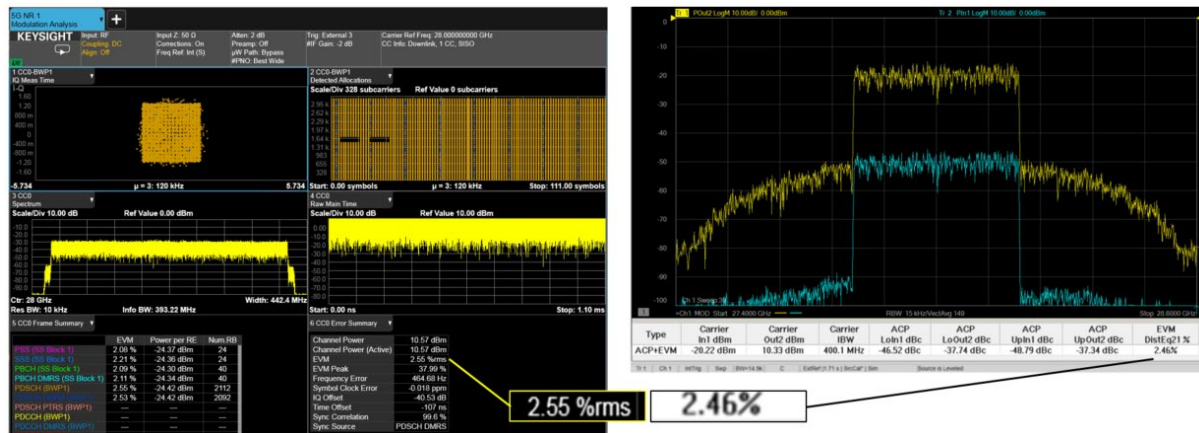

Measurement results comparison of an amplifier measurement using a 5G NR 400 MHz signal. UXA measurement (left) and PNA-X measurement (right)

## 802.11ac measurements comparison

EVM as a function of power for an 80 MHz 802.11ac signal with tone spacing of 102.4 kHz vs. measurements made using a Vector Signal Analyzer

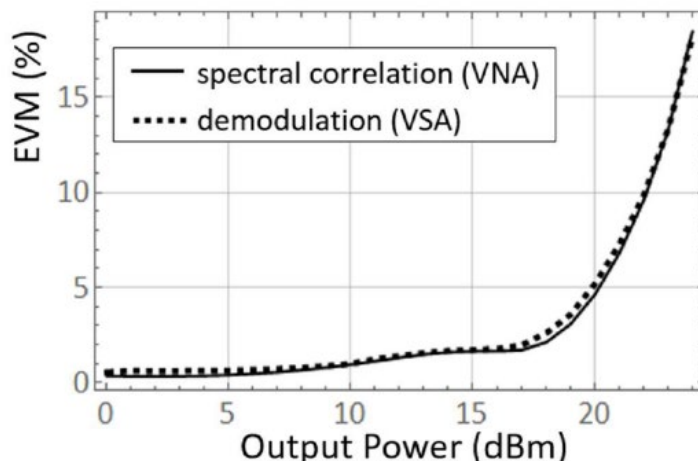

# ADS and SystemVue data flows comparison of a 180 nm CMOS pre-amplifier

Comparison of Advanced Design System (ADS) using Modulation Distortion simulation method and SystemVue using classical dataflow to calculate EVM of a 180 nm CMOS pre-amplifier.

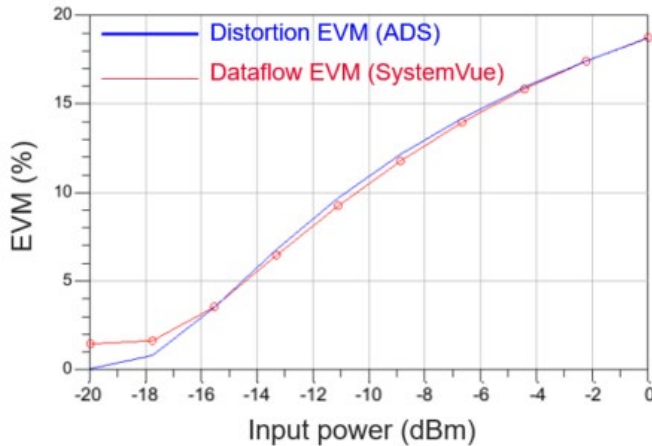

## Load Pull Capability for Modulation Distortion Measurements

### Evaluate device behavior for any arbitrary load

Extend the modulation distortion application by computing figure of merits such as EVM and ACPR for any desired load with arbitrary load control (ALC). Modulation distortion with ALC integrates the powerful capabilities of the PNA-X with an electromechanical tuner so a non 50  $\Omega$  load can be presented to the DUT and changes in device performance or sensitivity to varying load conditions can be accurately measured.

A passive electromechanical tuner used in load pull measurements allows for nearly any impedance to be presented to the DUT at a target frequency representing wide coverage of the smith chart.

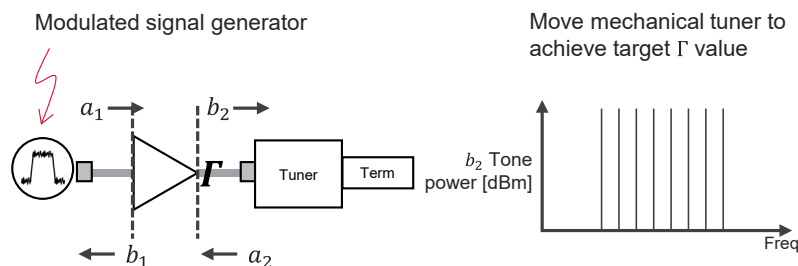



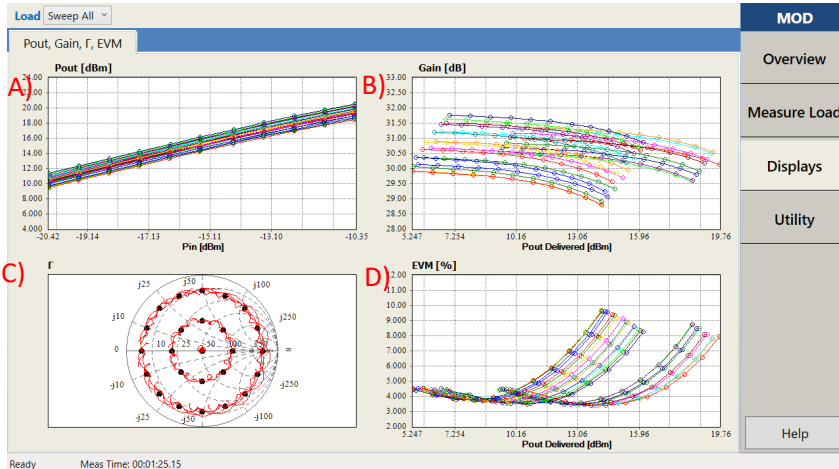

Passive Load Pull Measurement Results showing A) Pout vs Pin, B) Gain vs Pout Delivered, C) measured gamma across modulation bandwidth and D) EVM vs Pout Delivered

## Calibrate and verify tuner gamma

Keysight's Tuner Characterization provides guided calibration and verification for user defined gamma load grid at a target frequency. For a user specified load, requested and measured values at each load point are displayed, verifying the accuracy of the load points at the device reference plane and providing high confidence in the measurement setup.

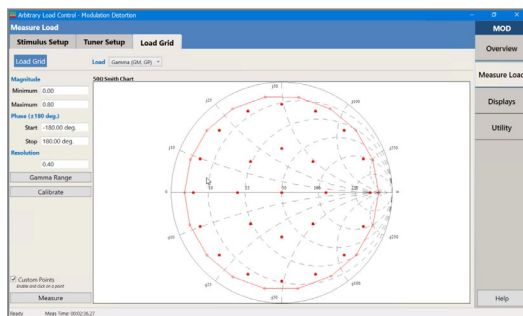

User specified load grid to be measured

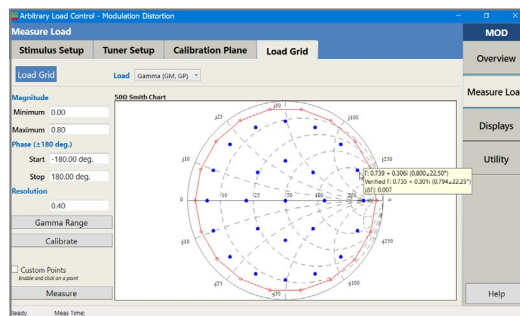

Gamma verification

## Modulation distortion with ALC HW and SW requirements

- N524xB PNA-X (Firmware A.15.0.15 or later)
  - S93070xB Modulation Distortion
  - S94570B Arbitrary Load Control for Modulation Distortion
  - Maury Mechanical Tuner (Requires Maury driver, MTune utility)
- OR**
- Focus Microwave Mechanical Tuner (Requires Load Pull Explorer, FDCS)
  - VSG (recommend M9484C VXG)
  - Dual Directional coupler (e.g. Marki C0250)
  - Accessories (cable, adapter, etc.)
  - Ecal (recommend N4693A male-female)

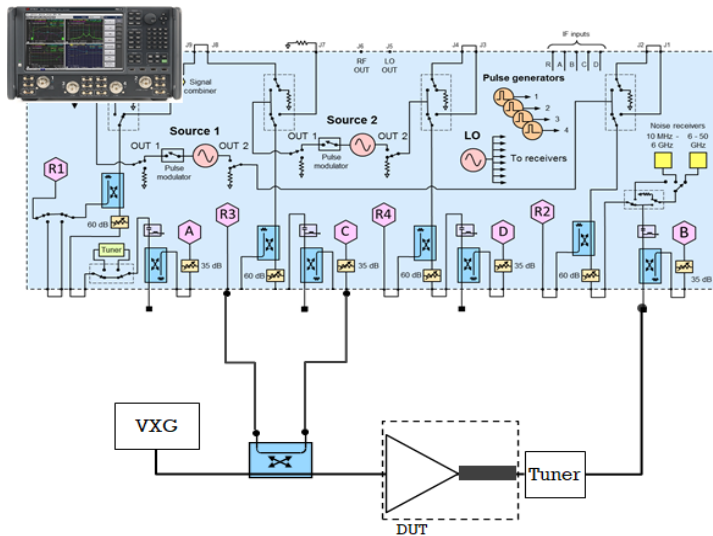

A typical external hardware setup using a VXG, directional coupler, tuner and DUT.

## Compatible passive electromechanical tuners

- Maury Mechanical Tuner
  - Communication interface: USB, LAN
- Focus Microwave Tuner
  - Communication interface: TCP/IPv4

# Active Load Pull Capability for Modulation Distortion Measurements

## Control gamma across entire modulation bandwidth

Integrate the benefits of the modulation distortion application with the active load pull solution for computing vector corrected EVM and ACPR.

The GUI/API allows the user to specify a gamma load profile across the entire bandwidth and includes the ability to import an S1P file. Keysight's dual channel VXG provides the modulated source for the input and output to synthesize and user specified gamma. The PNA-X's modulation distortion applications captures EVM and ACPR measurements as a function of the gamma profile. This gives the user insight into the optimal DUT behavior as well as robustness and reliability validation.

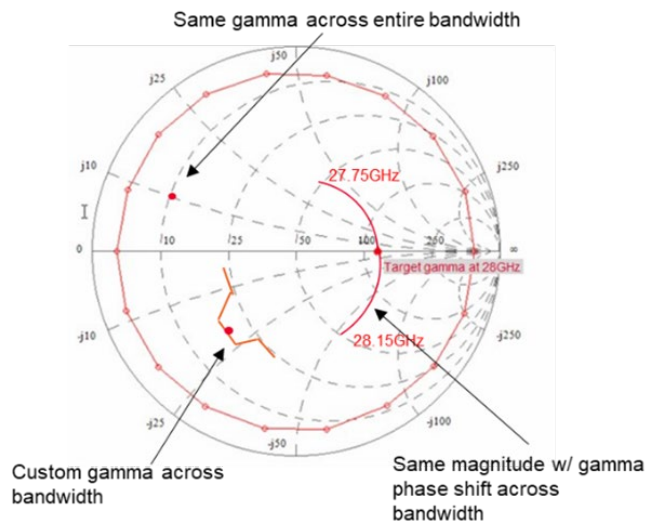

Gamma profile can be specified in several ways

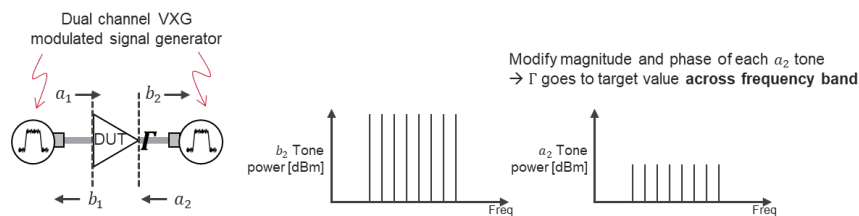

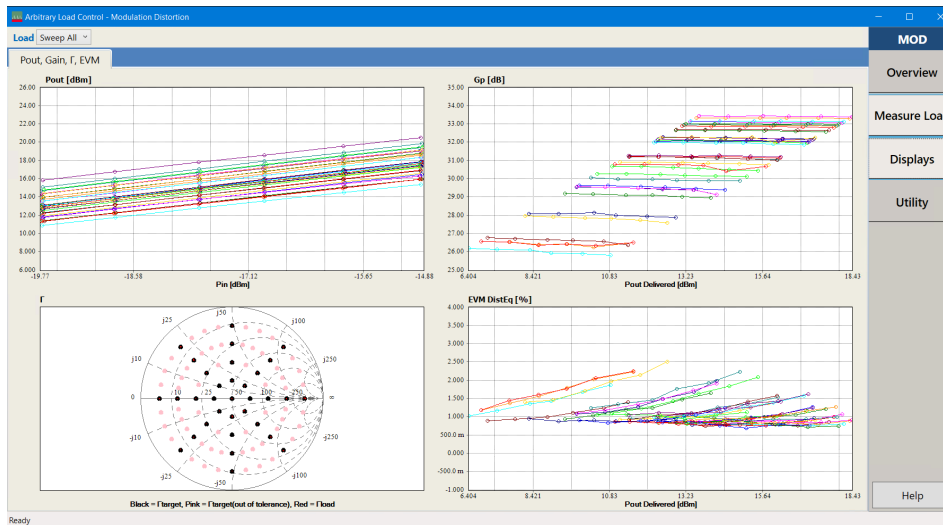

Active Load Pull Measurement Results showing A) Pout vs Pin, B) Gain vs Pout Delivered, C) measured gamma (specified with bandwidth rotation = 0° phase) across modulation bandwidth and D) EVM vs Pout Delivered

## Modulation distortion HW and SW requirements

- S93070xB Modulation Distortion application (see ordering information below)
- N524xB 4-Port PNA-X Microwave Network Analyzer, FW A.16.20.00 or later for active load pull compatibility
- Supported external sources<sup>1</sup>:
  - M9383B<sup>2</sup> VXG Microwave Signal Generator, 1 MHz to 44 GHz
  - M9484C<sup>2</sup> VXG Microwave Signal Generator, 9 kHz to 54 GHz
  - N5182B MXG X-Series RF Vector Signal Generator, 9 kHz to 6 GHz
  - N5192A UXG X-Series Vector Adapter Modified Version, 10 MHz to 20 GHz, with U3039ACK1 6 GHz Reference Source
  - M8190A 12 GSa/s Arbitrary Waveform Generator with E8267D PSG Vector Signal Generator
  - M9383A PXIe Microwave Signal Generator, 1 MHz to 44 GHz

<sup>1</sup> When Signal Studio is used, a waveform playback license N76xxEMBC is required for the external source. For more information, refer to Signal Studio. Brochure (5989-6448EN)

<sup>2</sup> Active load pull requires M9484C VXG.

# Ordering Information

- S930700B Modulation analysis up to 8.5 GHz
- S930701B Modulation analysis up to 13.5 GHz
- S930702B Modulation analysis up to 26.5 GHz
- S930704B Modulation analysis up to 43.5 GHz
- S930705B Modulation analysis up to 50 GHz
- S930707B Modulation analysis up to 67 GHz
- S94570B Arbitrary Load Control for Modulation Distortion, Passive Load Pull (Export controlled)
- S94571B Arbitrary Load Control for Modulation Distortion, Passive Load Pull (Functions limited to 50 GHz)
- S94572B Arbitrary Load Control for Modulation Distortion, Active Load Pull (Export controlled)
- S94573B Arbitrary Load Control for Modulation Distortion, Active Load Pull (Functions limited to 50 GHz)

See the PNA Configuration guide for available license types.

# Related Literature

Literature	Pub-Numbers
PNA Family Microwave Network Analyzers (N522x/3x/4xB) – Configuration Guide	5992-1465EN
Microwave Network Analyzers PNA-X Series – Brochure	5990-4592EN

# Additional Product Information

## PNA-X – multiple measurements on a single instrument

The N524xB PNA-X Microwave Vector Network Analyzer offers an indispensable set of measurement functions for testing 5G beamformer ICs. Its industry-leading performance and state-of-the-art error correction capabilities enable highly accurate S-parameter measurements. Moreover, the PNA-X provides measurement applications for testing amplifier's nonlinear characteristics and noise figure. All of these measurements can be quickly performed with a single connection.

- 900 Hz/10 MHz to 8.5/13.5/26.5/43.5/50/67 GHz
- Fast and accurate S-parameter measurement
- Gain Compression Measurements (S93086B)
- Intermodulation Distortion Measurements (S93087B)
- Noise Figure Measurements with Vector Correction (S93029B)
- Spectrum Analysis (S93090xB)
- Active Hot S-parameters (S93110/11B)
- Modulation Distortion analysis (S93070xB)



PNA-X vector network analyzer

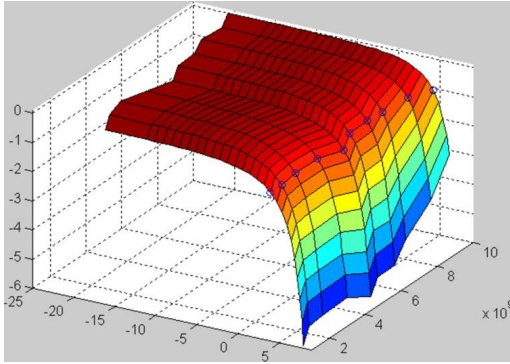

Gain compression application

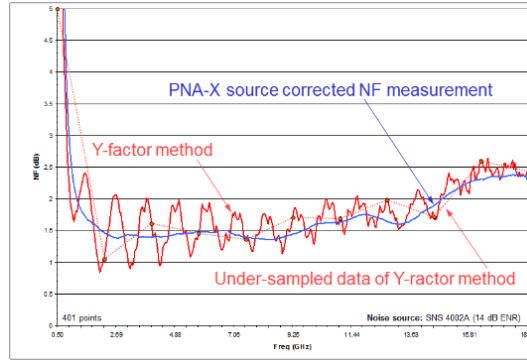

Accurate NF measurement with vector correction

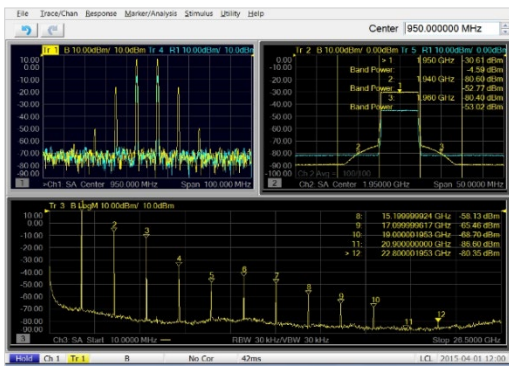

Distortion measurements with spectrum analysis

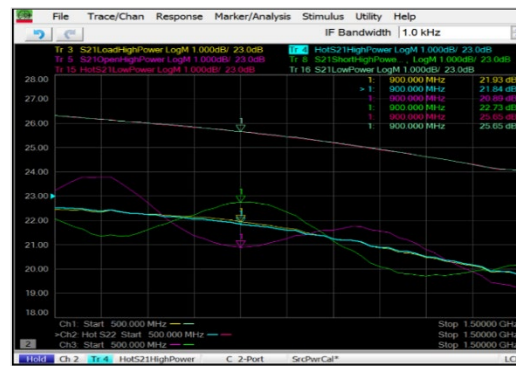

Active parameters hot S22 measurement

# VXG – mmWave Wideband Signal Generation

Combined with the PNA-X Modulation Distortion Application or the signal analyzer, the M9383B/M9384B VXG Microwave Vector Signal Generators delivers high performance, wideband mmWave signal generation for executing power amplifier measurements. The VXG offers a 2 GHz modulation bandwidth, high output power to compensate for system loss at mmWave bands, and an unmatched low 1% EVM to address critical requirements for 5G component testing.

- Frequency range from 1 MHz to 44 GHz
- 2 GHz modulation bandwidth
- 1% EVM (5G NR, 100 MHz, +10 dBm, 28 and 39 GHz)
- -50 dBc ACP (5G NR, 100 MHz, 0 dBm, 28 GHz)
- Maximum +24 dBm output power
- Dual coherent channels

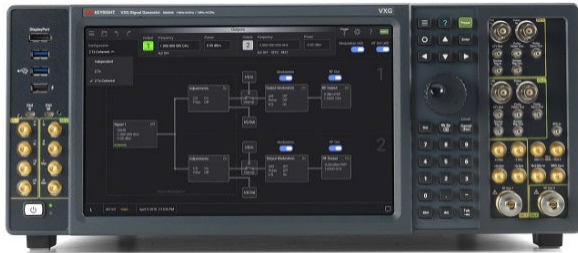

M9384B VXG signal generator



M9383B VXG-m signal generator



# Signal Studio – Simplifying Signal Creation

The N76xxC Signal Studio's basic playback waveform capabilities enable you to create and customize waveform files needed to test components and transmitters. For 5G applications, the N7631C Signal Studio Pro for 5G NR enables users to create 5G NR signals for characterizing modulated performance of power amplifiers. The tool simplifies the manipulation of a variety of signal parameters to streamline signal creation.

- Quickly configure and generate 5G NR test models for FDD and TDD.
- Create spectrally-correct signals for channel power, spectral mask, and spurious testing.
- View CCDF, spectrum, time domain, and power envelope graphs to investigate the effects of power ramps, modulation formats, power changes, clipping, and other effects on device performance.
- Adjust Peak-To-Average-Ratio (PAPR) with Crest Factor Reduction.
- Baseband filter and windowing for spectrum control to improve the out-of-band performance

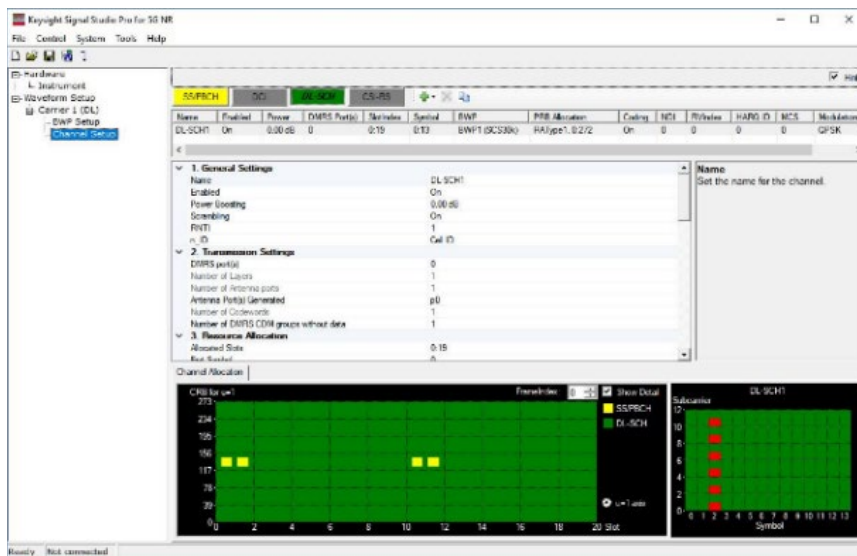

Signal Studio Pro for 5G NR

# ADS – An Industry-leading Design Platform

Advanced Design System (ADS) is an industry-leading electronic design automation (EDA) software for RF, microwave, and high speed digital applications. In a powerful and easy-to-use interface, ADS pioneers the most innovative and commercially successful technologies, such as X-parameters and 3D EM simulators. The EM-Circuit co-simulation capability allows the user to analyze the effects of various physical design aspects on the overall performance of the 5G transceiver capability.

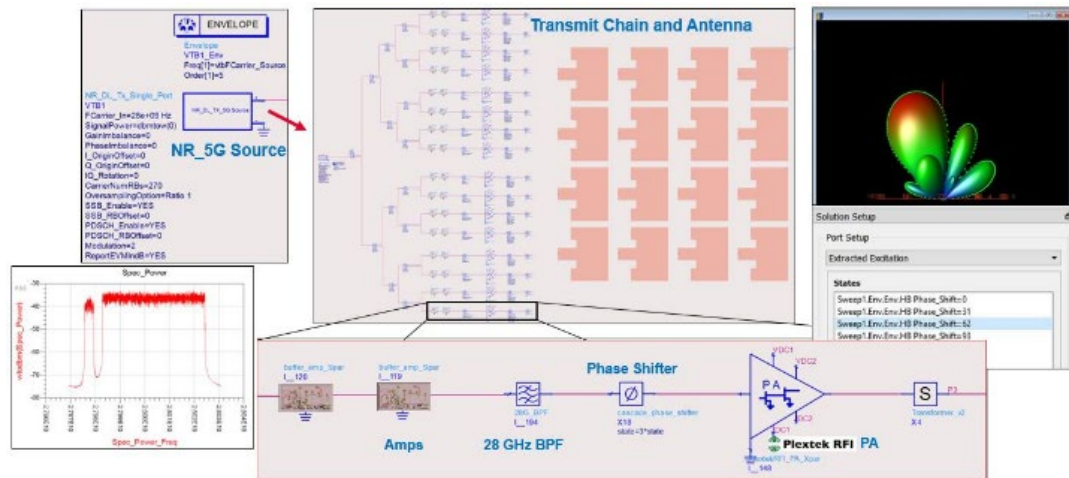

EM-Circuit co-simulation with ADS

Keysight enables innovators to push the boundaries of engineering by quickly solving design, emulation, and test challenges to create the best product experiences. Start your innovation journey at [www.keysight.com](http://www.keysight.com).



This information is subject to change without notice. © Keysight Technologies, 2021 – 2023, Published in USA, November 23, 2023, 5992-3974EN