

**Freeride 250 R EU**  
**Freeride 250 R AU**  
**Freeride 250 R US**

Art. no. 3213185en





# DEAR KTM CUSTOMER

Congratulations on your decision to purchase a KTM motorcycle. You are now the owner of a state-of-the-art sports motorcycle that will give you enormous pleasure if you service and maintain it accordingly.

We wish you a lot of enjoyment in riding this vehicle.

Enter the serial numbers of your vehicle below.

Chassis number (☛ p. 10)	Dealer's stamp
Engine number (☛ p. 10)	
Key number (☛ p. 10)	

The Owner's Manual contained the latest information for this model series at the time of going to print. Slight deviations resulting from continuing development and design of the motorcycles can, however, not be completely excluded.

All specifications are non-binding. KTM Sportmotorcycle AG specifically reserves the right to modify or delete technical specifications, prices, colors, forms, materials, services, designs, equipment, etc., without prior notice and without specifying reasons, to adapt these to local conditions, as well as to stop production of a particular model without prior notice. KTM accepts no liability for delivery options, deviations from illustrations and descriptions, misprints, and other errors. The models portrayed partly contain special equipment that does not belong to the regular scope of supply.

© 2014 KTM-Sportmotorcycle AG, Mattighofen Austria

All rights reserved

Reproduction, even in part, as well as copying of all kinds, is permitted only with the express written permission of the copyright owner.



ISO 9001(12 100 6061)













According to the international quality management standard ISO 9001, KTM uses quality assurance processes that lead to the maximum possible quality of the products.

Issued by: TÜV Management Service

REG.NO. 12 100 6061

KTM-Sportmotorcycle AG  
5230 Mattighofen, Austria





# TABLE OF CONTENTS

1	MEANS OF REPRESENTATION .....	4	7.8	Speed, time, and DST distance 1 .....	21
1.1	Symbols used .....	4	7.9	Speed, time, and DST2 distance 2 .....	21
1.2	Formats used .....	4	7.10	AVG average speed, ART operating hours, and ODO total distance covered .....	21
2	SAFETY ADVICE .....	5	8	PREPARING FOR USE .....	22
2.1	Use definition - intended use .....	5	8.1	Advice on first use .....	22
2.2	Safety advice .....	5	8.2	Running in the engine .....	23
2.3	Degrees of risk and symbols .....	5	9	RIDING INSTRUCTIONS .....	24
2.4	Tampering warning .....	5	9.1	Checks and maintenance work when preparing for use .....	24
2.5	Safe operation .....	6	9.2	Starting .....	24
2.6	Protective clothing .....	6	9.3	Starting off .....	25
2.7	Work rules .....	6	9.4	Shifting, riding .....	25
2.8	Environment .....	6	9.5	Applying the brakes .....	25
2.9	Owner's Manual .....	6	9.6	Stopping, parking .....	26
3	IMPORTANT NOTES .....	7	9.7	Transport .....	26
3.1	Guarantee, warranty .....	7	9.8	Refueling .....	27
3.2	Operating and auxiliary substances .....	7	10	SERVICE SCHEDULE .....	28
3.3	Spare parts, accessories .....	7	10.1	Service schedule .....	28
3.4	Service .....	7	10.2	Service work (as additional order) .....	29
3.5	Figures .....	7	11	TUNING THE CHASSIS .....	30
3.6	Customer service .....	7	11.1	Checking the basic chassis setting with the rider's weight .....	30
4	VIEW OF VEHICLE .....	8	11.2	Compression damping of the shock absorber .....	30
4.1	View of vehicle, front left (example) .....	8	11.3	Adjusting the low-speed compression damping of the shock absorber .....	30
4.2	View of vehicle, rear right (example) .....	9	11.4	Adjusting the high-speed compression damping of the shock absorber .....	31
5	SERIAL NUMBERS .....	10	11.5	Adjusting the rebound damping of the shock absorber .....	31
5.1	Chassis number .....	10	11.6	Measuring rear wheel sag unloaded .....	32
5.2	Type label (EU/AU) .....	10	11.7	Checking the static sag of the shock absorber .....	32
5.3	Key number .....	10	11.8	Checking the riding sag of the shock absorber .....	33
5.4	Engine number .....	10	11.9	Adjusting the spring preload of the shock absorber  .....	33
5.5	Fork part number .....	10	11.10	Adjusting the riding sag  .....	34
5.6	Shock absorber part number .....	11	11.11	Checking the basic setting of the fork .....	34
6	CONTROLS .....	12	11.12	Adjusting the compression damping of the fork .....	35
6.1	Clutch lever .....	12	11.13	Adjusting the rebound damping of the fork .....	35
6.2	Hand brake lever .....	12	11.14	Handlebar position .....	35
6.3	Throttle grip .....	12	11.15	Adjusting the handlebar position  .....	36
6.4	Kill switch .....	12	12	SERVICE WORK ON THE CHASSIS .....	37
6.5	Horn button .....	12	12.1	Raising the motorcycle with the lift stand .....	37
6.6	Light switch .....	13	12.2	Removing the motorcycle from the lift stand .....	37
6.7	Electric starter button (EU/US) .....	13	12.3	Bleeding the fork legs .....	37
6.8	Electric starter button (AU) .....	13	12.4	Cleaning the dust boots of the fork legs .....	38
6.9	Turn signal switch (EU/AU) .....	13	12.5	Removing the fork legs  .....	38
6.10	Emergency OFF switch (AU) .....	13	12.6	Installing the fork legs  .....	39
6.11	Overview of indicator lamps (EU/AU) .....	14	12.7	Removing the fork protector  .....	39
6.12	Overview of indicator lamps (US) .....	14	12.8	Installing the fork protector  .....	40
6.13	Opening the filler cap .....	14	12.9	Removing the lower triple clamp  .....	40
6.14	Closing the filler cap .....	15	12.10	Installing the lower triple clamp  .....	41
6.15	Fuel tap .....	15	12.11	Checking the steering head bearing play .....	42
6.16	Choke .....	15	12.12	Adjusting the play of the steering head bearing  .....	43
6.17	Shift lever .....	15	12.13	Greasing the steering head bearing  .....	43
6.18	Foot brake lever .....	16	12.14	Removing the shock absorber  .....	44
6.19	Side stand .....	16	12.15	Installing the shock absorber  .....	44
6.20	Steering lock .....	16	12.16	Removing the front fender .....	44
6.21	Locking the steering .....	17	12.17	Installing the front fender .....	45
6.22	Unlocking the steering .....	17	12.18	Folding the seat up .....	45
7	SPEEDOMETER .....	18	12.19	Locking the seat .....	45
7.1	Overview .....	18			
7.2	Activation .....	18			
7.3	Message on the speedometer .....	18			
7.4	Setting the speedometer .....	18			
7.5	Setting kilometers or miles .....	19			
7.6	Setting the clock .....	20			
7.7	Setting the service display .....	20			

12.20	Removing the air filter housing	45	15.6	Removing the headlight mask with the headlight	75
12.21	Installing the air filter housing	46	15.7	Refitting the headlight mask with the headlight	75
12.22	Removing the air filter	46	15.8	Changing the headlight bulb	76
12.23	Installing the air filter	46	15.9	Changing the turn signal bulb	77
12.24	Cleaning the air filter and air filter housing	47	15.10	Checking the headlight setting	77
12.25	Removing the main silencer	47	15.11	Adjusting the headlight range	77
12.26	Installing the main silencer	48	15.12	Changing the speedometer battery	78
12.27	Changing the glass fiber yarn filling of the main silencer	48	16	COOLING SYSTEM	79
12.28	Removing the fuel tank	48	16.1	Cooling system	79
12.29	Installing the fuel tank	49	16.2	Checking the antifreeze and coolant level	79
12.30	Checking for chain dirt accumulation	50	16.3	Checking the coolant level	80
12.31	Cleaning the chain	50	16.4	Draining the coolant	80
12.32	Checking the chain tension	51	16.5	Refilling coolant	81
12.33	Adjusting the chain tension	51	17	TUNING THE ENGINE	82
12.34	Checking the chain, rear sprocket, engine sprocket and chain guide	52	17.1	Checking the play in the throttle cable	82
12.35	Checking the frame	53	17.2	Adjusting the play in the throttle cable	82
12.36	Checking the swingarm	54	17.3	Carburetor - idle	83
12.37	Checking the throttle cable routing	54	17.4	Carburetor - adjusting idle	83
12.38	Checking the rubber grip	54	17.5	Emptying the carburetor float chamber	84
12.39	Additionally securing the rubber grip	55	17.6	Checking the basic position of the shift lever	85
12.40	Adjusting the basic position of the clutch lever	55	17.7	Adjusting the basic position of the shift lever	85
12.41	Checking fluid level of the hydraulic clutch	55	18	SERVICE WORK ON THE ENGINE	86
12.42	Correcting the fluid level of the hydraulic clutch	55	18.1	Cleaning the alternator	86
12.43	Changing the hydraulic clutch fluid	56	18.2	Checking the gear oil level	86
12.44	Removing the engine guard	57	18.3	Changing the gear oil	87
12.45	Installing the engine guard	57	18.4	Draining the gear oil	87
13	BRAKE SYSTEM	58	18.5	Filling in gear oil	88
13.1	Checking the free travel of the hand brake lever	58	18.6	Adding gear oil	88
13.2	Adjusting the free travel of the handbrake lever	58	19	CLEANING, CARE	89
13.3	Checking the brake discs	58	19.1	Cleaning the motorcycle	89
13.4	Checking the brake fluid level of the front brake	59	19.2	Checks and maintenance steps for winter operation	90
13.5	Adding front brake fluid	59	20	STORAGE	91
13.6	Checking the front brake linings	60	20.1	Storage	91
13.7	Changing the front brake linings	60	20.2	Preparing for use after storage	91
13.8	Checking the free travel of foot brake lever	62	21	TROUBLESHOOTING	92
13.9	Adjusting the basic position of the foot brake lever	62	22	TECHNICAL DATA	94
13.10	Checking the rear brake fluid level	63	22.1	Engine	94
13.11	Adding rear brake fluid	63	22.2	Engine tightening torques	94
13.12	Checking the rear brake linings	64	22.3	Capacities	95
13.13	Changing the rear brake linings	64	22.3.1	Gear oil	95
14	WHEELS, TIRES	67	22.3.2	Coolant	95
14.1	Removing the front wheel	67	22.3.3	Fuel	95
14.2	Installing the front wheel	67	22.4	Chassis	95
14.3	Removing the rear wheel	68	22.5	Electrical system	96
14.4	Installing the rear wheel	68	22.6	Tires	96
14.5	Checking the tire condition	69	22.7	Fork	96
14.6	Checking the tire air pressure	70	22.8	Shock absorber	97
14.7	Checking the spoke tension	70	22.9	Chassis tightening torques	97
15	ELECTRICAL SYSTEM	71	22.10	Carburetor	99
15.1	Removing the battery	71	22.10.1	EU/AU	99
15.2	Installing the battery	71	22.10.2	US	99
15.3	Recharging the battery	72	22.10.3	Carburetor tuning	99
15.4	Changing the main fuse	73	23	SUBSTANCES	101
15.5	Changing the fuses of individual power consumers	74	24	AUXILIARY SUBSTANCES	103
			25	STANDARDS	105
				INDEX	106

## 1.1 Symbols used

The meaning of specific symbols is described below.

- 
- |  |   |
|--|---|
|  | Indicates an expected reaction (e.g. of a work step or a function).   |
|  | Indicates an unexpected reaction (e.g. of a work step or a function).   |
|  | All work marked with this symbol requires specialist knowledge and technical understanding. In the interest of your own safety, have these jobs performed by an authorized KTM workshop. There, your motorcycle will be optimally cared for by specially trained experts using the specialist tools required. |
|  | Indicates a page reference (more information is provided on the specified page).  |
- 

## 1.2 Formats used

The typographical formats used in this document are explained below.

- 
- |                      |  |
|----------------------|--|
| <b>Specific name</b> | Identifies a proprietary name.                   |
| <b>Name®</b>         | Identifies a protected name.                     |
| <b>Brand™</b>        | Identifies a brand available on the open market. |
-

## 2.1 Use definition - intended use

KTM sport motorcycles are designed and built to withstand the normal stresses and strains of offroad use.



### Info

The motorcycle is authorized for public road traffic in the homologous (reduced) version only. In the derestricted version, the motorcycle must be used only on closed off property remote from public road traffic. The motorcycle is designed for trial riding and difficult offroad terrain and not for motocross.

## 2.2 Safety advice

A number of safety instructions need to be followed to operate the vehicle safely. Therefore, read this manual carefully. The safety instructions are highlighted in the text and are referred to at the relevant passages.



### Info

The vehicle has various information and warning labels at prominent locations. Do not remove information/warning labels. If they are missing, you or others may not recognize dangers and may therefore be injured.

## 2.3 Degrees of risk and symbols



### Danger

Identifies a danger that will immediately and invariably lead to fatal or serious permanent injury if the appropriate measures are not taken.



### Warning

Identifies a danger that is likely to lead to fatal or serious injury if the appropriate measures are not taken.



### Caution

Identifies a danger that may lead to minor injuries if the appropriate measures are not taken.

### Note

Identifies a danger that will lead to considerable machine and material damage if the appropriate measures are not taken.



### Warning

Identifies a danger that will lead to environmental damage if the appropriate measures are not taken.

## 2.4 Tampering warning



Tampering with the noise control system is prohibited. Federal law prohibits the following acts or the causing thereof:

- 1 The removal or rendering inoperative by any person other than for purposes of maintenance, repair, or replacement, of any device or element of design incorporated into any new vehicle for the purpose of noise control prior to its sale or delivery to the ultimate purchaser or while it is in use, or
- 2 the use of the vehicle after such device or element of design has been removed or rendered inoperative by any person.

Among those acts presumed to constitute tampering are the acts listed below:

- 1 Removal or puncturing of the main silencer, baffles, header pipes or any other components which conduct exhaust gases.
- 2 Removal or puncturing of parts of the intake system.
- 3 Lack of proper maintenance.
- 4 Replacing moving part of the vehicle, or parts of the exhaust or intake system, with parts other than those specified by the manufacturer.

## 2.5 Safe operation

-  **Danger**  
**Danger of accidents** Danger arising from the rider's judgement being impaired.
- Do not operate the vehicle while under the influence of alcohol, drugs and certain medications or physically or mentally impaired.
-  **Danger**  
**Danger of poisoning** Exhaust gases are toxic and inhaling them may result in unconsciousness and/or death.
- When running the engine, always make sure there is sufficient ventilation, and do not start or run the engine in an enclosed space without an effective exhaust extraction system.
-  **Warning**  
**Danger of burns** Some vehicle components become very hot when the vehicle is operated.
- Do not touch hot components such as exhaust system, radiator, engine, shock absorber, and the brake system. Allow these components to cool down before starting work on them.

Only operate the vehicle when it is in perfect technical condition, in accordance with its intended use, and in a safe and environmentally compatible manner.

An appropriate driver's license is needed to ride the vehicle on public roads.

Have malfunctions that impair safety promptly eliminated by an authorized KTM workshop.

Adhere to the information and warning labels on the vehicle.

## 2.6 Protective clothing

-  **Warning**  
**Risk of injury** Missing or poor protective clothing presents an increased safety risk.
- Wear protective clothing (helmet, boots, gloves, pants and jacket with protectors) every time you ride the vehicle. Always wear protective clothing that is in good condition and meets the legal requirements.

In the interest of your own safety, KTM recommends that you only operate the vehicle while wearing protective clothing.

## 2.7 Work rules

Special tools are necessary for certain tasks. The tools are not contained in the vehicle but can be ordered under the number in parentheses. E.g.: bearing puller (15112017000)

During assembly, non-reusable parts (e.g. self-locking screws and nuts, seals and seal rings, O-rings, pins, lock washers) must be replaced by new parts.

In some instances, a thread locker (e.g. **Loctite**®) is required. The manufacturer instructions for use must be followed.

After disassembly, clean the parts that are to be reused and check them for damage and wear. Change damaged or worn parts.

After you complete the repair or service work, check the operating safety of the vehicle.

## 2.8 Environment

If you use your motorcycle responsibly, you can ensure that problems and conflicts do not occur. To protect the future of the motorcycle sport, make sure that you use your motorcycle legally, display environmental consciousness, and respect the rights of others.

When disposing of used oil, other operating and auxiliary fluids, and used components, comply with the laws and regulations of the respective country.

Because motorcycles are not subject to the EU regulations governing the disposal of used vehicles, there are no legal regulations that pertain to the disposal of an end-of-life motorcycle. Your authorized KTM dealer will be glad to advise you.

## 2.9 Owner's Manual

It is important that you read this Owner's Manual carefully and completely before making your first trip. The Owner's Manual contains useful information and many tips on how to operate, handle, and maintain your motorcycle. Only then will you find out how to customize the vehicle ideally for your own use and how you can protect yourself from injury.

Keep the Owner's Manual in an accessible place to enable you to refer to it as needed.

If you would like to know more about the vehicle or have questions on the material you read, please contact an authorized KTM dealer. The Owner's Manual is an important component of the vehicle and should be handed over to the new owner if the vehicle is sold.



## 3.1 Guarantee, warranty

The work prescribed in the service schedule must be carried out by an authorized KTM workshop only and confirmed in the customer's Service & Warranty Booklet and in the **KTM dealer.net**; otherwise, all warranty claims will be void. No warranty claims can be considered for damage resulting from manipulations and/or alterations to the vehicle.

Additional information on the guarantee or warranty and the procedures involved can be found in the Service & Warranty Booklet.

## 3.2 Operating and auxiliary substances



### Warning

**Environmental hazard** Improper handling of fuel is a danger to the environment.

- Do not allow fuel to get into the ground water, the ground, or the sewage system.

Use operating and auxiliary substances (such as fuel and lubricants) as specified in the Owner's Manual.

## 3.3 Spare parts, accessories

For your own safety, only use spare parts and accessory products that are approved and/or recommended by KTM and have them installed by an authorized KTM workshop. KTM accepts no liability for other products and any resulting damage or loss. Certain spare parts and accessory products are specified in parentheses in the descriptions. Your authorized KTM dealer will be glad to advise you.

The current **KTM PowerParts** for your vehicle can be found on the KTM website.

International KTM Website: <http://www.ktm.com>

## 3.4 Service

A prerequisite for perfect operation and prevention of premature wear is that the service, care, and tuning work on the engine and chassis is properly carried out as described in the Owner's Manual. Incorrect adjustment and tuning of the engine and chassis can lead to damage and breakage of components.

Use of the vehicle under difficult conditions, such as on sand or on wet and muddy surfaces, can lead to considerably more rapid wear of components such as the drive train, brake system, or suspension components. For this reason, it may be necessary to inspect or replace parts before the next scheduled service.

It is imperative that you adhere to the stipulated run-in times and service intervals. If you observe these exactly, you will ensure a much longer service life for your motorcycle.

## 3.5 Figures

The figures contained in the manual may depict special equipment.

In the interest of clarity, some components may be shown disassembled or may not be shown at all. It is not always necessary to disassemble the component to perform the activity in question. Please follow the instructions in the text.

## 3.6 Customer service

Your authorized KTM dealer will be happy to answer any questions you may have on your vehicle and KTM.

A list of authorized KTM dealers can be found on the KTM website.

International KTM Website: <http://www.ktm.com>

## 4.1 View of vehicle, front left (example)

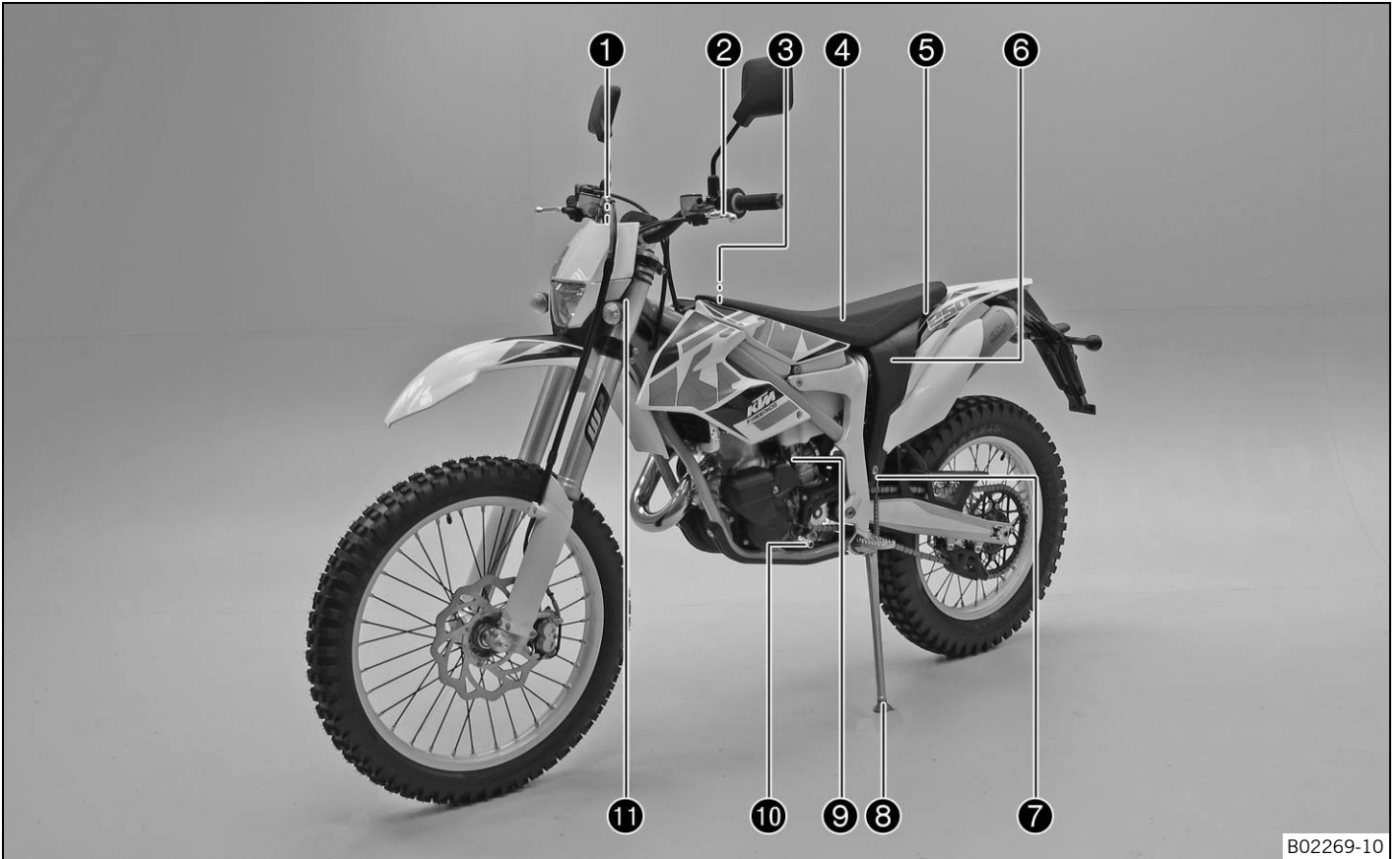

B02269-10

- |    |                                       |
|----|---------------------------------------|
| 1  | Speedometer                           |
| 2  | Clutch lever (☛ p. 12)                |
| 3  | Filler cap                            |
| 4  | Seat                                  |
| 5  | Seat release                          |
| 6  | Shock absorber compression adjustment |
| 7  | Shock absorber rebound adjustment     |
| 8  | Side stand (☛ p. 16)                  |
| 9  | Fuel tap (☛ p. 15)                    |
| 10 | Shift lever (☛ p. 15)                 |
| 11 | Steering lock (☛ p. 16)               |

## 4.2 View of vehicle, rear right (example)



B02270-10

- |   |                                    |
|---|------------------------------------|
| 1 | Kill switch (☛ p. 12)              |
| 1 | Horn button (☛ p. 12)              |
| 1 | Light switch (☛ p. 13)             |
| 1 | Turn signal switch (☛ p. 13)       |
| 2 | Electric starter button (☛ p. 13)  |
| 3 | Throttle grip (☛ p. 12)            |
| 4 | Hand brake lever (☛ p. 12)         |
| 5 | Fork rebound adjustment            |
| 6 | Fork compression adjustment        |
| 7 | Foot brake lever (☛ p. 16)         |
| 8 | Level viewer for brake fluid, rear |

## 5.1 Chassis number

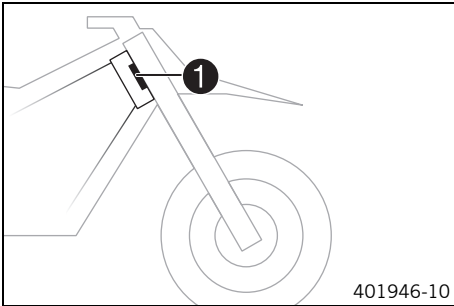

The chassis number ① is stamped on the right side of the steering head.

## 5.2 Type label (EU/AU)

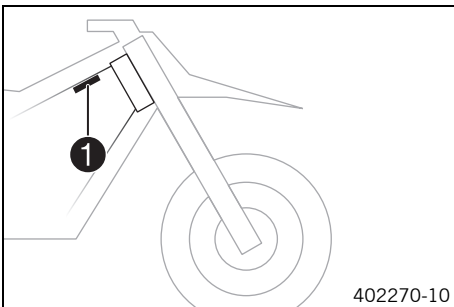

The type label ① is mounted on the frame at the front right.

## 5.3 Key number

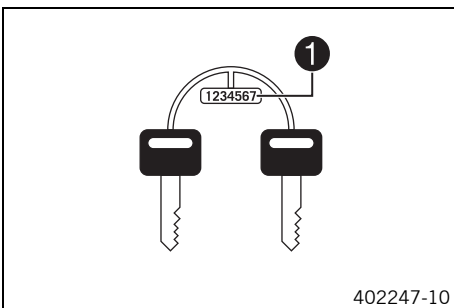

The key number ① for the steering lock is stamped onto the key connector.

## 5.4 Engine number

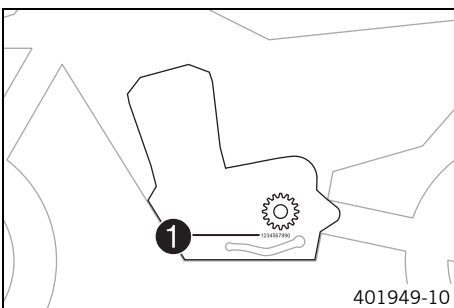

The engine number ① is stamped on the left side of the engine under the engine sprocket.

## 5.5 Fork part number

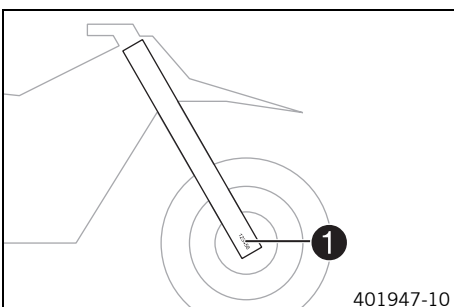

The fork part number ① is stamped on the inner side of the axle clamp.

## 5.6 Shock absorber part number

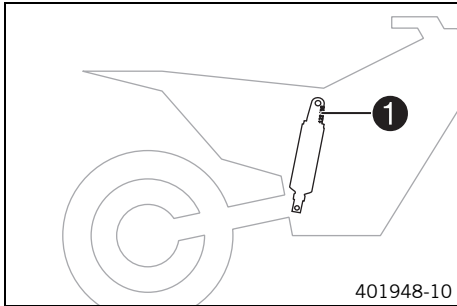

The shock absorber part number ❶ is stamped on the top of the shock absorber above the adjusting ring on the engine side.

## 6.1 Clutch lever



The clutch lever ❶ is fitted on the left side of the handlebar. The clutch is hydraulically operated and self-adjusting.

## 6.2 Hand brake lever

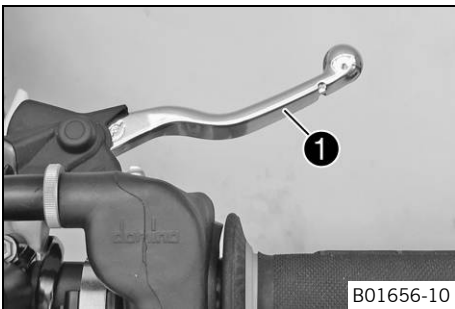

The hand brake lever ❶ is fitted on the right side of the handlebar. The front brake is engaged using the hand brake lever.

## 6.3 Throttle grip

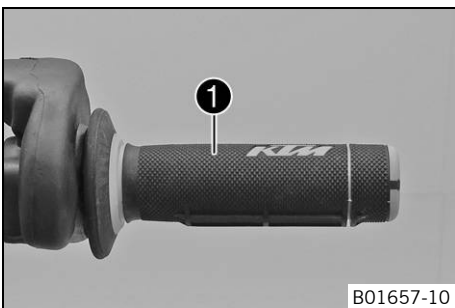

The throttle grip ❶ is fitted on the right side of the handlebar.

## 6.4 Kill switch



Kill switch ❶ is fitted on the left side of the handlebar.

### Possible states

- Kill switch ☒ in basic position – In this position, the ignition circuit is closed and the engine can be started.
- Kill switch ☒ pressed – In this position, the ignition circuit is interrupted, a running engine stops, and a non-running engine will not start.

## 6.5 Horn button



The horn button ❶ is fitted on the left side of the handlebar.

### Possible states

- Horn button 𐀀 in neutral position
- Horn button 𐀀 pressed – The horn is operated in this position.

## 6.6 Light switch



The light switch ❶ is fitted on the left side of the handlebar.

### Possible states

	Low beam on – Light switch is in the central position. In this position, the low beam and tail light are switched on.
	High beam on – Light switch is turned to the left. In this position, the high beam and the tail light are switched on.

## 6.7 Electric starter button (EU/US)

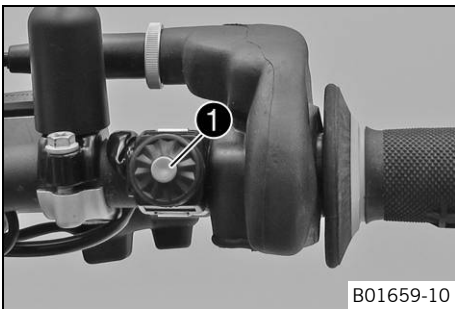

Electric starter button ❶ is fitted on the right side of the handlebar.

### Possible states

- Electric starter button ❶ in basic position
- Electric starter button ❶ pressed – In this position, the electric starter is actuated.

## 6.8 Electric starter button (AU)



Electric starter button ❶ is fitted on the right side of the handlebar.

### Possible states

- Electric starter button ❶ in basic position
- Electric starter button ❶ pressed – In this position, the electric starter is actuated.

## 6.9 Turn signal switch (EU/AU)



Turn signal switch ❶ is fitted on the left side of the handlebar.

### Possible states

	Turn signal light off – Turn signal switch is in the central position.
	Turn signal light, left, on – Turn signal switch is turned to the left.
	Turn signal light, right, on – Turn signal switch is turned to the right.

## 6.10 Emergency OFF switch (AU)



The emergency OFF switch ❶ is fitted on the right side of the handlebar.

### Possible states

	Ignition off – In this position, the ignition circuit is interrupted, a running engine stops, and a non-running engine will not start.
	Ignition on – In this position, the ignition circuit is closed and the engine can be started.

## 6.11 Overview of indicator lamps (EU/AU)



### Possible states

	High beam indicator light lights up blue – High beam is switched on.
	FI warning lamp (MIL) – inoperative
	Low fuel warning lamp – inoperative
	Turn signal indicator light flashes green – Turn signal is switched on.

## 6.12 Overview of indicator lamps (US)



### Possible states

	The high beam indicator light lights up blue – The high beam is switched on.
	FI warning lamp (MIL) lights up/flashes orange – inoperative
	The fuel level warning lamp lights up orange – inoperative

## 6.13 Opening the filler cap



### Danger

**Fire hazard** Fuel is highly flammable.

- Never refuel the vehicle near open flames or burning cigarettes, and always switch off the engine first. Be careful that no fuel is spilt, especially on hot vehicle components. Clean up spilt fuel immediately.
- The fuel in the fuel tank expands when warm and may emerge if overfilled. Follow the instructions on refueling.



### Warning

**Danger of poisoning** Fuel is poisonous and a health hazard.

- Fuel must not come into contact with the skin, eyes, or clothing. Do not breathe in the fuel vapors. If contact occurs with the eyes, rinse with water immediately and contact a physician. Immediately clean contaminated areas on the skin with soap and water. If fuel is swallowed, contact a physician immediately. Change clothing that is contaminated with fuel. Store fuel properly in a suitable canister and keep away from children.



### Warning

**Environmental hazard** Improper handling of fuel is a danger to the environment.

- Do not allow fuel to get into the ground water, the ground, or the sewage system.

### Preparatory work

- Fold the seat up. (☛ p. 45)

### Main work

- Press release button **1**, turn the filler cap counterclockwise, and lift it free.

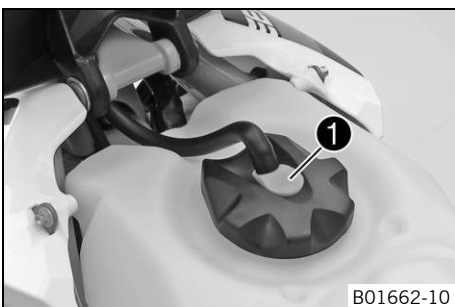



## 6.14 Closing the filler cap

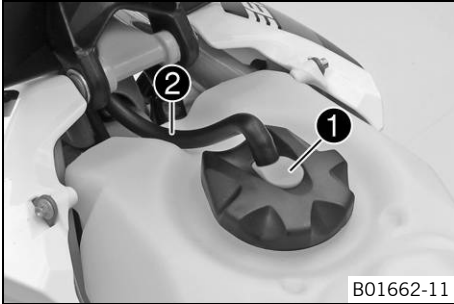

### Main work

- Replace the filler cap and turn clockwise until the release button ① locks in place.

### Info

- Run the fuel tank breather hose ② without kinks.

### Finishing work

- Lock the seat. (☛ p. 45)

## 6.15 Fuel tap

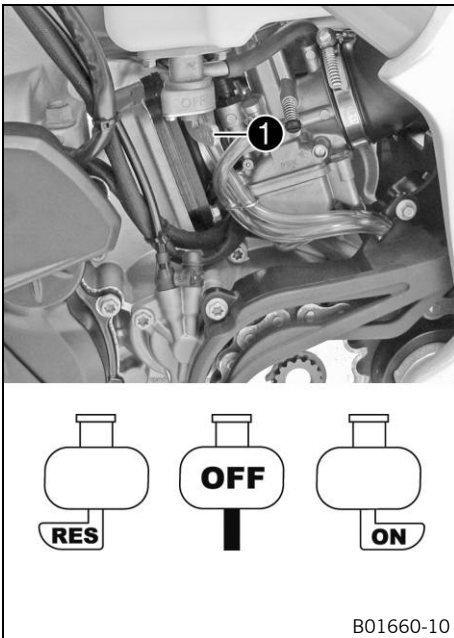

The fuel tap is on the left side of the fuel tank.

Using tap handle ① on the fuel tap, you can open or close the supply of fuel to the carburetor.

### Possible states

- Fuel supply closed **OFF** – Fuel cannot flow from the fuel tank to the carburetor.
- Fuel supply open **ON** – Fuel can flow from the fuel tank to the carburetor. The fuel tank empties down to the reserve level.
- Fuel reserve supply open **RES** – Fuel can flow from the fuel tank to the carburetor. The fuel tank empties completely.

## 6.16 Choke

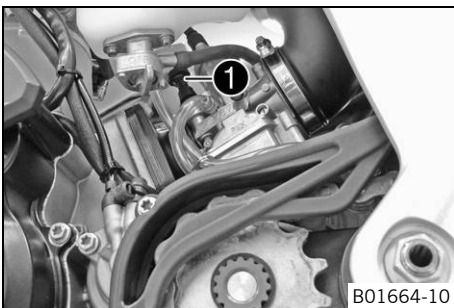

Choke ① is fitted on the left side of the carburetor.

Activating the choke function frees a drill hole in the carburetor through which the engine can draw extra fuel. This results in a richer fuel-air mixture, which is needed for a cold start.

### Info

- If the engine is warm, the choke function must be deactivated.

### Possible states

- Choke function activated – The choke lever is pulled out to the stop.
- Choke function deactivated – The choke lever is pushed in to the stop.

## 6.17 Shift lever

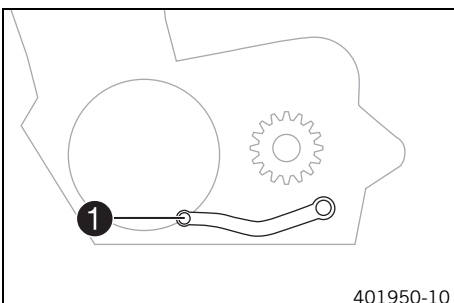

Shift lever ① is mounted on the left side of the engine.

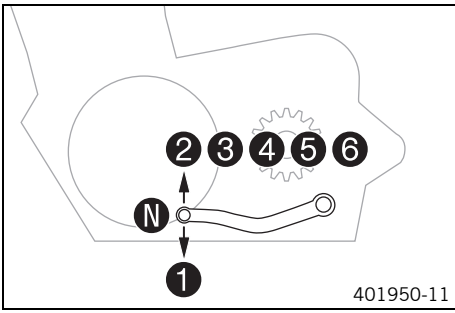

The gear positions can be seen in the photograph.  
The neutral or idle position is between the first and second gears.

## 6.18 Foot brake lever

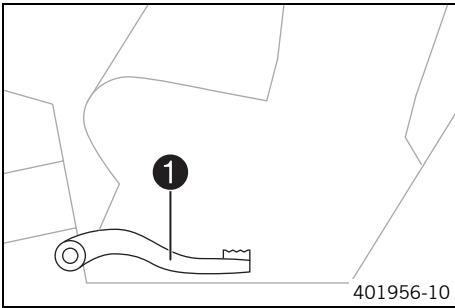

Foot brake lever **1** is located in front of the right footrest.  
The foot brake lever is used to activate the rear brake.

## 6.19 Side stand

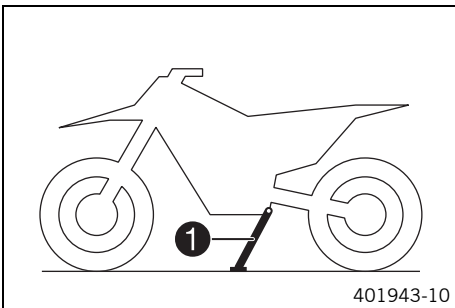

The side stand **1** is on the left side of the vehicle.

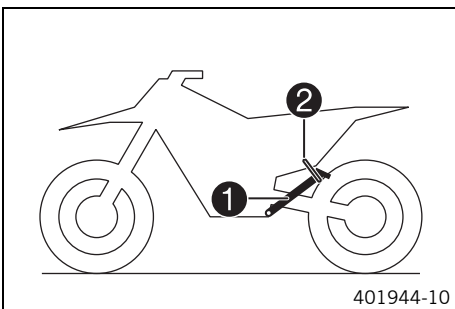

The side stand is used to park the motorcycle.

**i Info**  
When you are riding, side stand **1** must be folded up and secured with rubber band **2**.

## 6.20 Steering lock

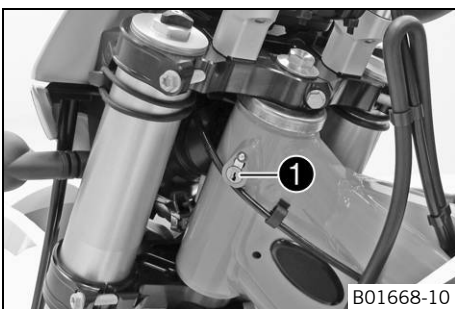

Steering lock **1** is fitted on the left side of the steering head.  
The steering lock is used to lock the steering. Steering, and therefore riding, is no longer possible.

## 6.21 Locking the steering

### Note

**Danger of damage** The parked vehicle may roll away or fall over.

- Always place the vehicle on a firm and even surface.



- Park the vehicle.
- Turn the handlebar as far as possible to the right.
- Insert the key in the steering lock, turn it to the left, press it in, and turn it to the right. Remove the key.
- ✓ Steering is no longer possible.



### Info

Never leave the key in the steering lock.

## 6.22 Unlocking the steering

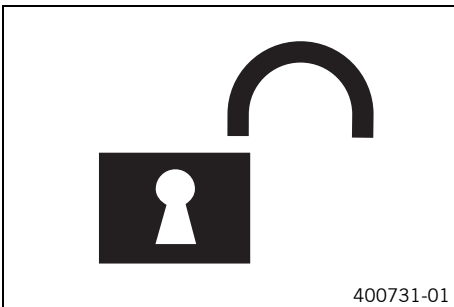

- Insert the key in the steering lock, turn it to the left, pull it out, and turn it to the right. Remove the key.
- ✓ You can now steer the bike again.



### Info

Never leave the key in the steering lock.

## 7.1 Overview

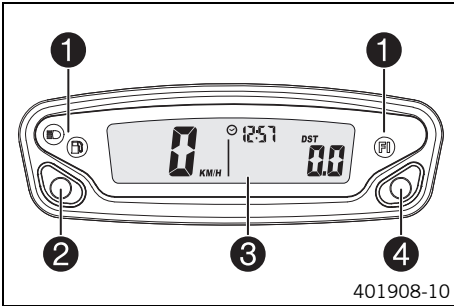

- |   |                                       |
|---|---------------------------------------|
| 1 | Overview of indicator lamps (☛ p. 14) |
| 2 | Left button                           |
| 3 | Display                               |
| 4 | Right button                          |

## 7.2 Activation

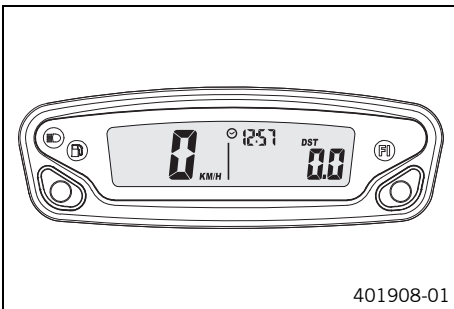

### Activating the speedometer

The speedometer is activated when one of the buttons is pressed or an impulse comes from the wheel speed sensor.

## 7.3 Message on the speedometer

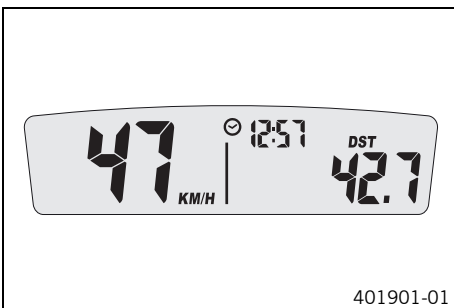

### Possible states

	Battery voltage of the speedometer – Battery voltage of the speedometer is too low. Change the battery.
	Service – A service is due. Contact an authorized KTM workshop.

## 7.4 Setting the speedometer

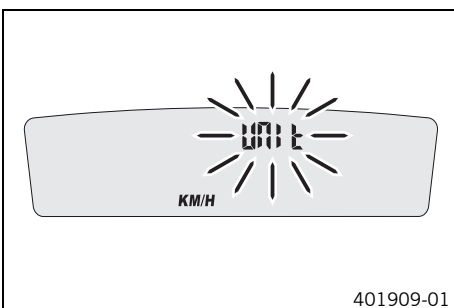

### Condition

The motorcycle is stationary.

- Press both buttons for 3–5 seconds.
  - ✓ The Setup menu is displayed. The **UNIT** display flashes.
- Press one of the buttons to select **UNIT** for the speed in kilometers **KM/H** or miles **M/H**.

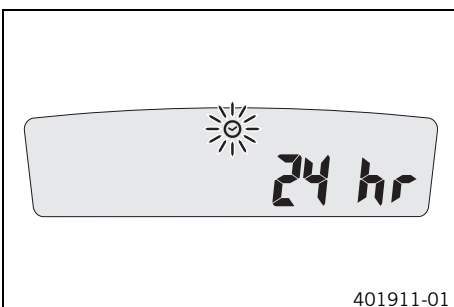

- Wait for 5 seconds.
  - ✓ The speedometer changes to the next menu item. The ☉ symbol flashes.
- Press one of the buttons to select the 24h or 12h display of the clock.

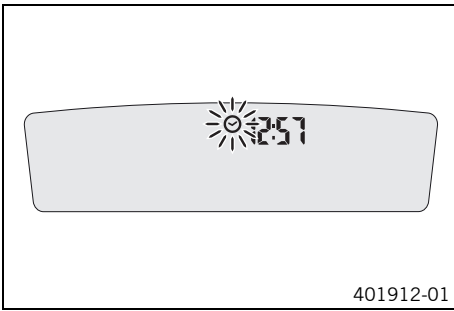

- Wait for 5 seconds.
- ✓ The speedometer changes to the next menu item. The ☀ symbol flashes.

**Resetting the time**

- Press the left button.
- ✓ The value decreases.

**Advancing the time**

- Press the right button.
- ✓ The value increases.

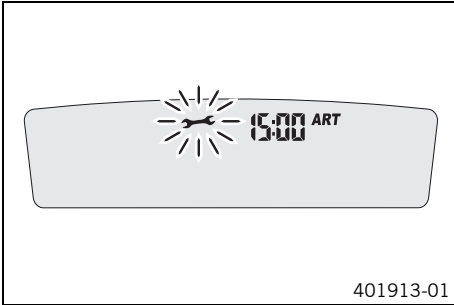

- Wait for 5 seconds.
- ✓ The speedometer changes to the next menu item. The ☀ symbol flashes.
- Set the service.

Guideline

50 h

**Shortening the service interval**

- Press the left button.
- ✓ The value decreases.

**Extending the service interval**

- Press the right button.
- ✓ The value increases.

**Switching off the service interval display**

- Press and hold the left button.
- ✓ **off** appears on the display.

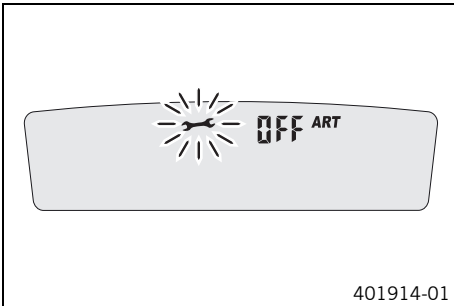

## 7.5 Setting kilometers or miles



**Info**

If you change the unit of measure, the **ODO** value is retained and converted accordingly.

**Condition**

The motorcycle is stationary.

- Press both buttons for 3–5 seconds.
- ✓ The Setup menu is displayed. The **UNIT** display flashes.
- Press one of the buttons to select **UNIT** for the speed in kilometers **KM/H** or miles **M/H**.

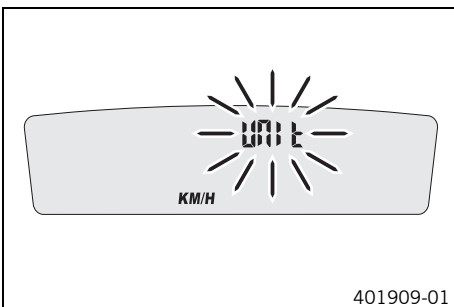

## 7.6 Setting the clock

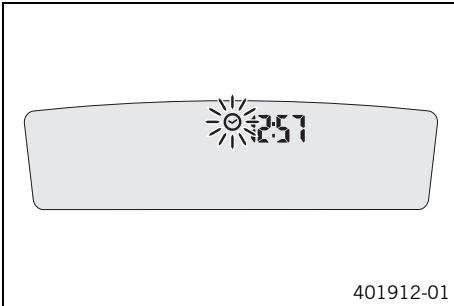
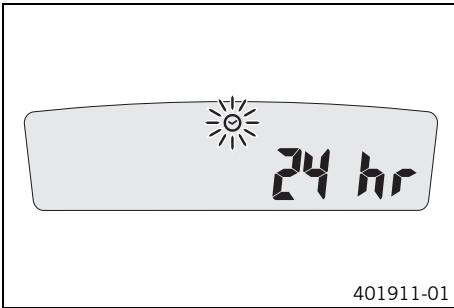

### Condition

The motorcycle is stationary.

- Press both buttons for 3–5 seconds.
  - ✓ The Setup menu is displayed. The **UNIT** display flashes.
- Wait for the menu of the clock ☀ to flash.
- Press one of the buttons to select the 24h or 12h display of the clock.

- Wait for 5 seconds.

✓ The speedometer changes to the next menu item. The ☀ symbol flashes.

### Resetting the time

- Press the left button.
  - ✓ The value decreases.

### Advancing the time

- Press the right button.
  - ✓ The value increases.

## 7.7 Setting the service display

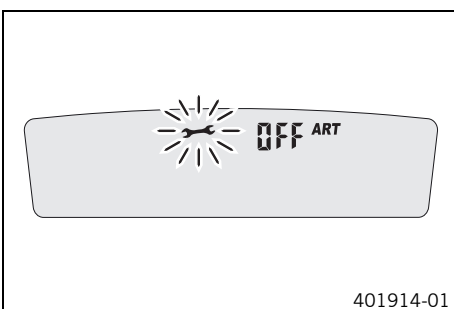
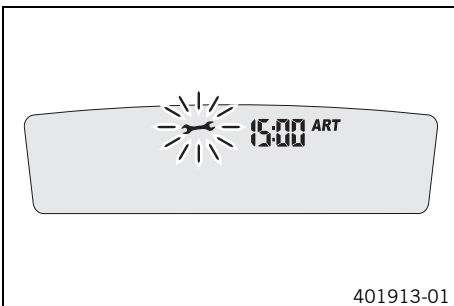

### Condition

The motorcycle is stationary.

- Press both buttons for 3–5 seconds.
  - ✓ The Setup menu is displayed. The **UNIT** display flashes.
- Wait for the menu of the service display ⚙ to flash.
- Set the service.

Guideline

50 h

### Shortening the service interval

- Press the left button.
  - ✓ The value decreases.

### Extending the service interval

- Press the right button.
  - ✓ The value increases.

### Switching off the service interval display

- Press and hold the left button.
  - ✓ **off** appears on the display.

## 7.8 Speed, time, and DST distance 1

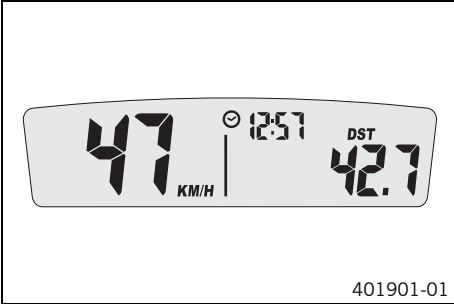

- Press one of the buttons until **DST** appears on the speedometer.
- KM/H** or **M/H** shows the speed.  
 ⌚ shows the time.  
**DST** shows the distance since the last reset, such as between two refueling stops.

<p><b>i Info</b>                  If the value of 39999.9 is exceeded, <b>DST</b> is automatically reset to 0.0.</p>	
Press the left button briefly.	Next display mode
Press the left button for 3 – 5 seconds.	<b>DST</b> can be preset to a value between 0.0 and 39999.9 by pressing the buttons.
Press the right button briefly.	Next display mode
Press the right button for 3 – 5 seconds.	<b>DST</b> is reset to 0.0.

## 7.9 Speed, time, and DST2 distance 2

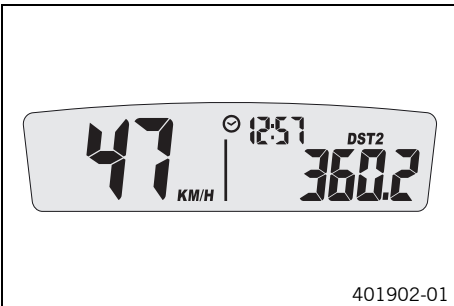

- Press one of the buttons until **DST2** appears on the speedometer.
- KM/H** or **M/H** shows the speed.  
 ⌚ shows the time.  
**DST2** shows the distance 2 since the last reset, such as between two refueling stops.

<p><b>i Info</b>                  If the value of 39999.9 is exceeded, <b>DST2</b> is automatically reset to 0.0.</p>	
Press the left button briefly.	Next display mode
Press the left button for 3 – 5 seconds.	<b>DST2</b> can be preset to a value between 0.0 and 39999.9 by pressing the buttons.
Press the right button briefly.	Next display mode
Press the right button for 3 – 5 seconds.	<b>DST2</b> is reset to 0.0.

## 7.10 AVG average speed, ART operating hours, and ODO total distance covered

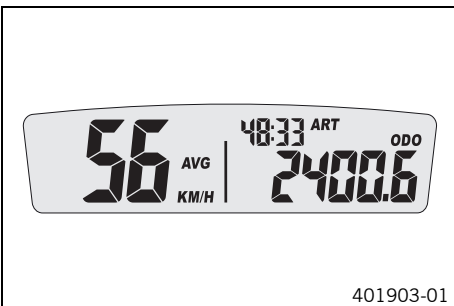

- Press one of the buttons until **AVG**, **ART** and **ODO** appear in the speedometer.
- AVG** shows the average speed since the last reset.  
**ART** shows the operating hours.  
**ODO** shows the total distance covered.

Press the left button briefly.	Next display mode
Press the left button for 3 – 5 seconds.	The OPEN END WRENCH SYMBOL shows the remaining operating hours until the next service is due.
Press the right button briefly.	Next display mode
Press the right button for 3 – 5 seconds.	<b>AVG</b> is reset to 0.0.

## 8.1 Advice on first use



### Danger

**Danger of accidents** Danger arising from the rider's judgement being impaired.

- Do not operate the vehicle while under the influence of alcohol, drugs and certain medications or physically or mentally impaired.



### Warning

**Risk of injury** Missing or poor protective clothing presents an increased safety risk.

- Wear protective clothing (helmet, boots, gloves, pants and jacket with protectors) every time you ride the vehicle. Always wear protective clothing that is in good condition and meets the legal requirements.



### Warning

**Danger of crashing** Poor vehicle handling due to different tire tread patterns on front and rear wheels.

- The front and rear wheels must be fitted with tires with similar tread patterns to prevent loss of control over the vehicle.



### Warning

**Danger of accidents** Critical riding behavior due to inappropriate riding.

- Adapt your riding speed to the road conditions and your riding ability.



### Warning

**Danger of accidents** Accident risk caused by presence of a passenger.

- Your vehicle is not designed to carry passengers. Do not ride with a passenger.



### Warning

**Danger of accidents** Failure of brake system.

- If the foot brake lever is not released, the brake linings drag continuously. The rear brake may fail due to overheating. Take your foot off the foot brake lever when you are not braking.



### Warning

**Danger of accidents** Unstable riding behavior.

- Do not exceed the maximum permissible weight and axle loads.



### Warning

**Risk of misappropriation** Usage by unauthorized persons.

- Never leave the vehicle while the engine is running. Secure the vehicle against use by unauthorized persons.



### Info

When using your motorcycle, remember that others may feel disturbed by excessive noise.

- Make sure that the pre-delivery inspection work has been carried out by an authorized KTM workshop.
  - ✓ You receive a delivery certificate and the service record at vehicle handover.
- Before your first trip, read the entire operating instructions carefully.
- Get to know the controls.
- Adjust the basic position of the clutch lever. (☞ p. 55)
- Adjust the free travel of the handbrake lever. (☞ p. 58)
- Adjust the basic position of the foot brake lever. ☞ (☞ p. 62)
- Adjust the basic position of the shift lever. ☞ (☞ p. 85)
- Get used to handling the motorcycle on a suitable piece of land before making a longer trip.



### Info

Offroad, you should be accompanied by another person on another machine so that you can help each other.

- Try also to ride as slowly as possible and in a standing position to get a better feeling for the vehicle.
- Do not make any offroad trips that over-stress your ability and experience.
- Hold the handlebar firmly with both hands and keep your feet on the footrests when riding.
- If you carry any baggage, make sure it is fixed firmly as close as possible to the center of the vehicle and ensure even weight distribution between the front and rear wheels.



**Info**

Motorcycles react sensitively to any changes of weight distribution.

- Do not exceed the overall maximum permitted weight and the axle loads.

## Guideline

Maximum permissible overall weight	280 kg (617 lb.)
Maximum permissible front axle load	135 kg (298 lb.)
Maximum permissible rear axle load	175 kg (386 lb.)

- Check the spoke tension. (☛ p. 70)

**Info**

The spoke tension must be checked after half an hour of operation.

- Run the engine in. (☛ p. 23)

## 8.2 Running in the engine

- During the running-in phase, do not exceed the specified engine performance.

## Guideline

Maximum engine performance	
During the first operating hour	< 50 %
During the second operating hour	< 70 %
During the third operating hour	< 100 %

- Avoid fully opening the throttle!

## 9.1 Checks and maintenance work when preparing for use



### Info

Before riding the vehicle, always check its condition and operating safety. The vehicle must be in perfect technical condition when used.

- Check the gear oil level. (☞ p. 86)
- Check the electrical system.
- Check the brake fluid level of the front brake. (☞ p. 59)
- Check the rear brake fluid level. (☞ p. 63)
- Check the front brake linings. (☞ p. 60)
- Check the rear brake linings. (☞ p. 64)
- Check that the brake system is functioning properly.
- Check the coolant level. (☞ p. 80)
- Check for chain dirt accumulation. (☞ p. 50)
- Check the chain, rear sprocket, engine sprocket and chain guide. (☞ p. 52)
- Check the chain tension. (☞ p. 51)
- Check the tire condition. (☞ p. 69)
- Check the tire air pressure. (☞ p. 70)
- Check the spoke tension. (☞ p. 70)
- Clean the dust boots of the fork legs. (☞ p. 38)
- Bleed the fork legs. (☞ p. 37)
- Check the air filter.
- Check the settings of all controls and ensure that they can be operated smoothly.
- Check all screws, nuts, and hose clamps regularly for tightness.
- Check the fuel supply.

## 9.2 Starting



### Danger

**Danger of poisoning** Exhaust gases are toxic and inhaling them may result in unconsciousness and/or death.

- When running the engine, always make sure there is sufficient ventilation, and do not start or run the engine in an enclosed space without an effective exhaust extraction system.

### Note

**Engine failure** High engine speeds in cold engines have a negative effect on the service life of the engine.

- Always warm up the engine at low engine speeds.



### Info

If the motorcycle is unwilling to start, the cause can be old fuel in the float chamber. The flammable elements of the fuel evaporate after a long time of standing.

If the float chamber is filled with fresh fuel, the engine starts immediately.

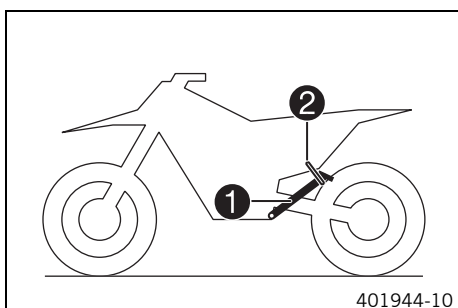

### The motorcycle has been out of use for more than 1 week

- Empty the carburetor float chamber. ☞ (☞ p. 84)
- Turn handle ❶ of the fuel tap to the **ON** position. (Figure B01660-10☞ p. 15)
- ✓ Fuel can flow from the fuel tank to the carburetor.
- Take the motorcycle off of side stand ❶ and secure the side stand with rubber band ❷.
- Shift gear to neutral.

### (AU)

- Press the emergency OFF switch into the position ○.

### The engine is cold

- Pull the choke lever out as far as possible.

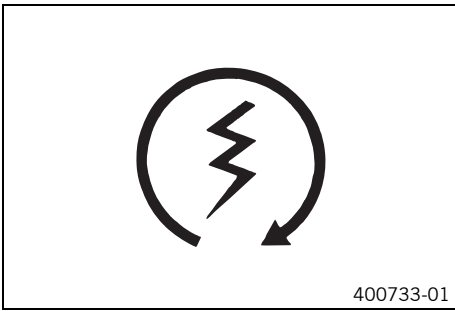

- Press the electric starter button.



**Info**

Press the electric starter button for at most 5 seconds. Wait for a least 5 seconds before trying again.  
Do not open the throttle to start.

## 9.3 Starting off



**Info**

If your bike has lights, switch them on before riding. You will then be seen earlier by other motorists.  
When you are riding, the side stand must be folded up and secured with the rubber band.

- Pull the clutch lever, engage 1st gear, release the clutch lever slowly and simultaneously open the throttle carefully.

## 9.4 Shifting, riding



**Warning**

**Danger of accidents** If you change down at high engine speed, the rear wheel can lock up.

- Do not change into a low gear at high engine speed. The engine races and the rear wheel can lock up.



**Info**

If you hear unusual noises while riding, stop immediately, switch off the engine and contact an authorized KTM workshop.  
First gear is used for starting off or for steep inclines.

- When conditions allow (incline, road situation, etc.), you can shift into a higher gear. To do so, release the throttle while simultaneously pulling the clutch lever, shift into the next gear, release the clutch, and open the throttle.
- After reaching maximum speed by fully opening the throttle grip, turn the throttle back so it is ¾ open. This will barely reduce the speed but fuel consumption will be considerably lower.
- Always open the throttle only as much as the engine can handle – abrupt throttle opening increases fuel consumption.
- To shift down, brake and close the throttle at the same time.
- Pull the clutch lever and shift into a lower gear, release the clutch lever slowly, and open the throttle or shift again.
- Switch off the engine if you expect to be standing for a long time.

Guideline

≥ 2 min

- Avoid frequent and longer slipping of the clutch. This heats the engine oil, the engine, and the cooling system.
- Ride with a lower engine speed instead of with a high engine speed and a slipping clutch.

## 9.5 Applying the brakes



**Warning**

**Danger of accidents** If you brake too hard, the wheels can lock.

- Adapt your braking to the traffic situation and the road conditions.



**Warning**

**Danger of accidents** Reduced braking efficiency caused by spongy pressure point of front or rear brake.

- Check the brake system and do not continue riding. (Your authorized KTM workshop will be glad to help.)



**Warning**

**Danger of accidents** Reduced braking efficiency due to a wet or dirty brake system.

- Clean or dry a dirty or wet brake system by riding and braking gently.

- On sandy, wet or slippery surfaces, use the rear brake.

- Braking should always be completed before you go into a bend. Change down to a lower gear appropriate to your road speed.

## 9.6 Stopping, parking

**Warning**  
**Risk of misappropriation** Usage by unauthorized persons.

- Never leave the vehicle while the engine is running. Secure the vehicle against use by unauthorized persons.

**Warning**  
**Danger of burns** Some vehicle components become very hot when the vehicle is operated.

- Do not touch hot components such as exhaust system, radiator, engine, shock absorber, and the brake system. Allow these components to cool down before starting work on them.

### Note

**Danger of damage** The parked vehicle may roll away or fall over.

- Always place the vehicle on a firm and even surface.

### Note

**Fire hazard** Some vehicle components become very hot when the vehicle is operated.

- Do not park the vehicle near flammable or explosive substances. Do not place objects on the vehicle while it is still warm from being run. Always let the vehicle cool first.

### Note

**Material damage** Damage to or destruction of components due to excessive load.

- The side stand is only designed for the weight of the motorcycle. Do not sit on the motorcycle when it is resting on the side stand. The side stand or the frame may become damaged and the motorcycle may fall over.

- Brake the motorcycle.
- Shift gear to neutral.
- Press and hold the kill switch ☒ while the engine is idling until the engine stops.
- Turn handle ❶ of the fuel tap to the **OFF** position. (Figure B01660-10 p. 15)
- Park the motorcycle on firm ground.

## 9.7 Transport

### Note

**Danger of damage** The parked vehicle may roll away or fall over.

- Always place the vehicle on a firm and even surface.

### Note

**Fire hazard** Some vehicle components become very hot when the vehicle is operated.

- Do not park the vehicle near flammable or explosive substances. Do not place objects on the vehicle while it is still warm from being run. Always let the vehicle cool first.

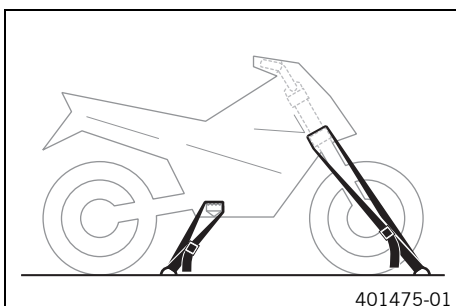

- Switch off the engine.
- Use tension belts or other suitable devices to secure the motorcycle against accidents or falling over.

## 9.8 Refueling

- Danger**  
**Fire hazard** Fuel is highly flammable.
- Never refuel the vehicle near open flames or burning cigarettes, and always switch off the engine first. Be careful that no fuel is spilt, especially on hot vehicle components. Clean up spilt fuel immediately.
  - The fuel in the fuel tank expands when warm and may emerge if overfilled. Follow the instructions on refueling.

- Warning**  
**Danger of poisoning** Fuel is poisonous and a health hazard.
- Fuel must not come into contact with the skin, eyes, or clothing. Do not breathe in the fuel vapors. If contact occurs with the eyes, rinse with water immediately and contact a physician. Immediately clean contaminated areas on the skin with soap and water. If fuel is swallowed, contact a physician immediately. Change clothing that is contaminated with fuel.

**Note**  
**Material damage** Premature clogging of the fuel filter.

- In some countries and regions, the available fuel quality and cleanliness may not be sufficient. This will result in problems with the fuel system. (Your authorized KTM workshop will be glad to help.)
- Only refuel with clean fuel that meets the specified standards.

- Warning**  
**Environmental hazard** Improper handling of fuel is a danger to the environment.
- Do not allow fuel to get into the ground water, the ground, or the sewage system.

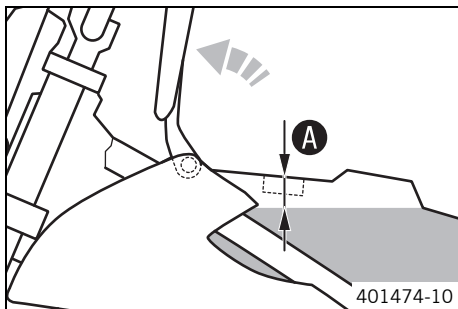

- Preparatory work**
- Switch off the engine.
  - Fold the seat up. (☛ p. 45)
  - Open the filler cap. (☛ p. 14)

- Main work**
- Fill the fuel tank with fuel up to measurement **A**.

Guideline

Measurement of <b>A</b>	30 mm (1.18 in)	
Total fuel tank capacity, approx.	7.0 l (1.85 US gal)	Super unleaded (95 octane) mixed with 2-stroke engine oil (1:80) (☛ p. 102)

- Finishing work**
- Close the filler cap. (☛ p. 15)
  - Lock the seat. (☛ p. 45)

## 10.1 Service schedule

	Every 50 operating hours
Check that the electrical equipment is functioning properly.	•
Check and charge the battery. 🛠️	•
Check the front brake linings. (🔧 p. 60)	•
Check the rear brake linings. (🔧 p. 64)	•
Check the brake discs. (🔧 p. 58)	•
Check the brake lines for damage and leakage.	•
Check the rear brake fluid level. (🔧 p. 63)	•
Check the free travel of the foot brake lever. (🔧 p. 62)	•
Check the frame and swingarm. 🛠️	•
Check the swingarm bearing. 🛠️	•
Check the heim joints at the top and bottom of the shock absorber. 🛠️	•
Check the tire condition. (🔧 p. 69)	•
Check the tire air pressure. (🔧 p. 70)	•
Check the wheel bearing for play. 🛠️	•
Check the wheel hubs. 🛠️	•
Check the rim run-out. 🛠️	•
Check the spoke tension. (🔧 p. 70)	•
Check the chain, rear sprocket, engine sprocket and chain guide. (🔧 p. 52)	•
Check the chain tension. (🔧 p. 51)	•
Grease all moving parts (e.g., side stand, hand lever, chain, ...) and check for smooth operation. 🛠️	•
Check the fluid level of the hydraulic clutch. (🔧 p. 55)	•
Check the brake fluid level of the front brake. (🔧 p. 59)	•
Check the free travel of the hand brake lever. (🔧 p. 58)	•
Check the steering head bearing play. (🔧 p. 42)	•
Check the inlet membrane. 🛠️	•
Check the clutch. 🛠️	•
Change the gear oil. 🛠️ (🔧 p. 87)	•
Check all hoses (e.g. fuel, cooling, bleeder, drainage, etc.) and sleeves for cracking, leaks, and incorrect routing. 🛠️	•
Check the antifreeze and coolant level. (🔧 p. 79)	•
Check the cables for damage and routing without sharp bends. 🛠️	•
Check that the cables are undamaged, routed without sharp bends and set correctly.	•
Clean the air filter and air filter box. 🛠️	•
Check the screws and nuts for tightness. 🛠️	•
Check the headlight setting. (🔧 p. 77)	•
Check idle. 🛠️	•
Check that the radiator fan is functioning properly. 🛠️	•
Final check: Check the vehicle for roadworthiness and take a test ride.	•
Make the service entry in <b>KTM DEALER.NET</b> and in the service record. 🛠️	•

- Periodic interval

## 10.2 Service work (as additional order)

	Once after 10 operating hours	Every 50 operating hours	Every 100 operating hours	Annually
Change the front brake fluid. 🛠️				•
Change the rear brake fluid. 🛠️				•
Change the hydraulic clutch fluid. 🛠️ (📖 p. 56)				•
Grease the steering head bearing. 🛠️ (📖 p. 43)				•
Change the glass fiber yarn filling of the main silencer. 🛠️ (📖 p. 48)				•
Check/adjust the carburetor components. 🛠️				• •
Perform a fork service. 🛠️	○	•	•	
Service the shock absorber. 🛠️		•	•	
Checking, cleaning, and lubricating the starter drive 🛠️		•	•	
Change the spark plug and spark plug connector. 🛠️		•	•	
Change the piston and check the cylinder. 🛠️			•	
Change the connecting rod, conrod bearing and crank pin. 🛠️			•	
Check the transmission and shift mechanism. 🛠️			•	
Change all engine bearings. 🛠️			•	

- One-time interval
- Periodic interval

## 11.1 Checking the basic chassis setting with the rider's weight

**i Info** When adjusting the basic chassis setting, first adjust the shock absorber and then the fork.

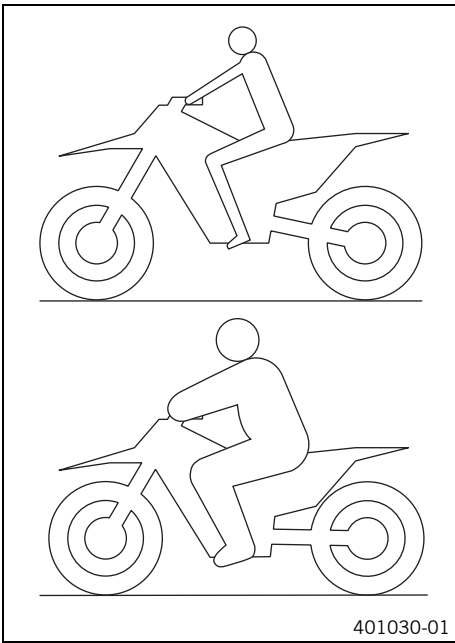

- For optimal motorcycle riding characteristics and to avoid damage to forks, shock absorbers, swingarm and frame, the basic settings of the suspension components must match the rider's weight.
- As delivered, KTM offroad motorcycles are adjusted for an average rider's weight (with full protective clothing).

Guideline

Standard rider weight	75... 85 kg (165... 187 lb.)
-----------------------	------------------------------

- If the rider's weight is above or below this range, the basic setting of the suspension components must be adjusted accordingly.
- Small weight differences can be compensated by adjusting the spring preload, but in the case of large weight differences, the springs must be replaced.

## 11.2 Compression damping of the shock absorber

The compression damping of the shock absorber is divided into two ranges: high-speed and low-speed. High-speed and low-speed refer to the compression speed of the rear wheel suspension and not to the vehicle speed. The high-speed setting, for example, has an effect on the landing after a jump: the rear wheel suspension compresses more quickly. The low-speed setting, for example, has an effect when riding over long ground swells: the rear wheel suspension compresses more slowly. These two ranges can be adjusted separately, although the transition between high-speed and low-speed is gradual. Thus, changes in the high-speed range affect the compression damping in the low-speed range and vice versa.

## 11.3 Adjusting the low-speed compression damping of the shock absorber

**⚠ Caution**  
**Danger of accidents** Disassembly of pressurized parts can lead to injury.

- The shock absorber is filled with high density nitrogen. Adhere to the description provided. (Your authorized KTM workshop will be glad to help.)

**i Info** The low-speed setting can be seen during the slow to normal compression of the shock absorber.

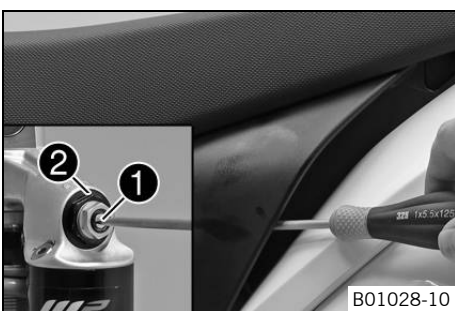

- Turn adjusting screw **1** clockwise with a screwdriver up to the last perceptible click.

**i Info**  
Do not loosen fitting **2**.

- Turn counterclockwise by the number of clicks corresponding to the shock absorber type.

Guideline

Compression damping, low-speed	
Comfort	20 clicks
Standard	15 clicks
Sport	10 clicks



**i Info**  
Turn clockwise to increase damping; turn counterclockwise to reduce damping.

## 11.4 Adjusting the high-speed compression damping of the shock absorber

**! Caution**  
**Danger of accidents** Disassembly of pressurized parts can lead to injury.

- The shock absorber is filled with high density nitrogen. Adhere to the description provided. (Your authorized KTM workshop will be glad to help.)

**i Info**  
The high-speed setting can be seen during the fast compression of the shock absorber.

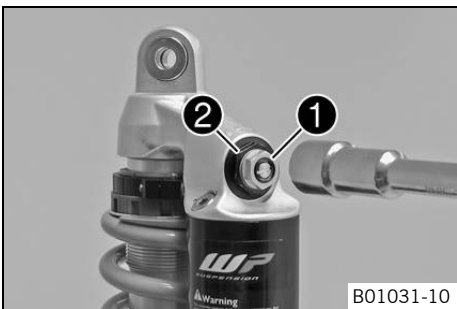

### Preparatory work

- Raise the motorcycle with the lift stand. (☛ p. 37)
- Fold the seat up. (☛ p. 45)
- Remove the shock absorber. ☞ (☛ p. 44)

### Main work

- Turn adjusting screw ① all the way clockwise with a socket wrench.

**i Info**  
Do not loosen fitting ②.

- Turn counterclockwise by the number of turns corresponding to the shock absorber type.

### Guideline

Compression damping, high-speed	
Comfort	2.5 turns
Standard	2 turns
Sport	1 turn

**i Info**  
Turn clockwise to increase damping; turn counterclockwise to reduce damping.

### Finishing work

- Install the shock absorber. ☞ (☛ p. 44)
- Lock the seat. (☛ p. 45)
- Remove the motorcycle from the lift stand. (☛ p. 37)

## 11.5 Adjusting the rebound damping of the shock absorber

**! Caution**  
**Danger of accidents** Disassembly of pressurized parts can lead to injury.

- The shock absorber is filled with high density nitrogen. Adhere to the description provided. (Your authorized KTM workshop will be glad to help.)

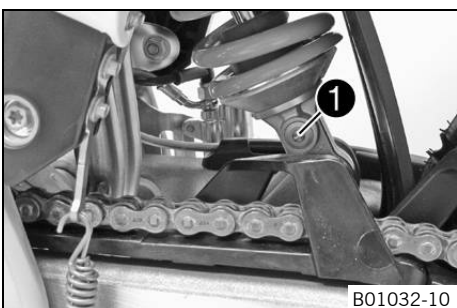

- Turn adjusting screw ① clockwise up to the last perceptible click.
- Turn counterclockwise by the number of clicks corresponding to the shock absorber type.

### Guideline

Rebound damping	
Comfort	20 clicks
Standard	15 clicks
Sport	10 clicks



**Info**

Turn clockwise to increase damping; turn counterclockwise to reduce damping.

## 11.6 Measuring rear wheel sag unloaded

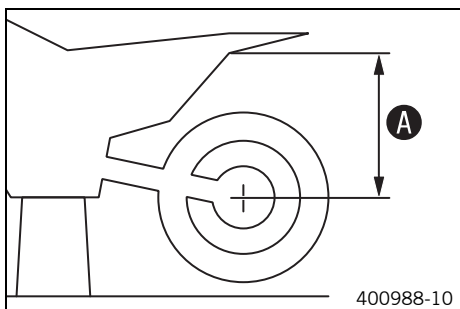

**Preparatory work**

- Raise the motorcycle with the lift stand. (☞ p. 37)

**Main work**

- Measure the distance – as vertical as possible – between the rear axle and a fixed point, for example, a mark on the side cover.
- Note down the value as dimension **A**.

**Finishing work**

- Remove the motorcycle from the lift stand. (☞ p. 37)

## 11.7 Checking the static sag of the shock absorber

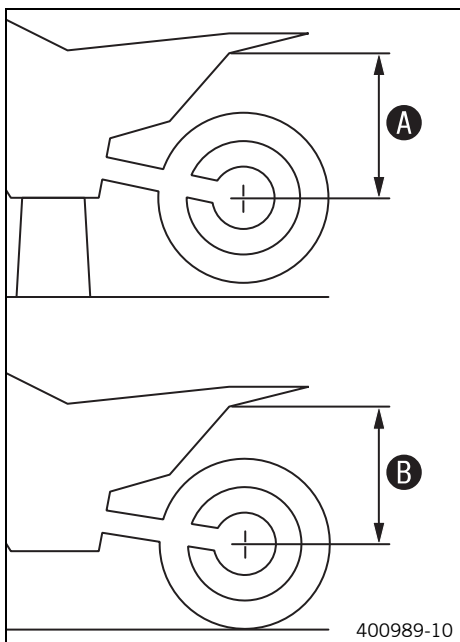

- Measure distance **A** of rear wheel unloaded. (☞ p. 32)
- Hold the motorcycle upright with the aid of an assistant.
- Measure the distance between the rear axle and the fixed point again.
- Note down the value as dimension **B**.



**Info**

The static sag is the difference between measurements **A** and **B**.

- Check the static sag.

Static sag	15 mm (0.59 in)
------------	-----------------

- » If the static sag is less or more than the specified value:
  - Adjust the spring preload of the shock absorber. ☞ (☞ p. 33)

## 11.8 Checking the riding sag of the shock absorber

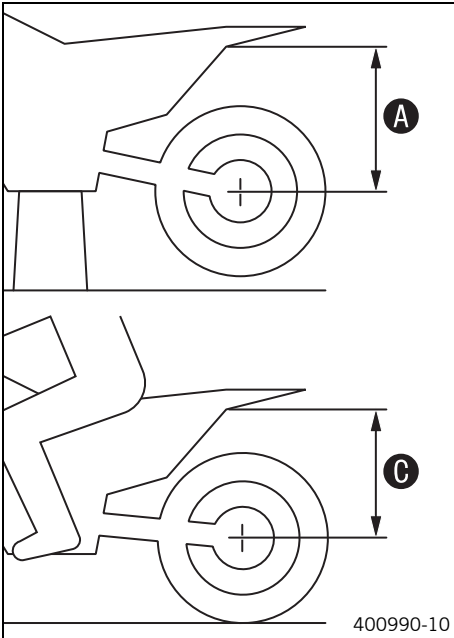

- Measure distance **A** of rear wheel unloaded. (☞ p. 32)
- With another person holding the motorcycle, the rider, wearing full protective clothing, sits on the seat in a normal sitting position (feet on footrests) and bounces up and down a few times.
  - ✓ The rear wheel suspension levels out.
- Another person now measures the distance between the rear axle and a fixed point.
- Note down the value as dimension **C**.

**i Info**

The riding sag is the difference between measurements **A** and **C**.

- Check the riding sag.

Riding sag	80 mm (3.15 in)
------------	-----------------

- » If the riding sag differs from the specified measurement:
  - Adjust the riding sag. ☞ (☞ p. 34)

## 11.9 Adjusting the spring preload of the shock absorber ☞

**⚠ Caution**

**Danger of accidents** Disassembly of pressurized parts can lead to injury.

- The shock absorber is filled with high density nitrogen. Adhere to the description provided. (Your authorized KTM workshop will be glad to help.)

**i Info**

Before changing the spring preload, make a note of the present setting, e.g., by measuring the length of the spring.

**Preparatory work**

- Raise the motorcycle with the lift stand. (☞ p. 37)
- Fold the seat up. (☞ p. 45)
- Remove the shock absorber. ☞ (☞ p. 44)
- After removing the shock absorber, clean it thoroughly.

**Main work**

- Loosen screw **1**.
- Turn adjusting ring **2** until the spring is no longer under tension.

Hook wrench (T106S)
---------------------

- Measure the overall spring length while the spring is not under tension.
- Tighten the spring by turning adjusting ring **2** to measurement **A**.

**Guideline**

Spring preload	
Comfort	8 mm (0.31 in)
Standard	8 mm (0.31 in)
Sport	8 mm (0.31 in)

**i Info**

Depending on the static sag and/or the riding sag, it may be necessary to increase or decrease the spring preload.

- Tighten screw **1**.

**Guideline**

Screw, shock absorber adjusting ring	M5	5 Nm (3.7 lbf ft)
--------------------------------------	----	-------------------

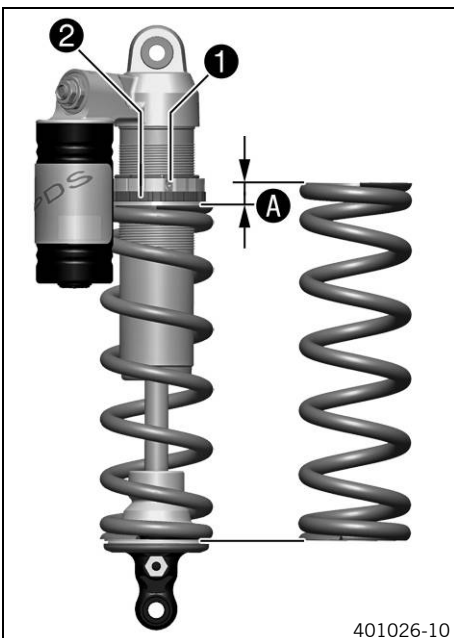

### Finishing work

- Install the shock absorber. ↘ (☞ p. 44)
- Lock the seat. (☞ p. 45)
- Remove the motorcycle from the lift stand. (☞ p. 37)

## 11.10 Adjusting the riding sag ↘

### Preparatory work

- Raise the motorcycle with the lift stand. (☞ p. 37)
- Fold the seat up. (☞ p. 45)
- Remove the shock absorber. ↘ (☞ p. 44)
- After removing the shock absorber, clean it thoroughly.

### Main work

- Choose and mount a suitable spring.

#### Guideline

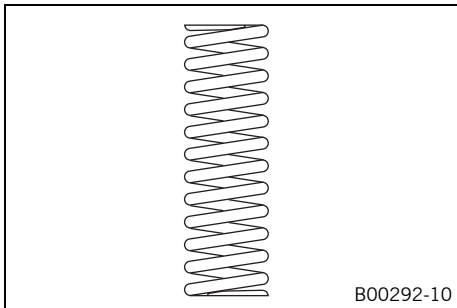

Spring designation	
Weight of rider: 65... 75 kg (143... 165 lb.)	(61/59) 55-215
Weight of rider: 75... 85 kg (165... 187 lb.)	(61/59) 55/63/71-215
Weight of rider: 85... 95 kg (187... 209 lb.)	(61/59) 58/62/74-215



### Info

The spring rate is shown on the outside of the spring. Smaller weight differences can be compensated by changing the spring preload.

### Finishing work

- Install the shock absorber. ↘ (☞ p. 44)
- Lock the seat. (☞ p. 45)
- Remove the motorcycle from the lift stand. (☞ p. 37)
- Check the static sag of the shock absorber. (☞ p. 32)
- Check the riding sag of the shock absorber. (☞ p. 33)
- Adjust the rebound damping of the shock absorber. (☞ p. 31)

## 11.11 Checking the basic setting of the fork



### Info

For various reasons, no exact riding sag can be determined for the forks.

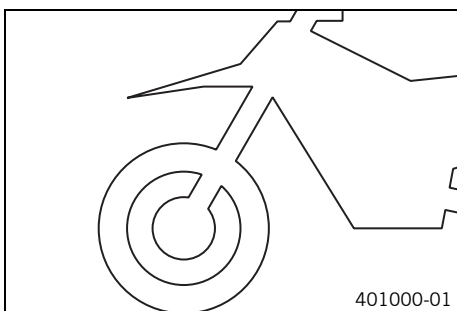

- As with the shock absorber, smaller differences in the rider's weight can be compensated by the spring preload.
- However, if the fork is often overloaded (hard end stop on compression), harder springs must be fit to avoid damage to the fork and frame.

## 11.12 Adjusting the compression damping of the fork

**i Info**  
The hydraulic compression damping determines the fork suspension behavior.

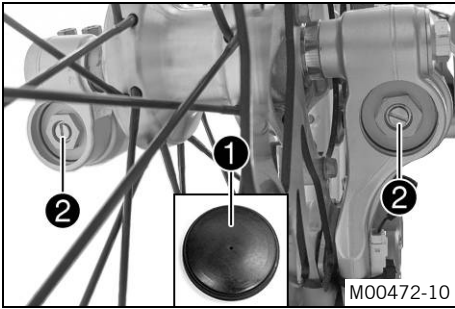

- Remove protection caps ①.
- Turn adjusting screws ② clockwise all the way.

**i Info**  
Adjusting screws ② are located at the bottom end of the fork legs. Make the same adjustment on both fork legs.

- Turn counterclockwise by the number of clicks corresponding to the fork type.  
Guideline

Compression damping	
Comfort	25 clicks
Standard	20 clicks
Sport	15 clicks

**i Info**  
Turn clockwise to increase damping; turn counterclockwise to reduce damping.

- Mount protection caps ①.

## 11.13 Adjusting the rebound damping of the fork

**i Info**  
The hydraulic rebound damping determines the fork suspension behavior.

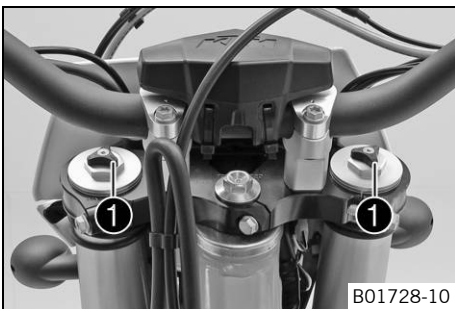

- Turn adjusting screws ① clockwise all the way.

**i Info**  
Adjusting screws ① are located at the top end of the fork legs. Make the same adjustment on both fork legs.

- Turn counterclockwise by the number of clicks corresponding to the fork type.  
Guideline

Rebound damping	
Comfort	25 clicks
Standard	20 clicks
Sport	15 clicks

**i Info**  
Turn clockwise to increase damping; turn counterclockwise to reduce damping.

## 11.14 Handlebar position

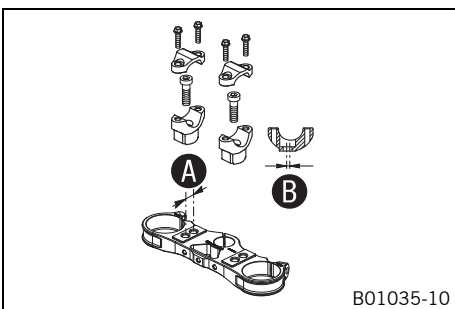

On the upper triple clamp, there are two holes at a distance of **A** to each other.

Hole distance <b>A</b>	15 mm (0.59 in)
------------------------	-----------------

The holes on the handlebar supports are placed at a distance of **B** from the center.

Hole distance <b>B</b>	3.5 mm (0.138 in)
------------------------	-------------------

The handlebar supports can be mounted in four different positions.

## 11.15 Adjusting the handlebar position ↩

**Warning**  
**Danger of accidents** Handlebar breakage.

- If the handlebar is bent or straightened it will cause material fatigue, and the handlebar can break. Always replace handlebar.

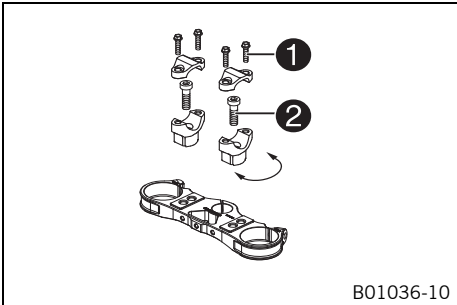

- Remove screws ❶. Remove the handlebar clamps. Take off the handlebar and lay it to one side.

**Info**  
 Cover the components to protect them against damage.  
 Do not bend the cables and lines.

- Remove screws ❷. Take off the handlebar supports.
- Move the handlebar supports into the desired position. Mount and tighten screws ❷.

Guideline

Screw, handlebar support	M10	40 Nm (29.5 lbf ft)	Loctite® 243™
--------------------------	-----	------------------------	---------------

**Info**  
 Position the left and right handlebar supports evenly.

- Position the handlebar.

**Info**  
 Make sure cables and wiring are positioned correctly.

- Position the handlebar clamps. Mount screws ❶ and tighten evenly.

Guideline

Screw, handlebar clamp	M8	20 Nm (14.8 lbf ft)
------------------------	----	------------------------

**Info**  
 Make sure the gap width is even.

## 12.1 Raising the motorcycle with the lift stand

### Note

**Danger of damage** The parked vehicle may roll away or fall over.

- Always place the vehicle on a firm and even surface.

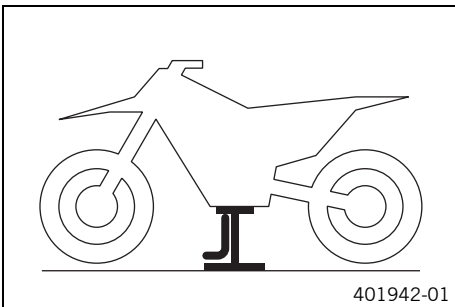

- Raise the motorcycle at the frame underneath the engine.

Lift stand (54829055000)

- ✓ Neither wheel is in contact with the ground.
- Secure the motorcycle against falling over.

## 12.2 Removing the motorcycle from the lift stand

### Note

**Danger of damage** The parked vehicle may roll away or fall over.

- Always place the vehicle on a firm and even surface.

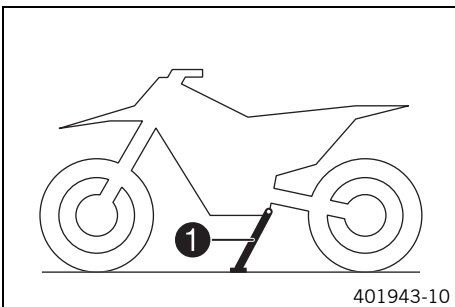

- Remove the motorcycle from the lift stand.
- Remove the lift stand.
- To park the motorcycle, press side stand ❶ to the ground with your foot and lean the motorcycle on it.



### Info

When you are riding, the side stand must be folded up and secured with the rubber band.

## 12.3 Bleeding the fork legs



### Preparatory work

- Raise the motorcycle with the lift stand. (☛ p. 37)

### Main work

- Release bleeder screws ❶.
- ✓ Any excess pressure escapes from the interior of the fork.
- Tighten the bleeder screws.

### Finishing work

- Remove the motorcycle from the lift stand. (☛ p. 37)

## 12.4 Cleaning the dust boots of the fork legs



### Preparatory work

- Raise the motorcycle with the lift stand. (☞ p. 37)
- Remove the fork protector. ☞ (☞ p. 39)

### Main work

- Push dust boots ① of both fork legs downward.



### Info

The dust boots remove dust and coarse dirt particles from the inside fork tubes. Over time, dirt can penetrate behind the dust boots. If this dirt is not removed, the shaft seal rings behind can start to leak.



### Warning

**Danger of accidents** Reduced braking efficiency due to oil or grease on the brake discs.

- Always keep the brake discs free of oil and grease, and clean them with brake cleaner when necessary.

- Clean and oil the dust boots and inner fork tube of both fork legs.

Universal oil spray (☞ p. 104)

- Press the dust boots back into their normal position.
- Remove excess oil.

### Finishing work

- Install the fork protector. ☞ (☞ p. 40)
- Remove the motorcycle from the lift stand. (☞ p. 37)

## 12.5 Removing the fork legs ☞

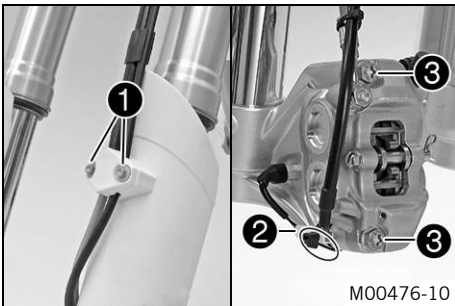

### Preparatory work

- Remove the headlight mask with the headlight. (☞ p. 75)
- Raise the motorcycle with the lift stand. (☞ p. 37)
- Remove the front wheel. ☞ (☞ p. 67)

### Main work

- Remove screws ① and take off the clamp.
- Remove the cable tie(s) and detach plug-in connector ②.
- Remove screws ③ and the spacers and take off the brake caliper.
- Allow the brake caliper and brake line to hang tension-free to the side.

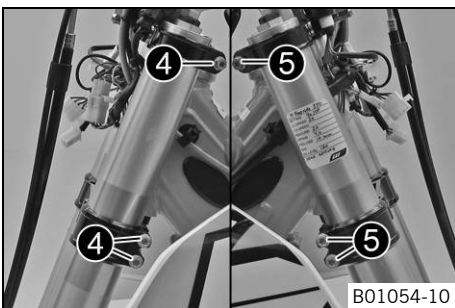

- Release screws ④. Take out the left fork leg.
- Release screws ⑤. Take out the right fork leg.



## 12.6 Installing the fork legs

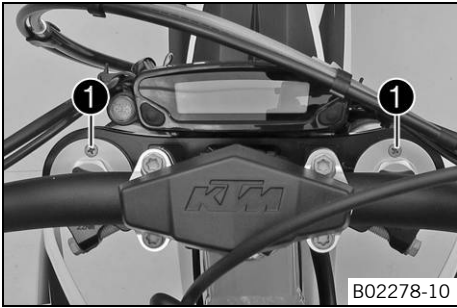

### Main work

- Position the fork legs.

### Info

The upper milled groove in the fork leg must be flush with the upper edge of the upper triple clamp.

Position bleeder screws **1** toward the front.

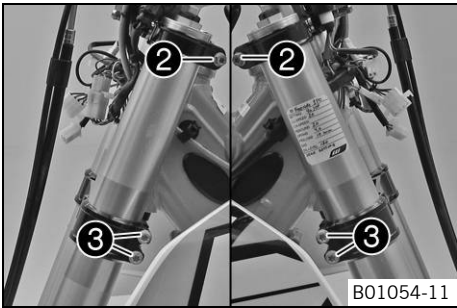

- Tighten screws **2**.

### Guideline

Screw, top triple clamp	M8	22 Nm (16.2 lbf ft)
-------------------------	----	------------------------

- Tighten screws **3**.

### Guideline

Screw, bottom triple clamp	M8	18 Nm (13.3 lbf ft)
----------------------------	----	------------------------

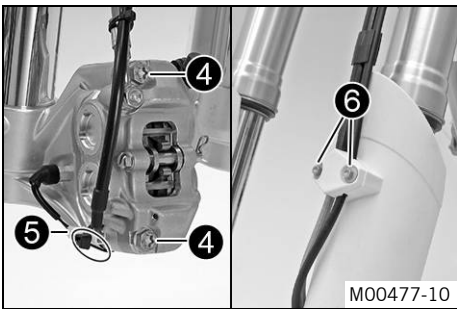

- Position the brake caliper. Mount and tighten screws **4** with the spacers.

### Guideline

Screw, front brake caliper	M8	25 Nm (18.4 lbf ft)	Loctite® 243™
----------------------------	----	------------------------	---------------

- Connect the plug-in connector **5** and mount the cable tie(s).
- Position the brake line, wiring harness, and clamp. Mount and tighten screws **6**.

### Finishing work

- Install the front wheel. (☞ p. 67)
- Refit the headlight mask with the headlight. (☞ p. 75)
- Check the headlight setting. (☞ p. 77)

## 12.7 Removing the fork protector

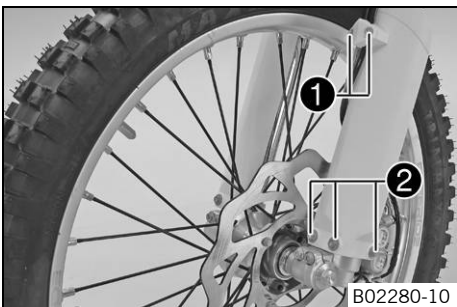

- Remove screws **1**. Take off the clamp.
- Remove screws **2** on the left fork leg. Take off the fork protector.

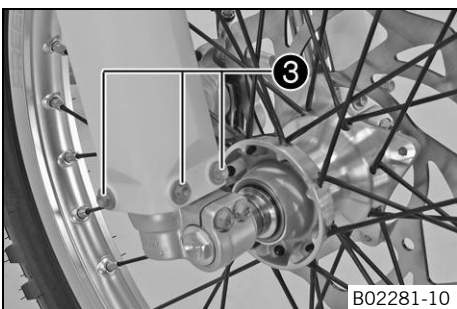

- Remove screws **3** on the right fork leg. Take off the fork protector.

## 12.8 Installing the fork protector

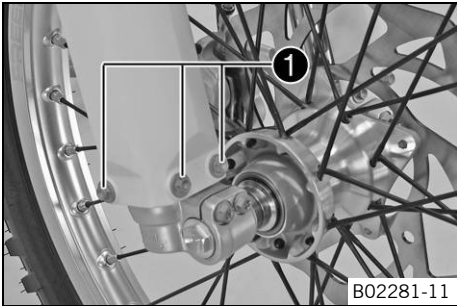

B02281-11

- Position the fork protection on the right fork leg. Mount and tighten screws ❶.

Guideline

Remaining screws, chassis	M6	10 Nm (7.4 lbf ft)
---------------------------	----	--------------------

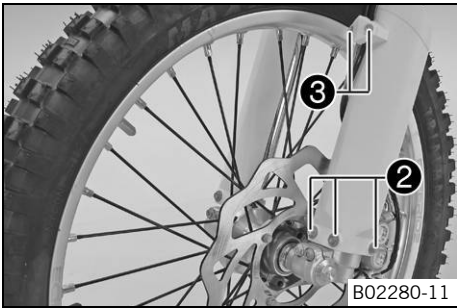

B02280-11

- Position the fork protection on the left fork leg. Mount and tighten screws ❷.

Guideline

Remaining screws, chassis	M6	10 Nm (7.4 lbf ft)
---------------------------	----	--------------------

- Position the brake line, wiring harness, and clamp. Mount and tighten screws ❸.

## 12.9 Removing the lower triple clamp

### Preparatory work

- Remove the headlight mask with the headlight. (☛ p. 75)
- Raise the motorcycle with the lift stand. (☛ p. 37)
- Remove the front wheel. ☛ (☛ p. 67)
- Remove the fork legs. ☛ (☛ p. 38)
- Remove the front fender. (☛ p. 44)

### Main work

- Remove the cable holder on both sides in front of the radiator.

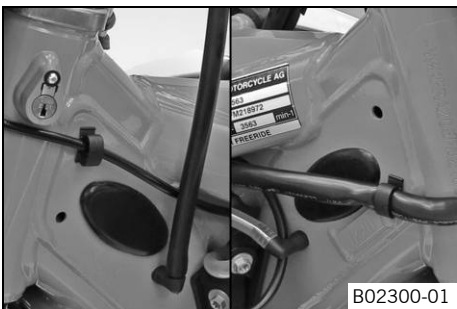

B02300-01

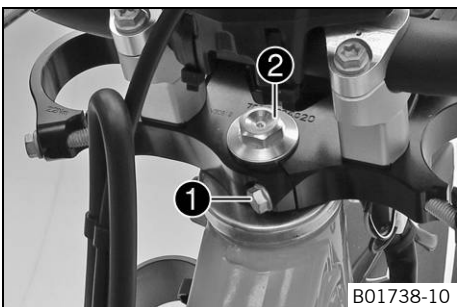

B01738-10

- Remove screw ❶.
- Remove screw ❷, take off the upper triple clamp with the handlebar and set it aside.



### Info

Cover the components to protect them against damage.  
Do not bend the cables and lines.

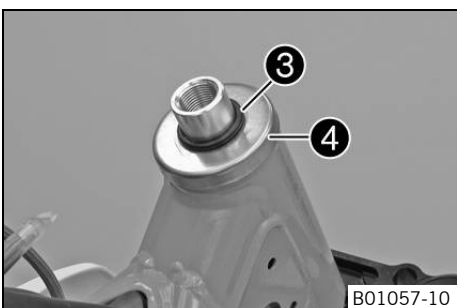

B01057-10

- Remove O-ring ❸. Remove protective ring ❹.
- Take out the lower triple clamp with the steering stem.
- Take out the upper steering head bearing.

## 12.10 Installing the lower triple clamp

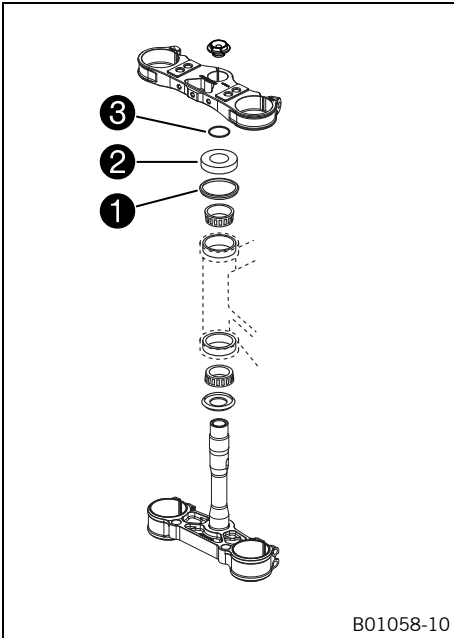

B01058-10

### Main work

- Clean the bearing and sealing elements, check for damage, and grease.

High viscosity grease (☛ p. 103)

- Insert the lower triple clamp with the steering stem. Mount the upper steering head bearing.
- Check whether the upper steering head seal ① is correctly positioned.
- Slide on protective ring ② and O-ring ③.

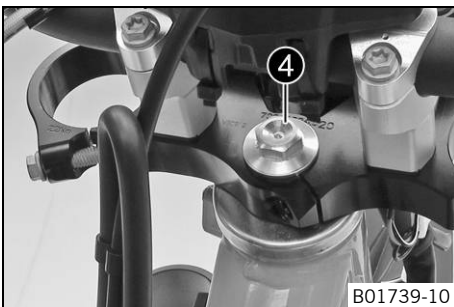

B01739-10

- Position the upper triple clamp with the handlebar.
- Mount screw ④ but do not tighten yet.
- Position the clutch line and wiring harness.



B02279-10

- Position the fork legs.

### Info

The upper milled groove in the fork leg must be flush with the upper edge of the upper triple clamp.

Position bleeder screws ⑤ toward the front.

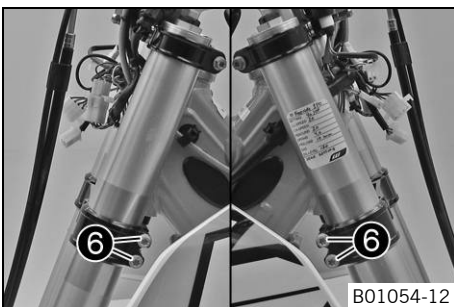

B01054-12

- Fully tighten screws ⑥.

### Guideline

Screw, bottom triple clamp	M8	18 Nm (13.3 lbf ft)
----------------------------	----	------------------------



B01744-10

- Tighten screw ④.

### Guideline

Screw, top steering head	M20x1.5	12 Nm (8.9 lbf ft)
--------------------------	---------	--------------------

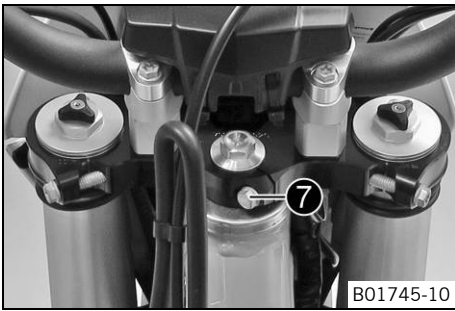

- Mount and tighten screw 7.

Guideline

Screw, top steering stem	M8	17 Nm (12.5 lbf ft)	Loctite® 243™
--------------------------	----	------------------------	---------------

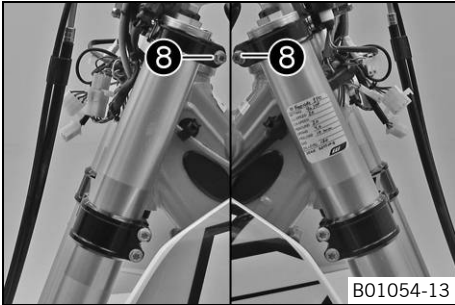

- Tighten screws 8.

Guideline

Screw, top triple clamp	M8	22 Nm (16.2 lbf ft)	
-------------------------	----	------------------------	--

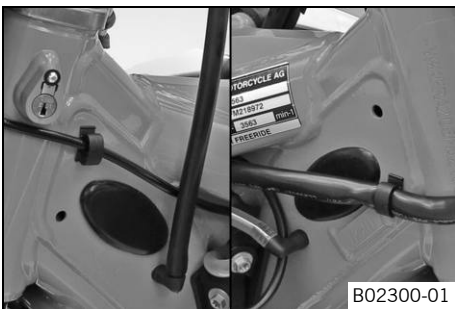

- Secure the cable holder on both sides.

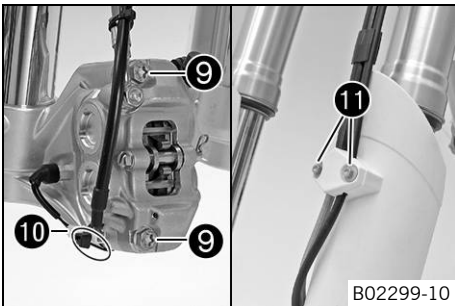

- Position the brake caliper. Mount and tighten screws 9 with the spacers.

Guideline

Screw, front brake caliper	M8	25 Nm (18.4 lbf ft)	Loctite® 243™
----------------------------	----	------------------------	---------------

- Connect the plug-in connector 10 and mount the cable ties(s).
- Position the brake line, wiring harness, and clamp. Mount and tighten screws 11.

### Finishing work

- Install the front fender. (☛ p. 45)
- Install the front wheel. ☛ (☛ p. 67)
- Refit the headlight mask with the headlight. (☛ p. 75)
- Check that the wiring harness, throttle cables, and brake and clutch lines can move freely and are routed correctly.
- Check the steering head bearing play. (☛ p. 42)
- Remove the motorcycle from the lift stand. (☛ p. 37)
- Check the headlight setting. (☛ p. 77)

## 12.11 Checking the steering head bearing play

**Warning**  
**Danger of accidents** Unstable vehicle handling from incorrect steering head bearing play.

- Adjust the steering head bearing play without delay. (Your authorized KTM workshop will be glad to help.)

**Info**  
 If the bike is ridden with play in the steering head bearing, the bearing and the bearing seats in the frame can become damaged over time.

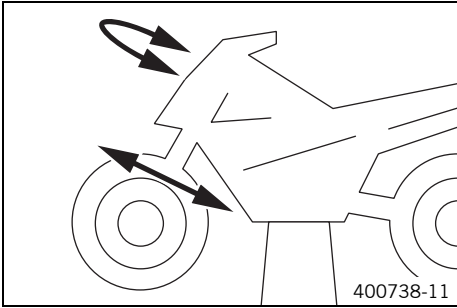

**Preparatory work**

- Raise the motorcycle with the lift stand. (☛ p. 37)

**Main work**

- Move the handlebar to the straight-ahead position. Move the fork legs to and fro in the direction of travel.

No play should be noticeable in the steering head bearing.

- » If there is noticeable play present:
  - Adjust the play of the steering head bearing. ☛ (☛ p. 43)
- Move the handlebar to and fro over the entire steering range.

The handlebar must be able to move easily over the entire steering range. No resting locations should be noticeable.

- » If click positions are noticeable:
  - Adjust the play of the steering head bearing. ☛ (☛ p. 43)
  - Check the steering head bearing and replace if required.

**Finishing work**

- Remove the motorcycle from the lift stand. (☛ p. 37)

**12.12 Adjusting the play of the steering head bearing ☛**

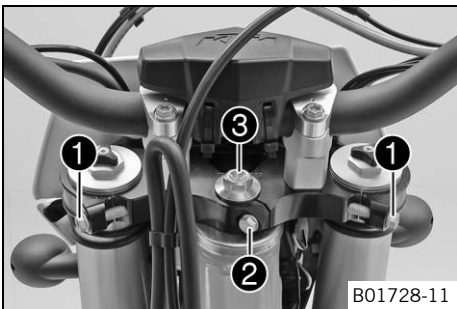

**Preparatory work**

- Raise the motorcycle with the lift stand. (☛ p. 37)

**Main work**

- Loosen screws ①. Remove screw ②.
- Loosen and retighten screw ③.

**Guideline**

Screw, top steering head	M20x1.5	12 Nm (8.9 lbf ft)
--------------------------	---------	--------------------

- Using a plastic hammer, tap lightly on the upper triple clamp to avoid strains.
- Tighten screws ①.

**Guideline**

Screw, top triple clamp	M8	22 Nm (16.2 lbf ft)
-------------------------	----	---------------------

- Mount and tighten screw ②.

**Guideline**

Screw, top steering stem	M8	17 Nm (12.5 lbf ft)	Loctite® 243™
--------------------------	----	---------------------	---------------

**Finishing work**

- Check the steering head bearing play. (☛ p. 42)
- Remove the motorcycle from the lift stand. (☛ p. 37)

**12.13 Greasing the steering head bearing ☛**

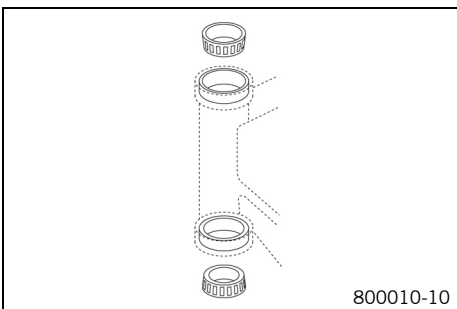

- Remove the lower triple clamp. ☛ (☛ p. 40)
- Install the lower triple clamp. ☛ (☛ p. 41)

## 12.14 Removing the shock absorber

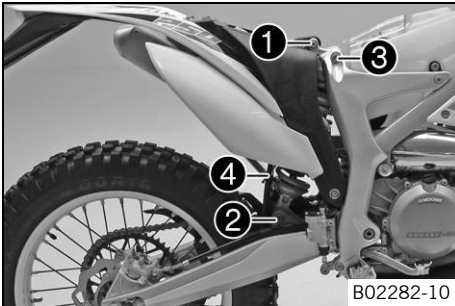

### Preparatory work

- Raise the motorcycle with the lift stand. (☛ p. 37)
- Fold the seat up. (☛ p. 45)

### Main work

- Remove screw ①.
- Remove screw ② and lower the rear wheel with the swing arm as far as possible without blocking the rear wheel. Fix the rear wheel in this position.
- Remove screw ③.
- Push splash protector ④ to the side and remove the shock absorber.

## 12.15 Installing the shock absorber

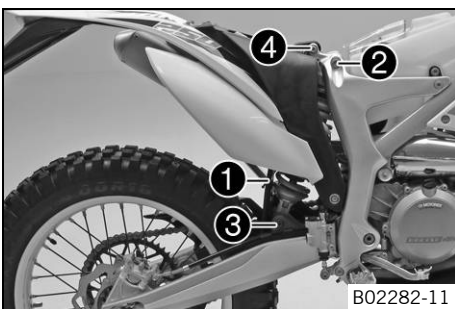

### Main work

- Push splash protector ① to the side and position the shock absorber. Mount and tighten screw ②.

#### Guideline

Screw, top shock absorber	M12	80 Nm (59 lbf ft)	Loctite® 2701™
---------------------------	-----	----------------------	----------------

- Mount and tighten screw ③.

#### Guideline

Screw, bottom shock absorber	M12	80 Nm (59 lbf ft)	Loctite® 2701™
------------------------------	-----	----------------------	----------------

### **i** Info

The heim joint for the shock absorber at the swing arm is Teflon coated. It must not be greased with grease or with other lubricants. Lubricants dissolve the Teflon coating, thereby drastically reducing the service life.

- Mount and tighten screw ④.

#### Guideline

Screw, upper subframe	M10	45 Nm (33.2 lbf ft)	Loctite® 243™
-----------------------	-----	------------------------	---------------

### Finishing work

- Lock the seat. (☛ p. 45)
- Remove the motorcycle from the lift stand. (☛ p. 37)

## 12.16 Removing the front fender

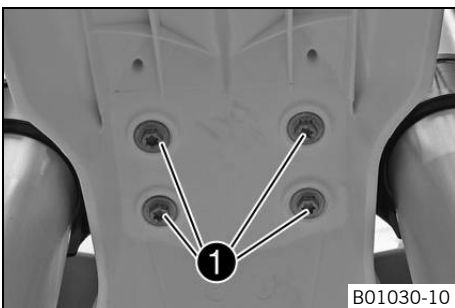

- Remove screws ①. Remove the front fender.
- Ensure that the spacers remain in place.

## 12.17 Installing the front fender

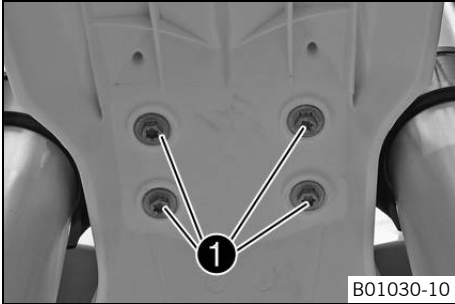

- Ensure that the spacers are mounted in the fender.
- Position the front fender. Mount and tighten screws ①.

Guideline

Remaining screws, chassis	M6	10 Nm (7.4 lbf ft)
---------------------------	----	--------------------



### Info

Make sure the holding lugs engage in the headlight mask.

## 12.18 Folding the seat up

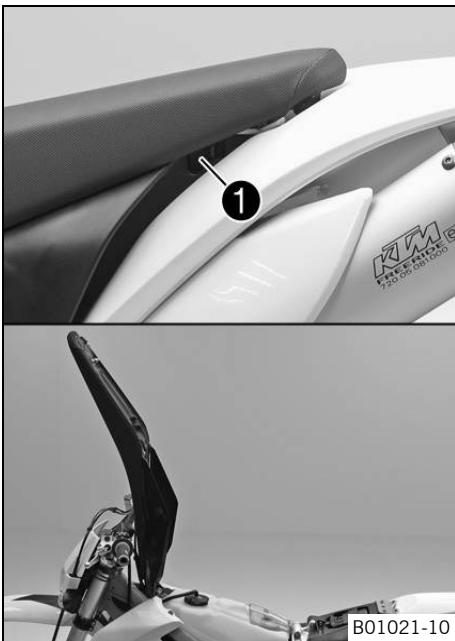

- Press release lever ①.
- Lift the seat and fold it up.

## 12.19 Locking the seat



- Fold down the seat and push it down.
  - ✓ The seat engages with an audible click.
- Finally, check that the seat is correctly locked.

## 12.20 Removing the air filter housing 🛠️

### Note

**Engine failure** Unfiltered intake air has a negative effect on the service life of the engine.

- Never operate the vehicle without an air filter as dust and dirt will enter the engine and lead to increased wear.

### Preparatory work

- Fold the seat up. (👉 p. 45)

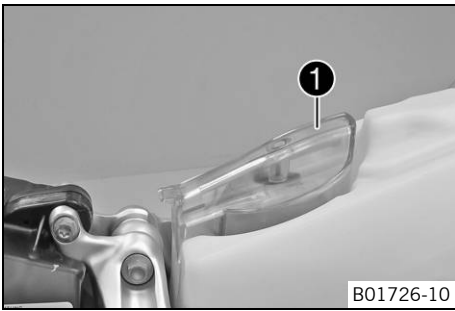

**Main work**

- Pull air filter housing ① up and off.

## 12.21 Installing the air filter housing

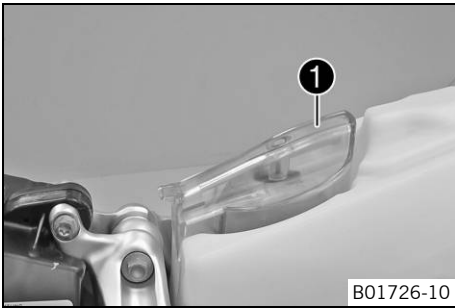

**Main work**

- Mount air filter housing ① on the intake flange.



**Info**

If the air filter housing is not mounted correctly, dust and dirt may enter the engine and cause damage.

**Finishing work**

- Lock the seat. (☞ p. 45)

## 12.22 Removing the air filter

**Note**

**Engine failure** Unfiltered intake air has a negative effect on the service life of the engine.

- Never operate the vehicle without an air filter as dust and dirt will enter the engine and lead to increased wear.



**Warning**

**Environmental hazard** Hazardous substances cause environmental damage.

- Oil, grease, filters, fuel, cleaners, brake fluid, etc., should be disposed of as stipulated in applicable regulations.

**Preparatory work**

- Fold the seat up. (☞ p. 45)
- Remove the air filter housing. ☞ (☞ p. 45)

**Main work**

- Open air filter housing ① by turning counterclockwise and take out air filter ③ with air filter support ②.
- Take off air filter ③ from air filter support ②.

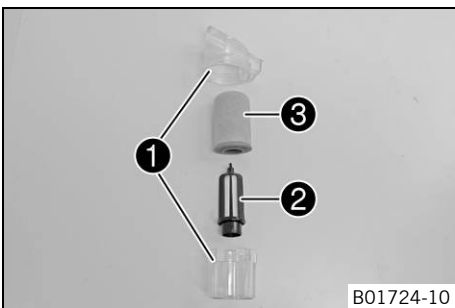

## 12.23 Installing the air filter

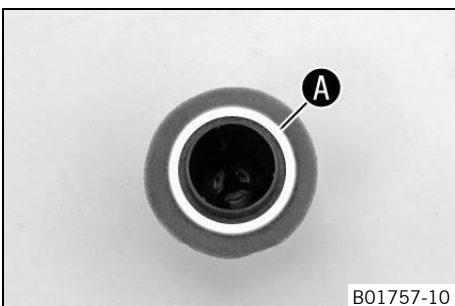

**Main work**

- Mount the clean air filter onto the air filter support.
- Apply grease to the air filter around area A.

Long-life grease (☞ p. 103)



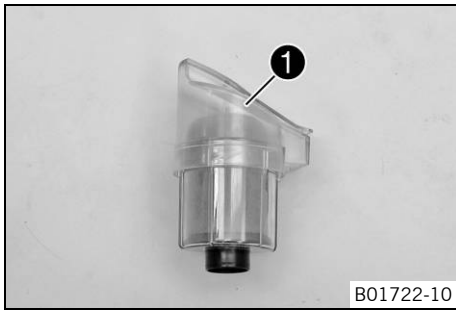

- Insert both parts together and close air filter housing **1** by turning clockwise.



**Info**

If the air filter is not mounted correctly, dust and dirt may enter the engine and cause damage.

**Finishing work**

- Install the air filter housing. ↘ (☞ p. 46)
- Lock the seat. (☞ p. 45)

## 12.24 Cleaning the air filter and air filter housing ↘



**Warning**

**Environmental hazard** Hazardous substances cause environmental damage.

- Oil, grease, filters, fuel, cleaners, brake fluid, etc., should be disposed of as stipulated in applicable regulations.



**Info**

Do not clean the air filter with fuel or petroleum since these substances attack the foam.

**Preparatory work**

- Fold the seat up. (☞ p. 45)
- Remove the air filter housing. ↘ (☞ p. 45)
- Remove the air filter. ↘ (☞ p. 46)

**Main work**

- Wash the air filter thoroughly in special cleaning liquid and allow it to dry properly.

Air filter cleaner (☞ p. 103)



**Info**

Only press the air filter to dry it, never wring it out.

- Oil the dry air filter with a high quality filter oil.

Oil for foam air filter (☞ p. 103)

- Clean the air filter housing.
- Check the intake flange for damage and ensure it is firmly seated.

**Finishing work**

- Install the air filter. ↘ (☞ p. 46)
- Install the air filter housing. ↘ (☞ p. 46)
- Lock the seat. (☞ p. 45)



## 12.25 Removing the main silencer



**Warning**

**Danger of burns** The exhaust system gets very hot when the vehicle is driven.

- Allow the exhaust system to cool down. Do not touch hot components.

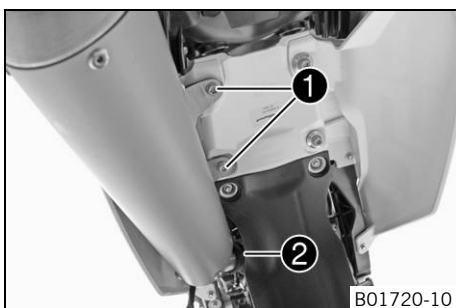

- Remove screws **1**.
- Pull off the main silencer from the manifold at rubber sleeve **2**.

## 12.26 Installing the main silencer

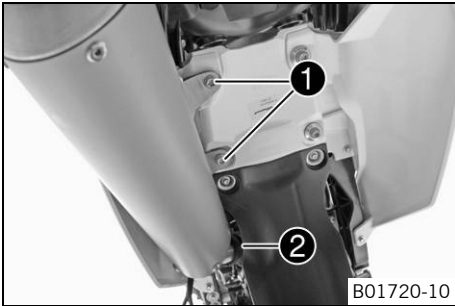

- Mount the main silencer with rubber sleeve ②.
- Mount and tighten screws ①.

Guideline

Remaining screws, chassis	M8	25 Nm (18.4 lbf ft)
---------------------------	----	------------------------

## 12.27 Changing the glass fiber yarn filling of the main silencer



### Warning

**Danger of burns** The exhaust system gets very hot when the vehicle is driven.

- Allow the exhaust system to cool down. Do not touch hot components.



### Info

Over a period, the fibers of the glass fiber yarn vanish into the air, and the silencer "burns out". Not only is the noise level higher, the performance characteristic changes.

### Preparatory work

- Remove the main silencer. (☛ p. 47)

### Main work

- Remove screws ①. Pull out connecting cap ②.
- Pull glass fiber yarn filling ③ from the connecting cap.
- Clean the parts that are to be reinstalled.
- Mount the new glass fiber yarn filling ③ on the connecting cap.
- Slide main silencer sleeve ④ over the connecting cap with the new glass fiber yarn filling.
- Mount and tighten all screws ①.

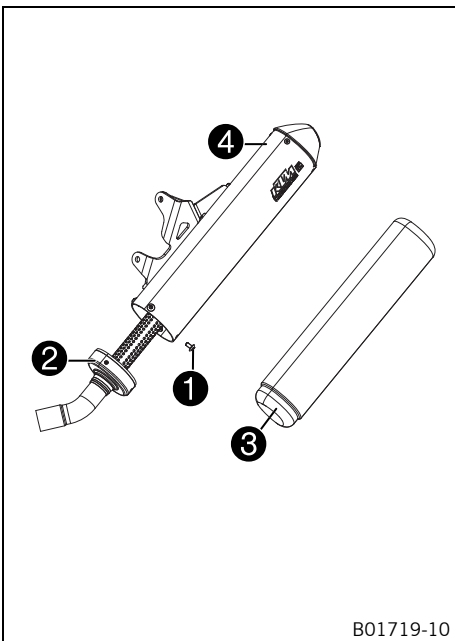

### Finishing work

- Install the main silencer. (☛ p. 48)

## 12.28 Removing the fuel tank



### Danger

**Fire hazard** Fuel is highly flammable.

- Never refuel the vehicle near open flames or burning cigarettes, and always switch off the engine first. Be careful that no fuel is spilt, especially on hot vehicle components. Clean up spilt fuel immediately.
- The fuel in the fuel tank expands when warm and may emerge if overfilled. Follow the instructions on refueling.



**Warning**

**Danger of poisoning** Fuel is poisonous and a health hazard.

- Fuel must not come into contact with the skin, eyes, or clothing. Do not breathe in the fuel vapors. If contact occurs with the eyes, rinse with water immediately and contact a physician. Immediately clean contaminated areas on the skin with soap and water. If fuel is swallowed, contact a physician immediately. Change clothing that is contaminated with fuel. Store fuel properly in a suitable canister and keep away from children.

**Preparatory work**

- Fold the seat up. (☛ p. 45)

**Main work**

- Turn handle ❶ of the fuel tap to the **OFF** position. (Figure B01660-10☛ p. 15)
- Pull off the fuel hose.



**Info**

Remaining fuel may flow out of the fuel hose.

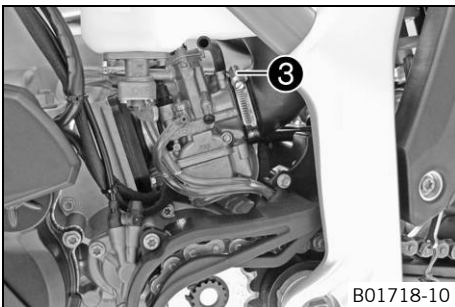
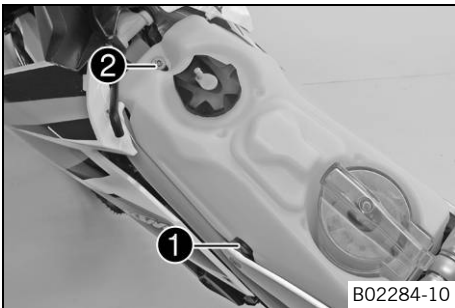

- Remove the tube from the fuel tank breather.
- Remove screws ❶ on both sides.
- Remove screw ❷.
- Release hose clamp ❸.
- Detach the intake flange from the carburetor.
- Remove the fuel tank from above.

**12.29 Installing the fuel tank ☛**



**Danger**

**Fire hazard** Fuel is highly flammable.

- Never refuel the vehicle near open flames or burning cigarettes, and always switch off the engine first. Be careful that no fuel is spilt, especially on hot vehicle components. Clean up spilt fuel immediately.
- The fuel in the fuel tank expands when warm and may emerge if overfilled. Follow the instructions on refueling.



**Warning**

**Danger of poisoning** Fuel is poisonous and a health hazard.

- Fuel must not come into contact with the skin, eyes, or clothing. Do not breathe in the fuel vapors. If contact occurs with the eyes, rinse with water immediately and contact a physician. Immediately clean contaminated areas on the skin with soap and water. If fuel is swallowed, contact a physician immediately. Change clothing that is contaminated with fuel.

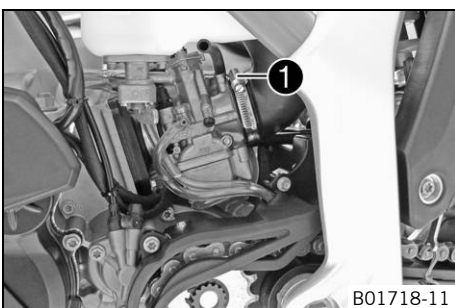

**Main work**

- Check the throttle cable routing. (☛ p. 54)
- Make sure that no cables are trapped or damaged.
- Position the fuel tank.
- Position the intake flange on the carburetor.
- Tighten hose clamp ❶.
- Connect the fuel hose.



**Info**

Route the cable and fuel line at a safe distance from the exhaust system.

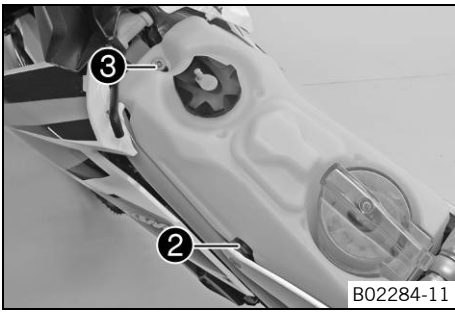

- Mount and tighten screws ② on both sides.

Guideline

Screw, fuel tank	M8	15 Nm (11.1 lbf ft)	Loctite® 243™
------------------	----	------------------------	---------------

- Mount and tighten screw ③.

Guideline

Remaining screws, chassis	M6	10 Nm (7.4 lbf ft)	
---------------------------	----	--------------------	--

- Mount the fuel tank breather.

**Finishing work**

- Lock the seat. (☛ p. 45)

## 12.30 Checking for chain dirt accumulation

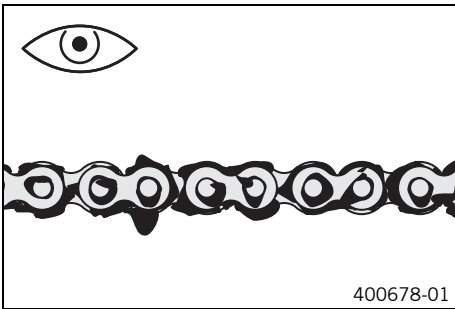

- Check the chain for coarse dirt accumulation.
  - » If the chain is very dirty:
    - Clean the chain. (☛ p. 50)

## 12.31 Cleaning the chain

**Warning**  
**Danger of accidents** Oil or grease on the tires reduces their grip.  
 - Remove oil and grease with a suitable cleaning material.

**Warning**  
**Danger of accidents** Reduced braking efficiency due to oil or grease on the brake discs.  
 - Always keep the brake discs free of oil and grease, and clean them with brake cleaner when necessary.

**Warning**  
**Environmental hazard** Hazardous substances cause environmental damage.  
 - Oil, grease, filters, fuel, cleaners, brake fluid, etc., should be disposed of as stipulated in applicable regulations.

**i Info**  
 The service life of the chain depends largely on its maintenance.

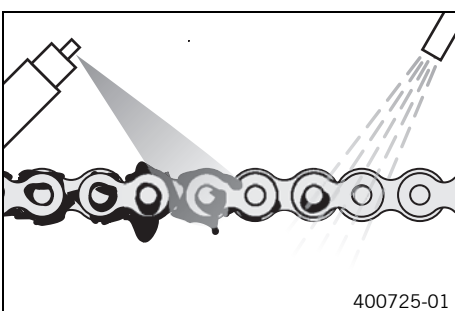

**Preparatory work**

- Raise the motorcycle with the lift stand. (☛ p. 37)

**Main work**

- Clean the chain regularly and then treat with chain spray.

Chain cleaner (☛ p. 103)
Off-road chain spray (☛ p. 103)

**Finishing work**

- Remove the motorcycle from the lift stand. (☛ p. 37)

## 12.32 Checking the chain tension

**Warning**  
**Danger of accidents** Danger caused by incorrect chain tension.

- If the chain is too taut, the components of the secondary power transmission (chain, engine sprocket, rear sprocket, bearings in the transmission and in the rear wheel) will be under additional load. In addition to premature wear, this can cause the chain or the countershaft of the transmission to break in extreme cases. If the chain is too loose, however, it may fall off the engine sprocket or rear sprocket and block the rear wheel or damage the engine. Ensure that the chain tension is correct and adjust it if necessary.

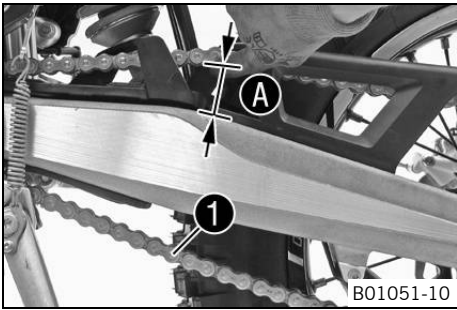

**Preparatory work**

- Raise the motorcycle with the lift stand. (☛ p. 37)

**Main work**

- Push the chain at the end of the chain sliding component upwards to measure the chain tension **A**.

**Info**

The lower chain section **1** must be taut.  
 Chain wear is not always even, so you should repeat this measurement at different chain positions.

Chain tension	36... 40 mm (1.42... 1.57 in)
---------------	-------------------------------

- » If the chain tension does not meet specifications:
  - Adjust the chain tension. (☛ p. 51)

**Finishing work**

- Remove the motorcycle from the lift stand. (☛ p. 37)

## 12.33 Adjusting the chain tension

**Warning**  
**Danger of accidents** Danger caused by incorrect chain tension.

- If the chain is too taut, the components of the secondary power transmission (chain, engine sprocket, rear sprocket, bearings in the transmission and in the rear wheel) will be under additional load. In addition to premature wear, this can cause the chain or the countershaft of the transmission to break in extreme cases. If the chain is too loose, however, it may fall off the engine sprocket or rear sprocket and block the rear wheel or damage the engine. Ensure that the chain tension is correct and adjust it if necessary.

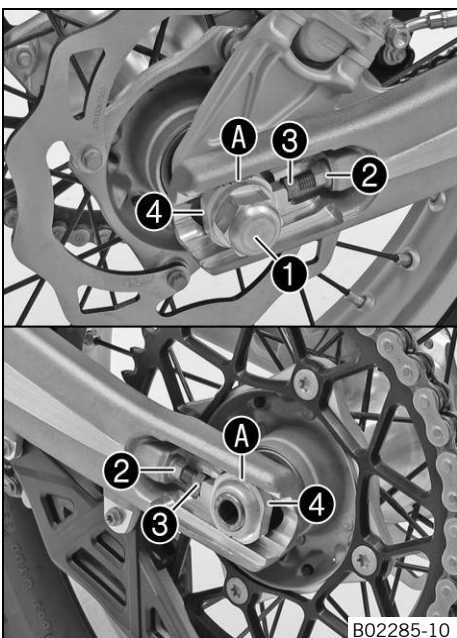

**Preparatory work**

- Raise the motorcycle with the lift stand. (☛ p. 37)
- Check the chain tension. (☛ p. 51)

**Main work**

- Loosen nut **1**.
- Loosen nuts **2**.
- Adjust the chain tension by turning adjusting screws **3** on the left and right.

**Guideline**

Chain tension	36... 40 mm (1.42... 1.57 in)
Turn adjusting screws <b>3</b> on the left and right so that the markings on the left and right chain adjusters are in the same position relative to reference marks <b>A</b> . The rear wheel is then correctly aligned.	

- Tighten nuts **2**.
- Make sure that chain adjusters **4** are fitted correctly on adjusting screws **3**.
- Tighten nut **1**.

**Guideline**

Nut, rear wheel spindle	M20x1.5	80 Nm (59 lbf ft)
-------------------------	---------	-------------------

**i Info**  
The wide adjustment range of the chain adjusters enables different secondary ratios with the same chain length.  
Chain adjusters **4** can be turned by 180°.

**Finishing work**

- Remove the motorcycle from the lift stand. (☛ p. 37)

## 12.34 Checking the chain, rear sprocket, engine sprocket and chain guide

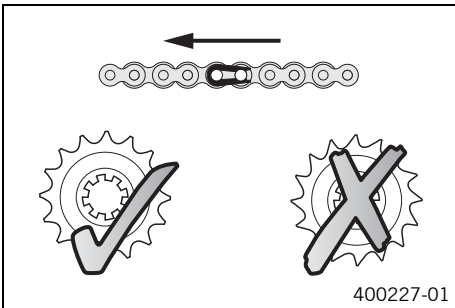

**Preparatory work**

- Raise the motorcycle with the lift stand. (☛ p. 37)

**Main work**

- Shift gear to neutral.
- Check the rear sprocket and engine sprocket for wear.
  - » If the rear sprocket and engine sprocket are worn:
    - Change the drivetrain kit. ☛

**i Info**  
The engine sprocket, rear sprocket and chain should always be replaced together.

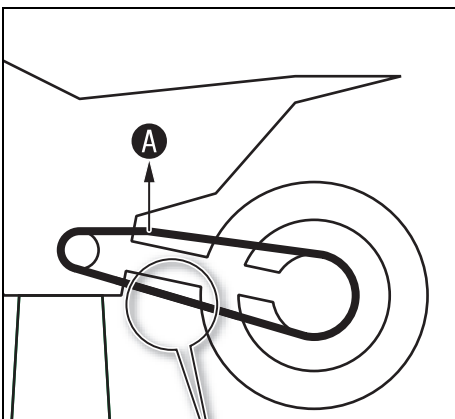

- Pull on the upper part of the chain with the specified weight **A**.

**Guideline**

Weight, chain wear measurement	10... 15 kg (22... 33 lb.)
--------------------------------	----------------------------

- Measure the distance **B** of 18 chain links in the lower chain section.

**i Info**  
Chain wear is not always even, so you should repeat this measurement at different chain positions.

Maximum distance <b>B</b> at the longest chain section	272 mm (10.71 in)
--	-------------------

- » If the distance **B** is greater than the specified measurement:
  - Change the power set. ☛

**i Info**  
When the chain is replaced, the rear sprocket and engine sprocket should also be changed.  
New chains wear out faster on old, worn sprockets.

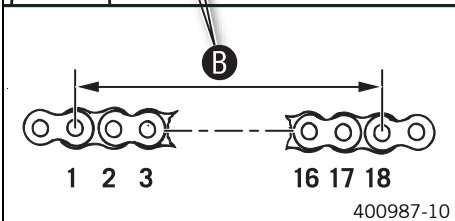

- Check the chain sliding guard for wear.
  - » If the bottom edge of the chain bolt is in line with or below the chain sliding guard:
    - Change the chain sliding guard. ☛
- Check that the chain sliding guard is firmly seated.
  - » If the chain sliding guard is loose:
    - Tighten the chain sliding guard.

**Guideline**

Remaining screws, chassis	M6	10 Nm (7.4 lbf ft)
---------------------------	----	--------------------





B01715-10

- Check the chain sliding piece for wear.
  - » If the bottom edge of the chain bolt is in line with or below the chain sliding piece:
    - Change the chain sliding piece. 🛠️
- Check that the chain sliding piece is firmly seated.
  - » If the chain sliding piece is loose:
    - Tighten the chain sliding piece.

Guideline

Screw, chain sliding piece	M8	15 Nm (11.1 lbf ft)
----------------------------	----	------------------------

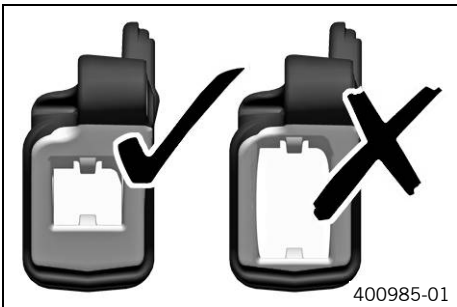

400985-01

- Check the chain guide for wear.



**Info**

Wear can be seen on the front of the chain guide.

- » If the light part of the chain guide is worn:
  - Change the chain guide. 🛠️



B01713-01

- Check that the chain guide is firmly seated.
  - » If the chain guide is loose:
    - Tighten the chain guide.

Guideline

Remaining screws, chassis	M6	10 Nm (7.4 lbf ft)
Remaining nuts, chassis	M6	10 Nm (7.4 lbf ft)

**Finishing work**

- Remove the motorcycle from the lift stand. (👉 p. 37)

**12.35 Checking the frame 🛠️**

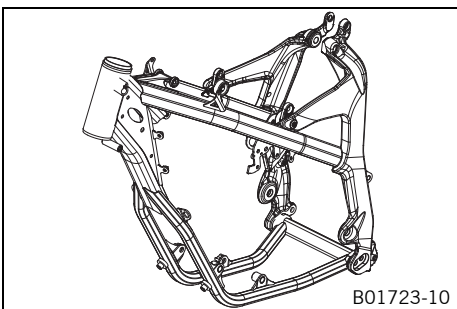

B01723-10

- Check the frame for cracking and deformation.
  - » If the frame exhibits cracking or deformation due to a mechanical impact:
    - Change the frame. 🛠️



**Info**

A frame that has been damaged due to a mechanical impact must always be changed. Repair of the frame is not authorized by KTM.

## 12.36 Checking the swingarm ↩



- Check the swingarm for damage, cracking, and deformation.
  - » If the swingarm shows signs of damage, cracking, or deformation:
    - Change the swingarm. ↩



### Info

A damaged swingarm must always be changed. Repair of the swingarm is not authorized by KTM.

## 12.37 Checking the throttle cable routing



### Preparatory work

- Fold the seat up. (↩ p. 45)
- Remove the fuel tank. ↩ (↩ p. 48)

### Main work

- Check the throttle cable routing.

The throttle cable must be routed to the carburetor along the back of the handlebar, below the seat fixing.

- » If the throttle cable is not routed as specified:
  - Correct the throttle cable routing.

### Finishing work

- Install the fuel tank. ↩ (↩ p. 49)
- Lock the seat. (↩ p. 45)

## 12.38 Checking the rubber grip

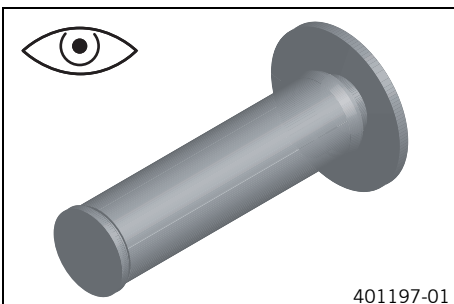

- Check the rubber grips on the handlebar for damage and wear and to ensure they are firmly seated.
  - » If a rubber grip is damaged, worn, or loose:
    - Change and secure the rubber grip.

Rubber grip adhesive (00062030051) (↩ p. 103)



## 12.39 Additionally securing the rubber grip

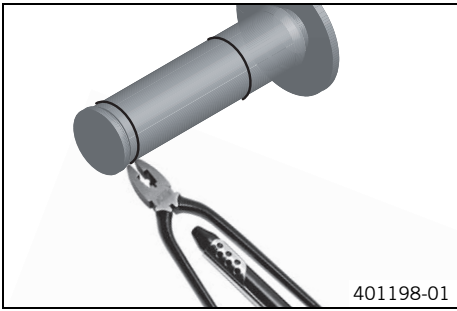

### Preparatory work

- Check the rubber grip. (☛ p. 54)

### Main work

- Secure the rubber grip at two points using the securing wire.

Securing wire (54812016000)
Wire twister forceps (U6907854)

- ✓ The twisted wire ends face away from the hands and are bent toward the rubber grip.

## 12.40 Adjusting the basic position of the clutch lever

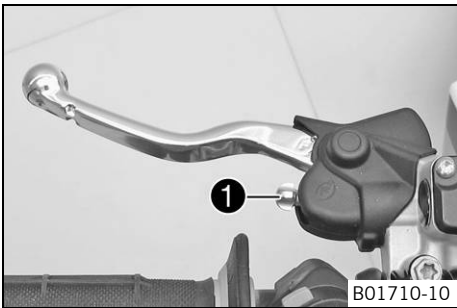

- Adjust the basic position of the clutch lever to your hand size by turning adjusting screw 1.

### Info

When the adjusting screw is turned clockwise, the clutch lever moves away from the handlebar.  
 When the adjusting screw is turned counterclockwise, the clutch lever moves closer to the handlebar.  
 The range of adjustment is limited.  
 Turn the adjusting screw by hand only, and do not apply force.  
 Do not make any adjustments while riding!

## 12.41 Checking fluid level of the hydraulic clutch

**Info**  
 The fluid level rises with increasing wear of the clutch facing discs.

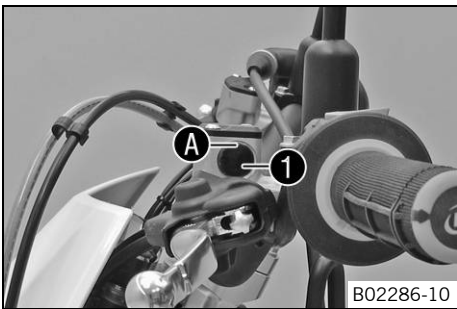

- Move the clutch fluid reservoir mounted on the handlebar to a horizontal position.
- Check the fluid level in viewer 1.
  - » If the fluid has dropped below marking A in the level viewer:
    - Correct the fluid level of the hydraulic clutch. (☛ p. 55)

## 12.42 Correcting the fluid level of the hydraulic clutch

**Info**  
 The fluid level rises with increasing wear of the clutch facing discs.

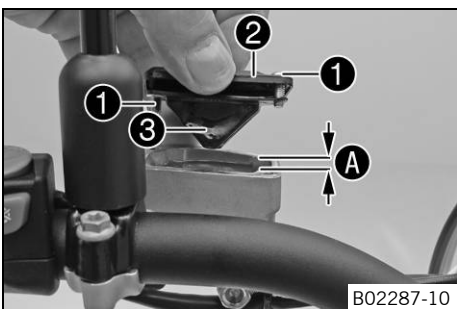

- Move the clutch fluid reservoir mounted on the handlebar to a horizontal position.
- Remove screws 1.
- Remove cover 2 with membrane 3.
- Add fluid to level A.

### Guideline

Level A (fluid level below container rim)	4 mm (0.16 in)
---	----------------

Brake fluid DOT 4 / DOT 5.1 (☛ p. 101)

- Position the cover with the membrane. Mount and tighten the screws.



**Info**

Clean up overflowed or spilt brake fluid immediately with water.

## 12.43 Changing the hydraulic clutch fluid



**Warning**

**Environmental hazard** Hazardous substances cause environmental damage.

- Oil, grease, filters, fuel, cleaners, brake fluid, etc., should be disposed of as stipulated in applicable regulations.

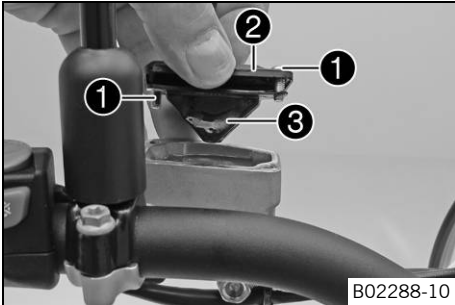

B02288-10

- Move the clutch fluid reservoir mounted on the handlebar to a horizontal position.
- Remove screws ①.
- Remove cover ② with membrane ③.

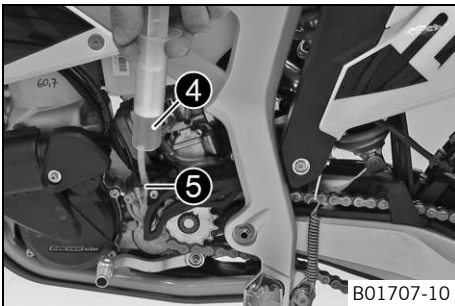

B01707-10

- Fill bleeding syringe ④ with the appropriate hydraulic fluid.

Bleed syringe (50329050000)
-----------------------------

Brake fluid DOT 4 / DOT 5.1 (☞ p. 101)
--

- On the clutch slave cylinder, remove bleeder screw ⑤ and mount bleeding syringe ④.



B02289-10

- Inject the liquid into the system until it escapes from opening A of the master cylinder without bubbles.
- To prevent overflow, drain fluid occasionally from the master cylinder reservoir.
- Remove the bleeding syringe. Mount and tighten screws bleeder screw.
- Correct the fluid level of the hydraulic clutch.

**Guideline**

Fluid level below container rim	4 mm (0.16 in)
---------------------------------	----------------

- Position the cover with the membrane. Mount and tighten the screws.

## 12.44 Removing the engine guard

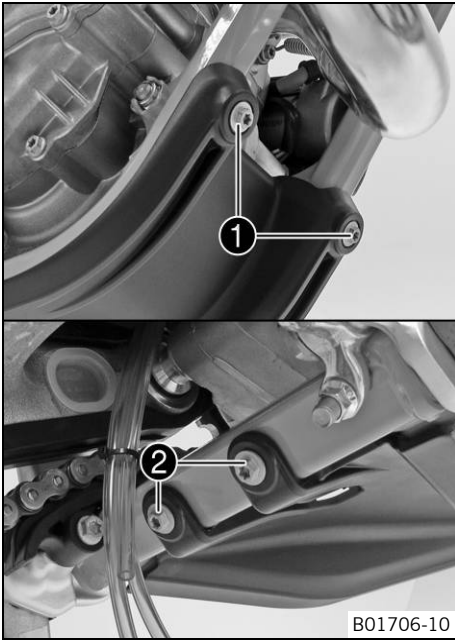

- Remove screws ❶ and ❷.
- Lower the engine guard at the rear and remove it toward the front.

## 12.45 Installing the engine guard

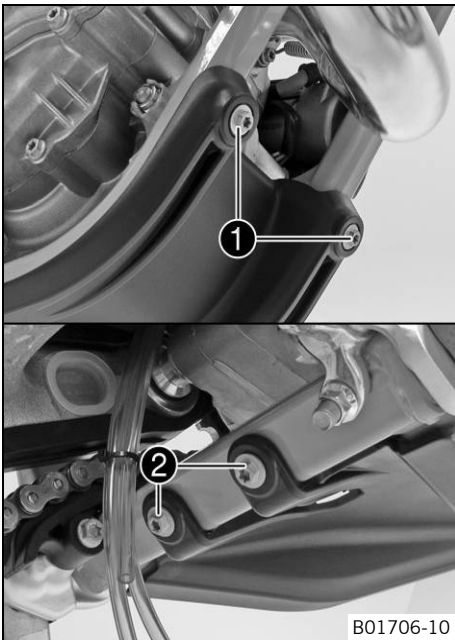

- Position the engine guard on the frame at the front and mount screws ❶ but do not tighten yet.
- Position the engine guard on the frame at the rear and mount and tighten screws ❷.

Guideline

Remaining screws, chassis	M6	10 Nm (7.4 lbf ft)
---------------------------	----	--------------------

- Tighten screws ❶.

Guideline

Remaining screws, chassis	M6	10 Nm (7.4 lbf ft)
---------------------------	----	--------------------

## 13.1 Checking the free travel of the hand brake lever

**Warning**  
**Danger of accidents** Brake system failure.

- If there is no free travel on the hand brake lever, pressure builds up on the front brake circuit. The front brake can fail due to overheating. Adjust the free travel on hand brake lever according to specifications.

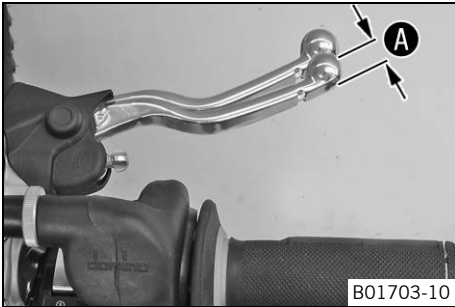

- Push the hand brake to the handlebar and check free travel **A**.

Free travel of hand brake lever	$\geq 3 \text{ mm } (\geq 0.12 \text{ in})$
---------------------------------	---

- » If the free travel does not meet specifications:
  - Adjust the free travel of the handbrake lever. (☛ p. 58)

## 13.2 Adjusting the free travel of the handbrake lever

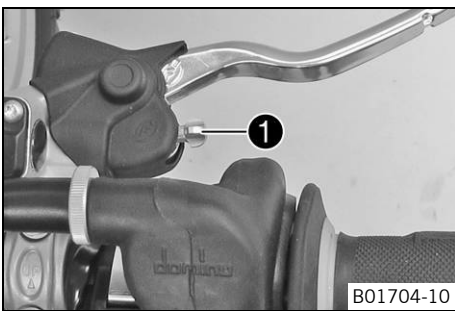

- Check the free travel of the hand brake lever. (☛ p. 58)
- Adjust the free travel of the handbrake lever with adjustment screw **1**.

**i Info**  
 When the adjusting screw is turned clockwise, the free travel decreases. The pressure point moves away from the handlebar.  
 When the adjusting screw is turned counterclockwise, the free travel increases. The pressure point moves towards the handlebar.  
 The range of adjustment is limited.  
 Turn the adjusting screw by hand only, and do not apply force.  
 Do not make any adjustments while riding!

## 13.3 Checking the brake discs

**Warning**  
**Danger of accidents** Reduced braking efficiency due to worn brake disc(s).

- Change the worn brake disc(s) without delay. (Your authorized KTM workshop will be glad to help.)

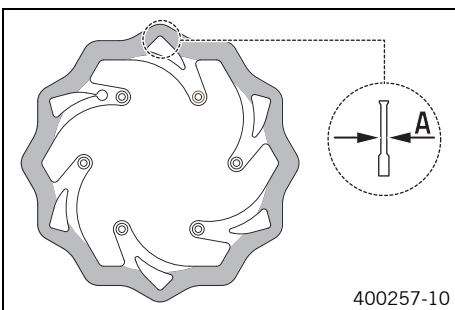

- Check the thickness of the front and rear brake discs at several places on the disk to see if it conforms to measurement **A**.

**i Info**  
 Wear reduces the thickness of the brake disc around the area used by the brake linings.

Brake discs - wear limit	
Front	2.5 mm (0.098 in)
Rear	3.5 mm (0.138 in)

- » If the brake disc thickness is less than the specified value:
  - Change the brake disc.
- Check the front and rear brake discs for damage, cracking and deformation.
  - » If the brake disc shows signs of damage, cracking, or deformation:
    - Change the brake disc.

## 13.4 Checking the brake fluid level of the front brake

**Warning**  
**Danger of accidents** Brake system failure.

- If the brake fluid level drops below the specified marking or the specified value, this is an indication that the brake system is leaking or that the brake linings are completely worn down. Check the brake system and do not continue riding. (Your authorized KTM workshop will be glad to help.)

**Warning**  
**Danger of accidents** Reduced braking efficiency due to old brake fluid.

- Change the brake fluid of the front and rear brake according to the service schedule. (Your authorized KTM workshop will be glad to help.)

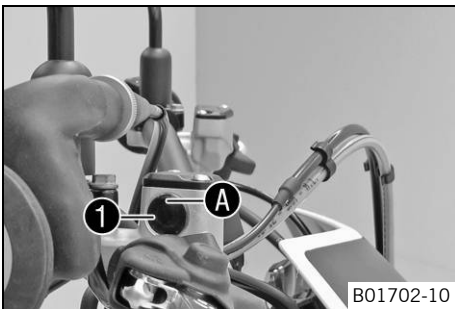

- Move the brake fluid reservoir mounted on the handlebar to a horizontal position.
- Check the brake fluid level in the viewer 1.
  - » If the brake fluid has dropped below marking A:
    - Add front brake fluid. (p. 59)

## 13.5 Adding front brake fluid

**Warning**  
**Danger of accidents** Brake system failure.

- If the brake fluid level drops below the specified marking or the specified value, this is an indication that the brake system is leaking or that the brake linings are completely worn down. Check the brake system and do not continue riding. (Your authorized KTM workshop will be glad to help.)

**Warning**  
**Skin irritation** Brake fluid can cause skin irritation on contact.

- Avoid contact with skin and eyes, and keep out of the reach of children.
- Wear suitable protective clothing and goggles.
- If brake fluid comes into contact with the eyes, flush the eyes thoroughly with water and consult a physician immediately.

**Warning**  
**Danger of accidents** Reduced braking efficiency due to old brake fluid.

- Change the brake fluid of the front and rear brake according to the service schedule. (Your authorized KTM workshop will be glad to help.)

**Warning**  
**Environmental hazard** Hazardous substances cause environmental damage.

- Oil, grease, filters, fuel, cleaners, brake fluid, etc., should be disposed of as stipulated in applicable regulations.

**Info**  
 Never use DOT 5 brake fluid! It is silicone-based and purple in color. Oil seals and brake lines are not designed for DOT 5 brake fluid.  
 Avoid contact between brake fluid and painted parts. Brake fluid attacks paint!  
 Use only clean brake fluid from a sealed container.

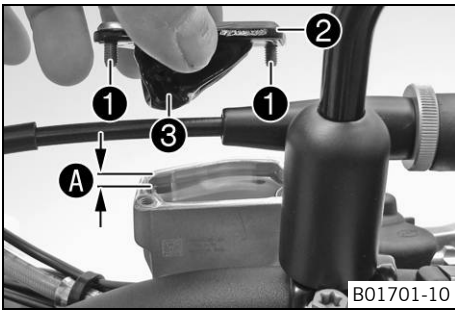

- Move the brake fluid reservoir mounted on the handlebar to a horizontal position.
- Remove screws ①.
- Remove cover ② with membrane ③.
- Add brake fluid to level A.

Guideline

Level A (brake fluid level below container rim)	5 mm (0.2 in)
---	---------------

Brake fluid DOT 4 / DOT 5.1 (☞ p. 101)
--

- Position the cover with the membrane. Mount and tighten the screws.

**i Info**  
Clean up overflowed or spilled brake fluid immediately with water.

## 13.6 Checking the front brake linings

**Warning**  
**Danger of accidents** Reduced braking efficiency caused by worn brake linings.

- Change worn brake linings immediately. (Your authorized KTM workshop will be glad to help.)

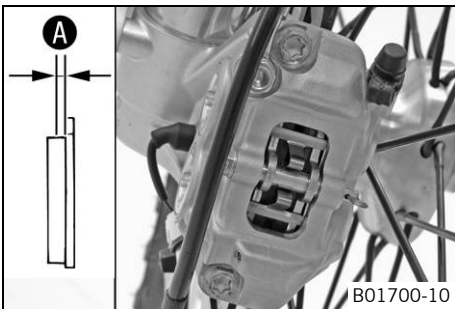

- Check the brake linings for minimum thickness A.

Minimum thickness A	≥ 1 mm (≥ 0.04 in)
---------------------	--------------------

- » If the minimum thickness is less than specified:
  - Change the front brake linings. ☞ (☞ p. 60)
- Check the brake linings for damage and cracking.
  - » If damage or cracking is visible:
    - Change the front brake linings. ☞ (☞ p. 60)

## 13.7 Changing the front brake linings ☞

**Warning**  
**Danger of accident** Brake system failure.

- Maintenance work and repairs must be carried out professionally. (Your authorized KTM workshop will be glad to help.)

**Warning**  
**Skin irritation** Brake fluid can cause skin irritation on contact.

- Avoid contact with skin and eyes, and keep out of the reach of children.
- Wear suitable protective clothing and goggles.
- If brake fluid comes into contact with the eyes, flush the eyes thoroughly with water and consult a physician immediately.

**Warning**  
**Danger of accidents** Reduced braking efficiency due to old brake fluid.

- Change the brake fluid of the front and rear brake according to the service schedule. (Your authorized KTM workshop will be glad to help.)

**Warning**  
**Danger of accidents** Reduced braking efficiency due to oil or grease on the brake discs.

- Always keep the brake discs free of oil and grease, and clean them with brake cleaner when necessary.

**Warning**  
**Danger of accidents** Reduced braking efficiency due to use of non-approved brake linings.

- Brake linings available from accessory suppliers are often not tested and approved for use on KTM vehicles. The construction and friction factor of the brake linings and therefore the brake power can differ considerably from the original KTM brake linings. If brake linings are used that differ from the originals, there is no guarantee that they comply with the original license. The vehicle no longer corresponds to the condition at delivery, and the warranty is no longer valid.



**Warning**

**Environmental hazard** Hazardous substances cause environmental damage.

- Oil, grease, filters, fuel, cleaners, brake fluid, etc., should be disposed of as stipulated in applicable regulations.



**Info**

Never use DOT 5 brake fluid! It is silicone-based and purple in color. Oil seals and brake lines are not designed for DOT 5 brake fluid.

Avoid contact between brake fluid and painted parts. Brake fluid attacks paint!

Use only clean brake fluid from a sealed container.

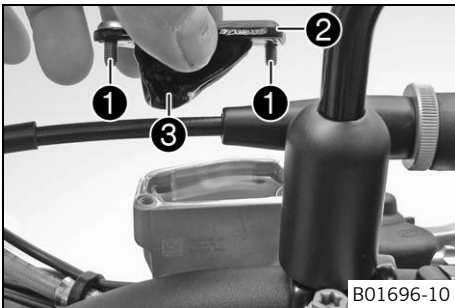

B01696-10

- Move the brake fluid reservoir mounted on the handlebar to a horizontal position.
- Remove screws ①.
- Remove cover ② with membrane ③.

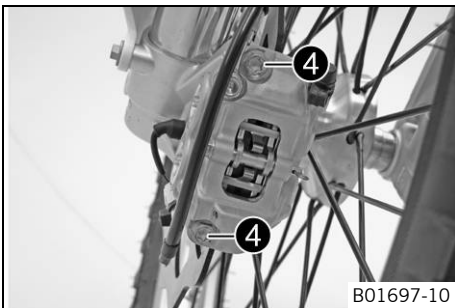

B01697-10

- Remove screws ④ and spacers.
- Press back the brake linings with a light lateral tilting of the brake caliper on the brake disc. Carefully pull the brake caliper backwards from the brake disc..
- Press the brake piston back to its basic position and make sure that no brake fluid overflows from the brake fluid reservoir.

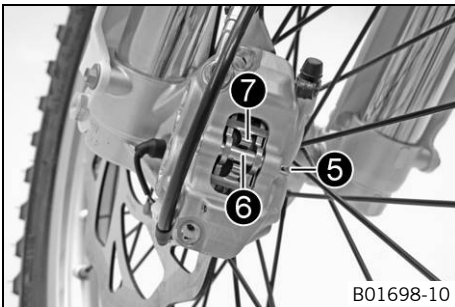

B01698-10

- Remove cotter pin ⑤.
- Remove pin ⑥.
- Take off retaining spring ⑦ and remove the brake linings.
- Clean the brake caliper.
- Position the new brake linings.



**Info**

Always change the full set of brake linings.

- Position retaining spring ⑦.
- Mount bolt ⑥.



**Info**

To make it easier to mount the pin, push the retainer spring down. Make sure the retaining spring is seated correctly.

- Mount cotter pin ⑤.
- Position the brake caliper. Mount screws ④ with the spacers but do not tighten yet.
- Operate the hand brake lever repeatedly until the brake linings are in contact with the brake disc and there is a pressure point. Fix the hand brake lever in the activated position.

✓ The brake caliper straightens.

- Tighten screws ④.

**Guideline**

Screw, front brake caliper	M8	25 Nm (18.4 lbf ft)	Loctite® 243™
----------------------------	----	------------------------	---------------

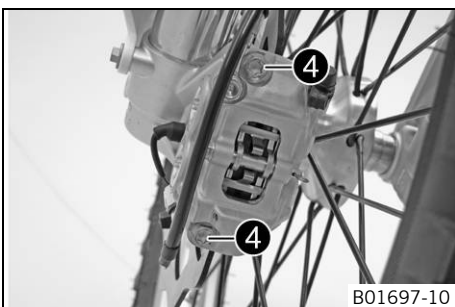

B01697-10

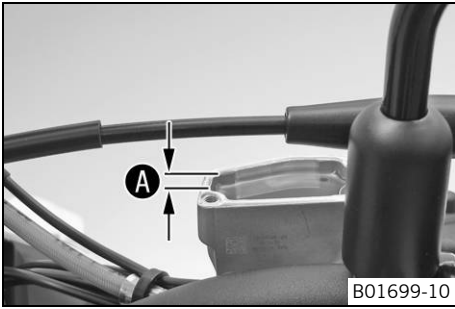

- Remove the fixation of the hand brake lever.
- Add brake fluid to level **A**.

Guideline

Level <b>A</b> (brake fluid level below container rim)	5 mm (0.2 in)
--	---------------

Brake fluid DOT 4 / DOT 5.1 (☞ p. 101)
--

- Position the cover with the membrane. Mount and tighten the screws.

**i Info**  
Clean up overflowed or spilt brake fluid immediately with water.

## 13.8 Checking the free travel of foot brake lever

**Warning**  
**Danger of accidents** Brake system failure.

- If there is no free travel on the foot brake lever, pressure builds up on the rear brake circuit. The rear brake can fail due to overheating. Adjust the free travel on foot brake lever according to specifications.

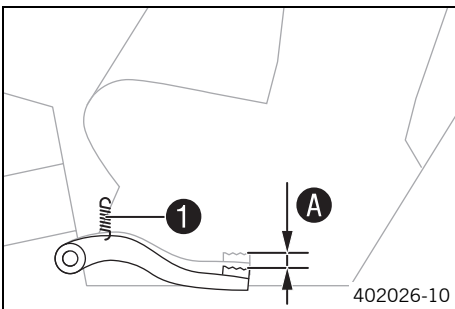

- Disconnect spring **1**.
- Move the foot brake lever back and forth between the end stop and the contact to the foot brake cylinder piston and check free travel **A**.

Guideline

Free travel at foot brake lever	3... 5 mm (0.12... 0.2 in)
---------------------------------	----------------------------

- » If the free travel does not meet specifications:
  - Adjust the basic position of the foot brake lever. ☞ (☞ p. 62)
- Reconnect spring **1**.

## 13.9 Adjusting the basic position of the foot brake lever ☞

**Warning**  
**Danger of accidents** Brake system failure.

- If there is no free travel on the foot brake lever, pressure builds up on the rear brake circuit. The rear brake can fail due to overheating. Adjust the free travel on foot brake lever according to specifications.

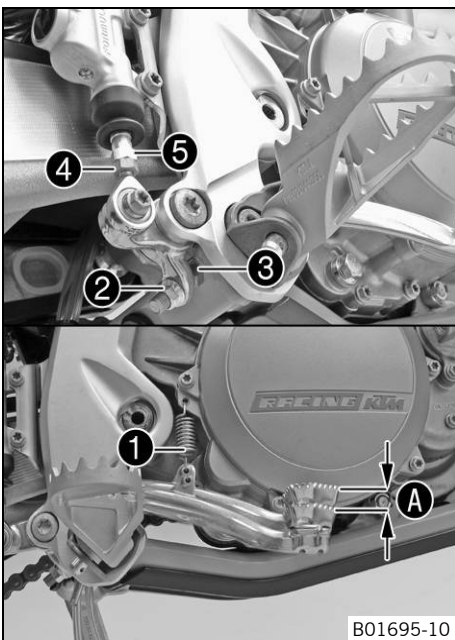

- Disconnect spring **1**.
- Loosen nut **4** and, with push rod **5**, turn it back until you have maximum free travel.
- To adjust the basic position of the foot brake lever individually, loosen nut **2** and turn screw **3** accordingly.

**i Info**  
The range of adjustment is limited.

- Turn push rod **5** accordingly until you have free travel **A**. If necessary, adjust the basic position of the foot brake lever.

Guideline

Free travel at foot brake lever	3... 5 mm (0.12... 0.2 in)
---------------------------------	----------------------------

- Hold screw **3** and tighten nut **2**.

Guideline

Nut, foot brake lever stop	M8	20 Nm (14.8 lbf ft)
----------------------------	----	---------------------

- Hold push rod **5** and tighten nut **4**.

Guideline

Remaining nuts, chassis	M6	10 Nm (7.4 lbf ft)
-------------------------	----	--------------------



- Reconnect spring ①.

### 13.10 Checking the rear brake fluid level



#### Warning

**Danger of accidents** Brake system failure.

- If the brake fluid level drops below the specified marking or the specified value, this is an indication that the brake system is leaking or that the brake linings are completely worn down. Check the brake system and do not continue riding. (Your authorized KTM workshop will be glad to help.)



#### Warning

**Danger of accidents** Reduced braking efficiency due to old brake fluid.

- Change the brake fluid of the front and rear brake according to the service schedule. (Your authorized KTM workshop will be glad to help.)

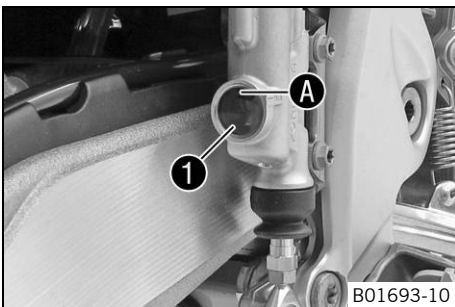

- Stand the vehicle upright.
- Check the brake fluid level in the viewer ①.
  - » If the brake fluid level drops below marking A:
    - Add rear brake fluid. ↗ (↖ p. 63)

### 13.11 Adding rear brake fluid ↗



#### Warning

**Danger of accidents** Brake system failure.

- If the brake fluid level drops below the specified marking or the specified value, this is an indication that the brake system is leaking or that the brake linings are completely worn down. Check the brake system and do not continue riding. (Your authorized KTM workshop will be glad to help.)



#### Warning

**Skin irritation** Brake fluid can cause skin irritation on contact.

- Avoid contact with skin and eyes, and keep out of the reach of children.
- Wear suitable protective clothing and goggles.
- If brake fluid comes into contact with the eyes, flush the eyes thoroughly with water and consult a physician immediately.



#### Warning

**Danger of accidents** Reduced braking efficiency due to old brake fluid.

- Change the brake fluid of the front and rear brake according to the service schedule. (Your authorized KTM workshop will be glad to help.)



#### Warning

**Environmental hazard** Hazardous substances cause environmental damage.

- Oil, grease, filters, fuel, cleaners, brake fluid, etc., should be disposed of as stipulated in applicable regulations.



#### Info

Never use DOT 5 brake fluid! It is silicone-based and purple in color. Oil seals and brake lines are not designed for DOT 5 brake fluid.

Avoid contact between brake fluid and painted parts. Brake fluid attacks paint!

Use only clean brake fluid from a sealed container.

#### Preparatory work

- Check the rear brake linings. (↖ p. 64)

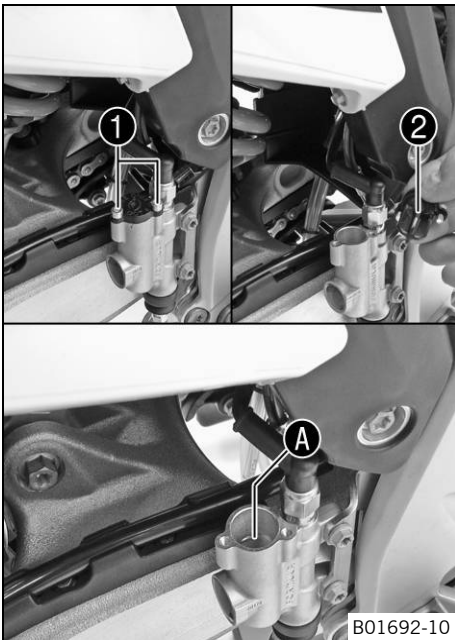

**Main work**

- Stand the vehicle upright.
- Remove screws ①.
- Remove cover with membrane ②.
- Add brake fluid to level A.

Brake fluid DOT 4 / DOT 5.1 (☞ p. 101)
--

- Mount the cover with the membrane.
- Mount and tighten the screws.

**i Info**

Clean up overflowed or spilt brake fluid immediately with water.

## 13.12 Checking the rear brake linings



**Warning**

**Danger of accidents** Reduced braking efficiency caused by worn brake linings.

- Change worn brake linings immediately. (Your authorized KTM workshop will be glad to help.)

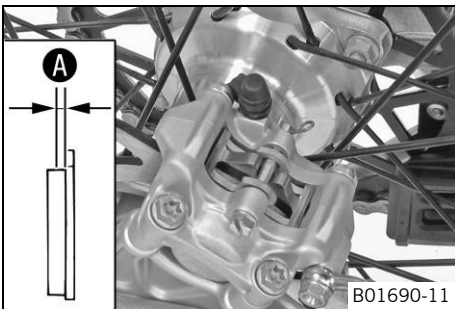

- Check the brake linings for minimum thickness A.

Minimum thickness A	≥ 1 mm (≥ 0.04 in)
---------------------	--------------------

- » If the minimum thickness is less than specified:
  - Change the rear brake linings. ☞ (☞ p. 64)
- Check the brake linings for damage and cracking.
  - » If damage or cracking is visible:
    - Change the rear brake linings. ☞ (☞ p. 64)

## 13.13 Changing the rear brake linings ☞



**Warning**

**Danger of accident** Brake system failure.

- Maintenance work and repairs must be carried out professionally. (Your authorized KTM workshop will be glad to help.)



**Warning**

**Skin irritation** Brake fluid can cause skin irritation on contact.

- Avoid contact with skin and eyes, and keep out of the reach of children.
- Wear suitable protective clothing and goggles.
- If brake fluid comes into contact with the eyes, flush the eyes thoroughly with water and consult a physician immediately.



**Warning**

**Danger of accidents** Reduced braking efficiency due to old brake fluid.

- Change the brake fluid of the front and rear brake according to the service schedule. (Your authorized KTM workshop will be glad to help.)



**Warning**

**Danger of accidents** Reduced braking efficiency due to oil or grease on the brake discs.

- Always keep the brake discs free of oil and grease, and clean them with brake cleaner when necessary.



**Warning**

**Danger of accidents** Reduced braking efficiency due to use of non-approved brake linings.

- Brake linings available from accessory suppliers are often not tested and approved for use on KTM vehicles. The construction and friction factor of the brake linings and therefore the brake power can differ considerably from the original KTM brake linings. If brake linings are used that differ from the originals, there is no guarantee that they comply with the original license. The vehicle no longer corresponds to the condition at delivery, and the warranty is no longer valid.



**Warning**

**Environmental hazard** Hazardous substances cause environmental damage.

- Oil, grease, filters, fuel, cleaners, brake fluid, etc., should be disposed of as stipulated in applicable regulations.



**Info**

Never use DOT 5 brake fluid! It is silicone-based and purple in color. Oil seals and brake lines are not designed for DOT 5 brake fluid.

Avoid contact between brake fluid and painted parts. Brake fluid attacks paint!

Use only clean brake fluid from a sealed container.

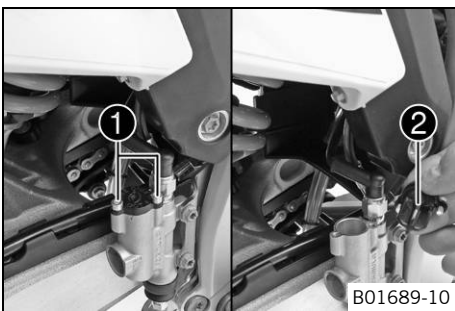

- Stand the vehicle upright.
- Remove screws **1**.
- Remove cover with membrane **2**.
- Press the brake piston back to its basic position and make sure that no brake fluid overflows from the brake fluid reservoir.

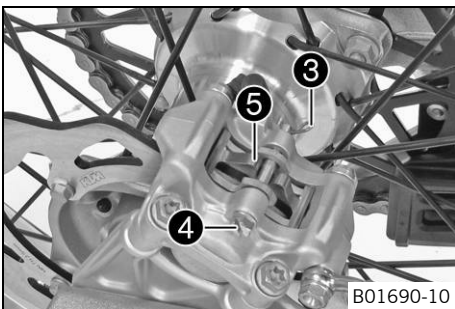

- Take off cotter pin **3** and remove bolt **4**.
- Take off retaining spring **5** and remove the brake linings.
- Clean the brake caliper.

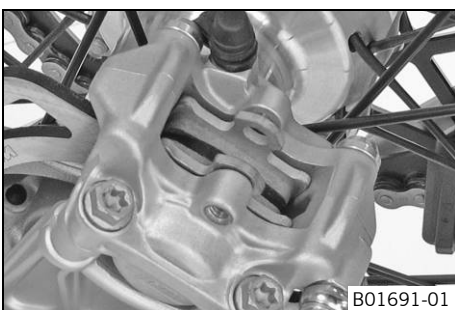

- Position the new brake linings.



**Info**

Always change the full set of brake linings.

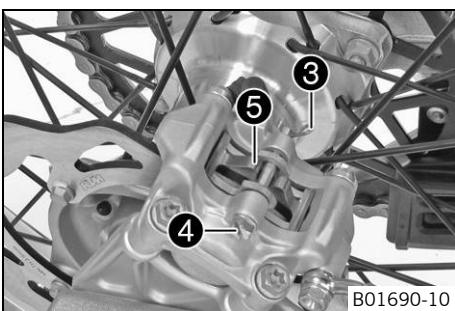

- Position retaining spring **5**.
- Mount bolt **4**.



**Info**

To make it easier to mount the pin, push the retainer spring down. Make sure the retaining spring is seated correctly.

- Mount cotter pin **3**.
- Operate the foot brake lever repeatedly until the brake linings are in contact with the brake disc and there is a pressure point.

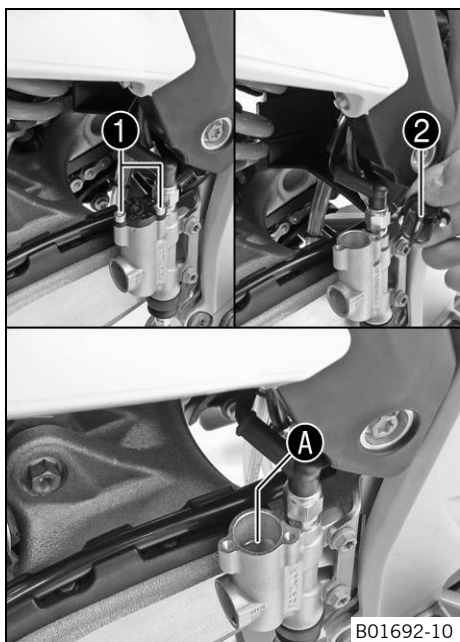

- Add brake fluid to level **A**.

Brake fluid DOT 4 / DOT 5.1 (☛ p. 101)

- Mount the cover with membrane **2**.
- Mount and tighten screws **1**.

---

**i Info**  
Clean up overflowed or spilt brake fluid immediately with water.

---

## 14.1 Removing the front wheel

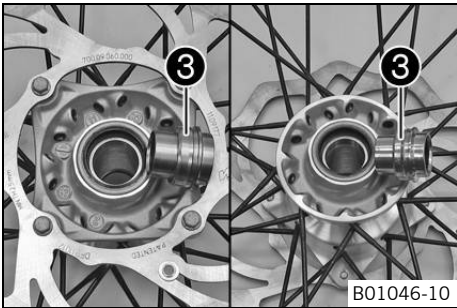
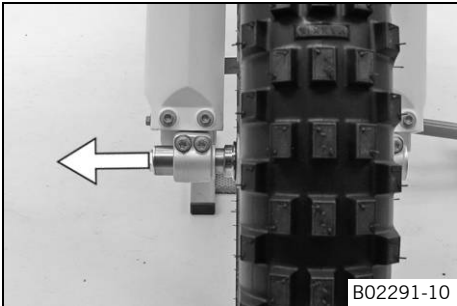
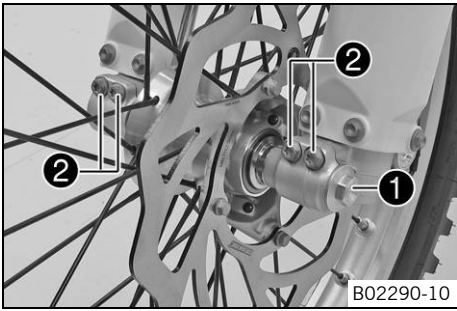

### Preparatory work

- Raise the motorcycle with the lift stand. (☛ p. 37)

### Main work

- Loosen screw ① by several rotations.
- Release screws ②.
- Press on screw ① to push the wheel spindle on the axle clamp.
- Remove screw ①.

- Holding the front wheel, withdraw the wheel spindle. Take the front wheel out of the fork.

### **i** Info

Do not pull the hand brake lever when the front wheel is removed. Always lay the wheel down in such a way that the brake disc is not damaged.

- Remove spacers ③.

## 14.2 Installing the front wheel

**Warning**  
**Danger of accidents** Reduced braking efficiency due to oil or grease on the brake discs.  
 - Always keep the brake discs free of oil and grease, and clean them with brake cleaner when necessary.

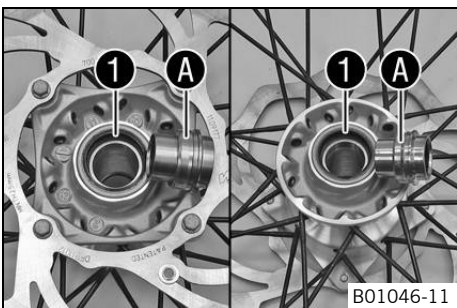

- Check the wheel bearing for damage and wear.  
 » If the wheel bearing is damaged or worn:  
 - Change the wheel bearing. ☛
- Clean and grease the shaft seal rings ① and contact surface A of the spacers.

Long-life grease (☛ p. 103)

- Insert the spacers.

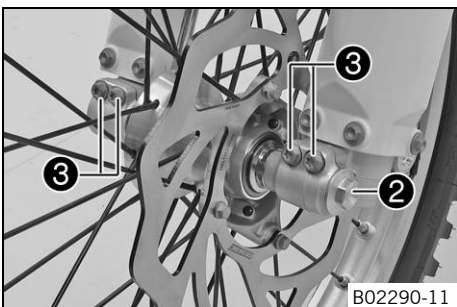

- Position the front wheel and insert the wheel spindle.  
 ✓ The brake linings are correctly positioned.
- Mount and tighten screw ②.

### Guideline

Screw, front wheel spindle	M20x1.5	35 Nm (25.8 lbf ft)
----------------------------	---------	------------------------

- Activate the hand brake lever multiple times until the brake linings are in contact with the brake disc.
- Remove the motorcycle from the lift stand. (☛ p. 37)

- Pull the front wheel brake and push down hard on the fork several times to align the fork legs.
- Tighten screw ③.

Guideline

Screw, fork stub	M8	15 Nm (11.1 lbf ft)
------------------	----	------------------------

## 14.3 Removing the rear wheel

### Preparatory work

- Raise the motorcycle with the lift stand. (☞ p. 37)

### Main work

- Remove nut ①.
- Remove chain adjuster ②.

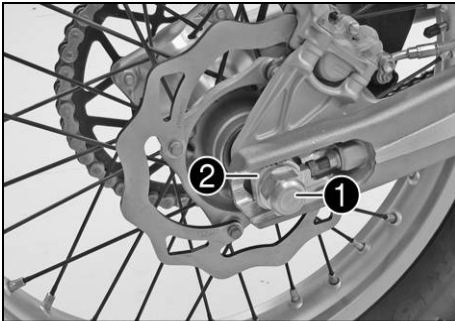

#### Info

Withdraw wheel spindle ③ only enough to allow the rear wheel to be pushed forward.

- Push the rear wheel forward as far as possible. Remove the chain from the rear sprocket.



#### Info

Cover the components to protect them against damage.

- Holding the rear wheel, withdraw the wheel spindle. Take the rear wheel out of the swing arm.



#### Info

Do not operate the foot brake when the rear wheel is removed. Always lay the wheel down in such a way that the brake disc is not damaged.

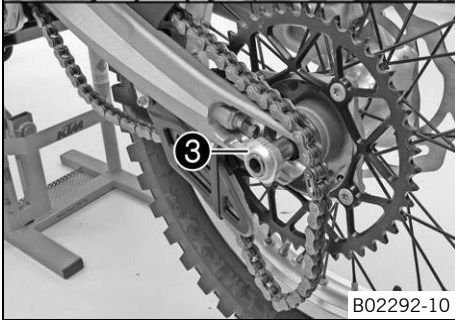

B02292-10

- Remove spacers ④.

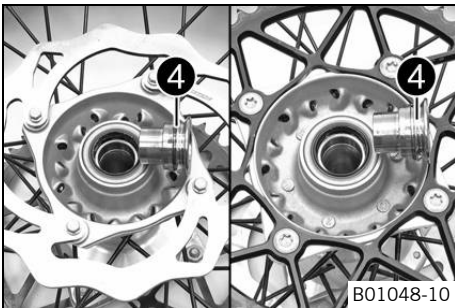

B01048-10

## 14.4 Installing the rear wheel



### Warning

**Danger of accidents** Reduced braking efficiency due to oil or grease on the brake discs.

- Always keep the brake discs free of oil and grease, and clean them with brake cleaner when necessary.

### Main work

- Check the wheel bearing for damage and wear.
  - » If the wheel bearing is damaged or worn:
    - Change the wheel bearing. ☞
- Clean and grease the shaft seal rings ① and contact surface A of the spacers.

Long-life grease (☞ p. 103)

- Insert the spacers.

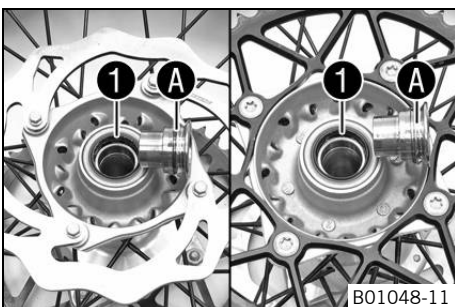

B01048-11

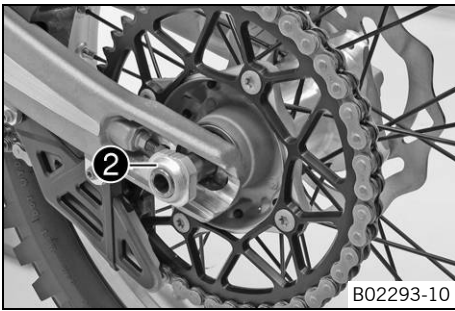

- Position the rear wheel.
  - ✓ The brake linings are correctly positioned.
- Insert wheel spindle ②.
- Put the chain on.

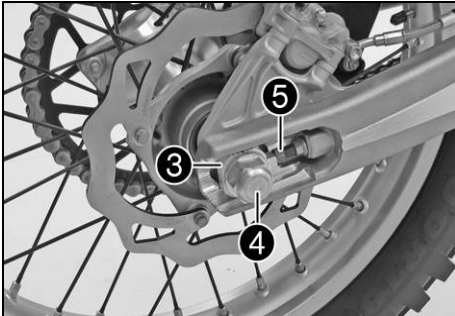

- Position chain adjuster ③. Mount nut ④, but do not tighten it yet.
- Make sure that chain adjusters ③ are fitted correctly on adjusting screws ⑤.
- Check the chain tension. (☛ p. 51)
- Tighten nut ④.

**Guideline**

Nut, rear wheel spindle	M20x1.5	80 Nm (59 lbf ft)
-------------------------	---------	-------------------

**i Info**  
 The wide adjustment range of the chain adjusters enables different secondary ratios with the same chain length.  
 Chain adjusters ③ can be turned by 180°.

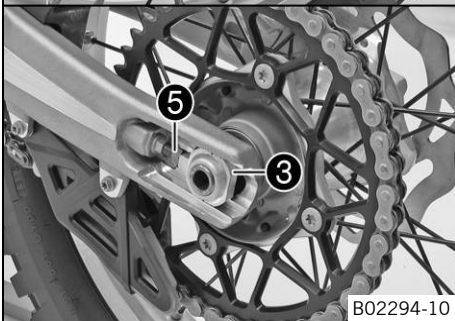

- Operate the foot brake lever repeatedly until the brake linings are in contact with the brake disc and there is a pressure point.

**Finishing work**

- Remove the motorcycle from the lift stand. (☛ p. 37)

## 14.5 Checking the tire condition

**i Info**  
 Only mount tires approved and/or recommended by KTM.  
 Other tires could have a negative effect on handling characteristics.  
 The type, condition, and air pressure of the tires all have a major impact on the handling characteristics of the motorcycle.  
 The tires mounted on the front and rear wheels must have a similar profile.  
 Worn tires have a negative effect on riding behavior, especially on wet surfaces.  
 If used regularly on public roads, tires wear much faster and the minimum tread depth and general condition of the tires must be checked more frequently.

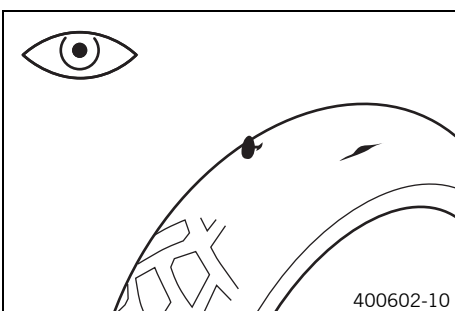

- Check the front and rear tires for cuts, run-in objects, and other damage.
  - » If the tires exhibit cuts, run-in objects, or other damage:
    - Change the tires.
- Check the depth of the tread.

**i Info**  
 Note local national regulations concerning the minimum tread depth.

Minimum tread depth	≥ 2 mm (≥ 0.08 in)
---------------------	--------------------

- » If the tread depth is less than the minimum permissible depth:
  - Change the tires.
- Check the age of the tires.



**Info**

The tire's date of manufacture is usually part of the tire markings and is indicated by four digits. The first two digits refer to the week of manufacture and last two digits refer to the year of manufacture. KTM recommends that the tires be changed after 5 years at the latest, regardless of the actual state of wear.

- » If a tire is more than 5 years old:
  - Change the tires.

## 14.6 Checking the tire air pressure



**Info**

Low tire air pressure leads to abnormal wear and overheating of the tire. Correct tire air pressure ensures optimal riding comfort and maximum tire service life.

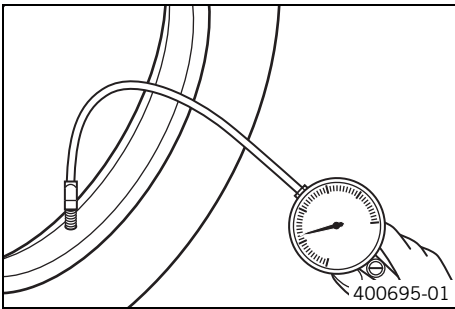

- Remove the protection cap.
- Check the tire air pressure when the tires are cold.

Tire air pressure, offroad	
Front	0.9 bar (13 psi)
Rear	0.7 bar (10 psi)

Tire air pressure, road	
Front	1.5 bar (22 psi)
Rear	1.5 bar (22 psi)

- » If the tire pressure does not meet specifications:
  - Correct the tire pressure.
- Mount protection cap.

## 14.7 Checking the spoke tension



**Warning**

**Danger of accidents** Instable handling due to incorrect spoke tension.

- Ensure that the spoke tension is correct. (Your authorized KTM workshop will be glad to help.)



**Info**

A loose spoke causes wheel imbalance and rapidly leads to more loose spokes. If the spokes are too tight, they can break due to local overload. Check the spoke tension regularly, especially on a new motorcycle.

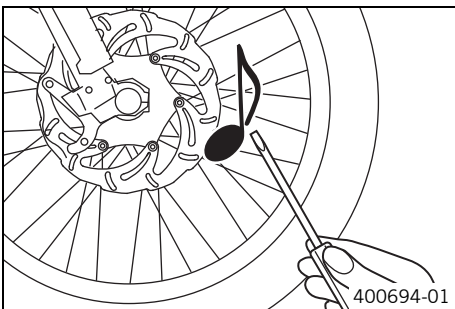

- Briefly strike each spoke with the tip of a screwdriver.



**Info**

The tone frequency depends on the length of the spoke and the spoke diameter.

If you hear different tone frequencies from different spokes of equal length and diameter, this is an indication of different spoke tensions.

You should hear a high note.

- » If the spoke tension varies:
  - Correct the spoke tension. 🛠️

- Check the spoke torque.

**Guideline**

Spoke nipple	M4.5	6 Nm (4.4 lbf ft)
--------------	------	-------------------

Torque wrench with various accessories in set (58429094000)



## 15.1 Removing the battery

**Warning**  
**Risk of injury** Batteries contain harmful substances.

- Keep batteries out of the reach of children.
- Keep sparks and open flames away from the battery. Only charge in well-ventilated rooms.

### Preparatory work

- Raise the motorcycle with the lift stand. (☞ p. 37)
- Fold the seat up. (☞ p. 45)
- Remove the shock absorber. (☞ p. 44)

### Main work

- Remove screw ①.
- Take off fastening plate ②.

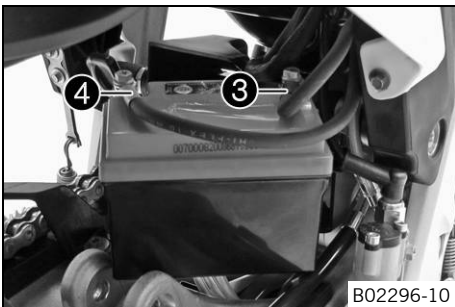
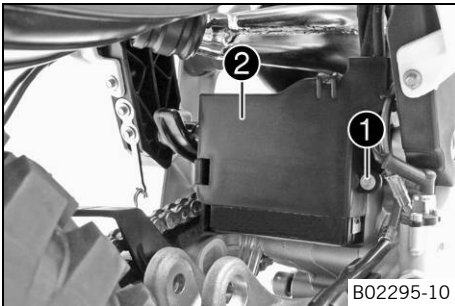

- Remove the battery out of the battery compartment.
- Disconnect negative cable ③ from the battery.
- Disconnect positive cable ④ from the battery.

## 15.2 Installing the battery

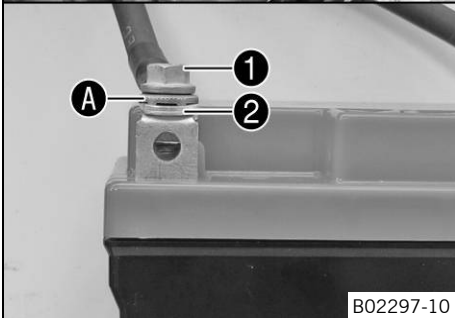
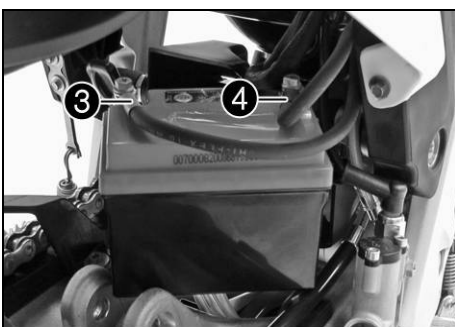

### Main work

- Position positive cable ③, and mount and tighten the screw.

#### Guideline

Screw, battery terminal	M5	2.5 Nm (1.84 lbf ft)
-------------------------	----	-------------------------

- Position negative cable ④, and mount and tighten the screw.

#### Guideline

Screw, battery terminal	M5	2.5 Nm (1.84 lbf ft)
-------------------------	----	-------------------------

Battery (HJTZ5S-FP) (☞ p. 96)

**i Info**  
 Contact disk **A** must be mounted between screw **1** and cable lug **2** with the claws facing down.

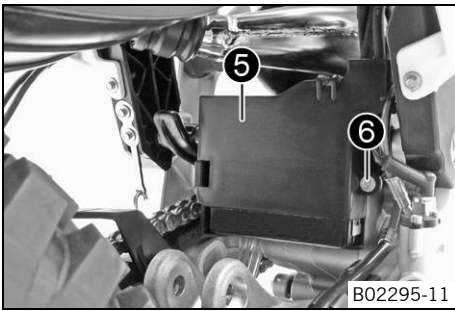

- Position the battery in the battery compartment.

**i Info**

Ensure that the battery cable is correctly routed.

- Attach fastening plate **5**.
- Mount and tighten screw **6**.

**Finishing work**

- Install the shock absorber. ↘ (☞ p. 44)
- Lock the seat. (☞ p. 45)
- Remove the motorcycle from the lift stand. (☞ p. 37)

## 15.3 Recharging the battery ↘

**Warning**

**Risk of injury** Batteries contain harmful substances.

- Keep batteries out of the reach of children.
- Keep sparks and open flames away from the battery. Only charge in well-ventilated rooms.

**Warning**

**Environmental hazard** The battery contains elements that are harmful to the environment.

- Do not discard batteries with the household waste. Dispose of faulty batteries in an environmentally compatible manner. Give the battery to your authorized KTM dealer or dispose of it at a collection point for used batteries.

**Warning**

**Environmental hazard** Hazardous substances cause environmental damage.

- Oil, grease, filters, fuel, cleaners, brake fluid, etc., should be disposed of as stipulated in applicable regulations.

**i Info**

Even when there is no load on the battery, it discharges steadily. The charge state and the type of charge are very important for the service life of the battery. Rapid recharging with a high charging current shortens the battery's service life. If the charging current, charging voltage and charging time are exceeded, the battery will be destroyed. If the battery is depleted from starting the vehicle repeatedly, the battery must be charged immediately. If the battery is left in a discharged state for an extended period, it will become over-discharged and will be destroyed. The battery is maintenance-free.

**Preparatory work**

- Raise the motorcycle with the lift stand. (☞ p. 37)
- Fold the seat up. (☞ p. 45)
- Remove the shock absorber. ↘ (☞ p. 44)
- Remove the battery. ↘ (☞ p. 71)

**Main work**

- Connect the battery charger with the battery. Switch on the battery charger.

Battery charger (58429074000)

You can also use the battery charger to test the rest potential and starting ability of the battery, and to test the alternator. With this device, you cannot overcharge the battery.

**i Info**

Only charge the battery with the specified battery charge. Read the notes in the battery package.

- Switch off the battery charger after charging and disconnect from the battery.



B02298-01

Guideline

The charging current, charging voltage, and charging time must not be exceeded.	
Charge the battery regularly when the motorcycle is not in use	3 months

**Finishing work**

- Install the battery. (🔧 p. 71)
- Install the shock absorber. (🔧 p. 44)
- Lock the seat. (🔧 p. 45)
- Remove the motorcycle from the lift stand. (🔧 p. 37)

## 15.4 Changing the main fuse

**Warning**  
**Fire hazard** The electrical system can be overloaded if the wrong fuses are used.

- Use only fuses with the prescribed amperage. Never by-pass or repair fuses.

**Info**  
 The main fuse protects all power consumers of the vehicle. It is located in the starter relay housing under the seat.

**Preparatory work**

- Switch off all power consumers and switch off the engine.
- Fold the seat up. (🔧 p. 45)

**Main work**

- Remove protection cap ❶.

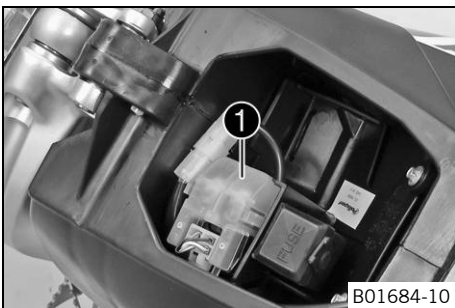

- Remove the faulty main fuse ❷.

**Info**  
 A defective fuse is indicated by a burned-out fuse wire **A**.  
 A reserve fuse **3** is located in the starter relay.

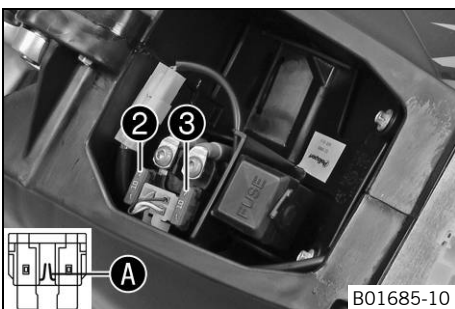

- Install a new main fuse.

Fuse (58011109110) (🔧 p. 96)
------------------------------

- Check that the electrical equipment is functioning properly.

**Tip**  
 Insert the spare fuse so that it is available if needed.

- Mount the protection cap.

**Finishing work**

- Lock the seat. (🔧 p. 45)

## 15.5 Changing the fuses of individual power consumers

**i Info**  
The fuse box containing the fuses of individual power consumers is located under the seat.

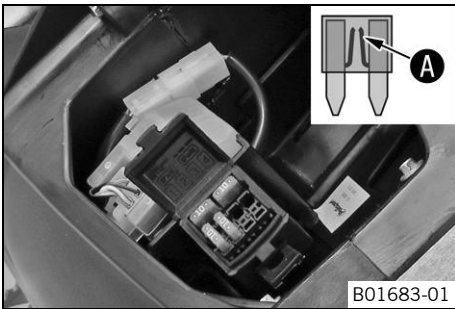
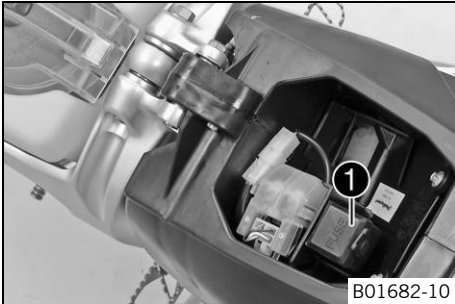

### Preparatory work

- Switch off all power consumers and switch off the engine.
- Fold the seat up. (☛ p. 45)

### Main work

- Open fuse box cover ❶.

- Remove the defective fuse.

#### Guideline

Fuse 1 - 10 A - horn, brake light, turn signal
--

Fuse 2 - 10 A - radiator fan
------------------------------

Fuses <b>res</b> - 10 A - spare fuses
---------------------------------------

**i Info**  
A defective fuse is indicated by a burned-out fuse wire **A**.

**! Warning**  
**Fire hazard** The electrical system can be overloaded if the wrong fuses are used.

- Use only fuses with the prescribed amperage. Never by-pass or repair fuses.

- Use spare fuses with the correct rating only.

Fuse (75011088010) (☛ p. 96)
------------------------------

**i Tip**  
Replace the spare fuse in the fuse box so that it is available if needed.

- Check that the power consumer is functioning properly.
- Close the fuse box cover.

### Finishing work

- Lock the seat. (☛ p. 45)

## 15.6 Removing the headlight mask with the headlight



- Switch off all power consumers and switch off the engine.
- Detach the brake line and wiring harness ①.
- Release rubber band ②. Slide the headlight mask up and swing it forward.

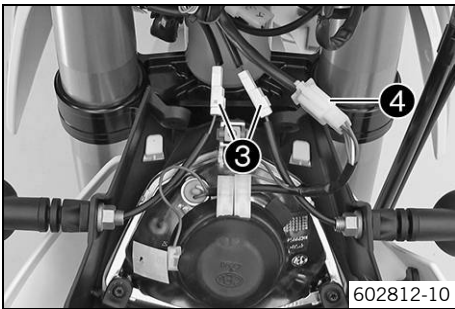

- Disconnect connector ③ of the turn signals and ④ headlight.

## 15.7 Refitting the headlight mask with the headlight

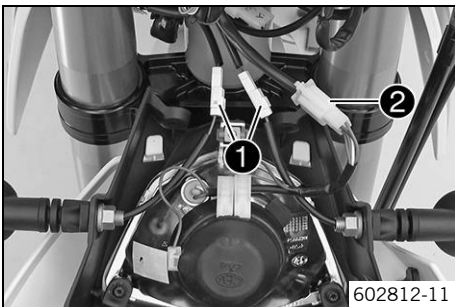

### Main work

- Connect connector ② of the headlight and ① turn signals.



B01041-11

- Position the headlight mask and fix it with the rubber band **3**.



**Info**

Make sure that the holding lugs engage in the fender.

- Position the brake line and wiring harness **4**.

**Finishing work**

- Check the headlight setting. (☛ p. 77)

## 15.8 Changing the headlight bulb

**Note**

**Damage to reflector** Reduced brightness.

- Grease on the lamp will evaporate due to the heat and be deposited on the reflector. Clean the lamp and keep it free of grease before mounting.

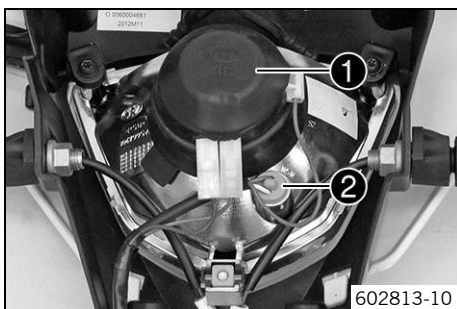

602813-10

**Preparatory work**

- Remove the headlight mask with the headlight. (☛ p. 75)

**Main work**

- Turn rubber cap **1** together with the underlying bulb socket counterclockwise all the way and remove it.
- Pull bulb socket **2** of the parking light out of the reflector.

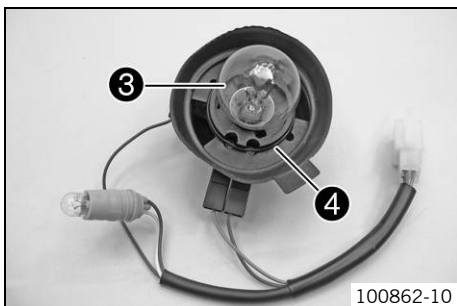

100862-10

- Press headlight bulb **3** lightly into the bulb socket, turn it counterclockwise, and pull it out.
- Insert the new headlight bulb.

Headlight (S2/socket BA20d) (☛ p. 96)

- Insert the rubber cap with the bulb socket into the reflector and turn it clockwise all the way.



**Info**

Ensure that O-ring **4** is seated properly.

- Insert the bulb socket of the parking light into the reflector.

**Finishing work**

- Refit the headlight mask with the headlight. (☛ p. 75)
- Check the headlight setting. (☛ p. 77)

## 15.9 Changing the turn signal bulb

**Note**  
**Damage to reflector** Reduced brightness.

- Grease on the lamp will evaporate due to the heat and be deposited on the reflector. Clean the lamp and keep it free of grease before mounting.

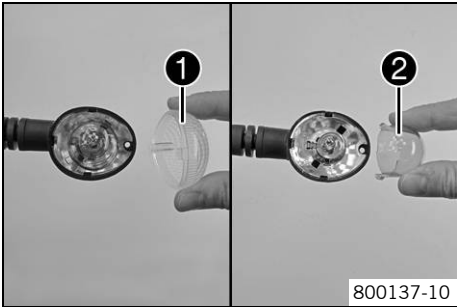

- Main work**
- Remove the screw on the rear of the turn signal housing.
  - Carefully remove diffuser ①.
  - Lightly squeeze orange cap ② in the area of the holding lugs and take it off.
  - Press the turn signal bulb carefully into the socket, turn it counterclockwise by about 30°, and take it out of the socket.

**Info**  
 Do not touch the reflector with your fingers, and keep it free from grease.

- Press the new turn signal bulb carefully into the socket and turn it clockwise until it stops.
- |   |
|---|
| Turn signal (R10W/socket BA15s) (☛ p. 96) |
|---|
- Mount the orange cap.
  - Position the diffuser.
  - Insert the screw and first turn it counterclockwise until it engages in the thread. Tighten the screw slightly.

**Finishing work**

- Check that the turn signal system is functioning properly.

## 15.10 Checking the headlight setting

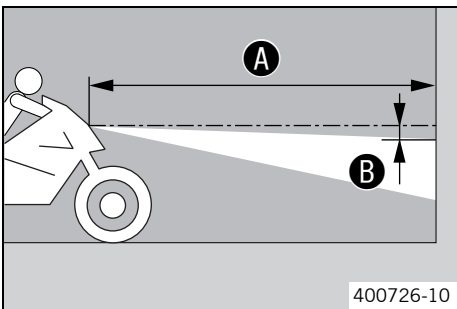

- Position the vehicle upright on a horizontal surface in front of a light wall and make a mark at the height of the center of the low beam headlight.
- Make another mark at a distance ② under the first mark.

Guideline

Distance ②	5 cm (2 in)
------------	-------------

- Position the vehicle vertically a distance ① away from the wall.

Guideline

Distance ①	5 m (16 ft)
------------	-------------

- The rider now sits down on the motorcycle.
- Switch on the low beam.
- Check the headlight setting.

The boundary between light and dark must be exactly on the lower mark for a motorcycle with driver.

- » If the boundary between light and dark does not meet specifications:
  - Adjust the headlight range. (☛ p. 77)

## 15.11 Adjusting the headlight range



**Preparatory work**

- Check the headlight setting. (☛ p. 77)

**Main work**

- Adjust the beam distance of the headlight by turning screw ①.

Guideline

For a motorcycle with rider, the light/dark boundary must be exactly on the lower mark (the mark is created in: Checking the headlight setting).
--



**Info**

Turn clockwise to increase the headlight range, turn counterclockwise to reduce the headlight range.  
A change in weight on the vehicle may require a correction of the headlight range.

## 15.12 Changing the speedometer battery

**Preparatory work**

- Remove the headlight mask with the headlight. (☛ p. 75)

**Main work**

- Remove screws ❶.
- Pull the speedometer upward out of the holder.

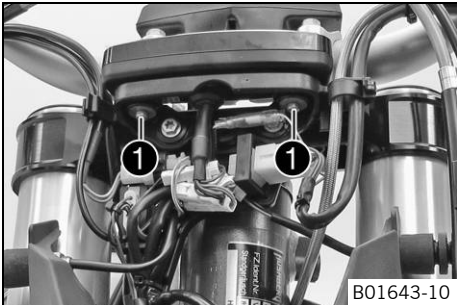

B01643-10

- Using a coin, turn protection cap ❷ all the way counterclockwise and remove it.
- Remove speedometer battery ❸.
- Insert the new battery with the label facing outward.

Speedometer battery (CR 2032) (☛ p. 96)

- Check the O-ring of the protection cap for correct seating.

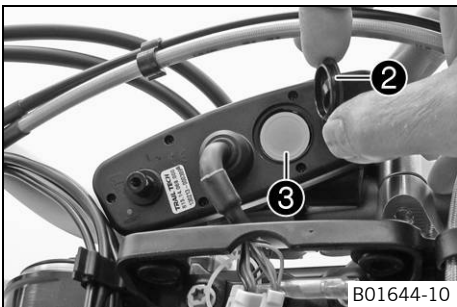

B01644-10

- Position protection cap ❷ and turn all the way clockwise using a coin.
- Press any button on the speedometer.
- ✓ The speedometer is activated.
- Position the speedometer in the holder.
- Mount and tighten the screws with washers.

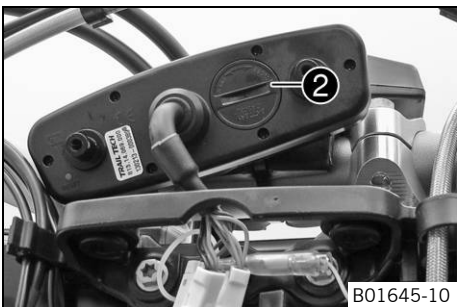

B01645-10

**Finishing work**

- Refit the headlight mask with the headlight. (☛ p. 75)
- Check the headlight setting. (☛ p. 77)
- Set the speedometer. (☛ p. 18)



## 16.1 Cooling system

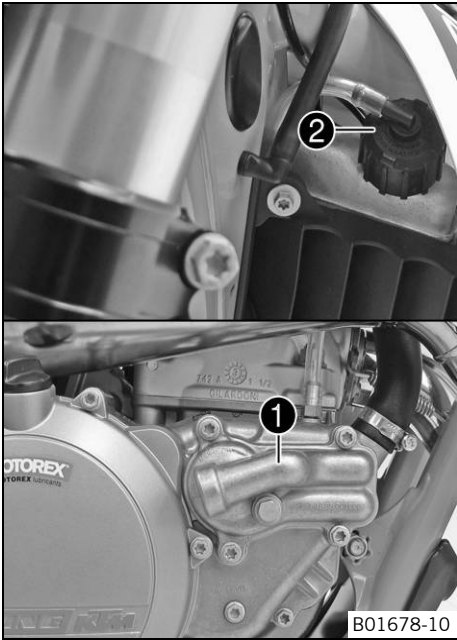

Water pump ❶ in the engine circulates the coolant. The pressure resulting from the warming of the cooling system is regulated by a valve in radiator cap ❷. This ensures that operating the vehicle at the specified coolant temperature will not result in a risk of malfunctions.

120 °C (248 °F)
-----------------

Cooling is effected by the air stream. The lower the speed, the less the cooling effect. Dirty cooling fins also reduce the cooling effect. The radiator fan provides extra cooling. It is controlled by a thermostwitch.

## 16.2 Checking the antifreeze and coolant level

- Warning**  
**Danger of scalding** During motorcycle operation, the coolant gets very hot and is under pressure.
- Do not remove the radiator cap, radiator hoses or other cooling system components when the engine is hot. Allow the engine and cooling system to cool down. In case of scalding, rinse immediately with lukewarm water.
- Warning**  
**Danger of poisoning** Coolant is poisonous and a health hazard.
- Coolant must not come into contact with the skin, eyes, or clothing. If contact occurs with the eyes, rinse with water immediately and contact a physician. Immediately clean contaminated areas on the skin with soap and water. If coolant is swallowed, contact a physician immediately. Change clothing that is contaminated with coolant. Keep coolant out of reach of children.

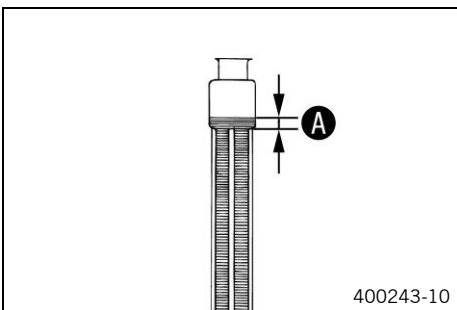

- Condition**  
 The engine is cold.
- Stand the motorcycle upright on a horizontal surface.
  - Remove the radiator cap.
  - Check the coolant antifreeze.
- |                               |
|-------------------------------|
| -25... -45 °C (-13... -49 °F) |
|-------------------------------|
- » If the antifreeze of the coolant does not meet specifications:
    - Correct the coolant antifreeze.
  - Check the coolant level in the radiator.
- |                                      |                 |
|--------------------------------------|-----------------|
| Coolant level ❸ above radiator fins. | 10 mm (0.39 in) |
|--------------------------------------|-----------------|
- » If the coolant level does not meet specifications:
    - Correct the coolant level.
- Alternative 1**
- |                    |
|--------------------|
| Coolant (☞ p. 101) |
|--------------------|
- Alternative 2**
- |   |
|---|
| Coolant (mixed ready to use) (☞ p. 101) |
|---|
- Mount the radiator cap.

## 16.3 Checking the coolant level

**Warning**  
**Danger of scalding** During motorcycle operation, the coolant gets very hot and is under pressure.

- Do not remove the radiator cap, radiator hoses or other cooling system components when the engine is hot. Allow the engine and cooling system to cool down. In case of scalding, rinse immediately with lukewarm water.

**Warning**  
**Danger of poisoning** Coolant is poisonous and a health hazard.

- Coolant must not come into contact with the skin, eyes, or clothing. If contact occurs with the eyes, rinse with water immediately and contact a physician. Immediately clean contaminated areas on the skin with soap and water. If coolant is swallowed, contact a physician immediately. Change clothing that is contaminated with coolant. Keep coolant out of reach of children.

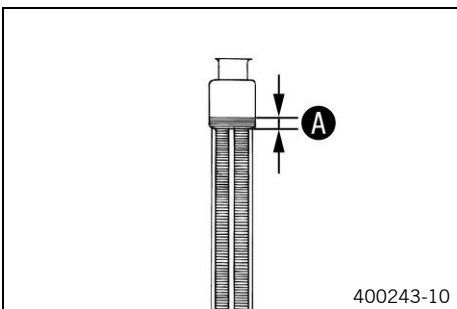

**Condition**

The engine is cold.

- Stand the motorcycle upright on a horizontal surface.
- Remove the radiator cap.
- Check the coolant level in the radiator.

Coolant level <b>A</b> above radiator fins.	10 mm (0.39 in)
---	-----------------

- » If the coolant level does not meet specifications:
  - Correct the coolant level.

**Alternative 1**

Coolant (☛ p. 101)
--------------------

**Alternative 2**

Coolant (mixed ready to use) (☛ p. 101)
---

- Mount the radiator cap.

## 16.4 Draining the coolant

**Warning**  
**Danger of scalding** During motorcycle operation, the coolant gets very hot and is under pressure.

- Do not remove the radiator cap, radiator hoses or other cooling system components when the engine is hot. Allow the engine and cooling system to cool down. In case of scalding, rinse immediately with lukewarm water.

**Warning**  
**Danger of poisoning** Coolant is poisonous and a health hazard.

- Coolant must not come into contact with the skin, eyes, or clothing. If contact occurs with the eyes, rinse with water immediately and contact a physician. Immediately clean contaminated areas on the skin with soap and water. If coolant is swallowed, contact a physician immediately. Change clothing that is contaminated with coolant. Keep coolant out of reach of children.

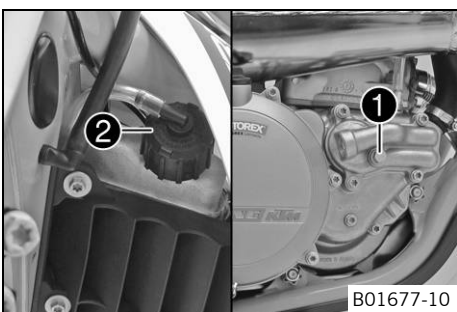

**Condition**

The engine is cold.

- Stand the motorcycle upright.
- Place a suitable container under the water pump cover.
- Remove screw **1**. Take off radiator cap **2**.
- Completely drain the coolant.
- Mount screw **1** with a new seal ring and tighten it.

**Guideline**

Drain plug, water pump cover	M10x1	15 Nm (11.1 lbf ft)
------------------------------	-------	------------------------

## 16.5 Refilling coolant

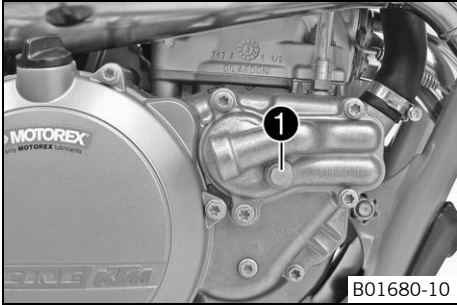

**Warning**  
**Danger of poisoning** Coolant is poisonous and a health hazard.

- Coolant must not come into contact with the skin, eyes, or clothing. If contact occurs with the eyes, rinse with water immediately and contact a physician. Immediately clean contaminated areas on the skin with soap and water. If coolant is swallowed, contact a physician immediately. Change clothing that is contaminated with coolant. Keep coolant out of reach of children.



### Main work

- Make sure that screw **1** is tightened.
- Stand the motorcycle upright.
- Completely fill the radiator with coolant.

Coolant	0.9 l (1 qt.)	Coolant (  p. 101)
		Coolant (mixed ready to use) (  p. 101)

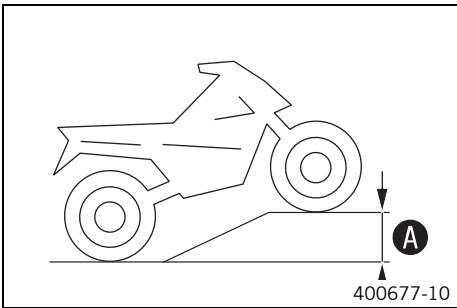

- Move the vehicle into the position shown and prevent it from rolling away. Height difference **A** must be reached.

### Guideline

Height difference <b>A</b>	75 cm (29.5 in)
----------------------------	-----------------

**i Info**  
 For all of the air to be able to escape from the cooling system, the vehicle must be raised at the front. If the cooling system is poorly de-aerated, its cooling power will be reduced and the engine may overheat.

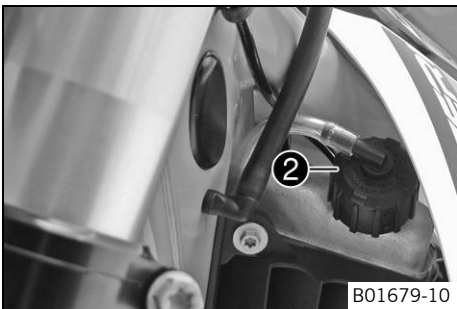

- Return the vehicle to the horizontal position.
- Completely fill the radiator with coolant.
- Mount radiator cap **2**.
- Let the engine warm up.

### Finishing work

- Check the coolant level. ( p. 80)

## 17.1 Checking the play in the throttle cable

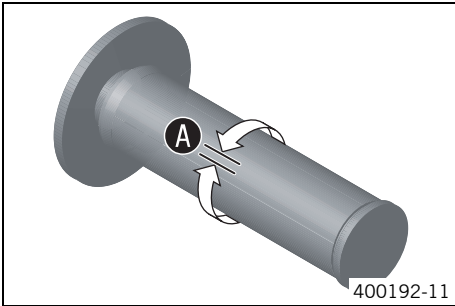

- Check the throttle grip for smooth operation.
- Move the handlebar to the straight-ahead position. Turn the throttle grip back and forth slightly and determine the play in throttle cable **A**.

Throttle cable play	2... 3 mm (0.08... 0.12 in)
---------------------	-----------------------------

- » If the throttle cable play does not meet specifications:
  - Adjust the play in the throttle cable. (☞ p. 82)



### Danger

**Danger of poisoning** Exhaust gases are toxic and inhaling them may result in unconsciousness and/or death.

- When running the engine, always make sure there is sufficient ventilation, and do not start or run the engine in an enclosed space without an effective exhaust extraction system.

- Start the engine and let it run idle. Move the handlebar to and fro over the entire steering range.

The idle speed must not change.
---------------------------------

- » If the idle speed changes:
  - Adjust the play in the throttle cable. (☞ p. 82)

## 17.2 Adjusting the play in the throttle cable ☞

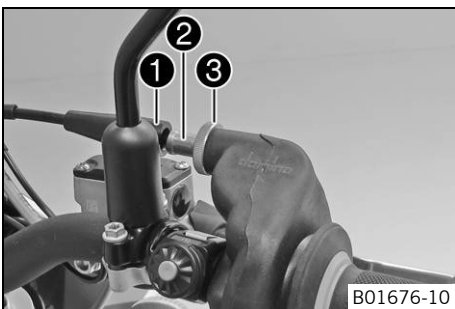

### Preparatory work

- Fold the seat up. (☞ p. 45)
- Remove the fuel tank. (☞ p. 48)
- Check the throttle cable routing. (☞ p. 54)

### Main work

- Move the handlebar to the straight-ahead position.
- Push back sleeve **1**.
- Ensure that the throttle cable sleeve is pushed fully into adjusting screw **2**.
- Loosen nut **3**.
- Turn adjusting screw **2** so that there is play **A** in the throttle cable at the throttle grip.

### Guideline

Throttle cable play	2... 3 mm (0.08... 0.12 in)
---------------------	-----------------------------

- Tighten nut **3**.
- Slide on sleeve **1**.
- Check the throttle grip for smooth operation.

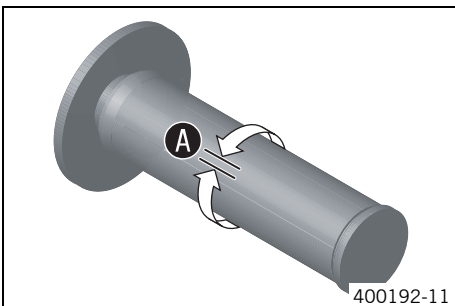

### Finishing work

- Check the play in the throttle cable. (☞ p. 82)
- Install the fuel tank. (☞ p. 49)
- Lock the seat. (☞ p. 45)

## 17.3 Carburetor - idle

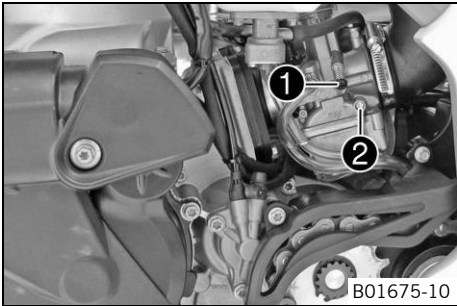

The idle setting of the carburetor has a big influence on the starting behavior, stable idling and the response to throttle opening. This means that an engine with a correctly set idle speed is easier to start than if the idle is set wrongly.

**Info**  
The carburetor and its components are subject to increased wear caused by engine vibration. Wear can result in malfunctioning.

The factory setting for the carburetor is set for the following values.

Elevation above sea level	500 m (1,640 ft)
Ambient temperature	20 °C (68 °F)
Super unleaded (95 octane) mixed with 2-stroke engine oil (1:80) (☛ p. 102)	

The idle speed is adjusted with adjusting screw ①.  
The idle mixture is adjusted with the idle air adjusting screw ②.

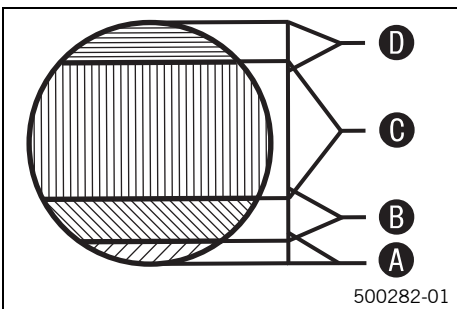

### Idle air range A

Operation with the throttle slide closed. This range is influenced by adjusting screw ① and the idle air adjusting screw ②.

### Transition range B

Behavior of the engine when the throttle slide is being opened. This range is influenced by the idling jet and by the form of the throttle slide.

If the engine sputters and smokes heavily when it starts despite a good idle and part-load setting, and if it abruptly reaches full power at a high rpm, the carburetor setting is too rich, or the float level is too high or the float needle valve is leaky.

### Part-load range C

Operation with the throttle slide partially open. This range is influenced by the jet needle (form and position). The idle setting influences the engine tuning in the lower range, and the main jet influences the engine tuning in the upper range.

If the engine stutters when accelerating with a partially open throttle slide, the jet needle must be lowered by one notch. If the engine knocks when accelerating at the full power rpm range, the jet needle must be raised. If the above events occur on idle or just above it, the idle system must be set to a leaner setting if the engine is stuttering or to a richer setting if the engine is knocking.

### Full-load range D

Operation with the throttle slide open (full throttle). This range is influenced by the main jet and jet needle.

If the insulator of a new spark plug is very light or white after a brief ride at full throttle, or if the engine knocks, a larger main jet needs to be used. If the insulator is dark brown or sooty, a smaller main jet needs to be used.

## 17.4 Carburetor - adjusting idle

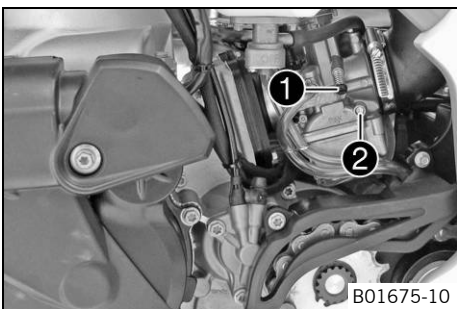

- Screw idle air adjusting screw ② all the way in and turn to the specified basic setting.

Guideline

Idle air adjusting screw	
Open	2.0 rotations

- Run the engine until warm.

Guideline

Warm-up time	≥ 5 min
--------------	---------



### Danger

**Danger of poisoning** Exhaust gases are toxic and inhaling them may result in unconsciousness and/or death.

- When running the engine, always make sure there is sufficient ventilation, and do not start or run the engine in an enclosed space without an effective exhaust extraction system.

- Adjust the idle speed with adjusting screw ①.

Guideline

Choke function deactivated – The choke lever is pushed in to the stop. (☛ p. 15)	
Idle speed	1,400... 1,500 rpm

- Turn idle air adjusting screw ② slowly clockwise until the idle speed starts to drop.
- Note the position and turn the idle air adjusting screw slowly counterclockwise until the idle speed falls.
- Adjust to the point between these two positions with the highest idle speed.

**i Info**  
 If there is a big engine speed rise, reduce the idle speed to a normal level and repeat the above steps.  
 If the procedure described here does not lead to satisfactory results, the cause may be a wrongly dimensioned idling jet.  
 If you can turn the idle air adjusting screw to the end without any change of engine speed, you have to mount a smaller idling jet.  
 After changing the idling jet, start from the beginning with the adjusting steps.  
 Following extreme air temperature or altitude changes, adjust the idle speed again.

## 17.5 Emptying the carburetor float chamber ☞

**! Danger**  
**Fire hazard** Fuel is highly flammable.

- Never refuel the vehicle near open flames or burning cigarettes, and always switch off the engine first. Be careful that no fuel is spilt, especially on hot vehicle components. Clean up spilt fuel immediately.
- The fuel in the fuel tank expands when warm and may emerge if overfilled. Follow the instructions on refueling.

**! Warning**  
**Danger of poisoning** Fuel is poisonous and a health hazard.

- Fuel must not come into contact with the skin, eyes, or clothing. Do not breathe in the fuel vapors. If contact occurs with the eyes, rinse with water immediately and contact a physician. Immediately clean contaminated areas on the skin with soap and water. If fuel is swallowed, contact a physician immediately. Change clothing that is contaminated with fuel. Store fuel properly in a suitable canister and keep away from children.

**☼ Warning**  
**Environmental hazard** Improper handling of fuel is a danger to the environment.

- Do not allow fuel to get into the ground water, the ground, or the sewage system.

**i Info**  
 Carry out this work with a cold engine.  
 Water in the float chamber results in malfunctioning.

**Preparatory work**

- Turn handle ① of the fuel tap to the **OFF** position. (Figure B01660-10 ☛ p. 15)  
 ✓ Fuel no longer flows from the fuel tank to the carburetor.

**Main work**

- Place a cloth under the carburetor to capture the draining fuel.
- Remove fitting ②.
- Fully drain the fuel.
- Mount and tighten the screw plug.

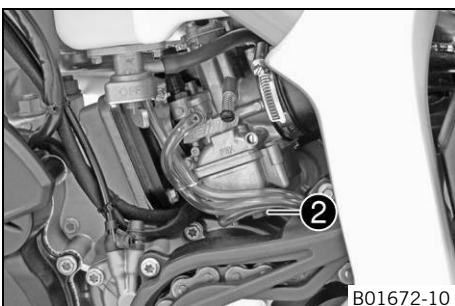

B01672-10

## 17.6 Checking the basic position of the shift lever

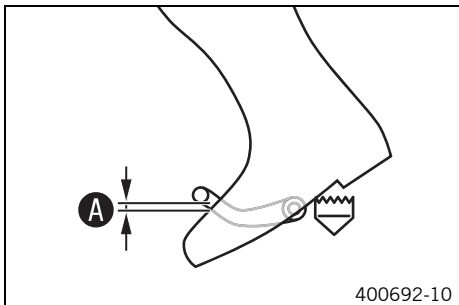

- Sit on the vehicle in the riding position and determine distance **A** between the upper edge of your boot and the shift lever.

Distance between shift lever and upper edge of boot	10... 20 mm (0.39... 0.79 in)
---	-------------------------------

- » If the distance does not meet specifications:
  - Adjust the basic position of the shift lever. (p. 85)

## 17.7 Adjusting the basic position of the shift lever

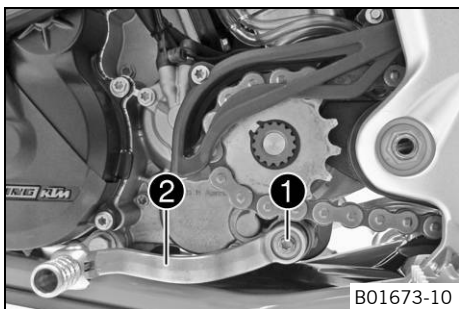

- Remove screw **1** and remove shift lever **2**.

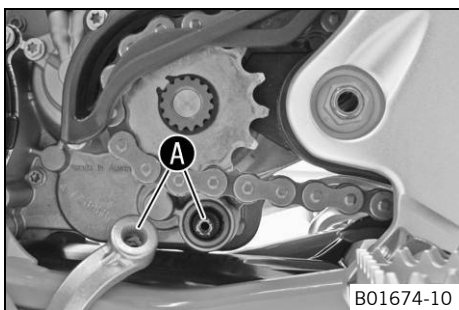

- Clean gear teeth **A** of the shift lever and shift shaft.
- Mount shift lever **2** on the shift shaft in the required position and engage the gearing.

**i Info**

The range of adjustment is limited.  
The shift lever must not come into contact with any other vehicle components during the shift procedure.

- Mount and tighten screw **1**.

Guideline

Screw, shift lever	M6	14 Nm (10.3 lbf ft)	Loctite® 243™
--------------------	----	------------------------	---------------

## 18.1 Cleaning the alternator ↗

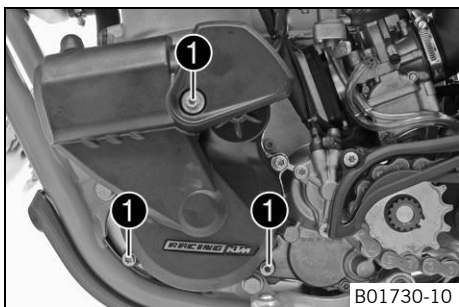

- Remove screws ①.
- Take off the cover.

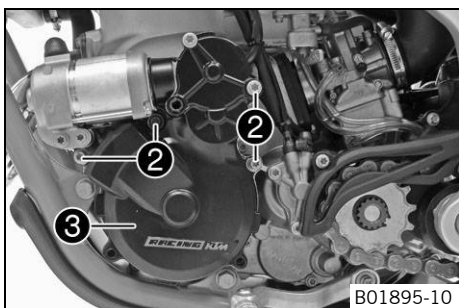

- Remove screws ②.
- Take off the alternator cover ③.

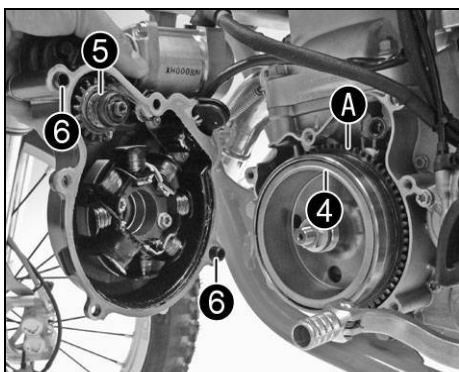

- Clean alternator cover and rotor ④.
- Take off Bendix ⑤ and clean.
- Grease gear teeth ① and the points marked with a ②.

Lubricant (T625) (↗ p. 103)

- Mount Bendix ⑤.
- Position the gasket.
- Check that dowels ⑥ are seated correctly.
- Mount alternator cover ③.
- Mount and tighten screws ②.

### Guideline

Screw, alternator cover	M6	8 Nm (5.9 lbf ft)
-------------------------	----	-------------------

- Mount the cover.
- Mount and tighten screws ①.

### Guideline

Screw, alternator cover	M6	8 Nm (5.9 lbf ft)
-------------------------	----	-------------------

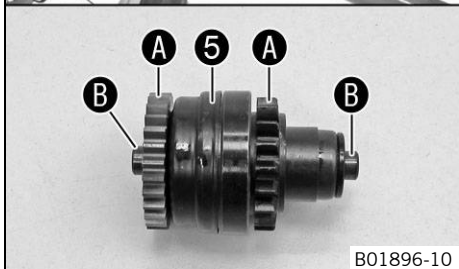

## 18.2 Checking the gear oil level



### Info

The gear oil level must be checked when the engine is cold.

### Preparatory work

- Stand the motorcycle upright on a horizontal surface.

### Main work

- Remove the gear oil monitoring screw ①.
- Check the gear oil level.

A small quantity of gear oil must run out of the drilled hole.

- » If no gear oil runs out:
  - Add gear oil. ↗ (↗ p. 88)

- Mount and tighten the gear oil monitoring screw.

### Guideline

Screw, gear oil level check	M6	10 Nm (7.4 lbf ft)
-----------------------------	----	--------------------

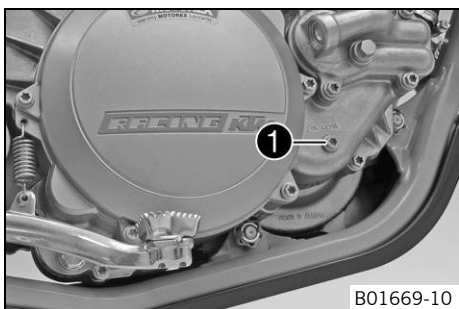



## 18.3 Changing the gear oil

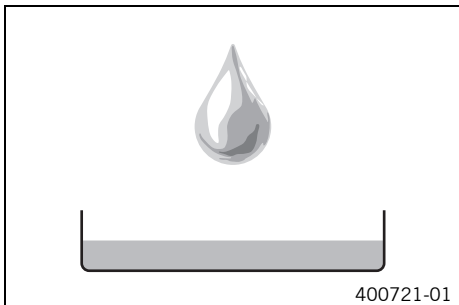

– Drain the gear oil. (p. 87)

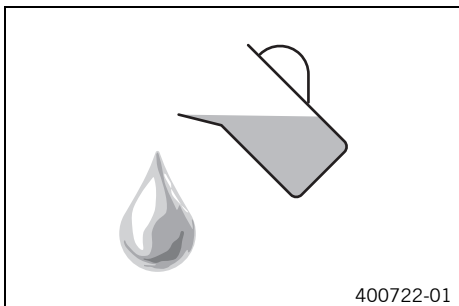

– Fill in gear oil. (p. 88)

## 18.4 Draining the gear oil



### Warning

**Danger of scalding** Engine oil and gear oil get very hot when the motorcycle is ridden.

- Wear appropriate protective clothing and safety gloves. In case of burns, rinse immediately with lukewarm water.



### Warning

**Environmental hazard** Hazardous substances cause environmental damage.

- Oil, grease, filters, fuel, cleaners, brake fluid, etc., should be disposed of as stipulated in applicable regulations.



### Info

Drain the gear oil while the engine is warm.

### Preparatory work

- Park the motorcycle on a level surface.
- Place a suitable container under the engine.

### Main work

- Remove the gear oil drain plug with magnet ①.
- Let the gear oil drain fully.
- Thoroughly clean the gear oil drain plug with magnet.
- Clean the sealing surface on the engine.
- Mount and tighten gear oil drain plug with magnet ① and seal ring.

### Guideline

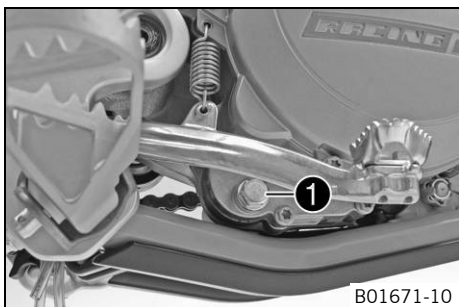

Gear oil drain plug with magnet	M12x1.5	20 Nm (14.8 lbf ft)
---------------------------------	---------	------------------------

## 18.5 Filling in gear oil

**i Info**  
Too little gear oil or poor-quality gear oil results in premature wear to the transmission.

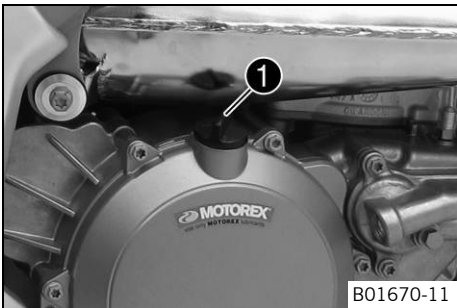

**Main work**

- Remove screw cap **1** and fill in gear oil.

Gear oil	0.80 l (0.85 qt.)	Engine oil (15W/50) (☛ p. 101)
----------	-------------------	--------------------------------

- Mount and tighten the screw cap.



**Danger**

**Danger of poisoning** Exhaust gases are toxic and inhaling them may result in unconsciousness and/or death.

- When running the engine, always make sure there is sufficient ventilation, and do not start or run the engine in an enclosed space without an effective exhaust extraction system.

- Start the engine and check that it is oil-tight.

**Finishing work**

- Check the gear oil level. (☛ p. 86)

## 18.6 Adding gear oil

**i Info**  
Too little gear oil or poor-quality gear oil results in premature wear to the transmission. The gear oil level should only be added when the engine is cold.

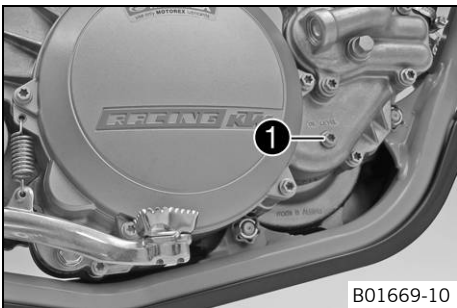

**Preparatory work**

- Park the motorcycle on a level surface.

**Main work**

- Remove the gear oil monitoring screw **1**.

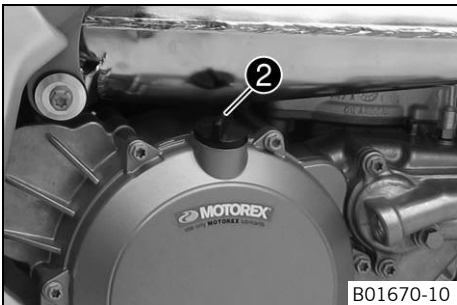

- Remove screw cap **2**.

- Fill in gear oil until it emerges from the drilled hole of the gear oil monitoring screw.

Engine oil (15W/50) (☛ p. 101)
--------------------------------

- Mount and tighten the gear oil monitoring screw.

**Guideline**

Screw, gear oil level check	M6	10 Nm (7.4 lbf ft)
-----------------------------	----	--------------------

- Mount and tighten screw cap **2**.



**Danger**

**Danger of poisoning** Exhaust gases are toxic and inhaling them may result in unconsciousness and/or death.

- When running the engine, always make sure there is sufficient ventilation, and do not start or run the engine in an enclosed space without an effective exhaust extraction system.

- Start the engine and check that it is oil-tight.

## 19.1 Cleaning the motorcycle

**Note**

**Material damage** Damage and destruction of components by high-pressure cleaning equipment.

- When cleaning the vehicle with a pressure cleaner, do not point the water jet directly onto electrical components, connectors, cables, bearings, etc. Maintain a minimum distance of 60 cm between the nozzle of the pressure cleaner and the component. Excessive pressure can cause malfunctions or destroy these parts.

 **Warning**

**Environmental hazard** Hazardous substances cause environmental damage.

- Oil, grease, filters, fuel, cleaners, brake fluid, etc., should be disposed of as stipulated in applicable regulations.

 **Info**

If you clean the motorcycle regularly, its value and appearance will be maintained over a long period. Avoid direct sunshine on the motorcycle during cleaning.

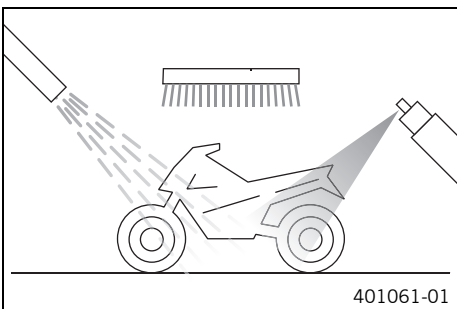

- Close off the exhaust system to keep water from entering.
- First remove coarse dirt particles with a gentle spray of water.
- Spray very dirty areas with a normal motorcycle cleaner and then clean with a paintbrush.

Motorcycle cleaner (☛ p. 103)

 **Info**

Use warm water containing normal motorcycle cleaner and a soft sponge. Never apply motorcycle cleaner to the dry vehicle; always rinse with water first.

- After rinsing the motorcycle with a gentle spray of water, allow it to dry thoroughly.
- Remove the plug from the exhaust system.
- Clean the alternator. ☛ (☛ p. 86)

 **Warning**

**Danger of accidents** Reduced braking efficiency due to a wet or dirty brake system.

- Clean or dry a dirty or wet brake system by riding and braking gently.

- After cleaning, ride a short distance until the engine reaches operating temperature.

 **Info**

The heat produced causes water at inaccessible locations in the engine and the brake system to evaporate.

- After the motorcycle has cooled off, lubricate all moving parts and bearings.
- Clean the chain. (☛ p. 50)
- Treat bare metal parts (except for the brake discs and exhaust system) with anti-corrosion materials.

Preserving materials for paints, metal and rubber (☛ p. 103)

- Treat all plastic parts and powder-coated parts with a mild cleaning and care product.

Special cleaner for glossy and matte paint finishes, metal and plastic surfaces (☛ p. 104)

## 19.2 Checks and maintenance steps for winter operation

- i Info**  
 If the motorcycle is used in the winter, salt can be expected on the roads. Precautions need to be taken against road salt corrosion.  
 If the vehicle was operated in road salt, clean it with cold water after riding. Warm water would enhance the corrosive effects of salt.

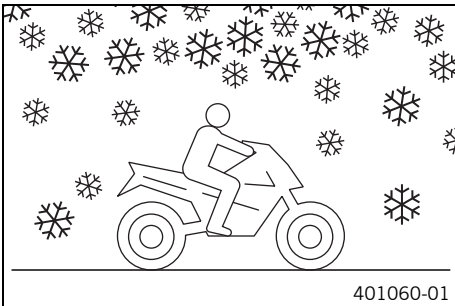

- Clean the motorcycle. (🔧 p. 89)
- Clean the brake system.

- i Info**  
 After **EVERY** trip on salted roads, thoroughly wash the brake calipers and brake linings with cold water and dry carefully. This should be done after the parts are cooled down and while they are installed.  
 After riding on salted roads, thoroughly wash the motorcycle with cold water and dry it well.

- Treat the engine, swingarm, and all other bright and zinc-plated parts (except for the brake discs) with a wax-based corrosion inhibitor.

- i Info**  
 Corrosion inhibitor is not permitted to come in contact with the brake discs as this would greatly reduce the braking force.

- Clean the chain. (🔧 p. 50)

## 20.1 Storage



### Warning

**Danger of poisoning** Fuel is poisonous and a health hazard.

- Fuel must not come into contact with the skin, eyes, or clothing. Do not breathe in the fuel vapors. If contact occurs with the eyes, rinse with water immediately and contact a physician. Immediately clean contaminated areas on the skin with soap and water. If fuel is swallowed, contact a physician immediately. Change clothing that is contaminated with fuel. Store fuel properly in a suitable canister and keep away from children.



### Info

If you want to garage the motorcycle for a longer period, take the following steps. Before storing the motorcycle, check all parts for function and wear. If service, repairs or replacements are necessary, you should do this during the storage period (less workshop overload). In this way, you can avoid long workshop waiting times at the start of the new season.

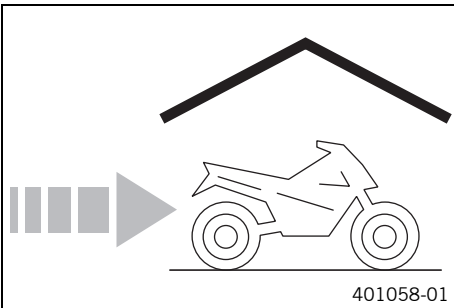

- When refueling for the last time before taking the motorcycle out of service, add fuel additive.

Fuel additive (☞ p. 103)
--------------------------

- Refuel. (☞ p. 27)
- Clean the motorcycle. (☞ p. 89)
- Change the gear oil. 🛠️ (☞ p. 87)
- Check the antifreeze and coolant level. (☞ p. 79)
- Check the tire air pressure. (☞ p. 70)
- Remove the battery. 🛠️ (☞ p. 71)
- Recharge the battery. 🛠️ (☞ p. 72)

### Guideline

Storage temperature of battery without direct sunlight	0... 35 °C (32... 95 °F)
--	--------------------------

- Store the vehicle in a dry location that is not subject to large fluctuations in temperature.



### Info

KTM recommends raising the motorcycle.

- Raise the motorcycle with the lift stand. (☞ p. 37)
- Cover the motorcycle with a porous sheet or blanket. Do not use non-porous materials since they prevent humidity from escaping, thus causing corrosion.



### Info

Avoid running the engine for a short time only. Since the engine cannot warm up properly, the water vapor produced during combustion condenses and causes valves and exhaust system to rust.

## 20.2 Preparing for use after storage

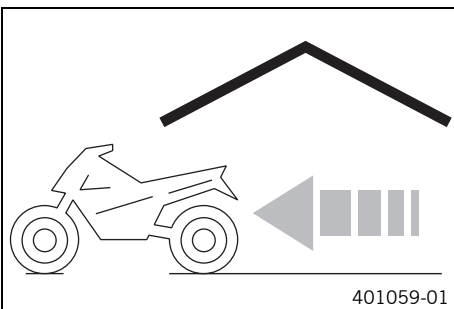

- Remove the motorcycle from the lift stand. (☞ p. 37)
- Install the battery. 🛠️ (☞ p. 71)
- Perform checks and maintenance work when preparing the vehicle for use. (☞ p. 24)
- Take a test ride.

Faults	Possible cause	Action
The engine cannot be cranked (electric starter)	Operating error	– Carry out the start procedure. (☛ p. 24)
	Battery is discharged	– Check the charging voltage. ☛ – Check the open-circuit current. ☛ – Check the alternator. ☛ – Recharge the battery. ☛ (☛ p. 72)
	Main fuse blown	– Change the main fuse. (☛ p. 73)
	Starter relay defective	– Check the starter relay. ☛
	Starter motor defective	– Check the starter motor. ☛
Engine turns but does not start	Operating error	– Carry out the start procedure. (☛ p. 24)
	The motorcycle has been in disuse for an extended period and old fuel is in the float chamber	– Empty the carburetor float chamber. ☛ (☛ p. 84)
	Fuel supply interrupted	– Check the fuel tank breather. – Clean the fuel tap. – Check/adjust the carburetor components.
	Spark plug oily or wet	– Clean and dry the spark plug, or change it if necessary.
	Electrode distance (plug gap) of spark plug too wide	– Adjust the plug gap. Guideline Spark plug electrode gap 0.60 mm (0.0236 in)
	Fault in ignition system	– Check the ignition system.
	Short circuit cable in wiring harness frayed, kill switch defective	– Check the wiring harness. (visual check) – Check the electrical system.
	Water in carburetor or jets blocked	– Check/adjust the carburetor components.
Engine has no idle	Idling jet blocked	– Check/adjust the carburetor components.
	Adjusting screws on the carburetor are in turned to the wrong position	– Carburetor - adjust the idle speed. ☛ (☛ p. 83)
	Faulty spark plug	– Change the spark plug.
	Faulty ignition system	– Check the ignition system. ☛
Engine does not speed up	The carburetor is flowing over because the float needle is dirty or worn	– Check/adjust the carburetor components.
	Loose carburetor jets	– Check/adjust the carburetor components.
	Fault in ignition system	– Check the ignition system.
Engine has too little power	Fuel supply interrupted	– Check the fuel tank breather. – Clean the fuel tap. – Check/adjust the carburetor components.
	Air filter is very dirty	– Clean the air filter and air filter housing. ☛ (☛ p. 47)
	Exhaust system leaky, deformed or too little glass fiber yarn filling in main silencer	– Check exhaust system for damage. – Change the glass fiber yarn filling of the main silencer. ☛ (☛ p. 48)
	Fault in ignition system	– Check the ignition system.
	Damaged membrane or membrane housing	– Check the membrane and membrane housing.
The engine stutters or there is back-firing through the carburetor	Lack of fuel	– Turn handle ❶ of the fuel tap to the <b>ON</b> position. (Figure B01660-10☛ p. 15) – Refuel. (☛ p. 27)
	The engine takes in false air	– Check the intake flange and carburetor for firm seating.
	Connector or ignition coil loose or oxidized	– Clean the connector and treat with contact spray.
Engine overheats	Too little coolant in cooling system	– Check the cooling system for leaks. – Check the coolant level. (☛ p. 80)

Faults	Possible cause	Action
Engine overheats	Too little air stream	– Switch off the engine when standing.
	Radiator fins very dirty	– Clean the radiator fins.
	Foam formation in cooling system	– Drain the coolant. 🛠️ (📖 p. 80) – Refill the coolant. 🛠️ (📖 p. 81)
	Damaged cylinder head or cylinder head gasket	– Check the cylinder head or cylinder head gasket.
	Bent radiator hose	– Change the radiator hose. 🛠️
	Incorrect ignition point due to loose stator	– Set the ignition. 🛠️
	Defect in radiator fan system	– Check fuse <b>2</b> . – Check the radiator fan. 🛠️ – Check the thermostwitch. 🛠️
White smoke development (steam in the exhaust)	Damaged cylinder head or cylinder head gasket	– Check the cylinder head or cylinder head gasket.
Gear oil emerges from the vent hose	Too much gear oil added	– Check the gear oil level. (📖 p. 86)
Water in the gear oil	Damaged shaft seal ring or water pump	– Check the shaft seal ring and water pump.

## 22.1 Engine

Design	1-cylinder 2-stroke gasoline engine, water-cooled, with membrane inlet
Displacement	249 cm <sup>3</sup> (15.19 cu in)
Stroke	72 mm (2.83 in)
Bore	66.4 mm (2.614 in)
Crankshaft bearing	1 grooved ball bearing/1 roller bearing
Conrod bearing	Needle bearing
Piston pin bearing	Needle bearing
Pistons	Aluminum cast
Piston rings	2 half keystone rings
X (upper edge of piston to upper edge of cylinder)	0... 0.10 mm (0... 0.0039 in)
Primary transmission	26:72
Clutch	Multidisc clutch in oil bath/hydraulically activated
Gearbox	6-gear, claw shifted
Transmission ratio	
First gear	13:32
Second gear	16:30
Third gear	16:24
Fourth gear	23:28
Fifth gear	23:23
Sixth gear	26:20
Ignition	Contactless controlled fully electronic ignition with digital ignition adjustment, type Kokusan
Ignition point (BTDC)	1.9 mm (0.075 in)
Spark plug	NGK BR 7 ES
Spark plug electrode gap	0.60 mm (0.0236 in)
Starting aid	Electric starter

## 22.2 Engine tightening torques

Screw, inner reed petals	<b>EJOT DELTA PT®</b> 35x25	1 Nm (0.7 lbf ft)	–
Screw, membrane core plate	<b>EJOT DELTA PT®</b> 30x12	1 Nm (0.7 lbf ft)	–
Screw, outer reed petals	<b>EJOT DELTA PT®</b> 30x6	1 Nm (0.7 lbf ft)	–
Screw, crankshaft position sensor	M5	6 Nm (4.4 lbf ft)	<b>Loctite® 243™</b>
Screw, locking lever	M5	6 Nm (4.4 lbf ft)	<b>Loctite® 243™</b>
Screw, water pump wheel	M5	6 Nm (4.4 lbf ft)	<b>Loctite® 243™</b>
Screw, alternator cover	M6	8 Nm (5.9 lbf ft)	–
Screw, bearing retainer	M6	10 Nm (7.4 lbf ft)	<b>Loctite® 243™</b>
Screw, clutch cover	M6	10 Nm (7.4 lbf ft)	–
Screw, clutch pressure cap	M6	10 Nm (7.4 lbf ft)	–
Screw, engine case	M6	10 Nm (7.4 lbf ft)	–
Screw, exhaust flange	M6	10 Nm (7.4 lbf ft)	–
Screw, gear oil level check	M6	10 Nm (7.4 lbf ft)	–
Screw, intake flange/reed valve housing	M6	10 Nm (7.4 lbf ft)	–
Screw, shift drum locating	M6	10 Nm (7.4 lbf ft)	<b>Loctite® 243™</b>
Screw, shift lever	M6	14 Nm (10.3 lbf ft)	<b>Loctite® 243™</b>
Screw, slave cylinder of the clutch	M6	10 Nm (7.4 lbf ft)	–
Screw, starter motor	M6	8 Nm (5.9 lbf ft)	–
Screw, stator	M6	8 Nm (5.9 lbf ft)	<b>Loctite® 243™</b>
Screw, water pump cover	M6	10 Nm (7.4 lbf ft)	–
Transmission venting connection	M6	4 Nm (3 lbf ft)	<b>Loctite® 243™</b>
Screw, cylinder head	M8	27 Nm (19.9 lbf ft)	–



Nut, cylinder base	M10	35 Nm (25.8 lbf ft)	–
Drain plug, water pump cover	M10x1	15 Nm (11.1 lbf ft)	–
Nut, rotor	M12x1	60 Nm (44.3 lbf ft)	–
Gear oil drain plug with magnet	M12x1.5	20 Nm (14.8 lbf ft)	–
Spark plug	M14x1.25	25 Nm (18.4 lbf ft)	–
Nut, inner clutch hub	M18x1.5	120 Nm (88.5 lbf ft)	Loctite® 648™
Nut, primary gear	M18LHx1.5	150 Nm (110.6 lbf ft)	Loctite® 648™

## 22.3 Capacities

### 22.3.1 Gear oil

Gear oil	0.80 l (0.85 qt.)	Engine oil (15W/50) (☛ p. 101)
----------	-------------------	--------------------------------

### 22.3.2 Coolant

Coolant	0.9 l (1 qt.)	Coolant (☛ p. 101)
		Coolant (mixed ready to use) (☛ p. 101)

### 22.3.3 Fuel

Total fuel tank capacity, approx.	7.0 l (1.85 US gal)	Super unleaded (95 octane) mixed with 2-stroke engine oil (1:80) (☛ p. 102)
Fuel reserve, approx.	1.65 l (1.74 qt.)	

## 22.4 Chassis

Frame	Perimeter, steel-aluminum composite frame	
fork	<b>WP Suspension 4357 MXMA</b>	
Suspension travel		
Front	250 mm (9.84 in)	
Rear	260 mm (10.24 in)	
Fork offset	20 mm (0.79 in)	
Shock absorber	<b>WP Suspension 4618 PDS DCC</b>	
Brake system		
Front	Disc brake with radially mounted four-piston brake caliper	
Rear	Disc brake with radially mounted dual-piston brake caliper	
Brake discs - diameter		
Front	260 mm (10.24 in)	
Rear	210 mm (8.27 in)	
Brake discs - wear limit		
Front	2.5 mm (0.098 in)	
Rear	3.5 mm (0.138 in)	
Tire air pressure, offroad		
Front	0.9 bar (13 psi)	
Rear	0.7 bar (10 psi)	
Tire air pressure, road		
Front	1.5 bar (22 psi)	
Rear	1.5 bar (22 psi)	
Secondary ratio (EU/AU)	14:46 (12:46)	
Secondary ratio (US)	12:46	
Chain	5/8 x 1/4" X-ring	
Rear sprockets available	46, 48	
Steering head angle	67°	
Wheelbase	1,418±10 mm (55.83±0.39 in)	

Ground clearance, unloaded	380 mm (14.96 in)
Seat height, unloaded	915 mm (36.02 in)
Homologated weight without fuel, approx. (EU/AU)	92.5 kg (203.9 lb.)
Weight without fuel, approx. (US)	91.5 kg (201.7 lb.)
Maximum permissible front axle load	135 kg (298 lb.)
Maximum permissible rear axle load	175 kg (386 lb.)
Maximum permissible overall weight	280 kg (617 lb.)

## 22.5 Electrical system

Battery	HJTZ5S-FP	Battery voltage: 12 V Nominal capacity: 24 Wh Maintenance-free
Speedometer battery	CR 2032	Battery voltage: 3 V
Fuse	75011088010	10 A
Fuse	58011109110	10 A
Headlight	S2/socket BA20d	12 V 35/35 W
Parking light	W5W/socket W2.1x9.5d	12 V 5 W
Indicator lamps	W2.3W/socket W2x4.6d	12 V 2.3 W
Turn signal	R10W/socket BA15s	12 V 10 W
Brake/tail light	LED	
License plate lamp	W5W/socket W2.1x9.5d	12 V 5 W

## 22.6 Tires

Front tires	Rear tires
<b>2.75 - 21 M/C 45M TT</b> MAXXIS TRIALMAXX	<b>4.00 R 18 M/C 64M TL</b> MAXXIS TRIALMAXX
Additional information is available in the Service section under: <a href="http://www.ktm.com">http://www.ktm.com</a>	

## 22.7 Fork

Fork part number	05.18.7N.42
fork	<b>WP Suspension 4357 MXMA</b>
Compression damping	
Comfort	25 clicks
Standard	20 clicks
Sport	15 clicks
Rebound damping	
Comfort	25 clicks
Standard	20 clicks
Sport	15 clicks
Spring length with preload spacer(s)	
Weight of rider: 65... 75 kg (143... 165 lb.)	445 mm (17.52 in)
Weight of rider: 75... 85 kg (165... 187 lb.)	445 mm (17.52 in)
Weight of rider: 85... 95 kg (187... 209 lb.)	445 mm (17.52 in)
Spring rate	
Weight of rider: 65... 75 kg (143... 165 lb.)	4.4 N/mm (25.1 lb/in)
Weight of rider: 75... 85 kg (165... 187 lb.)	4.6 N/mm (26.3 lb/in)
Weight of rider: 85... 95 kg (187... 209 lb.)	4.8 N/mm (27.4 lb/in)

Fork length	835 mm (32.87 in)	
Air chamber length	120 $\pm$ $\frac{10}{10}$ mm (4.72 $\pm$ $\frac{0.39}{1.57}$ in)	
Fork oil per fork leg	390 ml (13.19 fl. oz.)	Fork oil (SAE 4) (48601166S1) (☛ p. 101)

## 22.8 Shock absorber

Shock absorber part number	15.18.7N.42	
Shock absorber	<b>WP Suspension</b> 4618 PDS DCC	
Compression damping, low-speed		
Comfort	20 clicks	
Standard	15 clicks	
Sport	10 clicks	
Compression damping, high-speed		
Comfort	2.5 turns	
Standard	2 turns	
Sport	1 turn	
Rebound damping		
Comfort	20 clicks	
Standard	15 clicks	
Sport	10 clicks	
Spring preload		
Comfort	8 mm (0.31 in)	
Standard	8 mm (0.31 in)	
Sport	8 mm (0.31 in)	
Spring designation		
Weight of rider: 65... 75 kg (143... 165 lb.)	(61/59) 55-215	
Weight of rider: 75... 85 kg (165... 187 lb.)	(61/59) 55/63/71-215	
Weight of rider: 85... 95 kg (187... 209 lb.)	(61/59) 58/62/74-215	
Spring length	215 mm (8.46 in)	
Gas pressure	10 bar (145 psi)	
Static sag	15 mm (0.59 in)	
Riding sag	80 mm (3.15 in)	
Fitted length	367 mm (14.45 in)	
Shock absorber oil	Shock absorber fluid (SAE 2.5) (50180751S1) (☛ p. 102)	

## 22.9 Chassis tightening torques

Spoke nipple	M4.5	6 Nm (4.4 lbf ft)	–
Screw, battery terminal	M5	2.5 Nm (1.84 lbf ft)	–
Screw, shock absorber adjusting ring	M5	5 Nm (3.7 lbf ft)	–
Nut, cable on starter motor	M6	4 Nm (3 lbf ft)	–
Remaining nuts, chassis	M6	10 Nm (7.4 lbf ft)	–
Remaining screws, chassis	M6	10 Nm (7.4 lbf ft)	–
Screw, ball joint of push rod on foot brake cylinder	M6	10 Nm (7.4 lbf ft)	<b>Loctite® 243™</b>
Screw, front brake disc	M6	14 Nm (10.3 lbf ft)	<b>Loctite® 243™</b>
Screw, radiator bracket	M6	7 Nm (5.2 lbf ft)	–
Screw, rear brake disc	M6	14 Nm (10.3 lbf ft)	<b>Loctite® 243™</b>
Screws, throttle grip	M6	3 Nm (2.2 lbf ft)	–
Nut, foot brake lever stop	M8	20 Nm (14.8 lbf ft)	–
Nut, rear sprocket screw	M8	35 Nm (25.8 lbf ft)	<b>Loctite® 2701™</b>
Nut, rim lock	M8	10 Nm (7.4 lbf ft)	–
Remaining nuts, chassis	M8	25 Nm (18.4 lbf ft)	–

Remaining screws, chassis	M8	25 Nm (18.4 lbf ft)	–
Screw of rear brake caliper	M8	25 Nm (18.4 lbf ft)	<b>Loctite® 243™</b>
Screw, bottom triple clamp	M8	18 Nm (13.3 lbf ft)	–
Screw, chain sliding piece	M8	15 Nm (11.1 lbf ft)	–
Screw, engine brace on cylinder head	M8	33 Nm (24.3 lbf ft)	–
Screw, engine brace on frame	M8	25 Nm (18.4 lbf ft)	<b>Loctite® 243™</b>
Screw, fork stub	M8	15 Nm (11.1 lbf ft)	–
Screw, front brake caliper	M8	25 Nm (18.4 lbf ft)	<b>Loctite® 243™</b>
Screw, fuel tank	M8	15 Nm (11.1 lbf ft)	<b>Loctite® 243™</b>
Screw, handlebar clamp	M8	20 Nm (14.8 lbf ft)	–
Screw, side stand attachment	M8	25 Nm (18.4 lbf ft)	<b>Loctite® 2701™</b>
Screw, subframe	M8	30 Nm (22.1 lbf ft)	<b>Loctite® 243™</b>
Screw, top steering stem	M8	17 Nm (12.5 lbf ft)	<b>Loctite® 243™</b>
Screw, top triple clamp	M8	22 Nm (16.2 lbf ft)	–
Engine bracket screw	M10	60 Nm (44.3 lbf ft)	–
Nut, fuel tank attachment	M10	10 Nm (7.4 lbf ft)	–
Remaining nuts, chassis	M10	45 Nm (33.2 lbf ft)	–
Remaining screws, chassis	M10	45 Nm (33.2 lbf ft)	–
Screw, cross bar	M10	45 Nm (33.2 lbf ft)	–
Screw, foot brake lever	M10	30 Nm (22.1 lbf ft)	<b>Loctite® 243™</b>
Screw, footrest bracket	M10	45 Nm (33.2 lbf ft)	<b>Loctite® 243™</b>
Screw, handlebar support	M10	40 Nm (29.5 lbf ft)	<b>Loctite® 243™</b>
Screw, upper subframe	M10	45 Nm (33.2 lbf ft)	<b>Loctite® 243™</b>
Screw, bottom shock absorber	M12	80 Nm (59 lbf ft)	<b>Loctite® 2701™</b>
Screw, top shock absorber	M12	80 Nm (59 lbf ft)	<b>Loctite® 2701™</b>
Nut, swingarm pivot	M14x1.5	75 Nm (55.3 lbf ft)	–
Nut, rear wheel spindle	M20x1.5	80 Nm (59 lbf ft)	–
Screw, front wheel spindle	M20x1.5	35 Nm (25.8 lbf ft)	–
Screw, top steering head	M20x1.5	12 Nm (8.9 lbf ft)	–

**22.10 Carburetor****22.10.1 EU/AU**

Carburetor type	KEIHIN PWK 28
Carburetor identification number	BU0
Needle position	2nd position from top
Jet needle	JJH (JJG)
Main jet	110 (120/122/125)
Idling jet	40 (45/48)
Idle air adjusting screw	
Open	2.0 rotations
Throttle slide	3.5
Slide stop	Present

**22.10.2 US**

Carburetor type	KEIHIN PWK 28
Carburetor identification number	CC5
Needle position	4th position from top
Jet needle	JJG
Main jet	122 (120/125)
Idling jet	45 (48)
Idle air adjusting screw	
Open	2.0 rotations
Throttle slide	3.5
Slide stop	Present

**22.10.3 Carburetor tuning** ↗**Danger**

**Loss of approval for road use and insurance coverage** The motorcycle is authorized for public road traffic in the homologous (reduced) version only.

- In the derestricted version, the motorcycle must be used only on closed off property remote from public road traffic.

KEIHIN PWK 28							
M/FT ASL ↓	TEMP →	-20°C ... -7°C	-6°C ... 5°C	6°C ... 15°C	16°C ... 24°C	25°C ... 36°C	37°C ... 49°C
		-2°F ... 20°F	19°F ... 41°F	42°F ... 60°F	61°F ... 78°F	79°F ... 98°F	99°F ... 120°F
3.000 m 10,000 ft ↑ 2.301 m 7,501 ft	ASO IJ NDL POS MJ	2,5 50 JJG 4 125	2,5 48 JJG 4 122	2,5 45 JJG 4 120	3 45 JJG 4 120	2,5 48 JJG 3 122	
2.300 m 7,500 ft ↑ 1.501 m 5,001 ft	ASO IJ NDL POS MJ	2 50 JJG 4 128	2 48 JJG 4 125	2,5 48 JJG 4 122	2,5 45 JJG 4 122	3 45 JJG 4 122	3 45 JJG 3 122
1.500 m 5,000 ft ↑ 751 m 2,501 ft	ASO IJ NDL POS MJ	1,5 50 JJG 4 128	1,5 48 JJG 4 125	2 48 JJG 4 122	2 45 JJG 4 122	2,5 45 JJG 4 122	2,5 48 JJG 3 122
750 m 2,500 ft ↑ 301 m 1,001 ft	ASO IJ NDL POS MJ	1,5 50 JJG 4 128	1,5 48 JJG 4 125	2 48 JJG 4 122	<b>2</b> <b>45</b> <b>JJG</b> <b>4</b> <b>122</b>	2,5 45 JJG 4 122	2,5 48 JJG 3 122
300 m 1,000 ft ↑ 0 m 0 ft	ASO IJ NDL POS MJ	1,5 50 JJG 4 128	1,5 48 JJG 4 125	2 48 JJG 4 122	2 45 JJG 4 122	2,5 45 JJG 4 122	2,5 48 JJG 3 122

401798-01

M/FT ASL	Sea level
TEMP	Temperature
ASO	Open idle air adjusting screw
IJ	Idling jet
NDL	Needle
POS	Needle position from top
MJ	Main jet

Does not apply on sandy terrain.

## Brake fluid DOT 4 / DOT 5.1

**Standard/classification**

- DOT

**Guideline**

- Use only brake fluid that complies with the specified standard (see specifications on the container) and that possesses the corresponding properties.

**Recommended supplier**

**Castrol**

- **RESPONSE BRAKE FLUID SUPER DOT 4**

**Motorex®**

- **Brake Fluid DOT 5.1**

## Coolant

**Guideline**

- Use only suitable coolant (even in countries with high temperatures). Using inferior antifreeze can result in corrosion and foaming.

**Mixture ratio**

Antifreeze protection: -25... -45 °C (-13... -49 °F)	50 % anti-corrosion/antifreeze 50 % distilled water
--	--

## Coolant (mixed ready to use)

Antifreeze protection	-38 °C (-36 °F)
-----------------------	-----------------

**Recommended supplier**

**Motorex®**

- **COOLANT M3.0 Silikatfrei**

## Engine oil (15W/50)

**Standard/classification**

- JASO T903 MA (☛ p. 105)
- SAE (☛ p. 105) (15W/50)

**Guideline**

- Use only engine oils that comply with the specified standards (see specifications on the container) and that possess the corresponding properties.

**Recommended supplier**

**Motorex®**

- **Top Speed 4T**

## Engine oil, 2-stroke

**Standard/classification**

- JASO FD (☛ p. 105)

**Guideline**

- Only use high grade 2-stroke engine oil of a reputable brand.

Fully synthetic
-----------------

**Recommended supplier**

**Motorex®**

- **Cross Power 2T**

## Fork oil (SAE 4) (48601166S1)

**Standard/classification**

- SAE (☛ p. 105) (SAE 4)

**Guideline**

- Use only oils that comply with the specified standards (see specifications on the container) and that possess the corresponding properties.

## Shock absorber fluid (SAE 2.5) (50180751S1)

### Standard/classification

- SAE (☛ p. 105) (SAE 2.5)

### Guideline

- Use only oils that comply with the specified standards (see specifications on the container) and that possess the corresponding properties.

## Super unleaded (ROZ 95/RON 95/PON 91)

### Standard/classification

- DIN EN 228 (ROZ 95/RON 95/PON 91)

### Guideline

- Only use unleaded super fuel that matches or is equivalent to the specified fuel grade.
- Fuel with an ethanol content of up to 10 % (E10 fuel) is safe to use.



### Info

Do **not** use fuel containing methanol (e. g. M15, M85, M100) or more than 10 % ethanol (e. g. E15, E25, E85, E100).

## Super unleaded (95 octane) mixed with 2-stroke engine oil (1:80)

### Standard/classification

- DIN EN 228
- JASO FD (☛ p. 105) (1:80)

### Mixture ratio

1:80	Engine oil, 2-stroke (☛ p. 101) Super unleaded (ROZ 95/RON 95/PON 91) (☛ p. 102)
------	---

### Recommended supplier

#### Motorex®

- Cross Power 2T



## Air filter cleaner

Recommended supplier

Motorex®

- Racing Bio Dirt Remover

## Chain cleaner

Recommended supplier

Motorex®

- Chain Clean

## Fuel additive

Recommended supplier

Motorex®

- Fuel Stabilizer

## High viscosity grease

Recommended supplier

SKF®

- LGHB 2

## Long-life grease

Recommended supplier

Motorex®

- Bike Grease 2000

## Lubricant (T625)

Recommended supplier

Molykote®

- 33 Medium

## Motorcycle cleaner

Recommended supplier

Motorex®

- Moto Clean

## Off-road chain spray

Recommended supplier

Motorex®

- Chainlube Offroad

## Oil for foam air filter

Recommended supplier

Motorex®

- Racing Bio Liquid Power

## Preserving materials for paints, metal and rubber

Recommended supplier

Motorex®

- Moto Protect

## Rubber grip adhesive (00062030051)

Recommended supplier

KTM-Sportmotorcycle AG

- GRIP GLUE

### Special cleaner for glossy and matte paint finishes, metal and plastic surfaces

Recommended supplier

Motorex®

- Quick Cleaner

### Universal oil spray

Recommended supplier

Motorex®

- Joker 440 Synthetic

## **JASO T903 MA**

Different technical development directions required a new specification for 4-stroke motorcycles – the JASO T903 MA Standard. Earlier, engine oils from the automobile industry were used for 4-stroke motorcycles because there was no separate motorcycle specification. Whereas long service intervals are demanded for automobile engines, high performance at high engine speeds are in the foreground for motorcycle engines. In most motorcycles, the gearbox and the clutch are lubricated with the same oil as the engine. The JASO MA Standard meets these special requirements.

## **SAE**

The SAE viscosity classes were defined by the Society of Automotive Engineers and are used for classifying oils according to their viscosity. The viscosity describes only one property of oil and says nothing about quality.

## **JASO FD**

JASO FD is a classification for a 2-stroke engine oil that was specifically developed for the extreme demands of racing. Thanks to first rate synthetic esters and specially designed additives, superb combustion is achieved even under extreme operating conditions.

<b>A</b>	
<b>Accessories</b> .....	7
<b>Air filter</b>	
cleaning .....	47
installing .....	46
removing .....	46
<b>Air filter housing</b>	
cleaning .....	47
installing .....	46
removing .....	45
<b>Alternator</b>	
cleaning .....	86
<b>Antifreeze</b>	
checking .....	79
<b>Auxiliary substances</b> .....	7
<b>B</b>	
<b>Basic chassis setting</b>	
checking with rider's weight .....	30
<b>Battery</b>	
installing .....	71
recharging .....	72
removing .....	71
<b>Brake discs</b>	
checking .....	58
<b>Brake fluid</b>	
front brake, adding .....	59
rear brake, adding .....	63
<b>Brake fluid level</b>	
front brake, checking .....	59
rear brake, checking .....	63
<b>Brake linings</b>	
front brake, changing .....	60
front brake, checking .....	60
rear brake, changing .....	64
rear brake, checking .....	64
<b>Brake system</b> .....	58-66
<b>C</b>	
<b>Capacity</b>	
coolant .....	81, 95
fuel .....	27, 95
gear oil .....	88, 95
<b>Carburetor</b>	
adjusting idle .....	83
emptying the float chamber .....	84
idle .....	83
<b>Chain</b>	
checking .....	52
cleaning .....	50
<b>Chain guide</b>	
checking .....	52
<b>Chain tension</b>	
adjusting .....	51
checking .....	51
<b>Chassis number</b> .....	10
<b>Choke</b> .....	15
<b>Clutch</b>	
fluid level, checking .....	55
fluid level, correcting .....	55
fluid, changing .....	56
<b>Clutch lever</b> .....	12
basic position, adjusting .....	55
<b>Combination instrument</b>	
overview .....	18
<b>Compression damping</b>	
fork, adjusting .....	35
<b>Compression damping, high-speed</b>	
shock absorber, adjusting .....	31
<b>Compression damping, low-speed</b>	
shock absorber, adjusting .....	30
<b>Coolant</b>	
draining .....	80
refilling .....	81
<b>Coolant level</b>	
checking .....	79-80
<b>Cooling system</b> .....	79
<b>Customer service</b> .....	7
<b>E</b>	
<b>Electric starter button</b> .....	13
<b>Emergency OFF switch</b> .....	13
<b>Engine</b>	
running in .....	23
<b>Engine guard</b>	
installing .....	57
removing .....	57
<b>Engine number</b> .....	10
<b>Engine sprocket</b>	
checking .....	52
<b>Environment</b> .....	6
<b>F</b>	
<b>Figures</b> .....	7
<b>Filler cap</b>	
closing .....	15
opening .....	14
<b>Filling up</b>	
fuel .....	27
<b>Foot brake lever</b> .....	16
basic position, adjusting .....	62
free travel, checking .....	62
<b>Fork legs</b>	
basic setting, checking .....	34
bleeding .....	37
dust boots, cleaning .....	38
installing .....	39
removing .....	38
<b>Fork protector</b>	
installing .....	40
removing .....	39
<b>Frame</b>	
checking .....	53

<b>Front fender</b>	
installing	45
removing	44
<b>Front wheel</b>	
installing	67
removing	67
<b>Fuel tank</b>	
installing	49
removing	48
<b>Fuel tap</b>	15
<b>Fuse</b>	
individual power consumers, changing	74
main fuse, changing	73
<b>G</b>	
<b>Gear oil</b>	
adding	88
changing	87
draining	87
refilling	88
<b>Gear oil level</b>	
checking	86
<b>H</b>	
<b>Hand brake lever</b>	12
free travel, adjusting	58
free travel, checking	58
<b>Handlebar position</b>	35
adjusting	36
<b>Headlight</b>	
headlight range, adjusting	77
<b>Headlight bulb</b>	
changing	76
<b>Headlight mask with headlight</b>	
installing	75
removing	75
<b>Headlight setting</b>	
checking	77
<b>Horn button</b>	12
<b>I</b>	
<b>Intended use</b>	5
<b>K</b>	
<b>Key number</b>	10
<b>Kill switch</b>	12
<b>L</b>	
<b>Light switch</b>	13
<b>Lower triple clamp</b>	
installing	41
removing	40
<b>M</b>	
<b>Main fuse</b>	
changing	73
<b>Main silencer</b>	
glass fiber yarn filling, changing	48
installing	48
removing	47

<b>Motorcycle</b>	
cleaning	89
raising with lift stand	37
removing from lift stand	37
<b>O</b>	
<b>Operating substances</b>	7
<b>Overview of indicator lamps</b>	14
<b>Owner's Manual</b>	6
<b>P</b>	
<b>Play in the throttle cable</b>	
adjusting	82
checking	82
<b>Preparing for use</b>	
advice on first use	22
after storage	91
checks and maintenance work when preparing for use	24
<b>Protective clothing</b>	6
<b>R</b>	
<b>Rear sprocket</b>	
checking	52
<b>Rear wheel</b>	
installing	68
removing	68
<b>Rebound damping</b>	
fork, adjusting	35
shock absorber, adjusting	31
<b>Riding sag</b>	
adjusting	34
<b>Rubber grip</b>	
checking	54
securing	55
<b>S</b>	
<b>Safe operation</b>	6
<b>Seat</b>	
folding up	45
locking	45
<b>Service</b>	7
<b>Service schedule</b>	28-29
<b>Shift lever</b>	15
basic position, adjusting	85
basic position, checking	85
<b>Shock absorber</b>	
installing	44
removing	44
riding sag, checking	33
spring preload, adjusting	33
static sag, checking	32
<b>Side stand</b>	16
<b>Spare parts</b>	7
<b>Speedometer</b>	
battery, changing	78
clock, setting	20
kilometers or miles, setting	19
message	18
service display, setting	20
setting	18

<b>Spoke tension</b>	
checking	70
<b>Starting</b>	24
<b>Steering</b>	
locking	17
unlocking	17
<b>Steering head bearing</b>	
greasing	43
<b>Steering head bearing play</b>	
adjusting	43
checking	42
<b>Storage</b>	91
<b>Swingarm</b>	
checking	54
<b>T</b>	
<b>Technical data</b>	
capacities	95
carburetor	99
chassis	95
chassis tightening torques	97
electrical system	96
engine	94
engine tightening torques	94
fork	96
shock absorber	97
tires	96
<b>Throttle cable routing</b>	
checking	54
<b>Throttle grip</b>	12
<b>Tire air pressure</b>	
checking	70
<b>Tire condition</b>	
checking	69
<b>Transport</b>	26
<b>Troubleshooting</b>	92-93
<b>Turn signal bulb</b>	
changing	77
<b>Turn signal switch</b>	13
<b>Type label</b>	10
<b>U</b>	
<b>Use definition</b>	5
<b>V</b>	
<b>View of vehicle</b>	
left front	8
rear right	9
<b>W</b>	
<b>Warranty</b>	7
<b>Winter operation</b>	
checks and maintenance steps	90
<b>Work rules</b>	6



3213185en

08/2014

