

TTP 2000 Kiosk Printer

Technical Manual



Acknowledgments

Adobe and *Acrobat* are trademarks of Adobe Systems Incorporated

Windows is a trademark of Microsoft Corporation

This is a publication of Swecoin AB
Box 322, SE-192 30 SOLLENTUNA, Sweden

Phone +46 8 623 45 60

Fax +46 8 594 709 89

E-mail techsupport@swecoin.se
sales@swecoin.se

Web site <http://www.swecoin.se>

© Swecoin AB 2004, 2005

All rights reserved. Reproduction in whole or in parts is prohibited without written consent of the copyright owner. We have taken great care to ensure that the information in this manual is correct and complete. However, if you discover any errors or omissions, or if you wish to make suggestions for improvements, you are welcome to send your comments to us. Swecoin AB disclaims any liability resulting from the use of this information and reserves the right to make changes without notice.

Edition D, February 2006

Printed in Sweden

CONTENTS

1 Introduction.....	5
1.1 About this manual.....	5
1.2 Updating	5
2 Product presentation.....	6
2.2 Controls	8
3 Installation	10
3.1 Installing a paper guide	10
3.2 Installation considerations	11
3.3 Installing a paper-low sensor (option)	15
3.4 Connecting to the computer	16
3.5 Connecting the power	18
3.6 Making a test printout.....	19
3.7 Installing a printer driver	20
4 Operation	22
4.1 Installing a paper roll	22
4.2 Clearing paper jams	24
5 Programming	25
5.1 How the commands are described.....	26
5.2 Summary of control codes & escape sequences.....	27
5.3 Software command syntax.....	29
5.4 Font loading.....	54
5.5 Logotypes.....	56
5.6 Status reporting	58
6 Default parameter settings	59
6.1 How the parameters are described	59
6.2 Summary of parameter settings	60
6.3 Serial interface set-up	61
6.4 Parallel port setup	62
6.5 Print setup	62
7 Page setup.....	69
7.1 Printable area	69
7.2 Aligning preprint and thermal print	70
7.3 Parameters used	71
7.4 Black-mark sensing from within "Windows"	74

8 Interface	75
8.1 Serial, TTP 2010	75
8.2 Parallel, TTP 2020.....	76
8.3 USB, TTP 2030	77
9 Maintenance	78
9.1 Fault finding.....	78
9.2 Cleaning the print head	79
9.3 Firmware.....	79
10 Specifications	86
10.1 General.....	86
10.2 Paper.....	86
10.3 Text Mode	87
10.4 Miscellaneous.....	88
10.5 Life Expectancy	88
10.6 Ordering number list.....	89
10.7 Dimensions.....	90

REGISTER NOW!

If you wish to stay informed of product changes, manual updates etc., you are welcome to subscribe to our bulletin service.

To register as a subscriber, either visit our web site <http://www.swecoin.se> to fill in your subscription request, or send e-mail to bulletins@swecoin.se. Enter the text *Subscribe bulletins* as the subject. Do not enter any text in the message area.

Registration date (for your own records): _____

REVISION HISTORY

Edition A: This issue, describes TTP 2000 with firmware version 2.52

Edition B: This issue, describes TTP 2000 with firmware version 3.05+

Edition C: This issue, describes TTP 2000 with firmware version 3.10

Edition D: This issue, describes TTP 2000 with firmware version 3.20

1

INTRODUCTION

1.1 About this manual

1.2 Updating

This manual will be updated as, from time to time, printer functions and features may be added or amended. You will always find the latest edition on our web site (<http://www.swecoin.se>). You can order printed copies of the current manual by e-mail, fax, or phone.

If you require functions not found in the manual edition at your disposal, you are welcome to consult one of our representatives for information.

2 PRODUCT PRESENTATION

The TTP 2000 series are kiosk printers for 58 to 82.5 mm paper using direct thermal printing. It has integrated guillotine cutter, looping presenter with built in retract and retain function, and control board. The print speed is 150 mm per second, and the presenting speed 300 mm/s to ensure high throughput.

The printhead can easily be opened to give the operator access to the paper path, and print head, for maintenance purposes.

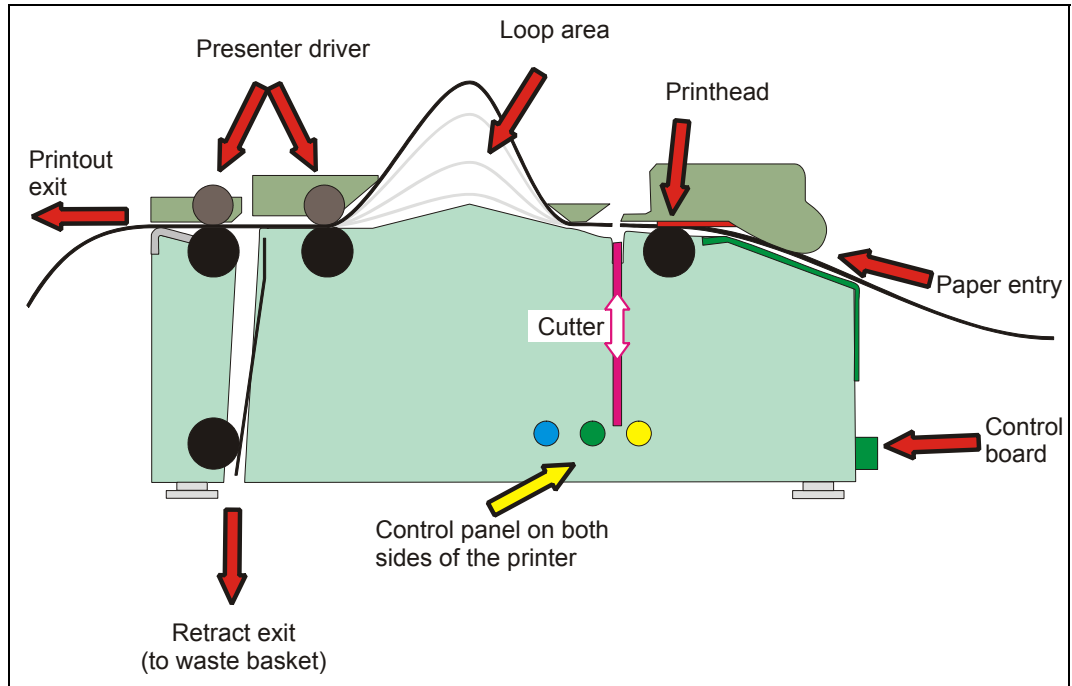

Figure 1 Principle of operation

The capability of the control board differs between the versions of TTP 2000:

	TTP 2010	TTP 2020	TTP 2030
Interface	Serial	Parallel	USB

Printer drivers for Microsoft Windows™ and Linux are available, and the printer is compatible with the Plug and Play standard.

The text capability makes it easier to print directly from the kiosk software without using a driver.

2.1.1 Looping presenter

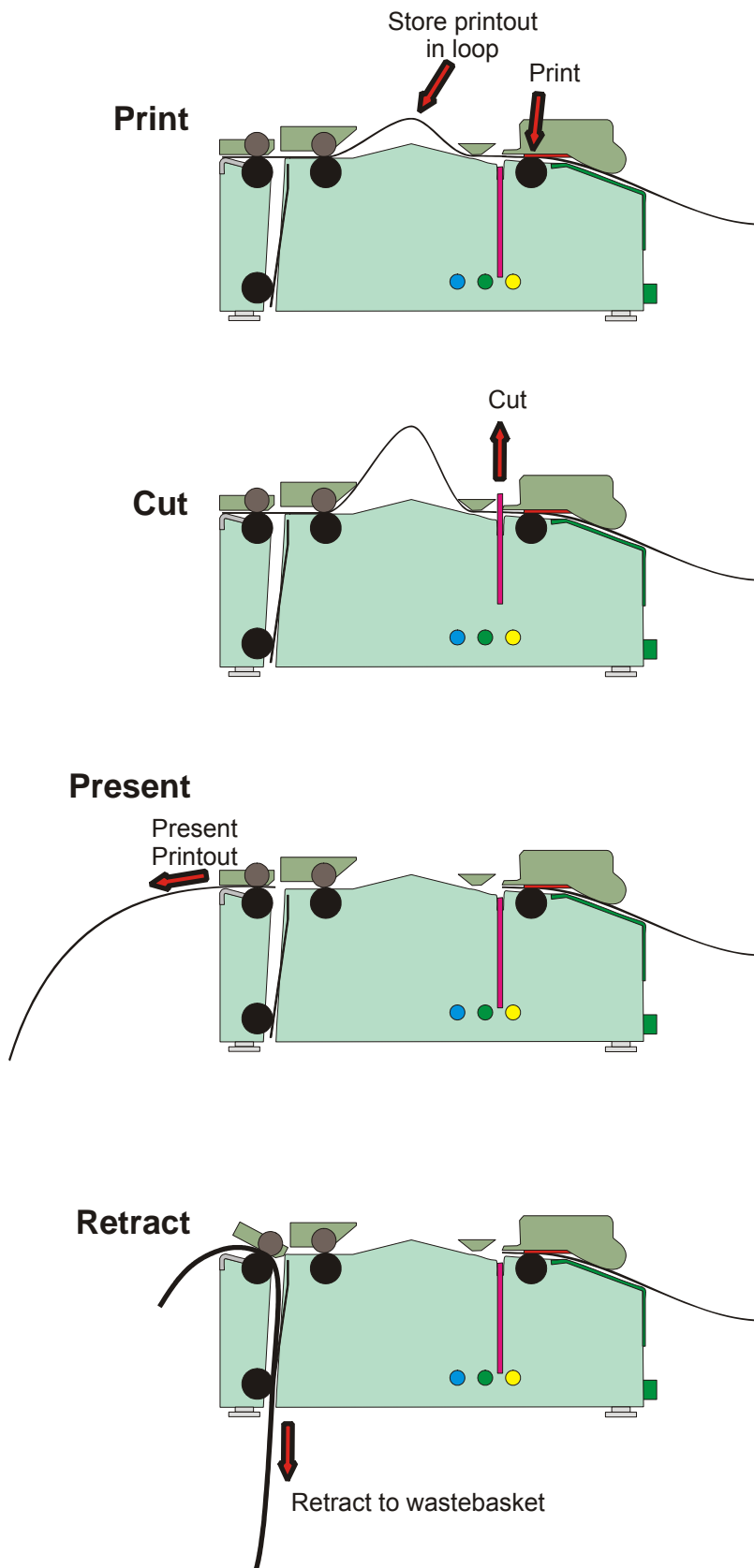

The loop generating presenter mechanism has many benefits;

- It handles documents of various lengths by storing the printed paper in a loop.
- It holds the printout until fully printed and cut before presenting the completed printout to the customer.
- When presented, only the very end of the printout is held by the printer so the customer can easily take the printout no matter how long or short it is. You can also select to eject a portion of the printout and then use the pull detector to eject the rest when the customer pulls in the paper.
- The retract-and-retain function can retract uncollected printouts and throw them in a wastebasket inside the kiosk. Retracts are reported to the driver so any remaining data for that printout can be deleted.

Figure 2 The Swecoin looping presenter

2.2 Controls

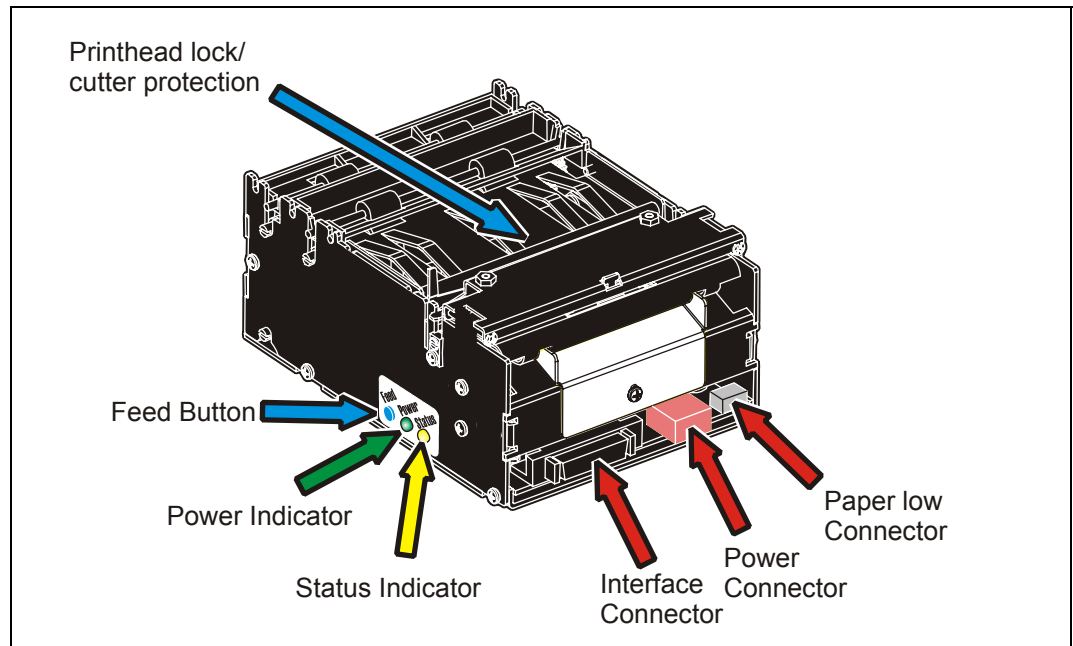

Figure 3 Rear view

The controls are duplicated on both sides of the printer so that they are easily accessible regardless of how the printer is installed.

2.2.1 Feed button

The **Blue** feed-button has several functions:

- Short press; eject printout from presenter
- Longer press; feed, cut, and present a complete page.
Any data in the print buffer will be printed. If the buffer is empty the page will be blank.
In black mark mode, the page will be synchronized with the black mark.
- Press and hold while turning on the power, or while opening and closing the printhead to print a self-test printout. See page 19.

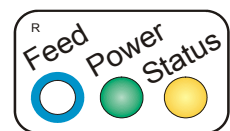

2.2.2 Status indicator

- The status indicator has several functions:

ON constantly — the printer is operational

Flashes rapidly — indicates error. Hold down the feed-forward button and the number of blinks will reflect the *status-code*.

1	Presenter jam, paper cannot be ejected / retracted
2	Cutter cannot return to home position
3	Out of paper
4	Printhead lifted
5	Paper feed error (under head)
6	Temp error, printhead is above 60°C
7	Presenter jam, motor cannot rotate
8	Paper jam during retract
Fast flashes	Checksum error, firmware
Steady light	Wrong firmware type or target for firmware loading

Status-codes are reset:

- 1 When the conditions causing them are removed
- 2 When the printer is turned off/on
- 3 When the printhead is lifted and then lowered.

Blink, blink, pause, blink, blink — is the *warning-code* for paper low¹
The warning-code is reset automatically when the condition causing it is removed.

2.2.3 Voltage indicator

- Green indicator constantly ON: 24 V present

¹ This signaling is disabled by default. It can be disabled/enabled by setting parameter p52

3

INSTALLATION

3.1 Installing a paper guide

The paper guide selects if the printer should use 58, 60, 80, or 82.5 mm paper width. The printer senses what paper guide is fitted and adjusts to it automatically. The TTP 2000 printers are delivered without paper guide fitted.

1. Select the paper guide you want to install¹
2. Open the printhead by pushing green printhead lock plate backwards and lifting up the printhead, see page 24.
3. Enter the T-shaped tab of the paper guide into the “T”-hole, and fasten the screw.
4. Close the printhead

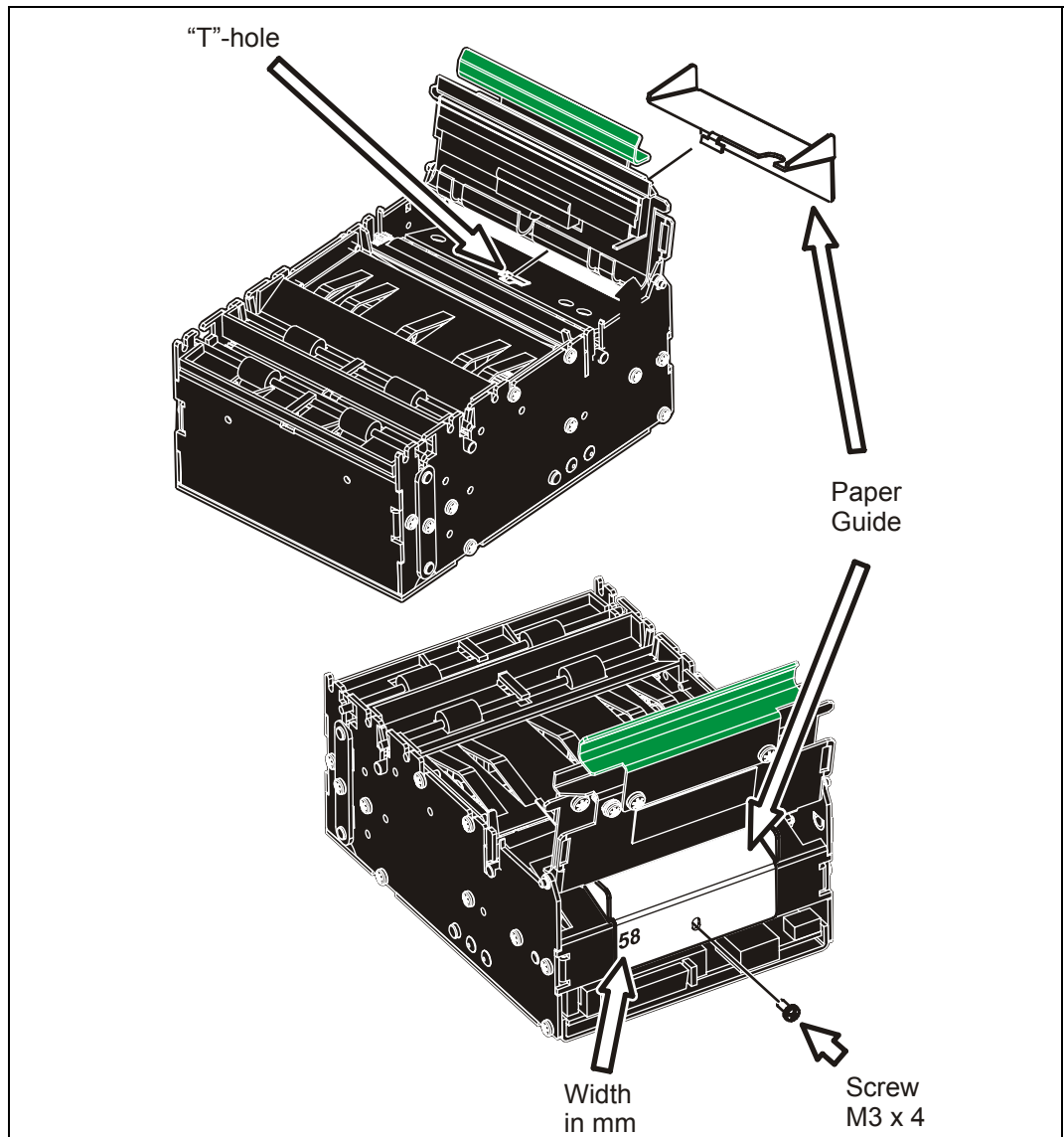

Figure 4 Fitting a paper guide

¹ Evaluation kits contain all input guides available. Regular volume deliveries only contain the appropriate guide for the customer in question.

3.2 Installation considerations

The TTP 2000 printer should be installed in some kind of enclosure such as a self-service kiosk. The footprint and the paper output height is identical to the TTP 1020 /TTP 1030.

3.2.1 Orientation

The TTP 2000 can be installed horizontally or vertically¹. Vertical installation is suitable for narrow kiosk designs. Here the printer swaps outputs; the normal output becomes the retract, and the retract output feeds the printout to the customer.

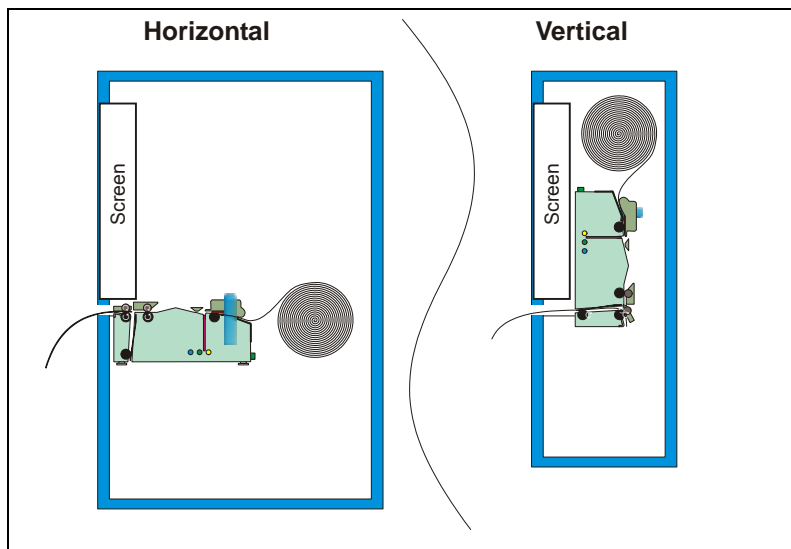

Figure 5 The printer can be installed in different orientations. Just set parameter n57 to the appropriate setting and the printer adapts to its new orientation. If you use the Windows driver, a selection in the driver sets horizontal or vertical mode.

NOTE! — In vertical mode the printer does not loop the paper but stores it hanging down, then cuts and ejects vertically when the printout is ready.

¹ Implemented in firmware version 3.20

3.2.2 Quick-fit hubs

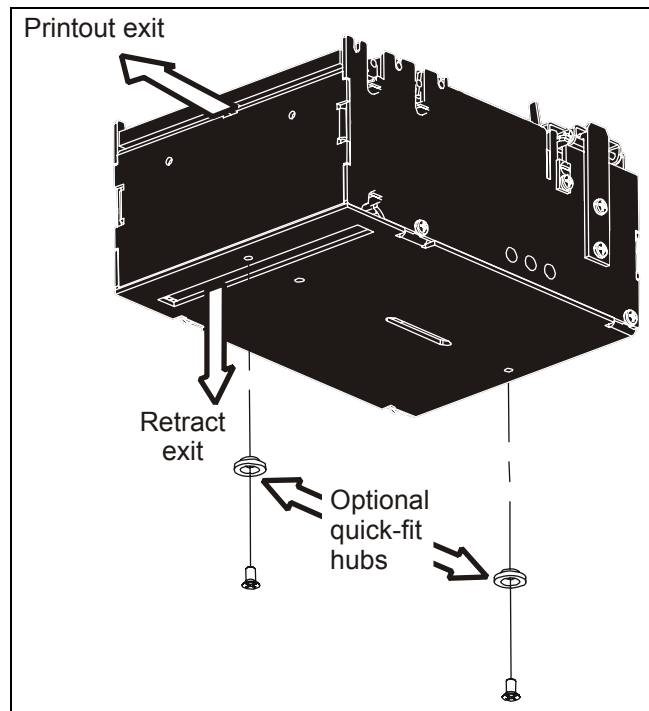

Figure 6 Front, bottom view

The printers attach to the kiosk using two screws, or just slides in place using the quick-fit hubs.

3.2.3 Using a Swecoin roll holder

The Swecoin roll holders fit paper widths, 58 mm, 60 mm, 80 mm, and 82.5 mm without adjustments, and takes minimum 150 mm rolls.

An example of a Swecoin roll holder is the shelf type that has the quick fit fastening so you just connect the cables to the printer then slide it onto the roll holder. It also has additional holes so that you can attach the 75 W PSU with straps, and fit an optional paper low sensor.

This roll holder both stands stable on your desktop, and can be fastened into your kiosk and used in normal installations.

More Swecoin roll holders can be found in chapter 10 of this manual.

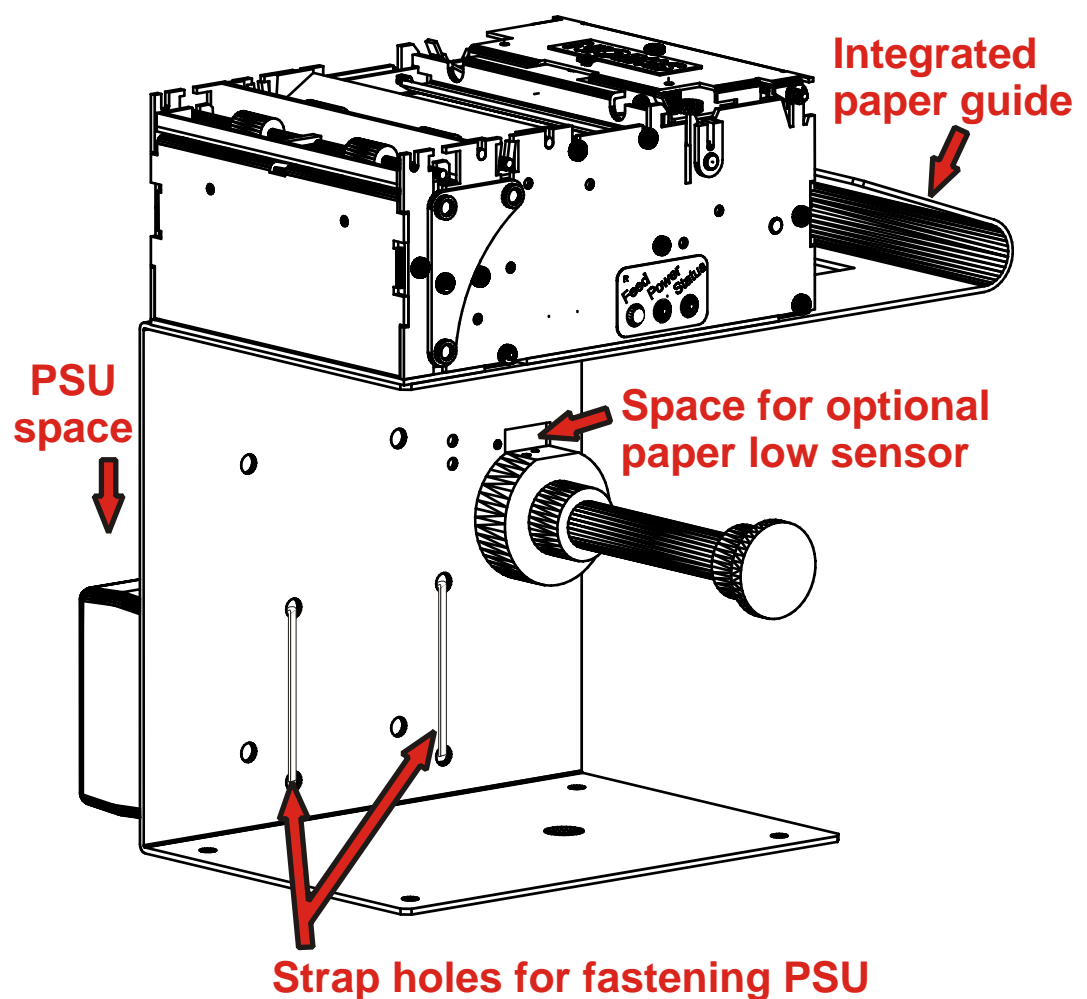

3.2.5 Electrostatic discharges, and earth currents

Preventing ESD and earth currents from affecting the printer operation *requires* proper connection of the printer chassis to protective earth through a mounting platform or through a separate earth conductor.

3.2.6 Ambient light

There is an optical sensor 20 mm behind the paper exit at the front of the printer.

To ensure proper printer operation, design the printer enclosure so that it prevents direct sunlight or light from indoor lamps from reaching the sensor through the paper exit.

3.3 Installing a paper-low sensor (option)

A paper-low sensor alerts the system when a certain length of paper remains on the roll. The purpose of this sensor is to get an early alert so that you can replace the paper roll in time in remotely located kiosks.

All paper roll holders supplied by Swecoin can be equipped with paper-low sensors. Just install it, and connect the cable to the paper low connector at the back of the printer.

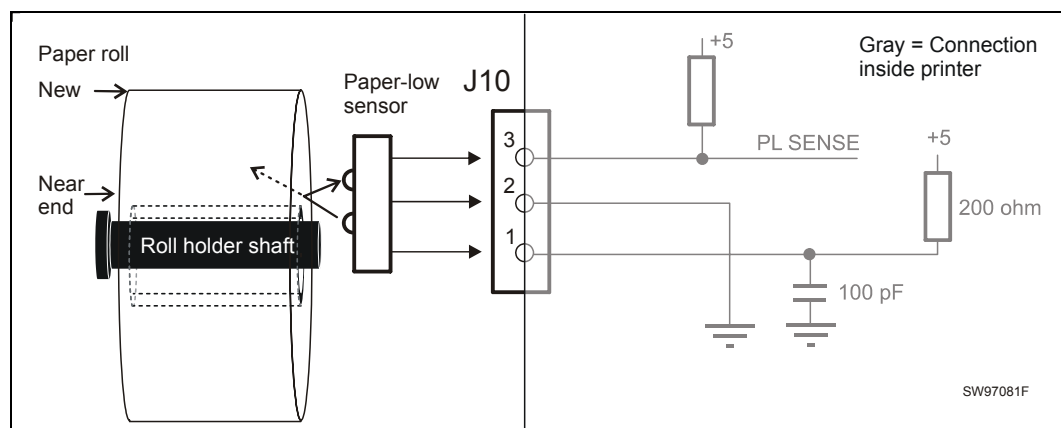

Figure 8. Paper-low sensor connection

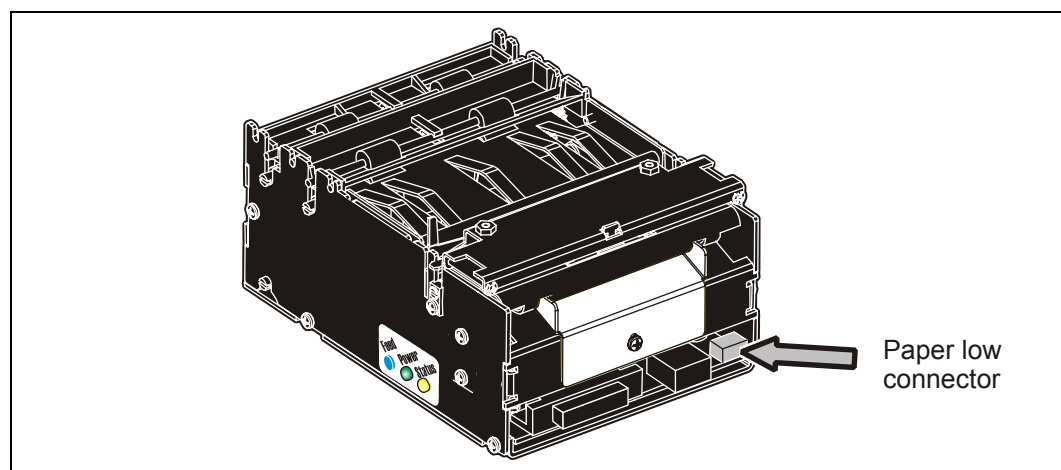

Figure 9. Location of paper-low connector

3.4 Connecting to the computer

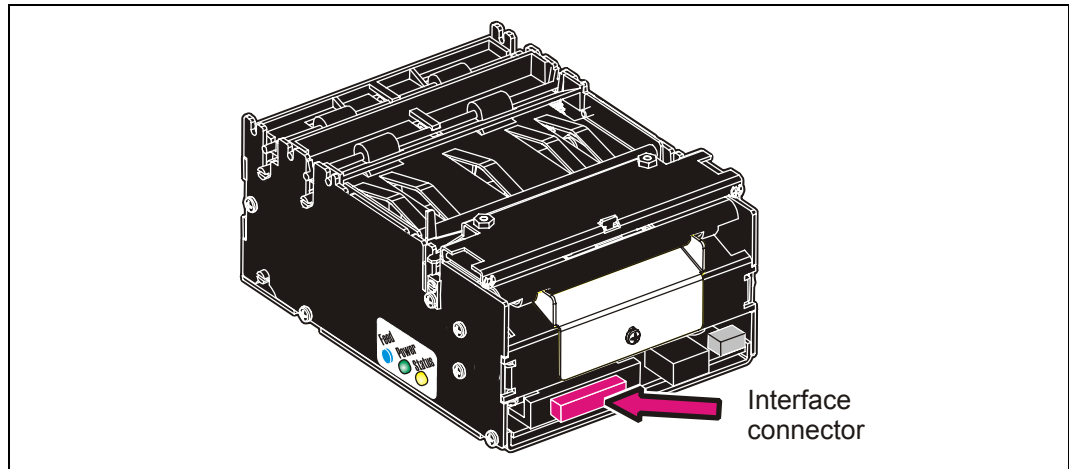

Figure 10. Location of interface connector

3.4.1 TTP 2010

Connect a Swecoin serial cable, ordering No. 10825-000, between the printer and the computer to be used. We strongly recommend using the Swecoin cable because many incompatible cables are available.

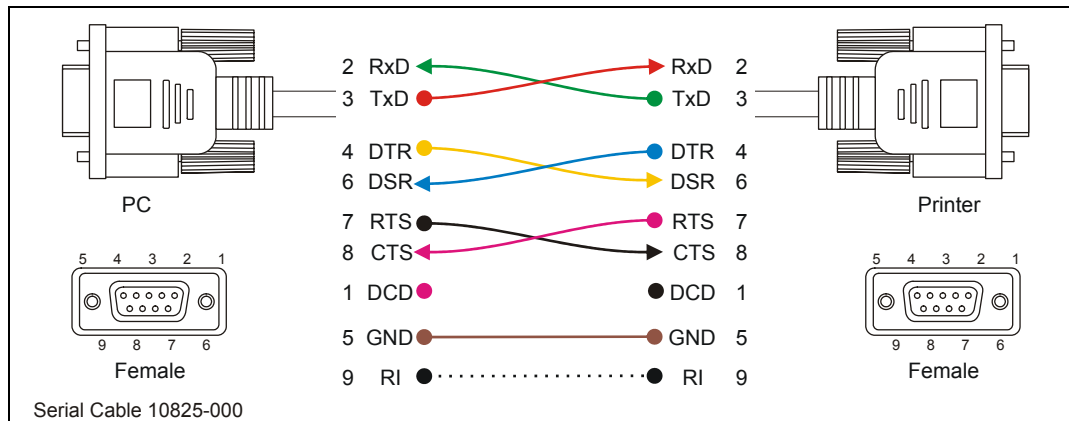

Figure 11. Serial interface cable 10825-000. Dotted leads are not connected in the printer. To be able to connect the cable in any direction, make symmetrical cables.

3.4.2 TTP 2020

Connect the printer to the parallel port of the computer to be used.

Use cables 01366-000 or 01366-090, see the illustration below.

The printer end of the cable should have an IEEE-1284 type C, 36-pole mini Centronics, with clip latches, see page 76 for pin assignment.

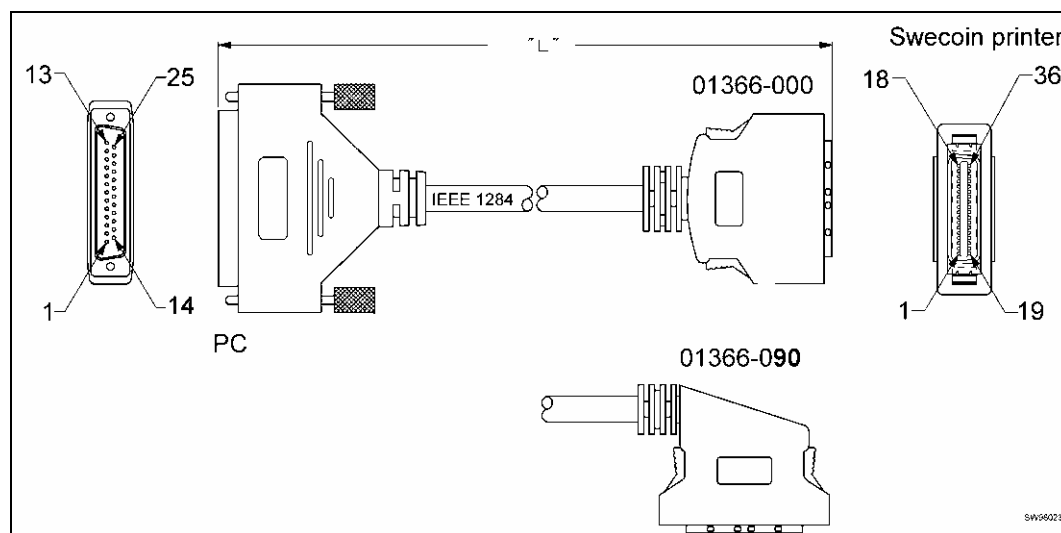

Figure 12. IEEE-1284 cable with type A and type C connectors

3.4.3 TTP 2030

Connect J13 of the printer to the USB port of the computer or the USB hub to be used.

USB connectors can be recognized by the following symbol: .

Connector J13 is a 4-pin USB type B connector. See Table 8 for pin assignment.

A suitable cable is available from Swecoin, ordering number 01542-000.

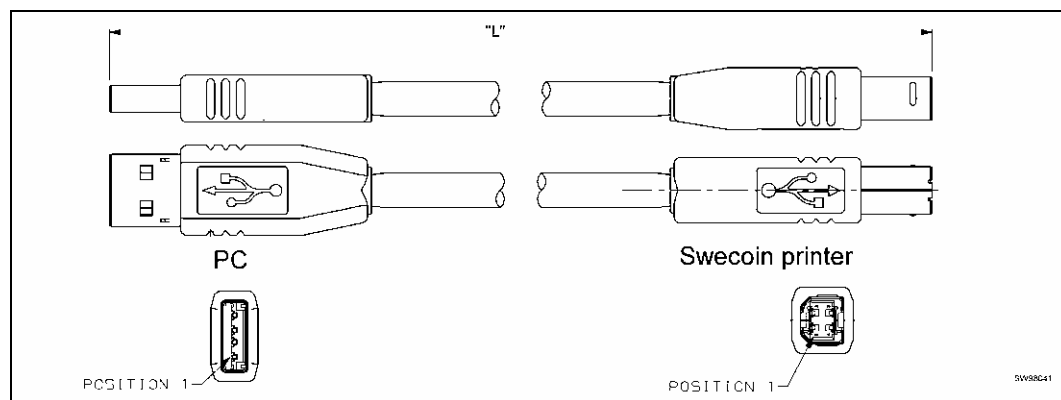

Figure 13. USB cable with type A and type B connectors

3.5 Connecting the power

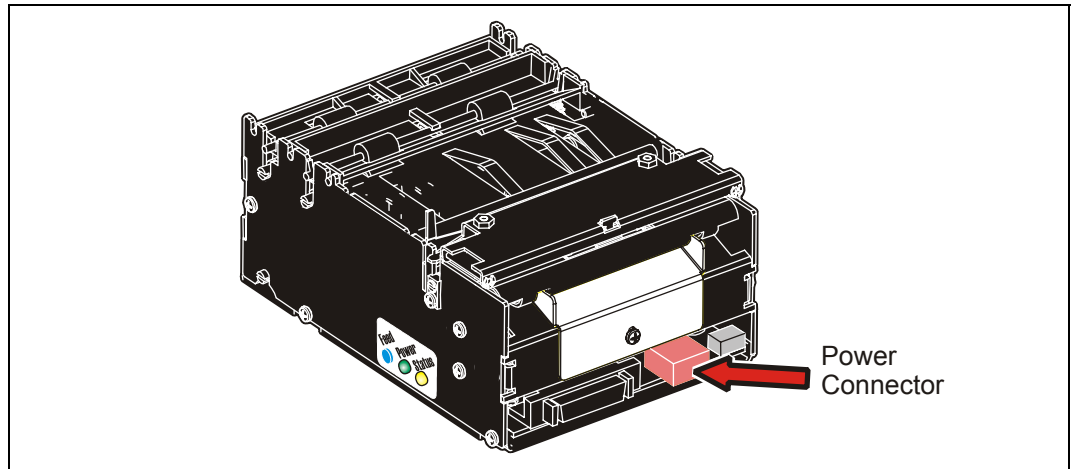

Figure 14. Location of power connector

Using a Swecoin power supply (page 95):

1. On power supplies with line voltage selector, make sure it is set to your local line voltage.
2. Connect the cable from the power supply the power connector on the back of the printer.
3. Connect the power cable to the line outlet.
4. Turn ON the power.

If you use another type of power supply unit, 24 V cables are available from Swecoin AB, order No. 01370-000. If you make cables of your own, connect the voltages according to the following illustration. Note that protective ground and minus output should *not* be interconnected in the power supply. At the printer end of the cable, use an AMP Mate-N-Lok connector housing and two contact-sockets:

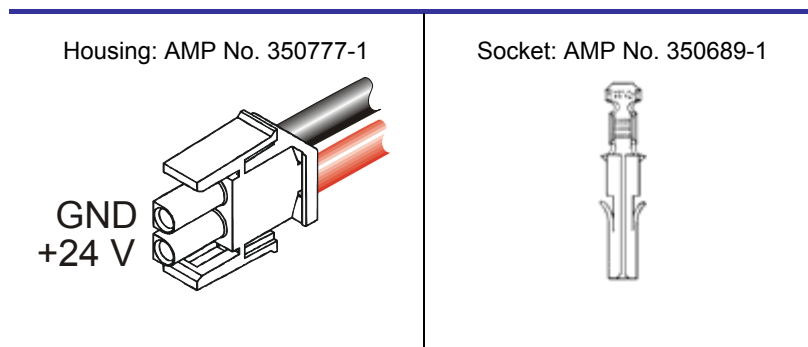

Figure 15. Power connection

Mode	58-60 mm paper width	80 – 82.5 mm paper width
Idle	150 mA	150 mA
Standard text printing	2 A average	3 A average
All black printing	6 A	8.5 A

Table 1. Current consumption

3.6 Making a test printout

1. Switch OFF the power.
2. Hold the feed-forward button depressed while powering ON the printer. Keep the button depressed until printing starts.

This produces a printout showing the firmware program version and date, control board revision number and serial number, name of loaded fonts and logotypes, and the parameter settings.

3. Each successive press of the button will produce a test printout.

Switch the printer OFF and ON again to exit self-test mode.

If a power button is not available for the printer, follow the below procedure:

1. Lift the printhead
2. Hold the FF-button pressed while lowering the head and hold it pressed while an auto load of paper is done
3. Release the button and a self-test printout will be printed
4. The printer exits self-test mode and goes on-line

Self-test

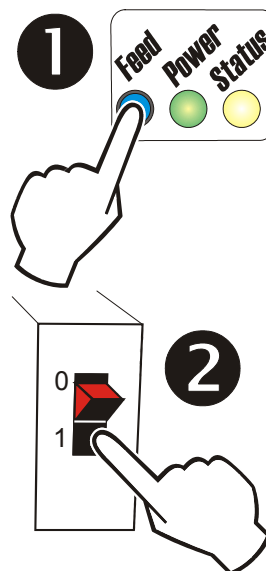

3.6.1 Customizing the self test printout

The self test printout starts with a text line, and then a Swecoin logotype. This logotype is just a printout of logotype No. 0., so if you want to personalize the self test printouts in your installation, delete all logotypes and store your own logotype as No. 0. See also logotypes on page 56.

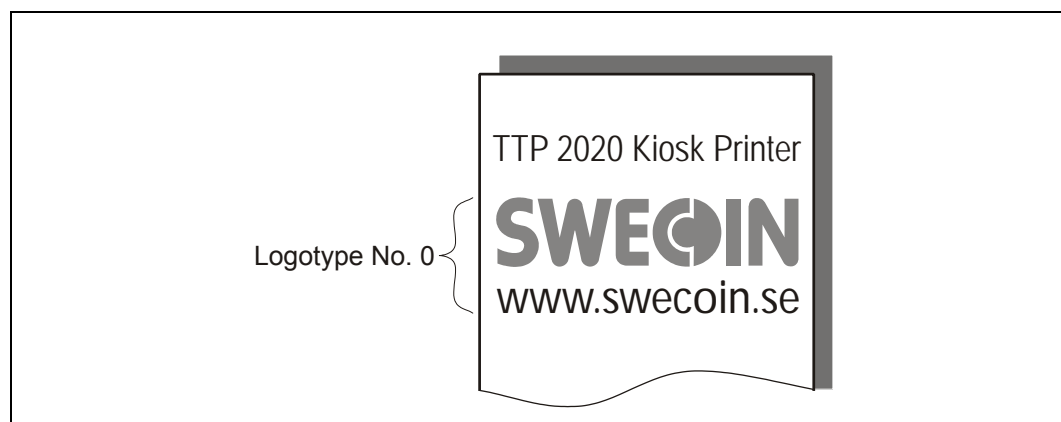

Figure 16. Logotype No. 0 is printed on the self test printout.

3.7 Installing a printer driver

Printer drivers for Linux, and Microsoft Windows™ are available on the Swecoin web site www.swecoin.se, or on disk from Swecoin, see page 2 for address. Please follow the installation instructions that accompany the drivers.

3.7.1 Status monitoring through Windows¹

Status can be fetched from a language monitor (20x0mon.dll) that is installed into Windows with the driver. Documentation of the language monitor is available on the drivers' page on the Swecoin web site.

If you want to monitor status through the language monitor, *make sure that the printer is selected as default printer*, and that bi-directional support is enabled in the port section of the driver settings.

NOTE! – On TTP 2020, parameter p5 should be set to 1 to make status replies possible when paper is out. See page 62.

3.7.2 Settings available in the driver

The looks of the dialogue boxes vary between driver versions, but essentially the same settings can be made.

You start with the Printing Preferences window. Here you find the portrait/landscape setting, and an advanced button.

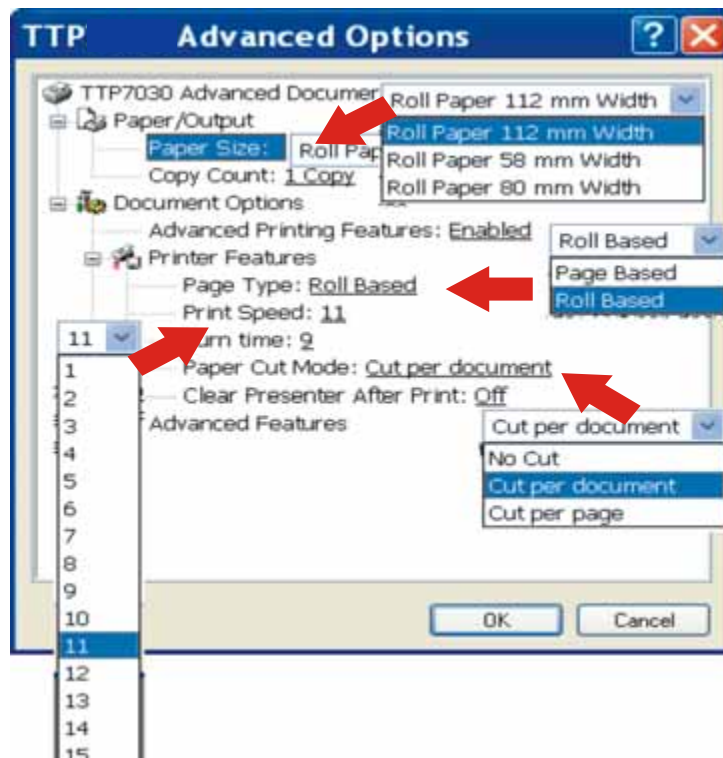

Figure 17. Example of setup window

¹ If a print server is used, it must support true binary communications, bi-directionally. If you use incompatible print servers, bidirectional support must be disabled in the driver properties.

The advanced button contain the Swecoin specific settings:

Paper/Output

- Paper size: Roll paper 58 - 60 mm / 80 – 82.5 mm
- Copy Count: 1 to 9999

Document options

Advanced printing features: **Enabled** / disabled

Printer features:

- Page Type: **Page based**/Roll based/Black Mark¹
- Printing Speed: 1 to 19
- Burn Time: 1 to15
- Retract Setting: Eject | Eject after x sec., Retract | Retract after x sec.²
- Paper Cut Mode: No Cut / **Cut per document** / Cut per page³
- Clear Presenter After Print: On / **Off**
- Hold Page After Print: On / **Off**⁴
- Vertical mount On / **Off**
- Slow present On / **Off**

Advanced features

- Advance After Print: 0-100 mm (**10 mm**)⁵
- Paper Eject: 0-100 mm (**30 mm**)⁶
- Reverse Before Print: 0-100 mm (**0 mm**)⁷
- Black mark Settings:⁸
 - Minimum black mark: 0-100 mm (**3 mm**)
 - Maximum black mark: 0-100 mm (**16 mm**)
 - Cut position: 0-100 mm (**25 mm**)
- Scaling: 10-400% (**100%**)⁹
- Contrast/brightness

¹ Page based give the page size set in the Paper Size setting (in server preferences, forms). Roll based saves paper by cutting after the last print on the page. Black Mark synchronizes with preprinted marks on the back of the paper.

² Interpret like; Retract page in presenter when a new page is printed, and retract uncollected pages after xx seconds.

³ “Cut per page” give three pages when a 3-page document is printed, while “Cut per document” give one long page with all information printed on it.

⁴ Holds printing of consecutive pages until the customer takes the presented page. If a page is not taken within the set retract timeout, the rest of the print job is deleted from the print queue in Windows This requires bidirectional communication.

⁵ Paper Advance is advance before cut, that is bottom margin.

⁶ This eject is in addition to the standard 50 mm, so a setting of 100 gives 150 mm total eject.

⁷ Paper reverse is reverse before print, and reduces the 9 mm top margin with the value entered here. So a setting of 4 gives 9 – 4 = 5 mm top margin.

⁸ Black mark synchronization ON /OFF is selected with Page Type.

⁹ Scaling to e.g. 99% can be used when you need to print forms with fixed page length that otherwise would not fit on a page.

4

OPERATION

4.1 Installing a paper roll

1. Turn the new paper roll as shown. The paper should be inserted into the printer with the temperature-sensitive side up.

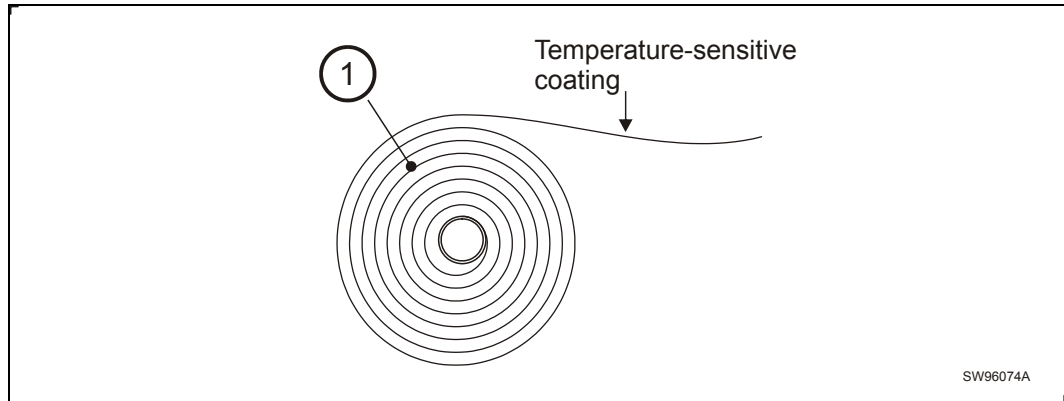

Figure 18. Turn the paper roll so that the paper leaves the roll from the top

2. Tear off a full turn of the paper from the new paper roll.

⚠ CAUTION!

This is important since the outer end of the paper is usually fixed to the roll with some type of glue or self-adhesive substance that might otherwise cause paper jam or even print head damage.

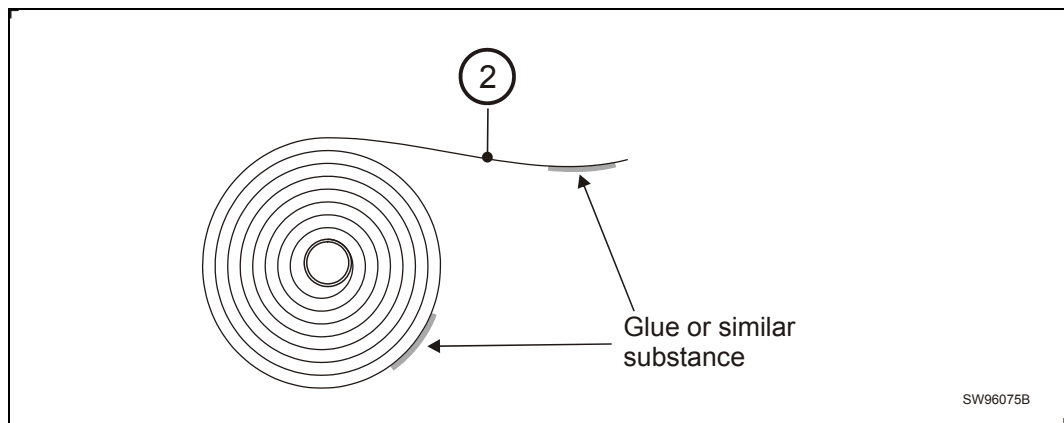

Figure 19. Tear off a full turn from the new paper roll

3. Make sure the printer is turned ON.

- Cut the paper in a suitable angle:

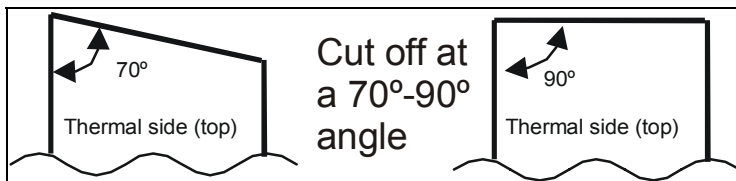

Figure 20. Suitable paper edge for auto load

NOTE 1! — The paper sensor is at the same side as the interface connector. If the paper is cut in a direction opposite to that as shown in the figure above, the sensor will not detect the paper.

- Insert the paper through the paper entry opening at the back of the printer. The printer will now feed, cut and eject a printout, and then automatically go on-line.

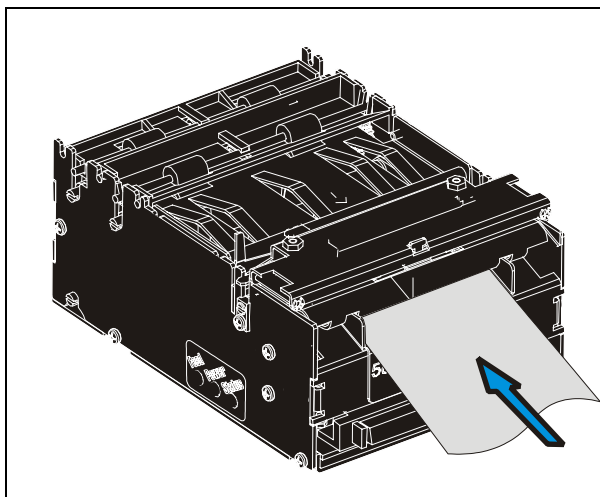

Figure 21. Insert the new paper

4.2 Clearing paper jams

Should a paper jam occur, follow the procedure below:

Open the printhead by:

1. Press the green release lever toward the rear of the printer.
2. Lift the head.

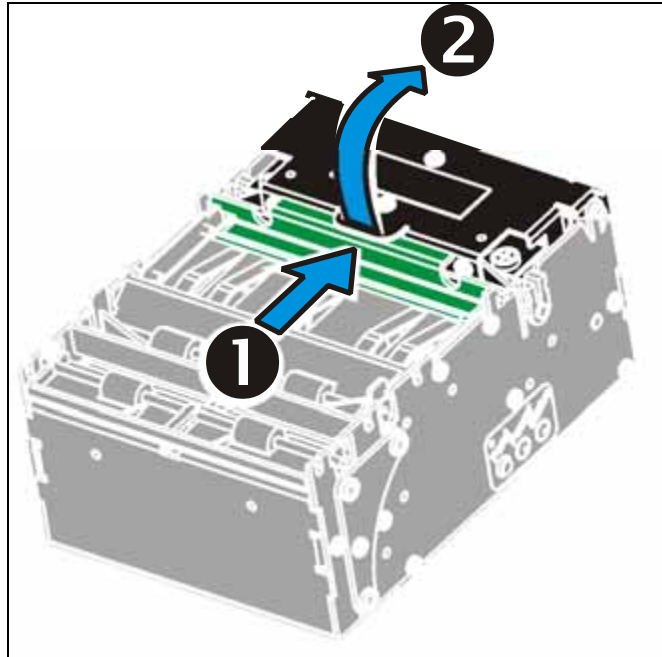

Figure 22. Opening the printhead

3. Remove any paper trash and close the printhead.

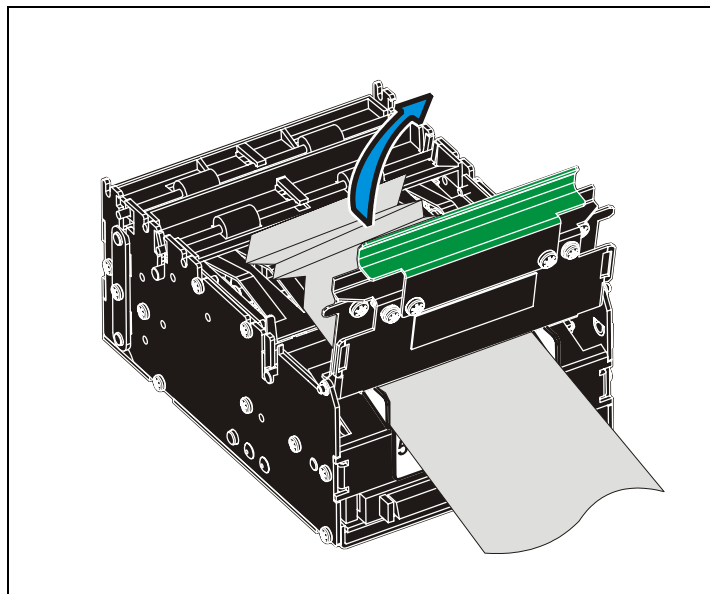

Figure 23. Remove paper trash

5 PROGRAMMING

There are two completely different ways of setting up the printout: Text oriented and driver oriented style.

Text oriented

The printout can be seen as the page of a simple word processor. You send text and graphics to the printer, which prints the information in the same sequence as the data is received. Design features are limited to the font stored in the flash PROM of the printer.

There are two text cursors, one for portrait, and one for landscape¹. The start positions of the cursors are the upper left corner for the portrait cursor, and the upper left corner for the landscape cursor, see Figure 24. You can switch between these cursors at any time; the cursor will retain its last position on the ticket.

Driver oriented

All TTP 2000 printers can print documents through a driver. When a Windows driver is used, you can use any Windows program to design the ticket with text, graphics, bar codes or whatever you want to print and in any orientation you want.

The Windows driver issues all the necessary commands. By setting up printing preferences in the driver you select how the printer should cut and present the printout.

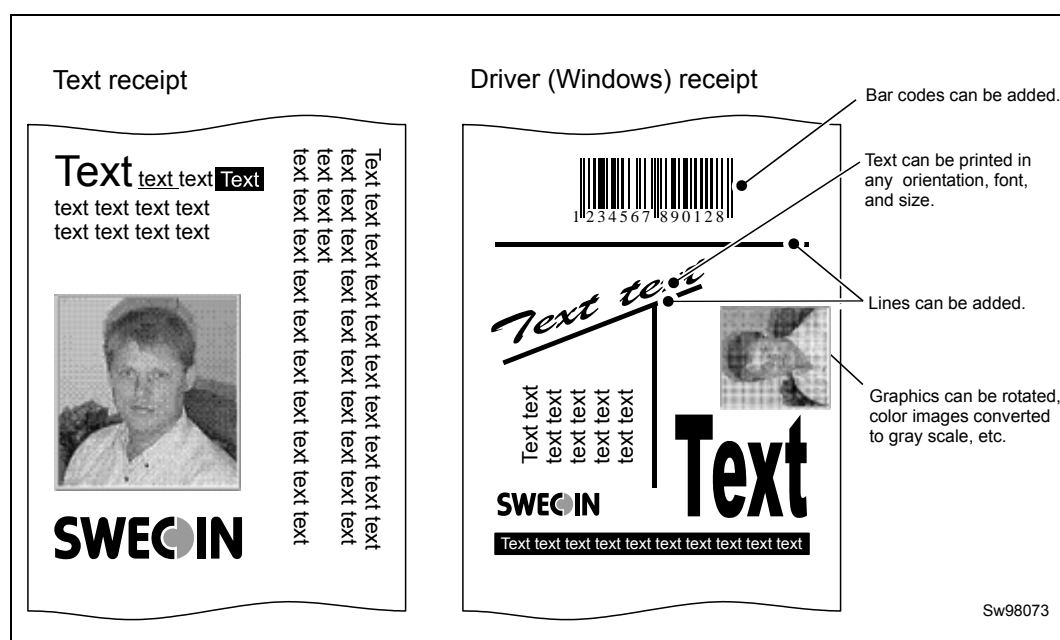
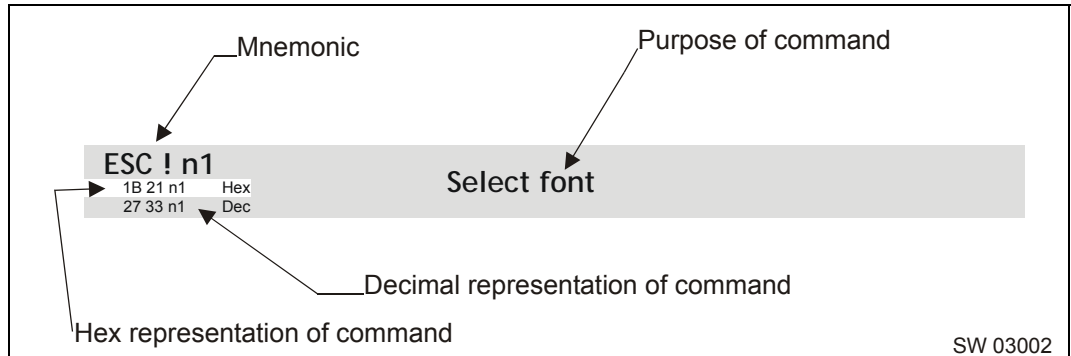

Figure 24. Printout styles

¹ Only available in Fixed Document Mode. See parameter n36.

5.1 How the commands are described



5.1.1 Mnemonic

Is the popular command name that should be easy to remember.

5.1.2 Hex

Give the command in hex representation

5.1.3 Decimal

Give the command in decimal representation

5.1.4 Values

`n1`, `n2`, etc. represents values that you set with the commands. What you should enter here depends on what you want the command to do.

5.1.5 Examples

Command examples are formatted in **Courier** and typed in the same way as used in the Swecoin TTP editor:

```
<ESC>&P<001><019>
```

Where `<ESC>` means the escape character 27 decimal (hex 1B). Numbers between less-than and greater-than characters, for example `<001><019>`, means 1 and 19 decimal. When the numbers indicate a hex value, h is appended to the number (`<01h><13h>`).

EXAMPLE:

`<065>`, `<65d>`, `<41h>` and `A` are four different ways of expressing the character A.

5.2 Summary of control codes & escape sequences

Command	Hex	Decimal	Function	Page
BS	08	8	Backspace	32
CAN	18	24	Cancel	32
CR	0D	13	Carriage return	32
EM	19 n1	25 n1	Enforced Clear Presenter	41
ENQ	05	5	Clear Presenter	41
ESC ACK	1B 06 n1	27 6 n1	Acknowledge Marker	53
ESC !	1B 21 n1	27 33 n1	Select Font	30
ESC #	1B 23	27 35	Calibrate Blackmark Sensor	29
ESC & 000	1B 26 00	27 38 0	Load Font	44
ESC & 001	1B 26 01	27 38 1	Load Logotype	43
ESC & 004	1B 26 04	27 38 4	Store current Parameter Values	43
ESC & C	1B 26 43	27 38 67	Erase all Fonts	44
ESC & D	1B 26 44	27 38 68	Erase Fonts 4 to 7	44
ESC & F	1B 26 46	27 38 70	Recall Parameter Profile	44
ESC & L	1B 26 4C	27 38 76	Erase all Logotypes	43
ESC & P	1B 26 50 n1...n2	27 38 80 n1...n2	Set Parameter Value	45
ESC ?	1B 3F	27 63	Reset (full)	43
ESC @	1B 40	27 64	Reset (initialize)	43
ESC b	1B 62 n1...n5	27 98 n1...n5	Print Bitmap at XY-position	36
ESC B	1B 42 n1	27 66 n1	Bold	31
ESC B C	1B 42 43 n1	27 66 67 n1	Barcode Clear	35
ESC B S	1B 42 53 n1...n11	27 66 83 n1...n11	Barcode field Specify	34
ESC B W	1B 42 57 n1	27 66 87 n1	Barcode Write	35
ESC d	1B 64 n1	27 100 n1	Make n Linefeeds	33
ESC ENQ 001	1B 05 01	27 5 1	Status Enquiry	46
ESC ENQ 002	1B 05 02	27 5 2	Paper-near-end Enquiry	47
ESC ENQ 004	1B 05 04	27 5 4	Fonts and Logotype Enquiry	47
ESC ENQ 005	1B 05 05	27 5 5	Sensor Enquiry	48
ESC ENQ 006	1B 05 06	27 5 6	Status Report	49
ESC ENQ 007	1B 05 07	27 5 7	Firmware-version Enquiry	50
ESC ENQ 009	1B 05 09	27 5 9	Serial-number Enquiry	50
ESC ENQ 010	1B 05 0A	27 5 10	Control board revision Enquiry	50
ESC ENQ 011	1B 05 0B	27 5 11	Head temperature Enquiry	50

ESC ENQ 012	1B 05 0C	27 5 12	Bootware version Enquiry	50
ESC ENQ c	1B 05 63	27 5 99	Device ID Enquiry	52
ESC ENQ E	1B 05 45	27 5 69	Read extended status	52
ESC ENQ p	1B 05 50 n1	27 5 80 n1	Parameter-setting data Enquiry	52
ESC ENQ P	1B 05 50 n1	27 5 80 n1	Parameter-setting data Enquiry	52
ESC f	1B 66 n1	27 102 n1	Presenter loop ON/OFF/max length	42
ESC FF	1B 0C n1	27 12 n1	Eject (run presenter)	41
ESC g	1B 67 n1...n5	27 103 n1...n5	Print Logotype	38
ESC h	1B 68 n1	27 104 n1	Text Height	31
ESC i	1B 69 n1	27 105 n1	Italics	31
ESC j	1B 6A n1	27 106 n1	Paper Reverse	39
ESC J	1B 4A n1	27 74 n1	Paper Advance	39
ESC L	1B 4C n1	27 76 n1	Print Logotype at Current Position	38
ESC N	1B 4E n1	27 78 n1	Align Text	30
ESC NUL	1B 00	27 0	Load Firmware	45
ESC o	1B 6F n1	27 111 n1	Text and logotype orientation	30
ESC p	1B 70	27 112	Print	39
ESC P	1B 50 n1	27 80 n1	Print Self-test Printout	39
ESC r	1B 72 n1...n9	27 114 n1...n9	Print Ruler Line	37
ESC RS	1B 1E	27 30	Cut only, no Eject	40
ESC s	1B 73 n1	27 115 n1	Send dot-line, 203 dpi	36
ESC t	1B 74 n1...n5	27 116 n1...n5	Print Text at XY	32
ESC T	1B 54 n1	27 84 n1	Reversed/Inversed Text	31
ESC u	1B 75 n1	27 117 n1	Underline	31
ESC w	1B 77 n1	27 119 n1	Text Width	31
ESC Z	1B 5A	27 90	Go to next Top of Form	29
FF	0C	12	Form Feed	33
HT	09	9	Horizontal Tabulation	33
LF	0A	10	Linefeed	33
RS	1E	30	Cut and Eject	40
US	1F	031	Partial cut	40

Table 2. Control codes & escape sequences in alphabetical order

NOTE! – In all responses from the printer the most significant byte (MSB) is transmitted first

5.3 Software command syntax

The commands in this section are grouped after what they do, and these groups are sorted in a theoretical usage sequence. It starts with commands for specifying the printed page — through text-and-graphics commands — to cut-and-present commands. System and status commands are presented at the end.

5.3.1 Black mark (top-of-form) commands

See also “Aligning preprint and thermal print” on page 69.

ESC #		Calibrate Blackmark Sensor
1B 23	Hex	Looks for a black mark, measures the contrast of the mark and sets parameter n51 to a suitable value for the detected voltage, then reverses to the start position.
27 35	decimal	
		To make the calibration permanent, send <code>ESC & 4h</code> , store parameter values.
		NOTE! – <i>Be sure to first set up the length of the black mark and the distance between two black marks in the parameter setup.</i>

ESC Z		Go to next Top of Form
1B 5A	Hex	In black mark mode, an <code>ESC Z</code> starts looking for a black mark at the current position and continues for one page length. If no black mark is found, the printer stops and bit 3 in status byte 2 is set to 1 (See <code>ESC ENQ 6h</code>).
27 90	Decimal	
		When black mark mode is disabled, ESC Z will perform a form feed.

5.3.2 Text commands

Text received by the printer is printed with the currently selected font and font attributes. Text exceeding the page width is wrapped with the line spacing selected.

ESC o n1		Text and Logotype Orientation
1B 6F n1	hex	
27 111 n1	decimal	

Changes the orientation of text and logotypes.

n = 0 Gives portrait orientation

n = 1 Gives landscape orientation

Portrait and landscape can be mixed on the same printout. There are two cursors, one for portrait and one for landscape. The cursor always starts at the top left corner of the document. Looking at the paper when it exits the printer, the portrait cursor is at the top left corner of the printout, moving to the right as text is typed, while the landscape cursor is at the top right corner, moving downwards.

NOTE! — *Landscape orientation can only be used with Fixed Document Mode.*

ESC N n1		Align Text
1B 4E n1	hex	
27 78 n1	decimal	

Changes the alignment of text and logotypes.

ESC N 0 = Left ESC N 1 = Center ESC N 2 = Right

ESC ! n1		Select Font
1B 21 n1	hex	
27 33 n1	decimal	

This command selects one of eight fonts. The font design depends on which fonts have been loaded¹ into the printer. Make a test printout to see which fonts are available in your printer.

ESC ! 0 selects normal font (font 0)	ESC ! 4 selects font 4
ESC ! 1 selects font 1	ESC ! 5 selects font 5
ESC ! 2 selects font 2	ESC ! 6 selects font 6
ESC ! 3 selects font 3	ESC ! 7 selects font 7

Table 3. Font selection commands

Lines, too long to be printed in the selected font, are automatically wrapped around.

Different fonts can be used on the same line.

Selecting an empty font location, will set bit 4 of byte 1 in the status enquiry response to "1". See "Parameter setting data enquiry" on page 52.

NOTE! — *If more than 379 characters are sent to the printer before an LF, the first part of the buffer contents is printed-out automatically. The text is formatted according to the already received formatting commands.*

¹ For font loading, see "Font loading" page 44.

ESC B n1		Bold	Normal Bold
1B 42 n1	Hex		
27 66 n1	decimal		

n = 0 Turns OFF bold (Normal)

n = 1 Turns ON **bold**

Bold is designed for normal character width and shows less and less as the width increases.

ESC i n1		Italics	Normal <i>Italics</i>
1B 69 n1	Hex		
27 105 n1	decimal		

n = 0 Turns OFF Italics (Normal)

n = 1 Turns ON *Italics*

ESC T n1		Reversed/Inversed Text	Reverse print
1B 54 n1	Hex		
27 84 n1	decimal		

Selects normal or reversed print.

n = 0 Gives normal print, black on white

n = 1 Gives reversed print, white on black

Single words, characters, or complete text lines can be reversed.

NOTE! – Reverse text and underline XOR's the background with the foreground. This means that the order in which the commands are issued affect the printout if one text overlaps another.

ESC u n1		Underline	Underline
1B 75 n1	hex		
27 117 n1	decimal		

n = 0 Turns OFF underline

n = 1 Turns ON a 1 pixel wide underline

n = 2 Turns ON a 2 pixel wide underline, etc. up to n=7.

Characters, single words, or complete text lines can be underlined.

ESC h n1		Text Height	Double height
1B 68 n1	hex		
27 104 n1	decimal		

Applicable n values are 000 — 015.

n = 1 Increases the character height to 2 times the basic character height.

n = 2 Increases the character height to 3 times the basic character height etc.

n = 0 Resets the character height to the basic character height.

In combination with variable character width (`ESC w n`), give highly legible characters depending on the font to which the command has been applied.

Different fonts and heights can be mixed on the same print line.

NOTE! – DO NOT use multiple height/width attributes when printing bar codes .

ESC w n1		Text Width	Double width
1B 77 n1	hex		
27 119 n1	decimal		

Applicable n values are 000 — 007.

n = 1 Increases the character width to 2 times the basic character width.

- n = 2 Increases the character width to 3 times the basic character width etc.
- n = 0 Resets the character width to the basic character width.

In combination with variable character height (`ESC h n`), give highly legible characters depending on the font to which the command has been applied.

Different fonts and widths can be mixed on the same print line.

NOTE! – DO NOT use multiple height/width attributes when printing bar codes .

ESC t n1...n5 data	Print Text at XY	
1B 74 n1...n5	data	hex
27 116 n1...n5	data	decimal

Prints a text string at the specified X-Y position. The string will use the formatting set by font, reversed, width, height, bold, italics, and underline commands.

n1n2 Two byte definition of the X print position (in pixels).

n3n4 Two byte definition of the Y print position (in pixels).

n5 The number of characters in the string.

data The text string. The length must be exactly the number of characters specified by n5, otherwise the printer will stop, waiting for more characters.

After the string has been printed, the cursor will return to the position it had before the string command was issued.

NOTE 1! — `ESC t` only works with fixed document mode (`p36=0`).

NOTE 2! — `ESC t` clears any text preceding it on the same line. Commands will not be cleared.

BS	Backspace	
08	Hex	
8	Decimal	

Moves the print-position one step to the left. Backspace can be used to combine characters. For instance to print a Ø, send text commands `O BS /` to the printer, and the slash will overprint the O.

Only one backspace can be used at a time. Excessive backspaces will be ignored.

CAN	Cancel	
18	hex	
24	decimal	

Cancels text and attributes sent before the `CAN` command on the same line. Commands, are not cancelled.

CR	Carriage Return	
0D	hex	
13	decimal	

By default, carriage return is ignored.

By changing the default settings, you can:

Interpret is as `CR` which returns print position to beginning of line without line feed.

Interpret `CR` as `CR/LF` which inserts line space as specified by the line spacing setting (see parameter p13), and returns the print position to beginning of the line.

See “Carriage return and line feed behavior” on page 64.

LF

0A	hex
10	decimal

Linefeed

Linefeed is interpreted as `CR/LF` by default. This inserts line spaces as specified by the line spacing setting (see parameter p13), and returns the print position to beginning of the line. LF also converts text from the input buffer to pixel lines and stores them in the line buffer, ready to be printed.

By changing the default settings, you can:

Interpret `LF` as Linefeed. This inserts line space as specified by the line spacing setting (see parameter p13), without returning the print position to the beginning of the line.

Ignore `LF`.

See “Carriage return and line feed behavior” on page 64.

ESC d n1

1B 64 n1	hex
27 100 n1	decimal

Make n Linefeeds

Executes the number of linefeeds as defined by variable n1. The length of each line feed is determined by the default value for selected font (see parameter p13 on page 63).

The print position is returned to the beginning of the line. Any text on the line is lost. To avoid losing text, send an `LF` before sending `ESC d n`.

FF

0C	hex
12	decimal

Form Feed

Prints data from the input buffer and feeds the paper to the top of the next page.

In fixed document length (FORM-mode) this command prints data in the input buffer and feeds the paper to the top of next page.

In variable document length mode `FF` advances to the minimum page length. If the printout already is longer than the minimum page length, FF does not feed the paper at all.

In black-mark mode, the `FF` command looks for a black mark, see `ESC z`

If "Auto cut" is set to 1 (see page 64), `FF` effects form-feed, cut, and eject.

NOTE! — Use parameter p37 and p38 to define page length.

HT

09	hex
9	decimal

Horizontal Tabulation

Shifts the current print position to the next Tab position.

Set tab positions with parameters p15 – p30.

5.3.3 Barcode Commands

TTP 2000 can print EAN 8, EAN 13, UPC, 2-of-5 Interleaved, ISBN, Code39, Code128, and EAN128 barcodes.

Example:

```
<ESC>BS<00h><00h><78h><00h>
<00h><0Ch><00h><50h><00h><02h>
<00h>
<ESC>BW<00h>733104000099<00h>
<RS>
```

The above will print an EAN barcode with height = 10 mm, 15 mm in from the right margin.

CODE 128 / EAN128

The following codes select function codes in Code 128:

Name	Dec	Hex
FNC1	193	C1h
FNC2	194	C2h
FNC3	195	C3h
FNC4	196	C4h

Figure 25. Samples of barcodes

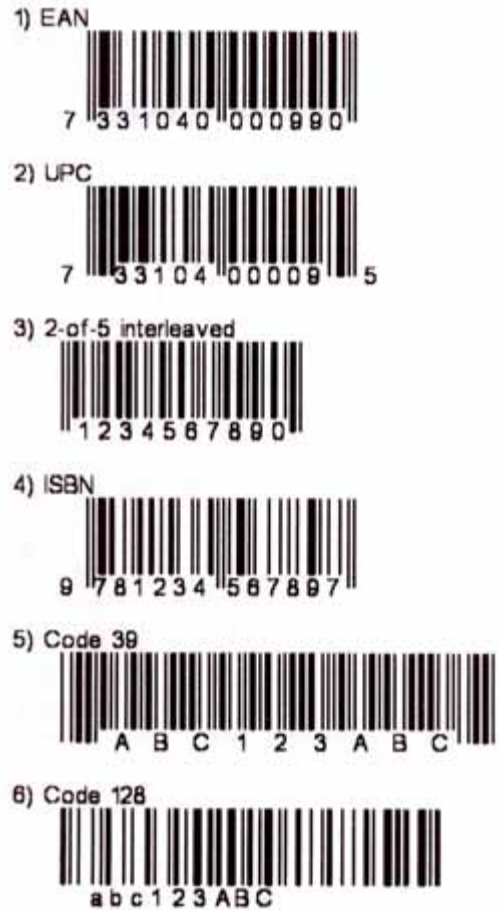

Starting the data string starts with FNC1 generates an EAN128 code.

ESC B S n1...n11	Barcode field Specify
1B 42 53 n1...n11	hex
27 66 83 n1...n11	decimal

Bar codes can only be printed in portrait mode unless Fixed Document Mode is selected with parameter n36.

The command reserves an information field as a bar code field. The command also identifies the type, number of digits, and the configuration of bars to be placed in the bar code field.

- n1 Specifies the bar code field No. (0—15). Bar code fields may be specified in any order.
- n2n3 Sets the X coordinate of the bar code field origin (n2 is the higher-order and n3 the lower-order byte).
n2 and n3 must be 1-byte hexadecimal or decimal numbers. The values must not place the bar code outside the total pixel count that can be handled by the printer.
- n4n5 Must be specified but the values are discarded by the printer.
- n6 Specifies the number of bar code digits, but is ignored by the printer.
- n7n8 Specifies the height of the bars.
- n9 Specifies the type of bar code. The following types are supported.
- n9 = 0 EAN 8 or 13 (auto detect). The printer calculates the necessary check digit.

- n9 = 1 UPC
- b9 = 2 2/5 Interleaved (even number of characters must be sent)
- n9 = 3 ISBN
- n9 = 4 Code128 (Start data string with C2h to encode EAN128)
- n9 = 6 Code39
- n10 Specifies the thickness of the narrow bar 0=1 pixel, 1=2 pixel, and so on.
- n11 Specifies the wide-bar-to-narrow-bar ratio. Only used in Code 39 and 2-of-5 interleaved where different ratios are allowed

ESC BW n1 nx

1B	42 57	n1	nx	Hex
027	066 087	n1	nx	Decimal

Barcode Write

Writes data to the bar code field reserved by the ESC BS command.

- n1 Specifies the field No. Range 0 to 15. Fields can be specified in any order but other values than 0 to 15 are ignored.
- n2 . . . nx Specifies bar code data bytes.
To create a bar code add-on, insert a space character and then the data for the add-on. Two of five characters are allowed of the add-on.
- NUL must be placed at the end of the bar code data.

Any invalid bar code character terminates the command, and print <Invalid barcode> on the printout.

5.3.4 Example:

```
<ESC>BS<h00><h00><h32><h00><h00><h0C><h00><h50><h00><h02><h00><<>>
<ESC>BW<h00>733104000099<h00><<>>
<RS><<>>
```

Will print one barcode with height = 10 mm and moved 10 mm to the right

ESC B C

1B	42 43	n1	hex
27	66 67	n1	decimal

Barcode Clear

Clears the bar code field reserved by command ESC BS.

- n Specifies which bar code field to clear. The range is 0 to 15. The fields may be cleared in any order.

5.3.5 Graphics commands

ESC b n1...n5		data		Print Bitmap at XY-position
1B 62	n1...n5	Data	hex	
27 98	n1...n5	Data	decimal	

Prints a black & white (1-bit color depth) Windows bitmap (BMP-file) at the specified X-Y position. The bit-map must be a complete uncompressed Windows bitmap where the data starts with BM. Max size is limited to the free RAM printed on the self-test printout.

n1 Always 0

n2n3 Two byte definition of the X print position (in pixels).

n4n5 Two byte definition of the Y print position (in pixels).

data Bitmap data.

After the bitmap has been printed, the cursor will return to the X-position that it had before the bitmap command was issued.

Selecting horizontal mode (with `ESC o 0h`) prints the image in portrait orientation, while selecting the vertical mode (with `ESC o 1h`) prints the image in landscape orientation.

NOTE! — *The Y print-position and horizontal/vertical orientation only works if Fixed Document Mode is set with parameter n36.*

ESC s n1		data		Send dot-line, 203 dpi
1B 73	n1	Data	Hex	
27 115	n1	Data	Decimal	

Sends one line of dot data. This command is used to build images, one dot line at a time by the printer driver and should not be combined with text commands.

n Determines the number of bytes. Range: 1-255.

<data> 1 – x bytes, where x is the printhead width in bytes. The printhead width is in the spec. of the printer.

For example:

- 58 mm printers use 54 bytes
- 80 mm printers use 72 bytes

CAUTION! – *Always send the No. of bytes that you specify!*

If more than the specified No. of bytes are received, the rest of the bytes will be interpreted as text or commands. This can cause any kind of problems in the printer as graphics data can contain any hex value.

If you specify less data than the actual printhead width, the printer will fill the rest of the dot line with spaces.

ESC r n1...n9		Print Ruler Line	
1B 72	n1...n9	hex	
27 114	n1...n9	decimal	

Prints a ruler line across the paper.

A ruler line is normally used to divide the printout into logical parts to make it easier to read. A ruler line is actually an area defined by a start X-Y position and a stop X-Y position. This area is filled with black or a checkered pattern.

n1n2 Two byte definition of the X start position

n3n4 Two byte definition of the Y start position

n5n6 Two byte definition of the X stop position (must be larger than x1x2)

n7n9 Two byte definition of the Y stop position (must be larger than y1y2)

n9 Fill pattern, 0=black, 3= Checkered

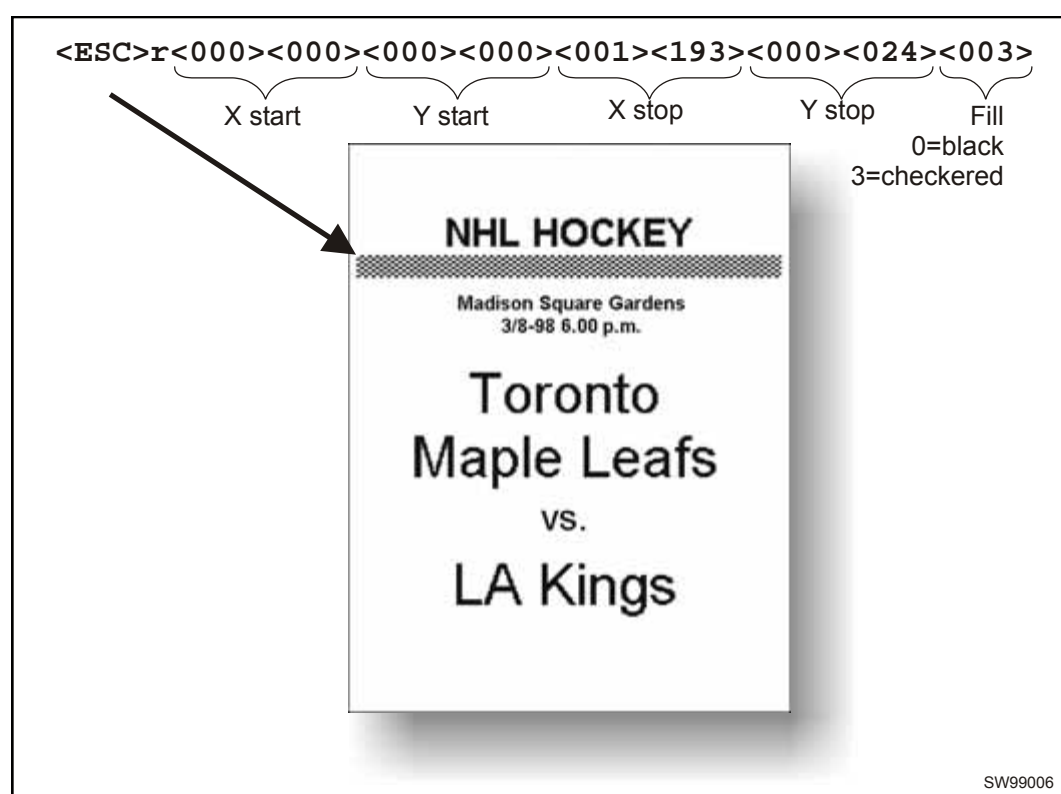

Figure 26 Printout with checkered ruler line

ESC g n1...n5		Print Logotype
1B 67 n1...n5	hex	
27 103 n1...n5	decimal	

Prints a customized logotype¹ stored in the flash PROM. See also “Logotypes” on page 56.

n1 One-byte logotype identification No. (0—15)

n2n3 Two-byte definition of desired print position in X-direction measured from left-hand edge of the page (see page 69 regarding definition of “page”). X-direction is perpendicular to the paper transport direction.

ESC L n1		Print Logotype at Current Position
1B 4C n1	Hex	
27 76 n1	Decimal	

Prints a customized logotype stored in the flash PROM at the position of the cursor. The bottom line of the logotype is positioned at the baseline of the text on the line. If the logotype is higher than the text, the line spacing is increased.

See also Logotypes on page 56.

n One-byte logotype identification No. (0—15)

¹ For logotype loading, see “ESC & 1” on page 43.

5.3.6 Print commands

ESC p		Print
1B 70	Hex	
27 112	Decimal	

This command makes the printer print the contents of the line buffer.

Text is converted from text to pixel lines and stored in the line buffer when an LF is received. If the line buffer is empty when ESC p is received, nothing is printed.

`Text to be printed <LF><ESC>p` prints "Text to be printed" on the paper.

Printout is effected automatically at:

Cut (RS and ESC RS)

Form feed (FF)

Clear presenter (ENQ)

Run presenter (ESC FF n)

Print buffer full

Press on FF-button

ESC P n1		Print Self-test Printout
1B 50 n1	Hex	
27 80 n1	decimal	

This command makes the printer generate a self-test page based on the current parameter settings and print that page. The parameter values printed are the ones currently being used. They can differ from Power-ON default values if for example a printout from Windows has been done before ESC p is sent to the printer. To make a self test printout with the Power-ON default settings, power up the printer with the FF button pressed.

n = 0 Gives standard self-test printout.

n = 1 Gives a character set printout using the font selected by parameter p14.

ESC J n1		Paper Advance
1B 4A n1	hex	
27 74 n1	decimal	

The value n represents the number of dot lines the paper is to be transported forwards. Range: 1–255.

A dot line is 0.125 mm, and 255 dot lines equal approximately 32 mm.

ESC j n1		Paper Reverse
1B 6A n1	hex	
27 106 n1	decimal	

The value n represents the number of dot lines the paper is to be transported backwards. Range: 1–255.

CAUTION! – NEVER reverse more than 6 mm at top of page!
You may lose grip of the paper.

A dot line is 0.125 mm, and 255 dot lines equal approximately 32 mm.

5.3.7 Cut and present commands

NOTE! – *The printer does not receive data while cut and present commands are executed.*

RS			Cut and Eject
1E	Hex		
30	Decimal		

Effects a paper cut-off and an eject through the presenter module. The RS command automatically give the eject length of 50 mm in addition to the factor stored in parameter p47.

If the printout length is too short, paper-feed is added until the minimum printout length (set by parameters 37 and 38) is reached, before execution of the Cut command.

NOTE! – *The cut position is 9 mm before the print line. This makes the last 2 lines on a page end up in the beginning of the next page. To get the cut after the text, Please have parameter 49 set to auto (default setting).*

If you do not use the auto setting you can use <RS> together with the paper advance command:

<ESC>J<110><RS>

Gives a cut & eject after the last text line.

ESC RS			Cut only, no Eject
1B 1E	Hex		
27 30	Decimal		

Effects paper cut-off only.

Eject can be effected with the **ESC FF n** command (see 41).

To avoid thin strips of paper in the printer, multiple cut commands without paper feed in-between will not be performed. If the printout length is too short, paper-feed is added until the minimum printout length is reached, before execution of the cut command.

See Also Note on cut position for the <RS> command above.

NOTE 1! – *Use the cut command if you want full control over the printer from your system. But remember that you also must add commands to feed to the correct cut position and eject the paper so that the customer can get hold of it.*

NOTE 2! – *Top margin settings that move the paper count as paper feed*

US			Partial cut (unit separate)
1F	hex		
031	decimal		

Prints a dotted line, a pair of scissors, and partially cuts the paper to make it easier to tear off the paper (a cut of about 5-mm in each edge).

ESC FF n1

1B 0C n1	hex
27 12 n1	decimal

Eject (run presenter)

ESC FF ejects the document through the presenter module. Variable **n** represents the eject-length in steps. The setting of parameter **n47** is always added to the eject **n** in all forms of eject.

The range for **n** is 1 to 127. The range 128-255 is reserved for future use.

One step is 1 mm

Place this command after a cut command (**ESC RS**) to partially eject the printout to the customer. Set the eject length so that the customer sees that the printout comes out of the kiosk wall. The pull-detector gives motorized eject of the rest of the printout when the customer pulls the paper.

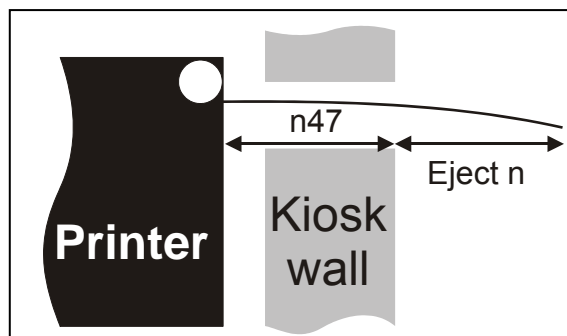

NOTE! – The cut and eject command **RS**, automatically give the eject length of 50 mm in addition to the factor stored in parameter **n47**.

EM n1

19 n1	Hex
25 n1	Decimal

Enforced Clear Presenter

Same function as **ENQ** but overrides the Retract and Retain parameter (p45) with another presenter behavior. The function of **n** can be 0 to 255 0-99 ejects while 100-255 retracts (see the description of parameter 45). The command will clear the presenter immediately (with printing synchronization).

<**EM**><000> Ejects the presented page

<**EM**><100> Retracts the presented page

ENQ

05	Hex
5	Decimal

Clear Presenter

Clear the paper-path in the presenter of printouts. For example, to eject a document not removed during the previous print/cut/eject operation. Parameter No. 45 controls how the presenter is cleared.

ESC f n1	Presenter loop ON/OFF/max length
1B 66 n1 Hex	
27 102 n1 decimal	

NOTE! – *Obsolete command, may disappear from future program releases. Use parameter p9 instead.*

n is the loop length limit in 3.2 cm steps. If the printout length exceeds the max loop limit, it is partially ejected before the printer continues.

range 0 and 3 to 255.

n = 0 The paper is fed straight through the presenter.

n = 18 Default setting which gives a loop of just above 0.5 m.

NOTE 1! – *The loop is limited to the value set by ESC f n to avoid paper jam. When the set length has been looped, the printer presents that part of the printout. Then, without cutting the paper, it continues to print the rest of the printout.*

NOTE 2! – *The loop is automatically disabled in vertical mode*

5.3.8 System related commands

ESC ?		Reset (full)
1B 3F	Hex	
27 63	Decimal	

Restarts the printer with a complete reset.

This is the same as power off/on and takes about a second to execute.

ESC @		Reset (initialize)
1B 40	Hex	
27 64	Decimal	

Terminates the processing and initializes the control board. The control board is reset to default-values (same as after power ON). Do not use this command as part of a print data command string.

ESC & 001		Load Logotype
1B 26 01	Hex	
27 38 1	decimal	

Stores a logotype bitmap in the flash PROM. The logotype is printed with the `ESC g` and `ESC L` commands, see page 38. Also see Logotypes on page 56.

NOTE! — *If the logo width exceeds the print width, the operation is aborted.*

ESC & L		Erase all Logotypes
1B 26 4C	Hex	
27 38 76	decimal	

Erases all logotypes stored in the flash PROM.

NOTE! — *This command is only executed if at least one logotype has been loaded*

ESC & 004		Store current Parameter Values
1B 26 04	Hex	
27 38 4	decimal	

Stores the current setting of all parameter values in the setting memory. These parameters are then used as default parameters. Storing takes approximately 4 seconds. The printer activates the presenter motor temporarily to indicate that storing is complete.

ESC & 000		Load Font
1B 26 00	hex	
27 38 0	decimal	

This command is used to load a font to the printer flash PROM. The font is placed in the first free address position in the order of load sequence.

A Swecoin font-file consists of a header containing data describing the font as well as data for each individual character in the font.

Fonts can be designed with the font editor and loaded or deleted with the software available for free on the Swecoin web site. The font loading and deleting commands described here should only be used if you do not work in the Windows environment.

For complete specification of the font format, see the Fonts section of www.swecoin.se.

NOTE! – *The available font memory is printed on the self-test printout. A maximum of 8 fonts can be addressed. Exceeding any of these limits will cause this command to fail.*

ESC & C		Erase all Fonts
1B 26 43	Hex	
27 38 67	decimal	

Erases all fonts stored in the flash PROM.

NOTE! — *This command is only executed if at least one font has been loaded*

ESC & D		Erase Fonts 4 to 7
1B 26 44	Hex	
27 38 68	decimal	

Erases fonts number 4–7. Fonts 0–3 are not affected by this command.

The operation is complete when the printer resets automatically and activates the presenter motor temporarily. Takes approximately 4 seconds.

ESC & F		Recall Parameter Profile
1B 26 46	hex	
27 38 70	decimal	

This command resets the parameters of the printer to default or any previously stored setup.

Temporarily sets all parameters to predefined values that are stored in the printer. To keep the values as default, store them in the flash PROM with command **ESC & 4**. Unless you save the parameters, a reset command or power OFF/ON will return the parameters to the settings stored in the flash PROM.

ESC & P n1...n2

1B 26 50 n1...n2	hex
27 38 80 n1...n2	decimal

Set Parameter Value

A number of bytes in the flash PROM hold various parameter values called *default parameters*. One or several of them can be overridden temporarily with this command.

n1 Parameter number, range 1 -255.

n2 Parameter value.

See “Default parameter settings” on page 27.

The permanently stored parameters will be used again after a printer-reset command or at power ON.

The temporary values can, however, be stored in the flash PROM as permanent values with command **ESC & 4**.

SET SEVERAL PARAMETERS AT ONCE

ESC & P <000> <FromPar><ParCount><Data>

FromPar is the parameter number to start writing and ParCount is the number of bytes being sent. For every byte sent the parameter number is incremented.

Example:

<ESC>&P<000><015><005><005><010><015><020><025><<>

Sets the first 5 tabs to 5, 10, 15, 20, and 25. (FromPar 15, ParCount 5)

ESC NUL

1B 00	Hex
27 0	Decimal

Load Firmware

This command should be used when you integrate firmware loading into your kiosk program.

NOTE! – Utility programs to load firmware into the printer are available from www.swecoin.se

5.3.9 Status reporting commands

See also “**Status reporting**” on page 58.

NOTE! – All status commands except for the acknowledge marker are immediate. That is they pass the print queue and are answered directly.

Status-codes are reset:

- 1 When the conditions causing them are removed.
- 2 When the printer is turned off/on or a reset command is received.
- 3 When the printhead is lifted and then lowered.

ESC ENQ 001

1B 05 01	Hex
27 5 1	decimal

Status Enquiry

A status enquiry results in response **ACK** (06h) if all sensors are clear, but **NAK** (15h) + code if one or more sensors report some condition.

Status code	Meaning
ACK	OK (printer is operable)
NAK 01h	Paper left in presenter module. Attempt to clear the paper path failed.
NAK 02h	Cutter jammed
NAK 03h	Out of paper
NAK 04h	Printhead lifted
NAK 05h	Paper-feed error. No paper detected in presenter although 10 cm has been printed. Paper might be wound around the platen or, in some way, has been forced above the presenter module.
NAK 06h	Temperature error. The printhead temperature has exceeded the 60 °C maximum limit.
NAK 07h	Presenter not running
NAK 08h	Paper jam during retract
NAK 0Ah	Black mark not found
NAK 0Bh	Black mark calibration error
NAK 0Ch	Index error
NAK 0Dh	Checksum error
NAK 0Eh	Wrong firmware type or target for firmware loading
NAK 0Fh	Firmware cannot start because no firmware is loaded or firmware checksum is wrong.
NAK 10h	Retract function timed out. If the customer doesn't take the paper and the printer clears the presenter due to a timeout, the pending error bit is set and error code NAK 10h is reported.
NAK 11h	Paused (ex. To avoid overheating of stepper motors)
NAK FFh	Undefined error

Table 4. Status codes

NOTE! — Errors 02h, 05h, and FFh are terminal faults that require you to reset the printer before it will be operable again. A reset means that any data in the buffer is lost.
The printer automatically recovers from the other conditions as soon as the condition is corrected, without data loss.

A status enquiry command can only return one status code at a time. If there are two or more simultaneous conditions, each condition should be cleared and the status enquiry repeated in order to get a complete report of all status codes.

The host computer cannot be certain that all conditions have been cleared until an `ACK` is received.

The possible conditions are reported in the above order.

NOTE! – If you want to read out all status information directly, use `ESC ENQ E`.

ESC ENQ 002

1B 05 02	hex
27 5 2	decimal

Paper-near-end Enquiry

This command requests a paper-near-end sensor (paper low) status from the printer in a 1-byte format.

Value = (01h) indicates "No paper"

Value = (00h) indicates "Paper present" at the sensor position

NOTE! – The status of the sensor is sampled every time the printout is cut. If three succeeding samples show "no paper", the status reply changes to 00. This is to prevent false alarm if the side of the paper roll is not clean. If you want the momentary status of the sensor, use `ESC ENQ 6` and extract the paper-near-end bit.

ESC ENQ 004

1B 05 04	hex
27 5 4	decimal

Fonts and Logotype Enquiry

Requests multiple bytes of information regarding loaded fonts and logotypes.

EXAMPLE (↵ = CR LF)

Send→ `ESC ENQ 04d`

Read← `0:7862 ATM9↵`

1: ↵

2: ↵

3: ↵

4: ↵

5: ↵

6: ↵

7: ↵

Free font memory:123082↵

00:38 117 Swecoin Logo ↵

01: ↵

02: ↵

03: ↵

04: ↵

05: ↵

06: ↵

07: ↵

08: ↵

09: ↵

10: ↵

11: ↵

12: ↵

13: ↵

14: ↵

15: ↵

16: ↵

Free logo memory:126352↵

ESC ENQ 005	Sensor Enquiry
1B 05 05	hex
27 5 5	decimal

Results in a 2-byte response, reflecting the status of all virtual sensors. Virtual sensors maintain their functionality in all configurations of this printer, while physical sensors reported by ESC ENQ 6 signals differently depending on if for example horizontal or vertical mode is enabled.

The same physical sensor give several virtual statuses depending on when, in the print cycle, the sensor is activated.

FIRST BYTE:

Reserved for future use.

SECOND BYTE:

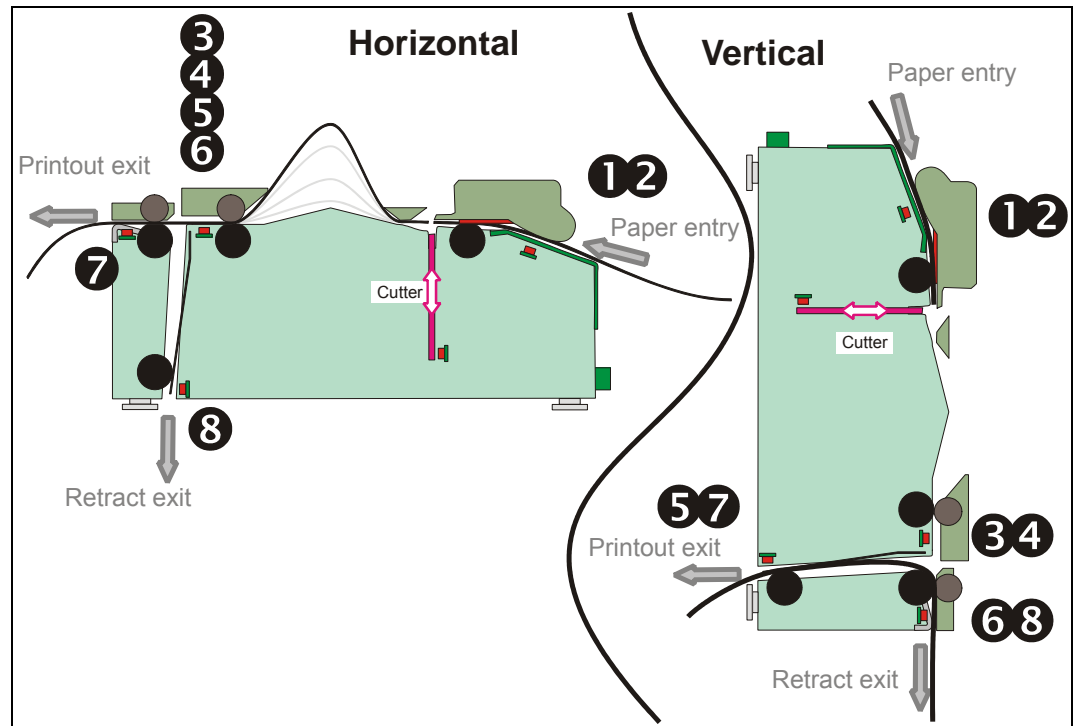
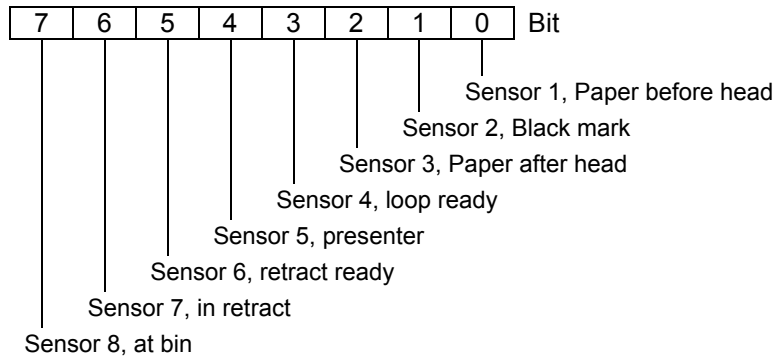

Figure 27. Physical-to-virtual sensor mapping

ESC ENQ 006

1B 05 06	hex
27 5 6	decimal

Status Report

NOTE! – The sensor status reported in the status report are for compatibility with older printers. Please use ESC ENQ 5 in new applications.

Results in a 2-byte response, reflecting the status of each sensor. This command is intended as a go/no go indication.

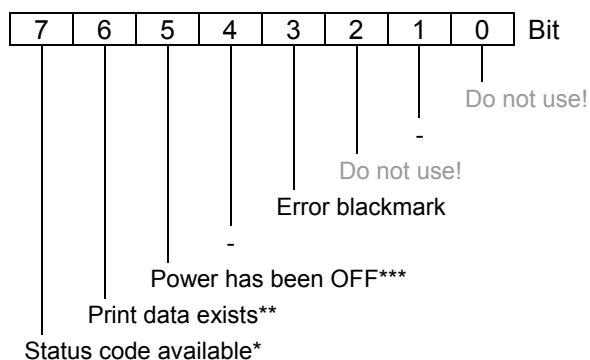
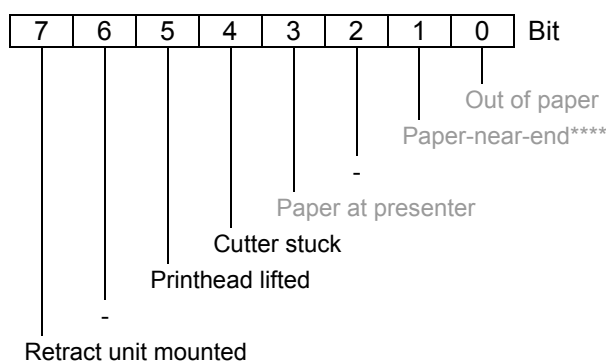
FIRST BYTE:**SECOND BYTE:**

HINT! – Mask away the undefined bits in your application program to avoid having to change the application, if future firmware releases starts using them. Mask first reply byte with **E8h**, Mask second reply byte with **BBh**

Table 5. Sensor status

- * This bit indicates that a status code is available. Use ESC ENQ 1 or ESC ENQ E to fetch it.
- ** This bit tells you that there are data in the printer that have not yet been printed. There are two possible reasons for that:
 - 1) The last command received by the printer was not a command that triggers a printout.
 - 2) The printer is printing
- *** When parallel cable is connected, both printer and host computer must have been off to set this bit. This is because the interface powers the RAM in the printer.
- **** This paper-near-end bit differs from the ESC ENQ 2 response, see page 47.

Bit 4 and 5 in the first byte are reset when read.

ESC ENQ 007		Firmware-version Enquiry
1B 05 07	hex	
27 5 7	decimal	

Results in a 2-byte response representing the version of the installed firmware.
 The first byte represents major versions, and the second byte minor versions.
 If no firmware is loaded, the printer will answer with 00h.

EXAMPLE

Send→ ESC ENQ 07d

Read← <02h><29h>

That is, a response with the value <02h><29h> indicates version 2.41.

ESC ENQ 009		Serial-number Enquiry
1B 05 09	hex	
27 5 9	decimal	

Results in an 6-byte response representing the serial number.

EXAMPLE

Send→ ESC ENQ 09d

Read← 00h 00h 02h 2Bh c6h 28h (hex), or 000 000 002 043 198 040 (dec)

ESC ENQ 010		Control board revision Enquiry
1B 05 0A	hex	
27 5 10	decimal	

Results in a 1-byte response representing the control board revision. A minus sign indicates that no revision has been made, while A indicates the first revision, and so on.

EXAMPLE

Send→ ESC ENQ 10d

Read← n Where n can be 'A' (ASCII) or 41h (hex) or 065 (dec)

ESC ENQ 011		Head temperature Enquiry
1B 05 0B	hex	
27 5 11	decimal	

Results in a 1-byte response representing the temperature of the Printhead.

EXAMPLE

Send→ ESC ENQ 11d

Read← n Where n is a value representing the approximate temperature in Celsius.
 The answer is an signed byte (two's complement). If bit7 is 1 than it's a negative value, invert all bits and add 1 the get the value.

ESC ENQ 012

1B 05 0C	hex
27 5 12	decimal

Bootware version Enquiry

Results in a 2-byte response representing the version of the installed bootware.

The first byte represents major versions, and the second byte minor versions.

EXAMPLE

Send→ ESC ENQ 12d

Read← <001><030>

That is, a response with the value <01h><30h> indicates version 1.48.

ESC ENQ c

1B 05 63	hex
27 5 99	decimal

Device ID Enquiry

Results in a string containing the device ID in the Windows Plug and Play string format.

The two first bytes represent the string length.

EXAMPLE

Send→ ESC ENQ 99d

Read←00d 106d This indicates that the string is 104 characters (plus two characters indicating the string length)

ESC ENQ E	Read extended status
1B 05 45 hex	
27 5 69 decimal	

Extended status is status from the printer together with devices connected to the I²C options-bus available in some Swecoin printers (the TTP 2000 series does not have any I²C bus so these parts of the command are superfluous). The short message protocol gives replies up to 255 bytes. Other protocols may be defined in the future. Protocols are described in separate documents.

ESC ENQ E results in a variable length reply:

- n1 Protocol version, 11h = Short Message Protocol
- n2 Protocol length in bytes
- n3-n255 Data specified by the protocol

SHORT MESSAGE STATUS EXAMPLES

Example 1 – Out of paper presenter Jam, and shutter open error.

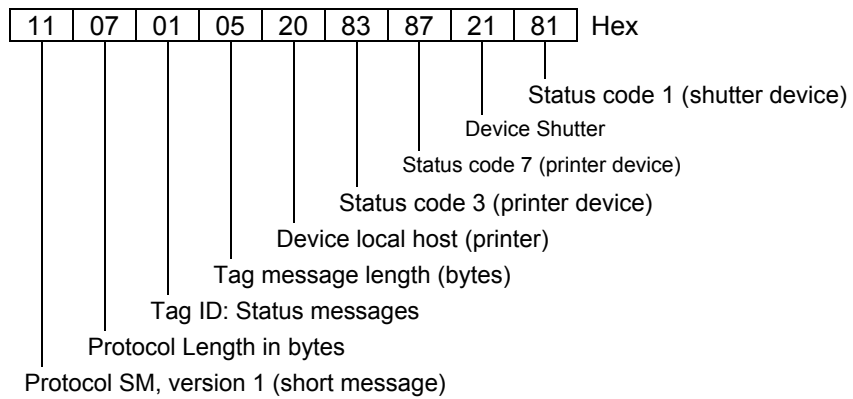

Example 2 – No errors in any device.

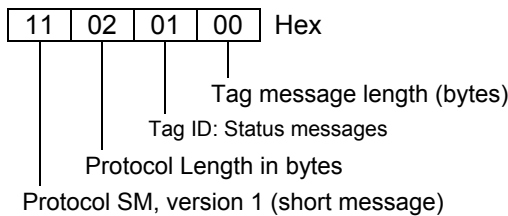

ESC ENQ P n1	Parameter-setting data Enquiry
1B 05 50 n1 Hex	
27 5 80 n1 Decimal	

This command requests information about the setting of parameter n1, that is, the parameter value stored in flash PROM or any parameter value temporarily set by other ESC commands.

n1= 1 gives the setting of parameter 1, etc.
 The parameter names are listed on page 61.

n1 = 0 gives a response where the first two bytes specifies the length of data to come, and then follows a block of data for all parameters in the temporary setup.

ESC ACK n1

1B 06 n1	hex
27 6 n1	decimal

Acknowledge Marker

n1 = One-byte marker. Range 1h to 255h

The "acknowledge marker" n is placed in the command queue and when the execution of commands reaches the marker it is sent back to the host computer. This is an addition to the status commands that pass the queue and are answered immediately when received.

EXAMPLE:

"Print data" <LF><esc>p<ESC><ACK><01h>

Wait for <01h>

<RS><ESC><ACK><02h>

Wait for <02h>

The printer will send <01h> when <print data> has executed and <02h> when the ejecting has been performed.

NOTE 1! — *You must wait for the acknowledge marker to return before sending any more data to the printer.*

NOTE 2! — *Acknowledge marker cannot be used for events that write to the flash PROM, for instance font loading. This is because the writing procedure erases the buffer, including the markers, and uses all RAM in the printer.*

5.4 Font loading

The printer can store 8 fonts in its flash PROM. The memory available for fonts is printed on the self-test printout. The character size is fixed¹, so you must load one font file for each character size you require. The fonts are given font numbers when they are loaded into the printer. The first font is assigned number 0 and the next font 1 etc. up to font 7. Parameter p14 "Font Selection" will determine what font to use when no font selection command has been received (see page 63).

You cannot erase a single font, but must erase font 4-7 with command `ESC & D`, or all eight fonts with `ESC & C`, then reload the fonts you wanted to keep.

Windows software for font generation and management is available on the Swecoin web site. If you need to load fonts in a non-Windows environment, use the `ESC & NUL` command.

The time required for processing the font data that is loaded is typically 15–20 seconds per font, excluding transfer time. During this time, any data sent to the printer will be lost.

NOTE! — *The font processing ends with a reset. The presenter motor runs momentarily to indicate that the printer is ready to be used.*

CAUTION! — *Loading to the flash PROM will erase the RAM completely since the RAM is used during the loading process. Any print data residing in RAM will thus be lost.*

5.4.1 File format

A font consists of a header describing the font, then data for every character in the font. The header has to be downloaded even if the font consists of a single character only. Below is a description of the font header.

1 byte	Reserved	Should always be 0 (zero)
1 byte	Reserved	Should always be 0 (zero)
1 byte	Char. width (X)	The number of bytes required for the width of one character, usually 2 or 3. Range 1 to 8.
1 byte	Character pitch	The maximum width of one character in the set. This value is used for tab position calculation. Range 1 to 255.
1 byte	Char. height (Y)	The maximum height of one character matrix measured in pixels. This is also the minimum line spacing for this character set.
27 byte	Font name	String of characters used to identify the character set. This will be printed on status printouts. (E.g. Swiss 10 cpi.)

Char_matrix table: 256 records, each containing 3 bytes.

3 byte Char_width (pixels) + Char_Ystart(pixels) + Char_Yheight(pixels)

Char_bitmap data: Bitmap data for all characters that are to be defined.

¹ Multiple height and width commands can be used on all fonts.

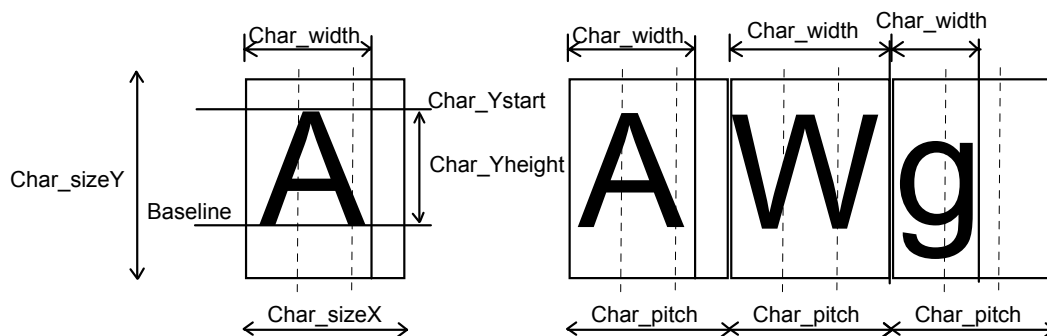

Character bitmap data:

A character is made up of a bitmap the size of which is:
 Char. width (X) * Char. Height (Y) bytes.

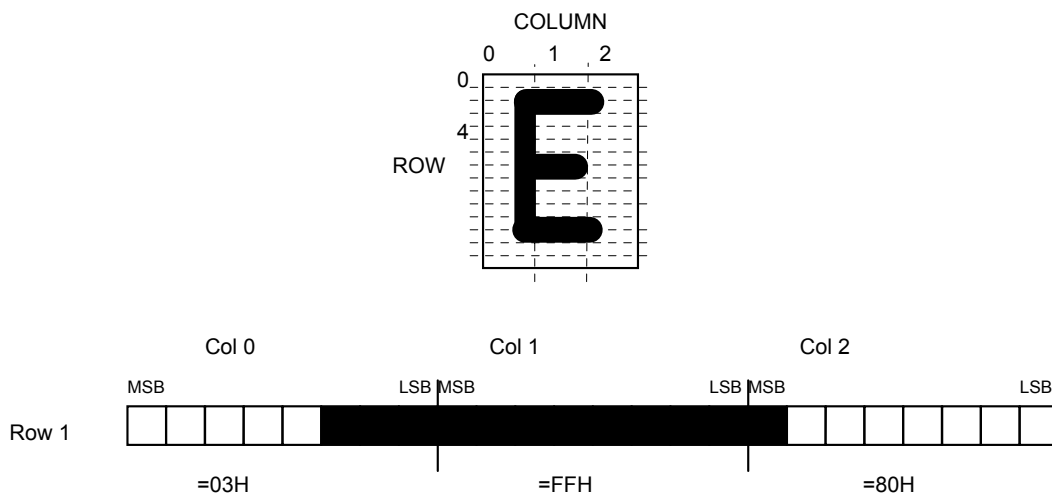

The bitmap data consists of bitmap patterns for each character in a character set for which the parameter Char_width in the Char_matrix table is set to a value between 1 and 24. A character that has its Char_width set to zero, is not included in the bitmap data.

The bitmap for one character is then defined according to the following table:

- (COL 0, ROW Ystart), (COL 1, ROW Ystart), (COL 2, ROW Ystart)
- (COL 0, ROW Ystart+1), (COL 1, ROW Ystart+1), (COL 2, Ystart+1)
- .
- .

(COL 0, ROW Ystart+Yheight), (COL 1, ROW Ystart+Yheight), (COL 2, ROW Ystart+Yheight)

In this example, each row consists of 3 columns equal to 3 bytes.

In order to minimize the required storage space, only rows between Ystart and Ystart+Yheight are included in the character bitmap.

5.5 Logotypes

Up to 16 logotypes can be stored in the flash PROM of the printer. The logotypes can be positioned and printed out with commands `ESC g` or `ESC L`.

The exact number of logotypes and their sizes is determined by the total amount of memory used for fonts, logotypes and loaded firmware. Make a test printout to see how much memory is available.

NOTE! – *Logotype No. 0 is printed in the top of the self test printout, so this can be used to customize the self test printout.*

5.5.1 Loading

Windows software that converts black and white BMP bitmap files to logotypes and load them into the printer is available on the Swecoin web site. If you need to load logotypes in a non-Windows environment, use the `ESC & 1` command.

The time required by the printer to process logotype data, excluding transfer time from the PC, is typically 15 to 20 seconds, per logotype. During this time, any data sent to the printer will be lost.

5.5.2 File format

A header containing information about the logotype number, size and logotype name shall define each loaded logotype. Immediately after the header follows the actual bitmap of the logotype.

`ESC & 01H <Header><Bitmap>`

Header:

Byte 0 Logotype number used to identify the logotype when printing.

Byte 1 X size measured in bytes.

Byte 2 Y size measured in pixels.

Byte 3—15 A logotype name that will be printed on test printouts.

Bitmap:

The bitmap **must** have exactly (X size * Y size) number of bytes. 1=black, 0=white dot.

Bit No. 7 in byte 0 represents the top left corner of the logotype.

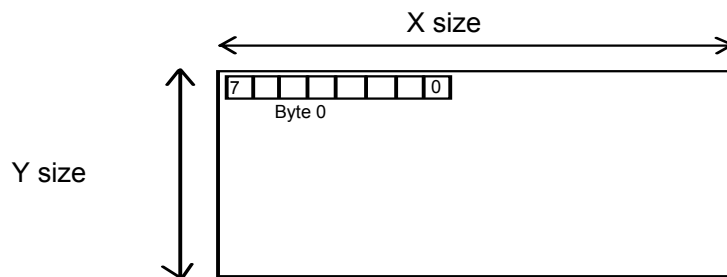

5.5.3 Printing

To print a logotype you can use two commands, `ESC L n1`, prints the logotype at the current cursor position, just like any character. `ESC g n1 n2n3 n4n5` prints the logotype at a specified X-Y position.

n1	One byte logotype number, (0—15)
n2n3	Two byte X position measured in pixels from the left hand edge of the print window.
n4n5	Two byte Y position in pixels from top of the page. These bytes must always be inserted but they are ignored in variable-page-length mode where logotypes are always printed at the current Y-position.

5.5.4 Erasing

All logotypes are erased with the `ESC & L` command.

CAUTION! — *Loading to the flash PROM will erase the RAM completely since the RAM is used during the loading process. Any print data residing in RAM will thus be lost.*

5.6 Status reporting

The printer is equipped with a number of sensors that report the printer status and various conditions such as out-of-paper, previous printout not removed, etc.

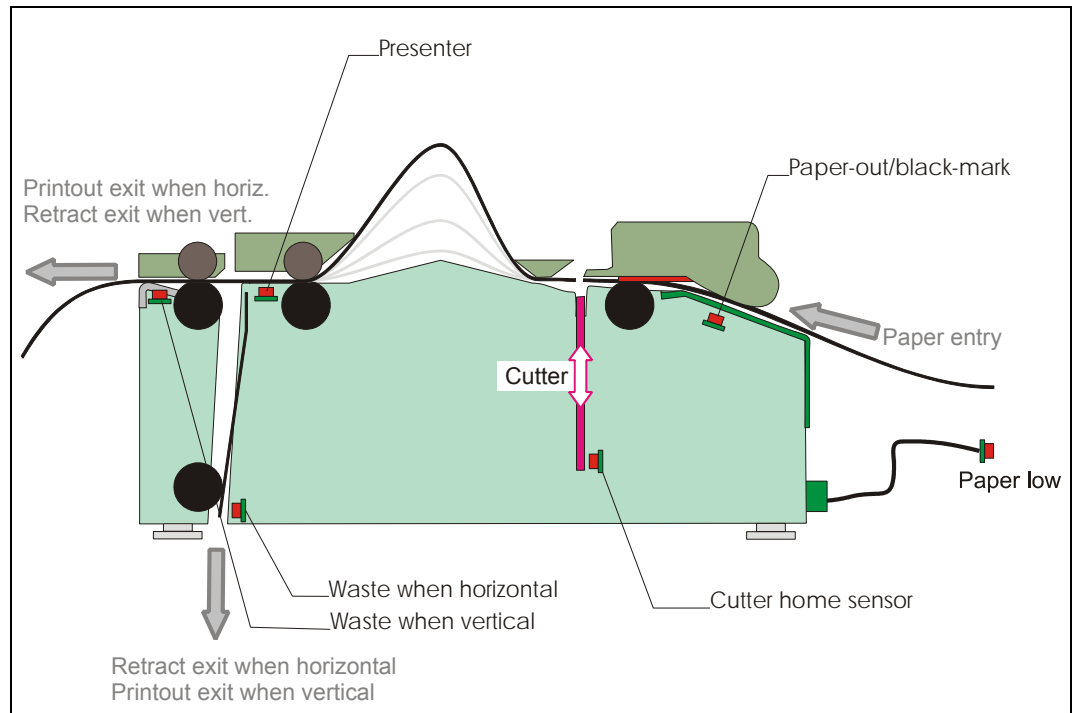

Figure 28. Sensor placement in the printer

A good practice in unattended printer applications is to check for errors and paper availability before printing.

1. Send a Status Report Query (`ESC ENQ 6`, page 49) and check that the answer is "No errors"
2. If "Status codes available" is indicated, read out the status message with Status Request (`ESC ENQ 1`, page 46), and take appropriate actions.
3. Send a paper-near-end query (`ESC ENQ 2`, page 47) to see if the sensor reports low paper level.
4. If paper-near-end is indicated, report the condition to the systems supervisor so that he can schedule a service visit to the printer.
5. Print the printout.

NOTE 1! — **A status reply must be read!** Sending a second status query without reading the reply of the first query may lock the printer.

NOTE 2! — When using a multitask OS, status queries and responses may not be transferred immediately from your application to the printer and vice versa. So write your program in such a way that it repeats the query if it gets a timeout or an invalid reply. Good practice is to ask once every ten seconds, five times before giving up.

NOTE 3! — You should construct your application in such a way so as not to request status while printing, as this can result in loss of data

6

DEFAULT PARAMETER SETTINGS

Some of the printer settings can be stored in the flash PROM so that they will be used also after power OFF.

The stored parameter settings are printed out on the self-test printout.

The number in front of the function is the parameter number (n) used when setting the parameter with the command `ESC & P n v`.

You can use the parameter settings pretty much like normal commands. Either send the parameter values with each printout, or set them up once and then send `ESC & 4h` to store all settings in the flash PROM.

You can always return to factory default settings by sending `ESC & F 10`, and then storing those settings with `ESC & 4h`.

NOTE 1! – The parameters can be locked so that no changes are possible. Check parameter 53 on the self-test printout to find out.

NOTE 2! – If you try to set a parameter to an invalid value, the parameter will be set to the nearest valid value below.

6.1 How the parameters are described

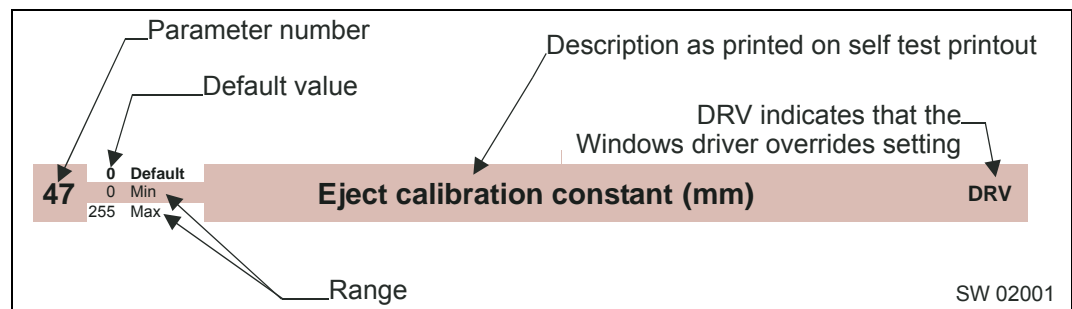

6.1.1 Default value

The default values indicated are "factory default settings" you get by sending `ESC & F 10`. These are not necessarily the settings that your printer was originally delivered with because many printers have customized settings when delivered.

6.1.2 Examples

Command examples are formatted in **Courier** and typed in the same way as used in the Swecoin TTP editor:

```
<ESC>&P<001><019>
```

Where `<ESC>` means the escape character 27 decimal (hex 1B). Numbers between less-than and greater-than characters, for example `<001><015>`, means 1 and 15 decimal (hex 1 and 13).

6.2 Summary of parameter settings

				TTP model		
Parameter	Description	ESC&F Default	Page	2010	2020	2030
1	Baud rate	96 (9600 Baud)	61	X		
2	Data bits	8	61	X		
3	Parity	0 (No parity)	61	X		
4	Flow control	2 (Hardware)	61	X		
5	Disable parallel port signaling	0 (No)	62		X	
7	Burn time	9	74	X	X	X
8	Print speed	19 (150 mm/s)	62	X	X	X
9	Presenter loop length	15 (48 cm)	63	X	X	X
10	Pulse control	3 (2 burn pulses)	63	X	X	X
12	Font attributes	0 (off)		X	X	X
13	Line spacing	0 (Auto)	63	X	X	X
14	Font selection	0 (TTP Mono 9)	63	X	X	X
15 to 30	Tab stop	4, 8, 12 etc.	63	X	X	X
33	CR/LF	0 (LF = CR/LF, CR=Ignored)	64	X	X	X
34	Auto cut after FF	1 (Off)	64	X	X	X
36	Document mode	1 (Variable)	64	X	X	X
37 and 38	Page length, Minimum / fixed / BM	2, 88 (75 mm)	65	X	X	X
39	Max black mark length	80 (10 mm)	66	X	X	X
40	Min black mark length	24 (3 mm)	66	X	X	X
41 and 42	Black mark cut offset	0, 0 (0 mm)	66	X	X	X
43 and 44	Black mark top margin	0, 0 (Disabled)	66	X	X	X
45	Trash bin mode (Retract function)	3 (Eject and retract after 30 s)	66	X	X	X
47	Wall compensation	0	67	X	X	X
49	Advance before cut	0 (Off)	67	X	X	X
51	Black mark level	75	67	X	X	X
52	Warning level	0 (Off)	67	X	X	X
56	Max status code	255	68	X	X	X
57	System	255	68	X	X	X

NOTE! – When the printer is set up the way you like it to be, you send **ESC & 4h**, and all settings will be stored.

6.3 Serial interface set-up

1 96 Default
11 Min
96 Max

Baud rate

Stores the communication speed on the serial interface.

<ESC>&P<001><024> 2400 bps
 <ESC>&P<001><048> 4800 bps
 <ESC>&P<001><096> 9600 bps
 <ESC>&P<001><019> 19200 bps
 <ESC>&P<001><038> 38400 bps
 <ESC>&P<001><057> 57600 bps
 <ESC>&P<001><011> 115200 bps

NOTE! – If you set an invalid value, the baud rate will return to the previous value.

2 8 Default
7 Min
8 Max

Data bits

Selects if 7-bit ASCII, or 8-bit, is used on the serial interface.

<ESC>&P<002><007> 7-bits (characters 0-127)
 <ESC>&P<002><008> 8-bits (characters 0-255)

3 0 Default
0 Min
2 Max

Parity

Select what parity to use on the serial interface.

<ESC>&P<003><000> No parity
 <ESC>&P<003><001> Odd parity
 <ESC>&P<003><002> Even parity

4 2 Default
0 Min
2 Max

Flow-control

Select what handshaking to use on the serial interface.

<ESC>&P<004><000> No flow control
 <ESC>&P<004><001> Xon / Xoff ¹
 <ESC>&P<004><002> Hardware

¹ DO NOT USE if you send any type of binary data like graphics data, status requests etc. Xon / Xoff only works when plain text is sent unidirectional to the printer. Graphics and status replies may well contain the Xon (11h) and Xoff (13h) characters and will obstruct the communication.

6.4 Parallel port setup

5 0 Default
0 Min
1 Max

Disable parallel port signaling

Pins 12 and 15 on the parallel port signal paper out and error. However, in an unattended kiosk you may not want this because it causes the host computer to stop communicating, and the operating system may display a warning or error message on the kiosk screen.

By disabling the hardware signals, the kiosk software can for example use status commands to find out paper level and alert appropriate personnel when the level is low, then close the kiosk when paper is out.

<ESC>&P<005><000> No, paper out and error signals are *not* disabled

<ESC>&P<005><001> Yes, paper out and error signals are disabled

NOTE! — *When enabled, the hardware signal on pin 12 and 15 will block all communication until the error is corrected. This means that it will be impossible to ask for status.*

6.5 Print setup

7 9 Default
1 Min
15 Max

Burn time

DRV¹

A long burn time gives darker print. On insensitive paper types you may have to increase the burn time to get an acceptable print quality.

8 19 Default
1 Min
19 Max

Max print speed

DRV

The main reason to decrease the print speed is to enhance print quality, and to reduce average current consumption.

n	1	2	3	4	5	6	7	8	9	10	11	12	13	14	15	16	17	18	19
mm/s	47	48	49	50	51	52	53	55	57	61	65	70	77	86	96	107	123	136	150

NOTE! — *Some settings result in printer chassis resonance causing increased noise and deteriorated print quality*

¹ DRV indicates that, when using Windows, the driver takes over this setting so please set appropriate value in the driver properties/document defaults.

9 15 Default
3 Min
255 Max

Presenter Loop length

Limits the maximum loop length. When the set length is reached, the printer ejects part of the printout and continues to print. You use this when you have very limited space for the loop inside the kiosk. Each step represents a 3.2-cm increment.

Setting the parameter to 0 disables the looping and feeds the paper straight out.

```
<ESC>&P<009><000>  Disable the loop
...
<ESC>&P<009><007>  16 cm loop
...
<ESC>&P<009><015>  48 cm loop
```

10 3 Default
3 Min
7 Max

Print head pulse control

Controls how the print head burns the pixels

```
<ESC>&P<010><003>  2 burn pulses
<ESC>&P<010><007>  4 burn pulses
```

CAUTION! – 3 and 7 are the only allowed settings, do not set anything else!

13 0 Default
0 Min
30 Max

Line spacing

The line spacing is normally set by the font height. With this parameter you can set a line spacing that is higher than the font height. Line spacing settings lower than the font height will be ignored.

```
<ESC>&P<013><030>  30 pixels or font height, whichever is the largest
```

14 0 Default
0 Min
7 Max

Font selection

Store which font number is used if no font is specified. Font is selected using the "Select Font" command `ESC ! n`. Selecting an invalid font gives a software error status message (invalid index).

15 to 30 - Default
1 Min
255 Max

Tab stop

Stores 16 different TAB stop positions. The position is set in increments of 2.5-mm.

Tab position 255 sets a tab stop on the last position of the line. Use this if you want underline or reversed text to extend across the full paper width.

To set all tab stops at once, follow the procedure "Set several parameters at once" described on page 45.

To move a single tab stop, use the set parameter command `<ESC>&P`. for example:

```
<ESC>&P<015><010>  Set the first tab stop 25 mm from the left margin.
```

Default positions are one TAB on each cm; that is parameter values 4, 8, 12 etc.

33 0 Default
0 Min
4 Max **CR/LF behavior¹**

Carriage Return and Line Feed can be interpreted in five different ways to suit different operating systems.

<code><ESC>&P<033><000></code>	LF = CR/LF	CR = Ignored
<code><ESC>&P<033><001></code>	LF = CR/LF	CR = CR
<code><ESC>&P<033><002></code>	LF = LF	CR = CR
<code><ESC>&P<033><003></code>	LF = LF	CR = CR/LF
<code><ESC>&P<033><004></code>	LF = Ignored	CR = CR/LF

NOTE! – The character currently interpreted as LF converts text from the input buffer to pixels on the paper. If no such character has been received after 379 characters, a linefeed is inserted automatically.

34 1 Default
0 Min
1 Max **Auto cut after FF**

Decides if the printer should cut after executing an FF command, or if it should just feed the form length.

<code><ESC>&P<034><000></code>	No cut
<code><ESC>&P<034><001></code>	Cut

36 1 Default
0 Min
2 Max **Document mode** DRV

Determines what should control the page length:

<code><ESC>&P<036><000></code>	Fixed Document Mode. Shorter documents will automatically be extended, while longer documents will be divided into several pages of the desired length. Page length will be the length set by parameters 37 and 38
<code><ESC>&P<036><001></code>	Variable Document Mode. The length of the page varies with the contents (printouts shorter than the value specified by parameters 37 and 38 will be extended to that length)
<code><ESC>&P<036><002></code>	Black Mark Mode. Marks on the paper set the form length. Minimum one form length is always fed. If a black mark is found before that, the printer feeds to the next black mark, then cuts and ejects. This ensures that no small paper stripes are cut off and left in the printer.

NOTE! – Max page length in Fixed Document Mode is A5-size, which is 148.5 mm.

¹ v=0 is suitable for Windows, v=1 for UNIX and Mac OS X, v=2 for DOS, and v=4 for Macintosh Classic

37 & 38	2, 88	Default	Page length	DRV
	2, 48	Min		
	255, 255	Max		

Defines three different things:

- 1) The minimum length of a page in variable document mode
- 2) The actual page length in fixed document mode
- 3) The distance between black marks in black mark mode

One step is 0.125 mm. Settings shorter than 70 mm, will be interpreted as 70 mm.

`<ESC>&P<037><006><ESC>&P<038><064>` Set page length to 200 mm.

Length	p37	p38
70 mm	<002>	<048>
75 mm	<002>	<088>
100 mm	<003>	<032>
150 mm	<004>	<176>
200 mm	<006>	<064>
250 mm	<007>	<208>
300 mm	<009>	<096>

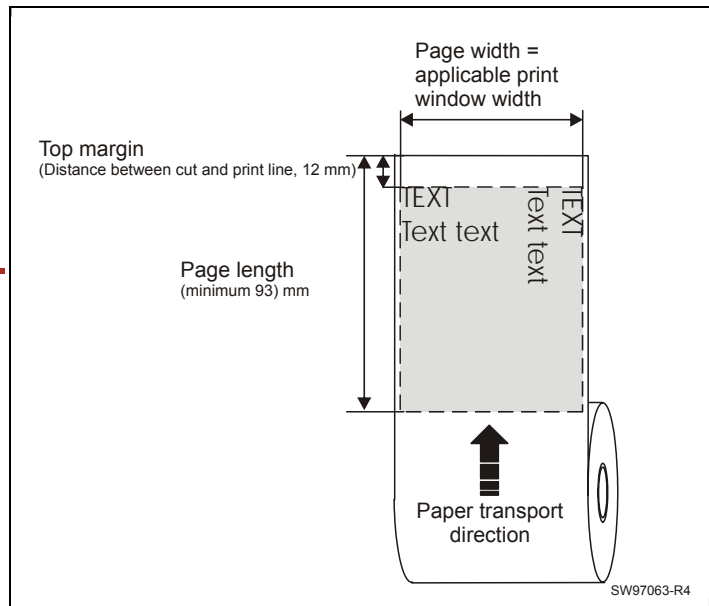

Figure 29. Definition of page size

Fixed document mode

Max *fixed document mode* page length is depends of the amount of free ram. Make a self-test printout to check how much is available in your printer. (Depends on firmware version).

$$Page\ length = \frac{Free\ RAM\ in\ bytes - 1024}{Paper\ width} - top\ margin - bottom\ margin$$

Paper length, top, and bottom margins are in pixel lines. Paper width is in bytes or mm. (1 byte = 1 mm.)

Example: If Free RAM on a TTP 2000 is 114627 bytes, print width is 80 mm = 80 bytes, top margin is 20 mm, and bottom margin 10 mm (20 x 8 = 160 and 10 x 8 = 80 pixel lines):

$$Page\ length = \frac{114627 - 1024}{80} - 160 - 80 = 1180\ pixel\ lines = 147\ mm$$

If a too large fixed page is specified the printout will be blank from memory full to the cut.

39	50	Default	BM (black mark) length	DRV
	1	Min		
	160	Max		

Specifies the length of the black mark in 0.125-mm steps. Measure the length of the black mark on your paper and enter that value here.

Marks 5 mm longer than this value are interpreted as paper out. The default value of 80 equals 10 mm.

`<ESC>&P<039><040>` Sets max black mark length to 5 mm.

40	30	Default	Min BM (black mark) length "Garbage Filter"	DRV
	1	Min		
	159	Max		

Specifies the minimum length of the black mark in 0.125-mm steps. Shorter marks are ignored. The default value of 24 equals 3 mm.

`<ESC>&P<040><036>` Sets min black mark length to 4 mm.

41 & 42	0, 0	Default	BM (black mark) cut offset	DRV
	0, 0	Min		
	255, 255	Max		

Defines the paper feed between the black mark detection and cut. One step is 0.125 mm.

`<ESC>&P<041><001><ESC>&P<042><144>` Feeds 50 mm between black mark and cut.

43 & 44	0, 0	Default	Top margin (mm)	
	0, 0	Min		
	255, 255	Max		

Defines the distance between the cut in Black mark mode and the top of the first text line in 0.125 mm steps. The top margin feed is effectuated when the presenter is cleared from the previous page.

0 = disabled top margin. This gives the physical top margin of the printer, which is 9 mm.

Avoid settings 1 – 8 mm because then the printer must reverse the paper before starting to print, which may cause paper jam, especially at small roll diameters.

`<ESC>&P<043><000><ESC>&P<044><240>` Add 30-mm top margin.

45	3	Default	Trash bin mode (Retract function)	
	0	Min		
	130	Max		

Sets the function of the "retract and retain" function.

`<ESC>&P<045><000>` Eject page when new page is printed. (Retract disabled)

`<ESC>&P<045><003>` Eject page when new page is printed. Page not taken after 30s will be retracted. (Range 1-30, 1 step = 10 s)

`<ESC>&P<045><100>` Retract page when new page is printed

`<ESC>&P<045><103>` Retract page when new page is printed. Page not taken after 30s will be retracted. (Range 101-130, 1 step = 10 s)

47	40	Default	Wall Compensation (mm)	DRV
	0	Min		
	255	Max		

When the printout is printed and cut, the presenter ejects 50 mm of the page so that the customer can grab it. If the kiosk wall is thick, or if you just want a longer part of the printout to be visible, this parameter adds extra eject length.

<ESC>&P<047><050> Adds 50 mm
extra eject = 100 mm in total.

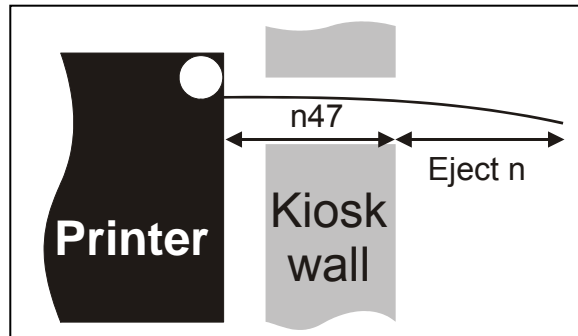

49	1	Default	Advance before cut	DRV
	0	Min		
	1	Max		

Selects if the cut command cuts at the position where the paper is at, or if the printer should advance the paper before cutting.

<ESC>&P<049><000> Off

<ESC>&P<049><001> Automatic Distance Calculation¹

Set to 1 if the printer is used in text mode and 0 if it is used from a driver that takes care of this in the driver.

NOTE! – The paper is advanced before the FF command calculates the page length to see if the page length is longer than the set minimum length.

51	50	Default	Black mark sensitivity	DRV
	0	Min		
	255	Max		

This parameter is used by command ESC # to store the calibration of the black mark sensor. Normally there is no need to set this parameter manually. 0 is white and 255 is pitch black (out of paper).

52	0	Default	Warning level	
	0	Min		
	255	Max		

Turns on/off indication of Paper near end level on the status indicator. This affects only the status indicator, not the status enquiries

<ESC>&P<052><000> No indication

<ESC>&P<052><001> Paper Near End indication

¹ "Automatic Distance Calculation" means advancing the paper with the Head-To-Cutter distance (12 mm on the TTP 2000).

56	255	Default	Max status code
	0	Min	
	255	Max	

This will control the highest status code that is reported by ESC ENQ x06 and ESC ENQ x01 (Pending-status-code bit). You use this if your kiosk software is not written so it masks away unknown status messages.

Example: If you want the TTP 2000 to be compatible with software written for TTP 1020, set parameter 56 to 6h and error codes 7 and up will not be reported.

57	255	Default	System
	0	Min	
	255	Max	

The system parameter will control up to eight system components in the printer.

Two are specified so far and those are:

Bit 0: Clear presenter at reset

Bit 1: Pull detector

Bit 2: Horizontal

Setting the bit to 1 enables the function and setting it to 0 disables it.

NOTE! – Bits who's function are not yet specified must always be set to 1.

Example:

- | | |
|-------------------|--|
| <ESC>&P<057><254> | Presenter will not be cleared at power ON and reset |
| <ESC>&P<057><253> | The pull detector is disabled |
| <ESC>&P<057><252> | The presenter will not be cleared at power ON and reset and the pull detector is disabled |
| <ESC>&P<057><251> | The printer is set to vertical mode, that is the retract output and the normal output are swapped. |
| <ESC>&P<057><255> | The printer is reset to normal behavior |

7

PAGE SETUP
7.1 Printable area

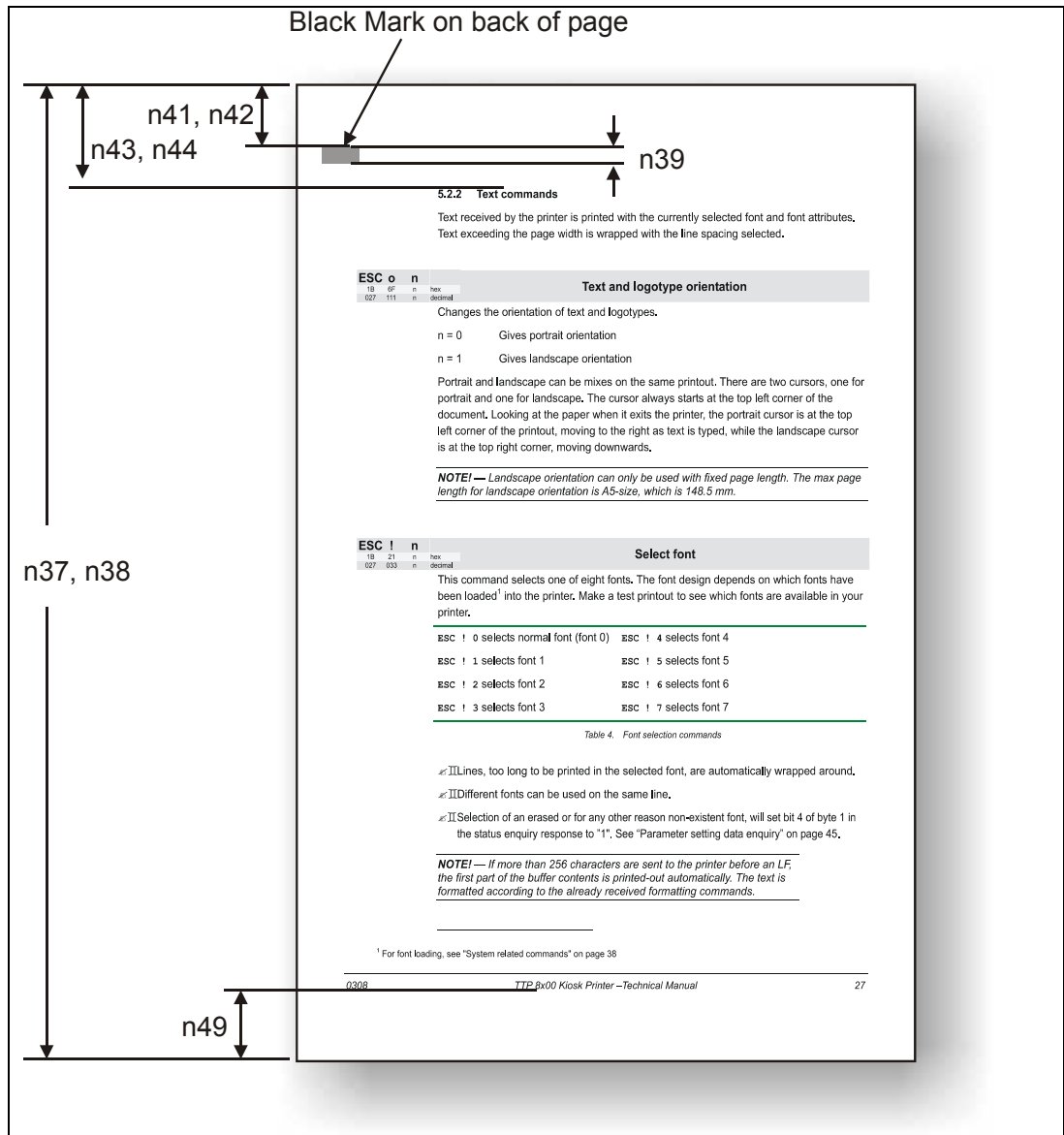

Top margin, bottom margin, page length, and synchronization with preprint are set up with parameters in the printer.

7.2 Aligning preprint and thermal print

The printer can synchronize the cutting of the printout with black-marks printed on the back of the paper. You use this function when you have preprint on the printout and you don't want a cut in the middle of that preprint, or text printed on top of the preprint.

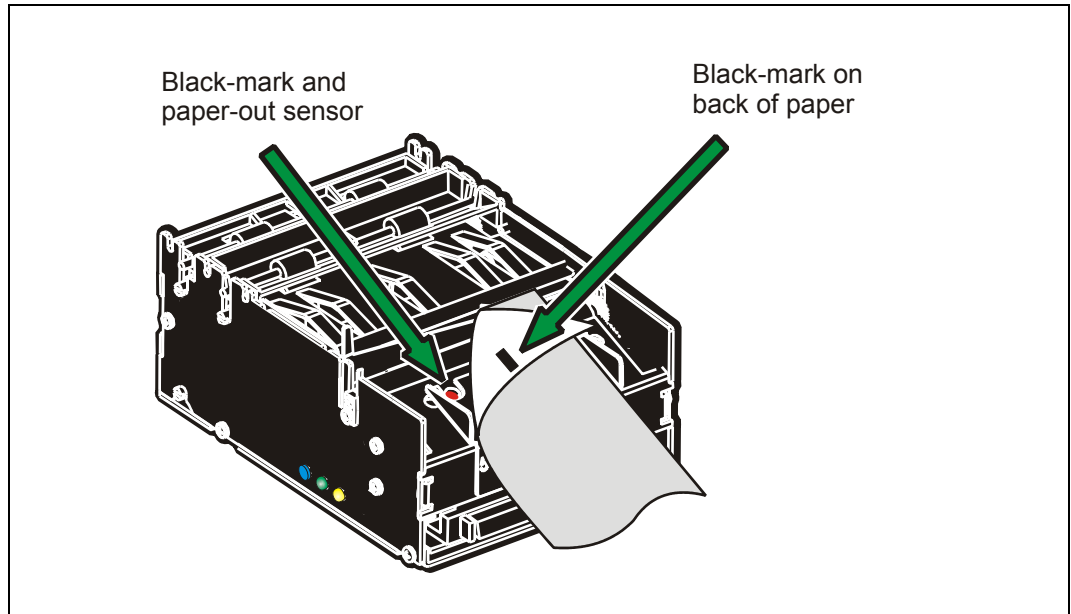

Figure 30. Black mark sensor

The sensor used to detect the black-marks is the same sensor as used for paper end detection. The sideways position depends on which paper guide is fitted. With 58 and 60 mm guides it is 22 mm to the left of the paper center, and with 80 and 82.5 mm guides, it is 30 mm to the right of the paper center. The distance from the sensor to the cutter is 25 mm. The sensor accuracy is about ± 0.5 mm so avoid designing receipts with too high demands for synchronization.

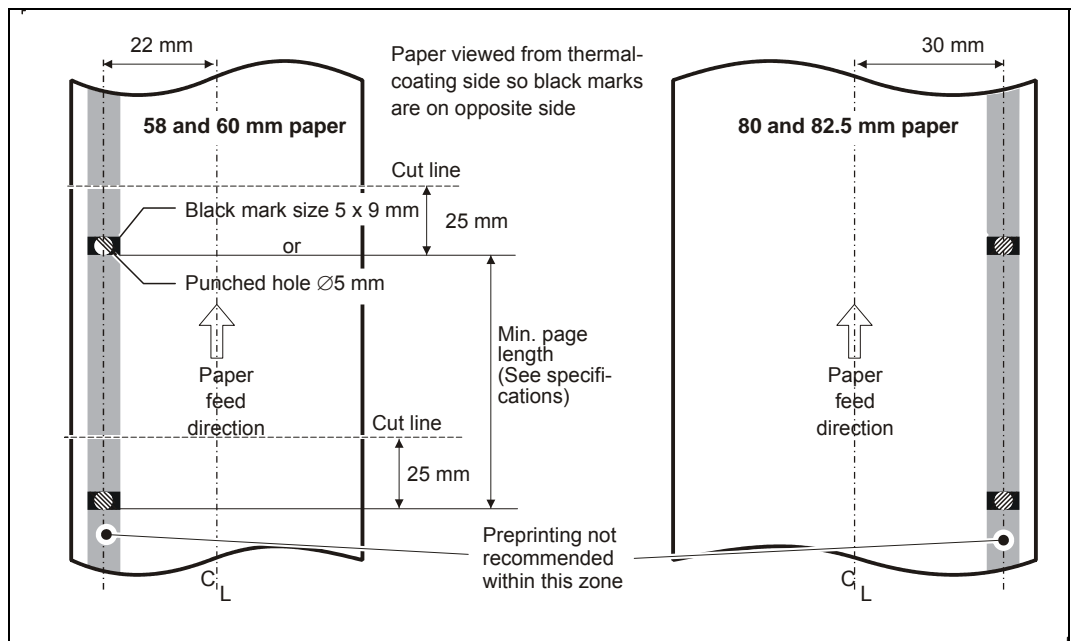

Figure 31. Recommended black mark size and position

The sensor triggers on the black-to-white transition of the black-mark, which is when the black print ends (trailing edge).

Since the same sensor is used for both paper end and black-mark detection, the printer must know the length of the black-mark to avoid signaling end-of-paper when it detects a black-mark. The default setting accepts black-marks in the range 3 –16 mm, and works perfectly with the recommended black-mark length of 5 mm. Marks shorter than 3 mm are interpreted as dirt, and marks longer than 16 mm as out-of-paper. You can change both these values by changing the printer default settings.

Black mark mode is selected by setting parameter 36 to 2, and storing the parameters.

NOTE! – *It is essential that you store the parameters in the printer for black mark synchronization even if you enable black marks in the Windows driver. This is because Windows is not used at paper loading, and feeding with the FF button on the printer.*

7.3 Parameters used

7.3.1 Parameter n36 Document mode

Set to 2 to enables black mark check.

7.3.2 Parameters n37 and n38 - Page length minimum

Measure the distance from the trailing edge of one black mark to the trailing edge of the next. The resolution is 0.125 mm so multiply the distance by 8, then calculate the value to enter as n37 and n38.

Example: If the page length is 100mm,
 $(100 \times 8) / 256 = 3.125$.
 n37 is the integer value, that is 3, while
 n38 is the fraction, $0.125 \times 256 = 32$

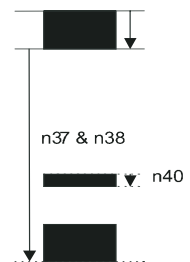

7.3.3 Parameter n39 – Max Black Mark length

Measure the height of the black mark. The resolution is 0.125 mm so multiply the black mark length (in millimeters) by 8 and enter the value as n39.

7.3.4 Parameter n40 – Min Black Mark length (Garbage Filter)

This parameter is actually a filter to filter-out garbage on the paper. If a spot is smaller than this value, it will not be regarded as a black mark. 1. About $\frac{1}{3}$ of the black mark length is usually a suitable setting.

GARBAGE, BLACK MARK AND OUT OF PAPER DETECTION

For every step the paper is feed, the black mark sensor is sampled to detect garbage, black marks or out of paper.

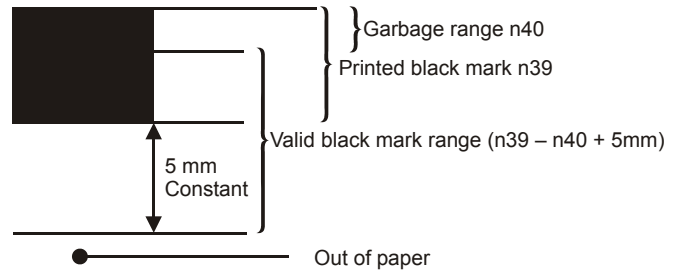

When the printer detects blackness it has to check if it is only garbage; if the paper gets white again within $n40 \times 0.125$ mm, then it is garbage and the spot is ignored. If it is still black after $n40 \times 0.125$ mm, it is probably a black mark.

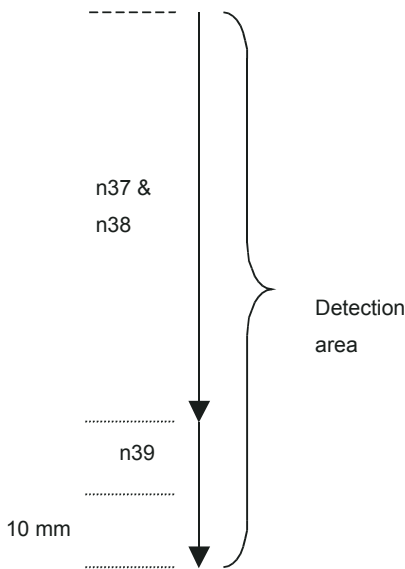

If the paper gets white within an additional $n39 - n40$ plus 5 mm then it is a Blackmark. The 5-mm is a constant added to make sure that noise on the edge not will interfere with the samples. If it at this point still is still black we have detected out of paper.

Be careful about $n40$ and $n39$. If $n39 - n40$ is to small, then the minimum detection area will be too little. This area should not be less than 2 mm.

7.3.5 Parameter n41 and n42 –Black mark cut offset

After the black mark is detected (black to white change) the printer feeds another distance to place the paper in cut position. This distance cannot be negative so placing the black mark too close to the paper edge is better than too far away.

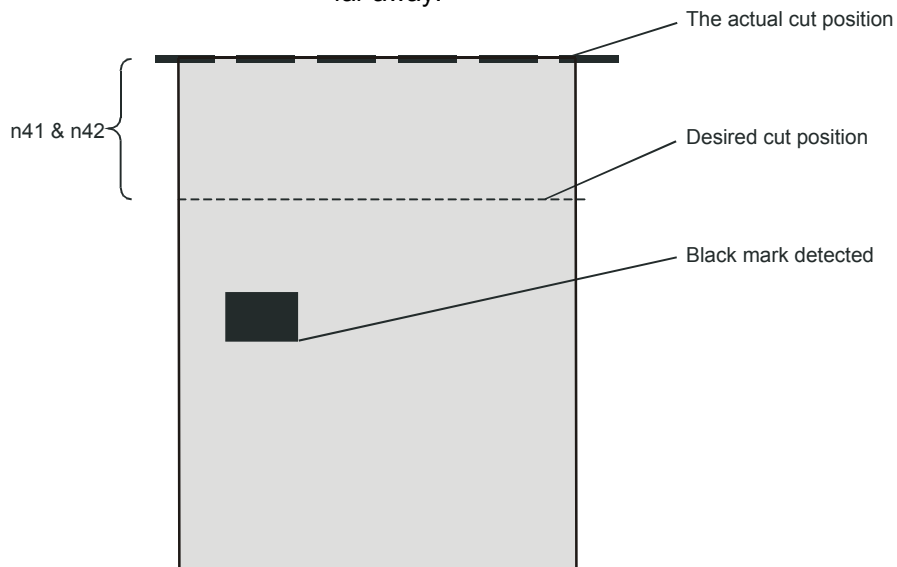

(ESC x n1 n2 is an obsolete command that sets $n41$ and $n42$. It is implemented for backward compatibility with old drivers. Set parameters $n41$ and $n42$ with the ESC & P n1 n2 command instead.)

FF (FORM FEED)

Use FF to print the buffer content, go to the next top of form (black mark), and cut the paper.

ESC Z (GO TO NEXT TOP OF FORM)

Use ESC Z to move the paper to the next top of form. This is practically a Form-Feed without printing and cut. It searches for the next black mark for maximum one page length + black mark length $(256 \times n37 + n38 + n39)/8$. An additional length of 20mm is added to be sure to pass the edge of the next black mark. If there is no black mark within the set distance plus 20 mm, an error is raised.

7.3.6 Example

The commands are used together in the following way:

The following examples are not made for a specific programming language or editor, but can be implemented with the tools of your choice. The data sent **to the printer** are marked with "Send→".

When setting up the printer:

Send→	ESC & P 35d 1d	Enables black mark sync
Send→	ESC & P 37d 4d	Sets distance between two black marks
Send→	ESC & P 38d 0d	n37=4d and n38=0d gives 128 mm
Send→	ESC & P 39d 80d	Sets max Blackmark to $80 \times 0.125 = 10\text{mm}$
Send→	ESC & P 40d 24d	Sets max Blackmark to $24 \times 0.125 = 3\text{ mm}$
Send→	ESC & P 41d 0d	
Send→	ESC & P 42d 200d	Sets Blackmark offset to $200 \times 0.125 = 25\text{mm}$
Send→	ESC & P 43d 0d	
Send→	ESC & P 44d 0d	Sets Blackmark top margin to 0mm
Send→	ESC & 4d	Stores the above parameters as default parameters.

The above set up and stores the parameters in the flash prom of the printer, so this need only be sent once to the printer when setting it up for Blackmark sync.

Document:

Send→ the text and graphics

At the end of the document:

Send→	ESC Z	Feeds the printout to the next black-mark + the additional feed specified by the ESC x command.
Send→	RS	Cuts and ejects the printout.

Simple calibration process:

1. Enable black mark mode by setting parameters n36 - n42 as described on the previous pages.

2. Load paper with black marks into the printer
3. Send the `ESC #` command and wait until the paper stops
4. If the paper has returned to its original position, the calibration is finished
5. If not, it was not possible to distinguish the black mark. Check the n37 and n38 settings and try again).
6. Save the settings with `ESC & 4`

7.4 Black-mark sensing from within "Windows"

In Windows, the printer driver controls when the paper is cut and ejected. Settings in the driver override the default parameter settings in the printer.

The settings are available in the Windows *Printing Preferences Menu*, in the Advanced Options window. The names of the options box differ between driver versions, but the same settings are available:

You set n36 to 2 by setting Page Type to Black Mark, and Black Mark Check: True.

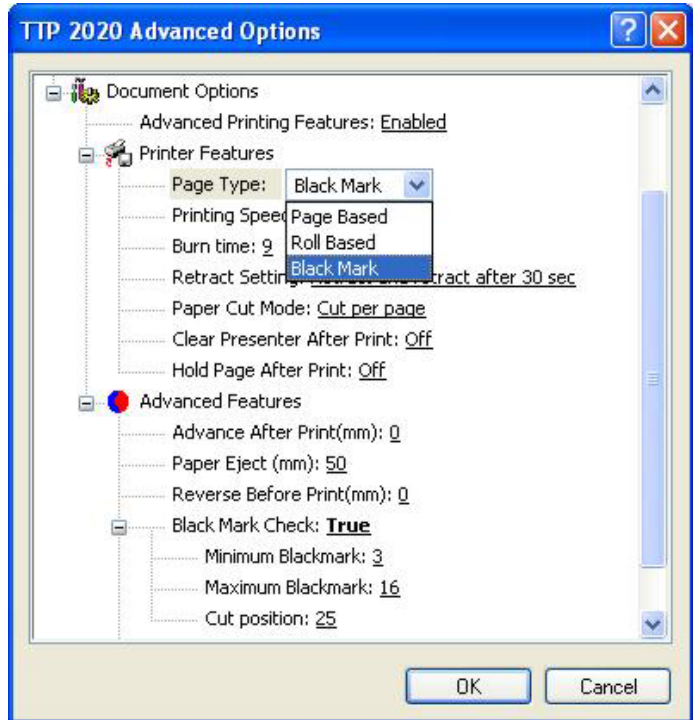

You set n37, n38 by setting Paper Size. If no standard paper size corresponds to the page length you have, create a new form with that length in the Windows "Printer Server Properties".

You set n39 by setting Maximum Black mark: to the length of the black mark on your paper

You set n40 by setting Minimum Blackmark: to the value you want for garbage filter

You set n41, n42 by setting Cut Position: to the length of transport that you want between black mark and cut.

HINT! – When everything is set up correctly and the printer prints as it should; print a page, then without switching the power off, send the store parameters command `ESC & 04h` to the printer (for example using the `PRTMON.EXE` program from www.swecoin.se). If you do this, parameters that the driver uses are stored in the printer as default parameters. This way the printer synchronizes on black mark also when you load paper, if you press the FF button, etc.

8

INTERFACE

The printer has one standard interface, and an optional serial interface. There are no selections to be made, but only one interface can be used at a time. The printer will not function properly if data is received on more than one interface at a time.

NOTE! — *If you use the printer through a Windows driver, you need not read the rest of this chapter.*

8.1 Serial, TTP 2010

The RS-232 interface of the TTP 2010 printer has a transfer speed that can be set to between 2 400 and 115200 bits/s.

Applications where text-only printouts are to be printed are suitable for serial interface because of its easy to use bi-directional capability. The relatively low transfer speed limits the printing speed when printing graphics. Full-width graphics with 115 200 bits/s result in printing speeds of about 24 mm/s for the 80-mm version of the printer.

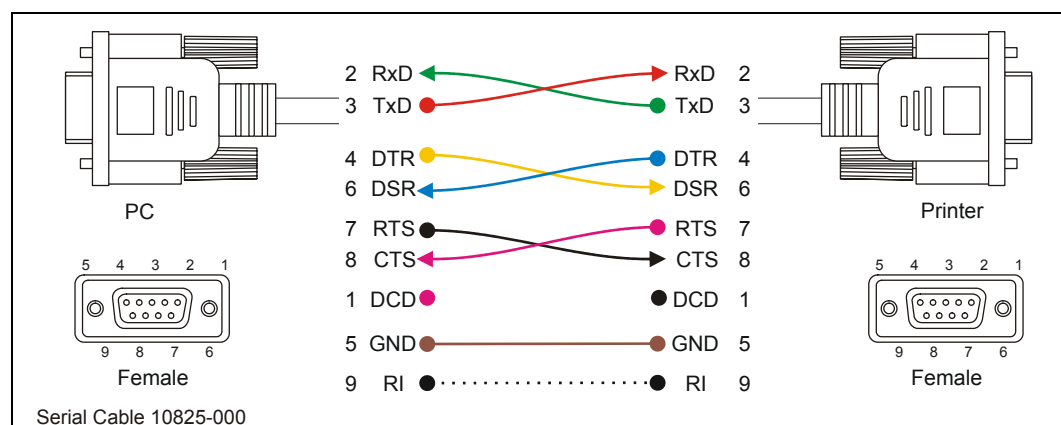

Figure 6. Serial connector pin assignment

Setup options

Baud: 2 400, 4 800, 9 600, 19 200, 38 400, 57 600, and 115 200 bits/s

Flow control: None, Xon / Xoff, or Hardware

Data bits: 7/8

Stop bits: 1 (fixed)

Parity: None, Odd, or Even

Default settings: 9600 bits/s, 8-bits, No parity, 1 stop bit, and hardware flow control.

See also: Default parameter settings on page 27

8.2 Parallel, TTP 2020

The TTP 2020 parallel port is bi-directional and support Compatibility and Reverse-Nibble modes.

NOTE! – If you intend to use any other mode than Compatibility Mode, we recommend you to get the documents for the IEEE-1284 standards, and study them thoroughly.

Pin Host IEEE1284-A (D-Sub)	Direction	Pin Printer IEEE1248-C	Compatible Signal names	Nibble and byte mode Signal names
1	⇒	15	nStrobe	HostClk
2-9	⇒	6-13	Data	Data
10	⇐	3	nAck	PtrClk
11	⇐	1	Busy	PtrBusy
12	⇐	5	PError	AckDataReq
13	⇐	2	Select	Xflag
14	⇒	17	nAutoFd	HostBusy
15	⇐	4	nFault	nDataAvail
16	⇒	14	nInit	nInit
17	⇒	16	nSelectIn	IEEE 1284 Active
18-25	GND	19-35	Ground	Ground
	+ ⇒	18	Host Logic High	
	. ⇐	36	Peripheral Logic High	

Table 7. Signal names for the parallel port.
Signal names starting with "n" are active LOW signals

8.2.1 Error signaling

All errors that are not reset when status is read will set the nFault signal, for example:

- Head lifted
- Cutter not home
- Out of paper

This error also sets the Paper Out/End (PE) together with nFault:

- Out of paper

NOTE! – The signaling of nFault and PE can be switched on/off with parameter p5.

8.3 USB, TTP 2030

The USB (Universal Serial Bus) is an interface designed to handle peripherals daisy chained to a single connector. The transfer speed is up to 12 Mbits/s, which is quite adequate for the printer. Use this interface in operating systems with USB support, for instance Windows XP. USB devices are Plug and Play compatible and hot swappable, which means that they can be connected and disconnected without turning off the power, or rebooting the computer.

	Contact Number	Signal Name	Comment
	1	VCC	Cable power
	2	- Data	
	3	+ Data	
	4	Ground	Cable ground

Table 8. USB connector (J13) pin assignment

9 MAINTENANCE

9.1 Fault finding

In connection with service of the printer it is good practice to remove paper dust and lint from the paper path, cutter and sensor areas. Paper dust, when accumulated, may interfere with printer functions such as optical sensors.

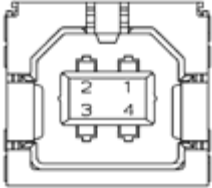
To avoid smudging the paper, do not apply oil on the cutting knife.

Symptom	Suggested actions
Nothing is printed when you press the feed button in self-test mode, but the document is transported, cut and ejected.	<ul style="list-style-type: none"> • Check that the paper roll is turned the correct way with thermal sensitive layer facing up. • Check that the paper used meets the paper • Check that the printhead cable is fully inserted into the connectors at each end.
Paper jam	<ul style="list-style-type: none"> • Check cutter-home sensor.
Printer does not work at all	<ul style="list-style-type: none"> • Check that the printhead is closed. • Check that power is supplied to the printer. • Check the function of the paper-out sensor.
Self-test prints OK, but the printer works strangely in normal operation.	<ul style="list-style-type: none"> • Check that both ends of the interface cable are properly connected. • Application program might be incorrect. Contact system manager.
No cutting	<ul style="list-style-type: none"> • Check that the connector for the cutting motor is fully seated on the control board.
Bad cutting (uneven top and bottom document edges).	<ul style="list-style-type: none"> • Switch OFF printer and remove any obstructing paper particles in cutter and presenter modules.
Inconsistent cutter operation	<ul style="list-style-type: none"> • Check/clean cutter-home sensor.
Paper is fed straight through the printer. Paper does not loop.	<ul style="list-style-type: none"> • Check/clean presenter sensor. • Check setting of parameter p9.
Missing print or irregular spots.	<ul style="list-style-type: none"> • Paper may be too humid. Let it adapt to ambient temperature and humidity for approximately 24 hours before use. • The paper used might not meet the paper specification.
White longitudinal lines in the printout.	<ul style="list-style-type: none"> • Faulty print head, replace.
Faint print.	<ul style="list-style-type: none"> • The paper used might not meet the paper specification. • Clean print head with ethyl or isopropyl alcohol. • Adjust print contrast, see page 74.
Strange characters or graphics printed, or any kind of strange printer behavior.	<ul style="list-style-type: none"> • Might be caused by erroneous data sent from the host. Check validity of transferred data.

Table 9. Faultfinding

9.2 Cleaning the print head

The print head can be cleaned without removal.

1. Open the printhead.
2. Clean the heat elements with a cotton swab immersed in ethyl or isopropyl alcohol.

9.3 Firmware

The firmware is stored in flash-PROM on the control board. A replacement control board may not contain the same firmware version that you are currently using, so if you replace control board for some reason, upgrade it to the firmware version you want to use.

9.3.1 Loading

REMEMBER! – *Always design your kiosk system so that remote upgrade of firmware is possible. If you need to upgrade firmware in the future, the kiosks can be spread over a vast area and upgrade can become very expensive.*

Fetch the firmware from the Swecoin web site <http://www.swecoin.se>. There you will also find a loader program (Windows™ software) facilitating the loading of the firmware into the printer.

The loader program contains a help file with detailed instructions on how to load the firmware into the printer.

In non-Windows environments, use the following procedure to load the firmware:

1. Send ESC NUL (1BH 00H) to the printer.
2. Wait 0.5 seconds.
3. Send the firmware file to the printer.
4. Wait until the printer buzzes to confirm that the loading is complete (the presenter motor runs for a second).

CAUTION! *The loading and burning can take up to one minute. Do not abort before one minute by turning OFF the power to the printer. Doing so may leave the printer in a state where new firmware cannot be loaded.*

9.3.2 Firmware history

Functions and features are being added from time to time affecting the firmware in the printer. The following table lists the changes of general interest.

Notice that the list may not contain the latest firmware versions. Please visit our web site <http://www.swecoin.se> for current information.

The firmware number is divided into two section, the header and the version, separated by a dash.

Firmware header 1814-xxx is for TTP 2020 and TTP 2030

Firmware header 1818-xxx is for TTP 2010

Other headers are for customized versions of the printer and only available for the customer for whom this version was developed.

A printer can only be updated with firmware that has the same header as the original number.

The -xxx indicates the firmware version and for example 310 means firmware version 3.10.

FW version	Change
1814-310	<i>First released firmware version</i>
1818-310	<p><i>Changes from last beta-release:</i></p> <ol style="list-style-type: none"> 1. <i>Accept larger firmware.</i> 2. <i>Hex mode detects how many bytes can be printed on each line.</i> 3. <i>Power-on reset code, and reset code after firmware-, font-, logo- and parameter changes cleared up.</i> 4. <i>Communication no longer locks up after loading an oversized font.</i> 5. <i>USB improvements in register and fifo handling</i> 6. <i>Parameter selected font will now check if font is available, use font 0 if not.</i> 7. <i>Quicker deletion of print nodes, when entered error state. Gives quicker response of ACK-marker in queue.</i> 8. <i>New fault code (08h) for retract-jam added to Status enquiry (ESC ENQ 01h), Extended status (ESC 'E'), and Status LED-indication</i>
1814-320	<p><i>Improvements</i></p> <ol style="list-style-type: none"> 1. <i>Added Vertical mode (parameter n57)</i> 2. <i>Added Partial cut (US command).</i> 3. <i>New command (ESC END 05h) has been added to be able the read all print sensors.</i> 4. <i>Supports new Parallel interface chip on TTP 2020(CPLD), in addition to the discontinued Intel chip.</i> 5. <i>Improved the automatic speed reduction at low temperatures</i> <p><i>Bug fixes</i></p> <ol style="list-style-type: none"> 6. <i>Changed SoftReset to fix problems with request sent to printer during font/logotype/parameter burn.</i> 7. <i>SELECT in the parallel interface will now go low during firmware burning.</i> 8. <i>PCA revision will be detected correctly</i> 9. <i>Fixed a bug that disabled the loop in black mark mode.</i> 10. <i>Fixed burn-time bug</i> 11. <i>Fixed bug that made Autoload delay disappear after 22 minutes.</i>
1818-320	







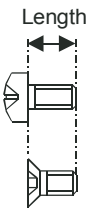

Replacement parts

Items coded **SP** are standard replacement parts.

1. Screws, washers, nuts etc. are available in a common hardware store, and are thus not supplied as replacement parts.
2. Parts that are considered as not being worn by normal printer use are not replacement parts, for example the printer chassis.

Should you require any of these "non-replacement parts", contact Swecoin for advice. Other price and delivery conditions may apply for non-coded items.

Standard hardware

Designation example	How to interpret the designation	Illustration	How to measure
Screw MRX-H M3x5	Panhead screw. Thread: M3. Length: 5 mm		
Screw MFX-H M3x6	Countersunk screw. Thread: M3. Length: 6 mm		
Screw M6S M6x16	Hex head screw. Thread: M6. Length: 16 mm		
Screw MC6S M6x12	Allen-head screw. Thread: M6. Length: 12 mm		
Screw FXS-H ST 2.9x6.5	Countersunk. Self-threading. Ø2.9 mm. Length: 6.5 mm		
Screw, RXK-H ST 2.9x8	Panhead screw, Self-threading. Ø2.9mm. Length: 8 mm		
Screw RTK ST 2.9x6.5	Torx panhead. Self-threading. Ø2.9mm. Length: 6.5 mm		
Nut M6M M2	Hex nut, M2 thread		

DO NOT OVER-TIGHTEN THE SCREWS!

The max torque for the different screw sizes are as follows:



M2 = 0,13 Nm

M2.5 = 0,26 Nm

M3 = 0,46 Nm

M4 = 1.1 Nm

TOOLS, THREAD LOCKING AND LUBRICATION

Tools	Swecoin Part No.
Screwdriver Phillips No. 1	02542-001
Screwdriver Torx T9	02449-009
 Thread lock for screws that hold plastic parts	103650
 Vaseline spray to lubricate moving parts	104237

Item.	SP	Part No.	Designation	Qty.
1	X	00375-000	Cog Wheel	2 Pcs.
2		01268-000	Tie wrap 71 x 1.8 mm	1 Pcs.
3		02096-001	Label TTP 2000 Button L	1 Pcs.
5	X	02382-000	Label, "Swecoin"	1 Pcs.
4		02096-002	Label TTP 2000 Button R	1 Pcs.
6	X	09022-309	Nut M6M M2.5	6 Pcs.
7		09045-105	Circlip RS 1.9	2 Pcs.
8	X	09045-107	Circlip RS 3.2	4 Pcs.
9	X	09100-121	Screw MRX-H M2x6	6 Pcs.
10	X	09100-197	Screw MRX-H M2.5x12	1 Pcs.
11		09100-218	Screw MFX-H M3x4	1 Pcs.
12		09101-220	Screw MFX-H M3x6	1 Pcs.
13		09200-188	Screw (TX) MRT M2.5x3	2 Pcs.
14		09200-189	Screw (TX) MRT M2.5x4	2 Pcs.
15		09200-191	Screw (TX) MRT M2.5x6	28 Pcs.
16		100060	Screw MFX-H M2x6	2 Pcs.
17		100479	Screw MFX-H M2.5x12	1 Pcs.
18	X	100481	Spacer DRM 2550x4	4 Pcs.
19		101771	Hub	1 Pcs.
20		102938	Bottom Protection	1 Pcs.
21		102947	Rear Plate	1 Pcs.
22		102949	Pressure Plate	1 Pcs.
23		102950	Front Plate	1 Pcs.
24		102951	Motor Bracket	1 Pcs.
25		102952	Stripper	1 Pcs.
26		102956	Hub	5 Pcs.
27	X	102958	Cutter Blade, Moving	1 Pcs.
28		102959	Side Plate	1 Pcs.
29	X	102963	Cog Wheel 0.5x40	3 Pcs.
30	X	102966	Pressure Roll	4 Pcs.
31	X	102967	Pressure Roll Shaft	2 Pcs.
32		102970	Cutter Drive Plate	1 Pcs.
33		102971	Drive pin	1 Pcs.
34		102974	Leaf Spring	1 Pcs.
35		103082	Cog Wheel 0.5x48	1 Pcs.
36		103083	Shaft Cutter	1 Pcs.
37		103084	Cutter Link	1 Pcs.
38		103090	Cog Wheel 0.5x54	1 Pcs.
39		103136	Hub Nut M2.5x4.0x1.6	3 Pcs.
40		103140	Cover Plate Assy	1 Pcs.
41		103142	Guide	1 Pcs.
42		103144	Spacer M2x35.0	2 Pcs.
43		103145	Spacer M2x40.0	2 Pcs.
44		103146	Side Plate	1 Pcs.
45	X	104399	Thermal Printhead with connector	1 Pcs.
46	X	103273	Sensor board Assy TTP 2000-80, PCA	1 Pcs.



= Apply on thread:
Loctite 243
Threadlocker,
medium strength,
removable, and
oil tolerant
103650



= Vaseline spray
104237



= Oil

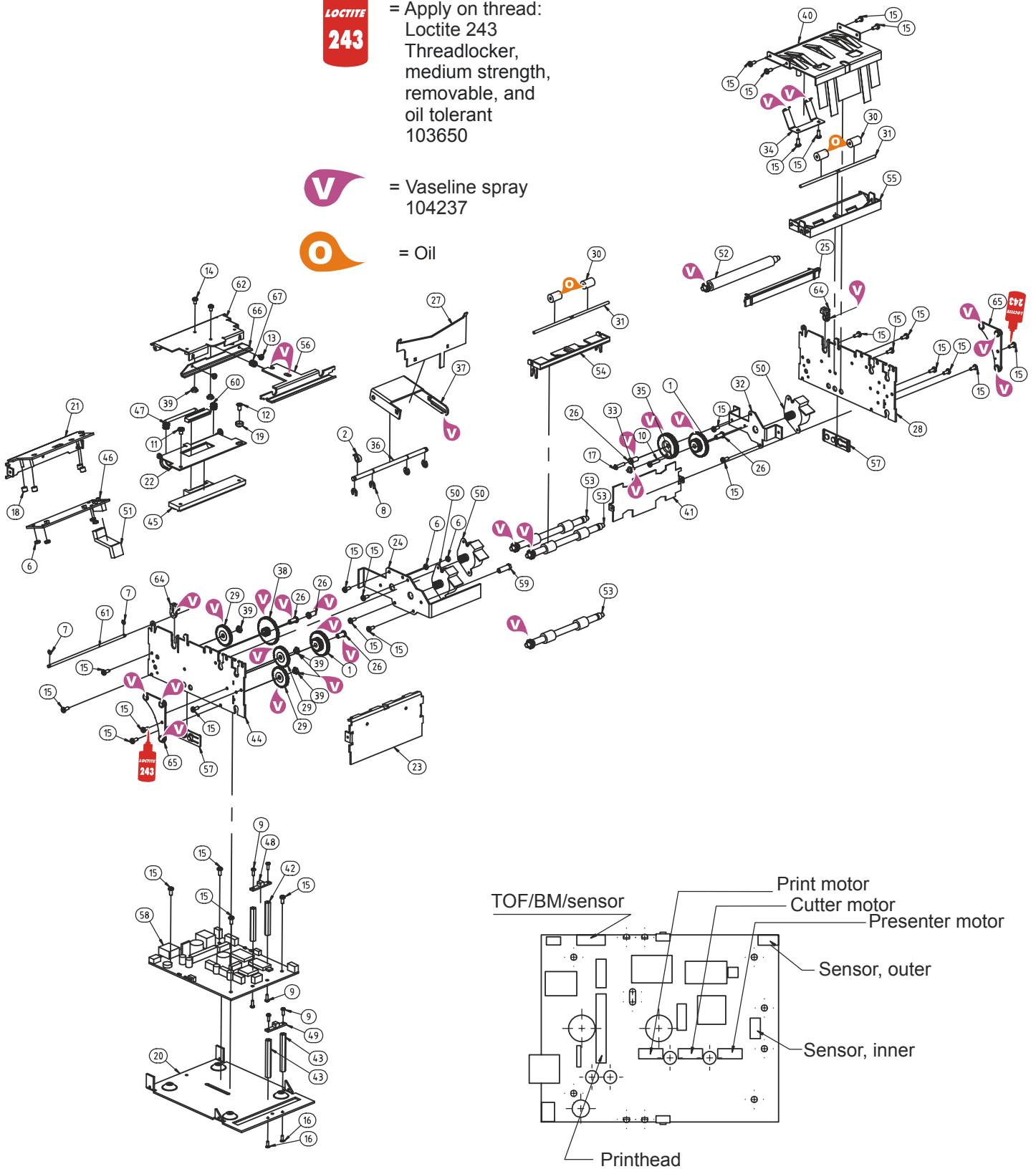

Item.	SP	Part No.	Designation	Qty.
47	X	103274	Printhead Cable assy	1 Pcs.
48	X	103275	Opto Sensor Assy, inner	1 Pcs.
49	X	103276	Opto Sensor Assy, outer	1 Pcs.
50	X	103289	Stepper Motor Assy	3 Pcs.
51	X	103306	Cable, Sensor Board	1 Pcs.
52	X	103350	Platen Assy	1 Pcs.
53	X	103351	Feed Roller Assy	3 Pcs.
54		103361	Exit Guide	1 Pcs.
55		103362	Guide front	1 Pcs.
56		103688	Guide	1 Pcs.
57	X	103690	Light Transmitter	2 Pcs.
58	X	102677	Controller Board TTP 2010 PCA	1 Pcs.
58	X	103015	Controller Board TTP 2020, PCA	1 Pcs.
58	X	103716	Controller Board TTP 2030 MKI, PCA	1 Pcs.
59		103725	Hub Nut M2.5x12.5	1 Pcs.
60		103726	Compression Spring SF-TF 0.5x5x9.4	2 Pcs.
61		103747	Shaft	1 Pcs.
62		103748	Cover, Printhead Module	1 Pcs.
63		103845	Label TTP 2030	1 Pcs.
64	X	104029	Bearing, Platen	2 Pcs.
65	X	104030	Bearing, Feed Roller	2 Pcs.
66	X	104032	Cutter blade, fixed	1 Pcs.
67		104097	Compression Spring 0.5x5x9.98	1 Pcs.
Not shown		103848	Complete packaging for TTP 20x0	1 Pcs.



= Apply on thread:
Loctite 243
Threadlocker,
medium strength,
removable, and
oil tolerant
103650



= Vaseline spray
104237



= Oil

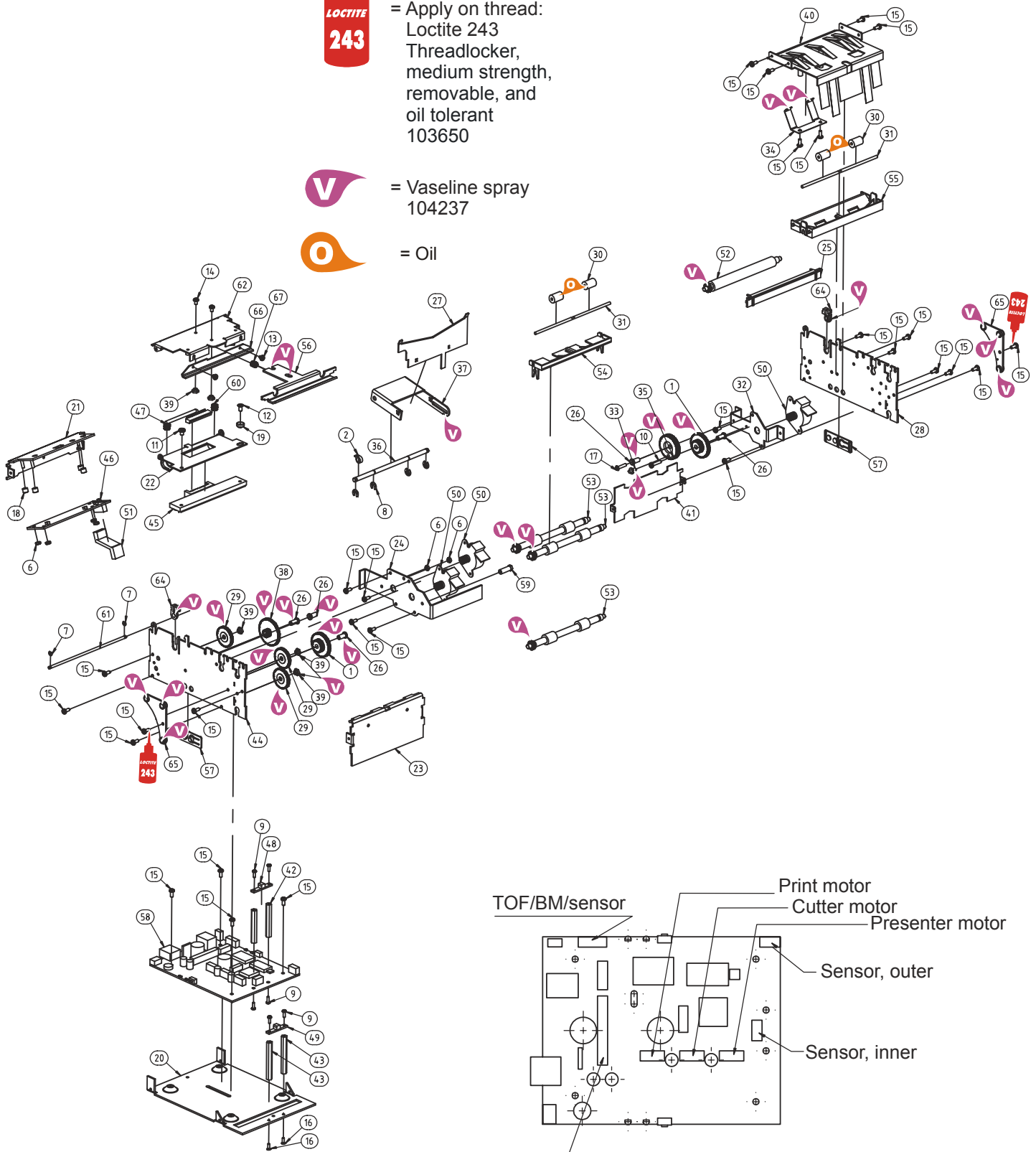

10**SPECIFICATIONS**

Specification subject to changes without notice.

10.1 General

Printer control	Windows and Linux drivers. Text print with ESC commands for formatting.
Print method	Direct thermal line printing (no ink, no toner, no ribbons, just the paper)
Resolution	8 dots/mm (203 dpi)
Print speed	Up to 150 mm/s
Max print width	
- 58 mm and 60 mm paper	54 mm = 432 pixels
- 80 mm and 82.5 mm paper	72 mm = 576 pixels
Interfaces	
- TTP 2010	Serial RS 232
- TTP 2020	Parallel IEEE 1284
- TTP 2030	USB
Presenter	Looping presenter with pull detector, and retract & retain function. Stepper motor control for exact positioning
Loop storage length	70 to 600 mm (max length may be limited by space in kiosk)
Cutter	Guillotine cutter. Stepper motor driven.

10.2 Paper

Paper supply	Roll paper
Image life	More than 25 years with appropriate paper quality.
Roll diameter	250 mm max (can be less depending on roll holder design)
Spindle diameter	40 mm (25 mm minimum)
Paper width	58, 60, 80, and 82.5 mm
Paper weight	55 –110 g/m ² (0.054 – 0.11 mm)
Paper sensors	Out of paper, paper in presenter, paper in retract path, black mark, and input for external paper-low sensor.

10.3 Text Mode

Orientation	Horizontal (portrait mode) and Vertical (Landscape mode)
Standard fonts	ATM9, 14 pixels/character fixed spacing font
Characters/line	30 characters on 58 mm and 60 mm paper using ATM9 font (max 61 characters using 29 cpi font) 41 characters on 80 mm and 82.5 mm paper using ATM9 font (Max 82 characters using 29 cpi font)
Text attributes	Underline, Bold, Italics, reverse print, multiple width and height
Bar codes	EAN, UPC, Interleaved 2-of-5, ISBN, Code 39, EAN128 and Code128
Graphics	Logotypes and b&w BMP-files

10.3.1 Basic character set

Dec Hex Key	32 20	33 21	34 22	35 23	36 24	37 25	38 26	39 27	40 28	41 29	42 2a	43 2b	44 2c	45 2d	46 2e	47 2f
		!	"	#	\$	%	&	'	()	*	+	,	-	.	/
Dec Hex Key	48 30	49 31	50 32	51 33	52 34	53 35	54 36	55 37	56 38	57 39	58 3a	59 3b	60 3c	61 3d	62 3e	63 3f
	0	1	2	3	4	5	6	7	8	9	:	;	<	=	>	?
Dec Hex Key	64 40	65 41	66 42	67 43	68 44	69 45	70 46	71 47	72 48	73 49	74 4a	75 4b	76 4c	77 4d	78 4e	79 4f
	@	A	B	C	D	E	F	G	H	I	J	K	L	M	N	O
Dec Hex Key	80 50	81 51	82 52	83 53	84 54	85 55	86 56	87 57	88 58	89 59	90 5a	91 5b	92 5c	93 5d	94 5e	95 5f
	P	Q	R	S	T	U	V	W	X	Y	Z	[\]	^	_
Dec Hex Key	96 60	97 61	98 62	99 63	100 64	101 65	102 66	103 67	104 68	105 69	106 6a	107 6b	108 6c	109 6d	110 6e	111 6f
	.	a	b	c	d	e	f	g	h	i	j	k	l	m	n	o
Dec Hex Key	112 70	113 71	114 72	115 73	116 74	117 75	118 76	119 77	120 78	121 79	122 7a	123 7b	124 7c	125 7d	126 7e	127 7f
	p	q	r	s	t	u	v	w	x	y	z	{		}	~	□
Dec Hex Key	128 80	129 81	130 82	131 83	132 84	133 85	134 86	135 87	136 88	137 89	138 8a	139 8b	140 8c	141 8d	142 8e	143 8f
	€		,	f	„	...	†	‡	^	%o	Š	<	œ			
Dec Hex Key	144 90	145 91	146 92	147 93	148 94	149 95	150 96	151 97	152 98	153 99	154 9a	155 9b	156 9c	157 9d	158 9e	159 9f
	□	ˆ	ˆ	“	”	•	—	—	~	™	š	>	œ	□	□	ÿ
Dec Hex Key	160 a0	161 a1	162 a2	163 a3	164 a4	165 a5	166 a6	167 a7	168 a8	169 a9	170 aa	171 ab	172 ac	173 ad	174 ae	175 af
	ı	ç	£	¤	¥	ı	ı	ı	ı	©	ª	«	¬	-	®	—
Dec Hex Key	176 b0	177 b1	178 b2	179 b3	180 b4	181 b5	182 b6	183 b7	184 b8	185 b9	186 ba	187 bb	188 bc	189 bd	190 be	191 bf
	o	±	2	3	µ	¶	¶	¶	¶	1	o	»	¼	½	¾	¿
Dec Hex Key	192 c0	193 c1	194 c2	195 c3	196 c4	197 c5	198 c6	199 c7	200 c8	201 c9	202 ca	203 cb	204 cc	205 cd	206 ce	207 cf
	À	Á	Â	Ã	Ä	Å	Æ	Ç	È	É	Ê	Ë	Ì	Í	Î	Ï
Dec Hex Key	208 d0	209 d1	210 d2	211 d3	212 d4	213 d5	214 d6	215 d7	216 d8	217 d9	218 da	219 db	220 dc	221 dd	222 de	223 df
	Ð	Ñ	Ò	Ó	Ô	Õ	Ö	×	Ø	Ù	Ú	Û	Ü	Ý	Þ	ß
Dec Hex Key	224 e0	225 e1	226 e2	227 e3	228 e4	229 e5	230 e6	231 e7	232 e8	233 e9	234 ea	235 eb	236 ec	237 ed	238 ee	239 ef
	à	á	â	ã	ä	å	æ	ç	è	é	ê	ë	ì	í	î	ï
Dec Hex Key	240 f0	241 f1	242 f2	243 f3	244 f4	245 f5	246 f6	247 f7	248 f8	249 f9	250 fa	251 fb	252 fc	253 fd	254 fe	255 ff
	ñ	ò	ó	ô	õ	ö	÷	ø	ù	ú	û	ü	ý	þ	ÿ	

The default fonts use Windows code page 1252 Western which contains ISO 8859-1 (ANSI) characters. You can use other character sets by creating and loading appropriate font files.

Characters 0 to 31 are control codes that cannot be changed, but 32 to 255 can be custom designed.

The table below shows the characters stored in flash PROM on the printer control board.

Table 10. Code page 1252 character table

10.4 Miscellaneous

Environment	0°C to +50°C, 35% to 75% RH, non-condensing
Size	107 x 68 x 144 mm (w x h x d)
Weight	1.1 kg
Power requirements	24 Vdc \pm 5% average 2 A when printing, 85 mA idle.

10.5 Life Expectancy

Printhead	More than 100 km paper More than 1×10^8 pulse lines (typically)
Control board	90 000 hours (typically)
Cutter	1 000 000 cuts (typically)

10.6 Ordering number list

10.6.1 Printer assembly

	Printer ¹	Evaluation kit ²
TTP 2010 (Serial)	01971-000	01971-800
TTP 2020 (Parallel)	01972-000	01972-800
TTP 2030 (USB)	01973-000	01973-800

10.6.2 Accessories

Shown on page:

Paper Guide Kit 58 mm	01970-058	10
Paper Guide Kit 60 mm	01970-060	—
Paper Guide Kit 80 mm	01970-080	—
Paper Guide Kit 82.5 mm	01970-082	—
Paper-low sensor w. 300 mm cable (5-15 mm focal dist)	01890-300	
Serial cable RS232, 9-pin, 1.5m	10825-000	16
Boot Cable, 9-Pin, 1.5m	01902-000	
Parallel Cable A-C IEEE-1284 1.8m	01366-000	17
Parallel Cable 90°A-C IEEE-1284 1.8m	01366-090	17
USB cable 1.8 m	01542-000	17
Roll holder for Ø 200 mm, adjustable position. 58-82.5 mm	103938	92
Mounting plate for the above roll holder	104208	92
Wall mount roll holder for Ø 150 mm roll below. 58-82.5 mm	104123	94
Shelf mount roll holder for Ø 150 mm roll below. 58-82.5 mm	104126	93
Paper roll 58 mm Ø ≈ 150 mm, 60g/m ² , length 300 m	01942-058	
Paper roll 60 mm Ø ≈ 150 mm, 60g/m ² , length 300 m	01942-060	
Paper roll 80 mm Ø ≈ 150 mm, 60g/m ² , length 300 m	01942-080	
Paper roll 82.5 mm Ø ≈ 150 mm, 60g/m ² , length 300 m	01942-082	
Technical manual	103471	
Printer driver CD, Windows and Linux	101368	
Quick-fit hub kit (2 pcs w. screws), see Figure 6	103939	12
Leaf-spring retainer for quick-fit hubs	01473-000	14
75W Power supply unit with 1.8m secondary cable ³	01776-000	95
150W Power supply unit with on/off switch, and 500 mm secondary cable ⁴	01035-014	95

NOTE! – Mains cord is not included in the PSU's.

¹ One paper guide is included with each printer. Please indicate what width you want on your orders.

² Evaluation kits contain printer, all paper guides, roll holder with 58 and 80mm paper rolls and sensor, interface cable, power supply, documentation and drivers.

³ Mains cord is not included in the PSU's.

10.7 Dimensions

10.7.1 Printer

NOTE! – Additional space is required for paper roll and handling

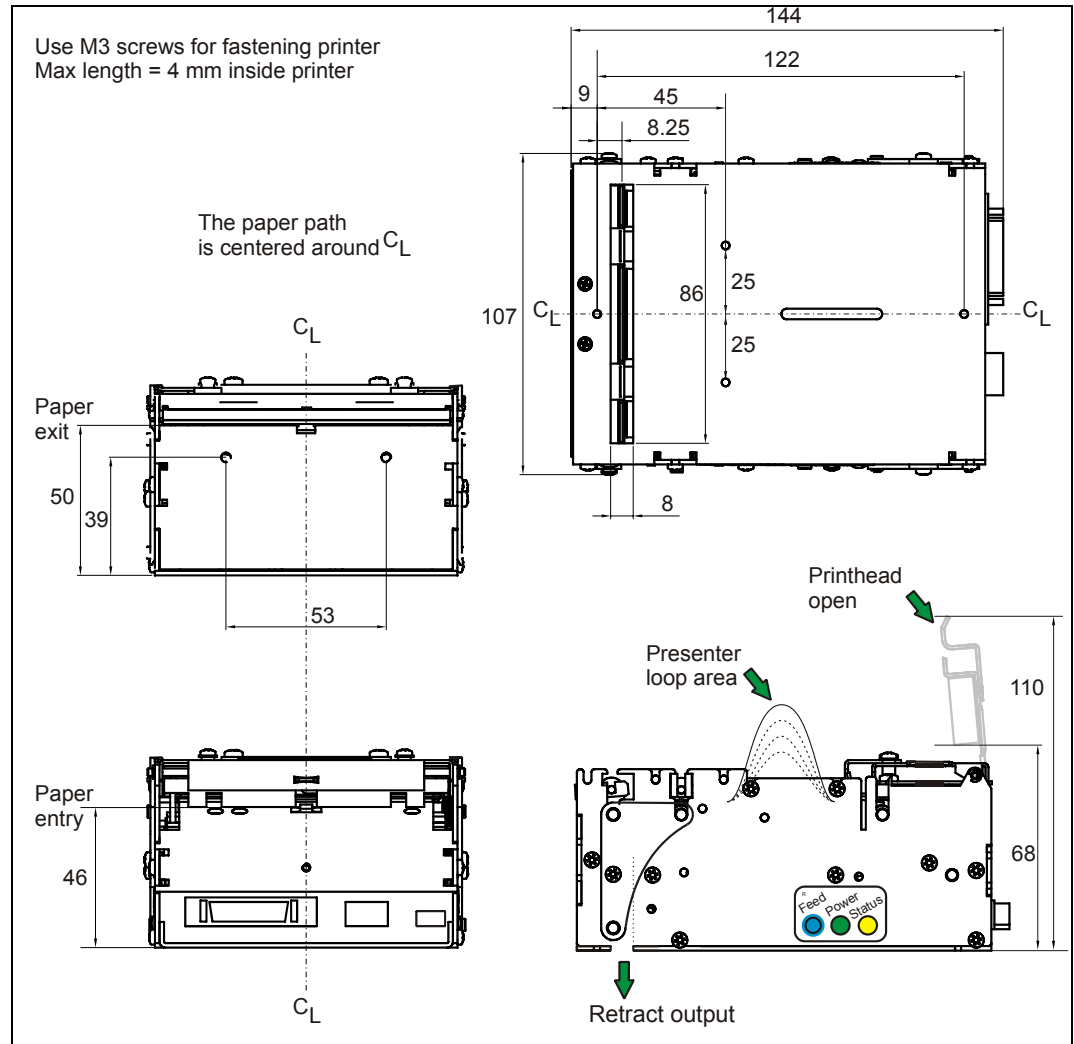

Figure 32. Measurements drawing

10.7.2 Universal roll holder

This roll holder can be fitted on the right or left side of the printer. The arm can be set in three different angles. This makes integration in the kiosk easy.

58 mm, 60 mm, 80 mm, and 82.5 mm paper widths can be used without adjustments.

The universal roll holder takes Ø200 mm rolls in the two high and low positions of the arm, and 250 mm rolls in the “under” position.

The arm only is required in the high position, while the guide plate with integrated strain-relief is required in the two other positions.

The optional paper low sensor can be fitted.

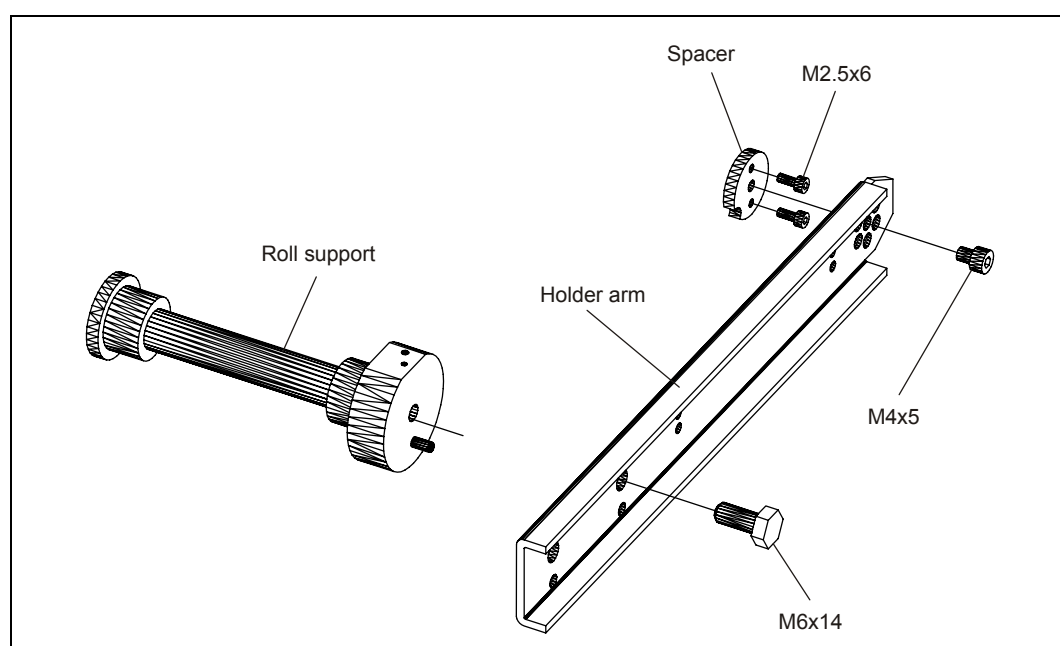

Figure 33. Universal roll holder

- 1) Fit the spacer on the side of the printer where you want the arm using the two M2.5x6 screws.
- 2) Push the arm onto the spacer screw heads in one of the three usable angles (Note that if you use the arm without the guide plate, only the high position is possible to use.)
- 3) Fasten the arm with the M4x5 screw
- 4) Move the roll support to the outermost position if you want to use bigger rolls.
- 5) Fit the optional paper low sensor onto the roll support, fasten the cable with tie wraps, and connect it to the connector on the back of the printer.

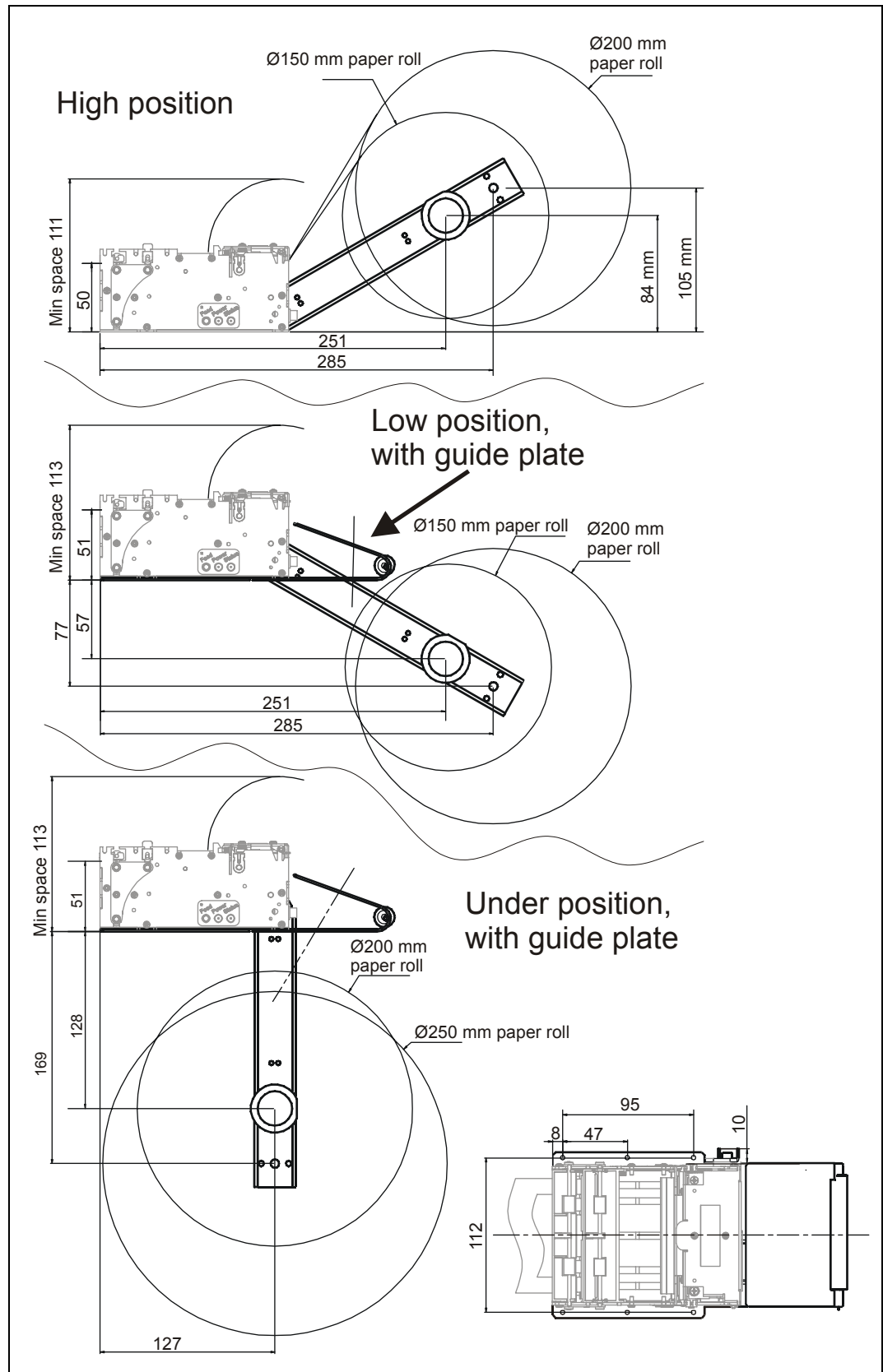

Figure 34. Universal roll holder, measurements drawing

10.7.3 Shelf type roll holder below, Ø150 mm rolls

This roll holder fits all paper widths, 58 mm, 60 mm, 80 mm, and 82.5 mm without adjustments, and it takes Ø150 mm rolls.

It has the quick fit fastening so you just connect the cables to the printer then slide it onto the roll holder. It also has additional holes so that you can attach the 75W PSU with straps, and fit an optional paper low sensor.

This makes it an ideal evaluation roll holder, which stands stable on your desktop, but also can be fastened into your kiosk and used in normal installations.

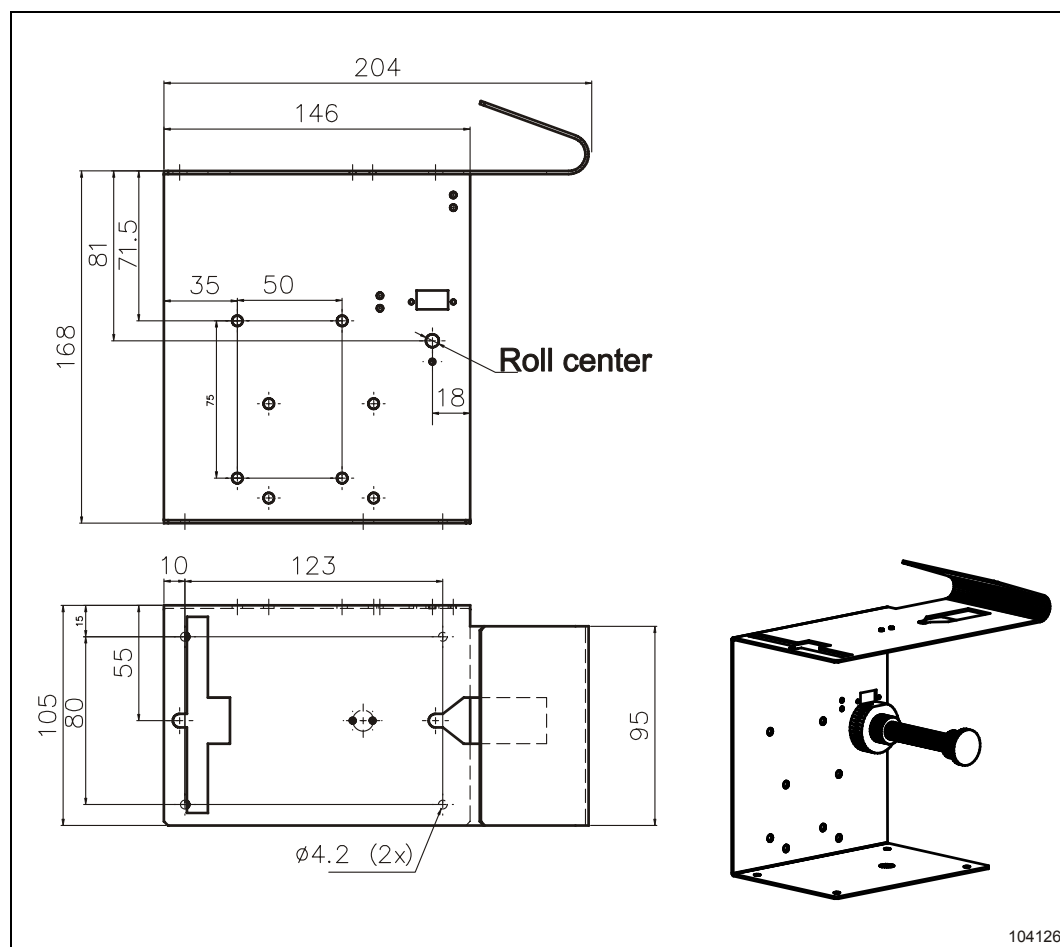
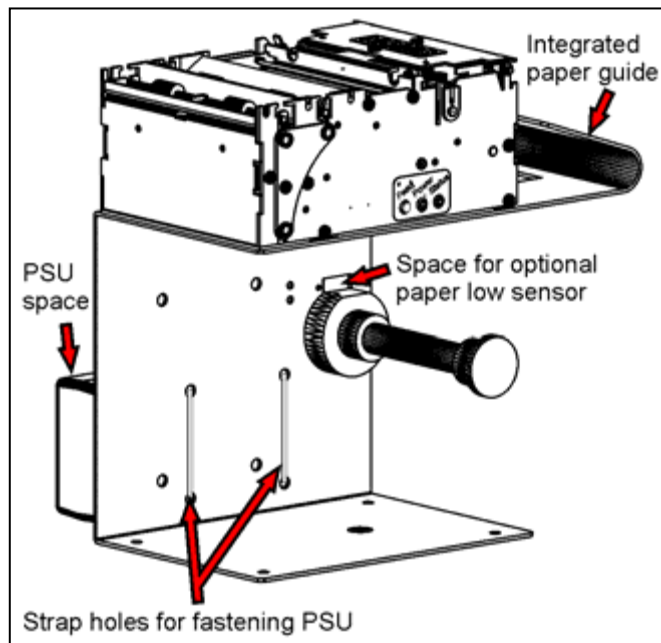

Figure 35. Roll holder 104126 measurements drawing

10.7.4 Kiosk wall type roll holder below, Ø150 mm rolls

This roll holder fits the same holls as the above but attaches to the front kiosk wall instead of a shelf.

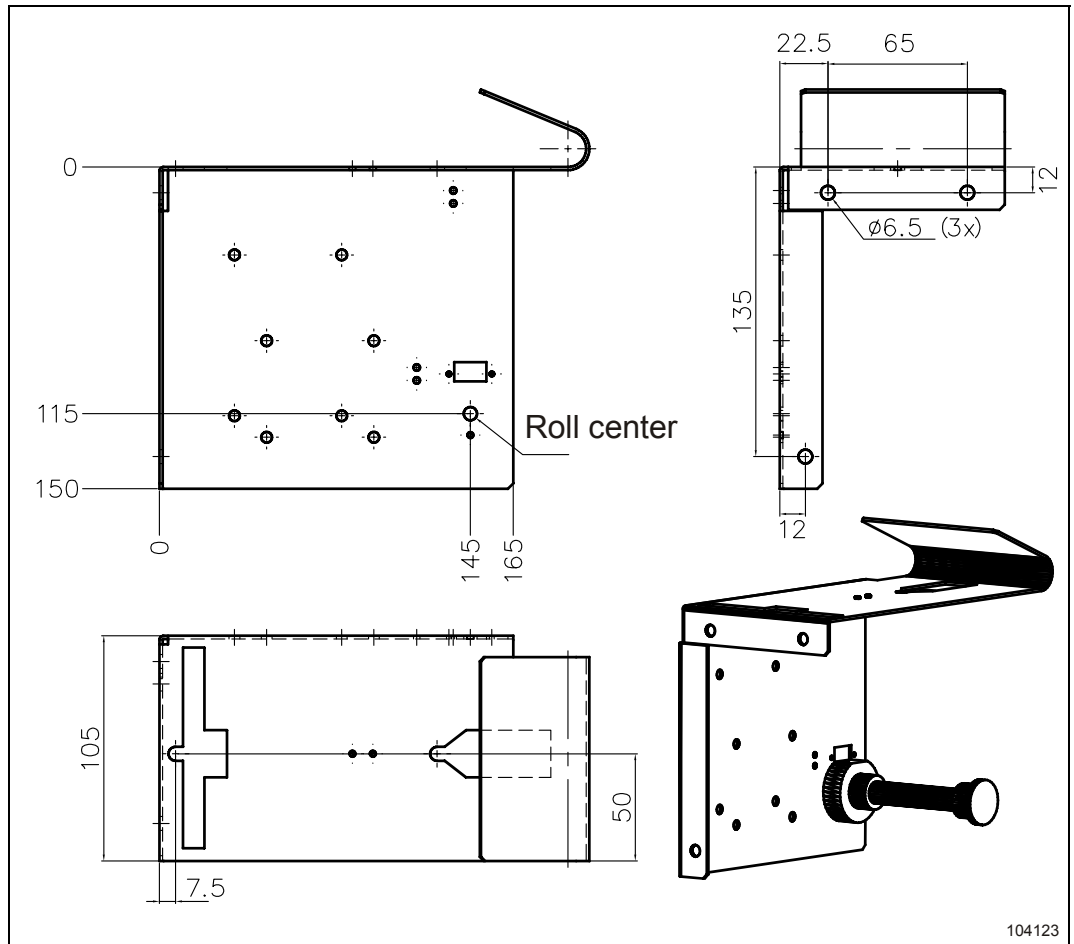

Figure 36. Roll holder 104123 measurements drawing

10.7.5 75W Power Supply

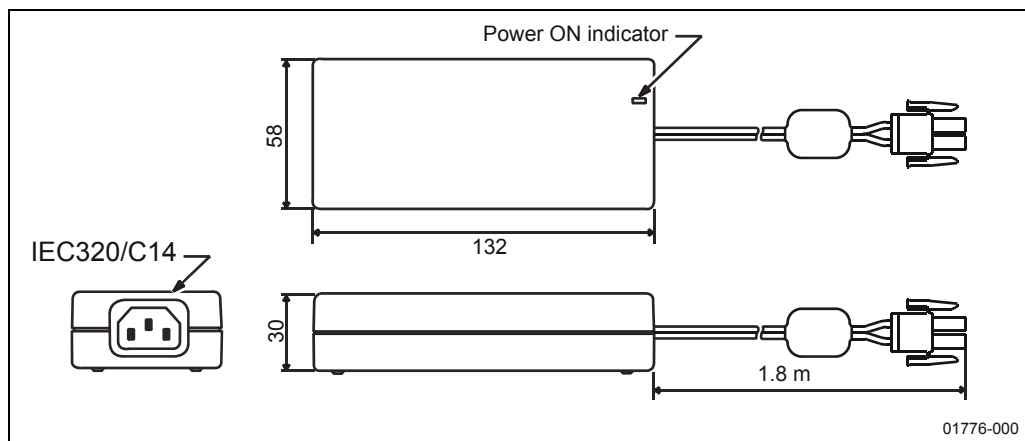

Figure 37. Measurements of 75W PSU

10.7.6 150W Power Supply

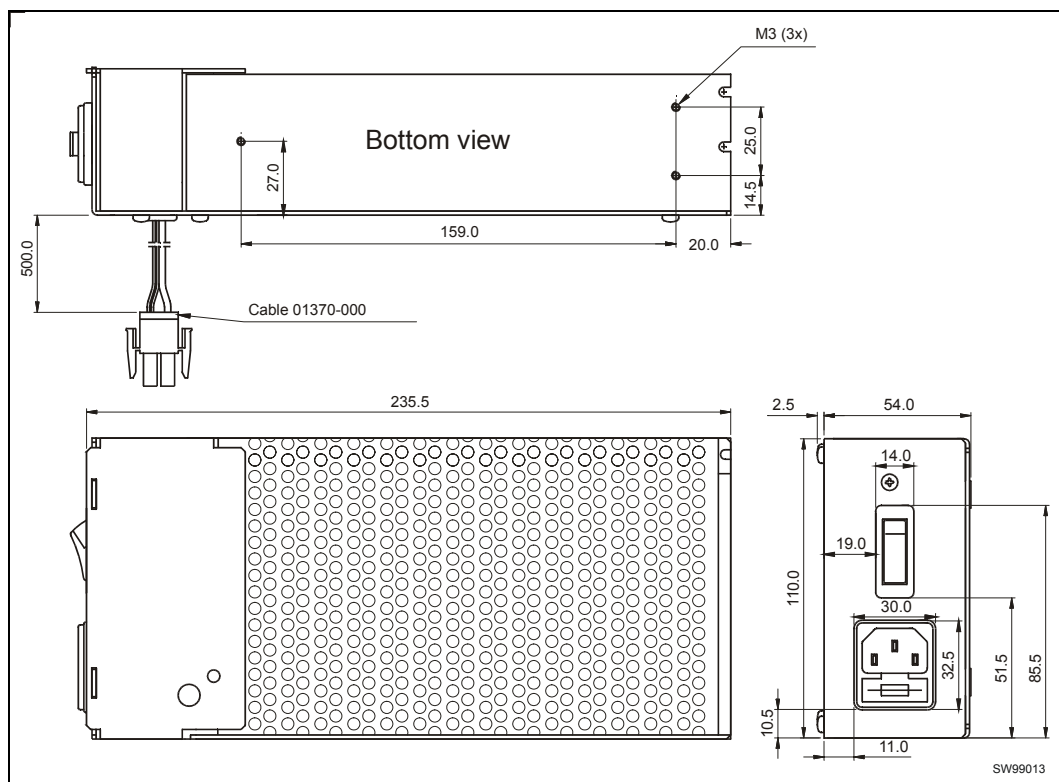

Figure 38. Measurements of 150W PSU

Index

<hr/>		
2		
2-of-5 Interleaved	34	
<hr/>		
A		
Accessories	89	
ACK	46	
Acknowledge marker	53	
Add-on, bar code	35	
Aligning preprint and thermal print	70	
Alignment	30	
Ambient light	15	
ANSI	87	
Auto cut after FF	64	
<hr/>		
B		
Backspace	32	
Barcodes	34	
Baud rate	61	
Black-mark	29, 70	
Check	21	
Length	66	
Sensitivity	67, 74	
BMP-file	36	
Bold	31	
Bootware	51	
Bottom margin	67	
Brightness	21	
Burn time	62	
Buttons	8	
<hr/>		
C		
Calibration	29, 67	
Cancel	32	
Carriage return	32, 64	
Center align	30	
Character set	87	
Cleaning the printhead	79	
Clear presenter	21, 41, 68	
Code page	87	
Code128	34	
Code39	34	
Commands summary	27	
Connecting to the computer	16, 17	
Connector		
Interface	16	
Paper Low	15	
Power	18	
Contrast	21	
Control board revision	50	
CR/LF behavior	64	
Current consumption	18, 62	
Cut	40	
Cut and eject	40	
Cut offset	66	
Cutter not in home position	46	
<hr/>		
D		
Data bits	61	
Decimal	26	
<hr/>		
Decimal codes	27, 60	
Default settings	59	
Serial interface	75	
Store	43	
Dimensions	90	
Document Mode		
BM	64	
Fixed	64	
Variable	64	
Dot-line	36	
Drawing		
shelf	14	
Driver		
Installation	20	
Mode	25	
Settings	20	
Status Monitoring	20	
<hr/>		
E		
EAN128	34	
EAN13	34	
EAN8	34	
Earth currents	15	
Eject	41	
Eject length	67	
Enclosure	11	
Enforced clear presenter	41	
Error codes	9, 46, 58	
ESD	15	
<hr/>		
F		
Fault finding	78	
Feed button	8, 19	
File format		
Font	54	
Logotypes	56	
Firmware	50	
history	80	
loading	79	
Fixed Document Mode	64	
Flow-control	61	
Fonts	30, 44, 47, 63, 87	
file format	54	
loading	54	
Form feed	33	
<hr/>		
G		
Garbage Filter	66	
Ground	See Earth	
<hr/>		
H		
Hardware handshaking	61	
Height	31	
Hex	26	
Hex codes	27, 60	
Hold after print	21	
Horizontal mode	68	
Humidity	88	
<hr/>		
I		
I ² C options-bus	52	
IEEE-1284	17	
Indicators	9	
<hr/>		
Installation	11	
paper roll	22	
paper-low sensor	15	
printer driver	20	
Interface	75	
Connector	16	
Inversed	31	
ISBN	34	
ISO 8859-1	87	
Italics	See	
<hr/>		
K		
Kiosk	11	
<hr/>		
L		
Landscape	30	
Language monitor	20	
Leaf-spring retainer	14, 89	
LEDs	9	
Left align	30	
Life Expectancy	88	
Light	15	
Line spacing	63	
Linefeed	33, 64	
Lines, horizontal	37	
Load paper	22	
Loading firmware	79	
Logotypes	38, 43, 47, 56	
file format	56	
Loop		
Disable	42, 63	
Length	63	
Limit	42	
Presenter	7	
<hr/>		
M		
Maintenance	78	
Measurements drawing	90	
Minimum printout length	40	
Mnemonic	26	
Mounting shelf	14	
<hr/>		
N		
n1, n2, etc.	26	
NAK	46	
Noise, excessive	62	
<hr/>		
O		
Operation	22	
Options-bus	52	
Ordering information	89	
Orientation	30	
Output slot	14	
<hr/>		
P		
Page		
Based	21	
Length	65	
Setup	69	
Type	21	
Paper		
Advance	21, 39	
Cut mode	21	

- Eject 21
 Feed backwards 39
 Feed error 46
 Feed forward 39
 Guide 10, 70, 89
 In presenter 46
 Jam 24
 Low sensor 89
 Near-end status 47
 Ordering numbers 89
 Page length 40
 Reverse 21, 39
 Roll installation 22
 Sensitivity 21
 Specifications 86
 Paper-low 15
 Connector 15
 Parallel
 Cable 17, 89
 Port 17
 Port setup 62
 Parameters 59
 recall 44
 reset to default 59
 set 45
 store 43
 Parity 61
 Partial cut 40
 Pin assignment
 Serial port 75
 USB port 77
 Pixel-line 36
 Plug and Play 6, 51
 Portrait 30
 Power
 Connection 18
 Connector 18
 Supply 18, 89, 95
 Present 40, 41
 Slowly 21
 Presenter 7
 Clear 41, 68
 Print
 bitmap 36
 commands 39
 logotype 38
 quality 62
 ruler line 37
 Speed 6, 21, 62
 Print head
 lifted 46
 pulse control 63
 temperature 50
 Printable area 69
 Printer
 driver 6, 20
 opening 24
 operable 46
 out of paper 46
 Printout length 40
 Printout, self-test 19
 Product presentation 6
 Programming 27, 60
 Protective earth 15
 Pull-detector 41
 Disable 68
-
- Q
- Quick-fit hubs 12
-
- R
- Replacement parts 81
 Reporting status 58
 Reset
 printer 43, 46
 Retract 7, 21, 66
 Reversed 31
 Right align 30
 Roll
 Holders 89
 Roll based 21
 Roll holders 13, 91
 Ruler line 37
-
- S
- Scaling 21
 Self-service kiosk 11
 Self-test 19, 39
 Send dot-line 36
 Sensors 47
 paper-low 15
 status 49
 Serial
 Cable 89
 Serial cable 16
 Serial interface 75
 Serial number 50
 Shelf 14
 Short Message Protocol 52
 Shutter 52
 Specifications 86
 Status
 acknowledge 53
 bytes 48, 49
 code 46
 commands 46
 Extended 52
 indicator 9
 messages 46
 Reporting 58
 Store parameters 43
-
- T
- Summary of control
 codes & escape
 sequences 27
 Syntax 29
-
- T
- Tab 33
 Stop positions 63
 Temperature 50
 Error 46
 Range 88
 Terminal faults 46
 Test printout 19
 Text
 alignment 30
 bold 31
 commands 30
 height 31
 italics See
 Mode 25, 87
 position 32
 reversed 31
 underline 31
 width 31
 TOF mark See Black-mark
 Top margin 66
 Torque, screws 81
 Trash bin
 See *Retract*
-
- U
- Underline 31
 UPC 34
 USB 77
 Cable 89
 Connector 17
 Port 17
-
- V
- Variable Document
 Mode 64
 Vertical
 Installation 11
 Mode 21, 68
 Voltage indicator 9
-
- W
- Wall Compensation 67
 Warning level 67, 68
 Waste
 See *Retract*
 Width 31
 Windows 2, 6, 20, 51, 79
-
- X
- Xon / Xoff 61

This page is intentionally left blank.