

TECHNICAL SPECIFICATIONS

---

# Ultra-Wideband (UWB) Vivaldi Dual-Polarized Antenna

Tapered Slot Broadband Dual-Polarized Antenna  
6 GHz – 10 GHz

**LITEPOINT**

© 2022 LitePoint, A Teradyne Company.  
All rights reserved.



## Overview

LitePoint's Dual-Polarized Vivaldi antenna is designed to perform over-the-air (OTA) test at UWB frequencies from 6 GHz to 10 GHz, covering band group 2 including UWB channels 5 to 15, and allows measurements for both horizontal and vertical polarizations for linearly polarized electromagnetic waves. The antenna is designed to deliver typical gain of 6-9 dBi across the frequency range, ideal for UWB ranging test as well as for parametric performance test.

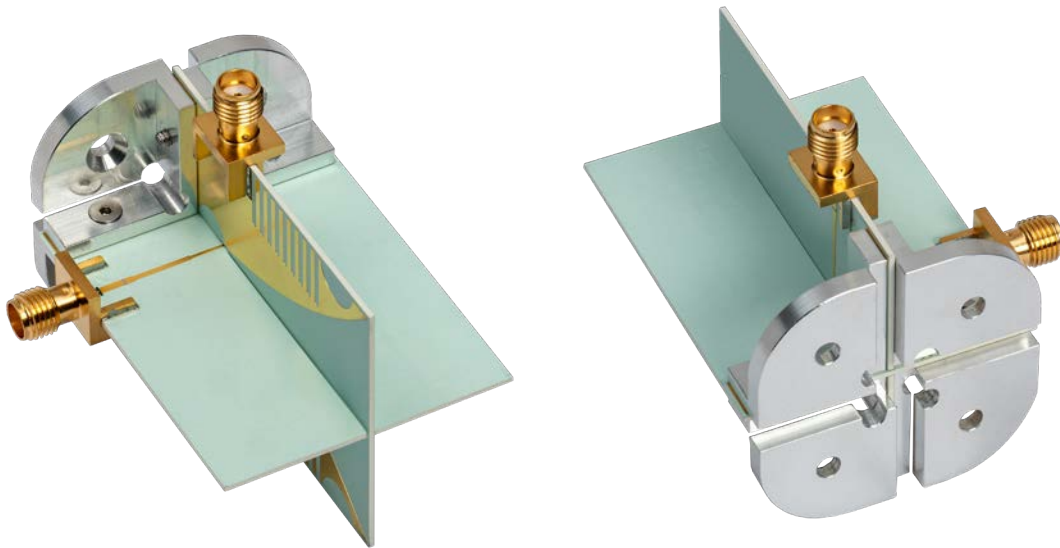

## Technical Specifications

Parameters	Value
Frequency Range	6 GHz – 10 GHz
Antenna Gain	6.2 - 9.5 dBi
Polarization	Linear Dual Orthogonal Polarization
3-dB Beamwidth (for both polarizations) 6 GHz, E-Plane 6 GHz, H-Plane 10 GHz, E-Plane 10 GHz, H-Plane	82° (Typical) 110° (Typical) 39° (Typical) 59° (Typical)
Return Loss 6 – 10 GHz	< -6dB
Time Delay 6 – 10 GHz	440 – 490 ps (Typical)

## Electrical Specifications

Parameters	Value
Power Handling	10 W
Specification Temperature	+5°C to +60°C

## Mechanical Specifications

Parameters	Value
Antenna Port	2 SMA Female (3.5mm)
Material	Ceramic laminates
Finish	Copper
Size	54mm (L) x 40 mm (W) x 40 mm (H)

## Mechanical Drawings

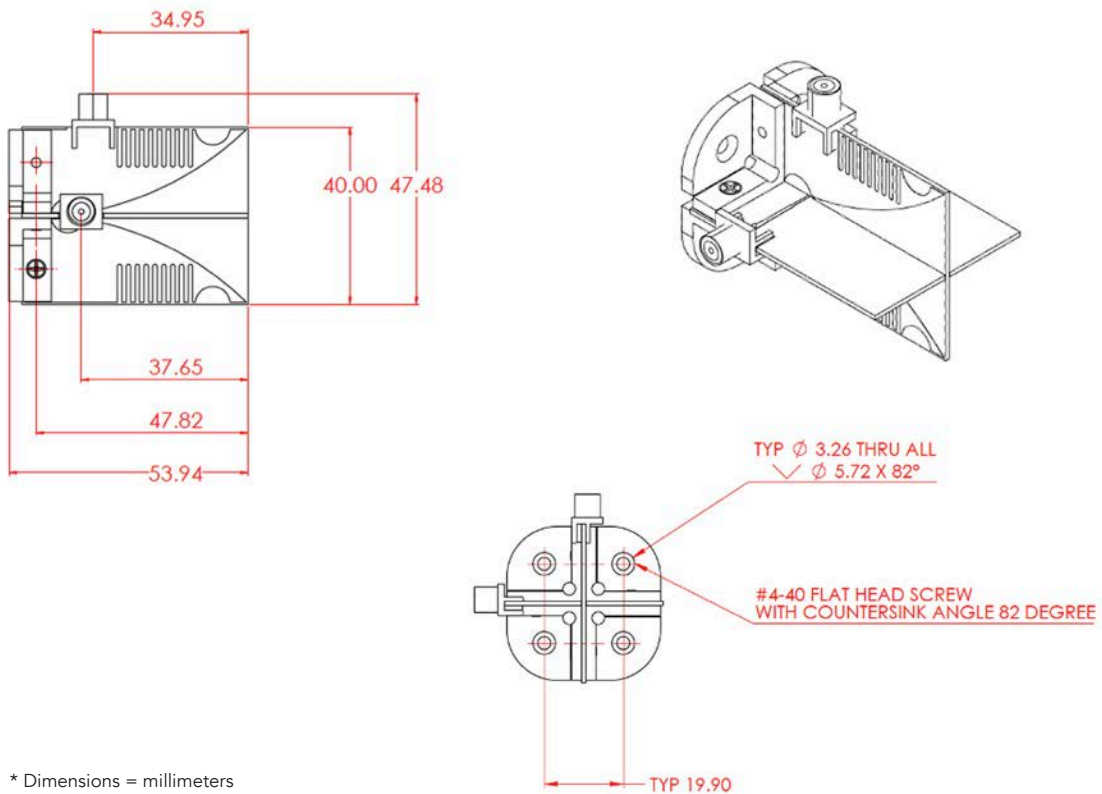

\* Dimensions = millimeters

Performance Characteristics

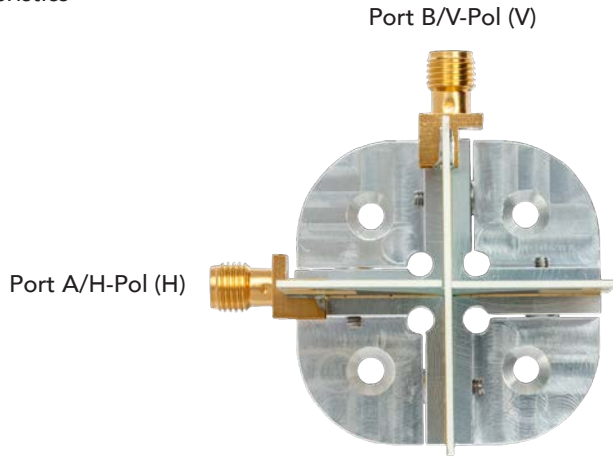

Note: The antenna ports are referred to as "Port A" and "Port B" in this data-sheet and as "H-Pol (H)" and "V-Pol (V)", respectively.

Antenna Gain

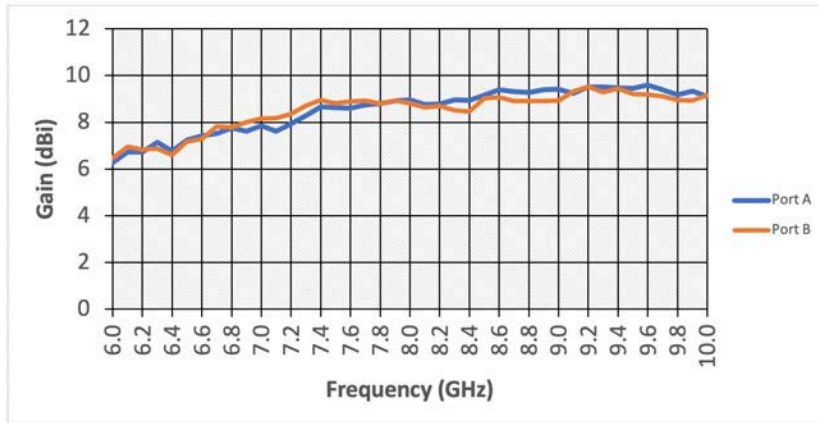

Return Loss

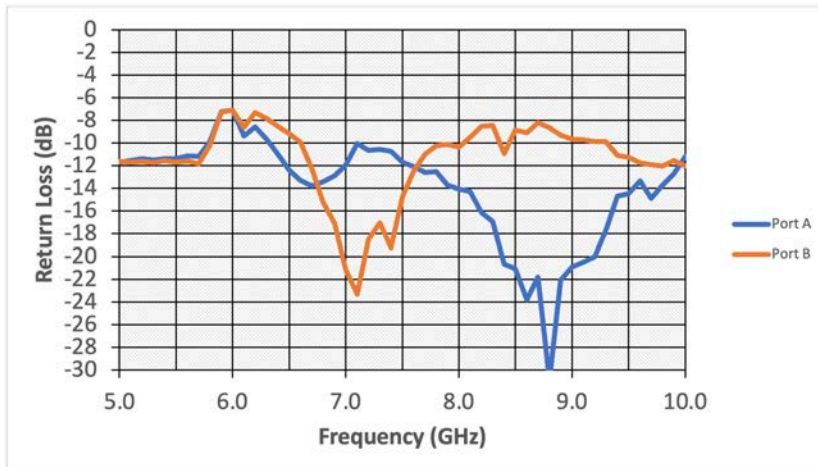

Port Isolation

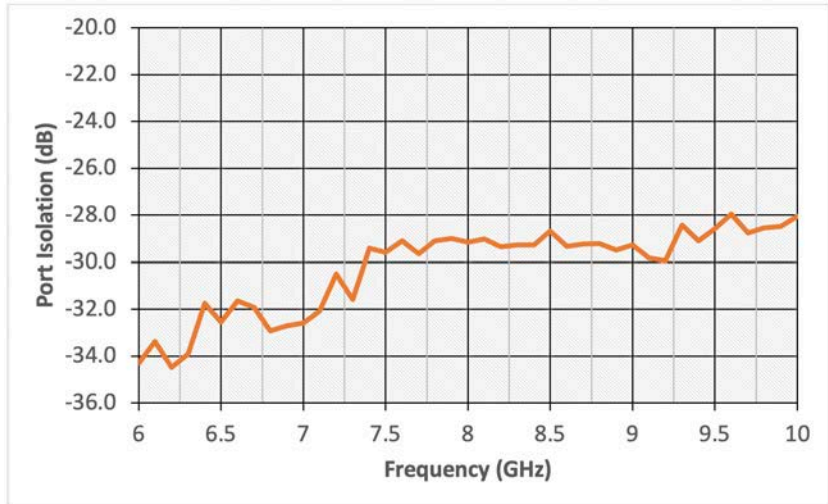

Cross-Polarization Discrimination

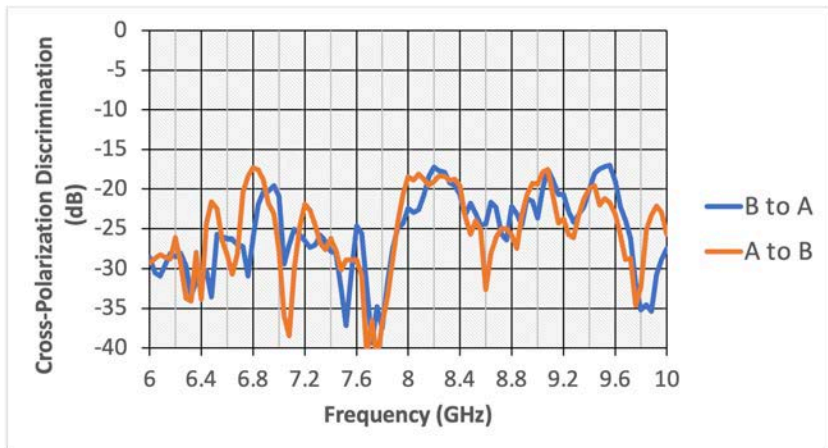

## Group Delay

For applications that require sending very wide bandwidth signals, it is important that the phase of the signals is not distorted within the signal bandwidth when they are transmitted through antennas over-the-air. The parameter that quantifies such phase distortion is Group delay (or GD). Group delay is defined as the total time delay or transmit time of the amplitude envelopes of the various sinusoidal components of UWB signals. It can also be computed as the negative slope of the signal phase as a function of frequency. If the phase of the signal is linear over the operating frequencies, the group delay will be a constant.

Two LitePoint UWB Vivaldi dual-polarized antennas are placed face-to-face in the maximum radiation direction at a distance of 30 cm, which meets the far-field region condition of  $r > D^2/\lambda$ , where  $D$  is the aperture of the antenna, 4 cm, and  $\lambda$  is the signal wavelength at the lowest operating frequency, 6GHz. One antenna is used to transmit the signal and the other receives the signal. Both transmit and receive antennas have the same polarization. The total GD of the current setup is shown in the figure below with average of 1.89 ns in the operating frequency band from 6 to 10 GHz. More importantly, the plot shows that LitePoint UWB antenna has a relatively flat group delay over the frequency band from 6 to 10 GHz as the total group delay only has a small variation of  $\pm 0.03$  ns.

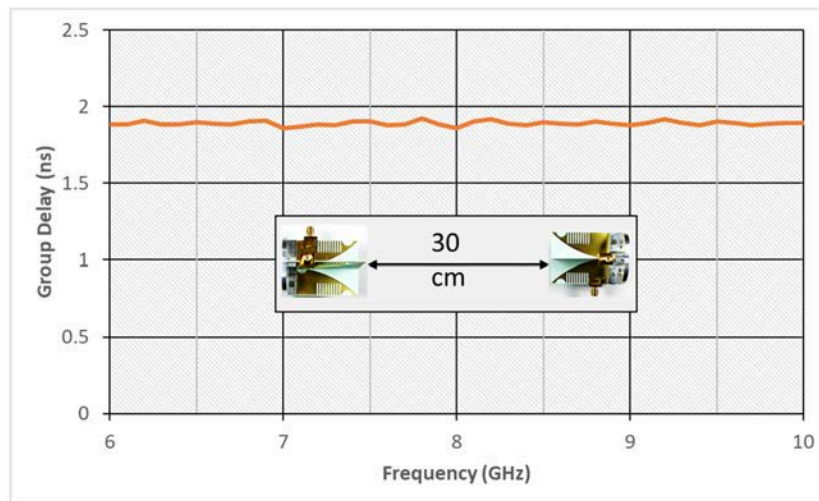

## Time Delay

For applications requiring time-of-flight or distance measurements, the time that a signal travels through the antenna is needed to make accurate measurements. Such a parameter is described by the antenna time delay (TD) and is defined by the travel from point P1 to point P2, and vice versa, as illustrated in the figure below.

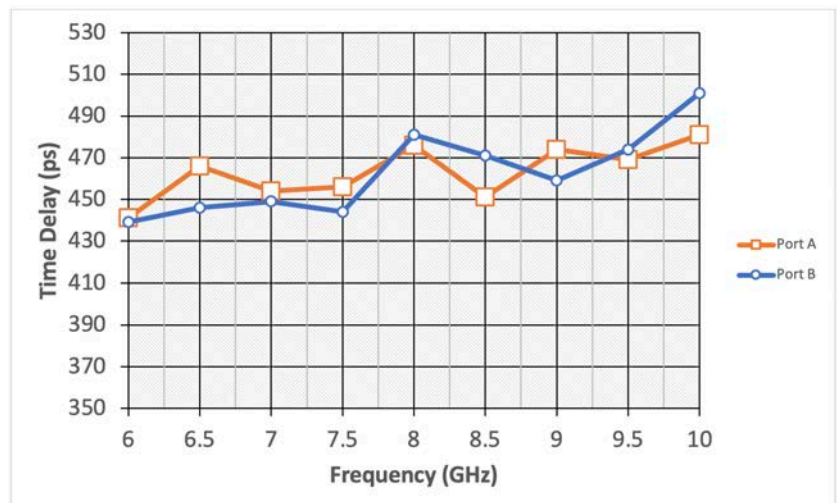
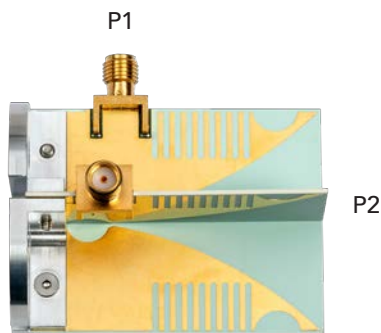

### Antenna Patterns

Illustrations of E-plane and H-plane

Illustrated below are the plane of electric field (E-plane) and magnetic field (H-plane) vectors observed with respect to the direction of maximum radiation from Port A.

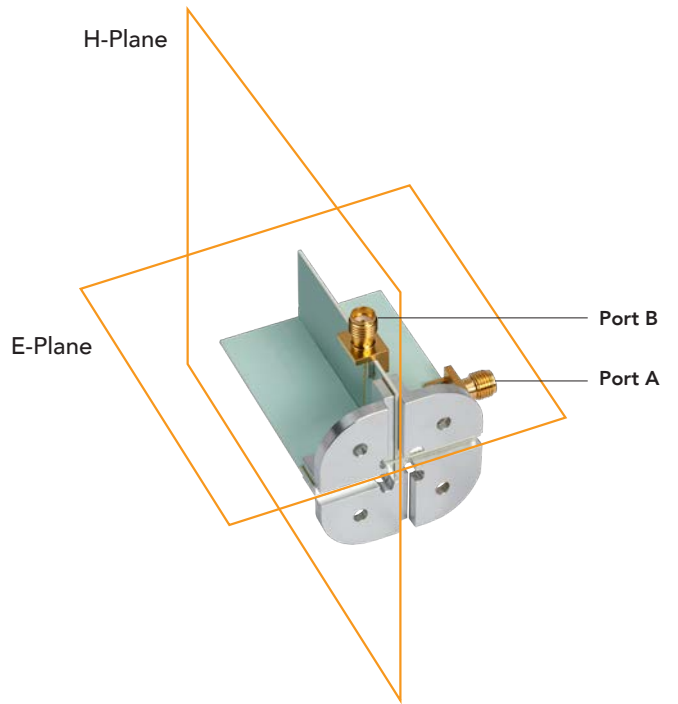

Illustrated below are the plane of electric field (E-plane) and magnetic field (H-plane) vectors observed with respect to the direction of maximum radiation from Port B.

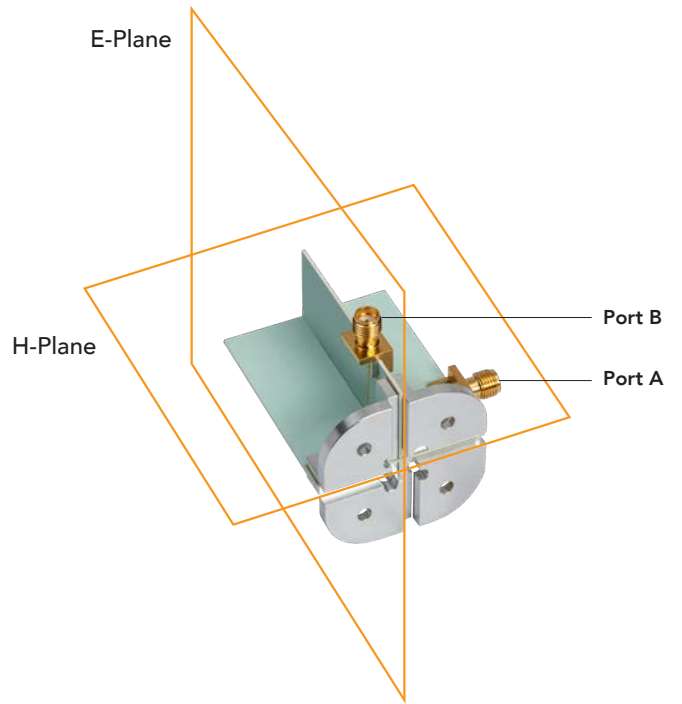

Patterns 6 GHz

Port A

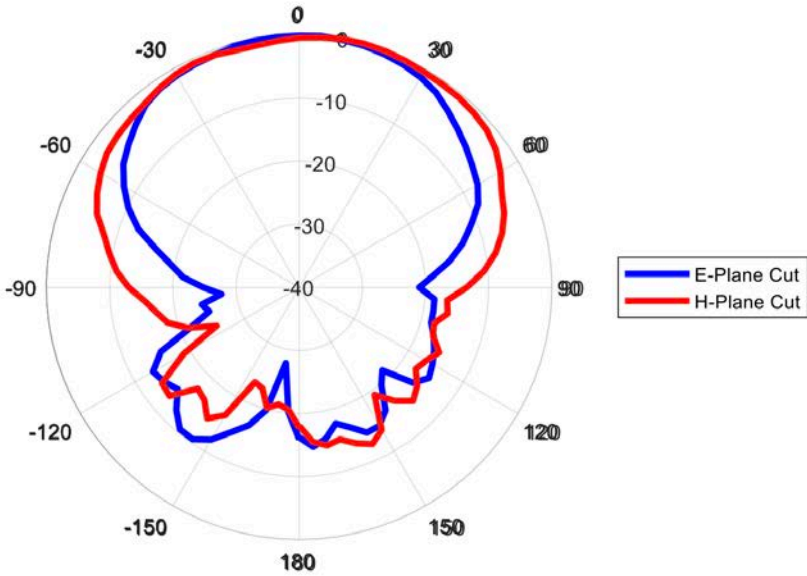

Port B

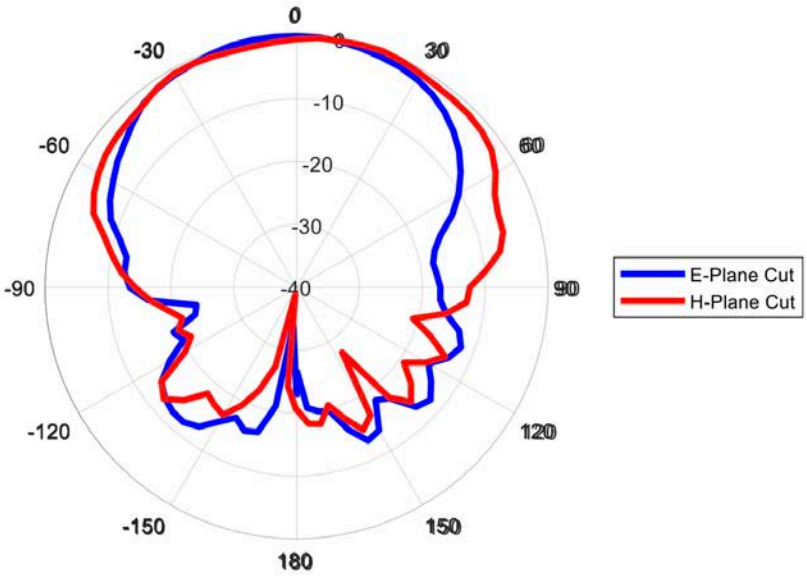



Patterns 8 GHz

Port A

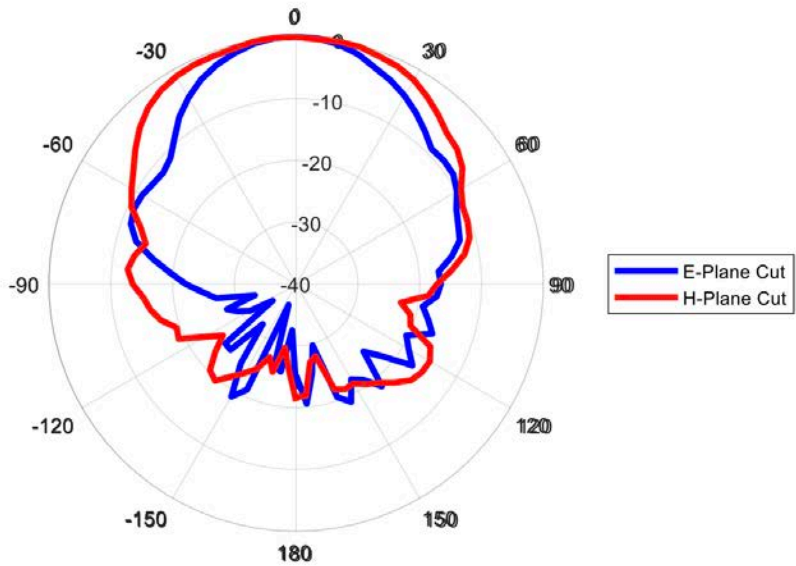

Port B

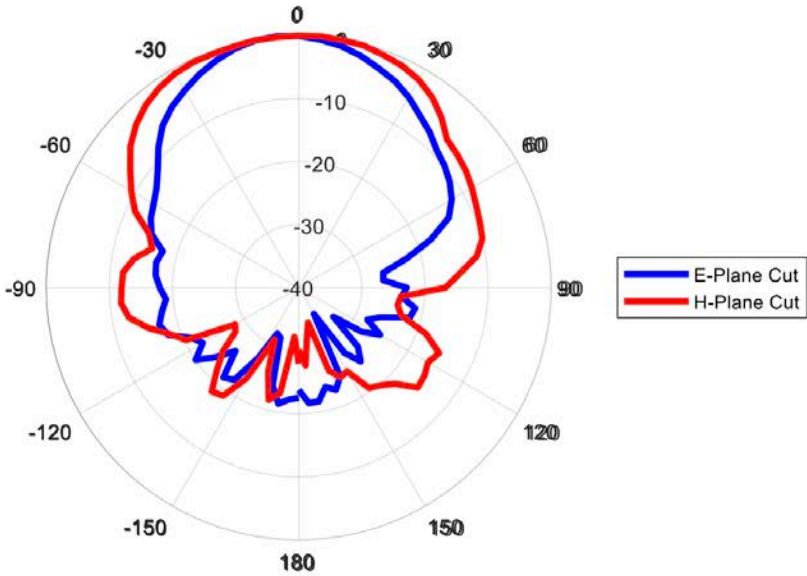

Patterns 10 GHz

Port A

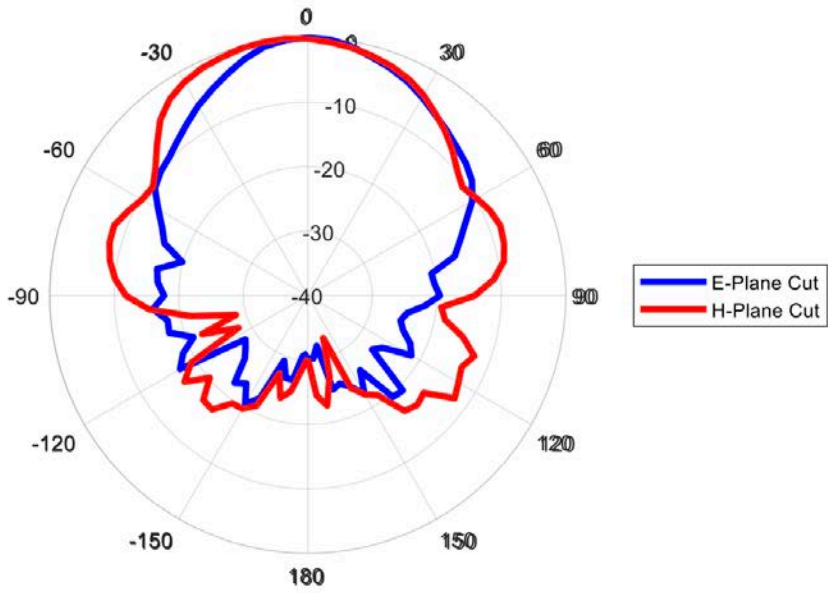

Port B

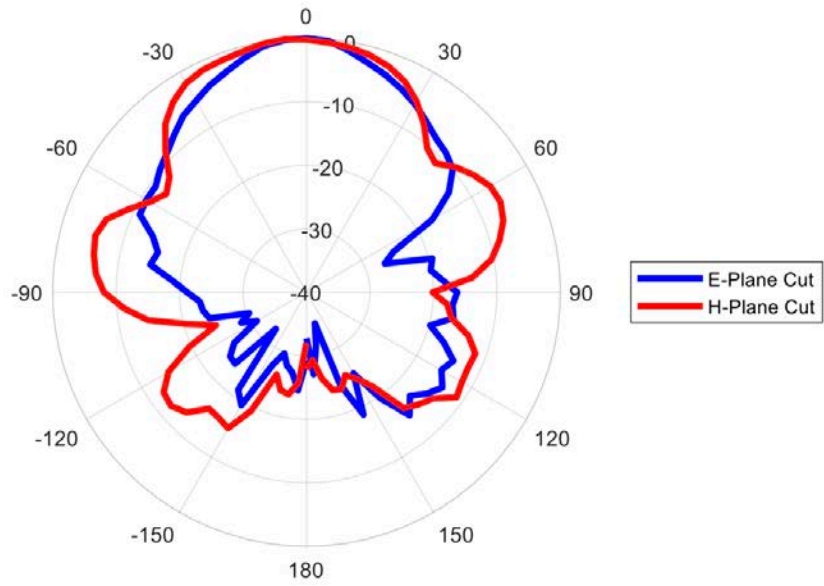

---

## Order Codes

Code	Product
0150-IUWB-021	UWB Dual Polarization Vivaldi Antenna 6-10 GHz

---

# LITEPOINT

© 2022 LitePoint, A Teradyne Company.  
All rights reserved.

## TRADEMARKS

LitePoint and the LitePoint logo are registered trademarks of LitePoint Corporation. All other trademarks or registered trademarks are owned by their respective owners.

## RESTRICTED RIGHTS LEGEND

No part of this document may be reproduced, transmitted, transcribed, stored in a retrieval system, or translated into any language or computer language, in any form or by any means, electronic, mechanical, magnetic, optical, chemical, manual, or otherwise, without the prior written permission of LitePoint Corporation.

## DISCLAIMER

LitePoint Corporation makes no representations or warranties with respect to the contents of this manual or of the associated LitePoint Corporation products, and specifically disclaims any implied warranties of merchantability or fitness for any particular purpose. LitePoint Corporation shall under no circumstances be liable for incidental or consequential damages or related expenses resulting from the use of this product, even if it has been notified of the possibility of such damages.

If you find errors or problems with this documentation, please notify LitePoint Corporation at the address listed below. LitePoint Corporation does not guarantee that this document is error-free. LitePoint Corporation reserves the right to make changes in specifications and other information contained in this document without prior notice.

## CONTACT INFORMATION

180 Rose Orchard Way  
San Jose, CA 95134  
United States of America

+1.866.363.1911  
+1.408.456.5000

## LITEPOINT TECHNICAL SUPPORT

[www.litepoint.com/support](http://www.litepoint.com/support)

Doc: 1075-0177-001  
May 2022 Rev 1